

NEW USES for FRAME AERIALS

Wireless Magazine

AUGUST

AND MODERN TELEVISION

Edited by PERCY W. HARRIS M.I.R.E.

**GEORGE
NEWNES
LTD. LONDON**

Full Details:
A.C. Four-valve
Short-waver

Gambling with
Television!

Receivers for the
Ultra-short Waves

Baird's Plans
for the Autumn

All About
Dust-Iron Cores

Tests of New Sets:
Hints for the
Serviceman,
and all the latest Radio
and Television News

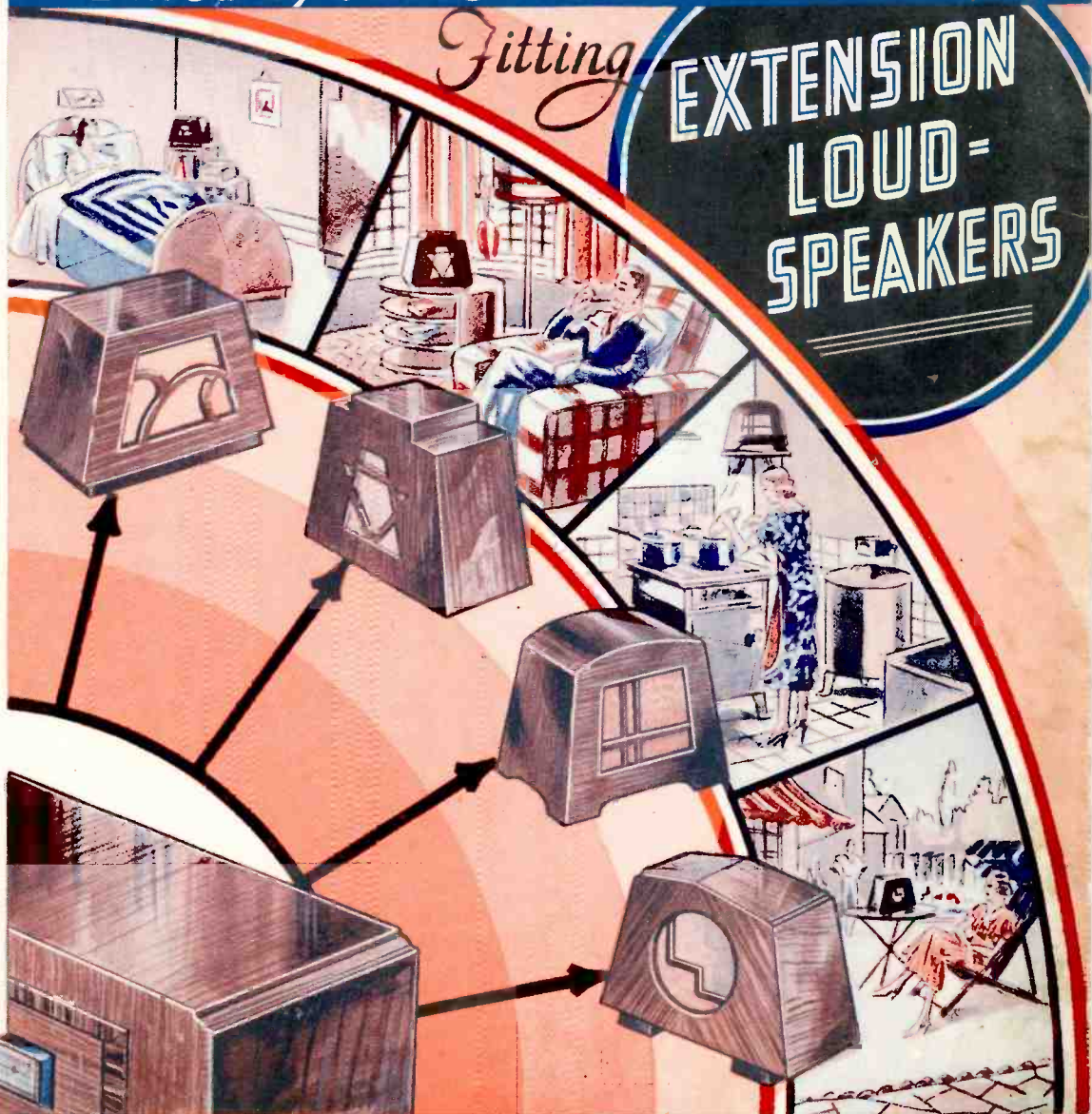

The **SUPERHET** PRINCIPLE SIMPLY EXPLAINED

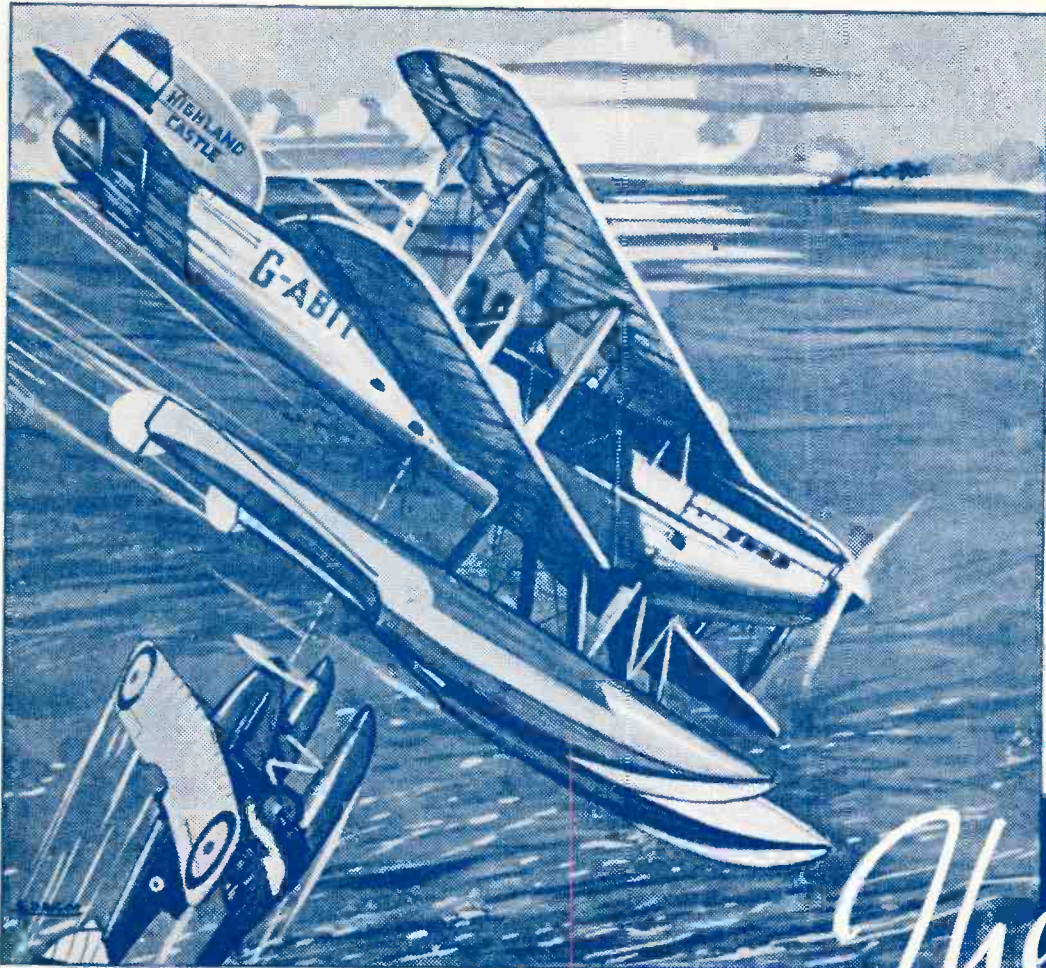

Bob nosed up again and let a short burst of Vickers belch full into the belly of the mail-carrier.

WHAT was the dread secret of the Calthorpe Catapult that brought death, swift, and terrible, to those who worked it? Even the Intelligence Service was powerless to arrest the grim sequence of disasters until Bob Rollins, Test Pilot and Adventure Seeker, found the clue to a ruthless plan of murder on the high seas.

Other dramatic adventures in the August
AIR STORIES

BLACK CAMELS By Arch Whitehouse

DELAYED DROP By Robert Wyndham

A MATTER OF LUCK
By Major L. S. Metford

THE DOLPHIN DEMON
By Jack Townsend

And Many Special Air Features

The Catapult of Death

**AUGUST NUMBER
OUT NOW**

AIR STORIES 7^D

THE NEW ALL-BRITISH AIR THRILLS MAGAZINE

Wireless Magazine

AND MODERN TELEVISION

Technical Editor :

Assistant Editor :

G. P. KENDALL, B.Sc. Vol. XXII : AUGUST, 1935 : No. 127

T. F. HENN.

Edited by Percy W. Harris, M.I.R.E.

FOR THE CONSTRUCTOR

THE A.C. STANDARD FOUR-VALVE SHORT-WAVER. Designed by G. Howard Barry . . . 4

HOW TO MAKE AN OUTPUT AND LOUDSPEAKER CONTROL UNIT. By James Shipley . . . 16

CALIBRATING THE "W.M." OSCILLATOR. By Paul D. Tyers . . . 49

COILS FOR THE CARRIER SHORT-WAVER. By Percy W. Harris, M.I.R.E. . . . 57

TECHNICAL ARTICLES

WHY CONFINE YOUR LISTENING TO ONE ROOM? By the "W.M." Technical Staff . . . 12

THE SUPERHIT SIMPLY EXPLAINED. By Percy W. Harris, M.I.R.E. . . . 17

ALL ABOUT DUST-IRON CORES. By Paul D. Tyers . . . 24

ADVANTAGES AND DISADVANTAGES OF THE A.C./D.C. RECEIVER. By the Technical Editor . . . 27

GETTING QUALITY WITHOUT WHISTLES. By P. Wilson, M.A. . . . 36

RECEIVERS FOR THE ULTRA-SHORT WAVES. By G. Howard Barry . . . 44

HINTS FOR THE SERVICE ENGINEER. By G. P. Kendall, B.Sc. . . . 47

Contents

QUERIES OF INTEREST . . . 56

A CHAT ABOUT QUALITY IN THE OUTPUT STAGE. By G. P. Kendall, B.Sc. . . . 60

THOSE NEW SEASON'S SETS. By the "W.M." Set Selection Bureau . . . 62

TESTS OF THE NEW SETS :—

G.E.C. BATTERY OVERSEAS SEVEN . . . 64

PYE MODEL TP/B BATTERY SUPERHET . . . 65

HYVOLISTAR A.C./D.C. AMPLIFIER, 10-11-WATT MODEL . . . 66

TESTS OF NEW APPARATUS. By the "W.M." Technical Staff . . . 76

GENERAL ARTICLES

RADIOLYMPIA PROSPECTS.—The Editor's Page . . . 3

FINISHING THE B.B.C. NETWORK. By T. F. Henn . . . 10

SHORT-WAVE CONDITIONS ARE STILL IMPROVING. By G. Howard Barry . . . 21

AUSTRALIA'S LUCERNE PLAN. By R. H. Atkinson . . . 22

DENMARK—THE COUNTRY WITH THE MOST LISTENERS. By Hans W. Priwin . . . 40

RADIO NEWS FROM ABROAD. By Jay Coote . . . 43

"W.M." SHORT-WAVE IDENTIFICATION PANELS. Compiled by Jay Coote . . . 46

BETWEEN OURSELVES. By Broadcaster . . . 52

NEWS FROM THE RADIO SOCIETIES. By G6QB . . . 70

WAVELENGTHS OF THE WORLD'S BROADCASTERS IN TUNE WITH THE TRADE. By Examiner . . . 78

NOTES AND NEWS FROM ALL PARTS . . . 79

NAME THIS SET! . . . 80

COUPONS : INDEX TO ADVERTISERS . . . 80

TELEVISION SECTION

GAMBLING WITH TELEVISION! By the Editor . . . 29

TELEVISION IN THE MAKING . . . 30

WHAT IS THE LIFE OF A CATHODE TUBE? By P. Woodward . . . 32

WHAT YOU SHOULD KNOW ABOUT LIGHT. By Morton Barr . . . 33

TELEVISION NEWS FROM E.M.I. . . . 35

GRAMO-RADIO FEATURES

RECORDS FOR YOUR RADIOGRAM. By T. F. Henn . . . 68

Subscription Rates: Inland and Abroad, 15s. 6d. per annum; Canada, 13s. 6d. per annum.

Editorial and Advertisement Offices—"Wireless Magazine," George Newnes, Ltd., Southampton Street, Strand, London, W.C.2. Registered at the G.P.O. for transmission by Canadian Magazine Post.

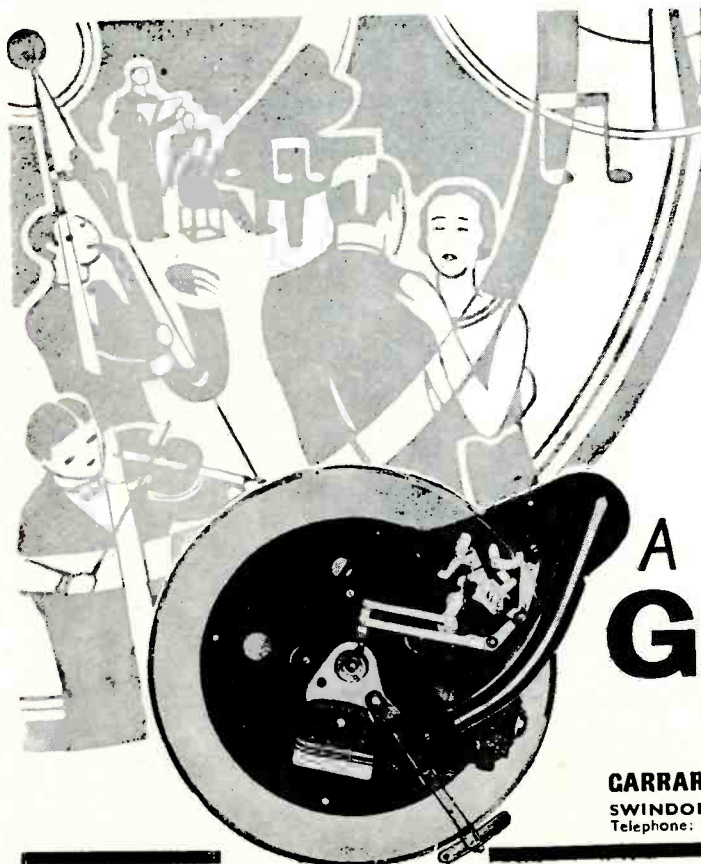

Tonal Balance!

Whatever your taste in music, from the balanced rhythm of a dance band to the sublimity of a classical symphony, the Garrard Radio-Gram ensures faultless reproduction. The new Type B is especially designed for the owner of the small set, fits into a space 14½ in. by 13½ in., and incorporates the proved Garrard Motor.

PRICES:

Type B Radio-Gram Unit—	
With A.C.4 Induction Motor	62/6
With 202A Induction Motor	69/-
With U.5 Universal Motor	87/-

A GARRARD

Quality Product

GARRARD ENGINEERING & MANUFACTURING CO., LTD.
 SWINDON, WILTS. Telephone: Swindon 534 & 535 (2 lines).
 17 GRAFTON ST., W.1. Telephone: Regent 7595.

To the TECHNICAL MAN

who isn't interested in
wireless set advertisements



THE object of this announcement is not to sell you anything. We know that there are still some people who would rather build their sets than buy them—even though it costs less to buy a “His Master’s Voice” set than to build one of comparably advanced circuit.

If you are in this category, we hope that in time you will realise as thousands of other home constructors have already done, that if only by virtue of their technical resources and equipment, there is nothing that you can make which “His Master’s Voice” cannot make better. Then, if not now, we know that you will buy an “H.M.V”.

At the moment, however, you have non-technical friends who ask your advice on which set *they* should buy. In their interests, as well as your own, visit the “His Master’s Voice” stand at Olympia, and see the best range of radio instruments ever produced by any manufacturer, at prices which make them also the best real value.

Be sure and visit us. We want to see you.

“HIS MASTER’S VOICE”

AT OLYMPIA—VISIT OUR STAND

THE GRAMOPHONE COMPANY, LTD., 98-108 CLERKENWELL ROAD, LONDON, E.C.1

Wireless Magazine

and Modern Television

The Editor's Page

August, 1935

Radiolympia Prospects

AT the time of writing there is a great deal of activity behind the scenes among manufacturers who are exhibiting at this year's Wireless Exhibition. While it is unlikely that Olympia will reveal any radical changes in design, it is certain that better value than ever will be offered.

But what of quality? With the exception of the few firms who are not prepared to sacrifice quality of reproduction to cost of manufacture, the general level is far below what it should be. It would almost appear that every technical advance making better reproduction possible has been used, not to give the public this better quality but merely to reduce the cost of maintaining the *previous* quality. In ease of handling, selectivity, reliability and cost the last few years have witnessed tremendous advances, but only in the laboratory do we yet hear the kind of reproduction that should be standard in the home.

One of the chief difficulties facing the manufacturer is to get sufficiently high selectivity for modern conditions without too great a sacrifice of quality. This month P. Wilson, M.A., whose previous articles have been so greatly appreciated, adds further to his laurels by solving for us the problem of "getting quality without whistles." Here, once again, we have a revival of an old idea in a greatly improved form, and we commend this article to all who consider quality is of paramount importance in broadcast reception. Admittedly the scheme is not perfect, but it certainly achieves what many people have said is impossible.

WHICH country has the highest percentage of listeners in its population? Great Britain you think? Not at all! Denmark holds the record. Remarkable figures regarding the radio conditions in this country are given by our Danish correspondent, Hans W. Priwin, in this number. This is the first of a series of articles dealing with reception conditions and the wireless organisations of different European countries which Mr. Priwin will be contributing to "W.M."

Short-wave reception continues in high favour among our readers, to judge by the popularity of our short-wave set designs. Those of us who have grown up with the art remember that not long ago 100 metres was considered a very short wave. Now, when everyday transoceanic reception on 25 or 30 metres

is commonplace the advanced amateur is hunting for new fields to conquer and is finding them in the ultra-short-waves below 10 metres. G. Howard Barry in a further contribution to his series on what you should know about short-wave design, discusses a number of practical points connected with ultra-short-wave receivers. All radio enthusiasts should study this article if only because these ultra-short-waves are of tremendous importance in the development of television.

And speaking of television, the present position in this country is, in our view, profoundly unsatisfactory. Notwithstanding the fact that the Television Committee Report made it quite clear that no time should be lost in developing a practical television service, most of the time is being spent in talk and little in action. Neither the trade nor the television companies are to be blamed in this connection, and our views on this important subject form the substance of a separate article, "Gambling With Television," which you will find on another page.

A PRACTICAL public television service is much nearer than many people think, and it is no good blinding ourselves or others to facts. Unfortunately certain sections of the wireless industry, frightened that the public would cease to buy ordinary wireless sets when the Television Report appeared, have rather overshot the mark in their campaign to prevent misunderstanding.

Once you have made it clear to the public that the present sound-broadcasting programmes will continue for many years to come and that television is a separate service requiring separate instruments there is nothing to be gained by belittling the prospects of the new art or trying to create the impression that it will be many years in arriving.

We are therefore glad that the previously made decision not to have a television section at Olympia this year has been reversed and that the public will now have television exhibits suitably displayed.

Percy W. Harris.

Gambling with Television!—See Page 29

The A.C. Standard

An A.C. Version of the Author's Successful

Designed
by
G. HOWARD
BARRY

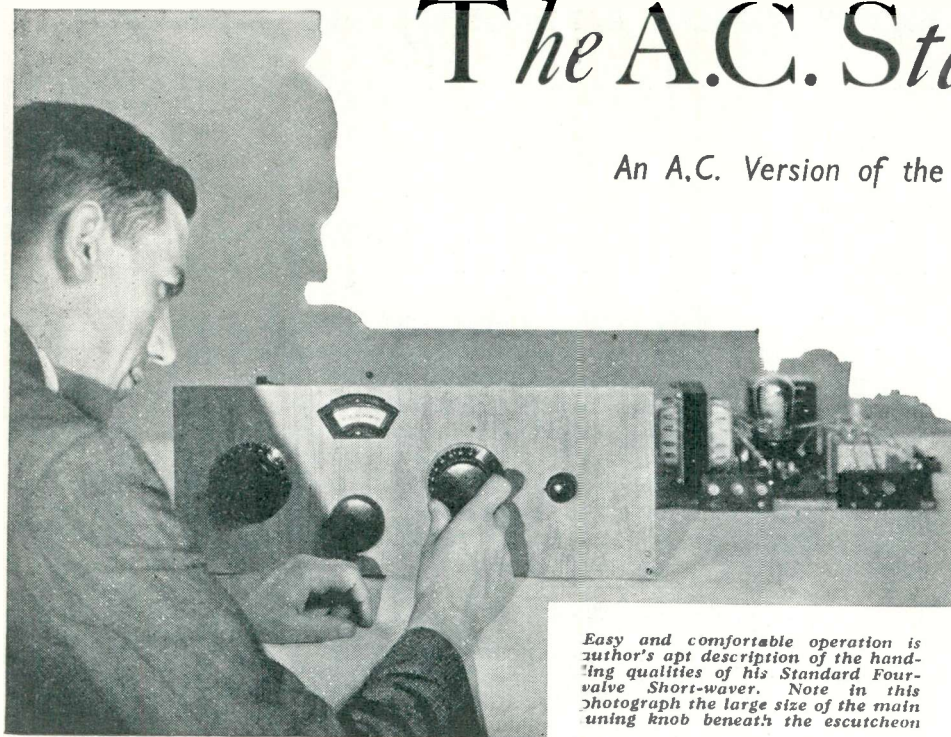

Easy and comfortable operation is author's apt description of the handling qualities of his Standard Four-valve Short-waver. Note in this photograph the large size of the main tuning knob beneath the escutcheon

IN the March issue of "Wireless Magazine" I described a four-valve battery-operated short-wave receiver which I designed with one idea—to give really *easy* and *comfortable* operation. Judging from readers' letters it seems to have fulfilled this object; and it has certainly been the means of introducing many people to the joys of short waves in a very painless manner!

Four-valve battery sets, however, are not so popular in these days of all-mains operation and it was decided quite a long while back that a mains version of the same set was definitely called for.

Never a Moment's Worry!

Mains valves today have very much better characteristics than their nearest equivalents in the 2-volt battery ranges; power transformers chokes and smoothing condensers are available at really reasonable prices; and a mains receiver has that beautiful quality of going on and on without frequent changes and charges.

I saw no reason to change, or even to modify the design of the original receiver. The circuit was absolutely straight and of the type that simply couldn't develop snags. My own battery set has never given me a moment's worry.

With this in view, therefore, I decided upon a conversion rather than

the planning of a new set and I operated upon the original battery receiver which, as a result, is now no more. It is presented here in its new guise—the A.C. Standard Four-valve Short-waver.

Since many readers will probably build this set without having previously tackled the battery version, I must cover some of the old ground once again; but I should like to refer anyone who is in doubt about any

points to page 124 in the March issue and to read my original article.

The circuit utilises an untuned high-frequency stage as an "aerial buffer." No amplification is expected from this stage; if a little is obtained, so much the better. This valve is parallel-fed and coupled through a neutralising condenser to the grid circuit of the detector.

The detector circuit is absolutely conventional except for the use of a



The general arrangement of the A.C. Standard Short-waver resembles that of the battery model: the layout on the top side of the chassis remains unaltered except that five-pin valve holders have been fitted

Four-valve Short-waver

Battery Version Described in the March, 1935, "W.M."

10,000-ohm resistance in place of the more usual high-frequency choke. The resistance gives an equally smooth reaction control and completely does away with the risk of dead spots due to choke resonance.

The first low-frequency stage is resistance-coupled; R.C. suiting the average short-wave detector very well. The values of the coupling components have been chosen to give a certain amount of correction, since full use is generally made of the reaction control for short-wave work and the usual values are apt to lead to "boomy" reproduction.

Circuit Details

The anode resistance is of 50,000 ohms, the grid condenser .002 microfarad and the grid leak 2 megohms. The valve used, an AC/HL, has a fairly high gain and is capable of fully loading the output valve (AC/P) on strong signals.

Transformer coupling is used between the last two valves and a volume control of 250,000 ohms is provided across the secondary of the transformer. Choke output, with a

coupling condenser of 2 microfarads, completes the story.

I should like, next, to enumerate the modifications that have been necessary to converting the set for A.C. operation. None have been made, as I have said, to the basic circuit. Automatic grid-bias, however, has naturally been provided for the three valves requiring it. Each valve except the detector has a 1,000-ohm resistance, by-passed by a 2-microfarad condenser in its cathode earth-return.

I am a firm believer in equipping an all-mains set with only two high-tension terminals —positive and negative —all voltage-adjusting being looked after in the set itself. The second H.T. + terminal, which formerly supplied an appropriate voltage to the screen of the first valve, has therefore

been removed, and the screen volts are provided by a fixed potentiometer.

From the screen terminal a 30,000-ohm resistance goes to earth and a 50,000 to H.T. +. The screen is by-passed to earth by a 1-microfarad condenser and obviously

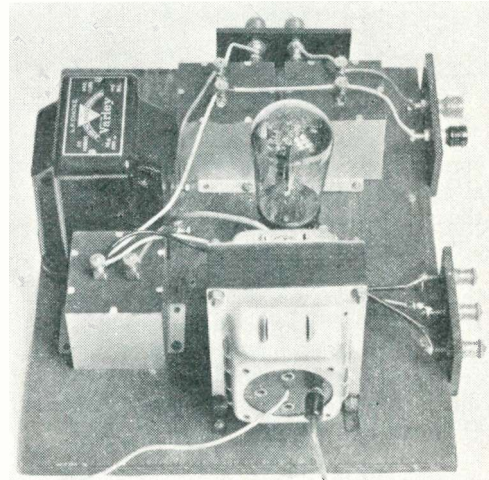

The mains unit is assembled on one side of a simple wooden baseboard. On the power transformer is the plug-and-socket method of mains-voltage adjustment

receives about three-eighths of the total high-tension voltage.

The latter being about 160 under working conditions, we have a steady 60 volts on the screen. This needs no adjustment and no provision has been made for such.

De-coupling

No elaborate de-coupling arrangements have been made. The detector, largely by virtue of the 50,000-ohm resistance in its anode circuit, is perfectly stable; the first and last valves receive the full high-tension voltage; and the first low-frequency stage is de-coupled by means of a 2,000-ohm resistance and 2-microfarad condenser to earth.

The major alterations that have to be carried out by owners of the battery version are, of course, the provision of 5-pin valve holders and re-wiring of the heaters with twisted wire; the automatic grid-bias

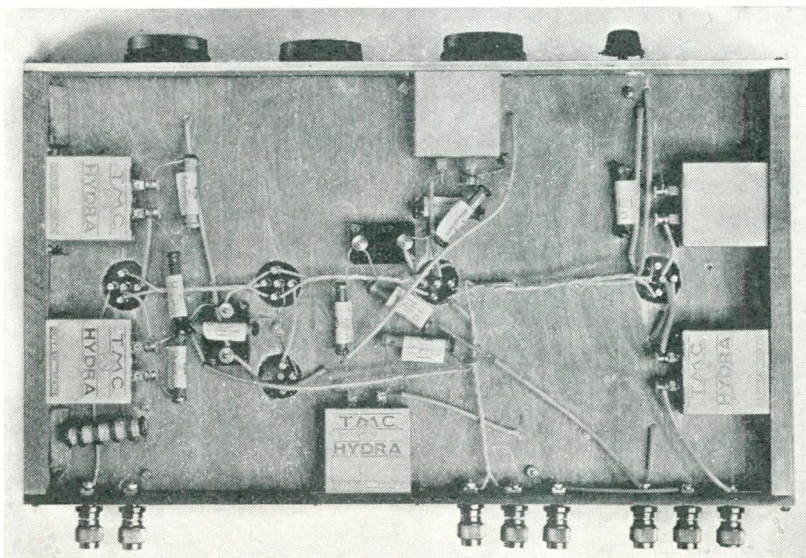

You will notice that in this set the underside of the baseboard carries all the biasing and de-coupling arrangements. Note, particularly, the method of mounting the large-capacity condensers on the sides of the wooden assembly

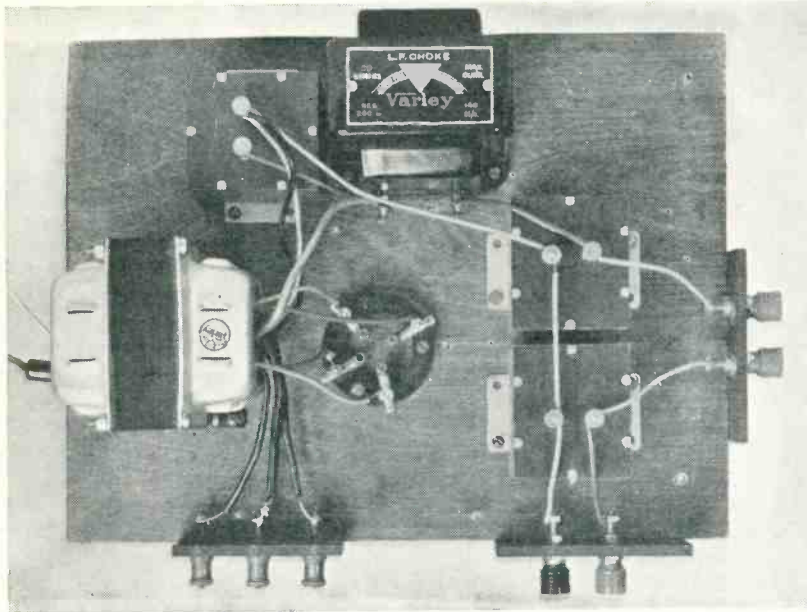

A plan view of the mains unit showing the extremely simple nature of the layout and the wiring. Observe that the heater leads run straight from the transformer to terminals A, B, and C

Its characteristics are sufficiently different from the choke in the anode circuit to ensure that no instability will result. Many people favour the use of a resistance in this position, but I have found it giving rise to very troublesome effects when one happens to live near a powerful station. Even in South London it is possible to detect a quiet background of both Brookman's Park stations spread over the entire short-wave spectrum like butter over bread! With the choke this trouble does not arise.

Band-spreading Scheme

Perhaps I should refer once more to the band-spreading scheme in use. The main tuning condenser—on the left—is of .00015-microfarad capacity, but in parallel with it, and driven by the slow-motion dial in the centre, is one of .000015-microfarad. All final tuning is carried out on this, and it is possible to set the larger condenser for each interesting band

components; and the installation of the fixed potentiometer already referred to. All these points are clearly shown in the under-chassis wiring diagram.

On the top deck the set is substantially unchanged, the only alteration that occurs to me being the connection of the low-potential end of the volume-control directly on to the metallised baseboard instead of to a grid-bias wander-plug. The former low-tension switch has, of course, been removed entirely, its absence leaving a hole that needs filling with one of the compounds prepared for this purpose. (For example, plastic wood.)

Home-made or Ready-made H.F. Choke

One slight change that has been carried out is the substitution of an Eddystone short-wave choke for the home-made affair that was formerly connected in the grid circuit of the first valve. The new choke is similar in appearance to a wire-end resistor and is connected straight across the aerial and earth terminals. (I have used it to show that it is not necessary to wind one's own if a purchased one is preferred.)

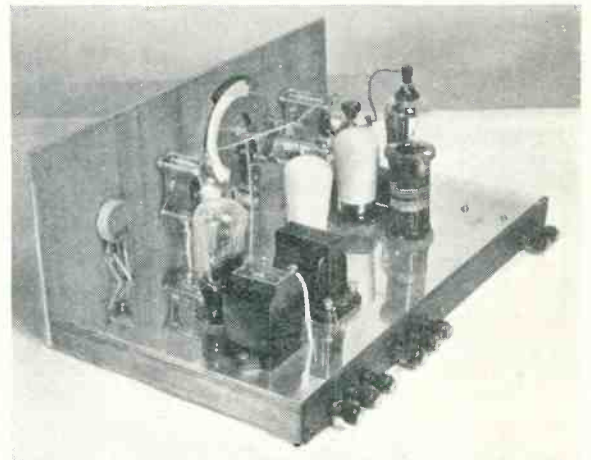

As in the case of the battery version, the mains receiver is assembled on a metal-covered baseboard

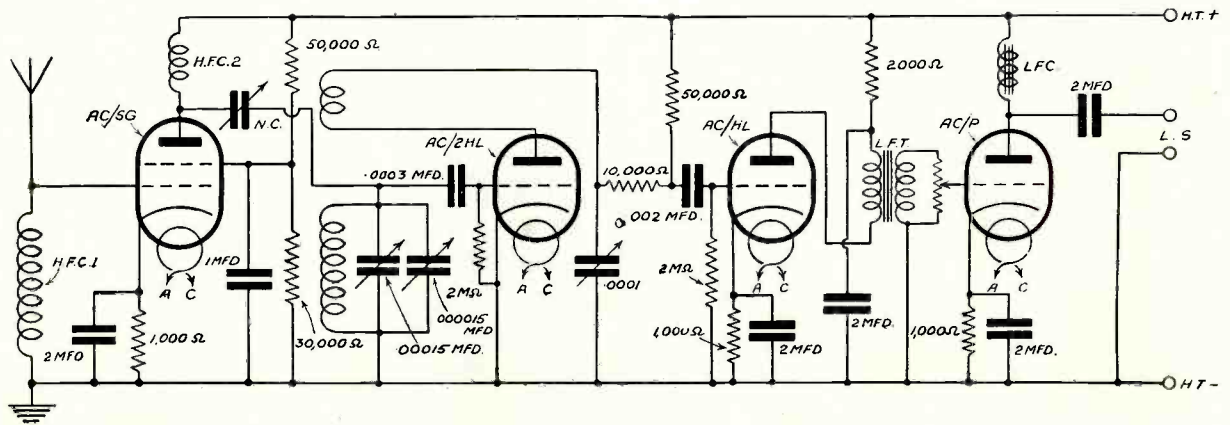

Here is the circuit of the Standard A.C. Four-valve Short-waver. It is similar to the battery version with modifications to include the necessary biasing and de-coupling arrangements for mains working. The points marked A and C, H.T.+ and H.T.— are connected to the corresponding positions on the mains unit

in such a way that the band is really well spread out on the dial of the other.

Tuning is in no sense a "three-dial business," however. By that I mean that the operator does not require three hands and only has to think of tuning on one condenser or the other and reaction control. The latter is an easy business and only implies an occasional lazy movement of the dial of the reaction condenser. For this we have to thank the untuned high-frequency stage, which effectively irons out the dead-spots and bumps which might otherwise be caused by aerial resonance.

Power-pack Circuit

We must now proceed to the power unit. Valve rectification has been chosen, using a full-wave rectifier rated at 350 volts R.M.S. and 120 milliamperes. Actually the total consumption of the set is less than 30 milliamperes.

The transformer chosen is rated at 325-0-325 volts and this necessitates the use of smoothing condensers of the 400-working-volt type. Directly across the rectifier output is connected a 4-microfarad condenser; following this there is a 20-henry choke in the positive lead, with another 4-microfarad condenser on the other side of it; finally there is a pair of terminals, marked X and Y, on the far side of which is a third condenser of the same size.

Output Voltage Adjustable

The purpose of these terminals is, in a way, to make the final output voltage adjustable; but their chief use is that they allow the individual reader to use an energised moving-

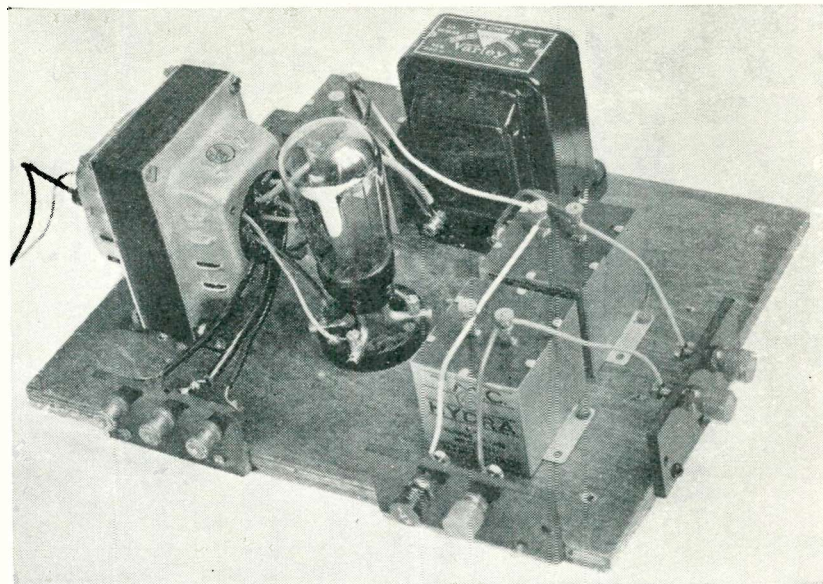

The two terminals on the right can be used to supply field current for the loudspeaker, the other pair are H.T. + and H.T. -, while those on the left are for the heater circuit

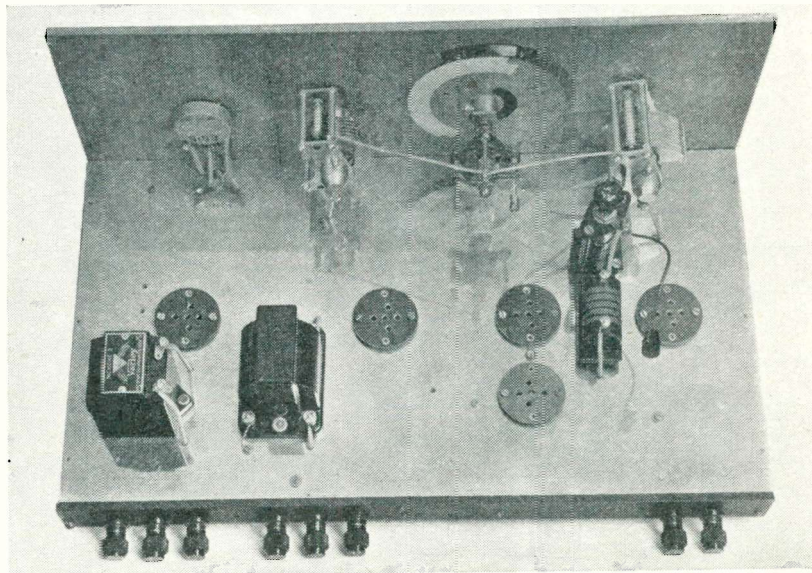

A plan view of the receiver without valves or coil. Note the extremely clean layout!

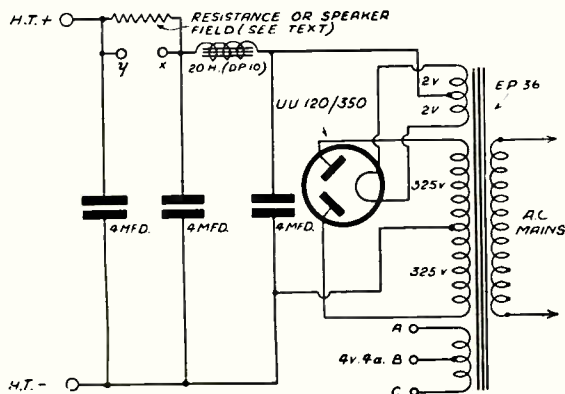

A special feature of the mains-unit circuit is the provision of the points X and Y from which current can be drawn for the field of a moving-coil loudspeaker

coil loudspeaker if he so desires. Any loudspeaker with a 2,000- or 2,500-ohm field winding is suitable; if a permanent-magnet type is used a 3,000-ohm resistance of the 3-watt type should be connected across the terminals X and Y. The supply to the whole set may be reduced further by substituting a 5,000-ohm resistance.

High-tension Voltages

Under these conditions the high-tension voltage applied to the set is about 160, at which voltage the last valve will pass about 14 milliamperes. The voltage actually measured at the detector anode was about 70 and on the screen of the first valve 60.

The power transformer has two 4-volt windings, one for the rectifier filament and the other rated at 4 amperes for the heaters of the four valves in the set. The connections to the latter have been brought out to the three terminals marked A, B and C. The "A.C." terminals, A and C, are,

Scale Layout and Wiring Diagram

(Note: the diagram for the mains unit will be found on page 71.)

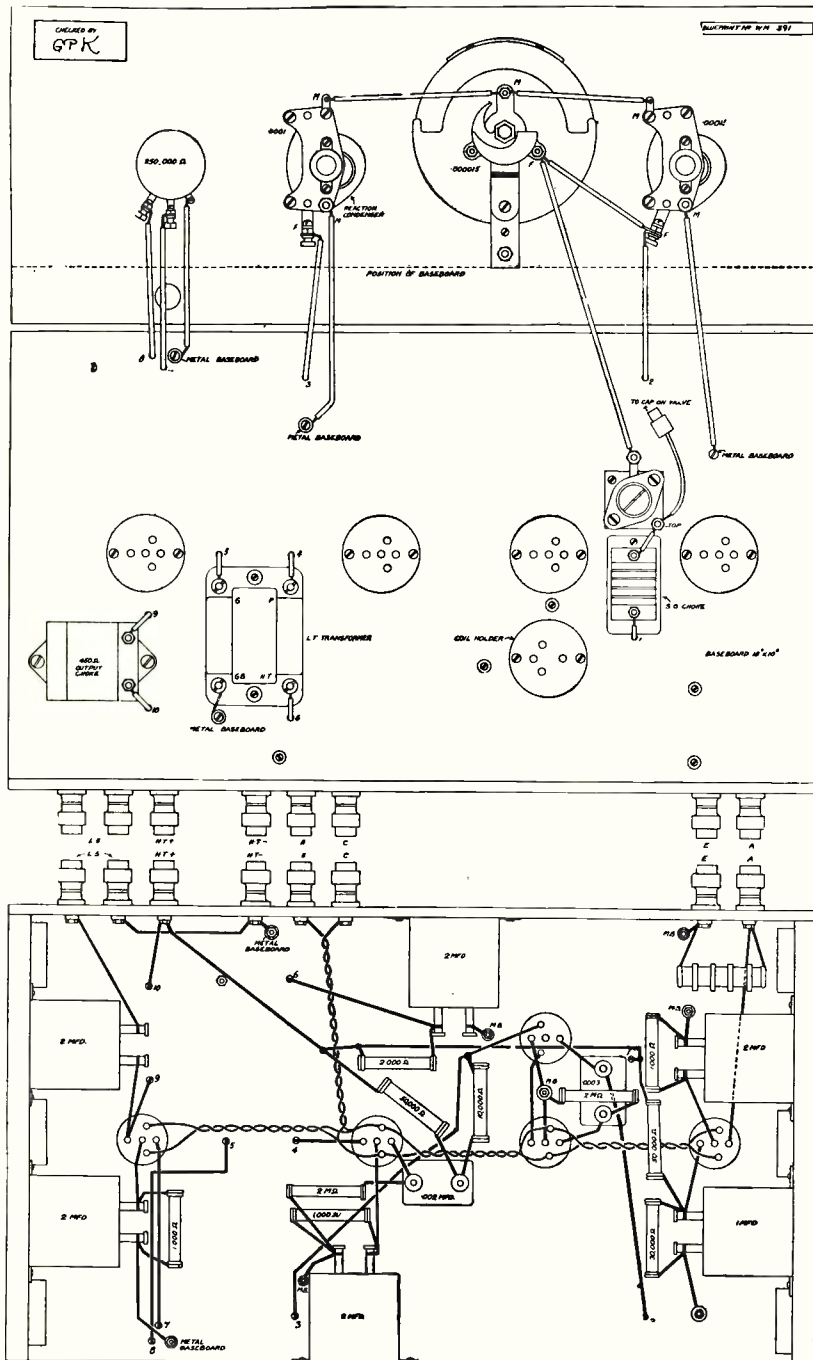

If desired, a full-size blueprint can be obtained for half-price, that is 9d., post paid, if the coupon to be found on the last page is used before August 31. Address your application to the "Wireless Magazine" Blueprint Department, George Newnes, Ltd., 8-11 Southampton Street, Strand, London, W.C.2. Ask for No. WM391

in any event, connected straight to the heater terminals at the rear of the set. The high-tension terminals, similarly, are connected in the appropriate places.

The point at which a little doubt may possibly occur is in the connection of the B terminal—the centre-tap. In some cases this will be connected, in quite the conventional matter, to the H.T.—terminal either on the power unit or on the set—it doesn't matter which. This connection has not been made permanently, as it might have been, because in my own case there was quite a trace of hum under these conditions.

Avoiding Hum

Hum-free reception was possible, however, by connecting the H.T.—terminal to either A or C, but *not* B. This is doubtless due to the fact that the heater winding likes to have a definite high-frequency earth at one end. If the earth connection goes to the centre there is, of course, quite an appreciable amount of inductance between it and the heaters themselves, which ever side of them we may be thinking of.

COMPONENTS—OUR POLICY

COMPONENTS used in receiver designs published in "Wireless Magazine" are chosen for their suitability, efficiency and reliability. Their selection must not be taken to indicate any more than this, nor that other good-quality components are not equally suitable, save in a few cases clearly indicated where there are no suitable alternatives.

In a large number of cases there exist numerous good alternatives, as a study of the advertisement pages of this journal will show

In the ordinary way the connection of a condenser of .01 microfarad across each half of the heater winding would put things right; but this particular set definitely preferred to have one end of the winding earthed. Try your H.T.—connection, therefore, on each terminal, A, B and C in turn, and leave it on the one that gives the greatest freedom from hum.

The omission of a direct earth connection from the set does not seem to have any effect whatever upon results. It is therefore worth while trying yet another adjustment—no

earth at all on the set and a direct earth-lead *and nothing else* on terminal B. This arrangement worked very well with the original set, but it is impossible to give a ruling that will suit each individual case.

Should you be absolutely unable to dispose of trouble from hum—particularly if it is that type of modulation hum that occurs only on the point of oscillation, it may be necessary to connect condensers of .01-microfarad from each anode of the rectifier valve to one filament terminal. These have not been installed permanently, because they should rarely be necessary.

A Valuable Tip!

The tip is worth passing on, though—and don't connect one from each anode to the centre-tap of the filament winding for it is better to take one to each side of that winding or, as I put it before, to each filament terminal on the rectifier valve holder.

The primary of the power transformer is readily adjustable for A.C. inputs of 200, 215, 230 and 245 volts merely by the placing of a wander-plug. Look to this small point before you connect things up.

Heater Wiring

The heater wiring in the set itself has been carried out with ordinary tinned wire in insulating sleeving, tightly twisted. The connections from the set to the power unit should similarly be made with twisted wire, preferably heavy flex. It is an advantage to leave the power unit quite a few feet away from the set; if a semi-permanent installation is contemplated lead-covered cable may

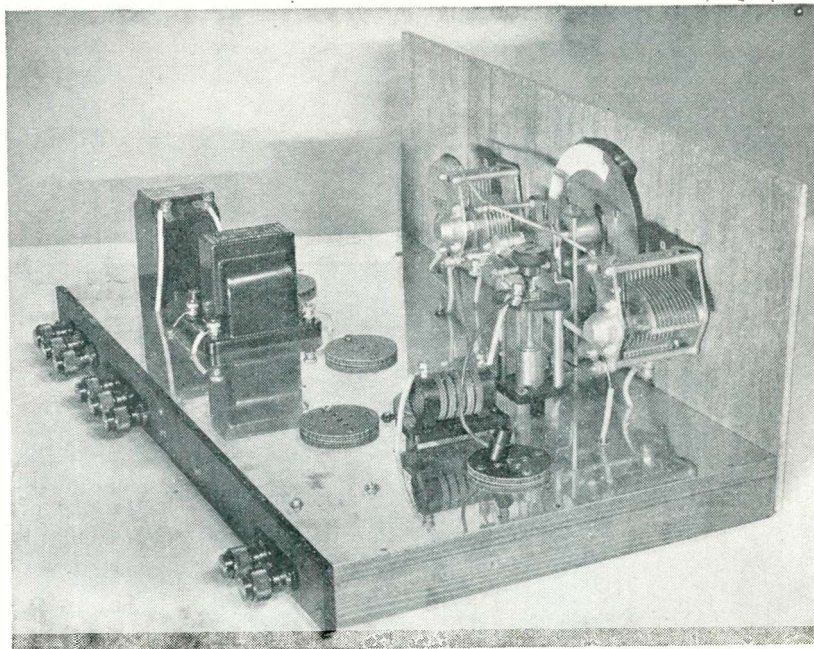

Here is another view of the set without coil and valves seen from the aerial end. Note the compact grouping of the condensers on and near the panel

be used for the H.T. and L.T. leads.

The transformer is provided with a primary screen brought out by a separate lead from a hole marked S. This is connected to H.T.— on the unit itself.

The foregoing, I think, cover all the important practical points concerning the construction of the receiver and power pack. There are one or two hints that I should like to pass on, chiefly from the point of view of sets that give trouble with a small amount of residual hum.

If your own happens to be stubborn and you have already tried out all the dodges I have referred to with

the B terminal, the first thing to try is a reduction in the value of the detector grid leak. Some A.C. valves seem to be much happier with a grid-leak of .5, or even .25 megohm. If you can make this substitution without upsetting the reaction control, by all means do; but don't try it unless it is absolutely necessary.

I am not claiming that the set will sound *quite* like a battery receiver—it is a tremendous business to produce an A.C.-operated short-wave set that does—but the amount of hum in the background should be infinitesimal, and certainly not

Continued on page 75

COMPONENTS NEEDED FOR THE A.C. STANDARD FOUR-VALVE SHORT-WAVER

	£	s.	d.		£	s.	d.
CHASSIS				HOLDERS, VALVE			
1—Peto-Scott chassis to specification	9	6		4—Clix 5-pin, Airsprung type	4	0	
CHOKES, HIGH-FREQUENCY				1—Clix 4-pin, Airsprung	11		
1—Bulgin short-wave choke	2	6		RESISTANCES, FIXED			
1—Eddystone short-wave choke	2	9		1—Erie 10,000-ohm, 1-watt type	10	0	
(or home-made; details as on p. 409 last month)				1—Erie 2,000-ohm, 1-watt type			
CHOKE- LOW-FREQUENCY				2—Erie 2-megohm, 1-watt type			
1—Varley output, type DP23	10	6		2—Erie 50,000-ohm, 1-watt type			
COILS				1—Erie 30,000-ohm, 1-watt type			
1—set B.T.S. short-wave	16	0		3—Erie 1,000-ohm, 1-watt type			
CONDENSERS, FIXED				RESISTANCE, VARIABLE	3	6	
1—T.C.C. .002-microfarad	1	6		1—Erie 250,000-ohm potentiometer			
1—T.C.C. .0003-microfarad	1	3		SUNDRIES			
1—T.M.C./Hydra 1-microfarad 300-volt working	2	3		Tinned wire for connecting, say	9		
5—T.M.C./Hydra 2-microfarad 300-volt working	15	0		Oiled cotton sleeving, say	1	6	
CONDENSERS, VARIABLE				1—Belling-Lee anode connector	4		
1—Polar .00015-microfarad slow-motion short-wave, type C	8	6		TERMINALS			
1—Polar .0001-microfarad slow-motion short-wave, type C	8	3		1—Peto-Scott terminal-strip, with 8 Belling-Lee terminals marked A, E, L.T. (2), H.T., H.T.—, L.S. (2)	5	6	
1—Eddystone .000015-microfarad short-wave, type 900	3	9		TRANSFORMER, LOW-FREQUENCY			
1—J.B. neutralising	3	6		1—Ferranti, type AF8	11	6	
1—Eddystone vernier slow-motion drive, type 938B	7	6		VALVES			
				1—Mazda AC/SG	17	6	
				1—Mazda AC/2HL, metallised	13	6	
				1—Mazda AC/HL	13	6	
				1—Mazda AC/P	14	0	
				LOUDSPEAKER			
				1—W.B. Stentorian, Standard model in cabinet	2	4	6

LIST OF COMPONENTS FOR POWER PACK

	£	s.	d.
CHOKE, SMOOTHING			
1—Varley 20-henry, type DP10	15	0	
CONDENSERS, FIXED			
3—T.M.C./Hydra 4-microfarad 400-volt working	19	6	
RESISTANCE			
1—Erie 3,000-ohm 3-watt type (see text)	3	0	
TERMINALS AND SUNDRIES			
2—strips with two Belling-Lee terminals (Peto-Scott)	1	9	
1—strip with three Belling-Lee terminals (Peto-Scott)	1	0	
1—Baseboard 12 in. x 9 in., say	9		
TRANSFORMER, MAINS			
1—Varley semi-shielded, type EP36, giving 325-0-325 v., 2-0-2 v. 2.5 amperes, and 2-0-2 v. 4 amperes	1	2	6
VALVE HOLDER			
1—Eddystone 4-pin, type 501	1	3	
VALVE, RECTIFYING			
1—Mazda UU120/350 (or Marconi-Osram U12, Mullard DW3)	15	0	



A new photograph of Harry Roy and his fiancée, Miss Elizabeth Brooke, daughter of the Rajah of Saruwak. Miss Brooke makes her "first appearance" on a gramophone record of "Mayfair Suite," which you will find reviewed on page 68

What the B.B.C. is Doing

Finishing the B.B.C. Network

By T. F. HENN

the B.B.C. for an entertainment service and the B.B.C. should provide it !

Talking of Continental stations, Radio Normandy has set me thinking. I can log that station in broad daylight here in London nearly as strong as London National. According to the book of words the power of Normandy is stated to be 10 kilowatts. It seems incredible that I can get splendid results on the smallest of indoor aerials from this relatively low-power transmitter some two hundred miles away.

I wonder whether the book of words is not wrong after all !

Radiolympia—opening August 14—will again provide a big attraction in the B.B.C. theatre. Three thousand people can be comfortably seated in this theatre and there will be three shows a day. Already some plans are cut and dried : *In Town Tonight* is one of the big features, Lily Morris will be there and it is certain that Henry Hall's band will be playing for three or four days while other dance bands will share the rest of the time.

As last year, the shows will be in charge of Eric Maschwitz and John Sharman and several relays will be broadcast during the run of the exhibition.

Last year a controversy arose over these shows. Some people put forward the view they attracted the wrong people to Olympia with the result that that the Radio Show was nothing less than a glorified theatre with stands as sideshows.

I take a very open view. Those really interested in radio will come along whether there is an entertainment or not, and those that come along primarily to see the show—well that is a matter for London's theatre managers and not for radio critics !

The really annoying part about Radiolympia is, to my mind, the entire absence

THAT the B.B.C. has no easy task in supplying reliable transmissions to all its customers is, I think, realised by most of us. Certain districts have been very badly treated and it is perhaps wise and interesting to examine the B.B.C.'s present building scheme. Altogether five new stations are planned : North-of-Ireland Regional (opening end of 1935), North-Scotland Regional (opening middle 1936), and North-East England Regional, Plymouth Regional and a North Wales relay at Beaumaris, which will be opened in that order in 1937 and 1938.

The new North Wales station, to be built in the Isle of Anglesey, will be rated at about 5 kilowatts and will work on 373.1 metres, and so synchronised with West (the future Welsh) Regional.

That is the building schedule as it stands now. To my mind this re-arrangement is ideal as a starting point. I do think that there are still many areas which could well do with small relays. A notable district is Thanet — Canterbury, Margate, Ramsgate, Deal, Broadstairs, Dover and so on round that way—where there is no alternative to Droitwich, though of course it must be remembered that listeners in this area are well provided for by Continental stations. However, they pay

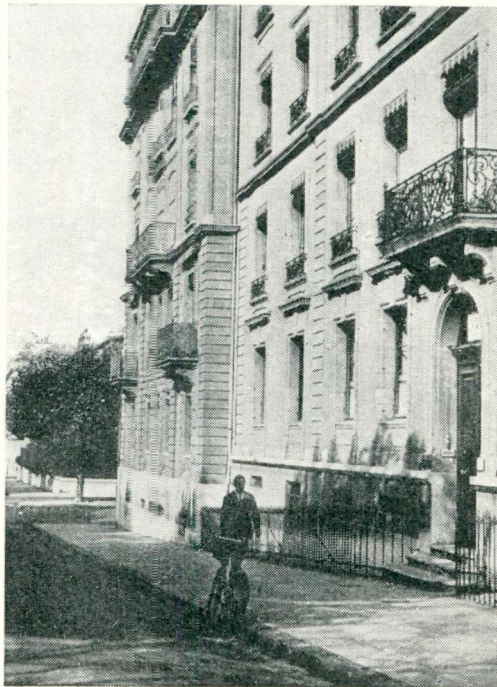

This year the I.B.U. celebrates its tenth anniversary. Here is its headquarters in the Cours des Bastions, Geneva

of fair play. Every set has a set chassis and a loud-speaker, the set chassis are all chromiomed up for the occasion and look very pretty. I take the strong view that if every exhibitor were allowed to demonstrate his sets, say on London Regional, then interest in the show would be really something to talk about.

As it is the exhibitor has to rely on getting a fair share of juice from the B.B.C.'s amplifier and if his loudspeakers are not so powerful as those of his next-door neighbour, then he is "sunk" as far as the non-technical visitor is concerned.

Something ought to be done about it!

I note from advance information that a relay of the Ceremony of the Keys—an annual institution now—is to be broadcast on July 23. Actually the story of how this came to be broadcast is particularly interesting. In the early years of broadcasting an officer of the Grenadier Guards, then on the staff of the B.B.C., put the suggestion of a relay forward. Outside broadcasts were then few and far between, and the first Keys relay was regarded as somewhat of a great technical achievement. So it was, and it attracted so much attention that it found its way on to the screen



Vice-Admiral Sir Charles Carpendale, C.B. (left), in a cheery mood, is chatting to M. le Chambellan Lerche (Denmark's representative) at the I.B.U.'s meeting in Warsaw this year



Columbia photo.

Exhibition time is upon us once again. Last year whenever Norman Long came out into the open he was besieged by admirers asking for his autograph

You have heard the story of the walk round the Tower, the locking up various doors and gates, many times and I am not repeating it here.

It is regarded as one of the "star" events of British radio, so much so, in fact, that last year when the I.B.U. (Union Internationale de Radiodiffusion) held its first meeting in London since it was founded in April, 1925, the visiting delegates attended the Tower to see and hear how the relay was carried out.

Talking about the I.B.U. reminds me that Vice-Admiral Sir Charles Carpendale, C.B., who has been president of the I.B.U. since its inauguration, resigned his position only a few weeks ago. His successor is

M. Maurice Rambert, Director of Swiss National Broadcasting.

There are few people who realise what a great amount of work is done by the I.B.U. It is an international organisation whose members do work in harmony—strange, but it is true. The I.B.U. is responsible for the allocation of wavelengths in this part of the world, and we must all agree that its Lucerne Plan is very successful.

The actual organisation and work is far too big a subject to describe in these notes. A fact worth knowing is that members of the I.B.U. represent the interests of about 200 million listeners—those figures include listeners of non-European countries whose representatives are associate members of the Union.

Coming back home again: a reader, of Levenshulme, Manchester, writes complaining that he hears the North Regional programme very faintly on the North National wavelength. He describes it as annoying and says that he has tried many sets (superhets included), but he can find no cure.

Actually, I have noticed the same fault here in London with the Brookman's Park transmitters, and I can assure my correspondent that this annoyance is no fault of his receiver. The reason is somewhat obscure, but it may be due to some inductive effect between the

two lines carrying the programmes from the studios to the transmitter.

My own experience is that the interference, down here at least, is so slight as to be negligible, and not half so troublesome as sideband whistles from next door stations.

Just one word about August programmes. Details are very scanty—mostly because holidays are holding up definite dates. I see, however, that Jack Hylton is following the "Party" craze and is broadcasting one during the week ending August 3.

More to my liking are two performances of an H. G. Wells "comedy-thriller," *The Purple Pileus*, on August 6 and 7. I am told that very special mystery music has been written specially for the broadcast performance. L. D. Gilliam is responsible for the production.

Another of the Drama department's specials for the summer is *Lost Horizon*, James Hilton's thrilling story of adventure in Tibet. It will be produced on August 1 and 2. This eerie play was first broadcast last year.

Again let me thank the many readers who have sent in reception reports of B.B.C. stations; I would appreciate more from the South and East coasts.



Why Confine

Listen in the Garden,

The "W.M."
 Technical Staff
 Tells You How
 Simply It Can
 Be Done



The new H.M.V. model 180 loudspeaker. It employs a dual-cone arrangement and costs eight guineas in its simple but attractive walnut cabinet. The special loudspeaker cone assembly is said to enable a wide frequency range to be handled

It has always seemed very probable that the great vogue at one time enjoyed by the portable and transportable set was in large measure due to the fact that these sets offered the advantage of "radio anywhere in the house."

That they have to some degree gone out of favour does not, we believe, indicate that this feature is no longer appreciated; rather is it the natural result of the introduction of fixed-location sets possessed of desirable attributes absent from the earlier forms of portable.

In short it appears that radio users have sacrificed the special convenience of being able to take the

programme into any part of the house in favour of the good points of the modern "stationary" set. That the former convenience can be regained with the aid of extension loudspeakers does not seem to be very widely realised by listeners.

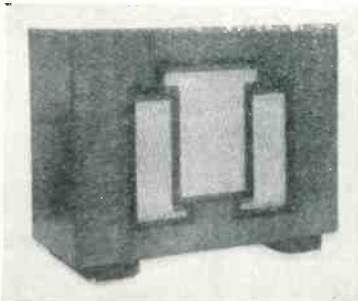

The 20C extension cabinet loudspeaker made by the Radio Development Company is suitable for use with most commercial receivers. It sells at £2 7s. 6d.

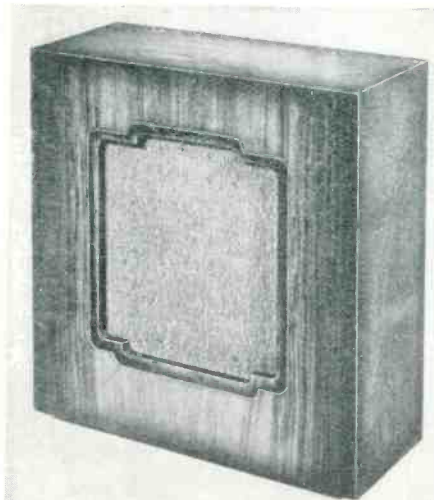

An ideal extension reproducer where quality is of greater importance than quantity is the W.B. Stentorian Baby, which costs only £1 9s. 6d. in a small oak cabinet of very neat design

Here we intend to deal with the technical and practical aspects of that question so that readers may discover how easily the matter may be arranged.

The first consideration must naturally be given to the question of how many rooms are to be served, and whether more than one point is likely to be in use at once. In the majority of cases it will most probably be decided that it will suffice to provide for the use of at the most two additional listening points, and that only one of these will be working at a time.

In such circumstances it is only necessary to acquire one extra loudspeaker, so that the business is both simple and inexpensive: the single loudspeaker can be moved to the room in which it is

Your Listening to One Room?

In the Bedroom or in the Kitchen with an Extension Loudspeaker

desired to listen and the wiring itself is easily installed.

Where two or more additional instruments are expected to be in use at any one time some consideration must be given to the question of power output; in general this arrangement demands a set with a fairly large output of the order of 3 watts as a minimum unless the rooms concerned are quite small. For a single extra point in use at once, on the other hand, almost any receiver giving good volume on its own loudspeaker will suffice.

Volume Adjustment

A word of warning is appropriate here regarding the question of volume adjustment when a number of speakers is in use in rooms of different size. It will be found that if the level is set to suit the bigger rooms

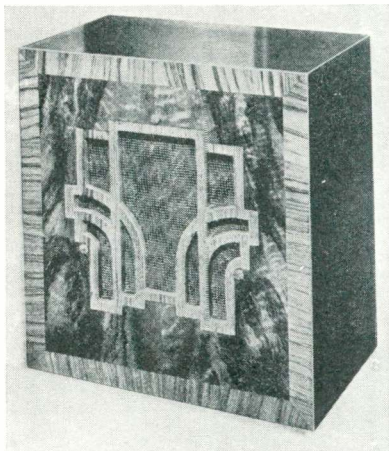

Good quality and high sensitivity is claimed by the G.E.C. for their "Junior" cabinet permanent-magnet extension speaker. The cost is two guineas in cabinet, or one guinea for the chassis alone

it will be quite unpleasantly high in any really small one: rooms less than about ten feet square are extremely difficult to group in with others more than about fifty per cent larger.

In all such cases it is necessary to find out by trial how much the volume can be lowered before it becomes inadequate for the biggest room concerned so that a reasonable compromise can be achieved.

In this connection we would offer the general advice that it is best not to be too ambitious in these matters. Rather than create difficulties of this sort for oneself it is better to decide to leave any very small room out of the scheme and concentrate upon those of roughly equal size. Naturally, the question does not arise in those cases where it is expected that only one extension point will be in use at a time; here it is merely necessary to learn by experience what volume level should be heard in the room containing the receiver to ensure satisfactory listening at the distant point.

The cost of the installation will obviously depend to a large extent upon the style and quality of the loudspeakers chosen. The cost of the wiring will normally be quite small, even if one does the thing in style with plug-and-jack connectors for the distant points.

Propos of the cost of the loudspeakers it may be remarked that a considerable part of the purchase price goes on the cabinet work, so that if a simple and unpretentious style of case is chosen the cost can be

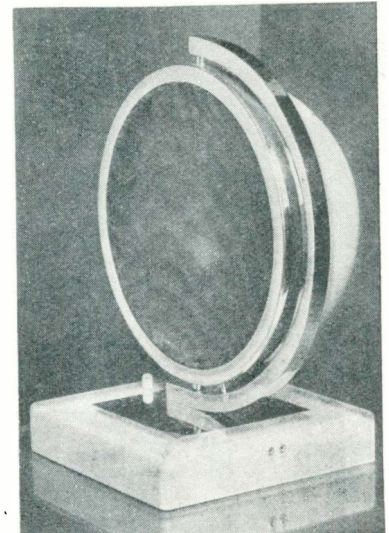

Something unusual in loudspeaker design, the bowl loudspeaker made by Kingsway Radio, Ltd., contains a permanent-magnet unit. It can be obtained in various colours and costs £5 5s. An output transformer for use with this unit costs 10s. 6d.

kept down without sacrifice of quality of reproduction.

Running the extension wiring is a comparatively simple task. Many readers will no doubt carry out the work themselves and our suggestion is that twin bell-wire of the cotton-covered and paraffin waxed type should be used.

Wiring the House

Insulated staples such as may be obtained from almost any electrician can be used for securing the leads in position; it is a good plan to drive each staple nearly but not quite home, then apply a steady pull to the free end of the wire and give the staple a final sharp tap with the hammer. In this way the leads are kept taut and neat.

Probably the best route for the leads will be found along the lower edge of the skirting board, as close to the floor as possible. If reasonable care is taken the result will not be at all unsightly, indeed, it

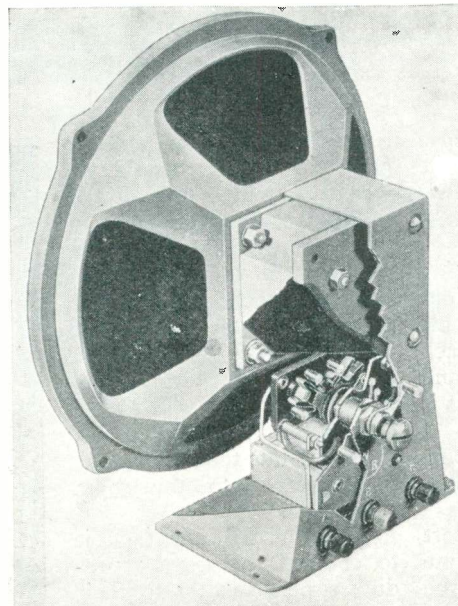

A cut-away photograph of the W.B. Stentorian Senior, showing the switching arrangement which enables the loudspeaker to be matched to any receiver. The price of the PMS1 chassis is £2 2s.

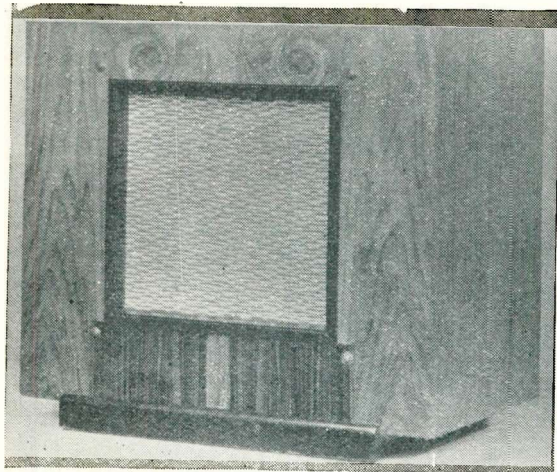

Specially designed for use with Ferranti receivers is the M5 permanent-magnet moving-coil cabinet loudspeaker. Made by Ferranti, Ltd., it costs £3 2s. 6d.

will be almost invisible if one takes a small brush and touches up both lead and staples with paint to match the colour of the skirting board.

Wiring System

The system of wiring should be such as to place all the loudspeakers in parallel, the series system of connection is only suitable in certain special cases. Actually neither method is ideal in theory unless special arrangements are made as to the output circuits of the receiver, but the practical falling-off in quality resulting from the inevitable slight degree of mismatching scarcely justifies the complication and expense of an extra correcting transformer to feed the extension system as a whole: individual matching of the separate speakers is sufficient.

A convenient method of connecting the loudspeakers to the various terminal points is very desirable unless one is prepared to fit each instrument as a permanency and allow it to work at all times. This is not wanted in most cases, so it becomes essential to provide some means of silencing the unwanted instruments.

If this takes the form of some sort of plug and socket connection scheme any particular loudspeaker can be put out of action by the simple expedient of withdrawing the appropriate plug. At the same time it is then made an easy matter to transfer

the instrument from room to room as required and one can reduce the total number of reproducers needed.

Quite simple and inexpensive connectors will serve the purpose, the miniature type of two-pin plug available from electrical stores being as good as anything so far as actual efficiency is concerned. Those who are prepared to spend a few extra pence to obtain

into circuit when required. It is very much a matter of taste which scheme you employ, but if your fancy inclines to the latter method you will find a descriptive note on page 16 of this issue.

The output arrangements of the receiver must be given some little consideration, especially if it is a mains set. Here it is necessary to make certain that there is no chance of high-voltage currents being allowed to get into the extension lines and wander around the house. Some form of output filter or transformer is the only positive protection, and it should always be provided.

The great majority of reputable commercial sets are quite safe in this respect, and if they are provided with terminals for an external loudspeaker all that is necessary is to connect up the extension leads thereto.

When no such terminals are provided the matter calls for a little care to ensure safety (that is, immunity from risk of shock to anyone handling the extension apparatus). Probably the simplest method is to proceed as follows: connect one lead of the extension pair to one side of the built-in loudspeaker transformer primary through a condenser of 2 microfarads. Connect the other lead of the extension line to the

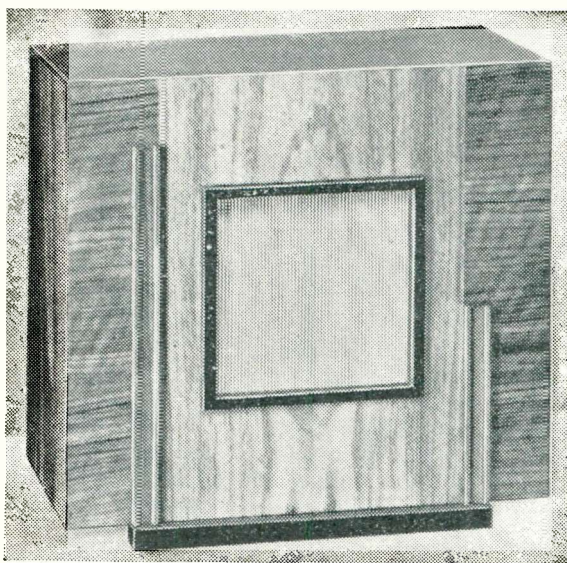

Gramplan Reproducers, Ltd., has introduced a handsome cabinet extension loudspeaker employing the latest nickel-alloy magnet. Two models are available: one with a 2-ohm speech coil and one with a 9-ohm coil—both sell at £3 15s.

good appearance and perhaps greater reliability would do well to obtain details of the Bulgin system of wall jacks.

Assuming that some such arrangement of plug and socket connection is used the extension line system can be kept permanently connected up to the output terminals of the receiver: plugging in a loudspeaker at any one of the distant points then brings the programme into the room concerned.

The alternative method is to connect the extra reproducers permanently to their respective extension points and use some form of switching system at the receiver to bring the required extension

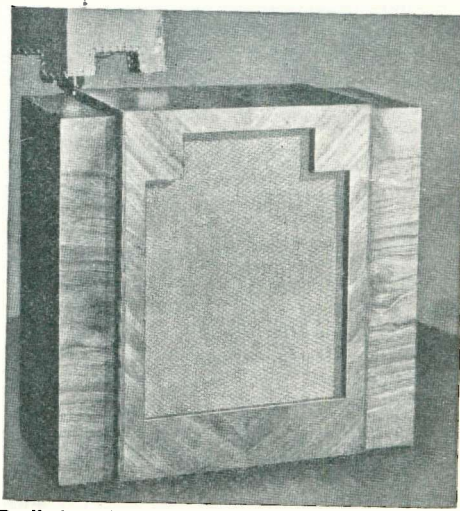

Really introduced for use with Pye receivers is the model S/MC permanent-magnet moving-coil extension loudspeaker (made by Pye Radlo). It provides a choice of matching impedances and costs £3 19s. 6d.

remaining side of the internal output transformer primary, also through a large fixed condenser. To avoid breaking into or otherwise interfering with the wiring of the receiver the connections from the condensers may take the form of short pieces of flex ending in crocodile clips: these can be attached to the required points inside the receiver without disturbing anything.

Connecting Up

In the case of a home-built set, of course, it may be that no such precautions will be needful; if the instrument already incorporates an output filter the extension line can be connected straight to the loud-speaker terminals of the receiver.

Many of the later commercial sets fitted with terminals for extra loudspeakers give what is called a low-impedance output. With these the ordinary type of step-down transformer often found fitted to extension loudspeakers is *not* required.

We will conclude our consideration of the practical and technical side of the question by adding a reminder that our earlier suggestion of twin bell-wire for the extension material applies only to lines actually inside the house; for a lead down the garden something weatherproof must naturally be provided; metal-braided wire is recommended.

Now let us look over some of the various types of exten-

sion loudspeakers on the market.

Baker

Fydelitone extension loudspeaker in bakelite cabinet measuring 8 $\frac{3}{4}$ in. by 8 in. by 4 in. Multi-ratio matching transformer built in if required. Prices range from 29s. 6d. to 45s. *Baker's Selhurst Radio, Ltd., 75 and 77 Sussex Road, Croydon, Surrey.*

British Rola

Cabinet model fitted with FR6-PM unit, matching transformer, if required, cabinet of burr walnut with Celotex "sound board." Chassis obtainable separately. Special claims are made for the dustproof properties of these speakers.

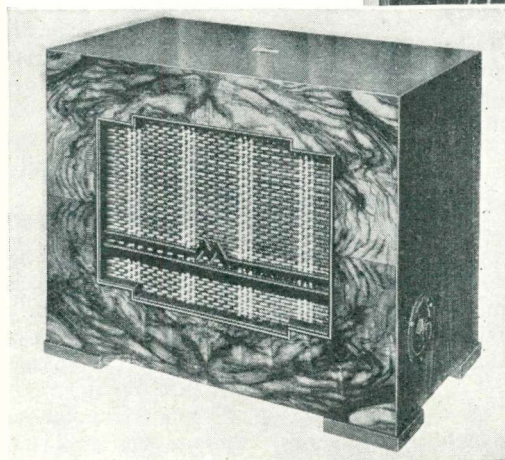

Marconiphone's multi-functional cabinet loudspeaker is fitted with an elliptical cone, metal reinforced to give high-fidelity response. Its price of £8 8s. does not include an input transformer

Price £3 10s. (with transformer). *British Rola Company, Ltd., Minerva Road, Park Royal, London, N.W.10.*

Celestion

Two cabinet models—PPM39 and PPM49. The former is contained in a polished walnut case, while the latter is finished in inlaid walnut. Both include transformers and are 14 in. high, 13 in. wide and 6 in. deep. Prices £3 10s. and £4 10s. *Cyril French, 29 High Street, Hampton Wick, Kingston-on-Thames.*

Ferranti

Two cabinet extension cabinet loudspeakers are listed. Both are suitable for

connection to Ferranti receivers without any matching transformers. The model M6 is a permanent-magnet unit in a plain clock-shaped cabinet while the model M5 is a handsome affair—the cabinet is finished in walnut and Macassar ebony—ideal for the best rooms in the house.

Prices: M6, £2 7s.6d. (chassis only,

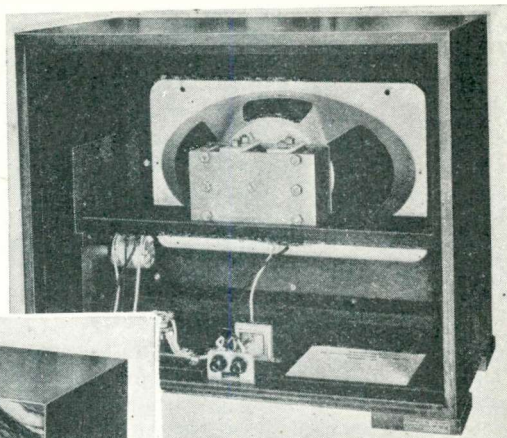

£1 5s.); M5, £3 2s. 6d. (chassis only, £1 10s.). *Ferranti, Ltd., Hollinwood, Lancs.*

Grampian

Cabinet model in two forms, low- and medium-impedance speech coil. Price: £3 15s. (with transformer, and volume control). *Grampian Reproducers, Ltd., Kew Gardens, Surrey.*

G.E.C.

Two cabinet models, both in figured walnut. Junior model measures 11 in. high, 9 $\frac{3}{4}$ in. wide and 6 in. deep. Senior is 12 $\frac{1}{4}$ in. high, 11 $\frac{1}{2}$ in. wide, 6 $\frac{1}{2}$ in. deep. Both are available with transformers. Prices: 42s. and 63s.

The General Electric Co., Ltd., Magnet House, Kingsway, London, W.C.2.

H.M.V.

Model 178 is intended for general use and incorporates a built-in volume control. Model 180 is described as a "High-fidelity duo-diffusion" loudspeaker. In effect this is a double type of instrument covering a very wide frequency range. The latter has a fine figured walnut cabinet.

Prices: £4 15s. and £8 8s. *The Gramophone Company, Ltd., 98-108 Clerkenwell Road, London, E.C.1.*

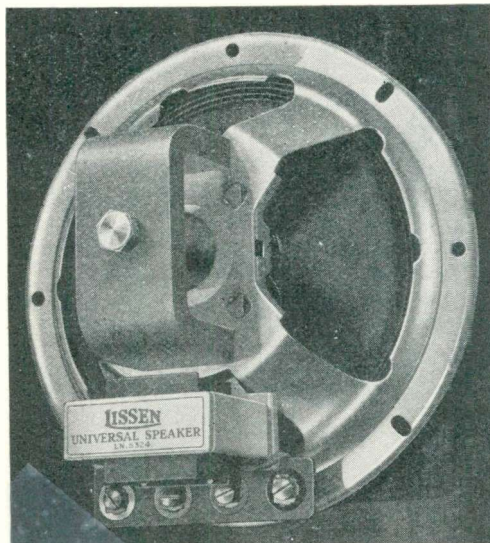

For the man with strictly moderate means there is the Lissen loudspeaker fitted with a universal matching transformer which sells at 25s. in chassis form. A cabinet model is available (£1 19s. 6d.)

Continued on Page 20

How to Make an Output and Loudspeaker Control Unit

By
James Shipley

ALTHOUGH considerable pleasure is to be had by making and working one's own receiving set the constructor cannot always be set-building. Fortunately, however, a deal of enjoyment can be obtained—as well as improved reception—by making accessories, as we call them, for use with an existing receiver. At the same time, improvements can be made to the aerial and earth system, loudspeaker and extension arrangements, etc., that make for better listening in the home.

Most Useful Accessory

One of the most useful accessories to a receiving set is an output unit. By its use fear of breakdown in the loudspeaker transformer is practically obviated and the loudspeaker may safely be used at any reasonable distance from the set without risk of the high tension being short-circuited.

The circuit arrangements for coupling up an output unit are shown in Fig. 1. Two components only are required—a 30-henry low-frequency choke with core and winding of sufficient size to carry safely the full anode current of the output valve in the receiver, and a fixed condenser of from 2 to 8 microfarads with a working voltage equal to or higher than the high-tension voltage used in the set.

Regarding the actual capacity of the condenser; although one of 2 microfarads will give quite satisfactory results the use of one of higher capacity will give increased bass response from the loudspeaker providing the set is passing bass notes and the loudspeaker is capable of reproducing them.

The connections—as the diagram shows—are quite

simple, but care should be taken to see that the fixed condenser is joined to the anode of the output valve and not to the high-tension lead or nothing will be heard when the set is switched on.

Making a Self-contained Unit

If a small box is available the two components comprising the output unit can be mounted inside, thus making a self-contained accessory which can be employed with any receiving set. Valve-pin sockets sunk into the sides or top of the box can be used for making the necessary external connections.

By going a step farther as shown in Fig. 2 an accessory, especially useful to the experimenter, can be built. By its use two loudspeakers can be switched on alternately for quick comparison, or the loudspeakers may be plugged in in parallel.

Ideal for Loudspeaker Experiments

In its simplest form two jacks only need be fitted while the actual switching is performed by an ordinary 2-way gramophone switch. If three jacks are employed two loudspeakers can be put in parallel while the use of four jacks enables two sets of paralleled loudspeakers to be switched in alternately.

The method of mounting the parts is shown in Fig. 3—the top panel of a box about 6 in. by 4 in. by 4 in. deep being utilised for the purpose.

If a slightly bigger box is available both the output unit and the jacks and switch can be fitted up as one accessory making a very useful aid for testing and experimenting.

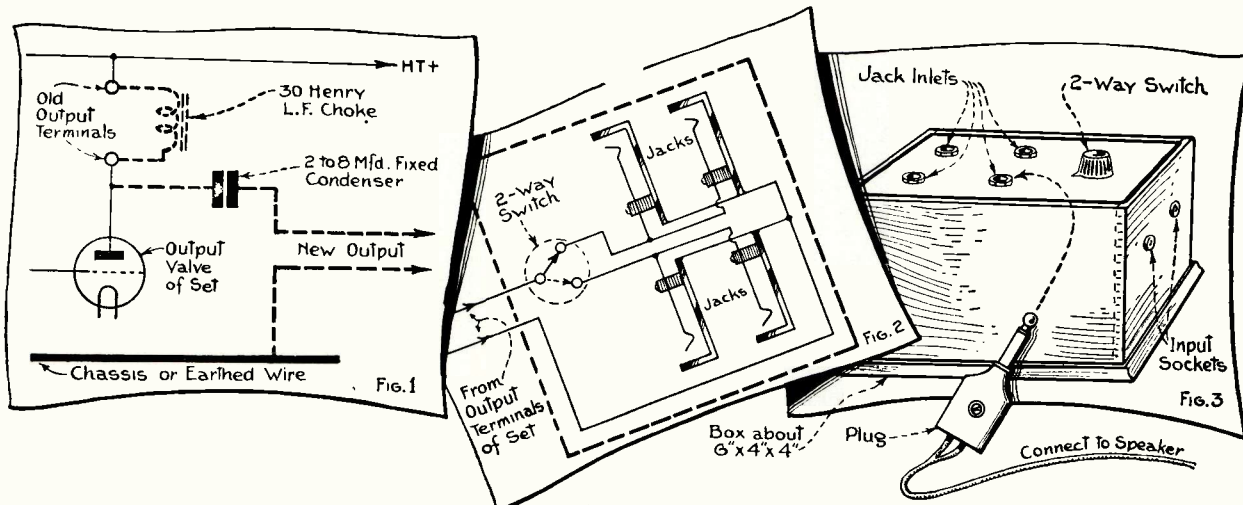

Fig. 1.—Showing in dotted lines the modifications necessary to produce a choke-condenser output system. The rest of the circuit is self-explanatory

Fig. 2.—The system of change-over switch and jacks suggested by the author for loudspeaker control and comparison purposes

Fig. 3.—Suggested practical make-up of the complete control and output unit. A box with a detachable bottom will make wiring easier

It can truthfully be said that the superheterodyne is the most popular class of set in use today. In this article, Percy W. Harris explains how this type of receiver has grown from a cumbersome device with two or more tuning dials into a single-knob outfit, capable of giving almost "hair-breadth" selectivity and really good quality, providing reasonable care is taken in manufacture



Two enthusiasts examining the layout of the H.M.V. 14-valve high-fidelity superhet radiogram. The superhet circuits are incorporated in the chassis mounted vertically on the left; at the bottom behind the balanced loudspeakers is the low-frequency and output stages together with the mains gear

The Superbet Simply Explained

By PERCY W. HARRIS, M.I.R.E.

YOU will have noticed, in this series of articles, that so far I have made only passing reference to the type of receiver known as the superheterodyne—a type of set that has rapidly come into prominence during the last year or two. The fact that thousands of receivers now sold are of this type, and that we have gone far enough in our talks to be able to grasp just what are its virtues (and vices) of this kind of set makes it a favourable opportunity for discussion.

Where the Super Differs

You will remember how a signal is picked up, how it is magnified, turned into the kind of current which will actuate a loud-speaker, and then converted into air (sound) waves. All these things are done in a superhet and from the detector onwards there is no essential difference between the "super" and the "straight set." It is in the higher-frequency portions that the "super" differs very considerably.

It is rather amusing to note that the special reason for which the superheterodyne was first developed, has long ceased to exist! When multi-valve sets were first made and

it was desired to gain sensitivity by magnifying the very feeble received signals prior to detection; the kinds of valve then available and the types of circuit produced considerable instability as soon as the "gain," as we call it, was made at all high.

It was also found that the longer the wavelength the easier it was to "hold down" the set and the greater the magnification that could be obtained before we reached the then practical limit.

Both French and American inventors turned their attention to the problem and it occurred to at least two of them that if we could only, in some manner, convert our received signal from its ordinary wavelength into a long wavelength and *then* magnify it at this long wavelength we could get much more magnification or gain than was otherwise possible. If, also, we could have several stages of magnification at this long wavelength, each of them tuned, then as the signal passed from one stage to the next it would become progressively more sharply tuned and we should not only increase our magnification, but also—and very considerably—our selectivity.

Magnification alone without selec-

tivity could of course be obtained after the detector but it was found that post-detector magnification to any considerable degree had its own special disadvantages and drawbacks one of them being an excess of unwanted noise.

Fessenden's Receiving Method

Some time before this a certain American, Professor Fessenden, had invented what was called the heterodyne method of reception. This system is rather difficult to explain in simple language, but briefly we can state that if we take a signal of one frequency and mix with it a second signal of a slightly different frequency "beats" will be produced.

Think for a moment and you will realise that if we superimpose one signal on another of exactly the same frequency each wave of one set will add itself to each wave of the other, so giving an increase of strength. If now we make the second or added signal of slightly lower frequency from the first the two signals will, so to speak, go in and out of step.

Balanced Out

For example, at one moment the two waves will be adding all their strength, a little later the second being out of step very slightly with the first, will add a little less. Still later the addition will be further reduced and ultimately we reach the point where the two waves, being

completely out of step, will actually balance one another out in an equal and opposite direction.

If we were to draw a series of curves (I have no intention of doing so in an article such as this) we should see the resultant mixture rising and falling at a frequency quite different from that of either of the signals, the actual frequency being precisely that of the difference. Thus, if we have a signal with a frequency of 1,000,000 and a second signal with a frequency of 990,000 then the progressive rise and fall will have a frequency of 10,000. Professor Fessenden used the beat or heterodyne method to make audible continuous-wave signals which otherwise were of a frequency well above audibility.

Mixing

Now if we take a wireless set and tune it to a 300-metre wavelength, which has a frequency of 1,000,000, and at the same time mix with it a frequency of either 900,000 or 1,100,000 beats or pulses will be produced with a frequency of 100,000 which corresponds with the wavelength of 3,000 metres. If now this complex mixture of the two waves is passed to a detector valve the output side will have a new signal of exactly 100,000 cycles or 3,000 metres.

Intermediate Stages

We can now pass this new 3,000-metre signal into a valve amplifier with one, two or even three stages of magnification each one being tuned to exactly 3,000 metres. After this we place a second detector acting exactly as a detector in an ordinary

or straight set and after that we can add the necessary low-frequency magnification and thereby operate a loudspeaker.

If (as was the case at the time of the invention of the superheterodyne) it happens to be easier to magnify at 3,000 metres than at 300 we shall get all the benefits described above.

But another advantage now appears. One of these signals is received from the outside or from the aerial, and the other is locally generated. If now we arrange that no matter what the wavelength of the signal we receive we mix with it a locally generated wave of a frequency difference of exactly 100,000, we can keep the tuning of our long-wave or, as they are called, intermediate-frequency, stages fixed.

This cuts out a lot of complications in manufacture, for you will remember that in a straight set every one of the high-frequency stages must be tuned for the actual signal received. This means either a series of tuning dials each with its own condenser or several variable condensers of other tuning devices all controlled on one shaft. This makes for much complication in manufacture and calls for a very high degree of accuracy.

In the case of the superheterodyne, however, we can tune our intermediate stage with fixed condensers to a definite frequency and leave them at this frequency, devoting our variable tuning to two circuits only—one, that of the incoming signals and the other that of the local signal. It is further possible to join up the two condensers so as to lock them and keep them at a con-

stant frequency difference of whatever we like to choose, say the 100,000 I have mentioned. We then have one tuning dial on a set which may control as many as four or five tuned circuits.

Early Superhets

The early superheterodynes were large, cumbersome and by no means satisfactory devices, but in their way they represented a very considerable advance. Invariably they had two tuning dials, one for the incoming signals and the other for the locally generated signals, for at that time radio engineers had not designed condensers and tuned circuits with sufficient accuracy to be able to fasten them in tandem or "gang" them as we now do.

Furthermore valves were very greedy in their filament current and the filament battery needed to run anything like a sensitive superheterodyne had to be so heavy that it could scarcely be lifted. There were no mains sets at all in these days.

Improvements

With the coming of the dull-emitter or low-consumption valve there was a big step forward and later a further advance when the screened-grid valve came along. But the screened-grid valve, in itself, abolished the trouble of getting considerable high-frequency magnification on ordinary wavelengths and it was really for this purpose that the superheterodyne was originally designed!

By this time, too, we had learned how to gang quite a number of

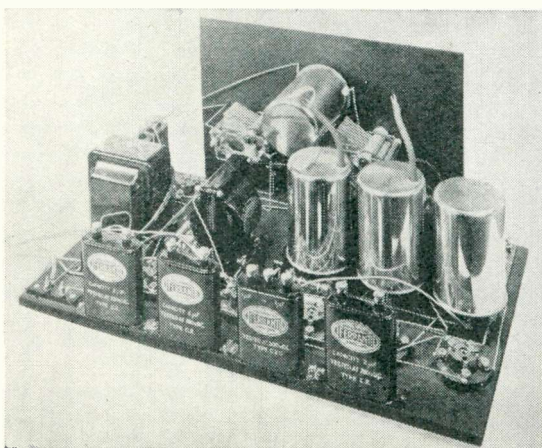

A modified version of the Super 60—a battery receiver described in these pages in March, 1931—which heralded the return of the superhet. On the panel are two tuning condensers—for oscillator and aerial—and the oscillator coil. The intermediate-frequency transformers are housed in the three copper cans

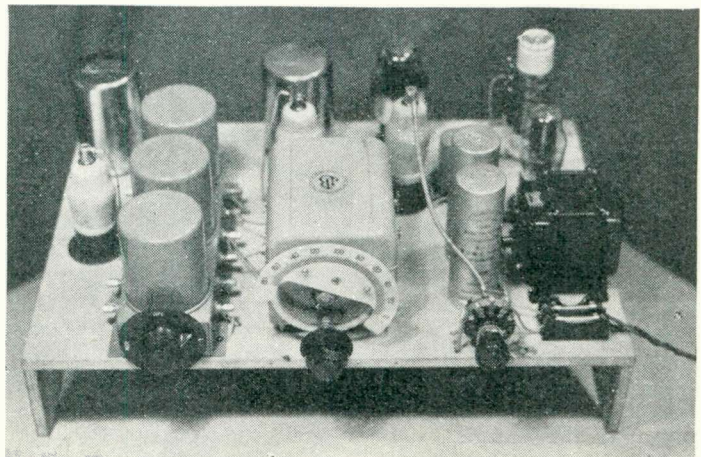

Another step in the progress of superhet design is exemplified by the layout of the Universal Merrymaker described in "Wireless Magazine" in April, 1934. The controls were reduced to three—tuner, volume, and wave-change—and the set operated off either A.C. or D.C. mains. The intermediate-frequency transformers are seen at the back of the receiver while the oscillator coil is one of the three in the coil unit

circuits provided we could devote enough time in manufacture to get sufficient precision and could spend a good deal of labour in accurate matching of coils and condensers. But the advantage of the lack of ganging, the fact that one could adjust the intermediate frequency once and for all and make everything with much cheaper parts, led to the commercial adoption of the superheterodyne in receivers where high gain and high selectivity were required.

A Big Problem!

Now all this sounds very practical, very useful, and very labour-saving, but you have no idea how many *special* problems and annoyances there are clustering around the superheterodyne circuit! We have seen that when you mix one signal with another a third signal is produced with a different frequency. Now that we have so many stations on the ether this is one of the biggest problems we have to face in superheterodyne design.

For example, let us imagine we choose a frequency of 100,000 for our intermediate stage. If now our receiver is tuned to a frequency of 1,000,000 and our local circuit or oscillator is arranged to give a frequency of 900,000 the different signal of 100,000 will pass through to our intermediate amplifier. *But*, a signal of a frequency of 800,000 will *also* produce a beat frequency of 100,000

so that if there should be another station on 800,000 (which corresponds with a wavelength of approximately 375 metres) *both* the 300-metre signal and the 375-metre signal will be simultaneously magnified!

Indeed in these days it is very difficult to find an intermediate frequency that will not produce this "second-channel" effect somewhere or other in the broadcast band, particularly if the second station, separated from the one we want by twice the intermediate frequency, happens itself to be very loud at our point of reception.

If also the second-channel station is of such a frequency that what gets through into the intermediate amplifier is slightly different from the 100,000 frequency we may get all kinds of heterodyne whistles or various notes, and indeed we do in many superheterodynes.

How can we overcome this? There is no perfect solution, but if we make our first tuned circuit very sharply tuned so that the second-channel signal is very weak indeed, we can reduce the interference to a negligible proportion. To do this we often add a further stage of magnification at the actual received signal frequency, thereby adding one further condenser to the gang (which already consists of the oscillator condenser and the signal-frequency condenser) and losing one of the advan-

tages that is the simplicity of this circuit.

There are a few other special ways to which only brief reference need be made here, such as a special wave trap for this second frequency, but generally speaking, an additional high-frequency stage fairly sharply tuned or a bandpass circuit will give us what we require.

A still further problem—or rather

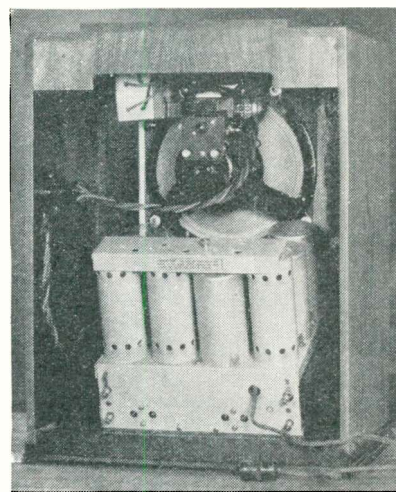

A contrast to the illustration below, the Ferranti four-valve superhet is a picture of neatness on the top of the chassis with all the valves and coils housed in metal cans

a whole series of problems—confronts us in the design of the "mixer" circuit. In the early sets an adjustment which was good for one part of the wavelength band proved unsatisfactory on another, and similarly reception conditions for weak and strong signals were found to be different.

Special Valves

To overcome these special difficulties a whole series of new valves with all kinds of complicated internal structures has been evolved, so as to enable us to do the actual mixing inside the valve itself.

One of the most popular methods of doing this is to cause one electron stream to serve for both the locally-generated oscillations and the first detector or mixer valve. In a valve containing several grids one grid can control the electron stream for detection while another may introduce or superimpose on to this same electron stream the locally-generated frequency which helps to produce the beat.

The circuits used can be made mechanically simpler with these multiple valves and in the constant struggle to reduce cost of manufac-

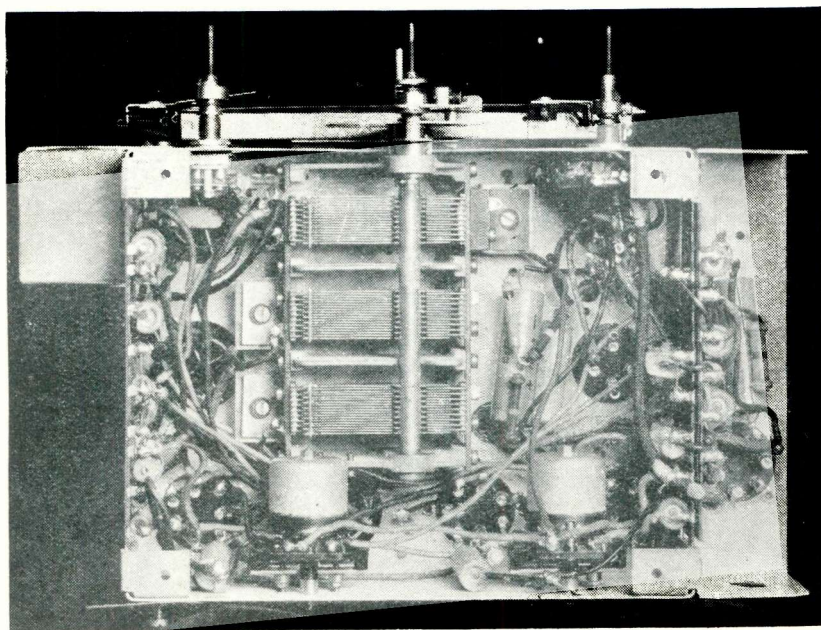

Here is a typical example showing the amount of work involved in a modern commercial superhet. The three-gang condenser controls the band-pass aerial circuit and the oscillator circuit. Incidentally, all the set's wiring is underneath the chassis. The set in question is a Ferranti product

ture so as to market superheterodynes at still more popular prices one can understand how the manufacturers jump at any such opportunity as this.

Quality Sacrificed?

In the matter of selectivity the superheterodyne enables us to reach almost any degree of sharpness in tuning, but if we are not careful we sacrifice a great deal of our quality in obtaining this selectivity.

I have shown in an earlier article how it is essential for proper musical reproduction to maintain the frequencies on both sides of the signal up to 6,000 or even 10,000. The intermediate circuits on most commercial superheterodynes are now made so sharp that this desirable state of affairs is very rarely reached, though by bandpassing the intermediates and adjusting our circuits carefully a reasonably high degree of quality can be obtained.

But you cannot get this high quality, which calls for a good deal of care in the factory and a great deal of time in the final balancing up of the set, in a receiver which sells for the ridiculously low price at which many superheterodynes are marketed today.

Because so many superheterodynes give such poor quality, many people have come to the conclusion that if you want first-class quality it is useless to use the superheterodyne circuit, but this is not true if sufficient care is taken in the design and manufacture.

Noise

One further trouble with the superheterodyne is its general noisiness. There are two causes of this noise. One is that the magnification or gain is so high that all kinds of atmospheric discharges, local interferences and what-not are magnified together with the signal to such an extent that there is a constant rushing noise in the background. A lot of this noise is not due to the circuit itself but to the high gain; we should get just as much of it if with a carefully designed "straight" circuit we had as much magnification.

This, however, does not account for all of the noise in the superhet. Some of the noise is undoubtedly inherent in the circuit itself. It is difficult to explain why without going more deeply into the theory, but I can give one indication here. Remember that in the superhet we

have an oscillator at work all the time producing beat frequencies with incoming signals.

Have you noticed on a "straight" set how, when you make the receiver oscillate by using too much reaction, the passing into the oscillating stage is indicated by the production of a rushing noise? The causes which produce this rushing noise in an oscillating straight set are closely allied to those which produce the same rushing noise in a superhet.

Summing up, then, we see that by means of the superhet circuit we can produce a multi-stage set cheaply and in this way get high magnification and high selectivity

at low cost. At the same time the simplest form of superhet circuit, which has no "pre-selector device" or high-frequency stage in front of the first detector, is of little use in modern ether-crowded conditions owing to the production of second-channel interference.

Best Intermediate Frequency

So far as this country and Europe are concerned it has been found that an intermediate frequency of 107 to 110 kilocycles is as good as any, and as the manufacturers of variable condensers and coils have now solved many of the manufacturing problems there is a greater standardisation of parts.

Why Confine Your Listening to One Room?

Continued from page 15

Kingsway

Permanent-magnet moving coil type fitted in special "Bowl" case. Many novel features, various colours. Height, 14 $\frac{3}{4}$ in.; diameter, 11 in. Price: £5 5s.

Kingsway Radio, Ltd., 3-9 Dane Street, High Holborn, London, W.C.1.

Lissen

Satin-finish walnut cabinet, built-in transformer, incorporating standard Lissen P.M. moving-coil chassis. Price: 25s.

Lissen, Ltd., Worples Road, Isleworth, Mdx.

Marconiphone

High-fidelity instrument covering wide frequency range in figured walnut cabinet. Incorporates tone compensated volume control, no transformer. Height 15 $\frac{1}{2}$ in., width 18 $\frac{1}{2}$ in., depth 10 $\frac{3}{4}$ in. Price; £8 8s.

The Marconiphone Company, Ltd., Radio House, London, W.1.

The Marconiphone Company, Ltd., Radio House, London, W.1.

Pye

Model S/MC in walnut cabinet. choice of two shades of grille fabric. Includes matching transformer with plug and socket adjustment. Price: £3 9s. 6d.

Pye Radio, Ltd., Africa House, Kingsway, London, W.C.2.

Radio Development Co.

Various models to suit the output requirements of the principal makes of sets. Special windings to suit

particular cases without extra charge. Price: £1 1 $\frac{1}{2}$ s. (20C model in cabinet). *Radio Development Company, Aldwych House, Aldwych, London, W.C.2.*

Voigt
Range of models suitable for extension work, with or without transformers.

Voigt Patents, Ltd., The Courts, Silverdale, London, S.E.26.

W.B.

The well-known Stentorian loudspeaker is available in cabinet form with matching arrangements to cover all requirements. The standard model can be obtained for £2 4s. 6d. in a tasteful walnut cabinet. An ideal extension loudspeaker is the W.B. Daley Stentorian cabinet model costing £1 9s. 6d.

Whiteley Electrical Radio Co., Ltd., Victoria Street, Mansfield, Notts.

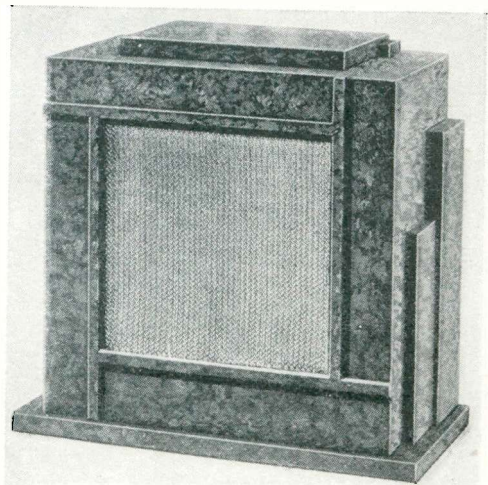

Probably the smallest extension loudspeaker made is the well-known Baker Fydelitone. It consists of a permanent-magnet unit in a bakelite cabinet. 8 $\frac{1}{2}$ in. by 8 in. by 4 in.

Short-wave Conditions Are Still Improving

Says G. HOWARD BARRY in His
Monthly Notes on Current Conditions

I AM not trying to cultivate the school of writing that resorts to "I told you so" methods, but I should just like to refer back to the last paragraph of my notes last month. I suggested there that the 10-metre band was definitely waking up and that long-distance work would soon be starting again.

Soon after I penned that paragraph, and before it actually reached you in print, 10 metres woke up with a vengeance! A British amateur has been in two-way communication with India; two others, at least, have worked with Argentina; and several have heard signals from South Africa.

Curiously enough, nothing has been heard from the U.S.A.; but 10 metres can once more be regarded

out on 5 metres within the next year.

Reception of short-wave broadcast has been very consistent during the month. I have been testing out the A.C. version of the Standard Four-valver against one or two other sets and therefore have done rather more listening than usual. During the course of some of my late bouts I have heard and identified stations that don't usually come my way, which just shows what persistence will do!

I am convinced that the readers whose logs take up more pages than anyone else's are simply blessed with a little extra supply of patience and ability to stick to it.

There seems to be a little misapprehension among readers about the limits of the *official* short-wave broadcast bands. New stations seem to plant themselves just where they like, but five main bands have been allotted exclusively for short-wave broadcasting and, when restrictions are tightened up a little, it will doubtless be feasible to construct a set which just covers these bands and shuts out all commercial Morse.

The bands, as near as I can get them, are fixed as follows: 16.85-16.90 metres; 19.52-19.85 metres; 25.22-25.64 metres; 31.12-31.56 metres; and 48.00-50.00 metres. In actual practice the latter band seems to extend from 45 to 53 metres without a perceptible break!

Conditions at the moment of writing are best of all on the 19- and 25-metre bands. The 16-metre band is usually good during the summer, and this summer is no exception, but there are not many active stations to listen for. "19", on the other hand, is a regular hive of activity, housing within its narrow compass the following stations, all of which may be heard at one sitting—Budapest, Schenectady, Zeesen (twice), Wayne, Daventry (twice), Taschkent, Pontoise, Eindhoven, Pittsburgh, and Vatican City.



This handsome silver trophy is presented yearly by Hugo Gernsback to the short-wave amateur whom he considers to have been most successful during the year

The width of the band is actually about 270 kilocycles, so there should be room for a few more; but 9-kilocycle selectivity is hardly the order of the day among short-wave sets, particularly on these frequencies in the region of 15,000 kilocycles!

The need for a really selective short-wave receiver is becoming more and more obvious every day. Improving conditions and a steady drive to increase the power of short-wave stations combine to make things most embarrassing to the owner of a flatly tuning receiver.

Sets that behaved well four years ago are pretty well hopeless now on a really good night when everything comes through at once!

Logs, Please!

May I appeal once more to readers to send me their logs? It doesn't matter if they do not contain anything of special interest—it is always interesting to compare logs from various parts. Although I can't always find time for a lot of listening myself, I have several reliable friends who do it for me, either on one of my own sets or on theirs, and I am thus kept *au fait* with current conditions in my part of the world.

Particularly, I should like logs from the Midlands and the North; comparisons would be valuable. Send them to me, c/o the Editor.

SEND US YOUR SHORT-WAVE LOGS!

Short-wave receiving conditions vary from hour to hour, and what an enthusiast records in, say, Glasgow is not necessarily heard in Exeter. Short-wave enthusiasts are always interested in what others receive. It is our intention to make this monthly feature of world-wide interest and all short-wave listeners are asked to send their reports on current conditions and outstanding captures to G. Howard Barry, "Wireless Magazine," 8-11 Southampton Street, Strand, London, W.C.2

as an international DX wavelength after a dead period extending over five years or more. (And there are still people who scoff at the sunspot-cycle theory!)

I am going to round off the prophecy department by merely making the statement that I shall be very surprised if long-distance (that is reflected-wave) work is not carried

Australia's "Lucerne Plan"

A year or two ago Europe's muddled ether conditions became such that it was well-nigh impossible to get even one's own local station free of interference. History is repeating itself in far-off Australia, and in this article R. H. ATKINSON explains the Australian system of broadcasting and gives details of the "Lucerne Plan" which is to be inaugurated there on September 1 next

AUSTRALIAN stations are to be given new wavelengths. This decision by the Commonwealth Postmaster-General's Department is the direct result of recently planned additions to the National broadcasting service of the "Island Continent."

During the decade or so of Australian broadcasting, the ether has steadily and consistently become more and more crowded. At the beginning long waves were used by the Sydney and Melbourne transmitters (the first stations to begin regular broadcasting on a planned and definite basis) and the 200-550 metre broadcast band as it is understood today was unused.

Later, however, as stations increased in number and as overseas customs were studied, broadcasting stations in Australia moved down to the medium-wave channels. At the same time the long waveband (1,000-2,000 metres) was deserted. This move has since been the subject

of much discussion and not a little heated argument.

It was with a view chiefly to discuss the re-opening up of the long waves that Capt. P. P. Eckersley came to Australia two years ago. Whatever the pros and cons of the whole business, Australia is today (although in the happy position of having the right to use the long waveband) relying entirely upon the medium band for housing its broadcasting services.

There are, of course, two services available to the Australian listener. That of the Australian Broadcasting Commission provides the advertising-free Australian equivalent of the B.B.C.'s service, while the other, the commercial or B-class stations service gives the "Aussie" listener alternative entertainment at the price of advertising matter.

With big business behind them in practically every case, the commercial broadcasters have progressed rapidly during the past seven or eight years. In 1927 there were only 13 B-class stations and 8 A-class stations in the Commonwealth. Today, in the new wavelength allocation prepared by the P.M.G.'s Department, there are more than 60 B-class stations on the air (with others allowed for at later dates), and over 20 National service transmitters, also with provision made for further increases in the near future.

Thus it will be seen that the rapid growth of Australian broadcasting has made it imperative for the controlling authorities to re-plan the Australian ether.

During the past year or two the need for a reorganisation of Australian wavelengths has become increasingly apparent. The DX listener has constantly been reminded of this necessity by the number of heterodyne whistles and side-band splashes heard on various parts of the band. Added to this already-existing trouble was the problem of finding room for the new transmitters to be put into service during 1935-6 of the Australian Broadcasting Commission.

During 1934 plans were drawn up for seven new stations to supplement the present National or A-class service. Only recently, however, emphatic demonstrations through the press and by public meetings of interested bodies of public feeling in and around Kalgoorlie made it obvious to the Department that an eighth transmitter would have to be provided.

With this and a hundred other considerations in mind, the experts and engineers of the Postmaster-General's Department (which has control of the licensing of all stations within the Commonwealth, the allocation of frequencies and the management of the technical side of the

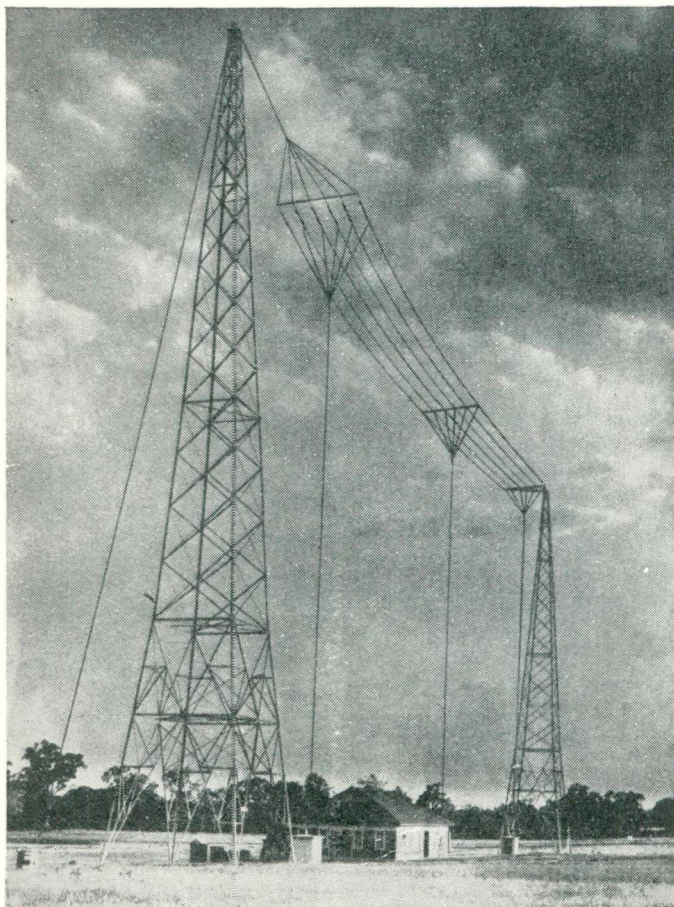

A typical Australian station layout—the station buildings of 2CO of Corowa, New South Wales. This station was built by Standard Telephones & Cables, Ltd., and is rated at 5 kilowatts. After September 1 the station will operate on 448 metres instead of 536 metres

Australian Stations

Showing the conditions which will prevail after September 1, 1935

National service) set to work and prepared a new wavelength scheme—indeed Australia's "Lucerne Plan."

Provision had to be made for the eight new National stations—mostly relays—as well as a possible half-dozen or so to be put into service later. In addition, progress among the commercial stations would have to be taken care of and allowances made for future additions to their numbers.

The upshot of it all was that an almost complete re-shuffle of channels was ordered. I have included a list here showing the complete wavelength scale as it will be on and after September 1 of this year. Many of the stations referred to will not be in operation at that date, but their frequencies are fixed for them in readiness for their radio debut.

You will see from the columns marked "New" and "Old" just how the changes have affected the various stations.

There will, of course, be the usual minor upsets in the change-over; these cannot be helped and are inevitable in a big scheme involving some 70 odd stations. One thing is certain, though, and that is that under the new arrangement ether congestion will be avoided. Most stations will be evenly spaced out with full 10-kilocycle separation and all with due consideration for power and geographical situation.

Looking over the station list, there are one or two things that call for attention and, perhaps, a little explanation. First of all, the significance of the numerals in the call signs. All stations with call signs commencing with 2 are situated in New South Wales or the Federal Capital Territory; all those with 3 in Victoria; those with 4 in Queensland; those with 5 in South Australia; those with 6 in Western Australia; and those with 7 in Tasmania. Thus it is always possible to tell the State in which a station is operating by the numeral in its call.

The new stations with call signs are the first to be erected, and they should all be in service by the winter of 1936. Those without call signs allotted are the first of the new stations planned for erection during 1936-7 or later.

The stations bracketed together are those sharing a common channel. In this connection it will be seen that the Department has been careful to allot shared frequencies only to stations of moderate power or to those some considerable distance apart.

Another interesting point is that the Department gives the National transmitters the most favourable wavelengths leaving the B-class stations the lower ones. There are exceptions, however, and in the new list we see 6PR, although retaining its present wave of 341 metres, relinquishing its position as the commercial station with the highest wavelength. 7HO Tasmania is to go up to 366 metres.

2UW, a Sydney commercial station which will move up from 266 metres to 270, has recently inaugurated a day and night service whereby it is on the air for twenty-four hours a day, seven days a week. They use two transmitters and double shifts of announcers and engineers. As the chimes of 8 p.m. and 8 a.m. are put on the air, one transmitter is closed down and the other opened up. The credit for being the first organisation in the world to commence a regular twenty-four hour broadcasting service must go to this station.

Call Sign	Station	OLD		NEW	
		Wave-length (metres)	Fre-quency (kc.)	Wave-length (metres)	Fre-quency (kc.)
2CR	Central Regional, N.S.W.			545	550
6WA	South-West Regional, W.A.			536	560
3WV	West Regional, Victoria			517	580
7ZL	Hobart, Tasmania	517	580	508	590
4QN	North Regional, Queensland			500	600
2FC	Sydney, N.S.W.	451	665	492	610
3AR	Melbourne, Victoria	492	610	476	630
5CK	Crystal Brook, S.A.	472	635	469	640
2CO	Corowa, N.S.W.	536	560	448	670
6WF	Perth, W.A.	435	690	435	690
2NR	Northern Rivers Regional, N.S.W.			429	700
6GF	Kalgoorlie, W.A.			417	720
5CL	Adelaide, S.A.	411	730	411	730
2BL	Sydney, N.S.W.	351	855	405	740
7NT	North Regional, Tasmania			400	750
31O	Melbourne, Victoria	375	800	390	770
4QG	Brisbane, Queensland	395	760	375	800
7HO	Hobart, Tasmania	337	890	366	820
3GI	Gippsland Regional, Victoria			361	830
5RM	Renmark, S.A.	319	940	353	850
2GB	Sydney, N.S.W.	316	950	345	870
6PR	Perth, W.A.	341	880	341	880
3ML	Mildura, Victoria	333	900	333	900
4WK	Warwick, Queensland			330	910
4RK	Rockhampton, Queensland	330	910	330	910
3UZ	Melbourne, Victoria	323	930	323	930
2UE	Sydney, N.S.W.	292	1,025	316	950
5DN	Adelaide, S.A.	313	960	313	960
3BO	Bendigo, Victoria	309	970	309	970
4AY	Ayr, Queensland			306	980
6BY	Narrogin, W.A.			306	980
4GR	Central, N.S.W.			303	990
4CR	Toowoomba, Queensland	300	1,000	300	1,000
3HA	Hamilton, Victoria	297	1,010	297	1,010
2KY	Sydney, N.S.W.	280	1,070	294	1,020
3DB	Melbourne, Victoria	254	1,180	291	1,030
SPI	Crystal Brook, S.A.	288	1,040	288	1,040
2CA	Canberra, F.C.T.	286	1,050	286	1,050
3YB	(Mobile) Victoria			283	1,060
4MB	Maryborough, Queensland			283	1,060
2KB	Katoomba, N.S.W.	275	1,090	280	1,070
6AM	Northam, W.A.			278	1,080
3SH	Swan Hill, Victoria	278	1,080	278	1,080
7LA	Launceston, Tasmania	273	1,100	273	1,100
2UW	Sydney, N.S.W.	266	1,125	270	1,110
4BC	Brisbane, Queensland	262	1,145	268	1,120
6ML	Perth, W.A.	264	1,135	265	1,130
2HD	Newcastle, N.S.W.	270	1,110	263	1,140
2WG	Wagga, N.S.W.	260	1,155	261	1,150
4MK	Mackay, Queensland	252	1,190	259	1,160
4TO	Townsville, Queensland	256	1,170	256	1,170
3KZ	Melbourne, Victoria	222	1,350	254	1,180
2CH	Sydney, N.S.W.	248	1,210	252	1,190
5KA	Adelaide, S.A.	250	1,200	250	1,200
2GF	Grafton, N.S.W.			248	1,210
6KG	Kalgoorlie, W.A.	246	1,220	246	1,220
—	South Queensland			246	1,220
2NC	Newcastle, N.S.W.	241	1,245	244	1,230
3TR	Sale, Victoria	234	1,280	242	1,240
3WR	Shepparton, Victoria	238	1,260	238	1,260
2SM	Sydney, N.S.W.	236	1,270	236	1,270
3AW	Melbourne, Victoria	210	1,425	234	1,280
4BK	Brisbane, Queensland	233	1,290	233	1,290
2TM	Tamworth, N.S.W.	201	1,490	231	1,300
5AD	Adelaide, S.A.	229	1,310	229	1,310
3BA	Ballarat, Victoria	231	1,300	227	1,320
4RO	Rockhampton, Queensland	226	1,330	226	1,330
2XN	Lismore, N.S.W.	224	1,340	224	1,340
3GL	Geelong, Victoria	214	1,400	222	1,350
2BH	Broken Hill, N.S.W.	221	1,360		
4PM	Port Moresby			221	1,360
7BU	Burnie, Tasmania	221	1,360		
3HS	Horsham, Victoria	219	1,370	219	1,370
4BN	Brisbane, Queensland	217	1,380	217	1,380
2GN	Goulburn, N.S.W.	216	1,390	216	1,390
6IX	Perth, W.A.	204	1,470	214	1,400
2KO	Newcastle, N.S.W.	212	1,415	213	1,410
3XY	Melbourne, Victoria			211	1,420
2WL	Wollongong, N.S.W.	209	1,435	210	1,430
2MO	Gunnedah, N.S.W.	227	1,320	208	1,440
5MU	Murray Bridge, S.A.	207	1,450	207	1,450
7UV	Ulverstone, Tasmania	205	1,460	205	1,460
—	Bega			207	1,450
4CA	Cairns, Queensland			204	1,470
2AY	Albury, N.S.W.	203	1,480	203	1,480
—	South, N.S.W.			201	1,490
—	Hobart, Tasmania			200	1,500
3AK	Melbourne, Victoria	200	1,500	200	1,500

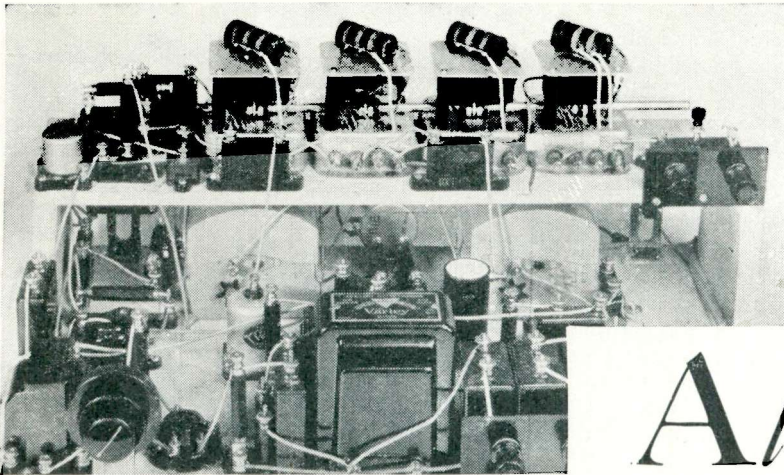

A fine battery receiver, the HK Four described in the March, 1935 issue of "W.M." made use of four iron-core coils arranged on a "bridge" above the tuning condensers

By
PAUL D. TYERS

All About Iron-dust Cores

ONE is frequently told that a dust core is simply particles of insulated iron. This statement is perfectly true, but dismissal of the subject by such a concise definition really leaves one in complete ignorance of the exact nature of a dust core.

First of all, the question arises as to where one obtains iron dust. This leads to two further considerations. How does one insulate the iron dust and, what is even more important, how does one make it into a core? This is a question which has been answered in a practical form by several investigators during comparatively recent times.

Anyone who has had experience of trying to make a dust core *ab initio* will be in a position to answer these questions and discuss the subject in some detail. As the writer is amongst those who have experimented

being in mind when the method of producing an iron dust was then considered.

It is perhaps well to mention at this stage the necessity of obtaining a fine dust, and that takes the reasoning even one step farther back as to why one wants a dust at all. Everyone knows by now that a well designed iron-core coil or, to be more precise, a dust-core coil, is more efficient than an equivalent air-core coil. This is so, for a very obvious reason.

Why the Dust-core Coil is Better

The presence of an iron core in any coil increases the inductance. The amount by which it increases the inductance depends upon the permeability of the core because the inductance of a composite coil is a direct function of the permeability of the core. For any given number of microhenries it is obvious that the presence of an iron core enables one to reduce the turns very considerably.

Now the result of reducing the turns is to reduce the

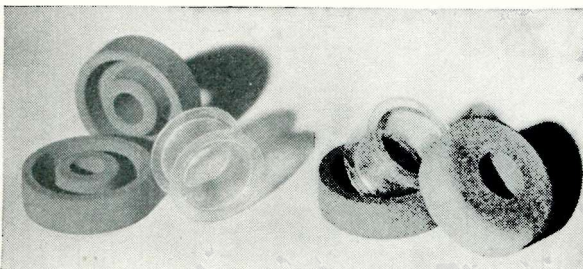

Examples of Continental closed-type cores. The inductance is adjusted by inserting a small dust-core rod through centre hole

in this direction for quite a long time and made many different types of dust cores, it is conceivable that readers may find something of interest in the consideration of some of the associated problems.

Finding a Supply of Iron Dust

Dust cores are referred to as dust cores because the iron really is in the form of a dust. Compared with the iron used in a dust core ordinary iron filings are like brickbats. The basic problem is therefore that of finding a source of supply of iron dust. Experimenters have set about the problem of producing iron dusts in many different ways.

In some cases the iron dusts have not been produced essentially for radio work, some totally different problem

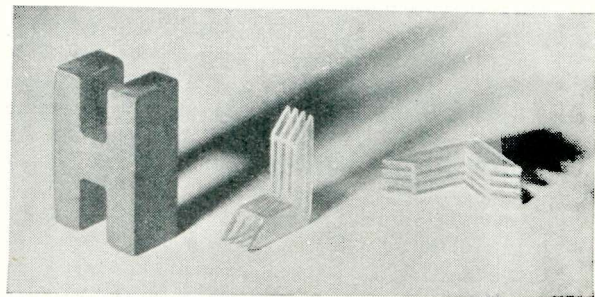

An H core semi-closed type of core with split bobbin—this example comes from Germany

amount of copper in the coil. However well a coil may be designed the presence of the copper introduces certain losses. In the first place the copper has an ordinary ohmic resistance. There will also be high-frequency losses depending upon the nature of the conductors and the frequency at which the coil is used. These losses must occur however well the coil is designed and however good may be the wire. If we have removed quite a large percentage of these losses we have obviously improved the coil.

One immediately queries this reasoning by suggesting that the presence of the iron may have introduced some iron losses. Such reasoning is perfectly correct because the iron core does introduce iron losses. Why then, one may ask, is the iron-core coil more efficient.

The Iron-core Coil is More Efficient

It is more efficient simply because by careful manufacture the losses due to the iron core can be made very much lower than the losses which would be due to the amount of wire we have been enabled to discard. Obviously, therefore, the whole success of an iron-cored coil depends upon the efficiency of the iron core.

As soon as a mass of iron is placed inside a coil in which a high-frequency field exists there will be serious losses and the losses will increase with the frequency. There will be eddy-current losses and hysteresis losses. It is not the purpose of this article to discuss the how and why of such losses as this is a matter of ordinary electrical theory which can be referred to in a text book.

In the case of a mains transformer a laminated core is used, the iron being split into a number of laminations more or less insulated from each other. The construction of an iron core is somewhat analagous. The particles have to be reduced to as small a size as possible consistent with the frequency at which the coil is used, and they must also be insulated in exactly the same way as one laminates a laminated core in a mains transformer.

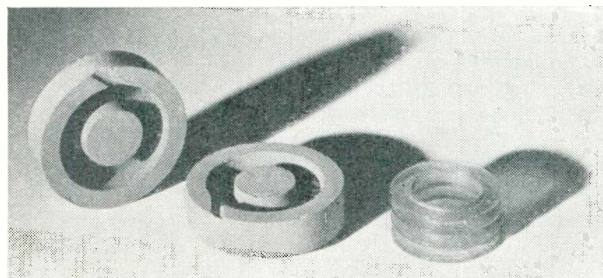

A French closed core. Note the grooves for the lead-out wires and the thick wall

It may surprise many readers to know that the size of the particles necessary for efficient working at high frequencies is only of the order of a few microns, a micron being a thousandth part of a millimeter. If this conveys little it may be mentioned that iron dust used for high-frequency cores is similar in size and texture to face powder.

Several processes have been used for the preparation of such fine iron powder, and it is in the production of such iron that the chemist has played an important part. Attempts, however, have been made to mill powders, but as it will be readily seen it is very difficult to obtain a powder of small enough grain size. Electrolytic methods have been tried and sputtering methods have also received attention.

For the most part, however, the iron dust is produced by some sort of pure chemical process. One form of iron most widely used is that produced from iron carbonyl, a substance which is manufactured in considerable quantity in Germany. Other forms of chemically produced iron are generally obtained by precipitation and reduction.

Ordinary reduced iron is a very well known substance to be found in almost any wholesale chemist's list. The size of the iron, however, is not much smaller than that of iron filings and is quite unsuitable for radio purposes. Iron powders produced by chemical means only are satisfactory because of the use of some special process or some particular method of control resulting in an extremely fine precipitate.

In passing it is interesting to point out that very fine

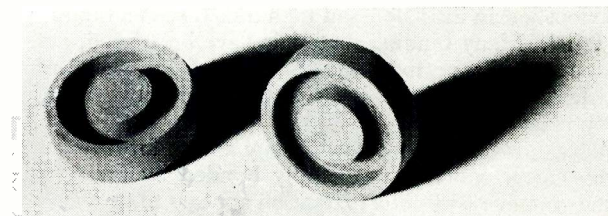

A German closed-type of core with a thin wall

iron powder is far from stable and is easily liable to self-ignition when exposed to ordinary moist atmosphere.

The necessary plant for making iron dust by some processes is extremely costly, whilst in other systems the plant may be less expensive but the production may cost more. It is easy to see, therefore, that an iron core is not likely to be very cheap, although the value of the iron as such in any given core is almost negligible.

Long before dust cores were used for radio purposes attention had been drawn to the use of powdered iron for other work, such as problems involved in telephone transmission where compact loading coils were required. In the circumstances it is not surprising to find that an extremely large number of systems of insulating the particles have been suggested. Some of the systems which are applicable to large sized powdered iron cores are applicable to the insulation of fine dust cores, but in many cases special methods have been developed.

Minute Grain Size of the Dust

When it is realised that the grain size of the dust used in a radio core is of the order of a thousandth of a millimeter it is obvious that complete insulation of every particle is a matter more likely to be hoped for than achieved. But, of course, on the other hand a few dozen particles in complete contact here and there won't make a tremendous difference.

Insulation methods can be divided into two groups, chemical systems and coating systems. A very common method is to treat the iron powder in a substance which tends to produce a minute skin of oxide or other insulating film. Accordingly it is not unusual to treat iron dust with some weak oxidizing agent, simply pouring the iron into a bath of the liquid which is accompanied by subsequent washing and drying.

This type of insulating film is satisfactory in so far as its insulation properties are concerned, but it very rarely stands up to pressure. It should be remembered that the iron powder is very light and some powders are almost flocculent. Accordingly they have to be com-

pressed, and it is during the pressing operation that the whole insulation may fail.

The skin insulation, however, is generally protected with the binding agent. Providing one has obtained an iron of sufficiently fine grain size the efficiency of a core depends almost entirely upon the insulating and subsequent pressing.

Readers who are particularly interested in the subject of insulation would no doubt be interested in examining the really large number of patents which have been taken out for insulation processes.

Two Classes of Cores

Cores for radio purposes can broadly be divided into two classes, those in which the binding agent is also used for insulation, and those in which the particles are previously skin insulated and then mixed with a binding material. Many binding materials have been used, and where a high permeability has not been necessary satisfactory cores have been made simply by mixing the powder with wax.

Wax, however, is not used to any extent for ordinary radio cores, which are generally bonded by means of some gum or resin. Most attention appears to have been

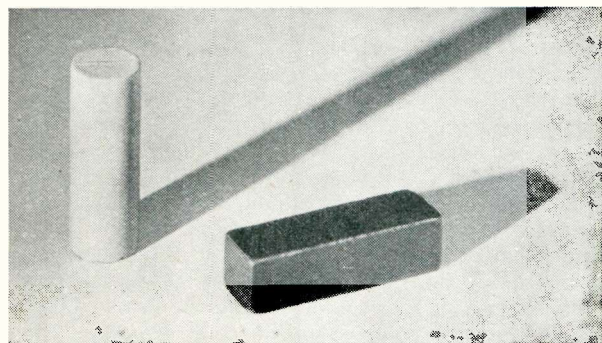

Two examples of the British box-type core

paid to synthetic resins, and it may surprise readers to learn that one of the most successful radio cores consists of practically nothing other than iron and bakelite.

The secret of such a core, however, lies in the processing, that is the method by means of which the particles are insulated and pressed. This, however, is actually not nearly so difficult as one might imagine and a highly satisfactory core can be made experimentally with the simplest of apparatus.

Substances for Insulating and Bonding

Amongst the substances used for insulating and bonding may be mentioned such common materials as resin, bakelite and urea. Much thought and care, however, is necessary in considering the insulating and bonding process. In the first place it is essential to obtain sufficient insulation to prevent losses due to eddy currents which would occur if too many particles were in contact.

Another very important point which has to be considered is the pressing operation. It is obvious that if one were to press unequal amounts of iron into the same size core the effective permeability of the cores would vary and as a result the matching of inductances would be different. Moreover, the losses would vary and practically no uniformity would be obtained in any of the constants. This means that the insulating and

bonding has to be carried out to quite fine limits, and the same may be said of the pressing operation.

Cores are generally pressed in quite a simple form of press, but the finer the iron used the greater tends to become the wear on the tool, and one of the practical difficulties in the manufacture of the core is the successful design of the tool.

In fact one may even go so far as to say the tool design and pressing operation is perhaps the most important factor in the mass production of an iron core. Experience gained in this subject, however, has led to the satisfactory design of multi-way tools enabling a number of cores to be pressed simultaneously.

Stabilising the Cores

Various treatments have also been suggested for stabilising the cores, such as artificial ageing, and both thermal and electrical experiments have been carried out with this object in view.

Experiments have been made in pressing cores both hot and cold, and experiments have also been made with cores in a semi-plastic state or lubricated with a liquid which is not a solvent of the binding material employed.

Theoretically an obvious way of increasing the efficiency of an iron core would be to use a nickel-iron alloy which from general theory would be likely to have a higher permeability, which would give an even greater reduction in the amount of wire used in the resulting coil. Nickel-iron cores are actually in use when very high permeabilities are obtained.

The insulation and treatment of such cores however is a far more complicated matter because in the majority of cases the maximum permeability is only obtained from a nickel-iron alloy when the alloy is annealed at the correct temperature, and the high temperatures involved call for a special system of insulation.

Most Interesting Development

One of the most interesting developments is probably the production of a nickel-iron dust of exceptionally small grain size which it is believed is much smaller than anything previously used. The successful development of a core using this material is decidedly one of the most interesting possibilities in radio technique.

It is impossible to predict what properties the resultant core may have, but present experiments indicate the possibility of the production of a core having exceptionally useful properties.

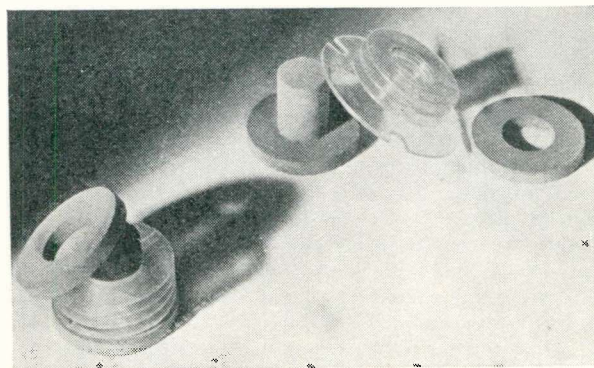

Another French core. This is a semi-closed type; it is adjusted by moving a ring and cementing in position

Advantages and Disadvantages of the

A.C./D.C. Receiver

In this interesting account of the hows and whys of the universal A.C./D.C. type of receiver, the Technical Editor explains its special features and advantages and shows why the universal principal is not applied to all types of sets.



The photograph on the right shows one of the experimental models of the new "Unicon" two-valver. Full constructional details of this efficient receiver will appear in our next issue

THE Universal, or A.C./D.C. type of receiver is just one of those things which the technical fraternity take for granted simply because they know how and why the type originated: to the layman it appears by no means so simple and, indeed, I gather that the whys and wherefores are really rather puzzling.

I say "I gather," because only the other day someone asked me series of questions on the subject that caused me to put in some serious thought and finally decided me to write this article.

The conversation went like this:

- "Will a D.C. set work on A.C.?"
- "No."
- "Will an A.C. set work on D.C.?"
- "No."
- "Will a universal set work on either A.C. or D.C.?"
- "Yes."
- "Then why don't they make all sets universal?"

A Rather Mysterious Business

The answer to that last quite natural question took a long time to give and it seemed to interest the inquirer so much that I realised afterwards that the whole business must seem rather mysterious to all those who have not been in a position to follow the progress of receiver

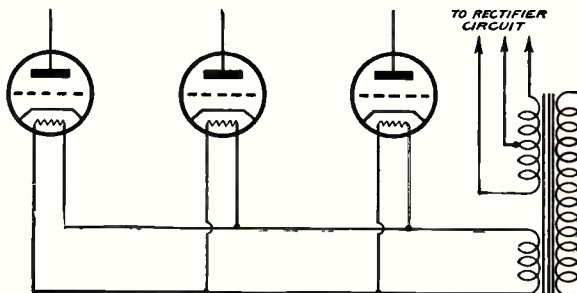

A large supply of current at a low voltage is readily available in an A.C. set and therefore the valve-heater circuits are connected in parallel. A rectifier must be provided for high-tension

design (especially commercial design) of recent years.

Here I propose to try to explain the fundamental facts concerned and put the reader in the position of being able to see for himself why the universal is a type in itself; why it is not used exclusively, and just what are the main technical questions involved. In so doing I shall endeavour to avoid going into any great elaboration of detail, treating the subject rather from the viewpoint of the set user or set builder who wishes to know the how and why in a general way, without burdening himself with a mass of technicalities.

Characteristics of True A.C. and D.C. Sets

Let us look first at some of the individual characteristics of the true A.C. and D.C. sets. For working on alternating mains the usual practice is to employ valves of the indirectly-heated kind with heaters requiring quite a large current at a low voltage; as a rule each valve requires a current of 1 ampere at a pressure of only 4 volts.

It is customary to arrange these heaters in parallel like the filaments of a series of battery valves. Thus the heaters of a three-valve A.C. mains receiver would call for a total current of 3 amperes at 4 volts, and this is easily provided from a suitable winding on a power transformer.

Valves Used in D.C. Sets

In a D.C. receiver, on the other hand, we cannot obtain large supplies of current at a low voltage because the transformer principle is not available to us: the transformer will not function on direct current. Some assistance might be obtained by connecting all the heaters in series instead of in parallel, but we should still require to draw 1 ampere from the mains and this would mean very expensive running.

It is therefore usual to employ a different type of indirectly-heated valve in D.C. sets. These special valves are fitted with heaters of the high-voltage low-current type, requiring perhaps only .18 ampere

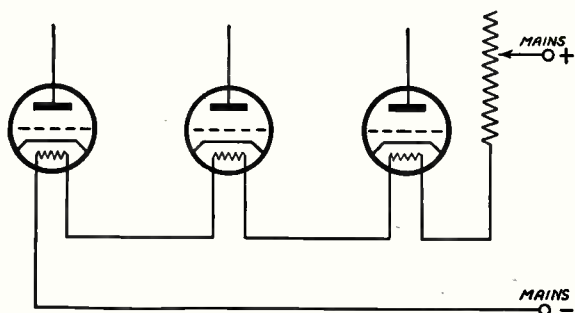

In a D.C. receiver the transformer principle cannot be used. To economise current the heaters are therefore connected in series and are of the high-voltage, low-current type

at something of the order of 20 volts or even more. A number of them can be connected up in series and so the total heater current drawn from the mains can be kept down to only .18 ampere. This gives quite a reasonable degree of economy of running and the characteristics of the valves can be made strictly comparable with those of the A.C. type.

In the D.C. set the high-tension current for the anodes of the valves can be taken straight from the mains: it requires merely a certain amount of smoothing to subdue hum and a little de-coupling to prevent interaction between the various anode circuits.

High Tension for A.C. Sets

In a receiver for A.C. mains, on the other hand, the high-tension supply must be rectified and turned into direct current before it can be applied to the anodes of the valves (raw A.C., as it is called would produce a terrific hum). This means that in addition to the smoothing and de-coupling arrangements present in a D.C. set the alternating current one must contain a rectifying circuit which allows current to pass in only one direction and suppresses the other half wave of each alternating cycle.

The special feature of the A.C. set, therefore, is found in the use of a transformer and a rectifier; this combination has one very important consequence—the voltage applied to the rectifier can be stepped up by the transformer to any required figure and so a high voltage can be obtained for the anode of the output valve if required. This means in effect that a large amount of output power can be achieved very easily.

Difficulties with D.C. Receivers

In the D.C. receiver, on the other hand, it is only possible to get the voltage of the mains less sundry voltage drops in smoothing circuits, bias resistances and so forth. Now, this is not a very adequate voltage for the anode of the output valve, and so it is not too easy to get really large amounts of power from a D.C. instrument. It can be done, but at the cost of push-pull circuits or some other special device for getting large power without a high anode voltage, and all this means expense.

The universal, or A.C./D.C. receiver embodies some of the features of both the A.C. and the D.C. set. The valves are usually of the high-voltage low-current heater variety, and series connection is used. Since the instrument must work on D.C. no transformer can be used, and so the high-tension voltage is limited as before.

In order that the set may work on A.C. a rectifier is provided, and this is fed straight from the mains. Hence

the high-tension voltage available can only be of the order of 200 volts or so and if we want large (really large) outputs we must be prepared for a certain amount of complication.

How the Universal Receiver Works

When working on D.C. the rectifier serves no particular purpose, but simply passes the high-tension supply along to the valves very much as though it were a simple resistance. This it can do, of course, because in these sets it is connected directly to the mains without the interposition of a power transformer. In certain forms of universal receiver provision is made for cutting out the rectifier when working on D.C. This enables a slightly higher value of anode voltage to be obtained by eliminating the normal small voltage drop in the rectifier but there are certain practical difficulties which render the expedient an unusual one.

It will be seen, I think, that the universal principle lends itself best to use in receivers of but moderate size.

There are many interesting technical problems involved in the design of a successful universal receiver,

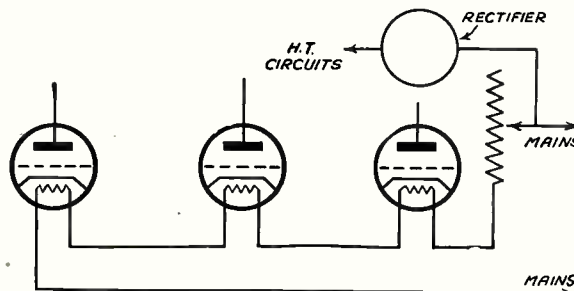

The universal receiver employs the series-heater arrangement of the D.C. set, with the rectification system of the A.C. type for the high-tension supply

but with these I must deal next month when I give the detailed description of the Unicon Two, which you see illustrated on the previous page. This little set represents my idea of the ideal economical small receiver for general mains use: it employs an efficient detector and pentode circuit and although intended chiefly for local work will give a surprisingly good all-round performance when local conditions are at least reasonably good.

The system of make-up is the efficient "semi-professional" style which I introduced for the P.T.P. Three recently, making the set easy to build, good-looking and reliable.

COMPONENTS FOR THE "UNICON" TWO

For the benefit of those readers who may wish to begin collecting the parts for this set in good time we give a list of the chief components used

COIL

1—Goltone, type G1C2.

CONDENSERS, VARIABLE

1—J.B. .0005-microfarad Nugang.
1—Graham-Farish .0003-microfarad Littos reaction.

CHOKE, HIGH-FREQUENCY

1—Varley Junior.

CHOKE, LOW-FREQUENCY

1—Ferranti, type B10.

RESISTANCE, MAINS

1—Bulgin, type MR25.

TRANSFORMER, LOW-FREQUENCY

1—Varley Ni-core No.2.

VALVES

1—Tungsram R2018.
1—Tungsram PP4118.
1—Tungsram V2118.

LOUDSPEAKER

1—W. B. Stentorian, standard model.

By the
Editor

An aerial view of Alexandra Palace, the site chosen by the Postmaster General's Television Committee as London's first official television station. The towers are only 300 ft. above sea level and one of these will be increased to 600 ft. to provide the desired height.

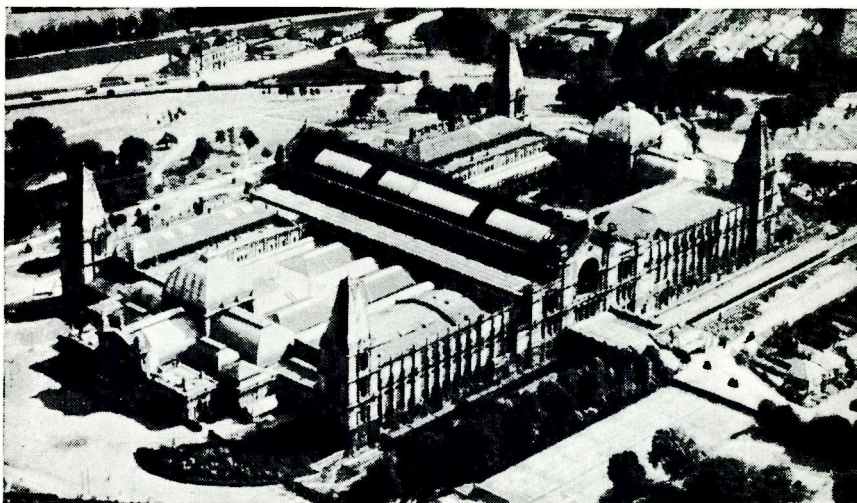

Fox photo

Gambling With Television!

Some Facts the Public Should Realise

WE are a complacent nation. A few words of assurance from some person in authority suffices to allay most public fears. Until it is too late!

Motorists recall with bitterness the cynical treatment they received from the Government with regard to the Road Fund. You will remember it was decided to form a fund for the development of the roads, a tax on motorists being imposed to provide the necessary money. Fears expressed that once the money started to pour into the exchequer the Government might be tempted to use it for other purposes were immediately allayed by a direct statement that the money would *not* in any case be used for other purposes.

This is called a "pledge." It is all a matter of record, and can be turned up in the Parliamentary Reports for the time, before first Mr. Churchill and then his successor calmly appropriated the alleged "surplus" to help them balance their particular budgets. A "surplus," mark you, obtained by not spending the money on the roads as arranged.

In just the same way at the beginning of broadcasting it was realised that a central organisation to control this new form of entertainment and instruction would be desirable. If such an officially approved company were formed, said the Government, it would be prepared to collect a licence fee from listeners, the money so received to be handed over to the new company to provide means for the service and broadcast programmes.

Naturally a small amount would have to be subtracted from the total sum in order to pay Post Office administration expenses, but this would be a negligible proportion. Few new officials would be needed as the licences would be issued through the ordinary Post Office channels.

This sounded an excellent scheme. Few people minded paying ten shillings in these circumstances, yet I wonder what would have happened to the Bill and to

public feeling at the time if the Government had had the temerity to say: "We propose to charge the public ten shillings a year for the right to use a wireless set. Five shillings of this will go to the company providing programmes and we shall take the rest as amusement tax!"

Broadcasting is the sole entertainment of many thousands of people in humble circumstances and of many in country districts where other forms of entertainment are denied them.

The idea that these people should pay five shillings amusement tax every year would have been so repugnant to the great majority of us that a protest would have been raised at once. Yet that is, to all intents and purposes, the position today, for out of your ten shillings nearly five shillings goes to the Government.

This country pioneered television. The work begun by Baird in England has been taken up all over the world and modern television is the product of many brains. After a period during which it seemed both Germany and America were forging ahead it was discovered that here in England so much progress had been made that it was high time the Government did something about it.

Accordingly the Television Committee was formed and reported early this year not only that television had reached a very advanced stage, but that it was highly advisable that a practical service should be started as soon as possible.

The committee reported that they had tried four systems which seemed to have promise and they recommended that two of them should be tried out "on the air" as soon as possible.

Now it so happened that one of these companies had a complete experimental transmission station together with all the necessary studios and equipment at the Crystal Palace all ready to start at once. Research work spread over many months and the most elaborate

Continued on page 75



One of the Baird receivers for vision and sound giving a sepia picture some 8 in. by 6 in.

WITHIN the next few months the first officially recognised television station in this country will be opened at Alexandra Palace in North London. Two companies have been entrusted by the Postmaster General's Television Committee with the task of supplying the equipment, Baird Television, Ltd. and the Marconi-E.M.I. Company.

We have had as yet no details from the Marconi-E.M.I. concern except the few which will be found incorporated in a short article on page 35. As soon as this concern's methods



Electron multiplier tubes developed by the Farnsworth Television Company of America. These tubes have no filament and give an amplification up to a million times

are made fully known we shall give them prominence in these pages.

Baird Television, Ltd. has its headquarters at the Crystal Palace from which it has been conducting experiments for the past two or three years. A floor space of 60,000 sq. ft. is occupied in experimental laboratories, studios, and even manufacture of television apparatus.

Experimental television transmissions of a practical service nature have been made from one of the Palace's towers, the top of which is 700 ft. above sea level.

Just one mention of the low-definition system. The B.B.C. has gallantly helped the Baird people in the pioneer work of 30-line transmissions. In the autumn when the Alexandra Palace comes into being 30-line television will be dead—it will never be revived!

The future high-definition transmissions by the Baird process will be standardised at 240 lines in the picture and 25 frames per second, and will be broadcast on a wavelength of between 6 and 7 metres.

There has been no little discussion in technical circles regarding the choice of the number of lines to make up the picture. Baird Television has its own views—and very strong ones—on this matter. Baird engineers say that they are prepared to transmit with 240 or 405 lines and that they

Baird Television, Ltd. has done an enormous amount of pioneer work and it is our object here to give a brief outline of this company's ideals and organisation so that readers will know what to expect when television gets really going later this year

Television in the Making

have carried out experiments in transmitting pictures with definitions of 120, 240, 400 and 700 lines, but they are convinced that the best results under existing conditions are obtained by the use of 240 lines.

Wavelength Problem

By using a picture definition of 240 lines many difficulties are avoided. Baird Television is of the opinion that if the number of lines is increased above 240 a lower wavelength of the order of 2 metres is required for transmission and this introduces many unfortunate complications.

Waves of 2 metres fail to make

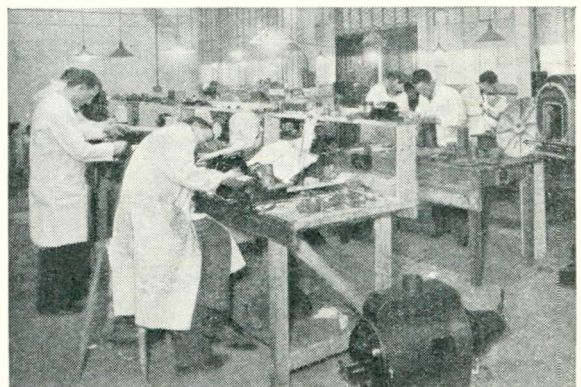

At the Crystal Palace Baird Television, Ltd. has complete workshops for making receiving and transmitting gear. Here is one of the shops devoted to the manufacture of transmitting gear

their way past obstacles such as hills and buildings, and shadow effects are pronounced. Interference from motor cars and electrical appliances—both commercial and domestic—is greatly increased when receiving on a wavelength of 2 metres.

For nearly two years transmissions from the Crystal Palace have been made on a wavelength of 6.6 metres—the wavelength chosen by the Television Committee. Actually these transmissions have been satisfactorily picked up within a radius of 30 miles from the Palace at sufficient strength to operate a high-definition television receiver and to give a picture of real entertainment value.

Entertainment Value

To define this value we can safely compare it with the home-cinema picture; it has the same or even greater brightness.

Only those who have visited the Palace can realise what a tremendous amount of work has been done. There are complete studios, the latest sound and lighting gear, high-power ultra-short-wave transmitters with advanced scanning apparatus for dealing with all manner of scenes, close-ups and long distance. Even the transmission of talking films is not beyond the realms of possibility.

The completeness of the equipment has brought technical and broadcasting representatives from America, Germany, France and other countries to inspect it. In addition to the transmitting station proper there are fully-equipped workshops for the manufacture of transmitting and receiving gear, cathode-ray tubes and so on.

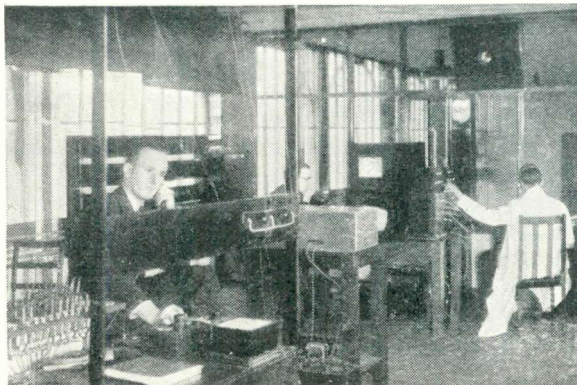

Baird's main control room for the control of vision, sound and synchronising of the four studios and two cinematograph transmitters radiating experimental programmes from the Crystal Palace

Scanning you will remember was fully discussed in articles by the Technical Editor in our May and June issues. The Baird company uses many methods of scanning—scanning being the art of transforming a scene into a series of electrical impulses.

There is the spotlight scanner for the transmission of close-ups of one or two people. With the intermediate-film method any scene that a cinematograph camera can take can be transmitted, and even stored for future use. This latter system will be found useful when television has developed to the stage when transmitters are dotted all over these islands.

Ordinary talking films can be transmitted and it is even possible to read the smallest letter on titles and sub-titles, so clear is the detail of the system.

Baird Television, Ltd. has a working agreement

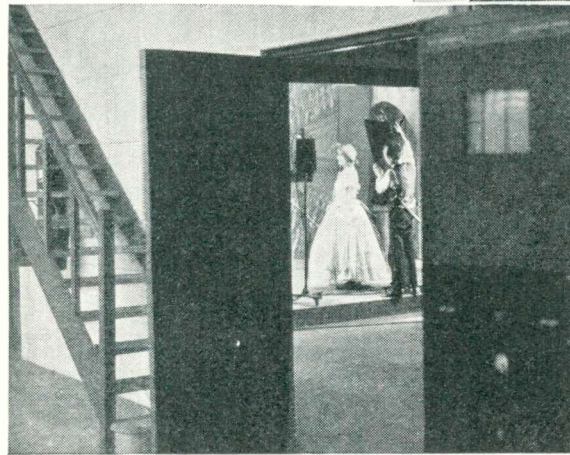

Wandering round the Crystal Palace one is likely to come up against scenes like this—an actress waiting to go on one of the studio sets

with the Farnsworth Television Company of America—another pioneer company responsible for the development of the Farnsworth electron camera already described in these pages. Another Farnsworth invention of vast importance is the electron multiplier, the function of which is similar to an ordinary radio valve.

These multipliers are being made now at the Crystal Palace laboratories. Recently the Baird organisation has been developing an electron multiplier giving an amplification factor of 1,000,000. Baird engineers have reasons to believe that in time the multiplier may oust the radio valve and so revolutionise the radio and television industry.

Our survey would not be complete without some mention of our end of

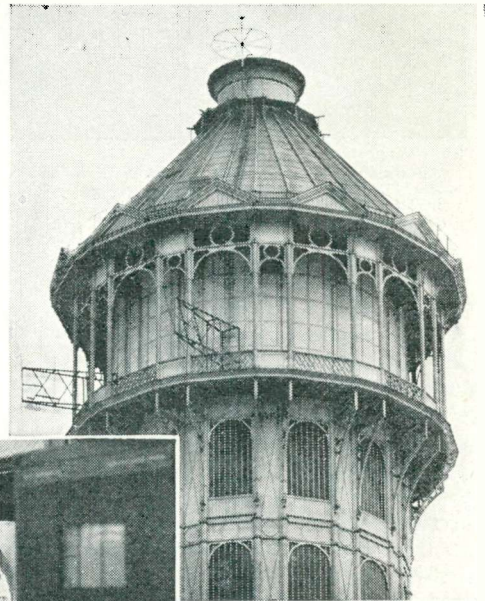

Sound and vision ultra-short-wave aerials for transmitting are seen on the balcony and the new high-power ultra-short-wave vision transmitting aerial at the top of one of the Crystal Palace towers

television—the receivers to use in our own homes. We are told that Baird Television, Ltd. has, and can supply in quantities when the time comes, two types of television receiver. The larger will

give a brilliant black and white picture some 12 in. by 9 in. and the smaller a picture 6 in. by 8 in.

Both types are entirely self contained—vision and sound receiving apparatus—and they will be easy to operate.

Price is, of course, the vital point for most of us. No definite figures have been given, but you can take it that they will compare very favourably with existing prices of really high-class radio receivers.

We have made this summary as brief and concise as possible, but from it you will see that television as a practical home entertainer is not very far away.

TELEVISION NOTES AND NEWS

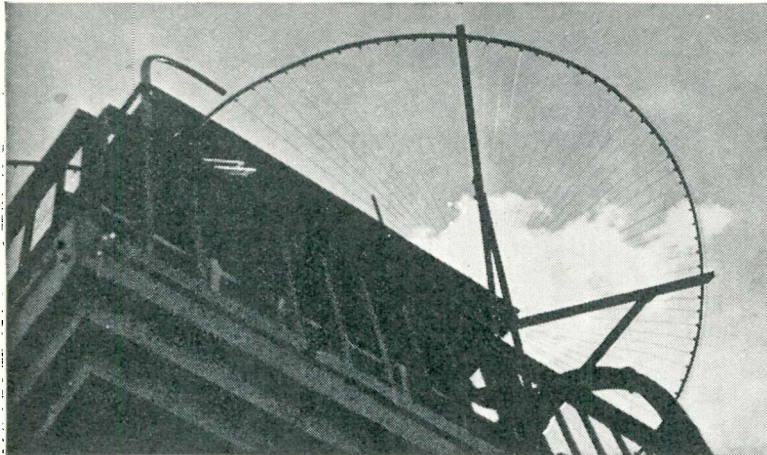

Gulliland photo

An unusual view of the top of the Berlin Funkturm from which the present German ultra-short-wave television transmissions are sent out. The umbrella-shaped structures are the aerial counter-poses

THOSE who make a practice of running down the cathode-ray method of picture reproduction are very fond of pointing out that the tubes cost a certain amount of money (quite a lot for the larger sizes, it must be confessed), yet their life is subject to time limits of a pretty definite nature. They add that the analogy with the more expensive type of moving-coil loud-speaker is therefore not sound: the latter does not wear out.

This has always seemed to me a very unfair kind of argument. The high-definition television tube is a relatively new device upon which research is still being done and both its life and its brilliance are steadily improving. The public are not yet being asked to buy cathode receivers, and it looks as though some months may yet elapse before they will be so asked. When the time does come I believe we shall find that very considerable progress has been made.

Just what figures can be obtained from the latest types of tube I find it difficult to discover; the manufacturers naturally do not wish to commit themselves to a premature estimate which may prove incorrect when production begins in quantity; it is an expensive business for the

What Is the Life of a Cathode Tube?

By P. WOODWARD

private experimenter to conduct life-tests otherwise than by the normal process of use.

Such information as one can obtain, however, does very strongly suggest that the glib estimates of "only a few hundred hours" are wildly out so far as the more recent types are concerned. For example, I saw the other day that a certain authority puts the life of the tubes

certainly enabling some valuable pioneer work to be done on the radio aspect of the problem of high-definition transmission on the ultra-shorts. Expectations in the matter of service areas are being considerably exceeded and a wealth of valuable information is being obtained regarding the behaviour of the waves.

In particular it seems that the fears of numerous "shadow areas" in cities are very much exaggerated. Really complete shadows are comparatively rare and in very few localities has it proved impossible to obtain at least fair results by shifting the aerial system a little this way or that.

The service in its present form appears to be the means of acquiring so much useful preliminary data that the expected increase of definition above the present 180 lines may very likely be delayed for a while.

That, to my mind, is an illustration of the danger of allowing a service to start on a basis which may require early change!

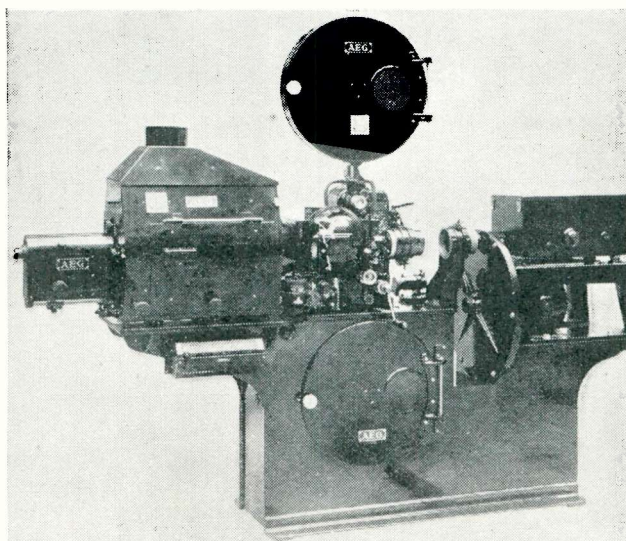

The A.E.G. film scanner used in the German service for transmitting cinematograph films. It employs a mechanical system of scanning with a high-speed disc

To acquire a full understanding of television principles one must be fully conversant with present-day theories of the nature of light. Our knowledge of light action is still very limited and in this article Morton Barr gives a miniature history of research and outlines certain recent developments



Preparing for the televising of a boxing match at the Baird Crystal Palace studios. As you can see great care is being paid to lighting (and make-up of the boxers)

What You Should Know About Light

By MORTON BARR

IN ordinary broadcasting, sounds are converted first into electric currents and then into ether waves. The change is from one kind of energy into a second kind of energy different both in form and in substance from the first.

Sound, as we know, consists of molecular vibrations in some material medium, which may be solid, liquid, or gaseous. The molecules of the medium alternately crowd together and draw apart from each other, thus producing what is called a compression wave. Such a wave travels forward as a whole in the same direction as the movement of the individual molecules.

Sound and Light

Sound cannot pass through empty space. The bell of an alarm clock, for instance, cannot be heard if the clock is suspended in a vacuum. Ether waves, on the other hand, are of the transverse type (like the ripples on the surface of water) and move forward in a direction at right-angles to the local crests and hollows. They are formed by electric and

magnetic displacements, as distinct from the bodily movement of material particles, and they travel best in the ether, or "empty" space, which separates us from the sun and stars. Finally, their velocity is immeasurably greater than that of sound waves; in fact, they travel faster than anything else known in nature.

All this emphasises the difference between the original sound wave and the broadcast carrier wave.

In television we start with a visible object or scene, the light from which, we may say, is also converted first into an electric current and then into a radiated ether wave. But here, in point of fact, the transformation is one more of form than of substance, because we begin and end with exactly the same kind of wave-energy, travelling in the same fashion, and at the same speed, through the same medium.

It is true that the radiated ether waves are enormously longer—in other words they have a much lower frequency than the original light waves; but otherwise both the waves

are identical in kind and quality, at any rate, according to our present knowledge of the nature of light—which while still far from complete has at least the merit of being based upon experimental facts.

Although, according to the very latest school of thought, there is still room for doubt as to whether light is made up of waves or corpuscles, it really makes no difference from a practical point of view.

Practical Basis

An engineer does not have to worry about the theory of wave mechanics when calculating the strains and stresses of the material he is using. He knows that he can depend upon established figures for the tensile strength, say, of an iron girder, without bothering about its precise atomic structure. In the same way we can rely with confidence upon the wave theory of light as being a safe guide to follow where television is concerned.

Early Ideas

The story of the attempts made by different thinkers to unravel the mystery of light and to discover something of its real nature makes one of the most interesting chapters in the history of science. To be able to see is one of the first of human experiences. It seems so natural that one is tempted to accept it as a matter of course, without attempting to ask why.

However, the early Greek philosophers were not so easily satisfied;

they speculated deeply upon most of the fundamental things in life. Empedocles in 440 B.C. held that light was a property of the human eye. He pictured the eye as sending out invisible feelers or tentacles which wrapped themselves around every object with which they came in contact, and so brought back impressions of its size and shape.

Radiation Theory

Whilst this was ingenious, it did not explain why one object appeared brighter than another, or why the eye ceased to function in the dark.

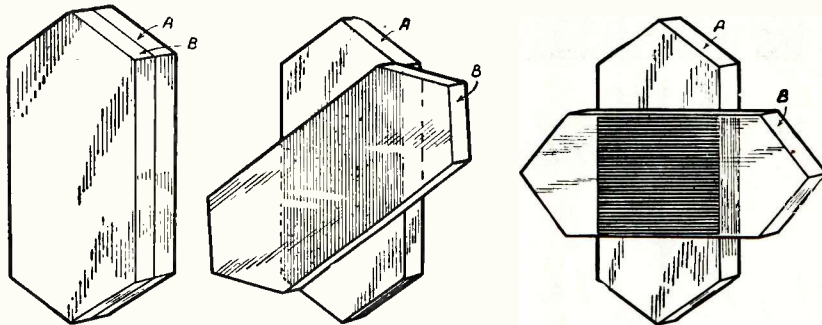

Fig. 2.—A diagrammatic representation of the action of crossed Nicol prisms on a beam of light

Pythagoras came nearer to the true solution by defining light to be a radiation given off in greater or less degree by every substance, thus conveying information as to its shape and appearance to the mind through the eye.

Problem of Colour

Colour proved another stumbling block because the ancients knew that the sensation of colour could be produced in complete darkness by a simple pressure on the eyeball. Even Leonardo da Vinci thought that pure sunlight was dyed in the process of passing through a red pane of glass, or when it was reflected back from a coloured object.

The first real advance may be said to date from the discovery that light could be bent by passing it through glass. When this knowledge was first acquired is not definitely known, but Roger Bacon in the thirteenth century certainly used a segment of a sphere of glass to magnify small writing.

This leads us in turn

to the spectacle makers and to the discovery by Jansen in Holland of the telescope, which he passed on in 1608 to Galileo, who used it to smash the notion that the earth was the centre of the universe. Then in 1621 Snell worked out the laws which governed the bending of light, and gave us our first notion of the refractive index.

Newton, whilst engaged on the problem of getting rid of the troublesome fringes of colour which appeared round the images formed by a telescope, came one day to suspect that they might be due to

always to be depended upon as a judge of the relative intensities or of all the sound frequencies, so the eye makes physiological distinctions of its own. For instance, it only responds directly to three primary colours, namely, red, green and violet, all other colours being built up inside the eye itself from combinations of these three. In other words, colour is very largely "all your eye."

Corpuscular Theory

This fact is bound to play an important part when television comes to the stage of reproduction in colour, just as another peculiar property of the eye—the so-called persistence of vision—is already utilised to build up the effect of smooth and continual movement from a rapid succession of still pictures.

Newton thought that all visible bodies radiate swarms of tiny corpuscles or particles travelling outwards at great speed, and giving rise to the sensation of light by striking against the eye. They are reflected from opaque bodies and pass between the atoms of transparent bodies. To explain the refraction or bending of light, Newton assumed that the corpuscles were attracted by the atoms of a transparent body by a force similar to that of gravitation and were accordingly speeded up as they passed through. This is an important point, because it was subsequently used as a deadly argument against the corpuscular theory of light.

Speed of Light

Meanwhile Roemer, in 1675, found that the interval between successive eclipses of one of Jupiter's moons was shorter than it should be when the Earth was travelling towards Jupiter, and longer when the Earth was moving in the opposite direction. His explanation was that light took a definite time to travel across the space separating the Earth from its fellow planet, and he calculated its speed to be of the order of 186,000 miles a second. This figure turned out to be wonderfully near the mark when tested by modern methods.

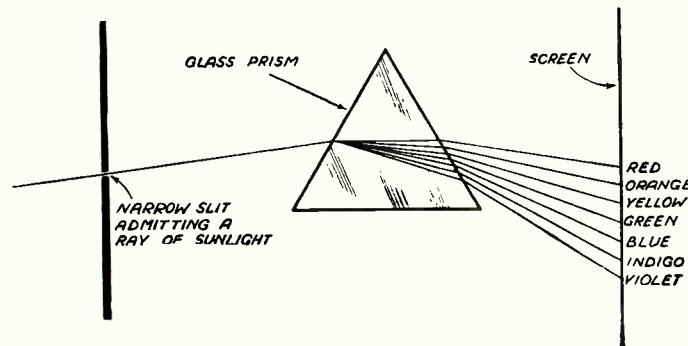

Fig. 1—Newton's original experiment to demonstrate the complex nature of "white" light

It gave perhaps the first blow to Newton's theory, because if light corpuscles really travel at that enormous speed, it is difficult to conceive how so delicate an organ as the retina could stand the terrific impact without damage.

About the same time Huygen, the Dutch philosopher, advanced an alternative theory to the effect that light was due to wave motion in an all-pervading fluid, which he called the luminiferous ether.

To cut a long story short, Huygen's wave theory finally won the day. First it was shown that light would bend or diffract around a narrow object, just as sound waves will pass around an obstacle in their path. This was, of course, contrary to Newton's assumption that light invariably travelled in a perfectly straight line through the same medium.

Evidence of Support

Next, light passing through a narrow slit was found to give rise to "interference bands" consisting of alternate zones of light and darkness. This can easily be explained if we imagine the crests and hollows of two sets of waves to coincide and so cancel each other, though there is no adequate explanation on the corpuscular theory.

The final blow was dealt by Fizeau, who showed that light travelled more slowly in water than it did through the ether. This is directly opposed to Newton's theory, which explains the refraction of light on the ground that the corpuscles increase their speed as they pass from a rare to a denser medium. The wave theory, on the other hand, calls for a falling-off in speed, to account for the bending of the wave front as it enters a denser medium.

Transverse Movement

It was next discovered that a pair of semi-transparent tourmaline or Iceland-spar crystals, A B, placed crosswise in front of a lamp, as shown in Fig. 2, will shut out some of the light from the source. On close consideration this establishes the fact that ordinary light consists of waves of the transverse type, like those produced by dropping a stone in water, or wagging the free end of a rope, as distinct from the compression waves associated with sound.

The molecules of the crystal are so arranged that they form a "grating" which only allows waves moving in

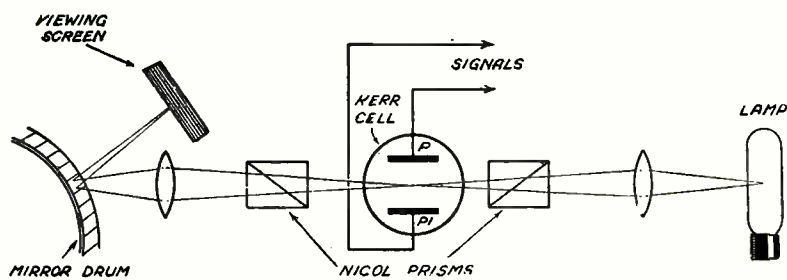

Fig. 3—The use of "polarised" light in a television receiving system: the action of the Kerr cell is to affect the plane of polarisation and so vary the total amount of light passing through the system

one plane to pass through. Since the emerging waves are now plane polarised, they are in turn completely blocked out if the "grating" of the second crystal is arranged at right-angles to the first.

This fact serves a useful purpose in television as applied to the well-known Kerr cell light valve or modulator.

The two crystals of the polarising Nicol, shown in Fig. 3, are "crossed" so as normally to prevent any light from the lamp from reaching the scanning-disc or viewing-screen. Between the crystals is the Kerr cell, consisting of two electrodes

P, P₁, immersed in nitrobenzine, which has the peculiar property of rotating the plane of polarised light under the influence of an applied electric or magnetic field.

A fixed biasing voltage is initially applied to the electrodes P, P₁, to give the ray a slight twist so that sufficient light gets through to produce a partial illumination of the viewing screen. Signal voltages applied to the same electrodes will then further rotate the plane of the ray so as to vary the intensity of the light reaching the screen from white to black, thus reproducing the light-and-shade values of the original picture.

Television News from E.M.I.

ON the occasion of the publication of the recent interim statement of the Television Advisory Committee interesting news was issued by the Marconi-E.M.I. concern on its proposed high-definition service.

These notes help to clear up the position in regard to the very advanced claims in regard to the number of lines and the picture frequency previously announced as part of the E.M.I. plans. It appears that the recommendation of 405 lines and 50 pictures a second must be interpreted in terms of the special E.M.I. system of "interlaced" scanning.

Some very interesting claims are made in the E.M.I. statement, from which we quote the following:

"(1) That with 405 lines the definition is adequate for all types of picture, either as seen at a cinema, or picked up from real life.

"(2) Due to the method of interlaced scanning, the transmission is equivalent to 50 pictures per second, and therefore flicker, which is so fatiguing to the eye, is entirely absent."

These features are stated to make no difference to the cost of the receiver as compared with one designed simply to comply with the minimum requirements of the Television Report. This in itself is reassuring to the prospective purchaser of a television outfit, but one point on which further information would be welcome concerns the actual circuit modifications needed when changing over from the interlaced-scanning system to one of normal progressive type.

It appears that the alternating Baird and E.M.I. transmissions proposed will raise this question in an acute form, and it seems that its effect on the cost of sets should receive due consideration.

The change from interlaced to simple scanning may be and probably is no very difficult matter with a cathode-ray type of viewer working under laboratory conditions, but whether the same thing can be done with facility by the non-technical user of a home television receiver seems to be a point calling for attention.

Getting Quality Without

A Special Article

IT is well known that the major problem of quality reception in these congested days (or should I say nights) is to obtain a long range of frequency response without at the same time producing an intolerable background noise in the nature of heterodyne whistles, side-band splash, atmospheric disturbances, and man-made static.

In the B.B.C. Annual for 1935, for example, I find the following statement: "Really high-quality musical reproduction can only be obtained where the strength from the wanted station is very large compared with the strength from the two unwanted neighbour stations. In

Closer to the centre of London the whistle goes fainter but man-made static is far worse. I have never quite made up my mind which of the two I dislike the most. I must confess that if there were no other method of avoiding either kind of interference than those which involve loss of high notes I for my part should choose to lose some high notes and with them the interference. Which, after all, is precisely what most commercial receivers do.

But is there no other choice? Is it possible to avoid either adjacent station interference or static or both without unduly curtailing high-note response? A little analysis will show that the position is not quite so hopeless as it may seem at first sight.

It is true that no complete solution of the problem has yet been propounded, or, at any rate, proved to be sound in practice. But there are a number of partial solutions

the tuned circuits are made exceptionally selective and the attenuation of high notes thereby caused is corrected by means of an ascending frequency response in the low-frequency amplifier. Unfortunately, in all the forms of circuit so far developed, if the correction is carried out completely some of the types of interference reappear, though not all. In particular, the heterodyne whistle at 9,000 cycles caused by carrier interference comes back again, but interference of side-band with side-band does not.

Stenode Possibilities

I believe, however, that it is possible to devise a Stenode circuit which will avoid many of the causes of interference, will be highly selective and yet will need no tone-correction. Before such a circuit can be made of practical use, however, a number of laboratory experiments are necessary to evaluate certain design questions; and, in fact, I started to look into some of them last winter but for reasons beyond my control had to postpone them for a while.

One Simple Expedient

There is, however, one simple expedient which all who will may try. It is an arrangement which I use myself with great success. Unfortunately it is not readily reconciled to the modern demand for simplicity of control. Tuning condensers cannot easily be ganged, and it may therefore be necessary to have three or four tuning dials. A tuning meter thus becomes essential but once that device has been fitted control is quite straight-forward.

The expedient in question is a highly directional, earth-balanced frame aerial. Readers will remember that when the superheterodyne receiver returned to favour with the publication of Mr. W. James'

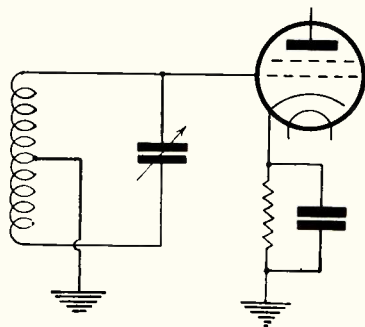

Fig. 1.—Centre-tapped frame aerial feeding directly to the grid of a triode or screened-grid valve

practice this is a radius of about 30 miles from 50 k.w. stations. At ranges greater than this, interference-free reception can only be got by so increasing the selectivity of the receiver as to lose the higher musical frequencies."

Quality with Whistles

This is a broad generalisation, but there is no doubt that for the usual reception conditions it does not err on the side of pessimism. I find it impossible, for example, in south-west London, even within 30 miles of Brookman's Park, to receive either the Regional or the National transmissions after dark on an ordinary type of high-fidelity receiver with a response extending up to 10,000 cycles without an intolerable heterodyne whistle.

each of which can give some relief and a combination of them can be very satisfactory.

That which is probably best known to readers of this magazine is the Stenode principle. By this method

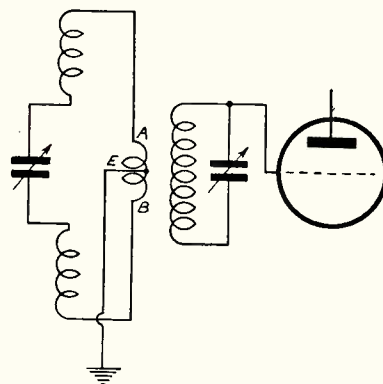

Fig. 2.—A circuit more highly directional than that of Fig. 1.

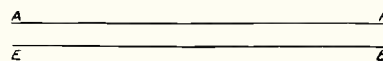

Fig. 3.—To wind the primary of the coupling transformer two wires are wound together in a slot on the coil former and the connections made as shown

P. WILSON DESCRIBES HIS OWN FRAME AERIAL AND

Whistles

by P. WILSON, M.A.

Super-60 receiver, a centre-tapped frame was one of the special features. I hold that this was one of the most valuable features of that design and that not nearly enough attention was paid subsequently to developments at that end. The later modifications to make the design adaptable for an outdoor aerial without re-radiation had no appeal to me, though, of course, they improved the sensitivity of the receiver.

Invaluable Directional Properties

The difference in sensitivity between a good outdoor aerial and a good frame aerial may roughly be taken as equivalent to one good high-frequency stage. The differences in other respects, however, are all to the advantage of the frame. Thus the frame automatically cuts out a lot of local interference especially if it is centre-tapped or otherwise arranged so that its two halves are balanced with respect to earth. And its directional properties are invaluable.

It is one of my favourite demonstrations to visitors at my house to tune in to a musical programme from a foreign station, preferably Leipzig or Munich, and then ask the listener to guess what station it is. So far as background is concerned the reception is indistinguishable from a local station transmission; only the musical quality is superior! I then slowly rotate the frame and show how background noises tumble into audibility. Even old hands at the game have been startled with this demonstration.

Nearly Perfect

The secret of it is just this: I have made the frame as nearly perfect, mechanically and electrically, as I have yet learned how to make it.

A glance through some of the points involved will, I believe, prove

"Is it possible to avoid adjacent station interference or static or both without unduly curtailing high-note response?" Although the author believes that no really complete solution, sound in practice, has been found, his suggestion of a highly-directional frame aerial is a very successful partial solution to the problem

instructive to many readers; and the construction of a suitable frame and its adaptation to an existing receiver need be neither too difficult nor too expensive for anyone with a mechanical bent.

Remember that what we are aiming at is to make the frame as directional as may be and at the same time to keep it balanced about earth potential. Fortunately the two requirements go together. The circuit from which we start is that shown in Fig. 1. Both the centre tap of the frame and the cathode line are shown connected directly to earth, but in the case of a superheterodyne receiver either of them may be taken to earth through the coupling coil of an oscillator.

The fault of this circuit is that full use is not made of the idea of a centre-tap since the load on the two sides is not balanced. One end of the frame is connected to the valve grid and the other end (apart, of course, from the tuning condenser which applies to both) is in the air, as it were. In short, the frame is not really centre-tapped at all from an electrical point of view.

A great improvement is effected at once if we add another tuned circuit as in Fig. 2. Here the frame is split into two halves with the tuning condenser linking them up.

Frame Connections

The extreme ends are taken to a small centre-tapped coupling coil which acts as the primary of a high-frequency transformer, the centre-tap being earthed. The secondary of the transformer is tuned and feeds to the grid of the first valve in the usual way.

Note that now the frame aerial can be exactly balanced since the load on it can be made symmetrical. This not only reduces noise but improves directional properties greatly.

At the minimum setting a rotation of one or two degrees of arc makes a big difference.

Super Selectivity

With this circuit at a distance of not more than 30 miles from Brookman's Park I can almost (but not quite) cut out London National on its own wavelength!

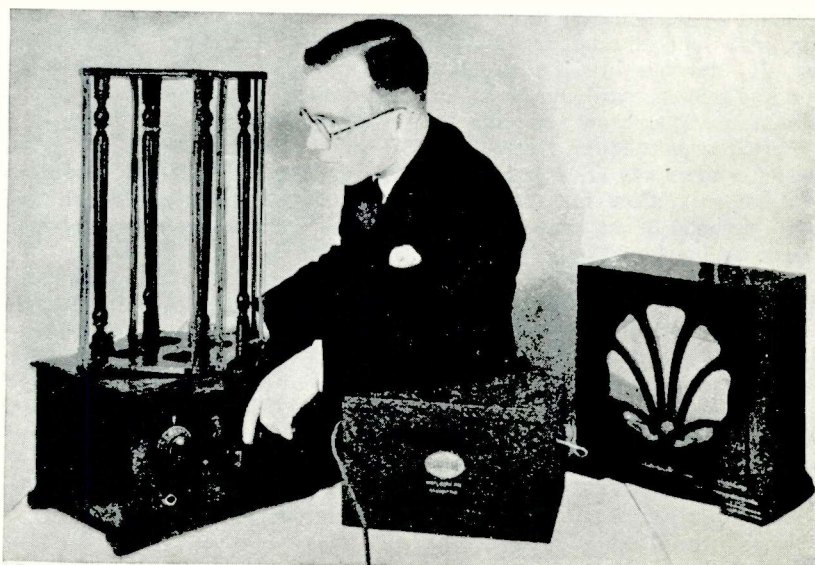

Many readers will remember that a centre-tapped frame aerial was used in the original Super 60 designed by W. James and described in these pages in March, 1931. We would remind readers that back numbers containing a description of the Super 60 are NOT available: actually the issue was out of print a week after publication

A NEW AMERICAN METHOD OF AERIAL COUPLING

Several precautions, however, are necessary to attain this degree of success. Thus the tuning condensers and coupling transformer have to be completely screened, as also has the wiring between them and the frame aerial, and for this purpose low-capacity screened wire must be used.

Then I took particular care in

holder in the rotation device. The frame for the medium waves consists of six turns of wire (three each side) arranged in the form of a square with 2 ft. sides and mounted on a cross as shown in Fig. 4.

The *inside* wires of each half are taken to the tuning condenser and the outside wires to the coupling coil. The frame is arranged to have

directional properties is no cause for anxiety. For any high-note attenuation caused by the tuned circuits may be corrected by a "tone-correction" device *without putting back any interference* which was cut out by the directional property. Band-pass tuning in these circumstances becomes unnecessary and indeed undesirable.

Valuable Features

These valuable features are possessed by no other aerial system yet devised. I understand that Dr. Robinson has suggested a method of cancellation of interference by means of anti-phasing in outdoor aerial systems, but so far as I am aware the idea is at present no more than a suggestion.

There is one respect, however, in which a suitably designed external aerial may have some advantages: where the background noise is caused by local electrical machinery (e.g. an electrical refrigerator, or a lift

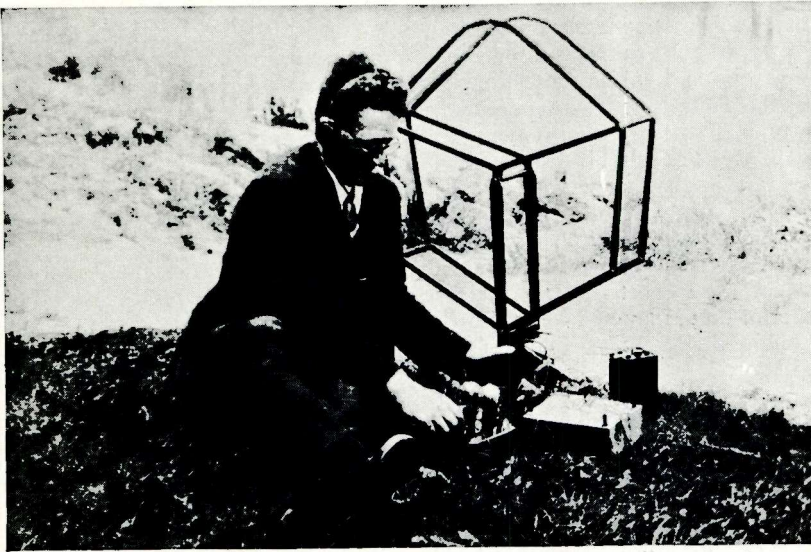

This photograph comes to us from a Continental agency with the following caption: "A Radio Enthusiast! The Radio Arrangement built in the free atr." There is no doubt that a properly designed frame is ideal for "hook-up" outdoor reception

winding the primary of the transformer that the inductive load on the two halves was evenly balanced. I found by trial that 15 to 20 turns for each half, wound in the slot usually devoted to the reaction winding in a standard coil on a 2-in. former, gave sufficient coupling for either long or medium waves. On the latter there was a double-humped or band-pass effect, but the humps were sufficiently far apart to allow one to use one hump only for tuning.

Coil Windings

To wind the coil I took two lengths of No. 30 enamelled wire and wound them together in the slot. I then made connections as shown in Fig. 3. A little consideration will show that this put A in the same electrical relation to E as E was to B, so that E was a true centre-tap.

The frame itself I made of Litz 27/48 wire. I have one frame for medium waves and a separate frame for long waves. Combining the two always leads to some loss of directional properties. The four ends are taken to a 4-pin valve base which plugs into a chassis-mounting valve-

holder in the rotation device. The frame for the medium waves consists of six turns of wire (three each side) arranged in the form of a square with 2 ft. sides and mounted on a cross as shown in Fig. 4.

The *inside* wires of each half are taken to the tuning condenser and the outside wires to the coupling coil. The frame is arranged to have a continuous rotation, by means of a knob mounted on my cabinet, with trouble-free contacts consisting of prongs dipping into four circular troughs of mercury. The device was set up two years ago and has not required touching since then.

What I want to emphasise now is this: a directional frame aerial can be used in suitable conditions to avoid interference between two stations without attenuation of high notes due to side-band cutting. By this means the strength of the unwanted station can be directly reduced to a very large extent, without appreciably affecting the strength of the wanted station. For a frame aerial is only sensitive at its minimum setting; there is very little reduction of signal strength within even 50 degrees of the setting for maximum signal strength.

This means that a frame aerial is a very effective agent for separating two stations except in those, let us hope, exceptional cases where the two stations and the receiver are in a straight line.

Even the fact that two tuned circuits have been used to obtain the

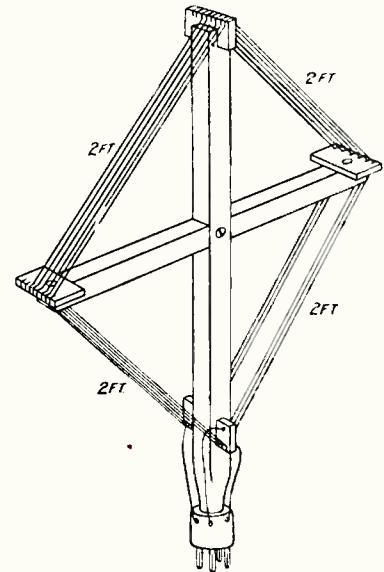

Fig. 4.—A diagram of the author's frame aerial; three turns to each half for medium waves. Connections are taken to a four-pin valve base

in a block of flats), and where it is not feasible to cure the disturbance at its source. It may not be possible in such circumstances to set the frame in its position for minimum pick-up of the disturbance, particularly as this may be radiated by a house-wiring system.

Reducing Interference

But it is usually possible to arrange an external aerial in a position where the effect of the disturbance is small. This might necessitate a long lead-in

and that lead-in must itself be screened from the source of interference; but these two problems have been overcome in most ingenious ways. With the usual form of aerial a long, screened lead-in would give rise to trouble not only because of loss of signal strength through the capacity to earth, but also because the very increase of capacity could only be compensated in the usual

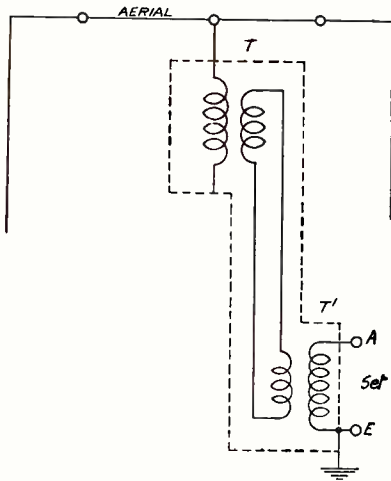

Fig. 5.—Simple form of screened lead-in with aerial and grid transformers

way by a small aerial series condenser which would reduce signal strength still more.

The reason is that the lead-in is normally part of a high impedance circuit so far as signal frequencies are concerned. If we could make the lead-in part of a low-impedance circuit the effect of the capacity would be much less.

Restoring the Balance

This is done by putting a step-down transformer close to the aerial and restoring the balance by means of a step-up transformer near the set. Suppose, for example, that the turns ratio of such transformers were 10:1 and 1:10 respectively. The impedance ratios would be the square of these turns ratios, that is, 100:1 and 1:100. The effect of a capacity to earth from the lead-in will in these circumstances be only 1/100th of what it would be if the transformers were absent.

Simplest Form

The arrangement in its simplest form is shown in Fig. 5, where T is the aerial step-down transformer and T₁ the grid transformer. An arrangement such as this might work all right on the medium waveband, but it is not found to be satisfactory for

long waves or for short waves. The best designs of this type employ a combination of condensers and resistances to give a damped tuning of the coils over particular ranges.

Another system is coming into great use in America, particularly as it overcomes many of the faults of ordinary aerials for short-wave reception. With it long waves and short waves may be effectively picked up on the same aerial simultaneously so that the system is likely to have a great vogue if and when short-wave television becomes established.

Essentially it is a "doublet" aerial arranged as in Fig. 6. L and L₁ are chokes which have a high impedance for short waves and a low impedance for medium and long waves. T is an aerial transformer arranged in such a way that the passage of signal current from aerial to earth through the primary induces equal and opposite current in the secondary.

For medium and long waves the arrangement acts as a T-aerial with twin low-impedance down-leads through which signal current is passing in opposite phase, to be combined again (exactly as in a push-pull valve circuit) in the receiver transformer T₁.

In principle, therefore, screened leads are not essential since interference would set up currents in the down-leads in the same direction and these would cancel out in T₁. The only essential in this case is to earth the centre point of the primary of

T₁ so that the centre point of the secondary of T would also be at earth potential.

How the "Doublet" Works

For short waves owing to the high impedance of L and L₁, the condensers C and C₁ (of the order of 100 micromicrofarads) come into play and transfer the signal in opposite phase to the secondary of T. The advantage of this arrangement is that in effect it gives a short doublet aerial for short waves and an electrically longer aerial for medium and long waves.

To keep short waves out of the long-wave receiver, T₁ is made of high inductance and to keep the longer waves out of the short-wave receiver the condenser K is incorporated.

It is only within the last few days that I have received an aerial of this type, so I am not able at the moment to comment on its performance. But the idea seems to me to be distinctly good.

One Aerial—Many Sets

I should perhaps add that one useful feature about both these screened lead-in systems is that a number of receivers, each with their own step-up transformer, may be connected to a single aerial and lead-in. In flats, where the greatest difficulties in providing good aerial arrangements are usually encountered, this is likely to prove a great attraction.

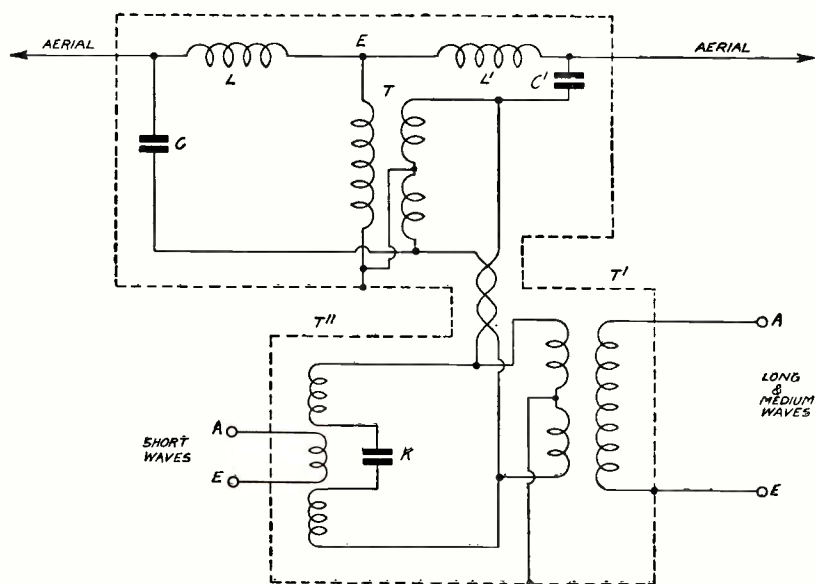
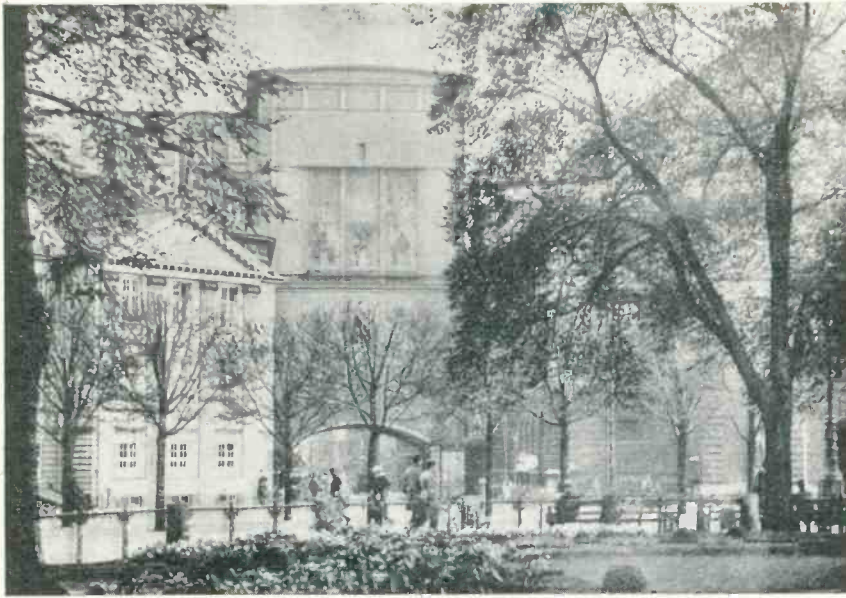

Fig. 6.—A doublet aerial for long, medium and short waves



By HANS W.
PRIWIN,
Our Danish
Correspondent

Copenhagen Broadcasting House, the headquarters of the Danish Broadcasting Company, is built across a road and joins on to the Opera House. Although only two years old, the broadcasting headquarters is to be replaced by a much larger building very shortly

Denmark—the Country with the Most Listeners!

THERE is only one town in the world where hardly any new radio listeners can be registered. It is Copenhagen.

This fact is not caused by bad programmes or a general strike of listeners, but is simply because practically every family in Copenhagen already possesses a wireless set. If you doubt this statement you can quite easily work it out for yourself.

Copenhagen has about 775,000 inhabitants. Of these 190,000 have a wireless set. This is about 25 per cent of the population, and since statistics tell us that the average family consists of four people, according to these figures every fourth person or, on an average, every family possesses a wireless set.

For the whole of Denmark the figures are not quite so favourable. Of a population of about 3,500,000 there are 583,000 listeners, or 16.3 per cent. This percentage is enormously high and much higher than in other countries. Denmark, therefore, has become the most radio-minded country in the world, and it is particularly interesting to study the conditions there and to compare them with other countries.

Above all, let us examine why it was in Denmark more than in any other country of the world that radio could find its way into all families. There are several reasons. First of all it is noteworthy from the sociological point of view that the standard of life in Denmark is very high—a standard which has kept on the same level because the country has known no war, no revolution, and no inflation.

Denmark's part on the stage of nations, therefore, has been and still is a small one, but it has been important—and, above all, profitable. Denmark, as a producer of important agricultural products, is an important factor in international trade relations.

By a cleverly guided policy the country has managed

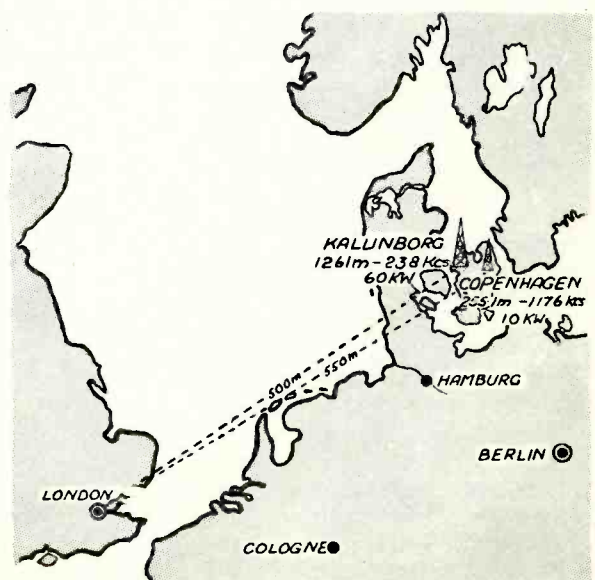

A map showing the stations in the neighbourhood of Denmark and the position of Denmark's two main broadcasting stations, Copenhagen and Kalundborg

to stand up to times of crisis and tariffs, and to keep unemployment on a comparatively low level.

One of the results of this good economic position has been the great interest taken by the population in radio. Nothing marks the standard of life of the nation more than the fact that of the 583,000 listeners less than 4 per cent possess a crystal set.

The others have valve receivers. This is all the more remarkable because the German policy of producing very cheap receivers has not been followed in Denmark where valve receivers still cost a good deal of money.

If it is the favourable economic position which is behind the astonishingly great interest taken by the Danes in radio, there is a further factor—a result of this position—which has helped radio to become so important in Denmark.

We may honestly maintain that the Dane—like all Nordic races—is less exacting and more cautious in his mode of living and in his demands, and is less pleasure-loving than the inhabitants of more southern or western lands. He does not move in extremes. He is a good average and his demands are also of a good average.

He does not expect radio—which is still something of a new wonder to him—to provide him with breath-taking sensations. He uses radio for relaxation. In his demands he is honest. He confesses that they are not extravagant; in most cases he asks only for light entertainment, and his radio programme is made up accordingly.

The result of a consensus of readers' opinions was published a short while ago which showed clearly that the Danish population wants broadcasts of an entertaining nature. This is practically the same in every country, but elsewhere the directors of the broadcasting companies, having a not altogether unnatural wish to raise the cultural level of their listeners, insist on putting before them rather more solid fare than is requested.

The Danish "Statsradiofonien," however, thinks exclusively of how best to please its "clients." If broadcasts of an entertaining nature are wanted, then the clients' wishes must be satisfied. Thus we get the excellent Danish programmes which are easy to understand, to which all classes of the population tune in, and which can be digested without much effort.

It is this excellent service which has helped Danish

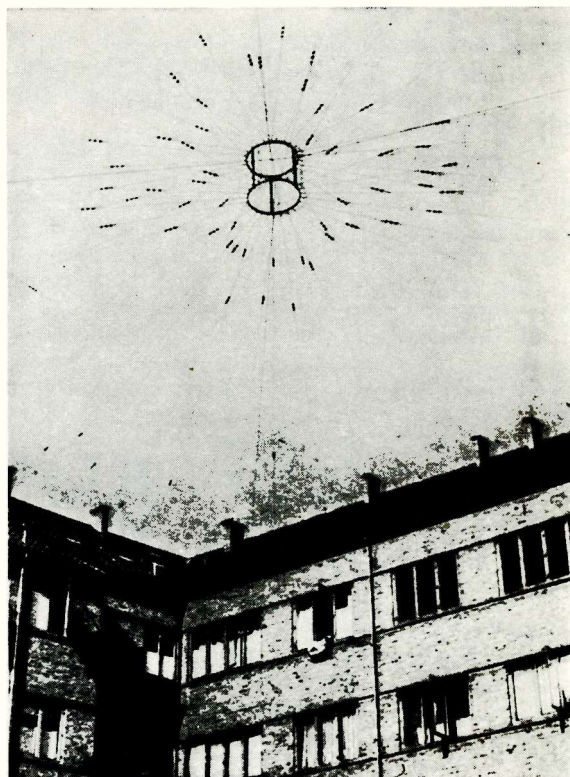

There are fifty-eight flats in one block in Copenhagen and of them fifty-six have separate aeriels all leading to a centre fixing like one huge spider's web. Radio plays a tremendous part in the national life of the country.



The Copenhagen Eskimo chorus before the Danish microphone. The choir is drawn from Eskimos studying in Copenhagen and they broadcast once a year to their relatives in the Arctic.

radio to its prominent position. Just as they broadcast from Denmark no star programmes of world importance, as they often do in other countries, so its broadcasters—if we except isolated engagements of artists with an international reputation—are not world-famous stars.

Those who have taken part in the fight for radio stars and have seen the homage paid to radio artists in many countries will heartily approve of the Danish way.

The clever business policy of the Danish Radio Company—the comparatively low expenditure on administration and the comparatively high expenditure on the programmes themselves—have made it possible for the Company to show since its foundation a profit of more than 7½ million kronen (about £345,000).

Last year's profit will allow for a further improvement of the pro-

grammes and the names of the artists who in the course of last winter were engaged by the Danish Radio Company show clearly that economies are not effected in the wrong places. Names like those of Fritz Busch, Adolf Busch, Vladimir Horowitz, Jascha Heifetz, Alexander Kipnis, Conchita Supervia, Wanda Landowska, Rudolf Serkin, Helga Rosvänge, and many others show the efforts that are being made to get the best.

The clients want little heavy music—good. But then this little must be the very best. This point of view of the programme directors has made Danish radio what it is.

The appearance of these famous artists before the Danish microphone was made possible by the initiative of the Director of the Danish Radio Company—Kammersänger Emil Holm. Kammersänger Holm, a man of sixty-five with the élan and enthusiasm of a youngster, is a radio fanatic. Anyone who is known in the music world he entices to Copenhagen.

The so-called "Torsdag-Konzerte" (Thursday concerts), held every week during the winter, are the result. These concerts have acquired the reputation which the Berlin Philharmonic Concerts used to have. Since they are held in the big concert hall of the Broadcasting House, and the public are admitted at abnormally low prices, they are extraordinarily popular and are the height of Scandinavian musical life.

These very enjoyable concerts, together with others of a heavier nature, form 5.6 per cent of the total programme, according to statistics just published for the period from April 1, 1934 to March 31, 1935. Almost half of the 4,885 annual broadcasting hours, namely, 2,157 hours, were filled with light entertaining music.

Comparatively high is the percentage of talks, with 532 hours or 10.9 per cent in which, it is true, are included those radio discussions which are so popular with the majority of listeners in Denmark.

In contrast to the English radio programmes, which show a comparatively high percentage of variety transmissions, this kind of entertainment is represented by no more than thirty-six hours a year, or 0.7 per cent. The reason for this is no doubt to be found in the fact that a big town like London has so many more variety artists than Copenhagen, and also perhaps because these programmes interest the Englishman so much more than the Dane.

Gramophone music is represented in the above-mentioned statistics by seventy-six broadcasting hours (1.6 per cent). In Denmark, as in many other European countries, the question of gramophone broadcasts was the subject of a fierce quarrel between the gramophone industry and the Radio Company, which was settled by the courts in favour of the former, deciding that the Radio Company had no right to give gramophone concerts without the specific sanction of the gramophone industry.

The whole question is, of course, an economic one—either the Radio Company pays the fees demanded by the industry for the use of the records or it must dispense with such concerts. The Danish Radio Company chose a middle course, and it now plays only records of such firms as do not belong to the international trust, thus, of course, giving them excellent propaganda for their products.

Many people are not aware that to Denmark belongs the Arctic colony of Greenland, inhabited by a very small number of Danes and a much bigger number of Eskimos. This colony, which is a part of America, is a sort of "spoiled child" of Danish radio. When Christmas draws near, the Radio Company invites all the relatives of the Danish civil servants in Greenland—and there are no others there—to send them greetings from the Copenhagen Broadcasting House or from one of the numerous provincial stations. Many hundreds of such greetings are sent every year, free of charge.

To the Danish population along the coast of Greenland they are a joy and a change in their monotonous life, to which they look forward for months beforehand.

Thus the number of Danish listeners has grown and with it the Broadcasting House. It is only two years since new headquarters were erected next to the Royal Opera House. And already the question arises—just as it has in London, Berlin, and other radio centres—whether the building should be enlarged or an additional one built.

Very bad acoustic conditions in the studios, which resulted in a very bitter lawsuit, have brought about the decision to build very shortly in the centre of the town a new Broadcasting House, the plans of which have already been published. By then the Danish Radio Company, continuing its progressive way, will have reached the maximum number of listeners a country can have, that is, 25 per cent of the total population.



Kammersänger Emil Holm, the Director of the Danish Radio Company, entices all the leading stars of the music world to Copenhagen



The charming lady announcer's voice you hear from Copenhagen and Kalundborg belongs to Grete Otto. Here you see her at the announcer's desk at Copenhagen Broadcasting House

Radio News from Abroad

By JAY COOTE

BELGIUM

THROUGHOUT the summer season concerts given at the Brussels International Exhibition will be broadcast alternately by the two Belgian stations on respectively 483.9 metres (620 kilocycles) and 321.9 metres (932 kilocycles). The times vary from day to day, but usually some entertainment is relayed from the Exhibition Concert Hall or Gardens at B.S.T. 12.30, 17.30 or 22.00. On many evenings the late dance music originates from the same source.



FRANCE

In late transmission, except for dance music or an occasional relay from a theatre, the Paris broadcasting studios have been somewhat neglected. In future, however, the P.T.T. network, fed by the *Ecôle Supérieure*, will transmit a special concert every Friday from B.S.T. 23.00-01.00. If this late show meets with the approval of the radio public it will be extended to other evenings of the week.



GERMANY

The 120-kilowatt Leipzig station working on 382 metres closed down for three months from July 3 last. It is being partly reconstructed and when completed will possess a new anti-fading aerial system similar to that now used by the other German stations. In the meantime the old transmitter will broadcast the programmes.

Berlin listeners, having appealed to the Reichsfunk to brighten up the programmes, in addition to the "Comic Hour" with which the studio greets them daily at B.S.T. 06.20 the authorities have acceded

to their wish by granting them light entertainments from mid-day to 15.00. Many of the talks and heavier items of the wireless programmes are to be cut out during the summer months; they will be replaced by the more popular brass band concerts and dance music.



HOLLAND

The *Algemeene Vereeniging Radio Omroep*, of Amsterdam, possibly the leading radio organisation in Holland, is planning to relay at regular intervals special programmes provided by the Bandoeng (Netherlands East Indies) studios. These would be broadcast through the Kootwijk or Huizen stations according to the transmitter at the disposal of the A.V.R.O. at different periods of the year.



ITALY

In addition to a development of the short-wave service for distant listeners, the E.I.A.R. is now carrying out further extensions of its broadcasting network. On October 28 the authorities will officially open the new 50-kilowatt Radio Marconi transmitter at Bologna, and simultaneously the reconstructed Bolzano station—10 kilowatts—will take the air.

By the end of 1936 Rome (1) on 420.8 metres will see its power attain 120 kilowatts, with another 30 kilowatts in reserve should need require it. Rome (2) is to be rebuilt and when completed will be a replica of the present station.

Finally, Turin (2) which is only used to broadcast the capital pro-

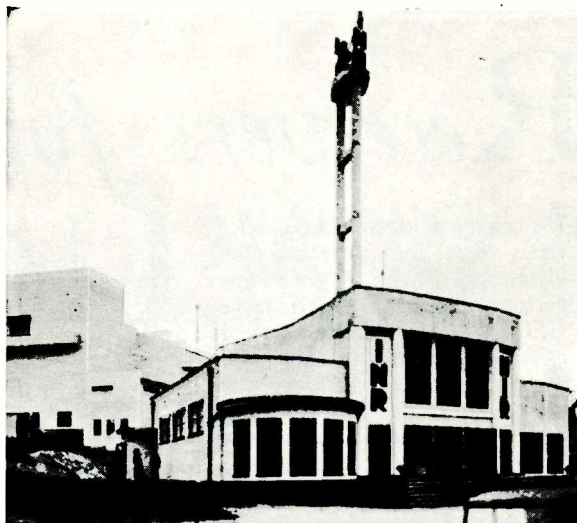

One of the pavilions at the Brussels International Exhibition from which concerts and dance music are relayed by the two Belgian stations this summer

grammes in the former city, is to become 1 kilowatt and will then work with Trieste on a channel common to both, namely 245.5 metres.



POLAND

Not content with the range covered by the Warsaw-Raszyn long-wave station, the Polish authorities have decided to increase its power to 200 kilowatts, and in order to provide an alternative service of programmes for listeners another transmitter will be built near the capital. Following the example of neighbouring states, the authorities also contemplate the possession of a short-wave station.



PORTUGAL

By next year it is anticipated that the Lisbon National transmitter (476.9 metres), which now only boasts of 20 kilowatts, will develop five times this power. Moreover, two regional stations are to be erected in North and South Portugal, the former at Oporto where programmes will be broadcast on 1,261 metres (238 kilocycles) and the latter, of which the site has not yet been selected, to operate on 291 metres (1,031 kilocycles).



RUMANIA

The 150-kilowatt National transmitter installed at Bod-Brasov is now testing on 1,875 metres (160 kilocycles), the channel which so far has been exclusive—although not so allotted—to Kootwijk (Holland).

Receivers for the Ultra-short Waves

By G. HOWARD BARRY

The coming of high-definition television bids fair to make the ultra-short waves of great importance to every listener. Here G. Howard Barry discusses some of the practical points associated with the design of receiving circuits for the waves below 10 metres and explains how the special difficulties of this band may be overcome

IT is natural that television should have been responsible for bringing the ultra-short waves to the notice of many who would, otherwise, have ignored or overlooked them. It is, too, so obvious that the future of television is going to be completely bound up with the ultra-short waves that one cannot wonder at the position of importance that they have suddenly assumed.

What is a constant source of wonder to me, however, is the fact that they are, in practically all quarters, being treated as some completely separate branch of radio

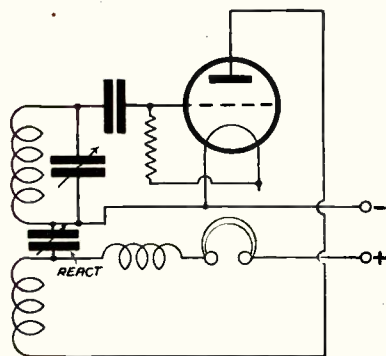

Fig. 1.—Fundamental circuit which forms the starting point of the author's discussion

—some new and freakish offshoot of the art.

In a way, I suppose, there is a little justification for this, since their behaviour is rather peculiar when compared with that of reflected waves of slightly greater length.

Twenty metres is an invaluable wavelength for long-distance work, by virtue of the reflected ray; 10

metres, for one or two "peak" years, may yield freakish long-distance results; but 5 metres, as far as we can tell at present, is a "local" wavelength only. If there is a "sky-wave," we don't know for certain where it goes to!

But this is no reason why we should forget all our 20- and 10-metre lessons when we come to design a receiver for 5-metre work, and I do want, in this article, to stress the importance of carrying our short-wave designing to a logical conclusion when we come to the ultra-short waves.

Suppose we deal, first, with a simple oscillating detector circuit, such as that shown in Fig. 1. There is no reason why this should not work well on wavelengths of 5 or even $2\frac{1}{2}$ metres; we simply prune down the coil and lop plates off the variable condenser until it gets there. Needless to say, it won't get there at all unless the layout is sound and the wiring short.

To make things easier for those who have difficulty in making that particular circuit oscillate, we generally advise the use of some form of Hartley circuit. Originally

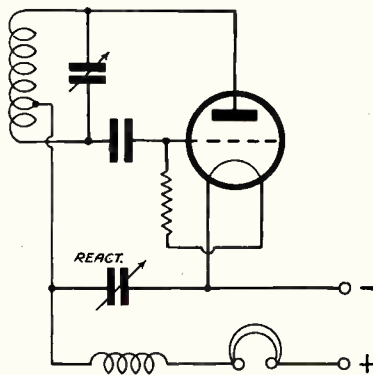

Fig. 2.—Hartley circuit in its simplest form. Note the use of a reaction tap on the tuning winding

developed purely for transmission purposes, the Hartley is a very freely-oscillating circuit, especially in the form shown in Fig. 2.

This, however, has certain disadvantages, chief of which is that both sides of the tuning condenser are "up in the air," both with regard to H.F. and D.C. The circuit is none too stable, either; its frequency of oscillation interlocking very badly with values of high and low tension.

"Split Hartley"

From the Fig. 2 arrangement was developed the "Split Hartley" of Fig. 3. Here, as you see, the single tuning coil of Fig. 2 is broken in the centre and a condenser inserted. Where the circuit is to be used as a simple oscillator this condenser would be fixed with a value of .0001 microfarad or thereabouts. A variable in the same position can be used for reaction control, although it naturally affects the tuning of the circuit considerably.

The variable condenser across the whole coil is now of the split-stator or series-gap type, and the spindle can be at earth potential. Sometimes it is beneficial to connect it to L.T.—, as shown; sometimes the circuit seems to be better balanced without this connection.

Hoffman Arrangement

The final development of the Split Hartley is a circuit known as the "Hoffman" arrangement, and shown in Fig. 4. Note that the grid condenser is dispensed with, the grid leak being taken off in series with the grid coil from the low-potential end.

The circuit has been drawn as a simple oscillator. In actual use as an oscillating detector, the connections

marked "plus" and "minus" would both be fed through high-frequency chokes, the headphones being wired in series with the positive line.

Perfectly Balanced

This arrangement will oscillate smoothly right down to 1 metre with an ordinary "HL" type valve, without the need for removing the base or of taking any unusual precautions. Re-draw the circuit in "bridge" form, and you will see how perfectly balanced the arrangement is.

Assuming, then, that this is to be the basis of our ultra-short-wave circuits, let us examine things further. A conventional receiver of the detector-and-low-frequency type will not be of very much use; possibly for receiving the "sound" accompanying the television transmissions it

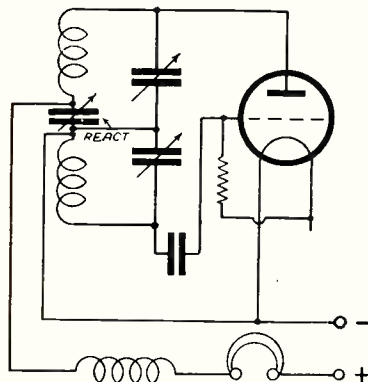

Fig. 3.—More advanced type of "Split Hartley" circuit for use on the ultra-short

would be satisfactory, because this will be put out on high power with a frequency-stabilised transmitter.

The main use of an ultra-short-wave receiver at present, however, is to listen to the amateur transmissions of the 5-metre band; these are generally carried out with pretty low power and accompanied by a large amount of frequency modulation.

All that a two-valve receiver with reaction will produce from these transmissions is a nasty noise like an automatic pencil-sharpener.

For this reason we seem to have fallen back on the super-regenerative circuit which, in addition to giving us the

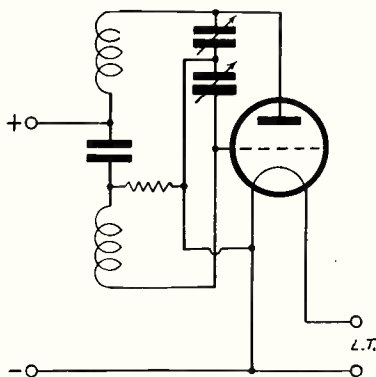

Fig. 4.—Split Hartley in the simplified form known as a Hoffman circuit: it gives excellent reaction effects down to 1 metre without the use of special valves

enormous sensitivity required, also helps us to cope with these frequency modulated transmissions by giving us a very broad resonance curve, which also makes for easy tuning.

Fig. 5 shows a complete two-valve super-regen. using the Hoffman detector circuit and a separate valve operating at the quenching frequency. I don't want to explain the whole why and wherefore of the scheme at this juncture; sufficient to say that a detector is most efficient when it is operated right on the threshold of oscillation, and that the function of the quench valve is to

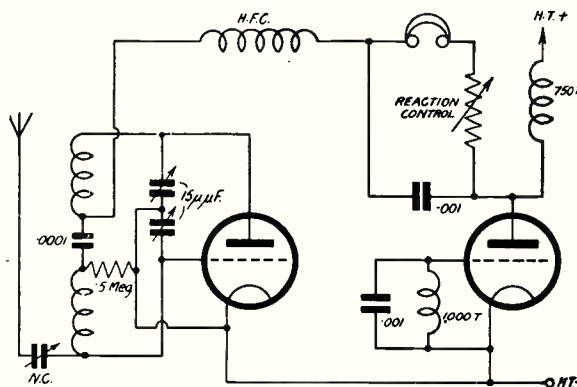

Fig. 5.—Two-valve super-regenerative circuit employing the Hoffman detector arrangement and separate quenching valve

keep it there by pulling it in and out of oscillation at some super-audible frequency—say about 20,000 cycles per second.

Quench Valve

The quench valve is, in other words, a long-wave oscillator, its output being used to modulate the high-tension supply to the detector. The detector is therefore kept in a state of abnormal sensitivity, no reaction control is needed, and we have a receiver that is extremely simple to operate.

The two coils for the quenching valve should consist of 1,000 and 750 turns of fine wire. Old "slab" coils, such as we used for listening to Bordeaux on 23,000 metres, will serve; or a grooved former may be filled with hank-wound turns. As an alternative, excellent quench coils are already on the market.

Easy Layout

The quenching circuit, however, is unimportant compared with the detector. Luckily for all of us, the Hartley and Hoffman circuits lend themselves to a splendid layout, especially as small-diameter coils are the fashion for ultra-short-wave

Prangins, the League of Nations short-wave station in Switzerland operates on 31.26 metres. Here you see a general view of the station buildings and the numerous aerial masts. Prangins is a fairly easy bag in this country

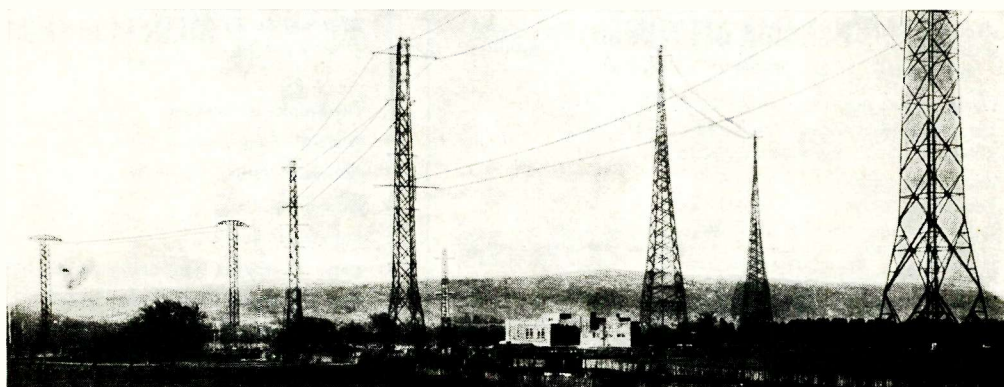

work. Two 5-turn coils of $\frac{1}{2}$ in. diameter should be used, and they may be mounted actually on the detector valve holder. The outside ends go respectively to the grid and plate terminals, and the middles are connected together by a small fixed

Incidentally, admirable condensers for the purpose are now obtainable from Jackson Bros. in capacities of 15, 30 and 45 micro-microfarads. The 15 micro-microfarad size is preferable for an amateur-band 5-metre receiver.

blocking" scheme. It consists of the Fig. 4 circuit with the addition of a large fixed condenser (Fig. 6). This condenser, between earth and the remote side of the ultra-short-wave choke, is simply increased in size and the high-tension increased until the detector howls violently at audible frequency.

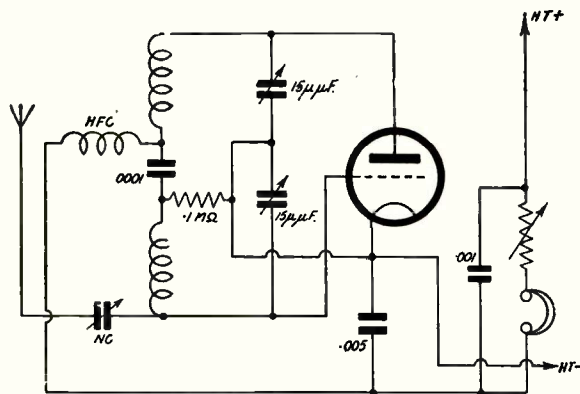

Fig. 6.—The "grid-blocking" type of super-regenerative circuit. Less easy to operate but capable of excellent results

condenser (the "postage-stamp" type is admirable.)

The tuning condenser is connected across the outside ends, and the rotor is earthed. If it is mounted on a metal panel, this looks after itself.

valve to do two jobs, and I have invariably managed to obtain better results by using one valve for each.

Another arrangement that possesses, at least, the merit of extreme simplicity is known as the "grid-

I could say a lot about "self-quench" circuits. Many ways of doing away with the second valve have been evolved, the simplest of which is to connect the two long-wave coils in the high-tension and earth-return leads of the Fig. 4 circuit. Being old-fashioned, I have never thought much of the idea of expecting one

Better Results

The resistance of the grid-leak is then reduced step by step until this howl goes out of the audible range and one is left with precisely the same rushing sound that one is used to hearing with a separate quenching circuit.

With the average valve of the HL class one generally ends up with a fixed condenser (C_1) of about .005 microfarad and a grid leak of 100,000 ohms. This circuit, in my experience, actually gives better results than the self-quenching detector with long-wave coils; but it is probably a trifle more difficult to start up.

Aerials for ultra-short-wave work should be very loosely coupled to the grid circuit. Capacity coupling is quite satisfactory if the capacity is

Continued on page 48

"W.M." Short-wave Identification Panels—Compiled by JAY COOTE

Metres : 24.2 **PAREDE (CT1G0)** Kilocycles :
48.4 (Portugal) 12,396
Power: 0.35 kw. 6,198

Geographical Position : 38° 42' 00" N; 9° 8' 00" W.
Distance from London : Approximately 970 miles.
Standard Time : G.M.T. (adopts B.S.T.).
Announcer : Man.
Language : Portuguese.
Call : "Estacao Radio Club Portugues."

Times of Transmission (B.S.T.) : 18.00-19.15 (Tuesday, Thursday, Friday); 15.00-16.30 (Sunday), 24.2 metres; 00.20-01.30 daily (except Tuesday); 16.30-18.00 (Sunday), 48.4 metres.

Closing announcements often given in English and French as well as Portuguese.

Occasionally relays from medium-wave station, CT1GL.

Metres : 31.58 **RIO DE JANEIRO (PRF5)** Kilocycles :
Power : 15 kw. (Brazil) 9,500

Geographical Position : 22° 57' 00" S; 43° 7' 00" W.
Distance from London : Approximately 5,870 miles.
Standard Time : B.S.T. less four hours.
Announcers : Man and woman.

Language : Portuguese.

Call : (phon) "Pay air effe sinko, La Voz do Brasil." (In English : PRF5, short-wave station of the Government of Brazil.)

Times of Transmission (B.S.T.) : 23.30-00.15 daily.

News bulletins are given in English, French, Spanish, and German.

Interval Signal : Three-note gong.

Closes down with Brazilian National Anthem and : "You have been listening to the short-wave station PRF5, Rio de Janeiro, Brazil. We thank you for your attention and wish you goodnight wherever you may be."

Metres: 49.75 **PANAMA CITY (HP5B)** Kilocycles :
Power : 100 watts (Republic of Panama) 6,030

Geographical Position : 79° 30' 00" W; 9° 00' 00" N.
Distance from London : Approximately 5,270 miles.
Standard Time : B.S.T. less six hours.
Announcer : Man.

Languages : Spanish and English.

Call : "Estacion Radiodifusora Miramar de la Radio Panama." In English : "This is Station HP5B in Panama City in the Republic of Panama." One of several slogans used : "Where the land is divided so the world could be united."

Times of Transmission (B.S.T.) : 18.00-19.00; 02.00-04.30 daily.

Closes down with call in Spanish and English, followed by : "A Happy Goodnight." Details are then given of the next day's programme.

Metres: 50.85 **MEDELLIN (HJ4ABE)** Kilocycles :
Power : 4 kw. (Colombia) 5,900

Geographical Position : 6° 2' 00" N; 75° 49' 00" W.
Distance from London : Approximately 4,650 miles.
Standard Time : B.S.T. less six hours.

Announcer : Man.

Language : Spanish.

Call : "Compania Radiodifusora de Medellin, Colombia."

Interval Signal : Morse letter M (-.-).

Times of Transmission (B.S.T.) : 01.00-04.00 daily.

Relays HJ4ABK, Medellin (broadcast band).

I HAVE this month another welcome piece of news for readers of this section: now that Mr. Tyers has finished describing his audio-frequency oscillator he has gone straight on to the production of a corresponding instrument for high-frequency work.

Details of this will begin to appear in an early issue (it is provisionally fixed for next month's menu), and it will have all the outstanding merits of the audio design in simplicity, excellent performance, and low cost.

It will differ in one important respect; while an audio type can be made up in any desired form, without much regard for layout, the

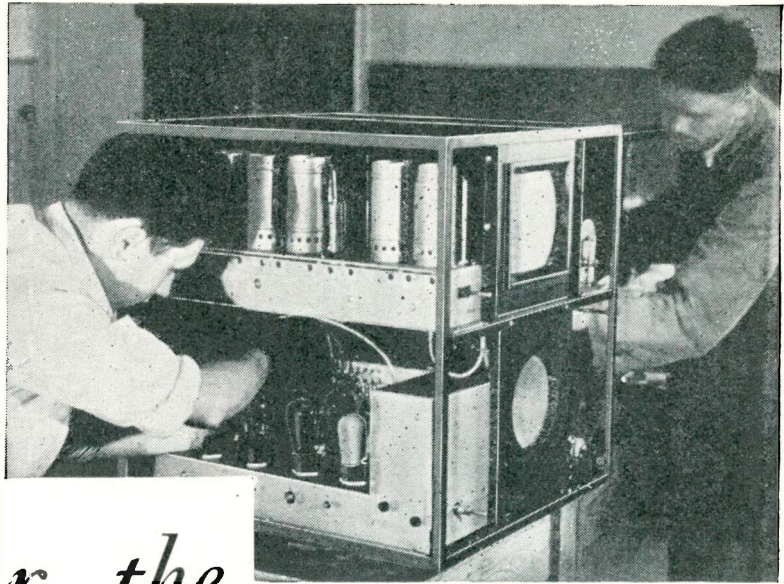

Television will soon be adding to the trials of the service engineer and demanding still higher technical qualifications on his part. Here are a couple of German engineers learning their way round in one of the big Telefunken viewers

Hints for the Service Engineer

Conducted by G. P. KENDALL, B.Sc.

high-frequency instrument calls for assembly in a reasonably precise fashion if the original performance is to be duplicated.

Accordingly Mr. Tyers has built his version of the design in a metal case of a convenient (and easily obtainable) type, and worked out a neat and workmanlike mechanical design. The appearance of the instrument is definitely such as to enhance the user's prestige among his customers.

Many Applications

It will permit test work to be done on both medium and long wavebands and provides all the needful conveniences for ganging operations, resonance-curve determination, sensitivity comparisons, and a host of other things. It contains its own modulating system, so that tests can be made on what is really an artificial carrier wave with its own constant modulation.

For special work it will be possible to connect up the audio oscillator and use this for modulating the output of the high-frequency instrument; this will enable the user to produce actual overall response

curves with the addition of the necessary measuring gear.

An oscillator such as this is a really invaluable piece of apparatus, not merely to the service engineer but to the serious amateur experimenter as well. It gives me all the greater pleasure to be able to announce its forthcoming description in these pages when I remember the extremely expensive nature of the commercially produced equivalents.



Have you ever stopped to consider what a very useful device is the simple ohm-meter? Probably not, because this is one of those things which one usually regards as a luxury and for the sake of one's peace of mind refuses to dwell upon!

Let us just yield to temptation for a few moments and think of all the things which could be done with such an instrument in readily portable form. In the first place, one could form the habit of making all continuity tests with it; the result would be that whenever a component or circuit was tested for continuity its resistance would at the same time be read. Think what an

invaluable thing that would be when going over the resistances in a mains set!

Here is an example of the way it can save time in service work: I recently built a set which did all that it should in every way except that the volume was well below par, and after some general investigation came to the conclusion that something was amiss in the low-frequency circuits.

Reversed Connections

Routine tests of components followed, and in testing the transformer for continuity I observed that the primary winding was of nearly three times the resistance of the secondary!

After a few moments of deep thought I connected the transformer up the other way round, and the circuit immediately gave normal results.

What had apparently happened was that the transformer had been inserted in its case the wrong way round and so had been reversed in its connections. Quite simple, but it would probably have taken some time to find without the aid of the ohm-meter.

All very interesting, but what about the cost? I admit that the commercially-made ohm-meter is a rather expensive instrument, but it happens that some few years ago I had to design a series of combined continuity testers and ohm-meters for



A good output meter enables a great variety of advanced test and experimental work to be done, especially when used in conjunction with a modulated high-frequency oscillator such as that which has been specially designed for readers of this section by Mr. Tyers for publication in an early issue

use in a test-room, and in the course of the work was very much impressed with the fact that a simple instrument of this type can be improvised extraordinarily cheaply if one goes the right way about it.

The essential idea is to render the instrument self-calibrating by the simple expedient of using a low-range milliammeter and a fixed resistance of accurately known value. An ohm-meter thus made will cover only a single range, but if one makes this extend up to perhaps 50,000 ohms it will cover a surprisingly large number of cases.

Of course, additional ranges can be provided by incorporating a switch of the stud type and extra resistances if one does not object to the slight additional cost and work involved.

Simple Circuit

The basic circuit of the instrument consists simply of a battery, milliammeter and known resistance in series. Then provision is made for inserting the unknown resistance likewise in series, and the calibration is obtained by making a set of calculations on Ohm's Law.

It is all quite simple, and next month I propose to go into it in

detail and give specimen calibrations which may save the reader some hard work.

The A.C./D.C. type of receiver is comparatively a newcomer on the British market, and so it is natural that some of its little ways should be capable of causing some puzzlement to those who are called upon to service it. Here, for example, is a case of which I heard the other day and strikes me as pointing a moral. The receiver in question had been working more or less normally until it developed loud crackles and bangs and then packed up altogether.

Investigation showed that every one of the valves, including the rectifier, had been damaged, some to the extent of blown-out heaters. Replacement and cautious switching on through an extra resistance which was gradually cut out of circuit failed to reveal any reason for the trouble; the set worked normally, and has continued to do so.

The service-man concerned was very puzzled for a time, but careful tests of the damaged valves brought enlightenment. It was found that in the rectifier the cathode was down

to the heater and the effect of this in the circuit in question was to short the heater right out of circuit. The current through the other heaters thereupon rose to an abnormal level and caused the mischief.

It is a curious thing, but undoubtedly true, that the simplest faults are always the ones which cause the most trouble in any kind of trouble-shooting work.

For example, the inefficient aerial: this is always a problem to the service engineer, for people are very often most reluctant to admit that the aerial which they have used for years can be anything but perfect. The fact that they have never been satisfied with the performance of any of their past sets is put down to all sorts of other reasons, and it is a difficult task to convince them that the aerial itself is fundamentally bad.

Probably the best way of satisfying oneself on the point is to carry round a small standard receiver of some sort and make oneself thoroughly familiar with its performance on efficient aerials in the district.

Even a single-valve set will serve the purpose admirably, but evidence of this sort usually has little weight with the customer; he merely looks incredulous and implies that he has only got your word for it that the test set is not working properly on his aerial.

To take his set away and give him a demonstration on a good aerial is rarely practicable and in any case it wastes much time.

Probably the most convincing test in these circumstances is to fit up the best indoor aerial that can be managed and demonstrate that the receiver works almost as well on this as it did on the outside wire.

Receivers for the Ultra-short Waves

Continued from page 46

kept really small, and there is much to be said for the use of an aerial cut to a length of one quarter-wave. For the amateur (5-metre) band this means about 4 ft. 2 in. An aerial of this type with moderately tight coupling will always give results equal to those obtained from a long outdoor aerial with the necessarily loose coupling.

Most amateur transmissions are very strongly polarised in either the horizontal or vertical plane, according

to the type of transmitting aerial in use; it is therefore worth while to install two receiving aerials, one horizontal and one vertical, and to try both on any transmission that may be picked up.

I had intended to touch upon the design of ultra-short-wave superhets, but I fear that space will not permit of it this month. In any case, they are largely the concern of the television specialists. I hope, however, to cover the subject in a later article.

Calibrating the "W.M." Audio Oscillator

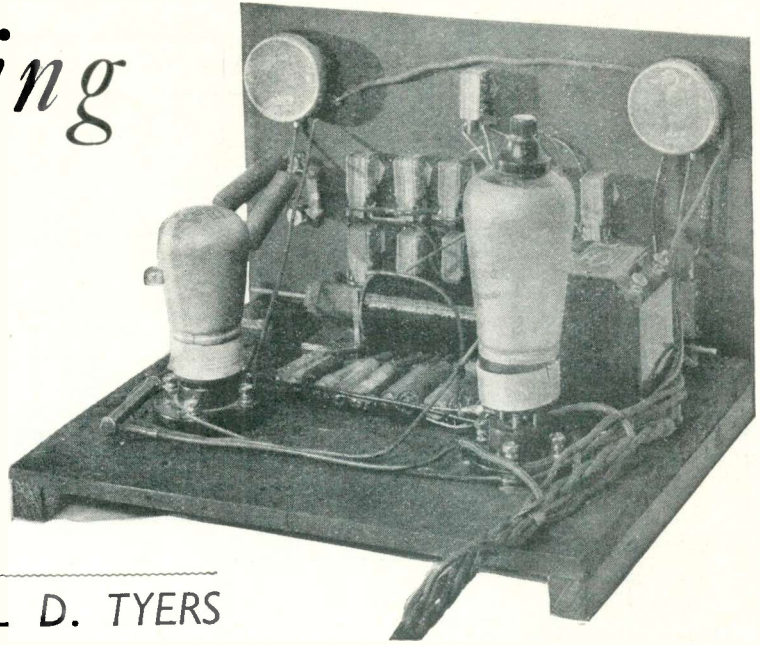

Designed by PAUL D. TYERS

Last month we described the technicalities of an audio-frequency oscillator designed by Paul D. Tyers for the benefit of our service-engineer readers. This month the designer gives clear and concise instructions for the calibration of the oscillator. We would remind readers that no blueprint is available

LAST month a description was given of a simple variable audio-frequency oscillator. This consisted of a dynatron oscillator followed by a separating or amplifying valve. The degree of oscillation determining the wave-form is controlled by varying the bias on the grid of the screened-grid valve used as the dynatron oscillator.

Calibration Methods

The frequency-determining circuit consists of two inductances, one fixed and the other variable, together with a bank of fixed condensers connected in circuit by means of small snap switches.

Owing to the fact that all condensers supplied to the constructor are sold with fairly wide tolerances it is impossible to give an exact calibration. Moreover, use is made of a transformer winding for the fixed inductance, and the variable inductance consists of a home-made coil. This again results in quite wide variations in the absolute inductance values. Accordingly some means must be devised for calibrating the oscillator.

Obviously the simplest method is to calibrate the oscillator with the aid of a series of constant-note gramophone records. If these are not available use can be made of an ordinary piano. In each case the method of calibration is identical.

The desired note is obtained either from a gramophone record or a piano and the oscillator is adjusted until the same note is obtained. Extremely accurate adjustment is possible by virtue of the acoustic beats set up due to the interference between the two notes. Two notes when combined give a third note equal to the difference of the two frequencies. This process, of course, is identical with that used in ordinary heterodyne or superheterodyne reception.

It is quite possible that at the outset many readers will not be able to identify the beats, but to do so is only a matter of a little practice. It is here interesting to note that a piano is tuned entirely by means of beats.

It is possible to observe the effect of the beats by an electrical means, and it is quite easily accomplished when use is made of a gramophone

A panel and baseboard construction was used by the designer but, of course, the fundamental circuit can be assembled in any desired form

record, but it is not so easy when a piano is used; it is, of course, necessary to use a microphone with the piano. The output of the oscillator under test and the output from a gramophone record or a piano and microphone output are combined in an amplifier fitted with a rectifying type of output meter. As the two frequencies become identical so a series of fluctuating oscillations or beats will be produced by the output meter needle, zero reading being obtained when the two notes are identical.

Not Very Practical

This method requires a suitable filter circuit in order to make it work properly, and it is not likely that such a procedure will be necessary unless any particular reader has absolutely no ear for music and is quite unable to identify the various tones.

First Step

It has already been pointed out that owing to the manufacturing tolerances of the components used no definite calibration chart can be given. The method of calibration is, first of all, to bring back the variable inductance to the zero position and adjust the oscillator with all the condenser switches open. This will give a very high note, probably in the region of 8,000 cycles. As the

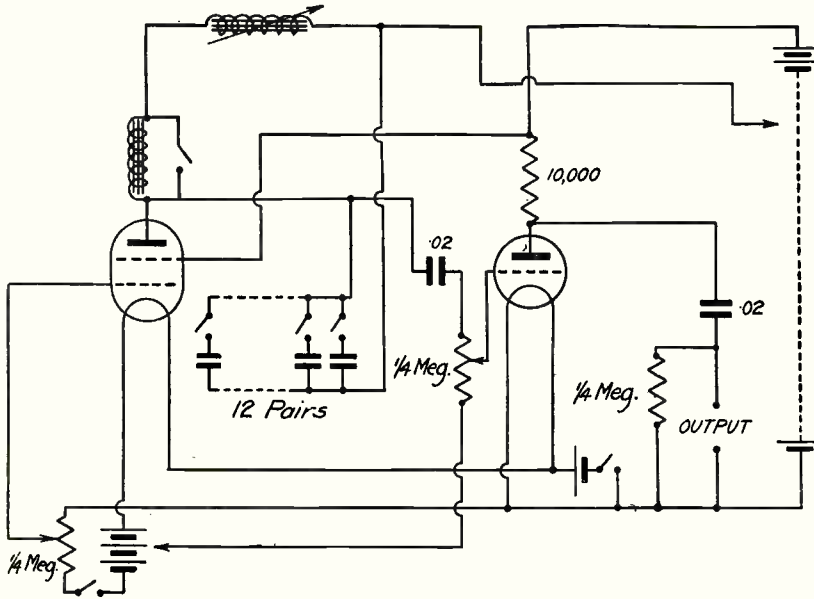

Circuit of the "W.M." Audio-frequency Oscillator. The anode resistance of the second valve is not critical in value, but the figure of 10,000 ohms shown gives good results

core is advanced so the note will fall. The next range is obtained by withdrawing the core and switching in a small condenser or combination of condensers until the same note is obtained as that given by the core in the maximum position and no condenser in parallel. The core is then advanced until the lowest note in the second position is obtained. This process is continued until the higher and middle frequencies are covered.

Lower Ranges

This adjustment, of course, is carried out with only the variable inductance in circuit. Both inductances are then switched into circuit and the lower ranges are obtained.

It will be found that the moving core makes very little difference to the low notes because the inductance change is comparatively small with relation to the frequency.

It will be seen that accurate adjustment of the low notes is easily obtained by various combinations of the smaller fixed condensers, and adjustment of the sliding inductance will have little effect.

Some rough idea can be obtained of the maximum and minimum frequencies on the various ranges whilst the preliminary range

adjustment is being carried out. This should then be followed by the final calibration.

If constant-note gramophone records are used the procedure is very simple, but it may be as well to deal with the subject of piano calibration at some length.

The note given by a piano is not a pure tone. It consists of a fundamental and a large proportion of harmonics which give it its characteristic tone. Most people are able to recognise an octave, which simply means two notes one of which has a frequency double the other; 2,000 cycles, for example, is therefore an

octave higher than 1,000 cycles.

Again, 256 cycles is obviously an octave lower than 512 cycles. These two last-named figures are actually the frequencies of middle C and an octave above middle C on an ordinary piano. Pianos are frequently tuned to slightly different pitches, but the pitch universally adopted, and used, for example by the B.B.C., is 512 cycles per second for the first octave above middle C.

Every octave above and below is simply respectively double or half that above or below it, and in this way it is quite easy to obtain the fundamental notes over the entire musical range. It is therefore easy to obtain seven or eight absolute settings. An even greater number of points, however, can be obtained by simple arithmetic.

Intermediate Points

Readers who have some knowledge of the theory of music will be familiar with what are termed intervals such as thirds, fourths and fifths. As the names imply, they are simply a third, a fourth, or a fifth higher than the starting note. We therefore have an easy means of obtaining some thirty or forty accurate calibration points simply by striking the appropriate note on the piano and adjusting the oscillator until the same tone is obtained.

Using a Piano

The best method of procedure is first of all to adjust the oscillator to somewhere in the region of the desired note. The piano note should then be struck and the output of the oscillator momentarily switched on. This is most easily done by turning up the volume control. A further adjustment is then made until the note more nearly approaches the desired frequency.

It will then be found that when the two notes are nearly correct it is an extremely easy matter to make a small adjustment to the oscillator when the formation of beats will begin to be heard. It is extremely difficult to describe exactly what a beat sounds like, but it is best referred to perhaps as a pulsating or throbbing sensation. When listening to

CALIBRATION CHART

FREQUENCY	INDUCTANCES	CONDENSERS
8,000-3,600 cycles	Variable.	None
3,600-1,400 "	"	.0025 microfarad
1,900-1,000 "	"	.0055 "
1,000- 800 "	Half way to max.	.009 "
800- 580 "	"	.016 "
560 "	Both	.0015 "
500 "	"	.002 "
460 "	"	.0025 "
400 "	"	.003 "
300 "	"	.0055 "
200 "	"	.013 "
100 "	"	.052 "
50 "	"	.159 "

the beats the strength of the two oscillations have a definite controlling factor on the intensity of the beats and it will be found advisable to experiment with the output of the oscillator until the most sensitive condition is obtained.

Getting a Pure Tone

It has been pointed out that a good wave-form is an essential property of an oscillator. For this reason the oscillator valve is provided with an adjustment to control the strength of the generated oscillations. It will be found that this adjustment tends to vary the frequency of oscillation to a slight extent, and accordingly the calibration should be carried out with the control knobs so adjusted that the valve is only just oscillating.

This, of course, gives the most pure wave-form and is representative of the condition under which the oscillator should always be used. If the knob is too far advanced the harmonic content will be high and there will be appreciable frequency shift.

In order to assist readers in finding the approximate calibration positions the accompanying table shows some approximate settings for a number of frequency points. These were obtained on the actual oscillator described last month, and it should be found that the settings will be fairly near to those of any oscillators built according to specification.

Apparatus for Calibration

When calibrating the oscillator it is very important to use a good amplifier and a loudspeaker with an excellent bass response. If the bass response is low there will be considerable difficulty in hearing the beats at the lower frequencies.

If constant-note records are used for calibration they can be employed

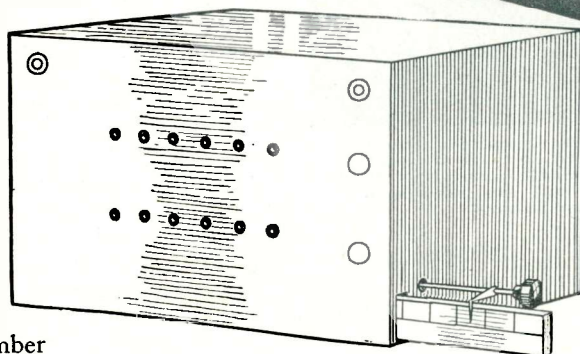
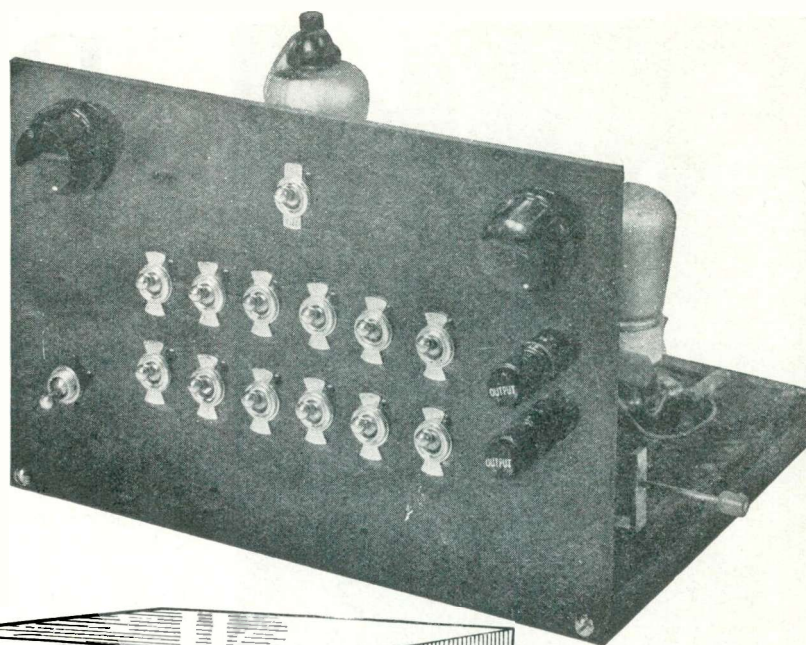

The fine tuning control takes the form of a rod carrying a small pointer. This can be brought out through the end of the cabinet, and provided with a small sliding scale in order that readings may be recorded. Cabinet-design questions are very much a matter for the individual constructor, but something strong and serviceable is recommended

in two ways. The oscillator and the pick-up can each be connected to a separate amplifier and loudspeaker. By this means acoustic beats are set up in the air by the interference of the sound waves from the loudspeakers.

Alternatively, the output of the oscillator and that of the pick-up can be combined electrically. This method requires the use of only one amplifier and one loudspeaker and is therefore the system most likely to be used.

Some little care is required in superimposing the two outputs.

The impedance of the pick-up will be very much lower than that of the oscillator output. A convenient method of working is to use a two-valve amplifier in which the first valve is resistance-capacity coupled to the second.

The pick-up is taken to the input of the amplifier and the oscillator output is taken to the grid of the output valve in the amplifier, the $\frac{1}{4}$ -megohm resistance in the oscillator serving as the grid leak. As, however, the lower end is earthed, separate batteries must be used on the oscillator.

COMPONENTS REQUIRED FOR THE "W.M." AUDIO OSCILLATOR

BASEBOARD ASSEMBLY

- 1—Baseboard, 10 in. by 8 in.
- 1—Panel, 10 in. by 7 in.

CHOKE

- 1—Special sliding core.

CONDENSERS, FIXED

- 2—.02 fixed.
- 12—Various (see separate list). (T.C.C. and T.M.C.-Hydra were used in the original; any good make can be used, but the wire-end cartridge type is probably the most convenient.)

RESISTANCES, VARIABLE

- 2—Reliance .25-megohm volume controls.

RESISTANCES, FIXED

- 1—Amplion .25-megohm.
- 1—Amplion 10,000-ohm.

SWITCHES

- 1—Bulgin D.P. on-off snap.
- 13—Bulgin S.P. on-off snap.

TERMINALS

- 2—Belling & Lee terminals, marked output.

TRANSFORMER, LOW-FREQUENCY

- 1—Varley Nicore II low-frequency.

VALVES

- 1—Mullard, type PM2A.
- 1—Mullard, type PM12A.

VALVE HOLDERS

- 2—Bulgin 4-pin valve holders.

CONDENSER TABLE

1	0.25	Mfd.
2	0.1	"
3	0.02	"
4	0.01	"
5	0.01	"
6	0.002	"
7	0.002	"
8	0.002	"
9	0.002	"
10	0.001	"
11	0.0005	"
12	0.0001	"

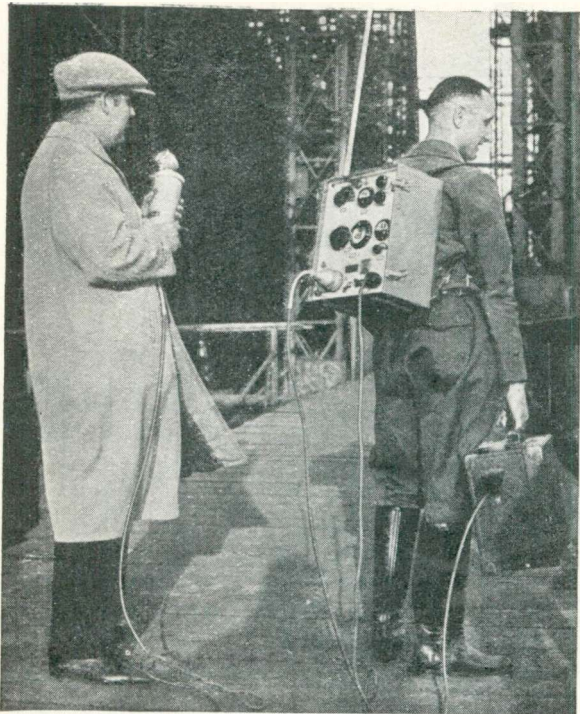

How useful the ultra-short waves are becoming is shown by this photo taken in a German shipbuilding yard. A running commentary on the work going on is being broadcast from small portable transmitter—seen on the man's back—and picked-up and re-broadcast by the main stations

DEATH rays, or something like them, have been to the fore again of late in the scare headlines of some papers. The first crop of rumours, subjected to amplification at both high and low frequency, appeared as a result of what were really ultra-short-wave demonstrations given by Marchese Marconi. For miles around, we were told, motor-cars had stopped dead and nothing that their puzzled drivers could do would re-start them. Clearly Marconi had invented the death ray at last!

The truth of the matter was probably something like this. One unfortunate motorist had a breakdown somewhere within 20 miles of the demonstration. His plight was observed by a fellow of the kind that puts two and two together and makes the answer fourteen; in this case the exaggerator performed the calculation $1+0=10$, and told another of his kidney that half a score of broken-down cars were lying about the country.

The number was soon multiplied into scores and then into hundreds. That there wasn't a word of truth in it was proved a day or two later when Marconi emphatically denied that he was using any lethal or motor-stopping ray.

The next fine journalistic effort originated in Germany, in which country it was stated that "a scientist" had evolved a ray with which he could melt the magnetos of aeroplanes or motor-cars at a couple of miles!

What a marvellous weapon of war! Aeroplanes would come fluttering down from the skies; tanks would groan to a standstill; the mechanised troops of today would find that mechanical horse-power was less to be desired than physical gee-gees.

You could, of course, make a rare mess of a magneto if you could devise some means of conveying through the ether a tremendous ionising force that would play

Between

BROADCASTER'S GOSSIP

havoc with its insulation. I am not going to say that the thing is impossible, but I don't believe that anybody yet has devised any workable method of doing this. And the answer to a death ray of this kind would be effective metal screening for the magneto.

Another little invention of which accounts have appeared is an apparatus which does all kinds of interesting things when activated by radiations from the human body. It is perfectly true that minute electric currents are generated in our bodies by the action of the heart and of other "components." But they are so tiny that if there be corresponding radiations they must be well-nigh infinitesimal.

The particular device which inspired this paragraph was described as a kind of super burglar alarm. A "charged electric wire," whatever that may mean, was placed near the door of the safe that required protection and connected to various relays. The approach of a human being, radiating unconsciously, but with great effect, "upset the frequency of the wire," with the result that what Shakespeare calls alarms and excursions were immediately in evidence. Lights flashed on, bells rang, and goodness knows what else besides.

It is a fine idea—but isn't the combination of the infra-red beam and the photo-electric cell a good deal simpler as a burglar alarm?

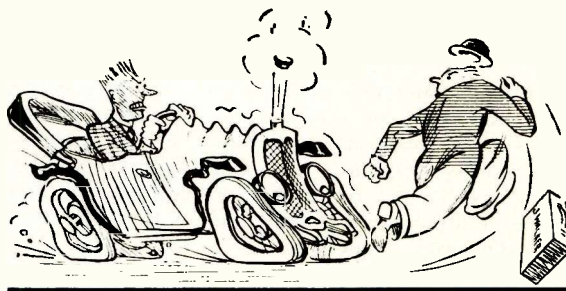

"... motor-cars stopped dead"

Talking of human radiations, I must thank the reader who sends me the prize short-wave story of the old days. Any of you who indulged in short-wave work in the days when short-wave receiving sets were in their infancy will remember the horrid effects of body capacity. You moved your hand towards the condenser knob and the station that you had almost "got" promptly faded out.

Performing miracles of hair's-breadth tuning, you worked it up to fine strength and then sat back to listen to the programme that was coming from thousands of miles away. But alas! The instant you removed

Ourselves

ON THINGS THAT MATTER

your hand from the aforementioned knob the station disappeared. If you wanted to hold the station you had also to hold the knob—and to keep still. Of course, this highly unpleasant effect wasn't due to radiations at all; it was caused by the capacity between some part of the set and the operator's body, which may or may not be at earth potential.

My kind reader tells me that in the wee small hours some years ago he was sitting up with his short-wave set. At long last he found KDKA coming in with truly remarkable strength, but rapid fading of the most extraordinary kind was in evidence. It took him, he assures me, some time to realise that this was due to the chattering of his teeth. What he calls the elbow effect rapidly set matters right. This consisted in raising the right elbow smartly in order to dispose of a draught of a medicine that is usually sold in quart bottles.

When you read this the 1935 Wireless Exhibition at Olympia will be only a week or two away—it opens on August 14. I've attended every British Radio Exhibition that there has been since the time when the exhibits formed just one section of a show of wider scope held in the Horticultural Hall at Westminster.

You might think that after all these years one so closely connected with wireless would tend to become somewhat blasé; but really it isn't so. I always thoroughly enjoy the Olympia Exhibition, particularly as for many years now the Editor and I have had a kind of standing appointment to make our first round of it together. I wouldn't miss it for anything. Nor would any wireless enthusiast if he could possibly help it. No matter how much previous information you have had there are always heaps of new things well worth seeing, and it is the opportunity of the whole year of examining under one roof the results of twelve months progress in radio.

It has frequently fallen to my lot to conduct American and other friends from abroad around Olympia. Invariably I find them much impressed by the variety of the exhibits and with the enormous public interest shown. This year I don't expect any startling surprises, but I do think that you will be very much struck with the big steps forward that wireless is making.

I'm not going to indulge in an orgy of bouquet throwing, for I feel that the Olympia Show can still be improved quite a bit and there is still time after these notes appear in print for one big improvement that I have in mind to come into being. On far too many stands you and I found in former years that there was no one who could properly answer the questions that we asked.

We wanted to know all kinds of details about the apparatus displayed, but when we inquired we were met far too often by the bland young man who was willing



"... the capacity of the body"

to talk to us about the beauty of the cabinet design, but knew nothing of what was inside it. The beauty of cabinets, like that of human beings, is apt to be skin deep and the innards are what really matter.

I do most emphatically suggest to exhibitors that if they want to make the 1935 exhibition the biggest success that ever was from the public point of view they should have plenty of people on their stands who are capable of explaining just what the sets shown can do and why they are superior to previous models.

The battery-set user is not too happily placed this year; in fact, he may feel when he visits Radiolympia that battery sets on the whole have gone backward rather than forward in some ways. Don't misunderstand me. There'll be plenty of good battery sets, but most of them will be of the smaller kinds using not more



James J. Braddock, who became the World's Heavyweight Champion by beating Max Baer in June, has an interview in front of the mike with Kase Smith (extreme left) and shows her how it is done!

than three valves. You are sure to see a certain number of battery superhets, but not as many probably as last year.

The reason's rather an interesting one. You can't work a big set efficiently without using a considerable amount—say 15 or more milliamperes—of high-tension current. But despite all that has been written on the subject the public has shown quite definitely that it will not buy large capacity high-tension batteries. It will, in fact, purchase only the small fellows whose absolute maximum load is 10 milliamperes—and that is really about double what they *ought* to be called upon to supply.

This means that designers of battery sets now have to work to a limit of 10 milliamperes or as much less as they can possibly manage. With only 10 milliamperes at your disposal the big superhet is clean out of the question.

It's a queer business, really, this high-tension battery mix-up. You can prove to the man in the street, as I have done many a time, by means of laboratory tests and cold hard figures, that a triple-capacity battery, costing 50 per cent more than one of standard size, has a life at least three times as long under a moderately heavy load. But for all that one says he will promptly go and buy the smaller battery, even though by doing so he spends in the course of a year more than twice as much on replacements as he need.

Considering that battery-operated wireless sets are in use in at least 3,000,000 homes in this country, and

that there are many people who are quite prepared to spend from £15 to £20 on such apparatus it seems to me a great pity that the three-valver capable of but modest volume is likely to be the staple battery set manufactured next season. I honestly believe that set-makers have formed their impression of the public's requirements from quite erroneous data. Last year and the year before a good many marketed battery superhets and battery radiograms; but in many instances they made the silly mistake of fitting them with small-capacity batteries.

The result was that these sets and radiograms soon gained the reputation for being pretty costly to run—a reputation that they never would have had if they had been supplied with batteries of adequate capacity. And what followed? Well, there is an old proverb about giving a dog a bad name, isn't there? These big sets met with no great success from the sales point of view; hence makers leapt to the conclusion that there was no real market for anything of the kind.

I have always been quite convinced myself that there is a big market waiting for the battery set of something approaching mains quality, volume, and sensitivity. There are hundreds of thousands of well-to-do folk whose homes are for one reason or another without electric lighting mains. Amongst them there would be a big demand for a battery set such as that indicated. But they will *not* buy a set whose high-tension battery is so small that the quality of reproduction rapidly falls off, whilst renewals are necessary every few weeks.

There are quite a few things in wireless that require de-bunking. Class-B amplification is one of them. You know the idea: two output valves (or the bits and pieces of a pair within the same bulb) are used in double harness and the circuit is such that only one is in action at any given instant. Further, the plate current drawn depends entirely upon the strength of the incoming signals.

On very soft passages the amount passing is minute, though it may leap up to considerable heights when loud sounds occur. In a word, the dual valve draws only the amount of high-tension current necessary for it to cope with any set of impulses.

Quite remarkable volume is obtainable from class B

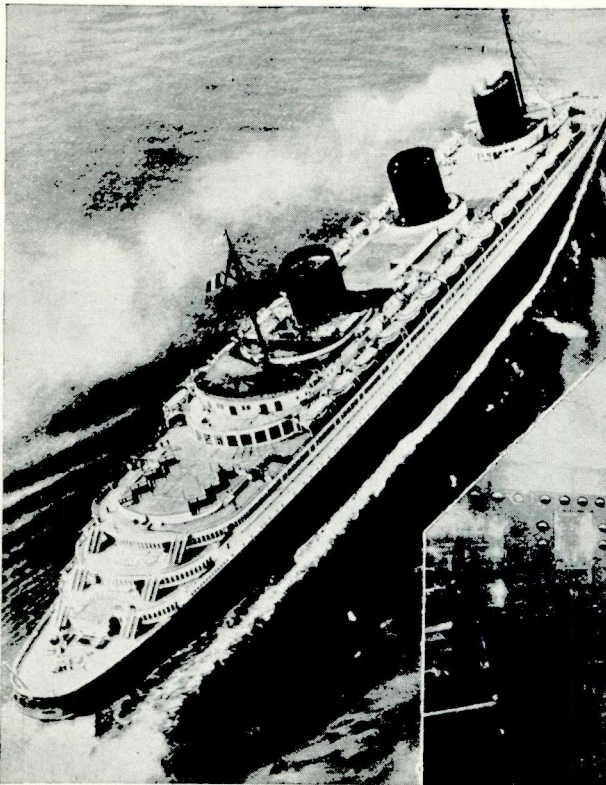

An exclusive picture showing the radio cabin on the new French liner "Normandie." Actually, the cabin is one of the deck houses nesting round the forward funnel. The gear used is said to be the biggest ever installed afloat

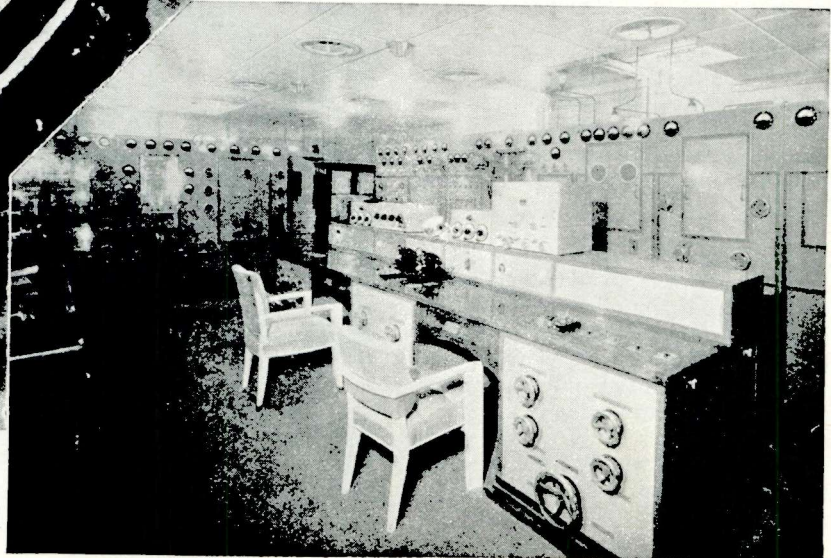

and the *average* anode current consumed by the output stage is much smaller than that needed by a single smallish power valve. It was therefore concluded that class B had solved one of the biggest problems of the battery set and that big volume with good quality could be obtained from a small high-tension battery.

But the average current of a class-B valve—5 or 6 milliamperes—is made up of peaks which may range up to 30 or 40 milliamperes, and troughs where the current is only 2 or 3. And it is in those peaks that the snag is to be found. Every one of them gives the small battery the proverbial kick in the neck, overloading it hopelessly for an instant and very much shortening its life.

There is all the difference in the world between a *level* current of 5 or 6 milliamperes and an *average* current of the same amount made up of peaks and troughs. Class B is a very fine thing so long as your high-tension battery is of adequate size to stand the kicks; but it is definitely not economically possible with the small-capacity battery.

Wireless technical men, even those of considerable eminence, are rather too prone to jump to conclusions—or rather I should perhaps say to arrive at conclusions based upon insufficient data. I could give you heaps of instances. The classic one is that of the short waves, which were condemned as pretty well useless for radio communications in the early days of the broadcasting era.

By short waves I mean those between about 10 and 100 metres. They were regarded as so completely hopeless from the commercial point of view that they were turned over to the amateurs in the belief that the latter could do no harm and

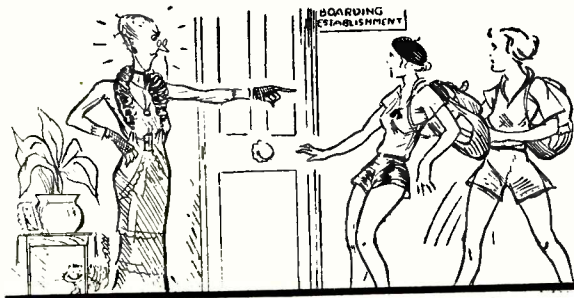

"... ideas about ultra shorts"

probably not very much good whilst working on them.

But the amateurs very soon began to get very astonishing results: on these "useless" wavelengths men in this country established contact with other enthusiasts at the opposite side of the world.

Then the Big Noises began to sit up and take notice. The despised short waves were soon recognised as one of the most valuable of all means of wireless communication over long distances. Now comes the news that quite remarkable ranges have been achieved on the ultra-shorts.

Just because in the course of the comparatively few experiments that had been made no one had succeeded in receiving ultra short-wave transmissions (those on 10 metres and below) at anything much outside what is known as quasi-optical range, heaps of people took it

for granted that reception at greater distances was not possible.

The Editor and I have often discussed the matter and we were both convinced long ago that time would show far greater ranges for the ultra shorts. And so indeed it has: the Radio Research Laboratories at Slough, whose accuracy is unquestionable, have received in this country signals from Buenos Aires, 7,000 miles away, working on 10 metres. 10 metres is, of course, a border line wavelength between the shorts and the ultra-shorts; but 7 metres is a cast-iron ultra-short, and



Major General James Harbord, Chairman of the Radio Corporation of America (left) and R. C. Patterson, jun., of the N.B.C., inspecting the tiny R.C.A.-Victor short-wave receiver and transmitter used by Captain Stevens and Captain Anderson on their recent stratosphere flight. The receiver weighs 15 lb. and the transmitter only 40 lb.

on this wavelength the Slough Laboratories have received telephonic working between Rome and Sardinia.

It can't be done at all hours of the day, or on any-day of the month. Everything depends upon the condition of what is known as the E layer, high up in the atmosphere that surrounds this Earth of ours. It has been found that the dates when long-distance reception will be possible can be predicted with fair certainty.

This means that we must revise our ideas about the ultra-shorts. It used to be thought that there was room within their limits for all the stations, television or otherwise, that could be erected. This was true enough if their range was no more than 25 miles, since stations in, say, Essex and Hampshire could use the same wavelength, but in view of the discovery that at times ultra-shorts have gigantic ranges everything in that garden is not so lovely as it once seemed to be.

When a great deal more experimental work has been done it will, I believe, be found that ultra-short-wave transmissions have skip areas in which reception is impossible. These skip areas may vary very greatly according to the state of the E layer. Thus Rome might easily be inaudible at all times in the south-east of France, but receivable periodically in the north-west.

If it was receivable in central France it might not be heard here. We live and learn! I believe strongly that the future of broadcasting is very closely bound up with the ultra-short waves.

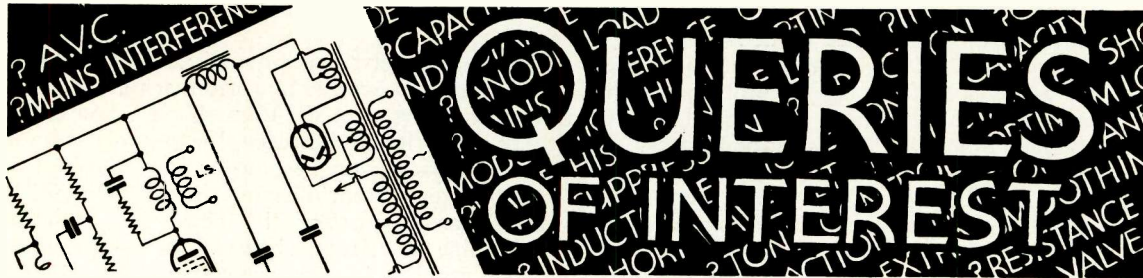

The selection of questions and answers appearing below is the result of a search through our post bag in quest of matter which we consider of general interest and having a direct bearing upon everyday practical problems. The readers who actually asked these questions have, of course, received a reply through the post

J. V. P. (Bodennick) asks whether we consider the piezo-electric type of gramophone pick-up to be as robust as the electro-magnetic form. He writes that he is much interested in the crystal type, but fears that it will not stand up to the somewhat rough handling to which pick-ups are exposed in his particular case.

In our experience the piezo-electric pick-up will stand any ordinary treatment, but whether it is quite so robust as the simpler kind of electro-magnetic instrument we find it difficult to say. In general, we imagine that there is little to choose, remembering that some of the better types of electro-magnetic ones are capable of being knocked out of adjustment by a sufficiently severe jar.

There is one particular kind of rough treatment, however, which the crystal pick-up seems definitely to resent, and that is being dropped upon the record from a height. Some folks seem rather fond of doing this after inserting the needle, and it is certainly not to be advised if the mechanism is of the crystal type.

B. S. J. (Blackpool) writes to say that he is very much interested in the Carrier Short-waver, but thinks he is likely to want to use a loudspeaker more often than 'phones. He inquires whether he can do anything to meet these requirements in the matter of increased volume.

The overall amplification of the Carrier was adjusted with some care to give good headphone volume on all the worthwhile stations, and loudspeaker results on some of the stronger ones. A general increase in volume can be obtained to meet a case such as our correspondent's by raising considerably the value of the resistance which forms the coupling between detector and low-frequency

amplifier. The original value for this was 20,000 ohms, but one of 50,000 may be employed if volume is the main consideration.

T. S. V. (Bradford) asks why what is called direct coupling is sometimes used in low-frequency amplifiers of the resistance type. He adds that he cannot see that this system can make any difference to the frequency response of the amplifier, and since it inevitably leads to some slight additional complication he fails to see why it should be used.

The frequency response curve does not tell the whole story of the performance of any sound-reproducing apparatus—a fact which even now is scarcely realised by many. A very important question in all cases is the response to transients, and this is not shown by the usual curve of frequency against amplification.

It would be quite possible to design an amplifier having an excellent curve and yet giving definitely bad quality as judged by the ear, simply by arranging for certain notes to persist, or "ring."

The direct-coupled resistance amplifier is believed by some authorities to treat transients much more kindly than any other type of circuit, and it must be confessed that the results obtained with certain commercial apparatus designed on these lines are very excellent. The cost of the system is unfortunately a little higher.

T. R. H. (Bridgwater) reports some difficulties with "flat spots" on a short-wave receiver of his own design. He has discovered that the trouble is apparently associated with his aerial, since the set behaves well on another aerial and earth system. He has tried all the usual remedies and asks for some unusual ones.

In all such cases it is probably simplest to add a stage of "buffer" high-frequency amplification, but failing that, relief will very likely be obtained by the following procedure.

First see that the aerial coupling is as weak as it can possibly be made without serious loss of strength. Then insert in series with the aerial lead (outside the set) a small coil of some five turns (usual spaced bare wire) on a 2-in. former with a crocodile clip arranged to enable the number of turns in circuit to be varied.

A little adjustment here will then enable any particular dead spot to be shifted right away from the wave-band being worked on at the moment. This remedy, be it noted, does not remove the dead spots altogether, but simply enables one to shift them about at will.

T. D. C. (Morecambe Bay) asks for further news of the Gordon battery, particularly as to the probable release date of a wireless version.

Sorry, but we have no additional information. The battery is still undergoing development and tests and there is no immediate prospect of a type for radio purposes being placed on the market. Readers may be assured that immediately there is any definite news it will be announced.

W. H. C. (Liverpool) expresses interest in the "Lazy Man's Gramophone Adapter" (last issue) and asks for suggestions as to a source of supply of suitable screened twin material for the extension lead.

Some quite good material can be obtained from Ward and Goldstone of Manchester. The two conductors are not quite so widely spaced as in the cable used by the author, but tests indicate that satisfactory results will be obtained.

We published full constructional details of the Carrier Short-waver in our last issue. The set, built by the Editor for his own use, is an entirely self-contained unit except for aerial and earth, the accumulator and batteries being housed in a compartment underneath the baseboard. Here we give useful operating hints and show how the design can be modified to use other makes of coils

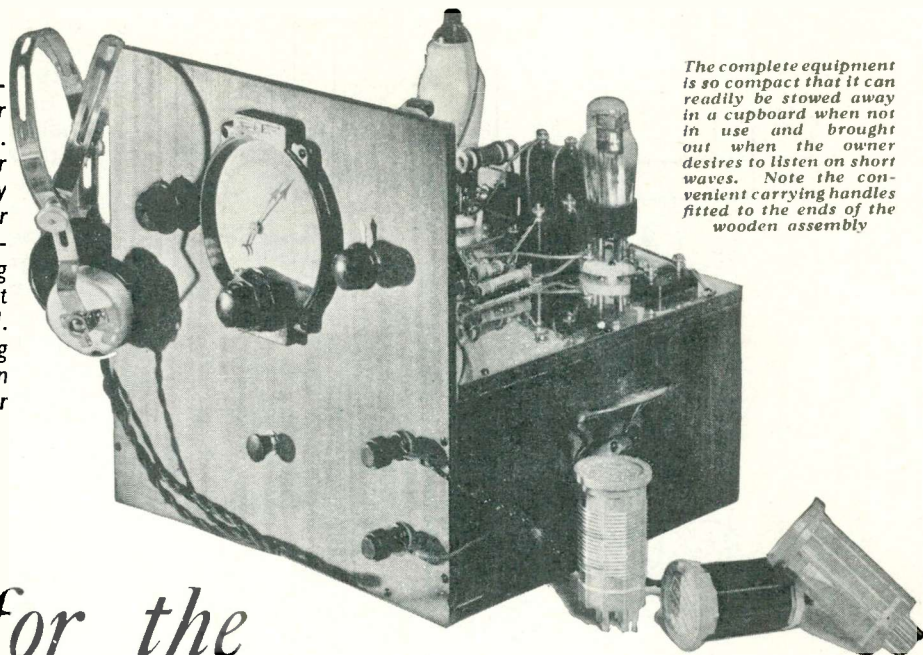

The complete equipment is so compact that it can readily be stowed away in a cupboard when not in use and brought out when the owner desires to listen on short waves. Note the convenient carrying handles fitted to the ends of the wooden assembly

Coils for the Carrier Short-waver

By PERCY W. HARRIS, M.I.R.E.

THE description published last month will have enabled readers to build the Carrier Short-waver and get it working. Here I propose to give a few more hints regarding its adjustment and use; they will add still further to the interest of working this most fascinating of receivers.

First of all, if you have built the receiver, may I particularly commend to you Mr. Godchaux Abrahams' excellent article in last month's "Wireless Magazine": How to Search on the Short Waves. You will learn from this that it is useless to wander idly round the dial on a short-wave receiver because broadcasting stations are confined to certain fairly narrow bands. If you have purchased the complete set of Hammarlund coils recommended for this receiver you will have four ranges, nominally 17 to 41, 33 to 75, 66 to 150, and finally a coil which will run right up to the broadcast band.

The two coils you will use

most will be those covering the first and second ranges, and I gave you some indication last month of where to begin searching. With so many short-wave stations now working and with numbers of them very close

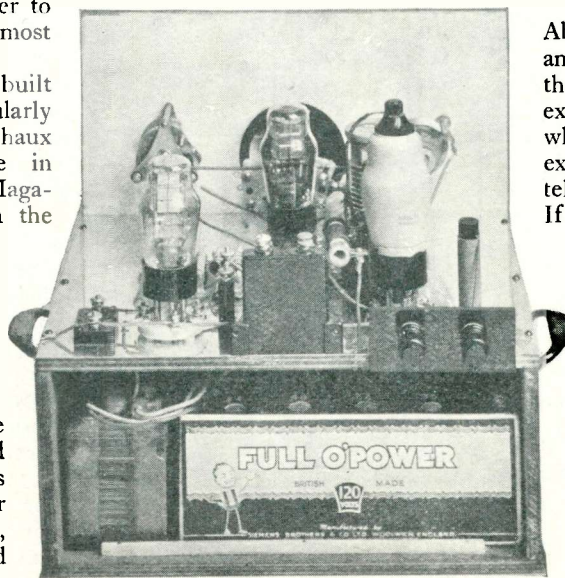

The batteries used by the designer fit snugly into the lower compartment, but there is reasonable space to allow for possible variations in dimensions if other makes or types are employed

together it is, of course, impossible for me to give anything like an exact calibration, but you can easily calibrate the set yourself since most short-wave stations announce their identity fairly frequently and often give the exact wavelength on which they are working.

Amateur Bands

Don't forget that a list of the world's broadcasting wavelengths, including all the leading short-wave stations, appears in the end pages of "W.M." each month; I actually used this myself in my own work.

You will notice from Mr. Abrahams' article that the amateurs have several bands; these are very interesting to explore, particularly at week-ends, when you will generally find both execrable and well-nigh perfect telephony from amateur stations. If you read morse you can have still further fun, for it is possible to hear morse stations much further than telephony transmitters.

Going Lower

You will have noticed that there are stations below 17 metres, the lower limit of the first coil in this set, and at the same time you will find that practically no use whatever is made of the fourth or longest wavelength coil in the series. You may therefore care to do as I have done—remove

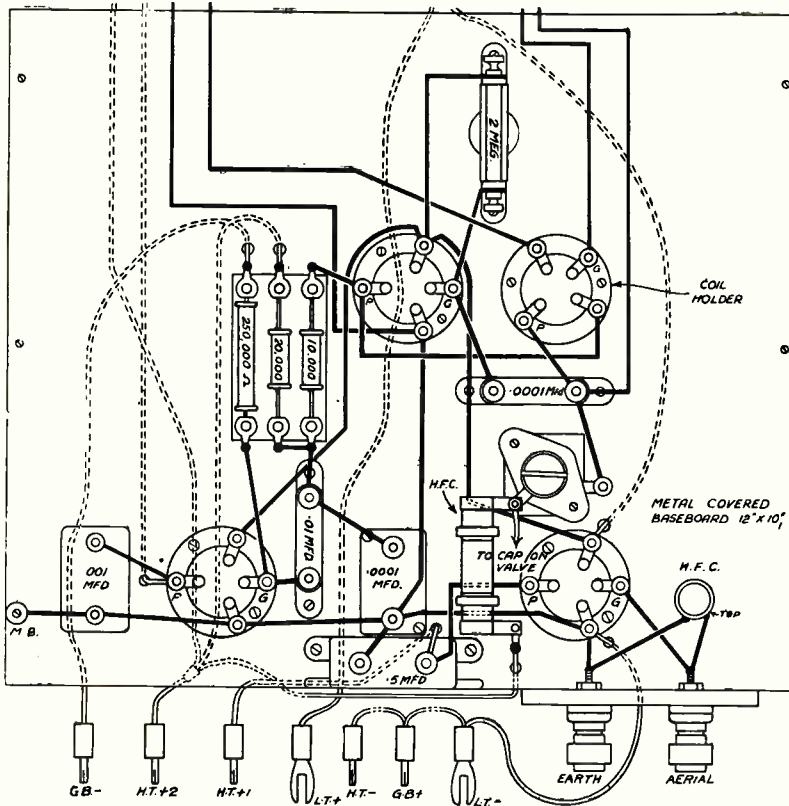

A few simple alterations in the connections and the use of a British type valve-holder permit other types of coils than those originally suggested to be used. The connections shown here are those for the B.T.S. coils

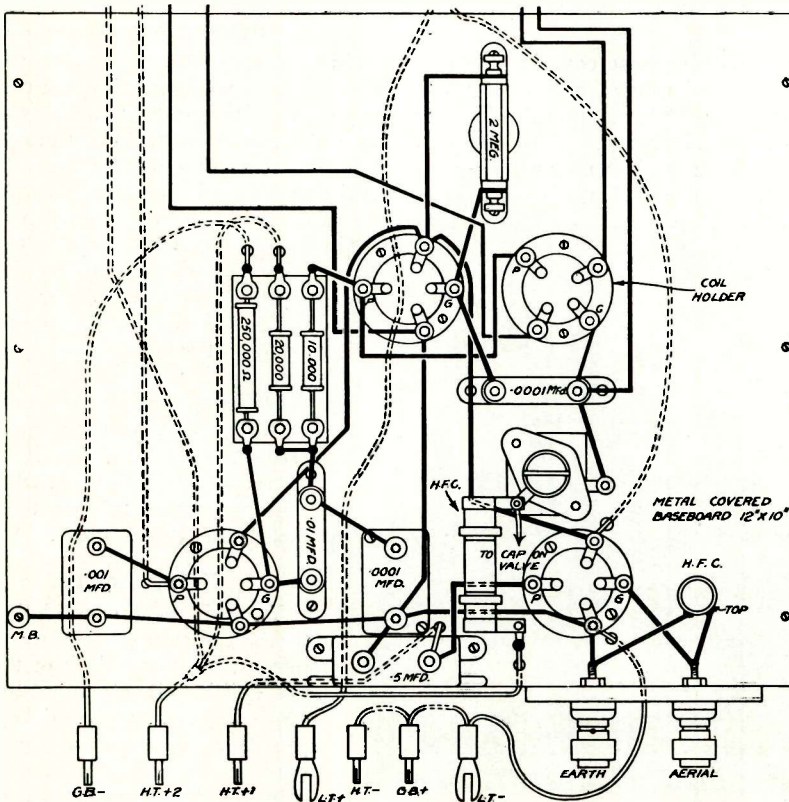

This diagram shows the connections for Eddystone short-wave coils in the Carrier Short-wave. It will be noted that both this and the upper drawing have been arranged to register with the corresponding portion of the original wiring plan published in the last issue

the wire completely from the fourth coil and wind yourself another one, modelling it on the first (17 to 41 metre) coil.

In this case you will want less inductance, so wind the grid coil with six turns of No. 22 tinned copper wire and the reaction coil with six turns of No. 28 double-cotton-covered wire.

If you remove the cardboard disc from the top of the coil you will see where the connections go inside. The old wire can be very easily removed by placing a hot soldering iron on the *bottom* of the pins; each of these is hollowed and has a spot of solder on the end for securing the lead.

Reaction Adjustment

Both grid and reaction windings are wound in the same direction, and you will have no difficulty in identifying the correct pins for joining up the windings if you examine one of the other coils. This new coil will extend your wavelength range well down below that of the first coil and will enable you to get several interesting stations.

Reaction control on this set should be very smooth. If it is not, the reason will be that you have screwed the neutralising condenser too far down, thereby giving too strong a coupling between the screened-grid valve and the detector valve. It should be screwed up *nearly out* of the lower portion. The best way of adjusting this is to pick some broadcasting station—say one around 31 metres—then gradually screw up the neutralising condenser, re-tuning and re-setting reaction each time you adjust it until you find that smooth reaction is obtained and sufficient selectivity is given without too great a sacrifice of signal strength.

Coupling Control

Then try out reaction over the whole tuning range of this particular coil, leaving the centre or sharp-tuning condenser at about its middle point and making the wavelength adjustments by the "tank" condenser knob. If, as will happen in ninety-nine cases out of a hundred, the reaction is smooth and sufficient over the whole tuning range, then your neutralising condenser adjustment will be correct on this and all the other coils.

If at one or two points reaction is insufficient or difficult to obtain

then you will have to unscrew the neutralizing condenser a little more until the defect is cured. Once you have found this setting it is improbable that you will need to alter it again.

As this is a short-wave set, do not keep changing your valves. Pull them out and make sure that the pins are quite clean and make good firm contact with the socket and then push them home and "leave them put." Bad contacts in the valve holders on short waves are much more likely to give trouble than on ordinary broadcast wavelengths, and I have even known bad reaction in a short-wave set to result from a faulty valve contact and cause the maker of the set to hunt everywhere else for the trouble, altering the reaction winding and spacing and everything else he could think of!

Coil Connections

Several readers have asked for the connections for Eddystone and B.T.S. short-wave coils for this set. These are given in the diagrams. In both cases the Hammarlund American-type valve socket, which is used as a coil holder, will have to be changed for a British valve holder, and here I would recommend you to use a duplicate of the valve holders described in the original set.

This is not to say that there are not other good short-wave valve holders, but by having a fourth to hold the coil of the same pattern as the others the set will look smarter.

It is not a bad precautionary

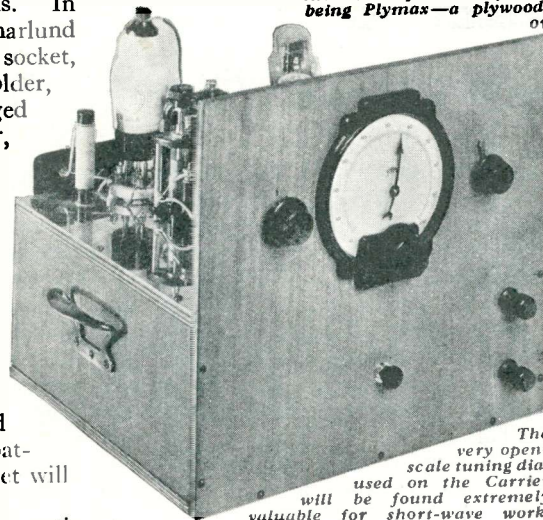

The very open-scale tuning dial used on the Carrier will be found extremely valuable for short-wave work, permitting accurate setting

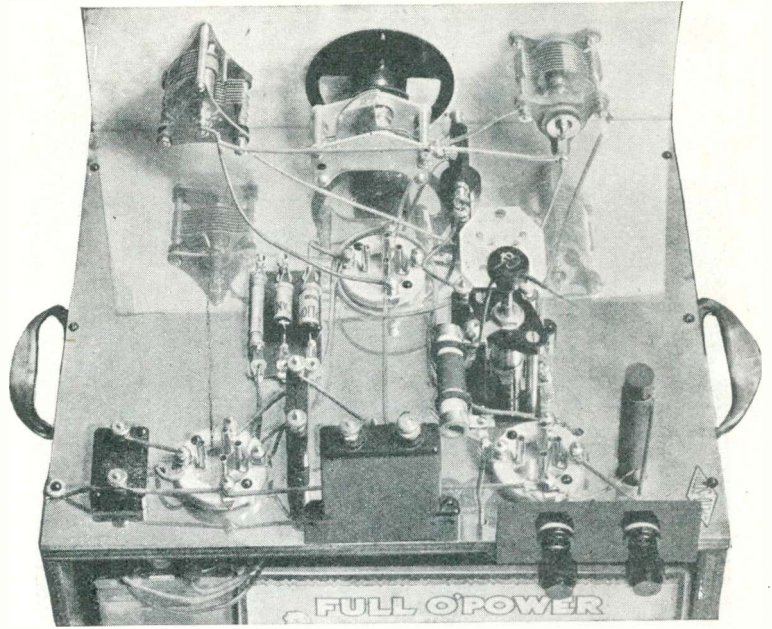

The baseboard of the Carrier is coated with a layer of aluminium foil (note the clear reflections of the parts on the panel), the material actually used being Plymax—a plywood base to which the metal is firmly attached over the whole surface

measure to place a piece of paper cut to size under the base of the neutralising condenser to avoid any risk of shorting the underside of this condenser on to the metal-covered baseboard. I have not done so in my own set because there was plenty of clearance, but I have heard of one or two cases where these condensers have shorted and the precaution just mentioned is easily taken.

Whether or not you need to use an earth connection with this set depends entirely upon circumstances. Try it with and without. In my own conditions an earth is an improve-

(Continued on page 80)

COMPONENTS NEEDED FOR THE CARRIER SHORT WAYER

		s. d.				s. d.				s. d.	
CHASSIS				CHOKES, HIGH FREQUENCY				SUNDRIES			
1—Wooden chassis to specification	...	2	6	1—B.T.S. Short-wave type	...	2	9	4—Belling-Lee terminals	...	2	0
1—with two carrying handles, say	...	2	6	1—Home-made to specification	...			1—terminal strip, 1 1/2 in. by 3 1/2 in., say	...		6
CONDENSERS, VARIABLE				DIAL				1—Benjamin on-off switch, push-pull type	...		8
1—Eddystone .00016 - microfarad "Scientific" type with plain knob	...	7	6	1—Graham-Farish "Snail" dial and drive	...	6	6	Screws as per author's specification, say	...		1 0
1—Polar Reaction type, No. 4 .00004 - microfarad	...	3	9	HOLDER, COIL				2—Wander plugs and spade terminals as per blueprint (Clix or Belling Lee) say	...		1 2
1—B.T.S. slow-motion reaction .0002-microfarad	...	5	9	1—Hammarlund	...	3	0	Accessories			
1—J.B. neutralising type	...	3	6	HOLDERS, RESISTANCE				BATTERIES			
CONDENSERS, FIXED				1—Bulgin 3-way group board (cut from standard 5-way board No. C31)	...	1	0	1—Full o' Power 120-volt high-tension size H3	...	13	6
1—T.C.C. .0001-microfarad, type 34	...	1	3	1—Graham-Farish horizontal Ohmite holder	...		6	1—Exide low-tension accumulator type PO-3	...	10	6
1—T.C.C. .0001-microfarad, type S	...	1	6	HOLDERS, VALVE				1—Full o' Power grid-bias battery 4.5 volt type	...		1 0
1—T.C.C. .01 -microfarad, type 34	...	3	0	3—B.T.S. special short-wave type, 4-pin	...	4	6	VALVES			
1—T.C.C. .5-microfarad, type T.C.C. 50	...	2	4	RESISTANCES, FIXED				1—Tungsram HP210	...	11	0
COILS				1—Amplion 10,000-ohm	...	1	0	1—Tungsram HR210	...	3	9
1—Set of Hammarlund short-wave coils (Rothermel, Ltd.)	...	17	6	1—Amplion 20,000-ohm (see text)	...	1	0	1—Tungsram LD210	...	3	9
or 1—set Eddystone short-wave coils, 4-pin type	...	16	6	1—Amplion .25-megohm	...	1	0	TELEPHONES			
or 1—set B.T.S. short-wave coils, 4-pin type	...	16	0	1—Graham-Farish 2-megohm Ohmite	...	1	6	1 pair of Ericsson 2,000-ohm	...	12	6



Gulliland photo

An interesting example of the ultra-modern, both in interior decoration and radio cabinet design. The receiver is the German Telefunken "Heimland"

A Chat About Quality in the Output Stage

By G. P. KENDALL, B.Sc.

IT is not my intention in this article to plunge into an abstruse and mathematical treatment of the higher theory of output circuits. My object is much more practical: I want to talk over just those aspects of the output stage responsible in my experience for the imperfections of quality still tolerated by many listeners.

Genuine Bass

For example, the question of bass response: we all want adequate bass of the genuine, non-booming type, yet to get it demands considerably more care than many people imagine. The fundamental requirement naturally concerns the choice of suitable values for the coupling condenser and grid leak (I assume resistance coupling, for obvious reasons), but this is a matter with which I have dealt quite recently ("Practical Resistance Coupling," May, 1935, issue).

The need for a good big output valve is well understood in this connection nowadays I think, but how many listeners realise that the nature of the output circuit is also an important limiting factor?

Consider the common output arrangement wherein the step-down transformer of the loudspeaker is

connected directly in the anode circuit of the power stage; that means that a steady current of perhaps 30 or 40 milliamperes may be passing through the primary, and what that does to the smaller type of iron core is just too bad! A good big transformer will stand up to such treatment quite happily, but it is decidedly a risky procedure with a small one.

If you want your output transformer to function according to plan and give you the correct ratio for full reproduction of the lower tones, it is certainly safer in my view to provide it with a suitable choke-condenser output filter. Note my careful use of the word "suitable" in this connection: it does not follow that better results will be obtained unless the condenser is of adequate capacity (I prefer one of 4 microfarads as a minimum here) and the choke is of sufficient inductance.

It must be remembered that the choke is in effect shunted across in parallel with the loudspeaker circuit. If the impedance of the choke falls unduly on the bass notes the output load is correspondingly reduced and trouble ensues: the lower tones are not fully rendered and all sorts of unpleasant harmonic distortion

effects are, therefore, to be expected.

An actual numerical example will make the point clear. Suppose that your output valve requires a load of 3,000 ohms, and the transformer ratio is of the correct figure to offer this impedance. Now imagine that you have rigged up an output filter with a choke of a nominal 20 henries inductance; if this is of the dubious type often unthinkingly employed its real inductance when passing a large current may well be no more than 10 henries.

Impairing Low-note Response

An inductance of 10 henries offers an impedance of but 6,000 ohms (in round figures) at a frequency of even 100 cycles. This is in parallel with the working output load of 3,000 ohms, and the effective combined load is then only 2,000 ohms—quite low enough to impair the response to notes of 100 cycles and below. Even if the choke had been possessed of 20 real genuine henries you have only to make the calculation at 50 cycles and the result would have been the same.

In all cases when the last valve demands an output load of 3,000 ohms or over, therefore, I personally always make it a rule to see that the choke is of at least 30 henries *working*

inductance. For complete assurance I like to use one of not less than 40 henries, but that is perhaps being over-particular.

Only when the output valve is of quite low impedance is it safe to use a choke of the nominal 20-henry rating unless it is known that the inductance does not fall off seriously at the working current. Even then I should always advise that the necessary simple calculation be performed to see that the load impedance remains adequate.

Simple Calculation

It is done as follows: Multiply the known inductance (working) by 2π times the lowest frequency which it is desired to reproduce. The result is the impedance of the choke at that frequency, and this should not be less than three times the correct output load of the valve. Put in mathematical form, $z = 2\pi fL$, where z is the impedance, $\pi = 3.1416$, f is the frequency and L the working inductance of the choke, i.e. its inductance at the particular value of current (anode).

Lowest Important Frequency

For all approximate purposes the value of π can be taken as 3, and the lowest important frequency as of the order of 50 cycles. This may not perhaps be quite low enough to satisfy the purists, but lower notes are only worth taking into account when the loudspeaker concerned is one with a quite exceptionally good bass response.

In any case notes of this order are of rare occurrence in normal broadcast. Naturally, there is no harm in aiming at a still lower bottom limit, but you will be surprised to find what a large inductance is then required.

Then comes the question of the power rating of the output valve. Here I find that most people have grasped the fact that a considerable reserve is needed and they accordingly use a valve with a fairly generous rating. I believe, however, that a more accurate choice could be made if the underlying reasons for this

reserve of power were better known.

In the main it is again a question of bass response. In my own case I find that from a quarter to half a watt of energy delivered to an efficient loudspeaker gives me ample volume in a room of moderate size, and it might therefore be concluded that a valve of, say, 1-watt rating would suffice to eliminate all risk of overload.

So it would if the mean level of volume included the bass impulses. Actually it does not, for the bulk of the volume is reckoned on the middle register which forms so large a part of the average musical broadcast. If it is required to render this at an average level of a quarter to half a watt one must be prepared for occasional bass notes demanding as much as ten times that power or even more.

In consequence of this requirement my own feeling is in favour of an output valve rated for at least 5 watts. That is quite a large valve, I admit, and imposes high-tension conditions of a rather expensive nature; it will be realised that I am here discussing the ideal case without much regard for the cost factor.

When costs must be

reckoned up carefully, as in the medium-size type of commercial set a somewhat different line is taken. One first makes a decision as to the lowest bass frequency to be handled, taking careful account of the characteristics of the proposed loudspeaker and cabinet.

Absolute Bottom Limit

In very many cases one comes to the conclusion that about 70 cycles will represent the absolute bottom limit, and it cannot be denied that very pleasing quality can be obtained by keeping above this point or even with a slightly higher cut-off.

It then becomes possible to decide upon an output valve of some 3 watts rating, but that is not quite the end of the story: having decided upon the lower cut-off one must take care to see that strong lower notes do not reach the output valve. This is necessary to prevent unpleasant blast effects from such notes on the rare occasions upon which they occur.

In practice this method gives results superficially much more pleasing than one would expect. It happens that most moving-coil reproducers of the small or medium-sized type have a resonance

down here, and this causes an enhanced response to the attenuated bass notes actually reaching them.

In practice, then, one arranges for the bottom cut-off of the circuits to be a gradual slope rather than a sharp drop, and if this is nicely proportioned it matches up with the incipient rise produced by the bass resonance of the loudspeaker to give quite a passable overall effect.

The method, as we all know, can be made by the skilful designer to yield extremely pleasing results. I cannot refrain from adding, however, that my own preference is very strongly in favour of the more expensive method wherein one chooses a loudspeaker where the bass resonance comes well down (off the bottom of the scale if possible) and feeds it with full-strength bass from a really large valve.

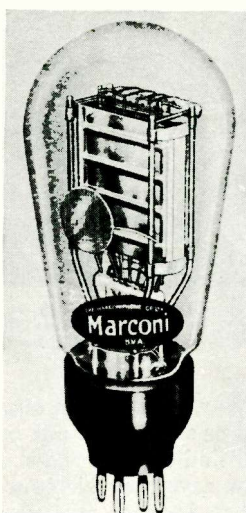

The modern output valve of high power is built up with an elaborate system of stiffening supports to ensure the rigidity essential to the proper performance of its task. The valve illustrated is the Marconi PX4—a power triode

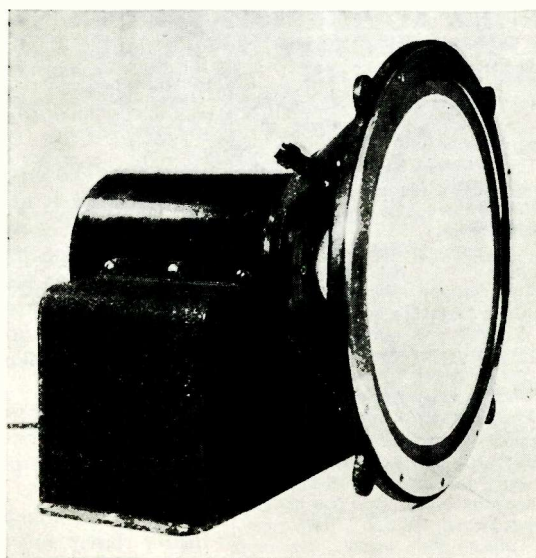

An example of the large type of loudspeaker capable of reproducing really low bass notes: the Baker Super Power A.C. model. It is reliable and robust



The model 580—an A.C. radiogram with automatic record changer—is one of H.M.V.'s most popular higher-priced instruments and is to be retained in the autumn range. The output is 5 watts

Those New Season's Sets!

By the "W.M." Set
Selection Bureau

points. There are some experts who take the view that quality has stood still among considerations during the past year or two. We would not go as far as to say that; but we do insist that there is wide room for improvement.

There are several ways in which set designers can give us better quality. They can give us bigger outputs and bigger loudspeakers and even bigger cabinets, but perhaps the real secret of the whole business is for them to pay more attention to the set design itself.

The chief fault has been the absence of any real top notes in the reproduction and far too much "boom-boom" bass. Several set makers have told us that quality—even if obtained at the expense of sharp selectivity—will be the big feature of the new sets.

Reliability is another point that calls for attention. The Bureau has had heaps of letters from people asking for advice about buying a set at such and such a price with the proviso that they are quite willing to pay an extra pound or two for a receiver that we recommend as being *trouble-free*.

No doubt the main cause of trouble in the past has been the absence of severe final testing, simply because manufacturers cannot afford it. The set has to be sold cheaply, the manufacturer, wholesaler and dealer have to make a profit, and the apportioning of the money spent in production has gone in actual value of materials

ABOUT this time, year in and year out, it has been the custom of us scribes to think out what new ideas we shall find in set makers' autumn programmes. In the past we have been fairly successful. We have spoken of superhet developments, the incorporation of automatic volume control in its many forms, and so on. Every year there has been some development or other that has made the new sets a little better than the old.

Now for the 1935-36 sets and consequent changes.

The first point that is forcibly brought to one's attention is that the reticence of set makers in giving away secrets is still as great as ever. But why? It is not our intention to go all pessimistic—far from it, in fact—but we do feel that there is nothing to gain from this attitude.

We firmly believe that there will be very few "secrets" revealed at Olympia this year. That there will be improvements we do not doubt. One has only to think of the performance—initial and enduring—of last season's sets to form a sane idea of what should be the leading sales points of the new 1935-36 receivers.

Quality is undoubtedly to be one of the strong talking

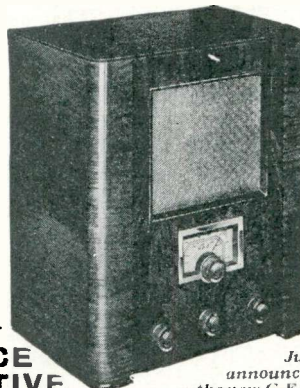

Just announced—the new G.E.C. "S.G.3," a battery set in the luxury class. It has a walnut cabinet and a big moving-coil loudspeaker

FREE ADVICE TO PROSPECTIVE SET BUYERS

To make the most of this free advice service, we ask you to answer the following questions:—

- (1) The maximum price you wish to pay, and whether you are prepared to exceed this if there is no suitable set at your desired price.
- (2) The locality in which the set will be installed.
- (3) The stations required, that is, locals only or a selection of foreigners.
- (4) Whether you want an entirely self-contained set or one with external aerial and earth.
- (5) Whether battery or mains driven. If the latter, whether A.C. or D.C.

A stamped-addressed envelope for our reply is your only expense. Address your inquiry to Set Selection Bureau, "Wireless Magazine," 8-11 Southampton Street, Strand, W.C.2. Tell your friends about this useful service, exclusive to "W.M."

used rather than in the process of paying for expert final testing.

Fortunately the price war is ending. It has done no one any good, and we do believe that reliability will be general in all the new season's receivers.

Perhaps that is rather plain, harsh speaking. The set makers send perfectly standard receivers to us for test. We treat them as we consider ordinary listeners would treat them. We can say quite truthfully that most of them are returned to the makers as they arrived—working very well—but quite a number are returned either not working at all or with silly faults—a switch not making good contact, the dial slipping, or some other equally annoying mechanical trouble.

We do not expect to see really big changes in the new sets. We do expect to see the visual-tuning indicator become a standard fitting; it is highly desirable if the ordinary listener is to get the best quality that his set will give him. Automatic volume control has not helped easy tuning, and it is surprising how many "novices" with "pukka" sets are just off the mark, listening to foul quality, when a slight turn of the tuning dial would bring them in the real stuff.

No doubt we shall see an increase in the number of all-wave sets on the market. Many listeners at home feel that there is a wealth of pleasure to be obtained in odd moments touring round the States, South America, Australia and Africa. Several sets capable of reception on wavebands from about 15 to 80 and 200 to 2,000 metres have been released quite recently, and we confidently expect to see this number greatly increased by show time.

Many listeners are inclined to think that tales of Australian reception at breakfast-time and America at tea-time are "bunk." Nothing is farther

from the truth; and it doesn't take a skilled radio engineer to get such startling catches!

A.C./D.C. sets are getting more popular every day. Incidentally from our end we are pleased to note that reliability is increasing at the same pace. The first ones caused us to think twice about their usefulness!

The public as a whole is appreciating the value of a complete radio gramophone. A standard table set costing between twelve and fifteen guineas can usually be obtained in radiogram form for an extra eight or ten



Nora Williams, the popular American stage and radio star, finds good listening with a Cosmor battery receiver. Cosmor's fame as battery-set makers started with the famous Melody-Maker and their battery receivers today still carry on early traditions for good results and reliability

pounds. Only those who have had a radiogram can appreciate their full value. Two or three big firms have told us that sales of the moderate-priced radiogram (£23 to £28) have greatly increased this last few months and they intend to concentrate on this market next season.

No reference to future tendencies would be complete without a word about cabinets! With one or two exceptions there has been little change in this part of radio-set make-up for the past few years; and from what we have heard we shall still have the conventional square box with a loudspeaker opening at the top or side and a few knobs and a tuning scale scattered somewhere on the front. But when all is said and done what we need is a cabinet of plain neat design with "innards" that give us good quality from the British and a fair selection of foreigners coupled with reliability—that is to say, freedom from minor mechanical faults.

That, to our mind, is peak efficiency. 1935-36 should see this achieved!



McMichael can certainly be said to have produced a really handsome set in their new Twin-speaker superhet—model 138

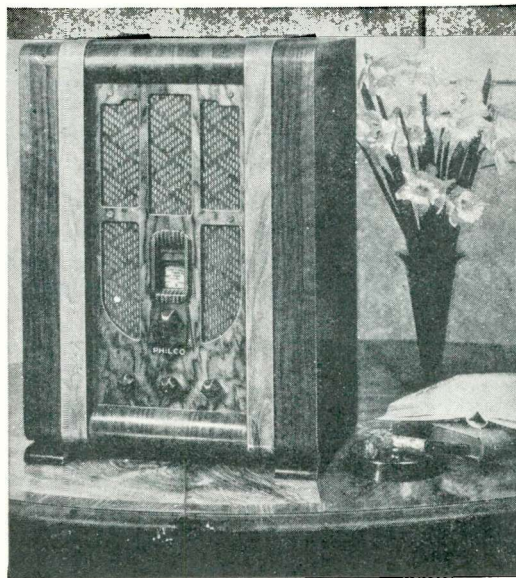

The new Philco model 265, a five-valve superhet for A.C. mains. This is the first of Philco's new season's models; the large diameter station dial is a somewhat unusual feature for sets manufactured by this firm

G.E.C. Battery Overseas Seven

GE.C.'s latest receiver, the B7, is a de-luxe battery model covering, without any gaps, a wave-range of from 12 to 550 metres. It has been specially designed for use abroad under the most exacting climatic and reception conditions. The set chassis—a most handsome affair with almost every part in a metal can—is housed together with a large permanent-magnet moving-coil loudspeaker in a bakelite cabinet, finished in a dull, chocolate colour.

Leads are provided for the batteries, but it is wise to note that these batteries do not fit inside the cabinet. Four controls beneath the tuning scale are so simple to handle that we can safely recommend the B7 to the merest novice. The drawing at the foot of this page shows the positions of the controls marked with their functions.

The big tuning scale is wavelength-calibrated in five ranges: range one covers from 12 to 30 metres; range two, 23 to 60 metres; range three, 43 to 115 metres; range four, 85 to 220 metres; and range five, from 220 to 550 metres.

There is no coil changing; the wave-change switch on the panel has seven positions, five for the ranges indicated above, one for when a pick-up—for which sockets are provided on the back of the chassis—is brought into circuit, and finally the on-off switch. The various positions are indicated by raised characters on the cabinet. We found this seven-way switching foolproof with no signs of poor contact.

About the circuit we need say little. The valve combination in the specification panel is self-explanatory. We would commend the method of delayed automatic volume control which is operative on all wavebands. Three valves are controlled, giving constant acoustic output for wide variations in the strength of signal received.

The question of power supply is carefully explained by the makers. The set takes approximately 14 milliamperes of high-tension current when silent, rising to

17 or 18 milliamperes at full volume. The variation in current consumption is due to the class-B output valve.

A mains unit can be employed with assured good results, for the set has ample decoupling; or, on the other hand, the makers recommend the use of a rotary converter of a special type made by Rotax, Ltd.

Our tests with the B7 were made just outside London using dry batteries and a 2-volt accumulator for power supply, and a 40 ft. outdoor wire as the aerial.

We were extremely pleased with the set's performance on the ordinary medium waveband. It behaved splendidly; quality was good, selectivity was of the 8-kilocycle variety and sensitivity such that in the late evening we had no difficulty in logging about sixty stations well.

On the short waves both sensitivity and selectivity was of a very high order. Our log over two nights brought in Moscow (25 metres) at simply terrific strength, Rio de Janeiro was almost as loud on 31.38 metres, LSX, Buenos Aires, on 28.98 metres was equally as good, while we logged no fewer than eight United States stations during the course of one evening. Perhaps the most striking point of all was the strength and quality of the transmissions received. One can truthfully say that the B7 provided entertainment—an asset of extreme value to those living in far-off parts of the Empire.

In addition to these we logged several other American stations, very weak and probably amateurs, Sydney (VK2ME) rather faintly in the early morning, besides the usual "locals" such as Zeesen, Rome, and Radio Coloniale (Paris). We have every reason to believe that this receiver will give good service abroad.

BRIEF SPECIFICATION

BRAND NAME : G.E.C.
 MODEL : Overseas B7—a short- and medium-wave superhet for battery operation.
 PRICE : £23 2s. in bakelite cabinet complete with valves and plugs. In chassis form with valves, £21. Both prices are exclusive of batteries.
 VALVE COMBINATION : Seven valves in superhet sequence. Signal-frequency amplifier (Osram VS24), oscillator (Osram LP2), first detector (Osram VS24), intermediate-frequency amplifier (Osram VS24), combined A.V.C. valve, second detector and low-frequency amplifier (Osram HD22), class-B driver (Osram L21), and class-B output valve (Osram B21).
 POWER SUPPLY : A large 2-volt accumulator (not supplied) for supplying 1.2 amperes for the filaments is needed. The set is designed for operation from a 150-volt triple-capacity high-tension battery. A 9-volt grid-bias battery is also required. The makers can supply suitable types.
 MAKERS : The General Electric Co., Ltd., Magnet House, Kingsway, London, W.C.2.

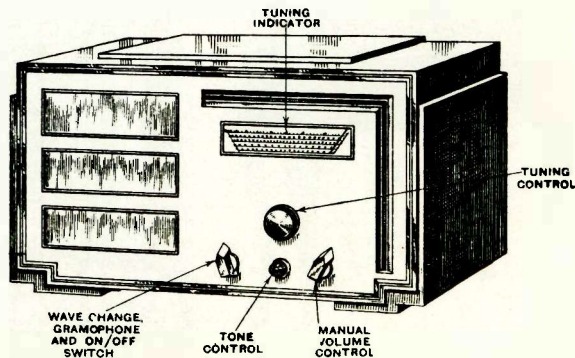
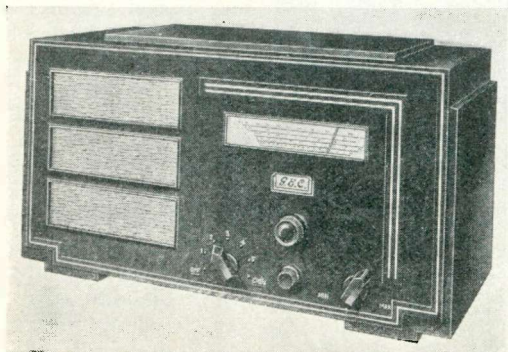

The General Electric Company's new short- and medium-wave battery superhet designed especially for use overseas. The cabinet is of bakelite and measures 23½ in. long, 12 in. high, and 11½ in. deep. The weight of the complete set is approximately 30 lb. Incidentally, the set chassis can be obtained as a separate unit, price £21, including valves. A version for operation of A.C. mains is also available, and complete details can be obtained from the makers

Pye Model TP/B Battery Superhet

THIS TP/B is the first of Pye's new season's sets that we have had the privilege of testing. We must apologise to Pye for the rough way we have handled the set. It was delivered to Southampton Street; from there it was sent on an eight-mile car journey *upside down*, and then dropped on to the hard pavement as it was unloaded. A nice beginning; it made no difference, however, for the set worked perfectly first time after battery connections were made.

There are few sets that would stand up to such rough handling, and our brutality with the TP/B is striking proof of the robust construction of Pye radio.

Pye's TP/B has been designed with one thought only, and that is to provide the best results from a battery-operated receiver. All the past few years' stunts have been carefully examined and the best of them will be found in the specification.

A glance at the valve combination in the panel will show that five multi-grid valves have been used to give a superhet with a preliminary H.F. stage, frequency changer, two I.F. stages, second detector, to provide A.V.C., and a quiescent push-pull output stage.

The makers believe that lower distortion is obtained with Q.P.P. than with class B; in fact, they say that the output from this receiver is as good as it is now possible to obtain from a battery-operated receiver. Quality and volume, we found, were *certainly exceptional*. Comparison with a mains-operated receiver is, to our mind, rather foolish, but we venture to put into black and white that users of mains sets with the proverbial 2-watt output pentode gain little or nothing over this Pye TP/B in quality!

Besides delayed automatic volume control, which makes it quite unnecessary to turn down the volume control to prevent unpleasant noises when tuning from one station to another, there is a commendable tone-control arrangement. The control is variable and in its "high" position gives a maximum response far above the average superhet standard.

We found the best setting to be about a quarter of an inch turn from the "high" position. At that setting quality was really delightful; perhaps the best description would be "crisp and natural"!

A novel extra: by pulling out the knob of the tone control (like a push-pull switch) an unusual tone-control effect is obtained. The position is fixed with average top-note response and a decided cut-off in the bass. There are still many listeners who prefer reproduction with little bass!

The set is housed in a plain walnut cabinet with slots at the side for carrying purposes. Pye's exclusive dial arrangement with a black background, and wavelength and station markings illuminated in daylight-blue, is very easy to read.



You can see exactly what the Pye TP/B looks like from this photograph—a handsome and solid walnut cabinet; white-on-black marked scale; large grille for the 9-in. cone speaker; and unobtrusive carrying handles on the side of the cabinet

Controls are four in number and are at the four corners of the tuning scale. On the left is the tone control above the combined wave-change and on-off switch; on the right the tuner is above the volume control.

There are built-in frame aerials; sockets are provided, however, for an external aerial and earth. Judging from our tests we do not think that many will have to take advantage of these sockets; sensitivity is really remarkable, and even in daylight satisfactory results were obtained on the self-contained frame.

Just one word about the layout. The TP/B is engineered; there is nothing tinny or slipshod about its construction. Very unique are the small rubber bands hitched between the top caps of the valves and small clips on the chassis top to give "extra support"; the rubber bands were probably responsible for the set arriving in a workable condition at our lab.!

The loudspeaker; very hefty with a 9-in. cone and a new nickel-aluminium-alloy magnet (claimed by the makers to triple the sensitivity). We found it to handle the full 1.5 watts given by the Mazda QP240 without any chatter.

All our tests were made with the frame aerials. In daylight our bag was six long-wave signals and ten medium waves excluding British stations. At night we prefer to say that we got altogether thirty-five to forty listenable signals.

Selectivity was sufficient for normal purposes. It was not of the Stenode variety, but sufficient to separate such signals as North Regional and Cologne, or London Regional and Strasbourg, here in London.

Selectivity on the long waves was above the average. We could listen to Luxembourg without any whistle. *Quality* is our lasting impression!

BRIEF SPECIFICATION

BRAND NAME: Pye.
MODEL: TP/B—a superhet portable for battery operation.
PRICE: £15 15s.
VALVE COMBINATION: Five valves in superhet sequence. Variable-mu pentode high-frequency stage (Mazda VP215), triode-pentode frequency-changer (Mazda TP22), variable-mu pentode intermediate-frequency amplifier (Mazda VP215), double-diode-triode for second detection, second intermediate-frequency amplifier and A.V.C. valve (Mazda L21/DD), and quiescent push-pull output pentode (Mazda QP240).
POWER SUPPLY: Self-contained combined high-tension and grid-bias battery and 2-volt accumulator.
MAKERS: Pye Radio, Ltd., Cambridge.

Hyvoltstar A.C./D.C. Amplifier

10-11-watt Model

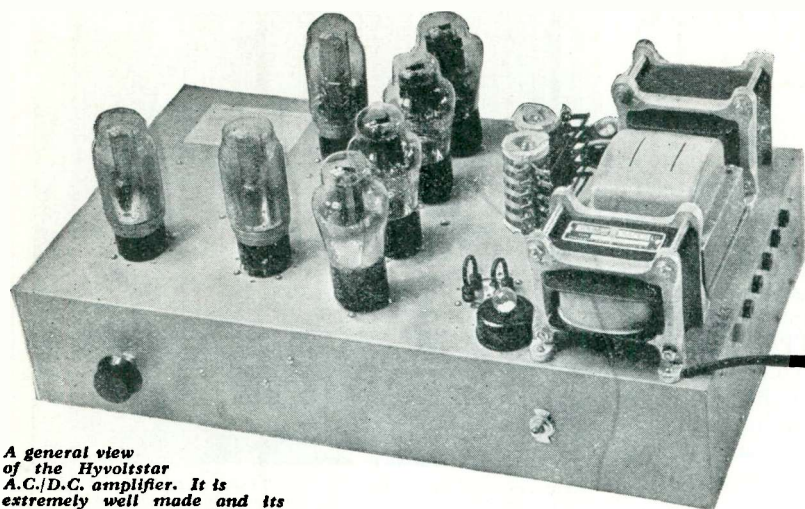

A general view of the Hyvoltstar A.C./D.C. amplifier. It is extremely well made and its performance on both A.C. and D.C. mains is satisfactory in all respects

BRIEF SPECIFICATION

BRAND NAME: Hyvoltstar.

MODEL: 10/11-watt Public Address.

PRICE: £21.

VALVE COMBINATION: A three-stage amplifier with an Ostar-Ganz A520 in the first stage; the output from this stage is fed into two Ostar-Ganz A520's in push-pull in the second stage and the output from this second stage is fed into four Ostar-Ganz K3560's in push-pull parallel in the output stage. Two valve rectifiers are also incorporated in the design (Ostar-Ganz NG100's).

POWER SUPPLY: A.C. or D.C. mains; standard voltages 200 volts and upwards (On A.C. mains the frequency must be 50 cycles).

MAKERS: Universal High Voltage Radio, Ltd., 28 Southampton Street, London, W.C.2.

THIS is the second of our reviews of amplifiers suitable for public-address work. The Hyvoltstar model is undoubtedly a useful specimen. It gives an undistorted output of a little over 10 watts—the actual figure depending upon the supply voltage. This means that its output is quite suitable to fill a small-to-moderate hall for entertainment purposes, or a small hall for dancing, while it can be used for outdoor work such as garden parties, fêtes, and so on.

The amplifier is designed for operation off either A.C. or D.C. mains (without alteration) of standard voltages of 200 and upwards. The fact that it is universal makes the amplifier ideal for one who is constantly installing public-address gear in different localities where the source of mains supply may be either A.C. or D.C.

Indeed, very interesting is the circuit. It employs Ostar-Ganz high-voltage valves, which have their heaters fed directly from the mains. There are three stages of amplification. The input is fed direct to the first valve and this is transformer-coupled by the parallel-fed method to two similar valves in push-pull. From here the output is again passed through a parallel-fed transformer to four valves in a push-pull-parallel arrangement.

High-tension supply is obtained on A.C. through two valve rectifiers. It is interesting to note that sufficient current is available from one of the rectifying valves for the excitation of a loudspeaker field winding.

Grid bias is obtained from a battery, for which there is plenty of room on the top of the amplifier chassis. The idea of using a battery is to prevent the loss of high-tension voltage when automatic grid bias is provided.

The output arrangement is of the low-impedance type and outputs are provided for loudspeakers with speech coils of 1.8, 3, 5, 10, and 15 ohms. Volume control is effected by means of a 100,000-ohm potentiometer across the input sockets.

Our illustration at the top of this page shows the amplifier with all valves, except the rectifiers, in position. You will notice that, behind one of the two fuses, is a rectifier valve holder with certain of its points strapped together. Actually, the amplifier can be used on D.C. mains without the rectifiers, but it must be borne in mind that should the mains be connected the wrong way round it would have the effect of de-polarising and therefore damaging the electrolytic condensers.

The makers are careful to mark the mains connecting plug positive and negative, and it is up to the user to ascertain the polarity of any D.C. supply on which he may use the amplifier, that is if he takes the risk of using it without the rectifiers.

We would make a passing reference to the sturdy construction of the outfit. Many proprietary lines, familiar to "Wireless Magazine" readers, are used and include T.C.C. condensers, Bulgin transformers, mains resistances and switch, Centralab potentiometer, Sound Sales smoothing chokes, and so on.

The construction is certainly a fine piece of workmanship; all joints are firmly soldered and the outfit has "finish" written on every part of it!

At the input end are two terminals on the side of the chassis for the pick-up or microphone; along the front are the volume control and the on-off switch, while at the other end are the six sockets for providing the different matching ratios to the loudspeaker.

We have thoroughly tested the amplifier ourselves on A.C. mains and have heard its performance on D.C. supplies. We have no criticism of a serious nature to offer. Quality is satisfactory; there is no trace of hum and the output as stated by the makers is reasonably accurate, though we imagine that it would drop a little when the amplifier is used on 200-volt supplies.

At its price, this is a good outfit for those in the trade or for those amateurs who take delight in helping out their friends at garden parties and the like.

Wireless Magazine
AGAIN specifies
TUNGSRAM

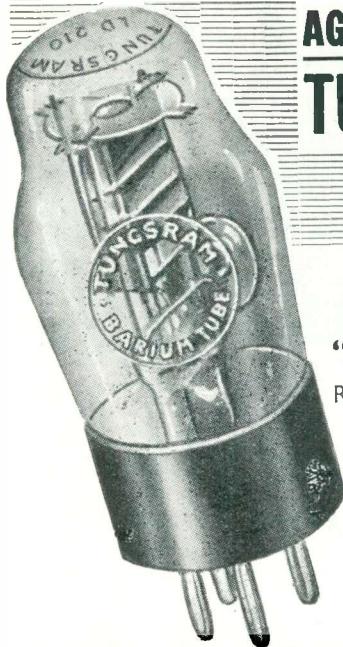

This month for
**THE "W.M."
"UNICON" TWO**
R2018 10/6 PP4118 14/9
RECTIFYING VALVE
V2113 10/-

The Tungoram Valves specified in this notable new set are not 'special editions.' They are identical in every way to those you can buy from your dealer. Tungoram's new factory and specialised production methods ensure a standard of uniform excellence, from stock, that satisfies the expert every time.

TUNGSRAM

BARIUM VALVES 72 OXFORD ST., W.1. Factories in London, Austria, Czechoslovakia, Hungary, Italy & Poland

The Pick-Up
of the Future

**THE ROTHERMEL-BRUSH
PIEZO-ELECTRIC PICK-UP**

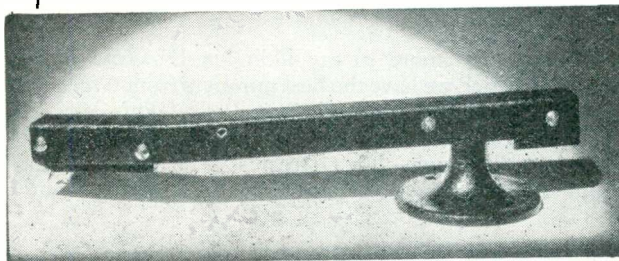

Acclaimed by the leading authorities as the greatest advance in design and performance that has ever been made, the Rothermel-Brush Piezo-Electric Pick-up gives a response of from 42 to 8,500 cycles with an output of 2 volts R.M.S. No other pick-up available can equal this performance. There is only 1½ ozs. weight on the record, thus ensuring an entire absence of wear and tear. This new and revolutionary non-magnetic and non-resonant pick-up represents the finest value available, and because of its outstanding performance has been adopted as standard equipment by R.G.D. and other prominent manufacturers of high-fidelity radio gramophones.

MODEL S.8.

42/- R.A.R. Rothermel LTD

Write for complete lists featuring "Rothermel-Brush" Piezo-Electric Pick-ups, Speakers, and Microphones, etc., post free.

Rothermel House,
CANTERBURY ROAD, HIGH ROAD,
KILBURN, LONDON, N.W.6.
Phone: Maida Vale 6066.

Better service results from mentioning "Wireless Magazine" when writing to advertisers

**A FERRANTI
SPEAKER
FOR ONLY**

30"

A triumph of radio engineering skill in design and production.

Capable of really excellent reproduction, the many claims of the Ferranti M5 simply cannot be ignored where ever economy of outlay is a dominating factor.



TYPE M5

Maximum A.C. input, 5 watts.
Diameter of cone, 6 in.
Price (chassis only) **30/-**

TYPE M5T

As illustrated: exactly as M5, but with substantial built-in multi-ratio output transformer.
Price (chassis only) **37/6**
In M5 Cabinet, 32/6 extra.

FERRANTI
MOVING COIL
SPEAKERS

Write for list Wg 550.
FERRANTI LTD.
HOLLINWOOD, LANCS.

**Three famous Varley
components chosen for the
"Standard S.W. Receiver"**

Again the "Wireless Magazine" have shown their trust in Varley parts by choosing two Chokes and a Transformer for the "A.C. Standard Four-Valve Short Wave Receiver" described in this issue. A post-card to Woolwich brings you our comprehensive illustrated catalogue of radio parts, which describes all Varley products in detail.

Varley

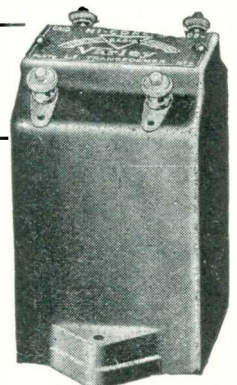

- Nicore II Transformer (DP2) 11/6
- Nichoke II L.F. Choke (DP23) 10/6
- Junior Multi-Cellular H.F. Choke (BP2) ... 3/6

Oliver Pell Control, Ltd., Bloomfield Road, Woolwich, S.E.18.
Telephone: Woolwich 2345.



The Six Swingers, who are directed by George Scott-Wood (third from left) photographed at the Regal-Zono studios. This combination is turning out really lively dance music and there is a great demand for their records

Records for Your Radiogram

MANY of you have frequently tuned to Continental stations, usually German, and have heard some really splendid martial music played by an orchestra. Our own B.B.C., apparently, thinks that British listeners are not keen on this class of entertainment for except a solitary exception at the beginning or end of a light-music programme we seldom hear a lively march. Anyway thanks to H.M.V. and Richard Crean with the Palladium Orchestra we can get a record—a twelve-incher—containing some seventeen different marches mixed up into one glorious medley.

This, to my lowbrow mind anyway, is the super record of the month. The number is C2745 (4s.) and the disc is called *March Review Medley*.

A real surprise—and quite a pleasant one—is Sir Henry Wood and the Queen's Hall Orchestra recording now on Decca. The star performance is Beethoven's lively *Symphony No. 5* and this you can get on four records for the modest outlay of 10s. (K757-760).

Sir Henry intends to give gramophone enthusiasts some of the popular works which always meet with appreciation at the Proms. I strongly recommend K762 with Rachmaninoff's *C-sharp Minor Prelude* on one side and Dvorak's *Humoresque* on the other. Both are superbly played on Decca K762 and the recording is without blemish (2s. 6d.).

Carrying on with the twelve-inchers comes *A Mayfair Suite*—played by Harry Roy's band with Miss Elizabeth Brooke, Harry's fiancée, singing *Mayfair Blues*. Rather a historic record for some, but personally I liked it for its freshness and for the fact that such records do not often come my way. Harry refrains from all nonsense and we have collection of really pleasant tunes in rhythmic style.

Something with a kick in it is a twelve-incher of all the star hits from *Anything Goes*.

Cochran's latest show now at the Palace Theatre, London, played by Jack Hylton's band. Somehow or other the music does not strike me as being "too tuneful." Perhaps it is that I am lagging a little behind the times. However, it is worth hearing!

Another of the same school is Jack Buchanan with Harry Perritt and band in some numbers from *The Flying Trapeze*. Jack Buchanan is the star attraction and if you like his singing you will like this record. Tunes here are quite fair, though not brilliant by any means. (Columbia DX696, 4s.)

Now much more to my liking is *West-end Nights* in which we have the best numbers from *Glamorous Nights*, *Gay Deceivers* and *Stop Press*. This is worth every penny; the hits from *Glamorous Nights* are "Shine Through My Dreams," "Her Majesty Millitza," "Fold Your Wings," and "Glamorous Night."



Jack Jackson is believed to be the only dance-band leader in the country to use two flautists. Here you see Jackson with his flautists at the H.M.V. recording studios

From *Stop Press* we have "Easter Parade" and "You and the Night and the Music"—two numbers whose popularity is unquestionable.

Grace Moore caused a minor sensation in Town when she sang at Covent Garden in June. Now from Brunswick comes a record of her singing two light songs; one is *For You*, and the other, *By the Bend of the Road*. Recording is good, the disc costs only 2s. 6d. and if you like Grace Moore's singing, here is your chance (02031).

One of the most attractive discs is a potpourri, *Listening to Paul Lincke* on Decca-Polydor P05122. Paul Lincke is conducting a really good orchestra and some excerpts of songs are sung by Max Mensing. Again this reminds me of a typically late-evening German concert—one of the delights afforded those possessing a good radio outfit. (2s. 6d.)

One of the joys of a radiogram is undoubtedly the ability to sit back and listen at will to songs chosen by yourself. Peter Dawson is one of my great favourites and I especially welcome his *Sea Call* and *Life and Death* recorded by H.M.V. on B8325. I am not saying anything else; you know Dawson too well!

Ernest Butcher—an old radio favourite—sings *How to Treat a Wife*, *A Fine Baby* and *With Me Hay Bag* on Columbia DB1555 (2s. 6d.). The last is a medley of sea chanties which Ernest Butcher sings with plenty of gusto. Very nice, this!

There is plenty of really good cheerful music this month among the ten-inch records. Our friends the Wireless Military Band know what to play when their playing is commercialised. They record two splendid marches, *L'Entente Cordiale* and *Castaldo* on Columbia DB1546, which really shows that this band can play. This is worth having as well as the Richard Crean medley, which to my mind is one of those super productions, so few and far between.

Three lady artists, Gracie Fields, Cicely Courtneidge and Elsie Carlisle. Gracie sings *Things Might Have Been So Different* and *I Haven't Been the Same Girl Since* on H.M.V. B8331 (2s. 6d.). The first is sung normally while Gracie plays the fool properly in the second. The two by Cicely are *The Sunshine Cruise*—very snappy—and the second, *Humpty Dumpty*, which is not varied enough for my taste. It becomes very monotonous about half-way through (H.M.V. B8329, 2s. 6d.).

Elsie sings *Waiting for the Lights to Change* and *The Gentleman Obviously Doesn't Believe* on Decca B5568 (1s. 6d.).

The dance music this month is the best for some while. As the best I pick out Nat Gonella and his Georgians playing *Jig Time* and an old favourite, *The Peanut Vendor* on Parlophone F180 (1s. 6d.).

It is hot, Nat Gonella sings the vocals, and altogether both tunes are played with that little difference from other bands that makes them stand out as masters among many.

Though perhaps not so polished, but equally entertaining, is a couple of tunes by the Six Swingers—a Regal-Zonophone band under George Scott-Wood. They play *What's the Reason* and *The House Where I Was Born*, both foxtrots; the number is 1732 (1s.).

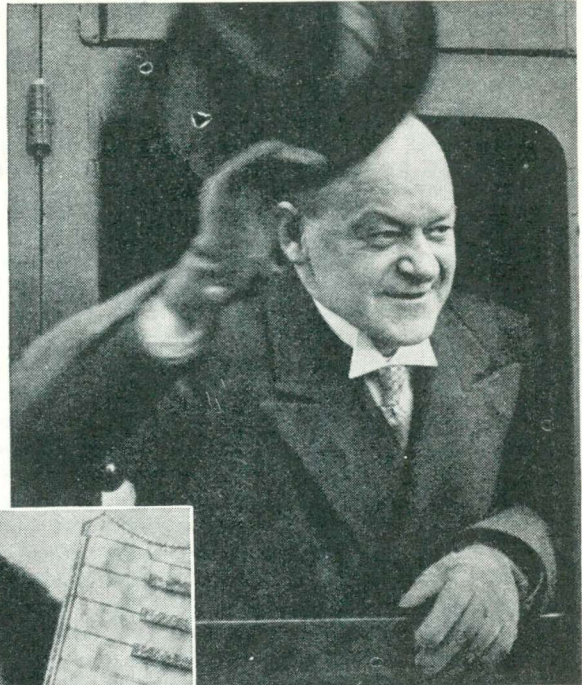

(Above) The most popular of recording baritones, Peter Dawson. H.M.V. has pressed nearly twelve million of his records. (Left) A famous American radio star, Gypsy Nina, has already made a name for herself in this country. She records for H.M.V.

Though not strictly a dance record the monthly contribution by Harry Roy's Tiger-ragamuffins is decidedly good. I don't think that there are two other pianists who can produce such tuneful variations of old dance numbers and yet still maintain such freshness.

Parlophone tell me that these records are selling like hot cakes. They deserve to! The number of the latest is F178 and some of the tunes are "Lovable and

Sweet," "Miss Annabelle Lee," "Japanese Sandman," and "April Showers." You can dance to this record, and it is equally fine to listen to!

Here are the other dance records which I pick out as being above the average.

****I've Got A Note* and *I'll Take the South* (foxtrots), Harry Roy and band, Parlophone F175 (1s. 6d.).

***On the Good Ship Lollipop* and *A Gypsy Loves Music* (foxtrots), Eddie Carroll and his Music on Parlophone F181.

***And finally, *Lonely Little Dancer* and *Honolulu Bay*—two delightful examples of Roy Fox's fine slow foxtrots on Decca F5576 (1s. 6d.).

T. F. H.

News from the Radio Societies

Under this heading we publish reports every month of the activities of short-wave and transmitting societies. We shall be pleased to give publicity to any announcement of forthcoming events, etc., and secretaries of short-wave societies, whether national or local, are asked to make the fullest use of this space

Radio Society of Great Britain

IN a little more than a month the R.S.G.B.'s Annual Convention will be in full swing. Held at the end of the Radio Exhibition, this event never fails to attract to London a good percentage of the active provincial members, many of whom visit the show for business purposes. Many so-called "amateurs," of course, are in the trade; this does not make them professionals where their own hobby of short-wave transmission is concerned.

An experiment is being tried this year, Convention being started on the Thursday evening instead of being confined to the Friday and Saturday. An attendance of over 200 is expected.

5-metre Tests

Five-metre tests by members during the month have included a very successful series of transmissions from Mount Snowdon, a range of 180 miles having been covered. London members, working from their home stations, have also been substantially increasing their reliable ranges and 20-25 miles with low power seems quite commonplace nowadays.

A very interesting aspect of 5-metre work has been the reception by several active transmitters of harmonics from commercial stations working on 15 and 20 metres. CNR, Morocco, is heard fairly regularly on about 5.5 metres and German stations, including DIO, DJL and DFJ, are often heard. This seems to indicate that the 5-metre band has distinct "DX" possibilities.

Ten-metre news this month is more exciting and includes three or four contacts between this country and South America. South African

stations have also been heard. There is a connection between conditions on 10 and 5 metres, since the harmonics already referred to only seem to be audible when stations in the countries concerned are coming through on 10 metres.

All radio societies should be interested in the meeting recently held between two societies, one in Sydney, and the other in Schenectady, by means of radio. The two stations handling the meeting were VK2ME at Sydney and the well-known W2XAF. A short account of the meeting is given in the current issue of the *Bulletin*, and is written by a British amateur who was in Schenectady at the time.

The R.S.G.B. will welcome reports of the reception of signals from the schooner *John Williams V*. Between July 25 and August 24 this vessel, belonging to the London Missionary Society, will be between Suva (Fiji) and the Gilbert and Ellice Islands. Messages will be transmitted on telephony on a wavelength of 48 metres at 9 p.m. B.S.T. every day and will be addressed to the society's station VP3AP located at Beru, Gilbert Islands.

A revision of the regulations governing the use of the 3.5-megacycle (80-metre) amateur band now opens this band to amateurs for the entire year with the exception of the month of September. Hitherto, during the summer the amateur has only been allowed to use this band for week-end work on account of service requirements.

Anglo-American Radio and Television Society

The A.-A.R. & T.S. has been organised and the London offices are

Conducted by
G6QB

now situated at 89-91 Wardour Street, the executive secretary being Mr. Malcolm Barr. The Society wishes to hear from any radio or ciné club which would care to consider affiliation; secretaries of such clubs should write to the above address. Prospective new members, however, are asked to write, as before, to the president, Leslie W. Orton, at "Kingsthorpe," Willowbank, Uxbridge.

I omitted to mention last month that a North Surrey branch is now active, under the guidance of Ralph Evans, 182 Ewell Road, Surbiton.

Another item of news is that the Hayes research station of the society will shortly be open for inspection by members.

◆ ◆ ◆
**Golders Green and Hendon
Radio Scientific Societies**

The fourteenth annual open direction-finding competition organised by the above societies was recently held, other societies sending groups of members including Southall, Northwood, Belsize, Pye and Southgate. The object of the competition was to locate the direction of a transmitting station and, later, its actual position.

A mobile transmitter designed and operated by D. N. Corfield (G5CD) operated in an area of 30 square miles which was placed out of bounds to the receiving groups. The wavelength used was 84 metres.

Fixed station G2JU, at Harrow, was also used for reference purposes.

The returns handed in by the various groups are described as having a very high degree of accuracy. At a distance of 15 miles an error of only one degree was made, the apparatus used being entirely amateur-constructed.

The Southall Radio Society took first and second place, with Golders Green and Hendon third.

A series of 5-metre field days has been arranged for the purpose of testing receivers and types of aerials. Among the stations co-operating will be G5RD, G2JU, G5BO, G2GG and G6SL. Any readers who are interested and would care to attend

are asked to write, enclosing a stamped addressed envelope, to the hon. secretary, at 8 Denehurst Gardens, Hendon, N.W.4.

Tottenham Short-wave Club

The above club, formerly known as the Pembury Short-wave Club, has now resumed activities after a short interval and is going ahead with preparations for the autumn. New members will be welcomed and should introduce themselves to the secretary at 57 Pembury Road, Bruce Grove, N.17.

South London and District Radio Transmitters' Society

The July meeting of the S.L.D. R.T.S. opened with a talk by T. C. Macnamara, of the B.B.C., on the subject of the Droitwich stations. The next meeting to be held on August 7 will probably be attended by quite a number of overseas visitors, some of whom will already have met many British amateurs at the R.S.G.B. Convention.

A record attendance is hoped for and new members will be heartily welcomed. Practically all members, however, are chiefly concerned with short-wave work.

Wiring Plan for Mains Unit

Of the A.C. Standard Four-valve Short-waver

See pages 4 to 9 of this issue

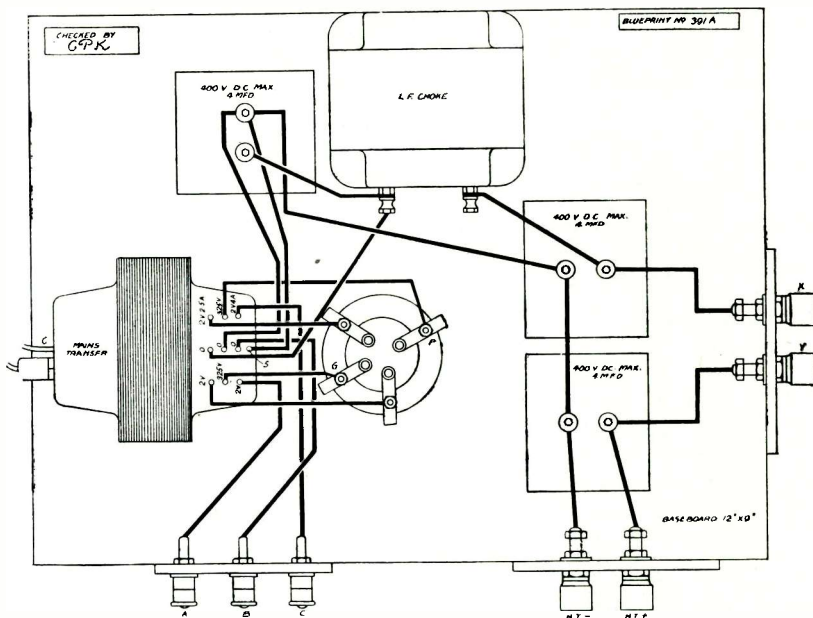

This is a scale reproduction of the wiring plan of the mains unit for use with the Standard A.C. Four-valve Short-waver. A full-size blueprint of the mains unit is supplied to those ordering No. WM 391 without extra charge



SOUND EQUIPMENT
Model No. 2

PARMEKO

Note the features

1. Direct amplification from microphone.
2. Suitable for use with Piezo or Carbon microphones.
3. Fitted with Piezo pick-up.
4. Plate diss. 50 watts.
5. Speech watts 25.
6. Frequency response within 3 D.B.'s between 30 and 10,000 C.P.S.
7. Price £45-0-0.

Other models are made by the manufacturers who will be glad to let you have particulars on application.

Partridge & Mee Ltd., Aylestone Park, Leicester

All Wireless Enthusiasts

will realise the large number of uses to which a wavemeter of this type can be put. It is buzzer excited, and can be used as a signal generator which will not vary. The circuit design also enables it to be used as an absorption meter with the same calibration holding good. The meter is built in a die-cast metal box of handy size and rigid construction. The wave-range is covered with three coils, a calibrated chart being supplied for each. The buzzer is rubber mounted and though mechanically hardly audible it gives a clear high-pitched note without splutter and is very sharply tuned.

RANGE
9.5-220 Metres

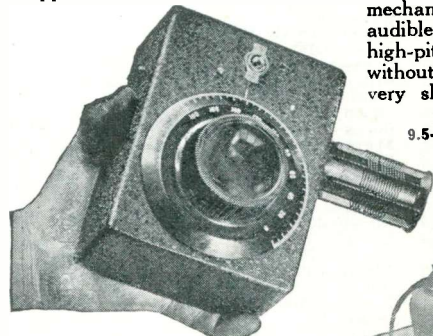

PRICE COMPLETE, £3.3.0
STRATTON & CO., LTD., Bromsgrove St., Birmingham
London Service Depot:
Webb's Radio Stores, 14, Soho Street, Oxford Street, W.1

EDDYSTONE SHORT-WAVE WAVEMETER

World's Broadcast Wavelengths

Stations best received in the British Isles are indicated in bold type. This list is corrected up to the time of going to press

Note: Names in brackets are those of the main stations from which the greater part of the programmes are relayed

Wave-length	Name of Station	Dial Readings	Country	Wave-length	Name of Station	Dial Readings	Country
13.92	Pittsburgh W8XK		United States	31.48	Schenectady W2XAF (WGY)		United States
13.97	Daventry (Empire) GSH		Great Britain	31.55	Daventry (Empire) GSB		Great Britain
14.49	Buenos Aires LSY		Argentina	31.55	Melbourne VK3ME		Victoria
15.92	Bandoeng PLE		Java	31.55	Caracas YV3BC		Venezuela
16.36	Lawrenceville (N.J.) WLA		United States	31.58	Rio de Janeiro PSA		Brazil
16.38	Rugby GAS		Great Britain	31.6	Skamlebaek		Denmark
16.5	Drummondville (CFA8)		Canada	31.7	Havana		Cuba
16.56	Bandoeng PMC		Java	31.71	New Brunswick WKJ		United States
16.56	Buenos Aires LSY3		Argentina	31.9	Bandoeng PLV		Java
16.81	Bandoeng PLF		Java	32.71	Lawrenceville WNA		United States
16.85	Kootwijk PCV		Holland	32.79	Maracay YVQ		Venezuela
16.86	Daventry Empire GSG		Great Britain	32.88	Budapest HAT4		Hungary
16.878	Boundbrook W3XAL (WJZ)		United States	33.26	Rugby GCS		Great Britain
16.88	Eindhoven PHI		Holland	33.59	Rocky Point (N.J.) WEC		United States
19.47	Riobamba PRADO		Ecuador	34.68	London VE9BY		Canada
19.52	Budapest HAS3		Hungary	36.65	Rio de Janeiro PSK (PRA3)		Brazil
19.56	Schenectady W2XAD (WGY)		United States	37.04	Quito HCJB		Ecuador
19.61	La Paz CP4		Bolivia	37.33	Rabat (CNR)		Morocco
19.64	New York W2XE (WABC)		United States	37.41	Suva VPD		Fiji Isles
19.66	Daventry (Empire) GSI		Great Britain	38.07	Tokio JIAA		Japan
19.67	Covtesville N.J. WIXAL (WEEI)		United States	38.47	Radio Nations HBP		Switzerland
19.67	Tashkent (Rim)		U.S.S.R.	38.65	Kootwijk PDM		Holland
19.68	Radio Coloniale FYA		France	39.34	Tashkent RIM		U.S.S.R.
19.72	Saxonburg W8XK (KDKA)		United States	39.76	Moscow RKI		U.S.S.R.
19.74	Zeesen DJB		Germany	39.82	Riobamba PRADO		Ecuador
19.82	Daventry (Empire) GSF		Great Britain	40.3	Radio Nations HBQ		Switzerland
19.84	Rome (Vatican) HVJ		Italy	40.5	Bogota HJ3ABB		Colombia
19.88	Moscow (RKL)		U.S.S.R.	40.54	Rocky Point WEN		U.S.A.
19.93	W8XK, Saxonburg (KDKA)		United States	41.55	Bogota HKE		Colombia
19.93	W8XK, Saxonburg (KDKA)		United States	41.6	Las Palmas EA8AB		Canary Isles
20.27	Rocky Point WQV		United States	41.67	Singapore VSIAB		Sts. Sett'l'mts.
20.31	Rocky Point N.Y. (WEB)		United States	41.84	Grenada YN6RD		Nicaragua
21.43	Cairo SUV		Egypt	41.9	Manizales HJ4AB		Colombia
21.53	Rocky Point WIK		United States	43	Madrid EA4AQ		Spain
21.58	Rocky Point WQP		United States	43.86	Budapest HAT2		Hungary
21.605	Rocky Point WQT		United States	44.61	Rocky Point WQO		United States
21.83	Drummondville CJAS		Canada	44.96	Maracay YVQ		Venezuela
22.26	Rocky Point WAJ		United States	45	Constantine FM8KR		Tunis
22.48	Santa Rita YVQ		Venezuela	45	Guatemala City		S. America
22.684	Zeesen (DHB)		Germany	45.02	Guayaquil HC2RL		Ecuador
23.39	Radio Maroc (Rabat) CNR		Morocco	45.38	Moscow RW72		U.S.S.R.
24.41	Rugby GBU		Great Britain	46.53	Barranquilla (HJ1ABB)		Colombia
24.9	Kootwijk PDV		Holland	46.69	Boundbrook W3XL (WJZ)		United States
25	Moscow RNE		U.S.S.R.	46.7	Boston WIXAL		United States
25.25	Radio Coloniale, Paris (FYA)		France	47	Caracas		Venezuela
25.27	Saxonburg (Pa.) W8XK (KDKA)		United States	47.5	S. Domingo HIZ		Dominican R.
25.28	Daventry (Empire) GSE		Great Britain	47.8	Domingo HIAA		Dominican R.
25.34	Wayne W2XE (WABC)		United States	48.75	Winnipeg CJRO		Canada
25.4	Rome 2RO		Italy	48.78	Caracas YV3RC		Venezuela
25.45	Boston WIXAL (WEEI)		United States	48.86	Saxonburg (Pa.) W8XK (KDKA)		United States
25.49	Zeesen DJD		Germany	48.86	Moscow (RKK)		U.S.S.R.
25.532	Daventry (Empire) GSD		Great Britain	48.94	Jeløy		Norway
25.63	Radio Coloniale FYA		France	49.02	Bandoeng (VDA)		Dutch E. Indies
26.83	Funchal CT3AQ		Madeira	49.02	Wayne W2XE (WABC)		United States
27.65	Nauen DFL		Germany	49.08	Caracas YV2RC		Venezuela
27.86	Rugby GBP		Great Britain	49.1	Daventry (Empire) GSL		Great Britain
27.88	Marapicu PSG		Brazil	49.1	Boundbrook W3XAL (WJZ)		United States
28.28	Rocky Point (N.J.) WEA		United States	49.18	Chicago W6XF (WENR)		United States
28.5	Sydney VLK		N.S. Wales	49.22	Bowmanville VE9GW (CRCT)		Canada
28.98	Buenos Aires LSX		Argentina	49.26	St. John VE9BJ (CPBL)		N. Brunswick
29.03	Bermuda ZFD		West Indies	49.3	La Paz CP5		Bolivia
29.04	Ruyssedele (ORK)		Belgium	49.34	Chicago W9XAA (WCFL)		United States
29.35	Marapicu PSH		Brazil	49.35	Zeesen (D9M)		Germany
29.59	Leopoldville OPM		Belgian Congo	49.39	Maracaibo V5BMO		Venezuela
29.64	Marapicu PSI		Brazil	49.4	Vienna OER2		Austria
29.84	Abu Zabel, Cairo SUV		Egypt	49.43	Vancouver VE9CS (CKFC)		Brit. Columbia
30	Radio Excelsior LRS		Italy	49.47	Nairobi VQ7LO		Kenya Colony
30.1	Rome IRS		United States	49.5	Pernambuco		Brazil
30.4	Lawrenceville WON		Japan	49.5	Skamlebaek		Denmark
30.4	Tokio JIAA		Japan	49.5	Philadelphia W4XAU (WCAU)		United States
30.43	Madrid EAQ		Spain	49.5	Cincinnati W8XAL (WLW)		United States
30.77	Lawrenceville WOF		Great Britain	49.586	Daventry (Empire) GSA		Great Britain
30.9	Rugby GCA		Mexico	49.6	Bogota HJ3ABI		Colombia
31.23	Mexico City XETE		Portugal	49.67	Boston WIXAL (WEED)		United States
31.25	Lisbon CT1AA		Switzerland	49.69	Priok (YDA)		Dutch E. Indies
31.26	Radio Nations HBL		Switzerland	49.83	Zeesen DJC		Germany
31.28	Philadelphia W3XAU (WCAU)		United States	49.96	Drummondville VE9DN (CFCF)		Canada
31.28	Sydney VK2ME		N.S. Wales	50	Moscow RNE		U.S.S.R.
31.32	Daventry (Empire) GSC		Great Britain	50.8	Barcelona EA3AB		Spain
31.34	Jeløy		Norway				
31.35	Millis W1XAZ (WBZ)		United States				
31.38	Zeesen DJA		Germany				
31.45	Zeesen (DJN)		Germany				

Continued on page 74

EXACTLY WHAT YOU WANT IN THE HANDY FORM YOU WANT AT THE PRICE YOU WANT TO PAY



These books are written, designed and published specially for the modern handyman—they are practical and helpful, explaining everything fully but without “bookish” elaboration—the illustrations are included to assist, not merely as decoration—and they cover the widest possible range of interests. Get one from your bookshop *now!*

NEWNES HOME MECHANIC BOOKS

Each 1/- net—Illustrated

MODEL BOAT BUILDING	25 SIMPLE WORKING MODELS	MODEL AEROPLANES AND AIRSHIPS
THE HOME WOODWORKER	MOTOR CAR OVERHAUL AND UPKEEP	POWER DRIVEN MODEL AIRCRAFT
THE HANDYMAN'S ENQUIRE WITHIN	ACCUMULATORS—CAR AND WIRELESS	SIMPLE ELECTRICAL APPARATUS
TOY MAKING FOR AMATEURS		LATHE WORKS FOR AMATEURS

From Booksellers Everywhere

GEORGE NEWNES LIMITED

WORLD'S BROADCAST WAVELENGTHS Continued from page 72

Note: This list is corrected up to the time of going to press

Wave-length	Name of Station	Dial Readings	Country	Wave-length	Name of Station	Dial Readings	Country
50.26	Rome (Vatican) HV		Italy	296.2	Midland Regional		Great Britain
50.42	Domingo HIX		Dominican R.	298.8	Bratislava		Czechoslovakia
50.6	Medellin HJ4ABE		Colombia	301.5	Hilversum		Holland
51.28	Maracaibo		Venezuela	304.3	Genoa		Italy
55.56	Szemesfehevar		Hungary	307.1	Belfast		N. Ireland
56.9	Königswusterhausen (DTG)		Germany	307.9	Odessa		U.S.S.R.
57.03	Rocky Point WQN		United States	312.8	Poste Parisien, Paris		France
58.0	Bandoeng PMY		Java	315.8	Breslau		Germany
58.31	Prague		Czechoslovakia	318.8	Goteborg		Sweden
60.3	Rugby GBC		Great Britain	321.9	Algiers		North Africa
62.5	Long Island (N.J.) W2X		United States	321.9	Brussels (2)		Belgium
62.56	London		Ontario	325.4	Brno		Czechoslovakia
65.93	Rocky Point WAD		United States	328.6	Radio Toulouse		France
67.11	Soerabaja (YDA)		Dutch E. Indies	331.9	Hamburg		Germany
68.18	Moscow (RFCK)		U.S.S.R.	335.2	Helsinki		Finland
69.44	Rugby GDB		Great Britain	338.6	Craz		Austria
70.2	Khabarovsk RV15		U.S.S.R.	342.1	London Regional		Great Britain
73	Quito (HCJB)		Ecuador	345.6	Poznan		Poland
80	Lisbon CTICT		Portugal	349.2	Strasbourg		France
84.5	Berlin D4GE		Germany	352.9	Bergen		Norway
85.9	Boston W1XAL		United States	352.9	Valencia		Spain
98.68	Plymouth		Dutch E. Indies	356.7	Berlin		Germany
203.5	Bournemouth		Great Britain	360.6	Moscow (4)		U.S.S.R.
204.8	Pecs		Great Britain	364.5	Bucharest		Roumania
206	Eiffel Tower		Hungary	368.6	Milan		Italy
208.6	Miskolcz		France	373.1	West Regional		Great Britain
209.9	Beziers		France	377.4	Lvov		Poland
210.7	Alexandria		Egypt	382.2	Barcelona (EAJI)		Spain
211.3	Radio LL		France	386.6	Leipzig		Germany
215.4	Tampere		Finland	391.1	Toulouse PTT		France
216.8	Radio Lyons		France	395.8	Scottish Regional		Great Britain
216.8	Warsaw No. 2		Poland	400.5	Katowice		Poland
218.2	Basle, Berne		Switzerland	405.4	Marseilles PTT		France
221.1	Turin (2)		Italy	410.4	Munich		Germany
222.6	Milan (2)		Italy	410.4	Seville		Spain
222.6	Dublin		Irish F. State	415.5	Tallinn		Estonia
224	Bordeaux S.O.		France	420.8	Madrid (Espana)		Spain
224	Königsberg		Germany	426.1	Kiev		U.S.S.R.
225.6	Montpellier		France	428.8	Rome		Italy
230.2	Lodz		Poland	431.7	Stockholm		Sweden
230.2	Hanover		Germany	431.7	Paris PTT		France
230.2	Bremen		Germany	437.3	Belgrade		Yugoslavia
230.2	Flensburg		Germany	443.1	Sottens		Switzerland
230.2	Stettin		Germany	449.1	North Regional		Great Britain
230.2	Magdeburg		Germany	455.9	Cologne		Germany
231.8	Danzig		Germany	463	Lyons PTT		France
231.8	Linz (Klazenfurt)		Austria	470.2	Prague (1)		Czechoslovakia
231.8	Dornbirn		Austria	476.9	Lisbon		Portugal
233.5	Aberdeen		Great Britain	483.9	Trondheim		Norway
235.1	Dresden		Germany	492	Brussels (1)		Belgium
235.1	Stavanger		Norway	499.2	Florence		Italy
236.8	Nurnberg		Germany	499.2	Sundsvall		Sweden
238.5	San Sebastian		Spain	506.8	Rabat		Morocco
240.2	Rome (3)		Italy	514.6	Vienna		Austria
242	Juan-les-Pins		France	514.6	Grenoble		France
242	Cork		Irish F. State	522.6	Riga		Latvia
243.7	Gleitwitz		Germany	531	Stuttgart		Germany
245.5	Trieste		Italy	539.6	Athlone		Irish F. State
247.5	Lille PTT		France	549.5	Beromünster		Switzerland
249.2	Prague Stranice (2)		Czechoslovakia	559.7	Budapest		Hungary
251	Frankfurt-am-Main		Germany	559.7	Wilno		Poland
251	Trier		Germany	569.3	Bolzano		Italy
251	Freiburg-im-Breisgau		Germany	569.3	Vuipuri		Finland
251	Cassel		Germany	578	Ljubljana		Yugoslavia
253.2	Kaiserslautern		Germany	578	Innsbruck		Austria
255.1	Kharkov (2)		U.S.S.R.	696	Hamar		Norway
255.1	Copenhagen		Denmark	748	Oulu		Finland
257.1	Monte Ceneri		Switzerland	748	Moscow		U.S.S.R.
259.1	Kosice		Czechoslovakia	765	Geneva		Switzerland
261.1	London National		Great Britain	834	Boden		Sweden
261.1	North National		Great Britain	845	Budapest No. 2		Hungary
261.1	West National		Great Britain	1,107	Finnmark		Norway
263.2	Turin (1)		Italy	1,107	Moscow (2)		U.S.S.R.
265.3	Horby		Sweden	1,154	Oslo		Norway
267.4	Newcastle		Great Britain	1,234	Leningrad		U.S.S.R.
269.5	Nyiregyhaza		Hungary	1,261	Kalundborg		Denmark
270	Fecamp		France	1,304	Luxembourg		Luxembourg
270	Moravska-Ostrava		Czechoslovakia	1,339	Ankara		Turkey
271.7	Madona		Latvia	1,389	Warsaw		Poland
274	Madrid EAJ7		Spain	1,442	Motala		Sweden
276.2	Falun		Sweden	1,500	Minsk		U.S.S.R.
276.2	Zagreb		Yugoslavia	1,571	Droitwich National		Great Britain
278.6	Bordeaux PTT		France	1,600	Deutschlandsender		Germany
280.9	Tiraspol		U.S.S.R.	1,648	Istanbul		Turkey
283.3	Bari		Italy	1,724	Radio Paris		France
285.7	Scottish National		Great Britain	1,807	Moscow No. 1		U.S.S.R.
288.5	Leningrad (2)		U.S.S.R.	1,807	Lahti		Finland
288.5	Rennes PTT		France	1,875	Kootwijk		Holland
291	Heilsberg		Germany	1,935	Huizen		Holland
291	Paredo		Portugal	1,935	Brasov		Roumania
293.5	Cracow		Poland	1,935	Kaunas		Lithuania

Gambling with Television

Continued from page 29

tests all over the country had provided figures to prove exactly the coverage of this station and that good reception could be expected throughout the whole Greater London area. All this work had been done and facts collected at the expense of the company.

To any other than the official mind the unanimous recommendation of this Committee that an experimental service should be started as soon as possible would have suggested taking

**Greatly Enlarged
Exhibition Number of
Wireless Magazine
will be on sale
Monday, August 19
Order Your Copy Early!**

over the already existing, tried and tested station which had been fully demonstrated to the committee. Experience with this could be obtained while the official and permanent station was being erected and there would be no loss of time, just as, at the beginning of broadcasting, the Marconi company's apparatus at Marconi House was used.

Later, it will be remembered, a special station was built on top of Selfridges and still later a move was made to Brookman's Park and the public had a continuous service.

Anticipation!

But no, a special television station is to be built at the Alexandra Palace, the two companies are being asked to submit tenders for entirely new apparatus and very expensive new equipment will have to be erected before even an experimental service can begin—and then what?

Listen to to what the Postmaster General says: "The Television Advisory Committee *anticipate* that this station will enable service to be provided for the Greater London

area, *but the limits of effective service can be determined only when it is in operation.* (The italics are mine.)

In other words, the Committee is gambling with television, wasting time and taking chances. They *hope* but they do not *know* that it will turn out satisfactorily. If it works out wrongly then a whole year will have been lost. And supposing it is O.K.? Don't forget that immediately our Television Report was published other governments sat up and took a great deal of notice. They also started to work hard and by the time this completely new and untried station gets on to the air other countries will be just as advanced as us and probably more so.

Remember it is *your* licence money that is being used to pay for all this. Worst of all, this totally unnecessary delay in providing an experimental service is likely to lose us the national prestige which the Television Committee's Report gave us.

Standard A.C. Short-waver

Continued from page 9

sufficient to get on the operator's nerves.

If the changing of the detector grid leak has no effect, do the same with the first low-frequency stage and give it a leak of .5 megohm. Please don't think I'm anticipating trouble when I make these remarks—I'm only remembering that "Forewarned is Forearmed."

Full details of the wavebands covered by the various B.T.S. coils were given in the original article, and these, of course, remain practically unchanged. It may be possible, next month, to give a few representative dial readings and in any case I want to say a little about the performance of the set during the month. I shall be using it regularly, checking it against my standard-receiver-which-never-alters!

It only remains for me to wish you Good Luck, whether you are tackling a conversion or a new set and to hope that everything turns out as straightforwardly for you as it did for me with the original receiver.

FIT AN EXTRA SPEAKER and double your Radio Enjoyment!

Do you know that **you** can easily fit an extra speaker in another room, to operate from your present set?

W.B. engineers, pioneers of accurate matching to the output stage, are the first to overcome the old difficulty of matching an "extension" speaker to **any** make of commercial receiver. **Whatever** your set, a W.B. moving coil speaker will give you full volume and remarkable reproduction

in any part of your house, leaving the operation of your receiver unaffected. Ask your wireless dealer **to-day!**

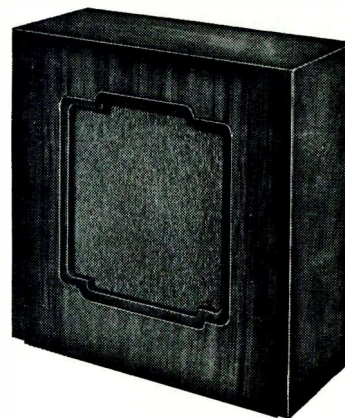

Cabinet models from 29/6.

Ask your dealer to demonstrate.

ANY W.B. MODEL MATCHES ANY COMMERCIAL RECEIVER

Whiteley Electrical Radio Co., Ltd. (Electrical Department), Radio Works, Mansfield, Notts. Sole Agents in Scotland: Radiovision, Ltd., 233 St. Vincent Street, Glasgow, C.2. Sole Agents in I.F.S.: Kelly & Shiel, Ltd., 47 Fleet Street, Dublin.

Conducted by the "W.M." Technical Staff

TESTS OF NEW APPARATUS

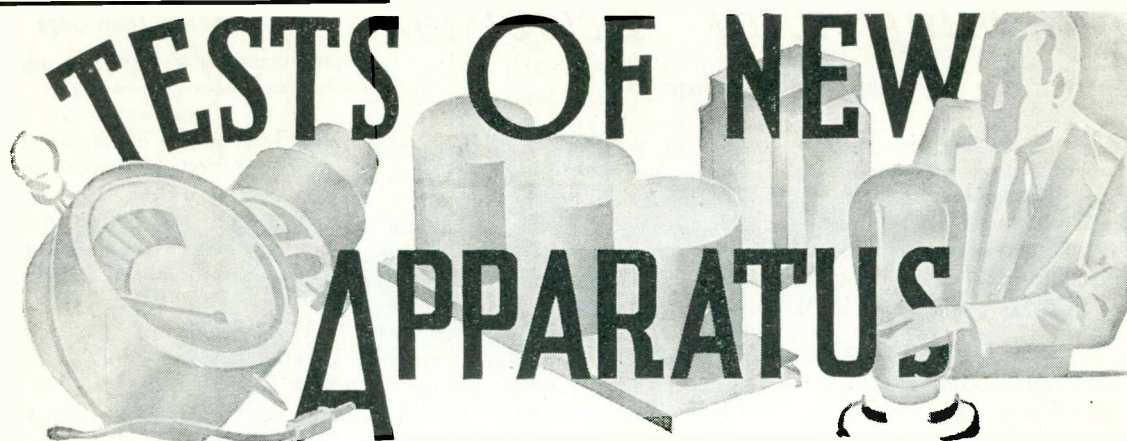

Amplion Dragon Permanent-magnet Moving-coil Loudspeaker :: Mullard Pen4VB Valve :: Rothermel Combined Permanent-magnet Reproducer and "Tweeter."

AMPLION DRAGON LOUD-SPEAKER

Description.

A USEFUL permanent-magnet loudspeaker featured in the Amplion range is the Dragon. This employs a flat section permanent magnet with a cylindrical centre pole-piece assembly. The magnet has bolted to it a pressed steel chassis which supports the diaphragm. The latter is made from the usual type of paper and the suspension is in the form of a back spider. Protection is afforded by a dust bag.

The input transformer is carried on a bracket and connections are made by means of screw-type terminals. These are quite large and are very accessible. Five terminals are provided giving a variety of ratios making the loudspeaker suitable for any input from a super-power triode to a small pentode. In addition, the terminals provide for push-pull working.

Observations

The loudspeaker is very nicely finished and the assembly appears to be exceptionally rigid. The diaphragm is accurately centred and is capable of being displaced through appreciable amplitude, which is necessary for good bass radiation.

Examination by an oscillator showed that the frequency response is very satisfactory. The higher resonance occurs in the region of 3,000 cycles, but is by no means marked. The remainder of the characteristic is very flat and there is good top response well above 5,000 cycles,

after which it tends to fall off, but not too rapidly. The bass resonance is just above 100 cycles and gives no accentuation of mains hum. The lower registers are reasonably well maintained.

A practical test shows that the overall balance is good and there is quite a reasonable amount of crispness and attack. The coloration is slight and the general result is pleasing. The transformer tapings are well chosen and they suit the working conditions of representative valves.

We regard the speaker as a thoroughly good example of a well-made, reasonably-priced permanent magnet type. The loudspeaker is made by Amplion (1932), Ltd., and costs £1 9s. 6d. in chassis form.

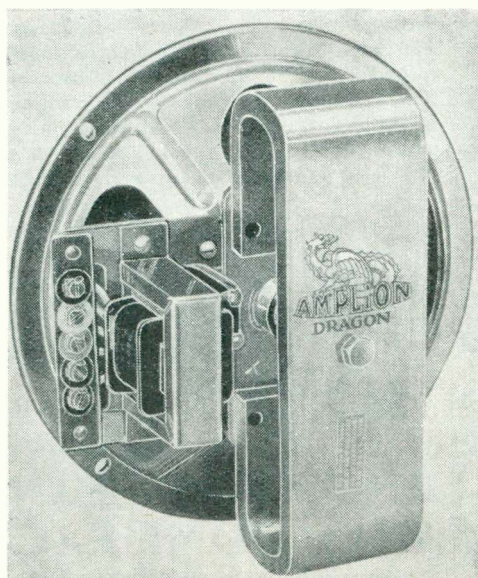

Our tests show that the Amplion Dragon loudspeaker has a very satisfactory frequency response

MULLARD PEN4VB VALVE

Description

A HIGH-slope pentode output valve has been introduced by the Mullard Wireless Service Co. under the title of Pen4VB.

The valve is fitted with a gauze anode, the electrodes being of cylindrical formation. Rigidity is ensured by the use of a mica bridge pushed into a reduced neck at the top of the bulb. All the electrodes are carried on a common foot and connections are brought out to a standard 7-pin base.

Observations

The valve is very rigidly constructed and mechanically appears to be an excellent production. A study of the constants reveals that the overall efficiency of the valve is quite good. It should be particularly suitable for directly following a diode detector valve as it will operate with quite a small grid base.

Under normal harmonic distortion conditions, that is about 5%, the valve will give 2.6 watts with substantially 2.5 volts R.M.S. grid swing. It is actually possible to bring the output up to just over 3.5 watts if a little extra distortion is considered permissible.

Measurements

Nominal heater voltage	4
Heater Current ..	1.95 amperes
Measured heater current ..	2 amperes
Nominal mutual conductance	10 milliamperes per volt
Measured mutual conductance	10 milliamperes per volt

You'll
need
this

Exide

BATTERY

for

**"THE
CARRIER"
SHORT WAVE
RECEIVER**

It is specified by Mr. P. W. Harris

**EXIDE
UNSPILLABLE BATTERY**
TYPE-PO3-2 volts, 16 amp. hrs. 10/6

And for the P.T.P.3 you need this
EXIDE BATTERY TYPE DMG - C
2 volts, 70 amp. hrs. 12/-

Obtainable from Exide Service Stations and all reputable dealers.

Exide Batteries, Exide Works, Clifton Junction, near Manchester. Branches at London, Manchester, Birmingham, Bristol, Glasgow, Dublin and Belfast.

TEST OF NEW APPARATUS
Continued

The valve is marketed by the Mullard Wireless Service, Co., Ltd., of 111 Charing Cross Road, London. W.C.2 and costs 18s. 6d.

**ROTHERMEL COMBINED
LOUDSPEAKER**

Description

A VERY interesting loudspeaker recently released by Rothermel consists of a large moving-coil model combined with a piezo-electric unit.

The construction of the moving-coil unit is fairly conventional.

The cone is substantially 10 in. in diameter. The front of the speaker is provided with a cast grille which is slightly convex and is of decorative swastika formation. There is an adjustment in the centre for controlling the clearance in the piezo-electric unit.

The input to both loudspeakers is by means of a common transformer, the piezo-electric unit being connected in parallel with the primary. The moving-coil loudspeaker has a low-resistance coil.

Observations

Examination of the frequency response shows that it is particularly level over the entire range and it is really very free from marked resonances. In fact, the resonances which we noted were too small to be worthy of mention. There is, of course, a low-note resonance, but there is no resonance in the region of 100 cycles.

The top response is amazingly good, the speaker reproducing very strongly well above 12,000 cycles.

Tests were carried out on a good quality amplifier and it was found that the reproduction was exceptionally pleasing. The attack is excellent and the general nature of the reproduction is very crisp and clean. This, in conjunction with the large diaphragm gives an excellent balance over the entire range, and the loudspeaker does not appear to introduce any marked coloration.

The loudspeaker is made by A. C. Rothermel, Ltd., and costs £5 5s.

BRITISH VALVES

The British valve with the longest guarantee

362

If your set uses valves then you should use 362.

and the finest performance of any. Write for latest list—
362 RADIO VALVE CO., LTD.,
STONEHAM ROAD, CLAPTON, LONDON, E.S.
(Telephone: Clissold 1294)

**last word
in condensers..**

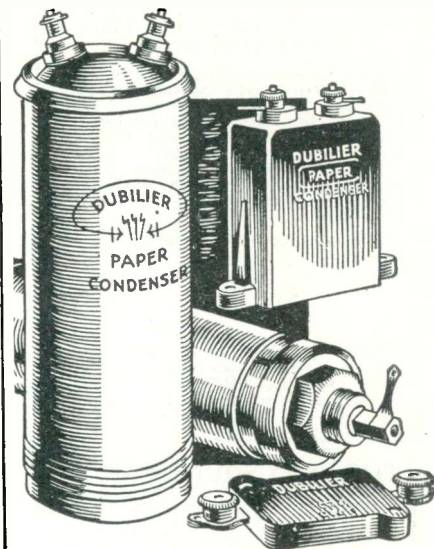

**.. your
first choice**

Dubilier Condensers are repeatedly specified by Set designers and constantly used by manufacturers and constructors alike. They have an unrivalled reputation for dependability, are soundly constructed, and suitable types can be obtained for your every requirement. The use of a Dubilier Condenser is an assurance of good performance, lasting value and trouble-free reception.

DUBILIER
CONDENSER CO (1925) LTD

Ducon Works, Victoria Road
N. Acton - - London, W.3

In Tune with the Trade

EXAMINER'S Review of the Latest Catalogues

SEND TO US FOR THESE CATALOGUES!

Here we review the newest booklets and folders issued by four manufacturers. If you want copies of any or all of them, just cut out this coupon and send it to us. We will see that you get all the literature you desire.

Please indicate the numbers (seen at the end of each paragraph) of the catalogues you want below:—

My name and address are :—

Send this coupon in an unsealed envelope, bearing 1d. stamp, to "Catalogue Service," WIRELESS MAGAZINE, 8-11 Southampton St., W.C.2. Valid till August 31.

"THE VERY SOUL OF MUSIC"

I HAD a most interesting conversation on the phone recently with Mr. Cyril French, who handles the sale to the public of Celestion loudspeakers. He had some rather startling news to impart about the recent developments that he hoped to show me in the course of the next week or two. He has a new idea for extension loudspeakers, but I found my interest to be centred on his model TK3 high-note speaker.

This speaker has a frequency range of from 1,500 to over 10,000 cycles and is designed for use in conjunction with an ordinary loudspeaker; the two together produce an effect of reality that only those who have heard it can appreciate.

If you are seriously interested in spending a pound or two in gingering up the quality of your reproduction ask for this booklet. **472**

FLEX-LEAD SUPPRESSOR

ANOTHER suppressor device from the enterprising Belling-Lee concern is a portable one, known as the Flex-lead

Suppressor. This latest interference device has been introduced for use in conjunction with portable electric appliances—such as vacuum cleaners, hair dryers, fans, electric egg-beaters and so on—having no earth connection to their frames or cases.

This new unit, No. L1174 as it is called, should be fitted in the leads of such appliances one foot away from the source of the noise. It is worth while pointing out that this suppressor is very effective in cutting out noise from *unearthed* appliances: the makers state that the efficiency is *not* so great if used with devices in which the frame is directly earthed.

Fans with wives who must have everything all-electric have the remedy in their own hands now! **473**

BENJAMIN PRODUCTS

IT is many moons since reference to Benjamin products was made in these columns. I have built a good many wireless sets in my time and I can remember very clearly that in my first set I used what are now known as the Clearertone valve holders; in fact I have stuck to this make for years and have always found them extremely reliable.

You know the type; the entire valve platform is sprung on one-piece contact springs with which is combined the soldering tags. Terminals are provided on the top for those who prefer that method of connection.

Benjamin's complete range of components is listed in a leaflet which I recently had from them; there is the famous range of Magnavox loudspeakers, the resistance-fed transformer known as the Transfeeda, besides other things, switches, chokes, etc., of interest to enthusiasts. This leaflet is worth getting! **474**

Next Month

The special Exhibition Number of "W.M." will contain detailed information of all that is new in radio. Every new development to be seen at Olympia will be described in our pages.

It will be a big bumper number with first details of a remarkable new circuit and articles by leading radio authorities including Dr. N. W. McLachlan, D.Sc., Paul Tyers, P. Wilson, M.A., G. P. Kendall, B.Sc., G. Howard Barry, J. H. Reyner, B.Sc., A.M.I.E.E., and Percy W. Harris, M.I.R.E.

**Greatly Enlarged
and on Sale
Monday August 19**

FERRANTI—MASTERS OF POWER

A NICE title this for Ferranti's first brochure of the 1935-6 range of receivers and radiograms! It is well printed in two colours—all very nice, but the real value is in what is listed. This consists of a collection of seven receivers with "hefty" specifications and in cabinets that really look as if some time and money had been spent on their design.

I still have recollections of hearing the Ferranti Gloria in the Set Selection Bureau's lab, and if these new sets are like that Gloria in performance I can see a mighty successful season for Ferranti sets.

Meanwhile ask for this catalogue—and when you get it look at the specification of the Gloria Radiogram! **475**

HYVOLTSTAR EQUIPMENT

Receivers:

- "Hyvoltstar 5" } All-wave
- "Hyvoltstar 7" } Superheterodynes
- "Luxury 4" } Broadcast straight circuit.

Available in many forms of Cabinets from Table models to Console Radiograms.

Write for all particulars to

Operates from A.C. or D.C. off any voltage from 100-250, private plant or mains supply. **30 per cent saving in current and 20 per cent in weight.**

Highest standard of workmanship inside and out.

Outstanding performance on all wavebands, including 13-50 metres.

Amplifiers:

10-12-watt, A.C./D.C., 3-stage, Push-Pull as described in current issue of "W.M."

6 watts, A.C./D.C., 2-stage, Push-Pull.

3 watts, A.C./D.C., 2-stage.

Compact, light in weight, operate anywhere without alteration.

THE UNIVERSAL HIGH VOLTAGE RADIO CO., LTD., 28/29, Southampton St., W.C.2

Notes and News from All Parts

JUST before closing for press comes news of extension loudspeakers from Philips Industrial of 145 Charing Cross Road, London, W.C.2. At present two models are listed. One costs 42s. and has four tapings which the makers claim make the speaker suitable for use with most commercial receivers. It is a permanent-magnet model in a walnut cabinet. A slightly improved model costs £2 5s.

We express our regret to R.A.P. (Radio Acoustic Productions), Ltd., for the printer's error which occurred on page 465 of our last issue in which a block of this firm's Oriental Radiogram was inserted upside down.

Mullards have just announced three new receivers, details and photographs of which will appear in our Exhibition number. Two are battery receivers—one a three-valve and the other a four—while the third set is a five-valve (excluding rectifier) A.C./D.C. superhet. The well-known Mullard MB3—the all-pentode battery receiver—is being continued in its present form.

The Stand Number of "W.M." at Olympia is No. 9.

Readers should note that the Sifam Electrical Instrument Co., Ltd., has moved to new premises at Hollydale Road, Queen's Road, London, S.E.15. By the way, this firm is busy developing amplifying equipment for P.A. work and will welcome inquiries.

Just how quickly broadcasting is developing is shown in news received from Marconi's Wireless Telegraph Co. This firm has no fewer than ten new medium- and long-wave transmitters destined for all parts of the world going through its shops and test rooms.

The largest of these, which is rapidly nearing completion, is a 220-kilowatt for Finland—it will be installed at Lahti and will work on the long waves.

APPEARANCE

"Clix" Chassis-Mounting Valveholders did more than anything else to develop the accepted modern chassis constructional methods.

"Heath Robinson" layouts are now things of the past. Neatness of appearance,

strength of construction, compactness of design, perfection of contact—all these features have resulted in the unassailable popularity of "Clix" Valveholders with both set manufacturers and amateurs alike.

CLIX

Specified for the "A.C." Standard Four-Valve Short Waver.

Ask your Dealer for "CLIX." Descriptive Folder "W.M." of the full range of Clix perfect contact components, free on request.

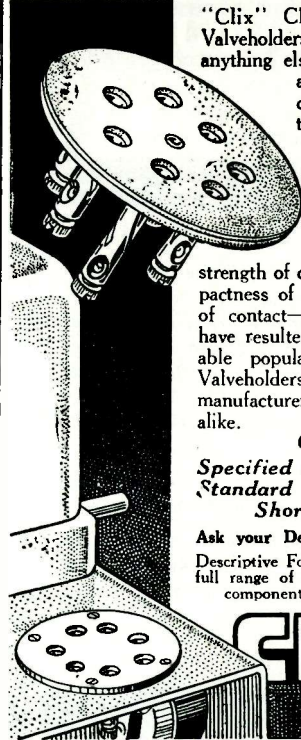

CLIX

LECTRO LINX, LTD.
79a, ROCHESTER ROW, LONDON, S.W.1



There was a young fellow named Wright
At Wireless—brighter than bright—
He got perfect reception
His set WAS perfection—
All connections were SOLDERED—with FLUXITE!

See that FLUXITE is always by you—in the house—garage—workshop—wherever speedy soldering is needed. Used for 30 years in government works and by leading engineers and manufacturers. Of Ironmongers—in tins, 4d., 8d., 1/4 and 2/8.

Ask to see the FLUXITE SMALL-SPACE SOLDERING SET—compact but substantial—complete with full instructions, 7/6.

Write for Free Book on the art of "Soft" Soldering, and ask for Leaflet on CASE HARDENING STEEL and TEMPERING TOOLS with FLUXITE.

TO CYCLISTS! Your wheels will NOT keep round and true unless the spokes are tied with fine wire at the crossings AND SOLDERED. This makes a much stronger wheel. It's simple—with FLUXITE—but IMPORTANT.

THE FLUXITE GUN is always ready to put Fluxite on the soldering job instantly. A little pressure places the right quantity on the right spot and one charging lasts for ages. Price 1/6.



ALL MECHANICS WILL HAVE

FLUXITE

IT SIMPLIFIES ALL SOLDERING

Flu. Co. Ltd., Dept. 332, Dragon Works, Burnhamsey St., S.E.1

CONSISTENTLY SPECIFIED

B.T.S. 4-PIN PLUG-IN SHORT WAVE COILS

Always preferred by the experts, once again these famous coils are exclusively specified for the

A.C. STANDARD Short Waver



Wound on formers constructed from the new B.T.S. low-loss high power factor insulating material Megacite, specially designed for short-wave efficiency, no other coils will ensure the complete success of your version of this Receiver.

SET OF FOUR, 13-190 metres.

16/-

FROM ALL DEALERS

If any difficulty, send direct. Ask for B.T.S. Short Wave and Television Lists.

Short Wave and Television Specialists

B.T.S.



BRITISH TELEVISION SUPPLIES, LTD., BUSH HOUSE, Dept. "W.M.", LONDON, W.C.2.

SPECIFIED for the A.C. Standard 4-valve Short-wave Receiver in this issue

Lasting Efficiency with the

ERIE VOLUME CONTROL

Again this better Volume Control is specified. It is the variable resistance that will never develop faults. Permanently noiseless. The Erie resistance element—plus precision construction—gives smooth and positive contact, without hop-off noises, for a life-time's use. All sizes 50,000 ohms to 2 m ohms.

Price 3/6

Or with built-in Mains Switch 5/-



ERIE RESISTORS

Specified All designers specify Eries; every manufacturer uses them. Their quality and stability are unequalled. All values, 1/- per watt

Free—To get best results, send for the Erie Service Instruction Booklet. Post Free. The Radio Resistor Co., Ltd. 1, Golden Sq., London, W.1

BLUEPRINT COUPON

Valid only until August 31,
1935 (or until Sept. 30,
1935, for overseas readers)

FOR ONE BLUEPRINT ONLY

If you want a full-size blueprint of the set constructionally described in this issue for half price, cut out the above coupon and send it, together with a postal order, to Blueprint Department, WIRELESS MAGAZINE, 8-11 Southampton Street, Strand, London, W.C.2.

This coupon is valid for one blueprint only at the price indicated:—

THE A.C. STANDARD FOUR-VALVE SHORT-WAVER (page 4), No. WM 391, price 9d., post paid.

INFORMATION COUPON

Valid only until August 31,
1935 (or until Sept. 31,
1935, for overseas readers)

If you want to ask any questions, cut out the above coupon and send it, together with a postal order for 1s. and stamped, addressed envelope, to the Information Bureau, WIRELESS MAGAZINE, 8-11 Southampton Street, Strand, London, W.C.2.

Note that not more than two questions may be asked at a time and that queries should be written on one side of the paper only.

Under no circumstances can questions be answered personally or by telephone. All inquiries must be made by letter so that every reader gets exactly the same treatment.

Alterations to blueprints or special designs cannot be undertaken: nor can readers' sets or components be tested.

If you want advice on buying a set, a stamped, addressed envelope only (without coupon or fee) should be sent to the Set Selection Bureau, WIRELESS MAGAZINE, 8-11 Southampton Street, Strand, London, W.C.2

Coils for the Carrier Short-waver

Continued from page 59

ment, but this is not always the case. The use of a screened-grid valve as a "separator" gets rid of nearly all of the aerial troubles of the average short-wave set, and you will find this receiver will work quite satisfactorily on any normal broadcast aerial.

"The Carrier" had prolonged tests before it was described last month, and its continued use since has confirmed the good impression I have formed in the first tests. Indeed, I have been in the habit of leaving it tuned to the Schenectady transmission (W2XAF on 31.48 metres) so that before going to bed in the evening (more truly the morning!) I can sit down to half an hour of American listening. With scarcely an exception the station is there immediately the 'phones are put on and the set switched on.

On the evening the *Normandie* arrived in New York on its first record-breaking crossing I came home about 7.20, went up to my laboratory, put on the 'phones and switched on to see what was doing on the short waves. Within a couple of moments I had picked up an American transmission giving an eye-witness account of the docking of the *Normandie* in New York.

Every word came through perfectly, and as a matter of fact the B.B.C. took a record of this transmission and re-broadcast it later on in the evening. This broad daylight reception from stations on the other side of the Atlantic is one of the most fascinating sidelines of short-wave reception, but I trust by now you have found this out for yourself with the Carrier—by far the best short-wave set I have ever built.

STOP PRESS!

The judges of the "Name the Receiver" competition have chosen the name

"LIGHTTIME RECEIVER"

We offer our congratulations to the successful entrant who is Mr. R. Hughes of 6 Olive Crescent, Tranmere, Birkenhead.

A LAST WORD!

Order Your
Exhibition Number
of "W.M."—NOW!

INDEX TO ADVERTISERS

	Page
"Air Stories"	Cover ii
British Insulated Cables	iv
British Television Supplies, Ltd.	79
Chloride Electrical Storage Co., Ltd.	77
Dubilier Condenser Co., Ltd.	77
Ferranti, Ltd.	67
Fluxite, Ltd.	79
Garrard Eng. & Mfg. Co., Ltd.	1
H.M.V.	2
Lectro Linx, Ltd.	79
Newnes' Home Mechanic Books	73
Partridge & Mee, Ltd.	71
Radio Resistor Co., Ltd., The	79
Rothermel, R. A., Ltd.	67
Stratton & Co.	71
Telephone Manufacturing Co., Ltd.	Cover iv
Tungsram Valves	67
Universal High Voltage Radio Co., Ltd., The	78
Varley (Oliver Pell Control Ltd.)	67
Whiteley Electrical Radio Co.	75
362 Radio Valve Co., Ltd., The	77

"Wireless Magazine" Blueprint Service

These blueprints are full-size. Copies of appropriate issues of "Practical Wireless," "Amateur Wireless," and of "Wireless Magazine" containing descriptions of most of these sets can be obtained at 4d. and 1s. 3d. each, respectively, post paid. Index letters "P.W." refer to "Practical Wireless" sets, "A.W." refer to "Amateur Wireless" sets, and "W.M." to "Wireless Magazine" sets. Send, preferably, a postal order (STAMPS OVER SIXPENCE UNACCEPTABLE) to "Wireless Magazine" Blueprint Dept., Geo. Newnes, Ltd., 8-11 Southampton Street, Strand, W.C.2.

CRYSTAL SETS

Blueprints, 6d. each.
Four-station Crystal Set ... 31.3.34 AW427

STRAIGHT SETS (Battery Operated)

Two-valvers: Blueprints, 1s. each.
Iron-core Two (D, QPP) ... 12.8.33 AW396

Three-valvers: Blueprints, 1s. each.
Transportable Three (SG, D, Pen) ... Feb. '32 WM271

Multi-mag Three (D, 2 Trans) ... June '32 WM288
Fercy Harris Radiogram (HF, D, Trans) ... Aug. '32 WM294

£6 6s. Radiogram (D, RC, Trans) ... Apr. '33 WM318
Simple-tune Three (SG, D, Pen) ... June '33 WM327

Tyers Iron-core Three (SG, D, Pen) ... July '33 WM330
Economy-pentode Three (SG, D, Pen) ... Oct. '33 WM337

All-wave Three (D, 2LF) ... Jan. '34 WM348
"W.M." 1934 Standard Three (SG, D, Pen) ... Feb. '34 WM351

£3 3s. Three (SG, D, Trans) ... Mar. '34 WM354
Iron-core Band-pass Three (SG, D, QP21) ... June '34 WM362

1535 £6 6s. Battery Three (SG, D, Pen) ... Oct. '34 WM371
Graduating to a Low-frequency Stage (D, 2LF) ... Jan. '35 WM378

P.T.P. Three (Pen, D, Pen) ... June '35 WM389
Carrier Short-wave (SG, D, Trans) ... July '35 WM390

Class-B Three (D, Trans, Class B) ... 22.4.33 AW386
New Britain's Favourite Three (D, Trans, Class B) ... 15.7.33 AW394

Home-built Coil Three (SG, D, Trans) ... 14.10.33 AW404
Fan and Family Three (D, Trans, Class B) ... 25.11.33 AW410

£5 5s. S.G.3 (SG, D, Trans) ... 2.12.33 AW412
1934 Ether Searcher: Baseboard Model (SG, D, Pen) ... 20.1.34 AW417

1934 Ether Searcher: Chassis Model (SG, D, Pen) ... 3.2.34 AW419
P.W.H. Mascot with Lucerne Coils (Det, R.C., Trans) ... 17.3.34 AW337A

Fentaquester (HF, Pen, D, Pen) ... 14.4.34 AW431
£5 5s. Three: De-luxe Version (SG, D, Trans) ... 19.5.34 AW435

Lucerne Straight Three (D, RC, Trans) ... 9.6.34 AW437
"Wireless League" Three (HF Pen, D, Pen) ... 3.11.34 AW451

Four-valvers: Blueprints, 1s. 6d. each.
Quadradyne (2 SG, D, Pen) ... Feb. '32 WM273

Calibrator (SG, D, RC, Trans) ... Oct. '32 WM300
Table Quad (SG, D, RC, Trans) ... Nov. '32 WM303

Calibrator de Luxe (SG, D, RC, Trans) ... Apr. '33 WM316
Self-contained Four (SG, D, LF, Class-B) ... Aug. '33 WM331

Lucerne Straight Four (SG, D, LF, Trans) ... Feb. '34 WM350
£5 5s. Battery Four (HF, D, 2LF) ... Feb. '35 WM381

The "HK" Four (2HF, D, LF) ... Mar. '35 WM384
"A.W." Ideal Four (2 SG, D, Pen) ... 16.9.33 AW402

Crusaders' A.V.C. 4 (2 HF, D, QP21) ... 18.8.34 AW445
(Pentode and Class-B outputs for above; blueprints 6d. each) ... 25.8.34 AW445A

Five-valvers: Blueprints, 1s. 6d. each.
Super-quality Five (2 HF, D, RC, Trans) ... May '33 WM320

New Class-B Five (SG, D, LF, Class B) ... Nov. '33 WM340
Class-B Quadradyne (2 SG, D, LF, Class B) ... Dec. '33 WM344

1935 Super Five (Battery Super-het) ... Jan. '35 WM379

Mains Operated

Two-valvers: Blueprints, 1s. each.
Economy A.C. Two (D, Trans) A.C. ... June '32 WM286

Consolectric Two (D, Pen) A.C. ... 23.9.33 AW403

SPECIAL HALF-PRICE OFFER
Blueprint of the following "Wireless Magazine" set described in this issue is obtainable at the special price, given below, if the coupon on facing page is used before Aug. 31.

The Standard A.C. Four-valve Short-wave WM391 ... 9d.

Three-valvers: Blueprints, 1s. each.
D.C. Calibrator (SG, D, Push-pull Pen) D.C. ... July '33 WM328

Simplicity A.C. Radiogram (SG, D, Pen) A.C. ... Oct. '33 WM338
Six-guinea AC/DC Three (HF Pen, D, Trans) A.C./D.C. ... July '34 WM364

Mantovani A.C. Three (HF Pen, D, Pen) A.C. ... Nov. '34 WM374
Home-lovers' New All-electric Three (SG, D, Trans) A.C. ... 25.3.33 AW383

S.G. Three (SG, D, Pen) A.C. ... 3.6.33 AW390
A.C. Triodyne (SG, D, Pen) A.C. ... 19.8.33 AW399

A.C. Pentaquester (HF Pen, D, Pen) A.C. ... 26.6.34 AW437
Four-valvers: Blueprints, 1s. 6d. each.

A.C. Quadradyne (2 SG, D, Trans) A.C. ... Apr. '32 WM279
All Metal Four (2 SG, D, Pen) A.C. ... July '33 WM329

"W.M." A.C./D.C. Super Four My 1935 Radiogram (SG., D., 2 L.F.) ... May '35 WM386
AC/DC Straight A.V.C. 4 (2 HF, D, Pen) A.C./D.C. ... 8.9.34 AW446

SUPER-HETS

Battery Sets: Blueprints, 1s. 6d. each.
Super Senior ... Oct. '31 WM256

1932 Super 60 ... Jan. '32 WM269
Q.P.P. Super 60 ... Apr. '33 WM319

"W.M." Stenode ... Oct. '34 WM373
Modern Super Senior ... Nov. '34 WM375

1934 Century Super ... 9.12.33 AW413
Mains Sets: Blueprints, 1s. 6d. each.

1932 A.C. Super 60, A.C. ... Feb. '32 WM272
Seventy-seven Super, A.C. ... Dec. '32 WM305

"W.M." D.C. Super, D.C. ... May, '33 WM321
Merrymaker Super, A.C. ... Dec. '33 WM345

Heptode Super Three, A.C. ... May '34 WM359
"W.M." Radiogram Super, A.C. ... July '34 WM366

"W.M." Stenode, A.C. ... Sep. '34 WM370
1935 A.C. Stenode (A.C. Super-het) ... Apl. '35 WM385

1934 A.C. Century Super, A.C. ... 10.3.34 AW425

SHORT-WAVERS (Battery Operated)

One-valvers: Blueprints, 1s. each.
New Style Short-wave Adapter ... June '35 WM388

Roma Short-wave ... 10.11.34 AW452
Two-valvers: Blueprints, 1s. each.

Home-made Coil Two (D, Pen) ... 14.7.34 AW440
Three-valvers: Blueprints, 1s. each.

Experimenter's 5-metre Set (D, Trans. Super-regea) ... 30.6.34 AW438
Experimenter's Short-wave ... 19.1.35 AW463

Four-valvers: Blueprints, 1s. 6d. each.
"A.W." Short-wave World Beater (HF Pen, D, RC, Trans) ... 2.6.34 AW436

Standard Four-valve Short-wave (SG, D, 2LF) ... Mar. '35 WM383

Mains Operated

Two-valvers: Blueprints, 1s. each.
Two-valve Mains Short-wave (D, Pen) A.C. ... 10.10.34 AW453

"W.M." Band-spread Short-wave (D, Pen) A.C./D.C. ... Aug. '34 WM369
Three-valvers: Blueprints, 1s. each.

Emigrator (SG, D, Pen), A.C. ... Feb. '34 WM352
Four-valvers: Blueprints, 1s. 6d. each.

Gold Coaster (SG, D, RC, Trans), A.C. ... Aug. '32 WM292
Trickle Charger ... 5.1.35 AW462

Amplifiers: Blueprints, 1s. 6d. each.
Enthusiast's Power Amplifier ... May & June '35 WM387

"PRACTICAL WIRELESS"

F.J.C. 3-valve A.V.C. (Transfer Print) ... 4.11.33 PW32

Luxus A.C. Superhet ... 14.10.33 PW33
A.C. Quadpak ... 2.12.33 PW34

Sixty-shilling Three ... 2.12.33 PW34A
Nucleon Class-B Four ... 6.1.34 PW34B

Fury Four Super ... 27.1.34 PW34C
A.C. Fury Four Super ... 10.2.34 PW34D

Leader Three ... 10.3.34 PW35
D.C. Premier ... 31.3.34 PW35B

A.C. Leader ... 7.4.34 PW35C
Atom Lightweight Portable ... 2.6.34 PW36

Ubique ... 28.7.34 PW36A
Four-range Super-mag. Two ... 11.8.34 PW36B

Summit Three ... 18.8.34 PW37
Armada Mains Three ... 18.8.34 PW38

Midget Short-wave Two ... 15.9.34 PW38A
All-pentode Three ... 22.9.34 PW39

£5 Superhet Three ... 27.10.34 PW40
A.C. £5 Superhet Three ... 24.11.34 PW43

D.C. £5 Superhet Three ... 1.12.34 PW42
Hall-mark Three ... 8.12.34 PW41

Universal £5 Superhet ... 15.12.34 PW44
A.C. Hall-mark ... 26.1.35 PW45

Battery Hall-mark 4 ... 2.2.35 PW46
Universal Hall Mark ... 9.2.35 PW47

Hall-mark Cadet ... 23.3.35 PW48
Short-wave Converter-Adapter ... 23.2.35 PW48A

F. J. Camm's Silver Souvenir (All-Wave Three) ... 13.4.35 PW49
F. J. Camm's A.C. All-Wave Silver Souvenir Three ... PW50

"Wireless Magazine" Blueprint Service George Newnes, Ltd., 8-11 Southampton Street, Strand, W.C.2

UNIFORMITY

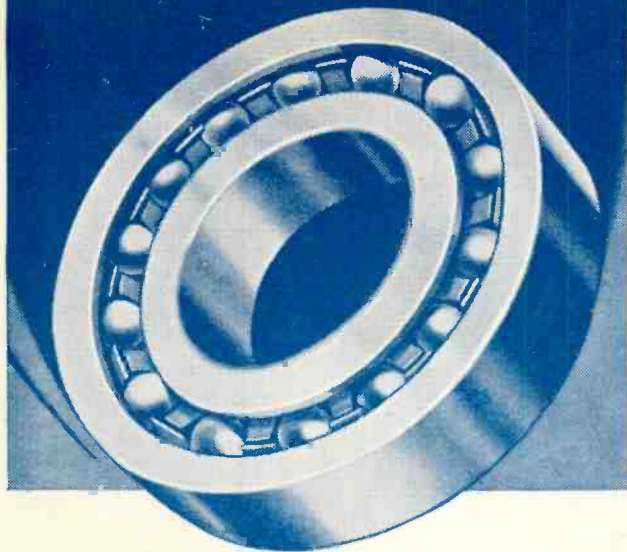

There's no room for individuality inside a ball-bearing. Every ball in it must be the same shape, the same size, the same material, the same weight—in a word, UNIFORM. So with T.M.C.-HYDRA condensers. Here, too, individuality is barred. Every T.M.C.-HYDRA condenser of the same rating is the same—exactly! Stringent testing ensures it. Take advantage of this greater precision when next you buy condensers.

T.M.C. BRITISH MADE HYDRA CONDENSERS

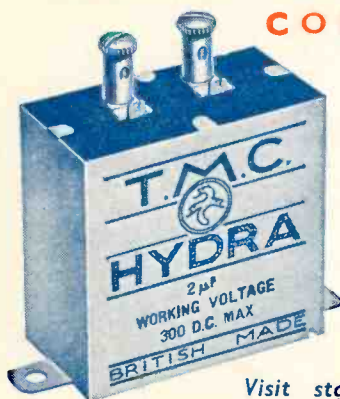

The special method of sealing T.M.C.-HYDRA condensers definitely prevents the penetration of moisture and so maintains their high electrical properties.

Visit stand 29 RADIOLYMPIA

T.M.C.-HARWELL (SALES) LTD
Britannia House, 233 Shaftesbury Avenue
London, W.C.2. (A few doors from New Oxford Street)

Telephone: Temple Bar 0055 (3 lines)

Made by TELEPHONE MANUFACTURING Co. Ltd.



B.I.

RESINKOR SOLDER AND CORALINE PASTE

are two aids to efficient soldering. B.I. "Resinkor" Solder is a solder with just the right quantity of resin embedded in it. It is invaluable for the soldering of electrical connections, particularly on fine work. "Resinkor" can be supplied in coils, on reels, or in cut lengths as required, in all diameters down to 20 s.w.g. B.I. Coraline Soldering Paste is suitable for copper, brass, tin, iron and lead and for electrical connections except the jointing of paper insulated cables. It is quite easy to apply, even in the most awkward corners, and once having been applied it does not run off the work, nor does it dry. It gives off no spray and is very economical.

Supplied in 1-oz., 2-oz., ¼-lb., ½-lb., 1-lb. and 7-lb. tins.



BRITISH INSULATED CABLES LTD. PRESCOT - LANCASHIRE

Telephone No. PRESCOT 6571

London Office:

Tel. Nos.:

Surrey House, Embankment, W.C.2. Temple Bar 4793-4-5-6