

HOW TO SEARCH ON THE SHORT WAVES

# Wireless Magazine

JULY

AND MODERN TELEVISION

Edited by PERCY W. HARRIS M.I.R.E.

GEORGE  
NEWNES  
LTD. LONDON

New Light on the  
Loudspeaker—

by Dr. N. W. McLachlan,  
D.Sc., M.I.E.E.

Oscillator for the  
Service Man

Making Superhets  
Behave!

A New Short-wave  
Valve Described

A Lazy Man's  
Radiogram Unit

What Set Do  
You Want?

An Opportunity for  
Every Reader



Short Waves  
for this  
Summer

SPECIAL  
ARTICLES  
AND  
A NEW  
SHORT-WAVE  
RECEIVER



POWER AMPLIFIERS FOR ALL OCCASIONS

# How the AUTOMATIC TELEPHONE Works



A FEW turns of the dial . . . a series of quiet clicks . . . and you are through! A wonder of modern science and ingenuity—the Automatic Telephone! PRACTICAL MECHANICS this month takes you behind the scenes and explains with photographs and intriguing diagrams the secret of “how it all works.”

## Other Special Contributions in the JUNE PRACTICAL MECHANICS

Building a 15 c.c. Petrol Engine for Model Aeroplanes. Building the “Genet” Midget Portable Three. Installing Domestic Electrical Appliances. Miniature Electric Motors. Model Electric Railways. Masters of Mechanics. How Water Mills Work. Television Made Easy.

Latest Tools, Novelties, Patent Advice, Etc. Small Charging Station for Accumulators. A Scale Model Sopwith Camel Aeroplane. Lathework for Amateurs. Wonders of Navigation. Why Petrol is Supreme. Model Aero Topics. A B C of Photography.

PRACTICAL MECHANICS is the only magazine dealing with modern subjects in everyday language. It is the magazine for those who wish to keep up-to-date with all that is happening in these days of super-science and invention

# PRACTICAL MECHANICS



JUNE  
NUMBER  
OUT  
NOW

# Wireless Magazine

Technical Editor :

AND MODERN TELEVISION

Assistant Editor :

G. P. KENDALL, B.Sc. Vol. XXI : JULY, 1935 : No. 126

T. F. HENN.

Edited by Percy W. Harris, M.I.R.E.

## FOR THE CONSTRUCTOR

THE CARRIER SHORT-WAVER. Designed by Percy W. Harris, M.I.R.E. . . . .	408
THE "W.M." AUDIO OSCILLATOR. Designed by Paul D. Tyers . . . . .	419
COILS FOR THE NEW-STYLE SHORT-WAVE UNIT . . . . .	423
GETTING THE BEST FROM THE P.T.P. THREE. By G. P. Kendall, B.Sc. . . . .	430
A LAZY MAN'S RADIOGRAM UNIT. By G. P. Kendall, B.Sc. . . . .	458

## TECHNICAL ARTICLES

WHERE THE LOUDSPEAKER FAILS! By Dr. N. W. McLachlan, D.Sc., M.I.E.E. . . . .	405
WORLD-FAMOUS AUTHORITY TO WRITE FOR "W.M." . . . . .	406
A TRIODE-HEXODE FOR THE ULTRA-SHORT WAVES . . . . .	415
HINTS FOR THE SERVICE ENGINEER. Conducted by G. P. Kendall, B.Sc. . . . .	417
THE VALVE FAMILY. By Morton Barr . . . . .	433
MAKING THE SUPERHET BEHAVE! By J. H. Reyner, B.Sc., A.M.I.E.E. . . . .	437
SIMPLE FACTS ABOUT LOUDSPEAKERS. By Percy W. Harris, M.I.R.E. . . . .	442

## Contents

THE "SINGLE-SIGNAL" SUPER. By G. Howard Barry . . . . .	446
QUERIES OF INTEREST . . . . .	452
POWER AMPLIFIERS FOR ALL OCCASIONS. By the "W.M." Technical Staff . . . . .	460
TESTS OF THE NEW SETS:	
K.B. CAVALCADE, MODEL 442 . . . . .	464
R.A.P. ALL-WAVE TRANSATLANTIC . . . . .	465
MARCONIPHONE 292 DE-LUXE RADIOGRAM . . . . .	466
PARMEKO No. 2 POWER AMPLIFIER . . . . .	467
TESTS OF NEW APPARATUS . . . . .	476

## GENERAL ARTICLES

LISTEN ON THE SHORT WAVES. The Editor's Page . . . . .	403
STANDARD FOUR-VALVE SHORT-WAVER.—Readers Report . . . . .	413
GOOD LOGS ON THE SHORT WAVES. By G. Howard Barry . . . . .	414
MOST INTERESTING! . . . . .	425
NEW STATIONS FOR EMPIRE BROADCASTING. By T. F. Henn . . . . .	426

NEWS FROM THE RADIO SOCIETIES. By G.G.O.B. . . . .	428
"W.M." SHORT-WAVE IDENTIFICATION PANELS. Compiled by Jay Coote . . . . .	429
WHAT KIND OF SET DO YOU WANT? . . . . .	435
RADIO NEWS FROM ABROAD. By Jay Coote . . . . .	436
HOW TO SEARCH ON THE SHORT WAVES. By J. Godchaux Abrahams . . . . .	440
BETWEEN OURSELVES. By Broadcatcher . . . . .	449
WAVELENGTHS OF THE WORLD'S BROADCASTERS . . . . .	468
IN TUNE WITH THE TRADE. By Examiner . . . . .	474
NOTES AND JOTTINGS . . . . .	475
NEW SETS . . . . .	480
COUPONS: INDEX TO ADVERTISERS . . . . .	480

## TELEVISION SECTION

TELEVISION NOTES AND NEWS. By Paul Woodward . . . . .	424
---	-----

## GRAMO-RADIO FEATURES

RECENT DEVELOPMENTS IN GRAMOPHONE RECORDING. By Donald W. Aldous, A.R.B.I. . . . .	453
"W.M." RECORD GUIDE. Compiled by Donald W. Aldous, A.R.B.I. . . . .	456
NEW RECORDS FOR YOUR RADIOGRAM . . . . .	472

Subscription Rates: Inland and Abroad, 15s. 6d. per annum; Canada, 13s. 6d. per annum.

Editorial and Advertisement Offices—"Wireless Magazine," George Newnes, Ltd., Southampton Street, Strand, London, W.C.2. Registered at the G.P.O. for transmission by Canadian Magazine Post.

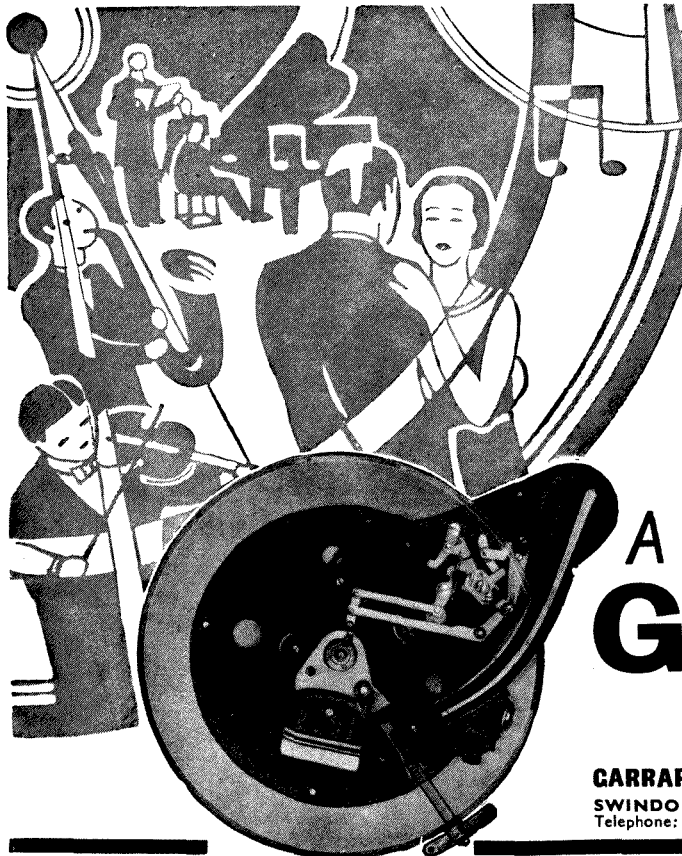

# Tonal Balance!

Whatever your taste in music, from the balanced rhythm of a dance band to the sublimity of a classical symphony, the Garrard Radio-Gram ensures faultless reproduction. The new Type B is especially designed for the owner of the small set, fits into a space 14½ in. by 13¼ in., and incorporates the proved Garrard Motor.

### PRICES:

Type B Radio-Gram Unit—			
With A.C.4 Induction Motor . . . . .	62/6		
With 202A Induction Motor . . . . .	69/-		
With U.5 Universal Motor . . . . .	87/-		

**A**  
**GARRARD**  
Quality Product

**GARRARD ENGINEERING & MANUFACTURING CO., LTD.**  
SWINDON, WILTS. 17 GRAFTON ST., W.1  
Telephone: Swindon 534 & 535 (2 lines). Telephone: Regent 7596.

# A WONDERFUL OPPORTUNITY for the TELEVISION Enthusiast

IN a few months' time high definition Television broadcasts will be available to the public. It is quite certain that there will then be a great demand in the wireless industry for people who have a reliable knowledge of the subject. And the man who can place on the market accessories which have special applications in connection with ultra short-wave reception, may easily lay the foundation of a modest fortune.

But it is of no use waiting until the high definition broadcasts begin. It will then be too late. Now is the time to acquaint yourself with the problem: which have to be solved.

In the pages of TELEVISION TO-DAY you will obtain authoritative information on all existing systems and you will see what special apparatus has already been devised.

More than thirty men who have been working on these problems for the past few years place the results of their investigations before you in the pages of this unique work.

IT CAN BE YOURS WITH ALL ITS AMASSED KNOWLEDGE! BOUND TO GIVE A LIFETIME'S SERVICE, IT WILL BE SENT TO YOU POST FREE ON PAYMENT OF A SMALL INITIAL SUM—A SHILLING OR TWO ONLY!

## TELEVISION TO-DAY

PRACTICE AND PRINCIPLES CLEARLY EXPLAINED

Delivered to you on small initial payment.

Some of the Brilliant Contributors:—

CAPT. A. G. D. WEST, M.A., B.Sc.

DR. V. K. ZWORYKIN F. J. CANN

PERCY HARRIS, M.I.R.E. L. M. MYERS, F.T.S. W. J. NOBBS, F.T.S., A.M.I.R.E.

H. J. BARTON CHAPPLE, B.Sc., A.M.I.E.E.

E. H. TRAUB, F.T.S.

G. BALDWIN BANKS, B.Sc.

R. C. WALKER, B.Sc., A.M.I.E.E., etc., etc.

Fully Indexed

Profusely Illustrated with Diagrams, Photos and Plans

Complete in 2 Big Volumes

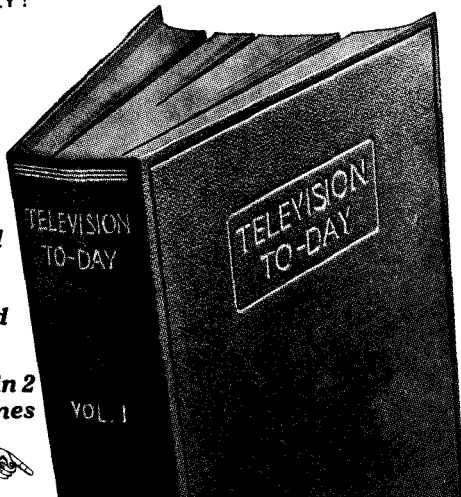

SEND FOR FREE BOOKLET TO-DAY BY FILLING IN THIS COUPON

If you do not wish to cut your copy, send a postcard, mentioning WIRELESS MAGAZINE and Modern Television, to address given.

To the Home Library Book Company, 23-24 Tavistock Street, London, W.C.2.

Please send me full particulars of TELEVISION TO-DAY.

Name .....

Address ..... W.M.735

Tungsrans again specified by the WIRELESS MAGAZINE -



— last month for the "W.M." Short Wave Adaptor —

THIS TIME FOR "THE CARRIER"

3-valve Short Wave Receiver

HP210	HR210	LD210
PRICE	PRICE	PRICE
11/-	3/9	3/9

The Tungsrans Valves used by Mr. Percy Harris in designing his new set are identical with those that you can buy from your dealer. Tungsrans manufacturing methods ensure a uniformity of efficiency which makes special selection unnecessary. Insist on the specified Tungsrans types when you buy.

# TUNGSRANS

BARIUM VALVES 72 OXFORD ST., W.C.1. Factories in London, Austria, Czechoslovakia, Hungary, Italy & Poland

# Hammarlund S.W. COILS

for the CARRIER S.W. RECEIVER

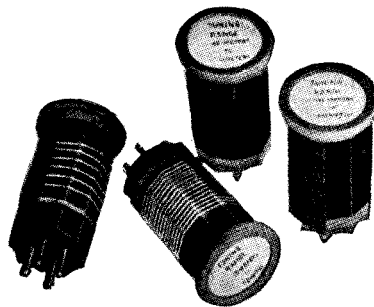

Mr. Percy W. Harris has chosen Hammarlund S.W. Coils for the "Carrier" Receiver described in this issue of the "Wireless Magazine," because they are designed and manufactured by a company with a world-wide reputation where short-wave equipment is concerned. The Hammarlund S.W.K.4 coil kit specified consists of 4 coils covering a range from 17 to 270 metres. Hammarlund short-wave plug-in coils provide maximum signal strength and greatest selectivity on all bands. Extensive laboratory work results in practically perfect design of primary, secondary and tickler, coupling and overlap.

Windings themselves are carefully designed for maximum efficiency with proper attention to the kind of wire, wire sizes, turns, spacing, form factor, co-efficients of coupling, etc. Greater signal strength thus obtainable. Comparative tests prove this conclusively.

S.W.K.4 Complete coil kit .. 17/6

S.4 Special Isolantite coil socket ... 3/-

Obtainable from all high-class dealers.

Exclusive Distributors:

*R.A.R. Rothermel* LTD

ROTHERMEL HOUSE, CANTERBURY ROAD, HIGH ROAD, KILBURN, N.W.6.

\*Phone: Maida Vale, 6066.

# Wireless Magazine

—and Modern Television

The Editor's Page

July, 1935

## Listen on the Short Waves!

LONG-DISTANCE reception has always exercised a fascination over the keen wireless enthusiast. Indeed, for several years after the introduction of broadcasting "station hunting"—a listing of as many stations as could possibly be identified quite regardless of programme or quality—was the main recreation of thousands of listeners.

There was—and still is—a certain fascination in receiving over the longest possible distance with the simplest possible apparatus, but with the tremendous sensitivity and selectivity of modern wireless receivers "station hunting" became too easy, and the hunt for quality took its place.

But just when we thought that everything that could be done *had* been done in this direction, certain totally unexpected properties of very short waves forced themselves on our attention with the result that the old hobby of long-distance reception has come into its own again in such an amazing manner that a one- or two-valve set can receive broadcasts from the Antipodes!

All our reports indicate that reception conditions on the very short waves has greatly improved in the last few months, and so in the present number of "Wireless Magazine" we publish several articles which we hope will introduce readers who have not hitherto attempted short-wave work to one of the most interesting aspects of our hobby.

A new short-wave set so constructed that it can be moved very conveniently from room to room, complete with all its batteries, is fully described and illustrated, while in "How to Search on the Short Waves" many valuable tips are given on the handling of this and other short-wave receivers.

Our popular contributor, Mr. G. Howard Barry, discusses the "Single-signal Super" for the benefit of the more advanced short-wave listener. All short-wave enthusiasts, whether beginners or not, are well catered for.

The general listener who does not necessarily build his own receiver, but nevertheless takes a great interest in the hobby, will find this month two articles which give much food for thought. Both deal with loudspeakers. The first is the continuation of the series, "Wireless for the Busy Man," in which readers have been taken in simple stages through the general principles of wireless reception and have now reached

the point where the importance of the loudspeaker can be correctly estimated. The second, by Dr. N. W. McLachlan, is more advanced in its scope but does not suffer in clarity for this reason.

Dr. McLachlan is one of our foremost radio engineers with a very wide experience in sound reproduction, and is indeed a world-famous authority on the subject. In his article—the first of a series he has kindly agreed to write for "Wireless Magazine" readers—he discusses some of the leading faults in loudspeakers and how many of the tests which are supposed to indicate the merits or otherwise of particular instruments are misleading, or even fallacious.

When broadcasting was first introduced it was thought by many to sound the death-knell of the gramophone reproduction, but far from doing this it has lent its aid not only in the popularising of records but in the development of apparatus to give far better gramophone reproduction.

Of special interest to those readers who combine the two hobbies is the article by our Technical Editor describing what he likes to call "the Lazy Man's Radiogram Unit," but which is just as likely to appeal to the busy and active man who shares our contributor's dislike of climbing out of an armchair every few minutes to change the record.

"Wireless Magazine" has a warm corner in its heart for the service man, that hard-working individual who is considered to be at everyone's beck and call, at any hour of the day or night, when "something goes wrong with the set." For his especial benefit we present this month a description of a new audio oscillator, designed specially for us by Paul D. Tyers and possessing many merits, not the least being low cost with high efficiency.

Our review of up-to-date public-address systems will, we think, appeal as much to the general reader as to the service man and may assist in raising the level of open-air reproduction.

With so many first-class P.A. systems available there should be no excuse for the very poor results from make-shift apparatus.

*Percy W. Harms.*

---

**What Kind of Set Do You Want?—see page 435**

---



**I**N the early days of broadcasting, over ten years ago, the reproduction of sound by loud-speakers was regarded as being so thrilling that one almost forgot to be critical of the quality! Today, the same standard of quality would virtually be "stoned."

But the question which arises is this: Is the quality of today everything that is to be desired? It may be good enough for those who either seldom listen, or whose critical faculties have had insufficient exercise, or for those who turn a deaf ear to any faults. To the enthusiast who is bent upon getting the very best that science can give, modern loud-speaker reproduction leaves something to be desired.

### One Reason

In this article I propose to indicate one reason why average loud-speaker reproduction falls short of what we would really like. For simplicity we preferably choose a type of loud-speaker familiar to all, and one which is used more than any other, namely, the hornless moving-coil type.

It is well known that the reproduction from any loud-speaker is different according to the conditions of use: (a) in the open air, (b) in a large highly damped room (with curtains and thick carpet), (c) a large



H. M. V. photo.

*A neat arrangement of extension loudspeaker and cocktail cabinet. This photograph was actually taken in the replica of the King's House at the recent Ideal Home Exhibition held at Olympia*

# Where the Loudspeaker Fails!

*We are proud to present an article from the pen of Dr. N. W. McLACHLAN, D.Sc., M.I.E.E., who is recognised as our leading authority on loudspeakers. His contribution provides a characteristically lucid explanation of the more common causes of imperfections in reproduction, in addition to useful hints on the placing of a loudspeaker in a room to get the best results*

empty room, (d) the average room in a *modern* house. Moreover, if a loud-speaker sounded perfect in the open, it would fail to do so in the average room, because the room modifies the sound a great deal.

### High Frequencies Absorbed

For instance, owing to the curtains, carpets and furniture, the high frequencies are absorbed to a greater extent than the low frequencies. Thus the perfect loud-speaker would be too powerful in the bass. The effect of the room complicates the problem too much, so to simplify the conditions, we shall assume that

the reproduction takes place in either the open air or in an acoustically-dead room.

A room of this type is one whose six surfaces (four walls, floor and ceiling), are covered with twelve inches or so of material which almost completely absorbs the sound. This gives the effect of free air conditions, which we wish to obtain in order to avoid acoustical coloration due to the room.

There are a number of studios of this type at Broadcasting House and they are used for talks. The idea behind an acoustically-dead studio for talks is that the reverberation

therein is negligible, so that the loud-speaker appears—or ought to do so—as though the lecturer were in the listener's own room, thereby introducing a decided atmosphere of intimacy.

By means of special apparatus it is possible to obtain what is known as a response/frequency curve of a loud-speaker. This can be taken in the open air or in an acoustically-dead room. A curve of this nature for a moving-coil loud-speaker is shown in Fig. 1. It is typical of curves taken with a microphone situated on the axis of the cone at a distance of several feet from the diaphragm.

## A World-famous Authority to Write Regularly for "W.M."

**HOWEVER** well designed a wireless receiver may be, it is the loudspeaker we hear. Curves and calculations which disregard the loudspeaker are of limited use when judging quality.

Dr. McLachlan, who is a world-famous authority on loudspeakers, begins with this article a special series on this subject designed to give the real facts to "Wireless Magazine" readers.

As a radio engineer of

lengthy experience, who combines advanced mathematical knowledge with an equally valuable practical acquaintance with his subject, Dr. McLachlan is in a unique position to help the practical man.

In his first article many of the present limitations of loudspeakers are discussed and in his next article the importance of a proper rendering of transients will be explained.

Some points which strike us about this characteristic curve are (a) the large number of minor irregularities, (b) the rise above 1,500 cycles per second, and (c) the falling off above 5,000 cycles per second. The rise in output above 1,500 cycles is due to the cone resonances and these impart a certain degree of acoustical coloration to the reproduction.

### Comparison !

If one tries out two different makes of moving-coil loud-speaker, using a change-over switch, the tonal quality of one is generally quite different from that of the other. This effect is due largely to the cone resonances occurring at different frequencies in the two cases, although

Dr. McLachlan's next article will appear in the September issue of "Wireless Magazine."

Order Your Copy Early !

the lower register may contribute to a certain extent, especially if it is more powerful in one reproducer than in the other.

The drop in output above 5,000 cycles per second is due to (1) the mass of the coil which reduces the amplitude of motion, and (2) mechanical losses in the paper of which the cone is made.

I said above that the characteristic curve of Fig. 1 was obtained at a point on the axis of the cone. A microphone was used and its output amplified and fed to a recording mechanism. The question which now arises is this: Is a curve of output taken on the axis a proper index to the performance of a loud-speaker?

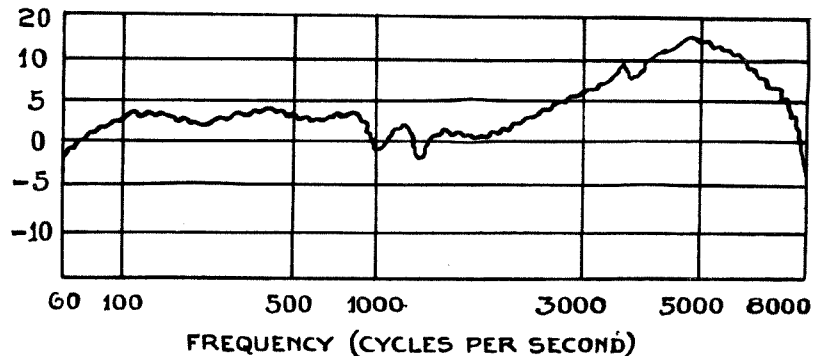

Fig. 1.—This is a good average specimen of the response curve of a moving coil loud-speaker. Note the rise above 1,500 cycles and the rapid fall above 5,000

Instead of answering this question in a sentence, let us view the situation from a practical standpoint. Anybody who has used his loud-speaker in the garden, well away from the house or from walls, knows that the quality of reproduction changes profoundly as one walks round it at a distance of, say, 5 ft. On the axis, that is to say in front of the loud-speaker, which we assume to be on a table, the reproduction is very crisp, but at one side or at the

back it is decidedly woolly. This is due to the fact that the high-frequency power is concentrated in a relatively narrow beam at the front of the loud-speaker.

### Uneven Distribution

On the other hand, the low frequencies are audible all round the loud-speaker so that they spread over a much greater area than the high-frequencies and the tonal balance is upset as one walks round.

If the characteristic curve of Fig. 1 were a horizontal line, when taken with the microphone on the axis of the loud-speaker, it follows from what I said in the preceding paragraph, that the total power radiated by the speaker at low frequencies would far exceed that at high frequencies because the latter is only spread over a small area at the front of the speaker.

### Reflection

In the average room, therefore, the low frequencies would overpower the high frequencies, unless one were seated on the axis of the speaker and fairly close to it. In a room the sound is reflected from the walls, and the beam or focusing effect at high frequencies is much less prominent than it is outside in the garden.

If the reader has not tried an open air test, he should do so because it

is not only interesting but entertaining. He will find that if the back of the loud-speaker is covered over with a thick blanket or suitably boxed in, speech will be difficult to understand behind the loud-speaker, unless, of course, the output from the front of the loud-speaker is reflected from a wall.

This reflection effect may be avoided to an extent by tilting the loud-speaker upwards through a suitable angle. Following this open air



experiment, the loud-speaker should be brought back to the house and the same test performed indoors. It will then be found that the focusing of the sound at high frequencies is much reduced, due to the levelling up effect of reflection from the six inner surfaces of the room.

**“Woolly” Sound**

Despite the levelling up at high frequencies due to reflection, a moving-coil cone speaker, the response curve of which was level throughout the entire frequency range, would sound “woolly,” owing to the high-frequency power being small in comparison with that at low frequencies. Thus to get an adequate upper register it is essential that the effect of focusing should be offset by a rise in the response characteristic above a certain frequency.

**Getting the Top**

The value of this frequency depends upon the dimensions of the cone. Now it happens that the cone does not lend itself to mathematical treatment, so far as the radiation of sound is concerned. Consequently, we replace it by a rigid disk (circular) set in a large flat wall which acts as a baffle. I have calculated what the axial response should be, if the sound power output were the same at all frequencies, and the result is given in Fig. 2\*.

For a disk 8 inches in diameter, this being about the normal size of an average speaker cone, the curve rises from 400 cycles and at 8,192 cycles, this being one octave above top C on the piano (grand), the axial level is 20 decibels above that at 400 cycles.

This means that owing to the beam effect, the power on the axis

\* See McLachlan *Loudspeakers* (Clarendon Press, 1934) p. 257.

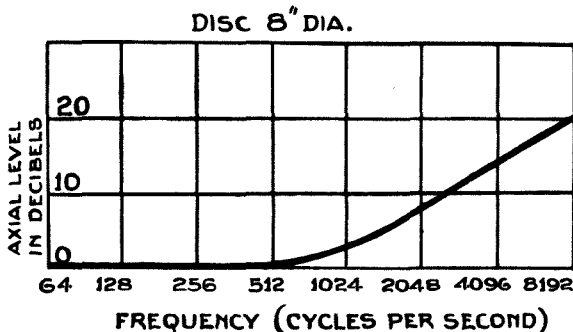

Fig. 2.—Illustrating the relative intensity of radiation of various frequencies from a flat disc 8 inches in diameter

is 100 times greater at 8,192 cycles than at 400 cycles. A loud-speaker having an axial response curve like that depicted in Fig. 2 would sound extremely shrill to a listener situated on the axis out of doors.

In a room there is every reason to believe that it would be necessary to employ some device which diffused the high-frequency sound over a wide angle.

In practice the cone resonances above 2,000 cycles cause the response curve to rise. Sometimes it rises too

a small horn loud-speaker taking the range about 3,000 cycles, these frequencies could be accentuated as desired and the human voice made to sound very harsh. Nevertheless, there was no lisping and whistling of sibilants which characterised reproduction from the cone.

**Due to Resonances**

This indicates that the cone resonances are responsible for the defect in question. Thus, although cone resonances are necessary to get



For public-address work the high efficiency of the horn-type loudspeaker constitutes an important advantage. It is even more directional than the open baffle type, however, and so must be placed carefully to cover the desired area

steeply and falls away rapidly, in which case the reproduction is unpleasant. At others it rises more gradually, but is maintained level over several thousand cycles, after which it falls away. This leads to more pleasant reproduction than the first case mentioned.

We see, therefore, that if there were no cone resonances, the reproduction would lack upper tones. In some cases these resonances are

unduly sharp and introduce lisping of the sibilants, which is distressing to the listener. To prove this point I have made experiments with paper cones and with a combination of non-resonant loud-speakers that reproduce up to 10,000 cycles. By increasing the output from

a good upper register, great care is required to prevent them from being unduly unpleasant, especially when reproducing speech.

**Performance Depends . . .**

We see, therefore, that it is not possible to give an absolutely reliable interpretation of a loud-speaker curve taken with a microphone on the axis. The curve should rise above a certain frequency and there should be no violent resonant peaks. The performance of any particular loud-speaker depends largely upon a number of factors, some of which are the acoustical properties of the enclosure or room where the instrument is used.

**Ideal Conditions**

In general, a very large heavily draped room is much the best. The majority of us have perforce to exercise our ears in less pretentious quarters where distortion is likely to be more conspicuous.

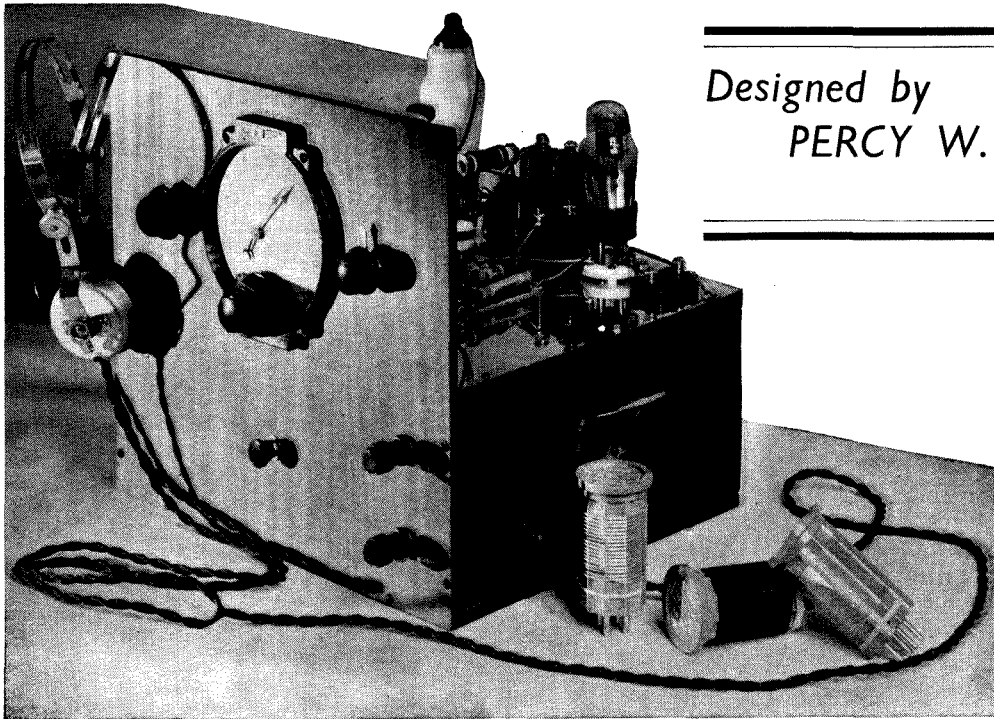

---

Designed by  
**PERCY W. HARRIS,**  
M.I.R.E.

---

*The complete installation with batteries, phones and spare coils can readily be stored away in a cupboard when not in use. This receiver was designed by the Editor for his own use*

# The Carrier Short-waver

*This very interesting short-wave receiver was designed by the Editor for his own personal use under conditions which must be very similar to those of many "W.M." readers. Its electrical performance is exceptionally fine and its highly novel and original system of construction offers many valuable advantages, not the least of these being portability.*

WITH the Jubilee Radiogram described in the May issue working so satisfactorily, I recently turned my attention to the building of a short-wave receiver for my own use. I have designed the Carrier to cover all wavebands from about 15 or 16 metres up to the lower limits of the radiogram in question. Some of the problems I had to solve were interesting and I think the receiver in its final shape is one which will appeal to many "Wireless Magazine" readers.

Short-wave reception in these days is a fascinating business. At almost any hour of the day or night it is possible to receive something or other of interest, and the carrying power of these waves and their consistency will surprise all who take

up this form of reception. With modern technique most of the trickiness has been taken out of short-wave reception and if the design is well worked out with properly chosen values the operation is almost as simple as that of a normal broadcast receiver.

However, this is not the place to discuss short-wave reception as such. You will find in the present issue a number of articles on the subject, notably "How to Search on the Short Waves" on page 440, and "Good Logs on the Short Waves" on page 414. From these you will see that, given a good receiver, a wide field of exploration is open to you.

My requirements were briefly these. First of all, the waverange from

about 15 or 16 metres up to the ordinary broadcast band had to be covered without any gaps. Secondly, the receiver had to work with telephones and not a loudspeaker, but at the same time had to have an adequate margin of strength so that there should be no straining while listening.

### Really Portable

Thirdly, it had to be as portable as possible, without encumbrances or trailing battery wires. A set of this kind is moved about from room to room and is not left in a fixed position, as is a broadcast receiver.

Fourthly, the tuning should be specially smooth and accurate.

Fifthly, as I sometimes wish to take the set with me in the car,

---

**A THREE-VALVE BATTERY-OPERATED SHORT-WAVE RECEIVER**

---

it should be a battery receiver.

The solution of all these problems was found after some little study and the make-up of the set is something in the nature of a novelty. The baseboard of the receiver, made of metal-covered plywood, forms the top of a box some 5½ in. deep, fitted with a pair of carrying handles.



The batteries fit neatly in the lower compartment. Note the carrying handles fitted to the ends of the set

The front panel, which is made of mahogany-faced plywood, screws on to the front of this box, the back being open. Inside the box go the accumulator, the high-tension battery and the grid-bias battery.

#### Simple Construction

Construction has been rendered exceedingly simple, not only by the layout of the receiver itself but by the fact that with the simplified wiring, which a good layout gives, all of the connections other than the leads to the battery and telephone terminals can be carried above the baseboard.

The front of the receiver carries a large tuning dial with twin gearing giving either an 8-1 or 60-1 reduction at will. This controls a .00004-microfarad condenser. This condenser in turn is in parallel with a .00016-microfarad condenser controlled by the knob on the left of the tuning dial.

This second condenser is for

rough tuning with a particular coil while the centre dial allows fine tuning.

The knob on this larger condenser carries a pointer and by marking the panel it is possible to set this condenser for a number of different waveranges on any individual coil.

The knob on the right of the tuning dial operates the reaction condenser through a slow-motion drive giving an exceptionally fine adjustment.

Immediately below the tuning dial we find the on-and-off switch while on the right a pair of telephone terminals are provided. If necessary these can be connected to an amplifier for loudspeaker working.

At this juncture I may say that the circuit is based on that very successfully used by Mr. Howard Barry in the March issue of

"Wireless Magazine," but as it is used for telephone work there is one valve less.

Looking down on the top of the receiver we see, at the back, the aerial and earth terminals immediately adjacent to the high-frequency valve holder.

#### Home-made H.F. Choke

Immediately in front of the aerial terminal is a special short-wave high-frequency choke consisting of sixty turns of No. 26 double-cotton-covered wire wound on a ½-in. rod of ebonite.

This rod is fixed to the base by drilling a ½-in. hole in the baseboard and driving the rod into this. This choke is home-made, but it can be purchased quite cheaply ready wound.

#### High-frequency Valve

On the right of this choke will be observed the screened grid high-frequency valve, the top cap or plate of which is connected by a very short lead to the upper terminal of a so-called neutralising condenser and at the same point is attached a high-frequency choke by the simple expedient of removing the condenser terminal from its connecting strip, inserting its shank through the high-

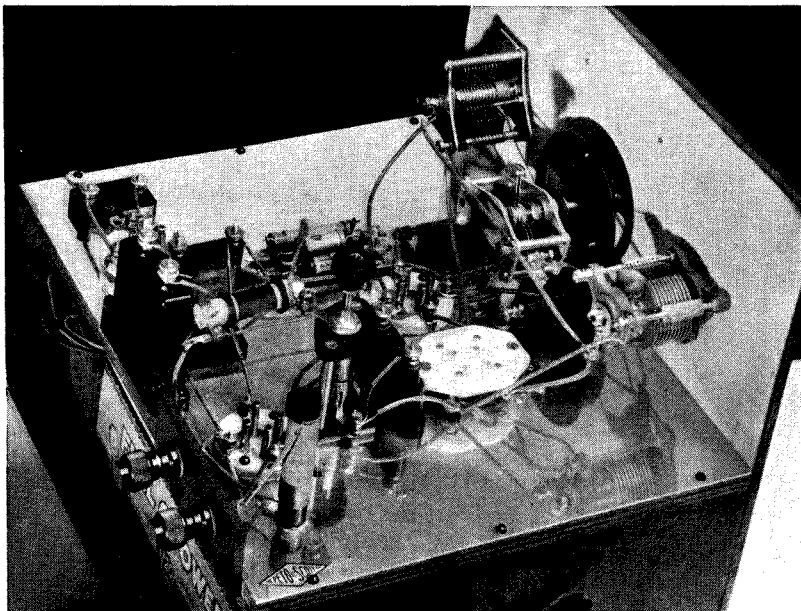

The very carefully worked-out design results in such simple wiring that all connections can be carried on the upper side of the baseboard. Only the connections to the batteries need pass through the board

INCORPORATING MANY NEW IDEAS OF PRACTICAL VALUE

# WIRING DIAGRAM

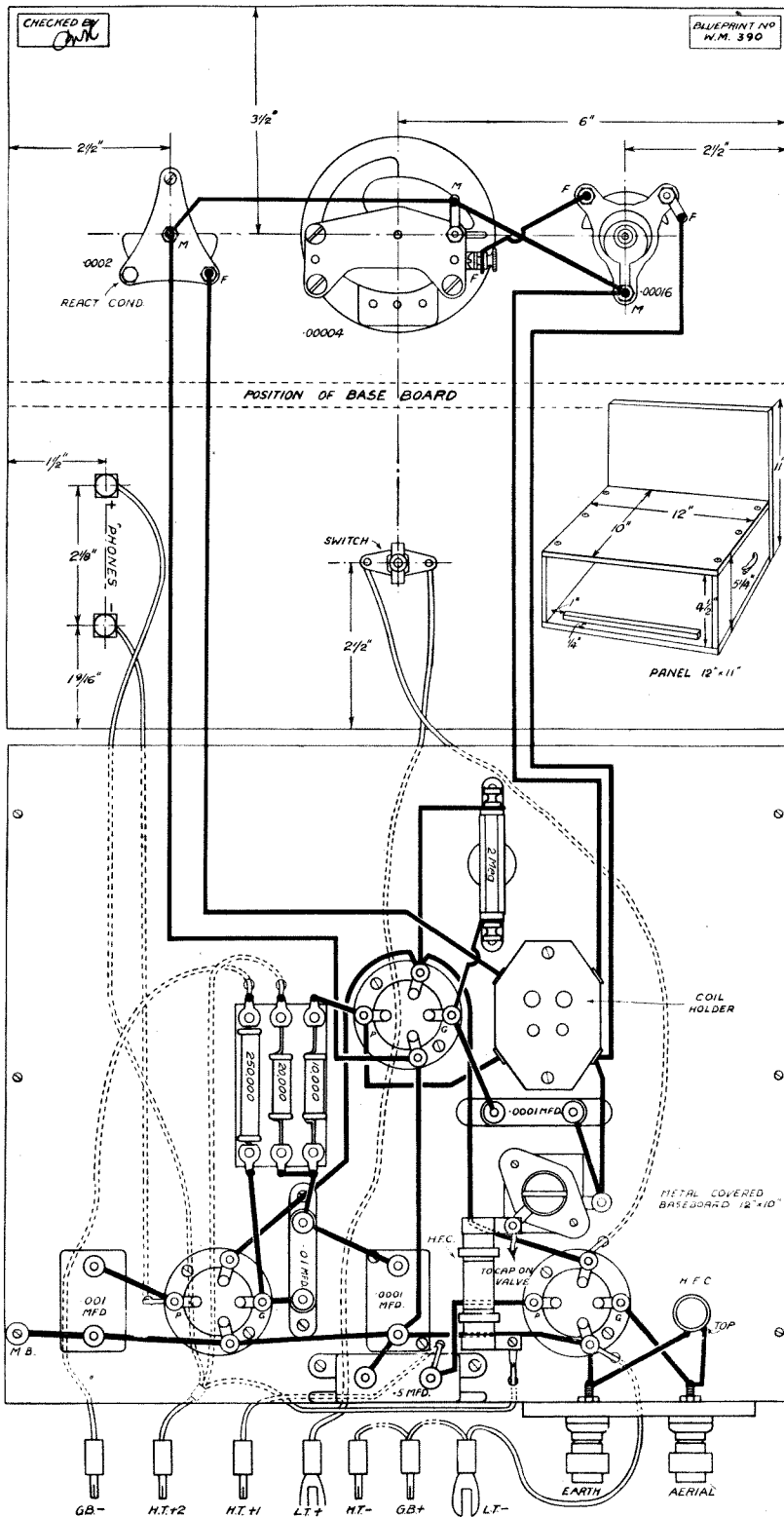

## BLUEPRINT FOR HALF PRICE!

A full-size blueprint of this wiring diagram is available, price 1s., or, if application is made before July 31, it can be obtained at the special price of 6d., post paid, providing the coupon to be found on the last page is used. Please quote No. WM390

frequency choke lug and replacing the terminal, thus locking the whole in place with the terminal which holds the flexible lead to the plate of the valve. The other end of this choke goes to a lead taken through the base-board to H.T. + maximum (120 volts).

The second terminal of the neutralising condenser goes to a point on the coil base and the .0001-microfarad grid condenser, the other side of which goes by a very short lead to the grid of the detector valve.

The point on the coil mount to which the neutralising condenser is connected goes also to the fixed plates of the larger tuning condenser which is also connected to the fixed plates of the centre or smaller one.

### Coil-holder Connections

There are four connections to the coil holder, the others going respectively to the moving plates of the tuning condenser, the plate of the detector valve and the fixed plates of the reaction condenser.

At this point I may pause to say something about the coils. While there are a number of good short-wave coils on the market in this particular set I have used the Hammarlund coils, the four pins of which fit into American valve-holders.

### Special Coil Holder

As the holder for these coils is of great importance I have used a special Hammarlund Isolantite socket. This socket is provided with two long fixing screws and collars which hold it well above the base-board, thus providing a kind of china platform for the coil and also placing the soldering lugs of the socket in a convenient position for soldering after the holder has been mounted up. This also dispenses with the need for any sub-baseboard wiring.

### Coil Wave-ranges

The Hammarlund coils are four to the set. The first one starts at approximately 17 metres and tunes with the .00016 condenser up to just above 41 metres. The second coil covers from 33 to 75 metres, the third from 66 to 150 and the fourth from 135 to 270 metres.

They work very well indeed, particularly with the condenser arrangement I have used. Actually it is probable that the bulk of one's listening will be done on the 17- to 41-metre coil.

Immediately to the right of this coil is the detector valve, while in front of it are the two condensers used for tuning, the grid leak falling between these two. Owing to the fact that the high-frequency valve grid circuit is untuned there is no need to bring leads from the back of the set to the front and then back again, all the parts now falling in position for short connections.

After the detector valve a lead goes to the little resistance board, through a 10,000-ohm resistance which acts as a radio-frequency choke and gives extremely smooth reaction, and thence through a .01-microfarad coupling condenser to the low-frequency valve.

### Coupling Resistance

A second resistance of 20,000 ohms "doubles back" to the front of the set again and a lead goes from this through a hole in the front of the resistance board to the necessary high-tension lead on the battery. This is the coupling resistance. A higher value would give greater amplification, but this is not needed. Alongside of this second resistance is a third which acts as a grid leak for the low-frequency valve, a flexible lead from this passing through the baseboard and going to the grid-bias battery. This arrangement of resistances makes the wiring very neat and short.

### By-pass Condensers

Immediately after the 10,000-ohm resistance and between this and the coupling condenser a .0001-microfarad fixed condenser goes to earth.

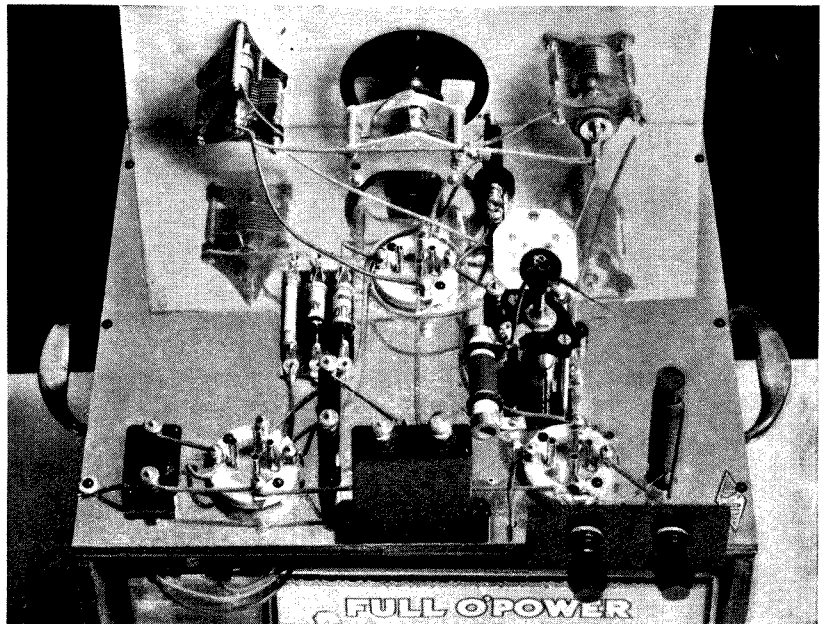

This view gives one a very good idea of the clean and simple nature of the wiring. Note the only connection to the metal surface of the baseboard—on the extreme left

This is seen at the back of the set immediately in front of the large .5-microfarad condenser which is used as a shunt between the screening grid and earth.

On the right of the output valve will be seen another condenser, this time .001 microfarad, shunted to earth from the plate of the output valve to by-pass any remaining radio-frequency currents that might possibly get through.

The first work in building this set is to construct the base and battery box if you do not buy all the woodwork ready made. The metal-covered baseboard of the set is of

"Polymax" and measures 12 in. wide by 10 in. deep and a plywood bottomboard must be cut of exactly the same size. You will then need two other pieces of wood 4 1/2 in. by 10 in. as the side pieces and the front plywood panel 1/4 in. thick measures 12 in. by 11 in.

This front panel, which as mentioned before is of mahogany-faced plywood, I purchased from a local fretwork dealer for 11d. and the other odd pieces of plywood can be obtained very cheaply from similar sources. The two handles are really trays and can be obtained from any ironmonger.

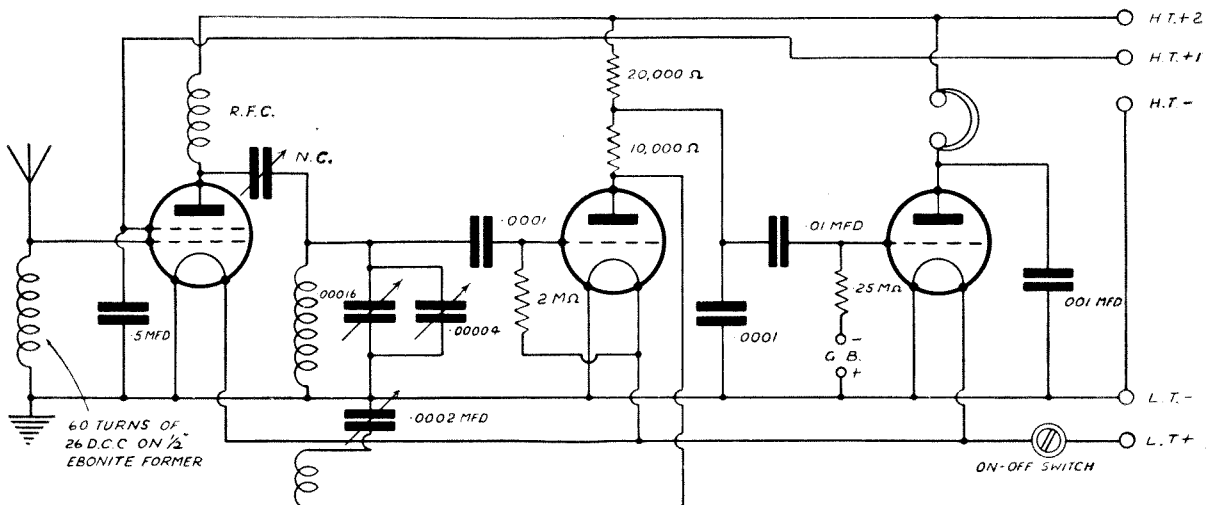

The circuit employs a screened-grid valve with untuned grid, parallel-fed tuned grid circuit for the detector, band-spread tuning, and a resistance-coupled low-frequency stage

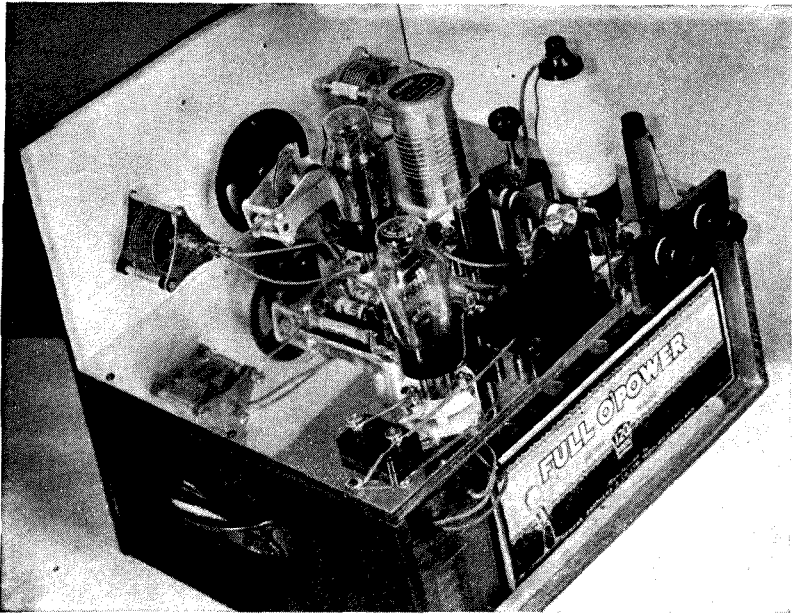

Although the back of the panel looks very light-coloured in this photo, it is not actually metal-covered: the only metal found necessary (or desirable) is that on the surface of the baseboard

The dimensions of the battery box are such that they will take a 120-volt high-tension battery, a 2-volt un-spillable accumulator and a 4½-volt grid-bias battery quite comfortably. Inside, near the front panel, I have fixed a small fillet of wood as a back-stop for the batteries and a similar fillet near the back prevents them sliding about.

#### Battery Connections

The battery leads are all made flexible so that they can be inserted in the correct sockets while the batteries are out of the box and then after the batteries have been slid into place the wires can be tucked in out of the way.

You will notice that the on-and-off switch and the telephone terminals fall below the baseboard; this is very convenient for wiring up as one of the on-and-off switch leads goes straight to the battery and one of the telephone terminals goes to high-tension positive.

#### Fixing of Components

The Graham Farish "Snail" reduction drive and the special dial which goes with it are very easily mounted and as full instructions are supplied with these components there is no need to go into details here. The large condenser and the reaction condenser are both of the one-hole fixing variety and here again there is no trouble. The front panel, by the way, is *not* metal covered so

there is no need to take special care to prevent shorting.

Here is a tip for mounting the various components on "Plymax." Take a sharp instrument such as a scribe and mark through the fixing holes of the various components when you put them in place, so as to make a small depression in the metal which can be very easily seen.

Now remove the components, centre-punch the holes and then with a small drill, drill just through the metal but not much into the wood. The components can now be screwed into place with great ease. Do not attempt to force the wood screws through the "Plymax" without making a hole first.

Many amateurs do not trouble to provide themselves with an adequate supply of screws for making sets of this kind. In my experience all this kind of work can be satisfactorily done if you have three sizes of screw and I always prefer the black japanned steel screws for this work.

Go to your local ironmonger and get a packet each of No. 4 japanned round-head screws respectively ½ in., ⅔ in., and ¾ in. long. You will then be able to make a neat job of fixing any of the components of a wireless set without your screws being either too short or projecting through the baseboard.

#### Sound Advice

I would advise you to use the actual components indicated, particularly as variations in short-wave sets *may* bring about quite startling changes in performance. So far as valves are concerned the set is not at all critical; I have used Tungstram valves in this receiver and they work very satisfactorily indeed, but I have tried other makes and they work just as well, providing they are of the same general type.

When the set is finished the adjustments for operation are extremely simple. You will connect

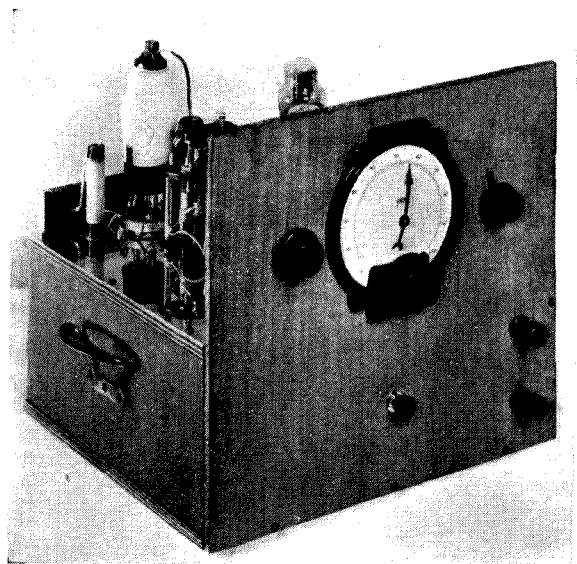

The small knob on the left controls the large range-adjusting condenser, the dial governs the band-spread (fine-tuning) condenser, and the knob on the right is the reaction control. Below is the low-tension switch

up the 2-volt accumulator and the grid-bias battery to suit the particular output valve you are using, while so far as high-tension is concerned all the H.T. leads other than the screening grid are joined together and taken to the 120-volt socket. The screening-grid plug can go in the 84-volt point, but this is not at all a critical value. Connect a good pair of 'phones (I have used Ericsson) to the terminals, turn the reaction condenser to the minimum and plug in the coil marked 17 to 41 metres. In my house I find an

earth an advantage on the set and the aerial used is the normal broadcast aerial.

Set the centre or fine-tuning condenser to about 50 and the left or main tuning condenser to minimum. Take the neutralising condenser knob and turn it so that the plunger comes upwards until it is nearly out of the lower tube.

### How to Tune

Now switch on and try the reaction and see that it is quite smooth over the whole tuning range of the larger condenser. If this is quite satisfactory, turn the large condenser knob until it is about halfway between minimum and maximum and adjust the reaction until the set is in its most sensitive condition, or just below oscillation.

Now turn the centre knobs and you are almost certain to find some short-wave broadcasting station working round about this range, which actually is about 31 or 32 metres.

### America for Two Hours

Within five minutes of joining up the batteries I picked up W2XAF (Schenectady) and listened to the programme for over two hours without a break. Tiring of this station I soon picked up several other Americans and on the next evening found the sensitivity and ease of handling of the set far exceeding my most optimistic expectations for stations all over the world were very readily and easily received at such a margin of power that the critical setting of the reaction was unnecessary.

You must remember that every new setting of the large condenser

alters the tuning on the centre dial, so it is best with any given coil to find experimentally the most interesting spots on the coil and then to make a mark so that the pointer of the small knob on the left can be so adjusted that the stations you most frequently want will come within the compass of the centre dial.

You can do this with the amateur bands around 20 metres, interesting broadcast stations in the middle of the dial and so forth, marking the panel to suit your own taste.

There are no other adjustments to worry about, but you will probably find it necessary to experiment a little to get the best setting of the neutralising condenser for volume and selectivity.

The more it is screwed down the less the selectivity of the set but on the other hand if it is screwed up too far you will lose sensitivity. The setting is not critical and once you have found it you will probably leave it untouched for a long period.

### COMPONENTS—OUR POLICY

COMPONENTS used in receiver designs published in "Wireless Magazine" are chosen for their suitability, efficiency and reliability. Their selection must not be taken to indicate any more than this, nor that other good-quality components are not equally suitable, save in a few cases clearly indicated where there are no suitable alternatives.

In a large number of cases there exist numerous good alternatives, as a study of the advertisement pages of this journal will show.

## Standard Four-Valve Short-Waver

This letter from a reader in Aberdeen is just one of many we have received praising the new "W.M." receivers

The Editor—

SIR,—A few days ago I wrote saying that I could get no results from the Standard Four-valve Short-waver. I write now to tell you that the trouble is entirely cured. On Saturday night while testing the circuit I found that the bottom terminal of the neutralising condenser was at earth potential, even when disconnected from the tuning condenser and band-spreader.

On investigation I found that the centre screw on the bottom of the N.C. was protruding slightly. As it would screw up no tighter, I insulated it from the metal foil with a small piece of cardboard. This procedure has cured the trouble.

These are the stations of which I have received the call signs. The last station I have just received and as I write it is playing "Come and do the hot-cha-cha." Most reception is on phones.

Station.	Call.	Metres.
Daventry	GSF	19.82
Zeezen	DJD	25.49
Rome	2RO	25.4
Daventry	GSE	25.29
Moscow	RW59	25.00
Rome	2RO	31.13
Madrid	EAQ	30.00
Zeezen	DJA	31.45
Zeezen	DJN	31.38
Zeezen	DJC	49.83
Vienna	DER2	49.4
Moscow	RW59	50.00
Pittsburgh	W8XK	25.27

Thanking you for a really good set with easy tuning.—L. H.

### COMPONENTS NEEDED FOR THE CARRIER SHORT WAYER

#### CHASSIS s. d.

1—Wooden chassis to specification with two carrying handles, say ... 2 6

#### CONDENSERS, VARIABLE

1—Eddystone .00016 - microfarad "Scientific" type with plain knob ... 7 6  
 1—Polar type Reaction, No. 4 .00004-microfarad ... 3 9  
 1—B.T.S. slow-motion reaction .0002-microfarad ... 5 9  
 1—J.B. neutralising type ... 3 6

#### CONDENSERS, FIXED

1—T.C.C. .0001-microfarad, type 34 ... 1 3  
 1—T.C.C. .0001-microfarad, type S ... 1 3  
 1—T.C.C. .001-microfarad, type S ... 1 6  
 1—T.C.C. .01-microfarad, type 34 ... 3 0  
 1—T.C.C. .5-microfarad, type T.C.C. 50 ... 2 4

#### COILS

1—Set of Hammarlund short-wave coils (Rothermel, Ltd.) ... 17 6

#### CHOKES, HIGH FREQUENCY s. d.

1—B.T.S. Short-wave type ... 2 9  
 1—Home-made to specification

#### DIAL

1—Graham-Farish "Snail" dial and drive ... 6 6

#### HOLDER, COIL

1—Hammarlund ... 3 0

#### HOLDERS, RESISTANCE

1—Bulgin 3-way group board (cut from standard 5-way board) No. C31 ... 1 0  
 1—Graham-Farish horizontal Ohmite holder ... 6

#### HOLDERS, VALVE

3—B.T.S. special short-wave type, 4-pin ... 4 6

#### RESISTANCES, FIXED

1—Amplion 10,000-ohm ... 1 0  
 1—Amplion 20,000-ohm (see text) ... 1 0  
 1—Amplion .25-megohm ... 1 0  
 1—Graham-Farish 2-megohm Ohmite ... 1 6

#### SUNDRIES s. d.

4—Belling-Lee terminals ... 2 0  
 1—terminal strip, 1½ in. by 3½ in., say ... 6  
 1—Benjamin on-off switch, push-pull type ... 8  
 Screws as per author's specification, say ... 1 0  
 2—Wander plugs and spade terminals as per blueprint (Clix or Belling Lee, say ... 1 2

#### Accessories

#### BATTERIES

1—Full o' Power 120-volt high-tension size H3 ... 13 6  
 1—Exide low-tension accumulator type PO-3 ... 10 6  
 1—Full o' Power grid-bias battery 4.5 volt type ... 1 0

#### VALVES

1—Tungsram HP210 ... 11 0  
 1—Tungsram HR210 ... 3 9  
 1—Tungsram LD210 ... 3 9

#### TELEPHONES

1 pair of Ericsson 2,000-ohm ... 12 6

# Good Logs on the Short Waves

Notes on Current Conditions and Interesting Stations to be Heard.

**L**AST month I had the pleasure of reporting on a spell of unusually good conditions; since I wrote those words there has been further improvement followed by a rather bad spell, which has coincided with the period of cold weather.

In one way, however, this year has differed widely from last in that conditions have *never* been bad throughout the twenty-four hours. We have had several days on which there has been little to listen to until the evening; but evening conditions seem to have been normal or super-normal all the time.

## 19-metre Americans

Those who are keen on short waves for their programme-value (as distinct from the thrills of occasional DX reception) must have been pleased with the behaviour of the 19-metre Americans during the past month. W2XAD, on 19.56 metres, has been tremendously strong and also perfectly reliable.

### SEND US YOUR SHORT-WAVE LOGS!

*Short-wave receiving conditions vary from hour to hour, and what an enthusiast records in, say, Glasgow is not necessarily heard in Exeter. Short-wave enthusiasts are always interested in what others receive. It is our intention to make this monthly feature of world-wide interest and all short-wave listeners are asked to send their reports on current conditions and outstanding captures to G. Howard Barry, "Wireless Magazine," 8-11 Southampton Street, Strand, London, W.C.2*

It seems a pity (from our point of view) that this station closes down at 9 p.m., since the American amateurs continue to increase in strength for fully two hours after that time.

At the time of writing W2XAD signs off at 9 p.m. and W2XAF

(31.48 metres) takes on the tale at 11.30 p.m. The new summer schedule may possibly be introduced before these notes appear in print.

An interesting station to listen to is PMA, Bandoeng, Java, on 15.5 metres. Officially, this is a commercial telephone station; but it may be heard in the guise of a broadcasting

By  
**G. HOWARD BARRY**

station during the mornings and early afternoons. When I first logged PMA it was putting over some of the most amazing native music I have ever heard, and I was quite at a loss to identify the station until I heard the familiar announcements in Dutch and English.

As I predicted recently, the 19-metre band is rapidly filling up and bids fair to become the centre of short-wave interest this summer. The 49-metre band is suffering somewhat from the tremendous strength of local stations and the approach of summer atmospherics; the 31-metre band is erratic, but the wavelengths below 30 metres are coming into their own once more.

Almost any evening on 19 metres one can hear eight or nine strong stations, many of which do not yet appear in the call-book. One, which I did not identify definitely, made an announcement about Costa Rica and I rather suspect that it was our old friend TI-4NRH at Heredia. This amazing little station used to make himself heard all over the world with an output of  $7\frac{1}{2}$  watts, and once claimed to be the smallest broadcasting station in the world.

VP-1A at Suva, Fiji Islands, has now been definitely logged in this country as well as in many parts of the U.S.A. This station works on 22.94 metres from 6.30 to 7.30 a.m. B.S.T. and is by no means easy to receive.

With regard to the amateur bands, as one would expect from the foregoing remarks the 20-metre band is the centre of activity. It is not uncommon to hear all continents on this band within a few minutes, conditions being at their best between 7 and 11 p.m. In the early mornings, however, stations in Hawaii, Alaska, British Columbia, and the West Coast of the U.S.A. may often be heard.

## Eight K6's at 7 a.m.

On one morning at 7 a.m. there were eight stations on the band and every one of them was a "K6" (Hawaii)! Stations in that part of the world seem to come in with unflinching regularity during the early mornings in May and June and are very seldom heard at any other time.

Short-wave enthusiasts who have no interest in Morse are being well catered for by the U.S.A. amateurs using telephony. Many of them use powers of 400 watts or more and come in nearly as well as the 20-kilowatt broadcast stations. W8GLY, W1AJZ, W2HFS, W2HHG, and W2GOQ are among the best that I have heard recently.

## British Amateurs on 20 metres

Our own amateurs are taking up the challenge and many British stations may be heard "Calling U.S.A. and Canada" on the 20-metre band after 10 p.m. I must not forget to compliment most of these stations on the admirable quality of their transmissions; much of the telephony is of quite irreproachable quality and would not disgrace that of the B.B.C.

10 metres, as I predicted, has awakened at last and we are already hearing distant stations in this country. Many Europeans come in quite strongly, and harmonics of American commercial stations show that it will not be long before two-way work with the U.S.A. is opened up again after a lapse of six years. Worth looking forward to!



# A Triode-hexode for the Ultra-short Waves

Of special interest is the introduction of the triode-hexode, a valve that will play an important part in the design of superhet receivers for use on the ultra-short waves, both for radio and television. Here we present a special contribution by an authority on valve design who describes the new valve and shows how it can be used

**T**O-DAY'S preference for the superhet renders the frequency-changing stage one of first importance, and the advent of television seems to indicate still further necessity for its development. Hence the more than ordinary interest attached to the new triode-hexodes, which have just been released to the public.

### Double Assembly

These valves, known as the X41 and X31, are for A.C. and A.C./D.C. sets, having 4-volt and 13-volt heaters respectively. They consist of two sets of electrodes built round one cathode (Fig. 1 (c)). Below the heptode assembly is a triode designed to oscillate easily at wavelengths down to 10 metres and lower; the four-grid hexode above is the rectifying unit of the frequency-changing circuit.

Signals are fed to the grid nearest the cathode ( $G_1$ ), which is of the variable- $\mu$  type. The second grid ( $G_2$ ) is merely a screen, as also is the fourth ( $G_4$ ). To the third grid ( $G_3$ ) is connected the grid of the triode ( $G_0$ ).

The connections for the triode-hexode are exactly the same as those

for the ordinary heptode—a seven-pin base and a top cap (Fig. 4).

So it appears that what we have done here is to split up a heptode and re-arrange the electrodes in a more complicated manner. The inevitable question is why?

We can best answer this by mentioning some of the problems that arise when frequency changing at the higher radio frequencies.

First of all, capacities which are a source of circuit coupling have an increased effect. This is reflected in the degree of "pulling" which the tuned input circuit (to  $G_1$ ) exerts on the oscillator circuits, and is aggravated

by the fact that the percentage frequency difference between these circuits is also reduced as the carrier frequency rises.

### Less Pulling

The heptode and octode both possess enough capacity between  $G_1$  and  $G_2$  (Fig. 1 (a)) to render "pulling" a nuisance below 15 to 20 metres, although the latter valve can be made to work as low as 10 metres reasonably well—this is, of course, with commercial circuits. The triode-hexode oscillator anode ( $A_0$ , Fig. 1 (c)) corresponding to the above ( $G_2$ , Fig. 1 (a) and (b)) is outside the

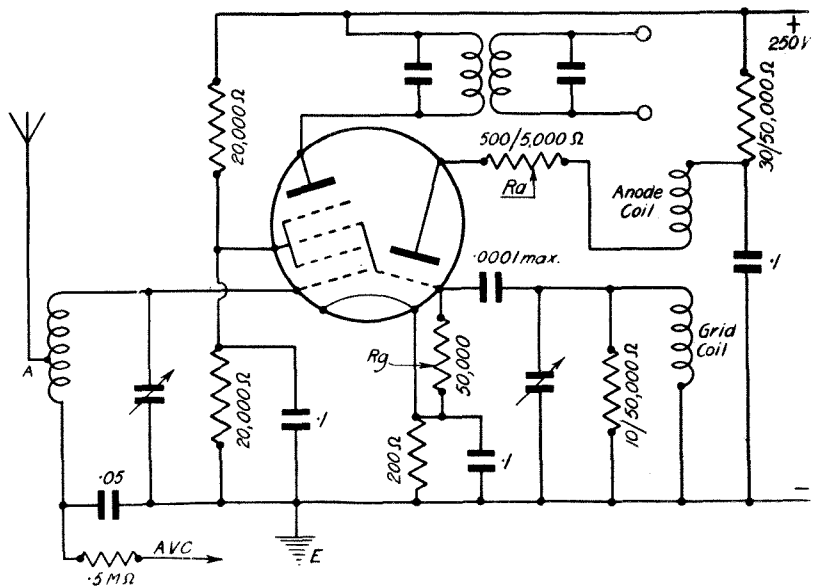

Fig. 2.—A basic circuit using the new triode-hexode intended for preliminary experiments

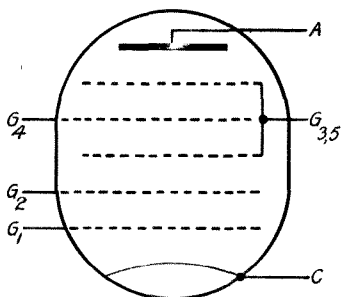

Fig. 1 (a).—The internal arrangement of the ordinary heptode

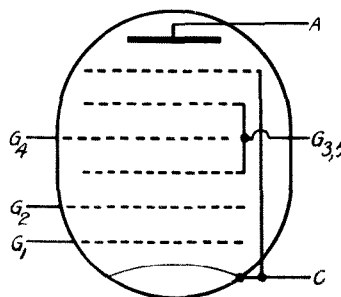

Fig. 1 (b).—The internal arrangement of the octode

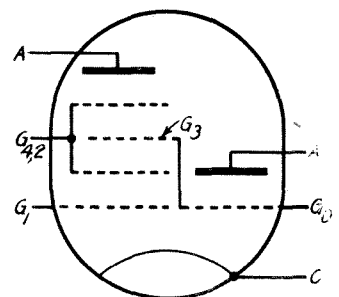

Fig. 1 (c).—The arrangement of the triode-hexode with two sets of electrodes grouped round one cathode

field of the hexode input grid, and this change reduces pulling to approximately one-tenth that of the heptode on the 10-to 20-metre range.

Then it is important, in order to maintain the highest possible conversion conductance, for the anode current to be modulated fully by the oscillator. This can only be achieved

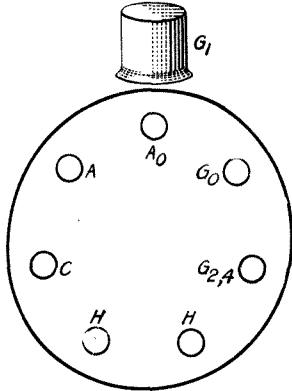

Fig. 4.—Showing the connections to the triode-hexode when looking at the underside of the valve base

by producing an adequate radio-frequency voltage on the modulating grid.

Whether this can be done with satisfactory coil design depends on several factors, including the ratio of maximum to minimum capacity across the tuned circuit, the coil efficiency, and the slope of the oscillator itself. The first is fixed by the type of condenser commercially available with a minimum around 30 to 50 micro-microfarads and the usual maximum, 350 to 450 micro-microfarads.

**Slopes**

The last is a function of the valve design, and in the cases under discussion is limited by the necessity for having a small anode area in order to keep down its modulation effect and its capacity to neighbouring electrodes; thus the slopes available are about 0.4 to 0.7 milliamperes per volt.

Short-wave-coil design with these slopes is difficult, as the L/C ratio is poor and a large reaction winding becomes necessary with the almost inevitable introduction of dead spots and spurious oscillations. But

in the triode-hexode the anode dimensions can be increased and a slope of 1.5 milliamperes per volt is actually used.

It then becomes quite a simple matter to design suitable coils of adequate efficiency and moderate cost.

The third advantage claimed for the triode-hexode is immunity from oscillator-frequency drift when the bias on the hexode input grid ( $G_1$ ) is varied. The phenomenon is noticed in single cathode stream valves because in these the change of bias produces an alteration in the oscillator anode current, resulting in a change in the inter-electrode capacity and impedance of the triode. Here the triode is a separate entity removed from the influence of  $G_1$ , and no such effect occurs.

The point may possibly be of minor importance in the ordinary broadcast receiver, where the tuning characteristic of the intermediate-frequency stage is of the band-pass type, but in highly selective circuits, such as those of the Stenode, or in short-wave receivers where the intermediate-frequency is, as we have seen, relatively small compared with the oscillator and signal frequencies,

the drift is enough to cause asymmetric amplification of the sidebands, with the usual unpleasant results. In bad cases it is possible that severe fading of the required station may result in the introduction of interference from the neighbouring channel.

As designed, the new valves have a maximum conversion slope of about 0.6 milliampere per volt, which is not a high value, but is a useful figure, particularly as their high impedance of 2 megohms enables really efficient I.F. circuits to be employed to fullest advantage, as regards both gain and selectivity.

**Basic Circuit**

We give a basic circuit (Fig. 2) with component values for preliminary work. A special point to note is that the oscillator condenser should be very small, the given value being a maximum; a thin piece of mica between two brass plates each the size of a sixpence is a useful construction.

The resistances  $R_a$  and  $R_g$  are inserted to assist in keeping a level oscillator voltage, and the wide range of values is shown in order to allow for individual layouts, etc.  $R_a$  should be as small and  $R_g$  as large as possible within the given limits.

Alternatively,  $R_g$  can be kept fairly high and the desired adjustment made by variations of the grid resistance marked 10,000 to 50,000 in the diagram. There is little to choose between the two methods.

Coils for the circuit can be of the usual interchangeable type, suitable forms being available in Eddystone, B.T.S., and Hammarlund makes. It may be found that a slight reduction in the number of turns on the reaction winding is permissible, but it is probable that satisfactory functioning will be obtained merely by adjustment of the resistances mentioned.

For the ultra-shorts it will usually be necessary to wind coils specially for use with the new valve. The customary construction with well spaced turns on a very small diameter former will serve.

F. Y.

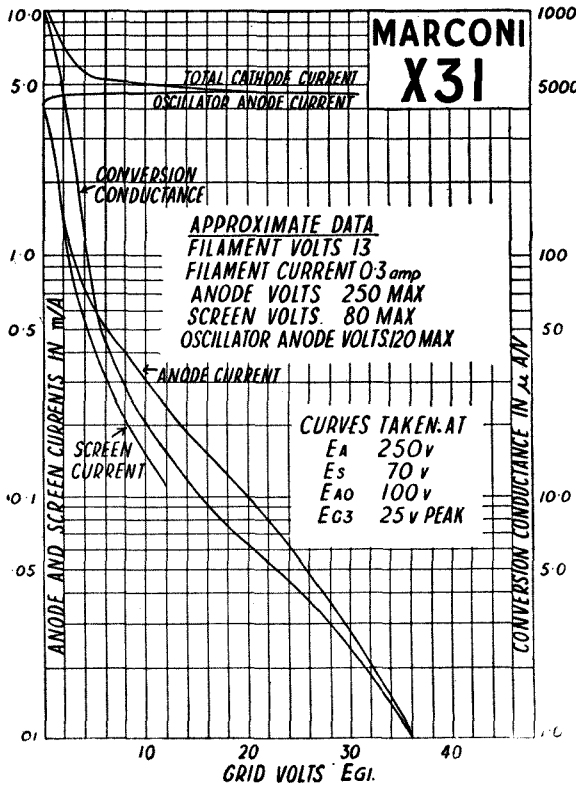
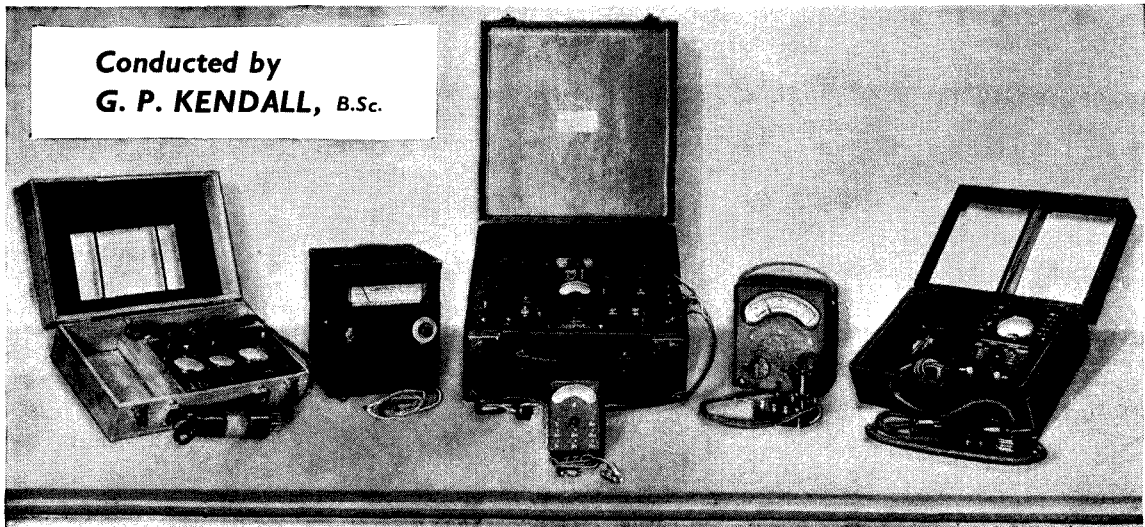

Fig. 3.—The characteristic curves of the Marconi X31 triode-hexode, a valve for use in universal A.C./D.C. superhets



A selection of test gear recommended by Brown Bros. for the service engineer. In the centre is the Radiolab test meter and in front of it is the Avominator. To the right of this is the Avometer and Weston Analyzer and on the extreme left is the Emco testing outfit and a Radiolab oscillator

# Hints for the Service Engineer

Each month an article appears in "W.M." designed to assist the radio service engineer. Any service engineer who comes up against knotty problems is invited to write to the author who will be pleased to discuss any questions sent to him. As so many interesting points are dealt with, every keen radio fan who makes his own "running repairs" is bound to find some subject or hint of interest to him

**M**Y first duty this month must be to direct your attention to the audio-oscillator design provided for us by Paul D. Tyers. A piece of apparatus of this type is really one of those luxuries which almost amount to a necessity; it is a design that can be put together so economically, that no one need have any doubts as to whether the expenditure is justified. An instrument like this can be made to pay for itself many times over.

## Full Measure

I should like to take this opportunity of expressing to Mr. Tyers the thanks of myself and, I am sure, the readers of this section, for the very excellent piece of work he has done for us. I originally asked him only for an oscillator to produce "a tuneable squeak," and should have

been content with one giving an output quite bristly with harmonics.

What he has actually given us is an instrument providing quite a respectable wave-form and with a harmonic output no higher than that of many oscillators intended for laboratory purposes.



Given a calibrated oscillator and some sort of output measuring device one can investigate the behaviour of low-frequency amplifying circuits very thoroughly. If a customer complains of lack of bass from some outfit with which you are not familiar, it becomes a very simple matter to hitch up the oscillator, run down the scale and see where the output begins to drop.

If it falls off audibly while the meter is still showing a useful amount of output you know that the trouble is loudspeaker deficiency, while a simultaneous drop both to the ear and the meter tells you that the low-frequency amplifier is most probably to blame.

Again, if you find what seems to be a nasty cabinet resonance in the bass, the combination of output meter and oscillator may save you a lot of time. First locate the boom frequency, then vary the oscillator setting a little either way and watch the output meter.

If the output remains sensibly constant your first guess was probably right—the cabinet is to blame. Sudden output current variations around the boom frequency, on the other hand, mean that the peak is more likely due to a loudspeaker imperfection.



Mention of output meters reminds me that I have recently received for review a sample Radiolab instrument which has interested me very much. One has been inclined in the past to regard output meters as expensive luxuries out of the reach of the average individual, but here is a perfectly practical instrument for the modest price of £3 15s.

## Compact and Neat

It is of small and convenient dimensions, measuring only 2 $\frac{3}{8}$  in. by 2 $\frac{7}{8}$  in. by 1 $\frac{1}{4}$  in. and weighs 17 oz.—almost a pocket instrument, in fact. (Not that small size is a merit in itself, but it is certainly a factor which the service engineer must take into account.)

There are three ranges: 0-40 milliwatts, 0-400, and 0-4000, covering the principal areas in which one is interested in most test work. The ranges are selected with a small switch, and the fact that the instrument is completely direct-reading

seems to me a very strong point in its favour; one does not appreciate even simple calculations in the middle of a hurried job of testing.

Another good feature is the fact that a scale of decibels is provided in addition to the milliwatt calibration. The datum line for this is fixed at 50 milliwatts, and the scale extends for 9 decibels above and 10 decibels below this level, which should cover the more ordinary

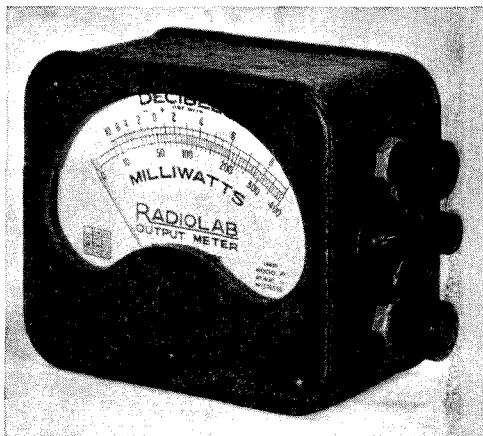

The Radiolab output meter has a switching device, giving three different ranges with an additional calibration in decibels

requirements. (Note: There is a type of customer possessed of a certain degree of technical knowledge who is definitely impressed with decibels. Whether it is fair to exploit the fact I leave to your own consciences, but if you decide that it is, well, here is an instrument which will be a great help!)

#### Excellent Value

I have given the meter quite an extended trial and have formed a very good opinion of its value. At £3 15s. it is definitely well worth consideration. Although a fully calibrated output meter has in the past been a dubious investment for the man engaged on the simpler types of servicing, at this figure it certainly becomes a potentially profitable investment.

Here is an old catch still capable of tripping up some of us in our unwary moments: a set gives acute signs of microphonic trouble, rings loudly when jarred, and may even build up into a howl, but complete change of valves makes little or no difference.

If ever you meet this in a superhet with built-in loudspeaker go straight to the tuning condenser and see if

it shows signs of undue flimsiness or looseness of plates. If the oscillator section can act as a microphone it can cause all these effects.

The vogue of all-wave receivers in America suggests that it will be as well to prepare for a similar popularity in this country. So far there are comparatively few such types on the market over here, most British manufacturers having declined to be stamped into producing half-baked designs to meet a sudden demand of unknown extent.

In America it appears that the opposite method was adopted, and the misbehaviour of many of these rushed jobs has given the all-wave idea a black eye in the public estimation. That is very unlikely to happen here, but it behoves the service engineer to acquaint himself with the facts of short-wave reception in anticipation of the time when he may expect to have to deal with all-wave types of sets.

It seems that some of the most acute troubles with the American sets have been due to slight weaknesses in the tuning dial: mechanism perfectly satisfactory on the broadcast waves may be quite incapable of the delicacy and accuracy of control essential on short waves. Servicing here is usually a matter of inspection and an attempt to remedy the mechanical weakness or misadjustment causing the trouble.

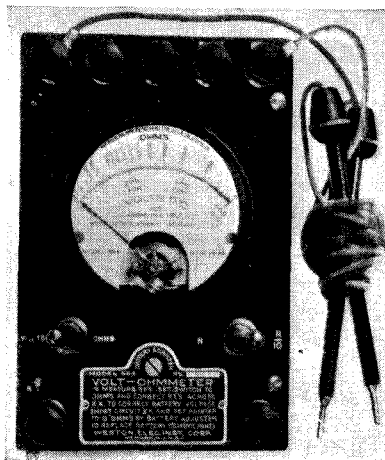

A useful accessory for the service engineer is the Weston volt-ohm-meter which measures from 0 to 600 volts (D.C.) in addition to a resistance range of from 0 to 1 megohm

In some instances aerial troubles are encountered, but in the case of the better types of superheterodyne receiver this is rare: there is usually proper provision for eliminating aerial effects in these circuits and they can be used with any aerial found to be of adequate efficiency on the broadcast waves.

#### Exaggerated Performance

Unscrupulous sales methods on the part of some of the smaller organisations would seem to be one of the real problems of the all-wave receiver in America.

The fact that phenomenal feats of long-distance reception are readily possible on short waves at certain times seems to fire the imagination of a certain type of advertisement writer to such an extent that he conveys the impression to the public that these wonderful results can be obtained *at any time*.

#### Short-wave Times

The natural result is considerable dissatisfaction with the actual performance obtained; it is therefore necessary for the service engineer to take the precaution of familiarising himself with the proper times for listening on the various wavebands.

Here's another puzzling fault with a simple explanation: there is a rather inexpensive battery set which employs a single screen-grid stage with a form of tuned anode high-frequency coupling, and its ganging adjustments behave in a peculiar fashion. I first heard of it when an acquaintance asked me to explain the mystery in the case of his particular set, which seemed to need retrimming at quite frequent intervals.

#### De-trimming

I found that it was true that the ganging adjustment did not seem to stay put, for I trimmed the set myself and asked the owner to leave it untouched until results again became poor, which in about a week they did.

Not to make too long a story of it, I found that this was one of those sets which gives only slightly impaired volume when the low-tension voltage has fallen quite considerably. The natural effect upon the valve characteristics altered the equivalent tune of the anode circuit to show up as a ganging

Continued on page 422

Intended originally for the benefit of our service-engineer readers, this audio-frequency oscillator has proved to be an instrument of such wide application and usefulness that we strongly commend it to the attention of everyone interested in serious experimental work. It costs very little to make and can be calibrated with sufficient accuracy by methods to be described later

The "W.M."

# Audio Oscillator

Designed by PAUL D. TYERS

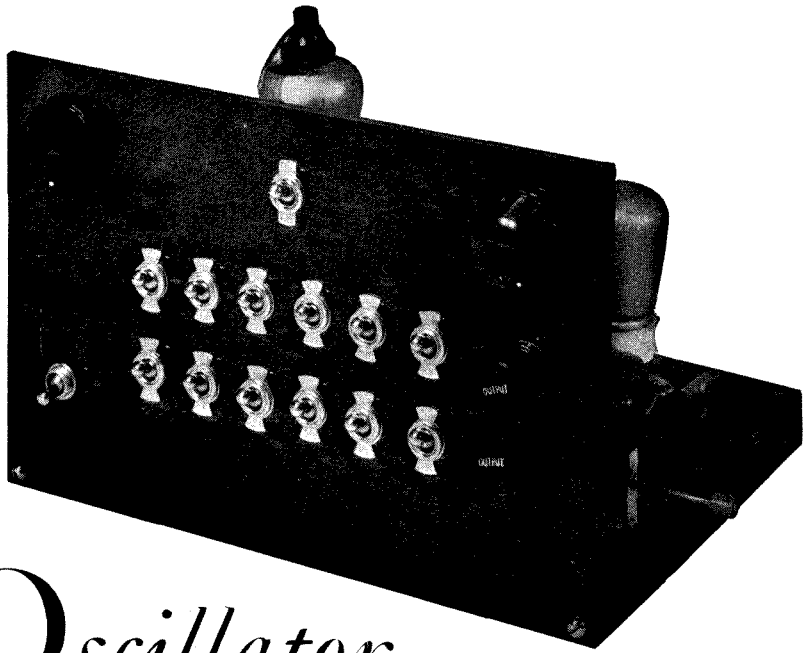

A very simple panel and baseboard construction is used, and control is effected partly by means of the range switches and partly with the aid of a variable-inductance choke

IT is unnecessary to point out that an audio-frequency oscillator is essential for any work involving investigation of the audio response of an amplifier or reproducing system. Laboratory-grade instruments are somewhat expensive, and accordingly they are not usually found amongst the service engineer's equipment.

Such an instrument, however, would be of value to the service man and it is for this reason that I have been asked to describe how such an oscillator may be constructed on simple and inexpensive lines.

## Pure Wave Needed

There is nothing easier than to make a valve oscillate at an audio frequency, but to obtain a sinusoidal wave-form is an entirely different matter. It is not exactly difficult, but it seems to be a subject to which little thought is given except by specialists.

I have actually noticed that in many modulated oscillators the so-called audio-frequency note frequently turns out to be nothing other than an appalling collection of harmonics. This is due to the fact that no trouble has been taken to ensure that the audio-frequency valve generates a sinusoidal wave.

Readers who attempt to construct an audio-frequency oscillator, therefore, should bear this point very fully in mind. An oscillator which does not give a good wave-form is sometimes even worse than useless because it may give fallacious results.

It is important to realise that all alternating current measurement implies a sinusoidal wave-form. If, therefore, one is taking measurements with an oscillator having a very badly peaked wave with a large harmonic content the results will be totally fallacious.

There are two fundamental methods of generating oscillations. In the first place one can use regeneratively coupled circuits with inductances or tuned circuits connected in the grid and anode circuits of a triode. The second system is to use the negative-resistance characteristic obtained by virtue of secondary emission in a dynatron circuit.

The latter seems more attractive because only a single coil is required, whereas a regenerative circuit requires two coils. As a result I would suggest the use of a dynatron oscillator because it is so easy to utilise simple inductances and condensers.

It would be out of place to go

fully into the theory of generation of oscillations by a triode or a dynatron. It is useful, however, to mention one or two rather important points that are best understood by considering the action of a regenerative triode.

## Maintaining Oscillation

An alternating voltage impressed on the grid causes an amplified voltage to be produced across any load in the anode circuit. If this load is in the form of an inductance magnetically coupled to an inductance in the grid circuit, energy will be transferred to the grid circuit and the process will continue indefinitely. In other words, the continuation of self-oscillation is maintained.

## Distortion !

It is obvious, however, that if one couples back too much energy there is a possibility of too great a grid voltage being produced which will sweep the operating point off the effective grid base of the valve. Immediately one produces a condition of distortion and the oscillation generated by the valve is no longer sinusoidal.

It is for this reason that a well-designed audio-frequency oscillator is always provided with some means

for controlling the oscillation, and the purest wave-form is obtained when just the right amount of voltage is fed back to the grid circuit.

The conditions in a dynatron oscillator are not exactly the same. In the first place oscillations are only produced on the negative resistance portion of the characteristic. The tendency for a valve to produce oscillations is dependent upon the dynamic resistance of the

utilised for the present oscillator.

The accompanying photographs show a convenient arrangement of the oscillator. Attention is drawn to the circuit, from which it will be seen that everything is very straightforward. Use is made of two inductances, which are connected in parallel with a number of condensers, each controlled by a snap switch.

One inductance has a fixed value and the other is variable. The

object of the variable inductance is to enable the frequency to be adjusted continuously, which is very necessary when searching for resonance points in a loudspeaker.

In order that the frequency shall not be affected by the external load a buffer amplifying valve is connected to the oscillator, simple resistance coupling being used between the anode of the oscillator and the grid of the isolating valve.

### How to Use It

The output of this is again resistance coupled and the final output of the unit is suitable for working into an amplifier or the pick-up sockets of a receiver. It is, of course, not intended for direct connection to a loudspeaker.

It is necessary to have an output volume control, and use is made of a potentiometer which actually serves as a grid leak to the separating valve. The other potentiometer controls the bias on the dynatron oscillator which is obtained from a grid battery. It is found convenient to utilise a double snap switch for the on-off control; one side of this connects the filament circuits and the other connects the bias battery to the potentiometer controlling the grid bias on the oscillator.

### "Elastic" Construction

In building an oscillator of this type practically no precautions are necessary: the components can be mounted in any convenient position,

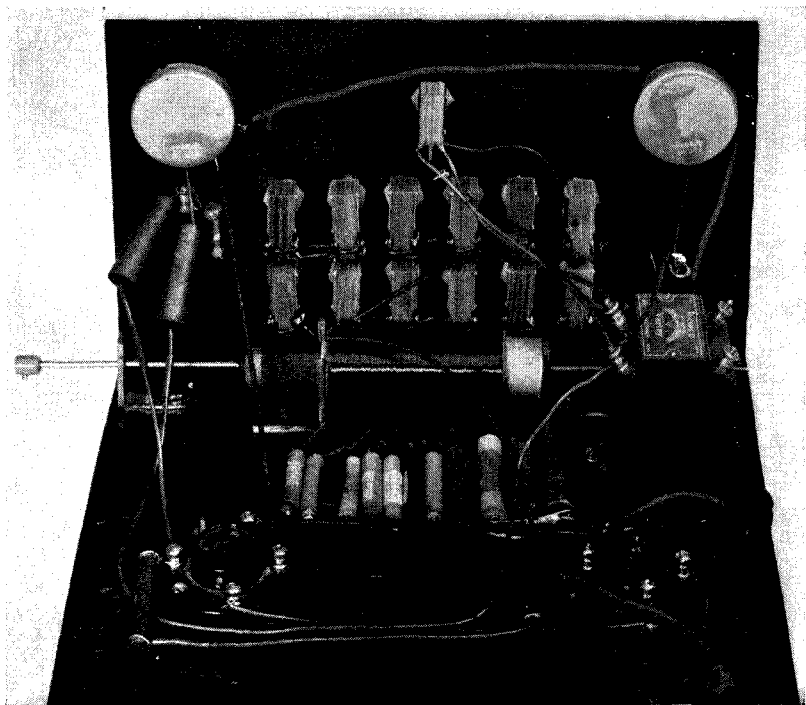

The variable-inductance choke is mounted by means of two small brackets fixed to the baseboard just below the group of range switches on the panel

frequency-determining circuit and the constants of the valve.

A very convenient way of controlling a dynatron oscillator is to utilise a screened-grid valve in the following manner. The frequency-determining circuit is connected to the anode and the screen grid is taken to a higher source of potential than that applied to the anode. Secondary emission is produced in the ordinary manner. The grid, however, is taken to a variable bias point so that the anode and screen currents can be controlled and the characteristic of the valve can be altered at will.

### Under Full Control

In this manner it is possible to control the oscillations so that the operating point on the anode-current anode-voltage curve only works between the desired limits. It is this system which I suggest is

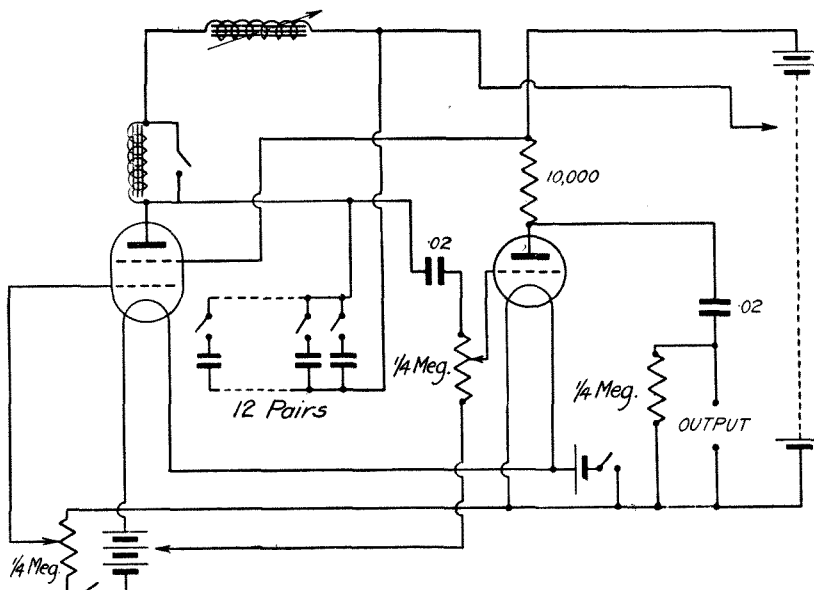

The circuit is comparatively simple. The oscillator is a screened-grid valve functioning as a dynatron and the necessary variations of frequency are obtained by means of a group of fixed capacities and a variable inductance

and the arrangement of the wiring is of little importance. Readers will no doubt have their individual views on the best method of making the oscillator, and in this direction there is considerable scope for ingenuity, particularly regarding the control device for the variable inductance.

In the experimental oscillator shown in the photograph a very simple push-rod system is used for moving the iron core, and it is suggested that the rod be fitted with a pointer which works in conjunction with a small scale divided into ten equal parts. The scale can be arranged to slip inside the cabinet, or, alternatively, it can be fitted on a hinge so that when the instrument is not in use everything is quite compact.

### Frequency Control

The various frequencies are produced by means of twelve condensers connected in parallel with separate snap switches. These are arranged to shunt either the variable inductance, or the variable inductance in series with the fixed inductance.

For the fixed inductance use is made of the primary winding of a Varley Nicore II low-frequency transformer. It is not essential to use this particular transformer, but the actual value of the inductance under working conditions happens to be quite suitable.

The variable inductance has to be built specially. This consists of a paxolin tube  $3\frac{3}{4}$  in. long and  $\frac{7}{8}$  in. internal diameter. It is fitted with two very small end cheeks and it is then filled with 7,600 turns of No. 40 gauge enamelled wire.

The sliding iron core is conveniently arranged by binding a number of strips of Stalloy on a central rod which can be carried on two small brackets. Movement of the rod, therefore, displaces the core inside the winding and varies the inductance.

The core should be of the same length as the tube, and should be a loose fit therein.

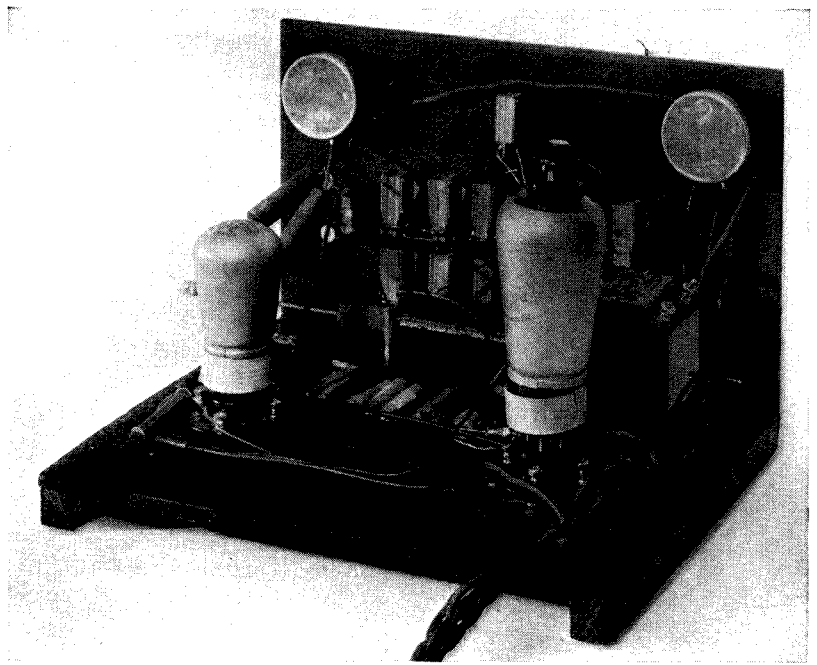

Battery connections take the form of a cable of flex leads joining direct to appropriate points in the wiring of the oscillator. Output connections, of course, come from two terminals on the front panel

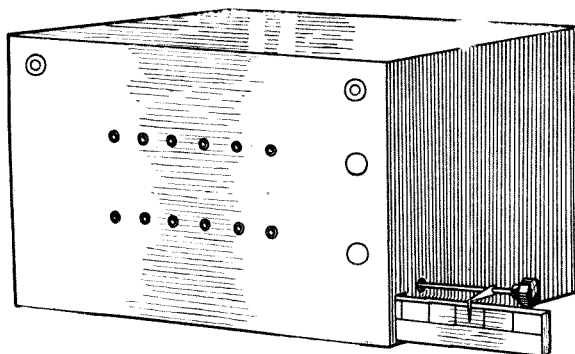

The designer suggests the use of a simple cabinet such as the one sketched here, provision being made to allow the control rod of the variable-inductance choke to project from the end

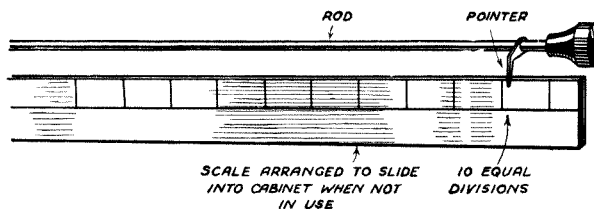

A simple sliding scale can be provided with advantage for the tuning-choke control

It has already been pointed out that the best wave-form is obtained when the valve is in a state of gentle oscillation. The oscillation condition is controlled by the grid potential. This control will slightly affect the frequency of generation and accordingly when calibrating each measurement should be made with the control set so that the valve is just oscillating.

Owing to the variations in tolerances of commercially produced inductances and condensers it is impossible to give the exact settings for various frequencies. The 1,000 cycle frequency setting can be checked approximately by comparison with the B.B.C. tuning note.

### Calibration

The easiest method of calibration, however, is to use a piano. The fundamental frequency of an octave above middle C is 512. The exact frequency varies slightly with various pianos, but that is the recognised modern orchestral frequency, and is that employed by the B.B.C. Octaves above and below are direct multiples or sub-multiples of this frequency, and accordingly it is a very easy matter to obtain accurate calibration.

Before calibrating, however, experiments must be conducted to determine the correct condenser groups to use for the various ranges. The highest frequencies are obtained with the aid of the variable inductance and the fixed condensers. The very highest note is given with all the condensers out and the moving iron core in the minimum position.

The first range is then obtained

**COMPONENTS REQUIRED FOR THE "W.M." AUDIO OSCILLATOR**

**BASEBOARD ASSEMBLY**  
 1—Baseboard, 10 in. by 8 in.  
 1—Panel, 10 in. by 7 in.

**CHOKE**  
 1—Special sliding core.

**CONDENSERS, FIXED**  
 2—.02 fixed.  
 12—Various (see separate list).  
 (T.C.C. and T.M.C.-Hydra were used in the original; any good make can be used, but the wire-end cartridge type is probably the most convenient.)

**RESISTANCES, VARIABLE**  
 2—Reliance .25-megohm volume controls.

**RESISTANCES, FIXED**  
 1—Amplion .25-megohm.  
 1—Amplion 20,000-ohm.

**SWITCHES**  
 1—Bulgin D.P. on-off snap.  
 13—Bulgin S.P. on-off snap.

**TERMINALS**  
 2—Belling & Lee terminals, marked output.

**TRANSFORMER, LOW-FREQUENCY**  
 1—Varley Nicore 11 low-frequency.

**VALVES**  
 1—Mullard, type PM2A.  
 1—Mullard, type PM12A.

**VALVE HOLDERS**  
 2—Bulgin 4-pin valve holders.

by pushing the core forward until it is completely inside the coil. A note of this frequency must be made, and the core is then withdrawn and fixed condensers are switched in parallel until the same note is obtained but with the core in the minimum position. This provides the next range.

**Range by Range**

The process is continued until the valve ceases to oscillate or will not go any lower with the first coil. The fixed coil, in the form of the primary winding of the transformer, is then switched into circuit, the moving inductance core withdrawn, and condensers are switched in parallel until the last note is duplicated. In this way various condenser groups are obtained for the various ranges. As soon as this is complete, calibration is then carried out with the aid of a piano as indicated.

So far as the valves are concerned, those used are of little importance. Any ordinary 2-volt screen-grid valve is suitable as the oscillator.

The output of this should be coupled to a small triode, such as a Mullard PM2A. The grid base of this valve is sufficiently large to prevent any possibility of overloading.

It will be found that with the grid-bias control on the oscillator set near the minimum the power output is very small, but this is desirable because otherwise there will be considerable harmonic distortion. As a result the total output from the oscillator unit is quite low and no attempt should be made to over-drive it with the object of getting increased power.

It is quite possible to form an opinion of the harmonic content merely by listening to the quality of the note. A pure note will have a clear ringing tone but any suspicion of a twang indicates a high harmonic content. This may be readily observed by reducing the bias on the operating valve, and it will be particularly noticeable on middle and low frequencies.

The uses of such an oscillator are many, amongst which may be men-

tioned the following. The location of cabinet resonances or mechanical jingles in loudspeaker systems are readily identified simply by connecting the output of the oscillator to an amplifier or the pick-up sockets of a receiver.

The oscillator can also be used for measuring the audio-frequency response of a set if an output meter and valve voltmeter are available.

It also provides a convenient power source for conducting measurements in which audio frequencies are required. It is sometimes necessary, for example, to

1	0.25	Mfd.
2	0.1	"
3	0.02	"
4	0.01	"
5	0.01	"
6	0.002	"
7	0.002	"
8	0.002	"
9	0.002	"
10	0.001	"
11	0.0005	"
12	0.0001	"

measure the impedance of a moving coil at a given frequency. The current for this purpose can be obtained by amplifying the output of the oscillator.

In short, the unit can be used for almost any purpose where an audio frequency is required, and provided no attempt is made to over-drive the valve the wave-form is sufficiently good for any ordinary measurement.

(Some further notes on calibration and working voltages will be given next month.)

**HINTS FOR THE SERVICE ENGINEER**

*Continued from page 418*

mis-alignment—if one took the trouble to trim on a really weak station with the reaction well up.

This is just one of those things which it pays to keep at the back of one's mind.



Another somewhat unusual but interesting battery set puzzle is provided by the receiver which appears to suffer from slow fading even on the local station. This effect is less common than it was in the earlier days of really bad high-tension batteries, but it still occurs in certain cases. It appears to be a battery phenomenon asso-

ciated with polarisation when the cells are growing old, and although unusual with modern batteries is not unknown.

**INTERESTING INSTRUCTIONAL COURSES**

WE have received a copy of the prospectus of the Technical and Commercial Radio College, of Cromwell House, High Holborn, London, W.C.1, which appeared to us of such general interest that we took steps to examine some of the actual material furnished to its pupils.

The favourable impression made by the prospectus is well borne out by the sample "lessons" which we

read, and which are very well prepared. The instruction provided is clear, painstakingly thorough, and appears to us to represent a very conscientious effort to impart a really sound professional knowledge.

Various courses are available, intended to cover the needs of the amateur who aims at the fuller enjoyment of his hobby which comes from greater knowledge, the man who wishes to make radio his profession, and the service engineer.

We commend the very straightforward policy of the College in the matter of the assistance it can give in obtaining employment for the students who have completed a course; no wild promises, but clear indications of a sincere effort to help whenever possible.



# Coils for the New-style Short-wave Unit

Last month we presented complete details for building a short-wave adaptor using Eddystone coils. As we promised in our June issue we are giving a revised wiring diagram showing the connections for B.T.S. coils. This adaptor can also be used as a single-valve receiver

**A** MONTH'S listening on the New-style Adaptor, in conjunction with a gramophone amplifier and loudspeaker, has convinced me that there is a certain thrill about short-wave loudspeaker work that is missing from headphone reception.

Conditions, admittedly, have been favourable, for the Americans have been coming over well on all bands; atmospheric, however, have been very troublesome on 31 and 49 metres although, admittedly, they do not worry one so much on the loudspeaker.

### Different Readings

I had intended to give a detailed list of dial-readings, but, in view of the fact that readers have been asking for the necessary modifications to enable the B.T.S. short-wave coils to be used, I have prepared a new diagram giving this information.

As the wavelength-ranges covered by these coils are quite different from those of the coils originally used, there does not seem to be much point in logging dial readings.

### B.T.S. Coil Ranges

Suffice it to say, however, that the ranges, as stated by the makers, with B.T.S. coils are 13-26 metres, 24-52 metres and 46-96 metres. Thus the three lowest broadcast bands (16, 19 and 25 metres) are most conveniently received on the smallest coil, while the second one includes both the 31- and 49-metre bands.

There is little point in using the biggest coil except for 80-metre amateur-band reception, although signal-strength on the 49-metre band is a trifle better than with the other coil—but at the expense of selectivity.

It must be clearly understood that the Eddystone and B.T.S. coils are

not interchangeable with the alterations in connections to the coil-holder. The B.T.S. coils have the grid coil wired across the plate and grid pins, while Eddystone coils have it across the grid pin and one filament pin.

There is little else to say about the Adaptor, except that I have found that the aerial-coupling condenser may need to be increased in capacity quite a lot when a really small aerial is used. This, however, is an adjustment that anyone can try out simply by varying the amount of twisted wire between the coil-holder and the aerial terminal.

I am strongly in favour of retaining

a fixed coupling of that sort (whatever value is chosen) since the accurate calibration of a short-waver is a tremendous help to the identification of new stations. It certainly is not possible when an adjustable coupling condenser is used.

One reader has written to me asking whether this unit can be used to bring in stations between 150 and 180 metres.

His object was to make certain that he could adapt his present set to Post Office messages to yachts at sea which are sent out on about 165 metres. This adaptor will be found quite suitable for the purpose.

G. HOWARD BARRY.

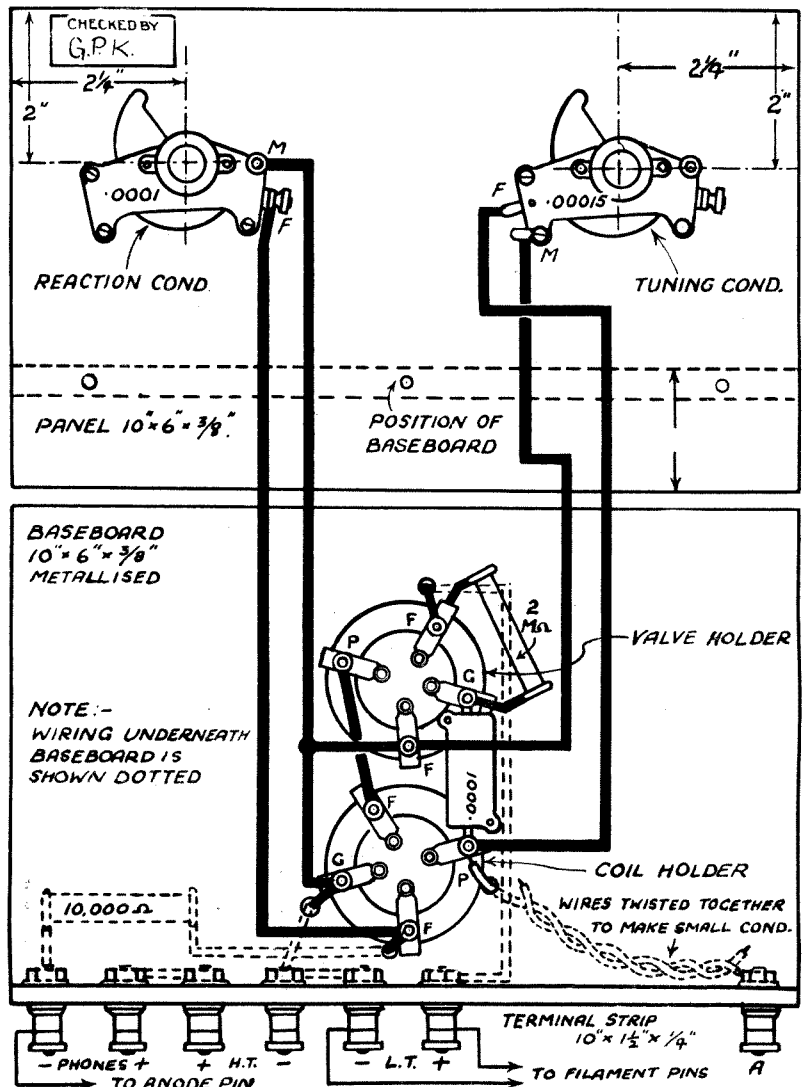

A wiring diagram of the "W.M." New-style short-wave Adaptor revised for using coils made by British Television Supplies. A full-size blueprint of this diagram is not available

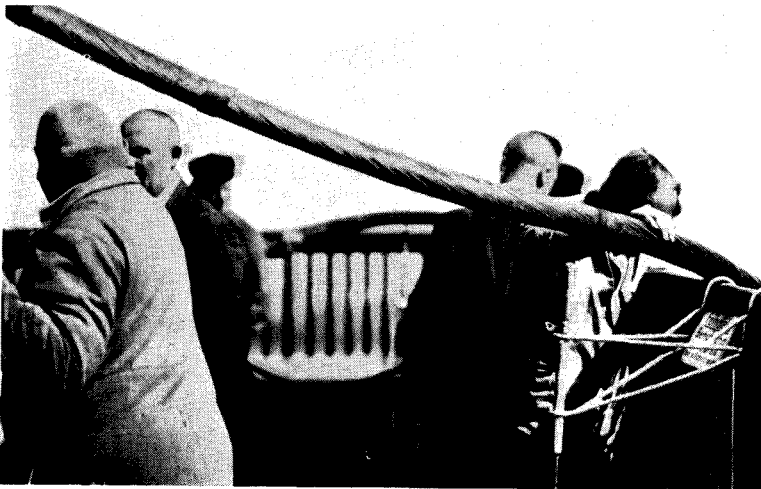

Special high-frequency cables are of great importance in television work of the high-definition type. Here is one of the new Berlin cable links being installed on the top of the Radio Tower

is stated to give a stage gain of over three times on a wave as low as 1 metre, and will naturally give a good deal more on longer waves. In spite of its very small size the valve has quite useful characteristics, the impedance being of the order of 1 megohm and the amplification factor about a thousand. Average plate current is about 1.5 milliamperes, while the screen takes another half milliamp.

Whether this particular valve will ever reach the British market I do not know, but I do hear rumours that the British companies are working on special types for the ultra-shorts. Such valves may not be strictly necessary for superhets of the basic

THERE are several interesting technical developments to report this month, for although there seems to be an irritating lack of major items of news, much research is being done behind the scenes and when we *do* get a service going many people will be surprised to find what progress has been made in the interim.

For example: the problem of juice supply for cathode tubes. It has been the custom of late to try to frighten the home constructor with stories of the extraordinary difficulty of this question, on the ground that, (a) dangerously high voltages are involved, and (b) rectifiers capable of dealing with these high pressures are bound to cost money in large lumps.

Those who have stressed the price question are likely to be annoyed when they see details of the new Mazda MU2 rectifier. It seems to be an extraordinary little tube, for it will withstand voltages up to 10,000 in the reverse direction and is rated for an actual working voltage of 4,000, at which pressure it will give 25 milliamperes. The filament requires only 1 ampere at 2 volts, and the price is 17s. 6d.!

Then there is the problem of a valve capable of giving H.F. amplification on such short waves as are likely to be used for the high-definition service. Such a valve is not essential in view of the probable use of superhets of comparatively simple types, but it would certainly be a handy thing to have available.

## Television Notes and News

By PAUL WOODWARD

It is consequently very interesting to see that a suitable type has just been introduced to the American market in the form of a high-frequency pentode of the R.C.A. "Acorn" variety. This valve, it may be remembered, is characterised by extremely minute size and exceptionally low inter-electrode capacity.

The size is actually so tiny that the bulb is no bigger than the end of one's thumb; it has no cap, and is usually suspended in the wiring like a wire-end resistance or other very small component.

The new type (known as the 954)

type, but they do open up interesting possibilities for the experimenter.

The German approach to the problem of developing a high-definition service seems to be very different from our own; not merely have they made a quick start with a service which they regard as definitely experimental, but they are taking steps to allow the public to form an opinion of its value without expense to themselves.

I learn that a number of public television receiving stations are being installed at various convenient points in Berlin, so that anyone interested may go and see for himself just what the service is like when properly received.

Here, by the way, is the latest information about hours of transmission in Germany. The figures it is to be noted, are in Central European time, but since there is little chance of any reader picking up the transmissions I have not wasted

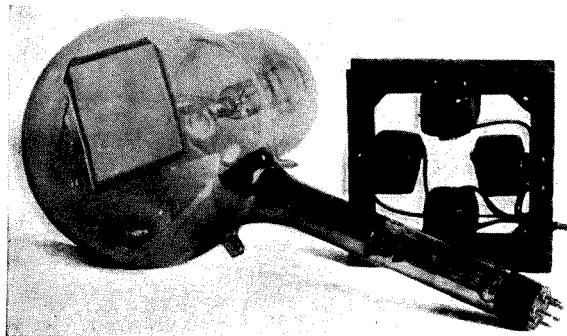

The essential parts of the Iconoscope television camera are seen here. The square frame carries an electro-magnetic system used in imparting the scanning movement to the electron beam

time converting them : they are just of interest as showing the amount of time being devoted to television in Germany.

	Broadcasting Company.	Post Office.
Monday	10-12 noon 8.30-10 p.m.	3-4.30 p.m.
Tuesday	3-4.30 p.m.	10-12 noon. 8.30-10 p.m.
Wednesday	8.30-10 p.m.	—
Thursday	3-4.30 p.m.	10-12 noon. 8.30-10 p.m.
Friday	8.30-10 p.m.	10-12 noon. 3-4.30 p.m.
Saturday	10-12 noon. 3-4.30 p.m.	8.30-10 p.m.
Sunday	8.30-10 p.m.	10-12 noon.

In addition to the above actual television transmissions there are "sound only" transmissions daily from 5 p.m. to 8.25 p.m. and from 10 p.m. to midnight. The vision wave is now 6.772 metres and the sound is transmitted on 7.06 metres.

Did you notice a highly significant remark that was made by the Chairman of the Marconi Wireless Telegraph Company in his speech at the Annual General Meeting? If you remember what I said last month about the real facts of the wavelength and definition question I imagine it will surprise you. Here it is, "We are ready to supply transmitters capable of providing a public service of high-definition television with 405 lines and 50 pictures per second."

I notice that those misguided people who spend a great deal of time and effort trying to prove that the mechanical system is better than the cathode tube, even for high-definition, are still claiming that the tube cannot be made to give enough light for domestic conditions.

To read some of these effusions always makes me wonder whether the writers have ever seen a modern high-intensity tube at work. The fact is that these tubes give a picture so bright that it can be seen by daylight without even darkening the room; that is more than can be said for the home-movie projector, but no one seems to complain in that case.

More rumours of big plans being formed in America, based on the

statement of David Sarnoff, President of the Radio Corporation, that his organisation had decided to spend a million dollars forthwith on television research. Although a good deal of commotion has been made over this, it really seems as though all that the R.C.A. plan amounts to is the installation of an experimental high-definition service on much the same lines as the German one. The amusing (to my mind) point of difference is that the American scheme exists so far only as a plan, whereas the German one is actually working!

But where is *our* service? After all the fine work which has been done by the Baird and E.M.I. companies and others, are we to be one of the last to get a service working? The one and only bit of news I have about our prospects this month is that there is *very* good reason to believe that the Alexandra Palace is to be the chosen site after all.

As soon as it has been officially denied a few times more we shall know that the matter is settled and can begin to take an interest in the probable service area of the station to be erected on one or other of the towers of the Palace.

Preliminary study of maps and sections would appear to indicate considerably greater areas in "shadow" than would be the case for a transmitter located at the Crystal Palace, but that, I suppose, is something on which it would be much safer not to theorise until actual trials have been made of the station itself.

And when will that be? The only people who are really in a position to make an estimate won't talk, but I imagine that it would be quick work to get the station on the air six months after the final decision is at last taken.

Now a word of discouragement which I feel in duty bound to hand out to those who may have been led by certain pseudo-authorities to think that the

problem of ultra-short-wave television can be solved by the use of a superhet-type adapter in conjunction with an ordinary broadcast receiver. This may be feasible so far as the sound signal is concerned, for here we shall be dealing only with the usual range of audio frequencies.

High-definition television, on the other hand, is quite clearly out of the

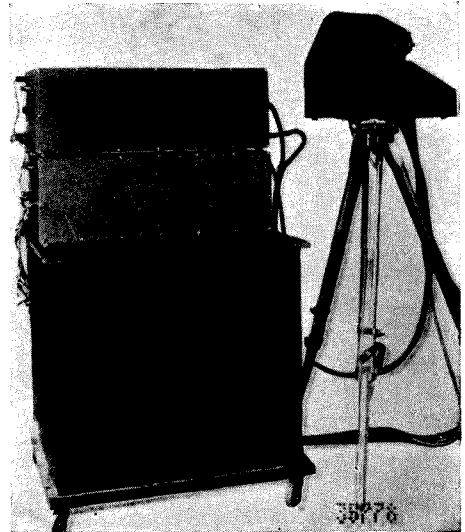

The complete "outside broadcast" Iconoscope outfit designed by the Radio Corporation of America. Note the "camera" standing on its tripod on the right of the photo.

question by any such method; to handle the extremely high modulation frequencies then involved it is necessary to use an intermediate-frequency amplifier of a kind totally unlike anything to be found in a broadcast receiver.

### MOST INTERESTING!

From the ever-resourceful Publicity department of H.M.V. comes a most interesting story of the finding of an Egyptian statuette in the course of the digging of foundations for an extension of the factory at Hayes. It appears that a strange object was seen to be in use by the builders as a door-stop and questions revealed that they had dug it up from a depth of nine feet.

The figure was recognised by a passer-by as being of Egyptian origin, and further investigation identified it as that of a priest of Isis carrying in his hands a shrine containing an image of the deity.

It is stated on the authority of the British Museum experts that the relic is clearly identifiable as belonging to the Ptolemaic period of the third or second century B.C.

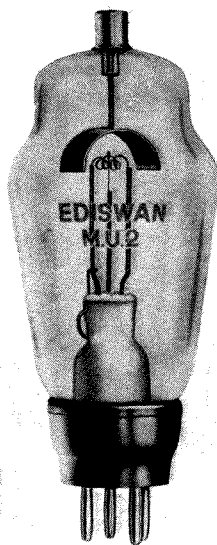

The new form of the Edison MU2 rectifier has been specially designed for the supply of high-tension voltage to cathode-ray tubes

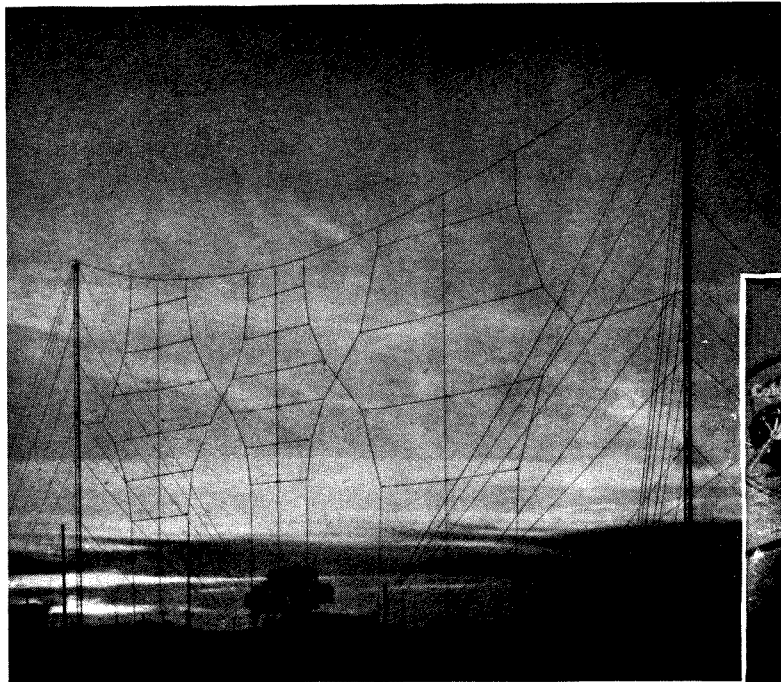

The two 500-ft. masts originally used for the old long-wave Daventry transmitter are now used to support the short-wave aeriels for transmission to Canada and East Africa. The 31-metre aerial is on the left, the 25-metre aerial in the centre, and the 49-metre aerial on the right

Old friends—Clapham and Dwyer (with their pet, Cissie), are to broadcast on July 9



# New Stations for Empire Broadcasting

WE have read a lot in our papers of armament races and suchlike: one nation likes to be as powerful as her next-door neighbour and, if the truth is generally known, just a little more powerful.

What applies to arms applies equally well to broadcasting. We have seen in Europe a race to erect high-power broadcasters—the race still continues. Every country, besides wishing to serve its listeners well, hopes, inwardly or outwardly, that listeners in neighbouring countries will hear as well.

And this race is not confined to the medium and long wavebands; it is beginning, and it will develop still more, on the short waves. All Europe is planning to carry its talks and music to the four corners of the earth. We have seen in the last twelve months a decided increase in the number and power of Europe's short-wave broadcasters.

Now the B.B.C. is taking a hand

By T. F. HENN

in the developments. It has announced that the Empire broadcasting service from Daventry is to be extended by the addition of two short-wave transmitters, both of which will be of higher power than the two at present in use.

The two new transmitters will each have a power of 50 kilowatts, but they are to be designed so that the power can be raised to 70 or 80 kilowatts. The actual power used depends to a large extent on the wavelength and type of aerial used. As a matter of fact, little is gained by using a lot of juice on the very low wavelengths. With the exception of the B.B.C., most European broadcasting concerns use sharp directional beam aeriels on the short waves, so concentrating a deal of energy in one particular direction.

The British Empire is no mean

territory to cover with only two transmitters, and therefore the B.B.C., although using directional aeriels, employs a much wider beam. Therefore it is easy to understand that really large power is a help in adequately covering each particular area.

The present two 25-kilowatt stations at Daventry will be combined to make a third Empire broadcaster having a power of 50 kilowatts. Work has already begun on the buildings to house the new plant and, at the same time, work is proceeding apace on extensions to the aerial system. The developments in the aerial system are the result of experiments carried out at Daventry over the past two or three years.

A question that automatically comes into our minds when we learn of all these improvements in the service to the Empire is: "Who is footing the bill?" The answer is very blunt. It is being

found out of the licence money paid by listeners in this country.

I do think that at least some of the huge amount of money earmarked for the Empire radio account could be better spent in gingering up our own programmes. They are good, I must admit, but if you take out twelve hours per week of the real highlights, there is little exciting left!

We do not begrudge the Empire the free service we give it, but I am not alone in thinking that some of the huge cost should be borne by the leading colonies and dominions.

Canada is particularly lucky in that she is to have a new regular service each day, in addition to the existing broadcasts, beginning on July 1. The broadcast will be given on 49.1 and 31.32 metres every morning between 2.30 and 3.30 a.m.

Experimental broadcasts on these wavelengths and at this time were begun in March and within four or

Vaudeville artists possessing real humorous talent are rare over here and we cannot afford to be without all we can lay our hands on. In fact, one of the reasons why vaudeville broadcasts are limited to one or two a week is because of the shortage of good artists.

There is more news about the relay of the Naval Review at Spithead by His Majesty the King on July 16. Four microphones will be installed aboard the battleship *Royal Sovereign*, together with a short-wave transmitter. A receiving station will be installed at Southsea—a lighthouse near Southsea Castle and an obsolete military tower will act as aerial masts—and this will pick up the signals from the *Royal Sovereign* and put them on the landline to London.

To make certain that there will be no hitches whatsoever, a further transmitter will be rigged up at the Southsea receiving station to keep engineers ashore in constant touch with those aboard the battleship.

It will be one of the grandest relays ever carried out by the B.B.C. We shall hear the Royal Salute fired by all the guns, the music of the bands aboard, and the cheers of the Navy as the Royal Yacht with the King and Queen aboard passes through the line of battleships, cruisers, destroyers, submarines and representative vessels of the Merchant Fleet.

Announcements will be given by Commander Stride, R.N. and Commander R. Woodroffe, R.N. The amount of work involved in carrying out such a tremendous relay is such that B.B.C. engineers have already started work. The transmitter, from the boat-race launch, *Magician*, is being thoroughly overhauled before its installation on the *Royal Sovereign*.

If we look back over past notable

broadcasts the record of the B.B.C. engineers for reliability and the absence of "technical hitches" must be considered remarkable. The Naval Review relay is the first of its kind ever attempted and the engineers mean to make it a huge success.

Many listeners may like to note that arrangements are well in hand for the forty-first season of Promenade Concerts which are to be held in the Queen's Hall, beginning on Saturday, August 10.

Sir Henry Wood, of course, is to be the conductor and it will be his forty-first season—this must constitute a record in the annals of music.

Exide recently held a convention at Eastbourne and Stanelli, the man who makes a quite passable musical noise out of an assortment of motor horns, was one of the artists at a cabaret show.

I knew that Stanelli was a superb violinist, but I was rather surprised to learn that he had appeared by Royal command with Fritz Kreisler at Dublin Castle at the very early age of seven and that he has conducted the Bournemouth Municipal Orchestra and the Minneapolis Symphony Orchestra in the U.S.A.



Arthur Salisbury, leader and conductor of his orchestra, which broadcasts from the Savoy Hotel

five days of the first broadcast the B.B.C. received 1,500 letters of appreciation from Canada. I think you will agree that there is some justification for my remarks about helping to meet the expense!

Back home again. Good news is that Clapham and Dwyer are announced to return to regular broadcasting on July 6. That last little affair has blown over and the hatchet—if there ever was one—has been buried.

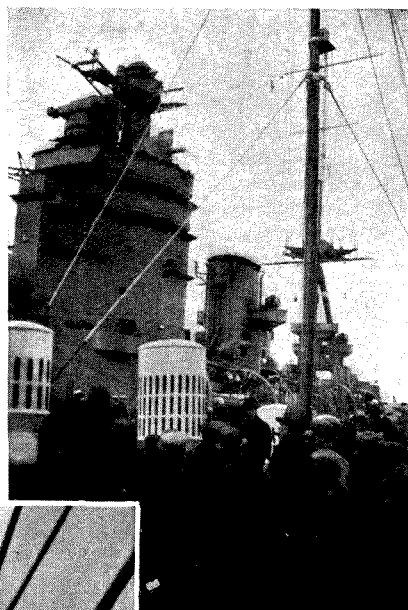

The relay of the Naval Review by H.M. the King from Spithead will be broadcast on July 16. These two photographs were taken during the Navy's recent visit to the Thames Estuary. Above, some of the thousands of visitors are seen crowding aboard the huge battleship, "Rodney"

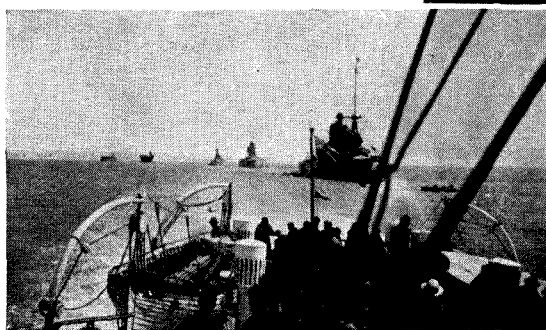



Members of the Anglo-American Radio and Television Society photographed during a recent meeting of the West Middlesex and East Bucks branch. That these meetings are not entirely technical is shown by the appearance of a banjo!

Under this heading we publish every month reports of the activities of leading short-wave and transmitting societies. We shall be pleased to give publicity to any announcement of forthcoming events, and secretaries of short-wave clubs, whether national or local, are invited to make full use of these columns

**N**ATIONAL FIELD DAY will be over by the time these notes appear and by next month it should be possible to form some idea of the positions of the various districts in "order of merit." Conditions just prior to the event—at the time of writing—seem to be a little unreliable, but there is hardly any limit to the capabilities of three enthusiastic operators, a good transmitter and a really good situation on the top of a hill!

#### The "Loyal Relay"

Another important event that will be taking place just as this issue appears is the "Loyal Relay of Birthday Greetings" to H.R.H. the Prince of Wales, on the occasion of his forty-first birthday on June 23.

For several years the R.S.G.B., in co-operation with the B.E.R.U., has been able to forward a splendid sheaf of loyal messages to its Royal Patron. These messages are initiated by the presidents of the various national radio societies, and it is open to any British amateur station to keep watch for them on short waves.

June 23, last year, came very near to the R.S.G.B.'s twenty-first birthday, and His Royal Highness in thanking the society for relaying the loyal messages congratulated it on attaining its majority.

#### Empire QSO Parties

There is a suggestion that a week-end each year should be set aside for "Empire QSO Parties"—in other words, for the promotion of friendly chats and contacts between R.S.G.B. members in all parts of the British Empire.

It has been decided to try out this

# News from the Radio Societies

Conducted by G6QB

scheme on August 10 and 11 this year with a view to ascertaining whether August really is a poor month for long-distance work, or whether the apparent absence of DX is simply due to the scarcity of active stations on the air. The Empire QSO Party should help to fill what has hitherto been rather a blank period for the short-wave radio amateur.

The Convention this year will be held, as usual, during the week-end following the Radio Exhibition at Olympia. The Society will run its usual stand at the Show, and Convention will commence on the evening of Thursday, August 22. The final meetings and the dinner will be held on Saturday, August 24.

On July 7 the London and Home Counties section holds its annual summer outing. This year it takes the form of a visit to the Ongar radio station. Non-members requiring full details of any of these activities should communicate with the secretary at 53 Victoria Street, S.W.1.

On the technical side, the most

startling news of the month (as yet unconfirmed) is that a member has actually made two-way contact with India on the 10-metre band. This has been expected to occur at any moment, although it is rather surprising that India should be heard before America in this country. 10-metre DX work will probably be in full swing by the end of June.

Recent 5-metre tests proved somewhat disappointing, none of the stations taking part having covered a distance of more than 15 miles or thereabouts. Further tests during July, in which a certain Welsh mountain may figure prominently, will probably yield more interesting results.

#### Anglo-American Radio and Television Society

The A.-A.R. & T.S. has an ever-increasing membership and will be glad to hear of prospective members from any part of the country. Its members, incidentally, are spread over no fewer than fifty-three

countries at present. There is no membership fee and all that a person desirous of joining has to do is to send his (or her) name and address to the headquarters. All such letters should be addressed to the honorary president, Mr. Leslie W. Orton, "Kingsthorpe," Willowbank, Uxbridge, Middlesex.

In order to bring members into closer personal touch with each other, branches have been organised both in this country and abroad. Several of them make a nominal charge to cover the cost of hiring a club-room, but others make no charges. Among the latter are the three Home Counties branches, the addresses being:—

*London:* E. Norman, 20 Varley Road, West Ham, E.16.

*Essex:* E. Hobden (G2YH), 10 Denecroft Gardens, Grays, Essex.

*West Middlesex and East Bucks:* Leslie W. Orton, address as above.

Readers of "Wireless Magazine" are cordially invited to attend meetings and to join this go-ahead society.

The A.-A.R. & T.S. now has a ladies' section under the care of Miss

Eileen G. Harris, "Frampton," Victoria Avenue, Porthcawl, and a junior section, represented by Arthur Jones, 27 Ringham Road, St. Johns, Ipswich.

The latter aims at the encouragement of international goodwill among the younger generation, with a special attempt to make them "radio-minded."

Radio Normandy broadcasts a special programme for the society on the first Friday in each month; reports on these concerts will be welcomed at headquarters.

**Golders Green and Hendon  
Radio Scientific Society**

At the annual general meeting of the above society, Mr. D. N. Corfield (G5CD) was elected president and the new honorary secretaries are Messrs. A. G. Griffiths and W. L. Pattullo.

Readers' co-operation is requested for two forthcoming 5-metre Field Days on June 23 and July 24.

At a recent meeting a demonstration of quality reproduction was given by Mr. R. D. C. Pedlar.

Full particulars of the Society may be obtained by forwarding a stamped-addressed envelope to Lt. Col. H. Ashley Scarlett, 60 Pattison Road, N.W.2.

**Society of Wireless Pioneers**

Readers interested in this Society are asked to note that Mr. R. L. Rawles has resigned from the post of publicity manager. The new manager is Mr. A. G. Cutts, 75 Broomhall Street, Sheffield, 3.

**International DX'ers  
Alliance**

The I.D.A. is now running a regular feature from Schenectady, W2XAF, on 31.48 metres. It is called "Out of the Short-wave Mail-bag," and is broadcast every Tuesday evening at 10.35 p.m.

The feature should be of interest to most short-wave DX listeners and is commended to their attention by the publicity director of the I.D.A., Mr. William Warner, 56 East Grove Road, St. Leonards, Exeter.

*Continued on page 477*

"W.M." Short-wave Identification Panels—Compiled by JAY COOTE

**Metres:** 31.34  
48.94  
**Power:** 1 kw

**JELÖY (LKJ1)**  
(Norway)

**Kilocycles:**  
9,572  
6,128

**Geographical Position:** 10° 35' 46" E.; 59° 26' 12" N.  
**Approximate Distance from London:** 710 miles.  
**Standard Time:** Central European (Tallies with B.S.T.).  
**Language:** Norwegian.  
**Announcer:** Man.  
**Call:** "Hallo! Oslo (phon: Ou-zlo) her."  
**Interval Signal:** Six notes *ad lib.*  
Relays programmes from Oslo.  
**Times of Transmission:** B.S.T. 11.00-14.00 (31.34 metres); 17.00-24.00 (48.94 metres).  
Closes down with words: "Hermed er programmet slutt for i dag" (With this item we conclude to-day's programme). "Godnatt, Godnatt."

**Metres:** 31.7  
**Power:** 150 watts

**HAVANA (COH)**  
(Cuba)

**Kilocycles:**  
9,464

**Geographical Position:** 23° 04' 51" N.; 82° 21' 35" W.  
**Distance from London:** Approximately 4,610 miles.  
**Standard Time:** B.S.T. less 5½ hours.  
**Interval Signal:** Chimes.  
**Languages:** Spanish and English.  
**Announcer:** Man.  
**Call:** "Estacion de onda corta COH, Vedado, Habana, Cuba."  
**Times of Transmission:** B.S.T. 16.00-17.00; 23.00-24.00; 02.00-03.00.  
Sponsored concerts are given by Cuban National Lottery Co., between B.S.T. 23.00-24.00 and by the General Electric Co. from 02.00-03.00.  
Sometimes relays programmes from CMCY, Havana (227.1 metres).

**Metres:** 49.5

**PERNAMBUCO (PRA8)**  
(Brazil)

**Kilocycles:**  
6,060

**Geographical Position:** 8° 5' 00" S.; 35° 10' 00" W.  
**Approximate Distance from London:** 4,500 miles.  
**Standard Time:** B.S.T. less 4 hours.  
**Language:** Portuguese.  
**Announcer:** Man.  
**Call:** "Radio Club de Pernambuco"; also "A Voz do Norte."  
**Interval Signal:** Siren (fade in and out).  
**Times of Transmission:** B.S.T. 22.30-02.30 daily, and between 18.00-18.30.

**Metres:** 51.28

**MARACAIBO (YV5RMO)**  
(Venezuela)

**Kilocycles:**  
5,850

**Geographical Position:** 10° 30' 00" N.; 72° 10' 00" W.  
**Distance from London:** Approximately 5,000 miles.  
**Standard Time:** B.S.T. less 5 hours.  
**Announcer:** Woman.  
**Languages:** Spanish and English.  
**Call:** "Aqui Estacion YV5RMO, Maracaibo 'Ecos del Caribe.'"  
**Interval Signal:** Gong struck once, followed by a short run of notes: C, E, G, C.  
**Opening and Closing Signal:** Extract from "The Blue Danube" waltz.  
**Times of Transmission:** B.S.T. 23.00-03.00 daily.  
Every Monday a broadcast of opera or classical music is given. The station belongs to the Indo-Americana Chain.

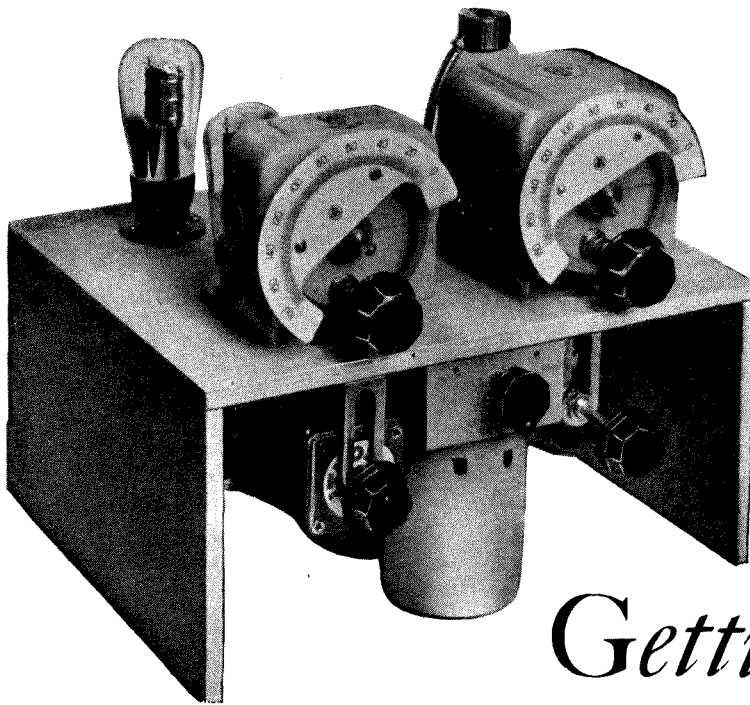

“W.M.’s” latest straight battery three-valver designed by G. P. KENDALL, B.Sc., was introduced to readers in our last issue. Here we present full constructional details; notes on the choice of suitable valves for varying conditions; instructions for trimming; and, in short, all about the practical use of the first set built on the new “W.M.” semi-professional system

## Getting the Best from the P.T.P. Three

I MUST start this month with an apology: so much space was devoted last time to explanations of the special system of construction of the P.T.P. Three that I had not much room to deal with the actual making and operation of the receiver. I hope that readers will agree that the occasion was an important one and justified me in taking this course.

Now for the benefit of those who have deferred starting construction until this month let me give more detailed information. The first step is to detach the “floor” of the

wooden structure from the sides and back and then set about mounting all the parts on this exactly as though it were an old-fashioned flat baseboard.

The positions for the components should be located with the aid of the blueprint and it is important to note that the coil unit should be attached last of all.

When this coil unit is mounted, take care to see that its feet make really perfect contact with the metallised surface of the baseboard; scrape away the cellulose paint on

both upper and under sides of the fixing lugs, but do not trouble to drive the screws right home at this stage. The point here is that earthing wires will be inserted under the heads of the screws later on, and only then need they be tightened right down.

### Insulate the Condenser

The double-gang condenser must be insulated from earth, so it is necessary to scrape away the metalising on the baseboard around the heads of the fixing screws on the underside and around the supporting pillars of the condenser on the upper surface. It is important to do this with thoroughness and care, for the moving vanes (i.e., the body) of the two sections should be connected to the earth circuit only through the .02-microfarad band-pass coupling condenser. This is achieved by running a wire from one of the condenser fixing screws to one terminal of the coupling condenser.

When all the parts have

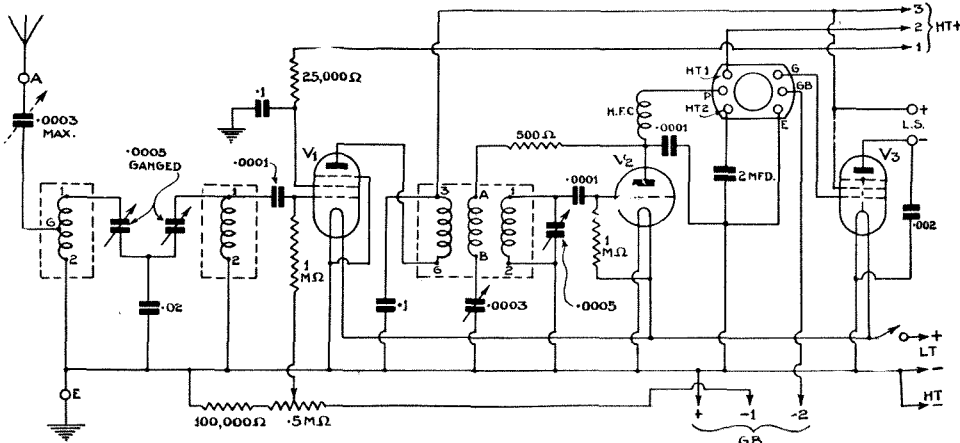

The P.T.P. employs a comparatively straightforward circuit: it owes its very excellent performance in the main to its high-efficiency system of construction



### THE LOG OF THE P.T.P. THREE

*Long Waves*  
 Huizen  
 Moscow No. 1  
 Radio Paris  
 Deutschlandsender  
 Droitwich  
 Motala  
 Warsaw  
 Luxembourg  
 Kalundborg  
 Moscow No. 2  
*Medium Waves*  
 Beromünster  
 Athlone  
 Stuttgart  
 Vienna  
 Florence  
 Brussels  
 Prague

Lyons PTT  
 Cologne  
 North Regional  
 Sottens  
 Paris PTT  
 Rome  
 Madrid  
 Munich  
 Katowice  
 Scottish Regional  
 Toulouse  
 Leipzig  
 West Regional  
 Milan  
 Berlin  
 Strasbourg  
 London Regional  
 Hamburg  
 Brussels No. 2

Breslau  
 Poste Parisien  
 Belfast  
 Genoa  
 Hilversum  
 Midland Regional  
 Scottish National  
 Bordeaux  
 Fécamp  
 Turin  
 London National  
 Trieste  
 Gleiwitz  
 Cork  
 Juan-les-Pins  
 Milan No. 2  
 Turin No. 2  
 Basle

*Note.—This list was not compiled under the usual "W.M." rules. Please read the author's remarks on it with care!*

been mounted the wiring can be started; it will be found that this process can be almost completed before it becomes necessary to attach the baseboard to the sides and back of the chassis framework, hence the work will be found extremely easy. This indeed is one of the great virtues of the new system of construction.

#### Earthing Points

One or two points in the wiring call for a little explanation. Note first that various earthing connections are made to each of the coil unit feet: to one of those nearest the front of the set goes a lead from the bottom terminal of the 100,000-ohm resistance and to the other runs one from the moving-plates terminal of the reaction condenser. To one of those at the rear you must run a wire from the earth terminal of the set and another from one of the filament points of the  $v_1$  valve-holder.

#### Valve Head

To the remaining rear coil-chassis foot you take a wire from one terminal of the .002-microfarad fixed condenser nearby, and also attach the end of the common flex lead which serves both as low- and high-tension negative. (The further end of this lead should be fitted with a

spade connector for making contact with the accumulator and a short extension ending in a plug for insertion in the negative socket of the high-tension battery.

A little care is needed in fitting the screened lead for the anode of the high-frequency pentode, by the way; first you must see that the screening cover does not slip inside the coil "can" and touch the terminal to which the lead is connected, since this would cause a short-circuit of the high-tension

supply. To prevent this it is a good plan to slip the covering back a little way and secure it in place with a binding of surgical or other adhesive tape.

The covering itself must be properly earthed, and for this purpose a clip is provided with the lead.

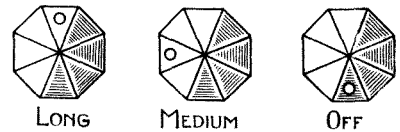

*The knob in the centre of the front layout controls both wave-range and filament current. This diagram gives a key to the various positions*

I found it convenient to bend the solder-tag portion of this clip out at right-angles and fasten it to the upper side of the baseboard with a very small nail of the sort called a panel pin. No doubt a very small wood-screw or a tack would serve just as well.

#### Valve-holder Connections

When wiring up the valve-holders I found that care was needed to ensure reliable connections. The wire which I used was a trifle thin (20-gauge, or thereabouts), and when the end of one of these leads was inserted in the hole in the holder shank it was nipped off very neatly if the clamping screw was driven down too hard. The remedy is to double over the end of each lead and give the screw two thicknesses to bite upon.

When the wiring is all complete save for the connections to the aerial and earth and loudspeaker terminals you must attach the sides and back

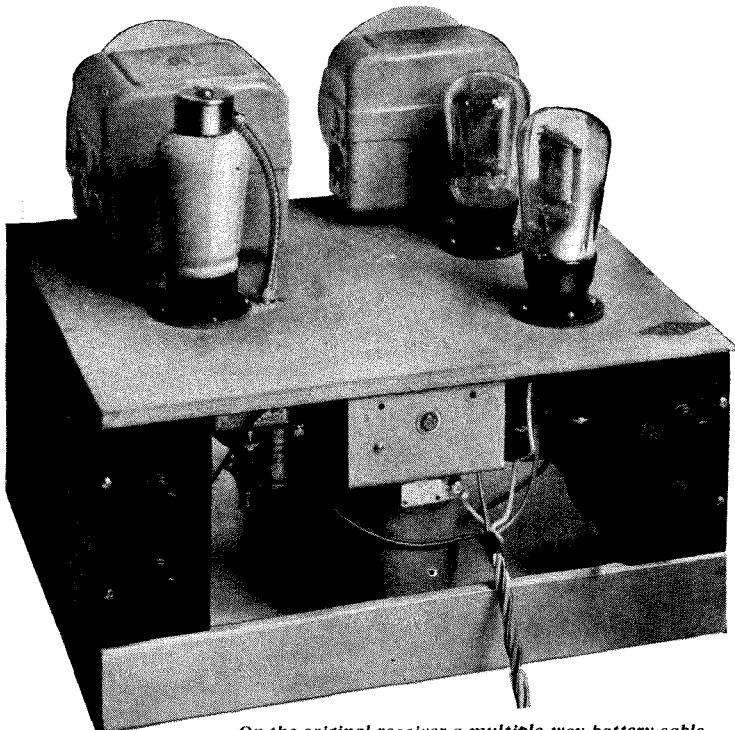

*On the original receiver a multiple-way battery cable was used; this certainly helps to maintain a tidy appearance*

of the chassis frame and also the two terminal plates. The remaining connections can then be inserted and there is your P.T.P. Three finished.

At this point it may perhaps be opportune to consider in slightly greater detail the question of the choice of valves. Naturally, any of the standard makes may be used, but it happened that I employed Mazda types for my tests, so I will give my

provides grid bias for volume-control purposes.

For the detector I suggest the HL2 if high-tension economy is of paramount importance. It gives good sensitivity and satisfactory reaction control but, of course, it may be overloaded if a powerful local is tuned in at short range.

If an odd milliamperes or so is not considered important then the L2 will remove this risk, but there is little point in using such a valve unless a more generous output type is also chosen.

Here one must pay more dearly for greater power-handling capacity. For example, while the PEN20A is certainly to be preferred if really adequate moving-coil loud-speaker volume is desired, to use this type means that a mains high-tension unit is highly desirable. With the economy set of valves the total high-tension current will be in the neighbourhood of 9 milliamperes, while with the

but some care is needed if one is to avoid overloading.

If just a little caution is exercised in volume adjustment there is no reason why anyone should be dissatisfied with the quality given by his P.T.P. Three with these valves, but if the user's taste runs to big "dollops" of volume then he will be well advised to select the other set of types.

**Ganging the Set**

This, let me explain, is *not* an individual characteristic of the P.T.P. Three; the same remarks apply with equal force to *any* three-valver employing the popular combination of one high-frequency stage, detector, and one audio stage.

"Trimming" this set is a particularly simple business. It is only necessary to tune in the carrier of a weak station with the set oscillating, adjust each trimmer on the twin condenser until you hear a sudden change in the heterodyne note, then slacken off the reaction until oscillation ceases and repeat the process to obtain maximum volume.

**Volume and Selectivity**

This method will be found very quick and easy and the ganging should hold quite well over the range if the trimming is done upon a station near the middle of the medium band.

The volume control on a set of this type will usually be required only on the local transmissions so far as actual volume limitation is concerned; it has, however, another use, which merits a little study, in connection with selectivity. It will be found that amazing feats of

*Continued on page 477*

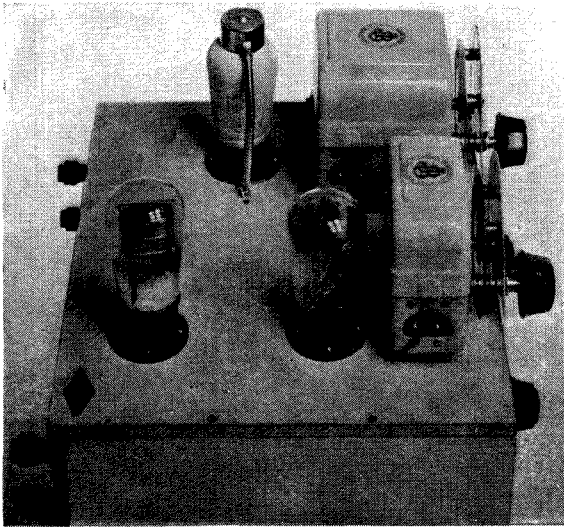

This photo shows the "economy" selection of valves in place. Some notes on a more generous choice of types will be found in the text

suggestions in terms of that brand. For the high-frequency stage I definitely prefer the VP215, since its relatively short grid base enables one to obtain full control of volume with only a moderate bias voltage; it will be remembered that I originally indicated that about 7.5 volts is enough for G.B.—1, which

more generous selection it may rise to something like double this figure, and to stand such a load one needs a *really large capacity* battery.

I must be careful not to depress the battery user unduly in this respect; quite a pleasant amount of volume can be obtained with the more economical selection of valves,

**COMPONENTS NEEDED FOR THE P.T.P. (Pentode-Triode-Pentode) THREE**

CHASSIS		£ s. d.	1—J.B. Nugang two-stage .0005-microfarad condenser (type A, with disc drive) ...		£ s. d.	SUNDRIES		£ s. d.	
1—Peto-Scott to specification, wood, sprayed Metaplex with terminal strips. ...	6	6	1—Graham-Farish Litlos .0003-microfarad reaction ...	2	0	1—Bulgin 5-way battery cable ...	1	6	
<b>CHOKE, HIGH-FREQUENCY</b>			1—Graham-Farish Forno .0003-microfarad compression ...	1	6	4—Belling-Lee terminals, type R ...	2	0	
1—Varley multi-cellular junior ...	3	6	<b>HOLDERS, VALVE</b>			2—Peto-Scott mounting brackets, short length, for reaction condenser and volume control ...	0	8	
<b>COILS</b>			1—Clix Air-sprung 7-pin ...	1	1	1—Belling-Lee screened low-loss valve-top connector ...	1	6	
1—Goltone 3-coil switch chassis, coil types G.I.C.3, G.I.C.4, and G.I.C.6. (G.I.C.4 coil in centre, G.I.C.6 nearest to switch knob)	1	16	1—Clix Air-sprung 5-pin ...	1	0	1—Set Bulgin matching knobs (if desired)			
<b>CONDENSERS, FIXED</b>			1—Clix Air-sprung 4-pin ...	11		Battery plugs, wire, sleeving, flex, etc.			
1—Dubilier .0001-microfarad, type 620 ...	1	3	<b>HOLDERS, RESISTANCE</b>			<b>ACCESSORIES</b>			
2—Dubilier .0001-microfarad, type 610 ...	2	6	4—Graham-Farish Ohmite, vertical type ...	2	0	<b>VALVES</b>			
1—Dubilier .002-microfarad, type 620 ...	2	0	<b>TRANSFORMER UNIT</b>			1—Mazda VP215 ...	13	6	
1—Dubilier .01 or .02-microfarad, type BS9200 ...	1	9	1—Benjamin Transeeda ...	11	6	1—Mazda HL2 ...	5	6	
2—Dubilier .1-microfarad, type BS9200 ...	3	6	<b>RESISTANCES, FIXED</b>			1—Mazda PEN220 ...	13	6	
1—Dubilier 2-microfarad, type BS	2	8	1—Graham-Farish Ohmite 500-ohm ...	1	6	<b>BATTERIES</b>			
<b>CONDENSERS, VARIABLE</b>			1—Graham-Farish Ohmite 25,000-ohm ...	1	6	1—Full O'Power 120-volt high-tension ...	17	6	
1—J.B. Nugang single-stage .0005-microfarad condenser (type A, with disc drive) ...	10	6	2—Graham-Farish Ohmite 1-meg-ohm ...	3	0	1—Full O'Power 9-volt grid-bias ...	1	3	
			<b>RESISTANCE, VARIABLE</b>			1—Exide 2-volt accumulator, type DMG-C ...	12	0	
			1—5-megohm Centralab volume control, long-spindle type ...	3	9	<b>LOUDSPEAKER</b>			
						1—Amplion Dragon (in chassis form) ...	1	9	6

# The Valve Family

Some Unusual Types  
Described by  
MORTON BARR

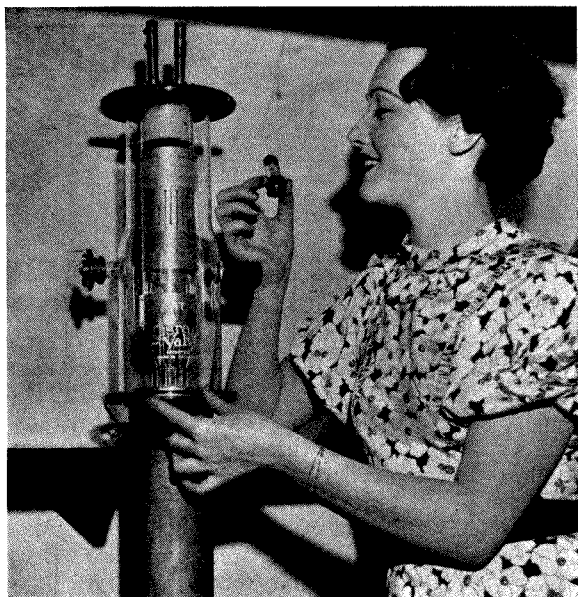

G.E.C. photo

The new midget valves enable this kind of comparison to be made even more striking than of old. Here is one being measured up against an Osram water-cooled transmitting valve

THERE are already so many different valves on the market that manufacturers are calling a halt in the production of certain types, such as the original variable-mu screened-grid and the double-diode-triode. Their place is apparently to be taken by the later and more efficient "pentode" varieties.

## Too Many Types ?

Most listeners will probably agree that the choice in valves is becoming excessive, particularly as regards the multi-grid family. It is difficult enough in practice to keep pace with purely circuit improvements, such as delayed and amplified A.V.C., tone-control, second-channel and static interference-preventers and the like, without having in addition to decide which of half-a-dozen different multi-grid valves is best suited for the particular purpose in view.

## "Drop in the Ocean"

At the same time the number of types with which we are at present faced is only a drop in the ocean compared with what it might be. That is to say if all those who have from time to time set their mind to the business of "improving" the valve could have their way.

Many of them have, of course, left their mark on the modern valve as we know it today. High

evacuation inside the bulb, the use of the dull-emitter filament and variable-mu grid and the introduction of extra grids to serve a special purpose, as in the pentode and pentagrid converter, are all now firmly-established practice. It may however be interesting to describe some of the attempts which have

been made to improve the valve along less orthodox lines.

For instance, one of the first principles in standard valve design is to make the electrodes inside the bulb sufficiently rigid to prevent relative movement. The filament may be spring-held so as to counteract any tendency to sag as it expands with heat, but otherwise the spacing between plate, grid, and filament is kept absolutely constant. And in the ordinary way it is very necessary that it should be so.

## Moveable Electrode

But it is possible to get some interesting results by deliberately making one of the electrodes so that it can move relatively to the others. As is well known, one of the objectionable symptoms of a loosely-mounted grid or filament is the microphonic noise caused by variations in the electron stream as the distance between the two electrodes changes.

## Small Diaphragm

This fact has been deliberately utilized by one designer, who replaces the usual grid by a small diaphragm which is so lightly supported that it can vibrate freely under the influence of speech. By speaking directly at the valve it is then made to act as a combined microphone and L.F. amplifier.

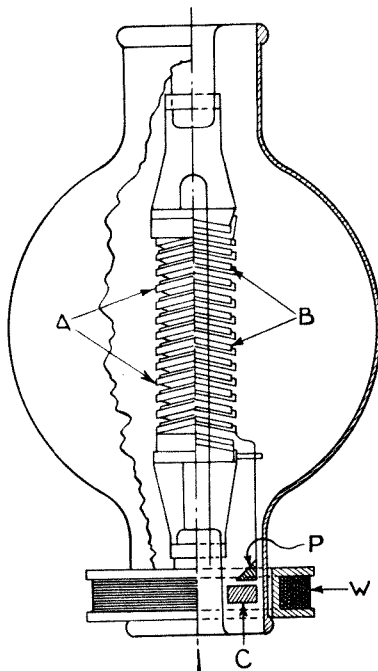

Fig. 1—A transmitting valve with moveable grid; this enables the characteristics of the valve to be adjusted within wide limits

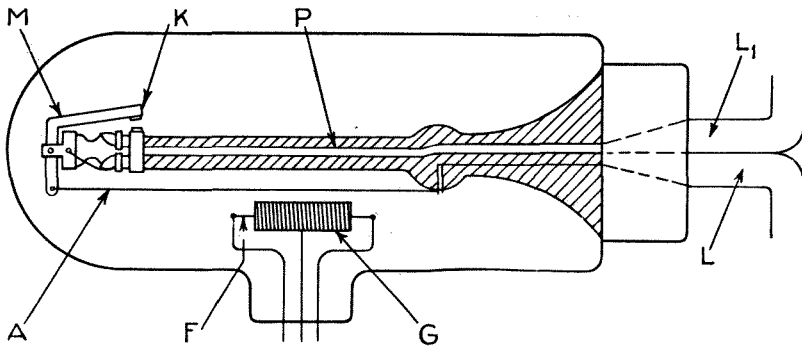

Fig. 2—A three-electrode valve combined with a mechanical relay. Variations in the anode current open or close the contacts at K

Again, the variable- $\mu$  valve, which is now so widely used for A.V.C., owes its peculiar properties to the shape of the grid. Instead of being formed as a spiral of uniform pitch, the turns are usually spaced more closely together at one end than at the other, thus giving the valve a characteristic curve which tails off very gradually at the negative end.

**Moveable Grid**

In certain circumstances it is useful to be able to vary the mutual conductance of a valve used for transmitting as well as receiving, and Fig. 1 shows a scheme whereby this advantage is secured by means of a "moveable" grid. Actually the grid is made in the form of two co-axial spirals, one of which can be rotated relatively to the other so as to open or close the effective spacing between the turns. Control of the moving portion is effected from outside the glass bulb by means of an electro-magnet  $w$  having a ring-shaped core  $c$ , which attracts and rotates a soft-iron pole-piece  $P$  connected to the grid-winding  $B$ .

Another interesting example of the use of a "moving" electrode is shown in Fig. 2. This time the moving member is the anode  $A$ , which is made to expand under the influence of the electron stream, and in so doing is caused to close the contacts of a switch,  $K$ , and so ring an alarm bell.

The anode  $A$  is a strip of nichrome,

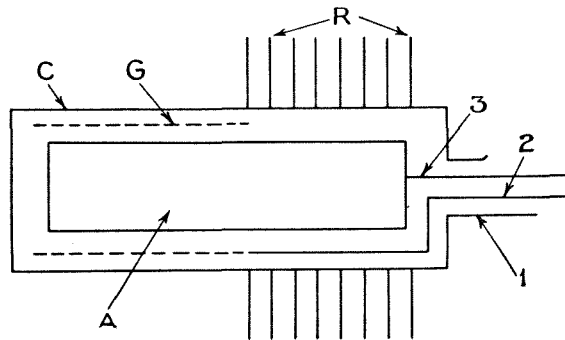

Fig. 3—This valve uses heat from a gas burner or spirit lamp instead of a filament current

which is mounted on a hollow glass pillar  $P$ , and initially heated through leads  $L$  to a temperature where it is critically sensitive to any further change in heat. The filament  $F$  and grid  $G$  are mounted on a separate "pinch" as shown.

As the electron stream passing from filament to anode increases,

under the influence of signals applied to the grid, the anode  $A$  is heated and expands. This allows a bell-crank lever  $M$  to close contacts  $K$ , thereby ringing an alarm bell in the external circuit  $L_1$ . The arrangement is intended to give automatic warning of the receipt of any prolonged "calling" signal, either at sea or elsewhere.

**Thermopile Battery**

The supply of filament juice is always of interest to battery users and is still a vexed problem to those country listeners who may not only be off the mains but also inconveniently placed for recharging accumulators. In such cases the thermopile battery, which creates an electric current when it is heated, has certain possibilities which have not yet been fully exhausted.

In Fig. 3, however, we have a type of valve which is intended to be operated, so far as the filament is concerned, by the direct application of heat in whatever form is most convenient, preferably from a gas burner or spirit stove.

**Heated from Outside**

The valve itself consists of a metal container  $c$  instead of the usual glass bulb. Inside is a spiral grid  $G$  and cylindrical anode  $A$ . When the outer container is heated by a naked flame, electrons are emitted from the oxide-coated interior of the surface casing and pass in the usual manner through the grid on the way to the positively-charged anode. The leads are taken out at 1, 2, 3. Cooling fins  $R$  are provided at one end of the container.

Finally, Fig. 4 shows a particularly ingenious application of a "magnetised" grid, which takes the form of a compass needle  $G$ .

The needle is pivoted on a support inside the bulb, so that it normally tends to point North and South in the ordinary way. In that position it lies immediately above a heated filament  $F$  and midway between two wire anodes  $A, A_1$ , as shown more clearly in Fig. 4 (a).

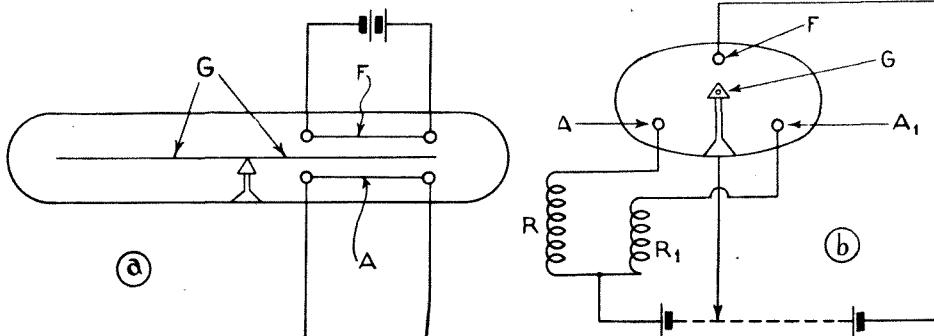

Fig. 4—(Left) A valve which contains a compass needle is used in automatic piloting devices. (Right) The associated electrical circuits

Continued on page 480

# What Kind of Set Do You Want?

Everyone has his own ideas about the ideal radio set; "Wireless Magazine" wants to know what its readers' ideas are so that the autumn programme can be arranged to include the wishes of the majority. You are invited to complete this questionnaire and send it (in an unsealed envelope bearing a  $\frac{1}{2}$ d. stamp) to the "Wireless Magazine" Technical Dept., 8-11 Southampton Street, Strand, London, W.C.2

Do you prefer a superhet set to a straight set? (Indicate Yes or No.)		Do you like a milliammeter in the detector (D) or or output circuit (O)? (Indicate D or O.)	
What is to be the total number of valves?		Do you want an intermediate stage of low-frequency amplification between the detector and the power stage? (Indicate Yes or No.)	
How will the set be operated: from batteries (B) alternating-current (A.C.), direct-current (D.C.) mains or Universal (A.C./D.C.). (Indicate B, A.C., D.C., or A.C./D.C.)		Is the low-frequency amplifier to be transformer-coupled (T), resistance-coupled (R), or a combination of both? (Indicate T, R, or C.)	
If from A.C. mains, do you prefer a metal rectifier (M) to a valve rectifier? (Indicate M or V.)		Do you want to incorporate a tone control? (Indicate Yes or No.)	
If not a superhet do you want one or two stages of high-frequency or none?		What type of output stage: three-electrode (T), pentode (P), or push-pull (PP)? (Indicate T, P, or PP.)	
If a superhet, how many intermediate-frequency stages do you want?		What undistorted output do you require? (Indicate number of watts.)	
Is the set to be a straight radio receiver (SR), to have provision for the use of a pick-up (PU), or to be a complete radio-gramophone (RG)? (Indicate SR, PU, or RG.)		What is to be the maximum high-tension voltage?	
Is your object to get the greatest possible number of stations (N) or really good quality from a few stations (Q)? (Indicate N or Q.)		What is to be the maximum anode-current consumption?	
Do you want the set to get short-wave stations as well as medium- and long-wave transmissions? (Indicate Yes or No.)		In the case of a battery set, will you get the high-tension from a mains unit? (Indicate Yes or No.)	
Do you want the set for short-waves only? (Indicate Yes or No.)		In the case of a moving-coil loudspeaker, is it to be of the permanent-magnet (PM), or energised (E) type? (Indicate PM or E.)	
What will be the distance, in miles, of the set from the nearest broadcasting station?		Do you want to incorporate two balanced loudspeakers? (Indicate Yes or No.)	
Is the set to have a self-contained loudspeaker? (Indicate Yes or No.)		Do you want terminals for connecting an additional loudspeaker? (Indicate Yes or No.)	
In the case of a table battery set, are the batteries to be contained in the cabinet? (Indicate Yes or No.)		Do you want to use an external open aerial (E), external frame aerial (F), or self-contained frame aerial (S)? (Indicate E, F, or S.)	
Do you want the superhet to have a preliminary stage of high-frequency amplification? (Indicate Yes or No.)		In the case of a set with self-contained aerial, do you want provision for an external aerial and earth? (Indicate Yes or No.)	
Do you want one-knob tuning control? (Indicate Yes or No.)		In the case of a mains set, is a mains aerial desired? (Indicate Yes or No.)	
Is the tuning dial to be calibrated in degrees (D), or wavelengths (W)? (Indicate D or W.)		How much (approximately) are you prepared to spend on the complete assembly?	
Do you prefer (in a mains receiver) the power pack to be separate or as an integral part of the set? (Indicate S or I.)		Reader's name and address (for reference only and not for publication).	
Do you want the set to incorporate reaction? (Indicate Yes or No.)			

By JAY COOTE

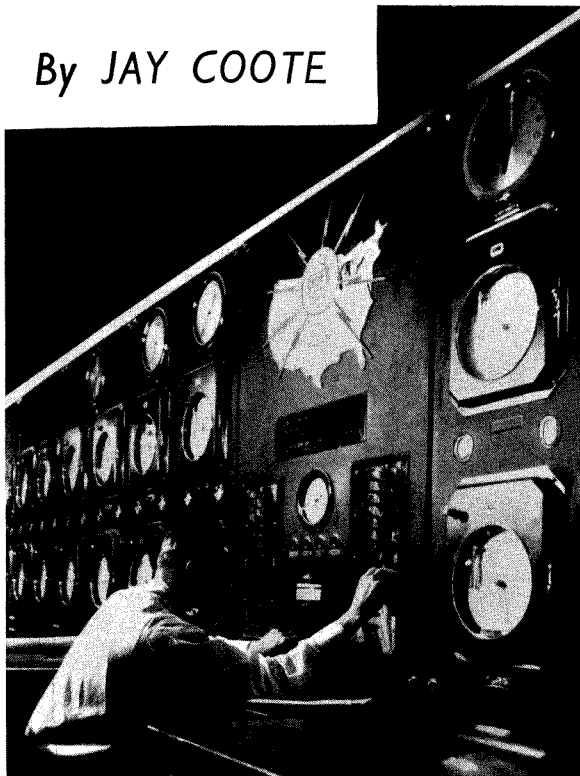

R.P. photo

They certainly believe in big control panels in the U.S.A. Here is the operator at the main studio control panel at N.B.C.'s Radio City, New York

# Radio News from Abroad

New Bulgarian 100-kilowatt :: Tests from France :: Germany Bans Records :: Drastic Alterations in Norway :: Spain's Latest

**BULGARIA**  
SO far, Bulgarian listeners have had to be satisfied with broadcasting from the little Radio Rodno station, the power of which does little more than cover the capital. A new 100-kilowatt transmitter, however, has now been ordered from Germany; it is to be a replica of the Vienna Bizamberg plant and every effort is to be made to get it ready by the end of 1935.

## CZECHOSLOVAKIA

The new high-power broadcasting station at Banska-Bystrica will shortly "take the air." As a tribute to the President of the Republic it will bear his name, Masaryk. For a further extension of the network two regional transmitters are to be built at Budweis (Bohemia) and at Karlsbad.

## FRANCE

There is a strong possibility that we may hear very shortly tests carried out by the new 100-kilowatt transmitter at La-Brague (Nice). The station is now built and the authorities hope to bring it into regular operation in July.

been fully carried out.

Notwithstanding the fact that broadcast entertainments from Eiffel Tower are now being transmitted on 206 metres, many listeners, no doubt, may have heard speech on the longer wavelength of 1,389 metres. It should be understood that two channels, namely 2,650 metres and 1,389 metres, are retained by the authorities for official transmissions.

Time signals, as has always been the case, are still put out twice daily, namely at B.S.T. 09.26 and 22.26 on 2,650 metres, and weather reports are still broadcast daily at 07.45 and 11.50 on the second of these long-wave channels.

## GERMANY

From May 5 no gramophone records have been broadcast from German stations. The time that was devoted to these transmissions is entirely given over to orchestral music.

## ITALY

As Rome, Milan and Turin, Bari is to be given a second transmitter for providing an alternative pro-

gramme. It is stated that the power will be less than 500 watts, and that the wavelength chosen will be in the neighbourhood of 200 metres. The transmitter will be used for relaying entertainments from the Northern group and will take its programmes mostly from Milan or Turin.

## NORWAY

We may expect drastic alterations in the Norwegian broadcasting system, although the scheme devised by the government may take seven years to mature. The network will eventually comprise nine main transmitters, ten relays, and one powerful short-wave station.

The main stations will include installations at Oslo (60 kilowatts), Flekkerø (Kristiansand) and Bergen, both 20 kilowatts, and other stations of equal power at Stavanger, Vigra (Aalesund), Bodo, Vadso (Finmark), Trondelag (Trondheim), and Tromso.

Bergen, although not entitled to do so, will work on a long-wave channel.

## SPAIN

Although many attempts have been made to reorganise the Spanish broadcasting system, it would appear that the latest scheme may now be carried out over the next three years. As planned, at the end of 1938, the country should be in possession of the following stations: Madrid-Nacional, 150 kilowatts (1,639 metres); Madrid-Centro (or Regional), 50 kilowatts (293.5 metres); Barcelona (Nordeste), 50 kilowatts (274 metres); Valencia (Este), 20 kilowatts (352.9 metres); Seville (Sur), 60 kilowatts (410 metres); to mention just some of them.

Most of us know that theoretically the superhet approaches the ideal receiver, but in practice we often find that it possesses unpleasant habits. In this special contribution J. H. Reyner explains the whys and wherefores of noises and whistles and gives valuable hints on how to cure them

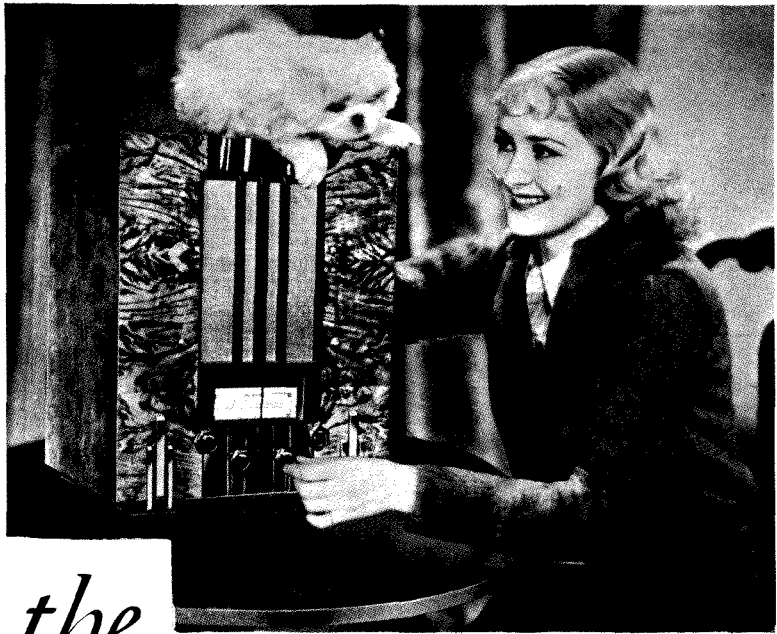

Miss Marian Marsh, the well-known B.I.P. star, appears to be getting complete satisfaction with her Marconiphone Jubilee superhet

# Making the Superhet Behave!

By J. H. REYNER  
B.Sc., A.M.I.E.E.

IT is an old saying that an ounce of practice is worth a pound of theory; this is never more true than when dealing with superhet receivers. As most experimenters will be aware, it is only too easy to design a superhet which one expects to be free from whistles and noise, and yet to find on test that its performance is disappointing in the extreme.

Recently I had an occasion to attack this problem very thoroughly. My investigations showed once more that the heart of a superheterodyne receiver is in the frequency-changer. We are able to construct intermediate-frequency amplifiers which not only give a high gain but are very selective.

The resonance curve of some of the intermediate-frequency transformers on the market today shows a performance of a very high order. Yet all this goodness can be lost if insufficient attention is paid to the initial stages of the receiver up to and including the frequency-changer.

## Noise and Whistles—the Big Problems

The two main problems with which we have to contend are whistles—the chirps and birdies which seem to appear out of the blue to spoil otherwise clear reception—and, of course, noise. The two problems are similar to some extent and the methods which I shall describe are effective in reducing interference from both causes.

Let us analyse first of all where the whistles come from. I know this has been done before, but it does no harm to run over the ground again so that we may have a clear understanding of the problem. With the set tuned to any one station we have two oscillations

to deal with. The first is the incoming carrier wave, which we will assume to be operating at a frequency of 1,000 kilocycles.

The second is the local oscillation which must be different from the carrier wave by an amount equal to the intermediate frequency. There are, of course, two such frequencies possible with normal intermediate-frequency circuits, and we usually choose the higher of the two, which in this case would be 1,110 kilocycles, assuming a 110 kilocycle intermediate-frequency.

## Producing the Whistle

Now let us consider what other frequencies can combine with these two to produce whistles. First and foremost there is the usual second channel. A station operating on a frequency of 1,220 kilocycles will also mix with the local oscillation on 1,110 kilocycles to produce the required intermediate frequency.

If, as is most likely, the second-channel frequency is not exactly on 1,220 kilocycles, there will be a slight difference between the intermediate-frequency produced by this station and that given by the original (wanted) station which will give rise to an audible whistle, varying in pitch as we alter the setting of the oscillator in the normal process of tuning.

To remove this whistle we must include in front of the frequency-changer sufficient tuning to cut out almost completely any station 220 kilocycles off the normal tune. This is not a very difficult proposition even with a single circuit, and as we usually employ two circuits the second channel whistle is not very troublesome.

Harmonics of the oscillator may produce whistles,

The second harmonic of the oscillator frequency is 2,220 kilocycles. If we have a station working on 1,110 kilocycles we shall get a difference of 1,110 kilocycles which will beat with the incoming signal on 1,000 kilocycles to give the intermediate-frequency of 110 kilocycles.

**Another Source of Whistle**

Here again, therefore, is another source of whistle. It is not so serious as the first because the oscillator harmonic is usually weak relative to the fundamental, and if we make the oscillator circuit good and do not

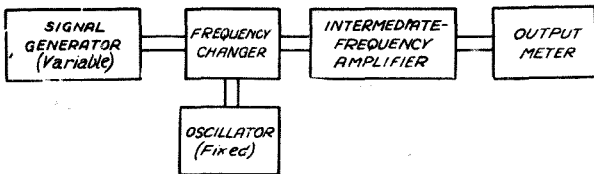

Fig. 1—Arrangement of apparatus used in the author's whistle test

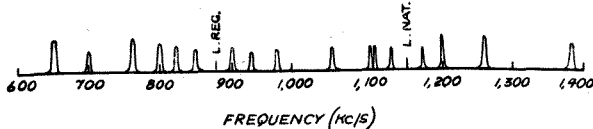

Fig. 2—Showing where whistles can occur near the London Regional and National transmitters

employ a small high-resistance coil such as is usually used, we can reduce this source of interference to very small dimensions.

The pre-selection or signal-frequency circuit helps to cut this source of interference down, but you will note that we have now to contend with a signal 110 kilocycles off tune and not 220, so that the selectivity required is becoming greater.

Unfortunately, there is worse to come. A very pronounced source of whistle is that due to a station half the intermediate frequency off tune. In our example this would occur with a station at 1,055 kilocycles. This would mix with the oscillator to give 55 kilocycles, which at first sight would appear to be of no importance. Unfortunately, every frequency-changer acts as a rectifier—the frequency-changing action is actually dependent upon this effect—and, as is well known, rectification of any particular frequency produces a frequency of twice the original value so that this 55 kilocycles is converted in the frequency-changer to 110 kilocycles where it gives rise to a pronounced whistle.

**Tests to Make Certain**

In order to verify these various points I connected up a frequency-changer circuit with a fixed oscillator, a fixed intermediate frequency, and a variable source of signal frequency. I noted the intermediate-frequency output for various values of signal frequency. The results were illuminating.

There was, of course, the main output when the signal was exactly 110 kilocycles different from the oscillator. There was a much weaker, but still well-defined, output from the intermediate-frequency amplifier at a frequency 220 kilocycles off tune. There was a small but measurable output at 110 kilocycles off tune, and there was quite a strong output 55 kilocycles off tune.

These results, of course, confirmed the existence of

the sources of whistles we have just discussed. There was, however, still another quite pronounced source of interference which occurred at a frequency *one-fifth of the intermediate frequency off tune*, namely, at 22 kilocycles away.

This was quite unsuspected, and arises once again from the rectifying action of the frequency-changer which is producing here a fifth harmonic as well as the ordinary second harmonic. The action is not peculiar to any one frequency-changer. I repeated the test with a heptode, an octode, and a triode-pentode, and obtained the same order of interference in every case. Consequently, the only remedy against this latter form of interference is to have a really efficient pre-selecting circuit which reduces any signal more than 20 kilocycles off tune to quite a small value.

It might seem at first sight that we are being academic. Surely any reasonable circuit would be able to cut out stations as far apart as 50 or 100 kilocycles? Perhaps 20 kilocycles is getting a little close, but even so a band-pass filter should cut down the strength sufficiently to avoid any trouble?

This argument might apply if it were not for the presence of high-power local stations. Unfortunately such stations exist, and they pump into the aerial such a strong voltage that even if we reduce their intensity a hundred times the residual signal is still very large.

**Selective Effect of a Tuned Circuit**

It is of interest to work out the selective effect of a tuned circuit. Suppose we take a standard coil of 157 microhenries and assume a high-frequency resistance of 5 ohms at a frequency of 877 kilocycles, corresponding to London Regional. This is not a bad coil, and probably many of the coils in use are worse than this.

In Fig. 3 I have shown the percentage of the resonant voltage (that is, the volts when the circuit is tuned in to London) at various degrees of mis-tune. You will see that with one circuit alone there is still 25 per cent of the voltage left 20 kilocycles off tune, and 7.5 per cent 60 kilocycles off.

Actually, of course, we usually use a band-pass

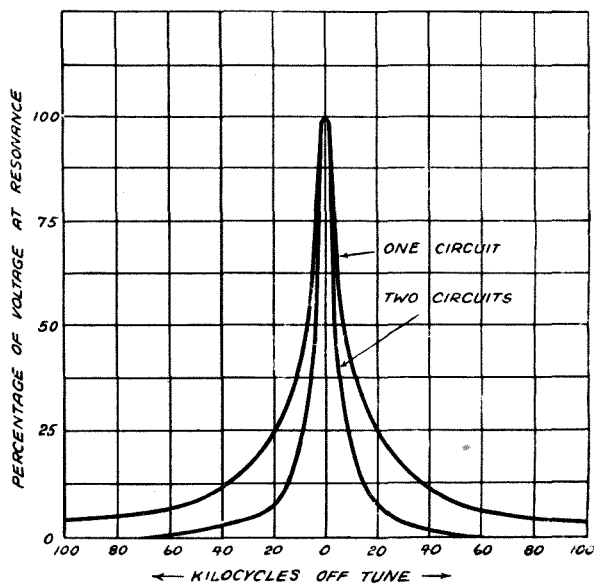

Fig. 3—Reduction of strength of local station when one and two circuits are used



filter employing two circuits. Now a band-pass filter does not give quite as good selectivity as two "cascaded" circuits, but I have worked out the curve for the ideal cascade case. This would apply to a set having a high-frequency stage. A band-pass circuit would not be quite as good. Here we find 7 per cent of the voltage left 20 kilocycles off tune and only about .1 per cent 60 kilocycles off.

### Hopes—then Disappointment

This, therefore, looks reasonably hopeful, except for the case of the whistle 22 kilocycles off tune, which is rather a problem, even with two circuits. However, armed with this information I set about analysing the performance of the particular set in question. This was provided with a band-pass filter of about the goodness assumed in the above example, so that I expected to be troubled only with the 22 kilocycle whistle. My hopes were vain! I found all the whistles which I have enumerated quite strongly in evidence, and then some!

It was not until I had spent quite a time in fruitless

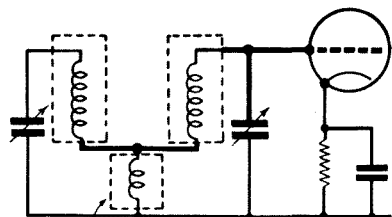

COUPLING COIL MUST BE SCREENED

Fig. 4—Showing some of the points on which direct pick-up may be obtained in a simple inductively-coupled band-pass filter. The leads in question are shown in heavy line

search that I discovered the reason. It was quite simple! The band-pass filter was not behaving according to the book, because of *direct pick up on the secondary*. The voltage from the aerial is supposed to be passed through the two circuits of the filter in turn. If, however, we allow the second circuit to pick up voltage direct, the filtering action of the first circuit is lost, and as we have just seen, one circuit alone is pretty hopeless.

Where is this leakage occurring? By direct pick up on the short lengths of lead connecting the coils and condensers to each other and to the frequency-changer valve!

### Sixteen Sources of Whistle

A comparatively short length of unscreened lead is sufficient to introduce quite a large voltage and nullify the selective action of the filter almost completely. Since there are eight possible whistle frequencies to each station and since there are usually two local stations, we have sixteen sources of whistle, most of which can be completely avoided if proper care is taken.

Fig. 4 is a circuit diagram of a simple inductively-coupled band-pass filter. The leads shown in heavy line are the points at which direct pick up can occur. If you want to see how serious this can be, disconnect the tuning condenser of the first circuit. You will usually find that quite strong signals can still be obtained from the local station. Keep the aerial on, as signals are often transferred direct from the aerial lead to the unscreened portions of the secondary.

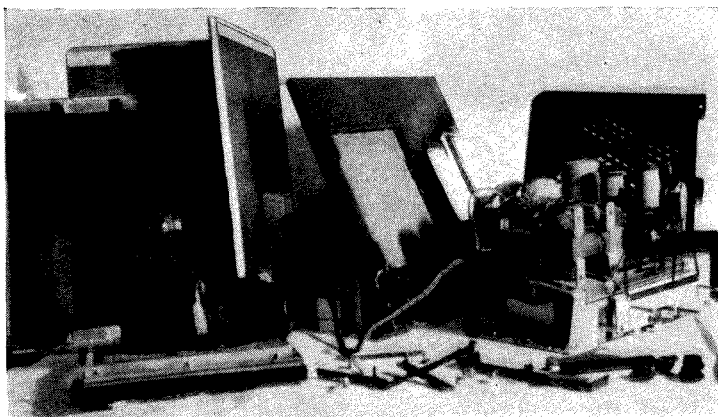

If you drop your superhet down a flight of steps it may resemble the wreckage shown in the above photograph. This is the remains of an H.M.V. Jubilee superhet after such an accident as described. We are told that in spite of a bent chassis this wrecked set worked perfectly!

The remedy is two fold. Mainly it consists in careful screening of all the live leads on the secondary circuit. Keep the leads short and enclose them in screen tubing. A particularly fruitful source of trouble is the lead to the grid of the frequency-changer itself. This is usually screened, but the short length at the end, and even the grid terminal on the top of the valve is sufficient to pick up. The remedy is to use a valve can—a metal cover which completely encloses the valve.

The earth return is the second point. All earth return points must go direct to one point, preferably the earth terminal itself. Connecting the leads to the chassis is not good enough. All these remarks, of course, still apply even when one uses a high-frequency stage instead of a band-pass filter.

### Careful Screening on the Secondary Important

Careful screening on the secondary side is even more important in such circumstances. The best plan is to disconnect the tuning condenser on the primary side and then to tune the set in to the local station. Bit by bit various leads should be shielded or shortened until there is practically no signal from the local station.

There should be none at all, because there is no proper circuit to the band-pass filter as long as the first condenser is disconnected. When the direct pick-up has been eliminated in this manner the first circuit may be wired up again and the whistles will be found to be considerably reduced in intensity.

Regarding noise, this is a subject requiring a special article. At the same time noise, which is due to the heterodyning by the oscillator of stray disturbances picked up by the aerial, is clearly minimised if we have a sharply tuned circuit in front of the frequency-changer. Without this tuning there are a large number of disturbances of varying wavelength which can mix with the oscillator.

If we restrict the number of such disturbances allowed to reach the frequency-changer by making them pass through a sharply tuned circuit we clearly shall reduce the noise level appreciably.

For this reason the adoption of the same precautions as have just been outlined for reducing whistles will also be found to be very beneficial as regards noise.

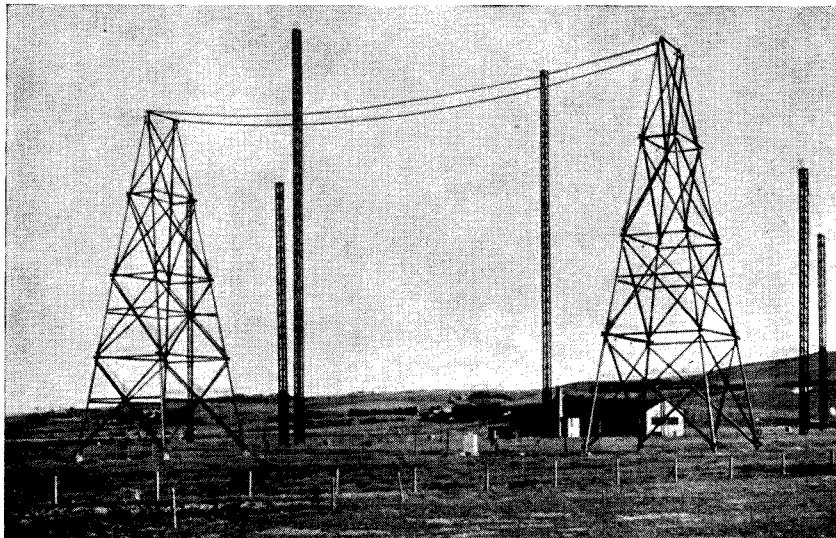

R.P. photo

# How to

Describing a Sure

The Danish short-wave station at Skamlebaek transmits special signals each Sunday on 49.5 metres in connection with experiments now being carried out to discover more about fading and its causes

**T**WIDDLING the tuning control of a short-wave receiver seldom produces any satisfactory results, though there is just a remote chance that by sheer good luck the "twiddler," much to his delight, may tune in one of the powerful broadcasts such as Berlin, Moscow, Daventry, and so on. But the method is an unreliable one, and if time is not to be wasted it should be studiously avoided.

### Only Certain Places

It must be borne in mind that *whatever* may be the range of the coil used in the set, broadcasting stations will not be found all over the dial, but only in *certain* portions of distinct wavebands.

Note that, as in the case of medium and long waves, the field covered is a very large one; it includes not only stations giving out or relaying broadcast programmes, but also maritime traffic (ships, transatlantic and other telephony), experimental amateurs, police, aviation and the innumerable morse transmitters dealing with press, commercial and other services.

### Waste of Time

It is well to understand these facts at the outset, for it is useless to spend time searching for a broadcast station in segments of the frequency band reserved for public or other services such as I have enumerated above, or which are "dead" at that particular hour of the day.

For the purposes of this article

we will take it that short-wave transmissions are those made on channels between roughly, 10 and 100 metres, but, as already stated, all portions of this scale will not be found of interest.

The diagrams reproduced here must on no account be taken as giving the *exact positions* of the indicated stations on an ordinary condenser dial; they are intended to show at a glance the segments in which actual broadcasting stations may be found. It will be clearly seen that after the listener has

searched the section, which includes the channels 13.92-13.99 metres (21,550-21,450 kilocycles), it is useless to waste any time—if broadcast entertainments are desired—on the following divisions, namely from, say, 14-16.80 metres, as it is only on 16.85-16.9 metres that any such station may operate.

Again, a jump must then be made to 19.54-19.87 metres before anything else of a similar nature can be logged. Broadcasting stations are authorised to use the following bands : 11.28-11.72 metres (26,600-

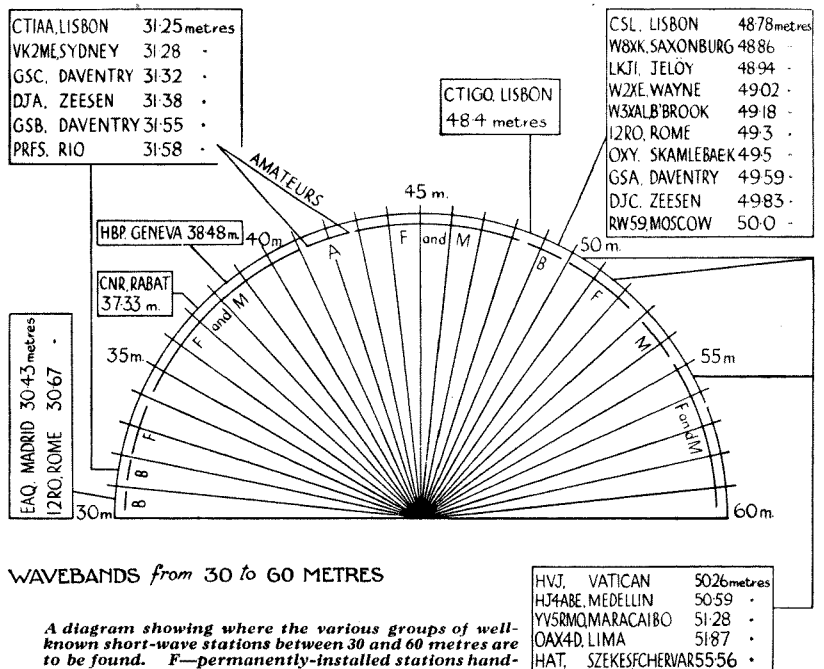

WAVEBANDS from 30 to 60 METRES

A diagram showing where the various groups of well-known short-wave stations between 30 and 60 metres are to be found. F—permanently-installed stations handling point to point traffic working with a selected opposite number. M—mobile stations covering shipping, coastal transmitters, aircraft, and so on. A—experimental amateur stations, and B—ordinary broadcasting stations

# Search on the Short Waves

Method of Success Devised for "W.M." by J. GODCHAUX ABRAHAM

25,600 kilocycles); 13.92-13.99 metres (21,550-21,550 kilocycles); 16.85-16.9 metres (17,800-17,750 kilocycles); 19.54-19.87 metres (15,350-15,100 kilocycles); 25.21-25.64 metres (11,900-11,700 kilocycles); 31.25-31.58 metres (9,600-9,500 kilocycles); 48.78-50.00 (6,150-6,000 kilocycles).

This, however, must not be taken as a fixed rule, because although in most instances certain bands have been monopolised by fixed and other services; some of the channels are being used by hitherto fixed transmitters now effecting broadcasts or experimental relays. Generally speaking, however, the bulk of the stations desired will be captured in the seven bands specified above.

In the two facsimile scales which, for the sake of convenience, have been marked in metres and not degrees, I have indicated in each interesting segment a few important transmitters which will serve as landmarks, or jumping-off places for starting a search.

The tuning-in of broadcasts on short waves must be carried out more carefully than when dealing with transmissions on, say, the

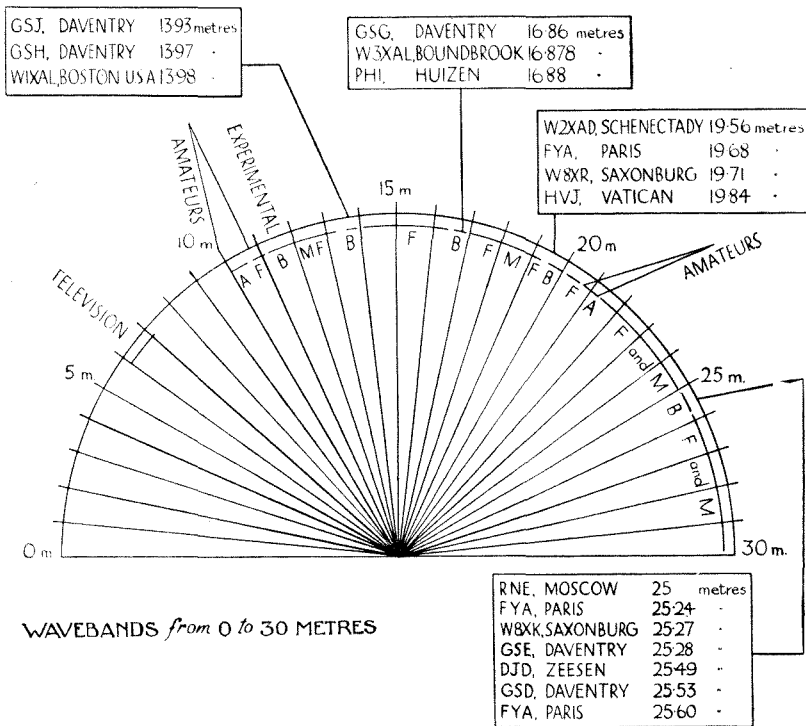

Another diagram showing the disposition of stations between 0 and 30 metres. These two charts should be of immense value to readers and should prevent them from wasting time searching in the wrong places!

medium-wave broadcast band, and if any recommendation is to be made it is that from the outset the listener should provide himself with, (a) a complete list of transmitters with their wavelengths and frequencies, and (b) some form of log in which to register the captures.

### Compiling a Log

As regards a log, I suggest a loose-leaf file, or as in my case, a series of them, of the kind one may buy at Woolworths. This system permits not only the recording of all details regarding a transmitter in sequence of wavelength or frequency, but allows the insertion of extra leaves in their proper order as and when new broadcasts are identified. If you add to these individual sheets the data collected at various times you will soon possess a full record of the activities of each individual station.



R.P. photo

The youngest short-wave amateur in the world is believed to be George Alan Bryan, of Derby; his call sign is 2AFV

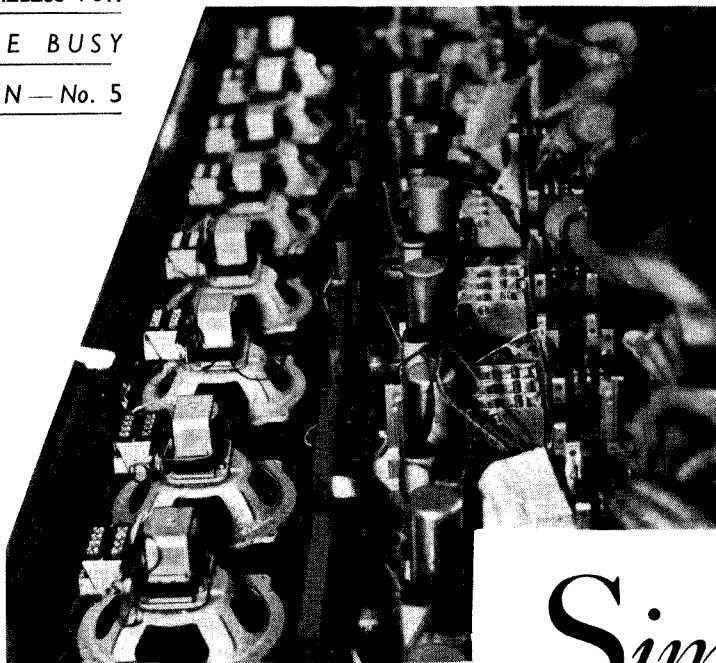

In the four preceding articles of this series the author has given a clear survey, starting from the speaker in front of the microphone at the broadcasting studio and finishing at the point where received signals were ready to apply to the loudspeaker. In this month's article the loudspeaker itself comes up for discussion

## Simple Facts

WHILE we are bound to judge a wireless set by what comes out of its loudspeaker, that instrument itself must be given neither too much credit nor too much blame for what you hear. Far too often I hear the exclamation: "What a splendid loudspeaker you have!" when as a matter of fact the reproducer is quite an ordinary one and the good quality, which has elicited this remark, is due almost entirely to the design of the set.

You may find it difficult to believe, but it is true, that with a poor and distorting set a poor loudspeaker will often give better general reproduction than one having far higher qualities.

### Hidden Defects

A badly-designed or faulty set may give heavy distortion in the bass and this will show up markedly on a good loudspeaker; if we connect to this bad set a loudspeaker which is incapable of giving any reproduction of the genuine low notes then distortion of those notes will not be heard, although the overall quality may sound rather "thin."

Again, at the other end of the scale many loudspeakers are very deficient in their reproduction of higher tones and any distortion in this region of the sound spectrum will show up distressingly on a good loudspeaker and not at all on one which has no proper "top."

Let us give a little further con-

sideration to the question of quality reproduction with loudspeakers. Assuming a set which is as near perfection as modern technique will allow, let us see what happens when different kinds of loudspeakers are connected. Here is one which makes the reproduction sound thin and edgy although its speech intelligibility is good. Such a speaker is deficient in low-note reproduction and the edginess is caused by oversensitivity to certain high notes.

Another speaker which we try sounds much more natural on certain types of music such as the organ, but before long one becomes conscious of a kind of "boom, boom, boom" due to a resonance in lower tone regions which, very likely, is accentuated by the box or cabinet in which the loudspeaker is placed.

Thus you may notice certain deep notes on the 'cello come out much stronger than others simply because they correspond with the natural frequency of the diaphragm and of the air space in the cabinet. Such loudspeakers nearly always make speech sound muffled, for resonance in the bass is often accompanied by deficiency in "top."

Far too many loudspeakers used in cheap commercial sets have a severe bass resonance and give very little reproduction of frequencies over about 3,000. Speech with such loudspeakers is muffled; one does

not get the characteristic sounds of the brass in an orchestra, and many of the percussion instruments in a jazz band (the wire brushes, etc.) are not heard at all.

### The Acid Test

A really good loudspeaker gives such a natural effect as to be quite startling—voices sound as if the lecturer were actually in the room. Perhaps the best test of all is when the set is turned up too loud for comfortable room reception and if one listens outside the room, this natural effect should not be lost.

You may think your present set is giving natural reproduction, but ask yourself dispassionately whether if when the set is turned on loud and you are standing in the passage outside the room, you could possibly mistake a piano reproduction by the wireless for the real thing. If you cannot notice the difference then you have a good set and a good loudspeaker, for the satisfactory reproduction of piano music is by no means easy.

### Universally Used

While there are many types of loudspeaker, what is known as the moving-coil type has now practically replaced every other kind in modern sets save in the very cheapest.

The moving-coil reproducer was very expensive when first produced,

but in the last year or two methods of manufacture and colossal output have enabled the price to be brought down so that it can be included in receivers, the price of which brings them within reach of practically everyone.

### Simple Principles

The actual construction of a moving-coil loudspeaker is easy to understand, although a good deal of skill both in design and manufacture is required to produce a satisfactory product. It consists essentially of a cone of treated paper or cloth with a small and short cylinder attached to its apex. The cone is supported round the edge in such a way that it can move quite freely.

There are several forms of sus-

This coil is now arranged to fit into a ring-shaped space between the two poles of an electro-magnet of peculiar construction.

Fig. 1 shows a simple cone flexibly mounted with its coil wound on the short cylinder, while in Fig. 2 a simple form of electro-magnet with a ring-shaped gap between its two poles is shown. The magnet may be either of the permanent or of the excited type, the former being permanently magnetised and the latter magnetised by strong direct currents.

Now there are advantages in each type. The permanent-magnet type needs no special energising current to magnetise the iron, but is dearer than the energised type. In many modern sets the coil winding of the

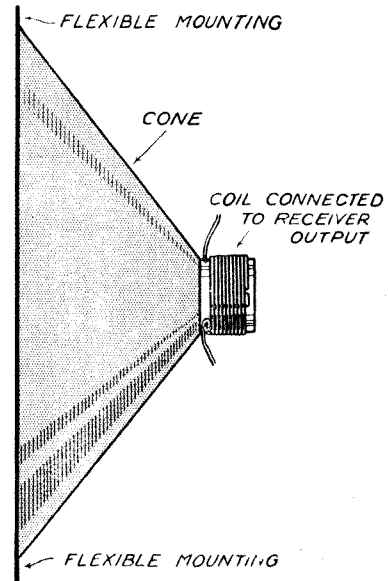

Fig. 1.—Showing the mounting of a loudspeaker cone, with the speech coil wound on the short cylinder at the apex

# About Loudspeakers

By PERCY W. HARRIS, M.I.R.E.

pension, one of the earliest being to attach the edge of the cone to a ring of flexible material such as thin indiarubber or wash-leather, this supporting material being attached in turn to a sheet of fairly thick wood known as a baffle. A hole is cut in the baffle slightly larger than the diameter of the cone but slightly smaller than the outer diameter of the flexible supporting ring. When so mounted the cone can move in and out for a short distance in a direction at right angles to the plane of the baffle.

### Cone Suspension

Sometimes the cone is moulded from some material in such a way that while in the main it is stiff, the circular edge is flexible. Whatever method is adopted, the purpose is to allow the cone to move in and out as freely as possible under the influence of the signal.

Now what makes it move? On the short cylinder attached to the apex of the cone is wound a coil of wire which carries the fluctuating signals from the output of the set.

electro-magnet (do not confuse this with the special winding on the "signal coil") is made to be part of the smoothing circuit for all anode currents in the set, thus effecting considerable economy.

The effect of making the poles of the electro-magnet of the shape indicated is to bring about an intense concentration of magnetic field in a ring or annular space. If now we put the small cylinder attached to the apex of our cone into this annular space and carefully support it in such a way that it does not rub on the magnet surface, we can try one or two experiments.

When there is no current flowing in the coil nothing happens, but directly we start a current it will set up its own magnetic field, which in turn will interact with that of the electromagnet and cause a movement of the cylinder into or out of the annular space.

### How the Coil Moves

Variations of current strength in our speech coil, as it is called, will cause variations of movement of our cylinder in and out of the annular space, and as the variations of current in the coil correspond with the signals, then the cone will move in and out in response to these changes.

The effect of moving the coil, and therefore the cone, to correspond with the signals produces a sound effect by impact on the air and sound waves are radiated from the surface of the cone and we come back again to the sound wave form with which our signal started in the studio.

The magnetic effect produced by

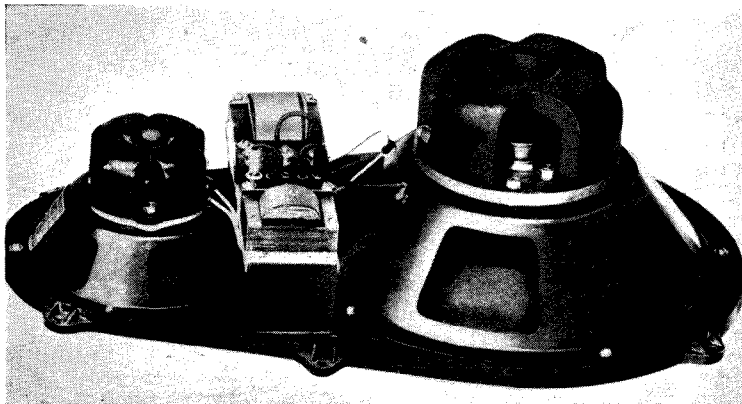

A composite loudspeaker assembly made by Celestion using two reproducers, one for good reproduction of the top frequencies and the other for good reproduction of low notes

the currents in the speech coil will depend upon their strength. For this reason, instead of having a small current at a fairly high voltage, which would involve many turns of very fine wire on the speech coil, it is

loudspeaker is to be used from a push-pull output stage then there will be three transformer terminals instead of two, two of these terminals being used for the two separate plates of the valves and the third for the high-tension connection. Push-pull, by the way, as we have not already mentioned it, is a form of output which employs two valves and enables a fairly high power to be handled with less distortion than would be the case with a single valve in the output stage.)

The amount of movement of the cone on low notes is quite considerable and can actually be seen. If the cone and loudspeaker are badly designed it may be found that the combination has a very strong natural resonance at a frequency somewhere within the audible scale. This means that it will tend to vibrate very easily indeed in its natural frequency

and this will accentuate such notes as fall on it. The effect can be very distressing, particularly when the volume is turned up fairly high.

Another important point regarding low frequencies is that it has been found impossible to reproduce them satisfactorily with a moving-coil loudspeaker unless it is mounted in a hole in a piece of wood which must be at least a yard square and preferably much larger.

### Frequency Limits

If the moving-coil loudspeaker is used alone without a baffle (or some box which gives a similar effect) the air waves from the front of the loudspeaker bend round and counteract those emitted from the back in opposite phase and so the low note effect is cancelled out. If, however, the loudspeaker is mounted on a baffle sufficiently large to make a fairly long path from the front to the back of the loudspeaker cone, then the low notes will be reproduced satisfactorily.

With regard to high notes, many if not most moving-coil reproducers are far from satisfactory in this regard. The cheapest kind may reproduce no notes over about 3,000 or 3,500 cycles, but still it manages to make speech and music sound fairly natural by deliberately creating a resonance round about the 2,500- to 3,000-cycle mark; certain important frequencies connected with intelligibility happen to fall here.

### Beam Effects

On the other hand, a well-designed instrument will satisfactorily reproduce frequencies up to 6,000 and 7,000 cycles and even more without much falling off in average strength.

Here again we are faced with another difficulty. The radiation of sound so far as low notes are concerned is fairly uniform in all directions, but the radiation of high notes is very directional, tending to fall along a line proceeding from the centre of the cone at right angles to the surface of the baffle.

This means that if one's ear is on this line (that is, right in front of the loud-

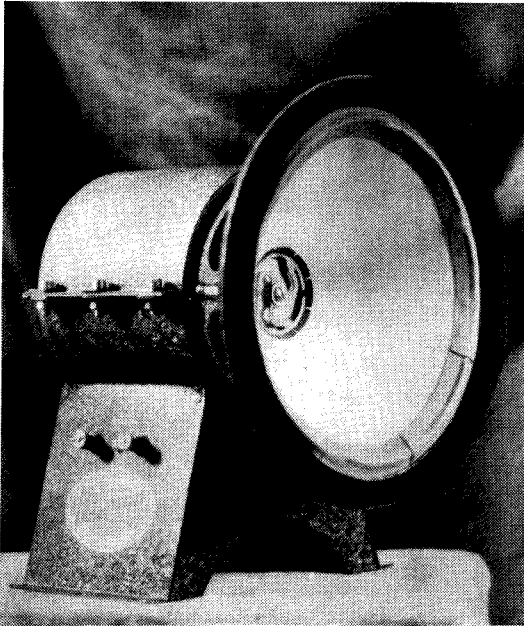

Here is a Ferranti moving-coil loudspeaker. Note the spider device in the centre of the loudspeaker cone to prevent the moving coil rubbing against the centre pole-piece

customary to have a few turns of fairly thick wire and supply them with a good deal of current at a low voltage.

In order that this large current may be obtained the speech coil is attached to a special transformer (usually mounted on the framework of the loudspeaker) which serves to step down the voltage of the output of the receiver to the low voltage and high current required for operating the moving coil.

### Speaker Connections

If the loudspeaker is of the energised type there will be four terminals on it, two for what is known as the exciting field and two for the transformer. (The transformer may sometimes have more terminals than this, the additional ones being for tapings which enable one to adjust the transformer winding to suit the various kinds of output. If the

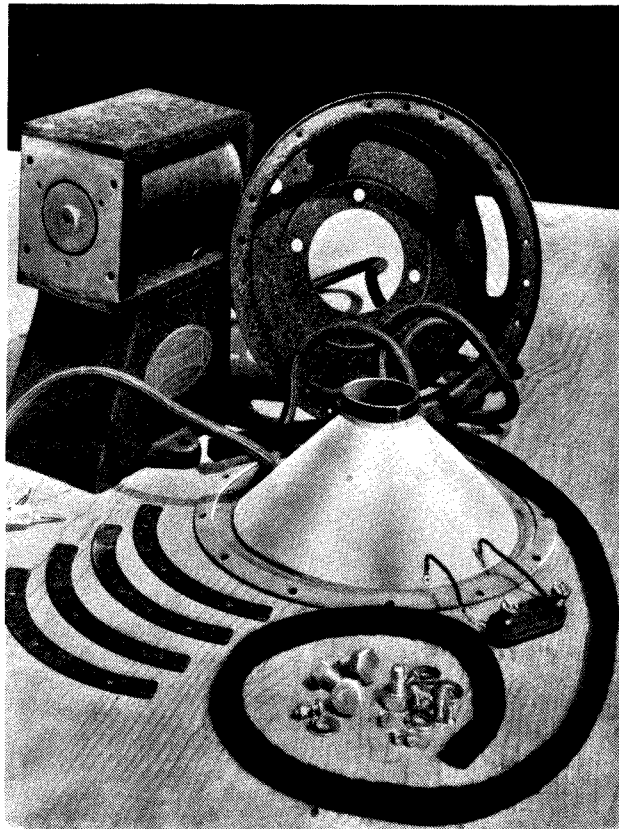

Showing the various parts that together make a Ferranti moving-coil loudspeaker. The way all these parts fit together is described in the accompanying article

speaker) then good high-note reproduction will be heard, but any considerable movement away from this line will bring about a loss of the high frequencies. For convenience many loudspeakers are placed near the floor, particularly in radio-gramophone sets and others of the "console" type, but from the point of view of good reproduction it is better to have the loudspeaker near ear level, and this can often be done conveniently with a table instrument.

### Separated Functions

The difficulty of obtaining in one loudspeaker satisfactory reproduction of both low and high notes has led to the use of two loudspeakers in many cases, one to cover the low-note region and the other the higher frequencies.

The use of a special loudspeaker for the higher frequencies originated in the talkies when a year or two ago several high-fidelity systems were introduced in which the greatest care was taken to record high frequencies satisfactorily and to reproduce them by means of the amplifiers.

### Upper and Lower

It was found quite early in these experiments that the ordinary loudspeakers used in cinema theatres would not satisfactorily reproduce the high frequencies, although the low tones came out very well. And so special reproducers for the high frequencies were used in addition to the normal ones and given the name of "tweeters," a descriptive if not a very scientific term. Later both loudspeakers were re-designed, the ones used for the low-note reproduction being known as "woofers."

We now have both woofers and tweeters in cinema theatres and a similar technique is being adopted in some wireless sets. The Jubilee Radiogram described in the May "W.M." is an example of a set using both forms of loudspeaker.

But no matter what care we take in the design and fitting of our loudspeakers, they can only reproduce what is put into them, and if the set itself is deficient in high or

low frequencies no loudspeaker can remedy the state of affairs. And here let me say that much confusion in the public mind has been caused by manufacturers who have endeavoured to give pleasing descriptions of the performance of their loudspeakers.

It is absurd to talk about a loudspeaker giving "mellow" reproduction, for this implies that the loudspeaker can itself give such a colouration to the output as will improve it. A good loudspeaker should have the same effect on sound as a perfectly clean and clear window has on light—which is to transmit every-

and who in the main use their wireless set to give a kind of musical and speech background to their general conversation. It has been found that proper reproduction of the higher frequencies which give naturalness to speech is unpopular among those who like to talk while the wireless is going; hence the popularity of the so-called tone controls which reduce the upper frequencies progressively as the knob is turned.

### Mistaken Idea

A tone control turned to the full-control position generally gives a great deal of "woolliness" to speech and music, but at the same time will remove those characteristic higher frequencies and make the speech and music much less obtrusive.

The idea that these controls should be used to adjust the tone to suit the individual tastes of the user is misleading, for if the set is a good one and the loudspeaker is working properly, speech and music should be reproduced just as they are occurring in the studio. If the set is right for one kind of music it is bound to be right for another, and if it is not, no tone control ever made can satisfactorily cope with the position.

### Removing Splash

There is one direction, however, in which tone controls, particularly if they are well designed, are helpful. In some distant station listening there may be a good deal of what is called "sideband splash" or a kind of hissing and spluttering interference from some adjacent transmission which

occurs almost entirely in the higher frequencies and so is very irritating.

By using the tone control to remove the higher frequencies and sacrificing some degree of naturalness in the programme, one can often eliminate this form of interference almost completely, so that the gain in comfort to the ear more than over-balances the slight loss.

Atmospheric interference and crashes which occur in some conditions in warm weather may also be reduced in intensity by the intelligent use of the tone control.

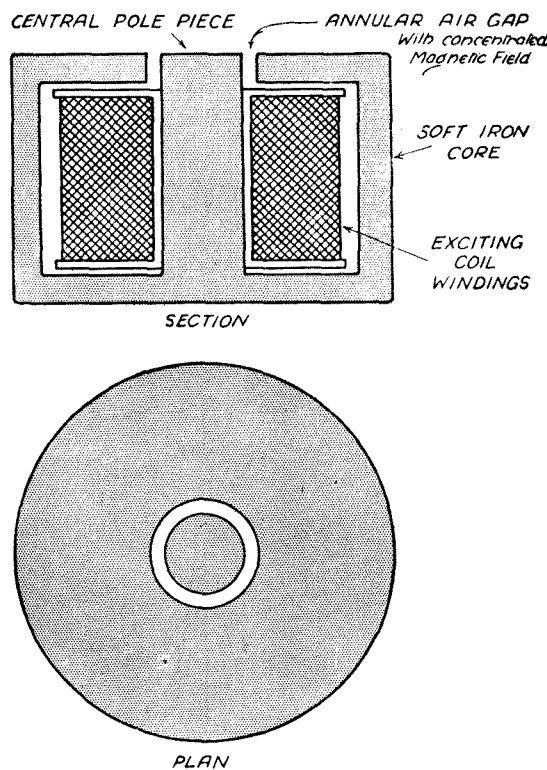

Fig. 2.—Showing a simple form of electro-magnet with a ring-shaped gap between its two poles. The magnet may be either of the energised or permanent type

thing perfectly without distortion.

A loudspeaker is not a musical instrument any more than is your ear; any description of a loudspeaker which suggests that it is, or that some method of construction is adopted similar to that in a musical instrument, is based on a misunderstanding of what the loudspeaker has to do. Unfortunately, almost every loudspeaker imparts some characteristic of its own to the reproduction, but this is a fault.

Of course, there are some people who do not like natural reproduction

# The "Single-signal" Super

Its Principles and Use described by G. HOWARD BARRY

**T**HE Single-signal superhet, facetiously described in a certain American journal as the "Siggle Sniggle Snooper," is perhaps the outstanding example of a good set spoiled by a bad name. Even now, when receivers of this type are becoming more and more popular in this country, hardly one person in four understands the true significance of the title.

### Increasing Selectivity

We must, therefore, begin right at the beginning. When the super-sonic heterodyne was first conceived, the main idea behind it, so it seems, was that amplification was more easily obtained at the so-called

"intermediate" frequency than at the signal frequency.

The more valuable notion of obtaining the *selectivity* of the set in the intermediate stages somehow did not seem to sink in during the early stages. For a matter of some years, however, we had the pleasure of seeing superhets grow more and more selective, the series culminating in Dr. James Robinson's Stenode receiver.

The original form of this used a quartz-crystal filter, or "gate," between the last I.F. stage and the second detector, and gave a degree of selectivity that was, at the time, quite incredible.

I need not enlarge on the contro-

versy that raged at the time. The sideband theory was questioned; the whole theory of modulation was cross-examined; the microscope was turned on several accepted ideas; and, so far as I know, some of the phenomenal results obtained have not been explained, even to this day, to the satisfaction of all parties.

The original Stenode was, of course, a receiver for telephony. The crystal filter served to pass only a very narrow band of frequencies and

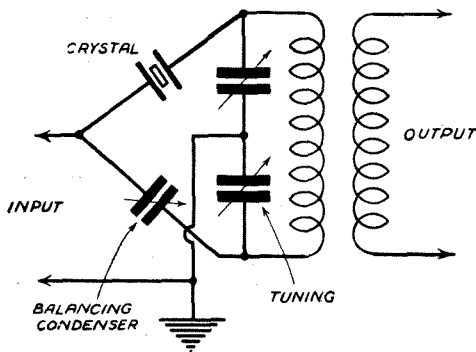

Fig. 2 (a).—A method of introducing the quartz-crystal filter. Here it is shown in the series position. It will be noticed that the resonance hump obtained with this circuit is similar to the curve C in Fig. 1

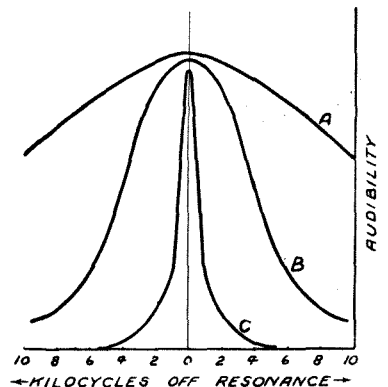
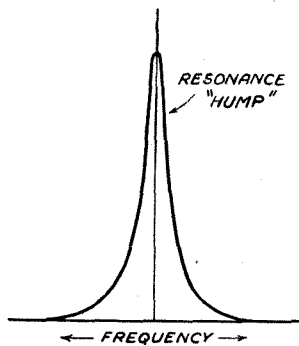

Fig. 1.—Three typical selectivity curves: A being that of an average detector-L.F. set, B a selective superhet, and C a superhet with a quartz-crystal filter introduced into the I.F. stage

a "tilted" correcting amplifier was used after the second detector to strengthen that "top" that was weak in the output of that valve.

### Doubled Accommodation

The Single-signal receiver uses a quartz crystal in quite a different way, the chief point of the whole thing being that beat-note reception of continuous-wave (C.W.) signals is revolutionised. An ordinary receiver, the tuning of which is swung across the frequency of a C.W. signal, will give the familiar effect of a high beat-note, falling in frequency until zero-beat position is reached, and then rising until it passes out of audibility. In other words, it really

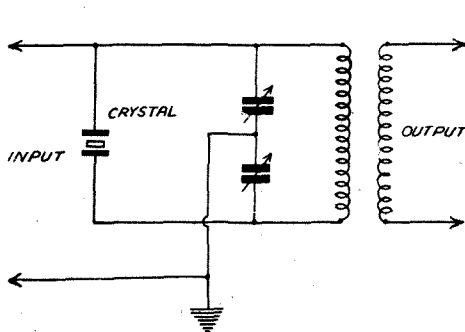
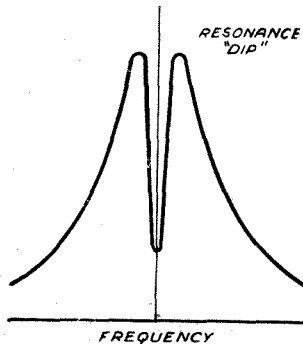

Fig. 2 (b).—Showing the quartz-crystal filter introduced in the parallel position. The resonance dip obtained by this method is made use of in the Single-signal Super





receives *two* audible signals—one on either side of the zero-beat position.

Obviously, if we could cut off *one* of these from every station, the total occupancy of the narrow amateur bands would, effectively, be halved. Just that, no more, no less! Put in another way: it would open the bands to twice the number of stations without increasing the interference caused by them. Hence the term "Single-signal."

**Alternative Methods**

Fig. 1 shows three typical selectivity curves: A represents that given by the average reacting detector-and-L.F. receiver; B that of a selective superhet with two or three tuned I.F. stages; and C that of a superhet with a quartz-crystal filter introduced into the intermediate-frequency stage.

Fig. 2 shows two completely different ways of introducing a quartz filter; A with the crystal in the series position, and B with it in the parallel position. The two small curves reproduced in the same figure show, roughly, the response of the circuit. It will be noticed that the resonance hump obtained by the series circuit (Fig. 2(A)) bears a close resemblance in shape to the curve in Fig. 1(C).

**Valuable Effect**

The other effect, however—that of a resonance dip (Fig. 2B) is a very different story, and extensive use of this effect is made in the modern S.S. Super.

Adjustments of the balancing condensers, as well as the tuning of the circuit across which the crystal is connected, will make it possible to obtain various degrees of sharpness for that dip.

It may, so to speak, be dropped on

the frequency of an incoming, interfering signal, thereby absorbing it; or it may be placed on one side of the zero-beat position of the wanted signal, reducing that side to a strength far below that of the other side.

It is not within the province of this article to describe in detail the theory of the high-frequency filter effect that may be obtained with the crystal used as a series resonator, but

I.F. stages. A shows the wanted and unwanted "sides" at the same strength, as they would be with accurate tuning and B shows how one side may be considerably dropped in strength by moving the oscillator setting so that the signal frequency falls at the side of the I.F. resonance curve instead of the centre (C).

Practically any superhet used for C.W. reception will show this effect

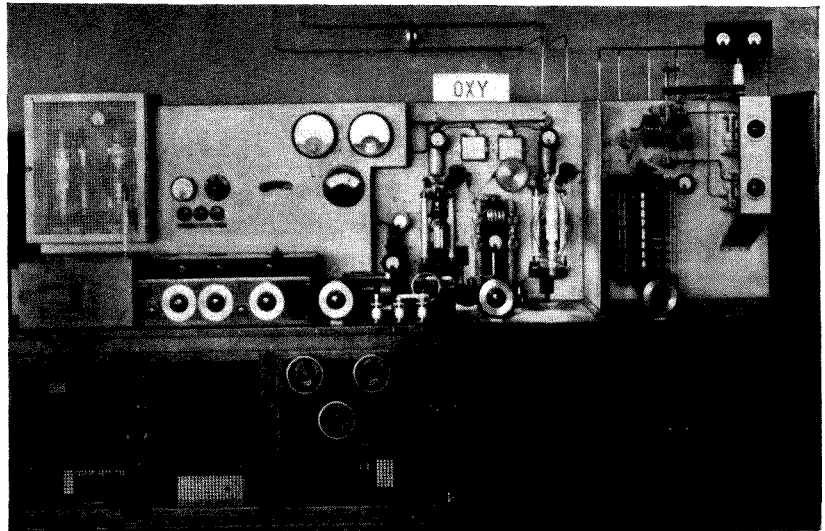

A favourite catch on the short waves is OXY, a Danish station. This photo shows the main transmitter

I have started off with the quartz-filter method of obtaining ultra-high selectivity as it is quite easily understood.

Many modern S.S. Supers, however, do not use a crystal at all; various forms of regenerative I.F. amplifiers have been found to give sufficiently sharp tuning to provide quite a marked difference between the wanted and unwanted "sides" of a C.W. signal.

Fig. 3 shows, in a simple form, the effect that may be obtained with "off-set" tuning of very selective

to a certain extent, provided that the oscillator beating with the I.F. (which is, of course, an absolute necessity for C.W. reception) is capable of adjustment.

Certain of the American Single-signal receivers, in practice, are provided with a fairly selective I.F. amplifier in addition to the crystal. The latter may be used in series or in parallel, or cut out of circuit completely by means of a neat three-point switch. A signal may therefore be tuned-in with the set working at maximum sensitivity, after which the

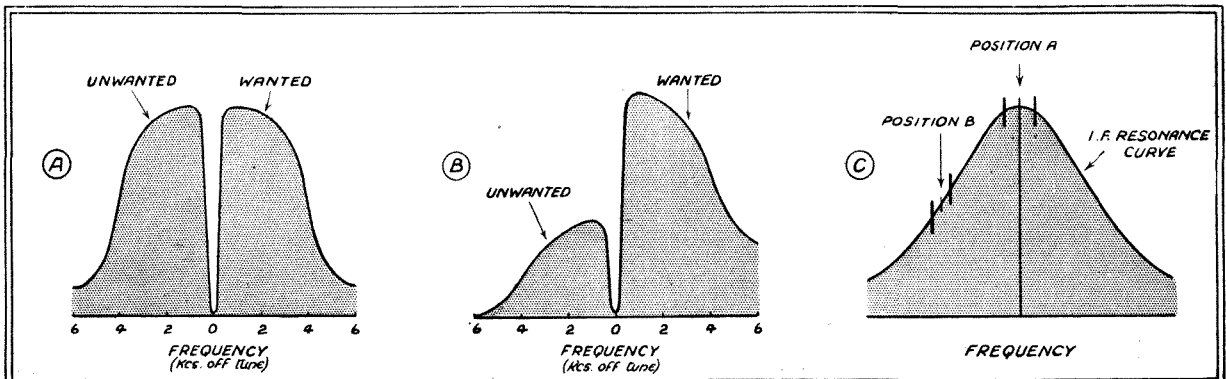

Fig. 3.—Showing in simple form the effect that may be obtained with "off-set" tuning of very selective intermediate-frequency stages

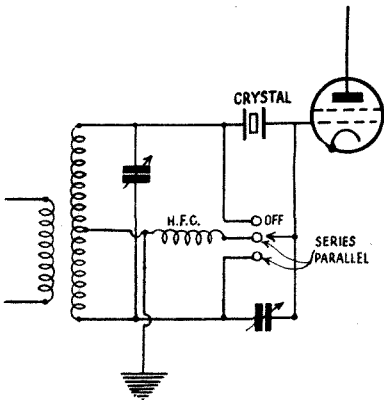

Fig. 4.—It is usual nowadays to use the crystal between the first detector and the first intermediate-frequency stage

crystal may be switched in, if necessary. The balancing condenser is usually made adjustable from the front panel or from the side, so that the very desirable feature of continuously-variable selectivity is provided.

**Crystal Position**

It is interesting to note, too, that the modern tendency is to use the crystal between the first detector and the first I.F. stage, instead of at the output from the I.F. amplifier. Fig. 4 shows the actual arrangement used in one of the commercial models.

Modern multi-electrode valves are used, a pentagrid type serving as first detector and oscillator, and a triode-tetrode as combined second detector and beat-note oscillator. Two high-frequency pentodes serve for the I.F. stages and an output pentode completes the picture. Five valves in all, but very effectively used!

A more ambitious receiver—also American—uses, in all, nine valves; two H.F. stages, first detector, oscillator, two I.F.'s, second detector, oscillator, and L.F.

**Prices in America**

It is a significant commentary on the popularity of amateur transmission in the U.S.A. that eight or nine firms should make receivers of this type especially for amateur-band work; and also that they should be able to sell them at prices equivalent to anything between £25 and £50 in this country! But when one remembers that there are over 30,000 amateurs in the States and they are given every encouragement by the Federal Government, and even allowed to handle private

messages, one begins to see how very different things are "across the pond."

What of the S.S. Super over here? One has either to build one's own or to lay out a very large sum of money in order to get one of the American models across. The fact of the matter is that we haven't yet acquired the American love of a multiplicity of valves.

The average short-wave enthusiast shrinks from the job of building a superhet with two H.F. stages in front of the first detector, with or

Well, there is no especial need to go up to nine valves for the kind of job that the average English listener wants. For one thing, *he* doesn't live in a country occupied by 30,000 amateur transmitters. He can, however, build a really good superhet, selective enough to give a marked single-signal effect, using five or six valves, and I propose to give full details of a suitable circuit at a later date.

Regenerative I.F. stages are the simplest scheme to use, and Fig. 5 gives a clue to one way of arranging them. Screen-grid valves used in this manner are simple to "tame," and it should be borne in mind that one does *not* want to use sufficient reaction to start the stage oscillating!

**Future Articles**

So much, then, for what I am afraid has been a very sketchy account of the Rolls Royce of amateur receivers. Articles, from now on, are going to be of a more practical nature; I hope to deal in detail with particular circuit arrangements and the difficulties that they bring with them.

(If readers have any special points of this kind they would like discussed, perhaps they will write to me.)

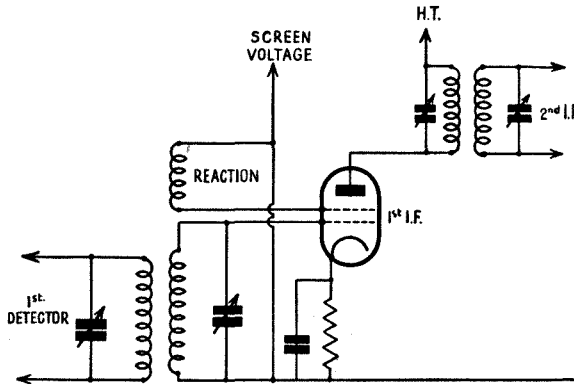
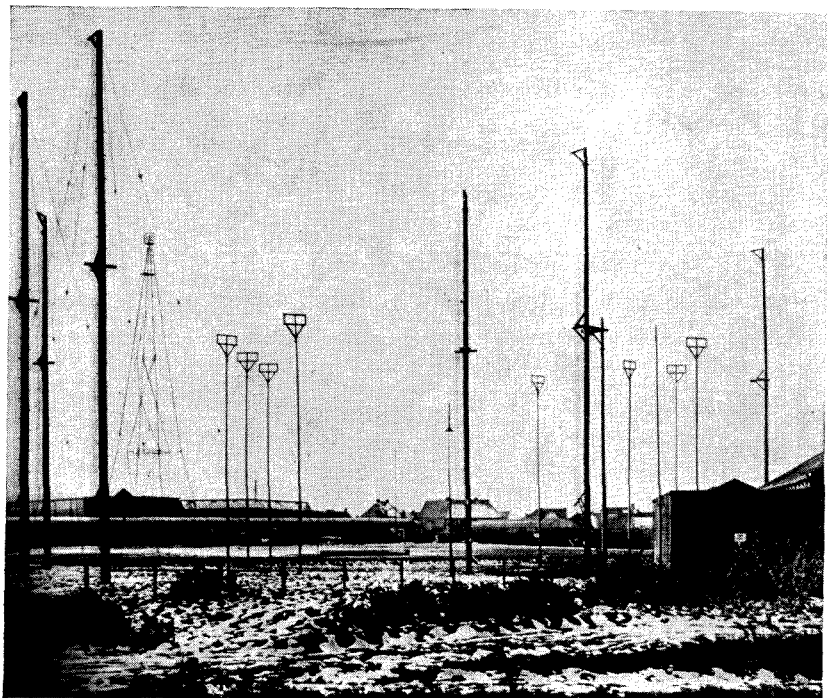

Fig. 5.—Regenerative I.F. stages are the simplest to use in a five or six-valve super, and this circuit gives a clue to one way of arranging them

without the complications arising from a super-selective I.F. side. (Incidentally, one of the first things that he finds out is that a really stable oscillator is not so easy to build as he had imagined.)



Short-wave aerials at transmitting stations take many shapes and forms. Here is a batch of the many used at P.C.J., the Philips station at Eindhoven, Holland

**W**HENEVER a fellow tells me that his set, be it three-valver or superhet, will receive every station in Europe at full loudspeaker strength I at once begin to suspect that he and I place somewhat different interpretations upon the meaning of the terms "receive," "every station in Europe," and "full loudspeaker strength." Further, I am reminded of the old crystal days when it was the wont of the radioliar to claim proudly that he could hear the programmes of this station or that with the 'phones on the table.

It was perfectly true that it could be done—but your head had to be on the table, too. "Wireless Magazine" never gives, without some qualification, lists of the stations received with the constructional sets described in its pages.

Such lists really mean nothing at all. It is, for instance, quite easy to claim with perfect truth the reception of, say, 100 European stations by the simple



*These youngsters appear to be keen radio fans. They are listening to the Children's Hour on their new Cossor radiogram*

# Between Ourselves

## A Chat on Things that Matter by BROADCASTER

process of making a straight set oscillate and heterodyne carrier after carrier, identification being done by means of a wavemeter. That kind of thing was all very well when wireless was young, for in those days we did not much care what we heard so long as it came from far enough away.

My own view is that no station is worth counting as received unless the set can obtain its programmes in such a way that they have real entertainment value. It is of little use to hear a trio of stations all at once and to mark them up in your list as three stations received. Heterodynes are not, of course, due to any fault in the receiving set, and a station that was accompanied by a whistle might be listed quite honestly since few heterodynes on important stations are permanent; on another

evening you might find the station perfectly clear of this interference.

Nor again—though it is not everyone that realises the fact, even in these days—can the set be blamed if a station is fading violently. That, too, may be a passing effect and the transmission may be found perfectly steady at another time.

You might, then, define the term "receive" as meaning: to bring in a station, herodynes and fading apart, at such strength, with such quality, and with such absence of interference that its transmissions are worth listening to as entertainment. I would, though, qualify that definition by mentioning that many of the smaller stations *are* permanently heterodyned and could never be received clear of interference by any set, no matter if it contained fifty valves.

### Receivable Stations Defined

The definition already put forward with the natural modesty which is one of my leading characteristics clearly limits the number of possible European stations. There are over 200 stations at work and my own experience is that the number receivable with nothing worse than temporary heterodynes or background interference on the best of sets seldom exceeds about 40 on favourable evenings in winter time, though it may run to 50 or more on odd occasions when conditions are particularly good.

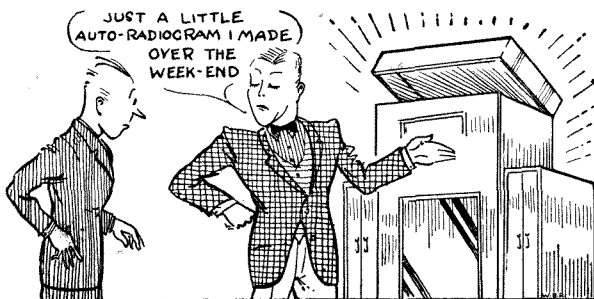

*"with natural modesty"*

Here is a list, which may be found useful. On the long waves Huizen, Moscow 1, Radio Paris, Zeesen, Motala, Warsaw, Luxembourg, Kalundborg, and Oslo are the possibles and on the average good evening seven or eight of these may be well received. On the medium waves Budapest, Beromunster, Stuttgart, Vienna, Florence, Brussels 1, Prague 1, Lyons (La Doua), Cologne, Sottens, Paris PTT, Rome, Munich, Leipzig, Barcelona, Milan 1, Bucharest, Berlin, Strasbourg, Hamburg, Toulouse, Brussels 2, Breslau, Poste Parisien,



"... full loudspeaker strength"

Genoa, Bratislava, Heilsburg, Rennes, Bordeaux, Madrid, Fécamp, Horby, Copenhagen, Frankfort, Trieste, Juan-les-Pins, Nurnberg, Klagenfurt, Bari, Milan 2, Gleiwitz, Katowice, Stockholm, and Turin represent pretty well the total number of stations from which anything approaching decent reception is to be obtained.

#### Valueless Additions to the List

Of course, you can considerably increase the total by adding such things as National and International common waves, but these are mostly quite valueless. One of the very few common-wave stations from which good reception is usually possible is Frankfort, and even Frankfort is not completely reliable for things do go wrong at times with the synchronisation. "Every station in Europe" then boils down to a maximum of something like 40, unless you are a member of that now rare clan, the knob-twiddlers, who are content to log every squeak as a station received.

So far, we have debunked two out of the three doubtful phrases mentioned in the first paragraph. We come now to a very different one—"full loudspeaker strength." In old days it was quite usual for the output of the receiving set to be fed at will to a pair of headphones or to a loudspeaker by means of a change-over switch.

#### What is Loudspeaker Strength?

At that time, which now seems so far away, the normal process was to search for stations with the telephones, and once you had picked up a transmission you flicked over your switch and attempted to "work it up" to loudspeaker strength. Nowadays, pretty well every commercial set has a built-in loudspeaker, and in any case few people make use of headphones. It may, therefore, be claimed that any station picked up on the loudspeaker is received at loudspeaker strength.

If you put your head far enough inside the cone it is quite remarkable what faint signals you can persuade yourself are audible, particularly if you are a long-distance enthusiast. Again, I hazard a definition.

I should classify full loudspeaker strength as volume adequate to fill a living-room of average size. Without

going into decibels and things of that sort, it is the volume that makes you feel that you would lose nothing of the clearness of speech or the beauty of music if the volume control were turned just a little way back.

And now, if you wish, you may seize your fountain pen and indite that stinging letter that is at times such a relief to injured feelings. Your epistolary missiles will break no bones, for I am completely filleted after many years of radio-scribbling. They will not even injure the outer insulating layer; I am not case-hardened, but rubber-covered—and the bricks that you heave will no doubt rebound to engender future paragraphs, the sting of which may be in their *tale*.

#### Inventions and Things

The number of patents taken out each year runs into colossal figures and there is nobody more enthusiastic about his own particular baby (even though it be really a wild kitten) or more convinced that the whole world is leagued in conspiracy against him, than the inventor who has produced something that, if not completely useless, is at any rate not a commercial proposition. Year by year, I receive wads of letters describing in the most glowing terms astounding "novelties" that were discovered ages ago.

Then there is the man who is obtaining some utterly freak result from a particular circuit. He is convinced that nothing like it has ever been done before. Often he is quite right, but he doesn't realise that nothing quite like it can be done again with any certainty. Ask him to duplicate his apparatus and he finds that he can't produce the same results. In other words, they were due entirely to some unrealised action—sometimes an unsuspected and completely undesirable back-coupling caused by components that were *defective* and



Congratulations to Professor Korn on his sixty-fifth birthday! This famous scientist was primarily responsible for the introduction of picture telegraphy

not super-excellent, when one comes down to brass tacks.

Perhaps the most pathetic type of inventor is the man who won't take the trouble to try out the progeny of his brain against the best available commercial or home-constructors' sets. He thinks that he has got something marvellous, though really he has got nothing at all. If his contraption contains snags that stick out a mile, his enthusiasm renders him snag-proof.

Should you have an idea that you consider revolutionary in wireless do, I beg you, take certain simple precautions. First of all make sure that it isn't something, if not as old as the hills, at any rate as old as the crests and the troughs of wireless waves. Don't be content with making up just one set; make up three or four and see if they all perform alike. Until you can duplicate and triplicate and quadruplicate the circuit with constant performance you can't be sure of getting away from freak effects.

### Fair Do's for Television

The announcement that television receiving sets are *not* to be shown at this year's Olympia Radio Exhibition will come as a shock to many enthusiasts. To my mind, the ban is utterly absurd and I am sure that most readers will be of the same way of thinking. The radio industry undoubtedly had a severe setback some months ago when certain lay journalists of the less responsible kind started a scare by ill-informed and utterly baseless statements about television.

Chief amongst these was the ridiculous assertion that all ordinary receiving sets would be out of date in a matter of months. In other words, television was going to kill ordinary "wireless." Of course, it isn't—any more than flying is going to kill motoring. For many years the television receiver must be something additional to the wireless set and not in any way a competitor to it.

### The Public Always Believes the Papers!

Unfortunately, when statements appear in print a large section of the public believes them, no matter how wild they may be.

That sentence seems to have taken the wrong turning somehow; it is the statements that are wild, not the public. The public becomes wild later.

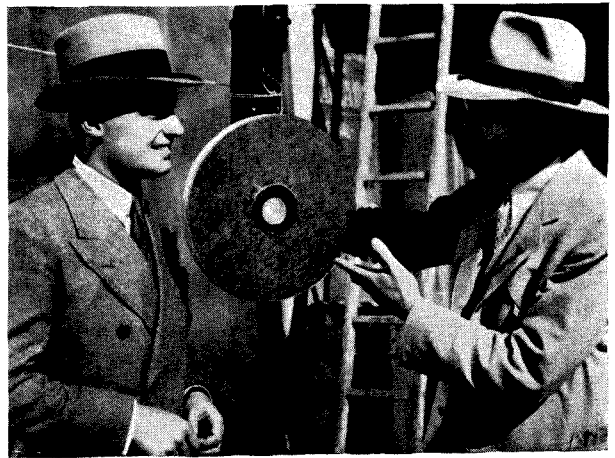

For outside broadcasts in America, radio engineers are trying a method whereby the microphone is mounted in a large piece of cork, the idea being to counteract any vibration

It was all very well for the radio industry to start a campaign for telling the public the truth about television. That was right and necessary. But you can't increase public interest in broadcast reception if you let your feelings run away with you so that your campaign turns into something like an attack on television. Nor is it ever wise to overdo things. If you continue to harp constantly on the same string your hearers become suspicious of your harping.

*Television is going to become a great national hobby within the next few years, and it must be given every possible chance of developing. Let us hope that the authorities will change their minds about Olympia for television sets would be a great attraction to all and sundry.*

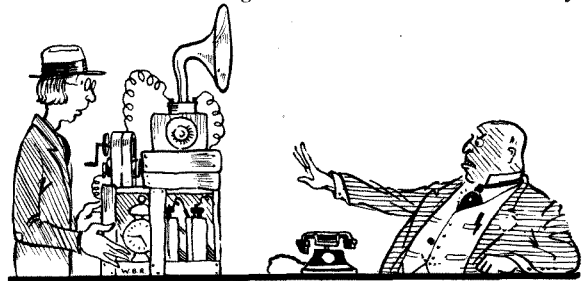

"... not a commercial proposition"

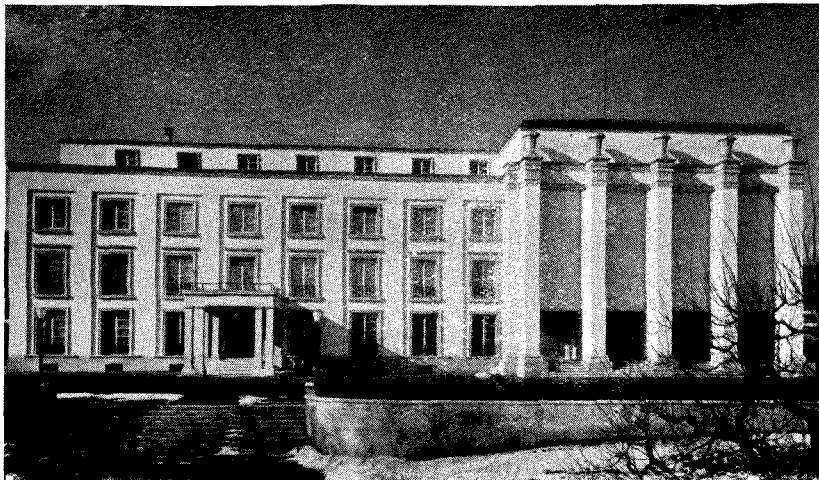

One of the finest radio headquarters in the world is the new Lausanne Broadcasting House—the home of the Swiss broadcasting authorities

### The Broadcasting Committee

By this time the committee inquiring into the B.B.C.'s future should have got well under way with its deliberations. A good many people, I daresay, were a little apprehensive when they read the names of its members. These are nine all told, and of the nine the chairman and at least five others are, or have been, Members of Parliament.

I can't help thinking that it is a pity that the political element is so overpowering. The control of broadcasting is—or, at any rate, should be—much more the concern of the private citizen than of the politician. We listeners, who now number well over 7,000,000, want only one thing—the best possible entertainment service.

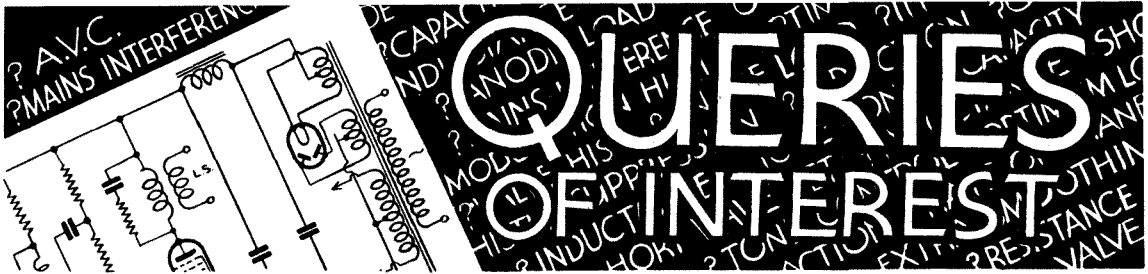

The selection of questions and answers appearing below is the result of a search through our post bag in quest of matter which we consider of general interest and having a direct bearing upon everyday practical problems. The readers who actually asked these questions have, of course, received a reply through the post

**A.** A.C. (Boroughbridge) raises an interesting question concerning the distribution of dance music from records in a small hall. His problem is mainly one of space; he would like to be able to arrange for the turntable and its associated apparatus to be located in a part of the building some 60 ft. away from the point where the music is required.

His suggestion is that the amplifier should be placed in the hall and the pick-up and turntable at the distant point, with a well-screened lead between the two places.

We do not recommend the proposed method. Although it might be possible to install a lead of this length capable of transmitting the pick-up output to the amplifier successfully, it would almost certainly be an expensive and troublesome business. We gather from our correspondent's letter that his desire to place the amplifier in the dance room was to enable him to adjust the volume on the spot.

We should advise him to sacrifice this convenience and install the complete equipment at the distant point. It is comparatively simple to run loudspeaker extension leads for the distance involved and it is quite possible that it will not be found necessary to screen them.

**K.** R.C., of Edinburgh, writes to say that he has built the HK Four and is in general pleased with the results. He complains that his set has one unpleasant habit; it suffers from a loud threshold growl when reaction is used on long waves, and that there is much hand-capacity trouble in the neighbourhood of the reaction condenser under these conditions. Our correspondent bravely con-

fesses that he used a number of fixed condensers of uncertain age in building the set and suggests that one of these may be defective.

The most probable fault in a condenser which has seen much service is an internal disconnection resulting in zero capacity: an internal short-circuit is less common unless the condenser has actually been punctured by a high voltage, and this fault would in any case be discovered quickly. We have tried disconnecting all the likely condensers in the HK Four, and we find that the absence of one of .1 microfarad, placed beside switch S2 on the circuit diagram, produces precisely the effect described.

**T.** C.D., of Waltham Cross, refers to the usually accepted belief that stations working on waves around 20 metres can only be heard at any distance during daylight hours, and reports that he has been hearing American amateur stations on this wave regularly up to midnight.

This experience is being reported from many quarters of late. It seems probable that our knowledge of short-wave phenomena, such as this, is even less complete than we had imagined; it is possible that waves of a given length may behave differently at different points in the eleven-year cycle, which we know governs many of their characteristics.

**W.** D.E. (Scarborough) inquires about a loudspeaker for the 1935 A.C. Stenode. He has a good quality instrument of a make other than that suggested in the original list and would like to use it if possible.

The particular loudspeaker used and

specified is one designed to give a special shape of response curve which completes the tone-correction of the Stenode. Any good instrument can be used, but the exact balance of tone intended by the designer may not be attained. An additional tone-correction or tone-control device would be advisable in such cases.

**L.** D.T., of Horsham, reports a difficulty with the short-wave adapter described last month. He has completed the unit and gets very fair results on the larger coils, but finds that to get full reaction he needs to use almost the maximum capacity of the reaction condenser. With the smallest coil he cannot obtain any reaction.

From the symptoms described it appears to us that the cause of the trouble must be a sluggish detector valve. While almost any valve will give results in this position, difficulty is always experienced if one chances to use a specimen the efficiency of which has fallen off to the point of being brought up to the verge of the oscillating condition only with an effort.

**L.** R.J., of Birmingham, writes rather sadly to say that he has tried a tweeter loudspeaker and doesn't like it. He reports that the reproduction is squeaky and jarring.

Quite a common experience with these speakers; the reason is that the user has not realised that the tweeter must be placed quite close to the main loudspeaker, and that one should take pains to listen only to the combined effect of the two. If the tweeter is mounted at a little distance, and the listener applies his ear to it closely, he will hear the most peculiar sounds.

The policy of "Wireless Magazine" is to cater for all interested in radio, television, and in the electrical reproduction of gramophone records. We make no apologies, therefore, for presenting this article, in which some of the technique involved in making records is carefully explained. The author's remarks about needle scratch and record wear will be found particularly interesting

His Majesty the King is seen watching with interest a process connected with the making of gramophone records during a visit to the H.M.V. factories at Hayes, Middlesex



# Recent Developments in Gramophone Recording

PROBABLY one of the most interesting of recent developments in gramophone recording is the growing tendency of some authorities, mainly in America, to think that a reversion to Edison's method of hill-and-dale, contour, or vertical recording, as used in the old phonograph cylinders, would have many advantages. This method cuts the sound vibrations on to the wax in an up-and-down spiral line producing a groove of varying depth, but with no lateral displacement (see Fig. 1 (b) and (c)).

## Longer Playing Time

It is stated that records made under this system would possess the advantages of longer playing time, reduction of record wear and surface noise, and would eliminate or reduce some of the other design defects of the lateral-cut disc.

Hill-and-dale records are used in the U.S.A. by the broadcasting concerns for "diagonalisation" purposes, or, in some cases, for "dub-

By DONALD W. ALDOUS,  
A.R.B.I.

bing" on to sound films. In America, owing to the different time-zones existent, it is impossible to broadcast any particular programme at a suitable time for the entertainment of the whole country. So the desired programmes are recorded, and the discs are forwarded to the various transmitters for re-broadcasting at an appropriate local time.

The records are of the flexible kind, made of cellulose acetate, and thus practically non-inflammable, while the radial pitch of the grooves is so small that the playing time is from fifteen to twenty minutes for a twelve-inch disc. A speech-to-noise (surface) ratio of more than 60 decibels is obtained, and a 30-decibels greater intensity variation than that of the normal record is possible.

The frequency range is two octaves wider, and as the discs are

reproduced with an extremely light moving-coil pick-up, fitted with a permanent diamond or sapphire stylus, or needle, the record wear is negligible for some thousands of playings. (See Fig. 2.)

It is interesting to observe that in the manufacture of these records another of Edison's ideas has been revived and utilised with modern improvements. This is "cathode sputtering," and is the process used for the preparation of the master matrix from the wax blank.

## "Cathode Sputtering"

This is generally done by brushing super-fine graphite or bronze powder on to the recorded wax blank to render the surface electrically conductive and so make electro-plating possible. In the cathode-sputtering method the wax is placed in a vacuum chamber and a thin layer of gold is deposited on the recorded surface by electronic bombardment. This system reduces the surface noise because the metal layer so

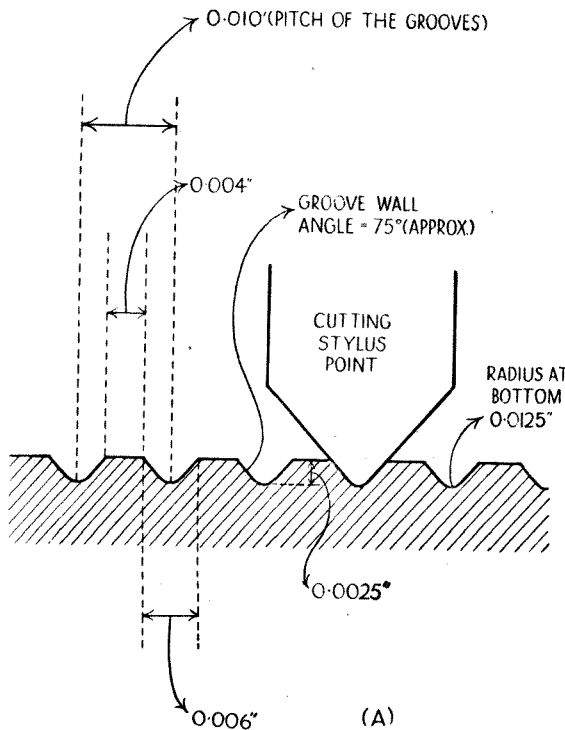
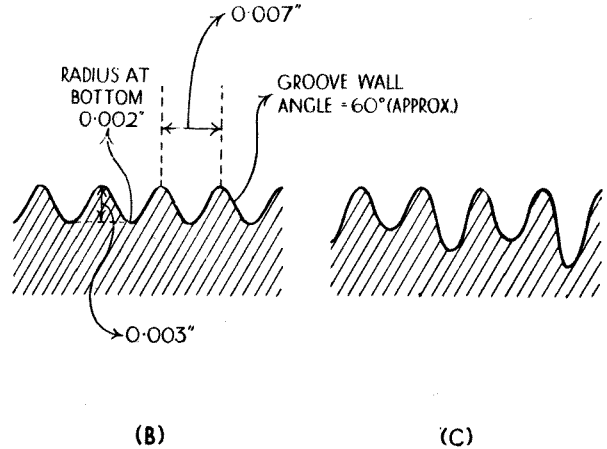

Fig. 1 (a).—A radial section of the recording wax for the standard-cut lateral disc, showing the average groove width, .006 in., the average groove-wall width, .004 in., and the average groove depth, .0025 in. The cutting stylus point is usually a sapphire. It should be understood that these figures are only representative and that various recording companies may use slightly different dimensions. Fig. 1 (b).—Showing hill-and-dale cut grooves. It can readily be seen that the groove wall-width can be made very small as it does not have to stand any lateral pressure. It is thus possible to have 150 to 200 cuts to the inch compared with the 100 cuts per inch of the lateral-cut record.

Fig. 1 (c).—Hill-and-dale grooves on a recorded disc



deposited is very smooth and uniform.

The method is also used nowadays in the manufacture of the ordinary record, as the discontinuities and finite size of the particles in the layer deposited by the graphite process are one of the main causes of the surface noise.

**Variable-pitch Recording**

Another old system which is being put forward to obviate bass cut-off and "too-short playing time" deficiencies of the normal record is variable-pitch recording. In this scheme the number of grooves per inch is made capable of continuous adjustment to conform to the sound level at any period during the actual recording. Perhaps this can be explained more clearly by stating that whenever a heavy passage—for example, an organ pedal note—occurs the groove spacing is widened to, say, 50 grooves per inch, and when a light passage—violin—is being recorded the spacing is lessened to, say, 150 grooves per inch.

**Constant-amplitude System**

Yet another feasible method of recording is on the constant-amplitude system. Here the notes of the same energy have the same amplitude, irrespective of frequency. This means that the amplitude of the cut is controlled by the loudness of the

sound alone and not at all by its pitch.

This, too, has the merits of longer playing time, improved quality, and less surface noise, but the demerits are the necessity for providing suitable tone-correcting circuits for bass and treble in the recording and reproducing amplifiers and, probably, a specially designed pick-up for reproduction.

Present methods, of course, are such that amplitude of recording cannot be allowed to vary inversely as the frequency for sounds below about 256 cycles per second or above 5,000 cycles because the restricted size of the present-day disc renders

the recording of low frequencies in their correct proportion commercially impracticable owing to the reduction in playing time involved and the inability of the reproducing needle-point to track accurately in grooves cut under such conditions.

**Constant-velocity Method**

This constant-velocity method of recording is, of course, the linear system, but were it to be used for the entire gamut of recorded sounds the large amplitudes involved at low frequencies would give rise to the risk of consecutive grooves running together, or, as it is termed, groove-wall breakdown might occur at the

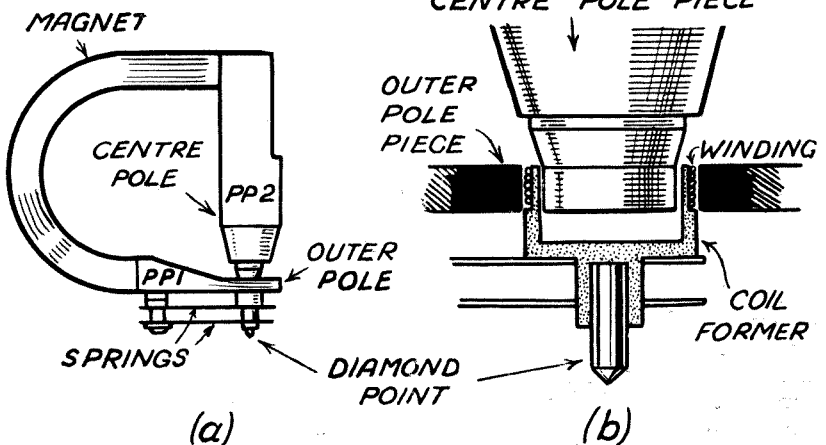

Fig. 2 (a).—The Western Electric Co.'s moving-coil pick-up for reproducing hill-and-dale records. The U-shaped magnet has unequal limbs attached to the pole pieces PP1 and PP2. Fig. 2 (b).—A close-up of the pole pieces. The space between them is the annular air-gap in which the pick-up coil is mounted.



high-frequency end, and for transients the curvature of the groove would become so acute that the reproducing needle-point could not follow it.

So under current conditions the recording characteristics are as follows: below 256 cycles to the cut-off at about 30 cycles the recording is approximately at constant amplitude, between 256 cycles and 5,000 cycles at constant velocity, and above 5,000 cycles to the cut-off at about 7,000 cycles it is approximately at constant acceleration.

**Quality Deteriorates**

Since the speed of rotation of the record is constant and the recording-groove spiral works inwards to the centre, causing a reduction in linear speed of the track past the needle-point as the centre is approached, there is a "packing" of the upper frequencies in the inner groove, and since this happens just when the needle-point is worn and so cannot follow the sinuosities of the groove properly, there is some deterioration in the tonal quality as the end of a record is reached. (See Figs. 3 and 4.)

**Not a Good Method**

It really seems that the present practice of beginning at the outer and working to the inner diameter is not the better method: it has probably remained from the early days when the weakness of the springs in the old motors made it necessary to provide a lighter load when the spring was almost run down.

This point was mentioned

in Berliner's first patent specification for the gramophone in 1887, and also was appreciated when disc recording for talking-pictures was in vogue as the 16-inch discs played from the inner to the outer diameter.

Finally we come to the question of surface noise: this so-called needle-scratch problem is often attributed to one cause only—the infinite size of the particles constituting the record material.

It is occasionally called shock excitation of the pick-up referring to the fact that the needle-point strikes

against the individual particles as it follows the groove.

The number, size and uniformity of the particles encountered are, admittedly, to a degree responsible for that annoying hiss, but it is more correct to apportion the cause, among many factors, beginning with the angle, shape and condition of the cutting stylus and wax recording blank, through imperfections in the many intermediate processes, up to flaws in the stamping mould.

**Problem Not Solved**

Incidentally, an exact exposition of this problem has yet to come, for it is at the moment not fully understood. One of the important questions is to determine the quota of noise introduced at each process in recording and manufacture.

In connection with the needle-scratch, or surface noise, two further points are noteworthy. A new record when played for, say, the first and second times with a fine, hard steel needle-point on a suitable reproducing equipment will for a certain number of subsequent playings exhibit less surface noise than was present in the original playings.

**Burnishing the Grooves**

This may not appear to be logical, but it is due to the fact that the first playings removed projecting particles and factory dust or dirt embedded in the grooves, and also probably burnished the grooves. This cleaning

*Continued on page 457*

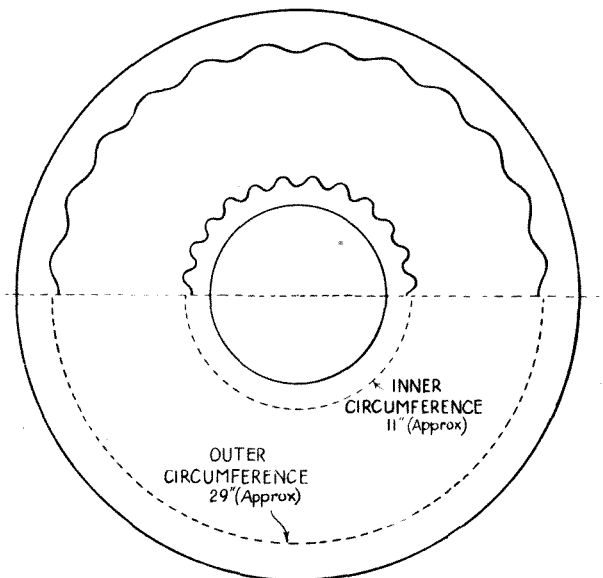
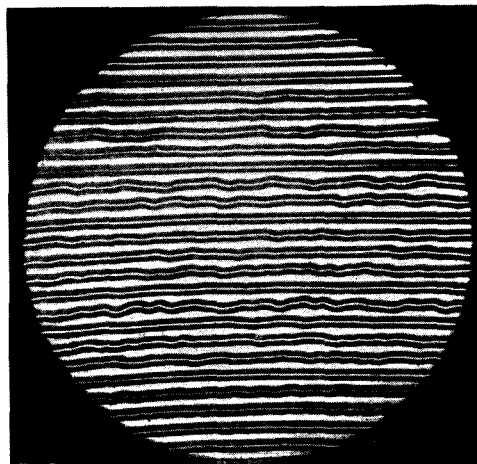

Fig. 3.—Showing in a greatly exaggerated way a section of a constant low-frequency note recorded on the inner and outer grooves of an average 10-in. record. Note the reduced wave-crest separation on a note of the same frequency in the inner cut



H.M.V. Photo. Fig. 4 (b).—A photomicrograph of wave-form on a record. The thin white lines are the bottom of the grooves

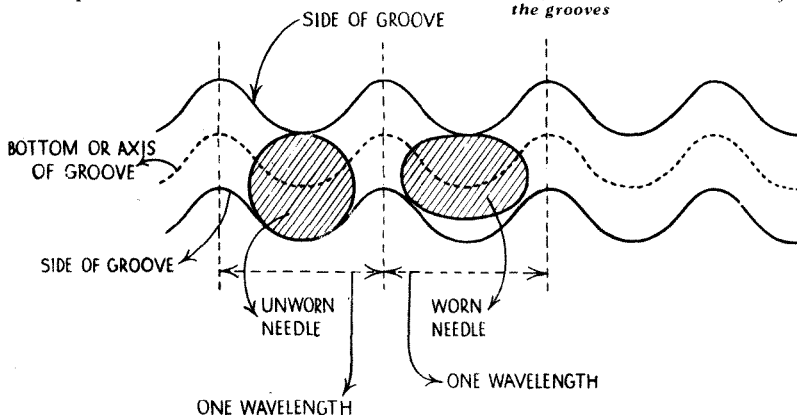

Fig. 4 (a).—An enlarged longitudinal section of a needle-point in a single record groove at the inner cut. By the time the needle is approaching the centre the needle-point has worn oval—probably with chisel shoulders—and so cannot follow the groove accurately. It skims along the tops of the grooves with little lateral vibration, hence the falling off in quality at the centre of a record

# Gramophone Record Guide

THE following list of gramophone records on the English market has been revised after the price alterations of January 23, 1935, and should enable readers to ascertain particulars of most records in general demand without recourse to supplements and catalogues.

Most recording companies release their supplements at the beginning of each month or a few days previously, but when intermediate issues are made they are usually released on or about the 15th of the month.

Name.	Size.	Label Colour.	Type Prefix.	Price.
†Brunswick, Ltd. (Branch of the Decca Record Co., Ltd.) 1-3 Brixton Road, S.W.9.				
<b>Brunswick</b>	10	Red ...	RL (Dance Records ...)	1/6
	10	Black ...	(Modern Rhythm Series)	2/6
	10	Black ...	(Standard) ...	2/6
	12	Black ...	—	4/-
Refer to complete general catalogue or separate catalogues for such discs as "Show Boat" album; "Blackbirds" album; "Short Survey of Modern Rhythm" album and any other albums or special records.				
*Columbia Graphophone Co., Ltd., 98-108 Clerkenwell Road, E.C.1.				
<b>Columbia</b>	10	Magenta ...	FB (Dance Records) ...	1/6
	10	Magenta ...	FB ("Hot" Dance Records)	1/6
	10	Dark Blue	DB (Standard) ...	2/6
	12	Dark Blue	DX ...	4/-
	10	Light Blue	LB ...	4/-
	12	Light Blue	LX ...	6/-
	10	Yellow ...	YB ...	4/-
	12	Yellow ...	YX ...	7/6
	10	Purple ...	PB ...	6/-
	10	Purple ...	PD ...	6/-
	12	Purple ...	PX ...	8/6
	12	Purple ...	PS (Single-sided)	7/6
	12	Pink (Ysaye) (Nordica)	PK (Single-sided)	12/6
Refer to complete general catalogue or separate catalogues for such discs as "Masterwork" albums; Collector's lists; Operatic or Foreign Language albums; Jewish records; Educational records; Automatic couplings; and any other albums or special records.				
†Decca Record Co., Ltd., 1-3 Brixton Road, S.W.9.				
<b>Decca</b>	10	Blue ...	F (Dance Records) ...	1/6
	10	Blue ...	F ("Hot" Dance Records)	1/6
	10	Blue ...	F (Standard) ...	1/6
	12	Blue ...	K ...	2/6
	10	Red ...	M ...	2/6
	12	Red ...	T ...	3/6
<b>Decca-Polydor</b>	10	Red ...	PO ...	2/6
	12	Red ...	LY ...	3/6
	10	Gold ...	DE ...	2/6
	12	Gold ...	CA ...	4/-
Refer to complete general catalogue or separate catalogues for such discs as "Selections from the Classics" albums, and any other albums or special records.				
†Crystalac Gramophone Record Mfg. Co., Ltd., 60-62 City Road, E.C.1.				
<b>Eclipse</b> ...	8	Red ...	— ...	6d.
	8	Blue ...	S.C. ...	6d.
Sole concessionaires: F. W. Woolworth & Co., Ltd.				
Edison Bell (1933), Ltd., 143-7 Rosebery Avenue, E.C.1.				
<b>Edison Bell</b>	10	Black ...	W (Winner) ...	1/-
	10	Gold ...	— ...	1/6
Sole concessionaires: The Decca Record Co., Ltd.				

Name.	Size.	Label Colour.	Type Prefix.	Price.
*Gramophone Co., Ltd., 98-108 Clerkenwell Road, E.C.1.				
<b>His Master's Voice (H.M.V.)</b>	7	Orange ...	AS ...	1/6
	10	Magenta ...	BD (Dance Records) ...	1/6
	10	Magenta ...	BD ("Hot" Dance Records)	1/6
	10	Plum ...	B (Standard) ...	2/6
	12	Plum ...	C ...	4/-
	10	Black ...	E ...	4/-
	12	Black ...	D ...	6/-
	10	Red ...	DA ...	4/-
	12	Red ...	DB ...	6/-
	10	Red ...	DR ...	4/-
		(Tamagno)		
	12	Red ...	DS ...	6/-
		(Tamagno)		
	10	Buff ...	DJ ...	7/-
	12	Buff ...	DK ...	10/-
	12	Green ...	DM ...	11/6
	12	Blue ...	DO ...	13/6
	12	White ...	DQ ...	16/-
	10	Black ...	(Single-sided) ...	4/6
	12	Black ...	Do. do. ...	6/6
	10	Red ...	Do. do. ...	5/6
	12	Red ...	Do. do. ...	7/6
	12	Pale Green	Do. do. ...	10/6
	12	Dark Blue (Butt)	Do. do. ...	12/6
	12	Pink (Patti)	Do. do. ...	12/6
	12	White ...	Do. do. ...	15/-
Refer to complete general catalogue or separate catalogues for such discs as Royal records; Connoisseur's lists; Records of Unique and Historic Interest; Educational records; Operatic and Foreign Language albums; "Hot" Rhythm album; Duke Ellington album; Automatic couplings, and any other albums or special records.				
†Crystalac Gramophone Record Mfg. Co., Ltd., 60-62 City Road, E.C.1.				
<b>Imperial</b> ...	12	Dark Blue and Red	Z ...	2/-
<b>Imperial-Broadcast</b>	10	Black ...	—	1/6
Great Scott Records, Megginch Estate, Errol, Perthshire.				
<b>Great Scott</b>	10	Orange ...	A ...	1/6
These lists contain mostly unusual Scottish records.				
Synchrophone, Ltd., 24 Berners Street, W.1.				
<b>Octacros</b>	10	White-Blue	—	2/6
Levy's Sound Studios, Ltd., 94-98 Regent Street, W.1.				
<b>Oriole</b> ...	10	Silver ...	P ...	2/6
	10	Gold ...	P ...	4/3
These lists contain mostly unusual dance and "hot" rhythm dance records.				
Sole concessionaires: Levy's, 19/20 High Street Whitechapel, E.1				
†"Panachord" (Branch of Brunswick, Ltd.), 1-3 Brixton Road, S.W.9.				
<b>Panachord</b>	10	Blue ...	—	1/-
*Parlophone Co., Ltd., 102 Clerkenwell Road, E.C.1.				
<b>Parlophone</b>	10	Magenta ...	F (Dance Records) ...	1/6
		in.		
<b>Parlophone</b>	10	Dark Blue	R (Rhythm Style Series)	2/6
	10	Dark Blue	R.100 Series (Standard)	2/6
	10	Red or Blue	E.3000 Series ...	2/6
	12	Dark Blue	E.10000 Series ...	4/-
<b>Parlophone-Odeon</b>	10	Dark Blue	OT.100 (Tango Series)	2/6
	10	Dark Brown	RO.20000 Series ...	4/-
	12	Dark Brown	R.20000 Series ...	6/-
Refer to complete general catalogue or separate catalogues for				

such discs as "Music of the Orient" album; Tauber's "German Folk Songs" album; Scottish records; Irish records; and any other albums or special records.

Name.	Size.	Label Colour.	Type Prefix.	Price.
§British Homophone Co., Ltd., Barry Road, Stonebridge Park, N.W.10. <b>Plaza</b> ...	8	Magenta ...	P ...	6d.
*"Regal-Zonophone," 98 Clerkenwell Road, E.C.1. <b>Regal-Zonophone</b>	10	Red ...	MR ...	1/-
	10	Brown ...	TG (Celebrity) ...	3/6
	12	Red ...	TA, MX ...	4/-
Refer to complete general catalogue or separate catalogues for such discs as Salvation Army records, Double- and Triple-Track records, and any other special records.				
‡Crystalate Gramophone Record Mfg. Co., Ltd. 60-62 City Road; E.C.1. <b>Rex</b> ...	10	Black ...	—	1/-
§British Homophone Co., Ltd., Barry Road, Stonebridge Park, N.W.10 <b>Solex</b> ...	10	Magenta ...	SX ...	1/-
§British Homophone Co., Ltd., Barry Road; Stonebridge Park, N.W.10. <b>Sterno</b> ...	10	Red ...	—	1/6
	10	Magenta ...	—	1/6
	12	Plum ...	(Long-playing)	2/6
"Teledisks," Crewsdon Rd., S.W.9	10	Red ...	—	1/6
	10	Blue ...	(Dance Series)	1/6
			(Concert Series)	2/6

For completeness mention must be made of Society records. The main Societies now in existence are:

Bach; Beethoven Sonata; Haydn Quartet; Hugo Wolf; and the Sibelius Society, all under the auspices of "His Master's Voice."

Delius Society, under the auspices of Columbia.

Also several limited editions of the following are available:—

Bach's "Goldberg Variations"; Couperin's Clavecin music; Kilpinen's songs; and Schubert's song cycles, "Schöne Müllerin" and "Winterreise."

For full particulars of any of the above write to W. Legge, Esq., Hon. Secretary, "Societies," 98-108 Clerkenwell Road, E.C.1.

The National Gramophonic Society (N.G.S.) provides selected Chamber Music records. For full particulars write to The Secretary, N.G.S., 10a Soho Square, W.1.

The object of these societies is to issue performances by eminent artists of hitherto unrecorded works of various great composers, and every effort is made not to duplicate works already available in the general catalogues.

In this way, little known but excellent works are recorded and these are available *only* to members. A subscription, usually £2 2s., which covers the actual cost of the records is necessary for membership, and a majority of members may request a particular item to be recorded.

The records are issued in volumes, housed in albums, together with analytical and explanatory notes.

\*The Electric and Musical Industries Ltd. group.

†The Decca Record Co. Ltd. group.

‡The Crystalate Gramophone Record Mfg. Co. Ltd. group.

§The British Homophone Co. Ltd. group.

## Developments in Gramophone Recording—Continued from page 455.

and polishing effect result in the reduced surface noise.

The second point concerns the common idea that surface noise is solely a high-frequency phenomenon. In fact, it extends over a wide frequency band, that is, it is of an aperiodic nature. Probably the reason for the misconception is the presence of pronounced resonances in the upper frequency range, from 3,000 cycles to 5,000 cycles of the average pick-up and loudspeaker, so causing the needle-scratch to be accentuated around that region.

In addition the portion from 1,000 cycles upwards is more prominent because the low-frequency component from about 50 cycles upwards is not noticed, or is swamped owing to the non-linear sensitivity level of the human ear. The minimum surface noise intensity is at 500 cycles.

It may also be observed that the surface noise on the outer grooves of a record is perceptibly more than on the inner grooves. This is due to the needle-point being unworn at the commencement and being ground off gradually towards the finish, thus

altering its shape and size, and so curtailing the high-frequency portion of the noise spectrum. (See Fig. 5.)

The problem of record wear is a difficult matter on which to comment as it is inevitably linked with the reproducing apparatus. Certain kinds

of recordings are more prone to wear than others.

Usually discs with heavy bass passages, transient, or sometimes treble passage will exaggerate the wear in the grooves where these passages occur.

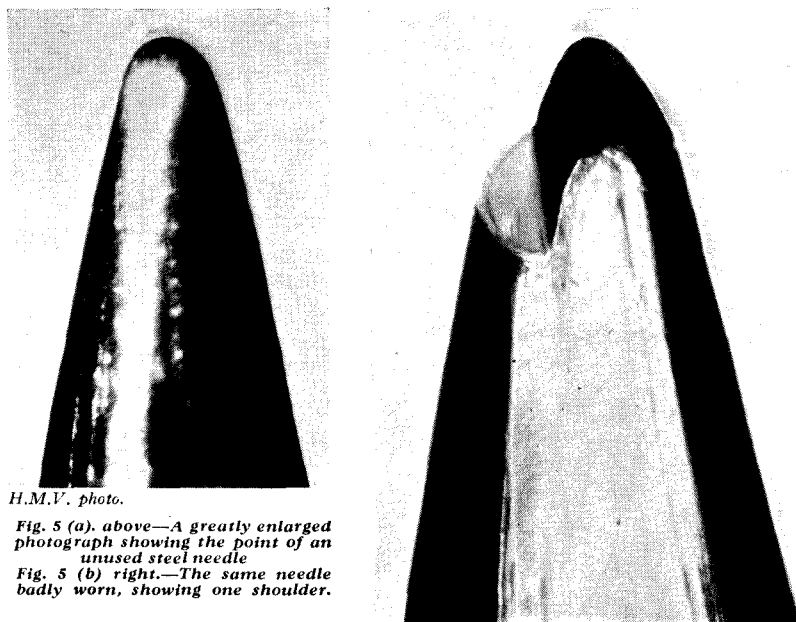

H.M.V. photo.

Fig. 5 (a) above—A greatly enlarged photograph showing the point of an unused steel needle

Fig. 5 (b) right.—The same needle badly worn, showing one shoulder.



*How to play records without exerting oneself; the Technical Editor shows how it is done*

I DON'T like to think that I am lazier than other people, but it is a fact that until a couple of years ago I never possessed a radiogram outfit which was not too much trouble to use frequently. All the earlier ones I built were of the conventional type with the gramophone apparatus on the top storey and a built-in loudspeaker; every one of them had, for me, a fatal defect.

You see, to put on a record I had to open a heavy lid, drop the disc in place, start the motor, apply the pick-up, adjust the volume control and then go and sit down in hopes of enjoying the music. As like as not I should next find that the volume adjustment was not quite to my liking and that meant another climb out of my chair to go over to the instrument again.

When all that had happened a few times I was apt to be a little annoyed; then my pipe would go out, and I should probably find that I had left the matches beside the turntable on one of my previous trips! The net result was that I used to play a new record just once and then it would stay in a drawer until some social occasion might spur me on to take all the trouble involved in the use of the gramophone.

I expect I am giving a mildly exaggerated account of the matter, but in all seriousness when one gets home at the end of a hard day it is a considerable temptation to leave the switch pointing to "Radio" and lie on one's back in a fat chair while the B.B.C. does the work!

I notice a very significant little fact about the radiograms owned by my friends: one and all they carry a vase or a flower-pot on the gramophone lid. I do not think one needs the powers of a Sherlock Holmes to see what that means!

The suspicion engendered in my mind by this observation leads me to believe that many readers of "W.M." would be interested in the solution I have devised for my own particular problem. It is really very

# A Lazy

Designed by  
G. P. KENDALL, B.Sc.

simple, being merely the separation of the radiogram apparatus into two parts, of which one is the radio set proper and the other an affair containing only the gramophone motor with turntable, the pick-up, and the volume control.

This unit is so designed that it may be placed anywhere in the room and just connected up by means of flex leads to the mains and to the pick-up terminals of the receiver. Thus I can set it beside the aforementioned fat chair with a pile of records on the floor alongside and proceed to enjoy myself with the very minimum of exertion!

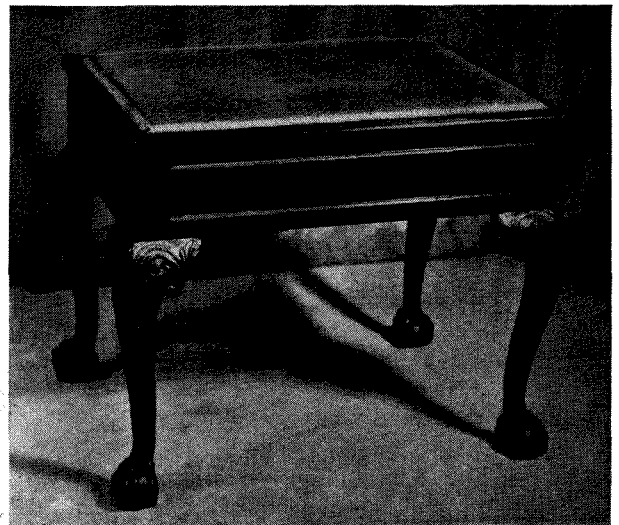

*"... with due apologies to the shade of the late Mr. Chippendale. . . ."*

The device actually takes the form of a four-legged music stool made for me (with due apologies to the shade of the late Mr. Chippendale) by a local cabinet-maker of some skill. Normally it stands before a writing-table in a corner and is sat upon by anybody who wants to write a letter.

There is indeed nothing in its appearance to suggest the secret of its interior unless it is very closely examined. Then one discovers that the padded seat is really a hinged lid; on being raised this reveals the turntable and all the usual accessories. Tucked away underneath

# Man's Radiogram Unit

*Lest it be thought that the title of this article is either a gibe at our hard-working Technical Editor or an unseemly reflection upon our readers, we must explain hurriedly that it was chosen by the author, and is intended to apply to himself! We ourselves should have preferred the word "ingenious"*

there are special plug-in connection points for the mains and pick-up leads, but these cannot be seen unless the stool is turned upside down.

I can imagine that somewhere around this point the reader will begin to wonder about the length of the lead from pick-up to set implied by these arrangements. We are always told that this lead should be kept as short as possible to avoid making the amplifier unstable, picking up hum, and impairing quality of the reproduction by shunting a large self-capacity across the pick-up; it may seem strange, therefore, to find someone who might be expected to know better using *a lead some fifteen feet long!*

By way of settling the argument before it begins let me say that I get a quite negligible amount of hum, my amplifier remains perfectly stable, and the quality is precisely the same as that obtained with the conventional lead only a few inches in length. The reasons for this happy state of affairs are three in number. In the first place, the amplifier is designed so that it is *really* stable and not merely kept in a state of tolerably good behaviour by being pampered with short external leads (loudspeaker connections run all over the house, too).

Absence of hum, and to some extent stability, is ensured by the use of a correctly screened pick-up lead. This consists of a cable containing two separate conductors with thick rubber covering, sundry other spacing layers, and finally a covering of copper braid on the outside *which is carefully earthed*. Such material is not easy to obtain nowadays, but I believe my piece came originally from London Electric Wire Company and Smiths, Ltd.

The question of the effect upon quality of the presence of a certain amount of capacity across the pick-up is one the importance of which would seem to me to have been exaggerated by some authorities. (It is noteworthy that the people who worry about this possibility do

not scruple on occasion to connect a condenser in this position for the purpose of reducing scratch!)

I have never actually measured the capacity of my piece of cable, but I have made tests with many different types of pick-up and have never been able to discover that the long lead has had the slightest audible effect on quality.

With the pick-up which I am now using the question does not arise, for a reason which may be of interest; the pick-up is a Rothermel-Brush piezoelectric type, and in this case shunt capacity has no effect upon the frequency response for reasons which will be apparent to the technically-minded when it is remembered that the pick-up is itself in essence a condenser. (That is the third of the three reasons which I mentioned just now.)

The mains lead, by the way, supplies merely the

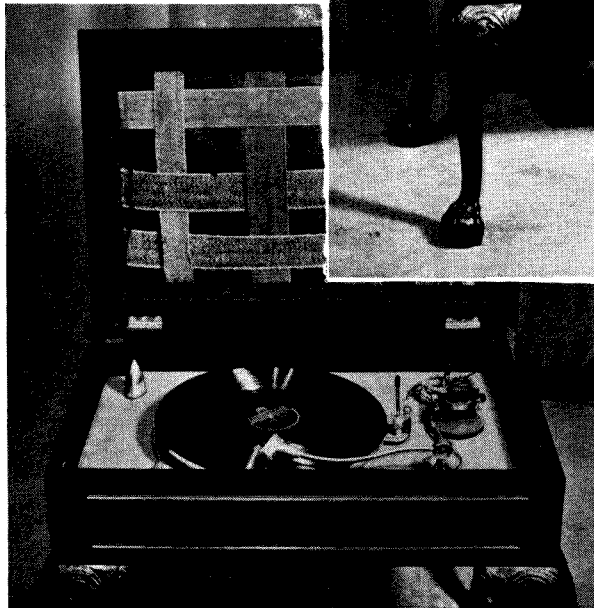
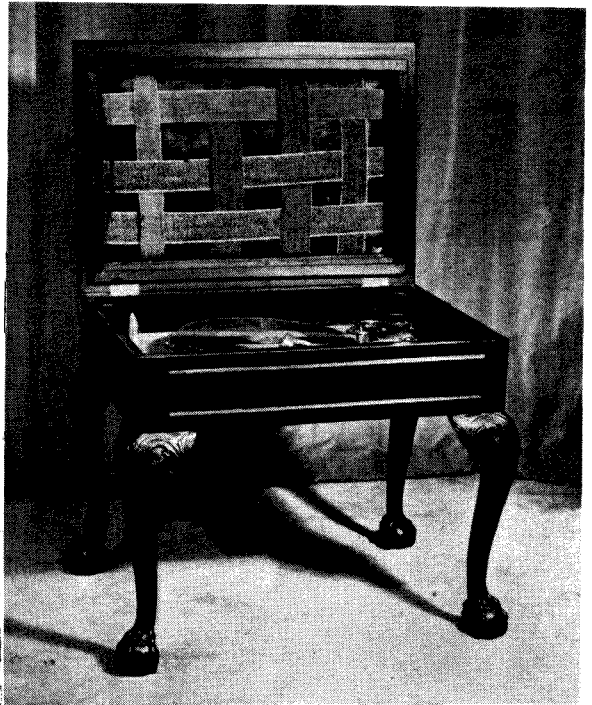

*When the lid is raised the turntable and usual fittings are revealed. Note: these photographs were taken some little time ago and do not show the particular pick-up now used by Mr. Kendall*

turntable driving motor and screening is unnecessary here; all that is required is a piece of good stout material which will stand being walked upon and even fallen over!

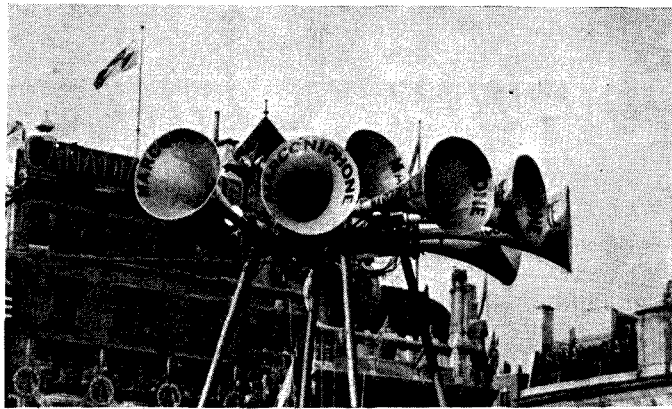

A group of Marconiphone public-address moving-coil loudspeakers of the exponential-horn type were used in the recent Jubilee festivities in London. Note how they are arranged to give a good coverage

By the "W.M." Technical Staff

# Power Amplifiers for All Occasions

**S**UMMER—and with it the season of buying, borrowing, or otherwise acquiring gear for making big noises in the open air—has arrived. The problem of determining just the right gear to suit the occasion is by no means an easy one; it is our intention in this article to give, first of all, the type of equipment most suitable for the job, then to detail briefly some of the leading commercial apparatus available.

windy on the day almost twice the volume will be required.

The second thing is not to have too much noise—too great a volume is as bad a crime as having too little; and finally, quality of the reproduction must be good if you want the audience kept in a good mood. If those three simple requirements are kept in mind when deciding on the gear to be used, more than half the way to a successful gathering is assured.

Now about the apparatus to be used.

The first point to be settled is obviously that of the amount of power output required: one must have enough for the work in hand, but to provide too much is merely wasting money.

The deciding factor is the

"coverage" required. This is usually expressed in terms of the number of persons to whom the loudspeakers are to be audible, and is interpreted in one way for indoor work and quite another when the open air is concerned. Indoors one can cover quite a sizeable audience with an output of 5 watts; outdoors this would be regarded as an output so limited as to serve only for small groups of people.

## Loudspeaker Efficiency

Here it is as well to realise that the amount of power which will be required for a given job depends not merely on the size of the area to be covered and the amount of wind (if in the open air), but also the acoustic efficiency of the loudspeakers to be used. We must remember that

the simple moving-coil with open baffle is a low-efficiency loudspeaker and demands considerably more power than would suffice if a type with greater conversion-efficiency were available.

An efficient loudspeaker of the horn type will often be found to cover a given area with a power only perhaps one-half that needed with the hornless type, and this may be an important consideration on occa-

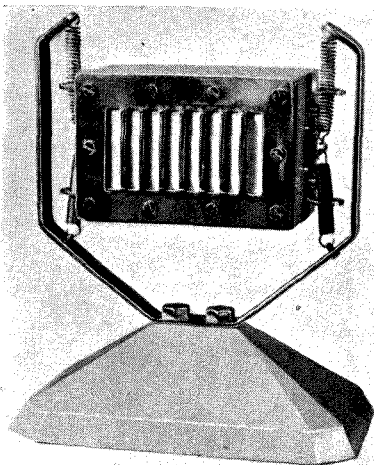

The Parmeko junior microphone on its stand. At the low price of £3 it will find a ready market among amateur users

The secrets of success in entertaining an outdoor audience are few and very simple. It is just this: make certain that sufficient power is available to cover adequately the whole of your audience. You need and must have volume in reserve. It may be fine when you make your tests, but should it happen to be

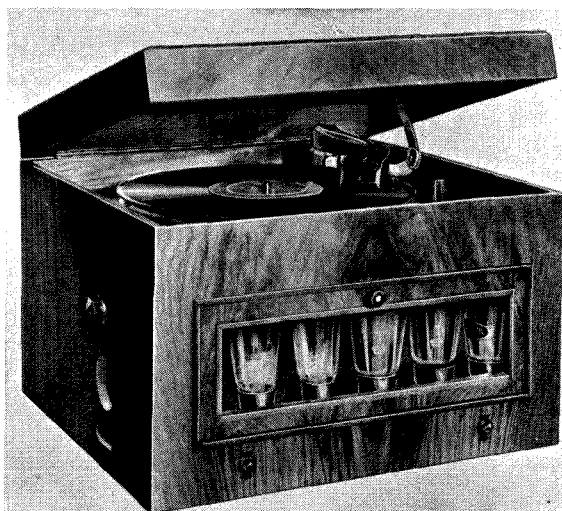

An undistorted output of between 4 and 6 watts is given by this C.A.C. quality amplifier. Two PX4's are used in the output stage

sion. The horn type is consequently to be advised whenever the area concerned is large, or when there is likely to be much wind or a good deal of general noise.

The plain baffle moving-coil should, in general, be reserved for quite small audiences under favourable conditions, unless one is prepared to provide a very large amount of power.

### Using a Horn Speaker

In using the horn type of loudspeaker it is necessary to make due allowance for the strong directional properties of the type. These are usually so marked that it is necessary to employ more than one speaker to cover a gathering of people who have not been specially grouped for the purpose. Of course, for a large crowd quite a battery of speakers is required, but for such occasions as those with which "W.M." readers are likely to be concerned a pair will usually suffice.

It is a mistake to place loudspeakers right among the crowd if it can be avoided. It is best to set the loudspeakers a little way back and so afford them a better chance of spreading their output over the required area. When they are set up right over the heads of the audience it is inevitable that those nearest to them should find the volume excessive.

Now a word about the amount of power needed under outdoor conditions. It

has been mentioned that a genuine 5 watts will serve quite a sizeable audience indoors, but such an output would be found decidedly meagre in the open air unless conditions were extremely favourable. A minimum of 10 watts is a very good rule here, for such an amount of power will serve for small sports meetings, fêtes, and so on where there is no great amount of competing noise.

Larger powers are needed when the wind is high or when there is much general noise, or when it is required to cover a really large gathering. In such circumstances it is wise to provide 20 or 30 watts as a minimum and arrange to distribute several loudspeakers over the area, remembering that it is best to place the speakers themselves in back-to-back pairs or other groupings found

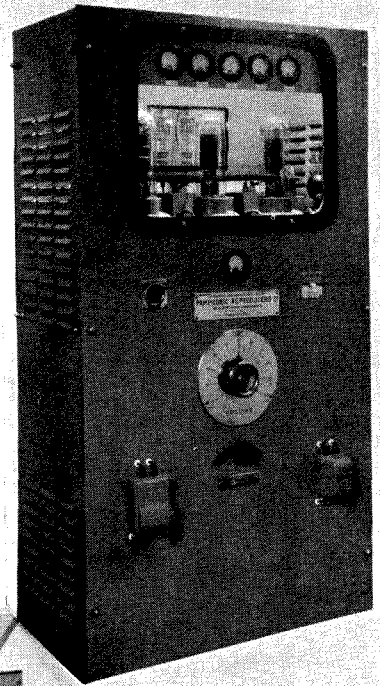

The huge Pamphonic 180-watt amplifier which is in use at the White City, London

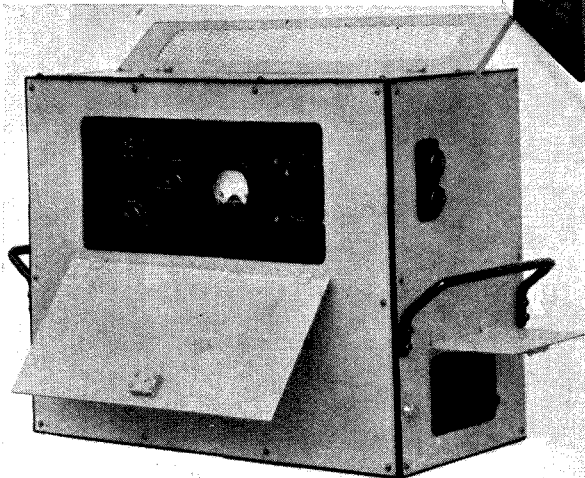

A portable public-address amplifier which gives an undistorted output of 25 watts made by Partridge & Mee, Ltd. It is for operation on A.C. mains and costs £85

effective on the ground.

Note that last remark: there is inevitably much trial and error involved in public-address work. It is difficult to lay down rules, but usually easy to try the speakers in a few likely positions and walk round while an assistant keeps up a steady flow of words into the microphone.

It is perhaps obvious, but all this *must* be done well before the crowd begins to arrive; nothing makes a worse initial impression than to hear that wearisome "Monday, Tuesday, Wednesday" business droning from the speakers while worried-looking individuals rush about making alterations.

And now for a brief résumé of the gear available on the market. We do not pretend this information to be complete, but it is sufficiently comprehensive to enable readers to gather a fair idea of the price that will have to be paid for reliable gear.

### Birmingham Sound Reproducers Ltd.

This firm markets an assortment of gear ranging from a 3-watt amplifier for A.C. mains operation to a high-

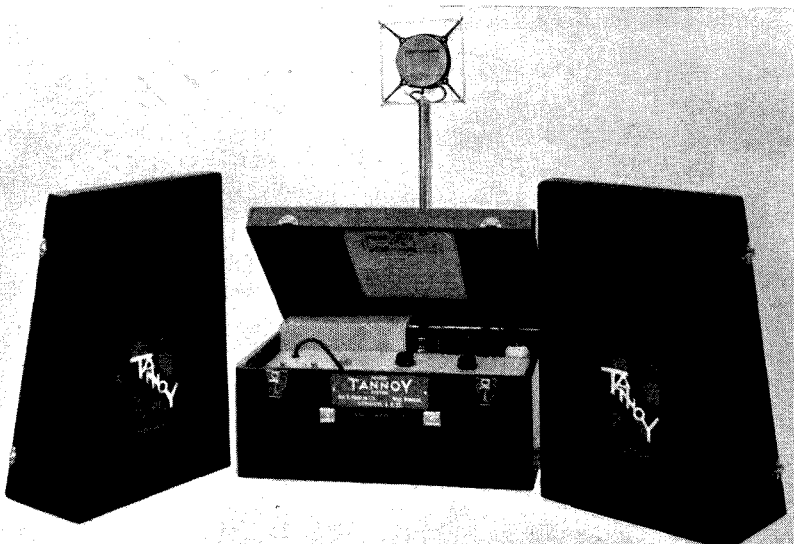

A universal A.C./D.C. equipment comprising an amplifier, microphone, and two moving-coil loudspeakers. This gear is particularly suitable for relaying dance bands or small orchestras

fidelity power equipment giving 30 watts undistorted output, also for A.C. operation. The small amplifier is ideal for the home as a deaf-aid equipment or for use where quite a small output is required. We do not consider this outfit suitable for outdoor work.

The big amplifier makes use of two PX25A's in the output stage, and

plete with output transformer and lead.

The price of the amplifier is £25, and the loudspeaker with its cabinet costs a further £11 10s. It is possible to obtain a radio-input unit for use with the amplifier for £10.

The address of the makers is 18-20 Norman's Buildings, Central Street, London, E.C.1.

input to be mixed with the pick-up or other input, thus permitting announcements to be made without spoiling the continuity of the music or ceremony being relayed. Full provision is made for polarising a 200-400-ohm carbon microphone, and no batteries are needed whatsoever.

A microphone amplifier for use with the above can be obtained for £6. Correx also make a light-duty permanent-magnet horn moving-coil loudspeaker with a power handling capacity of 5 or 6 watts. It is suitable for either outdoor or indoor use where great volume is not essential, and where lightness is an important factor. The price of this instrument is £6 16s. 6d.

Correx will be only too pleased to advise readers who care to get in touch with them at 21 Marmora Road, S.E.22.

#### Film Industries, Ltd.

This is a big concern which makes and loans public-address equipment of all sizes. A special product is the

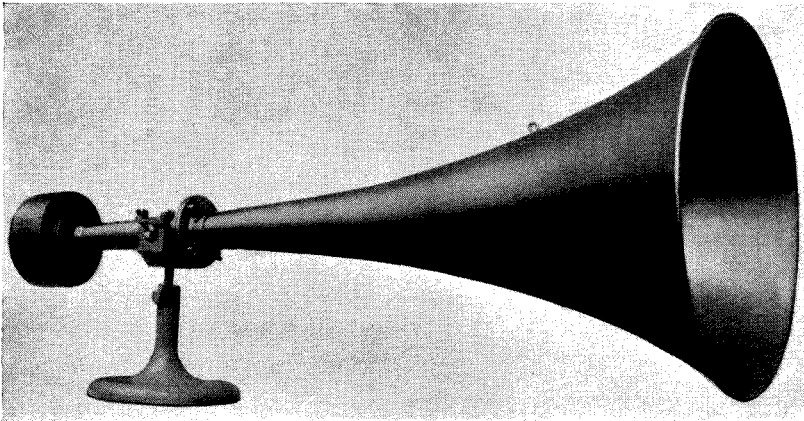

*A projection type of public-address loudspeaker primarily designed for outdoor use. It is driven by a moving-coil unit and will handle an input of 12 watts. It is made by Parmeko and costs £25*

is suitable for really large outdoor functions. Although designed primarily for use on the mains, the makers state that this outfit can be operated from batteries.

Actually the high-tension current required is 135 milliamperes at 420 volts, 4 volts 7 amperes for the low-tension, and a 120-volt battery for grid bias.

No prices have been supplied for this gear, but full details are available from the makers at Claremont Works, Claremont Street, Old Hill, Staffs.

#### City Accumulator Co., Ltd.

The A.C. amplifier marketed by this firm is intended for use where quality is of primary importance and excessive volume of secondary consideration. The amplifier uses two PX4's in the output stage, the undistorted output from which is about 4 or 5 watts.

The amplifier is supplied complete in an oak cabinet with gramophone motor and pick-up with plug adaptors for the loudspeaker, and the radio and microphone inputs. Either a Magnavox or Godfrey moving-coil loudspeaker in a special oak baffle cabinet is supplied com-

#### Correx Amplifiers

The main products of this concern are two A.C.-operated amplifiers giving 6 and 12 watts undistorted output respectively. Known as the types S25 and S50, the prices are £17 10s. and £21 10s.

These amplifiers are built into rigid steel cases finished in grey enamel. The operating controls on the front allow for the microphone



*An undistorted output of 6 watts is given by this Correx A.C. amplifier*



*A twin-turntable unit made by the Tris Electrical Company can be obtained in many forms*

Universal A.C./D.C. amplifier using two pentode valves, the output being 3.5 watts undistorted.

Cost is not really cheap, being £30; this includes the main amplifier, a microphone with an adjustable stand, and a folded horn and loudspeaker unit for indoor use. If a loudspeaker for outdoor use is required the price is £32 complete.

Full details are obtainable from 60 Paddington Street, London, W.1.

#### M.P.R. Electrical Co.

The M.P.R. amplifier, for A.C. mains, which gives an undistorted output of 6 watts, is designed for



reproducing gramophone records at a strength suitable for such places as cafes, swimming pools of small size, or at outdoor functions where not too large a volume is required.

Two valves are used, an Osram MH4 feeding into a PX25 with Westinghouse metal rectifiers to supply the necessary high-tension current. A loudspeaker of the energised moving-coil type is already fitted on the amplifier chassis, but provision is made for connecting

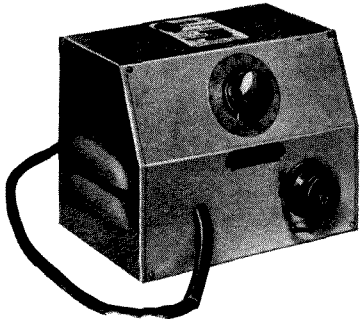

The microphone amplifier made by Correx for use with their public-address equipments

others. The price is quite reasonable, being only £7 17s. 6d. for the amplifier chassis; the valves cost a further £1 18s. 6d.

Details can be had from the makers at Eastern Road, Romford, Essex.

### Parmeko

This firm, which is well-known to "W.M." readers, makes a wide range of amplifiers and associated equipment for the public-address enthusiast. There is no room to give full details of the range here,

but the makers will be pleased to supply a comprehensive guide to those really interested.

A review of the new Parmeko No. 2 amplifying equipment will be found on another page of this issue. A handy gramophone amplifier for the quality fan is the model No. 1. The amplifier, for use on A.C. mains and giving an undistorted output of 6 watts, is housed together with gramophone motor and pick-up and accessories, in a sheet-steel cabinet finished in grey cellulose. The price complete with all valves is £30.

Those who require really large amplifiers will be interested in the big console model which costs £190 and is known as the 180-watt type.

Parmeko make a small microphone known as the Junior type which is ideal for recording, music relaying, and similar uses. "W.M." tested

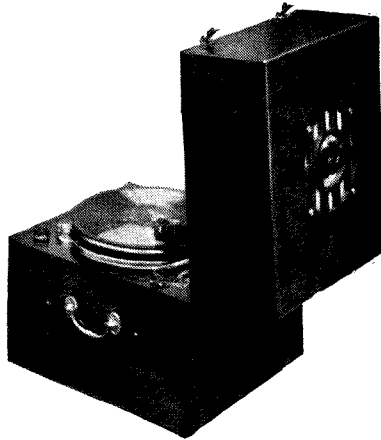

A self-contained electric gramophone made by the Trix Electrical Company which has a moving-coil loudspeaker in the hinged lid. It gives sufficient output to entertain between 200 and 300 people

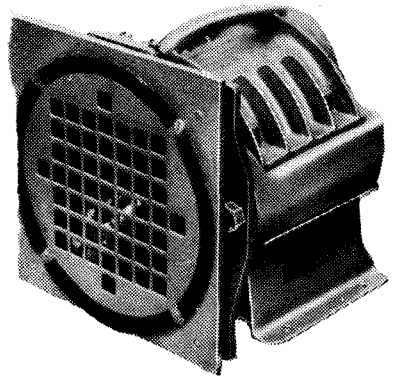

A twin-diaphragm moving-coil loudspeaker made by Voigt Patents, Ltd., is claimed to give remarkable results. It will handle all inputs up to 8 watts R.M.S.

this last year and found that the makers' claims for high sensitivity combined with a level response curve were fully justified. At its low price of £3 it is undoubtedly the very thing for the amateur as well as the professional man.

Further information can be obtained from Partridge & Mee, Ltd., Aylestone Park, Leicester.

### Pamphonic Reproducers

This firm supplies large installations suitable for race meetings, public stadiums, and swimming baths, Pamphonic designed and installed the big amplifier at the White City, which gives an undistorted output of 180 watts.

The address is 56 Albert Road, Regents Park, London, N.W.8.

### Philips Industrial

A big concern responsible for the installations at the Wembley Stadium and Empire Swimming Pool, and many leading restaurants, cathedrals, hospitals and universities throughout the country.

Equipments for any purpose can be hired at moderate charges.

An amplifier sold by Philips Industrial and very suitable for general use is the model 3726, which employs two stages and having an undistorted output of 10 watts. The output transformer of this unit is tapped to match loudspeaker impedances of from 2 to 40 ohms. It is obtainable for use on A.C. mains (£24 3s.) and D.C. mains (£36 15s.).

A comprehensive catalogue describing the complete range can be obtained from Philips Industrial, 145 Charing Cross Road, London, W.C.2.



An A.C./D.C. amplifier which gives an undistorted output of nearly 12 watts made by Universal High-voltage Radio, Ltd. It uses Ostur-Ganz valves and costs £21

Continued on page 478

# K.B. Cavalcade

## Model 442

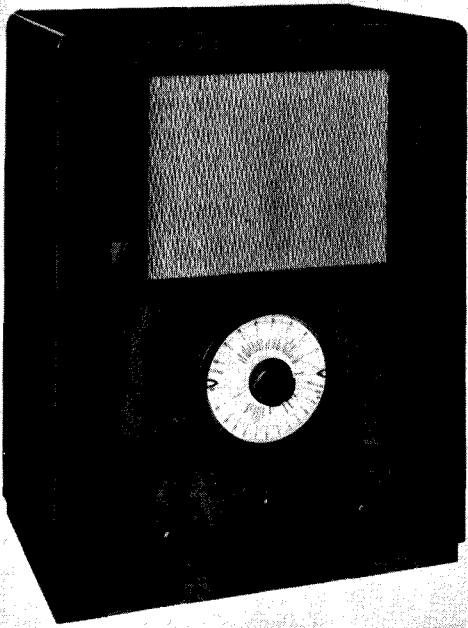

"The Cavalcade's fine walnut cabinet, artistically inlaid round the loudspeaker fret and down the sides"

**T**HERE is no question that modern sets are improving in two important directions: they can get more "listenable" stations in daylight, and they are now what might truthfully be termed completely hum-free. Both these improvements are to be found in this K.B. Cavalcade, a four-valve superhet for operation on either A.C. or D.C. mains.

Efficiency was no doubt the main objective of the designers of this receiver. They have achieved their object, but in doing so the accessibility of the valves on the chassis has been somewhat overlooked. We found it rather a tricky job to get at the rectifier. This is only a small point, but it does show that set makers are now out for super efficiency, and to get this layout plays a most important part.

**P**hotographs can hardly do justice to the Cavalcade's fine walnut cabinet, artistically inlaid round the loudspeaker fret and down the sides. The fret is backed with pale green silk, which greatly enhances the set's appearance.

Pride of place on the front is given to a circular tuning scale having the control knob in the centre. When this knob is turned the whole scale rotates, identification being obtained by two pointers, one on each side—long waves on the left and medium on the right. The scale is lavishly

engraved with station names and wave-lengths, and we found it to be accurately calibrated.

Of the three controls at the bottom, the wave-change switch is on the left, tone control in the middle, and a combined on-off switch and volume control on the right.

Those inquisitive listeners who want to examine the set's works automatically break the mains circuit when they remove the back,

a safety switch being incorporated between this back and the set chassis. A safety device that is strongly commended!

On the back of the set are two aerial and the earth terminals. One of the aerial terminals is for use with the ordinary aerial systems, the other being for use when the K.B. Rejectostat system of interference suppression is installed.

No provision is made for using a gramophone pick-up.

Our first tests with this receiver were made during daylight hours. Here is the log for the test, which was carried out five or six miles south of London. Long waves: Huizen, Radio Paris, Droitwich, Luxembourg, Kalundborg, and Heston and Croydon airports. Medium waves: Brussels, Cologne, Brussels No. 2, Poste Parisien, Hilversum, Radio Normandy

### BRIEF SPECIFICATION

BRAND NAME: K.B.  
 MODEL: Cavalcade, KB422.  
 PRICE: £12 1s. 6d.  
 POWER SUPPLY: Universal—A.C./D.C. mains, 195-255 volts.  
 VALVE COMBINATION: Four valves and rectifier in superhet sequence. The combination is a pentagrid frequency-changer (Brimar 15D1), variable-mu high-frequency pentode intermediate-frequency amplifier (Brimar 9D2), double-diode-triode second detector and A.V.C. (Brimar 11D3), pentode output (Brimar 7D3), and valve rectifier (for A.C. only) (Brimar 1D5).  
 MAKERS: Kolster Brandes, Ltd., Cray Works, Sidcup, Kent.

besides, of course, the majority of the British Regional stations.

**A**t night the majority of the sixty-odd stations marked on the scale were tuned in. We would point out that of these thirty could be relied upon to give *good listening entertainment*; the other stations were there for those who do not mind a proportion of crackle and similar noise.

This set gives good quality, taking into account the acoustic properties of the cabinet and that it is a superhet operating into a 2.5 watt pentode output valve. Believe us, that is no meagre praise; such a combination is capable of giving very pleasant quality.

We would like to pay tribute to the instruction booklet supplied with the set; it is clearly written and very comprehensive.

Kolster Brandes are to be congratulated on turning out a set that is every inch value for money.

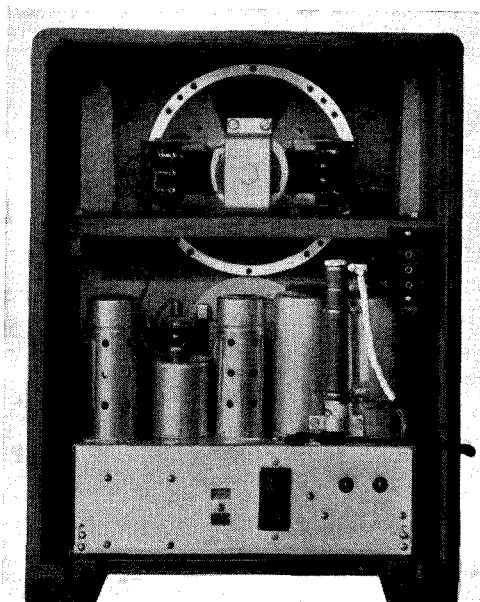

"Efficiency was no doubt the main objective of the designers of this receiver"

# R.A.P. All-wave Transatlantic

WE are very much impressed with the performance given by this new R.A.P. four-valve superhet. This receiver can truthfully be said to set a high standard for the commercial inexpensive superhet.

For twelve guineas one gets a four-valve receiver that will work from either A.C. or D.C. mains without alteration, and covering the

**BRIEF SPECIFICATION**  
 BRAND NAME: R.A.P.  
 MODEL: Transatlantic.  
 PRICE: £12 12s.  
 POWER SUPPLY: Universal—A.C./D.C. mains, 200-250 volts.  
 VALVE COMBINATION: Four valves and rectifier—the latter comes into use on A.C. supplies only. The combination is a pentagrid mixer (Tungsram 607), high-frequency pentode intermediate-frequency amplifier (Tungsram 78), second detector, low-frequency amplifier and A.V.C. valve (Tungsram 6B7), and pentode output (Tungsram 48). The rectifier is a Tungsram 252S.  
 MAKERS: R.A.P., Ltd., Ferry Works, Thames Ditton, Surrey.

short waves, from 19 to 52 metres, in addition to the ordinary medium and long wavebands. The results from all of those three wavebands are of a high standard.

It is not advertising jargon to say that if the user gets tired of European stations he can switch over to the "shorts" and listen to America. For three nights, during which the set was thoroughly put through its paces, we could log two or three Americans with ease. We would, however, make it quite clear that they were not received with the same clarity and constant strength that we have come to expect from European stations; but the Americans certainly did provide us with entertainment!

The circuit is an efficient one using four Tungsram valves for receiving and another as a valve rectifier, making five valves in all.

Appearance, as you can see from the illustration, is quite pleasing. The small loudspeaker fret is in one corner and the big tuning scale in the centre is marked with the names of fifty-two medium-

wave stations and ten long, in addition to wavelength calibrated scales for both these wavebands.

A further degree-marked scale from 0 to 100 is provided for calibrating the 19- to 52-metre short waveband. This full-vision scale is brilliantly illuminated when the set is switched on.

Underneath this are grouped the four tuning controls. The main tuner is at the top and below, from left to right, are the combined on-off switch and volume control, the tone control, and the three-position wave-change switch.

Inside the cabinet, finished in walnut with a bevelled top, one finds the same cleanness in the layout. At the top is the energised moving-coil loudspeaker—a fair-sized one with a 7-in. cone made of a celluloid-like substance. On the bottom of the cabinet is the set chassis, notable for a "plenty-of-room" arrangement—one can get at any valve or the trimmers of the ganged condenser without the slightest bother.

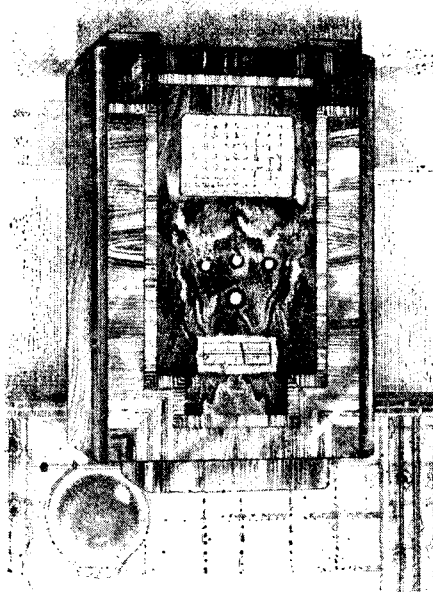

The Oriental, a nine-stage A.C./D.C. superhet radiogram for medium and long waves only and selling at eighteen guineas is another receiver in the R.A.P. range

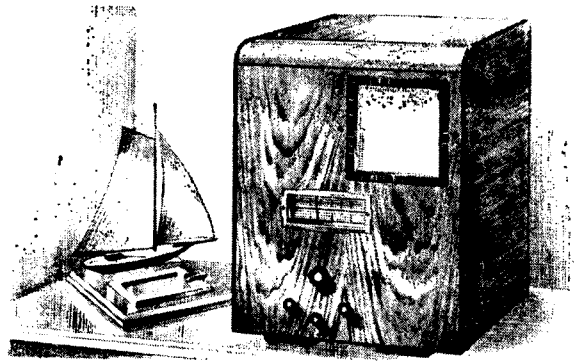

"Appearance is quite pleasing . . . the full-vision scale is brilliantly illuminated when the set is switched on"

The mains-adjustment device is on the back of the chassis as are the sockets for aerial and earth, pick-up and additional loudspeaker.

We were well satisfied with the performance put up on test. Our first experience with the set was during a morning between 11 a.m. and 12.30 p.m.

Altogether we logged fourteen medium-wave stations—the British stations were not working. Out of these Radio Normandy, Hilversum, Poste Parisien, Toulouse, Leipzig, Paris P.T.T., Langenberg, Brussels, and two others around the 500-metre mark gave definite entertainment value.

Kootwijk, Radio Paris, Zeesen, Luxembourg and Kalundborg were the long-wave stars, while a host of morse and dozens of British and French amateurs playing gramophone records, many of abominable quality, were the performers on the short waves.

Handling the set is no difficult task, though one has to train a steady hand for logging on the 19- to 52-metre band. It is a set that can give hours of continual entertainment for the ordinary listener, yet on the other hand the knob-twiddler will certainly find his mark!

We do feel that an extra word of praise is necessary for the high selectivity on both medium and long wavebands, and for the extreme sensitivity and "quickness" on all the short wavelengths.

Quality was pleasant to listen to, though it might not satisfy those whose ideas stretch far into terms of high fidelity. For a modest outlay of twelve guineas we know that purchasers will be getting extraordinarily good value for their money. That surely is the crucial test of any receiver!

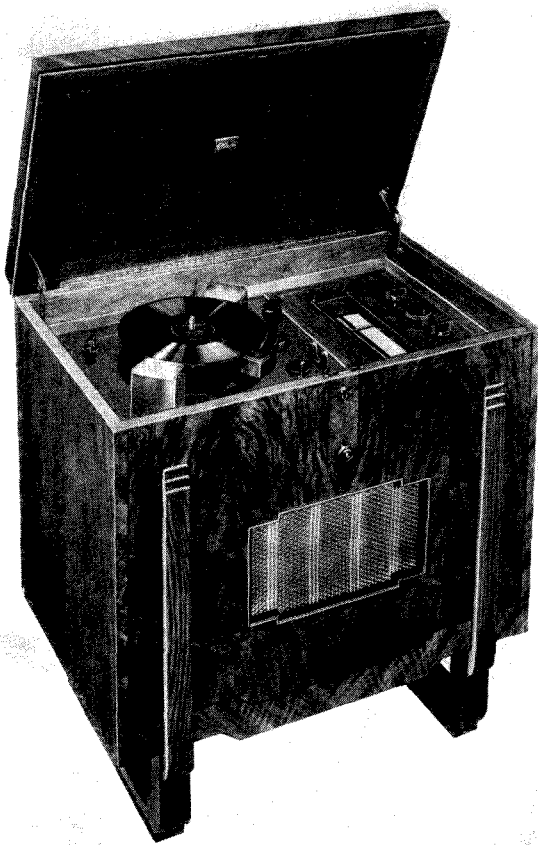

"The set is housed in a solid walnut cabinet, beautifully figured, with all the controls (except one) on the motor board"

## Marconiphone 292 De-luxe Radiogram

There is a visual tuning indicator: a small aperture being fixed at the top of the huge full-vision scale. The visual tuning device is of the very simple type; one simply tunes to get maximum light to ensure that the station is dead on tune.

The illuminated scale—about  $3\frac{1}{2}$  in. by 12 in.—is engraved with the names of sixty stations and is calibrated in metres from 200 to 550, and 1,000 to 2,000.

One of the most important features is the choice of two grades of selectivity. By the setting of a switch one can get 6-kilocycle separation—this means the whole of Europe at your command with a slight loss of top notes in the quality—or 12-kilocycle separation which, we found, gave us the choice of 30 foreign stations and our B.B.C. locals with quality of reproduction that can only truthfully be described as "almost perfect."

One gets this rich quality even at low volume, for the volume control potentiometer operates in conjunction with a tone-balancing arrangement, which maintains a wide frequency range at all settings of the volume control.

The set is housed in a solid walnut cabinet, beautifully figured, with all controls except the combined volume control and "record-rejector" knob, on the motor-board. In spite of its extensive specification—we have only touched the fringe of it—the makers have fitted a record-changing mechanism which plays up to eight 10-in. or 12-in. records without attention. If one does not like the record being played, the small metal button in the centre of the volume control is pushed in; the record stops playing and the next one on the pile falls down, and the music continues.

WHEN this receiver arrived for test it was accompanied by a brown and silver brochure on the front of which was a picture of the radiogram and the words, "The Marconiphone De Luxe." We are not attempting to supply strings of superlatives to describe our opinion of this Marconiphone de Luxe; let it be sufficient to remark that we agree with all the nice things the makers say about their set.

The 292 is, without the slightest doubt, an achievement; it does cost more than the average set, but we consider that the man who invests in a 292 gets the full value of his money.

Let us run—very briefly—through the specification. First: an eight-valve superhet circuit is used, with a variable- $\mu$  signal-frequency stage followed by a heptode detector-oscillator: then there are two intermediate-frequency stages, followed by a double-diode-triode as second detector and first low-frequency amplifier.

Another D.D.T. supplies automatic volume control and is used in the "silent-tuning" circuit, while in the output stage are two PX4 triodes in push-pull, giving a large undistorted output of five watts.

This is a more ambitious circuit than we usually find today; the two I.F. stages ensure a large bag of foreign stations, even when a short indoor aerial is used.

WE have had the set on test for a long time—and we shall be very sorry to return it to the makers. All the controls have worked smoothly and, in spite of "our eagle eyes," we haven't found something that isn't working just right.

With a small indoor aerial and no earth we could log any worthwhile station in Europe after nightfall. With the silent-tuning switch in position and on this short aerial we could log fifteen stations on the medium waveband as good as the locals.

Daylight results were extraordinary good. In London we logged Radio Normandy at full volume with only a 6 ft. indoor aerial. On a normal outdoor aerial at night we logged eighty-eight stations on the medium and long waves.

We cannot praise this 292 radiogram too highly; we agree that it is the finest home entertainer that Marconiphone has ever produced!

### BRIEF SPECIFICATION

BRAND NAME: Marconiphone.  
 MODEL: 292 Auto Radiogram.  
 PRICE: £54 12s.  
 POWER SUPPLY: A.C. mains only: 200-250 volts.  
 VALVE COMBINATION: Eight valves arranged in superhet sequence with a ninth as rectifier. Features are a preliminary stage of high-frequency amplification; two intermediate-frequency stages; a special valve for silent tuning; and ample power output is assured by the use of two PX4's in push-pull.  
 MAKERS: The Marconiphone Co., Ltd., Radio House, Tottenham Court Road, London, W.C.

# Parmeko No. 2 Power Amplifier

**W**E have made a speciality in the past in reviewing the latest products of set manufacturers; now as the policy of "Wireless Magazine" has been broadened to embrace every section of radio interest the Set Selection Bureau has undertaken the task of testing power amplifiers and including them in the free advice service to readers.

The Parmeko No. 2 A.C. amplifier is a noteworthy achievement and thoroughly deserves its inclusion as the first public-address amplifier to be reviewed in this section.

We have received the complete No. 2 amplifier from Parmeko: that is the self-contained unit with amplifier chassis, gramophone motor and pick-up, housed in a large sheet steel cabinet—finished in grey cellulose—measuring 26 in. wide overall, 17 in. high and 16½ in. deep.

The cabinet is provided with a hinged front and lid—under the latter are the gramophone motor and pick-up, but no controls. All controls are fixed on the front

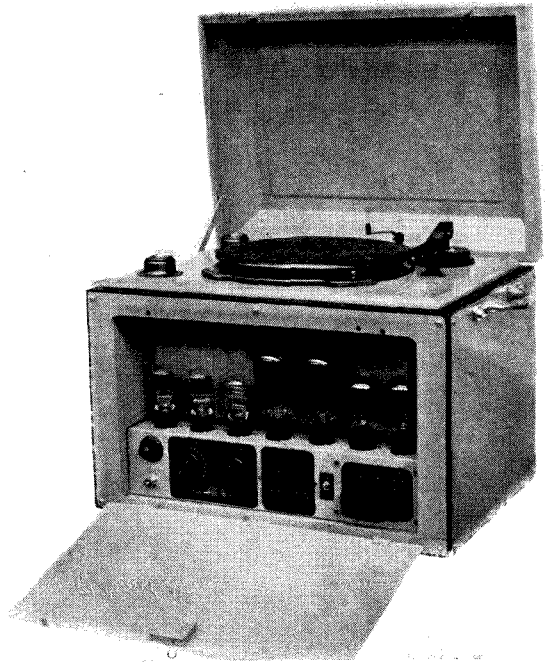

The complete Parmeko No. 2 Power Amplifier is housed in a grey cellulose steel cabinet, with gramophone equipment under a hinged lid at the top.

A frequency curve supplied to us by the makers shows a remarkably constant response between 50 and 5,000 cycles with only a very slight falling off below and above this range. From our tests we have come to the conclusion that the range claimed by the makers is undoubtedly obtained in practice.

**P**rovision is made for either pick-up or microphone input, and for the latter, either carbon, moving-coil or piezo-crystal types are suitable. Among the controls on the front is a pitch (tone) control which allows for the attenuation of the high or low notes at will. The control is variable and in its maximum "high" position gives a high-note cut-off at 3,500 cycles, and in the maximum "low" position, 600 cycles.

The volume control, graduated numerically from 0 to 38, exercises a wide control: we found that quality did not suffer when the control was reduced to give very low sound intensity.

The main on-off switch and mains-adjustment is to the right of the controls, together with mains input socket and fuses. The amplifier is designed for A.C. mains of standard voltages with a frequency of 50 cycles, but there is also a tapping for 100-volt supplies.

An important feature is the provision of an independent metal rectifier for supplying grid bias. So that the two output valves can be carefully matched, jacks for two milliameters and separate bias adjusters are provided.

Special provision is made for adjusting the output circuit to suit 7.5, 15 or 30-ohm loud-speakers.

Our tests were made on 200-volt mains with a fairly large moving-coil loudspeaker. We were greatly impressed with the overall quality.

With a big loud-speaker in a big hall, this amplifier could safely be used to provide unlimited entertainment.

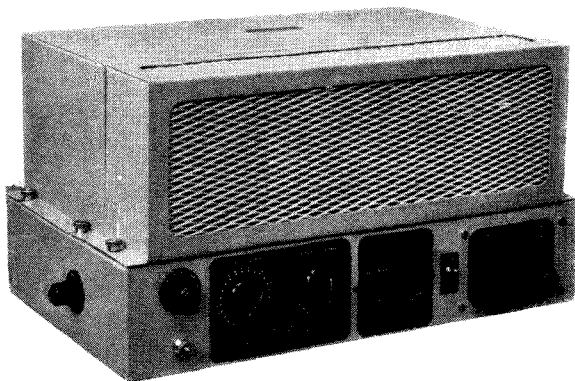

It is possible to obtain the amplifier, complete with valves, with a steel cover over the essential parts, as shown in this illustration, for £40

of the chassis proper, which is exposed when the front is let down. The layout can be followed easily from the illustration at the top of this page. A pick-up of piezo-electric type is fitted as standard.

**T**HE amplifier consists of four stages. The valves used will be found in the specification panel, but it is interesting to note that coupling between the first two stages is resistance-capacity, and push-pull transformer coupling between the third and output stages. An undistorted output of 25 watts is given by the two PX25A output triodes.

#### BRIEF SPECIFICATION

BRAND NAME: Parmeko.  
 MODEL: Power Amplifier No. 2.  
 PRICE: Complete as top illustration, £45; chassis only, £40.  
 VALVE COMBINATION: First stage (Mazda AC/HL), second stage (Mazda AC/HL), third stage (Mazda AC/P), push-pull output stage (two Osram PX25A's), Rectifiers (two Mullard IW4's).  
 POWER SUPPLY: Standard A.C. mains voltages, 50 cycles (25-cycle mains at small extra charge).  
 MAKERS: Partridge & Mee, Ltd., Aylestone, Park, Leicester.

# World's Broadcast Wavelengths

Stations best received in the British Isles are indicated in bold type. This list is corrected up to the time of going to press

Note: Names in brackets are those of the main stations from which the greater part of the programmes are relayed

Wave-length	Name of Station	Dial Readings	Country	Wave-length	Name of Station	Dial Readings	Country
13.92	Pittsburgh W8XK		United States	31.48	Schenectady W2XAF (WGY)		United States
13.97	Daventry (Empire) GSH		Great Britain	31.55	Daventry (Empire) GSB		Great Britain
14.49	Buenos Aires LSY		Argentina	31.55	Melbourne VK3ME		Victoria
15.92	Bandoeng PLE		Java	31.55	Caracas YV3BC		Venezuela
16.36	Lawrenceville (N.J.) WLA		United States	31.58	Rio de Janeiro PSA		Brazil
16.38	Rugby GAS		Great Britain	31.6	Skamlebaek		Denmark
16.5	Drummondville (CFA8)		Canada	31.7	Havana		Cuba
16.56	Bandoeng PMC		Java	31.71	New Brunswick WKJ		United States
16.56	Buenos Aires LSY3		Argentina	31.9	Bandoeng PLV		Java
16.81	Bandoeng PLF		Java	32.71	Lawrenceville WNA		United States
16.85	Kootwijk PCV		Holland	32.79	Maracay YVQ		Venezuela
16.86	Daventry Empire GSG		Great Britain	32.88	Budapest HAT1		Hungary
16.878	Boundbrook W3XAL (WJZ)		United States	33.26	Rugby GCS		Great Britain
16.88	Eindhoven PHI		Holland	33.59	Rocky Point (N.J.) WEC		United States
19.47	Riobamba PRADO		Ecuador	34.68	London VE9BY		Canada
19.52	Budapest HAS3		Hungary	36.65	Rio de Janeiro PSK (PRA3)		Brazil
19.56	Schenectady W2XAD (WGY)		United States	37.04	Quito HCJB		Ecuador
19.61	La Paz CP4		Bolivia	37.33	Rabat (CNR)		Morocco
19.64	New York W2XE (WABC)		United States	37.41	Suva VPD		Fiji Isles
19.66	Daventry (Empire) GSI		Great Britain	38.07	Tokio JIAA		Japan
19.67	Coytesville N.J. WIXAL (WEEI)		United States	38.47	Radio Nations HBP		Switzerland
19.67	Tashkent (Rim)		U.S.S.R.	38.65	Kootwijk PDM		Holland
19.68	Radio Coloniale FYA		France	39.34	Tashkent RIM		U.S.S.R.
19.72	Saxonburg W8XK (KDKA)		United States	39.34	Moscow RKI		U.S.S.R.
19.74	Zeesen DJB		Germany	39.76	Riobamba PRADO		Ecuador
19.82	Daventry (Empire) GSF		Great Britain	39.82	Radio Nations HBQ		Switzerland
19.84	Rome (Vatican) HVJ		Italy	40.3	Bogota HJ3AB		Colombia
19.88	Moscow (RKL)		U.S.S.R.	40.5	Rocky Point WEN		U.S.A.
19.93	W8XK, Saxonburg (KDKA)		United States	40.54	Rocky Point WEN		Colombia
20.27	Rocky Point WQV		United States	41.35	Bogota HKE		Colombia
20.31	Rocky Point N.Y. (WEB)		United States	41.6	Las Palmas EA8AB		Canary Isles
21.43	Cairo SUV		Egypt	41.67	Singapore VSIAB		Sts. Seatl'mts.
21.53	Rocky Point WIK		United States	41.84	Grenada YN6RD		Nicaragua
21.58	Rocky Point WQP		United States	41.9	Manizales HJ4AB		Colombia
21.605	Rocky Point WQT		United States	43	Madrid EA4AQ		Spain
21.83	Drummondville CJAS		Canada	43.86	Budapest HAT2		Hungary
22.26	Rocky Point WAJ		United States	44.1	Rocky Point WQO		United States
22.48	Santa Rita YVQ		Venezuela	44.96	Maracay YVQ		Venezuela
22.684	Zeesen (DHB)		Germany	45	Constantine FM8KR		Tunis
23.39	Radio Maroc (Rabat) CNR		Morocco	45	Guatemala City		S. America
24.41	Rugby GBU		Great Britain	45.02	Guayaquil HC2RL		Ecuador
24.9	Kootwijk P1V		Holland	45.38	Moscow RW72		U.S.S.R.
25	Moscow RNE		U.S.S.R.	46.53	Barranquilla (HJ1ABB)		Colombia
25.25	Radio Coloniale, Paris (FYA)		France	46.69	Boundbrook W3XL (WJZ)		United States
25.27	Saxonburg (Pa.) W8XK (KDKA)		United States	46.7	Boston WIXAL		United States
25.28	Daventry (Empire) GSE		Great Britain	47	Caracas		Venezuela
25.34	Wayne W2XE (WABC)		United States	47.5	S. Domingo HIZ		Dominican R.
25.4	Rome 2RO		Italy	47.8	Domingo HIAA		Dominican R.
25.45	Boston WIXAL (WEEI)		United States	48.75	Winnipeg CJRO		Canada
25.49	Zeesen DJD		Germany	48.78	Caracas YV3RC		Venezuela
25.532	Daventry (Empire) GSD		Great Britain	48.86	Saxonburg (Pa.) W8XK (KDKA)		United States
25.63	Radio Coloniale FYA		France	48.86	Moscow (RKK)		U.S.S.R.
26.83	Funchal CT3AQ		Madeira	48.94	Jelöy		Norway
27.65	Nauen DFL		Germany	49.02	Bandoeng (YDA)		Dutch E. Indies
27.86	Rugby GBP		Great Britain	49.02	Wayne W2XE (WABC)		United States
27.88	Marapicu PSG		Brazil	49.08	Caracas YV2RC		Venezuela
28.28	Rocky Point (N.J.) WEA		United States	49.1	Daventry (Empire) GSL		Great Britain
28.5	Sydney VLK		N.S. Wales	49.18	Boundbrook W3XAL (WJZ)		United States
28.98	Buenos Aires LSX		Argentina	49.18	Chicago W9XF (WENR)		United States
29.03	Bermuda ZFD		West Indies	49.22	Bowmanville VE9GW (CRCT)		Canada
29.04	Ruysselede (ORK)		Belgium	49.26	St. John VE9BJ (CFBL)		N. Brunswick
29.35	Marapicu PSH		Brazil	49.3	La Paz CP5		Bolivia
29.59	Leopoldville OPM		Belgian Congo	49.34	Chicago W9XAA (WCFL)		United States
29.64	Marapicu PSI		Brazil	49.35	Zeesen (D9M)		Germany
29.84	Abu Zabel, Cairo SUV		Egypt	49.39	Maracaibo V5BMO		Venezuela
30	Radio Excelsior LR5		Argentina	49.4	Vienna OER2		Austria
30.1	Rome IRS		Italy	49.43	Vancouver VE9CS (CKFC)		Brit. Columbia
30.4	Lawrenceville W0N		United States	49.47	Nairobi VQ7LO		Kenya Colony
30.4	Tokio JIAA		Japan	49.5	Pernambuco		Brazil
30.43	Madrid EAQ		Spain	49.5	Skamlebaek		Denmark
30.77	Lawrenceville W0F		United States	49.5	Philadelphia W4XAU (WCAU)		United States
30.9	Rugby GCA		Great Britain	49.5	Cincinnati W8XAL (WLW)		United States
31.23	Mexico City XETE		Mexico	49.586	Daventry (Empire) GSA		Great Britain
31.25	Lisbon CTIAA		Portugal	49.6	Bogota HJ3AB1		Colombia
31.26	Radio Nations HBL		Switzerland	49.67	Boston WIXAL (WEED)		United States
31.28	Philadelphia W3XAU (WCAU)		United States	49.69	Prisk (YDA)		Dutch E. Indies
31.28	Sydney VK2ME		N.S. Wales	49.83	Zeesen DJC		Germany
31.32	Daventry (Empire) GSC		Great Britain	49.96	Drummondville VE9DN (CFCF)		Canada
31.34	Jelöy		Norway	50	Moscow RNE		U.S.S.R.
31.35	Millis W1XAZ (WBZ)		United States	50.8	Barcelona EA3AB		Spain
31.38	Zeesen DJA		Germany				
31.45	Zeesen (DJN)		Germany				

Continued on page 470



By courtesy "Leicester Evening Mail."

**LORD HAILSHAM speaking at a large political gathering using "PARMEKO" Public Address Equipment.**  
 Two new high efficiency types available, write for full particulars.  
**PARTRIDGE & MEE, LTD. AYLESTONE PARK, LEICESTER.**

## CORREX AMPLIFIERS

FOR  
 SOUND  
 EQUIPMENT

Tel. 21, MARMORA ROAD  
 SYDENHAM 3782. E. DULWICH, S.E.22

## THE WIRELESS CONSTRUCTOR'S ENCYCLOPÆDIA

By F. J. Camm

(Editor, Amateur and Practical Wireless, Practical Television, etc.)

THIRD EDITION

Wireless Terms and Definitions stated and explained in concise, clear language by one of the best known and most popular designers and writers of the day. Profusely illustrated. A veritable treasury of wireless knowledge for amateurs and experts alike. Only 5/- net.

From Booksellers Everywhere

GEORGE NEWNES LIMITED

8-II, Southampton Street, Strand, London, W.C.2



# DUBILIER RESISTANCES

- 1 watt type - 1/- each
- 2 watt type - 2/- each
- 3 watt type - 3/- each

DUBILIER CONDENSER CO. (1925) LTD., DUCON WORKS, VICTORIA ROAD, NORTH ACTON, W.3

R6

# WORLD'S BROADCAST WAVELENGTHS Continued from page 468

Note: This list is corrected up to the time of going to press

Wave-length	Name of Station	Dial Readings	Country	Wave-length	Name of Station	Dial Readings	Country
50.26	Rome (Vatican) HVJ ..		Italy	296.2	Midland Regional ..		Great Britain
50.42	Domingo HIX ..		Dominican R.	298.8	Bratislava ..		Czechoslovakia
50.6	Medellin HJ4ABE ..		Colombia	301.5	Hilversum ..		Holland
51.28	Maracaibo ..		Venezuela	304.3	Genoa ..		Italy
55.56	Szehefehar ..		Hungary	307.1	Belfast ..		N. Ireland
56.9	Königswusterhausen (DTG)		Germany	309.9	Odessa ..		U.S.S.R.
57.03	Rocky Point WQN ..		United States	312.8	Poste Parisien, Paris ..		France
58.0	Bandoeng PMY ..		Java	315.8	Breslau ..		Germany
58.31	Prague ..		Czechoslovakia	318.8	Goteborg ..		Sweden
60.3	Rugby GBC ..		Great Britain	318.8	Algiers ..		North Africa
62.5	Long Island (N.J.) W2X		United States	321.9	Brussels (2) ..		Belgium
62.56	London ..		Ontario	325.4	Brno ..		Czechoslovakia
65.93	Rocky Point WAD ..		United States	328.6	Radio Toulouse ..		France
67.11	Soerabaja (YDA) ..		Dutch E. Indies	331.9	Hamburg ..		Germany
68.18	Moscow (RHCK) ..		U.S.S.R.	335.2	Helsinki ..		Finland
69.44	Rugby GDB ..		Great Britain	338.6	Graz ..		Austria
70.2	Khabarovsk RV15 ..		U.S.S.R.	342.1	London Regional ..		Great Britain
73	Quito (HCJB) ..		Ecuador	345.6	Poznan ..		Poland
80	Lisbon CTICT ..		Portugal	349.2	Strasbourg ..		France
84.5	Berlin D4AGE ..		Germany	352.9	Bergen ..		Norway
85.9	Boston WXAL ..		United States	356.7	Valencia ..		Spain
98.68	Priok (YDB) ..		Dutch E. Indies	360.6	Berlin ..		Germany
203.5	Plymouth ..		Great Britain	360.6	Moscow (4) ..		U.S.S.R.
203.5	Bournemouth ..		Great Britain	364.5	Bucharest ..		Roumania
204.8	Pecs ..		Hungary	368.6	Milan ..		Italy
206	Eiffel Tower ..		France	373.1	West Regional ..		Great Britain
208.6	Miskolcz ..		Hungary	377.4	Salonika ..		Greece
209.9	Beziers ..		France	382.2	Lvov ..		Poland
210.7	Alexandria ..		Egypt	386.6	Barcelona (EAJ1) ..		Spain
211.3	Radio LL ..		France	391.1	Leipzig ..		Germany
215.4	Tampere ..		Finland	395.8	Toulouse PTT ..		France
216.8	Radio Lyons ..		France	400.5	Scottish Regional ..		Great Britain
218.2	Warsaw No. 2 ..		Poland	405.4	Katowice ..		Poland
221.1	Basle, Berne ..		Switzerland	410.4	Marseilles PTT ..		France
222.5	Turin (2) ..		Italy	415.5	Munich ..		Germany
222.5	Milan (2) ..		Italy	420.8	Seville ..		Spain
222.6	Dublin ..		Irish F. State	426.1	Tallinn ..		Estonia
224	Bordeaux S.O. ..		France	431.7	Madrid (Espana) ..		Spain
224	Königsberg ..		Germany	437.3	Kiev ..		U.S.S.R.
225.6	Montpellier ..		France	443.1	Rome ..		Italy
230.2	Lodz ..		Poland	449.1	Stockholm ..		Sweden
231.8	Hanover ..		Germany	455.9	Paris PTT ..		France
233.5	Bremen ..		Germany	463	Belgrade ..		Yugoslavia
235.1	Flensburg ..		Germany	470.2	Sottens ..		Switzerland
236.8	Stettin ..		Germany	476.9	North Regional ..		Great Britain
238.5	Magdeburg ..		Germany	483.9	Cologne ..		Germany
240.2	Danzig ..		Germany	492	Lyons PTT ..		France
242	Linz (Klazenfurt) ..		Austria	499.2	Prague (1) ..		Czechoslovakia
243.7	Aberdeen ..		Austria	506.8	Li bon ..		Portugal
245.5	Dresden ..		Germany	514.6	Trondheim ..		Norway
247.5	Stavanger ..		Norway	522.6	Brussels (1) ..		Belgium
249.2	Nurnberg ..		Germany	531	Florence ..		Italy
251	San Sebastian ..		Spain	539.6	Sundsvall ..		Sweden
253.2	Rome (3) ..		Italy	549.5	Rabat ..		Morocco
255.1	Juan-les-Pins ..		France	559.7	Vienna ..		Austria
257.1	Cork ..		Irish F. State	569.3	Grenoble ..		France
259.1	Gleiwitz ..		Germany	578	Riga ..		Latvia
261.1	Trieste ..		Italy	696	Stuttgart ..		Germany
263.2	Lille PTT ..		France	748	Athlone ..		Irish F. State
265.3	Prague Strasnice (2) ..		Czechoslovakia	765	Beromünster ..		Switzerland
267.4	Frankfurt-am-Main ..		Germany	834	Budapest ..		Hungary
269.5	Trier ..		Germany	845	Wilno ..		Poland
270	Freiburg-im-Breisgau ..		Germany	845	Bolzano ..		Italy
271.7	Cassel ..		Germany	1,107	Viipuri ..		Finland
274	Kaiserslautern ..		Germany	1,186	Ljubljana ..		Yugoslavia
276.2	Kharkov (2) ..		U.S.S.R.	1,224	Innsbruck ..		Austria
278.6	Copenhagen ..		Denmark	1,261	Hamar ..		Norway
280.9	Monte Ceneri ..		Switzerland	1,304	Oulu ..		Finland
283.3	Kosice ..		Czechoslovakia	1,339	Moscow ..		U.S.S.R.
285.7	London National ..		Great Britain	1,389	Boden ..		Switzerland
288.5	North National ..		Great Britain	1,442	Budapest No. 2 ..		Hungary
291	West National ..		Great Britain	1,500	Finnmark ..		Norway
293.5	Turin (1) ..		Italy	1,571	Moscow (2) ..		U.S.S.R.
	Horbj ..		Sweden	1,600	Tromsø ..		Norway
	Newcastle ..		Great Britain	1,648	Leningrad ..		U.S.S.R.
	Nyiregyhaza ..		Hungary	1,724	Kalundborg ..		Denmark
	Fecam? ..		France	1,807	Luxembourg ..		Luxembourg
	Moravska-Ostrava ..		Czechoslovakia	1,875	Ankara ..		Turkey
	Madona ..		Latvia	1,935	Warsaw ..		Poland
	Madrid EAJ7 ..		Spain		Motala ..		Sweden
	Falun ..		Sweden		Minsk ..		U.S.S.R.
	Zagreb ..		Yugoslavia		Droitwich National ..		Great Britain
	Bordeaux PTT ..		France		Deutschlandsender ..		Germany
	Tiraspol ..		U.S.S.R.		Istanbul ..		Turkey
	Barl ..		Italy		Radio Paris ..		France
	Scottish National ..		Great Britain		Moscow No. 1 ..		U.S.S.R.
	Leningrad (2) ..		U.S.S.R.		Kaunas ..		Lithuania
	Rennes PTT ..		France				
	Heilsberg ..		Germany				
	Parede ..		Portugal				
	Barcelona (EAJ15) ..		Spain				



**Insure your set against  
condenser  
breakdowns**

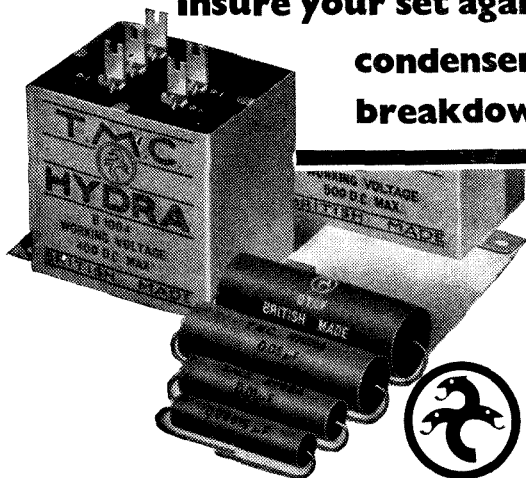

fit  
**T.M.C. HYDRA**  
BRITISH MADE **CONDENSERS**

Write for a copy of the new illustrated price list.

**T.M.C.-HARWELL (SALES) LTD.,**  
Britannia House, 233 Shaftesbury Avenue, London, W.C.2  
(A few doors from New Oxford St.) Telephone: Temple Bar 0055 (3 lines)

Made by TELEPHONE MANUFACTURING Co. Ltd.

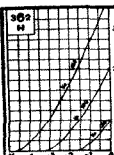

**QUALITY** *above* **ALL ELSE**

INSTALL "362" AND OBTAIN THE BEST POSSIBLE RESULTS FOR YOUR SET (BATTERY OR MAINS).

ENTIRELY BRITISH  
NON-MICROPHONIC HUM FREE

**362 ACPX 4a**  
(9s. 0d. Post Free)

The Truly Super Power Output Triode  
2.5 Watts UNDISTORTED Output.

(See special note in this issue on page 476)

Latest Booklet upon receipt of P.C.

**362 Radio Valve Co. Ltd.,** Stoneham Road,  
London, E.5. Phone: Clissold 1294.



SG. 7/6

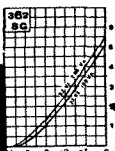

HL2. 3/6

**THE ONLY VALVE WITH  
A 6 MONTHS' GUARANTEE**

**BUILT TO GIVE SERVICE!**

● **PORTABLE RECORDER AND AMPLIFIER**

Complete Band, Public Address, and Recording Amplifier together with parallel action Tracker and specially designed Recording Head. Play-back Pick-up. Fully portable; housed in attractive Leatherette case. Will make perfect records on any type of blank. Supplied with separate Loudspeaker and 30 ft. lead. Carbon Mike on Floor Stand. Made in three models giving from 6 to 15 watts undistorted speech output according to size.

PRICES FROM **25 Gns.**

● **D.P. CONDENSER MICROPHONE**

Condenser Cap unaffected by climatic conditions, adjustable floor stand, chromium plated. **PRICE £25**

**ALL EQUIPMENT GUARANTEED FOR TWELVE MONTHS!**

Write for full particulars from sole makers:—

**THE DENNIS PARISH RECORDING STUDIOS,**  
5, Green Street, Leicester Square, W.C.2.

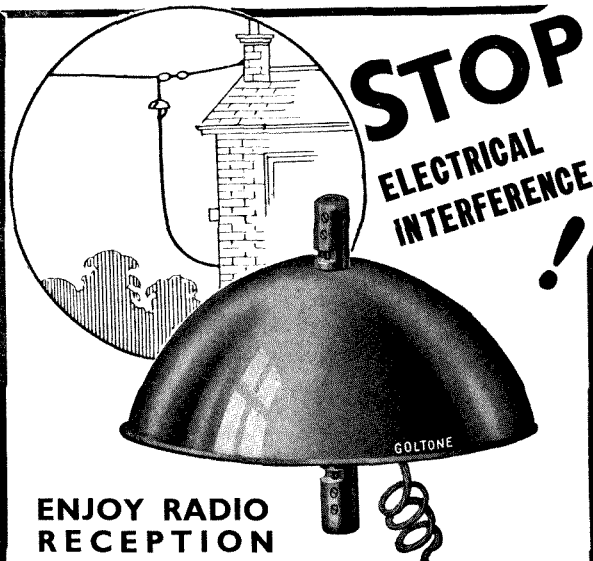

**STOP**  
ELECTRICAL  
INTERFERENCE

**ENJOY RADIO  
RECEPTION**

Fit the "Golitone" Statorformer system.

Over 10,000 of these units have been installed. One to four Radio Sets may be operated from one Aerial. Average Handy-man can install with a screw-driver. Cuts out electrical disturbances without loss of signal strength.

Complete Kit, including Aerial and Receiving Unit, with 50 feet Screened Lead. Price 16/3.

Obtainable from all Radio Dealers. Refuse substitutes.

Interesting pamphlet giving full details, sent on request.

**FREE**  
ON REQUEST  
60-PAGE RADIO  
CATALOGUE



INDISPENSABLE FOR THE  
"CARRIER 3"—



**SUPER  
SENSITIVE  
TELEPHONES**

No wonder the designer of the "CARRIER 3" features Ericsson Telephones. They are simply perfect for the 100 per cent functioning of this fine set.

Three resistances—one price.  
120, 2,000 and  
4,000 ohms.

**12/6**

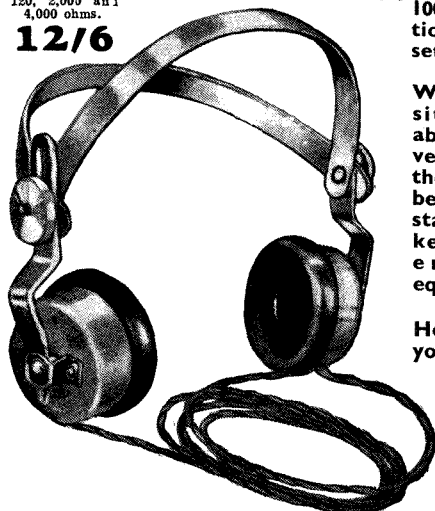

Wonderfully sensitive, comfortable in wear, and very pure in tone, they have come to be regarded as standard for the keen short-wave enthusiast's equipment.

Hook them up to your "Carrier 3."

At all good radio dealers. If you have any difficulty in procuring, write direct to:—

**ERICSSON TELEPHONES, LTD.**  
67-73, Kingsway, London, W.C.2, Eng. Telephones: 3271/3 Holborn.

# New Records for Your

A Review of the Latest Record Releases by

**H**IS MAJESTY'S Silver Jubilee speech broadcast from Buckingham Palace on May 6 has been recorded by His Master's Voice. It is a notable record that should be bought by everyone who possesses a radiogram or gramophone. There is no necessity to make any comment on the recording; it is as perfect as modern technique will allow.

On the other side is an actual recording of scenes along the route of the Royal Procession on Jubilee Day. The mad cheers of the crowd at Temple Bar, the pealing of bells of St. Paul's, the hoofs of the horses and playing of bands together with a commentary make a souvenir of an occasion that those who were there will never forget.

All profits from the sale of this record are being paid to charities nominated by the King. The number is H.M.V. RC2747 and the price is 4s.; it is a double-sided twelve-inch record.

**I** consider that one of the finest records issued of its kind is *State Ball Memories*. It is a selection of old dance music, polkas, veletas and waltzes, played by Marius B. Winter and his orchestra on Decca K756 (2s. 6d.). This is the band that supplied the music for the City of London's Jubilee Ball at the Guildhall, at which the King and Queen were present, and the selection is of tunes that were actually played at the ball. And a very entertaining record it is!

Two works by Eric Coates on Columbia DX690 (4s.) are worth getting. One, *Song of Loyalty* is very attractive with Lance Fairfax, baritone, as soloist. On the other side one of Eric Coates' best and most tuneful works *A Song by the Way*, which is from the suite *Meadow to Mayfair*, is delightfully rendered. Coates needs little recommendation these days and lovers of his music will not be disappointed by the efforts of the big orchestra that performs them.

There is a glut of piano records, but fortunately most of them are

good. The star is Eileen Joyce playing Debussy's *Reflets Dans L'Eau* and an intermezzo and capriccio by Brahms on Parlophone E11279. It is my idea of perfect piano recording. (4s.)

The big piano work of the month is Simon Barer playing Liszt's *Rhapsodie Espagnole* on three sides of two red-label H.M.V. twelve-inchers. On the fourth side he plays Valse Oubliée, also by Liszt. Twelve shillings is a lot to pay for two records, but they are worth every penny. Personally I think the waltz is the real masterpiece. Any music lover will enjoy every groove of it. Make a point of hearing this.

For half-a-crown you can get Mark Hambourg playing Liszt's *Hungarian Rhapsody No. 6* on two sides of a ten-inch H.M.V. (B8319, 2s. 6d.). A master musician playing a master work.

In a lighter vein Tony Lowry plays a selection of serenades by Schubert, Heykens, Toselli, Pierne, Moszkowski and Drigo on Decca F5533. This is well recorded, too, and those who like good fare mixed up should thoroughly enjoy Lowry's playing. (1s. 6d.)

So much for the best records of the more serious kind.

Sidney Torch delights me with another of his "organtricitities" this month. The record is Columbia DB1549 and the two numbers are *Temptation Rag* and *Orient Express*. The first is definitely hot and causes me to wonder how it is possible to get such a

smooth effect with such an ambitious assortment of queer noises and hot rhythm. *Orient Express*—quite an old favourite—is really descriptive of a railway engine, starting, at full speed and slowing up. But I am certain that there is not so much bass in the original as Torch puts in here. It shook my loudspeaker almost to pieces; the record provides a real endurance test for the reproducer (2s. 6d.).

**D**ixon at the Tower Organ, Blackpool, gives a selection from film, *Naughty Marietta* on Regal Zonophone MR1695 (1s.). This film features that famous waltz, *Ah! Sweet Mystery of Life*; Dixon plays as he broadcasts. The choice is yours.

I am very fond, personally, of Ambrose's records. He has issued two this month, both of which you must get. One is his version of



Richard Tauber, the famous tenor, who records for Parlophone, listening to one of his latest records on an H.M.V. model 580 radiogram

# Radiogram

T. F. HENN

(Right) Hildegarde, the well-known American cabaret star, has recorded two hits for Columbia this month

(Below) Lance Fairfax, baritone, sings the solo in the Columbia production of Eric Coates' "Song of Loyalty"—an outstanding twelve-inch disc just released



*Tiger Rag*, at which you must have been amazed when it was broadcast recently, backed with a lively foxtrot, *I've Got A Note*. The other is an arrangement of De Falla's *Fire Dance*—do listen to this because I think you will then realise why so many apparently sober musicians are terribly fond of Ambrose's playing.

Another *Tiger Rag* comes from Nat Gonella and his Georgians on Parlophone F161. This is backed with *Nagasaki*, a quickstep. Hot isn't the word for it; it is one terrific rush from the beginning of one side to the end of the other. Try both *Tigers*; I wonder which you think is the better.

Space is running very short, so here are a few more discs which I think are worth adding to the collection. *The Seaside and Clothes* are discussed by Murgatroyd and Winterbottom (Tommy Handley and Ronald Frankau) on Parlophone R2079. Something funny for once! (2s. 6d.).

I use the word crooners for the next two records—but in no disrespectful sense. Leslie Hutchinson (Hutch) sings *Zing! went the Strings of My Heart* and *If the Moon Turns Green* on Parlophone R2077, and Hildegarde gives us *I Believe in Miracles* and *Listen to the German Band* on Columbia DB1552 (2s. 6d.). I am more amazed at Hildegarde's versatility every time I hear her.

CONTINUING the practice started last month, here are my recommended dance records for the month. Stars denote my idea of their comparative merits:

\**Ah! Sweet Mystery of Life* (waltz), and *'Neath the Southern Moon* (foxtrot), Eddie Carroll and his Music, Parlophone F163, 1s. 6d.

\*\**The Girl With the Dreamy Eyes*, and *Orchids to My Lady* (foxtrots), Jack Hylton and his Orchestra, H.M.V. BD164, 1s. 6d.

\**For Me, For You* and *So Red the Rose* (foxtrots), Billy Cotton and his Band, Regal-Zono MR1687, 1s.

\*\**I've Found a New Baby* (described as an overture) and *China Boy* (foxtrot), Clyde McCoy and his Orchestra, Brunswick 2017, 2s. 6d.

\*\*\*\**Jubilation Rag* (quickstep), and *On the Night of June the Third* (foxtrot), Harry Roy and his Orchestra, Parlophone F158, 1s. 6d.

## You'll

need

this

# Exide

## BATTERY

for

# "THE CARRIER" SHORT WAVE RECEIVER

It is specified by Mr. P. W. Harris

EXIDE

UNSPILLABLE BATTERY

T PE-PO-32 volts, 16 amp. hr. 10/6

And for the P.T.P.3 you need this

EXIDE BATTERY TYPE DMG - C

2 volts, 70 amp. hrs. 12/-

Obtainable from Exide Service Stations and all reputable dealers.

Exide Batteries, Exide Works, Clifton Junction, near Manchester. Branches at London, Manchester, Birmingham, Bristol, Glasgow, Dublin and Belfast.

# In Tune with the Trade

EXAMINER'S Review of the Latest Catalogues

**SEND TO US FOR THESE CATALOGUES!**

Here we review the newest booklets and folders issued by six manufacturers. If you want copies of any or all of them, just cut out this coupon and send it to us. We will see that you get all the literature you desire.

Please indicate the numbers (seen at the end of each paragraph) of the catalogues you want below:—

My name and address are:—

Send this coupon in an unsealed envelope, bearing 4d. stamp, to "Catalogue Service," WIRELESS MAGAZINE, 8-11 Southampton St., W.C.2.  
Valid till July 31.

**W.B. STATION SUPPRESSOR**

**W**B. has other interests in life besides loudspeakers. This well-known concern has sent along a leaflet dealing with a new Dual-station Suppressor—which they call it—which is claimed to provide "a simple and effective way of cutting out annoying cross-talk between broadcast stations."

The gadget is connected between the aerial and the set, and control is effected by means of one knob for tuning and another for switching to either medium or long wavelengths.

If you have a really unselective set, or know of anyone who is troubled with interference through lack of selectivity, I suggest that you take the trouble to ask for one of W.B.'s leaflets describing this new accessory. **466**

**LITTLE DUTCH MILL!**

**R**OTHEMEL has again sent along interesting literature. This time it is about a Dutch Mill battery charger. As its name implies, the charger is worked on the windmill principle. According to the brochure the charger will charge a 6-volt motor battery at a 3- to 15-ampere rate according to the velocity of the wind. It is completely automatic and requires no attention except periodical lubrication.

Besides being of great use for supplying power to those poor unfortunates cut off from civilisation,

the charger can supply sufficient current for illuminating barns, small homes and advertising signs, and it will be found of great use on yachts and similar small craft.

It is rather heavy, weighing 84 lb. I have no details of the price, but if you are at all interested I suggest you write through this service for full details. **467**

**G.E.C. SHADOWBAND RADIOGRAM**

**I** AM always fascinated by reading about the latest improvements incorporated in radio gramophones. G.E.C.'s latest is shadowband tuning. This form of visual tuner is probably the most foolproof of them all.

There is a diamond-shaped patch of light with a band of shadow across the centre. When tuning to a station all that has to be done is to tune until the shadow contracts to its minimum. At that point the station is correctly tuned in.

This G.E.C. Shadowband radiogram incorporates a five-valve superhet chassis which was recently the subject of a test by the Set Selection Bureau who found it gave especially good results.

The complete radiogram costs only twenty-three guineas and is thoroughly recommended to those in search of a model at a very popular price. **468**

**THE ELECTRICAL ENCYCLOPAEDIA**

**W**ITH its usual initiative the Waverley Book Company has produced a sixteen-page folder describing the Electrical Encyclopaedia which is described as a handbook of modern electrical practice. Further the publishers describe it as the only book of its kind.

There is not space here, nor am I going to attempt to describe, the scope of this work, which is in four volumes with a total of 1,480 pages. It deals with electrical engineering in all its forms, including sections on radio and radio servicing and maintenance.

The booklet is certainly worth getting! **469**

**"NINE-TOOB" SUPERHETS**

**T**HERE are still radio fans among us who delight in possessing big multi-valve receivers covering all-wavebands from 12.5 to 2,000 metres. I would draw the attention of these fans to a range of such receivers marketed by Halford Distributors, Ltd.

Not only do these new Halford receivers use a goodly number of valves, but they deliver an output eminently suitable for small public-address work. One model employing eight valves gives an undistorted output of 4.5 watts, while another of the nine-valve class gives 12 watts.

These sets are designed for use both in this country and abroad and are really first-class productions, if I am any judge at reading between catalogue lines. **470**

**A.C./D.C. SUPERHET BY H.M.V.**

**G**LANCING through a pile of literature sent to me by the live publicity manager of H.M.V., I stopped to read a description of the new A.C./D.C. receiver. Judging by the well-advanced circuit used—a three-valve superhet with a fourth as rectifier—I should imagine that station-getting would be one of its big features.

My friends of the Set Selection Bureau seem to think that it is as good as any genuine "four" on the market. They should know; meanwhile, I am going to try one out for myself!

The literature is yours for the asking. **471**

**PUBLIC ADDRESS CATALOGUES**

**I**N another part of this issue you will find a special section devoted to public-address apparatus. If any readers would like catalogues of any of the firms mentioned they are asked to write to the Catalogue Service enclosing the coupon together with a piece of paper containing a list of the names of the firms from which they would be pleased to receive literature.

No stamps need be enclosed with the application.

**PUBLIC ADDRESS**



from a  
12-VOLT  
CAR  
BATTERY



This new outfit fills an increasing need for a mobile and, to a great extent flexible, P.A. System. It delivers 6-8 watts of high quality reproduction on speech and music for a total consumption of 4 1/2 amps. from a 12 volt car battery. The complete outfit including speaker and built-in converter costs only £25 17s. 6d., microphone extra. The speaker may be purchased separately for £5 17s. 6d.



**SAVAGE**  
SOUND

W. BRYAN SAVAGE LTD.  
56/58, CLERKENWELL ROAD - E.C.1.  
Telephone: Clerkenwell 3068

**SPECIFIED**

for  
"L.F.  
OSCILLATOR"

Bulgin Switches are specified again and again in every circuit. You cannot do better than follow the designer's example—use Bulgin for reliability. List No. S.102. **BULGIN TOGGLE ON-OFF SINGLE-POLE SWITCH.** Moulded bakelite. Rating, 3A 250V. Fully insulated. 1/3 each  
List No. S.104. **BULGIN TOGGLE ON-OFF DOUBLE-POLE SWITCH.** Moulded bakelite. Rating, 3A 250V. 2/- each

**BULGIN**  
QUALITY COMPONENTS.

To A. F. Bulgin & Co., Ltd.,  
Abbey Road, Barking, Essex.  
Please send a copy of your 80-Page Technical  
Manual and Catalogue, No. 154 "B".  
I ENCLOSE THREE PENCE IN STAMPS.

Name.....

Address.....

BLOCK LETTERS PLEASE

Notes and Jottings

**H**ERE'S an interesting bit of news from Philips: experimental television transmissions are shortly to begin from Eindhoven on a wavelength of 7 metres. The transmissions are intended primarily for use in developing designs for high-definition receivers, but no doubt they will also serve to stimulate interest among the Dutch experimenters.

From Philco comes an announcement of a new three-valve battery set priced at £7 10s. Model 234, as the new set is known, employs three valves (high-frequency, detec-

*The August "W.M." will be  
on sale Tuesday, July 23.*

tor, pentode output), has a built-in loudspeaker and introduces an interesting type of dial in which a light moves round to illuminate the name of the station tuned in.

A pronouncement from the Ministry of Transport should do much to allay the doubts of those who may have wondered whether the use of a car-radio set might be taken in some circumstances to indicate "lack of due care and attention" on the part of a driver. It seems that the Minister intends to make regulations to eliminate any fire risk, but beyond this sees no present need for restrictions.

All-British: 25 h.p. Daimler car fitted with Philco car radio set, ordered by Polish government for use of Prime Minister Kizlowski.

The number of wireless sets for the blind produced by one firm (Burne-

**FREE ADVICE for SET BUYERS**  
See page 480.

Jones) now approaches the 25,000 mark. The latest one- and two-valve receivers incorporated an improved form of Braille tuning and switching.

Cosmopolitan gathering: the Exide Convention at Eastbourne this year. Attended by delegates from India, New Zealand, Holland, Belgium, France, Germany, Sweden, South Africa, Denmark, Federated Malay States, and China.



The Designer

**SPECIFIES**

**T.C.C.**  
ALL-BRITISH  
**CONDENSERS**

for the

**CARRIER**

- One T.C.C. .0001 mfd. Type 34  
Price 1s. 3d.
- One T.C.C. .0001 mfd. Type S  
Price 1s. 3d.
- One T.C.C. .001 mfd. Type S  
Price 1s. 6d.
- One T.C.C. .01 mfd. Type 34  
Price 3s. 0d.
- One T.C.C. .5 mfd. Type 50  
Price 2s. 4d.

A highly efficient Short Wave Receiver—every component must be above suspicion—must pull its weight. That is why T.C.C. Condensers have been specified. Ever since the first radio receiver T.C.C. have found their place in leading specifications . . . because of **DEPENDABILITY.** Make sure of your results—follow the designer and use T.C.C.

If you are building the L. F. Oscillator described in this issue, insist on T.C.C. for the same reason—**DEPENDABILITY!** There's 27 years specialised research behind every T.C.C. Condenser.

**THE TELEGRAPH CONDENSER CO., LTD.,**  
Wales Farm Road, N. Acton, W.3.

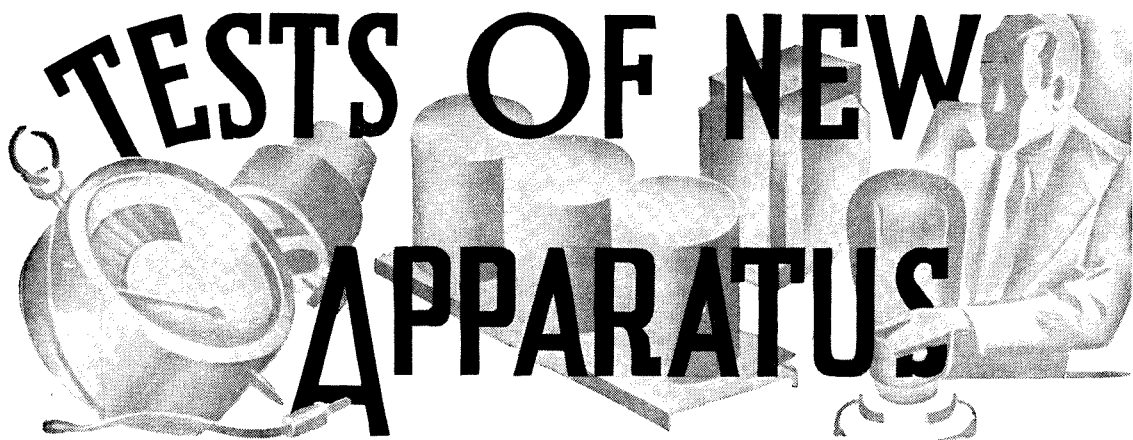

Conducted by the "W.M." Technical Staff

### CLIX "AIRSPRUNG" 7-PIN VALVE-HOLDER

#### Description

A 7-PIN chassis type holder has now been added to the range of Clix "Airsprung" valve holders. These, it may be remembered, comprise three bakelite discs eyeletted together through the medium of suitable spacing washers. The sockets are fixed to the middle disc which is punched with small slots, with the result that the whole forms a perforated resilient support.

The sockets themselves are spirally slit along the surface so that a slight spring action is obtained between the socket and the valve pin.

The valve holders are made in two types providing either for terminal connections or soldering slots.

#### Observations

Examination revealed that the sockets are accurately spaced and the mounting is definitely resilient. At the same time the holder appears quite strong mechanically.

The manufacturers claim that the holders have low losses. This statement refers to the cutting away of the insulating material between the sockets, but it should be realised, of course, that the actual losses depend very largely upon the grade of insulating material used. This, it should be mentioned, appears to be very high grade bakelite sheet which is satisfactory for all ordinary radio purposes.

#### Measurements

Diameter ..  $1\frac{1}{8}$  in. by  $\frac{3}{4}$  in.  
Fixing .. .. . 4-hole

These valve holders are made by Lectro Linx Ltd., 79a Rochester Row, London, S.W.1; price is 1s. 4d., with terminals, and 1s. 1d. without.

### GOLTONE LIGHTNING ARRESTER

#### Description

WARD & GOLDSTONE, LTD. has introduced a lightning arrester and lead-in insulator of simple construction. It takes the form of a composite bakelite moulded assembly which retains two brass rods. The ends are separated by what appears to be a small mica washer with a central hole.

The bottom rod is provided with a wing nut for attaching it to a galvanised bracket, the wing nut being used as a connection for the earth wire. The top wing nut is used for the aerial lead-in.

#### Observations

The appearance is satisfactory and the leakage path is quite long, due to the skirt construction of the moulding. The gap distance is such that there should be a spark-over on heavy static discharges quite apart from those due to lightning. The self-capacity is quite low, as will be seen from the recorded value, and as a result the insulator should be quite satisfactory.

The address of the makers is Frederick Road, Pendleton, Salford, 6, Lancs., and the price of the arrester is 2s. 6d.

#### Measurements

Capacity: 8.5 micro-microfarads.  
Insulation resistance, dry: Substantially infinity.

### 362 A.C.PX4a TRIODE

#### Description

A POWER triode of interesting construction is produced by the 362 Radio Valve Co., Ltd. This is known as the A.C.PX4a.

The valve utilises an unorthodox electrode assembly. A directly-

heated cathode is employed in the form of a triple hairpin filament, the sections being tensioned by means of springs. The electrodes are carried in mica bridges and use is made of a necked bulb fitted with a standard 4-pin base.

Instead of the usual type of anode there is a grid assembly which is electrically connected to an expanded metal formation. This is mounted so that the major surface is at right angles to the normal electrode plane and the assembly is some considerable distance from the filament.

#### Observations

The valve appears to be very rigidly constructed, and we actually had an opportunity of examining an electrode assembly out of the bulb.

Reference to the appended table shows that the constants of the valve are excellent, and it has a high degree of merit. A practical test showed that the valve will dissipate the nominally rated power without overheating, and the valve will also stand appreciable overload. It would appear therefore that the unorthodox construction proves highly satisfactory in practice.

The name and address of the makers are: 362 Radio Valve Co., Ltd., Stoneham Road, E.5. Price of the A.C.PX4a is 9s.

#### Measurements

Filament voltage	.. .. .	4
Filament current	.. .. .	1.1 amperes
Anode current	.. .. .	30 milliamperes
Impedance, nominal	.. .. .	2,000 ohms
" actual	.. .. .	1,750 ohms
Amplification factor, nominal	.. .. .	8
" actual	.. .. .	7
Mutual conductance,	.. .. .	nominal 4 m.a./v.
		actual 4 m.a./v.

# SPECIFIED for the CARRIER

**B.T.S. COMPONENTS** are once again preferred by the leading set designer. Follow the expert and insist on B.T.S. for your CARRIER.

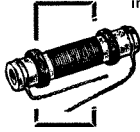

**B.T.S. SHORT WAVE H.F. CHOKES.** Wound on special low dielectric loss former. Connects straight into wiring. **2/9**  
TYPE NO. 103.

**B.T.S. Slow Motion Reaction Condenser** .0002-mfd. Type No. SSC 11. **5/9**

**B.T.S. Short Wave 4-pin Valve Holders.** Set of 3, Type No. 4 CH. **1/6**

● **B.T.S. Short Wave COILS** ●  
SPECIFIED for the  
"W.M." NEW STYLE S.W. ADAPTOR

- No. 1. 13-26 metres 4/- SET OF 4
- No. 2. 24-52 metres 4/-
- No. 3. 46-96 metres 4/6
- No. 4. 90-190 metres 4/6

**16/-**

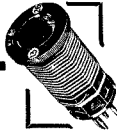

FROM ALL DEALERS  
If any difficulty send direct



Short Wave and Television Specialists  
**BRITISH TELEVISION SUPPLIES, LTD.,**  
BUSH HOUSE, Dept. "W.M.", LONDON, W.C.2

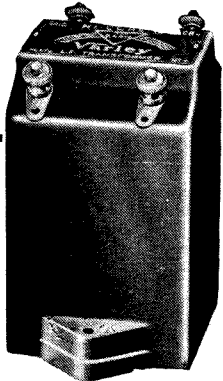

Mr. Paul D. Tyers

the well-known designer, has chosen the famous Nicore Two Transformer shown here, for his "Audio Frequency Oscillator" described in this issue of the Wireless Magazine. Write to Varley of Woolwich for further details and illustrated Catalogue. (Catalogue No. DP2. - Price 11/6)

# Varley

Oliver Pell Control Ltd., Broomfield Rd., Woolwich, S.E.18  
Telephone: Woolwich 2345

## NEWS FROM THE RADIO SOCIETIES

Continued from page 429

### Glasgow and District Radio Club

From Glasgow comes the welcome news of 5-metre activity, and the secretary of the above club (J. Hair, 42 Maryland Drive, Glasgow, S.W.2) informs me that some very interesting tests have been carried out.

Five members climbed Ben Lomond (3,195 ft.) with portable receivers of the super-regenerative type and listened to signals from G6ZX, thirty-five miles distant. Signals were R9 at nearly every halt, and even without aerials they were frequently heard at R6.

#### Power: 8 Watts

A power of only 8 watts was used at the transmitting end, together with a directional aerial.

The club particularly wishes to get into touch with another organisation desirous of obtaining co-operation in 5-metre tests. Contact between Scotland and England has not been established at the time of writing, and that is one of the ambitions of the Glasgow people.

Offers of help from individual readers would also be welcomed by the secretary.

### GETTING THE BEST FROM THE P.T.P. THREE

Continued from page 432

station separation can be performed if the volume control is turned down a trifle and reaction brought up to restore the strength of the signal. It is a simple trick but one well worth learning.

Now let me conclude by making a few remarks about the list of stations heard with the original P.T.P. Three. I promised last month that I would abandon my usual rules, stifle my conscience, and see what sort of a log I could make by counting every station which made some sort of a noise in the loudspeaker—with the result you will see elsewhere. I have only one comment to make: such lists mean just nothing at all!

Like most of its kind, this imposing bag was made by listening night after night, waiting for heterodyne effects to clear off, using a wave-meter for identification, and employing every unfair trick known to the old hand. Still, it may just serve for comparison with similar lists. (Not those published in "W.M.", of course: we do not use these methods.)

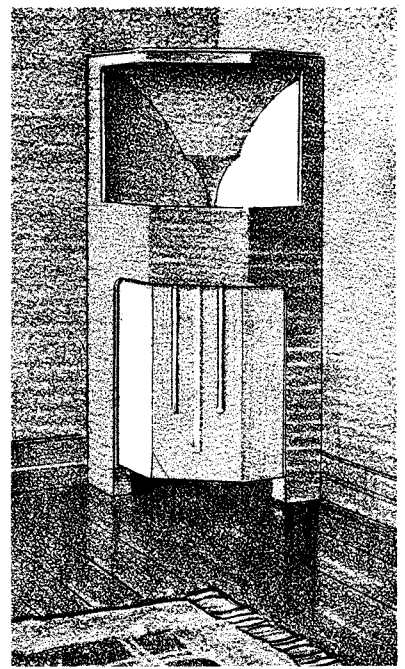

Prices (ex Works) D.C. In Standard form (unfinished wood) £29 5s. Finished, as illustrated, in Walnut £16 extra. Unit only, with twin diaphragm, £15. A.C. Field Supply Rectifiers from £3.

## VOIGT Corner Reflector SPEAKERS

distribute the sound with a substantially uniform characteristic over an angle of 90°. The direct and reverberant characteristics therefore show far less divergence than normal. This is a strong contributory factor in Voigt superlative quality.

Telephone Hillside 1144 for demonstration.

**VOIGT PATENTS LTD.**  
The Courts, Silverdale, Sydenham, S.E.26

Telephone: Sydenham, 4114.  
Registered Office—22 Castle Street, E.C.1

### L. ORMOND SPARKS

**Radio Consultant and Designer**  
(Late Technical Staff Wireless Magazine and Amateur Wireless)

Wishes to inform those requiring:-

**Technical Service and Advice, Quality Receivers and Amplifiers Constructed, Special Diagrams & Blueprints Modified**

that his personal services are now available. Short-wave Receivers, Converters and "W.M." Designs a Speciality.

Postal Queries 1/- (Two questions). Blueprint alterations and Special Diagrams on quotation. Consulting Hours: Monday to Friday 9 a.m. to 6 p.m. Evenings: Monday, Wednesday and Friday, 7 p.m. to 9 p.m.

**9, PHOEBETH ROAD, BROCKLEY, S.E.4.**  
(2 mins. Ladywell Station).

# Power Amplifiers for All Occasions

Continued from page 463

## Dennis Parish Recording Studios.

**A** WELL-DESIGNED range of amplifying and recording equipment with several special features is available from this firm. Among the microphones listed is an interesting condenser type likely to appeal to those who require exceptionally good quality. It is fitted in a floor stand of adjustable height which also incorporates the necessary single-stage pre-amplifier. A less expensive carbon type is also listed at £1 15s., complete with transformer for input coupling to the amplifier.

A very interesting portable equipment is listed at 25 guineas. This can be used as a public-address outfit, giving 6 watts output, or it may be employed for recording work.

Dennis Parish Recording Studios, Leicester House, 5 Green Street, Leicester Square, London, W.C.2.

## Electradix Radios

Those who build their own P.A. outfits should certainly obtain a copy of the Electradix catalogue; it contains a remarkable profusion of moderate-priced equipment of all kinds, including microphones and loudspeakers, and a wide selection of reduced price talkie and general public-address material.

In addition there are a number of complete outfits, such as the "Pentavox" which provides 6 watts output; can be run from either A.C. or D.C. mains; includes loudspeaker, gramophone motor and pick-up, valves and microphone, and costs only £12 10s. The address of the makers is 218 Upper Thames St., London, E.C.4.

## Epoch Reproducers

Epoch loudspeakers are too well known to need more than passing reference, but it is not so widely

realised that the same firm also supplies requisites for P.A. work, including microphones using the moving-coil principle.

## W. Bryan Savage

This firm has a very wide experience of public-address work, and is prepared to tackle almost anything; the catalogue which we have received from them quotes prices for twenty-two different equipments ranging in price from £8 to over £20, with outputs from 3 to 20 watts, and separate leaflets give details of several more, including an interesting "Mobile" equipment intended for use with a car-accumulator input. Microphones and various types of projector and other loudspeakers are also listed.

Specialities of Brian Savage include a range of D.C. to A.C. rotary convertors—very useful in fixing up public-address gear at short notice. Convertors can be obtained for a 12-volt D.C. input to give an output of 50 watts A.C. for the modest sum of £8 17s. 6d.

With input voltages of 24 volts D.C., outputs of from 90 to 180 watts A.C. can be obtained at prices ranging from £10 10s. to £13 10s.

W. Bryan Savage, Ltd., 56-58 Clerkenwell Road, London, E.C.1.

## Scientific Supply Stores

Here are specialists in high-power loudspeakers and their accessories. They supply amplifier equipment, too, but the main interest of their list is, we think, the great variety of types of loudspeakers and horns described.

Other interesting items are the special collapsible steel lattice pylons for supporting large loudspeakers, microphones and loudspeaker units of various kinds.

## Tannoy

Another firm with long experience of amplifier design, construction, and use, which has supplied apparatus to a long list of public and private undertakings in recent years. The Tannoy catalogue contains so many types that it is impossible to give more than the barest outline here. Suffice it to say that the simpler amplifiers range in price from 26 guineas (type G.U.25, complete with gramophone turntable, pick-up and loudspeaker) to 85 guineas for

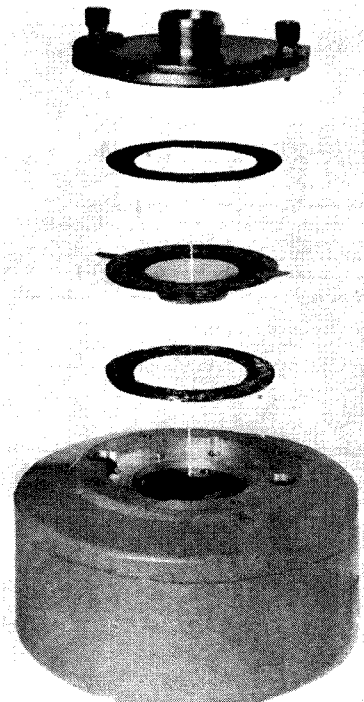

This "exploded" view of the unit of the Parmeko public-address loudspeaker unit shows very clearly how it is constructed. Starting at the bottom and moving up, we have: magnet and housing, felt ring, diaphragm, and the top cover plate and throat connection

WORLD-WIDE SELECTIVITY!

## HYVOLTSTAR

UNIVERSAL ALL-WAVE A.C./D.C. Undoubtedly the finest receiver of this year. Gives complete satisfaction in Tone-Volume-Selectivity and appearance. Operates with success on any mains of any voltage—13 to 2,000 metres, even on 100 volt plants. Hyvoltstar gives you assured reception at full loudspeaker strength from any station in the world including the low wave broadcasts. Write for Leaflet "E" giving full details. Deferred terms arranged.

UNIVERSAL HIGH VOLTAGE RADIO LTD., 28/29, SOUTHAMPTON STREET, STRAND, W.C.2.  
Telephone: TEMple Bar 4985.

## PUBLIC ADDRESS AMPLIFIER

12 WATTS UNDISTORTED OUTPUT straight from 250 volt on A.C. or D.C. Mains without out-down transformers or Baretters. Gives 10/12 Watts output and an anode dissipation of 40/50 watts according to mains voltage. Low resistance output suitable for speech coils of 1.8, 3.0, 5.0, 10.0 and 15.0 ohms—thus covering nearly all standard speakers. Incorporating the famous Ostar-Ganz Universal Valves and therefore suitable for use on A.C. or D.C. Supply, ideal for all public address work. Price 20 Guineas. Smaller amplifiers for home use supplied in kits or assembled from 55 6s. Send for interesting leaflets.

**BUILD** an All Wave Set. Send to-day for particulars of Universal All-Wave Kits for Receivers and Radiograms, and short-wave adaptors and amplifiers incorporating the Famous Ostar-Ganz Universal High Voltage Valves. Costing only from £4 4s.

**CONVERT** your present set into an up-to-date Universal AC/DC All Mains Receiver with Ostar-Ganz High Voltage Valves. The cost is low but the improved results will astonish you. Send us your Set carriage paid for free quotation, or full particulars from Conversion Dept., E. EUGEN J. FORBAT, 28/29 Southampton Street, Strand, W.C.2. Telephone: TEMple Bar 8608.

**OSTAR-GANZ**  
UNIVERSAL HIGH VOLTAGE VALVES



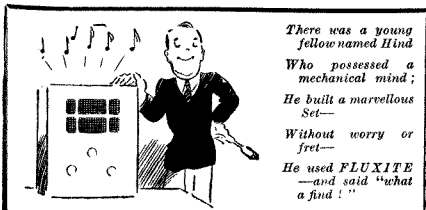

There was a young fellow named Hind Who possessed a mechanical mind; He built a marvellous Set— Without worry or fret— He used FLUXITE —and said "what a find!"

See that FLUXITE is always by you—in the house—garage—workshop—wherever speedy soldering is needed. Used for 30 years in government works and by leading engineers and manufacturers. Of Ironmongers—in tins, 4d., 8d., 1/4 and 2/8.

Ask to see the FLUXITE SMALL-SPACE SOLDERING SET—compact but substantial—complete with full instructions, 7/6.

Write for Free Book on the art of "Soft" Soldering, and ask for Leaflet on CASE HARDENING STEEL and TEMPERING TOOLS with FLUXITE. Dept. 332.

**TO CYCLISTS!** If your wheels are to keep round and true the SPOKES must be TIED with fine wire and SOLDERED at the CROSSINGS. This gives a more rigid wheel. It's simple—with FLUXITE—but IMPORTANT.

**THE FLUXITE GUN** is always ready to put Fluxite on the soldering job instantly. A little pressure places the right quantity on the right spot and one charging lasts for ages. Price 1/6.



ALL MECHANICS WILL HAVE

**FLUXITE**

IT SIMPLIFIES ALL SOLDERING

Fluxite Ltd., Dragon Works, Bermondsey St., S.E.1

## ELECTRADIX

### PUBLIC ADDRESS OUTFITS

Mobile Type complete with batteries and converter in case, mike and P.A. horn speaker, **£28.10**. 3-watt All-mains P.A. Amplifiers outfit and speaker complete, **£12.10**. 5-watt, **£14.10**. 10-watt with gramo, **£20**. 20-watt with gramo, **£27.10**.

Lesdix Piezo-Crystal Mike is now available. A microphone that is as far ahead of the Reis types as a 1935 Superhet is to an old one-valver. Fidelity of reproduction. Level Response. Stability. No battery or transformer, are its features. It costs a little more but is undoubtedly the Mike for the connoisseur. Price **£5.17.6**.

Write for special List "W.M." of amplifiers and mikes.

### ELECTRADIX RADIOS

218 UPPER THAMES ST., LONDON, E.C.4

Telephone: Central 4611

### Specified for the "Carrier"

Amplion Wire-Wound Resistances

A reliable and constant form of resistance means consistent radio enjoyment. Amplion wire-wound resistances are "entirely dependable"—that's why they are specified for the "Carrier."

Wire-wound 50-100,000 ohms.

Higher values, wire ends.

ALL VALUES 1/- EACH

**AMPLION**

AMPLION (1932) LTD

82-84 Roseman St., Rosebery Avenue, London, E.C.1



type G.A.120, giving 50 watts output and capable of driving up to twelve moving-coil loudspeakers of the heavy-duty type.

Full catalogue is obtainable from Guy R. Fountain, Ltd., Canterbury Grove, West Norwood, London, S.E.27.

### Trix Electrical Co., Ltd.

A wide range of portable and fixed sound amplifying equipment is available from this firm. A particularly interesting instrument is the portable amplifier intended for running from a car battery. This is entirely self-contained and includes the necessary rotary converter, and takes only 4½ amperes from a 12-volt battery to give an output of 8 watts. The makers are the Trix Electrical Co., Ltd., 8-9 Clerkenwell Green, London, E.C.1.

### Universal High Voltage Radio, Ltd.

This firm handles the interesting Ostar-Ganz indirectly-heated valves and employs them successfully in amplifiers capable of quite large outputs. This result is achieved by the use of groups of the valves in each power-handling stage, an example being the 10-watt instrument priced at £21; here the first stage contains a single valve, the second uses two in push-pull, while in the output stage there are four, again grouped in push-pull. A test report on this amplifier will appear in a forthcoming issue of "W.M."

A smaller amplifier is also available giving 5-7 watts with a somewhat simpler grouping of valves. All amplifiers made by this firm can be operated on either A.C. or D.C. mains.

The address is Universal High Voltage Radio, Ltd., 28-29 Southampton Street, Strand, London, W.C.2.

### Voigt Patents, Ltd.

Our review would not be complete without a reference to the excellent high-power loudspeakers made by this firm.

Of the coil-driven horn type, they are well known for extreme efficiency (i.e. large volume for a given input) and natural quality. Interesting technical and other details can be obtained from Voigt Patents, Ltd., The Courts, Silverdale, London, S.E.26.

# RESILIENCE

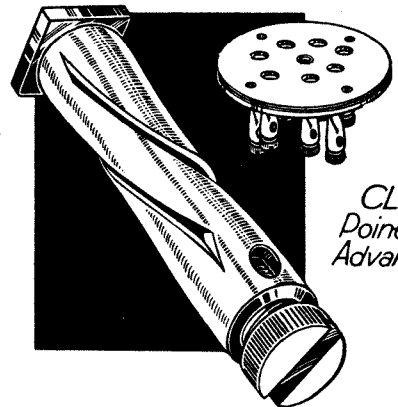

CLIX Points of Advantage

Each individual socket in Clix Chassis Mounting Valveholders is formed with a definite waist which, in conjunction with the helical slots, affords unique resilience and gives perfect contact with every type of valve pin without possibility of collapse.

CLIX Consistently specified by the technical press.

**CLIX**

Write for Folder "W.M." and special leaflet on Clix Heavy Duty A.E. Plugs and Spade Terminals

LECTROLINX, LTD.

79a Rochester Row, London, S.W.1

## 1935 EDITION... FREE!

A new and greatly enlarged edition of "ENGINEERING OPPORTUNITIES" is just off the Press. It describes the easy way in which you may become an A.M.I.C.E., A.M.I.Mech.E., A.M.I.E.E., A.M.I.A.E., A.M.I.W.T., etc., under our "NO PASS—NO FEE" guarantee, and contains the world's widest selection of courses in all branches of Civil, Mech., Elec., Motor, Aero., and Radio Engineering, Television, Building, etc.

If you are earning less than £10 per week, you cannot afford to miss this unique guide to a first-class job.



DON'T DELAY—send for your FREE copy of the Handbook today. No cost or obligation of any kind.

THE BRITISH INSTITUTE OF ENGINEERING TECHNOLOGY  
283 Shakespeare House,  
£9-31 Oxford Street, London.

For Modern

## P.A. EQUIPMENT

at lowest prices

Directional horns and baffles, Circular, square and monoplane sections. Central radiating horns and baffles. Pylons. Transverse current mikes. Transformers, Speaker Units and Amplifiers.

Lists on application. Trade Supplied.

SCIENTIFIC SUPPLY STORES (Wireless) LTD.

Dept. "W.M." 126 Newington Causeway, London, S.E.1 HOP. 4177

When writing to Advertisers please mention WIRELESS MAGAZINE

## BLUEPRINT COUPON

Valid only until July 31, 1935 (or until August 31, 1935, for overseas readers)

### FOR ONE BLUEPRINT ONLY

If you want a full-size blueprint of the set constructionally described in this issue for half price, cut out the above coupon and send it, together with a postal order, to Blueprint Department, WIRELESS MAGAZINE, 8-11 Southampton Street, Strand, London, W.C.2.

This coupon is valid for one blueprint only at the price indicated:—

THE CARRIER SHORT-WAVER (page 408), No. WM 390, price 6d., post paid.

## INFORMATION COUPON

Valid only until July 31, 1935 (or until August 31, 1935, for overseas readers)

If you want to ask any questions, cut out the above coupon and send it, together with a postal order for 1s. and stamped, addressed envelope, to the Information Bureau, WIRELESS MAGAZINE, 8-11 Southampton Street, Strand, London, W.C.2.

Note that not more than two questions may be asked at a time and that queries should be written on one side of the paper only.

Under no circumstances can questions be answered personally or by telephone. All inquiries must be made by letter so that every reader gets exactly the same treatment.

Alterations to blueprints or special designs cannot be undertaken: nor can readers' sets or components be tested.

If you want advice on buying a set, a stamped, addressed envelope only (without coupon or fee) should be sent to the Set Selection Bureau, WIRELESS MAGAZINE, 8-11 Southampton Street, Strand, London, W.C.2.

## THE VALVE FAMILY

Continued from page 434

Now imagine the valve to be mounted on an aeroplane which is intended to be flown automatically along a given course. For the sake of simplicity we will assume that the course is dead North, and that the valve is set along the "lubber line" or fore-and-aft axis of the machine.

So long as the craft keeps to the given course, the electron stream through the valve is equally shared between the two anodes A, A<sub>1</sub>, but as soon as the machine yaws to one side or other the grid, being in fact a magnet, must remain pointing North, and so will swing over towards, say, the anode A.

The electron stream reaching that anode will accordingly increase while the current through the other anode will diminish. The two anodes are connected externally to a differential relay R, which automatically moves the rudder so as to head the aeroplane back into its proper course. In this way the machine can be kept steadily on a given course without requiring any manual control of the steering gear.

## New Sets

By the "W.M." Set Selection Bureau

There is no need to remind readers that the "W.M." Set Selection Bureau is always ready to advise on the purchase of radio receivers. As we have pointed out elsewhere in this issue, the work of the bureau has been extended to cover public-address equipment.

### Next Month's Reviews

Next month the bureau will report on an imposing selection of the latest receivers. For battery-set users there will be a report on the new Pye TP/B, a five-valve self-contained battery superhet. Our preliminary tests indicate that Pye has turned out a very efficient battery super.

We are also hoping to report on a 10-watt A.C./D.C. amplifier, and a new Eddystone A.C. short-waver employing a six-valve superhet circuit. A feature of this set, which is housed in a teak cabinet, is that the makers have used the highest grade components and state that it is suitable for tropical use.

## INDEX TO ADVERTISERS

	Page
Amplion (1932), Ltd. . . . .	479, Back Cover
Blueprints . . . . .	Cover iii
Brit. Inst. of Eng. Tech. . . . .	479
British Insulated Cables, Ltd. . . . .	Back Cover
British Television Supplies, Ltd. . . . .	477
Bulgin, A. F., & Co., Ltd. . . . .	475
Chloride Electrical Storage Co., Ltd. . . . .	473
Correx Amplifiers . . . . .	469
Dubilier Condenser Co. (1925), Ltd. . . . .	469
Electradix Radios . . . . .	479
Ericsson Telephones, Ltd. . . . .	471
Fluxite, Ltd. . . . .	479
Garrard Eng. & Mfg. Co., Ltd. . . . .	401
H.M.V. . . . .	404
Lectro Linx, Ltd. . . . .	479
Partridge & Mee, Ltd. . . . .	469
Parish, Dennis Recording Studios, The . . . . .	471
Practical Mechanics . . . . .	Cover ii
Rothermel, Ltd. . . . .	402
Savage, W. Bryan, Ltd. . . . .	475
Scientific Supply Stores (Wireless), Ltd. . . . .	479
Sparks, L. Ormond . . . . .	477
Telegraph Condenser Co., Ltd., The . . . . .	475
Telephone Manufacturing Co., Ltd. . . . .	471
"Television Today" . . . . .	402
Tungsram Valves . . . . .	402
Universal High Voltage Radio, Ltd. . . . .	478
Varley (Oliver Pell Control, Ltd.) . . . . .	477
Voigt Patents, Ltd. . . . .	477
Ward & Goldstone, Ltd. . . . .	471
Wireless Constructor . . . . .	469
362 Radio Valve Co., Ltd. The . . . . .	471

## FREE ADVICE TO PROSPECTIVE SET BUYERS

To make the most of this free advice service, we ask you to answer the following questions:—

(1) The maximum price you wish to pay, and whether you are prepared to exceed this if there is no suitable set at your desired price.

(2) The locality in which the set will be installed.

(3) The stations required, that is, locals only or a selection of foreigners.

(4) Whether you want an entirely self-contained set or one with external aerial and earth.

(5) Whether battery or mains driven, if the latter, whether A.C. or D.C.

A stamped-addressed envelope for our reply is your only expense. Address your inquiry to Set Selection Bureau, "Wireless Magazine," 8-11 Southampton Street, Strand, W.C.2. Tell your friends about this useful service, exclusive to "W.M."

# "Wireless Magazine" Blueprint Service

These blueprints are full-size. Copies of appropriate issues of "Practical Wireless," "Amateur Wireless," and of "Wireless Magazine" containing descriptions of most of these sets can be obtained at 4d. and 1s. 3d. each, respectively, post paid. Index letters "P.W." refer to "Practical Wireless" sets, "A.W." refer to "Amateur Wireless" sets, and "W.M." to "Wireless Magazine" sets. Send, preferably, a postal order (STAMPS OVER SIXPENCE UNACCEPTABLE) to "Wireless Magazine" Blueprint Dept., Geo. Newnes, Ltd., 8-11 Southampton Street, Strand, W.C.2.

## CRYSTAL SETS

### Blueprints, 6d. each.

Four-station Crystal Set ... 3l.3.34 AW427

## STRAIGHT SETS (Battery Operated)

### Two-valvers: Blueprints, 1s. each.

Iron-core Two (D, QPP) ... 12.8.33 AW396

### Three-valvers: Blueprints, 1s. each.

Transportable Three (SG, D, Pen) ... Feb. '32 WM271

Multi-mag Three (D, 2 Trans) ... June '32 WM283

Fercy Harris Radiogram (HF, D, Trans) ... Aug. '32 WM294

£6 6s. Radiogram (D, RC, Trans) ... Apr. '33 WM318

Simple-tune Three (SG, D, Pen) ... June '33 WM327

Tyers Iron-core Three (SG, D, Pen) ... July '33 WM330

Economy-pentode Three (SG, D, Pen) ... Oct. '33 WM337

All-wave Three (D, 2LF) ... Jan. '34 WM348

"W.M." 1934 Standard Three (SG, D, Pen) ... Feb. '34 WM351

£3 3s. Three (SG, D, Trans) ... Mar. '34 WM354

Iron-core Band-pass Three (SG, D, QP21) ... June '34 WM362

1935 £6 6s. Battery Three (SG, D, Pen) ... Oct. '34 WM371

Graduating to a Low-frequency Stage (D, 2LF) ... Jan. '35 WM373

P.T.P. Three (Pen, D, Pen) ... June '35 WM389

Class-B Three (D, Trans, Class B) ... 22.4.33 AW385

New Britain's Favourite Three (D, Trans, Class B) ... 15.7.33 AW394

Home-built Coil Three (SG, D, Trans) ... 14.10.33 AW404

Fan and Family Three (D, Trans, Class B) ... 25.11.33 AW410

£5 5s. S.G.3 (SG, D, Trans) ... 2.12.33 AW412

1934 Ether Searcher: Baseboard Model (SG, D, Pen) ... 20.1.34 AW417

1934 Ether Searcher: Chassis Model (SG, D, Pen) ... 3.2.34 AW419

F.W.H. Mascot with Lucerne Coils (Det, R.C., Trans) ... 17.3.34 AW337A

Fentaquester (HF, Pen, D, Pen) ... 14.4.34 AW431

£5 5s. Three: De-luxe Version (SG, D, Trans) ... 19.5.34 AW435

Lucerne Straight Three (D, RC, Trans) ... 9.6.34 AW437

"Wireless League" Three (HF Pen, D, Pen) ... 3.11.34 AW451

### Four-valvers: Blueprints, 1s. 6d. each.

Quadradyne (2 SG, D, Pen) ... Feb. '32 WM273

Calibrator (SG, D, RC, Trans) ... Oct. '32 WM300

Table Quad (SG, D, RC, Trans) ... Nov. '32 WM303

Calibrator de Luxe (SG, D, RC, Trans) ... Apr. '33 WM316

Self-contained Four (SG, D, LF, Class-B) ... Aug. '33 WM331

Lucerne Straight Four (SG, D, LF, Trans) ... Feb. '34 WM350

£5 5s. Battery Four (HF, D, 2LF) ... Feb. '35 WM381

The "HK" Four (2HF, D, LF) ... Mar. '35 WM384

"A.W." Ideal Four (2 SG, D, Pen) ... 16.9.33 AW402

Crusaders' A.V.C. 4 (2 HF, D, QP21) ... 18.8.34 AW445

(Pentode and Class-B outputs for above; blueprints 6d. each) ... 25.8.34 AW445A

### Five-valvers: Blueprints, 1s. 6d. each.

Super-quality Five (2 HF, D, RC, Trans) ... May '33 WM323

New Class-B Five (SG, D, LF, Class B) ... Nov. '33 WM340

Class-B Quadradyne (2 SG, D, LF, Class B) ... Dec. '33 WM344

1935 Super Five (Battery Superhet) ... Jan. '35 WM373

## Mains Operated

### Two-valvers: Blueprints, 1s. each.

Economy A.C. Two (D, Trans) A.C. ... June '32 WM286

Consolectric Two (D, Pen) A.C. ... 23.9.33 AW403

## SPECIAL HALF-PRICE OFFER

Blueprint of the following "Wireless Magazine" set described in this issue is obtainable at the special price, given below, if the coupon on facing page is used before July 31.

The Carrier Short-waver ... WM390  
6d.

### Three-valvers: Blueprints, 1s. each.

D.C. Calibrator (SG, D, Push-pull Pen) D.C. ... July '33 WM328

Simplicity A.C. Radiogram (SG, D, Pen) A.C. ... Oct. '33 WM338

Six-guinea AC/DC Three (HF Pen, D, Trans) A.C./D.C. ... July '34 WM364

Mantovani A.C. Three (HF Pen, D, Pen) A.C. ... Nov. '34 WM374

Home-lovers' New All-electric Three (SG, D, Trans) A.C. ... 25.3.33 AW383

S.G. Three (SG, D, Pen) A.C. ... 3.6.33 AW390

A.C. Triodyne (SG, D, Pen) A.C. ... 19.8.33 AW399

A.C. Pentaquester (HF Pen, D, Pen) A.C. ... 26.6.34 AW439

### Four-valvers: Blueprints, 1s. 6d. each.

A.C. Quadradyne (2 SG, D, Trans) A.C. ... Apr. '32 WM279

All Metal Four (2 SG, D, Pen) A.C. ... July '33 WM329

"W.M." A.C./D.C. Super Four My 1935 Radiogram (SG, D, 2 LF) ... May '35 WM386

AC/DC Straight A.V.C. 4 (2 HF, D, Pen) A.C./D.C. ... 8.9.34 AW446

## SUPER-HETS

### Battery Sets: Blueprints, 1s. 6d. each.

Super Senior ... Oct. '31 WM256

1932 Super 60 ... Jan. '32 WM269

Q.P.P. Super 60 ... Apr. '33 WM319

"W.M." Stenode ... Oct. '34 WM373

Modern Super Senior ... Nov. '34 WM375

1934 Century Super ... 9.12.33 AW413

### Mains Sets: Blueprints, 1s. 6d. each.

1932 A.C. Super 60, A.C. ... Feb. '32 WM272

Seventy-seven Super, A.C. ... Dec. '32 WM305

"W.M." D.C. Super, D.C. ... May. '33 WM321

Merrymaker Super, A.C. ... Dec. '33 WM345

Heptode Super Three, A.C. ... Mar. '34 WM359

"W.M." Radiogram Super, A.C. ... July '34 WM366

W.M. Stenode, A.C. ... Sep. '34 WM370

1935 A.C. Stenode (A.C. Superhet) ... Apl. '35 WM385

1934 A.C. Century Super, A.C. ... 10.3.34 AW425

## SHORT-WAVERS (Battery Operated)

### One-valvers: Blueprints, 1s. each.

New Style Short-wave Adapter June '35 WM388

Roma Short-waver ... 10.11.34 AW452

### Two-valvers: Blueprints, 1s. each.

Home-made Coil Two (D, Pen) ... 14.7.34 AW440

### Three-valvers: Blueprints, 1s. each

Experimenter's 5-metre Set (D, Trans. Super-reges) ... 30.6.34 AW438

Experimenter's Short-waver ... 19.1.35 AW463

### Four-valvers: Blueprints, 1s. 6d. each.

"A.W." Short-wave World Beater (HF Pen, D, RC, Trans) ... 2.6.34 AW435

Standard Four-valve Short-waver (SG, D, 2LF) ... Mar. '35 WM383

## Mains Operated

### Two-valvers: Blueprints, 1s. each.

Two-valve Mains Short-waver (D, Pen) A.C. ... 10.10.34 AW453

"W.M." Band-spread Short-waver (D, Pen) A.C./D.C. ... Aug. '34 WM368

### Three-valvers: Blueprints, 1s. each.

Emigrator (SG, D, Pen), A.C. ... Feb. '34 WM352

### Four-valvers: Blueprints, 1s. 6d. each.

Gold Coaster (SG, D, RC, Trans), A.C. ... Aug. '31 WM292

Trickle Charger ... 5.1.35 AW462

### Amplifiers: Blueprints, 1s. 6d. each.

Enthusiast's Power Amplifier ... May & June '35 WM387

## "PRACTICAL WIRELESS"

F.J.C. 3-valve A.V.C. (Transfer Print) ... 4.11.33 FW32

Luxus A.C. Superhet ... 14.10.33 PW33

A.C. Quadpak ... 2.12.33 PW34

Sixty-shilling Three ... 2.12.33 PW34A

Nucleon Class-B Four ... 6.1.34 PW34D

Fury Four Super ... 27.1.34 PW34C

A.C. Fury Four Super ... 10.2.34 PW34D

Leader Three ... 10.3.34 PW35

D.C. Premier ... 31.3.34 PW35B

A.C. Leader ... 7.4.34 PW35C

Atom Lightweight Portable ... 2.6.34 PW36

Ubique ... 28.7.34 PW36A

Four-range Super-mag, Two Summit Three ... 11.8.34 PW36B

Armada Mains Three ... 18.8.34 PW37

Midget Short-wave Two ... 15.9.34 PW38A

All-pentode Three ... 22.9.34 PW39

£5 Superhet Three ... 27.10.34 PW40

A.C. £5 Superhet Three ... 24.11.34 PW43

D.C. £5 Superhet Three ... 1.12.34 PW42

Hall-mark Three ... 8.12.34 PW41

Universal £5 Superhet ... 15.12.34 PW44

A.C. Hall-mark ... 26.1.35 PW45

Battery Hall-mark 4 ... 2.2.35 PW46

Univeral Hall Mark ... 9.2.35 PW47

Hall-mark Cadet ... 23.3.35 PW48

Short-wave Converter-Adapter F. J. Camm's Silver Souvenir (All-Wave Three) ... 13.4.35 PW49

F. J. Camm's A.C. All-Wave Silver Souvenir Three ... PW50

"Wireless Magazine" Blueprint Service George Newnes, Ltd., 8-11 Southampton Street, Strand, W.C.2

# B.I. COPPER EARTHING RODS

for  
**WIRELESS  
APPARATUS**  
(PATENT APPLIED FOR)

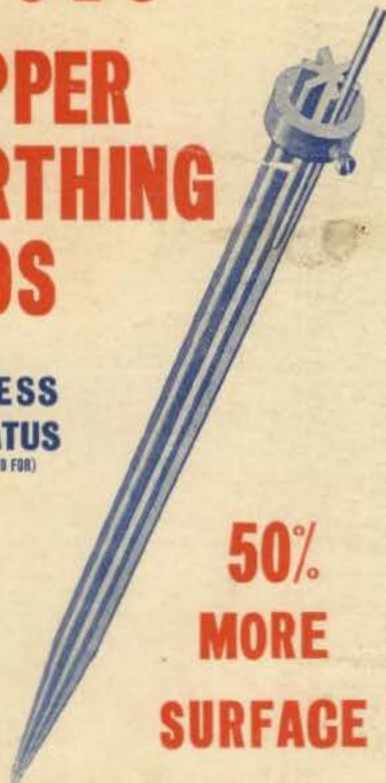

**50%  
MORE  
SURFACE  
AREA**



Here is a line which will interest every one of your customers, an Earthing Rod designed to give low resistance. Made from solid drawn H.C. copper. The multiple fins ensure larger surface area and better contact with the earth than any driving earth of similar diameter and weight on the market; and nearly 50% more contact area than a similar rod of equal diameter. The heavy centre core is strong and not easily turned aside by obstructions. Complete with clamp ring and binding screw. In two sizes 18 in. and 24 in. Write for terms.

**BRITISH INSULATED CABLES LTD.**

**Cablemakers and Electrical Engineers**

**PRESCOT - LANCASHIRE**

Telephone No. PRESCOT 6571

London Office:

Tel. Nos.:

Surrey House, Embankment, W.C.2. Temple Bar 4793-4-5-6

## THE CHOICE OF A LOUDSPEAKER

We most of us know just what we would like, but unfortunately, many of us have to choose that which is nearest to our ideal and is not beyond our purchasing power.

It is for this reason that in this month's advertisement we are listing the complete range of "Amplion" Permanent Magnet Moving Coil Speakers.

Each model is unquestionably wonderful value for money and we stake our reputation upon your being fully satisfied with your choice.

FIRST we call your attention to the latest Amplion—the "Dragon" model which Mr. G. P. Kendall specified for his P.T.P. THREE described in the June issue.

**HERE IS THE  
"DRAGON"**

PRICE  
**29/6**

Specified for the  
**"P.T.P. THREE"**  
described in the  
June issue.



THE "DRAGON"

### HERE ARE THE OTHER "AMPLION" MODELS

Model MC 22	-	(7-inch cone)	-	-	-	32/6
The "Audiola"	-	(9-inch cone)	-	-	-	42/6
The "Lion"	-	(7-inch cone)	-	-	-	47/6
"Lion" Super	-	(10-inch cone)	-	-	-	55/-

All fitted with Universal Transformers.

### AMPLION CABINET SPEAKERS

MC 33	-	-	-	13" x 13" x 5½"	-	-	-	47/6
MC 44	-	-	-	15½" x 13½" x 6½"	-	-	-	63/-
"LION" (7" cone)	-	-	-	12½" x 15½" x 6½"	-	-	-	75/-

All cabinets are of highly polished selected Walnut.

Descriptive Leaflets dealing with each model are obtainable. Just send a Post Card stating which models interest you.

# AMPLION

AMPLION (1932) LTD.

82-84 Rosoman St., Rosebery Avenue, London, E.C.1

Telephone: Clerkenwell 5440-5441