

The Wireless Constructor

Vol. XV.

DECEMBER, 1932.

No. 74.

SPECIAL DOUBLE NUMBER

John Scott-Taggart's
GREAT NEW SET

S.T. 400



1/2-FULL SIZE
BLUE PRINT

EVERYBODY'S
WIRELESS
HANDBOOK

1 BLUEPRINT
FREE

2 FREE GIFTS

All About
Simplified Servicing
Circuits and Components
Round the Square
Installing
...What

CHECKMATE INDIFFERENT RECEPTION

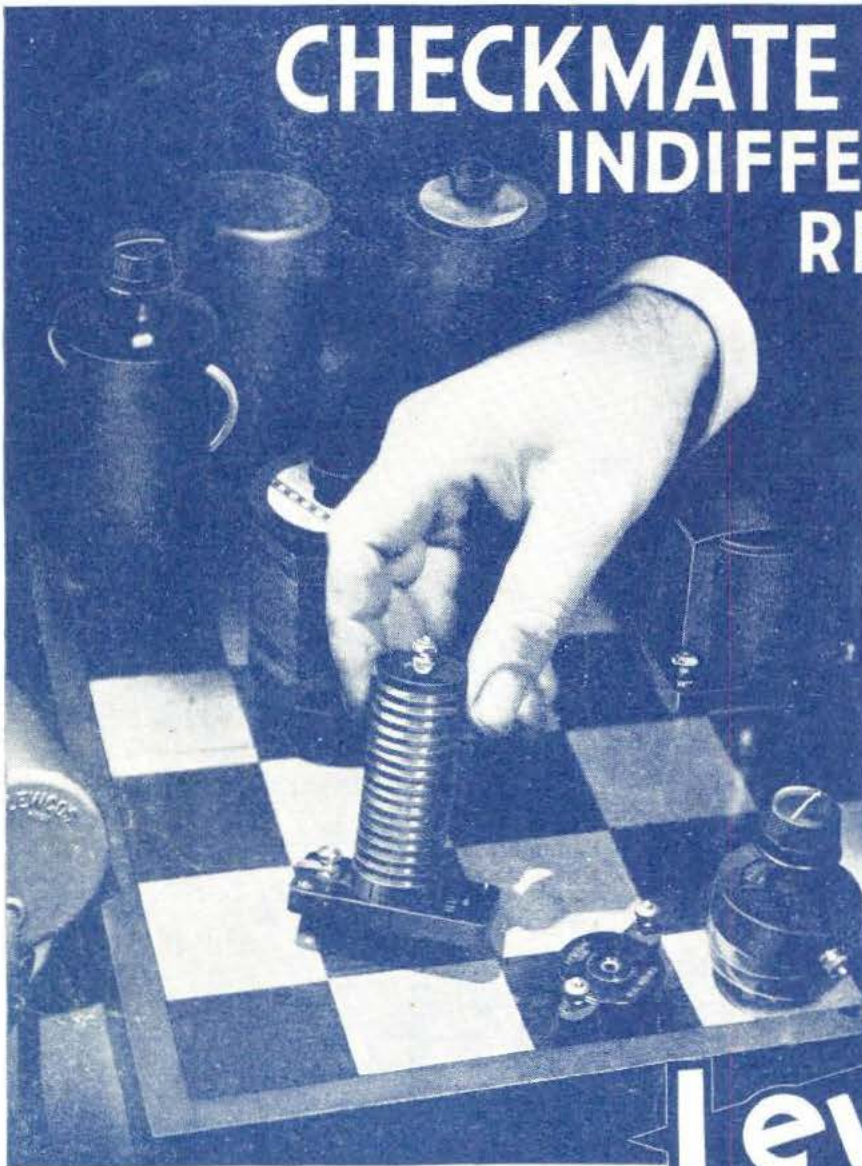

With

Lewcos

REGD

A LEWCOS M.C. H.F. CHOKE (PRICE 2/6) AND A 60,000 OHMS SPAGHETTI RESISTANCE (PRICE 1/6) ARE SPECIFIED FOR THE "S.T.400" DESCRIBED IN THIS ISSUE.

The following Lewcos products are also strongly recommended for use in the construction of the "S.T.400":

The L.F. Transformer. Ref. L.F.T.6.A. Price 10/-.

The Super H.F. Choke. Price 6/-.

2 S.T.400 Coils. Price 5/- each.

1 20,000 ohms and 1 50,000 ohms Spaghetti Resistance. Price 1/6 each.

Radio Components

DESIGNED and constructed by experts using only the finest British materials, Lewcos Components are the standard by which all others are judged.

Distorted and indifferent reception and reproduction are unknown in receivers built with Lewcos Units.

Every type of Radio Component is made by Lewcos and stocked by all reputable dealers.

Descriptive leaflets of the components you need will be supplied on request to Radio Publicity Dept. C.W.

LEWCOS RADIO PRODUCTS FOR BETTER RECEPTION

THE LONDON ELECTRIC WIRE COMPANY AND SMITHS LIMITED, CHURCH ROAD, LEYTON, LONDON, E.10

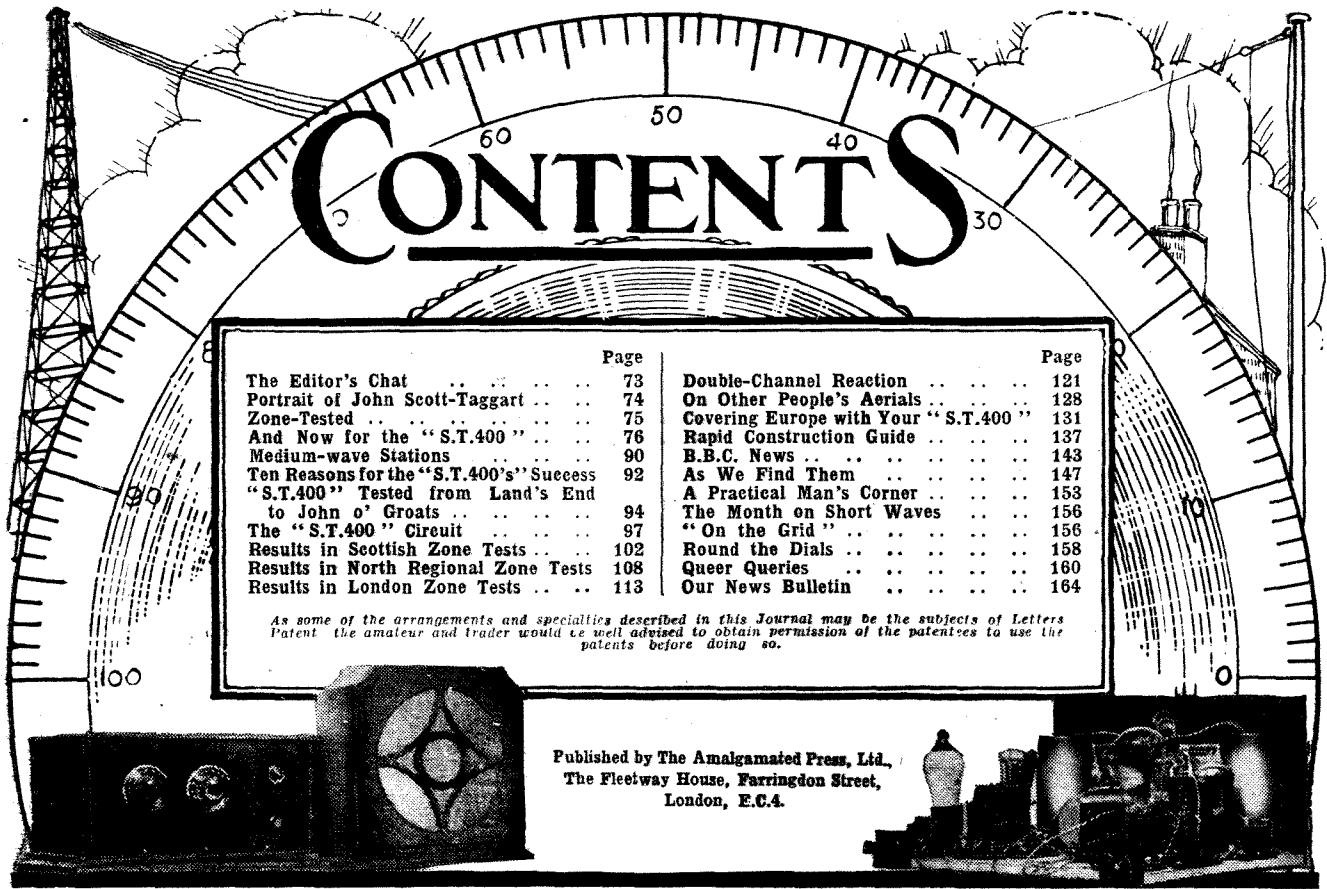

John Scott-Taggart is responsible!!!

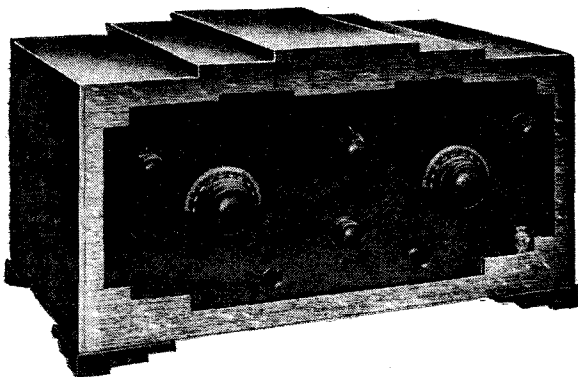

This is the cabinet for the "S.T.400." Modern and attractive, of solid construction from selected OAK with french polish finish.

Your Dealer can supply. Refuse imitations.

PRICE
19/6
Carriage Paid



CLARION
RADIO FURNITURE

28-38 Mansford Street, London, E.2.
Telephone: Bishopsgate 6371.

YES, it was no less than Mr. Scott-Taggart himself who chose this specially designed

CLARION
Radio Furniture
CABINET

for the

"S.T.400"

and you know that he always has the interests of his readers at heart from the efficient, artistic, practical and economical points of view.

An Invaluable Book for THE HOME CONSTRUCTOR



Tracing Trouble

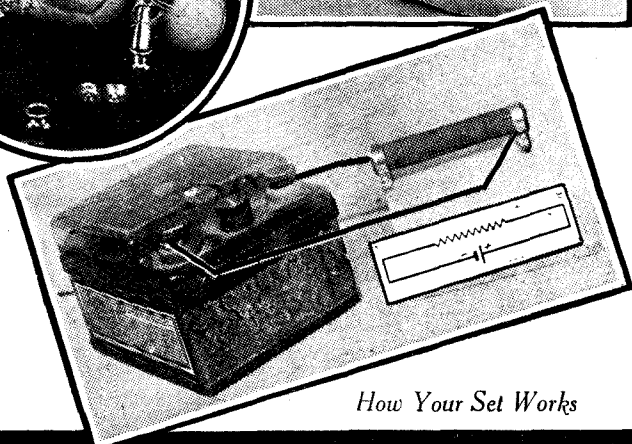
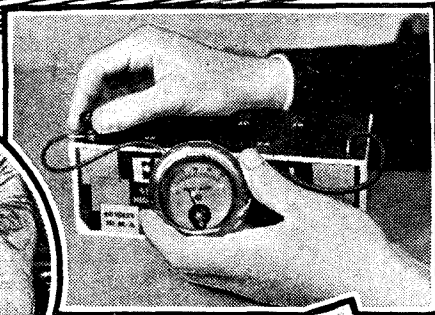
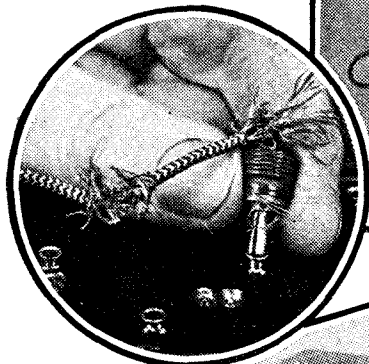

How Your Set Works

Every conceivable aspect of Radio is comprehensively dealt with in the Complete Handbook of PRACTICAL RADIO.

There are articles on the Simplicity of Modern Home Radio, Famous Modern Circuits, Short-Wave Favourites, "The Power They Use" (concerning Radio Stations), etc., etc.

There are pages of advice for those who are thinking about getting a set and exhaustive instructions on putting in a set.

There are hints on modernising old receivers, on tracing trouble, on finding Stations . . .

There are pages of constructional details and complete and lucid explanations of the whole principle of Radio.

So much that will be absolutely invaluable to you, whether you are a radio fan or just one of those who like to "listen-in." Here are just a few of the Contents :

- "What Set Do You Want?"**
- Erecting an Aerial**
- Choosing Your Loudspeaker**
- Your Valves**
- Hints on Super-Hets.**
- The Radio-Gramophone**
- How to Build a Simple Receiver**
- Television Developments**
- How Your Set Works**
- Searching for Stations**
- Separating the Programmes**
- Foreign Broadcasters**
- Radio Distances**
- How to Make an Adaptor for Short Waves**
- Short-Wave Favourites**
- Tracing Trouble**
- etc., etc., etc.**

All this, and much more, for Sixpence—in the

Complete Handbook of
**PRACTICAL
RADIO**

NOW ON SALE 6d.

At all Newsagents and Bookstalls

TRANSFORMER RESPONSE CURVES

and what they SHOULD mean

Once again it is left for Ferranti to draw attention to a practice which many will find misleading.

It is a matter of radio history that, from the first, Ferranti have stressed the importance of response curves as an indication of transformer performance.

To be of any practical value the curve should be simple, clear, and above all, accurate.

There is, however, a tendency to prepare such curves on the basis of the decibel—which is used properly to indicate power ratios. Applied to transformers this method makes the curve of even the poorest transformer approximate to an even, horizontal line, and is likely to prove entirely misleading to the uninitiated.

The Audio Frequency transformer is a voltage-amplifying device, and the object in plotting its curve is to demonstrate the transformer's amplification in relation to frequency. All experience proves that the clearest way in which this can be done is on a vertical linear scale.

The horizontal or frequency scale should, however, be drawn on a logarithmic basis which corresponds to a scale of equal octaves—the natural arrangement on which all music is based.

Ferranti curves are prepared always on the basis indicated. It is a method which is scrupulously fair to the buyer, emphasising, rather than disguising, any defects which may be inherent in the transformer.

Every Ferranti Transformer is guaranteed to give a performance within 5% of the published amplification curve, AND within 5% of every other Ferranti Transformer of the same type. Ferranti are the only transformers so guaranteed.

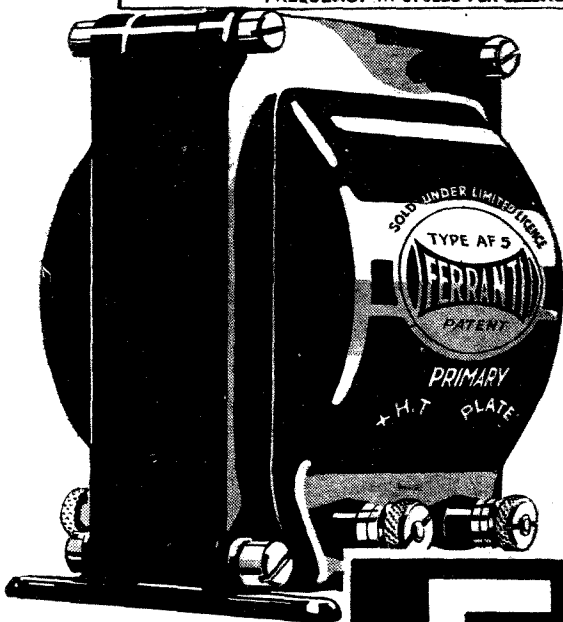
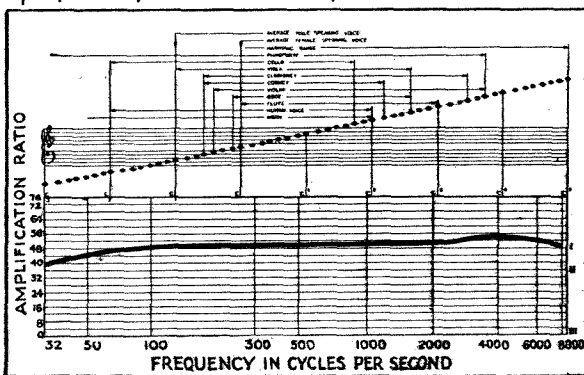

TRANSFORMER PRICES.

A.F.3 Ratio 1/3.5	- 25/-
A.F.4 Ratio 1/3.5	- 17/6
A.F.5 Ratio 1/3.5	- 30/-
A.F.6 Ratio 1/7	- 30/-
A.F.7 Ratio 1/1.75	- 30/-
A.F.8 Ratio 1/3.5	- 11/6
A.F.10 Ratio 1/3	- 6/6

FERRANTI

A.F. TRANSFORMERS

FERRANTI LTD., Head Office & Works: HOLLINWOOD, LANCASHIRE.
London: Bush House, Aldwych, W.C.2.



A momentous discovery by the 'W.B.' research engineers...



The new (patented) "Mansfield" Magnetic System lifts the whole subject of popular moving-coil speakers on to a higher plane. It makes possible a magnet 30% more efficient than the **best cobalt steel magnet of the same weight** and 10% more efficient than a **chrome steel magnet of three times the weight**. It enables a steel chassis to be used without magnetic loss. It eliminates the bug-bear of loss of magnetism.



There is nothing like it in the world. A magnet made on this principle comprises two steel alloys so arranged that the magnetic flux is concentrated in the small area where the work is done instead of being distributed over the whole system. Thus without extra weight or cost sensitivity is materially increased and the range of reproduction improved.



This secret, **now revealed**, accounts for the colossal demand for the new "Mansfield" permanent magnet moving-coil speakers (Senior and Junior) ever since we introduced them at Olympia. We have had to make repeated large extensions to our works and engage and train hundreds of additional workers—and **we can now meet demands for delivery**. Write for booklet then.

Ask your dealer for a demonstration: you will be **AMAZED**.

"Mansfield" Senior (Improved P.M.4) incorporates the new "Mansfield" system and gives astonishing results from any 2-, 3-, or any multi-valve set.

42/- complete with 3-ratio transformer.

"Mansfield" Junior (P.M.5) also incorporates the above.

27'6 complete with 3-ratio transformer.

WHITELEY ELECTRICAL RADIO CO., LTD.,
Dept. C, Radio Works, Mansfield, Notts.

A revolutionary development /

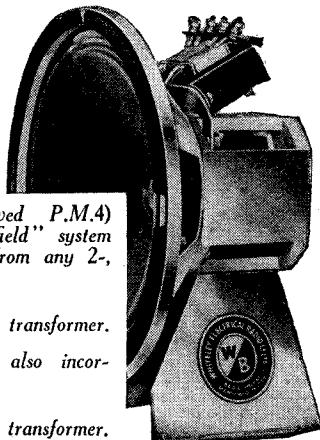

HERE IS A NEW DUBILIER DRY ELECTROLYTIC CONDENSER WITH 6 STAR FEATURES

In the new Dubilier Dry Electrolytic Condenser you have a component of outstanding features. Read for yourself of its six great advantages... and think how completely this Dubilier Electrolytic Condenser fills your every demand in this type of condenser. Then remember... it is made by Dubilier. And that means that it is as efficient as the finest craftsmanship in the industry can make it. It has already been adopted as a standard by leading set makers.

CONSTRUCTION.

★ The condenser consists of a positive and a negative electrode with a separator impregnated with the electrolyte. The whole is mounted inside a sealed aluminium container fitted with a moulded terminal insulator.

VOLTAGE RATING.

★ The maximum peak voltage (D.C. and A.C.) peak on these condensers should not exceed 450 volts. The actual A.C. ripple voltage impressed may be as high as 70 volts r.m.s.

OVERLOADS.

★ If Dubilier Electrolytic Condensers are subjected to a transient over-voltage, they reform on restoration of normal voltage.

LEAKAGE.

★ The D.C. leakage current of these condensers is very low. It drops quickly to a fraction of a milliampere after a short period on load. The recovery after a period of rest is also very rapid.

POWER FACTOR.

★ The power factor of these condensers is about 8%, which is less than half that of the aqueous types.

TEMPERATURE RANGE.

★ The electrolyte in these condensers contains no free water, and since it is not liquid there can be no splashing or creeping of electrolyte from them. It will not freeze and the condensers are undamaged by exposure to any extremes of cold.



4 mfd. Price 4/6
6 mfd. Price 5/-
8 mfd. Price 5/6

**DUBILIER
CONDENSER
CO. (1925) LTD.
Ducon Works
Victoria Road
North Acton, W.3**



Personally tested and recommended by J. Scott-Taggart for the S.T.400

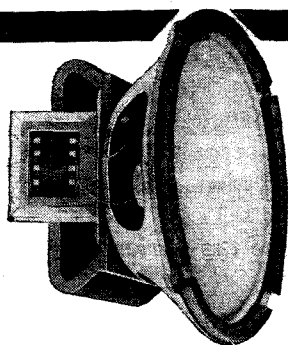

Speech and music with such amazing clarity that the artist seems in the same room. The piano, that acid test of every speaker, tone-true on every note from deepest bass to highest treble. No wonder "ATLAS" Permanent Magnet Speakers are specified for the S.T.400.

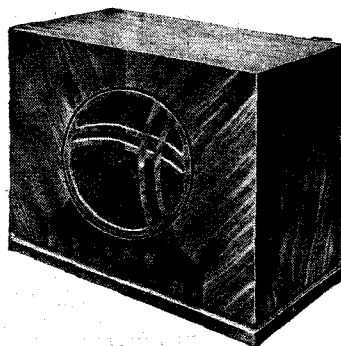

Heavy 35% cobalt steel Permanent Magnet. Moulded one-piece non-resonant diaphragm, suspension and centering disc. Complete with multi-ratio input transformer.

Chassis Type **42/-**
Cabinet Type **70/-**

Or 10/- down each.

Ask for a demonstration now.

There can only be one reason why every noted designer invariably specifies "ATLAS" — — unapproachable performance.

Following his specification of the specially designed "ATLAS" A.C.244/S.T. for the highly successful S.T.300, J. Scott-Taggart now recommends the same Model for his wonderful new S.T.400. No other unit combines such a reserve of hum-free power, such excellent electrical and mechanical design at anything like the price. Follow the author's lead. Insist on "ATLAS," the Olympia Ballot winners, and run your S.T.400 for less than 1/- a year. Ask for a demonstration to-day.

MODEL A.C.244/ST. Specially designed to supply H.T. power from A.C. Mains for J. Scott-Taggart's Receivers. Three H.T. Tappings: 60/80 v. (Min. and Max.), 50/90 v. (Min., Med. and Max.), and 120/150 v. Output 20 m/a at 120 v. Cash Price **59/6**
Or 10/- down.

MODEL A.K.260/ST. As above, but with Trickle Charger for 2, 4, and 6-v. L.T. Accumulators in addition. Cash Price **90/-**, or 10/- down.

MODEL D.C.15/25. For D.C. Mains. H.T. as for A.C.244/ST and A.K.260/ST. Alternative Outputs 15 and 25 m/a at 150 v. by switch. Cash Price **39/6**, or 10/- down.
Westinghouse Rectifiers. Guaranteed 12 months.

"CLARKE'S ATLAS"

MOVING COIL SPEAKERS
& MAINS UNITS

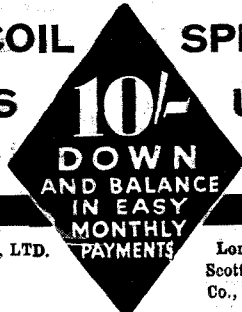

H. CLARKE & CO. (M/cr.), LTD.
PATRICROFT,
MANCHESTER.

London: Bush House, W.C.2.
Scottish Distributors: The G.E.S.
Co., Ltd., 38, Oswald St., Glasgow.

POST COUPON NOW!

Messrs. H. CLARKE & CO. (M/cr.), LTD., George Street, Patricroft, Manchester.
Please send me full details of the complete range of "ATLAS" Mains Units and Moving Coil Speakers.

NAME

ADDRESS

57/12

Specified in the 'ST400'

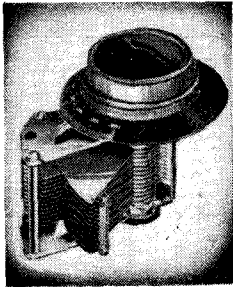

SLOW MOTION CONDENSER. Specially suitable for Superhets. Types S.M.3, capacity '0003; S.M.5, capacity '0005.
Price, each **6/6**

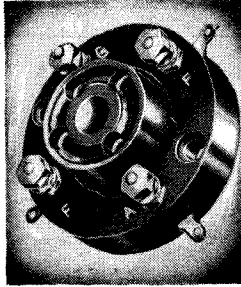

LOTUS VALVE HOLDER. Type V.H.K. Pin.
Price, each **6d.**

Here are five components (some of the LOTUS range of forty-five) which are specified in the "S.T.400," described in this issue.



BATTERY SWITCH. Type B.S.20.
Price **1/6**

LOTUS GUARANTEED COMPONENTS, specified by all the leading designers of the day, offer a short cut to certain success in Set building. They are matched to work in perfect unity, and the result is absolute fidelity and balance. Building a modern Radio Receiver is like forming a Symphony Orchestra—each member and each instrument must be picked for individual performance, and the whole must work in complete harmony and under perfect control. When you build with LOTUS Components, you guarantee the performance of the completed Set.

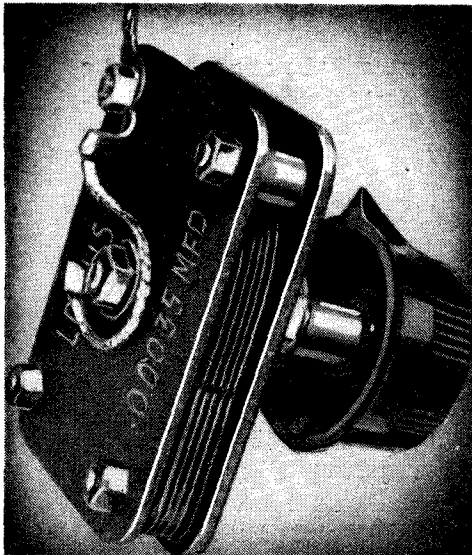

MINIATURE DIFFERENTIAL CONDENSER. Types M.D.15, capacity '00015; M.D.35, capacity '00035.
Price, each **3/-**

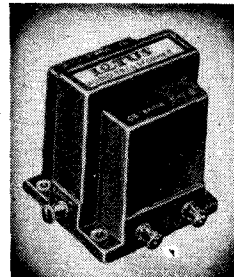

L.F. TRANSFORMER No. 2. Fitted with terminal for earthing the coil. Types A.T.23, ratio 3-1; A.T.25, ratio 5-1.
Price, each **7/6**

Be sure you specify . . .

LOTUS COMPONENTS

GUARANTEED

SEE THE OTHER 40

To LOTUS RADIO LIMITED, LIVERPOOL.

Please send illustrated lists of "Landmark 3" Kit. I enclose 6d. for "Landmark 3" Wiring Chart. (Strike out if not required).

NAME.....
ADDRESS.....

6d. stamp only if envelope is unsealed, and Wiring Chart is not required. W.C.15.11.32.

S.T.400 FREE

Full Size Blue-Print with every Complete Kit and copy "Wireless Constructor," S.T.400 issue

IMMEDIATE DELIVERY FROM STOCK

PILOT AUTHOR KIT

Exact to Mr. John Scott-Taggart's FIRST SPECIFICATION

Guaranteed to fit the Blueprint

This is the List of Parts first specified by Mr. John Scott-Taggart. ANY PARTS SUPPLIED SEPARATELY. If value over 10/- sent Carriage and C.O.D. Charges Paid.

	s. d.
1 PETO-SCOTT low minimum Aerial Coupler, MD.35	3 6
1 LISSEN Hypernik L.F. transformer	12 6
2 COLVERN coils, "S.T.400" type	9 10
2 GROUND .0005 variable condensers, type R.493	15 0
1 POLAR .0003 differential condenser	3 0
1 LOTUS .00035 differential condenser, type MD.35	3 0
2 TELSEN .0003 preset condensers	3 0
1 READY RADIO .0001 differential condenser	2 6
3 BENJAMIN Vibroder valve holders	2 6
1 W.E. Universal valve holder	1 0
2 FURWELL 2-point switches	1 8
1 TELSEN binocular S.G. choke	5 0
1 LEWCO reaction choke	2 6
1 GOLTONE .0003 fixed condenser	5 5
1 GRAHAM-FARISH .006 fixed condenser	1 0
1 DUBILIER .006 fixed condenser, type 670	1 6
2 IGRANIC 2-mid. fixed condensers, Nondu	5 6
1 DUBILIER 1-mid. fixed condenser, type 9200	2 9
1 FERRANTI synthetic grid resistance, 1 megohm, with holder	1 6
1 IGRANIC 1,500 spaghetti resistance	6 6
1 IGRANIC 50,000 spaghetti resistance	1 0
1 IGRANIC 20,000 spaghetti resistance	1 9
1 LEWCO 50,000 spaghetti resistance	1 6
1 BULGIN toggle switch, type S.80	1 6
11 BELLING & LEE terminals, marked	2 3 1/2
1 10" x 6" screen, drilled to specification	1 9
1 PETO-SCOTT baseboard, 16" x 10" with 10" x 7" aluminium foil ready mounted	2 0
1 RED TRIANGLE black ebonite panel, 16" x 7" x 3/16ths, ready drilled	3 3
1 RED TRIANGLE black ebonite terminal strip, 16" x 1 1/2" x 3/16ths, ready drilled	9
1 Each BELLING & LEE anode connector and twin tap plug, together with wire, screws, flex	2 1
1 FULL-SIZE BLUEPRINT, with copy "Wireless Constructor," S.T.400 issue	GRATIS

CASH OR C.O.D. KIT "A" .. £4 15 0

EVERY COMPONENT GUARANTEED 12 MONTHS

Buy by Post! Its Quicker..Send Coupon now and build your self an Exact Duplicate of Mr. John Scott-Taggart's S.T.400

DELIVERED Carriage Paid CASH or C.O.D. KIT "A"

95/-

with FREE Full size Blueprint & Copy Wireless Constructor

KIT "A" DELIVERED CARRIAGE PAID ON FIRST PAYMENT OF

Author's Kit of specified parts including FREE BLUE-PRINT, Ready drilled Panel

8/9

and Foil-covered Baseboard, but less Valves and Cabinet.

Balance in 11 monthly payments of 8/9

OR CASH or C.O.D. £4-15-0. Carriage Paid.

KIT "B"

As Kit "A" but with valves less cabinet
12 monthly payments of 12/3
Cash or C.O.D. £6.14.3

KIT "C"

As Kit "A" but with valves and cabinet
12 monthly payments of 14/-
Cash or C.O.D. £7.11.3

FINISHED INSTRUMENT

S.T. 400, Factory assembled, exact to Mr. John Scott - Taggart's specification ; Aerial Tested, with Valves and Cabinet.

CASH or C.O.D. Carriage Paid.

£9-12-6

or 12 monthly payments of 17/9

EXCLUSIVE FEATURES

- Contains parts only as chosen and first specified by Mr. John Scott-Taggart.
- Officially approved therefore by an authority you can trust implicitly.
- Complete down to the last screw and piece of wire.
- The only Kit of Parts that guarantee strict adherence to Author's first specified components and enables Mr. John Scott-Taggart's published S.T.400 to be duplicated in every way.
- All panels and terminal strips accurately drilled to specification.
- Matched knobs for all panel components.

C.O.D.
All orders over 10/- C.O.D. charges and carriage paid

EASIWAY
NO DEPOSIT. Strict Privacy. No third party collections. We deal with you direct

CASH
All orders over 10/- sent carriage paid

IMPORTANT Parts, Kits, Miscellaneous Components, Finished Receivers or Accessories for Cash, C.O.D. or H.P. on our own system of Easy Payments. Send us a list of your wants. We will quote you by return. C.O.D. orders value over 10/- sent carriage and post charges paid.

FOR PETO-SCOTT'S S.T.400 CABINETS SEE PAGE 172.

PETO-SCOTT CO. LTD. 77 City Rd. London, E.C.1. Telephone : Clerkenwell 9406/7
West End Showrooms : 62 High Holborn, London, W.C.2. Telephone : Holborn 3248

Dear Sirs,—Please send me CASH/C.O.D./H.P.

PILOT AUTHOR KIT, S.T.400 {KIT "A" (less valves and cabinet) £4.15.0.
KIT "B" (with valves less cabinet) £6.14.3.
KIT "C" (with valves and cabinet) £7.11.3.

for which I enclose £ s..... d. CASH/H.P. Deposit.

NAME

ADDRESS

W.C.12/32

The Best S.T.400 Kit whatever the Price

RESEARCH

What difference has two years made to radio reception? What are you missing by using old valves? Mullard research will tell you that. It has given you the finest range of 2-volt valves on the market, valves that give you performance you never dreamed of two years ago: it has discovered a non-vibrating filament and conquered microphony in the P.M.1H.L.; it has produced the P.M.22A—a low-consumption pentode for portables. Now it is looking ahead to experiment and improve to give you still better radio in the future.

The valves specified for the "S.T.400" described in this issue are: P.M. 12A. (Met.), P.M.1H.L. (Met.), P.M.2D.X., P.M.2A. or P.M.202.

Mullard

THE MASTER VALVE

ASK T.S.D.

Whenever you want advice about your set or your valves—ask T.S.D.—Mullard Technical Service Department—always at your service—You're under no obligation whatever. We help ourselves by helping you. When writing, whether your problem is big or small, give every detail. Ask T.S.D.



Advt. The Mullard Wireless Service Co., Ltd., Mullard House, Charing Cross Road, London, W.C.2
Arks.

The WIRELESS CONSTRUCTOR

The EDITOR'S CHAT

"S.T.400"—Unprecedented Success—"He Has Never Let Us Down"

IN this long-awaited issue of THE WIRELESS CONSTRUCTOR, readers will find complete and full details of Mr. John Scott-Taggart's latest set—the "S.T.400."

As our readers know, this is the second of Mr. Scott-Taggart's "national sets for international reception"—his second famous set introduced since his return to radio journalism.

We have read his article many times, and we have studied with the keenest interest the numerous letters sent to us by enthusiastic readers. Above all, we have had the opportunity of hearing the "S.T.400" in action, and we can realise Mr. Scott-Taggart's anxiety that the "S.T.400" shall be built by readers on the strength of those letters so kindly sent to us.

We certainly appreciate his point of view, although we admit it is difficult for us to avoid expressing our own enthusiasm at what is certainly going to prove the most popular four-valve set ever designed for the constructor. As Mr. Scott-Taggart so rightly pointed out in one of his consultations with us, adjectives have become rather absurd when referring to new sets, and one welcomes the restrained attitude our famous contributor has taken up. He has, very wisely, left others to voice the claims of his remarkable receiver.

We remember some months ago that Mr. Scott-Taggart told us that he was at work on a new circuit. "If it pans out as I hope it will," he remarked, "I intend to take it on a great tour of the country to test it out under all conceivable conditions."

Eventually the day came when he said the set was a four-valver, and had more than come up to his expectations. He was ready to meet readers with it, to test it under almost every set of conditions and, if necessary, to make such alterations, either

of a technical or of a practical nature, as might be required.

We think our readers will agree with us that the success of his plan for touring the country with the set was unprecedented in radio journalism, and we confess that we ourselves were amazed at the thoroughness with which he planned his comprehensive scheme of visiting readers in their own homes.

IMPORTANT

A Word to New Readers

This issue of "The Wireless Constructor" is, of course, not a normal one. Some of our most appreciated features, including Mr. Scott-Taggart's own immensely popular "From My Armchair" article, are not included in this special number, but let me assure readers they will return—with added vigour—next month.

"The Wireless Constructor" is published on the 15th of each month, and Mr. Scott-Taggart writes regularly and exclusively for this journal. No wireless enthusiast can afford to miss a single issue.

We venture to say that the full significance of this great tour which "S.T." has now completed cannot be over-estimated. Of course, the immediate results are to be found in the "S.T.400," but the close and intimate contact established between our contributor and the wireless public will undoubtedly prove of the greatest benefit to readers of THE WIRELESS CONSTRUCTOR, for they have in Mr. Scott-Taggart a friend and a counsellor, and one to whom nothing proves too much trouble.

"He has never let us down," a reader wrote in a letter to us recently. Those words represent the public's

estimation of Britain's most original and successful set-designer.

In the case of the "S.T.400," Mr. Scott-Taggart once more breaks new ground and exhibits the inventive talent which has earned for him an international reputation in the wider fields of radio science. On January 15th we referred to Mr. Scott-Taggart's ruthless policy of scrapping ideas which he regards as obsolescent, and we remarked later that he has a disconcerting habit—that is, disconcerting to his colleagues—of being right.

The "S.T.300" broke new ground, and many experts burnt their fingers by indulging in a scepticism which has since made them lose caste among their friends. We forecast a great success in the "S.T.300," but now we prophecy an even greater success for the "S.T.400."

Those who are now three-valve users will be unable to resist the temptation of converting their sets to the "S.T.400," or those who have not yet built one of "S.T.'s" sets will, we feel sure, not hold out much longer when they have read the exciting details of the "S.T.400."

Now is the time to build the set. The controls of the "S.T.400" will look after the future, and the policy of "fewer and better sets," which "S.T." has introduced, is your insurance against chopping and changing.

We believe that the description of the "S.T.400" is one to read and to re-read and re-read again; only on a second or third reading, after you have studied the circuit and examined the opinions of other radio enthusiasts, will you appreciate the full force of Mr. Scott-Taggart's compelling arguments.

We await with confidence the verdict of the wireless constructing public on this great new set.



JOHN SCOTT-TAGGART, M.C., F.Inst.P., A.M.I.E.E.

ZONE-TESTED

"Not tested on one aerial, but proved on scores"

THE "S.T.400," which is fully described in the pages which follow, is the result of many months preliminary work followed by a great tour of readers' aerals.

My object in undertaking the big task of visiting scores of readers in their own homes was two-fold. I desired to carry out tests on experimental versions of the circuit I had developed and obtain first-hand experience of the conditions under which constructors all over the country were working. Incidentally, the closer touch with readers has resulted in several of their practical suggestions being embodied in the design.

My second object was to prove the abilities of the "S.T.400" to my own satisfaction and to enable readers to be informed of how the set performed in their own areas.

The normal procedure for a designer is to carry out his work on his own aerial in London. This may be satisfactory enough for London constructors, but they form only a portion of the vast amateur movement.

A receiver which gets certain results in London will be faced with a very different set of conditions at, say, Land's End, John o' Groats, Glasgow, Leeds, Birmingham, Manchester, Yarmouth, Bristol, Edinburgh, Perth, or Rochdale.

The "S.T.400" is the result of visits to all these places and very many more. Batches of typical letters from readers whom I visited on my flying tour are reproduced. They tell you what the set did.

Much of this work was done in August—one of the worst months for reception. Conditions now are clearly much better. In reading the letters it must also be remembered that each station was identified by position, programme, language, etc., and in every case by a wavemeter whose accuracy was demonstrated to the

reader on innumerable stations.

If the results given in the letters could be obtained in a two-hour test on a strange aerial, you can imagine the performance under leisure conditions. Many stations were necessarily omitted owing to heterodyne interference, spark jamming, or because they were simply closed down when their turn came. Also, stations might come up in strength the next night—but next night meant a new strange aerial and another test.

In addition to tests in outlying districts, I adopted a systematic scheme of dividing the area round each B.B.C. regional twin station into zones. I drew circles at 12½ miles, 25 miles, and 50 miles. Zone "A" is the area within 12½ miles; Zone "B" is 12½ miles to 25 miles;

unprecedented. It has involved much work on my part and high merit in the set. But the results are very real. I cannot imagine a more convincing demonstration of a set's powers.

There is no room for all the letters from each zone in this issue, so they will be published in future numbers. But there will certainly be enough opinions this month to guide you!

I hope you will study the technical articles. There is a great amount of detail in my Rapid Construction Guide and other data given for the benefit of those who wish to waste no time. Only the utterly inexperienced will imagine that detail means difficulty. It actually spells speed and success. The "S.T.400" is an extraordinarily easy set to build.

I expect nearly all S.G.3 and Det.-and-2-L.F. readers will want to convert their sets to "S.T.400's." They will require an extra valve, but they will possess nearly all the components. Owing to the fact that anode-bend detection is used, the H.T. current for the "S.T.400" is actually *less* than that required for a three-valve set!

If you wish, I can show you later how to switch out one valve; most readers, however, told me they would prefer the

set issued as a clean straightforward "four." The set can be fitted with a radio-gram switch and details will be given next month. Meanwhile, I strongly urge readers to build the set as it is, or use two points of the recommended radio-gram switch in place of the toggle.

The "S.T.400" is very amply "decoupled," so that those who wish to do so can operate it off a mains unit.

The set is particularly suitable for giving loudspeaker results when used in conjunction with a short-wave adapter.

J.S.-T.

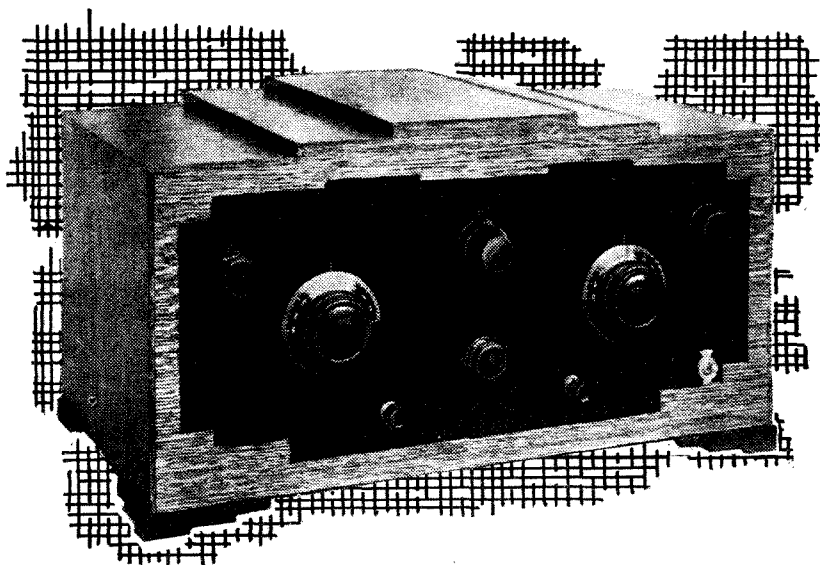

Zone "C" is 25 miles to 50 miles; Zone "D" is over 50 miles.

I then tested the set on readers' own aerals in each zone in each B.B.C. region. The interference from a B.B.C. station requires more combatting the nearer you live to it. By looking at the zone map you can find whether you are an A, B, C, or D man.

By then looking at the letters from that zone you can form an estimate of the results you are likely to obtain. It will be useful, incidentally, to study the set's performance in equivalent zones in the other regional areas.

I believe this scheme is unique and

AND NOW FOR

This is the "S.T.400." The Editor has placed forty-five pages at my disposal in which to tell you about it.

I shall need every page. Why?

Because ten months' solid work lies behind the "S.T.400"; because this receiver has been tested—actually and literally—from one end of Great Britain to the other; because the



circuit introduces new and vital principles.

But chiefly because I am enthusiastic about the set.

"S.T.400."

A simple enough name. My initials. The figure 4 to indicate four valves.

A Special Significance

Rather a meaningless name. A man who heard the set on his own aerial, however, gave it a special significance.

"Four valves and a 100 per cent from each," was his suggestion.

That makes 400, but to me "S.T.400" is just a label. It looks curiously unpretentious side by side with the

names of other sets which seek your patronage, sets often with fancy names and fancier claims.

This is the great season when you and thousands of others will build a set. What is going to be the influencing factor in your choice? The designer's reputation? The look of the set or circuit? The cost? The performance?

Frankly, I don't know. I will wager you have had a good look over the set before beginning to read this description. Which feature of the "S.T.400" has appealed most I cannot say.

But I certainly hope you will not build it merely because I have designed it. Hundreds of letters have reached

A Full Description—

me telling me to "buck up and let's have it," or asking for a strictly private hint of the circuit! (Stamped, addressed envelope enclosed.)

Hard Facts

All these letters contain the expressed determination to build the set. That is confidence. In me. Naturally I'm pleased. Who wouldn't be?

But though I want you to build this set, I want you to do so as a result of studying facts—cold, hard, uncompromising facts.

I intend to give you them. Forty-five pages of them!

I shall tell you the reasons for every line in the circuit, every wire in the set. You will hear my views on modern designs and perhaps disagree with them!

With every set I have invented I have courted controversy, acrimony and criticism. I rejoice in the first, regret the second, and respect the last.

But when my sets cease to arouse controversy, acrimony and criticism I shall have ceased to be a technical rebel. And ceased to count.

Reflex circuits. Multi-valve neutralised sets. One-knob receivers. The "S.T.300." All radical departures in their different ways. No one can accuse me of ever having taken the path of least resistance.

It is so easy to turn out a different-coloured jelly from the same old mould. And it is obvious that many constructors would swallow it.

How else can one explain the construction and reconstruction of the same old circuits?

SPECIAL NOTICE

Next month and in following issues there will be real "service" information and instruction for all interested in the S.T.400 and the principles involved. If you miss a copy you may miss items and hints of the greatest value.

J. S.-T.

THE S.T. 400!

—by *John Scott-Taggart, F.Inst.P., A.M.I.E.E.*

When, on January 15th last, I announced my own policy, I declared that only at long intervals would I issue new designs. "Fewer and better sets" was to be the slogan.

If a designer changes his mind every month, how can the public be expected to form any opinion?

Well, you have seen my methods in practice for ten months. You have had one circuit—the "S.T.300." Even after nearly a year I would still advise you to build it. I have nothing new in mind for a three-valve set. It still represents my conception of a three-valver for national construction.

Remaining Up-to-Date

If you build one of my designs you are certain of this: that it will not commence to become obsolete from the day it is built. You will not suffer the mortification of seeing a new competitive design displacing the set you have barely finished wiring.

Readers are tired of designers hurling a handful of burrs at them in the hope that one will stick.

Mr. Ramsay MacDonald's views on daily newspapers are, I believe, the real views of the wireless constructor. He recently declared: "I like the paper which stands by its colours, which wields a heavy sword deftly, and does not find it necessary to blazon forth daily sensations drawn from the imagination of the office in

order to gain a circulation one day and produce a contradictory sensation so that it may be maintained the next."

Forecast Months Ago

On January 15th I wrote: "I am left unconvinced by announcements of new miracles every week or every few weeks. It will be my intention to break away from this method and to produce only two or three sets a year, each of which will be the result of the most careful preliminary work.

"There will, of course, come up for consideration other types of sets, such as two-valve, four-valve, superhets. But the 'S.T.300' is my screen-grid three."

This undertaking has been more than fulfilled to the letter. And now you are reading about the "four-valve" set forecast nearly a year ago. I have received only one letter from an "S.T.300" user who feels aggrieved that I should design anything new.

Looking Ahead

And I know of not a single "S.T.300" builder who has changed over to another S.G.3 design. No better proof could be offered of the security I try to give you with my sets.

Only yesterday I received a letter from a reader who says: "I have had the 'S.T.300' going for 8 months. It is the first set I haven't scrapped within a month."

It is, of course, essential to design ahead of time; to envisage what the ether will be like not next week or next month, but next year and after.

In my new "S.T.400" you are provided with controls which can make the set progressively more selective as conditions get worse. And you will need them!

Difficulties Increase

Every week one reads of some station planning enormous power, some fiddling little Continental will suddenly develop into an overpowering giant. Unless you have progressively-adjusted controls you may find yourself in the position of a paralysed man watching the rising of a tide which will ultimately drown him.

Those of you with fixed or semi-fixed selectivity are in for trouble. Every piece of news about a foreign station will be bad news



Every Wire Has Been Carefully Planned

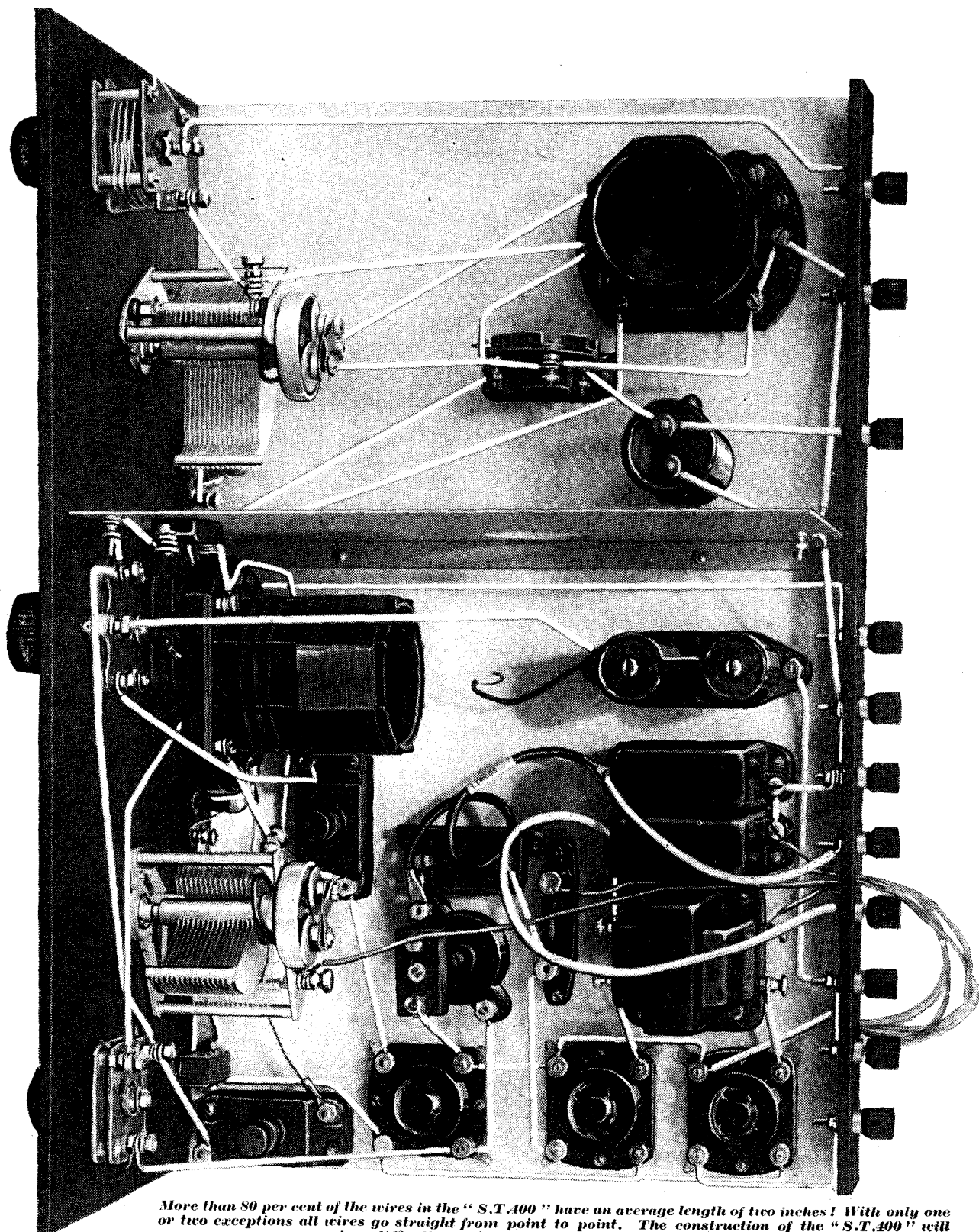

More than 80 per cent of the wires in the "S.T.400" have an average length of two inches! With only one or two exceptions all wires go straight from point to point. The construction of the "S.T.400" will present no difficulty to even those who have never built a set before.

Tone Tested—Zone Tested—Home Tested

for you. Even no news will be bad news. To-day you may be in the frying-pan, but to-morrow you will certainly be in the fire.

The "S.T.400" is designed to save you the discomfort of either position.

My new receiver employs four valves, and, no doubt, the first prejudice I have to overcome is that which has resulted in a welter of three-valve sets. Designers of repute have hated the restrictions imposed upon them by a reluctant public. But hating without daring, or daring without adequately designing, is not enough.

Converting "S.T.300's"

My experience of the wireless-constructing public is that if sufficient reason is given, the average man will gladly consider new departures with an open mind.

I believe that while you study this set you will preserve impartiality until all the facts are before you.

A four-valve set must obviously give better results than a three-valve set by the same designer. As regards the "S.T.300," I have never claimed finality for it. Such an attitude would be absurd. Results, however, have made it a set of national popularity. The "S.T.400" will be even more popular because even more successful.

I cannot imagine anyone who has an "S.T.300" not being tremendously tempted to change over to the new set this winter.

To all with "S.T.300's" I can give this cheering piece of news: The "S.T.400"—new circuit though it is—has been designed expressly to facilitate conversion from the "S.T.300."

The Constructor Considered

This accounts for the superficial similarity of the two sets. To save you money and trouble I have deliberately used the same panel, base-board, terminal strip and screen. I have kept all the holes the same, making one or two additions.

Go through your list of components one by one and you will find that you will be able to use all the "S.T.300" components for the "S.T.400" except for three cheap items.

This is the first time a radically new design has been able to use so much of a previous set. It is partly a piece of extraordinary good luck,

since the new circuit has been developed without the intention of using existing components. But the design part of the set has been carried out deliberately to give the "S.T.300" owner every consideration.

If you own an "S.T.300" you will be astonished at the little extra cost to obtain the greater results. Take the coils, for example.

Instead of being asked to scrap these, you use your existing "S.T.300" anode coil, and the new aerial coil is your "S.T.300" aerial coil with an extra winding which you yourself can put on at a cost of 2d.

If you prefer, you can buy a new aerial coil. Another alternative is as follows: if you used the Colvern make of aerial coil employed in the "S.T.300," you can tie a label (bearing your name and address) to one

WHICH ZONE ARE YOU IN?

The "S.T.400" is remarkable for the fact that no claims for it are made by the author! The universal praise comes from readers—in whose homes the "S.T.400" has been. Read the letters yourself. Apart from outlying towns, tests have been made in zones round each B.B.C. station. Find which zone you are in and study particularly the corresponding letters.

of its screws, hand the coil to your wireless dealer, and the coil will be converted by Colverns. The cost, I understand, is two shillings.

The process of conversion, however, is so simple that I can hardly advise you to spend even this reasonable sum.

Constructors by now must have realised that my concern is only for the reader. If I can save you money on coils, panels, etc., I am determined to do so, and the "S.T.400" is an astonishing example of what this policy can accomplish.

Nor does the industry suffer. It gains because so many more constructors will build the set. Those who have not built the "S.T.300" can go ahead and do so with the full knowledge that conversion to "S.T.400" will be a very simple and inexpensive matter at any time. Thus, while "S.T.300" people are graduating to the "S.T.400," I

expect a great increase in the number of newcomers who will build the three-valve set.

Even if you have an "S.T.300" and fight down your temptation to convert, you can still retain the friendliest feelings for my new set. You will be like a man who owns a bigger and better house next door into which he can move at any time, and into which all his furniture will fit most admirably. But why not move now?

Looking It Over

Incidentally, all the apparatus in both sets is of the best quality, of general usefulness and of permanent value.

And now for an inspection of the "S.T.400."

Probably the first thing you do on being introduced to a stranger is to "look him over"—unobtrusively and politely, but shrewdly.

In the case of a new wireless set, however, the first thing the hardened amateur turns to is the circuit. But few of us fail to give the "outside" of a set a preliminary passing glance.

How long our glance lingers there is an acid test of our experience and judgment. If one were engaging a staff of technical assistants one could do worse than hand a copy of this issue of THE WIRELESS CONSTRUCTOR and ask casually: "What do you think of this new set?"

The turning over of the leaves, the time spent on each page, would be almost as illuminating as the man's spoken judgment.

Performance Details

An ex-french-polisher or budding Mr. Drage would dwell longest on the "look of the thing." A man from the National Physical Laboratory would make straight for the circuit.

There is, of course, no doubt that the vital question which rises to the lips of every experienced constructor is: "What will this set do?"

Look at the descriptions of any dozen sets—take them at random or in any way you like. Comb the articles or pamphlets for details of performance—and you will be astonished at the almost universal absence of any concrete information, and such as is given is generally of purely local value.

Imagine yourself one of a jury before whom these sets are brought

"S.T.400's" Tuned Aerial and Anode Circuits

for trial. Each shows its face and layout, each discloses its circuit and each claims certain results. As regards the technical points, you are willing to listen; willing to be converted if necessary. You will be quick, however, to detect the old conventional circuits and quicker still to steel your mind against the suggestion that by dressing them up in a new suit of clothes they have been made any better.

As regards performance you have the right to have evidence placed before you, not vague generalisations, but concrete facts.

Two Tuning Controls

Meanwhile, you have my set on trial before you. Whether you look deliberately or not, the face-on view will have caught your eye first.

The veriest beginner will see that there are two tuning controls and a number of other "knobs." It is therefore not a one-knob set by any means.

Those who are familiar with my three-valve set, the "S.T.300," will not be frightened by the panel view. On the contrary, they will feel that something special is afoot, and that a new weapon to fight interference is not only being provided in the set, but literally placed in their hands.

Ten months ago set designers were startled to find that I was flying in the face of conventions gradually built up and strengthened in the course of ten years.

"I Believe in Simplicity"

The "one-knob" school of thought—paradoxically founded and fostered by myself in this country—had grown so strong that apparently no one thought of challenging its views. And had they thought they would not have taken the risk.

On January 15th I gave my version of a three-valve set to meet modern conditions. Apart from the circuitual invention, there was an array of knobs on the panel sufficient to startle every "one-knob" thinker.

Nor did I apologise in any way. I boldly justified every control. To the newcomer I may perhaps be permitted to reiterate my attitude on panel controls.

Let there be no misunderstanding on this point. I believe in simplicity. I therefore believe in the ideal of a single control.

It is obviously the thing to aim at. But simplicity of this kind calls for sacrificed selectivity, signal strength, flexibility and general efficiency. And when conditions are such that you need these factors—as you do to-day—well, the idea of "simplicity" is a thing to aim at—but with brick-bats.

My own shower of brick-bats on January 15th caused a lot of controversy. A few designers said: "Thank goodness someone has said what's wanted saying." The majority groaned: "The public won't stand for it."

Well, the public has not only stood for it, but stood up for it.

FITTING THE ANODE COIL

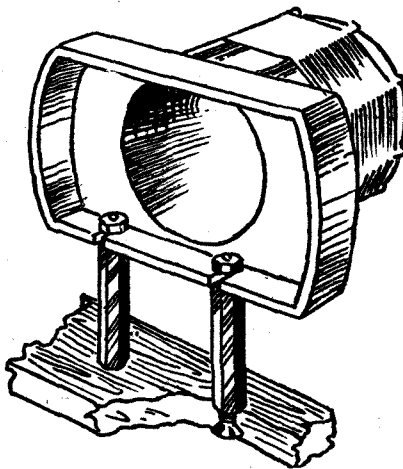

The two pillars supplied free with the anode coil are fixed to the base-board in the manner shown above.

When I introduced the principle of full-range progressively adjustable selectivity, I placed my faith in the ability of the constructing public to read with an open and not a prejudiced mind. In tens of thousands of homes to-day constructors are getting better, clearer, louder radio and from more stations, because they refused to be scared by panel controls which have proved so simple to operate.

In the case of factory-built sets, I appreciate to the full the need to cater for the most dithery of spinsters. But I do not believe that a home-constructor's set should be designed down to the lowest intelligence and the most wavering hand.

One of the essential merits of home construction is that you who are reading this *can* get more out of a set than could the dithering spinster. But if the set has no special controls for getting

extra strength, extra selectivity, extra stations, you are no better off than she!

No doubt I shall in the future design a one-knob set for this journal, but I foresee that if I do some compromise will be involved. The present time calls for a non-compromising attitude. Every pennyworth of value must be obtained for the money we expend, every microwatt of energy from the signals we receive.

More Stations

Therefore, you newcomers who see more knobs on my set than you have been accustomed to are asked to remember that each knob will give you more stations, freedom from mush, better selectivity—in short, better results. Eight or nine years ago sets bristled with knobs (e.g. filament rheostats, variable grid-leaks, etc.). But those knobs virtually did nothing.

But, frankly, the "results first" policy needed pluck. I had to sing out of tune with the whole chorus of modern wireless designers. When the choir is singing "One knob! One knob!" and the congregation is echoing their words (with a few exceptions muttering "two knobs," or even a muffled "three knobs") it needs courage—and a complete disregard for convention—to enter on the holy ground and shout out: "Lots of knobs! Lots of knobs!"

I knew that all faces would turn round and that one of two things would happen: either I would be turned out, or that most of the congregation would leave and allow the choir to sing on alone.

The Same Ideal

The worship of the one-knob fetish has gone far enough. It is a false god. Or, to be fairer, it is worshipped in the wrong way. It has also attracted false prophets. Whenever I see a "detector and 2 L.F." set with one tuned circuit extolled to the skies as a "one-knob" receiver, I am amazed at the exploitability of the non-technical public.

Happily, the technical press is free of such insincerity. If, upon occasion, I disagree with other press designers for the home-constructor, it is with no lack of respect for their work or the ideals they are aiming at. Our ideals are identical.

Circuits Individually Adjustable for Selectivity

What has caused most surprise, I think, is that I who was the high priest of one-dial control in 1926 should have forsworn my gods and set up another religion in 1932. I am at least consistent in this, that I start fashions and not follow them. I was right in 1926, and equally so, you may decide, to-day.

Faked Simplicity

The "simplicity" school has for years not only dominated, but finally domineered over the wireless constructor. No new-born babe has been more coddled and cosseted than has the amateur by kindly but rigid-minded designers.

Since achieving real simplicity is a highly technical and expensive business, largely outside the scope of the

average constructor, there has been an orgy of faked simplicity, and the wireless public is now waking up after a night of regretted intoxication.

"The public won't stand for any complication," has been the belief. Well, the public is now learning its lesson with a vengeance. With stations coming in two or three at a time they are learning that you can no more tour Europe with a so-called simple set than you could satisfactorily tour it on a car with one gear.

There are three million wireless sets in this country giving poor service.

Not only are foreign stations difficult to receive clearly, but even our local stations, dignified ether-shakers that they are, are being badgered. Their majesty and prestige are gone. Even on a

good set, foreigners are snapping at their heels, snarling, chattering, taking vicious bites out of the reproduction and leaving a badly mauled programme.

The Foreign Invader

These shores have not been invaded by the foreigner for nearly a thousand years. But to-day in hundreds of thousands of homes his whistle and chatter is an impudent accompaniment to the voices of our own powerful stations. The most solemn pronouncements of the Prime Minister are cynically ruined by a music-hall song from Paris or a cageful of monkeys from Berlin.

We lost the Battle of Hastings, but need we lose the battle of the ether? No, not if we are properly armed. In 1066 the brave English were no

DESIGNED FOR EFFICIENCY, BUT EASY TO BUILD

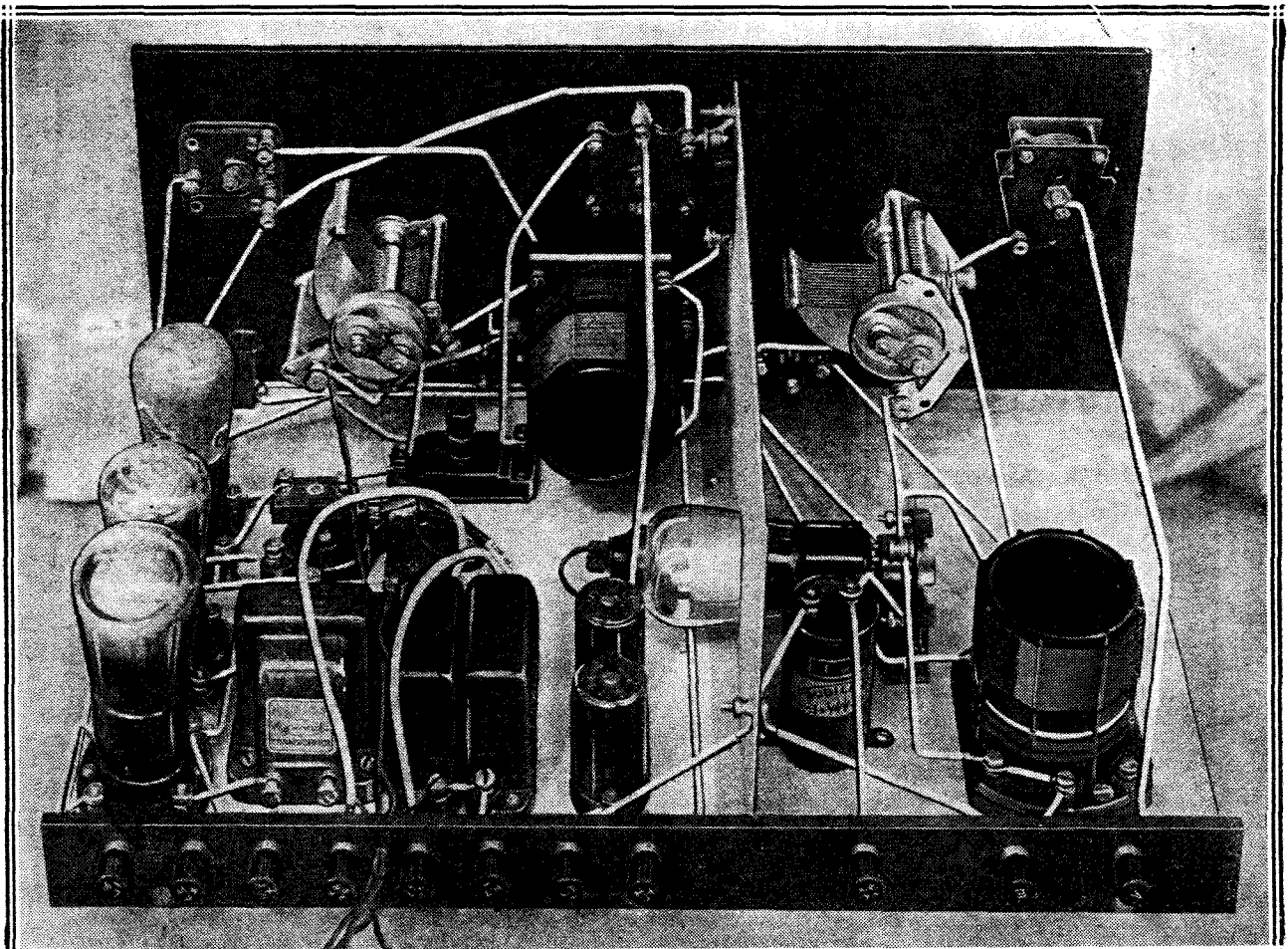

To the left of the anode coil is the Selectivity-Range-Adjuster pre-set condenser, which enables the absolute maximum to be obtained from the S.G. valve and H.T. voltages you are using. An equally important advantage is that the range of selectivity given by the differential anode coupler may be varied. The setting of the Selectivity Range Adjuster occupies about five minutes when first installing the set. Alternatively, it may be screwed up tight and adjusted later at any convenient time.

Introducing a New Invention

match for the better-equipped Normans.

Simplicity did not pay in 1066, and it will not pay to-day. We have to enter the fight against interference armed to the teeth, and in this new set—the "S.T.400"—I give you the weapons.

Separating Stations

I have spoken of foreign stations interfering with our own B.B.C. The extent of this trouble may not be fully appreciated by those readers who live close to a regional station. But in three-quarters of Great Britain the loudest stations are foreign ones!

It has become essential to have a highly selective receiver to get even the B.B.C. satisfactorily. Hundreds of thousands of sets cannot receive Daventry properly without interference from Radio-Paris, which is 19 kilocycles away! All the "regionals" and "nationals" have powerful neighbours which butt in whenever possible.

In London it is a feat to receive Mühlacker. But in other districts the problem is to receive London, so overwhelmingly stronger is the German station.

When the B.B.C. is to be received the foreigners are invaders, but to most of those who read this the greater problem is to cut out the B.B.C. and receive the Continent.

That, of course, was the problem I set myself. Its solution has also proved a settling of the difficulties of the country listener.

Up-to-Date "Foreigners"

We want the foreign stations. Their programmes are as good as—and often better—than our own. Their quality of transmission is often superior to ours. Many foreign stations have been recently built by the same British contractors who supplied the equipment to the B.B.C.—and are more up to date.

We want the foreigners, but only as invited guests to our fireside, not as a gang of quarrelling rowdies bursting into the room. The "S.T.400" admits stations "by ticket only." And the tickets are scrutinised by a system of vigilant "inspectors," so that only what is wanted is reproduced by the loudspeaker. All four valves and their associated components pull their

weight in "washing" and "brushing" the guest, so that, after his rough-and-tumble in the ether, he is finally as well-groomed as when he left the foreign station's studio.

The user of the set, of course, must do his share; but it is a share which he rapidly learns to contribute. It is true there is no shortage of knobs, but three can be ruled out immediately, as they are only wave-change and on-off switches. There are two variable condensers, which probably you are well used to. There is a master reaction control—and is not reaction common to practically all sets?

This leaves three unique selectivity controls which improve the two tuned circuits. One control—the aerial coupler—is seen at the top left of the panel. It varies the degree of selectivity of the aerial circuit only. The

second control is the anode coupler, which governs the selectivity of the anode circuit only.

Those who know the earlier set will see that I have retained the inventions which have made the "S.T.300" so extraordinarily successful. But interest will undoubtedly be focussed on that knob below the anode coupler. And this is what it is for:—

With the "S.T.400" I am introducing a new invention of mine. I have called it Double-Channel Reaction. It is the matured outcome of a principle patented by me a number of years ago. Like many another idea it was before its time. Selectivity was not then a matter of great concern. To-day it is vital.

Original Development

In presenting Double-Channel Reaction I am offering a new and original development which I

HOW UNWANTED INTERACTION IS "FOILED"

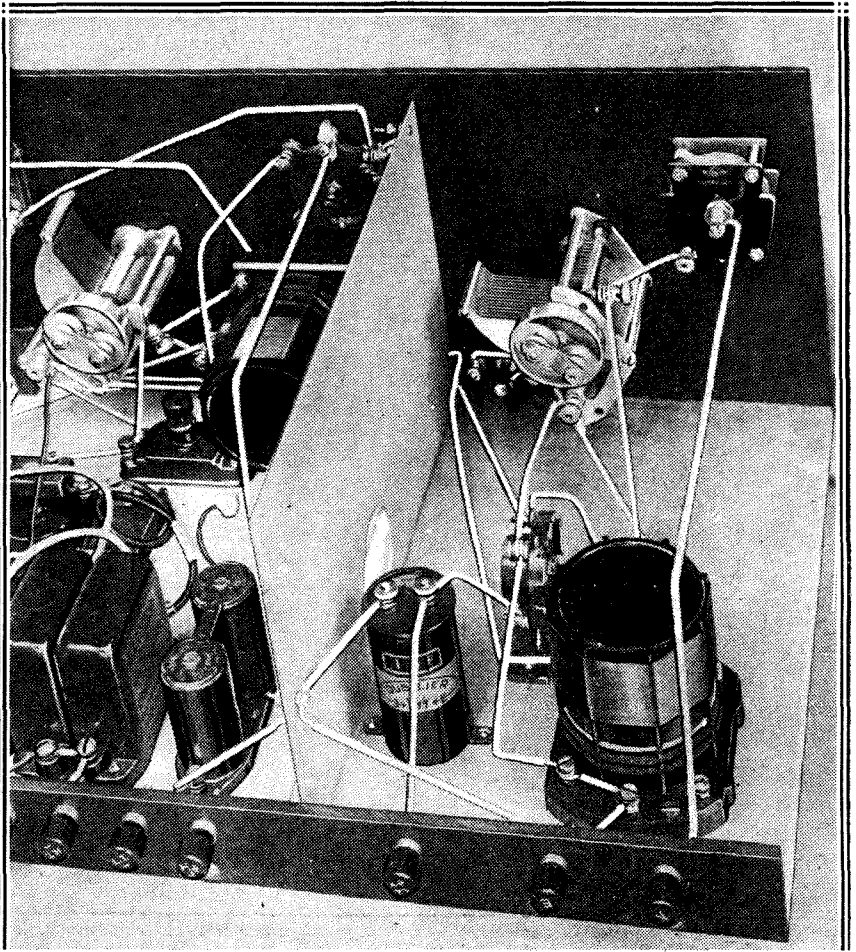

The foil on the baseboard, in conjunction with the vertical screen, effectively isolates the aerial circuit, which attains a new importance in the "S.T.400."

believe to be of the greatest value.

The combination of modern screen-grid valve technique and Double-Channel Reaction enables a far higher degree of selectivity to be obtained than is normally possible on a straightforward set.

My invention is described for the first time in this issue of THE WIRELESS CONSTRUCTOR, and I give the full details under a separate heading.

Meanwhile, I can briefly state that it consists in applying reaction not just once, as is done on radio receivers to-day, but *twice*. Reaction is applied both to the first tuned circuit and also the second, thereby increasing both selectivity and signal strength.

Those who are accustomed to work with two tuning condensers will

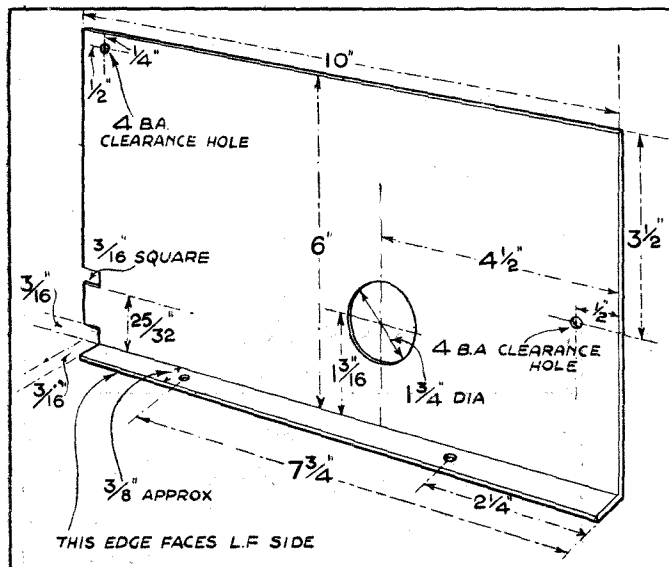
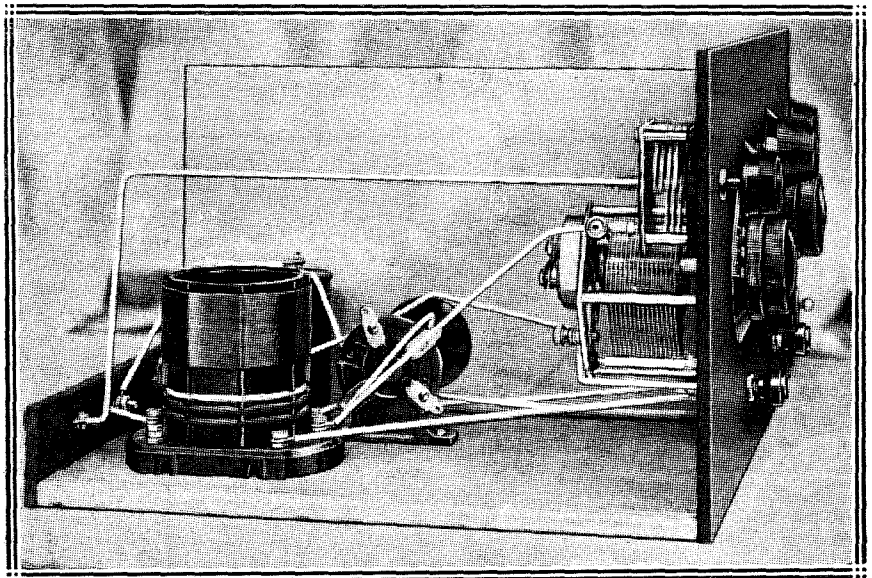

FRONT-DOOR SELECTIVITY

A vital part in the "S.T.400" is played by the aerial circuit, to which reaction is diverted by a unique distributor system.

Coupler is a valuable weapon to have in reserve. I am calling it the Reaction Distributor because by turning it one can balance the reaction in both circuits. The *total* amount of reaction is governed by the Master Reaction Control—the knob at the top right of the panel.

Those who are familiar with the "S.T.300" will see that the Reaction Distributor is the only additional control. The value of the others has already been proved up to the hilt.

I have spoken a good deal about the "simplicity" fetish and where it has led us. But there is one very important point about my own policy which I have not mentioned.

"Could Not Go Wrong"

It is this—and I would like every reader to note its importance: every single control in the set may be left untouched, if the reader desires. The "S.T.400" will then become a very good ordinary receiver. Tuning is then carried out on the two dials. Even the reaction knob may be left at zero and signals at excellent strength will be obtained.

If a person entirely new to radio were handed the "S.T.400" I would put all the controls to "normal," and he could not go wrong.

This is of vital importance to the beginner. If he sets everything to normal, the set will work from the moment he joins up the batteries. From that starting point he can leisurely try the effect of any control. He will learn rapidly how to get more strength and more selectivity; how to control in an instant the

know that ordinarily the tuning on the first circuit is flat, while that on the second is sharper, due to the reaction applied to it. By using my Double-Channel Reaction invention you can get very sharp selectivity on both circuits.

By its means I have received Wilno with but the slightest interference from two groups of "common waves," one on either side. By a slight turn of the dials either group of common waves could be received at full loud-speaker strength.

If you examine the official list of stations you will find that this feat involves a separation of only three kilocycles!

A Startling Example

I quote this example to show what can be achieved by Double-Channel Reaction. It represents the best that

can be done on the "S.T.400." In actual practice no one wants such a separation, and stations closer than 9 kilocycles are not intended to provide entertainment except to the populace in the neighbourhood of the stations.

I have demonstrated the Wilno or equivalent test to readers as a rather startling example of the possibilities latent in Double-Channel Reaction. The 9-kilocycle separation tests, however, form the basis on which one judges the ease of handling, selectivity and quality of reproduction of a set. How Double-Channel Reaction, together with other of my patented inventions, has fared under different conditions may be estimated from the letters of readers in this issue.

I wish to keep technicalities in a separate department, but even from this brief account you will realise that the extra control below the Anode

Britain's First Zone-Tested Set

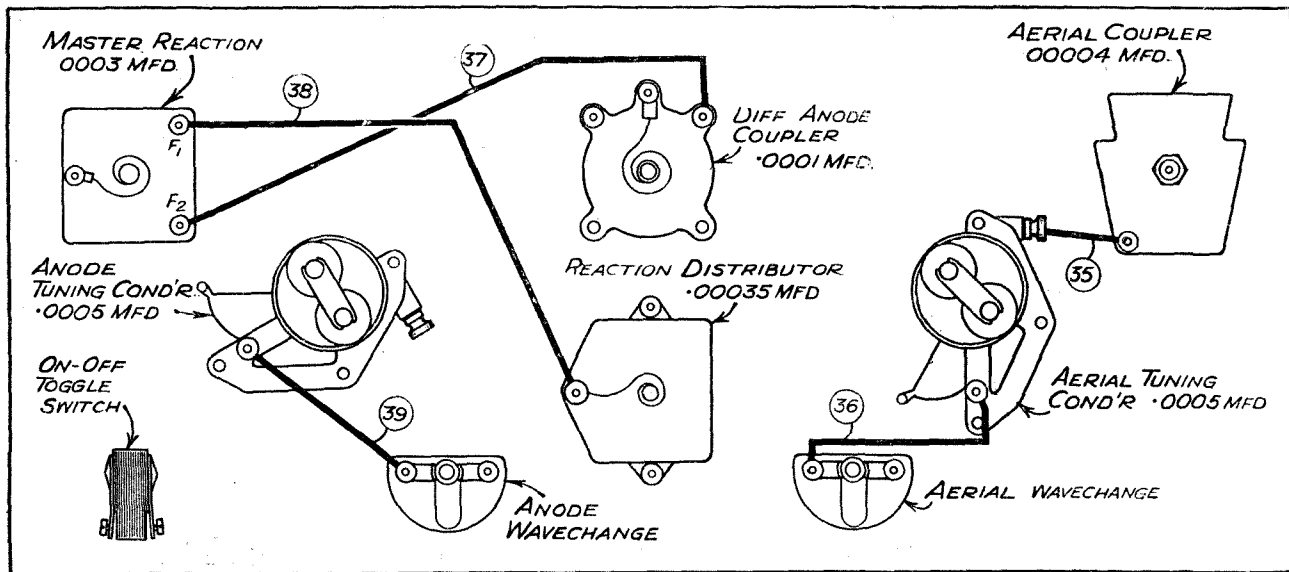

Before joining the panel to the baseboard, prepare wires for later connection to the toggle switch, viz. (12), (11), and (10). Full details for this will be found under (Q) in the accompanying Rapid Construction Guide.

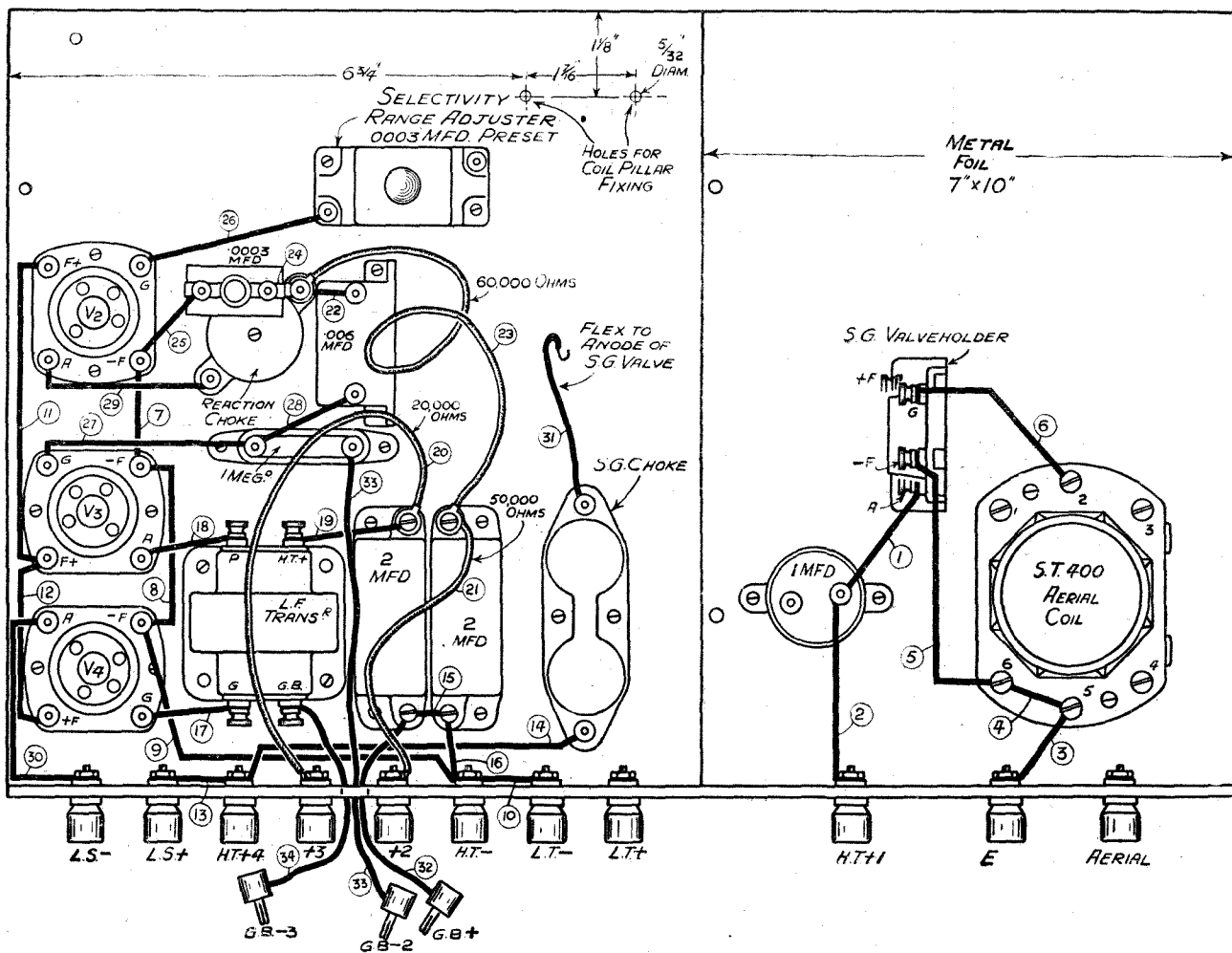

Over 110 Stations on Readers' Aerials

volume of music or speech from any station.

There is an underlying principle involved in my controls. It is this: the basic general operation of the set is not dependent on any "variables" except the two tuning condensers.

There is a type of set which will work well provided all the controls are correctly adjusted, but which will fail if you got a single one wrong. Such a set would be like a chain; it would be as strong as its weakest link. The set might work excellently in the hands of an expert, but might not receive a whisper if handled by a beginner.

I call such a set a "chain control" set. A good, simple example is a ganged condenser set. In this case there are "variables" in the form of trimmers. If a single trimmer is wrongly adjusted the whole set is a complete failure and remains so until the constructor learns what to do. Single-dial super-hets, likewise may come into the "chain control" class.

Such sets, excellent in themselves perhaps, present pitfalls to the novice. My own plan I call the "parallel control" system.

Any one—or even *all* of my special controls—may be wrongly adjusted, and yet you will still

have a good set. None of the "variables" can do any harm, but all can do a great deal of good.

Adjust the controls and as each is put right so will the "S.T.400" rise, step by step, above the average good four-valve receiver.

The "S.T.400" is rather like a sturdy house built of stone. You can strip it of all the refinements and it still remains a very good average property.

It is not like a jerry-built structure which, if a single brick is misplaced, will collapse like a house of cards.

HERE ARE SOME OF THE SUCCESS-BRINGING FEATURES

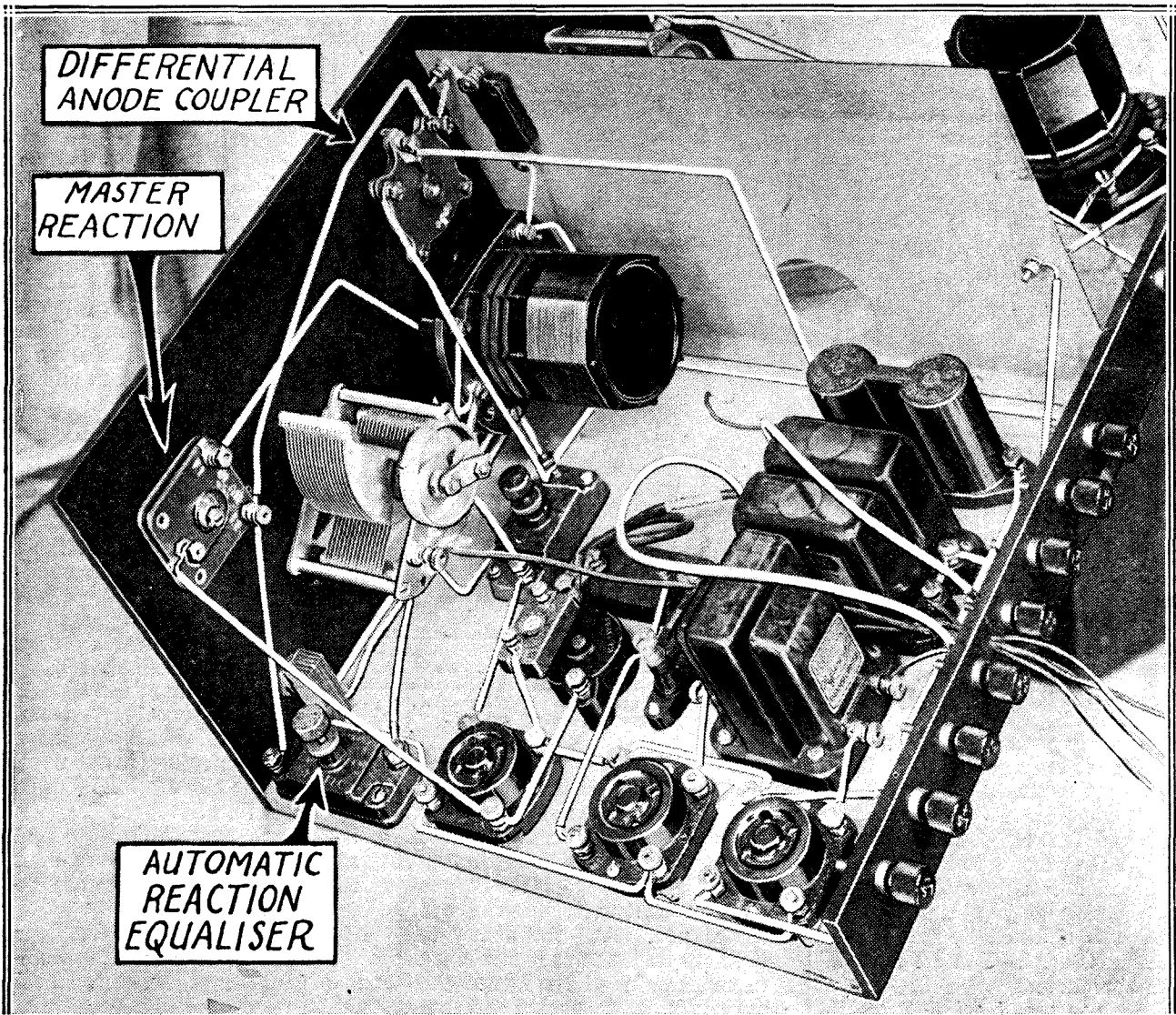

On this side of the screen will be seen the Differential Anode Coupler, the Master Reaction Control, Selectivity Range Adjuster, and Automatic Reaction Equaliser. The Double-Channel Reaction Distributor is not visible, as it is on the panel behind the anode coil. Other photographs and the perspective drawings illustrate its position.

Ease of Tuning—Smoother Reaction—Greater Selectivity

Let me prove my point to the more technical-minded reader. Take the case of Differential Anode Coupling, which I use in this "S.T.400."

If the anode coupler is at "normal" (half-way), the system of anode coupling gives results similar to those on an ordinary "compromise" set. This is equivalent to the bare house. The moment you turn the coupler anti-clockwise you get the full benefit of the "differential" effect and greater selectivity. You are now "furnishing" the house.

On many stations you need the advantages of greater selectivity, but if you get tired of me and my knob-requiring inventions you can instantaneously go back to what other designers are using!

Variations

Let us take the aerial coupler. Leave it at "normal" (also half-way). This is the bare house again—although actually even in this position I give you considerably greater selectivity. Turn it anti-clockwise and you get greater aerial selectivity. You are furnishing the house, getting greater comfort!

If you turn either coupler to the right of "normal" you will get signals stronger than normally obtained.

Take my latest control—the Reaction Distributor. If set at zero the whole of the reaction is shunted through the anode reaction coil only. All reaction is now applied to the anode circuit as in other sets, and reaction is adjusted by the Master Reaction Control. You are back in your bare house.

So, you see, I get things both ways on every control. I can appeal to the man who prefers a bare house because he is afraid

of falling over the furniture. I simply say to him—set your controls to "normal."

But I can also offer the amenities of a cosy house to the man who likes to settle down into a comfortable armchair!

To the beginner my advice is to operate the set as a "bare house" set and add the furniture (i.e. adjust the controls) as you wish.

As a matter of fact, on this aerial

A particularly convincing demonstration was carried out once or twice on London National's television transmission. This, of course, covers a very wide band of frequencies and its jamming powers are fierce. In the North of England, from a comparatively wide spread in both dials it was possible to narrow it down to a degree on each, and then, when the set was so adjusted, to turn the dials slightly and receive Leipzig—10 kilocycles off—perfectly clear of London's racket.

The joy of progressively shearing off the interference from a station must be tried on the "S.T.400" to be appreciated to the full.

A Thrill

There are two ways of working the set, either you can set it for a high initial degree of selectivity, or you can work on medium selectivity and then plane off the interference as you would plane off the rough outside of a plank of timber.

Personally, I get a real thrill—perhaps childish—out of the latter system. To get a distant station's signals as most sets would get them, and then to shave

off the interference, as it were, with a few clean strokes, gives me a lot of satisfaction. Perhaps it is merely because I am flattered at hearing my own inventions carrying out their purpose so effectively.

But if the "S.T.400" is initially adjusted to give the requisite selectivity, you can go round the dials and at nearly every two degrees you will have delivered to you the rich, clear music of a broadcaster. The stations will come in as solid and

AUTOMATIC REACTION EQUALISATION

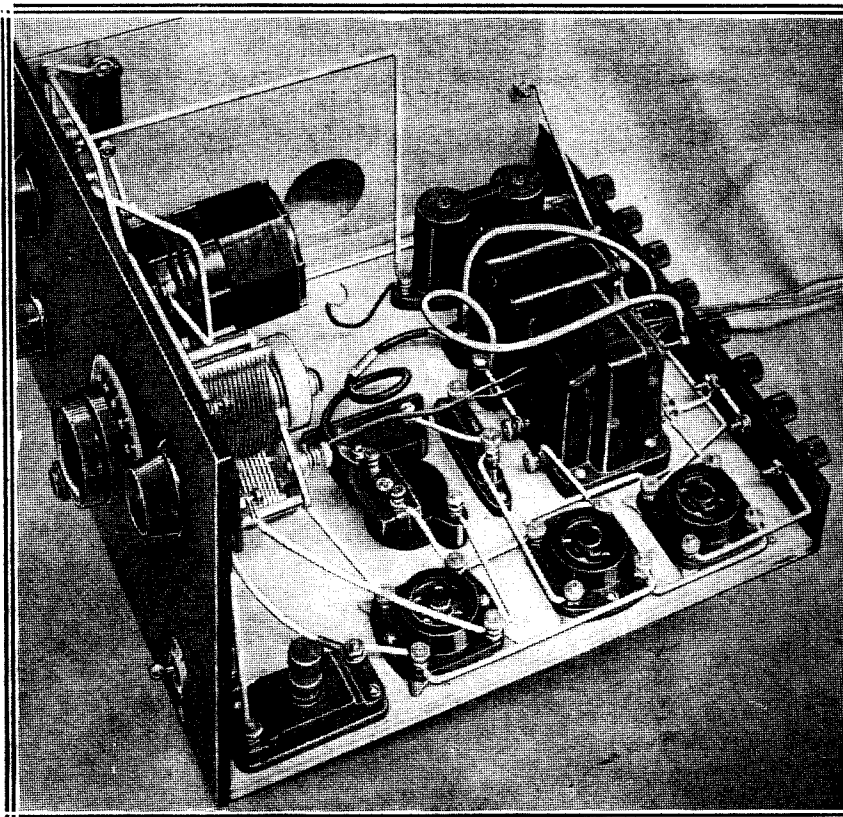

An intriguing feature of the "S.T. 400" is the provision for automatically maintaining a steady level of reaction over the whole tuning range. Ease of tuning, smoother reaction and greater selectivity are the fruits of an adjustment which takes only a few seconds to make when the set is first installed. The Equaliser "pre-set" is in the foreground, near the on-off switch.

tour which I have carried out, my own method of working the "S.T.400" was invariably to put the panel controls at "normal" and bring into action the controls as required.

But in some spots the "bare house" was pretty bleak, I can assure you. And the ability to clean up stations was a revelation to readers in whose homes the set was tried. The speed and ease with which the necessary selectivity was obtained is indicated by the letters.

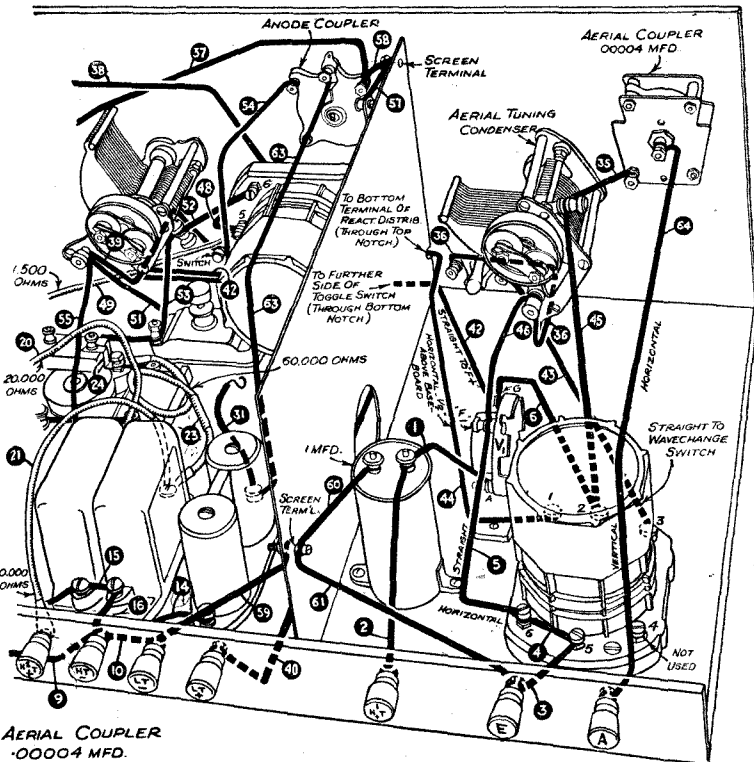
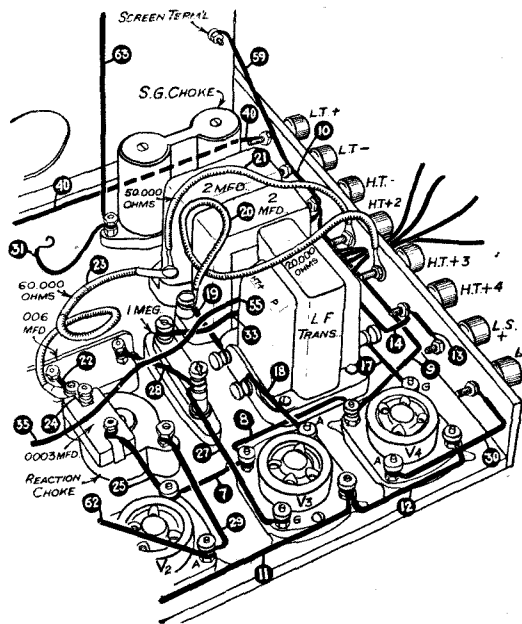

TO SIMPLIFY CONSTRUCTION
 Every lead is numbered in the most convenient order for wiring, and the shapes are shown in these views of the set from different angles.

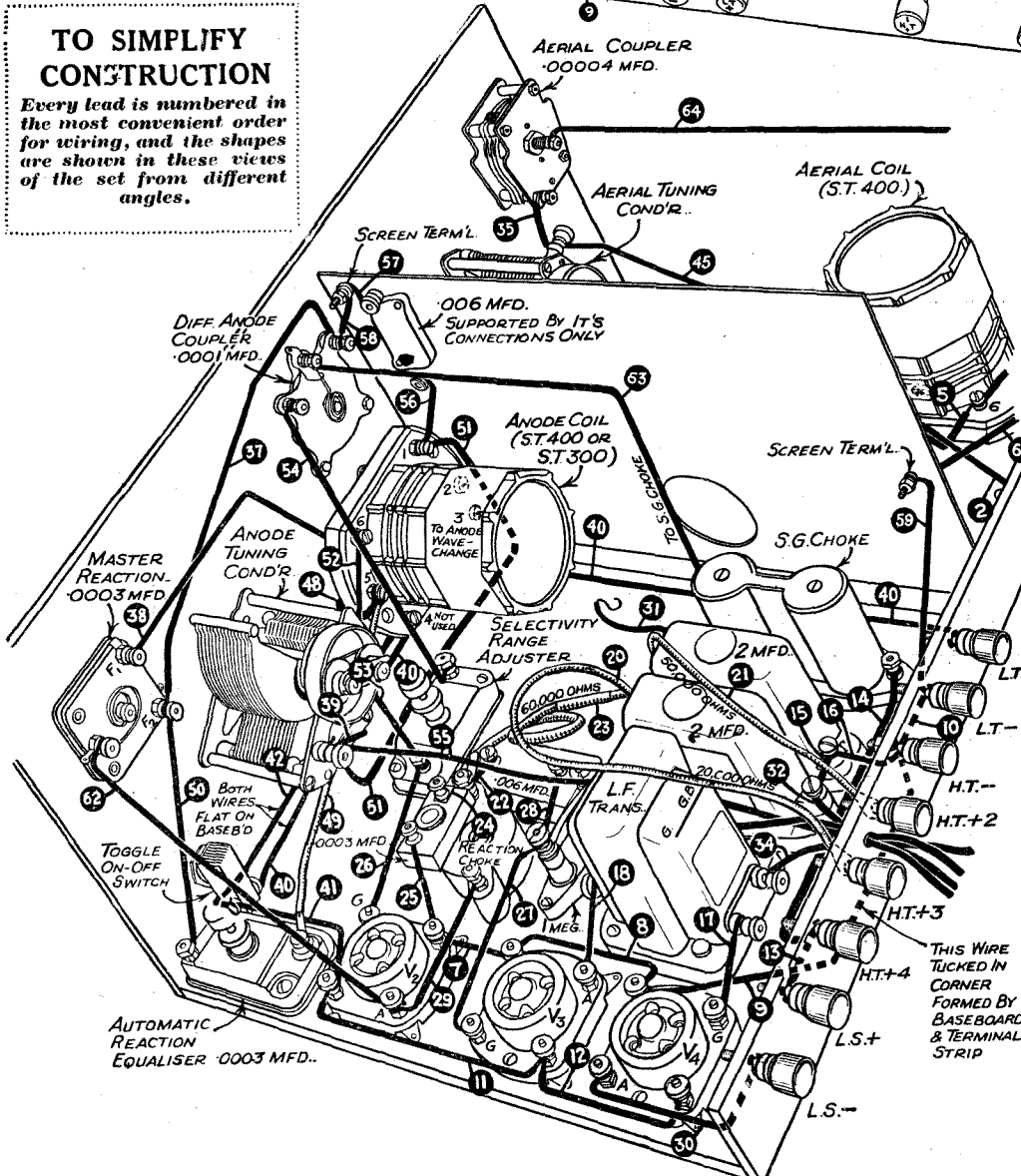

INDICATING THE SHAPES OF THE WIRES

The Rapid Construction Guide and Blue-print of the "S.T. 400" give the points between which wires are connected. These three perspective views are intended simply as an extra guide to indicate the shapes of the wires.

The only wires not clearly shown in full are those going to the Reaction Distributor, and these are clearly depicted in the separate sketch, in the blue-print and in the photographs accompanying the Rapid Construction Guide.

The actual simplicity of the wiring is best judged from the photographs of the complete set.

"No Separation Without Preparation"

separate as so many slabs of butter.

Mention of butter reminds me of those bacon-cutting machines which will give you any thickness from No. 1

with its wide range of selectivity, will give you practically any width of band you want or need.

The beginner, for example, will prefer at first a thickish slice of station with bits of its neighbours clinging to it. In this condition the set is plodding along. The process of "cleaning up" the station may take the user twenty to fifty seconds, but he hears the station all the time.

The process is so straightforward that I can do it with one hand and with eyes closed! The explanation is that the two circuits are practically water-tight as regards their own selectivity. Each is separately rendered selective—an innovation in itself quite apart from the circuit methods adopted.

I am sure I hear someone saying: "It is all right for you; you probably have the knack of it."

"Able to Challenge Me"

As a matter of fact, there is every likelihood that the average reader who builds this set will within a very short period be able to challenge me to a contest! The same suggestion of knack was made over the "S.T.300," but either it is a fallacy or else we are a nation of Reginald Foorts!

Setting the "S.T.400" to its extreme

condition of selectivity and then searching is not recommended to the beginner. He will readily miss the station he wants. A station will

ACCESSORIES FOR "S.T.400"

(The first type mentioned, in this case, does not indicate any preference on my part. As regards loudspeakers, the reader is urged to compare by hearing before purchase. Note that many makers produce differently-priced models giving commensurate "quality.")

Loudspeaker. Blue Spot, Ormond, W.B., R. & A., Marcomphone, H.M.V., Ferranti, Celestion, Igranic, Epoch, Atlas, Lancheater, B.T.-H., Baker's Selhurst.

Pick-up, etc. (see next month). B.T.-H. Minor, British Radiophone, etc.

Batteries H.T. and G.B.: Lissen, Ediswan, Ever Ready, Pertrix Milnes, Magnet, Drydex, Marcomphone, Siemens. Batteries should be of 120 volt super capacity type.

L.T.: Oldham, Exide, Pertrix, Ever Ready, Lissen, Fuller.

Mains Units. Atlas A.C.244, Ekco A.C.18 (or larger types), Regentone, Heayberd, R.I., Ferranti, Formo, Lissen. (The "S.T.400" has very thorough decoupling incorporated to ensure effective working if mains units are employed.)

Special Earths. Filt, Wearite, Goltone, etc.

to No. 36. (Incidentally, I have always wanted to meet a man who ate the 1/2-in. size.) The "S.T.400,"

THE VALVES TO USE

S.G. Cossor S.G.220.
Osram S.22.
Mazda 215B.
Mullard P.M.12A.
Marconi S.22.

(Above S.G. valves are preferably metallised.)

DETECTOR. Cossor 210Det.
Mullard P.M.1.H.L.
Mazda H.L.2.
Osram H.L.210.
Marconi H.L.210.

(Above detectors are preferably metallised.)

FIRST L.F. Mullard P.M.2D.X.
Mazda L.2.
Cossor 210L.F.
Marconi L.210.
Osram L.210.

OUTPUT. Mazda P.220A. (or P.220).
Mullard P.M.202 (or P.M.2A.).
Osram P.2 (or L.P.2).
Cossor 230X.P. (or 220P.).
Marconi P.2 (or L.P.2).

N.B.—The valves in brackets will give lower H.T. consumption and are rather more sensitive, but fullest volume from set is obtained with the others, which, on the whole, I should personally prefer.

The "smaller" valves, however, will give full room strength on the speaker; do not overload them, as the power behind the "S.T.400" is very great.

No special significance attaches to the order of makes of valves. The set will accommodate itself to many other types of these makes. For example, the later types of S.G. valves are specified above, but many tests were carried out very successfully on the same valves used in the "S.T.300."

The detector and both L.F. valves should be correctly biased. Make certain your valves are in healthy condition.

surge up out of silence to great volume and die out again with such

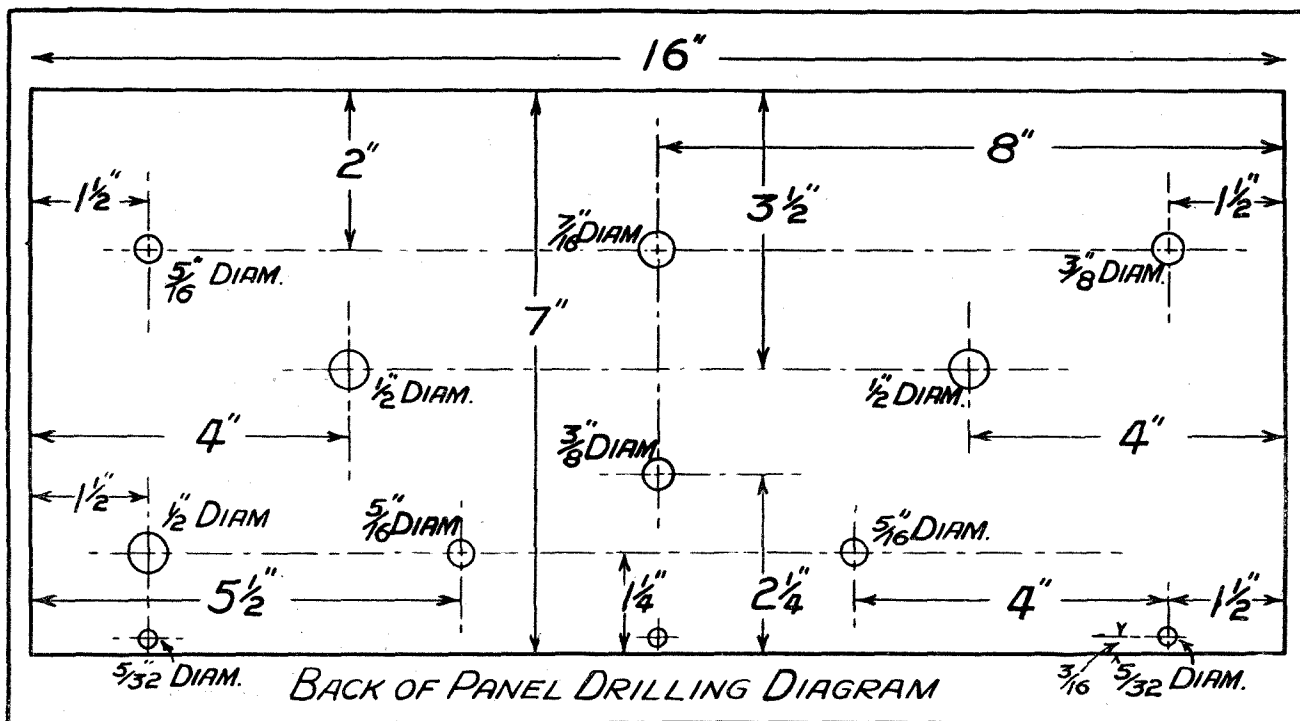

Here are not only the positions of the holes, but the sizes of the drills needed for the various panel components and screws

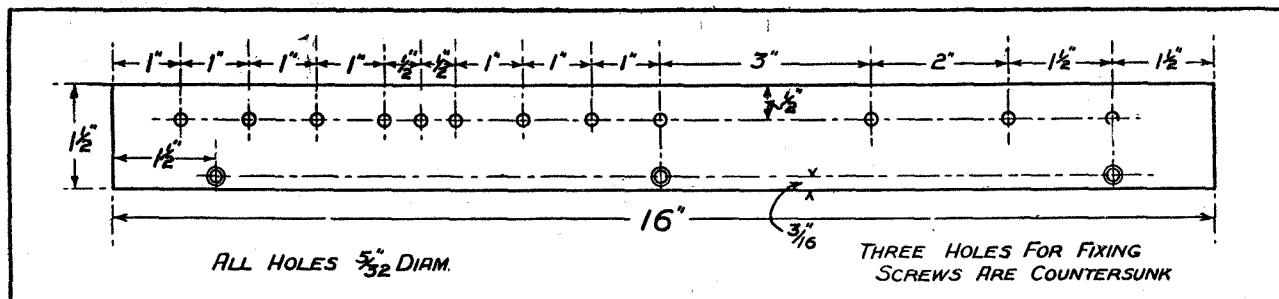

If you do not buy a ready-drilled terminal strip, here are the dimensions you will require.

a small movement of the dial that very powerful stations can be missed by one who is used to rough tuning.

Hence it is desirable at first to flatten the tuning. You can either flatten it all round or, as I often do, increase the aerial coupling and so flatten the tuning of the first circuit. Having got the station, a slight turn

to the left on the aerial coupler will put you back in the super-selective condition, and you will get the signals in all their purity. The station you want is given a chance to breathe.

This ability of the "S.T.400" to give any degree of selectivity desired makes it very easy to handle. Station finding with it

is not like looking for a needle in a haystack. It is like seeing the needle shining there all the time, and just removing the hay.

Obviously, the amount of selectivity you will want will depend upon your distance from a B.B.C. regional station, the relative strength of

(Please turn to page 175.)

THE "S.T.400" COMPONENTS AND ALTERNATIVES

- 1 **L.F. Transformer.** Lissen Hypernik, or Slektun 8/6 type (1 to 4), R.I. Hypermite, Lewcos L.F.T.6A., Niclet (Varley) 1:3.5, Tunewell, Igranic Midget (Ferranti A.F.3 and Lotus 10/6 type, require slight modification of layout), Multitone (1 to 4).
- 1 **Aerial Coupler** ('00004-mfd. variable with very low minimum). Peto-Scott, or J.B. Midget, Ready Radio "Micalog," Wavemaster (not metal end plates).
- 1 **Pair of "S.T.400" Coils.** Colvern, or Lewcos, Wearite, Tunewell, Goltone, Sovereign, Ready Radio (See notes on coils).
- 2 **'0005 Variable Condensers.** Ormond R.493, or J.B., Polar No. 2, Lotus (requires reaction condenser of different type or present type slewing round). Disc-drive types will normally necessitate some enlargement of set.
- 1 **'0003-mfd. Differential.** Polar, or Graham Farish, Magnum, Telsen, Lotus ('00035 mfd.), J.B., Bulgin.
- 1 **'00035-mfd. Differential.** Lotus '00035-mfd. M.D.35 (not their '00034-mfd. model), or '0003-mfd. of following: Graham Farish, Polar, Magnum, Telsen, J.B., Bulgin. There is no technical merit in '00035 mfd. over '0003 mfd.
- 1 **'0001-mfd. Differential.** Ready Radio, or Telsen, Polar, Graham Farish, Magnum, Bulgin, J.B., Utility, Lissen, Wavemaster.
- 3 **Valve Holders.** Benjamin Vibrolder, or Lotus V.H.K., Graham Farish, Telsen, W.B., Bulgin, Tunewell, Ferranti, Ready Radio.
- 1 **S.G. Valve Holder (horizontal).** W.B. Universal valve holder, or Lissen, Wearite, Telsen, Parex.
- 2 **2-pt. Switches.** Tunewell, or Telsen, Lissen, Ready Radio, Wearite, Sovereign, W.B., Igranic, Ormond, Lotus, Bulgin.
- 1 **S.G. Choke.** Telsen Binocular, or R.I. Dual Astatic, Lewcos, Ready

Radio, Watmel, Magnum, Wearite H.F.O., Bulgin S.5 type, Sovereign Super, Slektun.

- 1 **Reaction Choke.** Lewcos, or R.I. Quad Astatic, Telsen, Lissen, Graham Farish, Wearite, British General, Ready Radio, Tunewell, Watmel.
- 1 **'0003-mfd. Fixed Condenser.** Goltone, or T.C.C., Dubilier, Telsen, Graham Farish, Lissen, Bulgin, Ferranti.
- 1 **'006-mfd. Fixed Condenser.** Graham Farish, or T.C.C., Lissen, Graham Farish, Telsen, Dubilier 670, Bulgin.
- 1 **'006-mfd. Fixed Condenser.** Dubilier 670, or T.C.C., Lissen, Telsen, Bulgin.
- 2 **2-mfd. Condensers.** Igranic, or T.C.C., Telsen, Formo, Ferranti, Dubilier, Lissen, Helsby, Hydra.
- 1 **1-mfd. Condenser.** Dubilier 9200, or Telsen, T.C.C., Igranic, Ferranti, Lissen, Formo, Helsby, Hydra, Sovereign.
- 1 **Grid Resistance.** 1 megohm, complete with holder. Ferranti Synthetic type S with holder, or Graham Farish Ohmite, Dubilier, Loewe, Bulgin Ceramic, Ready Radio Thermium.
- 1 **1,500-ohm Spaghetti.** Igranic, or Graham Farish, Lewcos, Varley, Magnum, Telsen, Sovereign, Bulgin. Spaghetthis of this value are not catalogued by all alternative makers.
- 1 **50,000-ohm Spaghetti.** Igranic, or Lewcos, Magnum, Varley, Graham Farish, Telsen, Bulgin, Sovereign.
- 1 **20,000-ohm Spaghetti.** Igranic, or Lewcos, Graham Farish, Telsen, Magnum, Bulgin, Sovereign, Varley.
- 1 **60,000-ohm Spaghetti.** Lewcos, or Graham Farish, Varley, Magnum, Telsen, Bulgin, Sovereign.
- 1 **Toggle Switch (on-off).** Bulgin S.80, or Claude Lyons B.A.T., Igranic, Wearite. (Any 2-pt. switch may be used. If radio-gram switching is desired, Wearite three-pole double-throw is employed instead of toggle,

using only two points in the meantime until I publish details of slight modification to wiring.)

- 2 **Pre-set Condensers, '0003-mfd. maximum.** Telsen or Goltone. (These makes are chosen for their low minimum capacities.)
- 11 **Terminals.** H.T.—, H.T.+1, H.T.+2, H.T.+3, H.T.+4, L.T.—, L.T.+1, L.S.—, L.S.+1, A., E., Belling-Lee, or Bulgin, Clix, Eelex, Igranic, etc.
- 1 **"S.T.400" Screen (as sketch) and Foil, 10 in. x 7 in.** Magnum, or Peto-Scott, Direct Radio, Wearite, Parex, etc.
- 1 **Panel.** 16 in. x 7 in. x $\frac{3}{16}$ in. Goltone, or Permeol, Becol, Peto-Scott, Direct Radio, Magnum, Parex, etc.
- 1 **Baseboard.** 16 in. x 10 in. x $\frac{3}{8}$ in. Peto-Scott, or Direct Radio, Cameo, Magnum, etc. (Cabinets are usually ready fitted with baseboards.)
- 1 **Terminal Strip.** 16 in. x $1\frac{1}{2}$ in. x $\frac{3}{16}$ in. Goltone, or Peto-Scott, Becol, Permeol, Magnum, Direct Radio, Parex, etc.
- Wander Plugs.** G.B.—, G.B.—1, G.B.—2, G.B.—3. I advise types which can fit into each other in case of G.B.—1, G.B.—2 and G.B.—3, although not illustrated. Clix, or Belling-Lee, etc.
- H.T. Wander Plugs.** H.T.—, H.T.+1, H.T.+2, H.T.+3, H.T.+4. Belling-Lee, or Clix, Bulgin, Eelex, etc.
- 2 **Spade Terminals.** L.T.—, L.T.— (if desired) Belling-Lee.
- 1 **S. G. Anode Connector (if desired).** Belling-Lee.
- Cabinet.** Clarion Radio Furniture, or Peto-Scott, Morco, Cameo, Gilbert, Pickett, Osborn, Direct Radio. (The modernistic cabinet specially made for the "S.T.400" is by first-mentioned firm, but set will fit into usual types.)
- Wire.** Stiffish bell wire or Glosite No. 18, Quickwire, Jifilinx.

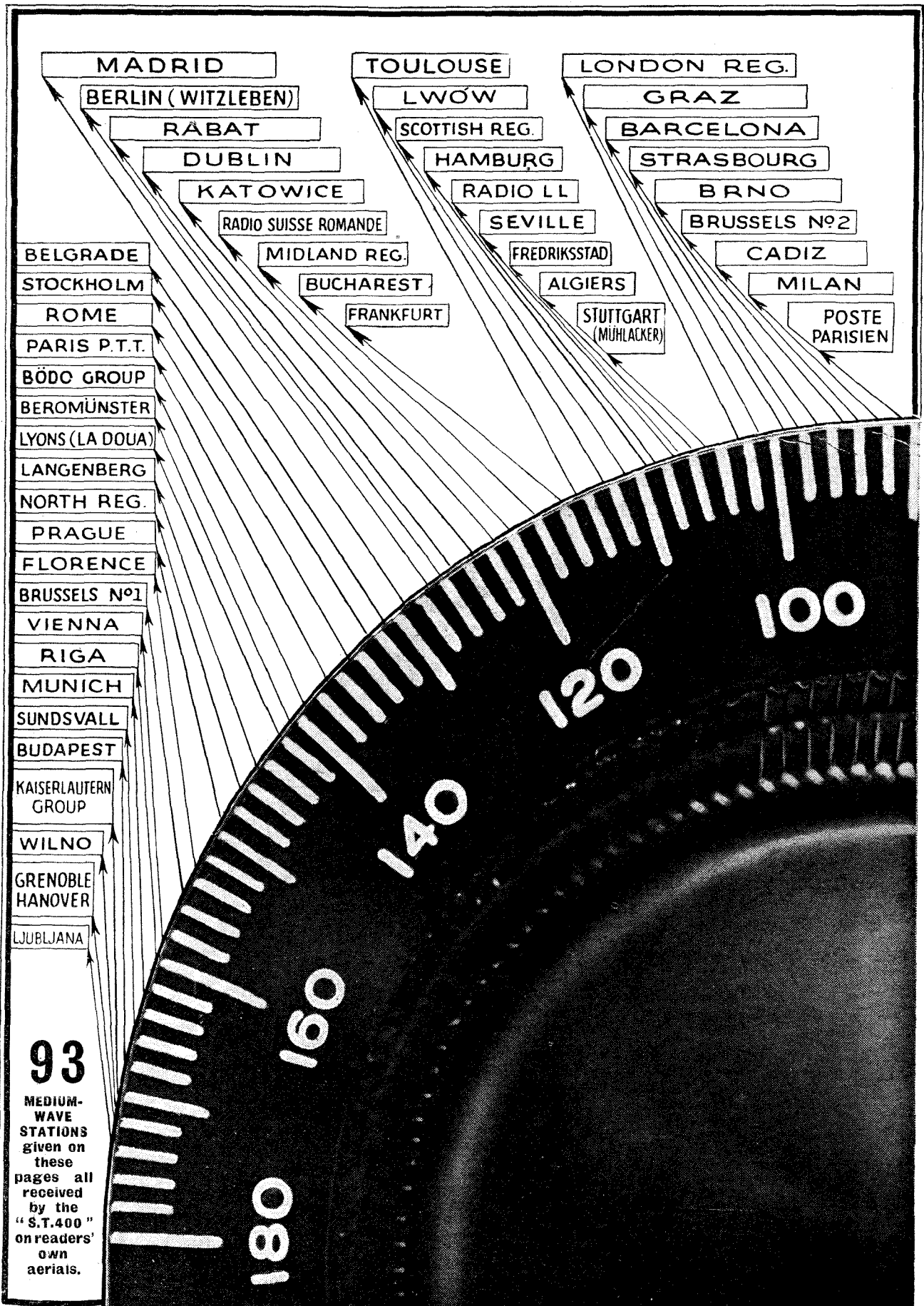

93
 MEDIUM-WAVE STATIONS given on these pages all received by the "S.T.400" on readers' own aerials.

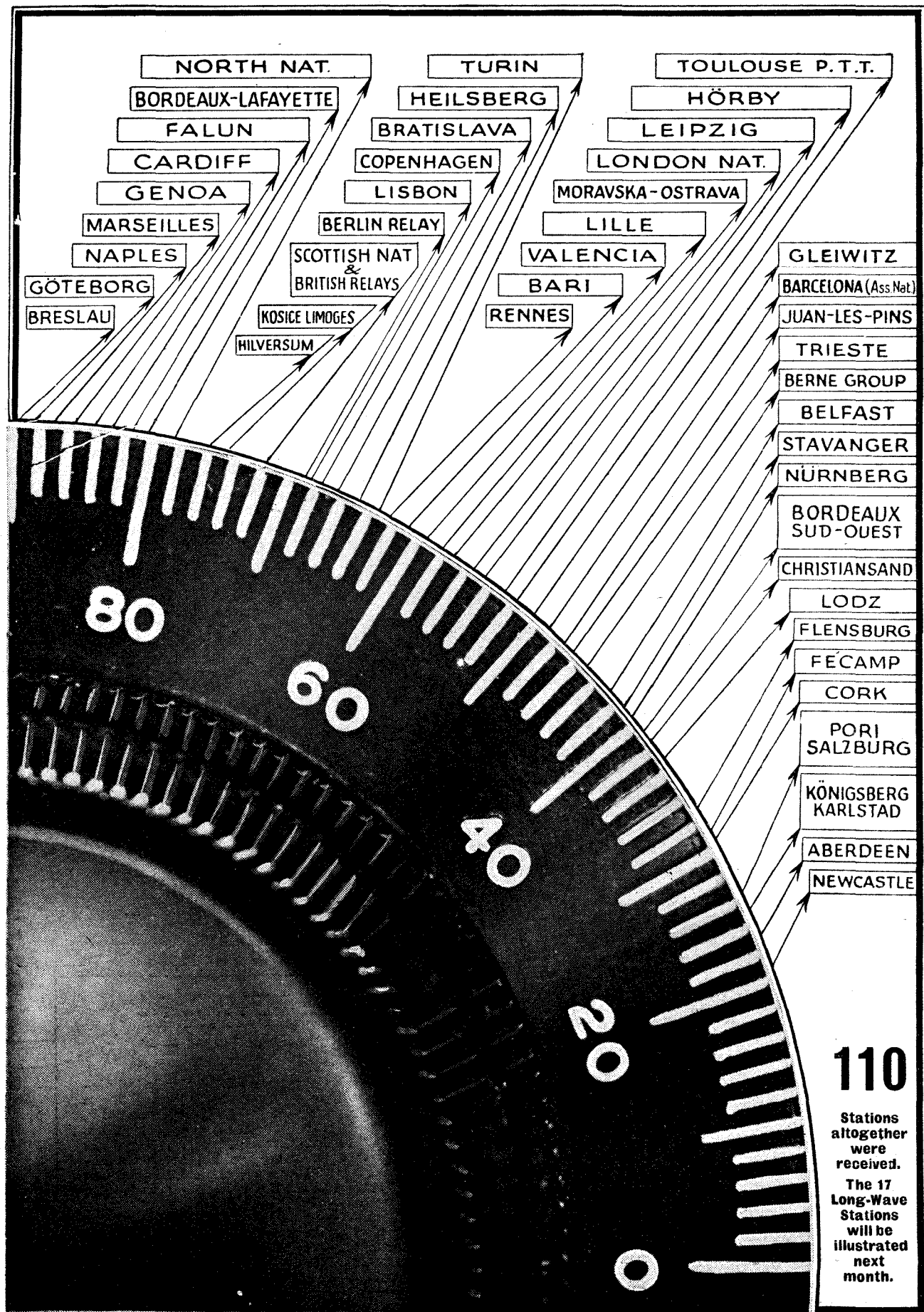

110

Stations altogether were received.

The 17 Long-Wave Stations will be illustrated next month.

1 DOUBLE-CHANNEL REACTION

Double-channel reaction is the "heavy artillery" of the "S.T.400." This patented "S.T." invention involves a strikingly original method of gaining selectivity. It consists in sharpening by reaction the tuning of the aerial circuit as well as the anode circuit. Other methods of sharpening aerial tuning on sets using H.F. amplification reduce signal strength. Double-channel reaction increases signals as it increases selectivity! The "S.T.400" has a master reaction control, and also a reaction distributor for applying reaction to anode or aerial circuit, or to both simultaneously in the right proportion.

2 ADJUSTABLE AERIAL SELECTIVITY

While double-channel reaction is for use in special circumstances, the highly important features of the "S.T.300" are embodied in the "S.T.400." Ordinary aerial circuit selectivity is obtained by the aerial coupler, an improvement by Mr. Scott-Taggart on his fundamental Patent 232,659. The aerial coupler is panel-controlled, an essential feature. This enables the user to obtain the correct balance between aerial circuit selectivity and signal strength, which varies on different aerials and stations. The aerial coupler compensates for differences in aerials and, in its low-capacity positions, acts as an excellent volume control.

5 SELECTIVITY RANGE ADJUSTER

This is an innovation of importance, which enhances all the merits of differential anode coupling without affecting the maximum amplification of the S.G. stage when the anode coupler is "full in"—i.e. to right. When, however, the anode coupler is at an intermediate position the selectivity range adjuster pre-set condenser provides an H.F. potentiometer effect which controls the selectivity range given by the anode coupler.

If the pre-set is tightened up to maximum capacity the whole system of differential anode coupling is substantially the same as if the pre-set were absent. If, however, the pre-set is reduced in value (by unscrewing its knob) a higher degree of selectivity will be obtained for any given intermediate setting of the anode coupler; the lower the value of the pre-set, the greater the selectivity. As S.G. valves and voltages vary widely, the adjuster has additional advantages as a means of stabilising (or "unstabilising") the set, and enabling "full anode coupler" to be used. The pre-set is adjusted when installing set.



TEN-

for the

7 SHARP-TUNING DETECTION

The system of detection adopted in the "S.T.400" is still a further contribution to its success as a selective receiver. The grid rectification system, employed on more than 99 per cent of the receivers in use to-day, has been jettisoned. Mr. Scott-Taggart has taken a very bold line in adopting anode-bend rectification, and his results certainly justify the step. Although formerly used on account of the "quality" it gives, "S.T." re-introduces the method to give higher selectivity on the anode circuit; grid condenser rectifiers, on the other hand, are all energy absorbers and flatten tuning.

8 EXTRA VALVE

The addition of an extra L.F. valve is technically of great importance having regard to the special circuit of the "S.T.400." Normally, an extra L.F. valve will simply give more "punch" to a set, but in the "S.T.400" it not only gives greater volume but greater selectivity. This is because the special aerial and anode couplers may be adjusted to give greater degrees of selectivity while leaving ample loudspeaker volume. The addition of the extra valve also permits a very cheap and simple tone-control arrangement. The four-valve arrangement, on the score of selectivity alone, is destined for greater popularity.

3**DIFFERENTIAL ANODE COUPLING**

The extraordinary success of the "S.T.300" is due in large measure to the invention by John Scott-Taggart of differential anode coupling. This system is also introduced into the "S.T.400," and enables panel-controlled, smoothly-adjustable selectivity on the anode circuit to be obtained. A by-product of the arrangement is that the best results may be obtained from the valves and batteries used; a set without such control must be "designed down" to remain stable at maximum voltages and with most efficient S.G. valves, and consequently becomes much less efficient under average conditions.

4**AUTOMATIC REACTION EQUALISER**

Automatic reaction equalisation is an ingenious scheme which simplifies tuning and also indirectly results in greater selectivity by making reaction constant around the dial reading of the station to be received. While not completely rendering reaction adjustments unnecessary, it is a big step in the right direction. On ordinary sets every degree rise on the tuning condensers requires an increase in reaction, and if one then "goes back" the set bursts into oscillation. Reaction equalisation obviates this. Reaction is made approximately equal for all dial settings.

-REASONS S.T. 400 SUCCESS

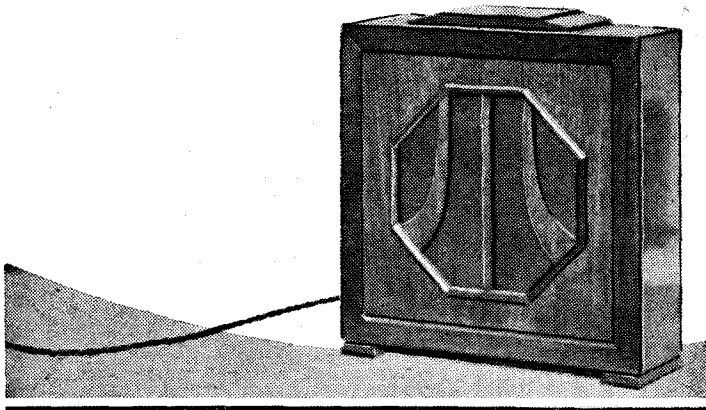
**6****6 TONE CONTROL**

Tone-control is achieving greater importance every year. The "S.T.400" circuit provides a means of achieving this at a cost which may be as low as 5d. ! The whole set is designed with a view to its operating essentially as a musical instrument delivering a large volume of pure sound. Nevertheless, tastes vary as to the proportion of bass and treble: moreover, no two loudspeakers give an identical response. Rooms, cabinets, baffles, etc., all affect the reproduction from any set.

In the "S.T.400," although already designed from end to end to give excellent quality on the average speaker, it is possible to vary the proportion of low to high notes by simply substituting, once and for all, some different value of L.F. coupling condenser. A lower value will reduce the bass response. The condenser acts in series with the grid resistance, the whole forming a potentiometer which has a discriminatory action on different frequencies. The tapping point on this potentiometer automatically moves up and down, as it were, with the frequency of the L.F. currents.

9**SMOOTH REACTION**

The importance of reaction for attaining selectivity is only now being fully realised, and the "S.T.400" is the first set to carry the invention to its logical conclusion. The desirability of smooth reaction has received very special consideration in this set. The introduction in the "S.T.400" of automatic reaction equalisation not only simplifies tuning, but results in smoother control. The detector valve anode circuit, moreover, is calculated to give a smoother reaction adjustment than that obtainable on, say, the "S.T.300" The differential anode coupler and the selectivity range adjuster both prevent "reaction overlap."

10**ADJUSTABLE PANEL CONTROLS**

The "S.T.400" is frankly a set for the man who wants to get 100 per cent from each valve. To do so there are three special selectivity-sensitivity controls, which are placed on the panel where they can be clearly seen and easily handled. These controls are not all used at once, but only as circumstances require. Every listener from Land's End to John o' Groats has a different location and aerial, and so a different problem. Also, some stations call for greater selectivity in the set. Hence the controls. They may be set at "normal" for family use, but the wonderful "flexibility" of the "S.T.400" accounts for its universal success.

S.T. 400

TESTED FROM LANDS END TO JOHN O'GROATS

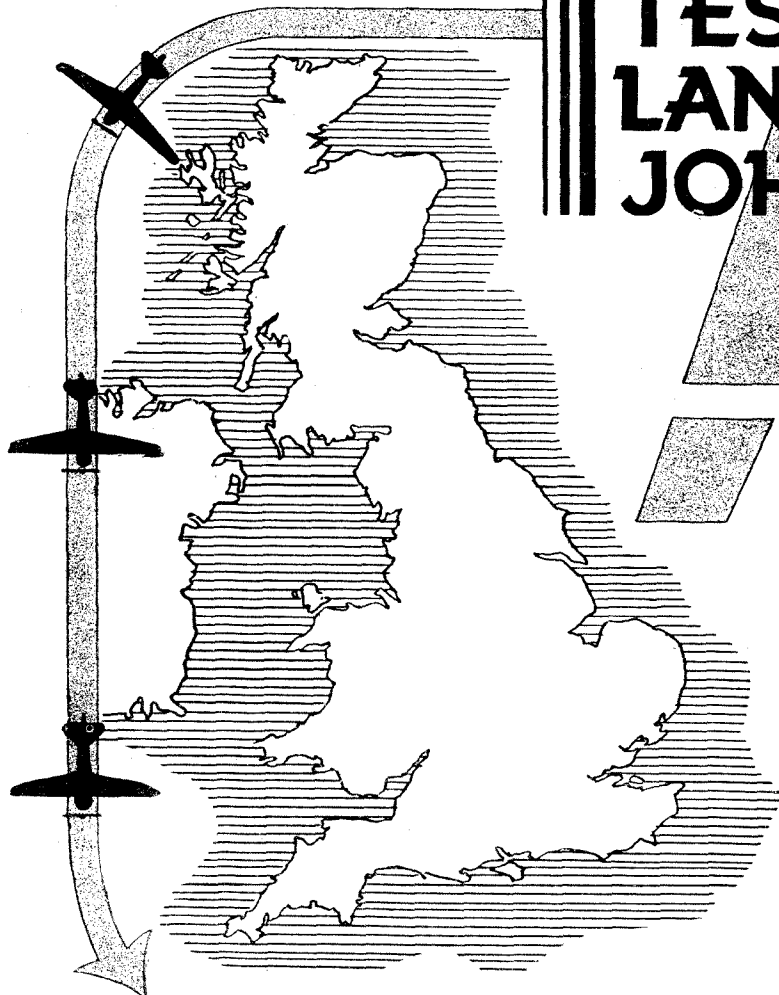

"S.T.400" HAS THE FOUR ESSENTIAL POINTS—SELECTIVITY, QUALITY, VOLUME, AND LOW COST

"Chy-an-als,"
Land's End,
Cornwall.

Sir,—I wish to thank you for the successful demonstration of your latest set, the "S.T.400," which took place at my above address.

I must confess that I did not think the receiving of so many stations possible in this district. Now I have been convinced.

Exactly 70 stations were identified. All of these were received clearly on the loudspeaker without interference, and during B.B.C. transmitting hours.

I have at present a 5-valve receiver. This I thought splendid until I had heard the "S.T.400." My next set will be your "S.T.400," as it is miles ahead of any receiver that I have yet heard for selectivity, this being the quality most necessary to-day.

To sum up the performance of this receiver, the "S.T.400" has the four essential points—selectivity, quality, volume, and low cost and maintenance. This should appeal particularly to home constructors.

My advice to anyone in the Land's End district is to build the set that has been tested so successfully under local conditions.

With my congratulations and good wishes for the success that such a good set deserves. Yours faithfully,

A. THOMAS.

(Mr. T. Hall, of Forthcurno, and Mr. C. Davey, of Land's End Hotel, both local amateurs, were present at the demonstration, and desire to associate themselves with Mr. Thomas' remarks.)

55 STATIONS QUITE ISOLATED AND CLEAR OF INTERFERENCE

1, Parkville Road,
Bell Lane,
Bramley,
Leeds.

Sir,—Referring to the recent test of your new set at this address, I must say, first of all, how glad I am to be one of the privileged few to be visited by you, and to hear in my own home a set which has apparently limitless possibilities in station isolation.

Being an enthusiastic user of the "S.T.300," I was somewhat dubious of any great improvement, but the new set is undoubtedly superior.

To receive, as we did, 55 stations quite isolated and clear of interference, while the Nationals and Regionals were working, is a great achievement; but later, when Naples was received, overpowering the Dresden group, and Leipzig (10 kc. from London National), and Toulouse (only 7 kw.), while television

FARTHEST SOUTH AND FARTHEST WEST

Cornwall—notorious as a bad district for reception—is enthusiastic about the "S.T.400." Mr. Thomas, Britain's "farthest west" constructor, is as pleased as "S.T." with the results obtained.

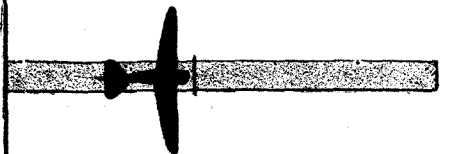

Here is Mr. John Scott-Taggart with his new set, which has been tested not only in the great centres of population but also enthusiastically received in the remotest parts of the country.



FARTHEST NORTH WITH THE "S.T.400"

from London National was operating, the set was definitely marked as a precision instrument of a higher class.

Throughout the test the volume of sound was adequate for a small hall even when low-powered, far-distant stations were tuned in, and the quality of reproduction left nothing to be desired.

I have checked up the log for the evening when the test was made, and find that altogether 65 stations were tuned in in just short of two hours, a remarkable record.

Constructional details are being eagerly awaited by myself and several friends, as I tell them "You can't go wrong" with a set designed by you, and this latest is indeed a brilliant effort.

Thanking you for the unique opportunity of hearing an as yet unpublished "S.T." design, and wishing you every success.

Yours faithfully,
N. STANLEY BLACKBURN.

84 STATIONS IN NEWCASTLE AREA
58, West Chirton,
North Shields.

Sir.—Mr. Scott-Taggart's aeroplane visit to test his new set, the "S.T.400," was an event of importance.

He tested the set in my presence at 36, Brampton Place on an aerial that was known to be none too good, being only 21 ft. high at the free end.

Eighty-four stations were logged, and, with the exception of one or two, were all at L.S. strength. All these stations were identified; also several others were received but not identified.

The selectivity of the "S.T.400" is really amazing, and each station was received perfectly clear of its neighbour. A remarkable test was the reception of Wilno and the clear identification of the station by the announcer. The reproduction was not perfect on this particular station, but was surprisingly good considering there was Grenoble-Hanover on one side (3 kc. off) and Augsburg, etc., 3 kc. on the other side.

The quality, too, of the receiver was above reproach, which goes to prove that Mr. Scott-Taggart has looked after the L.F. side of the set.

North Regional was received clear of Prague and Langenberg, with no trace of side-band interference. Stuttgart, London Regional, and Graz were clear of each other; while Toulouse, Lwow, Scottish Regional, Hamburg, Radio L.L., Seville, Fredrikstad, is a round of stations formidable enough to test any set's sensitivity or selectivity.

Another severe test was the separation of Leipzig from London National Television Transmission, and this was accomplished with the greatest of ease. Barcelona Nat. Assn. (1 kv. only) was a splendid signal.

Amongst my log I notice Bucharest, Seville, Belgrade, Rabat, Valencia, Lodz, Marseilles, Kannas, Moscow (Old Komintern), Kiev, Kosice, Fallun, Kharkov. Altogether the "S.T.400" put up a fine performance. Selectivity and quality are all that could be wished for, and it gives me great pleasure to submit this test report of the "S.T.400."

The "S.T.300" is no doubt a fine set, but I am convinced that this NEW addition to the fine range of "S.T." sets will break all records. It is a real STATION-GETTER.

In conclusion, as one who has had many years' experience of radio receivers of different types, I must congratulate Mr. Scott-Taggart on designing such a splendid set, and I wish the "S.T.400" all the success it deserves.

(Signed) T. MARSHALL.

80 STATIONS AT MARGATE
Ferndale Cottage,
Cliftonville,
Margate.

Sir.—I very much appreciate the privilege I had of hearing a test on your new set, the "S.T.400," which, in my opinion, is certainly the best set I have ever heard.

Its power, range, and selectivity are marvellous, and the fact that you were able to log eighty stations here, "Farthest East," free of interference, bears out that statement.

On the long waves, Zeesen (Konigs-Wusterhausen) came in clear of Daventry and Radio-Paris (that is an achievement here); and though I have a list of all the stations received and identified, it is almost impossible to single out any on the medium waves for special mention, as they were all so clear and free from interference.

One fact I should like to point out—the test took place when all the B.B.C. stations were working.

As an amateur I have heard and tested a great number of sets, including super-het. sets, but I have never heard one to compare with your "S.T.400." It was, candidly, the most interesting evening I have ever had with wireless. I feel I cannot say enough about the set, and I am now anxiously waiting the publication of particulars of your latest marvel.

Yours faithfully,
H. B. SMITH.

(Local readers will recall that Mr. H. B. Smith was Mayor of Margate some years ago.)

"BEYOND ANYTHING IN MY EXPERIENCE"

Gills,
John o' Groats,
Caithness.

Sir.—This is to certify that on the evening of September 1st, when I attested the performance of your latest circuit, "S.T.400," on my aerial and earth here, the results were beyond anything in my experience since radio began.

Although the night was far from satisfactory as regards atmospheric, and I am conscious of the defects of my aerial system, the results obtained were to me a revelation. Not only was station after station brought in, as given in "World Radio," with unflinching certainty, but the quality obtained from each was of a very high standard.

I must certainly congratulate you on your latest achievement.

A. MATHESON.

51 STATIONS AT JOHN O' GROATS
John o' Groats,
By Wick,
Caithness.

Sir.—Many thanks for your kindness in giving a demonstration in this far-northern spot of your new four-valve set. From notes taken during the actual test I find that fifty-one stations were logged, two of these on common wavelengths and one unidentified.

Poste Parisien and Breslau were distinctly separated, as also were Heilsberg and Bratislava.

Volume was more than adequate, while the tone was well above the average. The selectivity given by the set was all that could be desired.

Conditions were wretched for reception owing to bad atmospheric.

Wishing the new four-valve all success.

Yours faithfully,
N. McARTHUR LEES.

FARTHEST EAST

On this page a former Mayor of Margate, who has tested the "S.T.400," voices the satisfaction of the South-East. "Power, Range and Selectivity are Marvellous."

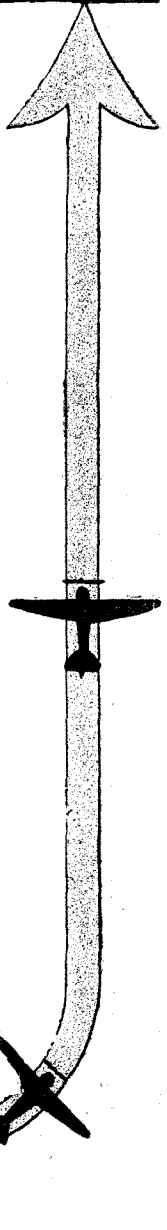

THE "S.T.400" CIRCUIT SPECIALLY DEVELOPED FOR "THE WIRELESS CONSTRUCTOR"

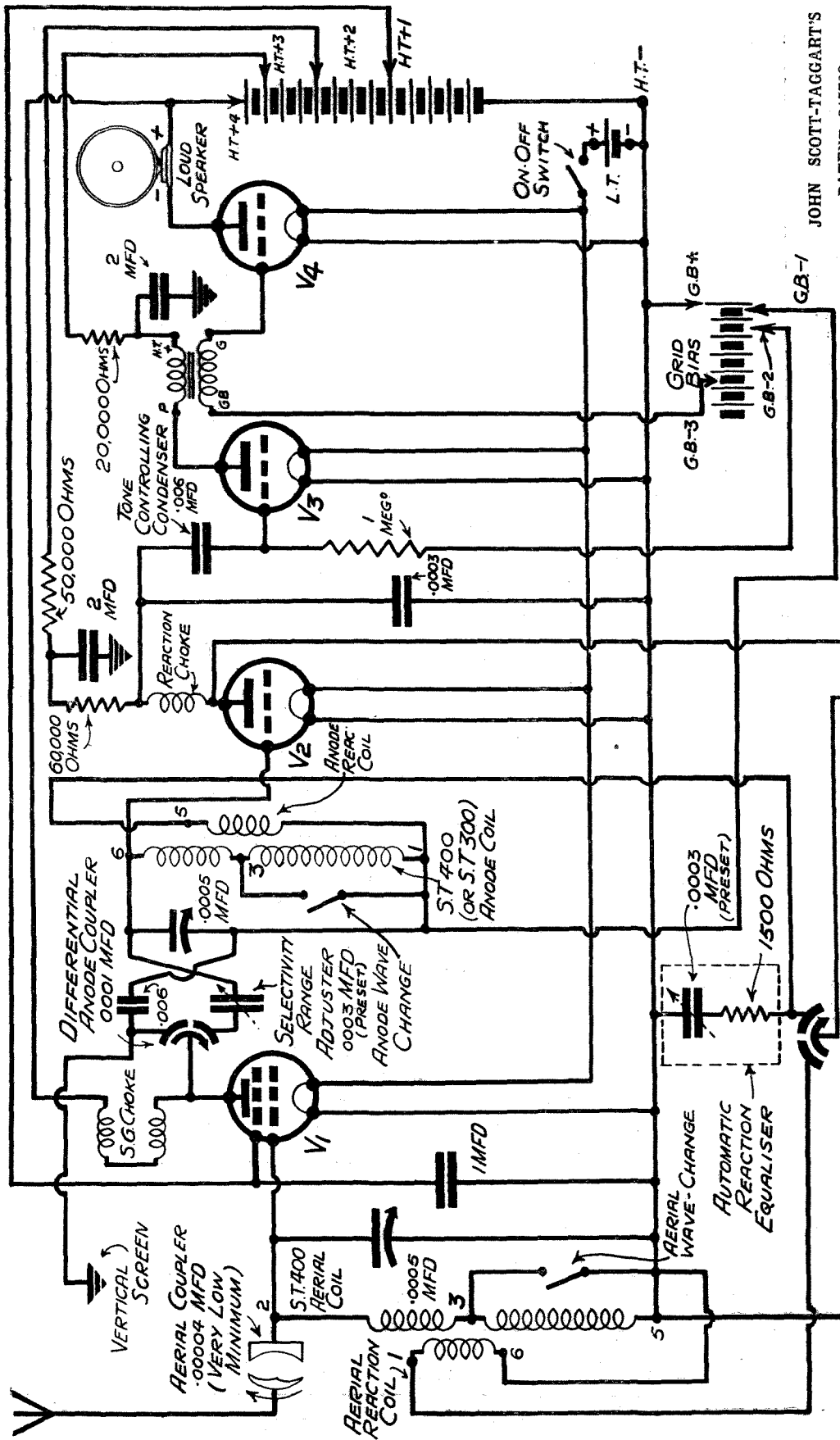

JOHN SCOTT-TAGGART'S
 PATENT 215798.
 PATENT 232659.
 PROV. PATENT 29839.
 AND OTHERS.

STRICTLY COPYRIGHT
 REACTION DISTRIBUTOR
 .00035 MFD OR .0003 MFD.
 MASTER REACTION
 .0003 MFD

Here is the S.T. 400 Circuit

BY
JOHN SCOTT-TAGGART
AMIEE, IRELAND

THE circuit, of course, is the thing. Not the only thing, but essentially *the* thing. The layout counts and so do practical considerations, but the basis of any new set will always be the circuit.

Herein lies the scope for new ideas and new methods. A few lines on a sheet of paper and the whole trend of radio may be altered. A few pencil marks on the table-cloth at a fashionable restaurant may start a new industry.

Just a Few Lines

I have seen these things happen. And always it has been some apparently trifling alteration or some simple combination of time-worn symbols.

Twelve years ago a large radio concern for whom I worked sold the American rights of an invention of mine for £4,000. A circuit. A few lines scribbled on a piece of paper—at two o'clock in the morning!

I had seen lying awake and the idea was hastily jotted down. I then went to sleep. Just a few lines on a scrap of paper, but the Commercial Cable Company of America paid four thousand pounds for it!

It is a pity that interest amongst amateurs has veered away from circuits. Nowadays, the average wireless man, however enthusiastic, is more concerned with appearance, price, layout, types of components—almost anything but the very thing that counts: the circuit.

"Set After Set is Built"

What is the result? Simply that set after set is built by the same man with some vague idea that a

different-looking set will give different-sounding results.

Why have a million—or perhaps two or three million—people got sets which give them no real satisfaction? Because they know nothing of circuits, and care less.

The other day I was looking over some periodicals of mine of seven years ago. In one was the identical circuit used on nearly all S.G., det. and L.F. receivers to-day; only the valve was different—the circuit, principle and operation remained unaltered. In another I had recommended and published (certainly not for the first time) an "ultra-modern" band-pass circuit!

If the public is to blame, so also is the average designer. A year ago, while I was at work on the "S.T.300," a cynical critic of the technical press remarked to me: "The trouble these days is not in designing new sets, but in finding new names for them."

" . . . Having examined the "S.T.400" circuit, you will see that it is no dusted aspidistra. If the schemes are unconventional, it is simply because I believe old circuits should not be raked up, but ripped up . . . "

J. S.-T.

The picture he drew of designers spending a day on the set and a month on finding a new name was not altogether fair. But there was sufficient truth in his accusation of lack of originality to encourage me to try to keep out of the well-worn ruts.

There can be no dispute that the ship of invention has become becalmed in the doldrums of sameness. Painting the sails a different colour may cheer up the

crew, but the ship will not budge.

What we want is an invigorating breeze which will get invention under way again and bring a tingle of enthusiasm to our blood. And only new circuits will do that.

You, as a constructor, can force me and others to give you a lead in this matter. Refuse to listen to the well-worn record grinding out the same old tune. Take it firmly in both hands and snap it across your knee.

The Salient Points

As far as I am concerned, I am anxious that THE WIRELESS CONSTRUCTOR reader should be a keen but critical one. Meanwhile I look to you for support in a vigorous aggressive policy of tackling the new problems of interference in a new way. The old nostrums have failed. My circuits are anything but conventional, but I believe they are the right medicine to take.

The "S.T.400" is a *circuit* first and foremost. And as such I am anxious to explain it so that you can pass your own judgment.

Here are the salient points. There are two main tuning circuits separated by a vertical screen and an earth-sheet on the aerial end of the baseboard. The screening and the screen-grid valve enable the aerial circuit and anode circuits to be tuned separately and to be adjusted *individually* for selectivity. It is therefore possible to receive a station with (a) flattish aerial tuning and sharp anode tuning; (b) sharp aerial tuning and flat anode tuning, or (c) sharp tuning in both circuits. In addition you can get flattish tuning on both circuits, or ultra-selectivity on both circuits.

Refined Reaction and Simplified Tuning

The latter is obtained by my new system of Double-Channel Reaction, introduced for the first time in this set and explained under a separate heading.

The degree of selectivity chosen will depend upon the degree of congestion of the ether, the station to be received, the aerial and location of the reader. The point to note is that aerial and anode circuit selectivity is separately obtained, this adding greatly to operating simplicity.

Patented Schemes

The aerial coupler system covered by my Patent 232,659, and Prov. Pat. 29889/31, governs the aerial selectivity, and in its minimum (left-hand) positions provides an excellent volume control. The anode circuit selectivity is governed by a differential anode coupler (covered by my Prov. Pat. 29889/31), which in the full-left position (moving vanes opposite "grid-end" set of fixed plates) gives highest selectivity and some reduction in signal strength; when over to the right, tuning is at its flattest.

AUTOMATIC REACTION EQUALISATION

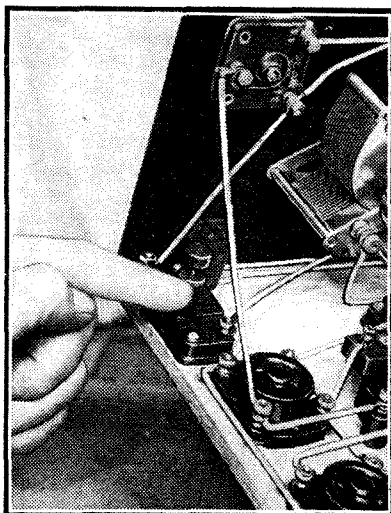

The Automatic reaction Equaliser gives an equal supply of reaction all round the dials. It is absolutely automatic and requires no ganged controls.

but signals are rather louder. The Master Reaction control should always be tried, if necessary, to bring up the dynamic impedance of the tuned anode circuit on different values of anode coupler. The technical function of Differential Anode Coupling is

the subject of a detailed article next month, but the beginner need only know what it does, not how it works. Its success has already been proven in the "S.T.300."

A Selectivity Range Adjuster is included in the new circuit. Its function is two-fold. I introduce this idea to the public as a solution of the problem arising out of the wide variety of valves and H.T. voltages in use.

Instead of designing a set "down" so that the tendency to instability inherent in all S.G. sets is completely insured against, I prefer to enable the constructor to work up to the set's limit of possible amplification (by increasing the capacity of the Selectivity Range Adjuster, or rotating the anode coupler to the right).

"Up to the Scratch"

The alternative would be to adopt many of the subterfuges (not at first visibly as such) to stabilise the set so that it would be stable with the very best possible valves and the absolute maximum H.T. When 75 per cent of the constructors made up such a set they would find a big drop in its efficiency and have no means of bringing it "up to the scratch."

Such a design policy, in my opinion, is wrong. It is as if a four-masted barque were fitted with one small sail because the designer did not trust the captain with more; he feared what might happen if it were rigged for anything but the roughest weather. Imagine this same captain's feelings as his vessel creeps along and he sees another ship spread its reserve sails and forge ahead.

Anode-Bend Detection

The special technical point to note about the Selectivity Range Adjuster is that when the anode coupler is full-right the H.F. currents are fed straight through into the tuned anode circuit; when the anode coupler is turned a little round to the left a potentiometer effect begins to operate.

This brings me to the second advantage of the .0003-mfd. pre-set Adjuster. It enables one to control the limits of selectivity as obtained by the anode coupler.

Many milliammeters are provided with two ranges to enable one to use the full scale on, say, 10 milliamps. or 100 milliamps. The Selectivity Range

Adjuster enables the same thing to be done for selectivity.

The next point to note about the "S.T.400" circuit is that anode-bend detection is employed.

In using this system I am flying in the face of current practice as embodied in more than

THE SELECTIVITY RANGE ADJUSTER

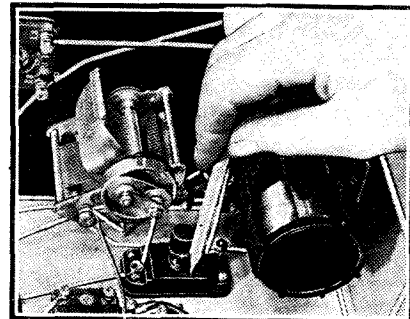

By increasing the capacity of the Selectivity Range Adjuster the constructor is enabled to work right up to the set's limit of possible amplification.

99 per cent of British sets. But all grid condenser and leak systems of rectification are energy absorbers. They involve the setting up of grid currents, and—from a selectivity point of view—running into grid current is as bad as running into debt. Damping is always introduced into the tuned anode circuit, and so encourage jamming. On the other hand, the anode-bend system, formerly used for the quality it gives, sets up no grid current and reduces interference.

It definitely contributes to the overall selectivity of the "S.T.400" and, incidentally, obviates "choking up."

Tone Control

The detector valve is coupled to the third valve by a 60,000-ohm spaghetti resistance and a .006-mfd. fixed condenser. A grid resistance of 1 megohm feeds the negative bias to the grid of this third valve.

The .006-mfd. is found admirable for quality reproduction under average conditions, but since speakers and rooms vary, and especially the tastes of listeners, an extremely simple way of modifying the proportion of bass to treble is to alter the value by trial in your own home. The simple

S.T.400

READY RADIO KITS

- ☞ Ready Radio are the largest Distributors and Manufacturers of Kits in the World.
- ☞ Ready Radio are recognised by Trade and Public as *the* Distributors for "Wireless Constructor" and all Press Sets.
- ☞ Ready Radio have distributed over twenty-five thousand Kits since Mr. Scott-Taggart described the S.T.300 last January.
- ☞ Thousands of letters of appreciation received.
- ☞ Every Ready Radio Kit is absolutely complete. You get *everything* you need.
- ☞ Ready Radio's huge Factory and Organisation are specially equipped for testing all components, and only those which pass a high standard are used. All testing is under the personal supervision of Mr. G. P. Kendall, B.Sc.

REGISTERED USERS' SCHEME

By sending us the card enclosed with every Ready Radio Kit you will be entered as a Ready Radio Registered User. You will then be entitled to the Ready Radio Complete Service. Mr. Kendall will, from time to time, send you notice of any new developments, and you will be able to write to him on any technical question and benefit by his exceptional knowledge and experience. Only purchasers of Ready Radio Kits are entitled to this unique service.

Ready Radio Kits and Components can be obtained from all leading radio dealers throughout the country. In case of difficulty, order direct.

READY RADIO LTD.,
 EASTNOR HOUSE, BLACKHEATH,
 LONDON, S.E.3
 Phone : Lee Green 5678
 Grams : Readirad, Blackvil, London

See also pages 103, 107, 110, 111, 114, 115, 119

JOHN SCOTT-TAGGART

SPECIFIES AND RECOMMENDS

POLAR

for his latest achievement, the

"S.T. 400"

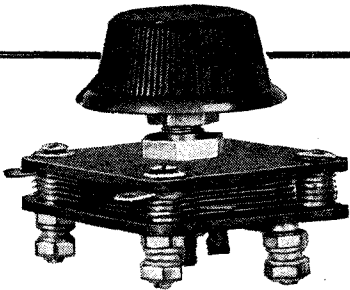

POLAR DIFFERENTIAL

Capacity .0003 each side, Specified.

Polar Differential Condensers are constructed of highest quality materials throughout. Smooth action gives very accurate control. Direct Drive. Insulated spindle. Supplied with knob.

.0001, .00015, 0003

3/-

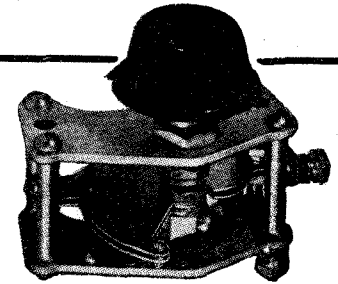

POLAR "No. 4" REACTION

A small air-dielectric reaction condenser. Made in aluminium with brass pillars. Robust construction. Bonded rotor vanes. Ball bearings give smooth, easy control. Supplied with pointer knob as illustrated.

.00004

.0001, .00015, .00025

3/9

POLAR "No. 2"

The precise workmanship and *amazingly low price* has proved this to be the most outstanding condenser of its type. Its popular features include Fast and Slow motion, ball-bearing spindle, positive pigtail connection, one-hole fixing. It follows mid-line law, and is made in hard aluminium, with brass pillars for rigidity.

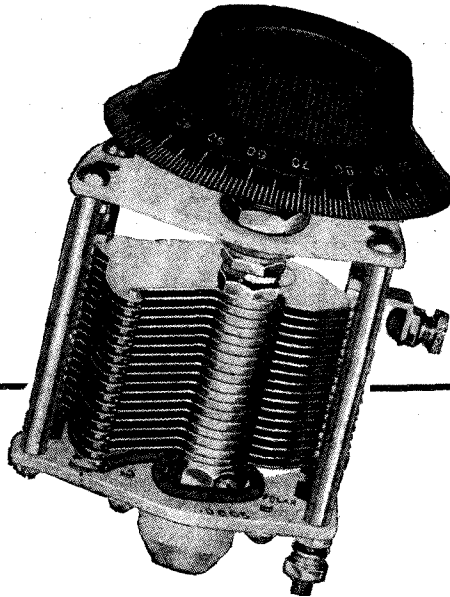

POLAR "No. 2"

.0005,
.00035,
.0003

6/6

POLAR PRE-SET

.0001, .0002, .0003 }
.0005, .001 }
.002 2/-

1'6

POLAR

WINGROVE & ROGERS LTD.

CONDENSERS

188-9, STRAND, LONDON, W.C.2

Polar Works, Old Swan, Liverpool.



WRITE FOR FULLY ILLUSTRATED CATALOGUE. CORRESPONDENCE IN ALL LANGUAGES

Tested in August—But Built in November

experiment need cost you as little as 5d. ! It can be done at any time, and will hold good as long as you use the same speaker.

The .006-mfd. and 1-megohm resistance form a tone-control circuit which acts as an automatically operating variable potentiometer giving true tonal reproduction.

Careful Decoupling

It will be noted that there is a fixed .0003-mfd. condenser to earth. This is to prevent H.F. currents getting into the L.F. circuits.

The detector valve is "decoupled" by 50,000 ohms and 2 mfd.—both essential if the set is to be worked off cheap "eliminators." The third valve is decoupled by 20,000 ohms and 2 mfd.

Wave-change switching is effected by two push-pull switches, while a toggle is used as an on-off switch.

We now come to a valuable feature of the "S.T.400" which consists of an Automatic Reaction Equalisation circuit. My object in introducing this device into the receiver is to refine the reaction control as well as to simplify tuning.

The second reason is the more obvious one. All of you know that if you start at the bottom of a tuning dial and work up, the reaction must be increased at every step. If the reaction is adjusted to the maximum you will find that even half a degree increase in tuning capacity will necessitate just a little more reaction to keep the set in its most sensitive and selective condition.

This constant fiddling with reaction is a nuisance, especially when moving back and forth amongst stations; you may be listening to North Regional in London, say, and turn the dial or dials to Rome, and the set at once bursts into oscillation.

Absolutely Automatic

The Automatic Reaction Equaliser gives a steady supply of reaction all round the dials. It is not a final solution of the problem, but it goes a long way to solve it. And it is absolutely automatic and requires no ganged controls.

Moreover, even if wrongly set it can do no harm! You simply lose its benefits. If you increase the value

of the Equaliser .0003-mfd. pre-set too far, you reverse the normal experience on ordinary receivers. You will now find that as you go up the dials you will need *less* reaction! And if you make the set oscillate at the top end, a movement of the dials towards the bottom end will at once stop oscillation!

The effect is uncanny, but the correct adjustment of the pre-set will give an approximately equal amount of reaction over the dials. This makes station-getting very much simpler, as the sensitivity of the set remains more clearly constant; on the ordinary reaction arrangement

reaction get a fall in signal strength or, at any rate, not the expected rise.

Lop-sided resonance is a definite cause of interference and inefficiency, and the simple addition incorporated in the "S.T.400" possesses many merits only appreciated when handling the set.

The amount of effective reaction applied still, of course, remains under the control of the user. The actual amount of reaction current, however, is automatically increased as one goes up the dials, even though one never touches a reaction knob.

This means that if, say, you are near the oscillation point at 40° you

LOADING-UP AT LAND'S END

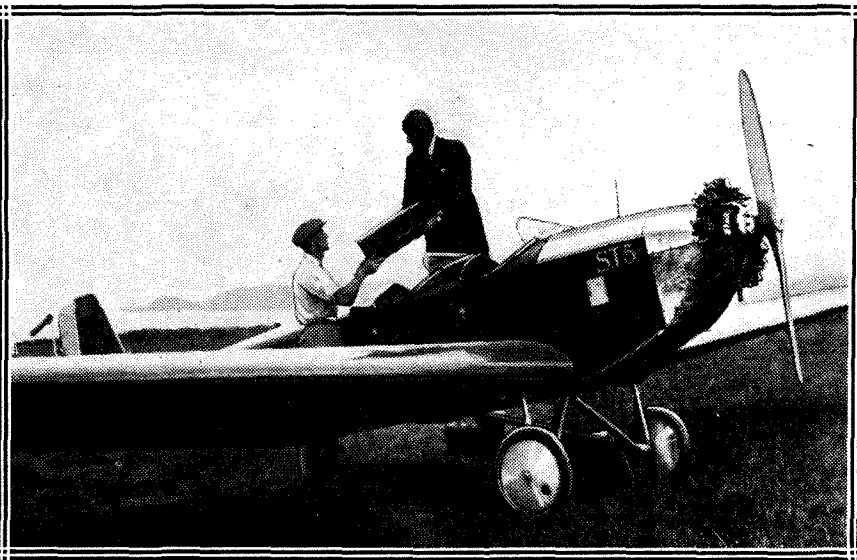

After a striking proof of the "S.T.400" circuit's powers, Mr. Thomas, a "Wireless Constructor" reader, is shown helping Mr. Scott-Taggart to load up his plane in a field at Land's End. The whole of the equipment was carried in the front cockpit.

adjusted for good results on a low dial reading, sensitivity falls off precipitously as one approaches the longer wavelengths unless reaction is increased; much the same thing applies to selectivity.

By the inclusion of the Reaction Equalisation Circuit (which only needs adjustment once—a matter of a couple of minutes—in the lifetime of the set) and the application of a medium amount of Master Reaction, searching is made very simple. Also, "the family" (perhaps with no tuning ability) are enabled to get many stations with ease.

A much subtler merit in the scheme is realised when a considerable amount of reaction is used. Ordinarily, you might on increasing

will be approximately the same "distance" off oscillation when at 120°. But the actual nearness to the oscillation point is governed in the ordinary way by a panel-controlled Master Reaction Condenser.

Another Invention

There remains now only my Double-Channel Reaction invention (covered by my Patent 215,798 and recent provisional patents. This is fully discussed elsewhere by me in this issue.

Having now examined the "S.T.400" circuit, you will see that it is no dusted aspidistra. If the schemes are unconventional, it is simply because I believe old circuits should not be raked up, but ripped up.

ZONE "A"

"RANGE, TONE, VOLUME, SELECTIVITY WERE A DELIGHT"

22, Faskine Crescent,
Airdrie,
Scotland.

Sir,—Please accept my sincere thanks for the demonstration of your new 4-valver. From all points of view the results were wonderful.

On the medium band stations came rolling in, from Kaiserslautern right down to Newcastle.

What struck me was the good volume of every station received—each was as loud and clear as its neighbour, big or small, nearer or more distant. Yet the volume had no distorting effects and could be controlled easily, without loss of the low tones.

Moreover, the stations high up in this medium-wave band—round about

RESULTS IN SCOTTISH ZONE TESTS

Vienna—were as loud and pure as those low down—round about Fécamp.

Vienna itself was remarkably good: the reception being the very best I have heard in Scotland for strength and tone values. Karlstadt (0.25 kw., 217 metres) was also very good and quite loud enough for an ordinary room.

On the long-wave band the dozen stations worth hearing were all received—from Kaunus, 1,935 m., to Leningrad, 1,000 m.

Here, too, volume and purity were

evident throughout—certainly the best I have heard from any set.

As to selectivity. On the medium waves I will mention merely some of the "separations," which are achievements in Scotland, in my opinion. Bodo, 5 kw., from its gigantic neighbour, Beromunster, 60 kw. (only 9 kilocycles); Leipzig, 2 kw., and Horby, 10 kw.; Paris P.T.T., 7 kw., from its neighbour, Rome, 50 kw. (9 kilocycles); Turin, 7 kw., and Rennes, 13 kw. (7 kilocycles).

On the long waves selectivity was like child's play; it was so simple as to seem commonplace.

Unusual stations for this area which came in uncommonly well included Kaunus, Kaiserslautern, Vienna, Rabat (Morocco), Nurnberg, Newcastle—the last is very rarely decently heard here.

The time spent in the actual demonstration was 1½ hours, in which 64

D

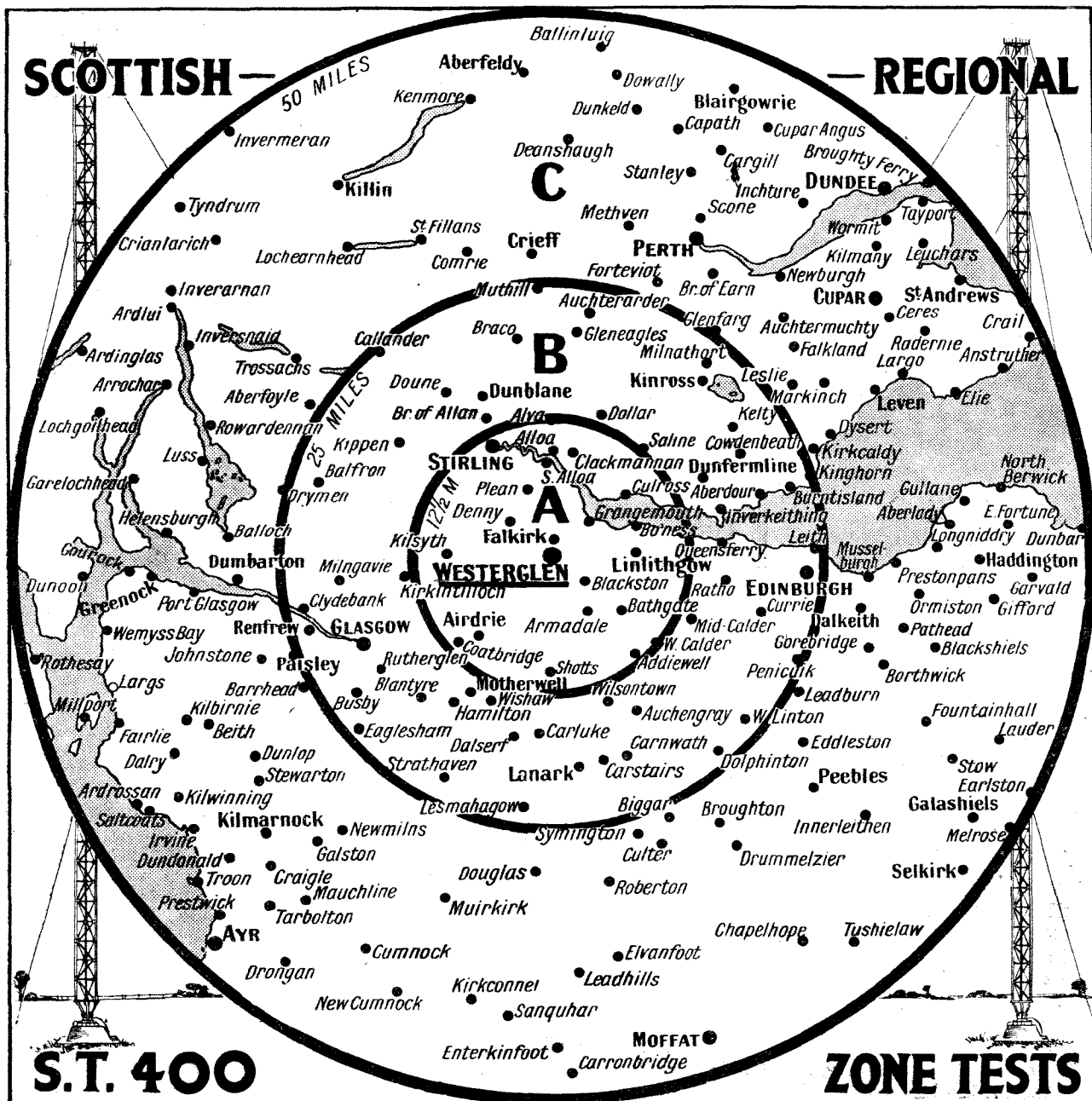

S.T.400

READY RADIO KITS

READY RADIO LTD.
 Eastnor House · Blackheath · London · S.E. 3

Telephone:
LEE GREEN 5678
 (Private Exchange)

Directors:
 IVOR W. E. HUSTLER F. T. PANKHURST



Telegrams:
 READRAD, BLACKVIL
 LONDON

Friday, 28th October, 1932.

My dear Mr. Scott-Taggart,

"It is a very long time since I first learned to associate the initials "S. T." with fearless originality and complete disregard of accepted shibboleths in radio receiver design. Your return to the home constructors' world, bringing back these qualities apparently even intensified by your absence, seems to me the most important event which has happened in radio for years.

Your first salvo in the battle for better radio, the "S.T.300," showed that my expectations of swift happenings were to be realised in full. That extraordinary set certainly made the somnolent exponents of the single dial realise their stagnation, for there can be no question that it set an entirely new standard of performance for three-valvers.

Incidentally I want to acknowledge my indebtedness to you for a great part of the remarkable success of my "Meteor" S.G.3 receiver. My instructions were to produce an ultra-high efficiency all-wave set, and I based it upon your "300" circuit, adding the short-wave features which I required, for I knew that I should thus be certain of the high level of performance which I wanted.

Now you have brought up heavier artillery into the line. The "400" is, definitely, a set which marks the beginning of a new stage in radio development. It will, I am quite certain, enforce the adoption of entirely new ideas of receiver performance, even by the one-dial brigade. I have tested it very thoroughly now, and much as I loathe the word 'wonderful' in connection with a radio receiver, I can find no better way of describing your "S.T.400."

Yours sincerely,
 (Signed) G. P. KENDALL,
 Chief Engineer,
 Ready Radio Ltd.



Mr. G. P. Kendall, B.Sc. the well-known designer, worked under Mr. John Scott-Taggart in the great pioneering days of "Radio Press." Read this appreciation and acknowledgment of his former chief.

See also pages
 99, 107, 110, 111, 114, 115, 119

BUILD

THIS S.T.400 ELIMINATOR

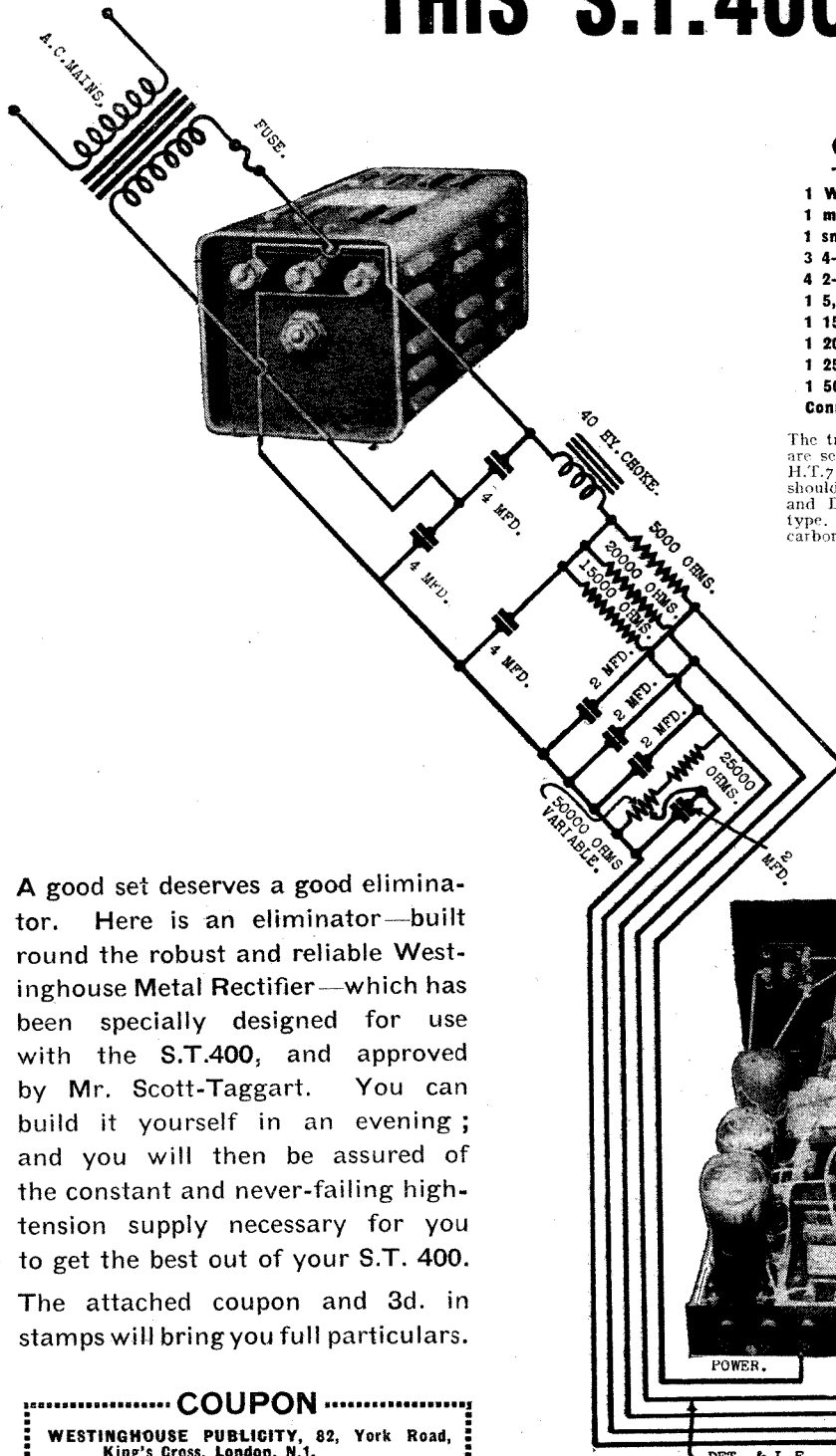

COMPONENTS REQUIRED

- 1 WESTINGHOUSE METAL RECTIFIER STYLE H.T.7.
 - 1 mains transformer.
 - 1 smoothing choke (40 henry, 1,000-ohm resistance type).
 - 3 4-mfd. condensers.
 - 4 2-mfd. condensers.
 - 1 5,000-ohm resistance.
 - 1 15,000-ohm resistance.
 - 1 20,000-ohm resistance.
 - 1 25,000-ohm resistance.
 - 1 50,000-ohm variable resistance.
- Connecting wire, fuse, etc.

The transformer must have an output of 135 volts, and there are several on the market designed specially for use with the H.T.7 Westinghouse Metal Rectifier. The Reservoir Condensers should be of the 200 D.C. Working Voltage type and the Filter and Decoupling Condensers of the 400 D.C. Working Voltage type. Resistances can be of the metallised 1-watt type, carborundum or spaghetti.

A good set deserves a good eliminator. Here is an eliminator—built round the robust and reliable Westinghouse Metal Rectifier—which has been specially designed for use with the S.T.400, and approved by Mr. Scott-Taggart. You can build it yourself in an evening; and you will then be assured of the constant and never-failing high-tension supply necessary for you to get the best out of your S.T. 400. The attached coupon and 3d. in stamps will bring you full particulars.

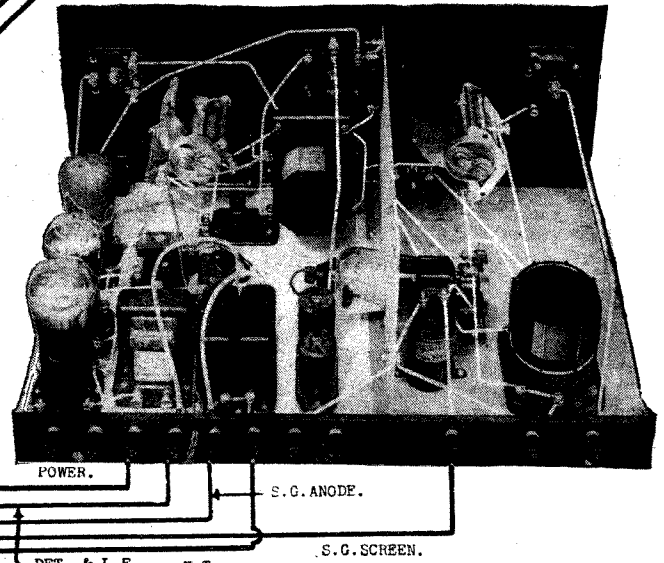

COUPON

WESTINGHOUSE PUBLICITY, 82, York Road, King's Cross, London, N.1.

Please send me "The All-Metal Way, 1933," containing full particulars of Westinghouse Metal Rectifiers, and telling me how to build an A.C. Eliminator.

Name

Address

..... W.C. 12.32.

**THE WESTINGHOUSE BRAKE & SAXBY SIGNAL CO. LTD.,
82, YORK ROAD, KING'S CROSS, LONDON, N.1.**

stations were received. Many more could have been got; several large fellows like Midland Regional and Sottens were not bothered about and passed over.

Range, tone, volume, selectivity were a delight, and I am sure will satisfy Scottish listeners. I am certainly going to convert my "S.T.300" to the new circuit.

Yours faithfully,
ARTHUR N. FERMIE.

(Ed. Note.—This reader's home is 9 miles from the Scottish regional station.)

ZONE "B"

"FAR OUTSTRIPS ANYTHING I HAVE HEARD"

Cardonald Gardens,
Glasgow.

Sir,—I had intended to apply for inclusion in Mr. Scott-Taggart's list of S.N.U.'s (stiff-necked unbelievers), but after he had "flown" in on us with his forthcoming new set, the "S.T.400," I was immediately converted.

We had a very pleasant evening with the new set on my aerial here, which is not too good, the lead-in being 25 ft. long, coming through the house from back to front and just tacked to the wall. (I offered to let Mr. Scott-Taggart test his set in the back room, and so cut out this lead-in, but he said he wanted to take conditions as he found them.)

The set was fixed up, and Mr. Scott-Taggart bagged a list of 55 stations on the medium waves and 12 on the long waves. Of these stations, two were not definitely identified, but were good,

while three were common waves and of no value. There was thus a grand total of 64 stations, all at real loudspeaker strength and perfectly clear of each other. This omits several stations which had closed down when their turn came.

The quality of reproduction was very fine indeed.

What struck me most of all was the keen selectivity of the set. Not only was a 9-kilocycle separation easily obtained, but when greater selectivity was needed the receiver proved equally satisfactory (e.g. separating Algiers from Stuttgart, 6.7 kc. apart, or Eiffel Tower from Warsaw, on the long waves, 5 kc. apart).

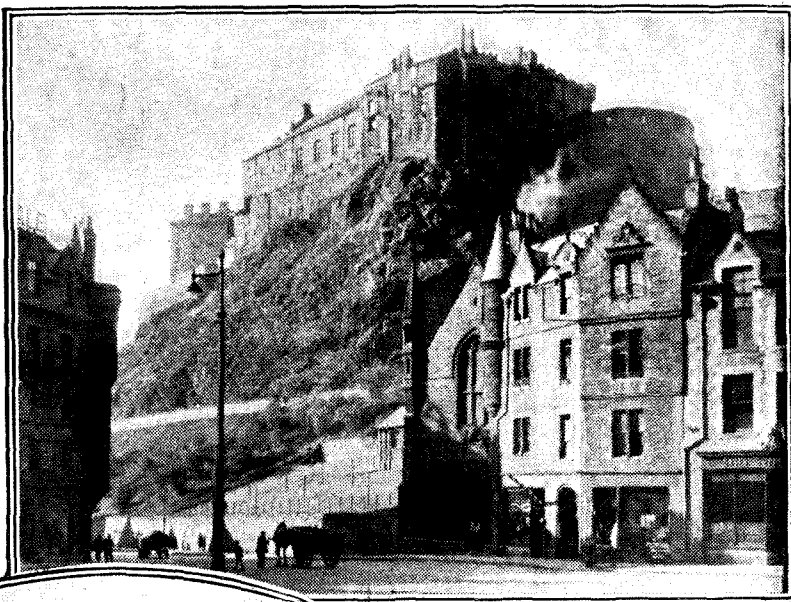

Edinburgh Castle.



Right: "S.T." at Westerglen.

*

Below:
Glasgow Bridge.



The station-separating powers of the set with the B.B.C. in operation were most marked, and were not obtained at the expense of quality.

The operation of the set seems perfectly simple, and, to my surprise, Mr. Scott-Taggart used no calibration chart to obtain the stations. But, once received, their identity was established by relative position, language, programme,

etc., and in each case by an accurate wavemeter.

Mr. Scott-Taggart is, I consider, the real friend of the constructor. He has faith in his work, and sets out on the bold policy of visiting the readers he caters for, coming right to their fireside and demonstrating what his set can do—not only to his host, but to himself.

He intends his sets to get certain results, and he travels round gathering experience as he goes, and this policy which he so whole-heartedly carries out for the constructor must be of great benefit to his readers.

I await with keen anticipation the published details of this new set, and I am confident that there will be very many constructors here in Scotland who will build this real "star" set, which has proved itself suitable to our geographical position.

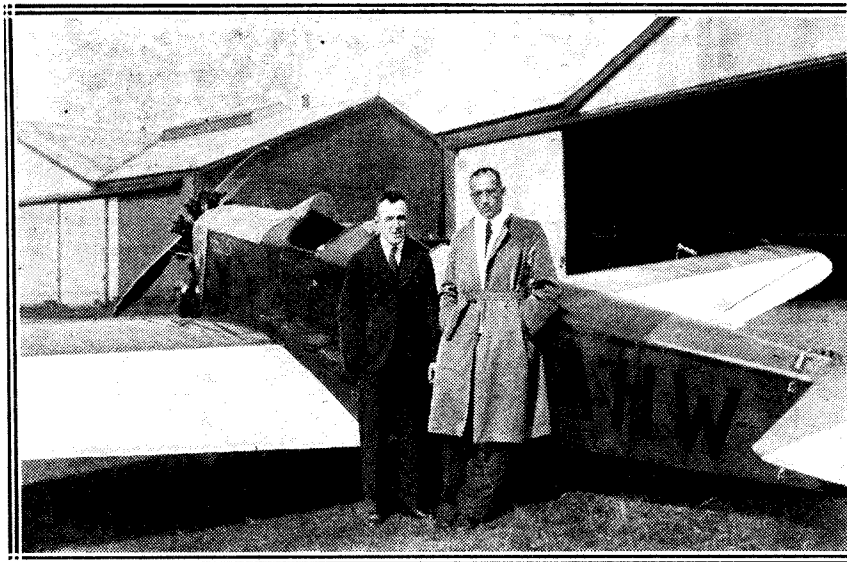

AT TURNHOUSE AERODROME, EDINBURGH

This is Mr. G. Mackenzie, who states in his report: "I was absolutely thunderstruck with the strength, tone and purity with which the stations came in, and in only one instance was there a faint whisper of Westerglen in the background."

I have been a radio enthusiast for many years, have built 26 different sets, and now possess a 50-guinea mains radio-gramophone, a leader in its class. All I can say is that the "S.T.400" far outstrips anything I have heard.

Mr. Scott-Taggart will be responsible for my hunting out the old tools and having a "go" again! I will report later on re the set I produce.

Yours faithfully,
ROBERT YOUNG.

ZONE "B"

AN ASTOUNDING PERFORMANCE

15, Brunswick Road,
Edinburgh.

Sir,—Allow me to express my thanks for the wonderful demonstration you gave me with your new set at the above address last night.

I've tinkered with radio receivers for the past five years, yet it wasn't until I built the "S.T.300" that I felt I had reached the goal of my ambition in radio—the possession of what I could really call a radio receiver.

However, since last night's performance that's all changed, and now I'm anxiously awaiting the publication of this new circuit.

The very fact that in the short space of two hours you logged no less than 54 stations (40 on the medium wave-band and 14 on the long wave) on my aerial, which is screened on three sides, convinces me that there's going to be at least double the number of "S.T.400's" built than there were "S.T.300's."

I was absolutely thunderstruck with the strength, tone and purity with which the stations came in, and in only one instance was there a faint whisper of Westerglen in the background.

I'd absolutely given up hope of possessing a receiver which could put up such an astounding performance in

this part of the country as your new set did here last evening, and I've no hesitation in saying that it'll knock any amateur or factory-made five-valver into a cocked hat—and I've handled not a few.

Readers got something exceptionally good in the form of the "S.T.300," but now they're being presented with an even better set, the results of which cannot fail to satisfy every wireless enthusiast.

Yours faithfully,
GEORGE MACKENZIE.

ZONE "C"

"ALL RECEIVED CLEAR OF INTERFERENCE"

8, Alexandra Street,
Perth, N.B.

Sir,—We beg to report the test that was held in our house on Wednesday, August 31st, 1932, of your wireless set "S.T.400."

But first we must describe the aerial on which the set was tested: 7-strand copper, about 65 feet, including lead-in, and **BOTH WIRES NEVER MORE THAN 18 INCHES FROM ROOF SLATES!**

About 50 stations were tuned-in at excellent loudspeaker strength, and several others which were marred by bad atmospherics.

All stations were received clear of interference before being logged, which shows the wonderful sensitivity and selectivity of the receiver.

We are,
**WALTER MILNE,
JOHN BLYTH.**

ZONE "D"

For results in Zone "D" see letters elsewhere in this number from John o'Groats and Newcastle areas.

THE WHOLE COUNTRY IN ZONES

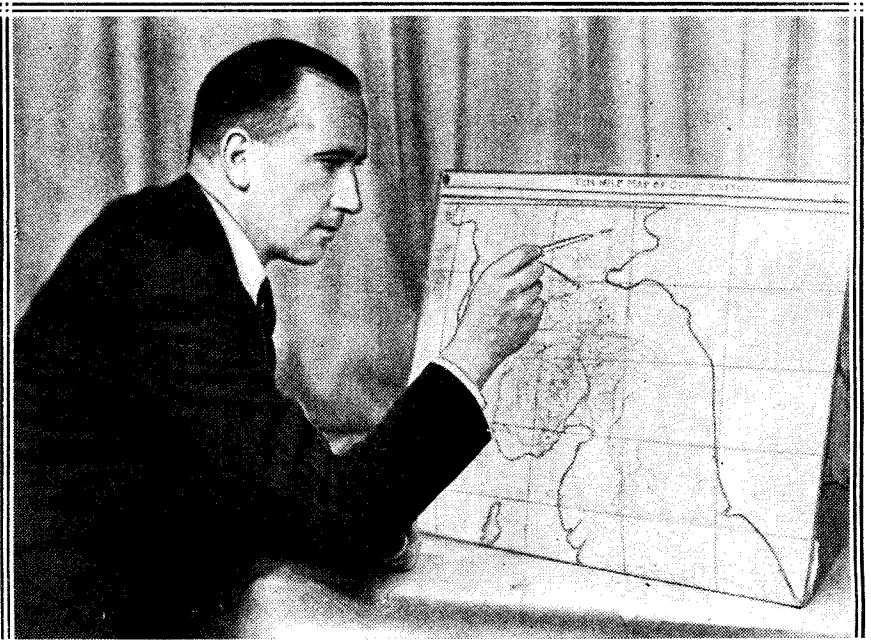

All localities have been zoned by Mr. Scott-Taggart, so wherever you live you can be sure of the sort of results to be expected from the "S.T.400." Note, too, how it behaves on all sorts of aeriels, as reported by other readers.

S.T.400

READY RADIO KITS

READY RADIO S.T.400 REBUILDERS' KIT FOR ALL S.T.300 OWNERS

35/-

Includes *everything* you require, to the last screw, to convert your S.T.300 to the *correct* S.T.400; *with* full instructions and full-size blueprint, *and* helpful instructions regarding the conversion, by
Mr. G. P. Kendall, B.Sc.

This Kit carries the usual Ready Radio guarantee, and its purchase entitles you to membership of our Registered Users' Scheme.

The components chosen for this Kit have been thoroughly tested in our laboratories and have proved themselves most suitable for the conversion. Be sure of satisfaction. Get a complete Ready Radio Rebuilders' Set.

SPECIAL OFFER TO ALL S.T. 300 OWNERS

Every S.T. 300 user wishing to convert can send us his aerial coil upon purchasing this Conversion Kit and we will allow him a rebate of 2/- on his order. If he wishes he can purchase the Ready Radio Kit from his dealer who will make him the same allowance.

Ready Radio Kits and Components can be obtained from all leading radio dealers throughout the country. In case of difficulty, order direct.

READY RADIO LTD.,
EASTNOR HOUSE, BLACKHEATH,
LONDON, S.E.3
Phone: Lea Green 5678
Grams: Readirad, Blackvil, London

See also pages 99, 103, 110, 111, 114, 115, 119

ZONE "A"

"IN A CLASS BY ITSELF"

70, Mitchell Street,
Rochdale, Lancs.

Sir,—Readers of "The Wireless Constructor" are, I feel sure, eagerly awaiting the issue of the particulars of your new set. As one of the fortunate ones who has had the opportunity to witness the set tested in my own home, I can assure your readers that when it is published its success will be far greater than the "S.T.300."

In 2½ hours 43 stations were received at good loudspeaker strength, the majority of them too loud for an ordinary room, and in every case the station was identified to my satisfaction beyond any possible doubt before continuing the test.

Hamburg was received quite clear of Scottish Regional, Prague without any trace of North Regional, and

RESULTS IN NORTH REGIONAL ZONE TESTS

Königswusterhausen quite clear of Daventry. Sottens, Midland Regional and Frankfurt were all clear. Algiers—only 7½ kc. from Stuttgart (Mühlacker)—was obtained without interference.

I have had many years' experience as an amateur with multi-valve sets, and believe the special controls and circuit of the "S.T.400" will place this set in a class by itself.

As the test was carried out on a summer evening, with atmospherics worse than I have ever heard them before, I think the performance was a wonderful one, especially taking into consideration the fact that my aerial is only 9 miles from the masts at Slaithwaite.

Yours faithfully,
E. LEIGH.

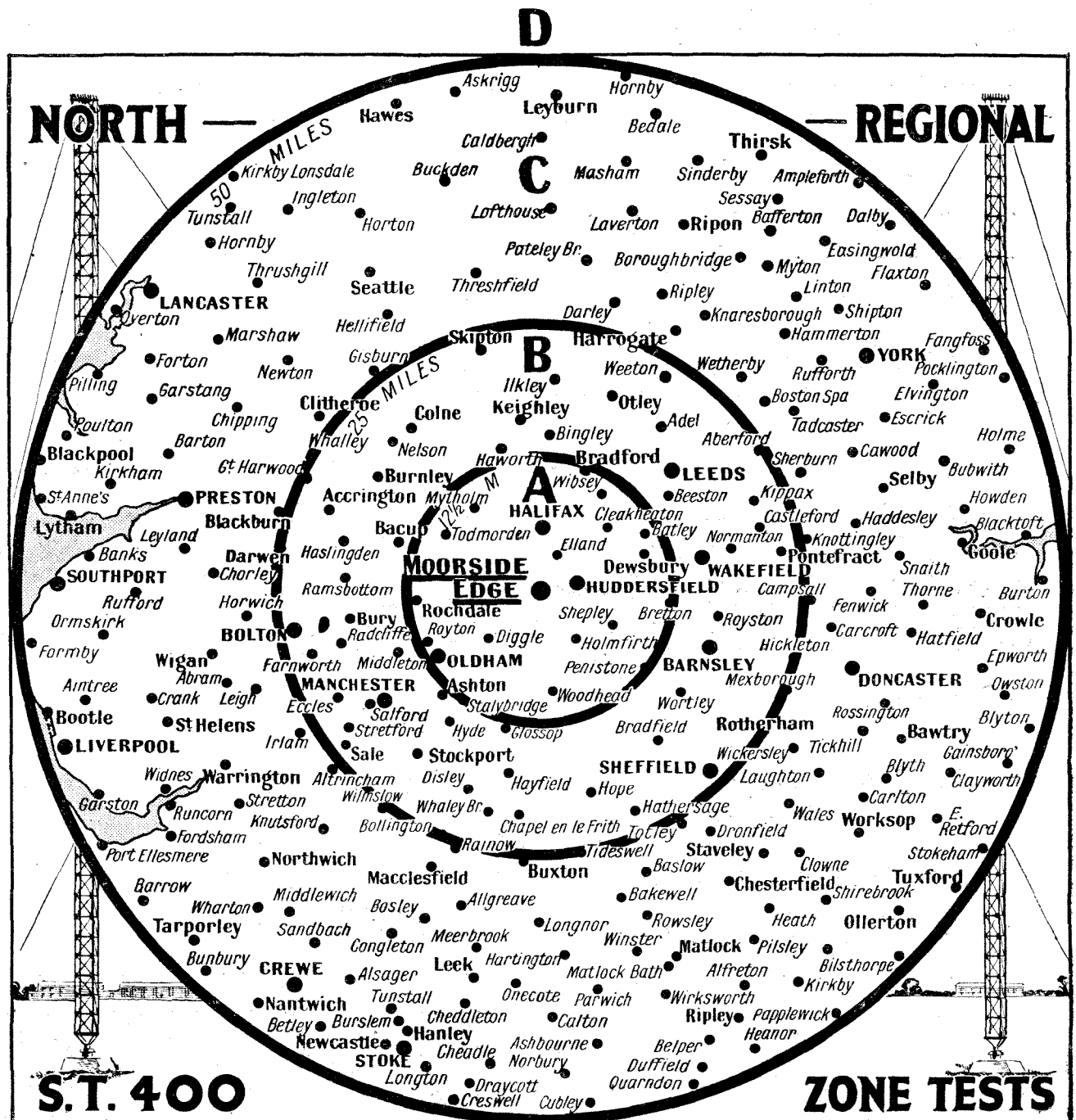

ZONE "B"

"THE SET WAS ABSOLUTELY UNCANNY"

112, Church Road,
Kearsley,
Lancashire.

Sir,—In the September issue of "The Wireless Constructor," Mr. Scott-Taggart advised anyone who, having built the "S.T.300" and were considering adding



Top picture : Manchester, Piccadilly.
In oval : Liverpool, Merseyside.
Right : Leeds, The Town Hall.

another stage, to wait until his latest set was published—and no wonder! It was, indeed, a pleasure to have him at the above address demonstrating his new production, the "S.T.400." The set was absolutely uncanny—what every wireless enthusiast has only dared to dream about.

My own aerial is a mediocre inside one, and I did not expect very much in the way of results.

55 stations from the "World Radio" list were on the ether, and each one of them was received clearly, strongly, distinct and absolutely separate on the loudspeaker.

Konigs Wusterhausen was clear. Eiffel Tower was separated from Warsaw with ease, as was Prague from North Regional. Hilversum and Bordeaux-Lafayette were clear of North National.

Mühlacker, London Regional and Graz were clear of each other. Leipzig and London National did not interfere. Lwow, Scottish Regional and Hamburg could all be got without interference from each other.

It must be noted that during the tests all the B.B.C. stations were working all the time.

Stations such as Vienna, Rabat and Riga came in wonderfully; truly everything at your feet—with an inside aerial, be it noted!

Throughout the scale on both wavebands the volume was wonderful.

The richness of tone I did not think could be achieved without the use of mains-operated valves, yet it was there in its entirety.

I have no hesitation whatever in saying that, in my opinion, 1933 all mains super-het. models will have to give way to this truly marvellous "S.T.400"; and if what I have seen and heard had only been reported to me, I would not and could not have believed it. Yet the above results were obtained on my own aerial.

Thanking Mr. Scott-Taggart for a very wonderful radio evening,

I am, Yours truly,
FRED HOWARTH.

ZONE "C"

"SELECTING ONE STATION FROM ANOTHER IS NO PROBLEM AT ALL!"

Lock-Keeper's House,
Lightbody Street,
Liverpool.

Sir,—Allow me to congratulate you on the designing of such a fine, powerful set as the "S.T.400."

For the benefit of those who are constructors, like myself. I would like to put down just what happened on the night that the test was made in my house.

We simply received one station after another. The number of stations for the evening was 62 at full loud-speaker strength, and at no time during the evening did one station overlap another. Every station was clear and only that one station could be heard.

The tuning in of so many stations was, in my opinion, very good, when conditions are considered. My aerial, although an outside one about 29 ft. high and 50 ft. long, is not a good one by any means—right underneath it, about 15 ft. high, is a sheet-iron building while about 50 yards away is a steel tower 94 ft. high, and at about 150 yards is another of these steel towers also 94 ft. high. and my aerial is right between them; and then at a distance of 150 yards is the gas works, with those great, large gasometers, which are well above me



S.T.400

READY RADIO KITS

MR. JOHN SCOTT-TAGGART writes to the Editor of "Wireless Constructor" :—

"With reference to my S.T.400 Receiver, described in the current issue of 'The Wireless Constructor,' I have received for test from Messrs. Ready Radio Ltd., a kit of parts in accordance with the circuit. This kit has been tested, and has proved entirely satisfactory."

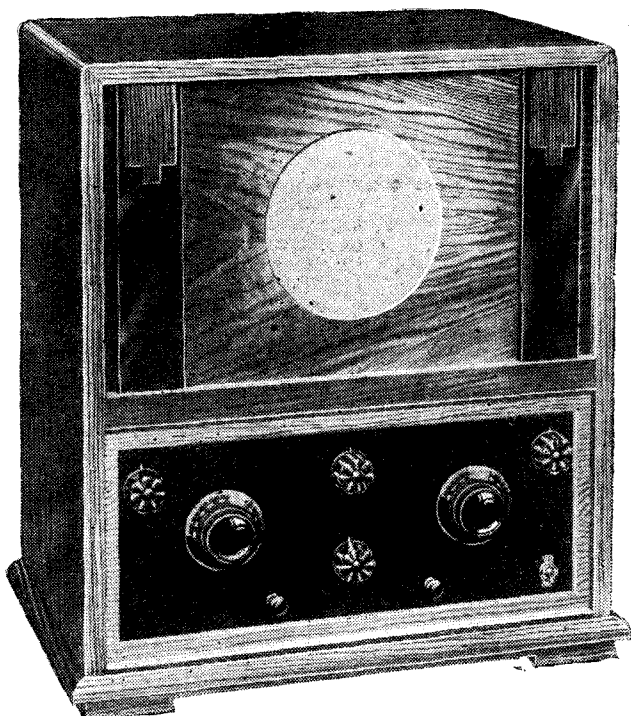

This handsome Walnut S.T.400 Cabinet can be supplied separately. Price £2 0 0.

Model A. Complete Kit of parts with 4 specified valves and cabinet **£10-10-0**
or deposit of 20/- and 11 monthly instalments of 21/-.

READY RADIO S.T.400 KIT

Complete Kit of tested and matched components. *Everything* you need to build the S.T.400 including panel, ready cut and drilled, baseboard, all screws and wire, Jiffilinx for wiring—the handiest form of connection ever invented. Every Jiffilinx is numbered—you can't go wrong.

£4·17·6

or deposit of 9/6 and
11 monthly payments of 9/9.

EVERY COMPONENT EXACTLY AS SHOWN ON BLUEPRINT, free copy of which is included with every kit, with free copy of "Wireless Constructor."

Model B. Complete Kit of parts with 4 specified valves **£6-16-9**
or deposit of 12/6 and 11 monthly instalments of 13/9.

Ready Radio Kits and Components can be obtained from all leading radio dealers throughout the country. In case of difficulty, order direct.

READY RADIO LTD.,
EASTNOR HOUSE, BLACKHEATH,
LONDON, S.E.3
Phone: Lee Green 5678
Grams: Readirad, Blackvil, London

See also pages 99, 103, 107, 111, 114, 115, 119

METEOR S.G.3

READY RADIO KITS

ALL-WORLD ALL-WAVE RECEPTION

You may require only a 3-valve set. You may want all-world reception on all waves. If so, you cannot do better than build the famous Ready Radio Meteor S.G.3. This wonderful set combines all the wonderful features of the S.T.300, plus the fascination of ultra-short-wave reception of stations in all parts of the World.

Mr. G. P. Kendall, B.Sc., whole acknowledgment and appreciation of Mr. Scott-Taggart appears on page 103, personally toured the country with the "Meteor" S.G.3, testing it in all districts. As the result of this convincing test we guarantee you reception of at least thirty stations—you will probably get two or three times as many.

"METEOR" S.G.3 KIT

Complete Kit of tested components to construct the "Meteor" S.G.3 in chassis form, as illustrated above,

Price £3 - 15 - 3

COMPLETE KIT, as above, with set of three Mullard Valves,

£5 - 7 - 6

or 10 monthly payments of 12/6

CABINET MODEL.

Complete Kit with valves as above and beautiful walnut cabinet fitted with moving-coil speaker,

£8 - 17 - 6

or 12 monthly payments of 17/-

Full building instructions, plans, photographs, diagrams and operating instructions FREE with every Kit.

Your safeguard—every owner a Registered User.

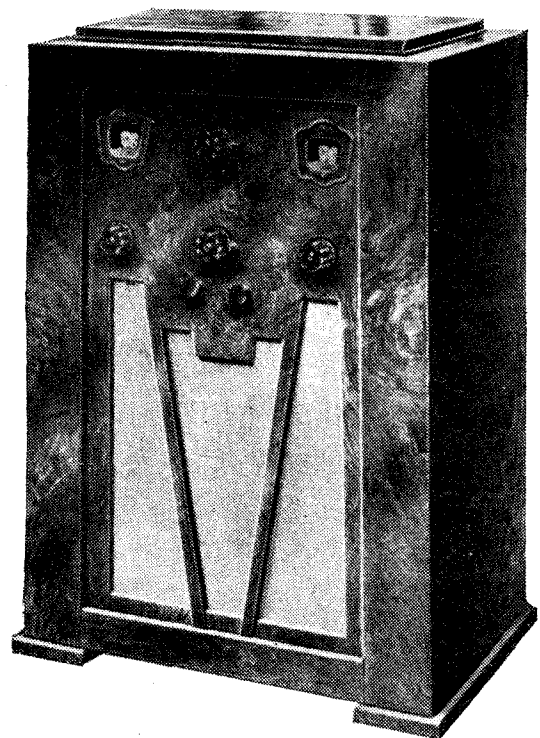

Ready Radio Kits and Components can be obtained from all leading radio dealers throughout the country. In case of difficulty, order direct.

READY RADIO LTD.
EASTNOR HOUSE, BLACKHEATH,
LONDON, S.E.3
Phone: Lee Green 3678
Grams: Readirad, Blackvil, London

See also pages 99, 103, 107, 110, 114, 115, 119

What the North Region Thinks of "S.T.400"

in height; while at about 40 yards distance are a number of steel tanks which are used for oil storage; these are also higher up than my aerial; and then 200 yards away is the L.M. & S. electric railway; and 150 yards, the corporation electric tramways.

I would like to mention three things that seemed to stand out in this receiver: (1) Station-getting power was so great that foreign stations were as strong, in most cases, as the local; (2) Tone, nothing better could be desired. While as to (3), namely, Selectivity—well, when you hear this set you wonder why there is so much talk of selectivity, because with the "S.T.400" the problem of selecting one station from another is no problem at all. Just the touch of the dial and you hear the station you want, and only that station.

During my 11 years' wireless experience of all kinds of multi-valve receivers, this is the finest set I have yet heard.

Yours truly,
JOHN A. PERRY.

ZONE "D"

"IMPRESSED BY THE GREAT VOLUME AND SELECTIVITY"

36, Brampton Place,
North Shields,
Northumberland.

Sir—It has just been my great privilege to hear in my own home (using my aerial) the testing of the new "S.T.400" by Mr. Scott-Taggart in person, and I feel that I must pass my humble opinion on it.

I was first impressed by the great volume and selectivity of the set. The separating of some of the more difficult stations was a revelation to me.

I fear I would have to cover several sheets of paper if I went into details describing the reception of various broadcasts, but I can assure my readers that the great majority of the 84 stations logged were of entertainment value.

In conclusion, I should like to congratulate Mr. Scott-Taggart on the production of a fine set which should prove a tremendous success.

Yours faithfully,
A. E. YOUNG.

ZONE "D"

123, Albert Avenue,
Hull.

Sir,—I still have pleasant recollections of your aeroplane visit to try out in this locality the "S.T.400," and of the log of 85 stations in a little over two hours.

The 100-station log would easily have been reached had the test commenced earlier, but owing to unavoidable delay it did not start until 9 p.m. and, therefore, a good many of the stations coming easily within the scope of the receiver had closed down when reached.

The whole test, however, was carried out during B.B.C. hours. There was no guesswork about the stations received; an oscillator wavemeter was used to identify all the stations and those which did not give a fair result were rejected.

I have handled and tested out a good many receivers of all types, from the early models to the latest super-het., my experience dating from the time when we had to make most of our own components. Then came your Radio Press designs, the "Elstree" Six, the "Solodyne" (the first attempt at gang control in this country), the "Elstrophone," a receiver of great adaptability and flexibility, and so to the most modern super-het.

I, therefore, speak with some experience of receivers when I say that "S.T.400" is the finest four-valve set I have yet heard. The rapidity with which it brings in the stations one after the other without the slightest interference is really amazing, and with a clarity and purity to satisfy the most exacting of purity fans.

TESTED ON THE SPOT



With S.T.5 on the ground behind him and the "S.T.400" under his arm, here is Mr. Scott-Taggart at the Cranlington Aerodrome, near Newcastle. Beside him stands Mr. Marshall (whose letter appears elsewhere in this number).

The flexibility of the receiver is another point which places it in the front of all others; it can obviously be readily adapted to suit all aeriels and all localities, broad or knife-edge tuning, and can be adjusted to meet the march of changing power and wavelengths in the Continental ether. It is a receiver not designed for to-day and changed tomorrow, but its flexibility is such that it can (without alteration to the receiver) cope with any drastic alteration in the power and wavelengths of stations in the near future.

When released for publication it will make a great stir in the world of wireless, and I can

with confidence recommend those interested to build the receiver. They will not be disappointed.

Should any of your readers in this locality desire any further particulars of the test I will be happy to supply same if they will get into touch with me.

Wishing you every success,
WM. T. FARROW.

MORE LETTERS

from "Wireless Constructor" readers, giving actual experiences of the "S.T.400," will be published

NEXT MONTH

ZONE "A"

"WITHIN TWO HOURS 48 STATIONS WERE RECEIVED, IDENTIFIED AND LOGGED"

17, Pelham Road,
Tottenham,
London, N.15.

Sir,—During the evening of October 14th, at the above address, Mr. Scott-Taggart gave an astonishing demonstration of the capabilities of the "S.T.400" which greatly impressed the audience, consisting of the family and a few friends.

I was specially impressed because my aerial is very poor, being not only short and low, but being also badly screened by trees and a huge building which completely dwarfs the house.

The quality of reproduction is excellent, and the volume, which is enormous both on home and distant stations, in no way affected the richness of tone.

A few simple operations of the controls proved the selectivity of the set. That Mühlacker was separated with ease

LONDON ZONE TESTS

from London Regional (extremely difficult in this particular area) is in itself evidence conclusive.

Within two hours 48 stations were received, identified and logged. Each station was at loudspeaker strength and free from interference.

Throughout the test Brookmans Park transmitters were working!

Yours faithfully, S. TAYLOR.

ZONE "B"

5, Beatrice Road, Bermondsey,
London, S.E.1.

Sir,—It gave me the greatest pleasure to hear a demonstration of your new receiver, the "S.T.400," in my own home. The test was carried out on a 30-ft. aerial, and the results were, in my opinion, extraordinarily good.

50 stations were recorded during the test, which lasted, approximately, one and a half hours. Each of these stations was received at excellent loudspeaker strength, without any interference whatever from any other station.

D

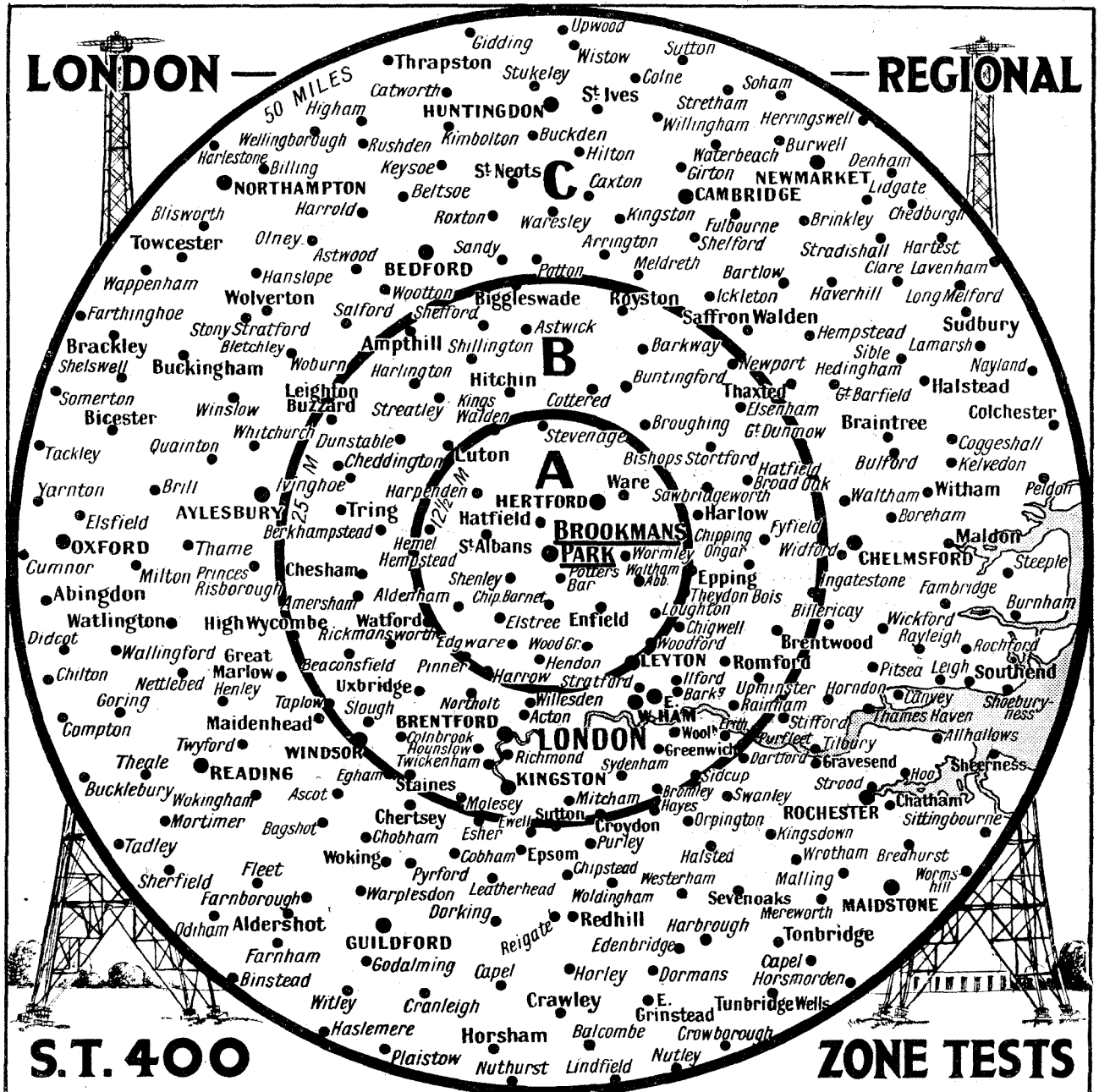

S.T.400

READY RADIO PARTS

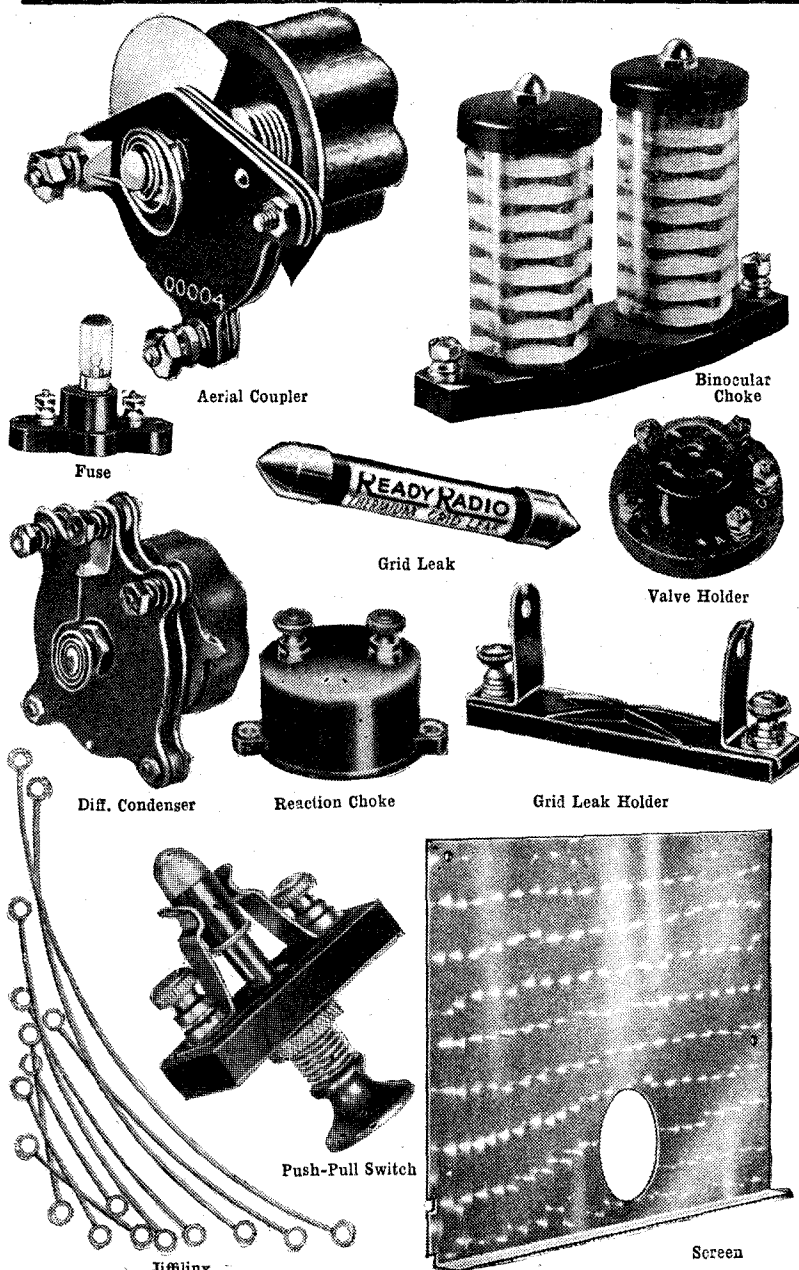

CHOSEN FOR THE S.T.400

If you do not require the complete S.T.400 Kit, choose the components you need from the following list. All Ready Radio Components have been specially chosen to give maximum efficiency; you should therefore insist on Ready Radio and see that every carton is marked "CHOSEN FOR S.T.400"

Aerial Coupler - - - -	1/6
Valve Holder - - - -	6d.
S.G. Binocular Choke - -	5/-
Reaction Choke - - - -	1/6
Differential Condensers	
'0001 - - - -	2/6
'0003 - - - -	3/-
'00035 - - - -	3/6
Push-pull on-off Switch -	10d.
Screen - - - - -	2/-
Foil - - - - -	1/-
Jiffilix for wiring	
	1/6 per packet
Thermium Grid Leaks - -	10d.
Grid Leak Holders - - -	6d.
Fuse & Holder - - - -	1/-

Ready Radio Kits and Components can be obtained from all leading radio dealers throughout the country. In case of difficulty, order direct.

READY RADIO LTD.
 EASTNOR HOUSE, BLACKHEATH,
 LONDON, S.E. 3
 Phone: Lee Green 5678
 Grams: Readirad, Blackvil, London

See pages 99, 103, 107, 110, 111, 115, 119

S.T.400

READY RADIO PARTS

READY RADIO S.T.400 COILS

Tested and passed by Mr. John Scott-Taggart.

Mr. G. P. Kendall's long association with Mr. Scott-Taggart, our unrivalled factory equipment, our organisation, and our long experience, assure you of the finest reception possible when you insist upon Ready Radio Coils for your set.

The importance of the coils cannot be over-emphasised. The purchase of inferior coils can easily mean that you will miss many stations which would otherwise come in at full strength.

Every Ready Radio Coil is 100% efficient and is manufactured, tested and passed under the personal supervision of Mr. G. P. Kendall, B.Sc.

BE SURE TO COMPARE READY RADIO COILS WITH OTHER MAKES BEFORE PURCHASE

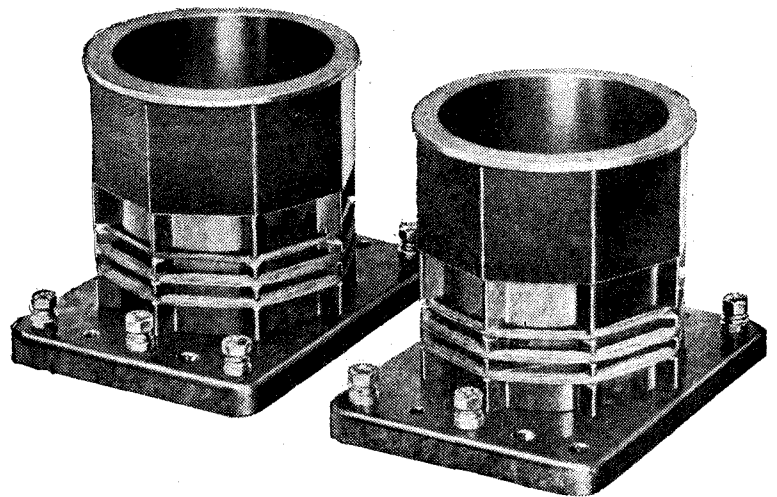

READY RADIO S.T.400 COILS

PER PAIR 9/10

AERIAL COIL - 5/-
(For S.T.300 Users)

Ready Radio Kits and Components can be obtained from all leading radio dealers throughout the country. In case of difficulty, order direct.

READY RADIO LTD.,
EASTNOR HOUSE, BLACKHEATH,
LONDON, S.E.3
Phone: Lee Green 5678
Grams: Readirad, Blackvil, London

See also pages 99, 103, 107, 110, 111, 114, 119

SPECIFIED

*and recommended by
Mr. John Scott-Taggart
for the*

S.T.400

*and specially selected for
the S.T.400 Ready Radio Kit*

The Varley NICLET was specified in the original "S.T.300," and Mr. G. P. Kendall, B.Sc., Chief Engineer of Ready Radio, has chosen it in preference to all alternatives for inclusion in the Ready Radio "S.T.400" Kit.

See that you get the correct Model. Not a standard "Niclet," but THE S.T. 400 NICLET—specially designed and labelled for this great set by Varley, and ready now.

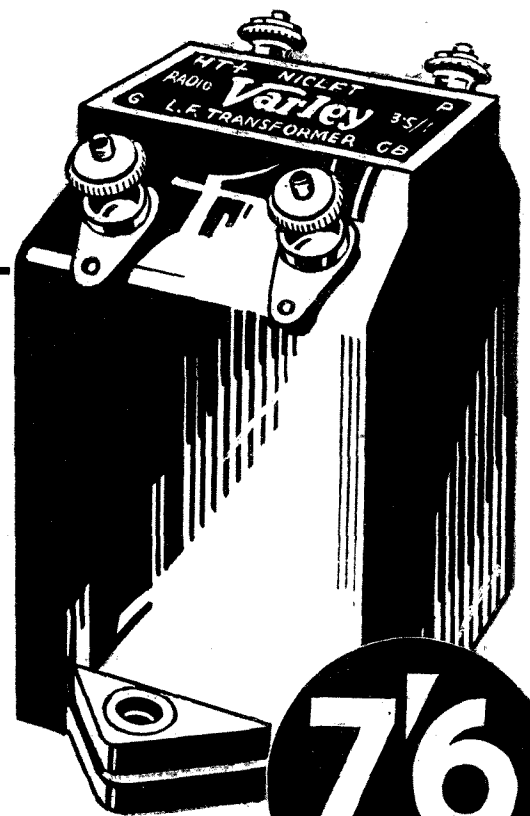

Varley "NICLET"

Advertisement of Oliver Pell Control Ltd., Kingsway, London, W.C.1.

Telephone: Holborn 5303.

The quality was very pleasing, and what impressed me more than anything throughout the whole test was that while London stations were broadcasting, foreign stations separated by only a few kilocycles were able to be received without the slightest mush from any other more powerful station.

Mühlacker, London Regional's neighbour, was also received with excellent volume, and without the slightest trace of the powerful London station.

Algiers, only 6.7 kc. from Mühlacker, was also received very well. Lower down the medium waveband, Moravska-Ostrava, 10 kc. above the London National, and Leipzig, 10 kc. below, both came through at full speaker strength, without any interference, while London National was broadcasting.

On switching over to the long waves, Konigs Wasterhausen, only 9.5 kc. from Daventry National, came through equally as well as any before-mentioned station on the medium waves.

I think that it will be a set that not only amateur constructors will welcome, but will be of universal appeal.

I certainly think that you have designed a four-valve receiver which, when known, will be far in advance of any other four-valve set yet designed, and I think it will take a lot of surpassing.

No matter how congested the ether may become, or whether the stations increase their power, the unique selectivity controls on your set will always be able to combat the ever-changing conditions.

Hoping to see soon the details of this wonderful set,

I am, Yours faithfully,
F. SCHUMACHER.

P.S.—I will be pleased to communicate with any "Wireless Constructor" reader who wishes to hear more about the test.

IN ZONE "B"

Two outstanding landmarks of Zone "B"

Centre:
The Tower Bridge.

Below:
The Houses of Parliament.

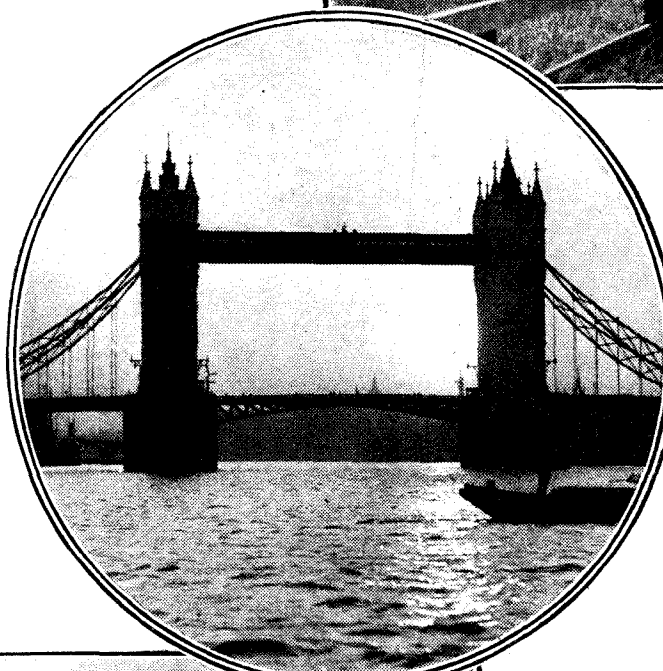

ZONE "B"

"ITS PERFORMANCE ASTOUNDED ME."

173, Gosset Street,
Bethnal Green,
London, E.2.

Sir,—Congratulations on evolving such a set for constructors such as the "S.T.400."

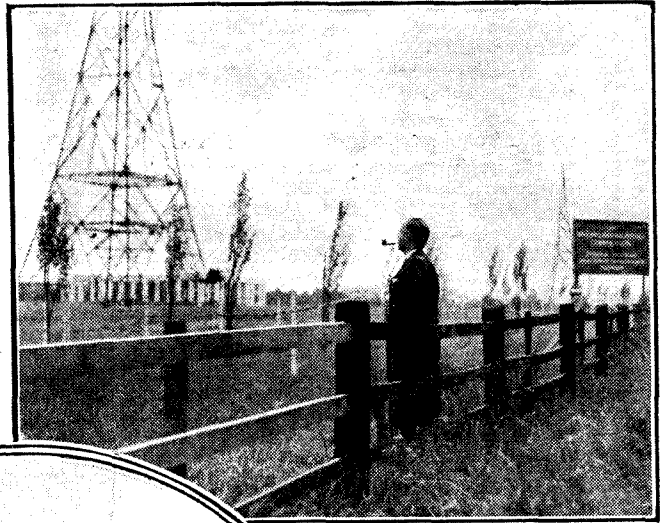

At Brookmans Park. Mr. Scott-Taggart studying the London Regional problem at the heart of it.

I have had the great pleasure of having your new set on my own aerial, and its performance astounded me. As you were not aware of my aerial conditions at the time of the test, I would like now to tell you that my aerial is only 20 ft. long (with 15-ft. lead-in doubled back), the highest point being only 18 ft. from the ground and the lowest 10 ft., and it is also tucked away in a triangle of three houses.

With regard to stations, 61 were picked up; all except two were definitely identified. The volume of 50 of these stations was what most people would

call full loudspeaker strength, or strength which would need cutting down in any ordinary living-room. The remaining stations were of a strength quite pleasant to listen to. Needless to say, the "locals" were working during the tests.

The quality, in my opinion, is even better than the "S.T.300," a set which also gives wonderful quality.

Your system of double-channel reaction, or shunting a certain amount of reaction on to the aerial coil, assists greatly in the isolation of stations; and the reaction equalisation system keeps the set wonderfully stable, and obviously contributes to the set's success.

Should you publish this letter I would like to add that no amateur constructor should be nervous of the knobs, as they are very simple in operation; in any case, they can all be set in a normal position, and the set will still bring in a goodly number of stations all worth listening to.

I may say in closing that I am converting my own "S.T.300" at the cost of

What the Midlands Think of the "S.T.400"

101, Sycamore Road, Aston,
Birmingham.

Sir,—On October 26th I had the pleasure of the company of Mr. Scott-Taggart, who brought with him the "S.T.400."

A test was conducted on a very poor indoor aerial, and a total of 60 stations were heard at full L.S. strength. All of these, with the exception of two, were received while the locals and other B.B.C. stations were working.

Selectivity was excellent. Volume was colossal, while very good quality was retained. Many stations would have been far too loud for comfortable listening.

At the conclusion of the test Mr. Scott-Taggart explained the circuit and referred to his methods of obtaining reaction equalisation and double-channel reaction. These, I am sure, mark a great improvement in reaction control.

I am an amateur with eleven years' wireless experience, and I can honestly say that the "S.T.400" is the finest set I have ever heard. I am sure Mr. Scott-Taggart is out to assist everyone as far as possible, this being proved by the fact that there will be no difficulty in converting the "S.T.300" into the "S.T.400."

In conclusion, I shall most certainly convert my own "S.T.300," and if I can assist anyone in my district in any way with regard to either the "S.T.300" or "400," it will be a pleasure to do so.

Yours faithfully, **LESLIE A. PERRINS.**

only a few shillings, a possibility which came as a great surprise to me. I recommend all "S.T.300"-ites, or any other "ites," to do the same, and those that have not built an "S.T." set to build this one immediately.

Wishing your set and journal all the success it deserves.
Yours faithfully,

W. IRONS.

(Ed. Note:—This reader attended the first demonstration of the "S.T.300" in London.)

"MORAVSKA-OSTRAVA, LEIPZIG, AND LONDON NATIONAL ALL CLEAR"

Herne Hill,
London, S.E.

Dear Sir,—I have very much pleasure in confirming, for the benefit of readers of the "Constructor," the results obtained with your new set, the S.T.400.

The S.T.400 was tested on my none-too-efficient aerial and earth system at Herne Hill, during August last, the special points of interest being as follows:

- (1) 47 stations were received when all the B.B.C. stations were working.
- (2) Selectivity was all that could be desired, Mühlacker and London Regional being easily separated; Moravska-Ostrava, London National and Leipzig received all clear of each other. In fact, in no instance was reception from any of the 47 stations spoilt by interference from another nearby station.
- (3) With regard to volume, every station received came in at comfortable strength for any normal-sized room, and in the case of the nearer and more powerful stations volume had to be cut down.
- (4) The quality of reproduction, using a Blue Spot 100.U speaker, was in every case all that could be desired.

I am taking this opportunity of congratulating you on the performance of the finest 4-valve set I have yet heard, and which I hope to be able to construct myself in the near future.

Wishing you the best of success and looking forward to many more "S.T." sets in the future,

I remain, yours truly,
B. RAY BOULLIN.

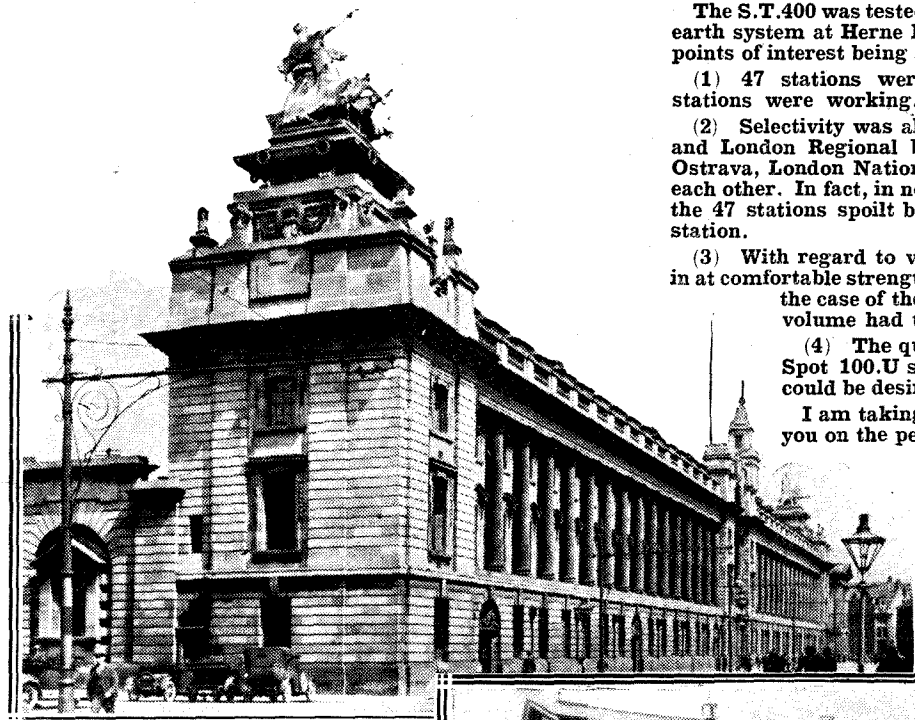

IN THE MIDLANDS

Representative letters from readers living in the Midlands show that the "S.T.400" is exactly suited to the very difficult conditions often experienced there.

Our pictures show:

(Above)

HULL: The Guildhall, Town Hall, and Municipal Chambers.

(Right)

BIRMINGHAM: The Town Hall.



S.T.400

READY RADIO KITS

Mr. John Scott-Taggart writes to the Editor of "The Wireless Constructor":

"With reference to my S.T.400 Receiver, described in the current issue of "The Wireless Constructor," I have received for test from Messrs. Ready Radio Ltd., a kit of parts in accordance with the circuit. This kit has been tested, and has proved entirely satisfactory."

DON'T RISK DISSATISFACTION
DON'T ACCEPT INFERIOR SUBSTITUTES
 INSIST ON **READY RADIO**

FOR YOUR S.T. 400

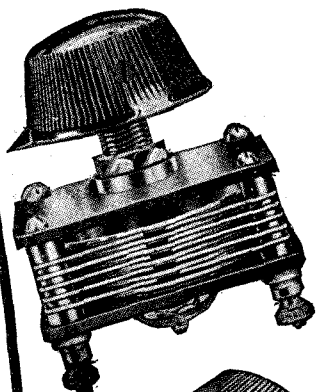

J. B. DIFFERENTIAL.
·0003, 4/6. ·0001, 4/-.
Insulated centre spindle. Bakelite dielectric between vanes.

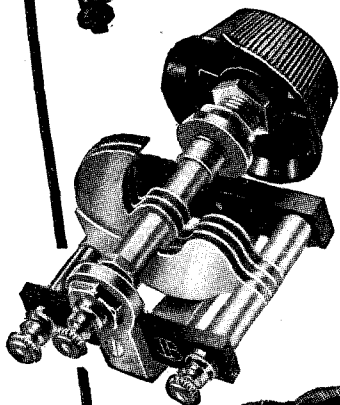

J. B. MIDGET.
·00004. Complete as illustrated, 4/-.
Small dimensions. Low minimum capacity. Ebonite insulation. Rigid one-piece frame.

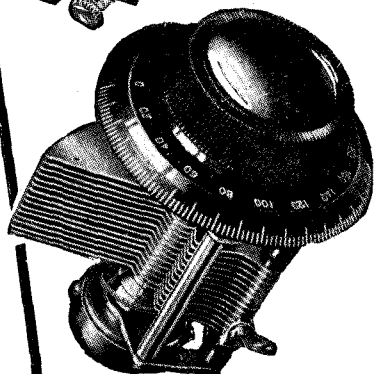

J. B. POPULAR.
Slow-motion type (35/1).
Capacity, ·0005. Complete with 3" dial, 8/6-Extra heavy-gauge brass vanes. Rigid nickel-plated frame. High-grade ebonite insulation.

Ask to see them at your dealer's



Advertisement of Jackson Bros., 72, St. Thomas' Street, London, S.E.1. Telephone: Hop 1929.

FREE PARTICULARS OF CHEAPER HIGH TENSION

MILNES H.T. SUPPLY UNIT HIGH TENSION CURRENT from L.T. ACCUMULATOR

SO great has been the demand for information of the Milnes H.T. Unit that we have had to re-print a much enlarged booklet. Illustrated photographically, with full details of the great advantages of the Milnes Unit and how it supplies a constant, noiseless H.T. current from your L.T. Accumulator, this booklet, "A Reservoir of H.T. Current," will be sent post free on request, together with the name of the nearest dealer in your district. Post the coupon at the foot of the advertisement in 1/2d. stamped envelope.

CUT OUT & POST THE COUPON TO-DAY FOR YOUR FREE COPY

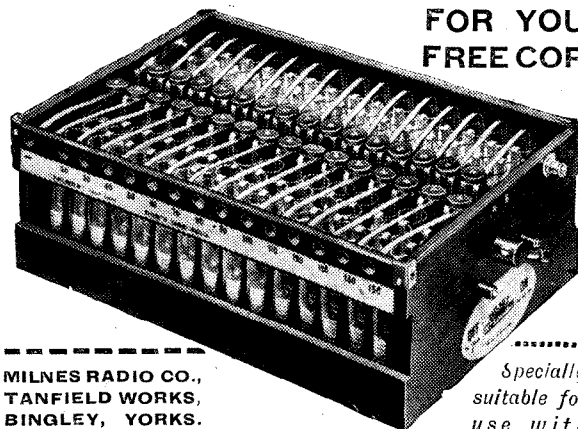

Specially suitable for use with the "S.T.400."

MILNES RADIO CO., TANFIELD WORKS, BINGLEY, YORKS.

Please send me FREE Illustrated Booklet of the Milnes H.T. Unit (post coupon in envelope 1/2d. stamp.)

Name.....

Address.....

PRICES IN UNITED KINGDOM

90 volt £2-18-0

120 volt £3-16-0

150 volt £4-14-0

FILL IN THIS COUPON TO-DAY!

Stove & Bowden

INTRODUCING A GREAT NEW DEVELOPMENT—

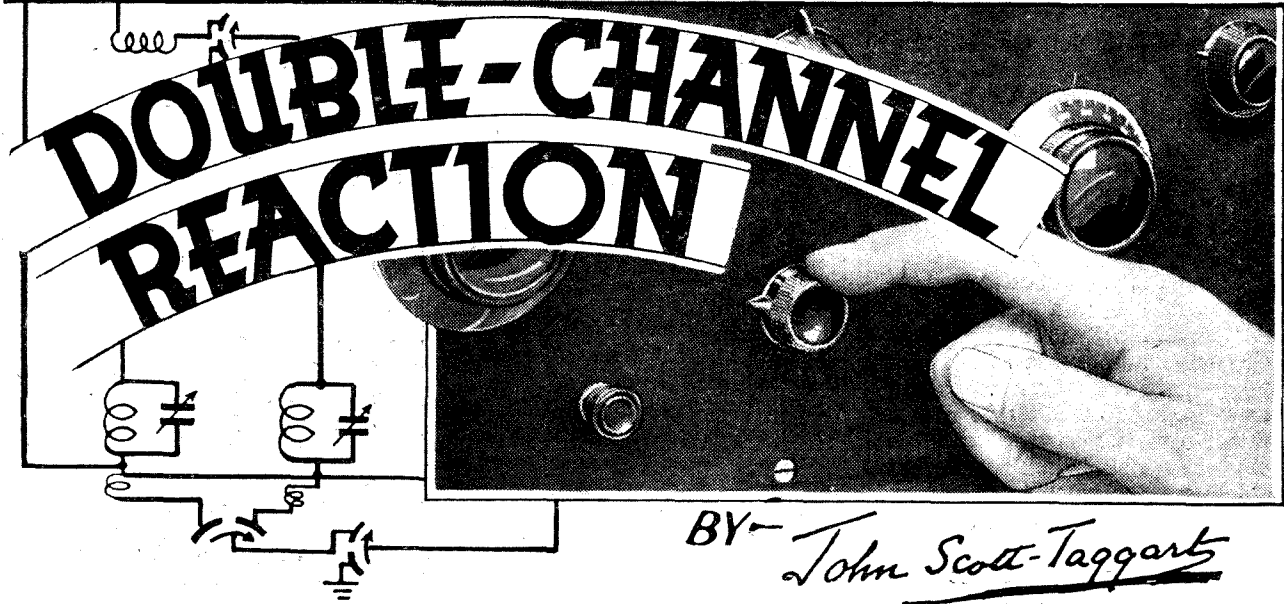

DIRECT REACTION—CHAIN REACTION—LINK REACTION

IN the "S.T.400" I have achieved an ambition which I have cherished for years.

Reaction! For years the word has rung in my brain with an insistence which scores of inventions have failed to silence. Reaction I regarded as a rich mine whose treasures have never been fully brought to light.

Numerous Claimants

The first shaft was sunk probably in 1912 by an American. A million dollars was his reward—and, incidentally, the gratitude of a continent.

The invention of reaction has been claimed by several engineers, scientists and dabblers. They have fought each other in the law-courts of the world like hyenas fighting for a bone.

But while they fought, technicians everywhere were using the new device. The invention, in fact, was greater than the man, and few of the wireless public to-day probably know who, in the outcome, won the honours in the legal battle.

Friend and Enemy

As British patent adviser to the ultimate victor, I was particularly "reaction-minded." But, apart from this, I felt that there was more in reaction than met the eye. My own patents since 1919 bear out the fact.

Reaction was primarily intended as a signal strengthener. It was so effective that the proper development

of high-frequency amplification was put back ten years!

Reaction has been both friend and enemy. It has resulted in a million cheap sets being built or sold. It has produced millions of squeals in a million homes. It has been outlawed by the Government, and then given a free pardon because we could not do without it.

Governments and engineers have, at last, decided to make a friend of a

AT THE NORTH REGIONAL



To test the circuit under the most exacting conditions, Mr. Scott-Taggart flew all over the country in his plane with the "S.T.400." He is here seen with the set under his arm at the North Regional station, Moorside Edge.

necessity. For the value of reaction on a straight set is now established. Home constructors do not attempt—and manufacturers do not dare—to do without it.

For Sharp Tuning

But the importance of reaction now lies more in the direction of a selectivity-producer than as a signal strengthener, although we use both functions. An ether cluttered up with conflicting programmes calls for ultra-selectivity, and so reaction's double function is now doubly welcome.

Those who boast of receiving stations "without any reaction" are, in many cases, using an accidental form of it. There is merit in using reaction—as a regular procedure and properly controlled it can give very effective results. The sharpness of tuning obtained can be increased until the valve oscillates—which, incidentally, is apt to occur prematurely.

Had Its Day!

On a det. and L.F. set the reaction is applied to the aerial circuit. On a set using H.F. amplification, the reaction is introduced into the S.G. anode circuit from the following detector valve.

The det. and 2 L.F. set in its ordinary form has had its day. The storm-clouds of interference are hastening the twilight of its simple glory.

Sharpening the Selectivity of Two Circuits

As for the S.G., det. and L.F. set, the average version is not only "straight," but inflexible. Moreover, the aerial circuit tuning is very much flatter than the anode circuit tuning. The "S.T.300" (my three-valve set), in spite of its selectivity controls, also suffers to some extent from this special but universal defect.

Some designers treat the deficiency almost as a merit because it "simplifies" tuning! This is certainly making a virtue of necessity! Actually it is as bad as expecting to win a race with a motor-cycle whose back wheel is efficiently mounted on rollers, but whose front wheel will hardly turn because of a plain rusted bearing.

Before the S.G. Came

What selectivity could be achieved if only *both* circuits of a set could be made equally sharp! This idea occurred to me before screen-grid valves were used. The result was my master Patent 215,798. The scheme involved the repeated individual application of reaction to different circuits.

The fourth claim covers:

"A radio receiver employing a plurality of valves containing grids, in which amplified currents from one valve are made to react directly and independently on both the input and output circuits of another valve." (The S.G. valve in the "S.T.400.")

The invention was certainly before its time in two senses. In the first place, it was unnecessary, as the selectivity problem had not then really arisen. Secondly, the technique of H.F. amplification at that time did not lend itself really properly to the scheme.

But I have ever since brooded over the theoretical advantages which must inevitably accrue from a succession of circuits *each* rendered highly selective.

After many disappointments with circuits which were too tricky to handle, I recently evolved the method which is now covered by my Prov. Patent and published here for the first time.

Startlingly Effective

This double-channel arrangement can give startlingly effective results. It introduces reaction on to both aerial and anode tuned circuits, there-

set. What may formerly have been a "spread" of ten degrees on that dial is now sharpened down to one degree.

And after this disciplinary treatment the signals are amplified by the S.G. valve and find themselves in a circuit equally stern and determined to keep out strangers!

Doubly Selective

A medley of incoming stations thus find themselves confronted by an unexpectedly well-guarded outer gate, followed by a second one. Only when the selected entrant has run the gauntlet twice is it allowed access to the detector.

You can, on the "S.T.400," increase or relax the guard at the two gates. I provide what I call a Reaction Distributor, which shunts the desired amount of reaction to both aerial and anode circuits. The *total* amount of reaction is adjusted by the Master Reaction Control—the top right-hand knob of the set.

When the Distributor (the lower middle knob) is at "normal" (i.e. at zero, the knob being turned anti-clockwise as far as possible), practically the whole of the reaction is applied to the anode circuit. A very small amount "tickles up" the aerial circuit owing to the impossibility of getting absolute zero on the Distributor, but the slight gingering-up is all to the good.

Three Kinds of Reaction

When you want extreme selectivity the Reaction Distributor is rotated clockwise a little. The Master Reaction is still used as the ordinary reaction control, and the Reaction Distributor is used for apportioning the total reaction you desire to supply to the two circuits.

The Distributor may thus be set at a value found convenient, and "left," all reaction adjustments being made on the Master Reaction control.

The full technical explanation of the *theory* of the system must be deferred till another issue of this journal. There are actually three kinds of reaction evolved in the circuit. I have called them, for convenience, Direct Reaction, Chain Reaction, and Link Reaction. The subject is extremely fascinating to the technical mind, but fortunately

TALKING OVER THE CIRCUIT



Mr. Manson, the postmaster of John o' Groats, and himself a wireless enthusiast, discusses the "S.T.400" circuit with Mr. Scott-Taggart.

The first claim of the patent reads: "(1) A wireless receiver, comprising two valves in cascade, the first acting as a high-frequency amplifier, and the second as a detector, in which the output high-frequency currents in the detector are utilised to introduce separate reaction effects into the input circuit of the first valve and also into a coupling circuit between the valves."

by obtaining a multiplied degree of selectivity.

The aerial circuit, normally less selective than the anode one, is now no longer a rough filter which leaves the chief burden of separating stations to the anode circuit. It becomes a vital factor in the

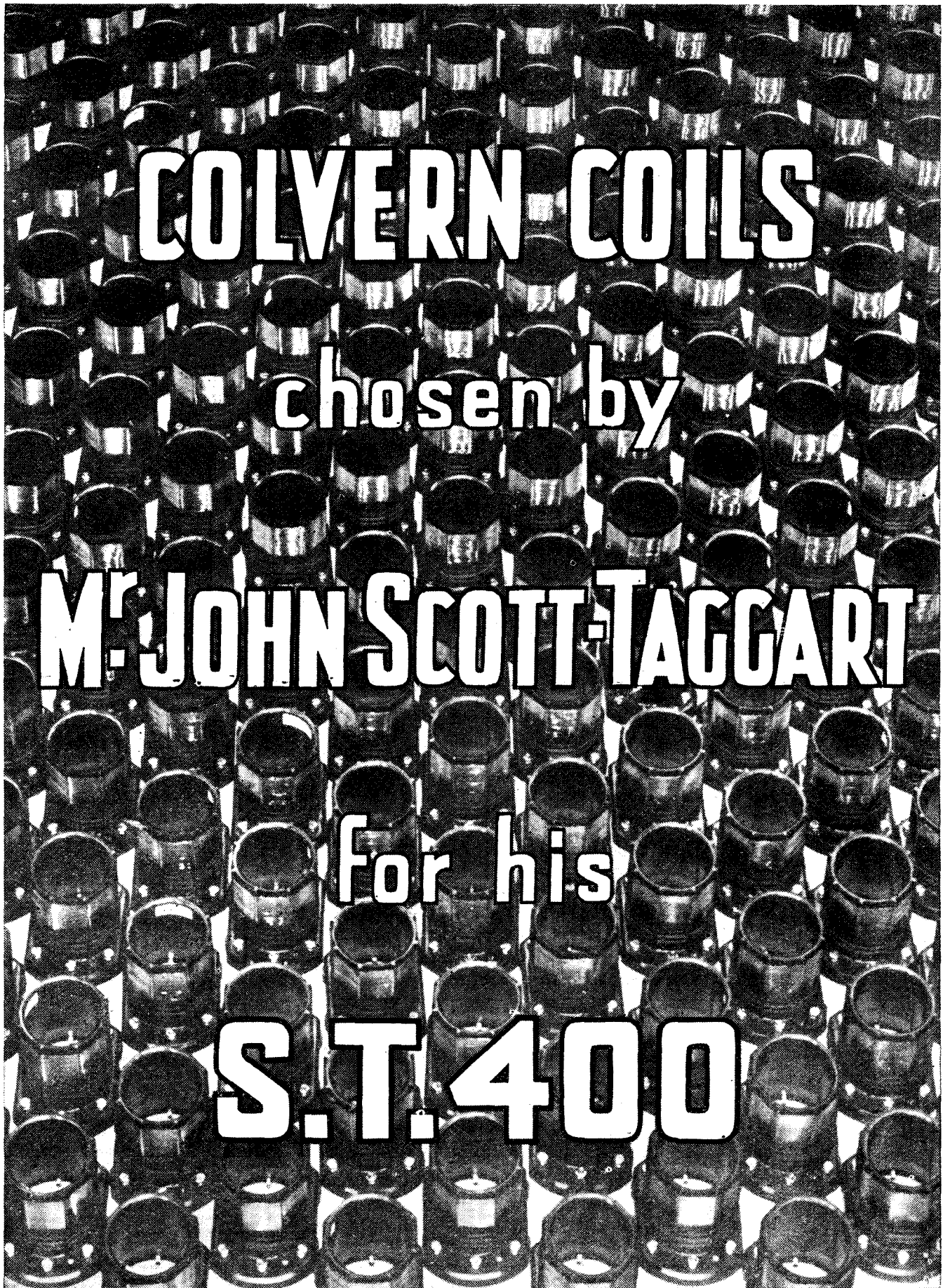

COLVERN COILS

chosen by

Mr. JOHN SCOTT-TAGGART

for his

S.T. 400

Advt. Colvern Ltd., Mawneys Road, Romford. Essex.

Direct Radio

**159
BORO
HIGH
STREET
LONDON
BRIDGE**

**John Scott-Taggart's
"S.T.400"—an even
greater achievement than
the famous "S.T.300" when
built with a—DIRECT RADIO
Guaranteed and Tested Kit**

**JUST SIX
OF MANY
REASONS
WHY YOU MUST
INSIST
ON A DIRECT RADIO
SCOTT TAGGART
ST400 KIT**

	£	s.	d.
1 F.I. "Hypermite" L.F. transformer	12	6	
1 J.B. aerial coupler, .0004-mfd.	4	0	
2 Colvern S.T.400 coils	9	10	
2 Ormond .0005-mfd. variable condensers, type R.495	15	0	
1 Polar .0003-mfd. differential condenser	3	0	
1 Lotus .00035 or Polar .0003-mfd. differential condenser	3	0	
1 Ready Radio .0001-mfd. differential condenser	2	6	
2 Teisen .0003-mfd. preset condensers	3	0	
3 Valve holders	1	6	
1 W.B. Universal valve holder	1	0	
2 Ready Radio 2-pt. switches	1	8	
1 Teisen binocular choke	5	0	
1 Ready Radio Standard H.F. choke	1	6	
1 T.C.C. .0003-mfd. fixed condenser, type "S"	1	3	
1 T.C.C. .008-mfd. fixed condenser, type "S"	2	0	
1 Dubilier .006-mfd. fixed condenser, type 670	1	6	
2 T.C.C. 2-mfd. fixed condensers, type 50	7	8	
1 Dubilier 1-mfd. fixed condenser, type 9200	2	9	
1 Dubilier 1-meg. grid leak with holder	1	4	
1 Igranite 1,500-ohm spaghetti resistance	1	0	
1 Leweos 50,000-ohm spaghetti resistance	1	6	
1 Leweos 20,000-ohm spaghetti resistance	1	6	
1 Leweos 60,000-ohm spaghetti resistance	1	6	
1 Bulgin toggle switch, type S.80	1	6	
11 Belling Lee terminals: HT-1, HT+1, HT+2, HT+3, HT+4, LT-, LT+, LS-, LS+, A, B, E	2	3	
1 Screen and foil	3	0	
1 Panel, drilled	4	6	
1 Terminal strip, drilled	1	3	
1 Easyfix baseboard	1	9	
Connecting wire, flux, plus, etc.	1	6	
4 Valves to specification	1	19	3
1 Special "159" cabinet	1	1	0
1 Calibrator, No charge.			

£7 19 9

KIT Model 1
(less valves and cabinet) **£4:19:6**

Or 12 equal monthly payments of **9s. 3d.**

KIT Model 2
(with valves less cabinet) **£6:18:9**

Or 12 equal monthly payments of **13s.**

KIT Model 3
(with valves and cabinet) **£7:19:9**

Or 12 equal monthly payments of **15s.**

S.T.400 ACCESSORIES

	£	s.	d.
1 Siemens 120-volt H.T. battery	13	6	
1 Siemens 9-volt G.B. battery	1	0	
1 Oldham 0-50 accumulator	9	0	
1 Enoch Twentieth Century permanent magnet moving-coil speaker with input transformer	1	15	0
1 Blue Spot 44R magneto type speaker in oak cabinet	2	12	6
1 Atlas A.C.244 mains unit	2	19	6
1 Atlas A.K.260 mains unit, with trickle charger	4	10	0
1 Atlas D.C. 15/25 for D.C. mains	1	19	6
1 Cop aerial lead-in and lightning arrester	2	6	
1 Selectanet indoor aerial	2	6	
1 Selectanet earth	1	6	

OFFICIAL DEMONSTRATION
The "S.T.400" will be demonstrated daily at 159, Borough High Street, London Bridge, S.E.1. Come and hear the amazing results for yourself.

any Component can be supplied separately

Direct Radio can supply all proprietary "S.T.400" Kits on usual Cash, C.O.D. and Easy Payments terms.

CASH, C.O.D. AND EASY PAYMENTS EXPRESS ORDER FORM

To: Direct Radio Ltd., 159, Borough High Street, London, S.E.1.

Please dispatch to me at once the following goods.....

for which (a) I enclose (b) I will pay on delivery (c) I enclose first payment of

{Cross out line} {not applicable}

NAME.....

ADDRESS.....

Wireless Con. Dec.

ST 400

DE LUXE MODEL

SPECIAL FEATURES EXCLUSIVE TO THE DIRECT RADIO DE LUXE "S.T.400" KIT

1	R.I. "Hypermite" transformer	12 6
1	J.B. -0004 aerial coupler	4 0
2	Convent S.T.400 coils	9 10
1	Simplicon slow-motion illuminated double full vision scale type FVV	12 6
2	Ormond No. 6 log condensers, -0005-mfd.	8 0
1	Polar -0003-mfd. slow-motion differential condenser	6 6
1	Lewis -00055-mfd. differential condenser	3 0
1	Ready Radio -0001-mfd. differential condenser	2 6
3	Valve holders	1 6
1	S.G. type valve holder	1 0
3	Becker walnut toggle type 2-pt. switches, No. 460	5 6
1	Tilsen binocular S.C. choke	5 0
1	Ready Radio Standard H.F. choke	1 6
1	T.C.C. -0003-mfd. condenser, type "S"	1 3
1	T.C.C. -006-mfd. condenser, type "S"	2 0
1	Dubilier -006-mfd. condenser, type 670	1 6
2	T.C.C. 2-mfd. condensers, type 50	7 8
1	Dubilier 1-mfd. condenser, type 9200	2 9
1	Dubilier 1-meg. grid leak and holder	1 6
1	Bulgin 1,500-ohm spaghetti resistance	1 0
1	Lewcos 50,000-ohm spaghetti resistance	1 6
1	Lewcos 20,000-ohm spaghetti resistance	1 6
1	Lewcos 60,000-ohm spaghetti resistance	1 6
1	Belling & Lee walnut terminals	2 3
1	Screen and foil	3 0
1	Special walnut panel, drilled	5 0
1	Special walnut terminal strip, drilled	2 0
1	Special "Easyfix" baseboard	9
1	Ready Radio H.T. fuse and holder	1 0
1	Dial light, low consumption type	6
2	Tilsen -0005-mfd. max. pre-set condensers	3 0
1	Special S.T.400 De Luxe "159" walnut cabinet	1 5 0
4	Valves: PM12A, PM2DX, PM1LF, PM202	2 2 0
	Flex, screws, battery plugs, etc.	2 0
1	Calibrator station finder. No charge.	
		9 2 0

1. Greatly improved and modernised panel layout.
2. Illuminated dials.
3. Side-by-side tuning dial indicators.
4. Slow-motion differential control.
5. Simplified tuning ensuring easy station searching and calibration.
6. Modern type walnut toggle switches throughout.
7. Modern design walnut cabinet with beautiful walnut grained ebonite panel.
8. Super-power output giving maximum volume without distortion.
9. All components exhaustively tested and especially chosen to give record results.
10. NO complications in wiring involved.

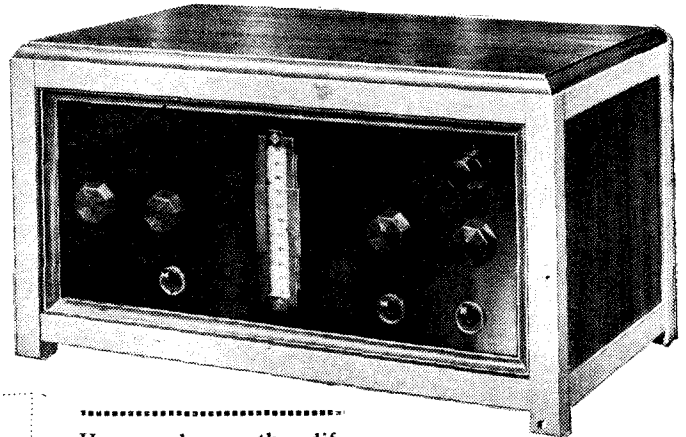

FREE CALIBRATOR

We supply free with every Direct Radio "S.T.400" Kit a Calibrator Automatic Easy Station Finder.

KIT No. 1 (less valves and cabinet) **£5:15:0**
or twelve equal monthly payments of **10/9**

KIT No. 2 (with valves less cabinet) **£7:17:0**
or twelve equal monthly payments of **14/6**

KIT No. 3 (with valves and cabinet) **£9:2:0**
or twelve equal monthly payments of **16/6**

KIT No. 4 (with valves and special "159" S.T.400 De Luxe Console cabinet and Epoch A2 Dance Orchestra Speaker). **£12:15:0**
or twelve equal monthly payments of **£1-4-0**

S.T.400 DE LUXE ACCESSORIES

Siemens 120-v. Power H.T. Battery	1 4 0
Siemens 16½-v. G.B. Battery	1 9
Oldham 0'75 Accumulator	12 6
Epoch A2 Dance Orchestra Permanent Magnet Moving-Coil Loudspeaker with Multi-Ratio Input Transformer	3 3 0
Oldham 120-v. Wet H.T. Accumulator 5500 m/a. hour Capacity	4 1 0
Atlas A.C.300 Super Mains Unit, giving H.T., L.T. and G.B.	6 10 0
Bowyer Lowe A.E.D. Mark III. Pick-up	1 10 0

OBTAINABLE ONLY FROM SOLE OFFICIAL DISTRIBUTORS

Direct Radio

159 BORO HIGH STREET LONDON BRIDGE

CASH, C.O.D., AND EASY PAYMENT ORDER FORM

To: Direct Radio Ltd., 159, Borough High Street, London, S.E.1.

Please dispatch to me at once the following goods.....

for which (a) I enclose (b) I will pay on delivery (c) I enclose first payment of

{Cross out line} {not applicable}

NAME

ADDRESS

S.T.400 DE LUXE

TELSEN DUAL-RANGE COILS

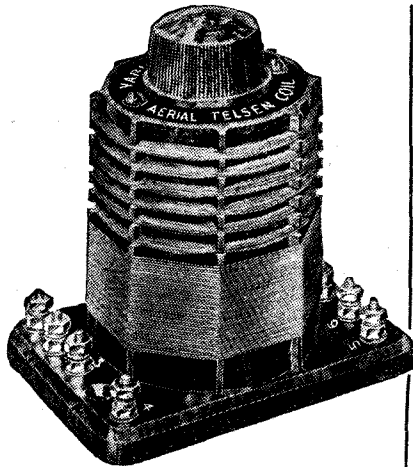

TELSEN DUAL-RANGE AERIAL COIL

Incorporates a variable selectivity device, making the coil suitable for widely varying reception conditions. This adjustment also acts as an excellent volume control, and is equally effective on long and short waves. The wave-band change is effected by means of a three-point switch and a reaction winding is included ...

7/6

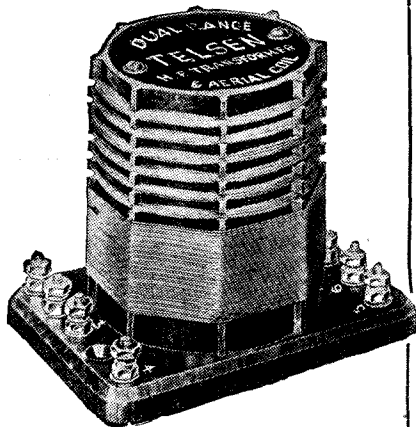

TELSEN H.F. COIL

May be used for H.F. amplification with Screened-Grid Valve, either as an H.F. Transformer or, alternatively, as a tuned grid or tuned anode coil. It also makes a highly efficient Aerial Coil where the adjustable selectivity feature is not required ...

5/6

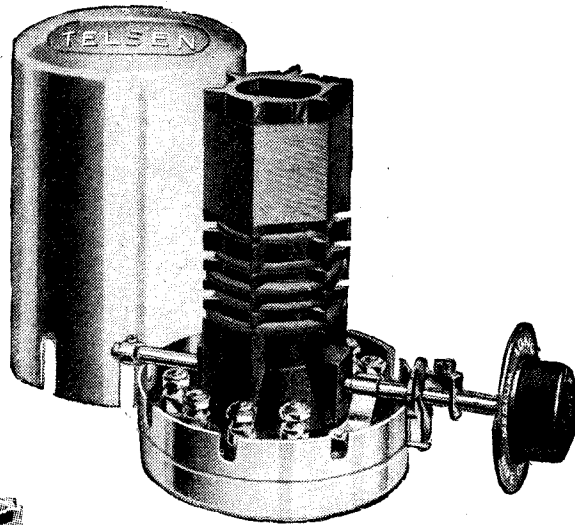

TELSEN SCREENED COILS

The result of much research and experiment, these coils embody the ultimate efficiency attainable in a perfectly shielded inductance of moderate dimensions. Provided with separate coupling coils for medium and long waves, they are suitable for use as aerial coils or as anode coils following a screened-grid valve, giving selectivity comparable only with a well-designed band-pass filter. The coils are fitted with cam-operated rotary switches with definite contacts and click mechanism, and are supplied complete with aluminium screening cans, bakelite knob, and handsome "Wave Change" escutcheon plate, finished in oxidised silver ...

Twin Matched Screened Coils
17/-

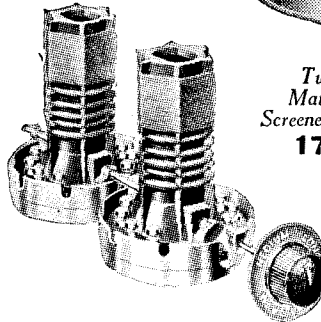

Triple Matched Screened Coils
25/6

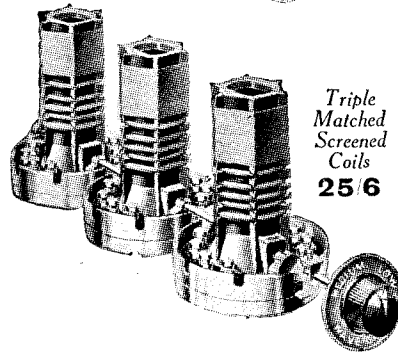

8/6

Full instructions are supplied with every Telsens Screened Tuning Coil, showing you the alternative methods of mounting the coils, either singly or in twin-matched or triple-matched form as required.

TELSEN

RADIO COMPONENTS

TELSEN RADIO COMPONENTS ARE 100% BRITISH

Cross-Modulation Interference is Eliminated

the beginner can get all the advantages of Double-Channel Reaction without understanding a word of how it works!

A virtually unique advantage of the method is that by sharpening the aerial selectivity, cross-modulation interference is eliminated. Selectivity on the anode circuit

Perhaps the most striking way of looking at the method is to imagine the screen-grid valve replaced by a non-amplifying device. Even in such circumstances the aerial selectivity improvement would still be obtained and be of paramount value; the signals would also be greatly strengthened

merits of this new system for combating interference.

 * NOTES ON "S.T. 400" *
 * COMPONENTS *

THERE are several points I wish to mention in connection with the "S.T.400" components. The first-mentioned make in the list is the one actually used in the set. This does not imply that the others are in any way inferior; any changes, however, should be made by those who fully realise that a change from the original may necessitate some alteration in layout. The Ormond type-number should be carefully noted, as this model is unquestionably better than their other types; the motion is very fine indeed, and non-slipping. (Prospective "S.T.300" builders also should note this.)

The two makes of pre-sets are specially chosen for their small minimum capacity; if you have other makes, try them, but if you buy new ones, keep to those mentioned. If a Telsen pre-set is used, you will find an Igranac 1,500-ohm spaghetti fits perfectly; other makes may straggle. Little things like this count. See that your earth is O.K. The "Fit" is proving popular.

Many readers will have dud pre-sets (usually stuck down) - they will ruin reaction equalisation so, if in doubt, try disconnecting that pre-set.

As regards coils, do not waste money buying new ones if you have built the "S.T.300." The "S.T.400" anode coil is identical with the "S.T.300" anode coil. The Colvern type of "S.T.300" aerial coil may be converted by yourself into an "S.T.400" aerial coil as follows: 14½ turns of 36 S.W.G. single silk-covered wire form a new winding between the medium-wave and long-wave windings. This single hank is wound in the same position on the former of this aerial coil as is the reaction winding on the anode coil former—i.e. in a slot exactly the same distance above the long-wave winding slots.

The new winding starts from No. 1 terminal, and is wound in a clockwise direction looking from the top of the coil, and ends at No. 6 terminal. The direction of the winding is vitally important, of course, as it is a reaction coil.

If not desirous of adding this winding yourself, you can buy a new aerial coil or have your existing one (if of Colvern make) converted by Colverns for 2s. by giving it to your retailer or sending it direct to Colverns.

[Prospective "S.T.300" builders should buy "S.T.400" coils leaving terminals 1 and 6 free;



ONLY
 TWO INCHES!
 Excluding the few panel-to-baseboard wires, 85 per cent of the connections in the "S.T.400" have an average length of two inches!

is valueless for this form of jamming.

I have left a very important merit of the system to the last. It is this: Whereas other methods of obtaining aerial selectivity involve a **reduction** of signal strength, Double-Channel Reaction actually **increases** the signal strength!

Selectivity and Sensitivity

The method of attaining aerial selectivity by reducing the aerial load with a series condenser has been common practice since my Patent 232,659 of 1923. But it results in a sacrifice of some signal strength. By means of Double-Channel Reaction I have been able to upset the vicious working of the "see-saw" law; when aerial selectivity goes up, signals now do not go down, but up!

On the "S.T.400," therefore, increased selectivity means increased signal strength when the Distributor is used, and greater values of aerial coupler may be used without disadvantage.

Double-Channel Reaction is, of course, applicable to circuits other than the "S.T.400," but this set is an ideal power-house in which to prove the new fuel.

by the reaction being applied to both circuits. Now add the H.F. amplifying powers of the S.G. valve (usable to the limit, thanks to the panel controls), and you can imagine the excellent results obtainable.

FITTING THE ANODE COIL

Easily fixed supporting pillars are used to hold the anode coil exactly as in the "S.T.300."

An obvious query will arise. Does Double-Channel Reaction impair quality of reproduction? The question may be answered *technically* by saying that the performance of the set taken as a whole governs the quality; it may be answered *practically* by inviting you to read the opinions of those who have heard the set.

But I am trusting you will build the "S.T.400." In which case you will discover, as I did, the unalloyed

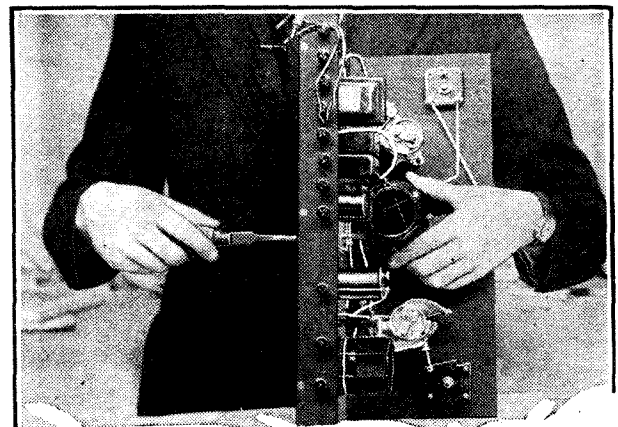

they can then convert their sets at any time to "S.T.400."

Other transformers than the Hypernik may accentuate heterodyne whistles; if you feel you are getting too much, try a '0003-mfd. pre-set (Telsen or Goldtone only) across the secondary terminals. This hint may prove an invaluable refinement which also sings off a certain kind of interference.

Let me warn you that the great demand for "S.T.400" parts will give a glorious opportunity for unscrupulous dealers to fob off on you components "just as good," possibly on the grounds of being "unable to get the recommended ones." Well, I've warned you! Try somewhere else.

J. S.T.

COLVERN COILS

again the choice of

MR. JOHN SCOTT-TAGGART

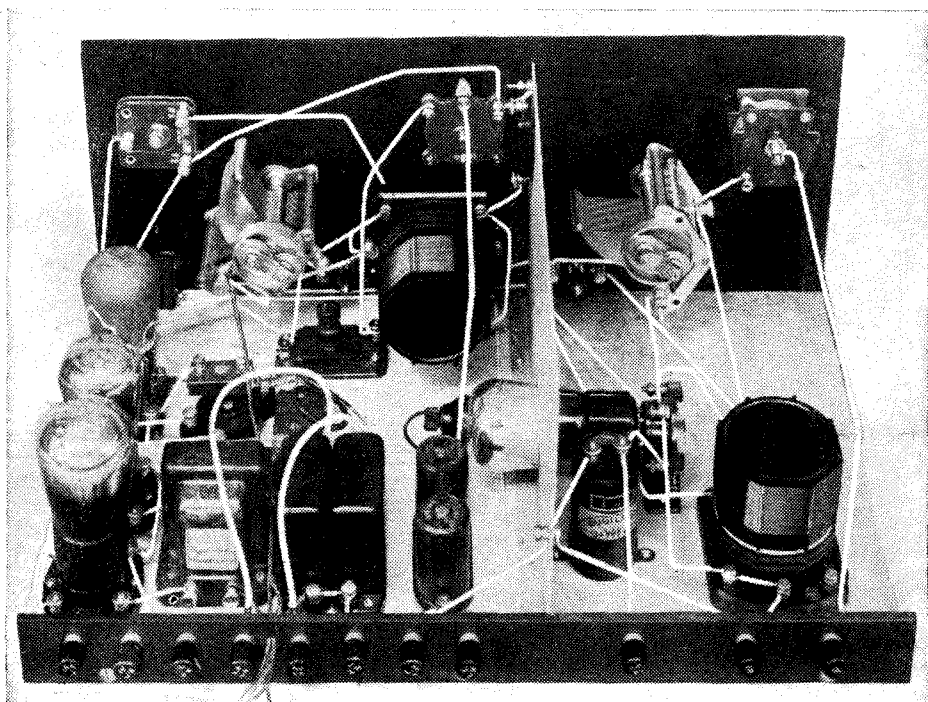

FOR HIS
LATEST
TRIUMPH

THE

S.T. 400

Colvern Coils are specified in the "S.T.300" and the "S.T.400," the two wonder sets designed by Mr. John Scott-Taggart. The efficient design of these receivers call for components of proven quality. Be sure that you use Colvern Coils as specified:—

One pair Type S.T.400 COILS—9s. 10d. pair.

COLVERN LIMITED

MAWNEYS ROAD

ROMFORD, ESSEX.

Mr. Scott-Taggart's latest and greatest!

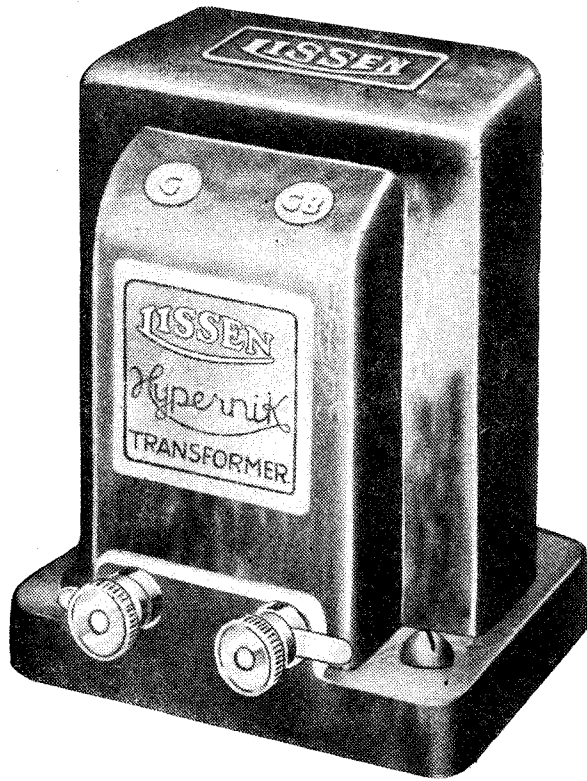

S.T. 400

HAS

LISSEN

HYPERNIK TRANSFORMER in its output stage!

What is the season's most notable advance? Better tone! What has contributed most to that improvement in tone? The increasing use of the Lissen Hypernik Transformer!

Those are the answers almost any set designer would give you! And you will notice that all the best published circuits are specifying a Lissen Hypernik Transformer in the output stage.

Mr. Scott-Taggart this month puts out his latest and greatest set—the S.T. 400. Look at the specification—see that Lissen Hypernik Transformer? You cannot get the fine results for which Mr. Scott-Taggart has planned unless you do use this big-hearted Lissen Hypernik.

PRICE

12⁶/₆

LISSEN HYPERNIK TRANSFORMER



IT is proposed next month to give full operating notes on the "S.T.400."

But long before then, tens of thousands of "S.T.400's" will have been built, and so I give here a brief account of what to do. The detail is for the benefit of absolute novices. Read my summary at the end first.

Having finished set according to "Rapid Construction Guide," check wiring while a friend reads out the guide. Connect requisite battery leads (complete with H.T. wander-plugs) to terminals on strip.

Grid-Bias Details

Mains-unit users should join by a wire the terminals H.T.+2 and H.T.+3 (unless four H.T. tappings are provided on the "eliminator"). Terminal H.T. + 3 is then used as intermediate H.T. voltage terminal.

Place set on table with panel facing you; set should not be in cabinet. Switch on toggle switch (i.e. pressed down). Place 9-volt grid-bias battery behind terminal strip. Insert the G.B.

+ plug in + socket of bias battery; G.B.—1 in $-1\frac{1}{2}$ volts; G.B.—2 in -3 volts; G.B.—3 in $-7\frac{1}{2}$ volts if a large power valve is used (e.g. P.M.202, P.2, P.220A., 230 X.P.), or -3 volts if using a small power valve (e.g. L.P.2, P.M.2A, P.220, 220 P.).

Connecting L.T. and H.T.

Place 2-volt accumulator behind set on table and 120-volt H.T. battery to right of accumulator. Connect up

L.T. See that free end of wire (31), the S.G. anode flex in set, is not touching anything. Connect aerial and earth to appropriate terminals. Connect loudspeaker to set, seeing that speaker is not near lead-in; speaker is preferably to right of set.

Insert H.T.— plug into negative socket of H.T.; H.T.+1 into 72 volts; H.T.+2 into 84 volts; H.T.+3 into 108 volts; H.T.+4 into 120 volts.

Insure against filament burn-outs (through possible wiring error) with a flash-lamp bulb which is connected in turn across the filament terminals of each valve holder (including the S.G. valve holder). If the bulb burns out, or does not light at all, there is some fault in the wiring.

valve in valve holder V_3 ; output valve in V_4 . Replace H.T.— plug in battery.

See that lock-nut of Selectivity Range Adjuster is at the top. Set adjuster pre-set to about its "half-in" position. Any position except fully screwed-up will do; adjustments are conveniently carried out by placing right hand over top of panel.

Setting Controls

Pull out both wave-change switches. (You are going to listen to the medium-wave stations first.) Set aerial and anode couplers to "normal," i.e. with pointers vertical. Set Master Reaction knob to zero (i.e. full left). Set Reaction Distributor to "normal" (i.e. full left).

Set aerial and anode condensers to some value and switch on toggle. Signals will now be received.

Full Amplification

You can now improve your set as follows, to get the fullest amplification out of your S.G. valve and H.T. voltage.

Proceed as follows:

Set aerial condenser to, say, 50° . Tighten-up Selectivity Range Adjuster clockwise a couple of turns; remove your hand. Rotate anode condenser. Tighten up Adjuster, remove hand, and rotate anode condenser again. As you do this you are increasing the H.F. amplification of the set. Keep on doing it until when you move the anode condenser the set will oscillate.

—FOR EVERY USER—the "S.T.400" may be—

- (A) . . . Worked as easily as the simplest of two-dial receivers by setting all panel controls at normal.
- (B) . . . Used as a very selective and sensitive set by using the couplers.
- (C) . . . Used as an ultra-selective set by using the Reaction Distributor.

Switch off toggle. Take out H.T.— plug. Insert S.G. valve, connecting flex (31) to anode. If S.G. valve is metallised, make sure metal covering does not touch S.G. choke terminal; the covering may, however, touch vertical screen as it is already connected to it; take care that no frayed, bare ends of flex (31) come into contact with metal covering.

Insert other three valves: detector valve in valve holder V_2 ; first L.F.

How to Work the "S.T.400"

Very probably you will be able to tighten adjuster to maximum even without oscillation, especially on valves such as P.M.12, Cossor S.G.215, etc. But the procedure is to enable you to make the most out of any S.G. valves (mains or battery) and any H.T. voltages. If the set should oscillate after a test, unscrew (anti-clockwise) knob on adjuster a few turns at a time (removing hand each time) until stability is obtained.

Once adjusted for your valve and H.T. there is no need to touch the adjuster again.

Normal Tuning. With both couplers at "normal" and Reaction Distributor at "normal" (full left), tune on two dials as usual, using Master Reaction to give reaction.

Improved Tuning. In case of interference, I suggest turning aerial coupler required amount to left, going up a little on aerial tuning condenser until station is accurately tuned in again. When attempting increased selectivity by any method, the Master Reaction should be used to assist.

Having thus proved the value of the aerial coupler, I suggest you return it to "normal" and prove the selectivity value of the anode coupler. Set the anode coupler to required amount left of vertical; retune the anode tuning condenser until station is once more heard at its best; after turning anode coupler to left, Master Reaction should be adjusted to get best results.

Reaction Sharpens Tuning

It should be noted that as in all circuits, reaction sharpens tuning; if tuning is flat and you apply reaction, you may actually get weaker signals unless you slightly retune the circuit to which reaction has been applied. This is usually because you were not

really tuned in accurately before. This applies to all sets with reaction.

It is very important, when desiring selectivity, to keep the signal input to any set no greater than that required to give full loudspeaker results with reaction. If you increase signal input unnecessarily you will get no louder results, but only distortion and interference.

Controlling Input

By turning aerial coupler to left on "S.T.400" you can reduce signal input at will.

Suiling Your Aerial. Small aerials

possible, *unless volume is already ample.*

To Avoid Oscillating. Keep Master Reaction control below what is required (i.e. more to left) while making changes of controls, and then bring up reaction as desired to improve station. (This advice applies to all sets.)

Reception of Long Waves. Pull out both wave-change switches.

Adjusting Battery Voltages. Any changes in grid-bias voltages should only be carried out with set switched off. This applies to all sets. By all means carry out any tests you like

with various H.T. voltages, etc., but see that all wander-plugs fit properly. A bad contact on the G. B. battery especially will spoil reception on any set.

Ultra-Selectivity. With couplers at "normal," and Master Reaction at zero, turn Reaction Distributor clockwise a little. Tune set as usual, using Master Reaction for reaction adjustments. Try different settings of Distributor. Do not overload set by too much aerial coupler.

A slight turn of Distributor knob has an important effect. Usually

you will probably set Distributor to normal again when ultra-selectivity is not required. Combinations of different coupler adjustments may be tried with Distributor. A special alternative use for Distributor is as follows: Set main reaction to zero (or small value) and carry out all reaction adjustments on Distributor. Note how signals are strengthened.

Before using the Distributor the absolute beginner is advised to keep it set at normal and familiarise himself with the benefits derived from adjusting couplers.

Calibrating Set. If the set is to be

(Please turn to page 174.)

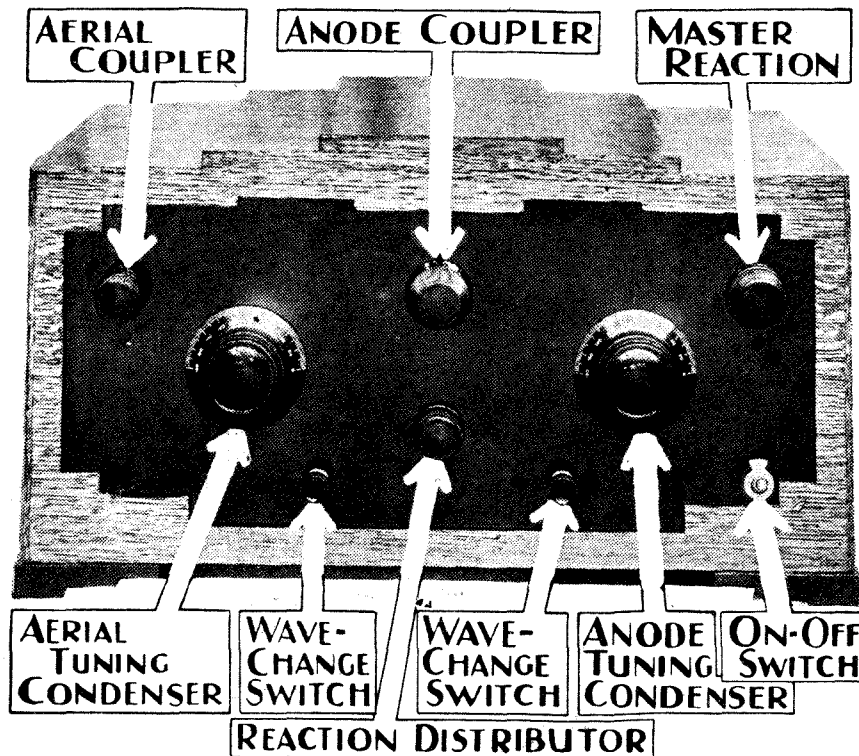

will require more aerial coupling than normal ones. More aerial coupling will usually be used on long waves than on medium waves. But sensitivity of set is so great that the sensitivity will in nearly all cases not be needed to the full, except to obtain special selectivity.

Use of Couplers. Try effect of each coupler on (a) signal strength, and (b) selectivity of set. Couplers to left of normal increase selectivity; couplers to right of normal increase volume—unless volume is already at a maximum, which it usually will be.

When interference is not experienced, use couplers as far to right as

TELSEN BAKELITE DIELECTRIC CONDENSERS

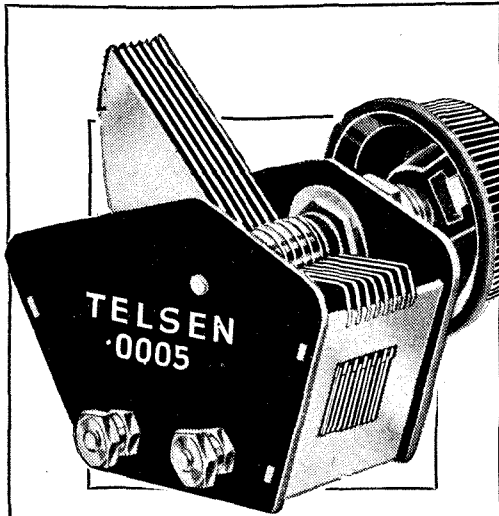

TELSEN BAKELITE DIELECTRIC TUNING CONDENSERS

New design of great rigidity and exceptional compactness, ensuring the utmost efficiency in use even where space is very limited. The well-braced vanes are interleaved with a minimum of the finest solid dielectric, giving absolute accuracy of tuning. Supplied complete with knob.

2/6

In capacities '0005 and '0003

TELSEN DIFFERENTIAL CONDENSERS

Improved type of exceptionally rigid construction. The rotor vanes are keyed to the spindle and fitted with definite stops. A strong nickel silver contact makes connection to the rotor, a positive connection being made to the stator vanes. Supplied complete with knob.

2/6

In capacities '0003, '00015 and '0001

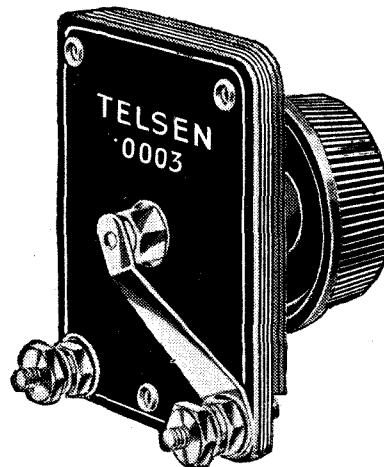
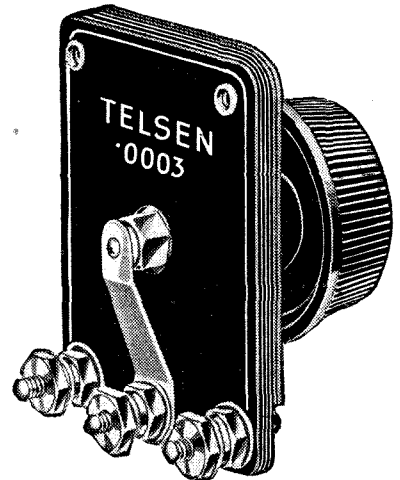

TELSEN REACTION CONDENSERS

In capacities '0003, '00015 and '0001

2/4

In capacities '00075 and '0005

2/6

TELSEN AERIAL SERIES CONDENSER

The ideal volume and selectivity control, solidly constructed, with very low minimum capacity. The externally keyed switch-arm when rotated to a maximum position, connects with a contact on the fixed vanes, thus short-circuiting the condenser for maximum volume. Supplied complete with knob.

2/3

Capacity '0003

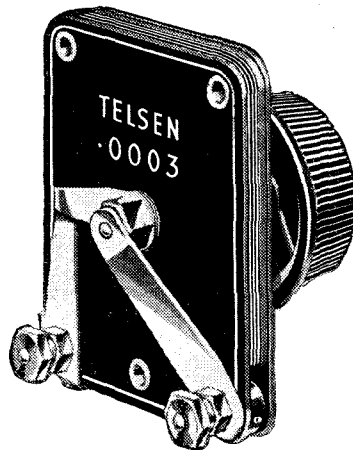

TELSEN

RADIO COMPONENTS

TELSEN RADIO COMPONENTS ARE 100% BRITISH

ANNOUNCEMENT OF THE TELSEN ELECTRIC CO., LTD., ASTON, BIRMINGHAM

The most
marvellous
home constructor
set ever
produced!

Super-selective!

TELSEN

Single knob tuning!

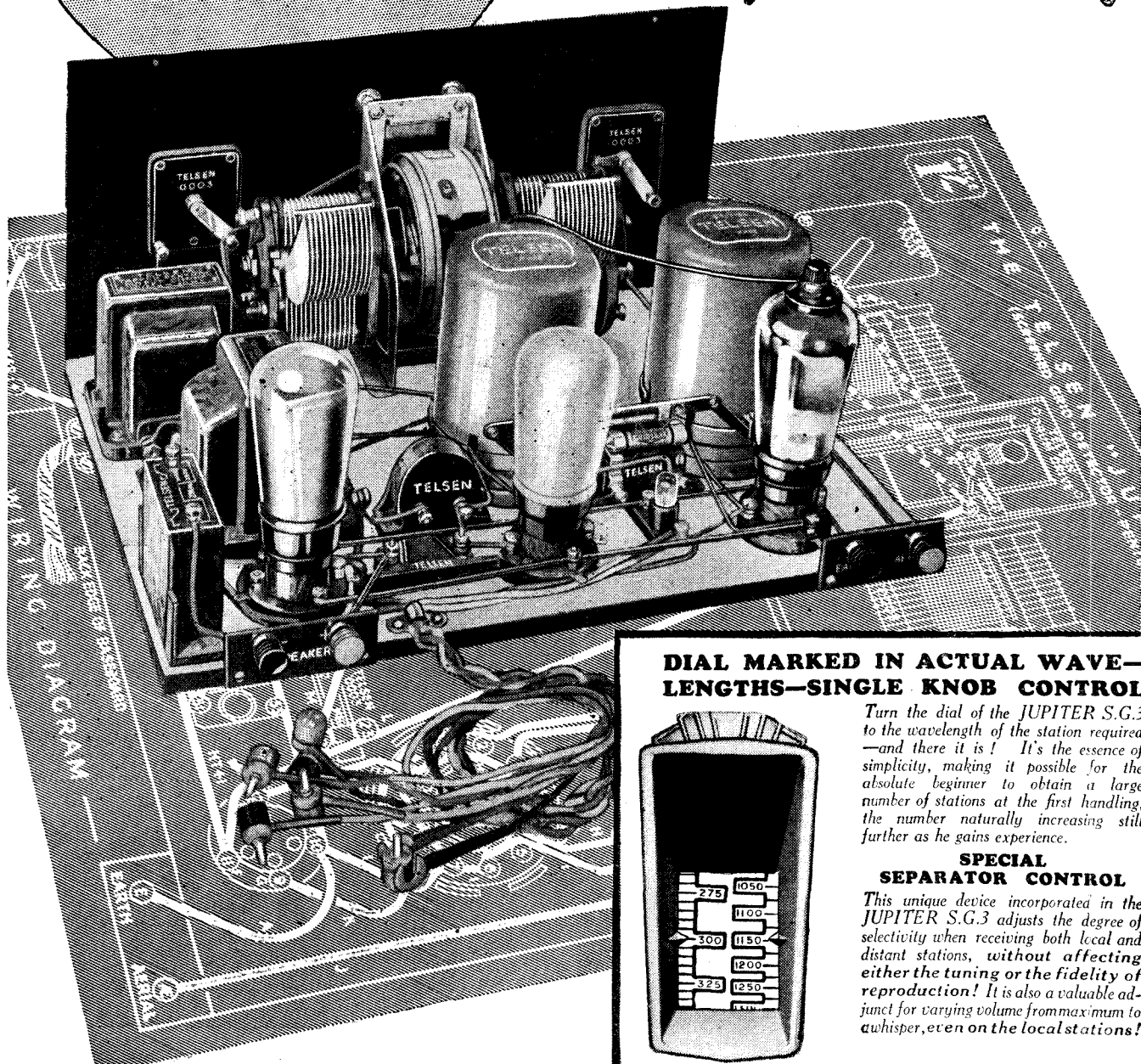

DIAL MARKED IN ACTUAL WAVELENGTHS—SINGLE KNOB CONTROL

Turn the dial of the JUPITER S.G.3 to the wavelength of the station required—and there it is! It's the essence of simplicity, making it possible for the absolute beginner to obtain a large number of stations at the first handling, the number naturally increasing still further as he gains experience.

SPECIAL SEPARATOR CONTROL

This unique device incorporated in the JUPITER S.G.3 adjusts the degree of selectivity when receiving both local and distant stations, without affecting either the tuning or the fidelity of reproduction! It is also a valuable adjunct for varying volume from maximum to a whisper, even on the local stations!

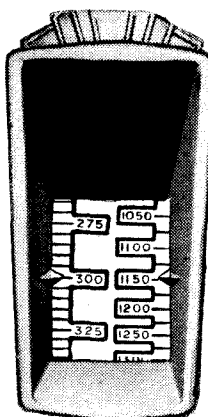

MAKE SURE YOU GET YOUR

ANNOUNCEMENT OF THE TELSEN ELECTRIC CO. LTD. ASTON, BIRMINGHAM

Hyper-sensitive!! Ultra-modern!!!

JUPITER S.G.3.

Dial marked in wavelengths! Special Separator Control!

Full size 1/- Blueprint given FREE with the TELSEN RADIOMAG No. 3.

Never before has it been possible for the ordinary home constructor to build so powerful a 3-valve receiver as the Telsen JUPITER S.G.3! For never before has such amazing power, such tremendous range and such superlative selectivity been attained with the use of only standard components! Child's play to build, child's play to operate, it is beyond

question the most *sensational home constructor set ever produced*. Yet it is not a "Kit" set, but purely a circuit design using specified components—some of which you may already have and will not therefore need to buy!

In keeping with the highest modern practice, the Telsen JUPITER S.G.3. incorporates Ganged Condensers, Ganged Coils, a Tuning Dial calibrated in wavelengths, and Matched Output, the brilliant circuit arrangement providing for absolute control of selectivity, with entire prevention of L.F. oscillation. The revolutionary 10-1 Coupling Unit specified gives an L.F. stage gain equal to that of a *two-stage* amplifier, ensuring (in conjunction with the special low loss coils) an overall amplification never hitherto approached in any receiver of its type.

Yet you can build it yourself—in an evening—with the aid of the full size 1/- Blueprint and complete constructional details contained in the Telsen Radiomag No. 3. PRICE 6d. Get your copy NOW!



3 full size 1/- Blueprints given FREE with the new TELSEN RADIOMAG

The Telsen Radiomag No. 3 tells you how to build the very latest types of receivers—how to modernise and improve your existing set—how to rectify little faults—how to get the best out of radio in every way. Get your copy now—price 6d. of all radio dealers and newsagents.

TELSEN

RADIO COMPONENTS

TELSEN RADIOMAG No. 3

ANNOUNCEMENT OF THE TELSEN ELECTRIC CO. LTD., ASTON, BIRMINGHAM

**USED
AND
RECOMMENDED
by**

John Scott Taggart

DON'T risk disappointment when you build your S.T. 400. You cannot expect good results with old valves. Scott-Taggart uses and recommends Cossor. Due to their many advanced constructional features—including the famous Mica Bridge—Cossor Valves will give you maximum performance. Ask your Dealer for the specified types (see list at right).

**COSSOR
VALVES**

Send for a free copy of the 42-page Cossor Valve and Wireless Book which contains a wealth of interesting and useful information including Radio Definitions—Useful Circuits—List of Stations, etc., etc. Please use the Coupon.

A. C. Cossor Ltd., Highbury Grove, London, N.5. Depots at Birmingham, Bristol, Glasgow, Leeds, Liverpool, Manchester, Newcastle, Sheffield, Belfast and Dublin.

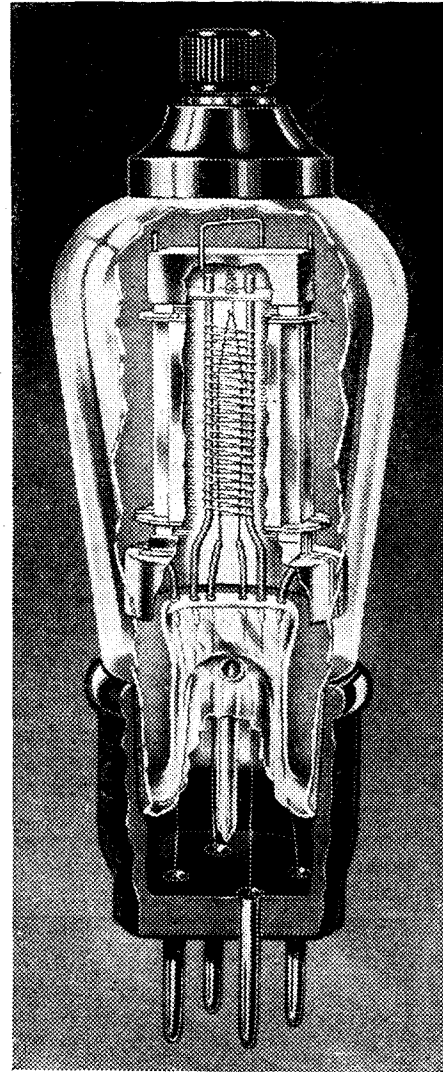

**—for the
S.T. 400**

- No. 1. H.F. Stage: **Cossor 220 S.G.*** - 16/6
- No. 2. Detector: **Cossor 210 DET.*** - 7/-
- No. 3. 1st L.F.: **Cossor 210 L.F.** - 7/-
- No. 4. Output: **Cossor 230 X P.** - 12/-
or 220 P. - 8/9

*Metallised.

To A. C. COSSOR LTD., Melody Department,
Highbury Grove, London, N.5.

Please send me, free of charge, a copy of the 40-page Cossor Valve and Wireless Book B.17.

Name

Address

W.C. 12/32

RAPID CONSTRUCTION GUIDE

This guide tells you every step to take in building your "S.T.400" in the minimum time.

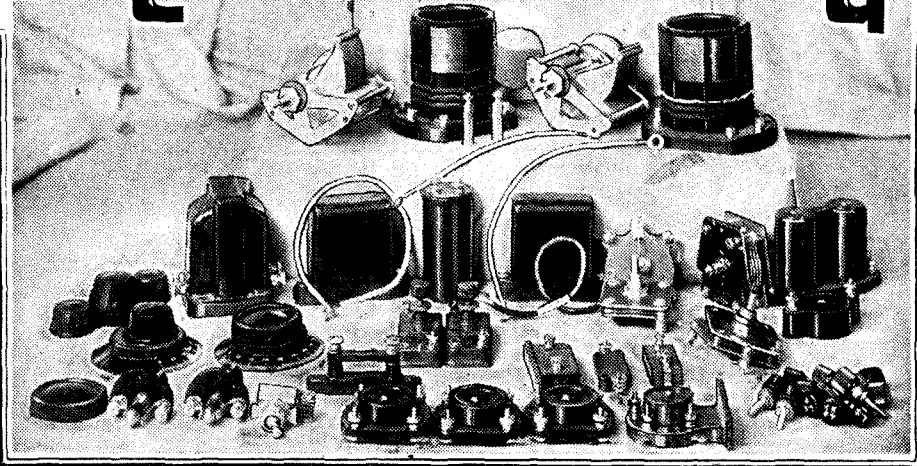

It will ensure that even the absolute novice will make a complete success of the receiver.

THIS guide tells you every single step to take in building the "S.T.400." No trouble has been spared in giving every detail in exactly the best and most time-saving order. To help beginners, it has been assumed that the reader has never built a set before.

Old hands will find my order very useful; this guide is used in my own laboratories in building duplicate "S.T.400" sets. The guide is an improvement on my former ones; it

contains more detail, and may be read out by a friend while the constructor checks the wiring on the finished set; there is no need to consult the blue-print.

If different components are used, slight obvious variations must be made.

(a) Collect and examine required components.

(b) Check size of baseboard (16 in. × 10 in.) and panel (16 in. × 7 in.). If you already have a cabinet, see that they will fit it.

(c) Examine screen to see that it conforms approximately to sketch, modifying it if necessary. Note the two holes for terminals.

(d) Take 7 in. × 10 in. earth sheet (metal foil) and fix it down over one end of baseboard by means of four tacks, one in each corner.

(e) Lay blue-print on baseboard. (The aerial end of blue-print, of course, goes over the earth sheet.) Keep blue-print steady with a weight. Using bradawl, prick through to baseboard the fixing holes of all baseboard components, including holes for anode-coil

countersink holes on underneath. (See holes go through baseboard, as shown in sketch illustrating method of mounting anode coil.)

(g) Prepare with a bradawl two holes through earth sheet and into baseboard for fixing vertical screen. (Holes are merely in preparation for receiving small wood screws; the vertical screen is not fixed at this stage.)

(h) Clean earth sheet (with emery paper) where it will later be held

down by ledge of vertical screen.

(j) Remove superfluous terminal C on the W.B. universal valve holder; discard the bent metal socket; put terminal aside for later use.

(k) Using blue-print as check for their positions, screw down the following in order given: W.B. universal valve holder, "S.T.400" aerial coil

(make *certain* you fit the right coil), 1-mfd. condenser, S.G. choke, both 2-mfd. condensers, L.F. transformer, three valve holders, reaction choke, base-

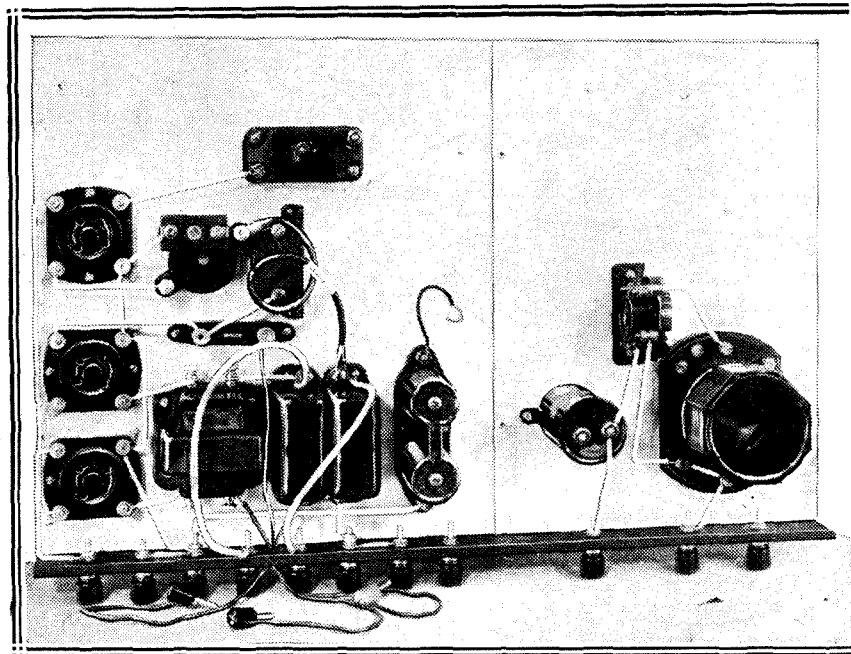

No. 1. Baseboard components shown mounted on baseboard and duly wired. The reaction pre-set condenser is fitted at a later stage.

pillars and holes for vertical screen fixing-screws.

(f) Remove blue-print and prepare holes in baseboard for anode-coil supporting pillars, and

DESIGNED BY
JOHN SCOTT-TAGGART
 "THE WIRELESS CONSTRUCTOR" DEC. 1932

**1/- FULL SIZE
 BLUE PRINT
 S.T. 400**

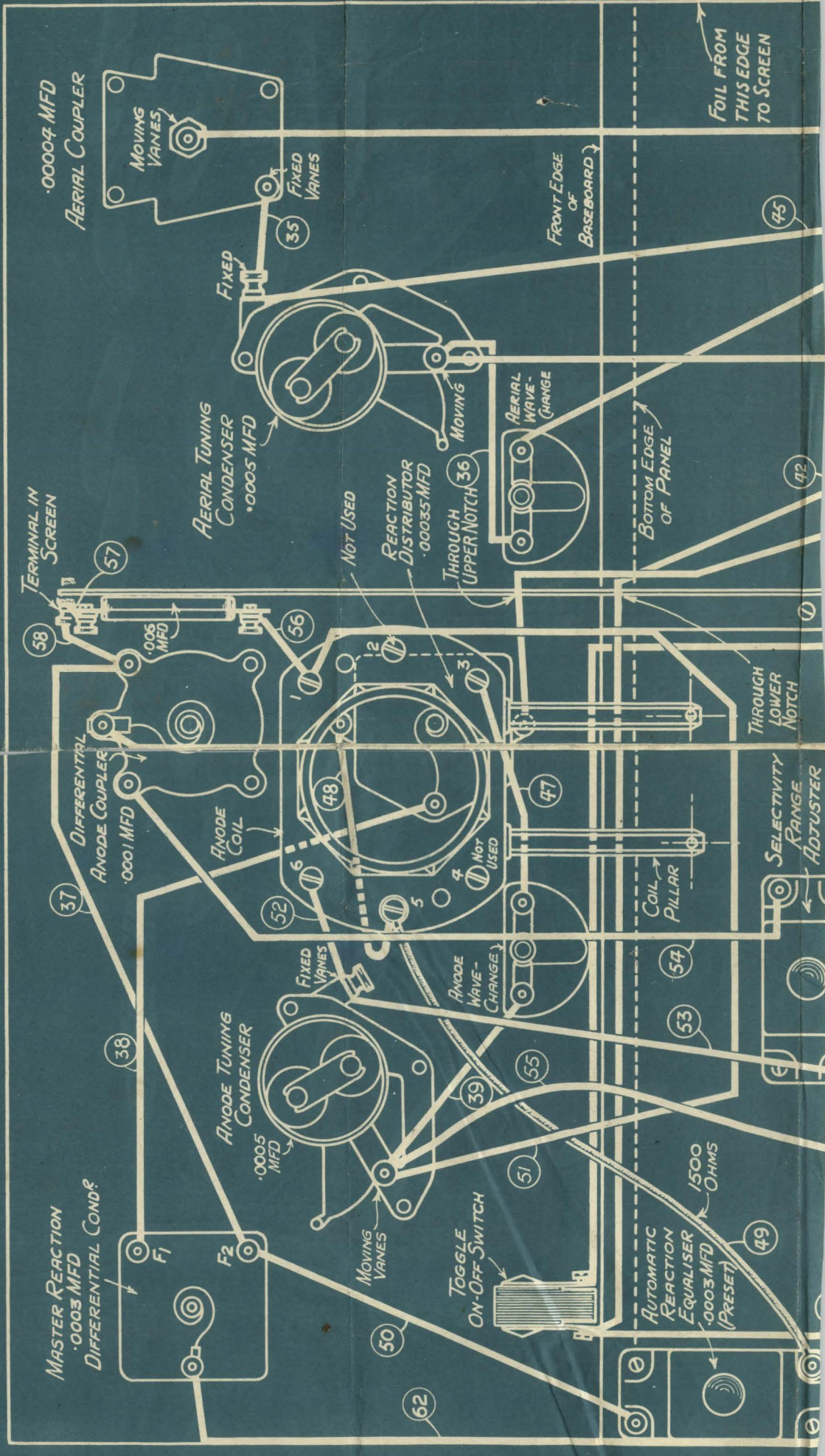

Foil from
 this edge
 to screen

FRONT EDGE
 OF
 BASEBOARD

BOTTOM EDGE
 OF PANEL

SELECTIVITY
 RANGE
 ADJUSTER

THROUGH
 LOWER
 NOTCH

THROUGH
 UPPER
 NOTCH

AERIAL
 WAVE-
 CHANGE

AERIAL
 WAVE-
 CHANGE

AERIAL
 WAVE-
 CHANGE

AERIAL
 WAVE-
 CHANGE

AERIAL
 WAVE-
 CHANGE

NOT USED

NOT USED

NOT USED

NOT USED

NOT USED

NOT USED

NOT USED

NOT USED

NOT USED

NOT USED

NOT USED

NOT USED

NOT USED

NOT USED

NOT USED

NOT USED

NOT USED

NOT USED

NOT USED

NOT USED

NOT USED

NOT USED

NOT USED

NOT USED

NOT USED

NOT USED

NOT USED

NOT USED

NOT USED

NOT USED

NOT USED

NOT USED

NOT USED

NOT USED

NOT USED

NOT USED

NOT USED

NOT USED

NOT USED

NOT USED

NOT USED

NOT USED

NOT USED

NOT USED

NOT USED

NOT USED

NOT USED

NOT USED

NOT USED

NOT USED

NOT USED

NOT USED

NOT USED

NOT USED

NOT USED

NOT USED

NOT USED

NOT USED

NOT USED

NOT USED

NOT USED

NOT USED

NOT USED

NOT USED

NOT USED

NOT USED

NOT USED

NOT USED

NOT USED

NOT USED

NOT USED

NOT USED

NOT USED

NOT USED

NOT USED

NOT USED

NOT USED

NOT USED

NOT USED

NOT USED

NOT USED

NOT USED

NOT USED

NOT USED

NOT USED

NOT USED

NOT USED

NOT USED

NOT USED

NOT USED

NOT USED

NOT USED

NOT USED

NOT USED

NOT USED

NOT USED

NOT USED

NOT USED

NOT USED

NOT USED

NOT USED

NOT USED

NOT USED

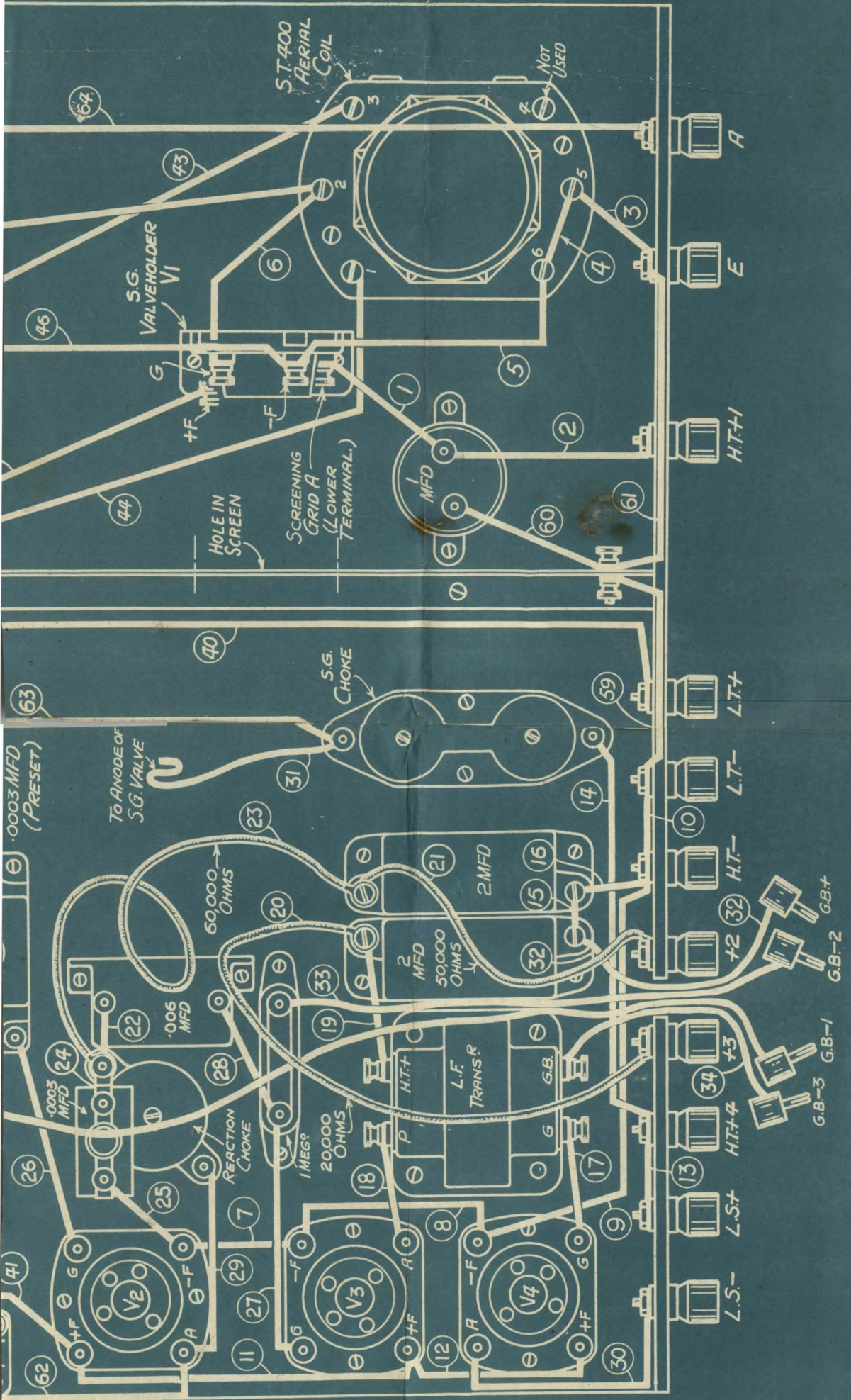

Every Step in Wiring Described in Detail

board .003-mfd. condenser (the larger sized one—Graham Farish was used), grid resistance holder with 1-megohm resistance in position, selectivity range adjuster (one of the .0003-mfd. pre-sets).

N.B.—The Automatic Reaction Equaliser (the other .0003-mfd. pre-set) is not fixed at this stage.

- (i) Mark out and drill terminal strip (or buy same).
- (m) Fit the 11 terminals loosely to terminal strip, which is then fixed to edge of baseboard by means of three countersunk-head screws. Unless fixing holes are countersunk, do not use countersunk-head screws.
- (n) Wire baseboard components with stiffish insulated wire (bell-wire will do, or one of the advertised varieties). To save the reader time and trouble I have numbered the wires in their most convenient order for connecting. Reasons are not given, but you will find them out if you depart from the order! Use the following list to find the wires quickly on the blue-print, and, if in doubt as to their shape, consult the perspective drawings and photographs. The numbers of wires are the same in all drawings. **You need not read the wording after the number of the wire if you can find the wire without.**

It is very important to tick off the numbers on this list after completing each connection. No terminal should be *finally* tight-

of my drawings to assist the reader to follow them.

1. Screening-grid terminal (marked A) of W.B. valve holder to 1-mfd.

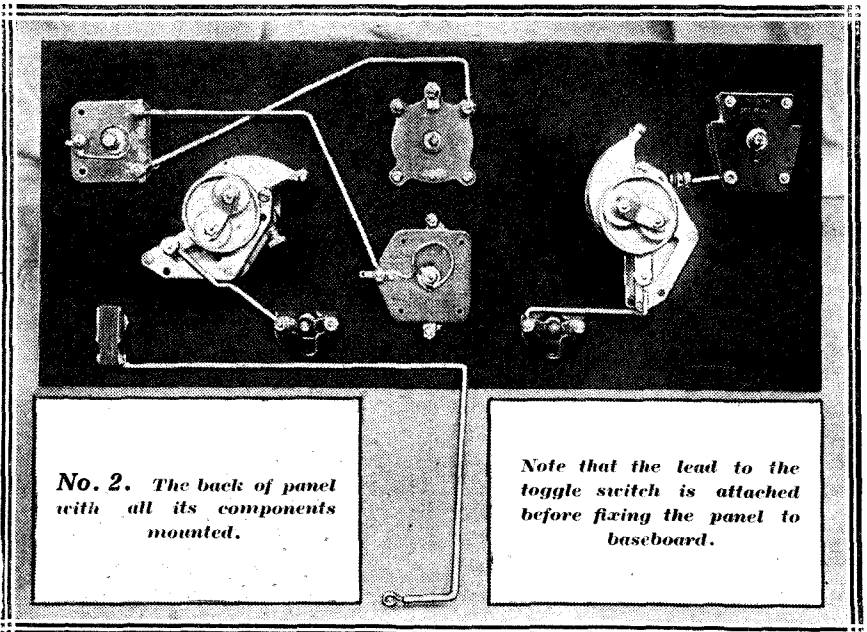

ened until all its wires (consult blue-print) are in place; once certain, tighten firmly.

N.B.—Valve-holder filament terminals are marked F on the actual valve holders, but are marked -F or +F in some

condenser (terminal nearest aerial coil).

2. Same terminal of 1-mfd. to H.T. + 1 terminal on terminal strip.
3. Earth terminal on strip to aerial coil terminal No. 5.
4. Aerial coil terminal No. 5 to aerial coil No. 6.
5. Aerial coil terminal No. 6 to upper filament negative terminal F on W.B. valve holder (shown as -F in drawings).
6. Aerial coil terminal No. 2 to normal grid terminal marked G of W.B. valve holder.
7. Valve holder V_2 filament negative -F (i.e. filament terminal farthest from baseboard edge) to valve holder V_3 filament negative terminal -F (farthest from baseboard edge).
8. Valve holder V_3 filament negative -F (farthest from baseboard edge) to valve holder V_4 filament negative -F (farthest from baseboard edge).
9. Valve holder V_4 filament negative -F (farthest from baseboard edge) to H.T. - on strip.
10. H.T. - on strip to L.T. - on strip.
11. Valve holder V_2 filament positive +F (nearest baseboard edge) to valve holder V_3 filament positive +F (nearest baseboard edge).

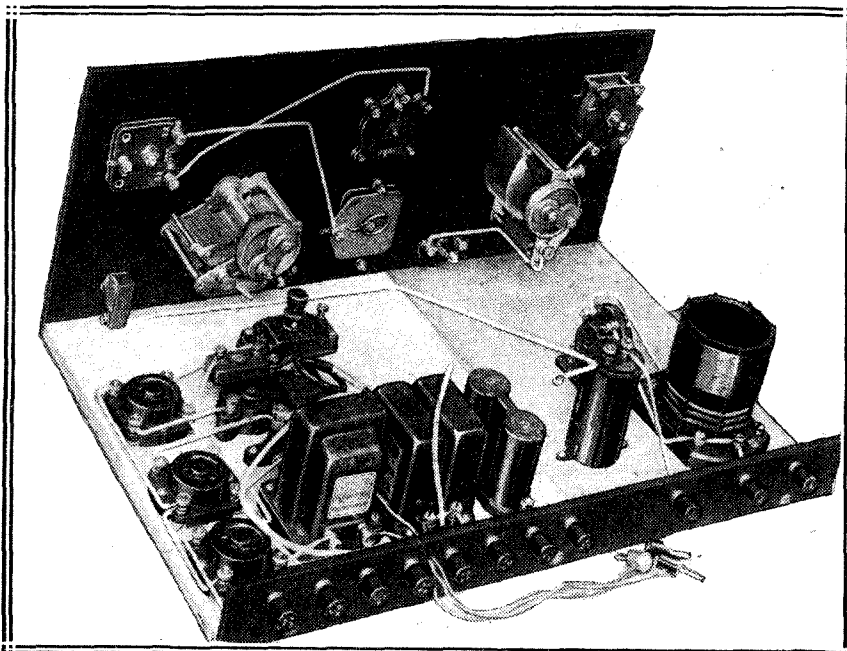

No. 3. When the panel has been screwed to the baseboard.

"PERFORMANCE THAT IS ABOVE THE AVERAGE

THESE NEW BATTERIES ARE REALLY GOOD"

says "Amateur Wireless"

Highly satisfactory reports of the new Ediswan Guaranteed H.T. Batteries continue to pour in. Experts and enthusiasts are unanimously agreed on their excellence. The listener who equips his set with Ediswan is absolutely assured of the greatest possible value for his money. Every Ediswan battery must pass numerous tests before it leaves the factory and additional protection is afforded by the Ediswan Guarantee of full voltage and capacity.

SPECIAL
Dust-proof and
Short-circuit -
proof cover.

Test hole enables
a complete volt-
age test to be
made without
breaking seals.

60 6'9
VOLTS

120 13'
VOLTS

9v. grid bias 1/-

108v. incorp. grid bias 12/-

Standard Capacity. Where the anode current required does not exceed 10 Ma these batteries will give highly satisfactory service. If super-power valves are used, the super-capacity type should be used.

Super Capacity. These batteries have twice the capacity of the standard type and, owing to their large reserve of power, last nearly three times as long when used as replacements to standard capacity batteries.

Send for your **FREE** copy of "How to get the most out of your H.T. Battery." Full of useful data, hints & tips.

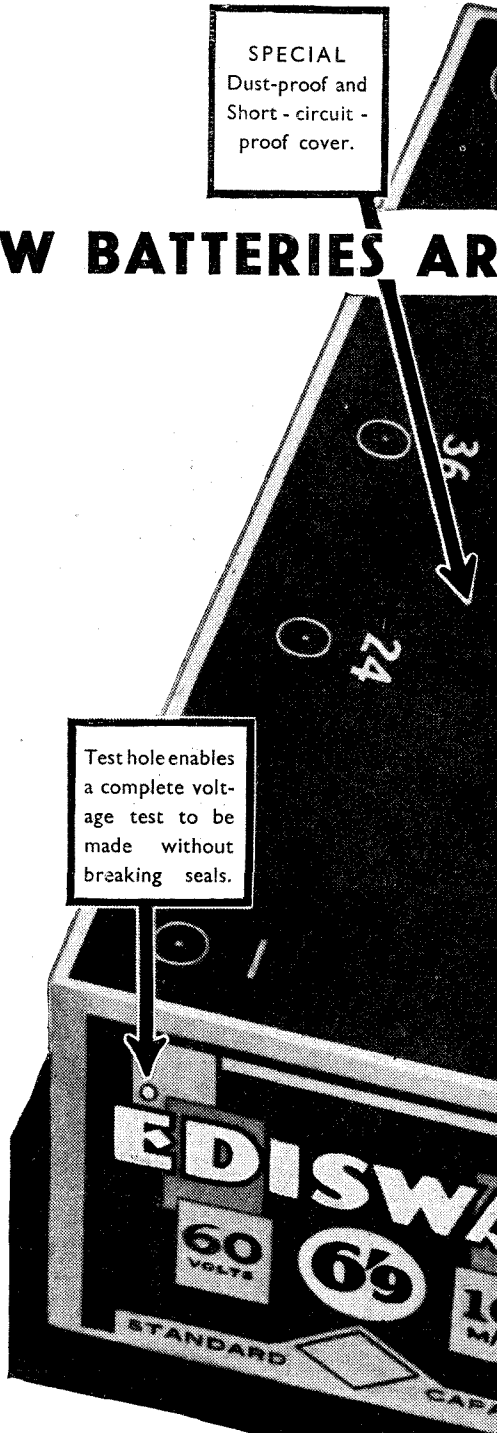

Guarantee

The Edison Swan Electric Co. Ltd. guarantees that Ediswan Batteries are of full voltage and capacity. Should any Ediswan Battery fail to give satisfactory service, we undertake to deal with customer's complaint within 24 hours of receipt of the defective battery.

All good radio dealers sell ...

EDISWAN

Guaranteed RADIO H.T. BATTERIES

THE EDISON SWAN ELECTRIC CO. LTD.



PONDERS END, MIDDLESEX

B.188

12. Valve holder V_3 filament positive +F (nearest baseboard edge) to valve holder V_4 filament positive +F (nearest baseboard edge).
13. L.S.+ on strip to H.T.+4 on strip.
14. H.T.+ 4 on strip to S.G. choke (terminal nearest strip).
15. 2 mfd. (terminal nearest strip) to other 2 mfd. (terminal nearest strip).
16. 2 mfd. (nearest S.G. choke) has its terminal nearest strip connected to H.T.— on strip.
17. Valve holder V_4 grid (marked G) to G on Hypernik transformer.
18. Valve holder V_3 anode (marked A) to P on transformer.
19. H.T.+ on Hypernik transformer to terminal (furthest from strip) on 2-mfd. condenser (nearest transformer).
20. Terminal (furthest from strip) on 2 mfd. (nearest transformer) via

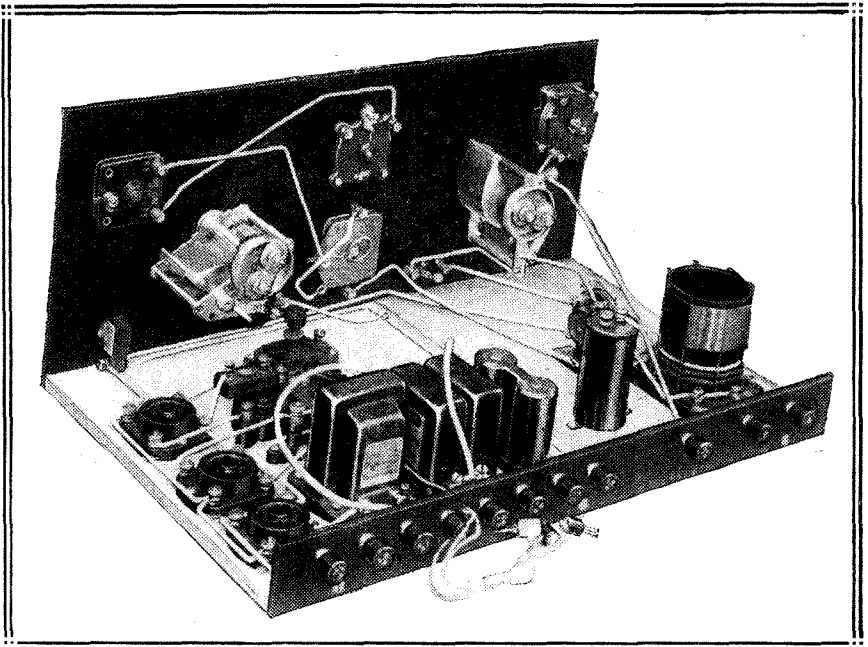

No. 4. Showing some of panel-to-baseboard wires now added. Note that a wire to reaction distributor and a wire to anode wave-change switch have ends in the air waiting to be fixed to anode coil when latter is fixed in position.

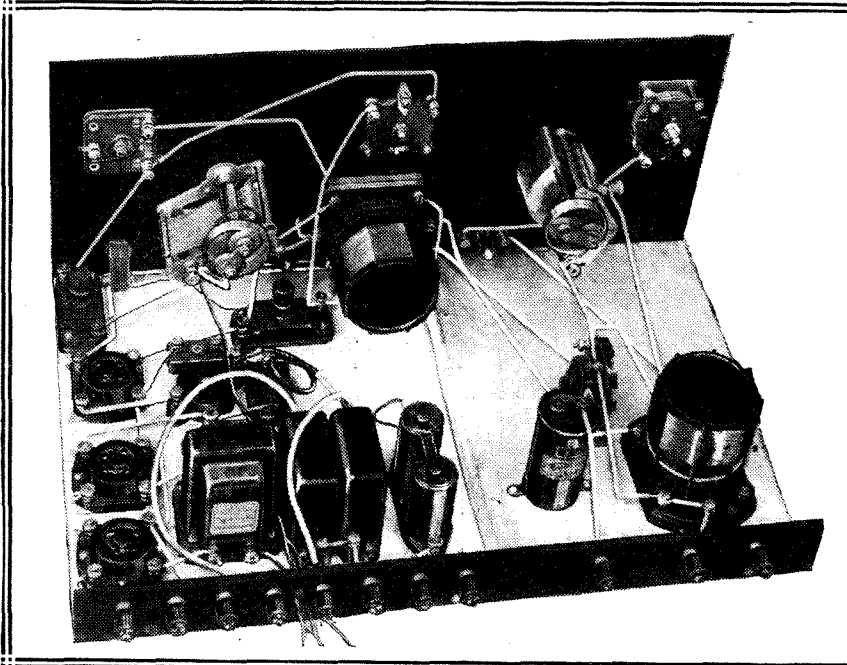

No. 5. Anode coil fitted, Reaction Equ'aliser pre-set fitted, and more wiring added. Fitting of screen and one or two final wires will complete the set, which is shown elsewhere in its finished form.

- 20,000-ohm spaghetti to H.T.+3 terminal on strip.
21. H.T.+2 terminal on strip via 50,000-ohm spaghetti to terminal (furthest from strip) on 2 mfd. (nearest S.G. choke).
22. .003-mfd. Graham Farish (terminal furthest from strip) to reaction choke (terminal furthest from strip).
23. Reaction choke (terminal furthest from strip) via 60,000-ohm spaghetti to terminal (furthest from

strip) on 2 mfd. nearest S.G. choke.

24. Reaction choke (terminal furthest from strip) to .0003-mfd. condenser (the Goltone .0003-mfd. used has metal straps at each end. One is used in present case as the connection to choke terminal; the other strap is bent underneath the condenser out of the way. The condenser is

(Please turn to page 169.)

Below is a photograph merely to illustrate the wires to the anode coil. Notice specially the lead which goes from the bottom right-hand terminal on the coil between the supporting pillars to anode wave-change switch; also the wire from the top right-hand terminal. Part of the Reaction Distributor differential may be seen through the coil.

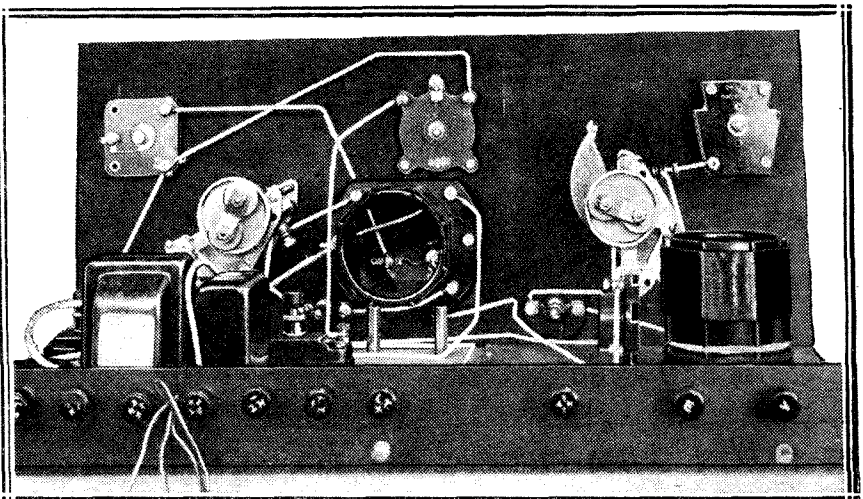

TELSEN

L.F. TRANSFORMERS COUPLING UNITS and OUTPUT CHOKES

TELSEN "RADIOGRAND" L.F. TRANSFORMERS

Typical of all that is finest in British Radio craftsmanship. Designed in accordance with recent research, constructed on the soundest engineering principles and tested rigorously for immaculate performance and enduring efficiency.

Ratio 3-1 **7/6**
Ratio 5-1 **7/6**

TELSEN "RADIOGRAND" (Ratio 1.75-1) TRANSFORMER

For use in high-class receivers employing two stages of L.F. amplification. When used following an L.F. stage employing choke or resistance coupling, it gives ample volume with remarkable reproduction ... **10/6**

TELSEN "RADIOGRAND" (Ratio 7-1) TRANSFORMER

Gives extra high amplification on receivers employing only one stage of L.F. amplification. Not recommended for use with two L.F. stages, as overloading is likely to occur. **10/6**

TELSEN POWER PENTODE OUTPUT CHOKES

For mains operated pentodes taking an anode current of up to 40 m.a. Serves both to prevent direct current passing through the speaker and to match the speaker to the pentode valve, with the choice of three ratios—1-1, 1.3-1, 1.7-1. Used with a 1-mfd. condenser it gives a great increase in both quality and volume. **10/6**

TELSEN TAPPED PENTODE OUTPUT CHOKES

For mains and battery operated pentodes taking an anode current of up to 20 m.a. The single tapping provides (by reversing) ratios of 1-1, 1.6-1, 2.5-1, ensuring perfect matching under widely varying conditions. Also suitable for matching a low impedance speaker with an ordinary power valve, a 1-mfd. coupling condenser being recommended for this purpose. **7/6**

TELSEN INTERVALVE L.F. COUPLING CHOKES

Primarily designed for use as coupling chokes, but may be used in any circuit carrying not more than the stipulated maximum current. The 100 H type is for H. or H.L. type valves, and the 40 H for L types.

Rating	Normal Current	Max. Current	
40 H. @	5 m.a.	10 m.a.	5/-
100 H. @	3 m.a.	8 m.a.	

TELSEN OUTPUT CHOKES

Designed for use with power or super-power valves taking an anode current of up to 40 m.a., this output filter provides an ideal response curve under all conditions. For use with a condenser of not less than 1 mfd. capacity. **7/-**

THE TELSEN "ACE"

The Telsen "Ace" is eminently suitable for Receivers where highest efficiency is required at low cost and where space is limited. As its characteristic curve will show, it gives a performance equal to that of the most costly transformers. Ratio 3-1 **5/6**
Ratio 5-1

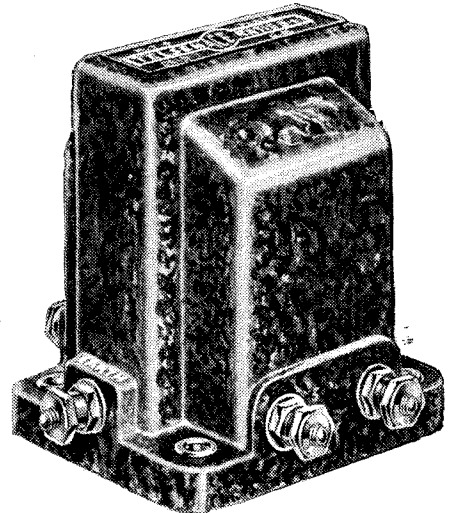
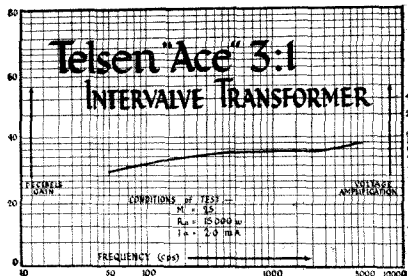

TELSEN 10-1 INTERVALVE COUPLING UNIT

A filter-fed transformer using a high permeability nickel alloy core, securing a 10-1 voltage step-up while preserving an exceptionally good frequency characteristic. The response is compensated in the higher frequencies for use with a pentode valve giving an amplification greater than anything previously achieved, equal to two ordinary L.F. stages but with better quality of reproduction.

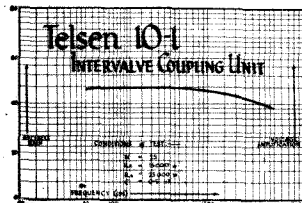

12/6

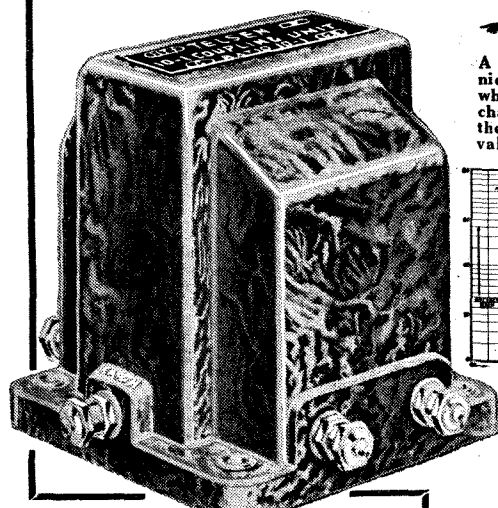

TELSEN MULTI RATIO OUTPUT TRANSFORMER

For use with moving-coil speakers, having a low impedance speech coil winding and suitable for anode currents of up to 40 m.a. Three ratios—9-1, 15-1, 22.5-1—allow for correct matching of speakers of widely varying characteristics. **10/6**

TELSEN OUTPUT TRANSFORMER (Ratio 1-1)

For connecting the speaker to the output stage, using a triode valve. Avoids saturation by isolating the D.C. from the speaker windings. Also keeps H.T. voltage from the speaker and its lead, which is especially important where a D.C. eliminator is being used. Suitable for anode currents of up to 40 m.a. ... **10/6**

TELSEN 1-1 INTERVALVE COUPLING UNIT

A modern development of the deservedly popular R.C. unit incorporating a low pass filter feed in its anode circuit, thus preventing "motor-boating," "threshold howl" and other instability due to common couplings in eliminator and battery circuits. Used with an H.L. type valve it gives an amplification of about 20 and a perfect frequency response on a negligible consumption of H.T. current. **7/6**

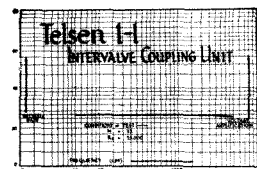

TELSEN
RADIO COMPONENTS

TELSEN RADIO COMPONENTS ARE 100% BRITISH

ANNOUNCEMENT OF THE TELSEN ELECTRIC CO., LTD., ASTON, BIRMINGHAM

TELSEN

H.F. CHOKES, PUSH-PULL SWITCHES & VALVE HOLDERS

TELSEN TWO-POINT SWITCH

For use as battery switch, or as wave-change switch, with the dual-range S.W. Coil unit. Employs a "knife" type self-cleaning contact, and a positive snap action, a series gap reducing self-capacity to a minimum. **1/4**

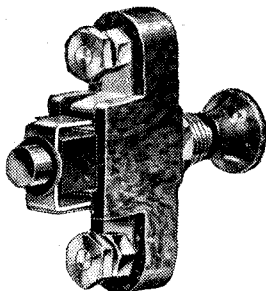

TELSEN THREE-POINT SWITCH

The perfect wave-change switch for use with a dual-range aerial coil or for breaking L.T. and H.T. currents simultaneously. **1/3**

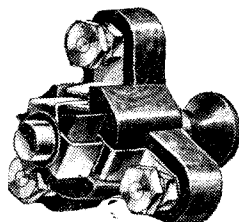

TELSEN FOUR-POINT SWITCH

Highly suitable for use in wave-changing on two coils or an H.F. Transformer, or for switching pick-up leads or an additional speaker. **1/6**

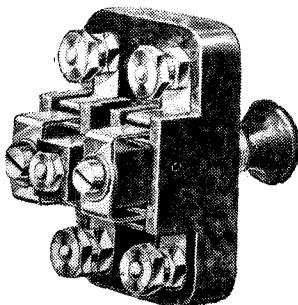

TELSEN VALVE HOLDERS

An improved range of valve holders in both solid and anti-microphonic types. Employ special contact sockets of one-piece design with neat soldering tag ends and terminals. Extremely low self-capacity.

- Solid type 4 pin 9d.
- Solid type 5 pin 1/-
- Anti-Microphonic 4 pin 1/-
- Anti-Microphonic 5 pin 1/3

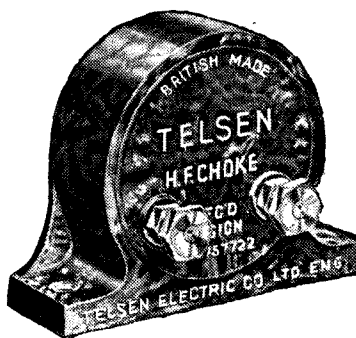
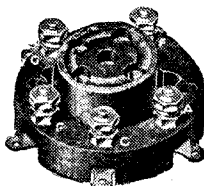
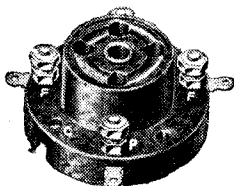

TELSEN BINOCULAR H.F. CHOKE

In H.F. amplification, the performance of a choke is of supreme importance. Where the very highest efficiency is the primary requisite, the Telsen Binocular H.F. Choke is the inevitable choice. It has a high inductance of 250,000 microhenrys, with a very low self-capacity and a practically negligible external field (due to its binocular formation). It is from every point of view the ideal choke—and where high-class circuits are concerned definitely the essential choke. **5/4**

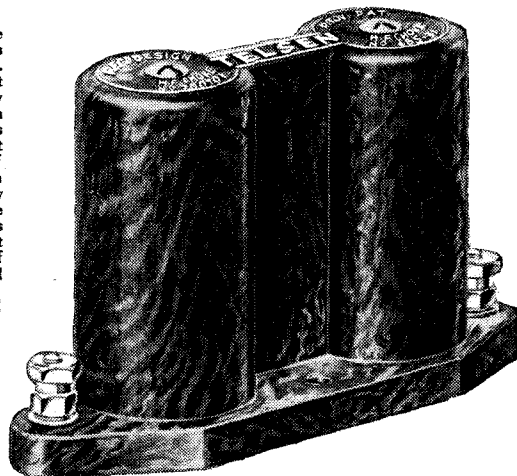

TELSEN STANDARD H.F. CHOKE

Covering the entire broadcast band, and occupying only the minimum of base-board space, the Telsen Standard H.F. Choke has proved deservedly popular ever since its introduction. With an inductance of 150,000 microhenrys, a resistance of 400 ohms, and an extremely low self-capacity, it is highly suitable for use in reaction circuits, and is constantly being specified in this respect by the leading set designers. **2/4**

TELSEN

RADIO COMPONENTS

TELSEN RADIO COMPONENTS ARE 100% BRITISH

ANNOUNCEMENT OF THE TELSEN ELECTRIC CO., LTD., ASTON, BIRMINGHAM

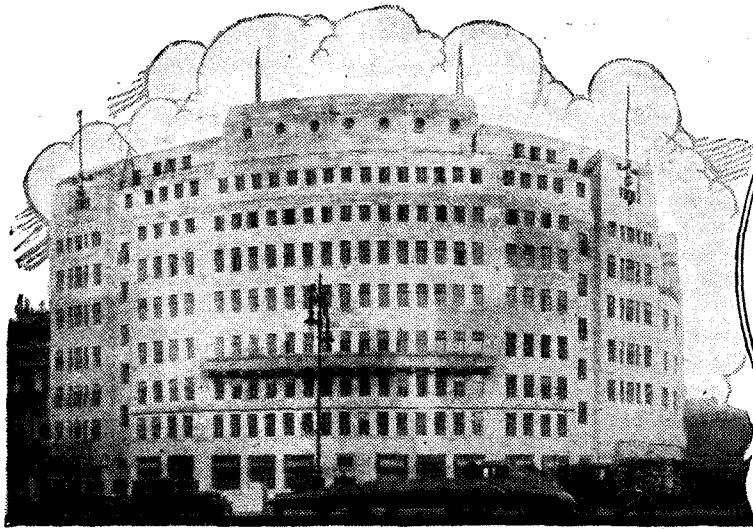

B.B.C. NEWS

Topical notes regarding British Broadcasting Stations and Programmes.

By Our
Special Correspondent

Married Women and the B.B.C.

I HEAR that there is an intense discussion proceeding at Langham Place about the rights and wrongs of retaining married women on the staff.

It seems that some years ago the matter was raised in connection with a specialised official regarded as important. In her case she was allowed to continue in her job.

Other cases, however, have arisen in which it has been suggested that as the husbands are supposed to be in a position to support their families, it is unfair from the point of view of general employment to allow them to continue in their job. The tendency appears to be in the direction of a firm rule against the employment of married women whose husbands are able to support them.

As to how this is to be applied is another matter.

Captain Eckersley in America

I learn from New York that Captain Peter Eckersley broadcast with great success during his recent visit there on his way back from Australia. One of his broadcasts on all the networks of the N.B.C. was a "take-off" on B.B.C. programmes which aroused enormous interest and amusement; Mr. Owen D. Young, telephoning him immediately afterwards, suggested that it was just as well that Sir John Reith was probably not listening!

As a matter of fact, Sir John Reith certainly would have enjoyed it much more than any American listener, because his sense of humour is much more alert than most people imagine.

December 20th

After all the fuss and bother about the B.B.C. and its tenth birthday, it

is amusing to note that this will not fall in November. The B.B.C. really began on the day in which Sir John Reith began to be paid as the first general manager, and that was December 20th, 1922.

I hear that the senior staff at Broadcasting House are planning a personal surprise for Sir John on this the real tenth anniversary of the B.B.C.

Settlement with the Salt Union

The serious danger to the B.B.C. plan for the re-erection of Daventry 5 X X and the Midland Regional transmitter at Droitwich has been overcome despite several initial mistakes. In the beginning the B.B.C.

entrusted its case to the ordinary channels of legal and business negotiations. Deadlock ensued and, what was worse, misunderstandings were generated.

Then the B.B.C. wisely set up a collateral method of approach along indirect private diplomatic channels. In the end the crisis was averted and an excellent agreement reached with honour both for the Salt Union and the B.B.C.

Some day I shall publish the full inside story. Meanwhile, I would say that it speaks well for the B.B.C. that it has available at hand alternative methods for handling difficult situations such as this.

LONDON'S "SEARCHLIGHT" LOUDSPEAKER

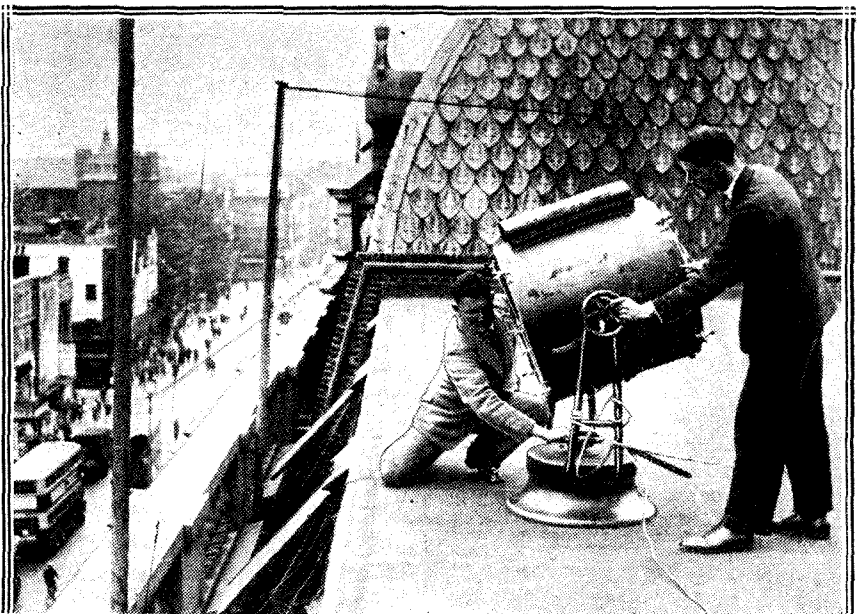

On a roof overlooking Tottenham Court Road this powerful "searchlight-pattern" loudspeaker has been installed to relay Big Ben to the West End. It is permanently connected to a microphone in the famous clock tower.

B.B.C. News—continued

B.B.C. Staff Honours

There is the usual crop of rumours about prospective honours for members of the B.B.C. staff. The rumours this time, however, are a little more persistent because of the elevation to knighthood in the last Birthday List of Admiral Carpendale, whose recognition was unexpected, but probably due more to his work in the international field than as disciplinary chief in Langham Place.

There was, however, some discontent among programme builders and engineers, more directly concerned with the work of British broadcasting.

tests will be complete and the various zones sorted out. There will be, of course, an auspicious opening, in which the voice of Sir John Reith, although not announced, will give the keynote; and quite right, too. His microphone appearances are too infrequent.

The Birthday Week

With the Prince of Wales and the biggest galaxy of stars that money and ingenuity can assemble, the B.B.C. birthday week looks like being easily the best in its history. I hope that Captain Eckersley is not omitted; nor Rex Palmer, nor Arthur Burrows,

was hoped as recently as July that the West Regional services would be inaugurated in February or March of next year.

As the situation now stands it is unlikely that this will be brought about until May. This is unfortunate in some respects, but, of course, it is much better to get the station right even at the risk of delay.

I submit, however, that the B.B.C. would be better advised than it is if it took listeners more into its confidence about the difficulties and problems involved in this pioneering work of twin-wave, high-powered station construction.

FLYING RADIO SALESMEN

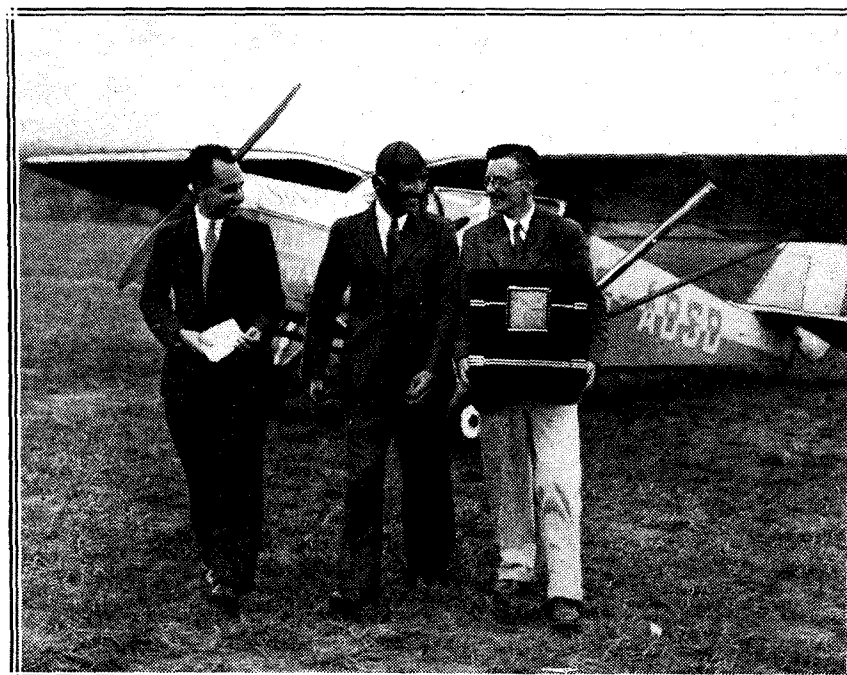

Here are the pilot and two radio salesmen who, in order to get the latest models on to the market in good time, flew from London to dealers in the North to give demonstrations.

It is not surprising, therefore, that there should be more definite expectation now than before, if only because Sir John Reith and Mr. Whitley are known to be keenly alive to situations such as this.

I think I know what will happen, but if I publish it and if it is true it will have a prejudicial effect on the chance of realisation for those excellent servants of the wireless public who are contemplated for recognition.

The Empire Service

December 19th is zero hour for the Empire broadcasting service of the B.B.C. By then the first series of

nor Eric Dunstan, nor R. E. Jeffrey, nor Donald Calthorp, nor George Grossmith.

Fortunately, David Tennant is already "epiloguing," having apparently overcome the somewhat vague doubts about his high seriousness and general attitude towards life which seem to bulk in the minds of the authorities at Broadcasting House.

Delay at Washford Cross

The building of the West Regional transmitters at Washford Cross, in Somerset, has not proceeded as smoothly as the building of the other Regional twin-wave transmitters. It

WORKSHOP HINTS
 * Two really practical tips for the *
 * home constructor. *

IN making up designs published by THE WIRELESS CONSTRUCTOR, or commercial kit sets, there is hardly any wiring to do that can possibly be called at all difficult. But many readers no doubt make alterations in existing sets or work out designs of their own—and then not infrequently the fun (or, rather, the reverse!) begins.

You can just manage to fit the components to the baseboard or chassis, but when you have done so you find that some of them appear to have been specially designed by their makers to render wiring-up difficult in your particular case.

Whenever I have an awkward component to wire up I make use not of stiff wire, but of flex. Before you screw the component down, fix a longish piece of flex to each of its terminals. You will not then have much difficulty in taking these wires to the terminals to which their other ends belong.

Watch Your Watch

And now let me give you one hint for wireless experimenting which may save a great deal of trouble. Always take off your wrist-watch before you start work.

I speak with some feeling, because recently I ruined a good watch of this kind by thoughtlessly wearing it whilst engaged in making adjustments to a moving-coil loudspeaker. Its steel parts became so strongly magnetised that the watch refused to function.

R. W. H.

TREMENDOUS EFFECT OF SKYSCRAPER VALVE POWER NOW REALIZED

IN PERTSHIRE'S ISOLATED HAMLETS AS IN LONDON'S POWER LADEN ETHER!

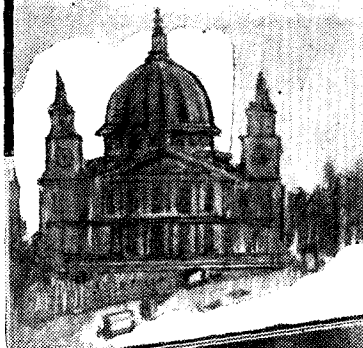

50-60-70 LOUDSPEAKER STATIONS

Say Constructor's Letters

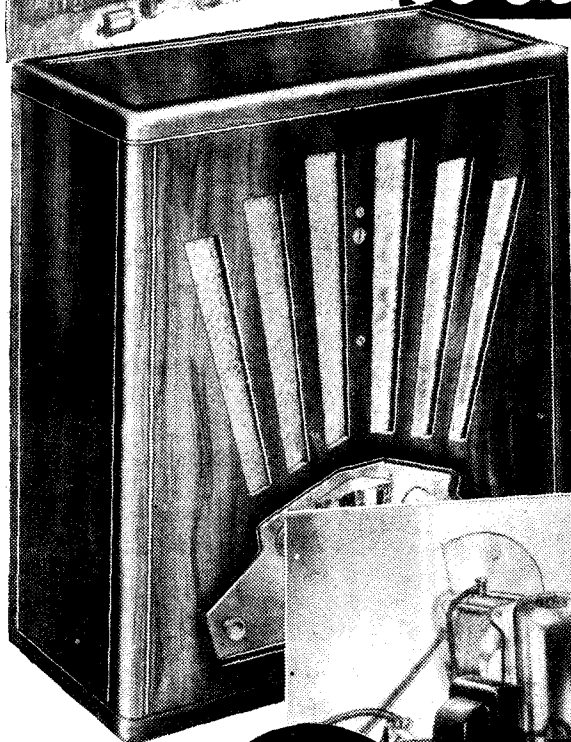

GREAT LISSEN CHART

- FREE

TELLS YOU EXACTLY WHAT TO DO WITH EVERY SINGLE NUT and SCREW

The ONLY set you CAN build yourself, employing Metallised Screened Grid, High-Mu Detector & Economy Power Pentode Valves.

"Astonished at the power from three valves." . . . "Every station mentioned on your Calibration List." . . . 50-60-70 Loudspeaker Stations! Never before such a set as the Lissen Skyscraper—never before such universal success in building—never before so many appreciative letters from constructors as this Lissen Skyscraper has elicited.

It is the only set on the market that you can build yourself employing Metallised Screened Grid, High-Mu Detector and Economy Power Pentode Valves. No factory—however well-equipped—can build a better receiver. No manufacturer, however large, can produce a receiver whose results will surpass those you will get from the Lissen Skyscraper you build yourself. It is the only battery set that can deliver such power—yet the H.T. current consumption is far less than that of the average commercially-designed 3-valve set.

Yet the Lissen Skyscraper is made simple for you to build. Elaborate care has been taken to ensure your success by giving—in the Skyscraper Constructional Chart—such detailed instructions and such profuse illustrations that everybody, with no technical knowledge or skill at all, can build it quickly and with complete certainty of success.

You buy the Lissen Skyscraper Kit complete with valves—a Lissen Metallised S.G., a High-Mu Detector, and a Lissen Economy Power Pentode Valve and the price is only 89/6. Or you can buy the Lissen Walnut Console Skyscraper Cabinet and Loudspeaker combined as illustrated. It holds all batteries, and accumulator, and Loudspeaker as well. It makes everything self-contained.

A special Pentode Matched Balanced-armature Loudspeaker of great power is supplied with the Cabinet and the price of the Skyscraper Kit complete with valves and this Cabinet and Loudspeaker is only £6 5s.

KIT COMPLETE WITH METALLISED SCREENED GRID HIGH MU DETECTOR & ECONOMY POWER PENTODE VALVES

89/6

Ask your radio dealer for FREE copy of the Skyscraper Chart or POST THIS COUPON!

LISSEN SKYSCRAPER 3 KIT



TO LISSEN LTD., Dept. C3,
WORLE RD., ISLEWORTH, MIDDLESEX.
Please send me FREE copy of the
Lissen Skyscraper Chart.

Name:
Address:

Micromesh

A MODERN VALVE WITH NEW PRINCIPLES

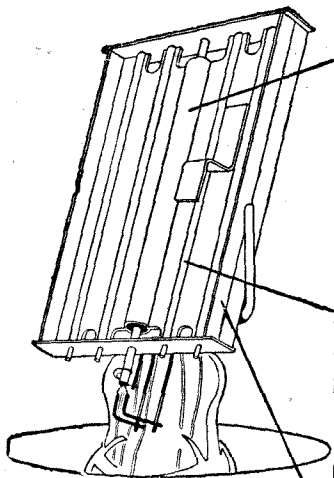

Extremely close spacing of the electrodes, assuring high slope.

Large surface radiation fins eliminate distortion through grid emission and furnish extra cooling for anode.

Assembly, constructed as separate unit, gives unusual accuracy and rigidity

Try a set of Micromesh Valves in your receiver. Note the vast improvement in crispness of tone and clarity of reproduction. Micromesh—the Modern Valve—gives perfect reception from every station.

Type H.L.A.1 Detector. List Price, 13/6.

Type P.A.1 Power Output. List Price 17/6.

Type R.1 Indirectly Heated Full-wave Rectifier. List Price 12/6.

Type R.2 Indirectly Heated Full-wave Rectifier. List Price 15/-.

Write for leaflet containing full details of Micromesh valves.

Standard Telephones  and Cables Limited

Radio Merchandise Dept., St. Chad's Place, 364, Gray's Inn Rd., London, W.C.1.

Telephone : Terminus 6255.

ST 400 CELESTION

The Very Soul of Music
LOUD-SPEAKERS

The OBVIOUS CHOICE

PPM 19

47/6
INCLUDING TRANSFORMER

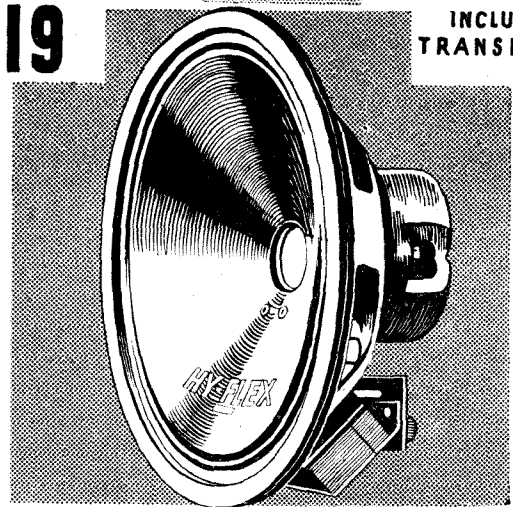

There is no need for you to hesitate in your choice of a speaker for the S.T.400. Follow the recommendation of Mr. Scott-Taggart, who chose the Celestion PPM19 as a speaker specially suitable for his latest set.

Mr. Scott-Taggart's choice was influenced by the remarkable true-to-life results obtained with this remarkable speaker achievement, and his knowledge of the dependability for which Celestion speakers are already famous. Listeners who have heard this latest speaker from the Celestion range of speakers are enthusiastic about its performance; you will be equally enthusiastic when you have heard this Celestion achievement.

Price only 47/6 including transformer.

THE CELESTION PPM RANGE OF SPEAKERS ARE PRICED BETWEEN 27/6 AND £6 10 0

Hear them at your local dealer.

FOREMOST NAME IN SOUND REPRODUCTION

CELESTION LTD., LONDON ROAD, KINGSTON-ON-THAMES
London Showrooms : 106, Victoria Street, S.W.1

AS WE FIND THEM

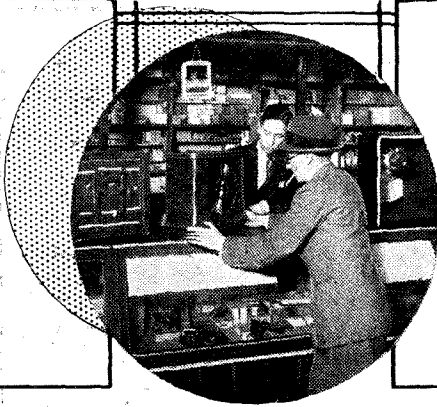

NEW APPARATUS TESTED

The Davenset Mains Transformer

ONE of the best mains transformers we have had through our hands is the Davenset, Class A, type No. 12, made by Messrs. Partridge, Wilson & Co., of Evington Valley Road, Leicester.

This component is a remarkably fine example of transformer construction; the mechanical construction being exceptionally clean and workmanlike.

SOUNDLY DESIGNED

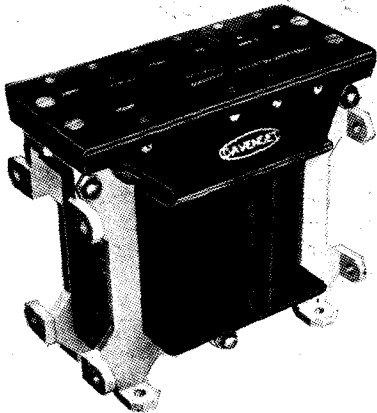

The latest Davenset mains transformer is a very fine example of its type. All the terminal connections are countersunk for safety.

Alternative feet are provided on the casting, so that the transformer can be placed either in an upright position or on its side, whichever happens to be the most convenient.

A stalloy core of ample dimensions is employed, while the coils are former wound and taped with superfine Egyptian cotton tape.

The temperature rise in these transformers is negligible, and the particular model submitted was designed for use on A.C. mains of from 200-250 volts 40-100 cycles. On the output side are tapplings of 2+2 volts, 4 amperes, for the heaters, the secondary output being 240 volts. When used with a H.T.9 Westinghouse metal rectifier, the maximum D.C.

Under this heading we publish reviews of apparatus submitted by radio manufacturers and traders for examination and test in "The Wireless Constructor" laboratories.

output is 300 volts 60 milliamps.

The price of this high-grade component is 47s. 6d.

Lissen Components

Tone compensation is now "the thing," and the latest component of this type is the Lissen.

In dealing with another make of tone control last month we explained how necessary it is to have some means of compensating for the effects of highly-selective high-frequency amplifiers, which by reason of their selectivity cut off a certain proportion of the top frequencies in music.

The Lissen tone control amply compensates for this loss due to selective circuits by over-emphasising at will the top end of the musical scale.

In addition, deficiencies in loudspeakers, heterodyne whistles and needle scratch can be put right, and altogether this tone control will be found a very valuable adjunct to a transformer-coupled receiver.

The unit is designed to fit underneath the "Hypernik" transformer, and it can be readily connected up to any receiver.

Another component we have received from the same firm is a ganged three-coil unit. The coils are "canned" and mounted on a metal sub-base, with a wave-change switch and filament switch operated by one knob.

When tuned with a ganged condenser having a maximum capacity of .0005, the wave range is approximately 200-530 metres and 800-2,000 metres.

We have had one of the units on test in THE WIRELESS CONSTRUCTOR

laboratory, and we found that both selectivity and power were of a high order.

The volume on the long waves is comparable with that on the medium waves, and there is not the marked falling off in strength sometimes associated with coils of the dual-range type.

A Good Terminal

Eelex terminals are well known to set constructors, and the makers—Messrs. J. J. Eastick & Sons, of 118, Bunhill Row, London, E.C.—have recently brought out a new type.

This particular terminal is known as the "A.1," and the constructor can buy them in sets of four, together with 24 indicating tabs. Hence, the same terminal can be used again and again for various purposes simply by removing the existing tab and replacing it by one with an appropriate marking.

The "A.1" terminal has several distinctive features, one of these being that the head, although free to rotate, cannot come off. Another point is the provision of a socket in the centre of the head for the reception of a wander plug.

The set of four terminals, together with 24 indicating tabs, is priced at 2s. 6d.

HIGH-GRADE BATTERY



This is one of the new Ediswan 60-volt standard capacity units, the cells of which are capable of supplying up to 10 m.a. of trouble-free energy.

"Ultrite" Aerial Wire

Ordinary bare 7/22 copper aerial wire has several disadvantages. For

As We Find Them—continued

one thing it tends to kink unless exceptional care is taken in handling it. Secondly, the lead-in has to be placed in such a way that it cannot swing against any conducting bodies which may cause a leakage of the minute high-frequency currents to earth. Thirdly, it is not suitable for use indoors.

We have had two samples on test for some time; one of these is a Standard Capacity 120-volt unit, having a current rating of 10 milliamps.; the other is a 20-milliamp. 60-volt Super Capacity battery. In each case the results of our tests reveal the fact that the capacities are well above the minimum laid down for high-grade batteries; the cells discharge perfectly evenly and noiselessly, and these Edison units are undoubtedly products of the highest class.

OVERCOMES HIGH-NOTE LOSS

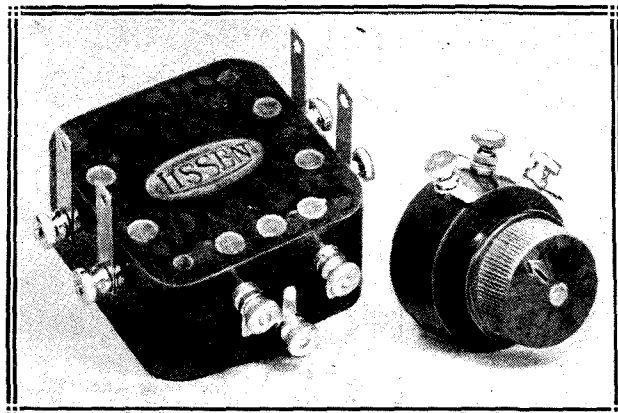

The Lissen tone control is designed to fit under the "Hypernik" transformer, and enables tone variations to be made at will simply by rotating the knob of the potentiometer.

Now Goltone people have brought out a different kind of aerial wire. They call it the "Ultrite."

It is flexible, and can be used equally well for both indoor and outdoor aerials. The conducting portion comprises eleven strands of No. 30-gauge copper, tinned to prevent oxidation, and over these strands is a braided and vulcanised covering to protect them against weather conditions.

The makers inform us that after twenty-four hours' immersion in water, an insulation test gives a measurement of 3,000 megohms per coil of 100 feet. This, of course, indicates a very high insulation, and we prophesy a well-merited popularity for this efficient and convenient aerial wire.

The price is quite moderate, namely, 3s. 6d. per 100 feet, and it can also be obtained in lengths of 25, 50 and 75 feet.

A High-Grade Battery

There was a time when one's suspicions were directed to the H.T. battery at the first sign of any falling off in volume or the presence of background crackles. Those days are over, if we may judge by the results obtainable with the new Edison dry batteries.

Covered Sockets

There are certain refinements worth noting. For instance, the tapping sockets are protected by a short-circuit-proof covering, so that there is no chance of damage should a metal article be

accidentally placed on top of the battery.

On the side of each unit there is a test hole, which enables a voltage test to be made without any necessity for breaking the seal. The 120-volt 10-milliamp. Standard Capacity units are priced at 13s., and the Super Capacity types at 12s. 6d. per 60 volts. Constructors should remember that it is an economy in the long run to purchase the Super Capacity batteries for sets employing three valves or over.

The makers are the Edison Swan Electric Co., Ltd., of Ponders End, Middlesex.

D.C. Set

We have recently had the opportunity of trying out two of the 1932/1933 G.E.C. receivers.

The first was the "Nomad," a four-valve set designed for use on D.C.

mains, selling at 23 guineas. There are, of course, many thousands of listeners who are not likely to be converted to A.C. for a long time, and to those the "Nomad" should make its appeal.

The circuit comprises two S.G. stages, followed by a screen-grid detector and pentode. The valves are indirectly heated and are intended for connection to D.C. mains of voltages from 200/260.

Heterodyne Filter

Among the special features of this receiver are a "long-distance" switch, which eliminates the possibility of valve overloading on local transmissions, and a heterodyne filter to remove the high-pitched heterodyne whistles, which are so prevalent in these days of many stations.

The three tuning circuits are ganged and operated by a single knob, and there is the usual arrangement whereby a pick-up may be switched into the grid circuit of the detector valve when it is desired to play gramophone records.

"Local-distance" Switch

The consumption of the "Nomad" is in the neighbourhood of 70 watts, which represents between 14 and 15 hours running per unit.

Our tests revealed excellent sensitivity and the alternative aerial

SIMPLIFIED GANGING

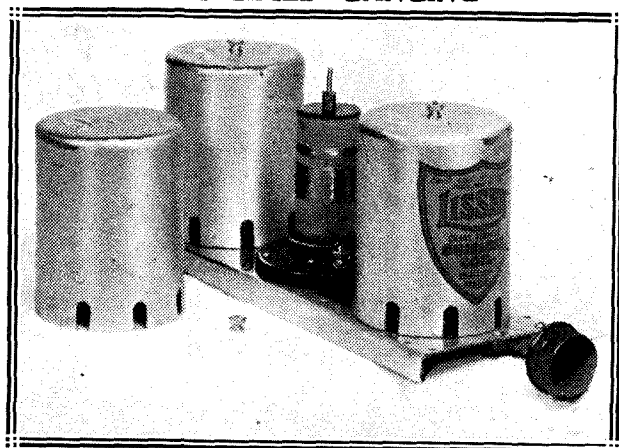

The latest Lissen screened coils are compact and efficient. The wave-change and filament switches are operated by one knob.

sockets provided all the selectivity needed for normal use. We found the "local-distance" switch a valuable adjunct when receiving the Brookmans "Twins."

SCOTT-TAGGART recommends GRAHAM FARISH PRODUCTS for the S.T.400

GRAHAM FARISH RIGID VALVE HOLDERS

S.T.400 requires Three 4-pin type.

These Valve Holders have exceptionally low-loss moulded bases, the insulating material between sockets being reduced to a minimum. Contacts are of phosphor bronze, sturdy in design.

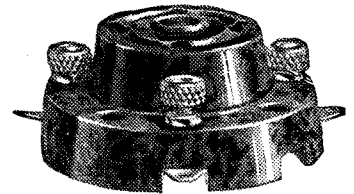

4-pin type **6D.** 5-pin type **8D.**



BETTER THAN WIRE - WOUND **1/6**

GRAHAM FARISH OHMITE RESISTANCES

S.T.400 requires One 1 meg.

The popular and efficient resistances for all general purposes. All values 300 ohms to 5 megohms.

GRAHAM FARISH LIT-LOS SOLID DIELECTRIC VARIABLE CONDENSERS

S.T.400 requires Two .0003 & One .0001 Differential Types

Compact in size and efficient in design, with accurately gauged bakelite dielectrics and solid brass pigtail connection to moving vanes. All capacities up to .0005 mfd. in tuning reaction and differential types. One-hole fixing; supplied complete with terminals.

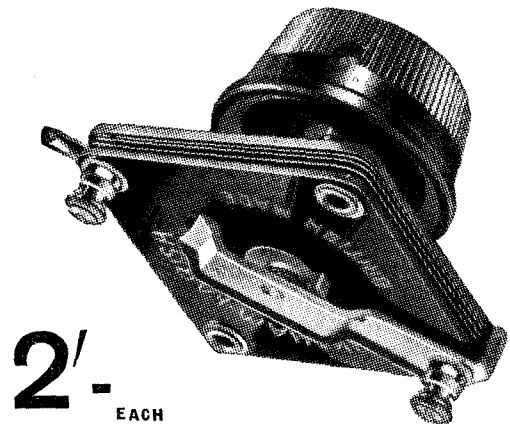

2/- EACH

Obtainable through all Radio Dealers or post free from Sole Manufacturers:

GRAHAM FARISH LTD., MASONS HILL, BROMLEY, KENT.

SEND FOR ILLUSTRATED CATALOGUE.



IT'S NO USE BUILDING S.T.400 unless you earth it efficiently—fit FILT—the earth Scott-Taggart recommends exclusively.

As We Find Them—continued

The receiver is intended for use in conjunction with a conventional outdoor or indoor aerial and earth, but the makers have also included a metal "plate" aerial in the set, and this may be employed in cases

READY TO ASSEMBLE

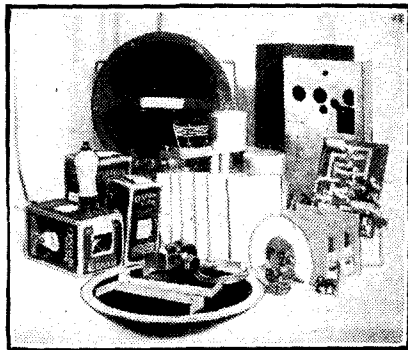

Here is the Osram "33" kit ready to build. A comprehensive instruction chart and the fullest constructional details are supplied by the makers.

where sensitivity is not vital, such as when working in the swamp area of a powerful broadcasting station.

The "Nomad" is a very fine example of its type, the reproduction from the moving-coil loudspeaker having just the right proportions of bass and high notes, while speech is crisp and natural.

The set is also remarkably free from hum.

The Osram "33"

The other receiver was the new Osram "Thirty-Three" kit set, which retails at nine guineas complete; this, of course, includes cabinet, loudspeaker, valves and royalties.

The circuit in this case is an S.G. followed by an S.G. detector, transformer-coupled to a triode output valve. It is not a mains set, the valves being of the two-volt type, and the batteries are contained in the cabinet.

The aerial and anode circuits are "ganged" and operated by a single knob on the front of the cabinet, and the only other controls are the wave-change switch and the volume control, which incorporates reaction.

There is only one H.T. positive tapping, voltage-dropping resistances being provided to maintain the screening grids at their correct potentials. A fuse is included in the H.T. negative lead as a protective measure against battery "shorts." Although

the receiver is intended to be used with an ordinary three-electrode power valve, those who wish to get the highest possible magnification may substitute a pentode for the output valve supplied.

As far as the L.F. side is concerned, the transformer-coupled stage is parallel-fed, a resistance being inserted in series with the grid of the output valve, presumably to act as an H.F. "stopper" and also for stabilising purposes when a pentode is employed.

Excellent Volume

A special word of praise is due to the construction chart accompanying each receiver. Nothing is left to chance; every component is numbered, even down to the fixing screws, and the constructor cannot possibly have any difficulty in building the set.

A FINE SET

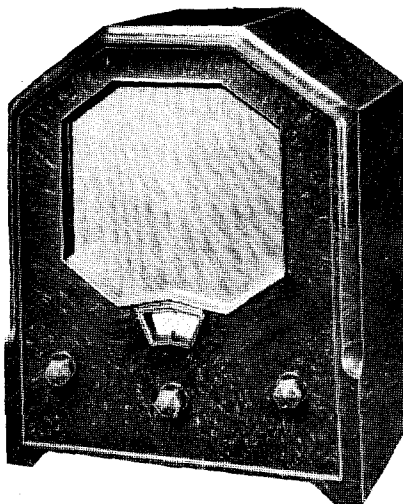

This is the Osram "33" in its handsome bakelite cabinet.

On actual test the performance was very good, and the majority of the big broadcasters on the medium and long waves came in at excellent volume.

The receiver, although not super-selective, provides an adequate degree of station separation for all ordinary purposes and is economical in anode current consumption, requiring no more than 9 milliamps., unless a super-power valve is substituted for the power type supplied.

In short, it is a real constructor's kit, bearing the hall-mark of a great firm, and fully in keeping with their variable reputation.

"Micalog" Condensers

Messrs. Ready Radio, of Eastnor House, Blackheath, London, S.E.6, will find the experience they have gained in supplying kits to home constructors invaluable to them in their new field as large-scale component manufacturers.

There is now a fine range of Ready Radio components available to the public, of which the "Micalog" condenser is a good example.

It is a solid-dielectric job, embodying a dielectric having electrical qualities far superior to the somewhat shoddy material often met with in components of this kind.

The moving vanes are of hard brass, and the single-hole fixing-sleeve is backed with a nut especially shaped to grip the panel firmly, so that there is no likelihood of the condenser rotating as a whole when in use.

The connection to the moving vanes is by means of a coiled spring, and it is a component that should give good service.

All the usual values up to .00075 are obtainable.

Bulgin Wall Jack

Messrs. A. F. Bulgin, of Abbey Road, Barking, Essex, recently sent us an extremely neat wall plug and jack which is particularly suitable for running loudspeaker extensions to various rooms in the house.

These jacks are available in either walnut or mahogany, and an insulated screw-on top is provided as a covering for the two connecting terminals.

The wall jack is priced at 1s. 6d., and the plug for it retails at the same figure. Both the jack and the plug are finely finished components.

CONCENTRATED EFFICIENCY

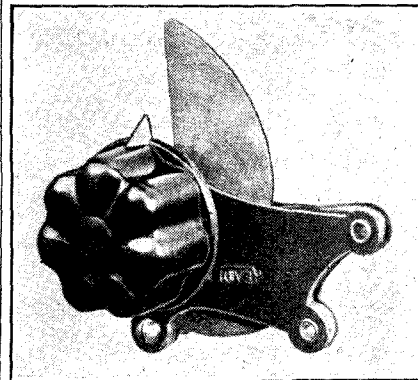

The Ready Radio "Micalog" is a solid-dielectric variable condenser built on sound principles.

MORE GRAHAM FARISH

Products recommended by

SCOTT - TAGGART

for the S.T. 400

GRAHAM FARISH FIXED CONDENSERS

S.T. 400 requires Two .006.

In a complete range of capacities, upright or flat mounting. Every condenser is tested on 750 volts D.C. The capacities are accurate within fine limits, and every condenser can be thoroughly relied upon.

.00005 mfd. to .004 mfd. **1/-** .005 mfd. to .01 mfd. **1/6**

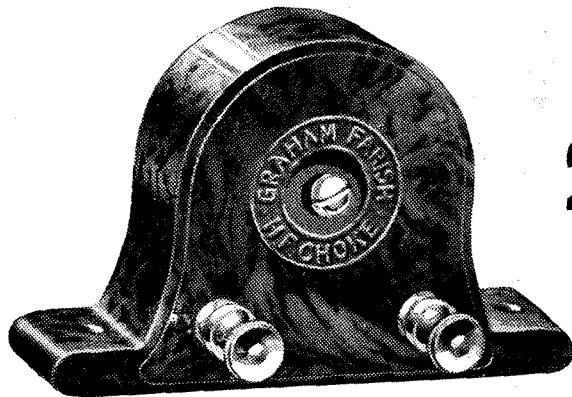
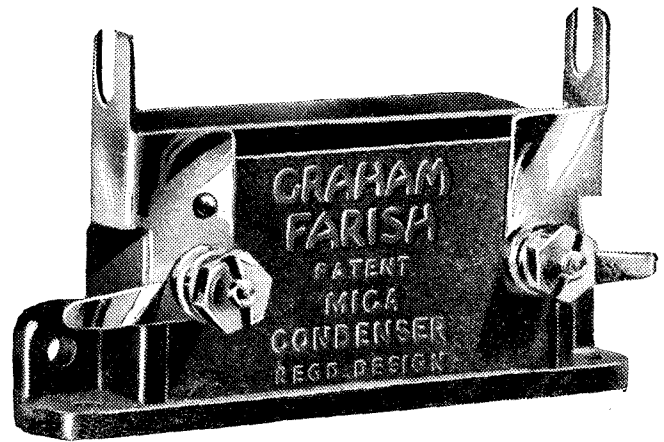

GRAHAM FARISH FLEXIBLE RESISTANCE LINKS

S.T. 400 requires One each of the following sizes: 1,500, 50,000, 20,000, 60,000.

Nickel Chrome wire wound, accurate and well within their ratings.

2/- EACH

GRAHAM FARISH 'SNAP' H.F. CHOKE

Of new design, wound to give high impedance on long and medium wave-bands. Has small self-capacity with large inductance. Totally enclosed in moulded case.

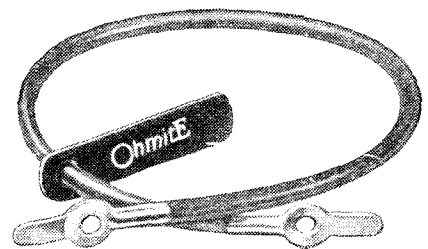

All sizes from 1,000 ohms to 25,000 ohms. **1/-** All sizes from 25,000 ohms to 100,000 ohms. **1/6**

Obtainable through all Radio Dealers or post free from Sole Manufacturers:

GRAHAM FARISH LTD., MASONS HILL, BROMLEY, KENT.

SEND FOR ILLUSTRATED CATALOGUE.



IT'S NO USE BUILDING S.T.400 unless you earth it efficiently—fit FILT—the earth Scott-Taggart recommends exclusively.

A Perfect Pair— the 'S.T.400' and the incomparable 'CHALLENGER'

A well-nigh perfect receiver, capable of extraordinary selectivity, sensitivity and undistorted output. A receiver you will be proud to build; a quality of reception you will fully enjoy, provided you let an R.&A. 'Challenger' deal with the output.

This set needs a 'Challenger' P.M. Moving Coil Reproducer if its performance is to be fully exploited—the clear-cut incisive top notes, the rich, full-bodied bass of orchestra.

None but a high grade reproducer can give you these, none so effectively and faithfully as the incomparable R.&A. 'Challenger.'

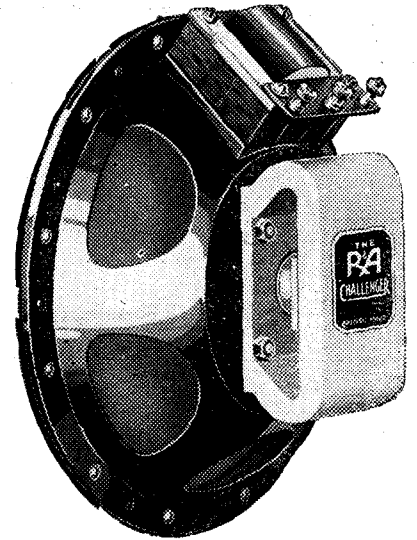

35/-

INCLUDING
MULTI-RATIO
FERRANTI
TRANSFORMER

(TO R&A SPECIFICATION)

THE "WIRELESS WORLD"
states:—

"The performance of this unit is such that it merits discussion from an absolute standpoint and without regard to the very reasonable price asked. . . Overall sensitivity slightly better than the average . . . reproduction of bass below 100 cycles quite definitely above average . . . as a result of the well-maintained output down to 50 cycles a full-bodied bass is obtained without 'boom.' Reproduction of speech natural and unforced, and the balance in music is exceptionally good."

Ask your dealer to demonstrate, and refuse any so-called substitute. **There is no substitute.**

REPRODUCERS & AMPLIFIERS LTD., WOLVERHAMPTON.



Holdens

10,000 Things a Child Should Know!

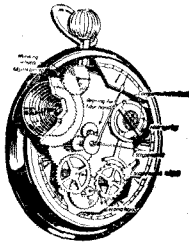

A watch is worked by its main spring, which keeps all the wheels going; the escapement prevents them from moving too fast.



A man's load on the Earth



The same man's load on the Moon

Work would be easy on the Moon, for we should all carry six times as much as we do now and jump six times as far.

Complete in ONE Volume

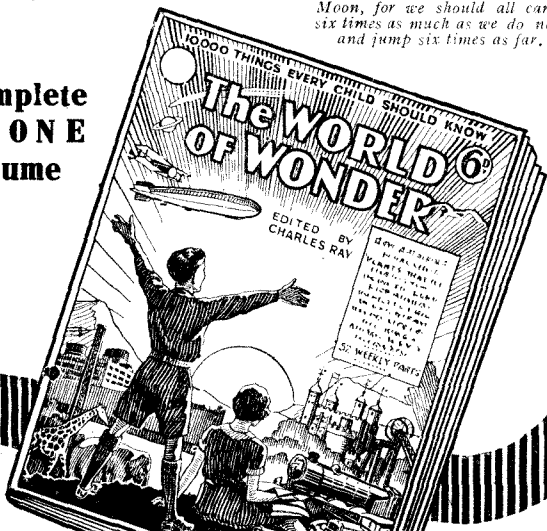

THE WORLD OF WONDER

The greatest book of popular science and general knowledge ever published. Written in simple language, illustrated with the most remarkable collection of explanatory drawings, photographs and pictures ever brought together.

6th Weekly Parts

PARTS 1 & 2 Now Ready

No intelligent child who glances inside this unique work will be able to resist its fascination. There are long articles and short articles, paragraphs, pictures and diagrams in profusion. Things to make at home, experiments which can be done with just the ordinary things of everyday life and without spending a penny.

It explains the why and wherefore of such familiar phenomena as the thunderstorm, the rainbow, the daily tides at the seaside, the regular succession of day and night, the procession of the seasons, and a thousand other things that are known to all but understood by few.

It explains how man has tamed the powers of nature, and how the many marvellous machines which he has invented are made to work. It shows the marvels of the plant and animal world; the wonders of geography and geology are explained in new and striking ways. The illustrations are wonderful. The collection of carefully worked-out diagrams and explanatory drawings, many of them full pages or double pages, is absolutely unique.

The weekly parts of THE WORLD OF WONDER can be bound up at home simply and neatly as they are issued by means of a special Self-Binder, which is offered to subscribers at a very low cost. Alternatively the complete set of parts can be bound in the ordinary way when the work is complete.



A PRACTICAL MAN'S CORNER

By R. W. HALLOWS, M.A.

Into these pages, month by month, our contributor packs a wealth of practical information and advice on constructional work. The regular reader of this "Corner" cannot help picking up a more or less complete training in radio workshop practice, while every month there are wrinkles to read, gadgets to make or hints to help you.

'Ware Live Spindles

In the modern wireless set considerable use is made of the potentiometer as either a volume control or a tone control.

In some cases it regulates the screening-grid potential of high- or intermediate-frequency valves; in others it controls the grid bias to S.G.s of the variable- μ type; in others again it is employed as a variable resistance in conjunction with tone-compensating transformers.

When you are fitting a potentiometer for any of these purposes, don't forget that its spindle in the metal bush through which it passes is probably "alive." This is particularly important if your set has a metal panel, as so many have to-day, or an aluminium liner behind the panel.

Failure to remember this may result in some very queer effects.

PREVENTING SHORTS

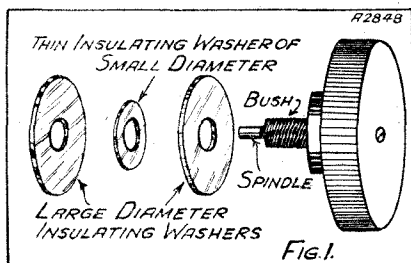

By means of insulating washers it is possible to prevent the bush from touching the metal panel.

There are two ways of dealing with the live spindle which has to pass through a metal panel or liner. One of these is illustrated in the first drawing.

It requires three insulating washers, each with a hole that will just allow the bush of the potentiometer to pass through. Two of them are of large diameter—big enough to cover completely the metal boss at the inner end of the bush and the fixing nut of the potentiometer.

The hole in the panel must be of such diameter that the small washer will pass through it. This washer should be of the same thickness as the metal. Pass one of the big washers over the bush of the potentiometer and follow this with the small washer. Insert into the hole drilled in the metal, put on the second large washer, and clamp down with the fixing nut.

The Second Method

It is more than likely that suitable insulating washers will not be available, so I am going to describe another method which is in every way as effective.

Begin by making a small ebonite mount for the potentiometer on the lines indicated in Fig. 2. Quite thin ebonite will serve admirably for the purpose, but it does not matter in the least if you use quarter-inch material. About $2\frac{1}{2}$ in. by $1\frac{1}{2}$ in. is a handy size. In the middle drill a hole to take the bush. This will generally be $\frac{3}{8}$ in., though in some cases bushes of larger or smaller diameter are used.

Near each end of the mount drill a 4 B.A. clearance hole. In your panel or liner drill first of all a $\frac{3}{8}$ -in. hole. Pass the bush of the potentiometer through the hole in the mount and that in the panel and secure it temporarily with the fixing nut.

Now use the mount as a template to drill holes in the panel for the two

4 B.A. bolts. This done, remove the potentiometer and mount and clamp the former to the latter with the fixing screw.

Now enlarge the hole drilled in the panel or liner until it is big enough to clear the fixing nut with a generous margin to spare, as illustrated in Fig. 3. Fix the mount in place by means of the two 4 B.A. bolts, put on the nut of the potentiometer and the job is done.

A MOUNT FOR A POTENTIOMETER

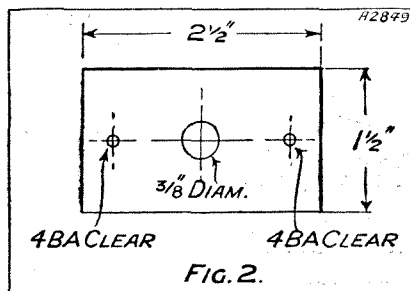

A handy size can be made by following these dimensions.

Enlarging Holes

At this point the reader may say: "That's all very well, but exactly how is one to enlarge a $\frac{3}{8}$ -in. hole in thinnish metal to a diameter of, say, $\frac{1}{2}$ in.?" It can be done with a round or half-round file, though I cannot say that I recommend this means except as a last expedient—filing sheet metal produces the kind of noise that sets the least sensitive of teeth on edge.

The simplest way of enlarging holes is to make use of what is known as a "D" bit, one of the most useful articles in the tool kit, for it comes in handy for all kinds of jobs.

The "D" bit fits into an ordinary

A Practical Man's Corner—continued

brace. It is semi-circular in section and tapered from about $\frac{3}{4}$ or $\frac{7}{8}$ in. at the shoulder to quite a fine point. With it a hole in soft metal, ebonite or wood can be enlarged suitably in a matter of moments, and, unlike quite "D-bitting" sheet metal is filing, painless to the operator.

"D" bits cost about a shilling apiece, but if you don't think it worth while purchasing one, an old half-round file of the tapered kind will do almost as well for emergency jobs. Simply fit its tang into the chuck of the brace.

Smoothing Down

You will find after using the "D" bit or the old file to enlarge a hole in sheet metal, that there is usually a raised rim round the hole that has been so treated.

This rim is most easily removed by a few turns with a large countersink. Or it can be smoothed down by the application of a rasp to both sides of the metal. The countersink has the advantage of not being liable to inflict scratches on the polished surface.

One Volt Negative

Many screen-grid valves work all the better for a little negative grid bias, and its presence, of course, makes for economy in high-tension current. Few of them will stand quite so much as $1\frac{1}{2}$ volts, which seems, unless a potentiometer is used, to be the smallest amount obtainable direct from a dry cell.

HOW IT IS DONE

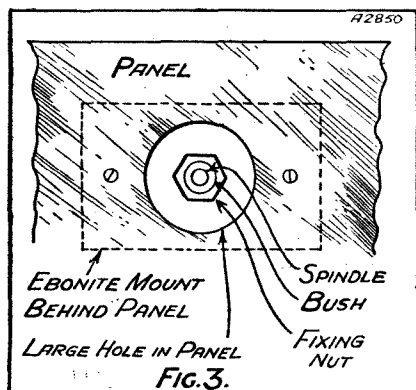

"Enlarge the hole in the panel until it is big enough to clear the fixing nut."

Actually it is quite easy to obtain 1-volt negative grid bias with valves whose filaments require 2 volts. This is illustrated in Fig. 4. How on earth can you obtain 1 volt from a biasing

battery which goes in $1\frac{1}{2}$ -volt jumps?

Remember, first of all, that the grid potential is measured in relation to the negative end of the filament. Thus when we say that the grid bias is, say, 3 volts negative, we mean that it is 3 volts more negative than the negative end of the filament. When we connect a dry biasing battery's positive to L.T.—, then we can obtain only $1\frac{1}{2}$ -volt steps in the bias.

But suppose that we connect the positive end of the biasing battery to L.T.+ and put the grid return wander plug into the -3-volt socket. The grid is now 3 volts negative to L.T.—, and L.T.+ is 2 volts positive to L.T.—. The grid is thus 1 volt negative to L.T.—, which is exactly what we want.

Avoiding a Switch

The best kind of volume control for a multi-mu screen-grid valve is a "tapered" potentiometer incorporating a switch which puts the battery out of action when the set is not in use. But the other day when I was finishing off a set I had no such component by me and there was no room for a separate switch.

It occurred to me, though, that an old volume control that I had would answer very well. This was a 2-megohm potentiometer of the graphite-track type. Tests showed that as a volume control it was absolutely silent and beautifully smooth in action.

It was therefore employed for the job and left permanently in circuit without any switch at all, though in this particular case an 18-volt biasing battery was required. But won't this run the battery down very quickly?

There are no signs of any such thing, and I don't think that there will be for a good many months. By Ohm's law the current passing is equal to the voltage divided by the resistance. In this case we have 18 volts divided by two million ohms, which comes to just 9 microamperes.

If you care to work it out you will see just how minute this drain is. There are 168 hours in a week, and this at 9 microamperes is equal to just over $1\frac{1}{2}$ hours' discharge at 1 milliampere. Grid batteries should, anyhow, be changed every nine months, and in the course of thirty-six weeks the drain upon this one will be equivalent to rather less than $54\frac{1}{2}$ hours at 1 milliampere.

Magnetising a Screwdriver

I have mentioned before how exceedingly useful it is to have a screwdriver so strongly magnetised that it will pick up and hold on to small steel screws. I don't recommend that every screwdriver should be magnetised, for this kind of tool can be a nuisance at times; but it is very handy to have one that has been so treated.

If you possess a moving-coil loudspeaker of any kind you can magnetise

A POSER!

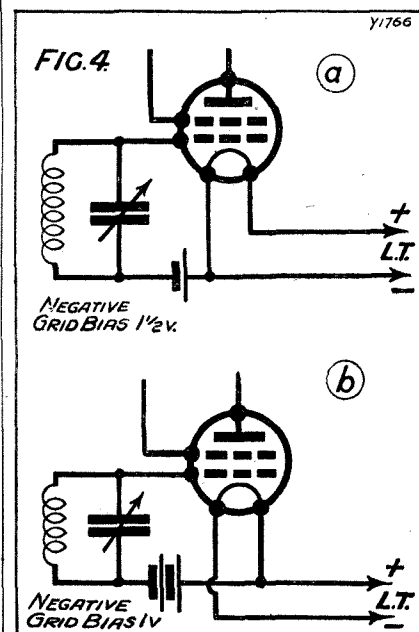

"How on earth can you obtain 1 volt from a bias battery which goes in $1\frac{1}{2}$ -volt jumps?"

a screwdriver strongly in next to no time by the simple process of rubbing its blade gently a few times over the base of the pot magnet.

Since they are not made of very hard steel, screwdrivers do not retain their magnetism too well, and its loss is accelerated by the knocking about to which they must be subjected. Still, they can always be touched up when necessary in the way suggested.

For fixing down components to a baseboard I always use Nettlefold's $\frac{1}{2}$ -in. No. 4 round-headed screws, made of steel and covered with copper electrolytically deposited. These have the advantage of looking very well besides responding to the attraction of a magnetised screwdriver.



**WHAT YOU EXPECT
FROM RADIO BATTERIES**

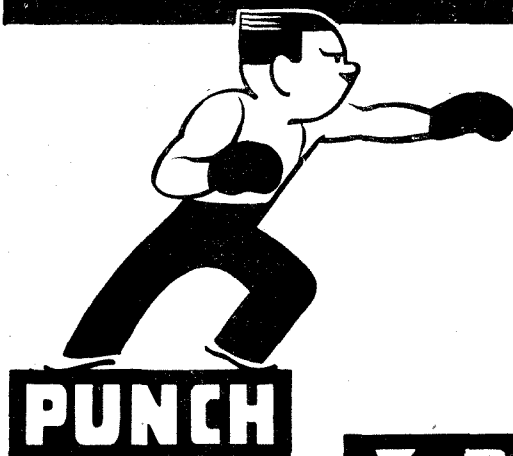

& PEP



YOU GET ALL THREE WITH

SIEMENS

Full O'Power
RADIO BATTERIES

- and they last!

Try one in YOUR set
*They cost no more than
ordinary batteries and
you will be more than
pleased with the result*

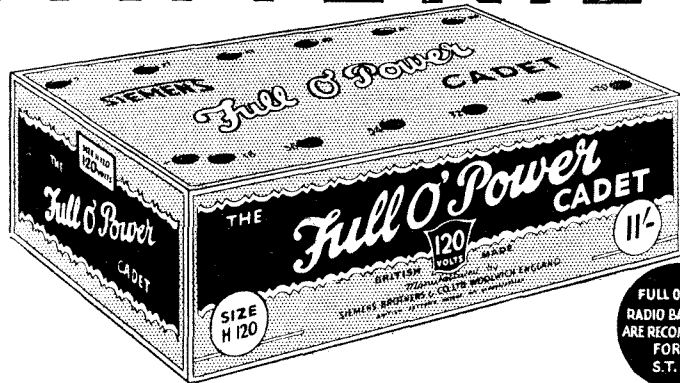

**FULL O'POWER
RADIO BATTERIES
ARE RECOMMENDED
FOR THE
S.T. 400**

MANUFACTURED BY SIEMENS BROTHERS & CO., LTD., WOOLWICH, ONE OF THE OLDEST COMPANIES IN THE ELECTRICAL INDUSTRY WHO HAVE BEEN MAKING BATTERIES FOR OVER 60 YEARS.

Adv of **SIEMENS ELECTRIC LAMPS AND SUPPLIES LIMITED, 38/39, Upper Thames Street, London, E.C.4.**

THE MONTH ON SHORT-WAVES



All the latest news about this interesting band.

THERE has been a lot of talk of late among short-wave folk concerning the Eleven-Year Cycle, and the effect that it is having on distant reception.

For the benefit of those who have never encountered the supposed phenomenon, perhaps I had better explain first of all that this particular "cycle" is not of the type that is pedalled! It is, as a matter of fact, a period of years during which short-wave reception conditions vary from good to bad; or, if you like, from bad to good.

Over the Worst

I am not going to fog you with a lot of technicalities which might (or, again, might not) offer some sort of explanation of this curious happening, but it is quite definite that something

of the kind takes place; and the only thing with which we need to be concerned at the moment is that we have just got over the worst patch, and we are now sailing ahead for better conditions.

Shouting the House Down

Whether or not this Eleven-Year Cycle has got anything to do with the last month on short waves, I rather hesitate to say. But, as far as my own experiences are concerned, and with one or two notable exceptions, I have had considerable difficulty in doing anything really brilliant on waves below 25 metres, whereas some of the "long-wavers"—that is, between 25 and 50 metres—have been shouting the house down!

For instance, W 1 X A Z, C T 1 A A, W 2 X A F and W 3 X A L have on

several occasions been coming over at real "wake-the-baby" strength, but none of them are anything like constant. There have been nights when even these "long-wave" punch-merchants have been all but missing, although towards the end of the period under review they have certainly shown signs of sobering down.

A Visit to CT1AA

Incidentally, while roaming round on the "49's" one evening, I came across quite a strong signal which turned out to be W 4 X B, Miami Beach, Florida. It's the first time I have heard a signal from that part of the world since our old friend H R B, in Honduras, closed down.

While in Portugal recently I had an opportunity of seeing part of the station of that famous amateur, Signor Abilio Nunes Dos Santos. I suppose that is one of the reasons why I get such a kick out of listening to him these days.

It is a fact that C T 1 A A, which is Abilio's call-sign, is coming over very well these days on his comparatively new wave of 31.25 metres, and the quality of the transmission, too, appears to have improved tremendously. Let us hope that it will not be long before we have another of those special broadcasts from our oldest ally.

G. T. K.

Do you realise—it's not important, but quite interesting—that conditions towards the centre of a record are not the same as at the outer parts of it? For one thing, the needle, in the former case, travels over the record at a slower rate; and, for another, the wavy lines for a given note are closer together.

These two items are naturally bound up in the same reason. The reason being that it takes just as long for a complete revolution of the inner grooves as for the outer; but, due to the smaller diameter towards the centre, the distance travelled by the needle is also smaller. Think it out!

Substituting a Choke

Five-valve portable sets with two aperiodic H.F. stages using ordinary three-electrode valves have been very popular in the past, and, as a matter of fact, there are still many for sale to-day, both old stock and new stock.

The aperiodic chokes are wound with very thin wire, and quite often a fault in one of these five-valvers

 * "ON THE GRID" *
 * Think it out!—A portable set *
 * repair tip—Would you have been *
 * puzzled?—Dry rectifiers versus *
 * valves. *

proves to be a break in one of these chokes. Alack, too often the makers cannot be traced, and a new component obtained. What's to be done?

A small H.F. choke of normal design makes a good substitute in nearly every case, and saves a tricky re-winding job. If the original choke had a tap, just ignore the fact and leave the point to which it went unconnected.

In the few cases where the idea won't work, you'll soon know—by a howl developing. Then, you are simply unfortunate!

The Speaker That "Clicked"

I don't wonder our Query Editor tears his hair at times! Just listen to this, from a non-technical friend.

"Whenever we try to get the set loud, we can't, because the atmospherics come in so badly. But it's all right when coming through softly."

So I hied me to his abode. A cursory inspection reveals that the loudspeaker adjustment has "clicked" over, and so made results weak in the familiar manner. Increasing reaction made the armature move so much that it rattled on the pole-pieces.

Fancy having to deal with that by post!

A Mains Puzzle

I don't know whether it has ever puzzled readers, but, personally, I have often wondered why commercial all-mains A.C. sets nearly all use a valve rectifier, whereas most ready-made A.C. mains units employ dry rectifiers.

Both methods are efficient, so one is led to ponder whether there is anything significant in the fact. Anyway, it is noticeable to a most marked degree with the apparatus at present on the market.

A. S. C.

From
SUCCESS
to
SUCCESS
!!!

First the S.T.300....

Now the S.T.400
incorporates the

**ORMOND N°6
FRICTION CONTROL
CONDENSER**

Mr. G. P. Kendall, B.Sc., Chief Engineer, Ready Radio Ltd., has also chosen these condensers for the Ready Radio Kit.

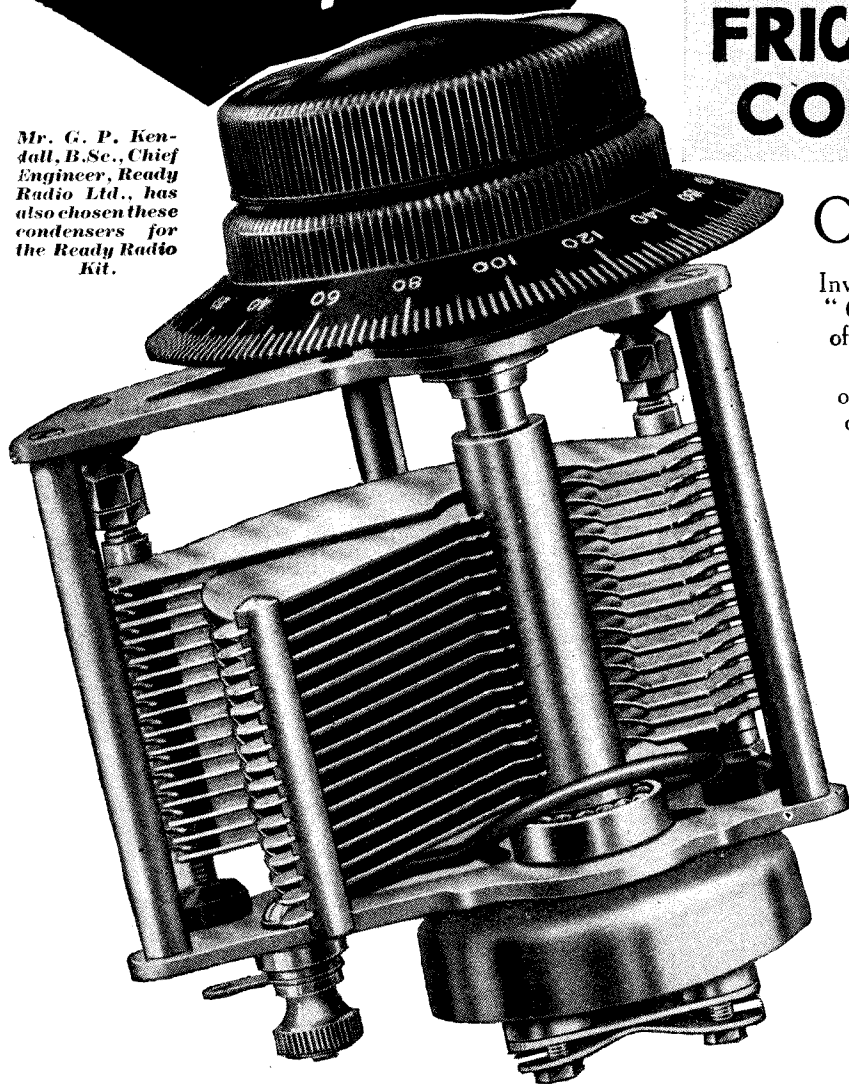

ORMOND Condensers were chosen for the S.T.300. Ormond Condensers have been incorporated in the S.T.400. Invariably those who know "best" specify "Ormond" when accuracy and precision are of paramount importance!

This condenser is similar in construction to our No. 6 slow-motion type. A friction device is incorporated at the rear end of condenser, giving a superb slow-motion movement with ratio of 55 to 1. Direct drive is obtained by means of Bakelite dial, engraved 0 to 180 degrees. Slow motion is controlled by the upper small knob. Fast enough for easy searching, it is yet slow enough for finest tuning.

This condenser is strongly recommended for general use, and particularly on short-wave sets, Super-heterodynes, etc.

Easy to mount. One-hole fixing. Terminals and Soldering Tags for connections. Complete with 2½-inch dial and slow-motion knob.

Cat. No.	Capacity	Price
R/491	·00025	7/6
R/492	·00035	7/6
R/493	·0005	7/6



THE ORMOND ENGINEERING CO., LTD.,
Ormond House, Rosebery Avenue, London, E.C.1.
Telephones: Clerkenwell 5334/5/6 and 9344/5/6 Telegrams: Ormondengi, Isling.

Also specified for the S.T.400 the Ormond Two Point Switch, Cat. No. R/323, and for perfect reproduction the Ormond Moving Coil Cabinet Loudspeaker, Cat. No. R/477.

ROBUST... RIGID... ACCURATE !

ROUND *the* DIALS

Practical notes on what stations to look for and how to get the foreigners that are coming over well.

YOU have probably heard all about this great Radio Conference at Madrid to settle the wavelength question. Delegates from all over the world sitting in solemn conclave, weighing up wavelengths and all that sort of thing.

But have you noticed that while these solemn sittings were in progress some intruding station sat right on Madrid's own wavelength? It's a fact!

Madrid is supposed to occupy 424.3 metres, but one of the Russian stations, Moscow-Stalin to wit, has fastened on it, too, and the resultant bad quality has been very apparent. If the Madrid Conference needed a spur Moscow has supplied it!

As a matter of fact, the heterodyne and mutual interference question has not really been too bad, considering how easily all the stations are reaching out nowadays. True, the lower part of the dial is largely ruined by duettists who should be soloists, but even there some good interference-free programmes can be picked up with remarkable ease night after night.

Paris and Breslau

Higher up there was always some difficulty in knowing which of the good stations to hang on to! Poste Parisien and Breslau, for instance, on 328.2 and 325 metres respectively, both came in with remarkable consistency. And being only about one degree apart on the dials, and yet

clear of interference, these two alone present quite a quandary, both being excellent in quality.

Incidentally, if you have not yet heard that "Ether Organ" of Poste Parisien's you ought to try for it. They generally wind up with a recital on this at about 10.50 p.m. on Sundays. It is no ordinary organ, but oscillating valves—and the Monsieur who plays it is no ordinary village organist either. He makes those valves oscillate to some purpose!

Prague has been my star turn at the top of the medium waves, and in the London area is often as strong and—curiously enough—as reliable as his neighbour the North Regional. His brother 120-kilowatt, Warsaw, on 1,411 metres, has also been in form, though not quite so strikingly as in November last year.

The other "regular" long-wavers—Kalundborg, Oslo, Motala, Eiffel Tower, Radio-Paris, Huizen and Co.—have all been spreading themselves in great style. And if Konigs-Wusterhausen was not too good some evenings there was always plenty of variety to be found on this waveband alone from the really consistent stations.

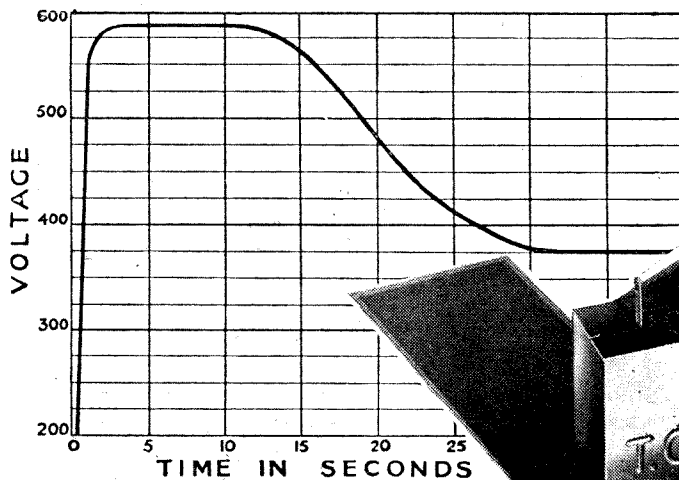

The above graph, an actual example, shows what happens when an A.C. Set is switched on—an immediate rise to 595 volts, then 30 seconds before normal conditions are reached. For half a minute smoothing condensers are subjected to this overload! Again to the fore in condenser practice, T.C.C. have produced a new condenser—the type 87—definitely built to withstand these dangerous surges—up to 650 volts. Play for safety! Ask for the surge voltage figure of your condensers, be sure they are T.C.C.—the condensers in the green case.

Capacity Mfd.	Dimensions			Price s. d.
	Height	Width	Thickness	
0.1	1 1/2"	1 1/2"	1/8"	2 3
0.25	2 1/2"	1 1/2"	1/8"	2 6
0.5	2 1/2"	2"	1/8"	2 10
1.0	2 1/2"	2"	1/8"	3 8
2.0	2 1/2"	2"	1/8"	4 9
4.0	2 1/2"	2"	1/8"	8 0

YOUR CONDENSERS MUST STAND UP TO THESE HIGH SURGE VOLTAGES

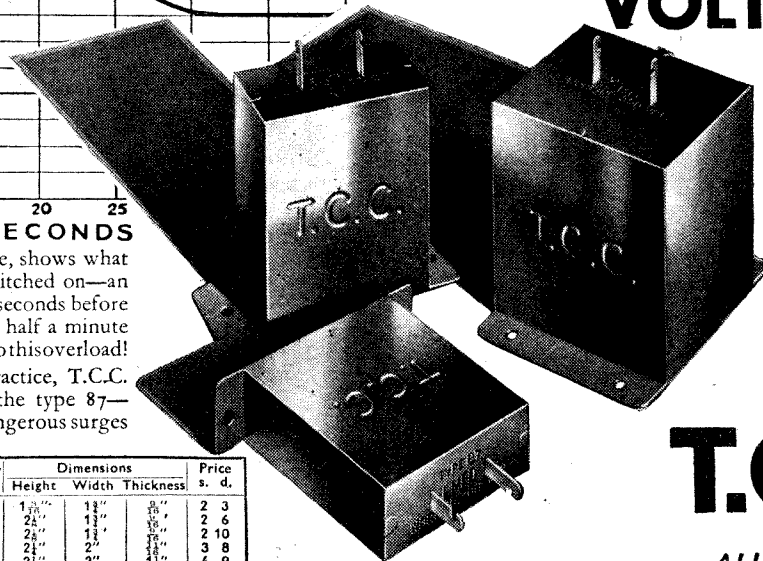

THE TYPE 87 Tested to 1,500 v. D.C. Normal working voltage 450. To withstand surges of 650 volts.

T.C.C.
TYPE 87
ALL-BRITISH
CONDENSERS

THE TELEGRAPH CONDENSER CO. LTD., WALES FARM ROAD, N. ACTON, LONDON, W.3

JOHN SCOTT-TAGGART SPECIFIES



IN THE S.T. 400

This famous designer trusts Igranite tested Components in his wonderful new set, the S.T. 400, and specifically recommends the following:—

- | | | | |
|-----------------------------------|-----|-------|------|
| * 1 2-mfd. Fixed Condenser | - - | Price | 2/9 |
| * 1 1-mfd. Fixed Condenser | - - | " | 2/3 |
| * 1 1,500 Spaghetti wire - wound | - - | | |
| Resistance | - - | " | 6d. |
| * 1 20,000 Spaghetti wire - wound | - - | | |
| Resistance | - - | " | 9d. |
| * 1 50,000 Spaghetti wire - wound | - - | | |
| Resistance | - - | " | 1/- |
| 1 'Midget' L.F. Transformer | - - | " | 10/6 |
| 2 Push-Pull Switches | - - | " | 9d. |
| 1 'Midget' Switch | - - | " | 1/6 |
| 1 'Midget' Switch, With Terminals | - - | " | 1/8 |
| 11 Terminals | - - | | |

* Incorporated in the model set.

Also the IGRANIC D.9 SPEAKER

This NEW type Permanent Moving Coil Speaker, since its introduction at Radiolympia, has achieved an amazing popularity. **PRICE 32/6**

Mr. Scott-Taggart uses Igranite Components because he has tested them and proved their superiority—due to the fact that all Igranite Components are built of the finest materials.

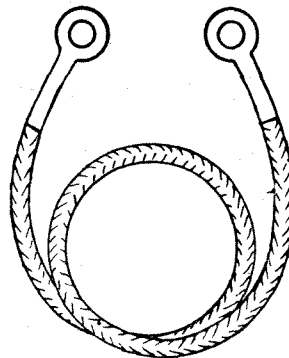

Igranite Spaghetti Resistance

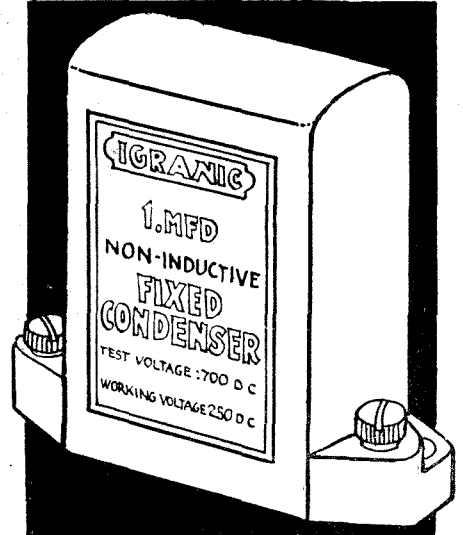

Igranite Fixed Condenser

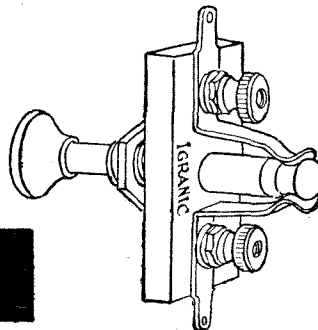

Igranite Push-Pull Switch

IGRANIC

COMPONENTS WILL

BE THE MAKING

OF YOUR SET.

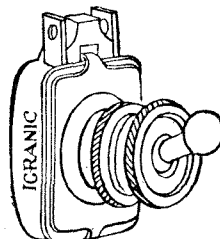

Igranite Midget Switch

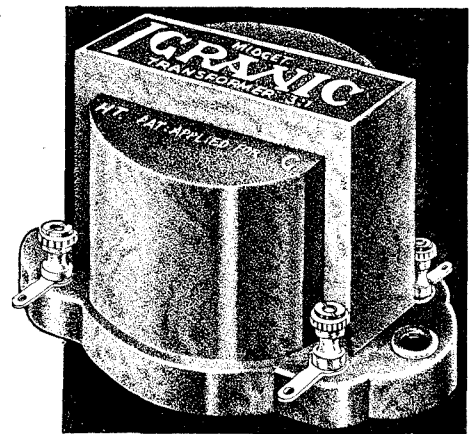

Igranite Midget L.F. Transformer

Write to-day for fully Illustrated Catalogue No. J1211 of complete new range of Igranite Components.

IGRANIC ELECTRIC CO. LTD., 149, Queen Victoria Street, London, E.C.4

CVS—38



Some details about unusual and interesting faults, and suggestions that may help you to better radio reception.

By P. R. BIRD

Why No H.T.?

A NORTHAMPTONSHIRE reader, in a cheerful report of the "S.T.300," got so enthusiastic when he got his subject fairly opened up that he filled an 8-page closely-written letter and gave an account of

all his wireless experiences! And, though most of his points have appeared at some time or another in these columns, he mentions two which are worthy of emphasis.

One was the case of an absolutely first-class well-made three-valver that gave poisonous (his adjective) results; and the surprising discovery was made that no H.T. was getting to one valve, although the connections from the H.T. battery were all perfect.

It took a lot of finding, for that was in the days when measuring instruments were dearer and rarer than

they are now. But in the end a voltmeter was requisitioned, and it showed up the fault.

There were 96 volts at the H.T.+ tapping, 96 volts at the other end of the H.T.+ lead, and 0 volts on the set's H.T.+ terminal, *although the lead was firmly joined to it!*

One side of the terminal 96 volts,

GRID WIRES MUST BE SHORT

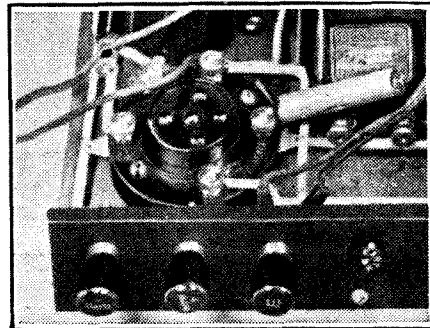

Experienced set-builders know how important it is to copy the original design as closely as possible. Grid wiring especially must be kept short, which is why grid resistances are often fixed direct to the grid terminal of the valve holder.

the other side 0! How in the name of goodness, he wondered, can a terminal—a good, sound, hefty terminal, all brass—stop volts?

(Continued on page 162.)

Now permanently matched!

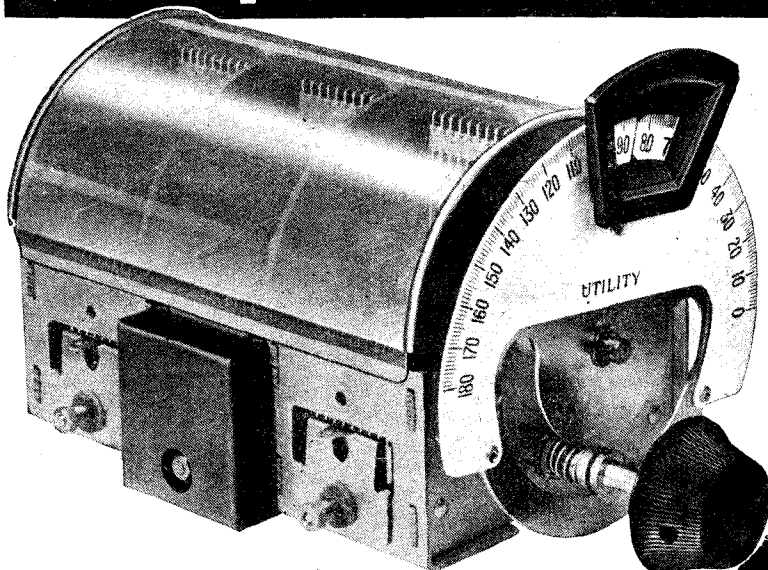

Utility was the first ganged condenser guaranteed matched to 1/10% accuracy. But it is not sufficient to know that your ganged condenser was accurately matched when it left the maker's factory. More important is it that the condenser should remain matched when it is functioning in your set.

You can depend on the new Utility ganged condenser remaining permanently matched. But only by the Utility method of manufacture can a constant accuracy factor be assured and thus only the Utility ganged condenser is guaranteed permanently matched.

PRICES:

	Less dial.	With dial.
W313/2 2-Gang, semi-screened	15/-	17/6
W313/3 3-Gang, do.	22/6	25/-
W313/4 4-Gang, do.	30/-	32/6
W314/2 2-Gang, fully-screened	17/-	19/6
W314/3 3-Gang, do.	25/-	27/6
W314/4 4-Gang, do.	33/-	35/6

A full range of super-het. condensers is also available. From your dealer or post free from the makers.

WILKINS & WRIGHT LIMITED

UTILITY WORKS, HOLYHEAD ROAD, BIRMINGHAM.

London Agents:

E. R. Morton, Ltd., 22 Barlett's Buildings, Holborn Circus, E.C.4.

Utility CONDENSERS

USE "GOLTONE" S.T.400 COILS

TESTED AND FULLY APPROVED

BY
Mr. John Scott-Taggart

PRICE
8/-
per pair

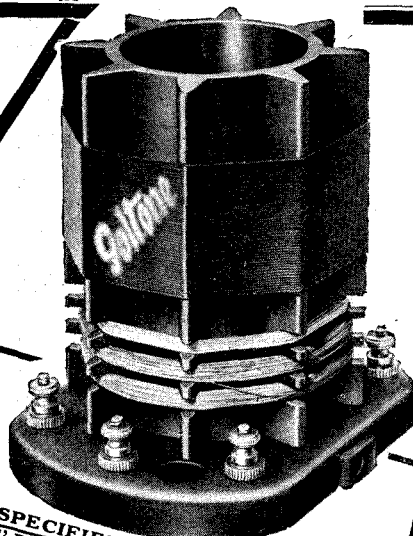
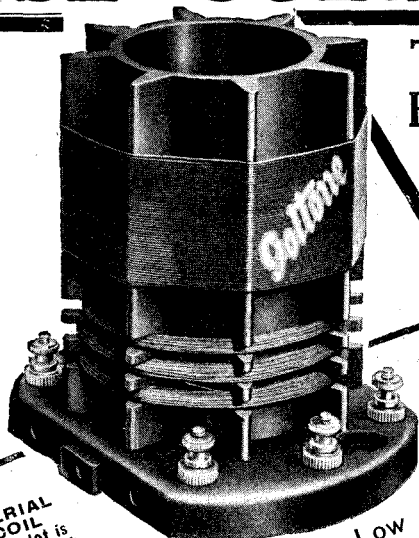

AERIAL COIL
Top slot is wound with **WHITE Silk Covered Wire**

Wound on Extremely Low Loss Ribbed Ebonite Formers, exactly to designer's specification.
List No. S.T./400 Price **8/-** per pair.
Panels and Terminal Strips for the "S.T.400" are available drilled to specification.

ANODE COIL

ALSO SPECIFIED FOR THE S.T.400.
"GOLTONE" Pre-set Condenser, Type J. R15/84. 1/- each.
"GOLTONE" Radio Earth Tube. R20/300. 2/9 each.
"GOLTONE" Super H.F. Choke, suitable for the above-mentioned circuit. R3/46. 4/6 each.
The outstanding performance and excellence in finish of "GOLTONE" COMPONENTS leads to their specification in all the leading Radio Journals, including THE WIRELESS CONSTRUCTOR.
Obtainable from all first-class Radio Stores. Refuse Substitutes. If any difficulty, write direct. Large illustrated Radio Catalogue sent FREE on request.



"MORCO" CABINET FOR THE S.T.400

RECOMMENDED BY MR. SCOTT-TAGGART
CASH OR C.O.D. ORDER FORM.

Please despatch to me Cabinet No. 78 for the S.T.400 for which { I enclose } s. d. { I will pay on delivery }

NAME

ADDRESS

W.C. Dec.

THE "MODERNIST" CABINET No. 78. In medium colour Fumed Oak finish with well-designed feet. "The Ideal Cabinet for the Modern Home."

PRICE:
17/6

WITH BASEBOARD

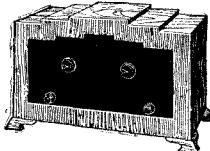

R. MORTON & CO. LTD.,
MAPPIN BUILDINGS,
NORFOLK STREET,
SHEFFIELD

GET Real SELECTIVITY

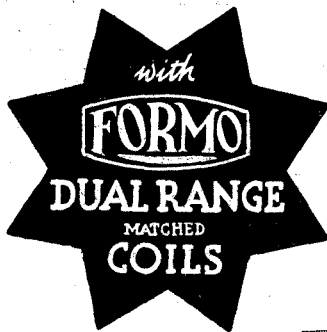

Formo Dual Range coils provide the finest selectivity obtainable. Separate coupling coils are provided for medium and long waves. Each coil is fitted with the most perfect of all switching mechanisms, embodying gold-silver contacts, and has an efficient screening can finished in distinguishing colours. A wiring diagram is included inside each coil. Each coil is matched to absolute perfection.

Aerial, H.F. 1st and 2nd Band Pass Coils with optional tappings.

7/6

Dual Matched Assembly, Aerial and 1st Band Pass.

16/-

Triple Matched Assembly, Aerial and 1st and 2nd Band Pass Coils.

23/6

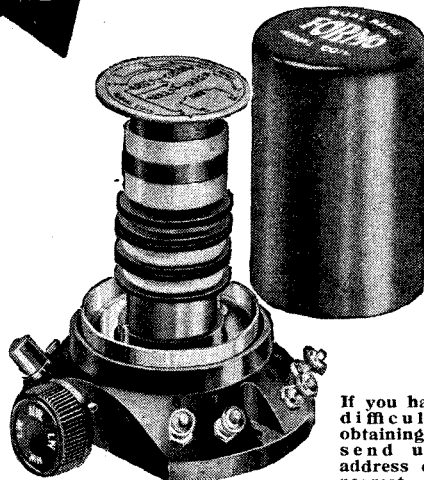

If you have any difficulty in obtaining, please send us the address of your nearest dealer.

FORMO London Showrooms: 23, GOLDEN SQUARE, PICCADILLY CIRCUS, W.1
Head Office & Works: Crown Works, Regents Park, Southampton.

The Magazine for the **MANLY Boy!**

CHUMS Monthly **1/-**

On Sale at all Newsagents

CHUMS has been famous for many years and is now more popular than ever. Every month it is crowded with splendid yarns of School, Sport and Adventures. There are also articles on interesting hobbies, illustrations, and Eight pages in PHOTOGRAVURE

QUEER QUERIES

—continued from page 160

It was one of those heavy old "War-office" type of terminals—and it was heavily lacquered. By some mistake the lacquer had covered it completely, contact surface and all, and was thick enough to form an insulator!

The second fault was crackling.

Long waves, short waves, day or night, the set softly crackled at intervals. It would stop completely when the aerial was off, so, noticing this, he put up a new aerial. And in spite of that the crackles continued!

In the end good luck showed him the fault, for in examining an insulator he noticed that the rather long supporting wire (seven-strand stuff) had a couple of its strands broken through. When that wire was renewed, and the same insulator put up, the crackles disappeared for good.

S.G. Valve Connections

When a letter arrives in a very pale-pink envelope, with the address in obviously feminine handwriting (of the kind that slopes over backwards) and exuding a scent of parma violets, one instinctively feels that here, in all probability, is a very

queer query. But the fact is that most of the ladies who take to set-building are of a very shrewd and sagacious class.

Occasionally, however, the feminine querist raises questions that betray

HOW IS YOUR SET BEHAVING NOW?

If you are troubled by a radio problem, remember that "The Wireless Constructor" Technical Queries Department is fully equipped to help you.

Full details of the service, including scale of charges, can be obtained on application to the Technical Queries Department, "The Wireless Constructor," Fleetway House, Farringdon Street, London, E.C.4.

SEND A POSTCARD, on receipt of which the necessary application form will be sent by return.

LONDON READERS, PLEASE NOTE. Application should not be made by telephone, or in person at Fleetway House or Tallis House.

an unmistakably unmasculine impatience with "things as they are."

This question of the terminal on the S.G. valves, for instance, has vexed a fair reader of THE WIRELESS CONSTRUCTOR beyond measure.

It appears that she had never needed an S.G. valve before, but decided to build up an amplifier incorporating one, and, alas, she built it up from the theoretical circuit diagram!

It wouldn't work. At least, not properly. Being a first-class constructor, she checked all the wiring, etc., and could find no fault.

She had a worrying time with it, one way and another, and eventually she called in a friend. He took one look at it, and then pointed out—tactfully, I hope—that, although there is a "plate" pin on the base of an-S.G. valve holder, opposite the grid pin, the real plate is connected to the extra terminal on the bulb. What in an ordinary valve would be the "plate" pin is, in fact, for the screening grid.

Well, it's all right now. When these two connections were changed over the amplifier went with a swing, and the lady forgave everybody everything.

But, as she so feelingly says in conclusion, "it certainly ought to be mentioned clearly in the CONSTRUCTOR that, for some reason of their own, the S.G. manufacturers have used what is generally the plate-pin to join the screened grid and not the plate!"

So mentioned clearly it is.

Mr. JOHN SCOTT-TAGGART recommends SOVEREIGN S.T.400 COILS

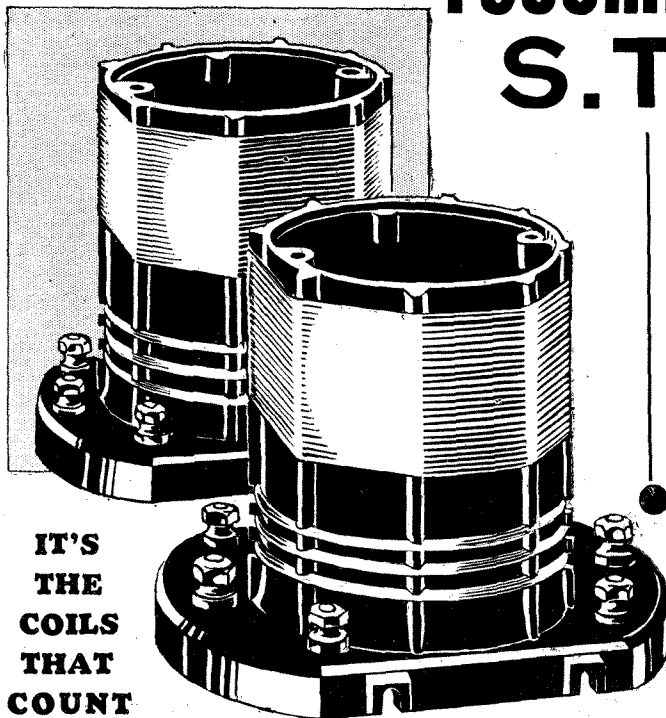

IT'S THE COILS THAT COUNT

Made with microscopic care to Mr. Scott-Taggart's exact specifications—tested and approved by the designer himself! Sovereign S.T.400 coils are securely wound on strong walnut-toned moulded bakelite formers with correctly numbered terminals at base. You can be sure of results by using Sovereign in your S.T.400.

ALSO OFFICIALLY RECOMMENDED FOR S.T.400

- 1 SOVEREIGN Super-H.F. Choke 3/6
 - 2 SOVEREIGN 2-point push-pull switches (7d. each) 1/2
 - 1 SOVEREIGN 1-mfd. Fixed Condenser 2/3
 - 1 SOVEREIGN 1,500-ohm Spaghetti Resistance 10d.
 - 1 SOVEREIGN 20,000-ohm " 10d.
 - 1 SOVEREIGN 50,000-ohm " 10d.
 - 1 SOVEREIGN 60,000-ohm " 1/1
- BY USING SOVEREIGN YOU SAVE MONEY

NOTICE TO S.T.400 CONSTRUCTORS

Use Sovereign as much as possible in building this wonderful set—it will save you money and you can rely completely on Sovereign Components. Send for the Sovereign catalogue to Dept. 1232—it's Free!



SOVEREIGN PRODUCTS, LTD. SOVEREIGN HOUSE, Rosebery Avenue, London, E.C.1

SOLDERED CONTACTS FOR BETTER RADIO

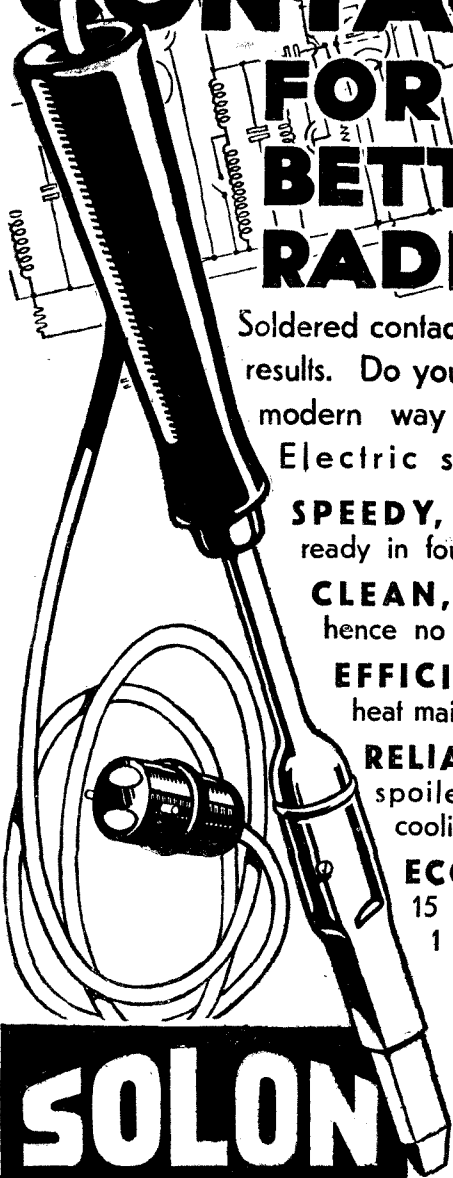

Soldered contacts give the best results. Do your soldering the modern way by electricity. Electric soldering is

SPEEDY, switch on—ready in four minutes

CLEAN, no flame—hence no dirt

EFFICIENT, constant heat maintained in the bit

RELIABLE, no jobs spoiled through bit cooling off

ECONOMICAL, 15 hours' use for 1 unit

MADE FOR STANDARD VOLTAGES

Please state voltage when ordering



COMPLETE WITH FLEX & ADAPTOR

POST FREE IN GREAT BRITAIN AND NORTHERN IRELAND.

SOLON

ELECTRIC SOLDERING IRON

(PATENT NO 243928)

WRITE FOR ILLUSTRATED LIST YW25.

If your local dealer does not stock SOLON send P.O. 7/6 direct to

W. T. HENLEY'S TELEGRAPH WORKS COMPANY LIMITED.
DEPT. YW25 — HOLBORN VIADUCT — LONDON — E.C.1.

BRITISH THROUGHOUT

Designed on a NEW PRINCIPLE to give LONGER LIFE and HIGHER AMPERE-HOUR EFFICIENCY

Type E.L.M.4. 45 a/h capacity. Price **8/-**

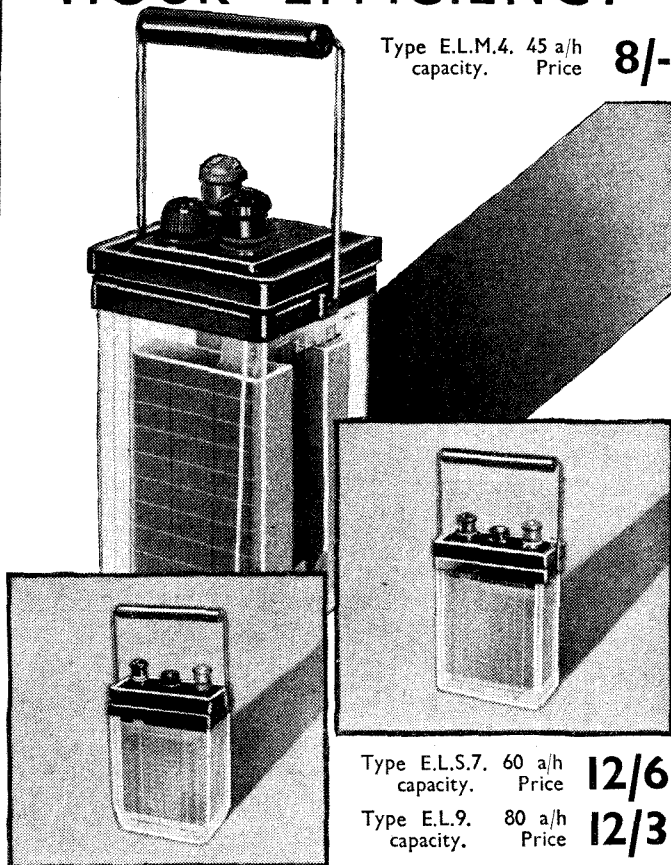

Type E.L.S.7. 60 a/h capacity. Price **12/6**
Type E.L.9. 80 a/h capacity. Price **12/3**

The new Ediswan "balanced capacity" accumulator is an entirely new development. The special design of the positive and negative plates which ensures exact electrical "balance," allows this accumulator to charge more rapidly, discharge more slowly and hold its charge longer than ordinary types. Twenty-five years of experience lie behind the production of Ediswan accumulators, while every possible mechanical refinement has been incorporated—British-made containers of clear glass, moulded ebonite lids, screwed vents, non-corrodible and non-interchangeable connectors and a metal carrier which fits neatly round the container.

Write for Leaflet No. A.B.736

EDISWAN ACCUMULATORS

EXTRA LIFE

THE EDISON SWAN ELECTRIC CO. LTD.
155 CHARING CROSS ROAD, LONDON, W.C.2 B.193





OUR NEWS BULLETIN

Three Musketeers," and a pianoforte recital by that famous pianist, Miss Myra Hess.

Friday's programme includes popular music by Edward

German and a political debate; while, to wind up with, on Saturday there is an all-star production of "Songs from the Shows," in which many famous actors and actresses will sing once more their old favourites.

On Armistice Day

It was at the suggestion of Sir Landon Ronald that the B.B.C. broadcast on Armistice Day Sir Edward Elgar's setting of Mr. Laurence Binyon's poem, "For the Fallen."

Sir Edward Elgar consented to conduct his work, and it was arranged that the performance should start on Armistice Night about 10.15 or 10.30, and would be given by sixty

members of the Wireless Orchestra and the Wireless Choir.

Twelve-Hour Broadcasts

The B.B.C. announces, that from December 19th additional programmes will be broadcast from the undermentioned transmitters in the afternoon, so that during school broadcasting holidays transmissions will remain continuous from 12 noon to 12 midnight:

Daventry National	1,554.4 metres.
London Regional	.. 356 metres.
North Regional	.. 480 metres.
Scottish Regional	.. 376.4 metres.
Cardiff	.. 309.9 metres.
Belfast	.. 242.3 metres.
Newcastle	.. 211.3 metres.
Aberdeen	.. 214.3 metres.
Bournemouth	.. 288.5 metres.
Swansea	.. 288.5 metres.
Plymouth	.. 288.5 metres.

As there is no school broadcasting on Saturdays, a general programme will be broadcast from twelve noon to midnight on that day throughout the year, from December 24th.

More High-Power

In an interesting review of foreign wireless stations published recently in the "Times," a correspondent

(Continued on page 166.)

Birthday Reminders

BY the time this issue of THE WIRELESS CONSTRUCTOR is on sale the B.B.C. will be celebrating the completion of ten years of British broadcasting, and there are one or two birthday programmes which should be borne in mind this week.

For instance, on Tuesday there is a special all-star radio production, including another appearance of A. J. Alan before the microphone; on Wednesday we shall hear a Symphony Concert from the Queen's Hall, followed by an hour of Tzigane music relayed from Budapest; on Thursday the star item is Part 1 of "The

SPECIFIED for the S.T.400

COMBINED PICK-UP AND TONE-ARM 22½

Embodying many refinements which are the outcome of careful research, the British Radiophone Combined Pick-Up and Tone-Arm reproduces voice and music with utmost fidelity.

This component is cased in moulded bakelite, finished in black or brown, and objectionable resonances are eliminated owing

to its robust construction and careful design.

The output shows an ample degree of sensitivity, is crisp and free from coloration and needle scratch. Perhaps the most important feature of this remarkably efficient component is the head, which, being fixed, eliminates lost motion and rattle.

Because the head is fixed at the correct angle, record wear is minimised, and light damping and good tracking is ensured. Full fitting instructions included.

A "rest" for the British Radiophone Pick-Up can be supplied. Price 1/6 each.

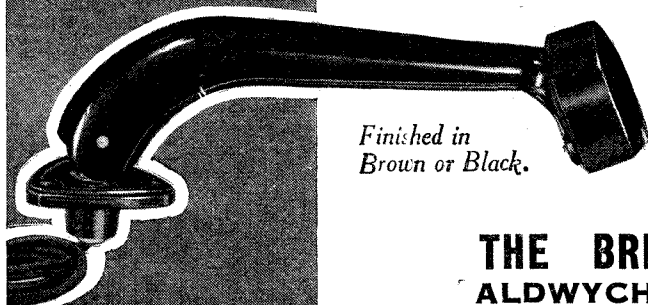

Finished in Brown or Black.

THE BRITISH RADIOPHONE, LTD.
ALDWYCH HOUSE, ALDWYCH, W.C.2.

BRITISH RADIOPHONE PICK-UP

SPECIFIED for STABILITY & QUALITY

Amplification governs the set's performance, thus, as in all good, modern circuits, R.I. transformers and chokes are specified to ensure the quality of reproduction in the S.T.400. Remember, no other components are as good and so satisfactory. Ask your dealer for them and for the latest R.I. catalogue and other useful literature.

in the **S.T. 400**

FOR DISTORTIONLESS AMPLIFICATION The HYPERMITE L.F. TRANSFORMER

The important L.F. stages will be safer and more satisfactory with "Hypermite," which is specified particularly for its high primary inductance, general superiority of performance and small size for compact assembly. It is the best nickel-iron alloy core transformer at its price. **12/6**

FOR CONSTANT H.F. STABILITY The QUAD-ASTATIC H.F. CHOKE

Specified for its high impedance and efficient operation over the entire broadcasting wavelengths. It ensures entire freedom from resonant losses and blind spots. Its astatic winding prevents any possible H.F. interference with adjacent components. **3/6**

The DUAL-ASTATIC H.F. CHOKE

Specified for its efficiency, particularly when used with screened-grid valves. Prevents L.F. feed-back and gives ease of bias voltage to following valve. Ensures absolute freedom from resonant peaks over the whole band of useful wavelengths, and will not cause interaction with adjacent components. **7/6**



COMPONENTS

The advertisement of R.I., Ltd., Croydon, Surrey. Phone: Thornion Heath 3211

Simpson's Electric Turntable



"goes by itself"

1. Only 2 1/2" deep.
2. Sizes 10" and 12".
3. 50 Cycles, 100/150 and 200/250 volts A.C.
4. Fits any Gramophone.
5. Costs less than 1/2. per week.
6. Correct speed of 78 revs. per minute.
7. Nothing to go wrong.
8. Anyone can fit it.

The most remarkable gramophone invention of the age—a gramophone turntable that "goes by itself." In a few minutes you can convert an ordinary gramophone into an automatic electric one. It takes little longer, following the simple instructions supplied, to convert your present Radio Set into a *super* Radio-gram. The total cost is only ... **39/6** It lasts a life time with no additional cost. Ask your Dealer for illustrated leaflet and demonstration.

SIMPSON'S ELECTRICALS LTD.,
GRANGE ROAD - LEYTON - E.10.



**THIS CABINET
ONLY 35/-**

For housing your set and speaker, there is nothing to beat the Camco "Empire" Cabinet which costs only 35s. Supplied in either mahogany or walnut, with or without the stool which is 25s. extra. It is only one of many fine Camco Cabinets to be seen in our Showrooms, open 9.15 to 5.45 (Sats. 12.30). **FREE** :—A copy of the new Camco Cabinet Catalogue will be sent **FREE** on receipt of coupon.

Carrington Mfg. Co. Ltd.
Showrooms: 24 Hatton Garden, LONDON, E.C.1.
Phone: Holborn 8222. Works: S. Croydon.

1 ost in *gd.* envelope.
Name
Address
4w.c.....



MR. SCOTT-TAGGART

Again specifies
MAGNUM
for his latest success
THE 'S.T.400'

- 1 Magnum Sandblast Screen .. 1/9d.
- 1 Piece Foil .. 9d.

Differential Condensers, S.G. Choke, Spaghettais and Panel are also recommended.

WE are specialising in the "S.T.400," and to meet the wishes of those requiring the set ready wired and tested, are producing this set completely wired and ready for use.

Available also as a constructional kit.

REMEMBER that every set manufactured by us is individually made by highly skilled craftsmen and undergoes rigid tests and inspection, thus ensuring perfect performance and satisfaction to the user.

Full particulars, including a brochure dealing with the latest "Stenode" and Short-Wave Adaptors, Free on request.

BURNE-JONES & CO., LTD.

"MAGNUM" HOUSE, 296, BOROUGH HIGH STREET, LONDON, S.E.1
Telephone: Hep 6257 & 6258.

Scottish Agent: Mr. Ross C. Wallace, 54, Gordon Street, GLASGOW, C.1.

OUR NEWS BULLETIN

—continued from page 164

pointed out that our nearest neighbours, the French, have the new Poste Parisien station now working with 60 kw. on a wavelength of 328.2 metres, for since last season this station has been replanned and its power very considerably increased.

Luxembourg is another new high-power station working on 200 kilowatts which may be heard testing this month. Another new station likely to be heard shortly is the 60-kw. transmitter, Rannes, Normandy. This will be one of the new stations of the Ferrie broadcasting system; and a similar station is shortly to be put into operation at Nice.

New Germans

New stations in Germany include the new Breslau transmitter, with a power of 60 kw., which was opened at the end of August, and may be heard on 325 metres, and also the 150-kw. transmitter at Leipzig. New Spanish stations include Madrid, on 120 kilowatts, and the short-waver

at Aranjuez (call-sign E A Q), using 20 kilowatts and directional aerials.

A One-Station Country

Latvia has one station at Riga, and its power will shortly be increased from 15 to 50 kilowatts, on a wave of 525 metres. Hilversum, on 296 metres, is now using 25 kw.; while Bari, Italy's newest and biggest station, on 270 metres, works on a power of 20 kw.

Starting Soon

The new Irish Free State high-power station at Moydrum, near Athlone, will probably be starting transmission tests this month, with 60 kw. in the aerial.

B.B.C. Tests

Now that the Scottish Regional station at Falkirk is on the air, the B.B.C.'s Regional Scheme for alternative programmes is almost complete. The West Regional station at Watchet, Somerset, is now under way, and construction is well advanced.

It is understood that tests are now being made with the B.B.C.'s short-wave transmitter (7 or 10 metres), which is housed on the top of the B.B.C. headquarters in Portland

Place. The B.B.C. has a number of mobile sets travelling about London, which are recording the various reception conditions of the metropolis. Much valuable data is being gathered concerning the shielding effect of London's high buildings, etc.

The Old Story

As we go to press with this issue of THE WIRELESS CONSTRUCTOR we understand that the Radio Telegraph Conference at Madrid is still squabbling over the matter of wavelength allotments.

The old story that there are too many claimants for the available wavelengths in the ether to-day is being dished up in a new guise; but, however new the guise, the problem is still the same and still as contentious as ever.

A Good Turn

The "Daily Mail" had a good story the other day about a boy who was regarded as the greatest vocalist in Australia. He was singing some songs in the weekly Empire broadcasting programme from station V K 2 M E, at Sydney, and his aunt, who was ill in the Cottage Hospital

(Continued on page 167.)

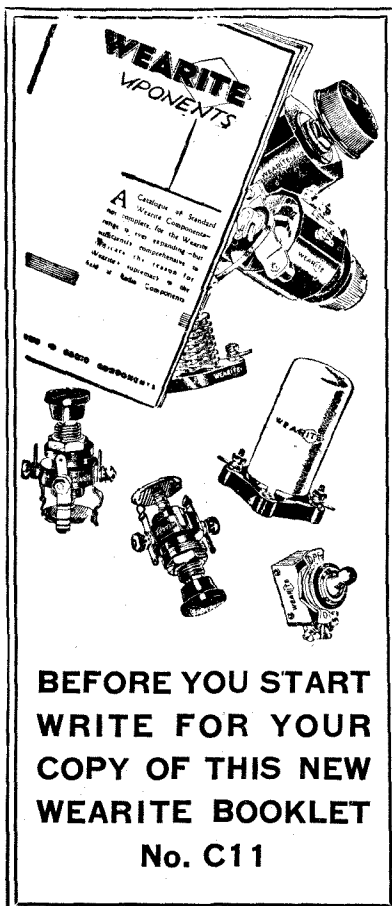

WEARITE COMPONENTS

A Catalogue of Standard Wearite Components for the Wireless Constructor. This booklet contains the names of the various components, their specifications, and the prices at which they are supplied. It is a most useful reference for the Wireless Constructor.

BEFORE YOU START WRITE FOR YOUR COPY OF THIS NEW WEARITE BOOKLET No. C11

BUILDING THE S.T.400? —then be SURE of your components

A set with the efficiency of the S.T.400 makes critical demands on its components—be sure that they are of proven reliability. When you use a Wearite part you use one made and backed by the first name in Radio components. Remember, too, all Wearite coils are subjected to special H.F. test apparatus used only by Wearite—all coils are strictly "up to specification," and have been approved by designer.

Use these WEARITE PARTS

	Price each
15-pin & 24-pin Valve Holders (S.1)	1/3
2 2-pt. Switches (G.S.P.)	1/-
1 S.G. Choke (H.F.O.)	6/6
1 Reaction Choke (H.F.P.), Screened	3/6
1 Toggle Switch (G.S.S.)	1/6
1 3-pole D.T. Switch (I.23)	4/-
and 1 S.T.400 Screen and Foil.	

Remember the 'EARTH' is part of the circuit. USE THE 'NO TOOL' WEARITE EARTH 3/6

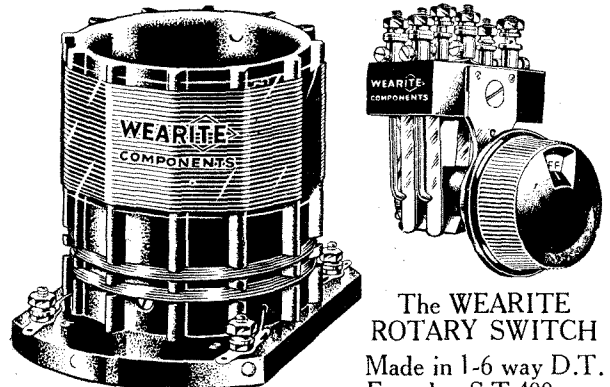

The WEARITE ROTARY SWITCH Made in 1-6 way D.T. For the S.T.400 use the I.23. Price 4/-
The WEARITE S.T.400 Coils 10/- per pair.

WEARITE
WRIGHT & WEAIRE, LTD., 740, HIGH ROAD, TOTTENHAM, N.17.
Telephone: Tottenham 3847/8/9.

OUR NEWS BULLETIN

—continued from page 166

at Oxted, Surrey, had a short-wave wireless set installed in the hospital, and a loudspeaker placed beside her bed.

Wonderfully Clear

Here various members of the family gathered to wait for the moment when their famous young relation should start his broadcast. To begin with the recital was marred by atmospherics, but later on reception became wonderfully clear and the boy wonder's aunt listened to her nephew's voice for the first time in her life.

Banned Records

The gramophone companies have banned the use of records for public performances, and cinema, dance-hall and restaurant managers are wondering what their legal position is. The ban, however, does not apply to records broadcast by the B.B.C. At present these reproductions are given under licence from the gramophone companies.

B.B.C. Not Affected

A B.B.C. official recently stated: "The arrangement between the gramophone companies and the B.B.C. is not likely to affect the listener, as the control which the B.B.C. has itself exercised in the past is such that the substance of the arrangement will probably be unchanged. A new contract shortly to be put into force will probably be for a term of years and the Corporation will be limited in the amount of record broadcasts."

In the Programmes

It is probable this new contract will allow for the announcing of the makes and numbers of the records as has been done in the past, and whenever possible the B.B.C. is to be asked to publish particulars of broadcast record programmes as it does of other programmes.

A Curious Story

A curious story was running round Fleet Street the other day to the effect that the William Penn Commemoration Committee of Philadelphia were arranging a broadcast from England to America in which King George, the King of Sweden, the Queen of the Netherlands, and the Lord Mayor of London had been

(Continued on page 168.)

S.T.400

Easibilt Constructor Kit

Efficiency with Economy

As pioneers of Radio on Easy Terms, we have created this wonderful opportunity. In order that you can enjoy the amazing performance of Mr. John Scott-Taggart's latest set, the "S.T.400," we have produced the **EASIBILT "S.T.400" KIT**, available **CASH, C.O.D., or H.P.** direct from us. **GUARANTEED EFFICIENCY WITH ECONOMY IS OUR SLOGAN**

YOURS FOR
FIRST PAYMENT OF

7/-

CARRIAGE PAID
Balance in 11 monthly payments of 7/-

EASIBILT "S.T.400" KIT

Contains these fully Guaranteed Parts

	s.	d.
1 Peto-Scott aerial coupler, .00004	3	6
1 Slekun super transformer, ratio 4:1	3	6
1 Sovereign S.T.400 coils	12	0
2 Keystone .0005 variable condensers	2	6
2 Sovereign .0003 preset condensers	2	6
1 Keystone .0001 differential condenser	1	6
3 Valve holders	1	0
1 W.B. universal valve holder	1	0
2 Peto-Scott 2-point switches	2	0
1 Peto-Scott binocular choke	2	0
1 Lewcos reaction choke	2	0
1 Goltone .0003 fixed condenser	5	0
2 Graham-Farish .006 fixed condensers	2	0
2 C.E.C. 2-mfd. fixed condensers	4	0
1 Dubilier 1-mfd. fixed condenser, type 9200	2	9
1 Keystone .0005 differential condenser	2	6
1 Keystone .00055 differential condenser	2	6
1 Sovereign 1-sec. grid leak with holder	1	3
1 Sovereign 1,500-ohm spaghetti resistance	1	10
1 Sovereign 50,000-ohm spaghetti resistance	1	1
1 Sovereign 20,000-ohm spaghetti resistance	1	1
1 Sovereign 60,000-ohm spaghetti resistance	1	1
1 Bulgin toggle switch	1	6
11 Keystone marked terminals	1	10
1 Aluminium Screen, 10" x 6", ready drilled	1	0
1 Red Triangle baseboard, 16" x 10" with 10" x 7" wiring foil ready mounted	1	6
1 Red Triangle black ebonite panel, 16" x 7" x 3/16", ready drilled	3	3
1 Red Triangle ready drilled black ebonite terminal strip, 16" x 1 1/2"	1	9
Wire, screws, flex, etc.	1	8
FREE FULL-SIZE BLUEPRINT, LARGE ACTUAL ASSEMBLY PHOTOGRAPH, and copy of "Wireless Constructor," S.T.400 issue	GRATIS	

Complete Kit, Cash or C.O.D. **£3 15 0**

Separate items in this Kit sent Cash or C.O.D. Part Kits value over 40/- on Easy Terms. Orders over 10/- sent Carriage and C.O.D. Charges Paid. Send for latest lists.

FREE FULL SIZE BLUE PRINT WITH EVERY KIT

and copy of "Wireless Constructor," S.T.400 issue.

Comprises Kit of Parts as listed, with Ready Drilled Panel and Terminal Strip; Drilled Screen, and foil-mounted ply Baseboard, less Valves and Cabinet.

7/-

Cash or C.O.D. **£3 15 0** with order Balance in 11 monthly payments of 7/-
Carriage Paid. **£5 14 3**

Complete Kit as above with Valves, Cash or C.O.D. or 12 monthly payments of 10/6 **£6 9 6**

FINISHED INSTRUMENT

Assembled with EASIBILT "S.T.400" Kit, exactly as listed and Aerial Tested, Complete with Valves and Table Cabinet.

£8.8.0

Cash or C.O.D., or 12 monthly payments of 15/6

New Times Sales Co

You may have absolute confidence in the EASIBILT "S.T.400" KIT. Every component included is guaranteed for 12 months. SEND THIS COUPON NOW FOR PROMPT SERVICE.

MAIL ORDER ONLY. NO CALLERS.

To **NEW TIMES SALES CO.** 56, Ludgate Hill London, E.C.4

Please send me EASIBILT "S.T.400" KIT for which I enclose £ s. d. Cash/Deposit

Name.....

Address.....

..... W.C.12/32

EXPRESS EASY PAYMENT SERVICE

EVERYTHING RADIO

STRICT PRIVACY GUARANTEED

S.T.400 STRUCTAKIT

**PANEL
ASSEMBLY
COMPONENTS**

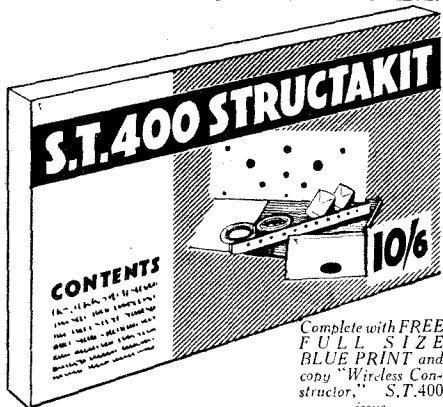

CONTAINS 'Red Triangle' Black Panel 16" x 7" x 1/8", ready drilled; 'Red Triangle' Terminal Strip 16" x 1 1/2" x 1/8", ready drilled; Peto-Scott non-warping Laminated Base-board 16" x 10", with Aluminium Foil ready mounted. Ready Drilled Aluminium Screen 10" x 6" and all necessary screws, wires and nuts to build complete **PANEL ASSEMBLY** for S.T.400.

Complete with **FREE FULL SIZE BLUE PRINT** and copy "Wireless Constructor," S.T.400 issue.

10/6

ASK YOUR DEALER!
for the **B.R.C. S.T.400 KIT**
Complete with **FREE FULL SIZE BLUEPRINT** and copy "Wireless Constructor," S.T.400 issue. **£4-5-0**

KEYSTONE LOW MINIMUM AERIAL COUPLER

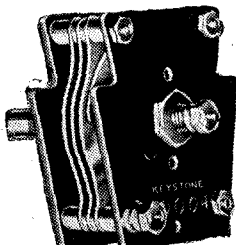

FIRST SPECIFIED by Mr. John Scott-Taggart for the S.T.400 because of its exceptionally low minimum and ideal construction for the important functions it has to perform. Don't substitute.

Registered Design. **3/6**
Obtainable from all Radio Dealers.

BRITISH RADIOGRAM
BRITISH RADIOGRAM Co., Ltd., Pilot House, Church St., Stoke Newington, LONDON, N.16.

OUR NEWS BULLETIN

—continued from page 167

invited to take part. Readings in reply were supposed to be arranged for to be sent by President Hoover.

"Nothing Known"

On inquiry it was found that the B.B.C. had not heard anything about this broadcast, and at Sandringham, where the King was staying at the time, it was also stated that nothing was known of the proposal.

However, the Secretary to the Lord Mayor said he had received a letter inviting him to speak, as had also Captain Davis, Mayor of Deal.

What a Nerve!

The letter received by Captain Davis was quoted in the "Evening Standard" recently, and indicates the "nerve" of whoever is behind the William Penn Commemoration Committee in Philadelphia. The letter ran as follows:

"In connection with the celebration of the 250th anniversary of the first arrival of William Penn in America, we are planning for an international hookup on Monday, October 24th, between the hours of 7 and 8 p.m. English time. We are asking His Majesty the King of Great Britain, His Majesty the King of Sweden, Her Majesty the Queen of the Netherlands, and the Rt. Hon. Lord Mayor of London to take part. We would like you to speak for three minutes, and particularly to refer to the fact that William Penn sailed from Deal on his first voyage. Our President Hoover is to respond, and the Governors of New Jersey, Pennsylvania, and Delaware have been invited to take part, etc., etc."

"Least Said . . ."

It makes one wonder in this country whether Americans who get brain-waves for organisations of this kind have the faintest idea of English etiquette. However, the less said about the business the better!

TO USERS OF THE "S.T.300"

A special article to users of the "S.T.300" was promised last month. Mr. Scott-Taggart found it would assist readers more to incorporate the information in his various articles on the "S.T.400" this month, so this has been done.

EVERYONE—
INTERESTED IN **SHORT WAVES**
SHOULD READ THIS BOOK!
CLEARLY WRITTEN.
PROFUSELY ILLUSTRATED.

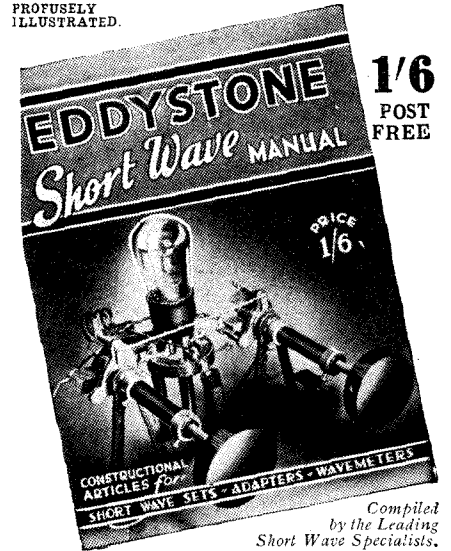

Compiled by the Leading Short Wave Specialists.
"The Eddystone Short Wave Manual" includes fully illustrated constructional articles for building 2-, 3-, and 4-valve short-wave receivers, a 1-valve super-het. S.W. converter, a 1-valve S.W. adapter, a dynatron and heterodyne wavemeter, and a 7-metre ultra S.W. converter. Articles on short waves, short-wave tuning, S.W. condensers, trouble locating, etc.

List and cost of parts given in detail for each set.
Ask your Radio Dealer for this splendid book.
EDDYSTONE
STRATTON & Co. Ltd. (D) BROMSGROVE STREET, BIRMINGHAM.
LONDON Service Depot: WEBB'S RADIO STORES, 161, Charing Cross Rd., W.C.2

RADIO SUPPLIES
Send your list of Radio needs for our quotation—Kits, Parts, Etc., etc. Everything in Radio stocked; prompt delivery. 7 days' approval. Catalogue free. Taylex and standard Wet H.T. replacements stocked.
C. TAYLOR, 57, Studley Rd., Stockwell, London.

WHOLESALE DEPOT
for (Home and Export)

LEONARD HEYS
EVERY PART FOR EVERY BLACKPOOL CIRCUIT

S.T.300
S.T.400
and all other COMPONENTS, KITS OF PARTS or ACCESSORY REQUIREMENTS.

PROMPT DELIVERY
Cash with order or C.O.D. at full recognised discounts (to bona fide dealers only: retail enquiries ignored). Enclose TRADE CARD or MEMORANDUM when ordering, or write for details of our splendid trade services.

**LEONARD HEYS, FARADAY HOUSE,
HENRY STREET, BLACKPOOL**
Eleven years experience in the Wireless Trade.

Make
The DAILY SKETCH
YOUR Picture Paper

S.T.400
THE BEST KIT
whatever the price
See Page 71.
Advt.

RAPID CONSTRUCTION GUIDE

—continued from page 140

- actually supported in the air; see blue-print and illustrations).
25. Other side of .0003 mfd. to valve holder V₂ filament negative —F (terminal furthest from base-board edge).
 26. Valve holder V₂ grid (marked G) to nearest terminal on Selectivity Range Adjuster .0003-mfd. pre-set.
 27. Valve holder V₃ grid (marked G) to nearest terminal on 1-megohm resistance holder.
 28. Resistance holder (terminal nearest the valve holders) to Graham Farish .006 mfd. (terminal nearest strip).
 29. Valve holder V₂ anode (marked A) to reaction choke (terminal nearest strip).
 30. L.S.— on strip to valve holder V₁ anode (marked A).
 31. This is a single insulated wire connected to S.G. choke (terminal farthest from strip). When set is finished, free end is connected to anode terminal on S.G. valve.
 32. Single insulated flex, about 9 in. long. First connect a G.B.+ wander-plug to one end. Then thread other end through hole between H.T.+2 and H.T.+3 on strip and connect to terminal (nearest strip) on 2 mfd. (nearest transformer).
 33. Single insulated flex about 12 in. long. First connect a G.B.—2 wander-plug to one end. Then thread other end through hole in strip and, passing it between transformer and adjacent 2-mfd. condenser, connect it to 1-megohm resistance holder (terminal furthest from valve holders).
 34. Single insulated flex about 9 in. long. First connect a G.B.—3 wander-plug to one end. Then thread other end through hole in strip and connect to G.B. on Hypernik transformer.

THIS CONCLUDES THE BASEBOARD WIRING.

Photo No. 1 shows how baseboard looks at this stage.

- (o) Mark out and drill panel (or buy same). My panel-drilling diagram is a back view, and is for making out the back of panel. (On no account use it to mark the front of panel.) Small pilot holes are first drilled from the back (the final holes being drilled

(Continued on page 170.)



When you throw away an old H.T. Battery, you throw away voltage you cannot use. You are wasting money.

The Lively 'O' H.T. Accumulator stops waste—definitely! From the moment it is charged, up to the time it needs recharging, it is full of power-giving life—full of powerful energy—full of punch! No self-discharge—no leakage—its "Air-Spaced" cells are leakage-proof. The Lively 'O' H.T. Accumulator gives you constant voltage. Smooth, silent current—power that never varies. Isn't that the kind of H.T. supply you've always wanted? Your dealer stocks the Lively 'O' H.T. Accumulator.

Oldham & Son Ltd., Denton, Manchester. Estd. 1865, and at London, Glasgow, Belfast & Dublin

TWO TYPES

Standard 10 volt unit capacity 2,750 milliamps -	5/6
Extra large capacity 5,500 milliamps (10 volt unit) -	6/9

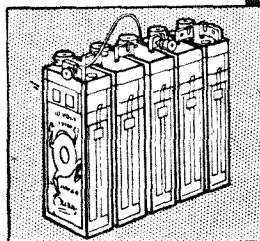

Tunewell Again!



Those countless S.T.300 enthusiasts who wisely chose Tunewell products know their marvellous efficiency—and value.

Now for Mr. J. Scott-Taggart's latest achievement! The S.T. 400! Tunewell Coils and Components recommended again! Include in your S.T.400 Shopping list Tunewell Coils, Switches, Transformer and H.F. Chokes.

You will find it well worth while to use Tunewell products always—for any Set. And if you want to be sure you have the best possible earth—get the new Tunewell Tentacle Earth (chemically-aided). Write for details and for "Guide to Super-Radio," which includes 8 Free Blue Prints (Kit Eliminator, All Mains Band Pass 3, etc.).



The following TUNEWELL Components are required:

1 Pair Tunewell Special S.T.400 Coils - 8/10

2 Tunewell 2-pt. Switches, each 10d.

Tunewell L.F. Transformer, 7/6

2 Tunewell H.F. Chokes each - 3/6

TUNEWELL TENTACLE EARTH (chemically-aided) 2/6

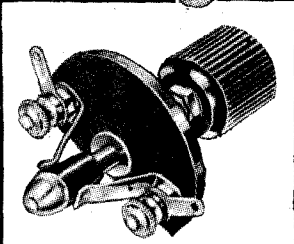

To TUNEWELL RADIO LTD.,
54, Station Rd., New Southgate, London, N.11

Send New "Guide to Super Radio" to:

Name.....

Address.....

My nearest Dealer is.....C.5.

TUNEWELL Super-Radio Components

RAPID CONSTRUCTION GUIDE

—continued from page 169

from the front). Any marks on panel front (to assist the reading of dial and coupler positions while working set) are best scratched immediately after drilling pilot holes. The three holes for the panel fixing screws should be countersunk, if not round-headed screws must be used.

(p) See that terminal bolts and nuts (not terminal heads) on the differentials, on the two push-pull switches and on the aerial coupler are firm. If not, tighten them up.

FIT PANEL COMPONENTS

as follows: Toggle switch, two push-pull switches, one .00035-mfd. (or a .0003-mfd.) differential for use as reaction distributor, one .0003-mfd. differential for master reaction, one .0001-mfd. differential anode coupler, one .00004-mfd. low-minimum variable aerial coupler, two .0005-mfd. slow-motion condensers. Do not fit knobs and dials at this stage.

WIRE PANEL COMPONENTS

- as follows:
35. Aerial coupler (fixed vanes) to aerial tuning condenser (fixed vanes, i.e. terminal on side, in case of Ormond).
 36. Aerial tuning condenser (moving vanes, i.e. terminal at end) to aerial push-pull wave-change switch (terminal nearest anode wave-change switch). This wire drops from end terminal on condenser and then follows bottom edge of condenser; when it reaches panel it bends at right angles and, lying close to panel, proceeds to wave-change switch.
 37. Master Reaction .0003-mfd. differential (lower set fixed vanes, i.e. terminal marked F₂ on Polar) to anode coupler .0001-mfd. differential (one set fixed vanes nearest aerial coupler, i.e. terminal nearest aerial coupler).
 38. Master Reaction .0003-mfd. differential (upper set fixed vanes, i.e. terminal F₁ on Polar) to distributor .00035 mfd. (moving vanes, i.e. terminal attached to pigtail and nearest anode tuning condenser).
 39. Anode wave-change switch (terminal nearest on-off toggle switch) to anode tuning condenser (moving vanes, i.e. terminal at end).

SPECIFIED FOR S.T.400

For eight years Belling-Lee products have been the most consistently specified components offered to the public. WHAT better recommendation is available?

Another interesting specification. Mr. G. P. Kendall, B. So., has again chosen Belling & Lee Terminals, etc. for all Ready Radio kits this year.



Type "R"
2½d.

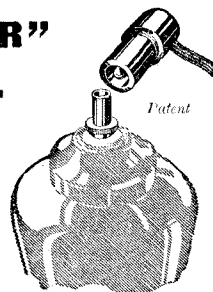

SPADE TERMINALS. With the patent Belling-Lee grip and permanent lettering on the handle. 2d. each.

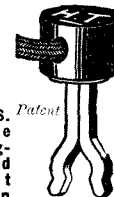

"BOW-SPRING" WANDER PLUG. Strong Spring and wide self-adjustment. 1½d. each.



(Regd. Design) TWIN-TAP BATTERY PLUGS. To take two connections from one Battery Socket. 1d. each.

S.G. ANODE CONNECTORS. Fully insulated even when disconnected. Safeguards S.G. and Pentode Valves. 4d. each.

BELLING-LEE FOR EVERY RADIO CONNECTION

Advt. of Belling & Lee, Ltd., Cambridge Arterial Road, Enfield, Mdx.

(Continued on page 171.)

RAPID CONSTRUCTION GUIDE

—continued from page 170

- (q) Hold panel temporarily in position against baseboard and mark on baseboard the points above which the on-off switch terminals will come. Remove panel. Prepare wires for later connection to toggle switch, viz. (42) from S.G. valve-holder filament positive +F (lower filament terminal on W.B. valveholder); this wire will leave toggle, go round behind toggle, and then run along baseboard *close* to the panel until the screen is passed. (41) from valve holder V_2 filament positive (terminal near baseboard edge) noticing where automatic equaliser pre-set will come; and (40) from L.T.+ on strip; this wire runs along baseboard and $\frac{1}{2}$ in. away from panel until it turns off near screen. The general shape of these three wires is obtainable from blueprint, drawings and photos. Connect end of last wire (40) to toggle (terminal nearest push-pull switches); other end of this wire is not connected until panel is fixed.

Photo No. 2 shows panel wired.

FIX PANEL TO BASEBOARD

with three screws. Under no circumstances use countersunk screws unless holes have been countersunk, otherwise panel will split.

Photo No. 3 shows how set looks at this stage.

- (r) Carry out following wiring:
40. Toggle switch (terminal nearest push-pull switches) to L.T.+ on strip. The toggle switch end of this wire has already been connected. This wire, as described above, runs along baseboard and *close* to panel.
 41. Toggle switch (terminal nearest baseboard edge) to valve holder V_2 filament positive +F (terminal nearest baseboard edge).
 42. Toggle switch (terminal nearest baseboard edge) to S.G. valve-holder filament positive +F (lower filament terminal F on W.B. valve holder). (This wire leaves toggle, goes round behind toggle, and then along baseboard, keeping close to panel; after passing through lower notch in screen it goes in a straight line to lower terminal F on W.B. valve holder.)

(Continued on page 172.)

And Now Specified AND RECOMMENDED by Mr. John Scott-Taggart

A.M.I.E.E.,
F. Inst. P.

for the
S.T. 400



Ensures Better Reception

You cannot hope to get the best results from this marvellous receiver unless you include the "Slektun" 4-1 Super Transformer. Mr. John Scott-Taggart specifies and recommends it—and it is guaranteed for a minimum period of 3 YEARS. The official guarantee and a copy of the N.P.L. frequency response curve is supplied with every transformer.

SLEKTUN

SUPER TRANSFORMER

If you have any difficulty in obtaining from your usual dealer, please write us direct.

SLEKTUN PRODUCTS LTD., 21, DOUGLAS ST., WESTMINSTER, S.W.1.

Telephone: Victoria 3405-6-7.

8/6

RATIOS: 2:1, 3:1, 4:1, 5:1

Guaranteed 3 Years

PETO - SCOTT
S.T. 400
CABINETS



OAK TABLE MODEL

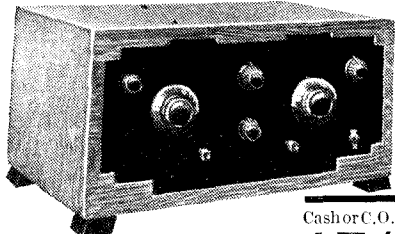

Figured hand French-polished oak Table Model Cabinet designed especially to make an attractive housing for the S.T.400.

Cash or C.O.D. **17/-**
Carriage Paid

OAK CONSOLETTA MODEL

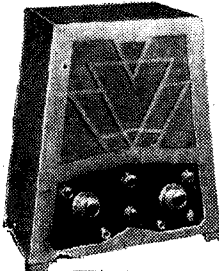

Specially designed for the S.T.400. Constructed of hand French-polished oak with attractive silk covered vignette complete with battery shelf and speaker compartments.

CASH or C.O.D. Carriage Paid. **25/-**

1933 INLAID WALNUT CONSOLE

BUILD YOUR S.T.400 INTO THIS BEAUTIFUL CABINET

Constructed of Solid Walnut with contrasting inlaid Walnut veneer panels.

With vignette front. Lift-up lid and shelf, ready to take your own S.T.400 Receiver. Ready Drilled Baffle Board 3/6 extra (if required).

CASH or C.O.D.

62/- Or 12 monthly payments of 5/8. Carriage and Packing 2/6 extra.

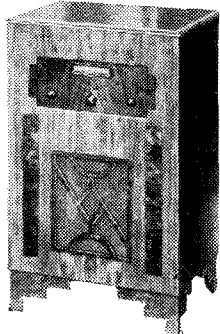

MADE IN OUR OWN FACTORY

To PETO-SCOTT CO. LTD., 77 City Road, E.C.1.

Dear Sirs,
Please send me by return CASH/C.O.D./H.P.

for which I enclose £ s. d.

Name.....

Address.....

W.C. 12/32.....

West End Showrooms: 62 High Holborn, W.C.1.

RAPID CONSTRUCTION GUIDE

—continued from page 171

43. Aerial wave-change switch (terminal nearest aerial tuning condenser) to aerial coil (terminal No. 3).
 44. Reaction distributor .00035 differential (lower fixed vanes, i.e. bottom terminal) to aerial coil (terminal No. 1). This wire must be kept close to panel where it will later pass through upper notch in screen. The wire will keep about 1/2 in. above earth sheet. It must not sag on to it.
 45. Aerial tuning condenser fixed vanes (i.e. terminal on side in case of Ormond) to aerial coil (terminal No. 2).
 46. Aerial tuning condenser moving vanes (terminal at end) to S.G. valve holder (negative filament terminal —F, i.e. upper filament terminal F on W.B. valve holder).
- (s) Take a 4-in. length of insulated wire, bare and loop its ends; attach one end to anode wave-change switch (terminal nearest reaction distributor); this wire is numbered (47) on blue-print. Take a 4 1/2-in. length of insulated wire; bare and loop its ends; attach one end to reaction distributor (upper set fixed vanes, i.e. top terminal); this wire is numbered (48). Both wires are for subsequent connection to anode coil and their direction is illustrated in a special perspective sketch.

Photo No. 4 shows set at this stage. Note the wires which will go to coil.

- (t) Fix the two mounting pillars on to "S.T.400" anode coil, putting aside the two countersunk-head screws for the time being.
 - (u) Fix anode coil in position, letting wire (47) pass between its pillars. (See sketch for method of fixing coil with countersunk-head screws which are screwed up from underneath baseboard.)
47. Anode wave-change switch (terminal nearest reaction distributor) to anode coil (terminal No. 3). The connection to the wave-change switch has already been made, and the free end, after passing between pillars, is joined to terminal No. 3 (see special perspective drawing and photos). An un-numbered photo (taken with some components removed) is worth looking at here because it shows the wires near anode

(Continued on page 173).

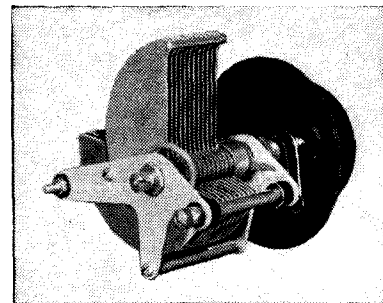

ALL VARIABLE CONDENSERS for the S.T.400 for only £1-1-3

2 Slow Motion Condensers (all brass)	
Type 27. Cap. .0005	10/6
1* Differential Condenser, Type 60. .0001	2/3
1 Differential Condenser, Type 60. .0003	2/3
1 Differential Condenser, Type 60. .00035	2/3
1* Aerial Coupling Condenser, Type 80. .00004	4/-

*Specified by the designer.

WRITE FOR ILLUSTRATED CATALOGUE

WAVEMASTER

The Webb Condenser Co., Ltd., 42, Hatton Garden, E.C.1

NOTICE

Send 6d. (post free) for UP-TO-DATE HANDBOOK of Tuning Coils for Circuits, Dual Range, Band Pass, and Super Het. Fully illustrated, with data.

THE BRITISH EBONITE CO., LTD.
Hanwell, London, W.7

JACK of all TRACKS



This motor-bike and its rider are ready for anything. They have thundered round the Wall of Death—greatest of all motor-cycling thrills. Their story is but one of a host of fascinating features of the MODERN BOY'S ANNUAL, which deals with ships, aeroplanes, railways, and the most up-to-date developments of to-day. There are hundreds of striking illustrations, three ripping adventure stories and two splendid coloured plates.

The MODERN BOY'S ANNUAL At all Newsagents **6/-** Net.

RAPID CONSTRUCTION GUIDE

—continued from page 172

coil, a difficult view to illustrate. The photo is not numbered because it is not actually of a stage in the construction of the set.

48. Reaction distributor (upper set fixed vanes, i.e. top terminal) to anode coil (terminal No. 5). The distributor end of this wire has already been connected. The special perspective drawing and the photos show way wire (48) is formed.
- (v) Fit automatic reaction equaliser (-0003-mfd. pre-set).
49. Anode coil (terminal No. 5) via 1,500-ohm spaghetti to automatic reaction equaliser pre-set (terminal furthest from panel). Spaghetti is right length with components actually used. If too short, an extension wire may be added, but should be joined to spaghetti by small nut and bolt to ensure perfect contact.
50. Automatic reaction equaliser pre-set (terminal nearest panel) to master reaction differential (lower set fixed vanes, i.e. bottom terminal marked F₂ on Polar).
51. Anode coil (terminal No. 1) to Anode tuning condenser moving vanes (terminal at end).
This wire (see blue-print and one of the photos) drops vertically from terminal No. 1 to baseboard, bulging outwards to clear terminals No. 2 and No. 3; it then proceeds parallel to panel along baseboard; immediately after passing selectivity range adjuster it rises diagonally straight to end terminal of tuning condenser.
52. Anode coil (terminal No. 6) to anode tuning condenser fixed vanes (terminal on side).
53. Anode tuning condenser fixed vanes (terminal on side) to selectivity range adjuster pre-set (terminal nearest toggle switch).
54. Selectivity range adjuster pre-set (terminal nearest anode coil) to anode coupler differential (fixed vanes terminal nearest anode tuning condenser). This wire starts at pre-set terminal, travels for 1/8 in. only in direction of pre-set knob, and then rises vertically; after rising 3 1/2 in., it goes straight to one set fixed vanes of differential anode coupler (terminal nearest anode tuning condenser).
55. Single insulated flex about 15 in.

(Continued on page 174.)

SPECIFIED by John Scott-Taggart
FOR
THE NEWS.T.400 List No. 580
BULGIN TOGGLE SWITCH

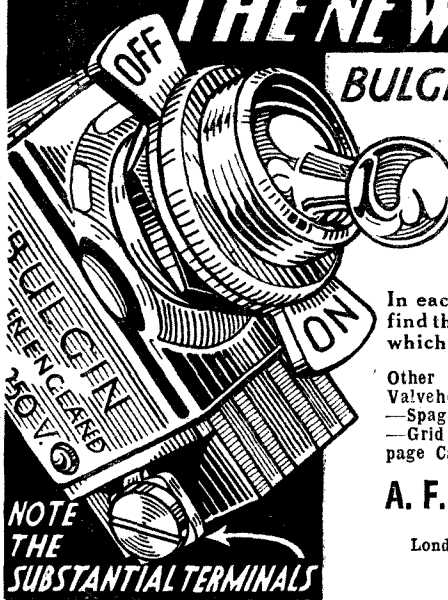

Whenever good, reliable switches are required you will find **BULGIN** specified. Government and Municipal Engineers, Chief Technicians of the Radio and Electrical Industry, all know the reputation of **BULGIN** switches and have no hesitation in recommending them.

In each and every Bulgin Product you will always find that little *extra* superior point which makes all the difference.

Other suitable **BULGIN** products:—
Valveholders—S.G. Chokes—Switches
—Spaghettis—Condensers—Terminals
—Grid Leaks. Full details in 80-page Catalogue "C."

A. F. BULGIN & CO., LTD., ABBEY ROAD, BARKING, ESSEX.
Phone: Grange Wood 3266/7.
London Showrooms: 9, 10, 11, Cursitor Street, E.C.4.
Phone: Holborn 2072.

Our new 80-page Catalogue "C" and Manual is a veritable mine of information. Constructors say it is honestly worth a 1/-, but all we ask is the 2d. postage.



Famous Makers Offer! £5 Radio-Gram CABINET for 65/-
7 DAYS' FREE TRIAL (OR 10/- MONTHLY.)
Polished Oak! and Piano built! the acoustic Tone brings a fine thrill. Makers to (Radio Press, B.C.C., 5,000 clientele).
Other Models 35/- to £15. Photographs and List FREE.
PICKETTS Piano-Tone Cabinets.
(G.W.) Albion Road, Bexleyheath

FOR "S.T.400" PICKETTS CABINETS
As Recommended by John Scott-Taggart.

S.T.400
START RIGHT
With the 12 months' Guaranteed Kit
See Page 71. Advt.

CUT OUT WHISTLES
THE "KINVA" WHISTLE FILTER IS AN INFALLIBLE CURE FOR THE HETERODYNE WHISTLES HEARD ON STATIONS WITH INADEQUATE SEPARATION. A SCIENTIFICALLY DESIGNED FILTER FOR USE IN DETECTOR ANODE, TO REPLACE OR FOLLOW H.F. CHOKE. DOES NOT IMPAIR REPRODUCTION. THREE TYPES AVAILABLE.
PRICES 7/-; 7/6; & 15/-.
Descriptive matter, connecting diagram, users' reports, etc., on receipt stamp.
POSTLETHWAITE BROS.
KINVER, NR. STOURBRIDGE.

PLEASE be sure to mention "Wireless Constructor" when communicating with Advertisers. Thanks!

RADIO BARGAINS
We have just bought a huge assortment of Wireless and Electrical Apparatus from a Govt. Depot and Liquidator. This is offered at SACRIFICE PRICES to clear. For experimenters, odd sets are dismantled, and with terminals, panels, holders, chokes, magnets, switches, fittings, wires, etc., made up into useful ASSORTED PARCELS. 7 lbs., 5/-; 10 lbs., 7/-. Post free. Extra weight to callers.
IF YOU WANT ANY AERIALS, BUZZERS, BELLS, CONDENSERS, CABLE CASES, CHOKES, COILS, CHARGERS, DYNAMOS, MOTORS, ENGINES, LAMPS, NEONS, MICROPHONES, METERS, RECEIVERS, SPARK COILS, VALVES, WAVE-METERS, WIRE, AND TESTING SETS, SEND FOR OUR SALE LIST, AND CALL AND SEE US.
Special attention paid to specified requirements, and quotations by return of post. Goods sent to all parts of the world.
ELECTRADIX RADIOS
218 UPPER THAMES ST., LONDON, E.C.4

The Picture Paper with the MOST News
SUNDAY GRAPHIC
and SUNDAY NEWS.

Write for Illustrated Catalogue of **RADIO-CRAMPHONE CABINETS**
of exclusive modern design, made by craftsmen, in highly figured Oak, Walnut, or Mahogany, post free.
REMARKABLE VALUES Cabinets made to order a speciality.
Maker, under licence, of the **HOWE BOX BAFFLE**. Recommended by the B.C.C. Full details on request.
GILBERT Cabinet Maker, **SWINDON**
Estimates Free. Estd. 1866



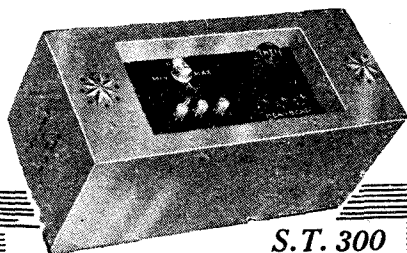

S.T. 300

MAINS UNIT

Mr. Scott-Taggart chose the Heayberd M.W.1 Mains Unit for the S.T.300. YOU should make it your choice for the S.T.400. The provision of an Alternative output switch makes it possible for you to run your Battery model from the minimum position, and then use the maximum output for the A.C. version.

Perfect smoothing—15 mf. Condensers (800v. Test) and double Chokes. Wire wound variable for S.G. Westinghouse Rectification. Neat metal case with flex and adapter. GUARANTEED Three Years.

HEAYBERD M.W.1 MAINS UNIT

Alternative Outputs: 39 ma. at 150v. or 50 ma. at 200v. Tappings: S.G. 40/120v. Var., 175v. and 290v. Fixed (MAX). L.T. Supply 4v. 5 amps.

Price.....127/6.....Complete

.....POST COUPON NOW.....

I enclose 3d. stamps for new Handbook "Mains Power for your Radio." Packed with technical hints, tips and diagrams.

M.....

Address.....

..... W. Cons.

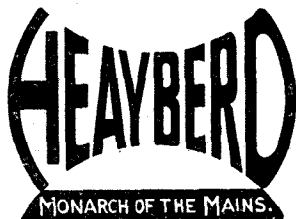

19, FINSBURY STREET, LONDON, E.C.2.
One minute from Moorgate Und. Station

STOP PRESS

Mr. Scott-Taggart has specified the HEAYBERD Mains Unit for the "S.T.400"—you cannot do better than follow his example.

TAYLOR WET H.T. BATTERIES.
Give long service, improved volume and tone; very economical.
Replacements for Taylex or Standard batteries at low prices; details post free; also Bargain List, Radio Kits and parts at lowest prices.
C. TAYLOR, 57, Studley Rd., Stockwell, London.

S.T.400

HOW TO DUPLICATE

Mr. John Scott-Taggart's Results

! See Page 71. Adv.

**LANCHESTER
M.C. SPEAKERS**
for your S.T.400

THROUGH YOUR DEALER
or write us for full particulars.

LANCHESTER LABORATORIES LTD.
SPRING ROAD, TYSELEY, BIRMINGHAM.

RAPID CONSTRUCTION GUIDE

—continued from page 173

long. First connect a G.B.—1 wander-plug to one end. Then thread other end through hole in terminal strip, and, after passing it between transformer and adjacent 2-mfd. condenser, connect it to anode tuning condenser moving vanes (i.e. terminal at end). This wire must not be allowed to sag on to reaction choke.

- (w) Give earth sheet and vertical screen a final rub with emery where they will come in contact with each other; do not blow dust away, but wipe carefully. Clean also round terminal holes in screen, and fit with terminals. Terminal previously taken off W.B. valve holder can be used as one of the terminals.

Photo No. 5 shows the set at this stage.

NOW FIX VERTICAL SCREEN,

seeing that wire (42) goes through lower notch next panel, and that wire (44) goes through the upper.

If necessary, slack off terminal strip fixing screws while getting screen into position.

56. Anode coil (terminal No. 1) to .006 mfd. (Dubilier), which is supported by wires connected to it.
57. Other side of .006 mfd. to upper corner terminal in screen.
58. Anode coupler differential (fixed vanes nearest screen, i.e. terminal nearest screen) to upper corner terminal in screen.
59. L.T.— on strip to screen terminal near strip. (This wire goes straight between the points it connects.)
60. 1 mfd. (terminal nearest screen) to screen terminal near strip.

(Note that this screen terminal has connections to it on each side of the screen.) Wire 60 goes straight between points it connects.

61. E terminal of set (on strip) to screen terminal nearest strip.
62. Master reaction moving vanes (i.e. terminal farthest from screen) to valve holder V₂ (anode terminal marked A).
63. S.G. choke (terminal nearest panel) to anode coupler differential (moving vanes, i.e. top terminal).

(Wire rises vertically from S.G. choke terminal and then proceeds horizontally to anode coupl. r.)

(Continued on page 176.)

COVERING EUROPE ON THE "S.T.400"

—continued from page 132

calibrated, I advise doing it with Distributor at normal and anode coupler at normal. A scratch or spot of white paint on panel is necessary for anode coupler. The aerial condenser may then simply be turned until station is heard, irrespective of aerial coupler position. If you desire to calibrate aerial condenser, it should be done with aerial coupler at a fixed value, say at "normal," using a scratch on panel.

Automatic Reaction Equalisation.

So far you have not used this. You could not do any harm by a faulty setting of it, but I prefer that you should be familiar with set before adjusting this refinement. It may be adjusted by simply screwing up clockwise a few turns at a time, leaving go of knob after doing so. With Equaliser pre-set at minimum (screwed out), the set if just oscillating at, say, 50° will stop oscillating if dials are moved to, say, 120°.

To prove merit of Equaliser, screw up to maximum, make set just oscillate at, say, 120° by use of Master Reaction. Then come down on dial. The set will stop oscillating—exactly the reverse effect to that on ordinary set.

Between these extremes the Equaliser pre-set may be adjusted to give approximately equal reaction over whole dial. Once set, the Equaliser is never touched again.

Having tested the "S.T.400" satisfactorily, it may be put in cabinet.

Summary. The Selectivity Range Adjuster and Automatic Reaction Equaliser are valuable refinements. If in the slightest doubt about their adjustment, you cannot do better than screw up (to maximum) the Selectivity Range Adjuster and screw out (to minimum) the Reaction Equaliser pre-set.

The "S.T.400" may be (a) worked as easily as the simplest of two-dial receivers by setting all panel controls at normal; (b) it may be used as a very selective and sensitive set by using the couplers; (c) it may be used as an ultra-selective set by using the Reaction Distributor.

J. S.-T.

THE FORMO TUNING UNIT

We are informed by the Formo Co., Ltd., that the price of their Formo Triple Gang Band-Pass Tuning Unit is 46s. 6d., and not 44s. 6d., as erroneously stated in their advertisement last month.

**AND NOW FOR THE
"S.T.400"!**

—continued from page 89

desired and undesired stations, the part of the dial you are on, and so forth.

No two wireless listeners, even if they live next door and have similar aerials, will have to contend with exactly the same conditions.

How much more different, then, will be the conditions of listeners at Land's End, at Margate, or at John o' Groats? And how different again are the problems of these folk from those who live, say, at Airdrie, Rochdale, or under the blanket cast by Brookmans Park?

The "S.T.400"—this set you are reading about now—has been to hear for itself the conditions in these and scores of other places. It has been connected to strange aerials—and stranger earths!—and when you yourself build the set and fix it to your aerial, the "S.T.400" will tell you, more convincingly than I can, the value of its controls.

If I say anything myself about the set's performance, I would rather you forget it. I resolved before settling down to talk to you about this receiver that I would make no claims.

The Editor is placing before you typical letters which either he or I have received from readers like yourself who have had the set on their own aerials. Let these be my witnesses.

It is my intention here not to say what the set does, but how it does it. I believe in explaining how my own mind worked in designing this set. If I take a lot of time in telling you, it is simply because my mind worked for a long time!

"Too Much 'Publicity' "

A second reason is that if I do something unconventional, something radically new, you have a right to demand a proper explanation.

I could, of course, simply say, "Here is the 'S.T.400.'" It is a good set." I believe that many thousands would build it on faith. One or two of my critics have written to the effect that there is too much "publicity" about my sets.

Apparently they would prefer me to produce a set in a hole-and-corner fashion and dump it on the public. I can assure you that such a procedure would be a great deal easier for me.

(Continued on page 176.)

On this

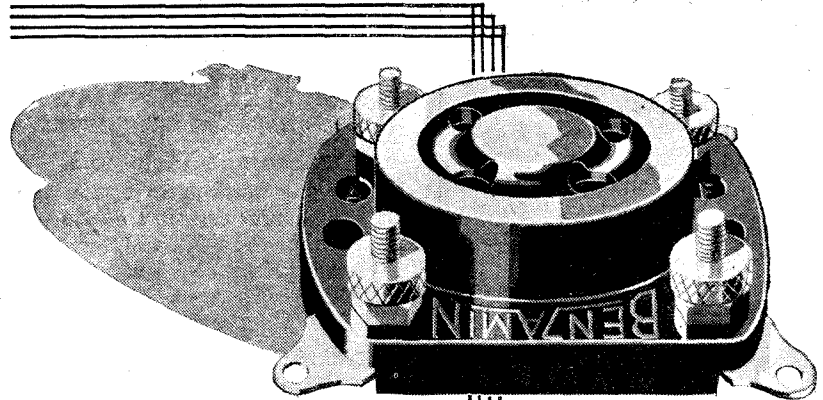

You are told by the designer of this, "the set of the season," which Valveholder is the best to use. Past experience has taught designers that to ensure public approval of their circuits they must specify the Vibrolider. It is inadvisable for you to substitute anything, if you want Scott-Taggart results, and the VIBROLIDER costs TENPENICE.

**depends
the success
of your
S.T.400**

BENJAMIN

THE BENJAMIN ELECTRIC LTD.,
TARIFF ROAD, TOTTENHAM, N.17.

CLIX

**SPECIFIED
for the
"S.T.400"**

**"DUAL"
WANDER PLUGS**

MR. JOHN SCOTT - TAGGART expressed the wish for this new type of wander plug and we have been pleased to add it to the wide range of 'Clix' components.

'CLIX' DUAL WANDER PLUG Specified for the "S.T.400."

**SPECIFIED
and
RECOMMENDED
CLIX "DUAL" AND
"MASTER" PLUGS
CLIX PANEL TERMINALS**

More robust. Completely insulated, non-removable head with clearly marked 2 1/2 d. readings.

CLIX KIT for the "S.T.400."

3 "Dual" Wander Plugs, 9 "Master" Plugs, 11 Terminals (Type A). All engraved. KIT Complete 4/-

From all dealers or direct.

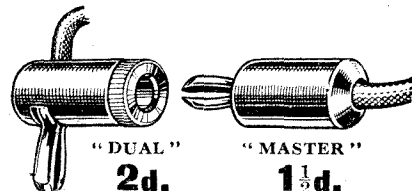

"DUAL" 2d.

"MASTER" 1 1/2d.

Whenever it is desired to apply the same H.T. or G.B. voltage to two points in a circuit, this double-purpose wander plug quickly and efficiently solves any difficulty.

Write for folder "C"

LECTRO LINX LTD.
254, Vauxhall Bridge Road, S.W.1

AND NOW FOR THE "S.T.400"!

—continued from page 175

But the constructing public has a right to know what it is getting. Treating it in a superior, rather contemptuous manner may obtain for one a petty niche in the esteem of a few, but there will be no niche for one's sets in the homes of the country.

If only a few thousands were to build my sets, I might get slack. I doubt it, but I might. There might be a temptation to scamp the preliminary work and skimp the description.

But each of my "big" sets has been built on a national scale. Probably a million pounds (of which none, unfortunately, goes into my pocket) will be spent by home constructors on the "S.T.400." My responsibility in the matter is a very real one. Is it any wonder that, realising that responsibility, I have taken such an amount of trouble over this set?

Publicity? Certainly! The trouble about most set designs is that there is not enough publicity. A new set cannot be "aired" sufficiently.

Likewise I believe the designer should meet his public. I have taken the experimental versions of the "S.T.400" into scores of homes where the occupier knows exactly what to look for, exactly what to ask me, and exactly what to tell me.

That is what I mean by publicity. Demonstrations night after

night before and after publication. Letting practical constructors tell other constructors what they thought of the set. And when the article is published, meeting—as I intend to meet—still more readers face to face with the "S.T.400" on their own aerial—and this article on their knees.

The Promise Fulfilled

I offer this receiver to you as the best I have ever designed. I do not tell you what the "S.T.400" will do. I let you hear from others what the set has done.

Tens of thousands are going to build this set. Within a week a neigh-

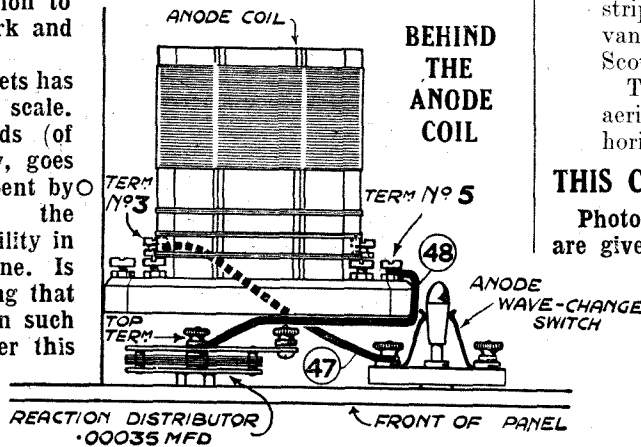

This illustration shows the position of the Reaction-Distributor differential condenser between the panel and the anode coil which usually hides it from sight.

bour will be telling you of his results—unless you have told him yours first.

Ten months ago I wrote: "I want to get into some of your homes—those who are working under particularly adverse conditions—and try my sets there while in the first design stages. I don't mind the trouble. I shall welcome it if it means that better sets will thereby result."

I have kept my word. I have been in your homes. From Land's End to John o' Groats. I do not even ask you to have faith in the set. I claim nothing. Others, forerunners of tens of thousands, have done that.

But I want to ask one thing: write to me about your "S.T.400." I shall be as keen to hear your results as I have been to help you get them.

RAPID CONSTRUCTION GUIDE

—continued from page 174

64. Aerial terminal of set (i.e. A on strip) to aerial coupler moving vanes (upper terminal on Peto-Scott model used).

This wire rises vertically from aerial terminal and then proceeds horizontally to aerial coupler.

THIS COMPLETES THE WIRING

Photos of set with completed wiring are given in main article.

Fit knobs and dials to panel components. First fit push-pull switch knobs. Then turn spindles of three differentials as far anti-clockwise as possible (looking from the front of set), and fit knobs with pointers pointing horizontally to left. Turn two tuning condenser spindles as far anti-clockwise as possible (i.e. vanes out), and fit dials with their zeros opposite scratch marks on panel; fit slow-motion knobs to tuning condensers. Turn spindle of aerial coupler until you see vanes full-in; then fix knob with pointer pointing horizontally to the right.

YOUR SET IS NOW COMPLETE!

J. S. T.

INDEX TO ADVERTISERS

Belling & Lee, Ltd.	170
Benjamin Electric, Ltd.	175
British Blue Spot Co., Ltd.	Cover iii
British Ebonite Co., Ltd.	172
Bulgin, A. F., & Co., Ltd.	173
British Radiophone Co., Ltd.	164
British Radio-Gramophone Co., Ltd.	168
Burne-Jones & Co., Ltd.	165
Carrington Manig. Co., Ltd.	165
Clarion Radio Furniture	65
Clarke, H., & Co. (M/cr.), Ltd.	69
Colvern, Ltd.	123, 129
Cossor, A. C., Ltd.	136
Celestion, Ltd.	146
"Chums"	161
Direct Radio Co.	124, 125
Dubilier Condenser Co. (1925), Ltd.	68
Edison Swan Electric Co., Ltd.	Cover iv, 139, 163
Electradix Radio	173
Ferranti, Ltd.	67
Forno Co.	161

Gilbert, J. C. (Cabinets)	PAGE 173
Graham Farish, Ltd.	149, 151
Hayberd, F. C., & Co.	174
Henley's, W. T., Telegraph Works Co., Ltd.	163
Heys, Leonard	168
Igranic Electric Co., Ltd.	159
Jackson Bros.	120
Lanchester Laboratories, Ltd.	174
Lectro Linx, Ltd.	175
Lissen, Ltd.	145, 130
London Elec. Wire Co. & Smiths, Ltd.	Cover ii
Lotus Radio, Ltd.	70
Milnes Radio Co.	120
Morton, R., & Co., Ltd.	161
Mullard Wireless Service Co., Ltd.	72
"Modern Boy's" Annual	172
New Times Sales Co.	167
Oldham & Son, Ltd.	169
Ormond Engineering Co.	157
Peto-Scott Co., Ltd.	71, 172
Pickett Bros. (Cabinets)	173
Postlethwaite Bros.	173
"Practical Radio"	66
Radio Instruments, Ltd.	165
Ready Radio, Ltd.	99, 103, 107, 110, 111, 114, 115, 119
Reproducers & Amplifiers, Ltd.	152

Simpson's Electricals, Ltd.	PAGE 165
Slektun Products	171
Sovereign Products, Ltd.	162
Standard Telephones & Cables, Ltd.	146
Stratton & Co., Ltd.	168
Siemens Electric Lamps & Supplies, Ltd.	155
Taylor, C.	174, 168
Telegraph Condenser Co., Ltd.	158
Telsen Electric Co., Ltd.	126, 133, 134, 135, 141, 142
Tunewell Radio, Ltd.	170
Varley Products	116
Ward & Goldstone, Ltd.	161
Webb Condenser Co., Ltd.	172
Westinghouse Brake & Saxby Signal Co., Ltd.	104
Whiteley Electrical Co., Ltd.	68
Wilkins & Wright, Ltd.	160
Wingrove & Rogers, Ltd.	100
Wright & Weaire, Ltd.	166
"World of Wonder"	152

All communications concerning advertising in "Wireless Constructor" must be made to John H. Lile, Ltd., 4, Ludgate Circus, London, E.C.4. Telephone: City 7261.

Can you afford a "cheap" MOVING COIL SPEAKER?

100U
32 1/6

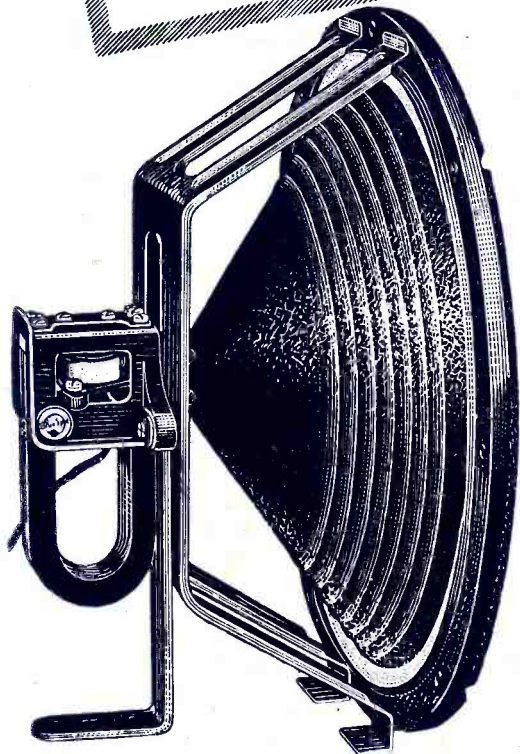

THE trend to-day seems to be to manufacture "down to a price" and let quality take care of itself.

Take Moving-Coil speakers for example—the market is flooded with cheap Moving-Coil speakers.

As one of the largest manufacturers of loudspeakers in the world, we can solemnly assure the public that a really first class, high quality Moving-Coil speaker cannot be produced at a *very* low price. We, ourselves, with a reputation for quality to uphold, would never attempt it.

We have, however, produced Blue Spot 100U which is equal in every degree of performance to an average quality Moving-Coil Speaker. The continuously increasing and very heavy demand for 100U has more than justified our confidence in this speaker. We have duplicated our tools and the greatly increased production has enabled us to effect savings which we are passing on to the public.

Seriously, then, can you *afford* to risk your money on Moving-Coil speakers at a price which makes real *lasting* quality extremely doubtful, if not impossible? Can you afford to risk disappointment and speedy replacement? If you *can* afford to take such risks, you can afford to pay for a first quality Moving-Coil speaker, in which case you cannot do better than consider a Blue Spot Moving-Coil Speaker.

Send for Catalogue W.C.23.U and learn all about 100U and cabinet model in oak (100D), Price 52/6.

EUROPE'S MOST MODERN RECEIVERS

You need a really modern set to enjoy all the niceties of modern programmes and even to hear the more-distant ones perfectly. The Blue Spot Battery "Four" and All-Mains "Five" are superlative in quality with a marvellous range, hair-line selectivity and perfect reproduction. Prices from 12 Gns. Catalogue No. W.C.23.R on request.

BRITISH MADE

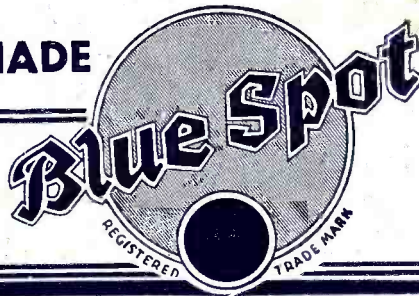

THE BRITISH-BLUE SPOT COMPANY LTD

BLUE SPOT HOUSE · 94/96 ROSOMAN STREET · ROSEBERY AVENUE · LONDON · E C 1

Distributors for North of England, Scotland and Wales: H. C. RAWSON (Sheffield and London), Ltd., 100, London Road, Sheffield; 22, St. Mary's Parsonage, Manchester: 44-46; High Bridge, Newcastle; 37, 38, 39, Clyde Place, Glasgow.

FACTS YOU SHOULD KNOW

... ABOUT THE MAZDA RANGE OF POWER OUTPUT VALVES

LOOK FOR "EDDY" IN YOUR DEALER'S WINDOW

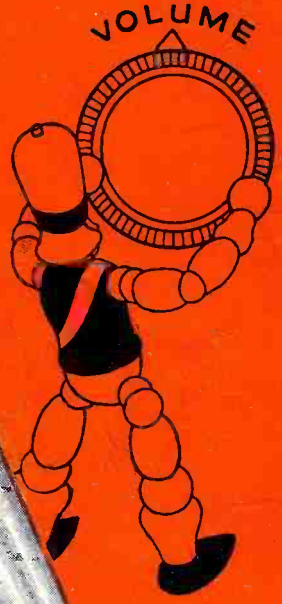

A good receiver, whether battery or mains operated, can be made or marred by the power valve. Each type of Mazda Power valve has been designed to give its most efficient performance under specific conditions. Here is a guide to the selection of the correct Mazda Mains Power Valve for your particular purpose.

THE AC/P—a low consumption power valve for operating balanced armature speakers. It is sensitive to comparatively small inputs, and will give good results on anode voltages as low as 150.

THE AC/P1 will handle a bigger signal input and will satisfactorily operate a moving coil speaker. It requires 200 volts H.T.

THE PP5/400 is a heavy power output valve capable of fully loading a large moving coil speaker. The anode current at 400 volts is 60m/a with 30 volts bias.

For Battery operated receivers there are the following:

P220 and P220A, both capable of giving ample volume with a reasonable input. The former valve is particularly recommended where economy of anode current is a consideration.

Full details of these and other useful Mazda types will be found in the Mazda catalogue, sent FREE on request.

Mazda valves are fitted by all the leading receiver manufacturers. All good radio dealers stock them.

100% BRITISH

Designed by British Engineers

The amazing
MAZDA
THE
BRITISH
VALVES

The Edison Swan Electric Co. Ltd



155 Charing Cross Rd. London. W.C. 2

Mazda Radio Valves are manufactured in Great Britain for

The British Thomson-Houston Co. Ltd., London and Rugby.