

The **Wireless Constructor**

6^d
MONTHLY

EDITED BY
PERCY W. HARRIS, M.I.R.E.

Vol. XI.

NOVEMBER, 1930.

No. 49.

THE "PARATUNE" THREE

by
VICTOR KING

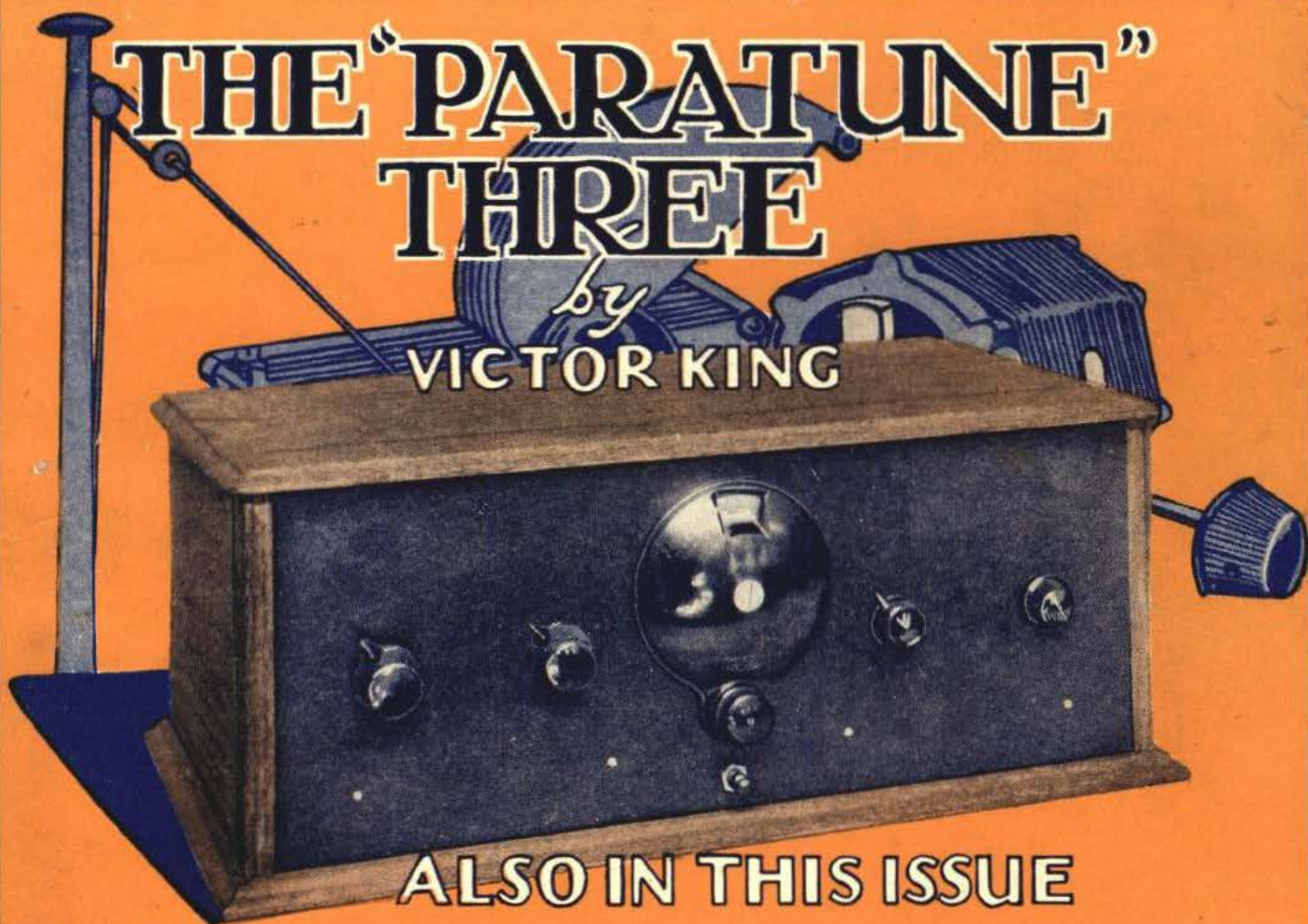

ALSO IN THIS ISSUE

DOWN QUALITY STREET

BY PERCY W. HARRIS M.I.R.E.

The P 240 will give you increased volume and far better quality

Its huge power handling capacity and extremely low impedance assure this. It is sensitive, too, thus requiring a minimum of early amplification and giving a greater output—sufficient, in fact, to work a moving coil speaker at ample volume for domestic purposes.

Quality, too, is vastly improved and the P.240 will make a world of difference to any set using 2-volt valves—from the modest 2-valver to large sets designed to give an appreciable output.

MAZDA P.240 CHARACTERISTICS

Amplification Factor	-	-	-	7
Anode A.C. Resistance (ohms)	-			1,900
Mutual A.C. Conductance (MA/V)	-			3.7

PRICE 13/6

THE AMAZING

MAZDA

RADIO VALVES



THE EDISON SWAN ELECTRIC CO., LTD.
Incorporating the Wiring Supplies, Lighting Engineering, Refrigeration and Radio Business of the British Thomson-Houston Co., Ltd.

Radio Division:
 1a Newman Street, Oxford Street, W.1
 Showrooms in all the Principal Towns

EDISWAN

V.81

CONTENTS

	Page		Page
The Editor's Chat	3	Points for Purchasers	36
Here and There	4	A Practical Man's Corner	39
The "Paratune" Three	5	Do We Want Super-Power?	43
My Visit to Olympia	11	With Pick-up and Speaker	47
Savoy Hill News	13	The "Max-Amp" Limiter	50
Down Quality Street	15	Framing Your Operating Panel	52
As We Find Them	21	Our News Bulletin	54
Recent Valve Releases	23	A Novel Idea	65
Queer Queries	24	Multi-Language Amplifiers	66
The Standard A.C. Unit	25	D.C. Mains Units	67
Prof. Goop at the Exhibition	32	Drilling in Corners	68

As some of the arrangements and specialities described in this Journal may be the subject of Letters Patent the amateur and trader would be well advised to obtain permission of the patentees to use the patents before doing so

Edited by PERCY W. HARRIS, M.I.R.E.

Chief Radio Consultant:
Capt. P. P. ECKERSLEY, M.I.E.E.



The ACME of Smooth Performance

Catapulted silently into the air, the glider taking advantage of every tiny air current soars noiselessly and gracefully up and down the air valleys at the touch of the control stick. It is the acme of smooth performance.

The modern radio receiver, if it is CENTRALAB equipped, figuratively speaking, rides the ether waves smoothly and noiselessly.

For real adventure in radio reception insist on CENTRALAB volume control equipment.

Write for complete Centralab catalogue —it's FREE.

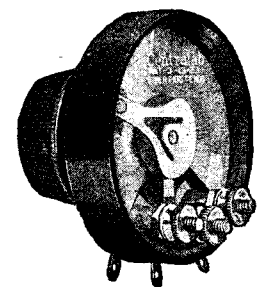

The Rothermel Corporation Ltd.
24, Maddox St., London, W.1.
Phone: MAYFAIR 0578/9.
CONTINENTAL SALES OFFICE:
27, Quai du Commerce,
Brussels, Belgium.

Highest *effective* amplification

yet attained with a
Screened Grid Valve

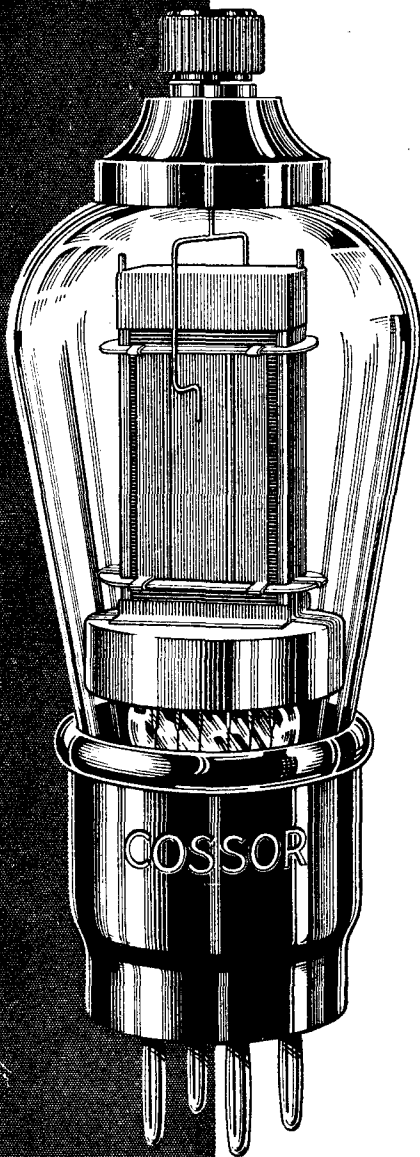

Radio technicians know that it is useless to expect a substantial stage gain from any Screened Grid Valve—however good its other characteristics—which has a high inter-electrode capacity. Cossor engineers have been striving for months past to reduce the self-capacity of Cossor Screened Grid Valves to a negligible figure. So successful have they been in their efforts that the new Cossor 215 S.G. has an inter-electrode capacity of the order of .001 micro-microfarads—lower than that of any other Screened Grid Valve on the market. As a result, this new Cossor Valve permits a degree of effective amplification which a year ago would have been considered utterly impracticable. The use of this Valve will considerably increase the efficiency of your Receiver.

THE NEW **COSSOR** 215 S.G.

Cossor 215 S.G. 2 volts, .15 amp.
Impedance 300,000. Amplification
Factor 330. Mutual Conductance
1.1 m.a./v. Normal working
Anode Volts 120. Positive
Voltage on
Screen 60-80.
Price **20/-**

A. C. Cossor Ltd.,
Highbury Grove,
London, N.5.

Record low inter- electrode capacity

The WIRELESS CONSTRUCTOR

Published by the Amalgamated Press, Ltd., Fleetway House,
Farringdon Street, London, E.C.4.

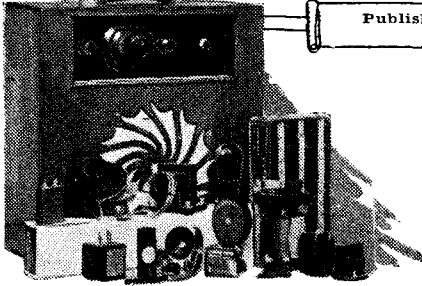

THE EDITOR'S CHAT

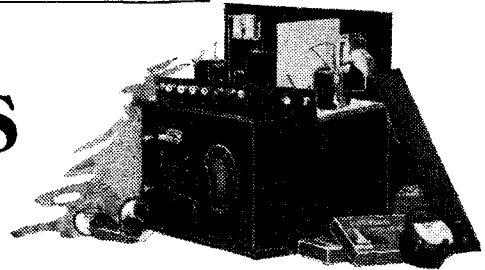

Settling Down After the Show—The New Sets—Improving Appearance—Where the Home-built Set Scores.

WITH the annual Radio Show over, and the dealers well stocked with the latest components, this month may be looked upon as the time when the majority of experimenters begin work on their new sets for the winter.

Not Extravagance

To the newcomer the building of a new set each year, or frequently two or three times a year, may appear, at first sight, as an extravagance, but when it is remembered that very rarely is it that the experimenter needs to buy anything new to make an entirely new design of set, it will be seen that the extravagance is more apparent than real.

Indeed, we have known many cases when a set has been entirely modernised with only one or two new components.

If, for example, your present set has one stage of high-frequency, a detector and one low-frequency stage, the high-frequency valve being of the older type, then the change over to a new circuit with a screened-grid valve can be made with a great increase in efficiency at a comparatively trifling cost.

Improvements that Count

As another example, perhaps when you built your original set you felt you could not go to the expense of a first-grade low-frequency transformer, and had to content yourself, for the time being, with something of an inferior quality.

In the great majority of cases the connections to a good transformer are precisely those to a poor one, so the substitution of a good modern instrument for a present component may consist merely in unscrewing four ter-

minals, removing the old transformer, substituting the new one, and joining up the four wires as before!

It is by no means unusual for the strength to be nearly double for such a change, while the improvement in quality must be heard to be believed.

But even supposing you desire to build an entirely new set, with more valves than you have at present, and with everything new. Study the designs which appear in this and other issues of the WIRELESS CONSTRUCTOR.

HIGH UP ON LOW WAVES



This is a short-wave test with aeroplanes, the "ground" station being on the roof of a New York skyscraper.

Turn to the lists of components and with the aid of a convenient dealer's catalogue work out the total costs of the sets.

You will be very agreeably surprised to find how cheaply first-class modern home-constructor's designs can be built. Notice, too, that you can strike out of the list quite a number of items which you already possess, for it is

one of the great advantages of wireless as a hobby that so much in the way of components is standardised.

Variable Condensers

There are dozens of makes of valve holders, but provided the particular holder chosen is soundly designed, the set will work just as well with this as with any other. Variable condensers, too, exist in vast numbers and in all kinds of designs, but, again, most of them are soundly designed, and the change from one to another will show no appreciable difference in electrical efficiency, although the mechanical convenience that appears on one may be superior to that of another.

Many sets built within the last year or two and still working excellently can be vastly improved in appearance by a new panel and new condensers of the drum type with neat escutcheon plates. You probably noticed when visiting the Radio Show at Olympia that the professional sets are more and more using the edgewise drum dial, and that the old flat exterior dial is rapidly dying out.

Your Set's Appearance

Practically all the types of variable condensers utilised by manufacturers of sets are available to the home constructor, and there is no reason whatever nowadays why the home-built set should not look every bit as "professional" as that made in a factory.

Indeed, I have seen quite a number of the cheaper factory sets (of course, I am not referring to those made by the well-known manufacturers) in which the workmanship and interior appearance were much inferior to that of a large number of home-built receivers I have seen.

HERE AND THERE

Television—Kensington's Super Set—Symphony Concerts—Broadcast Talks.

By Our Special Correspondent.

A TELEVISION broadcasting station will be in operation shortly. The station, now in course of construction near Hendon, is licensed by the Postmaster-General to employ two wave-lengths, and will be controlled by the Baird Co.

So far only a few hours' visual broadcasting are available during each week for experimenters who have televisions, and to increase the facilities for experimenters interested in television the Baird Co. have decided that practically an all-day service shall in future be put out from their transmitter, which will employ a twin wave, the lengths allocated by the Postmaster-General being 49½ metres and 155 metres. The power of the station will be 900 watts.

Television Transmissions

The transmissions from this new television transmitter will at first be only of an experimental nature, both wave-lengths being used for the radiation of vision. The two wave-lengths have been granted to the company so that the Baird Co. can determine the carrying properties of the two waves. Unless special permission is given by the P.M.G. it will be impossible for the transmissions to be of simultaneous sound and vision as at present sent out from Brookmans Park, as the B.B.C. has the monopoly of transmitting sound for entertainment purposes in this country. The Baird transmissions will therefore be unaccompanied by speech or music.

An official of the Baird Company is reported in the press to have expressed the hope that the B.B.C. in the near future will grant permission for the installation of a television transmitter in the B.B.C. London studios; then items in the programmes may be televised as well as broadcast by the ordinary means. An alternative method, he suggested, would be for the items to be televised in the studios and the transmissions passed by land line to the Baird station at Hendon and broadcast from there.

We also understand that the Baird Co. hope facilities will eventually be granted for them to transmit television from a station outside the London area, so that experimenters in other parts of the country may be brought within range. The Daventry station (5 X X) is unsuitable for television owing to its long wave-length; but similar arrangements to those projected for the London station could, it is suggested, be made at one of the new twin-wave regional stations. This, however, we believe to be very unlikely.

The present transmissions from Brookmans Park still continue, and reception has been noted in Glasgow. But exactly how many televisions have been sold to date, and how many television sets are in use in this country, still remains a mystery. It would be definitely useful and interesting if the Baird Company would throw some light on this question; the information would be welcome, and would enable critics to ascertain, with some degree of accuracy, the practical popularity of television among "listeners" as well as *bona fide* experimenters.

A Very Special Set

A broadcast receiver of extraordinary power has been designed and constructed in the Science Museum, South Kensington, to take the place of the old demonstration set. The object of the new installation is to demonstrate the extent to which it has now become possible to detect and amplify without distortion speech and music transmitted by radio-telephony.

It is also intended to provide regular opportunities for listening to reproduction of nearly uniform quality, and so establish a standard of

reference for judging the performance of any given radio outfit.

These objects would be defeated if the apparatus were used for the reception of difficult or uncertain transmissions, liable to be marred by interference. Reception will be confined therefore in normal circumstances to transmissions originating within the London area, and the apparatus will be pre-set, so that either the National or the Regional programme can be selected by the pushing or pulling of a single lever.

The loud-speaker horn which the set employs has been in position for some time in the wireless gallery of the Museum. It is a straight logarithmic horn, 27 ft. long, with a mouth 7 ft. square, and a lower cut-off frequency of 32 cycles a second. The 555W unit connected with the horn is of the same type as is used in the largest theatre equipments for talking films, and the first 8 ft. of the horn from this point is made of copper, the remainder of sheet iron, leaded and coated with pitch and canvas.

Museum Music

The tone and quality developed by this output unit are exceptionally good, and the construction of the receiving apparatus is of considerable interest. It contains no batteries at all, being operated entirely from alternating current mains, laid on to supplement the Museum's normal direct current supply. To maintain reception alternately with the National and Regional transmitters, a common detector and common low-frequency stages are employed in conjunction with separate high-frequency stages, entirely independent of one another. Low-tension current is first applied to the filaments of the valves and a time-switch allows 30 seconds to elapse before the high-tension current is connected. The interval permits the indirectly-heated cathode valves to warm up. The supply taken from the main at 230 volts A.C. is transformed and rectified for the

speaker, absorbs considerable power. The amplifier has, therefore, been constructed to give a distortionless output of some 40 watts, which is equivalent to that of a full-sized talking film installation.

In view of the high voltages employed, all panels and points of access to the set are protected by safety switches, which disconnect the high-tension current as soon as the glass doors are opened. The apparatus is designed to operate very simply and will normally be in charge of a Museum attendant in the wireless gallery.

The Symphony Concerts

The B.B.C. announces that twenty-three symphony-concerts will be given in the Queen's Hall on Wednesdays, at 8 p.m., during the 1930-31 season. The B.B.C. Symphony Orchestra of 114 players, led by Arthur Catterall, will make its first appearance at full strength at the opening concert on Oct. 22, when Adrian Boult will conduct. The orchestra will play throughout the season and each concert will be broadcast.

Conductors at other concerts will include Sir Henry Wood, Sir Landon Ronald, Adrian Boult, Albert Coates, Ernest Ansermet, Oskar Fried, and Hermann Scherchen.

Backhaus, Bartok, Cortot, Dohnanyi, Gieseking, Myra Hess, Lamont, Moisewitsch, Rubinstein, Samuel, Solomon, and Stravinsky are among the many eminent pianists who will be heard during the season. Solo violinists include Busch, Catterall, Sammons, and Sziget; and solo cellists: Casals and Suggia. Wanda Landowska will play the harpsichord.

The following vocalists have already been engaged: Isobel Baillie, May Busby, Gota Ljungberg, Maria Olczewska, Dorothy Silk, Stiles-Allen, Margaret Balfour, Muriel Brunskill, Astra Desmond, Farry Jones, Frank Titterton, Walter Widdop, Norman Allin, Keith Falkner, Roy Henderson, Horace Stevens, and Harold Williams. The Philharmonic Choir and the National Chorus will also take part.

Under a system whereby the public is enabled to pay a subscription for groups of six concerts spread over the whole season, it will be possible to obtain reserved seats for as low as 2s. 6d. a concert.

Harold Nicolson, who is now one of the B.B.C.'s most popular microphone personalities, had a very amusing article on "Behind the Scenes with a Broadcaster" in the

AN ELEMENTARY TELEVISION RECEIVER

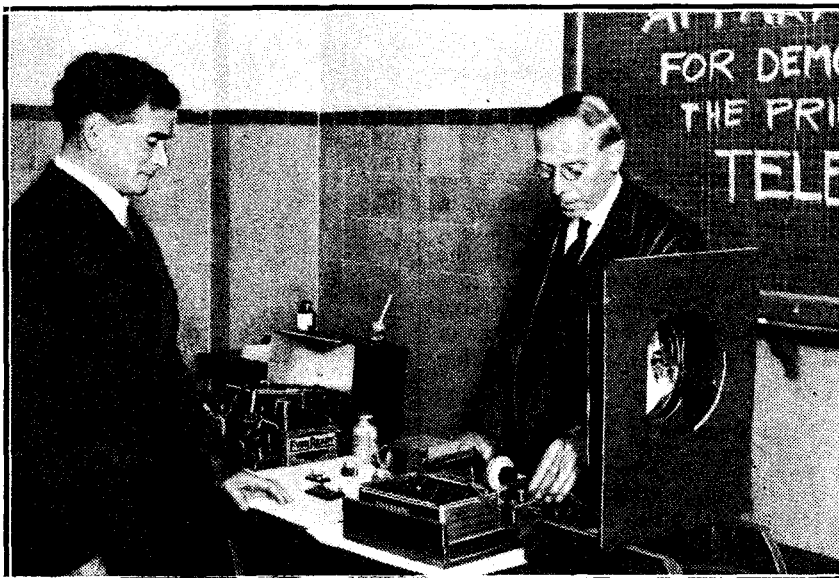

Demonstrating the principles of television at the London School of Economics.

early stages of the set to 480 volts D.C. The output stage current is rectified by means of hot-cathode mercury-vapour rectifiers, and gives a potential of 1,200 volts.

No part of the set is larger than is required to give a satisfactory margin of safety between the actual working conditions and those which would give rise to slight distortion, but an equalising network, which has been designed for use in conjunction with the large horn type loud

"Evening Standard" a few days ago. After the broadcasting of a talk it appears many listeners are still keen on "writing in." Here is Harold Nicolson's description:

(Continued on page 64.)

THE "PARATUNE" THREE



A magnificent receiver employing the new "Wireless Constructor" simple selectivity principle. It is an easy-to-build, easy-to-operate, inexpensive set that gives wonderful results. As well as its marvellous selectivity, it possesses colossal power and is undoubtedly a most outstanding design.

By VICTOR KING.

IN the light of modern receiver design one is rather apt to consider wave-length tuning entirely in terms of variable condensers. The part played by the coils is often completely overlooked, probably because they are usually right away out of sight.

The Art of Tuning

Nevertheless, these inductances are just as important, in connection with tuning, as the condensers. The latter, being the variable factors, are brought more into prominence, but it is chiefly a matter of convenience which of the two shall be variable.

Tuning is a function of two things, inductance and capacity, and by suitably adjusting these two we can

GOOD-BYE TO ALL THAT JAMMING!

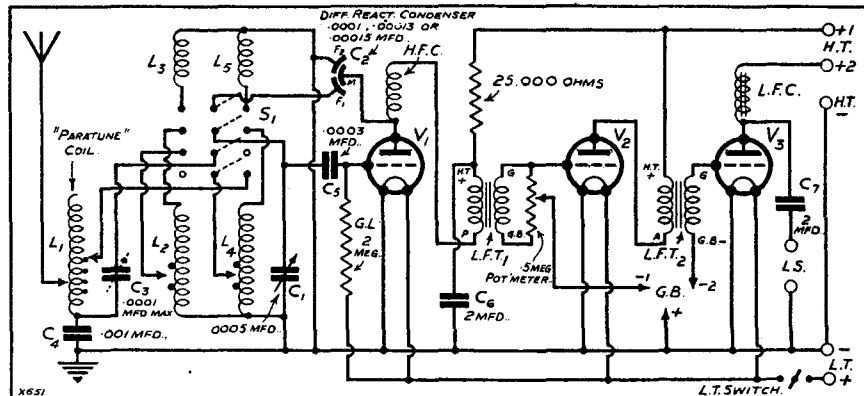

The three "Paratune" components are at the left-hand end of this theoretical circuit diagram. They are the inductance L_1 , the fixed condenser C_4 , and the compression type variable condenser C_3 . Quite simple components to produce such marvellous effects.

YOUR "PARATUNE" SHOPPING LIST

- | | | |
|---|--|---|
| <p>1 Ebonite panel, 18 in. \times 7 in. \times $\frac{3}{16}$ in. or $\frac{1}{4}$ in. (Lissen, or Trolite, Paxolin, etc.).</p> <p>1 Cabinet to take above, with base-board 10 in. deep (Pickett, or Camco, etc.).</p> <p>1 .0005 variable condenser (Lotus, or Lissen, J.B., Polar, Ormond, Dubilier, Formo, Ready Radio, etc.).</p> <p>1 Slow-motion dial, if condenser is of plain type (Lissen, or Igranic, J.B., Ormond, Formo, Lotus, etc.).</p> <p>1 .0001-, .00013-, or .00015-mfd. differential reaction condenser (Ready Radio, or Lotus, Lissen, Dubilier, Magnum, Formo, Polar, Wearite, Paroussi, etc.).</p> <p>1 .5-megohm potentiometer volume control (Igranic, or Magnum, R.I., Gambrell, Varley, Wearite, Centralab, etc.).</p> | <p>1 "Paratune" coil unit (Wearite, or Ready Radio, Paroussi, Magnum, etc.).</p> <p>3 Shock-absorbing valve holders (Benjamin, or W.B., Igranic, Lotus, Lissen, Bulgin, Telsen, Dario, Magnum, Junit, Burton, etc.).</p> <p>1 .0001 max. compression type adjustable condenser (Formo, or Lissen, R.I., Lewcos, Polar, etc.).</p> <p>1 .003-mfd. fixed condenser (Lissen, or T.C.C., Mullard, Igranic, Ediswan, Dubilier, Ferranti, Goltone, etc.).</p> <p>1 .0003-mfd. fixed condenser (Dubilier, etc.).</p> <p>2 2-mfd. fixed condensers (T.C.C. and Ferranti in set, or Hydra, Lissen, Dubilier, Mullard, etc.).</p> <p>1 2-megohm grid leak and holder (Graham Farish, or Ediswan, Dubilier, Lissen, Ferranti, Igranic, etc.).</p> <p>4 Single-coil holders (Bulgin, or Lotus, Lissen, Igranic, Magnum, Red Diamond, Wearite, Bulgin, etc.).</p> | <p>1 H.F. choke (Lewcos, or Varley, Lissen, R.I., Lotus, Dubilier, Telsen, Ready Radio, Watmel, Magnum, etc.).</p> <p>1 L.T. on-off switch (Red Diamond or Lissen, Lotus, Igranic, Benjamin, etc.).</p> <p>1 4-pole change-over switch, with $3\frac{1}{2}$-in. extension handle (Wearite, or similar type).</p> <p>1 25,000-ohm resistance and holder (Ready Radio, or Ferranti, etc.).</p> <p>2 L.F. transformers of normal ratio (Lissen and R.I. in set, or Telsen, Varley, Igranic, Ferranti, Lotus, Mullard, Lewcos, etc.).</p> <p>1 Output choke (Varley, or Lissen, Atlas, R.I., Ferranti, Wearite, Bulgin, Magnum, etc.).</p> <p>1 Terminal strip, 18 in. \times $1\frac{1}{2}$ in.</p> <p>9 Indicating terminals (Belling and Lee, or Igranic, Ealex, etc.).</p> <p>1 Spring clip, battery plugs, wire, screws, etc.</p> |
|---|--|---|

The "Paratune" Three—continued

set a receiver to receive any particular wave-length we desire. In actual practice it is impossible to limit our set to just one wave-length.

We have to put up with a band of wave-lengths, and the sharper our tuning the narrower is this band. With sets which do not employ an H.F. stage, the usual way of getting a moderately narrow reception band is by using what is called an aperiodic aerial circuit.

Complete Cure

Unfortunately, there is one very big drawback to this otherwise ideal arrangement. On long waves it often happens that a medium-wave broadcasting station will spread over a large part or, in some cases, the whole of the tuning range.

This interference cannot be tuned out, and has been worrying set designers for years. It appears to be a puzzling combination of shock excitation and the natural wave-length of the aerial circuit, or a part of it.

Whatever the cause may be, I am able to give you details of an absolutely complete cure for it. You will remember that this was hinted at last month in the article introducing

the new "Paratune" system of "simple selectivity."

This capability of the "Paratune" of cutting out such interference is an attribute quite apart from its remarkable selectivity on the medium broadcast band. But, in spite of this, it

I am only stating a concrete fact when I tell you that nothing in any way comparable with the "Paratune" Three has ever been produced before. Like the "Paratune" One, it is the essence of "simple selectivity," and, being a det. and 2 L.F. arrangement,

DOZENS OF STATIONS—ON ONE DIAL!

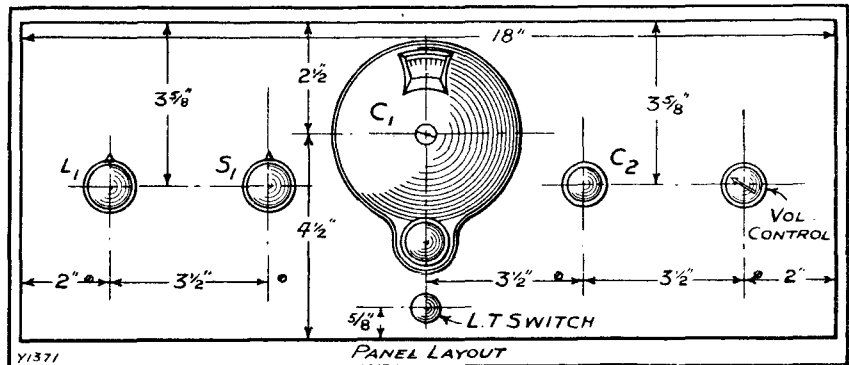

A perfectly balanced panel layout is provided with the one tuning condenser dial in the centre. The left-hand knob L_1 is the control for the "Paratune" inductance, while S_1 is the wave-change switch and C_2 the reaction condenser.

does not in any way affect its effectiveness on medium broadcast waves.

In designing the "Paratune" Three, advantage has been taken of both of these wonderful properties. The result is a three-valve receiver which represents the very latest design and advance in simple circuits.

it is also very sensitive and powerful.

Here you have a set which is extremely easy to operate, both on the long waves and the medium broadcast band. On the long waves, once the "Paratune" unit is set to remove the unwanted interference the set is operated just like any ordinary receiver.

The remarkable selectivity on the medium band is obtained by the addition of merely one small knob. This knob adjusts a special inductance which alters the aerial circuit so that it suits the particular wave-length being received. In this way there is a gain in sensitivity accompanying the great gain in selectivity.

Wave-Change Switching

In spite of the remarkable nature of the receiver, it has wave-change switching by means of one control on the panel. If you look at the theoretical circuit diagram you will be able to follow the complete arrangement employed.

The ordinary tuning inductances are "X" coils, L_4 being the lower wave one, and L_2 the one for long waves. L_5 and L_3 are the reaction coils, which are coupled to the two tuning inductances.

So far the scheme is quite normal. The difference comes in connection with the taps on the "X" coils. Instead of the aerial going direct to one of these taps, it is connected via the "Paratune" components.

COULD ANY SET BE SIMPLER?

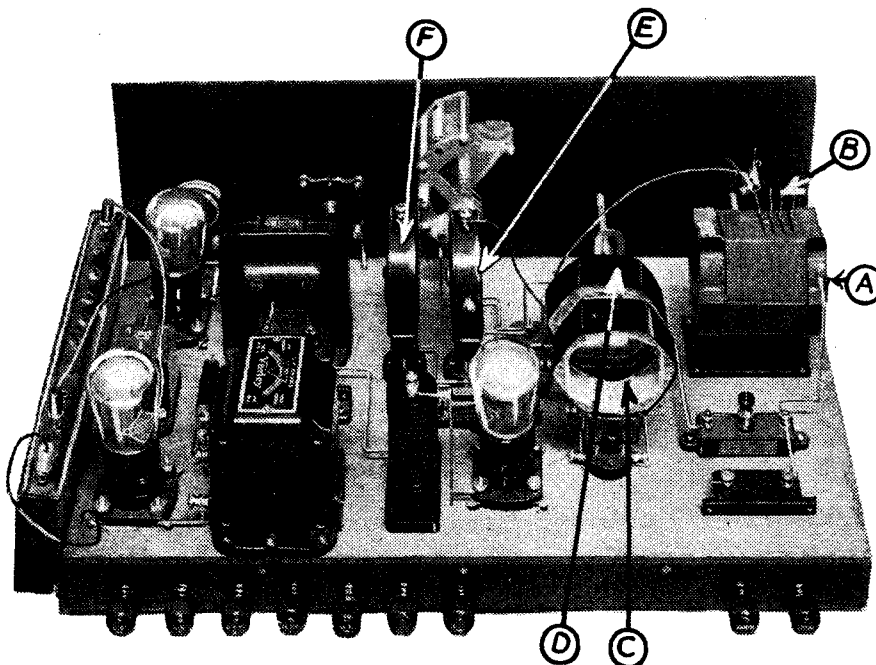

Apart from the "Paratune" coil (A), all inductances are of the ordinary plug-in type. (B) indicates the taps which are used to cut out medium-wave interference when working on long waves. (C) and (D) are the medium-wave reaction and tuned coil respectively, while (E) and (F) are the two long-wave coils, of which (F) is the one for reaction.

The "Paratune" Three—continued

These consist of the inductance L_1 , the compression type variable condenser C_3 , and the fixed condenser C_4 . The condenser C_3 provides a means of varying the degree of selectivity on the medium waves, so that once it is adjusted to suit a given set of conditions it does not have to be touched.

When working on medium waves the "X" coil tap is connected up via this condenser. On long waves, since the "Paratune" components are used for a different purpose, connection is made to them in a different way.

Volume Control

The condenser C_3 is no longer employed, and the tap on the long-wave "X" coil is joined to one of the four taps on the "Paratune" coil. These taps are not, of course, used on the medium wave-band.

The wave-change switch S_1 changes over the reaction coils and the grid end of the tuning coils, and also makes the necessary connection between the "Paratune" components and the right "X" coil tap.

The two L.F. stages are transformer-coupled, and you will note that a volume control is provided across the secondary of the first L.F. transformer. Other points worthy of note are that differential reaction is provided, and also an output filter circuit.

Apart from the "Paratune" coil, all the components employed are common ones which are in everyday use. The makes of the parts are not critical, and in the complete list of those required many suitable makes are given.

With regard to the "Paratune" coil, you can make this at home or buy it ready-made. If you wish to do the former you will find the necessary details in last month's WIRELESS CONSTRUCTOR.

The "Paratune" Coil

If you use a bought coil, you may find that the four taps for use on long waves have not been made. If this is the case with the one you obtain, you should proceed to make them as follows:

You will find that one end of the winding is joined to a terminal, the other being left free with no facilities for making connection to it. Counting from the end which is

attached to the terminal, you must make the taps at 10, 20, 30, and 40 turns.

To make the actual taps, first of all gently prise up the right turns with a screwdriver and slip pieces of matchstick under them. Then bare the wire at these raised points and solder short pieces of stiff wire to them. Connection is made to the taps by means of some sort of spring clip on the end of a short piece of flex.

If you make your own coil, since the details given last month do not include instructions for making the taps, you must follow those just given for treating a commercial coil.

The constructional work, except for that just described, is quite conventional and will not be found difficult. The sequence of the work is as follows:

Drill the panel and prepare the terminal strip, screw these two to the baseboard, mount all components, drill holes in baseboard through which wires have to pass, and then wire up.

Under the Baseboard

Much of the wiring is carried out below the baseboard, and for this reason it is arranged so that its top is $1\frac{1}{2}$ in. above the bottom of the panel. This enables the L.T. switch to be

THE WONDERFUL "PARATUNE" COIL

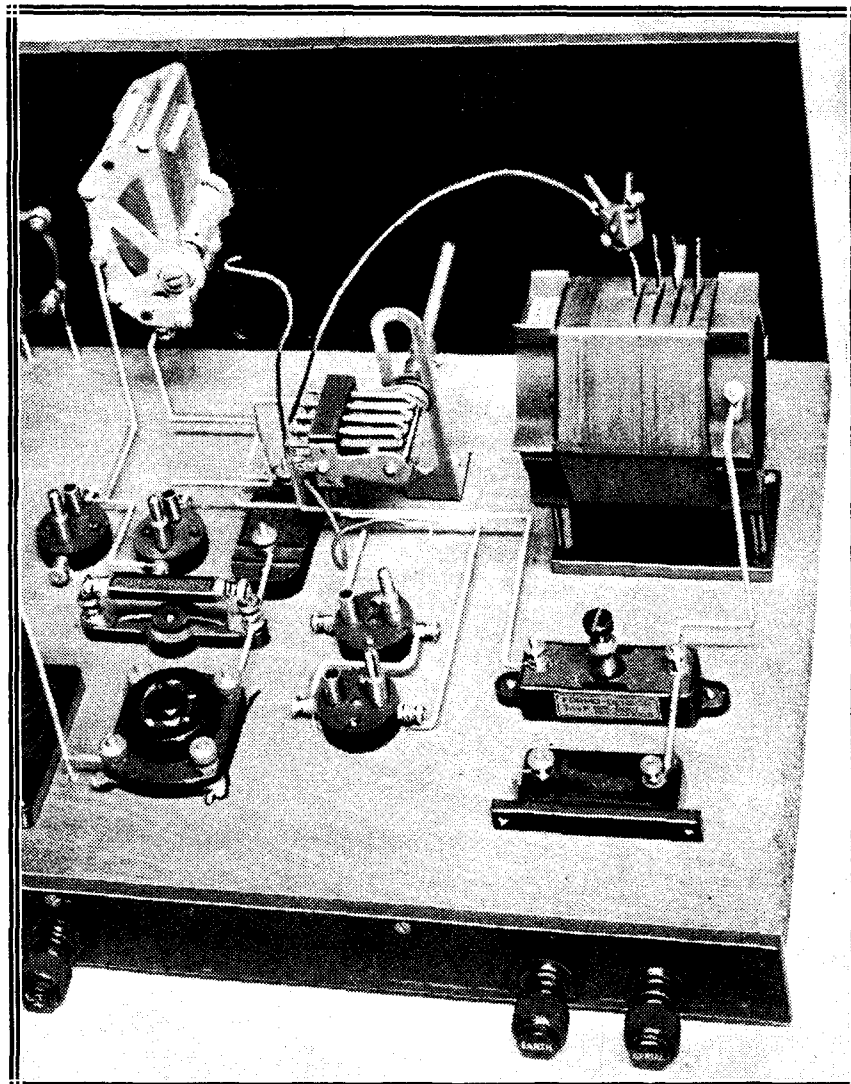

This is the aerial end of the set, and the "Paratune" coil is clearly seen, with the wave-change switch to its left. The two small components in front of this coil are the "Paratune" condensers, one of which is of the compression type.

The "Paratune" Three—continued

mounted so that it is below the baseboard, a position where it can very conveniently be wired up.

There is also a 2-mfd. condenser situated below the baseboard. This is the condenser C_7 , which forms part of the output-filter circuit. It is fixed in place by being screwed to a small length of square-section wood, which is in turn screwed to the underside of the baseboard.

The wave-change switch S_1 has an extension rod to which its actuating knob is attached. The switch should be arranged in such a position that this rod just projects through the panel far enough for the knob to be conveniently fitted to it.

An Important Point

When screwing the coil holders in place take care that you arrange the pins and sockets in the same order as that shown in the wiring diagram. Failure to do this may lead to a lack of selectivity, and no reaction effects.

Another important point in connection with the wiring is the way in which the potentiometer is connected up. If you use an Igranite volume control such as was used in the original set, take care that you join up the red and blue terminals just as shown in the wiring diagram.

Wave-Change Connections

This particular potentiometer volume control is graduated so that if the connections are wrong the control will be quite sudden and confined to a small movement of the potentiometer knob.

The contacts of the wave-change switch are shown in plan form to make them easier to follow. Do not think because of this that the wiring to this switch is difficult. If you follow the diagram carefully there is no reason for you to make a wrong connection.

You should note that the centre pairs of contacts (that is, the flat ones) are joined together in all four cases.

Apart from the points I have dealt with the wiring is all plain sailing.

The diagram of the wiring underneath the baseboard is shown as it would appear if the baseboard were transparent. This method of depicting it makes it very easy to follow out any lead in its travel under the baseboard. The numbers against the points in one diagram where wires pass through the baseboard correspond with those on the other.

There is no room for the grid-bias battery on the baseboard, so it should be fixed to the inside of the back of the cabinet.

Special Chart Provided

Nothing need be said here about the accessories or voltages required as all the necessary information about these is given in the special operating chart, which should be cut out and fixed to the lid of the cabinet of the set. Here it will prove a handy reference for all that is vital in connection with the "Paratune" Three.

SIMPLE, NEAT—AND SAFE

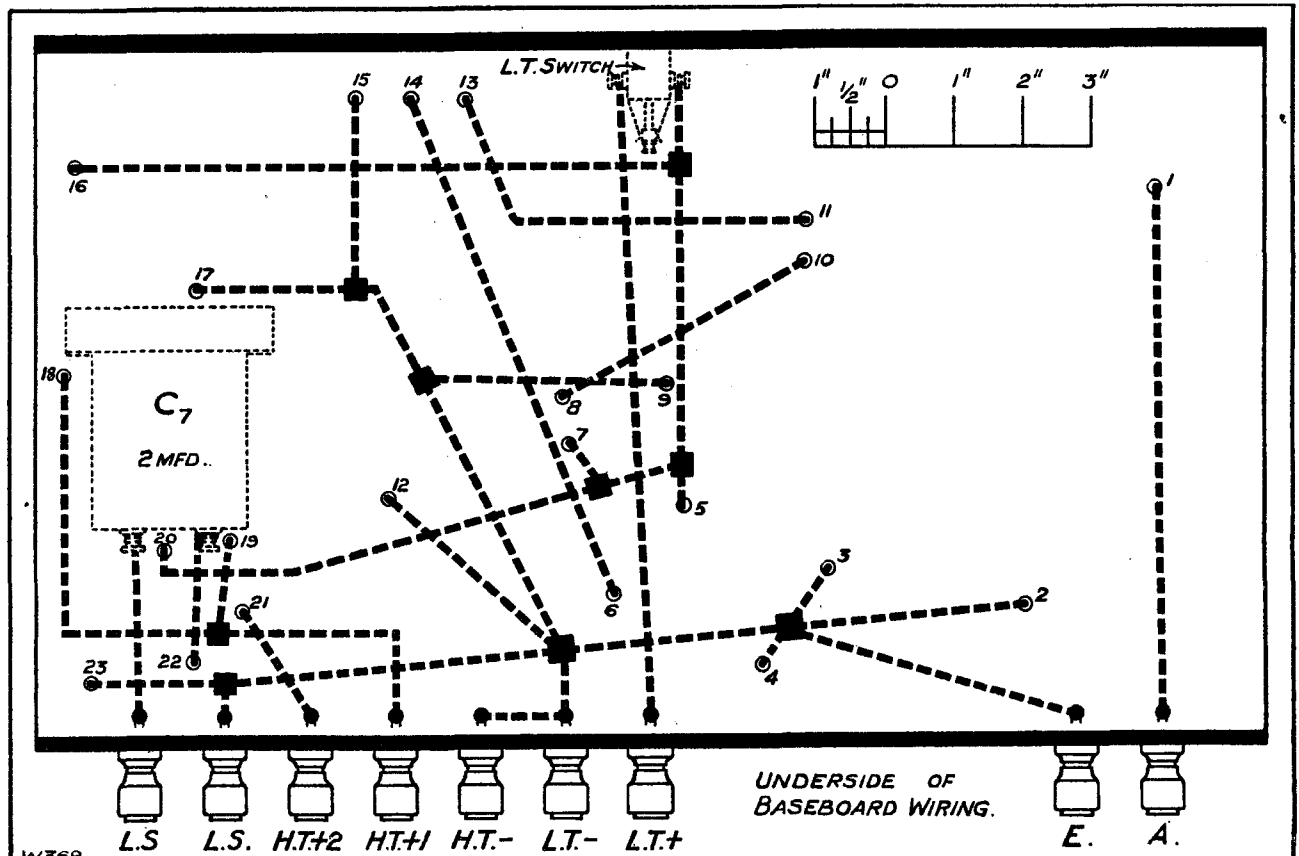

W369 Much of the wiring is arranged underneath the baseboard, a scheme which greatly simplifies wiring up and keeps the set neat. In this diagram the under-baseboard wiring is shown as it would appear if the baseboard were transparent.

The "Paratune" Three—continued

In explaining the operation I will deal with the adjustment of the set on the medium wave-band first. First of all you must insert the coils and valves, and join up the batteries and aerial and earth. You will find all the information needed for this in the special chart.

Operating the Set

The next step in receiving on the lower wave-band is to turn the wave-change switch over to the left and pull out the L.T. switch. Attach

the flex lead for the taps on L_2 to the larger tap on the coil, and put the condenser C_3 at its maximum. To do this you screw the knob on it down as far as it will go.

Some "X" coils are provided with three taps, one of which is a centre-tap. If you have this type of coil neglect the centre-tap and use the larger of the remaining two.

Having seen that the volume control is at its maximum, you can proceed to tune in some stations.

The tuning condenser C_1 and the reaction condenser C_2 are used in the ordinary way.

Keep in Step

The slider on the "Paratune" coil has to be kept "in step" with the tuning condenser; as the capacity of the latter is increased, turn the slider knob in a clockwise direction, and vice versa.

You will notice that as the tuning condenser and "Paratune"

ONE-HUNDRED-PER-CENT EFFICIENCY

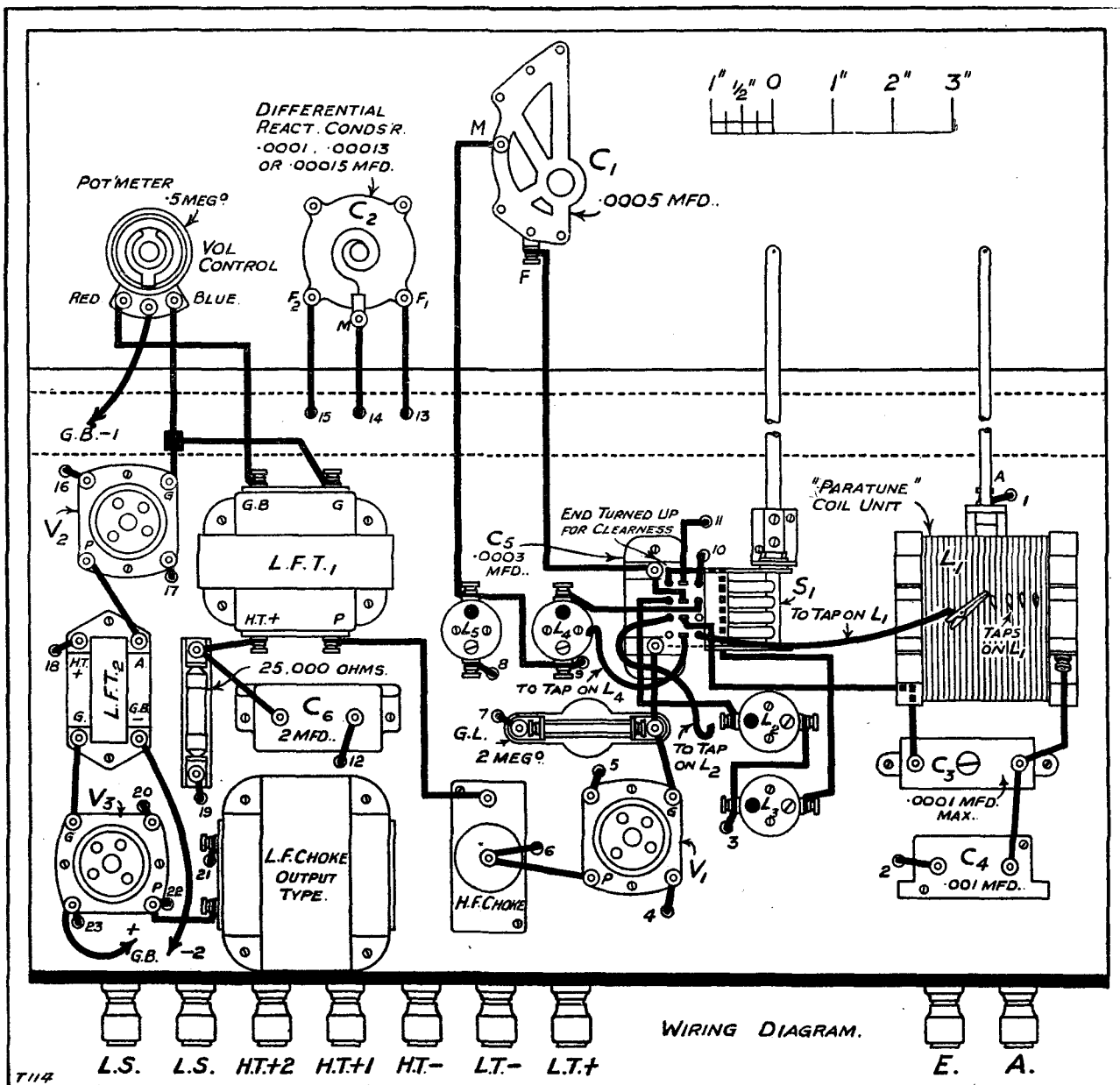

Here is the wiring above the baseboard. The numbers against the points at which wires pass through the baseboard correspond with the numbers on the wiring diagram on the opposite page, and enable the complete wiring to be followed very easily.

The "Paratune" Three—continued

coil are brought into step a little more reaction will be required. This is because as they become out of step less reaction is required before the oscillation point is reached. In practice you will find this a very useful indication of when the tuning condenser and "Paratune" inductance are in step.

Increasing Selectivity

If you find you need more selectivity, decrease the value of C_3 a little. As a final adjustment try the other tap on the "X" coil, and after adjusting C_3 again to give just enough selectivity, note whether results are louder. Then keep to the louder tap for all stations.

For long-wave reception turn the wave-change switch right over the

other way, and join the flex lead for the taps on L_1 to the larger tap on the "X" coil. The clip to the taps on L_1 should be on the tap nearest to the end of the coil which is joined to the terminal.

If you now hear a low-wave station jamming through, adjust the slider on L_1 until it disappears. The position for the slider should be somewhere between the first tap and the terminal end of the coil.

If you are unable to cut out the interference completely, move the clip to the next tap, and readjust the coil slider. It is just possible in cases of bad jamming that you will find it necessary to work on the third or even the fourth tap.

If you do not experience any interference on the long waves from

a medium-wave station, keep the clip on the first tap and turn the slider to approximately halfway between this tap and the terminal end of the coil.

Plenty of Stations

Once the slider and tapping clip are adjusted you simply have to tune on the C_1 condenser in the ordinary way, using C_2 to get reaction when necessary.

You will be able to hear so many stations on this set that I expect you will have difficulty in identifying some of them. In this connection you will find the "World's Programmes," a section in our contemporary, "Modern Wireless," devoted every month to transmission details, a great help.

THE "WIRELESS CONSTRUCTOR" "PARATUNE" THREE

(Circuit: Wave-change. Det., and 2 transformer-coupled L.F., with special selectivity scheme.)

VALVES.

1st: H.F. or special detector type.
2nd: (holder nearest panel) L.F. type.
3rd: Power or super-power type.
Valves may all be 2-volt, 4-volt or 6-volt.

VOLTAGES.

L.T. similar to that of valves.
H.T. + 1: 60 to 80 volts.
H.T. + 2: 120 or 150 volts, according to valv rating.
G.B.—1: $1\frac{1}{2}$ or 3 volts.
G.B.—2: To suit particular power valve used.

COILS.

The two coils nearer to the special inductance are for medium waves, and the other two for long waves.
Medium-wave holder nearer wave-change switch requires a No. 60X coil, and the other medium-wave holder a No. 30 or No. 50 ordinary coil.
In long-wave holder nearer wave-change switch use a No. 250X coil, and No. 100 or No. 150 in other long-wave holder.

OPERATION.

MEDIUM WAVES.

Pull knob at bottom of panel out to switch on set, and push in to switch off.
Tune on dial immediately above and adjust knob at left-hand end of panel to keep in step with tuning condenser.
The second knob from the left-hand end is the wave-change switch. Turn this to the left (turn to the right for long waves).
Knob immediately to right of tuning condenser is for reaction adjustment, and remaining knob is a volume control.
Use tap on X coil which gives louder results, and adjust selectivity by means of the compression type variable condenser mounted on the baseboard. (Keep this condenser as near maximum as possible.)

LONG WAVES.

Tune on variable condenser only, and adjust knob to left of panel to cut out interference from any medium-wave stations. Find best tap on special inductance by trial.
Use tap on long-wave X coil which gives best results.
Variable condenser on baseboard is out of circuit.
Reaction, volume control and two switches are used as above.

NOTES.

Flex lead with clip on end goes to taps on special inductance.
Of the other two flex leads attached to wave-change switch, the one joined to the contact nearer the back of the set is joined to long-wave X coil. The other goes to the medium-wave X coil.

* **A NARROW ESCAPE** *
* Unpleasant experience of a reader. *

Sir,—On page 202, column 1, of the August, 1930, issue of the WIRELESS CONSTRUCTOR you write of the danger of mounting the grid bias battery within the cabinet. I should like to give you an instance of the danger of this that happened to me.

About a year ago I constructed a straight four-valver for a friend, and the only convenient place which I could find for the grid-bias battery was to have it rest on the terminals which were mounted on the terminal

strip. I thought this was quite safe; dry battery, etc., and no danger of short-circuit. The receiver was worked off 120-volt wet batteries. A few weeks ago the owner asked me to attach the accumulators, which he had just had charged.

Really Dangerous

Within ten minutes of connecting the H.T. I heard a peculiar hissing noise within the set, and on raising the lid flames quite two feet high rushed upwards! The grid-bias battery had become perforated and had short-circuited most of the 120 volts—large capacity wet cells!

Had the short occurred a few minutes later, when the room might

have been unoccupied, there would certainly have been very serious damage done and every possibility of the house being set on fire. This experience has taught me to mount the grid bias either without the set or, at any rate, to keep it free from all wires if it must be mounted inside.

The WIRELESS CONSTRUCTOR continues to give some fine "dope," and I eagerly look forward to receiving it each month.

I am,
Yours faithfully,
Co. Galway. J. J. BEIRNE.

[The back of the cabinet, as mentioned in the description of the "Paratune" Three, is one of the best places for the G.B. battery.—Ed.]

MY VISIT TO OLYMPIA

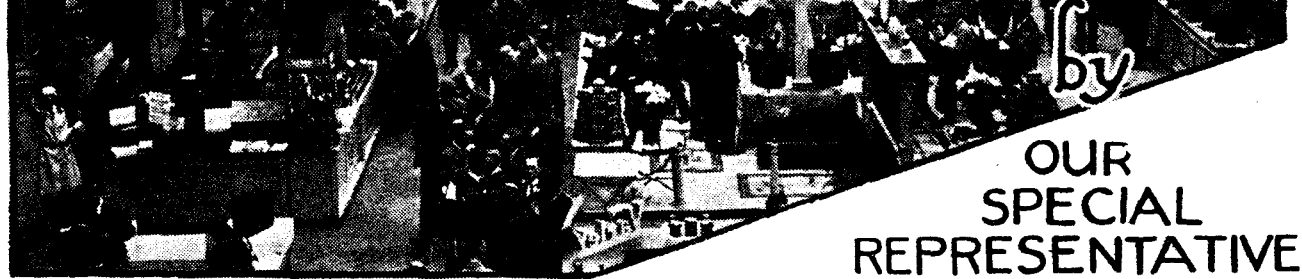

OUR
SPECIAL
REPRESENTATIVE

THE annual National Radio Exhibition is, of course, the most important event of the year for all classes of radio enthusiasts. My visit to this year's show, however, has left me with the impression that it is likely to prove even more memorable than any of its predecessors.

All my previous attendances at Olympia have been rather breathless affairs. In the past I have been accosted at the turnstiles by representatives of exhibitors issuing, by pamphlets and other propaganda, vague sorts of warnings that I'd better keep my eyes and mind open for wonders to come.

And I usually did find that Olympia was a bit of a shock. They used to spring on unoffending members of the public such surprises as the A.C. valve, the screened-grid valve, and the pentode. And, since new valves mean new circuits, and new circuits call for new components, the keynote of Olympia has been, in the past, "Innovation."

Stabilisation

Visiting the Exhibition this year was a much more peaceful affair, and the intelligent visitor soon discerned, as I did, that the radio industry's watchword for 1931 is "Stabilisation."

Technically, the exhibits this year were not startlingly novel. There was hardly a set or a component on show which had not a very close counterpart last year. There was, however, every evidence of that sort of improvement in material which results from designers having had ample time to develop familiar methods.

This state of affairs must, I think, afford the greatest possible satisfaction to everyone. It is, at last,

An impartial critique of the recent National Radio Exhibition in which the whole show is admirably summed up for the benefit of "Constructor" readers.

possible to choose one's set or components at the Exhibition with reasonable assurance that the purchase will not have been revolutionarily superseded before the lapse of a couple of months.

Steady Progress

My inspection of the exhibits of Messrs. E. K. Cole, Ltd., afforded

A SLIGHT DIFFERENCE!

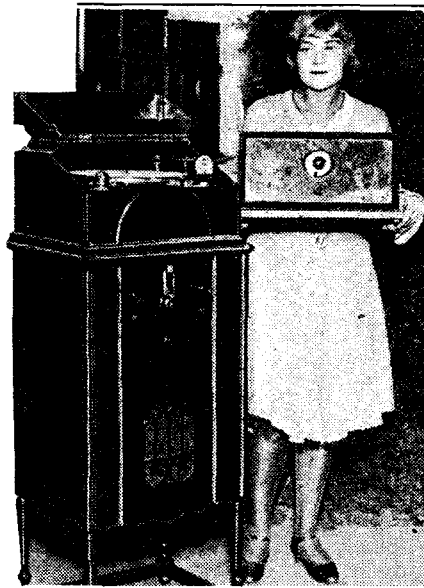

Although both sets are three-valvers, one costs sixty-seven shillings and the other forty-five guineas. The lady is holding the cheaper one!

ample indication of the manner in which manufacturers have taken advantage of a period of steady progress free from upsetting innovation.

This exhibitor has a range of products which are, without exception, examples of well-tried practice in all-electric radio. There was, however, on this stand a commendable absence of any experimental atmosphere.

I felt that Messrs. E. K. Cole could give me no greater assurance of their confidence in the performance of their instruments than that which was implied by the manner of their presentation to public judgment.

Confidence in their ability to satisfy the requirements of their customers was, too, exemplified by the Marconiphone Company's ingenious appeal for patronage staged in their Demonstration Room in the Gallery.

Speaker Demonstrations

This demonstration was given in the form of a short play, and a miniature theatre with comfortable seating accommodation was provided. A visit to a Mr. and Mrs. Wise by a Marconiphone agent was the "plot," and one gathered that there are few more delightful experiences in life than to be entertained in your own home by a Marconiphone demonstrator. He brings his own cigarettes.

There were a number of these demonstration rooms in the Gallery in which leading manufacturers of sets and loud speakers were enabled to give the public some idea of the capabilities of their exhibits.

Unfortunately, however, for some obscure reason actual radio reception was not permitted. Demonstrations

My Visit to Olympia—continued

of sets were, therefore, limited to the reproduction of gramophone records in cases where the apparatus includes provision for this.

The merits of loud speakers, however, could be assessed, as the B.B.C. distributed to all the stands and demonstration rooms programmes from Savoy Hill, and, when these were not available, electrically reproduced gramophone music. The amplifying apparatus used for this formed the major exhibit of the B.B.C. itself. The Corporation also showed some transmitting apparatus of historical interest.

Better Reproduction

Although this arrangement is not, of course, altogether satisfactory, it is better than an entirely dumb show. It is evident, though, that there has

previous years. There were quite as many speakers of this type to be seen as of the previously more common "moving-iron" types.

Great advances have apparently been made in moving-coil loud speakers with permanent magnets, and instruments of this nature can, of course, replace an existing cone without any complications.

With the modern power valve a permanent-magnet moving coil has quite sufficient sensitivity. Many new entries have been made into this field, notably Messrs. Lissen, whose speakers are very reasonably priced.

I *think*—but it's hard to be certain—that I saw fewer portables at Olympia this year. There seemed to be a tendency for the self-contained, console style of receiver, all-mains driven, to replace the portable.

siderably less than half the population of Great Britain, I am told, has access to electric mains, and therefore the large majority who will have to remain faithful to batteries might have been better catered for.

Like most of my readers, I have never bought a complete receiver, and I don't suppose I ever shall. I only write of and take interest in Olympia's display of complete sets so as to be aware of with what standard I have to compete to maintain the home-constructor's cherished ideal of always having a set better than you can buy.

Improved Components

Judging by the components seen on such stands as, for instance, Messrs. Ready Radio, it is going to be quite easy for home construction to maintain its supremacy.

With components, as with sets, I noticed no apparent revolutions in design. At first sight, as an example, the stand of Messrs. The Telegraph Condenser Co., Ltd., appeared no different from previous years. A few inquiries, however, showed that there was more in the "green case" than a mere Mansbridge condenser. Detail improvements, I learnt, have been effected so that at last perfect reliance can be placed in an H.F. by-pass condenser really allowing H.F. to flow "through" it.

Transformers are, perhaps, the components which have been most improved. Revolutionary changes *have* been made in these owing to the introduction of new materials for the cores.

Ganged Condensers

The Telsen people have improved their range of transformers, which are now enclosed in moulded bakelite cases with internal shrouding.

Tuning condensers, I noticed with relief, still conform to the familiar "laws." There were, though, some beautiful examples of ganging to be seen, especially on the stand of Messrs. Jackson Bros.

My visit to Olympia has shown me what high standards of performance can be achieved by commercial sets, and I have seen there an array of components which makes me more than ever anxious to show to what high standards home construction can aspire.

BRITAIN'S FIRST BROADCASTER

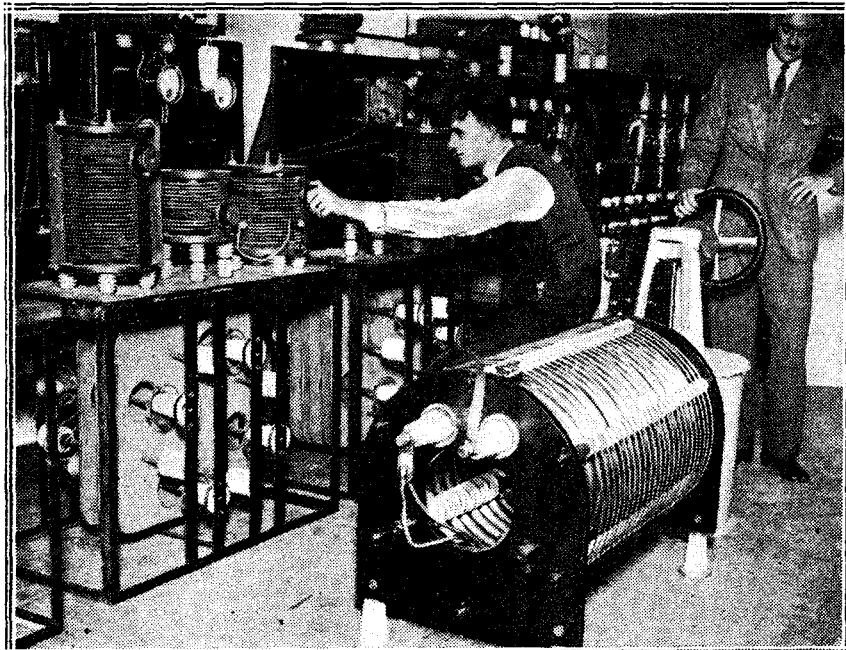

Evidently transmitting practice keeps pace with receiver progress. The old Marconi House transmitter (on left) required "both hands to it," but the new, like the modern receiver, has "one knob" control. A B.B.C. exhibit at Olympia.

been a very marked improvement in loud speakers, and from this it is safe to infer that similar attention has been paid to the problems of L.F. amplification.

In fact, some of the reproduction of gramophone records which could be heard in the demonstration rooms was a revelation.

The moving-coil loud speaker, incidentally, seems to be making a bid for more general adoption than in

This impression may, however, have been gathered because under the prevailing conditions exhibitors found it easier to demonstrate the big set. After all, a portable which gives volume adequate for home conditions can hardly be expected to speak up for itself and its designer at Olympia.

The show did, though, strike me as being rather too concerned in emphasizing the mains-driven set. Con-



Exchange of Music Directors—Land-line Troubles—“Wireless Exchanges”—“The Messiah”—A Gainsborough Programme—Centralising Variety—Sir Hamilton Harty and the B.B.C.—The Wine-Cellar Studio—Sir John Reith’s Holiday—Captain Eckersley and the B.B.C.—Song-Plugging Again—The New Empire Service.

By OUR SPECIAL COMMISSIONERS.

Exchange of Music Directors

As the result of a suggestion from Hilversum, it is understood that a regular scheme for the exchange of Music Directors is about to be announced. Mr. de Groot, the Music Director at the Hilversum station, is to be a guest conductor at some B.B.C. studio performances, and, in return, Dr. Adrian Boult will visit Hilversum and probably some stations in Germany as well.

Land-line Troubles

Remarkably clear relays from the Continent, particularly from Salzburg, have caused a good deal of comment to the disadvantage of the Post Office, which is responsible in this country for the efficiency of land-line arrangements.

The relay of the Tattoo from Tidworth this year was particularly bad. There were also many complaints about the “Diversion” programme organised by Manchester early in September.

Impetus will be given to the arguments of those who advocate that the B.B.C. should lose no time in securing its own system of cable communications at least between stations.

“Wireless Exchanges”

Recent statistics reveal that upwards of 15,000 licensed listeners take their services from “wireless exchanges” operating rediffusion; this means just over 0.4 per cent of the total number of licensed listeners.

Fifty-one firms are operating in forty towns throughout the country. Several attempts have been made to federate and unify these activities. Captain P. P. Eckersley, formerly

Chief Engineer of the B.B.C., is now actively interested.

“The Messiah”

The oratorio, “The Messiah,” will be relayed from York Minster in the National programme on December 10th.

A Gainsborough Programme

It is stated that the Gainsborough String Orchestra will broadcast from the Gainsborough Town Hall in the Midland Programme on November 19th.

Centralising Variety

Recent experiments in Variety programmes at Regional and other Provincial centres have not been

regarded as successful at Savoy Hill. The probable result will be further curtailment of local enterprise, at least in the sphere of Variety and Vaudeville.

Sir Hamilton Harty and the B.B.C.

The real inside story of this trouble, not so far published, is as follows: About four years ago Sir Hamilton Harty strengthened the Hallé Orchestra by importing a particularly good oboe player from Birmingham, actually from the flock of Dr. Adrian Boult, then in charge of the Birmingham Orchestra.

When the turn of the wheel of fortune brought Dr. Boult to Savoy Hill, in order to build up a new

LOOKING AT “THE WORKS”

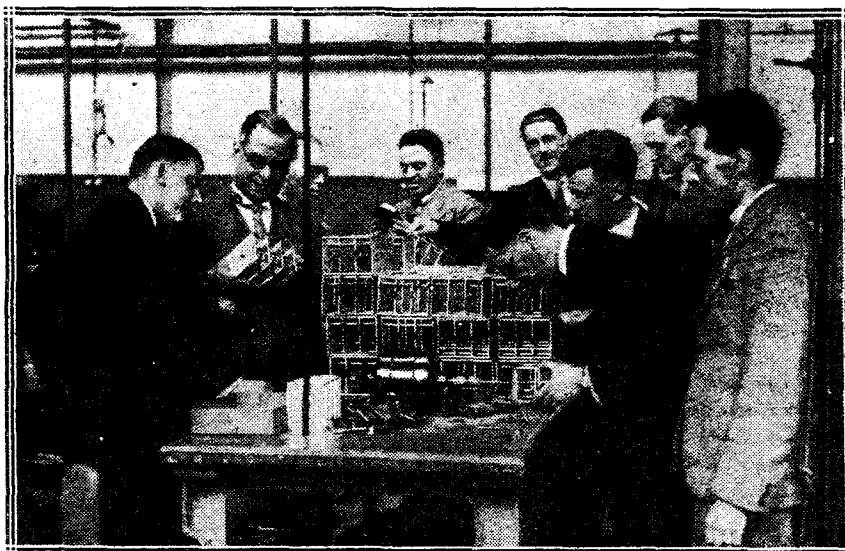

Some of the Radio trade wholesalers snapped during their recent visit to the G.E.C. factory at Coventry, where they saw the new “Osram Music Magnet Four” being manufactured.

Savoy Hill News—continued

orchestra of "super-executants" he naturally bethought him of the instrumentalist who had gone to Manchester from Birmingham. What's more, said instrumentalist was anxious to come to the new B.B.C. orchestra.

So that was that. In the considerable controversy that followed, the B.B.C. got the bulk of sympathy and support. In fact, Savoy Hill seemed a good deal less troubled about the matter than musical circles generally.

The Wine-Cellar Studio

The B.B.C. has been searching far and wide in London for a hall or a room big enough to accommodate rehearsals or studio performances of the new big orchestra. There is, of course, no place at Savoy Hill half big enough.

There was talk of the National Sporting Club and the Aeolian Hall, but I am told that the choice has

John Reith took a holiday this year. Previously he has gone away geographically, but has remained in close telephonic and postal touch with the business. Not so this year; he got clear away into the Black Forest, and from all accounts enjoyed himself immensely. In Sir John's absence, Admiral Carpendale carried on at Savoy Hill.

Captain Eckersley and the B.B.C.

There is an unconfirmed rumour that Captain P. P. Eckersley, formerly Chief Engineer to the B.B.C., and recently technical consultant, has now finally severed his connection with Savoy Hill. This, if true, is a great pity, although it has been an open secret for some time that Captain "P.P." has not seen eye to eye with the authorities of broadcasting. It is unlikely, however, that there will be open hostilities.

grammes so far as selection is concerned. On the contrary, the items are probably more acceptable than they would be if there were no plugging.

It stands to reason that music publishers would not waste good money on bad pieces. The B.B.C. has always been careful to draw the line between studio dance music and outside dance music, professing that at least the former was clear of any imputation of "plugging."

But now comes a new complication. Some of the dance music publishers who admit their system and justify it have decided to accept the challenge to prove that there is plugging within as well as without the B.B.C. This development creates a very interesting situation, with possibilities of difficulty for Savoy Hill if by any chance they are proved in the wrong.

The New Empire Service

Now that the Treasury has sanctioned the recommendations of the Colonial Conference to go ahead with a permanent service through G 5 S W, plans for the new organisation are being canvassed at Savoy Hill. There is great interest in the appointments that will have to be made.

The B.B.C. would like to give the jobs to members of the staff about to be axed on automatic reduction of work; but it is doubtful whether any of these unfortunates has the necessary qualifications. Mr. Beadle, the Belfast Station Director, is a strong candidate, his experience in South Africa fortifying his claim to the post of chief.

Mr. Edward Liveing, North Regional Director, is also a candidate. He has done so well in the North, and his experience is so wide and thorough that, although he has not lived overseas, he may be regarded as the "favourite" for the post at this moment.

One way out of the difficulty in making an invidious choice would be for the B.B.C. to regard the new service as merely an extension of the work of the Foreign Department, which is now fully staffed under Major C. F. Atkinson.

REMARKABLE RADIO RELAY

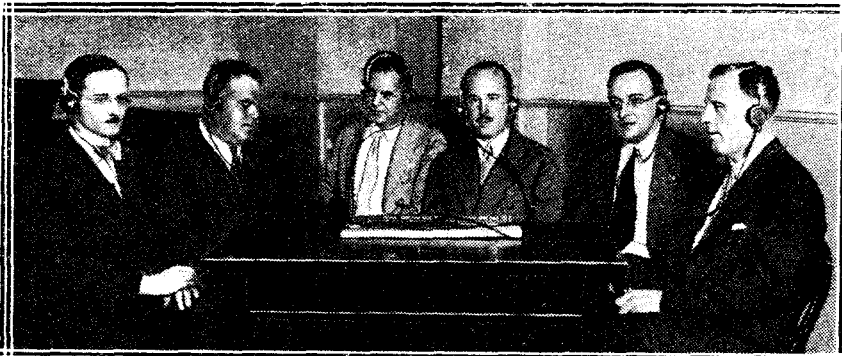

The officials of the American National Broadcasting Company responsible for relaying to American stations a broadcast from Marquis Marconi's yacht "Elettra," which was stationed off Rome during the terrible Italian earthquakes.

fallen on subterranean wine vaults near the south end of Waterloo Bridge. Apparently the ubiquitous Gerald Cock, the "O.B. King," happened on this place, which is admirably suited for the purpose.

It is spacious, has good natural acoustics, and is not troubled by traffic noises. I have not heard whether there are any choice old vats or barrels or "pipes" about; but one hopes there is something to cheer the great orchestra on its triumphant course.

Sir John Reith's Holiday

For the first time in the eight years he has been with the B.B.C. Sir

Song-Plugging Again

So acute has become the evil of "song-plugging" during some dance-music transmissions that the B.B.C. will soon sustain another big attack unless measures are devised to correct irregularity. The problem is a very complex one.

Everyone knows that some dance-music publishers (probably most) subsidise those "outside dance bands" that include their specialities in the broadcasts. This practice, of course, works to the considerable disadvantage of the smaller publishers and more obscure composers.

But it does not necessarily mean that the listener is getting bad pro-

**Don't Miss Next Month's
"WIRELESS CONSTRUCTOR"
Order Your Copy Now.**

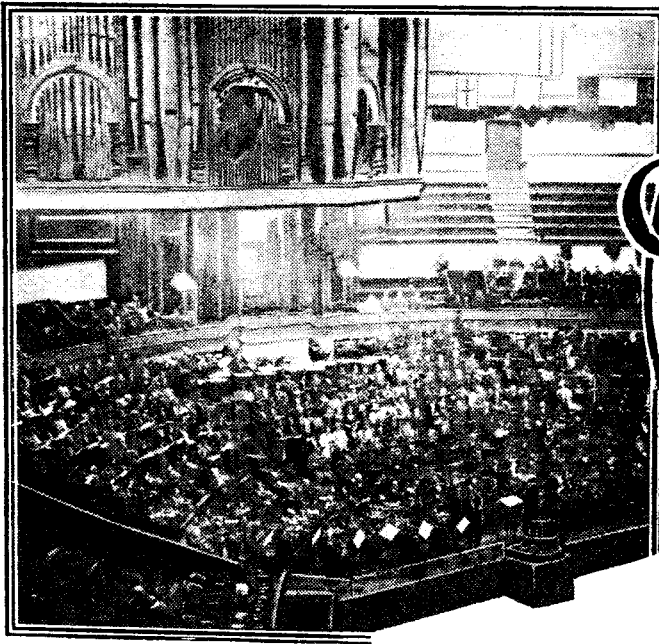

DOWN QUALITY STREET

by
PERCY W. HARRIS
M.I.R.E.

WHETHER or not you had an opportunity of visiting the Wireless Exhibition at Olympia, you probably know that both set and component manufacturers are paying ever-increasing attention to the subject of quality. Mere volume, which not so long ago was held out as an inducement to buy, is so easy to obtain with modern valves and modern transformers, coupled with mains units for high-tension supply, that it no longer attracts as such. Good quality reproduction, however, is far less easy to obtain, and is being increasingly sought by both the discriminating home constructor and the

Natural radio reproduction is the aim of all set owners, but the difficulty lies in attaining the ideal. In this article by the Editor of the "Wireless Constructor," readers will find much of interest and value in his description of tests and experiences during a long and untiring search for perfect quality.

shrewd purchaser of a finished set. I have written before in the WIRELESS CONSTRUCTOR on the subject of quality, and I hope, if the subject still interests you, that I may write on it again many times, for it is

a subject about which one cannot know too much. It so happens that for many months I have been engaged upon extensive research which has had for its object the design of wireless receivers of the highest possible standard, and as the facilities at my disposal have been quite exceptional the results have been very illuminating.

Hundreds of Tests!

Literally hundreds of tests have been made with various circuit arrangements, and hundreds of response curves plotted, the effect of each important change being carefully noted.

DO YOU GET THE TRUE BRASS EFFECT ON YOUR SET?



Dance bands vary in the amount of brass they include among their instruments, but Jack Payne's famous band is noted for its brilliance, so in checking your own output listen carefully to this band's broadcasts and ascertain whether you get the real brilliance that exists in the band. If you can, hear the band (or another one that broadcasts), direct instead of "over the air," compare the real with the radio version.

Down Quality Street—continued

At the same time, the reactions of a number of people have been tested in getting their opinions about the quality of reproduction and comparing the average of these opinions with the curves obtained. Incidentally, it is always wise when facilities offer to check up one's curves and experimental results against the opinion of the "man-in-the-street," for he comes fresh to the subject and gives a frank opinion of how the reproduction appeals to him.

Using Different "Parts"

The experiments, as might be expected, have proved what I have so often said is the case—that the indiscriminate "flinging together" of a number of different components, even when they are of a high grade,

one of these for what appears to be a component "just as good." The whole performance may be completely upset owing to an inherent instability in design which is kept in leash by, say, one make of transformer, but which may fly out with another having an even better curve when plotted in the conventional way.

We all agree that what we want is the best possible quality, but the first trouble we come up against is that no two people agree as to what is first-class quality. It is very difficult to define scientifically, and still less easy to define in general terms, for the simple reason that people differ fundamentally in what may be termed their "ear response" or their sensitivity to different sounds.

Furthermore, a great deal of nonsense has been talked about the importance of certain upper frequencies ;

But before dealing with methods and instruments let us touch upon a few facts regarding individuals and their response to various frequencies. We might as well start by dealing with the frequencies themselves, their relative importance, and the facts regarding intensity.

How High ?

First of all, how high do you think we should go in sound reproduction in order to obtain natural effects ? Let us examine a few instruments and see their musical range. We need not go below about 70 or 80 to reproduce most musical instruments, while the fundamental top note of any orchestral instrument is not above 4,000.

Instrumental notes, however, are rather complex sounds, and include certain harmonics which extend the range of frequencies required above this figure. Ideally we ought to go to 8,000 or 9,000, but actually all the important frequencies are below 5,000.

A great deal has been written about the importance of frequencies above 5,000, and, indeed, I saw an article in a responsible technical journal recently which said that receivers which did not reproduce notes above 5,000 lack distinctness and crispness. This is not really so, as I have proved recently with a receiver having substantially uniform reproduction of all frequencies up to 5,000 and a fair response beyond.

Cut-Off and Attenuation

A "cut-off" filter was arranged to give a complete elimination at 5,000 and above, and the addition of this brought no apparent difference to the sound of even those orchestral instruments which are rich in harmonics. Further tests showed that nine people out of ten could not detect any difference when a cut-off filter at 4,500 was introduced, although experienced musicians and those who had done a good deal of work in the study of sound and sound reproduction could notice a slight reduction in quality in the case of some instruments.

General crispness, however, the S sounds, intelligibility of speech, and so forth, were still far better than is obtainable with the majority of wireless sets sold, including those which are looked upon as outstanding examples of good quality.



HARK TO THE HARP!

If a harp (often to be heard in Promenade concerts) is not clearly distinguishable as a harp, your radio outfit is deficient in frequencies above three thousand.

may give you an appallingly bad overall result. It is for this reason that so much time is given in the designing of all WIRELESS CONSTRUCTOR sets to see that the design is not merely suitable for one particular set of components, but will also adapt itself to a number of others so as to give reasonable alternatives.

Many designs worked out in the laboratory have proved excellent with a particular set of components, but woe betide he who changes any

and there are a number of terms in use such as "mellow," "brilliant," and so forth, which are particularly misleading when used in conjunction with loud speakers.

These terms suggest that a particular type of reproduction, or what may be termed a particular colouration, suits all kinds of speech and music equally. Actually, of course, a loud speaker should impart no special colouration whatever to what passes through it.

Down Quality Street—continued

The fact is that receivers which reproduce very little above 5,000 in the ordinary way generally start to reduce the intensity of reproduction well below this, and have a gradual falling-off curve, which means in effect that frequencies above 2,500

THOSE HIGH NOTES

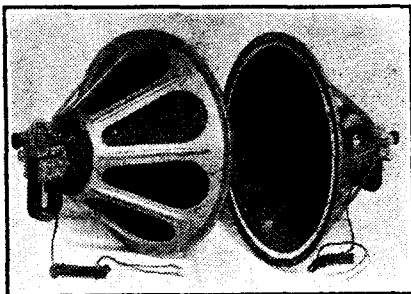

First-class quality is obtainable with the modern balanced armature and cone—sometimes even better musical balance than with many moving-coil speakers. Often the armature types give excellent reproduction of the upper frequencies, the importance of which is too often overlooked.

or so are not properly reproduced. It is therefore not the cut-off at 5,000 that is the trouble, but the attenuation before this.

A set which could be arranged to give substantially uniform reproduction of all frequencies from, say, about 80 to 4,500 and nothing above, would be so outstandingly good in reproduction compared to the average set sold to-day that most people would think it miraculous. Here, again, it is well to note the danger of generalising, for there are one or two sets on the market which give reproduction (when correctly used with a really first-class loud speaker) which is of this order.

Pick-Up Results

If you want any further proof of the nonsense that is talked about the upper-frequency reproduction, consider the modern electrically-made gramophone record. Quite a number of people have said to me that if only they could obtain from their wireless sets reproduction as good as that obtainable from good modern records on a first-class electric reproducing gramophone they would be more than satisfied, and they point out the brilliance which is obtainable with such a combination, the marvellous intelligibility and the uncannily natural reproduction of orchestral instruments.

Even with the very best makes reproduction starts to fall rapidly at about 4,500, and cuts off dead at about 5,500, save in a few exceptional cases, where a little bit of 6,000 may get in, but you can take it from me that if it does get in it is very little, even if the pick-up and the loud speaker are able to reproduce it, which is very doubtful!

The Vital Frequencies

Here is another important fact on quality. The modern distribution of wireless stations in Europe at nine kilocycles apart means that the authorities are agreed that if a set is to separate one of these from another without interference it will not be called upon to reproduce frequencies above 4,500.

Do not, however, take this as meaning that I agree with the statement, for Dr. Robinson's discoveries and demonstrations in connection with the Stenode Radiostat have shown that there is something wrong with this theory. I put it forward, however, as indicating the general

number of well-known people, and found, as is generally recognised by aural experts, that the ability to hear high notes falls off to some extent with age. This is not, however, an invariable rule.

While Sir Oliver Lodge was unable to hear what was to most of us a piercing note of 4,500, Earl Russell, who will forgive me, I am sure, for saying that he is not in his first youth, could hear notes well above 5,000. Several members of the laboratory staff can hear a note at 9,000, and even higher, quite distinctly, but as a general rule, and basing the statement on tests of a number of different ears, quality reproduction which is substantially uniform up to 4,500 and falls off afterwards is looked upon as really first-class.

Bass or Boom?

An astounding number of wireless receivers, particularly in the portable range, give practically nothing below 200 and very little above 3,000, the reproduction curve rising from about 200 to a maximum of about 2,000, and

DODGING THE REFLECTED WAVES

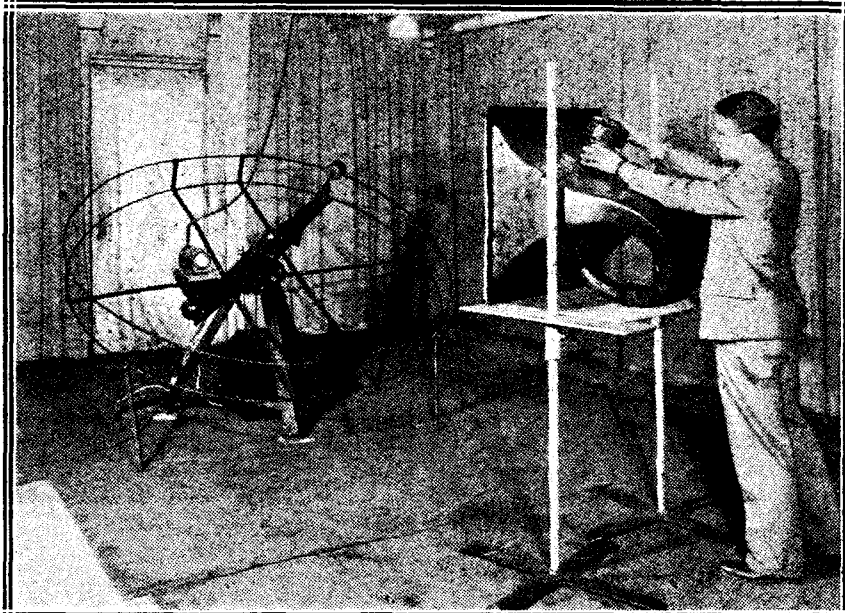

Elaborate apparatus is necessary for testing loud-speaker output in an ordinary room. Reflections may cause quite different effects at points a few feet apart. This picture shows the means for rotating a condenser microphone during such tests, to investigate standing waves and other peculiar phenomena.

agreement of authorities prior to the introduction of Dr. Robinson's work that frequencies up to 4,500 were the really vital ones.

Quite recently I had the opportunity of testing the ear response of a

falling fairly rapidly again to pass right out at about 4,000. Many people call such reproduction "mellow and pleasing," but it is none the less false.

There is remarkably little true bass in most wireless reproduction,

Down Quality Street—continued

especially in the cheaper sets, and loud speakers; far too many of these latter being so built that the box resonates round about 200 to 300, giving a boominess or false bass which often makes up for severe attenuation of these frequencies in the set itself. Remarkably good results are obtainable from modern balanced-armature cone units, and with suitable sets one can often get more true bass with balanced-armature units than with half the moving-coil speakers sold.

Here again there has been a lot of nonsense talked, and I can claim to be one of the first to point out, during the moving-coil boom of a year or two ago, that much of the bass in moving-coil speakers was due to a tremendous peak or resonance in

be enough feed-back from stray fields, etc., to send the set off into an audio-frequency howl or oscillation at this particular frequency. By using two transformers of different characteristics the two stages are out of tune, and thus have less tendency to resonate, but if there are strong feed-back effects and you do not attempt to eliminate them, the best transformers in the world will give poor quality.

Screening L.F.

Frankly, the only way to make the highest grade of low-frequency amplifier so as to obtain high gain and first-class quality (such as is required for electrical reproduction of dance music, public address systems, talkies, etc.)

transformer quite near a set which is working and you will often be able to hear admirable reproduction in the telephones when the so-called screened transformer is a foot or two away from the set, which itself also may contain screened transformers!

Some years ago I carried out some experiments in which the low-frequency transformer in the set was left entirely free on its secondary side and a second transformer placed nearby with its primary on open circuit and its secondary connected to the grid and filament of the next low-frequency stage. In the case of some transformers I got quite excellent reproduction (although at reduced volume) when the transformers were over a foot apart!

RADIO ROMA'S REPRODUCTION

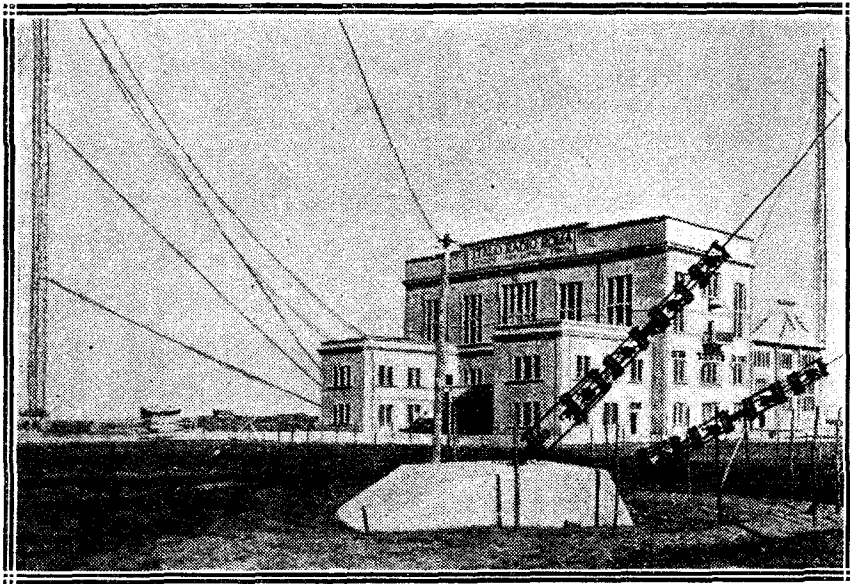

Radio Roma, fitted with a modern American radio installation, radiates a very good quality transmission, particularly where the upper frequencies are concerned.

the lower frequencies, giving that characteristic thump which, coming to a world totally unaccustomed to hearing anything below 200, was hailed as quite charmingly natural.

Feed-Back Faults

Poor quality, other than that given by loud speakers, is often due to low-frequency resonance and undesirable low-frequency reaction effects. A low-frequency transformer with its self-capacity and external capacity in wiring, etc., can often be made to resonate at a particular frequency.

If two transformers are incorporated in a set and both have the same natural frequency, there may easily

is not only to design the instrument as a whole with particular attention to the electrical characteristics of the individual parts, but the whole amplifier must carefully be screened with iron in such a way as to reduce feed-back effects between stages to a minimum. Quite a number of transformers are supposed to be screened, but in remarkably few of them is the screening really effective.

A Telling Test

If you want to check this, take an ordinary screened transformer, connect a pair of high-resistance telephones to its primary and leave the secondary open. Now stand this

The Overall Curve

To save myself being "shot at" by the few transformer manufacturers who make really well-screened instruments, let me say that this is only a general statement, and, of course, there are exceptions.

So much audio-frequency trouble has been due to feed-back effects in batteries, mains units, etc., and so much has already been written on the subject, that there is no need to dwell here on the merits of decoupling devices, the most important of which are the decoupling resistance and condenser placed in the plate circuit of the detector valve, and the proper decoupling of the output valve.

I am sometimes asked how it is possible to take the "overall curve" of a wireless receiver including the loud speaker. This is a very difficult task, the chief worry being that one cannot consider a set without the room in which it is being used.

Room Resonance

For example, if you place a loud speaker in a small room heavily carpeted, with a good deal of furniture and hangings, you will get comparatively little room resonance. Place it in a fairly large hall, with a stone or board floor devoid of any carpets, and with plain brick walls, large areas of window, and an arched roof above, and certain notes will reverberate through the building, echo back and produce a "peakiness" which may be unpleasant. One of the biggest problems in conjunction with the talkies has been to obtain a reproduction which is equally pleasing in

Down Quality Street—continued

the particular theatre where the film is being shown with both small and large audiences.

Comparatively empty picture theatres in a quiet part of the day

put of the microphone amplifier. So as to get complete data, a steadily rising musical note is given to the radio transmitter to which the set is tuned.

then we have something approaching the ideal set. Usually, even with so-called good sets, the curve so produced looks like the Himalayas viewed through a piece of bad window glass, with frightful and unclimbable peaks showing prominently.

WHERE PERFECT BALANCE IS MAINTAINED

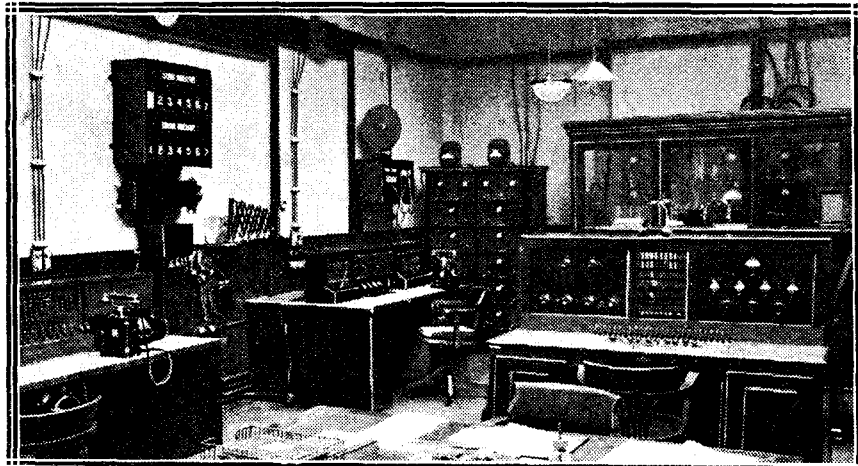

The B.B.C. engineers take extraordinary pains to keep up the quality of their transmissions. Here in the control room watchful engineers are on duty during broadcasting to maintain the correct balance, which in itself is a highly developed art.

will resonate much more freely than when packed in the busy time of the evening. More volume will be required in the full house, as there will now be more sound absorption.

Much depends upon the operator controlling the sound reproducing apparatus, and a talkie film is often blamed for defects of manipulation in the theatre. Again, both in talkies and in room reproduction we have to consider the problem of the human ear.

We have, for example, a certain response of the ear for a certain level of sound. Double the sound intensity and the ear response will not be similarly uniform. For this reason the human voice, when magnified up unduly, sounds boomy, as if certain frequencies have been over-accentuated.

The Whole Gamut

But I am rather wandering off the subject of taking an overall response curve for the receiver, including the loud speaker. The only way that is generally considered satisfactory is to take the curve in the room where the set is to be used and in normal conditions.

A carefully calibrated microphone is now suspended at the position where the listener will generally sit and a curve is plotted from the out-

If, for example, we start with a note of 50 and go progressively up the scale to 5,000 or 6,000, the sliding musical notes being impressed on a radio-frequency oscillator, which must in turn be picked up by the wireless receiver through its radio circuits, and if, furthermore, the output from

Power-Valve Possibilities

I know by now the reader will probably be saying to himself, "Yes, this is all very fine, but what am I to do about my own set? What can I do to improve it?" Here once more I would give you the advice so often tendered in this journal. Try and consider your wireless set as a whole.

If the set tends to over-accentuate certain high notes, you can, with care, choose a loud speaker which is a little weak on the high side and which will tend to give good overall response. Often a great improvement, especially in low-note reproduction, can be obtained by using a good super-power output valve.

If you can afford the high tension (and the use of a mains unit makes this possible), use a very low impedance output valve in the majority of cases; but if you are using a really high-grade loud speaker, it is just as well to consult the loud-speaker manufacturers and ask them what output valve and output arrangement they

THE WIRELESS ORCHESTRA TAKES A BREATHER



Sound intensities have to be carefully balanced in the studio. Long experience has taught the B.B.C. just how to place the various artistes and instruments in relation to the microphone.

the microphone amplifier (which is of the straight-line variety) shows uniformity between these two points,

recommend with their particular loud speaker.

They will willingly give this

Down Quality Street—continued

information if you write for it, because every responsible loud-speaker manufacturer wants his products used to the best advantage. The second tip is to make perfectly sure that you are not now getting even incipient low-frequency reaction, due to feed-back effects in the batteries or mains unit.

Decoupling devices are sold, and still more easily made by yourself with resistances and condensers. I am assuming, of course, you are using high-grade components. Spend a night or two listening to all orchestral pieces from your local station, and see if any one note tends to predominate in your reproduction.

Tips to Try

You can be sure that the station is sending out good quality, and there will be no peakiness there, so that an over-accentuation of certain notes (on the violin, for example) is fairly definite proof that you have got a "peak" in your set. Reversing either the primary or the secondary of the low-frequency transformer often improves reproduction. This tip is always recommended when the set howls, but is equally valuable when it does not.

If the set does not actually howl or whistle, this is not to say that there is no undesirable audio-frequency feedback, and many sets would be

megohm grid leak across the secondary terminals.

Even a lower value than this can be used, such as 100,000 ohms. You may lose something, even quite a lot, in strength, but in many cases you will be able to afford this if you have ample volume, and much more pleasing reproduction will result.

The Accommodating Ear

These last few tips are very simple, but are well worth trying, particularly now we are all becoming more critical of the reproduction from our sets. Remember, then, if organ solos seem to come out extraordinarily well and music of the average type quite mellow and generally satisfactory, while at the same time speech is none too good and dance bands lack that snap and brilliance, this is fairly definite proof that you are reproducing very little above 3,000.

Lastly, do not forget that the human ear is very accommodating, and it is very easy to become accustomed to faulty reproduction and think it is quite good. If you have the opportunity, try and visit one of the B.B.C. concerts to hear the actual orchestra to which you have become accustomed over the wireless.

Check up your ear response on the actual instruments, and the next

Far too much emphasis has been placed in the last year or two upon the importance of the low notes. Do

TESTING TONE

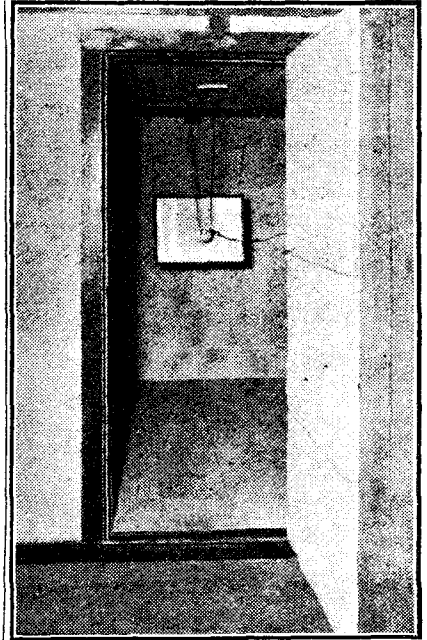

Testing an Ultra loud speaker, with a microphone, in a sound-proof room.

not forget the high notes are just as necessary for fidelity.

* INTERESTING *
* TRADE ITEMS *

THE radio department of Philips' Lamps, Ltd., of Charing Cross Road, London, W.C.2, have issued a booklet entitled "Music from the Mains." It contains illustrated descriptions of the various Philips' sets, radio-gramophones, loud speakers, eliminators, rectifiers, and so forth, and will be forwarded on application to the above address.

An entertaining and informative book on radio connections has been issued by Belling and Lee, Ltd., illustrating the different applications of this firm's plugs and sockets, fuses, battery connectors, etc., and will be forwarded to readers of the WIRELESS CONSTRUCTOR on application to the above firm at their address at Queensway Works, Ponders End, Middlesex.

AN ADVERTISER'S CORRECTION
The Telsen Electric Co., Ltd., advise us that the price of their H.F. choke shown on page 337 last month is 2/6, and not 12/6, as stated.

SEEING HOW THE SPEAKER SOUNDS

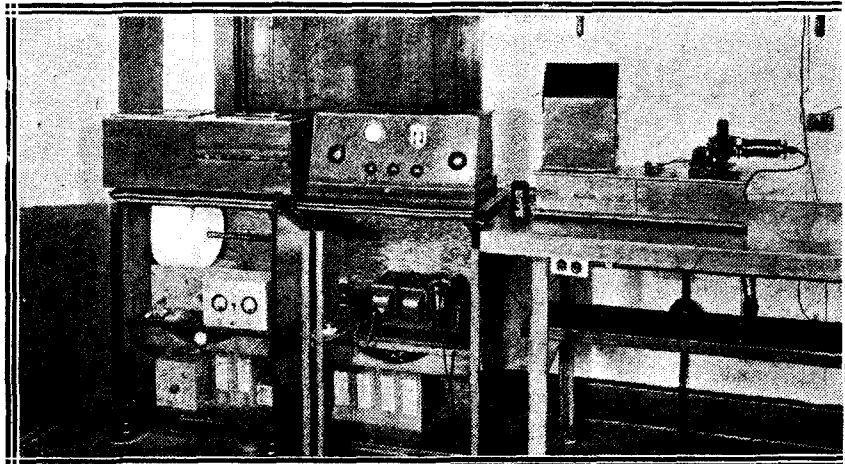

This illustration shows an automatic response curve device, complete with an oscillograph, providing a visible means of examining the reproduction of loud speakers. (Ultra Electric.)

greatly improved if the constructors troubled to try reversing the primary of the low-frequency transformer. Another good tip to try, with the idea of flattening out peaks in your reproduction, is to use a quarter-

time this orchestra broadcasts compare your impressions. In a large number of cases you will find that your set is weak in the upper frequencies and lacks the brilliance which is so important for faithful reproduction.

AS WE FIND THEM



A Good Cone Unit

THE Mullard Pure Music speaker unit is designed for use in portable and other types of self-contained receivers.

The movement is of the balanced-armature type, and is substantially

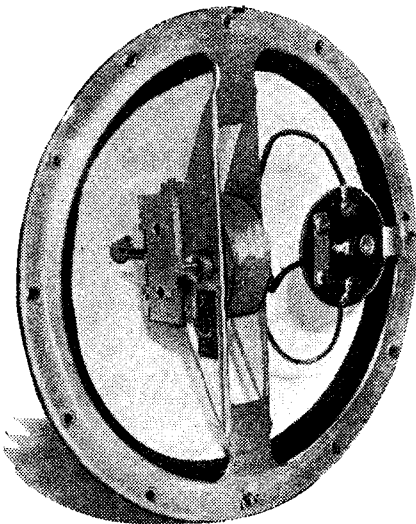

This is the Mullard Cone Unit. It is a well-made component, and is primarily designed for sets of the self-contained type.

made. The windings will carry 25 milliamperes quite safely, and the unit can therefore be connected directly in series with a power or even a super-power valve without any danger of a "burn-out."

A special feature of the Mullard unit is the method of arranging the magnet windings. The ends are brought out to two terminals, and there is also an intermediate tapping

connected to a third terminal. Thus it is possible to select a winding which will best suit the particular output valve employed.

The cone itself has a diameter of about 7 inches, and consists of a parchment which the makers claim to be unaffected by climatic changes.

We tested the unit on a good three-valve set, and in conjunction with a 3-ft. baffle of stout plywood. The sensitivity was excellent, and the general balance and tone were distinctly pleasing. There was no trace of chatter or other indications of any tendency for the unit to overload on full volume. This cone unit retails at 38s. 6d., and is a very nice job.

Pioneer Switches

The Pioneer Manufacturing Co., Cromwell House, Fulwood Place, W.C.1, have sent us two of their latest push-pull switches for test. These switches are stoutly constructed and are of the one-hole fixing type.

The three-point or triple-contact switch is suitable for certain types of wave-change circuits, and the two-contact switch can conveniently be employed as an L.T. "on-off" switch.

We were pleased to see that the terminals were of adequate size, and that neat soldering tags were provided. These tags, incidentally, are integral with the nickel silver contact springs. The insulation between terminals, with the switches in the "off" position, tested at 500 volts D.C., was found to be above reproach. When put to practical use the speci-

mens submitted carried out their duties efficiently and noiselessly, and we can recommend them. The two-contact model retails at 1s. 3d., and the triple-contact at 1s. 6d.

Eelex Terminals

Messrs. J. J. Eastick & Sons, of Eelex House, 118, Bunhill Row, E.C., have sent us a selection of their terminals, plugs and indicating tabs. These terminals are solidly made, and finished in nickel-plate.

The shanks are size 2 B.A., and are slotted at the ends, this procedure facilitating the wiring-up of the set.

The makers can supply over 40 different indicating tabs, and so it will be seen that every terminal used in a receiver or other unit can be suitably marked, and therefore readily recognised. The terminals themselves are made to take wander plugs, as well as the usual spades or pins, and therefore there is an ample

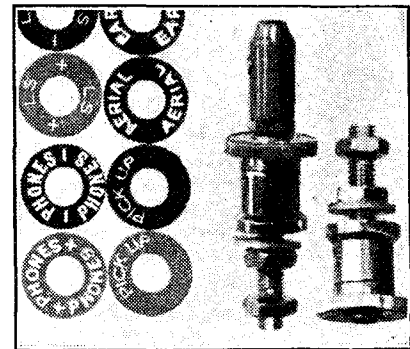

Eelex terminals are turned out of solid brass and are heavily nickel-plated. Over forty different indicating tabs are available, and the terminals are designed to take wander plugs.

As We Find Them—continued

choice of methods of connecting the leads. The terminals retail at 4½d. each, and can be recommended.

Amplion Portable Receiver

We were recently privileged to try out the Amplion "Two Screen-Grid" portable receiver. This receiver is a thoroughly up-to-date design, and, as its

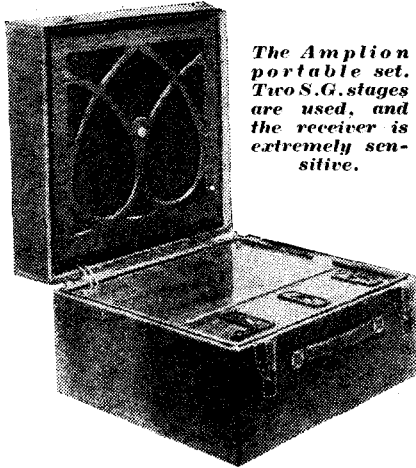

The Amplion portable set. Two S.G. stages are used, and the receiver is extremely sensitive.

name implies, makes use of two stages of screened-grid H.F. amplification.

The receiver is of the true portable type, inasmuch as the batteries and loud speaker are incorporated in the case, and, of course, the reception is carried out on a frame aerial. The frame, as a matter of fact, is wound round the loud speaker, which is placed in the lid of the case.

The operating panel contains three thumb-controlled dials. One is for the adjustment of volume or reaction, while the other two control the tuned circuits, that is, the frame and one H.F. stage. There is also a switch for changing over from the short to long waves, and for controlling the valve filaments.

We tested the receiver in Tallis House—a building possessing marked screening effects, and in no way flattering the performance of a frame-aerial design. On the medium wave-band the London Regional and National transmissions roared in, and had to be considerably detuned in order to obtain comfortable volume. The Midland Regional transmission was also brought in with ease, and the set showed remarkable sensitivity and good selectivity. On the long waves, it goes without saying that 5 X X could be brought in at full loud-speaker strength, and, moreover, the reception of such stations as Huizen gave no trouble at all.

With regard to tuning-in the various transmissions, we rather like Messrs. Amplion's scheme of supplying a chart with each receiver giving the dial readings for the better-known British and Continental transmissions. This does away with any preliminary difficulties of searching.

Sometimes with portable designs there is a tendency for the quality of reproduction to be a little below the average, but this does not apply in the case of the Amplion. The actual speaker used in this set is of the balanced-armature type, and it is adjustable for sensitivity. The reproduction is very good indeed.

The general appearance and performance of this receiver reach such a very high standard of excellence that it is difficult to find any point of criticism. At any rate, the possessor of one of these sets can rest assured

already extensive range. The first of these is the IV.20, and is designed for use with portable-type receivers the maximum anode current of which does not exceed 20 milliamps.

A dry rectifier is employed, and there is an S.G. tapping giving up to 1.5 milliamps. for the screening grid of an S.G. valve. The variable 0-120-volt tapping is suitable for the detector stage, and the power tapping for the remaining valves.

We tried the unit on an S.G., det., and 1 L.F. set and found it to be silent in operation, in spite of the fact that our mains are usually somewhat difficult to smooth. We were pleased to see that the various H.T. leads were clearly marked with their respective voltages so that there can be no possibility of any mistake in connecting it up.

The C.P.1. model is similar to the

Two examples of Pioneer switches. The soldering tags are integral with the contact springs, which are of nickel silver. These switches may be obtained with either black or mahogany coloured knobs to suit the type of panel used.

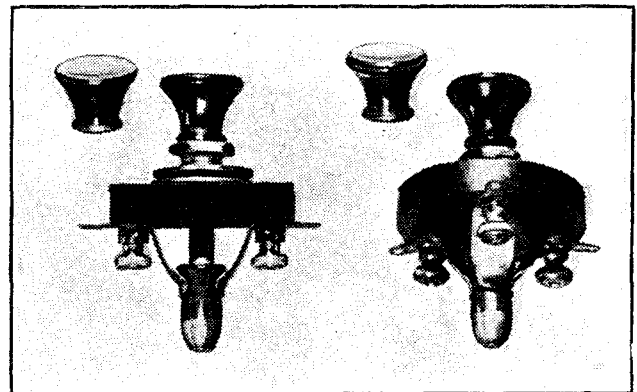

that if at any time a fault does develop, the Amplion Service Department will always be ready to extend a helping hand. "Service after Sale" is one of Messrs. Amplion's slogans.

"Ekco" Units

Messrs. E. K. Cole, Ltd., have added two new mains units to their

IV.20 except for the fact that it is also designed to supply an L.T. charging current of .25 ampere at 2, 4, or 6 volts. Thus even the smallest accumulator can be kept fully charged and always ready for use.

"Ekco" mains units have achieved a wonderful popularity, and this in itself is ample proof of their efficiency.

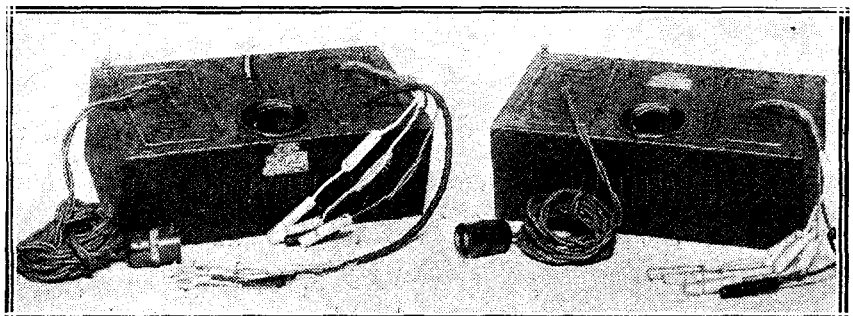

These two "Ekco" mains units are chiefly intended for portable designs. The one on the left is the C.P.1 and incorporates a trickle charger, while that on the right is the IV.20. Both are A.C. models.

RECENT VALVE RELEASES

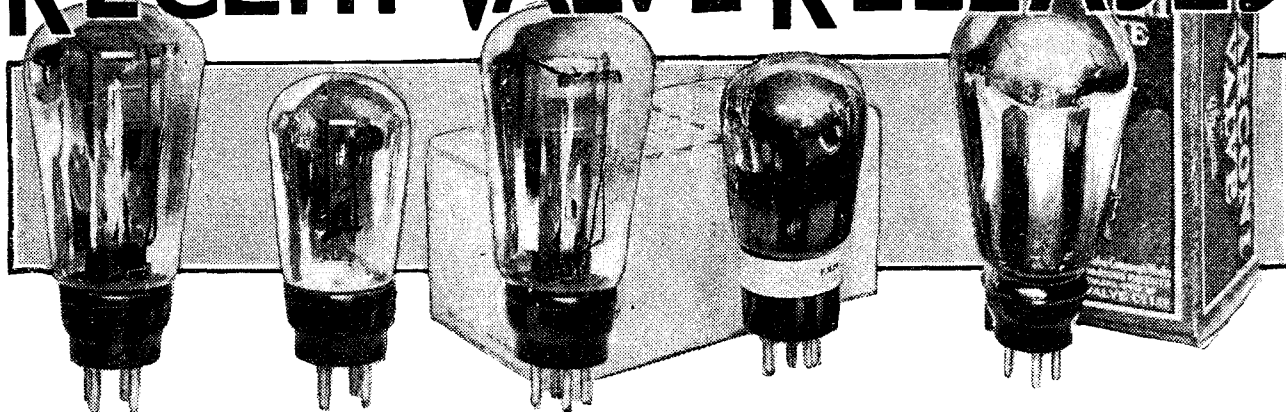

THIS article concerns some of the valves which I have had in for test during the last few weeks, and which have been undergoing our usual trials in the WIRELESS CONSTRUCTOR laboratory.

First of all there is a batch of Dario valves, 2- and 4-volters (for 6-volt Dario valves are not made), covering all the usual types, R.C., H.F., S.G., L.F., and power. These are remarkable valves, and a selection of them is shown in the illustration on this page.

Some New S.G.'s

The valves have quite usual characteristics, and while the screened-grid Bivolt and Forvolt will give excellent magnification, the super-power valve in each range will carry quite a considerable grid swing and handle quite a useful power.

Dealing with them more specifically, let us consider the S.G. valves first. These, the Screenodion Bivolt and the Screenodion Forvolt, have impedances of 250,000 ohms and magnification factors of about 250. Thus we see that they are quite useful S.G.'s for all ordinary purposes.

Recently the Dario valve people have also placed on the market an indirectly-heated cathode screened-grid valve. This has an amplification factor of 1,000 and an impedance of about 1 megohm.

Then there is the Super H.F. A.C. valve, having an impedance of 20,000 ohms and a magnification factor of 40.

On the L.F. side we have the Super-Detector and the "Mag. Power." The former has an impedance of 7,500 ohms and a magnification factor of 15. At 150 volts H.T. it takes about 16 milliamps at zero grid bias, giving roughly 7.5 milliamps when biased correctly in an L.F. circuit.

During the last month or so many of the new receiving valves have been tested in the "Wireless Constructor" laboratory, and here is a brief summary of the behaviour of some of the valves.

By L. ROBINS.

The "Mag. Power" takes a grid swing of a little under 20 volts when used with maximum H.T. The impedance is 2,200 ohms and the mag. factor 8.5.

The other Dario valves are well constructed and have valuable characteristics, as the details supplied by the makers will show.

And now we must discuss the latest valve turned out by the Mazda people. This, as you are probably aware, is the Mazda P.220A. It is really a sort of big brother of the P.220 and has a wonderful grid swing for a valve of its calibre.

It has the high magnification factor of 6.5, giving a mutual conduct-

ance of 3.5—a remarkably fine slope. The impedance of the valve is 1,850 ohms. The valve is remarkably easy on H.T. and L.T. batteries, the filament volts being 2, and the maximum H.T. voltage recommended by the makers is 150. As a super-power valve in a 2-volt set for operating a moving-coil loud speaker, the P.220A. is specially valuable.

The P.X.4

And now for the Marconi and Osram P.X.4. This is a valve primarily intended for use in all A.C. sets where other valves of the indirectly-heated type are used; the P.X.4 can be heated by A.C. being applied direct to its filament. It takes .6 amp. and has an impedance of 1,050 ohms with an amplification factor of 3.8.

The recommended H.T. voltage is 200, but I have had a couple of these valves working in parallel in the output stage of a large set at a pressure

(Continued on page 62.)

MEMBERS OF A FAMOUS FAMILY

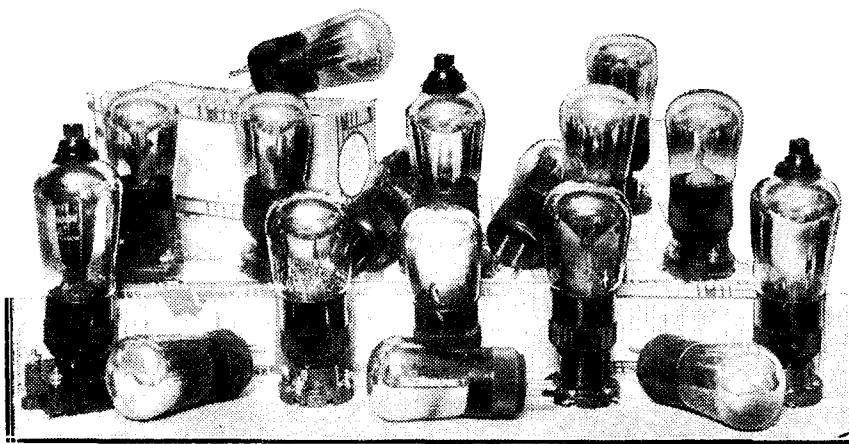

In this illustration we see a representative collection of 2- and 4-volt Dario valves ranging from the Screenodions to the Hyper-Powers.



Some interesting radio faults reviewed and questions answered.

By P. R. BIRD.

Cause of Bad Quality

WRITING from Marlow, E. G. adds a postscript to his letter which contains a good tip that is self-explanatory. He says:

"P.S.—I nearly sent you a Queer Query, until accident showed me what was wrong. The trouble was quality, which now and again went off suddenly without the slightest warning, quite noticeable distortion occurring and suddenly disappearing again.

"Piano notes became harsh and the low organ notes and drums were affected very badly. Also a scratching noise for which I could not account took place, so thinking one of the components had a faulty contact somewhere I overhauled the whole set.

"I was giving up in despair when I found I could bring the effect on or off by pressing the side of the output choke, and I afterwards proved that some of the turns in this were shorting, and so causing the trouble. I mention this in case you care to warn other readers, as it was only by a sheer fluke I discovered it."

Safety Fuses

In connection with the use of low-consumption flashlamp bulbs acting as fuses in wireless receivers, it was mentioned on this page some little time ago that these bulbs can be bought anywhere at the cost of only a penny or so. The General Electric Co., Ltd., point out that if bulbs of foreign manufacture are obtained for this purpose it is quite possible that the object of fitting them will be defeated, as in very many kinds the

fusing current of a flashlamp bulb varies between wide limits.

They say: "Cases have recently been brought to our notice where such bulbs have been fitted in place of the Osram flashlamp bulbs rated at 3.5 volts 0.15 amp. recommended, with the result that the fusing current was too high and the valves which the bulbs should have protected were destroyed before the lamp burnt out."

In cases of this kind, where possibly the cost of several valves is involved,

What puzzles him is that although he gets a reduction in H.T. current in this way, and a variation in volume, he also gets bad distortion. And he queries whether this latter can be stopped short of altering the voltages back to normal.

His suspicions that the valve itself is not all it should be are quite unfounded, for any S.G. valve is liable to behave in this way if liberties are taken with the voltages to the anode or the screen. One tip, however, is worth passing on, and that is that such a valve can very often be worked without the slightest apparent trace of distortion by reducing both the H.T. voltages considerably, but by making the anode voltage considerably lower than that of the screen.

Inverted Potentials

It often happens that a valve will work with, say, 18 volts on the anode and about 30 on the screen, the total H.T. current taken from the battery being much less than with its normal voltages, and this without any apparent loss of sensitivity or tendency to distortion.

If grid bias is fitted to the S.G. valve it may be necessary to reduce this, say, from 3 to 1½ volts negative, or from 1½ to nil, but this is a matter for experiment, as sometimes the alterations in H.T. voltages do not appear to require a corresponding

IS YOUR SET "PLAYING UP"?

Present-day radio is remarkably reliable. But every set "goes off" sometimes, and it should not therefore be assumed that it is wearing out. All it wants is proper maintenance—like a car or a bicycle, or any other similar contrivance.

If you have any knotty little problem requiring solution, remember that the WIRELESS CONSTRUCTOR Technical Queries Department is in a position to give an unrivalled service. The aim of the department is to furnish really helpful advice in connection with any radio problem, theoretical or practical.

Full details, including the scale of charges, can be obtained direct from the Tech-

nical Queries Department, WIRELESS CONSTRUCTOR, Fleetway House, Farringdon Street, London, E.C.4.

A postcard will do. On receipt of this all the necessary literature will be sent to you, free and post free, immediately. This application will place you under no obligation whatever. Every reader of the WIRELESS CONSTRUCTOR should have these details, which will enable him to ask his questions so that we can deal with them expeditiously and with the minimum of delay.

London Readers, Please Note: Application should not be made by telephone or in person at Tallis House or Fleetway House.

it is certainly worth spending an extra penny or two to obtain a British-made lamp such as the Osram described above, of which the rating is known.

S.G. Voltages

A Leicestershire reader of the WIRELESS CONSTRUCTOR has been greatly puzzled by the behaviour of his screened grid valve. With the idea of affecting economy in H.T. battery current he tried reducing the anode voltage from 120 right down to below 60, and finally fitted variable resistances to control the voltages of the H.T. + leads.

alteration in the grid bias in order to function as desired.

When trying this out do not forget that although the voltages recommended may vary in different cases, and although with some valves it is not possible to get this effect at all satisfactorily, it is quite usual to find that bad distortion sets in when intermediate voltages are tried. And the H.T. on anode and screen should be either those recommended by the makers or completely inverted ones, as named above, in order to get good quality, intermediate positions merely resulting in most cases in totally unsatisfactory operation.

The STANDARD A.C. UNIT

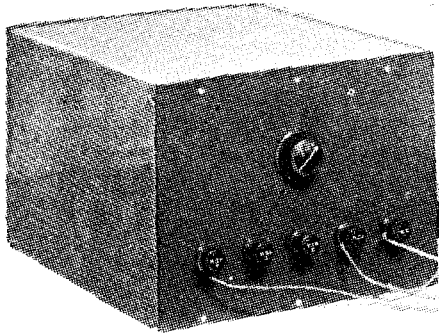

The A.C. mains H.T. unit described hereunder is specially designed to supply a long-felt want among builders of "Wireless Constructor" sets. It is capable of providing a steady and safe anode current supply to any of the sets described in recent numbers of this paper.

Designed and Described by the "Wireless Constructor" Research Dept.

At some time or the other most of us have experienced the feeling when listening to our radio set that it is not going so well as it was a month or two before. True, it seems about as good as it was, say, a week ago, but it has gradually

been dawning on us that the results have "fallen off."

The volume, for instance, does not provoke quite the same feeling of satisfaction that it once did; some of the loud notes seem harsh, and the reception of continental stations, once the envy of neighbours, no longer seems to thrill.

You may put it down to the fact that you have got used to the set; or, if you are not so easily pacified, you may begin to look for the reason.

This gradual deterioration does not take place in every sort of set, and it is no mere coincidence that the

receivers that generally treat listeners thus are run from battery H.T., and usually *dry* batteries. That is the clue to the mystery; the H.T. has run down!

The Remedy

All you can do is to renew the H.T. batteries and look pleasant about the cost, unless (and it is surprising how often this "unless" applies)—unless you have mains in the house!

If you have, you merely build an H.T. unit, connect it up, and forget the question of H.T. renewals for ever. Your set will always be up to

YOUR SHOPPING LIST

- 1 Panel, 9 in. × 7 in. (Trolite, or Lissen, Paxolin, Resiston, Becol, etc.).
 - 1 Baseboard for above, 12 in. × 9 in.
 - 1 Sheet of perforated zinc, 24 in. × 24 in.
 - 1 Mains transformer for U.S. or similar valve, with secondary output rating 200-0-200 to 250-0-250 (Ferranti E.V.2, or equivalent type, e.g. Heayberd, etc.).
 - 1 Sprung valve holder (W.B., or Igranic, Lotus, Lissen, Bulgin, Magnum, Wearite, etc.).
 - 2 L.F. chokes (Varley and Igranic Type G, or R.I., Ferranti, Wearite, Bulgin, Lissen, etc.).
 - 1 Fixed resistance and holder, for value see text (Ferranti, or R.I., Varley, etc.).
 - 1 20,000-ohm potential divider (Wearite, or Bulgin, Climax, etc.).
 - 1 50,000-ohm variable resistance (Rotorohm, or Harlie, etc.).
 - 5 Indicating terminals, for markings see diagrams (Belling-Lee, or other insulated type).
 - 1 2-mfd. fixed condenser, minimum working voltage 400 volts (T.C.C., or Hydra, Lissen, Mullard, Ferranti, Dubilier, etc.).
 - 1 4-mfd., 1 2-mfd. and 1 1-mfd. fixed condensers, working voltage not less than 250 volts (T.C.C., Dubilier and Lissen respectively, or Mullard, Hydra, Ferranti, etc.).
 - 1 2-mfd. fixed condenser, with minimum working voltage of 200 (T.C.C., or Mullard, Hydra, Ferranti, Dubilier, Lissen, etc.).
 - 1 Mains adaptor plug and electric bulb holder.
- Wood, ebonite, screws, wire, etc.

FULL-WAVE RECTIFICATION IS USED

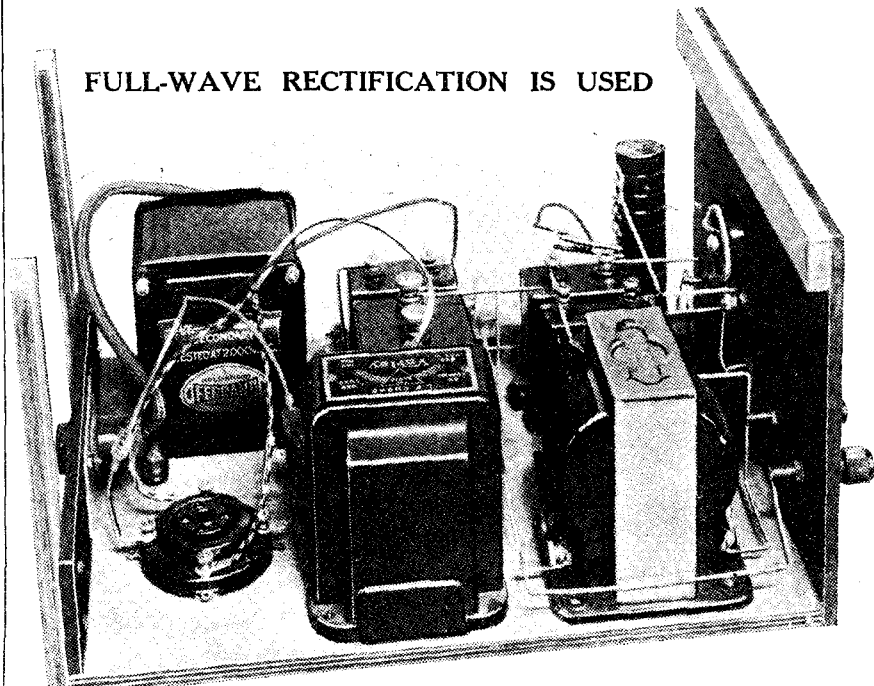

This photograph shows the rectifier side of the unit, in which a full-wave rectifying valve of the U.S. type is employed.

The Standard A.C. Unit—continued

scratch, and your pocket will be left in peace.

Of course, you must build a unit of really good design if you wish to be perfectly satisfied, and, first of all, you must find out from your electric-light meter whether you have D.C. or A.C. mains. If you have the former, then the Standard D.C. Unit, described in the June issue of the WIRELESS CONSTRUCTOR, is what you should build.

Four Positive Taps

If, on the other hand, you have A.C. mains, then you should build the Standard A.C. Unit which is described here. You will find it extremely easy to make and as "safe as houses" to use.

In reference to this last point, the unit is completely shut in with a metal cover which cannot be removed until the mains are disconnected. This avoids all possibility of bad shocks and shorted mains when the unit is open.

The unit is termed "Standard" because it is suitable for use with any of the sets recently described in the WIRELESS CONSTRUCTOR. Four H.T. positive tapplings are provided, two of which are variable.

If you look at the circuit diagram you will see that the arrangement employed, although simple, is quite efficient. Special attention has been

given in reports of the WIRELESS CONSTRUCTOR Ideas Committee, the output is limited to a suitable maximum.

smoothing, are supplied via a further L.F. choke L.F.C.₂.

This choke also ensures that the +1, +2 and +3 terminals are

IT CANNOT BE OPENED WITH THE CURRENT ON

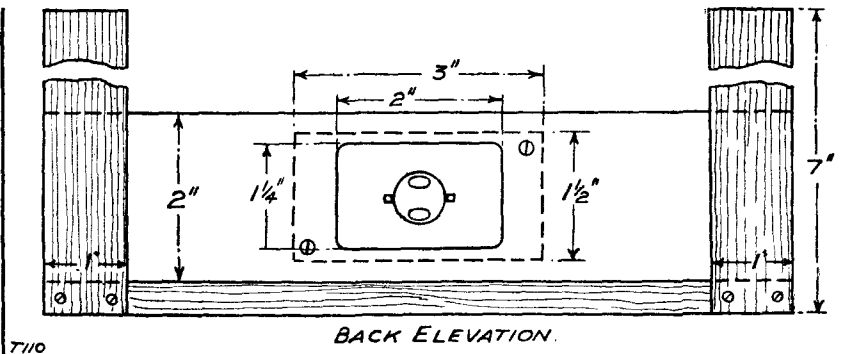

The dimensions of the safety plug and mounting are given in this diagram.

This is carried out by means of the fixed resistance, marked X. As the voltage drop across this will vary according to the current taken by the

The Standard A.C. Unit is the outcome of the deliberations of the Special "Wireless Constructor" Ideas Committee, and helpful suggestions contained in letters from our readers.

set, no definite value is given for it. Further details in connection with this are given later.

The H.T.+4 tap is intended for

properly isolated from H.T.+4. In sets employing S.G. valves H.T.+3 will supply their anodes, and +1 the screening grids. For this purpose H.T.+1 is supplied via a potentiometer instead of a plain resistance, so that voltage fluctuations are made very small.

H.T.+2 is used for the detector valve. Ordinary L.F. valves, that is, those other than the output valve, can be supplied by H.T.+3.

In a special list you will find all the components required, with suitable makes mentioned against them. With reference to the fixed condensers, it will be seen that minimum working voltages are given.

THE CIRCUIT EMPLOYED IN THIS STANDARD UNIT.

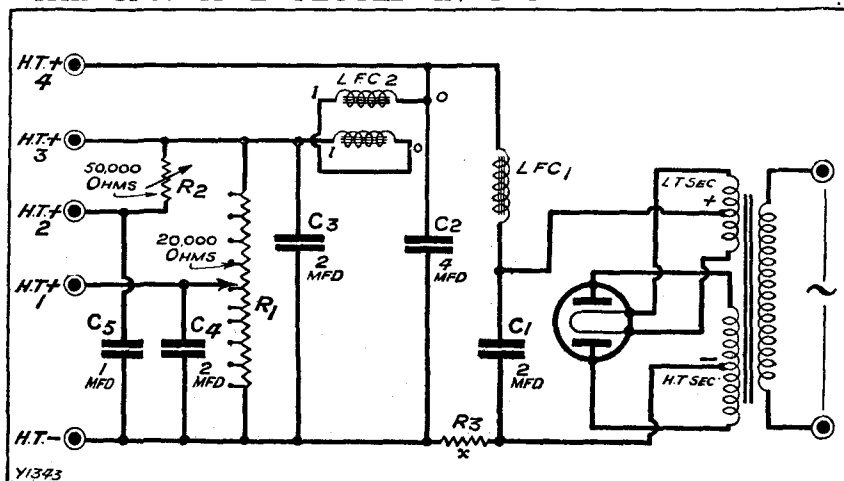

Note how the smoothing is carried out, and how the voltages to the various terminals are controlled.

paid to obtaining sufficient separation of the various positive outputs.

Full-wave rectification is employed, and a valve rectifier is utilised. In accordance with the ideas recently

supplying the last valve, or valves, if push-pull or paralleled valves are used, and the choke L.F.C.₁ provides ample smoothing for this tap. The other three taps, which require more

Making the Cover

It is impossible to give definite values, as different makers have different ranges for their products. So long as the condensers have working voltages equal to, or higher than, those given in the list, everything will be O.K.

The perforated zinc, of which the cover is made, has two very distinct advantages over solid metal. First, it allows any heated air produced by the valve to escape easily, and, more important, it is vastly easier to handle.

Actually the construction of the cover is a matter of minutes only, and entails the simplest possible tools. For this reason it is therefore suggested that it should be made first.

Lay the sheet of perforated zinc on the table and mark it out according to the diagram showing the sections A, B, C and D out flat. Section D

The Standard A.C. Unit—continued

will be 9 in. by 7 $\frac{3}{8}$ in., because $\frac{3}{8}$ in. has to be allowed for the part bent into a step.

top) and mount the terminals and resistance on it.

Screw the panel to the baseboard

strip which go on the back of the baseboard.

The details and dimensions given on the special diagram will make the job quite simple. The hole in the ebonite is best cut with an ordinary fretsaw.

The plate to which the mains adaptor plug is fixed is of aluminium or other soft metal such as copper. Take care not to drill the hole for the adaptor too large.

HOW THE CONTROLS ARE ARRANGED

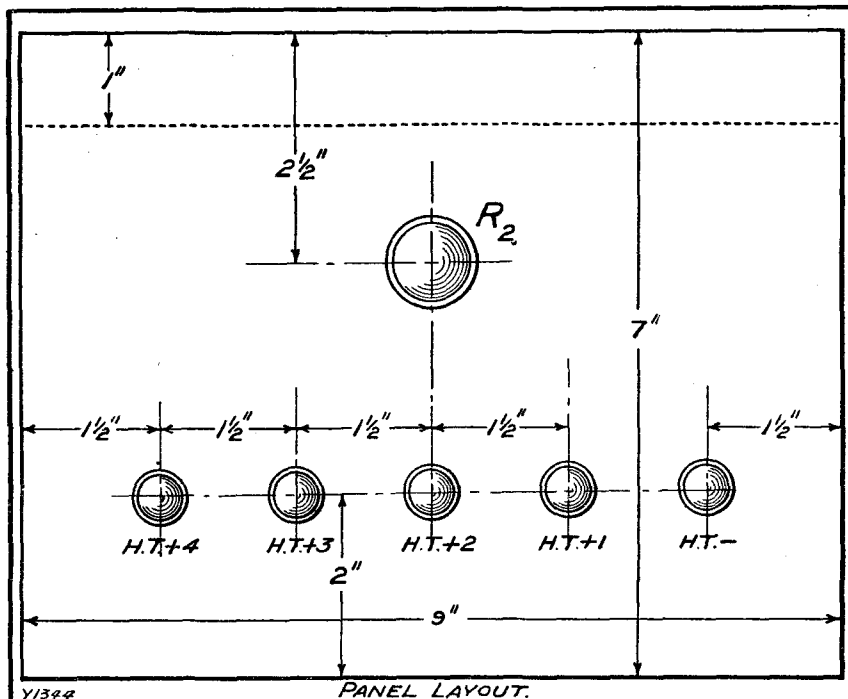

This is the panel drilling diagram. R_2 is the resistance controlling the voltage to the detector terminal, H.T.+2.

The marking out can be done quite well with a soft lead pencil, and you will find a pair of scissors quite suitable for the cutting business. The little slots in A and C should not be cut out yet.

When the sheet is cut out it should be bent into shape; the correct way

A safe, smooth and constant H.T. supply is assured to users of this simple but effective unit.

to bend the various sections being quite obvious after a short study of the photographs. Where A and D, and C and D come together they should be held tight by little pieces of copper wire threaded through the small perforations in two or three places.

Now lay the cover aside for a little while and turn your attention to the remaining constructional work. Drill the panel in accordance with the dimensions shown on the panel layout (not forgetting the small holes for fixing the piece of wood at the

and mount the remaining components. Next you should prepare the two wooden uprights and the ebonite

Wiring the Unit

When this back assembly and the strip of wood across the top of the panel are put in place you may wire up. Use some form of insulated wire and follow the connections shown in the wiring diagram exactly.

An ordinary pendant type electric bulb holder is used to make contact with the adaptor plug. The shade ring is used to hold this in place, and it should not be screwed up tight against the perforated zinc.

A slight twisting movement for the holder is necessary so that it may be given a twist when pushed over the adaptor. Four screws, two each side of the unit, are used to hold the front of the cover in place.

These screws are not turned right home, and four little slots are cut in the zinc so that it slides under the

READY FOR WORK

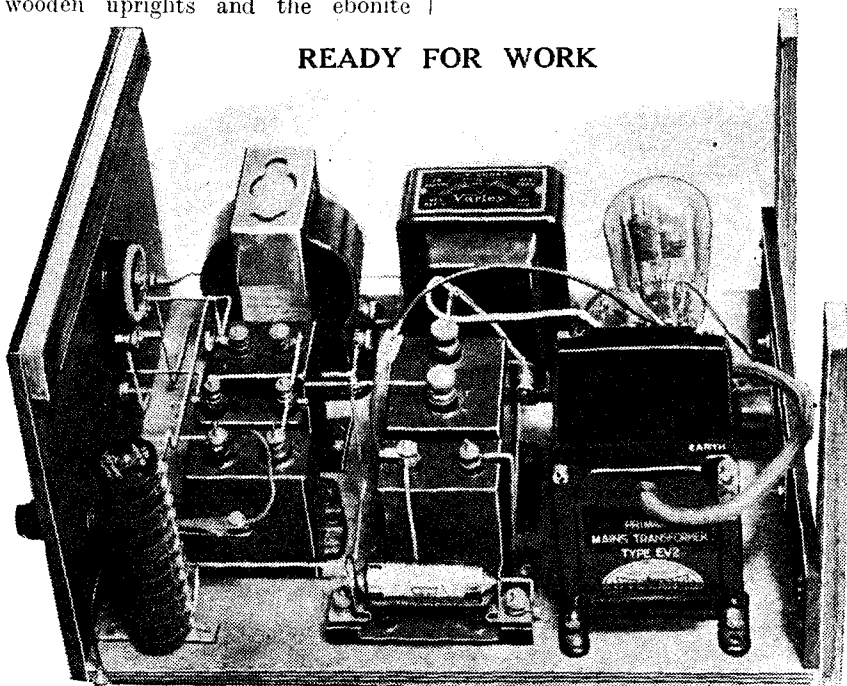

The Standard A.C. Unit is a hard-working unit that never shirks its job, but is always ready to supply power at a moment's notice.

The Standard A.C. Unit—continued

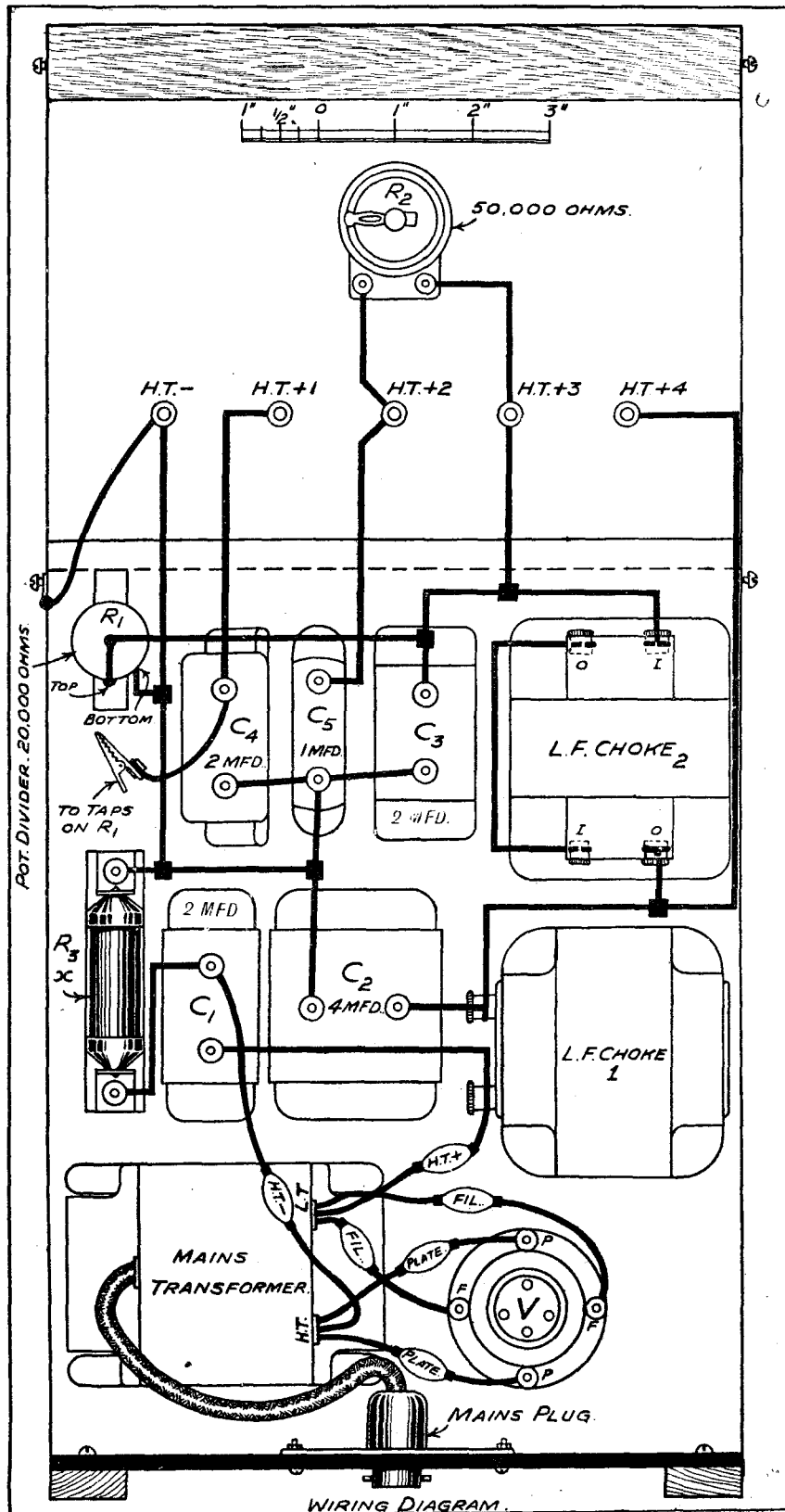

There is nothing difficult in the wiring or assembly, and provided you keep to the layout shown, and use insulated leads, you need have no qualms concerning the results.

screw heads. These slots can be cut as soon as the screws are in place.

Do not cut them before, as you may not get them in exactly the right place. Also use screws with round heads that are fairly large.

The flex lead from H.T. — should terminate in a washer which is arranged under one of the screws. This is for connecting the metal cover to H.T. negative.

Transformer Rating

The end of the twin-flex lead which comes from the lamp holder should terminate in another adaptor plug. This plug is then put into any convenient lighting socket. A wall plug adaptor could be used instead if desired.

The transformer should be rated to give an H.T. output of 200-250 volts

The safety-plug fitting makes it impossible for any adjustment to be made unless the power supply is cut off. This makes the unit perfectly safe.

and have a filament winding to suit a U.S valve or similar rectifying valve. Different rectifiers have different filament ratings, so be sure that you use the valve for which the transformer is designed.

Switching Off

With the particular transformer used and a value of 5,000 ohms for R_3 , H.T. + 4 will give 150 volts at 11 m.a., 120 at 17 m.a., and 100 at 21 m.a. The H.T. + 3 tap will be a little lower than the above voltages, and + 2 and + 1 will, of course, be variable up to the value of H.T. + 3.

With a 1,000-ohm resistance the values will be 150 volts at 40 m.a., 120 at 55 m.a., and 100 at 60 m.a. You will thus see that with values in between 1,000 and 5,000 ohms practically any desired current at a given voltage may be obtained to suit your particular set.

The mains switch should be put to the off position before the L.T. switch on the set itself is turned off.

The reason why this sequence should be adopted is to avoid the possibility of shocks from a charge held in one of the condensers in the unit. The large fixed condensers hold quite a considerable amount of current, which may be at a voltage high enough to give a strong shock.

C.P.C.

“CURRENT PER CELL”—that is the modern test of the H.T. battery for radio. Because with modern valves the drain upon your H.T. battery is very heavy and every cell to-day must do its share.

The cells of the Lissen Battery are large in size. Each cell is a deep reservoir of energy. Each cell is master of its work—ready to pour out its energy unstintingly—for month after month it will do that for you.

If you want most “Current per cell” get a Lissen Battery. 10,000 radio dealers have it. But ask firmly for it by name.

on “current per cell” Lissen scores every time!

PRICES

60 volt (reads 66)	7/11	60 volt (Super Power)	13/6
100 volt (reads 108)	12/11	100 volt	22/-
120 volt	15/10	4½ volt Grid Bias	10d.
36 volt	4/6	9 volt	1/6
60 volt (For Portable Receivers)	7/11	16 volt	2/9
99 volt (For Portable Receivers)	12/6	4½ volt Pocket Battery	5d. each (4/6 doz.)
		Single Cell Torch Battery	4½d.

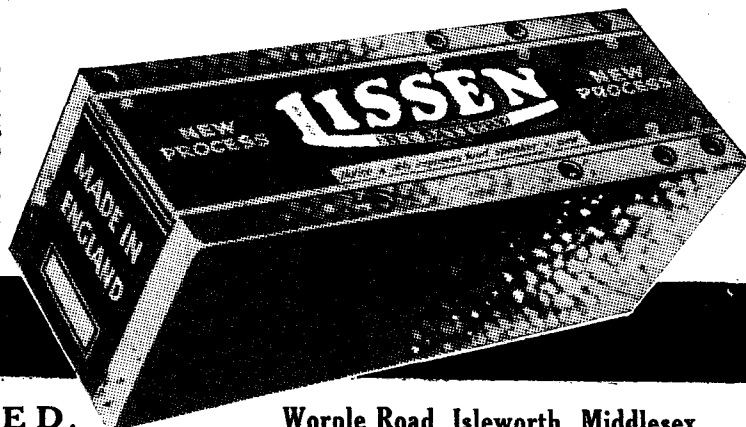

LISSEN LIMITED,

Worple Road, Isleworth, Middlesex.



H2!

**Beating Nature—
on her own ground!**

The nose of a bloodhound, the ears of a deer, the whiskers of a cat—fascinating instances of the acute degree to which nature has carried sensitivity in many of her amazing creations. Yet the scientists of the Marconi Valve Factory have devised an appliance which for sensitivity beats any of these. This marvellous achievement is incorporated in the new Marconi Valve H.2, the introduction of which marks an entirely new era in the "detector" field of radio science.

The Marconi H.2 is a new high magnification valve with a mutual conductance of 1.0 ma/volt—the highest yet attained in this class—particularly suitable for detection in portable receivers. The amplification factor of 35, and impedance of only 35,000 Ohms, are obtained by special constructional methods which at the same time give exceptional freedom from microphonic feed-back. Marconi H.2 should be fitted as "detector" in portables—or, indeed, in any set where maximum sensitivity is essential. It will give greater range, fuller tone and perfect stability. It will bring in new stations with amazing consistency and improved reproduction.

Marconi H.2, the new **EFFICIENCY** detector, with the highest conductance, costs only 8/6. It is **ALL BRITISH!**

MARCONI

H.2.

8/6

**REDUCED
PRICES
NOW IN
OPERATION**

Remember! Marconi Valves are used by the B.B.C., Imperial Airways, Croydon Control Tower, Metropolitan Police, Trinity House Beacon Stations and Lightships, Empire Wireless Communications, Large Passenger Liners, etc.—need more be said?

**Non-inductive
Condensers
the Latest
T.C.C.
Development**

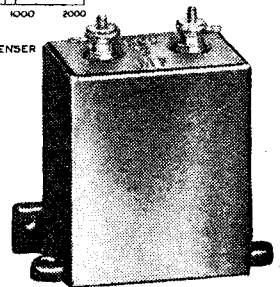
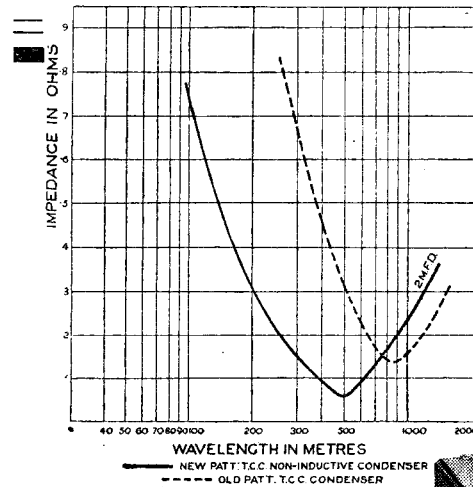

Here's the latest T.C.C. development—a Non-Inductive Condenser at no extra cost. The advent of the Screened Grid Valve has emphasized the need for a condenser having the minimum of impedance in order that small high frequency currents may be readily passed. How the new T.C.C. Non-Inductive Condenser achieves this result is shown on the curve above. The ordinary 1 mfd. condenser has a resonant point at about 900 metres whereas in the new T.C.C. Non-Inductive Condenser this has been reduced to nearly 500 metres. Be wise: always use

Available in all capacities from .005 mfd. to 2 mfd. from all wireless shops.

The above illustration shows the T.C.C. 2 mfd. Non-Inductive Condenser in moulded case 3/10.

Telegraph Condenser Co., Ltd., N. Acton, W.3



Always ahead in Condenser Design

The Standard A.C. Unit—continued

If the set is switched off before the mains circuit is broken, all the condensers except the one joined to

The one rated at 200 volts is joined to the H.T. +1 tap which is supplied via the potentiometer. This tap is

for supplying the screening grids of S.G. valves, or for other purposes where a comparatively low voltage is necessary.

In view of this the tap on the potentiometer will never be used right at the maximum end. If it were it would be just as necessary to use a condenser of the 250-volt rating as in the case of the tap supplied by the variable resistance.

Just a word about the position of the mains unit. Generally speaking, it is best to arrange the unit alongside the set and at the right-hand end of it.

Positions of Leads

In this position it will be in a convenient place for running the leads to the set in a neat manner. Should you find that there is a little hum present, move the unit a foot or two away from the set.

Always keep the flex leads which supply the mains unit well away from the set itself, and also see that they do not run near the loud speaker or its leads.

In cases where there is an obstinate hum, or a noisy background is present, the use of H.F. chokes in the mains leads will often prove helpful. A 2-mfd. fixed condenser can be connected across the unit side of the chokes.

THE PROTECTING COVER

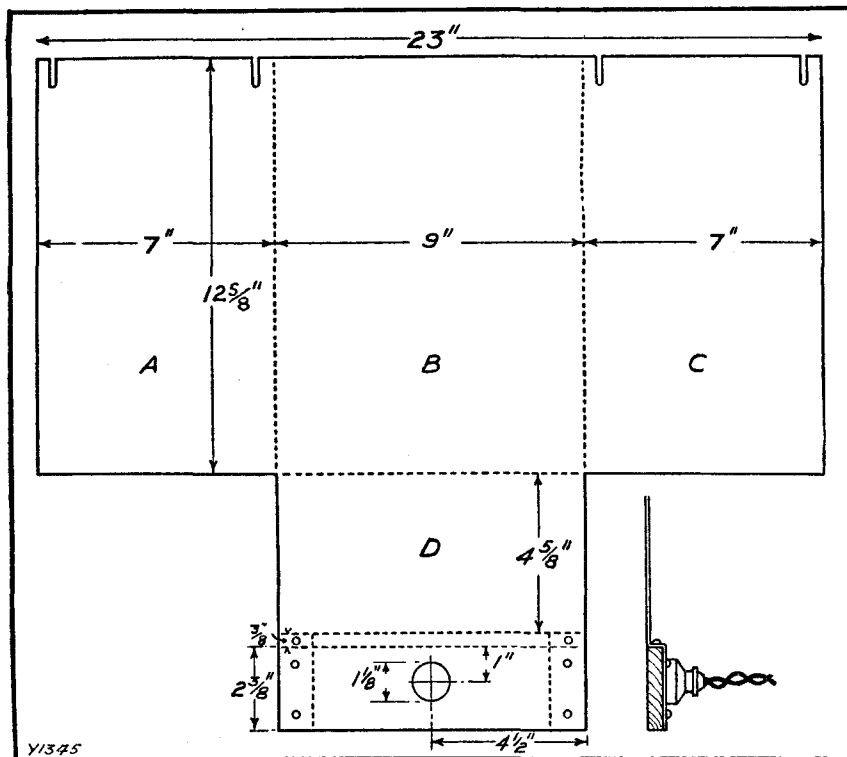

This diagram gives you the dimensions of the wire covering, the whole being flattened out into one plane for drawing purposes. The slots at the edges fit over small screws.

the tap supplied by the potentiometer will remain charged when the unit is turned off. When the mains are switched off first, the current in the reservoir condensers is quickly used up by the set.

Condenser Details

They are therefore left in a discharged or "safe" condition, and no one can receive a shock from them. (The condenser across the potentiometer tap would discharge itself through the section of the potentiometer across which it was tapped, in any case.)

It has already been mentioned that different working voltages for the fixed condensers are required, but it may not be quite clear which positions the various ones should occupy.

Since there is only one 4-mfd. and one 1-mfd. the positions for these two condensers are quite obvious. It will be noticed, however, that the three 2-mfd. condensers are all rated at different voltages. The 250-volt one goes to H.T.+2.

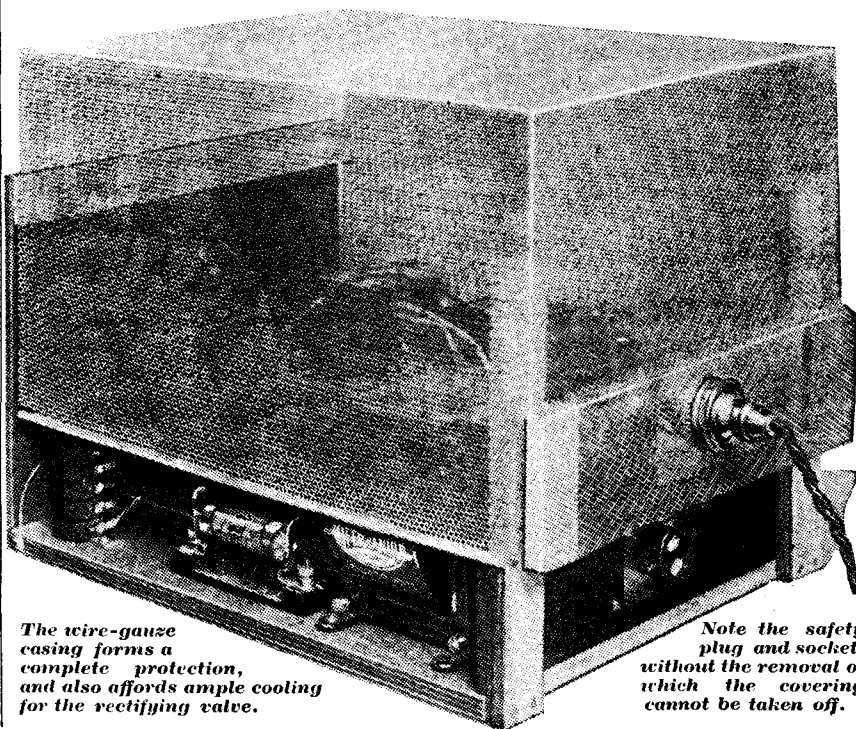

The wire-gauge casing forms a complete protection, and also affords ample cooling for the rectifying valve.

Note the safety plug and socket, without the removal of which the covering cannot be taken off.

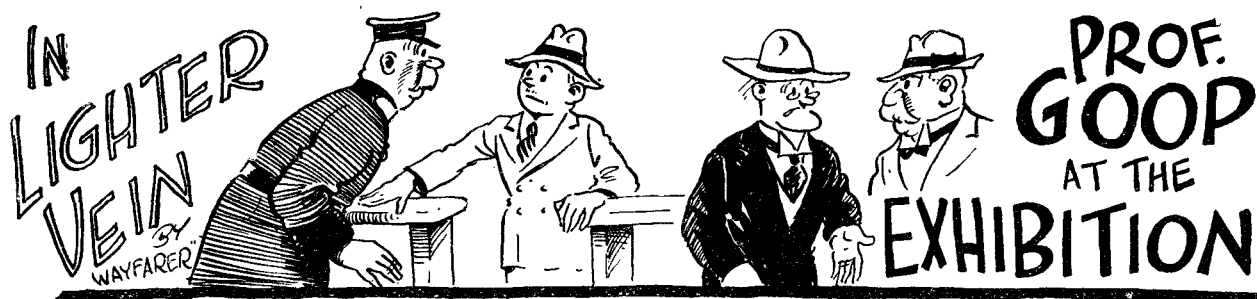

I TOLD the Professor flatly this time last year that I refused ever to accompany him again to the Wireless Exhibition. Practically the only exhibit looked at with any care in 1929 was the Mullard Girls. The best family of characteristic curves that he had seen for a long time, as he put it.

However, the kindly touch of Father Time, as they say in the movies, smooths out ill-feelings, and when this year's Olympia drew near I resolved to let bygones be havebeens. I decided not to let the past rankle, and invited the Professor to accompany me once more. Just as a precaution, though, I included Sir K. N. Pepper in the party as a kind of chaperon.

"Low Finance"

It was most unfortunate that when on the morning of our visit I came to examine my financial resources I should find that my trouser and other pockets yielded no better harvest

QUITE SIMPLE

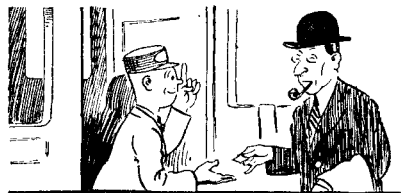

I strode to a first-class carriage and cried, "Tickets, please," with an engaging smile.

than two pennies, a halfpenny, and a latchkey.

An examination of my pass-book showed that there was no hope from that quarter. Many a man would have been daunted in such circumstances, but we Wayfarers are of the bulldog breed, which never takes no assets for an answer.

Neatly Done

I strolled down to the station in good time for the ten-forty, and found the Professor and Sir K. N. Pepper at the booking office.

"We're going first," said Sir K. N., "if that's all right for you."

"Perfectly," I replied, "unless, of course, you prefer to have a special train."

When the train drew in I was ticketless but undismayed. I had left the others and taken my stand opposite a door marked "Porters."

.....

Wireless Wayfarer has a good time very much at the expense of Prof. Goop and Sir K. N. Pepper.

As soon as its inhabitants rushed out to greet the ten-forty, I nipped in and found a cap hanging on a peg just inside the door.

Donning this, I strode to a first-class carriage, opened the door, and cried, "Tickets, please," with an engaging smile. The only passenger handed his over without a murmur. I had plenty of time to return the cap and to join the Professor and Sir K. N. in their compartment.

We Arrive at Olympia

On our arrival in London the other two were rather keen that we should go by tube to Addison Road, but I pointed out that a taxi would be quite cheap if we shared it, and they eventually agreed. The Professor and I were in first, so Sir K. N. Pepper had to occupy one of the fold-up seat things.

As a taxi passenger, Sir K. N. is by no means ideal. He has always an idea that the driver is doing him down by going the longest way round, so every now and then he leans out of the window and points out the proper route.

Probably he is not used to fold-up seats. The first time he withdrew into the taxi again he sat down on a seat that wasn't there. On the second occasion I thought I would be kind, so whilst he was standing up and pushing himself through the window I held the seat down with his umbrella.

And really I don't see why he should have been so annoyed about

it, for how was I to know that the taximan would let his clutch in with a bang, or that the umbrella was such a flimsy thing that it would simply fly to pieces when he sat on it?

And when we got to Olympia Sir K. N. was out first, and, as I was having a little trouble with a bootlace, the Professor easily beat me. By the time that I'd got the thing tied up they had paid the taximan, and by starting an argument between them as to which was the proper door to go in by I was able to shepherd them off the subject of my share.

I Get In

I lagged behind at the turnstile, and when they had entered sailed through the one marked "Officials Only," brushing aside the commissionaires and just saying: "Chief Engineer B.B.C. Great emergency; apparatus broken down. For heaven's sake don't delay me!"

It has always been an idea of mine that no one can possibly do justice to an exhibition unless the inner man is properly lined. When we arrived it was just lunch time, and I suggested to the other two that we should journey to the filling station forthwith. The proposal was carried by acclamation.

"This," I said, when we had sat down, "is an occasion which ought

THE SEAT FOLDED UP



He sat down on a seat that wasn't there.

to be marked. It is the first time that the three most distinguished members of the Mudbury Wallow Wireless Club have visited the exhibition together. Clearly a bottle of champagne is the only thing that can be drunk."

The other two assented after I had added that it was my birthday. We

EVERY PILLAR BOX IS A READY RADIO SHOP

*Ready Radio,
159, Borough High St.
London Bridge,
S.E.1.*

“PARATUNE” THREE

	£	s.	d.
1 Drilled ebonite panel, 18 × 7 in.	0	6	0
1 Hand-polished oak cabinet with 10-in. baseboard	1	10	6
1 ReadRad variable condenser, 0005	4	6	
1 ReadRad Duograph S.M. dial	6	6	
1 ReadRad differential condenser, 00015	5	0	
1 Igranite volume control, 5 meg.	6	0	
1 ReadRad Paratune coil	8	6	
1 Formodensor, type J	2	0	
3 Benjamin vibrolders	4	6	
1 ReadRad fixed condenser, 001	10		
1 ReadRad fixed condenser, 0005	10		
2 T.C.C. 2-mfd. fixed condensers	7	8	
1 ReadRad 2-meg. grid-leak and holder	1	4	
4 ReadRad single coil holders	3	4	
1 ReadRad “Hilo” H.F. choke	4	6	
1 W.W. 4-pole change-over switch, baseboard mounting, with 3½-in. extension rod	5	0	
1 ReadRad 25,000-ohm resistance and holder	2	6	
1 Lissen Super L.F. transformer	19	0	
1 R.L. Hypernite	12	6	
1 Varley output choke	1	0	0
1 Terminal strip, 18 × 2 in.	1	8	
9 Belling-Lee indicating terminals	2	3	
1 Lewcos 60X coil	4	9	
1 Lewcos 250X coil	6	6	
1 Lewcos 100X coil	4	6	
1 Lewcos 40X coil	3	6	
1 ReadRad on-and-off switch	10		
3 Valves as specified	1	7	6
1 Set ReadRad Jiffilux	2	6	
Spring clips, screws, flex, etc.	1	6	

TOTAL £10 6 0
(including Valves and Cabinet)

Any of the above Components can be supplied separately if desired.

IMMEDIATE DESPATCH
TO INLAND CUSTOMERS.
Your goods are despatched post free or carriage paid.
TO OVERSEAS CUSTOMERS.
All your goods are very carefully packed for export and insured, all charges forward.

KIT A
less valves **£7-8-6**
and cabinet ..
or 12 equal monthly payments of 13/7

KIT B
with valves **£8-16-0**
less cabinet ..
or 12 equal monthly payments of 16/2

KIT C
with valves **£10-6-0**
and cabinet ..
or 12 equal monthly payments of 19/-

RECOMMENDED ACCESSORIES

	£	s.	d.
Amplion cone loud speaker	1	19	6
Fuller (Sparta) 120 volts H.T. battery	15	10	
Fuller (Sparta) 9-volt G.B. battery	1	6	
Fuller (Sparta) 2-volt 30-amp. accumulator	11	0	
Atlas Eliminator A.C.72	3	17	6
Atlas Eliminator D.C.18	1	17	6

The Standard A.C. Unit complete kit of components can be supplied. Send for detailed Price List.

All Ready Radio Kits are officially approved by “Wireless Constructor.”

**Cash
or
Easy
Payments**

Ready Radio
159, BOROUGH HIGH STREET,
LONDON BRIDGE, S.E.1.

Telephone: Hop 5555 (Private Exchange) Telegrams: READIRAD, SEDIST

FOR RELIABILITY and EFFICIENCY

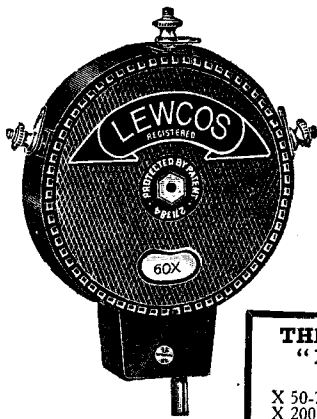

THE LEWCOS "X" COIL.
 X 50-75 .. Price: 4/9
 X 200-300 .. 6/6

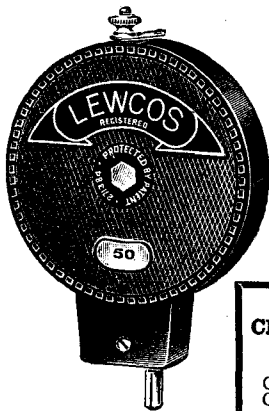

THE LEWCOS CENTRE TAPPED COIL
 CT 25-75 .. Price: 3/6
 CT 100-300 .. 4/6

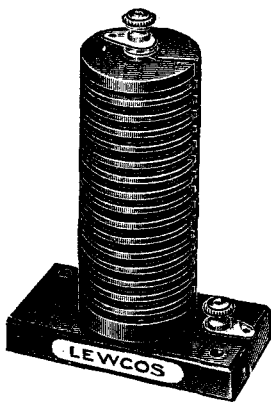

THE LEWCOS H.F. CHOKE
 Price 7/9.

THE LEWCOS "X" AND CENTRE-TAPPED COILS AND THE H.F. CHOKE ARE SPECIFIED FOR THE "PARATUNE THREE" DESCRIBED IN THIS ISSUE.

Many of the most successful receivers in the past depended in a large measure on the superlative qualities of Lewcos Radio Products.

Any one or all of the three Lewcos components illustrated above would improve your receiver to an astonishing degree.

"Perfection in every detail" is the keynote of the Lewcos Factory where these components are constructed.

Copies of the descriptive leaflets will be sent on request. Please quote reference.

Lewcos "X" and Centre-Tapped Coils—
Reference R34.

Lewcos H.F. Choke (giving tested values)—
Reference R33.

**READ THESE
UNSOLICITED
TESTIMONIALS**

- (1) "I have been experimenting 5 years and have not found any coils to come anywhere near Lewcos."
- (2) "With Lewcos Coils I find a wonderful difference in selectivity and volume."
- (3) "I am getting bad capacity effects and realise that I must have Lewcos Coils for efficiency."
- (4) "Very little reaction is needed when using Lewcos Coils, which in itself is worth a great deal."
- (5) "I have purchased a Lewcos Coil and the difference is marvellous."
- (6) "Lewcos Coils are the best plug-in coils on the market both for workmanship and results."

LEWCOS
 REGD.
RADIO PRODUCTS



THE LONDON ELECTRIC WIRE COMPANY AND SMITHS LIMITED.
 Church Road, Leyton, London, E.10.

Stocks held at the following Branches:—
 BELFAST
 BIRMINGHAM
 CARDIFF
 DUBLIN
 GLASGOW
 LEEDS
 LIVERPOOL
 LONDON
 MANCHESTER
 NEWCASTLE
 NOTTINGHAM

In Lighter Vein—continued

had a really excellent lunch, and the bill, all things considered, was most moderate, coming as it did to under a fiver. The Professor and Sir K. N. were by this time full of beans and bonhomie and readily fell in with my proposal that we should toss odd man out for who paid.

The Professor spun a coin

“Tails,” cried Sir K. N.

“Heads it is,” I said. “So Sir K. N. Pepper pays.”

“But what about you?”

“Me?”

“Yes, you!”

“Why,” I said, “I thought I explained it was my birthday, the time when a man expects his friends to rally round.”

Nasty Looks

And to rally round they started, but so nasty were their looks that I made a bee-line for the door before they knew where they were.

“On his birthday,” I said, “a man should not have to listen to unpleasant squabbles. Since you two are clearly in fighting mood I will leave you to fight it out between yourselves. I am now departing, and there will be no happy returns.”

When we met again some time later they had both cooled off considerably, and by raising an argument between them every time that either of them mentioned the topic of the lunch bill I managed quite easily to prevent any recriminations on that score. Tea was easy, for I simply invited a couple of the most attractive exhibits to have tea with the Professor and me, and he was so engrossed that he never noticed my exit.

Filling the Gaps

Even intermediate sustenance can be managed by those who know the ropes properly. For instance, I steered Sir K. N. in the direction of an extremely attractive stand marked refreshments.

“An extraordinary lot of old school ties one sees about,” I said.

“True,” said Sir K. N. “And, by the way, what’s yours?”

“That’s very kind of you,” I said.

You see, I hold very strongly that everyone should help on the Wireless Exhibition by filling up the gaps in his radio equipment during his visit to the exhibition.

True to my principles, I would have filled up a whole lot in mine if it had

not been for the fact that so many of the components were screwed down to the counters upon which they were displayed. Next year I shall take a screwdriver with me, for in these days of portables it is foolish to acquire a component unless one can test its weight by balancing it in the hand.

MARKING THE OCCASION

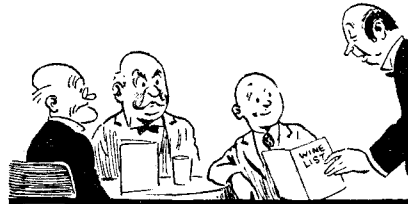

Clearly a bottle of champagne is the only thing that can be drunk.

Still, I enjoyed myself thoroughly, and acquired something like a record collection of catalogues. As I strolled round the gallery, in fact, it occurred to me that seldom had I spent a happier day, and I could not help thinking with scorn of the people who say that they cannot afford to go to the Wireless Exhibition.

Easy Money

“A penny for your thoughts,” said Sir K. N. Pepper at my elbow.

I held out my hand and pocketed the penny.

“I was just noticing that rope over there in the corner,” I said. “You see the one hanging down by the wall? I was thinking that even a fit man like yourself (Sir K. N. prides himself upon his thews and sinews) could not climb two yards up it without his feet.”

SCREWED DOWN

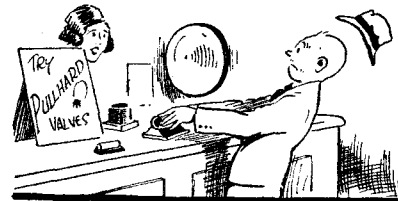

Everyone should fill up the gaps in his radio equipment during his visit to the exhibition.

“I bet you a fiver I could!” said Sir K. N.

“Done!” I cried.

It was a deserted corner, and nobody appeared to be looking. Sir K. N. removed his hat and coat and proceeded with much puffing and blowing to haul himself up by his hands. When he was about half-way towards the ceiling he looked down.

“I think I have won that fiver,” he panted.

“Not a bit of it. I have!”

“You have?”

“Yes.”

“What do you mean?”

“Well, you’ve got your feet with you.”

So that there shouldn’t be any squabble about his paying up, I extracted five Mahons from his note-case in the pocket of the coat that I was holding, left the garment upon the back of a packing case and departed ere he could slide down.

Exhibitions Not Expensive

Sir K. N. had no chance of being huffy, for the Professor took my part when the three of us foregathered again.

Professor Goop was in such a state of bliss that I had no difficulty in getting him to stand us dinner, and with a little urging he insisted upon paying for a taxi back to Euston. In some miraculous way I discovered the return half of a first-class ticket to Mudbury Wallow in my waistcoat pocket, whilst Sir K. N. Pepper, after searching in every pocket at the barrier, could not find his.

That night when I turned out my pockets I laid five one-pound notes, three pennies, a halfpenny and a latchkey upon the toilet table.

And yet there are those who say that exhibitions are expensive.

Psha!

* THE “EXPLORER” THREE *
* From a Reader. *

Sir,—I am a WIRELESS CONSTRUCTOR reader, and I feel very thankful to Mr. Victor King, who designed the “Explorer” Three, that I can get many stations on the short-wave band. I live in Hong Kong and still I can get G 5 S W and P C J at 2 a.m. every morning at loud-speaker strength. However, the coil of this set can only cover a certain wave-length, and the higher wave is impossible, such as 35–80 metres.

Yours faithfully,

WILLIAM LANG.

Hong Kong.

[Full details of a suitable coil for the wave-band mentioned by our correspondent will be given shortly.—Ed.]

POINTS FOR PURCHASERS

Some interesting items from the manufacturers about their latest lines.

New Igranic Dials

THE IGRANIC ELECTRIC CO., LTD., have forwarded details of two new slow-motion dials, namely, the "Igranic Minor" and the "Igranic Major." Very similar to the famous Indigraph vernier knob and dial, these devices are considerably cheaper, the Major coming out at 4s., and the Minor at 2s. 9d.

The scale on the dial is of white celluloid and is engraved 0 to 100. The $3\frac{1}{2}$ in. diameter (Major) has a ratio of approximately 6 to 1, and the $2\frac{3}{4}$ in. diameter (Minor) a reduction ratio of approximately 4 to 1. The dials are designed for use with condensers having $\frac{1}{4}$ -in. spindles and can be supplied in dark-brown finish if desired.

The Hypernik Transformer

From Lissen, Ltd., we have received some details of the new Hypernik transformer, which, as the name indicates, employs nickel alloy in the core. The makers claim that it operates perfectly when passing currents of 5 milliamps., the windings easily carrying this current without damage to themselves or to the quality of the reproduction.

Its primary inductance is 100 henries and its step-up ratio is 4 to 1. The Hypernik L.F. transformer can be used in all types of radio receivers, gramophone amplifiers, etc., while its conveniently small size automatically recommends it for use in portables and other compact types of sets. The base dimensions are only $2\frac{1}{4}$ in. by $2\frac{1}{8}$, and the height $2\frac{3}{4}$ in., and it is supplied in a handsome brown bakelite case for the price of 12s. 6d.

Dubilier Reductions

The Dubilier Condenser Co. (1925), Ltd., have made some considerable reductions in the prices of several of their well-known products for the present season. Both fixed and variable condensers, neutralising condensers, and wire-wound resistances are affected, representative reductions being from 2s. 6d. to 1s. 8d. in the case of the small mica condensers (types 610 and 620), 2s. 6d. to 1s. 9d.

in the case of the Dumetohm resistances, and from 6s. 6d. to 4s. 6d. for the Duwirohm wire-wound resistances of horizontal type in holder, 5,000 ohms.

The reductions are far too numerous to mention in detail, so particulars should be obtained from your dealer or direct from the firm.

A Book About Coils

A wide variety of circuits and much practical information are contained in a book recently prepared by the technical staff of Colvern, Ltd., for users of the Colvern coils. Notes on operation and simple formulae, etc., are included in the contents. The circuits alone would be interesting, and when backed by descriptive matter, as in this case, they form the basis of a valuable little book.

Department of Messrs. F. A. Hughes and Co., Ltd., and have acquired premises at 94-96, Rosoman Street, Rosebery Avenue, London, E.C.1, where showrooms and service departments are accommodated.

The telephone number is Clerkenwell 3570, and the telegraphic address "Bluospot Smith London."

Safeguarding Your Set

Readers who were interested in an article in our September issue called "Safeguarding Your Set" will recall that the author, Mr. H. S. Milnes, pointed out that many so-called safeguards are not safeguards at all. But he showed what a good investment small fuses are when connected in the common negative leads between H.T. and L.T.

Although Mr. Milnes had good results from flashlamp fuse bulbs by testing out a number, this process may seem tedious or risky to readers without facilities, and The Telegraph Condenser Co., Ltd., have pointed out that such risks can be entirely eliminated by using "Microfuses."

A HIVE OF RADIO INDUSTRY



Radio is one of the few industries that goes ahead in spite of trade depressions, and this view shows part of the big new Purley works of Radio Instruments, Ltd.

It is free to WIRELESS CONSTRUCTOR readers on application to Colvern, Ltd., Romford, but as the supplies were heavily depleted owing to the distribution at the Radio Exhibition, applicants should lose no time in applying for their copies.

British Blue Spot Products

British Blue Spot Co., Ltd., have notified us that this company has been formed for the distribution of the famous Blue Spot products, and to provide for their manufacture in Great Britain.

To ensure continuity of service they have taken over the staff and records of the Blue Spot

These ingenious devices have the advantage over the flashlamp bulb of being accurate, and as they are available to operate at currents from 5 to 1,000 milliamperes the current-carrying can be limited as desired with perfect safety.

The element in the Microfuse is gold film, which will not deteriorate with time, and the price of the Microfuse ranges from 1s. 9d., according to the current it is desired to carry. The smaller the current requirement the greater the accuracy required and the higher the price of the fuse, the 50-milliamp. size, for instance, coming out at 2s. 3d., while the 100-milliamp. is only 1s. 9d.

**They get more -
they make more of what they get**

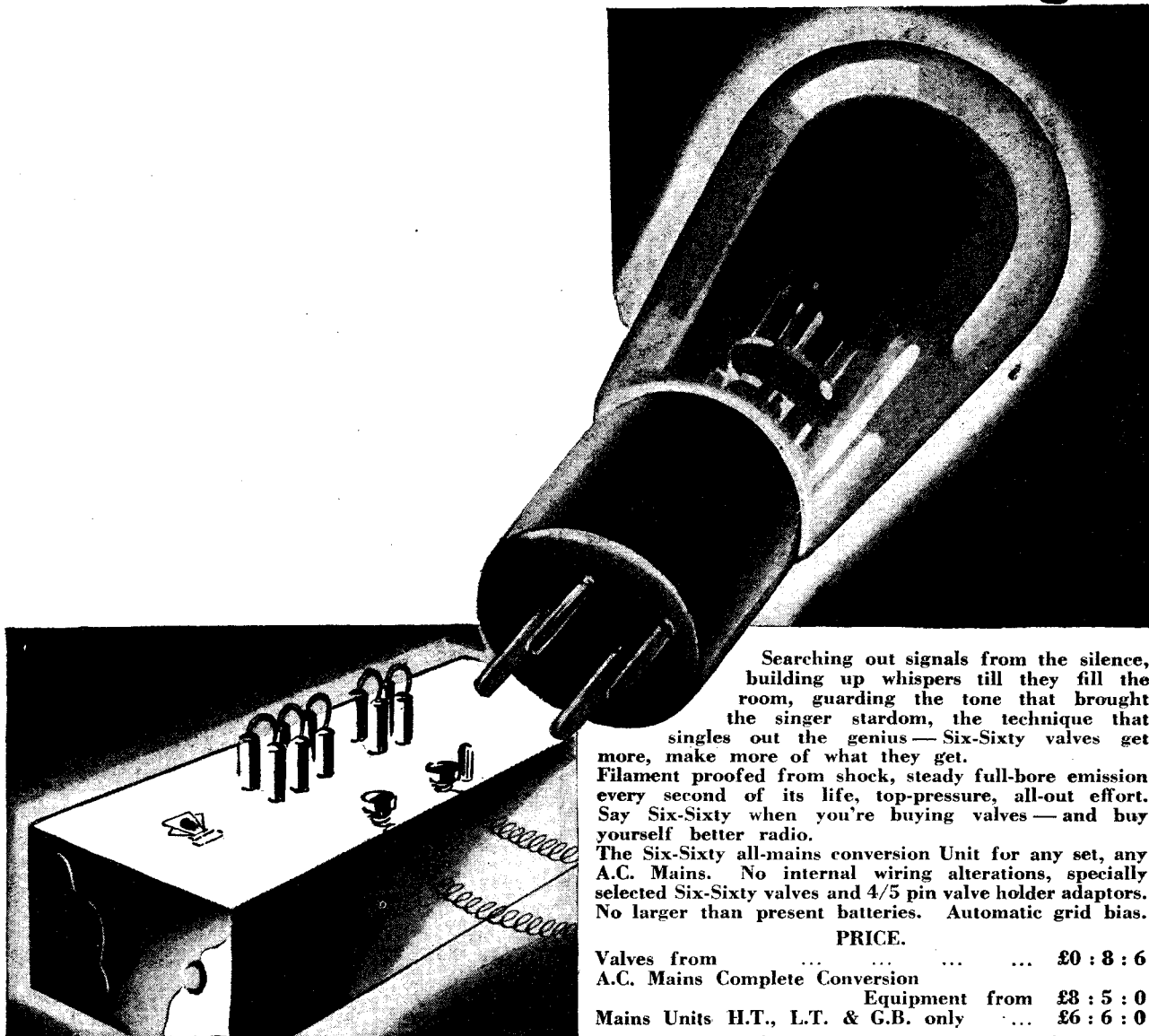

Searching out signals from the silence, building up whispers till they fill the room, guarding the tone that brought the singer stardom, the technique that singles out the genius—Six-Sixty valves get more, make more of what they get.

Filament proofed from shock, steady full-bore emission every second of its life, top-pressure, all-out effort. Say Six-Sixty when you're buying valves—and buy yourself better radio.

The Six-Sixty all-mains conversion Unit for any set, any A.C. Mains. No internal wiring alterations, specially selected Six-Sixty valves and 4/5 pin valve holder adaptors. No larger than present batteries. Automatic grid bias.

PRICE.

Valves from	£0 : 8 : 6
A.C. Mains Complete Conversion	£8 : 5 : 0
Mains Units H.T., L.T. & G.B. only	£6 : 6 : 0

Write for latest Six-Sixty Literature giving particulars of the complete range of Six-Sixty Valves, Mains Conversion Equipment, Valve Adaptors, Valve and Set Tester, Cone Speaker Unit and Cone Speaker Assembly, Cone Speaker Paper, Turntable, Grid Leaks, and Gramophone Pick-up Attachments.

SAY

SIX-SIXTY

(B.V.A. RADIO VALVES AND EQUIPMENT)

Six-Sixty Radio Co., Ltd., Six-Sixty House, 17/18, Rathbone Place, Oxford Street, W.1. Telephone : Museum 6110/7

*Dubiliers
make a
mica condenser
for every job!*

TYPE 620

For use in radio circuits where comparatively small capacity is required. Arranged for vertical mounting.

PRICES 1/8 to 3/-

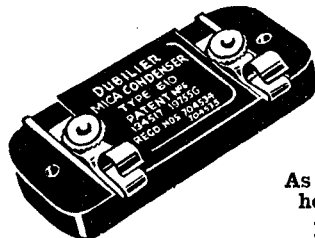
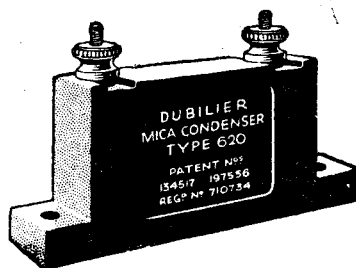

TYPE 610

As 620, but arranged for horizontal mounting.

PRICES 1/8 to 3/-

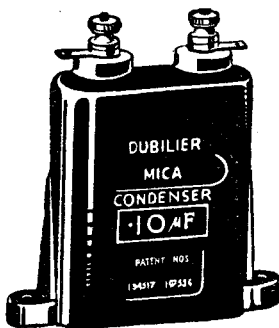

TYPE B775

Primarily designed for resistance coupling, but suitable for use in other circuits where a comparatively large capacity, capable of withstanding several hundreds of volts, is required.

PRICES 3/- to 18/-

Use Dubilier Condensers and be certain of satisfaction.

DUBILIER CONDENSERS

DUBILIER CONDENSER Co. (1925) Ltd.,
DUCON WORKS, VICTORIA ROAD, N. ACTON, W.3.

All you look for in a Reproducer you'll find in an R.K.

From whatever viewpoint you judge a reproducer you will find the R.K. completely satisfying.

FIDELITY

For four years R.K. has held unassailed leadership in the Reproducer field. For home

or public use there's no reproducer as good as the R.K.

VOLUME

There are three R.K. Reproducers, all obtainable complete in handsome cabinets of polished oak, mahogany or walnut; the Senior with built-in rectifier for use with A.C. mains, from £20, the Standard Senior and the Permanent Magnet from £16:16s., as well as the Junior

SENSITIVITY

Model, without cabinet, £4:15s., all of which are obtainable through your radio dealer.

Ask your dealer for particulars of hire-purchase terms.

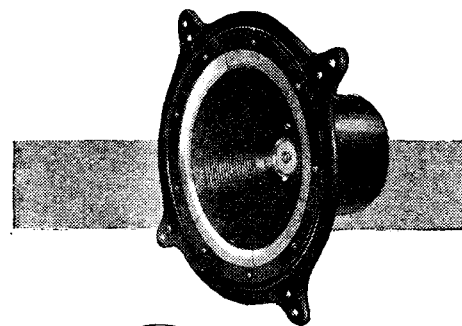

THE PERMANENT R.K. NEW MAGNET REPRODUCERS



THE EDISON SWAN ELECTRIC CO., LTD.
Incorporating the Wiring Supplies, Lighting Engineering, Refrigeration and Radio Business of the British Thomson-Houston Co., Ltd.
Radio Division:
1a Newman Street, Oxford Street, W.1
Showrooms in all the Principal Towns

EDISWAN

A PRACTICAL MAN'S CORNER



A special section for the set-builder, in which he will find many valuable hints.

By R. W. HALLOWS, M.A.

A Valuable Hint

I AM using wood screws just now of a particularly attractive kind, of which I am sure that readers will be glad to learn. They are made by Messrs. Nettlefold and they are of steel covered with copper electrolytically deposited.

There are several brands of copper-covered steel screws, but these are by far and away the best that I have used, since the copper is beautifully bright when you buy them and remains so for a long while.

For woodwork I like screws of steel far better than those of brass, for the latter have an unpleasant habit of breaking off short just below the head when you are giving the final turn into the cabinet material such as mahogany or oak.

Plain steel screws are not satisfactory, since they invariably rust as time goes on and do not look at all

AN "ATTRACTIVE" IDEA

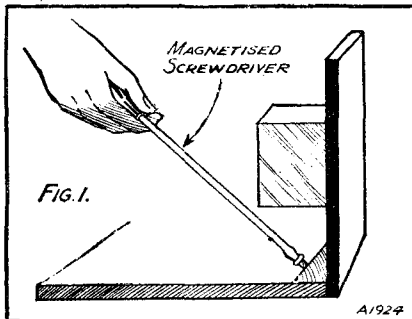

With a magnetised screwdriver you can fit copper-covered steel screws into the most awkward places.

nice. If rust develops upon the part of them that is in the wood it is sometimes extraordinarily difficult to extract them when required. Copper-covered steel screws, then, have every advantage and no drawbacks, for they are strong, they look well, and they last well.

THIS MONTH.

A Valuable Hint—Another Good Point—Cone Economy—A Useful Adaptor — Please Don't Do It! —The Cutter Cut!—Panel Fitting.

Another Good Point

Another advantage of using steel screws with a copper plating is that, as shown in Fig. 1, a magnetised screwdriver that is a good fit for the nick will enable you to put them in the most awkward corner without the slightest trouble. The size that I find most useful for fixing components to the baseboard for mounting panels and so on is the $\frac{5}{8}$ -in. No. 4.

A well-made screwdriver with a $\frac{3}{16}$ -in. blade is a good fit for the nicks of these, and if yours is not already magnetised you can soon make it so by pressing into service the magnet of your loud speaker.

A little gentle rubbing on the magnet will very quickly produce the desired effect. Magnetised screwdrivers require a "touch up" on the magnet from time to time, for they are not made of very hard steel and the knocking about that must come their way in a tool drawer tends to make them lose their magnetism rather quickly.

Cone Economy

I have always set my face against cheap-jack materials, but the other day I was rather struck by the cones and chassis offered for sale in the window of a wireless shop of the kind that the wise wireless man does not usually patronise. Since the price was only 2s. 11d. for the whole outfit, one did not seem to be risking much in making a purchase, so I went in and bought one.

Now it sometimes happens that those who run things together without any particular idea of what they are doing stumble upon something far better than the expert turns out after weeks of theoretical and experimental work. And this was just what I found had happened in the case of the cone that I am referring to.

It consisted of a light octagonal plywood frame in which was a cone that was quite freely suspended. The back of the frame was bridged by a bracket made of an exceedingly rough white metal casting. The whole thing looked 2s. 11d. all over.

After taking it home I mounted on it a balanced-armature unit which had always been far from satisfactory in its own expensive chassis, thinking that I would just see what it would do. You may gather how surprised I was to find that the quality was

TAKES ANY UNIT

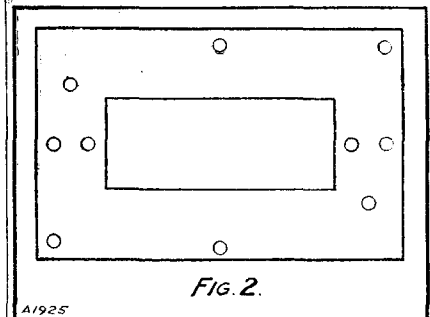

An easily-made adaptor enabling you to fit almost any speaker unit.

improved a hundred per cent, and that the zizzing from which the unit had previously suffered had entirely vanished.

I mounted this cheap cone chassis behind a baffle-board—and the heart does not grieve over what the eye cannot see. Actually it had produced one of the best loud speakers that I have.

A Practical Man's Corner—continued

These chassis are obtainable at many wireless shops, and I can recommend them as well worth trying. Of course, I can't guarantee that the reader will pick a good one every time.

A Useful Adaptor

Speaking of balanced-armature units and cone chassis reminds me of a problem that comes the way of most others. There is, unfortunately, no standardisation in the fittings of B.A. units. Most of them require two fixing bolts, but the spacing of the holes for these bolts differs greatly from make to make.

I have been dealing lately with a very large number of these units and with chassis of all kinds. My own plan is to make a number of adaptors, and with the help of these you can mount any unit in any chassis. Fig. 2 illustrates a typical example of such an adaptor.

The material used is sometimes three-ply and sometimes sheet brass. The plates are of various sizes, according to the units and the chassis being dealt with. In each is cut out a rectangular hole, the tool used being a hacksaw for brass and a fretsaw for wood.

PLIABLE PLIERS!

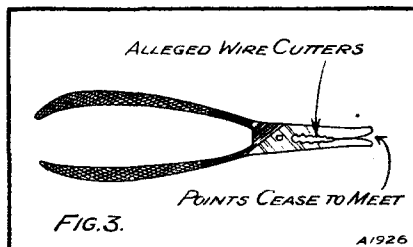

Cheap tools are often made of soft or badly tempered metal, and if they don't bend they break.

One pair of holes is drilled to take bolts passing through the holes in the unit itself. Then several other pairs are drilled at various distances apart. With an adaptor of this kind almost any unit can be fitted into any chassis with a minimum of trouble. If the reader happens to have purchased a unit and a chassis which don't appear to have been made for one another, he can easily bring about a satisfactory union by the method suggested.

Please Don't Do It!

Having suggested to the reader that cheap cone chassis may be satisfactory, I begin to feel a little guilty, fearing lest I should have set

his feet upon the downward path. I hasten, therefore, to tell a little story with a moral about some wonderful pairs of pliers, almost given away, that attracted a friend of mine the other day.

When they were new they did not look at all bad so long as you did not examine them too closely. Various kinds were offered, and, thinking that he would like a complete outfit of pliers, he bought one of each. Fig. 3 shows with fair accuracy the appearance of one particular pair after two or three days' use on jobs no heavier than those entailed in wiring up a set.

The Cutter Cut!

With the alleged wire cutters my friend endeavoured to snip off the end of the soft copper wire that he was using. He observed after two or three snips that cutting was becoming increasingly difficult, and when he held the pliers up to the light he found that each cut had been almost as hard on the cutters as it had been on the wire, for it had left a deep notch behind it.

In course of the work a few milled nuts were tightened with the jaws of the same pliers, and these also left their mark. The points of the pliers no longer came together; so far apart were they actually that it was quite impossible to grip a piece of No. 26 S.W.G. with them.

In fact, if you squeezed hard on the handles in an endeavour to do so the latter came together whilst the points of the jaws remained apart. Every other bargain pair that he bought proved equally bad, and he is now lamenting that he did not spend his shillings upon a small number of really good pliers.

Of the cheap tools to avoid, pliers, screwdrivers and drills stand in the forefront. These cheap tools are invariably made of soft or badly tempered metal, and if they don't bend they break.

Panel Fitting

When I watch friends who are beginners at the business of constructing wireless sets engaged in the job of putting one together I nearly always find that there is one task that they find particularly difficult—that of fitting the panel to the baseboard.

As often as not they get it on either askew or protruding beyond the baseboard at one end. The result in either case is the same—the baseboard and panel will not slide into the cabinet. And then begins an orgy of botching. Bits are filed off the panel or chipped off the inside of the cabinet with a chisel, a table-knife, or anything that comes handy.

When finished the set is not as pleasing to the eye as it should be, for somehow no one can help noticing if the panel is the slightest bit out of the true. Actually, panel fitting is a perfectly straightforward business if tackled in the right way. Personally, I don't like panel brackets. I much prefer to do my mounting in the way seen in Fig. 4.

WHY NOT WOOD?

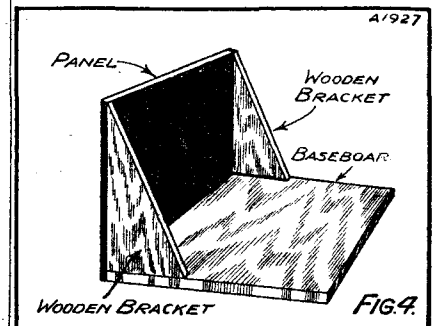

Wooden end-pieces make excellent alternatives to the usual panel brackets.

Instead of brackets triangular wooden end-pieces are used. These are fixed to the baseboard by means of countersunk screws driven up from beneath, and they are made of $\frac{1}{2}$ -in. white wood. Care must, of course, be taken to see that the front edges of the endpieces are absolutely at right angles to the baseboard. Here is the way in which the panel is mounted with this arrangement. Drill along its lower edge three or more holes half the thickness of the baseboard from the bottom.

Near each of the vertical edges make a couple of holes, the drilling centres being marked off half the thickness of the endpieces from the edge. Slide your baseboard into the cabinet. Then place your panel in position and drive in the fixing screws. If you do the job in this way the panel is always mounted as it should be mounted, and there is no difficulty in getting it in or out.

Now less recharging! Exide "D" Series L.T.

Batteries can last a long time on one charge . . . they are made for modern economical valves . . . they allow you to use a battery of sensible size . . . they don't sulphate even under the most severe conditions.

See how you save! You get an Exide "D" Series

Battery of twice the size of older types at the same price . . . add to this the saving in upkeep and you have the world's most economical battery.

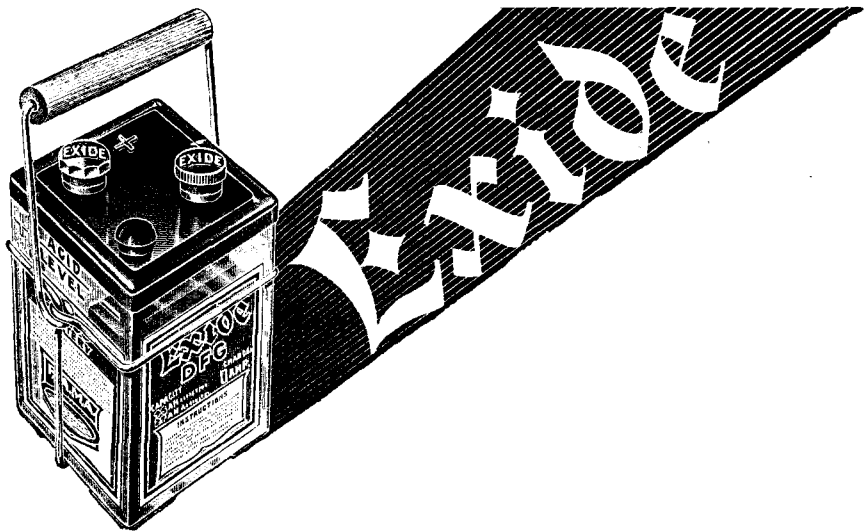

The battery for your set . . . a gem of con-

struction . . . differently coloured and shaped terminals distinguish positive from negative even in the dark . . . completely acid proof . . . strong metal carrier free. Remember, next time, Exide "D" Series for Low Tension.

Prices per 2-volt cell: DTG, 20 amp. hrs. 4/6 DFG, 45 amp. hrs. 8/6 DMG, 70 amp. hrs. 11/- DHG, 100 amp. hrs. 14/6

Obtainable from Exide Service Stations or any reputable dealer. Exide Service Stations give service on every make of battery Exide Batteries, Clifton Junction, near Manchester. Branches at London, Manchester, Birmingham, Bristol and Glasgow

L12

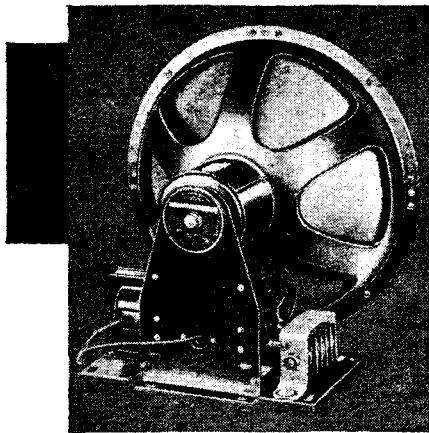

UNFETTERED REPRODUCTION

PERFORMANCE COUNTS

The purchaser knows that the name Magnavox means something definite, and that it indicates a maintenance of leadership for fifteen years in the manufacture of loud speakers. The new Magnavox moving-coil or dynamic speaker is the only type of unit capable of giving a perfectly natural performance and reproduction which cannot be distinguished from the original. There are positively no other loud speakers, irrespective of cost, which can possibly compare with a Magnavox in respect to design, construction and quality of reproduction.

The moving-coil type of loud speaker was originated by the Magnavox Company, and we have to thank their engineers for the great part they have played in this great development.

THE ROTHERMEL CORPORATION LTD.
 24, MADDOX STREET, LONDON, W.1.

'Phone: MAYFAIR 0578/9.

Continental Sales Office: 27, Quai Du Commerce, Brussels, Belgium.

Write for the new Dynamic Booklet and Special Folder.

JUNIOR MODELS.

7 3/4" Cone

No.	Field Voltage.	Price.
116	110-190 D.C.	£5 7s. 6d.
118	180-300 ..	£5 7s. 6d.
210	6-12 ..	£5 7s. 6d.
410	105-120 v. 50 cy. A.C.	£8 5s. 0d.
414	220-240 ..	£8 5s. 0d.

SENIOR MODELS.

10 1/2" Cone

117	110-190 D.C.	£6 10s. 0d.
119	180-300 ..	£6 10s. 0d.
211	6-12 ..	£6 10s. 0d.
411	105-120 v. 50 cy. A.C.	£9 15s. 0d.
415	220-240 ..	£9 15s. 0d.

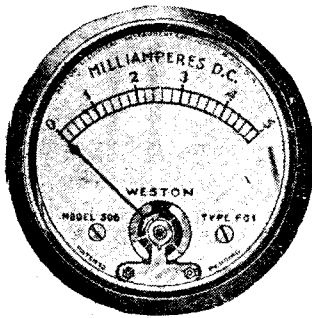
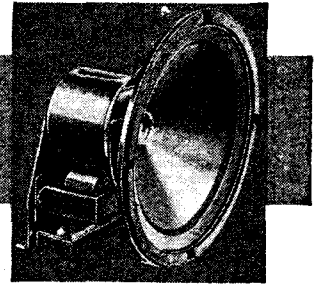

TO TRACE DISTORTION

It requires the accuracy and sensitivity of a Weston Mil-Ammeter to tell you exactly at which particular stage in your receiver distortion begins.

Try it in your H.T. leads in turn. Should the needle kick strongly either backwards or forwards when signal strength varies it indicates transformer distortion, over-saturation of the valve, incorrect grid bias, filament temperature or H.T. Potential.

A Weston Mil-Ammeter is the only instrument sufficiently accurate to be of any value to you when making readings. Weston Instruments are standard the world over, and since 1888 have been unrivalled for scientific precision, uniform accuracy and unvarying reliability.

Weston Model 505 Mil-Ammeter, Price 35/-

WESTON

ELECTRICAL INSTRUMENT CO., LTD.,

15, Great Saffron Hill, London, E.C.1. A.5.

A Tip-Top Book for Boys



All About the Folk of the Wild

The New Nature Book is a fascinating book for the boy who loves the great outdoors. It tells all about the wonders of Bird and Animal life and is profusely illustrated with remarkable action photographs. There are also two beautiful coloured plates by well-known artists. If you want a present that cannot fail to please any boy get this wonderful book.

The NEW NATURE BOOK

At all Newsagents and Booksellers 6/- net.



DO WE WANT SUPER POWER?

The "Wireless Constructor" Ideas Committee, under the enthusiastic leadership of Victor King, tackles another intriguing problem, and offers a précis of the most important observations made on it for the benefit of readers.

YOU all know of listeners who apparently have as their ideals perfect replicas of the various items broadcast, a singer at his or her natural power, and an orchestra at its full and original volume.

A praiseworthy idea—if you have a concert hall to accommodate the loud speaker!

On the other hand, there are those who prefer to cut down their loud-speaker strength to a quiet "background."

A Complicated Problem

However, between these two extremes are the great majority who desire realism at comfortable audibility.

The problem "Do we want super-power?" is a complicated one. It does not necessarily mean super-volume, but can imply a capacity to handle super-power.

At this meeting Mr. Victor King summarised the main points of the discussion under the following heads:

(1) Isn't there something of a tendency these days for amateurs to aim at developing power out of all proportion with that necessary for supplying comfortable "room-strength reproduction?"

(2) If so, are constructors wise to have as an ideal gear needing 400 volts or so at anything up to 100 milliamperes of H.T.?

(3) In any case, what is the best volume for ordinary listening?

(4) If you cannot get bass without big power and a big over-all volume, should bass be neglected?

The Miniature

(5) Can one visualise a miniature of a symphony orchestra, or other big broadcast, in which every shade of tone and every relative tone-strength is retained in an original proportion?

(6) If not, should set designers strive for full-blooded reproduction with all its original "thunder" (which brings us back again to the starting point!)?

Mr. Kelsey made the following very apt remarks:

"So much depends upon the individual in the matter of ideal volume that it is very difficult indeed to lay down any hard and fast rules.

"My personal opinion is that we should not aim too much towards the high-volume ideal, because quite apart from the practical difficulties, I do not think that under any circumstances is comfortable drawing-room listening obtained when the volume renders conversation difficult.

"How can the voice of an announcer sound natural when it is

spoken voice is always quite out of proportion to what it should be.

"The ideal must surely be to visualise a miniature—reproduced as faithfully as possible—of what is taking place at the transmitting end. But then we come up against another difficulty. To obtain reproduction as near to straight line as possible, with a pleasing amount of bass, powerful signals seem to be the order of the day.

Loss of Bass

"If the volume is reduced the bass seems to fall off very much more rapidly than the higher frequencies,

WHEN THEY RECORD "REALISM"

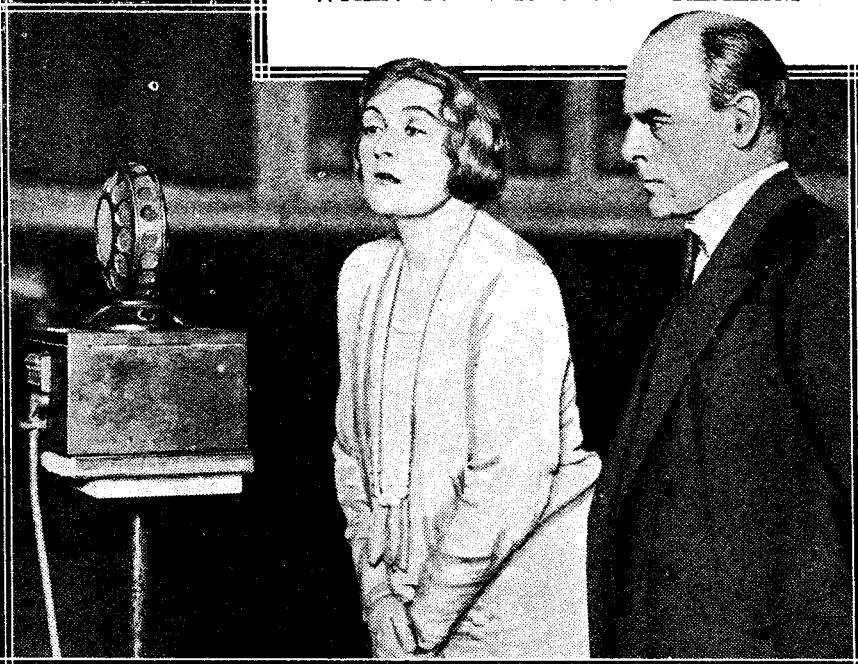

The gramophone companies score over our broadcasters in that they can and do repeat their items, adjusting the volume here and there until they achieve a perfect balance. There is no need for the more or less haphazard control that is often necessary in a radio transmission. Above you see Miss Sybil Thorndike and her husband, Mr. Lewis Casson, recording for H.M.V.

reproduced much louder than at the transmitting end? Certainly, compensation is made in this respect by the engineers at the modulating controls, but, even so, my own opinion is that when an orchestra is being reproduced really powerfully the

and, in consequence, the tonal balance is upset.

"So that, as things are at present, it would seem that to effect a compromise is the only way out. Personally, I do not think that the B.B.C. can do much in the matter,

Do We Want Super-Power?—continued

because if they increase the strength of the lower frequencies to give a more perfect tonal balance for the man of the comfortable listening class, then the bass will obviously be greatly overdone for the listener of the 'super-power' type.

"Give me comfortable listening, with its imperfections, rather than an unpleasant blast approaching the ideal. After all, if you are sitting at the back of a concert hall listening to an orchestra you do not hear so much bass as the people at the front; yet it does not interfere with your enjoyment of the programme. The chances are that you would not even stop to think about it!

Radio is Entertainment

"So I think it should be with radio. Go all-out in the first case to obtain as faithful reproduction as possible, consistent with your own particular

"I do not think that there is the slightest doubt that the majority of home constructors, and a very large majority at that, neither require, desire, or are in a position to afford super-power.

"This does not mean that super-power is not wanted at all, for you must have it if you are going to run a small dance or want to entertain a large number of people, but ordinary listening in an ordinary room is another matter altogether.

Smaller Volume Desirable

"Of course, it is quite true that if we want to produce the same effect as though we were listening in the studio to, say, an orchestra, we must get reproduction just as loud as the original. But that is no reason why a smaller volume should not be both pleasing and satisfying from an entertainment point of view.

volume is turned down. But why should we not have less volume and increase the bass so that the reproduction sounds right to the ear, no matter if it is not absolutely correctly proportioned?

Super-Announcers

"I think we should have just a pleasant volume without losing anything; in fact, we want to look through aural binoculars backwards, and as with vision the details should be *apparently* even sharper, without any of them fading away.

"With the human voice—namely, solo singers and talkers—we do not need the miniature effect, for super-power is not required to give them at more or less natural volume. Certainly we do not want them at greater than normal volume, and the super-power set's habit of producing super-announcers is one of the biggest things against it. True, there are such things as volume controls, but until these become magically automatic they only provide a partial solution if listening is to be a leisure.

"The technical side, particularly as regards the home constructor (and, after all, it is the home constructor with whom we are mostly concerned), has its bearing on the subject. It is far, far simpler to obtain really good quality and a moderately straight-line response, with normal loud-speaker strength, than with a stentorian output.

"Few people have the voltage or necessary apparatus to work super-sets properly, and even fewer are situated so that they can forget the question of neighbours.

"No, super-sets for super-power will always be in the minority, and our aim must be more apparent naturalness with moderate volume."

"Useless" Power

This is a précis of Mr. Johnson-Randall's views on the subject:

"It is difficult to give a definite answer to this question, since so much depends upon the individual requirements of the listener.

"There is perhaps in some quarters a tendency towards the development of what I call 'useless' power. That is to say, output stages capable of giving, or rather handling, far more than the listener's normal domestic requirements.

(Continued on page 64.)

THIS SEASON'S SETS



Here you see the Ideas Committee discussing some of the new designs projected by the Research Department and Mr. Victor King. A number of wonderful schemes are in the course of development, and we confidently anticipate that this season will prove one of the most successful in the whole notable history of this journal. Sitting are Mr. Clark and Mr. King, and, standing (left to right), Mr. Johnson Randall, Mr. Kelsey, Mr. Bassett, and Mr. Sanders.

domestic conditions, and then forget all about it. Concentrate upon what you are hearing and not so much on how you are hearing it. In a nutshell—take radio at its entertainment value.

"That, in my opinion, is the nearest answer to 'Do We Want Super-Power,' and I believe it to be the attitude of the great majority of the listening public."

Mr. A. S. Clark said:

"In fact, I think the smaller volume would be more desirable, because tremendous volume in an ordinary room is rather nerve-racking and really silly, because who would attempt to listen to a complete orchestra playing in a small drawing-room?"

"One of the chief arguments for great volume is that it is impossible to hear the bass in its right relative power to the high notes when the

THE NEW Varley NICORE L.F. AUTO-TRANSFORMER



VARLEY NICORE L.F.
AUTO TRANSFORMER.
(List No. D.P.13)
D.C. resistance, Grid to
G.B. . . . 17,000 ohms.
D.C. resistance, Tap to
G.B. . . . 3,000 ohms.
Inductance from Tap to
G.B. . . . 120 Henries.
Ratio 7 : 1.

£1

For
RADIO
MANUFACTURE
Varley

Write for Section D of the Varley Catalogue, which gives particulars of this and other Varley Transformers.

The highest possible amplification from a single stage, without sacrifice of quality, may be achieved with the new Varley Nicore L.F. Auto Transformer. It is ideal for those receivers which employ only one stage of L.F. amplification, because the very high ratio of 7 to 1 has been obtained without appreciable falling off at the extreme ends of the frequency gamut.

It is the famous Varley Bi-duplex method of coil winding and the development of the core so successfully used in the Varley Nicore 1 which have made this new Auto Transformer possible.

The Varley Nickel Iron Alloy Core has a far greater permeability than older types. By its use Varley have been able to cut down the number of turns on the primary and secondary and to reduce their self-capacity, while still keeping the inductance of the primary at a high value. At the same time, this new Varley Nickel Iron Alloy conduces to increased all-round efficiency, because it allows of a smaller core and windings. There is, consequently, a reduction in the losses due to hysteresis and eddy currents.

Only three terminals are on the Varley Nicore L.F. Auto Transformer. Being designed solely for the resistance or choke feed auto-transformer method of coupling, there is a permanent internal connection between the primary and secondary. Varley's experience in coil winding and transformer design has produced this new addition to the Varley range.

Test its performance for yourself.

NOW THE AF7 TRANSFORMER

Many constructors requiring greater L.F. amplification than is practicable with one stage find that two stages with transformers of the old standard ratio give excessive amplification.

As an instance, take first the case of a single L.F. stage employing the standard transformer ratio of 1-3½.

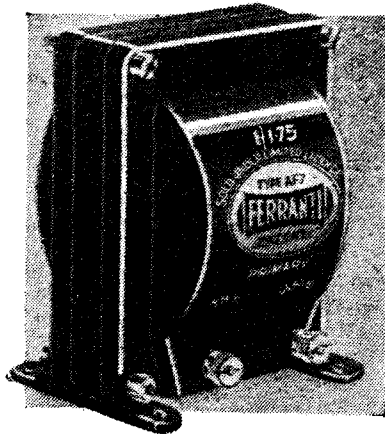

The amplification factor of the modern detector valve is about 16, and that of an output valve of the P625 class is 6. This gives the total L.F. amplification as

$$16 \times 3.5 \times 6 = 336$$

This may be increased by using a transformer such as the AF6, which with its higher ratio of 1-7 would give

$$16 \times 7 \times 6 = 672$$

Compare the above with two stages, employing the same valves and transformers of the standard ratio. The figures become

$$16 \times 3.5 \times 16 \times 3.5 \times 6 = 18,816$$

What is required is some combination capable of giving appreciably more amplification than the single stage, but appreciably less than that obtained from two.

Several methods offered a solution, but after investigation of all the possibilities we decided that a transformer with a ratio of 1-1¾ had, amongst others, one great advantage: the reduction in the secondary allowed us to increase the primary, thereby securing a primary inductance of 210 henries when carrying 1 milliamp. This transformer is therefore clearly the most suitable transformer to follow an anode-bend detector.

Compared with the figures given above, the total amplification using this transformer would be

$$16 \times 1.75 \times 16 \times 1.75 \times 6 = 4,704$$

This new transformer is the AF7. Price 30/-. It is also available for push-pull, AF7c, price 34/-.

FERRANTI

FERRANTI LTD.

HOLLINWOOD

LANCASHIRE

SPECIFIED AGAIN & AGAIN

DUAL RANGE TUNER (W.G.2)

Single-Hole fitting Inductance covering Broadcast and Daventry Bands. The short-wave section is single-layer wound and the long-wave portion section wound to avoid losses due to self-capacity in winding. Changing from long to short band is operated by a switch which is controlled by a small knob on top of dial. Dimensions 3½" deep x 3½" x 3".

Price **15/-**

FOR ALL
"WIRELESS
CONSTRUCTOR"
CIRCUITS

An entirely new L.F. COUPLING UNIT

Something really new for your set—an addition which will make a remarkable difference to your reproduction.

Complete with
Switch for
Tone Control

20/-

QUICK MAKE & BREAK SWITCHES

Supplied in Single and Double Pole Make & Break Change-over—with delayed action for indirectly-heated valves.

Price from **1/9 to 3/-**

OBTAINABLE in LEVER and ROTARY TYPES.

Send for Illustrated List of new Components.

WEARITE

COMPONENTS WRIGHT & WEARE, LTD.

740, HIGH ROAD, TOTTENHAM, LONDON, N.17.

Phone: Tottenham 3847-9.

MAINS TRANSFORMERS

An extensive range designed for use on all H.T. Supply Units.

Prices from

25/-

SPECIAL DESIGN FOR "ORGOLA" H.T. SUPPLY UNIT, 30/-

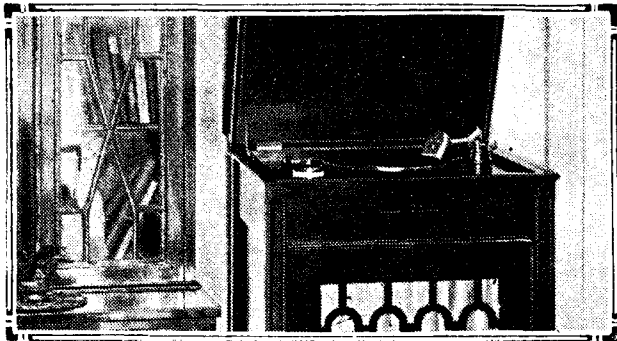

WITH PICK-UP AND SPEAKER

For the Beginner—How a Pick-up Works—Tracking—Using an Adaptor—“Is My Set Suitable?”—Motors, Clockwork and Electric.

Conducted by A. JOHNSON-RANDALL.

SINCE this is, to all intents and purposes, the commencement of the radio-gram season, I am sure that those of you who do know will forgive me if I devote myself this month largely to those who don't know.

THE CELESTION TONE-ARM

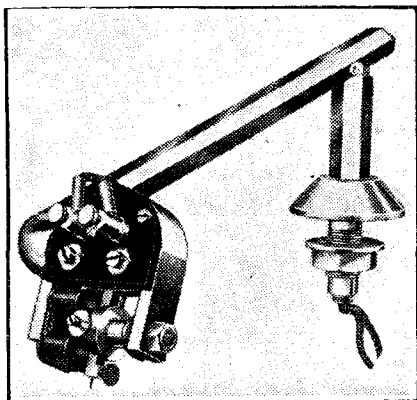

This is the new Celestion tone-arm for 1931. The pick-up shown here is the Celestion-Woodroffe.

After the Show a large number of new readers join up with us, and the greater part of these are beginners. Therefore I will try to describe in simple language what a pick-up is and what it does.

All of you are familiar with the ordinary gramophone with its sound-box and sound “channel,” or arm, which connects it to the “horn.” The needle makes contact with the grooves on the record and the mechanical vibrations of this needle are converted into speech or music and amplified up by the sound channel and scientifically designed horn.

How It Works

A pick-up in its elementary form is the most simple device imaginable. If you take a permanent magnet and surround it with a coil of wire, and then arrange a steel needle in a chuck so that it can move in sympathy with the channels on the record, you have a pick-up shorn of its refinements.

Suppose we place this needle so that it pivots freely in such a way that

it can move to and fro in the immediate vicinity of the magnet.

The minutest vibration of this armature will produce a small change in the magnetic field or flux, and if this is communicated to the “speech” coils surrounding the magnet (or sometimes the armature) a voltage will be set up across the ends of the winding.

Magnifying the Voltages

Having obtained these small voltages, if the two ends of the “speech” coils are taken to two terminals on the pick-up, and these two terminals are then connected between the grid and negative filament of an amplifying valve, the small voltages can be magnified up to any desired extent to operate a loud speaker.

In practice, of course, a pick-up is not quite so crude as this, since it is necessary to arrange the armature so that it is, as far as possible, free from any resonances, or any other shortcomings which might cause distortion.

acquired a mass of literature from the various makers of pick-ups. Having read the literature, you are wondering what type you should choose.

Choosing a Pick-Up

In the first place, let me tell you that there are a number of makes on the market all of which are capable of giving most excellent results, and you need have no fear of obtaining unsatisfactory results if you go to any of the reputable manufacturers.

You will find that there is a marked tendency these days for the pick-up to be sold complete with its tone-arm, as distinct from the procedure of a year or two back of designing the pick-up for direct attachment to the existing tone-arm of an ordinary gramophone. In other words, it is fairly common practice now to sell a pick-up and arm complete, and pick-ups are rarely used to replace the sound-box on the gramophone.

A USEFUL REFINEMENT

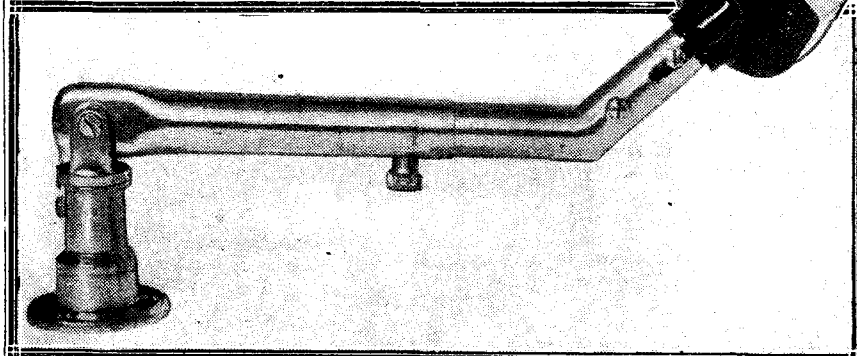

The well-known B.T.-H. pick-up and tone-arm has recently been improved. The pick-up now swivels and needle-changing is made much easier.

Various types of pick-ups have been tried, but the majority work on the principle that I have described, and are known as the electro-magnetic type.

Those of you are just thinking of installing a radio-gram attachment to your existing sets, or of building a radio-gram receiver, have no doubt

However, perhaps you prefer to carry out your conversion in the simplest possible manner, in which case it is still possible to obtain the pick-up by itself, so that you have just to remove your existing sound-box and replace it with its electrical counterpart. You must be careful to specify the make of gramophone

With Pick-Up and Speaker—continued

you are using when ordering a pick-up of this type, because H.M.V. and Columbia instruments require slightly different fittings.

On the other hand, I would strongly advise you to do the job properly, and to buy the pick-up complete with its tone-arm. This need not put your existing gramophone out of action, because you will find that on most instruments there is adequate space near the turntable for both fittings, namely, the pick-up tone-arm and the sound-box arm at present fitted.

Correct Tracking Is Important

Next there is the question of tracking. If your pick-up is not tracked up correctly you will tear up the grooves on the record in a very short time, and in consequence your supply of records will soon require renewing. The manufac-

procedure properly you will have no trouble whatever from incorrect tracking.

Connecting It Up

Those of you who already have a wireless set may not know where to connect the two leads on the pick-up. I have described this in detail in previous articles, but I am assuming that you are a beginner and that you have had little or no previous experience of radio-gram work. In these circumstances, unless your set has been designed for use with a pick-up, you will be well advised to buy an adaptor to plug into your existing detector valve holder. Then all you have to do is to connect the two leads from the adaptor to the two terminals on the pick-up, take out the detector valve and to insert the adaptor in its place. The detector valve is then placed in the adaptor.

adequate volume by using a pentode in the last valve holder, instead of a valve of the ordinary three-electrode type.

Most radio-gram enthusiasts have a gramophone of the ordinary clockwork motor variety, but there are others probably who have no gramophone at all, and who are only considering the installation of a pick-up because of its advantages from the point of view of quality over the ordinary sound-box arrangement.

A Gramophone Not Essential

In such a case it is obviously quite unnecessary to buy a complete gramophone when all that is wanted is a motor and turntable, together with a pick-up and its arm.

Motors can be picked up fairly cheaply second-hand. If bought new, a good clockwork single-spring motor costs about £2, complete with 12-in. turntable. So if we allow, say, 50s. for the cost of the pick-up and tone-arm, then we can instal our electrical equipment for something under £5, which compared with the cost of a really first-class gramophone is decidedly small.

Some people prefer to use the mains whenever possible, and these are catered for by the various high-class electric motors there are on the market. A good electric motor usually costs more than one of the clockwork variety, but then you must remember that even the best clockwork motor requires frequent rewinding.

If you buy a cheap electric motor you may have difficulty in getting it to run at a constant speed, and in addition there is some risk of crackling noises or humming being produced from induction effects. But provided you purchase a really high quality one you will not have any of these troubles, and you will do away with all the inconvenience of rewinding.

A Final Hint

In buying a motor take care to see that it is suitable for your particular mains. You can always seek the maker's advice on this point.

I feel sure that these hints will be of considerable value in starting you along the road which leads to successful results. Whenever you are in trouble, remember that there is a WIRELESS CONSTRUCTOR Queries Department, always ready and willing to extend a helping hand.

BRADMAN MAKES MORE RECORDS

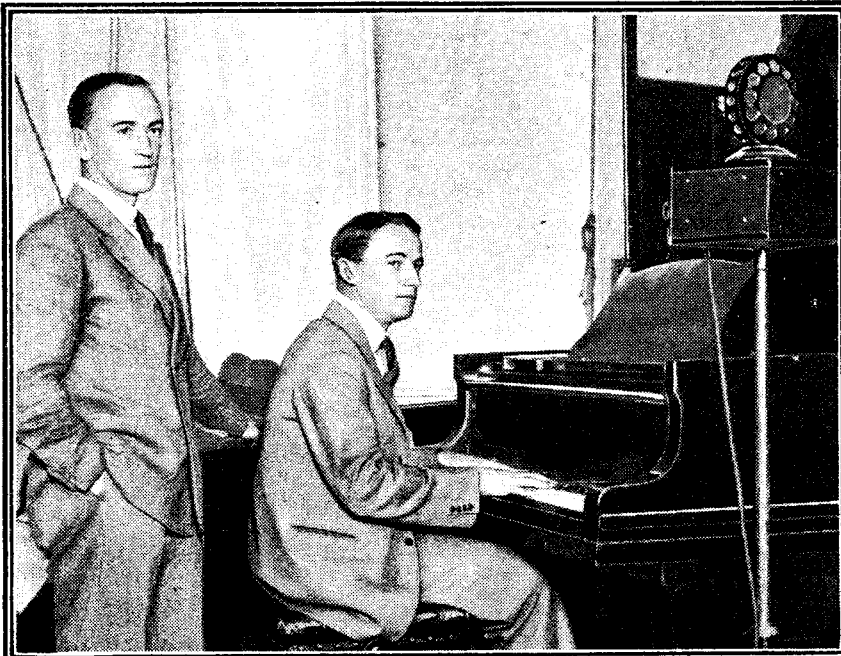

Here we see Don Bradman, the famous Australian Test cricketer, playing a pianoforte solo for recording purposes. With him is Mr. Harold Williams, the well-known singer.

urers, fortunately, have made your task an easy one, because they invariably supply a neat little cardboard template, together with the necessary instructions for fitting.

All you have to do is to place the template in the position marked, and then to screw down your pick-up arm as described in the maker's instructions. If you carry out this

Doubtless you will say, "Yes, but what type of set is suitable for radio-gram work?" Well, any set with two good L.F. stages. If your receiver is one of the H.F., det. and 1 L.F. variety, then I am afraid that you will have some difficulty in getting enough volume, unless you choose a very sensitive pick-up. In these cases you can often obtain

RADIO'S NEWEST TUNING DEVICE

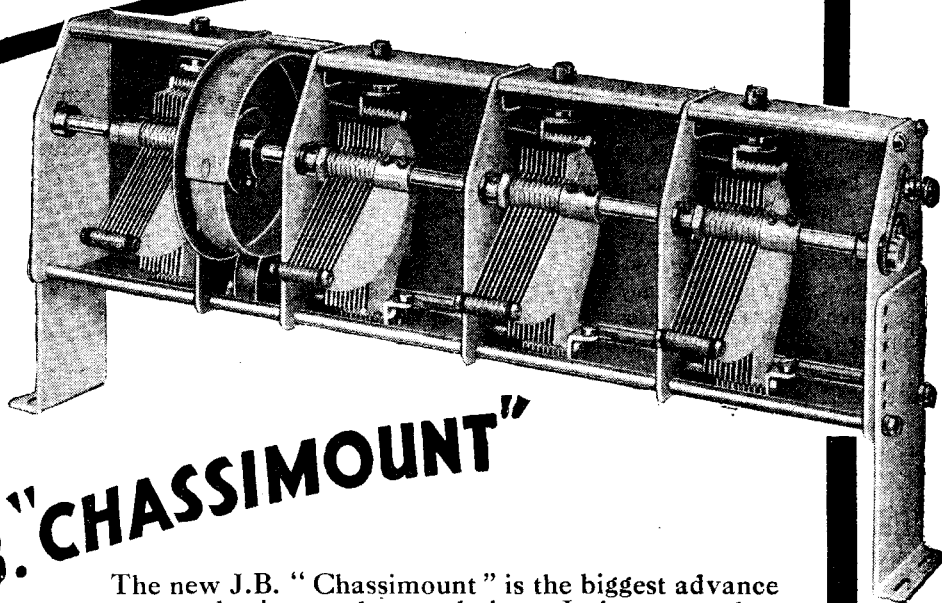

The NEW J.B. "CHASSIMOUNT"

The new J.B. "Chassimount" is the biggest advance yet made in condenser design. It is a complete breakaway, throws open new fields, and will be the basis of this year's popular circuits.

Two, three, even six tuned circuits—one knob controls them all, keeps them perfectly in tune, and brings in station after station.

Once again J.B. lead the way. J.B. precision has made the "Chassimount" possible and ensured the various condenser units matching over the whole range.

The J.B. "Chassimount" is built and designed as a unit. Each stage is adequately screened and has a special device which balances out all stray capacities.

AND IT COSTS LESS THAN SEPARATE CONDENSERS.

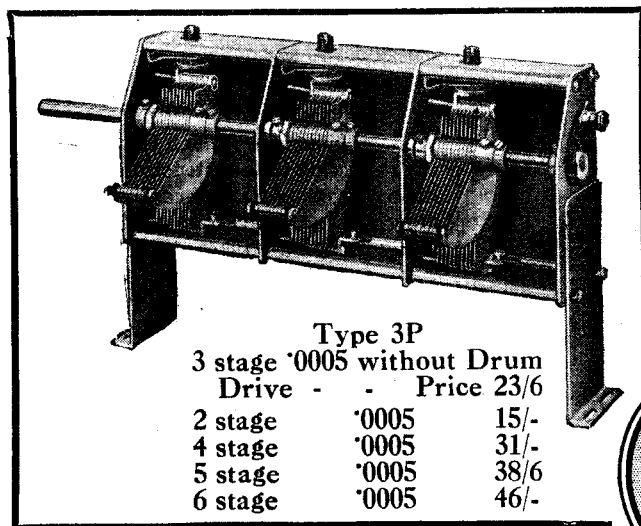

Type 3P
 3 stage '0005 without Drum Drive - Price 23/6
 2 stage '0005 15/-
 4 stage '0005 31/-
 5 stage '0005 38/6
 6 stage '0005 46/-

Type D4 (Illustrated above)

4 stage '0005 with Drum Drive
 Price - 42/6

2 stage	'0005	26/6
3 stage	'0005	35/-
5 stage	'0005	50/-
6 stage	'0005	57/6



PRECISION INSTRUMENTS

THE "MAX-AMP" LIMITER

By the "Wireless Constructor" Research Dept.

Valves are not so cheap that you can afford to risk burning them out, so build the little gadget described in this article and banish all worry of "burn-outs."

EXPERIENCE has taught us always to have some sort of H.T. limiting device in circuit before we undertake any kind of test work necessitating the use of valves. In these days of high-efficiency circuits, in which we have to use screening—in many cases, extensively—to obtain complete stability the number of places in a set in which an accidental short will be likely to damage the valves is positively astounding.

Easy to Do!

Just take, for example, the case of a set in which H.T. negative is joined to L.T. positive; an arrangement, incidentally, which is always most carefully avoided in WIRELESS CONSTRUCTOR designs.

H.T. negative is already connected to the positive side of the L.T. battery, and since the screen or screens in a set are always joined to L.T. negative, it requires only a flick of a screwdriver or knife between, for instance, an H.F. choke and any part of the screens, and all the valves may go west! That is but one example.

There are many ways and means of burning-out valves when "tinkering" inside the set with the common connection between H.T. negative and L.T. negative. May we cite one case in which a reader became minus valves without even going inside the set to do it?

Safety First

He merely dropped a piece of bare wire behind the variable condenser dial which was tuning the anode coil in an S.G. H.F. valve tuned-anode circuit. The other end of the wire, in dropping, fell on to the spindle of the L.T. switch (connected in the positive filament lead), with the result that since the spindle of the variable condenser was connected to the moving vanes, which in turn were joined to H.T. positive, the H.T. was joined across the L.T., and thus said gentleman went without his smokes for many a week!

As a research department it is, of course, our duty to point out that the H.T. negative plug should *always* be

disconnected before any adjustments are made inside the set. That is all very well to a point, but there are occasions when it is so much easier to make adjustments with the set actually working, and, in any case, as is obvious from the example given above, the mischief can be done even without as much as lifting the cabinet lid.

Fit a Fuse

So that really and truly there is only one satisfactory way in which to protect your valves from accidental short-circuits, and that is by means of an H.T. safety fuse. It is not always possible in designing a set, either for reasons of space or for other reasons, to include a safety fuse in circuit, and so it has now become standard practice in the research department to employ in the circuit some form of current-limiting device before we make any connections to the H.T. batteries or to the mains.

READY TO PROTECT YOUR VALVES

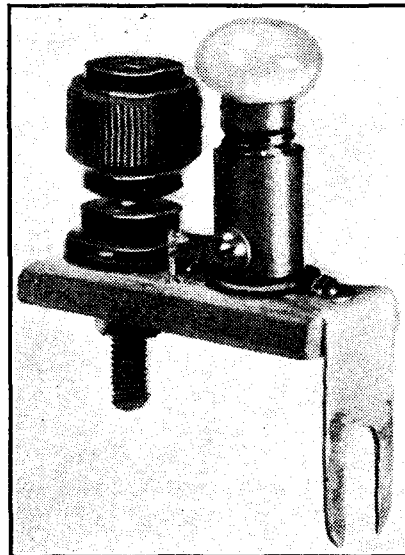

A close-up of the "Max-Amp" Limiter. You can see from this photograph how to cut the metal strip which fits under the terminal on the set.

The "Max-Amp" Limiters are nothing more or less than ordinary flashlamp bulbs of the low-consumption

type mounted on small inverted L-shaped brackets. The vertical stroke of the "L" is a piece of metal with a semi-circular piece cut out of it, and this is clamped under the ordinary H.T. negative terminal of the set.

Positive Protection

Another terminal is provided on the small unit, and it is to this new terminal that the H.T. negative battery connection is made.

The Limiter connected up in this way acts as an almost perfect safeguard against valve "burn-outs." As an additional safeguard, since these simple gadgets can be made so very cheaply, you can if you like use one on each of the H.T. positive tappings,

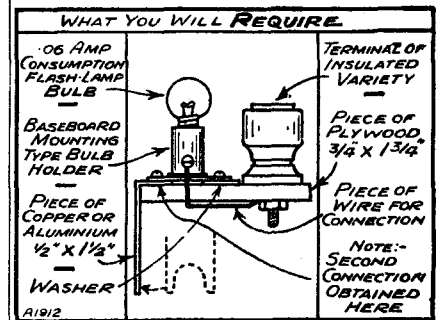

The details of the construction are clearly shown in this diagram, which also designates the various parts.

because it is remotely possible to get a short-circuit across the valves through two of the H.T. positive tappings.

This, however, is a thing which very rarely happens in practice, and if you just take the precaution of using one in the H.T. negative lead it is very unlikely that your valves will come to any harm.

Simple Safeguards

There is not very much that we can say regarding the construction of these little gadgets. All the necessary details are given in the diagram, and all that really remains to be said is simply that the flashlamp bulb or bulbs employed must be of the '06 amp. consumption type. Otherwise there is a danger of the valves blowing before the fuse in the event of an accidental short-circuit.

Although the Limiter is so easy to make, it does a very important duty. Some readers who may have neither time nor inclination to make a Limiter will prefer to buy a simple safeguarding device, and several are on the market, including the Osram, "Magnum" and Bulgin bulbs, the Gambrell fuse, and the T.C.C. "micro-fuse."

TELSEN TRANSFORMERS IMPROVED —

*in APPEARANCE
in PERFORMANCE*

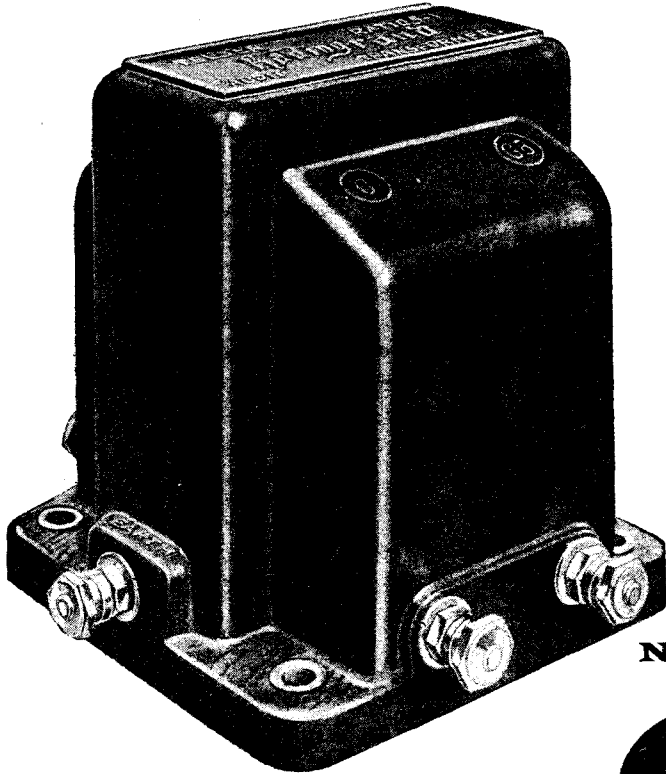

The New Model Telsen Transformers have met with instantaneous success throughout the country —no finer Transformer exists for efficiency and appearance.

They embody the latest ideas in transformer construction, each model now having improvements in the windings and core, in addition to which they are fitted with "Earth Terminals"—a very desirable feature in these days of two-transformer sets.

Finally they are shrouded in genuine Bakelite Mouldings.

PRICES STILL THE SAME

NEW TELSEN COMPONENTS

Telsen Transformers, new season's models, shrouded in genuine Bakelite cases and fitted with earth terminals, together with improvements in design of the windings and core, which give maximum amplification without distortion.

" Radiogrand " 7-1	Retail Price 17/6 each.
" " 5-1 and 3-1	" 12/6 "
" Ace " - - 5-1 and 3-1	" 8/6 "

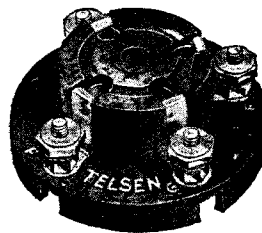

Telsen Valve Holders. Prov. Patent No. 20286 30. An entirely new design in Valve Holders, embodying patent metal spring contacts, which are designed to provide the most efficient contact with the valve legs whilst allowing the valve to be inserted or withdrawn with an easy movement, instead of being subjected to undue strain which often causes damage and loss of efficiency to the valves.

Low capacity, self-locating, supplied with patent soldering tags and hexagon terminal nuts.

Price 1/- each.



Telsen H.F. Chokes, designed to cover the whole wave-band range from 18 to 4,000 metres; extremely low self-capacity. Inductance—150,000 microhenries. Resistance—400 ohms.

Price 2/6 each.

TELSEN

COMPONENTS

ADVT. TELSEN ELECTRIC CO., LTD., BIRMINGHAM.

FRAMING YOUR OPERATING PANEL

Here are details of a neat and easily constructed frame to hold the operating panel of your set.

By **A. S. CLARK.**

NOTHING pleases the home constructor more than the remark of a visitor that his set looks just like a bought one, meaning, of course, one which is professionally made in a factory. Most of you will realise that it is chiefly upon the attention paid to details that this matter of appearance depends.

An Important Feature

One of the most commercial-looking details about a bought set is very often some form of printed instructions pasted on the inside of the lid of the cabinet. This is one point in connection with which the reader of the WIRELESS CONSTRUCTOR has a great advantage, because it is now our practice to print an operating chart for all the larger sets which are described in the pages of this magazine.

These charts are included in the article describing the set, and if you turn to page 10 you will see the one for the "Paratune" Three. Quite apart from their appearance, these charts have many advantages.

Valuable Information

Chief among these is the fact that should you lose the copy containing the instructions for operating and connecting up your set, it does not matter. You will always have the vital information handy.

Also, should you pass on the set to a friend at any time, he will always have the details he requires with reference to coils, valves, voltages, operating, etc., etc. The name of the set is always on it, often a useful point if further copies of the constructional details are required.

Simple Frame

While the operating chart looks quite well if merely pasted to the cabinet's lid, it looks infinitely better if mounted in the simple frame which is described in detail here. The frame enables a piece of celluloid to be covered over the operating chart, thus preserving it and keeping its appearance always fresh.

A glance at the photograph on

this page will give you a good idea of the method of constructing the frame. The materials you will require are as follows: a piece of sheet copper or aluminium, four short pieces of beading, a piece of celluloid, and eight very small countersunk brass screws.

The Back-Plate

The beading should be about $\frac{3}{8}$ in. wide and, of course, flat on one side, and the screws should be about $\frac{3}{16}$ in. long.

First of all you have to cut the sheet copper or aluminium to size. The actual size naturally depends upon the size of the chart.

We will suppose for purposes of illustration that the chart is 6 in. wide and 4 in. deep, and the beading exactly $\frac{3}{8}$ in. wide. The size of the metal back-plate will then have to be $4\frac{3}{4}$ in. deep and $6\frac{3}{4}$ in. long, so as to allow for the beading.

NEATLY AND SECURELY MOUNTED

This photo shows the operating panel of the "Explorer" Four mounted in the easily constructed frame described in this article. Such a frame keeps the panel cleaner and safer than merely sticking the paper to the lid of the cabinet.

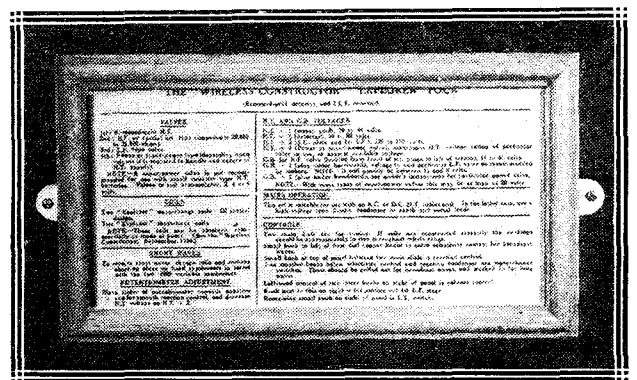

At either end of the plate you must leave a small tab through which a small hole is drilled. These are for the purposes of fixing the frame to the cabinet.

Cutting the Beading

Next cut the celluloid to the same size as the metal plate, except, of course, for the two tabs. Two pieces of beading as long as the back-plate now have to be cut, and two pieces the same depth.

These pieces have to be cut at an

angle of 45 deg. so that the corners will fit neatly together. Take care over the cutting of these pieces of wood, and the frame will look all the better for it.

Assembling the Frame

The next step is to drill eight small holes round the edges of the back-plate. These should be $\frac{3}{16}$ in. from the edge, and there should be two along each side.

Having drilled the holes, countersink them so that the small brass screws are flush with the surface of the aluminium when they are inserted. All that remains is to assemble the pieces you have prepared.

Place the chart over the back plate, holding it square with just a spot of gum if desired, then place the celluloid over the chart, and finally screw the pieces of beading in place. Take care when putting the screws in that the beading is held in its proper place.

A Final Point

The beading may be finished off with varnish stain, French polished, or enamelled according to your own taste. It is advisable to leave this job till the frame is assembled, because otherwise the finish is almost sure to be marked during the assembling process.

Two very small round-headed brass screws should be used to fix the frame to the cabinet lid. These screws will

naturally require quite small holes, so that the attachment of the complete assembly will not disfigure the cabinet, and so make it unsuitable for use with another set, should this be desired at a later date.

Incidentally, a similar frame would prove useful in which to mount a chart showing the dial settings of the set for various stations. The two frames could then be mounted side by side on the lid, or the station chart one could be fixed on the ebonite panel if a suitable place were available.

YOU MUST MATCH YOUR IMPEDANCES

IF YOU WOULD HAVE THE BEST RESULTS

The performance of your set depends upon the correct matching of impedances, for, by so doing it is possible to obtain as much as 200-300% improvement in quality and volume. Pickup to valve, valve to valve, valve to loud speaker, all have received years of attention from our engineers with the result that there is now available a complete range of transformers designed to meet all requirements.

PRICE

15/-

EACH

Ratios

1:1, 2:1, 4:1,
10:1, 15:1,
20:1, 25:1,
30:1.

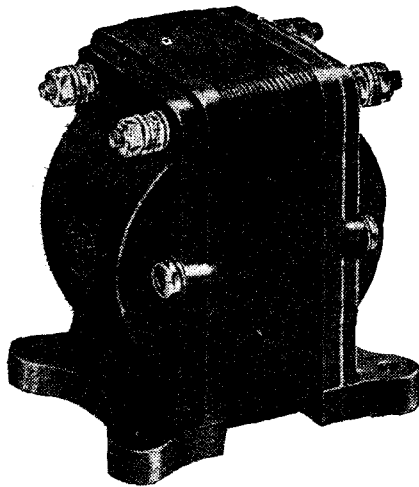

TRANSFORMERS



THE EDISON SWAN ELECTRIC CO., LTD.

Incorporating the Wiring Supplies, Lighting Engineering, Refrigeration and Radio Business of the British Thomson-Houston Co., Ltd.

Radio Division:

1a Newman Street, Oxford Street, W.1

Showrooms in all the Principal Towns

EDISWAN

W.103

INSPIRED! LEADERSHIP!

PRESCIENCE
EPITOMISED
INGENUITY

PRECISION
METICULOUS
ACCURACY

PERFECT
BALANCE

EXCEPTIONAL
MERIT

EXQUISITE
CRAFTSMANSHIP

THE QUINTESSENCE
OF EFFICIENCY



FOR ALL CONDENSERS

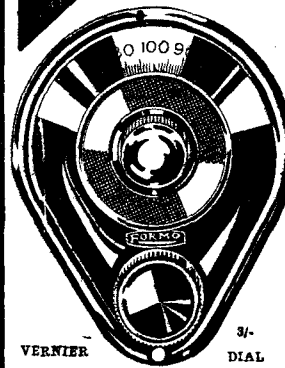

VERNIER DIAL

Easy reading. Smooth action.
Metallic continuity. No crackle

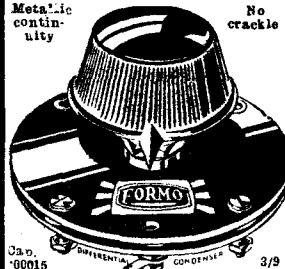

Cap. 00015

The highest lowest loss & most efficient Condenser extant

Capacities
0005
00035
00025
00015

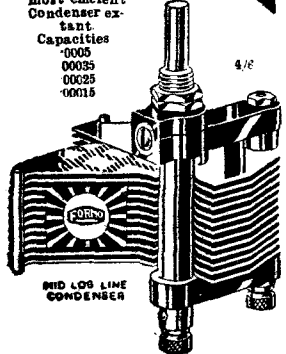

MID LOW LINE CONDENSER

Higher test, lower loss, great longevity.

Capa mid 2 1 5 7 1

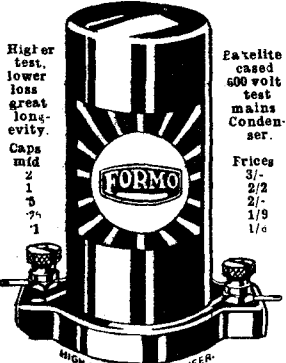

HIGH VOLTAGE CONDENSER

Exelite cased 500 volt test mains Condenser.

Prices 3/- 2/2 2/- 1/9 1/6



A great little variable compression type condenser

F 0001 }
J 0003 } 1/6
G 001 }
H 002 } 2/3



1000 volt test. Insulate and mica.

Capa. Prices
0001 }
0002 } 6d.
0003 }
0005 } 7d.
001 } 8d.
002 } 10d.

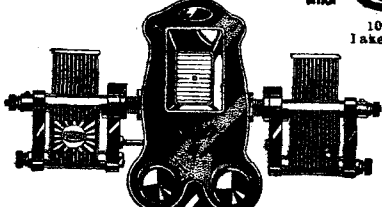

A truly phenomenal illuminated drum dial with trimmer control.

Drum dial, 3/6 with one Condenser, 13/- with two, 17/6

BRITISH LEADERSHIP
SUPPLIERS TO THE LEADING SET MAKERS OF THE COUNTRY

CATALOGUE FREE. GERRARD 1863, GOLDEN SQ. PICCADILLY CIRCUS, LONDON.

7 of our 25 Lines

C.H.S.



Our News Bulletin

Radio's High Wages

ONE of Sir Hamilton Harty's recent criticisms against the B.B.C. was that it has raided Manchester offering salaries to orchestral performers which it was impossible for others to give. We understand that the B.B.C. now pays members of an orchestra a minimum salary of eleven guineas a week.

This is two guineas in excess of the Union's minimum standard. For example, a girl just twenty-one among the musicians is paid eleven guineas weekly, while many other members of the orchestra receive considerably more.

B.B.C. Subsidies

The B.B.C. has undoubtedly done a good deal to help musicians, for in the last few years it has subsidised

the Hallé Concerts to the extent of £1,000 a year; while this year the B.B.C. financed a four-week series of Promenade Concerts in Manchester, Liverpool, and Leeds, involving an expenditure of several thousand pounds. Incidentally, Sir Hamilton Harty conducted these concerts.

A Programme Rumour

There has been a good deal in the papers lately about the B.B.C. considering the possibility of alternative programmes on a new long wave. This would be in addition to the present broadcast on 1,554.4 metres from Daventry. The suggestion has been made that this new transmission should be on 1,000 metres.

As a matter of fact, we cannot find any definite reason for this suggestion, as the B.B.C. denies that it has a new wave-length in mind, and says that the idea is not at the moment

practicable owing to the scarcity of available wave-lengths.

Important Wave-length Changes

The B.B.C. states that there will be no delay in starting preliminary signal tests from the Northern transmitter in about a month's time, and it is hoped to have the dual transmitters in regular operation early in 1931.

When this Northern station opens there will be some important changes in wave-lengths. The Northern Regional will use a wave-length of 479.2 metres for its Regional wave-length, and 301 for its National wave-length.

These wave-lengths are at present used by the Midland Regional transmitter (5 G B) and Aberdeen respectively. Consequently other wave-lengths will have to be found for these two stations.

More Shuffling

When the Northern transmitter is ready the Manchester transmitter will close down, and also the relay stations in those centres which will be served by the new station.

Consequently, the present Manchester station's wave-length of

(Continued on page 56.)

MAGNUM

RENOWNED PRODUCTS

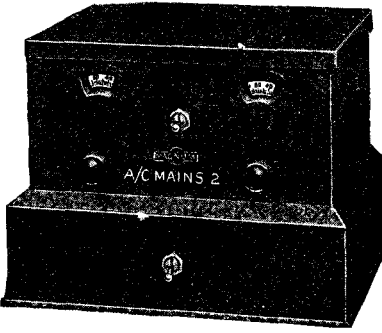

A.C. MAINS 2
A perfect little receiver, entirely A.C. Mains operated. Complete and ready for use.
£12:10:0

WE specialise in the "Paratone" Three, Standard A.C. Unit, and all "Wireless Constructor" sets. Full particulars, including latest 1931 Radio Lists, free on request.

SPAGHETTI RESISTANCES
Wire wound and made in all values from 1,000 to 40,000 ohms to carry 10 m/a, and 50,000 ohms to carry 5 m/a. Fitted in a few seconds, they effect a great economy of space and cost compared with the old-fashioned cartridge-type Resistances.
All values as above, each **1/6**

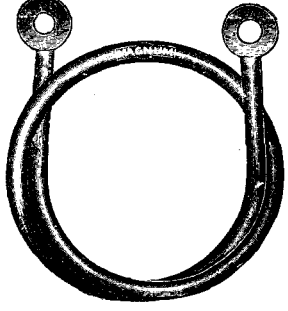

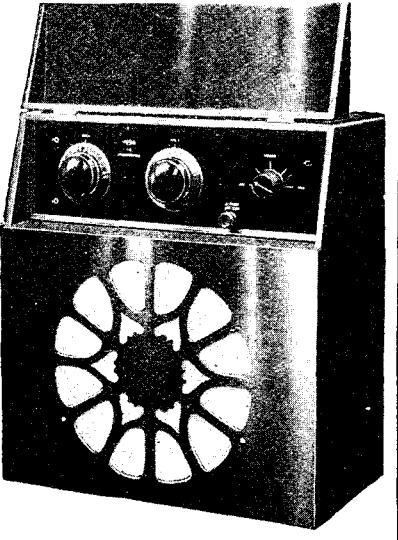

A.C. TRANSPORTABLE S.G.3
Entirely self-contained, this instrument operates from any A.C. lamp socket and may be carried from room to room. Beautiful tone and razor-sharp selectivity. Complete and ready for use. **£25**



WIRE-WOUND POTENTIOMETER
This component (50,000 ohms) is specified for the Mullard Orgola Four and several other modern circuits. Ideal for Screened-Grid voltage control.
5,000 to 25,000 ohms will carry 10 m/a.
50,000 ohms, 5 m/a. **7/6** each

BURNE-JONES & Co., Ltd.,

"MAGNUM" HOUSE,
296, BOROUGH HIGH ST., LONDON, S.E.1

Telephones: HOP 6257 & 6258.

THEY'RE BEST FOR EVERY SET

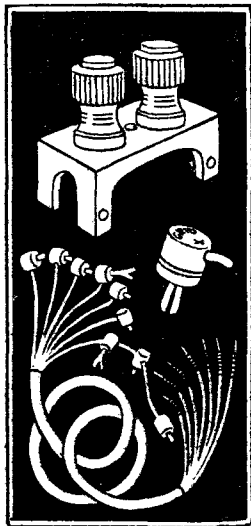
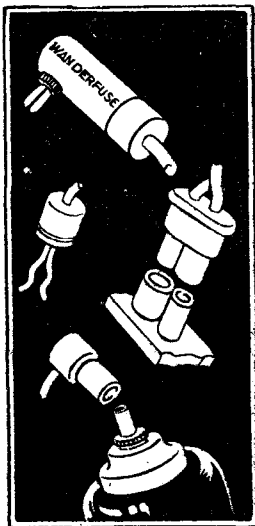
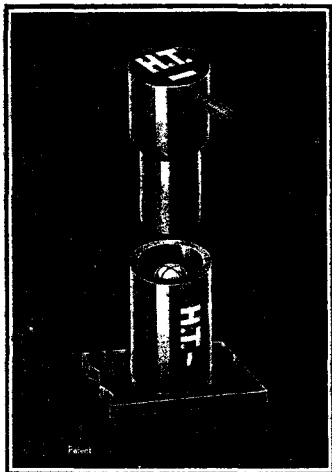

Whether your set is battery-driven or an All-Mains Model, the Belling-Lee Safety Plug and Socket will make costly short-circuits impossible. It is the last word in safety—even when disconnected it is fully insulated. High and low Voltage Plugs cannot be interchanged in error: and BOTH parts are clearly engraved in white. 26 different indications—fitted without tools—soldering unnecessary. Ample contacts—side entry for flex—a special device grips both wire and fray.

Price **9d.**

BELLING-LEE
FOR EVERY RADIO CONNECTION

Adv. of Belling & Lee, Ltd., Queensway Works, Ponders End, Mdx.

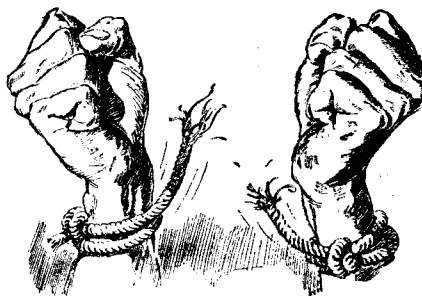

Break Those Bonds

Don't be a slave to circumstances all your life. Break loose! All around you are people with no more intelligence than yourself who have climbed out of the routine class and

are occupying good positions because they availed themselves of specialized training.

Waiting for you at this moment is a bigger and better position. You can have it as soon as you have secured the training that will qualify you for it. And you can get that training in the spare time that you now let go to waste.

No matter where you live, the International Correspondence Schools will come to you. No matter what your handicaps, or how small your means, we have a plan to meet your circumstances.

To thousands of men like you—hands tied, but eager to break free—I.C.S. training has brought success.

We have nearly 400 Standard Courses, including many in the following subjects:

Accountancy and Book-keeping	Engineering, all branches	Salesmanship
Advertising	French, Spanish, and Italian	Scientific Management
Architecture and Building	General Education	Shorthand-
Chemistry	Insurance	Typewriting
Commercial Art	Plumbing	Showcard Writing
Commercial Training	Railway Equipment and Running	Textiles
Draughtsmanship		Window Dressing
		Wireless Engineering
		Woodworking

ALL EXAMINATIONS—Commercial, Technical, Matriculation and Civil Services
Write to-day for free Booklet containing full information regarding the Courses in which you are most interested.

International Correspondence Schools, Ltd.,
172, International Buildings, Kingsway, London, W.C.2.

A New NOVOTONE MODEL

With the introduction of the TYPE "J" NOVOTONE

practically every user of an electrical pick-up is catered for, no matter what type of amplifier he is using.

The Type J Novotone can be used on almost any average circuit without alterations of any sort, while a standard form of volume control can be used across the output terminals without affecting the reproduction in any way whatever. The compensating curve of the Type J remains the same as that of the other two models, but the overall amplification is slightly less.

The result when reproducing records with the Novotone is 'amazing realism'

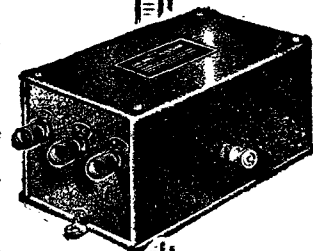

Type J - - £3 : 3s.
Type S (Standard Model) - £5
Type H (For high-resistance Pick-ups) - £5

GAMBRELL RADIO LTD., 6 Buckingham St., W.C.2

WRITE FOR FREE DESCRIPTIVE FOLDER (C)

OUR NEWS BULLETIN

—continued from page 54

376.4 metres will be available, and it is likely that this wave-length will be given to the Glasgow station and the wave-length of the latter—398.9 metres—will be transferred to 5 G B.

The B.B.C. considers that by this means a satisfactory separation of 90 kilocycles will be obtained between the London and Midland Regional transmitters.

Although the wave-length of Aberdeen on the opening of the Northern station has not yet been fixed, we understand that it will be under 300 metres.

Receivers in Schools

There are now more than two thousand schools in which children listen regularly to the B.B.C.'s educational broadcasts, and the Central School has decided to adopt a plan to ensure that the apparatus used is of the very best possible kind.

The Council apparently feel that school broadcasting is of little use unless reception is first-class, and there

is no doubt that many schools, through lack of technical guidance, are not receiving the B.B.C.'s educational broadcasts adequately.

Some definite and centralised organisation for advising schools on the technical installation and maintenance of apparatus seems to be indicated.

"Seeing-in" Cinemas

We understand from the "Daily Telegraph" that one of the large circuits of cinema theatres has been negotiating for an immediate installation in their cinema houses of the necessary apparatus for showing wireless news pictures.

Whether anything will come of these negotiations we do not know, but from the technical point of view it seems unlikely that television in cinema theatres will attract the attention of patrons who really wish to see in detail current events of the day.

As a technical experiment, however, it would undoubtedly arouse considerable interest, and a recent demonstration at the Coliseum Variety Theatre proved that the public is still interested in technical experiments in connection with television.

The Wireless Warehouse

It is reported that the B.B.C. has had a bit of a job in finding a temporary rehearsal studio large enough to accommodate the new National Orchestra and Chorus, a body of some 225 musicians and singers.

The problem, however, was solved in the end by hiring a disused warehouse on the banks of the Thames near Waterloo Bridge.

The B.B.C., it appears, had searched every corner of London for a suitable home for the orchestra.

Incidentally, this orchestra consists of: 10 double basses, 10 first violins, 16 second violins, 14 violas, 12 violoncellos, 2 tubas, 2 timpani, 3 percussion, 2 harps, 6 horns, 4 flutes (including piccolo, bass flute), 4 oboes (including cor Anglais, bass oboe, etc.), 5 clarinets (including bass clarinet, saxophone, etc.), 4 bassoons (including contra-bassoon), 5 trumpets (including cornets), and 5 trombones (including bass trumpet).

Marconi's Advice

In the course of an address before the Italian Society for the Progress of Science, Marchese Marconi urged radio engineers to keep in touch with meteorologists and astronomers, as

(Continued on page 58.)

NEW

WESTINGHOUSE

**HIGH TENSION
METAL RECTIFIERS**

ON

**STAND 66 (TONMAN
HALL)**

MANCHESTER RADIO SHOW.

Call at the stand for a copy of the

"All-Metal Way, 1931."

40 pages of technical and practical information, circuits, etc., for amateur constructors and mains users, or send 3d. stamp for a copy to:—

The Westinghouse Brake & Saxby Signal Co., Ltd.

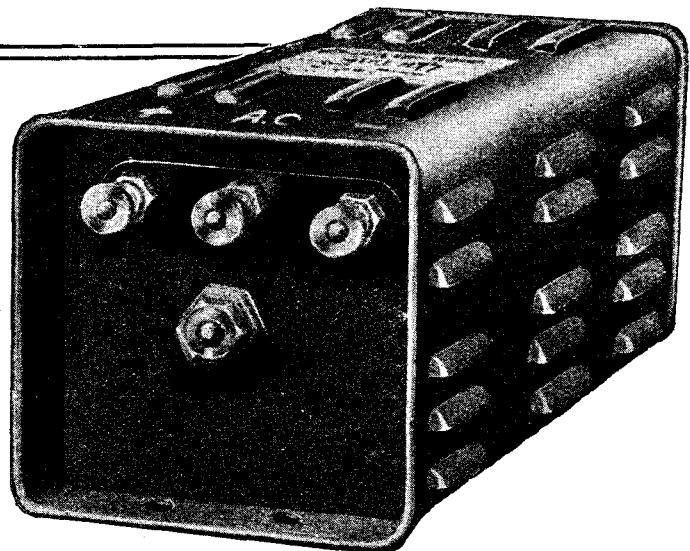

H.T.7. 200 volts, 28 m.a.

21/-

Also H.T.6. 175 volts 25 m.a. - 17/6
and H.T.5. 120 volts 20 m.a. - 15/-

**82, York Road,
King's Cross.**

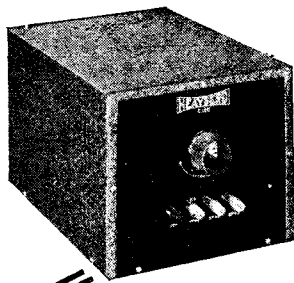

Make an eliminator

like this, with the **HEAYBERD** kit of components.

It's quite easy—the kit contains the very best components, including the new Heayberd Power Transformer and the new Westinghouse Metal Rectifier. You can build a trouble-proof unit that will save you pounds and never fail.

Full working directions are supplied. Write for particulars to-day.

Kits from 69/6 complete. Assembled, 10/- extra.



F. C. HEAYBERD & Co.
10 FINSBURY STREET E.C.
Telephone: Metropolitan 7315.

SPARE-TIME ££'s For Enterprising Men!

Start a Profitable Business With THE MACHINE THAT MAKES MONEY

Supply the **WEEKLY** demand for printed material in your own District and make **LARGE PROFITS** in your **SPARE TIME**. The Possibilities are Enormous—the market **HUGE**. Tradesmen, Cinema Proprietors, Dance and Concert Organisers, etc., etc.—**all MUST Have** a regular supply of Printed Material from Week to Week. **YOU** could easily produce this!

If you own a Business, **SAVE MONEY** by doing your own Printing! Produce your own Leaflets, Circulars, Noteheadings, etc., and put the Printer's Profits into your own Pocket.

EASY PAYMENT TERMS BY SMALL INSTALMENTS

My Machine (as illustrated) will print anything from a **CHEMIST'S LABEL** to an **ILLUSTRATED MAGAZINE**. Fully Illustrated Instruction Book included **FREE**. No Previous Experience is necessary. Many men, knowing nothing about printing, who started with a 45/- Adana, now own Profitable Businesses. Why not **YOU?** **SEND AT ONCE** for Full Free Particulars, Samples of Actual Work Produced, and Details of my Special Offer of Easy Payment terms by small instalments. Every machine guaranteed. Don't hesitate—Let me tell you all about it. Write to:—

D. A. ADANA
(Dept. W. C. 1) 17, Church St., Twickenham, Middlesex.

The Marvellous "Adana" All-Steel Super 1930 Model Automatic Self-Inking Printing Machine especially designed for Commercial Use in all Large and Small Printing Establishments. Price

45/-



What's Your Hobby?



A Wonderful "How-To-Make-It" Book

Here's a big book which will appeal to boys and their fathers as well! A book that shows "how things work," and how things can be made at home at very little cost. It is packed with fascinating articles and crystal-clear drawings and diagrams that "show how" in the simplest way.

The HOBBY ANNUAL is just the book to help while away the long winter evenings. Any boy who is keen on "making things" will treasure it for years.

The HOBBY ANNUAL contains fully-illustrated articles on all the following subjects:

- RAILWAYS**
- SPEED BOATS**
- WOODWORK**
- WIRELESS**
- MOTOR CARS**
- etc., etc.

EVERY BOY'S HOBBY ANNUAL

At all Newsagents and Booksellers - - - 6/- net.

BE PREPARED!

¶ The "Wireless Constructor" is frequently encountering enormous demands these days, demands that even the greatest periodical printing and publishing organisation in the World finds hard to meet.

¶ Therefore, readers would be well advised to place regular orders for their copies so as to ensure that they do not miss any one number that is even more than usually important and attractive.

¶ The "Wireless Constructor" programme is now arranged for the next four months (with ample provision for subjects of a topic character), and we confidently anticipate a most successful season.

¶ Do not fail to get your share of these good things—place a standing order with your newsagent at once.

EVERY MONTH

DO IT NOW!

PRICE 6d.

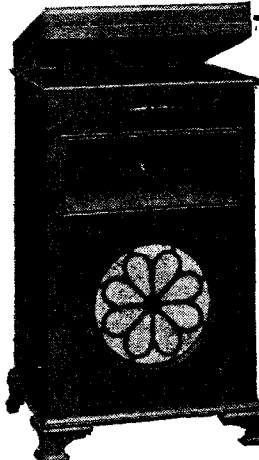

The "Waverley" Radio-Gram Cabinet

Prices: Oak, £5. 10s. Mahogany, £6. 15s. This is only one of many beautiful Cabinets described in our new 24-pp. Catalogue. Send for it, or call and see the full range at our Showrooms.



CARRINGTON MANUFACTURING Co., Ltd.
Showrooms: 24, Hatton Garden, London, E.C.1.
Phone: Holborn 8202.
Factory: Camco Works S. Croydon.

OUR NEWS BULLETIN

—continued from page 56

co-operation in this way would be of considerable help.

Marconi expressed himself in favour of the theory that electric waves can travel beyond the Heaviside Layer, since such layer, or layers, were constantly penetrated by the sun's heat and light.

Tapping the "Transatlantic"

Allegations were recently made in the Press that it is quite an easy matter for amateurs to listen in to conversations on the Transatlantic telephone service. As many of our readers know, this is fairly easy to do with an ordinary short-wave wireless set.

The G.P.O. state that, under some conditions of working, a wireless expert using a special apparatus may occasionally and spasmodically pick up fragments of speech on the transatlantic service, but it would be difficult for him to obtain reception of connected conversation.

We understand, however, that new secrecy devices have been adopted by the G.P.O. as a safeguard against illicit reception.

Fifteen Million Listeners!

Wireless licences issued in this country to the end of July numbered 3,162,460, exclusive of 17,019 issued free to the blind.

The B.B.C. estimates five listeners to each wireless licence, and consequently, on that basis, the B.B.C. believes that it has a potential audience of fifteen million listeners.

It is also estimated that there is a wireless set in two out of every three

set of his own design, and he picked up a picture which was being transmitted from New York. He held it on his reception screen until the end of the transmission.

Mr. Walters said he was not looking for television, but when hearing the characteristic note on a short wave he decided to investigate it, and about 10 p.m. he picked out the head and shoulders of a man. The picture, of course, was distorted, but Mr. Walters said he could make out the movements.

This, we think, is the first time a New York television broadcast has been received in this country by an amateur.

Police Radio

A powerful broadcasting set is to be installed at the new headquarters of the City of London Police at Old Jewry, E.C. Every effort is going to be made to co-operate with Scotland Yard, which was the first police organisation in the country to instal a wireless set.

Police motor-cars are to be equipped with receiving sets, and a city Flying Squad is also being formed.

The Champion Counties

Hertfordshire is the county with the highest percentage of listeners-in, 55.4 of its population being licensed

(Continued on page 60.)

A REMINDER!

Be sure not to miss the December "Wireless Constructor" which will be a

SPECIALY ENLARGED NUMBER

Order your Copy Now

Usual Price Out Nov. 15th.

homes in the country. The B.B.C. aims at having a wireless set in every home.

Transatlantic Television

Mr. Douglas Walters, a London amateur, recently made radio history by picking up television from America. He was using a short-wave

TO HOME CONSTRUCTORS

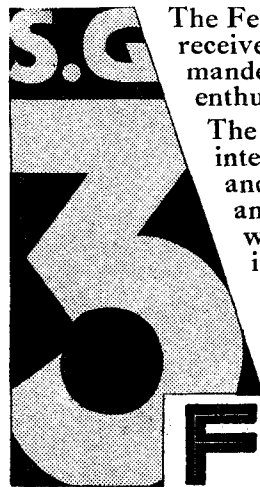

The Ferranti Screened Grid 3 was one of the outstanding receivers of last season. The charts were eagerly demanded, and from all parts of the country came keenly enthusiastic reports.

The 1931 Ferranti programme will be of even greater interest. There will be charts for a Screened Grid 3 and a Screened Grid 4 receiver—both for battery and mains operation. These receivers are well abreast of modern Radio practice, and incorporate improved coils and more efficient screening.

The charts will be ready almost immediately. Get yours before deciding upon your 1931 set.

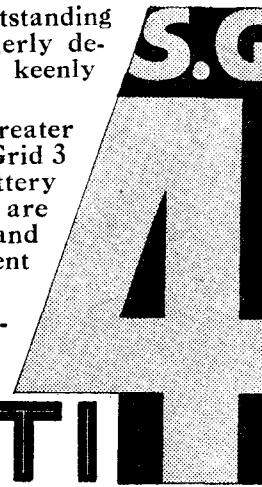

FERRANTI

FERRANTI LTD.

HOLLINWOOD

LANCASHIRE

THE "UNIVERSAL"

A new and aptly named Condenser—by Polar.

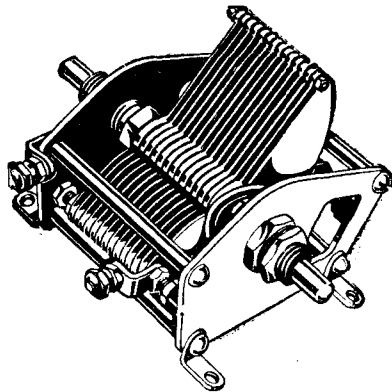

The "UNIVERSAL" condenser, in addition to being perfectly fitted for normal use, is specially adapted for ganging. It is unaffected by the withdrawal of the centre spindle and when ganged the space between each unit can be varied. Locked rotor vanes. Four lugs for rigid fixing. Strong terminals for wiring. Suitable for left or right hand drum control or one hole panel fixing. Construction is right up to the usual Polar standard. A point which those who are already Polar enthusiasts will appreciate.

ASK YOUR DEALER TO LET YOU EXAMINE A POLAR "UNIVERSAL"

New catalogue free on request.

•0003, 7s. 0d. •0005, 7s. 6d.

WINGROVE & ROGERS, LTD.,
188-9, STRAND, LONDON, W.C.2.
Polar Works, Old Swan, Liverpool.

Make These and Make Money!

**AT HOME!
AT ONCE!**

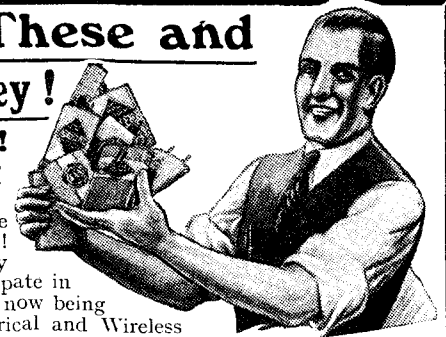

MEN!—Here is the chance of a lifetime! It is an opportunity for you to participate in the **BIG PROFITS** now being made in the Electrical and Wireless Industry, which has not yet reached a tenth of the size to which it will eventually attain. My new and improved Patents are in increasing demand everywhere, because they are such an improvement upon all others. Proved by Certified Tests.

A Genuine Spare Time Business!

The work is so easy that the whole family can help. Even though you have no knowledge of Wireless or Electricity you can commence at once to turn your spare time into CASH and earn anything up to

£300 a Year!

No expensive "plant" or machinery—only simple hand-tools and presses—no special skill is required. Your kitchen as a start, or any small Outbuilding can be your workroom. Nobody can encroach upon your business; it is protected under Royal Letters Patent.

WE GUARANTEE Your Profits. If necessary we arrange to purchase sufficient of your output to ensure a weekly profit to you, providing the same reaches the required standard of efficiency, which is easily attainable. Thus you are positively certain of profit.

Send at once for Full Free Particulars. Don't hesitate—this is a Straightforward, Genuine, Honest Proposition. Commence to earn easy EXTRA £££'s NOW, and become an independent Master Man.

Send this for FREE Particulars!

Write your name and address on a plain sheet of paper, pin this coupon to it and post, together with 2d. stamp, at once to

ENGLAND-RICHARDS CO., Ltd.,
919, King's Lynn, Norfolk.

"Wireless Constructor," November, 1930.

PICK YOUR OWN PROGRAMMES

If you use a radio set you can also use a pick-up. And with a pick-up you can choose your own programmes.

"MODERN WIRELESS"

will help you to do this, for in addition to its "DX" feature,

THE WORLD'S PROGRAMMES

—a boon to all radio listeners—it contains a special "record" section entitled

RECENT RECORD RELEASES

in which a monthly selection of specially chosen records are reviewed—records that will sound to the best advantage on your radio-gram. outfit.

Become a regular reader of

"MODERN WIRELESS"

and get the maximum entertainment out of your set.

Every Month

Price 1/-

Tell Your Friends About It

REACTION CONTROL
ON SHORT WAVES

NEARLY everybody knows nowadays that the great secret of success in long-distance short-wave reception is the smooth and easy control of oscillation. (At least, most of us get into the habit of *believing* that nearly everybody interested in the subject knows that, but enquiries are constantly arising that show there are exceptions!)

Failure to Oscillate

What is the greatest hindrance to such smooth control? The question has often been asked and usually an answer has to take into account the possibilities of poor H.T. supplies, unsuitable valves, components, etc.

When the trouble occurs in a well-designed set and with reasonably good components the usual cause is merely the faulty adjustment of the aerial coupling.

In some sets a small variable condenser governs this, or a separate aerial coil, but in most there is a crocodile clip which can be placed

upon one of the turns of wire in the grid coil.

Place this clip on one of the turns near the earth end of the grid coil, and coupling is "loose." Clip it on near the other end of the grid coil and coupling becomes "tight." Tight coupling of the aerial is one of the commonest upsetters of good reaction results that there is!

Careful Coupling

If you have been getting reluctant reaction, and have been frantically

|||||
A BIG DEMAND
 among the set-builders at
 this time of the year often
 causes a shortage of
"The Wireless Constructor."
 To avoid disappointment, place
 a regular order.
 |||||

altering the size of reaction coil, H.T. to the detector, filament volts, potentiometer position, etc., none of which seems to have hit the trouble on the head, try careful variation of the aerial coupling to see how this affects the set. Ten to one you'll find that this adjustment makes a world of difference to the attainment of smooth reaction control.

OUR NEWS BULLETIN

—continued from page 58

listeners. Oxfordshire comes next with 53.9 per cent, followed by Surrey with 50.2 per cent. Then follows Berkshire with 49.3 per cent, and Northampton with 48.3 per cent.

Among the counties with less than 30 per cent of population as listeners are Northumberland with 27.1, and Yorkshire with 26 per cent.

Marconi on Television

"Television is still in the experimental stage, but in the next decade I think you will find that it will be installed in as many homes as now have wireless sets. Television and wireless will bring the world to the cottage parlour. Wireless has speeded up life; it will speed it up still more when we are complete masters of the ether. This is not yet the case, but in ten years we shall be approaching complete control."

(The above opinion of television was given by Marchese Marconi in an interview which was recently published in "The Sunday Express.")

Electrad
Truvolt Resistances

Truvolt wire wound variable potentiometers simplify the construction of H.T. Eliminators and positively do away with all guesswork. The resistance element is a nickel alloy wire. There is no wire to rust or zinc to oxidise. Truvolt are air cooled and give a positive and lasting service. All the units listed below are rated at 25 watts. Electrad originated the Truvolt. Note these reduced prices and ensure that the units you buy have the name Electrad stamped upon them.

ALL SIZES
8/-
EACH

Type	Resistance Ohms	Current Milliamperes
T.5	500	224
T.7.5	750	182
T.10	1,000	158
T.20	2,000	112
T.25	2,500	100
T.30	3,000	91
T.50	5,000	71
T.75	7,500	58
T.100	10,000	50
T.200	20,000	35
T.250	25,000	32
T.500	50,000	22.5

ALL SIZES
8/-
EACH

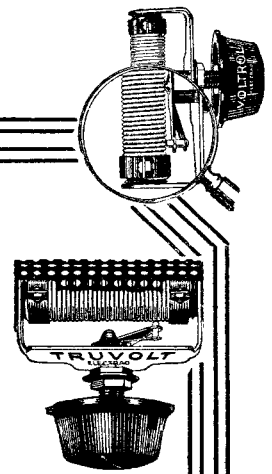

The Rothermel Corporation Ltd.
 24, MADDOX STREET, LONDON, W.1.

Phone: MAYFAIR 0578/9.

Continental Sales Office: 27, Quai du Commerce, Brussels, Belgium.

Write for
 the Electrad
 Catalogue—
 it's free.

The *NEW* LONDON Magazine *at the NEW PRICE 6^{D.}*

Here is a magazine of the highest quality at a price within the reach of every purse—a magazine that everybody has been waiting for! The LONDON at 6d. is big; it is bright; it is full of attractive stories, articles and illustrations all by authors and artists of world-wide reputation. If you want to make certain of the NEW LONDON you should get your copy at once.

Here are some of the well-known contributors:

MICHAEL ARLEN
GILBERT FRANKAU
E. BARRINGTON
RITA WEIMAN
SELWYN JEPSON

Interesting articles in this issue include:

Concerning Guest Rooms. How I Decorated My House for £25. An Impression of Maurice Chevalier. Colour in the Winter Garden. The Care of Clothes. The Glory of Glass. New Square Word Game—£100 for Highest Score.

FREE with Every
Copy

BEAUTIFUL FLOWER PAINTING
IN FULL COLOUR

by **H. DAVIS RICHTER, R.B.A., R.O.I.**
The Famous Flower Painter.



**BUY
YOUR
COPY
TO-DAY
6^{D.}**



GRAHAM FARISH

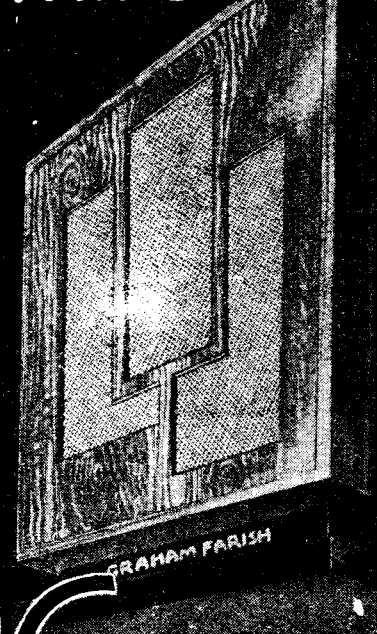

Compare

—and no other Speaker gives such value at the price

We can think of no flowery adjectives to describe our new Speaker—they have all been used up on other Speakers.

We make these two claims—and you are the judge—

1. The new Graham Farish Speaker tells the truth—it never distorts.
2. Compare—and you will agree that no other Speaker offers such value at the price.

Driven by adjustable A pole unit, the Graham Farish Speaker is obtainable in three attractive finishes: Mahogany, Walnut or Oak, price 42/-.

GRAHAM FARISH 42/-
BROMLEY · KENT

RECENT VALVE RELEASES

—continued from page 23

of far more than 200 volts and they have given excellent results. I do not want to bring this forward as advice to others to work the valve above its rated voltage, but it proves they are of perfect workmanship and that there is nothing in the way of any softness which might make itself felt after a little while if any voltage other than the usual is applied to the valve.

Six-Sixty A.C. Types

For instance, if the grid bias is a little less than it should be, or if the H.T. is increased too much. The best results and best life are obtained by working valves at their rated voltages and not exceeding them, and I have mentioned the above merely to show that the P.X.4 is a fine bit of work. The output is high and the grid swing is a matter of something like 80 volts, while the anode current is about 40 milliamps when the valve is properly biased.

Now let us leave the P.X.4 and have a look at the Six-Sixty valves, the S.S.4S.G. and the S.S.4X.S.G. The S.S.4S.G. is a screened-grid valve of the A.C. variety having a magnification factor of something like 1,000 and an impedance somewhere round about 1 megohm. It has a big brother in the S.S.4X.S.G., an A.C. valve which is of the indirectly-heated cathode type, of course, and which has the enormous magnification factor of 1,600.

Some Cossor Newcomers

The impedance is something like 485,000 ohms, giving a mutual conductance of roughly 3·3. The maximum anode voltage recommended is 200, and with carefully designed circuits the valve is capable of providing really colossal results.

As a matter of fact, the amplification is so great that one has rather a difficulty in stabilising the set when using this valve, and very careful screening has to be carried out.

Similar in characteristics to this valve is the Mullard S.4V.A., which is an indirectly-heated cathode valve having a higher amplification factor than the famous S.4V., and here again very careful screening has to be employed if the maximum amplification is to be obtained from the valve.

Finally, there are several Cossor valves to which I would like to draw readers' attention.

There is a new S.G. 2-volter, the 220 S.G., which has a magnification

factor of 320 with an impedance of 200,000 ohms; and there is a 230X.P., a super-power valve, which has the interesting characteristics of 1,500 ohms impedance and 4·5 magnification factor.

A larger new super-power is provided among the 4-volters in the 425X.P., which has 2,000 ohms impedance and a magnification factor of 7.

In addition to these, Messrs. Cossor have a number of special output valves, of which the 4X.P. will appeal to a number of WIRELESS CONSTRUCTOR readers. It has similar characteristics to the P.X.4, namely, 1,100 ohms impedance, a magnification factor of 3·2, but has a maximum voltage for anode potential of 220 volts. It takes 40 volts grid bias at maximum H.T.

And, lastly, I must mention the indirectly-heated mains super-power, the 41M.X.P., which has a slope of 3, with a magnification factor of 6—giving, of course, an impedance of 2,000 ohms.

* **A PROGRESSIVE** *
* **RADIO FIRM** *

PROGRESS and enterprise must be the watchwords of a radio firm the staff of which in the short space of five years has grown from three to approximately eleven hundred.

When Messrs. E. K. Cole and W. S. Verrells made their first successful mains unit in 1925, their "factory" consisted of a small room in a private house. To-day the "Ekco" works occupies a floor space of 80,000 square feet.

We were privileged to be present at the official opening of this great new works at Southend-on-Sea on September 12th, and during the tour of the factory we were exceedingly interested to note the extreme care which was being taken in the endeavour to mass-produce quality radio instruments at popular prices.

Tests on M.C. Speakers

Thoroughly up-to-date machinery is employed throughout, and at every stage in manufacture the various components undergo rigorous tests. It is clearly evident that Messrs. E. K. Cole are aiming at a very high standard of efficiency, and in proof of this we would state that the completed sets are all tested in conjunction with high-grade moving-coil loud speakers.

(Continued on page 63.)

A PROGRESSIVE RADIO FIRM

—continued from page 62

Apart from the question of output and the manufacture of a good quality article, it is evident that the management has the welfare of its employees at heart. An up-to-date heating and cooling system maintains the works at a temperature of between 60 and 70 degrees throughout the four seasons of the year, and means are provided whereby a constant supply of clean, pure air is continually circulating throughout the various departments.

Mains Sets and Units

The "Ekco" all-electric receivers are real "good-lookers." The cases are beautifully finished in tastefully coloured bakelite, and we can vouch

VICTOR KING

will be describing

"THE PARATUNER"

in the December

"WIRELESS CONSTRUCTOR"

Out Nov. 15th.

Order Now.

for the fact that the models we heard gave results which are in keeping with the appearance.

As for the mains units, these are known throughout the radio world as being sound value for money.

After-Sales Service

In their new factory, Messrs. E. K. Cole have a fully-equipped Research Department, which is striving unceasingly to improve the firm's products. There is also the Service Department to which purchasers may return their units or sets should they accidentally become damaged. The fact that such a department exists shows that the "Ekco" people have every desire to give their customers good "after-sales" service.

This new factory is evidence of hard work, perseverance and foresight, and we feel sure that "Ekco" products will achieve even greater popularity during the 1930-1 season.

In every corner of the radio world

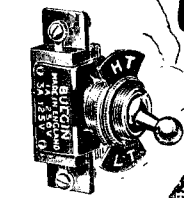

TOGGLE CHANGE-OVER SWITCH.

For changing over connections such as from H.T. to L.T. Trickle Charger. Carries 250 watts. **2/-**

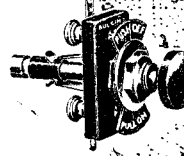

DE-LUXE PUSH-PULL SWITCH.

Pure nickel silver contacts, highly plated fittings, Bakelite base. For metal or ebonite panels. **1/6**

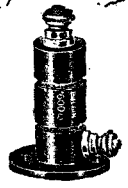

DE-COUPLING RESISTANCES. To carry 30 M.A. Prevent back coupling through the battery or eliminator. 600/1,000 ohms.

1/6

2,000 ohms 1/9

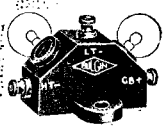

UNIVERSAL FUSE HOLDER.

An economical safeguard for sets where high values of G.B. current are used. **1/9**

BULGIN

The Choice of Critics

RADIO COMPONENTS

can be recognised and purchased without the least trouble. All the British Dominions, as well as Spain, India, Egypt, Italy, Sweden, Denmark, France, etc., regularly import large quantities of these original radio products. Bulgin Components are standard to-day in all the world's best sets.

Send 2d. postage for new 60-page Catalogue.

A. F. BULGIN & CO., LTD.,

9, 10, 11, CURSITOR ST., CHANCERY LANE, E.C.4.
Ph.: Holb. 1072, 2072.

IF YOU REQUIRE FIRST-CLASS



EBONITE PANELS & FORMERS

Look for this TRADE MARK. The Hall Mark of Quality.

Sole Manufacturers: **THE BRITISH EBONITE CO., LTD.,** HANWELL, LONDON, W.7.

15,000 SUCCESSES

is the record of The T.I.G.B.

If you, too, wish to advance to a well-paid post in any branch of engineering, T.I.G.B. home-study training offers you the surest means of achieving the success you desire.



ENGINEERS

This 124-pp. book furnishes the most complete information ever published about the many professional qualifications open to engineers such as A.M. Inst. C.E., A.M.I. Mech. E., A.M.I.E.E., A.M.I. Struct. E., etc.; describes nearly 200 Courses; the widest selection of engineering courses in the world; and is crammed with matters of interest to every engineer. If you are ambitious, The T.I.G.B. can help you—write TO-NIGHT for your FREE copy of "The Engineer's Guide to Success," stating branch, post, or qualification that interests you.

The Technological Institute of Great Britain, Established 1917
21, Temple Bar House, London, E.C.4.

Please be sure to mention WIRELESS CONSTRUCTOR when replying to Advertisements.

PURITY OF TONE

In the Lotus Power Transformer the output windings are planned to give their full load current without any noticeable drop in voltage. The high potential terminals are separated by divisions to reduce the possibility of accidental contact to a minimum. Price ... **£1 12s. 6d.** From all Radio Dealers.

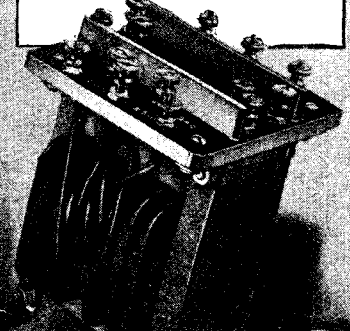

LOTUS POWER TRANSFORMERS

Write for illustrated Catalogue to GARNETT, WHITELEY & Co., LTD., LIVERPOOL.



**GREATEST
AMPLIFICATION**
**LESS
RECORD WEAR**

The reason why the Wates Pick-Up reproduces all those subtle gradations of sound with perfect balance and uniformity of tone, at any volume strength, is found in the scientifically correct combination of weight, balance and needle tracking. A unique adjustment is provided by the two screws securing the needle holder, and a half-turn is sufficient to detect by ear the best position. Ask your dealer to demonstrate side by side with any other—we are content if you select by test—your choice will always be a Wates.



Pick Up only 21/- Wates Pick Up Arm, 7/6

THE STANDARD BATTERY CO.
(Dept. W.C.),

184/188, Shaftesbury Avenue, London, W.C.2.

EVERYTHING WIRELESS
ON
EASY TERMS
COSSOR EMPIRE MELODY MAKER, KIT COMPLETE WITH VALVES. **£6:17:6**
CASH PRICE... or send 13/9 and balance by 11 monthly payments of 12/6.
ALL COMPONENTS, Kits of Parts for all Circuits, Loudspeakers, H.T. Units, etc.
CALL or SEND A LIST OF YOUR REQUIREMENTS; a Quotation of our BEST MONTHLY TERMS will be sent BY RETURN.
The P.D.P. CO., LTD. (Dept.)
46, WATLING ST., LONDON, E.C.4
Phone: Central 4468

PLEASE be sure to mention "Wireless Constructor" when communicating with Advertisers. **THANKS!**

DO WE WANT SUPER-POWER ?

—continued from page 44

"For ordinary listening in a room of average size I try to adjust my volume so that I get a 'picture' of what I would expect to hear if I had a good seat in the auditorium of a theatre or other place of musical entertainment.

Is Bass Important ?

"I do not think that bass reproduction is the most important factor. It is quite easy to get adequate bass with two modern L.F. stages and a good super-power output valve, operating with reasonable H.T. voltage. Those who require 400 volts

Don't Miss Our December
SPECIAL NUMBER.

Invaluable to every real
**Wireless
Constructor**

On Sale Nov. 15th

Usual Price. Unusually Good!

H.T. and something like 100 m.a. in order to get enough volume must either be deaf, or possess very insensitive loud speakers. I agree that where more than 'room strength' is required special amplifiers are necessary.

"Volumes sufficient for small dance halls, or for the open-air, cannot be obtained from the type of set designed for broadcast reception in the home.

A Miniature Orchestra

"The question has been raised as to whether it is possible to visualise a miniature of a symphony orchestra, in which every shade of tone and every relative tone strength retains an original proportion.

"While an expert musician may be able to do this, I, personally, cannot.

Most of us, however, know what a good orchestra sounds like, and if we can obtain a picture of the impression obtained, then I think that most of us are satisfied.

"In conclusion, I think that we should go on striving to attain the ideal in reproduction, in which the reproduced programmes are an exact counterpart in miniature of the original, but I do not consider that enormous output valves and high anode voltages are necessary in order to obtain adequate domestic volume."

In conclusion, Mr. Victor King gave it as his opinion that the ground had been covered adequately by the various speakers, and stated that he could add nothing to the excellent comments made.

Not Very Formidable

He suggested that the problem had proved, after discussion, much less formidable than he at first anticipated it would prove. Nevertheless, he thought there were one or two auxiliary questions relating to it, but that these had been dealt with in connection with various others of the committee's meetings.

Subsequently, the WIRELESS CONSTRUCTOR Ideas Committee discussed a proposed set construction programme, and examined various experimental hook-ups and gadgets, the perfected models of most of which CONSTRUCTOR readers will be able to read about in the coming months.

HERE AND THERE

—continued from page 4

"And then the next day come the letters! You will get ten letters saying you drop your voice at the end of the sentence. You will get ten letters asking you not to raise your voice at the end of the sentence like a curate. You will get twenty letters telling you that you are a marvel and a joy; you will get twenty letters telling you that you are an ass and a fool.

"Never, never," thus will run a letter from the Isle of Man, 'have I enjoyed a talk so much.' 'Please,' reads a post card from Porlock, 'go abroad again and don't come back.' There will be listeners who tell you that you are too high-brow, and listeners who write that it passes their conception how a man of education, etc., etc.

"You will get letters asking you to mention fountain pens, birth control, the charm of the Lake District, and the importance of cleaning one's teeth four times a day. You will be asked your advice on matrimony, incipient baldness, hotel prices in Transylvania, and how to cure ringworm.

"And among these letters will be one which will convince you that broadcasting is a useful, nay, a noble, function. That letter will contain your cheque from the B.B.C."

The concluding sentence is interesting. The cheque must be a healthy one to inspire such sentiments! It seems the B.B.C. pays better fees these days—at least, to its star performers. And quite right, too.

A NOVEL IDEA
 By A. B.

SOME months ago I was forced to use a spark-coil from a motor-car as an output transformer. The subsequent failure of this coil as an ignition unit permitted me to dissect it, and with the "bits" left over some very interesting experiments were carried out.

The coil was originally built up in accordance with the recognised automobile practice, which, although opposed to radio doctrine, makes a very sturdy job.

Thoroughly Insulated

The core of straight, soft-iron wires was thoroughly insulated with oiled silk, over which was wound the low-tension or primary winding, consisting of several layers of 24 S.W.G. silk-covered wire, each layer having 100 turns, or about 500 turns in all, the whole being again insulated with some more oiled-silk sheet.

The secondary or high-tension winding was built in two halves, one being slid over each end of the primary, and insulated from it and each other with still more oiled-silk.

At the bottom of this multiple coil was the condenser, snugly fitting into a small moulded pocket in the outer case. This condenser immediately found a home across the H.T. on my set.

After soaking the coil in methylated spirits for an hour or two, to wash off the shellac with which it had been liberally coated, it was possible to cut out and free the six ends of the three coils. I should estimate secondary winding to be about 38/40 S.W.G. enamelled and single silk-covered.

As L.F. Transformer

These ends were then soldered to six appropriately marked terminals on an ebonite strip, and the whole skeleton assembly was fitted permanently into a small wooden case.

By connecting the four terminals of the secondary winding in place of the usual I.P., I.S., O.P. and O.S. of an intervalve L.F. transformer, quite creditable results were obtained, considerably better than with some very cheap transformers.

Short circuiting the primary winding while the coil was being used in this manner resulted in an immediate drop in signal strength—almost to a whisper, in fact.

(Continued on page 66.)

BUILD YOUR MAINS SET THE



WAY

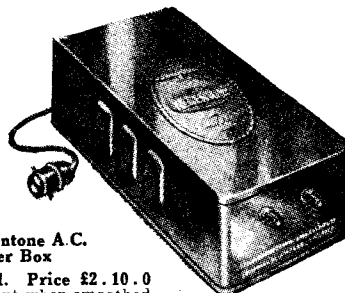

Regentone A.C. Power Box
 No. 1. Price £2. 10. 0
 Output when smoothed
 120 volts at 20 m.a.
 No. 2. Price £3. 10. 0
 Output when smoothed
 160 volts at 50 m.a.



Regentone Filter Compact
 No. 1. Price £1.12.6
 No. 2. Price £2. 5. 0

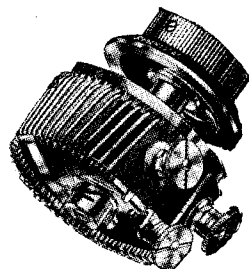

British Patent No. 3087.
 In two types, covering a wide range of values. Price 9s. 6d. and 11s. 6d.
 Terminals allow use as a Potentiometer or Series Resistance. Resistance value ranging from 500 ohms to 180,000 ohms.

IT'S simple to build an A.C. Mains Set if you use the Regentone Power Box and Filter Compact. Instead of 8 or 9 separate components to build into your mains drive, there are only two. Both are completely screened, preventing interaction between the mains portion and the rest of your set.

Two connections only, and the Power Box and Filter Compact become a complete H.T. and L.T. Eliminator for A.C. Mains, with two positive H.T. Tappings. An additional variable H.T. Tapping can easily be obtained by adding a Regentstat and a 2-mfd. decoupling condenser.

The Power Box contains a Regentone Transformer and a Westinghouse Metal Rectifier—no delicate Valves to break or wear out. Two tappings deliver L.T. for A.C. Valves—4 amps. at 4 volts. The other two give the H.T. Output, which is smoothed in the Filter Compact.

The Filter Compact is a complete smoothing unit. It contains a bank of high-voltage-test condensers and a Regentone Choke of generous dimensions. Though designed for use with the Power Box, the Filter Compact is equally suitable as a complete smoothing unit for other rectifiers of similar output. In the same way the Power Box may be used with any good smoothing unit.

The new Regentstat is the only TOTALLY WIRE-WOUND variable Resistance of high ohmic value capable of handling power. Wire is the only resistance element used. The resistance element is wound in spiral formation, preventing excessive rise on load. Variable spring-loaded arm does not ride on wire resistance element, thereby eliminating risk of breakdown. Special separate Nickel-Chrome contacts are provided for variable contact arm.

Remember, too, that in addition to saving yourself labour, you are getting the best components that money can buy—the components used by Regentone in their own Mains Units.

Write to-day for your FREE copy of our new Art Catalogue.

REGENT RADIO SUPPLY CO.

Regentone House, 21, Bartlett's Buildings, Holborn Circus, London, E.C.4.
 Telephone: 8745 (5 lines).

EASY TERMS

WE specialize in the supply of all good quality Radio sets and components on easy terms. We will give you efficient and prompt service. A few examples below:—

NEW COSSOR EMPIRE MELODY MAKER

Complete kit of parts including valves and cabinet

Cash Price **£6.17.6** or 10/- with order and 11 monthly payments of 12/6

NEW OSRAM "MUSIC MAGNET 4" KIT

Including cabinet and valves. First-class long-distance receiver incorporating 2 H.F. stages

Cash Price **£11.15.0** or 16/- with order and 11 monthly payments of 21/-

EKCO 2-VALVE ALL-MAINS RECEIVER

For alternating or Direct Current Mains

Cash Price **£14.10.0** or 18/6 with order and 11 monthly payments of 26/-

12 EXIDE W.H. UNITS

(12c V. 5000 MA.)

Cash Price **£3.15.0** or 5/6 with order and 11 monthly payments of 7/-

NEW BLUE SPOT 66R UNIT

with large cone chassis.

Cash Price **£2.10.0** or 5/- with order and 10 monthly payments of 5/-

Send us your enquiry and a quotation will be sent by return.

London Radio Supply Company,

11, OAT LANE, NOBLE ST., LONDON, E.C.2
TELEPHONE NATIONAL 1977

To House Your SET OR RADIO-GRAM
BUILT LIKE A PIANO

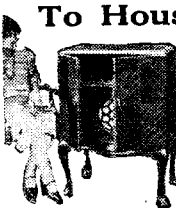

NOTE PATENT BAFFLE CHAMBER.

De Luxe Radio Furniture—famed for excellence. USED BY leading experts—Famous Engineers—5,000 delighted clients.

Direct from Craftsman's bench to your home. You may have **ON APPROVAL FREE TEST** and return at our expense if you wish to part with it. Prices run from £5 5 0 (or £10 to £15 15 0 for Exclusive models). Cash or Easy Payments. Photographs and full particulars FREE.

PICKETT'S, Radio Furniture Makers (W. Con.), Albion Road, Bexleyheath, Kent.

ROTOR-ΩHM

volume controls are velvet Smooth—Silent and deadily Accurate. That is why they are constantly specified for all circuits, and incorporated in all the best receivers.

ROTOR-ΩHM POTENTIOMETER (IN ALL CAPACITIES) 6/-
Rotor Electric, Ltd., 2/3, Upper Rathbone Place, W.1.

ELEX 2 DH

2DS  SPADES and PINS HOOKS and EYES

2DP  6 Colours .. 2d. each.

2D1  Write for List Y.79

J. J. EASTICK & SONS, 118, Bunhill Row, London, E.C.1.

Make **The DAILY SKETCH** YOUR Picture Paper.

A NOVEL IDEA

—continued from page 65

Using the primary winding as a choke, in an output filter circuit, gave very indifferent results, but the secondary winding responded admirably, or rather one-half of this winding I should say, for the two coils in series were not quite so good.

From the foregoing it will be seen that an old auto-ignition coil is quite a useful thing to get hold of, but the illustrations given do not exhaust its possibilities, for after adapting the condenser to the H.T. circuit and building one-half of the secondary into an output filter, the primary winding forms a welcome addition to the wire stock, also the secondary wire is quite useful for re-winding headphones or speakers.

* **MULTI-LANGUAGE** *
* **AMPLIFIERS** *
* By Dr. ALFRED GRADENWITZ. *

AN interesting arrangement has for the first time been used at the recent Second World-Power Conference held in Berlin, which was intended to do away with the inconvenient subsequent interpretation of speeches and addresses and the loss of

his version chosen by himself. In fact, the interpreters, called upon to translate simultaneously, were not allowed to address those present in the ordinary way, being heard by everybody.

They were instead expected to speak into their microphones in a low tone of voice, and in order entirely to concentrate the acoustic energy upon these and not to interfere with the attention of listeners to any other language the microphones had to be fitted with acoustic funnels.

Choice of Languages

The microphone currents were duly amplified, and by separate lines of conductors carried to the seat of every member of the Conference.

A special line had, of course, been provided also for the original language of the actual lecturer, who likewise spoke into a microphone placed on his desk.

Each member of the Conference thus had on the desk in front of his seat a pair of headphones for listening, and a small switchboard enabling the acoustic intensity to be controlled at will by turning a knob, while a switch provided to this effect allowed any language to be listened to. Though only German, English and French were admitted at the recent Conference, the installations made by the Siemens & Halske people have been developed for simultaneous reproduction in as many as six languages.

MAKING THEM ALL UNDERSTAND

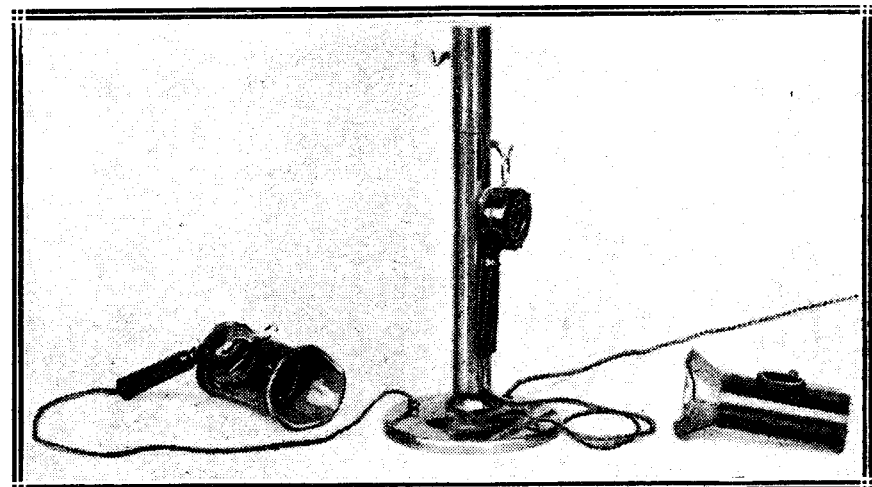

The telephone, microphones and earpieces used at the Conference.

time unavoidably connected therewith, a simultaneous multi-language reproduction being substituted for the successive rendering, so far indispensable.

This, of course, could only be done by enabling every listener to shut his ears hermetically to any but

As the translator in a given language—e.g. in English—is lifting his microphone, there is on a luminous sign visible to a large distance seen the word "English." Each member entering the Conference Hall thus can tell at a glance which languages are being used for interpreting.

D.C. MAINS UNITS
Avoiding mains short-circuits.

Sir.—We are writing to you with regard to what appears to be a very common trouble in connection with sets used in conjunction with H.T. supply units on D.C. supplies.

We have experienced a large number of cases where the primary winding of the high-frequency transformer used in the Ferranti Screened-Grid Three Receiver has been returned to us and found to be completely burned out, the trouble being caused by the use of the set with a D.C. H.T. unit without taking proper precautions.

A Safety Condenser

As most engineers are aware, trouble of this kind is likely to occur when wireless sets are used with D.C. units on the negative side of three-wire systems, that is, where the positive main is earthed.

One source of this trouble is not having a condenser in the earth lead of the supply unit, a condenser which, for safety's sake, should always be included; the earth connection from the receiver being disconnected entirely, the actual earth being made through the negative terminal of the supply unit, and the isolating condenser, which should be incorporated in it, and which is shown in our D.C. supply unit constructional chart.

Insulating the Aerial

The other source of trouble is the aerial, as if the aerial is not efficiently insulated—and very few aerials are insulated adequately to withstand a supply voltage of the order of 230 volts—a short-circuit can occur through the aerial coil of the set, with the result that it is destroyed, and, further, the whole aerial is at a pressure of 200 volts or more above earth, and is a source of considerable danger. This trouble is still further accentuated, even with the best aerial, if the aerial is earthed by means of a switch as is commonly done.

The remedy is, of course, to connect a small condenser, usually about .005, in series with the aerial terminal of the set inside the receiver, so as to prevent the aerial becoming alive.

As we have previously indicated, we have experienced such a lot of trouble due to this particular cause that we feel that it is a matter which should be ventilated in the Press.

Yours faithfully,
 FERRANTI, LTD.

Hollinwood,
 Lancashire.

NEW CLIX LINES



No. 25. Pat.

SOLID PLUG.

Maximum tensile strength. For use with Resilient Sockets. Engraved or Plain, Red or Black **2d.**

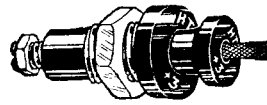

No. 15. Pat. Pro. Pat. Reg. Des.
CLIX NEW "ALL-IN" TERMINAL.
 Incorporating the new Clix Resilient Socket and Solid Pin. Entirely insulated at all times. FLEX portion **4d.** PANEL portion **4d.** COMPLETE **8d.**

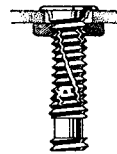

No. 23. Pro. Pat.
RESILIENT SOCKET.
 Short, uninsulated, for thin panels. Flush mounting **1d.**

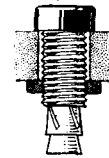

No. 24. Pro. Pat.
RESILIENT SOCKET.
 Insulated with bush head. For metal or any type of panel. Red or Black **2d.**

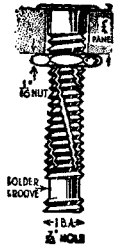

No. 22. Pro. Pat.

RESILIENT SOCKETS.
 Long, uninsulated. For panels up to 1/4 in. thick. Flush mounting . . . **1 1/2d.**

No. 6. ANODE CONNECTOR.

Solid Pin tag is permanently fixed to S.G. or Pentode valve terminal. The insulated resilient socket with wire fixing device gives certain push-pull contact. Impossible to short anywhere. Engraved. Price **3d.**

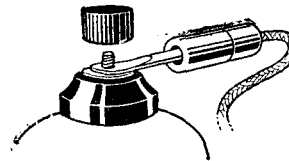

No. 6. Pro. Pat. Reg.

Free Illustrated Leaflet on request.

LECTRO LINX, Ltd., 254, VAUXHALL BRIDGE ROAD, S.W.1

10 Amps.!
 On test the new Benjamin Rotary Switch breaks 10 amps at 20 volts and does it 50 times in rapid succession. On 250 volts A.C. also, the switch behaves well, proving its complete adequacy for use with trickle chargers, eliminators, etc.
 One-hole fixing to either metal or insulated panels is obtained by drilling 1/4-in. clearance.
 Read all about these switches and the circuits in which they can be used, fully described with diagrams in our catalogue 1142.
 Without terminals, 3/-
THE BENJAMIN ELECTRIC LTD.
 Trafalgar Rd., Tottenham, N.17
 Tottenham 1500.

36

BENJAMIN

The Picture Paper with the MOST News

SUNDAY GRAPHIC

The best Eliminators
The best Mains Sets

Use
HYDRA CONDENSERS

LOUIS HOLZMAN, LTD.,
37, NEWMAN STREET, W.1.
 Telephone: Museum 2641

High-Grade
SET & SPEAKER CABINET
 Constructed of finely figured Oak on carved ball and claw legs, hand French polished.
THE ACME OF CRAFTSMANSHIP.
 £8.8.0, carriage paid.
RADIO-GRAMOPHONE CABINET.
 £10.0.0, carriage paid.
 Models from £2.2.0 to £20.
 Thirty-page illustrated catalogue, post free.
GILBERT, Cabinet Maker
 Established 1866 SWINDON.

SOLVE ALL H.T. TROUBLES

WET BATTERIES

TAYLEX

~ SELF GENERATING ~

Per doz.	No. 1, No. 2
	s. d. s. d.
Jars (waxed)	1 3 1 6
Sacs	1 2 1 9
Zincs	10 11
Rubber Bands (24)	4 4
Terminals	8 10

Trade Supplied.

LONG LIFE: SILENT: ECONOMICAL
 Sample doz. (18 volts), complete with bands and electrolyte. No. 1, 4/1; No. 2, 5/-; post 9d.; terminals extra. No. 3, with terminals, 7/6 (10,000 milli-amps) sample unit 6d. Orders 10/- carr. paid. New illustrated catalogue post free.
FREE Bargain List of Receivers Amplifiers and Components

C. TAYLOR, 57, Studley Road
 Stockwell, London

DRILLING IN CORNERS

A useful hint for the home constructor.

By C.P.A.

It is very awkward when you have just finished a receiver to find that you have left out one lead, and that this particular lead is situated in a corner, and that a hole has to be drilled in this corner for the lead to go through.

FIXING THE DRILL

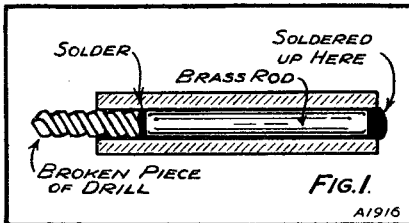

How the piece of drill is secured to the extension rod.

This is especially likely to be the case when sub-baseboard wiring is being used.

An Easy Solution

I myself came up against this snag the other day. I had just completed, as I thought, a three-valve all-mains receiver, and I was checking over the wiring when I found to my dismay that I had omitted to connect the cathode of the H.F. valve to its automatic bias resistance under the baseboard. The cathode tag of the valve holder was in the corner of the screen, and I had not drilled the hole for the lead to go through the baseboard.

The solution to the problem was an easy one, and it struck me that it

would be of interest to other experimenters.

To change the subject for a moment, I never throw away the ends of drills that get broken, so that my drill box usually has three or four pieces of drill of different sizes all about an inch long. Well, I found a piece that was just the right diameter for the hole to be drilled in the baseboard, and I soldered it into a piece of brass tubing (into which it just slipped) as shown in Fig. 1.

SOLVING THE PROBLEM

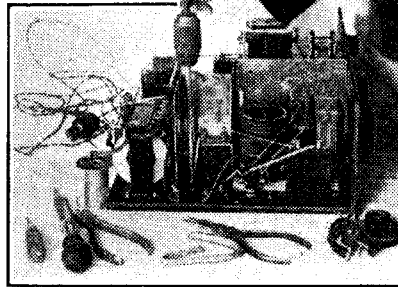

Using the drill extension in an awkward corner.

The tube was then plugged with a piece of brass rod which was also soldered in. Alternatively, you can

fill the whole tube with molten solder, whichever you prefer.

The tube was long enough for the drill to reach down into all kinds of inaccessible corners, and the photograph shows it being used in a most awkward corner.

Another Scheme

Sometimes, if you don't happen to have a long enough piece of the right kind of tubing you may have to solder the drill into a short piece of tube, and then solder the short piece into a longer piece again.

AN ALTERNATIVE

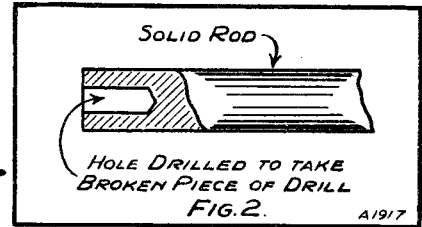

Solid rod can be used quite as well as tubing.

Alternatively, if you are sufficiently skilful you can drill a hole up the end of a piece of rod as shown in Fig. 2, and solder the drill into this. You have to be sure that the hole is central in the rod, and that it is drilled straight up it, otherwise the drill will not run true.

Money-Saving Device

This method is also a good one for making use of short pieces of broken drill that would otherwise be useless and have to be thrown away, and thus enables you to save the odd pence which you would have to pay for a new drill, for some more important purpose.

Apart from the particular instance given, you will find these extended drills useful for all manner of little jobs.

INDEX TO ADVERTISERS

	PAGE
Adana, D. A.	57
Belling & Lee, Ltd.	55
Benjamin Electric, Ltd.	67
Bulgin, A. F., & Co., Ltd.	63
Burne-Jones & Co., Ltd. (Magnum)	54
British Ebonite Co., Ltd.	63
British Blue Spot Company, Ltd. Cover iii	
Carrington Manfg. Co., Ltd.	57
Cossor, A. C., Ltd.	2
Dubilier Condenser Co. (1925), Ltd.	38
Edison Swan Electric Co., Ltd.:	
Mazda Valves	Cover ii
R.K. Reproducers	38
B.T.H. Transformers	53
England-Richards Co., Ltd.	59
Exide Batteries	41
Eastick, J. J., & Sons.	66
Formo Company	53

	PAGE
Ferranti, Ltd.	46 and 58
Gambrell Radio, Ltd.	55
Garnett Whiteley & Co., Ltd.	63
Gilbert, J. C.	67
Graham Farish Company	62
Heyberd, F. C., & Co.	57
Holzman, Louis, Ltd.	67
"Hobby Annual"	57
International Correspondence Schools	55
Jackson Bros.	49
Lectro Linx, Ltd.	67
Lissen, Ltd.	29
London Elec. Wire Co. & Smiths, Ltd.	34
London Radio Supply Co.	66
"London Magazine"	61
Marconiphone Co., Ltd.	30
"Modern Wireless"	59
"New Nature Book"	42
P.D.P. Co., Ltd.	64
Pickett's Cabinet Works	66
Radio Instruments, Ltd.	Cover iv
Ready Radio	33

	PAGE
Regent Radio Supply Co.	65
Rothermel Corporation, Ltd.:	
Centralab	1
Magnavox	42
Electrad	60
Rotor Electric, Ltd.	66
Six-Sixty Radio Co., Ltd.	37
Standard Battery Co., Ltd.	64
Taylor, C.	67
Technological Inst. of Gt. Britain	63
Telegraph Condenser Co., Ltd.	30
Telsen Electric Co., Ltd.	51
Varley Products	45
Westinghouse Brake & Saxby Signal Co., Ltd.	56
Weston Electrical Instrument Co., Ltd.	42
Wright & Weaire, Ltd.	46
Wingrove & Rogers, Ltd.	59

All communications concerning advertising in "Wireless Constructor" must be made to John H. Lile, Ltd., 4, Ludgate Circus, London, E.C.4. Telephone: City 7261.



BLUE SPOT'S MASTERPIECE **351**

• **THE BRITISH BLUE SPOT COMPANY LTD.** •

BLUE SPOT HOUSE, 94/96, ROSOMAN STREET, ROSEBERY AVENUE, LONDON, E.C.1.

'Phone: CLERKENWELL 3570

'Grams: "BLUOSPOT, SMITH, LONDON."

Distributors for Northern England, Scotland and North Wales: H. C. RAWSON (Sheffield and London) LTD., 100, London Road, Sheffield, 22, St. Mary's Parsonage, Manchester; 183, George Street, Glasgow.

*She can't sing
if she's gagged*



neither can your set pass the full volume and exquisite tone of that glorious voice perfectly unless—

your transformer is capable of giving the maximum amplification plus the uniformity that modern valves demand. Nikalloy, the marvellous metallurgical discovery, applied in a specially designed core makes the "Hypermu" absolutely unique in its performance and suitability for modern circuits. If you want to hear your radio favourites' voices reproduced louder, purer, better than ever before, fit

HYPERMU

the
L.F. INTERVALVE TRANSFORMER
with the **NIKALLOY CORE**

Ask your dealer or write to us for leaflets giving full particulars of the "Hypermu" and the other famous R.I. Nikalloy components. Components that set a new standard of radio efficiency.

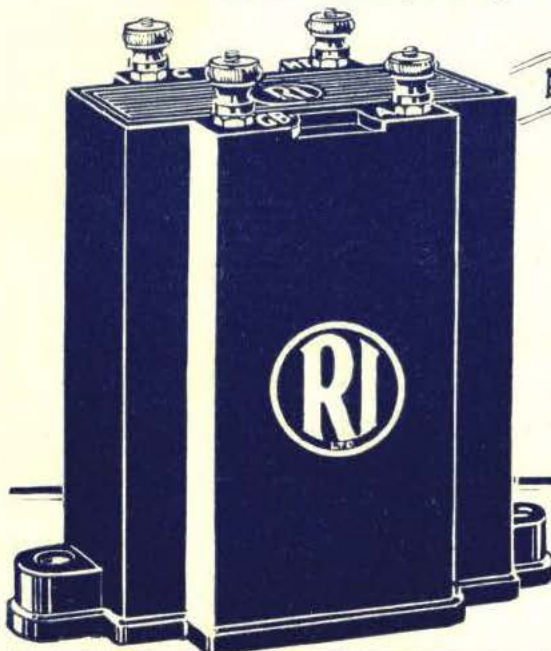

AND HYPERMITE

"Hypermu" is one of the famous Big Three and like the "Hypermite" and "Hypercore" its secret of success is the utilisation of Nikalloy cores which give a performance in the transformers and choke positively unequalled by imitations and other types.

Hypermu, the world's best transformer — proved alike by amateur and expert

21/-

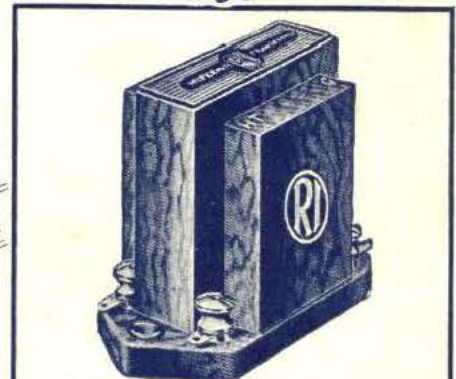

HYPERMITE Presents everybody an opportunity to test the superiority of R.I. Nikalloy core transformers at a price within the reach of all. Extremely small (2½ × 1½ × 2½ ins.) for compact set building. Eminent useful when used in conjunction with "Hypermu" in further stages of amplification

12/6



RADIO INSTRUMENTS LTD., "MADRIGAL" WORKS, PURLEY WAY, CROYDON