

The Wireless Constructor

6^D
MONTHLY

EDITED BY
PERCY W. HARRIS, M.I.R.E.
Vol. VII. MARCH, 1929 No. 29.

The REQUEST THREE

BY PERCY W. HARRIS
M.I.R.E.

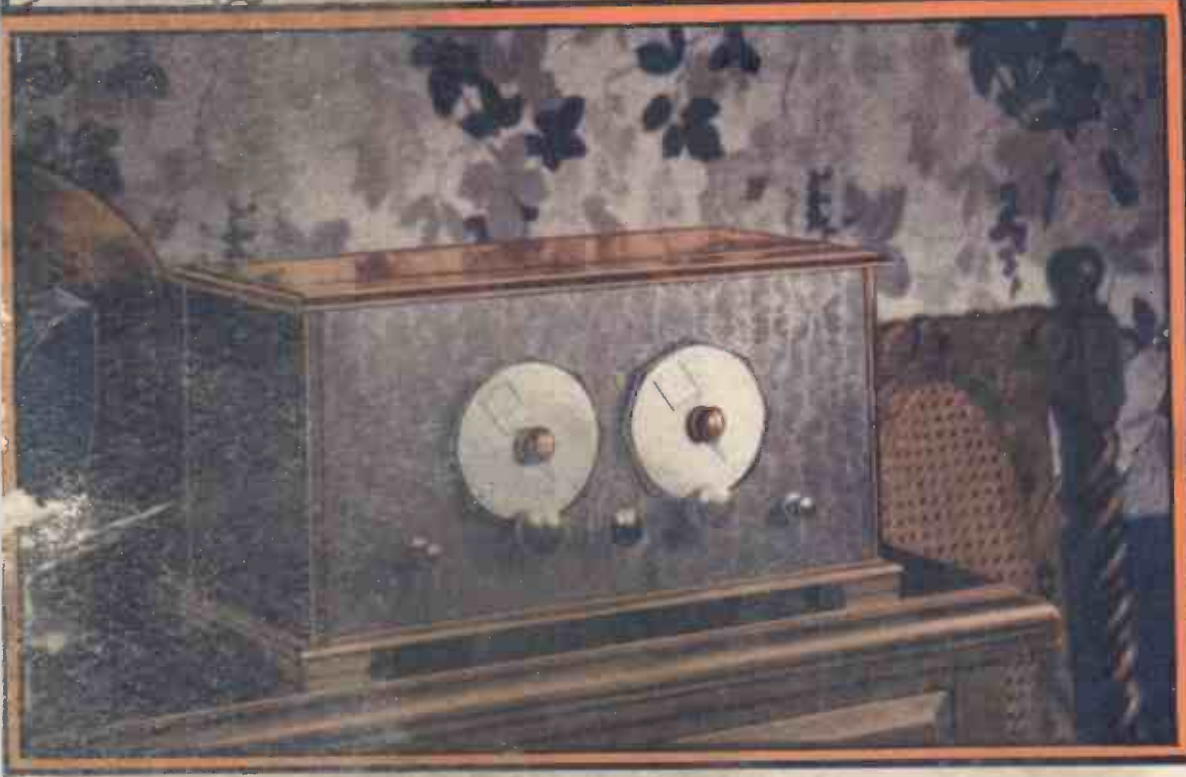

*The Editor
The Wireless Constructor
Harris
HARRIS HIRE
Wireless
House
44
London*



CLARITY

BETWEEN the far distant broadcasting station and your own fireside, Mullard P.M. Valves form the perfect link.

The tone they give you—the volume—the sensitivity to distant stations—Mullard P.M. Valves make an old radio set modern, a modern set perfect.

Your receiver is as good as your valves; your valves are as good as their filaments—and the Mullard P.M. Filament is unique.

Get a set of Mullard P.M. Valves to-day—all radio dealers sell them.

Mullard

THE · MASTER · VALVE

The WIRELESS CONSTRUCTOR

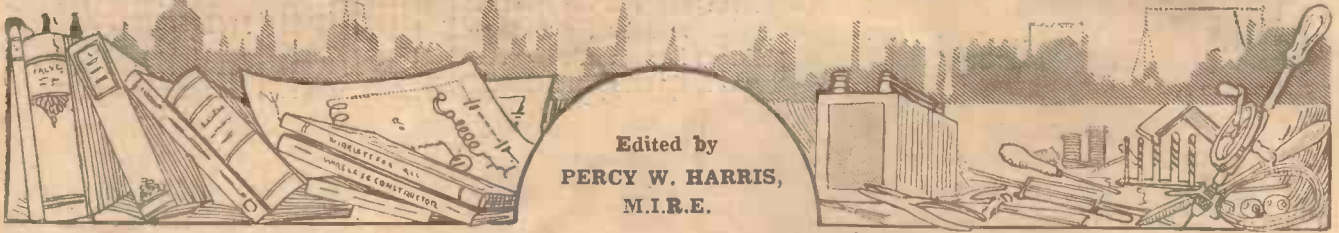

Published by the Amalgamated Press, Fleetway House, Farringdon Street, London, E.C.4.

THE EDITOR'S CHAT

Percy W. Harris, M.I.R.E., the Editor of the "Wireless Constructor," discusses the subject of picture broadcasting and introduces several important articles to readers.

AMONG the varied assortment of highly useful theoretical and practical articles in the current issue, much interest will be aroused by a very full and practical description of apparatus by means of which any possessor of a wireless set can receive still-pictures from Daventry 5 XX, and in a large number of cases from Königswusterhausen (Zeesen), Vienna and other stations which will shortly be transmitting picture programmes.

The British Broadcasting Corporation, having carefully investigated the Fultograph system, began regular transmissions from 5 XX in October last, but it is only comparatively recently that the company owning the rights in this country have been able to deliver machines. The great fascination of picture reception will be understood when the article is perused, and whether or not it is worth while to purchase a complete picture receiver, which costs little more than twenty pounds, the reader will decide for himself.

The "Request" Three

Still-picture reception is, of course, something entirely different from television, of which we have heard so much and seen so little. Still-picture reception is no longer in the laboratory stage, or requiring expert handling.

Continuing our policy of designing, testing and producing sets along the lines specially asked for by our readers, we present this month the "Request" Three, a wave-change set using the popular "X" coils and two transformers of the best modern type. We would draw particular attention

to the simplicity of the wave-change scheme, requiring no special coils or elaborate wiring; the compactness of the set, which occupies a 16 in. by 8 in. cabinet instead of a 21 in. by 7 in., which is often used for a three-valve receiver; and last, but not least, the wide opportunities for individuality of choice in the way of components.

A Powerful "Stedipower"

"Rigid" designs calling for exact duplication of the original parts and valves if proper results are to be obtained are far less interesting to build than those in which a man can profit by his previous experience in a choice of parts, while still deriving all the benefits of following a tried and tested design.

A third big item in what we think we may call without exaggeration a real "bumper" issue, is the two-ampere model "Stedipower" L.T. Unit brought out in response to a wide demand for an L.T. unit of greater output than the original design. Readers of the WIRELESS CONSTRUCTOR have already been given a one-ampere model, a half-ampere model, and, in the current number now, the two-ampere model. This last has been worked out with a view to keeping the cost down to as reasonable a figure as possible, and will supply adequate current for receivers in which quarter ampere valves are used throughout, provided that not more than eight are used—an extremely unlikely occurrence!—or alternately in an

BROADCASTING THE GULLS



Camouflaging the microphone used by the B.B.C. and Columbia Graphophone Co. to record the cries of seagulls in St. James' Park. The record was afterwards used as a background to the last scene of the broadcast version of Compton Mackenzie's novel "Carnival."

THE EDITOR'S CHAT

—continued.

ordinary four- or five-valve set we can use a high-voltage valve, such as the L.S.5 or L.S.5A., in the output stage without unduly robbing the rest of the set.

The Truth About H.F.

Equally well, parallel or push-pull output valves of the quarter- or half-amp. variety are available, and, in fact, with the exception of a "freak" set, all L.T. demands are now met by one of the "Stedipower" units for those who are fortunate enough to

"MIDGET" RESULTS

Sir,—I hope you will be pleased to know I got the following stations on my "Midget" receiver, described in the WIRELESS CONSTRUCTOR, 1928, by A. S. Clark :

	Dial Reading	Coils Used.
Germany	18 ..	S.W.
"	67 ..	S.W.
"	78 ..	S.W.
France	87 ..	S.W.
"	110 ..	S.W.
?	144 ..	S.W.

READY FOR THE ELECTION



Testing-out the open-air public address system in the Wembley Stadium in readiness for electioneering campaigns.

have alternating current supply in the house.

Just what is the difference between the magnification given by high- and by low-frequency stages? This is a question which experimenters often ask themselves and others. At one time it was the fashion glibly to answer "high-frequency increases the range while low-frequency increases the volume," but the answer is not quite so simple as this.

In our next issue an important article on the whole subject of high-frequency amplification and what is really obtainable by its help will be published. Some of the facts given in this article will come as a surprise to many readers!

?	147 ..	S.W.
Germany	162 ..	S.W.
"	177 ..	S.W.
Huizen, Holland ..	178 ..	L.W.
?	124 ..	L.W.
?	94 ..	L.W.
Germany	12 ..	S.W.
"	1 ..	S.W.
?	58 ..	S.W.
?	106 ..	S.W.
?	139 ..	S.W.
?	168 ..	S.W.
?	172 ..	S.W.
?	149 ..	S.W.
Gleiwitz, Germany	133 ..	S.W.
Breslau, "	127 ..	S.W.
Radio Paris, France	170 ..	L.W.
"	57 ..	L.W.

If anything is not marked we were unable to find out what it was.

Yours truly,
 BRYAN A. V. HENRY
 (Aged 10 years).

London, S.W.14.

'WARE BURN-OUTS!

 By A.B.C.

It occurred to me a few days ago, when I ruined two perfectly good valves through sheer childishness, that some readers might not realise fully what a difference the coming of the H.T. accumulator has made to us in many ways.

In the "old days" of dry batteries one could occasionally put the full H.T. across the filament of a valve momentarily without burning it out, as often as not one simply found that the emission was partly destroyed, and could generally be restored to health by judicious "cooking" overnight. This was, of course, on account of the fact that the high-tension battery was so ancient that a heavy load taken from it in this way—for the resistance of a valve filament is not above 20 ohms, as a rule—caused such a severe voltage drop that the filament was not burnt out.

DON'T FORGET!

The WIRELESS CONSTRUCTOR Envelope No. 1, The "Radiano" Three, has been reprinted and can be obtained from all dealers.

Price 1/6. Now on Sale

In these days, when the H.T. accumulator is in such common use, however, one simply puts the H.T. across the filament for the merest fraction of a second, and can be perfectly certain that the filament has gone. There is no need even to test it afterwards. An H.T. accumulator will deliver enormous currents when short-circuited or inadvertently discharged through a low resistance, although it is naturally not good for the battery to do this sort of thing to it. I have seen 5-amp. flex reduced to a small, red-hot ball of metal through a momentary short of an H.T. accumulator. It behoves us all, therefore, to be extremely careful with all our wiring, and to insert fuses wherever they are considered necessary. If you have any wiring of which you are not too sure, insert a fuse of appropriate size, and remember that a valve burn-out, humiliating and costly though it is, is as nothing compared with a house burn-out!

At Home with the FULTOGRAPH

By the Editor

An extremely interesting account of some recent experiments in picture reception from 5XX and Continental stations.

THE reception of still-photographs and drawings by radio is one of the most interesting branches of a hobby which, without it, is exciting enough. When, about a year ago, the first announcements were made that an apparatus would soon be marketed for attachment to any ordinary wireless set by which even the most unskilled user would be able to receive topical pictures, fashion plates, cartoons, sketches, and even letterpress by wireless, I was at least slightly sceptical.

A Practical Proposition

The fact that something is technically possible does not mean that it is commercially practicable, and so before enthusing about the new invention I decided I would see just what it would do, not at an exhibition, a special press demonstration, or in the hands of the inventor or other experts, but in my own home under conditions which I could observe accurately and could compare with those of any of my readers.

The Fultograph system, which has been very cleverly developed by Captain Otho Fulton, is being handled in this country by an organisation known as Wireless Pictures (1928),

Ltd. As soon as this company was in the position to give practical demonstrations, it approached the British Broadcasting Corporation, submitted the apparatus to a searching test by the engineering officials of that company, and proved to their satisfaction

that not only was the invention ingenious, but commercially practicable.

The Corporation thereupon decided that it would broadcast experimentally pictures by means of this method, at least for a short time, so to give it a try-out. After a period of trial the results were so successful that the British Broadcasting Corporation extended their transmissions for a further period, and they are now



Captain Fulton, inventor of the "Fultograph" system of wireless pictures, is here shown demonstrating his apparatus

At Home with the Fultograph—continued

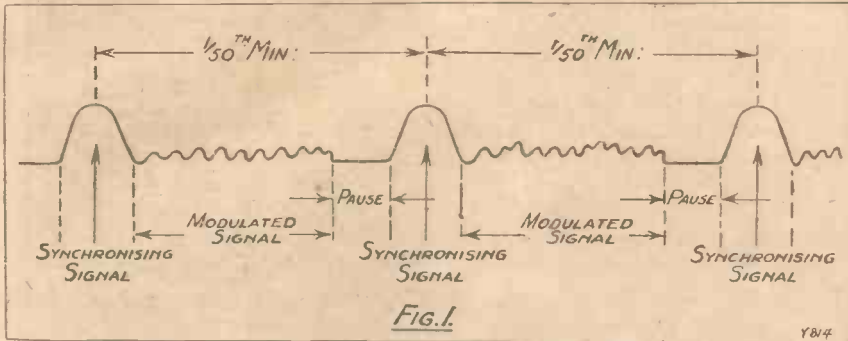

This diagram, which is not to scale, illustrates the sequence of events.

a regular feature of the daily transmissions from 5 X X.

Four pictures a day are being sent, at the time of writing, from 5 X X, six from Königswusterhausen, one or two from Vienna, and occasional pictures from other European stations. Probably before these lines appear in print there may be a considerable extension of picture transmission. There is no doubt that as the apparatus is a thoroughly practical proposition for the receipt of photographs, drawings, and, in fact, any kind of illustration in monochrome, there will soon be a very wide variety of choice, just as we have in the programmes themselves.

As soon as commercial delivery of the Fultograph began I obtained the

complete outfit as sold, installed it in my home, and within a quarter of an hour of unpacking the apparatus had received my first Fultograph from Vienna. Since that time I have received a hundred or two pictures from various stations, and the purpose of this article is to explain the method, how to use the apparatus, what kinds of results you will obtain, and how to get the best from your Fultograph receiver.

Fits Ordinary Set

One of the most fascinating features of the Fultograph receiver is that it requires no specially elaborate wireless set to work it, being merely attached to the loud-speaker terminals

of any reasonably good set capable of giving medium loud-speaker strength from the station you wish to receive. All of the Fultograph pictures illustrated in this article have been received on the New "Business Man's" Four, the only addition being the occasional use of an extra selectivity unit on the lines of one to be described in the next issue by Mr. G. P. Kendall, B.Sc., solely when it was desired to receive the Königswusterhausen transmission on a wave-length of 1,649 metres while 5 X X was working.

How It Works

It should be pointed out that the kilocycle separation between 5 X X and Königswusterhausen (Zeesen), which sends out Fultograph transmissions, is under 11 kilocycles, which is about the limit of separation possible with even a super-heterodyne! On Sundays, however, 5 X X does not work at "picture time" from Königswusterhausen.

In order that the reader may have an explanation of the working of the Fultograph system it may be helpful

Four typical Fultograph pictures received by the author from 5 X X. They are reproduced exactly as received and are not retouched. The three Egyptian boys are from a photograph in "World Radio," and the cartoon is from the B.B.C. handbook on oscillation.



The actual pictures as received are, of course, of a tint resembling a sepia print.



The remaining two pictures shown here are the copyright of the "Daily Express" newspaper.



At Home with the Fultograph—continued

to run over the whole scheme from the transmitter to the receiver. In doing this we may have to dodge backwards and forwards a little so as to explain each process and its bearing on the whole scheme, but I am afraid this is inevitable.

A Fultograph picture is sent by wrapping a prepared picture round a drum and rotating it at a steady speed, while a small pointer simultaneously moves slowly in the direc-

Now let us imagine that at the receiving end we have a similar cylinder with a piece of plain paper wrapped round it, the cylinder being made to rotate at exactly the same speed as the transmitting cylinder, and having a stylus of the same width, and traveling the same distance just as the stylus on the transmitter.

Let us now arrange that when a strong current comes to our receiver that the stylus will make a dark mark



The recording stylus bears lightly on the moist paper, which completes the circuit from stylus to cylinder.

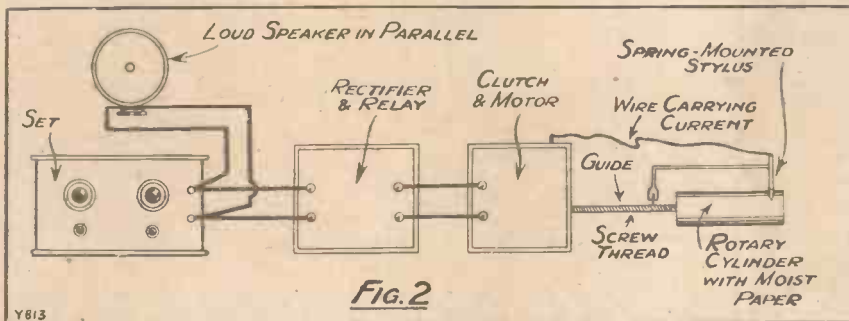

FIG. 2

A diagrammatic representation of the Fultograph receiving system.

tion of the axis of the cylinder. By the time the cylinder has made one revolution, the stylus, or pointer, has moved sideways by an amount equal to approximately its own width, and thus by the time the stylus has moved from one end of the cylinder to the other it has traced a spiral path which has completely "explored" the picture without missing any part. The time taken to complete this exploration of the picture is four minutes, and the cylinder revolves roughly fifty times a minute.

Obtaining Light and Shade

Think carefully for a moment and you will realise that sometimes the stylus will be travelling over a dark part of the picture and at other times over a light portion, the tiny part of the picture which the stylus is traversing at any given moment having any tint from pure white to jet black according to the kind of picture.

If now we arrange by some means to make the stylus control a strong current while it is passing over a dark portion of the picture, and no current at all while it is passing over a white part, with variations in strength of electric current according to variations in depth of tone, then this strong or weak current can be sent out as a wireless signal on any wavelength which we may choose.

and when no current comes it will make no mark at all, with variations in light and dark marking according

to the strength of the received current. What will then happen?

Whenever the stylus of the transmitter is passing over a dark portion of the picture it will make a dark mark on the paper at the receiving end and, in fact, the receiving stylus will reproduce the intensities of light and shade as a continual spiral on the receiving paper, consequently



Four pictures from Germany.

A morning's "haul" from Königsweusterhausen. Notice the typically German cartoons. All these were received while 5 X X was working on an adjacent wave-length.

At Home with the Fultograph—continued



A greatly enlarged picture to show how the received image is built up.

reproducing the transmitted picture at the receiving end, in synchronism with the transmitter.

Obviously it will not matter whether it is a photograph, a drawing, a cartoon or letterpress, the receiver should faithfully reproduce these variations of light and shade if only we can perform this series of operations just described.

Many Methods

The Fultograph apparatus performs just what we want it to do in an extremely ingenious manner. The actual methods used for converting the light and shade at the transmitting end into variations of strength of electric current are rather complex and, as a matter of fact, can be carried out in several different ways.

One method used for the 5 X X transmissions up to the time of

writing this article is to prepare special forms of negative on copper foil, but before these lines appear in print it is probable that a new photo-electric method will be installed by which variations of light and shade will affect a photo-electric cell and vary the current in this way. All kinds of methods are possible, but they do not affect the general principles we are describing.

Before we go farther let us briefly consider what happens with ordinary music when it is broadcast. The violin player, for example, playing his instrument in front of the microphone, causes a varying electric current in the microphone to operate

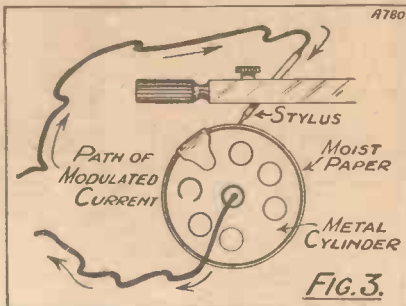

the transmitter, and the carrier-wave which is radiating at the frequency of the transmitting station varies in amplitude according to the variations of the music.

At our receiver we tune to this carrier frequency and our detector gives us a rectified current of varying strength, these variations being passed through transformers or resistance-

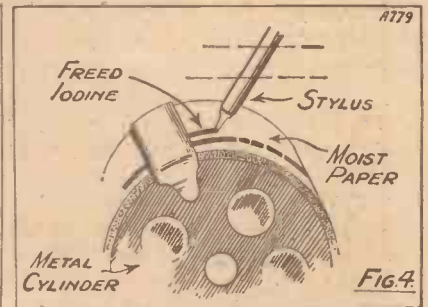

capacity-coupling units, and appearing as variations in electric current in our loud-speaker leads. Remember it is only variations of current or potential that can be amplified; a steady direct current through the primary of a transformer, for example, will produce no effect at all in the secondary, and it is only when the current varies that corresponding variations are set up in the secondary and so-passed on.

1,500-Cycle Note

Now, returning to the Fultograph transmitter, let us assume that the stylus is travelling over a black portion of the picture. Theoretically we should want a steady, strong current here, but a steady current in our receiver would have just the same effect as no current at all. Both would give no current whatever in the loud-speaker leads. If, however, we break up our steady strong current at the transmitting end, say, 1,500 times a second, then we shall get 1,500 strong pulsations per second in our loud speaker.

If all the variations of the transmitted current in the Fultograph are similarly broken up 1,500 times, then a strong current will give strong pulsations, and a weak current will give that number of weak pulsations, in the receiver per second. No current at all, of course, gives no pulsations. It was for this reason that the Fultograph signal consists of a modulated 1,500-cycle note.

There is no special virtue in the particular frequency chosen—it must not be too high or too low, and one is chosen which proves quite suitable.

If you have an opportunity, try and tune-in to a Fultograph transmission and listen to it on your loud speaker. These transmissions occur every day except Sundays and Mondays from 5 X X between 2 and 2.30 p.m., every day either between 12.45 and 1.15 (1.30 p.m.

These illustrations show faults. The first picture shows the effect of running the receiver too fast and with too strong a signal. The picture is elongated and too dark. The second shows a portrait from Vienna completely spoiled by continuous interference from Morse, while the third shows the effect of running the machine without grid bias. Here the synchronising does not occur.



At Home with the Fultograph—continued

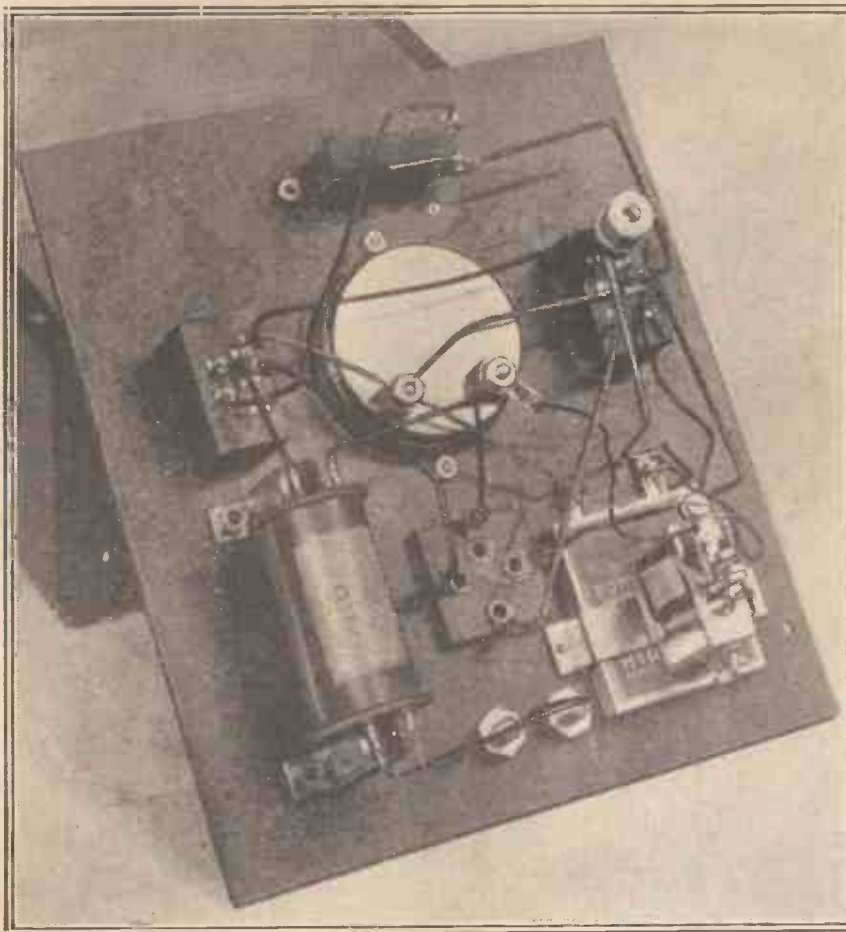

transmission; being a series of strong and weak dots made up according to the lines which the picture is traversing at the transmitting station.

Now it is quite evident that the system will only work if the receiving cylinder rotates in perfect synchronism with the transmitting cylinder. If it is even a tiny moment out, the picture will be distorted or entirely illegible. The Fultograph method of synchronising is remarkably ingenious and is carried out as follows.

The Relay

Once every revolution a pure note at 1,500 cycles is sent out by the transmitter, the duration of this note being about a tenth of a second. The receiving cylinder does not rotate continuously, but makes one complete rotation, stops for a moment and then starts again, making a further complete rotation, stopping once more at the end of this.

The receiving cylinder is made to rotate slightly faster than the transmitting cylinder, and, just at the moment that it stops, a relay is automatically switched into the receiving apparatus, so that when the piping note comes it passes a current through this relay which releases the cylinder for one more rotation.

It will thus be seen that the piping signal at the transmitter releases the

on Sundays) or 9.30 to 10 p.m. from Königswusterhausen, and every day after the programme from Vienna on 519 metres.

Vienna comes in very well over here on a set with a stage of high-frequency, and I often listen to the programme for hours on end. You will find this station just above 5 G B. Your tuning will have to be fairly sharp otherwise 5 G B will interfere. On the New "Business Man's" Four it is very simple to set the trap to absorb 5 G B, whereupon Vienna is left perfectly clear on 520 metres.

The Synchronising Signal

When you listen to the Fultograph transmission you will hear a sharp piping note, a kind of burbling noise of the same note, and another sharp note followed by a further burbling noise; these sharp piping notes actually occurring fifty-two or three times a minute. The sharp note is the synchronising signal which I will explain in a moment, and the burbling note is the actual modulated picture

The top photograph shows the underside of the Fultograph's separate relay panel, whilst below is illustrated the method of affixing the sensitised paper on the cylinder.

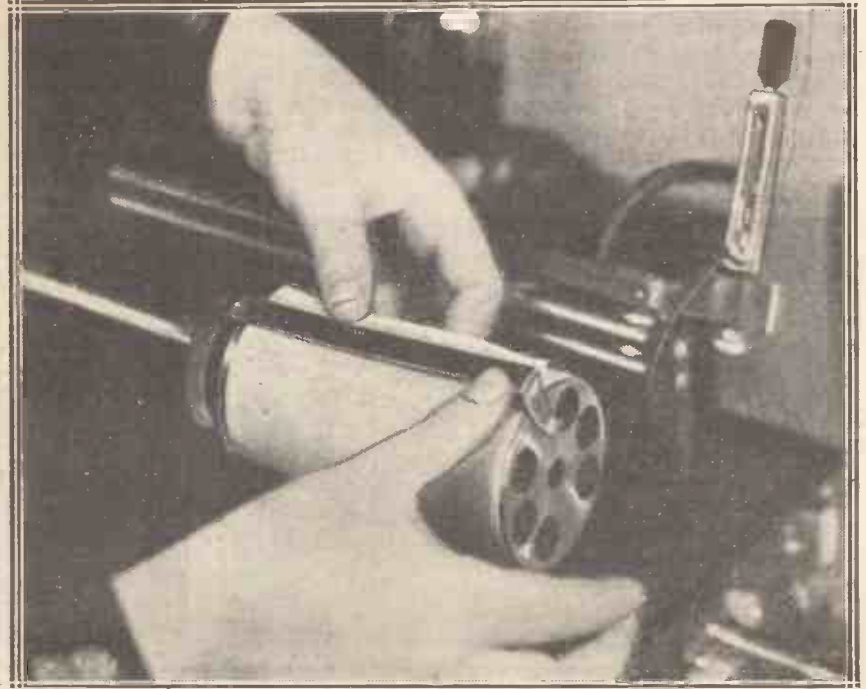

At Home with the Fultograph—continued

cylinder for a further rotation in exact synchronism with the transmitter, and the only possible error is a variation of speed in one revolution of the cylinder, which in practice does not occur. So accurate is the synchronising by this method that it is possible to receive detailed line drawings, cartoons, and quite good photographs in perfect register.

The first diagram gives you in graph form a rough idea of the kind of signal that comes over when receiving a Fultograph picture. We see the synchronising signal, then the modulated note, then a pause, and again a second synchronising signal, and so forth.

Fig. 2 gives you graphically the general arrangement of the apparatus. Fig. 3 shows in exaggerated form the path of the current through the receiving stylus, the moist paper and the metal cylinder; while in Fig. 4, again in exaggerated way, we show how the stylus in contact with the moistened paper causes the chemical change giving the brown coloration.

Actually when received the picture is of a deep purplish hue, very similar to the purplish tone obtainable by photographers on some self-toning printing-out papers, but as it dries it attains a sepia colour which is certainly very pleasing for portraits.

Before we proceed further a word or two about the treated paper may not come amiss. With the Fultograph outfit is supplied a bottle of solution which looks like water, and a packet of paper, each sheet measuring approximately 7 in. by 3 $\frac{3}{4}$ in. We need a dish for the solution, and

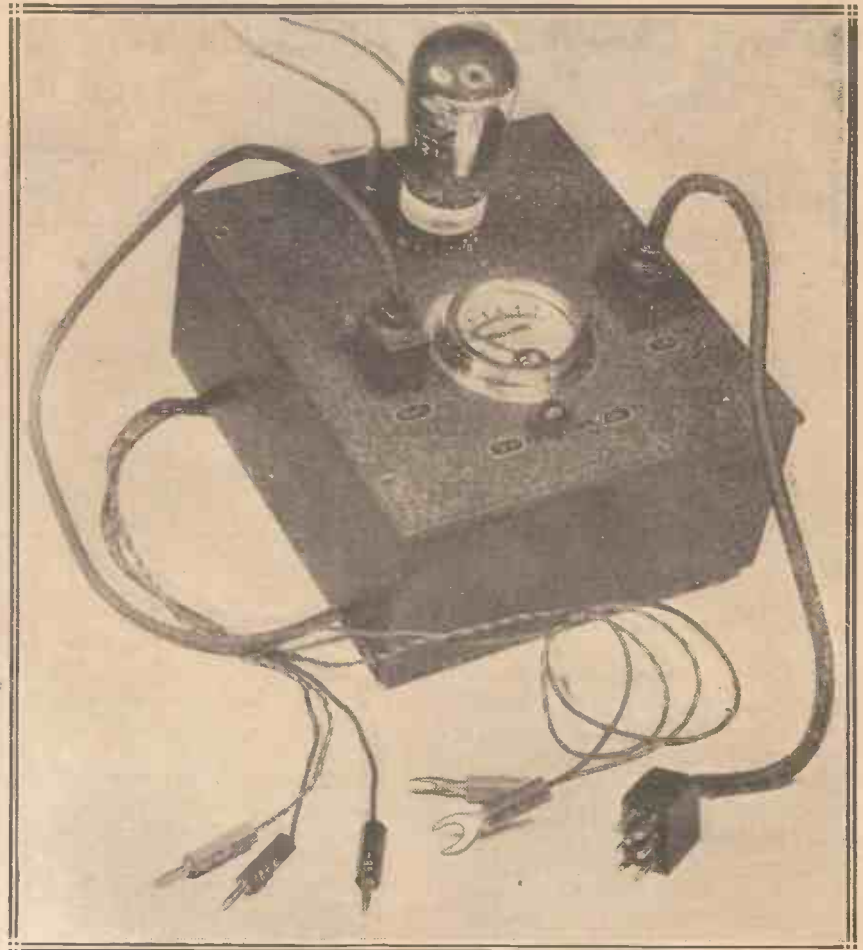

Here is the complete relay panel with leads for battery connections, and the multiple plug that is connected to the socket on the picture recorder.

a half-plate china developing dish is as good as anything, although any vessel which will hold the solution and enable the paper to be immersed will do.

I would particularly recommend the china half-plate developing dish

with a spout, as the solution should be poured back into the bottle afterwards, and not left in the dish. Such a developing dish takes a minimum of solution for the desired purpose, and the replacement of the

(Continued on page 386.)

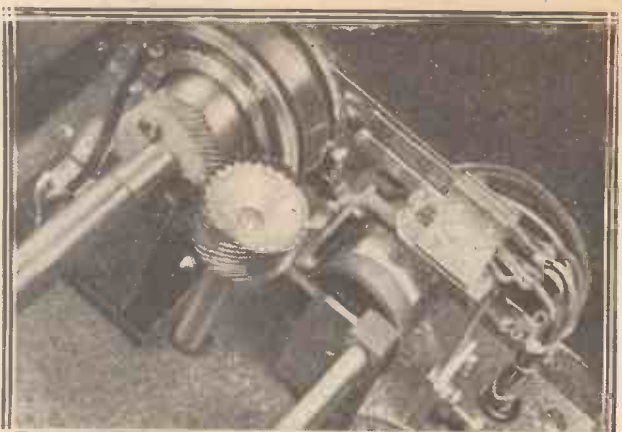
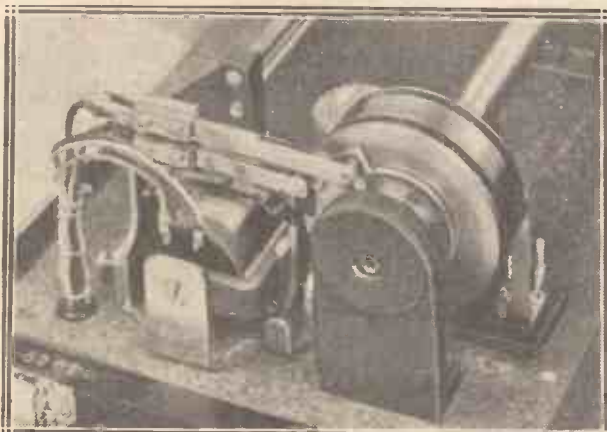

Two illustrations of the magnetic clutch and cam-operated contacts. By these the cylinder is stopped and started, and the necessary periodic switching effected. First-class workmanship is a feature of the Fultograph receiver.

EXPERIMENTING WITH THE THIRTY-ONE NEW CIRCUITS

BY THE EDITOR.

I MUST begin this month by apologising for a slight error in my last article. In referring to the Ediswan "Threesome" circuit published in the booklet, I stated that it was . . . "an improvement on that originally published and is that now circulated . . ." The first part of this statement is correct and the second incorrect. It has been still further improved, and in the 1929 Ediswan "Threesome" some of the components (which, by the way, were illustrated in my last month's article) enable us to abandon swinging-coil reaction and provide an ingenious unit (illustrated at the bottom of the third column last month) by which long or short waves can be obtained with a change-over switch.

New Ediswan "Threesome"

The inclusion of this and one or two other valve-makers' circuits in the circuit book was, of course, to give experimenters an opportunity of trying out arrangements which had already stood the test of time. There have been three Ediswan "Threesome" circuits published, and that given in our booklet was the second. The 1929 model is an improvement on the 1928 model (that given in the book), but, of course, the 1928 circuit lends itself more easily to the assembly of components which experimenters may have on hand.

A Useful Stand-by

The difference between the circuit published in the book and that now circulated is that, whereas in Circuit No. 7 the aerial is connected to the top of L_1 through a condenser C_1 , reaction being by the swinging coil marked L_2 , in the new circuit the coil L_1 is tapped some little way down without any series condenser being included, this giving the necessary coupling; while for the short-wave a section of the coil is short-circuited. The same size of reaction coil is used for both wave-lengths, the scheme being somewhat similar to that illustrated in Circuit No. 5. As far as the rest of the circuit is concerned the details remain the same, but, of

course, in the new circuit a variable condenser is used for control of reaction.

I hope readers will experiment with Circuit No. 8, to which a brief reference was made last month, as the new rearrangement of wave-lengths in Europe, and the still higher selectivity required by modern conditions, should make it particularly useful. Circuit No. 9 is, I think, novel, and is designed to overcome a difficulty with which many listeners are faced when their accumulator runs down. A single-valve set with reaction is capable of giving excellent headphone results over quite a considerable distance from the station, but when the accumulator runs down the receiver is put out of business until it is re-

In this article Mr. Percy W. Harris, M.I.R.E., discusses several more of the thirty-one circuits given away in book form with the December, 1928, issue of the "Wireless Constructor."

Special attention should be given to Circuit No. 10, which includes a constant-reaction scheme designed by the author.

charged, unless a second fully-charged accumulator is available, which is not always the case.

In Circuit No. 9 I have arranged a switch and jack, so that when the accumulator is taken away to be charged the headphones can be removed from the jack marked "Tel. 2" and inserted in the jack "Tel. 1," whereupon by the simple operation of a switch we have a crystal receiver. Obviously the strength will not be so great with the crystal as with the valve and reaction, but in many cases it will be quite good enough to follow such important matters as news items and any special announcements which it is desired not to miss. Full details of the coil are given in the notes below the circuit, and a crystal of one of the semi-permanent types is strongly recommended, as it is much less likely to go out of adjustment than the cat's-

whisker type, although this latter when a good specimen of crystal is obtained and is carefully adjusted, may give slightly more sensitive signals.

Personally, I always use the semi-permanent type, its general reliability far outweighing, in my opinion, the slight additional sensitivity (which cannot always be guaranteed) with the cat's-whisker type.

Constant Reaction

Circuit No. 10 is my constant-reaction circuit which was the basis of the original "Business Man's" Four. It enables a very sensitive single-control receiver to be built up for telephone work, or, when note-magnifying stages are added, for loud-speaker work. A careful layout and suitable components are necessary for this circuit, and the condenser C_2 must be one with a fine adjustment and a very low minimum. The interleaving vane type of neutralising condenser is not suitable for this circuit, as the minimum may be more than sufficient to give oscillation, while it is extremely difficult to get the critical adjustment necessary.

It should be remembered that in the interleaving vane type one passes from minimum to maximum in only half a turn of the controlling knob, whereas in the "screw-up-and-down" type many turns are required to pass from one end of the scale to the other. With a fine thread and a low minimum on the neutralising condenser (it is not used here as a neutralising condenser, but I give it that title as it is the name under which it is sold) the results are very good and the balancing is quite easy.

Component Considerations

Condenser C_2 , too, should have a low minimum; and there are a number of excellent condensers on the market, such as the Keystone, Cyldon, Polar, Igranic, Jackson, etc., with a maximum of .0001 mfd. and a minimum well below that necessary for the particular circuit.

The resistance R_1 is important and should be of good quality, as any

(Continued on page 392.)



Some typical faults and remedies reviewed.

By P. R. BIRD.

An H.F. Hitch

ALTHOUGH most readers who are old hands at the radio game will not need telling how necessary it is to prevent high-frequency leakage to earth from the aerial wire, cases are continually occurring where an inexperienced listener gets a shock on discovering this effect. Quite a surprising case of this kind occurred recently, the circumstances being these:

A listener who possessed a good outdoor aerial had arranged his lead-in to run from the lead-in tube along a neat and inconspicuous wire close to the picture-rail, and so to the set, which stood at some distance from the lead-in. One day, when the room was being redecorated, it became necessary to take down this lead-in wire in order that the wall behind it could be repainted or redecorated.

The Temporary Lead

As the job was not finished till the evening, the house was without wireless, and as so often happens in such circumstances there was a particular little piece of the programme which was especially wanted. The proper lead-in not being available, it was decided as a temporary measure to run a length of thin D.C.C. wire from the lead-in terminal direct to the set, which was placed on a table in the centre of the room.

Another piece of wire from the earth terminal was run across the floor to the external earth, the idea being that, although the arrangements were of a makeshift nature, the particular item which it was desired to hear would not be missed. Putting

on the 'phones, the listener was quite prepared to find that such a rough-and-ready arrangement had lost him a certain amount of signal strength. But to his surprise he found that, instead of suffering a loss, the set was actually far better than it was previously!

For some reason which he could not understand the temporary lead of thin

THE TECHNICAL QUERIES DEPARTMENT

Are you in trouble with your set?

Have you any knotty little Radio problems requiring solution?

The WIRELESS CONSTRUCTOR Technical Queries Department has been thoroughly reorganised and is now in a position to give an unrivalled service. The aim of the department is to furnish really helpful advice in connection with any radio problem, theoretical or practical.

Full details, including the revised and, in cases, considerably reduced scale of charges, can be obtained direct from the Technical Queries Department, WIRELESS CONSTRUCTOR, Fleetway House, Farringdon Street, London, E.C.4.

A postcard will do: on receipt of this all the necessary literature will be sent to you free and post free, immediately. This application will place you under no obligation whatever. Every reader of the WIRELESS CONSTRUCTOR should have these details by him. An application form is included which will enable you to ask your questions, so that we can deal with them expeditiously and with the minimum of delay. Having this form you will know exactly what information we require to have before us in order to solve your problems.

wire was giving him far better and stronger reception than he had ever obtained from his carefully arranged lead-in that he had placed along the picture-rail.

Picture-Rail Wiring

Probably the reader has already guessed for himself the cause of his previous poor results. The neat wiring

round the picture-rail was certainly a good and electrically efficient job from the point of view of ordinary electrical currents, but high-frequency currents such as those in the aerial are *not* ordinary, and wiring that would be very satisfactory from a lighting or bell-ringing point of view may be distinctly unsatisfactory from a high frequency point of view. In this instance, the fact that the aerial was placed close up against a wall meant that all the high-frequency currents flowing along it had to pass very close to some conductive object that was earthed.

The Damping Effect

It may have been a metal pipe such as a gas pipe, or it may have been some kind of metal actually in the wall itself, or merely a damp wall. Although the wire itself was insulated, and although there was probably a space between the insulated wire and the metal or other earthed conductive surface in question, yet the latter was sufficiently close to the lead-in to act as an escape condenser for the received signals.

When the temporary lead was put in, although it was not so good as the wire previously used, it was spaced away from the wall, and consequently signals came through better than they had ever previously done. It must be remembered that not only metal, but any conductor, sometimes a damp or wet wall, will serve to conduct away energy that should rightly pass down the lead-in. If this is not borne in mind, bad results may make you realise that the correct position of a lead-in wire is not a matter that depends only upon neat wiring and good joints, but is also a matter of what is in the space immediately surrounding the lead-in.

Chokes in Mains Units

A query raised by a Leytonstone reader of the WIRELESS CONSTRUCTOR reminds me that many other set-builders may be puzzled upon the point in question—namely, why is it that "H.F." chokes are now sometimes used in mains units? Apparently constructors are so used to seeing L.F. chokes in these units that the H.F. component seems an intruder.

Although large *low*-frequency chokes are always employed for smoothing purposes, etc., it must not be forgotten that a mains unit is connected to high-frequency circuits as well, and that H.F. leakage occurs so easily that low-capacity H.F. chokes may sometimes be necessary, especially if the mains unit is for a multi-valver.

The "REQUEST" THREE

by PERCY WHARRIS M.I.R.E.

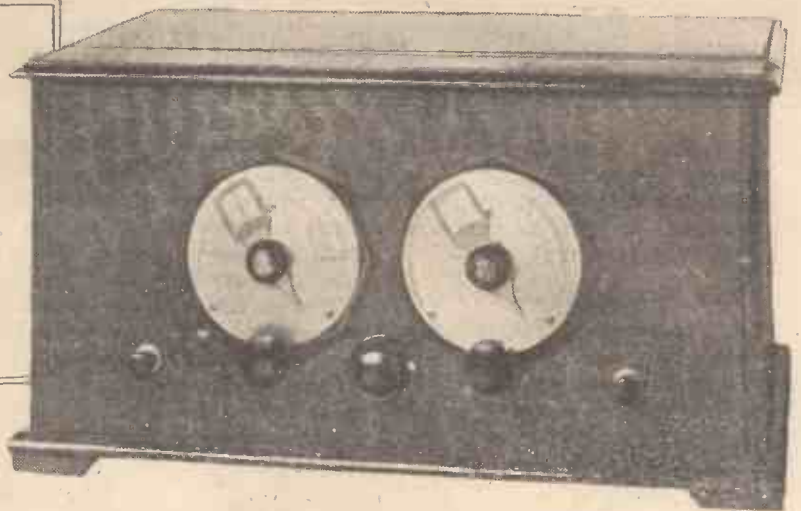

A specially designed wave-change three-valver, with two transformer-coupled L.F. stages, built in answer to the large number of requests received by the Editor for such a receiver.

READERS of the WIRELESS CONSTRUCTOR will remember that a few months ago, in response to an editorial invitation, numbers of them took the opportunity of stating the kind of receivers and articles they would like to see in our pages, and this information was carefully sorted out for practical interpretation. Already a number of receivers have been published in response to these requests, and now I am pleased to say that another, which I have called The "Request" Three, has completed its tests with flying colours.

The reason for it may best be explained by quoting the following communication:

"Dear Sir,—As one who has read the WIRELESS CONSTRUCTOR from the first number and built many successful sets from its pages, I well remember the popularity of your 'Powerful' Three, consisting of a well-arranged detector and two transformer-coupled low-frequency stages. Again, it is unnecessary to mention the continued popularity of the 'Radiano' Three, this again using two transformer-coupled stages. Could you not design for us a simply constructed three-valver using two modern transformer stages with wave-change by means of a simple switch, and, if possible, the readily obtainable 'X' coils, which your journal has done so much to popularise? It would also be an advantage if the set could be built into a cabinet of reasonable size as many three-valve designs published seem needlessly large."

A Much-Wanted Feature

This communication seemed to contain in it the gist of many others. For example, there was obviously a widespread demand for a simple wave-change scheme using existing "X"

coils. Numerous readers have also expressed the opinion that the modern transformer has been so much improved that the old argument of the necessity of combining one resistance and one transformer stage for best quality no longer carries the force it did. I have been experimenting for a long time on this problem, having found, as frequently explained in these pages, that good modern transformers will give an excellent reproduction of notes far lower than any but a laboratory-built loud speaker can reproduce, while with modern high-efficiency valves—they are really amazingly efficient compared with those on the market when the WIRELESS CONSTRUCTOR was first published—the magnification obtainable is very large indeed.

Why then do we not use two transformers in all sets where two stages of low-frequency amplification are used? The answer cannot be given in a few words, but it is certainly worth explaining, not only as a matter of interest, but to enable the reader to appreciate not only the difficulties of design, but perhaps many of his own particular problems.

It Seems Simple!

Let us assume for the moment that we are making a receiver consisting of a detector and two low-frequency stages, that we have solved all the problems in and prior to the detector stage, and that we are trying to get the low-frequency side right. We will assume that we have obtained two modern first-class transformers

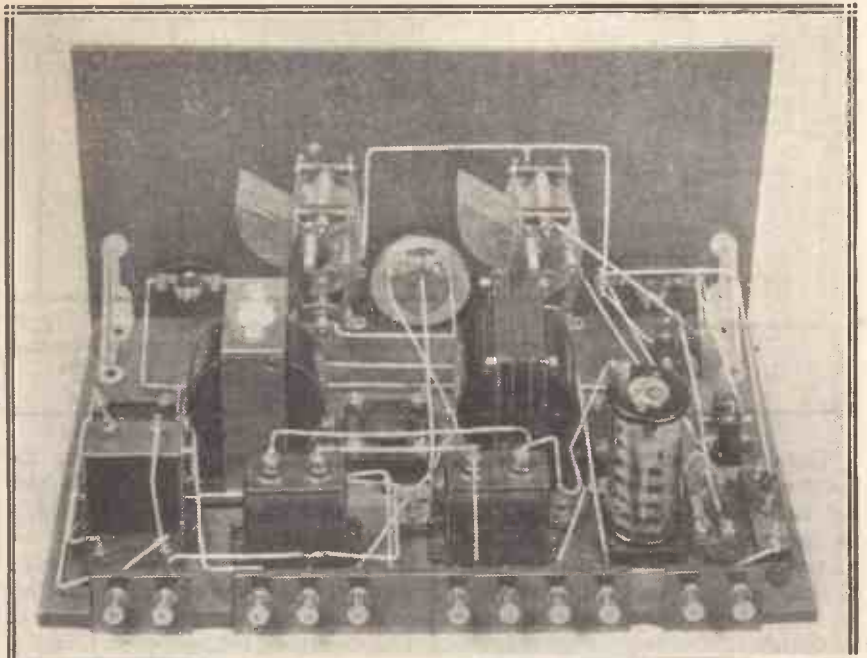

Compact and efficient are but two of the laudatory adjectives that can be applied to this remarkable receiver.

The "Request" Three—continued

each having National Physical Laboratory curves or other unimpeachable certificates of merit, showing perfectly uniform amplification from, say, 100 up to 6,000 cycles.

But Not In Practice!

Pick a good modern valve, join everything up and naturally you might expect to get an overall reproduction as perfect as that of the aforesaid curves. Results may very likely be quite good and pleasing, but if you had the necessary scientific instruments to plot the response curve of frequency for the whole receiver, you would find that this combination of two practically perfect stages did not give by any means a perfect output. Sometimes, and particularly when using some types of mains unit, or with certain picked valves, we may get either that nasty phenomenon known as motor-boating, or else an equally irritating howl.

Let it be said at once that there are a very large number of cases where the howl does not occur, and results will be perfectly satisfactory, but as transformers and valves improve, this tendency to motor-boat or howl increases also, this being not any defect in the valves and transformers themselves, but due to the greatly increased efficiency of each component.

was rarely great enough to provoke the trouble, for, roughly speaking, the greater the magnification per stage the greater will be the feed-back of energy through the means which exist for this. And long before oscillation occurs there may be enough feed-back to spoil the overall reproduction, this feed-back tending to over-accentuate certain notes—most likely in the higher frequencies—giving an irritating shrillness or over-accentuation of the "s" sound, which combined with faulty loud-speaker reproduction may give a thoroughly unsatisfactory result.

The Tuned Anode Again

Feed-back tendencies are always much more pronounced when there is any possibility of the stages themselves "tuning," and this, of course, happens with two transformers, as here we have the inductance of the windings and the self-capacity of the windings, wiring and the valve itself. Careful layout of wiring and the avoidance of complicated switching will reduce this feed-back tendency a good deal, and it can often be cured, or at least reduced, by reversing the connections to the primary of one or other of the transformers.

Because in a combination of one resistance and one transformer-coupled stage we do not have two tuned

but to the fact that the overall curve is far less likely to be upset by reaction effects. I have pointed this out before and I am glad to have the opportunity of pointing it out again.

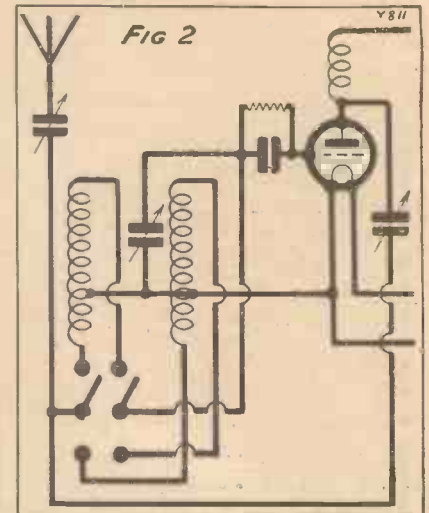

Now if we can only get rid of this feed-back effect and use the transformers in such a way that their individual merits will not be spoiled, we should get a total magnification in two low-frequency stages much greater than with any combination of one resistance and one transformer, while getting rid of certain troubles associated with the combination of one resistance and one transformer, which are just as irritating in their way when they do occur as those which come from the general combination of two transformers.

Some Surprising Results

For this reason, some months ago I commenced a series of experiments with the idea of getting to the bottom of the "two-transformer" troubles, and whilst space does not permit me to give details of them here, I can at least say that they have enabled me to produce the "Request" Three, a set with two transformers, which gives a much better overall reproduction than any set yet published in this journal with two transformers, while the magnification is tremendous. One of the leading aims in my investigations was to establish just what was the effect of the various so-called anti-motor-boating devices in different parts of the circuit and what were the best values to use.

Although it has been frequently stated that to get the best results a resistance shunted to filament by a

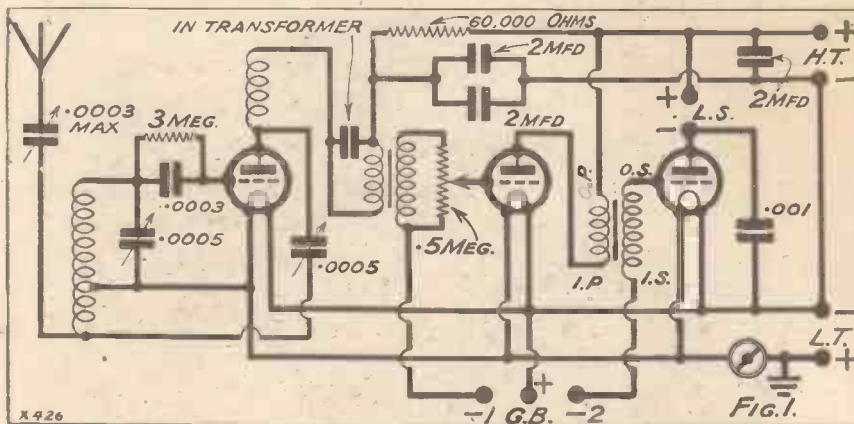

The trouble arises from a form of low-frequency reaction; energy being fed back from one stage to the preceding in such a way as to maintain a state of oscillation, just as if we use a high-frequency stage without some form of neutralisation, high-frequency oscillation will occur. With old low-efficiency valves and old low-efficiency transformers the step-up per stage

circuits following one another, the tendency is certainly less, and this reason has largely dictated the frequent use of one resistance and one transformer stage. The improved quality, it should be noted, of this combination over the usual pair of transformers is *not*, as is often thought, always due to the superiority of the resistance coupling over a transformer,

The "Request" Three—continued

condenser should be placed in the anode lead, not only of the detector valve but also of the first low-frequency stage, my experiments have shown that—in the great majority of cases, anyway—an anti-motor-boating

COMPONENTS REQUIRED.

- Panel, 16 in. × 8 in. × $\frac{3}{8}$ or $\frac{1}{2}$ in. (Ebonart Moire). (Resiston, Becol, Trolite, etc.)
 Pair of brackets (Raymond, Camco, Magnum, etc.)
 Cabinet with 9-in. baseboard (Arcraft, Camco, Pickett, Bond, Caxton, etc.)
 3 Valve holders (Lotus, Benjamin, Pye, etc.)
 2 Coil holders.
 1 Fixed condenser and clips, .0003 mfd. (Lissen, Dubilier, Mullard, Atlas, T.C.C.).
 1 Fixed condenser, .001 mfd. (Lissen, Dubilier, Mullard, Atlas, T.C.C.).
 3 Fixed condensers, 2 mfd. (Dubilier, T.C.C., Lissen, Ferranti).
 1 Grid leak, 3 mfd. (Dubilier, Lissen, Mullard, Pye, Ediswan, etc.)
 1 Adjustable condenser, .0003 max. (Formo, Igranic, etc.)
 1 D.P.D.T. switch for panel (Lotus push-pull).
 1 On-and-off switch (Lotus, Benjamin, Magnum, Duco, Decko, etc.)
 2 Variable condensers, .0005 mfd. (Lissen, Ormond, Lotus, Igranic, Jackson, Utility, Burton, etc.)
 2 Vernier dials (Ormond, Igranic, Polar, etc.)
 1 Volume-control potentiometer, .5 meg. (Magnum, Marconiphone, Gambrell, Igranic, etc.)
 1 Anode resistance holder, 60,000 ohms. (Ferranti, R.I.-Varley, Lissen, etc.)
 1 R.F. choke (R.I.-Varley). (Magnum, Climax, Bowyer-Lowe, Lewcos, etc.)
 2 L.F. transformers of good quality (see notes in text). (Ferranti A.F.5 and Igranic 7½ to 1 used here.)
 11 Terminals as shown.
 2 Ebonite strips, 2 in. × 1½ in.
 1 Ebonite strip, 8 in. × 1½ in.
 1 "X" coil, 60 turns (Lissen, Lewcos, Atlas, Gambrell, Raymond, etc.)
 1 "X" coil, 250 turns (Lissen, Lewcos, Atlas, Gambrell, Raymond, etc.)

device in the anode lead of the first low-frequency stage is valueless, whereas an increase of the conventional 2 mfd. to 4 mfd. in the capacity of the first anti-motor-boating device effects very considerable improvement.

The Volume Control

I am thus using a 60,000-ohm resistance and a 4-mfd. condenser in the anode circuit of the detector valve. No anti-motor-boating device in the first low-frequency stage is used. A volume control, consisting of potentiometer with a resistance of half a

megohm, is shunted across the secondary of the first low-frequency transformer, the slider of this potentiometer being connected to the grid of the first low-frequency valve. The resistance across the secondary of the transformer thus remains constant and is of such a high value that it has a scarcely appreciable effect on magnification, while we vary the volume by varying the voltage applied to the grid of the first low-frequency valve.

Avoid Over-Loading

This scheme has the very important advantage that for a given strength of signal picked up by the receiver we can adjust the grid swing on the first low-frequency valve up to the limit that valve will carry without distortion, while for the second transformer I have chosen one designed to give the best results with a valve which will carry quite an appreciable grid swing. In order to keep the total cost down, and to use the money we are prepared to spend in directions where expenditure is most important, I have not included any output filter, either choke or transformer, as many readers will like to use in the output an ordinary power valve which does not carry more current than is advisable

to pass through loud-speaker windings. If a super-power valve is used, the attachment of an output filter is very simply arranged, a design having already been published in our columns (see "Circuit 29," by L. H. Thomas, in the January issue).

The arrangement of the tuning, reaction and aerial coupling is rather unusual, but has the advantage of making efficient use of "X" coils with a very simple wave-change arrangement by a push-pull switch. Examine the photographs carefully and you will see that the wiring to this scheme is at least as simple as in many sets without wave-change, while the rather peculiar use of the lower part of the winding of each coil as a combination of reaction and aerial is very similar to the original and true Reinartz circuit, which I am proud to have been the first to introduce to experimenters in this country.

A Simple Tuning Scheme

If you look at the circuit you will see that signals from the aerial pass through the lower portion of the winding to earth, thus giving an impulse to the tuned circuit consisting of the remainder of the winding shunted by a variable condenser. By using an "X" coil in this way the

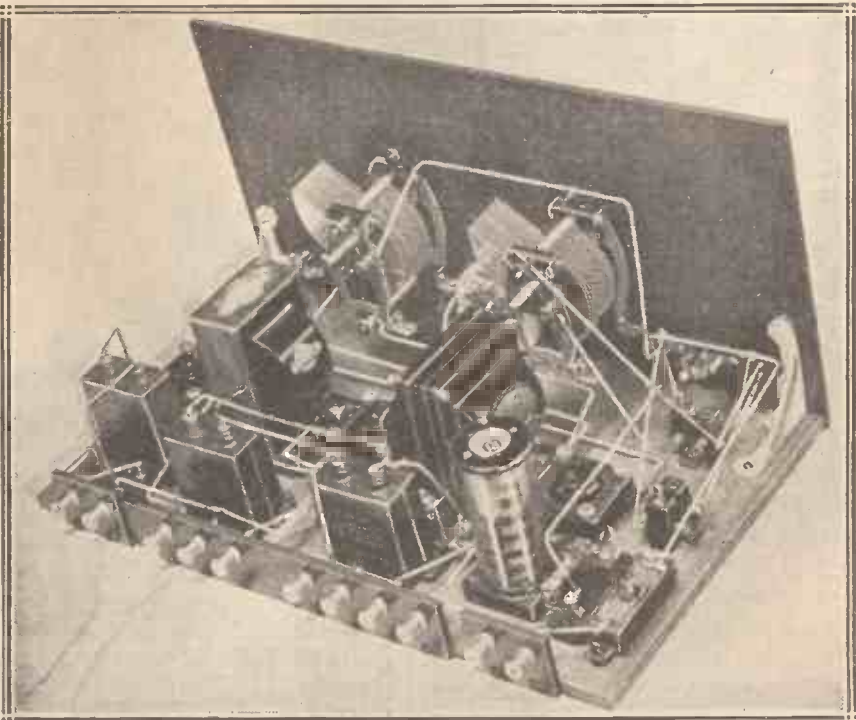

The anti-motor-boating condensers are shown near the terminal strip in the foreground of this photograph.

The "Request" Three—continued

whole of the winding does not form a portion of the tuned circuit, and therefore the wave-length range for a given coil is not so great as when the whole coil is used.

Using Standard Coils

The wave-length range covered by an "X" coil is more than enough for our purpose in the ordinary way, and it will be found that the tuned portion between the lowest tapping (six on the low-wave coil) and the other end will enable us to reach at least 550 metres with a .0005 mfd. condenser. At the same time, the reaction coil will be rather smaller than usual, and this must be compensated for by the use of a larger reaction condenser, namely, a .0005, than is customary. Of course, it would have been easy to design a special coil for this circuit, but I am much against the needless multiplying of wireless components. Standard "X" coils are obtainable in many different makes without any difficulty whatsoever.

The panel arrangement is perfectly symmetrical without any loss of efficiency in the arrangement of parts, for the wave-change switch comes on the left, the on-and-off switch in the

Vernier dials assure a smooth control and the operation of the receiver is particularly simple, in view of the fact that only one dial is for tuning, that on the right being for reaction only. The tuning is very sharp, because the very great

B.Sc., next month is used in front, it will give the sharpest tuning that anyone can want. This is particularly helpful when using the Fultograph on foreign stations, so as to clear the picture from interference.

In the choice of components for

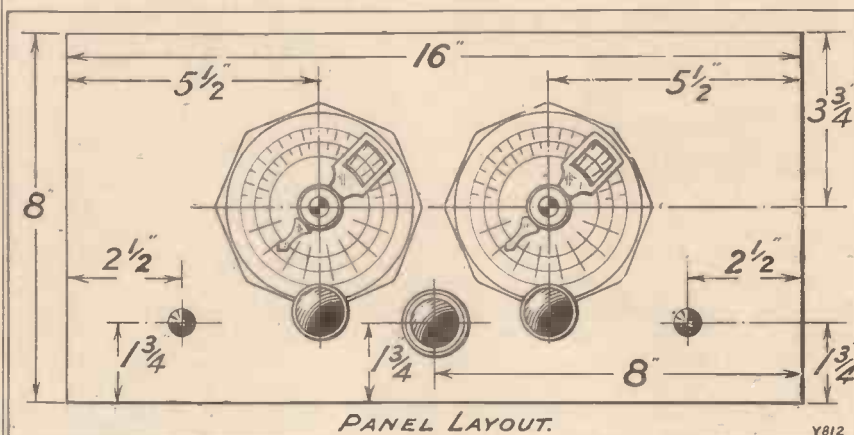

magnification—far more than usual—in the two low-frequency stages has enabled me to loosen the aerial coupling while still giving an excellent strength of signal on distant stations.

this set, the reader will find the widest possible range of alternatives, and I do not think there is a single item in the whole list which cannot be obtained in more than one make. To get the best, however, the reader is strongly advised to buy really good low-frequency transformers. There is no objection to using two of any good make, despite the fact that in the original instrument described and photographed I have used certain makes in a definite order.

An Important Point

This fact must not be taken to mean that I do not consider the first make is suitable for the second stage, or the second make is not suitable for the first stage, or anything of that kind. In using a high step-up ratio in the second stage I was actuated by two motives. Firstly, I wanted to make sure that the set would not give howling troubles with a high step-up ratio transformer, and, secondly, this particular transformer gives an excellent curve with valves of medium impedance which in their turn can carry fairly big grid swings.

There are available a number of first-class "X" coils, variable condensers, vernier dials, and all the rest of the list, and, incidentally, I should appreciate readers' reports on this set when they have built it, and,

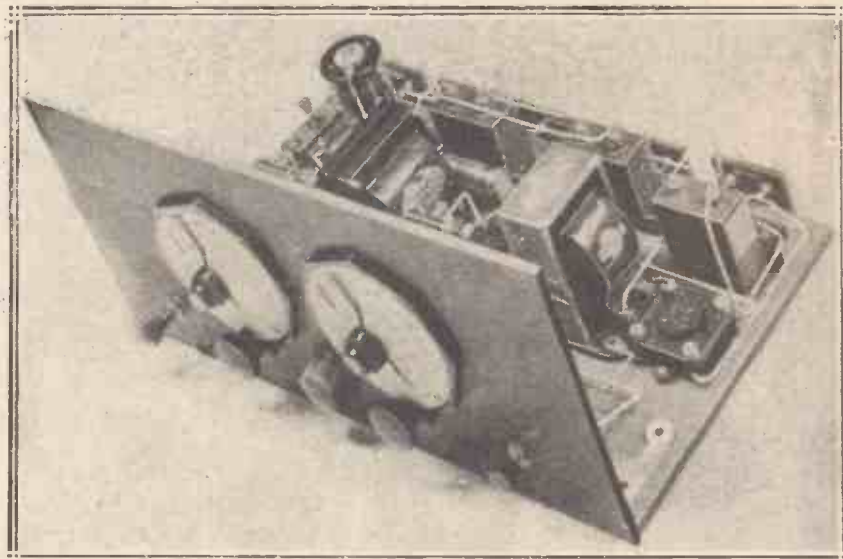

The symmetrical panel layout has been arrived at without in any way sacrificing efficiency or simplicity of wiring.

corresponding position on the right, while the volume control falls in the middle of the panel, which happened to be the best position for short leads to the secondary of the first transformer.

In fact, it is one of the sharpest tuning receivers using a detector not preceded by any high-frequency stage that I have ever handled, while if the special selectivity unit to be described by Mr. G. P. Kendall,

The "Request" Three—continued

in particular, if they would name the makes of transformers used. I have tried all kinds of makes in the laboratory with success, but obviously the possible combination of makes with the numerous excellent transformers now available runs into at least three figures, and it is interesting to hear from a reader that Messrs. So-and-So's transformer works particularly well with the So-and-So, and gives exceptionally good results.

Making a Start

Commence by preparing the panel and mounting the condensers, volume control, switches and the two brackets. I prefer to mount the brackets on the panel first of all, rather than to mount them on the baseboard and then attach the panel, as when the brackets are fixed in this way the whole panel assembly can be stood against the baseboard while one is arranging the parts on the baseboard itself, and we can avoid any fouling which might take place when components of slightly different size from those illustrated are used.

It will be noted that an adjustable condenser is fixed in series with the aerial lead, enabling one still further to sharpen the tuning if desired, while the form of coupling used makes the set peculiarly independent of varying aerial conditions.

The wiring diagram gives all the necessary data for wiring up, and as transformer makers still differ from one another in their method of marking, the following notes will be helpful where different makes of transformers are used. Some transformer makers label their products in the only sensible fashion, namely, plate (or anode), H.T. +, grid, and grid bias for the four terminals. Others put IP, OP, IS, and OS, which means nothing whatever to the average user nowadays, while others mark the transformer on one side with P, with I and O for the two terminals on that side, and the other with S, with I and O on that side.

A Confusing Method

Some makers mark the grid bias terminal with "negative L.T.," just as if any designer ever connected this terminal to negative L.T. direct! One might just as sanely mark the steering-wheel of a motor-car "garage," just because eventually it may take you there. The one

way of making perfectly sure of getting distortion with the modern good quality low-frequency transformer is to connect the terminal which is often marked L.T.—direct to L.T.—

However, if you find a transformer with IP, OP, IS and OS on it, or the similar arrangement with P and IO and S and IO, then, as a general rule, it will be found advisable to connect IP to the plate, OP to positive H.T., with OS to grid and IS to grid bias, although sometimes a reversal of connections such as OP to plate and IP to positive may be advisable.

Notice when wiring up the secondary of the first low-frequency transformer that the two terminals "grid" and "grid bias" go to the potentiometer here, the grid of the next valve being connected to the slider on the potentiometer. If you think for a moment, or, rather, if you examine the theoretical diagram, you will see that at the "full on" position

variable condenser. This should be made of flexible rubber-covered wire, although once the coils are in place it will not be necessary to move them.

Simple H.T. Connections

It will be noticed that one value of high-tension is used throughout, the 60,000-ohm resistance performing the function not only of preventing battery coupling troubles but also of reducing the voltage to the detector valve. In valves I would recommend the first to be what is known as the high-frequency type, the second a low-frequency or general-purpose, and the third a power valve or, better still, if you do not mind the extra high-tension demand these valves make, a super-power valve. When using a super-power valve it is advisable to use an output filter such as that previously mentioned.

It is not absolutely necessary, as most modern loud speakers will carry

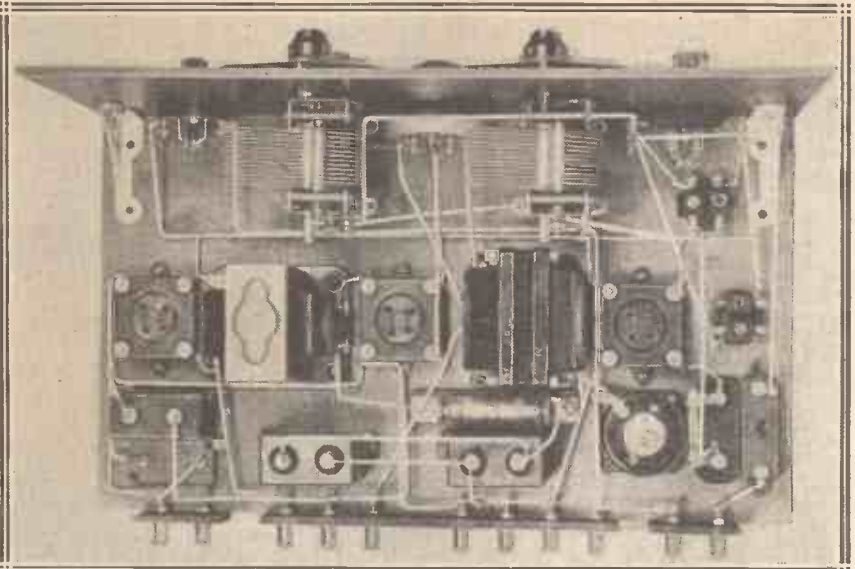

The wiring of the "Request" Three is particularly simple for a wave-change receiver and should present no difficulties even to the beginner.

the grid of the valve is actually connected to the grid terminal of the low-frequency transformer, and, of course, G.B.— goes to the terminal so marked.

When you have wired up, set the reaction condenser at zero and the volume control at the full on position, place the smaller "X" coil in the socket nearest the panel, and the 250 "X" coil in the other socket, connecting the lower tapping (marked by the lower number) to the lead which is common to each coil and the

without any harm the current even of a super-power valve provided you do not give it more than about 120 volts, which is quite enough in most cases. The trouble when using a loud speaker direct in circuit with a super-power valve is that the resistance of the speaker drops the voltage considerable. This will be understood if we consider a valve the working resistance of which when grid bias is applied is of the order of 6,000 ohms, used with a 2,000-ohm loud speaker.

The Latest and Biggest B.B.C. Controversy

| Some facts about a recent extension of the B.B.C.'s activities.

EVER since the inception of the old B.B.C. there have been periodical outbursts of fierce criticism against the management and general conduct of broadcasting in this country. And since the reconstruction of the old B.B.C. into the British Broadcasting Corporation, with its monopolistic charter and the many privileges in connection therewith, criticism has been, if possible, even fiercer and more frequent.

The Protest

From time to time the programmes have been the subject of an attack in the press, but probably the B.B.C. never supplied a better cause for adverse criticism than when it decided, on the recommendation of the Hadow Committee on Adult Education, to publish a new weekly literary journal entitled "The Listener."

As our readers know, "The Listener" has been advertised as "The B.B.C. Literary Weekly," the idea being that it should be primarily the medium for supplementing the broadcast talks, debates and other educational matter.

Now, this new venture has met with the very fiercest criticism, and practically every newspaper in the country has whole-heartedly condemned the B.B.C.'s policy in producing this new journal.

In the first place a protest was made, and the Postmaster-General invited to receive a deputation. Sir Wm. Mitchell-Thomson, the Postmaster-General, twice refused to receive this deputation representing newspaper and printing interests, and in consequence has himself come in for a good deal of criticism. He has been accused of high-handedness by stating that no good purpose could be served by receiving such a deputation.

Restriction Necessary

Legally, of course, the Postmaster-General was quite right, for the monopolistic charter of the B.B.C. does give that Corporation legal power to produce such a journal as

"The Listener," and, indeed, almost any other kind of journal. The Postmaster-General therefore must not be blamed for frankly admitting that no good purpose could be served by listening to any protests—as far as he was concerned. His power is a discretionary one as regards the B.B.C., and we doubt very much whether he, in any case, could have forbidden the publication of "The Listener."

Consequently, newspaper and printing interests arranged a deputation to wait upon the Prime Minister, to protest against the issue of the B.B.C.'s new weekly journal.

Some of our readers may wonder why all this fuss has been made, but the facts are very simple and undoubtedly point to the grave necessity of some definite limitations being placed upon the powers of the B.B.C. In other words, the monopolistic charter given to the B.B.C. should be more circumscribed, and the B.B.C.'s activities restrained by law from poaching upon the preserves of legitimate trade interests.

The journalistic activities of the B.B.C. undoubtedly mean a serious extension of State trading, and this will naturally be to the detriment of important industries employing thousands and thousands of highly-paid workers. And, remember, these industries pay enormous sums in taxation, and the B.B.C., as a State department, and possessing an absolute monopoly, cannot be competed with. No other broadcasting concern is allowed in this country bar the B.B.C., and, it is generally believed, it does not pay any Income Tax. Consequently, it enjoys great advantages over established businesses which, by its publication activities, the B.B.C. is undoubtedly attacking, although perhaps not maliciously and with no intention to harm.

Origin of the B.B.C.

The B.B.C. was primarily formed for the purpose of giving the public the best possible British broadcasting service, and in order that this should be borne out in practice it was given very wide powers.

RADIO-CONTROLLED 'PLANE



A Californian inventor is experimenting with a model rocket plane with the intention of controlling the flight by means of radio

The Latest and Biggest B.B.C. Controversy—continued

From the very first this journal and its contemporaries "Popular Wireless" and "Modern Wireless" have always deprecated the wide powers conferred upon the B.B.C., for it is undoubtedly true that, with a State concern such as the B.B.C., there is always the grave risk that if officials are given an inch they will take a yard.

This has been borne out in practice, for the B.B.C., instead of looking after its business and its proper duties (that is, the providing of first-class broadcasting), has frittered away a good deal of its energy and a good deal of valuable time in side lines which are alien to broadcasting proper.

"Mike" Publicity

Its publishing activities are absolutely unnecessary, with, perhaps, the possible exception of "The Radio Times." To be fair, it is only right that a Corporation such as the B.B.C. should have some sort of an official journal, but there is absolutely no necessity for the publication of a

its other publications by broadcasting—a privilege denied any other journal in the country.

"The Listener" has also received microphone publicity, despite the fact that in the licence granted to the B.B.C. by the Post Office there is a proviso that broadcasting shall not be used for advertising purposes except for the announcement of matter provided gratuitously, or for giving the names of publishers of works broadcast.

Apart from the moral principle involved in this controversy, the fact remains that if the B.B.C. goes on publishing, more and more time will be taken up at the microphone by boosting these publications, and consequently a very strong degree of advertising matter will inevitably creep into the programmes.

If the B.B.C. can go on producing handbooks and journals, etc., there is nothing, obviously, to prevent it entering into competition with existing radio manufacturers and, as the "Daily Mail" points out, start manufacturing wireless sets, valves,

facturers of wireless apparatus, but, nevertheless, as its Charter stands at the moment, it could do so, and could do so legally.

As the "Daily Mail" has also stated, it was never intended that the B.B.C. should become a huge Socialist organisation, stealthily extending State trade from its vantage ground of untaxed monopoly.

The Result

Well, as a result of all this bother, a deputation representing the newspaper publishing and printing industries has waited upon the Prime Minister at No. 10, Downing Street. The deputation was introduced to the Prime Minister by Lord Riddell, Chairman of the Newspaper Proprietors' Association, and the case was presented by Major the Hon. J. J. Astor, M.P., for the Newspaper Proprietors' Association. A general discussion followed, in which Mr. Baldwin took part, and the conference lasted nearly two hours, but was adjourned in order to afford the Prime Minister an opportunity of further considering the case submitted.

Later, at the suggestion of the Prime Minister, the leaders of the deputation conferred with Sir John Reith, Director-General of the B.B.C., and points of possible agreement emerged from this conference. A further meeting was held on January 14th. The following memorandum, being accepted by the leaders of the deputation as a basis of agreement, was later confirmed by both parties, when the full deputation met the Board of Governors of the B.B.C.:

The Basis of Agreement

1. "The B.B.C. contends that, although the Royal Charter contains comprehensive powers in respect to publishing, these powers have not been unfairly used, the criterion being that its publications are pertinent to the service of broadcasting.

2. "The B.B.C. will recognise and deal with a Committee to be established representing the interests which met the Corporation.

3. "The B.B.C. is prepared to discuss with the Committee any new publishing proposals and to consider representations by the Committee concerning existing publications.

4. "The B.B.C. states that it is not intended that 'The Listener' should

(Continued on page 348.)

WIRELESS IN PERSIA



The new wireless station at Tabriz favours the cage type of aerial which is suspended from one main mast, as shown.

paper like "The Listener," nor is there any necessity for the publication by the B.B.C. of handbooks, libretti, etc., etc.

Of course, all the profit from such a journal as the "Radio Times" is spent in the listeners' interests, but there again a great principle is at stake. For the B.B.C., by virtue of its monopoly, has been able to advertise "The Radio Times" and

batteries, etc., etc. And with such extraordinary advantages over other manufacturers our readers will see how easy it would be for the B.B.C. absolutely to eliminate any form of competition and, if its own powers were not curbed, create a very serious condition in the country.

It is, of course, not suggested that the B.B.C. has any intention of entering into competition with manu-

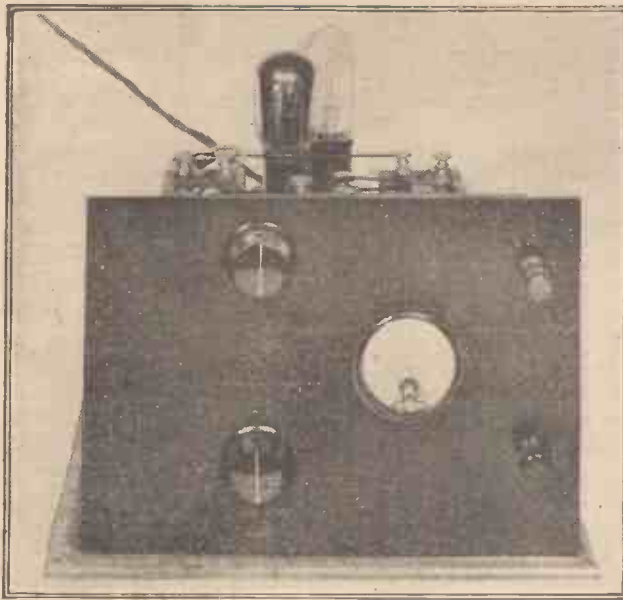

The "Stedipower"SM L.T. Unit Super Model

Here is a unit for the man with A.C. mains which is capable of supplying a really heavy current for a very large set—up to two amperes if necessary. It can thus be used to energise the field of a moving-coil speaker as well, if required—in fact, it is a complete solution of the L.T. problem.

By PERCY W. HARRIS, M.I.R.E.

WHEN the Harris "Stedipower" L.T. unit was first published in the August issue of the WIRELESS CONSTRUCTOR it provided readers, for the first time, with a means of running the filaments of their

bother, provided the total load was not greater than one ampere.

With modern valves, using only a tenth of an ampere or less, and a quarter-ampere valve for output, this unit obviously covered the great

majority of receivers, but many readers wrote asking whether it would not be possible to produce a large model with a two-ampere output for the benefit of those running sets with quarter-ampere valves, push-pull, parallel output and the like.

The Cost Difficulty

The problem is not quite so easy as would at first appear, for although the filter system is fairly easy to design, now that high-capacity electrolytic condensers are available, no suitable rectifier (bearing in mind both cost and efficiency) seemed available. Dry rectifiers of the copper-oxide type are now readily obtainable in models capable of providing one ampere, and in many cases parallel operation of two such units will be effective, but it must be remembered that they are quite expensive. and

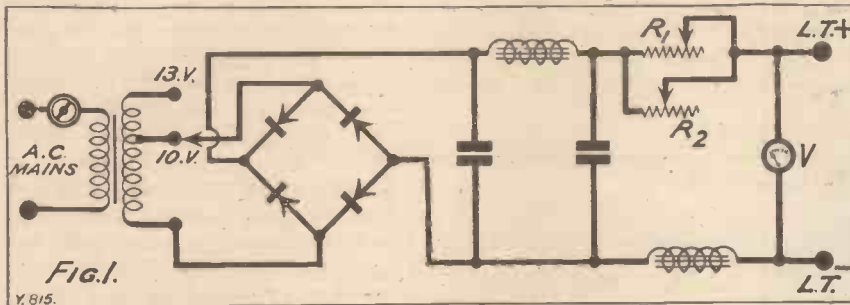

existing sets from A.C. mains (using ordinary valves), thus dispensing with accumulators and their mess and

majority of receivers, but many readers wrote asking whether it would

LIST OF COMPONENTS.

(Names in brackets are those illustrated in photographs.)

Baseboard of any reasonable size to suit convenience.

Ebonite or wood panel, 10 in. x 7 in. (any standard make).

Pair of panel brackets.

Pair of insulated terminals, L.T.— and L.T.+ (Belling-Lee). Igranic, etc.

High-grade voltmeter, 0 to 7 volts (Weston). Sifam, Hunt, Ferranti, etc.

1 6-ohm and 1 10-ohm heavy-duty rheostat. (SPECIAL NOTE.—These must be able to carry 2 amperes without undue heating. Those used in the set are the Centralab Giant Power Rheostats.)

Ediswan L.T. battery charger, complete.

On-and-off tumbler switch (lighting pattern).

3 Electrolytic condensers, 1,000 to 1,500 mfd approximately (T.C.C.). Tobe-Deutschmann, or Dubilier.

2 Harris "Stedipower" chokes, 2-ampere model (R.I.-Varley).

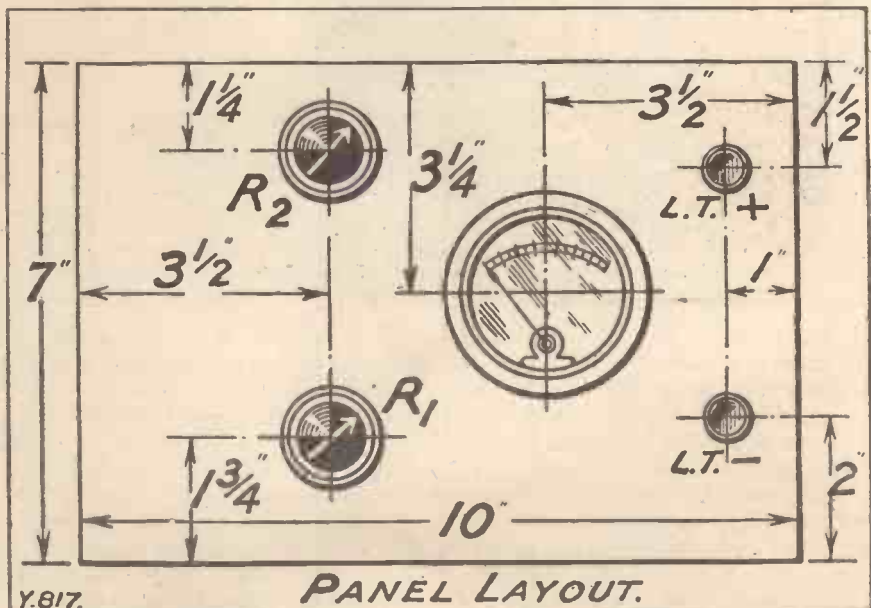

The "Stedipower" L.T. Unit Super Model—continued

two would bring the cost up to £2 10s. for the rectifier alone, which seemed too high.

Fortunately, however, I have found an excellent device—the Ediswan L.T. accumulator charger—to be immediately adaptable to the "Stedipower" scheme. This charger consists of a small casing containing a step-down transformer and two special valve holders. Into one of these sockets a special gas-discharge rectifying valve is fitted, and into the other a device known as a barretter, the

charger uses the same connection for all, and one can even short the output without the current in the leads rising above two amperes, this being the limit set by the barretter.

Striking the Arc

The gas-discharge rectifier has the appearance of an ordinary valve, but functions differently. It does not operate for four or five seconds after switching on, after which time there is then a slight flash within the bulb, which settles down to a purplish glow

the output comes in what may be termed smooth pulses of double the alternating current frequency, in the case of the gas-discharge rectifier the wave form is somewhat different. This makes no difference whatever in battery charging, but necessitates a slightly more elaborate filter system than in the original "Stedipower." For comparison the circuit of the original "Stedipower" one-ampere model is shown in Fig. 1, while in Fig. 2 the circuit of the two-ampere model is given.

Rectification and Smoothing

It will be seen that on the left we have a switch in the main lead of the transformer, the secondary of this transformer feeding a rectifier, the rectified current then passing through a current limiting device or barretter, shown as a zig-zag line in a circle. This part of the apparatus is not shown in full detail, as there is a special device for striking the arc, but this has no bearing on the general principles of operation.

After this the rectified current passes through a smoothing system consisting of three electrolytic condensers, of approximately 1,500 mfd. each, and two chokes. From here the output passes through two variable resistances *in series* (not in parallel as the original "Stedipower" unit). The fact that we require to pass two amperes necessitates different chokes and different output resistances from the original set.

In order that the electrolytic condensers should not be submitted to too high a voltage, we want to cut down the voltage applied to this filter to a minimum, and therefore the chokes are of a lower ohmic resistance than the "Stedipower" chokes for the one-ampere model, and with a slightly lower inductance for this reason. However, there is additional capacity which more than compensates for the loss of inductance, so that the output is perfectly smooth.

Need for Special Resistances

The voltage-controlling resistances in the output must be sufficiently robust to carry two amperes without overheating, and there are a comparatively limited number of such resistances available. Those used in the original "Stedipower" unit will not carry more than one ampere, and the reader is recommended to obtain the

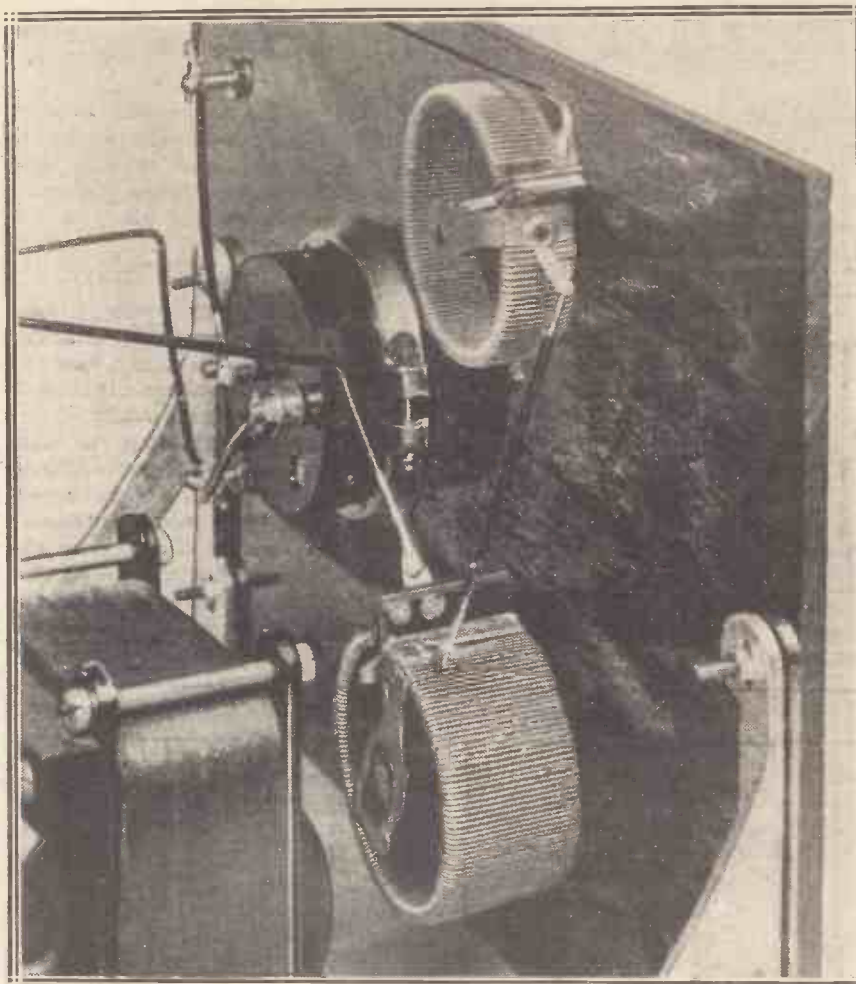

A back-of-panel view showing the main connections.

latter being a current limiting device.

There are, of course, input and output leads; the input leads being connected to a plug for insertion in the electric light socket, the output leads, marked positive and negative, giving a pulsating rectified current for accumulator charging. Unlike most battery chargers which require different terminals for two-, four-, or six-volt charging, the Ediswan L.T.

barely visible in daylight. Once started it will carry on indefinitely, and the laboratory tests to which this charger was subjected included day and night running without a break for over a week, to see what rise of temperature was obtained; no variation of output being found.

The output of this device is, of course, pulsating rectified current, but whereas from a good dry rectifier

The "Stedipower" L.T. Unit Super Model—continued

resistances named in the list of components in the present article.

The chokes are made by R.I.-Varley, Ltd., to my specification, and should be ordered as Harris "Stedi-

taining long life for the valve filaments. Too great a reduction of voltage, however, is inadvisable, and the makers' limits should be respected.

Of course, as in previous "Stedipower" units, the electrolytic condensers, which are of extremely high capacity compared with the ordinary Mansbridge types, are very important. When the "Stedipower" scheme was first published in the WIRELESS CONSTRUCTOR, the only high-capacity condensers available were the Tobe-Deutschmann, but since that date Messrs. The Telegraph Condenser Co., Ltd., and The Dubilier Condenser (1925), Ltd., have produced high-capacity electrolytic condensers, each being suitable for all three units.

The actual capacity of the electrolytic condenser depends upon a

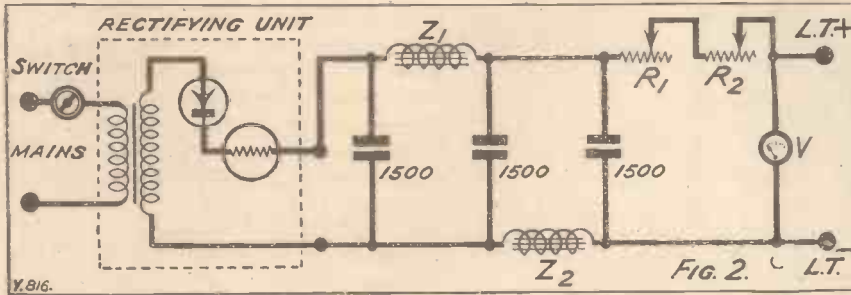

power" chokes (two-ampere model), to distinguish them from the one-ampere chokes which are of somewhat different construction.

As the Ediswan battery-charging unit contains a step-down transformer and the rectifier, and as the total cost with the rectifying valve and barretter is only £2 17s. 6d., it will be seen that the cost of the "Stedipower" two-ampere model, up to the filter, is not much more than the corresponding parts for the one-ampere model.

Switch Off Correctly

In this, as in previous "Stedipower" units, switching off the set should invariably be effected from the mains, so as to avoid the no-load voltage, which is always higher than the working, being applied to the electrolytic condensers. A good voltmeter is permanently fixed to the "Stedipower" unit, as this gives immediate indication of the actual voltage being applied to your valves, and being a high-grade model can be relied upon not only for accuracy, but also not to make an undue drain upon the supply unit, which would reduce the voltage available to the set.

As this unit will be used mostly upon four- and six-volt valves and very rarely upon "two-volters," it is not necessary to give a very wide variation of voltage control, and the set has been designed to give two amperes at six volts with practically all of the controlling resistance cut out.

Adjusting the Voltage

Most 6-volt valves work quite efficiently just below six volts, say, at 5.5, and it is useful to be able to reduce the voltage to this figure, thus main-

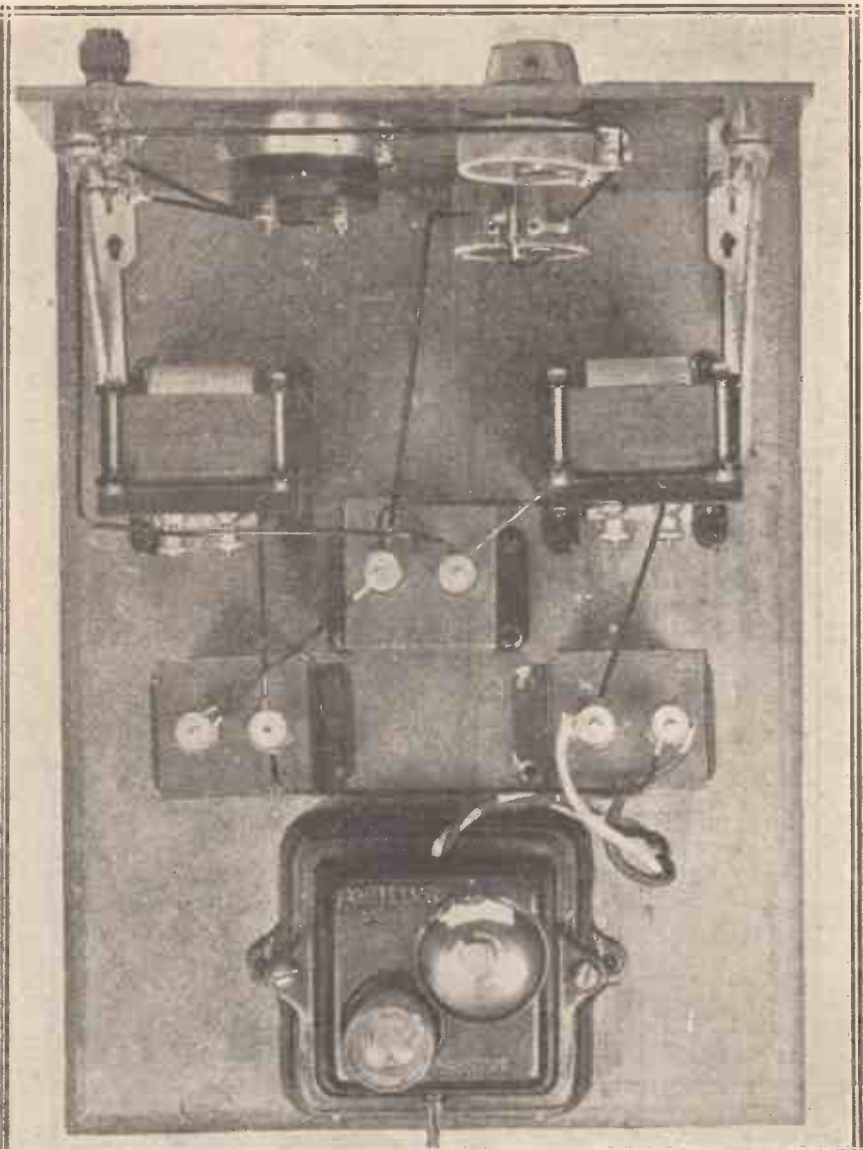

This "looking-down" view shows how the parts are arranged upon the baseboard, and should be compared with the wiring diagram during construction.

The "Stedipower" L.T. Unit Super Model—continued

number of factors, and all of them will give excellent smoothing if only they are used correctly. However, the peculiar construction necessary to

get the very large capacity makes it absolutely essential that these condensers should not be used on high voltages, for which reason they are

entirely unsuitable, nor are they intended for high-tension mains units.

As the "no load" voltage applied to the "Stedipower" unit condensers is in excess of the voltage when current is taken from the output, we must always switch off the mains before the filament circuit is interrupted, and as no high-tension will flow through the set when the low-tension current is switched off, the mains switch can, and should be, used as the ordinary on-off switch for the set.

Supplying "Field" Current

Some readers have asked for a large model "Stedipower" L.T. unit giving two amperes or so, in order that they may run simultaneously the filaments of their valves and the low-tension exciting current for a moving-coil loud speaker. I do not advise the use of the two-ampere model "Stedipower" for this purpose.

If it is desired to run a moving-coil speaker energising the windings from the mains, the best plan is to use a separate unit for the speaker consisting of a transformer and a one-ampere dry rectifier, such as the Westinghouse Model A3. The output from this rectifier can be passed straight to the 6-volt windings of a loud speaker without any special filter system, as the inductance of the speaking winding is so high that this will effect the necessary smoothing.

Don't Do It!

The placing of an electrolytic condenser across the speaker windings will eliminate any hum, but it is not recommended for the simple reason that when the loud-speaker-winding current is switched off the surge voltage so produced is so high that it may rupture the condenser and thus ruin it.

With loud-speaker windings designed to take half an ampere, the numerous half-ampere trickle-chargers, such as the Ferranti and Burndept, serve excellently as energising sources.

It should be noted with the "Stedipower" two-ampere unit that the steady voltage for the filaments is not reached immediately the unit is switched on, and the voltmeter should be watched for the first few minutes when the initial experiments are made. After the instrument has settled down the voltage will remain

(Continued on page 369.)

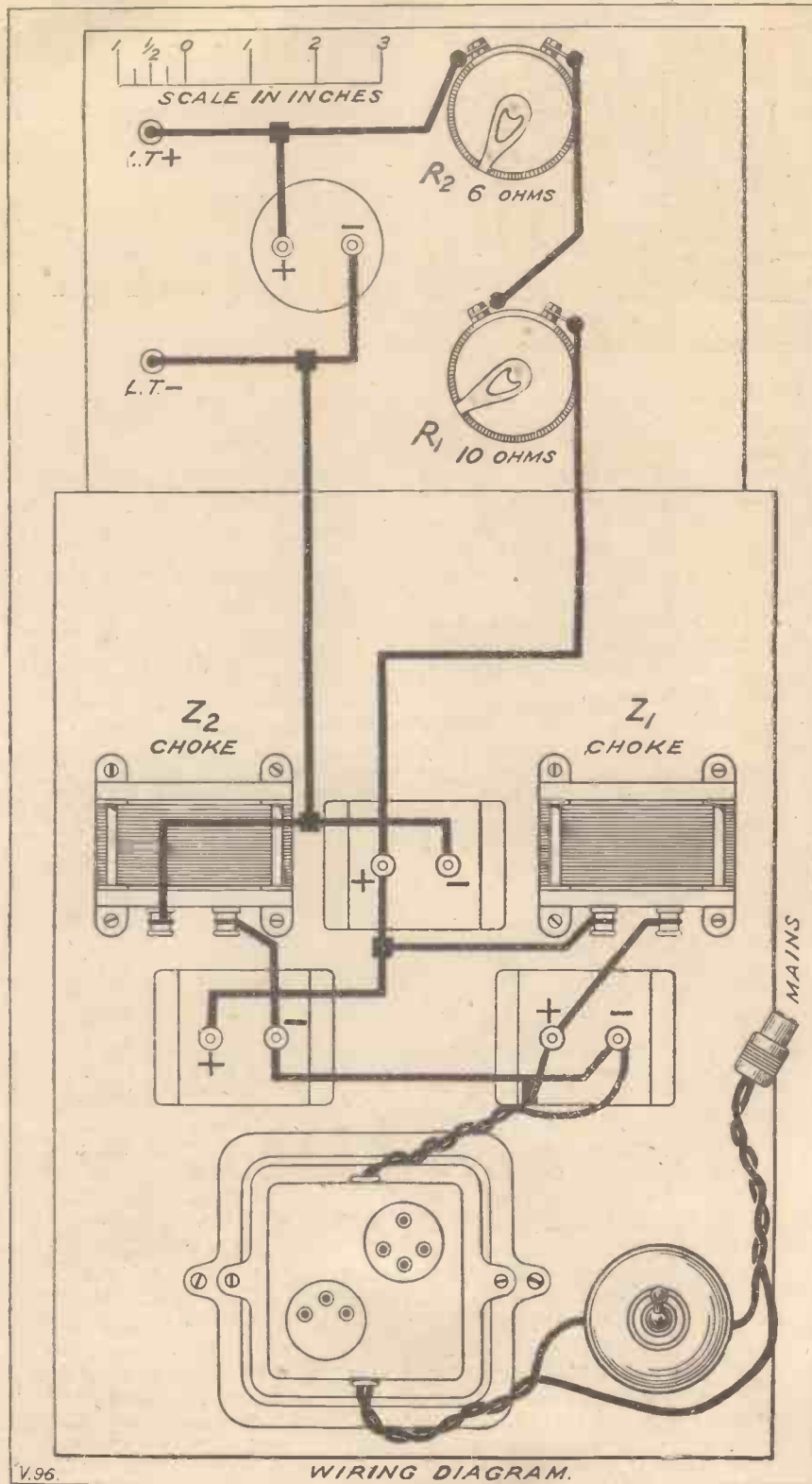

What the Pentode Really Does!

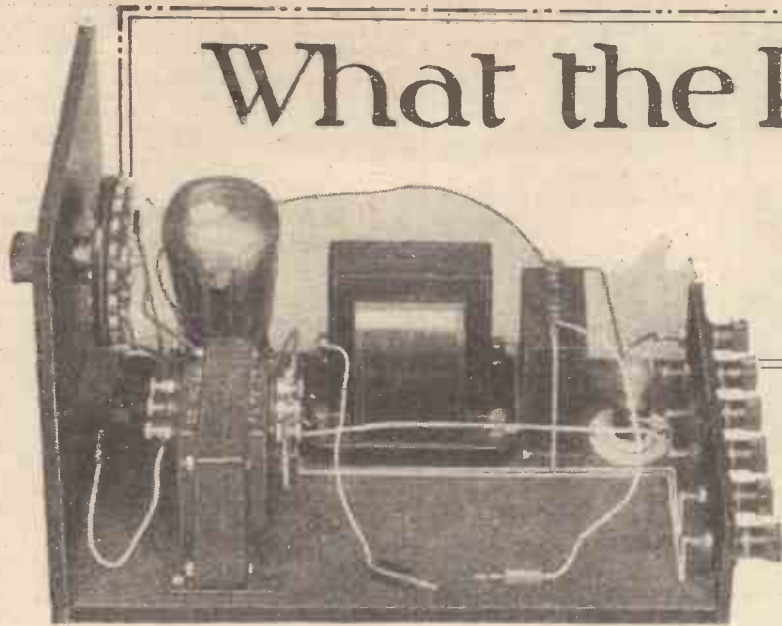

The second and concluding article upon the characteristics and use of the new 5-electrode L.F. valves.

By G. P. KENDALL, B.Sc.

WE dealt last month with most of the general practical points to be observed in using a Pentode. Now there are one or two miscellaneous matters in which the reader may be interested. First of all, what will the valve really do in the way of amplification? On test it would appear that the original estimate which made the valve equal to two ordinary L.F. stages was a rather optimistic one. It certainly does not give as much "mag." as two transformer-coupled stages, and it is doubtful whether it quite equals a good combination of one resistance and one transformer-coupled stage.

A Doubtful Question

However, it really does give a very great deal of magnification, and it is probable that if there is some really efficient H.F. amplification going on in front of the detector, a single L.F. stage using the Pentode would be sufficient for all normal purposes. Whether or not the Pentode can be used with an ordinary L.F. stage in front of it is a rather debatable point, and experimental work is still going on upon this question. It is certainly not an easy matter, for there are a number of "snags" involved, partly because one would then have an enormously powerful amplifier with a corresponding tendency to L.F. oscillation, and partly because of the danger of overloading the Pentode.

Now suppose that we are considering the actual use of a Pentode in an existing set, what are the points to which we must attend? Well, first of all, we must obviously see that our

H.T. supply can stand up to the load, then arrange a suitable output circuit, and finally turn to the question of the strength of the input to the Pentode.

This input question is a most important one, and if it is not given due attention, good results are extremely improbable. The point to grasp is this: The valve will give a very large power output with quite a small input, by virtue of its very high amplification factor. Further, and here is the important point, it will not stand more than quite a moderate

input to its grid. The grid swing which it can take without overloading is decidedly small, and if you give it more the inevitable result will be extremely bad quality.

Adjust Volume Carefully

Watch this point closely, therefore, and adjust the strength of the input to the Pentode carefully, by de-tuning or using a volume control when receiving the local station, and you will be well on the road to success. It follows from this that for all normal

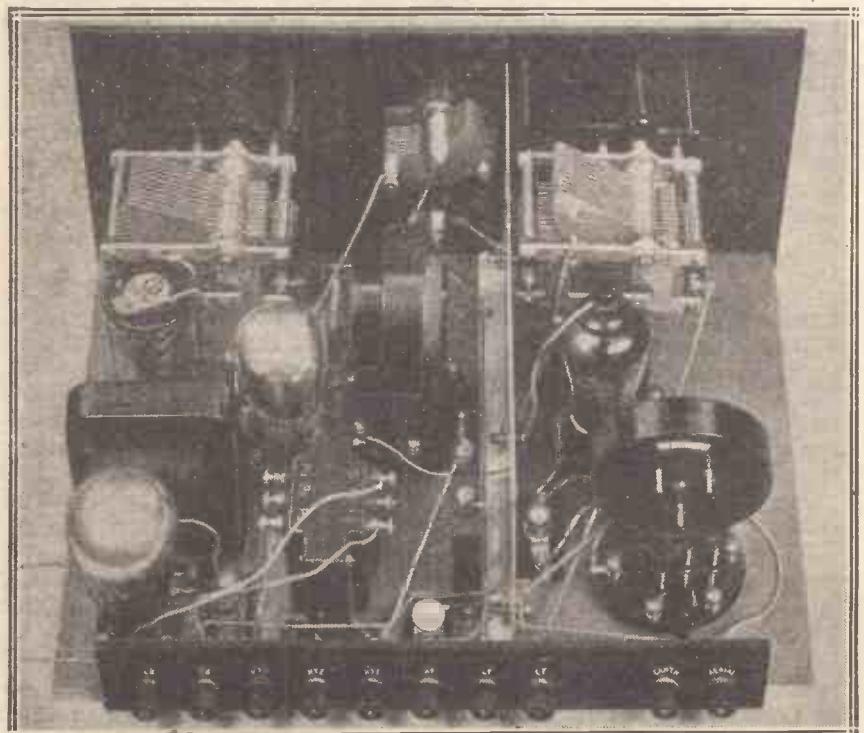

A three-valver using a Pentode for the L.F. stage. Note the special output transformer with six terminals on it.

WHAT THE PENTODE REALLY DOES

—continued

purposes the Pentode should follow straight after the detector valve without an intervening stage of L.F. On sets with two stages in use it is definitely wisest to cut out one of them when a Pentode is used—at any rate, at first.

A word of warning should perhaps be given at this point for the benefit of users of mains units. It has already been remarked that a high-tension supply, capable of providing a considerable current is necessary with the Pentode, and a good mains unit is obviously one of the best solutions of the problem.

Motor-Boating Troubles

My own work on the Pentode has very largely been done with mains H.T. supply, and I have experienced one particular snag so frequently that it seems to be one of the special points to be watched for in using this valve. The difficulty is that motor-boating is far more prone to occur with these very high-magnification valves with mains H.T. supply, especially with a fairly powerful type of set.

It is important to run each valve in the set from a separate tap on the H.T. unit as far as possible, and where this is not sufficient some sort of anti-motor-boating device should be inserted in series with the H.T. lead to the detector valve. For example, the standard type incorporating a resistance of 50,000 to 80,000 ohms and a 2-mfd. condenser shunted down to L.T. negative will usually do the trick.

Pentodes in Early Stages

In obstinate cases it may also be necessary to provide another device in the H.T. lead to the extra terminal on the base of the Pentode valve. In this case a filter of the choke-and-condenser type is best, in order to avoid dropping the voltage reaching the valve.

Just one final point. It has frequently been suggested that since the Pentode will only handle a relatively small input it should be used in the first L.F. stage, its output being fed on to the usual last stage. Well, it is never wise to say that a thing is impossible, and will never be done, so I will merely remark that this is going to be an excessively difficult proposition.

The difficulty arises from two main factors: (a) There is no really satisfactory device at present available to serve for inter-valve coupling with a Pentode; and (b) if such a device were produced (it is conceivable that a special L.F. transformer might be made to do it), the output of such a stage would be so enormous that it would only be handled by valves of the L.S.5a class in the following stage, with some 300 or 400 volts H.T.

Is the Pentode worth while? Well, that seems to depend upon circumstances, and the reader should by now be in a position to judge pretty well for himself. Its main application seems to me to be in the direction of producing small, compact receivers of very fine performance, without much regard to H.T. consumption.

THE LATEST AND BIGGEST B.B.C. CONTROVERSY

—continued from page 342.

contain more than 10 per cent original contributed matter not related to broadcasting. The rest of the paper will consist of talks which have been broadcast and comments thereon, articles relating to broadcast programmes and programme personalities, and news of the broadcast service generally.

5. "The B.B.C. has no intention of publishing any further daily or weekly newspaper, magazine or periodical. It has also no intention of publishing books or pamphlets not pertinent to the service of broadcasting.

6. "The B.B.C., as an evidence of its goodwill, states that it does not intend to accept for 'The Listener' more advertisements than are necessary, with its other revenue, to cover its total cost."

A most cursory perusal of the above salient points in the agreement will show that the B.B.C. still has a very nice loophole, should they wish to use it. Take paragraph five, the line "not pertinent to broadcasting." But what isn't pertinent to broadcasting? There is hardly a single subject covered by newspapers or magazines which cannot be said to be "pertinent to broadcasting"!

The situation still seems pregnant with future arguments and possibly "ructions." But the situation will certainly be watched very closely indeed, and future moves by the B.B.C. in the publishing line should prove fraught with difficulty and, indeed, considerable danger.

USEFUL CHARTS AND CATALOGUES

THE many admirers of the Ferranti components will be interested in the new chart now available from this firm.

It gives constructional details for a 3-valve receiver for local and other stations, including 5 X X and certain Continental ones.

On this chart the whole of the drawings are to scale, and the method of assembly is thus very clear. Panel and baseboard layouts of full size are given, and the theoretical diagram shows that the circuit employed is a well-trying one, viz., straight det. and 2 L.F. (transformer coupled), with reaction.

The various Ferranti components used are clearly illustrated, so that no constructor should find the slightest difficulty in duplicating the design.

A Very Complete Range

The new Gecophone catalogue, just received, shows that the General Electric Co., Ltd., has recently been adding to its wireless products, notably with the Gecophone "World-Wide" Screen-Grid Four, and the Osram Music Magnet "Kit" receiver.

Starting with a crystal set, the catalogue—which is handsome and elegantly illustrated—shows a range of receivers covering all sorts of requirements up to an eight-valve supersonic heterodyne that works from 250 to 2,800 metres on a frame aerial.

Illustrations and descriptions of loud speakers, components and accessories occupy a large proportion of the total space, and special attention is drawn to the new Gecophone battery eliminators, made for either alternating-current (A.C.) or direct-current (D.C.) mains.

A Commendable Example

The A.C. type embodies an Osram U.5 rectifying valve and is provided with three H.T. positive terminals, giving a fixed maximum supply of 180 volts on average load, and two variable voltage supplies. (This eliminator can be used with great success in screen-grid-valve receivers.)

An excellent feature of the catalogue is the ample spacing, generally each large page being devoted to only one type of article, thus allowing room for ample details. A great many technical details are given, and the descriptions are really helpful to the prospective purchaser.



The "Three-Choice" Four

A "no-tuning" set giving the local station or 5 GB, or gramophone reproduction at will.

By R. W. HALLOWS.

THIS is a set designed particularly for those who like wireless in its simplest form. It works in conjunction with a frame aerial and gives loud-speaker reproduction of fine quality of the local station and one other, and as well as playing gramophone records with the aid of a pick-up. Upon the panel there is not a single tuning knob; there are three jacks, a small switch, and the dial of a neat volume-control device.

To operate the set all that is required is to insert the plug attached to the frame into either the left-hand jack or that in the middle, and the plug to which the loud-speaker leads are connected into the right-hand jack. Since the tuning is fixed, this automatically brings in one station or the other, according to the jack in which the aerial plug is placed.

To play gramophone records, the loud-speaker plug is inserted as before,

and that attached to the pick-up heads is placed in the middle jack. In all cases the volume of sound obtained can be regulated to a nicety by means of the switch and the volume control.

Screened-Grid Valve

The set as seen in the photographs was designed for use in places where the shorter-wave transmission (2 L O in this particular instance) is the stronger. As will be shown in a moment, the circuit is easily adapted to meet the two other possible conditions: (1) where the two stations desired are of almost equal strength, and (2) where the longer-wave transmission is the stronger. A very small addition also makes it possible to use it either with an outdoor aerial or with an indoor aerial of other than frame type.

Fig. 1 shows the circuit diagram. It will be seen that it consists of a

screen-grid H.F. amplifier, followed by an anode-bend rectifier and two note-magnifiers. The first low-frequency valve is resistance-coupled to the rectifier, the grid leak taking the form of a variable resistance with a value of 0-1 megohm.

The next point of interest is the coupling arrangement between V_3 and V_4 . If the circuit is traced out it will be seen that when the switch is turned upwards transformer coupling is brought into action. When, however, it is turned downwards, the secondary of the transformer is cut out. The primary now functions as a low-frequency choke and V_3 is connected to V_4 through the coupling condenser C_{10} , grid bias being applied through the grid leak R_4 .

With a first-rate transformer containing plenty of wire on the primary and having a core of ample cross section, this arrangement gives excellent

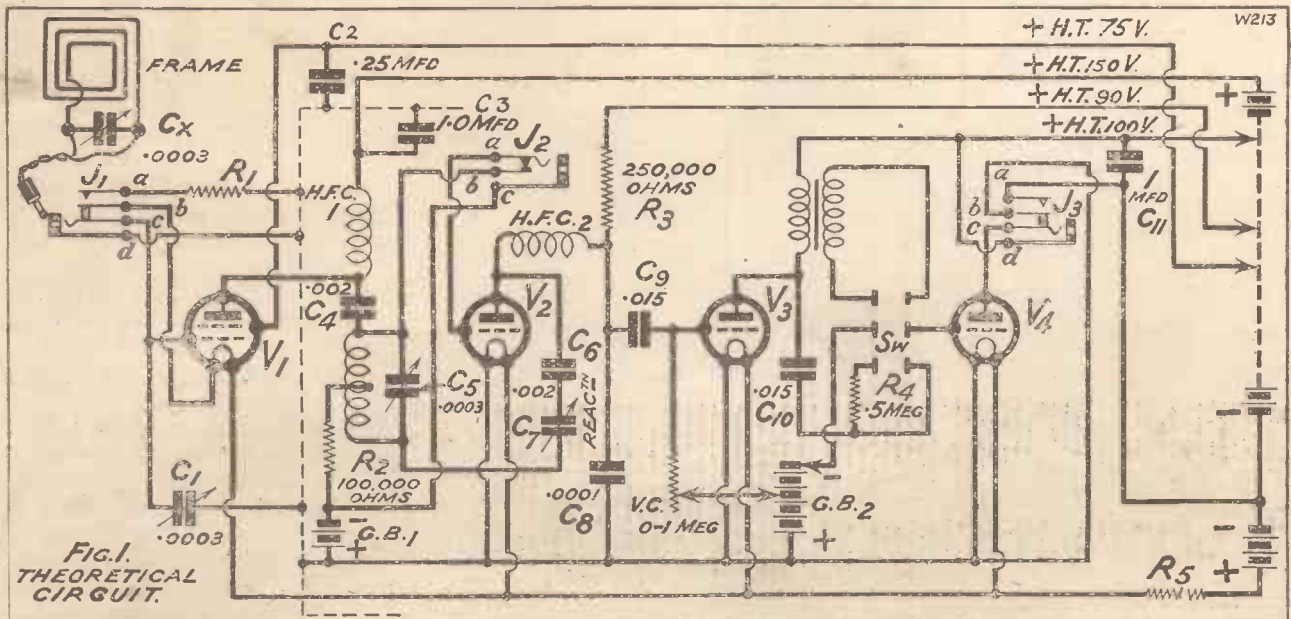

The operation of the set is remarkably simple, the various alternative programmes being available without any tuning being needed. Additionally the receiver is compact, easy-to-build and inexpensive.

The "Three Choice" Four—continued

results. Should the local station be just a little too weak with choke coupling between the last two valves, the switch is turned upwards and the volume control adjusted until the set is giving its maximum output without distortion.

Again, it may be found that the longer-wave station comes in too powerfully when all four valves are in use with transformer coupling between the last two. In this case the switch is turned downwards, bringing choke coupling into play.

Novel H.F. Scheme

The high-frequency side of the set can lay claim to a certain amount of novelty. It will be noticed that the frame aerial is shown as having a variable condenser of .0003 mfd. wired in parallel with its windings. This can be done very handily either by mounting an air dielectric variable condenser in a box (which forms a stand for the frame) and taking leads from it to the frame's terminals, or by wiring a condenser of the semi-adjustable type, such as the Formodenser, across these terminals.

When first bringing into use the set as arranged according to Fig. 1, one begins by inserting the aerial plug into J_2 , and that belonging to the loud speaker into J_3 . The latter action switches on all the valves and completes the plate circuit of the last valve, while the placing of the aerial plug in J_2 automatically cuts out the H.F. valve V_1 and its circuits and places the frame between the grid of V_2 and the grid-biasing battery

G.B.1. By adjusting the variable condenser in parallel with the frame, the local station is brought in and tuned to its best. This condenser is now left entirely alone.

The next process is to place the aerial plug in J_1 . The windings of the

If the shorter-wave station is very close, even the directional properties of the frame may not suffice to cut it out entirely in the first instance. A little reaction, however, applied by means of C_7 , will enormously increase the selectivity. The set under des-

COMPONENTS REQUIRED

- 1 Ebonite panel, 18 in. × 8 in. × $\frac{1}{4}$ in. (Any good branded material).
- 2 Pieces ebonite, 2 in. × 2 in. and 2 in. × 3 in., for terminals.
- Suitable cabinet.
- 2 Single filament jacks (Bowyer-Lowe, Igranic, Lotus, Ashley, etc.).
- 1 Single closed circuit jack (Bowyer-Lowe, Igranic, Lotus, Ashley, etc.).
- 2 H.F. chokes (R.I. and Varley, Lissen, Dubilier, Lewcos, Igranic, Climax, etc.).
- 2 .0003 or .0005 variable condensers (Any good make).
- 1 .0003 variable condenser or .00025 Formodenser (for frame).
- 4 Valve holders (Any good make).
- 1 3-in. length of 6-fln coil former (Becol). (Or paxolin or cardboard tube 3 in. diameter.)
- 1 Wire-wound resistance, 100,000 ohms (R.I. and Varley, Dubilier, Mullard, Lissen, Igranic, etc.).
- 1 Wire-wound resistance, 250,000 ohms (R.I. and Varley, Dubilier, Mullard, Lissen, Igranic, etc.).
- 1 Neutralising condenser, baseboard mounting (Bowyer-Lowe, Peto-Scott, Magnum, etc.).
- 2 Fixed condensers, .002 mfd. (Dubilier, T.C.C., Mullard, Atlas).
- 1 Fixed condenser, .0001 mfd. (Dubilier, T.C.C., Mullard, Atlas).
- 2 Fixed condensers, .015 mfd. (Dubilier, T.C.C., etc.).
- 2 Fixed condensers, 1.0 mfd. (Dubilier, T.C.C., Ferranti, Mullard, Lissen, Hydra, etc.).
- 1 Fixed condenser, .25 mfd. (Dubilier, T.C.C., Lissen, Ferranti, Mullard, Hunt, etc.).
- 1 3-volt flashlamp battery (Any good make).
- 2 9-volt grid batteries (Any good make).
- 1 0-1-megohm variable resistance (Igranic).
- 1 .5-megohm grid leak (Pye—this type needs no holder).
- 2 Fixed resistors to suit valves.
- 1 Four-way change-over switch (Grafton Electric Co., No. 16A/44; this type fits conveniently below the baseboard).
- 1 L.F. transformer from 4-1 to 7-1 (Marconi, Igranic, R.I. and Varley, Ferranti, Lissen Super, etc.).
- 7 Terminals.
- 2 Pieces sheet copper, 12 in. × 6 in., and 12 in. × 2 $\frac{1}{2}$ in. (for screens) (Paroussi, Peto-Scott, Magnum, Camden, etc.).
- Glazite for wiring.

frame are now connected between the control grid of V_1 and low-tension negative, C_1 being in parallel with the condenser wired across the frame. By adjusting C_1 and C_2 , and rotating the frame as required, the longer-wave station is tuned in.

cription is actually in use within less than half a mile of 2 L O, and no difficulty at all is experienced in bringing in 5-G B entirely free from interference.

Gramophone Reproduction

Having got so far, the next process is to find which position of the switch and what reading on the volume-control dial gives the best results on either station. As soon as these have been ascertained and noted (it is a good tip to fix a card inscribed with these data inside the lid of the cabinet by means of drawing-pins) the set is ready at a moment's notice to bring in either station without the necessity for any tuning.

If it is proposed to use the set for the reproduction of gramophone records, a high-resistance pick-up of good quality should be connected to a plug. Ample volume will be obtained with choke coupling between V_3 and V_4 , and with most records it is not necessary to use anything but a soft needle. The volume

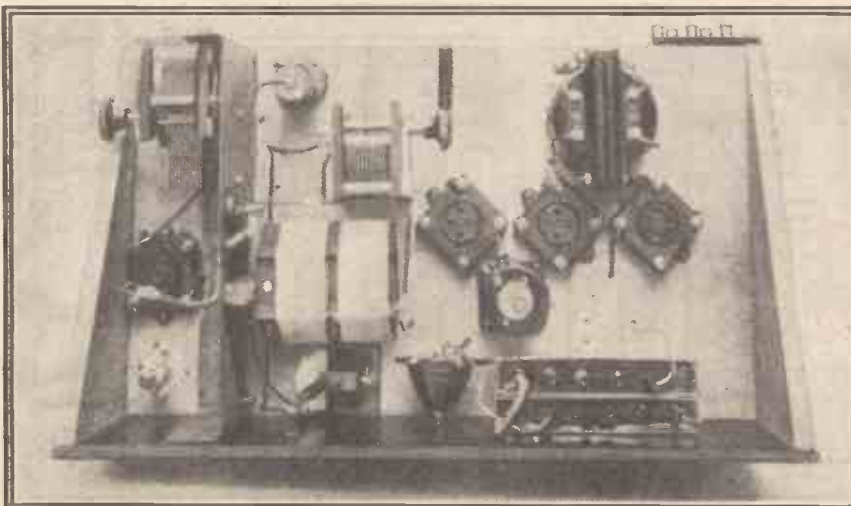

Nothing complicated about this set is there? The screening is simple, but efficient, and the components are standard and well disposed.

The "Three Choice" Four—continued

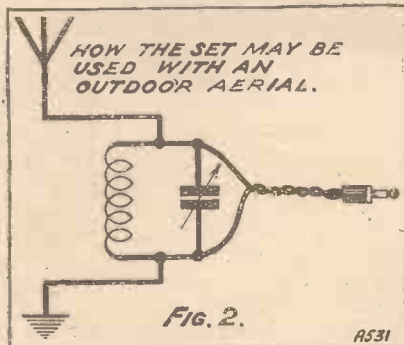

Should both of the desired alternative stations possess about equal strength, the circuit may be altered in the way seen in Fig. 3. Here a switch is fitted which enables C_1 to be cut out at will, and a second switch throws C_5X , wired in parallel with C_5 , into or out of circuit. With C_1 and C_5X out of action the condenser in parallel with the frame

of 2 L O and 5 G B at a place some distance to the north-east of London, where the strength of the two is nearly equal. A twin switch was used for S_1 and S_2 .

Should the longer-wave station be the most powerful transmission, the circuit of the actual set needs no alteration. All that is necessary is to provide the condenser across

control allows maximum strength with minimum distortion to be obtained.

Of the valves, V_1 is a screened-grid valve of the new four-pin variety.

It is provided with the usual four-pin base and a fifth contact fixed to the top of the bulb. The filament pins occupy their normal positions in the cap and the grid pin is connected to the inner or control grid. What is the plate pin in a three-electrode valve is here, connected to the screen grid.

With Outdoor Aerial

The contact at the top of the bulb is the anode connection. After trying several circuits the form of parallel feed (consisting of an H.F. choke plus a "Rice" circuit) seen in Fig. 1 was finally adopted.

Fig. 2 explains how the set may be adapted for use with an outdoor aerial or with a suspended indoor wire.

In a small box provided with two well-insulated terminals are mounted a coil and variable (or semi-variable) condenser in parallel. The leads from the circuit are connected to a plug.

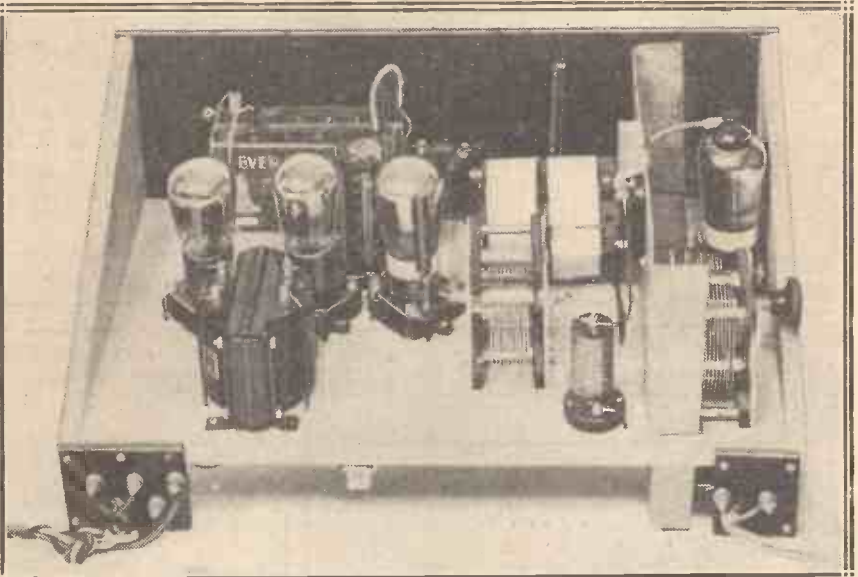

By raising the baseboard slightly and reversing the usual terminal strip positions it is easy to wire-up, and to place some components and the jacks on the underside.

tunes the control grid circuit of V_1 , whilst C_3 alone tunes V_2 . In this way the station using the shorter wavelength can be tuned in sharply with the frame-aerial plug in J_1 . To change over to the longer-wave station, close the switches and adjust C_1 and C_5X .

The set has been made up in this form, and gives excellent reproduction

the frame with a switch. To receive the station using the longer wave, in this case one turns the switch so as to bring the condenser across the frame into action and plugs into J_2 . By means of this condenser (in parallel with C_5) the station is tuned in. On changing over to the shorter-wave station the frame condenser is thrown out of circuit and tuning is done with C_1 and C_5 only.

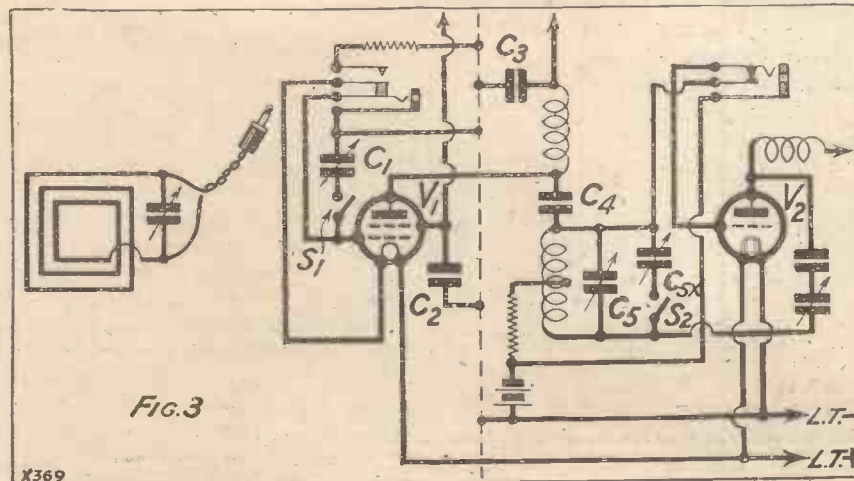

Sub-Base Mounting

It will be seen from the photographs that the sub-base method has been adopted in making up this set. One of the advantages of this system is that it gives far more room for components, since both sides of the baseboard can be used for mounting them. There is thus no necessity for crowding, with its attendant evils, and components can be well spaced.

The use of jacks, convenient as they are in most other ways, has the disadvantage that it entails a good deal of wiring as a rule. By mounting

The "Three Choice" Four—continued

the jacks below the baseboard all of this can be kept out of sight, and the same applies to the filament and

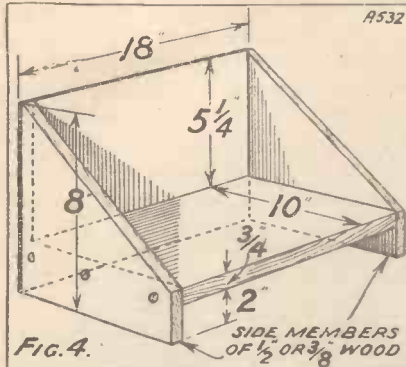

high-tension busbars, which are often such a nuisance to fit in satisfactorily. How great is the improvement in appearance may be judged both from

the photographs and from the remark of a friend who, on lifting the lid for a look inside, said:

"This is the nearest approach to wireless wireless that I have seen."

The dimensions of the baseboard and its frame are given in Fig. 4. Readers who do not care about woodwork will have no difficulty in getting this part of the apparatus made up by any carpenter at small cost.

Making the Screens

Begin by cutting out and making the screens—a very easy business. That for the upper side of the baseboard is made from a piece of sheet copper 12 in. in length by 6 in. in width. Make scribed lines parallel with and 1 in. from each of the short edges and one of the long ones as shown in Fig. 5.

With tin shears or strong scissors cut away these squares (shown shaded) between the intersections of these

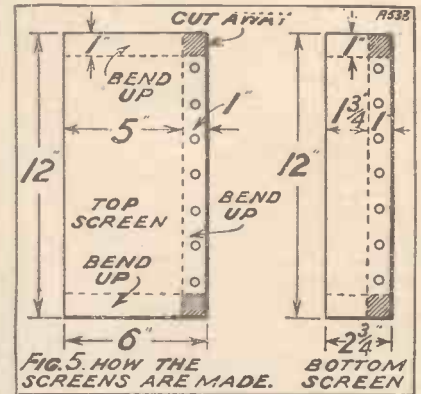

lines and the corners. Now bend the three flaps inwards, shaping them by means of a hammer or mallet and

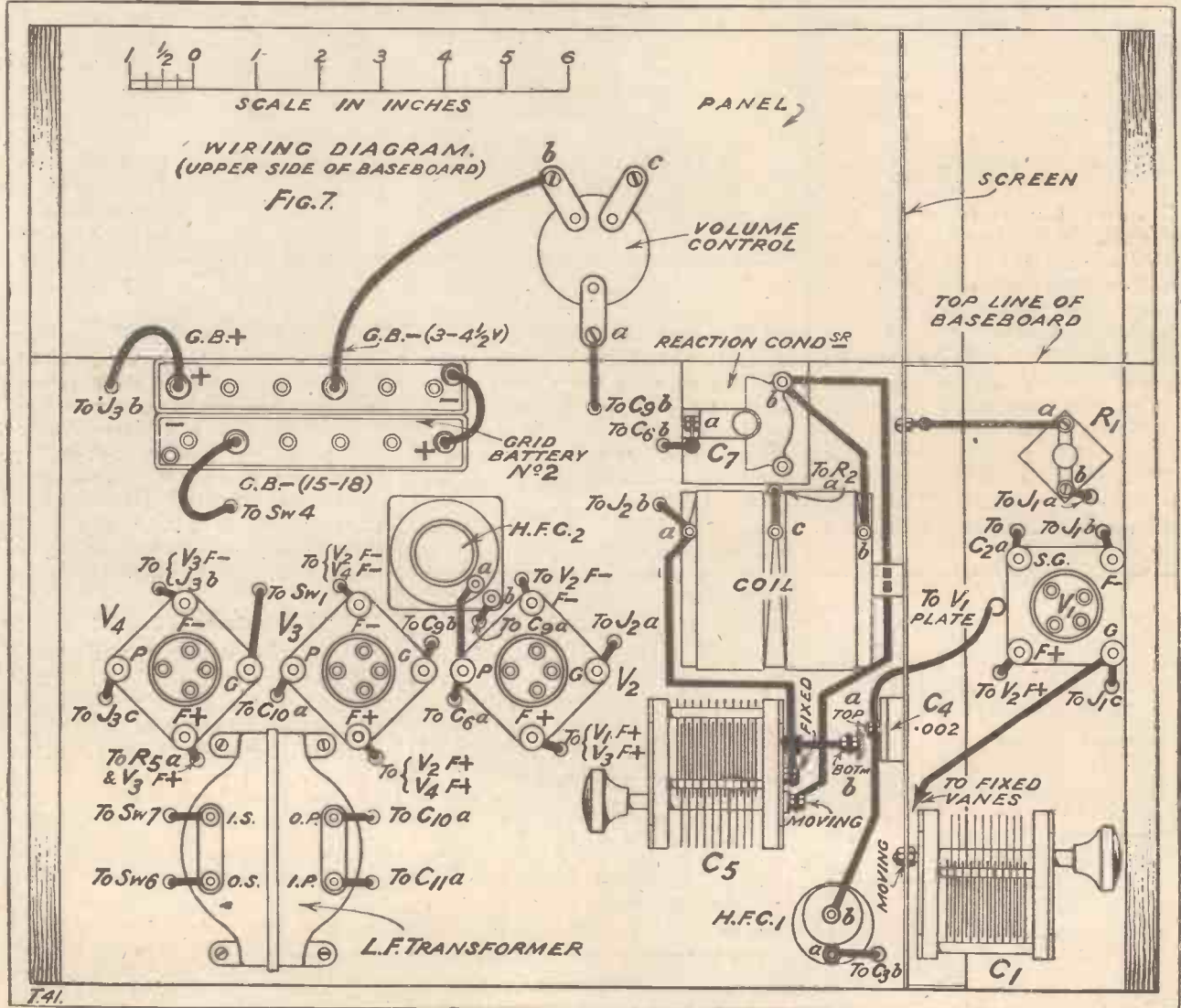

The "Three Choice" Four—continued

a rectangular block of wood, and the job is done. The under screen is made on exactly the same lines. Drill a row of holes fairly close together in the long flaps of both screens for

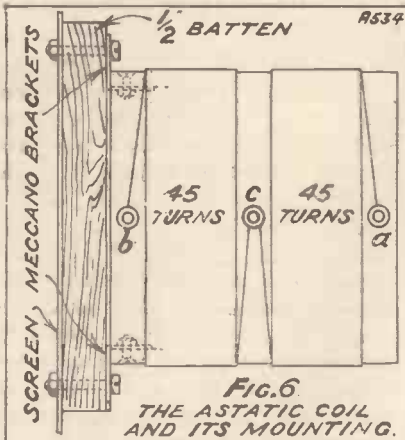

the brass nails, which will eventually fix them to the baseboard, and make three of these holes—it does not matter which—4 B.A. clearance size.

The next thing is to make the coil, which is again a very easy matter. The finished coil and its mounting are shown in Fig. 6. The former is a 3-in. length of Becol six-fin material, or it may be a simple tube 3 in. in diameter of pirtoid, paxolin, or even of dressed millboard.

The Astatic Coils

Three-sixteenths of an inch from either end and in the middle drill 4 B.A. clearance holes. Into each of these insert from inside a 1/2-in. 4 B.A. screw, running a nut lightly on to each. Bare the end of a reel of either No. 32 D.C.C. wire or No. 26 enamelled and attach it to one of the outside screws. Making the first turn 3/8 in. from the edge, wind on 45 turns evenly and tightly. Bare about an inch of the wire and take a turn round the middle screw, afterwards turning its nut hard down.

Turn the former over in the hands and wind on 45 turns in the opposite direction to those on the first half of the coil, working from the middle outwards. When all are on, bare the end of the wire and attach it to the third screw. In this way an astatic coil is made which, in conjunction with the screen, prevents any unwanted feed-back or interaction effects from occurring.

The coil is mounted in the following way. From any toyshop obtain a pair of small Meccano brackets and

fit them to one end of the former as shown in the drawing. Cut a 1/2-in. square wooden batten 4 in. in length, and drill near both ends a 4 B.A. clearance hole. Attach the coil to the batten by passing screws through the holes in the brackets, and then bolt the whole to the screen.

Assembly

Now mount the screens one above and one below the baseboard in the positions shown in Figs. 7 and 8, that is, 3 1/2 in. inside the panel supports. Do not fix them permanently in position, but merely tack them in place with two or three small brass nails. Drill the panel as shown in Fig. 9.

The holes for the screws fixing it to the baseboard will be drilled on lines a quarter of an inch from either vertical edge as well as on a line 2 3/8 in. above what is to be the bottom edge. Those for the three jacks and the switch are all drilled 1 in. above the bottom edge, and the last hole, that for the volume control, is 3 1/2 in. from the top edge of the panel and 9 in. from either end.

For the jacks and the switch 3/8-in. holes should be drilled in the first instance, these being subsequently enlarged to the required size by

baseboard as shown in Fig. 7. If C₁ and C₅ have rectangular frames with ebonite insulating bars they can be mounted very easily by drilling a small hole through each of the bottom bars and driving in wood screws.

Condensers of other patterns are best mounted by cutting out ebonite strips 3 in. in width and 4 1/2 in. in height, which are fixed vertically to the baseboard by means of small brackets. In each strip a 3/8-in. hole is drilled and the condenser is attached by means of its one-hole fixing. Next drill the holes indicated through which the leads will presently pass; then turn over and mount the components that are housed below the baseboard.

Earthing Points

You can now mark with a pencil on both screens the positions of the further holes that will require to be drilled in them. In the upper screen there will be two for the fixing screws of C₄, one to take a screw which will be attached to the lead running to connection A of the fixed resistor R₁, one for the lead connecting the plate of the first valve to one of the contacts of C₄, and one for the contact between the moving plates of C₁ and the screen

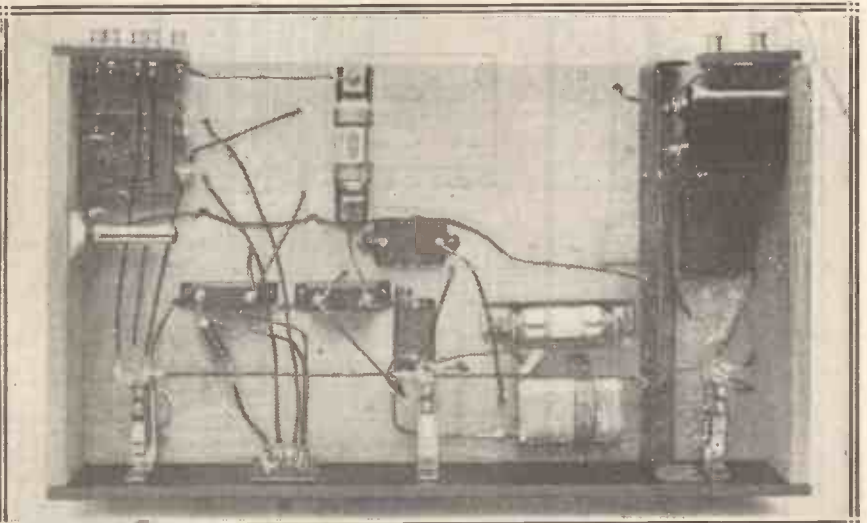

A view of the underside of the baseboard, showing the wiring to the jacks and switches.

means of a D bit. A 1/4-in. hole is needed for the volume control.

Having mounted the jacks, the switch and the volume control upon it, fix the panel to the baseboard and supporting frame. Now lay out your components on the upper side of the

In the under-screen four holes are required, two for the screw and nut terminals making the low-tension negative connections, one to pass the high-tension positive lead of the anode of V₁, and one for the low-tension positive busbar. These having been

The "Three Choice" Four—continued

drilled, the screens may be placed permanently in position by means of a number of brass nails and of three 4 B.A. bolts. The latter are essential in order to make sound electrical connection between the two screens.

Connect the moving plates of C_1 to the screen either by a lead, or if the condenser is of suitable pattern by passing the appropriate screw contact point through the screen and securing with a nut on either side.

plates of C_5 and to A of the coil. Connect the plate of V_2 to one contact of the second high-frequency choke. Attach a short length of flex to the contact marked B of the volume control device.

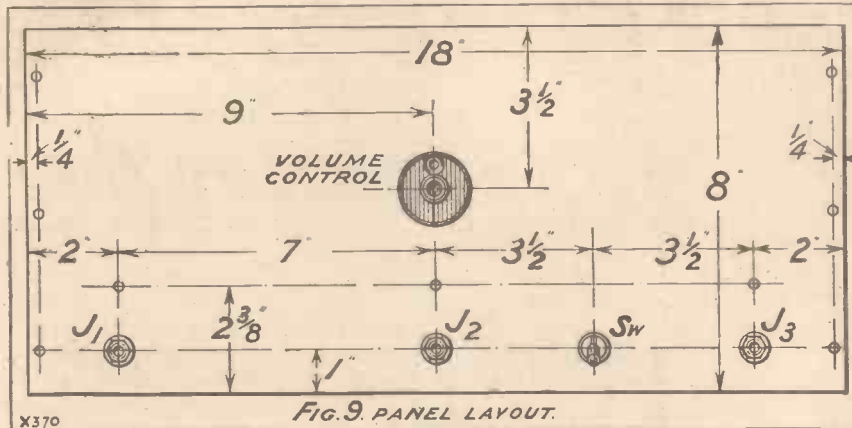

FIG. 9. PANEL LAYOUT.

We are now ready to begin the actual wiring. Start with that which lies entirely above the baseboard. Connect the grid of V_1 to the fixed plates of C_1 and one contact of R_1 to the upper screen.

Wire one contact of the reaction condenser C_7 to terminal B of the coil and to the moving plates of C_5 . Connect one terminal of C_4 to one of the first high-frequency choke and the other terminal of C_4 to the fixed

Filament Connections

The next process is to carry out the greater part of the filament wiring. A lead is taken from one contact of the fixed resistor R_5 to the positive filament terminal of V_4 , another from this terminal to the corresponding terminal of V_3 , and a further wire joins that terminal to the positive filament terminal of V_2 . A longer lead passes through the under-screen from the last-mentioned terminal to the positive filament terminal of V_1 . Make the filament negative connections of V_2 , V_3 and V_4 in the same way.

Next complete the wiring of the high-frequency end of the set. In soldering leads to the tags of jacks it is always best to begin with the lowest

(Continued on page 393.)

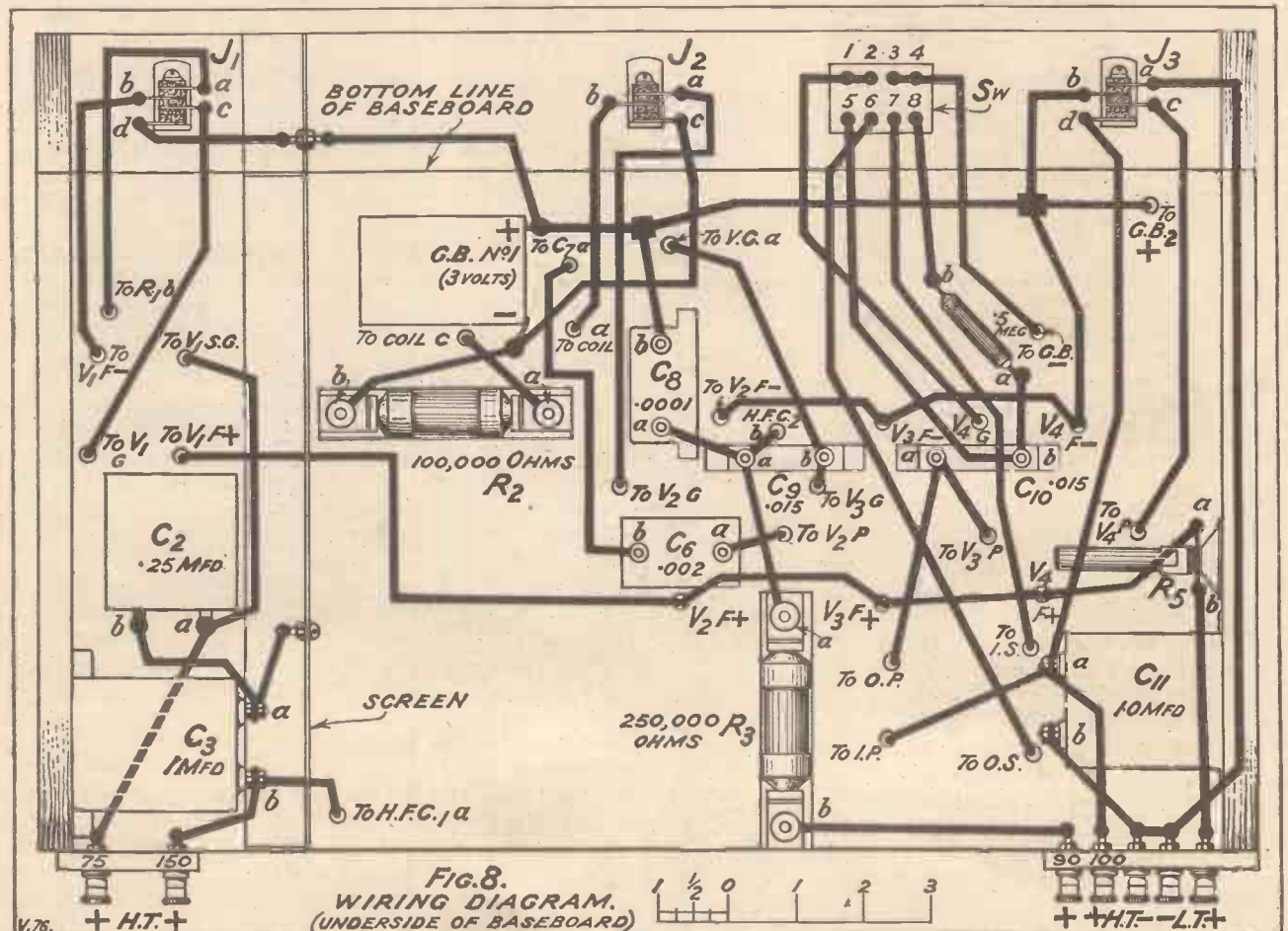

FIG. 8. WIRING DIAGRAM. (UNDERSIDE OF BASEBOARD)



That pure top note

upon this silent background -

High notes undistorted in amplification if you use the Lissen Transformer: they are given their true value against a background that is dead silent. That is why instruments like the tenor saxophone are so popular with the hundreds of thousands of amateurs who have a Lissen Transformer in their set. These transformers can be used in every modern circuit—no matter what receiver you are building, you will ensure the fine quality of reproduction by using a Lissen Transformer in each stage of amplification.

The FAMOUS 8/6 LISSEN TRANSFORMER

The famous 8/6 Lissen Transformer has won for itself the reputation of "The Transformer that will never break down." Suitable for all ordinary purposes. Turns ratio 3 to 1. Resistance ratio 4 to 1 **8/6**

The LISSEN SUPER TRANSFORMER

This Super LISSEN Transformer is made in two ratios, $3\frac{1}{2}$ to 1 and also $2\frac{1}{2}$ to 1. The $3\frac{1}{2}$ to 1 is suitable for use in either the first or the second stage of an L.F. amplifier, or can be used in cascade for both stages, and with practically any valve. The $2\frac{1}{2}$ to 1 transformer is suitable for use after a high-impedance rectifier valve without fear of distortion or loss of high notes and overtones. The price is the same for both ratios **19/-**

LISSEN LTD. 26-30, Friars Lane, Richmond, Surrey
(Managing Director Thos. N. Cole)

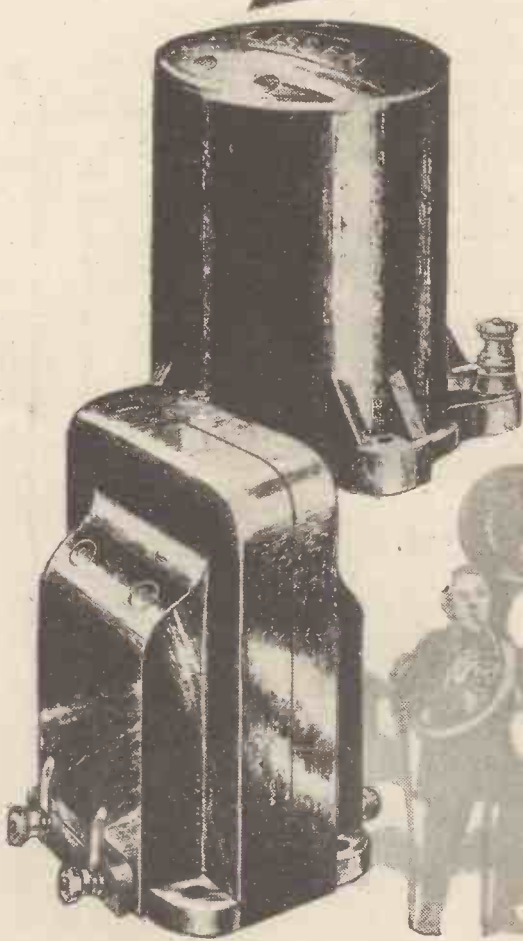

RADIOGRAMOPHONICS

A monthly article for the gramophone enthusiast.

The problem of providing suitable amplification for the successful electrical reproduction of gramophone records is discussed below.

By A. JOHNSON-RANDALL.



JUDGING from the correspondence received from readers, there appears to be some doubt as to the most suitable method of amplifying the comparatively weak impulses from a pick-up.

Now, let us consider what we have to do when we step-up these small voltage variations. We have got to build up these voltages without distortion to a strength sufficient to operate a loud speaker with a volume at least equal to that of an ordinary gramophone.

A Suitable Amplifier.

If our pick-up is to be of any real advantage the resulting reproduction must be an improvement in quality over the average gramophone and sound-box, otherwise it will not be worth while going to the trouble of obtaining the necessary effects electrically.

Our method of amplifying simply boils down to that of a normal low-frequency magnifier. If we can build up our wireless impulses satisfactorily, then we can do just the same with those from the record, and the type of amplifier will be identical.

The answer to my correspondents, therefore, is that if they stick to straight resistance or resistance-transformer coupling they will not go far wrong. If the amplifier is to work a moving-coil speaker, three stages of R.C. coupling or one stage of R.C. and one of transformer are about the minimum. If I were choosing straight-forward resistance coupling, I would use medium values for the anode resistances. The first stage would have one of 250,000 ohms, and the second 150,000 ohms. The coupling condensers would be .01 mfd., and the grid resistances 2 megohms. These values would give me all the bass that my speaker could reproduce.

Transformer Ratio.

If I decided to use a stage of transformer-coupling, I would choose an instrument with a ratio not exceeding $3\frac{1}{2}$ or 4-1. The last stage would have

a filter output, the choke having a value of 20 henries and a low D.C. resistance (300-350 ohms).

In designing a pick-up amplifier one has to be extremely careful not to hit against that bugbear "motor-boating."

If there is any tendency for this trouble to occur, it will do so when the amplifier is connected to a pick-up and gramophone turntable. This is particularly the case where a mains unit is being used for H.T. supply. I would strongly recommend enthusiasts to incorporate an "anti-mobo" device in series with first L.F. valve.

"Motor-Boating."

I described in a previous article how this might be carried out, but there is one improvement I should like to suggest. Mr. Harris has recently been carrying out research work on motor-boating and its elimin-

ation, and from the information he has given me I suggest the use of a 4-mfd. by-pass condenser in preference to the 2-mfd. usually employed. Thus our "anti-mobo" device can consist of a 50,000-ohm resistance and a 4 mfd. Mansbridge-type condenser.

By the way, it is possible to get very good reproduction from one of those units which are intended for use with home-constructed cones.

There is a number of these neat little fittings now on the market, and the prices are round about 25s. One of these, in conjunction with an aluminium frame and paper cone of the floating or free-edge type, will give surprisingly good quality. In fact, I am of the opinion that it is possible to make up a speaker nearly approaching a moving-coil instrument in this way.

For the operation of a moving-coil loud speaker a straight-forward resistance-capacity-coupled amplifier takes a lot of beating. The amplifier shown here has two paralleled valves in the last stage and a filter output circuit. This is a very efficient scheme for moving-coil work, but it is advisable to use a mains H.T. unit owing to the heavy anode current taken.

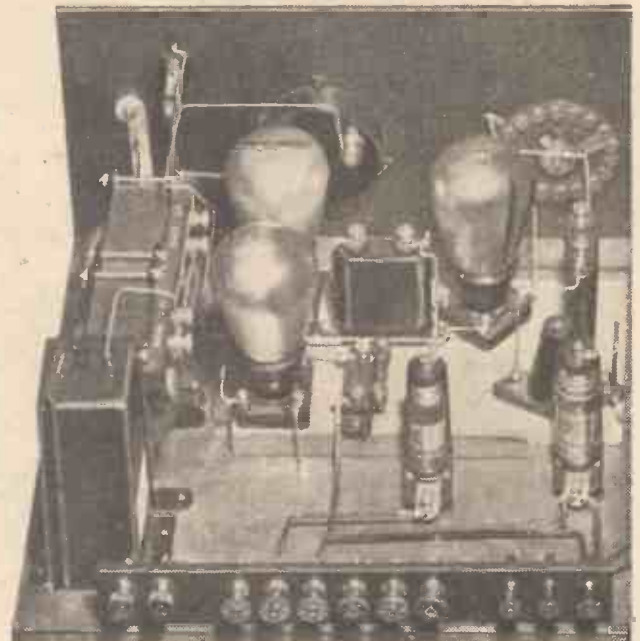

IN EVERY
SET YOU
BUILD OR
BUY
INSIST ON

LOTUS COMPONENTS

For your set choose—

Lotus Dual Wave Coil,
15/-, 16/6, 21/-;
Lotus Vernier Dial, 4/9;
Lotus Variable Condens-
ers, from 5/-; Lotus
Buoyancy Valve Holders,
1/3 to 1/9; Lotus
Jacks, Switches and
Plugs; Coil Holders,
Single Coil Holders,
Lotus Remote Control
for reception in every
room from any type of
set.

From all Radio Dealers.



Garnett Whiteley & Co., Ltd., Broadgreen Road, Liverpool

Causton

MR. STRADIVARIUS DID NOT MAKE KETTLE DRUMS!



ANTONIUS STRADIVARIUS was a specialist. He devoted his entire life to one thing—the making of violins. For three-score years he laboured lovingly at his craft, so that, to this day, his violins are cherished treasures and their maker acclaimed the first in his art for all time. Like the violin-maker of Cremona, we are specialists. For nearly a quarter of a century we have made nothing but condensers. And because we have never deviated from our task—never expended our energy in the making of other components—the name T.C.C. on a condenser is accepted throughout the world as the undisputed hall-mark of accuracy and dependability. Take no risks: use T.C.C. Condensers in your next Set.

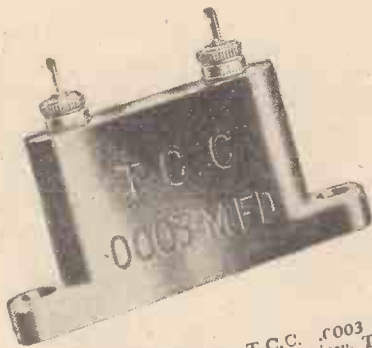

Illustrated above is T.C.C. .0003 mfd. Mica Condenser, price 1/10; below, T.C.C. .0003 mfd. Condenser, price 1/10.

SEND 1D. STAMP FOR FREE BOOK

A penny stamp will bring you a book which will show you how anyone can build an L.T. or H.T. Eliminator. Send for it to-day and save money, time and trouble.

FOR OVER 22 YEARS WE HAVE MADE NOTHING BUT

T.C.C. CONDENSERS



CHATS AT THE WORK-TABLE



Many points of practical interest to all radio constructors are dealt with under this heading.

By R. W. HALLOWS, M.A.

Neatness in Coil Winding

QUITE a number of people who have tried their hands lately at winding solenoid coils tell me that they find it difficult to get the turns on neatly and so tightly that they will remain in position when the coil has been in use for a little while. Though solenoids are really very easy to make, one can give a few tips about winding them which may be of considerable use to readers whether they are old hands or beginners at the business.

My own feeling is that by far the easiest kind of former to work with

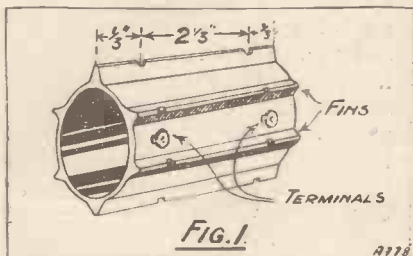

is the extruded ebonite pattern with a number of ribs or fins. They have also the virtue of being quite inexpensive, and they lend themselves to the making of coils that are highly efficient besides being as neat as could be desired. Here is the way in which you can make quite sure of getting your turns on evenly, and in such a way that they will not subsequently move out of position.

Begin by deciding what gauge and what kind of wire you are going to employ for the windings. We will suppose that you have to put on 60 turns and that you propose to use No. 22 D.C.C. Look up in a table the number of turns that this wire

makes to the inch, and then work out what the width of your windings will be.

No. 22 D.C.C. gives 26 turns to the inch. Two inches will, therefore, hold 52 turns, and the remaining eight turns will occupy about $\frac{1}{3}$ in. The total width of the windings then will be, as near as possible, $2\frac{1}{3}$ in.

We will suppose that you are using a former 3 in. in length. Take a scriber and a ruler and make a scratch on each fin $\frac{1}{3}$ in. from either end. Now take a small hacksaw and make a very shallow cut at each of the marks that you have made on the fins. The result will be, as shown in Fig. 1, two rows of saw-cuts $2\frac{1}{3}$ in. apart. Now take a small triangular file and open out the top of each cut very slightly.

What you want to achieve is a little hollow which will allow the wire to seat itself to about half its diameter. The next process is to put in your terminals. Drill your holes so that they will be comfortably clear of the windings. Place a soldering tag under each terminal and clamp them tightly.

The Winding Process

Solder the end of the wire to the "in" terminal, and take the wire into the notch cut for it in the first fin. Wind on the turn, seating it securely in the notch at each fin. Before you go any further see that this turn is tight. Now wind on the remaining turns.

The last one will fall into the second set of notches. See that it is quite tight and then secure by soldering the end to the tag of the second terminal. The beauty of this method is that only two sets of notches need

be cut—a business which takes a very short time—and that the first and last turns being securely seated hold the rest immovably in place.

On plain cylindrical formers the basic principle remains the same; the first and last turns are the most important of all, and they should be put on so tightly that they will act as barriers to prevent the rest from slipping. Curiously enough, it is always a matter of some difficulty to get these two turns on really tightly, though the rest can be wound quite taut without much trouble.

For "Tube" Formers

Should you find that, despite all your efforts, you cannot get these two tight enough, another good method is to make use at either end of what we may call a dummy turn. This consists simply of a ring of wire, the ends being crossed over and twisted up

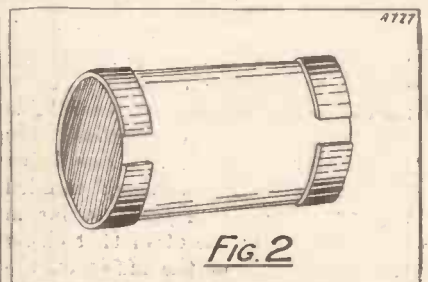

with pliers until the dummy turn grips like the proverbial vice.

The genuine turns will then lie securely between the dummies at either end. Should the former be of millboard or paxolin a good tip is to cut off two narrow rings of the same material, afterwards splitting them with scissors. They may then be

Chats at the Work-Table—continued

slipped over the end of the tube and glued or seccotined in place, as shown in Fig. 2. They thus act as cheek pieces, preventing the outside turns, and therefore the rest of the winding, from slipping.

A Novel Frame Mounting

The most convenient place for the frame aerial used in conjunction with a super-heterodyne or any other receiving set with generous high-frequency amplification is as near the apparatus as it can be without introducing interaction effects. With modern screened receivers, or those provided with astatic coils, the frame may be placed very close to the set itself without any trouble from interaction being experienced.

A tip that I have adopted lately, and found very handy, may commend itself to any readers who use frames for reception purposes. Briefly, it consists in using a piano candlestick fixed to the high-frequency end of the cabinet as a bracket for supporting the frame. This is illustrated in Fig. 3.

I am *not* suggesting that the enthusiast should invade the drawing-room during the absence of his better-half and remove a candlestick from the Broadwood. Speaking as a married man, he would, I think, be better advised to betake himself to a musical instrument shop, where he will be able to obtain what he wants quite cheaply. The most suitable kind of candlestick is a perfectly plain type without any twiddle bits or frills.

Socket and Stop

It should be hinged on to a small metal plate and the candle-holder end should be massive enough to allow for the drilling of a hole of respectable size. Most piano candlesticks are provided with stops, the idea being that no one in an absent-minded moment shall swing them so far in one direction or the other that either the piano itself or the music on the rest is burnt. These stops must be filed off when the candlestick is promoted (as we would say) or degraded (as the musician might have it) to service in the wireless receiving set.

Next remove the candle socket. Often these screw out. If so, so much the better; if not, ruthless work with the hacksaw is indicated. This having

been done, drilling is the next process. Should there be plenty of metal to allow for a reasonably deep seating for the pivot of the plug, a hole into which this pivot is a good push fit may be drilled without further ado.

It may, however, happen that sufficient depth is not to be obtained. In this case cut off about $1\frac{1}{2}$ in. of brass tubing whose internal diameter is such that it fits tightly on to the pivot of the frame, drill a hole in the candle-holder, insert the tube and sweat in a little solder. Another possible difficulty is that there is not sufficient metal to allow a hole large enough to take the tube to be drilled.

In this case the hacksaw must be used again to cut off the end of the arm. With a round file, a vertical groove is cut in the end to fit the tube and the two are brazed together.

"Easy to Look At"

Anyone who has not in his own workshop facilities for brazing can get the job done at any garage or cycle repair shop for a few pence.

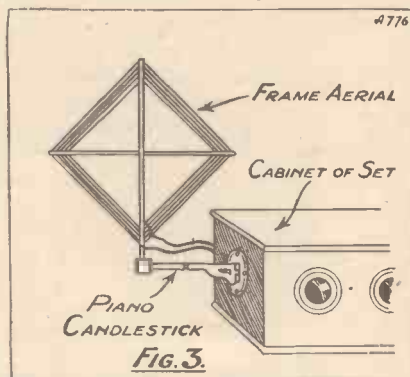

How a small frame aerial can be firmly fixed to a cabinet by means of an ingenious "wangle" with an ordinary piano candlestick is illustrated above.

Besides being quite easy to look at, as our American friends say, this type of mounting for the frame has much to recommend it. When the frame is not in use it can be unslipped by the simple process of detaching its leads from the terminals at the back of the cabinet, and removing its pivot from the socket provided. The candlestick is then folded right back against the end of the cabinet—you now see the point of filing off those stops that I spoke about a minute or two ago.

To bring the frame into action the process is reversed. Since both the frame and the arm which supports it

are pivoted, turning to any required direction is simplicity itself, and the double adjustment possible makes it, as a rule, an easy business to get rid of an interfering transmission by a small movement in one direction or another.

Some Wood-Screw Tips

When wood screws are to be driven into white wood or medium-hard wood, such as walnut, the holes for them may be made with a bradawl of suitable size. In soft wood little more than a prick with the point of the bradawl is necessary—just enough to enable the point of the screw to start in the proper place. If the wood is of a kind that is at all liable to split I always prefer to make my holes with the hand-drill, for this is by far the safest method.

The correct size is easily found with the drill plate; try the screw until you find a hole in the plate into which it is a good fit, then use a drill about two sizes smaller. Fairly stout screws will pull themselves in easily, even if the holes for them are not drilled to the full depth, in soft or medium wood.

Very thin screws, however, such as those that we are occasionally called upon to use in wireless constructional work, should always have holes of almost the full depth drilled for them. If this is not done they are liable, especially if they are made of brass, to break just when the last few turns are being given. There are few things more annoying than to have the head of a screw twist off leaving the greater part of its shank buried in a hole made in the one and only place where the hole for that particular screw can be.

The Soap Stunt

An excellent tip when driving fine screws into any kind of wood is to apply a little yellow soap, first of all, to their threads. This acts as a lubricant, considerably reducing the amount of force necessary to turn them in and therefore the risk of breakage.

When driving screws into hard wood, always be careful that the holes are both wide enough and deep enough. It is a very good tip to enlarge them a little at their tops, so that there may be plenty of room for the largish and unthreaded portion of the screw to go in without much force.

SHORT-WAVE DIFFICULTIES

Sometimes in testing a new short-waver we find that the slightest movement of the head, or of the hands, causes alteration in the tuning. This is usually caused by H.F. currents going astray from their proper paths, and upsetting the operation of the set.

By R. W. HALLOWS, M.A.

MANY of the troubles experienced with short-wave receivers are caused by high-frequency impulses getting through into the note-magnifying department. The higher the frequencies the more difficult it is to stop them from making their way to places where they have no right to be.

One of the commonest causes of such high-frequency "leakage" occurs in the rectifying valve itself, for in the plate circuit there is always a certain high-frequency component in addition to the low-frequency. Unless precautions are taken to shunt this away it will get through into the note-magnifying stages, and will cause a good deal of trouble on the very short waves.

By-Passing the H.F.

In the majority of short-wave receiving sets a single high-frequency choke is employed between the plate

The value of the condensers C_4 and C_5 will usually be of the order of .0003 microfarad, though sometimes a lower capacity will suffice. It should not greatly exceed .0003 microfarad, or a cut-off of the upper audio-frequencies is likely, which means that the quality of reception will suffer.

In addition to the filter circuit the use of the resistance R_3 , which may have a value of 250,000 ohms, is recommended between the O S terminal of the transformer (or the grid condenser, if resistance-capacity coupling is used) and the grid. This acts as a fairly effective stopper and reinforces the action of the filter circuit. It is also rather important to place C_6 , the condenser shunting the portion of the high-tension battery which supplies the rectifier, in the position indicated. It should be wired, that is to say, directly

The radio-frequency component in the plate circuit of this valve, however, will be so small that if there is no following note-magnifier its presence will hardly be noticed. But when there is a second valve a rather interesting train of events appears to take place. A feed-back of radio-frequency energy occurs by capacity from the plate to the grid of the first note-magnifying valve, thus producing a reaction effect which may cause this valve to oscillate at radio-frequency.

To Prevent Capacity Effects

Further, a coupling exists between the first and second note-magnifying valves through the high-tension battery. Nor must it be forgotten that when telephones arranged as shown in Fig. 1 are worn, a portion at any rate of any high-frequency component in the plate circuit of the last valve will pass through the cords and through the windings of the receivers.

Since there is capacity between the telephones and one's head a feed-back of energy into the high-frequency circuits may take place when the head, the body, or the hands approach the receiving set. It is therefore exceedingly important to keep radio frequencies out of the high-tension battery.

Fig. 2 shows how, by means of the chokes SWC_3 , SWC_4 , and SWC_5 , this may be accomplished. It is not suggested that it will be necessary in every case to use all of these chokes; quite possibly the use of SWC_3 alone will have the desired effect. In any case they are so easily made that no great amount of trouble is involved if several have to be used. It will be noticed that in every case the 2-mfd. shunting condensers are connected directly between the H.T. positive terminal of the coupling impedance and L.T. negative.

Threshold Howling

The use of an output filter circuit as seen in Fig. 2 is advisable, partly for the usual reasons, and partly because its presence helps to keep the tuning the same whether the telephones or the loud speaker are in use.

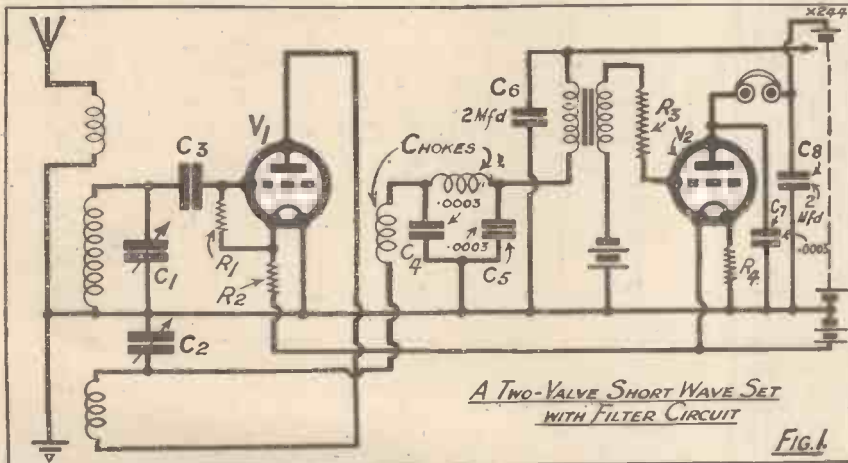

of the rectifying valve and the coupling impedance. In theory this should offer a barrier to high-frequency impulses, but in actual practice a proportion of them manages to pass when one is operating on the short waves, reaching the note-magnifying valve or valves.

An exceedingly effective arrangement in which two chokes and two condensers are used to form a filter circuit is shown in Fig. 1. The chokes may be made by winding 40 turns of No. 40 double cotton-covered wire on tubular formers of ebonite or paxolin about 1 in. in diameter.

between the H.T. positive terminal of the anode impedance and L.T. negative.

Where one note-magnifier only is used the precautions so far described will generally suffice, but with a second note-magnifying stage, particularly if the first produces a big voltage step-up, it is quite likely that a certain amount of trouble will still persist. Despite all the steps that have been taken, a very small amount of the radio-frequency component will still probably make its way to the grid of the first low-frequency valve.

Short-Wave Difficulties—continued

If it is still found that there are slight variations, or if touching the telephone cords still either causes squeaks or produces variations in the tuning, then the chokes SWC₆ and SWC₇ may be fitted in the output leads, and a very small condenser may be wired as shown at C₁₁ in the diagram.

Another unpleasant phenomenon, that known as threshold howling, is also due, as a rule, mainly to a leakage of high frequencies into the note-magnifying stages.

Efficient Reaction

This is a terrible fault in a short-wave set, for in order to hear weak and distant transmissions properly the set must be adjusted until it is just below the point of oscillation. Where a threshold howl is present any such thing becomes impossible. If there is only one note-magnifier, and in many cases where two are used, the

ally realised that the grid potential that is best from the point of view of rectification is not always so from that of reaction. By means of the potentiometer the grid potential of V₁ can be finely adjusted until a "compromise potential" is applied, which allows both smooth reaction without threshold howl, and efficient rectification to take place.

Reaction is again made smoother if the anode potential of the rectifying valve is kept as low as is consistent with good results.

With the average medium-impedance valve of the 20,000-ohm class I seldom use more than 40 or 50 volts in the short-wave set. There is no need whatever to fit a filament rheostat.

A fixed resistor may be used with a value sufficient to reduce the filament voltage to the figure advised by the makers. But if the rectifying valve

short-wave sets there are what are known as "holes in the tuning." In severe cases the set refuses altogether to oscillate over certain sections of the condenser dial; in others oscillation can be produced, but only by applying a great deal of reaction.

This is due, as a rule, to the set being tuned to a harmonic of the natural wave-length of the aerial. The only thing to do is to avoid the dead spots by shifting the natural wave-length of the aerial. This can be done by means of the aerial series condenser (AC in Fig. 2), which should have a value of .0001 mfd.

A Simple Matter

By means of a switch this condenser can be thrown into or out of action as required and all holes in the tuning avoided.

In a recent issue of the WIRELESS CONSTRUCTOR a method was given

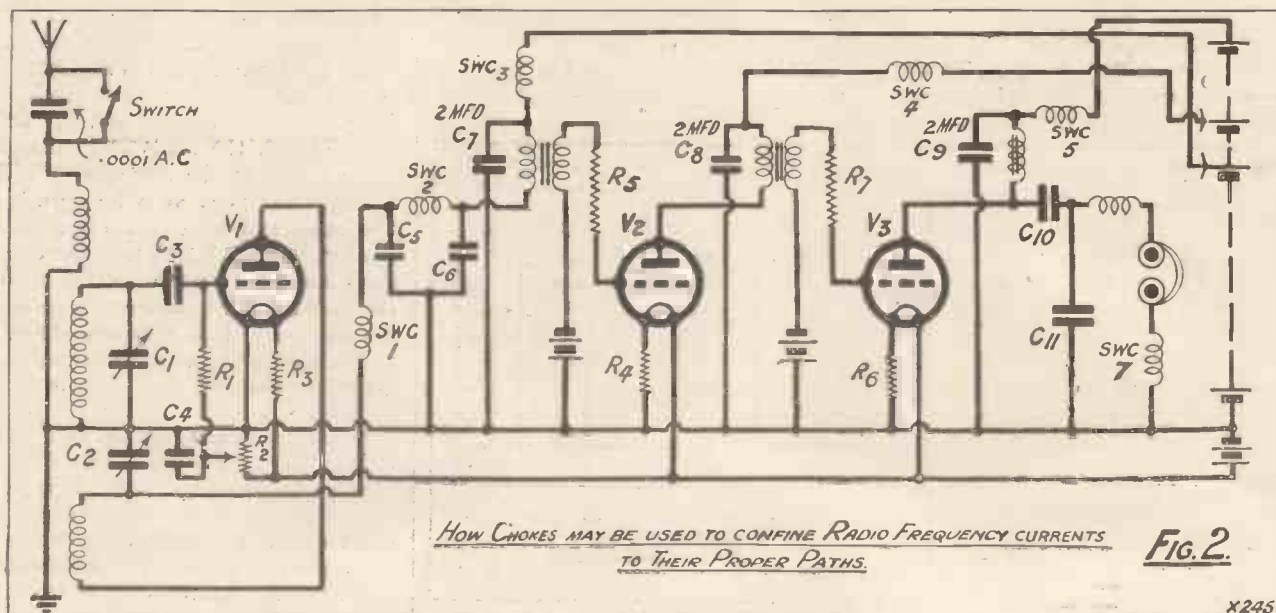

filter circuit shown in Fig. 1 will serve as a preventative; but with a second note-magnifier it is often desirable to use, at any rate, two more chokes, those seen at SWC₃ and SWC₄ in Fig. 2.

There is, however, another method of dealing with threshold howling, which is illustrated in the same figure. This is to wire the grid-leak return not directly to low-tension positive, but to the slider of a potentiometer such as R₂. Between the slider and earth is placed a condenser C₄ with a capacity not less than .001 mfd. It is not, perhaps, gener-

ally found to be at all microphonic it often pays to use a resistor of higher value so as to cut down the filament potential to something a good deal smaller; for some reason valves are often much less microphonic when the filament potential is kept low.

To Eliminate "Dead" Spots

This tip applies only to those with coated filaments. It is thoroughly bad practice to run thoriated filaments at too low a temperature, for this leads more or less rapidly to loss of emission.

One last hint. In the majority of

of making a switch which can itself be placed upon the baseboard near the aerial and earth terminals, whilst the operating knob is upon the panel of the set.

In this way long leads are avoided with all their attendant disadvantages.

To sum up, where telephone reception alone is required upon the short waves, it is a fairly simple matter to keep high frequencies out of the note-magnifying stages and of the H.T. battery to an extent sufficient to prevent serious body-capacity effects.



WHEN, as I walked up the drive of The Microfarads, I heard the strains of the Spring Song in a fruity tenor coming out of the bathroom window, two things occurred to me at the same moment. The first was that the Professor was having an annual, and the second that the days were indeed growing longer and the nights shorter. A terrible time for us wireless folk!

That chappie Shakespeare who had, usually, a happy knack of hitting the nail on the head and wrote, if you will believe me, some quite good stuff, even if his plays are a bit chock-a-block with quotations, went right off the track over the question of the



... I was able to snap up quite a nice little haul ...

seasons. "Now is the winter of our discontent," he burred.

Discontent! Ye gods, just as if winter wasn't the only time when a D.X. man can lie with a reasonable chance of being believed. Jorlocks, though also belonging to the pre-wireless era, took a much saner view of life when he proposed to bring out a revised almanac containing no summer.

A Profitable Visit

I went into the Professor's den and potted about waiting for him. Luckily I happened to be wearing my specially designed visiting suit with its seventeen capacious pockets, and I was able to snap up quite a nice little haul in the way of unconsidered trifles, such as a battery eliminator, two loud speakers, an accumulator, four valves, half a dozen transformers, and a pair of 4 B.A. nuts. I mean to say, if people will leave small parts lying about in this careless way I think that they ought to be taught a lesson.

I was just wondering whether I couldn't get a rather nice-looking five-valver into my hare pocket when the door opened to admit the Professor, who was positively brimming over with high spirits.

"Good morning, good morning," he cried, slapping me heartily on the back, and then recoiling to nurse his injured hand, which had come into violent contact with the works of one of the loud speakers that was reposing in its little nest between my shoulder-blades. A neat place that for a pocket, what?

The Professor drew back a step or two and examined me curiously.

"You seem to be a queer shape this morning," he remarked. "Is anything the matter?"

"Noo," I said thoughtfully. "Nononono. I have just begun a course of very special physical jerks and the wonderful development that they eventually produce is always, so to speak, a bit local to begin with."

The Prof. Overdoes It

The Professor was immensely impressed. He himself, he assured me, always did his daily dozen, unless, of course, it happened that he forgot, as he had to admit was usually the case. In fact, now he came to think of it he had forgotten that very morning. He would do them now. He pulled off his coat and waistcoat. He said that he would show me how easy it was to touch your toes without bending your knees.

He did it very slowly. Farther and farther he went down, the elastic of his braces stretching like that of a catapult. He was within an eighth of an inch of his goal when a queer little ripping noise occurred. The two back brace buttons flew each through a separate pane of the window, and the braces caught him such a saucy one on the back of the brainbox that not only his knees but everything else seemed to bend all at once, and the next moment he was lying on the carpet shouting for the ambulance. I picked him up and administered first-aid.

Directly he was on his feet it was manifest that the missing buttons had played a very responsible part, for the Professor always wears 'em rather loose in the waist. As Mrs. Goop was out we found ourselves in a rather awkward predicament. We tried safety pins first of all, but they didn't seem to answer a bit.

A Good Mechanical Job

The Professor was always forgetting that he was what one may call jury rigged, and would keep on stooping down for one reason or another. Every time he did so the safety pins belied their name; they flew open and the back of his braces promptly knocked him out.

Eventually I made a very neat job of it (being an earnest student of Chats At The Work-Table) with two short lengths of 2 B.A. studding and a couple of nuts. The only little difficulty I found was in drilling the required holes through the Professor's trousers. He held the garment well away from himself, but these drills have a way of going through with a jerk, and the result was that with the trousers as an entirely unintended jig I drilled the Professor's back to a considerable depth. I suggested making a real job of it by tapping his back O.B.A., and inserting short lengths of studding of that size held in place by locknuts, but strangely enough he would have none of it.



... the braces caught him on the back of the brain box ...

My exertions in tightening up the brace-retaining nuts were such that, in giving the last turn to the second of them, I broke my back collar stud. A gleam of joy came into the Professor's eyes when I told him of the accident. He was all for fixing me now with another bit of 2 B.A.,

In Lighter Vein—continued

but I said we must not waste time over trifles like that; it was now up to us to get down to serious work.

After ineffectual attempts to play the good Samaritan the Professor at length started to begin the labours of the day. First of all, he said, I must hear about his newest invention. Had I read that one, Jix, was seriously perturbed over the uproar caused in our towns and villages by the hooting of motor horns? I had. Very well then.

Professor Goop had completely solved all his little problems by the invention of the Goop Hooter Silencer. A neat little fitment this, easily and cheaply fixed to any car. When in position it would prevent any horn from making the slightest noise, no matter how hard one pressed the push, or the ring, or the knob, or whatever else you do push to actuate any particular brand of welkin-render.

A Proud Moment

"But how about pedestrians?" I queried.

"The pedestrians can go to blazes," said the Professor.

"Yes," I murmured thoughtfully; "that is where they usually do go to!"

"And now," said the Professor, "I will give you a demonstration of what can be done with the latest addition to my laboratory equipment."

"What is that?"

The Professor drew himself up to his full height, caught the butt ends of the bits of studding in the small of the back and thought better of it.

"I," he said, assuming a position

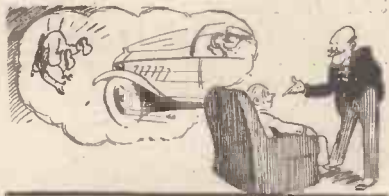

"The pedestrians can go to blazes."

that reminded one rather less of one's war-time sergeant-major, "I have"—he fixed me with a glittering eye—"I possess"—his eyes became positively gleaming—"a picture receiver."

I made suitable noises to express envy, admiration and polite incredulity.

"Yes," cried the Professor, "for some days past I have had to put my hat on with a shoe-horn. Other men

are content with mere noises from the old-fashioned loud speaker; I can receive pictures from the ends of the earth."

I tried to bow, but the accumulator in my hip pocket rather cramped my style, and not wishing to have any accidents with *my* braces I contented myself with a deferential gesture of the hand and arm.

Goop's New Gear

"It is two minutes to two!" cried the Professor. "In a few moments 5 X X will be sending pictures. You shall see how it is done."

He went down very carefully, one knee at a time, and fished out a wonderful piece of apparatus from under the table. A second came after a prolonged search from a drawer in his desk. "Catch!" he yelled, hurling at me in rapid succession a photo-developing dish, a large bottle, an envelope full of paper, a valve, and a big blotter.

Even as I caught, two leads with very prongy plugs at their ends wound themselves round my neck. The Professor twined them off, taking my unanchored collar with them.

"Tune in 5 X X!" he yelled, and with a loud "Aye, aye, sir!" I leaped to the wheel.

"Miss Mamie Nasalo will now sing 'When I Slipped on a Slide and Fell,'" said a culchahed voice. Having rhymed ice with great big eyes, love with heaven above, dove and all the usual things, Mamie syncopated to the ending, and the announcer said that he was very sorry, or words to that effect, to interrupt our pleasure by sending out pictures, but this kind of thing had to be done and that the copyright was reserved, whatever that may mean.

We "Start Up"

"Crank her up!" cried the Professor, pointing to a handle.

"Are you sure the spark isn't too forward and she won't back-fire?" I asked, duly seizing the handle with the safety-first thumb-grip.

I wound and wound and wound. The Professor slobbered the contents of the bottle into the dish, dipped the paper into it, blotted, cussed, wrapped the paper round the cylinder, found it too slack, cussed again, tore it, tore his hair, did some more cussing, took another piece of paper—

And then the loud speaker, after some rather gobbled remarks about the pictures that were to follow, said "Feeeee," and went on doing it for a couple of minutes. The Professor leaped to the controls, leaped back to the milliammeter, leaped to the controls again. Even the 2 B.A. studding wouldn't stand this, and the braces also leaped. He seized a length



"A jolly little photograph of a cemetery."

of flex, wrapped it tightly round his waist, and went on leaping. "Tick-tick-tick-tock," remarked the loud speaker three times, and the Professor twiddled a little knob. Weird noises came from the loud speaker. Weirder still from the Professor, who had absent-mindedly placed his hand in the developing dish.

"Still" Pictures

"Wet another piece of paper!" cried the Professor. "Dry it, for heaven's sake, man, hurry up! Look here, man, the picture's coming through! Stay where you are or you will fall over that lead! Come here, quick; this is really worth seeing!"

I mopped my brow. The Professor mopped his. On the paper what looked like rows of tombstones were building up.

"A jolly little photograph of a cemetery!" I cried.

"No, no," said the Professor. "It's Stonehenge!"

And presently we saw that it was Miss _____, the movie star, broadcasting her beautiful smile.

"Quick, man, the next piece of paper."

In the heat of the moment I flung off my coat, which fell with a crash and a reek of acid fumes on to the floor.

I handed over another piece of paper.

"I am afraid that it has rather taken it out of you," said the Professor, after the fourth picture had come through. "Most of those physical jerks bumps have disappeared."

Precision *plus* Performance

Following the line of the "ORMOND" Slogan "High in Quality"—"Low in Price," ORMOND Components are the experts' choice. The discerning constructor gets Ormond because he knows that he is getting products of proved efficiency.

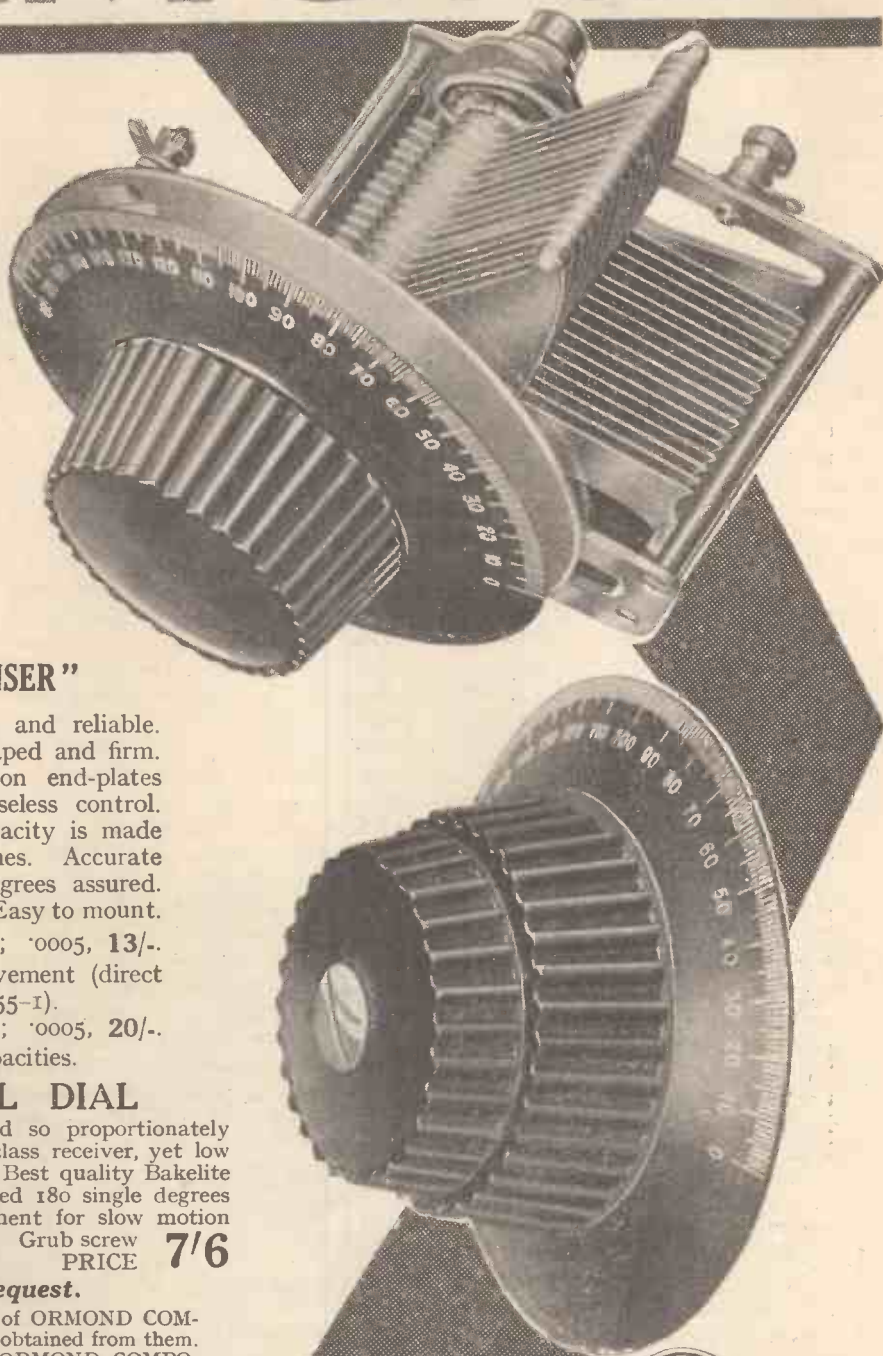

The "ORMOND S.L.F. CONDENSER"

as illustrated here is especially sturdy and reliable. Its bright brass vanes are perfectly shaped and firm. Heavily nickelled and polished skeleton end-plates ensure smooth velvety action and noiseless control. High maximum and low minimum capacity is made possible by the scientifically shaped vanes. Accurate readings over the scale throughout 180 degrees assured. Anti-capacity earthing shield supplied. Easy to mount.

Capacity: '00025, 12/-; '00035, 12/6; '0005, 13/-.
Also supplied with Friction Control movement (direct drive and Slow Motion Ratio 55-1).

Capacity: '00025, 19/-; '00035, 19/6; '0005, 20/-.
Also models of all the usual capacities.

FRICITION CONTROL DIAL

Here is a dial so beautifully finished and so proportionately designed that it is worthy of the highest class receiver, yet low enough in price for the average pocket. Best quality Bakelite Combined Knob and 4-inch dial. Engraved 180 single degrees for direct drive. Friction control movement for slow motion ratio 55-1. No cogs, no slip, no back lash. Grub screw fixing. PRICE 7/6

Details and Leaflets on Request.

All high class radio dealers stock a full range of ORMOND COMPONENTS. Fully descriptive leaflets may be obtained from them. If any difficulty is experienced in procuring ORMOND COMPONENTS write to the address below:—

The ORMOND ENGINEERING Co., Ltd.,
199-205, Pentonville Rd., King's Cross, N.1

Phone: Clerkenwell 9344-6. Grams: "Ormondengi, Kincross."
Factories: Whiskin St. and Hardwick St., Clerkenwell, E.C.1.
Continental Agents: Pettigrew & Merriman, Ltd., "Phonos House," 2 and 4 Bucknall St., New Oxford St., London, W.C.1.



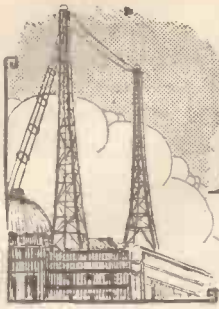

HAPPENINGS AT SAVOY HILL



By OUR SPECIAL COMMISSIONER

B.B.C. Publishing

THE appearance of yet another B.B.C. publication has caused justifiable alarm among commercial publishers. Savoy Hill profess that they are bringing out "The Listener" reluctantly and in deference to the recommendations of Sir Henry Hadow's Committee on Adult Education by Wireless. This argument hardly holds water when it is realised that the most elaborate and careful plans were made to secure extensive advertising for the new journal. It would appear that the real reason is to add to profits from publications in order to find money for the Regional Scheme and the new building. As long as the B.B.C. restricts the contents of the paper absolutely to the talks, and excludes all original journalism, attacks on the editorial side will lose most of their sting." But the objections to a further privileged intrusion into the advertising field will not be met so easily. The solution, of course, is for the P.M.G. to release his reserve of licence money and then curtail the activities of the B.B.C. in publishing.

Mr. Cecil Graves of Savoy Hill

There is not much of interest to say about personalities at Savoy Hill just now. There seems much less "individualism" than before, and the change is not all to the good. Listeners are tremendously interested in microphone personalities. I understand that the most remarkable development now taking place is the rise of Mr Cecil Graves, a nephew of Viscount Grey of Fallodon. Mr. Graves came to the B.B.C. after serving with distinction in the Foreign Office.

His job at Savoy Hill was to look after all the details of programme organisation, acting as "Executive" for Captain Eckersley's brother, Mr. R. H. Eckersley. Mr. Graves had been in school with Sir John Reith. So well did he carry out his job that it has steadily grown in magnitude

and responsibility until to-day Mr. Graves is the real head of the Programme Department of the B.B.C.

If possession is any advantage, Mr. Graves is a certainty to succeed Mr. R. H. Eckersley if there is anything in the persistent rumour of his early retirement to the country.

The Wave-length Muddle

The wave-length position goes from bad to worse. The loudly-heralded "single-wave-length working" is a dubious blessing. The "Plan de Bruxelles," brought in on January 13th, has not materially improved matters because of the vagaries of many Continental stations either unwilling or unable to keep to their allotted channels.

France is trying to steal a wave for Eiffel Tower, which has been evicted from its old channel by the Washington Conference. There is trouble in Denmark, Holland and Germany. It looks very much as though the

international agreement solution will fail. I warned the B.B.C. two years ago and again last year that this would happen. But there has been no sign of real independence and courage in connection with this comparatively simple problem.

Now, however, things are getting into such a state that the B.B.C. will have to wake up from its dream of international pleasantness and peace. If the B.B.C. is to carry out its duties to British listeners it should withdraw from the Geneva Broadcasters' Union forthwith, and seize the waves it needs for its service. If there is any interference, drastic jamming reprisals should be started at once.

Every other nation gets its wave-lengths by the simple expedient of taking them. Why should Britain stand out in the cold? There you are, Lord Clarendon! Show your proud British traditions by exorcising the dangerous spirit of supineness which seems to have grown in the B.B.C.

A MIDNIGHT PROGRAMME

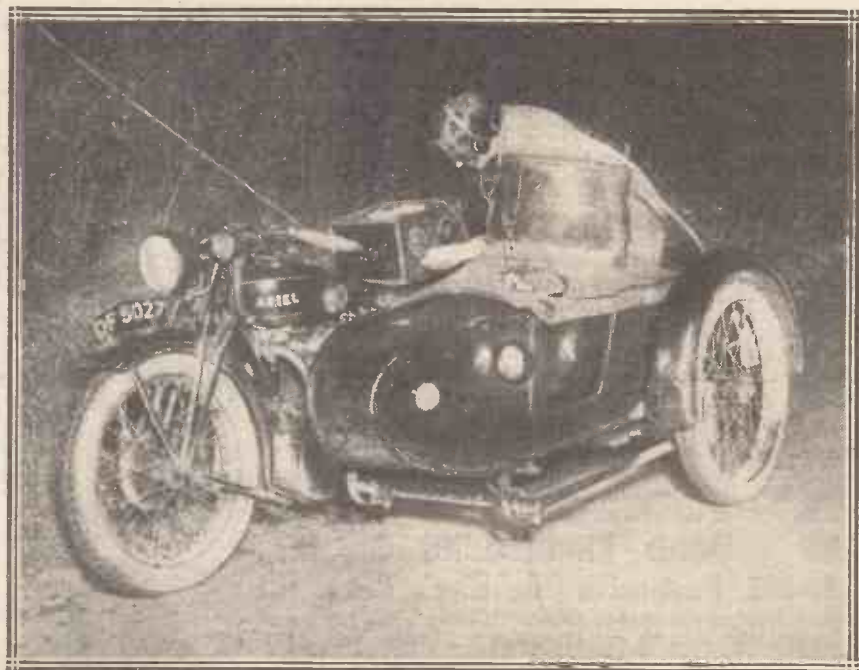

Listening to America on a short-wave set during a midnight test on the Chiltern Hills.

**THIS
CURVE
TELLS
THE
TRUTH**

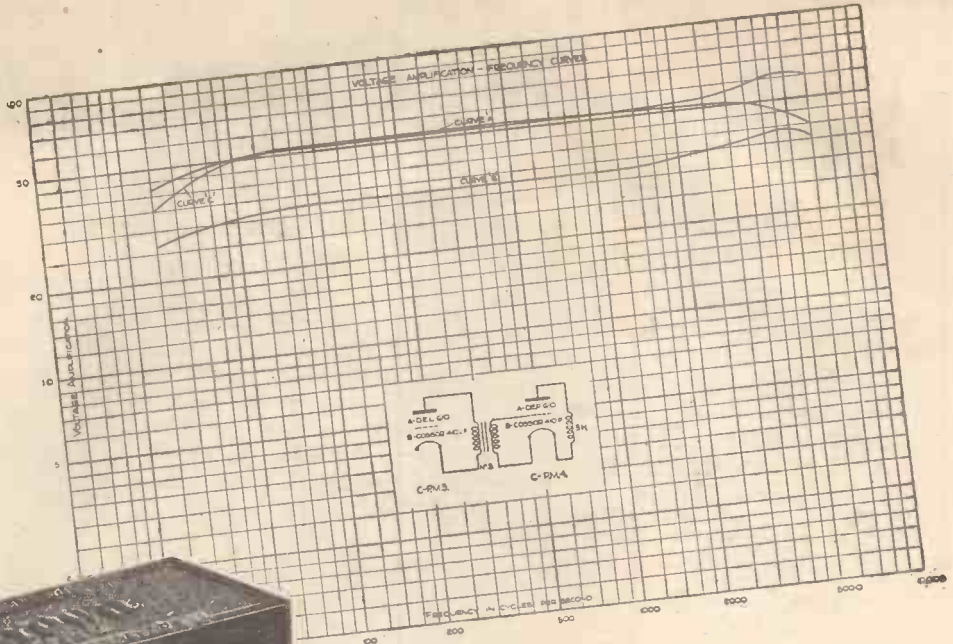

**ABOUT THE
TRANSFORMER
THAT TELLS
THE TRUTH**

THIS National Physical Laboratory Curve tells the truth about the BROWN L.F. Transformer. It proves beyond all words, that the BROWN evenly amplifies every note throughout the whole harmonic scale. Treble and bass—the delicate strains of the violin and the deep notes of the bassoon—the BROWN gives you them all distinct and clear, yet each in its proper place and at its correct strength. In short, the BROWN Transformer tells the truth about the broadcast. The secret is in its special alloy core and its unique method of winding. Ratio 3.5 to 1. Ask your Dealer for further particulars.

MADE BY
Brown
of Loud Speaker Fame

Price
30/-

THERE'S A Polar CONDENSER

FOR EVERY PURPOSE

TUNING

Polar Ideal (as illustrated)

·0005 12/6
·00035 12/3
·0003 12/-

NOW AVAILABLE IN
DRUM CONTROL TYPE.

Complete with scale, escutcheon
and template in all above
sizes.

14/6 - 15/-

IF YOUR DEALER CAN-
SEND HIM ONE

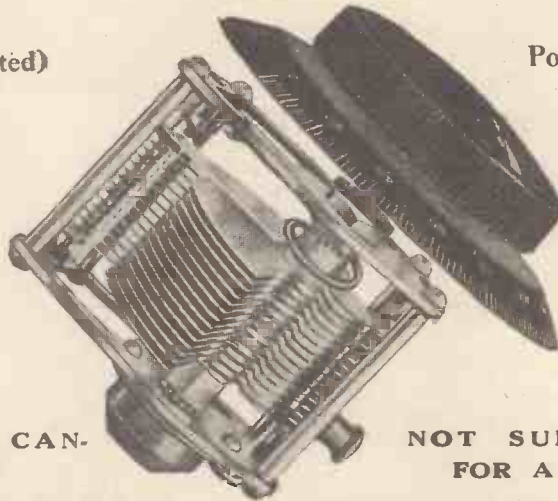

REACTION

Polar Ideal (as illustrated)

·00025 12/-
·00015 11/6
·0061 11/6

FOR SHORT WAVE
TUNING.

Fitted with phosphor-bronze
balls, 6d. extra.

NOT SUPPLY WE WILL
FOR A TRIAL PERIOD.

WINGROVE & ROGERS LTD.
188-189, STRAND, LONDON, W.C.2.

INVALUABLE TO EVERY AMATEUR & CONSTRUCTOR

"POPULAR WIRELESS" BLUE PRINTS

of Tested Circuits

The following is a list of the "P.W." 6d. Blue Prints for Constructors in stock, showing the different circuits available.

P.W. BLUE PRINT Number.

1. DETECTOR VALVE WITH REACTION.
2. OUT OF PRINT.
3. 1-VALVE L.F. AMPLIFIER.
4. CRYSTAL DETECTOR WITH L.F. AMPLIFIER.
5. H.F. (Tuned Anode) AND CRYSTAL WITH REACTION.
6. H.F. & CRYSTAL (Transformer Coupled, without Reaction).
7. 1-VALVE REFLEX WITH CRYSTAL DETECTOR (Tuned Anode).
8. 1-VALVE REFLEX AND CRYSTAL DETECTOR (Employing H.F. Transformer, without Reaction).
9. H.F. AND DETECTOR (Tuned Anode Coupling, with Reaction on Anode).
10. H.F. & DETECTOR (Transformer Coupled, with Reaction).
11. DETECTOR AND L.F. (With Switch to Cut Out L.F. Valve).
12. OUT OF PRINT.
13. 2-VALVE REFLEX (Employing Valve Detector).
14. OUT OF PRINT.
15. OUT OF PRINT.
16. H.F. (Tuned Anode), CRYSTAL DETECTOR AND L.F. (With Switch for Last Valve).
17. CRYSTAL DETECTOR WITH TWO L.F. AMPLIFIERS (With Switching).
18. 1-VALVE REFLEX AND CRYSTAL DETECTOR, with 1-VALVE L.F. AMPLIFIER, Controlled by Switch.
19. OUT OF PRINT.
20. OUT OF PRINT.
21. THE 2-VALVE LODGE "N."
22. "THE GUARANTEED REFLEX."
23. THE 1-VALVE "CHITOS."
24. THE "SPANSPACE THREE." Three-Valve Receiver employing 1 Neutralised H.F. Valve, Detector with Non-radiating Reaction Control, and 1 L.F. Valve.

P.W. BLUE PRINT Number

25. OUT OF PRINT.
26. A "STRAIGHT" 4-VALVER (H.F., Det. and 2 L.F. with Switching).
27. OUT OF PRINT.
28. A "MODERN WIRELESS" 5-VALVER (H.F. Det. and 3 L.F.).
29. AN H.T. UNIT FOR DIRECT-CURRENT MAINS.
30. A REINARTZ ONE-VALVER.
31. A STANDARD TWO-VALVER (Detector and L.F.).
32. THE "CUBE SCREEN" THREE (H.F., Det. and L.F.).
33. A "KNIFE EDGE" CRYSTAL SET.
34. AN H.F. AND DETECTOR TWO-VALVER.
35. THE "UNIVERSAL THREE" (Det. and 2 L.F. stages resistance-coupled).
36. THE "SPANSPACE FOUR" (H.F., Det. and 2 L.F.).
37. THE "LONG SHORT" CRYSTAL SET.
38. A TWO-VALVE L.F. AMPLIFIER.
39. THE "SYDNEY" TWO.
40. THE "SUPER SCREEN" THREE.
41. THIS YEAR'S "CHITOS" ONE-VALVER.
42. THE "Q AND A" THREE. A simple set (Det. and 2 L.F.).
43. THE "INEXPENSIVE FOUR."
44. THE "ECONOMY FIVE." For long-range loud-speaker work.
45. A SIMPLE A.C. H.T. UNIT.
46. THE "REGIONAL" THREE.
47. THE "WAVE-CHANGE" ONE.
48. THE "REGIONAL" CRYSTAL SET.
49. THE "ANTIPODES ADAPTOR."
50. THE "ANY MAINS" TWO.
51. OUT OF PRINT.
52. THE "BANDMASTER."

ALL "POPULAR WIRELESS" BLUE PRINTS 6d. EACH

All orders for these Blue Prints should be sent direct to the "Popular Wireless" Queries Department, Fleetway House, Farringdon Street, London, E.C.4, enclosing a stamped addressed envelope and a postal order for 6d. for each Blue Print ordered.

Happenings at Savoy Hill—continued

since it adopted the ridiculous motto: "Nation shall speak peace unto nation."

More Concentration

A provincial station director tells me that he and his colleagues are very disheartened about the way in which Savoy Hill continues to encroach on local initiative and effort. The latest move is to reduce the orchestras at main stations to octettes.

This would mean washing out the National Orchestra of Wales, the North of England Wireless Orchestra, and the strong radio orchestra at Glasgow, and perhaps the Birmingham Orchestra as well. The head office argument appears to be that this reduction is necessary if the money is to be found for the new National Symphony Orchestra under Sir Thomas Beecham.

On the other hand, the provincial station people see considerable danger in such a drastic affront to the local pride of such places as Manchester, Cardiff, Glasgow, and Birmingham. I have heard enough to convince me

is naturally the most active, her correspondence on broadcasting being quite considerable.

Lord Clarendon interests himself mostly in bringing forward original programme ideas, and is not easily discouraged. Sir Gordon Nairne keeps his experienced eye on finance, and it would be impossible, humanly speaking, to "get past" both Mr. Lochhead, the Chief Accountant, and his patron, Sir Gordon Nairne.

Dr. Rendall is appropriately seen about a good deal with Mr. Stobart, the Director of Education. Lord Gainford spreads his favours evenly but appears to retain his early fondness for Captain Eckersley. The term of service of the present Board of Governors will be half-up at the end of June. The new Board will be under consideration by the Government in twelve months' time.

It is known that already a number of interesting moves have been made behind the scenes, and there is a fair prospect of a fine old scramble when the time comes to make the new appointments. Captain Ian Fraser

ever, she is not tied up by "office," then I am sure she will take another term with the B.B.C., of which she has come to be fond. Lord Gainford's name is mentioned in connection with the post of Chairman; but it is too early yet to say whether Lord Clarendon will wish to be relieved.

 * THE "STEDIPOWER" *
 * L.T. UNIT *
 * —continued from page 346 *

constant, and if at the end of the first quarter of an hour the voltage is checked and the controlling resistances adjusted to give exactly six or four volts, as the case may be, this adjustment can be left permanent, the slight difference between the switching-on voltage and the voltage to which the unit settles down after a few minutes not having any practical effect on reception.

In the constructional work be particularly careful to notice that the condensers, unlike the ordinary pattern of condenser, have terminals marked negative (black), and positive (red) respectively. It is vital that these shall be connected up correctly, so make certain that your condensers are joined the right way round. The two filament resistances are joined in series, and either one or both can be used according to the amount of voltage drop desired. The object of using two in series is that one gets the maximum heat dissipation for the resistance used. Be careful not to turn either of the rheostat knobs at any time to an "off" position.

When you desire to use one and not the other, see that the one not to be used is full on. Any interruption of the circuit here will cause the full no-load voltage to be impressed upon the electrolytic condensers, and this is inadvisable.

The on-off switch is inserted by cutting one of the flexible leads going to the lamp socket and putting the switch in series. In the photograph it will be noticed that no on-and-off switch is mounted on the panel, as in the model illustrated all switching was done from a remote source, controlling both H.T. and L.T. mains units.

DUBLIN'S NEW STUDIO



Members of the Dublin station (2 R N) orchestra playing in the new main studio which has recently been opened.

that the B.B.C. should hesitate before actually giving the orders for this threatened "wrapping-up."

The Governors at Work

The Governors of the B.B.C. cannot be accused of obtruding themselves. They stay very much in the background, and never say anything about their work in public. Mrs. Snowden

is a strong favourite for the Vice-Chairmanship, now filled by Lord Gainford. This carries £1,000 a year, and Captain Fraser's appointment to it would be universally applauded. Some of the present Governors may seek re-nomination.

Mrs. Snowden's case, of course, will depend on the political situation. She may be in Downing Street. If, how-

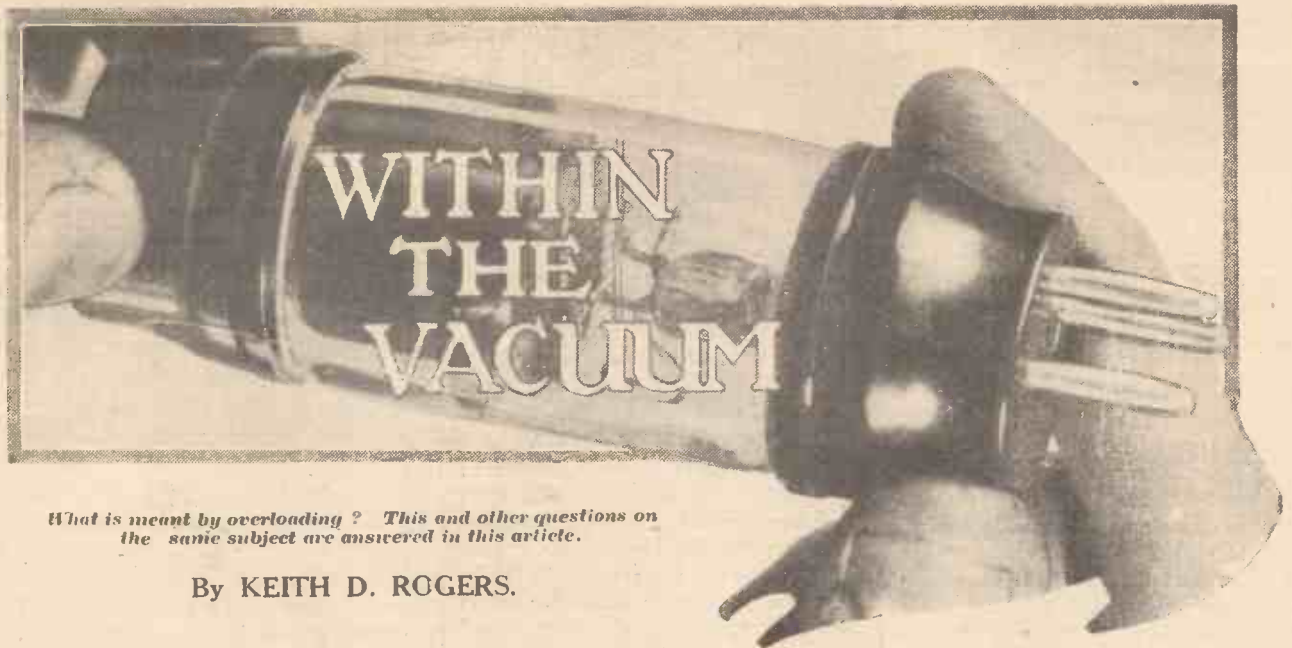

What is meant by overloading? This and other questions on the same subject are answered in this article.

By KEITH D. ROGERS.

THE meaning of the term "overloading" as applied to valves seems to many listeners a difficult one to understand, and I am often asked whether overloading hurts a valve, or if it does it any material damage.

Now, by overloading is usually meant that the valve has too much signal input or voltage applied to its

in no uncertain manner by terrible distortion in the loud speaker or 'phones. Furthermore, to get overloading in any one stage of a set not only causes a distorted output in the plate of the particular valve which is being overloaded, but that distorted output is further magnified by any further stages, and so is still further magnified as stage after stage is passed in a receiver.

It is not always the last valve which is the one which is overloading, very often the detector can be overloaded, or the first low-frequency valve, and because distortion (apparently due to overloading) is heard in the loud speaker, you must not jump to the conclusion that the overloading is in the last valve. It may quite easily be in one of the preceding low-frequency stages, or even in the detector.

A Common Occurrence

Now, let us see what happens when a valve is overloading. In the case of a detector, overloading has the effect of the valve not rectifying properly, some of the impulses getting through being only partially rectified. Low-frequency overloading is more easy to understand, and is a common occurrence in ordinary everyday radio reception.

In the first place, let us look at a typical valve curve such as is shown here in Fig. 1. While we must remember that this curve is taken under static (or non-working) conditions, yet we can see by this that the application of too much grid voltage either one way or the other will cause unequal amplification.

Exactly what happens when the valve is under working conditions we do not know. It is practically impossible to work out a dynamic curve, and so we have to take the static curve as a guide and try to imagine the effects as applied to actual working conditions.

What the Curve Shows

Now, if we take this curve we shall see that to the left of the vertical line, on the foot of which is marked "zero grid volts," and up which is "anode current," we find that the

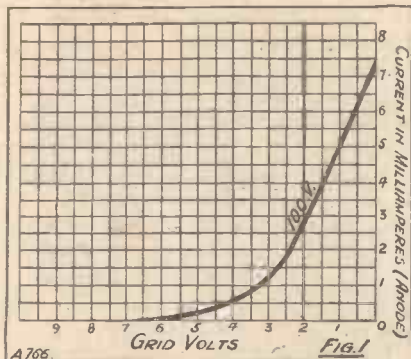

The effect of grid voltage variations upon the plate current can be seen in this figure.

grid, and consequently it cannot produce the required variations in its electron stream properly. Overloading due to much H.T. (overloading from the point of view of pressure between the filament and the plate) is another matter, and may do the valve material damage by ruining its emission, but the overloading which I want to discuss in this article is that caused by supplying more signal energy to the valve than it can possibly amplify in an efficient manner.

This type of overloading does the valve no harm, but makes itself felt

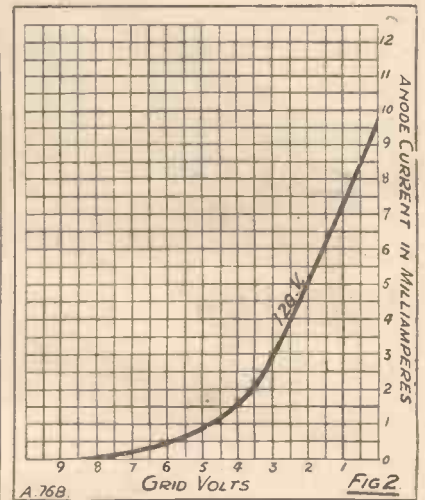

Increasing the H.T. gives a greater available grid swing.

curve comes down fairly straight up to a certain point, when it begins to bend and flattens out till it tends to become horizontal.

Now, this bend is not very sharp, but it is quite sharp enough to show

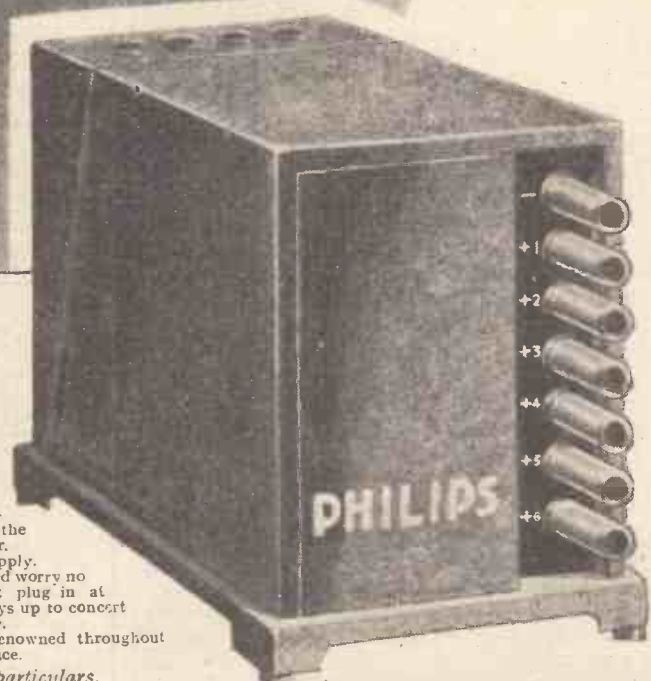

H.T. UNITS & BATTERY CHARGERS.

You will find a wonderful difference in your reception if you instal a Philips High-Tension Supply Unit.

No battery renewal problems, but a constant and powerful current direct from the mains, sufficient for any type of receiver. There are models for A.C. and D.C. Supply.

With a Philips Battery Charger you need worry no further about charging stations—just plug in at home and keep your accumulator always up to concert pitch. It works silently and efficiently.

PHILIPS Units and Chargers are renowned throughout the world for their excellent performance.

Ask your dealer for full particulars.

Type 3002.	High-Tension Supply Unit for A.C. Mains	£7 0 0
Type 3003.	High-Tension Supply Unit with Grid-Bias for A.C. Mains	£8 15 0
Type 3005.	High-Tension Supply Unit for D.C. Mains	£3 17 6
Type 450.	Low-Tension Battery Charger for A.C. Mains	£3 10 0

PHILIPS
for Radio

ADVT. OF PHILIPS LAMPS, LTD., RADIO DEPT., PHILIPS HOUSE, 145, CHARING CROSS RD., LONDON, W.C.2.

S.4.

Ark.

Within the Vacuum—continued

that some change in the action of the valve begins definitely round about that point. The valve I have taken as an example is quite a well-known low-frequency valve of the usual 10,000 ohms type, and the curve shows the state at a H.T. voltage of 100.

Fixing Grid Bias

Now, you will see that if we apply a grid pressure of 1.5 volts negative, we come somewhere in the centre of the straight portion of that curve which goes up straight from 1.5 to 0 grid volts and down straight from 1.5 towards 3. Perhaps we are a fraction below the actual middle at 1.5, but this is the usual point where we take our grid bias for the reason that in actual practice it is found that we cannot operate successfully on the straight portion of that curve right as far as the zero vertical line. We have to stop short some little way before that, and so we can say that our straight portion in this case is that portion between about -2.5 grid volt and just under -3.

Effect of the Signal

Here we can see that any variation in grid voltage (along the bottom) between -2.5 and -3 will produce a steady variation in plate current (along the vertical). Suppose we are starting to tune-in a station with our grid bias at -1.5, and receive signals from that station which cause our grid potential to fluctuate between -2 and -1, that is a difference of 1 volt, we can see that the effect on plate current of changing from -1.5 to -2 is going to decrease it by a certain amount, and also that to increase grid volts from -1.5 to -1 will increase the plate current by an equal amount to that by which it was decreased when we changed from -1.5 to -2.

Very well, between -2 and -1 we have what can be termed "straight amplification," free from distortion, and that is what we aim to get when using an L.F. amplifier.

Overloading Commences

Now, suppose we tune-in that station much stronger, and there is a signal which includes impulses causing our grid variation to go between 0 and -3. What is going to happen?

Between the -1.5 and -1 we are

going to get absolutely straight amplification, and between -1.5 and -2 we get the same, but as we go towards -3 we find that the effect of each definite fraction of a grid volt upon the plate current becomes less, so that between -2 and -2.5 we have a certain variation of plate current, but between -2.5 and -3 we have less variation. In other words, the -2.5 to -3 signal is being amplified less than is the -2 to -2.5.

Similarly, in actual practice, -1 to -1.5 gives a certain increase in plate current, but between -5 and 0, although we get a certain increase of plate current, we also get another effect, and that is the effect of grid current flowing due to the grid having become nearer the positive, a certain amount of the electrons

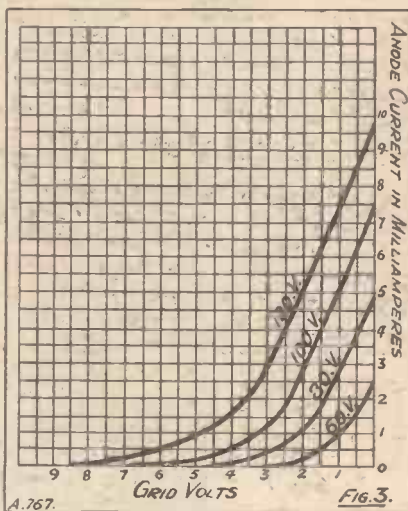

The various curves of a typical 10,000-ohm general-purpose or L.F. valve.

collecting on it and flowing through the grid circuit, thereby upsetting the balance of the circuit. This in itself causes distortion, upsetting the control of the incoming signals upon the plate current.

Now, at the other end, round the -3 mark, we find that although the curve is not sharply defined anything approaching -2.5 to -3 causes the plate current to fall, while continuing further we come to a point where any extra negative added to the grid volts has very little effect upon the plate current.

So that if we suddenly get a signal taking us from -1.5 to -4, and then another signal which takes us from only -1.5 to -2.5, we get the -1.5 to -2.5 signal amplified perfectly. We

get the -1.5 to -4 signal amplified in a perfectly ordinary manner up to a certain point, past which the plate current is very little decreased.

We then get a variation of plate current which, instead of being absolutely regular and in proportion to the change in grid volts, is regular up to a point, and then decreases, due to a lack of effect, as it were, of the extra negative grid volts upon the electron stream.

Partial Rectification

You can see how this works from the second curve shown in Fig. 2, where I have shown a curve having a straight part between the vertical line and -3, and a more definite bend at -3.5.

Now if you have an L.F. valve which has such a "kink" in the curve (as they all do), and you apply your signals so that they come across that "kink," you are going to get all the portion of the signal to the right of that bend amplified normally, and all the voltage of the signal which fluctuates to the left of the bend very little amplified.

You are going to get partial rectification, and that causes distortion, which is generally known as "overloading." This term is used because we are really giving the grid more potential than the valve can handle in an efficient manner in order to produce a uniform variation of plate current for given variations in grid voltage.

Providing Longer Swing

Now there are two ways of overcoming this. One is to decrease the input and leave the valve's grid-bias and high-tension voltage as they are, and the other is to increase the H.T. voltage and the grid bias. This latter, up to a point, according to the physical limits of the valve, is a good method, as will be seen from Fig. 3, where an increase of the H.T. from 100 to 120 volts gives you a longer straight portion of the curve on which to work, so that you have a greater possible grid swing, while the magnification properties of the valve remain the same.

In the case of an output valve, this lengthening of the straight portion is usually more marked, and is a valuable feature to remember when you are troubled with overloading.

Now!

A wonderful New Transformer



..... with a
marvellous
performance
on the lower
tones.....

Price 2/6

With the new Cossor L.F. Transformer you'll hear the roll of the drums — the double bass — the piping of the piccolos — the violins — you'll hear every instrument faithfully reproduced. Fit this wonderful new Cossor Transformer to your set and get a new standard of realism. The superb reproduction of the famous Cossor Melody Maker is largely due to its Cossor Transformer. A Cossor Transformer will give your set a better tone than it has ever had before. See one at your Dealer's.

Made and guaranteed by
the makers of the famous
COSSOR VALVES

The COSSOR L.F. Transformer

Adv. A. C. Cossor Ltd., Highbury Grove, London, N.5.

91 10

WHAT'S NEW

Well-Designed Drum-Drive Condenser

THE twin condenser illustrated below was originally designed as part of the General Electric Co.'s excellent kit for their "Music Magnet," although we understand it can be obtained separately. Careful measurements with the capacity bridge shows that the two condensers are well matched over the whole range, while the method of drive is unusual, a knob on the front of the panel (not shown

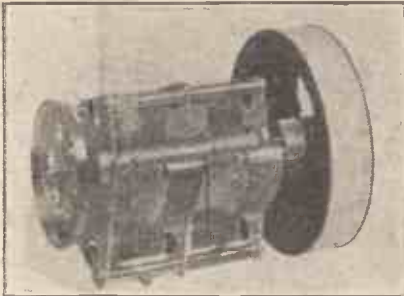

The G.E.C. condenser described above.

in the illustration) operating the shaft, the edge of the drum showing in a well-designed window. This method, in our opinion, is much preferable to the "thumbing" process required by some drum-dial condensers. A very well-designed and well-made instrument.

Good Loud Speakers

We have recently had the opportunity of testing thoroughly two of the loud speakers in the Marconiphone range, namely, the model 75 cone loud speaker which sells at 75s., and the Marconiphone moving-coil loud speaker (cabinet type). Each instrument is an excellent performer in its own price class, the quality and strength of reproduction on the 75s. model being surprisingly good. Some clever design work has obviously been put into this speaker which gives an appreciably better tone than many at considerably higher prices. Both in sensitivity and quality of repro-

A MONTHLY REVIEW OF TESTED APPARATUS.

(Note: All apparatus reviewed in this section each month has been tested in the Editor's private laboratory, under his personal supervision).

duction this instrument can be recommended.

The Marconiphone moving-coil loud speaker, designed to run from a six-volt battery with the very economical consumption of only half an ampere, is in the very front rank of such instruments, reproducing the low notes with considerable fidelity and a refreshing freedom from the "boominess" which so often characterises moving-coil speakers.

It is also very sensitive in the upper range, this combination of good high- and low-range reproduction being very rare in moving-coil speakers; indeed, we have yet to test a loud speaker of any type which has such a remarkably uniform response over the whole frequency range. Furthermore, unlike nearly all moving-coil speakers, it does not suffer by comparison with the magnetic type when we come to sensitivity.

It is quite evident that proper design of the cabinet has a good deal to do with the reproduction obtained from this speaker, the sides being cut

away somewhat and perforated metal inserted, probably to eliminate box resonance, which is only too prone to occur when a moving-coil speaker is placed in a cabinet. The fact that it will operate on half an ampere enables the field current to be supplied by any of the ordinary trickle chargers giving half an ampere from a dry rectifier—the Ferranti, Burndept, Regentone and others being quite suitable for this purpose. Although the price is fairly high the results warrant it, and we can heartily recommend this as a first-class example of a moving-coil loud speaker without the defects which accompany so many instruments in this class.

High-Tension Battery

During the last year we have used and tested a number of Ripault high-tension batteries in sizes that vary from the smallest to the super-power models which will satisfactorily drive super-heterodyne receivers and others with extravagant appetites. Prolonged tests are necessary in order to gauge the practical performance of a high-



One of the "Elco" H.T. units (for use on D.C. mains) described in the January issue of the "Wireless Constructor."

**YOU CAN USE YOUR SET
TO REPRODUCE PICTURES**

— *by the
addition of a*

Fultograph

To WIRELESS PICTURES (1928)
Ltd., Dorland House, 14/16,
Regent St., London, S.W.1.

Please send me full particulars of
the Fultograph, together with Kit
Prices for Amateur Constructors:

NAME

ADDRESS

W.C.

Please write in block letters.

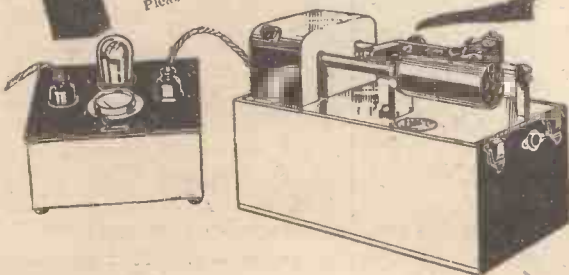

If your set works a Loud-speaker it will work a Fultograph, by means of which you can receive the pictures which are being broadcast daily from this country and the Continent.

It's a matter of taste whether you buy a Fultograph in oak or mahogany; but you can, if you like, construct your own. Kits are available for the amateur constructor containing all the necessary components as used in the official models, together with full details as to assembly. The components supplied by the manufacturers of the Fultograph will ensure the best reception.

PRICES OF COMPLETE FULTOGRAPH

In Oak .. £22 15. 0

In Mahogany £24 15. 0

Send Coupon for full particulars



What's New—continued

tension battery, and we are satisfied that the Ripault batteries in all sizes sold are thoroughly satisfactory for the purposes and the outputs for which they are designed. The internal resistance of the batteries when new is very low and the discharge curves of all types is remarkably uniform.

We particularly like the subdivision of the battery in the one-and-a-half tappings for the first nine volts and subsequent tappings at each nine, this enabling any voltage from $1\frac{1}{2}$ to the maximum of the particular battery to be obtained with ease. When using screened-grid valves and combining grid bias in the same battery as the high tension, such an arrangement is very useful. Both with heavy discharges over short periods and slow discharges over long ones, all batteries proved thoroughly satisfactory and can be recommended to the discriminating experimenter who likes to obtain value for money.

A High-Quality Low-Frequency Transformer

Messrs. S. G. Brown, Ltd., pioneers of loud-speaker reproduction, are now producing a very excellent low-frequency transformer, "type A," in a handsome moulded bakelite case, and giving a performance which



The Amplion "Swan Neck" model, type A.R.9.

places it in the very front rank of such instruments, both in regard to uniformity and response over the frequency range required and magnification obtainable with modern valves. On listening to the reproduction given by this transformer in a well-designed set, one is powerfully reminded of the tremendous progress made in audio-frequency magnification in the last few years.

While the price of the instrument (30s.) is comparatively high, the high performance must also be taken into account, for many of the so-called cheap transformers give so little magnification that an extra valve is required to give the results obtainable with the better instrument. We congratulate the makers on adopting a sensible marking for their terminals—a point which we have often commented upon in these columns.

In the case of the Brown type A transformer we have P., H.T. +, G. and G.B., common-sense markings which everyone can understand. Why in the name of common sense, many manufacturers of low-frequency transformers persist in the old IP, OP, IS, OS markings we cannot understand. The user is not in the slightest degree interested in which is the beginning and which is the end of the primary or the secondary windings.

We can thoroughly recommend the new Brown transformer as a worthy product of a firm with a high reputation.

Good Horn Speaker

The Amplion "Swan Neck" model type A.R.9, illustrated herewith, is a powerful little instrument, of good quality for a horn type and sold at a most reasonable price. While, of course, not approaching in reproduction the Amplion cone types, it will be found very useful for those whose sets are rather weak and who desire to get maximum loud-speaker strength from a small receiver. It is quite a good representative of the horn type and can be recommended as an inexpensive loud speaker of good sensitivity.

Unique Receiver

One of the most ingenious of wireless inventions is the Loewe multiple valve which has already been described in these pages and is now

manufactured in England. This valve, which is really three valves in one, contains within its glass bulb all the components necessary for a detector and two stages of resistance-coupled low-frequency amplification, namely, three valves, three anode resistances, two grid leaks, and two coupling condensers! The valve itself is a miracle of ingenuity and when fitted with the necessary tuning apparatus a loud speaker set can be compressed into a minimum of space.



The Loewe receiver, employing one of the three-in-one valves.

Our illustration shows the complete Loewe loud-speaker set with its battery cable and coils in place. Tuning is carried out by means of the variable condenser knob, whilst variable reaction is obtainable by means of two coils in a two-coil holder. On test the set gave very good and pure results, adequate strength for loud-speaker reproduction being obtained on the outside aerial from 2 L O and 5 G B at Wimbledon. The tone is very good and pure and the whole set sells for a remarkably low price.

A point to be noted is that the set works quite well on the 90-volt battery, and although, of course, two resistance stages do not give the same magnification as a resistance and a transformer stage, the set functions admirably as a local receiver with the alternative station available when required. By changing coils the set will work quite well on 5 X X. If one filament should burn out, the valve can be repaired at a cost appreciably lower than that of a new valve, and the total high-tension consumption of the set is quite low. It can certainly be recommended for the purpose for which it is designed.

C.O.D.
Phone: City
3788.



FOR

ONLY

3/6

Post and Packing 4d.

POWER GRIP, SELECTIVITY & TONAL QUALITY

We say P.R. valves are as good as the best. If you don't think so, the trader you buy them off will refund your money without question. If not we will! Bear in mind P.R.'s are the only valves with a written guarantee as to life and performance. You are the sole judge. Just try one—refund by return of post if not satisfied

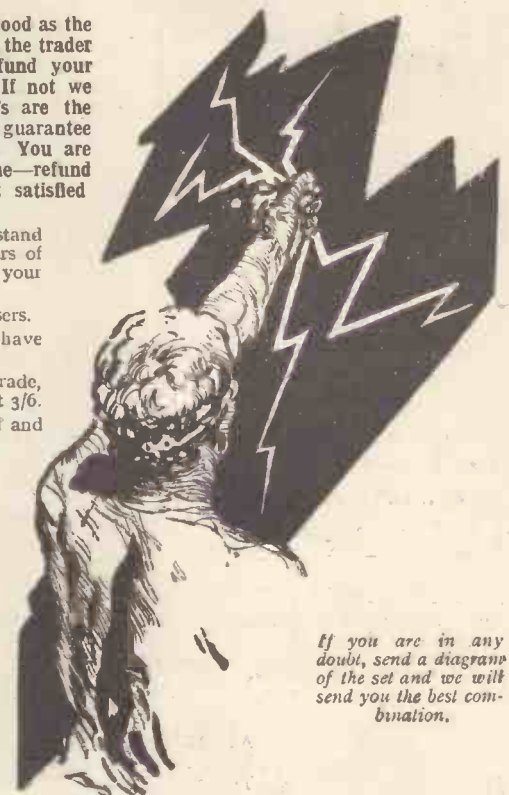

If you are in any doubt, send a diagram of the set and we will send you the best combination.

A standard 10/6 valve for 3/6! A perfectly coated "super" filament, strong enough to stand postal despatch—you know what that means—with an astounding emission that makes users of P.R. valves order again and again for their friends. As one man wrote, "I can't 'keep' your valves, my friends are always 'borrowing' them!"

Startling as this may sound, it is backed up by the wireless press and thousands of satisfied users. For years it has been impossible to get a good reliable valve at a reasonable price. Many have tried and failed.

We have cut down overheads, eliminated factors' profits, insisted on cash business with the trade, and by strict economy and attention to business made it possible to supply a first-class valve at 3/6. We have profited by others' mistakes. The chief reason for failure has been want of careful and repeated testing before sale, and the policy of allowing rush work during the season.

OUR AIM

We want our name, P.R., to represent Perfect Reliability in your mind. Our only aim, the aim of our staff, is to give satisfaction if it is humanly possible. Don't hesitate to ask us for a refund if you are not entirely satisfied. Our tests are as thorough as possible. P.R. valves are tested twice at the factory and once in our London offices—yet with all the care a "bad-un" will get through. Don't nurse a grievance, let us know, let us settle it. We are building up a business—we want to be proud of it—we want to make friends all over the country—friends who will trust us to give them a square deal. We want this because we know it is the only way to build up a sound, solid business.

A year's experience, during which we have made many friends, has proved our treble test policy to be right. At our works in Birmingham each valve has to pass through two exacting tests before despatch to us. Each valve is again tested on broadcast conditions in London before being sent out. These tests weed out the undesirables and ensure you getting the best humanly possible.

SPECIAL CIRCUITS

Since some circuits are very ticklish as regards valves—Super-hets, for instance—the intermediates of such sets require to be matched so that they come into oscillation together—we do this for you at a charge of 1/- a set.

Choke-coupled H.F. stages are very touchy to suit because only by trial on a set can the best valves for the purpose be found. In such cases half a dozen assorted valves should be ordered and the ones required picked out—the others can be returned for refund.

Our valve list has a full page of valve notes. We are told that this page contains more honest information than many expensive books on the subject. Please send addressed envelope for full lists.

GUARANTEE

Each valve has attached to it a written guarantee covering 7 months. In the event of the valve losing emission or becoming inefficient in any way during this term a new valve will be supplied under the terms of the guarantee. If not fully satisfied that the valves received are equal to any they should be returned within a week, full refund will be made by return of post.

LIST OF DULL EMITTERS

	Type	Fil. Volts	Amp.	Imp. Ohms.	Amp. Fac.	
3/6 Post 4d.	PR 2	2	·095	28,000	13	H.F. Det.
	PR 3	2	·095	15,000	8	L.F.
	PR 4	2	·095	120,000	32	R.C.
	PR 9	3.5-4	·063	18,000	14	H.F. Det.
2 VALVES & OVER POST FREE.	PR10	3.5-4	·063	10,000	8.7	L.F.
	PR11	3.5-4	·063	88,000	40	R.C.
	PR17	5-6	·1	18,000	17	H.F. Det.
	PR18	5-6	·1	9,500	9	L.F.
POWER	PR19	5-6	·1	80,000	40	R.C.
	7/6	Each				
	Post 4d.					
SUPER POWER	PR20	2	·15	7,000	6	Power
	PR40	4	·15	7,000	6	"
	PR60	6	·1	5,000	6	"
12/6 Post 4d.	PR120	2	·3	2,750	4	Super
	PR140	4	·2	2,500	4	Power

RADIO PRODUCTS



17-PATERNOSTER-SQUARE
LONDON-E.C.4

P.R. VALVES,
17-45, PATERNOSTER-SQUARE
(Opposite G.P.O. Tube Station)
LONDON, E.C.4.

COUNTRY AND SUBURBAN STOCKISTS:
ALFRETON—Vasey, Hall St. BARNSELY—E. T. Budd, 15, Westville Rd. BARGOED—Evans Bros., 28, Hanbury Rd.; Jones Bros., 53, Cardiff Rd. BLACKBURN—Speak, 5, Library St. BUCKLEY—G. P. Metcalfe, Buckley. ENFIELD WASH—Macfarlane, 15, Rotherfield Rd. ERITH—Milner, 114, West St. EDINBURGH—Redpath Radio, 103, Brunswick St. GLASGOW—Mugoch, 14, Cathcart Rd. GRAVESEND—Fairlamb, 8, Stone St. GRIMSBY—Victor Radio, 73, Victor St. GOODMAYES—Bylands Electrical Co., Goodmayes Rd. LEICESTER—Birmingham Cycle Co., Coalville. LIVERSEDGE—Kershaw, 162, Roberttown Lane, Roberttown. RAMSGATE—Casa Blanca Garage, Belle Vue Road. SHAFTESBURY—Gault & Son, Sherborne Causeway. NORTH SHIELDS—W. Tate, 23, Spencer St.; G. Swan, The Market, Tyne St.

LONDON STOCKISTS:
ABBEY WOOD—Abbey Wood Radio Depot, 14, Harrow Manorway. BATTERSEA—F. O. Allen, 542, Battersea Park Rd. BOW—Bishop's Stores, 309, Roman Rd.; Louis Saverna, 19, Roman Rd.; Harrison, 119, Roman Rd. CAMBERWELL—Camberwell Stores, 185, Camberwell Rd. CLAPTON—Clapton Radio, 32, Lower Clapton Rd.; Humphreys, 5, Chatsworth Rd. Clapton Park. CLAPHAM—The Electric Shop, 13a, Clapham Park Rd. CITY—Mrs. K. Raymond, 27/28a, Eisle St. W.O.2; Simons, 100/101 Houndsditch. E.I.1; P.R., 17, Paternoster Square, E.C.4. FOREST GATE—T. F. Trudgen, 79, Upton Lane. GREENWICH—Radio Box, 18/18a, Blackheath Rd. HAMMERSMITH—D. S. Atlass, 141, Fulham Palace Rd. HOLLOWAY—John Burns, 103, Holloway Rd. LEFORD—Lesard & Sons, 237/239, Hord Lane; Ajax & Co., 291, High Rd. KILBURN—North Western Light Supply Co., 40, High Rd., Despatch Co., 243, High Rd. PLAISTOW—P. A. Downes, 584, Barking Rd., Green Gate; Syd. Bull, 194, Plaistow Rd. LEYTONSTONE—Jarrett, 131, Leytonstone Rd.; Martin's Mart, 159, Leytonstone Rd. MANOR PARK—Felix Radio, 943, Romford Rd. LEYTON—Flower & Son, 621/623, Lea Bridge Rd.; J. Saunders, 359, High Rd.; Trumbley, 424, High Rd. NORWOOD—Fred. Chidsey, 24, Knight's Hill. POPLAR—Bottoms & Co., 241 East India Rd. PLUMSTEAD—Grover & Smith, 152, Plumstead Rd. PECKHAM—C. & W. Thew, 5, Station Parade, Queen's Rd. PUTNEY—Job-co, 24, Florian Rd.; Putney Bridge Rd. SHEPHERD'S BUSH—W. Canning, 47, Goldhawk Rd. SOUTHWARK—S. A. Smith, 159, New Kent Rd. TOTENHAM—Ruskin's Accumulator Service, 660, High Rd. UPTON PARK—Messrs Pryor, 69, Plaschet Grove. WALTHAMSTOW—Wilkin, 12, Blackhorse Lane.

OUR NEWS BULLETIN
*Some of the More Interesting Happenings
 in the Radio World this Month.*

Good News

As we go to press, the B.B.C. announces that arrangements have been concluded with Sir Oswald Stoll for the regular broadcasting of excerpts from the London Coliseum and Alhambra theatres.

Coliseum Calling

The first of these broadcasts will probably have taken place by the time this issue of the WIRELESS CONSTRUCTOR is on sale, but the excerpt to be broadcast from the Coliseum programme will probably be given on February 26th.

Every Other Week?

It is stated that vaudeville features from these theatres will be taken at about fortnightly intervals. Sir Oswald Stoll, the managing director of the London Coliseum, has for a long time past refused permission

for broadcasts either from his theatres or by artistes under his control, and it is good news now to notice that the situation has completely changed.

Turn and Turn About

A B.B.C. official, interviewed in connection with this new arrangement, said that it was now possible that broadcasts might be made from two variety theatres at the rate of about four a month.

Naughty Norway!

It appears that the Broadcasting Company in Norway has had to call in the help of the police to put an end to radio pirates. In Norway there are 62,832 licensed listeners, but the books of the Norwegian Broadcasting Co. show that 27,000 listeners did not renew their licences in 1928. It is estimated that the number of those who did not take out a licence

is well over 20,000, and at the end of the year the number of pirates was quite 50,000.

Keeping it Sweet

Professor Siedel, of Vienna, has discovered that warm milk, when affected by high-frequency oscillation, will remain sweet for a month. High-frequency currents have already been used with success in the steel industry for smelting purposes, and by the medical profession as a means of cauterisation, but this new application of high-frequency currents as a steriliser has not been used previous to Professor Siedel's discovery.

Another Death Ray

It is reported that Professor Esau, of Gena, Germany, has succeeded in sending extremely short waves without an aerial up to a distance of about 250 miles. The report goes on to say that his set is contained in a cigar box, that the waves can be used for medical purposes and that small animals are killed by the waves.

Sir Thomas Beecham

Discussing his arrangement with the B.B.C., Sir Thomas Beecham
 (Continued on page 380.)

MAGNUM VOLUME CONTROL



As specified for The "Request" Three. Made in two values, 2 meg. and 1/2 meg.

Price
7/6

MAGNUM STANDARD SCREENS



Specified for several "WIRELESS CONSTRUCTOR" and other Modern Receivers.

10 in. by 6 in., with 3 terminals, **2/6**
 7 in. by 6 in., with 2 terminals, **1/9**

Sets and apparatus described in this issue can be supplied as constructional kits or ready wired and tested. Catalogue and comprehensive lists dealing with all the latest developments in Radio on application.

CONSTRUCT THE "REQUEST" THREE

as described in this issue.

	£	s.	d.
1 Mahogany Cabinet 16 x 8 ins. with baseboard	1	4	0
1 Moire Finish Panel, ready drilled	10	6	
1 Magnum Volume Control	7	6	
2 Magnum Single Coil Holders	3	0	
1 Magnum On & Off Switch	1	6	
3 Magnum Vibro Valveholders	6	0	
2 Magnum Panel Brackets	1	6	
3 Magnum Terminal Strips	3	6	
1 R.I.-Varley H.F. Choke	9	6	
1 Lotus Jack Switch	4	0	
2 Variable Condensers, .0005	11	6	
2 Ormond Slow-Motion Dials	10	0	
1 R.I.-Varley Resistance, 60,000 ohms, & Holder	7	6	
1 Lissen Grid Leak and Condenser	2	0	
1 Ferranti A.F.5 Transformer	1	10	0
1 Igranic type G Transformer, 7.2 to 1	1	10	0
1 Formodensar, as described	2	0	
3 Dubilier 2-mfd. Condensers	10	6	
2 X Coils	13	3	
Glazite and Sundries	2	3	
	£9	10	0

Any of the above components supplied separately as required.

THE ABOVE SET, ready wired and tested and including Royalty **£11 0 0**

BURNE-JONES & CO. LTD.,
MAGNUM HOUSE
 TELEPHONE: HOP 6257
296, BOROUGH HIGH ST. LONDON. S.E.1

MAGNUM H.F. CHOKES



Recognised as the most efficient of their types. Made in two ranges.

STANDARD, 50 to 3,000 metres. Price **7/6**
 SHORT WAVE. From below 10 metres up to 100 metres Price **7/6**

"STEDIPOWER" L.T. UNIT 2-AMPERE MODEL
 as described in this issue.

	£	s.	d.
1 Panel, ready drilled	4	6	
1 Baseboard	1	6	
2 Magnum Panel Brackets	1	6	
2 R.I. L.T. L.F. Chokes	2	2	0
3 T.C.C. Electrolytic Condensers	2	5	0
1 Voltmeter, 0-7 volts	1	0	0
1 Rheostat, 10 ohms	4	0	
1 Rheostat, 6 ohms	4	0	
1 Ediswan A.C. Rectifier, as described	2	17	6
2 Belling-Lee Terminals	1	0	
Connecting Wire	1	0	
	£9	2	0

The above Unit, assembled and tested **£9 10 0**

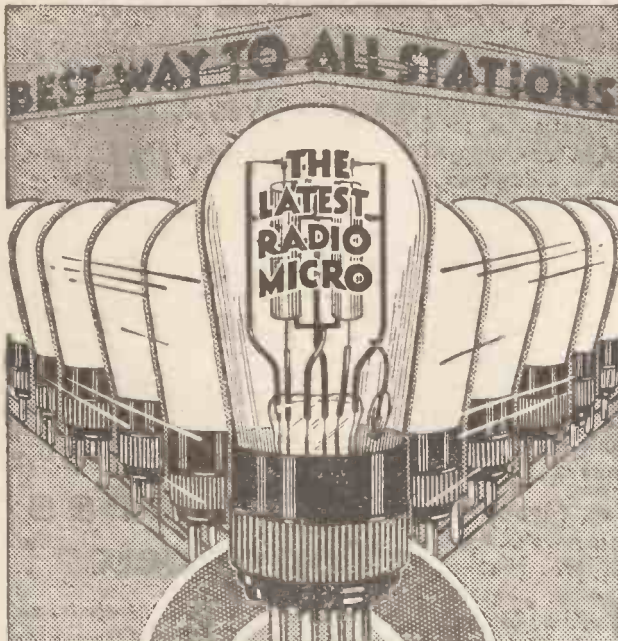

DARIO

VALVES

-AND THE CHEAPEST WAY, TOO,

guaranteeing utmost satisfaction. Just look at the prices below—made possible by reason of the biggest valve output in the world. Radio without Dario can never be radio at its best.

• SUPERLATIVE FINISH - LOWEST CONSUMPTION

TWO VOLTS.

General Purpose.	
'05 amp.	5/6
R.C.C. '06 amp.	5/6
Super-Power.	
'18 amp.	7/6
Super H.F. & R.C.C.	
'18 amp.	7/6
Pentodion	
'15 amp.	21/-

FOUR VOLTS.

General Purpose.	
'05 amp.	5/6
R.C.C. '07 amp.	5/6
Super-Power.	
'1 amp.	7/6
Super H.F. & R.C.C.	
'1 amp.	7/6
Pentodion.	
'15 amp.	21/-

From your dealer or direct.

IMPEX ELECTRICAL, LTD.

(Dept. L.)

5'6

538,
High Road,
Leytonstone,
E.11.

7'6

Weston sets the world's standard



Model 506 Pin Jack Voltmeter with High Range Stand, Measures High and Low Tension Voltages. The Weston free booklet "Radio Control" explains the uses of this and other Weston Radio Instruments. Write for your copy.

Price £2 10 0



Model 506 Mil-Ammeter should be placed in the H.T. circuit of the valve to ensure correct operation and check distortion. Panel mounting type.

Prices

£1.15.0—£2.15.0

Model 506 Panel Voltmeters ensure permanent accuracy. With a high internal resistance of 125 ohms per volt, they make practically no load on the batteries. Neat and compact.

Prices

£1.15.0—£2.15.0

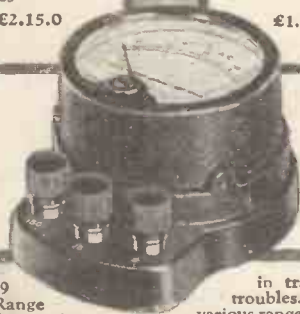

Model 489 Double Range D.C. Voltmeter is a necessary portable testing instrument for every radio enthusiast. It is of great use

in tracing circuit troubles. Made in various ranges with different sensitivities. Similar instrument for A.C. Model 528.

Prices £3.15.0—£7.5.0

WESTON ELECTRICAL INSTRUMENT CO. LTD.

15 GT. SAFFRON HILL, LONDON, E.C.1

OUR NEWS BULLETIN

—continued from page 378

recently said in an interview that the scheme is a partnership between equals, in which the independence of each side is well secured. The scheme really began on Sir Thomas Beecham's side, it appears, about a year ago, when he decided to found an orchestra to play six or seven months in the year.

The B.B.C. also wanted an orchestra to play regularly about eleven months in the year.

A First-Class Symphony Orchestra

So, with these two separate schemes in the air, it became desirable, said Sir Thomas Beecham, that some union should take place. Some time last spring, negotiations began between Sir Thomas Beecham and the B.B.C. with this object in view, and a comprehensive and workable arrangement is now being arrived at. So at long last we may soon expect a first-class Symphony Orchestra controlled equally by the B.B.C. and Sir Thomas Beecham.

Cardiff's Complaint

There have been a good many complaints lately from North Wales listeners who say they are unable to get wireless programmes clearly on ordinary receiving sets. Reception from the Cardiff station is reported as very indistinct in many districts, and there is a widespread movement to ask the B.B.C. for a more satisfactory service.

Wales and The B.B.C.'s Regional Scheme

The B.B.C. says that at the moment some areas have difficulty in receiving Cardiff, but by the Regional Scheme plan which they are hurrying on as fast as they can, North Wales will be particularly well served.

Twenty Times as Strong!

The B.B.C. says there will be a station for Wales in the West of England, twenty times as powerful as Cardiff, and this should be of great benefit. Also, listeners in Wales will be able to get alternative programmes from the station in the Pennines. The site for the new station in Wales is not yet definitely fixed upon, but it is believed that the final steps will shortly be taken in this direction.

It is safe to say that by the end of 1930 every resident in North Wales will be thoroughly satisfied.

NEXT MONTH

LOOK OUT FOR
"The Air Commander"

Be sure to order your copy of the April issue in which will appear full details exclusive to the

"Wireless Constructor"

Usual Price. Order Now.

Canada's Commission on Broadcasting

A Commission is now in this country, sent over by the Canadian Government, to report on British
(Continued on page 382.)

IGRANIC and H.T. SUPPLY



POWER TRANSFORMER

For H.T. Supply Units. Highly efficient and suitable for full wave rectification. Completely enclosed in metal screening case with ebonite terminal board carrying input and output terminals. Separate winding giving 4 volts for lighting filament of Rectifying Valve. Output 250 volts to each anode, 75 milliamps.

Price 45/-



Ask your dealer for Igranice lists of Supply Units and radio components. If he is unable to supply, write direct to

**Dept. J797,
147, Queen Victoria Street,
LONDON, E.C.4**



POTENTIAL DIVIDER

For H.T. Supply Units. A most useful component for operation across output in order to obtain various H.T. voltages. Has a total resistance of 15,000 ohms, and is divided into ten equal steps of 1,500 ohms each. Completely enclosed in a metal case with ebonite terminal board carrying contact sockets to which connections may be made by means of Igranice Springmore wander plugs.

Price 12/6

Fit a
BRITISH GENERAL
AERIAL TUNING
UNIT and be sure
of every wave-length



Alterations do not affect the set which has a British General Tuning Unit, which covers ALL Wave-lengths between 220-2000 metres. Plug-in coils are designed for a very small range and with the new B.B.C. and Foreign wave-lengths you may find reception difficult. Fit a British General Tuning Unit and make certain. Easy fixing, simple tuning. Price **18/6**

From all good dealers, or direct from

BRITISH GENERAL
 MANUFACTURING CO., LTD.
 BROCKLEY WORKS LONDON, S.E.4.

The Essence of Craftsmanship

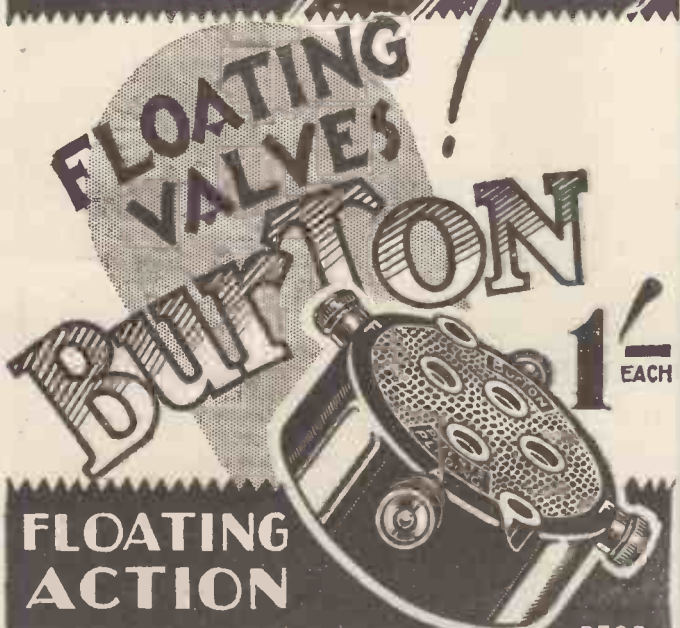

FLOATING ACTION
 ANTI-PHONIC & SELF LOCATING
VALVE HOLDER
 C.F. & H. BURTON PROGRESS WKS. WALSALL

REGD. DESIGN
 RUPERT COLLINS SERVICE.

A Happy, No-Drudgery, Spare-Time Business for YOU



Here is YOUR chance to become a Master Man in a Spare-Time Business which is expanding enormously; one which is competing successfully against large combines.

Just sit down and think over this carefully. Our enormously successful Patents are in great demand everywhere. They have become tremendously popular, and as the Wireless and Electrical Business extends, which it will do, and is doing, to an unthinkable degree, this demand will increase proportionately. We will licence you to manufacture our articles under our own Patent Rights, so that you can participate in the Big Profits.

Profits Guaranteed!

No Plant Needed.

No special knowledge or skill is needed, and you will find no difficulty about the manufacture. With our new and improved process, no expensive "plant" or machinery of any kind is required, and, even though you have not the slightest knowledge of Electricity or Wireless, you can commence to turn your spare hours into GOLDEN Hours! There is no drudgery. Indeed, the work is so simple and easy that you require no special accommodation—the kitchen or any spare room can be your work-room—and the whole of the family, including the children, can help you. The work is of fascinating interest, and your profit is only limited by the amount of time you have to spare.

We positively Guarantee your profits. Only a limited number of persons are allowed to manufacture. There is not the slightest chance of your market being overcrowded. If necessary we will purchase all your stocks—a fact which assures that you make PROFIT whatever may be the peculiarities of your own case!

Earn up to £300 a Year!

£300 a year EXTRA can easily be yours. New vistas will open out to you. It will smooth the way to Success and enable you to be independent of Employers and Industrial Upheavals. All those luxuries and necessities you have long desired will be yours. Let us hear from you NOW!

You are not asked to attempt to revive a "dud" industry, but are offered a Novel and Live Business—a growing business which has now been Established a Decade! Somebody is going to make a BIG PROFIT in your district, and that somebody can be YOU! Send the coupon AT ONCE, and Full Free Particulars will be forwarded. Any questions you ask will be answered fully. We have nothing to hide—no expensive "plant" to sell you. This is a plain, STRAIGHTFORWARD, MONEY-MAKING Proposition. As man to man, can you afford to let it pass by?

Send this Coupon NOW!

To Mr. V. ENGLAND-RICHARDS,
 THE ENGLAND-RICHARDS CO., LTD.,
 910, King's Lynn, Norfolk.

Sir,—Please send me at once, and FREE, full details as to how I can make Money at Home in my spare time. I enclose 2d. stamp for postage.

Print your name and address boldly in capital letters on a plain sheet of paper and pin this coupon to it.
 "Wireless Constructor," March, 1929.

OUR NEWS BULLETIN

—continued from page 380

broadcasting methods. It has been stated that there is a strong feeling in Canada that it would be better if the Canadian Government followed Great Britain's example and had State-control of broadcasting, said one of the members of the Commission. It is considered in Canada that the British system is simpler, cheaper and more satisfactory to listeners generally.

The Plan de Bruxelles

Under the new wave-length scheme there was a considerable amount of chaos to begin with in the ether, but things seem to have settled down a bit now. From the minute the change was made, stations all over Europe were heterodyning and jamming each other, and listeners trying to find their new adjustments were causing a good deal of interference. Nevertheless, the plan now seems to have settled down and looks like working very well.

Out of Place

It must be remembered, however, that stations above 300 metres have

now one-tenth less wave-length room than before the change to the Brussels plan, and still quite a number of them are out of place as regards wave-length. Consequently, until things have become even more settled, chaos is inevitable.

No Escape

The "Teacher's World," in an article reviewing the latest activities

NEXT MONTH

The April issue of WIRELESS CONSTRUCTOR will be a

Special High-Frequency Number.

It is sure to sell at high-frequency, too, so

Order Your Copy in Advance.

of the B.B.C., says that the Corporation is to become: "A universal fountain of printed matter using the money received from licences, the power of its monopoly and its position as a semi-State department to ensure that we shall none of us escape from its beneficent flow of wisdom."

"Teachers will find themselves reduced, to a greater or lesser extent, to the position of mechanics tending wireless sets and supplementing as best they may the information transmitted," continues the article.

The Deputation

However, the writer of the above article was certainly pessimistic when he wrote, for although the B.B.C. has been severely criticised for its educational efforts, things are not quite so bad as the writer in the "Teacher's World" makes out, and in any case the question of further publications has been definitely settled, thanks to the deputation's good work when it interviewed the Prime Minister with regard to the publication of "The Listener."

B.C.C.'s Postbag

The "Daily Telegraph" pointed out the other day that during 1928 the Technical Correspondence Section of the B.B.C. received over 26,000 letters. Nearly 50 per cent of this correspondence originated through complaints of interference by oscillation, while straightforward technical queries concerning sets accounted for nearly 5,000.

(Continued on page 384.)

GRADUAL PAYMENT

on all Wireless and Gramophone Goods

Why wait—take advantage of our scheme of gradual payments. You can have gramophone or wireless goods to the value of £5 or over without financial worry or embarrassment.

AN EXAMPLE.

£5 worth of goods supplied on DEPOSIT OF **20/-** and 9/- per month for 10 months.

COSSOR MELODY KITS.
£7 : 15 : 0 Cash, or 31/- deposit and 12/5 per month for 10 months.

MAGNAVOX MOVING COIL SPEAKER.
£8 : 5 : 0 Cash, or 33/- deposit and 13/3 per month for 10 months.

ANY GRAMOPHONE, WIRELESS SET, SPEAKER, RECORDS OR COMPONENTS SUPPLIED ON THE SAME TERMS.

Please write for full details.

For the Best in Radio

WILL DAY LTD.

(THE BEST IN THE WEST)

19 LISLE STREET, LEICESTER SQUARE, LONDON, W.C.2.

Telephone: (2lines) Regent 0921 and 0922 Telegrams: Willco, Westlond, London

ASTONISHING RESULTS

From the

PRECISION RADIO

H.F. SUPER-CHOKE



LABORATORY tests prove that the new "Precision Radio" H.F. Super-Choke is a winner. Its inductance value is astonishingly high (85,000 microhenries), its self-capacity quite negligible (2.5 micro-

microfarads). It has been constructed in a highly scientific manner and gives the most perfect choking effect attainable between 10 and 2,500 metres. Critical enthusiasts are hailing this as the most perfect H.F. Choke yet produced. Try it in your own set and note the difference. **PRICE 6/9**

USE ALSO "PRECISION RADIO"

Wire-wound Anode Resistances, non-microphonic Valve Holders, Wire-wound Rheostats and Potentiometers, etc. They all help to give you better results.

If your dealer cannot supply, send us his name.

PRECISION RADIO & MFG. CO., LTD.,

8, Board School Road, WOKING :: SURREY



**UNBEATABLE
AT THE PRICE!**
*says delighted
user*



MAGNIFICENT
TRIBUTE TO
"WEILO"
TRANSFORMERS

EXAMINE
THE PRICE!

Model 10.
POWER.

11'6

Model 3.
HEAVY TYPE.

8'6

Specified for many
leading circuits.

Listener after listener pays tribute to the value and efficiency of these wonderful transformers. They know Weilo to be a thoroughly sound job, and ideal for general radio work. For sheer excellence of workmanship and design, they cannot be excelled. No longer need you pay high prices—specify Weilo!

The Opinion of an Expert.

Reading, Jan. 23rd, 1929.

"Dear Sir,— I have been using Weilo Transformers for a long time, and they are unbeatable at the price."
(Signed) F. G. Downes, Wireless Engineer.

Obtainable by post direct, or from most good dealers. Stocked by Harrods. Send now for wonderful catalogue describing N.S.P. and Weilo quality components. FREE

S. W. LEWIS & CO., LTD.,
(Dept. W.C.), 39, Victoria Street, S.W.2.
Indian Agents: Bombay Radio Co., Bombay & Calcutta.

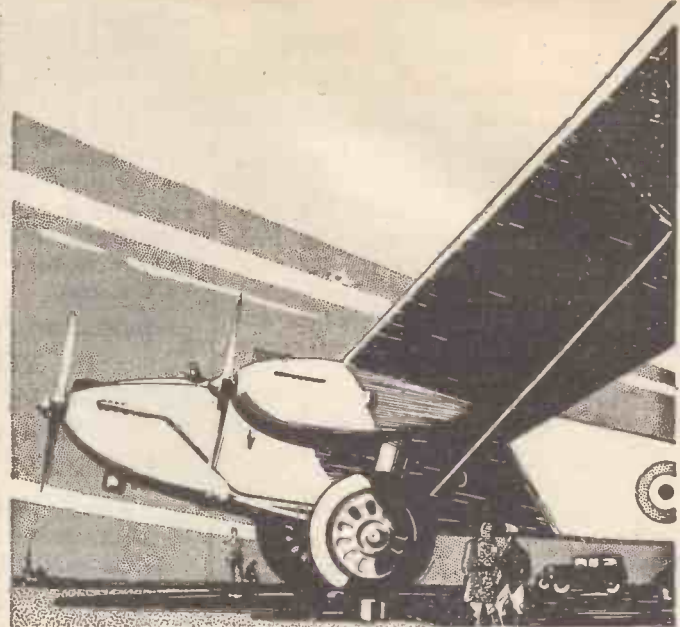

**ENGINEERING
PRECISION.**

When this huge Monoplane first streamed, roaring through the air, climbing, banking, diving, looping, its safety seemed a miracle—a favour from the gods. Yet it was not. It was the final compliment to man's toil, to the months of care expended on it, to the brains that designed it, to the accuracy and precision lavished on its construction.

Engineering precision is a feature of all J.B. wireless instruments. This J.B., S.L.F. Condenser (Plain Type) is made as if lives depended on its accuracy. And that is how a condenser should be made. The S.L.F. has the same mechanical and electrical features as the Logarithmic type, except that the Vane form is our very popular True Tuning S.L.F. Remember that True Tuning S.L.F. means selectivity with ease of tuning.

Prices complete with 4-in. Bakelite Dial:—
'0005 .. 11/6 '00035 .. 10/6
'00025 .. 10/- '00015 .. 10/-

High-grade
**QUEEN ANNE STYLE
FIGURED OAK CABINET**

Designed to take Sets, Loud Speaker, Accumulators, Batteries, etc. Height 3 ft. 6 ins., width 2 ft. 4 ins. For panels up to 24 ins. x 8 ins. Baseboards up to 12 ins.

£6 : 12 : 6

Packed Free.
Carriage Paid

Prices of other sizes in proportion. Manufacturer of all types of wireless cabinets and furniture of every description. Illustrated lists free.

**GILBERT,
CABINET MAKER,
SWINDON.**

Estimates Free Estd. 1866.

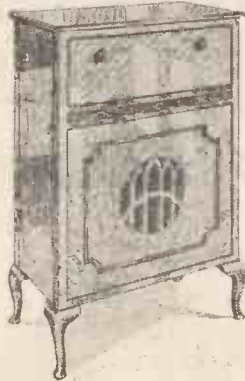

**SILENT
ELIMINATORS**

The secret of obtaining powerful, silent, and enduring results from the H.T. or E.T. Eliminator you are about to build depends entirely upon the right selection of its component parts.

Success with SUPRECISION Power transformers and chokes is a guaranteed certainty. Specify them and you follow the lead of thousands of satisfied Customers.

How to build your own Eliminator inexpensively is explained in the new list 935. Any output obtainable from 2 volts to 500 volts.



Write, 'phone or call.

F. C. HEAYBERD & Co.

8/9, Talbot Court, Eastcheap, E.C.3.
(One minute from 'Monumen' Underground Stat'ion.)

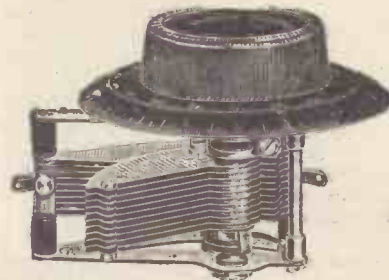

PRECISION INSTRUMENTS

Advt. of Jackson Bros., 72, St. Thomas' Street, London, S.E.1. Telephone: Hop 1837

OUR NEWS BULLETIN

—continued from page 382

Our Own Experience

The technical staff dealing with this correspondence seems to have the same opinion as the Technical Query Department of this journal, for they say that letters are becoming more and more difficult to answer from the technical point of view. They point out that the growth of technical knowledge in wireless seems to be extremely rapid.

Armistice in Antipodes

At the invitation of the B.B.C., the Wellington station relayed the Armistice Day's Service given in London, from 5 S W. It appears from reports now received that atmospheric conditions were not conducive to good reception until near the conclusion, when reception became excellent. Later on, the proceedings at Trafalgar Square were heard so clearly that, it is reported from Wellington, New Zealand, it would have been possible to take a shorthand report of the speeches.

Trouble on the Long Waves

There is a good deal of trouble being caused by the Danish station at Kalundborg which some time ago changed its wave-length from 1,153 to 1,680 metres. And then wasn't too sure about the matter when the change had been made! However, it is announced that the station has reverted to its former wave-length of 1,153 metres.

Do YOU Read POPULAR WIRELESS

The paper that made WIRELESS POPULAR?

Every Thursday :: Price 3d.

When Kalundborg moved up its wave-length, Königswusterhausen had to transmit on 1,649 metres, and Daventry (5 X X) was badly heterodyned and had to lower its wave-length by 42 metres.

Daventry's Neighbours

Even when these changes had been made, many listeners found that Kalundborg was causing a good deal of interference. The Berlin station will continue to transmit

on wave-lengths of 1,250 and 1,694 metres. The lower one, however, will be abandoned if the higher one is found O.K.

It is interesting to note that the higher wave-length of Königswusterhausen is only separated by 11 kilocycles from that of 5 X X, and if Daventry moves back by the time these words are read, it will be interesting to see whether serious interference is caused or not. Theoretically, it should be.

Geneva's Studio

The Secretariat of the League of Nations announces its intention to resume shortly experimental long-distance short-wave broadcasts. These will probably be made through the short-wave station at Kootwijk, the Netherland Government station. This station will be coupled to a small studio at the Palais des Nations in Geneva, by means of a telephonic cable circuit between Switzerland and Holland. Reports on previous experiments with Kootwijk have suggested that the wave-length of 18.4 metres was the best for reception from the Netherlands, East Indies, South Africa, and the southern part of the Indian Ocean.

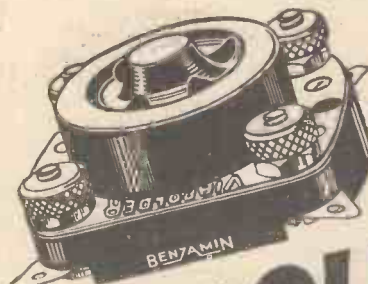

VIBROLIDER



The valveholder that keeps your valves young!

Section through the Vibrolider showing self-aligning contacts and jointless one-piece springs.

The valve-leg sockets of the Vibrolider are unique because they are formed by the coils of the shock-proof springs themselves. For this reason Vibroliders are exceptionally suitable for portable sets, for while the filament is protected from every shock, no amount of vibration can cause the valves to work loose. Price **1/6**

1,500,000 Benjamin valveholders are already in use

BENJAMIN

BENJAMIN ELECTRIC LTD., Brantwood Works, Tottenham, London, N.17

New Controls

CONSTANT INPUT RESISTANCE

An entirely new and revolutionary resistance designed for use in controlling the volume of one loud speaker without affecting the other.

The constant Input Resistance will maintain a constant resistance in the line equal to the impedance of the speaker used. List Price 17/6.



PICK-UP "FADER"

Is another revolutionary unit designed for volume control of two pick-ups with dual turntable. List Price 17/6.

Write for full details and the new Centralab Circuit booklet.

Centralab

ROTHERMEL CORPORATION, LTD.

24-26, MADDOX STREET, W.1.
Telephone: MAYFAIR 0578.

TELSEN TRANSFORMERS

The TELSEN "RADIOGRAND" Transformer at 12/6, and the "ACE" (a compact, light and efficient instrument specially designed for Portables) at 8/6, are two models which have achieved overwhelming popularity with Radio enthusiasts. Install a TELSEN and note the extraordinary amplification and purity. Entirely British, guaranteed 12 months, and obtainable everywhere. Ratios 5-1 and 3-1 shrouded and with detachable feet.



Illustration shows the "RADIOGRAND."

TELSEN ELECTRIC Co., Ltd.,
207, Aston Road, Birmingham



What About Your Future?

ARE you content with the position you occupy now—with the money you are earning, or do you wish for something better and something more?

Ask yourself these questions; then consider for a moment what you ought to do. Don't for a moment imagine that integrity, punctuality and length of service will of themselves carry you far. The one thing more than any other that enables a man to rise above his fellows and win a way into the better-paid jobs is a sound and practical technical training. He cannot possibly get such a training in the course of his everyday work.

The I.C.S. originated spare-time technical training by post 38 years ago, and is by far the largest institution of its kind in the world. It has teaching centres in eleven countries and students in fifty.

Write to-day for full information as to how the I.C.S. can help you in your chosen vocation. There are 360 Standard Courses, of which the following are the most important groups:—

- | | |
|---------------------|---|
| Accountancy | Wireless Telegraphy (Elementary and Advanced) |
| Advertising | Draughtsmanship |
| Architecture | Engineering (all branches) |
| Building | French and Spanish |
| Commercial Art | General Education |
| Commercial Training | Professional Exams. |
| | Salesmanship |
| | Scientific Management |
| | Showcard Writing |
| | Textiles |
| | Window Dressing |
| | Woodworking |

There is a special booklet for each group, which will be sent free on request. Tell us the one you would like to see.

International Correspondence Schools, Ltd.
172, International Buildings, Kingsway London W.C.2

THE 100% Broadcast Receiver

BUILD AND OPERATE IN ONE EVENING



BRITISH Components Throughout. Send for Catalogue

FAMOUS FORMO COMPONENTS as used in this Set and in ALL NOTABLE PUBLISHED CIRCUITS

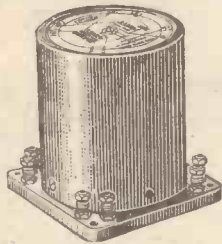

TRANSFORMER-OUTPUT FILTER CHOKE 25/-

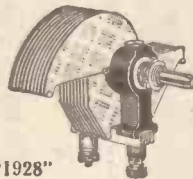

"1928" LOG CONDENSER 5/-
'0005 '00035 '00025



TWO-RANGE TUNER 10/6



FORMO-DENSOR 2/-
In four variable capacities

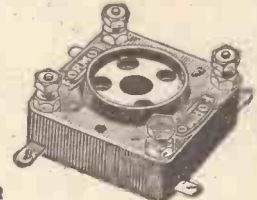

VALVE HOLDER 1/3

"De Luxe" Model 6/-
'0005 '00035 '00025 '00013

THE FORMO CO., CROWN WORKS, CRICKLEWOOD LANE, LONDON, N.W.2.

This CONE UNIT was badly needed

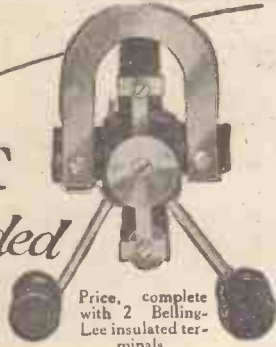

A new and remarkable Cone Unit marketed in response to a popular demand. Is entirely British made, and incorporates a Vickers-Armstrong Cobalt Steel magnet. Specially prepared Cone paper, cut to shape, complete with instructions, can be had from the Manufacturers at 2/- per sheet.

Price, complete with 2 Belling-Lee insulated terminals, 18/6

WHITELEY BONEHAM & Co., Ltd., Nottingham Rd., Mansfield, Notts.

TO OBTAIN THE BEST RESULTS FROM YOUR SPEAKER USE A

CAMCO CABINET

Suitable for all popular makes of Moving Coil Loudspeakers
Finished Oak or Mahogany.

38/-

Mr. Percy Harris writes in "Wireless Constructor, Sept., 1928": "The Camco Moving Coil Speaker Cabinet gives an effect equivalent to a large baffle"
CARRINGTON Mfg. Co., Ltd.
Camco Works,
Sanderstead Road, South Croydon
Telephone: Croydon 0623 (2 lines)



**AT HOME WITH
THE FULTOGRAPH**

—continued from page 332

liquid in the bottle becomes very easy. I can speak with feeling on this matter, having made a terrible mess trying to pour back the solution from a pie-dish.

Preparing The Paper

The paper is pure white, of quite smooth surface on one side, and unglazed. It is highly absorbent, and immediately it is dipped into the liquid it absorbs the solution. As soon as the paper is thoroughly wet it is withdrawn and placed between two pieces of blotting paper with the idea of removing the surplus solution.

The damp sheet is then laid aside for about five minutes. After this it is wrapped round the receiving cylinder with the overlap of the paper arranged to come under the spring bar which holds it in position. A little practice is desirable in placing the wet paper on the cylinder, for it is not quite easy to get it straight at once.

The solution consists of a salt known as potassium iodide dissolved

in water, the solution so formed being again mixed with diluted starch paste. I have made up and used my own solution and obtained quite good results with it, but I find the results given by the "official" liquid to be better.

I have made a number of experiments to see whether the degree of dryness of the paper after it has been immersed in the solution is important, but find that it can be used almost in a soaking wet condition if desired. It is, however, advisable to follow the instructions given, otherwise there is a risk of tearing, and the spring bar tends to distort the too-wet paper.

Direct Current Necessary

In the numerous photographs accompanying this article the details of the receiving apparatus can be clearly seen. We are now in a position to understand in further detail the operation of the receiver, and it should be said that as a direct current is necessary for the particular chemical process and relay used, the output from your receiver must be rectified. This is done by passing the received signals from your set to a box which contains a rectifying valve using the anode-bend principle.

This is called the relay panel (the small square piece of apparatus seen in the photograph). The panel carries a valve holder with a special valve, a milliammeter, a switch, and sockets for connecting cords. A multiple cord goes from a special plug on this relay and has leads for H.T., L.T., and G.B.

The grid bias is adjusted so that when no signals are coming no current passes through the plate circuit of the valve, and nothing is shown on the milliammeter.

A Sensitive Relay

When we connect the leads from our receiver to the panel, and the tuning note which precedes a Fultograph transmission comes through, the strength of signal in the receiver is adjusted until the milliammeter needle comes between two red lines which are marked at 2½ and 3½ milliamperes respectively. This means that satisfactory results will be obtained so long as the needle falls somewhere between these two red lines when the tuning note is sent. It is easily adjusted by altering the tuning of the receiver or varying the reaction.

Underneath the panel is a small input transformer and a relay which

(Continued on page 388.)

**HERE IS
THE LIFE FOR YOU!**

The whole of the radio technical press is unanimous in its praise of the life and practical performance of

RIPAULTS SELF-REGENERATIVE H.T. BATTERIES

In "Light on the H.T. Battery," a 24-Page Booklet, sent Free for a 2d. stamp, there is a complete list of the full range of Ripaults H.T. Batteries and the Life of each is stated; also, a "Right Choice" Table is given so that you can select exactly the battery that your set needs to give of its very best. Replace your present battery with a "Ripaults" and you will be astounded at the enormous improvement in your set.

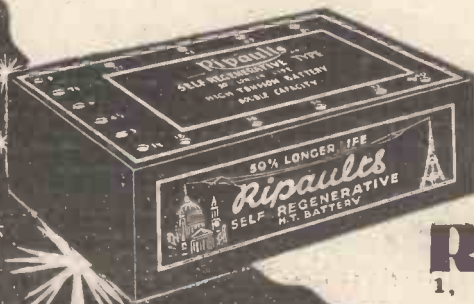

All the "Stars" in Radio can be heard with wonderful purity and clarity because of the absolutely silent background when Ripaults H.T. Batteries are used.

Write for the 24-page Booklet; it gives the secret of good reception.

The Best is Good—Ripaults is 50% Better.

STANDARD CAPACITY - 60 volts, 10/6. 99 volts, 16/6

DOUBLE CAPACITY - 60 volts, 15/6. 90 volts, 22/6

TREBLE CAPACITY - 60 volts, 19/6. 90 volts, 29/6

Also supplied in Quadruple Capacity. Obtainable through all Dealers.

RIPAULTS Ltd.
1, King's Road, London, N.W.1.



BLUE SPOT 59

Speaker — £4.4.0

To listen to the Blue Spot 59 model is a revelation in loudspeaker reproduction. The secret lies in Blue Spot 66K, the adjustable 4-pole armature unit. It is the finest unit obtainable, and can be supplied separately with full directions for the home constructor, price 25/-, from any leading wireless retailer. It will give results that will astound you.

F. A. HUGHES & CO., LIMITED,

204-6, Great Portland Street, London, W.1
 DISTRIBUTORS FOR NORTHERN ENGLAND, SCOTLAND AND NORTH WALES: H. C. Rawson (Sheffield and London) Ltd., 100, London Road, Sheffield; 185, Princess Street, Manchester.

"Ideal Blue Spot Cone Speakers are sold under full protection of the patents owned by Standard Telephones and Cables and the Hopkins and Lektophone Corporations."

BLUE SPOT
66K Unit
 25/-



FAULTLESS RECEPTION
 depends upon the efficiency of your coils

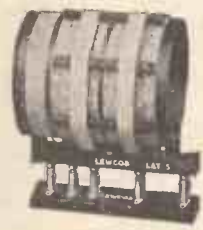

1928 SOLODYNE COIL
 B.B.C. Coils 10/- each. Daventry Coils 12/- each.



LOADING COIL
 (Patent No. 271,384)
 7/6 each.

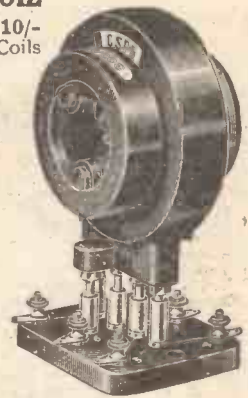

SUPER COIL
 (Patent No. 285,723)
 B.B.C. Coils 10/6 each. Daventry Coils 12/6 each.

LEWCOS

(REGD.)

RADIO PRODUCTS



LEWCOS RADIO PRODUCTS FOR BETTER RECEPTION

THE LONDON ELECTRIC WIRE COMPANY AND SMITHS LIMITED,
 CHURCH RD., LEYTON. LONDON. E.10

'Phone: Walthamstow 2531.
 'Grams: "Lewcos," Phone, London."
 Trade Counter and Cable Sales:
 7, Playhouse Yard, Golden Lane, E.C.1.

READY RADIO

SUPPLY COMPANY,

159, BOROUGH HIGH ST.,
LONDON BRIDGE, S.E.1.

3 Minutes from London Bridge Southern Rly. and
Tube Stations.

Telephones : HOP 5555 (Private Exchange):
Telegrams : READY HOP 5555, LONDON.

Price List of ALL the CORRECT
PARTS for the

REQUEST THREE

(Described in this issue).

	£	s.	d.
1 Ready Radio Cabinet, with baseboard	1	5	0
1 Ebonart Moire Panel 16 in. x 8 in.		8	0
1 pair Quest Panel Brackets		2	6
3 Lotus valve holders		5	3
2 Coil holders		1	4
1 Lissen fixed condenser, with clips		1	0
1 Lissen '001 mfd. fixed condenser		1	0
3 Dubilier 2 mfd. fixed condensers		7	6
1 Dubilier 3 mfd. grid leak		2	6
1 Formo '0003 adjustable condenser		2	0
1 Lotus push-pull switch D.P.D.T.		4	0
1 Lotus on-and-off switch		1	6
2 Lissen .0005 variable condensers		13	0
2 Ormond Vernier Dials		10	0
1 Gambrell volume control potentiometer, 5 meg.		6	9
1 R.I.-Varley 60,000 ohms anode resistance holder		7	6
1 R.I.-Varley H.F. choke		9	6
2 L.F. transformers (1 Ferranti A.F.5 and 1 Igranic 7½ to 1)	3	0	0
1 Belling & Lee indicating terminals		2	9
1 Lissen X coil, 60 turns		6	4
1 Lissen X coil, 250 turns		9	9
1 Ebonite strips (2 in. x 1½ in. and 8 in. x 1½ in.)			10
Valves as specified		1	13 6
Total (including valves)	£11	1	6

STEDIPOWER L.T. UNIT SUPER MODEL

	£	s.	d.
1 Baseboard 10 in. x 10 in.		2	0
1 Ebonite panel		4	4
1 Quest panel brackets		2	6
1 pair indicating terminals (Insulated)		1	0
1 Sifam high-grade voltmeter	1	5	0
2 Igranic Rheostats (as specified)		5	0
1 Ediswan complete battery charger	2	17	6
1 Tumbler switch		1	6
1 T.C.C. electrolytic condensers		2	5
2 R.I.-Varley Harris Stedipower chokes		2	2
Inclusive Price	£9	5	10

UNIT READY BUILT & TESTED
£9 10. 0 Complete.

Please state main's voltage when ordering.

IMMEDIATE DISPATCH
OF ANY OF THE ABOVE SPECIFIED PARTS.

WE HAVE SATISFIED CUSTOMERS
ALL OVER THE WORLD.

CALL OR 'PHONE
WRITE OR WIRE.

COME TO US FIRST—
AND SAVE TIME.

Send for our 144-page General Catalogue. Price One Shilling. Free with all Orders if requested.

INLAND: All orders post free. OVER-SEAS: Consignments carefully packed and insured, charges forward.

AT HOME WITH THE FULTOGRAPH

—continued from page 386

is so sensitive that it will operate at a current as low as 1 milliampere. This relay is only switched into circuit at the correct position of revolution of the receiving cylinder, the switching being effected for this and other purposes by a number of spring contacts which are seen in some of the photographs of the actual receiver.

An Electro-Magnetic Clutch

When the synchronising signal is rectified by the valve and passes through this relay it pulls over the tongue and switches the accumulator current through an electro-magnet which is situated on the main instrument. This electro-magnet pulls out a catch which, having previously fallen into a slot, has stopped the rotation of the cylinder, and, of course, immediately the catch is pulled out the cylinder rotates once more.

In order to avoid jarring the clockwork and generally to afford smooth running, the clockwork mechanism is rotated continuously. Simultaneously with the stopping of the cylinder by this catch an electro-magnetic clutch is brought into action and releases the clockwork from the drive, just as by pressing on the clutch of a motor car we release the engine from the gear-box.

It will be seen that the apparatus is quite complicated, but it is very well made and seems to work faultlessly. Remember that three things have to happen. The relay has to be switched in and out, the releasing magnet for the catch has to be operated, and the current has to be switched on or off the recording stylus.

The Stylus Movement

I have not shown any photograph of the underside of the recording instrument as this merely carries a high-grade phonograph or gramophone motor for driving the spindle. Incidentally, the spindle carries a fine screw thread and a knife-edged wheel fitting into this brings about the gradual movement required for the recording stylus.

To summarise, we have thus seen that at the transmitting end the picture to be transmitted is explored in such a way that the variations of light and shade at the particular point being explored are turned into varying strengths of a 1,500-frequency

electric current, and that periodically a timing signal is sent.

This combination of the modulated current and the shorter timing signal goes off from the broadcasting station, is picked up on any receiver, magnified in the usual way at the low-frequency end, and passed to the Fultograph relay panel. Here the alternating currents are rectified and at the correct moment the timing signal releases the cylinder and allows it to rotate.

Faulty Pictures

As soon as it has started to rotate the modulated signal comes along and makes a brown mark of varying strength on the moist paper. Just before a revolution is complete the marking current is switched off, the cylinder is stopped, and a moment later the timing signal releases the cylinder for a further rotation.

A
SPECIAL
HIGH-FREQUENCY
Number of
THE
"WIRELESS
CONSTRUCTOR"

will be on Sale

NEXT MONTH

At the end of the complete travel of the stylus we have a completed picture which has only to be removed from the cylinder by releasing the spring clip and dried in front of a gas, electric or coal fire. Among the illustrations I have included two or three faulty pictures for the purpose of showing what happens if adjustments are not right, although anyone capable of switching a receiving set on and off and tuning it on one dial can operate a Fultograph.

If, for example, we have adjusted the grid bias wrongly the cylinder will rotate continuously without being synchronised, and we shall get a weird effect that gives no resemblance whatever to the transmitted picture. If the machine is run too fast the picture will be too long compared with its width, as shown in the photograph of the choirboy.

If we use too strong a signal or too much reaction the picture will tend to

(Continued on page 390.)

FERRANTI

RADIO PRODUCTS



SPEAKER
with the exponential horn



PERMANENT TRICKLE CHARGER
Incorporating the Westinghouse Metal Rectifier



AUDIO FREQUENCY TRANSFORMER
TYPE AF3



FIXED CONDENSERS
TYPE C1 & C2

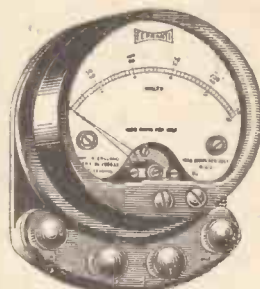

RADIO METER, PORTABLE
PATTERN

FERRANTI LTD.
HOLLINWOOD
LANCASHIRE

DUBILIER MIDGET CONDENSER



A small variable condenser for panel mounting. Especially appropriate for use as a reaction condenser, it can also serve when a neutralising condenser of large capacity is required.

If unobtainable from your dealer write direct to us giving his name and address.



DUBILIER
CONDENSERS

DUBILIER FOR DURABILITY

Advt. of Dubilier Condenser Co. (1925), Ltd., Ducon Works, Victoria Road, N. Adon, London, W.3

PRICE
Complete with knob
"00005", "0001" or "0002"
5/6

NOW ON SALE

WIRELESS CONSTRUCTOR ENVELOPES

Envelope No. 1.—THE "RADIANO" THREE. (Recently reprinted). A famous loud-speaker set which you can build in an hour or two—no soldering and a wide range of components to choose from.

Envelope No. 2.—THE "CONCERT" FOUR. Made of standard parts, all easily obtainable, this is a highly-sensitive long-distance set, giving powerful reproduction of wonderful quality on 3 or 4 valves.

In these envelopes you will find every detail of the set simply explained, photographic reproductions and diagrams are included as well as a full-size Blus Print.

AT ALL BOOKSTALLS Price 1/6

By post, 1/9, from Wireless Constructor Envelopes, the Amalgamated Press, Ltd., Bear Alley, Farringdon Street, London, E.C.4.



WIRELESS ACCESSORIES

are specially designed to minimise the possibility of a wrong or accidental connection.

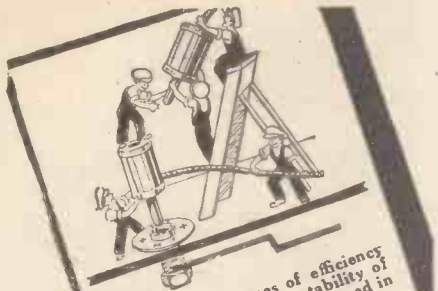

THE EELEX gnomes of efficiency illustrate here the adaptability of EELEX Plugs and Sockets used in connection with an indicating top. Plugs cost 3d. each, Sockets 1d., Indicating Tabs 1d.



That is why EELEX TREBLE-DUTY TERMINALS are different and better. By using coloured flex in conjunction with EELEX TERMINALS, mistakes and wrong connections are impossible. (T2LC) 4!d. each. (T2LN) Without indicating top, 3d. each.

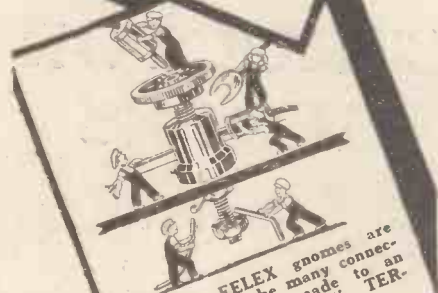

Here the EELEX gnomes are demonstrating the many connections that can be made to an EELEX TREBLE-DUTY TERMINAL.

These are a few of the EELEX wireless accessories: write for the new EELEX BOOKLET Y66 which gives full details.



Jelex House, 118, Bunhill Row, London, E.C.1

Phone: Clerkenwell 9282-3-4.

AT HOME WITH THE FULTOGRAPH

—continued from page 388

be muddy, and if we get interference, say, from a spark station, which is sometimes inevitable, the picture will tend to be obliterated owing to the brown marks caused by the interference which may come from Morse, atmospheric or another transmitting station. The first picture I received from Vienna is reproduced here, and it was almost completely spoilt by Morse interference, but the outline of a man's head can be clearly seen.

It is always advisable to connect the Fultograph receiver in parallel with the loud speaker, as we can then hear the signals coming over. The whole instrument is marvellously sensitive and will operate quite well with a far weaker signal than you would imagine. Here are a few practical points which will help you in operating the Fultograph receiver.

Some Practical Points

(1) Always use at least as much grid bias as that recommended in the instructions. Personally, I find it advisable to use about three volts more than the makers state.

(2) Be sure to adjust your receiver on the tuning note so that the needle comes within the line indicated. If your signals are too strong and you have the option of reducing strength either by detuning or by reducing reaction, always do it by reducing the reaction, as the picture will be clearer in this way. While a fair amount of reaction can be used for a successful Fultograph picture, the less one uses the better if a clear picture is desired.

(3) When you are first trying the instrument, take one picture with the tuning note adjusted to the lower red line, another to the middle and the third to the upper. Probably one of these positions will give the best picture for your particular circumstances. I find the picture is best when the needle is on the lower line.

(4) Do not use the paper too moist, and, on the other hand, do not leave it too long after wetting. I personally recommend the reader to prepare one sheet of paper before the transmission begins and to place it on the cylinder in good time and then, as soon as the first picture has begun, to moisten a second sheet, blot it off and lay it by. It takes about four minutes for each transmission, and by preparing the

(Continued on page 391.)

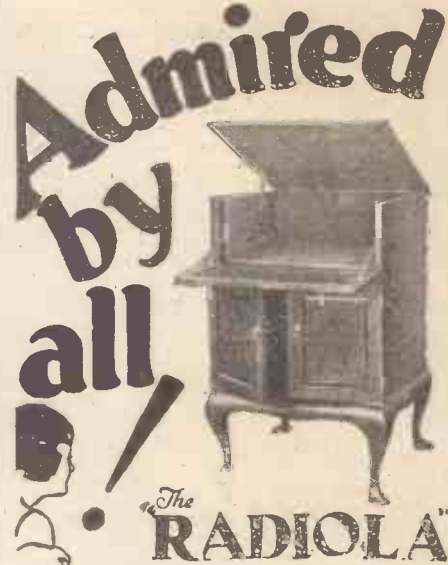

The RADIOLA

is the ideal Wireless Cabinet you have always wanted to put the finishing touch to your Set. It's a Writing Bureau, Wireless Cabinet, Gramophone Record Storage Cabinet, and a beautiful article of furniture, too! Think of the delight it will give you and your friends! Then remember you can have it on 7 days' free trial, carriage paid to your home. In polished oak or mahogany we sell it at maker's price—the lowest you can pay! Write for illustrated lists of all beautiful models, from..... 75/-

PICKETT'S Wireless Cabinets

CON. WORKS, BEXLEYHEATH, N. LONDON.



The genuine HYDRA will never break down

If you have ever had, or ever heard of, a silver grey condenser which broke down in normal use—IT WAS PROBABLY A CHEAP IMITATION OF HYDRA. There are always spurious imitations of a good article—and HYDRA condensers are so good that they have many imitators—see the label, therefore, and do not accept a silver grey condenser without the name.

HYDRA CONDENSERS

PRICES

Tested at 500 A.C. Work
Volts 240 A.C. 1 mf 3/-
2 mf 4/- 4 mf 6/9.
Tested at 1000 V.D.O.
Work Volts 300 A.C.
or 450 D.C. 1 mf 4/-
2 mf 5/- 4 mf 10/-.

Do not accept a silver grey condenser without the HYDRA label. Others are imitations and we are not responsible in case of breakdown.

LOUIS HOLZMAN,
34, Kingsway, London, W.C.2.

KEEP YOUR EYE ON THE NEEDLE OF A

SIFAM

RADIO METER AND LET IT TELL YOU WHERE DISTORTION ENDS AND PURITY BEGINS

Ask your dealer or write to Dept. W.C. for leaflet. "What simple meters can show you."

SIFAM Electrical Instrument Co., Ltd.



Dept. W.C., Bush House, Aldwych, W.C.2

AT HOME WITH THE FULTOGRAPH

—continued from page 390.

piece of paper in this way it will be quite fresh and not too moist when the picture begins.

(5) In wrapping the paper round the cylinder you will find it best to adopt the following procedure. First of all lift up the spring clip; secondly, place one edge of the paper on the cylinder in the position which will fall immediately under the clip, pass the paper round the back of the cylinder, up the front, and then lap it over so that the part which comes at the front of the cylinder lies across the other part.

READ POPULAR WIRELESS

AND KEEP IN TOUCH WITH RADIO PROGRESS.

BRITAIN'S BEST RADIO WEEKLY

Every Thursday. Price 3d.

The thumb of the right hand can hold the back of the paper and the fingers of the left should be used to smooth the moistened paper round the cylinder to prevent bulging or crinkling. It is not a bad plan to scratch a line with a sharp-pointed instrument across the cylinder, using the spring clip as a guide. This will help you to get the paper on straight.

Occasional Interference

Do not get "jumpy" about results on a distant station when fading occurs, and do not attempt to vary the strength while a picture is in course of reception. Even if interference by atmospherics, Morse and other stations seems to be making the experiment hopeless, let the instrument carry on until the whole picture is finished.

Occasionally, atmospherics or interference may trip the synchronising relay at the wrong time and foul a small portion of the picture, but immediately interference stops the machine will synchronise correctly again and you cannot really tell what the picture will be like until you have removed it from the cylinder.

At present there are comparatively few transmissions, but remember that every night you have a sporting chance on a fairly good receiver of receiving a Vienna picture.

K. RAYMOND

27 & 28a, LISLE ST., LONDON, W.C.2

Come to LEICESTER SQUARE CLUB. This address is at the back of Daly's Theatre. Phones: Gerrard 4637 and 2821

WE ARE OPEN

ALL DAY EVERY DAY Hours 9 a.m. to 8 p.m.
ALL DAY SATURDAY Sat. 9 a.m. to 9 p.m.
ALL DAY THURSDAY Sunday morning 11-1

C.O.D. SEND ORDER. PAY POSTMAN. (U.K. Only.)
Must be over 5/- value.

MULLARD MASTER 3*

5 Valve Holders, Lotus, at 1/3; Combined Wave Coil, 17/6; Permacone Transformer, 25/-; Climax 'LFA' Transformer, 25/-; Climax H.F. Choke, 7/6; Benjamin Battery Switch, 1/3; J.B. '0005 Log, 11/6; '00035, 10/6; Mullard '0003 and 2 meg. 5/-; Magnum Panel Brackets, 2/6; Mullard '0001 Fixed, 2/6.

Total £5 : 12 : 6 Carriage free, U.K.

FOR 3/6 EXTRA, I will include:
2 Handsome S.M. Dials, Set of Connecting Links, 8 Plugs, 2 Spades, 4 Engraved Terminals, 2 Ebonite Strips, Twin Flex, Splendid Aluminium Panel, 18 x 7, drilled ready for use, 9-volt Grid Bias Baseboard.

LEADING HOUSE FOR KITS OF PARTS

See Weekly Advt's.

Any list of components over 25/- quoted for at a special price, where possible.

HANDSOMELY OAK POLISHED SPEAKER CABINETS 13 x 13 x 6



12/11 POST
1/3

Cannot guarantee exact pattern of front panel, but all good designs.

Blue Spot 25/-
66K (101)

OR THE LOT WITH BUCKRAM CONE 12" Carriage **35/-** Paid

SQUIRE CONE UNITS

For Bal. Armature Units.

No. 75 Cradle ... 10/-
7 in. Cone Kit ... 2/3
No. 60 Cradle ... 8/6
6 in. Cone Kit ... 2/-
Postage extra under 5/-.

A PLYWOOD CLAMPING WASHER IS SUPPLIED FREE WITH EACH COMPLETE SET.

Comprising No. 97, KRAFT Diaphragm, CARD Ring and Seg-ments. (Postextra).
Aluminium Cradle Frame; ready to use (post free) **12/6**
Complete Lot 15/-.

DARIO RADIO MICRO.
2-v. and 4-v. G.P. 5/6;
Power, 7/6; H.F. Super, 7/6.
Post 6d. (3 free)

ALL PARTS FOR MULLARD MASTER 5 IN STOCK.

BULGIN MULTI-COIL 15/6

140 p. CATALOGUE ILLUSTRATED ALL LATEST 3rd COMPONENTS

P.R. VALVES IN STOCK.

OSRAM MUSIC MAGNET Kit of Parts & Valves, £8 : 12 : 6.

BOOKLET FREE.

STANDARD (P.W., M.W., A.W.) LOADING COILS, 7/6.

DUAL 6 PIN COIL (Finston) 7/9

ORMOND

3.M Drum Dial, 5/-; Rheo-stats, 6, 15, 30 ohm, 2/-; Midget '0001 max., 4/-; Log. '0005 and 4" Dial, 3/-; Log. '0003 and 4" Dial, 3/6. S.L.F. No. 3 same price. We always stock all ORMOND PARTS

COUPON. W. CON. MARCH

ONLY ONE COUPON ON ANYONE ORDER
If you spend 25/- or more you can buy for 3d. extra any one (only) of the following:
S.M. Dial, 100 ft 7/22 Copper Aerial, 12 yds. Lead-in Fuse and Holder, 12 Nickel Terminals, 60X Coil, H.F. Choke, Permanent Detector, Battery Switch, '0003 and 2-meg. Leak, 9-volt Grid Bias, Panel Brackets, 6-pin Coil Base, 100 ft. Insulated Aerial, Loud Speaker Silk Cord, 30 ft Covered Connecting Wire, Ebonite Panel, 9 x 6, 12 yds. Twin Flex, 00 ft. Indoor Aerial, Cycle Rear Reflector.

SPECIAL COUPON.

(Only available at K. Raymond's).
POST or CALL with this coupon, and if your order is £3 or over FOR 6d. EXTRA you can buy one of the following (state which required):
2 mfd. Mansbridge Condenser; '0005 S.L.F. Variable Condenser; 4 in. Slow Motion Dial; 100 ft. Silk Frame Aerial Wire; '0001 Reaction Condenser; 16-volt Grid Bias, tapped 11; 12 yds. Extra Heavy Double Rubber Lead-in; 5-way Battery Cord for H.T. and L.T.; 10 Engraved Terminals (take plug or spade), state names required.
DON'T FORGET THE COUPON (W.Con.)

THE ONLY UNIVERSALLY STANDARDISED COMPONENT IN RADIO!

TYPE 'B' 6d.
TYPE 'M' 4 1/2.
TYPE 'R' 3d.



BELLING-LEE TERMINALS

BELLING & LEE, LTD., Queensway Works, Londers End, Mdx.



EVERY VALVE SET USER NEEDS A WATES "three in one" VOLT-AMP RADIO TEST METER

YOU may have a caseboard full of components—BUT you cannot hope to obtain a real QUALITY in reception unless you have that perfect set control ensured by accurate Volt and Amp. readings! All you want is a Wates Meter. With its three readings on one dial feature it has an immensely wider range of usefulness—yet it costs no more than single-purpose instruments. Obtain one now and let it reveal what a world of difference lies in the expert handling of your set. Obtainable from your dealer or direct, complete with explanatory leaflet. Stocked by Halford's Stores, Curry's Stores and all Radio Dealers.

READINGS:
 0—150 VOLTS.
 0—6 VOLTS.
 0—30 MILLIAMPS.
 Res. 5,000 ohms.

PRICE
8/6

Crystallised black finish.

THE STANDARD WET BATTERY Co. (Dept. W.C.4) 184-188, Shaftesbury Ave., LONDON W.C.2.



Three in One M.B.

Keep on Saying DARIO for Radio See page 379.

The Picture Paper with the MOST News :: SUNDAY GRAPHIC ::

ARTCRAFT RADIO CABINETS
 BRITAIN'S BEST VALUE
 New Catalogue Free
 THE ARTCRAFT COMPANY
 156, CHERRY ORCHARD ROAD, CROYDON

EXPERIMENTING WITH THE 31 NEW CIRCUITS

—continued from page 333

fluctuation in its value will completely upset adjustments and produce noise. A wire-wound resistance is advisable here, although a good make of grid leak will be quite suitable, and was indeed used in some of the original experiments.

Circuit No. 11 opens up a wide field for experiment, and will give the reader a good opportunity of seeing just how easy it is to make a three-valve receiver. There are no transformers, and it is quite easy to make experimental resistances for anode and grid leaks at home by rubbing a thin layer of Enameline stove polish on paper and cutting the blackened paper so obtained into strips of varying width, say, an inch and a half long and half an inch wide for the anode resistances, and an eighth of an inch for the grid leaks.

The Coupling Capacities

This will make the leaks four times as high in resistance as the anode resistance, which is a good general proportion. In order to get good reaction effects the combined value of R_2 and R_3 must be fairly low, for which reason two $\frac{1}{2}$ -megohm grid leaks in parallel are suggested here. The set will work well with any good grid leaks, and the value of the coupling condensers C_5 and C_6 can both be .006 mfd., not because this is the best capacity here, but because .006 mica condensers are obtainable very cheaply and will, after all, give excellent reproduction even if it is slightly deficient on the lowest tones.

A Wave Change Scheme

Circuit No. 12 incorporates a wave-change scheme which is quite simple and will give the maximum strength of signal, but the selectivity is not very high with this arrangement. To get greater selectivity the circuit used for the "Request" Three, in the current issue, is much better, but when a man wants to get the maximum strength from one station the arrangement in Circuit 12 is preferable.

It must not be imagined, however, that the selectivity with the arrangement shown is very poor; it will probably give all that is needed provided you have no station nearer than thirty or forty miles. But as the great majority of readers have a station closer than this, the very high selectivity given by the arrangement in the "Request" Three is preferred.

TO HOME CONSTRUCTORS

Build the Peerless "Resonic 2"



Regd. No. 456002

Anyone can build this set in 60 minutes. No drilling. No soldering. All wires cut and bent. JUST ASSEMBLE and then immediately enjoy the radio entertainment which is of splendid tone and comes in at good loud-speaker volume. Circuit allows use of standard valves (1 H.F. and 1 Power). Blue Print and easily followed Diagram of Connections included with every set. Cabinet and full Kit supplied in Carton.

COST ONLY
£3.15.0

Obtainable from all dealers or THE BEDFORD ELECTRICAL & RADIO CO., LTD., 22, CAMPBELL ROAD, BEDFORD. Scottish Office: 113, St. Vincent St., Glasgow, C.2.

SOLVE ALL H.T. TROUBLES

LONG LIFE SILENT ECONOMICAL

— SELF GENERATING —

JARS (waxed, 2 1/2" x 1 1/2" sq. 1/3 doz. ZINCS, new type 11d. doz. BACS 1/2 doz. Sample doz. (18 volts), complete with bands and electrolyte. 4/3, post 9d. Sample unit, 6d. illus. booklet free. Bargain list free.

AMPLIFIERS 30/- 3-VALVE SET £5
 G. TAYLOR, 57, Studey Road, STOCKWELL, LONDON

CLIX The Better Terminal

CLIX PANEL TERMINAL 4^D



Better in many ways. It takes Spade, Pin, or bare wire connection quickly and gives perfect contact. Has polished insulated knob with metal inserts. The non-soldering wiring device gives excellent contact and makes assembly easier. Is highly nickel-plated and improves the appearance and performance of any receiver. Ask your dealer or write for the Clix catalogue. LECTRO LINK LTD., 254, Vauxhall Bridge Road, S.W.1.

QUALITY COUNTS!

The persistent high quality, in every way, of Gam-brell Products keeps them ever to the fore. The two described here, the Voluvernina and the Neurovernina, have both consistently proved their worth under all conditions of use.

GAM-BRELL NEUROVERNINA

The fact that this is chosen for inclusion in so many commercial sets and receivers described in technical papers is proof that it is a real quality component and one which does its duty as Reaction Control, Balancing Condenser or Neutralising Condenser with perfect efficiency.

PRICE **5/6**

GAM-BRELL VOLUVERNINA

A small, neat, compact and efficient Volume Control. The movement is smooth and velvety and gives a continuous and evenly variable control of volume from full strength right down to nothing. Its resistance value makes it also suitable for use with Gramophone pick-ups.

PRICE **6/9**

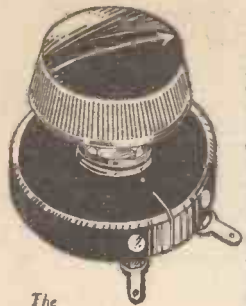

The Voluvernina

Please write for the Gam-brell Components Booklet (C)
GAMBRELL RADIO, LTD.
6, Buckingham St., Strand, London, W.C.2.

for **10/6**

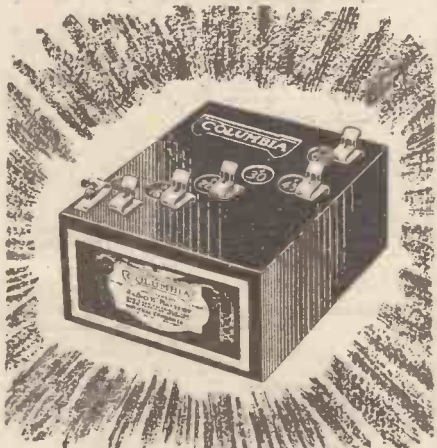

The World's BEST Battery Value

The new 10.6 60-volt Columbia brings the world's most famous battery into your home. Columbia are definitely the world's best H.T. Batteries and every discriminating radio enthusiast uses them.

Columbia RADIO BATTERIES

J. R. MORRIS, Imperial House 13 King'sway London, W.C.2
SCOTLAND: J. T. CARTWRIGHT, 3 Cadogan Street, Glasgow

THE "THREE-CHOICE" FOUR

—continued from page 354.

contacts, for if these are left till later some awkward tasks may result. Connect the bottom contact of the first jack, which is of the single filament pattern, to the nearest terminal of the under-screen and the next contact to the grid of V_1 by means of a lead passing through the baseboard.

Another lead through the baseboard connects the filament negative terminal of this valve to the second jack contact, and the top contact is wired to the unoccupied terminal of the fixed resistor R_1 . From the plate terminal of the valve holder (that is, the screen grid of the V_1) a wire is brought through the baseboard to one of the contacts of C_2 , the other is wired to a terminal of the under-screen and this lead is continued to one of the contacts of C_3 .

Connect the second contact of C_3 to the unoccupied terminal of the first high-frequency choke. Now attach the 2 in. by 2 in. terminal panel, with two holes drilled in it for the H.T. +75 and H.T. +120 terminals. To the former terminal take a wire from the contact of C_2 , which is connected to the screen grid. The second terminal is connected to the contact of C_3 , to which the lead from the first high-frequency choke goes.

The G.B. Battery

Place the first grid battery, G.B.₁, in position by cutting out a thin strip of tin or sheet copper and fastening it down over the battery with a couple of screws. Connect the negative terminal to one terminal of R_2 and to the lowest contact of the second jack, which is of the single closed-circuit pattern.

From the second terminal of R_2 take a lead to the centre tapping of the coil. Join the positive contact of the grid battery to one terminal of C_3 and connect this terminal also to one of those upon the under-screen. A third wire from the condenser terminal is taken to the second contact of J_3 , which is of the single-filament, control pattern.

The actual soldering of this wire may be left until the jack itself comes to be dealt with. From terminal A of the coil take a wire to the second contact of J_2 , and connect the top contact to the grid of V_2 . Connect one contact of C_6 to the unoccupied terminal of C_7 , and the other to the plate of V_2 .

(Continued on page 394.)

BETTER THAN YOU EVER DREAMT OF—



CELESTION, the Loud-Speaker used by all the leading national set manufacturers, is "Better than you ever dreamt of." Celestion has been acclaimed "First On Merit—On Demonstration" because of its realistic powers of reproduction, its symmetrical beauty and finished craftsmanship, which together create an atmosphere of rare distinction in the most discerning home. Hear Celestion for yourself at our showrooms, one minute from Victoria Station, where you can also hear the finest radio sets.



Model C.14.

BRITISH THROUGHOUT

Made under Licence. Models from £5.10.0

SHOWROOMS:

106, VICTORIA STREET, LONDON, S.W.1.

CELESTION

The Very Soul of Music

Write for Illustrated Booklet "L."

CELESTION, KINGSTON-ON-THAMES.

WHEN A BETTER LOUD-SPEAKER IS MADE—CELESTION WILL MAKE IT.

**END
COSTLY
REPLACEMENTS**



**Install once & for all
STANDARD**
SAC RECLANCHE
PERMANENT H.T. SUPPLY

Why put up with out of date and costly forms of H.T. supply when for 7/6 down you can obtain the wonderful Standard Wet H.T. supply that lasts for years. It banishes all worry over high tension. It is always up to voltage because IT RE-CHARGES ITSELF OVER-NIGHT and in the morning is as fresh as the dawn. All that is necessary to maintain the voltage is replenishment of the elements at long intervals, beyond which little or no attention is needed. The Standard Battery ensures A VAST IMPROVEMENT IN RECEPTION because its super cells maintain a constant pressure of current.

**REDUCED
PRICES** NOW **7/6
DOWN**

Prices are now reduced on all models of the battery and all spare parts. 96-volt Popular Model "Umblo" Cabinet was 3/1 down, now 7/6 down and five monthly payments of 1/6. Cash £2. 3s. 1d. Obtainable from Halford's Stores, Curry's Stores and all Radio dealers on cash or deferred terms.

Also Super Capacity No. 2 Battery 3/8 down and five instalments of 2/8.

WRITE NOW FOR FREE NEW BOOKLET giving full details of new price lists, and complete table showing life of battery, which assists in selection of right battery for your set. Take the first step to permanent H.T. SEND NOW.

THE STANDARD WET BATTERY CO.
(Dept. W. C.), 184-188, Shaftesbury Avenue, W. C. 2

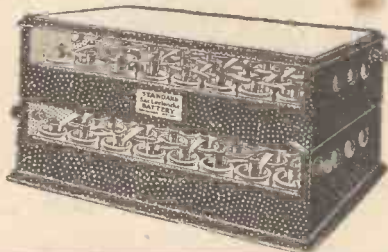

M. B. 2028

CLAROSTAT



VARIABLE RESISTANCES FOR VOLUME, TONE, DISTANT CONTROL, ELIMINATORS ETC.,

As frequently specified by "The Experts."
• HIGH QUALITY • LOW PRICE •
New 20 Page Brochure free on request.
Many unique circuits.

CLAUDE LYONS LTD.
76, OLDHALL ST., LIVERPOOL.

Make
The DAILY SKETCH
YOUR Picture Paper

THE "THREE-CHOICE" FOUR

—continued from page 393

Take a wire from the unoccupied terminal of C_8 to one of those of C_9 , and connect this terminal of C_9 also to the unoccupied terminal of the resistance R_3 . The second terminal of C_9 is connected to contact A of the volume control and to the grid of V_3 .

Connect the plate of V_3 to one terminal of C_{10} , and take a wire from this terminal also to OP of the transformer*. IP of the transformer is connected to one contact of C_{11} . From this contact a wire is taken to the lowest of J_3 . The soldering of this last connection can again be left for the moment. To the second terminal of C_{16} attach the grid leak R_4 .

We are now ready to tackle the switch. In this, contact No. 1 must be connected to contact No. 2 and No. 3 to No. 4 to begin with. Connect OS of the transformer to contact No. 6, and IS to No. 7, the grid leak R_4 to No. 8 and terminal B of the condenser C_{10} to No. 5. To contact No. 4 attach a length of flex and bring this up through the baseboard.

Second Terminal Panel

Drill the second terminal panel as shown in Fig. 9 and place it in position with its terminals mounted. Connect H.T.— and L.T.— together. Take a wire from L.T. + to the unoccupied terminal of R_6 , one from H.T. + 100 to terminal A of C_{11} , from H.T.— or L.T.— to the terminal B of that condenser and from H.T. + 90 to terminal B of the resistance R_3 .

Connections may now be soldered to J_3 . Begin with the lead already mentioned from terminal A of C_{11} , which goes to the lowest contact. To the contact next above goes a wire from the plate terminal of V_4 . To the second contact from the top we connect the wire from terminal B to C_8 , and to a bared portion of this wire a piece of flex is soldered and passed through the baseboard.

We complete the job by connecting the L.T. negative terminal to the top contact of the jack. All that remains to be done is to place the grid battery in position—it may be fixed by jamming it against the panel with a couple of small Meccano brackets—to measure off suitable lengths for the positive and negative leads to it and to provide these with wander plugs.

*This is the connection for the Marconi Ideal and for certain other transformers; there are, however, others which work better with the plate connected to IP.



**LISENIN
MADE THEM—**

Lisenin, pioneers of the plug and socket terminals, once and for all banished the old eyesore of untidy terminals. Lisenin introduced—and patented—the fool-proof positive Cone grip terminals—the only terminals that ensure a neat and absolutely secure connection.

That is why Mullard and the Sixty circuits specify Lisenin; that is why YOU should adopt Lisenin terminals. Obtainable at all dealers.

Lisenin Wander Plugs and Spade Ends are also specified by the "Wireless World" for the Picture Receiver.

Worth writing for—the New Lisenin Booklet.

**MULLARD
ADOPTED THEM**

Look for the Lisenin Show-case on your dealer's counter.



LISENIN

Sole Manufacturers and Patentees:
1C, Edgware Road, London, W. 2.

REPAIRS

Any make of L.F. Transformer, Loudspeaker or Headphones repaired and despatched within 48 HOURS—TWELVE MONTHS' GUARANTEE with each repair. 4/- Post free.

Terms to Trade.
TRANSFORMER REPAIR CO.,
Dept. "C,"
214, High Street, Colliers Wood, London, S.W. 19

Write for the New
**DARIO
Folder**
See page 379.

PLEASE be sure to mention
"Wireless Constructor"
when communicating with
Advertisers. THANKS!

The BEST WAY

to achieve

IDEAL RADIO RECEPTION

is to scrap your OLD and OUT-OF-DATE Components and build a set with the latest products of TECHNICAL SKILL.

OUR

EASY TERMS

Enable you to reach this Ideal.

ALL COMPONENTS SUPPLIED FOR MULLARD MASTER 3*; COSSOR MELODY MAKER; LISSON S-G-3; MASTER 5 PORTABLE, Etc.

EVERYTHING WIRELESS

PORTABLE SETS from 16 gns.—Pye, Lotus, Halcyon, Lissen, etc.
H.T. UNITS from 17/6—EKCO, ATLAS, MARCONI, etc.
LOUDSPEAKERS from 20/6—Celestion, Amp-lion, M.P.A., etc.

BEST MONTHLY TERMS QUOTED BY RETURN

CASH ORDERS PROMPTLY EXECUTED

Call or send list of requirements. Hundreds of Satisfied Customers recommend us.

The P.D.P. Co., Ltd. (Dept. C.), 121, CHEAPSIDE, E.C.2

Telephone: City 9846

DARIO

This month's best bargain
See page 379.

MONOTUNE ENVELOPE FREE. INCREASE YOUR RANGE. ORDER YOUR PARTS C.O.D.

Send 1/2 for comp. Construct. Envelope of this 10-station single tuning Set by Allinson. 1/- allowed on first 10/- order for any radio goods. Circular and list parts free. Particulars of my new SCREENED GRID UNIT which gives great selectivity and almost unlimited range to Monotone. Melody Maker Master-3 or any similar Set. Immediate despatch of Polar, Colvern, Mullard, Telsen, Lotus, McMichael, Dugiller, Radiax or other standard goods, cash on delivery or Easy Payments for lists of parts.

OAKLEYS, 43, CARLETON ROAD, LONDON, N.7.
ALL APPLICATIONS FOR ADVERTISING SPACE IN "WIRELESS CONSTRUCTOR" must be made to the Sole Advertising Agents, JOHN H. LILE, LTD., 4, LUDGATE CIRCUS, LONDON, E.C.4.

The **SIFAM** RADIO FUSE completely PROTECTS RADIO CIRCUITS



Protects your radio circuit just as an electrical house circuit. Connected in series, completely protects valves and meters from overload. Saves untold trouble and cost. Price: 50 up to 500 M.A., Complete with slip from dealers, or direct. Send for yours NOW!

SIFAM LTD., Dept. W.C., Bush House, Aldwych, London, W.C.2. M.B.

TRADE JOTTINGS

A brief review of recent issues of trade catalogues and literature.

If you jot down some notes about an ordinary trade, and then compare them with some wireless trade jottings, you will see why it is that no other hobby can touch radio. There is always something interesting going on and it is this romance behind the radio trade that makes it such a thrilling hobby and never-fading delight.

Not only large cities and the centres of civilisation have felt the radio fever, but even Tristan da Cunha, the world's loneliest island, is to have a three-valve short-wave wireless receiver. Not many people have heard of Tristan da Cunha, and only very, very few have been there.

Revolutionised by Radio

Ever since the first settlement by Peter Glass, in 1816, the inhabitants of this tiny Empire post have been cut off from the world except for an occasional visit by some specially chartered ship every twelve months, two years, or so.

But is Tristan da Cunha going to do without a wireless? Not a bit of it! For when the Rev. A. G. Partridge takes up his voluntary duties as chaplain there, he will have with him a standard Marconiphone three-valve short-wave set. This set has been presented to the Tristan da Cunchans by the Editor and friends of "The African World," and thus at one stroke the little island community will be revolutionised by radio.

The Charging Question

Instead of hearing a strange voice once every two years or so, they will be brought into daily contact with three continents—Europe through 5 S W, the Chelmsford station, and P C J, Holland; America through 2 X A D, 2 X A F and other short-wave stations; and Australia through 2 F C, Sydney, and perhaps 3 L O, Melbourne. It is possible also that the Cape Town station may be received, but even if touch cannot be established with Africa, the Tristan da Cunchans will find there is plenty going on in Europe, America, and Australia. I wonder what they will make of all the jazz and jiggery-pokery that goes on in the ether?

Naturally there are no facilities for charging batteries upon Tristan da Cunha, so the high-tension supply to

A HIGH MAST IS EQUAL TO TWO EXTRA VALVES

Everybody knows that to have a high aerial is to get extra powerful signals. The difficulty of fixing up a high aerial is banished if you fit a

P.R. WIRELESS MAST

DAMP PROOF!
ROT PROOF!!
GALE PROOF!!!

26 Feet high. In 3 sections of 1 1/2 in. Steel tube tapering to 1 in. Carriage, London, 1/6; Midlands, 2/6; elsewhere, 3/6. Weight 24 lbs. Two masts for 28/8.

34 Feet high. In 4 sections of 1 1/2 in. Steel tube tapering to 1 in. Carriage, London, 2/6; Midlands, 3/6; elsewhere, 4/6. Weight 34 lbs. Two masts for 40/-.

15'-
21'6

THE JOY OF SURPLUS POWER

The "Super" Mast.
42 Feet high. In 5 sections of heavy 1 1/2 in. Steel tube tapering to 1 in. A real bargain. Carriage, London, 2/6; Midlands, 3/6; elsewhere, 4/6; Weight 46 lbs. Two masts for 55/-.

P.R. MASTS are made of British Steel in 9 ft. lengths, from 1 1/2 in., tapering to 1 in., and are supplied with cast-iron bed plate, steel ground pegs, stay rings, galvanised steel flexible wire stays cut to lengths; pulleys, bolts, and fullest erecting instructions. No further outlay necessary.

NO HOLES TO DIG. ONE MAN'S JOB.

Any intelligent man can assemble and erect a P.R. Mast in a couple of hours. Our patent Mast being tapered, it is easy for anyone to raise it from the ground into position. Ordinary tubular Masts require several hands and difficult rigging to do this. To help you the wire rope is sent cut to size—a saving of endless worry. Imagine sorting out 500 ft. of rope in your back garden!

Minimum Radius 3 ft. 6 in.	GUARANTEE Money refunded without question if not satisfied.	The easiest Mast to erect.
----------------------------	---	----------------------------

PAINTING. Any protective coating applied before dispatch gets so damaged by the Carriers that it is essential to paint the Mast before erection. All P.R. Masts are sent out oxide-finished ready for painting. One coat of P.R. Colloid covering applied—a 10 minutes' job—to all parts of the Mast when ready to erect sets dead hard in an hour and protects it against all weathers.

PRICE OF ACCESSORIES. P.R. Colloid Covering sufficient for a Mast—with brush, 2/6. Halyard Log Line—Byland's patent rot-proof; For 26-ft. Mast, 1/6; 34 ft., 2/-; 42-ft., 2/6. Per 100 ft., 3/-. Note—Double length supplied to make lowering of Aerial easy.

A HIGHLY EFFICIENT AERIAL. P.R. Aerial is made of 14-28 High Conductivity Pure Copper Enamelled Wire—each strand insulated from its neighbour to give the highest signal strength obtainable. 100 ft., 4/3; 50 ft., 2/3.

C.O.D. Telephone: City 3788.
17-46, PATERNOSTER SQUARE, LONDON, E.C.4
Opposite G.P.O. Tube.

P.R. MASTS
IF YOU USE VALVES it will pay you to write to us for particulars of the famous 3/6 range of P.R. valves. Each valve has a written guarantee of life and performance.

(Continued on page 396.)

TRADE JOTTINGS

—continued from page 395

the set will be taken from a bank of ninety large Leclanché cells of the type used for bell circuits, and the valve filaments will be heated by special Sterling Invicta cells. It is calculated that these should last twelve months, and as it is hoped that arrangements will be completed for a special schooner from Cape Town to call once every year, there should be no interruption of reception on Tristan da Cunha.

The Radio Cabinet

“What is the difference between a Prime Minister and a home constructor?” I’ll tell you: “If the Prime Minister has a split in his Cabinet he goes to the country. But if the home constructor has a split in his cabinet he goes to the town—and curses the man in the shop who sold him a dud cabinet!”

I am reminded of all this by particulars I have just received from the Pickett people, of Bexleyheath, of the various cabinets and loud-speaker containers which this well-known firm manufactures.

Readers will remember that the “Business Man’s Four” cabinet was a Pickett production (a handsome Queen Anne affair, which that lady would have been proud to possess had she not unfortunately gone to ground before the radio pioneers came along). But what is not so well known is that the Pickett Bros. have a great number of comparatively inexpensive cabinets for smaller sets, so that constructors who want to make sure of good quality, and yet have not many of those nice new Treasury notes, need not be afraid of letting

Pickett Bros. know their requirements, for the firm is doing a very large trade in this class of work.

A Change of Address

Traders and the many other radio friends of Mr. J. L. Goldsman will be interested to know that he has now severed his connection with Fada Radio, Ltd., as service engineer. Mr. Goldsman is still acting in a consulting capacity to the Fada people, but he has now opened new offices and testing laboratory in his own name. All enquiries, therefore, for service under Fada or any American and English apparatus

Don't Miss

“The Air Commander”

in next month's

Wireless Constructor

Order Your Copy Now!

will be efficiently conducted by Mr. J. L. Goldsman, of 4, Great Queen Street, Kingsway, London, W.C.2, and if you want him on the 'phone ask for Holborn 8338. (It's quite likely you will get the wrong number, of course, our telephonists being the girls they are—but you stick out for Holborn 8338, and eventually you will get Mr. Goldsman.)

Standard Wet Batteries

The Standard Wet Battery Co., of 184-8, Shaftesbury Avenue, London, W.C.2, have just sent me a copy of their latest book on the

Standard Wet H.T. battery, and also the complete instructions for the assembly and maintenance of the Standard Sac Leclanché battery. Both of these books are thoroughly up-to-date new issues, revised up to January 1st, 1929, and both of them are uncommonly attractive.

The Standard Wet Battery Co. are pioneers in developing and manufacturing wet Sac Leclanché cells for radio work, and that they have nothing to learn at the game is shown by the complete and painstaking nature of the books, which are full of really practical information about the supply of current for radio receivers. Instead of answering in queries merely by sending a price list, the Standard Wet Battery Co. issue this in the form of a well-illustrated book, dealing with the whole subject of Leclanché batteries for either H.T. or L.T. supply, and no constructor who is interested in the subject should fail to get this book of simple instructions and practical information.

As readers will know, it is necessary with this type of battery first to assemble it and then occasionally to renew the parts, i.e. the sacs, zincs, and the electrolyte. This assembling and maintenance is quite as important a part of the business as the purchase of the cells in the first place, and it is with a view to making it both simple and satisfactory that the instructions for assembly, maintenance and use have been issued. Nothing could be clearer than the directions given in these books, and the hints cover every practical point that arises, such as the housing of the battery, its dimensions, suitable containers, etc.

Even a space for notes is provided, so that everyone interested is recommended to write for this copy straight away, for there is sure to be a big demand.

INDEX TO ADVERTISERS

Artercraft Company, The	PAGE 392
Bedford Electrical & Radio Co., Ltd.	392
Benjamin Electric, Ltd.	384
Belling & Lee, Ltd.	391
British General Mfg. Co., Ltd.	381
Brown, S. G., Ltd.	367
Burton, C. F. & H.	381
Burne-Jones & Co., Ltd.	378
Carrington Mfg. Co., Ltd.	385
Celestion Radio Company	393
Cosser, A. C., Ltd.	324 & 373
Day, Will, Ltd.	382
Dubilier Condenser Co. (1925), Ltd.	389
Eastick, J. J., & Sons	390
England-Richards Co., Ltd.	381
Ferranti, Ltd.	389
Formo Company, The	385
Gambrell Radio, Ltd.	393
Garnett, Whiteley & Co., Ltd.	357

Gilbert, J. C. (Cabinets)	PAGE 383
Holzman, Louis	390
Hughes, F. A., & Co., Ltd.	387
Heyberd, F. C., & Co.	383
Igranic Electric Co., Ltd.	380
International Corr. Schools, Ltd.	385
Impex Electrical, Ltd. (Dario Valves)	379, 392, 394, 395
Jackson Bros.	383
Lissen, Ltd.	355
Lisenin Wireless Co.	394
Lectro Linx, Ltd.	392
Lewis, S. W., & Co., Ltd.	388
London Elec. Wire Co. & Smiths, Ltd.	387
Lyons, Claude, Ltd.	394
Marconiophone Co., Ltd.	321
Metro-Vick Supplies, Ltd.	Cover iii
Morris, J. R.	393
Mullard Wireless Service Co., Ltd.	Cover ii
Oakleys	395
Ormond Engineering Co., Ltd.	395
P.D.P. Company	395
Pickett's Cabinet Works	390
Philips Lamps, Ltd.	371

Precision Radio & Mfg. Co., Ltd.	PAGE 382
P.R. Valves	377
P.R. Masts	395
“Popular Wireless” Blue Prints	368
Raymond K.	391
Ready Radio Supply Co.	388
Rothermel Corporation, Ltd.	322, 323, 384
R.I. & Varley, Ltd.	Cover iv
Ripaults, Ltd.	386
Sifam Electrical Inst. Co., Ltd.	391, 395
Standard Wet Battery Co.	392, 391
Taylor, C.	391
Telegraph Condenser Co., Ltd.	358
Telsen Electric Co., Ltd.	385
Transformer Repair Co.	394
Weston Elec. Inst. Co., Ltd.	370
Wingrove & Rogers, Ltd.	368
Whiteley Boneham Co., Ltd.	385
Wireless Pictures (1928), Ltd.	375
“Wireless Constructor” Envelopes	389

All communications concerning advertising in “Wireless Constructor” must be made to John H. Fildes, Ltd., 4, Ludgate Circus, London, E.C.4. Telephone: City 7261.

Reliable Resistances result in Rich Reception

The most perfect form of Coupling between Stages

Lowest in Cost due to 'Met-Vick' Moulded Resistances



MET-VICK COUPLING UNITS

complete for

5/-

MET-VICK DETECTOR UNITS

complete for

2/6

MET-VICK MOULDED RESISTANCES

Anode & Grid Leak for

1/2

The results obtained from Met-Vick Skeleton Resistance Units cannot be improved upon, even by using expensive wire-wound resistances. The values of the components have been carefully calculated to give maximum amplification per stage and as moulded resistances and leaks are used, their values are retained indefinitely and they are noiseless in operation. List MS 4761

The use of moulded resistances in 'Met-Vick' Skeleton Detector Units, ensure freedom from 'rushing' noises often experienced with surface deposit leaks. Both the condenser and the grid leak components retain their original values, quite unaffected by climatic or other variable conditions.

List MS 4761.

Similar to those embodied in the Coupling and Detector Units 'Met-Vick' Moulded Resistances are available as separate components. They are chemically inert, the entire material being the actual resistance element. They

1. Carry heavy currents 5-10 milliamps without becoming noisy.
2. retain their values
3. Are non-inductive. They are ideal and inexpensive.

List MS 4760

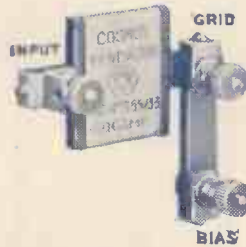
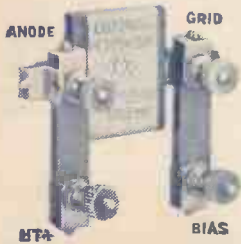

Met-Vick Skeleton Resistance Coupling Units for Mains Operation with Met-Vick A.C. Valves:—

Anode Resistance 200,000 ohms }
Grid Leak 1 megohm } **5/-**
Coupling Condenser '005 mfd. }

Similar for Battery Operation:—

Anode Resistance 400,000 ohms }
Grid Leak 3/4 megohm } **5/-**
Coupling Condenser '005 mfd. }

Extra for Moulded Base . . . 1/3

Met-Vick Skeleton Detector Unit for Mains Operation:—

Grid Condenser '0003 mfd. . . } **2/6**
Grid Leak 1/2 megohm . . . }

Similar for Battery Operation:—

Grid Condenser '0003 mfd. . . } **2/6**
Grid Leak 2 megohms . . . }

Extra for Moulded Base . . . 1/3

Anode Resistances:—			
100,000 ohms	.	.	1/2
250,000 "	.	.	1/2
500,000 "	.	.	1/2

Eliminator Resistances:—			
25,000 ohms	.	.	1/2
50,000 "	.	.	1/2

Grid Leaks:—			
1 megohm	.	.	1/2
2 megohms	.	.	1/2
3 "	.	.	1/2

Clips for mounting . . . 1/3

MET-VICK

Components, Valves and Sets

Metro-Vick Supplies Ltd., 155 Charing Cross Road, London, W.C.2

WE ARE EXHIBITING AT THE BRITISH INDUSTRIES FAIR, BIRMINGHAM, FEBRUARY 18th TO MARCH 1st, BLOCK 20M

Used by
Mr. Percy Harris



In choosing this L.T., L.F. Choke by R.I. & Varley for his new Stedi-power, Mr. Percy Harris showed a fine discretion. He could not have made a better choice. None of the usual troubles, generally associated with smoothing chokes, are to be found in this instrument which will carry loads up to 3 amperes while maintaining its remarkably high efficiency. It is the ideal smoothing choke, and has the very low D.C. resistance of 0.5 ohms.

Like all the famous R.I. & Varley components it is sturdily built, and attractively finished in neat metal shroud.

Price
21/-

This component conforms in every way to the Recommendations laid down by the I.E.E. Sub-Committee, relative to eliminator components.

Section E of our new Catalogue, free on request, gives full particulars.

PERFECT BALANCE

4 TERMINAL TRANSFORMER

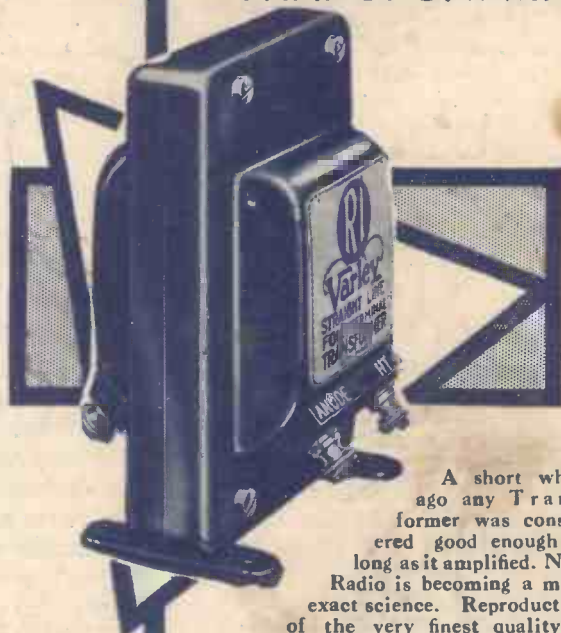

A short while ago any Transformer was considered good enough as long as it amplified. Now Radio is becoming a more exact science. Reproduction of the very finest quality is demanded, and only high-class transformers ensure really good results.

This R.I. & Varley Straight Line Transformer is a wonderful example of mechanical efficiency. Its National Physical Laboratory curve proves beyond doubt its exceptional capacity for amplification over the whole musical scale. A huge range of frequencies—25 to 6,000 cycles—is covered. This means equal volume on high and low notes, and thus an added balance and realism to the music.

Ask for a demonstration of this instrument—stocked everywhere.

4-Terminal Straight Line Transformer.

22/6

Section D of our new Catalogue, giving full particulars, will be sent free on request.



THE MARK OF BETTER RADIO

LTD Kingsway House, 103, Kingsway, London, W.C.2. Telephone: Holborn 5303

