

# The Wireless Constructor

EDITED BY  
PERCY W. HARRIS. M.I.R.E.



Vol. II, No. 3 JANUARY 1926

**Special Features :**

*How to make :*

- Five Complete Receiving Sets
- X An H.T. Accumulator *Home made*
- A Wireless Cabinet

**SELECTIVITY AND THE CRYSTAL USER**

By J. H. Reyner, B.Sc., A.C.G.I., D.I.C., A.M.I.E.E.

**HOW TO USE A POWER VALVE**

By G. P. Kendall, B.Sc.

FREE · BLUEPRINT · INSIDE

*Christmas Number*

# A Dull Filament Valve in the TRUE Sense



## The Wonderful "N" Filament valve

Requires only ONE-TENTH AMPERE filament current from 3 dry cells or a 4-volt accumulator.

Gives majestic volume free from microphonic disturbance.

The heat present in the unique "N" filament is so small that no sign of glow can be discerned.

**THE FINEST LOUD SPEAKER  
VALVE EVER PRODUCED**

**THE P.M. 4 - 22/6**

Leaflet V.R. 26, free from any dealer, gives complete information.

# Mullard

**THE MASTER VALVE**

# The WIRELESS CONSTRUCTOR

— Edited by Percy W. Harris —

Vol. 11 No. 3 CONTENTS JANUARY

Selectivity and "Range," a Compact Two-Valve Receiver .. 243	Mr. Gumplethorpe makes a Wave-meter .. 277
By A. V. D. HORT, B.A.	A Single-Coil Two-Valve Receiver .. 289
How to Make a H.T. Accumulator Unit .. 249	By E. J. MARRIOTT
By H. J. BARTON-CHAPPLE, Wh.Sch., B.Sc., A.C.G.I., D.I.C., A.M.I.E.E.	How to Use a Power Valve .. 287
The "All-Purpose" Crystal Set .. 252	By G. F. KENDALL, B.Sc.
By PHILIP H. WOOD, B.Sc., F.P.S.L.	Problems of Short-Wave Reception .. 293
Famous Artists of 1925 .. 257	By C. F. ALLINSON
By "CARRIER WAVE."	A Single-Valve 3-Circuit Set .. 300
Selectivity and the Crystal User .. 262	By JOHN UNDERDOWN
By J. H. REYNER, B.Sc., A.C.G.I., D.I.C., A.M.I.E.E.	Radio Games for Xmas .. 307
Making a Cabinet for your Set .. 270	Useful Distributing Board .. 308
	Questions for our Readers .. 311
	Smooth Reaction Control—a Three-Valve Loud-speaker Receiver .. 313
	By J. H. REYNER, B.Sc., A.C.G.I., D.I.C., A.M.I.E.E.



"SPARTA" is a speaker that does its own sales talk. Its tone appeals at the first hearing. The reason lies in a construction that is different. That difference is the outcome of long experiment.

The large "Sparta" has a unique feature—an additional tone selector which enables very delicate refinement of tone values. The new patent magnetic compensator gives remarkably distinct rendering.

Type	Ohms
A	120
HA	2,000
HHA	4,000
	£4 : 15 : 0
B	120
HB	2,000
HHB	4,000
	£6 : 0 : 0
J	120
HJ	2,000
HHJ	4,000
	£2 : 10 : 0

London Depot:  
176, Tottenham  
Court Road, W.1  
Phone: Museum 9030

FULLER'S UNITED ELECTRIC WORKS, LTD.  
Chadwell Heath - - - Essex  
Telephone: Ilford 1200 Telegrams: "Fuller, Chadwell Heath."

— sells on the test of tone

174-11

# Marconiphone and STERLING Radio Components

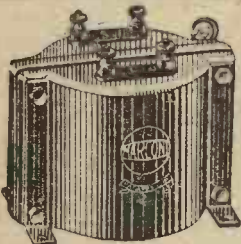

MARCONIPHONE "IDEAL" RANGE OF TRANSFORMERS.

A type for every specific purpose. With their use very extensive amplification is possible without distortion. "Ideal" Transformers undergo a special impregnating process using Marconite, the most perfect insulating material obtainable and non-corrosive. Each Transformer is within 5% of the guarantee curve.

"IDEAL" TRANSFORMERS are supplied as follows:—Type "A," ratio 2.7 to 1; Type "B," ratio 4 to 1; Type "C," ratio 6 to 1; Type "E," ratio 8 to 1. Each complete in metal case (as illustrated) **30/-**

"IDEAL JUNIOR" TRANSFORMER. This type has been produced in a ratio of 3 to 1, for it was found possible at this ratio only to successfully retain in a simplified form the standard "Ideal" principles of construction. Supplied at the popular price of **25/-**

For perfect results build your radio set with the best components. Marconiphone and Sterling Components are easily the best by every test. Absolute satisfaction is assured, as these components are correct in design and made of the finest materials. The test is—results. They stand by that alone.



MARCONIPHONE AUTO SERIES PARALLEL VARIOMETER.

An entirely new pattern which will tune an aerial from 230—1630 metres with a single revolution of the 360 degs. scale. This extensive wave-range capacity is effected by means of a patent parallel switch. The action of this variometer is remarkably smooth and even. **PRICE 16/-**

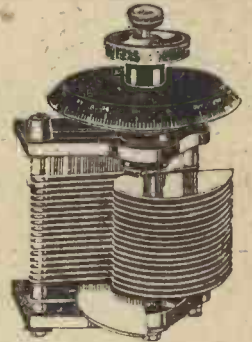

STERLING SQUARE LAW VARIABLE CONDENSERS. With and without vernier adjustment; also geared; double and triple, and balanced types. Full range of prices on application.



MARCONIPHONE BATTERY RESISTANCE. A very compact filament rheostat of novel design. Especially suitable for attaching to an accumulator or dry battery when employing D.E. 3 type valves. **PRICE 6/6**

STERLING "NON-PONG" VALVE HOLDERS. Obviate microphonic noises and lengthens the life of valves. **4/3**

Valve Holder **4/3**  
Adapter (as illustrated) **5/-**

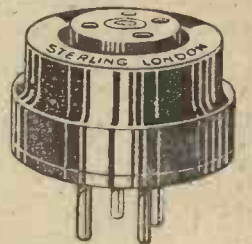

STERLING "LILLIPUT" HEADPHONES

**20/-**  
per Pair

STERLING "LILLIPUT" HEADPHONES

A veritable masterpiece of headphone efficiency. Clear in tone, light in weight and extremely comfortable. Easily adjustable to any head. The most efficient 'phone obtainable. **PRICE 20/-**

MARCONIPHONE "VELVACT" POTENTIOMETER

Specially designed to ensure perfectly smooth and silent operation. Contact with the resistance wire is made by a spiral of thick wire mounted on a metal roll. Resistance 350 ohms. **PRICE 9/-**

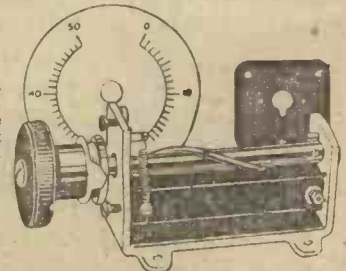

at all radio dealers

THE MARCONIPHONE COMPANY LIMITED. Registered Office: Marconi House, Strand, London, W.C. 2  
And 210-212 Tottenham Court Road, London, W.1. Branches:—Aberdeen, Bristol, Birmingham, Belfast, Cardiff, Cheltenham, Dublin, Glasgow, Leeds, Liverpool, Manchester, Newcastle, Nottingham, Southampton, Swansea.  
Sole Agents for STERLING TELEPHONE & ELECTRIC CO. LTD.

*Editor-in-Chief:*  
**JOHN SCOTT-TAGGART,**  
 F.Inst.P., A.M.I.E.E.  
*Director of Research:*  
 Major **JAMES ROBINSON,**  
 D.Sc., Ph.D., F.Inst.P.  
*Deputy Director of  
 Research:*  
 Capt. **H. L. CROWTHER,**  
 M.Sc.

The  
**WIRELESS  
 CONSTRUCTOR**

*Editor:*  
**PERCY W. HARRIS,**  
 M.I.R.E.  
*Scientific Adviser:*  
 Prof. **G. W. O. HOWE,**  
 D.Sc., M.I.E.E.  
*Advisory Editors:*  
 Prof. **R. WHIDDINGTON,**  
 M.A., D.Sc., F.R.S.  
 Prof. **C. L. FORTESCUE,**  
 M.A., M.I.E.E.

Vol. II. JANUARY, 1926 No. 3.

**SELECTIVITY AND "RANGE"**

**A COMPACT TWO-VALVE RECEIVER**

By **A. V. D. HORT, B.A.**

*A headphones set which gives "range" both in distance and waveband covered*

WHATEVER may be the result of international deliberations on the subject of the broadcasting stations of Europe, the present conditions demand that certain features receive special attention in a set designed for reception over even moderate distances. On the lower broadcast band the small wavelength separation between some stations calls for selectivity. This feature should be operative in more than one direction, not only to discriminate without undue difficulty between two stations at a distance, but also in particular localities to enable the listener to hear a distant programme without serious interference from the local station. On the higher wavelengths this same feature of selectivity is called for

though at present there are not so many stations operating in the neighbourhood of Daventry's wave.

**The Lower Frequencies**

The programmes sent out by Daventry and Radio-Paris on the longer wavelengths may perhaps

wavelength is desired in these circumstances, and any time saved by avoiding the changing of coils is therefore well gained.

**How Selectivity is Obtained**

In the design of the receiver to be described here, selectivity and range have been studied, "range" in this case being intended to include both wavelength range and actual distance. Fig. 1 shows the circuit diagram. The aerial may be attached to the top of either  $L_1$  or  $L_2$ , the former position providing an "aperiodic" aerial circuit, with a consequent improvement in the sharpness of tuning of the circuit  $L_1, C_1$ , so long, that is, as the coupling between  $L_1$  and  $L_2$  is not made too tight. Reaction effects and also a still further increase in

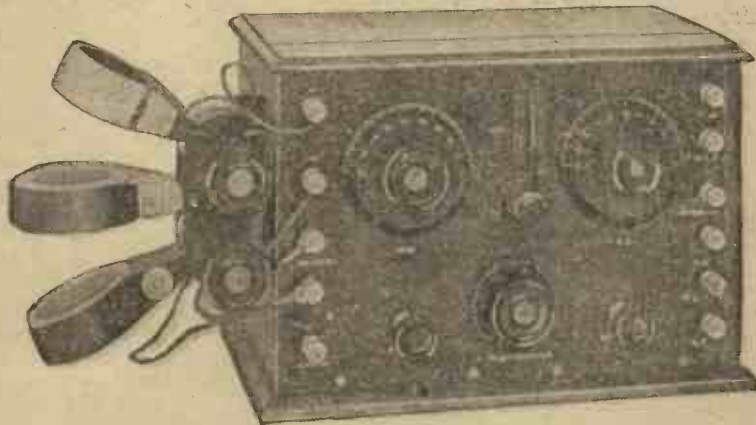

The completed receiver, showing the three-coil holder mounted on the side of the cabinet.

be at some time more attractive than those available at the moment on the lower band. It is often the case that quick change of



selectivity owing to the reduced damping of  $L_1, C_1$  are obtained by coupling to  $L_1$  the coil  $L_2$ , which is included in the anode circuit of the detector valve  $V_2$ .

**Switching Arrangements**

In the anode circuit of the H.F. valve  $V_1$  is a switch  $S_1, S_2$ . With this

that the H.F. valve is little, if at all, inclined to instability. When the tuned-anode method of coupling is in operation, however, self-oscillation of  $V_1$  is liable to occur when the circuits  $L_1, C_1$  and  $L_3, C_2$  are brought into resonance. In order to stabilise  $V_1$  under such conditions, a potentiometer  $R_3$  is

divergence from the components specified should be made with caution, especially if the sizes of panel and baseboard are adhered to exactly. The list of the actual components used is as follows:—  
Ebonite panel,  $10" \times 7" \times \frac{3}{16}"$  (Radion; American Hard Rubber Co.)

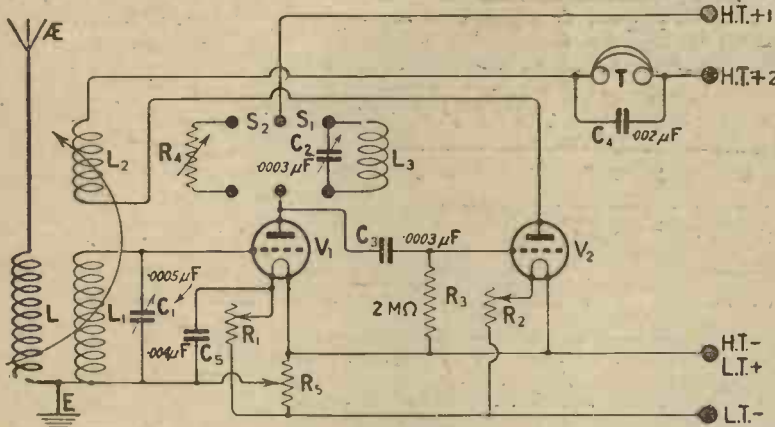

Fig. 1.—The circuit. The switch  $S_1, S_2$ , permits the change over from tuned anode to resistance coupling.

switch in the position  $S_2$ , the anode resistance  $R_4$  is brought into circuit. This resistance is of the variable type, so that it can be adjusted to give the best results with the particular valve in use. When the switch is set thus, with suitable coils for  $L_1$  and  $L_2$ , the receiver is suitable for use for 5XX and other long-wave stations.

**For the Broadcast Band**

On the lower broadcast band, however, resistance-capacity coupling fails to give the desired amplification. For the reception on this band, therefore, the switch is placed in the position  $S_1$ , bringing into circuit the tuned-anode coil and condenser  $L_2$  and  $C_2$ . The anode coil is enclosed inside the cabinet of the receiver since there will normally be no need to change it, once the best size has been ascertained. The coils  $L_1, L_2$  and  $L_3$ , being mounted in a three-coil holder outside the cabinet, are readily changeable. It will be clear that it is not essential always to use the resistance-capacity method of coupling when receiving on the longer waves. A suitable coil for the anode circuit can readily be inserted. But normally any alterations inside the cabinet can be avoided if preferred, changing the coils in the three-coil holder and putting over the switch being all that is necessary.

**Stabilising the H.F. Valve**

When the anode resistance is in circuit, it will probably be found

provided; the condenser  $C_4$  acts as an H.F. bypass across the winding of this potentiometer and also the filament rheostat  $R_1$ .

**Separate H.T. Terminals**

For the best results when receiving on the longer waves with the resistance-capacity coupling, it is necessary to have some means of raising the H.T. battery voltage, in order to compensate for the drop in voltage across the resistance. If only one H.T. terminal were provided, common to both valves in the receiver, such an increase in the H.T. value would tend to affect the detector valve  $V_2$  adversely. It is therefore essential to provide separate H.T. terminals for each valve. When the tuned-anode system is in circuit, these may quite well be joined together and taken to a suitable tapping on the H.T. battery. When the resistance is in the anode circuit of  $V_1$ , this tapping will serve for  $V_2$ , while a higher one must be used for  $V_1$ .

**Components**

In view of the compactness of the receiver, a point which may be appreciated by some constructors whose space is limited, any wide

- Baseboard,  $5\frac{1}{2}" \times 10" \times \frac{3}{8}"$  (Camico).
- Cabinet (Camico).
- One  $0.005 \mu F$  variable square-law low-loss condenser (Ormond).
- One  $0.003 \mu F$  variable square-law low-loss condenser, one end plate only ("Utility," Wilkins & Wright).
- One  $0.003 \mu F$  fixed condenser (Watmel).
- One  $0.002 \mu F$  fixed condenser (Watmel).
- One  $0.004 \mu F$  fixed condenser ("Paragon," Peter Curtis).
- Two Microstats (Wates Bros).
- One  $2 M\Omega$  gridleak (Dubilier).
- One double-pole double-throw low-capacity switch ("Utility," Wilkins & Wright).
- Eleven terminals.
- Two valve-holders for board mounting (Burwood):
- One three-coil holder ("Lotus," Garnett, Whiteley & Co.).
- One variable anode resistance (Bretwood).
- One board-mounting coil-plug (Burne-Jones).
- One potentiometer (I. McMichael, Ltd.).
- Two gridleak clips, piece of ebonite,  $1" \times 2\frac{1}{4}" \times \frac{3}{16}"$ .
- A pair of brackets to secure panel to baseboard.
- Glazite for wiring up.
- Radio Press panel transfers.

**Constructional Details**

The first operation in the construction of the receiver is to mark out the panel. This can be carried out quite easily by clamping the

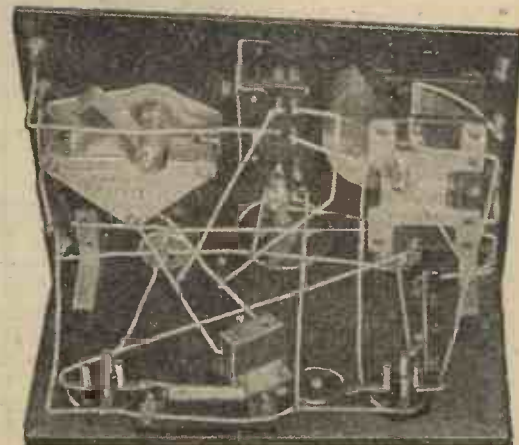

The free blueprint is a complete guide to the panel and baseboard wiring shown in this photograph.

blueprint supplied firmly to the back of the panel and, with a sharp point, pricking through the centres of the holes to be drilled. It should be noted that the exact positions for the bolts securing the supporting brackets to the panels will depend on the type of bracket obtained. It will be best to mark the holes for these with aid of the brackets themselves.

**Fixing the Switch**

When the straight forward drilling has been completed, there is a slot to be cut for the change-over switch. First of all, drill the holes for the bolts which hold the switch on the panel. Now, bolt the brass plate which comes on the front of the panel in position and, with a sharp point, mark the panel round inside the slot cut in it. After removing the plate again, a chain of holes should be drilled inside the area marked, as close to each other as possible. With the aid of a small file, the holes may then be joined up and, with a thin flat file, the sides of the slot may be trimmed square up to the marked lines.

**Baseboard Components**

Before the panel is attached to

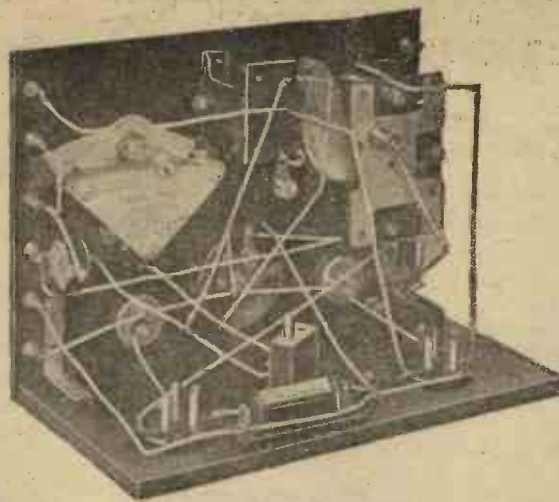

Another interior view. Note the telephone condenser supported by wiring on the left.

the baseboard, the two valve-holders, the grid condenser and leak, the anode coil-holder and the .004 $\mu$ F bypass condenser may be screwed down on the latter. This bypass condenser, at any rate, should be fixed in position first, since it will be no easy matter to reach it when other components have been assembled. The mounting of the components on the panel calls for no special comment, with the exception of the anode resistance. A short length (about 3 in.) of connecting wire should be soldered to the lug nearest to the

panel before it is mounted. Otherwise it may be difficult to reach this point with the soldering iron.

**Wiring**

The wiring of the receiver shown is carried out with Glazite. The mounting of the switch should preferably be deferred until the connections to the filament rheostats and the potentiometer have been soldered. If the switch and the anode resistance are correctly mounted in the positions shown, it will be found that the outer soldering lug of the latter comes close enough to one of the lower switch tags to enable the two to be soldered together direct, without any connecting wire.

**Grid Leak Connections**

The connections to the grid leak are made via two small springy brass clips, which are mounted on a strip of ebonite screwed to the baseboard. One end of the grid condenser is soldered direct to the anode soldering tag of the H.F. valve-holder. Similarly, the condenser shunting the telephones has one of its lugs soldered direct to the shank of the appropriate terminal, a short length of wire being used for the other side.

(Continued on page 328.)

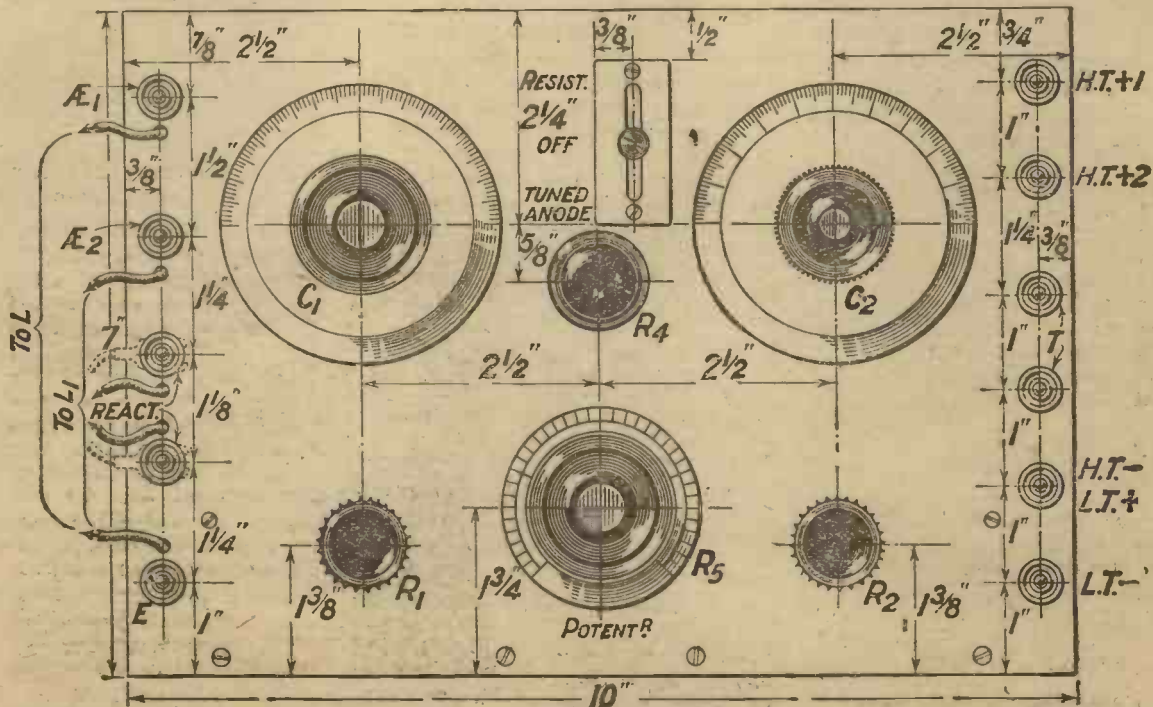

Fig. 2.—The panel layout. Note that the reaction leads may either be brought through holes in the panel or fitted with spade-tags and screwed under the terminals. Blueprint No. C1026A, price 1/6 post free.

# How to Make a Semi-Permanent Detector

By H. BRAMFORD

THE making of a semi-permanent detector is a comparatively simple matter, as this article explains. The cost of construction is quite low, the only materials required being as follows: Two crystal cups (screw grip type), a short length of  $\frac{1}{2}$  in. diameter ebonite tubing, some brass sheet, a few inches of hard drawn copper wire, a piece each of bornite and arzenite crystals, and the other small items as shown in Fig. 1.

### The Diagrams

A detailed sectional drawing of

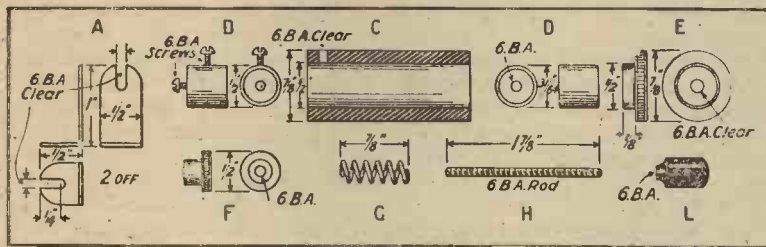

Fig. 1.—The component parts and their dimensions.

the complete detector is shown in Fig. 2, which makes the assembly of the parts quite clear, while the various parts to be made or procured are shown in Fig. 1.

### Components and Assembly

First prepare the two crystal cups which are intended to hold the bornite and arzenite crystals respectively, as shown in Fig. 1. Cup B has two screws in use as shown. The screws should be temporarily removed, and the bornite crystal fixed in the cup with Wood's metal. The contact surface of the crystal should present as flat a face as possible. During this operation see that the screw holes are kept clear. Next prepare crystal cup D, which should be the same size as cup B. Reduce the external diameter of the cup slightly by filing, then fix the arzenite crystal in the cup by means of Wood's metal, as before. The surface contact of this crystal should be somewhat pointed if possible, and should be out of line with the centre of the cup. A length of ebonite tubing is next cut off about 2 ins. long and a 6 B.A. clearance hole drilled for the purpose of securing cup B by means of its contact screw. The piece of

from strip brass to the dimensions given.

### Mounting

The complete detector may be mounted on a small ebonite base by means of small terminals, or direct on the panel of the receiver, as desired. To operate, pull the plunger back and gently release it when the spring should cause suit-

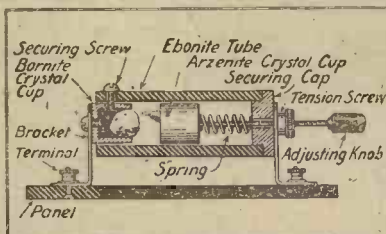
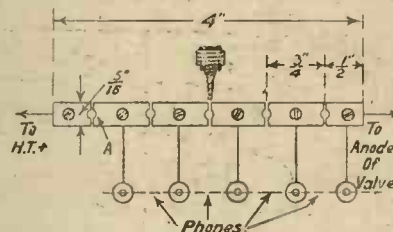

Fig. 2.—The completed Detector shown in section.

able contact to be made between the two crystals. On no account turn the knob round when the crystals are in contact, as this will injure their surfaces. The tension of the spring may be altered by means of nut F, while the fact that the crystal in cup D is not fixed centrally allows the crystal in B to be extensively searched.

## A Telephone Switchboard

WHEN it is required to provide for connecting a varying number of pairs of telephones in circuit, it is often inconvenient to be continually attaching and detaching the leads from the telephone terminals. If a telephone switchboard of the type shown in the accompanying sketch is employed, the telephones or loud-speaker not required for use at the moment may be left attached permanently to their terminals, without necessarily being connected in circuit. The assembly shown provides for four pairs of telephones, but of course the device may be extended. Five terminals are needed, a strip of brass  $\frac{1}{4}$  in. long,  $\frac{1}{8}$  in. thick, and about  $\frac{3}{8}$  in. wide, and five tapered metal plugs with ebonite bushes, such as "Clix" plugs. Holes are drilled in the strip as shown, those for the securing bolts being counter-sunk; the holes for the plugs should be of a size just to accommodate the type selected. The strip is bolted to the ebonite strip or receiver panel, and the terminals are mounted in the appropriate positions, the connections being soldered to the bolts and terminal



The lay-out and connections.

slanks underneath the panel. Cuts are then made right through the strip across the centres of the holes.

### Operation

The insertion of a plug in the hole marked A connects the switchboard in circuit, while by placing plugs in any of the other holes one or more pairs of telephones may be short-circuited and so cut out of circuit. In order to ensure a good contact and avoid "frying" noises a plug should be inserted with a screwing motion, using slight pressure, until it is felt to grip in the hole. The plugs may conveniently be attached to the switchboard by short pieces of stout thread.

A. V. D. H.



# MAY NOTHING YOU DISMAY!!!

THERE'S A SPECIAL TREAT ON THE WIRELESS TO-NIGHT - REAL CHRISTMAS CAROLS



CHRISTMAS IS COMING -



-AND THE GOOSE IS GETTIN' FAT-



-REST YOU MERRY MERRY GENTLEMEN-



WHAT THE DEUCE D'YOU MEAN BY KICKING UP THAT DIN?

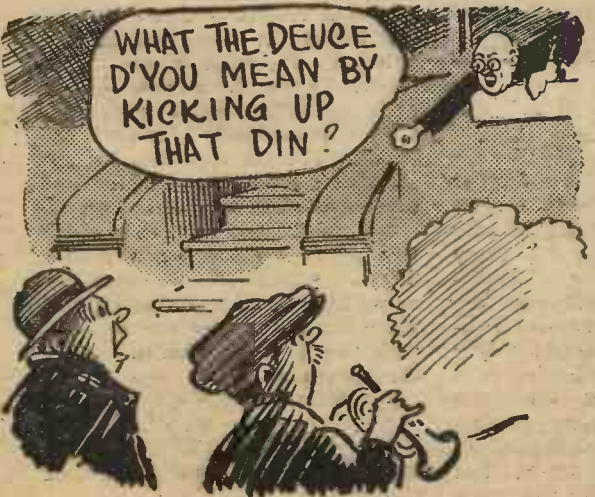

-I WANT TO LISTEN TO SOME CAROLS!



CON SHAW



### THE POWERFUL 3-VALVE SET

SIR,—Just a few lines to record my appreciation of the "Powerful Three-Valve Set" described by Mr. Percy W. Harris, M.I.R.E., in the April, 1925, number of THE WIRELESS CONSTRUCTOR. I have just built up the set, and I must say myself and friends are amazed at the results, being great believers in H.F., D. and L.F. for all-round loud-speaker results, but this set is far better. My results are as follows:—

Leeds, relay, 9 miles, too loud on loud-speaker.

Sheffield, relay, 26 miles, loud on loud-speaker.

Nottingham, relay, 60 miles, fair on loud-speaker.

Manchester, main, 40 miles, loud on loud-speaker.

Newcastle, main, 80 miles, loud on loud-speaker.

Glasgow, main, 180 miles, fair on loud-speaker.

Aberdeen, main, 220 miles, fair on loud-speaker.

Bournemouth, 260 miles, very fair on loud-speaker.

Daventry, 130 miles, too loud on loud-speaker.

Petit Parisien, fair on loud-speaker.

Madrid, fair on loud-speaker.

Brussels, loud on loud-speaker.

I have also had many other foreign stations on phones. My aerial is 30 ft. long and 4 ft. above the roof of the house, from a chimney stack to a 15 ft. pole. My earth consists of six tin plates 8 in. square, 2 ft. deep in clay, so I do not know what the set would do on a good aerial and earth.

Please accept my thanks for such a fine circuit and such an interesting magazine.—Yours faithfully,

ANDY THOMPSON.

Wakefield.

### SELECTIVITY

SIR,—I have pleasure in stating that I have constructed the "Selective Three-Valve Receiver" described by Mr. A. V. D. Hort, B.A., in the September, 1925, issue of THE WIRELESS CONSTRUCTOR.

The results obtained will no doubt be of interest to those readers who are unfortunate to live within close range of a broadcasting station, as I reside within 200 yards of the Stoke relay station.

The components used in the construction of the set are of good manufacture, but all are not of the makes recommended by Mr. Hort, as I already possessed several parts. I first of all tried the aperiodic loose coupling—i.e., the primary aerial coil untuned—and found I could eliminate the local station, but could not receive the distant stations with sufficient signal strength.

In consequence, I use a  $0.005\mu\text{F}$  variable condenser to tune the primary coil, and the results are very satisfactory. During local transmissions I can receive Manchester, Birmingham, Newcastle, Belfast, London, Madrid and Hamburg. I have not yet tried to receive stations nearer the Stoke wavelength, but I think this could be accomplished with patience. I have logged numerous other stations (English and foreign) when the local station has closed down. I am particularly pleased with the results, more especially as I was advised by several well-known makers of radio components that it would be practically impossible to cut out a station (even a relay) at 200 yards.—Yours faithfully,

V. L. F. DAVIS, A.M.I.E.E.  
Stoke-on-Trent.

### THE "A.-A. SIX" AGAIN!

SIR,—I have been a reader of THE WIRELESS CONSTRUCTOR since it started, and have temporarily made up all the sets by Mr. Percy Harris, including the "Anglo-American Six," which was described in the January and February, 1925, issues. I must say how surprised I am at not having read more letters in THE WIRELESS CONSTRUCTOR from your readers regarding this set. This is the best set of all I have made, has given me more pleasure than any set I have worked, and is quite fascinating to use.

Wishing THE WIRELESS CONSTRUCTOR every success.

Yours faithfully,

F. HAYWARD.

Ipswich.

### THE SELECTIVE SINGLE-VALVE RECEIVER

SIR,—I wish to thank Mr. G. P. Kendall, B.Sc., for the excellent Selective Single-Valve Receiver appearing in the September, 1925, WIRELESS CONSTRUCTOR. This set, coupled to a stage of power amplification, gives me all three South African stations on telephones—in fact, too loud to be comfortable; Durban and Johannesburg, respectively 300 and 140 miles away, at night come in clearly at fairly good loud-speaker strength. Cape Town, 1,000 miles, at night also on loud-speaker. This is not all. On the night of September 29 I held a Spanish station for half an hour, from 11.25 p.m. African time, and a British station, presumably Bournemouth, from 12 to 12.50 p.m. Musical items were clearly heard. I am struck with the purity and wonderful selectivity. Tuning in my case is very sharp, and the reaction control is delightful. I also operate a five-valve tuned anode circuit and a special Reinartz type short-wave circuit. I have a very fine aerial system, the height at the lead-in end being 85 ft., with a stretch of 40 ft. across to a pole 95 ft. high. Earth: water pipe running immediately under the aerial. The set described by Mr. Kendall is certainly one of the best one-valvers I have yet come across.

I found the best valve to use with this set, in my case, was a B.T.H. Type B4 power valve—an excellent valve indeed. I use this type of valve for my short-wave receiver, with the greatest success. Many thanks again.

Yours faithfully,

G. W. SMITS.

P.S.—After nightfall all African stations excellent signal strength on one valve only.—G.W.S.

East Transvaal,  
South Africa.



# How to Make a Useful Accumulator H.T. Unit

By H. J. BARTON-CHAPPLE, Wh.Sch., B.Sc. (Hons.), A.C.G.I., D.I.C., A.M.I.E.E.

WHEN employing a multi-valve set, it is often found that the high-tension batteries run down in a surprisingly short time, so that the experimenter is often obliged to see if he can find a substitute for the ordinary dry-cell unit. If the house is wired for electricity, recourse can be had to smoothing devices used in conjunction with the mains to supply the high-tension voltage, or an accumulator unit can be utilised. It is the purpose of this article to describe the construction of an accumulator high-tension battery which has a capacity of

be required, the waste pieces being the two portions  $1\frac{1}{2}$  in. by 1 in. Thus the total area for the 30 pairs of plates will be  $9\frac{1}{2}$  in. by  $2\frac{1}{2}$  in. by 15, equals 350 sq. in. (approximately), equals  $2\frac{1}{2}$  sq. ft. (approximately).

### Increasing the Plate Surface

The portions A and C must be bent round mandrils to a cylindrical form, the diameter of the larger one being just over  $\frac{3}{4}$  in. and of the smaller one just over  $\frac{3}{8}$  in. As it is essential to present the largest possible plate surface to the electrolyte, the writer has found it a distinct advantage to serrate the surfaces of the positive and negative plates. This can easily be accomplished if the A and C portions are separately gripped between the jaws of a bench vice. To provide adequate pressure between the vice jaws, a lever, such as a 3-ft. length of conduit or metal piping, should be slipped over the vice handle, and the lead can then be squeezed sufficiently to leave the jaw serrations on the lead surface. With the aid of a wooden mallet, the plates can now be bent round the mandrils, only light taps being given with the mallet, so as not to damage the previously prepared surface of the plates. The larger cylinder will become the positive plate of one cell and the smaller cylinder the negative plate of the adjoining cell, and the lead connecting strip B must now be bent in the form indicated in Fig. 2. The bend serves the purpose of supporting the two plates on the edge of the container, and gives the plates a  $\frac{1}{4}$  in. clearance at the base of the container, and will prevent any sediment which may settle at the base from causing a short-circuit. (See Fig. 5.)

and 3 in. long, which can be purchased at any shop retailing chemical apparatus. Thirty of these will be required for each 60-volt unit, as each cell gives approximately 2 volts; and these should be thoroughly washed and dried before use.

### The Battery Box

To accommodate the cells a box is required, the dimensions being

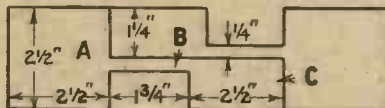

Fig. 1.—How the lead is marked out for two pairs of plates.

about 500 milliampere-hours, and which will give yeoman service if treated with normal care.

### Battery Plates

It is well known that an ordinary accumulator has specially-formed plates immersed in a suitable electrolyte, the chemical reactions supplying the requisite electrical energy. For the plates of this battery good quality commercial sheet lead is employed, either  $\frac{1}{8}$  in. or  $\frac{3}{16}$  in. thick. As will be seen later, about  $2\frac{1}{2}$  square feet of lead will be required for each 60-volt unit, and by cutting up the plates in the manner to be described, only a small percentage of this quantity will be wasted. Fig. 1 shows the template, which may be made from any convenient material, A being the positive plate of one cell, C the negative plate of the adjoining cell, and B the connecting strip between the cells. By marking out the lead in the manner indicated in Fig. 1 for two pairs of plates, it is clear that a strip  $9\frac{1}{2}$  in. by  $2\frac{1}{2}$  in. will



Fig. 2.—A pair of plates after bending to shape.

shown in Fig. 4. Wood  $\frac{1}{4}$  in. thick should be employed, the best kind being teak; and in order to keep the glass containers in position, a top for the box must be made in the form indicated in Fig. 3. The rectangular piece of wood has the dimensions  $8\frac{1}{2}$  in. by  $7\frac{1}{4}$  in. by  $\frac{1}{4}$  in., so that it can just fit inside the box, being finally held in position by wood screws. The layout of the holes, which must be carefully drilled, gives the unit a symmetrical appearance. The diameter of the holes is given as 1 in., but this can be slightly

### Cell Containers

The most convenient container for each cell unit is a glass "sample tube" 1 in. in diameter

exceeded, so that the sample tubes will readily slip in to their places, even if just over the correct size, but the distance of  $1\frac{1}{8}$  in. between centres should be kept constant, otherwise the external dimensions will be exceeded. To

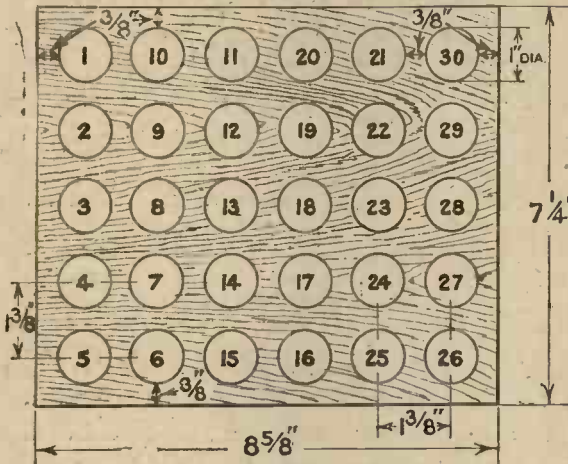

Fig. 3.—Details of the lid of a battery box for 30 cells are shown above.

minimise the effects of any spilled acid, the box and perforated lid should be well soaked in oil for a few hours, and then allowed to dry; but this refinement is not essential.

**Plate Separators**

To prevent the positive and negative plates touching, it will be necessary to employ separators in the cells. These can be made from thin perforated ebonite sheet, each cell requiring a cylinder  $2\frac{1}{8}$  in. long and  $\frac{1}{2}$  in. diameter. To bend the ebonite, it should be immersed in hot water to soften, and a metal mandril  $\frac{1}{2}$  in. in diameter should be obtained, when the ebonite will be found to bend readily round this. An alternative material for the separators is thin corrugated celluloid sheet, which has been perforated. If neither of these materials is available, a cheaper, and equally good substitute will be found in the prepared wood separators supplied for the ordinary low-tension accumulators. This material can be purchased at an accumulator repairshop, and can be new material or that which has been removed from a dismantled accumulator. The separator should be cut into strips to form a triangular prism  $2\frac{1}{8}$  in. long, and when in position will give the appearance of Fig. 6, which shows a cross-section of one 2-volt unit.

**Assembling the Components**

Having made the wooden box and fixed the top, the thirty sample

tubes should be inserted in position, and these will project  $\frac{1}{4}$  in. above the surface of the wood. For the first positive plate the portion C should be cut down so as to form an extension of B—i.e., a lead strip  $4\frac{1}{8}$  in. by  $\frac{1}{4}$  in. projecting

from the top of the cylinder A. This strip will form a connection to the positive battery terminal on the outside of the box. The bend should still be made, and this plate with the lead strip extension can be inserted in the glass tube (1) (see Fig. 5). Now add the separator, and take one of the units which have been made to the form shown in Fig. 2, and insert the smaller cylinder in the centre of the

separator, the larger cylinder then fitting into the glass tube in the position marked (2) (see Fig. 3).

**How to Proceed**

Repeat the same operation of adding separators and units similar to Fig. 2, following the numbers (1) to (30), as marked in Fig. 3. The negative plate of position (30) should be provided with a lead extension strip similar to the positive plate of position (1), by cutting away the A portion to add to the length B. Thus altogether 31 complete double

units A, B, C will have to be provided for, but the estimated  $2\frac{1}{2}$  sq. ft. for each 60-volt battery just allows for this provision.

Terminals, mounted on an ebonite strip, should now be fixed in place on the box side, so that the lead extension pieces from positions (1) and (30) can be fitted under the terminal shoulders to make good electrical contact.

**Charging**

A quantity of sulphuric acid of "1200" strength must now be poured in each sample tube so as just to cover the top ridges of the positive and negative plates. A

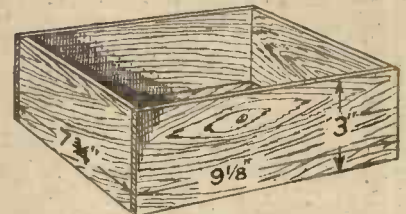
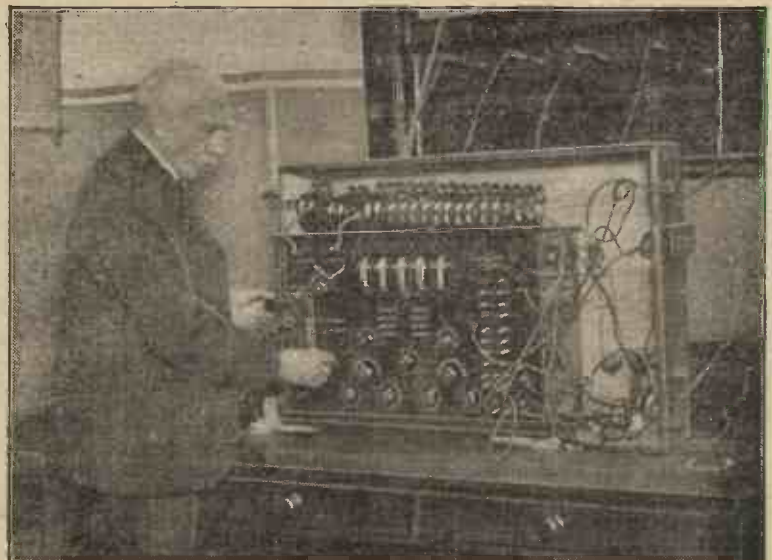

Fig. 4.—The battery box is made from  $\frac{1}{4}$  inch wood.

thin layer of oil, such as Blancol oil, may then be added to the acid surface if desired, but this is not essential. The complete accumulator unit is now ready for charging, and initially periodic charges and discharges must be made in order to "form" the plates. A suitable charging current is 50 milliamperes, and 100-volt 8 candle-power lamps are convenient series resistances to employ for this purpose with 220-volt d.c. mains. Connect up the lamp and battery in series (use two lamps in series with the



The inventor of the thermionic valve, Prof. J. A. Fleming, D.Sc., F.R.S., with some radio apparatus in his laboratory.

battery if only one 60-volt unit is being charged across 220-volt mains), so that the positive main joins the positive plate of the battery. Allow current to pass for about 10 hours, and then reverse the connections and repeat

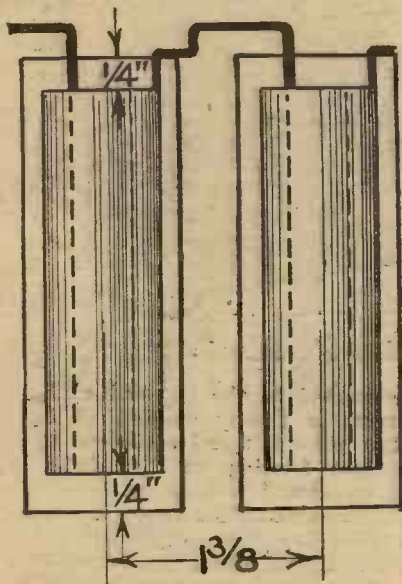

Fig. 5.—A sketch showing the plates arranged in the glass tubes.

for another 10 hours. This double charge and discharge should be performed three or four times, and then the plates should be found to be properly formed, the characteristic dark chocolate and grey colours being noticeable for the positive and negative plates respectively. The last charging current should, of course, be in the right direction—i.e., positive main connected to positive battery plate, and then the battery will be ready for use.

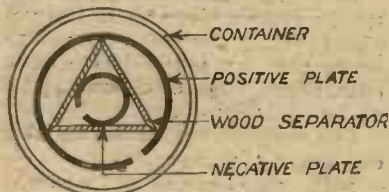

Fig. 6.—The plates are separated as shown by prepared wood strips.

The same care should be exercised with this unit as with all other accumulator units, especially for the first month or so, but after complete plate formation this source of high-tension voltage will be found to function quite well. If the house is not provided with D.C. mains, the charging and "forming" will have to be carried out by a battery-charging station, of course.

## What Transformer Ratios Are You Using?

*If you employ low frequency transformers you will be interested in this article*

IN the majority of cases it is quite safe to say that transformers for audio-frequency amplification are not selected for the conditions under which they are to operate. Generally speaking, the influencing factors in the final choice of an instrument are an arresting advertisement, good appearance, attractive price, or the fact that so-and-so has one like it and says that it is very good.

### Its Importance

When we consider the important part played by this instrument, and remember that upon its efficacy depends to a large extent the success of any set using low-frequency amplification, it seems strange that there is not a more general knowledge of the requirements of a transformer for functioning in a certain set. It is true that manufacturers do not state all the useful data concerning their products, but were there a greater demand for this information it would probably be forthcoming, and amateurs could then proceed to design their sets more intelligently, and with a greater degree of certainty that they would be doing the right thing in the given circumstances.

From the point of view of effective operation it is essential that the impedance (the resistance offered to the applied fluctuating impulses) of the primary winding of an audio-frequency transformer shall be greater than the plate to filament impedance of the preceding valve, both these values being taken under working conditions. On the other hand the efficiency of the transformer (using the term in its true scientific sense implying absence of losses) demands a low primary impedance. Here then are two conflicting desiderata.

### The Question of Ratio

It may be said that little is to be gained by making the primary impedance more than three times that of the valve. If the latter value is high, this means that the primary will have a large number of turns. Now, since the transformer ratio is determined by the value of number of turns on secondary (=  $T_2$ ) to the number of turns on primary (=  $T_1$ ), it is seen that for a high-im-

pedance valve, a high-ratio transformer would necessarily have a very large number of turns in the secondary, making the instrument bulky and expensive. Besides this, the capacity of the secondary would be higher than for one with fewer turns. It thus appears advantageous to use a low-ratio transformer having a primary winding of high impedance.

In the case of a low impedance power valve it is permissible to employ a higher ratio transformer, since the primary impedance, and therefore the number of primary turns, is low, and the ratio  $\frac{T_2}{T_1}$  may be increased without using too much wire in the secondary.

The plate to filament impedance of the valve preceding a transformer may have a value ranging from 40,000 ohms for a detector or L.F. to 6,000 ohms for a power valve. It is obviously impossible for any one transformer to operate efficiently over this entire range, and yet that is what is expected of it when it is bought without any regard being had to the valve impedance.

### Special Purpose Transformers

Some manufacturers produce transformers especially designed for different stages of low-frequency amplification. This is good practice worthy of support, and increases the advantages of using special purpose valves in their correct places. It is not improbable that general purpose valves and transformers will dwindle in popularity, giving place to special components designed to operate together in their allotted stages.

### Why not Publish Data?

Meanwhile it would be a great improvement if the impedances of audio transformers were made known to the buying public in the same way as are the impedances of valves. Until this desirable state is reached it would appear, from the foregoing considerations, advisable to keep to low ratio transformers such as 1-2, or 1-3, except in the last stage where, if a power valve is employed, a higher ratio is permissible. G. F.

# The "ALL-PURPOSE" CRYSTAL SET

By  
**PHILIP H. WOOD**  
B.Sc.(Hons), F.P.S.L.



A neat enclosed receiver for 5XX and the local station giving a choice of two circuits

THAT the popularity of the crystal set is as great now as ever it was is not to be wondered at, since for purity of reproduction, ease of operation and negligible cost of upkeep this form of receiver remains unequalled. At the same time, however, modern developments require that the present-day crystal set should possess certain refinements. The most obvious is that there should be some provision for the reception of Daventry, and where a special coil for the ordinary broadcast band is incorporated within the set itself, as in the present case, a loading coil plug and socket is the only means of adding the extra inductance for 5XX.

### Selectivity.

The question of selectivity is one which invites discussion, and Mr. J. H. Reyner, in an interesting article elsewhere in this issue, shows that selectivity is in many cases essential to the crystal user. As, however, increased selectivity is frequently accompanied by some

loss of signal strength, many listeners who only occasionally experience interference hesitate to incorporate a selective device in their sets.

### The Circuit used

In designing the receiver described below, I have borne these

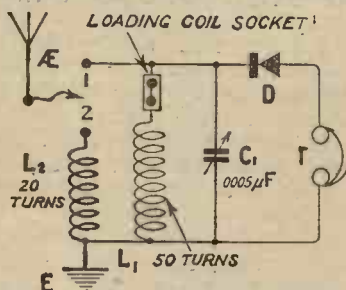

Fig. 1.—The two-circuit arrangement used.

points in mind, and provided a means whereby direct or selective tuning may be employed at will, together with facilities for inserting a loading coil for the reception of the Daventry station.

### The Circuit

The circuit—or rather, circuits—employed are shown in Fig. 1, and will be familiar to all readers. By connecting the aerial to terminal 1 the usual straight circuit is employed, coil  $L_1$  being connected direct to the aerial and tuned by the parallel condenser  $C_1$ . If terminal 2 is used, however, the aerial is

connected to the top end of  $L_2$ , which is tightly coupled to  $L_1$ . The latter is tuned as before, the system forming an "aperiodic" aerial circuit wherein the energy is transferred from  $L_2$  to  $L_1$ , and thence to the crystal. This arrangement gives greater selectivity but rather poorer signal strength.

### Components

The receiver is totally enclosed when not in use, as the cabinet is provided with a hinged lid. The crystal detector is of the glass-enclosed type with micrometer adjustment. The special coil is wound on a cross-former, and will be described later.

The following components, none of which is expensive, were used in the set, and, to guide constructors, I give the names of the manufacturers:—

Ebonite panel, 8 by 6 by  $\frac{1}{8}$  in., Paragon (Peter Curtis, Ltd.).

One "X" coil-former, made to the dimensions given later. (Burne-Jones & Co.) Readers who wish to make this for themselves should obtain two pieces of ebonite  $4\frac{1}{2}$  by  $1\frac{1}{2}$  by  $\frac{1}{8}$  in.

One  $0.0005 \mu F$  square-law variable condenser (Jackson Brqs.).

N.P. panel-mounting enclosed crystal detector (Service Radio Co., Ltd.).

N.P. panel-mounting plug, socket and link for loading coil (Burne-Jones & Co.) (This must not exceed  $1\frac{3}{8}$  in. height above panel.)

Five N.P. 4B.A. terminals.

One N.P. 4B.A. countersunk-head screw.

Two oz. No. 22 s.w.g. D.C.C. wire.

"Glazite" for wiring (London Electric Wire Co.).

"Camco" leatherette-covered cabinet,  $4\frac{1}{2}$  in. deep inside, to take

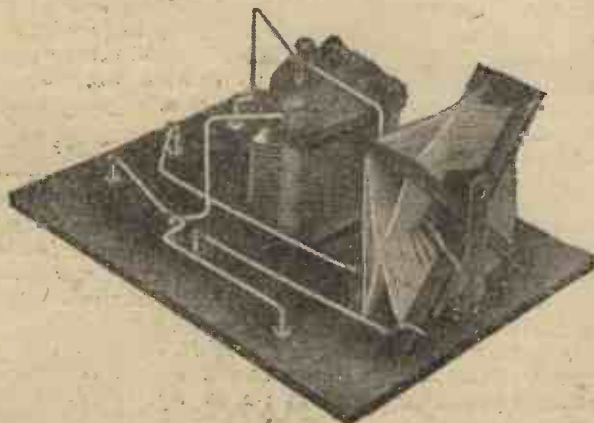

The special X coil is supported by a small metal bracket as shown.

panel 8 by 6 in., with  $1\frac{1}{2}$  in. deep lid, (Carrington Manufacturing Co.), Radio Press Panel Transfers.

**Panel Lay-out**

The panel arrangements may be seen in Fig. 2, from which it is seen that the terminals on the left, reading from the top, are Aerial 1, Aerial 2, and Earth respectively. To the right of these is the condenser, behind which is the loading-coil link, plug and socket. The telephone terminals are in front on the right-hand side, while the crystal detector is mounted behind them, with its adjusting knob to the front.  $\frac{1}{4}$  B.A. clearance holes must be drilled for the five terminals and the detector-mounting screws, while two  $\frac{1}{4}$  in. holes  $\frac{1}{16}$  in. apart are necessary for the loading-coil sockets. The condenser requires a  $\frac{3}{8}$  in. hole, and a further

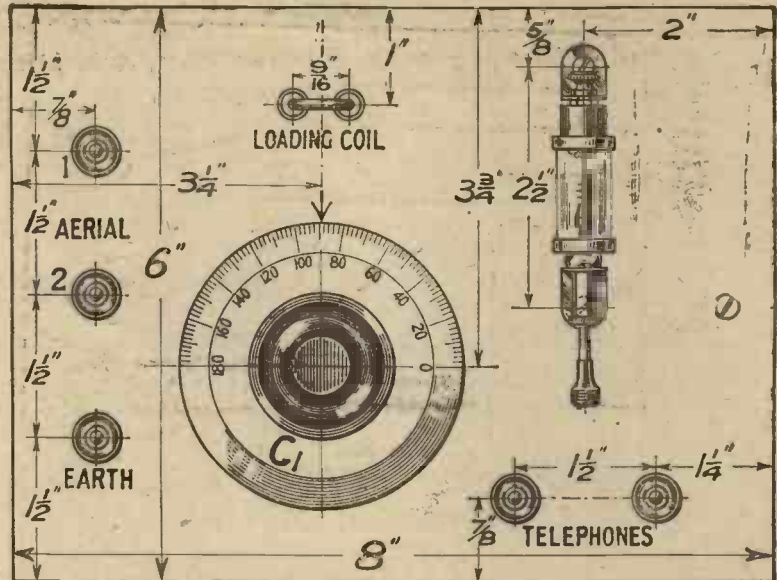
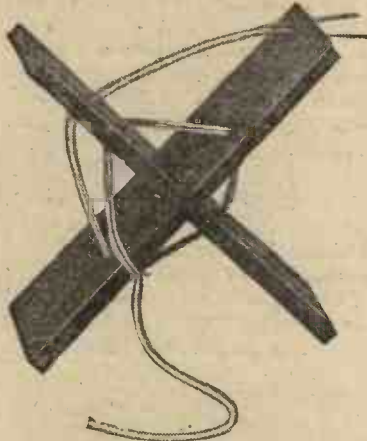

Fig. 2—The panel is drilled as shown above. The screw holding the bracket is seen on the right of the detector.



The double-wire winding is commenced as shown. The fifth quarter-turn seen on the extreme left is taken "straight" across from right-hand slot to right-hand slot, while the zig-zagging is recommenced with the sixth quarter-turn which is just being put on as shown at the top of the photograph.

$\frac{1}{4}$  B.A. hole, countersunk, is wanted to the right of the detector to fix the coil-bracket to the underside of the panel, as explained later. After drilling, the panel should be rubbed clean, the components mounted, and terminals, etc., marked by means of panel transfers.

**The Coil Former**

The coil used in this receiver aims at "low-loss" design combined with ease of construction. The coil-former is made of two pieces of ebonite slotted at their centres as shown in Fig. 4, so that they can be put together to form a rigid cross. Two cuts are also made with a hacksaw at each end of both pieces of ebonite, the

slots thus formed being  $1\frac{1}{2}$  in. deep and placed  $\frac{1}{8}$  in. away from the edges of the ebonite strips. It will be found that the average hacksaw blade will make a cut just wide enough to take the 22 S.W.G. wire.

**Winding the Coil**

Since close coupling between  $L_1$  and  $L_2$  is desirable, these two coils are wound on together as follows: First cut off about 10 ft. of the 22 S.W.G. d.c.c. wire, and twist one of the ends of this to the loose end of the wire on the reel. Suppose the "legs" of the "X" former to be numbered 1, 2, 3, 4. Starting with the right-hand slot in leg 1, leave about 6 in. of wire free, take a couple of turns round the ebonite strip between edge and slot, and commence winding, basket-coil fashion, with the double wire—i.e., laying on together the wire on the reel and the portion of wire cut off. Go from the right-hand slot of leg 1 to the left slot of leg 2, then to the right of leg 3, the left of leg 4, and so on back to the right slot of leg 1, when, obviously, one complete turn has been made. In commencing the second turn, however, we do not wish to follow the previous turn, so, instead of taking the fifth quarter-turn to the left

slot of leg 2 as before, take it to the right slot of leg 2, then to the left of leg 3, and so on, zigzagging as before, until another four quarter-turns have been made in addition to the fifth. This process is carried on with the double wire for 20 complete turns, every fifth quarter-turn being taken "straight across," as above, in order that consecutive turns cross one another instead of being parallel.

**Continuing the Single Winding**

After 20 turns it will be found the 10 ft. of wire which has been employed in conjunction with the wire on the reel is nearly all used up, and its free end should be pulled clear and cut down, so that a few inches only remains in excess of that wound on the former.

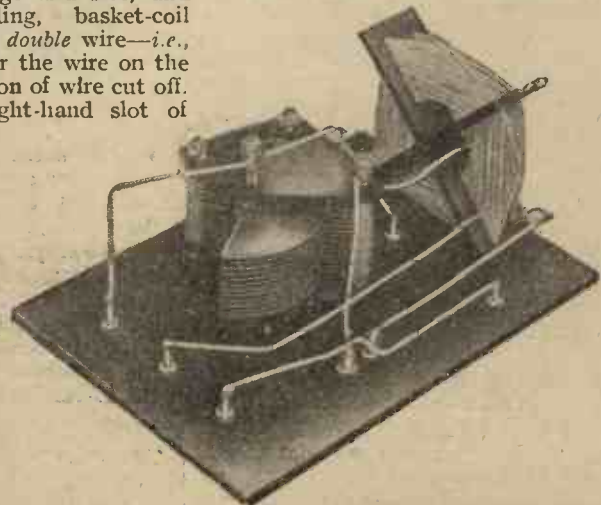

The "flat" appearance of this side of the coil is due to the "straight" quarter turns.

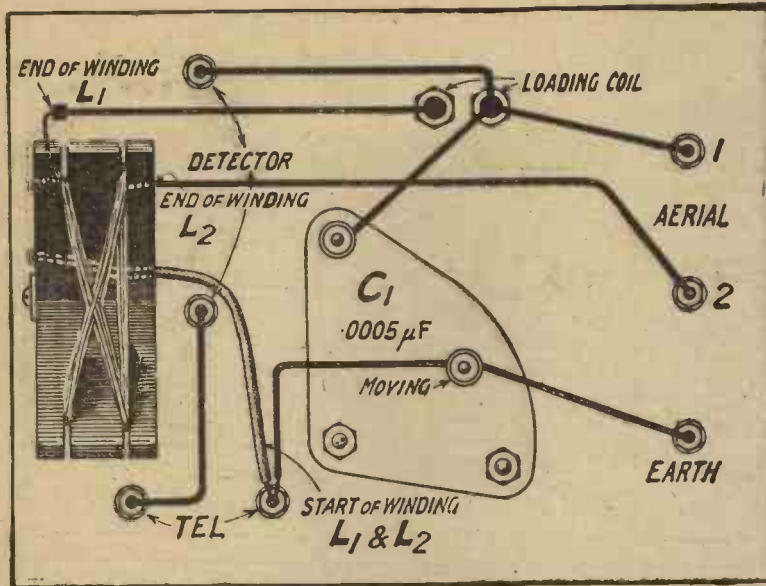

Fig. 3.—The wiring is simple, but the coil connections should be noted carefully.

Continue winding with the single wire from the reel until another 30 turns have been put on in the same fashion as before, then cut off with a few inches free.

**Number of Turns Required**

We now have two coils on the former—one of 20 turns ( $L_2$ ) and one of 50 turns ( $L_1$ ), the two having been wound on together for the first 20 turns. At this point it is well to note that the number of turns necessary on  $L_1$  depends on the wavelength of the local station. I have used 50 turns, because that

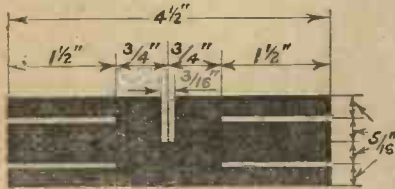

Fig. 4.—Two pieces of ebonite, each  $4\frac{1}{2}$  in.  $\times$   $1\frac{1}{2}$  in.  $\times$   $\frac{1}{8}$  in. must be slotted as shown above to make the coil former.

is about right for 2LO, but listeners at, say, Cardiff or Hull will probably find that 45 turns will be sufficient, while a Birmingham resident may require 60 turns for 5IT. The best plan is to wind on a few extra turns—they can easily be removed, if necessary, when testing-out, even if the coil has been mounted on the panel.

**Mounting on the Panel**

The coil is mounted on the back of the panel by means of a small bracket made of strip brass or "Meccano," as shown, the bracket being fixed to the centre of the

"X" former by a small wood screw forced into a little hole drilled in the ebonite. The bracket is secured to the panel by the 4 B.A. countersunk-head screw mentioned before.

**Wiring**

Twist together the inside ends of both coils (where the double winding commenced), cover with a short length of insulation sleeving, and solder to one of the telephone terminals, and thence to earth and the variable condenser, as shown in the wiring diagram, Fig. 3. The other phone terminal goes to the "whisker" end of the detector. "Aerial 1" goes to the fixed plates of  $C_1$ , the socket of the loading coil arrangement and to the crystal, the loading coil plug being connected to the outside end of the 50-turn coil  $L_1$ . "Aerial 2" is connected to the outside end of the 20-turn coil,  $L_2$ .

**Operation**

To receive the local station, short the loading coil plug and socket by means of the link, take the aerial to "Aerial 1" and connect up earth and phones. Adjustments of the variable condenser and

catwhisker should bring in the station at good strength. The aperiodic arrangement can now be tried, the aerial now being taken to "Aerial 2" terminal. The condenser will have to be adjusted, and the receiver will be found to be very much more selective, although signal strength may not be as good as before.

For 5XX only the direct coupling method should be used, the shorting link being replaced by a suitable loading coil—say a No. 150.

**Test Report**

The set gave good crystal results 9 miles from 2LO in a very "crowded" wireless district. Selectivity was noticeably improved when the aperiodic circuit was used, but signal strength fell off by about 20 per cent.

The increased selectivity was evidenced by the fact that 2LO could be tuned out with a few degrees rotation of the condenser dial, while there was a definite "peak" point giving maximum signal strength.

**5XX**

Daventry was received at excellent strength with a No. 150 loading coil, using the direct circuit with aerial connected to "Aerial 1."

Those readers who desire to wind a suitable loading coil for 5XX for themselves should read Mr. Kelsey's

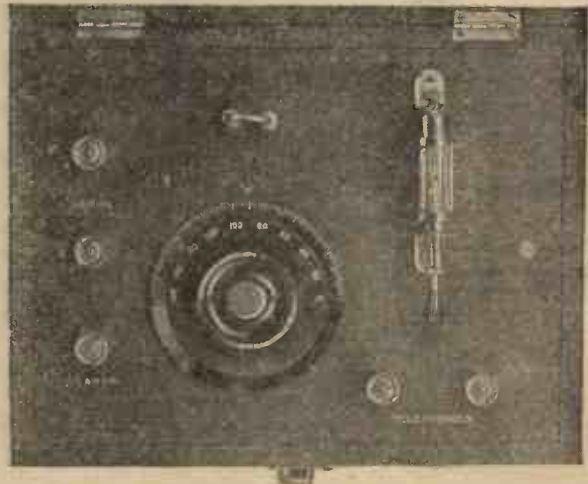

A photograph of the panel. The loading coil plug and socket are seen above the condenser dial, shorted by a link.

article in "Wireless," Vol. I, No. 10, where the method of construction of a very efficient coil is explained.

**"MODERN WIRELESS"**  
Xmas Double Number  
Now on Sale Price 1/6



**LISSENIUM**

# Sharp tuning coils are the mainspring of a receiver

**F**ITTING the new LISSEN COIL-MOUNT to all LISSEN-AGON COILS has made still sharper the well-known sharp-tuning characteristics of these coils.

Low loss and low capacity in the coil are now accompanied by a power loss and capacity in the holder reduced practically beyond the possibility of further reduction.

Next time you want a set of coils (or one coil, for LISSENAGON coils are interchangeable with coils of other make) call for the coils which intensify tuning.

LISSENAGON COILS may be a few pence higher in price, but they are incomparable in their sharp-tuning qualities—their suitability for sensitive work is most pronounced.



No. 25	...	...	4/10
30	...	...	4/10
35	...	...	4/10
40	...	...	4/10
50	...	...	5/-
60	...	...	5/4
75	...	...	5/4
100	...	...	6/9
150	...	...	7/7
200	...	...	8/5
250	...	...	8/9
300	...	...	9/2

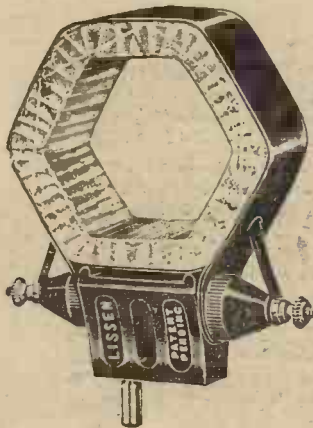

No. 50	...	...	6/-
60	...	...	6/4
75	...	...	6/4
250	...	...	9/9

## Two tappings for special uses—

The aerial coil for a Reinartz circuit must be tapped. The position of the tappings on the LISSENAGON "X" coils has been selected carefully, and the coils will be found very highly efficient for Reinartz circuits, aperiodic aerial tuning, neutrodyne sets, auto-coupled tuned anode circuits, etc.

Made at present in four sizes, "X" coil No. 60 covers the broadcasting band, but in order to obtain the best coil combination for all conditions "X" coils Nos. 50 and 75 are recommended for the lower and higher broadcasting wavelengths respectively. "X" coil No. 250 covers Daventry and Radio-Paris.

## THE EXPERIMENTER USUALLY BUYS THE COMPLETE SET

*Readers should ask their dealer for a copy of the leaflet describing the uses of LISSENAGON "X" coils, or should send direct, when a copy of the TEXT BOOK OF LISSEN PARTS will also be forwarded post free.*

Tune your inductance with the LISSEN MICA VARIABLE CONDENSER, 17/6

# LISSEN LIMITED

Lissenium Works, 26-30, Friars Lane, Richmond, Surrey

**ALWAYS USE LISSENAGON COILS FOR SENSITIVE WORK**



## CLARITONE HEADPHONES

embody many modern improvements designed to give increased audibility and clarity of tone and maintain their world-wide reputation. They are light in weight, easily adjustable, and exceptionally comfortable to the head.

Supplied by all reputable dealers. W.216. Price 20/-

### CLARITONE LOUD SPEAKERS



Senior Model,  
2000 ohms W.290  
120 ohms W.291  
**£5 : 0 : 0**

Junior Model,  
2000 ohms W.295  
120 ohms W.296  
**£2 : 15 : 0**

Sole Distributors:

**ASHLEY WIRELESS TELEPHONE COMPANY**  
69, RENSHAW ST., LIVERPOOL

Telephone: 4628 Royal. Telegrams: "Rotary, Liverpool"



**NO CONDENSER**  
of the Mansbridge type is a genuine product of the Mansbridge Condenser Co. Ltd. - unless the words **MANSBRIDGE CONDENSER** are plainly embossed on the metal case. The colour of the case is maroon. Guaranteed by the Dubilier Condenser Co. (1925) Ltd. who are the sole concessionaires.

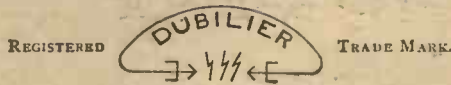

Specify Mansbridge  
PRICE AND CAPACITY.

Capacity	Price	Capacity	Price	Capacity	Price
0.02-0.05 mfd.	2/8	0.25 mfd.	3/-	0.50 mfd.	3/8
0.10 mfd.	2/8	0.30 "	3/-	1.00 "	4/-
0.20 "	2/8	0.40 "	3/3	2.00 "	5/-



ADVT. OF THE DUBILIER CONDENSER CO. (1925), LTD.,  
DUCON WORKS, VICTORIA ROAD, NORTH ACTON, LONDON, W. 3.  
Phone: Chiswick 2241-2-3. E.P.S.3

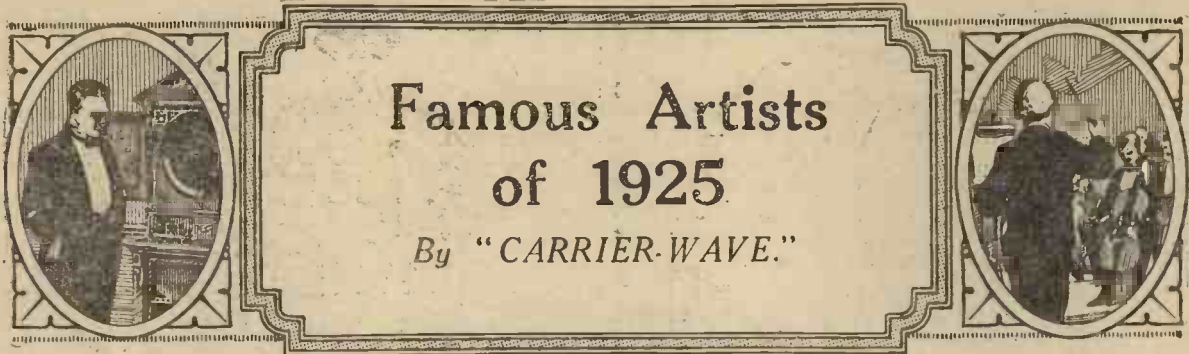

# Famous Artists of 1925

By "CARRIER-WAVE."

*Notes on well-known singers and instrumentalists who have broadcast during the past year*

WITH the passing of another year of broadcast music, it is worth while calling a halt to give a glance back to the events which may be safely said to have made it a memorable one. In the first place, it has seen the freedom of the individual artists established, since most of the agents under whose contracts they were bound have yielded to the advancing spirit of the age. This has given the British Broadcasting Company opportunities of obtaining the great musicians of the world: a chance of which they have gladly availed themselves. Accordingly, the wireless public



Thanks to the B.N.O.C., we have heard Robert Radford's fine bass singing.

off," though following in the wake of Melba, heard from Covent Garden. At the same concert given early in the year, M. Dinh Gilly, the famous operatic tenor, appeared. He was first known here for his appearance in Puccini's opera, "Girl of the Golden West," at Covent Garden, in 1911.

Other great operatic stars have been Romano Ciaroff, creator of over forty different rôles on the Continent before he came over here to broadcast. Also Riccardo Stracciari, a chance performance of his being of particular wireless interest, for prior to his becoming one of the finest international



Horace Stevens—a Colonial singer of note.

has been actually enabled to hear the artists who were hitherto but names, or only heard through the medium of the gramophone.

One can therefore divide the programmes into two sections, those in which the artists have appeared before the microphone in the broadcasting studios, others in which their performances have been relayed from hall or theatre. In both cases, however, world-famous musicians have been brought literally within our homes

—singers, instrumentalists, chamber music players, artists of the stage, variety and revue, as well as celebrated military and dance bands.

#### The Vocal Art

In this, I suppose, Madame Tetrzzini may be said to have "led



Chaliapin has taken many parts in well-known Russian operas.



The great Italian soprano—Madame Luisa Tetrzzini.

baritones, he was for eight years interested in wireless work with Senatore Marconi. His chief rôle is in the "Barber of Seville" with its famous aria "Largo al Factotum," which he broadcast. Of operatic interest, too, have been the appearances of Ulysses Lappas, the Greek tenor, Vladimir Rosing, John Coates, Norman Allin, Frank Mullings, and possibly greatest of all, last month, Chaliapin himself. This great Russian artist had consistently refused to



Miriam Licette as Eva in "The Mastersingers."

with such "giants" of their art as Frederic Lamond, king of Beethoven players, Francesco Ticciati, Gieveking, the Belgian pianist, Sapellnikoff, Harold Samuel, the Bach player, Benno Moisewitsch, Ieff Pohnishnoff, Evelyn Howard Jones, William Murdoch, the Australian artist, Herbert Fryer, Miss Irone Scharrer and Madame Fanny Davies.

**Instrumental Soloists**

While the English public as a whole are great admirers of stringed instruments as well as the piano, and they admire the technical difficulties, and here



Benno Moisewitsch is a very well-known pianist.

broadcast in other countries, so naturally the B.B.C. considered his consent a signal triumph.

Other famous vocalists include Madame Clara Butt, Miss Carrie Tubb, and the Australian bass baritone Horace Stevens, who was heard last year at the Royal Albert Hall in the production of "Hia-watha."



The Catterall String Quartet includes two violins, a viola and violoncello.

including Ysaye, the great Belgian; Zacharewitch, the Russian prodigy violinist, Miss Isolde Menges, Miss Daisy Kennedy and Mr. Albert Sammons. For the 'cello we have had Guilhermina Suggia, the greatest of women 'cellists, also Miss Beatrice Harrison, of "nightingale broadcast" fame. Cedric Sharpe, W. H. Squire and Charles Ham-bourg had also won fame before they came to broadcasting.

**Operatic Stars**

Thanks to the British National Opera Company, during its various seasons, we have had opportunities of hearing its best artists, amongst them Miss Rosina Buckmann, of Beecham opera fame, and an ideal Isolde, Florence Austral, Miriam Licette, Maurice d'Oisly, and Robert Radford; the last-named justly acclaimed one of our finest bass singers since he first appeared at the Norwich Musical Festival in 1899 in Berlioz's "Faust." He has played leading rôles in French, Italian, German and English operas, and is also an able pianist and composer.

Norman Allin is a Wagnerian singer *par excellence*. Frank Mullings hails from Walsall, and, apart from his operatic rôles, chief of which is in "Othello," his hobby is conducting.

**The Pianists**

The "national instrument," as the piano has been called, has given us perhaps the greatest surprises of the year, beginning with Paderewski, and continuing

again we have been privileged to hear many very famous artists,



Another instrumentalist of note is Isolde Menges, the violinist.

**Chamber Music**

Other interesting items in the programmes have been the performances of chamber compositions, thus reviving the almost forgotten 17th century style of music. We have heard the London String Quartet, now consisting of Mr. Jas. Levey, Thomas H. Petre, H. Waldo Warner and C. Warwick Evans; the Spencer Dyke Quartet, led by that well-known violinist; the Music Society String Quartet, led by Andre Mangeot; the Samuel Kutcher String Quartet; the Catterall Quartet, led by the famous leader of the Hallé Orchestra; the Snow String Quartet; and the Aeolian Players, led by Gordon Bryan; as well as the foreign Hungarian Quartet and the Modern Trio (Messrs. Manucci, Melzak and Krish).

**The Funny Side**

This year has seen a very great improvement on the humorous side of the programmes:

OURSELVES AND THE ELECTRICAL IMPULSE

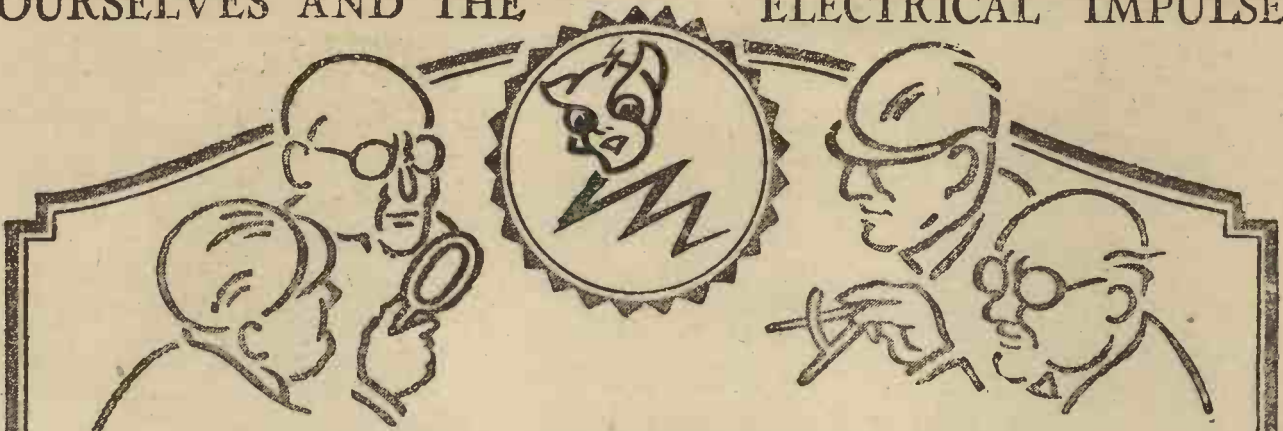

—a carefully cultivated acquaintance

Certain of our technical experts, having foregathered in the sanctum of our chief-of-staff, did ponder with deliberation on the wisdom of his discourse. "Now gentlemen," he said, "you will have to exercise considerable mental brilliance and thoughtful friendliness in pursuit of the electrical impulse. We know that he is the electrical energy which quickens the radio receiver into pulsating life; our job is to tempt him just a little further without fraying his temper. That is, to transform him into voice and music with radio instruments having the correct scientific elements for a really natural transformation. Build, gentlemen," he added, "and remember, he is to be carefully cultivated." But that was long ago. After seventeen years' peaceful penetration in the Brandes laboratories, we are perfectly acquainted with the best methods of effectually harnessing the properties of this elusive spirit of radio sound. Get Brandes radio instruments, built by master craftsmen and scientists in the reproduction of radio sound.

**THE TABLE-TALKER**  
The new goose-neck design is the result of research in radio acoustics, which definitely establishes its value in relation to the diaphragm fitted. Patent material used in the construction of the horn eliminates metallic harshness. Volume and sensitivity controlled with small lever located at the rear of the base. Elegantly shaped, tasteful neutral brown finish, felt-padded base. Height 18 ins., bell 10 ins.

30/-

**MATCHED TONE HEADPHONES**  
The whole secret of Matched Tone is that one receiver refuses to have any quarrel with its twin. Aply schooled in these generous sentiments by our specially erected Matched Tone apparatus, their synchronised effort discovers greater sensitivity and volume and truer tone. There is no possibility of the sound from one earpiece being half a tone lower than its mate.

20/-

**THE AUDIO TRANSFORMER**  
Ratio 1 to 5. The main objects in view are high amplification of applied voltage, together with a straight line amplification-frequency curve. That is to say, for a given input voltage, the amplification is constant over a wide band of frequencies, thus eliminating resonance. Mechanically protected and shielded so that the transformers may be placed close together without interaction.

17/6

**THE BRANDOLA**  
Specially built to bring greater volume with minimum current input and exceptional clarity over the full frequency range. A large diaphragm gives new rounded fulness to the low registers and new clarified lightness to the high. Reproduction controlled by a thumb screw on the base. Polished walnut plinth with electro-plated fittings. Height 26 ins., bell 12 in.

90/-

Brandes Limited, 296 Regent Street, W.1. Works—Slough, Bucks.

**Brandes**



EXPERTS IN RADIO ACOUSTICS SINCE 1908



# Ribbons of steel

—the same century-old principles of construction are employed in every Cossor Grid.

FROM bank to bank across a girder bridge a train speeds on its way. A hundred tons or more of living freight suspended in mid-air on a few ribbons of steel. Such is the skill of man. Rigidity is the Alpha and Omega of bridge construction. Without rigidity no bridge can withstand the devastating forces of Nature.

Rigidity, too, is the very essence of successful Valve construction. Without rigidity there must be distortion and microphonic noises. Compare the Cossor Grid with the ordinary spiral Grid and you'll instantly appreciate why the Cossor Valve has won such a unique reputation for purity of tone.

The Cossor Grid is a wonderful piece of miniature engineering. It is built up on a stout metal Grid band, and each turn of the wire is secured in three positions—35 places in all. Was there ever such rigidity?

Combine that with the Cossor electron-retaining system of design and you'll readily recognise why the Cossor is by far the most popular British Valve.

Everywhere it is earning golden laurels for a mellowness of tone hitherto considered impossible.

Before choosing your next Valve ask your Dealer to show you the Wuncell — the Cossor Dull Emitter. Functioning at a dull red glow (almost invisible in daylight) it is, indeed, a super-economy valve with an abnormally long life. For the first time it is possible to obtain a low temperature valve in every way as sensitive as the best bright emitter. The secret of Wuncell success is to be found in its wonderful filament. Instead of a wire, whittled down to the point of fragility, the filament used in the Wuncell is built up layer upon layer under the Cossor patent process. Instead of weakness there is strength.



**The Wuncell Dull Emitter**  
Voltage 1·8 volts. Consumption '3 amp.  
•W1 for Detector and L.F. 14/-  
•W2 for H.F. amplification 14/-

**The Cossor Loud Speaker Valve W3**  
Voltage 1·8 volts. Consumption '5 amp.  
Price 18/6

•Also in WR Series, with special switch and resistance in base to enable Valve being used with 2- 4- or 6-volt Accumulator:  
WR1 for Detector and L.F. 16/-  
WR2 for H.F. amplification 16/-





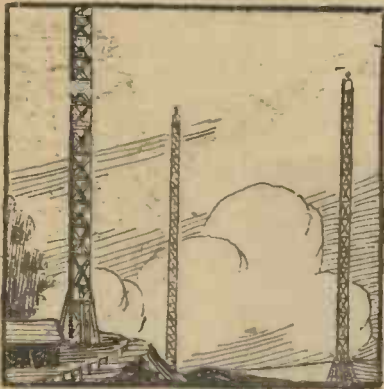

# Of What Use is Selectivity to the Crystal User ?

By J. H. REYNER, B.Sc. (Hons.), A.C.G.I.,  
D.I.C., A.M.I.E.E.

A GOOD deal of prominence has been given recently to the question of selectivity. Owners of multi-valve sets judge the capabilities of their receivers in terms of the possibility of receiving distant stations when the local station is working. There can be little doubt that the problem of eliminating the signals from the local station and still receiving signals from stations only 10 or 15 kilocycles away is one which forms a very fascinating study, and in the present overcrowded state of the aether a very necessary problem.

The question may be asked, however, "How does this question of selectivity affect the crystal user?" The average man possessed of a crystal set is interested solely in the local station, and by reason of the limitations of the apparatus he is unable to tune in to the more distant stations because the signal strength is too weak. The crystal user, therefore, is somewhat inclined to say, "Well, what use is this selectivity to me, anyhow? Why should I take the trouble to construct a low-loss receiver if I do not wish to receive the distant stations?"

### Interference

This question is certainly a legitimate one, and the answer to it depends very much upon the local conditions under which the particular user has to work. There are many places in which the reception from the local station is good and strong, and no appreciable interference is experienced from any outside source.

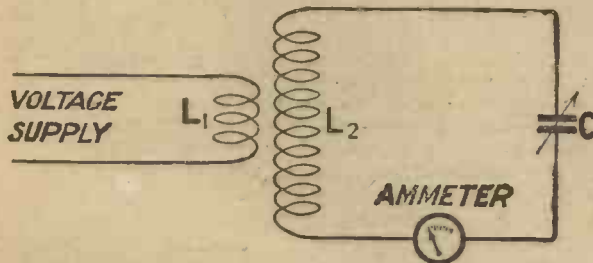

Fig. 1.—As the frequency of the supply in  $L_1$  is varied, the current induced in the tuned circuit  $CL_2$  falls away.

In such a case a very selective circuit is unnecessary. I shall discuss shortly one or two possible methods of obtaining selectivity, and it will be seen that with some of these methods the increase in selectivity is accompanied by an increase in the signal strength, while with other methods the resultant signal strength is the same as with an ordinary circuit, or possibly even somewhat less, although the actual selectivity is considerably improved. This latter type of circuit

would possess no advantages for the crystal user who is favourably situated.

We have, however, to consider the crystal user in a locality where interference is troublesome. Such a case is that of the coastal dweller. Here interference is experienced from spark stations operating at frequencies comparatively near to the broadcasting

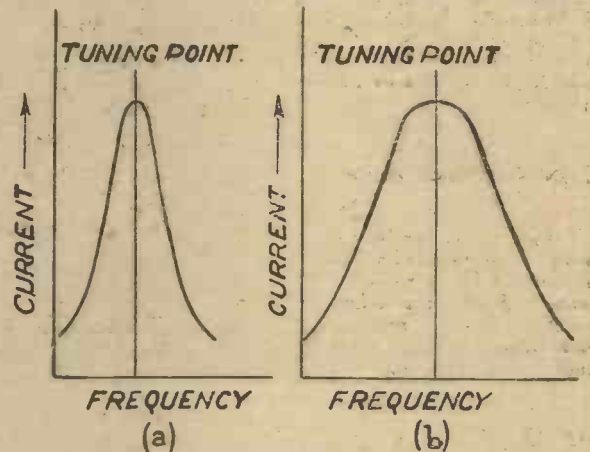

Fig. 2.—(a) shows a resonance curve for a selective circuit, but (b) represents one with flat tuning.

band, and in some cases actually within the latter. In such a case a selective receiver is very helpful. This will readily be appreciated if the meaning of selectivity is investigated a little more closely.

### Resonance Curve

If a tuned circuit such as is shown in Fig. 1 is supplied with currents at varying frequencies, the current which will be produced in the circuit is a maximum when the circuit is in tune with the frequency of the voltage supplied. This is the ordinary principle of tuning. As the frequency is varied on either side of the tuning point, so the current falls away more or less rapidly until at a frequency considerably different from the tuning frequency the current in the tuned circuit is negligibly small.

Now the selectivity of the circuit is that property which governs the falling away of the current as the frequency is varied. Fig. 2 shows two of these resonance curves, as they are called, one for a selective circuit, and one for an unselective circuit. In the former case, shown in Fig. 2(a), it will be seen that falling away of the current as the frequency is varied is very rapid, so that at a frequency very little different from the tuning point the current has only a comparatively small value. This means that the tuning will be sharp. Referring to the second resonance





# More Opinions

# of Famous Amateurs

**Mr. A. Garrett.**

Station 5RB.

"I find it really excellent. The absence of any possible backlash, and quietness in working, are two great points, especially for short-wave work. I shall have no hesitation in recommending to my friends, and other amateurs."

**Captain Percy Baker.**

Tewkesbury.

"You are too modest in your advertisements. I can tune in Continental stations as easily as Daventry, with good sharp tuning. If only your condenser had been invented earlier I should have saved pounds, for I have tried about 14 different kinds. You cannot miss a station on it."

**Mr. D. McAteer.**

Dublin.

"I can report quite shortly that it is better than any of the well-known makes on the market. The smooth action makes tuning to the low wavelengths, such as KDKA, quite a simple matter."

**YET** more impressive tributes to the **GECOPHONE Condenser** are reproduced here. *Fit a GECOPHONE Condenser in your own set to-day!*

**Mr. John Sadler.**

President, Aberdeen Radio Society.

"Your advertisements in no way exaggerate the superior quality and tremendous advance in variable condenser design. My own practical appreciation has taken the form of ordering two more."

**Mr. Louis J. Wood.**

Hon. Sec., Halifax Radio Club.

"A combination of the finest condenser features which has yet been manufactured in this country. The reduction gear is as near perfection as it is possible to get—the fixing, simplicity itself. You are to be congratulated."

**Mr. T. McNamera.**

Swansea.

"The slow-motion mechanism is the most ingenious that has yet come to my notice. Another point which impressed me was the increase of one's tuning range... the efficiency of the receiver in which the condenser is has gone up 50 per cent."

**Mr. Maurice Child.**

Director London Telegraph Training College.

"I have considered it sufficiently accurate to form a unit in a Heterodyne wavemeter which is being constructed in our students' workshop. You are to be congratulated on having produced such a really practical article."

**Mr. J. A. Partridge.**

Station G2KF.

"... the slow-motion device was found to be an ideal arrangement. The entire freedom from backlash and the smoothness of movement were very agreeable. There was a complete absence of hand-capacity."

## GECOPHONE LOW LOSS-SLOW MOTION VARIABLE CONDENSER

Sold by all GECOPHONE Service Depots,  
Wireless Dealers and Stores

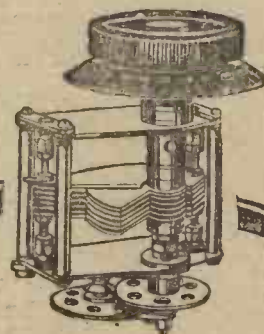
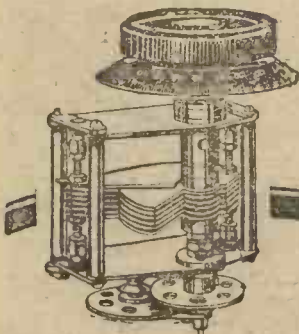

Advertisement of The General Electric Co., Magnet House, Kingsway, London, W.C.2.

THE FIRST WIRELESS LOUD SPEAKER WAS A BROWN



## Worthy of the honoured name it bears

FOR more than 15 years the name Brown has been recognised throughout the electrical industry as a name to conjure with. First the famous Brown Relay—used by Cable Companies throughout the world—then the superb A-type Headphone, setting entirely new standards for sensitiveness.

Afterwards there followed the marvellous Brown Gyro Compass—a wonderful instrument capable of pointing true North under all conditions without the aid of magnetism. And then, finally, the Brown Loud Speaker—the first British Loud Speaker ever used for Wireless. Sponsored by such supreme technical skill and daring originality, it is small wonder that Brown Loud Speakers have won for themselves in all corners of the globe a reputation for sensitiveness and mellowness of tone as yet without equal.

Time and again the insistent demand for Brown Wireless apparatus has necessitated expansions of factory space. Invariably the demand for Brown products is far ahead of available supply. But at no time has the standard of workmanship been relaxed. In spite of the ever-growing demand for Brown Loud Speakers not a hair's-breadth deviation from the recognised Brown standards of performance would be tolerated.



### The New H 3

Standing 15 inches high and fitted with the standard Brown tuned reed movement, this new H 3 will give an exceptionally generous volume of tone. Owing to its greater sensitiveness it will give much louder results than any other Loud Speaker of equal size. In resistances of 2000 or 4000 ohms

£3

**S. G. Brown, Ltd., N. Acton, London, W.3**

*Retail Showrooms: 29 Mortimer Street, W. 1.  
15 Moorfields, Liverpool. 67 High Street, Southampton.  
Depots (Wholesale only): 13 Bushy Park, Bristol.  
Cross House, Westgate Road, Newcastle.*

¶ If the Trade have difficulty in obtaining Brown Wireless Instruments they should write to us without delay.

BRITISH **Brown** THROUGHOUT

curve, Fig. 2(b), it will be seen that in this case the falling away of the current is much more gradual, giving much flatter tuning. At a point differing in frequency by the same amount as in the first case, it will be seen that the current here is still large, and is not negligible as it was in the previous case.

**Effect on the Receiver**

Let us consider now the effect of such a circuit in a receiving set. We tune the circuit to the frequency of the local station and thus obtain the maximum

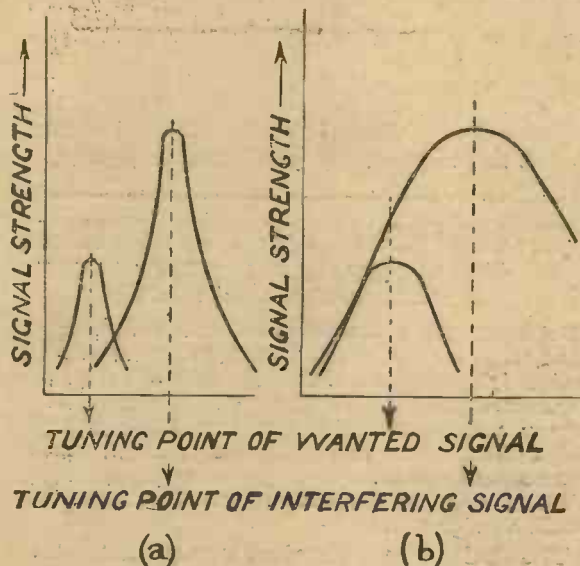

Fig. 3.—(a) With a selective circuit the interfering signal is negligible when the wanted station is tuned in, but in (b) the reverse is the case.

possible current. That is to say, we are working at the peak of the resonance curve. If there is now an interfering station at a frequency comparatively near to that of the local station, then, if the circuit is selective, the current produced by this interfering station will be very small, as shown in Fig. 3(a). If, on the other hand, the circuit is poor from the point of view of selectivity, then the interfering station will still be able to produce an appreciable current, although the circuit is not actually tuned to it. This, therefore, shows the benefit which is derived by employing a selective circuit in a locality where interference is experienced.

**Relative Signal Strength**

The problem is still more aggravated by the fact that the interfering signal is very often considerably stronger than that received from the broadcasting station. In this case it is more than ever necessary to have a selective circuit. If the two signals were both of equal strength when they were both tuned in, then if the set was tuned to the broadcasting station, the interfering station would be noticeably weaker, the actual reduction depending on the selectivity of the circuit as we have just seen.

If, however, the interfering signal when tuned in, is several times stronger than the broadcasting signal, then even when the set is tuned to the broadcasting frequency, the interfering signal may conceivably be stronger than the wanted signal. This point will be made quite clear from Fig. 3, which illustrates the current produced in the circuit both by the local station and the interfering signal. In Fig. 3(a) the circuit is selective, so that both the resonance curves are steep-sided, the current falling away very rapidly,

and the current actually produced by the unwanted transmission in the receiver when the circuit is tuned to the broadcasting station is only comparatively small. In the case shown in Fig. 3(b), however, the circuit is unselective, and the resonance curves therefore are flatter. It will be seen in this case that even when the circuit is tuned to the local station, the current produced by the interfering station is stronger than that of the local station.

This is the trouble which is likely to be encountered in a locality where interference is experienced. There is little doubt that the use of a selective circuit is amply justified in such a case. We have seen that in the case of a good receiving area where interference is small, then the use of a highly selective circuit is not so essential.

**Methods of Obtaining Selectivity**

Let us consider some methods of obtaining selectivity. The first method is, of course, the reduction of the resistance in the circuit. The lower the resistance can be made, the sharper becomes the resonance curve for a particular circuit, and the more selective the circuit becomes. An advantage of this method of reducing the resistance lies in the fact that not only does the selectivity increase, but the current at the actual tuning point increases appreciably. This method of producing selectivity is one which is strongly to be recommended, wherever the receiver is situated. The coil employed should be of as low a resistance as it is possible to make it, consistent with reasonable size, and if this is done, not only will selectivity be increased, but the signal strength also.

This statement must not be construed into a recommendation to use abnormally thick wire, because there are certain secondary effects which have to be taken into consideration, and the design of a low-loss coil for a tuning circuit is one which requires considerable skill and knowledge. Designs of suitable

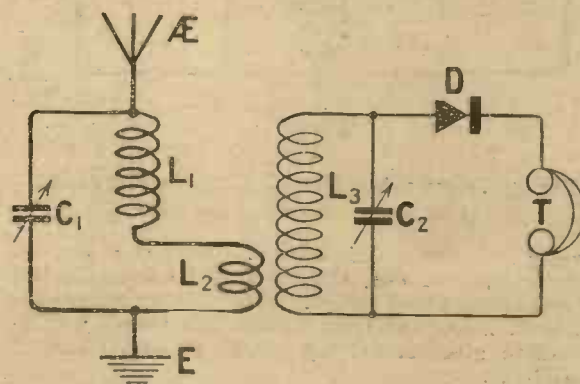

Fig. 4.—A two-circuit tuner in which the small coil  $L_2$  effects the coupling with  $L_3$ .

coils, however, appear from time to time in THE WIRELESS CONSTRUCTOR, and our readers may rest assured that everything is being done to present the best possible designs of coils to their notice.

**Use of Coupled Circuits**

The only other method of improving the selectivity of the crystal set lies in the use of two or more tuned circuits. In practice it is found that the use of more than two circuits on a crystal set is accompanied by such a large decrease of signal strength and such difficulties of tuning that the arrangement becomes impracticable. A two-circuit tuner, however, is often employed. The aerial circuit is tuned, and loosely coupled to the tuned secondary circuit.

Two Useful Circuits

The coupling may be by means of a small coil, as in Fig. 4, or of a direct tapping (Fig. 5). Both of these methods are capable of giving an increased selectivity. It should be noted, however, that this method may not give rise to any increase in signal strength, though on a poor aerial a noticeable increase may result. With a properly designed circuit, the maximum signal strength with such an arrangement is quite as good as it would be with a good single circuit, while the selectivity is definitely improved. A circuit of this type is very suitable for a coastal area, where interference is heavy, and very selective circuits can be made by utilising this principle. These advantages, however, are not noticed in a locality where interference is not troublesome, and there is little reason for the additional complication.

Tapped Aerial

A third type of circuit, which is in reality a species of coupled circuit, is that shown in Fig. 6. Here the aerial, instead of being connected right across the coil, is only connected across a comparatively small portion of it. It is found that with a circuit of this type the signal strength obtained is not usually impaired, and may even be increased, while the selectivity is very

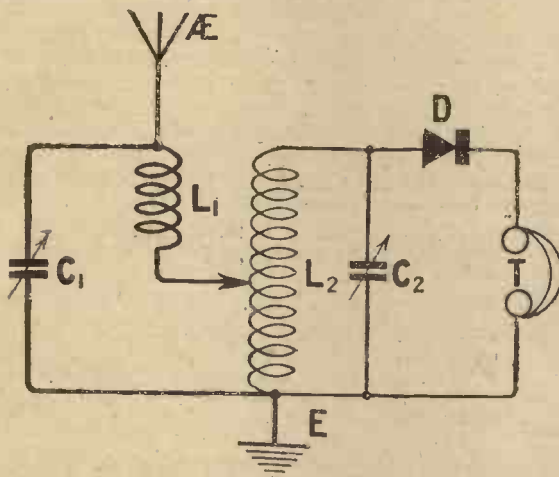

Fig. 5. Here a direct tapping couples the aerial and tuned secondary circuits.

largely increased. This type of circuit is a particularly convenient one, since it only involves the use of one actual tuned circuit. If the tuning coil used is made of a low-loss construction, this circuit will be found to give satisfactory results under all normal conditions.

Wave Traps

Another very effective method of reducing interference is that in which a wave trap is employed. In this case a suitable circuit, tuned to the interfering station, is connected across the main circuit in such a position as to divert the interfering currents from the detector without appreciably affecting the wanted signals. One way in which a wave trap is employed was shown in Fig. 5 on p. 133 of last month's issue.

This method, however, I have not discussed here, because I have been confining my remarks principally to straightforward circuits actually tuned to the wanted station.

It will be seen from these remarks, therefore, that selectivity is a question which affects the crystal user under normal conditions, so that the extra trouble involved in the construction of low-loss sets does produce better results.

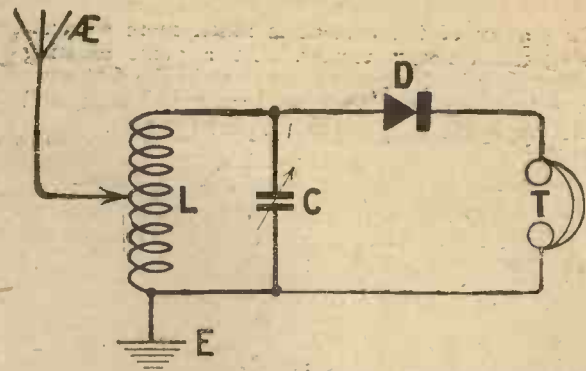

Fig. 6.—A tapped aerial circuit. The inductance L should preferably be of low-loss type.

OUR ELSTREE TEST DEPARTMENT  
IMPORTANT NOTICE

Readers availing themselves of our Test Service are asked, when forwarding sets for test, to enclose with the receiver full particulars of the behaviour of the set and of the valves and batteries employed. Coils, H.F. Transformers and Neutrodyne Units should always be included with the set. Valves, if sent, should be forwarded under separate cover.

Where sets are despatched by rail or post, they should be addressed to:—

The Radio Press Service Department, Ltd.  
(Test Department),  
Shenley Road, Elstree, Herts.

Elstree Station, L.M.S. Rly.

By carrying out these instructions, readers will facilitate the testing and return of their sets.



Mr. Donald Calthrop, the well-known revue artist, broadcasting from 2LO. He is a member of the B.B.C. advisory board which is concerned with studio productions.



# Dubilier everywhere

—in Arctic Seas.

Every year many Whaling Vessels such as this spend all the long summer months am'd the ice and black waters of the Polar Seas, entirely alone save for the slender contact with the outside world that wireless gives them. Reliability is therefore essential in their wireless equipment; and that is why in all wireless gear that is installed to go far North or South you will find Dubilier Products of Standard Type—ample proof that they are good enough for every purpose.

Dubilier Products include: Fixed Mica Condensers, Variable Air Condensers, Anode Resistances, Grid Leaks, the Dubrescon Valve Protector, the Ducon Aerial Adaptor, the Mansbridge Variometer, and the Minicap Switch. The Company are also sole concessionaires for the products of the Mansbridge Condenser Co., Ltd. Whenever any of these products are required, it is always safest to—

**Specify Dubilier**



The Dubilier Mansbridge Variometer. All wave-lengths to 1,800 metres, 12/6

The Dubilier Dubrescon Permanent Valve Protector. In use in H.T. lead, 6/-

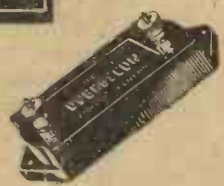

ADVERTISEMENT OF THE DUBILIER CONDENSER CO. (1925) LTD., DUCON WORKS, VICTORIA ROAD, NORTH ACTON, W.3 TELEPHONE: CHRISWICK 2241-2-3 E.P.S. 158

In replying to advertisers, please mention THE WIRELESS CONSTRUCTOR.

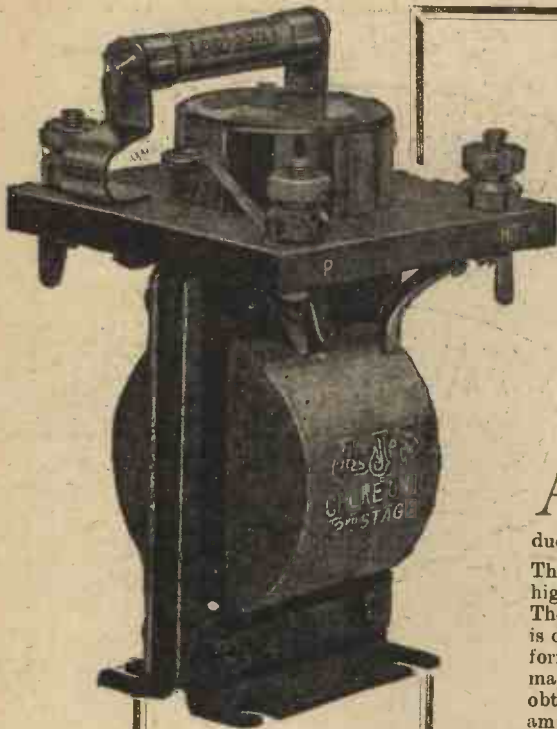

# CHOKES AND WHY

A GOOD choke can be produced to sell at a lower figure than a good transformer, and there are very few moderately priced transformers on the British, or any other market, that are capable of reproducing speech and music with such fidelity as a well-designed choke.

There is no foundation for the rumour that it is impossible to obtain such high amplification with choke as when ordinary coupling is employed. The fact is that few people use the correct valves. If pure reproduction is desired it is not possible to use a high amplification valve with a transformer, but with choke coupling a valve with a high amplification factor may be used with perfect safety, and is, in fact, essential if it is desired to obtain the best results. It is interesting to note that valves with a high amplification factor take considerably less H.T. supply than those whose amplification factor is of a low order.

Chokes are more reliable than transformers, there being only one winding, therefore the full H.T. voltage is not between turns or between primary and secondary as in the case of transformers.

The A.J.S. choke gives practically constant amplification over the whole musical scale, thus the quality of reproduction is equal to resistance coupling without the disadvantage of having to increase H.T. supply.

Three types are supplied. Choke only, may be used in conjunction with fixed condensers in place of a telephone transformer. Price 15s.

Choke unit, 1st stage, comprising choke, combined by-pass condenser and grid-leak - - - Price £1 0 0

Choke unit, 2nd stage, similar to first stage but without by-pass condenser and different value grid-leak - - - Price £1 0 0

*The units only require the addition of a valve-holder resistor and necessary connections to complete a low frequency amplifier.*

Send for Publication No. 115

## Chokes for Perfect Reception



**A. J. STEVENS & CO. (1914) LTD.**

Radio Branch - - - - WOLVERHAMPTON

Telephone: 1748 (7 lines). Telegrams: "RECEPTION, WOLVERHAMPTON."

LONDON SHOWROOMS:

122-124, Charing Cross Road, LONDON, W.C.2

Telephone: REGENT 7161-2. Telegrams: "AJAYESSCO, WESTCENT, LONDON!"

GLASGOW SHOWROOMS:

240, Great Western Road, GLASGOW

Telephone: DOUGLAS 3449. Telegrams: "RECEPTION, GLASGOW."



### Fixed Condensers

THE dielectrics are of the very best selected ruby mica, and the total losses of these Condensers are negligible.

The ebonite moulded container is conveniently arranged for single hole fixing.

Tags are fitted to permit of easy soldering, or, if desired, terminals can be fitted in the eyelets securing the Condenser tags.

Capacities:

'0001 '0002 '0003 '0005 Mfd.  
Each 1s. 9d.

Capacities:

'001 '002 '006 Mfd.  
Each 2s.

# They Reproduce Faithfully

**M**USICIANS speak of the violin as though it had a soul. How many Loud-speakers deserve such a praise? The A.J.S. models certainly have a good claim. In addition to reproducing the high and the low notes with equal fidelity, all the overtones receive instant response. It is this fact which gives to our instruments the soul of the violin.

They are beautifully made in our own factories, and each one has to pass the exacting test of delivering an enormous volume of undistorted speech and music.

The Mahogany and Oak flares are constructed by an A.J.S. patented process, which makes them better in appearance, mechanically, and as reproducing instruments.

We have designed for those who prefer the hornless type, cabinet models which are fine examples of artistic woodcraft, without in any way sacrificing their qualities of reproduction.

If metal horns are preferred, these may be obtained with glossy black or matt finish. We also supply them so skilfully hand-finished with colour and graining that it is difficult to believe that they are metal and not the highly polished woods they are made to resemble. These grained models can be obtained in two shades of Oak, Mahogany, Rosewood and Walnut.

*Visit our Showrooms in London or Glasgow and hear these Loud-speakers at your ease.*

We will gladly send to those interested, publication No. 118 which describes our full range.



### STANDARD LOUD SPEAKERS

In Wood, Mahogany or Oak flares - £4 15 0  
In Metal, Black Matt or Stove finish - £4 0 0  
Grained, various wood finishes - £4 5 0

### JUNIOR LOUD SPEAKERS

In Metal, height 19in. black horn - £1 15 0  
Grained, wood finish - £1 17 6  
Cabinet Model in Mahogany - £4 15 0

Pedestal Model in Mahogany or Rosewood  
£22 10s. 0d.

## A.J.S. HEADPHONES

**T**HESE Headphones give loud and clear signals. They are particularly sensitive, and are designed to give fine tone. They do not clamp the ears, being very light and comfortable to wear. They are very easy to adjust, but once set they remain, even after removal from the head.



High Resistance Only - £1 0s. 0d.

# A.J.S.

**A. J. STEVENS & Co. (1914) Ltd.**

**RADIO BRANCH - - - WOLVERHAMPTON**

Telephone: 1748 (7 lines) Telegrams: "Reception, Wolverhampton"

**LONDON SHOWROOMS: 122/124, Charing Cross Road, W.C.2**  
Telephone: Revent 7161/2 Telegrams: "Ajayessco, Westcent, London"

**GLASGOW SHOWROOMS: 240, Great Western Road, Glasgow**  
Telephone: Douglas 3449 Telegrams: "Reception, Glasgow"

# Making a Cabinet for Your Set

*A description of a useful cabinet with several novel points*

**A**N important but unfortunately often neglected branch of work in connection with the construction of wireless receiving sets is the making of cabinets. A well-designed and thoroughly-made cabinet will always easily repay the time and trouble involved in its construction, since it forms a protection for the various components of the set.

### Planning Out

In all cases the first consideration should be that of the space to be occupied by the various parts and their most advantageous disposition. The size of the panel or panels being given, the depth required for the parts should be calculated, allowing just sufficient accommodation without undue cramping. A good plan even when making the simplest of cabinets is first to make a full size drawing and to take all measurements from this. In this way one can not only calculate the exact sizes required but can also determine the best proportions in its design.

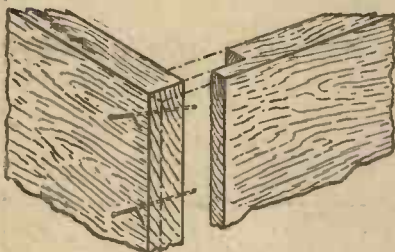

Fig. 1.—A lap joint, secured with glue and nails driven askew.

### The Wood

Of the woods most suitable for the work, the hard woods such as mahogany and oak are the best, especially for all outside show work, although pine and deal if suitably treated form quite good substitutes. The latter woods are used by many experimenters, as they are more easily obtainable and are inexpensive. The most useful thicknesses of boards are  $\frac{1}{2}$  in. and

$\frac{3}{4}$  in., these being obtainable in widths varying from 6 in. up to 11 in. Prepared boards should be obtained, as these are already machine-planed and brought to an equal thickness and thus save



Fig. 2.—The finished cabinet. The set is completely enclosed.

the worker a good deal of labour. The thicknesses mentioned are quite optional, the thickness of wood being decided according to circumstances.

### Simple Joints

The simplest type of cabinet is the plain box, the top being occupied by the panel of the set. There are various methods of joining the corners, from the simple nailed butt joint up to the more elaborate dovetailed joints. The latter are extremely strong and when well cut are very neat. A good alternative method is the lap joint, of which an example is shown in Fig. 1. Two of the sides are cut to the full outside size of the case, and a lap formed by cutting a rebate on the inner edges to a depth equal to the thickness of the wood. The remaining sides are less in length by the thickness of the lap allowed on the other sides. The joints are secured with glue and nails, the latter being driven askew as shown, to form a dovetail grip. A simple and effective method of securing the bottom is to screw it straight on underneath, hiding the consequent joints at the sides by mitring a moulding round.

An unusual and useful cabinet is illustrated in Fig. 2, and involves in its construction most of the joints which occur in general cabinet construction. The panel is enclosed behind a sloping fall and is fixed to a separate case, which is free to move from back to front. The fall is connected to the inner case and when opened draws the latter forward, thus bringing the panel flush with the front so that the dials are easily operated. The fall when open rests upon a drawer, as in Fig. 3, in which headphones and any other small parts are kept. The mechanism of the movement can be seen in Fig. 3, fuller details being given in Fig. 8.

### How to Make the Sides

The first step in making is to prepare the sides, which are of  $\frac{1}{2}$  in. material, and conform to the measurements indicated in Fig. 4. Both pieces should be first cut to the full size rectangular shape and carefully planed true. They are then clamped together and the



Fig. 3.—The wooden fall or "flap" when opened pulls forward the inner case and panel.

position of the slope marked on both edges. The waste portion is cut off and the edges planed square before the pieces are separated, thus ensuring their identity in size. The top and bottom are also prepared to size, allowing sufficient width in the former for the bevelled front-edge. The corners are lapped together in a similar way to that





# Sound advice — follow the experts



BEFORE the Harlie-Detector was officially adopted for use on *Lifeboats* and in the *Mercantile Marine* it had to fulfil these requirements:—

1. It must be capable of instant adjustment.
2. Once adjusted, it must withstand vibration and even hard knocks without disturbing reception.
3. It must be capable of being adjusted in the dark.
4. It must pass a stringent test for clarity of reception.
5. Contact must be continuous—even whilst being adjusted.

The Harlie-Detector has proved no exception to the rule that official recognition brings in its wake a huge public demand. Since the experts have proclaimed it the world's most efficient crystal detector, sales have soared beyond all bounds.

Remember, the Harlie-Detector can be fixed on any crystal or crystal-valve set in a few minutes, and when required, a new crystal can be inserted in an instant.

Don't tickle the crystal—get a

*Harlie*  
SUPER-SENSITIVE  
**DETECTOR**

*There is no substitute!*

If your Dealer does not stock, fill in this coupon and post to us with Postal Order for 5/6.

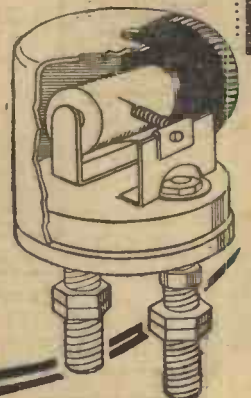

**5/6**  
COMPLETE  
WITH CRYSTAL

Merrill Service

HARLIE BROS., 36, WILTON ROAD, LONDON, E.8

Dear Sirs,

I enclose herewith 5/6 for one HARLIE-DETECTOR to be sent to me post free on the understanding that my money will be refunded, without question, if I return the Detector undamaged within ten days.

NAME.....

ADDRESS.....

WC4

shown in Fig. 1, except that a double lap is allowed at the top corners. The bottom will, therefore, be less in length by the thickness of both laps on the sides. Allowance must also be made in the latter for the laps at the top.

the grooves. The top and sides are rebated at their back inner edges to take the back, which may be very suitably made from three-ply. It is unnecessary to rebate the bottom, as the back may fit right over this, the back edge being

not run right through. The sides are cut first, and the front and back marked out from these.

**Making the Inner Case**

Fig. 6 shows the drawer being put together, and indicates clearly the lap at the front. Before glueing up the drawer, a groove to take a

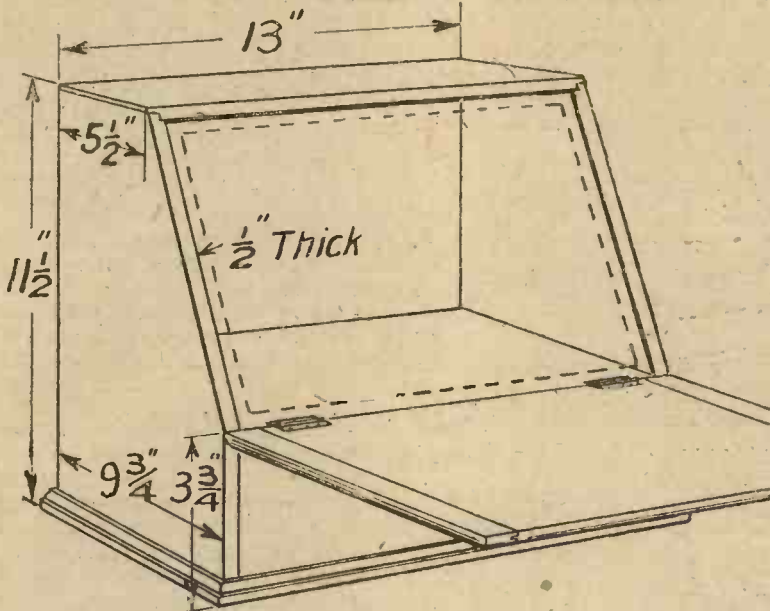

Fig. 6.—The drawer is dovetailed, and grooved to take a three-ply bottom.

Fig. 4.—Dimensions of the cabinet. The inner case has a width of 12 ins. and a sloping height of about 8 3/8 ins. The panel fits over this, but has an allowance of 1/8 in. off each edge, so that beading can be mitred on. The panel size is therefore about 11 1/8 ins. by 8 ins.

three-ply bottom must be worked on the front and two sides. The inside case is simply butted and nailed together, the exact size being taken directly from the outer cabinet. It should be carefully trimmed and levelled after being put together, so that it fits nicely in position. Small recesses are cut at the front corners as shown in Fig. 7. These are cut out to allow clearance for the brass stays which connect the inner case with the fall. The latter should be clamped at the sides to obviate any tendency to warping. The clamps are joined with a tongue and groove. After setting, it should be fitted in position, and a small moulding worked at the top and two sides. When hinging it to the shelf the hinges should be let in half-and-half into both shelf and fall.

**Cutting Grooves for the Shelf**

Grooves are now cut across the inner faces of the sides to take the centre shelf. These grooves are stopped near to the front, so that the joint will not show at the front of the cabinet. The best method of cutting the grooves is first to mark out their position with a chisel, cutting deeply across the grain. The wood on the inner sides of these cuts is then eased

planned to fit level with the rebate on the sides.

**Assembling**

The whole is now ready for assembly. The bottom is first glued and nailed to the sides, driving in the nails askew from the underside, in the manner shown in Fig. 1. The shelf is next fitted in place with glue, sliding it into the grooves from the back, the top being fitted last of all. The nails for this should be driven in from the sides, after which the whole should be tested to see that it is square, and then put aside to set thoroughly.

**The Drawer**

The best method of making the drawer is to dovetail it. The front is first cut to size, and is carefully fitted into the space it will occupy, planing the edges slightly askew, so that it wedges in tightly. The sides are also cut off square to length, and fitted into the cabinet, being planed to fit just hand tight. The back will be made less in depth by the extent to which the bottom stands up, as it fits above the latter. The depth of the dovetails is gauged on all four pieces, making an allowance at the front for the lap, as the front dovetails should



Fig. 5.—A central shelf is fitted into grooves cut in the sides.

away with a chisel, thus forming a small groove in which a saw may be worked. The groove may be made of equal depth by using a router. An extra allowance in the length of the centre shelf must be made for the portion fitting into

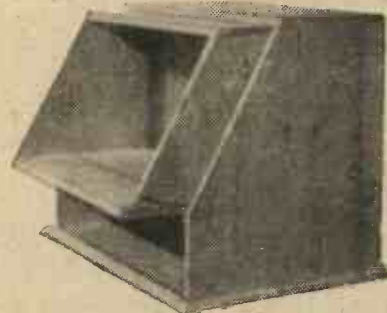

Fig. 7.—The inner case is cut to fit the main cabinet. Note the recesses at the front bottom corners for the brass stays.

**The Stays and Brackets**

The exact position at which to fix the stays and the brass angle-brackets is given in Fig. 8. The panel is cut with an allowance of  $\frac{1}{8}$  in. on each edge, so that a bead can be mitred round the edge. This not only gives a neat finish, but obviates the necessity of cutting away the panel to allow for the stays. A back view of the cabinet, showing the rebate to take the three-ply back is shown in Fig. 9.

The base moulding is mitred round, and is fixed with glue and fine pins.

**Applying Stain**

The best finish for such a case as this made in deal is to first stain it, and finish off when dry with wax polish. The stain may be applied with a rag, rubbing it well into the corners, and finishing off with light strokes in the same direction as the grain of the wood.

**Polishing the Cabinet**

Oak may also be treated in a



Fig. 9. The cabinet from the back.

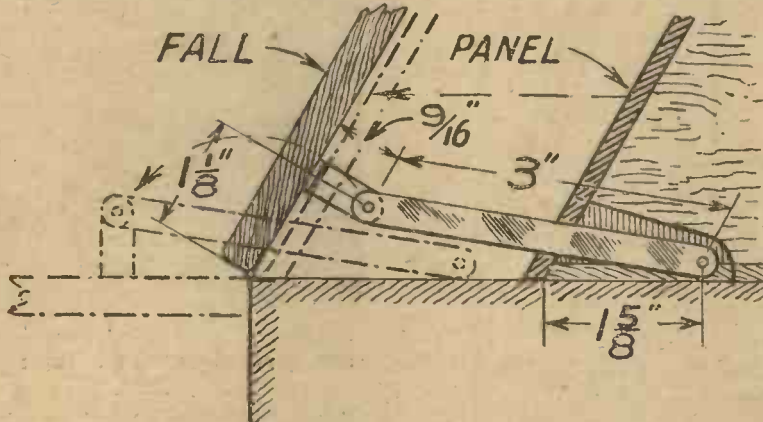

Fig. 8.—Details of the brass stays and their mode of attachment to the fall and inner case. The allowance of  $\frac{1}{8}$  in. on each edge of the panel leaves room for the stays and for ornamental beading.

similar manner, or, if desired, may be fumed. Mahogany is best treated by french polishing. It should be first stained or darkened with a coating of bi-chromate of potash, and when dry the grain should be filled in with plaster of paris suitably coloured with powder colours.

Before polishing, a rag lightly soaked in linseed oil is passed over it, this having the effect of toning the plaster down, as the natural tendency of the plaster is to dry a light colour.

If the inner case is found to move tightly and is apt to bind or to squeak, a little candle grease should be rubbed over all working surfaces.

## The "Twin-Valve" Receiver

SIR,—Six months ago I had a plain one Det., one I.F. valve set, and felt fed-up because I could not get anything like good results. I could at times get Birmingham, Bournemouth and Cardiff, but at no great strength. Then reading the January, 1925, issue of THE WIRELESS CONSTRUCTOR, I noted the Twin-Valve Receiver, described by John Scott Taggart, F.Inst.P., A.M.I.E.E., comprised all my components except two fixed condensers. So I "rewired" my set to your circuit, and although the layout of components is somewhat different, results have really been excellent.

I can get all the B.B.C. stations at good phone strength (I have a very poor aerial and worse earth) Le Petit Parisien, P.T.T., Hamburg, Madrid (R.I.), Radio-Sud-Est, Brussels, Munich, Radio Toulouse, Radio-Paris, Hilversum, Stockholm, Dresden and WGY (U.S.A.) (twice).

Every station is clear, and I think that, given a better aerial and earth, the majority would work a loud-speaker (small type).

Later I intend to add the "Two-stage Choke Amplifier," by John W.

Barber, described in the September, 1925, issue of THE WIRELESS CONSTRUCTOR.

Many thanks for the circuit.

Yours faithfully,

J. SHANN.

West Kensington.

SIR,—I made up the Twin-Valve set as described by John Scott Taggart, F.Inst.P., A.M.I.E.E., in the January, 1925, issue of THE WIRELESS CONSTRUCTOR about six months ago, and am very pleased with results.

I have had all the main stations and several relays and continentals. Being situated about 25 miles from the nearest station (Cardiff), this comes in after dark rather too loud for phones (five pairs), while Daventry, much louder still, has worked a loud-speaker.

I do not, however, want to work a loud-speaker, but prefer the more distant stations, such as Bournemouth, Birmingham, Newcastle, etc., at excellent phone strength to accommodate the whole five pairs of phones.

Perhaps the following would be of interest. My aerial is of the

"birdcage" type, 5 ft. across and 4 ft. above the roof (no room for any other type), and was erected by the trade, and seems quite efficient for Cardiff and Daventry.

My earth is a copper tube with a 15 ft. lead of five strands of No. 20 and  $\frac{7}{22}$  twisted together.

My coils are home made basket on card formers of nine slots, 22 gauge wire, and Cardiff requires 80 turns using C.A.T. and 15° condenser reading and 75 turns of 26 gauge for reaction.

Daventry requires 260 turns of 26, same reaction, and comes in at 20° condenser.

I might say in closing that I made for a friend the "Powerful 3-Valve Receiver" by Percy W. Harris, M.I.R.E., described in the April, 1925, issue, and he was delighted. Cardiff 25 miles, Bournemouth 65, and Daventry coming in on an Amplion L.S. at full-strength.

Yours faithfully,

A. L. MARTIN.

Bristol.

## "WIRELESS"

The One - Word Weekly

On Sale Every Tuesday

2d.

# The ROYAL Super Transformer is the ONLY Transformer which carries a **2 YEARS GUARANTEE**

## A SOUND INVESTMENT

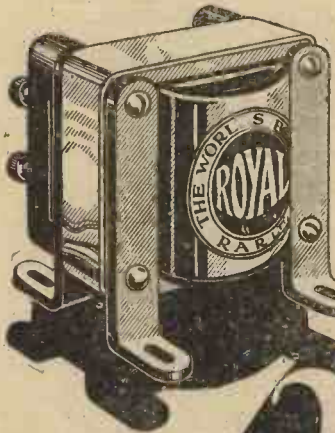

When you equip your set with Royal Super L.F. Transformers, you are assured of perfect reception, faithful reproduction of speech and music and, moreover, are given an unconditional guarantee for 2 years. We shall be pleased for readers of Radio Press Journals to try out one or two Royals on the understanding that, if results are not satisfactory or better, we will refund purchase price in full.

STANDS ALONE FOR PURE TONE

This Transformer carries an Unconditional Guarantee for 2 YEARS during that period if defective return to ROTHERMEL RADIO CORP. LTD. 24-26, MADDOX ST., LONDON, W.1.

**ROTHERMEL  
RADIO CORPORATION  
OF GREAT BRITAIN, LIMITED.**

24-26, MADDOX ST., REGENT ST., LONDON, W.1  
Phone: Mayfair 578 & 579. Grams: "Rothermel, Wesdo, Lon.Lon."

**20/-  
EACH**

# CLARITY-VOLUME-DISTANCE

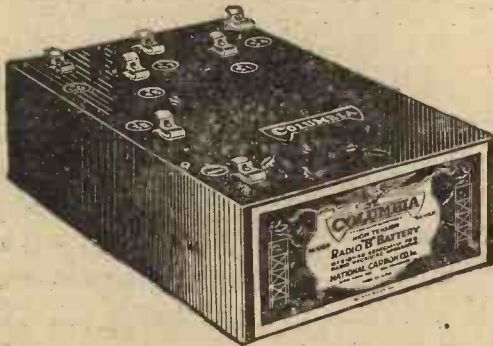

Look into the workshops of radio amateurs, into the laboratories of radio engineers. Observe the radio battery equipment in the homes you visit. Everywhere you will find

**Columbia  
Dry Batteries**  
*— they last longer*

The No. 4780 60 VOLT HIGH CAPACITY BATTERY is by far the most satisfactory plate battery you can use. The extra large sized cells used in the construction of the battery not only supply sufficient power for the finest reception, but give an unusually long service life as well. The heavy spring clips ensure *quick and secure* connections.

**Price 22/6**

**Columbia** RADIO "A" DRY CELLS  
ESPECIALLY DESIGNED FOR WIRELESS  
and suitable for use with all types of dull emitter valves, the Radio "A" is the most reliable and efficient filament heating unit manufactured.

**Price 2/6**



Send for our new **FREE BOOKLET**—  
35 pages of valuable information pertaining  
to care and operation of your batteries.

**No. 4770 45 VOLT EXTRA HEAVY DUTY IS ESPECIALLY RECOMMENDED FOR NEUTRODYNE CIRCUITS**

ADVERTISEMENT OF J. R. MORRIS, 15, KINGSWAY, LONDON, W.C.

In replying to advertisers, please mention THE WIRELESS CONSTRUCTOR.

# Guaranteed up to the hilt for Twelve Months

**B**UILD your Super-Heterodyne with Bowyer-Lowe Parts because every one is guaranteed against faults for a year and will be exchanged if it does not give you the fullest satisfaction.

Use these parts for another reason—the makers are the pioneers of Super-Het. development for amateurs in this country. Amateurs who have made sets with Bowyer-Lowe parts and plans report results that are unusual even in Super-Heterodyne reception. Easy to build, easy to use are these sets.

Send for a complete catalogue of Bowyer-Lowe Components for all types of receiver. Use the coupon.



### "ANTIPONG" The All-in Valve Holder

Some Valve Holders are anti-capacity but not anti-microphonic; some are anti-microphonic but not anti-capacity. Some valve holders are one of these but not universal fitting; some, again, are universal fitting but not anti-microphonic or anti-capacity.

ANTIPONG is anti-capacity, anti-microphonic and universal fitting. The three shillings it costs insures your valves against shocks and helps to secure for you richer, purer signals.

Buy  
ANTIPONG  
to-day.

PRICE **3s.**



### KIT for Building A SEVEN VALVE SUPER-HET

An ideal Xmas Gift for yourself or a friend. Contains the principal parts required for building the Bowyer-Lowe Seven-Valve Super-Het. Receiver which receives over thirty English and Continental stations at Loud-Speaker strength on a frame aerial. Kit contains Transformers, Oscillator coupler, Square Law and Vernier Condensers, Panels, baseboard, Anti-Capacity Valve Holders, etc., with full-size blueprints of panels and wiring, diagrams and illustrated book of instructions. PRICE

**£10**

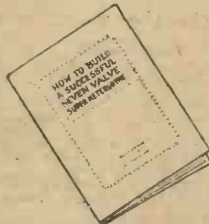

### NEW EDITION of The Super-Het. Book

The third edition of this popular book has been enlarged and now contains "Step by step" instructions for assembling and wiring a Seven Valve Super-Het. Receiver, as well as assembly photographs, new wiring diagram and hints on operation. Many amateurs have built successful sets receiving over thirty stations at Loud-Speaker strength with the aid of this book. Send P.O. and the coupon to-day. PRICE

**6d.**



### Tested Super-Heterodyne Transformers

Build your Super-Heterodyne with these transformers. Every set is individually matched and tested. Each one is guaranteed for twelve months. The complete set is sold in a distinctive box containing booklet of instructions for building The Bowyer-Lowe Seven Valve Super-Heterodyne Receiver. Amateurs who have made it report results that have surpassed their expectations because these transformers are built expressly for use with British valves and therefore give higher amplification with absence of background noise. Users everywhere remark on the purity of signals yielded by sets made with these transformers. Order a set from your dealer and build your Super-Het. for Christmas. Set complete with instructions. PRICE

**£4**



### THE NEW Oscillator Coupler

Model II, a late development of Super-Het. design. Operates on direct coupled system without a pick up coil. More sensitive than older types of coupler. Covers 260 to 550 metres when tuned with Bowyer-Lowe '0005 Square Law Condenser. PRICE

**£1**



### Neutrodyne Condensers

Designed for use in Neutrodyne circuits, this instrument has also proved exceedingly sensitive as a Vernier when used in parallel with a larger condenser. It is invaluable in Super-Het. circuits. Fitted in panel with single screw and 1/8 inch hole for spindle. PRICE

**5s.**

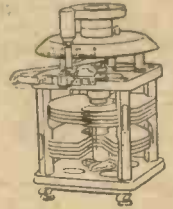

### The FOUR-SQUARE Ball Bearing Condenser

This precision instrument meets the highest demands of the most critical experimenter. Its brass vanes, soldered in position and mounted on ball bearings, are balanced to give tuning of the most accurate order. The instrument has the lowest losses of any condenser yet devised and yields signals of remarkable strength and purity. Oscillation on wavelengths below 20 metres is a simple matter with this instrument. Each condenser has four alternative capacities, three single and one double. The two models cover most amateur needs.

Model I. Nominally '0005 Mfd. (converts to '0015 and '00075 single; and '00015 double) PRICE **28s.**  
Model II. Nominally '0025 Mfd. (converts to '0025 and '00125 single; and '00025 double) PRICE **30s.**  
Vernier attachment 3s. to 1 rat'o. for either model, 5s.

**POST  
THIS NOW**

**BOWYER-LOWE CO. LTD., LETCHWORTH.**  
Send me the items marked with a cross in the spaces below. (Enclose P.O. 6d. for Super-Het. book. Other items free.)

Instructions for Building 7-Valve Super-Het. at 6d.

Component Catalogue ...

Leaflet re Popular Condenser ...

Name.....

Address.....

**BOWYER-LOWE Tested  
Radio Components  
BOWYER-LOWE CO LTD LETCHWORTH**



ONCE his big set had been constructed there was, so to speak, only one fly in Mr. Gumplethorpe's ointment, though, if the insect in question was a single one, it made up in size for what it lacked in numbers. The trouble was that he simply could not run round the stations as he would have liked to do, because there were so many things to be twiddled all at once that, if he was trying to find Newcastle, he was never quite sure whether he was going up or down the scale when he turned the knobs.

**Up or Down?**

And it is obvious that if you are running up the scale in wavelengths, you are running down it in kilocycles and *vice versa*. Owing to his inexperience and to the difficulty he had in getting the old-fashioned wavelength idea out of his head, Mr. Gumplethorpe not infrequently went up the scale in wavelengths



... conducted to the bicycle department....

with C<sub>1</sub> and up the scale in kilocycles with C<sub>2</sub> simultaneously. Such was the state of frenzy produced in him by his frantic, but unsuccessful efforts to give his friends a round-Europe programme that he very nearly went up the pole as well. Mr. Gumplethorpe always started by tuning in London. This was comparatively easy, since the distance from his desirable villa, messuage or demesne to 2LO's aerial was not great. Having found London, he then set himself the task of going down (or up, if you are old-fashioned) to Belfast. After a few careful movements of the knobs faint music would be heard from the loud-speaker. "Aha!" said Mr. Gumplethorpe. Further small twiddles brought the music up to splendid strength

"Belfast," said Mr. Gumplethorpe. "2LO," said the announcer. Mr. Gumplethorpe then tried again, always with the same result. Whenever he tuned in Rome or Vienna or Oslo or Toulouse, his little sigh of satisfaction ever turned into a grunt of disgust or a scream of dismay, because, as soon as the music came to an end, the announcer told the world that 2LO was calling. At one time Mr. Gumplethorpe thought that there must be a world-wide conspiracy and that all stations were calling themselves 2LO. Several of his friends agreed with him when he told them about this, but others were quite rude about it.

**2LO's Wavelength**

Mr. Gumplethorpe was delighted to see the remarks that appeared in the publications of the Radio Press about 2LO's wavelength. He wrote a long letter to the Editor, saying that his own observations had proved that 2LO had no fixed wavelength or kilocyclage, but was transmitting upon all wavelengths between 300 and 500 metres or upon every frequency between one million and 600,000. He next consulted an expert friend, who, having heard his tale of woe, recommended him to purchase a wavemeter. Mr. Gumplethorpe disliked the name, but thought that the idea was a good one. On his next visit to London he entered a wireless shop and asked to be shown the latest thing in kilocyclometers.

**Cyclometers**

The salesman promptly conducted him to the bicycle department, where he was shown those funny little things that people fix to their front wheels for reasons best known to themselves. A friend of mine in the early days of cycling once fitted up one of these on the eve of a ride from London to York. Arriving at the northern city, he consulted the gadget to see how many miles he had done and found that it registered 9,802. As he had performed the ride in 12 hours, he claimed a world's record, but this

was disallowed when the authorities found that he had clamped the ticker thing to the spoke in such a way that the instrument read backwards. Mr. Gumplethorpe, on being shown things of this sort, became livid with fury, and such was the torrent of speech that issued from his lips that it was some time before the man behind the counter could grasp what he was talking about. At length he was led back to the wireless department, where he demanded to see a frequency-meter. They were just taking him off to the gas department, when he flung his principles to the winds and explained that what he wanted was a wavemeter.

**A Heterodyne Wavemeter**

All was now comparatively plain sailing. The salesman having heard of Mr. Gumplethorpe's sad experience, and having been furnished with a lengthy description of his



... found that it registered 9,802 miles....

super-set, prescribed a heterodyne wavemeter. "For ordinary, non-expert wireless men," he said, "we would recommend the buzzer article. But this does not give the accuracy that a person such as yourself would require. For you the heterodyne wavemeter is obviously the only suitable type." He demonstrated to Mr. Gumplethorpe how to find the silent point between squeaks and assured him that the whole thing was as easy as pie, if not easier. Mr. Gumplethorpe left the shop minus several Fishers and plus a parcel whose sharp corners he dug into the vulnerable spots of numerous fellow strap-hangers in the course of his journey on the Tube to the railway station, whence he was whirled home at the giddy speed of 10 miles

per hour, perhaps, by a Southern Railway flier.

**Silent Points**

Having reached his little dovecot, he repaired to his radio den and prepared the heterodyne wavemeter for action. Now, at last, he thought, he would be able to go up in wavelengths or down in kilocycles just as he desired. He would make his first attempt, he decided, with Glasgow. He set the wavemeter at the appropriate reading and switched it on. Then he switched on the set. He gave C a slight clockwise twist. "Wheeeeeee—silence—ooowheee!" said the loud-speaker. There were the squeaks, and there was the silent



... a parcel with sharp corners ...

point. For the next half-hour Mr. Gumplethorpe chased that silent point round and round the dials of his condensers. Whenever he found silence as regards the wheees he found noise from 2LO. Not until the next morning did he learn that his next-door neighbour, Jones, one of the most renowned oscillators in the district, had been trying out a new set. The next night the wavemeter was all silent points, and all the silent points were 2LO.

**The I.S.R.L. Again**

Poor Mr. Gumplethorpe was in a terrible state. Every morning when he travelled up in the train his friends told him of the marvellous reception obtained on the previous evening from all kinds of stations. It was bad enough to have them telling him this kind of thing, but it was far worse when they asked him what stations he had got. Having been elected some time previously, as you may remember, a member of the Incorporated Society of Radio Liars, he gave quite a respectable list; but he felt all the time that the Recording Angel's self-filler was working pretty hard, and he had what the Americans call a lunch that, even with the handicap allowed to members of the Incorporated Society of Radio Liars, his card was well over bogey. He therefore pulled the heterodyne wavemeter to pieces, obtaining from it a valuable collection of components which went to join the members of the

unemployed (without dole) upon the shelves of his wireless cupboard. He next decided to construct for himself one of the despised buzzer wavemeters.

**Quite Simple!**

This, of course, is the easiest task in the world. The only materials required, to quote the words of those who tell us how to make things, are a buzzer, a condenser, a single cell, a coil, a switch, an ebonite panel and a neat cabinet. Anybody in one afternoon can make a buzzer wavemeter. I make this statement without the slightest fear that any reader will contradict it. But many afternoons and evenings and mornings may pass before he can make the buzzer buzz. I have told you that there was a fly in Mr. Gumplethorpe's ointment. But the fly apparently was not a bluebottle; certainly it was not a mosquito. The buzzer which he purchased was a small affair which appeared at first sight perfectly harmless. The instructions accompanying it said, "Adjust screw A and screw B until a high singing note is obtained." Mr. Gumplethorpe adjusted screw A until its threads were worn out and had to be replaced by screw A<sup>1</sup>. He then adjusted the screw B until there was simply no nick left in it and screw B<sup>1</sup> had to take its place.

**Getting it Calibrated**

Mr. Gumplethorpe called them much worse things than A dash and B dash. The instructions referred, as I have mentioned, to a high singing note. It did not state whether the note was produced by a soprano, an alto, a tenor or a basso. All that Mr. Gumplethorpe could obtain even with screw A<sup>11</sup> and B<sup>11</sup> was a noise rather like the tearing of American cloth. Having got so far, Mr. Gumplethorpe completed his wavemeter and sent it round to a super-expert friend to be calibrated. After many days the friend returned it calibrated in wavelengths. Utterly disgusted, Mr. Gumplethorpe handed it over to a second friend, requesting him to calibrate it in kilocycles. The second friend returned it with a polite note, stating that the buzzer had apparently been struck by lightning. He then handed the instrument to yet another friend who promised to calibrate it for him in anything he liked. A week or two later the wavemeter was returned with a most beautifully drawn calibration chart. Mr. Gumplethorpe was in ecstasies.

**The Buzzer Buzzes**

That evening he switched on his set and switched on the wavemeter. The buzzer would not buzz. He tapped the instrument. The buzzer would not buzz. He rapped the instrument. The buzzer would not buzz. He banged the instrument. The buzzer would not buzz. He replaced screws X and Y with screws O and P. The rest of the evening he spent in making the buzzer buzz. Just before midnight it zizzed with a high super-soprano singing note. Mr. Gumplethorpe retired to bed, resolving to leave the final trial until the following evening. He came back to his little home prepared to have things all his own way. Did he find them so? He did not. The buzzer would not buzz. He fitted a new battery. The buzzer buzzed. Full of hope and enthusiasm he tuned in 2LO and set the meter at the appropriate reading. By exceedingly careful manipulation he advanced from a hoarse rending noise to the love song of a mosquito. This he found was perfectly possible with the condenser set at zero. If, however, he turned its knob ever so little in a clockwise direction things at once went wrong. Examination showed that C was suffering from touching plates. Having replaced C with C<sup>1</sup> he found that battery B was simply shouting to be relieved by B<sup>1</sup>. And when a new battery had been installed and the buzzer was singing its shrillest not a sound could be heard from the loud-speaker even



... a house agent in Aberdeen ...

though the coil L of the wavemeter was held tightly against L<sub>1</sub> of his super set.

**Off to Bonnie Scotland?**

Mr. Gumplethorpe is of an opinion that 2LO is not playing the game. For the moment he has given up the stations upon the broadcast waveband (or kilocycleband) and has taken to Daventry. This would be quite satisfactory but for the fact that 5XX now nearly always relays 2LO. Mr. Gumplethorpe when I last heard from him was in correspondence with a house agent in Aberdeen. Meantime, should you happen to meet him, I do not advise you to mention the subject of wavemeters.



## Easier Soldering for Wireless Constructors

The most complicated soldering job is made easy by "Maymore"

### ELECTRIC SOLDERING IRONS



which — owing to their unique construction — facilitate access to otherwise inaccessible connections. Even temperature maintained without withdrawing iron for heating. Consumption of current only that of an ordinary lamp.

Supplied (complete with lamp-adaptor and flex) in the following voltages—

100/110, 200/220, 230/250  
Any other voltage 2/6 extra.

Absolutely perfect in design and construction. Guaranteed 6 months.

Illustrated literature free on request

**GOODWINS**

2, Edmund St. BIRMINGHAM

**10/6**

Post Free

## Liberty Permanent Detector

The Original One-Hole Fixing Detector  
Stop Fiddling with Cat's Whiskers



Refuse inferior imitations. Insist on 600 mg the name Liberty.

Technical Reports

Amateur Wireless:  
Popular Wireless:  
Wireless Weekly.

Every Liberty tested on actual broadcasting and fully guaranteed.

50% more efficiency  
50% lower price  
**"THE 100% DETECTOR"**

FIXING.—One-hole clips or by two pieces copper wire to existing detector terminals.



The "Liberty" Detector gives more sensitive reception. Permanently than a cat's whisker gives temporarily. No hunting for that "special spot" lost by the slightest vibration. The "Liberty" is entirely unaffected by vibration, sensitive all over, and that loud spot cannot be lost.

Radi-Arc Electrical Co., Ltd.  
Bennett Street, London, W.4

From all dealers or direct  
**PRICE 3/6 COMPLETE**

## GET TO KNOW Pickett Brothers for Radio CABINETS



BEING actual manufacturers of Wireless Cabinets we can offer an unrivalled selection of De Luxe and Parlour Models which should be of considerable interest to you. Prices ranging from 1s. 6d. to £5 from stock, or made to order in seven days, and expertly constructed to your own specification. Write for illustrated list. Estimates post free. Panels for any cabinet and complete accessories can be supplied. 100-page Accessory Catalogue, post free 3d.



Get your Cabinets built by:—  
**PICKETT BROS.** (members B.C.C.)  
O.W. Cabinet Works,  
Bexley Heath nr. London.

*Howell Repairs*

**Stop that FILAMENT VIBRATION!**

get purer tone by using this shock absorbing valve holder

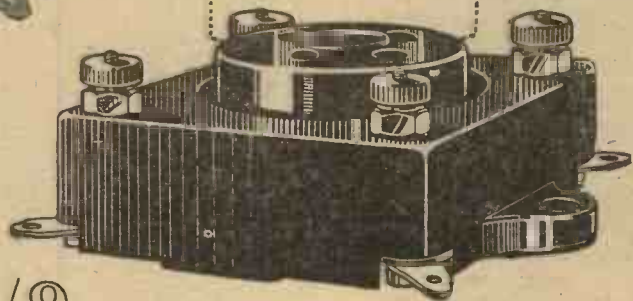

**2/9 EACH**

This new shock-absorbing isometrically constructed valve holder is securely floated on delicately adjusted springs. So strongly constructed are these springs that the tightest valve can be inserted or removed without fear of damaging them. EACH SPRING HAS ONE TURN ONLY. Bakelite construction ensures high insulation, low capacity and sturdiness.

isometrically constructed valve holder is securely floated on delicately adjusted springs. So strongly constructed are these springs that the tightest valve can be inserted or removed without fear of damaging them. EACH SPRING HAS ONE TURN ONLY. Bakelite construction ensures high insulation, low capacity and sturdiness.

There are terminal connections for the experimenter and soldering tags for the permanent set. The Benjamin Clearer Tone Valve Holder is easily cleaned—little or no dust can collect in the sockets.

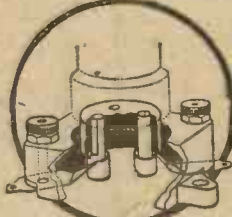

Sectional View

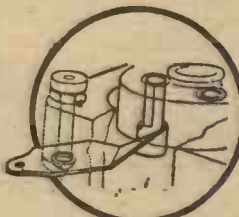

Spring Feature

The springs themselves form the valve pin sockets. No soldered joints—all one solid metal piece from tag to valve leg. No flexible wire connections. The spring supports are not affected by stiff bus-bar wiring. FOR GOOD RECEPTION WITH DULL EMITTER VALVES BENJAMIN CLEARER TONE ANTI-MICROPHONIC VALVE HOLDERS ARE ESSENTIAL.

# BENJAMIN CLEARER TONE VALVE HOLDER

(ANTI-MICROPHONIC)  
Pats. Pending.

FROM YOUR DEALER OR DIRECT FROM

**THE BENJAMIN ELECTRIC LIMITED**  
Brantwood Works, Tariff Road, TOTTENHAM, N.17

The Benjamin Battery Switch gives perfect battery current control. 2/- each.



# A "Single Coil" Two-Valve Receiver

By E. J. MARRIOTT

*This set will give loud-speaker reproduction on the local station and bring in one or two other B.B.C. transmissions on the headphones*

WHAT type of receiver to make is very often a problem which some constructors find difficulty in solving. There are so many points to be reckoned with, and so many types of receivers, that it is really no wonder that a choice is somewhat difficult. One thing, however, must be realised, and that is unless you are prepared to spend a considerable sum of money it will not be easy to construct a set which will fulfil all needs. That is to say, if distant reception on the loud-speaker is required, local loud-speaker reception, and extreme selectivity, together with a simple control, then a receiver which will satisfy all these demands will not only be decidedly expensive, but will be no simple matter to construct.

### What the Set will Do

In designing the receiver to be described in this article, the author had in mind certain requirements, and has attempted to attain these objectives, not forgetting at the same time to study economy to a certain extent. Generally speaking, two valves at least are necessary to obtain moderate loud-speaking on the local broadcast station, and are employed in this receiver. It was desired to be able to receive one or two of the other B.B.C. stations at good headphone strength, together with a possibility of hearing, under favourable conditions, some of the well-known Continental stations. How far success was attained will be seen

later on by the test report at the end of this article.

As previously stated, the number of valves was limited to two, this number being economical, and as loud-speaking from the local station was desired, it was essential that the second valve should act as a low-frequency amplifier. The first valve then, is a detector, and reaction is incorporated in order that the strongest signals may be obtained from any station within range.

### The Special Coil

A home-made coil is used in the set as a fixture, and a form of Reinartz reaction is employed, thus simplifying the tuning operation, which consists merely of adjusting two variable condensers. Again, for the sake of simplicity, no provision is made for receiving stations outside the normal 250-600 metre band.

In this way all moving coils are

eliminated from the receiver, which consequently is comparatively small and, as may be seen in the photographs, presents a handsome appearance. Its general appearance is further enhanced by the absence of any terminals whatever on the front of the panel, all the terminals being on ebonite strips at the back of the set.

### The Circuit

The actual circuit used may be seen in the theoretical diagram, Fig. 1, and many readers, no doubt, will be familiar with it. The same winding,  $L_1$ , acts both as the aerial coil and reaction coil, and it is coupled to the grid coil,  $L_2$ , which is tuned by a  $0.0005 \mu\text{F}$ . variable condenser. Except for the possible movement of the aerial connection to the centre tapping shown on  $L_1$ , the coupling between  $L_1$  and  $L_2$  is fixed.

A radio frequency choke,  $L_3$ , is connected in the anode circuit of  $V_1$ , and a variable condenser,  $C_2$ , is joined between the anode and the aerial lead. A variation of this condenser varies the reaction effect, an increase in capacity causing an increase in reaction and *vice versa*.

The low frequency rectified currents, however, find no obstacle in the R.F. choke  $L_3$ , and so pass through the primary winding  $T_1$  of the low frequency transformer,  $T_1 T_2$ , being passed on to  $V_2$  in the usual way, and appearing in the anode circuit of  $V_2$  in a greatly amplified form.

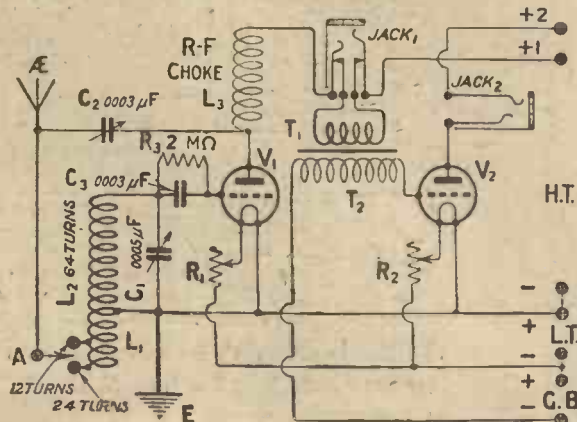

Fig. 1.—The circuit. Plugs and jacks are employed to allow the use of either one or two valves.

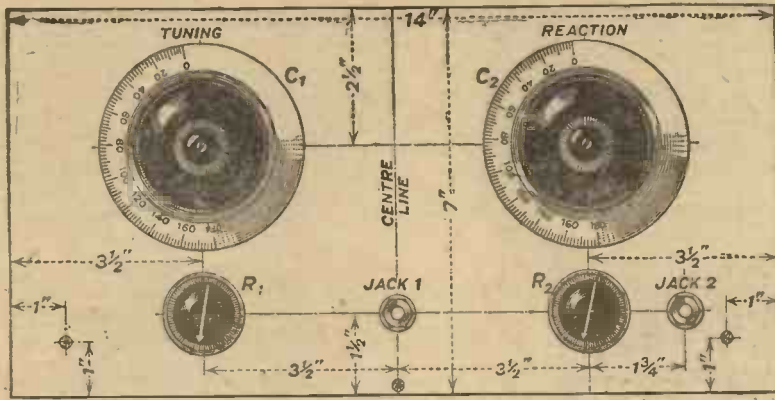

Fig. 2.—The panel is exceptionally neat. Vernier dials are employed on the condensers.

A double contact telephone jack has been made use of between  $V_1$  and  $V_2$ , in order that headphones may be plugged in, in place of the winding  $T_1$ , when it is desired to listen on a single valve.

**Components**

In order to build this set exactly as described you will require the following components. The makes actually used are indicated, but other good quality makes may, of course, be substituted, any difference in size being allowed for when arranging the layout.

One Radion Mahoganite panel, 14 in. by 7 in. by  $\frac{3}{8}$  in. (American Hard Rubber Co., Ltd.).

One cabinet with baseboard, 8  $\frac{3}{8}$  in. deep, to take above panel (Camco).

Two variable low-loss square-law condensers, one .0005  $\mu$ F. and one .0003  $\mu$ F. capacity (Jackson Bros.).

Two "Pelican Univernier" slow-motion dials (Cahill & Co., Ltd.).

Two 30 ohms filament rheostats (Yesly, Engineering Supplies Ltd.). (The resistance of these must be decided by the type of valves you intend using).

One 2 M $\Omega$  grid leak and .0003  $\mu$ F. condenser, mounted (L. McMichael, Ltd.).

One single contact, and one double contact telephone jack (General Radio Co.).

One power L.F. transformer, type 84 (General Radio Co., Ltd.).

Two "Magnum" anti-microphonic valve holders (Burne-Jones & Co., Ltd.).

One radio frequency choke (Lissen, Ltd.).

One Kendall "X" former (Burne-Jones & Co., Ltd.).

Two strips of ebonite for terminals, one 7 in. by 2 in. by  $\frac{1}{4}$  in., and the other 3 in. by 2 in. by  $\frac{1}{4}$  in.

One spring clip (S. H. Collett).  
Nine terminals.

Glazite for wiring up.  
Half-pound of No. 24 d.c.c. copper wire for coil.  
Short length of flex.

Radio Press panel transfers.  
Two 3 in. angle brackets (R. Melhuish).  
One small metal angle piece for holding coil.

Wood screws and usual sundries.

**Constructional Work**

With regard to the actual construction, much time and trouble will be saved if the following directions are carefully observed.

First of all wind the coil. To do this, take the "X" former, and make fast the end of the 24 d.c.c. wire through the hole provided near the centre of the former, leaving an inch or two free for connecting. Now commence the winding in the usual manner, until twelve turns have been wound in

the first slot. A loop must now be twisted (this is the tapping indicated at Y in Fig. 3), and twelve more turns wound on in the next slot, after which another loop is twisted, this time about 2 in. or so in length. (This is the earth connection indicated at Z in Fig. 3.) Again continue winding in the same

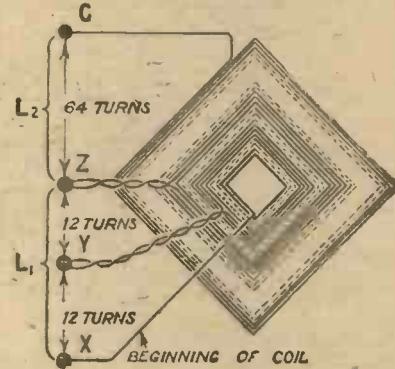

Fig. 3.—A diagrammatic representation of the coil and its connections.

direction, putting sixteen turns in each of the other four slots. Now make the end of the wire fast in the hole provided, leaving here also a few inches free for connecting. (This is the grid connection shown at G in Fig. 3.)

Having wound the coil, place it for the time being on one side, and proceed with the set.

**Drilling**

Drilling the panel will not be found a difficult matter, all the necessary measurements being given in the drilling diagram, Fig. 2,

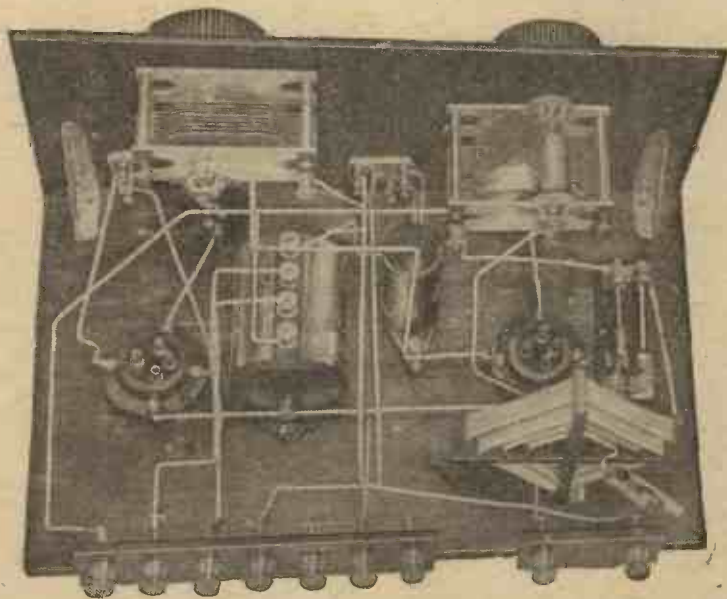

The back of the cabinet must be cut away to give access to the terminal strips, seen at the lower edge of this photograph.



Some Gift Suggestions

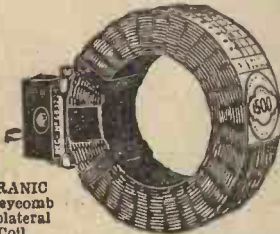

**IGRANIC Honeycomb Duolateral Coil**  
 (Plug Mounted) De Forest Pat. No. 141344. Low self-capacity. Small absorption factor. Minimum H.F. Resistance. No dead end losses. High self-induction. These qualities of the ideal inductance are found to perfection in Igranic Honeycomb Duolateral Coils. Obtainable in 19 sizes to cover wave-length ranges from 100 to 23,000 metres. Prices from 4/3 to 17/6 ea.

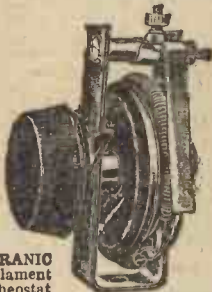

**IGRANIC Filament Rheostat**  
 (Plain Type) (Pat. No. 195903). Supplied with 4, 6, 8 or 10 ohms resistance. Specially suitable for highly efficient filament control and critical control of regeneration. Prices with fixing screws and drilling template for panel mounting. Plain type, 3/6. Vernier type, 5/8, and Dual Emitter type, 20 or 30 ohms, 5/6.

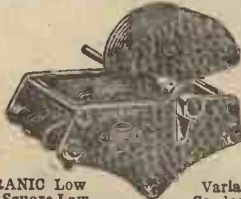

**IGRANIC Low Loss Square Law Variable Condenser.**  
 (Patent No. 220312). Sharp and selective tuning. Extremely low electrical losses. The same change in wave-length for each dial division at every part of the scale. Smooth in operation and practically indestructible ball bearings. Freedom from body capacity effects. Noiseless operation, very low minimum capacity, and consequent wide tuning range with a given coil. Supplied complete with 4 in. Combined Knob and Dial.  
 Capacities. Price. Capacities. Price.  
 .00015 mfd... 19/6 .0005 mfd... 24/-  
 .0003 .. 21/- .001 .. 27/6

Xmas Gifts that give lasting pleasure —



Whether your friends be mechanically or artistically inclined you could not choose for them better Xmas Gifts than IGRANIC RADIO DEVICES. To the radio enthusiast, the excellent performance and perfect workmanship of all IGRANIC RADIO DEVICES—from a grid-leak to a splendid outfit for building the Igranic Six-valve Super-Heterodyne Receiver—will be a source of lasting pleasure and satisfaction. To your friend who is keenly appreciative of good music artistically rendered, the broadcast concerts which may be so faithfully reproduced by a set built with IGRANIC RADIO DEVICES, will give sheer joy. By either of them your Xmas Gift is sure of a warm welcome and will be an enduring reminder of your friendship and goodwill.

All IGRANIC RADIO DEVICES are built of the best, by the best craftsmen—to give better results.

IGRANIC RADIO DEVICES include:

Honeycomb Duolateral Coils, Variable Condensers, Fixed Condensers, Filament Rheostats, Intervale Transformers, Variable Grid-Leaks, Variometers, Vario-Couplers, Coil Holders, Potentiometers, Combined Instruments, Vernier Tuning Devices, Switches, Valve Holders, etc., etc., and also the IGRANIC Supersonic-Heterodyne Receiver Outfit. All carry the IGRANIC Guarantee.

Write for List Z894



149, Queen Victoria St., London.  
 Works: BEDFORD.

IGRANIC Super-Het Receiver Outfit.



and when this is completed the various components may be mounted temporarily and the panel affixed to the baseboard by means of the angle brackets and the three wood screws, as shown in the diagrams.

**The Baseboard Layout**

Now place the various components on the baseboard in as nearly as possible the same positions as shown in the photographs and diagram, and screw them down. Take care that the positions of the valve-holders allow large valves to be plugged into them without fouling the condensers.

The method of fixing the coil to the baseboard is made quite clear by the diagram given in Fig. 5.

**Wiring**

Having got so far, the wiring up may be commenced. It will be found advantageous at this point to remove the variable condensers temporarily, in order to facilitate the soldering to the rheostats. When the connections to the components fixed near the condensers (*i.e.*, the telephone jacks and the rheostats) have been made the condensers may be re-mounted and the wiring-up completed. Be sure the connections to the coil are exactly as shown, and as far as possible bend the wires to take the same paths as those seen in the photographs.

If you use a different make of L.F. transformer the connections may be made as follows. From the bottom right-hand terminal on the jack No. 1 to OP; from the top left-hand terminal to IP; from OS to the grid of  $V_2$  and from IS to G.B. negative terminal.

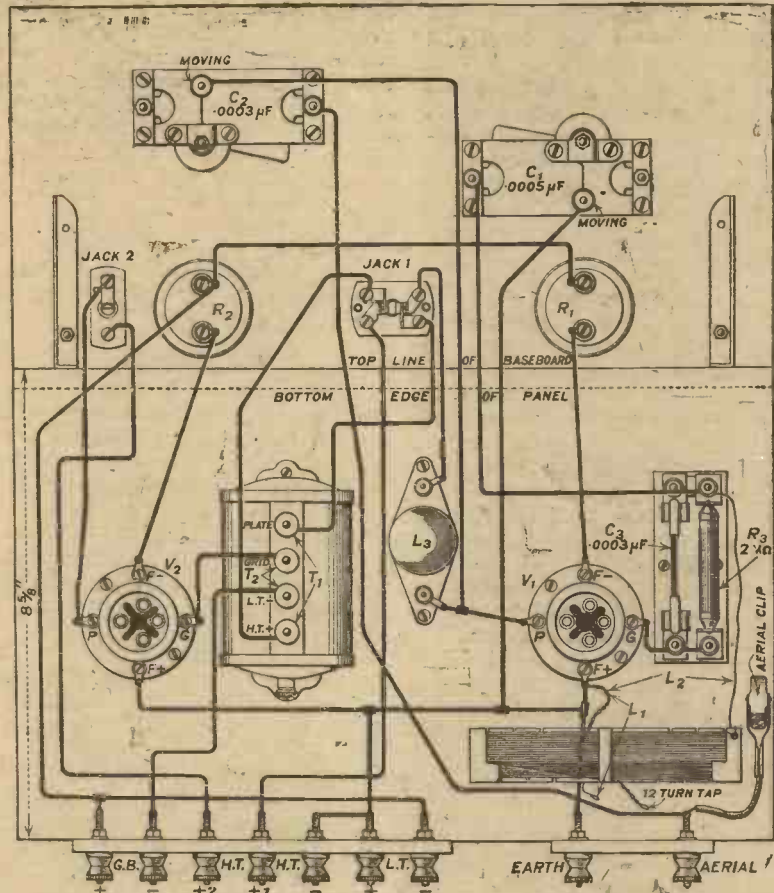

Fig. 4.—The wiring to the jacks needs care, but all connections can be followed easily from the above diagram.

Before testing the set, check the connections very carefully once more against the wiring diagram. This may take a few minutes, but it is well worth while.

Instructions for fitting the "Universier" dials are given with each

one, and these may now be fixed on the condenser spindles.

**Testing Out**

The set is now ready for testing out. Connect up the aerial and earth leads and the various batteries, and plug in the telephones after the second valve. The aerial clip should be attached to the 24 turn tapping on the coil. Note the following regarding the telephone connections to the plug. The negative tag (the positive will probably have a red mark in the insulation) must go to the centre connection, in order that the steady anode current will pass through the phone windings in the correct direction.

Insert two valves in the sockets; two of the general purpose types will do for the time being, and slowly turn on the filament current by means of the rheostats. It is wise to have only three volts H.T. plugged in at first, until you are sure that all is O.K., and then the two H.T. tappings may be increased to about 30 to 40, and 60 to 80 volts respectively.

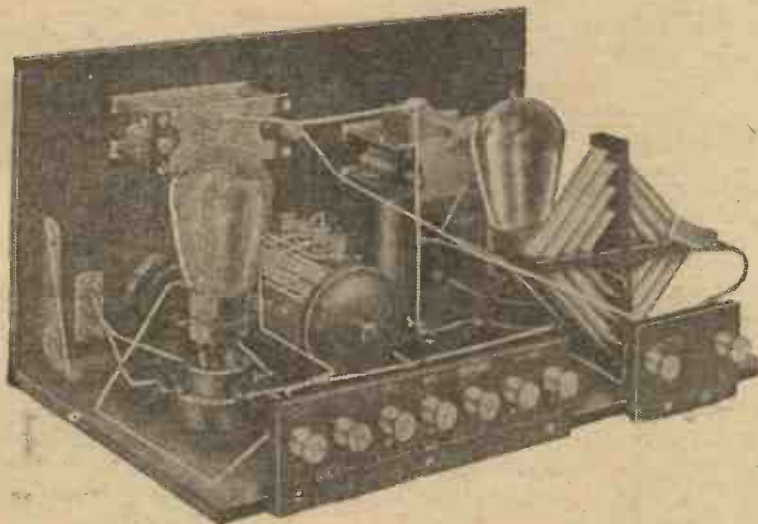

This photograph gives a clear view of the special coil.

**Grid-Bias**

Grid-bias may not be found necessary just yet, in which case the terminals marked G.B. should be joined together with a short piece of wire. The reaction condenser  $C_2$  must be adjusted to zero (i.e., all out), and the tuning condenser,  $C_1$ , turned slowly from the minimum to the maximum position.

**Operation**

Now, if the local station is working you will certainly hear it at some adjustment of this condenser, which should be carefully set to the position giving maximum signal strength. The reaction condenser may now be gradually increased, and it will be found that signal strength will also increase, until a point is reached where the set will oscillate and signals become distorted. Immediately this happens, turn the condenser back from this point until oscillation ceases, when a final adjustment can be made on the tuning condenser.

If you are near to a broadcast station you will find that the use of the reaction condenser is unnecessary for headphone reception, signals being, in most cases, too strong already.

**Using One Valve**

Should you desire to use only the first valve, merely turn the second valve out, and insert the telephone plug into jack No. 1. The same procedure regarding tuning, as just described, will still apply.

**Valves to Employ**

The above tests will show you whether every connection is correct and enable you to get the "feel" of the set, which in any case is not at all difficult to handle. To obtain the best results however, valves specially suited to their positions should be used in the receiver. In the first socket, any good detector valve, or one of the well-known small power valves will be found to give excellent results. Actually, the author has tried a general purpose type, a D.E.5 B., a D.E. 4, and a D.E. 5, and in each case commendable results were obtained. In the second stage, use a power valve, such as the B.4, B.6, D.E.4 or D.E.5, choosing the type according to the filament voltage rating, which should be somewhat similar to that of the detector valve used. The high-tension value on this last valve, when a loud-speaker is used, should be the maximum advocated

by the manufacturer, the grid-bias also being adjusted according to the maker's instructions. If, however, telephones are being used after the second valve, a much lower H.T. value will be found satisfactory, the grid-bias being again adjusted accordingly. If the maximum value of H.T. is used on the low frequency valve whilst telephones are plugged in jack No. 2, the appreciable steady anode current flowing may possibly injure the phone windings.

**H.T. Values**

With regard to the H.T. value for the first valve, this will in most cases need to be fairly low if smooth reaction control is to be obtained. In fact, too high a value here, or running the filament of  $V_1$  too brightly is almost certain to result in floppy control of reaction, and might in some cases cause a certain amount of backlash.

**Further Points**

Selectivity is not a strong point of this receiver, but several stations can be heard whilst 2LO is working,

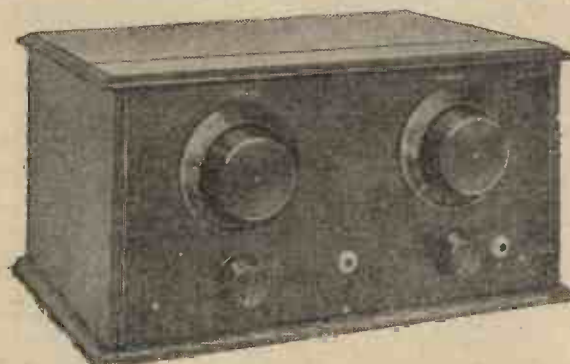

The completed receiver. All front of panel connections are made by plugs and jacks.

providing they are not on a frequency too near that of the London station.

The writer lives within four miles of 2LO, consequently it is a difficult matter to obtain selectivity in a degree sufficient to eliminate that station whilst working on a near-by wavelength.

The tuning range of the coil used, in conjunction with the  $0.005\mu F.$  condenser, is sufficiently wide to include the wavelength used commercially by ships—i.e., 600 metres—and those who possess a workable knowledge of the Morse code will no doubt derive some pleasure from this.

**Test Report**

Tested on a mediocre aerial about 4 miles west of 2LO, that station was received at excellent

loud-speaker strength, using the two valves. Using only the detector valve, 2LO came in loudly on the telephones. It was noticed that in order to obtain a smooth reaction adjustment a very low H.T. value was necessary on the detector valve, somewhere in the region of

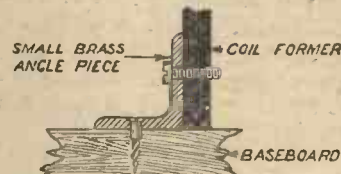

Fig. 5.—A bracket is used to mount the coil on the baseboard.

30-35 volts. This may vary, of course, with different valves, but every effort should be made to improve the reaction adjustment by varying both the H.T. value and the filament current, if the best results are to be obtained. Tested one Sunday evening before 2LO had commenced their evening service, ten stations were received by turning the tuning condenser slowly from the minimum to the maximum adjustment, whilst keeping the reaction condenser adjusted accordingly for the greatest sensitivity. The stations heard were mostly German and French by the language being used, but their call-signs were not given. Bournemouth and Birmingham both came in at good headphone strength.

**Tested at Elstree**

This receiver has also been tested at the Radio Press Elstree Laboratories with quite satisfactory results. Reports regarding results obtained with it in different localities would be both helpful and interesting.

The  
Radio Press  
**YEAR  
BOOK**  
for 1926

See the  
Important Announcement on  
page 324

MOTOR CAR  
ELECTRICAL  
EQUIPMENT  
MANUFACTURERS



By Appointment  
to  
H.M. The King



# RADIO PRODUCTIONS

**REAL LOW-LOSS COILS**  
Wound with base wire on a bakelite former

Approx. W/L	Price
200-400 ..	6/9
350-600 ..	6/9
450-900 ..	8/-
1000-2000 ..	9/6



**MULTIPLE FIXED CONDENSER**  
Specially designed to enable a selection of fixed capacities being obtained from one instrument

Value	Price
.001 to .015 M.F.	5/-
.001 to .015 M.F.	5/-



**C.A.V. LOUD SPEAKERS**  
For those requiring a non-metallic horn, we can supply our speakers with imitation tortoise-shell

STANDARD	5/5/0
NEW JUNIOR	2/15/0
TOM-TIT	1/10/0



**FILAMENT RHEOSTAT**  
With interchangeable resistance unit. Very smooth action

6 Ohms resistance	5/-
30 Ohms resistance	5/-
6 Ohms resistance only	2/3
30 Ohms resistance only	2/3



**A.C.A.V. VALVE HOLDERS**  
Unequaled for their achievement of Anti-Capacity and Anti-Vibration results

Cat. No.	Price
5200 A.C.A.V. Valve Holder	4/6
5201 A.C.A.V. Valve Holder Adaptor	5/-



**GRAMOPHONE ATTACHMENT**  
By utilising the tone-arm of a gramophone for the acoustic amplification of radio reception, a very effective Loud-speaker is provided

Cat. No. 5210	25/-
1000 ohms	25/-



**CRYSTAL DETECTOR**  
Adjustment permits of nearly the whole of the crystal being explored, and the catwhisker is capable of fine regulation

Cat. No. 5120	10/-
---------------	------



**ALL PURPOSE TRANSFORMER**  
As used in many Radio Press circuits including the new S.T. 100. In brown metal case

Cat. No. 5152	15/-
---------------	------

have quickly attained a position of pre-eminence by reason of their efficient design and exceptional performance. Being produced in the same works as the world-famous C.A.V. Car Lighting and Starting Equipments they have behind them an organisation second to none. Every production illustrated on this page is fully guaranteed.

Write for a copy of our complete Radio Catalogue

**C.A. Vandervell & Co., Ltd.**  
WARPLE WAY, ACTON, LONDON, W.3

*The World's Best*



# Your Best Xmas Gift

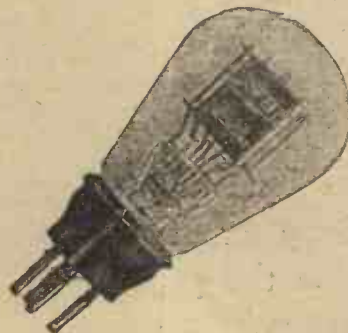

The Wireless enthusiast of your family will appreciate no gift more than an equipment of OSRAM VALVES

## Suggested OSRAM Valve Combinations

# Osram

## VALVES

Ensure Perfect Radio Reception

	2valves Det. and L.F.	Price	3 valves 1 H.F. Det., 1 L.F.	Price	4 valves 1 H.F. Det., 2 L.F.	Price
2-volt Accum.	D.E.R. D.E.6	14/- 18/6	D.E.R. D.E.R. D.E.6	14/- 14/- 18/6	D.E.R. D.E.R. D.E.6	14/- 14/- 18/6
4-volt Accum.	D.E.3 D.E.4	16/6 22/6	D.E.3b D.E.3 D.E.4	16/6 16/6 22/6	D.E.3b D.E.3 D.E.3 D.E.4	16/6 16/6 16/6 22/6
6-volt Accum.	R.5v D.E.5	8/- 22/6	D.E.5b R.5v D.E.5	22/6 8/- 22/6	D.E.5b R.5v R.5v D.E.5	22/6 8/- 8/- 22/6

Sold by all leading Wireless Dealers, Electrical Contractors and Stores

Advt. of The General Electric Co., Ltd., Magnet House, Kingsway, London, W.C.2





*All loud-speaker users will find hints for their guidance in this article*

I CAN imagine some readers upon seeing the title of this article asking themselves some such question as, "Why use a power valve, anyway?" Many people who do not actually use power valves will know that their friends have discovered for themselves that the use of such a valve does not in many cases increase the strength of signals, and it is natural to inquire why one should use these valves, since they are expensive and they do undoubtedly put a heavy load upon the high-tension battery.

#### Is it Worth While?

The answer to the question is that, properly used, a power valve is well worth the expense and the small amount of trouble involved; it gives one the power to obtain signals of greater purity for a given volume, and if a suitable type of valve is chosen for the particular conditions, loud-speaker, etc., there will be an increase of volume. In passing, it should be remarked that the correct type of power valve to use in any given case, apart from matters of convenience of filament supply, is a matter of suiting the valve to the strength of signal which is to be handled, and to what is known as the impedance of the loud-speaker.

#### The Question of Input

I mention this point merely in order that the reader may be warned that he will *not* improve matters by buying one of the large and expensive power valves, intended to handle quite large outputs, if his sole object is to produce such a strength of signals as will serve for domestic purposes. These large valves are intended merely to handle large powers without distortion, and do not in themselves result in a large power output when the input is small.

There are technical reasons for the points mentioned, but they do

not concern us here, since we are concerned rather with the practical arrangements which must be made to achieve the desired improvement in reproduction, which, it must be emphasized, only occurs under proper conditions when a power valve is employed.

#### Requirements

It is to be realised that the main characteristics of a modern power valve (the dull emitting variety

his investment has been a very sound one.

#### A Warning

Since one of the main objects in using a power valve is to permit signals of full loud-speaker volume to be reproduced with the minimum of distortion, it is to be understood that it is not worth while to buy a power valve simply to use with a set which is never employed to work a loud-speaker, since when signals are only of telephone strength the advantage of a power valve is only very slight.

#### Where to Use the Valve

This brings us to the fact that the proper position for the power valve in a set is in the last socket—namely, the final stage of low frequency amplification, which works the loud-speaker itself. Thus, in a four-valve set with two L.F. stages, the power valve will be in the second low frequency stage; in a three-valve set consisting of a high-frequency valve, detector, and one low-frequency stage, the power valve will be the low-frequency valve, and so on.

#### High Tension Values

Having decided that the function of the power valve is to permit of the amplification of strong signals without distortion, and that it should occupy the last stage in the set, let us proceed to see how the necessary adjustments may be made in order that the valve may function properly. Take first the question of the adjustment of the high-tension voltage; most power valves require something like 80 volts to 120 volts to give the best results, and this value is, of course, too high to apply to the preceding valves, such as the high-frequency valve, and the detector, under most conditions, and it is when a valve of this type is used that we realise to the full the convenience of having separate high-tension



The Philips-Mullard PM4 is a small dull-emitter power valve taking .1 amp. with 4 volts on the filament, which is N shaped.

such as the DE 4, DE 5, B 4 and other types) are that they require 80 or, perhaps, 100 or more volts H.T., and a considerable amount of grid-bias. When these two conditions are fulfilled, the reproduction of speech and music will in practically every case be materially improved, and I think that anyone who has invested the necessary sum in a power valve will find that

terminals for the different valves in the set.

**Sets with one H.T. Terminal**

When these are present no difficulty arises, and one simply applies the extra H.T. to the particular terminal, and that is the end of the matter. However, quite a number of sets of a simple nature are built which have only one common high tension terminal for all valves, and



A Cleartron valve of the small power class.

it is, of course, something of a problem to see how the extra value should be applied to the last valve without structural alterations.

**Adding Extra H.T.**

As a matter of fact, however, it is not a very difficult matter. Decide upon a suitable value of high-tension voltage to apply to the main positive terminal of the set, say, 72 volts. Now obtain a 36-volt high tension unit, and connect this in series with the loud-speaker, and the result will be that this additional voltage is applied to the anode of the last valve only, giving a total of 108 volts, quite a suitable value. It is necessary that the additional unit should be connected the right way round, but this is quite easy to determine by trial and error. Simply reverse the connections to the additional unit, and notice which way round gives the loudest signals.

**Importance of Grid-Bias**

So much for the high-tension voltage adjustment. The provision of proper grid-bias is just as important from the point of view of quality of reproduction and economy of high-tension current. If too little grid-bias is used, not merely will an especially heavy drain of high-tension current take place, with consequent speedy running down of the battery, but the

quality of the speech and music will be adversely affected. Most modern sets are provided with special terminals for the application of grid-bias to the separate low-tension valves and all that we have to do is to choose a suitable value. To ascertain the correct value for the particular valve which is being used, reference should be made to the box or packing in which the valve was received. It will be found that the instructions are something to the effect that the anode voltage should be from, say, 50 to 100 volts, while the values for the grid-bias will be from, perhaps, 3 to 6 volts. This means that when the maximum of 100 volts is being employed upon the plate, the grid bias should be 6 volts. Intermediate values should be estimated in proportion.

**Saving the Battery**

It pays to employ the maximum grid-bias possible without the introduction of the distortion which results from the use of an excessive value. The higher the grid-bias which is used the smaller the amount of high-tension current which is drawn from the battery, and the longer will the battery last.

**A Problem**

When a set is not provided with grid-bias terminals, the application of grid-bias (which must be made when a power valve is used) is not, unfortunately, as easy as the application of extra H.T. An alteration to the wiring must be made, and a further terminal added upon the panel, but this difficult should not lead the constructor to dispense with the



L.S.5 type valves are designed for power amplification.

very necessary item of a grid-bias battery.

**G.B. Connections**

The procedure is to investigate the inside of the set, and discover which is the L.F. transformer which supplies the valve socket in which the power valve is to be used. It



A resourceful refreshment vendor who has equipped his coffee-stall with a wireless receiver complete with headphones and loud-speaker.

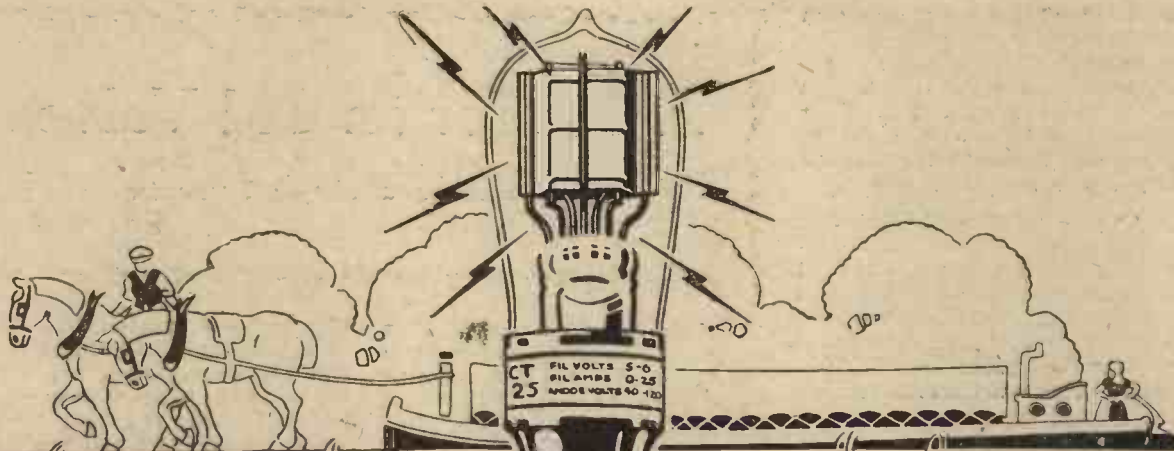

# ELECTRONS

## A SMOOTH AND EASY PATH

The efficient operation of your valve depends upon the electron stream having an easy and unhindered path. The "CLEARTRON" anode is built with this special object in view. It is different from others, and protected by patents pending. The "CLEARTRON" anode ensures a more uniform electron flow and helps the filament to yield 40% to 60% greater emission. And this, of course, means greater power and sensitivity.

### *the Ironclad Guarantee*

C.T.03 and C.T.15

# 12'6

Also makers of American type C.T. 199 at 12/6. Full technical data on request.

ALL CLEARTRON VALVES ARE DULL EMITTERS.

invites the full confidence of the purchaser. He is definitely assured of more than ordinary satisfaction or instant replacement. There is rarely need for replacement, but the assurance that your interests are secure is there. CLEARTRON guarantees greater distance, volume and purity, and keener selectivity. Send for technical data.

Write for particulars and specification of the CLEARTRON Console Master Speaker.

CLEARTRON RADIO LIMITED  
1 CHARING CROSS, LONDON  
AND BIRMINGHAM

Phone: Regent 2231/2. Grams: Cleartron, Westrand, London.

C.T.25 and C.T.25B

# 15'6

Also makers of American type C.T. 201A at 15/-. Full technical data on request.

ALL CLEARTRON VALVES ARE DULL EMITTERS.

# CLEARTRON

BRITISH  MADE

America's foremost valve made in Britain's newest factory with British bases for British sockets.

In replying to advertisers, please mention THE WIRELESS CONSTRUCTOR.

Service Advertising

will be found that a wire runs from one end of the secondary of this transformer to the grid pin of the valve socket in question, while from the other secondary terminal of the same transformer a wire will be found which runs to the filament circuit at some point.

**One New Terminal Wanted**

The second wire should be removed, and a wire taken instead from the secondary terminal to a new terminal upon the panel, conveniently arranged somewhere near to the low-tension negative terminal. This new terminal becomes



The Ediswan P.V. 5D.E. is a typical 5-volt dull-emitter power valve.

the grid-bias negative terminal, the positive terminal of the grid-bias battery being connected to low-tension minus. If desired, of course, an extra terminal can be provided also for grid-bias positive, and wired internally to low-tension negative.

**An Alternative Scheme**

If it is not possible or desirable to add further terminals upon the panel, the grid-bias battery can, of course, be placed inside the set, and wires taken direct to each of its terminals.

Don't Forget  
to  
Answer the  
Questions on  
Page 316

## A Use for an Old Valve

*How to make a simple barometer*

**W**ILL it rain to-day? How often we ask this question when deciding whether some long-deferred visit shall be undertaken. Those who are possessed of a barometer can, within certain limits, answer this question for themselves. The barometer merely indicates the change in atmospheric pressure, and years of observation combined with meteorological theory have led weather forecasters to infer that as the pressure falls rain and storm may be expected, and when the pressure rises fine weather may be counted on.

**Making the Instrument**

An old valve, which should be one of the type with a "pip," can be made into a very useful atmospheric pressure indicator, and a little daily observation will soon enable one to make a quite accurate estimate of the pressure changes. If it can be observed in conjunction with a good barometer for a week, it can even be calibrated. A valve is exhausted to a high degree of vacuum, and if the "pip" is broken air will rush in until the internal pressure equals the external pressure. If the valve be held under water and the pip snipped off with a pair of pliers, water will rush in (with a very pretty fountain effect) until the pressure of the small air residue in the valve is equal to the external pressure.

**How it Works**

The valve may then be taken out of the water. It will now be found to be almost filled with water with a small air bubble inside. If it is held upside down and slung with a piece of string, the water will not run out, but a small drop of water will be noticed almost ready to drip out of the hole where

the pip was previously. This drop will exude further as the external pressure decreases and will recede as the external pressure increases. This is caused by the small air bubble inside the bulb expanding and contracting. The valve should be converted into a barometer preferably on a day when the barometer reading is low, thus ensuring that the drop of water is protruding as much as possible, and will not fall off when the pressure falls still further.

**Calibration**

In my own case the valve is slung up in a small cardboard box, open at the bottom. A small pin-hole enables me to view the drop of water, and the opposite side of the box has lines drawn across to correspond with different pressures. This, of course, was calibrated against a good aneroid. It is not necessary to be so careful, as a period of observation, as previously suggested, will enable one to get a quite accurate estimate of the pressure. Another refinement is to colour the water before breaking the pip with some such substance as red ink or methyl orange, which defines the edge of the drop of water much more clearly. I have had one of these in use for a long time now, and can obtain almost as accurate readings as with a barometer, and its cost—nil. E.H.B.

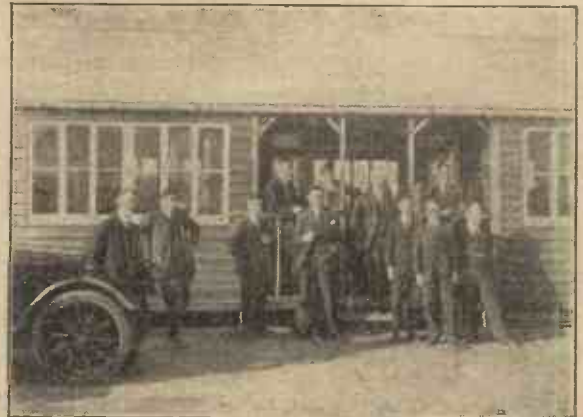

Some of the staff outside one of the Radio Press laboratories at Elstree. Dr. Robinson is in the centre of the porch.



**An R.C.C. unit for each L.F. Stage—for really musical radio**

*Why Resistance Capacity?*

Because if inductance—in the form of a choke or transformer—be used the impedance is proportional to the frequency, and consequently the output voltage varies at different audible frequencies, resulting in distortion and incorrect rendering. On the other hand, the impedance of the wire resistance used in the R.C.C. Unit varies less than 1 per cent. and gives

**Practically Constant Amplification Factor at all Audio Frequencies,**

from 100 to 10,000 cycles per second. The special wire-wound anode resistance is capable of dealing with high voltages, and is absolutely free from extraneous noises.

**Use correct Grid Bias, Mullard Valves—and R.C.C. Units.**



The Sign that means Service.

A clear and complete diagram of a resistance coupled 4-valve receiver is enclosed in each carton.

**FOR** *real* music—as against *noise*—the nearest to the ideal rendering is achieved by the use of resistance-capacity coupling when more than one stage of L.F. is used.

If Polar R.C.C. Units are used, with, of course, a Loud Speaker of good quality, and correct valves, the **QUALITY** of reproduction, in comparison with ordinary transformer amplification, is amazing.

The Polar R.C.C. Unit consists of wire-wound anode resistance, grid-leak and specially built Dubilier Condensers. It is perfectly self-con-

tained, with four clearly-marked terminals, correctly positioned for easy wiring. Size: 3 in. deep by 2 in. wide. Price 15/-.



Sold by Radio Dealers everywhere.

Manufactured by:—

**Radio Communication Co. Ltd.**

34-35, Norfolk Street, Strand, London, W.C.2.

# Efficiency plus Economy

**T**HE B3 Valve has a very low filament current consumption. Whilst retaining all the excellent qualities of the well-known R Valve, it has in addition, the economies of a dull emitter. It is a really good all-round valve working exceptionally well in all positions, detector, H.F. or L.F. amplification. Undoubtedly it is the most efficient and economical valve on the market at the price. Here are its chief electrical characteristics:—

- Filament Voltage - - - 1.8 volts
- Filament Current - - - 0.35 amp.
- Anode Voltage - - - 20 to 80 volts
- Anode Resistance - - - 27,000 ohms

PRICE  
**14/-**

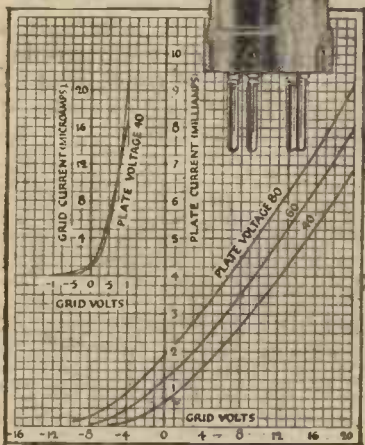
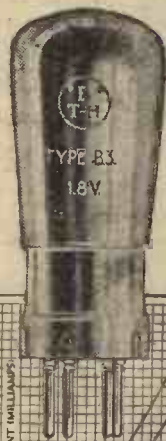

When next you require a valve which will give perfect reproduction combined with good volume, specify B.T.H. and make sure of getting good results.

## B.T.H. Radio Valves

General Purpose		Power Amplifying	
<b>R</b>	Filament Voltage 4 Volts. Filament Current 0.7 Amp. Max. Plate Voltage 100 Volts. <b>8/-</b>	<b>B4</b>	Filament Voltage 6 Volts. Filament Current 0.25 Amp. Max. Plate Voltage 120 Volts <b>22/6</b>
<b>B3</b>	Filament Voltage 1.8 Volts. Filament Current 0.35 Amp. Max. Plate Voltage 80 Volts <b>14/-</b>	<b>B6</b>	Filament Voltage 2.8 Volts. Filament Current 0.12 Amp. Max. Plate Voltage 120 Volts <b>22/6</b>
<b>B5</b>	Filament Voltage 2.8 Volts. Filament Current 0.06 Amp. Max. Plate Voltage 80 Volts <b>16/6</b>	<b>B7</b>	Filament Voltage 6 Volts. Filament Current 0.06 Amp. Max. Plate Voltage 120 Volts <b>24/6</b>

*Insist on B.T.H.—the Best of ALL*



Advertisement of The British Thomson-Houston Co. Ltd.

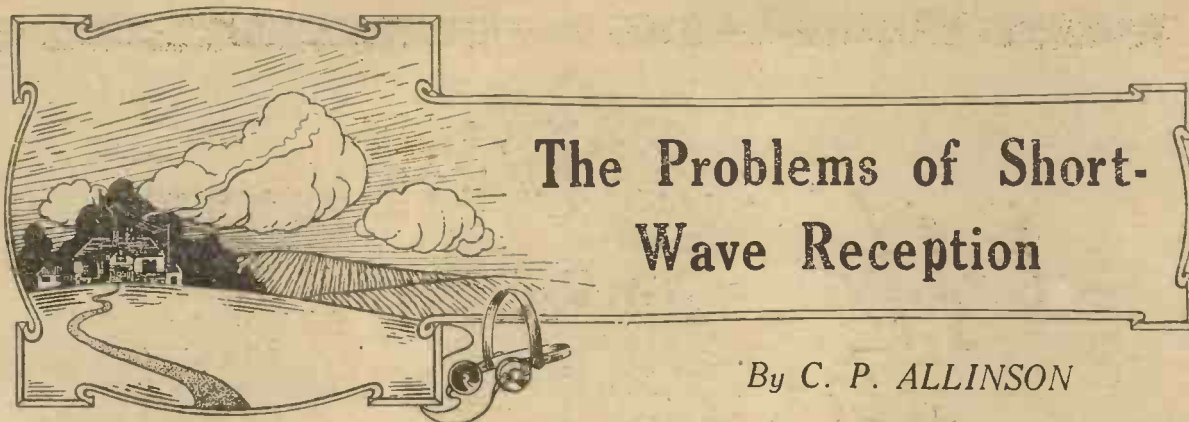

## The Problems of Short-Wave Reception

By C. P. ALLINSON

*Above the broadcast frequencies special precautions have to be taken to ensure satisfactory reception*

**T**HE amazing developments of the last two years have shown the possibilities of the very high wireless frequencies (or ultra-short waves) for long-distance work to be remarkable. KDKA's telephony on 65 metres and thereabouts is a long established fact; Nauen has conducted experiments on 73 metres both on telephony and Morse, and 30 metre Morse only; various Continental transmissions are also to be found in the neighbourhood of 70 metres, while WGY has even worked as low as 15 metres on telephony, and is now working on about 42 metres every night except Sunday. Senatore Marconi's short wave work is now too well known to need detailed mention, for the erection of long distance high-frequency transmitters is already more or less an accomplished fact. These use the "beam" system, to which these very short waves are particularly suited, and it is claimed that this system allows far greater distances to be covered with the same power.

### Communicating with Australia

More recent developments are those with regard to the wavelengths of 20 metres on which such good work has been done during the summer. Not only has the Atlantic been spanned in daylight, but two-way communication with Australia during daylight has been successfully accomplished — an achievement of no mean order in view of the low power used. The latest news received from Senatore Marconi with regard to short-wave work deals with the 17-metre wavelength. Numerous experiments, we learn, have proved that this wavelength, which is excellent for use in daylight, is absolutely useless at night, as it appears to be absorbed rapidly. Work of this description is one more feather

in the cap of the amateur who has done so much in the furtherance of the wireless science. Especially must it be remembered that only comparatively low powers in the region of about  $\frac{1}{4}$  kw. have been used.

### 150,000 Kilocycles!

Further researches are being carried out on the 4 and 5 metre and the 2 and 3-metre wavebands, and already one article of absorbing interest has been available from John L. Reinartz, who is one of the pioneers of short-wave work.

### Long-Wave Congestion

Everywhere we see the headlong fall going on which first commenced some two years ago when the 200-metre band was opened up in face of "expert technical" advice to the effect that the short waves were no good. Amateur transatlantic work on low power speedily disproved this statement, and soon after the 100-metre band was being worked. And so the drop in wavelength went on, and there is no doubt that the great strides that have already been made will make these ultra-short waves of the greatest value. If we examine the higher wave bands we find a state of congestion that is fast becoming a serious problem. Let us consider the question rather from the angle of frequency and we find that the wavelengths between 5,000 and 29,000 metres (the latter is the longest wavelength at present in use) represent a total difference in frequency of roughly 50,000 cycles. Yet a frequency difference of 50,000 cycles is found between the small band between 50 and 50.42 metres. Already several commercial stations are carrying on work on these short wavelengths where there is plenty of room without congestion resulting, with its accompanying problems. Some of these are in the region of 100 metres, such as WGH and

WGG, the stations of the U.S. Government at Tuckerton, and also IHU and IDO, belonging to the Italian Government at Rome, and others such as WIZ, WQN, WIR on wavelengths between 70 and 30 metres.

### The "Super-Het."

Naturally the problems of transmission on the ultra-short waves are of no mean order, but it is the purpose of this article rather to consider the problems accompanying reception on these wave bands, especially as applied to the higher frequencies. Of the systems in use, first and foremost is the well-known Supersonic Heterodyne. This is as yet undoubtedly the best method, and has been successfully used down to 18 metres, by Mr. W. K. Alford, for one. Further work on it will no doubt show it to be suitable for even shorter wave work than this.

### H.F. Amplification

Second, one or more stages of H.F. amplification, a detector valve, and then stages of L.F. amplification may be used. Although this may be suited to commercial work, it is not so for the amateur who wishes to search quickly. In any case it is considered highly doubtful if any real measure of effective H.F. amplification is obtained even with low capacity valves at these higher frequencies.

### The Popular Arrangement

Last, but not least, is the detector with reaction followed by one or more stages of L.F. This is by far the most popular arrangement with amateurs, one stage of L.F. only being preferred in general.

### A Novel Receiver

A method that has been used successfully for long-wave reception

is the Einthoven galvanometer, in which a wire is deflected by the signal current, thereby allowing a light beam to shine on a sensitized film, thus recording the signal photographically. Nothing as yet seems to have appeared as to whether it can be used for the high frequencies, and it is rather doubtful whether it would be of use, for though the mass and therefore the inertia of the quartz fibre used may be negligible for low frequencies corresponding to wavelengths of the order of 30,000 metres, they may be sufficiently great at the high frequencies to render the instrument inoperative.

#### Problems of Design

Considerations of design then that affect the experimenter most widely are those applying to the popular "detector and note-mag" combination which has been used with great success by amateurs all over the world.

The first question is probably that of layout. This requires careful attention. First of all the inductances must be placed so that their fields are as free as possible. Metallic objects in particular, such as variable condensers, L.F. transformers, filament resistances, heavy metal brackets, etc., must not be placed so as to lie in the magnetic fields of the tuning inductances. Otherwise eddy current losses may be great, and in some cases sufficient to prevent the receiver from oscillating. It has frequently occurred that a short-wave receiver that stubbornly refused to oscillate merely required a slight rearrangement of the components to overcome the trouble.

#### Choke Coils

R.F. choke coils, where used, should be placed with their fields at right angles to the field of tuning coils, and should preferably have the lowest possible self-capacity, although in some cases plug-in coils have been used successfully, as, for instance, in the short wave receiver described by Mr. G. P. Kendall in *Wireless Weekly* of August 26, 1925.

#### Low-loss Inductances

The second consideration is, the construction of the tuning inductances. For maximum efficiency these should be as nearly self-supporting as possible, yet they should be fairly rigid, as a shaky coil may cause signals to swing in and out when the coil is subjected to vibration. One method is to use a low-loss former such as is

being produced by several firms at the moment, another is to use strips of ebonite with small holes drilled through them through which the wire is threaded (a rather tedious process), a third is used and described by the writer in a short wave receiver in *Wireless Weekly* for October 7, 1925, and other methods if suitable, may, of course, be used.

As the H.F. resistance of an inductance rises rapidly with the frequency, this resistance must be kept down as low as possible by using a suitable gauge of wire, such as 12 or 14. Above this size little advantage may be gained; in fact, various authorities state that the increased eddy current losses within the wire more than offset the gain due to the larger surface. Also, when working at frequencies such as those corresponding to a wave-

to space all wiring out as far as possible.

Only the best ebonite should be used in a short wave receiver, and as little of that as is practicable. Poor ebonite or some of its substitutes may cause extremely high losses.

#### A Note on Valves

It may be necessary to remove the valve cap. The additional capacity of this may be quite high, and when dealing with the very high frequencies may have detrimental effects in limiting the tuning range.

Another point is, that it appears to be preferable to use a detector valve having a low amplification factor ( $m$ ) in order to get down to the lowest wavelengths; for the effective additional capacity placed across the tuning condenser is the value of the grid-filament

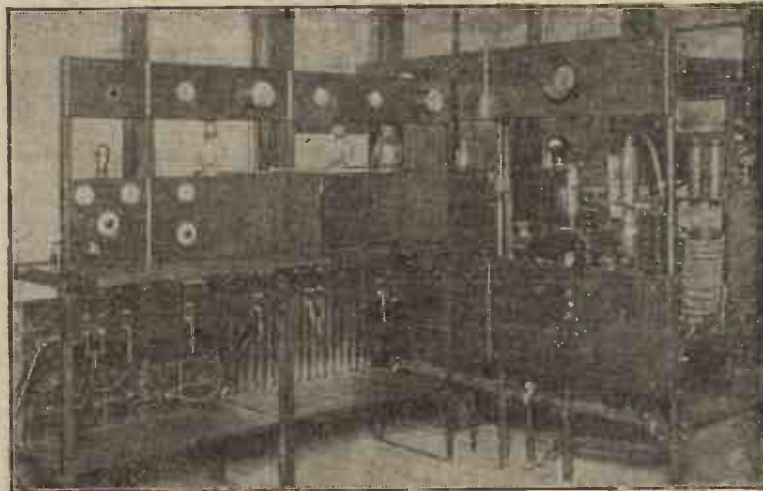

The transmitting equipment at KDKA, the famous American short-wave station.

length of 5 metres (60,000 kilocycles), it may even be found necessary to keep the wire or strip with which the inductance is wound brightly polished, for the increase in H.F. resistance, due to even the slightest film of oxide, may prevent the receiver from working.

#### Other Components

The mountings and holders for the coils in a short wave set must have a low capacity, for every little added capacity will limit the lowest wavelength which the set will receive, as well as limiting the tuning range of the receiver. This was dealt with in some detail by Mr. D. J. S. Hart in the August 19, 1925, issue of *Wireless Weekly*.

It is, therefore, necessary to use very small tuning condensers with a low minimum capacity and

capacity plus  $(m + 1)$  times the grid-anode capacity. This may amount to as much as  $100 \mu\text{F}$ , in some cases making the reception of certain wavelengths nearly impossible.

#### Obtaining Smooth Reaction Control

A variable grid-leak will probably be found a necessity if smooth control of reaction is to be obtained, while a grid condenser smaller than that used on the B.B.C. wavelength may be employed with advantage. A suitable value is from  $.00005$  to  $.0001 \mu\text{F}$ , although in some cases the capacity of the grid condenser may be as small as  $.00001 \mu\text{F}$ .

#### Use of Capacity Reaction

Capacity reaction should be employed if possible, as then the variation in tuning arising from an alteration of the reaction setting



**THE CURTIS DOUBLE CIRCUIT SUPER-HET. 8 (PATENTS PENDING)**

The IDEAL RECEIVER for those living in close proximity to a broadcasting station

**TWO DISTINCT RECEIVERS IN ONE**

A STRAIGHT CIRCUIT of two or three valves for loud-speaker reception from your local station.

A SUPER-HETERODYNE CIRCUIT of seven or eight valves for loud-speaker reception of any station in the Continent of Europe at any time from anywhere in the United Kingdom.

The Curtis Double Circuit Super-Het. 8 operates on a frame aerial and either circuit is brought automatically into operation by the means of a switch.

Total current consumption of all 8 valves is less than that of a single bright emitter valve.

NO SEARCHING REQUIRED. Stations are tuned to a log supplied with every set.



Curtis Double Circuit Super-Het. 8  
Imperial Model

Prices range from £40

**BUILD YOUR OWN  
CURTIS DOUBLE CIRCUIT SUPER-HET. 8**

The Super-Het. Treatise Contains:

1. Circuit Diagrams.
2. Simplified Layout and Wiring Chart.
3. Instructions for Operation.
4. Complete Schedule of Components.

Price 2/6

**WRITE FOR CATALOGUES**

All communications to:—

**PETER CURTIS, LTD.**

**75a, CAMDEN RD., N.W.1**

Telegrams: PARACURTEX Telephone: NORTH 3112-3

Branches:

MANCHESTER: 312, DEANS GATE

Telephone: CENTRAL 5095

GLASGOW: 47, CARRICK STREET

**HERE is EFFICIENCY**

The problem of the distorting transformer is solved!

Get a Seagull choke instead; this remarkable instrument is easily fitted (the connections are the same as for a transformer) but the resulting clear, distortionless reproduction satisfies the most exacting. There is no loss in volume. You require the best components, then here is another Seagull product that abolishes the plug-in coil trouble, a low-loss tuner covering a wave band of 30-2,000 metres. So efficient that 1,000 miles range on one valve is easily accomplished. You cannot beat Seagull!



**SEAGULL LTD.**

REGENT HOUSE,

KINGSWAY, LONDON, W.C.2

Phone

HOLBORN 6383

22/6



Set of three low-loss  
LONG WAVE COILS  
12/-

Set of three low-loss  
SHORT WAVE COILS  
7/6

10/6

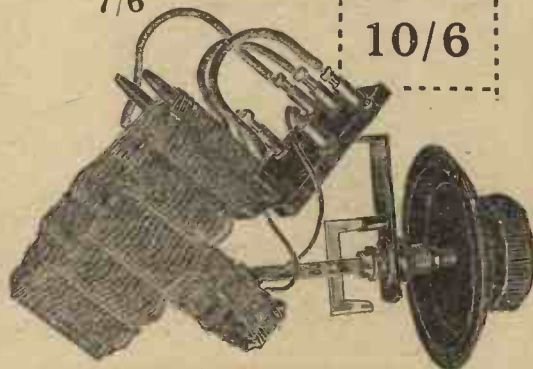

CRICHTON AD.

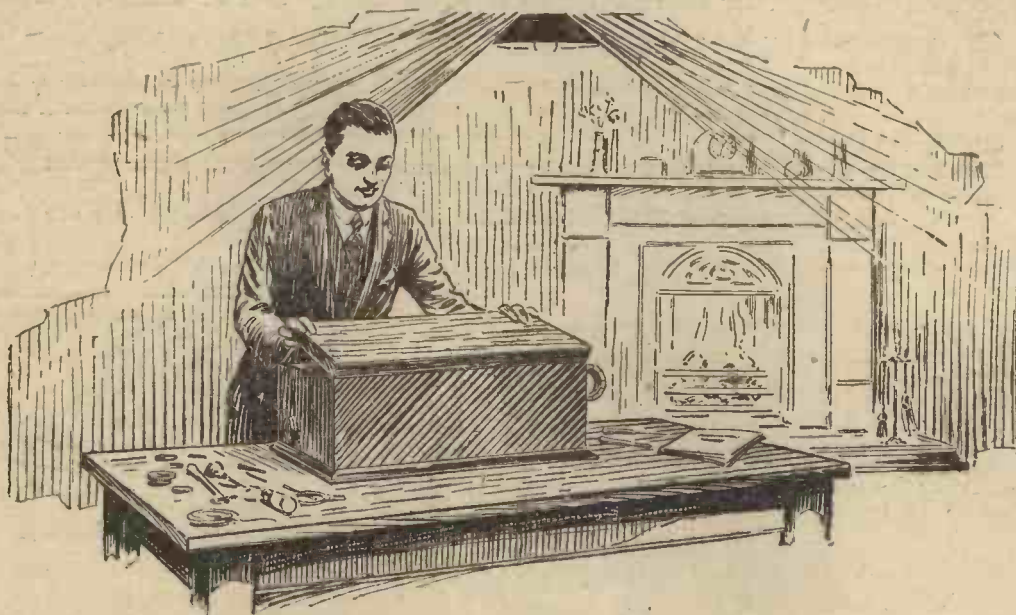

## The Constructor's Loud Speaker

**F**INISHED! Good components and a sound design—unstinted effort and minute attention to detail. Result—a set worthy of a good loud speaker.

A "Dragon" AMPLION is the very thing. Its sensitivity, clarity of reproduction and fullness of volume make it *par excellence* the ideal loud speaker for the discerning constructor. It will do justice to the set.

AMPLION Loud Speakers are characterised by their fine workmanship and design, the result of over thirty years' experience.



# DRAGON AMPLION

Model A.R. 19, as illustrated

**PRICE - £5 5 0**

Other models from 25s.

Obtainable from AMPLION STOCKISTS, Radio Dealers or Stores.

PATENTEES AND MANUFACTURERS:

**ALFRED GRAHAM & CO. (E. A. Graham), Crofton Park, S.E.4**

*Demonstrations gladly given during business hours at the AMPLION Showrooms:*

25-26, SAVILE ROW, LONDON. W.1.  
79-82, HIGH STREET, CLAPHAM, S.W.4.

101, ST. VINCENT STREET, GLASGOW.  
10, WHITWORTH STREET WEST, MANCHESTER.



will not be found to be nearly so great as with magnetic reaction. Down to 40 metres it may be found that the setting of the reaction condenser hardly affects the tuning at all. Two circuits are shown herewith employing capacity control of reaction that may be tried.

**Condenser Control**

Some form of gearing or vernier

dead spots, which, however, may be overcome by the use of a very small series condenser or a detuning coil of about 50 turns on a 3 in. former. Some form of loose coupling is certainly desirable, and the aerial coil will preferably be untuned while the aerial needs to be a very small one: at 5 metres a couple of 3 ft. rods for aerial and counterpoise are suitable.

stant resetting of the reaction control that is usually necessary at present? If this can be done, searching will be greatly simplified, as well as actual tuning. It is most troublesome to find a signal on the edge of a partial dead spot so that a slight decrease, say, of the tuning condenser requires a large increase of reaction. This then sends the wavelength up, requiring

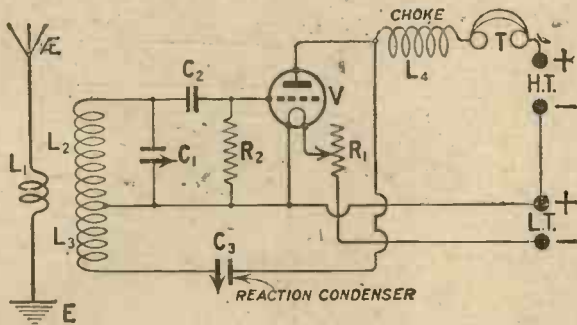

Fig. 1.—The coils  $L_2$  and  $L_3$  are here shown wound as one, but may be separated and the reaction condenser  $C_3$  placed between them.

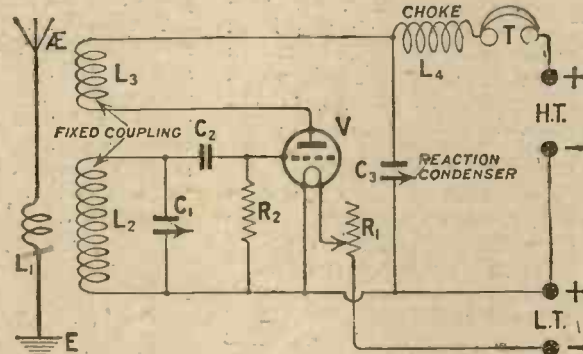

Fig. 2.—Another useful circuit which, like Fig. 1, has capacity controlled reaction.

control on the tuning condenser will be found imperative below about 40 metres, and even at this wavelength a considerable delicacy of touch is required if such gearing or vernier control is not employed. Below about 15 metres extension handles become the order of the day, increasing in length with the frequency. At seven metres a movement of the body of about 6 in., 2 ft. away from the receiver is sufficient to start or stop it oscillating. Chokes may be required in the L.T. leads as well as the phone leads, and perhaps even in the grid-leak to L.T. lead. A circuit suitable for five-metre work is shown in Fig. 3, and it should be noted that the chokes all consist of about 30 turns of 20 S.W.G. on a  $\frac{3}{4}$  in. former. Lorenz winding is employed so as to make the chokes self-supporting. Shields for tuning condensers may be used and other steps taken to avoid capacity effects. In one case where unsuitable reaction control was in use a movement of a foot on the floor would tune a signal in or out.

**Loose Coupling**

Next we have to consider the method used of coupling the receiver to the aerial and the correct aerial to use. With even a small indoor aerial the receiver may have many

**Effect of a Large Aerial**

Having considered the chief points dealing with the design of the receiver a few problems may be mentioned which await a satisfactory solution.

Firstly, is it best to use an aerial having a wavelength above that to be received or below it? The tendency with a large aerial seems to be for the receiver to find dead spots at settings corresponding to harmonics of the fundamental wavelength of the aerial. Is it better under these circumstances to use the detuning coil or the series condenser?

**Constancy of Reaction**

Secondly, can the control of reaction be made so constant that the reaction coil or condenser can be set for large ranges of wavelength so as to eliminate the con-

a further decrease of the tuning capacity and so on, *ad lib.* Under these circumstances it may become exceedingly difficult to tune in the signal at all.

Thirdly, is the use of shielding, so as to reduce hand capacity effects, advisable, or is it liable to introduce extra stray capacity into the receiver, thus limiting the lowest wavelength receivable?

**Metallic Objects**

And again, how far does the presence of metallic objects within 2 ft. or 3 ft. of the receiver affect its efficiency? A case has been heard of in which an amateur, experimenting on 5-metre transmissions, burnt out an expensive milliammeter which was not connected to anything but was lying on the bench about 3 ft. from the transmitter.

Other questions may arise, and most of these are well worth having a little time in experimental work devoted to them.

**A Fascinating Hobby**

The fascination of short-wave reception is very great, as many difficulties have to be overcome, and it presents a comparatively new field for experiment in many directions. These short notes will, it is hoped, be of use to those just entering this new field of reception.

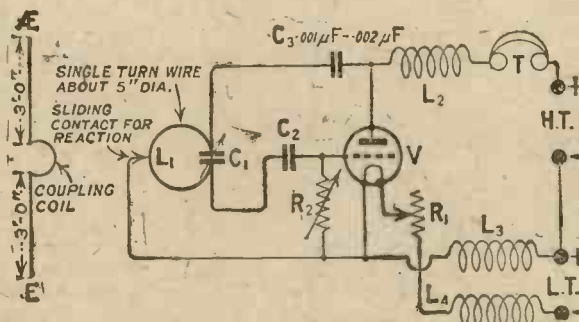

Fig. 3.—A five-metre receiver. The valve should have the cap removed. Values of components given will serve as a guide and  $C_1$  may consist of 2 brass plates about 2 in. square and  $\frac{1}{4}$  in. apart.

# A Novel Switch

By W. H. FULLER

THE hanging of a pair of telephones on a hook protruding through the front of a panel may be made to switch off the filaments of the valves of a receiving set by means of the simple switch described here.

### The Principle Employed

On reference to Fig. 1 it will be seen that the switch consists of a brass arm, so shaped that a pair of telephones may be hung on it at one end, and pivoted on a screw at the other. The pivot screw is fixed to a brass bracket, which is

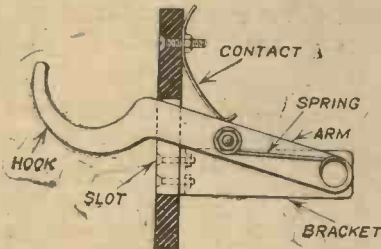

Fig. 1.—This diagram shows the method of assembly.

secured to the panel. A small wire spring keeps the arm against a springy brass contact until a pair of telephones is hung on the hook, when disconnection between the arm and the contact takes place. The switch may be arranged in the filament circuit of the valves, so that when the telephones are hung up the circuit is broken, and the current switched off.

### Component Parts

The bracket and the arm are cut from 16 S.W.G. brass, and the dimensions may be obtained from

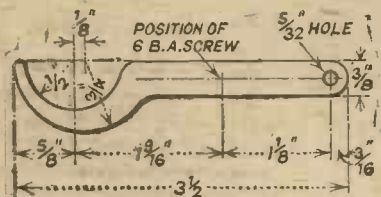

Fig. 2.—Dimensions of the hook-shaped arm.

Figs. 2 and 3. The brass may be cut first with a hack saw or a pair of snips, and then finished with a file. The contact is made from a piece of springy brass, and bent to

shape with the aid of a pair of pliers and the fingers.

The tension spring of the arm is made from a piece of steel wire, and after being bent to the shape shown in Fig. 3, is soldered in the slot of a 1/2 in. 4 B.A. screw. The end of a spring engages on a 6 B.A. screw soldered to the arm, and a nut is fitted to prevent the spring jumping off.



The finished switch mounted on ebonite.

The screw is passed through the 3/16 in. hole drilled in the arm, and a washer placed behind it, and then secured to the bracket, and locked in position with two 4 B.A. nuts, with sufficient room to allow the arm to move freely.

### The Slot in the Panel

A slot 1 in. long and 1/16 in. wide is then cut in the face of the panel,

the arm passed through, and the fixing holes marked through the holes in the bracket. The bracket may then be secured by two 1/2 in. 6 B.A. screws. The pivot screw is then adjusted, so that the spring forces the arm to the top of the slot.

The contact spring is secured to the panel by a 1/2 in. 6 B.A. screw

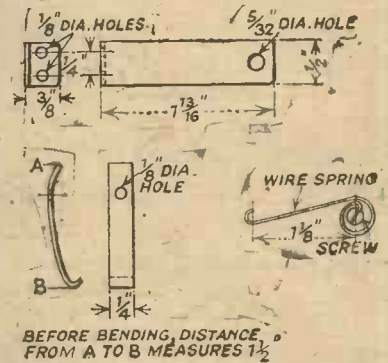

Fig. 3.—Details of the smaller metal parts.

and nut in such a position that good contact is made with the arm when the latter is released.

### Battery Connections

One battery connection is soldered to the bracket and the other to the brass contact.

This type of switch offers many opportunities to the constructor, and it would be quite an easy matter by a suitable arrangement of contacts to disconnect the H.T. as well as the L.T. or to disconnect the aerial from the set, and automatically earth it at the same time.



Sir Henry Thornton inspecting a wireless set made by the boys of St. John's School, Ealing.

*— Say it with a*  
**KONE**  
**this Christmas,**  
**or better still let the**  
**KONE say it for you.**

LET us suggest your Xmas Present to your friend or relative, the "Kone" Loud Speaker. It is impossible to think of a gift that will give greater pleasure or indicate better taste on the part of the giver.

The "Kone" has won fame upon sheer merit. It is the one wireless musical instrument and is giving pleasure to many thousands of keen musicians to-day. Order yours now!

*Standard Telephones and Cables Limited*

Connaught House, Aldwych, London, W.C. 2.

CENTRAL 7345 (10 lines).

Works: NORTH WOOLWICH, NEW SOUTHGATE AND HENDON.

Branches:—Birmingham, Leeds, Manchester, Newcastle, Glasgow, Cardiff, Southampton, Liverpool and Dublin.

**Standard**  
 FORMERLY  
**Western Electric**

**KONE SPEAKER**

PRICE:

**£6 6s. 0d.**

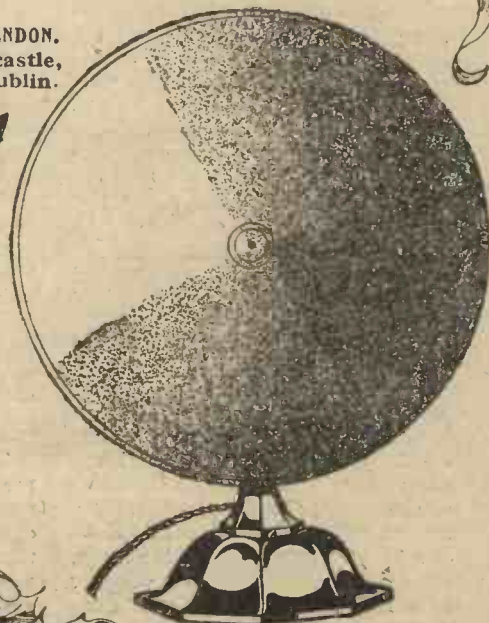

# A Single Valve 3-Circuit Receiver

By JOHN UNDERDOWN

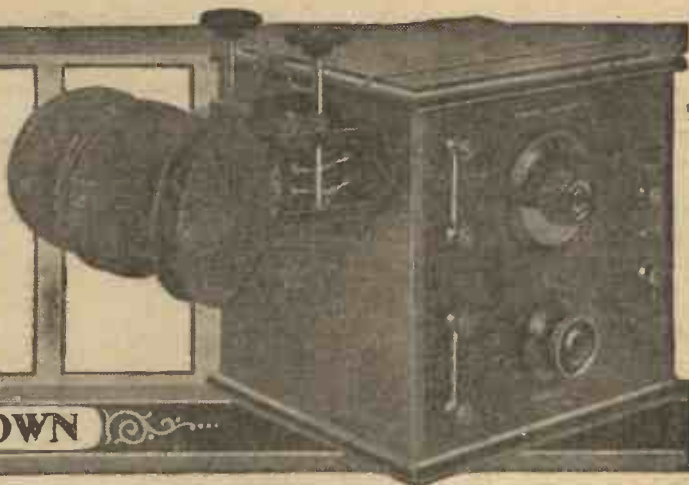

ALTHOUGH a good crystal receiver is an excellent piece of apparatus for listening on headphones to the local station, there usually comes a time when the listener either wishes to hear other stations or wants stronger signals to work a loud-speaker. In the former case the question at once arises, "What set shall I build?" Where the question of cost has to be borne in mind the choice is generally narrowed down to the building of a high frequency amplifier to add to the existing set or the construction of a single valve reaction instrument. To the beginner graduating from a crystal to a valve user I personally should advise the latter course.

### Progress by Steps

Until a certain amount of skill has been acquired a direct-coupled circuit, with reaction on to the

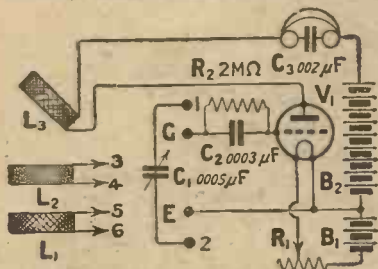

Fig. 1.—The general circuit diagram of the set.

aerial coil is to be preferred. Later, a higher degree of selectivity than can be obtained with this arrangement may be considered desirable if the experimenter lives within, for example, 12 or 15 miles' radius of a main station, or near the coast, where interference from shipping or a shore station is troublesome. A receiver, therefore, which is flexible within limits, that will

allow progressive experiments with several circuits to be carried out, should prove a boon to the single-valve man who wishes to try several of the popular straight types, in order to see which best suits his particular requirements. Bearing these points in mind, the receiver about to be described was designed.

### Three Circuits

Without making the set unduly complicated, it was found quite an easy matter to arrange that three circuits could be obtained with little difficulty. This was effected by the employment of flex leads with spring clips, allowing connections to be changed with a minimum amount of trouble, and by means of four terminals.

### The General Scheme

The general scheme is outlined in Fig. 1, from which it will be seen that three plug-in coils are mounted in a three-coil holder, and the leads from two of them,  $L_1$  and  $L_2$ , are terminated by spring clips (shown as arrow heads), and are numbered. A tuning condenser,  $C_1$ , of  $.0005 \mu\text{F}$ , is connected between the two terminals 1 and 2, the moving vanes going to 2. G and Earth are the other two terminals, the former being connected to one side of the usual grid condenser of  $.0003 \mu\text{F}$ , and leak of  $2\text{M}\Omega$ , and the latter to L.T. positive and one filament leg of the valve.

### Permanent Connections

The remainder of the connections are permanent, and call for little comment.  $L_3$  is the reaction coil, connected in the plate circuit of the valve and reacting on to  $L_2$ , which is placed in the centre or fixed socket of the three-coil-holder. To facilitate smooth reaction control a by-pass condenser

$C_3$  of  $.002 \mu\text{F}$  is placed across the telephones.

### The Direct Coupled Circuit

Fig. 2 shows the direct coupled or single circuit arrangement, which is the most simple and obviously the first to try.  $L_1$  is not used here.  $L_2$  serves as the aerial coil, and may be tuned by the condenser in parallel, as shown, or else in series. Direct magnetic reaction is here obtained, as it is throughout, by coupling  $L_3$  to  $L_2$ .

### A Form of Loose Coupling

In Fig. 3, the second circuit, and one which is more selective than that of Fig. 1, is given. Here  $L_1$ , coupled to  $L_2$ , which acts as a tuned secondary coil, is used as an untuned aerial coil, and by varying the coupling and the size of the former coil, tuning may be considerably sharpened, with but very slight loss of signal strength. On

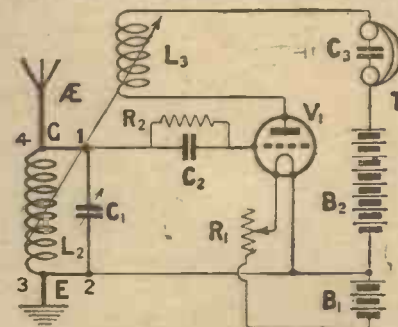

Fig. 2.—The direct coupled circuit.

my aerial, which is a fairly large one, 12 miles from London, Bournemouth can be received without interference from 2LO.

### A Trap Circuit

A circuit which should prove of value to listeners in coastal areas, where interference from ships mars reception, will be seen in Fig. 4.



An interior view of the receiver. The phone condenser is in the foreground.

This circuit is rather tricky to work, and on my particular aerial and earth system gave a certain drop in signal strength, but was found to be particularly selective. For the explanation of its working the reader is referred to "Trap Circuits," by Mr. John Scott-Taggart, F.Inst.P., A.M.I.E.E., in the February, 1925, issue of *Modern Wireless*, to whom the circuit is due.  $L_1$  is the trap coil tuned by the condenser  $C_1$ .  $L_2$ , connected across the grid and filament of the valve, should be small in size, and is untuned. Reaction is obtained

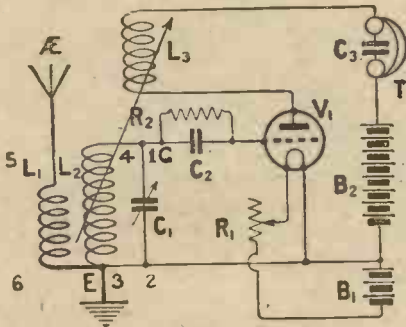

Fig. 3.—A selective circuit in which  $L_1$  is untuned.

by coupling  $L_3$  to it, and, in my particular case, had to be somewhat larger than usual.

**General Layout**

From the photographs the neat and symmetrical appearance of the receiver will be appreciated. An American type cabinet has been used, so that the valve is placed out

of harm's way. Constructional work is also reduced to a minimum by this method of building. The three-coil holder, of vernier type, is mounted on the side of the case, and the leads from it taken through six small holes drilled in the woodwork before it is fixed in position.

**The Panel**

On the panel itself are mounted the tuning condenser, the filament rheostat and six terminals. Four of the latter, on the left-hand side, are marked 1, G, Earth and 2 respectively, from top to bottom, and correspond to these markings in Fig. 1. The two on the right are the telephone terminals, the positive one being at the top.

**The Baseboard**

On the baseboard, which is 8 in. by 7 in., the shock-absorbing valve holder and the two fixed condensers  $C_2$  and  $C_3$  are mounted by means of suitable wood screws. To simplify construction, the usual terminal strip has been omitted, and leads are taken direct to the batteries, thus effecting a saving of both time and expense.

**Components**

For the convenience of the constructor, a list of the components employed, and also of the makers' names, is given. Provided, however, that good-quality material is used, a large number of other types will prove equally suitable if to hand.

One ebonite panel, 8 by 8 by  $\frac{1}{4}$  in. thick ("Paragon," Peter Curtis, Ltd.).

One mahogany case for above, with lift-up lid and sub-base 8 by 7 in. (W. H. Agar).

One vernier three-coil holder (Peto-Scott Co., Ltd.).

One filament rheostat (L. McMichael, Ltd.). (I have used a dual type, but one suited to the particular valve to be employed may be substituted.)

One shock-absorbing valve holder (Burne-Jones & Co., Ltd.).

One type 610  $\cdot 0003\mu\text{F}$  grid condenser.

One type 620  $\cdot 002\mu\text{F}$  fixed condenser.

One  $2\text{M}\Omega$  grid leak (all three by Dubilier Condenser Co.).

One  $\cdot 0005\mu\text{F}$  low-loss variable condenser ("Utility," Wilkins & Wright).

Six terminals.

Four spring clips (Peto-Scott Co., Ltd.).

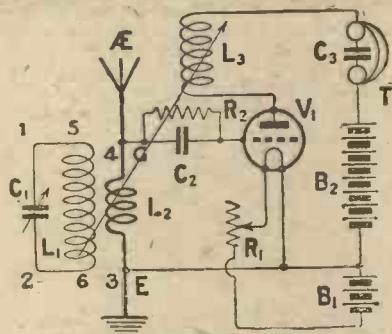

Fig. 4.—The most selective of the three circuits employs "trap" tuning.

Quantity of "Glazite," V.I.R. flex and heavy twin flex.

**Construction**

The constructional work is extremely simple, and little need be said here. Both the filament rheostat and the condenser are of single-hole fixing type, so that they are very easy to mount. To drill the large holes required, I find a carpenter's brace and bits very handy. Small holes should first be drilled to form a centre for the bit. Having mounted the components on the panel, affix the valve holders and fixed condensers to the wooden baseboard. At this stage also the coil holder should be secured to the left-hand side of the case, after the six holes to take the leads therefrom have been drilled.

**Wiring**

Simplicity is the keynote struck by the wiring. As far as possible, whilst apart, wire the components

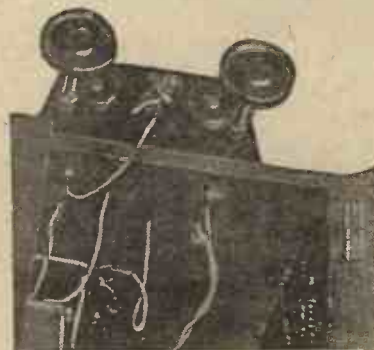

This view shows how leads are taken to the coil holder.

on the panel and on the baseboard by leads shaped as shown in the photographs. Finally attach the panel to the sub-base by two or three  $\frac{1}{4}$ -in. No. 4 wood screws, and complete this part of the wiring. Certain leads, which can be distinguished in the photographs and

# GAMBRELL BROADCAST RECEIVING SETS

The Best to Have or to Recommend

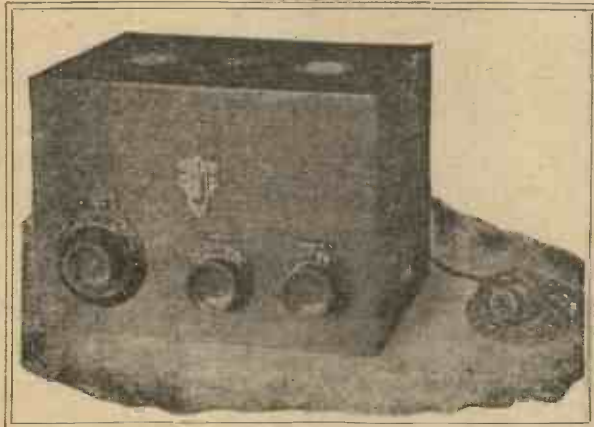

The Gambrell Baby Grand

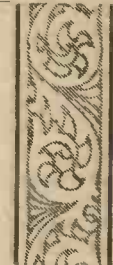

Illustrating a Gambrell Cabinet & with doors open



All enquiries, which will be answered by return, should be addressed to **RADIO SALES MANAGER:**

**GAMBRELL BROS. LIMITED**  
76, VICTORIA STREET, LONDON, S.W.1

## First and Foremost—

The

**NO BATTERY—NO ACCUMULATOR—  
NO TECHNICAL KNOWLEDGE—  
NO TROUBLE SET**

### The GAMBRELL BABY-GRAND

Draws all current (H.T., L.T. and G.B.) from D.C. Mains. Simply plug in to ordinary lamp socket. A wonderful 2-valve set for loud-speaker reception of local and high-power stations, complete with 2 B.T.H. B6 Valves, Coils for B.B.C. High Power and Local stations, length of flex and adapter

**£15 15s. 0d.** Royalty, £1 5s. 0d.

Everything accommodated within the case which is 10 in. × 7½ in. × 7½ in.

## Then—

### The GAMBRELL BABY-TWO

Which has the same circuit as the Baby-Grand but uses batteries. Is the ideal low priced set for loud-speaker reception of Local (up to 60 miles) and High Power Stations (150 to 250 miles). It is possible to receive several B.B.C. Stations on Loud-speaker and many Continental stations on phones.

Price including coils for 300 to 500 metres,

**£6 15s. 0d.** Royalty, £1 5s. 0d.

Or complete with Dull Emitter Valves (B.T.H. B5 and B6) 108 volt H.T. Battery, 3 volt L.T. Battery and Loud-speaker

**£13 0s. 0d.**

## and Finally—

A range of Cabinet Sets for all purposes and purses. Advice on the selection of suitable receiving sets will be supplied by return of post if particulars of requirements are forwarded. Prices from

**£15 15s. 0d. to £35**

**Cut this out and post at once!**

Messrs. Gambrell Bros., Ltd.  
76, Victoria Street, London, S.W. 1

Dear Sirs,  
Please send the Leaflets marked with a X.

1. Receiving Sets..... 2. Wavemeter.  
3. Components

Address.....  
Name.....

TWO



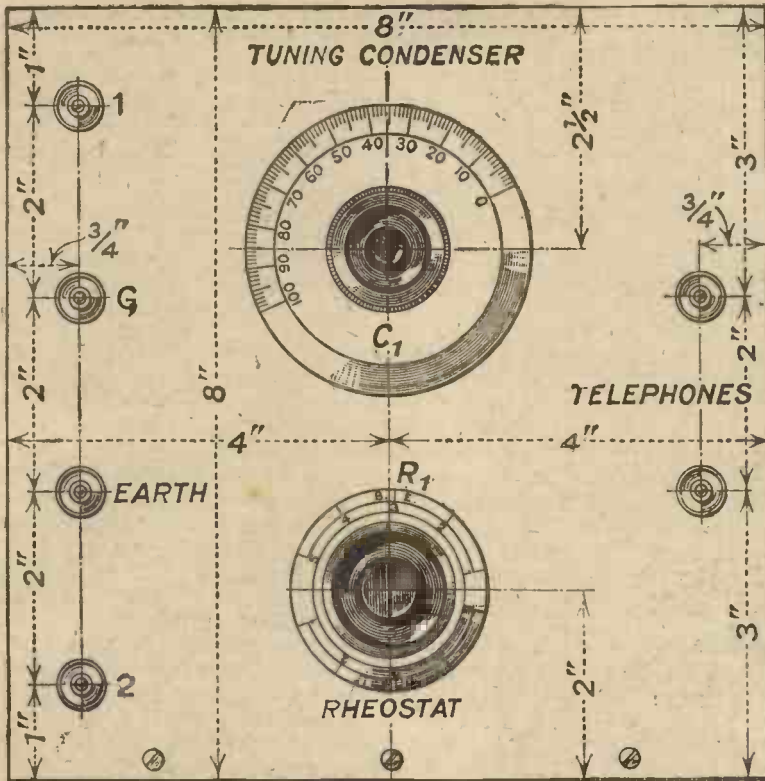

Fig. 5.—Extreme simplicity characterises the panel layout.

drawings, are carried out in rubber-covered flex, and sufficient length should be allowed for those which go to the reaction-coil block (shown twisted together) and to the H.T. battery. These two latter leads are, together with the twin flex L.T. leads, secured to the baseboard by a strip of fibre or wood and two tacks. Certain wires connected to 1, G, Earth and 2 are bared in convenient positions, as seen in the photographs, so that the spring clips for the coil holder leads make good connection.

**Completion**

Having wired so far, drill a 1/2-in. diameter hole in the back of the cabinet and take the battery leads through when inserting the panel and baseboard into the cabinet. Secure the panel in position by two wood screws at the sides, and then prepare four rubber-covered leads about 8 in. long, and solder one spring clip to an end of each. Take the flex lead from the plate of the valve to the socket of the coil block nearest the back of the case. The other lead from the lower telephone terminal should be connected to the plug of the same block.

**The Flex Leads**

It now remains to wire from the other two coil blocks. That nearest the panel takes the coil L<sub>1</sub>, and the

fixed block takes L<sub>2</sub>. The socket of L<sub>1</sub> corresponds to 5 in the diagram and the plug to 6. With L<sub>2</sub>, 4 and 3 correspond to the plug and socket respectively. Connect the four leads terminated by the clips to the points 5, 6, 3 and 4.

**Circuit Connections**

A tabular list of the connections necessary for the three circuits follows. For convenience throughout, the terminal marked Earth is shown as E. All aerial and earth connections are made externally to the terminals mentioned below, except with the Fig. 3 arrangement. In this latter case clip 5 is joined to the aerial externally, the flex lead 5 being taken outside the cabinet. The other connections made by the spring clips are effected inside the case, either to terminal shanks or to the bared parts of leads from them. For safety when changing circuits, remove the valve and disconnect the H.T. battery.

**Table**

Fig. 2.—Direct-coupled Arrangement with Parallel Tuning.

Aerial to G	1 to G	4 to G
Earth to E	2 to E	3 to E

With Series Tuning.

Aerial to 1	2 to G	4 to G
Earth to E		3 to E

Fig. 3.—Loosely-coupled Arrangement.

Aerial to 5	1 to G	4 to G
Earth to E	2, 3 and 6 to E	

Fig. 4.—Trap Arrangement.

Aerial to G	5 to 1	4 to G
Earth to E	6 to 2	3 to E

**Testing**

As a preliminary test, connect the L.T. battery only and insert a valve into the socket. Turn the filament resistance and note whether the valve lights correctly. Next remove the valve and connect as for the Fig. 2 circuit, employing, say, parallel tuning. The two pairs of terminals to the left will be joined by two short lengths of wire. The aerial is taken to G and the earth to Earth. Within the case 4 is clipped to the shank of terminal G and 3 in a similar manner to the earth terminal. A No. 25, 35 or 50 coil should be inserted into L<sub>2</sub> coil socket and a 50 or 75 into L<sub>1</sub>. No coil is placed in L<sub>1</sub>, and the clip leads 5 and 6 remain disconnected and left clear of the other wiring.

**Tuning**

Insert any general purpose type valve in the valve holder and apply a suitable valve of H.T. With the two coils well apart tune on C<sub>1</sub>. The



Another back of panel view. Note the flexible leads on the left which go to the batteries.

local station should be heard, and by bringing  $L_3$  towards  $L_2$  whilst re-tuning slightly on  $C_1$ , its strength should improve.

**Coils to Use**

With series tuning a No. 50 or 75 should be employed for  $L_2$ . When receiving 5XX, connect for parallel tuning, and use a No. 150 for  $L_2$  and a 200 or 250 for  $L_3$ .

With the Fig. 3 circuit  $L_1$  should be a No. 25 or 35,  $L_2$  a 50 or 75, and  $L_3$  a No. 50. For 5XX the order should be a No. 100, 250 and 200 respectively.

Employing the trap circuit of Fig. 4 I find a Gambrell "a" most suitable for  $L_2$ , a B or C for  $L_1$ , and a C or D for  $L_3$ .  $L_1$  and  $L_2$  gave best results when tightly coupled

together. For 5XX,  $L_1$  may be an F coil,  $L_2$  a D and  $L_3$  an E. Probably on other aerial and earth systems some experiment may be required to find the best combination of coils to use.

**Test Report**

Tested on a good aerial 12 miles S.E. of 2LO, that station gave un-comfortably loud signals with all three circuits, and with the Fig. 3 and 4 arrangements Bournemouth was quite free from interference from 2LO. The Fig. 4 circuit was extremely critical to tune, and proved effective in minimising Morse interference. A large number of other British and Continental stations were logged at good phone strength, among them Toulouse, Madrid and Münster; but

it is not proposed to take further space in giving a detailed list, since I would prefer the reader to judge the set on its own merits. I have no hesitation, however, in saying that the receiver functions in a very satisfactory manner, and should render yeoman service to the constructor.

**Conclusion**

In conclusion, it should be pointed out to the constructor that for loud-speaker work note magnifying valves may be added as circumstances demand. Transformer, choke or resistance coupling may be used, and the reader will find many suitable designs in back numbers of this journal. It should be noted, however, that a high-frequency valve cannot be added in a simple manner.

**The Midget Single-Valve Receiver**

SIR,—In reading your most interesting publication THE WIRELESS CONSTRUCTOR, I came across some of your readers' experiences with the Midget Single-Valve Receiver. I have been a reader of your paper for some time, but many of the sets which were described in it were beyond my pocket. So I waited and then I saw the Midget Single-Valve Receiver, by Mr. A. S. Clark, in the May, 1925, issue, which was very neat and very easy to wire up. Being the first time I had attempted to make a valve set, I thought that I would make this one. I was not only surprised but amazed at the result. I am sure it is quite as good as any two-valver—there is not a bit of harshness—absolutely a clear background when working. The only alteration I made was to use a larger piece of ebonite and a different condenser. I first made it up on an old piece of ebonite just to see what it would do, and I can tell you I was extremely pleased with it. Then I built a cabinet for it with a glass panel door. I use a 4-volt bright-emitter power valve. These are the stations I have heard up to now: 2LO, 5XX (too loud), 6BM (good), 2ZY, 5IT, 5WA, 5NG, 2BE, 2DE, 5NO, EAJ6, EAJ1, EAJ13, and also Oslo, and a number of French and German stations yet to be identified. All were heard on two pairs of phones loudly, some with the receiver tuned down. The climax came the other night. I made up my mind to try for something big, and about 2.25 (after hearing Madrid and a few more stations close down) I picked up a carrier wave. I heard speech which came in well and then seemed to fade, but came back again as quietly as it went. I moved the condenser dial round a few more points and picked up another station which was transmitting music. I continued the experiments till past 4 o'clock in the morning, and I was still getting them. It is the best little one-valver that is round about here, I am sure, and I thank Mr. Clark for his most helpful guidance and also the way THE WIRELESS CONSTRUCTOR prints it so clearly for the novice.

Yours faithfully,

Ely. A. E. A. NORMAN,

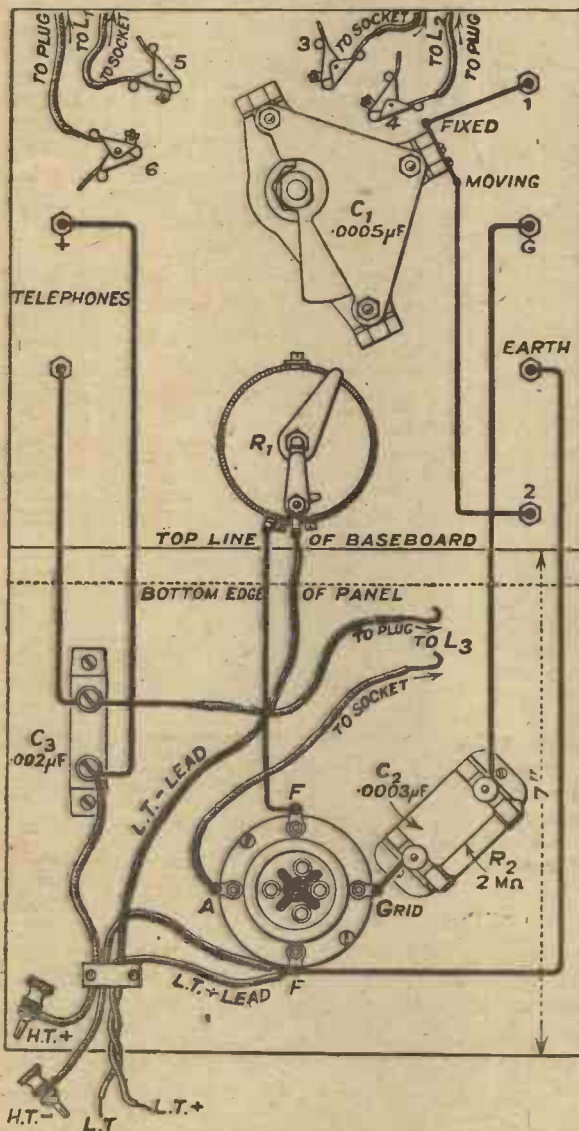

Fig. 6.—The wiring diagram. The uses of the flexible leads are marked, and the clips numbered in accordance with Figs. 1, 2, 3 and 4.

**Six important points:—**

The Burndept method of one-hole fixing is unusual in that the pointer-knob will remain flush with any panel from  $\frac{1}{8}$  to  $\frac{1}{2}$  an inch in thickness. *There is only one hole to drill and one nut to tighten.*

The element is wound with thick wire, having high current-carrying capacity.

The brush moves over a flat surface with a very smooth movement and cannot work loose. The contact resistance is low.

The neat scale saves one the trouble of engraving the panel. It is interesting to note that either the scale or knob will cover holes previously drilled for our old rheostats.

As these rheostats are made almost entirely of metal, the heat dissipation is increased. On account of this and the fact that there is ample air-space between element and panel the ebonite cannot be damaged by heat.

Large headed screws are provided for connecting wires.



**Burndept Rheostats quickly become popular**



An important feature of the new Burndept Rheostat is the special contactor-spring between spindle and body. It ensures perfect contact and complete absence of "frying" noises.

ON account of the Burndept reputation as makers of "quality" components it was natural that the new Burndept Rheostats should attract considerable attention. Not only have they found favour in the public eye, but they have added to the reputation enjoyed by Burndept as producers of the world's best wireless apparatus.

In appearance, efficiency, and durability, these new Burndept Rheostats are a distinct advance. The movement is perfectly smooth and absolutely noiseless. The Rheostats are very easy to fit, and are each supplied complete with a scaled aluminium plate and a neat pointer-knob, ready for mounting on any panel.

In addition to our well-known Dual Rheostat, we now market a Super-Dual Rheostat, which enables one to use any valve with any battery (up to 6 volts). It is truly described as a "universal" rheostat.

Full particulars and prices of the new Burndept Rheostats will be sent on receipt of the coupon below.

The Burndept Range includes everything for radio reception, from components to complete installations.

**CUT HERE**

To BURNDEPT WIRELESS Ltd.,  
Aldine House, Bedford Street,  
Strand, W.C.2

Please send me Publication No. 28r

NAME .....

ADDRESS .....

.....

Date ..... *Wireless Constructor, Jan.*



Head Office: Aldine House, Bedford St., Strand, London, W.C.2  
Telephone: Gerrard 9072.      Telegrams: Burndept, Westrand, London.  
BRANCHES at Belfast, Birmingham, Brighton, Bristol, Cardiff,  
Exeter, Glasgow, Leeds, Liverpool, Manchester, Newcastle,  
Northampton and Nottingham.

# Scrap that obsolete Coil-Holder and get the utmost pleasure from your set by fitting a LOTUS GEARED VERNIER COIL-HOLDER

Side Plates, Coil Blocks and Knob made in Artistic Bakelite Mouldings

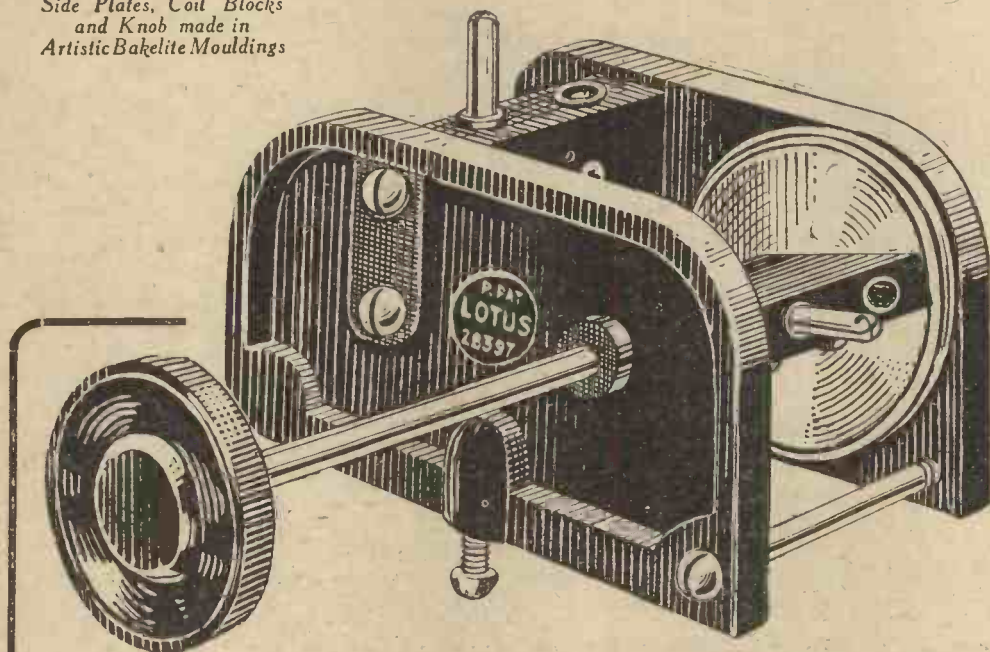

## AN UNSOLICITED TESTIMONIAL

"I take the opportunity of congratulating you on putting such a sound engineering job on the market as this coil-holder at such a reasonable price. After experimenting for three years, I have not found its equal."

ASK TO SEE A LOTUS AND YOU WILL BUY IT

**Y**OU have experienced that annoying and irritating fading away of volume after tuning your coils; this is due to the moving block falling. *The Lotus Moving Block CANNOT FALL.*

The Vernier movement comprises three sets of enclosed precision machine-cut gears, and reduces the speed of the moving coil-block by eight times.

The best appreciation of the superiority of the Lotus is that it has the largest sale of any type of Vernier Coil-Holder

¶ There are Two Types of Lotus Coil-Holders For Outside Panel Mounting, Two-way 7/6, Three-way 10/6. For Inside Baseboard Mounting with 6 in. handle. Two-way 8/6, Three-way 12/6.

¶ THESE CHARMING AND EFFICIENT LOTUS COIL-HOLDERS HAVE ACHIEVED SUCCESS THROUGH A DISCERNING PUBLIC

from all First-Class!  
RADIO DEALERS.

GARNETT, WHITELEY & CO., LTD.  
BROADGREEN ROAD LIVERPOOL



# Radio Games for Christmas

*How to get  
your family  
interested  
in wireless!*

**H.** G. WELLS has invented a game, so that I am in good company if I do it, too. It is the right spirit for Christmas. Mr. Harris's Centodyne really suggested it, and for the wireless man it is just as good as a crossword puzzle. It also enables the married man to spend a little time with his wife, and perhaps get her interested in wireless. No more wireless widows, in fact. You can play

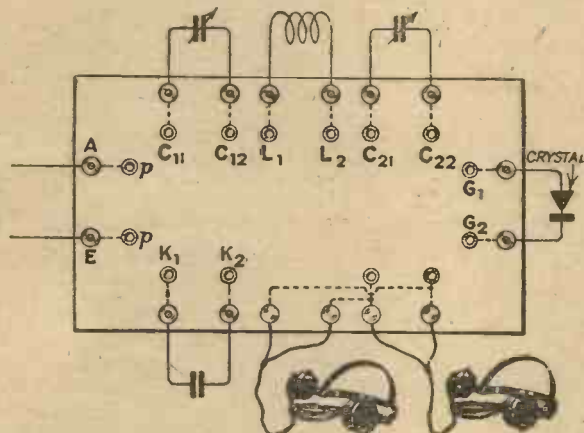

Fig. 1.—The layout for the Chequerphone. The wiring between terminals and sockets is below the panel.

the games, too, without any apparatus, on paper, but it will not be half so lively. The set of rules I give are only suggestions, and better ones can, no doubt, be established.

### CHEQUERPHONE

This is a simple form for crystal users.

Requirements :—

- An ebonite panel (quite small).
- A number of plugs, sockets and terminals.
- Two pairs of phones.
- Aerial and earth.
- A No. 50 coil.
- Two variable  $.0005\mu\text{F}$  condensers.
- One fixed condenser,  $.001\mu\text{F}$ .
- Crystal detector.

The arrangement of the panel is as in Fig. 1, each terminal being connected to a socket (*pp*) of the "Clix" type. Across the terminals are put the various instruments shown. The two players each put on a pair of headphones, and each is provided with a set of leads with plugs at the ends. Preferably one set of cords is white and the other black. Toss for first

move. Winner takes white cord. Then White makes first connection. The winner is the one who gets 2LO first.

Rules :—

1. Any connections can be made, and, if the opponent wishes to change, he pulls cord out, but that counts as one move.
2. No repetition of the same connection is permitted by the same player. (For instance, if Black shorts  $G_1 G_2$ , White will then remove the connection as his move, but Black must not again make that move.)
3. Adjustment is permitted on variable condensers as part of a move.

### CHESSOPHONE

Chessophone is similar, but played with a valve set.

Requirements :—

- Three loud-speakers.
- Three variable condensers (say, each  $.0005\mu\text{F}$ ).
- One  $2\text{M}\Omega$  grid leak.
- Three fixed condensers.
- One L.T. battery and variable rheostat.
- One H.T. battery.
- Three coils (two No. 50, one No. 25, say).
- Valve sockets and valve.

Rules :—

1. Same as Chequerphone.
  2. Same as Chequerphone.
  3. Same as Chequerphone.
  4. Any move which shorts battery, mover removes the short and gives two moves to the opponent.
  5. Burning out valve filament loses game.
  6. Oscillation by either player loses one move.
- Chessophone gives all sorts of possibilities of freak

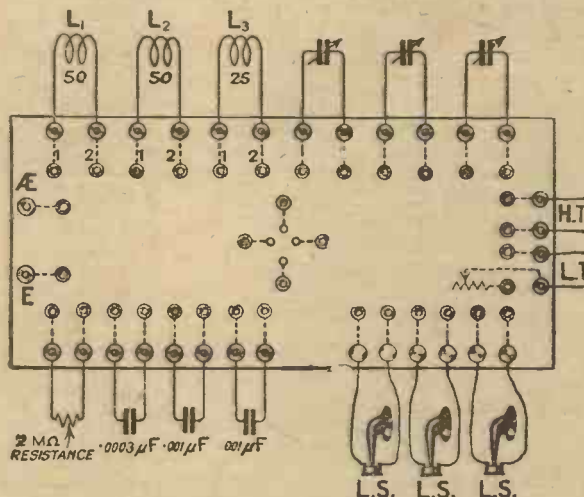
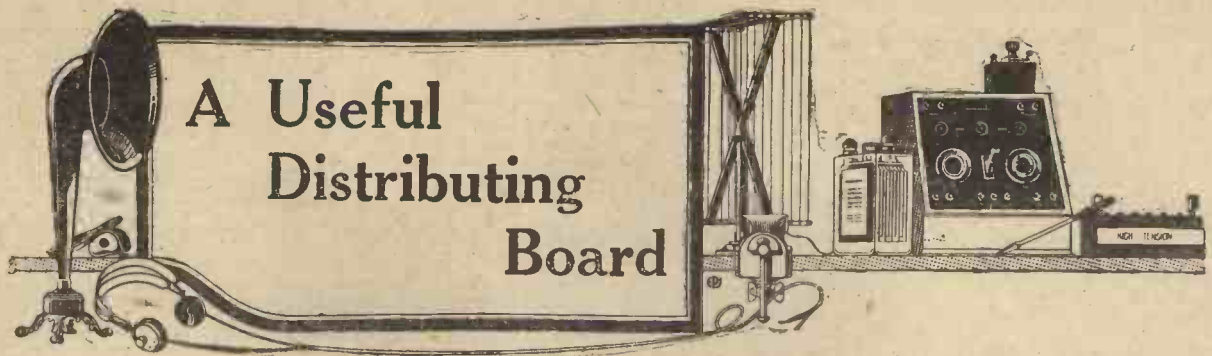

Fig. 2.—The Chessophone board.

circuits and, of course, to make it more difficult, the local station may be barred. The great point will be to try and deceive the other man as to the circuit you are after.



A device of interest to accumulator owners who have occasion to use different filament voltages

IN these days when valves vary considerably in their filament requirements the experimenter needs some handy device upon his wireless table which will

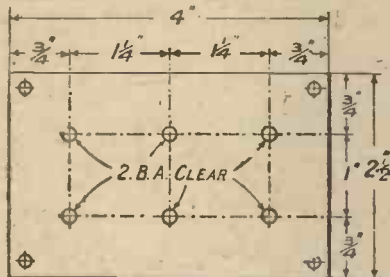

Fig. 1.—How to mark and drill the ebonite panel.

enable him to obtain a maximum low-tension potential of 2, 4 or 6 volts at will, without having to use a rheostat containing a high resistance winding. One of the simplest and most convenient ways of doing this is described in this note.

**Making the Board**

Cut out first of all a piece of  $\frac{1}{4}$  in. ebonite 4 in. in length by  $2\frac{1}{4}$  in. width, marking it out and drilling as shown in Fig. 1. The holes arranged in two rows of three each are made 2B.A. clearance (No. 12 drill), whilst those at the corners are of suitable size for the wood screws which fix the panel to a shallow box or to a small block of

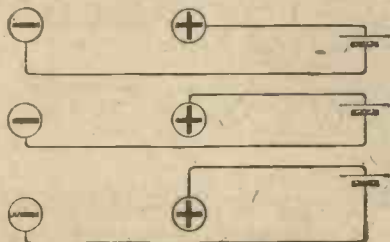

Fig. 2.—The accumulator cells are wired to the sockets as above.

wood in which hollows are made to clear the shanks of the Clix sockets mounted in the 2B.A. holes. We require here plain Clix, each with a single bush, three red and three green. Place all the reds in one row to mark the positives and the greens in the other. It is next necessary to "split" the cells of the accumulator in order that they may be wired to the terminals, as shown in Fig. 2.

**Wiring-up to the Accumulators**

This is made a very easy matter with Exide and other accumulators, in which screwed-down lead strips are used as inter-cell connections by simply removing the strips.

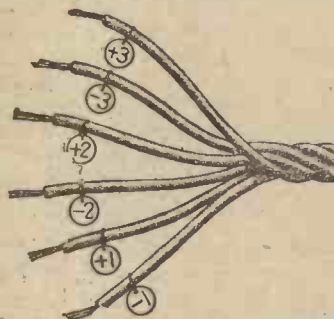

Fig. 3.—The six accumulator leads are marked and twisted together.

Should the connections be made with fixed rods of lead, cut a gap in each about an inch wide with a hacksaw, drill a 4B.A. clearance hole close to each end, and fit terminals, taking care either to coat them with anti-acid paint or to cover them with grease, so that they may not corrode. Between the battery and the "Clix Board" we require six leads made into a cable. One end of each should be soldered to its Clix socket, and to the other is fixed a very small ivory key tag marked, as shown in Fig. 3, with the sign of the terminal and the number of the cell to which it belongs.

**Connecting Links and Leads**

We next require some short lengths of good flex to each end of which is fixed a Clix connector

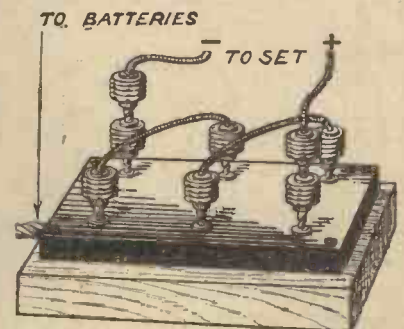

Fig. 4.—The board will look like this in use.

complete with insulator. The leads which are to run from the distributing board to the set will also require to have Clix terminals at their ends. The colour of the insulators used on the small connecting pieces does not matter—it makes a neat job to use black ones throughout—but those at the ends of the leads on the set should be red and green to denote positive and negative respectively. Fig. 4 shows the distributing board in use. It will be seen that in this case the three cells of the battery are connected in series, so that the total E.M.F. delivered is 6 volts.

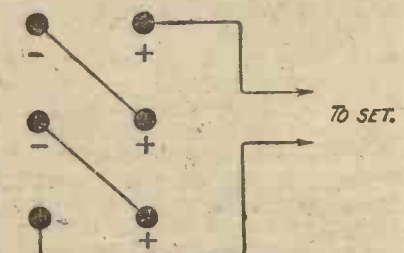

Fig. 5.—A 6-volt output results from these connections.

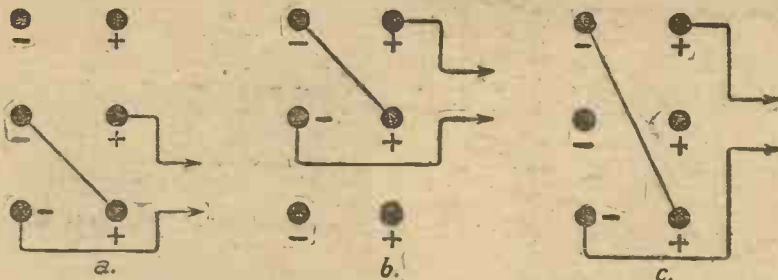

Fig. 6.—All three arrangements shown here give 4 volts, and each should be used in turn.

**Getting Different Voltages**

In Figs. 5, 6 and 7 are seen combinations which give respectively 6, 4 and 2 volts. An examination of Fig. 6 will show that by means of the Clix connections any two cells can be used in series to give 4 volts, the third being cut out. Most distributing boards use only one pair of cells to obtain the 4-volt E.M.F. This is a bad practice for it means that if much work is done with a 4-volt supply two of the cells are badly run down, whilst the third is hardly touched. The device described enables one to work all cells evenly by making occasional changes in the connections.

**A Precaution**

The distributing board will be found most satisfactory to use

since connections can be made in a moment. There is only one thing to be careful of, and that is on no account must any metal object be laid on the board, for if this were done a short circuit would occur.

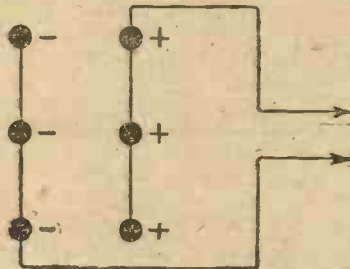

Fig. 7.—In the 2-volt arrangement all three cells are used.

*The All-Enclosed Local or Daventry Receiver*

SIR,—I have just completed the Local-Daventry receiver described by F. English in the September issue of THE WIRELESS CONSTRUCTOR, and I think it is the most wonderful crystal set I have ever possessed. I have had several sets (ready made), but I've not had one that can be placed in comparison with this, and I feel that I must sincerely thank the author for furnishing us with the details or such a perfect little model.

Yours faithfully,  
ALBERT BERESFORD.

Derby.

**WIRELESS WEEKLY**

*The paper for the serious experimenter —*

**6d.**

**EVERY WEDNESDAY**



**I'm proud of these jobs**

NOT a tile chipped, not a crack in the wall—every fixture neat, firm, clean and workmanlike. You don't need to be an expert to put up fixtures that will stay fixed and be a credit to your home. Just get the handy Rawlplug Outfit and follow the simple directions. Send for illustrated literature (free)

From Ironmongers, Electricians or Stores

Household Outfit 3/6



Amateur Mechanic's Outfit 5/6

THE RAWLPLUG CO., LTD., LONDON, S.W.7.

A53

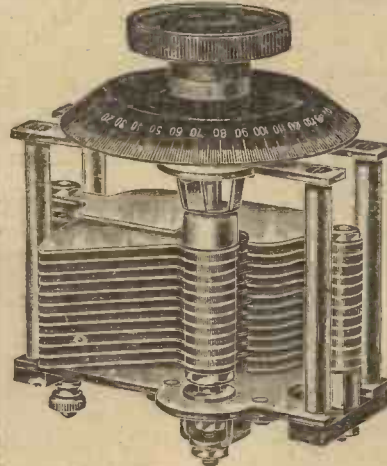

*features that stamp the new*



**Superior**

J. B. LOW LOSS	
'001	13/-
'0075	11/9
'0105	10/6
'0003	9/-
'00025	8/9
'0002	8/6
'0001	8/3
J. B. LOW LOSS GEARED VERNIER	
'001	17/6
'0075	12/3
'0005	15/-
'0003	13/6
'00025	13/3
'0002	13/-
'0001	12/-
Post, One 6d., Two 9d. Three 1/-	

J. B. Condensers have stood pre-eminent since the early broadcasting days, incorporating always those finer points of construction which makes for high-grade condenser efficiency. In the new J. B. Models recently placed on the market, the high standard is rigidly maintained, embodying the following features of improved design. Losses absolutely negligible (1.2 ohms at a million cycles 1000 mod.). Plates rigidly supported at two points. Pigtail connection. Earthed Rotor and Frame (giving perfect freedom from hand capacity). Minimum solid dielectric. Ingeniously designed Frame (giving exceptional rigidity). Metal End Plates. Conforming to modern practice. Minimum capacity scarcely affected. Correct Square Law. Gear Ratio 60-1.

**JACKSON BROS.**  
8, POLAND ST-OXFORD ST  
LONDON - W.1.  
(First Floor) Telephone GERRARD 7414

**big bargains for Wireless Dealers**

The Superlamp Net Trade List No. 9 contains hundreds of bargains in British, American and Continental Radio goods. Write for a copy today. Trade only supplied.

**SUPERLAMP**  
ELECTRICAL AND WIRELESS ACCESSORIES LTD.  
92-94, Paul St., Gt. Eastern St., London, E.C.2

**180 TO 1 COMBINE**  
REDUCTION I  
A NEW BRITISH INVENTION FOR FINE TUNING. NO GEARS. NO BACKLASH. SUITABLE FOR 2 B.A. 3/16" OR 1/4" SHAFTS  
PRICE 5/9 EACH  
FROM ALL DEALERS OR DIRECT FROM  
**A.F. BULGIN & CO**  
9-11 CURBITOR STREET  
CHANCERY LANE, LONDON.  
Holborn WC2R 2DZ



**"You Won't Always Have A Fire"**  
in the room where your set is fixed.  
**A PHONEREEL**  
will allow you to listen in, in whichever room you happen to have a fire, without the trouble of moving the whole set; just connect the terminals on end of flex to the set, hold the Phonereel by knob on base and walk to desired room allowing wire to unwind as you go along, always free from knots and tangles.  
Each Phonereel carries four pairs of terminals and 12 yards good quality twin flex.  
Price complete 15/- Trade enquiries invited  
Any length of wire can be fitted up to 25 yds. at 3d. per yd.  
"Fit a PHONEREEL and listen in comfort."  
**J. MERRETT & Co.**  
Trowbridge, Wilts.



Why Waste Time with Solder  
USE  
**IFIX CONNECTORS**  
Perfect Contact Without Soldering (patents applied for)  
Send Stamped Addressed Envelope for Samples.  
See Test Report in Wireless Weekly, Oct., 28th, 1925.  
No. 1 for Terminals and Screws 4BA 5BA 6BA 2/1 doz.  
No. 2 for Butt and Cross Joints ... 1/ doz.  
Your dealer or patentee  
**W. E. BOTTOM, 34, Denham Rd., SHEFFIELD**



## Selectivity or Simplicity ?

IN view of the rapid spread of the "itch for distance," selectivity is becoming more and more desirable in the ordinary broadcast receiver. It is, however, well known that a really selective receiver is much more difficult to operate than one merely intended for reception of the local station. The most popular method of combining a reasonable amount of selectivity with ease of operation is to use the well-known "untuned" or "aperiodic" aerial circuit. The question frequently arises, however, whether this method of coupling is really as efficient and selective as it should be. All readers interested in this question will derive great help from the series of articles commencing in *Wireless Weekly* for November 25, by Mr. G. P. Kendall, B.Sc., on "Selectivity and the Tight-Coupled Aerial."

### Wave-Traps

There are some, however, who feel competent to operate a really complicated receiver, and rather than use this method of obtaining good selectivity prefer to use a wave-trap. These will find their needs catered for, and also may receive some slight surprise, in the very comprehensive series of curves

in the article entitled, "What is the Best Wave-Trap to Use?" by Mr. C. P. Allinson, in the Nov. 18 issue of the same publication.

### The Oscillation Nuisance

Mr. Percy W. Harris has written an article of great importance to all users of valve sets, in "Chasing the Oscillator," which appears in the November 14 issue of *Wireless*, the one-word weekly. He also continues to give new circuits for use on the "Centodyne" receiver each week in the same paper.

### A Three-Valve Super-Het.

Few readers know that, although the super-heterodyne is frequently called the best of all receivers, still it may not necessarily be the most expensive and difficult to construct. It will come as a decided encouragement to these to know that a perfectly efficient "super-het." may be constructed which needs only three valves. Several variations of this, all the result of practical experiments, are dealt with in "Super-heterodyne Development," an article by the staff of the Radio Press Laboratories, in the Double Christmas Number of *Modern Wireless*. For those who already possess one of these receivers,

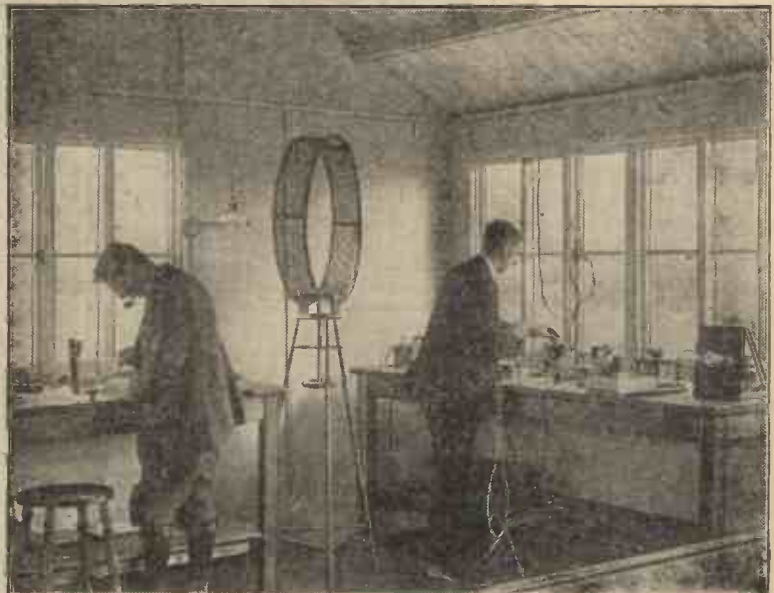

A corner of one of the Elstree Research Laboratories at present devoted to Super-heterodyne work.



Can they be combined in one receiver?

there is a short treatise on "Faults in Super-heterodyne Receivers," by Mr. John Underdown, who is already noted for his knowledge of "faults." Of equal interest is Mr. A. Johnson-Randall's article entitled, "How to Get the Best from Your Set," in the same number.

Tuning Coil Resistance

For the constructor looking for fresh worlds to conquer, there is a five-valve receiver, embodying two stages of radio-frequency amplification using a novel method of coupling, described by Mr. Hartt under the title of the "DX Five." There is also an interesting article on "Wireless Tricks for the Christmas Party," by Mr. A. V. D. Hort, which offers ample opportunities for the budding inventor and constructor to show his skill.

For the more mature readers, however, who prefer to find out what there is in their present receivers that might be improved from the theoretical point of view, Mr. Reyners' discourse on "What is the Resistance of Your Tuning Coil?" will open fresh fields. Major J. Robinson describes a method of using valve-filaments in series, showing how much more economical this is than the usual method, especially when D.C. mains are available.

Special-Purpose Valves

Many owners of receivers are guilty of the fault of expecting one particular valve to do any work which may be required of it. Mr. Hartt shows how fallacious this is in his comprehensive articles on "Choosing Valves to Suit Your Circuit," which appear in

*Wireless Weekly* for November 18, and the December number of *Modern Wireless*.

Amateur Transmitters

Those interested in transmission generally suffer from lack of practical information on the subject. They will, however, have no difficulty in following the articles entitled "Some Problems of Radio Transmission," by the Radio Press Laboratory Staff, now appearing in *Wireless Weekly*. These articles commenced in the December 2 number. Matters of general interest

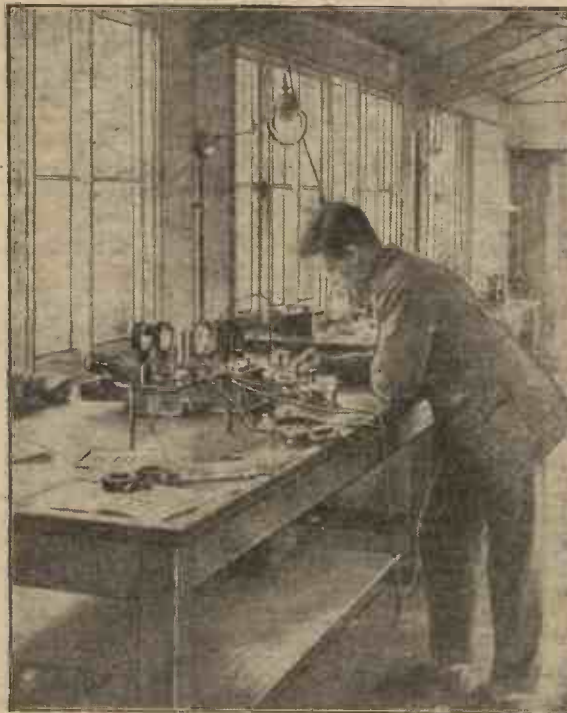

A member of the Elstree Research Staff engaged in experiments for obtaining resonance, curves of tuned circuits.

to short-wave enthusiasts also appear in "Short-Wave Notes and News" each week in the same paper.

Equally interesting articles, of a more specialised nature, are "How the Valve Works," by Major James Robinson, and "Wireless Under the Sea," by Lt.-Commander J. M. Kenworthy, R.N., M.P. These both appear in the December 12 issue of *Wireless*, the One-Word Weekly.



Drat it!

"DRAT-it," said father for the third time, as he tried to adjust the catwhisker of his Crystal Set. "These fiddling little Detectors are the devil's own invention. One day some bright fellow will come along with a Crystal Detector that even an old fogey like me can adjust in the dark."

Flimsy catwhiskers and insensitive crystals have caused more profanity than even golf. But now peace and quietness will reign supreme in the home once more. The new Eureka Rotary Detector abolishes the catwhisker and makes use of an entirely new principle. A rotary cam causes a series of points to rise and fall into contact with the Crystal. The pressure of each point can be adjusted with the greatest nicety. And because the Crystal also rotates, an infinite variety of points are available.



Takes any crystal

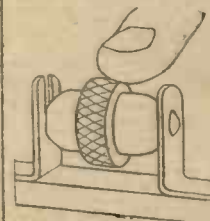

Abolishes the catwhisker

When you buy a Eureka Rotary Detector you finish with the Detector problem. You get a Detector that can never wear out. One that will take any crystal—if a new super-crystal is discovered tomorrow you can try it out.

Its contact is firm and secure—a hammer-blow on the table on which the Eureka Rotary is placed will fail to shake the point from the Crystal. For Reflex Circuits such as the S.T.100, the Eureka Rotary is ideal. And because the whole Detector is completely enclosed out of harm's way, the Crystal will retain its sensitiveness much longer.

Supplied mounted on convenient Ebonite base, with two plated terminals, but can be easily mounted on panel direct if required.

From all Wireless Shops

Fully guaranteed

5/6

EUREKA Rotary

Detector

Portable Utilities Co., Ltd., 3 Fisher Street, W.O.1

A Eureka Radio Product Gilbert Ad. 3945



**K. RAYMOND**  
**7, GRAPE ST.**  
**Shaftesbury Av., W.C.2**

Back of New Princes Theatre

- 1 minute Museum Tube
- 1 minute Tottenham Court Road Tube
- 2 minutes Holborn Tube
- 2 minutes Palace Theatre

Open all day Saturday. Two shops, one always open.  
 Phone: GERRARD 2821 (private line)

**Post orders from all columns EXCEPT CALLERS COLUMN**

**COIL WINDERS** (Money comb.—Westminster, 4/—“Kay Ray” well made, 4s 6p so handle, cannot be equalled, 2/.

**FLEX Twin**. Not less supplied.—Red and Black, 12 yds., 2/—Miniature Silk, 12 yds., 1/6. Rubber Lead in 10 yds., 1/8. Extra heavy, 4/—doz. Insulating Hooks, 1/8 doz. Empire Tape, 1 in., 12 yds., 1/—

**AERIAL WIRE** (100 feet).—Heavy, 7/22, 2/6; Ribbon (Tape), 2/9.

**ATROL VALVE HOLDERS** 1/3; Aeronic, 1/8.

**COIL STANDS**—2-way Standard, 2/8. Cam, V, 4/6; Geared, 5/8, 6/; 3-way Standard, 5/; Cam, 6/6; Geared, 7/11.

**COIL PLUGS** (Ebonite).—Fitted Fibre, 1/8 pair. Shaped. Brass sides, 1/8 pair. Standard, 2/—pair.

**PHONE CORDS**, etc.—6 ft. Rubber Insulated, 1/11; 7 feet do., 2/6. Loud Speaker, 2s, 12s, 2/8.

**“PEERLE S”**—6 ohm, 15 ohm or 30 ohm Rheostat, 2/; Dual Rheostat, 3/8.

**CO MMS VALVE** (Met. Vickers)—A. 4s 7/6; SP. 18 12/6; DE. 11 12/6. Old Valve allowed for.

**GUARANTEE**  
 Purchaser of proprietary and other goods buying their goods here will be covered under the Radio Press Guarantee as per postcards, one of which must be sent with order to M.E.A.S.O. Valves, Batteries, Job and Counter Lines excluded.

**WONDER AERIAL**—40 strands. Not cheap rubbish. 110 ft. 3/6. Phosphor Bronze.  
 Send a postcard for our folders and bargain Lists.

**BREWSTER—V lve Holders**, 1/9; Grid Leak 3/; Anode Res., 3/; Grid Leak and Condenser, 50,000 ohms to 15 meg., 4/6.

**BATTERY BOXES**—With 14 B-batteries. Caps fitted in box. Post free, 10/— 6/3 volts.

**BUREKA REFLEX** and **BABY GRAND**, Nos. 1 & 2, 15/—

**SHROUDED ANTI-CAPACITY VALVE HOLDERS**—Polished Ebonite, black with rel for plate terminal. Maximum efficiency. Lowest price. For panel or baseboard mounting, 1/3 each.

**ALL ORDERS IN STRICT ROTATION**  
 Not Answerable for Manufacturers' Delays

**COLLISON'S COLVERN X** Selector Low Loss Geared Variable 0003, 20/; 0'05, 21/— Vernier, 2/6; Neutrodyne, 3/6.

**DUILLIER CONDENSERS**—0001 to 0005, each, 2/6; 001 to 0'05, 2/ each. Grid Leaks, 2/6 each. Type, 610, fixed, 9/—3/6; 4/—48. Anode, 70, 80, 100,000, each, 1/6 on stand. Mansbridge Variometer, 30/1,800, 12/6.

**DORWOOD FIXED**—01 to 006, 3/ each; 0003 (with grid leak chip), 2/6.

**EUREKA TRANSFORMERS**—Concert Grand, 25—2nd Stage, 21/—Baby Grand, 15/; Gravity Detector, 5/8.

**ENERGO H.F. TRANSFORMERS**—R.B.C., 3/11; Daventry, 4/8. Other sizes stocked. L.F. Transformer, 15/—

**ELISON BELL PARTS**—Ser. Par. Variometer, or D.H.C. or 5XX, 16/6; Ohm Mod. 10—. Fixed Condens. 001, 0001 to 0003, each, 1/3; 0'2 to 006, each, 2/; 0003, with grid leak, 2/5. Shunt Plug, 2 for 1/4. Loud Speaker, 42/—Doicevox, 42/—

**GO SWELL QUALITY RADIO**—Coils, mounted 1/5, 1/6; 3/5, 1/3; 2/2, 2/—7/5, 2/3; 100, 2/9; 150, 3/4; 175, 3/6; 200, 3/9; 250, 5/3; 300, 6/— Valve Holders, Legless, 1/3. Sub-Panel, 1/3. 4-Valve Socke s, 1/1. Coil Stands Panel—2-way, 3/; 3-way, 5/4. Cam operated—2-way, 9/4; 3-way, 12/6; Low Loss Coil Former, 3/9.

**GAMBELL PARTS**—L.F., 1st or 2nd Stage, 27/6 each. 2-way Anti Cap Switch, 7/4; 4-way, 9/6. Neutrodyne Cond. nver, 5/6. Coils all sizes.

**E.T.C. VALVE HOLDERS**—A, or B, 1/9; C, 1/6.

**H.T. BATTERIES** 6 A B C, 39/— 6/3; 60V, 8/4; Extra Large B.B.C., 10/6; Ever-ready, 66/—, 12/6; 108/—, 20/; 60V, best made, 8/11; 4/5, 5/8, 6/—dozen.

**HEADPHONES, BRITISH 4.0.0 OHMS**—B. T. H., Browns, Br nides, 20/—pair; Sterling, English Ericsson, 22/6 pair. Bowerman's Super Phones, 12/6 pair.

**HEADPHONES GENUINE** 4.000 ohms.—Dr. No per Adjustable, 12/11; Telefunken Adjustable, 16/3; N and K Stampel on back, 14/11; Brunet, new model, 14/11.

**IGRANIC PARTS**—L.F., 1st Stage, 21/—; 2nd Stage, 19/6. Coils, Ultrinic, 9/—; Unitone Major, 9/—; Minor, 7/8. Honeycomb, 4s, 3s, 4/3; 50, 4/8; 75, 4/10; 100, 6/3; 150, 7/4; 200, 8/; 250, 8/6; 300, 9/; 400, 10/—; 500, 10/3; 600, 11/—; 750, 12/6; 1,250, 15/6; 1,500, 17/6; Rheostats 3/6, 5/6. Variometers, 10/—12/6. Potentiometer, 5/6. H.R. Variometer, 8/6. Variable Grid Leak, 8/6. New Square Low Variable Condensers, 0'1, 2/7/6; 0005, 2/4/—; 0003, 2/1/—.

**BURNDEPT PARTS**—Rheostats, 5/—; Dual, 7/5. Detector, 4/—; L.F., 2/4/—; Potentiometer, 7/6. Anti-Phonic, 9/—; Coils from 3/—

**CRYSTALS (Best)**—Neutron 1/6. Listron, 1/6. Uralium, 1/3. Shaw's Genuine Herzbite (Sealed), 1/—; Silverox, 2/6.

**“KAY RAY” DETECTORS**—Enclosed nickel fittings, trigger movement, 2/6; L'ernant, 2/—; Do. one-hole fixing, 2/6.

**LOUD SPEAKERS (Various)**—Sterling “Baby”, 50/—; 5/4/—; Dinkie, 30/—; Primax, 15/—; Amplions Dragon Fly, 25/—; Junior, 27/8; A.B., 111, 40/—; A.R., 114, 65/4; A.R. 19, 105/—; Browns, all models, Ultra, 27/8; C.A.V., 27/8. 30/—; And all new models makers' prices.

**LISSEN PARTS**—Anode or Variable Grid Leak, 2/8 each; L.F. or H.F. Choke, 13/—; Switches, D.P.D.T., 5-point Reversing, 4/— each. 2-way series Par., 2/9 each. Minor, 3/6; Major, 7/8. Universal, 10/6. Potentiometer or Wire Rheos, 4/4/— each. Neutrodyne Condenser, 4/5. Coils 2s, 3s, 4/10 each; 50, 5/—; 60, 7/5, 5/4 each; 100, 6/9; 150, 7/—; 200, 8/5; Lissen X 30, 6/4—60, 8/4; 75, 6/5; 250, 9/9. Tuner, 22/6. Mark III, Par., 47/6.

**MARCONIPHONE**—Potentiometer, 11/—; Ideal L.F. Transformers, 6/1, 4/1, 2/7. 1, 30/— each. Automatic Detector, 8/—.

**MCMICHAEL PARTS**—Rheostat, 5/8; D.E., 6/6; Dual, 7/6; Triple, 22/6; Potentiometer, 7/6; H.F. Transformers, 10/— each. Supersonic A7 12/6. Fixed and clips, 0001 to 001, 2/6 each; 002 to 001, 3/4 each. Grid Leaks, 2/6. Anode, 70, 80, 1,000 ohms, 2/6. L.F.T., 21/—.

**MAGNUM (BURNE-JONES)**—H.F. Transformers, 7/— each. Coil Holders, 2-way, 9/5; 3-way, 12/6. Valve Holders, 2/5. Vibro, 5/—; T.A.T. Tapp. Coil, 8/6. Neut. Cond., 4/6. All parts stocked.

**POLAR (RADIO COMM CO.)**—R.C.R. Unit, 15/—; Condensers, Micro, 5/6; Neut. 5/8. Variable, 001, 00 5, 0003, 1/6 each. Coil Stnds, Cam, V., 2-way, 6/—; 3-way, 9/8. Polar Sets stocked. Polar Junior Variable 0005, 0003, 5/6 each.

**LOTUS (GEARED)**—2-way, 7/—; 3-way, 10/6.

**R.I. (RADIO INSTRUMENTS)**—L.F. in sealed box, 25/—; Anode Choke, 10/—; Permanent Detectors, 6/—; 7/6. New Var. Air Condensers and V. 0003, 22/6; 0005, 24/—.

**REFLEX RADIO COILS** (Made under Burniepit Licence).—35, 6d.; 50, 9d.; 75, 1/—; 100, 1/2; 150, 1/8; 200, 2/9; 250, 3/3. Post 2d. each. Mounts, 1/— each extra.

**STERLING PARTS**—00025 Square Law and V., 23/6; 00035, 25/8. Non Pong Valve Holder, 4/8.

**T.O.C. (MANSBRIDGE)**—2 Mfd., 4/8; 1 Mfd., 3/10; 25, 3/—.

**SUCCESS (BEARD & FITCH)**—L.F., all black Super, 21/—; 21/4; Ormond, 14/—; Royal, 20/—; Lissen, T1, 21/—; T2, 15/—; T3, 12/6. Powquip, 14/6; Pormo Shrouded, 10/6; Ormond Latest Shrouded Model, 18/6; Croix, 9/6; Waites Supra, 12/6.

**SHIPTON**—Rheostats, 7, 30, 60 ohms, 3/— each. Potentiometer, 600 ohms, 4/6.

**PANEL SWITCHES**, Nickel SPDT, 1/—; DPDT, 1/3.

**TRANSFORMERS (L.F.)**—Feranth, 17/6; Pye, 22/8; Silverox, 21/4; Ormond, 14/—; Royal, 20/—; Lissen, T1, 21/—; T2, 15/—; T3, 12/6. Powquip, 14/6; Pormo Shrouded, 10/6; Ormond Latest Shrouded Model, 18/6; Croix, 9/6; Waites Supra, 12/6.

**UTILITY (WILKINS & WRIGHT)**—Coil Changing Unit, 7/8. Variable Condensers, 0003, 8/9; 0005, 10/6 (Vernier 2/6 extra). Switches, Knob, 2-way, 4/—; 4-way, 6/—; 6-way, 8/4; Lever, 8/4, 7/8, 10/—; Nickel, 6d. extra.

**VALVES**—Bright, 8/— each. Mullard Ora, Red or Green Ring, Marconi, R4, R5 B.T.H., R. Pillsbury, Cossor Pl., P2, 14/— each; Mullard D3 Cossor W1, W2, Ediswan ARDE, B.T.H. B3, Marconi DER, 16/6 each; Mullard 06, DE3, Cossor W1, W2, Ediswan 60, B.T.H. B3, Marconi DE3 18/6 each; Cossor W3, Marconi DE3, 22/6; Mullard DF, “AO”, “A1” Ediswan 17V1, 2, 5/8, B.T.H. B1, B6, Marconi DE4, 4, 5/8, etc.

**WATMEL**—Variable Grid Leak, 2/6. Anode, 3/6. Green Knob, 3/6. Fixed Condensers, 2/6, 3/8 (all sizes).

**WOODHALL PARTS**—L.F. Transformer, 23/8. Vernier Rheostat, 7 ohms, 2/6; 30, 3/6; 2-way, 10/6.

**ACCUMULATORS**—2 v. 40 amps., 9/6, 10/6; 4 v. 40 amps., 15/11, 17/6; 4 v. 60 amps., 22/8, 23/11; 4 v. 80 amps., 25/—, 26/—; 6 v. 60 amps., 30/—, 33/—; 6 v. 80 amps., 37/6, 38/6; 6 v. 100 amps., 45/—; Radio-cell Rotax, etc., etc.

**BENJAMIN**—Valve Holder, 2/9.

**R.I. Permanent Detector** 6/—; R.I. One-hole Fixing 7/6. “Kay Ray” Permanent One-hole Fixing 2/6.

**RADIO MICRO VALVES**—00G SPECIAL F.V. 3 to 35 A.V. 40 to 80 10/6

**RADIO PRESS ENVELOPES**  
**SETS OF PARTS**  
*All Less*  
 Box, Valves and Panel.

2 Valve Amplifier De Luxe (No 7) £4 16s. 6d.  
 Single Valve Reflex (No. 8) £3 2s. 2d.

“Simplicity” 3 Valve (No. 3) £3 7s. 10d.  
 All Concert De Luxe (No. 4) £6 18s. 2d.

Efficient Single Valve £1 16s. 10d.  
 9 Valve Supersonic £18 5s. 0d.

4 Valve Family (No. 2) £6 15s. 0d.  
 Twin-Valve Loud-Speaker Receiver by J. Scott-Taggart £4 13s. 0d.

Above are prices for AUTHOR'S Specification of parts. Reliable substitutes quoted for. High quality, very moderate prices.

**QUOTATIONS GIVEN FOR** Parts where it is possible to do so and give Early Delivery.

**WOODHALL PARTS**—L.F. Transformer, 23/8. Vernier Rheostat, 7 ohms, 2/6; 30, 3/6; 2-way, 10/6.

**ACCUMULATORS**—2 v. 40 amps., 9/6, 10/6; 4 v. 40 amps., 15/11, 17/6; 4 v. 60 amps., 22/8, 23/11; 4 v. 80 amps., 25/—, 26/—; 6 v. 60 amps., 30/—, 33/—; 6 v. 80 amps., 37/6, 38/6; 6 v. 100 amps., 45/—; Radio-cell Rotax, etc., etc.

**BENJAMIN**—Valve Holder, 2/9.

**R.I. Permanent Detector** 6/—; R.I. One-hole Fixing 7/6. “Kay Ray” Permanent One-hole Fixing 2/6.

**RADIO MICRO VALVES**—00G SPECIAL F.V. 3 to 35 A.V. 40 to 80 10/6

**QUOTATIONS GIVEN FOR** LISTS OF PARTS  
*Please write plainly*

Send a Postcard for our folders and bargain Lists

**THORPE K.4 VALVES** (5-PIN)  
 Complete with Ebonite 5-Pin Valve Holder  
 12/- post free

**HEADPHONES**  
**ERICSSON (E.V.) CONTINENTAL**  
 STILL UNBEATABLE 4,000 ohms. Sample pair, 10/6.

**“BRUNET”**  
 The old original phones, a little lighter in weight, very fine value, 4,000 ohms  
 Post free, 12/11 pair

**TELEFUNKEN**  
 In sealed boxes. Genuine Phones, 4,000 ohms (adjustable magneters), in sealed boxes. Many thousands sold without a complaint. Light as a feather. Post free, 16/— pair.

**N. and K.**  
 Guaranteed genuine stamped N. and K. on Cases.

**NEW LIGHTWEIGHT MODEL**, with all the old characteristics  
 4,000 ohms, 13/6 post free

**BROWNE'S A2 HEAD- PHONES**  
 4,000 ohms 30/—

**SIEMENS EBONITE**—Special sizes, 3/16 in. 3d. per sq. in. 1/4 in. 3d. per sq. in. Post extra

**SIEMENS “QUALITY” HEAD- PHONES**  
 4,000 ohms 20/— pair

**DEKKO VALVE WINDOWS, Nickel 6d. KEYSWITCH 2/9 PUSH-PULL 1/6**  
 Post 2d. under 2/—

**PLEASE WRITE PLAINLY AND REGISTER CASH.**

**BURNT-OUT VALVES**  
 1 Burnt-out Valve accepted in part exchange for each new British Valve bought. Usable Valves purchased or exchanged.

**“BRUNET”**  
 The old original phones, a little lighter in weight, very fine value, 4,000 ohms  
 Post free, 12/11 pair

**TELEFUNKEN**  
 In sealed boxes. Genuine Phones, 4,000 ohms (adjustable magneters), in sealed boxes. Many thousands sold without a complaint. Light as a feather. Post free, 16/— pair.

**N. and K.**  
 Guaranteed genuine stamped N. and K. on Cases.

**NEW LIGHTWEIGHT MODEL**, with all the old characteristics  
 4,000 ohms, 13/6 post free

**BROWNE'S A2 HEAD- PHONES**  
 4,000 ohms 30/—

**SIEMENS EBONITE**—Special sizes, 3/16 in. 3d. per sq. in. 1/4 in. 3d. per sq. in. Post extra

**SIEMENS “QUALITY” HEAD- PHONES**  
 4,000 ohms 20/— pair

**DEKKO VALVE WINDOWS, Nickel 6d. KEYSWITCH 2/9 PUSH-PULL 1/6**  
 Post 2d. under 2/—

**PLEASE WRITE PLAINLY AND REGISTER CASH.**

**27 and 28a,  
LISLE ST.  
LEICESTER SQ.**

W.C.2  
(Right opposite Daly's  
Gallery entrance)

I advertise for our mutual benefit, so  
see the shops you enter are the adver-  
tised ones, bearing the name

**K. RAYMOND**

Send for new picture lists  
and special bargain offers  
in NEW lines

No second-hand goods are  
EVER SOLD BY POST

TRADE SUPPLIED SEND FOR CIRCULAR

**CALLERS' COLUMN**  
Strictly Nett Prices  
ALL POST ORDERS ELSEWHERE



**Re-Echo Pat-  
tern Crystal  
Set**  
Handsome Present.  
Fitted per  
manent Detector.  
Variometer Tun-  
ing. Complete  
with Head-  
phones, aerial  
wire, insulators,  
lead-in wire.  
The LOT 21/9  
post free

Cheaper to Callers

**COILS (Mounted)**

All highest quality, post pd.

FINSTON—25, 1/3; 35, 1/6; 50, 1/3; 75, 2/-;  
100, 2/6; 150, 2/9; 200, 3/6; 250, 3/9;  
300, 4/-

STAR—25, 1/3; 35, 1/6; 50, 1/9; 75, 2/-; 100,  
2/3; 150, 2/6; 200, 2/9; 250, 3/6; 300, 3/9

GRAM (Patent)—25, 1/6; 35, 1/6; 50, 1/8;  
75, 1/11; 100, 2/3; 150, 2/3; 200, 2/11;  
250, 3/3; 300, 3/6

**ORMOND**

Shrouded L.F. ... .. 18/6  
Standard L.F. ... .. 14/-  
6 ohm Rheostat ... .. 2/-  
New Model Rheostat ... .. 2/6  
30 or 6 ohms.

**One Valve Amplifiers**

ready to assemble.

Drilled Panel, L.F. Transformer,  
valve-holder, terminals, etc. Screws,  
wire, sloping box, high-class set,  
only wants fixing np.  
POST FREE, NETT 14/11

**MULLARD'S VALVES**

Highly recommended. P.M.4  
Loud-Speaker Valve. 22/6  
4v. accu. or 3 dry cells.

All Mullard's Stocked  
TRADE SUPPLIED

**MICHROM  
VERNIER.**

Max. 000015 Min. Neg.  
Each 2s. 6d.



**"Service"  
Crystal  
Set**

Very handsome design.

SOLID  
POLISHED BOX  
(enclosed)

Complete with Siemen's  
Phones (4,000 ohms.)  
lead in, insulators, etc.

POST FREE

39/11



**KAY RAY**



**"DE LUXE"  
LOW-LOSS MODEL  
SQUARE LAW**

Prov. Pat.  
80-1 Worm reduction gear.  
Impossible to equal such  
fine tuning.  
0003, 13/6 0005, 15/-

High-grade Ebonite ends,  
one-hole fixing, knob and dial

G. Robinson, Esq., 4, Gladstone Street, DERBY.  
says: 21/10/25  
"Have tested your Condensers and they are  
the best money's-worth I have ever had. The  
workmanship is su-prem; and gives entire  
satisfaction."

**ORMOND**

American Type Low-  
Loss, skeleton ends,  
perfectly rigid, mov-  
ing vanes and end  
plates are at earth  
potential. Each com-  
plete with dial and  
knobs.

001 ... .. 10/6  
0005 ... .. 9/6  
0003 ... .. 9/-

Above with vernier. Deduct 1/3 each if no  
vernier required. Also with Ebonite Ends.  
same price.



**CROIX L.F.**

In new boxes  
9/-  
5-1 or 3-1.



Apex V.H. Anti-Capacity  
Baseboard Type, Nickel  
Screws, Soldering Tags,  
1/6, post 2d.

LISLE STREET IS  
OPEN SUNDAY

11 to 1.  
SEE THE NAME  
"RAYMOND"

Retail purchasers of £5  
worth of our own goods—  
offered as an advertisement  
one pair of 4,000 ohms  
Headphones FREE

Select from  
SIEMEN'S, BRUNET  
Genuine N & K, or  
BOWERMAN'S  
BATTERY BOXES  
With 14 Batteries.  
Clips fitted in Box.

Post free, 10s. 63 volts:

1/9 2/3  
2/6 3/-

**Bowyer-Lowe**  
Ossitator Coupler, 20/-

**Cam Vernier  
Coil Stands**

2-way ... 3/6  
3-way ... 5/6



Lotus 2-way geared, 7/-  
Lotus 3-way geared, 10/6

**Harmony Four** By Mr. Percy W. Harris  
ALL PARTS SOLD:

**IGRANIC**

Last word in  
Condensers,  
0005 ... 24/-  
0003 ... 21/-  
Square Law  
with Vernier.

**R. I.  
variable**

0005 ... 24/-  
0003 ... 22/6  
Tuner ... 39/6

**Star  
Variometer**

**DUPLEX**

for  
B.B.C.'s and 5XX  
Prov. Patent  
9/6



Brownie Set, No. 3  
new model com-  
plete with coils,  
phones, aerial and  
insulators. post  
free, 22.6.



**Dorwood Precision Condensers**  
The only grid condenser having  
a three-point connection. 0003,  
with Grid-Leak Clip, 2.6.



**BUY  
MULLARD  
VALVES**

**ACCUMULATORS.**  
2 v. 40 amp., 8/6, 9/6, 10/6.  
4 v. 40 amp., 13/11, 15/11, 16/11  
2 v. 60 amp., 10/6, 11/6, 12/6.  
4 v. 60 amp., 17/11, 18/11, 19/11  
4 v. 80 amp., 23/6, 25/-,  
6 v. 60 amp., 25/11, 27/6, 30/-,  
6 v. 80 amp., 33/-, 35/6.

**HIGH-TENSION BATTERIES.**  
B.B.C. 80 volts, 5/11  
B.B.C. 60 volts (extra large),  
8/11.  
B.B.C. 36 volts, 5/6.  
Crown Long Life, 60 v., 6/11.  
Alco, High Quality, 60 v., 6/11.  
Grid Bias, various, 1/11, 2/-, 2/3

**AERIALS, etc.**  
7/22 Heavy, 100 ft., 2/3.  
7/22 Good Value, 100 ft., 1/11.  
Phosphor-Bronze, 49 Strands—  
100 ft., 1/8.  
"Wonder," do., 110 ft., 3/-.  
Rubber Lead-in, 10 yds., 1/-.  
Heavy Lead-in, 3d. & 4d. yard.  
Empire Tape, 12 yards, 6d.  
Fibre Strip, 3d. for 1, for 24d.  
Twin Flex, red, yards, 1/4.  
Twin Flex, doz and black, 1/4.  
Min. Silk, 6 yards, 6d.  
Coil Former, 46 Spokes (wood  
handle), 1/6.  
Insulating Hooks, 4 for 3d.  
Egg Insulators, 2 for 1d.

**TERMINALS, etc.**  
Complete, with Nut and Washer  
W.O. or Pillar (large), 1d.  
Small Pillar, 4 for 3d.  
Small Fancy, 4 for 3d.  
Telephone, 1d. each, 10d. doz.  
Nickel W.O., 2 for 1, for 24d.  
Nickel Pillar, 3 for 4d.  
Nickel Phone, 3 for 4d.  
Contact Studs, complete, 2 a 1d.  
" (Nickel), 2 for 1d.  
Stop Pins, complete, 2 a 1d.  
" (Nickel), 2 for 1d.  
Brass Spade Screws, 2 for 1d.  
Nickel ... .. 1d. each.  
Pin, ditto, same price.  
Red or Black Spades, 1d.  
Lead-in Tubes, 8d., 8d., 10d.  
Copper Earth Tubes, 3/3.  
Wate's Microstat, 2/9.  
Enclosed Detectors, 8d.  
Large ditto, 1/-, 1/3, 1/6.  
Micrometer, Enclosed, 1/6, 1/9.  
Brass Spade Tags, 6 a 1d.  
Nickel Soldering Tags, 4 a 1d.  
Ormound Screws and Nuts, 4 or 6  
B.A., 2 a 1d.  
Push and Pull Switch, 1/3.  
On and Off Switch, 1/-.  
D.P.D.T. Panel Switch, 1/-.  
S.P.D.T. Panel Switch, 10d.  
8 Twist Drills, 1/2.

**D.C.C. WIRE.**  
Per lb. Reel—20 g., 8d.  
22 g., 10d.; 24 g., 11d.;  
26 g., 1/-; 28 g., 1/2.  
Switch Arm, 12 Studs, 10d.  
Nickel, ditto, 1/2.  
Flush Panel Sockets, 3 for 24d.  
Shorting Plug & Socket, 24d.

**E.F. TRANSFORMERS.**  
Portland ... .. 8/11  
Formo Type ... .. 8/11  
Supra Pattern ... .. 8/11  
Shrouded "Kay Ray" ... 12/6

**HEADPHONES.**  
Adjustable Phones ... 8/11  
Telefunken, genuine ... 14/11  
Ericsson, Continental ... 10/6  
Brunet ... .. 11/9  
French Thomson-Houston 11/9  
All 4,000 ohms.

**VARIABLE CONDENSERS.**  
Sq. Law, Ebonite Ends, Knob  
and Dial, 0003, 5/-;  
0005, 5/6.

**CUSTOMERS** requiring these  
Special Lines must please ask  
for same. No Post Orders  
from this column.

**EBONITE PANELS, 3/16 in.**  
6 by 6 or 7 by 5, 1/2; 8 by 6,  
1/8; 9 by 6, 1/9; 10 by 8,  
2/8; 12 by 6, 2/8; 12 by 9,  
3/11, etc. etc. MATT.

**SIEMEN'S.**  
Cut to size, 1d. per sq. in. 3/10th.  
Cut to size, 1d. ... .. 1/11.  
**RADION PANELS CUT.**

**CRYSTALS.**  
Shaw's genuine Hertzite, 8d.  
Neutron, Liatron, Ohray, Su-  
vaez, Zucite, Ebonite.

**AT LOWEST PRICES**

# Three Simple Joints

By R. W. HALLOWS, M.A.

When wiring up a set, we often have to join two wires together. Read how to do it

WHEN wiring up a receiving set or a smaller piece of apparatus one frequently has to make joints between leads. There are several ways of doing this, and the constructor must choose that which he finds the



Fig. 1.—A simple joint with round wire.

most convenient for his purpose. In Fig. 1 is seen a joint which may be made with round wire of not very heavy gauge. In this case the end of the lead to be connected up is twisted round the other two or three times with the pliers and solder is run into the joint with a hot iron. This kind of joint is very strong, and though it does not look particularly neat it may be relied upon not to come adrift provided that the soldering is properly done. Wire of heavy

gauge or square tinned rod cannot be treated in this way owing to the difficulty of twisting either.

### Joining Square Wire

Square tinned rod is liable to break if subjected to much bending, and it is very difficult indeed to make anything like a good-looking job in this way with such wire as No. 16 or No. 18 S.W.G. For these materials use either of the joints shown in Figs. 2 and 3. The "T" joint if well made is the neatest of all, and it can be relied upon if properly done. It is not, however, an easy joint to make well unless one has a certain amount of skill with the

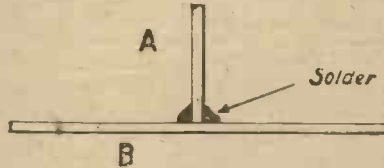

Fig. 2.—How to make a "T" or butt joint.

soldering iron. When making a "T" joint the wire A should be cut to such a length that it just

touches the proper point in B. At the point at which A is cut the copper will be exposed; it is therefore advisable to tin the end. When this has been done lay the two together in the proper position, apply a little flux and run in a good blob of solder with a very hot iron. When the solder has cooled make sure that your joint really has stuck by giving the lead A a good pull with the pliers. Another quite reliable is the "L" joint shown in Fig. 3. As the portion of the

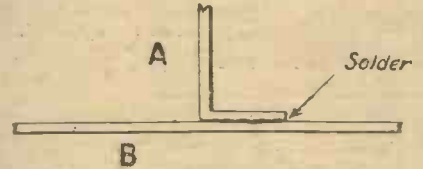

Fig. 3.—The "L" joint is very strong.

lead A bent round at right angles need not be more than a  $\frac{1}{4}$  in. in length a joint of this type looks quite well. To make the "L" joint cut the wire A so that it is slightly more than a  $\frac{1}{4}$  in. longer than is required. Bend the end round at right angles with the pliers and lay it against B. Hold the two in position with the pliers, apply a little flux and run solder well in with a hot iron. Test the joint as before by giving it a good pull when cool.

□

since its two halves can be twisted apart quite easily, and replaced when the work is done. Solder in thin sticks can be held as shown in the drawing, whilst thicker stuff fits nicely into the hollow jaws of the peg. When one is making joints the solder is held conveniently by the peg, and one can take the required blob on to the bit of one's iron without letting go one's hold of whatever is being joined. Many other uses for this handy little contrivance will suggest themselves to the man who makes a hobby of constructing wireless apparatus. A further refinement easily carried out is to make a hollow in the top of the wood block to receive a small tin containing liquid or solid flux. One then has everything at hand, and need never experience the bother of making a frenzied search for solder or flux when the critical moment arrives. Both of these things have in the ordinary way a knack of hiding themselves, but when a third hand is used they are always to be found when they are required.

## A Useful "Third Hand" for Soldering

*"I wish I had been born with three hands!" Here's one to fill the deficiency!*

MOST of us have felt the need when doing soldering work, and particularly when making the connections necessary during the wiring up of a set, of a third hand. The right hand is occupied with the soldering iron, whilst the left is needed to hold together the pieces that are to be joined. How is one to pick up the stick of solder? If one abandons one's hold of the portions about to be joined, and uses the left hand to pick up the stick of solder, it is quite probable that by the time the parts of the joint have been arranged once more the iron is too cold to do its work properly. I have found most useful for soldering work the "third hand," illustrated in the drawing. This is the simplest thing in the world to construct, and its cost is trifling. All that is required is a

single-spring clothes-peg, which can be bought anywhere for a half-penny, and a small block of wood from one's workshop scrap. The peg is fixed to the block of wood by means of a couple of small screws. There is no difficulty in doing this,

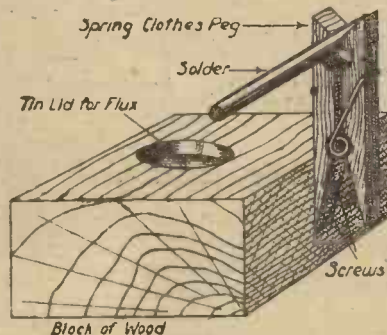

How the "third hand" is made.

—here's solid proof of Pilot economy

It is impossible to obtain a cheaper Set than a Pilot. You choose the design from among the large selection of Sets made famous by well known Radio Press authorities, and you pay only the bare price of the components—not a penny more. A Pilot Set is easy to build and failure is impossible. Send the coupon for a Pilot Manual at once. Here are some prices of famous Pilot Sets:—

**The Modern Wireless Crystal Set**

Complete kit of components.....	£1 16 0
Engraved panel drilled complete	5 6
Cabinet to fit.....	10 6

**The S.T. 100**

Complete kit of components.....	4 17 6
Cabinet to fit .....	7 6

**The "P.W." 2-Valve**

Complete kit of components.....	1 18 0
Engraved panel drilled complete	8 6
Polished cabinet to fit .....	1 1 0

**The P.S. 1-Valve Reflex**

Complete kit of components.....	2 13 0
Engraved panel drilled complete	6 6
Polished cabinet to fit .....	4 6

**The Twin-Valve**

Complete kit of components.....	3 6 3
Engraved panel drilled complete	10 0
Polished cabinet to fit .....	1 12 6

**The Puriflex**

Complete kit of components.....	3 15 0
Engraved panel drilled complete	16 6
Polished cabinet to fit .....	17 0

**The All Concert-de-luxe**

Complete kit of components.....	4 12 2
Engraved panel drilled complete	16 6
Polished cabinet to fit .....	17 0

**The Harmony Four**

Complete kit of components.....	7 10 3
Engraved panel drilled complete	17 0
Polished cabinet to fit .....	1 15 0

**The Special Five**

Complete kit of components.....	9 0 0
Engraved panel drilled complete	1 10 0
Polished cabinet to fit .....	3 3 0

**The Keystone Super-Het.**

Complete kit of components.....	10 12 8
Engraved panel drilled complete	1 3 0
Polished cabinet to fit .....	2 2 0

When all parts are bought with panel a Marconi Royalty of 12/6 per valve holder must be remitted with order

**Jim Vesey builds the Modern Wireless Special Five—**

A few days ago I ran into Jim Vesey in the Strand. "I want you," he said, "to come over to Golders Green one evening next week to see my new set." "What, another new one?" I asked, for Jim has made so many that I lost count. "Yes," said he, "but this one is a winner. Bournemouth on the Loud Speaker without a trace of 2 L O—how's that for selectivity?" "Easy," I said, with a chuckle, "when London has closed down." "No, don't be silly—I have really built a selective set at last, and if you come along I'll show you how it's done."

Of course, with my curiosity thus whetted I couldn't resist going over to Golders Green to see this wonderful set. "Here you are," said Jim, pointing to an imposing-looking five-valve set. "Yes," I replied, but I came to see the one you built." "That is the one," he said, indignantly. "Except for the cabinet, which cost three guineas, I built up the whole set." I hastened to congratulate him and smooth his ruffled feelings. "Splendid," I said, "it is a better-looking set than my neighbour, Alec Hurley, paid £43 for last month." "And I'll bet it gives better results," cut in Jim, as he lifted up the lid and exposed the rear of the panel. "What peculiar-looking coils!" I remarked. "Yes," he replied, "they are the little fellows that enable me to cut out 2 L O, and get Bournemouth on the Loud Speaker. Pass me that H.T. Battery and we'll see what's on." He connected up, adjusted the rheostats and plugged in the Loud Speaker. "London calling," said the voice, "Mr. Walter Hyde will now sing 'Vagabond' by



John Ireland." The song began, "Now listen," said Jim, as he rotated the three dials a few degrees to the left. "In three minutes the Bournemouth Orchestra will play 'La Berceuse,'" came a voice from the Loud Speaker. "There," said Jim, "now be convinced." "Well," I had to admit, "it is a good job I heard it myself as I should not have believed it possible to cut out 2 L O as close as this. Tell me, how long did it take you to build this set?" "Two evenings only," he said, "one to assemble the components and one to wire up." "But what about the drilling and cutting of the panel?" I asked. "Oh, you don't need to worry about that—do as I did—send to Peto-Scott's for a complete kit. It comes already for assembly with panel drilled and engraved—everything down to the last screw. All the lot cost me only a ten-pound note." "Good heavens! that's cheap," I said. "Yes," he replied, with a twinkle in his eye, "and if you make a mess of it they'll put you right for a few shillings! Just send for a copy of their Pilot Manual\* and read all about it."

\* Detach the coupon below and post to us with three penny stamps to cover postage and we will send you a copy.

**PETO-SCOTT CO. LTD.**

77 CITY ROAD, E.C.1

BRANCHES: 62 High Holborn, London, W.C.1.  
Walthamstow: 230 Wood Street.  
Plymouth: 4 Bank of England Place.  
Liverpool: 4 Manchester Street.

Peto-Scott Co. Ltd.  
77 City Road, E.C.1

Please send me a copy of the Pilot Manual, giving detailed working instructions and illustrations for building many of the well-known Radio Press Sets. I enclose 3d. to cover cost of postage, etc.

Name.....

Address.....

**PILOT SETS**

for home constructors

# Tell Us Your Views !

*We are very anxious that THE WIRELESS CONSTRUCTOR shall publish the type of articles you require. You will assist us in our efforts to improve the standard of each issue if you will fill in the form below and return it to the Editor, THE WIRELESS CONSTRUCTOR, Bush House, Strand, London, W.C.2.*

1. What features in THE WIRELESS CONSTRUCTOR do you like best ?
2. Have you any suggestions for regular features ?
3. Do you think we neglect any aspect of Wireless ?
4. Would you like articles on manufactured sets, and how to operate them ?
5. In constructional Articles, please place in order of preference :—
  1. Crystal Sets.
  2. One-Valve Sets.
  3. Two-Valve Sets.
  4. Three-Valve Sets.
  5. Multi-Valve Sets.
6. Do you wish the humorous feature to be continued ?
7. Please state in the order of personal preference :—
  1. Sets for Telephone Use.
  2. Sets for Loud-speakers (*i.e.*, those including stages of L.F. Amplification).

(NOTE.—For the same number of valves, the telephone set will give longer range, while the loud-speaker set will give louder signals, but the range will be shorter.)
8. Place in order of preference :—
  1. "Straight" circuits.
  2. Reflex circuits.
  3. Supersonic Heterodyne Circuits.
9. Place in order of preference :—
  1. Good all-round sets, suitable for 5XX or 200-600 metre stations.
  2. Specialised sets giving high selectivity and long range on the 200-600 metre band only.
10. Which articles in recent issues do you consider most interesting ?

*Please write here any general criticisms you wish to make. The more candid your remarks the better.*

IF YOU ARE QUITE SATISFIED, PLEASE SAY SO.

**U.S. Transformers give Unequaled Service**



**SUPER TRANSFORMER**  
"Modern Wireless," says of the U.S. Super Transformer:—

"The present instrument, of the high quality of the specimen submitted is an indication, can be heartily recommended, and indicates the vast strides that have been made recently in the design of really effective transformers for L.F. amplification."

**Fidelity**

JUST as the master musician interprets with absolute fidelity the creation of a composer, so does the U.S. Super Transformer interpret radio transmissions. Every shade of musical tone colour, stirring overtures, whispering sonatas, are reproduced faithfully and without distortion. U.S. Super reproduction is in fact—a revelation of what a good transformer is really capable of. It gives unusually high amplification over the whole band of audio frequencies which is consistently maintained throughout the entire range. Know the joy of perfect audio amplification and faithful radio reproduction—incorporate the U.S. Transformer in your set.

The U.S. Transformer's success lies in the excellence of its design. The core, with no bolts through it, is packed with finest stalloy iron, allowing fullest amplification without hint of distortion; winding is done by experts; terminals are large and comfortable, with ebonite strips at top and soldering tags. Ratios guaranteed 5-1 and 3-1.

**PRICE 18/6**  
From all dealers or direct from the manufacturers

**TWO VALVE CABINET SET**

Complete Outfit including—Set (Two Valve, cabinet as below), High Tension Battery 60v., Low Tension Battery, Coils (for 300-500 metres), Valves (two Dull Emitter), Standard Loud-Speaker, Aerial Equipment. Flex for connecting up.

**No Accumulator Required**

**PRICE £8 : 10 : 0**

Including Marconi Royalties  
**Nothing else required**  
**Nothing else to pay**  
**Absolutely Complete**



**The U.S. Radio Co., Ltd.**

Radio Works, Tyrshitt Road, Erectley, S.E.4  
\*Phone: Lee Green 2,04. Wires: Supertran, Lewis, London.

**EVERY "Utility" Component is fully and unconditionally guaranteed. If for any reason it proves unsatisfactory in service, return it to us and it will be replaced by a new component by return of post.**

**"UTILITY" SQUARE LAW CONDENSERS**

are old favourites. Thousands of keen wireless users have already proved their excellence. The report of the National Physical Laboratory is equally favourable. Their square law scale makes close tuning an easy matter. Fixing is the usual "Utility" one hole method.

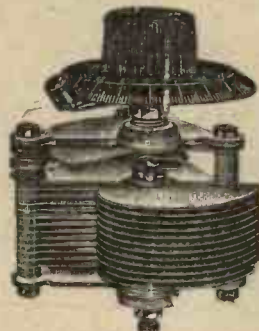

Ref. No.	Max. Cap.	PRICES	
		Square Law	Vernier Square Law
W.C.123	0010 mf.	12/6	15/-
W.C.144	00075mf.	11/9	14/3
W.C.124	0005 mf.	10/6	13/-
W.C.125	0003 mf.	8/9	11/3
W.C.145	0002 mf.	7/9	10/3
W.C.146	0001 mf.	7/6	10/-

These condensers are also available at the same prices with ordinary semi-circular plates. If required, specify "Standard" type.

**"UTILITY" NO CAPACITY CHANGE OVER SWITCHES**

Made to change over any number of contacts. The design ensures that self-capacity is negligible and contacts are rubbing and therefore self-cleaning.

Made in two Styles—Knob and Lever Patterns.

PRICES (Each)			
No.	Knob	No.	Lever
W.C.130/1*	3/6	W.C.147/1	4/6
W.C.130/2	4/-	W.C.147/2	5/-
W.C.130/3	5/-	W.C.147/3	6/-
W.C.130/4	6/-	W.C.147/4	7/6
W.C.130/5	7/-	W.C.147/5	10/-
W.C.130/6	8/-	W.C.147/6	10/-

\*This figure shows the number of poles changed over, e.g., W.C.130/4 indicates Knob type 4-pole change over.

Nickel-plate finish—Knob type 3d., Lever 6d. each extra.



**Utility**  
**GUARANTEED**  
**COMPONENTS**

**WILKINS & WRIGHT, Ltd., Utility Works**  
**Kenyon Street, Birmingham.**

E.P.E.A.





# A Three-Valve Loud-Speaker Receiver Using Plug-in Coils.

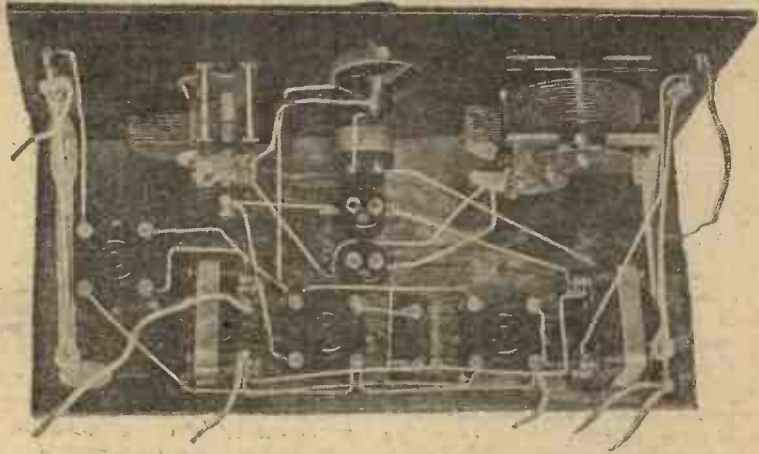

A photograph of the interior showing the wiring and flexible leads

the point of view of one's own satisfaction, but also from regard to one's neighbour. A set which slips in and out of oscillation in a wild and unruly manner causes all sorts of interference to the other listeners in the vicinity, whereas a set which is smooth in control only oscillates very feebly when it does commence to do so, so that the interference caused by inadvertent oscillation is minimised.

### Effect on Tuning

These two points can be controlled almost entirely by a suitable adjustment of the filament brilliancy and H.T. voltage of the valve in question. This was explained in an article on Reaction Control Circuits in the November, 1925, issue of *Modern Wireless*.

The question of alteration of tuning is not so simple, however.

The simple method of obtaining reaction by means of a coil in the anode circuit which is moved relative to the grid coil, causes variations of tune, because the effective inductance of the grid coil is altered by the presence of the other coil, the extent of this variation depending on the position of the reaction coil.

Thus the movement of the reaction coil causes variations in the tune of the grid circuit.

### Condenser Control

This defect led to a type of circuit which has become very popular, in which the reaction coil is fixed relative to the grid coil, but the current through it is controlled by a suitable means. Such a circuit is shown in Fig. 1.

Here some of the high-frequency current in the anode circuit flows

through the reaction coil, and then through the condenser  $C_2$  back to the filament. The amount of such current, which will, of course, produce reaction if the coil  $L_2$  is in the right direction, depends on the value of the condenser  $C_2$ . If this is small, its "impedance" to the high-frequency currents is large, and little current flows. As the condenser is increased the current increases, and with it the reaction effect, until finally oscillation is produced if the coil  $L_2$  is large enough.

This circuit will give very good results if suitable precautions are taken. The coil  $L_2$ , however, must not be too large, or very large variations of tune will occur. In fact, unless correctly proportioned values are used throughout the circuit, it is possible to obtain quite disappointing results.

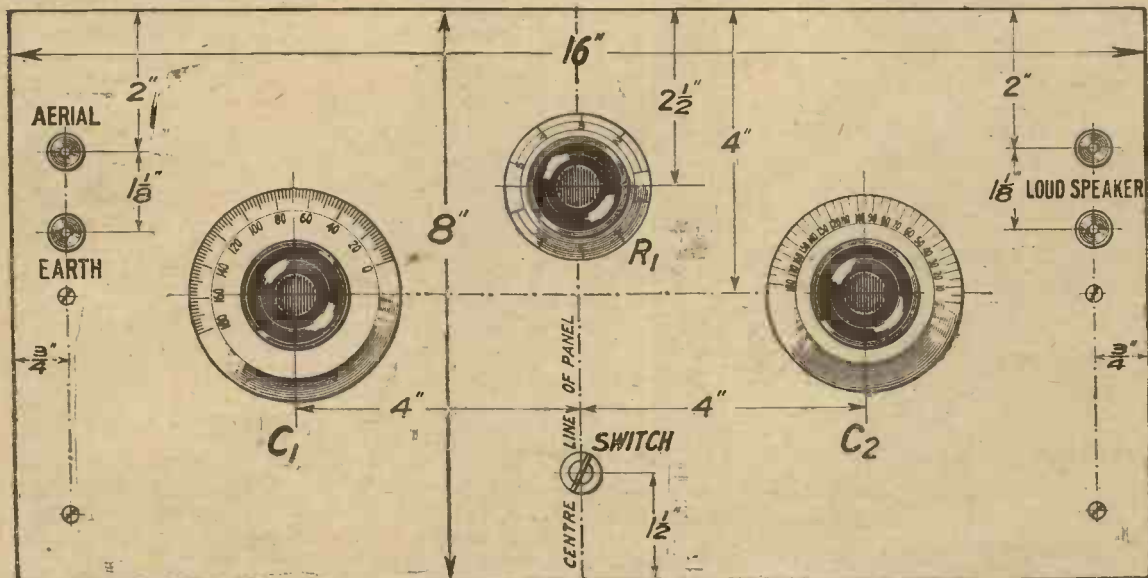

Fig. 3.—The panel layout. A full-size drilling blueprint No. C 1027A, may be obtained, price 1/6 post free.

**Another Method**

A modification of this form of control is shown in Fig. 2, which is the circuit finally adopted. Here the reaction coil, as before, is fixed, the current flowing through it being controlled by a by-pass condenser  $C_2$  connected across the anode and filament of the valve. Such a condenser forms an easier path for the high-frequency currents than the route through the coil  $L_2$  and the transformer, the larger the condenser the greater being the by-passing action.

There are other methods of condenser control, one of these being the shunting of the condenser across the primary of the intervalve transformer  $T_1, T_2$ , and the particular set described here is capable of being readily modified from one type of circuit to another.

**High Tension Battery**

There are one or two other features about the set in question. In order to simplify controls, only one filament resistance has been provided. The instrument is designed to operate with dull-emitter valves so that such a step is practicable.

Arrangements are made to house the grid-bias batteries inside the case, and also the H.T. battery if not too large, while the L.T. leads are taken through the back.

It should also be noted that the negative of the high-tension battery is connected to the negative of the low-tension battery, and not to the positive as has become the general practice. The connection to the positive is satisfactory when bright-emitters are employed, and in such there is a definite gain,

owing to the slight extra anode voltage so obtained.

With dull-emitter valves, however, more particularly of the 60 milliampere class, there are definite disadvantages. The anode current of the valve flows between the anode and the negative of the filament. If the H.T. battery is connected to the positive of the L.T., then this anode current will flow through the filament, and this will cause slight variations in the filament current, which give rise to instability in working.

**Panel Layout**

The layout of the apparatus on the panel is very simple. All four components are of the one-hole fixing type, so that this portion of the work is quickly accomplished. The components required for the complete set are:—

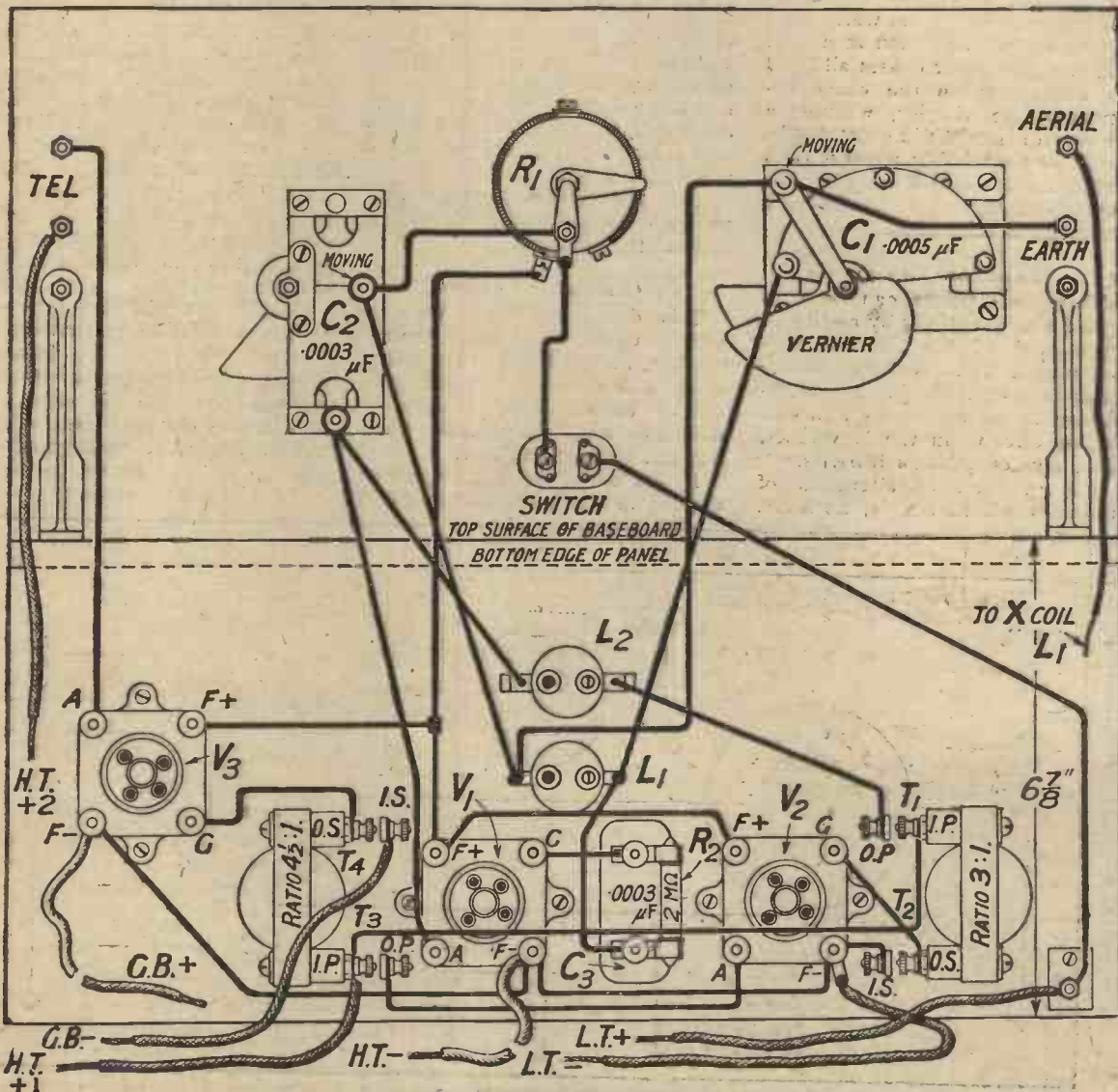
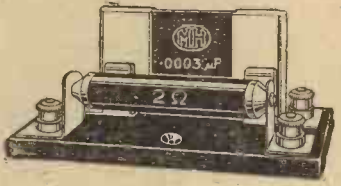

Fig. 4.—The wiring is not very complicated, but for the benefit of readers Blueprint No. C1027B can be supplied for 1/6 post free.



# GRID LEAKS & FIXED CONDENSERS



THE sign **MH** is synonymous with GOOD RADIO, maintaining always a rigid standard of supreme quality. This is particularly evident in **MH** Fixed Condensers and Grid Leaks

The products embody all the principles that make for the provision of noiseless control and consequently better reception

Incorporate them into your receiver. You will not be disappointed. They eliminate all those harsh noises produced by inferior devices. Call in at your dealers and see them to-day

### **MH** MICA FIXED CONDENSERS

Are of the permanent capacity engraved thereon. Are instantly interchangeable.

0.0001 μF to 0.0000 μF (030)	.. ..	2/6 each
0.001 μF to 0.01 μF (031)	.. ..	3/- each
0.015 μF to 0.04 μF (034)	.. ..	4/- each

(Two clips are supplied with each condenser)

Above mounted on ebonite base with terminals as illustrated, any value, 1/- extra.

### **MH** COMBINED GRID LEAK AND CONDENSER

Price .. .. 5/- each

### **MH** GRID LEAKS

All values 2/6 each. Mounted on ebonite base, as illustrated, 1/- extra.

### **MH** Resistance Capacity Coupling

Consists of three well-known **MH** units:—a .005 μF Mica Fixed Condenser, a 0.6 MΩ Leak, and an 80,000 Ω Resistance mounted on ebonite base. Price 12/6

### **MH** ANODE RESISTANCE

All values 4/6 each. (Each supplied with two clips) Mounted on ebonite base with terminals, as illustrated, all values, 5/6 each.

Other **MH** Components of high efficiency include:

- H.F. Transformers. Tuned Supersonic Units. I.F. Transformers. Autodyne Units. Filament Rheostats. Potentiometers. Grid Leaks. Coil Holders.

Head Office & Works:  
WEXHAM ROAD, SLOUGH  
BUCKS.

Telephone: SLOUGH 441 & 442  
TELEGRAPHIC ADDRESS: RADIETHER, SLOUGH.

## L. M. MICHAEL LTD

Manufacturers of Wireless and Scientific Apparatus  
WEXHAM ROAD, SLOUGH, BUCKS.

London Office & Wholesale Showrooms:  
HASTINGS HOUSE,  
NORFOLK ST. STRAND, W.C.2

Telephone: CENTRAL 8272  
CABLE ADDRESS: RADIETHER, SLOUGH

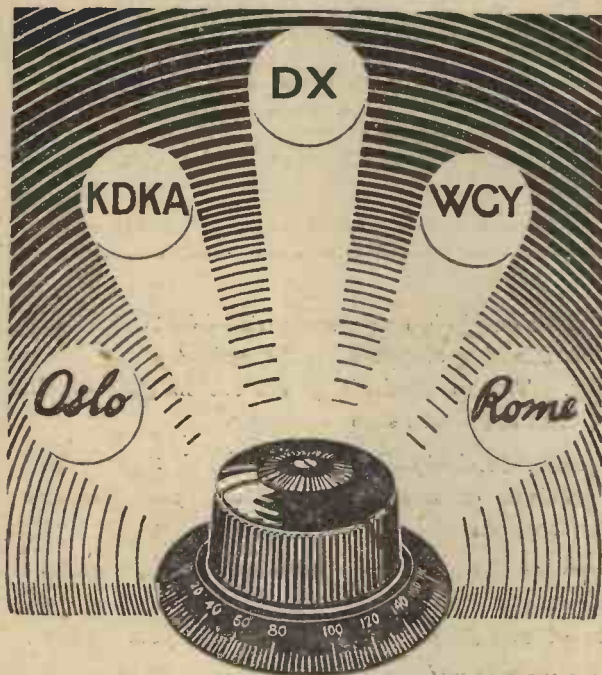

**The Pelican Univernier brings them all in—**

REALISE the height of your ambition. Make your receiver Selective; capable of bringing in everything within range; distant stations and local at maximum signal strength. The first step in the right direction is toward more efficient tuning. Replace your old condenser dial with the Pelican Univernier. You can't know the difference a dial can make until you've handled the Pelican Univernier. It responds to your slightest touch, gives a "dead on wave-length" tuning, bringing in stations at full strength. The Pelican Univernier is easily fitted; it is not necessary to cut condenser shafts or drill panels, simply unscrew your old dial and replace with the Pelican. Super-excellent in finish and performance—the Pelican Univernier is just the tuning control you need for selectivity.

Price 6/-, fits any standard condenser

**PELICAN WIRELESS SETS**

No Aerial - Earth - Recharging - Extras - Trouble

The Pelican Wireless Sets represent the highest standard of British workmanship, and besides being conveniently portable and simple to operate, need no Aerial or Earth. The Pelican Sets, however, allow for the attachment of aerial and earth for extreme long distance reception.

**THE PELICAN ONE-VALVE SET**

An efficient single valve receiver which under normal conditions gives perfect reception on headphones up to 10-15 miles without attachment of any kind. With an outdoor aerial its range is increased to 60-100 miles. Light, compact and has only one control. Price inclusive of valve, headphones, batteries and royalties, £10-0-0

**Pelican 3 Valve Set.** Range 15-20 miles on loud-speaker, 100-150 miles on phones. With outside aerial, loud-speaker results up to 100 miles. Price inclusive £20. Loud-speaker extra. Supplied to your own specification.

**Pelican 4 Valve Set.** Perfect loud-speaker reception of local broadcast. Continental stations on loud-speaker with outside aerial. Loud-speaker is contained in cabinet. Price inclusive £32-10-0.

**CAHILL & COMPANY Limited**

64, NEWMAN ST., LONDON, W.1

Telegrams: Pelicard, Wesdo, London  
Telephone: Museum 9226



**FAMOUS FORMO PRODUCTIONS**

THE NEW FORMO-DENSOR with 200 to 1 MICRO-VERNIER DIAL, Straight Line Wavelength. Ultra Low Loss.

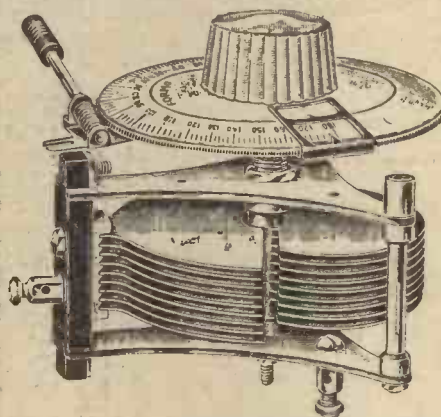

An instrument of advanced design, fulfilling all requirements of low loss design and electrical and mechanical efficiency. A single friction device enables the Dial to be quickly turned to the desired position, before fine tuning is effected by the 200-1 vernier movement. Stations are "logged" on the Dial.

Price Complete 17/6

Other Famous Formo Products.

The Popular Shrouded Transformer. The new "Perfection" Transformer, The Formo Jointed Baseboard Brackets. The Formo Portable Aerial.

Illustrated leaflets on request

The FORMO Company  
Crown Works, Cricklewood, N.W.2  
'Phone - - - - Hamp. 1787

Manchester:  
Mr. J. B. Ievce  
23, Hartley Street  
Levenshulme

**RECO CONTINUOUS L.T. BATTERIES**



enable you to dispense with accumulators and heat your filaments direct from your electric light supply.

PRICES FROM 30s. TO 130s.

Write for full particulars and state if your light supply is D.C. (Direct Current) or A.C. (Alternating Current).

All communications to:  
**RADIO EQUIPMENT CO. LIMITED,**  
5, Dyer's Buildings, Holborn, LONDON, E.C.1

Barclays Ad.

One panel 16 by 8 by  $\frac{3}{8}$  in. ("Radion" black, American Hard Rubber Co.).

One baseboard 16 by 7 in. (W. H. Agar).

One cabinet to suit panel, 10 ins. deep (W. H. Agar).

One .0005  $\mu$ F. variable condenser with vernier (Ormond).

One .0003  $\mu$ F. variable condenser (Jackson Brothers).

One dual rheostat (McMichael).

One "Radioloc" switch (Igranic).

Two "Royal" intervalve transformers (see text for ratios) (R. A. Rothermel).

Three vibratory valve-holders (Benjamin Electric).

Two board-mounting coil-holders (L. McMichael, Ltd.).

Two panel brackets. (Burne-Jones & Co.).

One grid condenser (.0003  $\mu$ F.) and leak (2M $\Omega$ ) (Dubilier Condenser Co.).

Four terminals.

Quantity of "Glazite," flexible wire and tags.

One packet Radio Press panel transfers.

**Baseboard Layout**

The next step is to lay the requisite components out in position on the baseboard. This can be done quite readily from the drawing given in Fig. 4, the only point to note being that the rectifier is the

centre valve of the three. This was done in order to keep the high-frequency leads short. It will be seen that with this arrangement the tuning and reaction coils are next to the appropriate valve, the tuning condenser is on the left of the panel and the reaction condenser on the right. This construction also keeps the low-frequency transformers well apart.

**Intervalve Transformers**

The actual make of transformers employed is relatively unimportant if suitable ratios are obtained, but I have found the ones used in this set quite good. If the detector valve is one having a high impedance and a high amplification factor, as is usually the case, then the first transformer should have a ratio of about 3 to 1, while for the second

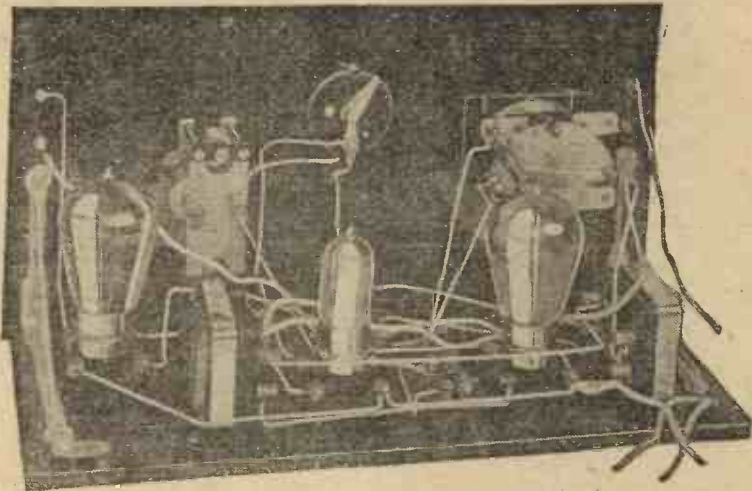

The disposition of the various components is well shown in this back-of-panel view.

# Duodyne

## THE WORLD'S MOST POWERFUL LONG DISTANCE RECEIVER

**For RANGE**

Wonderful results are still being received on my "Duodyne" V. Loud speaker reception of KFI and KHJ Radio Central KFI, and KHJ The Times, Lockard Building, Los Angeles, California. Other stations heard were WTAM, WJL, special tes, and KUD on phones, a so one XAD, two latter stations unknown, possibly American W. J. McC., S.S. "—," Moller-nik, Finland.

Sirs—On a voyage to the Caribbean Sea, I received Darenty daily on a large loud speaker. Up to 900 miles signals were so loud that instrument had to be detuned. At 2,000 miles Chu Ch Service transmitted by Darenty was audible 40 ft. from loud speaker. P.M.S. (Chief Engineer), s.s. "—," Rotterdam

**For POWER**

On a home constructed Set, using two wires, one for Aerial and one for Earth I received as the S. I have received KDKA, WBZ and several other American stations. As a Wireless Engineer, I should like to definitely state that the results with the "Duodyne" are immeasurably superior to the e with any other Set I have tried. F.S.B., St George's Road, London, S.W.

Using all 5 valves the B.B.C. stations are much too powerful, so am only using the 2 H.F., 1 Detector and 1 L.F. With these I get all the main B.B.C. Stations at full loud speaker strength, and all on an i do r a r l; quite a number of Continental Stations also com; in quite clear and loud. F.G.G., Felixstowe.

**For SELECTIVITY**

I live within a mile of a relay station, and with this in full blast I can cut out and receive all the other B.B.C. Stations on the loud speaker, as I can not more than four valves. I can receive on the loud speaker Oslo, Leipzig, Madrid, Paris Ecole, Petit Parisien, Brussels, Toulouse, Hambu, Berlin, Rome, and many other continental stations. W.S., Bradford.

In two hours I listened to the following (cutting out Manchester, 3 miles away): Leeds and Bradford, Sheffield, Liverpool, Stoke-on-Trent, Hull (London direct when Manchester was off), Birmingham, Aberdeen, Glasgow, Two German Stations, Post-Parisien, Chelmsford and Radio-Paris, without any Wave Trap. H.J.B., Manchester.

**For EFFICIENCY**

Will you please send me your Circuit and Wiring Chart for your Duodyne Five and Three-Valve receivers, as I have heard your Sets and I think they are the best I have ever heard, so I am making one for myself. I have made all kinds of sets, from Crystal Sets to 4-Valve Sets, but I think yours are the best. F.P., Hey-Lees, Nr. Oldham, Lancs

At the present time I can definitely say that it is the best 5-Valve Set I have operated, and I have made somewhere between sixty and seventy from a Crystal Set to 5-Valve Sets. F.V., Southall, Middlesex.

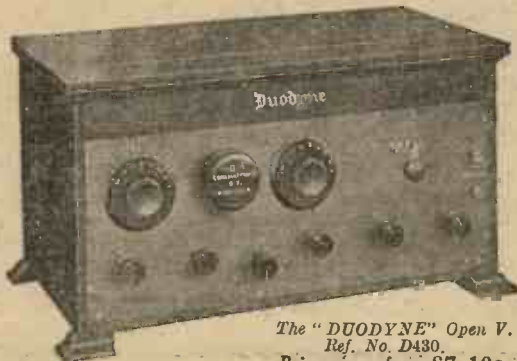

The "DUODYNE" Open V. Ref. No. D430. Prices range from £7 10s.

WRITE NOW FOR CATALOGUES OF COMPLETE RECEIVERS AND COMPONENTS.

All Communications to: **PETER CURTIS, Ltd.** 75a, CAMDEN RD., N.W.1. Telegrams: PARAGURTEX. Telephone: NORTH 3112.

Branches: MANCHESTER - 312, Deansgate. GLASGOW - 47, Carrick Street

BUILD YOUR OWN Duodyne

The Duodyne Treatise contains

1. Circuit Diagrams, 3 and 5 Valve.
2. Simplified Wiring Chart and Layout for 3 and 5 Valves.
3. Instructions for Operation.
4. Complete Schedule of Components.

Price - 1s. 6d.

stage using ordinary G.P. or, better still, L.F. valves having a lower impedance, a ratio of 4 or 5 to 1 will be suitable.

I actually used a 3 to 1 in the first stage and a  $4\frac{1}{2}$  to 1 in the second stage.

#### Wiring Up

On the panel the filament circuit may be wired in part, and on the baseboard all the filament circuits and the L.F. circuits may be wired almost completely.

The panel may now be mounted in position relative to the baseboard and the wiring completed. The only points to note are that the moving plates of the variable condensers both go to the filament side of the circuit. There will be no difficulty if the wiring diagram is followed exactly.

#### Operation of Set

The operation of the set is comparatively simple. First of all connect up the L.T. leads, insert the valves, and test out the filament circuits. Then connect up the H.T. and plug in suitable coils for the reception of the particular station desired. Suitable sizes are given in the accompanying test report. The set may then be tuned in to the local station, and the reaction control tested. It will be found that decreasing the condenser increases the reaction, and the filament brilliancy should be suitably adjusted at this stage until the control is smooth and free from backlash

and plonking. Care should be taken not to let the set oscillate during testing, and it is preferably when carrying out these preliminary adjustments to mistune from the local station so as to cause as little

For higher frequencies I used 50X coil for the grid circuit and 60 for the reaction. A slightly larger reaction coil is required in some circumstances. The coils for 5XX were 250X and 200 respectively.

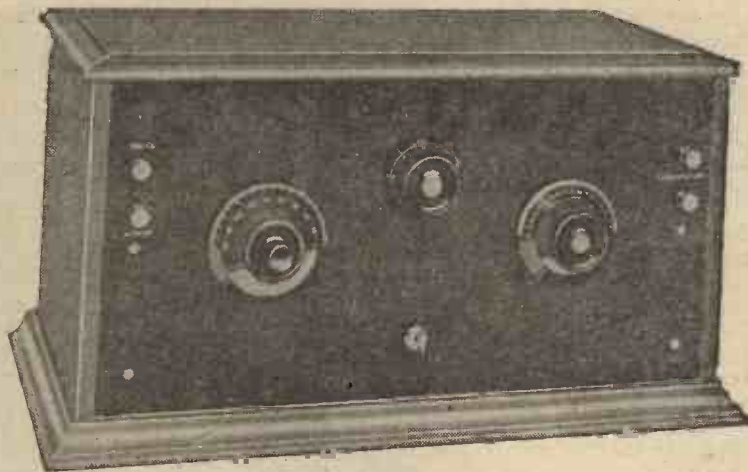

The completed set is very handsome. The key switch can be seen below the rheostat.

interference as possible in the event of a "howl."

#### Use of Aerial Series Condenser

In many cases, particularly if a large aerial is employed, an improvement is obtained by connecting a small fixed condenser in the aerial circuit before connecting to the X coil. A value of  $0.001\mu\text{F}$  to  $0.003\mu\text{F}$  is satisfactory, the actual size depending on the aerial.

On test, 2LO, 6BM, 5SC, 5IT and 2BD were all obtained on the loud-speaker, as also were Radio-Toulouse, Ecole Superieure, Hamburg and other unidentified stations. 5XX and Radio-Paris were tuned in at good strength.

An interesting point is that, when the filament current is correctly adjusted, the reaction adjustment remains "put" over a wide range of frequency.

# THE RADIO PRESS YEAR BOOK

## PRELIMINARY ANNOUNCEMENT

**E**ARLY in the new year Radio Press, Ltd., will publish, at the popular price of rs. 6d., the Radio Press Year Book. This publication, which will contain a mass of data, collated in the most useful form, will be found invaluable to all home constructors and experimenters, while listeners whose interests are of a non-technical nature will also find much to interest them.

A special section has been prepared to place in the hands of the experimenter who does not care for abstruse mathematical calculations, a quantity of valuable data in easily assimilable form. By its aid and with nothing more than a knowledge of elementary arithmetic, such calculations as the ascertaining of the inductance of tuning coils, constants of tuned circuits, condenser capacities, and other similar matters can be arrived at very rapidly and with minimum of labour.

The Valve Section will be found not the least important part of the volume, for it will contain full details of all makes of valves, and skilled advice on their use in different types of circuit.

**HOME WORKSHOP DATA SECTION.**—Wire tables, drill sizes, data on ebonite and other insulating materials, soldering hints, advice on wiring, transformer data, the choice of tools—these are but a few of the contents of this section.

Special articles by the Radio Press Laboratory and general staff, by eminent contributors in every branch of the science, will also appear, together with a number of special features which cannot at present be disclosed.

# BRETWOOD PRODUCTS - carry a guarantee for 3 years

FOR THE BEST RESULTS IN RADIO

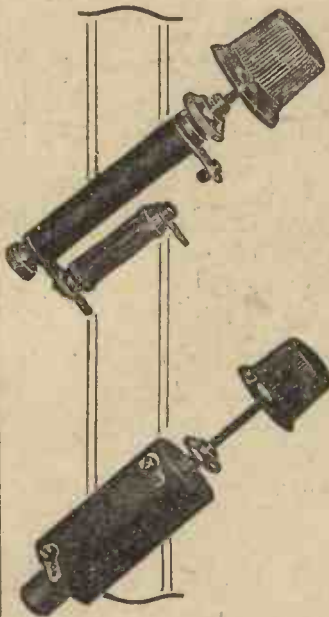

**B**RETWOOD Components give the maximum of good radio results, because they are designed with that precise end in view. The exact and careful method of their manufacture results in every individual Bretwood product being guaranteed for a period of 3 years.

Let this fact guide you in your choice of components—Specify Bretwood.

### THE "BRETWOOD" VARIABLE GRID LEAK AND ANODE RESISTANCE

(Patent No. 224295)  
The only reliable grid leak. The plastic resistance gives smooth, perfect control, and is absolutely constant in action. Gives accurate readings consistently from 100,000 ohms to 10 megohms ... PRICE 3/-  
With Condenser (as illustrated) ... .. 4/-

### THE "BRETWOOD" FILAMENT RESISTANCE (Patent No. 29284)

This instrument is the result of exhaustive experiment along new lines by Bretwood engineers. The Bretwood Rheostat takes up very small space on or behind the panel. It is extraordinarily smooth in action, effects perfect continuous contact, and does not depreciate through long use. It is capable of rough as well as a very minute Vernier adjustment, and is one hole fixing. Extremely well made...PRICE 5/-

Other guaranteed Bretwood Specialities include :  
The "BRETWOOD" Anti-Capacity Valve Holder, Price 1/9. Postage 3d.  
The "BRETWOOD" Anti-Capacity Switch, Price 5/- Postage 3d.

**BRETWOOD LIMITED**  
12-18, London Mews, Maple Street, LONDON, W.1

Obtainable from most Wireless Dealers



Bretwood Super - Het. Transformer (Tunable)

WE are shortly putting on the market the following new and interesting Bretwood products:  
Bretwood Super - Het. Transformer (Tunable)  
Bretwood Super - Het. Oscillator  
Write for particulars!

## FOR ALL PURPOSES

the



Will serve you as meritoriously as it has these users

#### DISTANCE

Harperley  
I may add that it is indeed a most wonderful general purpose valve. I myself can tune in America on one of these valves four times out of six tries.

W. G.

#### DETECTOR

Grangetown, Yorks.  
As a detector I got MANCHESTER, LONDON, ABERDEEN, and NEWCASTLE all on the LOUD SPEAKER, and a great many stations came swarming in on the 'phones.

J. C. M.

#### VOLUME

Nottingham.  
I am at present using two "Six Sixty" valves for power work - - - quite equal to many of the expensive power valves.

F. C. M.

Filament Volts 1.5-2  
Filament Current 0.3 amps.

14/-

British Made  
Stamped B.B.C.

If your local dealer is unable to supply, send to us. Please give local dealer's name and address. Write to-day for free leaflets.

THE ELECTRON CO., LTD., Triumph House, 189, Regent Street, London, W.1 Phone: Regent 5336



### "SUCCESS" OSCILLATOR UNIT

Price - 21/-

Covers a waveband of 250 to 550 metres; a very efficient component

### The "Success" Superforma

Ask your dealer for the Super - Success L.F. TRANSFORMER in Standard Ratios and 2-7-1.

For 1st & 2nd Stages,  
PRICE - - 21/-

The outstanding feature of the "Success" Superforma is the incorporation of a '0003 Variable Condenser as an integral part of the unit. The fact that it is tunable is a consideration which enables the experimenter to balance up the stages for himself, after the set is built, and to tune out interference. That the "Success" Superforma is tunable considerably increases the selectivity of the receiver, gives greater amplification and generally improves the efficiency of any Super Heterodyne Receiver employing the type of Transformer balanced by the manufacturer. After finally balancing up the Superforma, by turning the small knob, the tuning condenser may be locked in position.

"SUCCESS" SUPERFORMA, Price 30/-

### BEARD & FITCH, LTD.

34, AYLESBURY STREET, LONDON, E.C.1 Phone: Clerkenwell 8941  
North of England Branch: 1, DEAN STREET, PICCADILLY, MANCHESTER Telephone: Central 8240



**FREE!** and full of wiring diagrams

Do you want to get the best from your set? Do you want wiring wrinkles? Do you know how best to place your components on the panel? Do you...? Well, if so, send to-day for the Ericsson Handbook of Components and Circuits. Full from cover to cover with useful radio information—and post free to every constructor.

Write to-day for your copy and get busy on that latest Radio Press set.

The BRITISH L.M. ERICSSON MFG. CO., Ltd.,  
67/73, Kingsway, London, W.C.2

**Ericsson**  
COMPONENTS  
and CIRCUITS  
HANDBOOK

# HAND CAPACITY can't get past the



## Fulstop Variable Condenser

FULSTOP Condensers absolutely cut out all hand capacity and every model made is unconditionally guaranteed to this effect. The new Super-Fulstop achieves wonderful results by its exceptional selective powers. It is designed with a patent clockwork multigear and gives the use of two ratios of movement, a 2 to 1 and 125 to 1, enabling the most minute adjustment to be made with ease. You can't go past a station with a Fulstop.

The Fulstop is a no-loss condenser, perfectly square law and has brass vanes.

Send for full descriptive leaflet. All models are guaranteed for 12 months.

SUPER FULSTOP VARIABLE CONDENSER Guaranteed to abolish hand capacity.		STANDARD FULSTOP (GEARED 2 TO 1) Guaranteed to abolish hand capacity.	
'00025	.. .. 25/6	'0002	.. .. 9/6
'0005	.. .. 28/6	'0003	.. .. 10/3
'001	.. .. 30/6	'0005	.. .. 11/3
		'001	.. .. 13/6

Also the Plain Fulstop, no gears. Guaranteed to abolish hand capacity. If any difficulty in obtaining, write us. All guaranteed for 12 months.

**Fulstop**  
VARIABLE CONDENSER

J. H. NAYLOR, LTD., WIGAN



# Do You Know — ?

By C. P. ALLINSON

That a soldered joint may often look all right on the surface, and yet be faulty. This may be due to what is known as a dry joint. In order to obviate any risk of a dry joint resulting when soldering connections to terminal shanks (where these faults most frequently occur) the shank should be carefully cleaned with a file before tinning.

\* \* \*

That nickelled metal is particularly likely to be the cause of a dry joint, as nickel does not take solder well. The nickel plating should, therefore, be removed with a file before commencing work.

\* \* \*

That copper wire at the temperature of boiling water has a resistance which is 30 per cent. greater than its resistance at ordinary temperatures. A rise in resistance as great as 10 per cent. may be experienced on a very hot day, as compared to a cold day.

\* \* \*

That the letters S.O.S., popularly supposed to represent the words "Save Our Souls," actually have no such significance, but have been arbitrarily assumed as the distress signal, being selected by the International Radio Telegraphic Conference, which was held in 1908 in Berlin.

\* \* \*

That valves occasionally go "soft." When this occurs they are useless for amplifying, and a high plate voltage will produce a blue glow inside the bulb. They are, however, excellent as detectors when used with a low plate voltage in the region of 20 to 30 volts.

\* \* \*

That leads going to a set from batteries should be disconnected at the battery end first. If this is not done, should the bare ends of the leads touch, the battery will be short-circuited, thus possibly damaging it.

\* \* \*

That angle-brackets can, in an emergency, be made from old strips of ebonite. Place a piece of ebonite in boiling water, and it will become quite soft, so that it can easily be bent to the desired angle. It should be fixed in some way till cold, when it will be found to have set quite hard again.

That it is well worth while to clean valve pins and legs occasionally to ensure that a perfect contact is being made. This may be done with a little fine glass paper. The same procedure should be followed with plug-in coils and coil-holders.

\* \* \*

That records show that severe atmospheric disturbances are experienced whenever an earthquake occurs. No theory has as yet been advanced to explain this fact.

\* \* \*

That high frequency currents are used in furnaces for producing very high temperatures. Temperatures exceeding those produced in arc furnaces have resulted. The metal to be melted is placed in a crucible or furnace, round which is placed an inductance carrying a very heavy high frequency current. This results in eddy currents being induced in the metal, which are great enough to heat and melt it at an exceedingly high temperature. This form of furnace has the added advantage of heating the metal only, no energy being wasted on heating the furnace first.

\* \* \*

That it is better to use a master filament resistance than a snap on-off switch, as it is better for the life of the filaments. With the switch the current is suddenly turned on, thus causing sudden expansion of the filament, and similarly sudden contraction when switched off, while the resistance turns the valves on and off gradually, eliminating sudden stresses and so preserving them.

\* \* \*

That one of the best double crystal detectors is the zincite-tellurium combination. Not only is this a very sensitive detector, but it is also quite stable, as a fair amount of pressure may be used.

\* \* \*

That a small single wire aerial is far more selective than a "big twin," and that in actual practice only a slight drop in signal strength from distant stations may be observed.

\* \* \*

That a reliable variable grid leak is of very real assistance in long-distance reception, not only in obtaining maximum signal strength, but also smooth reaction control.

That an emergency grid leak may be made from a match stick cut in half lengthwise (so as to make it thinner), and dipped in Indian ink. When dry it may have a resistance of about one megohm.

\* \* \*

That if accumulator acid is spilt on cloth some ammonia should be poured over it at once to neutralise the acid. If no ammonia is handy, bi-carbonate of soda will do. It should be sprinkled on, and then moistened with a little water. Keep adding fresh bi-carbonate till the fizzing stops.

\* \* \*

That if ammonia is used the cloth should be thoroughly washed as soon as possible, for sulphuric acid is a strong acid and ammonia only a weak alkali. Otherwise the material will be corroded in time by the action of the acid.

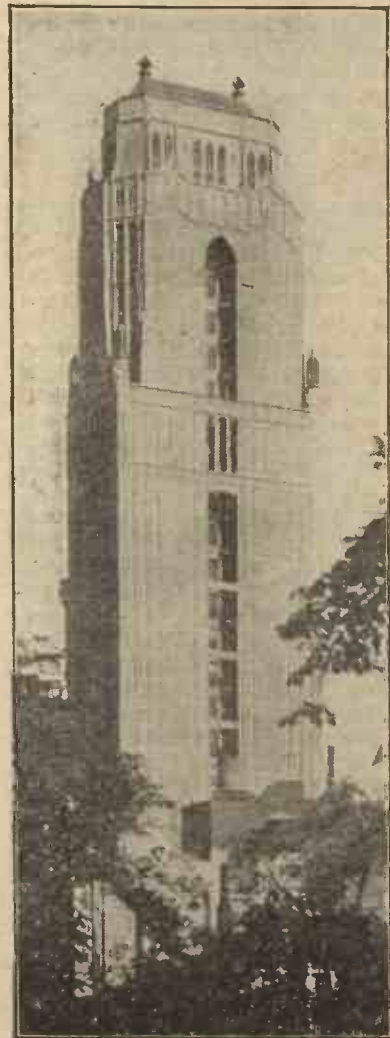

The Bush Building in New York, where the American offices of Radio Press, Ltd., are situated.

# Selectivity and "Range"

(Continued from page 245)

## The Coil Holder

For making connections to the three-coil holder, flexible leads are soldered to the shanks of the aerial and earth terminals, and brought out through holes in the panel. The earth-terminal lead goes to one side of both the fixed-coil and one of the moving-coil holders. The other side of the fixed coil is connected to  $A_2$ , while the lead from  $A_1$  is taken to the remaining point on the moving holder. Flexible leads are permanently attached to the second moving holder, which is for the reaction coil. The other ends of these are to be connected to the two reaction terminals. These reaction-coil leads must be reversed when the change-over is made from resistance-capacity to tuned-anode coupling or vice versa.

## Alternative Arrangements

An alternative method of connecting the leads to the reaction coil is that shown on the blueprint and Fig. 2. There two bolts are inserted in place of the terminals for the reaction connections, and the stiff wire leads inside the cabinet are soldered to the ends of these bolts. To the same points are soldered the ends of two flexible leads, and these leads are brought out through holes in the panel. Spade tags may be fitted on their free ends for insertion under the connecting bolts on the coil-holder.

## A Precaution

When terminals are used, as shown in the photograph of the receiver, it will be found a wise precaution to disconnect the H.T. battery from the receiver when the reaction coil is to be reversed. If this is not done, accidental contact between the spade tag removed from the terminal connected to the detector valve anode and the earth terminal, the other spade tag being still in position, will cause a short-circuit of the high-tension battery.

## Test Report

The receiver was tested on two separate aerials, the same valves being used in each case—namely, a Cossor red top bright emitter and a Marconi R5V, the latter for detector. The first test was carried out on a short indoor aerial in N.W.

London, about one and a half miles from the London station. In this situation it is with direct aerial coupling practically impossible to eliminate 2LO's transmission altogether and to receive more distant stations. With the help of the untuned aerial circuit, it was found possible to reduce the signals from 2LO sufficiently to receive Bournemouth, though of course signals were not strong on such an aerial system. After the London station had closed down, Edinburgh was picked up at quiet telephone strength.

## A Test in Hampshire

A subsequent test was carried out on a moderate outdoor aerial, 60 ft. long, about 15 ft. high, in a valley of the Hampshire Downs. With direct coupling of the aerial, Bournemouth (about 40 miles) was heard at good full telephone strength, sufficient to drown any spark signals from coastal and ship stations. Loose coupling gave a slight reduction in the strength of signals from 6BM, with a marked decrease in spark mush and similar interference. Other British stations heard were London, Cardiff, Manchester and Newcastle, all at readable strength. The Ecole Supérieure (Paris) was excellent, and the programme from EAJ7 in Madrid was received at good strength, the announcer's voice being particularly clear. On the longer wavelengths, using resistance coupling, Daventry and Radio-Paris were both received at good telephone strength. As both these stations were at some distance from the locality where reception was carried out, no great advantage was gained by using the untuned aerial circuit. In situations close to Daventry, this arrangement would no doubt be of some advantage.

## Direct Coupling

When direct aerial coupling was in use, the circuit appeared quite stable without the use of stabilising potentials on the grid of the H.F. valve. Some adjustments with the potentiometer were necessary when the aerial was connected to  $A_1$ , instead of  $A_2$ , owing to the decreased damping of the grid circuit of the H.F. valve.



## One hole fixing

The L. & P. Coil Holder, besides having the smoothest movement of any on the market, has a one hole fixing that STAYS FIXED. It operates through worm and pinion together with a compensating spring that makes backlash impossible. Hence the wonderful ease with which reaction can be controlled with this coil holder. From all Good Dealers or Write at once for list. Sent free on request.

LONDON & PROVINCIAL RADIO CO. Ltd.,  
27, Colne Lane,  
COLNF, Lancs.

L & P Coil-Holder now reduced to **8/6**

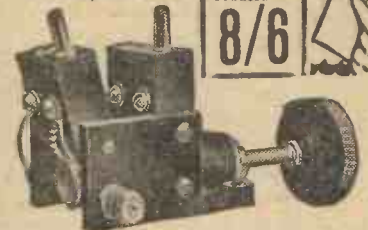

Other leading "Ellapec" Lines.—L. & P. Valve Windows enhance the appearance of any set. Small size 2/6 each. Large size 3/6 each. L. & P. Miniature Switches, D.P.D.T. 1/6 each. L. & P. Pull and Push Switch—positive action, positive satisfaction—only 2/- each.

REFINEMENT  IN RADIO



## Finston

### LO-LOSS COILS

No. 25 .. 1/3	No. 75 .. 2/0	No. 200 .. 3/6
No. 35 .. 1/6	No. 100 .. 2/4	No. 250 .. 7/9
No. 50 .. 1/9	No. 150 .. 2/9	No. 300 .. 4/0
	No. 175 .. 3/3	

Obtainable from all Dealers  
**FINSTON MANUFACTURING Co. Ltd.**  
45, Horseferry Road, London, S.W.1  
Phone: Victoria 1644

MAKE YOUR OWN ELECTRIC LIGHT—These wonderful Dynamos light brilliantly 4-6v. lamps and are very easy to work. 1925/4 new "De Luxe" model, 5/8, most 6/1. (Reduced from 7/6) GREENS Dept. E.H.1, 65, Long Acre, W.C.2





## The First Low-Loss H.F. Transformer

This H.F. Transformer (patent applied for) represents an entire departure from all other designs. In selectivity and amplification it is far ahead of the ordinary barrel type of Transformer. Its primary is aperiodic and its exclusive design and shape make it the last word in low-loss and efficiency. The secondary is air spaced on a grooved ebonite former, and each one is made to an exact standard, resulting in the condenser scale reading being practically identical in each successive stage of H.F. amplification. The main feature of this new Peto-Scott production is that the capacity coupling has been reduced to an absolute minimum resulting in an exceptional degree of selectivity.

- No. 1. 250 to 550 metres, with base 15/-
- No. 2. 350 to 700 metres, without base 15/-
- No. 3. 1,200 to 2,300 metres, without base 15/-

As chosen by Mr. P. W. Harris for the "Modern Wireless" Special Five



Send for 48 Page Catalogue

No backlash—no gear wheels but a delightful smooth vernier movement always

This new Peto-Scott de luxe is the ideal condenser—built by a man who knows how imperative it is to use a slow motion for all the plates and not to use a separate vernier plate. Its slow movement is obtained by means of a smooth 8 to 1 rubber friction gearing. Only solid ebonite is used—no cheap substitutes.

0003 mids. 18/8      0005 mids. 21/-

## Peto-Scott Co., Ltd.

HEAD OFFICE:

77, CITY RD., LONDON, E.C.1

Branches: LONDON, 62, High Holborn, W.C.1. WALTHAMSTOW, 230, Wood Street. PLYMOUTH, 4, Bank of England Place. LIVERPOOL, 4, Manchester Street. P.S. 3950

## Moisture and Dirt

### —a Radion panel checkmates these twin robbers of signal strength

**R**ADION is a unique panel material. Although it has a hard rubber base it is much more than ordinary ebonite. It was the first—and to our knowledge is still the only—panel material specifically produced for wireless use. Because it is made with a high percentage of rubber its insulation properties are exceptional, and owing to its unique formula it can be drilled, tapped and sawn without a suspicion of a crack. Indeed, Radion—in spite of its toughness—is the easiest material of all to work.

Just now experts are debating this serious question of low loss. When dealing with weak signals you cannot afford to take risks with your panel. Indeed the panel can be said to exert a greater influence over your set than any other part. Radion is recognised as being the highest grade of panel in the world. Moisture and dirt are the twin thieves of signal strength. Use a Radion panel and you checkmate their activities. Its superb mirror-like surface repels dirt and is impervious to moisture. Ask your Dealer to show you a Radion panel. Instantly you will appreciate why technical journalists specify it so frequently in their sets.

DIALS  
KNOBS  
HORNS

Black and Mahoganite  
in twenty-five sizes

VALVE-  
HOLDERS  
PANELS

TRADE MARK

# RADION



INTERVALVE

# TRANSFORMER

TYPE AF3

British Made

Transformer Amplification Curves are of great interest to every Radio user.

The Curves must be on the Musical Scale to give the true value.

Curves on a Frequency Scale, of which equal lengths represent equal differences of frequency, are misleading.

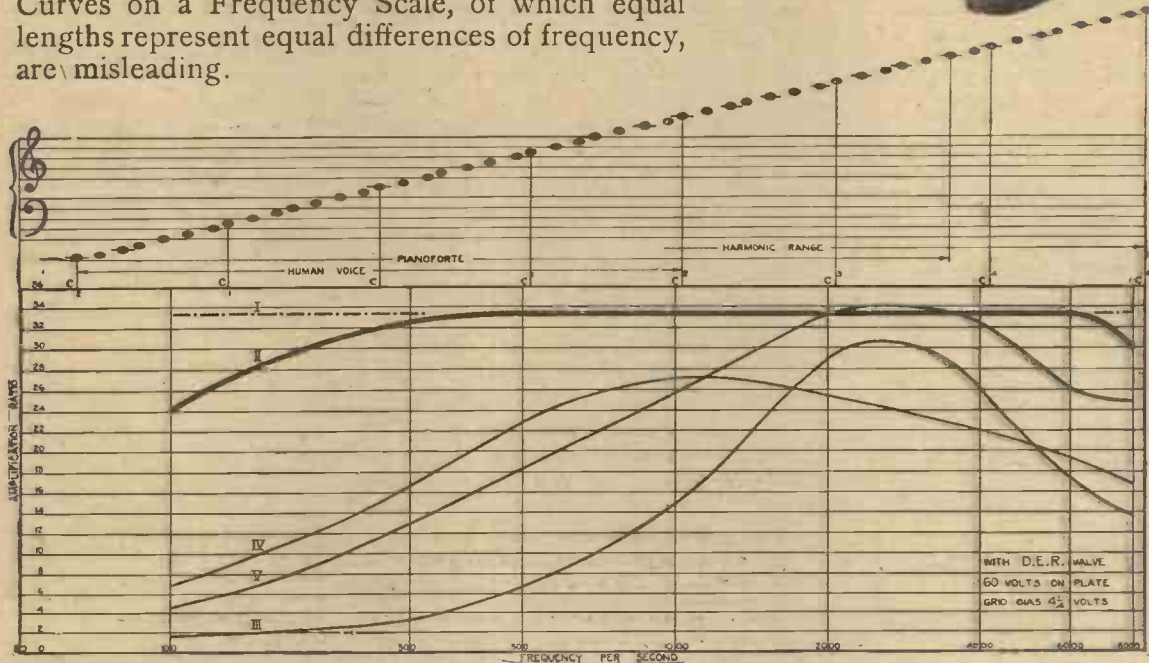

I. Perfection.

II. **FERRANTI AF3, VERY NEARLY PERFECT**

**25/-**

**NO BETTER TRANSFORMER IS AVAILABLE AT ANY PRICE**

- |               |  |
|---------------|--|
| III. 16s. 6d. | } Curves and Prices of other Transformers on the Market. |
| IV. 25s. od.  |  |
| V. 24s. od.   |  |

*If you have any difficulty in buying, send to us the name of your dealer and P.O. 25/-, and we will despatch a Transformer by return. In any case, write to us for leaflet W4401*

**FERRANTI LIMITED, HOLLINWOOD, LANCASHIRE**



## Where the Listener Scores

By

CAPTAIN A. G. D. WEST,  
M.A., B.Sc.

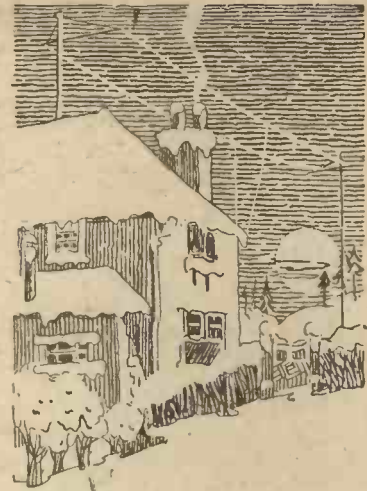

**I**N aiming at perfect broadcasting, which means perfection in the whole chain throughout from the microphone in the studio or hall to the loud-speaker or head telephones at the receiving end, the B.B.C. is trying to give listeners an opportunity of hearing concerts and speakers exactly as if they were situated in the position of the microphone. That is to say, in most cases, if receiving sets were designed to be practically distortionless and quite faithful in reproduction, the results should be exactly as though the listener himself were placed exactly where the microphone is, thus having the opportunity of enjoying the programmes in a privileged manner. In the other cases the listener is even better off, because steps are taken sometimes to improve even on what the microphone itself alone would pick up.

To go into this in further detail, I will mention a few examples.

### After-Dinner Speeches

The first case to which I refer is when certain speeches are broadcast from a dinner. If the listener himself were at the dinner, he might be one of the privileged few sitting at the head table or fairly close to the speakers taking part. But this privilege is confined to only a few, and the others who are present at the dinner often have difficulty in hearing what the speakers say on account of the general noises in the hall and the clatter of dishes and the clinking of glasses; half of them usually have to occupy a strained position in turning round to watch the speaker and straining their ears so as not to miss any of his words. On the other hand, the microphones present at the dinner are placed in very close proximity to the speaker. The listener in his home at Balhair, or in his cottage in the north of Scotland, can sit in his armchair

in front of the fire with phones on or listening to his loud-speaker, and thus hear the speech with just as much effect as if he were actually a few feet away from the speaker at the banquet itself.

What an advantage it is to the listener to hear speeches in this manner! The broadcast engineer, wherever he goes, takes his microphones and places them in a privileged position, and thus brings the nation of listeners into the closest possible contact with events of this nature that may be taking place.

### Two Striking Examples

It has often been brought to my notice how striking this result may be. For instance, when broadcasting a military service from York Minster several months ago it was remarked that, although the preacher's sermon could not be understood at a distance of more

than about twenty feet from the pulpit, every word was heard in detail by those who cared to listen in to the broadcasting of this event. Knowing the bad acoustics of this cathedral as far as listening to sermons is concerned, a local enthusiast even installed a receiver and loud-speaker in one of the smaller York churches, and by picking up Daventry on his set gave to the congregation of that church a much clearer conception of the military service than if they had been in the cathedral itself. In fact, they had heard better at a distance of two hundred miles (via Daventry) than if they had been actually inside the cathedral.

Another similar thing happened when a resident in Canterbury said he had been living in Canterbury for forty years, and had attended cathedral services, and had never heard a sermon so clearly as when he listened in to the Archbishop's



The Author and Canon Larken at Crowland Abbey on the occasion when the famous bells were broadcast.

address from the pulpit. This aspect of broadcasting has perhaps not been so much appreciated as it should have been.

**Unsatisfactory Acoustic Properties of Halls**

Now, turning to another view of this matter, there have been cases

ratus capable of giving faithful quality, a musical performance so well balanced and so acoustically perfect that he will in every case listen to it with pleasure.

**Some Acoustic Effects Desirable**

It is well known, and it has been more or less proved by practical

most desirable and the most pleasant result.

**Pure Echo**

Considering the latter first, this effect depends entirely upon the construction of the halls or studios where the transmission takes place. The effect has two distinct forms. First of all pure echo, that is to say, every sound is heard by anybody in the room where the transmission is taking place first of all direct, and, secondly, by a direct reflection from one or more of the walls. This rarely occurs to an objectionable extent in halls in general use, because to be really serious and distinct the reflecting surfaces require to be large and flat, and usually the decorations in the halls do not satisfy this condition.

**Reverberation**

The second effect is that which is called reverberation, and this is due to a general mingling together of the sound, as it is reflected from all the various walls in large or small proportions, the result being that any definite impulse of sound is heard followed by a prolongation of sound.

Music in a perfectly dead room and music in a hall where reverberation is large can be compared respectively with piano playing without and with the loud pedal on. It is, of course, obvious that no

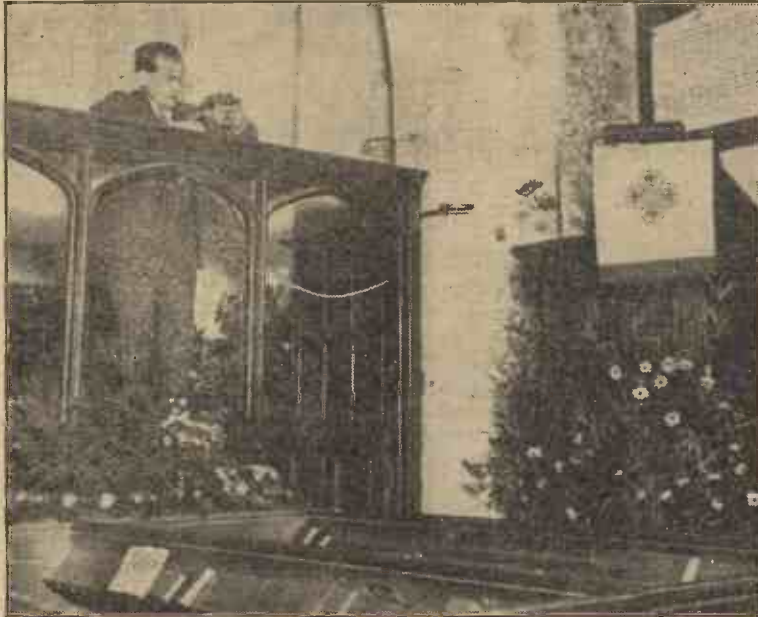

With the microphone so close to the pulpit, not a word of the sermon is missed by the home listener.

when certain concerts have not been musically satisfactory to members of the audience in certain parts of the concert hall or the theatre, on account of the unsatisfactory acoustical properties of these places. For instance, the hall itself may be very echoey, or the concert-goer, in buying his ticket at the last moment, may find that the only seats left are those near the drums or double basses. In these cases, if the concert is being broadcast, and the broadcast engineer has an opportunity at rehearsals of finding the best places to put his microphones, the late concert goer would be much more happy musically if he went home, and tuned in on his receiving set, provided that the latter were capable of giving good reproduction.

**A Balanced Performance**

The problem of transmitting satisfactorily musical concerts from halls or theatre transmissions is continuously being attacked by the broadcast engineer. In time, perfection (according to our present ideas, at any rate) should be obtained in every transmission of this type. The aim is to give every listener, if he provides himself with a receiver and reproducing appa-

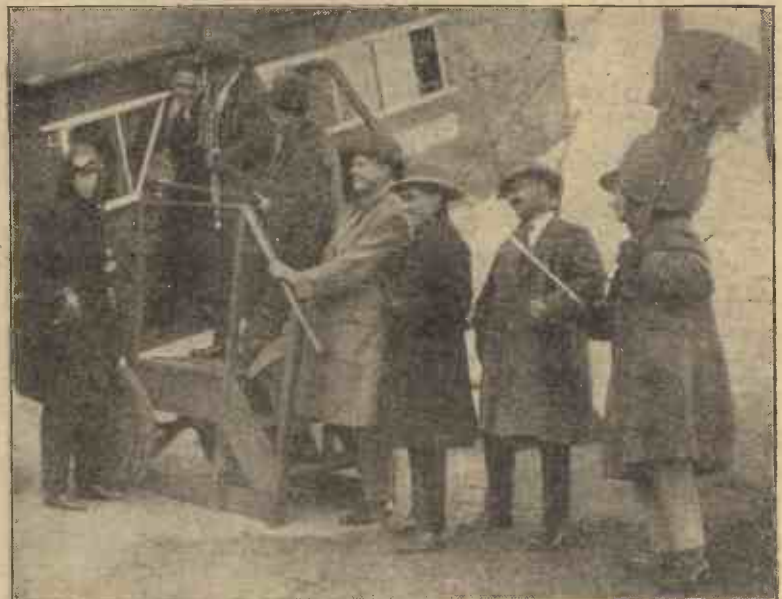

Serious problems in acoustics arise when an orchestra broadcasts in a confined space, such as the cabin of an aeroplane.

tests, in which well-known musicians have taken part, that for any given type of musical transmission, there is a certain very definite amount of acoustic effect required to give the

direct echoes are necessary, in fact, they must be avoided.

**The Type of Music**

As regards reverberation, it has been found, as mentioned before,

# KING IN RADIO

## King Components Are Carefully Made

THE success of radio reception depends largely upon the quality of the components—if one is faulty, the whole receiver is at fault.

“King in Radio” Components are made with the utmost care from the very best materials obtainable. The designs are the best—when the best is made by some other manufacturer, as in the case of Cardwell Condensers, we manufacture it under licence from the original manufacturer.

All the facilities of an eight-acre plant equipped with the most modern machines for the making of radio components help to maintain the “King in Radio” high quality standards. Each component goes through a thorough system of inspection before it leaves the plant.

## KING QUALITY PRODUCTS INC.

EUROPEAN BRANCH:

27-28, Anning Street, London, E.C.2  
ENGLAND

GASTON E. MARBAIX, *Manager.*



King-Cardwell Condensers manufactured under licence from the A. D. Cardwell Manufacturing Corporation



Dials in black bakelite



Single hole mounting rheostat



Inductance and “B” battery control switch



Single hole mounting potentiometer







that a certain definite value of this reverberation is desirable in all music, the amount of the effect depending entirely on the type of

There is no scientific criterion in either case. The decision rests with the general conception and feeling as expressed by artistic taste.

*The Low-Loss  
Reinartz Set*

SIR,—So far, I have seen no comments from readers on the low-loss Reinartz one-valve set described by G. P. Kendall, B.Sc., in the September WIRELESS CONSTRUCTOR. It looked so simple in construction that I made it the subject of my first essay in the making of a set—in fact, it is the only valve set I have worked with, which confirms how much of a novice I am—and I thought you would be interested in the results achieved. First of all, on a fairly good aerial, 30 miles from London, it gives excellent tone to a fair-sized loud-speaker, using 78 volts H.T., and 2L.O comes through splendidly. On the phones one evening I had Hamburg, Rome, Toulouse, Paris, and, with the loading coil, of course, Daventry and Radio-Paris, these latter stations being particularly easy to separate.

Strangely enough, I have not received any other B.B.C. stations, but I hope to be more successful when I have had more opportunity of studying Mr. Kendall's article in the October CONSTRUCTOR, and have become more accustomed to the tuning of a valve set.

I must congratulate Mr. Kendall on the design of a simple set, which to me seems ideal for the beginner.

Yours faithfully,  
GEO. W. BAKER.  
Chelmsford.

**Progress in Technique**

There is a good deal to learn in all this, but I feel sure that in time the whole problem will be solved,



The microphone used at the foot-lights at the Barnes Theatre.

and the ideal at which broadcast engineers are aiming will be fulfilled, and that full satisfaction and pleasure will be obtained from every musical transmission. Technique is so far developed in this way that there should be no doubt that the broadcast listener will have a very great advantage, from a musical point of view, over the concert-goer, and it is this point of view that I have tried to bring forward, that even now in many cases the listener is at a greater advantage in this respect and will be increasingly so as broadcast technique progresses.



When "Tess of the D'Urbervilles" was broadcast from the Barnes Theatre, one microphone was placed in the fireplace on the stage.

music that is under consideration. I strongly believe that if every musical transmission can be broadcast with just the right amount of effect in every case listeners will be inclined to keep listening to transmissions of a type that they did not previously enjoy.

**A Comparison**

Music in this respect can be compared with painting. The dull painting where colours are not artistically blended does not appeal to the eye, neither will people look a second time at some of the uncouth masses of brilliant colour which characterize certain of the posters we see in the streets. The two cases are similar to music from the heavily draped studio and the very echoey hall; but people do look again at that combination of light and shade or of colours which has just that right balance that is particularly pleasant to the eye, and which represents a good picture. This corresponds to the acoustically perfect musical transmission.



Waiting for Father Xmas! These tiny tots while away the time by listening-in.

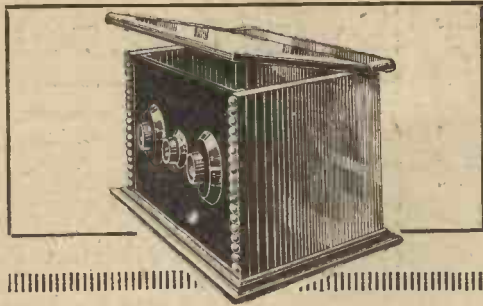

## The Artcraft Cabinet for Radio Receivers

Sizes of "Artcraft Popular Type" Cabinets		
Panel Size	Depth	Price in
		Oak Mahog.
9 x 6 x 6		8/0 8/0
10 x 8 x 6		8/0 10/0
10 1/2 x 8 x 6		8/6 10/6
10 x 9 x 7		10/0 12/0
12 x 10 x 8		12/0 14/0
13 x 6 x 7		10/0 12/0
14 x 10 x 8		14/0 17/0
16 x 8 x 8		14/0 17/0
16 x 10 x 8		16/0 19/0
18 x 12 x 9		21/0 27/0

Prices include packing, carriage and insurance to any station in England and Wales. Prompt delivery guaranteed.

ARTCRAFT Cabinets are made in either light or dark Oak or Mahogany, and are of very attractive and pleasing design.

Baseboards are included with all sizes.

Cabinets can be supplied for all sets described in Radio Press publications. If the special design you want is not listed we will quote price and deliver seven days after receipt of order.

Write for Illustrated Brochure of Standard "Artcraft" Cabinets

THE ARTCRAFT COMPANY, 156, CHERRY ORCHARD RD., CROYDON. Phone: Croydon 1981



### ANTI-PHONIC ANTI-CAPACITY VALVE HOLDER

Body of Genuine BAKELITE reduced to a shell, ensures highest insulation and lowest ca. ac. ty.

1. One-piece silver-plated phosphor-bronze contact that "FILES" the valve pins—ensuring perfect contact.
2. Air spacing and special design of contacts make "FILE-GRIP" positively the lowest capacity—and therefore the most efficient Valve Holder that you can buy.
3. Special terminals, tightened with screw-driver, force the wire into ACTUAL CONTACT with the spring (an exclusive TONEX feature) which can be used along with the handy soldering lug that holds the wire for soldering. No more bruised and burnt fingers. See Figs. 2 and 3.

Non-Microphonic, the springs insulate the valve from all troublesome vibration—ensuring purer tone. Valve cannot be damaged by wrong insertion. Two types I Base-board and Panel Mounting, supplied complete with mounting screws and fully guaranteed against all defects. All good dealers sell them! If yours is without, send his name along with your remittance of 2/9 each postpaid. But for RESULTS, take see that you get "FILE-GRIP". Send for folder "Why FILE-GRIP is better." A post-card will do.

THE TONEX CO., TONEX WORKS, BLACKPOOL, N.

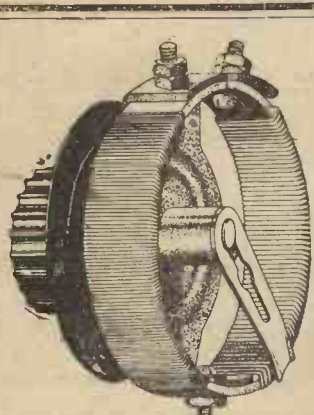
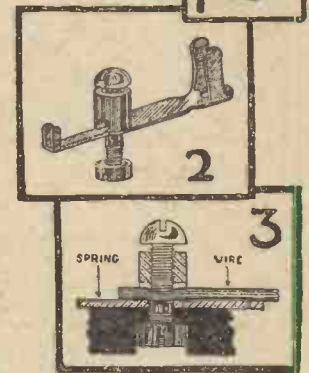

## Two in One!

The new Dual Rheostat—a "Peerless" product in every way. Specially designed to meet the demand for a resistance equally applicable to bright or dull emitters. It has two windings—one offering a resistance of 6 ohms, whilst a continuation of this is of 30 ohms resistance. The resistance element is wound on a hand fibre strip under great tension. One hole fixing is provided, and the terminals are placed in convenient positions. The contact arm has a smooth, silky action, and all metal parts are nickel-plated.

3/9 Retail PEERLESS 3/9 Retail  
DUAL RHEOSTAT

Send now for full details

The Bedford Electrical and Radio Co., Ltd.  
22, CAMPBELL ROAD - - - - - BEDFORD

May we send you also details concerning our new "Resicon" Condensers? Precision Instruments—made to an ideal

THREE WAY JOINT

FOUR WAY JOINT

THREE WAY ANGLE

THREE WAY TERMINAL CONNECTOR

ONE WAY TERMINAL CONNECTOR

Make your Circuit Joints neat & efficient WITH J.E.G. SOLCLIPS REGD. DESIGN 714545-6 PRO. PAT. NO 25976 & 13295. WIRING CONNECTORS

Both Amateur and Professional will find "Solclips" exceedingly useful in the construction of wireless sets. The simplicity and ease with which joints are rendered neat and effective without the possibility of fracture, give absolute assurance of electrical continuity and perfect reception.

Samples free on request 1/- per box of 18 either type

Includes solder pellets, flux and instructions. Can be used for either 1, 2, 3 or 4 perfect joints, any angle required, without bending wire, which may be either square or round.

DALE FORTY & CO. LTD. BIRMINGHAM  
Selling Agents: COOKE & WHITFIELD WIRELESS, LTD. St. Pauls Square, BIRMINGHAM

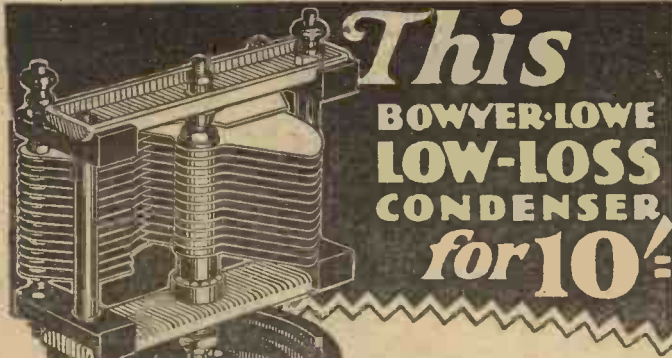

**This**  
**BOWYER-LOWE**  
**LOW-LOSS**  
**CONDENSER**  
**for 10/-**

It is an instrument of real precision. Its ball-bearing spindle gives smoothness of control and makes fine tuning a joy. Its low-loss design gives electrical efficiency and unusually great wavelength range. Its compensated square law ensures the availability of the whole dial for tuning. Test this instrument. Its quality will surprise you. Remember that the reputation of The Bowyer-Lowe Company is behind it and that it is guaranteed up to the hilt for twelve months. Build this condenser into your sets. At a price you can afford it gives you precision tuning, with all that that means in signal strength, purity and range. Order from your dealer. Descriptive leaflet free on application to Bowyer-Lowe Co., Ltd., Letchworth. See also Advt. on page 278.

•0003 M.F.  
**10/-**  
 •0005 M.F.  
**10/6**

**The Bowyer-Lowe**  
**'POPULAR' CONDENSER**  
**BALL BEARING-LOW LOSS-SQUARE LAW**  
 Bowyer-Lowe Co. Ltd. Letchworth



FOR  
**PERFECTION OF RECEPTION!**

The importance of employing the best battery to achieve the best radio results is appreciated by amateur and expert alike—

You know this—therefore, to avoid expense and disappointment, cut out experiments—equip your set with a PETO & RADFORD Battery and be safe

**PETO & RADFORD**

**BULL DOG BATTERIES IN "DAGENITE"**

**PETO & RADFORD**

Are recognised by experts to be "the best that Britain produces"

Highest in efficiency and economy and therefore the very best you can obtain.

Proprietors:

Pritchett & Gold and E.P.S. Co. Ltd.

Ask your Dealer for details.

50, Grosvenor Gardens, Victoria, London, S.W.1

*"fits like a grid-leak"*

Capacities can be changed in 33 seconds while the set is functioning.

THE  
**"K" TUBULAR**  
**FIXED CONDENSER**

fits to the panel in clips, and you slip it in or out like a cartridge in a gun. No tools—the work of a moment. Capacities are accurate.

Send at once for our New Illustrated Free Catalogue giving particulars of this and many other of our Specialities.

**WYATES**  
 BROS., LIMITED

Head Office: 13-15, Queen Street, Kingsway, W.C.2  
 Phone: GERRARD 575-578  
 Grams: "ZYWATESENG" Westcott  
 Works: LONDON and BIRMINGHAM

PRICES

•0002 •0003 •0005  
 1/9 each  
 •001 •002 •003  
 2/- each  
 •006.. 2/6 each



Britain's Best in Rad.o

THE LAMPLUGH PATENTED  
**MICROMETER**  
**DETECTOR**

Adjustment to 100,000th part of an inch made with ease. Enables you to retain the very loud signals momentarily obtained when approaching a ca-whisker on a crystal

**RADIO**  
**LAMPLUGH**  
**PRODUCTS**

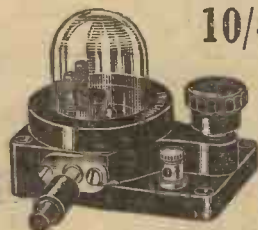

Price complete.

**10/-**

If your dealer cannot supply—we can.

**S. A. LAMPLUGH LTD**  
 Kings Road, Tyseley  
**BIRMINGHAM**

**SPECIALISTS IN**

**SUPER HETERODYNE**

British and American Components and Kits  
**VAST STOCKS. 24 HOUR SERVICE**

The very nature of the Supersonic Heterodyne circuit demands  
**SKILLED ASSISTANCE BY EXPERTS**  
 for successful results, and we place our resources at your disposal.

**THE BRIGHTON RADIO STORES,**  
 163, Western Road, BRIGHTON

**CABINETS CAMCO CABINETS**

Free

Write at once



For our illustrated list, contains 100 VARIETIES, including many of the latest circuits described in WIRELESS CONSTRUCTOR, MODERN WIRELESS, etc., etc.

**THERE IS A CAMCO CABINET FOR EVERY CIRCUIT**

TRADE ENQUIRIES ESPECIALLY INVITED.

**THE CARRINGTON MANUFACTURING CO., LTD.**  
 18/20, Normans Buildings, Central Street, London, E.C.1

Telephone: Clerkenwell 6903

# "CROIX"

The world's greatest  
**TRANSFORMERS**  
over 500,000 in use



one year's guarantee

RATIO  $\frac{5}{1}$

9/-

RATIO  $\frac{3}{1}$

9/-

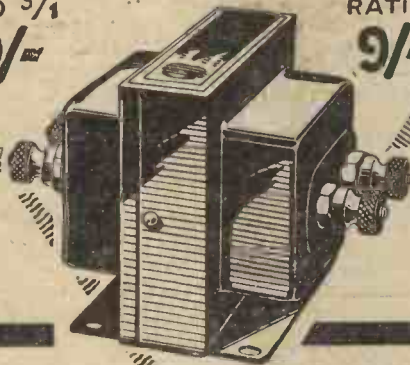

*an opinion.*

33, Church Street  
Rotherham  
Nov. 5th, 1925

The Wholesale Wireless Co.  
Dear Sirs,

I have been very busy experimenting in the various methods of wireless reception for some years, long before broadcasting commenced, and claim to have accomplished what few have, and that is to design and construct a five-valve H.F. Amplifier and to successfully operate it over a period of eighteen months, without the aid of any stabilising apparatus whatever, no potentiometer or grid bias, and not a single fixed condenser in the set, except the grid condenser before the 5th valve, the detector. No reaction, and American stations as clear and plain as British.

*I had one of your Croix Transformers brought to me to try out. I gave it a thorough trial and kept it, and honestly say it is quite as efficient as any I have, and some of them cost me eight times the price of the "Croix." Nuff said.*

Yours faithfully,  
Alfred France.

### WARNING—"Croix" Transformers

This is to give notice that genuine "Croix" Transformers will in future be bound in white boxes, with the Trade Mark "Croix" stamped in black and gold on each end, and will be numbered individually. No other Transformers are genuine or are guaranteed by us, and the Trade and Public are warned against them.

SOLE DISTRIBUTORS, United Kingdom:

**THE WHOLESALE WIRELESS CO.**

103, FARRINGTON ROAD, LONDON, E.C.

Colonies and Dominions:

**A. VANDAM,** CAXTON HOUSE,  
WESTMINSTER, LONDON, S.W.

## THE SEAMARK CONNODE



19/6

## THE SEAMARK CONNODE

IS A

## STRAIGHT LINE

Wavelength Tuning Device specially designed to simplify set construction.

That all the possible losses are

## REDUCED TO A MINIMUM

is clearly proved by the fact that, using the simple circuit shewn below, with plug-in coils, composed of 10 and 20 turns wound round a  $1\frac{1}{2}$ " former for aerial and reaction, wavelengths as low as

## 45 METRES

can be received with great ease.

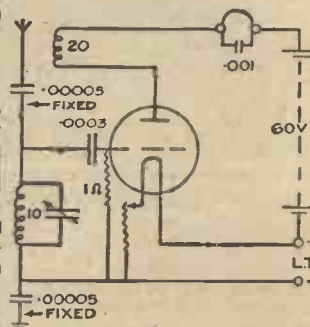

Radio station 2GN reports "Signals from the famous amateur 2NM of London successfully received on 45 metres using CONNODE."

**IT WILL IMPROVE ANY SET**

Sole Patentees and Manufacturers—

**C. E. NEEDHAM & BRO., LTD.**

10, MILK STREET, SHEFFIELD



**NICKELLED BRACKETS**  
4" x 1 1/2", 1/3 pair

**HIGH & LOW READING VOLT METER**  
0-6, 0-100 Volts.  
Current consumption only '03 amp.  
ALL BRITISH, 13/9

**CABINET, COVERED IN BROWN GRAINED "REXINE,"** complete with loose mounting board, overall size 16 1/2" x 9" x 8 1/2", panel size 16" x 8", price 12/6. Overall size 12 1/2" x 9" x 8 1/2", panel size 12" x 8", price 8/9.





**"H.T." & "L.T." BATTERY CORD** complete with connectors, strong and well insulated. Fixed in a moment. Price 2/9.

**ECONOMIC ELECTRIC, LTD.** Head Office: 10, FITZROY SQUARE, LONDON, W.1 Showrooms: 303, EUSTON ROAD, N.W.1

# The CYLDON VARIABLE CONDENSER

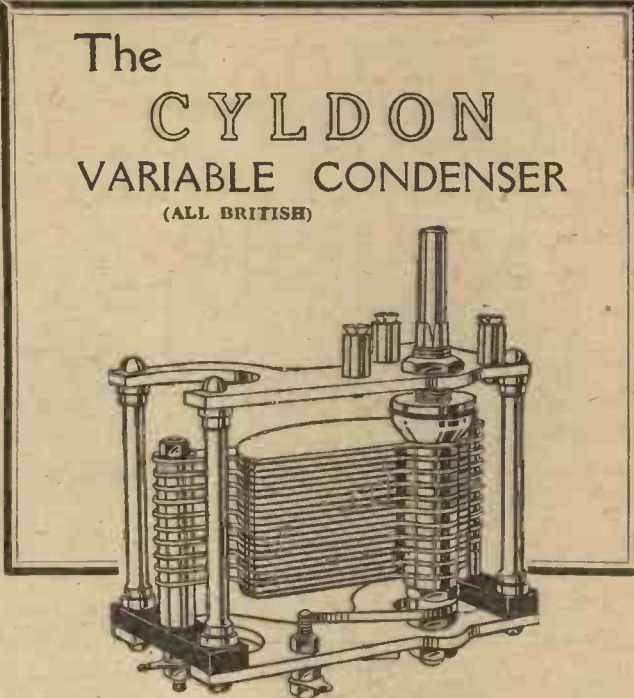
(ALL BRITISH)



— a sound engineering job electrically and mechanically perfect

**THE** Cyldon Variable Condenser is a triumphant combination of electrical engineering and mechanical ingenuity.

Electrically, it is efficient in every feature; each a point of superiority essential to easy, sharp tuning and clear reception.

Mechanically, it is ingenious in correcting the faults in construction of other condensers besides embodying distinct improvements of its own.

Conforming to modern practical design and scientifically low loss in construction, the Cyldon represents a high standard in Radio condenser efficiency, and stands pre-eminent in finish and performance.

## 6 points of Cyldon superiority

(Incorporated in Standard Models.)

- (1) The product of life-long experience of electrical and mechanical experts.
- (2) A positive compact instrument absolutely noiseless in operation. No backlash.
- (3) Rugged compact construction. One hole fixing. Extended side rod prevents condenser being bodily rotated when fixed to panel.
- (4) Rotor shaft can be adjusted to any tension desired without altering position of vanes, thus ensuring suitable movement.
- (5) Takes geared or vernier dials without alteration.
- (6) Watchspring pigtail connection throughout, from rotor and vernier plate to main terminals, therefore no rubbing contacts.

### The "CYLDON" Grounded Rotor SQUARE LAW MODEL

(As Illustrated.)

1/2-inch Plain Spindle, Radion Insulation Strips, Watchspring Pigtail, 3 screw panel fixing, with drilling template, and 4 inch diameter American pattern Knob and Dial.

Capacity s. d.	Capacity s. d.
'0005...17 6 each	'00025...16 0 each
'0003...16 6 ..	'0002 ...15 6 ..

With Vernier Control for extra fine tuning. 3/6 extra on prices quoted.

From all Dealers or direct, post free.

**SYDNEY S. BIRD**  
"CYLDON" WORKS  
SARNESFIELD RD., ENFIELD TOWN, MIDDLESEX

**CYLDON**  
VARIABLE CONDENSERS  
Guaranteed for 12 months

# "TANGENT" The Better Coil!



You would wish—as we all would wish—to make radio reception as perfect as possible. Every separate part of your set goes to making it so. Every separate part, then, needs thought in purchase. The coil you use is not the least important of these parts.

**For Efficiency, Stability and Soundness, "TANGENT," the Better Coil, has no equal.**

Made to fit all standard coil holders. See "TANGENT," the better coil, now.

*All good houses sell Tangent fitments*

**RADIO TANGENT FITMENTS GENT & CO. LTD. Established 1872**

**Tangent Tuning Coils ensure:—**  
Self capacity reduced to a minimum.  
High-frequency resistance extremely low.  
No dead-end effects  
Sharp tuning.  
No distortion at any frequency.  
Substantial and robust construction

Ask for Leaflet W.C. free on request.

**GENT & CO., LTD., Faraday Works, Leicester**

# Sangamo



## The New Fixed Condenser is accurate - stays accurate

FIXED condensers are important units in a radio receiver and should be carefully chosen for **sustained accuracy**. In reflex and other circuits where capacity is a critical factor, accuracy in the fixed condenser may make the great difference between a set that performs perfectly and one that is uncertain as the weather.

Sangamo Fixed Mica Condensers are guaranteed to be accurate under all temperature and humidity conditions. Neither the intense heat of soldering nor the rain-soaked atmosphere will impair their accuracy. Even at the seashore, where the salt air creeps in to change the capacity of exposed condensers, the accuracy of the Sangamo is not affected in the least.

Moulded in smooth brown bakelite, the Sangamo Fixed Condenser is most pleasing in appearance.

Sangamo Condensers are made in all standard capacities, and are supplied with or without grid leak clips.

### SPECIAL WHOLESALE DISTRIBUTORS

- R. A. Rothermel, Ltd., 24 & 26, Maddox St., Regent St., W.1  
 Electrical Installation & Repairing Co., 40, Berry St., Belfast.  
 Priestly & Ford - - - 3, Carrs Lane, Birmingham  
 The Carfax Company, Ltd. - 312, Deansgate, Manchester  
 Lowke & Sons, Ltd., Electrical & General Engineers,  
 Northampton.  
 Mr. W. J. Pulford - - - 109, Kingsway, London, W.C.2  
 Keith & Irwin - - - 35, Robertson Street, Glasgow, C.2  
 Fred Burris & Sons - - 7-11, Redcliffe Street, Bristol  
 J. W. Carr & Co., Ltd. - 35, Queen Victoria Street, E.C.4  
 Lincoln Smethurst - 17, Hanover Buildings, Southampton

### PRICES:

0.0001-0.0009 mfd. ... .. 2/6  
 0.001 -0.009 mfd. ... .. 3/-



THE BRITISH SANGAMO Co., Ltd.  
 Ponders End, Middlesex.

WE SPECIALISE IN  
**SETS OF PARTS**  
 AND  
**PARTS FOR SETS**  
 WE SUPPLY  
**EVERYTHING WIRELESS**

with Quick Service and  
 Guaranteed Satisfaction

We Want Your Custom and Your Recommendation  
 While your Local Dealer is thinking where to  
 get your Supplies we despatch per return

### "OCTOPUS"

Our Trade Mark "OCTOPUS" is known all over the world



REGD. TRADE MARK  
 No. 458314.

WRITE FOR FREE LIST  
**RADIO "STOCKS"**

(B. HAINE, Proprietor)

NOW REMOVED TO LARGER PREMISES AT  
**14, Rathbone Place, W.1**  
**LONDON**  
 Phone: MUSEUM 3205.

### IMPORTANT NOTICE

THE MAXEL WANDER-PLUG TERMINAL IS NOW ON SALE  
 This is a fitting that should be on every set and battery  
 where a quick change of connections is desirable

NON-CORROSIVE  
 Trade enquiries invited

Extract from "Popular Wireless," April 25th, 1922  
 The tops of the terminals, which can be used in the ordinary manner if desired, form sockets into which standard wander plugs can be inserted similarly to an H.T. battery. This is an improvement which is decidedly a brain-wave, and one of those obvious little things which are overlooked until some genius brings it to light and then everybody wonders why everybody did not think of it.



PROV. PAT.  
 4<sup>D</sup>. POST EACH FREE

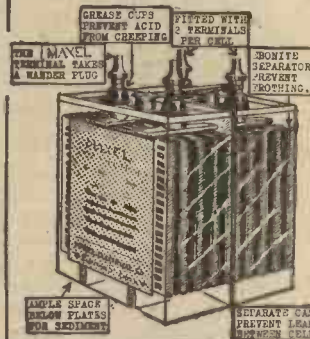

## The New MAXEL Accumulator

Specially designed for Wireless  
 GUARANTEED TWELVE MONTHS.  
 If you live too far away to call and see the Battery Mail your Order to us for the size you want. We will willingly return your money if you are disappointed.  
 Now fitted with NON-CORROSIVE Wander Plug Terminal

	AMPS.			
	4	6	8	110
2 VOLT ..	7/6	9/6	11/0	14/6
4 VOLT ..	15/-	19/-	22/6	26/6
6 VOLT ..	22/6	27/9	33/6	39/-

Packing 1 extra per battery

H. T. BATTERIES 60 VOLT - POST 7/6 FREE

## What Maxel users say!

Maxel Electrical Co. Belfast, 5/9/25  
 Dear Sirs,  
 I am not in the habit of writing firms in praise of their products but your accumulator and battery which I have received urge me to do so.  
 I only wish to say that you, the Maxel Electrical Co. live up to every point you advertise. It is one thing to look at the advertisement of your accumulator and quite another to look at the article itself, and above all use it. It is then that one can appreciate all the smart points of the Maxel, and realise just what an accumulator should be.  
 I shall recommend them to anyone I know who is wanting a battery. Yours etc.,  
 R. A. B.

**MAXEL ELECTRICAL CO.** 28, Clipstone Street, Great Portland Street, W.1  
 Telephone: MUSEUM 708.

## GET A "LOWFORMA"

The most convenient and efficient low loss coil former obtainable.  
AN IDEAL PRESENT for anyone interested in Wireless.

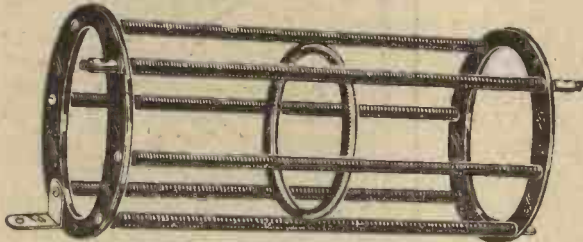

Prices: 3 1/4" diameter x 5" long, 4/9, 6" long, 5/-, 7" long, 5/6.  
Order from your dealer. If unobtainable send to the Makers:  
A. H. CLACKSON, Ltd., Dept. C, 119, Fleet Street, London, E.C.4

## YOURS FOR 20/-



Send 20/- to-day, together with your order for the "Tonyphone," and this wonderful set, which receives all B.B.C. Stations, will be sent on approval, complete with all accessories. You pay a further £1 each month, or 5/- each week until completed.

### 'Tonyphone' Super Two-Valve Set

Complete with Accumulator, H.T. Battery, Aerial, one pair of 4,000 ohms Headphones and two Valves—one High Frequency and one Detector. All Royalties paid

Send to-day and enjoy broadcasting NOW. Illustrated Price List free on application  
**BRITISH ENGINEERING PRODUCTS CO.**  
(Battery Dept.), Abbey House, Victoria Street, London, S.W.1

S.S.A.

## A Micrometer-like Variation of Resistance

from zero to 100 ohms is obtainable from the Wates

## MICROSTAT Filament Resistance

Silky Silent Action. One-Hole Fast-Lock Fixing. Minute Under-Panel Space. No Soldering. Packing Impossible. Suitable for Bright or Dull Emitter Valves. PRICE

# 2/9

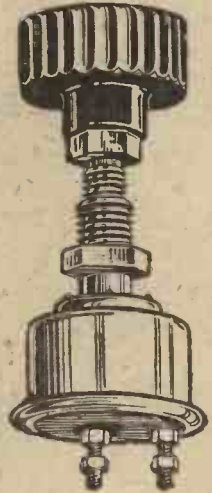

Send at once for our New Illustrated Free Catalogue, giving particulars of this and many other of our specialities.

## WATES BROS., LIMITED

Head Office: 13/14, Great Queen Street, Kingsway, W.C.2  
Phone: Gerrard 575/576. Grams: "Zywtaweseng, Westcent."  
Works: LONDON and BIRMINGHAM

THE WORLD'S  
SIMPLEST PATENT  
FLEX CONNECTION



6<sup>D</sup>.  
EACH

NICKEL PLATED INDICATING PLUGS & SOCKETS 1d. each extra



Ask for them of your Dealer or the Manufacturer:—  
**E. A. WOOD, ASTON RD, BIRMINGHAM**

## THE "SECURITY" VALVE HOLDER

(Prov. Pat. No. 2187/25).

**ANTI-CAPACITY**  
PROTECTS THE VALVE  
METAL DRILLING  
TEMPLATE Included.

PRICE  
**1/-**  
NETT

OBTAINABLE FROM ALL RETAILERS & FACTORS.

Advert. of Williams, Ellis & Co., London.



## Perfect Reception this Christmas

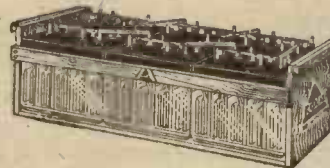

YOU do not know how good your set may be until you discard the dry battery and cut out faults due to irregularity, varying resistance, falling voltage and parasitic noises.

**RADIAX H.T. ACCUMULATORS** give you a perfect H.T. supply. Many months with one charge simply filled with acid and used right away.

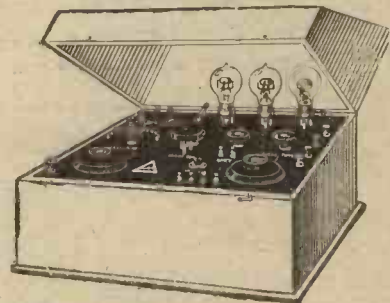

### BUILD OR BUY COMPLETED A RADIAX PROVED SET

Hundreds of continually arriving testimonials prove that Radiax Constructors' Sets are not only easily built but give their owners a wonderful range of reception. Ready built sets for those who don't want to bother. LIST FREE.

	Kit of Components	Panel Engraved & Drilled	Polished Mahogany Cabinet
No. P. 24	£ s. d.	£ s. d.	£ s. d.
'The Famous 9'	2 4 6	10 6	1 2 4
No. P. 28 sv. ..	3 9 0	13 6	1 7 6
No. P. 30, 4v. ..	4 17 6	17 6	1 10 0

If components and panel bought at one time, Royalty 12% per valve.

Send 3d. stamps for Radiax Catalogues covering Sets, Super Het. Kits, H.F. Couplings, Load Speakers, Condensers and all accessories.

## RADIAX, Ltd.

44, Radio House, 4, Percy Street, Tottenham Court Road, London, W.1  
Phone: Museum 400

# S. SMITH & SONS (M.A) LTD

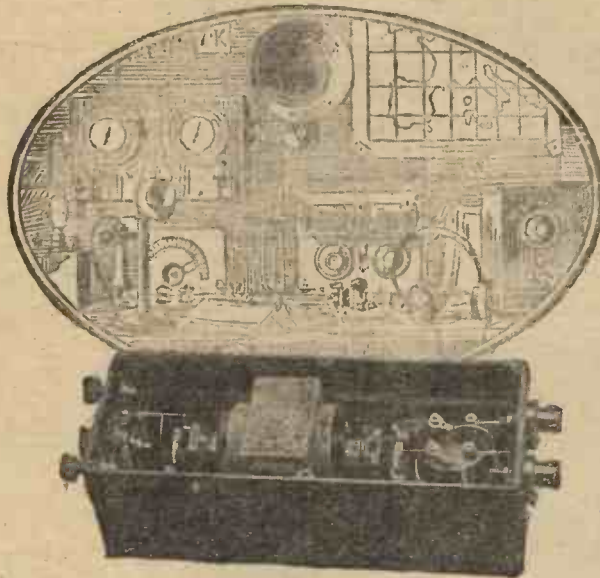

## The M-L anode converter

THE M-L anode converter dispenses with high tension batteries. Supplied from the usual 4 or 6-Volt Accumulator, it generates H.T. current of the order of 30 milliamps for Power Amplifying Valves. Mechanical noise and current ripple are entirely eliminated owing to special features of the design, and the Two Voltage Type incorporates L.T. Choke, double smoothing circuit and Variable Intermediate Voltage and full Variable Voltage Controls all in one case. It will supply up to 80 volts for Detector Valves and up to the full voltage of the machine for Power Amplification Valves.

Current consumption is extremely low owing to the high efficiency of the motor, and the M-L anode converter is a much cheaper source of H.T. current than any H.T. battery.

We shall be glad to send full particulars of all types of M-L anode converters on request.

### Two Voltage Types

Type BX (6-70/120 v. or 4-40/80 v.)... .. £12 15 0  
 Type CX (12-70/300 v.) ... .. £15 0 0

We also make Single Voltage Types.

Type D is specially designed for Transmitting purposes.



S. SMITH & SONS (M.A) LTD.  
 179-185 Great Portland Street, London, W.1

Telephone: Langham 2323

E.P.5410

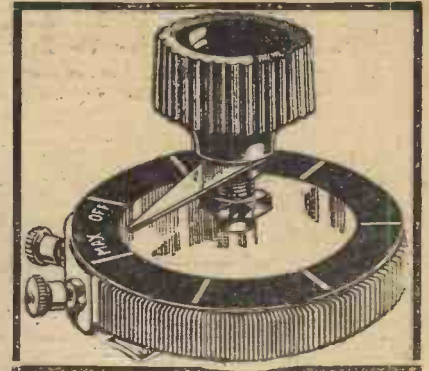

### FILAMENT RESISTANCES ON BAKELITE MOULDINGS

7 ohms	- - -	2/3
15 ohms	- - -	2/6
30 ohms	- - -	2/6

FINSTON MANUFACTURING CO., LTD.  
 45, Horseferry Road, London, S.W.  
 VICTORIA 1644

BRITISH MADE

TRADE DECKO MARK  
**RADIO KEYSWITCH**  
 EASILY FITTED PREVENTS INTERFERENCE, LOCKS SET OBTAINABLE FROM ALL THE BEST DEALERS  
 PRICE 2/9 EACH WITH ONE KEY IN CARTONS  
**A.F. BULGIN & CO**  
 9 11 CURSIOR ST., CHANCERY LANE LONDON.

**EBONITE BUSHES**  
 FOR MOUNTING ON WOOD. PERFECT INSULATION  
 Two required for each hole  
 Orders under 1/- send 1/4d.  
 NUMBER 1 2 3 4 5  
 Size of hole 4BA, 2BA, 1/4", 5/16", 3/8"  
 Prices each: 1d. 1d. 1 1/2d. 2d. 2d.  
**DAREX RADIO CO.**  
 Standard Works Forest Hill, S.E.23

**Increase Your Signal Strength**  
 by winding your own coil on the W.W. Coil Former, price 1/6, and get the most out of your set. Made in 3 sizes, 17 23 and 24 pegs per side, 2-in. core. All pegs pack inside the handle. Full instructions enclosed. From your Wireless Dealer, or post free 1/8, from W. WILKINSON & CO., Bedford Street Nth., Halifax (state size required).  
 Trade enquiries invited.

We supply sections cut to size for making cab.net. Immediately ready for assembling and polishing. Any type of cab.net can be supplied. 5nd for quotations. Satisfaction guaranteed. Prices reduced. Send for illustrated list. 12x10 sections 6/0, 9x8 sections 4/0, made up and polished. 8/6, 7/6.  
**F. & J. FLETCHER**  
 Ordish Timber Yard  
 Water Lane, HALIFAX  
 YORKS.

**Experimenters—Constructors**  
 Electric Soldering Sets; work from Wireless accumulators. No gas, fire or lamp needed, no tinning or cleaning. Packed in neat wooden box with solder and flux. Price 5/6. Money Back Guarantee. Write for catalogue.

Allan Ramsey, Parkhead, Sheffield



**F.W. LOWE & ADLERS**  
**TRELLEBORG**



**FAMOUS GENUINE**  
**EBONITE**  
**PANELS**



**MODEL "C"**

**THE HOME FOR YOUR WIRELESS SET**  
**THE FINEST VALUE FOR MONEY IN CABINETS ON THE MARKET**

**THE "MIRRI'S" STANDARD WIRELESS CABINET**, made on mass production lines, accommodates any kind of Receiver and Panel up to 30" x 18" with all accessories.

Solid oak throughout and perfect workmanship guaranteed (smaller size 26 lbs. net). No plywood used.

Satisfaction guaranteed or money refunded.

MODEL "A" 22" inside width	£7 5 0
" " " 25" " " "	£5 5 0
" " " 22" Jacobean panels	£5 10 0
" " " 25" " " "	£5 15 0
" " " 30" " " "	£8 15 0
" " " 22" Solid Mahogany	£7 5 0
" " " 30" Pine Wood	£2 10 0

Carriage paid and packed free England and Wales.

**MAKERIMPORT CO. (Dept. 2)**  
 Melville Chambers,  
 50a, Lord Street, LIVERPOOL

**ACCUMULATORS RE-CHARGED FREE**  
 IN YOUR OWN HOME  
**WITH THE "CHASEWAY" CHARGER**



An efficient apparatus which removes the re-charging bugbear. Accumulators charged without cost by using current lighting lamps and heating irons, kettles, radiators, etc. Any amateur can connect it to any DIRECT CURRENT supply. Once fixed requires no attention.

No. 1 MODEL for 110/250 volts .. Price 2/6  
 Special Models for Garages and Electrical Dealers for Service charging.

Write for particulars of **ALTERNATING CURRENT BATTERY CHARGERS.**

**A WONDERFUL VARIABLE GRID LEAK.**  
 The "Chaseway" Variable Grid Leak is the greatest advance yet made. Always reliable. Wonderful results. Simple one-hole fixing. Price 4/-. Extraordinary testimonials received. **ASK YOUR DEALER FOR ONE** or send your remittance direct if any difficulty. Illustrations of other Chaseway Specialities free on receipt of stamp.

Dept. C.  
 "CHASEWAY," 193, Archway Rd., London, N 6  
 Telephone: Mountview 691.

Price 25/- .. .. . Price 4/- each

**WRITE FOR**

**"SALIENT FEATURES"**

Our new 100-pp. ILLUSTRATED BOOKLET  
 (Price 6d. Credited against first purchase)

CONTAINS ARTICLES ON:

"Care and Maintenance of Valves," by the Mullard Radio Valve Co. "Hints and Tips," by "Pilgrim." How to wire up and connect panels. Tables and data, etc. Also specifications and prices for all popular Radio Press Sets, and full details of the unique "RADIO SUN" 5-Valve Receiver.

**"S. A. CUTTERS," LTD.**  
 18, BERNERS STREET, LONDON, W.1  
 Telephone .. .. . MUSEUM 6273



**TEST! MICA INSULATION UP TO 2,000 VOLTS**  
**"2 COMPLETE CONDENSER UP TO 1,000"**  
**"3 CAPACITY CHECKED**  
**"4 AFTER FINAL ASSEMBLY INSULATION UP TO 500"**  
**"5 FINAL CAPACITY TEST**

**PRICES:**  
 Capacities for Standard Grid Condensers '00005 to '0005 2/- each  
 Standard Fixed Condensers '002 to '001 2/6 each  
 '0025 to '006 3/6 each  
 Combined Grid Leak and Condenser 3/- each

**LEADS THE FIELD!**

THE Watmel Fixed Condenser is quite a new-comer to Radio, yet its standard of efficiency has already elevated it to a foremost position amongst products of its type. The Watmel is distinctly different from other fixed condensers. First, in its unusual design, which being symmetrical ensures an even distribution of electrical charges and the reduction of edge losses to a minimum. In its construction no wax whatever is used. Wax being subject to dielectric losses and temperature changes with consequent results of noises and changes in capacity, it will be readily appreciated that the absence of wax in the Watmel is a vital improvement.

Only the very best gauged ruby Mica is used for insulation, while the outer case is of high grade Bakelite.

Each condenser is individually tested and is guaranteed to be correct within 5 per cent. From all dealers.

**WatMel**



**Watmel Wireless Co. Ltd.**  
 33 'a, Goswell Road, London, E. C.1  
 Agent for Lancashire and Cheshire—  
 Mr J. B. Levee, 23, Hartley St., Levenshulme, Manch.

**"Touching RADIO CONDIT, what is the Low-Loss Law?" asks CLIXIE**



**"CLIXIE"**

Fingers to bend  
**CONDIT**  
 No Pliers, please!

"To avoid, as far as possible, all insulation other than air; and always to employ the practicable minimum of capacitive areas of metal; that is an important Low-Loss Law," says CLIXIE. "How does RADIO CONDIT answer these requirements?"

"CONDIT is made of copper tape which has two highly polished surfaces and is curled into the form of split tubing, equal in external diameter to 16' gauge wire. "CONDIT therefore provides double the conducting sectional area of wire—gauge for gauge. How's that for sensitivity?"

"CONDIT presents an external capacitive area of metal which is but half that of wire of equivalent surface area. How's that for selectivity?"

"Then profit by the Low-Loss Law. Make CONDIT your conductor and improve out of knowledge the performance of your set."

**RADIO CONDIT**  
 (P. Patl.)  
**The H.F. CONDUCTOR**

Per packet of six 2-ft. lengths .. .. . 2/-  
 Per coil of 12 ft. .. .. . 2/-

Obtainable from all Wireless Dealers or direct from the Patentees:

**AUTOVEYORS LTD., 84, Victoria St., LONDON, S.W.1**

# Get it at Day's

AND SAVE DELAYS

We have a full stock of all the latest productions, including the following:—

<b>H.T. ACCUMULATORS</b> Ediswan, 60-volt 2 10 0 " 100-volt 4 3 4 Exide, New Pattern, 24-volt. 1 15 0 Fuller's, Block 30 volt. 1 10 0 Longlyffe, 60-volt 2 19 6 " 100 " 4 17 6 " 150 " 7 7 6	<b>LOW LOSS FORMERS</b> Dayzite Low Loss £ s. d. Formers, Threaded Type 7 x 3½ ins. . . . 6 0 5 x 3½ ins. . . . 5 0 Other sizes to order. A B C Wave Trap Formers, Cut-away type 3½ x 3 . . . . . 3 0 All above made in Guaranteed Grade "A" Ebonite	<b>ANODE RESISTANCES AND CHOKES</b> New Pattern Mul-lard Wire-Wound Anode Resistances 5 6 Success L.F. Chokes 10 0 Super L.F. Chokes . . . . 13 0 Lissen L.F. Chokes 10 0 " H.F. " 10 0
<b>VERNIER DIALS</b> Pico Vernier Dials 4-in 5 6 E-Z-Toon " 3-in 10 6 Accuracy, " 4-in 17 6 National Velvet, Vernier Dials, 4-in 14 6	<b>LOUD SPEAKERS, DIAPHRAGM TYPE</b> Western Electric Kone . . . . . 6 8 0 Sterling Primax 6 0 0 Sterling Mellovox 2 8 0 Edison Bell, New Pattern . . . . . 2 2 0	<b>VALVE HOLDERS</b> Benjamin Antiphonic Valve Holders, Baseboard Type. 2 9 Ellis Anti-Capacity Valve Holders, Baseboard Type, with one red leg. 2 3 H.T.C. Anti-Capacity Under Panel Type . . . 1 8 H.T.C. Anti-Capacity Over Panel Type . . . 1 9 Aermonic Back of Panel Type . . . 1 6
<b>COILS</b> Igranic Atlas Lissen Tandoo Plug-In Tandoo Basket Coils Reflex Unmounted	<b>CABINET TYPE</b> BROWN CABINET MODEL . . . 6 6 C <b>TRUMPET TYPE</b> ALL STANDARD MAKES IN STOCK	

Send 6d. for the World's Finest Radio Catalogue. (Callers free)

**WILL DAY, LTD.** 19, LISLE STREET, LEICESTER SQUARE, LONDON, W.C.2  
TELEPHONE: Regent 4577 TELEGRAMS: "Titles. Westrand, London"

## TUNING

**Keen as a Razor!**



Successful reception of distant radio demands the utmost tuning accuracy. Every radio enthusiast of experience appreciates this fact which accounts for so many having incorporated the Microhm Vernier Condenser into their receivers. They have proved it to be an instrument capable of sharp and accurate tuning always, with the greatest ease of adjustment. Until you have fitted the Microhm into your set, you cannot know what fine tuning really is. For a negligible outlay you can greatly improve upon present results. Remember it must be the—

**MICROHM VERNIER CONDENSER**

For use in parallel with aerial and anode tuning condensers.  
Indispensable for "Neutrodyne's."

24 turns of tuning adjustment. Single 1/4 in. hole fixing. Maximum capacity '00015 mfd. Minimum capacity Negligible. Price 2/6.

**MICROHM ENGINEERING CO.** VARSITY WORKS, COLLEGE ST., LONDON, E.9  
CLISSOLD 2887  
Scottish Agents: KEITH & IRWIN, 35, Robertson Street, Glasgow, G.2  
Barclays Ad. 1316

## JUNIT Wire

PATENTED

### Needs no Solder

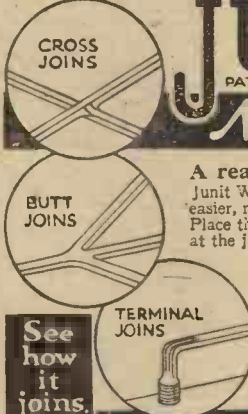

A real boon to wireless constructors—Junit Wire carries its own solder and makes wiring work easier, neater and better. No unsightly blobs of solder. Place the wires in position, moisten with flux, touch them at the junction with a soldering iron, and the job's done. Obtainable from dealers or from address below.

No. DG/1 (18 w.g.) 3 yd. coil 6d.  
No. DG/2 (17 w.g.) 2 ft. lengths 2d.

Dealers should apply to their usual Wholesalers

**REXO ENGINEERING CO.**  
2 RAVENSCOURT SQ., LONDON, W.6.

## The AERMONIC VALVE HOLDER

Anti Capacity  
SOUND MECHANICAL CONSTRUCTION



Base Board Mounting 3/- Model "E"



Model "F"  
Behind the Panel Type 3/-  
Sole Manufacturers & Exporters:  
**James Christie & Sons, Ltd., 246, West St., Sheffield**  
If your dealer cannot supply please send his address to the distributors for your district and Holders will be sent direct on receipt of P.O.

It is a well-known fact that there are grave High Frequency Losses in the four-pin type of valve mounting. The "Aermonic" Anti Capacity Valve Holder has been designed to reduce these losses to a minimum. The construction is sound and the material used is the best moulded insulant on available and will withstand very rough usage. The "Aermonic" Anti Capacity Valve Holder is made in two styles: Base Board Mounting and Back of Panel.

Strongly recommended for use in Neutrodyne type of High Frequency Amplifier, and in the Detector, Oscillator and Intermediate Frequency positions of the Super-heterodyne. In fact in any position in which the valve has to deal with high frequency signals.

Sole Distributors—  
London & South of England: **CHRISTIE & HODGSON, Ltd.** 246, West Street, SHEFFIELD  
The British Isles excluding the above: **V. R. PLEASANCE** 56, Fargate, SHEFFIELD

## Radio for the Million!

BUY DIRECT FROM THE U.S.A.  
FACTORY REPRESENTATIVES

Highest Class "Lo-Loss" American Components at Popular Prices. Will give you Greater Selectivity, and Better and Sweeter Reception

<b>Variable Lo-Loss Condensers</b> Grounded rotor, aluminium end plates, brass plates, pig-tail connection, complete with 4" dial. '0005 @ 11/- '00035 @ 9/- With vernier. '0005 @ 15/-	<b>Audio Frequency Transformers</b> Ratios 3½ to 1 and 5 to 1 Shielded . . . . . @ 17/6 Standard . . . . . @ 13/- <b>Crystal Detectors, Panel Mounting, Finest Obtainable</b> . . . . . @ 2/- <b> Loud Speaker Gramophone Attachment</b> @ 15/-
--	--

Prompt dispatch on receipt of P.O.  
**THE AMERICAN RADIO CO.**  
20, Grosvenor Gardens, London, S.W.1  
'Phone: Victoria 5268

## SUPER SETS and ACCURACY

For efficient results, absolute accuracy and low loss are essential. You must therefore fit

### The Dorwood Precision Condensers



which have their rate capacities actually adjusted on a capacity bridge. The only grid condenser having a three point connection.

The DORWOOD has often been used in sets described in Radio Press publications. As used by Mr. J. H. Reyner, B.Sc., in "The Auto Resonator," described by him in "Wireless Weekly," Nov. 4th & 11th.

**GET DORWOOD PRECISION CONDENSERS**—direct from us if your dealer cannot supply at once, post free at list prices as follows:—

Capacities '0001 to '0009 MF. with or without Grid Leak Clip	2/6
'001 to '006	3/-
above '006 to '01	4/6

Sole Manufacturers: **HERBERT BOWYER & CO.** 1a, Railey Mews, Leventon Street, LONDON, N. W.5

# ELECTRADIX RADIOS

Have opened a large City Showroom at 218, UPPER THAMES STREET, E.C.4, and are selling an enormous stock of Radio and Electrical Goods of the highest grade—Marconi, Siemens, Sullivan, Brown, Western Electric, at bargain prices. Send 4d. for illustrated catalogue and price list. The Stores at 9, Colonial Avenue, Minorics, contain tons of goods at sacrifice prices to save removal. Callers only. Telephone: Avenue 4166.

"NEW WESTERN ELECTRIC LOUD SPEAKERS." Complete with Cord in Maker's Sealed Carton, 20/- Cheaper than elsewhere 4,000 ohms, 22/6. 2,000 ohms, 20/- 70 ohms. 17/3



"The Catalogue that saves you pounds"

Its scope ranges from a 5s. pair of British Headphones or a 1/2s. 6d. Milliammeter to a 50,000 volt Generator, and covers all requirements.

If you cannot call and inspect goods in our showrooms between 9 a.m. and 6 p.m. it will pay you to send 4d. for our Catalogue at once. Goods promptly despatched all over the world.

## ELECTRADIX RADIOS,

218, Upper Thames Street, London, E.C.4  
9, Colonial Avenue, London, E.1.

\*Phones: City 191: Avenue 4166.

Address all Post Orders to City Showroom:

218, Upper Thames Street, London, E.C.4



## Oldham Standard Accumulator

Supplied in 2-volt Units as follows:

10 amp. hours actual	8/9
20 " " "	11/1
30 " " "	13/7
40 " " "	16/1
50 " " "	18/9
60 " " "	21/4

4-volt and 6-volt at proportionate prices.

## Oldham H.T. Accumulator

An entirely new high-grade Accumulator with cells constructed of stout glass boxes instead of flimsy test tubes. Each cell can be tapped by a wander plug. Assembled in 20-volt Units. Price 20/- per 20-volt Unit and *pro rata*. Particulars post free.

## MIRACLE BARGAIN Two Valve Set



with the POWER & RANGE OF FOUR VALVES Stations over 200 miles distant clearly heard on the Loud Speaker.

Complete with B.C.C. Coils. Royalties not included. List free. Special terms to the trade

£3-12-6

THE WORLD'S WIRELESS STORES, WALLINGTON

## Secure GRID BIAS BATTERY HOLDER



Fits any standard dry-cell. Screws on to baseboard. No space wasted.

Price 6d. pair 7d. post free

From all dealers or direct from—  
**A. G. BRINE**  
732, Lea Bridge Road  
Leyton, E.10. Tel  
Walthamstow 1.57.

Trade Enquiries Invited

TRADE DECKO MARK

### DIAL INDICATORS

SIMPLY DRILL ONE HOLE AND FIX AT ANY POINT OF DIAL, BEAUTIFIES THE PANEL. OBTAINABLE FROM ALL THE BEST DEALERS.

**A.F. BULGIN & CO.**  
9-11 CURSITOR ST.  
CHANCERY LANE E.C.4.

Price 9 per Pair

## POWQUIP

TRANSFORMERS

### MEAN MELLOW MUSIC

The Power Equipment Co. Ltd. The Hyde, Hendon, N.W.9.

## This day twelvemonth will tell you

It is not what you pay to-day in first cost but what you'll have paid in charging fees during the next twelve months that will prove the wisdom of your accumulator choice.

Perhaps you selected haphazardly and chose the first offered to you. Maybe already you have noticed that it needs to be recharged rather more often than when it was new. That's the worst of accumulators built to a price.

We could make an accumulator at half the price but it would not be an Oldham and it would certainly not be made under the Special Activation Process. And after quite a short while you'd be

complaining of its lost power.

So we make the Oldham Accumulator to a definite standard of performance. We make it to hold up under all circumstances. Even if left idle for several weeks on end it must not sulphate. And above all it must deliver up the whole of the electrical energy stored within its four walls.

Ask your Dealer to let you examine one. Note its robust case, its specially constructed plates—its generous moulded coloured terminals—its screw-in vent plug.

Compare it with any other Accumulator and you'll inevitably choose the Oldham—none other can compare with it for honest value.

OLDHAM & SON LTD., DENTON, MANCHESTER

London: Hazlitt House, Southampton Buildings, W.C.2  
London Service Station: 6 Eccleston Place, S.W.1  
Glasgow: 120 Wellington Street



Gilbert Ad. 3955

# Guard Your Valves with "SAVE IT"

Fig. 828

## SAFETY WANDER PLUG

This Fuse replaces one of the Wander Plugs, and is therefore provided with a split plug to fit the Standard Battery sockets, and when thus fitted it is impossible to burn out your valves. Any cheap 6d. flash-lamp bulb will replace the fuse. Equal protection to Bright or Dull Emitter Valves.

**2/-** each

postage 2d. extra

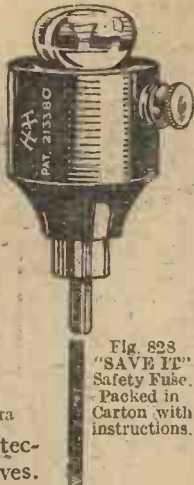

Fig. 828 "SAVE IT" Safety Fuse. Packed in Carton with instructions.

**HEATS**

## SPADE TERMINAL "THREEDIE"

The "THREEDIE" Spade terminal with red or black body and nickel plated spade, cartoned in one dozens and grosses, and one dozens on display card No. D/161 3/- complete.

**3 D.** each



Fig. 1200

A. H. HUNT, LTD.  
(Incl. 15)  
Tunstall Road,  
CROYDON

H.P.

# CAXTON 4-VALVE CABINET

Made for Editor of Wireless Magazine for Set "As good as money can buy" described in issue February, 1925.

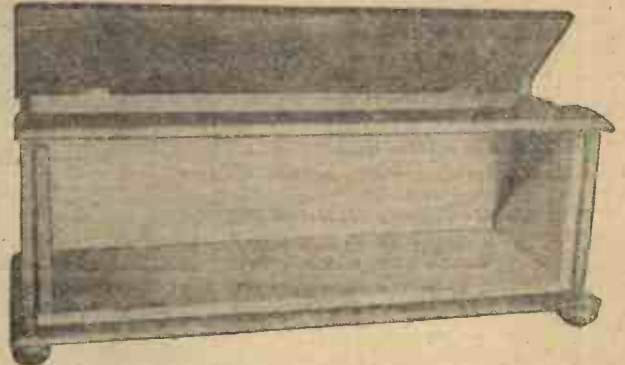

Cash with Order. Fumed Oak ... £1 5 0  
or Real Mahogany polished ... £1 14 0

With detachable recess fitted Base Board to mount 21 in. by 7 in. panel to slide out of Cabinet front. Extra 10/- with two beaded front doors totally enclosing fitted panel. Cabinet overall length 22½ ins. Width 8½ ins. Height 9 ins.

Polished with the new enamel that gives a glass hard surface that cannot be soiled or scratched.

SENT FREE.—Catalogue of standard Wireless Cabinets in various sizes and woods. Special Cabinets made to customer's orders.

PACKED AND DELIVERED FREE IN U.K.

CAXTON WOOD TURNERY CO., Market Harborough

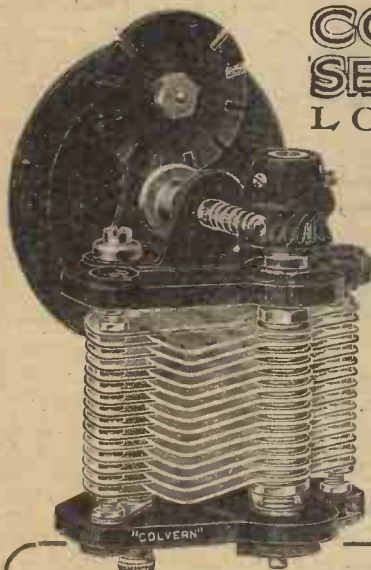

# COLVERN SELECTOR LOW LOSS

The Colvern Selector Low Loss, Reading to 1/3,600th capacity.

Capacity 0005 mfd. £1 1 0

0003 mfd. £1 0 0

Type F, without gear attachment.

Capacity 0005 mfd. 15s. 0d.

0003 mfd. 14s. 0d.

One hole fixing. Other capacities if required. Descriptive Folder upon request.

Colvern Independent Vernier. Price 2s 6d

Ask your dealer also for the Colvern Low Loss Coil Former. Price 6s. 0d.

## COLVERN ESSENTIALS to long distance work

Every reader of this journal may, upon application, receive illustrated literature of Colvern essentials to a very efficient long distance receiver.

The Colvern Selector Low-Loss Condenser (true geared 20 to 1) and capable of relocation to 1/3,600th part of the variable capacity.

The Colvern Low Loss Coil Former, provides a very efficient inductance of low self capacity and low H.F. Resistance.

Write to us to-day and your long distance experiments will be successful.

COLLISON PRECISION SCREW CO., LTD., Provost Works, Macdonald Rd. Walthamstow, London, E.17. Telephone: Walthamstow 532

# Multi-purpose

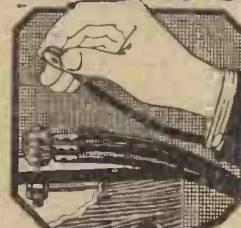

JUST think of the advantages of the many and varied applications of the Newey Snap Terminals. You can have all the phones your set will stand from no terminals only. There is no screwing of nuts and twisting wires round the screw; just press the connector to the stud and the connection is complete and perfect. You can switch over from phones to loud-speaker at a moment's notice. Battery connections are perfectly simple, and for experimental circuit work the Newey Snap Terminals will save the constructor precious hours.

Get the Newey Snap Terminals for your set to-day and you will soon find out the extent of their utility.

Experimental Sets (in brass) ... 2/-  
Experimental Sets (nickel plated) ... 2/6

# Newey SNAP TERMINALS

Wholesale Distributors: P. TIGREW & MERRIMAN (1925) Ltd. 122-124, Tooley St., London, S.E.1. (and Branches). Tel.: Hop 134

Leaflet (W) gives complete information. Ask your nearest Dealer. If you have any difficulty write direct.

Just send a subscription for your favourite Wireless Journals.

Promptly delivered through the post.

### MODERN WIRELESS

Twelve months - 15/- Six months - 7/6

### WIRELESS WEEKLY

Twelve months - 32/6 Six months - 16/3

### THE WIRELESS CONSTRUCTOR

Twelve months - 8/6 Six months - 4/3

### WIRELESS

Twelve months - 13/- Six months - 6/6

### WIRELESS DEALER

For the Trade only: Send business letter heading with subscription.

Twelve months - 7/6 (U.K.); 10/- Abroad.

RADIO PRESS, LTD. BUSH HOUSE, STRAND LONDON W.C.2

**MAP**  
Receiver Terminal No. 84  
STOCKED BY ALL DEALERS  
MAP Co. 246, Gt. Lister St., Birmingham

**VALVES Repaired Quick**  
Let our valve making plant repair your broken or burnt-out valves efficiently and promptly (most makes). Amplification, radiation, and current consumption guaranteed same as new.  
Bright emitters 5/- "D.E.'s" (2 and 9 v. types) 7/6. - Radions Ltd., Bolton, or, Macclesfield & Linc. Largest Valve Repairing Firm in the world. List Free.

**RADION**  
Reliable Repairs

**2-VALVE AMPLIFIER, 35/-**  
1-Valve Amplifier, 20/- both perfect as new; Valves, 4/6 each; smart Headphones, 8/6 pair; new 3-Volt Accumulator, celluloid case, 13/-; new 66-Volt H.T. Battery, guaranteed, 7/-; 2-Valve All-Station Set, 24. Approval will give.  
C. Tavior, 57, Studley Rd., Stockwell, London

**GOOD NIGHT!**  
As soon as the announcer utters this phrase, clip on Gold Seal H. m. and keep your batteries fresh. Gold Seal H. m. chargers work out cheaper, save money, time, labour and batteries. Before adopting any system of charging, write for free book explaining all methods.  
The CARPAX COMPANY, Ltd., 312, Teanogate, Manchester.

GET YOURS NOW  
**FREE**

**A GUARANTEED VERA VOLT METER**  
VALUED 7/6 IS GIVEN FREE TO EVERY PURCHASER OF A PRIMUS 90 VOLT HIGH TENSION BATTERY OR TWO PRIMUS 60 VOLT H.T. BATTERY

90 VOLT HT BATTERY 12/6 Each Post Fr.  
60 VOLT " " 8/6  
THIS AMAZING OFFER IS OPEN FOR A LIMITED TIME ONLY ORDER NOW

PRIMUS MANUFACTURING CO  
114, GREAT SAFFRON HILL, LONDON E.C.1

**BARCLAYS SERVICE**

The experience of the whole of the staff of this Agency is such that their advice and assistance, freely given to wireless manufacturers and retailers, is accepted as sound, accurate in every detail and of proven value.

The Manager was intimately associated with wireless and advertising before the advent of British Broadcasting. He is well known to the trade generally, and has chosen a staff of experienced men, each of whom, in his own sphere, is able to solidify the complete service rendered by the Agency.

Why not take advantage of this accumulated experience so essential to the expansion of your business?

**BARCLAYS ADVERTISING Ltd**  
Advertising Consultants & Contractors  
Bush House, Strand, London, W.C.2  
Telephone: City 9911

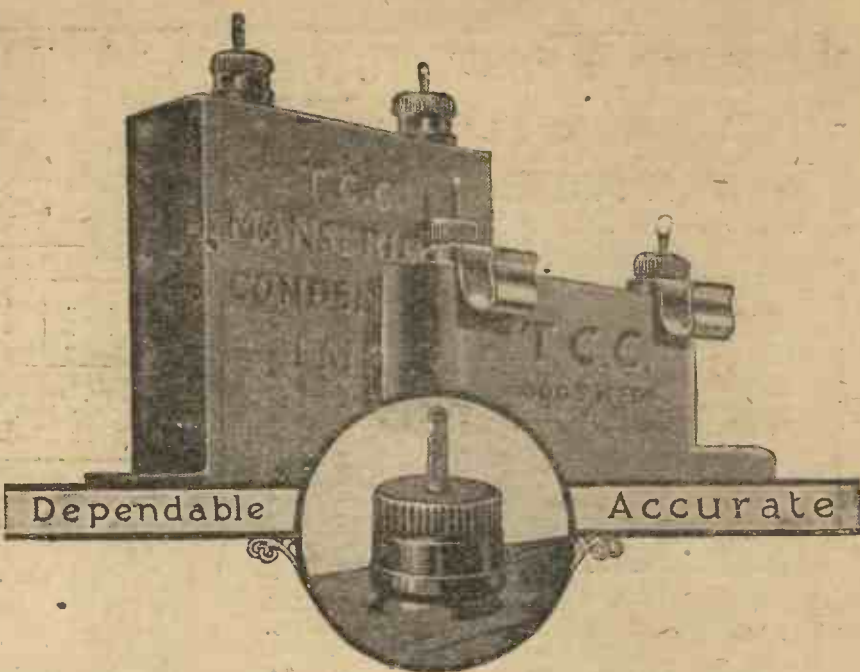

# Twenty years of knowing how!

THERE'S one thing every manufacturer needs but which money can't buy—experience. It is experience which has brought T.C.C. Condensers to the forefront today. Experience in manufacturing all types of fixed condensers—experience in dealing with the problems peculiar to insulation and capacity—experience in producing millions of condensers, large and small, Mansbridge and Mica

the passing years. For twenty years the Telegraph Condenser Co. Ltd., have been designing and building all types of Condensers. This invaluable knowledge is now passed on to you in the form of T.C.C. Condensers. By specifying T.C.C. in your next Set you will be assured of extreme accuracy and uncommon dependability. Remember, all T.C.C. Condensers in metal cases are genuine Mansbridge, while those in moulded cases are Mica. Each case is green in colour and bears the sign T.C.C. stamped on its side.

Money could not buy this experience. It can only be obtained by paying the price—the price of



Look for the name T.C.C. Mansbridge stamped on the side of the green metal case.

PRICES AND CAPACITIES			
Mansbridge, 2 mfd.	- 4/8	Mansbridge, 1 mfd.	- 2/6
Mansbridge, 1 mfd.	- 3/10	Mansbridge, '09 to '01	- 2/4
Mansbridge, 5 mfd.	- 3/4	Mansbridge, '009 to '005	- 2/-
Mansbridge, 4 mfd.	- 3/2	Mica '004 to '001	- 2/4
Mansbridge, 25 mfd.	- 3/-	Mica '0009 to '0001	- 2/4

Every T.C.C. Mica Condenser is contained in a moulded green Case.

**T.C.C. MANSBRIDGE Condensers.**

# AMATEUR CONSTRUCTORS

We supply complete sets of components and cabinets for all sets described in "The Wireless Constructor," "Modern Wireless," etc., etc.

## A COMPACT 2-VALVE RECEIVER

As described by Mr. A. V. D. HORT in this issue.

	s.	d.
1 Radion Panel 10 x 7 x 3/4	5	9
1 '0005 Low Loss Condenser, Ormond	8	-
1 '0003 " Utility	10	6
1 '002 Fixed Condenser, Watmel	2	6
1 '0003 " "	2	6
1 '004 " Dubilier 600A	3	-
2 Microstats	5	6
1 2-meg. Grid Leak, Dubilier	2	6
1 Double Pole, Double Throw, Utility Switch	5	-
11 Terminals Nickelled Complete	1	10
2 Valve Holders, Burwood Board Mounting	2	6
1 3-way Coil Holder, Lotus	10	6
1 Variable Anode Resistance, Bretwood	3	-
1 Board Mounting Coil Plug	1	6
1 Potentiometer, McMichael	7	6
2 Grid Leak Clips and Piece of Ebonite	-	9
1 Pair Brackets	2	6
Glazite Wire	1	2
R.P. Transfers	-	6
Polished Mahogany Cabinet with Baseboard as described, Camco	19	-

£4 16 0

Large 145 page illustrated catalogue of components, etc., price 3d.

Send stamp for lists and let us quote you for Parts for the set you contemplate building.

Write for list of Type B. Kit. Carriage and Packing Free on Orders Value £2 and over.

Book to Cross Street

Buses Nos. 4A, 30A, 19, 19c, 43A, 144A, 144B, 143F. Trams pass the Door, Nos. 33, 79T, 19, 13, 39, 35.

## NORMAN RADIO LTD.

133a, UPPER STREET, ISLINGTON, N.1

Telephone: Clerkenwell 3081.



"SCIENTIFIC" LOW LOSS SQUARE LAW CONDENSERS. ONE-HOLE FIXING. A: Illustrated or with EBONITE END PLATES. PRICES: (Postage 3d. extra.)

"SCIENTIFIC" VERNIER TUNING STANDS. Gear Ratio 4:1



Maximum Capac. ty.	Without Vernier.	With Vernier.
'0010 mf. .. ..	7/6	8/6
'0005 mf. .. ..	5/6	7/6
'0003 mf. .. ..	4/9	7/-
'0002 mf. .. ..	3/6	6/6
5-pl. vernier ..	3/-	-
3-pl. vernier ..	2/3	-

2-coil stand 3/9  
3-coil stand 5/9  
Post 3d.

Combined Rheostat Valve-Holder, one-hole fixing, Overhead or underhang 1/3  
Combined Omnistat Valve-Holder, one-hole fixing ..... 3/6  
(Postage 3d. extra.)

SCIENTIFIC SUPPLY STORES, 126 & 80, Newington Causeway, London, S.E.1. Branches: 7, St. George's Circus, S.E.1; 16, Manette Street, Charing Cross Road, W.1; 291, Edgwar: Road, W. 2; 84, Church Road, Upper Norwood, S E 23. Phone: HOP 4177



## HAVE YOU TRIED ONE? THE "FAMA" POWER VALVE

Four reasons why every wireless enthusiast should have one:  
(1) Fama Valves have been tested and found unsurpassed by any, irrespective of price  
(2) The Power Valve works on the low amperage of '3  
(3) Less than half the price of any other Power Valve.  
(4) Works on 4 or 6 volts accumulator

TYPE POWER, DOUBLE PLATE. Fil. 4 to 6. Anode 100-250. Amps. 0.3 8/6  
TYPE D.E. THE DRY CELL VALVE. Fil. 1.8 to 3. Anode 20 to 100. Amps. 0.08 9/6  
TYPES 4 VOLT AMPLIFIERS AND DETECTORS 4/-

Of all Wireless Dealers or Post Free from—  
H. D. ZEALANDER & CO. ST. JOHN'S HOUSE, 124-127, MINORIES, LONDON, E.1



## Backed by the personal guarantee of Faraday House

That's the reason why Therla Fixed Condensers and Grid Leaks should have a place in your receiver. They are guaranteed to give you good service. Every Therla product is individually tested by the famous electrical laboratory of Faraday House, and carries the hall mark of efficiency issued by this Institution—a personally signed blue label signifying that the product is correct to within a narrow commercial limit of the stated capacity. This guarantee means that you get what you need and what you pay for. Yet Therla Condensers and Grid Leaks cost less than many other instruments of similar type.

**THERLA GRID LEAKS**  
Size  
250,000 ohms  
500,000 ..  
1,000,000 ..  
1 megohms  
2 ..  
5 ..  
Price 1/9  
Grid Condenser and Leak 3/-



**THERLA FIXED CONDENSERS**  
PRICE  
'0001 to '0015 mfd. 1/3 each  
'002 mfd. do  
'006 mfd. 2/- each  
Grid Condenser with Clips 1/3

From all Dealers!

Sole Distributors:

SEL-EZI WIRELESS SUPPLY CO. LTD.  
6 CREEK ST., LONDON, W.1. & 20, OLD HAYMARKET, LIVERPOOL.  
Telephone Regent 1140 LIVERPOOL Royal 1682

BUY GUARANTEED PRODUCTS & BUY SATISFACTION Barclays Ad.

## DORWOOD CONSTRUCTOR'S GAUGE

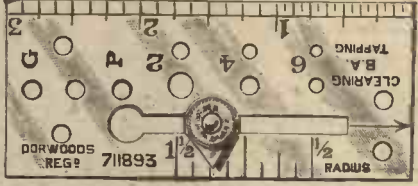

BRITISH MADE

1/9

From your dealer, or post free from makers

Will save you hours of labour, and turn out better work. Automatically spaces contact studs to any radius, sets out valve sockets truly, gives B.A. tapping and clearing drill sizes, and has 3 in. rule and square, on hard silvered metal. Will last lifetime, and is most useful gadget in tool kit.

DORWOODS, 274a, Kentish Town Road, London, N.W.5  
Have you used Dorwood Precision Condensers? They are the standard of accuracy and construction. Ask for List.

## Something New in Detector Crystals

This new Crystal Detector, Kathoxyd, is ideal for reflex circuits. It will be found capable of withstanding high potential without the deterioration to which ordinary crystals are subject.  
Kathoxyd consists of local statin use, the a smooth metal plate other a fine graphite in a brass mount, for long-dis- which fits your Crystal tance work. Each con- cup. It is supplied with tact is readily fixed two contacts—one a in place of your orbi- ball of zinc iron, for nary cat's-whisker.

1. The "Crystal"—A Metal Plate  
This consists of a brass Holder, in which is mou- ted the specially pre- pared Kathoxyd m. tal plate.



2. The "General Purpose" Contact.  
A zinc, ball-ended rod, held in a spiral spring, is merely d ipped at any point on the Kathoxyd plate.



3. The "Long-Distance" Contact.  
Co' sists of a specially-pointed 70 l held in spring, for use in place of ordinary cat's- whisker.

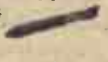

## KATHOXYD DETECTOR CRYSTAL

is sold by most Wireless Dealers. If unobtain- able locally, send 1/6 and your Dealer's name and address to—

KATHOXYD, LTD.  
41, High Holborn, London, W.C.1  
Phone: Chancery 8542  
when the Detector will be sent by return post

The Kathoxyd Element and two contacts are supplied in attractive cellophane-wrapped carton at— Retail price 1/6

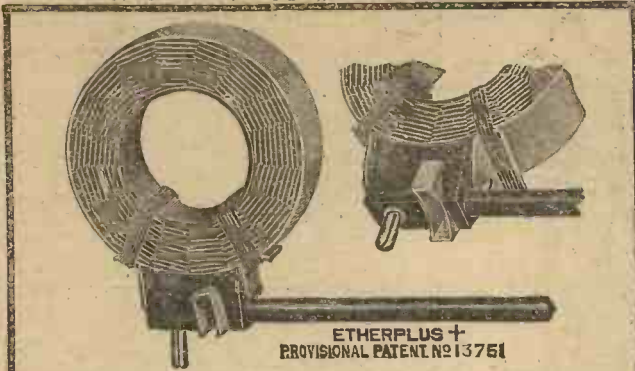

ETHERPLUS +  
PROVISIONAL PATENT NO. 13751

There's a reason why  
Etherplus + Vernier Inductance Coils  
SHOULD BE ON YOUR SET!

PRICES:

W/41/25	-	3/9	ca.
W/42/35	-	4/-	"
W/43/50	-	4/-	"
W/44/75	-	4/3	"
W/45/100	-	4/6	"
W/46/150	-	5/6	"
W/47/200	-	6/6	"
W/48/250	-	7/-	"
W/49/300	-	7/6	"
W/50/400	-	8/6	"
W/51/500	-	9/6	"

A Brass Contact Slot takes the place of the usual socket and allows 85° rotary movement of the coil itself! This gives you an extra increased selectivity. You can tune in local station with fixed blocks only, or these Etherplus + Coils convert existing movable holders into verniers with universal movement.

BRITISH MADE.

From all Dealers or direct from  
**MANDAW**  
9-15, Whitecross St., LONDON. E.C.1

Full illustrated catalogue of "Etherplus +"  
Components on application.



He never gets  
let down now!

A FEELING  
OF COMPLETE  
CONFIDENCE

He knows how to avoid those disappointing evenings when he had to announce to his friends in the middle of an enjoyable programme, "Sorry, the battery has run out."

He remembers too how that meant missing the following evening's programme as well, because he wasn't able to get his batteries charged in time.

To-day it is all changed. A month with PHILIPS RECTIFIER has given him a feeling of complete confidence that he will never be let down now, and that there is one battery charger that always gives complete satisfaction.

PHILIPS RECTIFIER works off A.C. supply, requires no supervision, works silently, and automatically regulates the current supply.

There are no objectionable chemicals, no buzzing noises, and you have, in short, a most reliable battery feeder with an extraordinarily low running cost.

**SIMPLE, CONVENIENT,  
EFFICIENT.**

It charges while you sleep.

**£4.150**  
COMPLETE

Write for leaflet W.C., free on application.  
Trade enquiries invited.

**PHILIPS  
RECTIFIER** R.A.  
Advt. Philips Lamps, Ltd., 60, Wilson Street, London, E.C.2

positive  
micrometer  
adjustment



British made  
in  
every detail.

Price:  
**10/6**

Extraordinary selectivity can be obtained by using this new "Eclipse" Micrometer Coil-holder. By means of a specially designed micrometer screw action, the most minute adjustments can be made, with absolute rigidity at any required angle. The blocks and milled handle are of moulded bakelite. Other parts metal and machined ebonite. Connections below the panel.

Ask your radio supplier to get it for you.  
2-way holder only at present available. (3-way coming shortly)

**Eclipse** MICROMETER  
COIL-HOLDER

P. & C. MANUFACTURING COMPANY, LTD.  
6, BATH STREET, CITY ROAD, LONDON, E.C.1



## The Spirit of Adventure

THOSE courageous mariners of old were not content to take life as they found it. For them the humdrum spelt inaction. So leaving the sheltered comfort of their homes they set out to brave the dangers of the unknown—to return, maybe, with rich prizes.

It was this same restless spirit which prompted the designers of the Eureka to forsake the old and seek new ideas in transformer construction. The extent of their success can be gauged by the fact that the Eureka is now the largest selling quality transformer on the market. Obviously such a rapid recognition of merit is proof of the many exclusive features possessed by the Eureka. The non-laminated core—the 2½ miles of wire—the hermetically sealed contents—the coppered steel case. These are the features which have built up a nation-wide reputation for Eureka.

Eureka Concert Grand . . . 25/-      No. 2 . . . 21/-  
 Baby Grand, Nos. 1 and 2 . . . 15/-      Reflex . . . 15/-

# EUREKA

Advertisement of Portable Utilities Co. Ltd., Fisher St., W.C.1      Gilbert Ad. 3025



## Make your own Components!

Wireless components are expensive, and an enthusiast can appreciably lower the cost of building a set by making his own. Such things as grid leaks, fixed and variable condensers can be easily constructed at home with the minimum of expense and trouble.

Among the many books published by Radio Press, Ltd., is one called "Home-Built Wireless Components." With the aid of this useful book you will find it an easy matter to build your own components.

You require no more tools than those to be found in every wireless man's workshop. Besides, it will give you great satisfaction to be able to say that you built everything in your set except the valves.



## "Home-Built Wireless Components"

PRICE 2/6

Obtainable from all Bookstalls, Newsagents, your local Wireless Dealer, or 2/8 direct from Dept. W.

RADIO PRESS, LTD.  
 Bush House, Strand, W.C.2

Barelays Ad.



**British Made with British Materials**



**LIBERTY  
SUPERSONIC  
Heterodyne Receiver**

Note.—TWO CONTROLS ONLY.

British Patent No. 143583.

RECEIVES any BRITISH, CONTINENTAL AND PRINCIPAL AMERICAN STATIONS at will, not by accident.

250 to 3,000 metres

PRICE

5 VALVE SET Plus Royalties. **£27**

PRICE

8 VALVE SET Plus Royalties. **£32**

DEMONSTRATIONS WILLINGLY GIVEN AT ANY TIME.

**LIBERTY  
SUPERSONIC UNITS**

(Provisionally Patented.)



Comprising four intermediate matched transformers, filter, long and short wave oscillators and balancing device, enabling all stations from 250/3000 metres to be received.

Each transformer matched to half a turn, also secondary windings of the filter.

Full description and illustrated leaflet on request.

Note.—Knobs controlling mechanical balancing device which enables the constructor to select his supersonic frequency peak and to match each individual stage to a frequency not merely a number of inductive turns. Any variations of valve capacities can be accurately rectified.

PRICE

4 Matched intermediate Transformers. 1 Filter. 1 Long Wave Oscillator, 750/30,000 metres, 1 short wave Oscillator 250/800 metres, including mechanical balancing devices. Also blue print and wiring diagram showing all other accessories required and their positions. **£5** SET COMPLETE

SOLE MANUFACTURERS—

**The Radi-Arc Electrical Co., Ltd.**

BENNETT STREET, CHISWICK, LONDON, W.4

Telegrams: "Radiarc, London." Telephones: Chiswick 1834 and Gerrard 1706

*Constructors!*  
**Insist on LEW  
Covered wire**



THERE is over forty years of specialised knowledge behind LEW Wire. Manufactured for the electrical industries during this period, LEW Wire of quality has stood the test of time. Constructors of wireless sets who use products bearing the LEW seal can be sure of quality and satisfaction. Next time you buy wire insist upon reels bearing the LEW seal.

Products guaranteed, by the LEW seal

**COTTON COVERED WIRE  
SILK COVERED WIRE  
ENAMEL INSULATED WIRE**



**THE LONDON ELECTRIC  
WIRE CO. & SMITHS Ltd.**

(Makers of Electric Wire for over 40 years)

PLAYHOUSE YARD, GOLDEN LANE, LONDON, E.C.1

Telegrams Electric, London.

Telephone: Clerkenwell 1388, 1389, 1390, 1391

JUDD

# Answers to 500 QUESTIONS

PRICE  
**2/6**

Obtainable from all News-agents and Bookstalls.  
If any difficulty in obtaining locally send P/o. for 2/8 to Sales Dept. W., Radio Press, Ltd., Bush House, Strand, London, W.C.2, and a copy will be sent you post paid.



**When in doubt —**  
you will be wise if you refer to a standard book on the subject of your choice

**In wireless, the Radio Press Book  
(500 WIRELESS QUESTIONS ANSWERED)**

is a standard publication that covers so remarkably wide a sphere that it is practically sure to solve those queries which arise in your mind at the critical moment of wiring up some component, in choosing the correct capacity for your variable condenser, and the other puzzles which arise so constantly that it is a real help to have a book like this always at hand.

Here truly is a book which you will be glad you bought, and further, it is a very diplomatic move if you make a gift of a copy to that persistent seeker of knowledge who at times drops in to seek your advice, and, so keeps you from going ahead on that set you are constructing at home.



**Radio Press, Ltd.**  
Bush House, Strand, London, W.C.2

*Barclays Ado.*

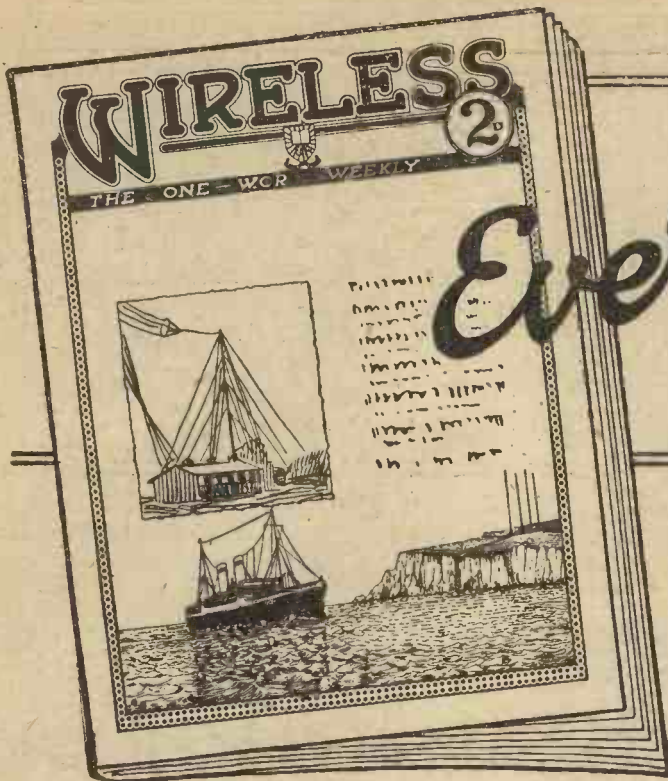

Every Tuesday

For Two Coins  
of the Realm—

**“WIRELESS”**

(The One-Word Weekly)

Edited by Percy W. Harris, M.I.R.E., is always full of interesting and instructing reading matter, and its fifty-two pages are profusely illustrated. Place an order at once for it to be delivered to you every Tuesday.

**52 PAGES  
FOR TWOPENCE**

YOU can secure every Tuesday the greatest obtainable value in wireless publications.

“WIRELESS” (The One-Word Weekly) counts among its contributors numerous British wireless experts and popular authors.

The Editor, Percy W. Harris, M.I.R.E., and the experienced staff of the Radio Press, Ltd., keep you well and truly informed of the trend of wireless design, development and experimental results written in simple and popular language which the beginner can understand. Some of the interesting articles that have recently appeared include the following:—

- HOW TO RECEIVE AMERICA**  
By Percy W. Harris, M.I.R.E.
- WHAT IS REACTION?**  
By J. H. Reyner, B.Sc.(Hons.),  
A.C.G.I., D.I.C., A.M.I.E.E.
- HOW THE VALVE WORKS!**  
By Major James Robinson,  
D.Sc., Ph.D., F.Inst.P.
- A SINGLE VALVE ULTRA-AU-  
DION RECEIVER**  
By Stanley G. Rattee, M.I.R.E.
- LONG WAVE COILS ON THE  
“THREE-STEP” FORMER**  
By G. P. Kendall, B.Sc.

- DRY CELLS OR ACCUMU-  
LATORS:**  
By A. Johnson-Randall
- ADDING VALVES TO YOUR  
CRYSTAL SET**  
By E. J. Marriott
- THE COSY CORNER CRYSTAL  
SET**  
By A. Johnson-Randall
- A SIMPLE LONG-DISTANCE  
RECEIVER**  
By G. P. Kendall, B.Sc.

Buy “WIRELESS” (The One-Word Weekly) every Tuesday. It is a pleasing companion to your favourite monthly in which this notice appears.

*Obtainable from all Newsagents and Bookstalls. If any difficulty in obtaining locally send P.O. 13/- for 12 months or 6/6 for 6 months' subscription to Sales Dept. W., Radio Press, Ltd., Bush House, Strand, London, W.C.2*



Published by

**RADIO PRESS LTD., BUSH HOUSE, STRAND, LONDON, W.C.2**

*Barclay's Ad.*

*In replying to advertisers, please mention THE WIRELESS CONSTRUCTOR.*

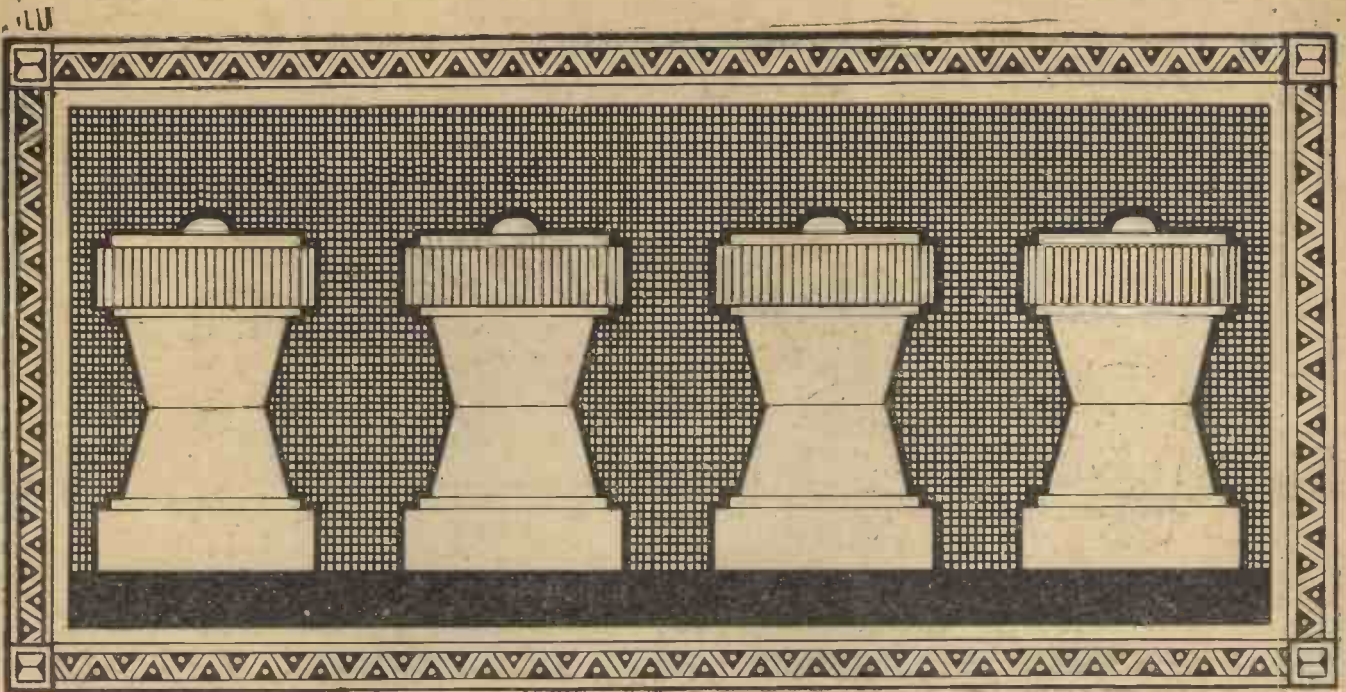

# There is a similarity

between one pair of terminals and another which may prove fatal to your valves if you are careless in connecting up L.T. and H.T. leads. Only by marking your terminals legibly can you expect to avoid this danger. Aerial, Earth, Telephones, Batteries, all must be properly connected for efficient reception. Do not "try" connections to see whether they are right. Make certain by marking them at once with their correct indications. It is easy to ruin a set completely through not clearly marking every terminal, switch, dial and valve socket.

Do away with the danger of similarity. Go to your local wireless dealer, newsagent or bookstall and give them sixpence for a packet of Radio Press Panel Transfers.

TO BE KEPT PERFECTLY FLAT.

## RADIO PRESS Wireless Panel Transfers

**The most complete set of  
Transfers on the Market.**

"Engross" your own panels and give your set a distinctive appearance. The process is so simple that this set of a child's hand will use the process with an extraordinary precision.

This transfer set contains 80 different transfers for marking a wide range of panels. It is the only set of transfers of this kind ever issued. It is the only set of transfers of this kind ever issued. It is the only set of transfers of this kind ever issued.

**INSTRUCTIONS**  
1. Each transfer set is enclosed in a separate envelope. The transfers are marked with their correct indications. 2. The transfers are marked with their correct indications. 3. The transfers are marked with their correct indications. 4. The transfers are marked with their correct indications. 5. The transfers are marked with their correct indications. 6. The transfers are marked with their correct indications. 7. The transfers are marked with their correct indications. 8. The transfers are marked with their correct indications. 9. The transfers are marked with their correct indications. 10. The transfers are marked with their correct indications. 11. The transfers are marked with their correct indications. 12. The transfers are marked with their correct indications. 13. The transfers are marked with their correct indications. 14. The transfers are marked with their correct indications. 15. The transfers are marked with their correct indications. 16. The transfers are marked with their correct indications. 17. The transfers are marked with their correct indications. 18. The transfers are marked with their correct indications. 19. The transfers are marked with their correct indications. 20. The transfers are marked with their correct indications. 21. The transfers are marked with their correct indications. 22. The transfers are marked with their correct indications. 23. The transfers are marked with their correct indications. 24. The transfers are marked with their correct indications. 25. The transfers are marked with their correct indications. 26. The transfers are marked with their correct indications. 27. The transfers are marked with their correct indications. 28. The transfers are marked with their correct indications. 29. The transfers are marked with their correct indications. 30. The transfers are marked with their correct indications. 31. The transfers are marked with their correct indications. 32. The transfers are marked with their correct indications. 33. The transfers are marked with their correct indications. 34. The transfers are marked with their correct indications. 35. The transfers are marked with their correct indications. 36. The transfers are marked with their correct indications. 37. The transfers are marked with their correct indications. 38. The transfers are marked with their correct indications. 39. The transfers are marked with their correct indications. 40. The transfers are marked with their correct indications. 41. The transfers are marked with their correct indications. 42. The transfers are marked with their correct indications. 43. The transfers are marked with their correct indications. 44. The transfers are marked with their correct indications. 45. The transfers are marked with their correct indications. 46. The transfers are marked with their correct indications. 47. The transfers are marked with their correct indications. 48. The transfers are marked with their correct indications. 49. The transfers are marked with their correct indications. 50. The transfers are marked with their correct indications. 51. The transfers are marked with their correct indications. 52. The transfers are marked with their correct indications. 53. The transfers are marked with their correct indications. 54. The transfers are marked with their correct indications. 55. The transfers are marked with their correct indications. 56. The transfers are marked with their correct indications. 57. The transfers are marked with their correct indications. 58. The transfers are marked with their correct indications. 59. The transfers are marked with their correct indications. 60. The transfers are marked with their correct indications. 61. The transfers are marked with their correct indications. 62. The transfers are marked with their correct indications. 63. The transfers are marked with their correct indications. 64. The transfers are marked with their correct indications. 65. The transfers are marked with their correct indications. 66. The transfers are marked with their correct indications. 67. The transfers are marked with their correct indications. 68. The transfers are marked with their correct indications. 69. The transfers are marked with their correct indications. 70. The transfers are marked with their correct indications. 71. The transfers are marked with their correct indications. 72. The transfers are marked with their correct indications. 73. The transfers are marked with their correct indications. 74. The transfers are marked with their correct indications. 75. The transfers are marked with their correct indications. 76. The transfers are marked with their correct indications. 77. The transfers are marked with their correct indications. 78. The transfers are marked with their correct indications. 79. The transfers are marked with their correct indications. 80. The transfers are marked with their correct indications.



6<sup>p</sup>

Produced by  
**Radio Press Ltd.**  
11, Abchurch Lane,  
London, E.C. 4.

Obtainable from all newsagents, bookstalls, your local wireless dealer, or direct for 8d. post free from Dept. W, Radio Press, Ltd., Bush House, Strand, London, W.C.2.

PRICE

6<sup>D.</sup>

A PACKET OF 80 LABELS

## On in a moment—

Just moisten the transfer with a little methylated spirit, having removed the backing. Press it on to the panel where it is required and let it dry. If you then moisten with water the thin paper that is left it will come away quite easily, leaving the transfer tightly fixed. Another simple method is described on the envelope.



# The Wireless Dealer

AND MANUFACTURER  
Edited by John Scott-Jaggart, F.Inst.P.A.M.I.E.E.

November 16th, 1925



### Special Features:

One Wireless Exhibition for 1926!

A Searchlight on the V.M.A.

Modern Tendencies in Radio Design  
By Major JAGGER BOURNE  
12 S. 2nd 1 and 2

The Manchester Wireless Exhibition

Why I Should Join the N.A.R.M.A.  
By A. HARRISON

First Steps in Advertising  
By THOMAS W. GILL

Modern Testing Methods  
By GUY H. GROWLER, M.A.

## Found on every Business Man's Desk

*THE WIRELESS DEALER is as necessary as the Telephone Directory to every member of the Wireless Industry.*

**Send your Subscription NOW!**

Supplied to the Trade only. Please order on business letter heading.

### SUBSCRIPTION ORDER FORM

To RADIO PRESS, LTD., Sales Dept.  
Bush House, Strand, London, W.C.2.

Please enter my/our name for a twelve months' subscription to "THE WIRELESS DEALER" commencing with No. 1. Enclosed is remittance of 7/6 (10/- abroad)

NAME .....

ADDRESS .....



# RADIO PRESS ENVELOPES



## RADIO PRESS ENVELOPES

- 1 How to Build an 8T100 Receiver - 1/6 1/9  
By John Scott Taggart, F.Inst.P., A.M.I.E.E.
- 2 How to Build the Family-4-Valve Receiver - - - - - 2/6 2/9  
By Percy W. Harris, M.I.R.E.
- 3 How to Build the "Simplicity" 3-Valve Set - - - - - 2/6 2/9  
By G. P. Kendall, B.Sc.
- 4 How to Build the All-Concert de Luxe Receiver - - - 2/6 2/9  
By Percy W. Harris, M.I.R.E.
- 5 How to Build the Omni Receiver - 2/6 2/9  
By John Scott Taggart, F.Inst.P., A.M.I.E.E.
- 6 How to Build the ABC Wave Trap - 1/6 1/9  
By G. P. Kendall, B.Sc.
- 7 How to Build a 2-valve Amplifier de Luxe - - - - - 1/6 1/9  
By Herbert K. Simpson.
- 8 How to Make a 1-valve Reflex Receiver - - - - - 1/6 1/9  
By Herbert K. Simpson.
- 9 How to Build an Efficient Single-Valve Set - - - - - 1/6 1/9  
By Herbert K. Simpson
- 10 How to Make the Twin-Valve Loud Speaker Receiver - - - 2/6 2/9  
By John Scott Taggart, F.Inst.P., A.M.I.E.E.
- 11 An Adaptable Crystal Set and How to Build it - - - - - 1/6 1/9  
By Percy W. Harris, M.I.R.E.

## Christmas Gifts ! ! !

YOU cannot all afford to present your friends with a complete wireless receiving set, but you can select for them a Radio Press Envelope and help them to build economically just the type of set you know they would like.

Besides the pleasure of pleasing others by giving, there is real enjoyment to be had in constructing sets according to the simple methods

so clearly described in each Radio Press Envelope.

Each envelope contains working diagrams, exact size blueprints for wiring, reproductions of actual photos of the set, and clear, concise and easily followed instructions which will ensure one successfully building an efficient set.

Have a real Radio Christmas this year and the enjoyment obtained from the set you build will help you to realise the seasonable greeting

*"A Merry Christmas and a Happy New Year."*

Radio Press Envelopes are obtainable from all Bookstalls, Newsagents, your local Wireless Dealer, or direct from Dept. W, Radio Press, Ltd. For prompt and sure delivery when ordering direct from Radio Press, Ltd., please write your name and address in BLOCK LETTERS



RADIO PRESS, LTD., Bush House, Strand, London, W.C.2

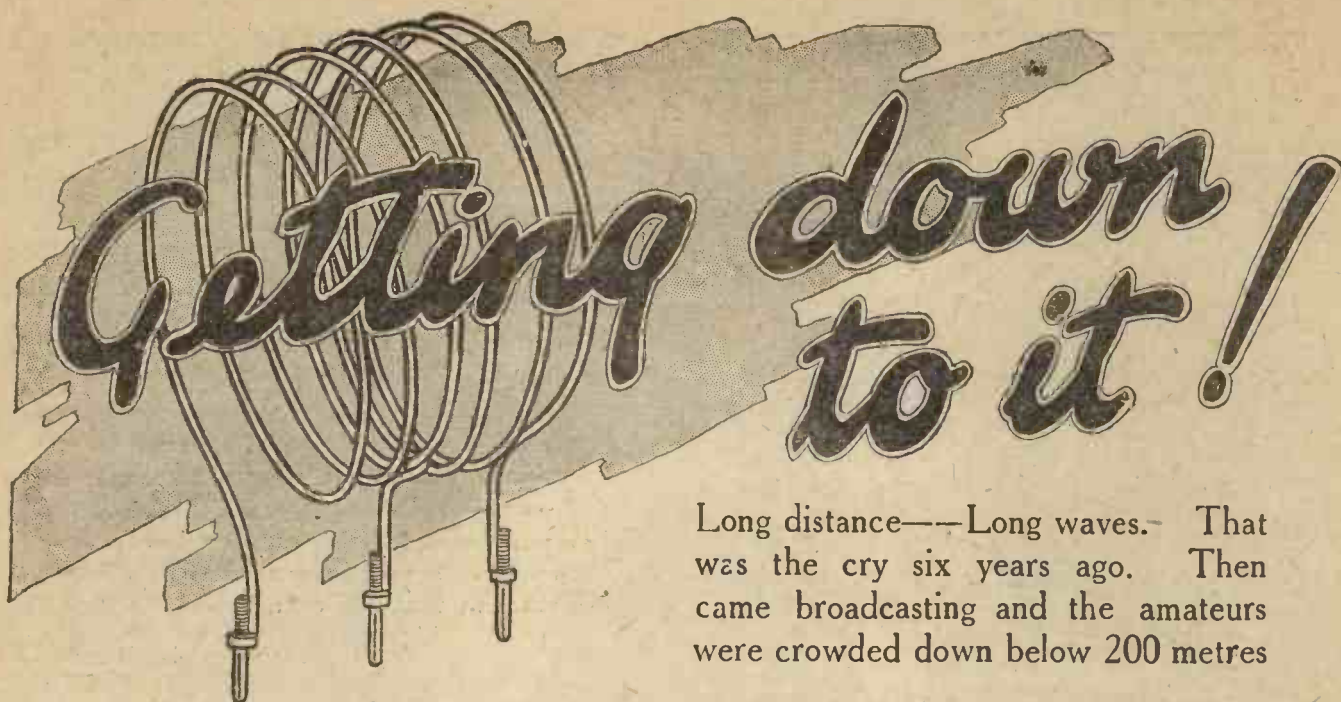

*Most fascinating of all is the range of frequencies above 3,000 kilocycles.*

*There are new problems to be solved, new phenomena to note, and much work to be done with the simplest apparatus.*

*Why not take up the study of this branch of radio?*

**WIRELESS WEEKLY**

*Obtainable from all Newsagents and Booksellers. If any difficulty in obtaining locally, send P.O. 32/6 for 12 months' or 16/3 for 6 months' subscription to Dept. W, Radio Press, Ltd., Bush House, Strand, London, W.C.2.*

Long distance—Long waves.— That was the cry six years ago. Then came broadcasting and the amateurs were crowded down below 200 metres

Undaunted, they set to work to prove that even with these restrictions they would "cross the world." Down came wavelengths to 100, 75, 60, even 20 metres, and, using only a fraction of the power of commercial stations, they talked across the world!

As usual, keenly alive to the interests of the amateur, WIRELESS WEEKLY now devotes a special section to the latest features in Short Wave Work.

If you wish to construct an efficient short-wave receiver, WIRELESS WEEKLY will show you how.

**6<sup>d</sup>. Every Wednesday**  
**ORDER YOURS TO-DAY**

*Obtainable from all Newsagents and Bookstalls.*

# Wireless Weekly

*Edited by John Scott-Taggart, M.C., F.Inst.P., A.M.I.E.E.*



## An Inexpensive Yet Valuable Gift!!!

The season of good cheer and good will is almost with us, and one's thoughts, not always selfish, turn to "what shall I give?"

In these days millions of people have a real interest in wireless which gives them a home pleasure undreamt of a year or two ago, and that pleasure is increased two-fold if they possess a knowledge of the whole or some particular section of the science embodied in their receiving set.

Here is an opportunity for you to decide on an inexpensive yet valuable gift for your wireless friends. Choose one or more of the series of books published by Radio Press, Ltd.

All Radio Press Books are written by men who know how to impart technical knowledge in a manner both easy of understanding and interesting to the layman, constructor and experimenter alike.

*Radio Press Books are obtainable from all Bookstalls, Newsagents, your local Wireless Dealer, or direct from Dept. W., Radio Press, Ltd. For prompt and sure delivery when ordering direct from Radio Press, Ltd., please write your name and address in BLOCK LETTERS*

### RADIO PRESS BOOKS

No.		Price	Post Free
1	Wireless for All. By John Scott-Taggart, F.Inst.P., A.M.I.E.E.	9d.	11d.
2	Simplified Wireless. By John Scott-Taggart, F.Inst.P., A.M.I.E.E.	1/-	1/2
3	How to make Your Own Broadcast Receiver. By John Scott-Taggart, F.Inst.P., A.M.I.E.E.	1/6	1/8
4	How to Erect Your Wireless Aerial. By B. Mitchell, A.M.I.E.E.	1/-	1/2
5	The Construction of Wireless Receiving Apparatus. By P. D. Tyers.	1/6	1/8
6	The Construction of Crystal Receivers. By Alan L. M. Douglas.	1/6	1/8
7	How to Make a "Unit" Wireless Receiver. By E. Redpath.	2/8	2/8
8	Pictorial Wireless Circuits. By Oswald J. Rankin.	1/6	1/8
9	Wireless Valves Simply Explained. By John Scott-Taggart, F.Inst.P., A.M.I.E.E.	2/8	2/8
10	Practical Wireless Valve Circuits. By John Scott-Taggart, F.Inst.P., A.M.I.E.E.	2/6	2/8
12	Radio Valves and How to Use Them. By John Scott-Taggart, F.Inst.P., A.M.I.E.E.	2/6	2/8
13	500 Wireless Questions Answered. By G. P. Kendall, B.Sc., and E. Redpath.	2/8	2/8
14	12 Tested Wireless Sets. By Percy W. Harris, M.I.R.E.	2/6	2/8
15	More Practical Valve Circuits. By John Scott-Taggart, F.Inst.P., A.M.I.E.E.	3/6	3/10
16	Home-Built Wireless Components	2/8	2/8
17	Wireless Sets for Home Constructors. By E. Redpath.	2/6	2/8
18	Tuning Coils and How to Wind Them. By G. P. Kendall, B.Sc.	1/8	1/8
21	Six Simple Sets. By Stanley G. Rattee, M.I.R.E.	1/6	1/8
22	Switches in Wireless Circuits. By Oswald J. Rankin.	1/6	1/8
24	Wireless Faults and How to Find Them. By R. W. Hallows, M.A.	1/6	1/8
	Elementary Text-Book on Wireless Vacuum Tubes. By John Scott-Taggart, F.Inst.P., A.M.I.E.E.	10/-	10/6
	Radio Engineering. By J. H. Reyner, B.Sc. (Hons.), A.C.G.I., D.I.C., A.M.I.E.E.	15/-	15/6
	Modern Radio Communication. By J. H. Reyner, B.Sc. (Hons.), A.C.G.I., D.I.C., A.M.I.E.E.	5/-	5/6



## Radio Press, Ltd.

BUSH HOUSE, STRAND, LONDON, W.C.2

Barclays Ad.





# Splendid Christmas Double Number



THE EDITOR  
**JOHN SCOTT-TAGGART.**  
 M.C. F.Inst.P., A.M.I.E.E.

NOW ON  
 SALE

# 1/6

CHRISTMAS  
 DOUBLE NUMBER

You should at once secure a copy of the biggest issue of "Modern Wireless" that has ever appeared. It has no less than 24 pages more than any previous double number.

# 180 PAGES!!!

You can at once see from the contents given below that this issue is one you should not miss reading.

### CONTENTS.

News of the Month.  
 Super-Selective Single-Valve Receiver. By C. P. ALLINSON.  
 In Passing.  
 Long-Distance Communication. By Lt.-COL. CHETWODE CRAWLEY, M.I.B.E.  
 Crystal Sets on Loop Aerials. By W. S. PERCIVAL, B.Sc. (Hons.), A.R.C.S.  
 The "Simple-Tune" Three. By JOHN UNDERDOWN.  
 The Christmas Spirit. By CAPT. P. P. ECKERSLEY, M.I.E.E.  
 A Novel Smoothing Unit. By MAJOR JAMES ROBINSON, D.Sc., Ph.D., F.Inst.P.  
 A Visit to Our Elstree Laboratories.  
 Amplifier Noises. By CAPT. H. L. CROWTHER, M.Sc.  
 The D.E. Five. By D. J. S. HARTY, B.F.  
 The Woman's Point of View. By BERYL LEE BOOKER.  
 Some Further Notes on the Special Five. By PERCY W. HARRIS, M.I.E.E.  
 Broadcasting in Every Room. By H. J. BARTON-CHAFFLE, Wh.Sch., B.Sc. (Hons.), A.C.G.I., D.I.C., A.M.I.E.E.  
 A Loud-Speaker Crystal Set. By PERCY W. HARRIS, M.I.E.E.  
 What is the Resistance of Your Tuning Coil? By J. H. REYNER, B.Sc. (Hons.), A.C.G.I., D.I.C., A.M.I.E.E.

Wireless Tricks at the Christmas Party. By A. V. D. HORT, B.A.  
 Reaming Valve Filaments in Series. By MAJOR JAMES ROBINSON, D.Sc., Ph.D., F.Inst.P.  
 Double Re-action Control. By STANLEY G. RAYNE, M.I.E.E.  
 Super-Heterodyne Developments.  
 Adding Refinements to your Set. By G. P. KENDALL, B.Sc.  
 A Single-Valve Reverse-Reaction Receiver.  
 The Nature and Causes of Fading. By GREENLEAF, W. PIKARD.  
 Are You Using the Right Valve? By D. J. S. HARTY, B.Sc.  
 Simplifying Crystal Set Operation. By A. S. CLARK.  
 Round the European Stations.  
 The Choice of L.F. Transformer Ratio. By J. H. REYNER, B.Sc. (Hons.), A.C.G.I., D.I.C., A.M.I.E.E.  
 How We Have Reached 15,000 Kilocycles. By L. H. THOMAS (SQB).  
 Series and Parallel Tuning Circuits.  
 How to Get the Best From Your New Receiver. By A. JOHN-ROSE-BAMALL.  
 A Low-Loss Coil and Mounting. By C. P. ALLINSON.  
 Faults in Super-Heterodyne Receivers. By JOHN UNDERDOWN.  
 Apparatus We Have Tested.

If any difficulty in regularly obtaining locally, send P.O. for 15/- for 12 mths., or 7/6 for 6 mths. subscription to Dept. W., Radio Press, Ltd., Bush House, Strand, London, W.C.2.

Secure your copy now. Obtainable from all Newsagents and Bookstalls.

# Modern Wireless



# EFESCA COMPONENTS

embody many patents which enable the amateur constructor to design novel circuits and add greatly to the efficiency and appearance of the finished set. Wherever practicable Efesca Components are One-Hole-Fixing, making the task of panel-drilling and assembling as simple as possible. Efesca Components are sold by all good Wireless Dealers. Send for Catalogue No. 559/4—it is free and full of interest.

## EFESCA Type B Transformer

has been designed so that, while maintaining a 4 to 1 turns ratio—the accepted ratio for 1st stage low frequency amplification—the primary winding consists of the number of turns necessary to produce an impedance at average speech frequency to match the average impedance of an "R" Type Valve. The Secondary Winding is of the correct resistance to obviate the possibility of grid current flowing, thus ensuring freedom from breakdown, purity of reproduction and maximum amplification. An important feature is the heavy insulation between the primary and secondary windings, every Transformer being tested to withstand 2,000 volts. Price 25/- each.

## EFESCA Regenerative Aerial Tuner

A specially designed form of Tapped Aerial Coil incorporating Aerial Reaction in a self-contained unit. Reaction is effected by means of a rotor revolving in a separately wound section of the aerial coil thereby effecting maximum and uniform reaction over the whole wave band covered by the coil. Wavelength range 150 to 2,600 metres in conjunction with a .0005 Variable Condenser in parallel. Price complete with knob, pointer and scale, 32/- each.

## EFESCA Vernistat

The Efesca Vernistat provides the most delicate filament control yet invented, and is particularly useful in circuits requiring individual control of valves, where filament temperature plays an important part in efficient reception. It is especially suitable for the control of H.F. and detector valves.

The Vernistat absolutely safeguards valves from accidental burn outs, as three complete turns of the knob are required to bring in or take out the whole resistance.  
For Bright Emitter Valves, Resistance 5 ohms :: :: 6/-  
For Dull Emitter Valves, Resistance 30 ohms :: :: 6/-

Send now for our  
FREE CATALOGUE

# OF EFESCA COMPONENTS

Wholesale only: FALK, STADELMANN & CO., LTD.  
Efesca Electrical Works, 83/93, Farringdon Road, London, E.C.1



**EFESCA**  
Popularity  
Competition  
**£200**  
IN  
CASH PRIZES  
Ask your dealer  
for entry form or  
write direct to  
FALK STADELMANN  
& CO. LTD.  
83-93 FARRINGTON  
ROAD, LONDON, E.C.1

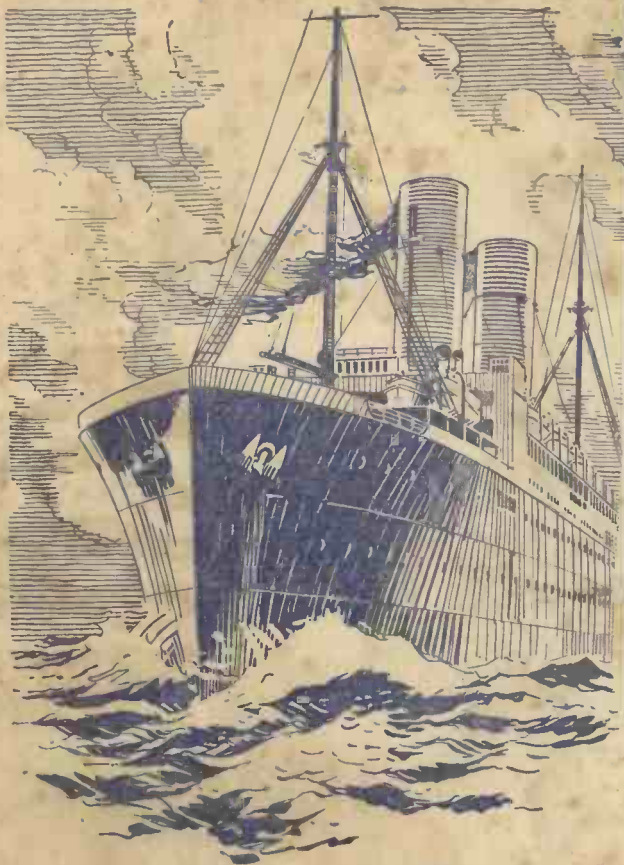

# SUPREMACY

Unequaled for perfection of design and workmanship, the Supremacy of the R.I. Transformer has never really been challenged.

And yet there is no mystery about the design of the R.I. Transformer. It is simply a question of an iron circuit of ample area, correct ratio of the number of turns of both primary and secondary, and last and most important the subdivision of the windings into sections to reduce the self-capacity to a minimum.

Before the present model was adopted, every possible type of transformer was made and tested under the most searching conditions. The present design was selected as giving the most consistent and best results with the various valves on the market, the final confirmation of our selection being decided by musical critics with no knowledge of electrical design. No better proof of the wisdom of the final choice can be cited than the popularity of this transformer, considerably over half-a-million being now in use.

Our latest model has proved so successful that many attempts have been made to emulate the almost perfect transformer—the R.I. Transformer—which still retains its original form and is still considered by all users as the type which gives the most natural reproduction of speech and music it has so far been possible to obtain.

Amongst the many thousands who read this advertisement will be found a large number of actual users of the "R.I." and they will endorse this claim Do not be put off; if you want perfect reproduction, insist on having an R.I.

Write for the new R.I. Blue and gold Catalogue, free on application

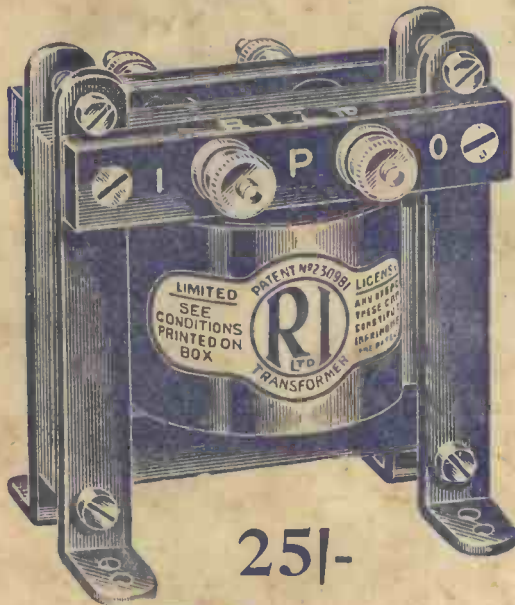

25/-



When buying R.I. Transformers see that they are contained in the R.I. standard sealed boxes

❖ THE MARK OF BETTER RADIO ❖

Advt. R. I. Ltd, 12, Hyde Street, New Oxford Street, London, W.C.1

P.C. 11