

A Monthly Magazine Published by The Television Publishing Co., Inc.
417 Fifth Avenue, New York City

35¢
PER COPY

Television

Volume 1

No. 3

JANUARY-FEBRUARY, 1929

**NEW REALISM WITH THE
TELEVISION STEREOSCOPE**

By DENISON A. VERNE

**SYNCHRONIZING TELEVISION
WITH LIGHT BEAMS**

By PAUL L. CLARK

**HOW TO DRILL SCANNING DISCS
IN JIG TIME**

By PIERSON E. CUSHMAN

**DR. ALEXANDERSON PUTS
TELEVISION ON THE WALL**

By MORRIS DUNN

**FOURTEEN YEAR OLD BOY MAKES
OWN SUCCESSFUL TELEVISION
RECEIVER**

By GASTON P. FONTAINE

AMERICA'S FIRST TELEVISION JOURNAL

Practical Television



\$5.00
List

Given a good signal and neon lamp, satisfactory television comes down to the correct scanning disc driven at proper speed and in perfect step.

The speed control CLAROSTAT has been designed to serve both functions. Provides stepless speed control for universal or condenser type motor up to 1/8th horsepower. Push-button serves for momentary acceleration, in getting into perfect step. Sturdy, ventilated metal casing with mounting feet, 80-watt rating. Convenient. Easily operated. Ideal for experimental television—but also excellent for many other applications.

Neon Lamp Control



The Standard CLAROSTAT is indispensable for applying a critical voltage on the neon lamp for the desired contrast between light and shade. A satisfactory image, with sufficient detail, depends on proper direct-current voltage for normal glow, yet low enough to permit of ample contrast with

increased brilliancy due to signal modulation.

WRITE for descriptive literature on Television Clarostat and other Clarostats for every radio purpose. Better still, send 25 cents in stamps or coin for "The Gate-Way to Better Radio"—88 diagrams and over 20,000 words of practical data.

CLAROSTAT MFG. CO.
Member R.M.A.

Specialists in Variable Resistors
285-7 NORTH SIXTH STREET
BROOKLYN, N. Y.

CLAROSTAT
Reg. U. S. Pat. Off.

When you are experimenting with TELEVISION



—you must be certain of the quality of the parts you use in your receiver, if you would be certain of your results. That's easy—use Polymet Fixed Condensers and Resistances.

Polymet is known throughout the radio industry as manufacturers of thoroughly dependable parts, indicated by the choice of Polymet Products by 2/3 of the RCA Licensed Set Manufacturers. Now, in this experimental stage of Television, it is reassuring to the builder to be certain of the perfect functioning of standard Polymet Products.

If your dealer does not carry Polymet write us direct. We will see that you are promptly served.

Send for Polymet catalogue

POLYMET MANUFACTURING CORP.
595 Broadway New York City

POLYMET PRODUCTS

COMPLETE APPARATUS

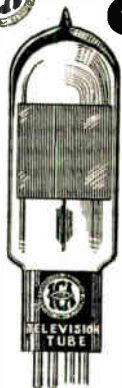

I.C.A.

Television Lamp
Striking Voltage 160.
Minimum Current to cover plate 5 Mils. Maximum Current 80 Mils. Internal resistance 1000 Ohms. UX Four-Prong Bakelite Base. Plate Area 1 1/4" square.
Price \$12.50

I.C.A. Complete Essential Kits

Model B-1—Without amplifier or Television Tube	\$37.50
Model 45—Same as B-1 with improved motor	45.00
Model 52—Same as 45 with four stage amplifier	52.00
Model 65—Same as 52 with Television Tube	65.00
Model A-1—Model 65 completely built up on metal stand	100.00

I.C.A. TELEVISION AMPLIFIER



A most advanced four stage amplifier, complete with all resistors and coupling condensers. Uses any power tube. Battery connections on all stages mounted on amplifier. Price (without tubes).....\$17.50



Complete Parts CATALOG

We can supply all parts of our kits separately. Write for our complete catalog
FREE

I.C.A. SCANNING DISCS



Renowned for their accuracy and precision, giving best quality image.
24 lines, 12" disc \$5.00
48 lines, 16" disc \$9.00
Universal Disc (Aluminum) Combination 24-36-48 lines, \$15.00

I.C.A. UNIVERSAL MOTOR & RHEOSTAT

Non-sparking type with correct power for synchronization, complete speed control. AC or DC, 110-volt, 25, 50 or 60 cycle —\$27.50. Special Rheostat—\$3.00.



INSULINE CORP. of AMERICA

RADIO - Standard Products since 1921 - TELEVISION
78-80 CORTLAND ST., NEW YORK CITY, N. Y.



Thru the Editor's Spectacles

THE Radio Manufacturers' Association, through its anti-television department, headed by that pseudo-propagandist, Mr. R. P. Clarkson, is issuing reams of publicity warning the public not to withhold the matter of purchasing a new radio receiver for fear of the early appearance of television equipment for home use. This propaganda is not insidious. It is too obvious for that. It is just plainly stupid. The idea of Mr. Clarkson laying his pen across the path of progress is ridiculous if not humorous.

The Radio Manufacturers' Association should not be too sure that certain very powerful manufacturing groups are not contemplating the early production of television equipment suited to home use. Official and semi-official information from reliable sources would seem to give the lie to this claim. The RMA repeatedly reminds us that television is not good enough for home entertainment. At least it is as good as were the first movies and in its way certainly as good as the first radio music that filtered in through "peaked" audio transformers and stovepipe radio horns.

The RMA appears to have left no stone unturned in its attempt to dampen public ardor for pictures by radio. The newspapers, so enthusiastic a few weeks ago, have since become ominously silent concerning this new scientific colossus. Is it possible that the potential buyers of newspaper ad-

(Continued on page 59)

Television

AMERICA'S
FIRST TELEVISION JOURNAL

Official Organ of The Television Society, Inc.
417 Fifth Avenue, New York

VOLUME ONE

NUMBER THREE

Contents for January-February, 1929

Thru the Editor's Spectacles	47
New Realism With the Television Stereoscope.....	49
By DENISON A. VERNE	
What Causes Photo-Electric Cell Fatigue?.....	51
By H. WOLFSON	
Four "Best Ways" for Photo-Electric Amplification.....	55
By D. E. REPLOGLE	
Synchronizing Television With Light Beams.....	56
By PAUL L. CLARK	
How to Drill Scanning Discs in Jig Time.....	58
By PIERSON E. CUSHMAN	
New Liquid Photo Cells Amaze Engineers.....	60
By H. WOLFSON	
Kerr Cell Feature of Karolus Television.....	62
By HARRISON MAPES	
Television at the London Radio Show.....	63
Dr. Alexanderson Puts Television Pictures on the Wall.....	64
MORRIS DUNN	
What Television Experimenters Should Know About Radiation.....	65
By Dr. J. A. FLEMING, F.R.S.	
Optics for Television Experimenters.....	69
By PROF. CHESHIRE, C.B.E., A.R.C.S., F.I.P.	
A B C of Television.....	72
By RAYMOND FRANCIS YATES	
Television, When and By Whom.....	74
A New Method of Amplifying Photo-Electric Currents.....	74
With the Television Inventors.....	75
Fourteen-Year-Old Genius Makes Own Television Receiver.....	76
By GASTON FONTAINE	
If You Would Know Television, First Know Light.....	77
By CYRIL SYLVESTER	
Tasmanian Receives New York Pictures.....	80
Analyzing the Scanning Problem.....	81
By J. ROBINSON, Ph.D.	
A New Television Battery.....	85
Tune In on Short Waves With Your Present Receiver.....	87
By HOLLIS S. BAIRD	
Marconi Predicted Television.....	89
Broadcasting Television—And When.....	89
Licensed Television Stations.....	89
Synchronization the Main Television Problem.....	90

TELEVISION

AMERICA'S FIRST TELEVISION JOURNAL

Published by

THE TELEVISION PUBLISHING CO., INC.

417 Fifth Avenue

New York

Branch Offices: Chicago Office, G. E. Glenn, 307 No. Michigan Ave.; London Office, A. C. Blackall, 28 St. George's Square; Paris Office, Sidney B. Velt, 42 Faubourg Poissonniere; Los Angeles, Cal.; San Francisco, Cal.; Portland, Ore.; Seattle, Wash.; Berlin Office, "Ads" Actien-Gesellschaft, Winkler Str., 11, Berlin-Grunewald.

Copyright, 1929, by THE TELEVISION PUBLISHING CO., INC.

Editor-In-Chief

RAYMOND FRANCIS YATES

Member Institute of Radio Engineers, Fellow Radio Club of America

Managing Editor

GROSVENOR K. GLENN

Associate Editor

HENRY M. LANE, E. E.

Technical Advisor

RUTHERFORD KENNEDY

**Raytheon
Kino-Lamp**

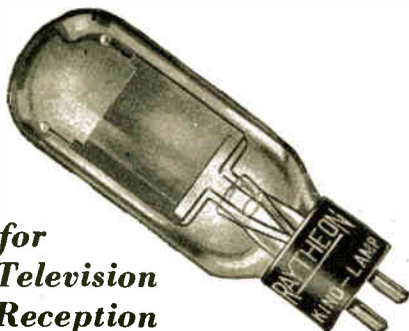

for
**Television
Reception**

This lamp is made in numerous types and styles, which provide suitable light sources and light-sensitive relays for all systems.

List Price, \$7.50

**Raytheon
Foto-Cell**



for
**Television
Sending**

This is an extra-sensitive broadcasting tube, supplied in either hard vacuum or gas-filled types, and in two sizes of each.

Information and prices on application

Raytheon BH
LONG LIFE RECTIFYING TUBE



for
**"B" Power
Eliminators**

Over a hundred different makes of "B" Eliminators require this tube, and take no other. There are millions of them in daily, satisfaction-giving use.

List Price, \$4.50

Write for further information on any of this equipment

RAYTHEON MFG. CO.
CAMBRIDGE, MASS.

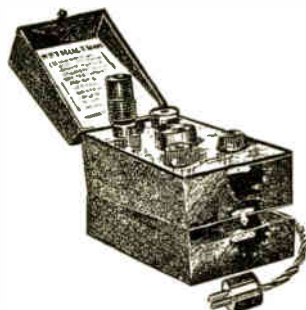

**At Last! A Real
Short Wave Adapter**

Plugs into any receiver, tunes efficiently from 16-225 meters, works on any antennae. No hum on A.C. Sets. S. L. F. Condenser, with vernier knob, separates stations.

TUNES IN TELEVISION SIGNALS!

DELUXE MODEL	\$20.00	} Complete with Set of Four Octocoils
GRANDE MODEL	\$18.00	
STANDARD MODEL	\$15.00	

Same Chassis on all Models. In Ordering Specify Make of Set and if AC or Battery

**SET OF FOUR
OCTOCOILS \$5.00**

16-225 meters. Heavy bare wire on Bakelite Red, Green, Brown and Blue Forms



SHORT WAVE AND TELEVISION LABORATORY, INC.
104 Brookline Avenue, Boston, Mass.

**Practical
Television**

Complete Stock of Television
Parts Receiving and Trans-
mitting Apparatus

Special Parts Developed
and Built to Order

Television experimenters are invited to write us. Our engineers will be glad to help you.

WRITE for descriptive literature on Television parts. Better still, send fifty cents, stamps or coin for full instructions on how to build a Television Receiver, including diagrams.

MARION ENGINEERING CO.
151 Norfolk St., New York City, N.Y.

Orders - Inquiries



**POLK'S REFERENCE BOOK
and Mailing List Catalog**

Gives counts and prices on over 8,000 different lines of business. No matter what your business, in this book you will find the number of your prospective customers listed. Valuable information is also given as to how you can use the mails to secure orders and inquiries for your products or services.

Write for Your **FREE** Copy
R. L. POLK & CO., Detroit, Mich.
Largest City Directory Publishers in the World
Mailing List Compilers—Business Statistics
Producers of Direct Mail Advertising

DAVID SARNOFF

General Manager and Vice-President

RADIO CORPORATION OF AMERICA

PREVISIONS TELEVISION

In the Next Issue of This Magazine

Television

AMERICA'S
FIRST TELEVISION JOURNAL

OFFICIAL ORGAN OF THE TELEVISION SOCIETY, INC.

Volume 1.

JANUARY-FEBRUARY, 1929

Number 3

New Realism With the **TELEVISION** **STEREOSCOPE**

Baird, the English Television experimenter, has added a new touch of realism to picture transmission by producing a stereoscopic effect. In stereoscopic transmissions a three dimensional illusion is produced. In this article, Denison Verne describes the very simple experiment Baird used in this history-making television development.

By DENISON A. VERNE



John L. Baird

THERE is no doubt that one of the outstanding characteristics of the human race is its natural propensity for taking things for granted; of settling down in a comfortable and uninquiring manner, most beautiful in its unswerving faith, to the interpretation of the warnings, prodings and general everyday communications of some five or six senses, without really bothering to observe if there is any particular reason for a noise appearing to come from the direction of its origin, or that the moon should seem farther away than the sixpence which just covers it. "Ah, yes," the layman says, in preoc-

cupied detachment, "let Newton, Darwin, Faraday, Clerk-Maxwell, and Hertz spend their lives in realms of nice intellectual discrimination: these points, though interesting, are not of vast moment to me!"

Layman's Interest in Science

While not disputing the implied truth of this, in so far as these Masters are far more capable of intuitive conception, concise thought, and exact statement than the average muddled brain, I should like to point out to John Smith that it would be a matter of no small moment to him if he were incapable of stretching out his hand for a glass of sherry

without spilling it woefully, or of attempting to pick a rose without thrusting his fingers against a dozen thorns; and such would assuredly be the case, but for the fortunate circumstance that he has two eyes and not one.

The essential truth of this may be simply demonstrated. Look out of the window at a group of objects between, say, twenty and fifty yards away. The nearer units of the group appear unmistakably nearer, and it would probably not be difficult for the observer to form some rough idea of the positions of the elements of the group in terms of a preconceived length unit. On shut-

ting one eye, however, it would be impossible for the observer to form any such estimate without relying on previous or subconscious knowledge.

A single eye sees most distinctly any point on its optical axis, and less distinctly other points also, towards which it is not directly looking, but which are still within its circle of vision. It is able to judge of the direction of such a point but unable by itself to estimate its distance. When the two eyes are directed upon a single point, we then gain the power of judging its distance compared with any other point, and this we seem to gain by the sense of greater or less effort required in causing the optical axes of the eyes to converge upon the one point or upon the other.

Sensation of Distance

Now a solid object may be regarded as composed of points which are at different distances from the eyes. Hence, in looking at such an object, the axes of the two eyes are rapidly and insensibly

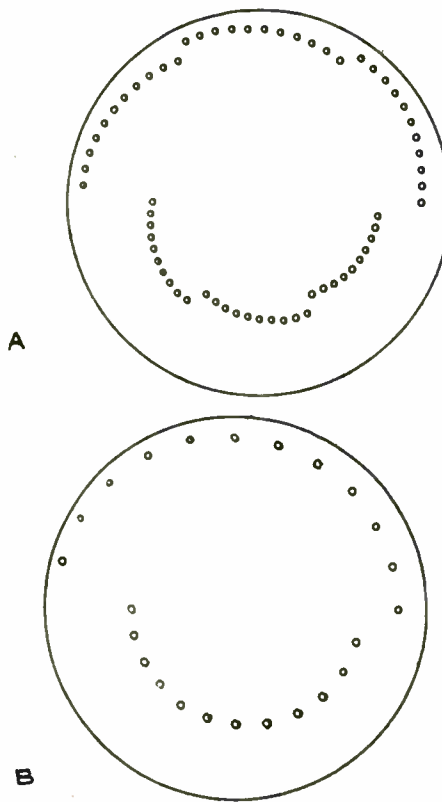

Fig. 1.—Disc perforated as shown in Fig. 1B for monochromatic representations or as in 1A for three-color transmission, the slots being covered with light filters.

varying their angle of convergence, and we as rapidly are gaining experience of the distance of the various points of which the object is composed, or, in other words, an assurance of its solidity.

Let any solid object, such as a small box, be supposed to be held at some short distance in front of the two eyes. On whatever point of it they are fixed they will see that point the most distinctly, and other points more or less clearly. But it is evident that, as the two eyes see from different points of view, there will be formed in the right eye a picture of the object different from that obtained by the left; and it is by the apparent union of these two dissimilar pictures that we see the object in relief. If, therefore, we delineate the object, first as seen from the position of the right eye, and then from that of the left, and afterwards present these dissimilar pictures again to the eyes, taking care to present to each eye that view which it would normally see, there would seem to be no reason why we should not see a representa-

(Continued on page 79)

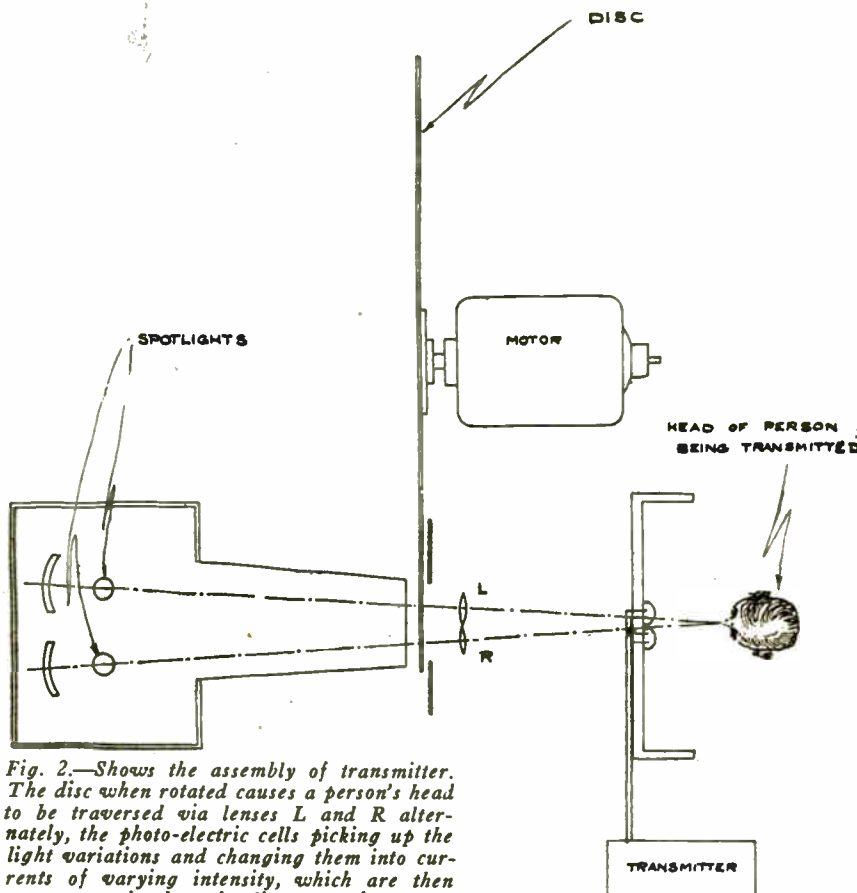

Fig. 2.—Shows the assembly of transmitter. The disc when rotated causes a person's head to be traversed via lenses L and R alternately, the photo-electric cells picking up the light variations and changing them into currents of varying intensity, which are then transmitted to the distant receiver.

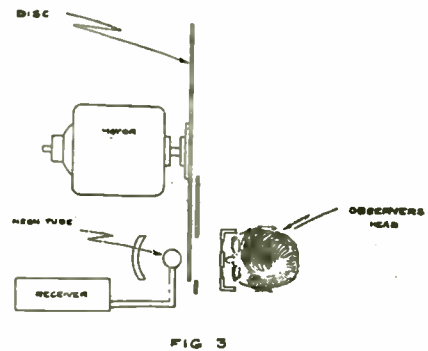
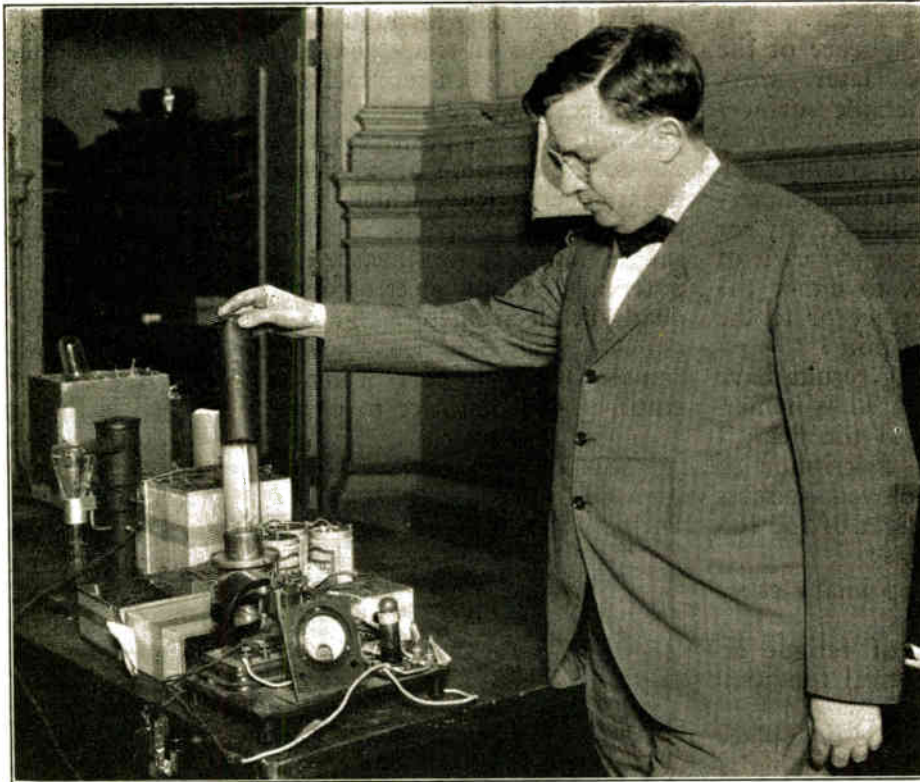

Fig. 3.—The observer looks through a stereoscope at a disc similar to that at the transmitter, while the light of a neon tube behind the disc is modulated by the incoming signals. Two images are formed, which are merged by the eyes, giving one representation of the object in stereoscopic relief. For color stereoscopic television red, green and blue images are transmitted and received successively, the combined effect on the retina being that of one image in natural colors.



Here is a photo-electric cell with its associated amplifying circuits. After photo-electric cells become exposed to light over a long period, the photo-electric current which they produce becomes gradually reduced and eventually disappears altogether.

What Causes Photo-Electric Cell Fatigue?

Like human beings, photo-electric cells are troubled with fatigue—they become lazy and inactive when overworked. The production of "tireless" television cells is one of the major problems of the new art. Here we learn what causes this effect and what the possible solution may be.

By H. WOLFSON

ONE of the most important problems in the designing of photo-electric cells is the elimination of what is known as the "fatigue" to which all early types of photo-electric cells were subject.

Photo-electric fatigue manifests itself by a falling-off in the current generated by the cell after it has been in use for a short period. The phenomenon of fatigue is one which has engaged the attentions of a large number of investigators, and we can now consider ourselves in a position to make definite state-

ments as to its nature and cure.

Since the fatigue effect is a cumulative one, it becomes at once apparent that any cell suffering from this defect will become useless in course of time, this time depending on the type of cell and the conditions obtaining in each particular case. This would, of course, make it impossible to employ the cell in a television transmitter with any degree of success, so that in this article I shall endeavor to explain to the readers of TELEVISION the underlying principles of photo-electric fatigue in a manner as

simple as the subject will allow.

The first observation of the fatigue effect was due to Hertz, who found that while the photo-electric effect was shown by the freshly polished brass terminals of his spark coil, the effect was either considerably diminished, or entirely absent, when the terminals were tarnished.

This result was confirmed by Hallwachs in his first paper on photo-electricity, which appeared only one year after the discovery by Hertz of the existence of currents generated by the action of

light. In this paper he states that the "ageing" of the surface is accelerated by the influence of the illumination, while later work showed that old metallic surfaces no longer show that activity which they exhibited when freshly polished. He states quite definitely that this decrease in activity or fatigue is not due, in the case of copper at any rate, to either the oxidation of the surface or to the presence of water vapor.

Since the foregoing results have been amply substantiated by numerous other workers in the field, I shall, after a brief description of the apparatus employed, discuss the problem in the light of the following four questions:

- (a) Is light the primary cause of the fatigue?
- (b) Is the rate of fatigue influenced by the electrical condition of the cell?
- (c) Does the fatigue take place in gases other than air or in a vacuum?
- (d) Has the size of the containing vessel any influence on the effect?

The vessel in which a large number of experiments were carried out by H. S. Allen is illustrated in Fig. 1. It consists essentially of a cylindrical brass box with brass end plates screwed on. One end is provided with a window of clear quartz, marked *Q* in the figure, in contact with which is placed a piece of metal gauze, which makes an electric connection with the brass case.

Through an insulating bush of ebonite (*E*) in the opposite end passes the central electrode (*A*), to which we can attach a plate of any desired metal which we have under review. The apparatus is completed by mercury cups attached to the case and the central electrode, marked *D*₁ and *D*₂ in the figure. A lever serves to connect or disconnect these two cups, thus making it possible to have electrical connection at will between the central electrode, the case, and the gauze screen.

Let us now place on the central electrode a plate of freshly polished zinc, and illuminate it by light from a mercury vapor lamp, which enters the vessel through the quartz window. In passing, I might men-

tion that the purpose of the quartz is to allow to pass through into the vessel light of all frequencies, from ultra-violet to infra-red, inclusive.

On receiving the light energy the zinc will acquire a positive potential due to the emission of particles of negative electricity, which we call photo-electric electrons, and it is a simple matter to measure this potential on an electroscope or quadrant electrometer. Since it is not essential that we know the actual value of the current in microamperes, it will suffice to obtain a

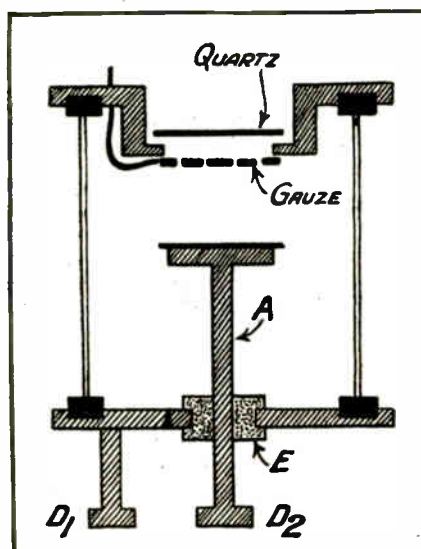

Fig. 1.—Apparatus designed by Allen for conducting experiments on photo-electric fatigue.

comparative value only from the scale reading of the electroscope, assuming, of course, that our instrument has an even scale, that is, a deflection of one millimetre at any part of the scale always corresponds to the same increase in value of the current.

The procedure now is to measure the relative value of the photo-electric current at regular intervals of time; these intervals can conveniently be minutes, as it will be found that the fatigue proceeds with sufficient rapidity to cut down the value of the current to about one-third its original value in 16 minutes.

Discussing first the influence of light on the rate of fatigue, it is important to note that Allen has shown quite definitely that the rate at which the current falls off is exactly the same whether X-rays are present in the exciting light or not.

Experiments made by Buisson led him to the conclusion that the surface of the metal was in some way modified under the influence of the light. He states that the rapidity of diminution of the photo-electric current depends on the richness of the light in ultra-violet rays. He is also of the opinion that the decrease in sensitiveness is not essentially due to an alteration by oxidation, which might be produced by the air, but he thinks that it is light alone which is the active agent. In the work of Schweidler, also, the fatigue was thought to be due to ultra-violet light.

The first worker to question the correctness of the supposition that light was the primary cause of the fatigue was Hallwachs, who pointed out that it was necessary to keep the size of the testing vessel constant if comparable results were to be obtained. Experiments carried out with two similar zinc plates in sunlight and complete darkness showed no difference in the rate of fatigue.

In sunlight (% fatigue)	40	78	88	93
In darkness (% fatigue)	44	81	88	94
Time in minutes	6	24	52	135

Hallwachs was also unable to find a recovery of activity which other workers had claimed to be brought about by keeping the plate in darkness. Ultra-violet light, while not the direct cause of the fatigue, may be a secondary cause, since under certain conditions ozone may be formed by its agency, and it has been found that ozone is capable of reducing photo-electric activity.

The results of Hallwachs were, however, disputed by a number of other workers, and it is to the English worker, H. S. Allen, that we are indebted for the thorough investigation which settled the controversy. The following experiment gives a general idea of the nature of the work which was carried out.

A zinc plate was polished with emery and rouge and then exposed to ultra-violet light for a period of 16 minutes, and the fall in activity noted. On repolishing, the plate was again exposed to ultra-violet light this time for only a small part

of the total time of 16 minutes. For the remainder of this period the plate was allowed to stand in total darkness. The decrease in activity was again measured.

Both experiments were repeated a number of times, and the average of each set of results was taken as the correct value. In each case the activity was found to have decreased from 100 per cent to 45 per cent. This result then completely refutes the idea that ultra-violet light is instrumental in bringing about fatigue, and we must therefore look elsewhere for an explanation of the phenomenon.

The second question is more easily disposed of, for by a series of simple experiments incontrovertible results have been obtained which prove that the electric condition of the plate has no influence on the rate of diminution of photoelectric activity. A general idea of the type of experiments can be conveyed in a few words.

If we carry out measurements of the activity of the plate in the apparatus shown in Fig. 1, and charge the gauze screen first positively and then negatively, no difference in the rate of fatigue can be detected. Similarly, it is immaterial whether the plate under observation is surrounded by a brass case, or whether it is unshielded by

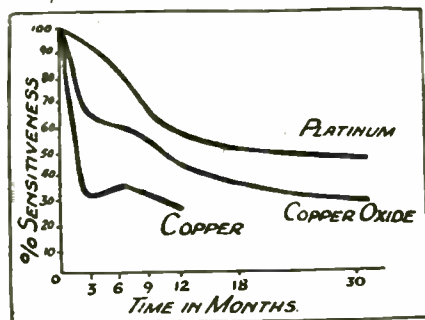

Fig. 3.—The rate of decrease in sensitivity of various metals over a period of months.

a metal case, being simply enclosed in a glass vessel containing air.

Whenever one obtains a series of results in the form of a table of figures, and it has been impossible to decide the true conditions under which the experiments have been carried out, there inevitably arises a doubt as to the correct manner in which the results are to be interpreted. Other factors are constantly cropping up of which the worker is totally unaware, which falsify his conclusions, and it may

be some considerable time before the mistake is discovered, often more by accident than by design, by further experiments along similar lines.

So with the subject of photoelectricity we find many discordant theories, and carefully reasoned conclusions have often to be abandoned in the face of more recent research. Thus the need for a careful sifting of the results relevant to the third question on our list is important.

Early workers wrongly ascribed fatigue to oxidation effects produced by the oxygen of the air. Though certain people found no fatigue in the presence of hydrogen, Hallwachs, Ullmann and Allen have all shown that fatigue does take place under these conditions. In the experiments of Hallwachs it was found that while the fatigue of copper was less rapid in hydrogen than in air, that of platinum was slightly more rapid in hydrogen.

In the experiments performed by Allen, with the metals aluminium, copper and zinc, the metal plate was first polished with emery and rouge paper and at once placed in the testing vessel. The air was displaced by a current of hydrogen, and measurements of the activity taken a few minutes after polishing. No difference from the results in air was detected, though it is improbable that the gas was entirely free from water-vapor, or that the air film on the surface of the plate was immediately replaced by a layer of hydrogen.

Chlorine and ozone, in the presence of water-vapor, had a marked effect on the rate of fatigue. With moist ozone the value of the photoelectric current fell to half its value in one minute, whereas in dry ozone the time required for this decrease was 15 minutes. This has been thought to be due to the formation on the metal surface of hydrogen peroxide, synthesized by means of a photo-chemical reaction from ozone and water under the action of ultra-violet light, since it has been shown that hydrogen peroxide has an enormous absorption for ultra-violet light, and thus a very thin surface film would suffice to reduce very considerably the intensity of the exciting light.

Having so far discussed possible explanations which have proved to be only blind alleys, we are in a position to consider the effect of the size of the vessel on the photoelectric effect. While working with a silver plate Allen found that the activity remained unaltered even after two hours' exposure to ultra-violet light. This result was obtained with air in the vessel as well as when the vessel was evacuated.

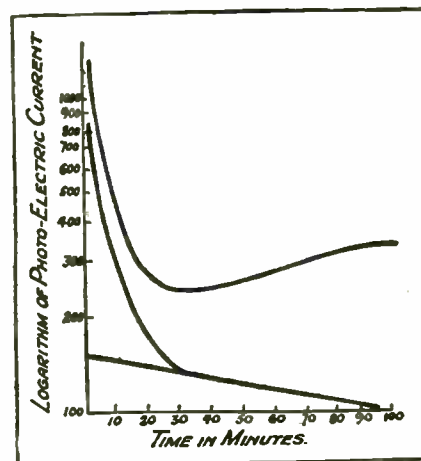

Fig. 2.—Showing rate of decrease in sensitivity for different metals

The same plate when tested later in the air of the room showed a fatigue, the activity falling by 50 per cent in two hours. The explanation of this disparity of results is due apparently to the effect of the size of the containing vessel.

Highly polished copper plates were placed in a cell and their activity determined in the usual manner. They were then removed from the vessel and placed in receptacles of various sizes, from which they were taken periodically and their activities determined by transferring them to the vessel shown in Fig. 1.

Plates lying in the open air lost 50 per cent of their initial activity in one and a half hours, while those in the laboratory required three hours for the same percentage loss. When the plate in a vessel of half a cubic metre was tested it was found that its half value period was 22 hours, while for the plate in a one-litre flask a period of from 8 to 20 days was required before the activity suffered a 50 per cent decrease.

In Ullmann's experiments vessels of capacity one litre, 600 litres, and a room of volume 9,400 litres

were employed. If we assume the original activity to be 100 per cent, then the percentage fatigue noted for these three vessels, tested over the same period of time, amounted to 27.4 per cent, 32.8 per cent, and 40.5 per cent, respectively.

Thus we see now quite clearly an instance of a factor, hitherto unknown, which has been the cause of so many varied results in earlier experiments. Exactly why the size of the vessel should be the ruling factor in causing photo-electric fatigue I shall discuss a little later, after I have treated the subject of fatigue in a vacuum, which I purposely omitted to deal with when answering question (c), since most modern photo-electric cells are either highly evacuated or else filled with a gas such as helium.

In recent years the technique of obtaining a high vacuum has attained a high order of perfection, and many doubtful results dealing with fatigue in a high vacuum have been completely revised.

Lenard was responsible for a series of exact measurements of fatigue in a very high vacuum. He placed a freshly cleaned and polished aluminium plate in the apparatus to be evacuated, and commenced observations of the activity about one hour after the plate had been polished. For the first 45 minutes of his observations bubbles of gas were still being removed from the apparatus, and there was a steady diminution in the value of the photo-electric current over this period. A vacuum as nearly complete as possible having now been attained (*i. e.*, without having recourse to methods other than pumping), it was found that the activity did not change further over a period of ten days.

Some interesting results were obtained with a freshly deposited surface of lampblack. There was first a rapid decay of activity during the first day, which gradually became very slow, and extended over a period of many months, when the activity had fallen to one-seventh of its initial value. On admitting air and then re-exhausting the original activity returned. When the lampblack surface was finally examined an image of the gauze appeared on its surface. This suggests some alteration in the

chemical or physical nature of the carbon itself.

Elster and Geitel found no fatigue in cells of potassium and sodium containing either hydrogen at very low pressure or else a high vacuum. Other workers on the whole confirm the absence of fatigue in the case of the alkali metals, though Dember found a slight fatigue in cells containing hydrogen, which might be attrib-

The March Number of TELEVISION will contain many new features bristling with progress of television throughout the world. One of the most important problems of television, that of wave-length allocation, will be treated by J. Robinson, Ph.D., who, incidentally, takes a most optimistic viewpoint of one of the problems that has received such disparaging attention from the critics of pictures via the ether

uted to a change of gas pressure within the cell, since as mentioned in a previous article there is an optimum pressure, called the critical pressure, at which the photo-electric current is a maximum. Cells containing a colloidal modification of potassium show a remarkable constancy, though cells made on the gas-free principle are claimed to be free from either fatigue or time lag.

Before drawing my article to a close, a short mention of the time of photo-electric fatigue from a mathematical point of view may prove of interest to my readers.

H. S. Allen found in the case of zinc and aluminium that the rate of fatigue at any time after polishing the plate could be found by applying an equation containing two exponential terms, as follows:

$I = K_1 e^{-\kappa_1 t} + K_2 e^{-\kappa_2 t}$, where K_1 and K_2 are of the same order of magnitude, and κ_1 is about ten times κ_2 .

These two terms can be explained if we assume that a freshly polished plate of metal X gives out negative ions under the influence of ultra-violet light and changes to a form represented by Y . Under the same conditions this also gives rise to negative ions and changes to a form Z , which is supposed to be inactive. The change may, of

course, be either physical or chemical. Thus in the equation the first term is represented by Y and the second by Z .

The chief conclusions drawn are five in number, the first supposing the fatigue to be due to oxidation, which I have already shown to be untenable. Since the fatigue depends on the size of the vessel, but is not directly due to light, we can definitely dispose of the next two theories, which assume photo-electric fatigue to be the result of a physical change in the surface, such as roughening, or, in the theory of Ramsay and Spencer, a disintegration of the metal due to exposure to light. Lenard thought he could explain fatigue on the assumption of an electric double layer, but experiment has shown this view to be erroneous.

The explanation of photo-electric fatigue which is most in agreement with experimental facts is due to Hallwachs, who states that the main cause of photo-electric fatigue is to be found in the condition of the gaseous layer at the surface of the metal plate or film. I have already mentioned that ozone produces a rapid fatigue, and we observed that there was a probable formation of hydrogen peroxide, which has the power of absorbing ultra-violet light to a very great extent, and the presence of a very thin film is sufficient to cause very rapid decrease in activity, or fatigue.

This last view is also supported by the following experiments. If we observe the photo-sensitiveness of platinum at room temperature, after it has been heated for some time to red heat, we find a value greater than normal, while after cooling the value of the current is less than normal. On Hallwachs' theory, in the first case heat removes part or all of the occluded gas, and the current is greater than the equilibrium value, while cooling causes the surface to absorb more gas, thus lowering the activity, as we have seen to be the case.

The nature of photo-electric fatigue is still obscure since vast research reveals evidence of the action of various factors, such as variations in quantity, and kinds, of absorbed or occulted bases and vapors.

Four "Best Ways" for Photo-electric Amplification

By D. E. REPLOGLE

WITH the increased knowledge of radio frequency amplifier circuits there has come an insistent demand for a light-sensitive cell which will give a linear response to light over a reasonable period of time. In

face. It is adaptable for television as already mentioned, for picking up varying light through film as employed in the broadcasting of radio movies from films, and for use as an input to an amplifier from sound recording films.

such applications as daylight-recording apparatus, photometers, fire alarm systems, operating relays in various commercial processes and so on. There are many uses for these, and the gas-filled photo cells for the control of an

For the so-called indirect system of television pickup, or where the object, normally in darkness, is scanned with a beam of light, another type is admirably adapted. Its tubular form lends itself readily to arrangement around the object to be televised. A larger photo cell for use where increased sensitivity is required, or where

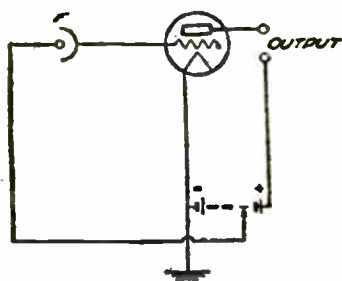

Fig. 1

some cases this demand requires that the cell be permanent in its characteristics for precise measurements. In other applications this factor is not so essential, as the performance of the cell is automatically checked when using.

To meet conditions where permanent characteristics are of paramount importance two types of cells have been perfected by a manufacturer. These cells are of the high vacuum type, and will give a response which is linear in respect to light intensity and in respect to plate voltage. To meet the demand for a highly sensitive cell that is linear in response to light and which will maintain its characteristics over a reasonable length of time three cells of the gas-filled type have been developed.

One of the gas types is of bulb shape and is essentially designed for television broadcasting where the so-called direct illumination system is employed, or, to be more explicit, where the object is flood lighted and the photo cell is scanned. It has equal illumination characteristics over its inner sur-

less illumination is available, is offered, also of tubular form.

Where extreme precision is required in translating light values into corresponding electrical values the vacuum type photo-cell is preferable. These vacuum tube photo cells are finding extensive use in

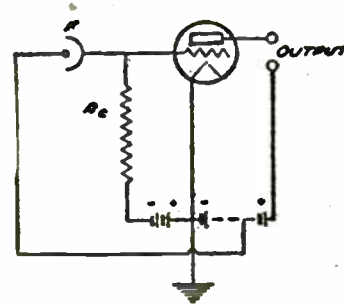

Fig. 2

electric circuit by means of light offers almost no end of applications.

There is nothing intricate about applying a photo-cell to any given purpose, so far as actual connections are concerned. However, it is well to note that the currents dealt with through photo cells are of comparatively small magnitude, so that leakage current becomes a real factor. Two of the newly perfected photo cells of bulb shape are provided with the long-prong base. Care should be taken that the best grade of rubber or porcelain sockets is used and that there is no leakage current passing between the terminals of the socket or through the insulation of the lead wires. In this connection it is well to note that much of the commercial rubber insulation used on small wire will have a leakage factor which cannot be tolerated in a photo-cell circuit.

The simplest circuit for the photo-cell is shown in Figure 1. The photo cell, indicated by F, is connected to the grid of an amplifying tube. In this arrangement

(Continued on page 79)

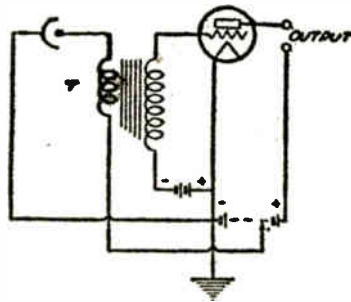

Fig. 3

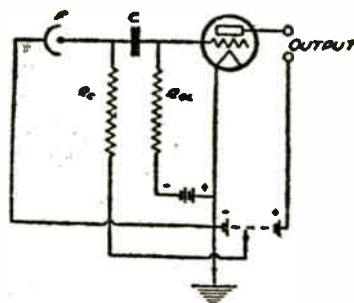

Fig. 4

SYNCHRONIZING TELEVISION WITH LIGHT BEAMS

By PAUL L. CLARK

Briefly describing a new Synchronizing Method which employs the flashes of a picture light to produce an Oscillatory Current for Synchronizing regulation so that but one channel is required for entire supervision of the Television Receiver

THE basic requirement of television transmission is accurate synchronization of the transmitting and receiving apparatuses. The synchronizing devices and circuits should be simple, semi-automatic and reliable, so that the operator of the television receiving set need control merely the tuning of his set and the brilliancy of his picture, and let the synchronizing take care of itself.

Since a deviation of even a single picture point (area) from synchronous registration produces inaccurate delineation, it is evident that the two apparatuses should be phased together at all times, regardless of speed and their distance apart.

Light Choppers Used in Both Transmitter and Receiver

The object of the semi-automatic control is to *limit* the deviation from registration to less than half the width of a picture point, by causing the scanning beam in the receiver to traverse the bars and apertures of a chopper in consonance with the traversal of corresponding bars and apertures of the scanning beam which sends out the electrical signals from the transmitter. The scanning beam in the receiver, when registering exactly with the apertures or bars of the chopper, has no effect on synchronizing; but a *partial* registration produces a tendency to restore the speed of the small driving motor to synchronous speed, by producing variable illumination on a photoelectric cell or cells connected through a suitable amplifier to control the speed of the small (1-20th h.p.) motor by either a tangential brake or a coil on the regular or auxiliary poles.

Maintaining Synchronism within Narrow Limits

The electrical energy required by the automatic control is of the order of one watt, since the motor is manually controlled within 1 per cent or 2 per cent of synchronous speed, say, 1,200 r.p.m., and is preferably shunt-wound, battery driven. The instantaneous auto-

matic photoelectrically energized field coil should be of sufficient sensitivity to restore the speed to insure registration within half the width of a picture point.

The Apparatus

Fig. 1 shows two photoelectric (Continued on page 84)

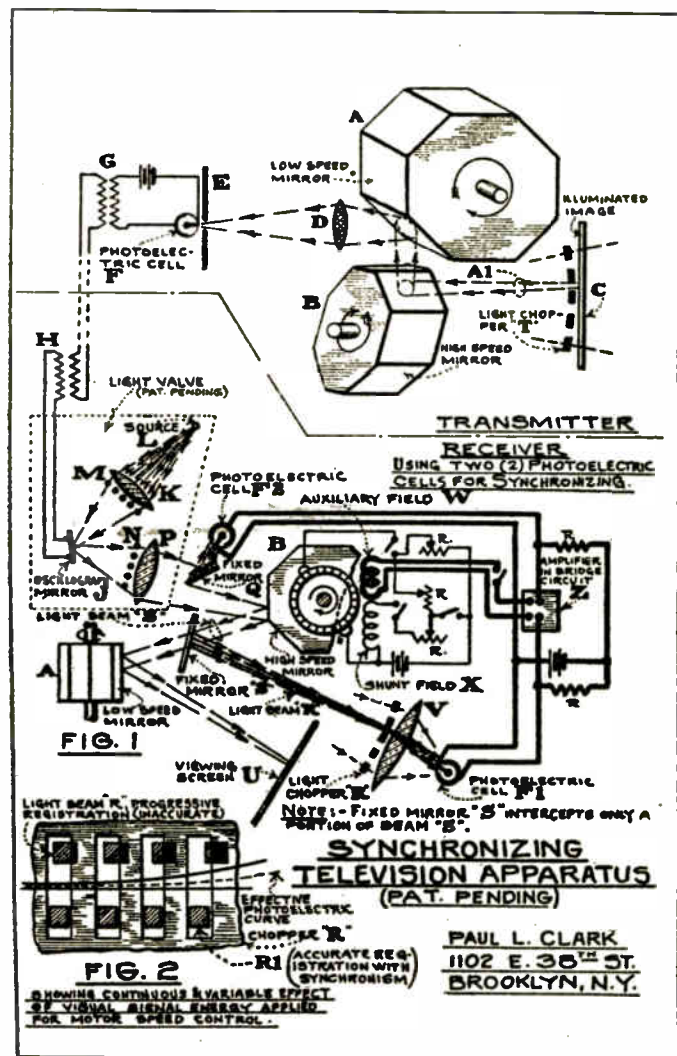

Figs. 1 and 2.—Here we see the details and circuit diagram of the Clark synchronizing apparatus. This diagram also shows how the continuous and variable effect of visual signal energy is applied for the control of the motor driving the scanning disc.

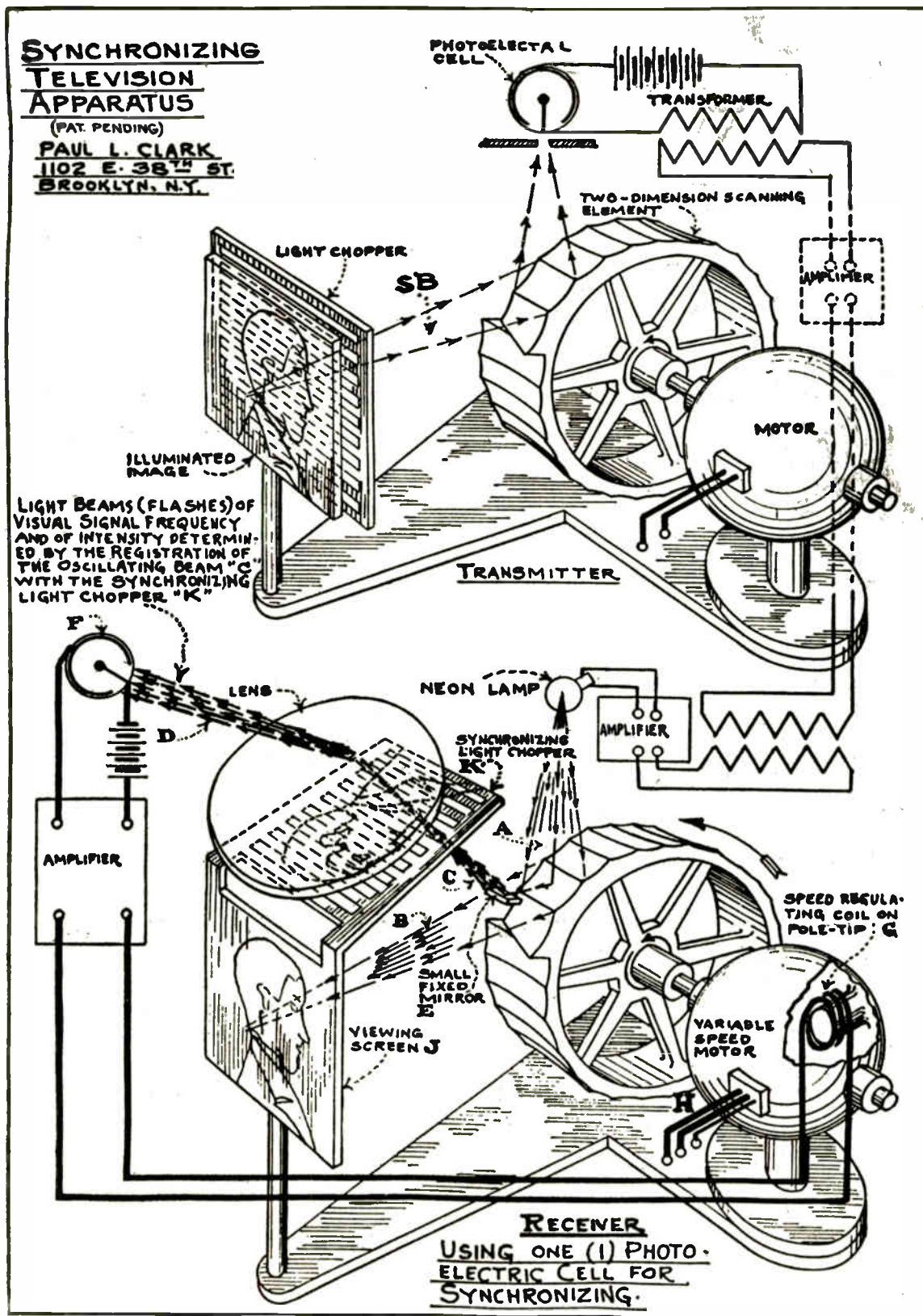

The use of light choppers of similar dimensions in the transmitter and the receiver is the key to Mr. Clark's solution of the synchronization problem shown diagrammatically above. The transmitting scanning element scans the image through a light chopper; hence it delivers to the photo-electric cell a series of light lines alternating with dark lines caused by the bars of the chopper. At the receiver, part of the light energy of the neon lamp is reflected by a small mirror through another light chopper to a photo-electric cell whose output controls the speed regulator of the receiver scanning motor. It is the registration of the light and dark flashes on the second photo-electric cell that is used to bring about proper synchrony.

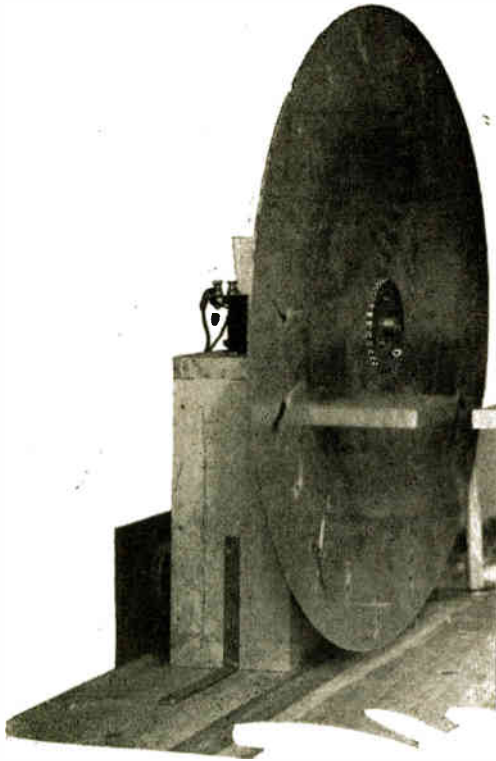

How to Drill Scanning Discs in Jig Time

By PIERSON E. CUSHMAN

Inexperienced mechanics who have tried to drill spirally arranged holes in scanning discs have found themselves confronted with a job that usually outwits them. All these difficulties may be avoided by the use of a little jig here described. The components of the jig can usually be found in the junk box under the bench.

OF all the problems that the television experimenter is called upon to solve in constructing a television receiver, perhaps none is so difficult as that of drilling the scanning disc accurately enough to give a smooth, unruffled picture. In the average case, the experimenter will lack both the skill and tools to say nothing of finding a method of marking out the holes. Ordinary measuring tools will be found practically useless when drilling a large disc. Of course, with a disc measuring only 1 foot in diameter a novice might, providing he was careful enough, manage to drill a series of scanning holes with presentable accuracy.

Before describing a small, inexpensive tool that offers a beautiful solution to this most difficult problem, the writer wishes to impress his reader with the fact that the holes in a scanning disc **MUST BE ACCURATE**. If they are too far apart, the picture will be broken up by a series of ugly black lines. If the holes overlap too much the picture will be streaked with bright lines. In the perfect scanning disc, the scanning holes should overlap by about $\frac{1}{2}$ of one thousandth of an inch. It is perfectly obvious that the attainment of such accuracy does not lie with-

in the power of a wooden ruler or the finest mechanic's scale for that matter.

The drilling jig or tool, about to be described, is one of those things that was brought into being from the junk box. All that is needed is a few pieces of scrap metal, a piece of metal rod provided with an 8-32 thread, a No. 78 drill and what is known as a pin vise. The pin vise is used in place of a hand drill, owing to the small size of the No. 78 drill. An ordinary hand chuck would be much too large and clumsy for such a tiny drill. Both the pin vise and drill may be purchased for under a dollar.

Those who know their mechanics are aware that an 8-32 thread

when turned a full revolution in a nut provided with the same kind of a thread will advance one 1-32nd of an inch. If only one half of a revolution is made, the threaded rod will advance only one half of this distance or one 1-64th of an inch. It is upon this action that the scanning disc drilling jig is based.

The construction of the little tool will be seen from the drawing. The length of the piece of threaded rod will depend entirely upon the diameter of the scanning disc that is to be drilled. Consequently the author has not taken the trouble to provide the drawing with any dimensions. The brass piece carrying the two 8-32 nuts is

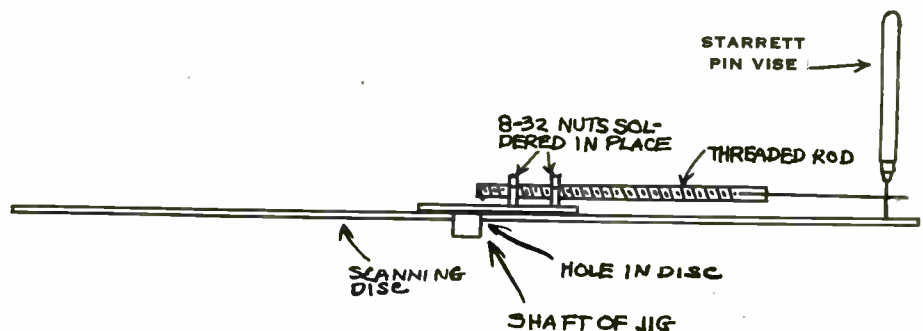

Here we see the details of the jig. A threaded brass rod, two 8-32 nuts and a few odd pieces of sheet brass are all that are needed to complete it. With this jig a scanning disc may be drilled accurately within a half hour.

also provided with a small piece of shaft. This shaft which is soldered to the underside of the brass piece is about one-quarter inch long. Its diameter will depend entirely upon the diameter of the hole in the center of the scanning disc. It should fit this hole accurately, for the accuracy of the entire job depends largely upon this.

Passing through the two 8-32 nuts, there is a piece of brass provided with the same thread. The opposite end of this brass rod is slotted with a hack saw and a small flat piece of sheet brass is inserted and soldered in place. When this is done, the No. 78 drill is placed in the chuck of the pin vise and a hole is drilled near the end of the piece of sheet brass. In drilling this hole the pin vise, which is provided with a knurled handle, is manipulated back and forth between the thumb and index finger of the right hand, the left hand being used for a guide. One not accustomed to the use of a pin chuck might feel that the drilling of a hole through metal with such an instrument would be a long and tedious job. Such, however, is by no means the case. These tiny drills are very sharp and a hole may be drilled through a piece of sheet metal in a surprisingly short time. The writer has succeeded in drilling forty-eight holes through a piece of 1-16 inch aluminum in less than half an hour. Any greater speed might make for inaccuracy and several broken drills.

The placing of the hole in the sheet brass at the end of the rod finished the work on the jig. To use it, the shaft is first placed in the hole at the center of the disc. (The writer is assuming that the disc has previously been marked off in the proper number of degrees to accommodate the number of scanning holes to be used.) The hole in the end of jig is then brought to the proper position and the drill in the pin vise is inserted and the hole drilled. The drill is then removed from the jig and the flat piece of brass at the end of the jig is turned one half a revolution. Make sure that this is not turned a full revolution. To turn it only one half a revolution, the flat piece at the end of the rod should simply be turned upside-down. This

will advance the rod in the jig 1-64th (1-64th equals .015625 inch) of an inch and inasmuch as the drill produces a hole with a diameter of .016 inch an overlap of .000375 inch is made possible. This, as a matter of fact, is just about the correct amount of overlap needed for good reproduction.

In marking off the degrees of a scanning disc only ordinary care may be exercised for great accuracy is not needed. It is in producing the correct distance between the holes in the other relationship where skill and ingenuity are certainly needed. By the use of this little tool, however, the whole operation is now brought within the realm of the possible for even the

rankest kind of a ham mechanic.

The experimenter will understand that he need not be limited to this size drill or to the 8-32 thread. He may use many different combinations depending upon the size of the scanning disc he wishes to make and upon the size and number of holes he wishes to place in it. Threads with greater or less lead may be used. The threads with a greater lead would be used for larger holes and threads with less leads for smaller holes. It should be understood, however, that a 4-32 thread does not have less lead than a 6 or 8-32. The 4, 6 and 8 in these figures is a function of diameter. They all have the same lead.

THRU THE EDITOR'S SPECTACLES

(Continued from page 47)

vertising space who are members of the RMA have entered into a little "whispering campaign" with the editorial departments of our big dailies? We know of at least one paper that was threatened with cancellation of contracts if it persisted in the perfectly outrageous notion that the public was interested in television.

Oftentimes comparisons are more illuminating than odious. Perhaps this might be true of the comparison between an average radio receiver and an up-to-the-minute television receiver. We dare say that a well-designed television receiver will reproduce a picture better than the average radio receivers will reproduce music. God help television if picture signals had to be chewed up by passage through the audio systems with which some of our modern radios are equipped.

Some day, in the not-far-distant future, the RMA and the very busy Mr. Clarkson, are going to be quite sanguine concerning television. No longer will they attempt to suppress news. Indeed, the RMA members who now shudder at the thought of a public captivated with the idea of pictures via ether, will be anxious to supply that public with smiling propaganda of

another color. The age in which we move and live does not long countenance any attempt to place bunk and subterfuge in the way of progress.

The fact that television is here is accepted by the best technical minds of our times. The idea that it will need considerable improvement is not new with Mr. Clarkson. Any schoolboy knows that. Every scientific instrument and device in use at the present time will eventually have to be invented all over again. Television is no exception. We began to use automobiles before we had four-wheel brakes and ethyl gasoline. We were glad to have "carpet sweepers" before we had vacuum cleaners.

This is a funny world. Stupidity and skepticism is always poking its head out of dark holes to leer and scoff at progress. The "it-can't-be-dones" are forever and anon eating the dust of those forward-looking and courageous humans who are foolish enough to try and do it. The world grows on the thoughts of fools. It would perish with the thoughts of the Clarksons—provided, of course, that the Clarksons really believed what they were shouting about.

NEW LIQUID PHOTO-CELLS AMAZE ENGINEERS

Certain liquids in connection with certain metals have been found to exhibit a photo-electric activity when exposed to light. It is more than possible that the vacuum type of photo-electric cell will one day find a keen competitor in cells of the liquid type

By H. WOLFSON

THE light-sensitive cell, in one form or another, is the most important part of a television transmitter. The selenium cell is totally inadequate for the purpose, and even the potassium type of photo-electric cell does not conform to the stringent requirements of practical television. The purpose of the present article is to bring to the notice of readers a new type of cell, as yet very little developed, but which has, nevertheless, considerable possibilities.

The cell in question is of the type first discovered by Becquerel, in which two metal plates are placed in a glass cell containing a liquid (the nature of which I shall discuss in detail a little later), which, when illuminated, gives rise to a small photo-electric current.

An Experimental Cell

The effect has been observed in the following manner. Two copper plates (thin foil as used for fixed condensers) are thoroughly cleaned by immersing in a strong solution of caustic potash, and then washed under running water for some time to remove all traces of the potash, after which they are immersed in a very dilute solution of copper sulphate, made by dissolving 0.2 grams of crystallized copper sulphate in 1000 cubic centimetres of water. These are allowed to stand in the daylight (sunlight if possible) for eight days, after which time the plates will have become coated with a thin, bluish colored film, which chemical analysis has shown to be cuprous oxide. If now the cell be so arranged that one copper plate can be illuminated while the other is in the dark, it is found that a very small current will flow while the plate is exposed to the light, and will cease with the extinguishing of the light.

This elementary experiment was

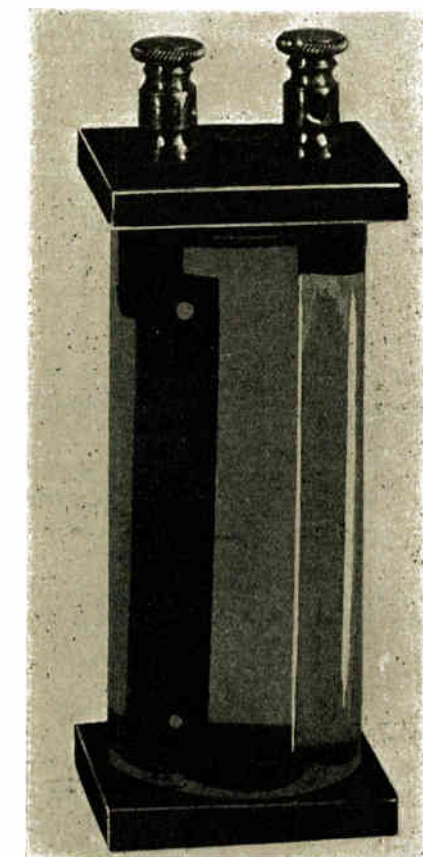

Here is shown one of the latest liquid type photo cells, developed by the well-known photo-electric authority, Mr. Samuel Wein. With this cell Mr. Wein has been able to produce, without batteries, a photo-electric current of several milliamperes even with very weak illumination.

improved upon by the American experimenter, Case, who proceeded as follows.

Copper electrodes size 4.4 cm. by 23 cm. long and thickness about 0.02 cm. were placed in a solution made by dissolving 6.25 gm. of pure crystallized copper formate in water and adding to the solution so obtained 0.5 per cent of 80 per cent formic acid. The plates were, of course, cleaned in the usual manner and polished with steel wool be-

fore immersion. Photo-electric effects were clearly shown when this cell was illuminated. It is not, however, my intention to go into details in connection with this early work, as much of it was unsuccessful in obtaining any definite results with other copper salts, or in fact with others which were tried.

The next important step was made by Baur, in Switzerland, in an important series of researches with uranium compounds. The Becquerel effect is shown by a number of inorganic salts. As a result of the Becquerel effect one experiences a change of electrode potentials, which are brought about in certain solutions by exposure to light.

In every case this change is reversible; it disappears again in the dark, reappearing with the switching on of the light, while the solution, by repeated changes from dark to light, undergoes a perceptible change. It has been shown by a number of people (Scholl, Goldmann and Brodsky, and Samsnow) that this is only a type of Hallwachs effect such as is shown by the potassium cell; that under the effect of light the light-sensitive molecules give off free electrons, which are collected by the electrodes. Baur thinks that the primary reaction in a photo-chemical modifying change of the light-sensitive substance occurs, and that these form material new compounds of their oxidation and reduction products.

These discussions are shown to be correct in a new degree, for by a continuation of his studies Baur has confirmed his hypothesis. After the photolysis of uranyl formate had been demonstrated, and it had been shown that a com-

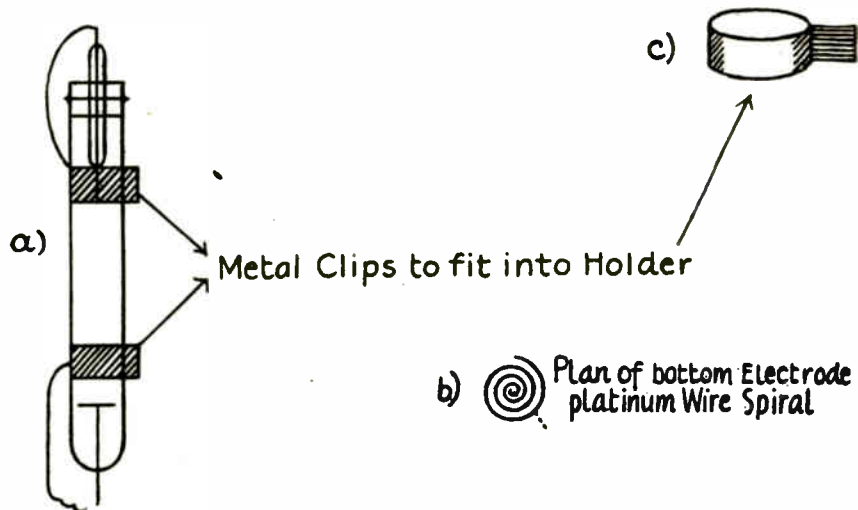

This is a diagram of an experimental set-up by which the phenomenon of photo-electricity may be demonstrated by very simple apparatus.

plete analogy existed between the existing photo-chemical and the observed electro-chemical delayed action of uranyl compounds, Baur decided that the primary action of light is to transform the light-sensitive substance into a higher or lower state of oxidation.

Stated in his own words, "The molecule of a chemical light-sensitive substance appears, therefore, by the absorption of light to undergo a form of electric polarisation, through which an outward operating potential difference results. This appears to be the primary photo-chemical change, and all photolysis and Becquerel effects are derived from it."

This brings us to the question of the Becquerel effect in dyestuffs. If Baur's view of the primary photo-chemical change occurs, the molecule of the light-sensitive substance loses one of its electrons through the absorption of a quantum of energy, and thus a potential difference exists between the positive nucleus and the lost valency electron, whose maximum value is limited by the magnitude of the absorbed quantum, so that the primary photo-chemical change can be represented by the equation:

$$E + hv = E^{\oplus}$$

where E stands for the receiver of the light quantum hv , and the symbol on the right-hand side of the equation indicates the condition of the light, that is, the condition of photo-chemical polarity.

Going back to our example of

the uranyl compounds, how can we explain the Becquerel effect on these grounds? In uranyl sulphate the effect develops by the presence of U^{IV} ions or of oxalate ions, etc.

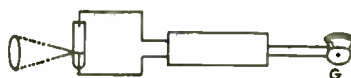

Alternative arrangement using valve amplifier and sensitive millivoltmeter or galvanometer.

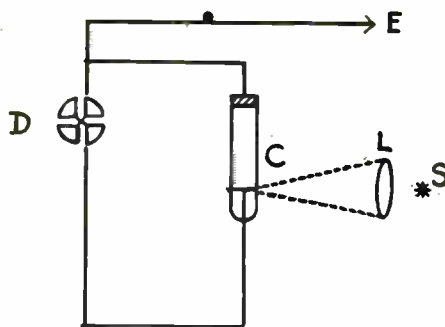

Arrangement for the illumination of the cell and the detection of photo-electric current. C represents the cell; D the Dalazalek electrometer; E the earth; L the lens and S the lamp.

In this case the appropriate photolysis can be written thus:

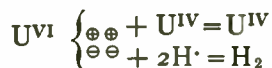

If we have undistributed photolysis of a hydrogen-oxygen mixture (in the proportion 2:1 as in the electrolytic gas from water) and an electrode at the hydrogen potential, the photolytic oxygen will be depolarized, thus bringing about the positive effect. If, on the other hand, there is an oxygen electrode, the photolytic hydrogen becomes

depolarized, and we then have a negative effect.

The results of a large number of experiments with solutions of dyes and of quinine sulphate are of the greatest interest, in that they show us the possibilities of improving and using such an arrangement, which is the essence of simplicity and cheapness, in place of selenium or other types of cells which are characterized by their time lag inefficiency or initial high cost.

Experimental Solutions

The following are the most important of the substances used by Staechelin in his researches, which were conducted in the laboratory of E. Baur:—

- (1) Quinine sulphate, in the presence of a little sulphuric acid.
- (2) Rhodamine B.
- (3) Rhodamine 3B.
- (4) Tetrachlorfluorescein.
- (5) Sodium salt of Eosin.
- (6) Phosphin, a mixture of hydrochlorides of chrysanilin and crysotoluidine.
- (7) Amido G. salt. 2.6.8 sodium naphthylamine disulphonate.
- (8) Amido G. salt 2.5.7.
- (9) Resorufin. an oxazine dye.

In order that the reader may realize the order of magnitude of the photo-electric current generated by this type of cell, I give below a selection of typical results obtained by Staechelin.

SOLUTION NO.	Dark P.D. Millivolts.	Light P.D. Millivolts.
(1) 0.5 per cent. rhodamine B. (IV.)	265	267
(2) 0.5 per cent. rhodamine B. (V.)	294	320
(3) 60 c.c. above + 5 c.c. 3.5 N potassium chloride . . . (I.B)	223	240
(4) 60 c.c. above + 40 c.c. 3.5 N potassium chloride . . . (III.)	244	319
(5) 96 per cent. alcoholic soln. rhodamine B. . . (VI.)	200	317
(6) 60 c.c. 0.5 per cent. rhod. B. + 20 c.c. acetaldehyde . . (II.B)	178	229
(7) 100 c.c. 0.5 per cent. rhod. B. + 3 c.c. M/5 oxalic acid . . (V.)	422	412
(8) 100 c.c. 0.5 per cent. rhod. B. + 3 c.c. M/5 oxalic acid . . (VI.)	412	402
(9) 100 c.c. 0.5 per cent. rhod. B. + 10 c.c. M/5 oxalic acid . . (V.)	396	407
(10) 2.5 grm. quinine sulphate in 250 c.c. water + 25 c.c. M/1 sulphuric acid . . . (II.B)	474	448
(11) 80 c.c. 10 per cent. quinine sln. + 40 c.c. vanadium dioxide in sulphuric acid . (I.B)	453	485
(12) 20 c.c. 10 per cent. quinine soln. 20 c.c. 40 per cent. formalin (II.B)	189	250

Experiments with alcohol, acetaldehyde, ferrous and ferric sulphate, ammonium oxalate, hydroquinone, potassium chloride, hydro-
(Continued on page 86)

KERR CELL FEATURE of KAROLUS TELEVISION

By HARRISON MAPES

A TELEVISION system which is receiving considerable attention in Europe is that of Dr. Karolus, a professor at the University of Leipzig. Some years ago Dr. Karolus began experimenting with still pictures transmission with the idea that through the evolution of still picture transmission would come television. Through the intervening years of effort, Dr. Karolus aimed at reducing the time element until today he is able to transmit his still pictures at a rate sufficiently great to produce the optical illusion of motion.

For the first time the Karolus television system was demonstrated in public at the Berlin Wireless Exhibition where it brought words of praise and approval from many of the great European scientists who had the opportunity of examining it.

The Karolus system possesses many ingenious and unusual features. It does not use scanning discs in the sense that we know scanning discs on this side of the Atlantic, nor does it use neon tubes. Instead of the Nipkow disc Karolus uses a transmitting disc provided with radial slots. This slotted disc is illustrated in Fig. 1. The beam of light which is provided by a beam of high intensity is concentrated by passing it through a cylindrical lens (5). Thus a strip of light of suitable width is caused to be projected. This strip of light is marked by (2) in Fig. 1. The moving picture film which is to be transmitted is represented at (1) in Fig. (1) and this passes continuously before a narrow wedge of light (2). It should be noted that the width of this light beam just corresponds to the width of one line of picture elements. The rate of the motion of the film bears a certain ratio to the number of

Not to be outdone by television experimenters of other countries. Dr. Karolus, a German scientist of note, has developed a most ingenious television system which, although not elaborate, promises big things.

One of the outstanding features of the Karolus system is the Kerr Cell which takes the place of our neon lamp. The Kerr cell is an inertia-less light valve demonstrating ideal properties for television use.

revolutions of the rotating disc (3). Each one of the slots in the disc picks out a picture element. The beam of light allowed to pass through this element strikes the photo-electric cell (4). It is through this method that the transverse line of the film picture passing through the wedge of light (2) is decomposed into a sequence

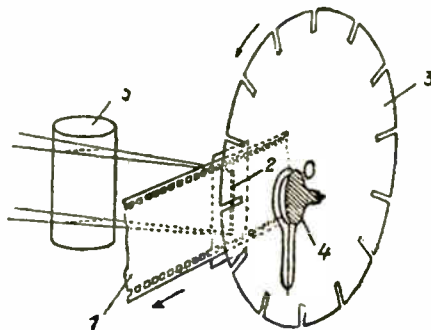

Principal components of the Karolus scanning system for motion pictures. (4) the photo-electric cell; (3) the disc; (0) the photo-electric cell; (5) a cylindrical lens and (7) the motion picture film.

of elements. While the film actually scanned is continually advancing by the width of one transverse line the disc (3) will rotate through an angle corresponding to

the distance between two successive radial slots. The width of light (2) passes through the cylindrical lens (5) and is thus accurately positioned by a slot diaphragm.

As yet all the American television receiving systems take advantage of the luminous agility of the neon lamp. Not so with the Karolus receiver which employs as its variable illuminant what is known as the Karolus cell, a device based on a discovery that Kerr made in 1875. The cell operates on what is known as the Kerr effect, i. e., the electric double refraction of polarized light when permitted to pass through nitro-benzol or carbon disulphide. The Karolus cell takes the form of a miniature condenser filled with nitro-benzol and provided with two electrodes. The output of the special short wave receiver, after being amplified at audio frequency, is fed directly to the electrodes of the Karolus cell. This is the "light loud speaker" of the Karolus system. The polarized beam of light when passing through the electrostatic field set up by the potential differences between the electrodes is caused to rotate and the intensity of the emerging beam is thus varied in accordance with the varying electric tension.

A picture diagram showing the source of light (2) at the Karolus cell (1) is given in Fig. 2. After the light passes through a series of lenses at the Karolus cell, it strikes a Weiller mirror wheel which has attached to its periphery a large number of slightly tangent mirrors. Karolus has used both fifty- and hundred-mirror wheels. Due to the slight and varying angles at which these mirrors are placed on the periphery, this wheel causes the beam of light to sweep the screen completely once for every revolution. Thus, instead of peeping

through a peep-hole as the American television amateur must do, the Karolus system provides projection on a wall.

Special means are provided for holding the mirrors to the wheel so that the centrifugal force, although not great, will not suc-

Radio Show pictures made up of 10,000 picture elements were successfully projected. The inventor, Dr. Karolus, believes that this number of picture elements can be greatly increased without unduly taxing his equipment. Both the photo-electric cell used at the trans-

position, either in the vertical or horizontal direction as the direct-current driving motor got in advance or behind synchronous phase. The speed has therefore to be continually adjusted by a rheostat to keep it in position. The motor appears to hold in phase for periods of about thirty seconds.

The Manchester Commercial says: "In considering Mr. Baird's achievement we have to remember that the radio transmission involving the reception of two carrier waves and the control of the motor speed, was not demonstrated, and there is no indication at present of the degree to which this will affect the image. We have further to emphasize that the more moderate-priced set was not demonstrated, and it would appear to be commercially certain that its image must be very much cruder than that of the more expensive model."

A rival model exhibit was the Fultograph, which is being produced by the recently floated Wireless Pictures, Limited, and sold by Burndept and Selfridge. This apparatus is to be used for the reception of still pictures and charts, which, it is stated, will be broadcast from certain stations by the B. B. C. in the near future.

It consists of a slowly rotating drum on which is placed a strip of paper dipped in a sensitizing solution, such as ferro-cyanide and ammonium nitrate. A stylus traverses the whole surface of the paper as the drum rotates, the whole appearance being reminiscent of the old Edison phonograph. When a strong current is passed through the stylus and the paper a deep blue mark is made on the paper and a fainter mark for a weak current. If then the impulses of current received correspond to the successive light tones of the picture at the sending end a picture will be reproduced.

The sending apparatus consists of a similar clock-work driving drum. Instead of a piece of sensitized paper, however, an engraved copper foil is placed in the drum, the picture to be transmitted being produced by varying thicknesses of insulation over the copper foil—a light-toned part being reproduced by a point of bare copper and a dark tone by a point covered by the maximum thickness of insulation.

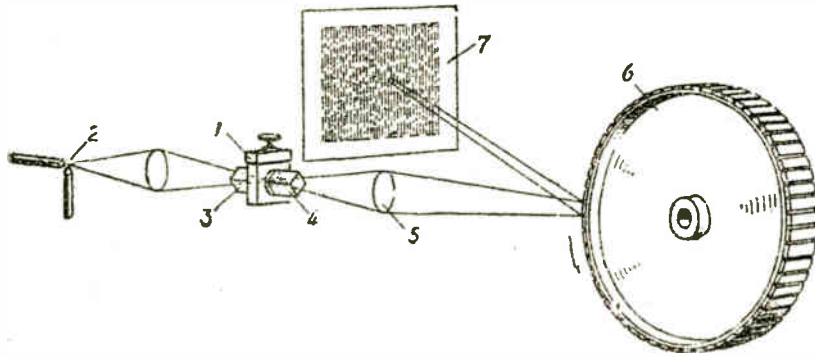

Here are shown the principles of the optical system employed by Dr. Karolus. Light from a source (2) passes through a Karolus cell (4) the lens (5) on to the periphery of a wheel (6). This wheel carries staggered mirrors which flash the light over the entire surface of the screen (7).

ceed in dislodging them. The mirrors being mounted parallel to the axis of rotation are slightly inclined, their respective angles gradually increasing from one mirror to another.

So accurately are these mirrors arranged that when the wheel is revolving, the screen upon which the incident mean of light is reflected appears to be uniformly illuminated over its entire area.

In the exhibition at the Berlin

mitting end and the Kerr cell used at the receiving end are capable of handling much greater speeds, inasmuch as both are free from any measurable inertia at even the highest frequencies. If the number of picture elements were doubled from 10,000 to 20,000, an increase which seems to be easy attainable, the Karolus system would, without doubt, take on a highly perfected form.

TELEVISION AT THE LONDON RADIO SHOW

LONDON. At the Radio Exhibition recently held at Olympia, television easily took first place in public estimation. Probably, among the "novelties" the Baird "dual" sets for simultaneous reception of speech and television attracted most attention. This company exhibited three sets which ranged in price from \$130 to \$800. The low-priced set consists externally of a box about two feet square with a screen about three inches by 4 inches let into one side and on which the image appears. The higher priced set is a handsome piece of cabinet work standing about four feet high. On one side is the loud speaker and on the other a cylindrical hole about 8

inches in diameter, at the back of which is the screen on which the image appears. With the most expensive set a demonstration, which proved exceedingly popular, was given, simultaneous speech and television being transmitted over a land line from a station three-quarters of a mile away. On the screen appeared in the faint pink light of a neon glow tube an image of first a dummy and then a man. The latter spoke and informed the audience what he would do next. The image was recognizable, and such actions as the rolling of eyes and putting out the tongue were plainly perceptible. The image was divided into about thirty strips, and was continually getting out of

DR. ALEXANDERSON *Puts* *Television Pictures on the Wall*

By MORRIS DUNN

THE public has, since the inception of television, persistently held to the belief that a television performance must be in the form of a moving picture display. In this, of course, the public has been a bit presumptuous although technical workers in the field well realize that this notion of the public must be fulfilled before picture entertainment by radio will be ready for commercial exploitation. To be entertained at a peephole is something one used to expect at the penny arcades and it is reasonable to believe that television will have to measure up to better standards than this before it can be accepted in the homes of the country as something to rival the movies.

When movies are projected on a screen, a powerful source of light must be used. This light, except in the case of small home movie outfits, is usually an arc consuming as much as 3,000 watts. As yet, of course, it is quite impossible to control such a vast amount of energy with the small amount of current represented by an amplified television signal received on a conventional set. If some means could be found to make a powerful arc light fluctuate between the limits of bright and dim, the prospects for large television pictures on the wall of the home living-room would be much better. However, that is not the case and other and less efficient source of light similar to the neon lamp must be used.

Patrons at the New York Radio Show were quite amazed to find that television pictures could be projected upon the wall even with the modest equipment now available in the way of controllable light sources.

The picture projected there was about fifteen inches square, and, like all pictures, produced by neon lamps, in tones of red. The television experimenters who witnessed

this program, were curious to know how Dr. Alexanderson of the General Electric Co., had managed to project such a presentable picture with the means at his disposal.

In the first place, a special neon lamp was employed. Instead of the conventional form having two flat electrodes, Dr. McFarland Moore, the inventor of the neon lamp, designed a special form which was provided with circular electrodes, one arranged concentrically within the other. When supplied with the correct voltage, this form of lamp will provide light of greater intensity suitable for projection. Of course, this did not solve the problem entirely, nor should the novice believe that to have television pictures on the wall he need only have a special and more powerful neon lamp. There is more to it than that.

In Dr. Alexanderson's experiments, the usual scanning disc was replaced with one having 48 one-half inch lenses arranged spirally. This was necessary to increase the efficiency of the optical system. To

the illustration and while the distances are by no means proportional a general idea of the operation of the equipment will be gained by the student.

Using this special equipment, Dr. Alexanderson was able to project exceptionally good pictures a little better than one foot square. The transmission, however, was confined to land wires inasmuch as the frequencies ran as high as 20,000 cycles. During a special demonstration at the plant of the General Electric Co., a picture of a boxing match, in which the full forms of the participants were shown, was projected. Those who witnessed the experiment claimed that the detail of the pictures was nothing short of marvelous.

The reader of this article cannot help but come to the conclusion that the major problem of television lies in light control. What is needed is a powerful source of light that may be delicately regulated between wide limits by the small amount of energy available in television signals. Pow-

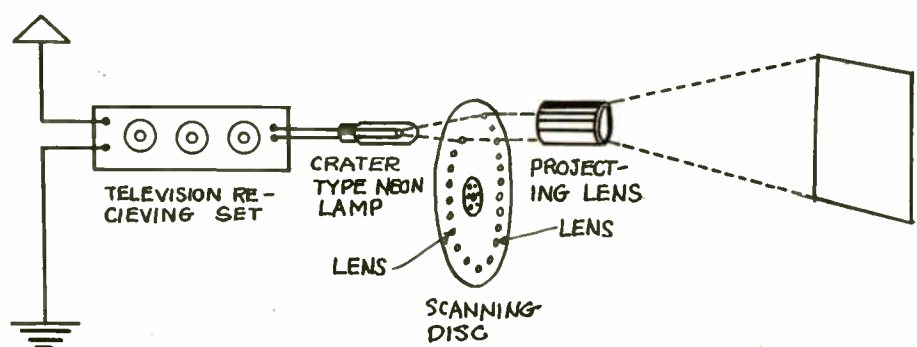

In projecting pictures on the wall, Dr. Alexanderson employs a special crater type of neon tube which is far more powerful as a source of illumination than the plate types ordinarily employed. The light from a neon tube passes through a large projecting lens.

still further increase the efficiency of the system, a high-grade projector lens similar to that employed in a motion picture machine was pressed into service. The arrangement of this apparatus is shown in

erful lights, either arc or incandescent, are pretty rugged devices and it would seem that some altogether new system must be devised if this problem is to yield.

(Continued on page 86)



Invisible radiations of all sorts constantly pass through the earth's atmosphere. These experimenters are shown watching special apparatus used for making visible electronic bombardment.

WHAT TELEVISION EXPERIMENTERS SHOULD KNOW ABOUT RADIATION

By DR. J. A. FLEMING, F.R.S.

IF any of the leading physicians in the mid-Victorian age had been asked whether they knew anything about the nature of a ray of light and how it is produced, they would have replied: "Why certainly! Light consists, physically speaking, of transverse vibrations in the ether, and is produced by the like small tuning-forks, vibrate and produce ether waves of the same frequency as the atomic vibrations."

We now think that the above statements are of questionable accuracy. We have no direct experimental proof that there is an ether, and we have good reasons for thinking that the rate at which an atom or any part of it can oscillate

has no simple relation to the frequency of the resulting emitted radiation, such as was formerly assumed.

In view of the use in television by Mr. Baird of a certain range of radiation, which cannot directly affect the eye, it may be useful to set out some modern knowledge on the production of radiation, visible and invisible.

Structure of Atoms

First, as regards the structure of chemical atoms, the hypothesis widely accepted at present is that they are built up of two kinds of more elementary particles, named protons and electrons, which, taken collectively, form the so-called positive and negative electricities.

The protons with some electrons

are united in a very small and dense nucleus of the atoms and the remainder of the electrons revolve round the nucleus in various orbits called the K, L and M, etc., orbits. The number of these planetary electrons, or the excess of the number of protons over and above the nuclear electrons, is called the atomic number of the element.

The proton has about 1,800 times the gravitative mass of an electron, but they have equal electric charges of opposite sign. Hence protons attract electrons powerfully; and electrons repel electrons. Both protons and electrons may be considered to be centers from which a system of lines of electric force radiates, the direction of the lines

being opposite in the two cases (see Fig. 1).

Hence, if an electron and a proton were to meet squarely at the same place they would annihilate or destroy each other.

When an electron or a proton is in motion, in addition to its system of divergent lines of electric force its path of motion is surrounded or embraced by closed lines of magnetic force, and in its equatorial plane the lines of electric force and magnetic force are at right angles to each other and to the direction of motion (see Fig. 2).

If an electron or a proton is accelerated or is increasing its speed along a straight line, then "kinks" are created in the lines of electric force which fly outwards along the line with a speed of 300,000 kilometres per second, and these moving kinks are accompanied by lines of magnetic force at right angles (see Fig. 3).

This motion of lines of electric force in a direction perpendicular to themselves, accompanied by lines of magnetic force also mutually perpendicular, is called electromagnetic radiation, and it involves the passage of energy through space. This energy is drawn from that of the accelerating electron or proton.

Let us consider, then, the sim-

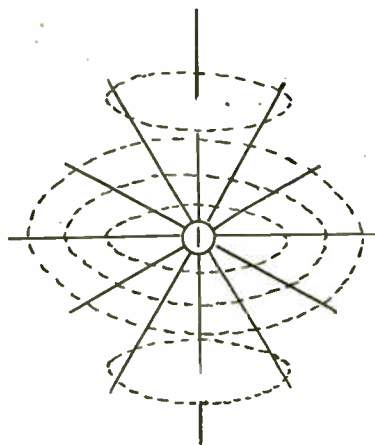
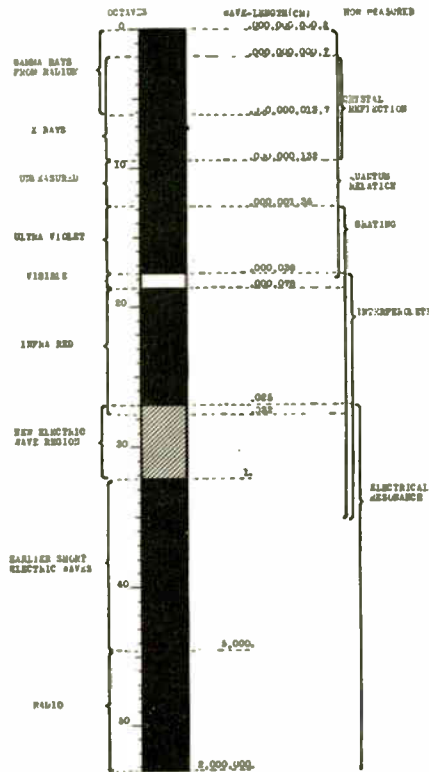

Fig. 2.

An electron in motion has not only radiating electric lines represented by the firm black lines but a system of circular lines of magnetic force represented by the dotted lines. These circles are seen in perspective as oval curves and have their planes perpendicular to the direction of motion of the electron.

plest atom, viz., hydrogen gas. The molecule consists of two atoms, each of which comprises a single

proton with an electron revolving round it. According to the Newtonian or classical system of dynamics a particle revolving uniformly in a circular orbit is being accelerated because the direction of its motion (though not its linear speed) is continually being changed.



In this list all of the known radiations are listed in relation to their wave-length. It will be noticed that the visible portion of the spectrum occupies a surprisingly small section of the scale.

Hence such a revolving electron should radiate electromagnetic energy and in a short time the electron and proton would fall together, and the atom of hydrogen would disappear in a flash of radiation.

Bohr's Hypothesis of Atomic Radiation

But this does not happen, and an hypothesis to explain the permanence of the atom was suggested by Dr. Niels Bohr, the Danish physicist. He supposes that the planetary electron cannot revolve round the proton at any distance, but only in certain orbits, called permissible orbits, in which it does not radiate; and that the electron only radiates when it jumps or is knocked from an outer orbit into an inner one.

If we imagine a wood board

with circular grooves in it, and a marble were pitched on to the board, it would fall into one of the grooves and travel round it. If another marble were pitched at the first and hit it, the latter might be knocked out of one groove into another.

Something of this kind happens in the case of an atom. The space round the nucleus is altered in some way so that an electron can only revolve round the nucleus in certain orbits spaced apart, but not in any intermediate orbit. The radii of these orbits are proportional to the squares of the natural numbers, viz.: 1, 4, 9, etc. When revolving in an outer orbit the electron has more energy than when revolving in an inner orbit.

Suppose, however, that when revolving in an outer or large orbit some stray electron comes along and knocks it into an inner or smaller orbit, then the energy of the revolving electron is diminished, say, from W to w units.

Bohr's hypothesis is that when the electron is revolving in any permissible orbit it does not radiate, but when it is knocked or jumps from a large to a smaller orbit it gives out radiant energy of a frequency n such that $nh = W - w$ where h is a constant of nature equal to $6.5 \div 10^{27}$, called Planck's Constant. The electromagnetic radiation which results is not given

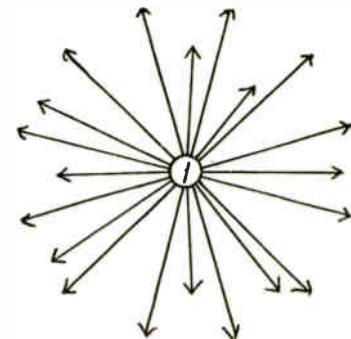

Fig. 1.

Lines of electric force proceeding from an electron at rest. These lines run out in all directions and not merely in one plane as shown in the diagram.

out in a single pulse, but in a series of pulses coming n times per second, and this wave train is like a short musical sound or note issuing from a horn when it is blown.

Effect of Change of Orbit

When a free chemical atom such as an atom of hydrogen gas is

struck by a wandering electron in such a way as to make its own revolving electron fall from one orbit to another inner one, the radiation given out will have a certain pitch or frequency depending on the two orbits concerned. The atom of hydrogen as well as other atoms may be compared to a bell which, when struck in a certain way, gives out a short musical note of a certain pitch.

When a tube full of rarefied hydrogen is subjected to an electric discharge some atoms are giving out one note and others are giving out notes of different pitch. If we analyze this complex radiation by a prism or spectroscope we are able to see the radiations of various frequency separated as "lines" in the spectrum. Some of this radiation is of such a frequency as to affect the eye as light, and these are the visible "lines" or rays.

Others do not affect the eye, but affect a photographic plate or a sensitive instrument of some kind, and are called the ultra-violet or ultra-red lines, according to whether their frequency is greater

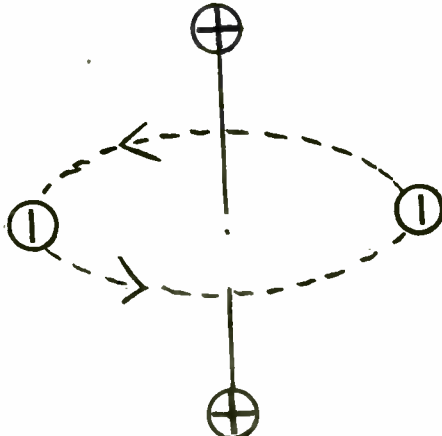

Fig. 4.

A diagram of a molecule of hydrogen. Two negative electrons rotating round two protons. The protons occupy positions at the ends of an axis and the electrons revolve round this axis with the plane of their motion at right angles to the axis.

or less than that of the visible lines.

Result of Orbital Changes

In the case of the hydrogen atom there are five or six or more permissible orbits. When the orbital electron falls from an outer orbit to the third orbit it produces the ultra-red lines. When it falls into the second orbit it produces the vis-

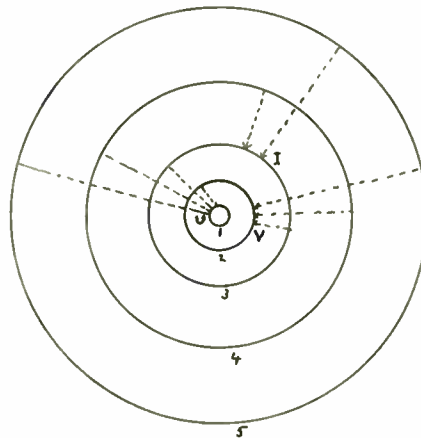

Fig. 5.

A plan of the permissible orbits of a hydrogen atom. When the revolving electron jumps from any orbit to an inner one electro-magnetic radiation is produced.

ible lines, and when it falls into the first orbit it produces the ultra-violet lines or rays (see Fig. 5).

Bohr and others have shown that the frequency or number of vibrations per second of the radiation corresponding to each "line" in the spectrum can be calculated from a formula

$$n = B \left(\frac{1}{s^2} - \frac{1}{m^2} \right)$$

where B is a certain constant number and s has the values 1 for the ultra-violet lines, 2 for the visible, and 3 for the ultra-red lines; and m takes various integer values, 2, 3, 4, 5, 6, etc., for the different lines.

Thus the hydrogen spectrum has three visible "lines," red, blue and violet in color; and the frequencies of these are respectively 460, 625 and 691 billion. (N.B.—A billion in English measure is a million times a million.) These are calculated from the formula

$$n = 3289 \times 10^{12} \left(\frac{1}{4} - \frac{1}{m^2} \right)$$

where m=3, 4 or 5.

It should be noticed that an atom of a gas cannot radiate unless an orbital electron in it has first been lifted from an inner orbit to an outer one, and then falls back from this outer one into an inner one again, thus producing radiating of definite frequency, or emitting a "line" spectrum.

The reader should understand that the method adopted here of explaining radiation as a kind of

vibration transmitted along a line of electric force, just as a jerk or hump can be propagated along a stretched cord, is only one of several different modes of explanation which might be adopted.

The question whether the lines of electric force proceeding out from electrons and protons have a real existence, or are only imaginary lines indicating the direction of electric force, is one which cannot be discussed here. The actuality of these lines, and that vibrations can be transmitted along them is, however, an hypothesis which was suggested by Faraday and has been developed by Sir J. J. Thomson. It has much to be said in its favor as a simple mode of making things intelligible; but on the other hand, there are objections to it.

Radiation From Incandescent Solids

Let us next consider the radiation from atoms of an incandescent solid, such as a tungsten filament in an incandescent electric lamp, or the lime cylinder in a lime light.

In a solid substance the atoms are jammed together in nearly close

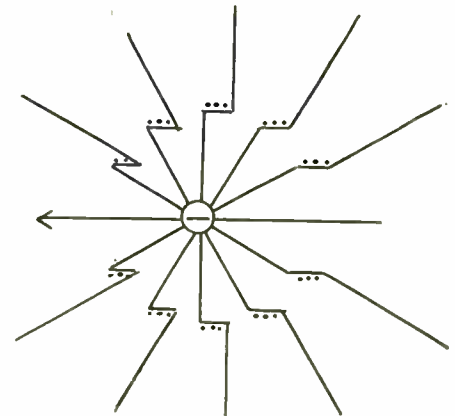

Fig. 3.

An electron jumping forward (to the left). The inertia of the lines of electric force causes a "kink" or bend in the line to occur. These "kinks" fly outward with the speed of light and are accompanied by lines of magnetic force embracing them. The sections of these lines of magnetic force are represented as dots.

contact, but they vibrate or oscillate when the solid is hot. In this process electrons are detached from atoms with very various velocities and energies.

When a free electron finds its way back into the family circle of an atom which has already lost an orbital electron from one of its

outer orbits, the newcomer brings with it a certain amount of energy which may have any value within limits. The new arrival then settles down in an orbit of the ionized atom and the difference between its energy then and before its impact is converted into radiation. Since the impinging electrons are not able to penetrate very far into an ionized atom's private family circle of orbital electrons, the energy available for conversion to radiation is not large; and hence the frequency of that radiation will be small. This implies that the radiation will lie chiefly in the ultra-red part of the spectrum.

Since these impinging electrons may have energy of very various amounts, the emitted radiation will have frequencies which are not definitely separated in amount like those of the spectral lines of a free gas molecule; but the radiation from a solid has frequencies of all kinds over a wide range, and it thus yields a continuous spectrum when the radiation is analyzed by a prism.

Line and Continuous Spectra

Hence, whilst the radiation from a gas which is being subjected to an electric discharge or is otherwise heated is a series of radiations of isolated and different wave lengths forming a "line" spectrum when viewed through a spectro-scope, the radiation from an incandescent solid is, on the other hand, of every possible wave length within certain limits, and is a continuous spectrum.

Thus when we look at a straight incandescent filament of tungsten through a prism we see a rainbow-colored strip of light which forms the visible spectrum. But beyond the red end there is an invisible spectrum of dark radiation; and the same beyond the violet end. The visible radiation is only a small part of the total radiation.

Ultra-red or Dark Radiation

By far the larger part of the radiation from ordinary sources of light is dark or ultra-red. Thus 90 per cent of the radiations from an electric arc lamp with carbon electrodes is non-luminous; and so, probably, is 95 per cent of that of an ordinary incandescent lamp.

The great problem of artificial

illumination is to discover a source of "cold light" which yields eye-affecting radiation without the waste involved in the production at the same time of a large amount of dark or infra-red rays which cannot affect the eye.

The radiation from an electric discharge through a rarefied gas (as in the neon tubes used for shop advertisement) is more "efficient" in this sense than the ordinary electric lamp, though it yields, as does the mercury arc lamp, a very special "bright-line" radiation far from being equivalent to white light in its power of revealing colors correctly.

Filtering Out Dark Radiation

These different parts of the total radiation, viz., the infra-red of thermal, the luminous or visible, and the ultra-violet or actinic, can be separated in various ways, as, for instance, by screens.

Thus glass is transparent to the luminous part, but not to the actinic or dark heat. The glass roof of a green house admits the light of the sun, and this, galling on the objects within it, is absorbed and heats them. But the radiation from these objects is infra-red; and this will not pass out through the glass and, therefore, the temperature within rises much above that of the outside air.

On the other hand, a thin sheet of ebonite is quite opaque to light, but very transparent to dark heat or infra-red rays. Again, quartz is very transparent to ultra-violet radiation up to a certain limit. A solution of iodine in bisulphide of carbon is transparent to dark heat, but opaque to light rays.

Selective Reflection

There is another method by which infra-red or dark heat rays can be separated out, viz., by means of repeated reflection from certain surfaces. Certain objects which we call colored have a selective reflection for luminous rays of a certain wave length.

Thus a geranium petal is red because when white light composed of a mixture of radiations of very different wave lengths falls upon it it reflects only those of that wave length which affect the eye as red rays and absorbs the rest. If there were no red rays in the incident light the petal would appear to be

black. It does appear black when placed in the green part of a visible spectrum.

In the same way certain materials, such as thallium iodide exert a selective reflection on certain wave lengths of infra-red or dark heat-radiation. If then a beam of complex infra-red radiation is repeatedly reflected from several such surfaces, a ray of a particular wave length will be weeded out and can be detected as surviving these numerous reflections by its effect on a thermopile.

Also the wave length of these sifted out ultra-red rays can be measured. By this means it was found possible by Rubens, Nichols and Wood to filter out from the dark-heat radiation of a Welsbach gas mantle or other source invisible rays the wave length of which was as much as 1/75th of an inch, that is, about 500 times the wave length of the extreme red rays in the visible spectrum, or 9 octaves below it in a musical sense of the word.

Dark Heat and Electromagnetic Radiation

The eminent British physicist, Clerk Maxwell, predicted in 1865 the possibility of producing electromagnetic radiation, and that light was of this character; but it was not until 1887 that the German physicist, Hertz, succeeded in actually producing such radiation. Little by little the methods were found of producing this electromagnetic radiation of ever-increasing and also continually decreasing wave length and all intermediate wave lengths.

Nichols and Tear succeeded in 1923 in producing electromagnetic radiation with a wave length of only 1/100th of an inch, whilst wave lengths up to 50,000 feet are in use in wireless telegraphy in the large all-round stations.

We have thus succeeded in producing by purely electrical methods Hertzian waves which are shorter than the longest of the ultra-red rays in a gas lamp. There is, therefore, no gap in the continuous spectrum of electromagnetic radiations extending from the longest wireless waves to the short ultra-violet or actinic rays; and little or no gap between these and the X and gamma rays.

OPTICS FOR TELEVISION EXPERIMENTERS

In this, the beginning of a new series, Prof. Cheshire makes of optics an absorbing and fascinating study. Since the science of optics is a most important one in connection with television, all television experimenters will do well to become more familiar with its principles

By PROFESSOR CHESHIRE, C.B.E., A.R.C.S., F.I.P.

OPTICAL Pointers.—Every schoolboy who has temporarily blinded his classmates by surreptitiously flashing a beam

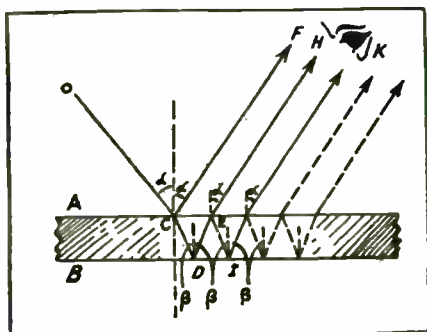

Fig. 2.—Optical action of plane-parallel plate.

of sunlight into their eyes, with a bit of broken looking-glass, knows what an optical pointer is: it is a narrow beam of light of any desired length which can be turned in any desired direction.

Fig. 1 shows in plan an optical pointer as applied to Thomson's (later Lord Kelvin) mirror galvanometer—the instrument which played such an important part in the successful introduction of submarine telegraphy more than half a century ago.

A small mirror, M, about the size of a threepenny piece, and weighing a few grains, has stuck upon its back two or three tiny magnets. This mirror is suspended by a silk fibre and adjusted so that it lies across the axis of a wire coil through which passes the electrical current to be measured.

Light from an illuminated slit

falls nearly normally upon this mirror and is reflected back again in the same vertical plane, on to a scale S, the zero of which is immediately above the illuminated slit. The mirror is slightly lenticular in shape, so that a sharp image of the slit is thrown on to the scale.

When a weak current passes, the magnets and the mirror are twisted through a small angle α . The angle of incidence, originally zero, is now α , and since the angle of reflection is equal to the angle of incidence, it follows that the reflected beam has been deflected through an angle equal to 2α , and this angle is represented on the scale S by a length l , which depends upon the distance of the scale S from the mirror M.

Multiple Images by Reflection

When a candle, placed at a distance of, say, 15 to 20 feet, is seen by glancing reflection in an ordinary looking-glass, lying flat upon a table, a number of images of the candle are usually seen, tailing off in one direction or the other with diminishing intensities, and if the looking-glass is rotated in its own plane—i.e., about a vertical axis—the tail of images will be seen to waggle slowly and change in length. If now we substitute for the looking-glass a plate of glass which has been worked accurately to plane-parallelism—a first-class sextant horizon glass silvered at the back will

do—it will be found that only one image of the source of light (which in this case should be a distant hole in a piece of cardboard with a candle behind it) will be seen; and rotating the glass in its own plane produces no effect.

This experiment, giving "one image all round," is an old workman's test for plane-parallelism. In more modern shops the more delicate test afforded by interference phenomena is used. The light in the last experiment should be not less than 15 to 20 feet away. If only a few feet away multiple images will be seen, but

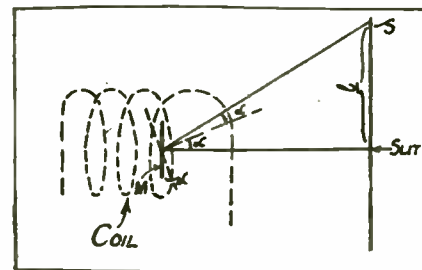

Fig. 1.—Optical pointer fitted to a galvanometer.

they will be unaffected by the rotation of the plate.

Anent the experiment with the ordinary looking-glass referred to above, a story is told which is too good to be lost.

Many years ago someone wrote to the *Daily Graphic* and explained that although it was generally believed that the satellites of Jupiter could not be seen without the help, at least, of a pair of opera-glasses, he possessed a re-

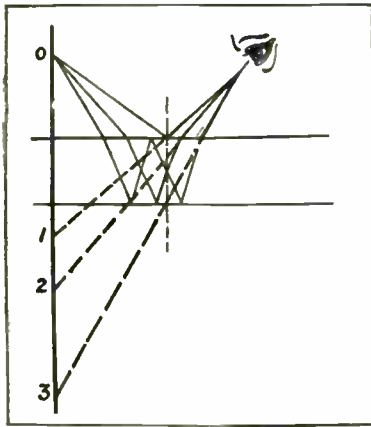

Fig. 3.—Multiple images in plane-parallel plate.

markable looking-glass—a treasured heirloom—in which the satellites could be seen by simple reflection.

The next day, however, a wag wrote to say that he possessed a still more wonderful glass, for not only did it show the satellites by reflection, but, when the glass was rotated in its own plane, it showed the satellites rotating around Jupiter!

The correspondence then ceased.

How Multiple Images Are Produced

When light falls upon a plane surface of a transparent body it is split into three parts. One of these is scattered or reflected in all directions, one is regularly reflected in accordance with the law of reflection, whilst the third part enters the medium and is transmitted in accordance with the law of refraction.

In the case of polished glass the scattering is negligible. Suppose, then, that light falls upon such a glass, plate AB, Fig. 2. At every point of the surface A, such as C, the light falling in the direction OC is divided into two—one CF, reflected; and the other CD, transmitted. Similarly when the ray CD falls upon the second surface B it is divided again into two, a reflected ray DE, and a transmitted one DG (not shown).

Again, at E, EH escapes into the air and is refracted, whilst EI is reflected. If the surface B, which may be silvered, is accurately parallel to the first surface A, then the angles x are equal, as

are also the angles B , from which it follows that the rays CF and EH, together with an indefinite number indicated in dotted lines, emerge parallel to one another.

If the source of light be at such a distance that the angle of incidence x does not change appreciably from point to point of the surface A, then all the rays will form a parallel bundle, which, filling the eye anywhere as at K, will come to a single-point focus on the retina producing the single image seen.

In many text-books the diagram Fig. 2 has been given erroneously to explain multiple images. So long as all the imaging rays are parallel to one another one image only can be seen.

When a near source of light, some two or three feet away, is

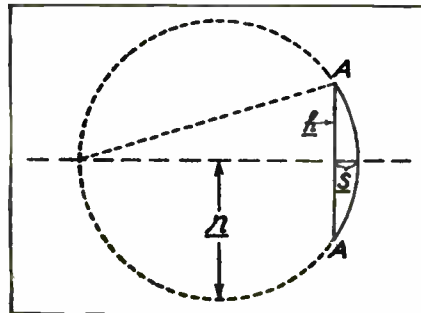

Fig. 5.—Relationship of radius and sagitta.

used with a true plane-parallel plate, the angle of incidence x changes from point to point of the surface A, and multiple images result, as shown by the diagram, Fig. 3.

The first image seen in the direction EI is due to reflection at the first surface A only. The second image, 2, is due to light reflected once from the surface B, whilst light reflected twice at this surface produces the third image, 3. It is important to remember that the crucial test for plane-parallelism is to rotate the mirror in its own plane. If the image or images do not move, the plate is plane-parallel to a fairly high order of accuracy; if the images do move, the glass is wedge-shaped.

Curvature—Newton has given us for the expression of the curvature of a line at any point the equation—

$$C = \frac{1}{r} \dots (1)$$

where C is the curvature, and r the radius of the circle which fits the curved line at the point considered—the so-called osculating or kissing circle. Newton in thus defining curvature as the reciprocal of the radius of curvature was simply giving mathematical expression to the popular conception of curvature. The smaller a circle the greater its curvature.

The curvature of the line L at the point A is equal to $1/r_1$, the reciprocal of the radius r_1 of the kissing circle shown; similarly the curvature at B is equal to $1/r_2$.

Radii of Curvature

Let us consider for a moment the varying curves which occur on a railway line, taking conveniently a mile as our unit of length. A section of the line, described with a radius of one mile, would have a curvature of $1/1 = \text{unity}$. A sharper curve with a radius, say, of a quarter of a mile, would have a curvature of $1/1/4$, equal to 4 , and so on. For a straight line, which may be looked upon as part of a circle with a radius infinitely great, the curvature is $1/\infty$, equal to 0 or zero, the symbol ∞ indicating that r is taken as very great—strictly speaking, infinitely great.

Fig. 5 shows a circle with a radius r and a curvature therefore of $1/r$. Let a diameter be intersected rectilinearly by a chord cutting off the arc AA , and a segment s † of the diameter. By the

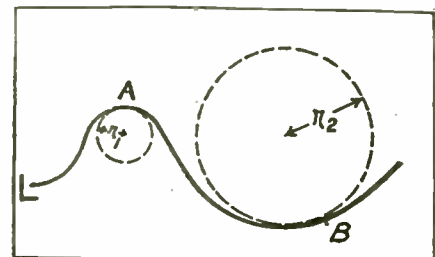

Fig. 4.—Line with varying curvature.

geometry of similar triangles—

$$s : h :: h : (2r - s) \dots (2)$$

If the arc AA is but a small part of the complete circle, as it is in most mirror and lens problems, then $2r$ can be taken as equal, very

nearly, to $(2r-s)$, so that we can write—

$$s = \frac{h^2}{2r} \dots (3)$$

i.e., so long as h is constant in length, the length of the segment s varies directly with the curvature $1/r$.

Measurement by Spherometer

In the case of large lenses, such as the object-glasses of astronomical telescopes, it is not practical to measure the radii of curvature directly, but with the aid of the spherometer shown by Fig. 6 the operation is a simple one. The spherometer in one form consists of a short length of tube P, the radius h of which is accurately known, fitted with an axial micrometer screw Q. The tube P is placed upon the spherical surface O to be measured and the screw Q adjusted to touch that surface.

The distance s —the sagitta—between the lower end of the screw Q and the plane defined by the lower edge of the tube P is then read off on a circular scale T, carried by the screw Q. Let the radius of the sphere O be r ; then, from equation (2) above, it follows that:

$$r = \frac{h^2}{2s} + \frac{s}{2}$$

This segment s , from the similarity of the figure to a bow and arrow, was called by Kepler the "sagitta" of the arc; hence the modern method of dealing with mirror and lens problems by the consideration of waves and their curvatures, originally introduced by Porro, is often referred to as the sagitta method.

so that if $h=6$ inches and $s=0.1$ inch, then

$$r = \frac{6 \times 6}{0.2} + 0.05 = 180.05 \text{ inches.}$$

The approximate formula (3) above, gives 180 inches.

The result arrived at in equation (3) is a very important one, because one of the most delightfully simple and natural methods of solving mirror and lens problems is based upon it—the method in which waves are considered

rather than rays. Obviously, by using a standard aperture in which h is made equal to $\sqrt{2}$, $h^2/2$ is made equal to unity, so that the sagitta s of an arc becomes numerically equal to $1/r$.

This really arises from the fact that in all the problems with which we shall be concerned we shall have to deal with linear equations only, in which $h^2/2$ is a multiplier of both sides, so that it cancels out.

Thus, using this standard aperture on a sphere with a radius of 10 inches, it would be found that the corresponding sagitta had a length of $1/10$ inch.

The reader is strongly advised to draw a number of circles on paper with different radii, then draw a chord of 2.83 inches in each one. Measure the sagitta and check it against the reciprocal of the radius.

Reflection by a Curved Surface

When a light-wave falls upon a plane surface it is reflected, as we have seen, without change of curvature; but if the reflecting surface be curved it then impresses a curvature upon the incident wave during the act of reflection, with the result that the curvature of the reflected wave differs from that of the incident wave. Indeed, a curved mirror might be defined as an optical contrivance for changing the curvature of light-waves.

In Fig. 7 a plane wave is shown falling symmetrically upon a convex mirror M, which may be looked upon as a circular disc, with a linear aperture ABA, cut out of a hollow sphere with its centre at O, and having a radius r . The wave, at the instant shown, has reached the vertex V of the mirror, but it has still a distance s , equal to VB, to go before it strikes the rim of the mirror at A.

Whilst it is moving through this distance near A from right to left, the part of the wave at V will move from left to right to the point V_1 , also through a distance s , so that, when the reflection is completed, the wave will have the shape shown by the dotted line, passing through the three points AV_1A .

Assuming that the angular aper-

ture α of the mirror is small, the new wave AV_1A may be treated as part of a circle with a curvature equal to the length of the sagitta BV_1 , which is equal to $2s$, and which again is equal to $2/r$. But the curvature of the mirror is s , equal to $1/r$, so that we have arrived at the conclusion that a plane wave—i.e., one with zero curvature, falling upon a convex mirror, has impressed upon it during reflection a curvature equal to twice that of the mirror itself—i.e., the reflected wave appears to diverge from a point F, called the principal focus, situated halfway between the vertex V, of the mirror and its center, O. The distance FV, usually written f , is defined as the principal focal length of the mirror. Its reciprocal $1/f$, equal to $2/r$, is a measure of the curvature impressed upon plane incident waves.

A Summing-up

We might go on to consider combinations of convex and concave-fronted waves with convex and concave reflecting surfaces, when we should find that all our results could be generalized by the statement: *When a wave is reflected by a mirror its curvature is increased (algebraically) by an amount equal to twice that of the mirror itself.*

But the reader will ask, What does all this mean arithmetically? Let us see. We will start by agreeing to treat as positive the curvature of a wave converging to a focus, and as negative that of a wave diverging from a focus. Similarly, the curvatures of concave and convex mirrors will be treated as positive and negative respectively, because by the first type a plane wave is made to converge to a focus, whilst by the second type it is made to diverge as from a focus.

The general statement italicized above may now be put more concisely into the equational form:—

$$\text{Final Curvature} = \text{Initial Curvature} + \text{Impressed Curvature.}$$

If the distance from the mirror of the final image be denoted by v , that of the object by u , and that of the principal focus by f , the curvatures in order will be $1/v$,

(Continued on page 86)

A B C of TELEVISION

By RAYMOND FRANCIS YATES

Former Managing Editor of Popular Science Monthly, Editor of Popular Radio, Member Institute of Radio Engineers and American Physical Society.

CHAPTER 1 (Continued)

(Synopsis of Preceding Portion of Chapter I.)

An elementary treatment of the basic principles of Television, concluding with an account of an evening in the near future when Television will be as common in the home as radio is today.

Adam Gleek is entertaining in his luxurious living room his old crony H. Budington Lyman, M.D.

Sixteen cameras fitted for television transmission have been set up in the Yosemite Valley and the scenes are being broadcast.

The sound of the waterfall suddenly grew dim and the same clear voice returned. It was of such volume that it could just be heard above the sound of the falling water."

"You have before you," it said, "a picture of the Bridal Veil Falls, Yosemite Valley." The sound of the gushing water and the voice of the announcer melted away and the charming strains of the Bridal March from Lohengrin filled the room.

The voice returned. "Our next scene," it said, "will be presented from another camera located in one of the smaller streams of the Valley. Although this scene is not so well known it is one of the picture gems of America."

The picture of the Bridal Veil passed away and there appeared in its stead the picture of a bounding brook dashing down a mountain side amidst pines and huge, moss-covered outcroppings of rock. Its rapidly moving waters chattered gayly in the background of Mendelssohn's Spring Song.

For a solid hour Dr. Lyman and his friend Adam Gleek sat and feasted their eyes upon the stupendous scenery of the Yosemite. When it was over Adam jumped to his feet in his usual quick way and walked over to the television receiver. "And now," he said, "Let us see what the Century Gardens have to offer. What do you say, Old Top?" This, looking at his crony.

"I refuse to be disappointed," chuckled H. Budington Lyman.

Mr. Gleek carefully turned the tuner knob to LV29; the television transmitter of the Radio Amusement Corporation of America. The shrieks of the jazz orchestra poured into the room and simultaneously there appeared on the wall a blackfaced comedian who was the son of the old-time Eddie Cantor. A dozen pretty young ladies with veil-like gowns danced into the background.

Adam adjusted his spectacles to his nose. "Not bad," he said.

"Like the morning sunshine," came back H. Budington.

After the picture of the dancing girls had disappeared, the screen was occupied by a gentleman in evening dress, evidently the manager.

"Ladies and gentlemen of the television audience," he began, "I have a very important announcement to make to you this evening. I regret to say that it is an announcement that will cause you no pleasure. One of your favorite entertainers is terminating her contract with this company tomorrow for an age-old reason. She is going to be married."

Before the gentleman had finished speaking, a captivating brunette appeared. She was a subject for the poets, with roguish eyes and divine figure. She smiled demurely. Adam leaned forward quickly at the sight of her, adjusting his spectacles as he did so. H.

Budington followed. There was a moment of silence.

"Irene," moaned Adam, though speaking to himself.

H. Budington Lyman turned quickly and shot a questioning glance at his friend. There was a moment of silence.

"Did she hook you, too, Adam?" growled H. Budington settling back into his seat. "Well, I was going to marry her in June myself so I guess we are both old fools."

So much for the future of television.

Electric Eyes

Today the devices and instruments of science are so multitudinous and far-reaching in their scope of application, that dreams rapidly harden into realities and the imaginative vaporings of yesterday are the actualities of the moment. Material equipment is at last bidding fair to match the needs of our mental equipment. Ideas, no matter how startling they may be, do not wither and die in the minds of their creators for the want of practical components and accessories.

Five years ago science completed its task of supplying the necessary wherewithal for television. The coordinating genius of a score of independent experimenters triumphed in bringing the accessories to function as a composite whole and today television is an accomplished fact. "Electric eyes" that catch the fleeting impressions of a

moving image with a speed and accuracy that match the human optical organs is but one of the wonders that had to be perfected before seeing over a distance came within the realm of the possible. Perhaps even a more prodigious task was that of developing an electric light that would be completely extinguished and relighted to full brilliancy no less than 100,000 times a second. Radio, too, made its contributions to the success of the new marvel for, whether we see over the air or by wire, that useful tool of science, the vacuum tube must be used.

The dispatching of a picture by wire or the ether is divided into three distinct departments and before delving further into the intricacy of the art, we shall do well to establish our nomenclature. Telephotography has to do only with the transmission of photographic facsimiles. Photographic prints are translated into equivalent electric impulses at the transmitter and the effects of these are automatically coordinated and recorded at the receiver in such a way as to recreate the varying tones of the prototype which may be thousands of miles distant. Television, on the other hand, is the art of seeing living scenes. Technical immaturity at present limits these scenes to a rather narrow scope but, even with the present encumbrances, we may witness a performer strumming a guitar. We might even count the freckles on his nose or number the rings in the smoke from his cigarette.

In telemovies or telecinematography, reproductions from standard moving picture film flowing through a standard projector are used to modulate the wave or current at the rate of sixteen pictures per second.

Considering the appalling technical difficulties that confronted the pioneers of television, the progress of the last five years has been sufficient to gratify the most hopeful observers. From an unruly splash of light that bore not the slightest resemblance to the object at the transmitter, we are now able to view scenes sharply focused and steady.

Television Is An Illusion

To say that television is an illu-

sion may seem somewhat paradoxical. However, it is just that. Nothing more, nothing less. It is obvious that we cannot transmit physical realities or even pictures of physical realities. What we can do, however, is to transmit impulses of varying amplitudes and so arrange these impulses at the receiver that they will appear as pictures of the object or objects at the transmitter. This is exactly what television does, the weaknesses of the human eye being the key to the solution of the problem. If the human eye was instantaneous in its response to light impulses, television would today be nothing but the misty dream of attic inventors.

What happens when sound strikes the diaphragm of the microphone at the broadcasting station? That is a question that must be fully answered before we can hope to fathom the mysteries of "seeing by radio." When sound strikes the diaphragm, several interesting things happen. First and foremost, the diaphragm of the microphone responds to the impinging vibrations by vibrating itself. If it is a good diaphragm, it will faithfully keep in step with the vibrations that strike it. This diaphragm then communicates these vibrations to a small container filled with highly polished carbon granules through which the electrical current is permitted to pass. When no sound is striking the diaphragm of the microphone, these little carbon granules are all at rest, and the current proceeds through them, smoothly and uniformly. When the diaphragm is thrown into vibration, this vibration is communicated to the carbon granules and they rub against each other, this rubbing and jostling causing a variation in the electrical current passing through the microphone. In other words, the resistance that the carbon granules offer to the passage of current is varied in exact accordance with the sound being impressed upon the microphone. This is called modulating; the microphone modulates the currents passing through it. These currents, in turn, are picked up, amplified with vacuum tubes, and then again modulate the radio wave passing out from the broadcasting

station.

In the broadcasting of television we must have a microphone that will be modulated with the less tangible medium of light. Inasmuch as light exerts no measurable pressure upon striking an object, it is plain that a microphone cannot be used to impress the light impulses upon the broadcast wave. There is, however, a "microphone" that will perform this function. It is the photo-electric cell.

The "Microphone" of Television

We might look upon the photo-electric cell as a "light microphone," one in which the degree of current passing through will be varied in accordance with the intensity of the light striking it. The photo-electric cell does not depend for its action upon carbon granules; for, compared to the minute pressure exerted by light in falling upon an object, the carbon granules contained in a sound microphone would be the equivalent of thousands and thousands of tons of carbon.

Hallwachs observed, way back in 1888, that when certain metals are exposed to light they shoot off electrons; actual particles of electrical current. Later experimenters found that this effect could be greatly convenienceed by enclosing these light-sensitive metals in a glass tube devoid of air. By inserting two electric terminals in this cell and bringing the wires to the outside, the electrical effects could be observed more readily. When photo-electric cells are exposed to light they actually generate a minute current; a current, however, that is so small that it must be measured in millionths of amperes. Furthermore, the degree of this current is regulated in exact proportion to the intensity of the light striking the cell. If the cell is in the dark, no current will pass. If it is placed in close proximity to a powerful arc light, the current will reach maximum amplitude, providing all other conditions are suitable.

Assuming that we could impress light waves upon the broadcast wave, through the medium of the photo-electric cell, how would these radio waves be received on an ordinary receiving set? If the photo-electric microphone was in-

termittently exposed to light, we might hear the effect of this in an ordinary loudspeaker. If the light at the broadcasting station was interrupted, say, sixty times a second, there would be produced in the loudspeaker a humming sound which would have a frequency of sixty. Thus we see that every picture might have its equivalent in sound and that is actually received as a sound impulse. However, we cannot see sound waves.

Our next problem, then, is that of finding a loudspeaker that will transform these picture impulses into light waves of varying intensity. A neon lamp will perform this function. When the gas, neon, is enclosed in a glass container and subjected to an electrical current of sufficient intensity, the gas will glow, giving forth a pinkish light. The degree of brilliancy will depend entirely upon the amount of current passing through the lamp.

The uninformed reader might well ask: "Why cannot an ordinary lamp be used for this purpose?" Ordinary electric lamps give forth light due to a current passing through and heating a metal fila-

ment. A measurable period elapses between the instant the current is turned on and the time this filament reaches the point of incandescence and the lamp full brilliancy. The neon lamp is far more agile in its performance. It has no filament; its illumination being caused entirely by the movement of gas atoms. Consequently, such a lamp may be turned on and off as many as 100,000 times a second; so fast, indeed, that the human eye is led to believe that there has been no interruption.

Yet the neon lamp will register from total darkness to full brilliancy this prodigious number 100,000 times per second.

Broadcasting Living Objects

Now that we have provided ourselves with the "light microphone" and the "light loudspeaker," we are equipped with the necessary components for television, and we shall proceed to learn how these two instruments may be applied so that living objects in a broadcasting studio may be "seen" through the medium of an ordinary radio receiver located at a distant point.

(To be continued)

When, How and By Whom?

GENIUS is rarely discovered in high places. Its presence there is generally taken as a matter of course. However, genius may also be obscure. The capacity to work well within a chosen field, coordinate results, and use those results best in the evolution of things to serve the increasing need of mankind is the formula laid down for achievement by the world's greatest thinkers.

To search out all facts of, and pertaining to, television; to aggregate and foster a body of television and allied experimenters, or those genuinely interested in this new application through contact or association therewith, and the presentation of an historical account of achievement in this channel without bias or allegiance in any form, is the avowed scope of the new Television Society.

The society already numbers many leading radio industry personages and engineers of this

country. It is allied with no manufacturer or groups of manufacturers in the United States or abroad. It is avowed to take part in no promotional schemes.

Nothing is found so deterrent to the gaining of an objective as the stirring of premature desire in the imaginative. The society stands squarely against the instillation of false hopes, which are bound to react to the detriment of the industry's development.

On the other hand few stories can be made more readable and interesting than those concerning scientific achievement. The development of television promises huge results of this nature and the Television Society of America has set its editors to the task of making the pages of the Television journal a real history of the development of sight by electrical means or by whatsoever medium is to be utilized, from this time onward.

A New Method of Amplifying Photoelectric Currents

Harold A. Wheeler, Johns Hopkins University has devised a convenient and rugged amplifying apparatus for the direct measurement of very small photoelectric currents. The light beam is interrupted by a rotating sector wheel at a frequency of 150 cycles per second; the resulting 150-cycle alternating component of the photoelectric current is amplified more than 10^8 times by a three-stage, broadly resonant, vacuum-tube amplifier; the amplified current is rectified by a synchronous commutator with adjustable brushes; and the rectified current is measured by a portable micro-ammeter whose deflection is directly proportional to the photoelectric current. The factor of proportionality is determined by introducing a known current into the photoelectric-cell circuit from a second set of brushes on the same commutator. The only time lag in this measurement is the period of the micro-ammeter about two seconds. The accuracy of measurement of very weak currents is limited by fluctuation phenomena in the amplifier. In selectivity against fluctuations and other disturbances, this system is equivalent to a sharply resonant amplifier with a resonance curve only one-half cycle in width. In the experiments performed, the fluctuations caused a "probable error" of between 10^{-14} and 10^{-13} ampere (for a single observation). Improvements have been outlined which should reduce this error to below 10^{-15} ampere.

—Physical Review.

"Television Society, Inc., Grosvenor K. Glenn, Executive Secretary, 417 Fifth Avenue, New York City.

"Dear Mr. Glenn: Please accept my sincere thanks for your prompt reply as well as your efficient service in sending me the extra copies of TELEVISION.

"The information secured was all that I could have hoped for or desired, aiding me in rounding out my talk on Television before the Scientific Society.

"Wishing the Television Society much success, and your publication, TELEVISION, I am, Yours very truly, Professor H. G. Jordan, 202 West Magnolia Street, Fort Collins, Colo."

"The Television Society, Inc., 417 Fifth Avenue, New York, N. Y.

"You may put my name down as a Charter Member of The Television Society. Yours truly, Charles Nagata, P. O. Box 815, Auburn, Wash."

FOURTEEN YEAR OLD GENIUS BUILDS TELEVISOR

By GASTON FONTAINE—Himself

New Bedford, Mass.
"Television Publishing Co.
417 Fifth Avenue, New York.
Dear Sir—

"I am going to tell you about my experiments with the television receiver I made.

"I work in a radio store after school and on Saturdays. Dr. Bussy and I were talking about television and I told him I was saving up money to build a receiver but I only had about five dollars which would not get me very far.

"He came in a day or two afterward and said if I wanted to build one he would finance it for me. Of course I did not miss this opportunity to build a television receiver.

"First I bought an old squirrel cage motor for five dollars. I wrote for and received a 24-hole scanning disc and power resistors. I mounted the motor on a wooden box in which a speaker had come. I mounted it so the least possible vibration would occur while it was running. I bought a resistance coupled amplifier from one of the service men, rewired it for a power tube and hooked up an additional socket in parallel with last stage amplifier tube and added two

(Continued on page 88)

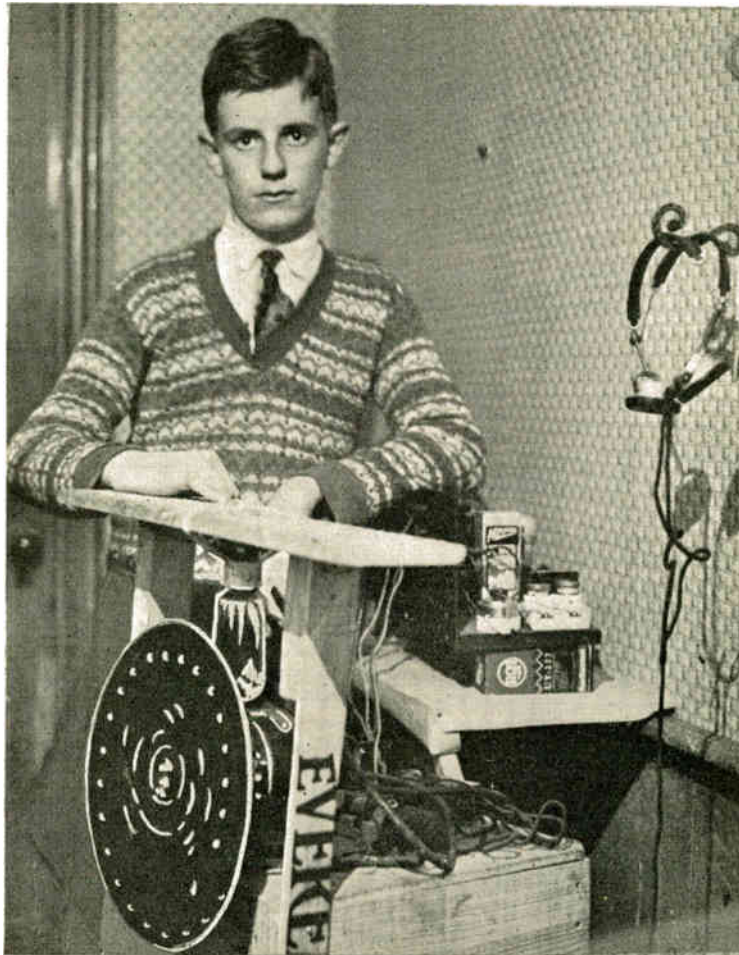

Here is Master Gaston P. Fontaine of New Bedford, Mass., with the television equipment which he assembled himself and with which he successfully received pictures from the laboratories of the General Electric Company at Schenectady.

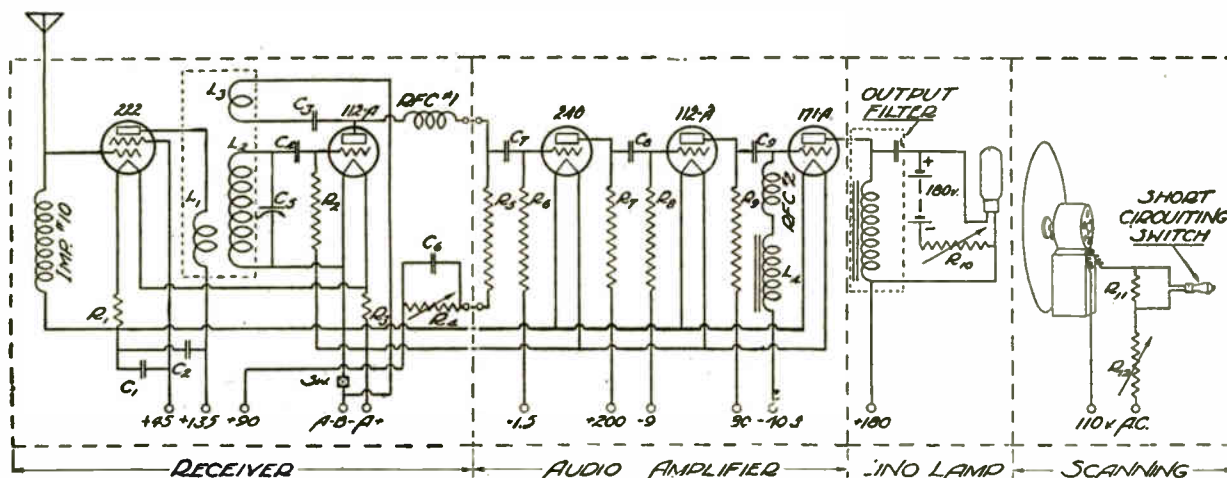

The complete wiring diagram of the National short wave receiver and the resistance coupled amplifier which Master Fontaine used in his television experiments.

With the TELEVISION INVENTORS

What the inventors are doing to improve the transmission of living and still pictures and how they propose to do it. The Television magazine does not in any case hold itself responsible for the technical correctness of the ideas proposed. A résumé of each patent issued is given solely for the purpose of permitting the reader to keep abreast of the art

ONE objection which could be foreseen in the structure of the television image as it appeared on the receiving screen is that the picture is gradually built up of strips. One side of the picture is reproduced one-sixteenth of a second later than the forward end. This would appear to introduce a stroboscopic effect in the case of moving objects; in other words, the effect would be to make the wheels of a moving car appear a foot or so ahead of the body. Some method must therefore be devised for fixing an instantaneous image, and in *Patent*

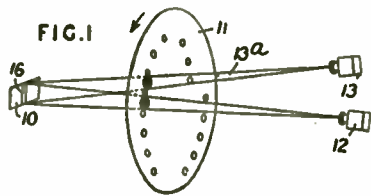

No. 291121 J. L. Baird seeks to do this by securing persistence of the image and at the same time obliterating the individual elemental parts thereof before each new picture signal is screened.

A screen (10) (Fig. 1), having on its surface a fluorescent material such as calcium sulphide, may be activated by a beam of light from a source (12) which traverses an exploring device such as a rotating disc (11) carrying a spiral of lenses. Immediately before the small elemental area (16) of the picture is traversed by the activating pencil of light from the source (12) it is traversed by another beam of different wavelength from a source (13), which has the effect of obliterating the previous fluorescence. Various modifications of putting into effect the same idea are given in the complete specification.

Patent No. 291786. The Telefunken Company (Berlin) seek patent rights for a type of scanning disc to be used in building up a television image in a receiver. The disc (Fig. 2) has a number of spirally arranged apertures, in each of which is fixed a small glow discharge lamp (shown as I, II, III, etc.), weighing from 5 to 10 grams. The detailed structure of the lamp is illustrated in Fig. 3, where 25 is the metal casing into which the lamp fits, and 9 is the cylindrical glass bulb having a cemented plane glass window (10). The cathode, in the form of a cylinder, is shown by 11 together with a co-axial anode (12), the latter being connected to the body of the scanning disc by a wire connection (14). The special anode construction, it is claimed, allows only a very fine pencil of light to pass out through the window (10).

A picture is built up by the television signals being applied through conductors 7 and 8 to brushes 4 and 5. Brush 5 is connected through a slip ring (6) with the

metal body of the scanning disc (1) and so with the anodes of all the lamps in turn, while brush 4 is connected through the commutator segments *a, b, c*, etc., to the cathodes of the lamps in succession. By these means

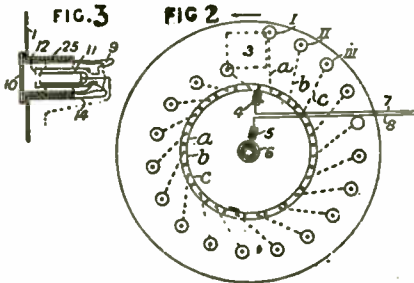

the signals are applied at the right moment to the lamp which is traversing the picture area (3).

In a revolving disc of this structure, centrifugal displacement is bound to take place, and is allowed for by having the lamps adjustably centered.

As far back as 1923 Denès von Mihaly was using small vibrating mirrors for the purpose of exploring an image. A somewhat similar system, in which oscillographs carrying small mirrors and operated by tuned oscillating circuits fulfil the same purpose, is the subject of *Patent No. 292659*, granted to F. M. Robb (Canada) recently. In Fig. 4 the oscillograph (10) consists of a double wire (11) set between the poles of an electro-magnet and the vibrating mirror is shown by 16. A similar oscillograph (17) is set up at right angles to the first with vibrating mirror 18. The first mirror is caused to vibrate at a high frequency by an oscillator (19) and tuned circuit control (20); the other oscillograph being vibrated at low fre-

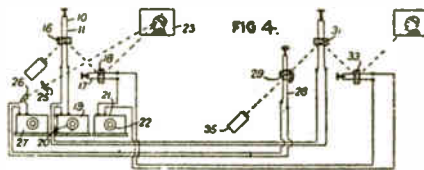

quency by an oscillator (21) tuned by the control (22). A spot of light is reflected by the mirrors to an object (23) and thence to a lens (25), which focusses the light spot on to a photo-electric cell (26). At the receiver a beam of light from a source (35) is modulated by an opaque disc (29) controlled by an oscillograph (28), which in turn is connected to the photo-electric circuit of the transmitter. This disc (29) is placed in the path of the light beam to exploring mirrors 31 and 33, which are operated similarly to those at the transmitter; 27 is an amplifier introduced in the transmitting line.

Patent No. 291365. L. Thurm and Etablissements Ariane. A feature of the television system described in this patent is the construction of the photo-electric "retina" illustrated in Fig. 6. This "retina" is composed of a mosaic of photo-electric cells (7a), so disposed that there is no longitudinal break in the continuity of sensitive surface. The photo-electric "retina" (7) (Fig. 5) explores the surface of an illuminated object (1) behind a lens (2) by means of a moving shutter (6) and a set of rotating mirrors (4). The shutter has perforations to correspond with the cells and so arranged that each half of each cell is alternately exposed. By this means continuous modulation of the current in each cell is obtained. At the receiving end the image is reproduced by a similar apparatus in which modulated beams of light take the place of the elements of the cell.

Selenium Cells. No. 294108. H. J. Küchenmeister seeks patent rights for a selenium cell of the condenser type illustrated in Fig. 1. The sensitive material is applied along an edge *h*, which is formed by laying the two sets of conducting sheets *a, b* crosswise. The surfaces *c, d*, which meet in the edge, are provided with a sensitive layer near the edge, so that the cell may be influenced by light from more than one direction. Detailed considerations are given to the use of the cell in the reproduction of sound from a film record.

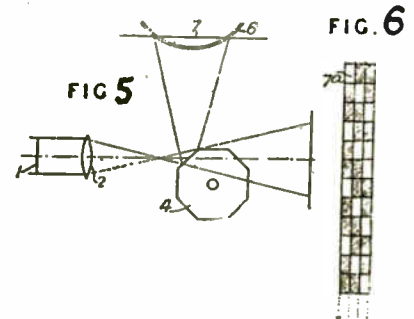

Patent No. 294719. (Granted to S. G. S. Dicker and Philips, Gloeilampenfabrieken (Holland). In Kew cells having a liquid dielectric for use in photo-telegraphy or television the conductivity due to the impurity of the liquid is kept down by causing the liquid to flow through the cell. It is suggested that a fixed quantity of liquid should be made to circulate through the cell and be subjected to a purifying process.

The use of internally reflecting rods or tubes has been the subject of more than one patent recently. In *Patent No. 294267* J. L. Baird employs such tubes for receiving or transmitting light (by internal reflection within the tubes) from different directions. In Fig. 2 the exploring disc 23 is represented in section with a number of sets of light-transmitting devices 27, which latter

(Continued on page 85)

IF YOU WOULD KNOW *TELEVISION*, FIRST KNOW LIGHT

Television is based upon light phenomena as well as radio phenomena. In this article, Cyril Sylvester, a scientist of high standing, analyzes the scanning disc problem in simple, penetrating style without labored mathematical discussion and goes into every phase of this important angle of the subject.

By CYRIL SYLVESTER

SINCE white light consists of a combination of colors, it may be said that a beam of white light is composed of light rays of different frequencies. The velocity of light is the velocity of any kind of light, that is, light of any spectral character, from which it follows that waves of high frequency have a shorter wavelength than low frequency waves. The waves may be compared with sine waves, so that they have definite values from zero to zero, or from

crest to crest. The relative values of red, green and blue are illustrated in Fig. 1.

These wavelengths are measurable, the unit of measurement being the Angstrom unit (ten-millionths of millimetres). The number of Angstrom units in the visible spectrum is about three thousand. Of this the blue-violet is between 4,000 and 5,000, and the green between 5,000 and 6,000, and the red between 6,000 and 7,000. The units below 4,000 are associated with the ultra-violet

rays, sometimes termed the actinic rays; the units above 7,000 are associated with the infra-red rays, sometimes termed the dark heat rays.

Although normal daylight is generally accepted as white light it may be said that it varies in colour quality. A most conspicuous example of this is the colour change which the sun appears to undergo in passing from zenith to horizon. The reason for this may be said to be due to the composition of the "body colour" of the

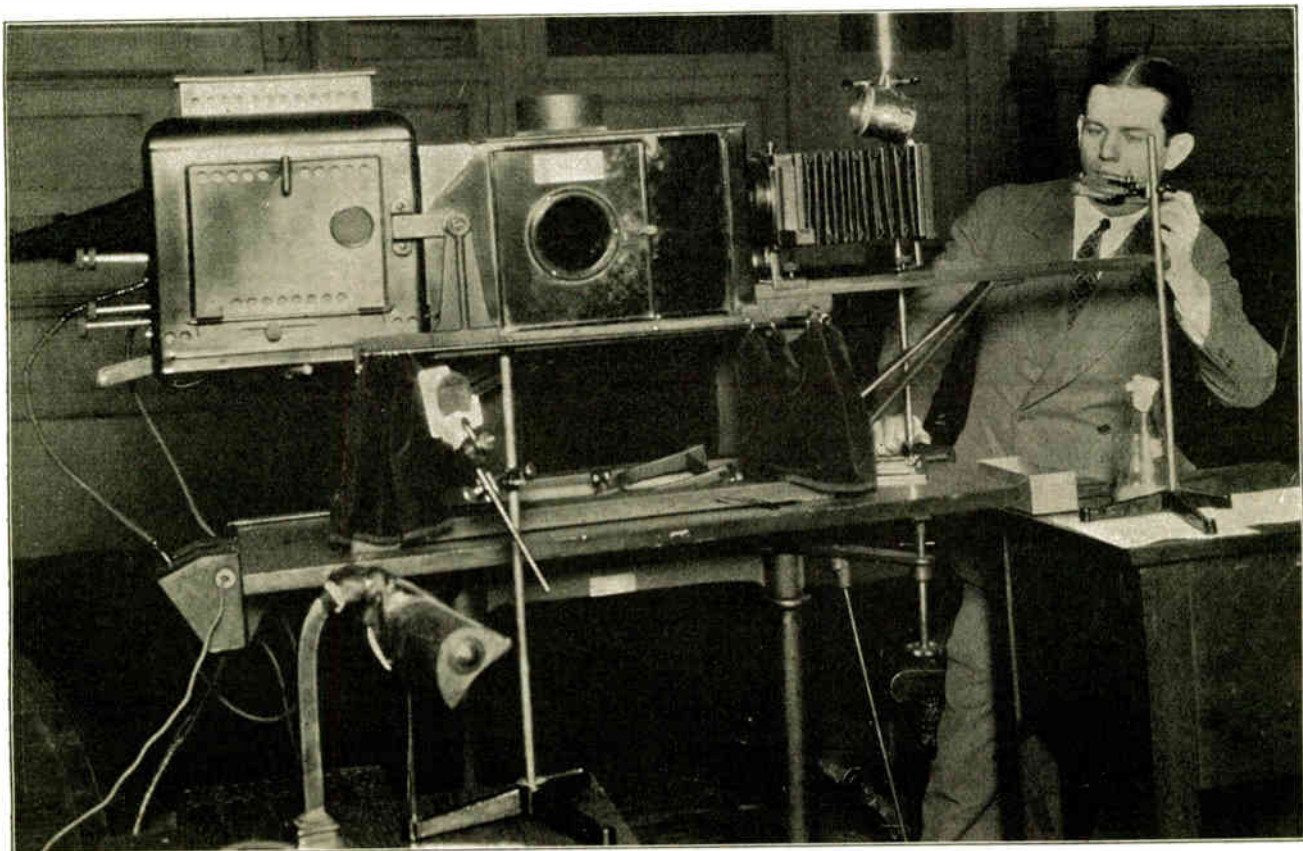

Here we see an experimenter engaged in studying light phenomena, using a powerful arc lamp as a source of illumination

atmosphere. That is, the colour which is possessed by an object by virtue of its selective action in absorbing, refracting, and transmitting the rays of various wavelengths in such a manner that certain rays are reflected or transmitted more than others.

In the normal atmosphere the selective effects are produced by



Fig. 3.—A double colour filter.

particles of dust of various colours, minute drops of water (these are the cause of refraction) and the molecules of air. When the sun's rays pass through the atmosphere, the selective effects of the media referred to result in the scattering of light rays of all wavelengths, but more so those of the short wavelengths, the blue. The colour of the sun, to us, appears to be more red. We know that outside the layer of atmosphere it is not so, but to us it appears to be so. Since the light which has been scattered, or refracted, is blue, the scattering medium is also blue. It is in this way that we appreciate the colour of the sky as being blue. In other words, the atmosphere acts as a screen through which light from the sun passes to the earth. The quality of the light we receive depends upon the position of the sun in the sky; it is for this reason that the colour quality varies between white at noon and red at sunset.

We can only appreciate the colour of objects in their true colours when they are viewed under normal or natural daylight. I have already pointed out that, in television, many scenes will be broadcast under artificial light; and it is very safe to say that no method of producing artificial light is constant, even with the so-called daylight lamps. This means that the colour, and even the shape of objects cannot be appreciated under artificial light, unless means are taken to correct for colour quality. We will consider the production of coloured light and its effect upon coloured objects.

The general conception of colour is somewhat loose; I have referred to blue—sky blue—but this varies in colour quality. Violet, blue and green-blue when combined form blue, but the quality of this blue will depend upon the mixture of these colours. Blue-green, green and yellow-green when combined will produce green; and green-yellow, yellow and orange gives us amber. Here, again, the quality of amber depends upon the quality of the colours used to produce it. Let us consider the factors which affect the variation in the production of artificial coloured light.

Artificial light, or electric light, since this is the only kind of artificial light which can be produced in high intensities, depends upon the passage of electric current through some form of conducting medium. In the modern gas-filled lamp the conducting medium, the lamp filament, is tungsten steel. This, with an exhausted globe refilled with an inert gas (argon),



Fig. 2.—The three primary colours (light).

permits the filament to be run at a high temperature, thus producing as white a light as is possible. The quality of this light, however, is inferior to normal daylight.

The difference in this quality of artificial light and normal daylight is that the former contains an excess of yellow and red rays. We can correct for this by filtering the excess rays out, by fitting a colour screen of blue which will absorb the rays which are not required. The colour quality of the screen, however, is constant, and the factors which produce the artificial light are variable; the quality of the artificial light will therefore vary, although a colour filter may be used.

The variable quantities are:—
(a) The possibility, in fact probability, of voltage variation due to increased or decreased loads on the lighting service. The effect of this is to increase or decrease the voltage applied to the lamp terminals; this results in a variation of filament current and temperature, and therefore in the colour

quality of the light. (b) Decrease in initial efficiency according to the length of life of the lamp. All electric lamps are made to a specification which demands a definite efficiency (subject to small tolerances) at the commencement of the lamp's life. After the first 100 hours the efficiency falls very rapidly; that is, the light output is decreased and the colour quality of the illumination is altered.

We know that the effect of normal daylight falling upon coloured objects is to enable them to be seen in their true coloured quality. They appear coloured because they pick out certain rays from the light and reflect these back to the eye, absorbing the whole of the other rays in the spectrum. Now what is the effect of coloured light upon coloured objects?

A pure red light falling upon a red object will enable the latter to be seen in its richest quality. If we project red light upon a green object the whole of the red rays will be absorbed and the object, since no rays remain to be reflected, will appear to be black. If the red light is projected upon a yellow object, the latter can be identified as red, because yellow reflects red, among other colours. The primary colours (and these refer to light and not to pigments) are red, green and blue, the intermediate colours are illustrated in Fig. 2. Mixtures of two, or even the three,

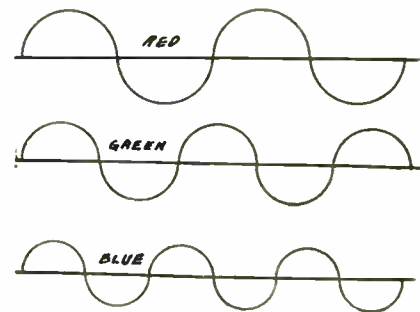

Fig. 1.—The relative values of red, green, and blue.

primary colours in varying proportions will give all the intermediate colours. Red and green will produce yellow; blue and green, blue-green; blue and red, purple; red and green, with more red than green, orange, and so on.

A white object will reflect all colours, and thus its apparent colour depends upon the colour of light projected upon it. In this

way if a red object on a white background is illuminated with red light, the background and the object will both reflect red light at its full value; and the object will be invisible. The same effect is obtained if green light is projected upon a green object on a white background.

This phenomenon in colour can be used to produce some very interesting and startling effects. A simple effect is to paint the outline of an egg in green on a white background. Then, near it, paint an egg in red with the top broken, with a chicken's head and wing poking through the top. A double colour filter should then be made with two windows as illustrated in Fig. 3; it may be made of wood with a small handle with a slide, so that red or green light can easily be projected upon the background and sketches.

The light source should be an ordinary flash lamp, the demonstration being carried out in a dark room. When red light is projected upon the sketches the red sketch becomes invisible and the full egg can be seen. When green light is projected upon the sketches the full egg becomes invisible and the chicken coming out of the egg can be seen. If the colour filters are moved quickly in the slide the effect is an animated picture of a chicken coming out of an egg and, not liking the look of the world, going back into the egg again.

Selection of the right colours will produce almost any effect. A clown painted in various colours on a white background, if illuminated with various coloured lights obtained through the medium of a rotating colour wheel, will create the illusion of dancing and juggling, etc. It is wonderful what can be done with coloured light. I have seen a picture painted with it. It was a country scene; first the tree trunks appeared, then the branches and leaves, and then flowers, a bridge, water, and, finally, the sky. The importance of light as an essential of television can be readily seen.

STEREOSCOPIC TELEVISION

(Continued from page 50)

tion of the object, as we saw the

object itself, in relief. Experiment confirms this supposition.

The latest advance in Television is the production of television images in stereoscopic relief, which was demonstrated recently by Mr. Baird to the Press, and also to a number of scientists, a demonstration at which I had also the privilege of being present.

The transmitting apparatus consists essentially of a disc perforated with two sets of holes arranged in spirals. The arrangement is shown in Fig. 1. Through these perforations are projected pencils of light from a spotlight lamp, the pencils of light scanning the object to be transmitted through the lenses marked L and R in the diagram, Fig. 2. In this way the object is completely traversed alternately from two positions, one a little to the right of the normal to the surface, and the other a little to the left of the normal.

Four Best Ways for Amplification

(Continued from page 55)

the vacuum tube must be correctly biased for best operation.

A more elaborate and better arrangement is shown in Figure 2, wherein a separate battery is required for the photo cell, F. The resistance, R_c , is determined by actual test. This arrangement is most useful in connection with high vacuum photo-cells. A further refinement is shown in Figure 3, in which a suitable transformer, T, is introduced as a coupling means between photo cell and amplifier tube. It is essential that the characteristics of the transformer be adequate for the service required. A resistance coupling arrangement may prove more satisfactory where a wide range of light variations must be handled accurately, in which case the arrangement shown in Figure 4 may be preferable, comprising resistance R_c and RGL, coupling or blocking condenser C, the photo cell F and the vacuum tube, with suitable battery for biasing purposes. Increased coupling will

The Transmitter

The rays are reflected back, and to a certain extent diffused, the intensity of this reflected light causing corresponding variations in the resistance of a photo-electric cell, which in turn controls the current passing through it. This undulatory current is transmitted to a distant receiving station, where it is used to vary the light emitted by a neon tube behind an exactly similar disc which revolves synchronously with that at the transmitting station.

The arrangement of the receiver is shown in Fig. 3.

The two images formed side by side on the receiving disc are viewed through a stereoscopic viewing arrangement consisting of two prismatic lenses which cause the two images to be superimposed and merged into one, giving an impression of solidity to the received picture, so that an object seen appears as if one were looking at an actual solid object.

usually be experienced with this arrangement.

On the vacuum type photo cells high voltage is essential for best operation. Voltages up to 600 volts D.C. are recommended. The gas-filled photo cells, on the other hand, should be operated as close to their ionization voltage as possible. The best way to obtain this condition is to expose the photo cell to the maximum light to be used and gradually increase the applied voltage until ionization occurs. This voltage is noted and a voltage 10 volts lower is then selected as the best voltage to be applied. Ionization occurs when a pinkish glow can be seen in the photo cell.

"TELEVISION has just come to my attention. After careful reading, I am convinced it is a timely publication, one that will meet the increasing demand for Television information.

"I should like to become a Charter Member of The Television Society. Kindly send me the necessary application blank. Yours very truly, A. Wyeth, 152 Prospect Avenue, Mt. Vernon, N. Y."

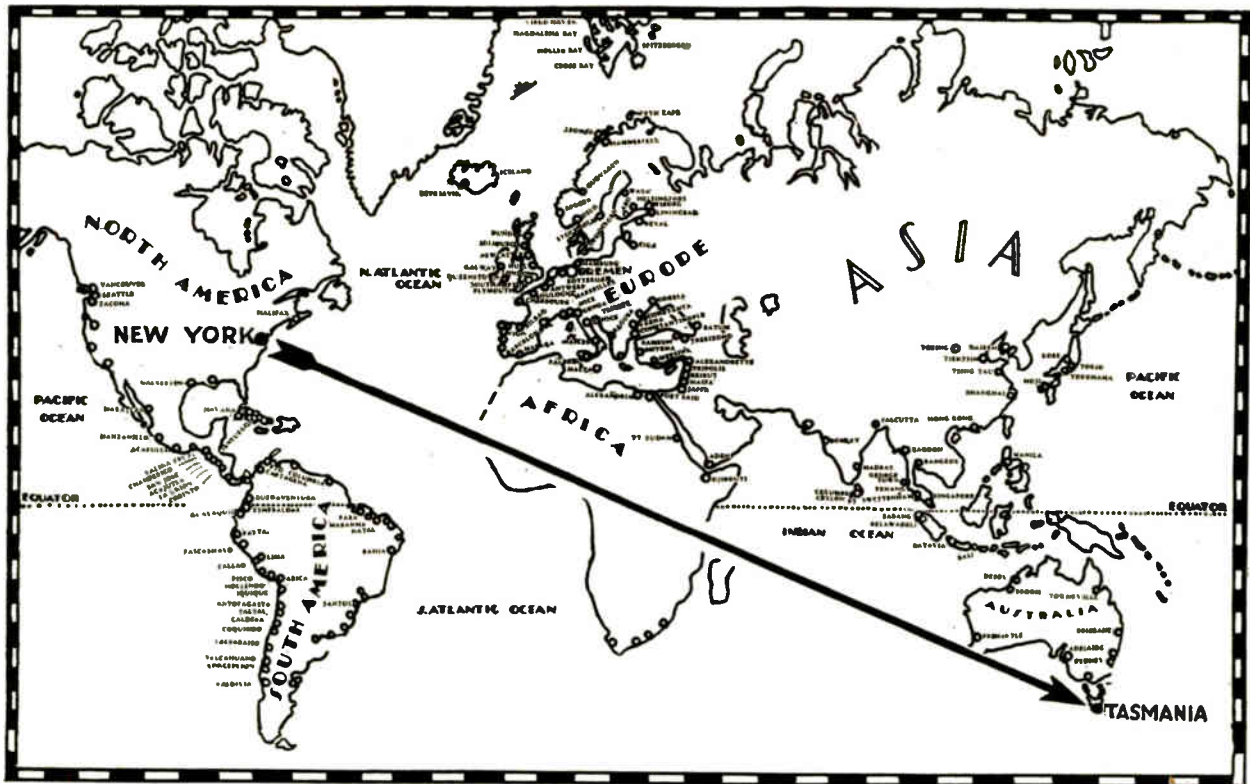

TASMANIAN

Amateur at Home

SEES NEW YORK

AN amateur in Tasmania, the island forming the southeastern tip of Australia, tuned in an image from W2XBV, New York! On the other side of the world! The antipodes of New York! New York is 41 degrees north of the equator and Tasmania 41 degrees south. Westward from New York it is 135° west to the longitude of Tasmania, or 225° east, from New York.

A letter received by this magazine from the publishers of "Wireless Weekly," at Sydney, N. S. W., states that a local amateur experimenter in Tasmania is reported to

have "tuned in a faint image broadcast from a United States Station, W2XBV."

"This fact has created a considerable stir among radio experimenters and broadcast listeners in Australia and New Zealand.

"There has arisen overnight a demand for television receivers for which there is no supply.

"We will be very glad to know what this station proposes to do in regard to future television transmissions.

"We expect a great number of broadcast listeners and experimenters in this country will take up

this side of radio science and expect you will receive many reports on long distance reception."

W2XBV is the signal call of Radio Corporation of America (Portable) station. Frequency 4500-4600 Kcs. and its waves transmitted images to an amateur 12,000 miles away.

Does it not thrill you to anticipate seeing and hearing men and women who are 12,000 miles away? To anticipate the time when you may be in Europe and talk with the folks at home, 'face to face'?

ANALYZING *the*

SCANNING PROBLEM

By J. ROBINSON
M.B.E., D.S.C., PH.D., M.I.E.E., F.INST.P.

Scanning is still another perplexing problem of television. What is needed is a scanning mechanism that does not need mechanical power and does not destroy the picture value with lines.

IN these early days of television there is considerable ignorance of the elements of the subject, and in consequence there are criticisms which are not warranted. One feature which is wrongly quoted by critics relates to how a scene is scanned, and by virtue of their method of looking at the subject they draw incorrect conclusions. In order to reproduce the whole of a scene it is essential to divide it into a large number of parts, to obtain a light effect from each part in turn, and to convert each light effect into an electrical effect which can be suitably transmitted to the receiver.

The first point on which to concentrate attention is how the scene is divided into parts, and the usual remark of critics is that it must be divided into a large number of dots. The use of this word "dots" is very loose, and I have never seen any attempt to explain definitely what is implied. I shall assume here that what is meant is that a scene is divided into a large number of squares by two series of parallel lines at right angles to each other, and that one square is what is meant by the word "dot."

The critics then proceed to calculate how many dots are required to

define a picture or scene perfectly. It is assumed that the intensity of light over the area of any dot is the same, and thus, in order to obtain the utmost detail of a picture, it is essential for the dots to be exceedingly small. A typical case is a picture in one of the newspapers of an area of, say, one square foot. In order to give suitable detail of such a picture it is assumed that there should be 40 lines per inch, and thus there are 480 lines parallel to each edge, giving the huge number of the square of 480, or about 250,000 dots.

In order to obtain great detail it is essential to transmit one signal for each square or dot, thus requiring a quarter of a million signals for one picture, this being a still picture. For television it is essential to record motion, and thus a single scene must be transmitted in a very short interval of about 1/16th of a second, thus meaning that we must transmit 16 times 250,000 signals per second, or 4,000,000 signals per second.

Having reached this huge figure, and remembering what is done at present in telegraph signaling where a high speed is about 100 words per minute, the conclusion is drawn that at the present moment

4,000,000 signals per second makes the whole idea of television impossible. We must, however, examine these calculations in detail and find out what is wrong.

In the first place the idea of dividing a picture into dots is unsound. If we think of transmitting 4,000,000 distinct signals per second, the whole thing is absurd. It would be impossible to allow a spot of light to fall on one dot, then to extinguish the light or shade it until the next dot is in position for exposure, at the rate of 4,000,000 per second. Such a motion would be similar to the gate motion of the cinematograph, which operates at the rate of 16 per second, or in the case of the high-speed camera at a somewhat higher rate.

For such large signaling speeds as those in television we must have continuous motion, and a spot of light must fall on one dot or square after another in turn without extinguishing the light or shading it at all. But this means that our spot of light will be on one square at one instant, and then partly on one square and partly on the next, and later on the second square completely, and thus we must give up the idea of dots or squares and have parallel strips instead.

This completely alters our conceptions of numbers, and instead of having to contemplate the transmission of 4,000,000 dots, we have instead a number of strips equal to 4,000,000 divided by 480—*i.e.*, about 8,000 strips per second. Our spot of light must now move along a strip of a picture in $1/8,000$ th part of a second and, in doing so, it will cause a varying light effect along each strip, depending on the density of the picture or the light and shade along each strip.

This different conception of the problem brings television more into the field of practicability, but we must go still farther in our examination of the conditions postulated by the critics.

Is it necessary to proceed to the detail of a picture as already given here—*i.e.*, a picture of one square foot divided into parts of $1/40$ th of an inch? This is a very rigorous condition, and probably completely outside of commercial requirements. The analogy that we must have is, in my opinion, the detail given by an ordinary cinematograph. The detail demanded above is, I think, far greater than that of the cinematograph. It would correspond to the division of a cinematograph negative, which is of the order of one square inch, into parts of $1/500$ th of an inch, and in order to give the same results as the cinema a much coarser grain would suffice, say into $1/100$ or even $1/50$ th of an inch. Thus, even on the original calculation of millions of dots per second, we should get very satisfactory television if we divided the picture or scene into fewer parts, say 10,000 instead of 250,000, thus requiring on the original calculation about 160,000 signals per second when considering dots, or 1,600 strips per second.

So far we have discussed the conditions for television of large scenes which would allow the whole of a theatrical performance, or a boxing match, to be transmitted and reproduced. Such, however, has not yet been achieved practically for the reason that there is something in what the critics say. The problem is difficult, without a doubt, but it is not incapable of solution.

To transmit even fewer signals per second than those for the complete cinematograph screen, and to arrange the received signals correctly to form a good reproduction

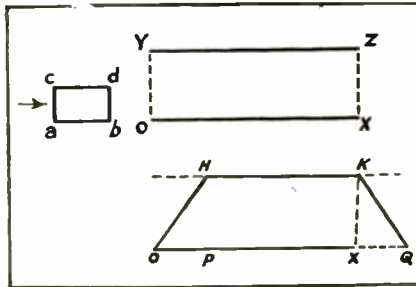

Fig. 1.—A rectangular slit.

is not easy, but television is of the nature that we can deal with smaller dimensions, and thus transmit a smaller portion of the complete scene. We are fortunate in this respect that we can solve the problem almost completely for small scenes, after which the ex-

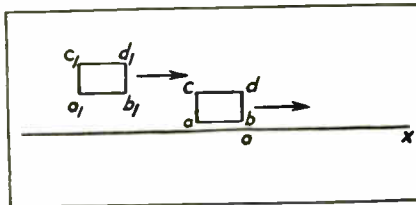

Fig. 2.—Showing how distortion can arise.

tension to larger scenes should follow without very great difficulties.

In this respect television differs in its development from such things as the gramophone. In the initial stages of the gramophone, it was never possible to obtain clear speech or music at all, and there

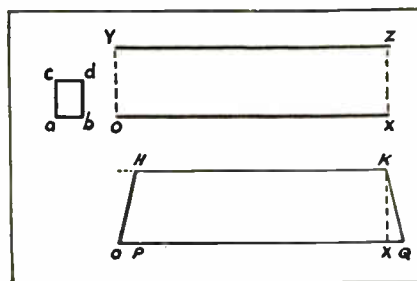

Fig. 3.—A narrower slit causes less distortion.

was always considerable distortion. Thus the commercial application of gramophones had necessarily to wait until the distortion had been sufficiently removed to allow speech and music to be recognized with fair clearness.

In television, however, it is possible to give very good reproduction of small scenes, and the type of development required is to increase the size of the scene that can be dealt with. At present the type of scene that gives satisfactory television is of the order of magnitude of the head and shoulders of an individual, and this is being achieved with from 15 to 30 strips, each being scanned 16 times per second. Thus, for practical purposes, at present it is necessary to scan from 240 to 480 strips per second, and this is now being satisfactorily performed by all of the television systems.

Examining the criticisms of television still further, the statement is made that there is really no difference between the dot and the strip method for considering television. Critics state that in the strip method each strip is continuously viewed or illuminated through a slit, and that ultimately the dimensions of the slit really determine the number of dots into which the picture is to be divided.

There is something to be said for this point of view, but there are so many consequences of the practical method of operation that it is necessary once and for all to abolish the idea of dots in order that we may understand clearly what is happening. The first aspect of the subject is the definition of the picture that is possible, and how this is practically obtained. On the dot idea, if we could have the clear-cut illumination of each separate dot without the intermediate stages, where the illumination passes gradually and continuously from one dot to the other, thus sometimes including parts of two dots at once, then the determination of the definition of the picture would be very easy, and we could have a scene reproduced as accurately as we wish by making the dots as small as we wish.

Owing, however, to the fact that we must employ strips and scan along each strip continuously, the definition of a picture or scene is not so easily determined, and it depends on the dimensions and shape of the scanning slit. If we make this scanning slit very small indeed, we should obtain the best

possible definition, and in doing so, it is equivalent to increasing the number of dots of a picture, but without increasing the mechanical difficulties of scanning.

However, in practice, there is a limit to the smallness of the scanning slit, which is that it

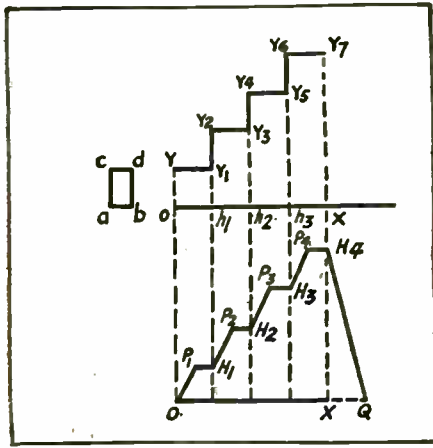

Fig. 5.—The type of record obtained from a narrower slit.

must be large enough to allow sufficient light to pass to influence the photo-electric cells. We could, of course, increase the intensity of the source of light used for illumination and thus cut down the size of the slit, but practical experience determines the magnitude of both of these factors.

As the slit must have definite dimensions, it is necessary to examine what influence these have on the possible definitions of the picture which is reproduced. This is a very interesting subject, and one which is certain to be discussed very fully in the future as television progresses, and it will be profitable to consider some simple cases in detail. Further, this problem has some influence on another aspect of television, which is referred to below.

It is fairly well known to readers of this journal how a scene is scanned completely. There is a series of holes or slits on a disc which is rotating, the holes being staggered so that the successive holes scan neighboring strips of the scene. We must, for the moment, concentrate on a single hole or slit which scans a particular strip of the scene. In practice it is convenient to make these holes circular, but for our present purpose, that of the influence of the shape

and dimensions of the hole on the quality of the reproduced scene, a circular hole does not lend itself readily to easy discussion. It will be much easier to consider this problem with rectangular holes.

In Fig. 1 a rectangular slit *abcd* is shown, this slit being arranged to traverse the scene in the direction *OX*. The width of the strip thus scanned is *ac*, and if *OX* is the width of the scene, there would be another slit similar to *abcd* at *a'b'c'd'*. However, we shall for the moment consider only one slit, *abcd*. As it travels to the right the edge *bd* comes into view first, and the whole of the slit is not in view until the edge *ac* has reached the point *O*. Thus, in this initial stage near the point *O*, complications are introduced owing to the width of the slit *ab*. There are similar complications at the end *X* of the strip.

To examine how this influences a special case, let us assume that the strip of the original scene is of uniform density, as shown at *YZ* in Fig 2. As the slit moves towards the right we shall not get the full effect of it until the edge *ac* has reached the point *O*, when the edge *bd* is at *P*.

During the interval for the slit to move so far we shall have the effect of the slit increasing uniformly, as shown at *OH*. From the point *P*, until the edge *bd* reaches *X*, the intensity will remain constant, as shown at *HK*, but after this the slit will still have some effect until the edge *ac* reaches *X*, and we obtain a light effect *KQ*. Thus, with a slit *abcd*, we find that the original scene as at *YZ* becomes distorted in the reproduction, as shown at *OKHQ*, there being two features to observe, first that the slit, as reproduced, is longer by the width of the slit, and secondly that there are two end effects which are quite different from the original picture.

In Fig. 3 similar effects are given for a narrower slit, when it is seen that the distortion, both as regards the lengthening of the reproduction, and of the end effects, is much less pronounced. Obviously, from these two figures, to eliminate distortion completely the slit should be very narrow indeed, which is an impossible condition owing to the

necessity for obtaining sufficient illumination.

Consider a more advanced case, such as that shown in Fig. 4, where the light of the original strip varies in steps from *O* to *X*, being constant for *Oh₁*, then rising suddenly to double its value for an equal length, *h₁h₂*, then rising suddenly to three times the value for another equal length, *h₂h₃*, etc. In a case of this kind of distribution of light and shade, the dimensions of the scanning slit are exceedingly important. For the best reproduction we must have all changes of light intensity faithfully recorded, but as will be seen there is one particular width of slit which will not record these abrupt changes.

This width of slit is that which is equal to the distance *Oh₁*, *h₁h₂*, etc. As the slit *abcd* moves to the right, so that the edge *bd* travels from *O* to *h₁*, we have a similar condition to the initial condition of Fig. 1 and we obtain our record *OH₁*. When the edge *bd* reaches *h₁* we obtain the full effect of the light in the region *YY₁*, but as the slit moves further to the right the original intensity is doubled to *Y₂Y₃*, so that we have the

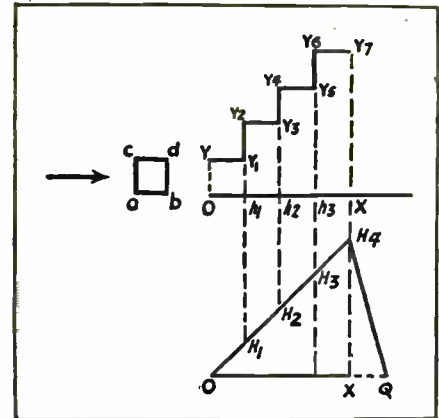

Fig. 4.—Analysis of causes of distortion.

initial conditions of Fig. 1 produced again. Thus, in the second period, *h₁h₂*, our reproduction is given by *H₁H₂*.

Similarly for the third and fourth periods, so that until the edge *bd* reaches the point *X* there is a constant increase in the intensity of the reproduction. After the edge *bd* passes *X* we have the end condition similar to Fig. 1, so that our complete record is two straight lines, *OH₄* and *H₄O*. All abrupt changes in the original strip *Y₂Y₁Y₂Y₃ . . .* have thus been

deleted, except that at the end.

In order to retain some traces of these abrupt changes, and we must do so for faithful reproduction, it is thus necessary to use a narrower slit. Fig. 5 shows the type of record obtained with such a narrower slit, though even now the slit is fairly wide. The record obtained consists of slanting parts OP_1 , H_1P , H_2P_3 . . . and of horizontal parts P_1H_1 , P_2H_2 , etc., and is more faithful to the original than the record OH_4 of Fig. 4. There is still, however, the tendency to round off abrupt changes.

Such examples could be multiplied as much as we wish and, in fact, as television proceeds, this aspect of the subject will certainly be of such importance that many examples will be worked out. However, for the moment, sufficient examples have been given to indicate how the dimensions and shape of the scanning slit tend to produce distortion.

Although it is dangerous to generalize from a few simple examples the principal feature which emerges is that the necessity for having the slit of finite magnitude tends to prevent abrupt changes of light intensity in the original from appearing in the reproduction. Further abrupt changes occurring within distances equal to, or less than, the width of the slit will not be recorded at all. Hence the width of the slit determines the fineness of the grain of the reproduction.

So far we have discussed only one dimension of the slit and that is the width in the direction of motion. The discussion of the length of the slit in the other direction need not affect us here very much, for it is obvious that this dimension should also be small to allow of as good definition as possible. Further, we have considered a very simple shape for the slit, the rectangular shape. Discussion and calculation become somewhat complicated when we depart from this simple shape. Without attempting to make any calculations, the simple case of Fig. 2 is given again in Fig. 6, where the aperture or slit is circular instead of rectangular. The end conditions are modified to give curved lines $OLMNH$ and $KN^1M^1L^1Q$ instead of the straight

lines OH and KQ of Fig. 2.

This preliminary discussion should be sufficient to dispose of the loose talk of dividing a picture or scene into dots, for it now appears that the practical method of strips introduces peculiarities of definition which are ignored when discussing the partition into dots. The distortion thus introduced by the magnitude and shape of the scanning slit is not too serious a matter, although it is a necessary evil, and much attention will undoubtedly be given to this subject in the future to allow of more and more faithful reproduction.

There is one other criticism of television which requires to be answered in some detail, and this also arises to some extent from the loose "dot" method of considering the subject, and that is that for perfect television one single wireless transmission would absorb almost the whole available space in the ether, leaving no room for the ordinary radio services.

So far, however, enthusiastic supporters of television need not be discouraged by the criticism already answered above. I hope that a case has been made out to show that many of the criticisms lose their significance when the conception of dividing a picture into dots instead of into strips has been definitely abandoned. Then the criticisms which put forward such huge figures as millions of dots, and millions of signals per second, do not appear too bad, because when we consider the practical strip method, our conception involves numbers which are not nearly so terrifying.

AUTOMATIC SYNCHRONIZATION

(Continued from page 56)

cells connected to a Wheatstone bridge, an amplifier being connected to an auxiliary (pole-tip) coil on a shunt motor, so that changes in the registration of a scanning beam R with the light chopper R produce a corresponding oscillatory current in the amplifier Z and in the field coil W. The motor should be slightly oversped or undersped (de-

pending upon the adjustment of the apparatus) so that the compensating corrections impressed upon the speed by the automatic excitation of the coil W have a counter effect, tending to check or accelerate the motor speed. The scanning elements A, B, in both the receiver and transmitter, and the light choppers T, R, should be similar, the transmitter motor being run at constant speed and the receiver motor being automatically maintained at synchronous speed.

Fig. 3 shows a typical transmitter and a corresponding receiver having identical two-dimension scanning elements provided with concave mirrors, adapted to explore the viewing field simultaneously and synchronously, and respectively convert picture areas into electrical signals; and in the receiver, translate the electrical signals through the medium of a suitable light valve, back into luminous signal flashes of intensities corresponding to those received from the illuminated image in the transmitter. Only one photoelectric cell is required for the control of the automatic synchronizing energy, the intensity of the light in the beam D being determined by the instantaneous out-of-phasing of the receiver scanning element. This out-of-phasing condition is shown in Fig. 2. With the apparatuses synchronized, successive light flashes register with successive apertures or bars of the receiver chopper, as shown at R1; this condition occurs in the middle of each half-cycle of the synchronizing impulses produced by the speed variation slightly above and below synchronism. During the latter portion of the cycle, the effect obtained by using a normally oversped motor, will resemble the condition shown at the upper part of Fig. 2; namely, a gradual interception or fade-away of successive signal flashes directed upon the cell, the excitation of the pole-tip coil G, Fig. 3, being controlled by energy derived from the cell, which energy is controlled by variations of registration of the rays comprising the signal beams C, with chopper bars, thereby restricting the "hunting" of the motor

(Continued on page 92)

A New Television Battery

WITH THE TELEVISION
INVENTORS

(Continued from page 75)

BURGESS "PL" batteries are an assembly of a number of cylindrical dry cells to furnish potentials of over 100 volts. Equivalent voltages might be obtained by connecting together a proper number of "B" batteries, but "PL" batteries have many advantages over this arrangement. Some of these are:

1. *Weight*: "PL" batteries weigh less than the equivalent number of cells of "B" batteries.
2. *Shape*: "PL" batteries, being long and narrow, lend themselves to easier installation.
3. *Reduction of Connections*: "PL" batteries for high voltages require no intermediate terminals.
4. *Insulation*: "PL" batteries have the cells insulated better than in any "B" batteries.
5. *Cell Characteristics*: "PL" batteries have cells that are more carefully selected and matched than in "B" batteries.

Electrical Construction

The cylindrical cells, which experience shows are superior to any other shape, are regular Burgess grade but are especially selected for "PL" batteries. Burgess-made seamless drawn heavy pure zinc cans are used.

All cells are aged ten or more days before they are tested and selected for assembly in a "PL" battery.

The cells are soldered together in series and wrapped in asphaltum-lined kraft paper tubes. These cell-tubes are in turn assembled together with air spaces between them. Cross connections between tubes, link all the cells in series, but with a minimum voltage between any adjacent points. The tubes are finally assembled in a box and sealed with insulated screw terminals.

Mechanical Construction

All assembly parts are of insulating materials, or are thoroughly impregnated to remove moisture and to fill up the voids with non-conductors. The cell-tubes are, in

themselves, rigid. By assembling these together, a strong unit is secured without the use of weighty sealing-in compounds.

In emergency, a battery may be disassembled by chipping off the top seal and slicing out the paper bottom. This exposes the ends of the tubes of the cells which can then be tested with a voltmeter.

Electrical Characteristics

The electrical characteristics of the two sizes of "PL" batteries are shown on the attached sheets.

General Utility

"PL" batteries lend themselves to the following uses, and are superior to an assembly of "B" batteries, under conditions of:

- Vibration or bumping
- Minimum weight
- Less volume
- Higher voltage
- Continuous low current drains
- Interrupted higher current drains
- Longer service
- Unwavering voltage
- Portability
- Minimum of connections
- Moisture proof

Suggested Uses

(a) Continuous low current

Photoelectric cells: Here the current drain is low and the "PL" batteries can be kept in service for months. On talking movie recorders their light weight and simplicity make them practical.

Neon lamps: Certain Neon lamps flash intermittently under a high voltage. "PL" batteries are convenient for this use.

(b) Interrupted high current

Radio Transmitters: Low power transmitters with an interrupted plate key circuit can operate from "PL" batteries. For non-continuous service they may be used on phone, therefore they have a field in portable or aircraft radio transmitters.

Grid bias: For providing a grid bias or "C" voltage on transmitters.

may be openings in the disc or mirror reflectors. Each set of holes is arranged in the familiar spiral formation, and when the disc is rotating, light rays passing through the holes are bent within the tubes 26 into substantially different directions, 29 or 30, according to whether the tubes are working in conjunction with one set of holes or the other.

When finer picture detail is sought after recourse must generally be made to multiple exploring systems. That is to say, several different areas of the object are explored separately and simultaneously. Baird's patent just dealt with, and the two patents which follow, are examples of this.

A modification of the usual type of scanning disc is the subject of *Patent No. 295653*, by L. Szenyovszky. The object or image *a* (Fig. 3) is explored by two rotating discs mounted on the same shaft and revolving in opposite directions, and having slots or rows of holes 1, 2 crossing each other at a constant angle. The slots 1 are in the form of arcs of a circle; slots 2 are cut straight. It will be noticed that the slots are in a similar relative position at a number of positions represented by *a, b, c, d*, so that a corresponding number of identical objects or images can be simultaneously explored to obtain color or stereoscopic effects.

Another form of multiple scanning disc is described in No. 293308, whereby a number of light beams are made to scan separate areas of an object 10 (Fig. 4) simultaneously. 22 is the scanning disc having apertures 23 provided with light filters arranged radially and producing a number of scanning beams having different wavelengths. These different beams impinge on the object along adjacent paths and are reflected to light-sensitive cells 40, 41, 42, 43. The cells are either inherently selective to different wavelengths, or are rendered so by placing light filters 50, 51, 52, 53 in front of them. A second group of cells, 44, etc., may also be used, the modulated currents from each pair being sent to line to operate a multiple electrode glow discharge lamp at the receiver.

"Television is the next step in radio development," says President Garside of De Forest Radio Company.

Two hundred and fifty thousand shares of no par value of Jenkins Television Corporation were offered to the public December 6 at \$10 per share and oversubscribed in one hour. Eleven dollars was bid for the stock by some of those who applied too late to acquire the stock direct.

The company is incorporated under the laws of the State of Delaware with 1,000,000 shares of no par value to commercialize the television inventions of C. Francis Jenkins, Washington inventor, who years ago gave to the world its first motion picture projector, later developed many new creations in motion pictures and for three years has been perfecting his invention for broadcasting radio "movies."

Formation of the new company, in which Mr. Jenkins will have a substantial interest, will make it possible to develop radio television of movies on a national scale, it is felt. Capitalization will consist of 1,000,000 shares of no par common. The company has no funded debt, no bank debt and no preferred stock. This offering does not represent any financing by the corporation, but consists of stock purchased from individuals.

ALEXANDERSON PUTS PICTURES ON THE WALL

(Continued from page 64)

Mechanically operated devices appear to be tabooed when the high frequencies necessary for television are considered. Some delicate principle similar to that employed by the Karolus cell must be perfected.

The transmitting system employed by Dr. Alexanderson in his recent work involved no new or radical principles. He simply used powerful light to illuminate the boxers with a conventional scanning disc sweeping the beam across the moving forms. The "light pick-up" was formed by four special photo-electric cells connected to the input of a special amplifier designed to handle the high frequencies necessary to accurately transmit the rapidly moving forms.

Aside from the problem of light, the other major problem is that of frequency accommodation on the available wavelength channels. With these two problems solved, television would be immediately available for home use on a nation-wide scale.

OPTICS FOR TELEVISION EXPERIMENTERS

(Continued from page 71)

$1/u$, and $1/f$, where $1/f$ is equal to $2/r$, twice the curvature of the mirror. Thus finally we get—

$$\left(\frac{+1}{v}\right) = \left(\frac{+1}{u}\right) + \left(\frac{+1}{f}\right) \dots (4)$$

This equation, which is the key to the numerical positioning of object and image points on the axes of the mirrors (and lenses), put into words reads: The curvature, either positive or negative, with which reflected waves start from the mirror is equal to the curvature, either positive or negative, with which the incident waves strike the mirror, added to the curvature, either positive or negative, which the mirror itself impresses. To show how simple this all is in practice we will solve two or three problems:

Experiment 1.—A candle is placed 30 inches away from a concave mirror with a radius of cur-

vature of 10 inches. Find the direction and distance of the image. The waves in this case, falling upon the mirror, are diverging from a focus, and have therefore a negative curvature. Since the mirror converges, it impresses a positive curvature, so that we have in equation (4) above:

$$\frac{1}{v} = -\frac{1}{30} + \frac{1}{5}$$

or $v = +6$.

Thus the reflected waves converge to a focus, or image, 6 inches away in front of the mirror.

Experiment 2.—A candle is placed a foot away from a convex mirror with a radius of curvature of 6 inches. Will the image be real or virtual, and where will it be found?

In this case the incident waves are of negative curvature and the impressed curvature is also negative, thus—

$$\frac{1}{v} = -\frac{1}{12} - \frac{1}{3}$$

Whence $v = -2.4$ inches.

The reflected waves diverge as from a point 2.4 inches away behind the mirror, so that the image is virtual.

The equation (4) above is not only true for mirrors; it is also true for lenses—a subject which we have not yet dealt with, but which we will anticipate by the solution of a problem.

Experiment 3.—A thin lens (Fig. 8) which gives an image of the sun 3 inches away, is required to give a real image of a candle a foot away. Where must the candle be placed to obtain this image?

The transmitted or refracted waves in this case are by supposition converging to a focus, so that their curvatures are positive. The line is also a converging one, thus—

$$\frac{1}{12} = \frac{1}{u} + \frac{1}{3}$$

Whence $u = -4$.

The candle, therefore, must be placed 4 inches away from the lens. The negative sign means that the incident waves are diverging as they strike the lens.

LIQUID PHOTO-CELLS

(Continued from page 61)

chloric acid, etc., added to the quinone showed mainly a drop in potential on illumination, due to increase in resistance.

(13)	0.5 per cent. resorufin. . . (IV.B)	270	243
(14)	90 c.c. + 10 c.c. picric acid solution . . . (I.)	474	414
(15)	90 c.c. + 3.5 mol. potassium chloride . . . (III.B)	172	201
(16)	100 c.c. + 50 c.c. formalin . . . (IV.B)	126	146
(17)	50 c.c. + 50 c.c. M/10 ammonium oxalate . . . (V.)	165	134

Electrodes are denoted by the figures in brackets and are of size (I.)-(VI.) 300-400 sq. mm., (I.B.)-(VI.B) 800-1,200 sq. mm.

I have for some time been carrying out experiments with a new type of photo-electric cell, which should, from theoretical considerations, give a much more sensitive response to slight variations of light such as are experienced in a television transmitter.

This is also a liquid type of photo-electric cell, and contains a colloidal solution, the nature of which I shall give, together with a description of the apparatus employed, in a later article, so that the ardent television experimenter can investigate these phenomena for himself, with little trouble or expense.

THE light sensitive cell in one form or another is the most important part of the television transmitter. It is the electrical "eye" of the television camera. Accomplishment of television or "still" picture transmission by radio or wire is essentially dependent upon means by which the variation in intensity or brightness of a ray of light may be made to vary the strength of a current of electricity in exactly the same proportion. Mr. Wolfson looks forward to the perfect "pan-chromatic" photo-electric device, making it possible to equal response over the entire visible spectrum of light, facilitating the further development of color television.

—The Editor.

EXCHANGE IDEAS
on Television through
TELEVISION
America's First Television Journal

Write of your experiments and results to
Editor-in-Chief, Television Publishing Co.,
417 Fifth Ave., New York

TUNE IN TELEVISION WAVES WITH YOUR PRESENT RECEIVER

By HOLLIS S. BAIRD

A SHORT Wave Adapter is a very useful accessory for the Television Experimenter as it enables him to tune in on the Television Signals on the Short Waves with his present receiver. Or he may buy an adapter and a resistance coupled amplifier and have a complete receiver.

The designing of a Short Wave Adapter is quite a problem due to the fact that it must operate satisfactorily with practically any type of broadcast set now in use and it must work on any antenna. I have tried to incorporate in the Baird Short Wave Adapter all of the features that are desirable in a Short Wave Receiver. I will describe these different features in succession, starting from the antenna.

Fixed Antenna Coupling for each band is at once prohibited if we wish the set to oscillate over the complete scale on each coil. The antenna coupling may be varied in three ways. By a different antenna coil for each secondary, by varying the antenna coil coupling with the secondary, and by capacitive coupling with a midget variable condenser. This last method was chosen for an adapter as being the most practical and efficient. For a condenser I use a small 5-plate .00005 capacity.

Next came the choice of the secondary tuning condenser. Most adapters use a small midget for the tuning condenser to save cost but at the expense of crowding the stations on the dial. To avoid this last bad feature I use a standard S.L.F. Variable Condenser .00015 capacity as Short Wave stations bunch together a certain amount at best.

The Octocoil

The coils now came in for consideration. The idea of winding them on a tube base as some adapter manufacturers have done was discarded due to poor appearance and the fact that fine wire must be used. After spending con-

siderable time experimenting with different forms and sizes of wire the OCTOCOIL was the result, pictures of which appear and the description follows: The form is $1\frac{7}{8}$ inches in diameter and has eight ribs from which it gets its name. The wire used is No. 12, 14, 16 and 22 for the four coils which cover a band from 16-225 meters. This is a much wider band than most other adapters cover and takes in the lower part of the broadcast band which many broadcast receivers will not tune down to. There is some demand for broadcast coils in the adapter but I do not advise them as of course the adapter is a single circuit set and the receiver it is being used with will in the majority of cases be more selective than this. The different sizes of wire used and the ranges of each are as follows:



Octocoils

GREEN COIL No. 12 bare wire, 16-32 meters.

BROWN COIL No. 14 bare wire, 30-60 meters.

BLUE COIL No. 16 bare wire, 55-110.

RED COIL No. 22 enameled wire, 105-225 meters.

These secondaries are all space wound. The ticklers are wound with No. 25 wire and are not spaced as it is unnecessary.

These features just described all combine to make a very efficient and attractive coil plus strength which is never obtained in the air wound coils.

Next we will mention the method of regeneration used. The "Throtle" method was chosen as being

very smooth and having the least effect on tuning. A .0001 Midget Condenser is used to control the regeneration as using a smaller condenser with a larger tickler would increase the effect on the tuning of the secondary.

When the coil is pulled out of most adapters a loud howl is heard which is due to the grid circuit being opened and the plate circuit still being closed and this noise is rather objectionable when changing coils frequently. I have eliminated this by having the tickler carry the plate current which keeps the plate circuit open until the coil is plugged in.

A vernier dial is a necessity and we have provided a large vernier knob with lithographed scale on the panel. The grid condenser and leak are .00015 mfd and ten megohms which combination was

found to work very effectively for short waves.

It is quite well known that A.C. operation on short waves is usually unsuccessful due to a bad hum being present. This comes from using a 227 detector tube in the adapter. We have overcome this by using a 199 detector in the A.C. model which is lighted by a small C Battery in the lower compartment. Our only source of hum is now the B supply which is usually well enough filtered so as not to bother reception.

The lower compartment on the adapter accommodates the coils when not being used and prevents them being mislaid or damaged.

The Short Wave Adapter ful-

fills all of our demands for a good adapter.

1. Any antenna may be used, due to adjustable control.
2. Very efficient coils which cover a wide band 16-225 meters.
3. S. L. F. Tuning condenser with vernier dial.
4. Successful A.C. operation.
5. Compartment in base for coils.

In the three months which we have been manufacturing the adapter, we have received reports of reception of the following Short

Wave stations, from all parts of the world:

- JB Johannesburg, South Africa.
- 5SW Chelmsford, England.
- PCJJ Eindhoven, Holland.
- PCLL Kootwijk, Holland.
- CJRX Winnipeg, Manitoba.
- YN Lyons, France.

These were all heard in the eastern part of the country. In the west most of these have been heard together with,

- JHBB Ibarakiken, Japan.
- RFM Knabarovsk, Siberia.

Fourteen Year Old Boy Makes Televisor (Concluded from page 76)

chokes in plan of last plate resistor.

"I hooked up the amplifier and receiver and I received vibrations of music dancing across the "Screen". The next Tuesday night the doctor and I saw the first television picture we had ever seen, the first ever seen in New Bedford.

"For the first fifteen minutes of the television broadcast, we saw only dots and dashes crossing the screen. Then I was able to control the motor so that the lines crossing the screen so rapidly, began to slow down and finally two of them seemed to jump into the screen, bordering or framing the image of a man visible down to the waist.

"On Tuesday, November 20, I again received pictures, but this time they were much better than the first ones.

"The first scene was a man turning his face from side to side and talking. The second was a man sitting down, reading a book and the third sitting at the end of a table eating or drinking. It seemed about as easy to control the synchronism this time as it is easy for a driver to steer his automobile. There was only one fault, the picture was negative.

"Most of the men interested in radio whom I know, told me when I started that whether on short wave or broadcast frequencies, it would be impossible to receive pictures because I would have to be either very near or quite far from the short wave transmitter, on account of the skip distance, and on broadcast frequencies, there would be too much interference from other stations, and even if

the television transmission did come in like a "ton of bricks", I could not receive pictures, but since they had never tried it, I kept on building it. I am glad that I was not discouraged by these "radio engineers", because now I have had the thrill of seeing a man in Schenectady and also have had the pleasure of building a television receiver by myself.

"The receiver is a superheterodyne (L. C. 7), using 201A tubes; the last two Audio frequency amplifier tubes originally in the receiver being omitted. The amplifier is a Daven resistance-coupled amplifier which has been rewired for a power tube, and in place of the last grid resistor is a 500mh radio frequency choke in series with a National 100mh Audio frequency choke.

"There is an Aerovox 2mfd. Filter Condenser and a Jefferson 20h. choke in the filter circuit, and the Raytheon Kino-lamp is controlled by a Frost 0-20,000 ohm variable resistor.

"I will soon change the receiver to a National Screen-Grid Short-Wave Receiver, with which I expect to be able to receive more stations such as W-2-XAL (WR-NY) New York on 30.9 meters; W-2-XAF, Schenectady on 31.4 meters; W-1-XAY, Lexington on 61.5 meters, or W-3-XK, Washington.

"I will order a Clarostat Motor control and a Clarostat Neon tube control, and a Baldor motor. Would you please tell me what type Baldor Motor you would use for a Daven combination 24, 36, and 48 hole disc?

"Yours very sincerely
Gaston Frontaine"

Vision and Television

"I regret that the Commission has admitted television to the broadcasting band. . . . The American public have for several years been entertained by broadcast programs of speech and music. Why give them a whistle or blur a part of the time in which they have received so long something intelligible and entertaining?"

This from the chairman of the Federal Radio Commission dissenting from an opinion of his four colleagues that visual broadcasting should be allowed to encourage an infant art.

Oh man of vision! Less than a hundred years ago eminent engineers saw nothing practical in the railroad and one of them declared:

"The noise of the railways would stop hens from laying and prevent cattle from grazing; the poisoned smoke from locomotives would kill the song-birds, scare the game, and that all houses anywhere near the railways would be set on fire by the engines."

The Radio Commission Chairman who sees in television only the present "whistle and blur" might remember Charles Carroll of Carrollton then the last surviving signer of the Declaration of Independence who made a speech when ground was broken for the Baltimore and Ohio Railroad in 1828 and said:

"I consider this among the most important acts of my life, second only to that of signing the Declaration of Independence, if second even to that."—*The Nation's Business*.

Television Lets Doctor See Tongue Miles Away

John Ambrose Fleming, inventor of the thermionic valve and professor-emeritus of electrical engineering at University College, London, after a demonstration of Dr. John L. Baird's television apparatus exclaimed:

"I could even see that the subject's tongue was in good condition. Capital! A doctor could diagnose the tongue of a patient 100 miles away!"

From the Herald Tribune London Bureau.

*Predicted Television
Marconi*

Perhaps the world's most famous radio personage, Senatore Guglielmo Marconi, spurred and stirred the popular imagination greatest, when he predicted the ultimate scope of television. He said: "The scope of television, coupled with wireless telephony and broadcasting, both of sound and power, is limitless. Secretary of State may one day sit in his office in the State Department building in Washington and converse with the Premier in Downing Street (London). The young army lieutenant at Fort Gibbon, Alaska, will watch the Army-Navy football game thousands of miles away. He will hear the cheers, watch his old corps march around the field, see the Army mule look with scorn upon the Navy goat. He will get every thrill that his closer brothers get. A New York banker may be crossing the Indian Ocean on a world tour in his private yacht, yet he will talk face to face with his partners in their Wall Street office."

"Why continue? It leaves one at a loss to picture such a future—a future that is apparently close at hand." The possibilities of unlimited sight through television, or whatsoever common usage of the future may see fit to assign it as a name, stagger the very power of thought, however, he admonished: "I must leave to your imagination the uses which can be made of these new powers."

David Sarnoff, Vice-President of the Radio Corporation of America, in an address given April 16, 1928, before 250 students of the graduating class of the Harvard School of Business Administration, said: "No division of the radio art can remain indifferent toward the developments that our great electrical laboratories promise for the future. * * * Fundamentally, the problems of radio still call for study and experimentation. We do not yet know to how many uses a given radio device may be put. We know little of the laws that govern radio transmission. We have only an inkling of what the next day may bring forth from the laboratory."

*Who Is Broadcasting Television
and When*

EASTERN STANDARD TIME					
Station	Location	Broadcasting Time	Waves in Meters	Disk Holes	Motor R.P.M.
WCFL	Chicago	Daily between 1:00 and 2:00 P. M.	309.1	48	900
W9XAA	Chicago	Irregular A.M. Hours	4560 KYC	48	900
W4-XA	Memphis, Tenn.	Irregular Experimental	120 to 125	24	900
WLEX and 1-Xay	Lexington, Mass.	Nightly irregular hours; from 3:00 to 4:00 P.M.	61.5	48	900
WGY and W2XAD	Schenectady	Tuesdays, Thursdays and Fridays at 1:30 to 2 P.M.	380 and 21.96	24	1,200
WGY and W2XAF	Schenectady	Tuesdays, 11:30 to 12:00 P.M.	380 and 31.4	24	1,200
WGY and W2XAD	Schenectady	Sundays, 11:15 to 11:30 P.M.	380 and 21.96	24	1,200
W3XX	Washington, D. C.	Mondays, Wednesdays and Fridays, 8:00 to 9:00 P.M. (silhouettes).	46.7	48	900
KDKA	Pittsburgh	Irregular-experimental (Radio motion pictures).	62.5	60	1,000
WRNY and W2XAL	New York	Mondays, 3:00 P.M. to 8:15 P.M.; Wednesdays: 2:45 P.M. to 3:00 P.M.; Thursdays: 12:45 P.M. to 1:00 A.M.; Fridays: 3:00 P.M. to 3:15 P.M.	297 meters 30.91 meters 9,700 kilocycles	44	450 450

Television Broadcasting

The Radio Division, Department of Commerce, furnished this list of stations licensed for Television Broadcasting:

Station	Location	Kcs.
W9XAG	Aero Products, Inc., 1768 Wilson Ave., Chicago, Ill.	4700-4900
W2XBT	Frank L. Carter, 3978 Bliss St., Long Island City, N. Y.	8195
WCFL	Chicago Federation of Labor, Ft. of Grand Ave., Chicago	620
W9XAA	Chicago Federation of Labor, Ft. of Grand Ave., Chicago	4460-4660
W1XAY	J. Smith Dodge, Adams St., Lexington, Mass.	4800-4900
W6XN	General Electric Co, 5555 E. 14th St., Oakland, Cal.	2052-4560
W3XK	Jenkins Laboratories, 1519 Connecticut Ave., Washington	4900-5000
W6XBW	P. S. Lucas, 422 Holland Ave., Los Angeles	2140-4280
6XAM	Ben S McGlashan, Wash. and Oak Sts., Los Angeles	2000-2100
W6XC	Robert B. Parrish, 5155 S. Grammercy Place, Los Angeles	4500-4600
W2XAL	Hotel Roosevelt, 45th and Madison Ave., New York	3091-9700
W2XBS	Radio Corp. of America (Portable), 70 Van Cortlandt Park, S. Bronx, New York, N. Y.	2100-330 4500-4600
W2XBV	Radio Corp. of America (Portable)	4500-4600
W2XBW	Radio Corp. of America (Portable), Initial location: River Road, Bound Brook, N. J.	15100-15200
W6XF	Calvin J. Smith, 334 N. Serrano Ave., Los Angeles	4700-4900
W2XBU	Harold E. Smith, Beacon, N. Y.	4700-4900
W8XAV	Westinghouse Electric Mfg. Co. E. Pittsburgh, Pa.	4700-4800 15100-15200
W4XA	WREC, Inc., Whitehaven, Tenn.	2400-2500
WIBO	Nelson Bros. Bond & Mfg. Co., Milwaukee Ave., at Ballard Rd., Chicago, Ill.	570

SYNCHRONIZATION

The BIG Television Problem

Successful television with the technique now in vogue calls for the synchronization of both transmitting and receiving scanning disks. Unless the two disks, at widely separated locations, are kept in perfect step, the image at the receiving end is badly distorted. While it has been suggested that automatic synchronization may be obtained through the use of synchronous motors at transmitting and receiving ends, operating on the same power supply, it must be evident that this requirement would greatly limit the scope of a television service. Almost any television service is certain to take in "lookers-in" located in many communities served by as many electric power systems, so that the use of synchronous motors is hardly a practical solution of the problem.

The generally accepted practice is to employ a variable speed motor together with a series resistance for controlling the speed. However, the ordinary motor control is useless for television scanning disk control. A positively stepless adjustable resistance is required, capable of dissipating up to 80 watts if a motor of 1/8th horsepower or less is to be controlled. Also, the resistance setting must be stable, so as to maintain a constant resistance in the circuit. A push-button to short-circuit the resistance is required for quick starting and also for momentarily short-circuiting the scanning disk so as to get the holes as well as the scanning disk speed in proper phase with the transmitted image.

In an endeavor to meet all these requirements, there has been developed the Clarostat Speed Control. This comprises a special heavy-duty form of stepless adjustable resistance, together with a short-circuiting push-button housed in a ventilated metal casing with suitable mounting feet. A re-

movable metal end cap protects the two screw terminals. The device is inserted in one side of the power supply to the motor. Either a universal or a condenser type motor up to 1/8 horsepower may be controlled from a dead stop to practically full speed, in several turns of the Clarostat knob, while

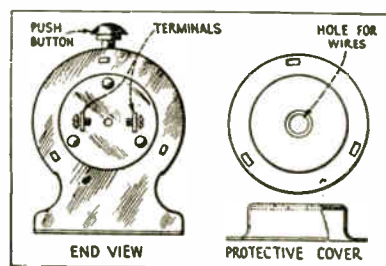

the push-button provides a quick start and momentary acceleration.

The Clarostat Speed Control is mounted in front of the television cabinet, close at hand for ready

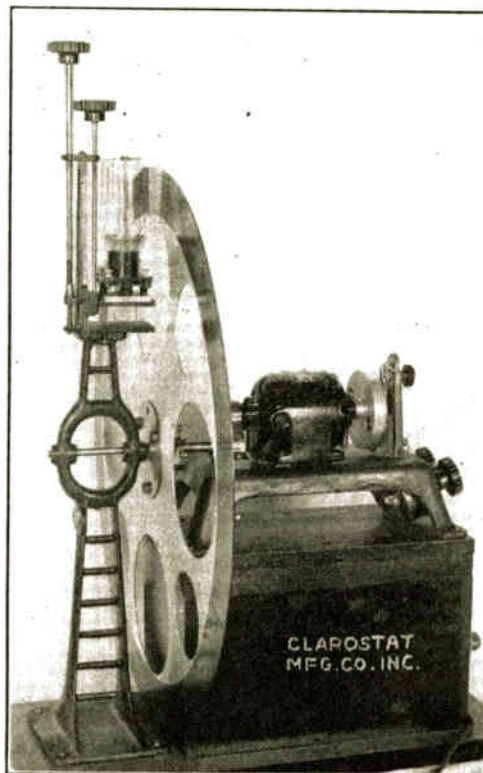

Automatic Control of Scanning Disc

manipulation. In actual practice, the scanning disk is adjusted by means of the Clarostat Speed Control knob. The conglomerate streaks are seen to assemble themselves into masses of lights and shadows. Still closer adjustment of the control knob causes those meaningless masses to arrange themselves into grotesque shapes, followed by further adjustment, together with the aid of the push-button, until a satisfactory image is obtained. The image is then held on the screen by proper manipulation of the push-button, somewhat after the fashion of steering a car down the center of a road. If the scanning disk gets out of step with the transmitted image, the image on the screen is seen to slide over to one side or the other, depending on whether the receiving disk is ahead or behind the transmitted image. A little practice serves to supply the necessary dexterity for controlling the scanning disk.

The accompanying diagrams show the application of the Clarostat Speed Control, together with the protective cover for the screw binding post.

Having provided manual control for the television scanning disk, the Clarostat Engineering Staff some time ago turned its efforts to the study of automatic control. It was realized that while manual control might meet the requirements of an extensive, experimental television outfit, it would hardly serve for the ultimate television receiver for lay use. The results of our study, research and development are now available in the tangible form of an automatic television control unit, which we are offering to the radio trade at this time.

From the first, we realized that the comparatively large motors of

1/10th or 1/8th horsepower are quite unnecessary and, indeed, quite detrimental to satisfactory results because of their sluggish response to control. Instead, we selected a smaller, high-speed motor and made use of suitable gear reduction drive for the scanning disk, so as to obtain a highly responsive and flexible control.

The present Clarostat Automatic Television Unit comprises a driving motor, the adjustable speed control, and the adjustable kino-lamp or neon glow tube mounting, ready for use in any cabinet or simply exposed. The scanning disk is optional with the experimenter, since different television signals call for different scanning disks.

The motor is of 1/25th horsepower, high-speed type, with suitable reduction gearing and flexible coupling for driving the scanning disk. This arrangement provides the greatest degree of correction, and eliminates fussy and troublesome alignment of drive shaft and scanning disk arbor. On the motor shaft is mounted a special centrifugal governor actuating a pair of contact points in series with the motor current supply. The contact points are shunted by an adjustable resistance. Thus when speed of the motor rises above a given point, the centrifugal governor opens the contact points, thereby reducing the currents to the extent of the resis-

tance then thrown into the circuit. As the speed of the motor falls below a given point the contact points close, short-circuiting the resistance and restoring full current to the motor.

Two special Power Clarostats are employed as the controls for obtaining any desired speed and also for trimming the sparking at the contact points by varying the degree of short-circuited resistance. The knobs of the Power Clarostats are at the front end of the motor base. In addition, there is a small knob for adjusting the contact points, which serves as a vernier in obtaining precise speed even to one revolution.

Provision is made for mounting any scanning disk on the drive shaft. The kino-lamp or neon glow tube is mounted on an adjustable platform which, by means of rack pinion movements, may be micrometrically raised or lowered as well as shifted from side to side. In this manner the light source can readily be adjusted for any variations in the kino-lamp, as well as to align the image with the opening through which the image is visible.

In operation, the speed control knob is adjusted for the necessary speed, which may be anything from a few revolutions to many hundred. Vernier or delicate adjustments to within a single revolution or less, are made by means

of the small knob that regulates the contact points. Finally, sparking at the contact points is reduced by the knob controlling the short-circuited resistance until it is almost imperceptible. A constant speed is now maintained with speed correction at every fraction of a revolution. The sparking at the contact points in no way interferes with the delicate receiver employed for television signal reception.

With this device, television becomes simple, positive and enjoyable, within the limitations of the balance of the technique. We might say that it is almost practical. The television image is brought on our screen by varying the motor speed until the correct speed is obtained. This speed is then held just so long as the controls are left alone. In our experimental work we have held the television signals for a full 20 minute program, without once having to adjust the controls. The image stays centered on the screen, without troublesome weaving or swaying or scrambling. It would seem, in short, as though this automatic television unit has taken television out of the purely experimental class and given it a standing in the lay world.

Full details regarding either the manual or the automatic Clarostat Television Control will be gladly sent to any engineer requesting same.

Westerlund Goes to Polymet

Geo. E. Westerlund, for the past three years Purchasing Agent of the Charles Freshman Co., Inc. has resigned and is now head of the Purchasing Department of the Polymet Manufacturing Corporation, makers of Polymet Fixed Condensers and Resistances.

Mr. Westerlund's wide experience includes a previous connection with the New York Edison Company in a designing and testing capacity. He has just returned from a four month tour of Europe where he studied radio development on the continent. Mr. Westerlund's headquarters are in the executive offices of the Polymet Manufacturing Corporation—599 Broadway, New York City.

Tobe A-Filter

Contains the Tobe 7,600 Mfd. A-Block and two large capacity chokes, properly connected, so that when the proper rectifier is used on one pair of binding posts, the other pair may be connected direct to A-plus and A-minus binding posts on the set, through a 2-ohm rheostat of heavy duty design. Max. current-carrying capacity, 2½ amperes (to obtain amperage of battery set, add the amperes taken by each tube. For example, a 6-tube set using two UX-222 Tubes, three UX-201-A Tubes, and the UX-171-A Tube, will take .132 plus .132, plus four times .25 amperes, or a total of 1.264 amperes—well within the capacity of the Tobe A-Filter.)

Daven Photoelectric Cells

For Television Transmission

For the advanced experimenters who desires to work with television transmission, the Photoelectric Cell opens up a new field. This cell, ruggedly designed, can be used in experimenting with not only the art of television transmission, but talking movies, circuit control devices, relays, etc.

With a single step of amplification, a deflection of 30 milli-amperes has been obtained with a 100 watt lamp as a light source.

Type PC-175 (1¾" bulb diameter).

Type PC-300 (3" bulb diameter).

HOOK UP YOUR RADIO FOR MOVIES

Radio movies are being broadcast every Monday, Wednesday and Friday nights at present from the Jenkins' Laboratories, Washington, D. C.

Resistance coupled amplifier sets are best. Wiring diagrams will be furnished on request. If you do not care to make your picture receiving set yourself a set that has been tried and found excellent will be recommended by this magazine or by writing the Jenkins' Laboratories, 1519 Connecticut Avenue, Washington, D. C.

In broadcasting you get the announcement in your radio set and then switch into the picture receiving apparatus.

Each picture story is preceded and followed by the familiar movie sign "End." At that signal you switch back to your loud speaker and get the announcement for the next picture. Then you switch in the picture once more.

The pictures are in silhouette, like those that are so amusing on the silver screen, with the added mystery of receiving them by radio.

There are sets available, for the reception of these radio movies, which are comparable with the first crystal and head phone radio sets, which can be bought as low as \$2.50, but these are not as satisfactory as the better kinds.

Far from perfect are the radio receivers for pictures, but the American radio amateur demonstrated cleverness equal to that of engineers; indeed surprised trained scientists, for amateurs developed the worthless frequency, below the 200 meter band." That outstanding accomplishment is only one of many victories which have crowned with laurels the brows of the indomitable amateur investigator.

Radio transmission of pictures and television are so closely allied that the general public will probably call both by the same name.

This is the beginning of a new industry. It is a new form of

JUST AMONG US GIRLS



Courtesy Chicago Evening Post.

entertainment and that is what the restless spirit of the people of the world demand today.

The public will not long be satisfied with pictures alone. Soon dual sets will be demanded and be available. That is inevitable. Music will accompany the pictures and the dramas we now hear, will be brought before us in action as well.

The Happiness Boys, Smith Brothers, Thompkins Corners and all the characters will pass in review and their antics will make us laugh still more heartily. The announcements in the newspapers will be scanned to "see what to see" as well as what to hear.

We will see whether the voice divine emanates from the vocal organs of the ideal being we subconsciously vision, or from an ordinary woman or man, like unto the great majority of us.

The Family Circle

The introduction of radio in the homes of America has had a great influence upon the family circle, for before radio came, attractions irresistible drew the younger folk from the living room.

Distance is an inconsequential thing today, when a dance, a dinner, a party, an entertainment, 50 miles away is quite as easily attended as a neighborhood gathering was before the advent of the automobile.

Radio was a novelty, a mystery, a curiosity; an adventure into the unknown. Out of the air came voices, laughter, songs. Everyone was impatient for the headphones so they might be thrilled by the marvel of "listening in."

What Will Television Do?

Think, then, if audition made such an impression, created such tremendous interest, caused pater or son to stay at home, tinker and build, tear down and rebuild, a radio receiver, what television will do. Radio held the experimenter in thrall. Reaching out into thin air and bringing sounds from across the state, across the continent and then half way round the world!

When the loud speaker was introduced the neighbors were called in to marvel and the pleasure was shared by all.

How much greater will be that mutual interest when the entire family circle will simultaneously hear and see.

In "The Jazz Singer," Al Jolson made an instantaneous success and talking movies will dominate the palaces devoted to moving pictures.

Television, coupled with radio, will hold the interest to a greater extent than anything ever introduced in the home and there will be less nervous anxiety, and less reason for sobbing when someone sings a repertoire of "the songs of yesteryear," and gargles "Where is My Wandering Boy To-night."

AUTOMATIC SYNCHRONIZATION

(Continued from page 84)

relatively to synchronism, within predetermined narrow limits.

In the scanning beam B, from the explorer, is placed a small fixed mirror which reflects a constantly oscillating beam C to form on the chopper an image identical with that formed on the viewing screen J, and this beam should register with successive bars of the

chopper, as already pointed out in connection with Fig. 2. This small mirror intercepts only a *portion* of the light, so as to permit the scanning beam B to trace a brilliant succession of flashes on the screen J, to produce the transmitted image.

Continuous Application of Synchronizing Energy

By referring to Figs. 2 and 3, it is seen that the photoelectric cell is *continuously* illuminated by successive flashes of the beam D, but in proportion to the accuracy of registration with the chopper; and the exciting current controlling the motor speed and angular position varies correspondingly. Speed regulation may be considered instantaneous, since there is no inertia in the photoelectric cells, and the current in said cells is at all times proportional or inversely proportional to the instantaneous out-of-phasing, producing a minimum of "hunting" and assuring stability of operation, employing simple apparatus and circuits, and disposing of synchronization uncertainty.

I. C. A. UNIVERSAL MOTOR AND RHEOSTAT

The most essential factor for satisfactory reception of television pictures is absolute synchronization of the two scanning discs;

that is, both the broadcasting disc and the receiving disc must operate at exactly the same speed, no matter how far apart they may be, even if thousands of miles may intervene. Consequently it is necessary to have an absolutely reliable and smooth-running motor of suitable size. Too large a motor may hold back results on account of the difficulty of controlling speed.

Fixed Resistance Necessary

In order to keep the receiving disc revolving at the same speed as the broadcasting disc it has been found necessary to use a fixed resistance which will operate the motor at slightly above the desired speed, and then a rheostat so as to reduce it slightly below this desired speed. The use of the rheostat will eliminate the difficulty of keeping the disc at synchronous speed.

All these conditions are met by the I. C. A. Universal Motor and Rheostat, made by the Insuline Corporation of America, 78-80 Cortland Street, New York City. The motor is of the non-sparking type, with just sufficient power to time correctly with the broadcasting fluctuations of speed and is made for 110 volts, either A.C. or D.C. and 2, 50 or 60 cycles. The price is \$27.50 and the special rheostat for speed regulation costs \$3.00 additional.

TELEVISION

Wide and intense interest has been manifested in this magazine, all over North America and in Europe, Africa, Asia and Australia.

203 ELECTRICAL ENGINEERS subscribed in December. This signifies an appreciation of the valuable information presented in the magazine.

FAMOUS ELECTRICAL ORGANIZATIONS honor our Subscription Rolls. Among the leaders are: Thomas A. Edison, Inc., Orange, N. J. General Electric Co., Schenectady, N. Y., and Pittsfield, Mass. Westinghouse E. & M. Co., East Pittsburgh, Pa. Bell Telephone Laboratories, New York City. Hudson's Bay Co., Radio Dept., Winnipeg, Canada.

RENOWNED RADIO MEN AND CONCERNS now listed among subscribers to TELEVISION reads like the "Who's Who?" of the Trade, starting with the Radio Corporation of America.

RADIO RESEARCH LABORATORIES find the magazine helpful. Praises for the contents are received with pleasing frequency.

COLLEGES and SCHOOLS in all parts of the country appreciate TELEVISION, among them: Massachusetts Institute of Technology, University of Michigan, Kansas State College, Agricultural & Mechanical College of Texas, State Agricultural College, Colorado; Rose Polytechnic Inst., Indiana; Montana State College, Louisiana State University, Swarthmore College, Pennsylvania; School of Engineering of Milwaukee, etc., etc., etc.

Send in your subscription today—In the next Issue Read "DAVID SARNOFF, PREVISIONS TELEVISION," H. WOLFSON ON "INFLUENCE OF POLARIZATION ON PHOTO ELECTRIC EFFECT," J. ROBINSON, M.B.E., D. Sc., Ph.D., M.I.E.E., F. Inst. P. on "AMOUNT OF ETHER REQUIRED BY TELEVISION," Raymond Francis Yates "A B C OF TELEVISION," (continued) and many other articles to aid you in keeping up to date on Television.

TWO Outstanding Raytheon Achievements



Raytheon Kino-Lamp

Already Raytheon has brought television tubes past the "anything that works" stage to a point where reliability and long life are added to practicability. The Raytheon Kino-Lamp is the long-life television receiving tube—adapted to all systems and made in numerous types.

List Price. \$7.50



Raytheon Foto-Cell

Again, in this sending tube, Raytheon has developed plus-service through long experimentation and research. The Foto-Cell comes in either hard-vacuum or gas-filled types, and in two sizes of each.

Information and prices upon application

Write us for further information regarding Raytheon Television Tubes

RAYTHEON MFG. CO.
CAMBRIDGE, MASS.

ONIONS? NO!

Bermuda Knows Her Television!

The visitors no less than the home folks of Bermuda are still excited by the regular reception of Television programs at Hamilton from General Electric Company's broadcasting station at Schenectady.

From WGY and W2XAF on wave length fixed at 380 and 21.96 meters simultaneously the radio signals and Television pictures are received on Tuesdays, Thursdays and Fridays from 1:30 P. M. to 2 P. M. A twenty-four hole disk is used and the pictures are received surprisingly clear and distinct.

Everyone is eager to see the new marvel, Television. To see men and women as they move and breathe and have their being! "seeing" across 32 hours of travel by water and 6 hours more by land by fast train.

Were televisors available half the better homes in Bermuda would be immediately equipped with them.

Now— TELEVISION

—and the accepted motor for it!

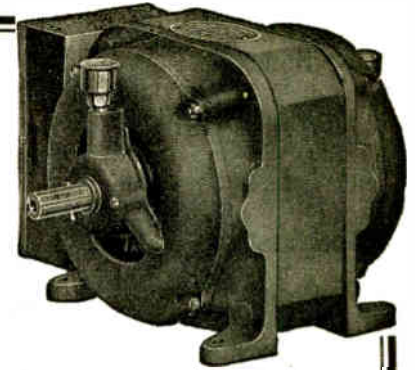

Television requires a motor which will not spark; sparking distorts the received picture.

The Baldor Variable Speed Motor has no brushes, commutator or automatic switch, or any device that can spark.

Television requires a motor with little friction, so as to be able to follow the moving picture accurately.

The Baldor Motor is ball bearing, which means minimum friction, and is easy to keep accurate.

Television requires a very quiet receiver, so as not to transmit noises to the receiving set.

The Baldor Motor is quiet and humless.

The Baldor motor is also made in synchronise speed models.

The synchronise speed motor is being used by the leading television engineers and experimenters for both the transmitting and receiving of television images.

Variable Speed Models

Type Y1V, 1/4 H.P., 110 volt, 60 cycle, single phase, 1800 R.P.M., recommended for receiving sets using 24-inch disc.

Type Y2V, 1/4 H.P., 110 volt, 60 cycle, single phase, 1200 R.P.M.

Type M2V, 1/15 H.P., 110 volt 60 cycle single phase, 1800 R.P.M.

Synchronise Speed Models

Type X1S, 1/4 H.P., 60 cycle, 900 R.P.M. Synchronise speed.

Type Y2S, 1/4 H.P., 60 cycle, 1200 R.P.M. Synchronise speed.

Type Y1S, 1/4 H.P., 60 cycle, 1800 R.P.M. Synchronise speed.

Type Y1S, 1/6 H.P., 60 cycle, 3600 R.P.M. Synchronise speed.

Television experimenters are invited to write us. Our engineers will be glad to help you on your motor troubles. Write for Bulletins Nos. 11 and 11A.

Interstate Electric Co.

4339 Duncan Ave., St. Louis, Mo.

BALDOR

A BETTER MOTOR

Factory Representative: H Marshall Scolnick, 151 Norfolk St., New York City, N. Y.

To Encourage the Development of Television Join the

TELEVISION SOCIETY, Inc.

417 Fifth Avenue, New York City

DO IT NOW!

OBJECTS

To encourage experiments in the transmission and reception of vision by evincing a lively interest and sympathy therein:

To spread the knowledge of the means and processes by which such transmission is made possible, and by any and all legitimate means furthering the progress of visualization by electrical impulses:

To afford a center where all who are interested in the Science of Television may meet and interchange their knowledge and experience.

Members. Any reputable person who is in sympathy with the objects of this Society may become a member when duly

nominated and accepted, upon the payment of the annual dues; and as long as such members remain in good standing, they shall receive all the benefits which the Society affords for the study of the Science of Television, including the special literature which the Society may, from time to time, produce for members, including the Official Monthly Journal of the Society.

Certificate of Membership. There shall be issued to each Member a membership identification card, designating the class of the membership.

DUES

The Annual Dues shall be Five (\$5.00) Dollars, payable in advance; which shall include an annual subscription to the official monthly publication of the Society.

"To Encourage The Development of Television"

TELEVISION SOCIETY OF AMERICA

417 FIFTH AVENUE, NEW YORK, N. Y.

The undersigned desires to be enrolled as a member of The Television Society, Incorporated. Herewith find remittance covering the annual dues, which include one year's subscription to TELEVISION, the Official Monthly Publication of the Society.

ANNUAL DUES	NAME
In U. S. \$5.00	STREET
Canada 5.50	CITY
Foreign 6.00	STATE
Life 100.00	PLEASE GIVE VOCATION

Now EVERYONE Can Understand TELEVISION!

Announcing the Publication of the

A B C of TELEVISION

For the Inquiring Layman or the Practical Amateur

By

RAYMOND F. YATES

Formerly *Managing Editor* of POPULAR SCIENCE
MONTHLY; *Editor* of POPULAR RADIO
now *Editor* of "TELEVISION"

Member A.I.E.E., A.S.M.E., I.R.E., R.C.A.
Am. Phys. Soc.

Now in process of printing

Sent Postpaid for \$2.60



RAYMOND F. YATES

TELEVISION

Yesterday's Dream
... Today's Reality

THE practical introduction of TELEVISION into the realm of every-day things is of far greater importance than was the development of sound by radio. The development of TELEVISION in the immediate future will be none the less amazing, and even more marvelous.

Now is the time for those who wish to follow the progress of this new miracle of science and engineering, to grasp and firmly fix in the mind its engrossing fundamentals. To grow with new art is easy; to catch up with an old one requires perseverance and tenacity.

THE "A B C OF TELEVISION" is not a book for "engineering high-brows," nor is it a superficially prepared volume written to amaze and entertain the novice. Rather, it is an intensely practical volume written for the practical amateur who wants to "do things" in television, or for the serious student who would keep abreast of the times. The "A B C OF TELEVISION" stresses the "how" of the art rather than the "why,"

although sufficient space has been devoted to underlying physical and electrical laws to satisfy the most critical.

The book is, in its essence an academic treatise brought down to the level of the lay mind. Engaging in its simplicity, penetrating and wide in its scope, it stands as the first popular American book devoted to television and telephotography.

THE "A B C OF TELEVISION" comprises 250 profusely illustrated pages. The first portion throws the soft light of understanding on the subject of the different television systems in use today. In so doing, it clearly, concisely, and in the simplest of terms, outlines the real fundamentals of each system. The problems of scanning, amplification of light-modulated signals, photo-electric and selenium cells, neon lamps and synchronizing appurtenances are covered in detail.

The practical aspects of the art are at all times foremost.

The book has been written essentially for those who wish to build television receivers and transmitters either for entertainment or research purposes. It is a book for those who crave action and results, rather than theory and headaches.

TABLE OF CONTENTS

Chapter	Introduction
1—The New Conquest of Space.	
2—Television Systems.	
3—Telegraphing Pictures.	
4—Photo-electric Cells—Eyes of Television.	
5—Amplifying Pictures.	
6—The Agile Neon Lamp.	
7—Selenium Cells.	
8—The Problem of Scanning.	
9—Synchronizing Television.	
10—Transmitting Television at Home.	
11—How to Make a Television Receiver.	

FREE

Examination with no obligation to buy

The "A B C OF TELEVISION" is now on the press. If you wish to examine one of the first copies to leave the presses without obligation to buy, write your name and address on the coupon and mail it to the TELEVISION PUBLISHING COMPANY, INC., 417 Fifth Avenue, New York.

TELEVISION PUBLISHING COMPANY, INC.
417 Fifth Avenue, New York, N. Y.
(Publishers of *Television*, Official Journal
of the *Television Society, Inc.*)

Please send copy of the "A B C OF TELEVISION" on approval. Finding the book meets my needs, I will immediately remit \$2.60 to cover the cost of the book and postage.

Name

Address

City

State

Desiring book sent by
mail, C.O.D., place X
in square below.

GROUND

ANTENNA

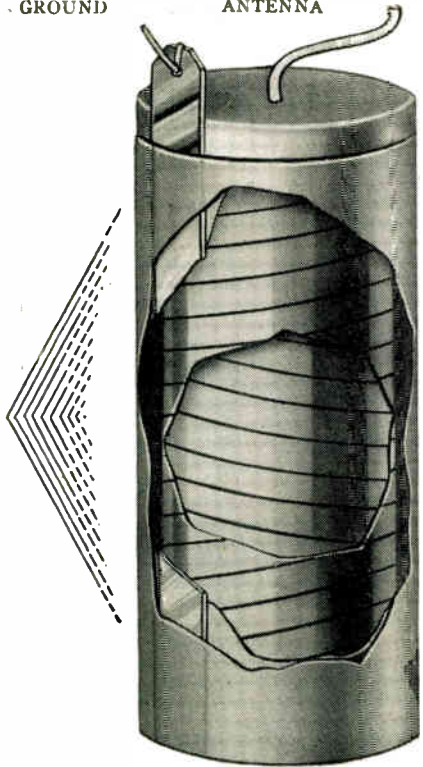

NEW

ANTENNA and GROUND

Combined in one convenient Unit

A wonderful thing has happened in radio! Convenience never before dreamed of! Clearer, sweeter-toned reception! Radio pleasure with less interruption! These things are brought to you by the amazing, tested, approved, EARTHANTENNA.

Many set owners have come to realize the importance of using a dependable antenna, also the value of perfect grounding in getting good reception. Now science has gone a step further; it says that the LOCATION of the antenna is an equally important factor in getting best results. Because the radio wave goes right into the earth—where obviously there is less atmospheric disturbance and interference—it is claimed the logical place for the antenna should be the EARTH, not the air. This important conclusion allowed Radio Engineers to work out the EARTHANTENNA.

Reduces Static—

Gets Clearer, Sweeter Tone

Have you ever listened to reception that almost took your breath away with its faultless reproduction, its pure, melodious tone? And then gone home and compared its haunting beauty to YOUR receiver's often unsatisfactory, static-ridden performance? Probably nine out of ten set owners who formerly thought they were getting "pretty good" reception have had this experience.

They accepted the shrieks, whistles, knocking and howls due to atmospheric conditions—the weak, faulty results of sagging, broken or soot-laden aerial wires—the interference of other aerials or power line noises—the fading often caused by corrosion or imperfect contact in an unscientific ground—all as necessary evils.

Progressive radio refused to stop there. The new Scientific successful EARTHANTENNA is designed to give you clearer, better, more dependable reception—and it costs no more than the old inefficient aerial—in fact less than many.

EARTHANTENNA is so easy to install that soon people will wonder how they ever put up with the old, dangerous, slow methods. You simply dig a small hole only two feet below the surface of the ground, drop the EARTHANTENNA into it and attach the lead-in wires to your set. Now you are ready to listen to earth-clarified, sweeter toned ground wave reception. You never need to touch the EARTHANTENNA again.

Shielded Antenna Gets Better Reception

The antenna is insulated or "shielded" against electro-static disturbances as are the most advanced, expensive receivers and their various parts. Science declares that the earth itself "shorts" the electro-static capacity before it reaches the Antenna. This acts as another shield. The ground element is constructed of copper, undisputed as the most effective material for obtaining a perfect ground connection. This section of the unit is separated from the antenna by the insulation which shields the Antenna. So in the EARTHANTENNA you have a scientific ground and an antenna of modern shielded construction combined in one compact unit. You can test it yourself right now at our risk. Hear the wonderful results!

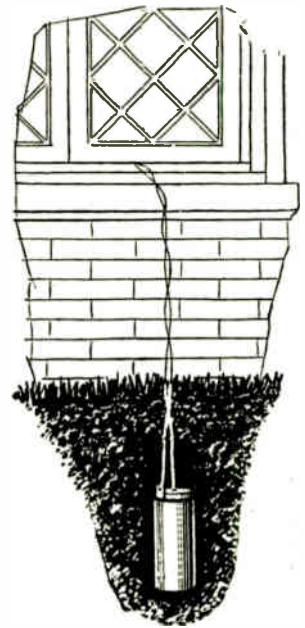

Test EARTHANTENNA at Our Risk

Let EARTHANTENNA prove its own value without your risking one cent. Don't remove your old aerial and ground until you've compared the old and modern methods and hear the vast improvement with the new. If possible pick a time when static is bad. Then if you are not convinced that EARTHANTENNA is the greatest discovery you've ever found for your radio—if you are not enthused over the improvement—you don't pay us a cent. The thrilling details of this important development—illustrated—will be sent immediately on receipt of this coupon. Mail it NOW!

THE MODERN ANTENNA COMPANY

Dept. 1009-A.E., St. Clair Bldg.
Cor. St. Clair & Erie Sts., Chicago, Ill.

EARTH ANTENNA
THE MODERN
COMBINED ANTENNA AND GROUND

THE MODERN ANTENNA CO. Dept. 1009-A.E.
St. Clair Bldg., cor. St. Clair & Erie Sts.,
Chicago, Ill.

Rush literature on EARTHANTENNA and Free
Trial Offer. No obligation.

Name

Address

City