

ELECTRONIC ENGINEERING

VOL. 27

No. 332

OCTOBER 1955

Commentary

THREE important features characterized the National Radio Show at Earl's Court this year. They were the arrival of the alternative television service, the BBC's new v.h.f. broadcasting service and the growing interest in high fidelity sound reproduction.

To these may be added yet another which, although attracting less attention from the general public, was nonetheless welcome and praiseworthy—the "Careers in Electronics" section.

The vigorous post-war plans launched by the BBC have done much to stimulate the growth of television in this country and with a present coverage of well over ninety per cent of the population—a coverage unequalled by any other country—it comes as no surprise that for the first time in the history of broadcasting the viewing audience now exceeds the listening audience.

There are approximately 9.4 million licences issued to sound listeners and 4.7 million television licences (combined with sound) but, according to recent figures issued by the Audience Research Department of the BBC, the average audience for the evening period of the television programme is estimated to be 14.9 per cent of the adult population, the corresponding listening audience during the same hours is for the first time slightly less at 14.7 per cent.

The predominance of television over sound broadcasting was therefore very much in evidence at Earl's Court and the emphasis was on the television receiver—the television receiver as represented by the new multi-channel type making its appearance for the first time on a large scale.

From now on there will be a choice of programmes, namely, the BBC's television service and that of the Independent Television Authority whose first station was opened last month. This choice of but two programmes is likely to continue for some time to come for the BBC's second network is not yet in sight and with only one transmitter in operation—the second at Lichfield is not due for completion until next year—the ITA cannot be expected to have any concrete plans in this respect at this early stage of its life.

At Earl's Court this year we have nevertheless bid farewell to the fixed tuned single station receiver which has served us so well for nearly twenty years and the multi-channel monochrome receiver with all its attendant complications now has pride of place, where it will remain until it, in its turn, is deposed when colour television arrives.

But in spite of the spectacular growth of television, there is ample evidence that "steam radio" is by no means a thing of the past. It is true that sound broadcasting has suffered considerably in the post-war years from the growing congestion of the European channels, but a big step forward was taken by the BBC earlier this year with the opening of the first of its v.h.f. stations at Wrotham. An interference-free sound broadcasting service has now been started which will gradually extend to cover the whole country and the "sound only" adherents, who are likely to be numbered in their millions for many years to come, will find their needs adequately met by the wide range of v.h.f. receivers on display at Earl's Court.

Before the war, the electronic industry was, to all intents and purposes, the radio industry, which concerned itself almost entirely with communications in all its forms. Perhaps it is a truer statement to say that the radio industry was the electronic industry, for such electronic developments as there were, emanated mostly from the radio industry. But during and since the war advances in electronic techniques have been considerable and today there is scarcely any phase of life in which electronic techniques have not made important contributions. There has, as a result, grown up a flourishing electronic industry which to some extent is distinct and separate from what we regard as the radio industry. But whether we look upon them as separate entities or as one integrated whole—it is indeed difficult to distinguish them since so many of the fundamental techniques are common to both—there is one disturbing feature applicable to both which may set a limit to their growth and development, namely, the acute shortage of technically qualified personnel.

Commendable, therefore, were the Radio Industry Council's efforts in staging a "Careers in Electronics" section at Earl's Court. But, if after visiting this section, the young man seeking a career in electronics came to the conclusion that such a career could be obtained only by joining one or other of the Services, it would be due to the excellent display organized by them. For the young man who has a liking for Service life there is no doubt that a specialist training in one of the many radio and radar branches of the Armed Forces can lead to an interesting and remunerative career. However, not all young men are so minded and it would seem that by comparison the industry, which achieved a record production of some £200 million worth of equipment last year, offers much less attractive prospects.

A Balanced Equalizer-Amplifier for Transmitting Video Signals over Telephone Lines

By J. B. Sewter*, A.M.I.E.E., and D. Wray*, B.Sc., A.M.I.E.E.

Ordinary balanced telephone pairs are now used extensively for carrying telephone signals from outside broadcast sites to control centres or to the permanent cable networks. A new technique is to use balanced equalizer-amplifiers in which control of the common cathode feedback networks of balanced valve pairs, can equalize the cable response in different parts of the cable spectrum. One such unit can give up to 70dB lift at 3Mc/s and can compensate for irregularities in the cable characteristic. The balanced form makes decoupling components and stabilized power units unnecessary. Up to five telephone links, each corrected by an equalizer-amplifier, have been connected in tandem to give a video line about eight miles long.

THE possibility of using balanced telephone lines for the transmission of video signals was demonstrated as far back as May 1927, when Baird used them for showing pictures in Glasgow derived from scanning equipment situated in London. Since then balanced-pairs have been extensively used, both in this country and abroad, for conveying video signals over comparatively short distances. In 1937, for instance, the Coronation procession was televised by cameras disposed along the route which fed signals into a heavy-gauge balanced-pair cable^{1,2} laid especially for the purpose. In 1938, development on apparatus and techniques made possible the transmission of television signals over ordinary telephone pairs, and so extended the coverage that this balanced-pair cable afforded. Nowadays a large proportion of the outside broadcast material originating in London and the larger provincial centres is conveyed from the site of the broadcast to the television control centre over telephone pairs³.

Requirements

Normally, the video signal from the mobile control van at the scene of an outside broadcast is conveyed to the nearest telephone exchange over 6½lb subscriber's cable*, the highest gauge pair in general use. Heavier gauge junction cable connects exchanges, being of 10lb, 20lb, or even 40lb gauge. In London, telephone exchanges are approximately 2 miles apart, and if 20lb pair is used to carry the vision signal over this distance, the insertion loss between 150Ω terminations balanced to earth may vary from 4 to 8dB over the audio band up to as much as 70dB at 3Mc/s. Three-quarters of a mile of the 6½lb subscriber's pair will have a similar attenuation range. At the other extreme, a circuit only a few score yards long may be required, needing very little top lift. The repeater equipment installed at the telephone exchanges must therefore be very flexible in the range of equalizer characteristics that it provides. Moreover although a simple balanced-pair cable should have a loss that increases monotonically with frequency, the circuits encountered in reality frequently consist of different lengths, impedances, and gauges, connected in tandem and

possessing a lamentably discontinuous loss characteristic.

Ordinary unscreened telephone lines may pass through areas subject to interfering signals of considerable intensity. These induce spurious signals in the pair which are, in the majority of cases, in phase in the two conductors and so can be separated from the desired balanced signal. Types of interference which have been picked up on telephone pairs include: impulsive (including dialling and teleprinter); electro-medical; and radiation from nearby and foreign broadcast stations working in the long, medium, and short-wave bands. One of the requirements of the repeater equipment is, therefore, that it must attenuate in-phase signals (sometimes called 'longitudinals'), which are often several times the amplitude of the wanted signal, to a level which will produce no discernible effect on the pictures.

The required suppression of single-frequency interference to achieve threshold visibility on a television picture is given below.

FREQUENCY OF INTERFERING SIGNAL	100c/s	1kc/s	100kc/s	0.5Mc/s	1Mc/s	3Mc/s
REQUIRED SUPPRESSION IN DB BELOW SIGNAL LEVEL	47	55	58	52	45	25

The impedances between which the repeater equipment must work, considered over the greater part of the video spectrum, may be anything from 90 to 180Ω depending on the nature of the cable in use.

Conventional Repeater Equipment

The repeater equipment used for outside broadcast circuits has formerly, although passing through several variants, always consisted basically of blocks of passive equalizer networks, which could be selected in combination to fit the cable in use, followed by high-gain video amplifiers, and preceded by a unit to convert the balanced signal from line into an unbalanced form suitable for the amplifiers and equalizers. The most widely used British equipment†, for instance, has 64 non-resonant equalizer sections of low basic loss with half-loss frequencies distributed over the video spectrum; it employs two video amplifiers

* Post Office Engineering Department.

† Telephone cable gauge is usually referred to in terms of weight per mile of a single conductor.

with a combined gain of about 110dB. This equipment is portable, and is set-up in the appropriate telephone exchange to equalize the circuit a few days before the broadcast is due.

A system used in America⁵ employs a small number of fixed equalizers which have loss characteristics similar to the inverse of the cable characteristic; these can be connected in combination to approximate to the particular cable length used, and there is a variable equalizer to trim the final response. This repeater also uses two video amplifiers and a balance to unbalance unit to precede the rest of the equipment. This equipment is usually kept permanently in suitable exchanges, and sends over special heavy-gauge screened pairs.

These equipments, although often providing excellent circuits, have several inherent disadvantages. The translation of a balanced signal into an unbalanced form, and then back again to balanced for transmission over the next line section, introduces complications; the use of passive equalization before amplification necessitates a very low signal level into the amplifiers, with consequent disadvantages such as poor signal-to-noise ratio and the possibility of hum and microphonic noise entering the signal channel. (The Bell Telephone equipment avoids this to some extent by introducing pre-emphasis at the beginning of the link, but this involves terminal apparatus at the outside broadcast site, which is often undesirable.) It is also very difficult to prevent impulsive interference from being picked up by unbalanced equipment when working in a telephone exchange. These disadvantages can be largely overcome by adopting the balanced equalizer-amplifier technique described below.

Balanced Amplifiers

Much of the pioneer work on balanced amplifiers was carried out with medical applications—particularly encephalography—in view, and it is from this work that the definitions quoted below are derived. Consider the basic balanced amplifier stage shown in Fig. 1(a). If e_1 and e_2 are equal in amplitude but opposite in sign, the input is said to be balanced; if they are of the same amplitude and of the same sign, the input signal is “in-phase”; but for any values whatever of e_1 and e_2 , the input can be regarded as comprising a balanced component of $\frac{1}{2}(e_1 - e_2)$ and $-\frac{1}{2}(e_1 - e_2)$ applied to the two grids, plus an in-phase voltage $\frac{1}{2}(e_1 + e_2)$ applied to each grid. The output voltages E_1 and E_2 may be split up into balanced and in-phase components in a similar way.

In-phase signals applied to the grids of the stage tend to cause in-phase currents to flow in resistance R_k , giving rise to negative feedback and so reducing the gain of the stage to in-phase signals. Balanced signals, however, produce mutually-cancelling currents in R_k and the stage operates at full gain. This discriminating action against in-phase signals increases with the value of R_k , and if this can be made very large without causing excessive reduction in the anode-cathode voltages of the two valves—by using a pentode for R_k , for instance—the discrimination can be made very high.

Offner⁶ quotes four factors which completely describe the performance of a balanced amplifier. These are:

(a) Differential Gain, $G = \frac{E_1 - E_2}{e_1 - e_2}$ when $e_1 = -e_2$

(b) In-phase Gain, $G_c = \frac{E_1 + E_2}{e_1 + e_2}$ when $e_1 = e_2$

(c) Inversion Gain*, $G_i = \frac{E_1 - E_2}{e_1 + e_2}$ when $e_1 = e_2$

(d) Differential Unbalance, $G_u = \frac{E_1 + E_2}{e_1 - e_2}$ when $e_1 = -e_2$ (1)

The differential gain, G , is the factor of greatest interest as it is the ratio of the output balanced voltage to that at the input, i.e. the useful gain of the amplifier. It is sometimes referred to as the anti-phase gain.

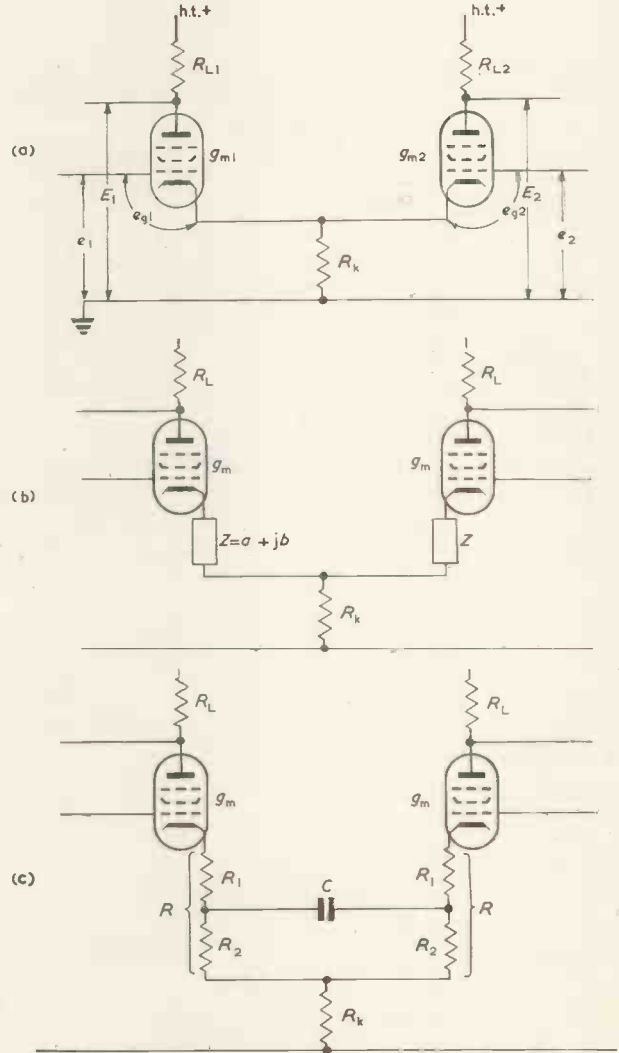

Fig. 1. Basic balanced amplifier stages

Since in-phase voltages are generally unwanted, the usual requirement for the in-phase gain, G_c , is that it should be less than unity, so that there is increasing discrimination against longitudinal signals as the number of stages is increased. Johnston⁷ makes the ratio of differential to in-phase, G/G_c , as a criterion of the performance of a balanced amplifier and calls it the “discrimination factor”. It should, of course, be as high as possible.

If the two halves of a balanced amplifier are not perfectly balanced, an in-phase input will produce a balanced output component, and a balanced input will produce an

* Offner included a factor of 2 in this term, but it is considered better to quote a balanced voltage as the voltage from each leg to earth, in which case the 2 is eliminated.

in-phase output. These two effects are assessed by the inversion gain, G_i , and the differential unbalance, G_u , respectively, and both these factors should be as small as possible. The production of a spurious balanced output component by an in-phase input component is of particular importance for it is not eliminated by making R_k very large. The figure of merit for this aspect of the amplifier has been called the "transmission factor" by Parnum⁸, and is the ratio of the differential to the inversion gain, i.e. G/G_i . The inversion gain of the basic stage in Fig. 1 is

$$G_i = \frac{1}{2} \cdot \frac{R_{L1}g_{m1} - R_{L2}g_{m2}}{1 + R_k(g_{m1} + g_{m2})} \quad (2)$$

This factor can be made zero, and hence the transmission factor infinite, by equating the product of load and conductance for both sides of the pair.

It is necessary for the first stage of a balanced amplifier to have a high transmission factor so that any in-phase input signal produces negligible balanced output, since, once produced, such a balanced component cannot be eliminated subsequently. Normally, therefore, it is necessary to control the balance of the first stage of the amplifier. Even so, with a resistor R_k of finite value, the discrimination factor is still finite, and a small in-phase voltage is passed on to the next stage, which, if unbalanced, will in its turn produce a spurious balanced output. But as the discrimination against in-phase signals increases with the number of stages, the in-phase voltage decreases and the necessity for accurate balance becomes less important with successive stages; after the first stage, therefore, the use of resistors and capacitors within commercial 2 per cent tolerances is sufficient to prevent spurious signals being transmitted.

CATHODE FEEDBACK CONTROL

If the basic stage of Fig. 1(a) is extended to include an impedance Z in each leg of the cathode circuit, as in Fig. 1(b), the differential gain of the stage under such conditions is given by:

$$G = \frac{g_m R_L}{1 + g_m Z} \quad (3)$$

Thus the variation of stage gain with frequency is governed by the cathode impedance, Z . If the latter is a complex quantity, then G is also complex, and the useful gain of the stage is the modulus of the differential gain:

$$|G| = \frac{g_m R_L}{\sqrt{[(1 + g_m a)^2 + (g_m b)^2]}} \quad (4)$$

where a and b are the real and imaginary parts of Z respectively.

In the present application a further quantity which may be called the "relative differential gain", G_r , is of interest, and this is the ratio of the gain at frequency f to the gain

at zero frequency. Then:

$$G_r = \frac{1 + g_m Z_0}{1 + g_m Z_f} \quad (5)$$

where Z_0 and Z_f are the values of Z at zero frequency and frequency f respectively. Furthermore:

$$|G_r| = \frac{1 + g_m Z_0}{\sqrt{[(1 + g_m a_f)^2 + (g_m b_f)^2]}} \quad (6)$$

where a_f and b_f are the real and imaginary parts of Z_f .

A simple method of providing a gain characteristic that rises with frequency is illustrated in Fig. 1(c). The capacitor C is connected between corresponding points on the two cathode-feedback resistors. At low frequencies, the effect of C on the operation of the stage is negligible, and there will be feedback in each valve due to R_1 and R_2 . At

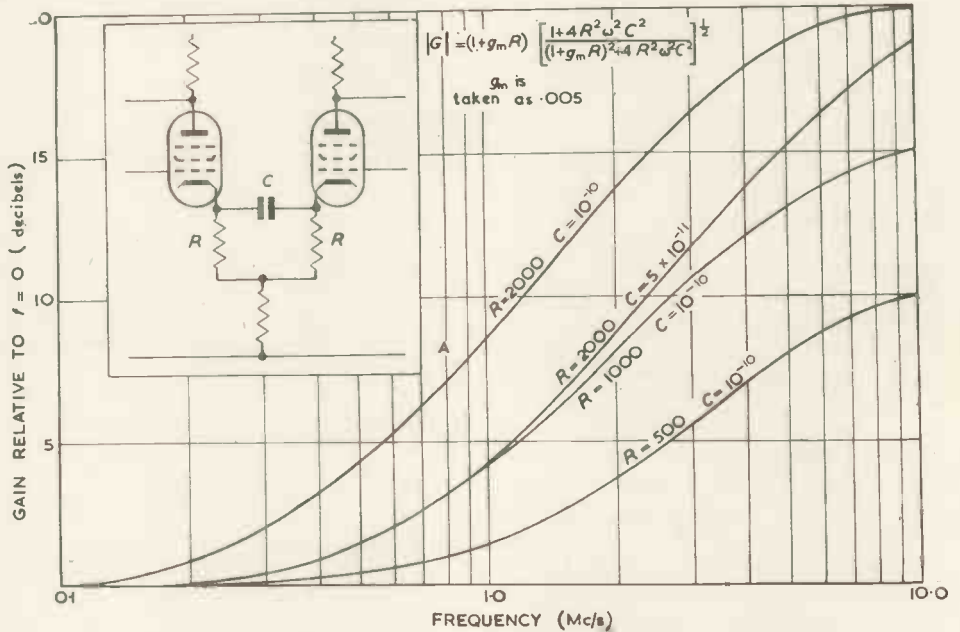

Fig. 2. Characteristic curves for basic stage

high frequencies the impedance of C approaches zero and the points between which it is connected are effectively connected together. The feedback resistance, therefore, is decreased from $R_1 + R_2$ to R_1 , and the stage gain is correspondingly increased. The effective Z in each cathode circuit of this arrangement is:

$$Z = R_1 + \frac{R_2 X_f^2}{(R_2^2 + X_f^2)} + j \frac{R_2^2 X_f}{(R_2^2 + X_f^2)} \quad (7)$$

where X_f is the reactance of $2C$ at frequency f . The variation of gain with frequency can then be calculated using equation (6). Typical examples of this variation of gain with frequency for a stage of this type with the capacitor connected between cathodes (i.e. $R_1 = 0$) are shown in Fig. 2. The shape of these curves is similar to the gain-frequency curves of non-resonant constant-impedance equalizer sections.

The "mean-gain frequency" of such a stage, that is, the frequency at which the gain is the geometrical mean of the limiting values (or the arithmetic mean when the gain is expressed in decibels) is:

$$f_m = \frac{\sqrt{1 + g_m R}}{4\pi RC} \quad (8)$$

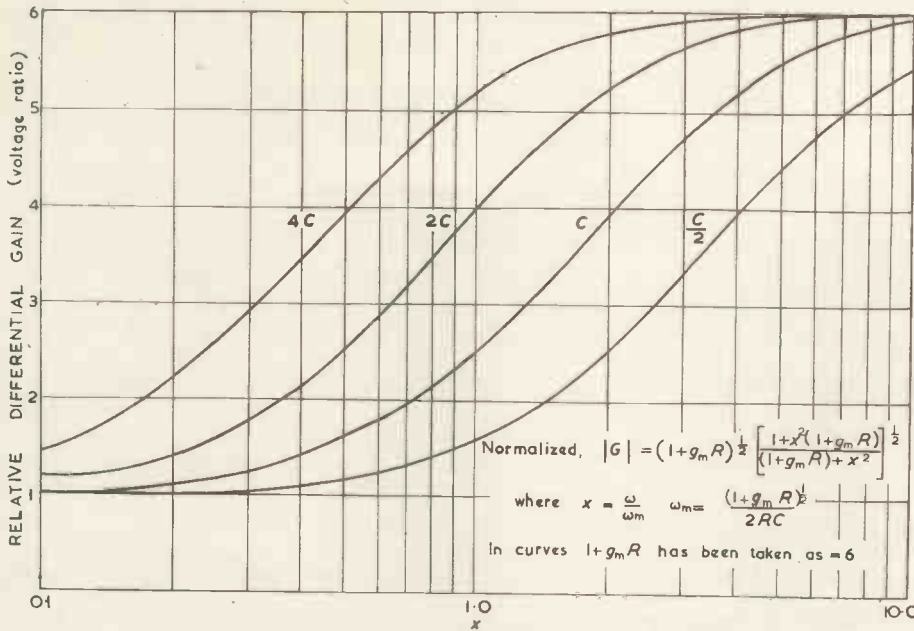

Fig. 3. Variation of basic stage characteristic with bridging capacitance

and so is inversely proportional to the value of the shunting capacitor. Different stages can therefore be arranged to have mean-gain frequencies at different points in the video spectrum by having different values of the shunt capacitor C . Typical performances are shown in Fig. 3.

As already indicated, further control of the characteristic is possible by arranging for the capacitor to shunt across only part of the cathode resistor R , so that the range in gain between frequency extremes is reduced proportionately. Thus by a switch or potentiometer action the amount of top lift can be varied from unity gain to maximum stage gain. However, when the capacitor is moved down the tapping points on the cathode resistors, the mean gain frequency is no longer simply inversely proportional to the shunt capacitance but is also related to the ratio in which the cathode resistor is divided. The mean-gain frequency is now:

$$f_m = \frac{1}{4\pi C R_2} \times \sqrt{\left(\frac{1 + g_m R}{1 + g_m R_1} \right)} \quad \dots \dots \dots (9)$$

This variation of mean-gain frequency may be appreciable when g_m is small; this would have the practical effect that when the lift of any stage was varied, the frequency at which this lift was centred would also shift. It may then be preferable to switch both R_2 and C so that their product remains constant, using a system such as that shown in Fig. 4; there is then less variation of f_m with capacitor position.

A disadvantage of the simple shunt-capacitor circuit is that, considering the three design features for a stage, viz: —the slope of the characteristic, the relative differential gain, and the mean-gain frequency, the first is dependent on the other two. This may be particularly objectionable at the low and high frequency extremes of the video spectrum. At low frequencies, where the slope of the cable loss-frequency curve is very slight, but where television channels are very sensitive to variations in their frequency response, the change of gain with frequency of such a stage as that shown in Fig. 1(c) may not be sufficiently flexible

to match the cable characteristic. By connecting a variable resistor in series with the bridging capacitor, as in Fig. 5 the low-frequency end of the spectrum can be controlled at the expense of some loss in stage gain. To calculate the gain variation with frequency, using equation (6), take

$$a_f = R_1 + \frac{R_2[r/2(R_2 + r/2) + X_f^2]}{(R_2 + r/2)^2 + X_f^2},$$

$$\text{and } b_f = \frac{R_2^2 X_f}{(R_2 + r/2)^2 + X_f^2}$$

Typical curves are shown in Fig. 5.

Near the upper end of the video band, where the loss of the telephone cable increases rapidly, the slope of the gain-frequency curve of a single capacitor-bridged stage is not sufficiently steep to equalize the cable; the

use of several stages with the same mean-gain frequency in an attempt to increase this slope causes an undesirable excess of gain in the lower part of the frequency band. To achieve a steep slope without superfluous low-frequency gain, the bridging impedance between cathodes can consist of a series-resonant circuit with its resonance frequency just above the upper limit of the required working band. Using equation (6) to plot the gain variation with frequency,

Fig. 4. A method of reducing variation of mean gain frequency

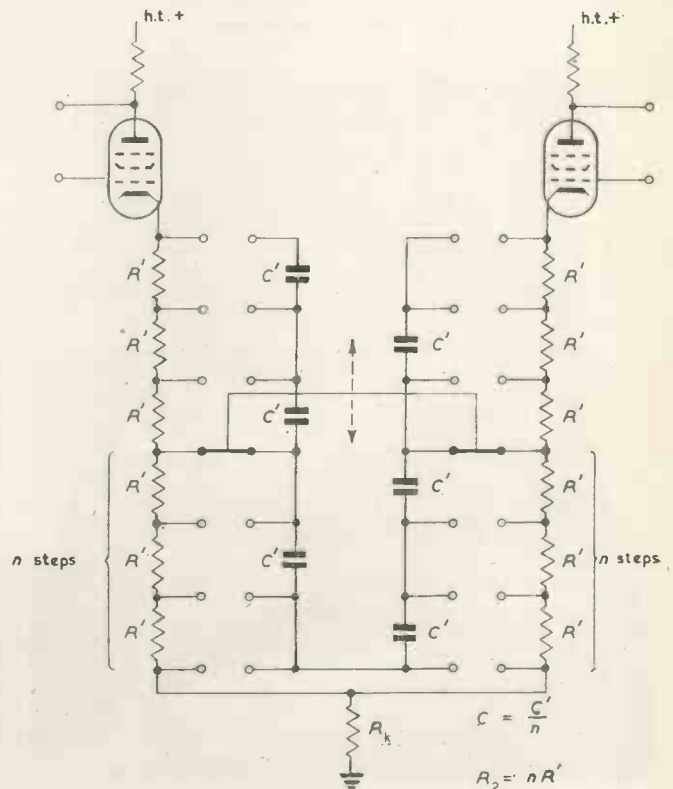

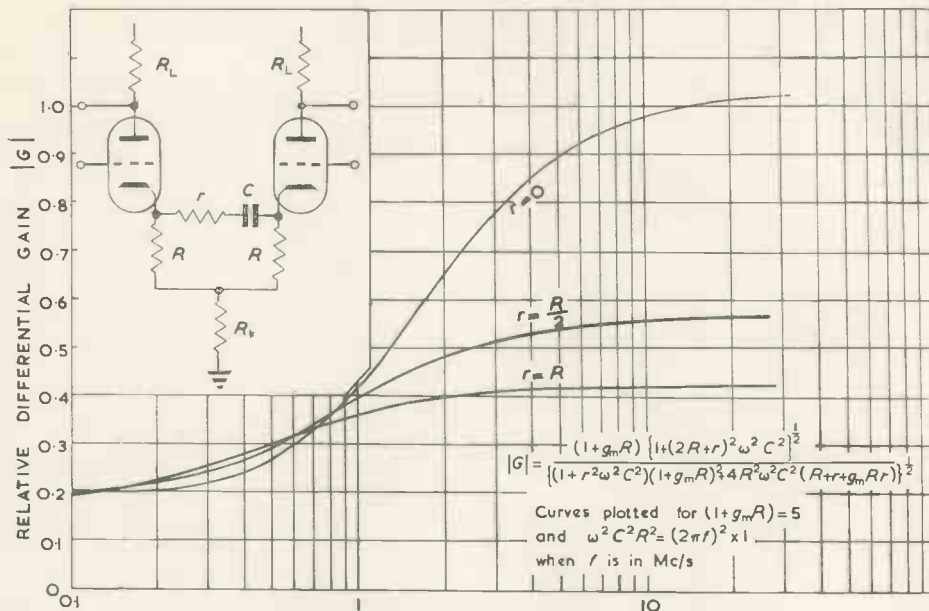

Fig. 5. Series resistor and capacitor as bridging impedance

$$a_f = R_1 + \frac{R_2 X_f^2}{R_2^2 + X_f^2}, \text{ and } b_f = \frac{R_2 X_f}{R_2^2 + X_f^2},$$

where $X_f = fL - \frac{1}{4fC}$.

The gain curve of the stage is similar to that of the resonant circuit itself.

The Equalizer-Amplifier

A view of the equalizer-amplifier which has recently

Fig. 6. The equalizer-amplifier



come into use on television outside broadcasts is shown in Fig. 6, which shows the equalizer-amplifier mounted in the wooden carrying case. A block schematic diagram of the equipment is given in Fig. 7.

The input to the balanced stages of the amplifier is via an input impedance control, continuously adjustable between 90 and 180Ω, a phantom coil, and an input attenuator adjustable in four steps of 0, 6, 12 and 18dB; this is used to prevent overloading of the amplifier when pre-equalization is employed on the cable pair.

There are ten balanced stages, nine employing CV138's (EF91) and one employing CV455's (12AT7), in which the control

of the cathode feedback allows adjustment of the frequency response and gain, and a balanced cathode follower output stage using CV2127's (6CH6). The second half of each CV455 is used to supply a monitoring output; since they are before the cathode-follower the shunting effects of any pair connected to the output are masked.

No individual decoupling capacitors and resistors are needed for the screens and anodes of each stage, since signal currents in the pairs of valves are self-cancelling and there is no coupling between stages via the h.t. line; furthermore hum and other low-frequency interference on the h.t. supply of any stage acts as an in-phase signal to the next stage which is then heavily attenuated. A hum level less than 10mV on a terminated 75Ω unbalanced output is easily obtainable. A stabilized h.t. supply is unnecessary.

The first stage of the equalizer-amplifier (shown in Fig. 8(a)) is intended for low frequency equalization and operates from just below 10kc/s. The cathode circuit bridging impedance comprises a 2kΩ variable resistor and a series fixed capacitor of 2200pF, which are tapped across 1kΩ cathode resistors arranged as semi-log ganged potentiometers. These two controls enable adjustment to be made of both the low frequency slope and the relative differential gain that can be introduced. The curves given in Fig. 8(b) show some of the typical responses made possible by the use of these controls.

Although theoretically, it might appear that difficulty would be experienced in balancing stages, it was found in practice that by using 2 per cent tolerance capacitors and resistors, the resistors largely of preferred value, and by choosing valves having similar mutual conductance for stage 1, satisfactory balance could be achieved. The balance is checked by injecting an identical signal into both inputs, and measuring the equalizer-amplifier output. No "selected on test" components other than the valves for stage 1 have proved to be necessary.

The rejection of the amplifier to in-phase signals is greatest at the low frequencies, and decreases with frequency, while the rejection of the phantom coil increases

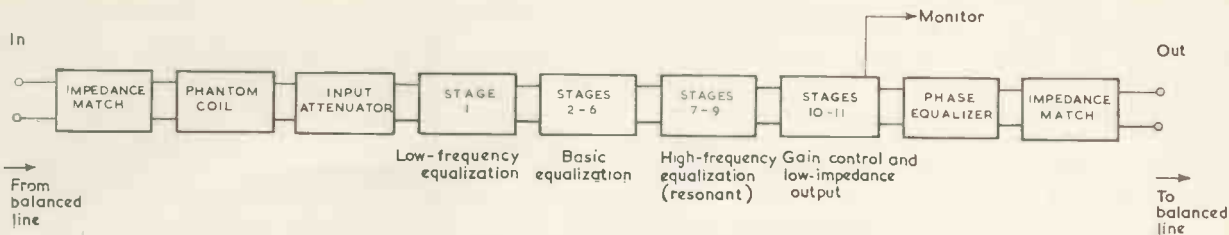

Fig. 7. Block schematic diagram of equalizer-amplifier

with frequency and can be designed to compensate for the fall in rejection of the amplifier in the video band. In practice, both the amplifier and the phantom coil give small balanced outputs for truly in-phase inputs. By careful attention to the connexions between the phantom coil and amplifier, it can be arranged that these two outputs tend to cancel each other out. A typical rejection characteristic of a phantom coil and amplifier is given in Fig. 9.

The insertion loss of the phantom coil, which is permanently in circuit increases with frequency, being about 0.2dB at 3Mc/s.

The bulk of the equalization of a telephone-pair link is achieved by using five stages having the basic circuit of Fig. 1(c), that is, a bridging impedance consisting of a single capacitor. The capacitance values are chosen to give mean-gain frequencies of 250kc/s, 500kc/s, 750kc/s, 1.1Mc/s and 1.7Mc/s, when at the top of the 1kΩ cathode resistor chain. The 1kΩ cathode resistor is made up of ten series resistors which decrease in value in approximately a logarithmic sequence; the capacitance values were determined from equation (8). In spite of the variation in mean-gain frequency with cathode chain tapping point, a single capacitor only is used as the bridging impedance. An experimental model was made in which the stages did have cathode circuits in the form shown in Fig. 4, in which a constant R_2C value is maintained, but since the greatest variation from the design value of mean-gain frequency for the constant capacitance type is when the switch is in the lowest lift position, the differences between the lift curves for the constant- C and constant- R_2C types are unimportant, and the additional complexity of the latter system was not justified in this application.

The gain-frequency characteristics introduced by the five

stages are shown in Fig. 10(b) and the circuit diagram for these stages in Fig. 10(a).

Stages 7, 8 and 9 in the equalizer-amplifier have series resonant circuits as bridging impedances, with resonance frequencies at about 3.1Mc/s, 3.5Mc/s, 4.1Mc/s. This staggering of resonance frequencies tends to improve the phase response at the top end of the vision-frequency band. As with the preceding stages, the impedance can be tapped across the 1kΩ cathode resistors at any of the ten division points.

Since the equipment is intended to equalize telephone-

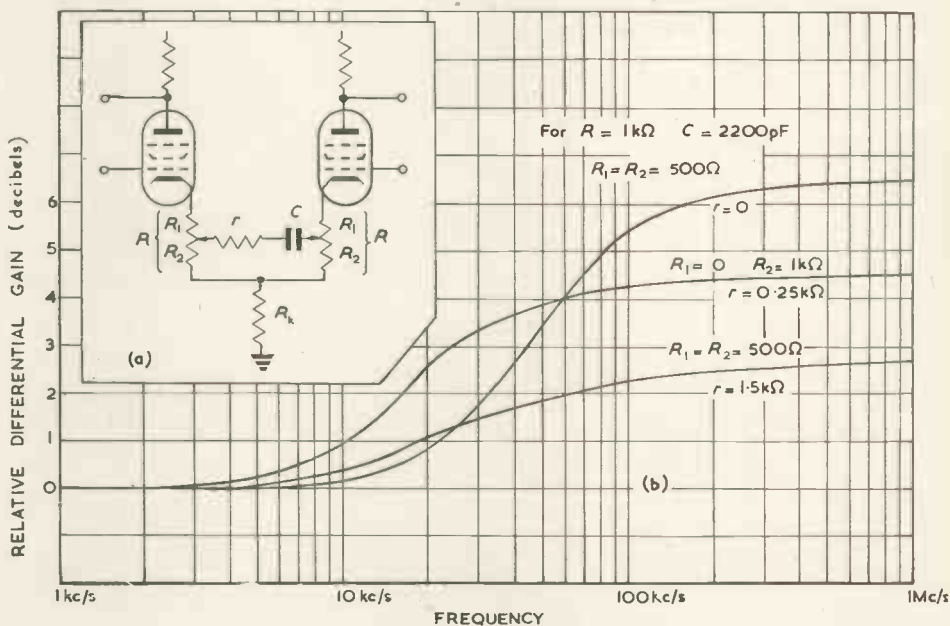
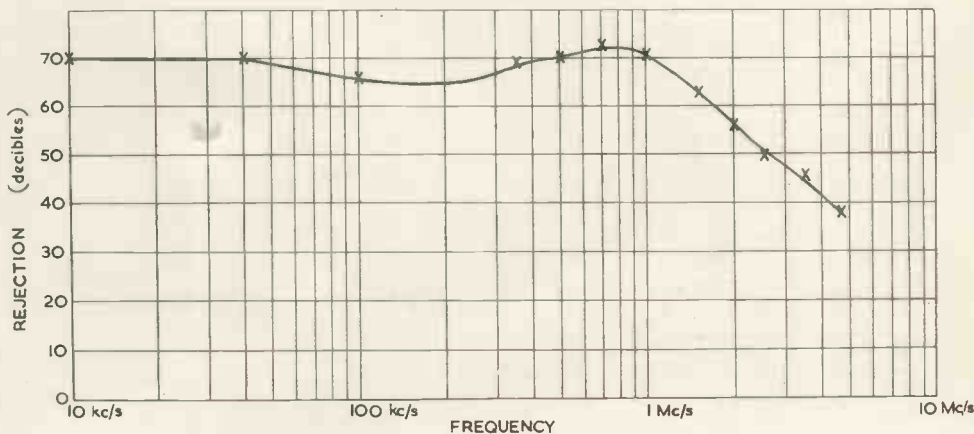

Fig. 8. Stage 1 characteristics

Fig. 9. Rejection of equalizer-amplifier to in-phase signals



pairs which, in general, have a loss which increases rapidly with frequency, it is possible to give the amplifier a basic overall rising gain characteristic when all the cathode circuit switches are set to position 0, and yet still retain flexibility of equalization. Indeed, as this basic rising-gain characteristic is equivalent to having a fixed attenuation equalizer in circuit, the control given by changes in cathode feedback is extended. This rising-gain characteristic is

achieved by connecting a 10pF fixed capacitor between the cathodes of the two valves in each stage, which gives a relative differential gain of 12dB at 3Mc/s for the complete amplifier. There may be occasions, however, when very short cable lengths do not require even this small amount of equalization. To meet such a contingency variable ganged capacitors of 60pF maximum capacitance are connected between the grids of the valves and earth on two stages. When set to maximum capacitance they introduce a drooping gain characteristic that cancels out the basic rising gain of the amplifier. These two variable capacitors enable short lengths of cable to be equalized, and, in addition, provide a continuously-variable method of trimming the high-frequency equalization that has been found to be extremely useful when aligning normal circuits.

The output from the equalizer-amplifier to the load (either another section of telephone pair or the final termination) is via a balanced cathode-follower stage, and each of the stages 1 to 9 has a basic gain slightly greater than unity to compensate for the loss it introduces. However the telephone line itself may introduce a basic loss of a few decibels, and the variable input impedance control will also reduce the voltage swing to the first stage when set to match a low impedance line. To compensate for these losses a stage 10 has been interposed between stage 9 and the cathode-follower stage; this can introduce amplification from 0dB to 10dB variable in 1dB steps, by cathode-feedback control, with a flat frequency response for all steps.

In television outside broadcast equipment it is essential to be able to quickly localize faulty components, and in the equalizer-amplifier a "percentage variation" measurement facility is provided in the anode circuit of each pair of valves to facilitate localization to a stage.

The cathode-follower output stage is followed by a switched lattice-section phase-frequency equalizer (Type A) to compensate for any phase distortion introduced. The equalizer has 10 steps of 0.025μsec zero frequency delay. Since the attenuation equalization of a many-octave band simultaneously corrects the phase characteristic through the greater part of the band, it is only at the high-frequency extreme of the video spectrum—at the point where resonant cathode bridging impedances are employed—that this additional phase equalization is necessary. The output stages are shown in Fig. 11.

The output impedance can be adjusted to be 75Ω unbalanced, or 100, 120 and 150Ω balanced.

In the portable power unit, a regulating transformer which caters for mains inputs between 190V and 260V a.c. is employed, and for the h.t. full wave metal rectifiers

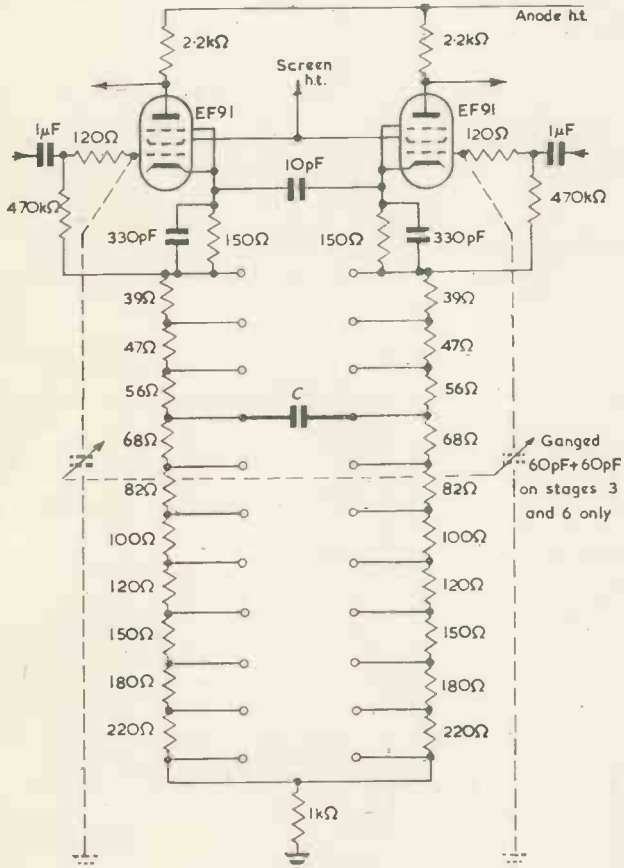
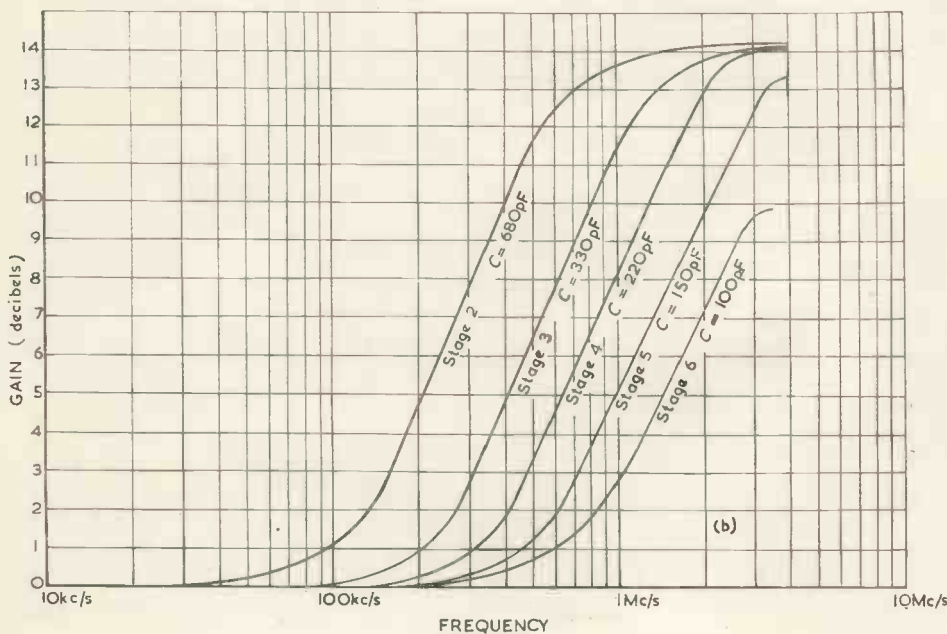

Fig. 10. Stages 2-6 and their response characteristics



with conventional choke input smoothing filters are used. The h.t. is 220V and the l.t. 6.3V.

Alignment of Video Circuits with the Equalizer-Amplifier

When a television outside broadcast circuit is equalized, a test waveform generator is taken to the site of the broadcast and transmits video waveforms in a balanced form over the telephone pair to be used. At the telephone exchange to which this pair leads, a set of equalizing equipment is installed, working into a triggered sweep oscilloscope. The equalizer is adjusted until the viewed waveform is satisfactory, whereupon the equalizer output is connected through to the next telephone pair, and the equalization continued at the second telephone exchange in the link, and so on.

When using the equalizer-amplifier, the test waveform first employed is a rectangular pulse associated with line-synchronizing pulses; the rectangular pulse is 40 μ sec. in duration and has transitions which are approximately integrated sine-squared in shape, with a 10 to 90 per cent rise

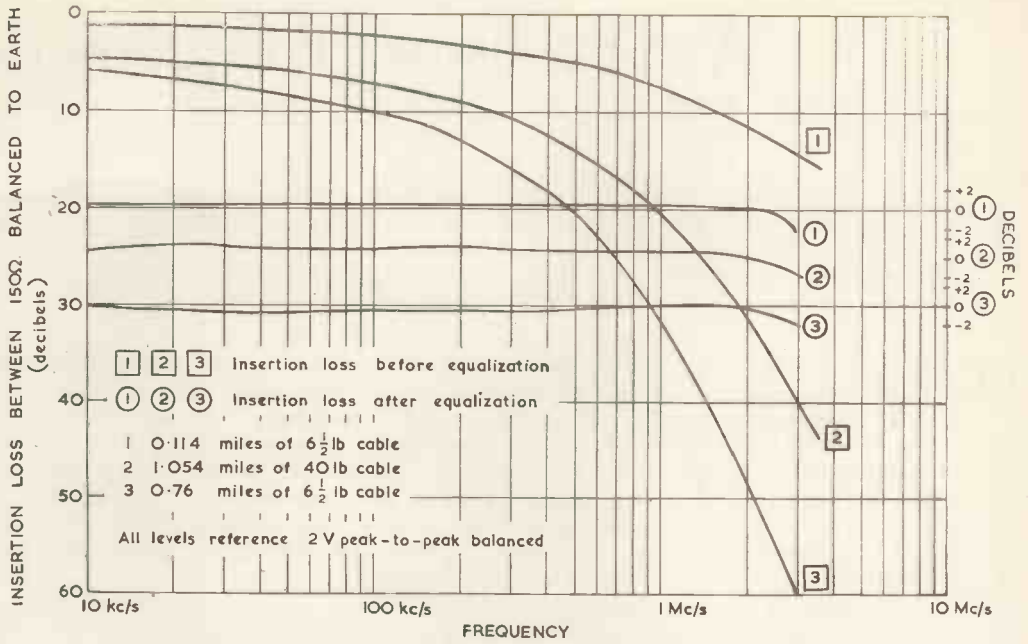
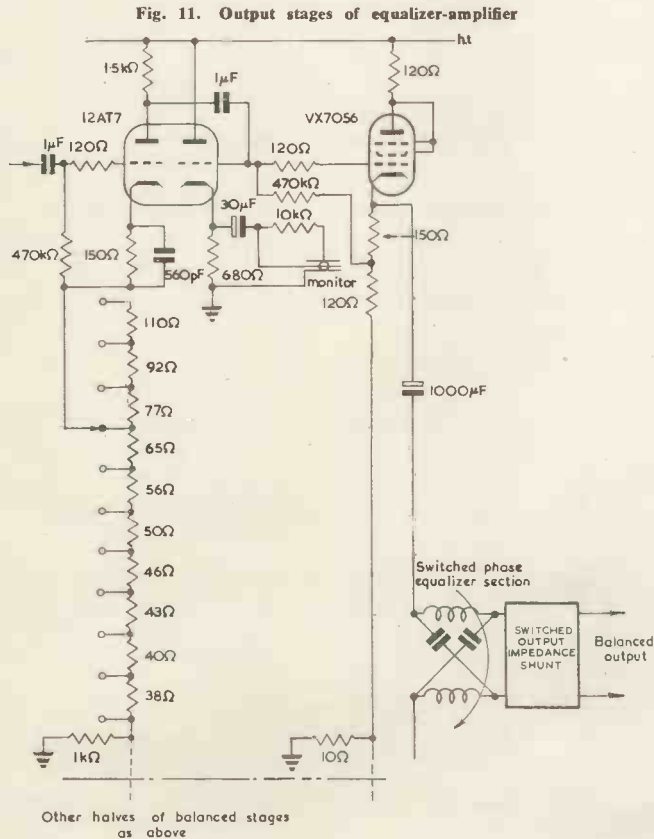

Fig. 12. Typical insertion loss characteristics before and after equalization

time of 0.33 μ sec. Stages 1 to 6 are lined up on this pulse to give the most faithful output. Stages 7 to 9 are adjusted using a sine-squared test pulse¹⁰ having a half-amplitude duration of 0.17 μ sec., and is also superimposed on normal synchronizing pulses. Stage 10 is adjusted to give a 2V peak-to-peak balanced output.

When several circuits are connected in tandem, each equalizer-amplifier is aligned in the manner described above, and the overall response is checked for gain/frequency characteristic, 50c/s square wave decay, and a test picture over the link is examined on a picture monitor for signs of ringing, echoes, noise and interference.

Up to five links, each equalized by an equalizer-amplifier, have been connected in tandem to give a total circuit length of seven or eight miles. Frequency responses of some typical circuits after equalization are given in Fig. 12.

Acknowledgments

The authors are indebted to their colleagues in the Radio Experimental and Development Laboratory and in the Lines Branch of the Post Office Engineering Department who contributed to the work described in the article. In particular they wish to thank Mr. T. Kilvington, to whom the conception of the equalizer-amplifier is due, and Messrs. F. Leggett, L. R. Meatyard and R. Gardiner for their work on the experimental and prototype models. They are also indebted to the Engineer-in-Chief of the Post Office for permission to publish this article.

REFERENCES

1. COLLARD, J. London's Television Twin-Cable Links. *Post Off. Elect. Engrs.* J. 30, 215 (1937).
2. ROSEN, A. The London Television Cable. *Engng. Supplement to Siemens Mag.* No. 145 (1937).
3. KILVINGTON, T. Cable Links for Television Outside Broadcasts. *Proc. Instn. Elect. Engrs.* 99, Pt. 3A, 415 and 472 (1952).
4. KILVINGTON, T. A New Television Repeater for Telephone-Cable Circuits. *Post Off. Elect. Engrs.* J. 42, 76 (1949).
5. MORRISON, L. W. Television Transmission in Local Telephone Exchange Areas. *J. Soc. Mot. Pict. Televis. Engrs.* 56, 280 (1951).
6. OFFNER, F. D. Balanced Amplifiers. *Proc. Inst. Radio Engrs.* 35, No. 3 (1947).
7. JOHNSON, D. L. Electro-Encephalograph Amplifiers. *Wireless Eng.* 24, 231, 271 and 292 (1947).
8. PARNUM, D. H. Transmission Factor of Differential Amplifiers. *Wireless Eng.* 27, 125 (1950).
9. BODE, H. W. Network Analysis and Feedback Amplifiers. Ch. 14.3, 14.4 (Van Nostrand, 1945).
10. LEWIS, N. W. Waveform Responses of Television Links. *Proc. Instn. Elect. Engrs.* 101, Pt. 3, 258 (1954).

A Transistor Torquemeter

By J. A. Freer*, B.A.

An instrument is described in which point-contact transistors are used in measuring the steady component of the torque transmitted by a rotating shaft. The equipment was developed for use in aircraft flight tests where the use of transistors gives a valuable reduction in bulk. The value of torque is inferred from a measurement of the relative phase between the waveforms produced by generators attached at either end of the shaft.

DURING the development of an aircraft frequent tests are made to investigate the stresses set up in its structure when in flight, and in these tests it is often necessary to measure the steady component of the torque transmitted by a rotating shaft. Several types of torquemeter are known but, in spite of the variety of available methods, it has sometimes proved difficult to obtain reliable results in this particular application. For instance, in some situations any attachments to the shaft may need to be very compact and may be subjected to large temperature changes or contamination by oil, while the size and weight of the complete equipment must always be kept to a minimum.

The instrument described here was developed in an attempt to overcome some of these difficulties. A review of the torquemeters available suggested that the most suitable would be one measuring the angle of twist in a length of the shaft by using two waveform generators and a phase-meter. Having found this angle it is easy to calculate the torque transmitted. A torquemeter using this principle has been described recently¹.

The magnitude and sign of torque is indicated directly on a centre-zero meter and by using transistors in the associated circuits it has been possible to obtain a valuable reduction in the size and weight of the equipment. At the same time a simple waveform generator is used which is compact and cheap to manufacture. It should be noticed that point-contact transistors are used in the phasemeter and that only transistors of this type have characteristics like those referred to in the descriptions of the switching circuits.

Principle of Torque Measurement

Fig. 1 shows a block diagram of the instrument. Impulse generators, *A* and *B*, at each end of the shaft produce two similar trains of pulses, shown in Fig. 2(a). It is normally arranged that these two waveforms have a 180° phase difference when the shaft is transmitting no torque and for the time being it is assumed that each generator produces one pulse per revolution of the shaft. These pulses are amplified by the pulse standardizing amplifiers, the circuits associated with transistors *X*₁ and *X*₂ of Fig. 3, and the outputs of the amplifiers trigger the phasemeter.

The phasemeter consists of a symmetrical flip-flop, *X*₃ and *X*₄ of Fig. 3, and a centre-zero meter. The flip-flop ensures that, if the collector current of *X*₃ is high, the current through *X*₄ will be low and vice versa, and the meter is arranged in a split shunt circuit to subtract these two currents. Pulses from each generator are fed only to one particular transistor in the flip-flop. Thus a pulse from *A* causes a positive trigger pulse at the base of *X*₃ and switches it into its low current state. It remains in this

state with *X*₄ passing a high current until a pulse arrives from generator *B* to switch *X*₄ off, when *X*₃ immediately returns to the high current condition. This sequence is shown in Fig. 2(b). In a static condition the meter deflection is proportional to the difference between the collector currents of *X*₃ and *X*₄, but in normal operation these currents switch between their high and low values at a fairly high frequency which, because of its inertia, the meter

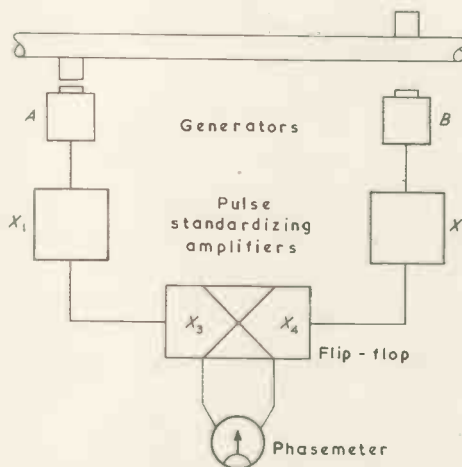
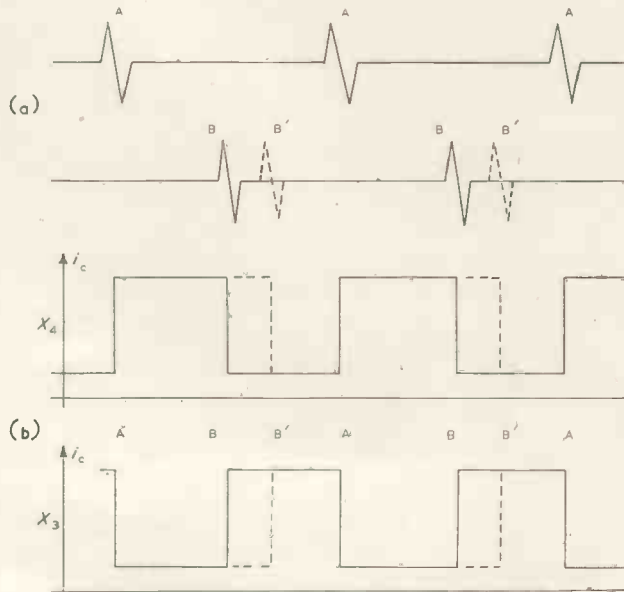

Fig. 1. General arrangement of the instrument

Fig. 2(a). Generator waveforms (b) Flip-flop collector currents



* Ferranti Ltd., formerly Bristol Aeroplane Co. Ltd.

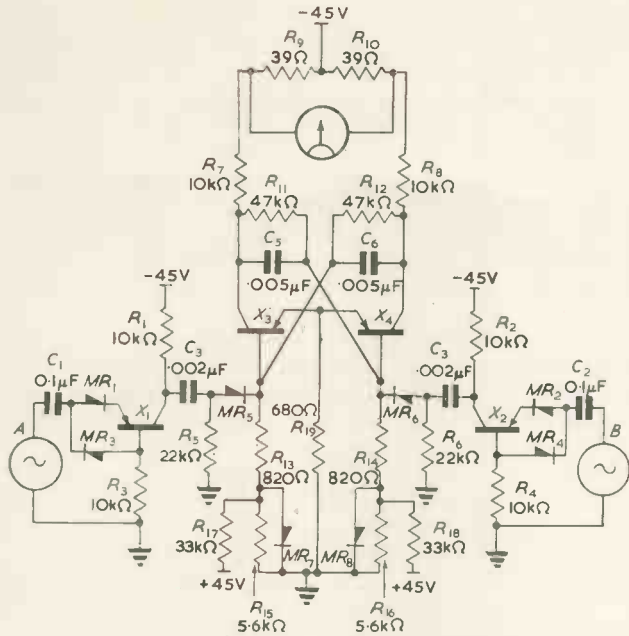

Fig. 3. Complete circuit diagram

cannot follow. Thus the actual indication is proportional to the difference between the mean values of the two collector currents.

If the shaft is unstrained the phase difference between the two generator waveforms will be 180° and both transistors will be on for the same time as they are off, the periods AB and BA in Fig. 2 being equal. In this case the meter is subtracting two currents whose mean values are equal and thus gives an indication of zero torque. But, if the shaft now transmits torque it will twist and the phase relation between the generator waveforms will alter. Suppose the pulses from B now occur at B', later with respect to those from A. The period during which X_1 is passing a high current will increase by BB' which is proportional to the angle of twist of the shaft, while that of X_3 decreases similarly. In this way the meter shows a deflexion proportional to the angle of twist. It also gives an unambiguous indication of the direction of twist since the difference between the mean values of the two collector currents changes sign depending on whether the pulse from B occurs earlier or later than 180° after A.

For the sake of clearness in the explanation above, it was assumed that each generator produced one pulse per revolution of the shaft and in this case the relative phase change between the two waveforms is clearly equal to the angle of twist of the shaft. However, if the generator produces a number of pulses each revolution then the sensitivity, which depends on the ratio of the apparent phase change to the angle of twist, will be multiplied by the same number. At the same time the repetition rate of the generator pulses will be increased similarly.

Description of the Instrument

WAVEFORM GENERATORS

Torque measurements may have to be made on shafts of different diameters and in different situations so the waveform generators have been made as simple and as cheap to produce as possible. The rotor of the generator is a mild steel wheel with a number of projecting arms, carried on the shaft and rotating with it. The stator, a permanent

magnet with a coil wound round it, is fixed near to the wheel so that, as the shaft rotates, each rotor arm disturbs the flux linking the coil and induces a short pulse in it.

PULSE STANDARDIZING AMPLIFIERS

It is clearly desirable that, if the value of torque in the shaft remains the same, the meter indication shall not vary over as wide a range of the speed of rotation of the shaft as possible. It would also be an advantage if considerable latitude could be allowed in adjusting the gap between the rotor and stator of the generator. The pulse standardizing amplifiers, which are the circuits associated with X_1 and X_2 of Fig. 3, are designed to meet these requirements. Basically their mode of operation is the same as that of the monostable circuit described elsewhere^{2,3} which produces a pulse of standard height and width regardless of the shape or amplitude of the triggering pulse, provided this exceeds certain minimum requirements. Clearly the amplifiers should be as sensitive as possible without their becoming unstable.

A first condition on any design of amplifier is that it shall deliver a pulse of sufficient energy at the base of a saturated transistor to switch it into its off state. Because of the hole-storage effect the charge required to do this is comparatively high⁴ and any design must be based, in the first instance at least, on experiment. Tests showed that a positive going step of about 10V coupled to the base by a $0.001\mu\text{F}$ capacitor were the minimum requirements for reliable triggering of the flip-flop. The collector voltage swing of the amplifier must therefore be at least 10V.

The basic switching circuit is shown in Fig. 4(a), where the arrows indicate the direction of positive current flow and voltage. If certain conditions² on V_c , R_c , R_b and the current gain of the transistor are satisfied the circuit will have characteristics similar to those of Fig. 5. These curves may be divided into three regions. Firstly a high impedance region (1) where i_e has a negative or very small positive value. The collector current is low in this region which is therefore known as the cut-off or off region. Then as i_e increases positive there is a transition region (2) where the emitter input impedance is negative and finally a low impedance state (3) where i_e is high which is termed the saturated, or on, state.

It is possible in part to design this circuit using load lines drawn on the emitter input characteristic. The emitter load of the monostable circuit is essentially that shown in Fig. 4(b) and in the steady state it is an open-circuit. The stable operating point is thus represented in Fig. 5 by the intersections of the curves with the $i_e=0$ axis, at A in the cut-off region.

In practice the peak of the $i_e - v_e$ curve is at a small positive value of i_e , and in order to start the pulse forming action the generator must provide sufficient voltage to raise the operating point above, and enough current to shift it to the right of this peak in the characteristic. When this is done the operating point is moved into the unstable negative impedance region and due to the capacitor the emitter and collector currents increase rapidly, producing a steep positive step in collector potential.

The generator is made part of the emitter circuit in order that it may inject maximum current into the emitter. For maximum sensitivity the topmost point of the peak must be as close as possible, in both current and voltage directions, to the stable operating point at A. Unfortunately, the shape and position of the peak varies with the circuit parameters, so that once again the choice depends on experi-

ment. The values chosen as most suitable were $R_b = R_c = 10k\Omega$, $-V_c$ having been standardized at $-45V$ for convenience. These values ensure a positive step in collector potential of about $13V$, which is ample for triggering the phasemeter.

The amplifiers in the final circuit of Fig. 3 have a crystal diode such as MR_3 connected between the capacitor C_1 and the base of the transistor X_1 . After the pulse has been generated, C_1 is left storing a charge which in the absence of MR_3 can only discharge slowly through the reverse resistance of MR_1 and the high input resistance of X_1 . At

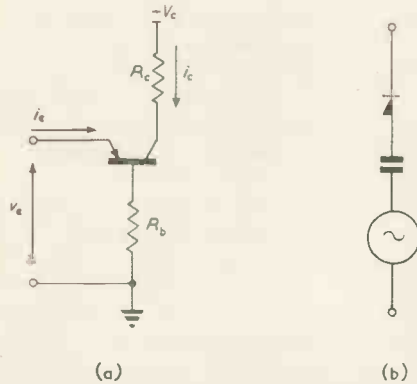

Fig. 4(a). Basic switching circuit (b) Emitter load of amplifier

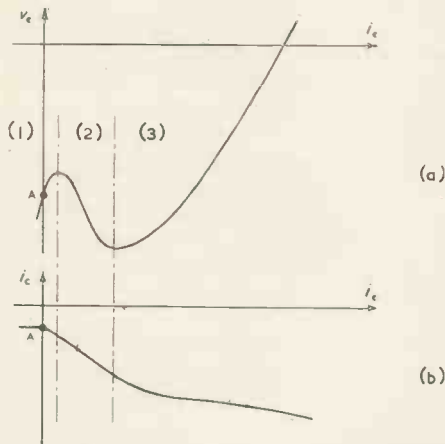

Fig. 5(a). Emitter characteristic (b) Collector characteristic

high repetition rates this would mean that C_1 might not be fully discharged by the time the next generator pulse arrived and cause the phasemeter to fail. MR_3 provides a low resistance path for the discharge of C_1 without otherwise affecting the operation of the circuit.

PHASEMETER CIRCUIT

The description of the way torque is measured makes it clear that the phasemeter requires a symmetrical flip-flop capable of passing a positive or negative unbalance current through a meter. Circuits of this form have been described by Trent⁵ and Harris⁶.

While it may be possible to describe the behaviour of a circuit by using load lines drawn on a characteristic curve it is sometimes more fruitful to work in terms of equivalent circuits². For the present purpose it is sufficient to use only the two simple equivalents shown in Fig. 6 represent-

ing, at (a), a transistor in the cut-off region and, at (b), a saturated transistor. The transistor used in this equipment had $r_c = 30k\Omega$ and $r_e = 100k\Omega$ approximately. A saturated transistor does not behave exactly as a perfect conductor, and in practice potentials of 2 to 3V may be measured between emitter and collector. However, these potentials are, on the whole, small compared with the other potentials in the circuit and the two representations in Fig. 6 provide a very useful basis for design and are found to predict results which lie within the range of error caused by the spread of transistor characteristics and component tolerances.

The phasemeter flip-flop consists of transistors X_3 and X_4 of Fig. 3 and their associated circuits. Each of these, X_3 for example, is connected in a switching circuit similar to that of Fig. 4(a) but with an emitter characteristic

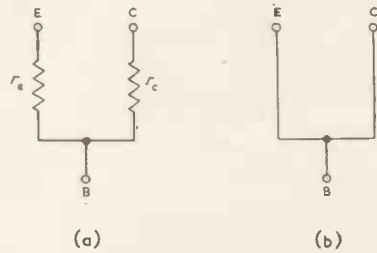

Fig. 6. Equivalent circuits

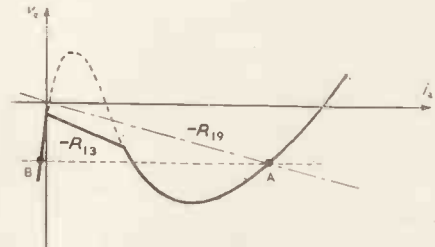

Fig. 7. Modified emitter characteristic

(shown in Fig. 7) modified by the biasing components R_{13} , R_{15} , R_{17} and MR_7 . The reasons for this modification will be discussed later. The split-shunt circuit used passes a current through the meter equal to at the most, half the difference between the high and the low collector currents. Since a $500-0-500\mu A$ meter is used, a collector current swing greater than $1mA$ is required. The values of collector load and base resistor were chosen ($10k\Omega$ and $5.6k\Omega$ respectively) to form a switching circuit giving not less than $2mA$ difference in order to allow a margin for adjusting the electrical sensitivity.

The two switching circuits have their emitters connected together and share a common emitter load R_{19} . The components R_{11} , C_5 and R_{12} , C_6 are included to transfer changes in the collector potential of each transistor to the base of the other, but their effect will be ignored for the present. If X_4 is assumed to be stable in the cut-off state its high emitter resistance r_e effectively isolates it from R_{19} and the emitter of X_3 . In this condition R_{19} is chosen so that X_3 is on, i.e., so that its load line intersects the emitter characteristic in the saturation region, for instance at A in Fig. 7. Since the emitter potentials of X_4 and X_3 must be the same, X_4 will be operating at the point B, in the cut-off region as was assumed. So the flip-flop state described, with X_3 on and X_4 off, must be a stable one and because the circuit is symmetrical it must have another

stable state with X_4 on and X_3 off. It is also possible for the flip-flop to be stable with both transistors on but this condition cannot happen when the instrument is in use, because the trigger pulses from the amplifiers always act to switch a transistor off.

It was mentioned in the description of the pulse standardizing amplifiers that a positive pulse is applied at the base of the saturated transistor in order to switch it off. The action which takes place is as follows: Since the transistor which is on, say X_3 , is virtually a perfect conductor the pulse is transmitted directly to the emitter of X_4 which will normally be off with its operating point at B in Fig. 7. The effect of the rise in emitter potential may be represented by shifting the line joining A to B upwards. If the pulse has sufficient amplitude the line will no longer intersect the curve for X_4 in the cut-off region and the operating point for X_4 will switch rapidly towards the intersection in the on region.

During this transition the collector current of X_4 changes from a low to a high negative value, producing a positive step in collector voltage. C_6 and R_{12} transfer this step to the base of X_3 where it adds to the effect of the initiating pulse. The effect of this can be shown by moving the curve for X_3 upwards and if this shift is sufficient the "valley" of the emitter characteristic will be raised above the level of the emitter potential. The operating point of X_3 then switches to the remaining intersection of load line and curve which is in the cut-off region. Thus when the triggering action is complete X_3 is off and X_4 is on.

The biasing network is included to improve the performance of the flip-flop by making it easier to switch off the saturated transistor. Its effect is to raise the valley of the emitter characteristic nearer to the common emitter potential so that a smaller voltage rise is required at the base to produce the switching action described in the last paragraph. Consider the bias arrangements associated with X_3 . The bias supply potential of +45V is chosen for convenience so that batteries of the same type may be used for both supplies. The bias network R_{13} , R_{15} and R_{17} is designed so that, with MR_7 disconnected, it would have the effect of raising the peak of the curve to about 0.75V positive as shown dotted in Fig. 7. However, with MR_7

in circuit the junction of R_{13} and R_{15} will be effectively clamped to earth and the resistance of R_{13} is large enough for the voltage dropped across it to allow the peak point to become slightly negative. On the other hand the value of R_{13} must be somewhat greater than that of the emitter load R_{19} to allow adequate negative resistance for rapid switching.

Fig. 7 shows the resultant characteristic. The potential levels of the peak and the valley have been brought closer together, so that smaller triggering voltages are needed, without sacrificing the collector current swing which may be obtained from the circuit.

The average total current drain is about 8mA from the collector supply and 2.5mA from the bias battery.

Conclusion

All the measuring circuits have been fitted into a cylindrical case 2½in in diameter and about 5in in height. Thus the equipment occupies little space and can be mounted in an instrument panel if required.

The sensitivity and the range of speeds over which reliable measurements may be made depends on the mechanical arrangements and may be varied to suit different requirements. Considered as a phasemeter the instrument described here will give reliable readings over a frequency range of 10 to 1 000p/s. The shape of the waveforms whose phase relation is measured is not important and the accuracy is of the order of ±2 per cent of full scale.

Acknowledgments

The author wishes to express his thanks to the Bristol Aeroplane Company for permission to publish this article.

An application for a Patent has been filed in connexion with this instrument.

REFERENCES

1. FIELD, J. F., TOWNS, D. H. A Torquemeter for Testing Gas Turbine Components. *Electronic Engng.* 26, 486 and 529 (1954).
2. LO, A. W. Transistor Trigger Circuits. *Proc. Inst. Radio Engrs.* 40, 1531 (1952).
3. ANDERSON, A. E. Transistors in Switching Circuits. *Ibid.*, p. 1541.
4. COOKE-YARBOROUGH, E. H. A Versatile Transistor Circuit. *Proc. Instn. Elect. Engrs.* 101, Pt. 3, 281 (1954).
5. TRENT, R. L. A Transistor Reversible Binary Counter. *Proc. Inst. Radio Engrs.* 40, 1562 (1952).
6. HARRIS, J. R. A Transistor Shift Register and Serial Adder. *Ibid.*, p. 1597.

Development of an Electron Astronomical Telescope

In a paper read at the 9th General Assembly of the International Astronomical Union, Dr. Peter Fellgett described work which has been carried out on an electron telescope.

The modern astronomical telescope is fundamentally a light gathering device, which, in conjunction with photographic methods, has greatly extended the range at which very faint objects, such as the distant galaxies, can be recorded. The giant 200-inch reflecting telescope at Mount Palomar has already photographed galaxies at the range of two thousand light years. To achieve this result, an exposure time of one hour was required, using the most suitable photographic plates.

The cost of the Mount Palomar telescope was six million dollars and it took twenty years to build. This and other factors render improbable the construction of a larger telescope using purely photographic recording methods. It would also appear that any considerable improvement in photographic emulsions is improbable in the near future, and in consequence the exploration of an alternative method of making more effective use of the light collecting power of existing telescopes is being undertaken at Cambridge.

In 1951, a possible solution to the problem was proposed by Mr. Bruce Somes-Charlton, an amateur astronomer on the staff of Pye Limited. The project involves the development of an electron telescope based on the light storage properties associated with certain types of photo-electric television camera

and image storage tubes operating in conjunction with special circuit techniques.

With the approval of the Technical Director of Pye Limited, Mr. B. J. Edwards, an approach was made to the Cambridge University Observatories with a view to securing advice and co-operation in conducting initial experiments. With the support of Dr. Fellgett, tests were carried out using a new 12-inch horizontal solar tunnel instrument and the 25-inch Newall refractor. The results achieved using substantially normal television equipment were so encouraging that it was decided to proceed at once with the design of more specialized equipment. Photographic images were obtained showing details of the sun's disk in ultra-violet and infra-red light. The solar telescope and spectrograph developed by Dr. von Klüber was used, and spectrum phenomena which had never before been viewed directly were observed and recorded; previously, many of the sun's phenomena obtained spectrographically were extremely difficult to photograph without being able to view directly beforehand.

Successful results were also obtained using the Newall Refractor for observations on the Moon, Jupiter and Saturn. The focal images produced by the 25-in objective were sufficiently large and bright to reveal detail such as the cloud belts on Jupiter and small lunar craters. Comparisons were made with photographs obtained under the same conditions which revealed the advantages of the electronic technique over photography in overcoming the effects of atmosphere tremor.

Electronic Stimulators

For Physiological Use

By W. J. Perkins*, A.M.Brit.I.R.E.

Three types of stimulator are described, using the same basic circuit, and the operation of this circuit is explained. The requirements of the physiologist are stated and it is shown how these are obtained. An r.f. probe unit, which effectively isolates the stimulating electrodes from earth and at the same time allows large pulse widths to be passed, is also described.

THE various methods of electrical stimulation for determining the response of muscle and nerve are well known¹. The advantages of electronic stimulators lie in the fact that the pulse can easily be independently varied in frequency, width and amplitude. The pulse can be made either constant current or constant voltage and the wave-shape either rectangular or exponential.

For the stimulators used at the National Institute for Medical Research the general requirements are as follows:

- (1) Constant voltage pulse.
- (2) Rectangular wave with sharp leading edge.
- (3) Frequency range 1 pulse in 20sec to 2 000pulses/sec.
- (4) Pulse width 20 μ sec to 4sec.
- (5) Positive output voltage 0 to 100V, variable with coarse and fine control.

Three types of stimulator were made, all following the same basic circuit design. The first type was intended for general use, so that particular attention was paid to simplicity of operation. For this reason a mechanical linking arrangement was used between the frequency and pulse width controls to prevent the pulse width being set at a greater time interval than that corresponding to the frequency. The frequency range of 2pulses/min to 2 000pulses/sec was covered in eight coarse steps with an intermediate fine control. For the pulse width control, nine coarse ranges were used, again with intermediate fine control. The output stage covered 0 to 90V in 10V steps with an additional 10V of fine control, together with a 0 to 1V range. For larger output voltages, the last position of the switch covered the range of 90 to 150V.

Circuit Description

A block schematic of the stimulator is shown in Fig. 1 with the appropriate waveforms, and the theoretical circuit is shown in Fig. 2. The first stage comprising V_2 and V_3 is a free running

multivibrator producing a symmetrical waveform the frequency of which is determined by C_1 , C_2 and VR_1 , oscillation being maintained by feedback from each screen to the opposite valve grid. The pulse at the anode of V_2 is differentiated and clipped to provide a negative pulse for triggering a c.r.o. and the V_3 anode pulse is fed through S_3 to a differentiating and clipping circuit which provides a positive trigger pulse for operating the pulse width circuit of V_5 . This circuit can also be triggered by positive external pulses via S_3 and single pulses can be obtained by connecting the input of the differentiating circuit to the h.t. line by a push button S_2 . V_5 has a normal steady state of the second half conducting, due to the h.t. voltage applied to its grid through VR_2 and a fixed resistor, and the first half cut-off due to the negative voltage on its grid obtained from the potentiometer chain across the second anode. The clipper stage V_4 removes the negative pulse of the differential waveform and the positive pulse applied to the first grid of V_5 dis-

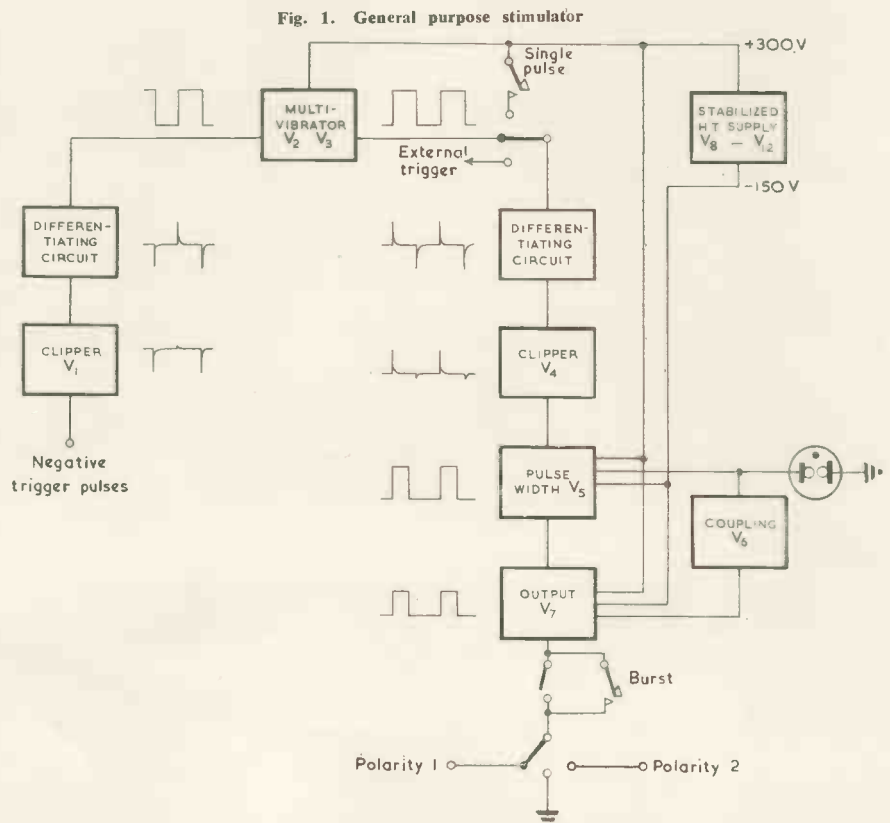

* National Institute for Medical Research.

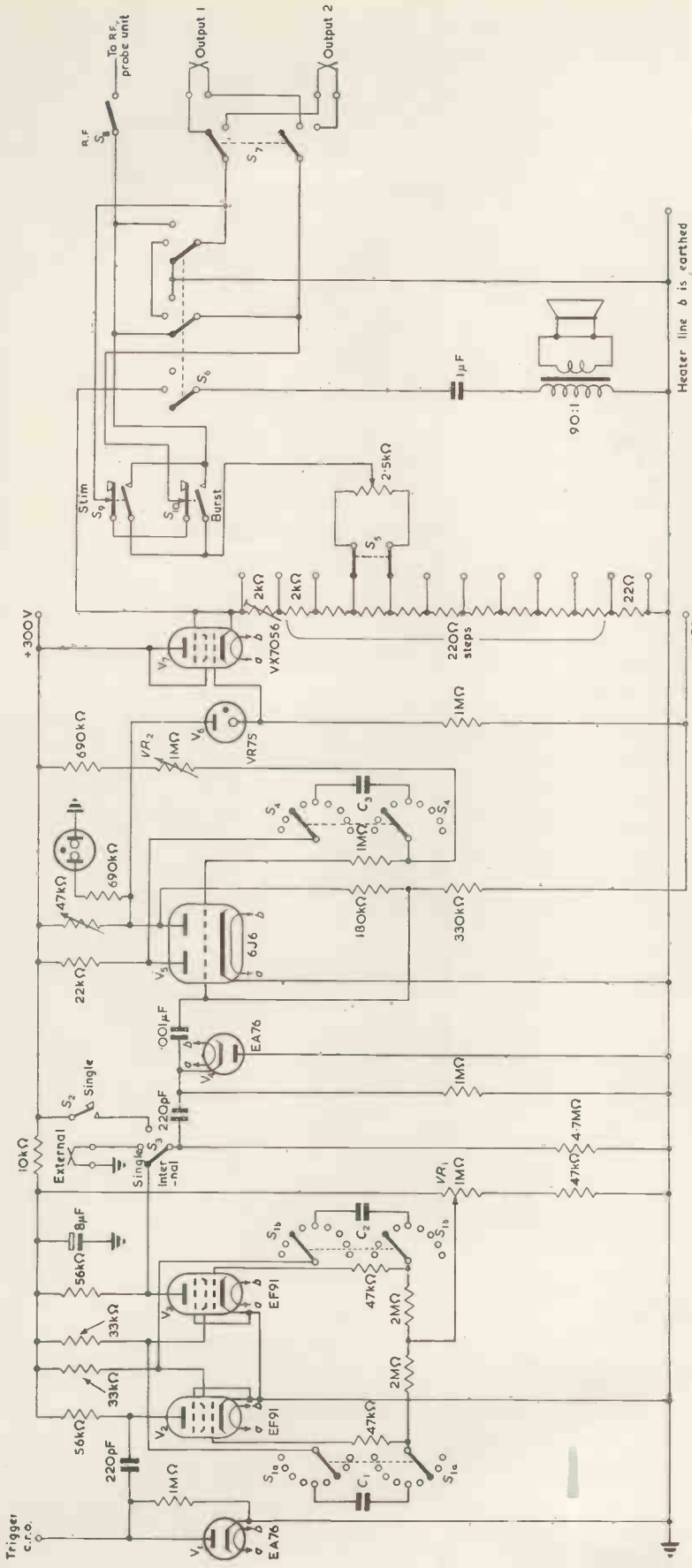

Fig. 2. General purpose stimulator—Theoretical circuit
See Table 1 for timing component values

TABLE I
Component Values for Figs 2 and 6

S_1 RANGE	C_1 & C_2	S_4 & S_{12} * RANGE	C_3 & C_4 *
2 cycles/min	4 μ F	4 to 1sec	8 μ F
8 "	1 μ F	1sec to 250msec	2 μ F
32 "	0.25 μ F	250 to 64msec	0.5 μ F
2 c/s	0.0625 μ F	64 to 16msec	0.125 μ F
8 "	0.0156 μ F	16 to 4msec	0.031 μ F
32 "	3 900pF	4 to 1msec	7 750pF
125 "	975pF	1msec to 250 μ sec	1 850pF
500 "	240pF	250 to 64 μ sec	350pF
		64 to 16 μ sec	150pF

* S_{11} and C_1 refer to Fig. 6 only

charges C_3 and triggers the valve over into its second state with the first half conducting and the second half cut off. The charge on C_3 recovers through VR_2 until the voltage on the second grid causes the second half to conduct, triggering the valve back to its original steady state. The pulse width is thus determined by C_3 and VR_2 , coarse control being provided in nine steps by variation of C_3 and a 4:1 fine control by VR_2 , giving a total range of $16\mu\text{sec}$ to 4sec . Visual indication of this pulse is provided by a neon indicator, N .

As this stimulator was intended for general use, it was thought desirable to prevent the pulse width circuit being set at a greater time interval than the multivibrator setting, particularly as the multivibrator was to be calibrated in frequency, not time. This was achieved by the following arrangement, which was designed by Mr. D. C. Gold. The pulse width ranges were adjusted to be half the multivibrator times, this ratio being chosen for ease of calibration, and the frequency and pulse width controls interlocked mechanically, so that the maximum pulse width on any range did not exceed half the multivibrator setting. Fig. 3 shows the mechanical interlock arrangement.

SP_1 is a 2in diameter sprocket wheel fixed to the frequency range switch and coupled by a chain to another similar wheel, SP_2 , which is attached to the shaft of the pulse width switch but free to rotate. A short arm, A , is fixed to this shaft and a small stud, B , is fixed to the sprocket wheel SP_2 so that the wheel can be turned by the arm, A . The two wheels are aligned so that the arm, A , rests against B when the maximum pulse width of a range is set at half the minimum multivibrator time for a given range. Thus, with the frequency switch set at 8p/s , the maximum frequency on that range is 32p/s , giving a maximum time of 32msec , so that the arm, A , should be against the stop, B , on the pulse width range of 4msec , which has a maximum time of 16msec . Should the pulse width switch be turned to increase the width, the frequency switch will also be turned to a lower frequency. Alternatively, if the frequency switch were turned to a higher frequency, the width switch would be turned to a shorter width. All pulse widths below the maximum allowed for any given frequency range can be selected, as also can any frequency above the minimum allowed for any pulse width setting.

The pulse height at the anode of V_5 is approximately 200V and a variable output pulse up to 100V is required, working into loads varying from approximately $100\text{k}\Omega$ to $2\text{k}\Omega$. A larger output pulse is also required for occasional experiments and, in the eventuality of using r.f. stimulation, d.c. coupling is essential in order to preserve the wave shape at the larger pulse widths but, using resistance coupling, the input voltage at the grid of the output valve would be considerably reduced. It is desirable to use a cathode-follower output stage to obtain a low output impedance and thus a pulse voltage of approximately 180V is required at the grid of V_7 . In order to achieve this, a neon stabilizer is used in the coupling stage. It is essential that no standing d.c. voltage should be present across the output electrodes, so the output valve is cut off by connecting the input circuit down to the 150V negative rail. The cut-off voltage is about -15V and the anode voltage of the pulse width valve is adjusted to be $+60\text{V}$, so, by using a neon stabilizer $VR75$, the full pulse voltage can be transferred to the grid, which is always held 75V away from the anode swing. It is necessary, however, to run the discharge tube well below its normal current limit,

otherwise the pulse at the anode is reduced, due to the additional discharge tube current flowing through the anode resistance. The voltage across the $VR75$ remains constant when the current through it falls to $200\mu\text{A}$ and, although the tube is not so stable in this region, it is quite adequate as a coupling circuit, the only effect being to

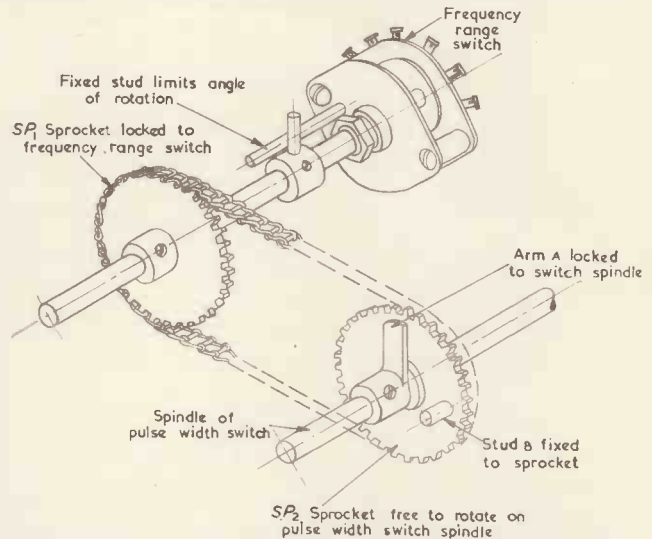

Fig. 3. General purpose stimulator—Frequency/width mechanical interlock



Fig. 4. General purpose stimulator

reduce the pulse by the amount of voltage variation. The tube is thus used in this condition, the current changing from 200 to $400\mu\text{A}$ with each pulse, resulting in an effective pulse of approximately 190V being fed to the output valve.

Although a fairly low output impedance is desirable, it is necessary to provide a fine variation of output voltage in order to locate the threshold point and it is not essential that this voltage be accurately known. The output attenuator is quite satisfactory for this purpose, giving a coverage of 0 to 100V in 10V steps with a 10V fine control together with a 0 to 1V range.

It is often required to use a negative pulse, but this is not easy to obtain from a cathode-follower circuit where d.c. coupling is essential for large pulse durations and no standing voltage is allowable on the output. A common arrangement is to earth the h.t. rail and take the output from the anode load, in which case a power valve is required to keep the output impedance down to a reason-

being applied to the load when the stimulus is disconnected, the output terminals are shorted.

A conventional series-parallel stabilizer is used for the h.t. power supply in order to provide a low coupling impedance. An effect of poor regulation is to cause a distortion of the wave shape at the larger pulse widths. It should be stressed at this point that one of the main causes

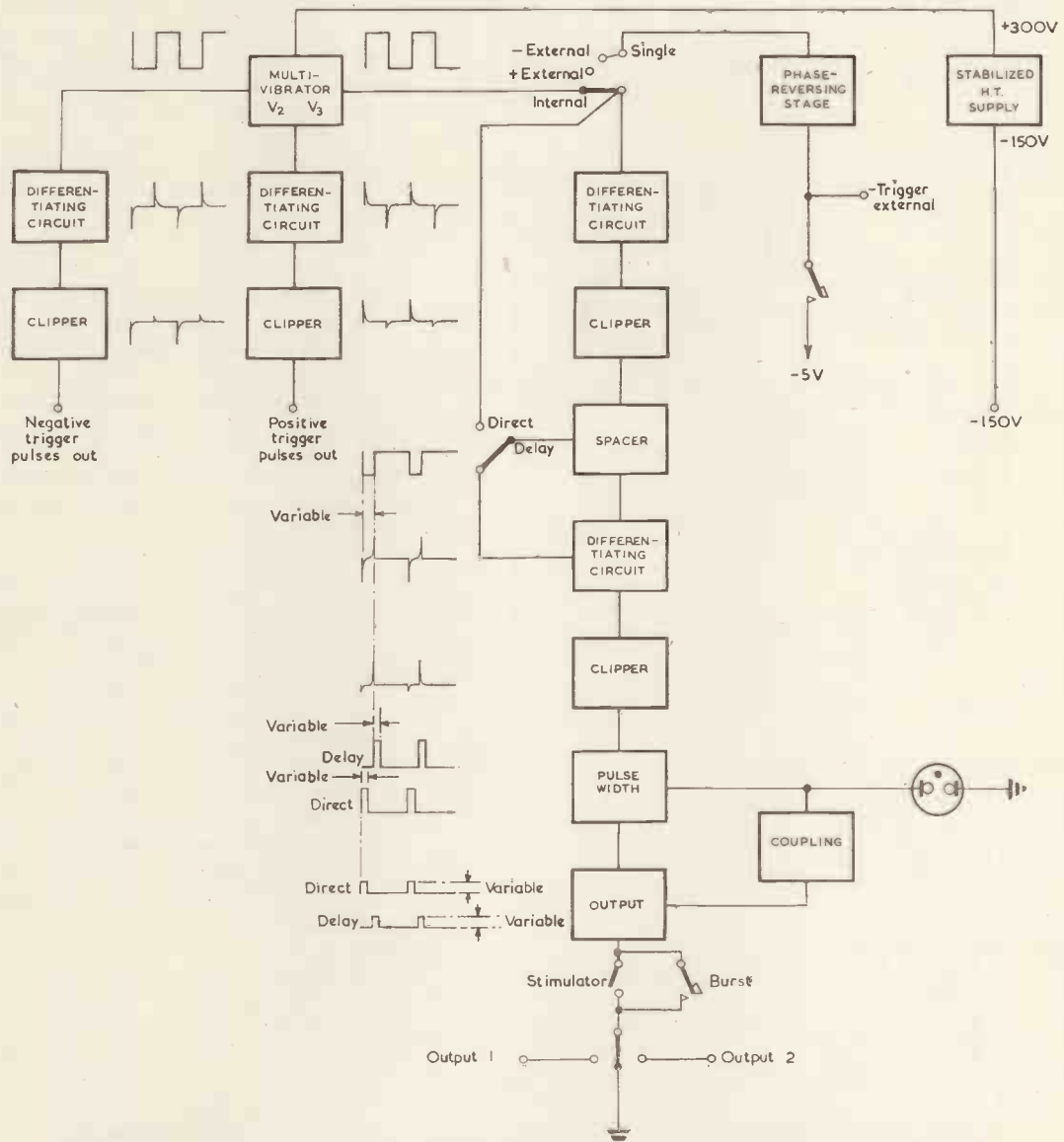

Fig. 5. General purpose stimulator with spacer

able value. If large pulse widths are not required, a pulse transformer can be used and it was decided to provide a positive output only and to use an external transformer when negative pulses were required.

The other facilities consist of a loudspeaker, which can be switched in to check the stimulator output, a push-button which allows pulses to pass when pressed and two output sockets to allow switching to either of two sets of electrodes. A reverse polarity switch allows the electrode leads to be easily reversed without having to move the electrodes. To avoid the possibility of spurious pulses

of distortion is poor layout and it will be observed from Fig. 2 that double pole switching of the capacitors was used to reduce the effect of stray capacitance. It was also found necessary to isolate the cases of the large capacitors from earth.

These instruments have been in use in the Physiology and Biological Standards Divisions of the Institute as general laboratory stimulators and have been found very satisfactory, particularly in ease of operation. A photograph of one of these instruments is shown in Fig. 4.

For the use of specialist workers in the Physiology and Pharmacology Division, a further requirement to the above

of Fig. 8, which is similar to that used by Schmitt and Dubbert^{3,4}, was used and is a 3Mc/s oscillator anode modulated by the stimulator output. The resultant train of r.f. pulses is contained within the

pulse. It was also possible to vary the output pulse amplitude by using the stimulator attenuator giving a coarse and fine control of output pulse down to zero volts. The r.f. unit was used in the form of a probe, approximately

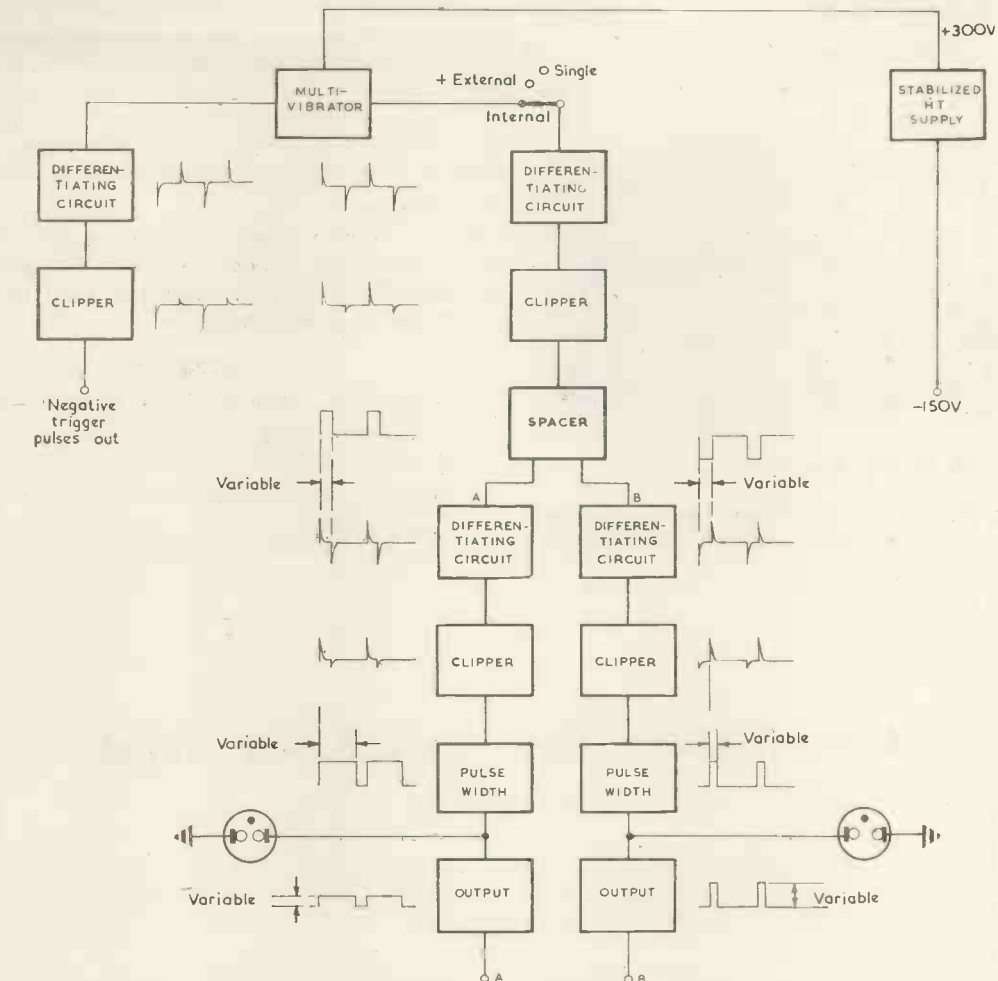

Fig. 7. General purpose double stimulator

envelope of the stimulator output. After passing through the transformer they are rectified, producing an output corresponding to that of the stimulator but isolated from earth. The output impedance of this circuit was $5k\Omega$ and on no load the output voltage was 90V for a 150V input

3in long and 1in diameter, the input leads to the load being kept as short as possible. Fig. 9 shows a photograph of the second type of stimulator and the r.f. probe unit is shown

Fig. 9. Stimulator with spacer

Fig. 8. R.F. probe unit for use with general purpose stimulator

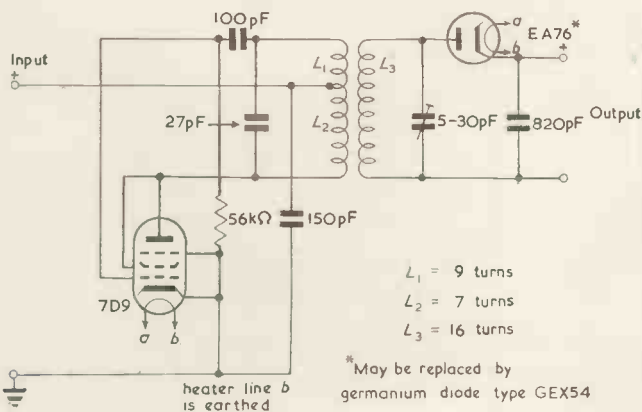



Fig. 10. R.F. stimulator unit

in Fig. 10. Using the CV469 (EA76) some ripple output was observed, due to the heater supply, and this was eliminated

by replacing with a germanium diode CV448 (GEX54). Where the large output voltage was required two of these were used in series.

By using the same circuits throughout, the production was made very much easier and because the calibration methods were standardized a user experienced little difficulty in changing over from one instrument to another. There are, of course, other facilities that could have been provided, but it is felt that the second instrument described, in addition to satisfying most requirements, can provide most of these facilities in conjunction with other equipment.

Acknowledgments

It is a pleasure to acknowledge the help of Mr. D. C. Gold, who was responsible for the construction, the mechanical interlock arrangement and the method of calibration of these instruments.

REFERENCES

1. DICKINSON, C. J. Electrophysiological Technique. *Electronic Engng. Monograph* (1950).
2. HAAPANEN, L., *et al.* The Application of Radiofrequency Coupled Input Stages and Stimulators to Neurophysiological Experiments. *Acta Physiol. Scand.* 29, 394 (1953).
3. SCHMITT, O. H. A Radio Frequency Coupled Tissue Stimulator. *Science* 107, 432 (1948).
4. SCHMITT, O. H., DUBBERT, P. R. Tissue Stimulators Utilising Radio-frequency Coupling. *Rev. Sci. Instrum.* 20, 170 (1949).

A Crystal Controlled 50c/s Power Supply

By L. F. Sinfield

An economical unit is described designed mainly for use in process and sequence timing and as a standard for production testing and timing in the watch and clock industry. A reliable and consistent accuracy of within a few seconds a day has been maintained over a period of several years.

FOR industrial timing there are many applications where the mains frequency is far too inaccurate for the precise timing required. Such applications need a power supply with frequency controlled by a considerably more precise source, such as a tuning fork or crystal. Fortunately the normal power requirements, to drive timers of the synchronous clock type, only amount to a few watts; if greater power is needed it is easy to add a further power supply in the form of any commercial audio amplifier that will give the correct output matching.

In the particular case involved there were several basic design requirements apart from the frequency stability and output. It was necessary for the cost of the units to be comparatively low and for the reliability to be such that it can be operated by unskilled personnel either intermittently or virtually continuously and maintain a consistent standard.

The number of valves and valve types was therefore reduced to the absolute minimum consistent with reliable operation.

The initial standard consists of a 3kc/s quartz crystal, mounted in an evacuated glass envelope. This frequency is sufficiently low to enable a reasonable division rate and yet maintain a frequency accuracy which is well within most normal requirements. There is no temperature control but

the crystal is mounted in a corner of the cabinet well away from the output valves and rectifier and is well ventilated so that its temperature is in fact very little different from room temperature. Under these conditions the accuracy is within a few parts in a million. The oscillator circuit consists of a cathode coupled arrangement, so eliminating the need for inductors and making it extremely simple. The component values are chosen so as to limit the amplitude of the crystal drive and to reduce the squareness of the waveform. No buffer stage is used after the crystal; isolation being obtained by means of a high series resistor to the following stage.

Due to isolation requirements, limited amplitude and sinusoidal waveform which make the triggering of the first divider rather low, it is desirable to have the first divider of low division ratio and it is consequently a divide by two stage. An Eccles-Jordan type of stage would seem obvious but, however, this requires rather more drive to lock than a free running multivibrator and so the latter was chosen. Output from this stage consists of normal square multivibrator waveform so that the following division ratios can be higher.

In order that the output be made to resemble a sine wave it was desirable that the last divider be of an even number to give a balanced waveform. Also to maintain

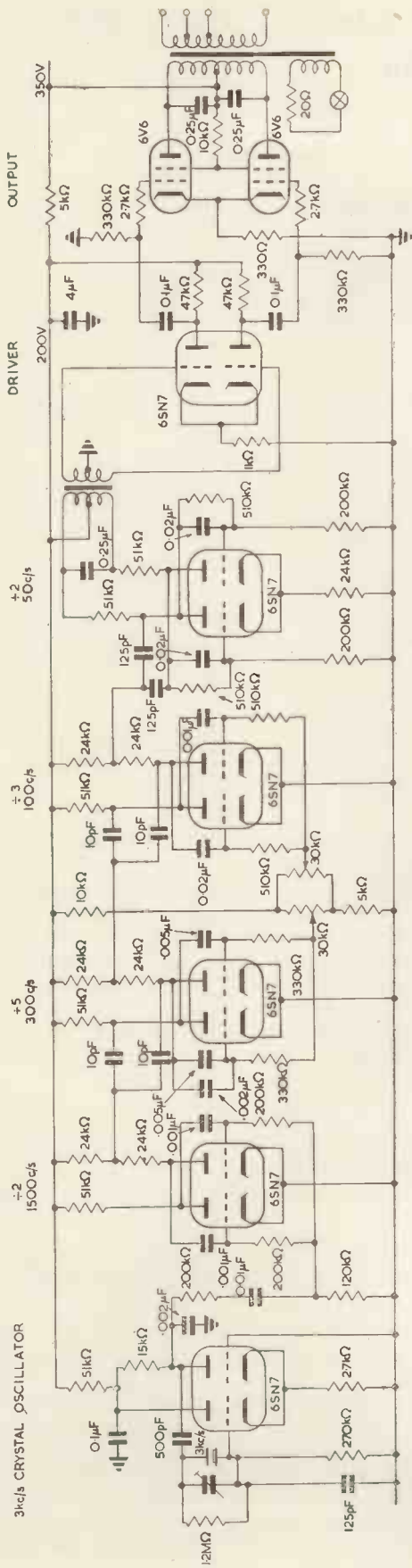

Fig. 1. The complete circuit

high stability this stage should not divide by a high ratio as it has to provide drive for the filter and power amplifier. This stage was therefore made a divide by two and as there is ample drive from the previous stage this one is an Eccles-Jordan type; with the addition of coupling capacitors to make it reasonably selective of input frequency and to improve voltage transfer to the grids.

This leaves intermediate dividers to cope with a division rate of fifteen, which is accomplished in two stages. The first is made the divide by five as the frequency is higher and the coupling capacitors smaller values. This enables these capacitors to be of silvered mica type and gives better stability to this stage. The next stage is a divide by three. Both stages have their grid leaks returned to variable positive potentials to vary the leakage rate. The potentiometers allow these two stages to be set precisely in the centre of their correct dividing range and are simpler and more convenient than selecting critical time-constant values.

The anodes of the final divider stage obtain their feed via a transformer with push-pull primary and secondary. The primary winding is tuned to 50c/s by a 0.25μF capacitor and with the anode loads forms a filter giving an output close to sinusoidal.

The driver and output stages are not designed to give a perfect waveform as any waveform which reasonably resembles a sine wave is suitable for driving most types of timers. The main requirement of the output stage is that it gives at output which remains within reasonable voltage limits over its full range of output power. The valves used are 6V6's and give up to 10VA. Output voltage is 230V r.m.s. and remains within ±10 per cent over the range of no load to 10VA. This is comparable to normal mains conditions, apart from the frequency now being precise.

The output transformer is an ordinary 'mains' type with 250-0-250V and 6.3V secondaries. The 6V6's work into the h.t. winding and a pilot lamp on the heater winding operates to give indication that the output stage is functioning. The h.t. winding has capacitors fitted across it to provide additional filtering.

Output is taken from the 230V tap on the transformer mains winding.

The power pack is conventional and uses a stock size of mains transformer and other stock components. In order to maintain maximum reliability, electrolytic capacitors have been completely eliminated. The sole h.t. smoothing is by three oil-filled paper capacitors of 4μF. The smoothing choke is tuned to 100c/s and the overall result is quite satisfactory. A resistor is used to drop the voltage on the 6V6 screens to keep down their dissipation and a waveform does exist at the screens. A further decoupling capacitor here will eliminate this but as it makes no measurable effect on the output supply it was not fitted.

The frequency was adjusted by a small trimmer across the crystal to be 3kc/s when checked against the 1kc/s tuning note radiated by the BBC the latter being an accurate and very convenient source of calibration. Stability was checked by over-running and under-running the mains; varying the h.t. voltage and interchanging valves with others in various emission conditions. In all cases the unit remained stable. It has since been used over a period of several years and given no trouble whatsoever. Frequency has been periodically checked against the 1kc/s standard and there has been no need to alter the trimmer setting.

The Response Functions and Vector Loci of First and Second Order Systems

By David Morris*, D.Sc., A.M.I.E.E.

(Part 2)

The Symmetrically-Resonant Response and the Circular Locus

In this article attention is confined to certain second order systems having a circular vector response locus. For such systems the magnitude of response is truly symmetrical when plotted against a logarithmic frequency scale, and Q can be determined by the bandwidth method without approximation.

Fig. 9 illustrates two second-order systems. The systems are described as second order, because their transient behaviour is governed by second-order differential equations. If their response to a sustained sinusoidal disturbance is investigated, their behaviour may be expressed by equations of the second degree in frequency. There are several different responses to be investigated; for example in the system of Fig. 9(a), for a given input voltage V_1 the output voltage could be drawn from across C , or L , or R or from across various combinations of these elements.

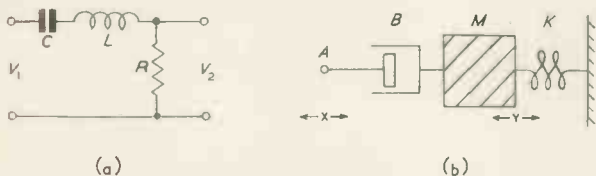

Fig. 9. Examples of second order systems

The simplest and most basic response is obtained if the output is taken from across R as shown, and this forms the subject of the present article. When plotted in conjunction with a logarithmic scale of frequency, the curve of response magnitude is symmetrical, and the curve of response phase is skew-symmetrical. When plotted vectorially, the response follows a circular locus.

In communications work, the vector locus is of little interest, because for high- Q systems the extremely non-uniform frequency calibration renders the locus uneconomical as a means of describing the magnitude of the response. For low- Q systems, however, the frequency points are spread more evenly round the locus, which then forms an effective means of conveying information concerning both magnitude and phase. Corresponding responses are obtainable from mechanical systems such as that of Fig. 9(b), the symmetrically-resonant response being obtained when the input is the displacement of the point A and the output is the displacement of the mass M .

The Symmetrically-Resonant Response Function

Fig. 9(a) illustrates a four-terminal network consisting of a capacitor C , a loss-free inductor L and a resistor R . If a voltage V_1 of constant magnitude and variable frequency is applied to the input terminals, the output voltage V_2 is given in terms of the input voltage by the transfer function:

$$V_2/V_1 = \frac{R}{1/j\omega C + R + j\omega L} \dots \dots \dots (3)$$

* University College of North Wales, Bangor.

Set $T_0 = 1/\omega_0 = \sqrt{LC}$, and $Q = (1/R) \sqrt{L/C} = \omega_0 L/R$, then:

$$V_2/V_1 = \frac{j\omega T_0/Q}{1 + j\omega T_0/Q + j^2\omega^2 T_0^2} \dots \dots \dots (4)$$

Introduce a "relative frequency" $\gamma = \omega/\omega_0 = \omega T_0$, then:

$$V_2/V_1 = \frac{j\gamma/Q}{1 + j\gamma/Q + j^2\gamma^2} = \frac{1}{1 + jQ(\gamma - 1/\gamma)} \dots (5)$$

The expression $(\gamma - 1/\gamma)$ is of frequent occurrence in the treatment of resonant systems, and for the purposes of these articles it is convenient to introduce a "geometric detuning" Δ , where:

$$\Delta = \frac{1}{2}(\gamma - 1/\gamma) = \frac{\gamma^2 - 1}{2\gamma} = \frac{(\gamma - 1)(\gamma + 1)}{2\gamma} \dots (6)$$

Near resonance, $\gamma \approx 1$, and we may write:

$$\Delta \approx (\gamma - 1) = \delta \dots \dots \dots (7)$$

that is, the geometric detuning Δ is approximately equal to the arithmetic detuning factor $\delta = (\gamma - 1)$. The geometric detuning is negative for frequencies below resonance and positive for frequencies above resonance. The detuning is termed "geometric" because, as will be seen later, the resonant frequency is the geometric mean of the two frequencies below and above resonance that correspond to the same magnitude of geometric detuning.

Substituting in equation (5), and letting $\rho = 2Q\Delta$, we have without approximation:

$$V_2/V_1 = \frac{1}{1 + j2Q\Delta} = \frac{1}{1 + j\rho} \dots \dots \dots (8)$$

Similarly, if the input voltage is varied in such a manner as to maintain the output voltage constant as the frequency is varied, the necessary input in terms of the output is given by the function:

$$V_1/V_2 = 1 + j2Q\Delta = 1 + j\rho \dots \dots \dots (9)$$

The frequency-dependent functions (8) and (9) are dimensionless, and have the value unity at the resonant frequency $\omega_0/2\pi$. Function (9) also equals Z/R , and thus describes the input impedance in terms of its value at resonance. Similarly, function (8) equals Y/G , where $G = 1/R$, and thus describes the input admittance in terms of its value at resonance. The performance of the second order system is governed by the function $(1 + j\rho)$ in much the same way as the performance of the first order system³ is governed by the function $(1 + j\gamma)$. A point of difference is that the full range of negative and positive values of ρ is required for describing the physical performance of the second order

system, whereas the range of positive values of γ suffices to describe the performance of the first order system.

The Vector Loci of the Symmetrically-Resonant System

The behaviour of the function V_1/V_2 as ω varies from zero to infinity may be represented by a vector plot of $1 + jQ(\gamma - 1/\gamma)$ as γ varies from zero to infinity, or by a plot of $(1 + j\rho)$ as ρ varies from $-\infty$ to $+\infty$. The locus is a straight line. At resonance $\gamma = 1$, $\rho = 0$, there is zero phase shift and a minimum in the magnitude. A comparison with the plot of $(1 + j\rho)$ for a first order system described in the previous article shows that evenly graduated scales for ρ and $1/\rho$.

The behaviour of the function V_2/V_1 as ω and γ vary from zero to infinity may be represented by a vector plot of the function $1/(1 + j\rho)$ as ρ varies from $-\infty$ to $+\infty$. The locus is a circle. At resonance $\gamma = 1$, $\rho = 0$, there is zero phase shift and a maximum in the magnitude. A comparison with the previous article shows that evenly

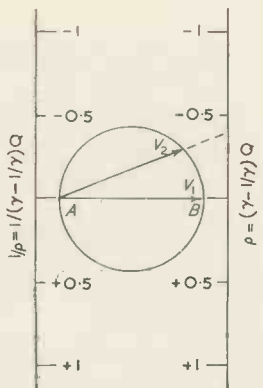

Fig. 10. Vector locus of symmetrically resonant system
Vector V_2 drawn for $\rho = -0.4$

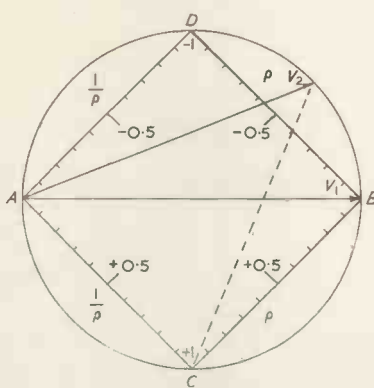

Fig. 11. Vector locus with more compact scales
Vector V_2 drawn for $\rho = 0.4$

graduated scales for ρ and $1/\rho$ may be inserted. In Fig. 10, the scale of ρ is used in conjunction with construction lines drawn from the pole A, to fix points on the right-hand half of the circle. The scale of $1/\rho$ is used in conjunction with construction lines from the pole B, to fix points on the left-hand half of the circle. Alternatively, the more compact scales described in the previous article may be used, as shown in Fig. 11. The scales AD and DB are used in conjunction with the pole C for negative values of ρ (i.e. for values of γ less than unity), while scales BC and CA are used in conjunction with pole D for positive values of ρ (i.e. for values of γ greater than unity). The whole circle can thus be calibrated for frequency by the use of scales of limited size. Over the whole frequency range, the construction lines cut both scale and locus at an angle sufficient to define adequately the points of intersection.

If γ is specified, the corresponding point on the locus may be determined by substituting in the formula:

$$\rho = 2Q\Delta = Q(\gamma - 1/\gamma)$$

and using the appropriate scale of ρ or $1/\rho$. The inverse problem, to find the value of γ corresponding to a specified point on the locus, requires the solution of the quadratic equation in γ :

$$\rho\gamma = 2Q\gamma\Delta = Q\gamma^2 - Q \quad (10)$$

The solution is most concisely expressed in terms of Δ , and is:

$$\gamma = \Delta + \sqrt{\Delta^2 + 1} \quad (11)$$

In most cases, only the positive sign to the radical is required, the negative sign always yielding negative values of γ , which are of merely formal interest.

The distribution of values of ρ on the circular locus has two axes of symmetry: for points symmetrically placed about the line AB, we have $\rho_1 + \rho_2 = 0$. For points symmetrically placed about the line CD we have $\rho_1\rho_2 = 1$. In the case of the second order system, it is the symmetry about AB that is of practical interest, because by expressing ρ_1 and ρ_2 in terms of the relative frequencies it is easily shown that for such points $\gamma_1\gamma_2 = 1$. This is comparable with the same relationship that held in the first order system for points symmetrically placed about the axis CD.

Since $\gamma_1 = 1/\gamma_2$, if the magnitude and phase of the response are plotted separately against the logarithm of the frequency, curves respectively symmetrical and skew-symmetrical are obtained.

Magnitude Relationships: the Determination of Q from Bandwidth

For the circuit of Fig. 9(a):

$$V_2/V_1 = (V_2/V_{2\max}) = \frac{1}{1 + j2Q\Delta} \quad (12)$$

$$\text{Let } x = |V_2/V_{2\max}| = \sqrt{\left(\frac{1}{1 + 4Q^2\Delta^2}\right)} \quad (13)$$

Hence:

$$Q = (1/2\Delta) \cdot \sqrt{\left(\frac{1}{x^2} - 1\right)} \quad (14)$$

Now for each value of x , two equal and opposite values $\pm\Delta$ can be found for the geometric detuning, giving:

$$\gamma_1 = -\Delta + \sqrt{\Delta^2 + 1} \quad (15)$$

$$\gamma_2 = +\Delta + \sqrt{\Delta^2 + 1}$$

Hence:

$$\gamma_2 - \gamma_1 = 2\Delta \quad (16)$$

and also, as before, $\gamma_1\gamma_2 = 1$.

Substituting in equation (14):

$$Q = \frac{1}{\gamma_2 - \gamma_1} \sqrt{\left(\frac{1}{x^2} - 1\right)} \quad (17)$$

or:

$$Q = \frac{\omega_0}{\omega_2 - \omega_1} \sqrt{\left(\frac{1}{x^2} - 1\right)} = \frac{V(\omega_2, \omega_1)}{\omega_2 - \omega_1} \sqrt{\left(\frac{1}{x^2} - 1\right)} \quad (18)$$

In particular, if $x = 1/\sqrt{2}$:

$$Q = \frac{\omega_0}{\omega_2 - \omega_1} = \frac{V(\omega_2, \omega_1)}{\omega_2 - \omega_1} \quad (19)$$

This forms the basis of the well-known "bandwidth" method of determining Q . It should be noticed that as derived above, equations (18) and (19) involve no approximations, and may be used however low the value of Q . The determination of Q by this bandwidth method is strictly legitimate only if the output points of the circuit are so chosen that the response is symmetrically-resonant and can be expressed in terms of a frequency-dependent function of the type given in equation (4). In many systems, Q is large enough to make this precaution unimportant.

Phase Relationships

If θ is the phase-angle by which V_2 leads V_1 :

$$\theta = -\tan^{-1} 2Q\Delta = -\tan^{-1} Q(\gamma - 1/\gamma) \quad (20)$$

The rate of change of phase with relative frequency is then :

$$d\theta/d\gamma = \frac{-(\gamma^2 + 1)Q}{\gamma^2 + (\gamma^2 - 1)^2 Q^2} \dots\dots\dots (21)$$

For the in-phase condition, $\gamma = 1$, hence $d\theta/d\gamma = -2Q$. Differentiating equation (21) with respect to γ^2 and equating to zero, we find that the relative frequency at which $d\theta/d\gamma$ is a maximum is given by :

$$\gamma^2 = -1 + \sqrt{4 - 1/Q^2} \dots\dots\dots (22)$$

Hence the maximum rate of change of phase-angle with respect to frequency always occurs at a frequency below resonance. When $Q \leq 1/\sqrt{3}$, the maximum rate of change of phase-angle with respect to frequency occurs at zero frequency, and equals $-1/Q$.

Practical Examples

There are many practical systems which have the symmetrically-resonant type of response described above. Such

systems always have two distinct locations of energy storage, and the input and output are arranged in such a way that the response is zero at zero frequency and at infinite frequency. An example is the acceleration of a separately-excited d.c. motor in response to a voltage applied to its armature terminals, the armature being free to run apart from restraint by inertia and viscous friction. Another example is the response of a tuned-anode amplifier to grid voltage, when the output voltage is taken from a coil inductively coupled to the anode inductor. Further examples are the RC networks described in a previous article⁴.

Asymmetrically-resonant second order responses and loci will be considered in subsequent articles.

REFERENCES

- 3. MORRIS, D. The Response Functions and Vector Loci of First and Second Order Systems (Part 1). *Electronic Engng.* 27, 402 (1955).
- 4. MORRIS, D. Q as a Mathematical Parameter. *Electronic Engng.* 26, 306 (1954).

(To be continued)

Britain's Second Television Network

The Independent Television Authority's transmitter which was opened on September 13 is the first stage of the Authority's network of transmitters, and constitutes at the same time the first Band III television transmitter to be operating on a regular basis in this country.

It also marks the beginning of Britain's second television network and as from September 22, when full scale service was started, viewers in the London and Home Counties will have the choice of an alternative programme.

The I.T.A. transmitter is located at Croydon, some 375ft above sea level and is expected to provide a primary service area extending west to east from Henley to Tilbury and from Welwyn in the north to Crawley in the south.

The Croydon transmitter, designed and built by Marconi's Wireless Telegraph Co., Ltd., operates at a frequency of 194.75Mc/s and consists of a 10kW vision transmitter and a 2½kW sound transmitter feeding into an 8-stack aerial array providing an effective radiated power of 60kW.

The Band III 10kW Vision Transmitter

The production version of the Band III vision transmitter consists of a 2kW transmitter Type BD.357B, together with a Band III Amplifier Type BD.360.

The complete transmitter is designed to give a peak output power of approximately 10kW under vestigial sideband conditions, at any chosen channel in the upper frequency band of 170 to 216Mc/s, using the British standard 405 line system.

Push buttons are provided on a Transmitter Control Panel for normal day-to-day operation of the transmitter, which may thus be brought up on power from the control desk. A black level control and calibrated input attenuator are also provided on the control panel. Air cooling is used throughout.

2kW Transmitter Type BD.357B

DRIVE CIRCUITS :

Crystal controlled: The crystal itself is oven-controlled and operates at a sub-multiple of the output frequency. Long-term stability better than .0002 per cent, which permits off-set carrier operation of two adjacent transmitters on the same channel. The crystal oscillator, together

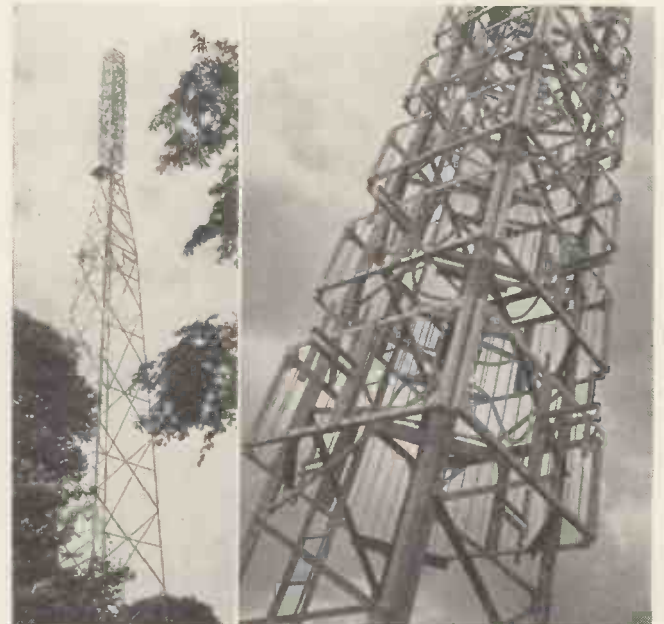

The aerial array of the I.T.A. transmitter showing the 8-stack vertically polarized aerial system.

(Below) Part of the Control Room showing the programme input equipment. The Telecine equipment can be seen in the room beyond.



with associated frequency multipliers and stabilized h.t. supply, form a complete unit with an output of approximately 15 watts at the operational frequency.

R.F. CIRCUITS:

The first and second r.f. amplifiers consist of triode valves (ACT-25's) working in single-ended grounded grid circuits, using coaxial lines as circuit elements. The final (modulated) amplifier employs an air cooled tetrode (QY5-3000A) in a single-ended coaxial line circuit.

MODULATOR:

The output signal from the control desk is bridged across the input of two units, namely a Clamp Pulse Generator and a Correction Unit.

CLAMP PULSE GENERATOR:

This produces a clamping pulse of 2V amplitude, which will remain correctly timed in presence of noise pulses on the incoming signal, positive or negative going, up to 1.5 μ sec duration.

CORRECTION UNIT:

In this unit the sync. pulses are stretched, clipped to standard level, and pre-correction applied to compensate for transmitter non-linearity. A fine gain control is provided on this unit. Signals are clamped by pulses from the Clamp Pulse Generator, and the output is approximately 1.5V d.a.p. to the next stage, the Pre-Amplifier.

PRE-AMPLIFIER:

Here the signal can be increased to approximately 50V d.a.p. Since the input is correctly clamped, the black level is maintained in the succeeding stages by d.c. restoration. Coarse and fine pre-set gain controls are provided on this unit.

FINAL CLAMPING AND BLACK LEVEL FEEDBACK UNIT:

A signal is obtained via a probe in the aerial feeder, rectified and fed to this unit. The amplitude of the sync. pulse in the signal thus derived is used to maintain the black level constant. The signals are also clamped by pulses from the Clamp Pulse Generator. Should a fault occur in the feedback path, the feedback control may be switched out of operation.

FINAL AMPLIFIER AND MODULATOR:

This unit is fed from the final clamping stage through an input cathode-follower, the whole circuit being directly coupled to maintain the constancy of black level. A cathode-follower feeds a normal shunt regulated amplifier, followed by a shunt regulated cathode-follower stage, in order to supply the large reactive current demanded by the stray capacitance appearing at the modulation terminals of the amplifier. A peak modulation limiter is incorporated in this unit.

Band III Amplifier Type BD.360

The modulated output of the 2kW transmitter Type BD.357B is fed to the input of this amplifier, which consists of a single-ended air-cooled triode (BR.1106) operating in a coaxial line circuit to raise the power output level to approximately 10kW peak.

Studio Equipment

The programmes to be radiated by the I.T.A. are to be provided by the programme contracting companies who will set up their own studios and equipment.

One of these companies, The Associated-Rediffusion

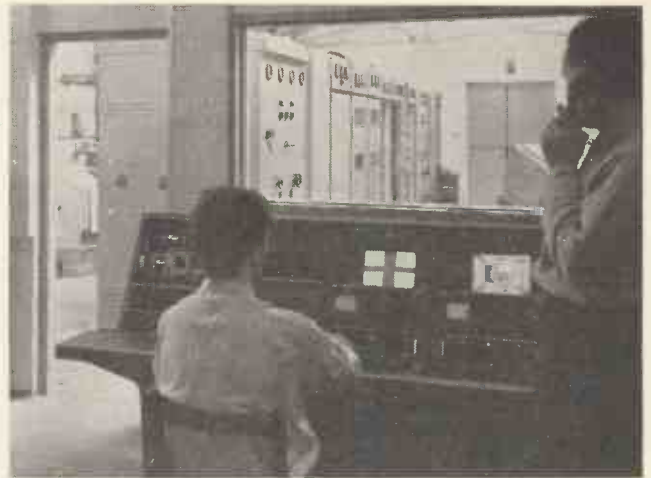

The control desk. The transmitter can be seen in the room beyond.

Ltd., has set up a permanent studio centre at Wembley consisting of five studios with a master control system designed specifically for commercial television.

The layout of the studios has been designed to provide a compact technical area isolated from visitor and programmes traffic, but with direct contact between studio personnel and the master equipment room staff.

The technical area is a two/three storey structure within the main building, and separating Studios 2, 3 and 4 from Studio 1. It is on two floors for most of its length and on three floors in the area dividing Studios 1 and 2. On the first floor are situated the operational control rooms for the various studios, and on the second floor is the master equipment room (master control room) and the remote control of the lighting equipment for Studios 1 and 2. The telecine room is adjacent to the entrance to the technical area.

On the first floor are the vision, sound and camera control rooms for Studio 1, a similar set of rooms for Studio 2, together with vision and sound control rooms for Studio 3 and vision and sound control rooms for Studio 4. Three announcer's rooms also are on this floor.

The second floor is occupied (between Studios 1 and 2) by the master equipment room, a lighting control room and a lighting equipment room.

Some twenty-one cameras of the Marconi Mark 3 type with 4 $\frac{1}{2}$ in pick-up tubes are in use at the studios, and similar cameras with 3in tubes are in use for O.B. work.

The telecine equipment is of the 16 or 35 millimetre Flying Spot type, and produces pictures which can be fed into the various studios or direct to the master control. In addition, some American telecine equipment is similarly available for remote control. This is the R.C.A. Vidicon Equipment in which the projectors throw their outputs on to a small Vidicon camera via an optical multiplexing unit.

The master control equipment provides for the simultaneous switching of sound and vision from eight input channels to two transmission channels, with adequate pre-viewing facilities.

From the Wembley Master Equipment Room, the signals are passed to Associated-Rediffusion's Headquarters at Television House in Kingsway (formerly Adastral House), thence, via the Museum telephone exchange to the Croydon transmitter.

A Non-Linear Resistance-Capacitance Circuit

By F. A. Key* and W. G. P. Lamb*, Ph.D.

A non-linear RC circuit used in an analogue to represent air pressure variations due to transient airflow in a system of interconnected chambers is described. The necessary non-linear behaviour has been obtained by the use of a non-linear amplifier in a negative feedback loop.

THEORETICAL consideration of a problem concerned with the airflow in a network of interconnected chambers led to the suggestion that resistance-capacitance circuits could be used to construct an electrical analogue of such a system provided the resistances were non-linear.

In the simplest case, the analogue took the form of a single RC circuit connected to a generator as shown in

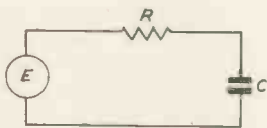

Fig. 1. The simple RC circuit

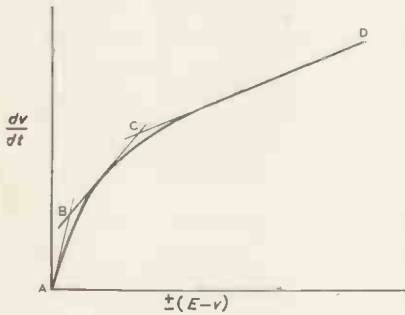

Fig. 2. The required characteristic

Fig. 1. If v is the potential across the capacitor C , and E is the generator output then the behaviour of the circuit may be described by the equation:

$$R \frac{dv}{dt} + v/C = E/C \dots\dots\dots (1)$$

or if $f(E-v)$ represents the behaviour of R as a function of the potential across it then:

$$f(E-v) \frac{dv}{dt} + v/C = E/C \dots\dots\dots (2)$$

The required nature of this function was available from theoretical and experimental investigations in the form of a plot of dv/dt against $(E-v)$ as shown in Fig. 2. $f(E-v)$ is represented by the ratio of the abscissa to the ordinate at a point on the curve and increases from a small to a relatively large value with increasing $(E-v)$.

An analogue of a more complicated case where the flow and pressure variations in a number of chambers were to be studied is shown in Fig. 3. In this example, several non-linear RC circuits have been connected in a series-

parallel arrangement to represent a small labyrinth of interconnected volumes.

A Circuit with the Required Characteristic

An approximation to the required characteristics was obtained by a negative feedback method which gave a curve consisting essentially of three straight line sections. This was achieved by the network shown in Fig. 4 where r_1 represents the generator impedance and a series resistance, r_2 the resistance which is to have a non-linear behaviour and C the capacitance.

An amplifier of high input impedance is connected across r_2 with its output fed back to the input points in anti-phase.

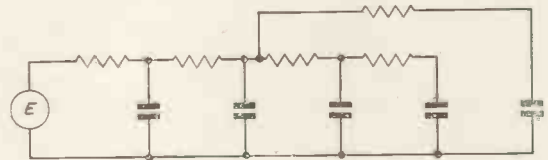

Fig. 3. A typical network

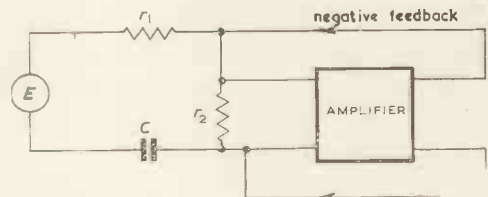

Fig. 4. Schematic arrangement for single network

If a current I is considered to be flowing from the generator into the remainder of the circuit then:

$$E = Ir_1 + x + v \dots\dots\dots (3)$$

where x is the potential across r_2 and v that across the capacitance C . If G is the loop-gain of the amplifier network:

$$x = Ir_2 - Gx$$

or:

$$x = \frac{Ir_2}{1 + G}$$

so that:

$$E = Ir_1 + \frac{Ir_2}{1 + G} + v \dots\dots\dots (4)$$

From equation (4) it is evident that the effective value of the resistance r_2 in the circuit is $r_2/(1 + G)$. Thus by making the gain G a function of $(E-v)$ the required non-linear behaviour for r_2 may be obtained. This was done by

* United Kingdom Atomic Energy Authority.

simply designing the amplifier to run into non-linearity and saturate. In the "saturated" or "blocked" condition the amplifier feeds back a potential independent of the input signal so that in equation (4) the term $Ir_2/(1 + G)$ is replaced by Ir_2 minus a constant potential say P , hence:

$$E = I(r_1 + r_2) - P + v$$

or:

$$E - v + P = C(r_1 + r_2) dv/dt$$

A plot of dv/dt against $E - v$ in the blocked condition

therefore yields a straight line of slope $\frac{1}{C(r_1 + r_2)}$ cutting

the two feedback paths which saturate at different input levels since the third stage of amplification runs into non-linearity before the second due to the higher signal level at the input to the final pair of valves. With the gain control set at maximum, saturation occurs in the second and third stages for input potentials of about 0.5V and 0.1V respectively. Complete blocking, however, takes place gradually and a reasonably smooth transition from one straight line section to the next is obtained. A constant current pentode valve V_5 is used as a common cathode load in the third stage to ensure that both sides of the stage block together.

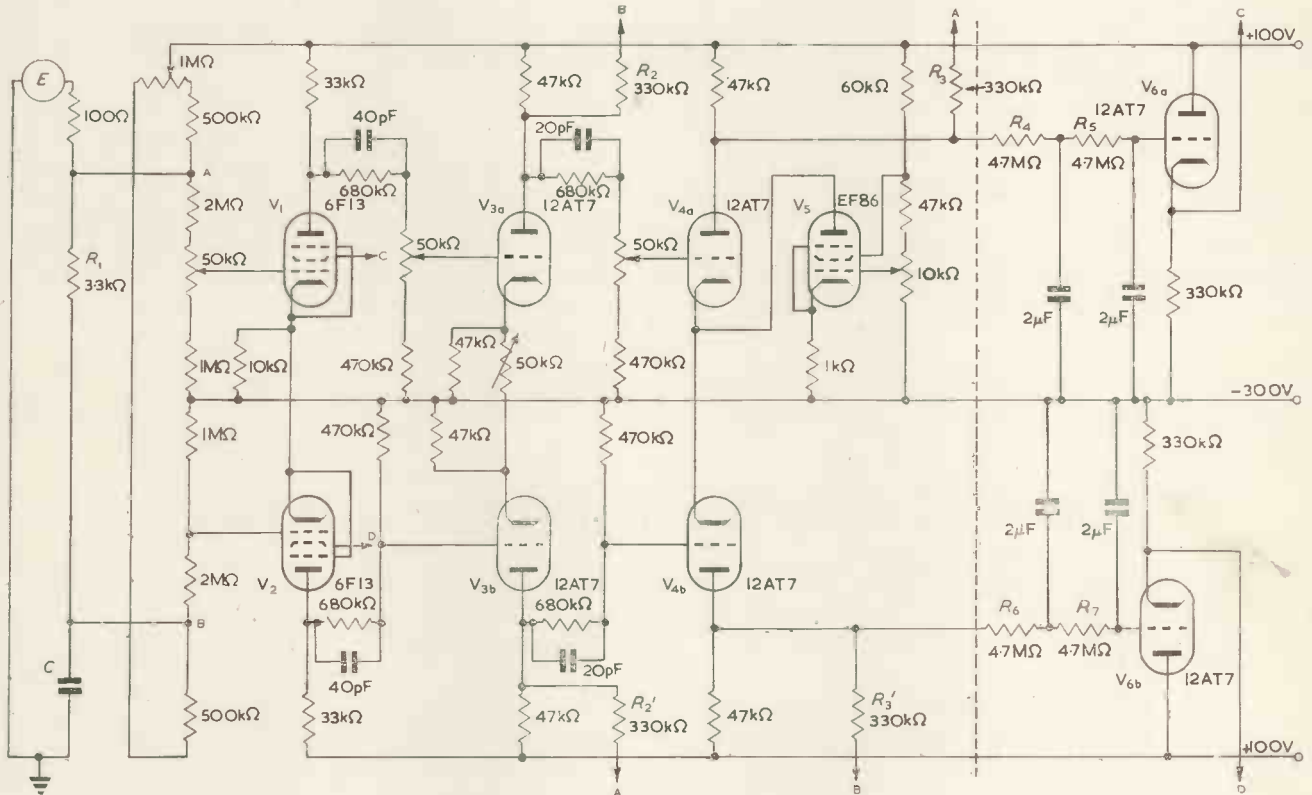

Fig. 5. Circuit of non-linear amplifier

the $(E - v)$ axis at $-P$. By using two separate feedback loops saturating at different input levels, a characteristic consisting essentially of the three straight line sections AB, BC and CD of Fig. 2 is obtained. If G_1 and G_2 are the gains associated with the two loops the slopes of the three straight sections are given by:

$$\frac{1}{C\left(r_1 + \frac{r_2}{1 + G_1 + G_2}\right)}, \frac{1}{C\left(r_1 + \frac{r_2}{1 + G_1}\right)} \text{ and } \frac{1}{C(r_1 + r_2)}$$

respectively.

A single RC network and its associated amplifier are shown in Fig. 5 in some detail. The amplifier is of the push-pull type and incorporates three stages of amplification. The potential appearing across the resistor R_1 is fed via the resistor attenuator to the control grids of the valves V_1 and V_2 and the output from the second stage fed-back in anti-phase to the input by the resistors R_2 and R_2' and from the third by R_3 and R_3' . This arrangement constitutes

A self balancing control for the amplifier is provided by the action of the valves V_{6a} and V_{6b} . An out-of-balance condition in the amplifier proper results in an out-of-balance signal at the anodes of V_{4a} and V_{4b} , and is passed via the long time-constant filter network composed of the resistors R_4, R_5, R_6 and R_7 and the associated capacitors to the grids of the valves V_{6a} and V_{6b} which in turn control the screen potentials of V_1 and V_2 until balance is restored. The filter network has a response time of several seconds and thus ensures that a negligible correction signal is passed back during the application of the driving function by the generator or the preceding circuits, since these functions are transients of relatively short duration lasting only a few milliseconds.

Adjustment of the circuit in order that the required characteristic may be obtained is facilitated by applying a repetition square waveform used in place of the generator, differentiating the potential v appearing at the capacitor, and displaying dv/dt against $(E - v)$ on a cathode-ray tube screen.

The Function Generator

The input waveform is produced by a function generator of the edge-follower type. A 4kV cathode-ray tube with a 6in screen having either a 10 or a 1 μ sec afterglow is used.

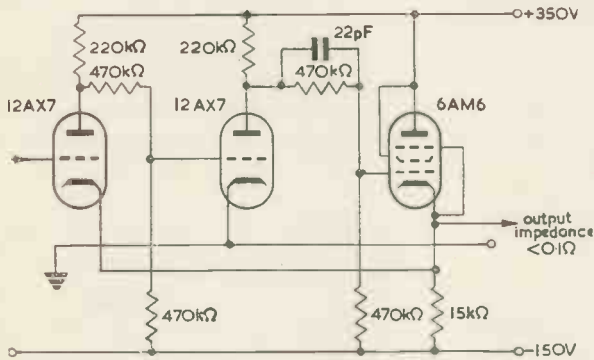

Fig. 6. Low impedance output stage

The feedback system for this edge-follower is d.c. in action and incorporates a high speed response photo-multiplier feeding an amplifier driving the cathode-ray tube. The

time-base is of the Puckle type except that a constant current pentode has been used in place of the charging resistor in order to ensure good linearity. Provision has been made for continuous or single sweep operation of the time-base, and time calibration may be carried out by the application of millisecond marker pulses. The d.c. amplifiers for the time-base and feedback loop employ sufficient negative feedback to give an amplitude linearity of about 1 per cent. A low impedance output circuit shown in Fig. 6 having an output impedance of less than 0.1 Ω is used to drive the analogue network and is incorporated between the attenuated output of the function generator and the network. This ensures that any variation in generator output impedance is negligible when valves or other components are changed.

Conclusion

The use of non-linear amplifiers has facilitated the construction of non-linear resistance-capacitance circuits which have been used in an analogue to represent to a useful degree of accuracy the airflow and pressure variations in connected chambers. Combined with a function generator of the edge-follower type, the response of such networks to a variety of transient inputs may be studied.

Some Transmission Line Devices For Use With Millimicrosecond Pulses

By I. A. D. Lewis*, M.A., A.Inst.P., A.M.I.E.E.

A phase inverter, impedance transformers, and a valve heater isolating transformer are described. Being composed of lengths of coaxial cable, the arrangements can handle pulses of millimicrosecond duration with very little distortion at all signal levels.

WITH the present growing interest in electronic equipment designed to handle pulses of millimicrosecond duration, it might be of service to bring to the notice of readers a number of novel devices which are available to the electronic engineer in this field. A phase inverter, a 2:1 pulse transformer (together with further suggested possibilities) and a new valve filament isolating transformer will be described. The arrangements are composed essentially of lengths of transmission line and are therefore perfectly linear and capable of passing high powers without distortion.

Phase Inverter

A pulse inverter, employing a length of coaxial line, has been fully discussed elsewhere^{1,2,3,4} but a brief description will be repeated here.

Suppose a wave of amplitude V , a voltage step function for example, is launched at the end A of the cable (Fig. 1), the cable sheath being earthed at this point only. The wave travels from left to right in the principal, or TEM, mode and

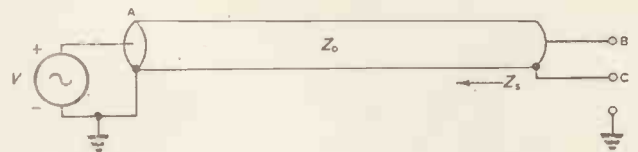
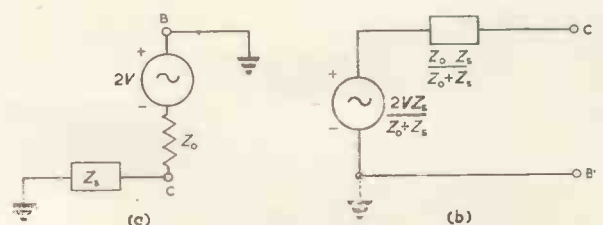

Fig. 1. Basic arrangement

Fig. 2. Equivalent circuit when terminal B is earthed



* Radar Research Establishment, Malvern.

gives rise to an e.m.f. $2V$ across the open-circuited terminal B,C (up to the time of arrival of the first reflection along the path BAB). The output impedance is equal to the characteristic impedance of the line, Z_0 (with the same proviso). Propagation is quite unaffected by any connections which are made to B or C and we are therefore at liberty to earth B thus obtaining an inverted output pulse between C and earth. If this is done, however, the impedance to earth Z_s of the outside of the cable sheath is of importance, as indicated by the equivalent circuit of Fig. 2.

The impedance Z_s is rather vague in character and it is desired to control its nature and arrange its value such that $Z_s \gg Z_0$. This may be achieved in a number of ways:

(1) The cable may be coiled up in the form of a u.h.f. choke and mounted in a screening box. Care must be taken to keep the capacitance between the coil and the screen small, and also to minimize the self-capacitance between turns of the coil.

(2) The line may be laid straight and enclosed in a coaxial cylindrical sleeve such that the outer conductor of the cable forms a transmission line, of characteristic impedance Z_s , in association with the sleeve. The sleeve is earthed to the cable at the end A and may be earthed anywhere else in addition if desired.

(3) The cable may be wound as a single layer helix, on an insulated former, the whole being housed in a coaxial cylindrical sleeve. In this case⁵ the outer conductor of the cable constitutes the coiled inner conductor of a helical transmission line of characteristic impedance Z_s .

Arrangement (2) is reminiscent of the balance to unbalance transformer with quarter-wave sleeve⁶ (infinite impedance) which is in use in r.f. systems. By adjusting the length of the helix in arrangement (3) the same effect is produced with considerable saving in space. In wide-band pulse applications one is concerned with frequency components for which the sleeve is many quarter-wavelengths long; the characteristic impedance is the relevant parameter and this can be made much higher in case (3) than in case (2). Performance at the highest frequencies, however, is better with (2) than with (3) owing to the falling off in inductance per unit length of the helix and the self-capacitance between turns.

The low frequency performance, which determines the length of the pulse which can be transmitted is limited by the inductance of the choke, case (1), and by the electrical length of the sleeve in systems (2) and (3). In the latter cases the initial portion of the output pulse (for a step function input) has a perfectly flat top; the pulse then falls in a series of small steps as successive reflections up and down the sleeve arrive at the output (assuming that the source feeding the inverter, and also the load, are resistive impedances of value Z_0). The helical arrangement (3) occupies much less space than does the linear coaxial system (2), for the same transit-time in the sleeve.

Pulses with a rise-time of the order of $1\mu\text{sec}$. have been successfully inverted with all three arrangements.

2:1 Transformer

The transformer depicted in Fig. 3(a) follows naturally from the preceding considerations. The input signal, of voltage amplitude V , is fed into two lengths of coaxial cable which are connected in parallel at the input end and

in series at the output end. Cable Y may be coiled up as in (1) or (3) above; cable X is included simply to compensate for the normal signal delay which occurs in the cable Y.

The equivalent circuit is shown in Fig. 3(b), for times up to the arrival back at the output of the first pulse reflected either within the cables themselves, or along the sleeve. The input impedance is $Z_0/2$ and an output e.m.f. of $4V$ is observed (provided $Z_s \gg Z_0$) from an output impedance of $2Z_0$. The arrangement may be matched, for all pulse lengths (provided $Z_s \gg Z_0$) by connecting a resistive load of magnitude $2Z_0$; a voltage $2V$ will then be developed. If the output is not matched, multiple reflections will be suppressed if the source feeding the transformer has an internal resistance $Z_0/2$.

Such a transformer has been found to function very satisfactorily in practice, but the choice of impedance levels is limited by the available range of flexible coaxial cables. Higher impedances might be realized by using open twin transmission lines; coiling would not then be easy, however, and the line pairs would need to be well separated

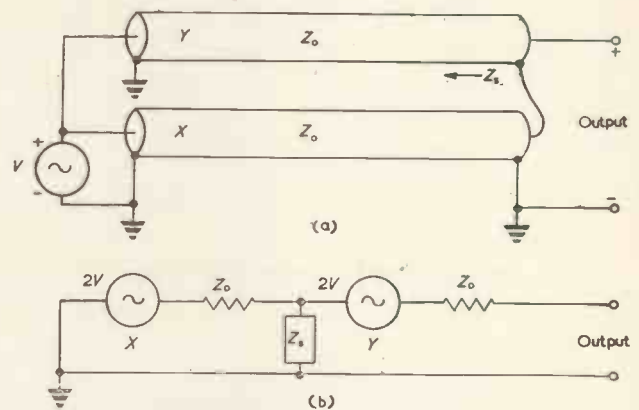

Fig. 3. 2:1 transformer and equivalent circuit

from each other and removed as far as possible from earthed objects, except near the input and output ends. Shielded twin cable has been considered; the relevant ratio here is Z_0'/Z_0'' (corresponding to Z_s/Z_0), where Z_0', Z_0'' are the characteristic impedances in the pure unbalanced mode and in the pure balanced (or normal) mode, respectively. This ratio is not large enough in available types of cable.

The possibility of using delay cable⁷, in order to raise the signal impedance level, has been entertained, but dismissed, owing to the difficulty of maintaining $Z_s \gg Z_0$ with cable which is not very flexible mechanically and cannot therefore be coiled in a small space.

Further Possibilities

The principle of the 2:1 transformer may be readily extended, theoretically at least, to embrace a large number n of cables. The lines are all connected in parallel at one end, giving an input impedance of Z_0/n , and in series at the other end, yielding an output e.m.f. $2nV$, at an output impedance of nZ_0 (again assuming Z_s to be infinite). Since Z_s is finite there is a definite useful upper limit to n . When further sections are added to the right-hand side of the network of Fig. 3(b), an analysis shows that the output

e.m.f. E_n is given by

$$E_n = \frac{4VZ_s}{(\lambda+1)Z_o} \cdot \frac{1 - \left(\frac{\lambda-1}{\lambda+1}\right)^{2n}}{1 + \left(\frac{\lambda-1}{\lambda+1}\right)^{2n+1}}$$

where $\lambda = \sqrt{1 + 4Z_s/Z_o}$

The output obtainable, even with an infinite number of cables, is accordingly

$$E_\infty = \frac{4VZ_s}{(\lambda+1)Z_o}$$

which reduces to $2V\sqrt{Z_s/Z_o}$ when $Z_s/Z_o \gg 1$.

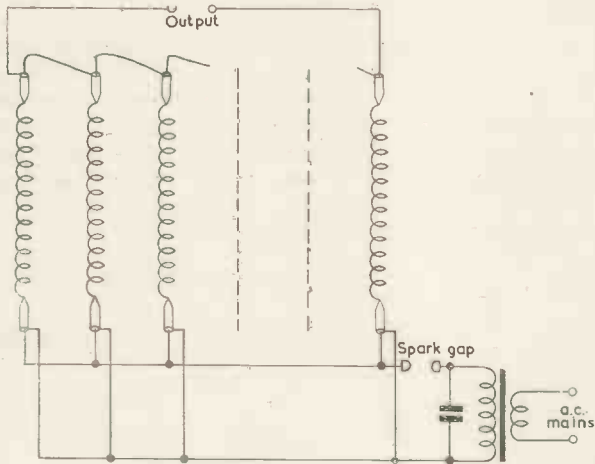

Fig. 4. Suggested impulse generator circuit

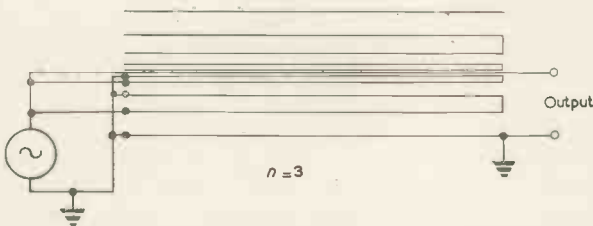

Fig. 5. Compact, low impedance, 3:1 transformer composed of coaxial cylinders the radii of which are in geometric progression

With $Z_s/Z_o = 27$, for example, and using 9 cables, one gets 95 per cent of the output which would be obtained if an infinite number of cables were employed; also, the value of the output is just over one-half the ideal e.m.f. which would be obtained if Z_s were infinite and $n = 9$. It is thus of paramount importance that Z_s be made high; herein lies the limitation of the arrangement.

In narrow-band r.f. applications it would be comparatively easy to make the impedance Z_s high, by using resonant sleeves surrounding each cable, but the problem is more difficult when a large bandwidth is involved. As previously described, each cable might be coiled in the form of a solenoid and the solenoids arranged side by side in a row. In applications involving pulses of microsecond duration, where very short connecting leads are not essential, the solenoids may be placed some distance apart and need not necessarily be screened from one another (see Fig. 4). This arrangement is offered as an alternative to the multiple

spark-gap Marx circuit for use as an impulse generator or as a high voltage radar modulator⁸.

When low signal impedances can be tolerated the very compact arrangement of Fig. 5 suggests itself; lead inductance can be reduced to a minimum and the device should function up to very high frequencies. The input impedance is $Z_o/2n$ (for pulses shorter than the double transit-time) but can be raised for narrow-band r.f. applications by making the short-circuited sections of line resonant. The output e.m.f. in the case of short pulses, again has the value $2nV$ from an impedance nZ_o .

Filament Isolating Transformer

The arrangement shown schematically in Fig. 6 has been suggested, and tried out, by J. B. Gunn of this Establishment. It may be employed as a substitute for a low capacitance heater transformer for use when a valve is operated with pulse voltages on the cathode-heater system.

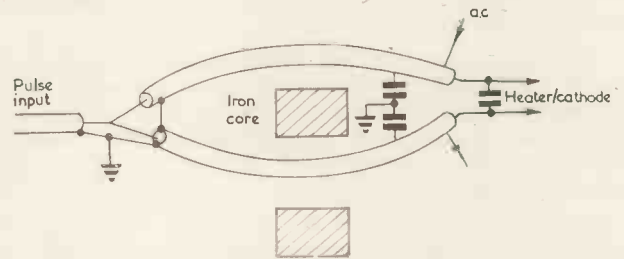

Fig. 6. Filament isolating transformer

The input signal pulse divides and reaches the two sides of the filament after traversing equal lengths of coaxial cable (if the valve is indirectly heated, the cathode should be joined to one side of the heater and a capacitor included to reunite the signal pulses). An alternating magnetic flux, at mains frequency, is generated in an iron core, either by means of a separate primary winding, or by passing a current along the insulated cable sheaths which encircle the core. The e.m.f. induced in the loop formed by the inner conductors produces the desired heater current. A 1:1 isolating transformer is thus readily constructed by winding a few turns of cable, split into two sections, round a conventional transformer core.

The signal input impedance is $Z_o/2$ and will therefore be restricted to a fairly low value, since the inner conductor of the cable must be capable of carrying the heater current required by the valve.

Acknowledgments

Acknowledgment is made to the Chief Scientist, Ministry of Supply for permission to publish this article.

REFERENCES

- LEWIS, I. A. D., WHITBY, H. C. A Simple Inverting Transformer for Millimicrosecond Pulses. *A.E.R.E. Rep. G/R751* (1951). Patent No. 723119.
- LEWIS, I. A. D., WELLS, F. H. Millimicrosecond Pulse Techniques, p. 91. (Pergamon Press, London, 1954.)
- ROCHELLE, R. W. Transmission-line Pulse Inverter. *Rev. Sci. Instrum.* 23, 298 (1952).
- LEWIS, I. A. D. Note on a Transmission-line Pulse Inverter. *Rev. Sci. Instrum.* 23, 769 (1952).
- KALLMAN, H. E. High Impedance Cable. *Proc. Inst. Radio Engrs.* 34, 348 (1946).
- TERMAN, F. E. Radio Engineers' Handbook, p. 855. McGraw-Hill, New York, 1943.)
- BLACKBURN, F. (Ed.). Component Handbook, M.I.T. Radiation Lab. Series No. 17, p. 27 (McGraw-Hill, 1949).
- WILKINSON, K. J. R. Some Development in High-power Modulators for Radar. *J. Instn. Elect. Engrs.*, 93, 1090, Pt. IIIA (1946).

A High-Q RC Feedback Filter

for Low Audio Frequencies

M. J. Tucker*, B.Sc., A.Inst.P., and L. Draper*, B.Sc.

The acceptor filter described uses the well-known principle of connecting a twin-T rejector filter in the negative feedback path of an amplifier, so that the gain is reduced at all frequencies other than the rejection frequency of the twin-T network. The limiting performance has been investigated theoretically and practically and a 175c/s acceptor filter has been built which will maintain a Q of 1 000 stable to within about 2 per cent for a period of one hour and a Q of 500 stable to about 2 per cent over considerable periods of time.

THE frequency analyser for recorded waveforms described by Barber et al¹ was originally required to give an accurate measure of frequency, but only a quantitative measure of amplitude. Recently the analyser has been used for problems requiring a greater amplitude accuracy (about 2 per cent) and the filter has had to be improved. The filters are the equivalent of simple resonant circuits, and have a fixed frequency which is in the range 70c/s to 300c/s with Q values in the range 500 to 1 000. An inductance-capacitance tuned circuit satisfying these requirements, possibly with the aid of positive feedback, could be made but the inductance would be bulky (its weight would be of the order of 100kg). The original filter was a robust vibration galvanometer with a second coil to give an output voltage proportional to the amplitude of vibration and with provision for neutralizing the direct mutual inductance between the two coils. This was non-linear, lacked long-term stability, and had an inconveniently low power efficiency. Tuning-fork filters had been avoided since they are very liable to secondary modes of resonance.

When the more stringent requirements arose it was decided to pursue three lines of investigation:—

- (1) To try to improve the existing vibration-galvanometer type filters.
- (2) To examine the principles of tuning-fork filters to find the causes of the secondary resonances.
- (3) To examine the possibilities of RC feedback filters.

It has not yet been found possible to produce a completely satisfactory vibration galvanometer type filter, though considerable improvements have been made.

The causes of secondary resonances in tuning-fork filters were not difficult to find and eliminate, but to achieve the necessary Q values at low audio frequencies large forks were required which, with their shock-proof mountings, were inconveniently bulky.

RC filters have been investigated thoroughly, and rather to the authors' surprise it has been found possible to achieve the required Q values with an adequate long-term stability and a comparatively simple circuit.

The filter described below is of the twin-T feedback type, which is well known in its simple form. The principle of controlling the Q by varying the balance of the twin-T network has been described by Gatti². The present authors have refined the theory and practice of this type of filter to produce a more convenient instrument with a greatly improved performance.

Choice of RC network

The three well-known RC networks that can be used in conjunction with an amplifier to form a tuned acceptor filter are the twin-T bridge, the Wien bridge and the ladder phase-shift network. The twin-T is a rejector circuit used in the negative feedback path of an amplifier, whereas the other two are used in the forward path of an amplifier with overall positive feedback, that is, they are in effect oscillator circuits with just insufficient gain to maintain oscillation. It is often thought that the negative feedback type of filter is fundamentally more stable than the positive feedback type, but if adequate gain is available in the amplifier and the circuits are arranged correctly, the limiting stability in each case is governed solely by the stability of the frequency controlling network. For example, in the case of the phase-shift ladder network, the gain of the feedback amplifier can be stabilized by negative feedback round a path not including the network, the only limit to the stability achievable being set by the stability of the feedback divider resistors.

In all the filters a small proportional change in the value of one network component changes the resonant frequency by a proportion which is of the same order, but the proportional change in the Q is greater by a factor of the order of the Q, and this is therefore the critical effect in high-Q filters. The Q is, however, only affected by changes in the relative values of the resistors or the relative values of the capacitors: a simultaneous and similar proportional change in all the resistors or all the capacitors only affects the resonant frequency.

When the networks are analysed by a process similar to that outlined below for the twin-T network, it is found that a proportional change in one component has approximately the same effect in all cases. If, in fact, 4 resistors and 4 capacitors may be used for each network, this allows the more critical circuit arms to be constructed of two components in parallel, and the effect of a change in any one component is then the same in every case.

The choice of the frequency determining network is therefore one of convenience, and the twin-T was chosen since it is slightly simpler to use than the other two.

Principle of Operation

The principle of operation of the feedback filter is shown in Fig. 1. The gain of the amplifier is reduced by negative feedback at all frequencies except the rejection frequency of the twin-T filter. Analysis shows that near the resonant frequency the frequency response is similar to that of a simple LC filter. If the twin-T network is perfectly bal-

* National Institute of Oceanography.

anced, the Q of the equivalent LC filter, which will be called the Q of the RC feedback filter, is given by $Q_N = A/4$ where A is the voltage gain of the amplifier. (Using the normal design criterion that $R_1 = R_2 = 2R_3$ and $C_1 = C_2 = C_3/2$. See Fig. 2). Q_N denotes the natural Q , that is, the Q with the network balanced.

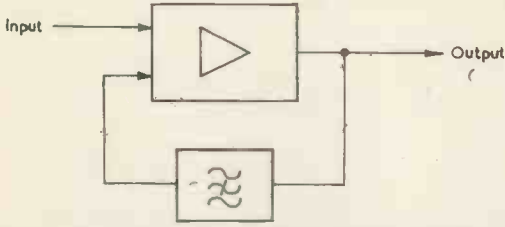

Fig. 1. The method of producing an acceptor-filter by connecting a rejector filter in the negative feed-back path of an amplifier

Network theory

The twin- T network is shown in Fig. 2. It can be shown that at an angular frequency ω_0 there will be no transmission if the following conditions are satisfied:—

$$\omega_0^2 = \frac{1}{C_1 C_2 (R_1 + R_2) R_3} \dots \dots \dots (1)$$

$$\omega_0^2 = \frac{C_1 + C_2}{C_1 C_2 C_3 R_1 R_2} \dots \dots \dots (2)$$

Eliminating ω_0 gives the condition that the network will have complete rejection at an unspecified frequency.

$$(C_1/C_3 + C_2/C_3) (R_3/R_1 + R_3/R_2) = 1 \dots \dots (3)$$

These equations show that to achieve balance at a specific frequency it is necessary to adjust the value of two components, but that if the exact frequency of balance is unimportant only one component need be varied. By a series of partial differentiations of equation (3) it can be shown that with the usual design criterion that $R_1 =$

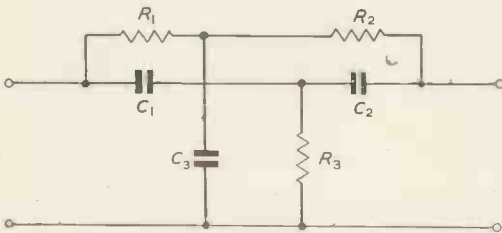

Fig. 2. The twin- T rejector network

$R_2 = 2R_3$ and $C_3 = 2C_1 = 2C_2$, a proportional change in R_3 has the same effect as the same proportional change in C_3 , but twice the effect of the same proportional change in R_1 , R_2 , C_1 , or C_2 . It is therefore necessary to vary only one component from the balance condition to find the effect of variations in all the components. Increasing R_3 from the balance value by a small proportion ϵ can be shown to affect the Q in accordance with the equation

$$Q = \frac{1}{4(1/A) - (\epsilon/2)} \dots \dots \dots (4)$$

Thus, when ϵ is negative the Q is reduced, i.e. negative feedback is being applied; when ϵ is positive, positive feedback is being applied, increasing the Q and causing oscillation when $\epsilon \geq 8/A = 2/Q_N$.

To adjust the Q , R_3 is unbalanced by means of a variable resistor until the circuit, when excited, maintains a constant amplitude of oscillation (i.e. $Q = \infty$). A small

resistor R_4 of magnitude calculated from $R_4 = 2R_3/Q$ (this relationship is derived from equation (4)) and which is in series with R_3 , is then short-circuited to bring the Q to the desired value. In this way the Q is known accurately and can be reset at any time.

Partial differential of equation (4) with respect to ϵ shows that $\frac{1}{Q} \frac{\partial Q}{\partial \epsilon} = \frac{Q}{2}$ that is, for a given incremental

change in the value of a component the variation in Q is proportional to the Q in use. Therefore the stability of a given filter is inversely proportional to the Q used.

Partial differentiation of equation (4) with respect to A shows that the proportional change in Q caused by a proportional change in A is given by

$$(A/Q)(\partial Q/\partial A) = 4(Q/A)$$

Thus, the higher the value of the amplifier gain the less the effect of any variations in it. It is therefore advantageous to make the amplifier gain as high as possible, and to reduce the Q to the required value by unbalancing the filter. It can be seen that this has the same effect as a separate negative feedback path.

Variation of any component to alter the Q will also affect the resonant frequency, but with comparatively high Q values these changes will be negligible.

In the analyser for which this filter was developed it is not usually necessary to achieve an exact specified frequency. Should an exact frequency be required, the component values must be calculated and achieved to within about 1 per cent, the fine adjustment being made with a small variable resistor in series with R_1 on the input side. The Q and frequency controls will interact and repeated adjustments will be necessary.

Stability of the Network

The stability required of the components is, of course, very great. At a Q of 1000, for example, a change of 0.002 per cent in R_3 will cause a 1 per cent change in Q . However, it can be seen from equation (3) that it is only change in the ratios of the resistors to one another and of the capacitors to one another which are important. To ensure the maximum similarities of temperature coefficients the resistors are wire wound using the same alloy, and the capacitors are silvered mica all from the same batch, C_3 being constructed from two capacitors in parallel. It is advantageous to select components to be similar within about 1 per cent. Balance can be brought within the range of the fine control by connecting a small resistor in series with either R_1 or R_3 . In spite of these precautions the network was found to have a small overall temperature coefficient, and this was compensated by including in R_3 a small value resistor (not shown on the diagram) with a different temperature coefficient. Its value was found by trial and error, but it could have been calculated from the measured temperature coefficient of Q . Leakage resistance is obviously also of importance, but its effect can be minimized if the construction is such that all possible leakage paths go to earth. To avoid differential heating of the components, the twin- T network is contained inside a small separate heat-insulated box where temperature variations are slow and uniform.

Circuit Details

A high- Q RC feedback filter constructed on these principles has been in operation for over six months in a stan-

standard wave analyser at the National Institute of Oceanography. It consists of a three stage amplifier with a voltage gain of 11 600, input attenuator, input and output stages. The twin-T network is enclosed in a small metal box surrounded by cotton wool heat insulation, only the Q-control potentiometer and resistor being outside. All sources of heat, of which the valves are the most important, are in a separately ventilated compartment.

At frequencies away from the resonant frequency the circuit is a high gain amplifier with its whole output fed

less than 4 per cent over a period of 3 months and stability over a one hour period is better than 2 per cent. The Q of the filter was determined by exciting it and measuring the rate of decay of the oscillations after the excitation was removed.

Since the amplifier gain is high, its value is not critical and stabilized supplies are not necessary. For the tests described above the circuit was energized by a simple conventional power unit supplied from the mains through a stabilizing transformer.

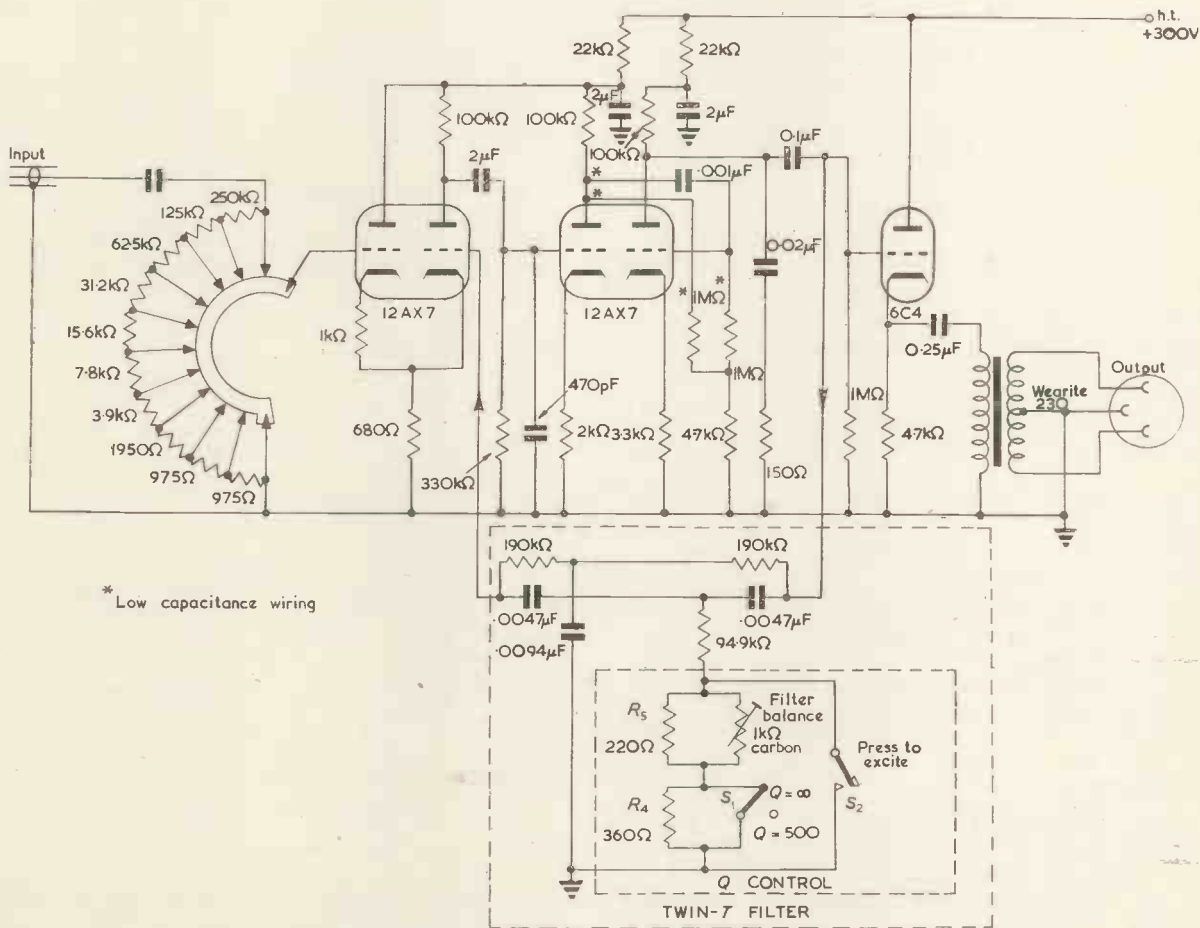

Fig. 3. Circuit diagram of a 175c/s filter

The Q is proportional to $1/R_4$ and is 500 with the values shown in the diagram. All resistors in the twin-T circuit should be wirewound except R_5 which may be high-stability carbon. To obtain the correct filter balance set S_1 to "∞" and adjust the control until a constant amplitude of oscillation is maintained after the filter has been excited by pressing S_2 .

back to its input, so that some difficulties were experienced in preventing the circuit oscillating. For use with a fixed frequency filter the amplifier need only have full gain at frequencies near the resonant frequency, and this helps in the circuit design. The various time-constants have been chosen to suit a resonant frequency in the region of 150 to 200c/s, and for frequencies outside this range they might have to be changed. The mechanical lay-out must be arranged to minimize stray capacitances.

It has been shown above that extremely high Q values can be obtained by unbalancing the filter, and a Q of 80 000 has been maintained within 20 per cent for 2 hours. With an initial Q of 1 000, measured variation has been

Conclusion

The theory of a high Q resistance-capacitance feedback filter using the twin-T bridge has been examined with particular emphasis on the factors affecting Q stability, and a low frequency filter has been built which has a stability of the same order as that obtainable with inductance-capacitance filters at high frequencies. A simple control allows the Q to be set accurately to a predetermined value.

REFERENCES

1. BARBER, N. F., URSELL, F., DARBYSHIRE, J., TUCKER, M. J. A Frequency Analyser used in the study of Ocean Waves. *Nature*, 158, 329 (1946).
2. GATTI, E. Amplificatore A Sellettiuita Variabile por Basse Frequenze. *Alta Frequenza*, 17, 20 (1948).

The Synchronization and Delay Correction of Scattered Television Picture Sources

By A. B. Shone*, B.Eng., A.M.I.E.E.

On television outside broadcasts it is often desired to synchronize a number of independent master pulse generators and in this article a method of achieving this is described. The method employed utilizes a goniometer and enables the generators to be synchronized by means of a single tone which can be sent over telephone circuits

WHEN a considerable number of cameras are in use at scattered points on a large outside broadcast such as the Coronation or the General Election programme, they are frequently supplied with master pulses from several independent synchronizing generators at various different locations.

The problem is to synchronize these generators and if possible correct for the varying cable delays in such a way that all the pictures arrive at the central switching point in line and frame synchronism, thus avoiding frame roll-over on viewers' receivers and inertia problems in the telerecording equipment.

The solution developed by the BBC is to synchronize all the synchronizing signal generators to a common sinusoidal tone of line frequency distributed over telephone circuits. A phase shifting device (the goniometer) in the feed to each generator is used to adjust the phase of the sinusoidal tone, if necessary through many complete rotations until the picture associated with each generator arrives at the central switching point correctly related to the other pictures arriving at that point.

Basic Principle

All synchronizing signal generators have a master oscillator which develops master pulses at twice line frequency on interlaced systems. The frame pulses are obtained by dividing down from the master pulses. Synchronization of the master pulses of two generators will not necessarily synchronize their frame pulses unless all the dividers in both generators are in step. To synchronize both sets of dividers would require a system of pulses covering a band of frequencies approximately as great as the complete video picture, and therefore the synchronizing line between the two generators would have to be a high grade vision circuit.

The goniometer solution to the problem synchronizes the master pulses at both generators by means of a single tone which can be sent over a telephone circuit but allows the two sets of dividers to start up in a random manner, thus producing frame pulses which are isochronous but not synchronous. The goniometer then adds or subtracts the required number of cycles of the synchronizing tone until both sets of dividers are in step and the frame pulses become synchronous.

Description of Goniometer

A 10.125kc/s sinusoidal tone is fed in quadrature to two pairs of coils set at right-angles to each other to produce a rotating field as shown diagrammatically in Fig. 1.

A pick-up loop, normally stationary, is placed inside the rotating field which cuts it at 10.125kc/s and the output will be at the same frequency as the input, but it will have a phase relationship dependent on the orientation

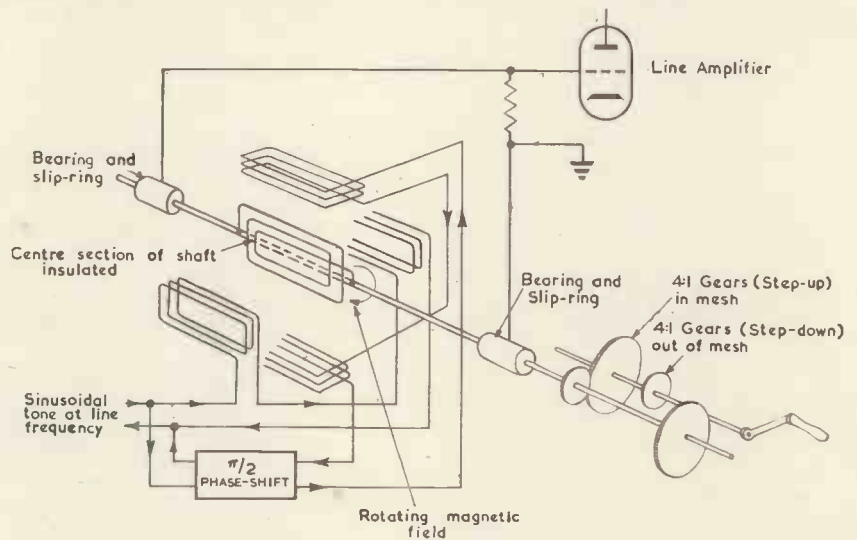

Fig. 1. The goniometer

of the pick-up coil relative to the two sets of field coils. Moreover, if the pick-up coil is rotated one or more complete cycles, the output gains or loses that number of cycles depending on which way it is rotated.

A standard pair of magnetic deflexion scanning coils is used to obtain the rotating field of the goniometer. The line coils having less turns than the frame coils require more current to produce the same field: also the current in the line coils has either to lag or lead by $\pi/2$ on the current in the frame coils. Both requirements are met by feeding the frame coil in series with the line coil, the latter being resonated at 10.125kc/s by a suitable capacitor and shunted by a resistor which is adjusted until the circulating current in the resonant circuit produces the same ampere-turns as the series current in the frame coils.

At the central point there is a master generator of synchronizing pulses which produces pulses locked to the 50c/s grid mains frequency. From this master generator a 10.125kc/s pulse is derived from which is filtered the fundamental 10.125kc/s sine wave (see Fig. 2). This

* Engineering Division, British Broadcasting Corporation.

sinusoidal waveform is fed to all the goniometers in series so that in the event of any phase change in the tone from the master generator all the other generators change by the same amount.

In the British system, the frame pulse generated by the dividers can be in synchronism with any one of 405 successive line pulses and the goniometer must be capable of adding or subtracting up to 202 complete cycles of the master tone. Suitable gearing is required to accomplish this reasonably quickly. At the same time it must not be done too quickly or the dividers will fall out. For instance, if with a master pulse frequency at 20.250kc/s a phase change

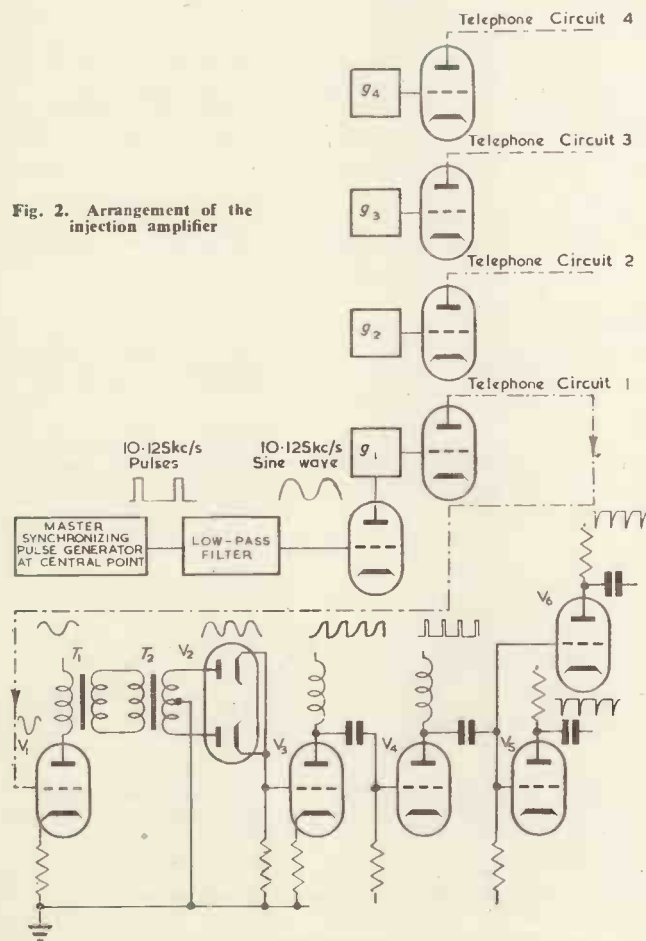

Fig. 2. Arrangement of the injection amplifier

of 200 cycles is put in by the goniometer in a period of one second, the frequency of the master oscillator is momentarily changed about 10 per cent and a "divide by nine" divider would probably divide by eight or ten. In practice it is desirable that the goniometer should not change the phase more rapidly than about 10 cycles a second. On this basis it may take up to 20 seconds to put in the necessary correction, but when once adjusted the two generators remain in step indefinitely.

To correct for cable delays quite small fractions of a rotation of the goniometer are required. With a 10.125kc/s tone one complete rotation will correct for a delay of 100μsec or 1° is the equivalent of approximately 1/4μsec.

The goniometer is therefore fitted with a four to one step-up gear, so that the picture can be rotated through a complete frame in under a minute, and a four to one

step-down gear so that the cable delay can be corrected for to an accuracy of approximately 1/4μsec.

The pick-up coil in each goniometer has approximately 750 turns and feeds to a potentiometer in the grid of the output valve. The latter can send up to 20 volts (peak-to-peak) to line. The normal sending level is 2 volts (peak-to-peak), which is quite adequate for any line where the loss at 10.125kc/s does not exceed 20dB.

At the far end of each locking line is the synchronizing pulse generator to be synchronized. In general all generators have a master oscillator A (see Fig. 3) and a reactor valve B. The d.c. control voltage to the latter is normally derived from a bridge circuit fed with 50c/s mains on one side and on the other side the 50c/s output divided down from the output of the master oscillator. The d.c. on the reactor valve alters the frequency on the master oscillator until the divided down 50c/s is in step with the 50c/s mains. In the case of the satellite generators the above mains hold circuit has to be switched off and a resistor and capacitor are inserted in the screen grid of the reactor valve, as shown dotted in Fig. 3, in such a way that the d.c. conditions on the valve

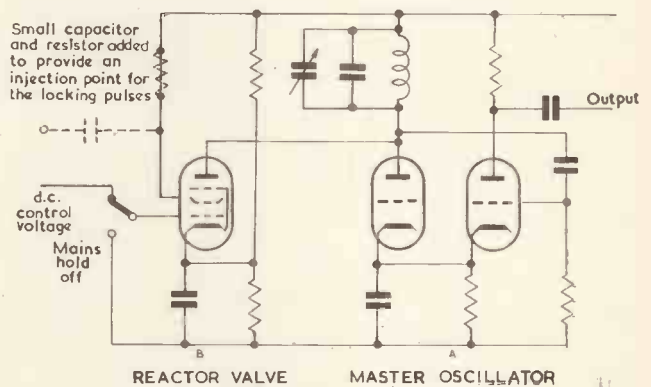

Fig. 3. A pulse generator

remain unchanged. The locking pulses are then fed to the screen grid. The advantage of this arrangement is that should the locking pulses fail, due to line trouble or any other reason, the master oscillator will carry on oscillating at approximately the right frequency and the only immediate fault apparent to the viewer is the hum bars which may become visible.

The arrangement of the injection amplifier is as in Fig. 2. V₁ is an amplifying stage having a gain of 44dB. The output at the terminals of T₁ is 20 volts peak-to-peak, and this feeds into a wideband transformer T₂, the secondary of which feeds a full wave rectifier V₂. The important point in the waveform is the sharp discontinuity at the beginning and end of each half sine wave. To keep this discontinuity sharp it was necessary for T₂ to be a wideband transformer. T₂ could have been omitted if a special transformer had been designed for T₁, having a suitable turns ratio and the requisite bandwidth. In practice it was quickest and cheapest to use two separate transformers. (N.B. As the timing of the discontinuity between successive half sine waves is independent of their amplitude it was not necessary to stabilize the power supplies. This was an important design consideration which materially contributed to the compactness of the equipment).

The output of the fullwave rectifier V₂ is differentiated twice in the anodes of valves V₃ and V₄ to obtain a sharp

spike. V_5 and V_6 are two separate outputs, the one for the main waveform generator and the other for the spare. In order that the two waveform generators should not cross-talk into each other, great care had to be taken to minimize all wiring capacitance between valves V_5 and V_6 .

Method of Adjustment

The simplest way of lining up the pictures from the various remote generators is to display each one on a separate picture monitor, at the same time arranging for all the horizontal and vertical scans to be driven from the master source. If the incoming picture is in step with the master picture, it will fit exactly into the scans and the displayed picture will look normal. If it is locked to, but not in step with, the master signal, it will appear displaced in the scans in the line or frame direction, or probably both, but by adjustment of the goniometer in its locking line the picture can quickly be made to fit inside the scans of the master signal. If it is not even locked to the master signal it will appear to wander around inside the scans of the master signal.

This type of display is very simple and convenient, as it

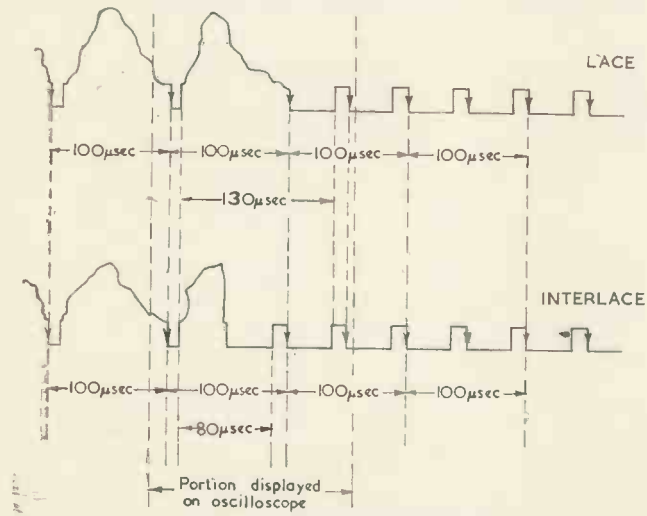

Fig. 4. Synchronizing waveforms

is immediately apparent if the signal from the remote generator becomes unlocked. It has, however, one drawback, for it is not readily obvious if the picture is on the correct laced or interlace. This information can be seen by a skilled observer, but even then not at a glance. Another slight drawback from the operational point of view is that the production staff see the lining up process, which can be rather irritating for them. This could be avoided, though very uneconomically, by having two picture monitors on each line, one scanned normally for the use of programme staff and the second scanned from the master source for the use of the engineers.

Another type of display is to use a double beam oscilloscope to display the waveform of the master signal on one trace and the remote signal on the other trace. The oscilloscope is triggered at 25c/s by a line selector which is adjusted so that the oscilloscope displays the last line and first broad pulse of the master signal. The goniometer is then adjusted until the same portion of the remote signal is displayed. This is undoubtedly the best type of display as there is no ambiguity between laced and interlace. (See Fig. 4.) It is, however, an expensive arrangement as it requires a double beam oscilloscope, and a line selector unit. In addition, for outside broadcast work, it is extra equipment

to be carried in the television scanner vans which are already very heavily loaded.

For the Coronation Broadcast both the above types of display were used.

The picture monitor on each line was fitted with a switch which could change the scans between normal operation and master scans. Normally it was left switched to master scans, and so the picture monitor gave immediate warning if the remote waveform generator went out of lock. When this happened the picture monitor was switched to normal operation to avoid distracting the programme staff, and the remote waveform generator was resynchronized by means of the double beam oscilloscope and the line selector unit. The picture monitor was then switched back to master scans.

The above display arrangement was very suitable for a large and complicated broadcast like the Coronation.

A simpler and much more compact method of display has now been developed. The picture modulation is removed from synchronizing pulses of the local waveform,

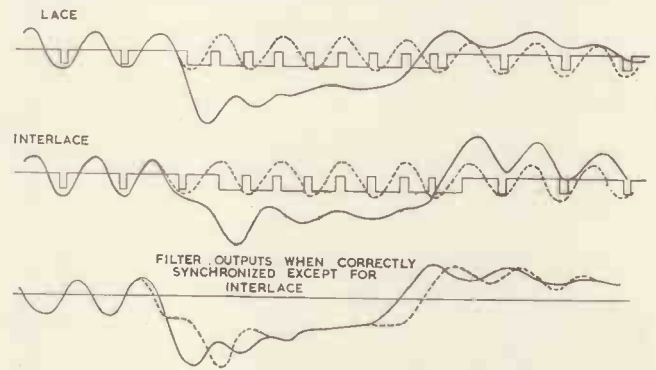

Fig. 5. Synchronizing waveforms

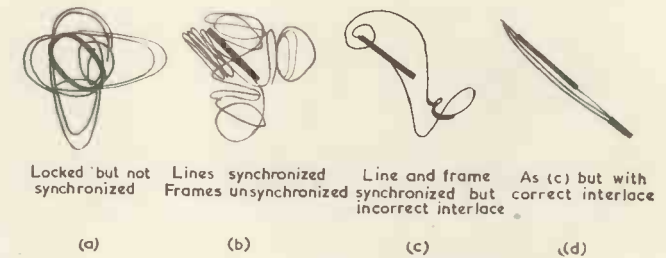

Fig. 6. Patterns obtained from filter outputs

and the latter are passed into a low-pass filter having a cut-off frequency of 12kc/s. Excepting during the broad pulse period, the output of the filter is a 10-125kc/s sine wave. During the broad pulse period the 10-125kc/s sine wave ceases to exist and decays, but during the "lace" broad pulses its decay is different from its decay during the "interlace" broad pulses, as can be seen in Fig. 5.

Similarly the picture modulation is removed from the synchronizing pulses of the waveform from the remote generator and these are likewise fed into a second low-pass filter with a cut-off frequency of 12kc/s.

The outputs of the two filters are fed respectively to the X and to the Y plates of a miniature cathode-ray display tube. The various patterns obtained are shown in Fig. 6.

If there is neither line nor frame synchronism the pattern is as at A. If there is line synchronism without frame synchronism the centre ellipse becomes a 45° line, but the longer frame trace remains a complicated pattern as at B.

If there is line and frame synchronism but the wrong interlace the pattern appears as at c. If the goniometer is wound through a complete frame to correct the interlace, the pattern appears as at d, which is the correct setting. This method of setting up is simple, accurate, inexpensive and compact. The total requirements are four valves and a miniature C.R.T., all operating on a 300 volt H.T. supply. One slight disadvantage over the more elaborate displays is that there is no indication which direction to turn the goniometer to obtain synchronism with the minimum of winding. It is quite possible to wind 400 turns forward before synchronism is obtained, whereas 5 turns backward were all that was required; but this really is not an objection as it only takes a few seconds and when once done it should not be necessary to do it again.

United Kingdom Programme in The International Geophysical Year

Over forty scientific research stations in the United Kingdom, over thirty stations in the Colonies and seven research vessels at sea will contribute to this country's International Geophysical Year programme. The International Geophysical Year programme is a world-wide large scale scientific study of the earth and its relation to the sun, the activity of which governs the natural physical forces acting on the earth. The period of study, July 1957 to December 1958, coincides with a time when sunspots and other activities on the sun are expected to be at a maximum. The Royal Society, which is co-ordinating the U.K. programme, recently announced its programme.

Scientists at these British stations are now making preparations to observe a great variety of natural phenomena. Their observations will be synchronized with others to be made in 35 other countries in accordance with a pre-arranged calendar of "Regular World Days". In addition to these Regular World Days, which will occur about three times a month, a special alert will be given when a major geophysical disturbance, for example, a flare on the sun, is expected.

A more intimate knowledge of the weather—the winds, the temperatures and humidities in the earth's atmosphere—is one of the chief purposes of the International Geophysical Year and the Meteorological Office of the Air Ministry is proposing that about 30 of its stations should participate in this world-wide observational programme. Balloons carrying radio transmitters sending information back to earth about temperature, humidity and barometric pressure will be launched from 21 stations, some of which will be on Ocean Weather Ships, some at Colonial weather stations in Malta, the Falkland Islands and elsewhere overseas as well as in the United Kingdom. In addition some of these stations will measure continuously the amount of radiation from the sun received on the earth's surface and using a special instrument designed by Professor G. M. B. Dobson of Oxford University the amount of ozone in the earth's atmosphere will be measured.

Variation of the earth's magnetic field, especially the sudden disturbances at times of solar flares, sunspots and eclipses can throw light on the mechanism connecting the sun's radiation and the earth's magnetism. As part of the world network of geomagnetic stations observations will be made at Lerwick, Shetland Islands, Eskdalemuir in Southern Scotland, at the Hartland and Abinger stations of the Royal Observatory, Greenwich, and in the Falkland Islands Dependencies as well as at a station on the Antarctic continental land mass.

Simultaneous with these magnetic disturbances often appear the polar aurora. The appearance of the *aurora borealis* or northern lights will be recorded not only by a team of observers, but also by a number of photographic and radar instruments. Pilots of aircraft and the merchant service will co-operate in this part of the programme. The U.K. record of the *aurora australis* or south polar lights will be made from the Falkland Islands Dependencies.

The United Kingdom has always taken a leading part in radio science and at six centres at home—Swansea University College, the Cavendish Laboratory (Cambridge University),

Conclusions

The system provides a cheap but elegant solution to the problem of synchronizing signals from remote generators. It has a lot of advantages, not least of which is that, as the synchronizing is effected by locking and slowly phasing the master oscillator, the waveform generator continues to produce complete picture waveforms while this is being done and the viewer remains unaware of the operation, except for a hum bar which may move slowly across his picture.

Acknowledgment

The author wishes to express his thanks to the Chief Engineer of the British Broadcasting Corporation for permission to publish this article.

Jodrell Bank Station (University of Manchester), Edinburgh University, the Slough and Inverness Radio Stations of the Department of Scientific and Industrial Research—and at five stations overseas an important programme of observations on the ionosphere has been prepared.

Three Royal Astronomical Observatories, those of Greenwich, Edinburgh and the Cape of Good Hope as well as the Cavendish Laboratory and the Jodrell Bank Station, will participate in the continuous patrol of the sun's activity and the Royal Greenwich Observatory both at its Greenwich and at Herstmonceux stations will play a prominent part in longitude and latitude observations in which very accurate time determinations are essential.

Herstmonceux will also be one of the four stations in the U.K. programme observing the incidence and nature of cosmic rays. The other three stations will be at Imperial College, London, the University of Bristol and Makerere College, Uganda.

A better understanding of the relation of glaciers to the sun's radiation may have important economic consequences, e.g. the retreat of glaciers in Scandinavia has been associated with a rise in temperature of Arctic waters with consequent gain to fisheries and a potentially greater yield of timber in northern lands. This retreat is not world wide and more exact information on glaciers is desired. The U.K. programme will be a study of glaciers in U.K. southern polar possessions and in high mountains in equatorial colonial territories in Africa.

A study will be made of short period and long period changes in sea level and of the general circulation of water in the oceans. The Royal Research Ship *Discovery II* and the Fishery Research Vessels *Scotia* and *Ernest Holt* as well as land stations at Lerwick (Shetland Islands), Freetown (West Africa), Takoradi (Gold Coast) and at South Georgia and Argentine Islands (Falkland Islands Dependencies) will participate in this oceanic part of the programme in the planning of which the National Institute of Oceanography is playing a prominent part.

An outstanding feature of the International Geophysical Year is the exceptionally large effort which will be made to make an unprecedented scientific study of south polar regions and the geophysical phenomena which occur there. Among other objectives, a study of atmospheric flow over this, the greatest and coldest land mass of the world, a study of oceanic currents therefrom, a study of its geomagnetic and ionospheric characteristics, the determination of gravity and of earth tremors there. The United Kingdom will make substantial contributions to this scientific exploration. As already announced, the Royal Society is to set up, with the help of the Governor of the Falkland Islands, a special International Geophysical Year station in the neighbourhood of Vahsel Bay and a full programme of geophysical observations is to be put in hand.

Direct observation of the upper atmosphere by sending into it by rocket scientific apparatus capable of sending messages to earth by radio is a new technique which can make a significant contribution to the International Geophysical Year studies. It is hoped that the recently announced rocket programme under the auspices of the Royal Society and the Ministry of Supply may have developed sufficiently for U.K. rocket firings to take place in the International Geophysical Year.

A Voltage Controlled Attenuator

By G. M. Ettinger*

A three-stage voltage controlled germanium diode attenuator is described. Transmission may be varied over a range exceeding 35 decibels by a 12V control signal. Push-pull operation is discussed and various applications are suggested.

THE essential non-linearity¹ of germanium diodes and other semi-conductor devices may be utilized to provide variable ratio potential dividers. These have been employed in logarithmic function generators² and in non-linear compensating circuits³. The instrument here described per-

forms a non-linear control function on low level a.c. signals and produces little waveform distortion. The forward characteristics of germanium point contact diodes are used in a way which is similar to that employed in saturable reactor practice. Consider Fig. 1(a) which shows a germanium diode MR_1 connected in series with a resistance R_1 and a source of alternating voltage V_1 . Bias current is fed to the junction of R_1 and MR_1 through relatively high resistance R_B .

For small a.c. input, the operating point of the diode in the case of zero bias current, will be at A (Fig. 1(b)). For increasing negative bias the operating point shifts progressively to B and C on the characteristic. The slope of the characteristic increases and a greater fraction of the alternating signal voltage is developed across R_1 . The derivative

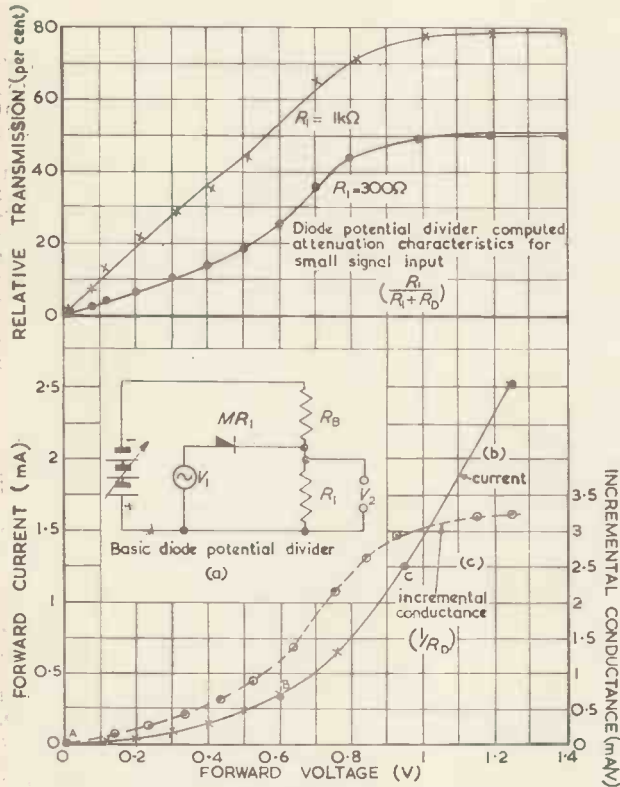

Fig. 1. Germanium diode characteristics

of a diode characteristic, representing incremental conductance, is plotted against bias voltage in Fig. 1(c). This, of course, would be the attenuation characteristic for the circuit of Fig. 1(a) for infinitely small R_1 . On the same graph is plotted the function $R_1/(R_1 + R_D)$ against bias voltage for two values of R_1 .

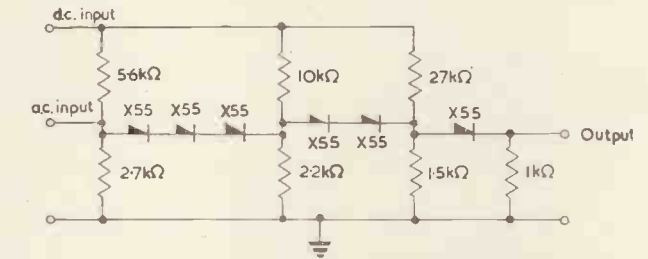

Fig. 2. Three-stage voltage controlled attenuator

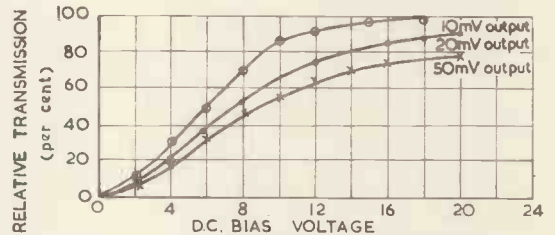

Fig. 3. Characteristics of three-stage diode attenuator for various output levels

were applied. Hence several diodes are connected in series, as shown in Fig. 2.

Circuit Description

Three diode potential dividers are shown connected in cascade in the circuit of Fig. 2; the dividers comprise various numbers of diodes. Under conditions of maximum attenuation or zero bias, most of the alternating signal voltage is developed across the six diodes; signals of the order of 1.5V r.m.s. can be handled without appreciable distortion.

Bias resistors of 5, 10, and 27kΩ are employed in conjunction with suitably scaled divider resistors (2.7, 2.2 and 1.5kΩ) so that the d.c. bias is divided equally among the diodes; their operating points are, therefore, approximately the same.

Characteristics of the three-stage attenuator are plotted in Fig. 3 for various output levels. Linearity is maintained over a dynamic range of approximately 50 to 1.

Fig. 4 shows a characteristic taken with constant ampli-

* English Electric Co. Ltd., formerly Air Trainers Ltd.

tude input for two attenuators connected in push-pull (Fig. 5). The same signal is applied to the a.c. input terminals of the two units; the diodes of one attenuator are, however, reversed. Difference output is taken by connecting the two output terminals to the ends of a transformer primary winding. The push-pull unit is, in effect, a modu-

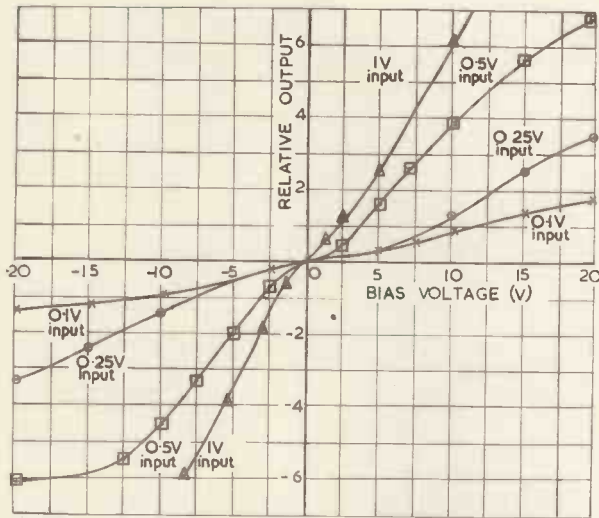

Fig. 4. Characteristics of two push-pull connected three-stage diode attenuators for various input levels

lator. Non-linearity near the origin may be reduced by supplying forward bias separately to each of the two attenuators in addition to the common bias which, of course, may be varied from positive through zero to negative.

TACAN—A New 1000Mc/s Air Navigational System

The TACAN system of air navigation has been evolved in the United States primarily for use by military aircraft. A British version of both the airborne and ground equipment is being developed by Standard Telephones and Cables Limited, under a Ministry of Supply contract.

The TACAN system is a tactical air navigational aid capable of giving bearing and slant line distance to a number of aircraft relative to a fixed ground station. The normal maximum range of the system is of the order of 200 nautical miles and the presentation in the aircraft is in the form of meter indications. It operates in the frequency band 962 to 1214Mc/s and is very complex in its detail. The chief constituents are a ground beacon transponder and an airborne interrogator-receiver with indicator. Up to 100 aircraft can be "accommodated" by each ground station.

Bearing information is generated in the aerial system of the ground beacon which contains a central radiating array so designed as to produce a field pattern which gives best coverage for the tactical uses envisaged. Around this central array is rotated a system of vertical parasite elements which distort the circular pattern in a sinusoidal fashion. Since the output from the beacon consists of a series of equal amplitude pulses the radiated signal will consist of pulses having a superimposed sinusoidal amplitude modulation not exceeding a maximum of 50 per cent. Thus an aircraft at a fixed point in space can, by demodulating the received signal, recover a sine wave signal corresponding to the aerial rotation. Also in the aerial is means of producing sharp trigger pulses whenever fixed points on the rotating part of the aerial pass through a given bearing with respect to north compass point. These signals are coded in the beacon into short identifiable pulse trains which are radiated as part of the beacon output signal. These pulse trains or "marker trains" as they are called, are detected by the airborne equipment and by comparing them with the phase of

Applications

Applications are envisaged for the voltage controlled attenuator in signal fading circuits for navigational radio aid simulators, in oscillator amplitude stabilizing circuits, and in wide range automatic gain control systems. For the last-named application, the all-pass characteristics of the attenuator (limited only by the capacitances of point contact diodes) may be useful.

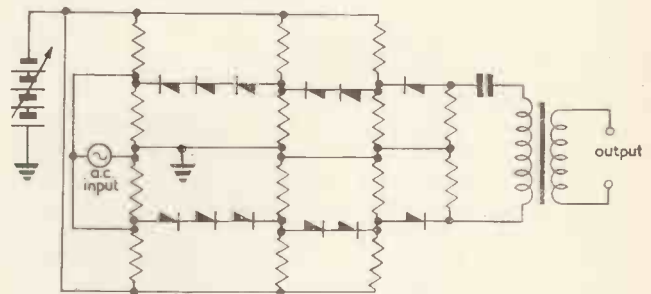

Fig. 5. Push-pull attenuator

Mechanical Construction

Two attenuator circuits, each comprising six germanium diodes and seven resistors, are mounted on a plug-in assembly. Component interconnexions are made by means of painted conductors, using Du Point air setting conducting coating material, type A, No. 4817. The double unit fits into a dust cover of dimensions $1\frac{1}{4}$ in. \times $2\frac{3}{8}$ in. \times 4 in.

REFERENCES

1. TRIMMER, J. D. Response of Physical Systems, p. 226 (New York, John Wiley, 1950).
2. SCHAEFFER, N. M., WOOD, G. W. The Application of some Semiconductors as Logarithmic Elements. *Proc. Inst. Radio Engrs.* 42, 1113 (1954).
3. ETTINGER, G. M. Stabilizing Circuit for X-ray gauges. *Electronics* p. 210 (Oct. 1954).

the sine wave, extracted from the aerial rotating pattern, the bearing of the aircraft can be ascertained and indicated directly.

The marker pulse trains are of relatively short duration and in order that the aerial space modulation pattern can be conveyed to the aircraft the spaces between the marker pulses are filled with pulses of similar shape, but of random repetition rate averaging 2 700 pairs per second—each pair having a spacing of 12 μ sec.

In order to increase the bearing accuracy provided, a coarse-fine system is used so that the radiated aerial pattern actually consists of a fundamental sine wave modulation of 15c/s corresponding to the aerial rotation speed of 900rev/min with a ninth harmonic modulation superimposed of 135c/s. In the aircraft equipment the 15c/s modulation is used as a gate to select part of the 135c/s signal and eliminate ambiguity. In conjunction with this, appropriate marker pulse trains are transmitted every 40° of aerial rotation for phase comparison in the aircraft and these are differently coded from the fundamental pulse train.

When the aircraft requires range information from the beacon it transmits a signal consisting of pulse pairs spaced 12 μ sec and at a repetition rate of between 24 and 30 pairs per second on a frequency differing by 63Mc/s from that transmitted by the beacon under interrogation. This signal is received by the beacon receiver and delayed by 50 μ sec and is then retransmitted, displacing the equivalent number of random pulse pairs. The aircraft receives this reply and distinguishes it from the random pulses by reason of its phase coherence with the signal it is transmitting. The aircraft then determines its range from the beacon by measurement of the time between transmitted signal and reply, taking into account the known fixed delay in the beacon.

It is desirable to have a large number of operational channels so that an adequate number of beacons can be placed in a given area without mutual interference and the TACAN system provides 126 channels spaced 1Mc/s apart.

Notes from North America

The following conferences and symposia are to be held during October and November.

1. *Audio Engineering Society*

Audio and transistor application problems, sound creation, magnetic tape, standard measurements, disk recording and audio equipment will be the subject of sessions at the Seventh Annual Convention of the Audio Engineering Society, to be held from October 12-15 in the Hotel New Yorker, N.Y. It will be held concurrently with the Audio Fair, in the same hotel.

2. *World Symposium on Applied Solar Energy*

Equipment illustrating recent development in the field of solar engineering, including a 5 to 10 horsepower sun-driven engine, will be on public display in Phoenix, Ariz., from October 29 to November 13 at the Solar Engineering Exhibit planned in conjunction with the World Symposium on Applied Solar Energy.

The symposium, meeting in Phoenix from November 1-5, will be attended by 1 000 scientists and engineers from all over the world interested in the effort to harness energy from the sun's rays.

Lewis W. Douglas is the general chairman of the symposium, sponsored jointly by the Association for Applied Solar Energy, Phoenix; Stanford Research Institute, Menlo Park, California, and the University of Arizona.

3. *The Eastern Joint Computer Conference*

This is to be held at the Hotel Statler, Boston, Mass. on November 7-9 under the chairmanship of Irven Travis, Vice-president, Burroughs Corporation. Some 12 papers will be presented, the principal speaker being J. G. Brainherd, Director of the Moore School of Engineering, University of Pennsylvania.

4. *A Symposium on "Communications by Scatter Techniques"*

This will be held in Washington D.C. on November 14 and 15 and is jointly sponsored by the I.R.E. Professional Group on Antennas and Propagation, the Professional Group on Communications Systems, and The George Washington University.

The technical programme, to be held at The George Washington University, will include four sessions. The first session of the programme will be devoted to Propagation Mechanisms. Authorities in the fields of Auroral, Tropospheric, Ionospheric, and Meteoric Ionization propagation will discuss the mechanics of each of these modes of transmission. The remaining three sessions of the programme will include practical and descriptive discussions by authorities in the fields of Communication Systems, Antennas, and Propagation Studies. Dr. Allen B. Dumont will address a combined meeting of symposium visitors and the Washington Section of I.R.E. on commercial aspects of the symposium topic.

Further details can be obtained from:

The Secretary, Scatter Symposium, School of Engineering, George Washington University, Washington, D.C.

Massachusetts Institute of Technology

The appointment of Dr. G. Wesley Dunlap as a visiting professor at Massachusetts Institute of Technology has been announced by Dean C. Richard Soderberg of the School of Engineering.

Now manager of the Instrument and Nuclear Radiation Engineering Services Department for General Electric at Schenectady, Dr. Dunlap will be on leave from the company while at M.I.T. during the academic year beginning in September.

Dr. Dunlap will be the third distinguished engineer to hold the Edwin Sibley Webster Professorship of Electrical Engineering. Last year the chair was held by Dr. Robert A. Ramey, Jr., of Westinghouse Electric Corporation and the previous year the appointee was Professor Arnold Tustin of the University of Birmingham, England.

Early Warning Defence Line

The Canadian Marconi Company announce they have been awarded a contract running into several million dollars for radio relay equipment for the Mid-Canada early warning defence line. When completed and installed this equipment will perform a key function in one of Canada's early warning defence lines.

Designed by Canadian Marconi engineers, these units will provide the essential link between the scanning antenna of the radar units which would first detect enemy intruder planes and the defence forces which would be brought into action to deal with them.

F.M. Mobile Radio Equipment

The Canadian Marconi Company also announce the production of a new f.m. mobile radio equipment. Known as the DT-45-C, this new mobile equipment consists of three separate units—a receiver, a transmitter and a power supply—and is of the type that has met with great operational success in a variety of fields—police and fire departments, taxi and trucking fleets, the lumber and petroleum industries and many others.

The DT-45-C was designed and built specifically for Canadian conditions of operation. All requirements of the Department of Transport and the Radio Manufacturers' Association have been incorporated in the unit's specifications.

In actual field tests of this equipment, extremes of temperature, humidity, vibration and shock failed to interfere with its operational quality in the slightest degree.

Among its many attractive features are the high quality of voice reproduction and the low battery drain. These have been attained through the use of a dynamic microphone and a low distortion receiver and a new type of circuit.

Railway Track Testing

The Canadian National Railways are to carry out during the next few months the testing of some ten thousand miles of track between Halifax and Vancouver for cracks and other rail defects.

The survey will be carried out by a team of four engineers using electronic apparatus which will automatically record any defects in the rails caused by flaws or cracks. The apparatus is carried in a self-propelled car and will cover some 50 miles of track per day.

LETTERS TO THE EDITOR

(We do not hold ourselves responsible for the opinions of our correspondents)

Transistor Isocline Diagrams

DEAR SIR,—May I point out an error in reasoning in the article by Mr. Francis Oakes in the July 1955 issue.

In his derivation of a simple geometric means of drawing an isocline section, he obtains an expression (equation (18)) for the radius a of the circle whose short arc approximates to the isocline section. After stating that "a function multiplied by its first derivative is equal to the sub-normal", a statement I would not question, he then applies it to Fig. 4 and obtains an equation that is neither relevant nor accurate.

A rigid interpretation of the above stated equality, would give us the sub-normal AB , (formed by extending PQ to cut the x axis in A and extending PV to cut the x axis in B), equal to

$$v_c' dv_c'/du$$

As this is obviously not what is required, we could forget the sub-normal, examine the triangle PQV , and evolve the fundamental relationship that enabled Fig. 4 to be drawn,

$$\text{i.e. } \frac{u}{v_c' - v_t} = \tan QPV \\ = dv_c'/du$$

This is of course equation (11), and in a slightly modified form, we have

$$-u = (v_c' - v_t) dv_c'/du$$

If we could assume v_t to be a constant with respect to u , and thus replace

$$dv_c'/du \text{ by } \frac{d(v_c' - v_t)}{du}$$

we could reach Mr. Francis Oakes' equation (19).

Unfortunately, the slope of v_t is comparable with that of v_c' , and by ignoring dv_t/du in comparison with dv_c'/du one is introducing a large inaccuracy in what was otherwise a delightfully simple isocline construction.

Yours faithfully,

A. J. BUXTON,
Highcliffe, Hants.

The author replies:—

DEAR SIR,—Although an error was introduced in the reasoning following equation (18) of my article on isocline diagrams, (by mistaking QV for the sub-normal) this fortunately has no serious effect upon the validity of the method described. Contrary to Mr. Buxton's last statement, Lienard's construction is quite sound, and, as shown by the proof leading up to equation (12), isocline diagrams can be obtained as described in my article. The only consequence of the argument of Mr. Buxton—to whom I am grateful for drawing my attention to the error mentioned above—is that the radius of curvature cannot generally be approximated by PQ in Fig. 4. This, in turn,

only restricts the useful length of the circular arcs, since they themselves approximate the isocline tangent in any point P chosen. Re-stating equation (18):

$$a = \frac{-k^3}{(v_c' - v_t)^2 - u (v_c' - v_t) d/du (v_c' - v_t)}$$

and it can be seen that

$$(v_c' - v_t) d/du (v_c' - v_t) = (v_c' - v_t) dv_c'/du - (v_c' - v_t) dv_t/du \\ = -u - (v_c' - v_t) dv_t/du$$

Thus, equation (18) can be re-written as

$$a = \frac{-k^3}{(v_c' - v_t)^2 + u^2 + u(v_c' - v_t) dv_t/du} \\ = \frac{-k^3}{k^2 + u(v_c' - v_t) dv_t/du}$$

In other words,

$a = -k$ only if, at least, one of the following conditions is fulfilled:

- (a) $u = 0$
- (b) $v_c' = v_t$
- (c) $dv_t/du = 0$

Condition (a) means that $a = -k$ for all points P on the vertical axis.

Condition (b) means that $a = -k$ for all points P on the curve v_t . Condition (c) means that $a = -k$ for all points P on the vertical lines intersecting v_t at $dv_t/du = 0$.

Somewhat larger arcs of approximation can be used where these conditions are fulfilled. Elsewhere, shorter arcs must be used, because the centre of curvature will no longer be in point O but at a distance a from P along the line PQ , so that

$$a = \frac{-k}{1 + u/k^2 (v_c' - v_t) dv_t/du}$$

For practical purposes it is far easier to use sufficiently short arcs obtained by Lienard's construction as described, than to take the trouble of finding the true radius of curvature. Apologies are made to the readers for the error contained in equation (19) to (22). However, bearing in mind the argument outlined above, this error does not affect the usefulness of the method described, nor the conclusions reached in the article.

Yours faithfully,

FRANCIS OAKES,

Ferguson Radio
Corporation Ltd.

Transistor Voltmeters

DEAR SIR,—In your August, 1955, issue, Mr. M. H. N. Potok and Mr. R. A. McF. Wales in their interesting article, claimed that "In its final form the voltmeter would be an improvement on the characteristics of most popular multi-range test meters on the market."

In this respect it would be useful to know in what way the calibration of this voltmeter was affected by changes in

temperature. It is well known that "In general the temperature coefficient of I_{e0} is about 5 to 10 per cent per degree centigrade. In view of this, temperature compensation of the d.c. transistor amplifier becomes a serious problem." (Richard F. Shey, *Principles of Transistor Circuits*, page 168).

In practice it appears that most transistor amplifier parameters change with temperature and unless some form of negative feedback circuit is used, or the amplifier operated at a constant temperature, the calibration of a voltmeter using such an amplifier would be expected to vary as the temperature changed.

The multi-range voltmeters already available are relatively unaffected by temperature and to compete with these the transistor voltmeter would need to have a performance comparable in this respect.

Yours faithfully,

F. SLATER,

St. Albans,
Herts.

The author's reply:—

DEAR SIR,—Mr. Slater is, of course, quite right in pointing out the effects of temperature changes on the transistor characteristics (I would also like to acknowledge here a private letter from Mr. A. R. Dabrowa making the same point). May I make the following comments:—

(a) Our article was a report on an initial investigation to be used as a basis for further research. Thus only the principle was examined. No specific temperature tests were carried out at that stage except to note that the readings remained virtually constant over several hours. The temperature changes were fully realized, but it was considered that since the changes in I_{e0} can be counterbalanced by zeroing while changes in current amplification factor are not so pronounced, any attempt at compensation should be left to a later stage. It would no doubt complicate the circuitry but would not be very likely to increase the size, weight or consumption to any large extent.

(b) Both correspondents stress the loss of accuracy, (an aspect of instrumentation which tends to be exaggerated) but our article claimed a possible improvement not over precision meters but over multi-range meters whose primary use is not in laboratory but in servicing and "field" work where weight, size and consumption taken together with high input impedance may outweigh in importance absolute calibration.

Yours faithfully,

M. H. N. POTOK,

The Royal Technical College,
Glasgow, C.1.

Short News Items

Nominations for Council of The British Institution of Radio Engineers. Rear-Admiral Sir Philip Clarke, K.B.E., C.B., D.S.O., has been nominated for re-election as President of The British Institution of Radio Engineers for the year 1955-56. G. A. Marriott, L. H. Paddle, J. L. Thompson and Professor E. E. Zepler have been nominated for re-election as Vice-Presidents. Nominations for ordinary members of Council are: Members—Air Vice-Marshal C. P. Brown, C.B., C.B.E., D.F.C.; J. W. Ridgeway, O.B.E.; Professor E. Williams, Ph.D., B.Eng.; Associate Member—R. N. Lord, M.A.(Oxon); Companion—A. H. Whiteley, M.B.E. The election of officers will take place at the Annual General Meeting on 26 October.

The Council of The British Institution of Radio Engineers has announced the recipients of Institution Premiums for papers published in the Brit.I.R.E. Journal during the year 1954, and for papers read at the Industrial Electronics Convention held at Oxford in July, 1954. The premier award, the Clerk Maxwell Premium, is to be presented to Mr. F. N. H. Robinson, a Research Fellow at the Clarendon Laboratory, Oxford, for his paper, "Microwave Shot Noise in Electron Beams and the Minimum Noise Factor of Travelling Wave Tubes and Klystrons", published in February, 1954.

The Ministry of Supply announces that a third series of atomic weapon tests will take place in April next. As the proving ground at Maralinga in the central Australian desert will not be ready for use until late in 1956, the Australian Government have agreed to the use of the Monte Bello Islands for this third series of tests. The fall-out on the islands and the nearby sea will be less than that caused by the explosion of 1952. There will be no danger to people or stock on the mainland and detonation will only take place when the meteorological conditions are fully satisfactory. The Scientific Director will be Mr. C. A. Adams, who was Deputy Scientific Superintendent at the first Monte Bello tests in 1952 and was Scientific Superintendent for the second series staged at Emu under Sir William Penney in 1953.

Mr. Harold Lister Kirke, C.B.E., M.I.E.E., formerly Assistant Chief Engineer of the BBC, died in London on 25 August. In 1924 he joined the BBC, becoming in the following year head of what was later on the Research Department. In this capacity he was responsible for many of the technical advances made by the BBC. His study of the problems associated with v.h.f.

sound broadcasting was specially valuable, and led to the BBC's decision to adopt this system. From 1950 until he retired through illness two years later, Mr. Kirke was Assistant Chief Engineer. He was Chairman of the Radio Section of the Institution of Electrical Engineers in 1944/45, and a member of Council from 1947 to 1950. He was Vice-President of the Institution of Radio Engineers in 1952.

Decca Radar Ltd are to equip four of Venezuela's most important civil and military airfields with radar equipment. Decca Type 424 Airfield Control Radars have been ordered to be installed at Maiquetia, Puerto Cabello, Maracaibo and Barcelona airfields. Also two Decca Type 41 Storm Warning Radars have been purchased to assist in the preparation of aviation weather forecasts.

International Aeradio Ltd have been appointed consultants on communications to the Antarctic Aerial Survey Expedition to the Grahamland Peninsular which is being undertaken by Hunting Aerosurveys Ltd, under the auspices of the Colonial Office for the Falkland Islands Dependencies. Besides advising on the equipment required for the expedition, for use on the survey vessel, the amphibian aircraft, helicopter and the base station at Deception Island, International Aeradio Ltd are providing staff to install and maintain it. Communications equipment and radio aids to navigation will be supplied.

Redifon Ltd announce that orders for forty-six air navigation beacons and communications transmitters have recently been placed with them by India's Civil Aviation Department. Thirty similar radio installations supplied by Redifon are already in use at many of India's main airfields.

British Overseas Airways Corporation have placed an order with Redifon Ltd for a second Britannia flight simulator. The first is now undergoing calibration tests. After this it will be installed in the new terminal building at London Airport for use by the Corporation's Training Unit.

Ekco Electronics announce that, by arrangement with the British Overseas Airways Corporation, Ekco search radar will be used by BOAC in their present route-proving flights on the Bristol Britannia, and will also be fitted by the Corporation on their fleet of Britannia aircraft.

Tannoy Ltd have been awarded the first Canadian contract for a public address installation. It is a municipal contract to equip a reformatory in Ontario.

The Australian national television service is expected to be inaugurated towards the end of next year upon the completion of the first two Government-controlled stations and studio centres, at Sydney and Melbourne. Most of the equipment for the Sydney and Melbourne transmitting stations is to be provided by Marconi's Wireless Telegraph Co Ltd, under the terms of a recently signed contract worth more than £250 000 which was obtained through their Australian associates, Amalgamated Wireless (Australasia) Ltd.

Marconi's have received a large order from Granada T.V. Network Ltd, the Monday to Friday Programme Contractors for the Manchester area. The contract was placed through Granada's agents, Kinematograph Equipment Ltd. The equipment, which will be of the most modern type, is to be installed in a studio in the Granada Television Centre, now being built in Manchester.

Marconi's have also recently been awarded a contract by the Iranian Ministry of Posts, Telegraphs and Telephones for equipment to modernize the Iranian radio communications system to Europe and overseas countries by setting up of a high quality independent sideband radio telephony and telegraphy service.

RCA Photophone Ltd, an associate company of the Radio Corporation of America, announce that their Engineering Products Division, which was a section of the General Sales Department, has now become a separate department with Mr. E. A. Sabine as Sales Manager. The Company's Cinema Sales Division has also become a separate department, with Mr. R. F. Collins as Sales Manager.

Mr. W. P. Rowley, who since 1952 has been Sales Manager of the Electronic Division of Elliott Brothers (London) Ltd, will be joining the Company as General Sales Manager.

To accommodate the expansion in the activities in the Engineering Products and Motion Picture fields, RCA Photophone have recently acquired a new and modern factory at Sunbury, Middlesex. The head office and main works have now moved from 36 Woodstock Grove, London, W.12, to Lincoln Way, Windmill Road, Sunbury on Thames, Middlesex. Telephone: Sunbury on Thames 3101.

The BBC's V.H.F./F.M. sound broadcasting station at Wrotham, Kent, is now working on full power, the Home, Light and Third programmes each being transmitted with an effective radiated power of 120kW.

Redifon Ltd have received a contract for the construction of a flight and tactical simulator to familiarize aircrews of the Royal Canadian Navy with the Grumman S2F anti-submarine aircraft. The value of the order, which was awarded by the Canadian Department of Defence Production, is in excess of one million dollars. This follows a contract placed by the Department in 1953 for four million dollars' worth of Sabre jet fighter simulators for the R.C.A.F. The Redifon S2F is the first British simulator to combine facilities for flight familiarization with training in the use of radar and tactical anti-submarine equipment.

British Insulated Callender's Cables Ltd announce that the telephone number of their London Branch Sales Office, 10-14 White Lion Street, London, N.1, is now Terminus 2701.

The Electrical Industries Benevolent Association will be moving offices towards the end of the year. The new quarters are in Buckingham Palace Gardens, alongside Victoria Station.

Wickman Ltd, of Banner Lane, Tile Hill, Coventry, have assumed the sole agency for the products of Arthur Scrivener Ltd, Tyburn Road, Birmingham.

Mr. Christopher E. G. Bailey, who for some time has been a consultant to The Solartron Electronic Group Ltd, Thames Ditton, Surrey, has been appointed Technical Director of Solartron Electronic Business Machines Ltd.

Mr. S. H. Parker has recently resigned his position as General Sales Manager of Sunvic Controls Ltd to take up an appointment as General Manager of Teddington Industrial Equipment Ltd.

Mr. William Stern, Manager of the International Division of Brush Electronics Corporation, Cleveland, Ohio, visited B & K Laboratories Ltd, 59/61 Union Street, London, S.E.1, at the end of August at the commencement of a six weeks' European tour. Dr. Bruel, of Bruel & Kjaer, Denmark, was accompanying Mr. Stern on this tour.

Mr. H. L. Ranson has been appointed General Sales Manager of Besson & Robinson Ltd, specialists in electrical relays, waveguides and controls, of Harlow, Essex.

The British Institute of Management is organizing a national conference to be held at Harrogate from 2-4 November. The conference will have as its theme "The Impact of Science on Management in the Future". Application forms and advance details are available from the British Institute of Management, Management House, 8 Hill Street, London, W.1.

Mr. G. Kron, Consulting Engineer, General Electric Co, New York, will be giving the following lectures during his visit to this country. On 7 and 8 October at the Imperial College of Science and Technology; "Numerical and Analytical Solution of Highly Complex Physical Systems by the Method of Tearing". From 10 to 14 October at King's College, University of London; a course on "Tensor Analysis of Rotating Electrical Machinery". Fuller information may be obtained from Mr. B. Adkins, Electrical Engineering Department, City and Guilds College, Exhibition Road, South Kensington, London, S.W.7. From 17 to 21 October, Mr. Kron will be visiting Rugby, Manchester and Liverpool under the auspices of The Tensor Club of Great Britain. In each of the three towns referred to, Mr. Kron will lecture on "Numerical, Analytical and Eigenvalue Solution of Highly Complex Physical Systems by the Method of Tearing". Details may be obtained from Dr. W. J. Gibbs, 53 Hillmorton Road, Rugby.

Hartley-Ward Films Ltd, producers of industrial films, are about to launch a new scheme to cover the electronic field. Further details may be obtained from them at 3 Albemarle Street, Piccadilly, London, W.1.

The Fifth Electrical Engineers Exhibition will be held at Earls Court from 20-24 March, 1956.

Borough Polytechnic are proposing to repeat their special course of evening lectures on the subject of Pulse Techniques in the forthcoming session. In addition to the lecture course, there are fully equipped laboratories for carrying out experimental work covered by the lectures. Details may be obtained from the Head of Department of Electrical Engineering and Physics, Borough Polytechnic, Borough Road, London, S.E.1.

A course of six lectures on the Writing of Technical Reports will be given by Mr. G. Parr, M.I.E.E., at the Borough Polytechnic on Thursdays at 6.30 p.m. commencing on 20 October, 1955. The fee for the course is 10s. The course will cover the preparation of reports, collection of data and practical advice on the submission of papers and publications. Enrolment forms can be obtained from the Secretary, Borough Polytechnic.

A course of eight lectures on Basic Principles of Transistors will begin on Tuesday, 18 October. A further course of ten lectures on Special Applications of Transistors will begin on 17 January next. Enrolment forms are available from the address mentioned.

The Science Museum has just completed a small group of exhibits, relating to linear electron-accelerators, in the Atomic Physics Collection. The exhibit comprises sectional parts of an actual accelerator, presented by Mullard Ltd, a mechanical model illustrating the principle of the travelling-wave accelerator,

lent by the Metropolitan-Vickers Electrical Co Ltd, several diagrams showing the construction and operation of these accelerators, and a group of photographs showing them in use in Hammersmith Hospital and in the Megavolt Treatment Unit at Newcastle-upon-Tyne. Other exhibits in this field recently placed on view in the Science Museum are a betatron presented by the Clarendon Laboratory, Oxford, a model of the Philips cascade generator at the Cavendish Laboratory, Cambridge, and a mechanical model illustrating its principle lent by the Westinghouse Brake and Signal Co.

The Physical Society's Autumn Meeting will be held at Cambridge in December. The meeting will be a conference on "Applications of Modern Methods of Computation in Physical Research", and will probably be of not less than two days' duration. Programmes and application forms will be circulated when arrangements have been completed.

The Spring Meeting of the Society will be organized by British Thomson-Houston Co Ltd, and will be held at Ashorne Hill on 10-12 April, 1956. The meeting, which will be a conference on Semiconductors, will include a one-day visit to the BTH Research Laboratories, Rugby, on Wednesday, 11 April. The meeting will be open to non-members on payment of a 10s. conference fee. Accommodation will be limited to 150. Application forms are now available from the Physical Society, 1 Lowther Gardens, Prince Consort Road, London, S.W.7.

A Course on Film Production for Television will commence on 14 October at the Lighting Service Bureau, 2 Savoy Hill, London, W.C.2, at 7.45 p.m. Application for particulars should be made to the Secretary, British Kinematograph Society, 164 Shaftesbury Avenue, London, W.C.2.

The Manchester Municipal College of Technology announces post advanced lectures in electrical and mechanical engineering for the session 1955-56. Among these are a course of eight lectures on "The Application of Digital Computers to Accountancy, Costing and Managerial Control", and a course of six lectures on "Linear Network Synthesis". Further details may be obtained from the Registrar, College of Technology, Manchester, 1.

The North Gloucestershire Technical College, Cheltenham, is opening a new electronics laboratory which will be equipped with apparatus suitable in a wide variety of work from low frequencies to v.h.f. In particular, measuring instruments have been acquired which will permit work to be carried out on the new f.m. and Band III channels. Introductory and advanced courses in electronic engineering are to be held in the forthcoming session, in addition to Higher and Ordinary National Certificate Courses in Electrical Engineering. Details may be obtained from the head of the Engineering Department.

ELECTRONIC EQUIPMENT

A description, based on information supplied by the manufacturers, of a small selection of the exhibits shown at the Society of British Aircraft Constructors Exhibition at Farnborough, from 5 to 11 September

U.H.F. Airborne Transmitter-Receiver (Illustrated below)

WEIGHING only 9½lb and housed in a case 9½ by 7 by 4½in, this u.h.f. unit is for use as main equipment in air-to-ground communication in the 238/240Mc/s band, and for emergency use on the international distress frequency of 243Mc/s. Designed for easy maintenance and low power consumption, the B.E.234 is of rugged construction combined with light weight and small size.

The equipment comprises two units mounted one above the other. The bottom unit consists of the rotary generator and the modulator chassis,



while the top unit, on a single chassis, provides the transmitter-receiver. Extensive use has been made throughout of sub-miniature valves and components, but ease of maintenance has been provided by the use of sub-assemblies where wired-in valves are required.

The transmitter has an output of 2.5W with adjustable speech clipping. The receiver is a double superheterodyne for 100kc/s channel working.

**Burdett Ltd,
Riverside,
Erith,
Kent.**

Airborne Search Radar

THE new high power airborne search radar type E120 has been designed primarily for use in civil aircraft.

This equipment incorporates many modifications introduced as a result of experience gained with other Ekco search radar systems. These features are:—

- (1) Longer range—detection of cumulo-nimbus clouds up to 120 miles.
- (2) Iso-Echo contour facilities, which distinguish between dangerous and non-dangerous cores in cumulo-nimbus clouds. Precautions have been taken to ensure stability of operation of this unit.
- (3) High brightness display.
- (4) Improved pitch stabilization limits

of the scanner unit, from +18° to -22°.

The electronic units of the type E120 are unpressurized and are for installation in the pressurized cabin. The Ekco airborne search radar type E38 is a lower power equipment giving ranges up to 40 miles. The units are sealed and pressurized and can be installed outside the pressure cabin.

**Ekco Electronics Ltd,
Southend-on-Sea,
Essex.**

Heavy Duty Vibrator (Illustrated below)

Designed for vibration testing on heavy structures, this electromagnetic vibrator has a resonance-free working range of from 20c/s to 1kc/s. The maximum thrust and excursion are 2 000lb and 1in respectively and the audio drive power approximately 5kW. A built-in accelerometer gives continuous indication of the force exerted.

**E.M.I. Ltd,
Hayes,
Middlesex.**



A.C. Pick-offs

THESE devices are data transmission elements of very small size and weight, whose principal function is to convert an angular displacement input into an a.c. voltage output. The output bears a linear relation to the input over an operating range of ±30 degrees, the output gradient being of the order of 0.58V r.m.s. per degree of angular movement. The nominal design excitation for the pick-off is 36V 1 200c/s, but the device will operate satisfactorily at other frequencies between 400c/s and 2 400c/s, subject to re-evaluation of the excitation voltage. Discrimination is better than 0.5 minute of arc, and the maximum non-linearity occurring at the limiting displacement is ±1 per cent.

No slip-rings or brushes are required, and consequently the frictional forces

are extremely small. Stiction torque is zero for the open types, and for the enclosed type is only that inherent in the bearings.

**Elliott Brothers (London) Ltd,
Century Works,
London, S.E.13.**

Variable Frequency Audio Oscillator (Illustrated below)

THIS oscillator gives a sinusoidal output of a relatively high amplitude and frequency stability in the frequency range 50c/s to 50kc/s. The frequency calibration can be accurately set by monitoring against an internal crystal calibration.

The unit consists of a two stage Wein bridge oscillator operating in three



frequency ranges, the amplitude being stabilized by means of a thermistor degenerative loop. The output is isolated through a cathode-follower stage which feeds, via a potentiometer, a conventional amplifier with degeneration to reduce the output impedance to 600Ω. The output itself is monitored by means of a meter incorporating a germanium bridge rectifier and multiplier, terminals or a jack point being used to provide a balanced output.

The cathode-follower also feeds a signal to a pentode which functions as a non-linear mixer of this signal with the output of a 5kc/s crystal oscillator, the amplitude of which is controlled by a diode rectifier. The beat frequency output from the mixer is fed through a high-pass filter to a magic eye tuning indicator; in order to render the calibration inoperative when not in use, a switch is provided to remove h.t. from this section.

A calibration trimmer enables the frequency to be set to a very much higher order of accuracy over a restricted part of the range, and the accuracy at the check points can approach that of the crystal itself, i.e. 0.01 per cent.

The output amplitude is 60V r.m.s. on open-circuit and 30V r.m.s. with a load of 600Ω.

**The General Electric Co Ltd,
Magnet House,
Kingsway, W.C.2.**

Sub-Miniature Direction Finder

(Illustrated below)

WITH an all-up weight of only 20lb this radio compass is primarily intended for pilot operation in fighter and small civil aircraft, but is nevertheless suitable for all types, as in spite of its small size and weight it meets all the major operational requirements of a radio compass and is not merely a "homer".

The type AD.722 has a frequency coverage of 200kc/s to 1700kc/s, tunable in three bands, and provides automatic relative bearings on a panel-mounted indicator, with simultaneous aural reception of modulated or unmodulated signals.

A special feature is the fixed loop aerial system, consisting of two crossed iron-cored loops in a sealed unit only $\frac{1}{2}$ in high. A low drag installation can consequently be achieved without recessing the unit beneath the aircraft skin, thus obviating the necessity for cutting



a large hole. The loops feed into a goniometer which is embodied in the bearing indicator.

Further features include a choice of two indicator sizes to suit individual cockpit panels; alternatively, a suitable bearing indicator already incorporated in the panel may be used. Plug-in sub-units are used for ease of replacement, while for simplicity of servicing, a portable test set has been specially designed to check the main units and each of the sub-units. The h.t. supply is taken direct from the standard aircraft 28V d.c., thus dispensing with the conventional rotary transformer, and thereby effecting a valuable saving in weight.

Marconi's Wireless Telegraph Co Ltd,
Chelmsford,
Essex.

Transistor Loud Hailer

THE spectacular saving in space and weight which can be achieved by using transistors is demonstrated by this device, which is essentially a megaphone of normal dimensions, but containing batteries, a microphone, an amplifier using junction transistors, and a loud-speaker. The equipment is completely portable, and to all intents and purposes can be treated as a normal megaphone, with the advantage that speaking into it at normal voice level produces an output loud enough for use in hangars and on airfields.

Mullard Ltd,
Century House,
Shaftesbury Avenue,
London, W.C.2.

U.H.F. Communication Equipment

PRODUCED to a Ministry of Supply specification, this new equipment is made in single-channel and multi-channel forms (the main difference between them is in the frequency control arrangements) and is designed primarily for ground-to-air operation. It is quite suitable, however, for other point-to-point working.

Maximum power delivered by the transmitter into the aerial is normally in excess of 10W. By the addition of a power amplifier this can be increased to 150W.

Where necessary, a cooling unit is built into the equipment to enable it to operate at between -40°C and $+37^{\circ}\text{C}$. If the external mass blowing unit is added, the upper working temperature can be as high as 55°C .

The equipment gives a working band of 175Mc/s from 225 to 400Mc/s; this wide band allows for 1750 frequencies at 100kc/s intervals.

The multi-channel equipment provides selection of 12 pre-set channels by simple panel or remote switching. It employs 32 crystals, and from the selection of suitable combinations of these the 1750 pre-set frequencies are obtained. Tuning of the equipment takes place automatically by built-in motors as soon as the crystal combination has been selected.

In the multi-channel equipment, frequency is maintained within ± 10 kc/s of nominal frequency to crystal accuracy by a special a.f.c. circuit. Frequency drifts up to ± 30 kc/s are instantly corrected by a reactance valve, while the larger variations cause the servo motor to restore frequency. In the single channel equipment frequency is maintained by a temperature controlled crystal.

The transmitter modulator circuit incorporates "vogad" and an "enabler" device which provide complementary functions by preventing the transmitter from radiating operating room background noise and by maintaining 100 per cent modulation for wide changes in input level.

The Plessey Co Ltd,
Ilford,
Essex.

High Frequency Electric Motors

THESE components have been developed to meet the demand for a range of small electric motors capable of operating from supplies in the 400 to 3000c/s frequency range, but with shaft speeds very much lower than the normal (2-pole) synchronous speed. By a suitable choice of the numbers of stator and rotor teeth it is possible to obtain shaft speeds as low as 1200rev/min on 400c/s, or 7200rev/min on 2400c/s, resulting in a considerable simplification of the design of any subsequent reduction gearbox. The normal rotor is designed to give a self-starting characteristic with synchronous running, and is therefore particularly suitable for driving timing and programming devices.

The mechanical construction of these motors has been deliberately simplified to make them suitable for incorporation in "expendable" equipment, and, to this end, moulded magnetic parts are used instead of laminations. However, with

suitable bearings, they are equally suitable for long-life applications.

Short Brothers and Harland Ltd,
Montgomery Road,
Castlereagh,
N. Ireland.

100-Channel Combined ILS/VOR Airborne Navigational Equipment

THE SR. 32/33 is an airborne navigational and landing aid receiving v.o.r., i.l.s. and marker beacon information.

The equipment is capable of receiving the following frequencies:—

(a) Any one of 100 channels in the I.C.A.O. navigational frequency band 108 to 117.9Mc/s.

(b) Any 20 spot frequencies in the I.C.A.O. navigational frequency band 329.6 to 335Mc/s allocated for the glide path portion of the i.l.s. system.

(c) 75Mc/s, the frequency allocated for the marker beacon.

The SR. 32/33 equipment comprises four main units and a control unit. The four main units are the localizer-v.o.r. receiver, the glide path receiver, the marker receiver and a power supply unit.

Standard Telephones & Cables Ltd,
Connaught House,
Aldwych,
London, W.C.2.

Emergency V.H.F. Transmitter

(Illustrated below)

ORIGINALLY designed for the protection of life from terrorists in Kenya, this transmitter has since been found useful in providing either automatic or manually operated warning of, say, excessive temperature or other danger on isolated locations. The transmitter has a coding cam cut to radiate the signal which can be, for example, "FIRE" followed by a map reference of the location. The transmitter is started, and the predetermined signal automatically radiated, by the closing of a single switch on the front panel or by the closure for $\frac{1}{2}$ minute of a light current contact.

The transmitter is operated from a 12V accumulator, is crystal controlled and has an output of 14 to 20W (e.r.p. approx. 80W).

Venner Electronics Ltd,
Kingston By-Pass,
New Malden,
Surrey.



**SMITH'S FOR
TECHNICAL
BOOKS**

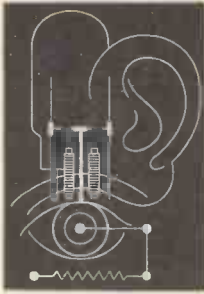

Books on radio theory, practice and maintenance for the beginner and books on new developments in circuit design, new components, methods of application, and the established text books can be obtained through your local Smith's shop or bookstall. Books not in stock at the branch can be quickly obtained from Head Office.

★ *Your stationery and printed matter can also be supplied through our local branch.*

W. H. SMITH & SON
FOR BOOKS ON ELECTRONICS

Head Office:
STRAND HOUSE, LONDON, W.C.2

**VOLTAGE
STABILIZERS**

By
F. A. Benson, M.Eng., A.M.I.E.E., M.I.R.E.
(University of Sheffield)

Price 12/6
(Postage 6d.)

This monograph describes the various devices employing saturated elements, glow-discharge tube circuits and thermionic valve arrangements for voltage stabilization. A comprehensive bibliography is included.

Order your copy through your bookseller or direct from

Electronic Engineering

28 ESSEX STREET, STRAND, W.C.2

BOOK REVIEWS

1954 Proceedings of the National Electronics Conference

808 pp. 539 figs. Vol. X. National Electronics Conference, Inc., Chicago. 1955. Price \$5.

THIS volume contains the texts of the ninety-one papers read at the National Electronics Conference held at Chicago in October 1954. As in previous years, a wide range of electronic topics is covered including microwaves, radar, communications, magnetic amplifiers, circuit theory and servomechanisms. However, it is rather surprising to find that there is relatively little on transistors and only one paper on colour television.

Two papers discuss the use of strip transmission line (stripline), at frequencies in the range 2.5 to 10kMc/s. The type of stripline described has no significant dielectric or radiation losses and can be used for resonators, filters and other high-Q microwave components. The two-dimensional structure makes it possible to fabricate complex assemblies by etching techniques with a considerable saving in cost over conventional waveguides and coaxial lines.

A two-stage magnetic-amplifier suitable for use with a thermocouple or a barrier layer photocell is described. The amplifier uses an 800c/s supply and responds to a step input change in 0.1sec. Another magnetic-amplifier paper gives performance figures for an amplifier system having a response time considerably shorter than one-half cycle of the a.c. supply. Unfortunately circuit details and analysis of this device are not yet published.

Ferrites are discussed in two papers, the first gives design techniques for low-power pulse transformers and the second describes a wide-band transformer covering a frequency range of 0.5-30Mc/s.

A c.r.t. deflexion system using transistors and one valve is described, the valve is used to drive the deflexion coils and transistors are used in the low-level parts of the circuit. The remaining transistor papers describe a bistable flip-flop and give a method of design for high-frequency circuits using junction units.

One electro-medical paper is included; this describes an instrument for measuring "Deception Induced Physiological Changes" (i.e. a Lie Detector). The instrument records blood pressure, blood oxygen content and respiration; no circuit details are given.

A number of papers are concerned with considerations of valve reliability. Two papers describe the production of 6J4 triodes and of OA2 and OB2 voltage regulators of "premium" quality. The problems dealt with are the usual ones of lint control, grid winding and electrode insulation and it is clear that U.S. and British work in this field are closely parallel. Three papers give the result of valve reliability experience in computer, industrial and military applications. The subject of reliability also receives atten-

tion in two papers which express the probability of equipment failure in terms of the performance of individual components. It is difficult to see how such an analysis can be particularly rewarding as it is virtually impossible to obtain adequate initial data to insert into the equations.

A group of four papers deal with the management of small research and development organizations. These papers show clearly how much such organizations depend on Government contracts, a situation not unknown on this side of the Atlantic.

The volume, which is the tenth in the present series, has a complete index covering all the papers presented since the Conference was instituted in 1944. The index is classified under both author and subject and, further, the contents of each volume are listed separately. The total coverage is some 750 papers and for this reason the present volume is particularly useful for reference purposes.

V. H. ATTREE.

High Fidelity Home Music Systems

By William R. Wellman. 168 pp. 60 figs. Demy 8vo. D. van Nostrand Inc., New York. Chapman & Hall Ltd., London. 1955. Price 30s.

IN recent years we have been able to welcome a number of books of American origin on subjects of current interest. In spite of the high price, the contents are generally interesting, sometimes indispensable, and the bibliographies comprehensive.

This present book falls into an indefinable class. It is not a musical book, not an engineering one, and not one on measurements. It purports to be an ABC of high fidelity, a guide for the tyro, and is perhaps best described as an essay on the fundamentals of this art. Unfortunately it is a negative essay, in which the theme is, "you ought to have this; but if you can't, you can get along quite well with something simpler".

To the uninitiated, clarity and accuracy are "firsts". Although the book contains much matter descriptive of the essential parts, it can only confuse the inexpert. One must naturally compare the price and subject matter with similar books in this country, and for 168 pages at 30s. the opinion of this reviewer is that the balance comes down very heavily in favour of British authors.

Samples extracted from the text include:—

"The decibel represents the change in pressure that is just discernable to the ear".

"Very often the h.f. system may appear to lack highs and perhaps lows too; it is only after a period of prolonged listening that their presence becomes evident".

On examining the interior of a radio set: "If you find there are two identical

tubes placed rather close together, you may suspect that a pushpull (output) stage is used".

The negative tenor of the book is illustrated by a passage from page 52. After describing the construction of a bass reflex cabinet, the author states that if the listener decides it is no good, "no material and very little time will have been wasted, for it is always possible to block up the port and use the cabinet as a simple box type baffle".

The materials and components are entirely American. There are no references to other published work and none to British equipment. Apart from the errors in the components, if the 12-watt amplifier high fidelity circuit on page 137, employing no negative feedback, is typical of the author's standards, it can only be assumed that American enthusiasts are very easily pleased. The description of a tape recording system omits any reference to a.c. bias and the radio tuner briefly described has no a.v.c. Five pages are devoted to the procedure for knocking a hole through a wall, and there are eighteen on how to make a loudspeaker enclosure conforming to the "golden triangle" of American architecture. There is no mention of any interior acoustic treatment for this box, but there is a subtle scheme for mounting a loudspeaker in a fireplace in which case "it is possible that the sloping walls of the fireplace act as the sides of a horn".

This book contains nothing to interest British readers.

ALAN DOUGLAS.

Etude Logique des Circuits Electriques et des Systemes Binaires

By R. Higonnet and R. Gréa. 452 pp., 538 figs. Crown 4to. Editions Berger-Levrault, Paris. 1955. Price Fr.3 500.

THE authors point out in their introduction that the technique of switching circuits has for long been based upon the accumulated experience of those specialists in the art, the designers of automatic telephone systems; today, however, the increasing use of automatic control devices and calculating machines is bringing an increasing number of engineers face to face with switching problems, and to them this work is addressed.

It is a work of exploration, classification, tabulation, in which the immense versatility of even a small number of switching relays is exhibited by examining them in all their possible ways of association.

The earlier chapters deal with the use of Boolean algebra, a branch of formal logic, in handling combinations of classes, and with its application to switching circuits. The introduction of Euler diagrams helps to a clearer mental picture, as does a geometrical approach (wherein, to take a simple example, the four permutations of two two-state variables may be represented by the four corners of a square, the eight permutations of three two-state variables by the eight summits of a cube, and so on). The geometrical figures bring out clearly such circuit properties as symmetry, and "m/n" behaviour. (An "m/n" circuit is one, having n relays, which is closed

upon the operation of any m of these).

The work advances to consider bridge or non-planar, multi-terminal, time-sequenced, and coding/decoding circuits, and to an extensive classification of two-terminal circuits having up to four relays. In some cases, such as with bridge circuits, algebraic methods are not wholly applicable and an empirical approach is necessary, but even here much systematization is effected. In a chapter dealing with relay control circuits, the notion of logical subtraction is introduced to enable the algebra to embrace the effect of control paths which are in shunt with controlled relay coils; this notion is necessary because, in contrast to a series path whose closure operates a relay, a shunt path prevents operation on closure.

The final chapters deal with circuits employing not relays but rectifiers and valves, and with various applications of switching principles including their use in railway signalling and in a novel printing machine.

The intending reader must not expect to find here an ideal introduction to Boolean algebra, which is used in a manner often ponderous. Further, extensive use is made of a system of numerical designations (corresponding to spaces in the Euler diagrams or summits in the geometrical figures) for the various combinations of the variables, and it is some time before one realises that these numerical tags, while convenient abbreviations, contribute little to the algebra.

One error must be mentioned, because of the difficulty it may cause. On page 17, and elsewhere, we are told that any combination can be represented in two ways: as the logical sum of its elements, or as the logical product of the complements of its elements. This should be: as the logical sum of its elements, or as the logical product of the complements of the elements which are absent from it. The student would here be well advised to look up De Morgan's theorem in any elementary textbook of formal logic.

But the scope of the work is wide, and it is to be admired for the patient and thorough way in which it considers and tabulates all the alternative approaches to the various problems. It will assist the student by indelibly impressing upon him the fact that most switching problems have a multiplicity of solutions, and are amenable to systematic approach as well as to intuition.

The French text is easy to follow, particularly as a vocabulary is given at the end. There is a most excellent bibliography.

T. L. CRAVEN.

Radio Valve Data

100 pp. Royal 8vo. 4th Edition. Hiffe & Sons Ltd. 1954. Price 3s. 6d.

THE latest edition of this reference book contains full operating data on over 2 000 types of British and American radio valves and some 200 cathode-ray tubes. Compiled by the staff of Wireless World, seventeen British valve manufacturers are represented, all of whom have co-operated in ensuring that the information given is accurate, comprehensive and up to date.

CHAPMAN & HALL

Just Published

High Vacuum Technique

by

J. YARWOOD

M.SC., F.INST.P.

(Head of Dept. of Mathematics & Physics
The Polytechnic, Regent Street, W.1)

Third Edition—Revised

208 pages

Illustrated

25s. net

Vapor-Plating

The Formation of Coatings

by

Vapor-Deposition Techniques

by

C. F. POWELL
I. E. CAMPBELL
B. W. GONSER

(Battelle Memorial Institute, U.S.A.)

158 pages

Illustrated

44s. net

37 ESSEX STREET, LONDON, W.C.2

PHILIPS TECHNICAL LIBRARY

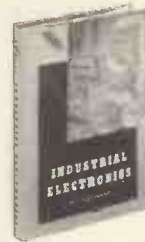

Kretzmann's

Industrial Electronics

Foreword by

Prof. JAMES GREIG

M.I.E.E.

This widely appreciated volume devotes a chapter to each main type of application, describing the operation of each in considerable detail. Profusely illustrated with photos and circuit diagrams. 230 pages, 250 illus. 25s.

Vacuum Valves in

Pulse Technique

P. A. Neeteson

A theoretical approach to the analysis of circuits using valves for switching, with a view to indicating more efficient usage and new applications. November, c. 180 pages, illus., c. 21s..

Descriptive Folders from
CLEAVER-HUME PRESS LTD.
31 Wright's Lane, W.8



MEETINGS THIS MONTH

THE BRITISH INSTITUTION OF RADIO ENGINEERS

Date: 26 October. Time: 6 p.m.
Held at: The London School of Hygiene and Tropical Medicine, Keppel Street, Gower Street, London, W.C.1.
Annual General Meeting (Members of the Institution only).
Followed at 7 p.m. by a paper: Recent Advances in Microwave Tubes.
By: R. Kompfner.

Merseyside Section

Date: 5 October. Time: 7 p.m.
Held at: The Chamber of Commerce, Council Room, 1 Old Hall Street, Liverpool 3.
Lecture: Stereophonic Sound.
By: R. A. Bull.

North-Western Section

Date: 6 October. Time: 6.30 p.m.
Held at: Reynolds Hall, College of Technology, Sackville Street, Manchester.
Lecture: Colour Television.
By: G. N. Patchett.
Followed at 8.30 p.m. by the Annual General Meeting of the Section.

West Midlands Section

Date: 12 October. Time: 7.15 p.m.
Held at: Wolverhampton and Staffordshire Technical College, Wulfruna Street, Wolverhampton.
Lecture: Frequency Modulation Broadcasting and Reception.
By: H. E. Farrow.

THE BRITISH KINEMATOGRAPH SOCIETY

Date: 12 October. Time: 7.15 p.m.
Held at: The Gaumont British Theatre, Film House, Wardour Street, London, W.1.
Lecture: Magnetic Sound on 16mm Film.
By: K. C. Rgerson, E. G. J. Saunders and N. W. Wooderson.
Date: 19 October. (Time and place as above.)
Lecture: Magnetic Recording in Film Production.
By: H. V. King and A. W. Lumkin.
Date: 26 October. (Time and place as above.)
Lecture: Special Effects for Television and Electronic Films.
By: A. M. Spconer.

THE INSTITUTION OF ELECTRICAL ENGINEERS

All London meetings, unless otherwise stated, will be held at the Institution, commencing at 5.30 p.m.

Date: 6 October.
Inaugural Address as President.
By: Sir George H. Nelson.

Measurement and Control Section

Date: 11 October.
Chairman's Address.
By: W. Bamford.
Date: 25 October.
Lectures: An Electrostatic Particle Accelerator.
By: D. R. Chick and D. P. R. Petrie.
An Electrostatic Analyser for the Absolute Measurement of Proton Energies and the Establishment of Fixed Points on the High-Voltage Scale.
By: S. E. Hunt, D. P. R. Petrie, K. Firth and A. J. Trott.

Radio and Telecommunication Section

Date: 19 October.
Chairman's Address.
By: H. Stanesby.
Date: 31 October. Time: 2.30 p.m.
Lectures: The Technique of Ionospheric Investigation using Ground Back-Scatter and A Study of Ionospheric Propagation by means of Ground Back-Scatter.
By: E. D. R. Shearman.
An experiment to Test the Reciprocal Radio Transmission Conditions over an Ionospheric Path of 740km.
By: R. W. Meadows.
An Experimental Test of Reciprocal Transmission Over Two Long Distance High-Frequency Radio Circuits.
By: F. J. M. Laver and H. Stanesby.

Date: 31 October. Time: 5.30 p.m.
Lecture: V.H.F. Propagation by Ionospheric Scattering and its Application to Long Distance Communication.
By: W. J. Bray, J. A. Saxton, R. W. White and G. W. Luscombe.

East Midland Centre

Date: 11 October. Time: 7 p.m.
Held at: Loughborough College.
Chairman's Address.
By: F. R. C. Roberts.

Cambridge Radio and Telecommunication Group
Date: 11 October. Time: 6 p.m.
Held at: Cambridgeshire Technical College, Collier Road, Cambridge.
Chairman's Address.
By: E. J. H. Moppett.

East Anglian Sub-Centre

Date: 12 October. Time: 7.30 p.m.
Held at: The Assembly House, Norwich.
Chairman's Address.
By: E. T. Norris.

Mersey and North Wales Centre

Date: 3 October. Time: 6.30 p.m.
Held at: Liverpool Royal Institution, Colquitt Street, Liverpool.
Chairman's Address.
By: J. M. Meek.

Date: 17 October. (Time and place as above.)
Lecture: High-Speed Electronic Analogue Computing Techniques.
By: D. M. MacKay.

North-Eastern Centre

Date: 10 October. Time: 6.15 p.m.
Held at: Neville Hall, Newcastle-upon-Tyne.
Chairman's Address.

North-Eastern Radio and Measurements Group
Date: 17 October. Time: 6.15 p.m.
Held at: King's College, Newcastle-upon-Tyne.
Chairman's Address.
By: C. H. W. Lackey.

North Midland Centre

Date: 4 October. Time: 6.30 p.m.
Held at: The Central Electricity Authority, Yorkshire Division, 1 Whitehall Road, Leeds.
Chairman's Address.
By: F. Barrell.

Sheffield Sub-Centre

Date: 19 October. Time: 6.30 p.m.
Held at: The Grand Hotel, Sheffield.
Chairman's Address.
By: W. Rewcastle.

North-Western Centre

Date: 4 October. Time: 6.15 p.m.
Held at: The Engineers' Club, Albert Square, Manchester.
Chairman's Address.
By: G. V. Sadler.

North-Western Measurement and Control Group
Date: 25 October. Time: 6.15 p.m.
Held at: The Electrical Engineering Department, Lecture Theatre, Manchester University.
Lecture: Electrical Automatic Control.
By: J. C. West.

North Scotland Sub-Centre

Date: 6 October. Time: 7 p.m.
Held at: Electrical Engineering Department, Queen's College, Dundee.
Chairman's Address.
By: J. Knox.

South-East Scotland Sub-Centre

Date: 4 October. Time: 7 p.m.
Held at: The Carlton Hotel, North Bridge, Edinburgh.
Chairman's Address.
By: W. B. Laing.

South-West Scotland Sub-Centre

Date: 5 October. Time: 7 p.m.
Held at: The Institution of Engineers and Shipbuilders, 39 Elmbank Crescent, Glasgow.
Chairman's Address.
By: J. A. Akeed.

South Midland Centre

Date: 3 October. Time: 6 p.m.
Held at: The James Watt Memorial Institute, Great Charles Street, Birmingham.
Chairman's Address.
By: H. S. Davidson.

South Midland Radio and Telecommunication Group
Date: 24 October. (Time and place as above.)
Lecture: Colour Television.
By: L. C. Jesty.

Southern Centre

Date: 5 October. Time: 6.30 p.m.
Held at: The College of Technology Extension, Anglesea Road, Portsmouth.
Chairman's Address.
By: L. H. Fuller.

Date: 7 October. Time: 6.30 p.m.
Held at: The South Dorset Technical College, Weymouth.
Lecture: High Speed Photography: Methods and Applications.

By: W. D. Chesterman.
Date: 12 October. Time: 7.30 p.m.
Held at: The R.A.F. Technical College, Farnborough.

(Joint meeting with the Southern Branch of The Institution of Mechanical Engineers.)

Lecture: Nuclear Reactors and Power Production.
By: Sir Christopher Hinton.

Date: 19 October. Time: 7.30 p.m.
Held at: The University, Southampton.
Lecture: A Transatlantic Telephone Cable.
By: M. J. Kelly, Sir Gordon Radley, G. W. Gilman and R. J. Halsey.

Western Centre

Date: 10 October. Time: 6 p.m.
Held at: The South Wales Institute of Engineers, Park Place, Cardiff.
Chairman's Address.
By: T. G. Dash.

Western Supply Group

Date: 17 October. (Time and place as above.)
Chairman's Address.
By: E. K. Wood.

THE INSTITUTION OF POST OFFICE ELECTRICAL ENGINEERS

Date: 4 October. Time: 5 p.m.
Held at: The Institution of Electrical Engineers, Savoy Place, London, W.C.2.
Lecture: Radio Aids to Marine Navigation.
By: W. Dolman.
Date: 19 October. Time: 5 p.m.
Discussion: What Makes an Engineer.
Opened by: J. G. Straw.

THE PHYSICAL SOCIETY

Date: 18 October. Time: 5 p.m.
Held at: The Lecture Theatre, The Science Museum, Exhibition Road, London, S.W.7.
Presentation of the Duddell Medal and the Charles Vernon Boys' Prize.
Duddell Lecture: Travelling Wave Tubes.
By: Dr. R. Kompfner.
The Charles Vernon Boys' Lecture to be delivered by Dr. J. W. Mitchell.

Acoustics Group

Date: 20 October. Time: 5.30 p.m.
Held at: The Physics Department, Imperial College, London, S.W.7.
Lecture: The Mechanics and Acoustics of Singing.
By: G. Mackworth-Young.

THE RADAR ASSOCIATION

Date: 12 October. Time: 7.30 p.m.
Held at: The Anatomy Theatre, University College, Gower Street, London, W.C.1.
Lecture: Deep Sea Diving by Radar and the Underwater Camera.
By: J. Gilbert.

RADIO SOCIETY OF GREAT BRITAIN

Date: 28 October. Time: 6.30 p.m.
Held at: The Institution of Electrical Engineers, Savoy Place, London, W.C.2.
Lecture: Amateur Radio in the Antarctic.
By: Roth Jones.