

# ELECTRONIC ENGINEERING

VOL. XXV

No. 320

OCTOBER 1954

## Commentary

THE crystal detector of the early days of radio was probably the first practical example of what is now known as a semi-conductor, but the theory of its operation was not understood at the time and it never developed much beyond the primitive stage of the "cat's whisker" in contact with a galena crystal. With so many new and fascinating things then being discovered in the world of radio, little attention could be given to the crystal detector and the advent of the thermionic valve soon rendered it as obsolete as the coherer.

Interest in the crystal detector was revived to some extent during the war and resulted in the silicon crystal diode for use as a mixer or frequency changer in radar equipment, but this was not much more than an "engineered" version of the temperamental crystal detector of the earlier days and the stress of war allowed no opportunity for further development and investigation. To all intents and purposes, the study was permanently shelved.

The interest of the scientific world was therefore considerably aroused when in 1948 the discovery was announced by the Bell Telephone Laboratories of a new semi-conducting device that was capable of the amplification of electric currents. The importance of this device, which became known as the transistor, was immediately appreciated and a good deal of publicity—much of it over-optimistic—heralded its birth. Here at last was the device that would, in a very short space of time, oust the thermionic valve from most, if not all, of its applications. Unlike the thermionic valve, it required no cathode heating power, it was rugged and compact, and it promised an indefinite life.

Not all these claims could be substantiated initially, and the early enthusiasm for the transistor was chilled by many setbacks. The transistor, a remarkably simple device in itself, consisting of two wires in close proximity and in point contact with a slab of germanium of about one millimetre cube, proved an extraordinarily difficult thing to manufacture on a production basis and, even today, is being made on a scale which is no more than an extended laboratory production. Moreover, its range of frequency over which it would operate was limited and its power-handling capacity was very small.

Some two years after the discovery of point contact

transistors came the junction-type diode and this was followed by what promised to be the greatest step forward of all, namely, the junction-type triode. This consisted again of germanium containing three sections or zones in which impurities were deliberately introduced, with accurate control both of the amount and kind in each section. The whole assembly is thus very small and although it is essential to seal it against moisture penetration, an evacuated envelope is not necessary. Tremendous impetus was given to the investigations being pursued on both sides of the Atlantic, and as further thought and effort was being brought to bear on the subject of semi-conductors, it became apparent that the development of the transistor was the most significant since the thermionic valve itself. A most promising future is being unfolded and the transistor is now being regarded as something more than a mere replacement of the valve. As its fundamental properties are being more fully investigated it is clear that the transistor of the future will fulfil many purposes other than the rectification and amplification of electric currents. It is interesting to learn, for example, that both the point contact and the junction diodes can now be constructed so as to be light sensitive and at the same time having efficiencies considerably greater than existing photoelectric devices. Possibilities of equal importance will undoubtedly follow as the electromagnetic, photoelectric and thermoelectric properties are explored.

The original material which formed the basis of the original transistor work was germanium and one of the early preoccupations in this country was the hunt for an indigenous source of this material.

An extensive survey was carried out by the General Electric Company and, as a result, the material now used by British manufacturers is obtained from the dust and soot collecting in the flues of gas works, particularly where coals from Northumberland and Durham are used. A substantial tonnage of such flue dust is now available containing as much as one per cent by weight of germanium in the better qualities. But the search for still better materials continues and the new semi-conductors such as tellurium bismuth and indium antimony show great promise in extending the range of operation of both frequency and power.

# The Dampometer

An Electronic Apparatus for Automatic Recording of the Logarithmic Decrement and Frequency of Oscillations in the Audio and Sub-audio Frequency Range

By Carl Olof Olsson\* and Kazimierz Orlik-Rückemanh\*

*An electronic apparatus for automatic evaluation of the damping of a harmonic oscillation has been designed and constructed. The apparatus is based on the idea of representing the harmonic damped oscillation by a rotating vector on the screen of a cathode-ray tube in such a way that the rate of decrease of the length of the vector is a measure of the damping. The results are obtained simultaneously with the oscillation test as two numbers in decimal digits, which are inversely proportional to the logarithmic decrement and the frequency, respectively. The apparatus, which is named the "Dampometer", has been used for some time for free oscillation measurements of the dynamic stability derivatives of aeroplane models in wind-tunnels, and has proved to be very satisfactory. It gives results of usually higher accuracy than evaluation methods in common use, and permits a most considerable saving of time.*

THE usual method to measure the damping of a mechanical or an electrical linear system is to let the system perform decaying oscillations and to register the amplitude of the oscillations as a function of time. The logarithmic decrement and the frequency can then be obtained, permitting the damping factor of the system to be determined. This procedure is straightforward, but rather tedious. Furthermore, due to the many steps involved, the accuracy of the procedure is not always very good. There has, therefore, for a long time been a need for an apparatus designed to evaluate automatically the logarithmic decrement and the frequency of decaying oscillations. Such an apparatus which gives the values of the above mentioned quantities in decimal digits simultaneously with the oscillation test, has now been constructed.

## General Layout

### BASIC FEATURES

The apparatus†, which has been named the "Dampometer", is based on the idea of representing the harmonic damped oscillation by a rotating vector in such a way, that the rate of decrease of the length of the vector is a measure of the damping of the oscillating system. The curve thus described by the end of the vector is a logarithmic spiral.

The oscillation to be investigated is introduced as a voltage to the four deflecting plates of the cathode-ray tube with a 90° phase shift between successive plates‡. The resulting deflexion of the cathode-ray, i.e. the length of the radius vector to the spot on the screen, is proportional to the ordinate of the envelope of the oscillation. When the oscillation is damped, the spot moves on a logarithmic spiral towards the centre of the screen (one revolution corresponding to one cycle of oscillation), as is shown in Fig. 1.

The screen is covered by a circular disk with a number of equally spaced radial slots, all of which are of the same length and are situated at the same distance from the centre, see Fig. 2. While the spot moves on the spiral, it passes the slots in the screen and thus gives light pulses to a photocell. The number of pulses produced by the cathode-ray tube, while the radius vector of the spiral decreases from the outer to the inner radius of the slots, is registered on an electronic counter, which gives the number directly

in decimal digits. The logarithmic decrement of the oscillation is inversely proportional to this number.

A second electronic counter is used to measure the time over a number of pulses thus determining the frequency of the oscillation.

The frequency range of the present apparatus is 0.5 to 500c/s, but the principle can be adapted to frequencies up to the order of 1Mc/s.

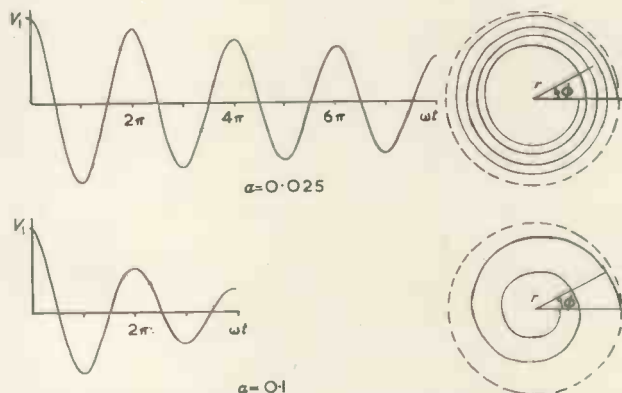

Fig. 1. Damped oscillation and corresponding logarithmic spiral

## THEORY

The network used to produce the suitable phase shift between the deflecting plates ( $D_1$  to  $D_4$ ) of the cathode-ray tube is shown in Fig. 3. The plates  $D_1$  and  $D_3$  are directly connected to the push-pull output of an amplifier. Thus, if the plate  $D_1$  has a voltage of  $+V_1$ , the plate  $D_3$  has a voltage of  $-V_1$ . Similarly, the plates  $D_2$  and  $D_4$  have voltages of  $V_2$  and  $-V_2$  respectively. If the current  $I$  between  $D_1$  and  $D_3$  is considered, the following relations

† Patent applied for.

‡ The voltage between one of the two pairs of opposite plates can be said to represent the potential energy of the oscillation while the voltage between the other pair of plates represents the kinetic energy of the oscillation. The resulting deflexion is approximately (if the damping is not too high) proportional to the square-root of the total energy of the oscillation. Thus, if the damping is not too high, the screen of the cathode-ray tube can be said to represent the phase plane of the oscillation, i.e., a plane with instantaneous values of the amplitude of the oscillation and its time-derivative plotted in a Cartesian co-ordinate system. An apparatus using an exact phase plane representation can be easily constructed, but has been found to be less suitable for evaluating damping than the present one. Reference should also be made to the Appendix.

\* The Aeronautical Research Institute of Sweden (FFA).

can easily be obtained:

$$dI/dt + I/RC = 2/R : dV_1/dt \dots\dots\dots (1)$$

$$V_2 = V_1 - RI \dots\dots\dots (2)$$

The general solution of equation (1) is:

$$I = e^{-t/RC} (A + \int e^{t/RC} 2/R dV_1/dt dt) \dots\dots\dots (3)$$

where  $A$  is a constant. In the case of decaying harmonic oscillation the incoming voltage may be written:

$$V_1 = V_0 e^{-\alpha\omega t} \cos \omega t \dots\dots\dots (4)$$

where  $2\pi\alpha$  is the logarithmic decrement of the oscillation. Inserting into equation (3) and integrating by parts, one obtains:

$$I = k e^{-t/RC} + 2V_0/R \cdot \frac{e^{-\alpha\omega t}}{(1/RC - \alpha\omega)^2 + \omega^2} \cdot [(\alpha^2\omega^2 - \alpha\omega/RC + \omega^2)\cos \omega t - \omega/RC \sin \omega t] \dots\dots (5)$$

Taking the initial condition to be:

$$I = 0 \text{ for } t = 0 \dots\dots\dots (6)$$

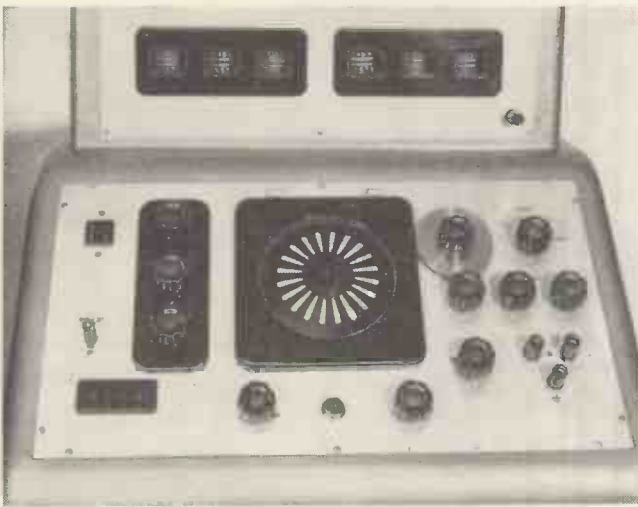

Fig. 2. Control panel of the Dampometer

the constant becomes:

$$k = -2V_0/R \cdot \frac{(\alpha^2\omega^2 - \alpha\omega/RC + \omega^2)}{(1/RC - \alpha\omega)^2 + \omega^2} \dots\dots\dots (7)$$

Inserting equations (4) and (5) into equation (2), the voltage  $V_2$  can be expressed as follows:

$$V_2 = 2V_0 e^{-t/RC} \frac{\alpha^2\omega^2 - \alpha\omega/RC + \omega^2}{(1/RC - \alpha\omega)^2 + \omega^2} - \frac{V_0 e^{-\alpha\omega t}}{(1/RC - \alpha\omega)^2 + \omega^2} \cdot [(\alpha^2\omega^2 + \omega^2 - (1/RC)^2) \cos \omega t - 2\omega/RC \sin \omega t] \dots\dots (8)$$

The distance of the cathode-ray spot from the centre of the screen, i.e. the length  $r$  of the radius vector, is then:

$$r = k_1(V_1^2 + V_2^2)^{1/2} \dots\dots\dots (9)$$

where  $k_1/2$  is the deflexion factor of the tube.

The angle  $\phi$  of the radius vector measured from the direction  $D_3 \rightarrow D_1$ , is:

$$\phi = \tan^{-1} V_2/V_1 \dots\dots\dots (10)$$

If the input  $V_1$  is undamped ( $\alpha = 0$ ), the curve described by the spot approaches the following form (since  $e^{-t/RC} \rightarrow 0$ ):

$$r^2 = \frac{k_1^2 V_0^2}{[\omega^2 + (1/RC)^2]^2} \left\{ 2[\omega^4 + (1/RC)^4] \cos^2 \omega t + 4\omega^2 / (RC)^2 \sin^2 \omega t - 2\omega / RC [\omega^2 - (1/RC)^2] \sin 2\omega t \right\}$$

$$\phi = \tan^{-1} \left\{ \frac{[(1/RC)^2 - \omega^2] \cos \omega t + 2\omega / RC \sin \omega t}{[(1/RC)^2 + \omega^2] \cos \omega t} \right\} \dots\dots\dots (11)$$

This curve becomes the circle:

$$\left. \begin{aligned} r^2 &= k_1^2 V_0^2 \\ \phi &= \omega t \end{aligned} \right\} \dots\dots\dots (12)$$

if  $R$  and  $C$  are adjusted so that:

$$RC = 1/\omega \dots\dots\dots (13)$$

The apparatus allows a continuous adjustment of the product  $RC$ .

If the input  $V_1$  is damped ( $\alpha \neq 0$ ), the curve described by the cathode-ray spot will be a spiral, which will in a sense have rotational symmetry when the product  $RC$  is adjusted according to equation (13), as will be assumed henceforth. Since the coefficients of  $e^{-t/RC}$  and of  $e^{-\alpha\omega t}$  in equation (8) are of the same order of magnitude, it can be seen, that after a short time the last term of equation (8) will dominate if  $\alpha \ll 1$ , e.g.:

$$\begin{aligned} \text{if } \alpha &= 0.1; t = 2\pi/\omega; e^{-t/RC} = 1/284 e^{-\alpha\omega t} \\ \alpha &= 0.2; t = 2\pi/\omega e^{-t/RC} = 1/153 e^{-\alpha\omega t} \\ \alpha &= 0.3; t = 2\pi/\omega e^{-t/RC} = 1/82 e^{-\alpha\omega t} \end{aligned}$$

This means that after one or two revolutions of the spot the term proportional to  $e^{-t/RC}$  can be neglected. The amplification has to be chosen in such a way, that the spot

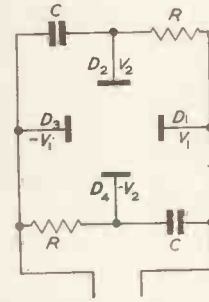

Fig. 3. Phase shift network for the deflecting plates

makes one or two revolutions before entering the slots. Another way of eliminating the term  $e^{-t/RC}$  is to start the oscillation by feeding energy into the system with the frequency  $\omega$ , thereby gradually approaching the starting amplitude at which the energy source abruptly is disconnected.

After setting  $RC = 1/\omega$  and neglecting the term proportional to  $e^{-\alpha\omega t}$ , the equation for the curve described by the spot becomes:

$$r^2 = k_1^2 V_0^2 e^{-2\alpha\omega t} \left[ \cos^2 \omega t + \frac{\sin^2 \omega t - \frac{1}{2}\alpha^2 \sin 2\omega t + \frac{1}{4}\alpha^4 \cos^2 \omega t}{(1 - \alpha + \frac{1}{2}\alpha^2)^2} \right]$$

$$\phi = \tan^{-1} \left( \frac{\tan \omega t - \frac{1}{2}\alpha^2}{1 - \alpha + \frac{1}{2}\alpha^2} \right) \dots\dots\dots (14)$$

For  $\alpha \ll 1$  this curve reduces to a logarithmic spiral

$$\left. \begin{aligned} r &= k_1 V_0 e^{-\alpha\omega t} \\ \phi &= \omega t \end{aligned} \right\} \dots\dots\dots (15)$$

For higher values of  $\alpha$  the spiral will be somewhat elongated in the direction of one pair of the plates. This can be eliminated by multiplying the voltage on plates  $D_2$  and  $D_4$  by the factor:

$$1 - \alpha + \frac{1}{2}\alpha^2 \dots\dots\dots (16)$$

and for this purpose a special correction device can be used, calibrated directly in  $\alpha$ . Neglecting terms of order  $\alpha^4$ , the spiral then becomes:

$$\left. \begin{aligned} r^2 &= k_1^2 V_0^2 e^{-2\alpha\omega t} (1 - \frac{1}{2}\alpha^2 \sin 2\omega t) \\ \phi &= \tan^{-1} (\tan \omega t - \frac{1}{2}\alpha^2) \end{aligned} \right\} \dots \dots (17)$$

If  $\alpha^2$  can be neglected, the curve will be the logarithmic spiral given by equation (15). Higher values of  $\alpha^2$  introduce an elongation of the spiral along an oblique axis passing through the centre of the screen and being symmetrically situated with respect to the plates  $D_2$  and  $D_3$ . The angle  $\Delta(\omega t)$ , needed for the radius vector to decrease from a given value  $r_1$ , to another given value  $r_2$ , is a function of the angular position at which the radius vector is  $r_1$  and  $r_2$  respectively. The angle  $\Delta(\omega t)$  is largest, when  $r=r_1$  at  $\omega t = \pi/4 + n \cdot \pi$  and  $r=r_2$  at  $\omega t = 3\pi/4 + n \cdot \pi$ , and lowest when it is the other way round. From an energy consideration (see the Appendix) it follows that, if only  $\alpha \geq 0$  the radius vector cannot increase, i.e., a given value of  $r$  can be passed only once. The angular position at which the length of the radius vector has a given value is difficult to control. The difference between the highest and the lowest value of  $\Delta(\omega t)$ , obtained for a given  $\alpha$ , is thus a measure of the maximum error due to elongation, that is:

$$\epsilon(\omega t) = \frac{1}{2} \{ [\Delta(\omega t)]_{\max} - [\Delta(\omega t)]_{\min} \} = 1/\alpha \ln(1 + \frac{1}{2}\alpha^2) \approx \frac{1}{2}\alpha \dots \dots (18)$$

As an example,  $\alpha = 0.3$  gives an error of  $8.6^\circ$ .

The second expression of equation (17) indicates a slight variable phase shift between  $\phi$  and  $\omega t$ . This phase shift is zero at  $\omega t = \pi/2 + n \cdot \pi$ , and maximum at  $\tan \omega t = \frac{1}{2}\alpha^2$ , where it is:

$$(\omega t - \phi)_{\max} = \tan^{-1} \frac{8\alpha^2}{16 - \alpha^4} \dots \dots (19)$$

For  $\alpha = 0.3$  the maximum phase shift is  $2.6^\circ$ .

Since  $\omega t$  is thus practically equal to  $\phi$ , the error according to equation (18) is almost the same whether the quantity measured is the angle  $\Delta(\omega t)$  or the time  $\Delta t$ . The

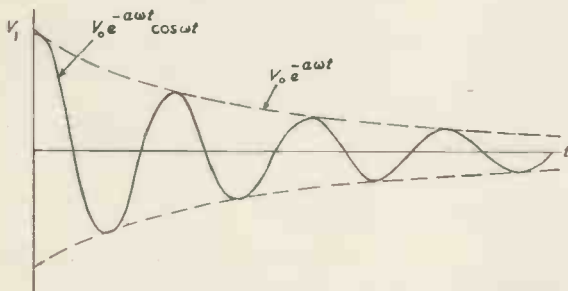

Fig. 4. Curve of  $V_1$  in oscillation

Dampometer expresses consequently a damped harmonic oscillation as a logarithmic spiral on the screen of the cathode-ray tube. The length of the radius vector of the spot on the screen is proportional to the ordinate of the envelope  $V_1 = V_0 e^{-\alpha\omega t}$  of the harmonic oscillation (Fig. 4). The higher the damping of the harmonic oscillation is, the faster the length of the radius vector decreases. If the screen is covered with a disk having  $s$  radial slots, the outer and the inner radius of each of them being  $r_1$  and  $r_2$  respectively, then the logarithmic decrement  $\delta$  of the oscillation can be shown to be inversely proportional to the number of slot passages,  $n$ , between the outer and the inner radius. Denoting the time at which the spot enters the slots by  $t_1$

and the time at which it leaves by  $t_2$ , the following expressions can be derived:

$$\left. \begin{aligned} r_1 &= k_1 V_0 e^{-\alpha\omega t_1} \\ r_2 &= k_1 V_0 e^{-\alpha\omega t_2} \end{aligned} \right\} \dots \dots (20)$$

$$\therefore \ln(r_1/r_2) = \alpha\omega(t_2 - t_1) = 2\pi\alpha n/s = \delta n/s$$

$$\therefore \delta = 2\pi\alpha = s/n \ln(r_1/r_2)$$

The number  $n$  is registered by an electronic counter, the damping counter, which is actuated by a photocell. The number of slots,  $s$ , and the radius ratio  $r_1/r_2$  can be chosen at will. In practice the radius ratio is determined by calibrating against a known input and does not necessarily coincide with the geometrical ratio. The frequency of oscillation,  $f$ , is measured using an oscillator of known frequency  $f_{osc}$ . A second electronic

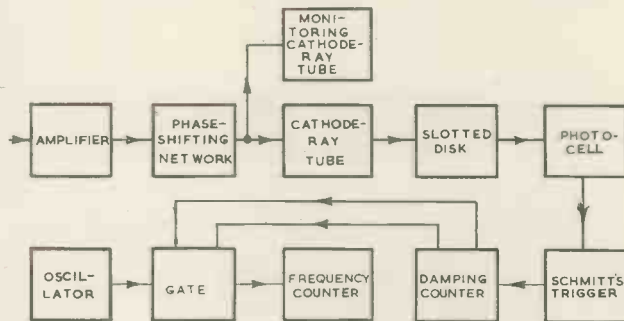

Fig. 5. Block diagram of Dampometer

counter, the frequency counter, starts when the damping counter shows  $n_1$  and stops when the damping counter shows  $n_2$ , and counts the number of cycles,  $n_{osc}$ , of the oscillator during that time. Hence the frequency of oscillation is determined by the relation:

$$f = \frac{n_2 - n_1}{s} \cdot f_{osc} / n_{osc} \dots \dots (21)$$

The values of  $n_2$ ,  $n_1$  and  $f_{osc}$  can be chosen within a suitable range.

### Design

The arrangement of the different parts of the apparatus is shown in the block diagram of Fig. 5. The wiring of each part is given in the corresponding diagrams (Figs. 6 to 9). A photograph showing the final assembled Dampometer is presented in Fig. 10.

The amplifier and phase shifting network is shown in Fig. 6. The amplifier is of D.C. type and has an amplification of 20 000. The first stage is a double triode 12AY7 with coarse and fine balancing potentiometers and amplification variation. The next stage employs two 12AU6 connected as starved amplifiers. This method can be used because the required frequency range is only 500c/s. The positive voltage of 2 000V feeding this stage is also used as the acceleration voltage for the cathode-ray tube. The amplification of this stage is about 3,000.

The amplifier ends with two cathode-followers 12AU7, which feed one pair of deflecting plates and the phase shifting network. This is followed by two more cathode-followers, feeding the other pair of deflecting plates.

It is possible to change the ratio of the voltages of the two pairs of plates in order to compensate for different deflexion factors. The same arrangement is used to introduce the correction according to equation (16), which can be carried out on the control panel of the instrument.

The light pulses are converted into voltage pulses by means of a multiplier photocell 931A, which is fed from

the high voltage supply. A Schmitt trigger, 12AX7, is used as a pulse shaper and is followed by a differentiating network. The pulses are counted by the damping counter (see Fig. 7). This consists of a scale of 1 000, employing 3 high vacuum decade counter tubes, Philips E1T, and necessary trigger tubes E90CC. The counter tube is a new all-electrostatic and inexpensive type, which has proved to be reliable.

The frequency of the damped oscillation is measured by comparison with the frequency of an RC oscillator (see Fig. 8). A frequency counter, of exactly the same type as the damping counter, counts the number of cycles of the RC oscillator between two selected light pulses, for instance, between the 10<sup>th</sup> and the 100<sup>th</sup>. These pulses can be chosen within reasonable limits, with the start and stop selectors on the front panel, in order to suit different damping ratios and disks.

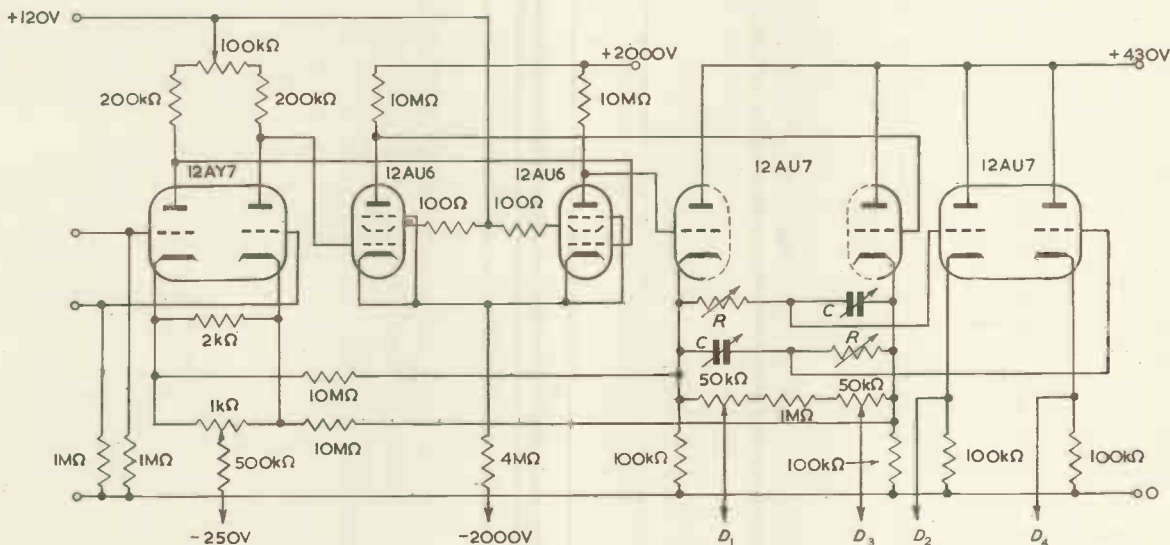

Fig. 6. Amplifier and phase shifting network

In an earlier version, gas-filled counter tubes with separate cathodes for every figure were used, and it was then possible to choose any pulse as a start or stop pulse. The E1T counter, however, can supply only the 1<sup>st</sup>, 10<sup>th</sup>, 100<sup>th</sup> and 1 000<sup>th</sup> pulse. This difficulty has been overcome by using an additional scale of 4, which can be switched to give the 1<sup>st</sup>, 2<sup>nd</sup>, 4<sup>th</sup>, 10<sup>th</sup>, 20<sup>th</sup>, 40<sup>th</sup> or 100<sup>th</sup> pulse.

The power supply, shown in Fig. 9, provides a number of regulated voltages, including the acceleration voltages. Three stabilizer tubes 85A2 are used to provide the reference voltage.

To facilitate the adjustments of the instrument and to check that the spiral is undistorted, a monitoring cathode-ray tube is used. It is connected in parallel with the main one, which is covered by the slotted disk.

## Operational Experience

### MANIPULATION TECHNIQUE

The technique of use of the Dampometer is given in this section in chronological order. It has been found that a warm-up time of about 15 minutes is necessary before use. After that time the following adjustments should be made to secure the desired accuracy:

### SPOT ADJUSTMENT

The effective ratio of the outer and the inner radius of slots usually differs a little from the geometrical ratio, due to the finite dimension of the spot. The focusing is adjusted to make the spot as small as possible. The intensity is

then continuously increased to a value, at which the damping counter commences to function regularly; this value is then increased by a certain amount to provide a safety margin. The adjustment is made with the spot moving on a circle, which can be achieved by connecting the RC oscillator of the apparatus to the amplifier.

### CALIBRATION OF THE SLOTTED DISK\*

The effective ratio of the outer and the inner radius of the slots has to be determined experimentally using the same spot intensity and focusing as chosen above. An undamped voltage which can be accurately measured, is connected to the amplifier. A circle is then obtained on the screen, which can be expanded or diminished by altering the input voltage. When the circle is well within the ends of the slots, the frequency counter will register a number  $n_{080}$  corresponding to the time between the  $n_1$ <sup>th</sup> and

$n_2$ <sup>th</sup> light pulses. If the circle is expanding (diminishing) towards the outer (inner) end of the slots,  $n_{080}$  will increase due to the longer time required to get  $(n_2 - n_1)$  pulses. By plotting  $1/n_{080}$  against the input voltage, a curve is obtained, from which an effective value of the outer (inner) radius can be evaluated. See the example in Fig. 11. This calibration also eliminates errors due to non-linearities of the amplifier and cathode-ray tube.

### ADJUSTMENT OF THE PHASE SHIFTING NETWORK

The voltage to be investigated is connected to the Dampometer and the values of  $R$  and  $C$  are adjusted by direct observation to make the curve on the screen as circular as possible. The frequency is thus preliminary determined from the frequency counter and is used to correct the value of  $RC$  according to the condition  $RC = 1/\omega$  (see equation (13)). At high values of  $a$  it may be necessary to iterate this procedure.

### NUMBER OF SLOTS

It is desirable to obtain numbers on the counters that are high enough to provide reasonable accuracy. Thus if  $a$  is high, the number of slots should be high, the limit being determined by the spot diameter and the speed of the damping counter. If  $\omega$  is high, and if many slots are used, the number on the frequency counter will be low. In such case it might be preferable to use only a few slots. Therefore, a number of different slotted disks are used,

\* This is required only when a new disk is used and thereafter only very seldom.



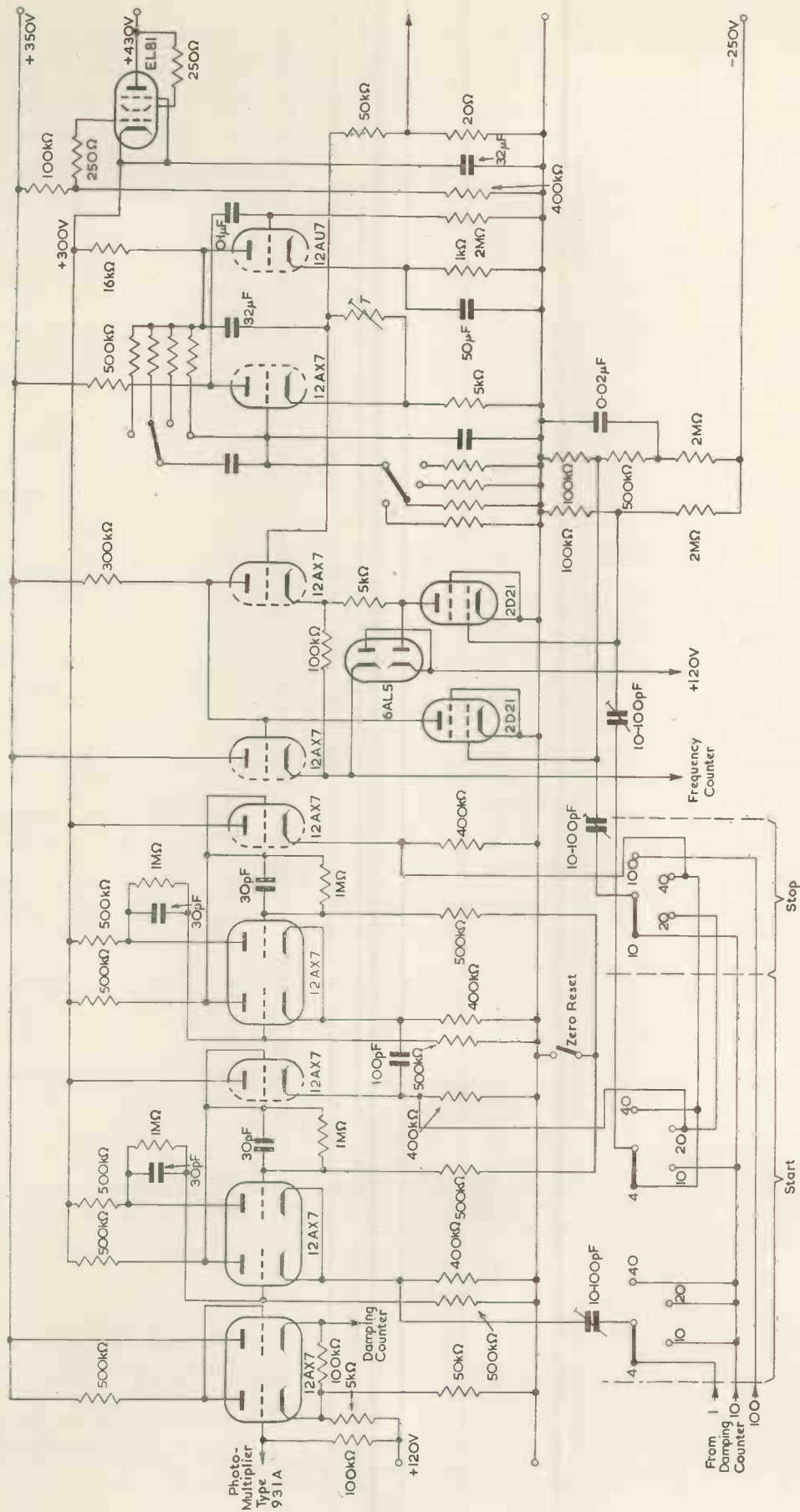

Fig. 8. Schmitt trigger, gate and RC oscillator circuits





difference between the exit angle and the entrance angle is constant. In any case, as the errors according to equations (25) and (26) are symmetrically distributed with respect to zero and thus no systematic error is involved, the result can be essentially improved by taking the arithmetic mean of repeated measurements.

The total maximum error in the logarithmic decrement obtained from a single measurement for  $\alpha = 0.3$  can in the worst case be as high as 10 per cent, but the probable error can easily be reduced to 1 to 1.5 per cent by repeating the measurement.

If the rules given under STARTING AND STOPPING are observed, the error in frequency measurement is seen to be the same as the error in frequency of the RC oscillator.



Fig. 10. View of the Dampometer

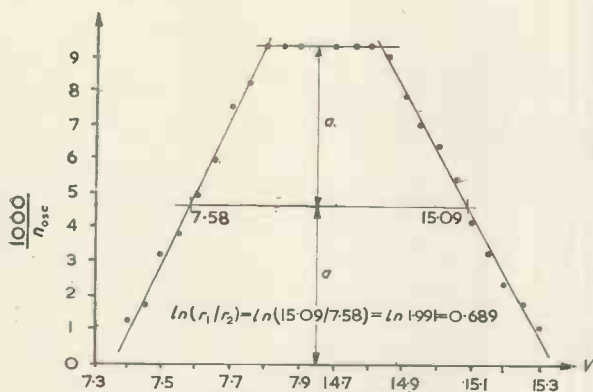

Fig. 11. Typical calibration of slotted disk

Calibrating the RC oscillator at suitable time-intervals (e.g. once a month) this error can easily be kept within 0.5 per cent.

In many cases it is of interest to investigate the damping factor, i.e. essentially the product  $\alpha\omega$ . It therefore follows that with the present apparatus the damping factor can be determined within 1.5 to 2 per cent (in the range of  $\alpha$  and  $\omega$  considered here).

The Dampometer is very suitable even for the case in which the logarithmic decrement is not linear with respect to the amplitude. Using a small radius ratio, it is possible to analyse a small amplitude range and thus upon repeating the investigation for different amplification factors, the effect of amplitude on the logarithmic decrement can be obtained.

## Conclusions

The present apparatus for automatic evaluation of damped oscillations, can be used with good accuracy (< 2 per cent) for a logarithmic decrement absolutely smaller than 2 in the frequency range 0.5 to 500c/s. The apparatus can, of course, even be used for negative damping. For higher absolute values of the logarithmic decrement the accuracy decreases. The apparatus provides the results simultaneously with the oscillation test. Thus several tests can be performed and evaluated in a short time to give a representative mean value.

The range and the accuracy of the apparatus can be increased by using a larger cathode-ray tube, faster counters, higher radius ratio and larger number of slots. Thus the principle can be adapted up to frequencies of the order of 1Mc/s, if damping is not too high, which makes the Dampometer useful for a number of widely different research fields. For current aerodynamic investigations, however, the present range has been found quite satisfactory.

## Acknowledgment

The authors are indebted to the Director of the Aeronautical Research Institute of Sweden for permission to publish this article.

## APPENDIX

### EXACT PHASE PLANE REPRESENTATION AS AN ALTERNATIVE BASIC PRINCIPLE

As pointed out, the basic principle might be interpreted as an approximate phase plane representation of the oscillation, when  $\alpha \ll 1$ . It is therefore of some interest to investigate the consequences of using an exact phase plane representation. This can be obtained by replacing the phase shifting network by a differentiating unit, which makes the voltage  $V_2$  proportional to the time-derivative of  $V_1$ . If the oscillation equation is:

$$d^2V_1/dt^2 + 2\alpha\omega dV_1/dt + \omega^2(1 + \alpha^2)V_1 = 0 \quad \dots (A1)$$

the voltages can be written:

$$\left. \begin{aligned} V_1 &= V_0 e^{-\alpha\omega t} \cos \omega t \\ V_2 &= -k_2 dV_1/dt = k_2 V_0 \omega e^{-\alpha\omega t} (\sin \omega t + \alpha \cos \omega t) \end{aligned} \right\} \dots (A2)$$

The instantaneous value of the total energy of the oscillation is defined as:

$$E = 1/2 \omega^2 (1 + \alpha^2) V_1^2 + 1/2 (dV_1/dt)^2 \quad \dots (A3)$$

The first term represents the potential energy and the second, the kinetic energy. The curve described by the spot on the screen is, as before:

$$\left. \begin{aligned} r &= k_1 (V_1^2 + V_2^2)^{1/2} \\ \phi &= \tan^{-1} V_2/V_1 \end{aligned} \right\} \dots (A4)$$

Inserting equation (A2) the curve can be written as:

$$\left. \begin{aligned} r^2 &= k_1^2 V_0^2 e^{-2\alpha\omega t} [\cos^2 \omega t + k_2^2 (\omega^2 \sin^2 \omega t + \alpha \omega^2 \sin 2\omega t + \alpha^2 \omega^2 \cos^2 \omega t)] \\ \phi &= \tan^{-1} [\omega k_2 (\tan \omega t + \alpha)] \end{aligned} \right\} \dots (A5)$$

To obtain a circle in the case of constant total energy ( $\alpha = 0$ ), the scale factor has to be chosen  $k_2 = 1/\omega$ . In the general case ( $\alpha \neq 0$ ) one has to take:

$$k_2 = \frac{1}{\omega(1 + \alpha^2)} \quad \dots (A6)$$

which follows from equation (A3). Then the length of the radius vector will be proportional to the square root of

the instantaneous value of the total energy. The curve can then be expressed as:

$$r^2 = k_1^2 V_0^2 e^{-2\alpha\omega t} \left[ 1 + \frac{\alpha}{1 + \alpha^2} \sin 2\omega t + \frac{\alpha^2}{1 + \alpha^2} \cos 2\omega t \right]$$

$$\phi = \tan^{-1} \left[ (1 + \alpha^2)^{-1/2} (\tan \omega t + \alpha) \right] \dots \dots \dots (A7)$$

For  $\alpha \ll 1$ , this curve reduces to the logarithmic spiral:

$$\left. \begin{aligned} r &= k_1 V_0 e^{-\alpha\omega t} \\ \phi &= \omega t \end{aligned} \right\} \dots \dots \dots (A8)$$

Retaining terms of the order of magnitude  $\alpha$ , but neglecting those of order  $\alpha^2$ , the spiral becomes:

$$\left. \begin{aligned} r^2 &= k_1^2 V_0^2 e^{-2\alpha\omega t} (1 + \alpha \sin 2\omega t) \\ \phi &= \tan^{-1} (\tan \omega t + \alpha) \end{aligned} \right\} \dots (A9)$$

This spiral is elongated in the direction of an oblique axis going through the centre of the screen and being symmetrically situated with respect to the plates  $D_1$  and  $D_2$ . The general character of the curve is the same as of the curve given in equation (17), but the effect of  $\alpha$  is of a higher order of magnitude. Thus the maximum error due to the elongation is:

$$\epsilon(\omega t) = 1/\alpha \ln(1 + \alpha) \dots \dots \dots (A10)$$

and yields for  $\alpha = 0.3$ , an error of  $50^\circ$  as compared to  $8.6^\circ$  from equation (18).

The maximum phase shift between  $\phi$  and  $\omega t$  occurs at  $\tan \omega t = \frac{1}{2}\alpha$  and is:

$$(\omega t - \phi)_{\max} = \tan^{-1} \frac{4\alpha}{4 - \alpha^2} \dots \dots \dots (A11)$$

For  $\alpha = 0.3$ . This expression gives  $17^\circ$  as compared with  $2.6^\circ$  from equation (19).

Thus it is seen that for  $\alpha \ll 1$  (terms proportional to  $\alpha$  can be neglected) both principles give the same results (see equations (15) and (A8), but for higher values of  $\alpha$  the principle given (equation (17)) is far superior to the principle of exact phase plane representation (equation A9).

### SYMBOLS

- $C$  = adjustable capacitance in phase shifting network
- $I$  = current between  $D_1$  and  $D_3$
- $R$  = adjustable resistance in phase shifting network
- $V_0$  = input voltage at  $t = 0$
- $V_1$  = input voltage (on  $D_1$ )
- $V_2$  = voltage on  $D_2$
- $f$  = frequency of the oscillation
- $f_{osc}$  = frequency of the RC oscillator
- $k_1$  = double deflexion factor of the cathode-ray tube
- $n$  = number of slot passages between the outer and the inner radius (number shown on the damping counter)
- $n_1, n_2$  = number on the damping counter, when the frequency counter starts and stops, respectively
- $n_{osc}$  = number of cycles of the RC oscillator for the same time that the damping counter goes from  $n_1$  to  $n_2$  (number shown on the frequency counter)
- $r$  = length of the radius vector of the spot
- $r_1, r_2$  = outer and inner radius of the slots, respectively
- $s$  = number of slots in the disk
- $t$  = time
- $\alpha = 1/2\pi\delta$
- $\delta$  = logarithmic decrement of the oscillation
- $\epsilon(\omega t)$  = maximum error in  $\omega t$  due to the elongation of the spiral along an oblique axis
- $\phi$  = angle of the radius vector from the direction  $D_3 \rightarrow D_1$
- $\omega = 2\pi f$

### Improvements in U.S.A. Primary Standard of Frequency

Accompanying the maintenance of America's primary standard of frequency is a continuing investigation by the U.S. National Bureau of Standards of methods for improving the constancy and reliability of the standard. Some modifications incorporated within the last few years include the use of resonator crystals to sustain the accuracy of the standard, more sensitive and reliable temperature controls, and precise clock mechanisms to monitor time signals.

The Bureau's primary standard of frequency is the foundation upon which are based all time and frequency transmissions from the Bureau's radio broadcasting stations, WWV in Beltsville, Maryland, and WWVH, Maui, Territory of Hawaii. From these stations, standard radio frequencies of 2.5, 5, 10, 15, 20, and 25Mc/s are transmitted continuously with accuracies of 2 parts in 100 million. Two standard audio frequencies, 600 and 440c/s are broadcast on all of the radio carrier frequencies. A pulse of 0.005sec duration occurs on each carrier frequency at intervals of 1sec. The time intervals, as transmitted, are accurate within  $\pm 2$  parts in  $10^8 + 1\mu\text{sec}$ .

The primary standard of frequency consists of 9 crystal-controlled oscillators and 8 quartz crystal resonators. All of the crystal-controlled oscillators are kept in continuous operation and the best ones, those having the least amount of deviation from 100kc/s for the immediately preceding 6-month period are the units from which the standard frequency is determined.

The oscillators are controlled by GT-cut quartz crystals. In examining the crystals, it has been observed that generally their performance curves (frequency-amplitude) have a flat region within which the crystal frequency is relatively constant. When the driving current reaches a value of about  $150\mu\text{A}$  the frequency decreases sharply. In view of this fact, the driving current applied to the crystal units of the newer oscillators is less than  $100\mu\text{A}$ .

Once a day, the value of each resonator crystal and each standard oscillator is determined. First a precision variable oscillator is adjusted to the frequency of one of the resonators. The variable oscillator is then compared to one of the standard oscillators, and the beat or difference frequency is counted on an electronic frequency counter with a precision of the order of parts in  $10^{10}$ . The variable oscillator is re-adjusted to the second resonator crystal and again compared to the same standard oscillator. The difference frequency between these two oscillators is again recorded. This procedure is continued until data are available indicating the amount of frequency deviation present between the standard oscillator and each of the resonator crystals. One of the remaining 8 oscillators is used as a reference against which all of the other oscillators are compared.

A more precise and reliable temperature control of the ovens enclosing the oscillators has been developed. The oven is essentially 4 concentric cubical chambers: the centre chamber holds the oscillator unit, and the space of the next and outer chamber is filled with felt insulation. An air-chamber containing mat heaters separates the insulated chambers. The outer heater is controlled by a simple mercury thermostat. Control of the inner heater is achieved by using a network in which the heater element is part of the sensing circuit. In effect, one pair of arms of a resistance bridge is made up of wire with a high temperature coefficient and the other pair, of wire of negligible temperature coefficient.

In order to monitor the time signals generated by the frequency standard, one of the Bureau's standard oscillators is used to drive a synchronous clock. The 100kc/s output of each oscillator is divided to a frequency suitable for driving a spark chronograph and chronoscope. The instruments are designed so that the driving oscillator may be compared to the time signals of the other 5 oscillators in the Washington laboratory and those at the WWV installation to differences as small as 20 millionths of a second.

# Direct Current Stabilizers for Electromagnets

By M. W. Jervis\*, M.Sc.Tech., A.M.I.E.E.

Many papers have been written describing current stabilizers designed for specific purposes. The general principles of operation of some of these are considered and factors affecting their stability are reviewed.

**CURRENT** stabilizers are often required for use with power supplies which energize electromagnets used for producing constant magnetic fields. Typical examples are found in connexion with mass spectrometer and cyclotron magnets and with electron microscope magnetic lenses. In these cases, considerable change in resistance occurs during operation due to temperature rise of the copper windings. Usually, the power supply voltage also fluctuates.

## Basic Equations

In the notation used by Hill<sup>1</sup>, for a current stabilizer operating in the linear region:

$$\delta I_L = g_s \delta V_i - g_o \delta V_o$$

where  $\delta I_L$  = stabilized output current change

$\delta V_i$  = input voltage change

$\delta V_o$  = output voltage change

and  $g_s = \partial I_L / \partial V_i$  = stabilization transconductance

$g_o = -\partial I_L / \partial V_o$  = output conductance.

The terms  $g_s$  and  $g_o$  indicate the effect of input voltage and load resistance changes on the output current. Clearly for effective stabilization  $g_s$  and  $g_o$  must be small. It is also seen that since  $V_o = I_L R_L$ :

$$g_o = -\partial I_L / \partial V_o = -\frac{\partial I_L}{I_L \partial R_L} \dots \dots \dots (1)$$

where  $R_L$  is the load resistance.

If the stabilizer is regarded as a voltage source of output resistance  $R_o$ , and a change  $\delta R_L$  in the load resistance causes an output current change of  $\delta I_L$  then:

$$\delta I_L / I_L = -\frac{\delta R_L}{R_o + R_L} \dots \dots \dots (2)$$

Combining equations (1) and (2) we obtain:

$$g_o = \frac{1}{R_o + R_L} = 1/R_o \text{ if } R_o \gg R_L$$

In practice the input voltage  $V_i$  often contains high frequency ripple, so to prevent its appearance in the output current  $I_L$ ,  $g_s$  must be small up to quite high frequencies. This is not so in the case of  $g_o$ , as rapid changes in the load  $R_L$  are not usually encountered, and  $g_o$  need be small for low frequencies only.

It is sometimes advantageous to pre-stabilize the voltage feeding the current stabilizer, thus permitting a higher value of  $g_s$ . The effect of load resistance changes on load current can only be reduced by making  $g_o$  small, unless some form of compensation is possible. If load changes are large they can be the main source of instability of the output current.

## Stabilization Using Non-Linear Elements

Non-linear devices such as barretters have current stabilizing properties, but their application is limited since they are commercially available only for certain currents. With some barretters the stabilized current is sensitive to ambient temperature and their action has a long time lag<sup>2</sup>,

though improved types are available<sup>3</sup>. The high anode resistance of pentodes can be utilized for current stabilization, and may be increased by negative current feedback.

## Feedback Stabilizers

### CIRCUIT ARRANGEMENTS

The simplest form of feedback valve stabilizer is a triode with a resistor  $R_k$  in the cathode circuit and the load in the anode circuit (Fig. 1). The output resistance of this arrangement is  $r_a + (1 + \mu) R_k$  where  $r_a$  is the valve anode impedance without feedback and  $\mu$  the amplification factor. If a non-linear device, such as a metal filament lamp, is used for the cathode load, a high effective value of  $R_k$  is obtained for a small cathode load voltage drop<sup>4</sup>. The time lag of the filament, however, makes this effect smaller for the higher frequency components present in power supply ripple and transients.

Pentodes produce better results than triodes since  $\mu$  and  $r_a$  are higher and because of the contribution of the screen

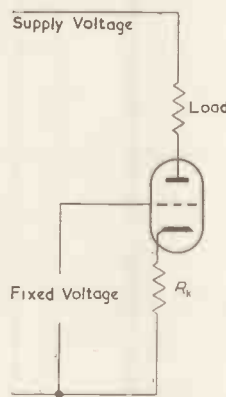

Fig. 1. Triode valve with cathode resistor feedback

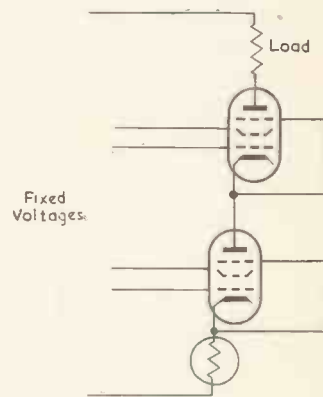

Fig. 2. Cascode circuit with metal filament lamps as cathode resistor

grid  $\mu$ . Measurements on a 6F6 pentode circuit made by Hill<sup>1</sup> with  $R_k = 1000\Omega$ ,  $\mu = 200$ , show  $g_s = 11 \times 10^{-6} \text{ mho}$   $g_o = 5.3 \times 10^{-6} \text{ mho}$ ,  $R_o = 190000\Omega$  in fair agreement with predicted values. The degree of stabilization is limited by the constants of the valves used and the maximum value of cathode resistor permissible.

The efficiency of the cathode feedback circuit can be further improved by using a pentode as the cathode load, i.e. a cascode amplifier using two pentodes with the load in the anode of the upper valve (Fig. 2). This circuit has been analysed by Van Scoyoc and Schulz<sup>2</sup> and can have a very high output resistance, though it has the disadvantage that both valves pass the load current.

As an alternative to increasing the effective value of  $R_k$ , the effective value of  $\mu$  can be increased by introducing a separate amplifier. The basic arrangement then becomes that shown in Fig. 3(a); the load current  $I_L$  is passed through a reference resistor  $R$  and the voltage drop across it is opposed by the reference potential  $E$ . The difference is then

\* Research Laboratory, Associated Electrical Industries, Ltd.

applied to a D.C. amplifier, the output of which is fed into a current control device placed between the supply and the load. An alternative to using reference resistor and voltage is to compare the load current with a reference current in a transducer, the output of which is rectified before final D.C. amplification<sup>5</sup>.

The main requirement of the control device is that it should suit the load current. For loads up to about 1A, a parallel combination of valves is suitable; larger currents can be stabilized by shunting the valves with resistors, at the expense, however, of reduced control. Many different arrangements have been used for higher load currents. The choice of system depends on the same factors as occur in voltage stabilizers, which have been reviewed by Benson<sup>6</sup>.

For currents up to 5A, Wills<sup>7</sup> describes a current stabilizer employing a power amplifier controlling a 3-phase A.C. supply feeding a rectifier set. Alternatively some form of transducer can be used<sup>8</sup>. For larger currents motor generators are usually necessary, the output being controlled via the field windings with a bank of valves<sup>9</sup> or a small generator<sup>10</sup>.

#### ANALYSIS OF TYPICAL CASE

The exact analysis of such a circuit depends on the form taken by the control device. As an example, a circuit including a series triode (Fig. 3(b)) will be analysed approximately.

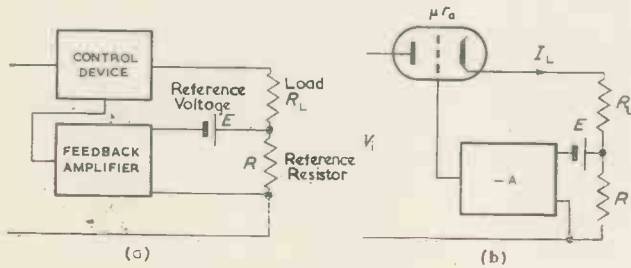

Fig. 3 (a) and (b) Feedback stabilizer with separate D.C. amplifier

The voltage drop across the series valve is given by:

$$V_{ak} = I_L r_a - \mu V_{gk}$$

now:

$$V_{gk} = -A[I_L R - E] - I_L[R_L + R]$$

where  $r_a$  and  $\mu$  relate to the series valve and  $R$  and  $E$  are the reference elements.

$I_L$  and  $R_L$  are the load current and resistance respectively.

$$\begin{aligned} \therefore V_i &= V_{ak} + I_L[R_L + R] \\ &= I_L r_a - \mu[-A(I_L R - E) - I_L(R_L + R)] + I_L[R_L + R] \\ &= I_L[r_a + \mu A R + \mu R_L + \mu R] - \mu A E + I_L[R_L + R] \end{aligned}$$

$$\therefore I_L = \frac{V_i}{r_a + \mu A R + (R_L + R)(1 + \mu)} + \frac{\mu A E}{r_a + \mu A R + (R_L + R)(1 + \mu)} \quad (3)$$

$$\begin{aligned} \therefore \text{Stabilization transconductance } g_s &= \frac{dI_L}{dV_i} \\ &= \frac{1}{r_a + \mu A R + (R_L + R)(1 + \mu)} \approx \frac{1}{\mu A R} \text{ if } A \text{ is large} \quad (4) \end{aligned}$$

i.e., changes in output current which would have been caused by an input voltage change are reduced by a factor  $\mu A R$ , where  $\mu$  is the amplification factor of the series valve,  $A$  the amplifier gain and  $R$  the reference resistor value.

$$\therefore \text{Output transconductance } g_o = -\frac{dI_L}{dV_o} = -\frac{dI_L}{I_L dR_L}$$

$$= \frac{1 + \mu}{r_a + \mu A R + (R_L + R)(1 + \mu)} \approx 1/A R \text{ if } A \text{ and } \mu \text{ are large}$$

$$\therefore \text{Output resistance } R_o = 1/g_o \approx A R \quad (5)$$

i.e., the output resistance of this stabilizer is approximately given by the product of reference resistor and voltage gain.

The change in current  $\delta I_L$  for a load change  $\delta R_L$  is, therefore, given approximately by

$$\frac{\delta I_L}{I_L} = -\frac{\delta R_L}{A R}$$

From equation (3) it can be seen that if  $A$  is large

$$I_L \approx \frac{\mu A E}{1 + \mu A R}$$

$$\text{i.e. } I_L \approx \frac{E}{R} \quad (6)$$

#### IMPROVEMENTS BY COMPENSATION

##### Input Voltage Compensation

For the simple cathode resistor feedback stabilizer, the addition of a resistor  $R_b = \mu R_k$  (Fig. 4) makes the load current  $I_L$  independent of supply voltage fluctuations; this resistor causes only a small reduction in output resistance.

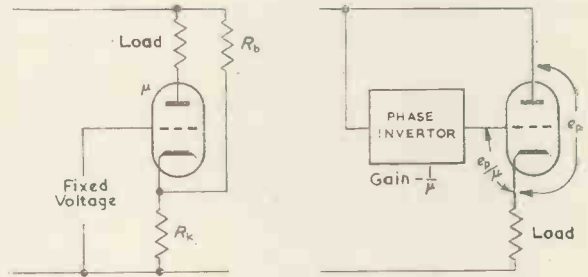

Fig. 4. Cathode resistor stabilizer with input voltage compensation

Fig. 5. Hill's "degenerative mu-balance" arrangement

Since  $\mu$  varies with the working point of the valve, however, perfect compensation is not obtained for all currents. Compensation over a wider range can be obtained by the "degenerative mu-balance" scheme described by Hill<sup>1</sup> and shown in Fig. 5. Any change in voltage drop across the valve is reversed in phase and a fraction is applied to the grid of the valve. If this fraction is  $1/\mu$ , the anode current remains constant in spite of changes in voltage drop across the valve. The practical circuit described by Hill gives infinite stabilization at two points, with values between these points of  $g_s = g_o = 0.25 \times 10^{-6} \text{ mho}$  ( $R_o = 4 \text{ M}\Omega$ ) for a  $3000\Omega$ ,  $50 \text{ mA}$  load.

In a series parallel stabilizer using a pentode amplifier (Fig. 6), input voltage compensation can be obtained by a suitably proportioned potential divider  $R_1 R_2$  fed from the input voltage<sup>11</sup>, an arrangement often used in voltage stabilizers<sup>6</sup>.

##### Load Resistance Compensation

The output resistance of the series parallel circuit (Fig. 6) can be raised by load resistance compensation. A fraction of the output voltage is fed into the cathode circuit of the amplifier by the resistors  $R_3$  and  $R_4$  so that variations in the load resistance cause a compensating voltage to be added to the reference potential  $E$ . For a certain ratio of  $R_3$  and  $R_4$ , the output resistance of a typical circuit<sup>11</sup> can be increased from  $0.5$  to  $4 \text{ M}\Omega$  over the load resistance range  $3000$  to  $4000\Omega$ . Similar compensation could be applied to more complicated amplifier arrangements.

It should be noted that although compensation can often

effect an improvement, it should not be relied upon to a great extent. Permanency of the compensation adjustment depends on the stability of valve characteristics in addition to resistors, and since valve characteristics change with time, the degree of compensation is likely to alter.

## Factors Affecting Stability

### REFERENCE ELEMENTS

It can be seen from equation (6) that the stability of the load current depends directly on that of the reference resistor and potential.

For the best stability, the reference resistor is made from low temperature coefficient material, suitably baked and annealed. Unsealed resistors stable to 10 parts per million per year can be made, sealed resistors are some 10 times more constant<sup>12</sup>. Temperature control of the resistor is often necessary for the highest stability and separate potential and current terminals are essential when the load current is large. In this case, a small value of reference resistor must usually be chosen to minimize power dissipation, but then the reference potential is small, and stray potentials and the d.c. amplifier stability problem become troublesome. In one way the resistor problem here is more difficult than in voltage stabilizers. In the latter case the potential divider ratio only is required to be

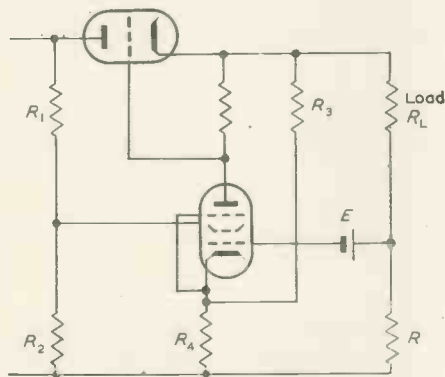

Fig. 6. Two valve feedback stabilizer with compensation

kept constant, but in current stabilizers the absolute value of the resistor must be stable.

Gas discharge tubes are a convenient source of reference potential, but have been shown by Benson<sup>13</sup> to exhibit random variations of running voltage of about 0.4 per cent, though manufacturer's data for type 85A2 gives 0.1 per cent per 1 000 hours. Dry Leclanché cells are often used as a more stable reference source<sup>6</sup>, though mercury cells such as the Ruben<sup>14</sup> and Kalium<sup>15</sup> types have the advantage of smaller temperature coefficients of voltage (about 20 parts in  $10^6/^\circ\text{C}$  compared with some 200 for Leclanché cells). These have been used in a voltage stabilizer giving an output stability of a few parts in  $10^6$  per hour<sup>14</sup>. Weston standard cells can also be used, though their relatively high internal resistance (about  $1\,000\,\Omega$ ) is a drawback if appreciable current is drawn. Sometimes the feedback amplifier does not permit the use of such a high input load resistance.

### FEEDBACK AMPLIFIER

In addition to requiring a certain gain to reduce the effects of supply voltage and load variations, the feedback amplifier must also have a good input stability. Variations in the amplifier, referred to the input, have the same effect as changes in the reference voltage, so affecting directly the output current stability. The properties of various types of amplifiers have been reviewed by Kandiah and Brown<sup>16</sup>, but a few examples will be quoted to illustrate their use in current stabilizers.

Simple valve circuits usually have a stability of the order of  $10\text{mV/h}$ , i.e. 1 in 5 000 for a 50 volt reference potential. This arrangement is often used in electron microscope magnetic lens stabilizers in a circuit (Fig. 6) closely resembling the conventional series parallel valve voltage stabilizer<sup>11</sup>.

For higher stability or when large currents are to be stabilized it is usually necessary to use a contact modulated or galvanometer amplifier<sup>16</sup>. An example of the galvanometer system is that due to Chang<sup>10</sup>, where a stability of 1 in  $10^4$  was obtained using a reference potential of  $200\text{mV}$ . Using a contact modulator amplifier and 1 volt reference potential, Sommers, Weiss and Halpern<sup>9</sup> obtained a stability of 1 in  $10^6/\text{min}$  for an electromagnet current of  $160\text{A}$ .

### PREVENTION OF OSCILLATIONS

In order that the effect of input voltage and load resistance changes may be reduced to the required degree, a certain loop gain is necessary. The maximum loop gain which can be applied in a feedback circuit before the onset of oscillations is related to the frequency response in a manner investigated by Bode<sup>17</sup>. It can be shown that oscillations are likely if the gain falls with frequency resulting from two or more comparable time-constants. This situation obtains when such combinations as galvanometer amplifiers and motor generators are used. Conventional contact modulator amplifiers have a poor high frequency response because of the modulating frequency input and output filters, though the parallel-T d.c. amplifier<sup>18</sup> does not suffer from this defect.

In some cases oscillations can be prevented by obtaining derivative feedback from anti-hunt coils wound on the electromagnet core and injecting the voltage induced in them into the feedback loop<sup>10</sup>. Alternatively the frequency response of parts of the loop can be improved by auxiliary feedback loops. In the case of a motor generator this can take the form of a voltage feedback loop from the generator output which has the effect of improving the frequency response and reducing the output ripple due to commutation, etc. The generator then becomes a low noise power amplifier with a good frequency response.<sup>9</sup>

### Acknowledgments

The author is indebted to his colleagues for helpful suggestion and criticism, and to Dr. T. E. Allibone, F.R.S., for permission to publish this paper.

### REFERENCES

- HILL, W. R. Analysis of 'Current' Stabilizer Circuits. *Proc. Inst. Radio Engrs.* 33, 785 (1945).
- PATCHETT, G. N. Precision A.C. Voltage Stabilizers. *Electronic Engng.* 22, 424 (1950).
- MORTON, C. Precision A.C. Voltage Stabilizers. *Electronic Engng.* 23, 70 (1951).
- VAN SCOYOC, J. N., SCHULZ, E. H. Current Stabilizers. *Proc. Inst. Radio Engrs.* 32, 415 (1944).
- CARO, D. E., PARRY, J. K. A Stabilized 100 Amp Power Supply. *J. Sci. Instrum.* 26, 375 (1949).
- BENSON, F. A. Voltage Stabilizers. (Electronic Engng. Monograph, 1950). Also *Electronic Engng.* 25, 202 (1953).
- WILLS, M. S. An Electronic Current Stabilizer for a Low Resistance Solenoid. *Electronic Engng.* 25, 250 (1953).
- SMITH, H. G. A Transducer Controlled Stabilizer. *Electronic Engng.* 24, 173 (1952).
- SOMMERS, H. S., WEISS, P. R., HALPERN, W. Magnet Current Stabilizer. *Rev. Sci. Instrum.* 20, 244 (1949) and 22, 612 (1951).
- CHANG, W. Y. A Study of Alpha Particles from Po with a Cyclotron-Magnet Alpha ray Spectrograph. *Phys. Rev.* 69, 60 (1946).
- HAINES, M. E. The Design and Construction of a New Electron Microscope. *J. Instn. Elect. Engrs.* 94, Pt. 1, 447 (1947).
- THOMAS, J. L. Precision Resistors and their Measurement. U.S.A. Dept. of Commerce N.B.S. Circular 470, (1948).
- BENSON, F. A. A Study of the Characteristics of Glow Discharge Voltage-Regulator Tubes. *Electronic Engng.* 24, 456 (1952).
- SENETT, W. P., PIERCE, R. W. Exceptionally Stable Regulated Power Supply for Electrometer Tubes. *Rev. Sci. Instrum.* 23, 534 (1952).
- JERVIS, M. W. The Temperature Coefficient of the E.M.F. of Kalium Cells. *J. Sci. Instrum.* 30, 60 (1953).
- KANDIAH, K., BROWN, D. E. High Gain D.C. Amplifiers. *Proc. Instn. Elect. Engrs.* 99, Pt. 2, 314 (1952).
- BODE, H. W. Network Analysis and Feedback Amplifier Design. (Van Nostrand, 1945).
- BUCKERFIELD, P. S. T. The Parallel-T D.C. Amplifier. *Proc. Instn. Elect. Engrs.* 99, Pt. 2, 497 (1952).

# Relay Scale-of-Two Circuits

(Part 1)

By R. C. M. Barnes\*, B.Sc.

*The scale-of-two is a basic element of many relay circuits but the limited information which has been published does not indicate the numerous circuits that have been developed, nor assist in the choice of an appropriate circuit for each particular application. This article therefore reviews a typical selection of relay scale-of-two circuits.*

**R**ELAY scales-of-two and other counting elements do not form a prominent feature of automatic telephone equipment in this country and are given, at the most, a passing reference in the literature. Thus the circuit designer has so far had very little guidance in choosing an appropriate scale-of-two circuit for each of the varied applications in the field of relay control, switching, and counting, since there is no single circuit which gives the optimum performance in all cases.

Sixteen circuits of practical value are described, with rather more information about the operation of each circuit than will be required by those familiar with the design of relay circuits, and with comments on any outstanding characteristics or design difficulties. Reference is also made to a few circuits which have been published but which appear to be of no practical value.

## Principal characteristics of Relay Scales-of-Two

The circuit designer will be mainly concerned with the resolution time of the scale-of-two, the input conditions which are necessary and the type of output which it provides. If cost or pan-climatic protection is important he may also wish to specify a particular type of relay.

### RESOLUTION TIME OR OPERATING SPEED

As a general rule it may be assumed that a scale-of-two consisting of type K3000 or K600 relays will accept pulses at rates up to 10 per second, and circuits with high speed or polarized relays will accept pulses at 50 per second. It may sometimes be possible to improve on these figures, but seldom by more than a factor of two, by very careful choice of circuit and components and by providing an input pulse with the optimum make-break ratio.

### INPUT CONDITIONS

It is often desirable to choose a scale-of-two circuit which is controlled by a simple on-off condition, particularly where there are several inputs in parallel or connected by complicated switching networks. In some cases the scale-of-two can be simplified if the input condition is more complicated, for instance a make-before-break changeover contact can be used to control a very simple scale-of-two.

### OUTPUT CONDITIONS

Outputs at half the input frequency can often be taken from suitable points in the scale-of-two circuit and may be the only possible outputs from high speed relays with only one contact. Where the scale-of-two relays are required to have contacts in several other circuits the use of multi-contact relays is essential.

### TYPE OF RELAY

If sealed or miniature relays are necessary the choice of circuit will be restricted by the limited contact actions and coil windings which are available on these relays.

## Definitions of Standard Terms

The reader who is not familiar with relay circuit design will need to be reminded of the standard functions for which a relay is designed, the correct names for the contact actions, and the conventions used in circuit diagrams.

In general a relay can be designed to meet one or more of four circuit application current conditions which can be summarized as:—

### OPERATE CURRENT

The minimum current which the circuit must provide under adverse conditions of voltage and resistance in order that the relay will always operate fully and at a reasonable speed.

### HOLD CURRENT

The minimum current which the circuit must provide under adverse conditions in order that the relay will remain fully operated.

### NON-OPERATE CURRENT

The maximum current at which the relay will not operate at all.

### RELEASE CURRENT

The maximum current at which the relay will release completely after the magnetic circuit has been saturated.

### CONTACT ACTION

Four types of contact action are available on most relays. A "make" contact (abbreviation *M*) is normally open, and closes when the relay is energized. A "break" contact (abbreviation *B*) is normally closed, and opens when the relay is energized. A changeover contact (abbreviation *C*) has a break-before-make action, and on some relays a special type of changeover with make-before-break action is possible (abbreviation *K*). It is usually specified that a relay must be adjusted so that, as the relay operates, all the break contacts open before any make contact closes (*K* contacts excepted).

### CIRCUIT DIAGRAMS

The diagrams show the relays in the unenergized condition, i.e., with the power supply disconnected. For convenience in the circuit descriptions where a coil has two windings these have been labelled *V* and *W* without reference to the relative resistances or turns, or to the order in which the windings may appear on the actual relay. On most type K3000 relays with double windings the resistances are approximately equal but one winding has slightly more turns. Special "balanced" coils are available with equal resistance and turns. On inter-service preferred high speed relays the two windings have equal turns and resistance but have different sensitivities.

The diagrams in this article are drawn assuming a positive power supply. Wherever possible circuits have been drawn in a uniform manner to emphasize similarities, and in some cases this has necessitated a slight re-arrangement of circuits which have already been published. The

\* A.E.R.E. Harwell.

denominators of the relay codes show the minimum number of contacts which are essential for the scaling sequence. In many cases, extra contacts on the relays would be used in other associated circuits.

### A Simple Relay Scale-of-Two

Most relay scales-of-two consist of two relays, which will be referred to as *A* and *B* throughout. These relays operate in a sequence such that *A* changes its state when each pulse is received and *B* takes up the same state as *A* after each pulse: i.e.:—

- |                                      |  |
|--------------------------------------|--|
| 1 <sup>st</sup> , or odd, pulse on   | relay <i>A</i> operates                            |
| 1 <sup>st</sup> , or odd, pulse off  | relay <i>A</i> remains operated, <i>B</i> operates |
| 2 <sup>nd</sup> , or even, pulse on  | relay <i>A</i> releases, <i>B</i> remains operated |
| 2 <sup>nd</sup> , or even, pulse off | relay <i>B</i> releases                            |

The circuit of Fig. 1(a) gives this sequence in a simple manner, although it is controlled by a make-before-break contact, *I*. When the contact *I* operates it completes a circuit through winding *A<sub>v</sub>*, and *A* operates. When *I* releases it establishes a circuit with contact *A<sub>1</sub>* closed and winding *W* of both relays in series before disconnecting the operating circuit of *A*. *B* now operates and *A* remains operated. The next operation of *I*, with *B* operated, allows current to flow in *B<sub>v</sub>* winding and then disconnects the path by which

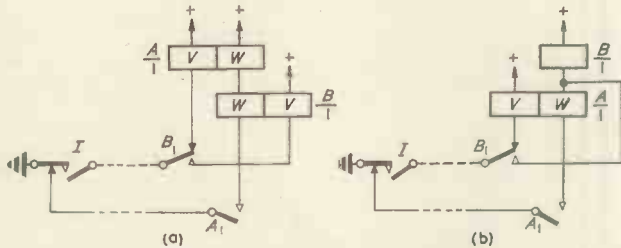

Fig. 1(a) and (b). Two versions of a simple scale-of-two

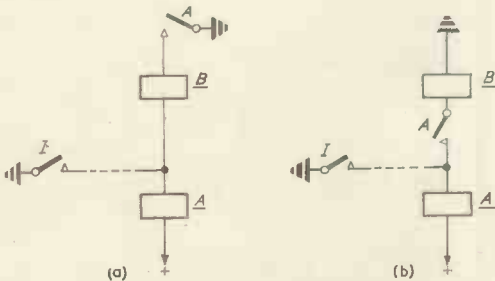

Fig. 2(a) and (b). The prime pair circuit element

*B* and *A* have been energized. *A* releases. When *I* releases at the end of this second pulse the holding circuit for *B* is broken and *B* releases, completing the required sequence. It is assumed that the make-before-break contact *I* is bunched for a time less than the operate time of *A* relay. Fig. 1(b) shows an alternative version of the circuit in which *B* has only one winding. If the transit time of contact *I* is short compared with the releasing time of relays *A* and *B* it is permissible to use a break-before-make changeover.

### Prime Pair Scales-of-Two

A well known circuit element for providing the correct sequence when odd pulses are received is shown in Fig. 2(a) and 2(b). This arrangement is sometimes called a prime pair. When the input lead is earthed current flows through the coil of *A* relay, which operates. The *A* con-

tact prepares a circuit which will be used to operate *B* and hold *A* in series, but during this pulse *B* is short-circuited. At the end of the input pulse *B* operates in series with *A*. A contact of *B* relay then prepares a route for the next pulse to a circuit element which will release first *A* and then *B*.

The prime pair circuit element is used in the complete circuits of Figs. 3 to 9, together with another circuit element which secures the subsequent release of *A* by one of the following methods:—

- Routing the second pulse to short-circuit *A*.
- Passing the second pulse through a winding on *A* which opposes the first winding and provides more ampere-turns so that the magnetic flux tends to reverse and in doing so releases the relay.
- Passing the second pulse through a balancing winding on *A* which opposes the first winding and provides approximately equal ampere-turns so that the magnetic flux is reduced to a value at which the relay releases.
- Routing the second pulse to operate a third relay *C* which disconnects *A*.

### SECOND PULSE SHORT-CIRCUITS RELAY *A*

In the circuit<sup>1</sup> of Fig. 3 the prime pair circuit element causes *A* to operate during the first pulse and *B* to operate in series with *A* after this pulse. The two contacts of *B* now reconnect the driving contact *I* so that, when it next closes, the coil of *A* will be short-circuited. Consequently *A* releases during the second pulse and *B* continues to be energized via *B<sub>v</sub>*, *I* and *B<sub>1</sub>* until the end of the pulse. Some resistance is added in the power supply lead to protect the relay contacts in the event of an earth fault. This circuit is simple, suitable for use with sealed relays which have only one coil winding and the relay design is not critical.

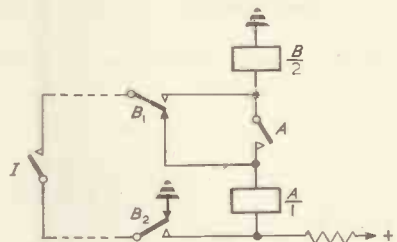

Fig. 3. Circuit for relays with single windings

It cannot be used to count fast pulses since the release of *A* under short-circuit conditions is very slow.

Fig. 4(a) shows a similar circuit in which the input contact is earthy. When *B* is normal the first pulse is applied to the prime pair circuit element, operating *A* during the pulse and *B* at the end of it. The next pulse is routed to winding *B<sub>w</sub>*, holding *B* operated for the duration of the pulse, and it also short-circuits *A*. The resistor limits the current which flows during the short-circuit period. It should be noticed that winding *B<sub>w</sub>* is in parallel with the limiting resistor during the first pulse. The components must be chosen so that there is no risk of *B* operating prematurely due to this condition.

An alternative version of the circuit in Fig. 4(b) uses a rectifier to isolate the hold winding of *B* during the first pulse. *A* is shunted by the rectifier during the second pulse and the components must be chosen so that the current in *A* falls below the release current. Both forms of this circuit are suitable for high speed relays, although the release of *A* will be comparatively slow.

The circuit<sup>2,3</sup> shown in Fig. 5 has a prime pair circuit element to give the first pulse sequence. Winding *B<sub>w</sub>* appears in series with *A* during the first pulse, but is chosen so that *B* does not operate. *B* holds over this winding

during the second pulse and  $A$  is short-circuited. The following conditions must therefore be satisfied:

- (1) Relay  $A$  will operate in series with winding  $B_w$ .
- (2) Relay  $B$  will not operate when winding  $B_w$  is in series with relay  $A$ .
- (3) Relay  $B$  will operate when both windings are in series with relay  $A$ .
- (4) Relay  $A$  will hold in series with windings  $B_v$  and  $B_w$ .
- (5) Relay  $B$  will hold when only winding  $B_w$  is energized.

These conditions can be met with non-preferred high speed relays; for working on a 50 volt supply relay  $A$  could be a Siemens type H85L (1700 + 1700 ohms in series) and relay  $B$  a Siemens H85J (winding  $B_v$  is 500 ohms and  $B_w$  is 145 ohms). It should be possible to make  $B$  a preferred relay, with equal windings, by adding a shunt across  $B_w$ .

#### SECOND PULSE REVERSES FLUX IN RELAY A

The circuits which have been discussed above all have the defect that the short-circuit release of  $A$  is slow. This situation can only be improved by using a large residual air-gap and heavy springset loading with consequent increase in operating time.

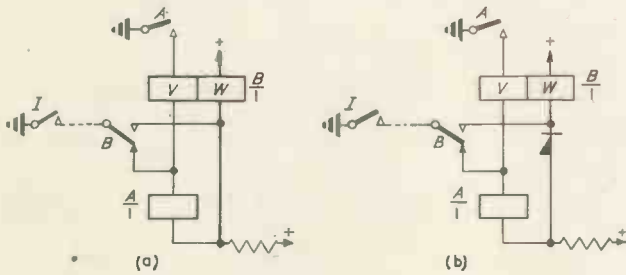

Fig. 4(a) and (b). Two circuits suitable for high speed relays

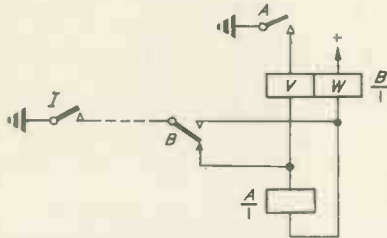

Fig. 5. A further circuit for high speed relays

If the second pulse releases relay  $A$  by energizing a second winding on  $A$ , tending to reverse the magnetic flux, the release may be as fast as that which could be expected if the relay windings were disconnected.

Fig. 6(a) shows a circuit embodying this principle. The prime pair circuit element gives the usual sequence when the first pulse is received. Then, with  $A$  and  $B$  operated, the second pulse is applied to windings  $A_w$  and  $B_w$  in parallel. Winding  $B_w$  is connected to assist winding  $B_v$ , but winding  $A_w$  opposes  $A_v$  and develops more ampere-turns. The magnetic flux in  $A$  decays rapidly and, ideally, contacts  $A_1$  and  $A_2$  disconnect the operating and release windings of  $A$  simultaneously.  $A$  releases fully and  $B$  remains operated until the end of the pulse. If relay  $A$  is adversely adjusted so that, on release, contact  $A_2$  opens before  $A_1$ , the relay will attempt to re-operate over contact  $A_1$  until  $A_2$  recloses. It is therefore necessary to guarantee that the operating circuit of  $A$  is broken before the release condition is removed.

Many relays are adjusted so that, on release, all make

contacts open before any break contacts close and this feature has been employed in Fig. 6(b) to ensure the correct sequence of the operating and release circuits for relay  $A$ . The second pulse is applied to the release winding of  $A$  and the hold winding of  $B$  in series. Contact  $A_1$  opens as  $A$  releases and disconnects the hold winding of  $A$  before contact  $A_2$  short-circuits the release winding.  $B$  remains operated until the end of the pulse.

A minor defect of this circuit is that the operation of relay  $A$  is retarded while winding  $A_w$  is short-circuited by contact  $A_2$ . This can be corrected by a second  $B$  contact or a rectifier as shown in Fig. 6(c).

#### SECOND PULSE APPLIED TO BALANCING WINDING ON A

The circuits of Figs. 6(a), 6(b) and 6(c) require the relay to have two contacts; one in the holding circuit, and one to

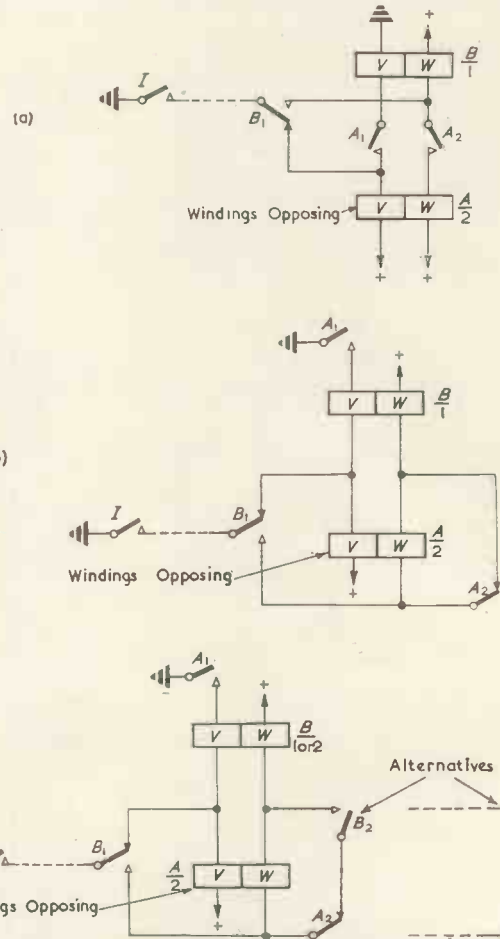

Fig. 6(a). Circuit for two multi-contact relays; (b) improved version of Fig. 6(a); (c) further improvements applied to Fig. 6(b)

disconnect the releasing winding and prevent re-operation on reversed energization. These circuits are therefore unsuitable for single contact high speed relays. The necessity for a contact controlling the releasing winding can be avoided if the two windings of  $A$  have approximately equal and opposite energization. Fig. 7 shows a circuit of this type. The first pulse is applied to the usual prime pair circuit element, with the rectifier isolating winding  $A_w$ . With relays  $A$  and  $B$  operated, the second pulse is routed through winding  $B_w$  to both windings of  $A$  in parallel. Winding  $B_w$  is connected to assist winding  $B_v$ , so that relay  $B$  remains operated until the end of the pulse. Windings  $A_w$  and  $A_v$  give equal and opposite energization and relay  $A$  releases.

The minimum conditions which must be satisfied are



that any out-of-balance between the  $A$  windings should produce less than the release ampere-turns of energization in  $A$  when the second pulse is received and less than the non-operate ampere-turns after the  $A$  make contact has opened. If the second pulse produces an exact balance between the  $A$  windings the release of  $A$  is much slower than its release on disconnection, while a residual energization equal to the release ampere-turns will give an even worse performance. A second difficulty is that any out-of-balance after  $A$  releases may result in prolonged contact bounce at the break contact of a high speed relay and prevent its use for providing an output. This can be minimized by a second rectifier or equivalent resistance in series with the  $A_w$  winding.

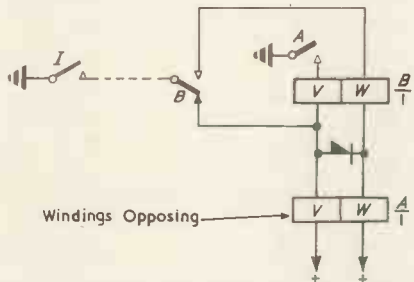

Fig. 7. Circuit for high speed relays using a balanced release

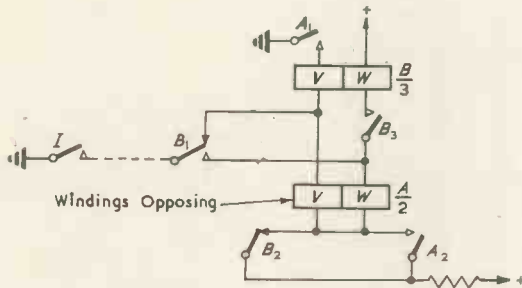

Fig. 8. Circuit designed to tolerate adverse relay adjustments

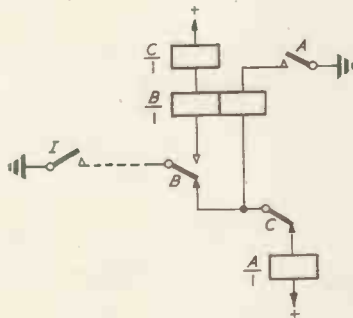

Fig. 9. Circuit with three high speed relays

A more complicated circuit, suitable for multi-contact relays, and using balanced windings on the  $A$  relay is shown in Fig. 8. Relays  $A$  and  $B$  operate as before. The second pulse is routed by contacts  $B_1$  and  $B_3$  to  $B_w$  and  $A_w$  windings in parallel. Windings  $A_v$  and  $A_w$  then provide equal and opposite energization so that relay  $A$  releases. If contact  $A_2$  breaks first, both windings of  $A$  are disconnected simultaneously and the relay continues to release. If contact  $A_1$  breaks first the releasing winding  $A_w$  continues to release  $A$  until  $A_2$  breaks. The resistor limits the current carried by contacts  $B_2$  or  $A_2$  in the event of an earth fault in this part of the circuit. Contact  $B_3$  ensures that the voltage developed across the resistor

during the first pulse does not produce current in windings  $A_w$  and  $B_w$ . The circuit is claimed to work satisfactorily with adverse adjustments of both relays.

#### A CIRCUIT WITH THREE RELAYS<sup>5,6</sup>

Fig. 9 shows a circuit designed for single contact high speed relays which uses a third relay. It avoids the very slow release of the  $A$  relay inherent in circuits using short-circuit or balanced release principles. The first pulse operates  $A$  and  $B$  as before. The second pulse holds  $B$  and operates  $C$  in series.  $C$  disconnects  $A$ , which releases rapidly.

(To be continued)

#### REFERENCES

1. PACKARD, C. A. *Relay Engineering*. (Struthers-Dunn Inc., 1945.)
2. FRENCH, J. L., and LANE, G. M. A Relay Scale-of-Two. *J. Sci. Instrum.* 26, 160 (1949).
3. BATCHER, MOULIC. *The Electronic Control Handbook*, 248 (1946).
4. SHAW, A. H. A Relay Scale-of-two Circuit. British Patent No. 647635.
5. TAYLOR, D., and BENNETT, A. E. *J. Sci. Instrum.* 25, 283 (1948).
6. KEISTER, RITCHIE, WASHBURN. *The Design of Switching Circuits*, 243 (Van Nostrand, 1951).

## New Airfield Surface Movement Indicator at London Airport

The imminent transfer of traffic to the central area at London Airport and the continued increase in aircraft movements has led the Ministry of Transport and Civil Aviation to make a detailed study of the problem of directing and controlling aircraft when they are on the ground. It is now clear that the present system of visual supervision from the control tower coupled with radio telephone position-reporting by the aircraft will have to be augmented if the increasing traffic is to flow smoothly in bad weather.



The high definition obtained is shown in the accompanying illustration, reproduced from a photograph taken during recent trials at London Airport. An aircraft may be seen taking off from the lower runway — its movement over three successive rotations of the scanner being clearly defined. Another aircraft is shown at the right-hand end of the upper runway awaiting take-off clearance.

With this in mind the Ministry have carried out a number of experiments at London Airport designed to put the complex pattern of runways and taxiways to the most efficient use. These experiments have shown that the introduction of a high discrimination radar, so sited as to give an uninterrupted picture of runways and associated taxiways, would give great assistance to the controller. The Ministry have therefore decided to install an Airfield Surface Movement Indicator (ASMI) with its aerial on the top of the new central Air Traffic Control Tower and they have selected for this purpose the Decca Millimetric Radar operating on a wavelength of approximately 8 mms (Q Band).

Primary features of the new set are high discrimination derived from the narrow horizontal beam of 23 minutes and the short pulse of 0.05 microsecond. This discrimination in bearing and range, combined with the high quality receiver and display system used, produces a radar picture of exceptional clarity. The set is, therefore, capable of providing precise information at short range on the movement of aircraft and vehicles on the runways and taxiways of large modern airfields.

# A Differential Leak Detector for Evacuated Vessels

D. A. Lundberg \*, B.Sc.

*It is necessary in the production of cathode-ray tubes, to have apparatus capable of locating very small leaks in the evacuated tubes.*

*The development of a suitable apparatus is described and operating instructions are given in an appendix. The apparatus uses two Klemperer-type cold-cathode ionization gauges in a bridge circuit, the balance of which is disturbed when a jet of calor gas is passed over a leak in the tube.*

**T**HE increasing use of metal-to-glass seals in the production of cathode-ray tubes has made it essential to have apparatus which is capable of detecting and locating very small leaks. Apparatus for this purpose depends for its operation on the detection of a gas which is applied, either internally or externally, to the vessel.

In the internal method, the vessel to be tested is filled with the gas to a pressure greater than that of the atmosphere and the gas is thus forced through the leak. The leak is detected by passing a probe slowly over the surface of the vessel. The probe is a tube through which air is drawn by a fan; the air is then passed over a detector which is sensitive to the gas. In the vicinity of a leak, the air drawn through the tube will be contaminated and the detector will indicate the presence of gas.

In the external method, the vessel is evacuated and the detector is inserted in the vacuum system. The probe is a small jet of the gas; when it passes over the leak some of the gas will enter the system and its presence will be indicated by the detector. The differential leak detector operates on this principle.

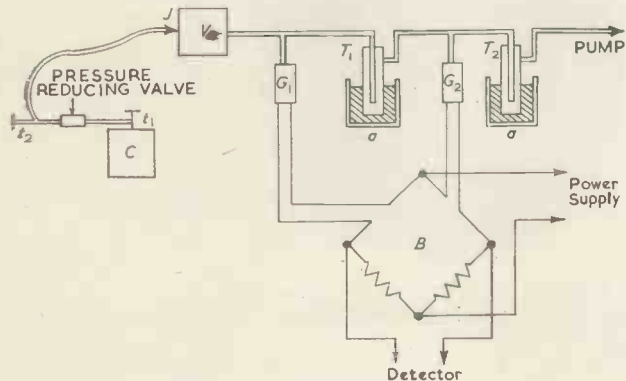

Fig. 1. Differential leak detector

$G_1, G_2$  Vacuum gauges     $B$  Bridge circuit     $a$  Dewar vessel  
 $T_1, T_2$  Cold traps     $C$  Gas cylinder    containing refrigerant  
 $V$  Leaky vessel     $J$  Probe jet     $t_1, t_2$  Taps

## Principle of Operation of the Differential Leak Detector

Fig. 1. illustrates the principle of operation.

The system is evacuated to as low a pressure as possible, and traps  $T_1$  and  $T_2$  are cooled with liquid air. The pressure in gauges  $G_1$  and  $G_2$  should be approximately the same since the only pressure difference between them will be that causing the flow of gas through  $T_1$  and the connecting tubes. The bridge circuit  $B$  is then balanced and the leak in vessel  $V$  is searched for with the probe jet  $J$ , through which is flowing a suitable gas. Calor gas is normally used, but any gas having a negligible vapour pressure at the

temperature of liquid air could be used. When the probe is over the leak, only calor gas will enter the system and as a result of this, the differences of pressure in the ionization type vacuum gauges  $G_1$  and  $G_2$  will change and the bridge will become unbalanced.

Since no air is now entering the system through the leak and the calor gas is prevented from reaching gauge  $G_2$  by the trap  $T_1$ , the pressure in  $G_2$  falls, the air previously in it being removed by the pump. The pressure changes in the first gauge  $G_1$ , however, are more complex and the ion current will change as follows:

- (1) It will decrease since calor gas is denser than air and will, therefore, leak in more slowly.
- (2) It will increase or decrease according to whether the pumping speed of the trap  $T_1$  for calor gas is less than, or greater than the pumping speed for air at trap  $T_1$ , produced by the pump.

The calor gas reaching the trap is frozen on the cold surfaces of the trap and is thus effectively "removed" from the system. The speed at which the calor gas is removed from  $G_1$  and the leaky vessel is the pumping speed of trap  $T_1$  for calor gas. The pumping speed for air at trap  $T_1$ , as produced by the pump, is the speed at which the pump removes air from  $G_1$  and the leaky vessel.

- (3) The ion current will also increase because the molecules in calor gas are larger than those of air.

It was found by experiment that the  $G_1$  reading increased; thus, when calor gas passes the leak,  $G_1$  reading

Fig. 2. Klemperer ionization gauge

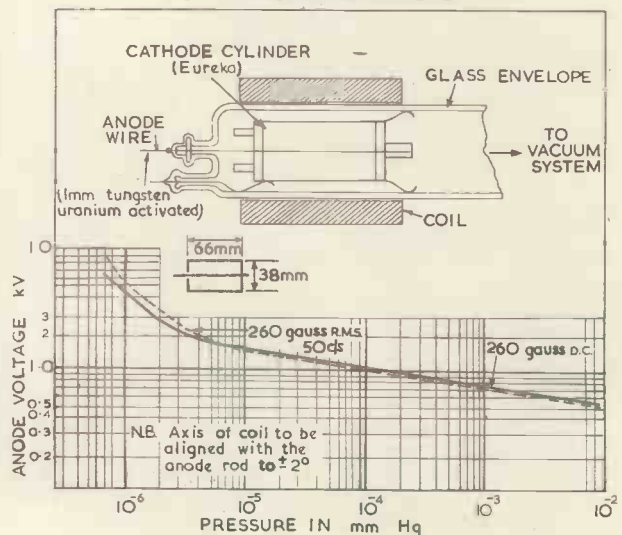

\* E. M. I. Engineering Development Ltd.

increases,  $G_2$  reading decreases, the bridge becomes unbalanced and the detector indicates the passage of the probe over the leak.

### Development of the Apparatus

#### CHOICE OF VACUUM GAUGES

The choice of gauge is determined by the pressure range over which the gauges must operate; this range may extend from  $10^{-2}$  to a minimum of  $10^{-6}$  mm Hg. Thus hot filament gauges cannot be used since their maximum operating pressure is  $10^{-3}$  mm Hg. Pirani-type gauges could be used, but they are not so sensitive as ionization gauges, especially at very low pressures. Therefore, cold-cathode ionization gauges are used since they will operate over the required pressure range and are reasonably sensitive over this range.

The cold-cathode ionization gauge is a discharge tube whose electrode system consists of a cylindrical cathode which surrounds an anode rod of tungsten coated with uranium oxide. When a high potential is applied to the

gauss; the coil has the following dimensions.

Length	82mm.
Inside diameter	52mm.
Outside diameter	95mm.
Resistance	2 000 $\Omega$ at 20°C.

Fig. 2. shows a sketch, and the characteristics, of the Klemperer type gauges which are used in the differential leak detector. The characteristic curves plot the pressure of the gas in the ionization chamber against the anode voltage when a constant discharge current of  $10\mu\text{A}$  is flowing. The Klemperer type of ionization gauge is used because, at low pressures, its change of impedance with pressure is large.

These gauges were initially operated in a circuit designed to keep the gauge current constant as the pressure in, and consequently the impedance of, the gauge changed. Later, however, a different circuit was used in which neither the current through, nor the potential across, the gauge is constant.

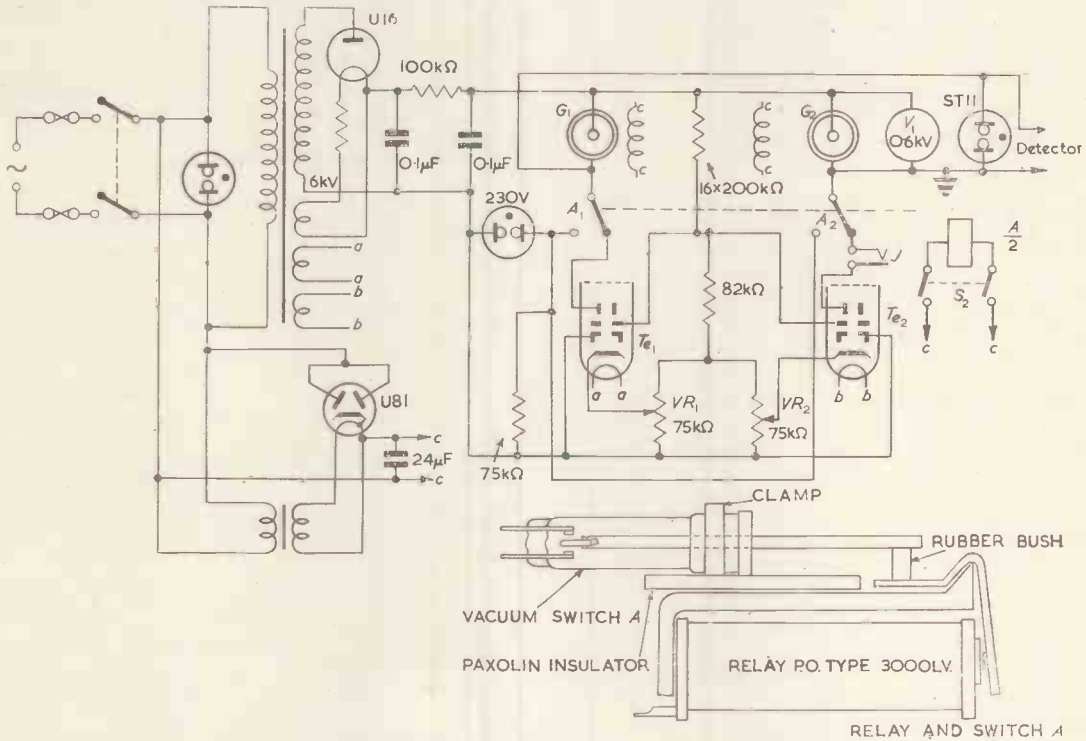

Fig. 3. First bridge circuit.

electrodes a glow discharge results when the tube is connected to a vacuum system, and the discharge current is a function of the total gas pressure. The discharge would normally cease at about 10 microns (1 micron =  $10^{-3}$  mm Hg) since the mean free path is then too great for ionization by gas molecule collision within the dimensions of the gauge. The tube is therefore placed in a powerful magnetic field which is arranged substantially at right angles to the electric field so that electrons cannot travel directly from the cathode cylinder to the anode, but must describe helical paths of considerable length. The probability of ionization by collision is therefore very greatly increased. Under these conditions appreciable ionization currents are produced at pressures so low that a discharge would not otherwise occur, because the mean free path is very much greater than the dimensions of the gauge.

In the differential leak detector, each gauge is surrounded by a coil which produces a field intensity of 260

#### BOMBARDMENT OF GAUGES

New gauges, and gauges which have been exposed to the atmosphere for some time, absorb gases, which are slowly released when the system to which they are connected is evacuated. These gases can be released quickly by bombarding the gauges, i.e., by increasing the current through the gauge and thus raising the electrode temperature to red heat by electron bombardment.

The current required for bombardment is obtained by raising the potential across the gauges and the leak detector includes circuits for this purpose.

#### THE FIRST BRIDGE CIRCUIT

In this circuit, shown in Fig. 3, the two gauges formed two arms of the bridge, which was completed by two tetrode C.R.T. guns sealed in envelopes. These guns maintained the gauge currents at a constant value since their anode current is approximately independent of anode potential from 500 to 6 000 volts. The gauge current is

initially adjusted by altering the bias on these tubes.

A 300V electrostatic voltmeter was used as a detector; it was found impracticable to use a more sensitive instrument since, in the best balance position, the potential across the detector fluctuated by about 100 volts. Because of these fluctuations the circuit was eventually discarded.

The bombarding switch  $A_1, A_2$  has to break 6kV at 10mA and therefore vacuum switches Type CV.298, were used. Two of these were mounted side by side on an ordinary relay, in place of the normal contacts.

#### FIRST VACUUM SYSTEM

This system, shown in Fig. 4, was an experimental one for preliminary trials in conjunction with the first bridge circuit. It consisted of a 1½in mercury diffusion pump, a "Hyvac" rotary pump, a spherical liquid-air trap  $T_2$ , a ½in bore glass tap, and two gauges with a cylindrical liquid-air trap between them. Although the system had a very slow pumping speed, it served to check the electrical apparatus, and gave an indication of the sensitivity. In operation, after the motor pump had been started and a few minutes had elapsed, the diffusion pump heater and the cooling water to the pump were switched on. The controls  $VR_1$  and  $VR_2$  on the bridge unit were set to give minimum gauge current and the unit was then switched on. A microammeter was connected via the jack into  $G_2$  cir-

meter reading with pressure. This microammeter takes the place of the voltmeter  $V_1$  in the first bridge system.  $VR_3$  is used to set the meter range so that  $VR_1$  and  $VR_2$  will swing the meter a small amount on either side of full-scale deflexion when  $S_2$  is open (i.e., gauges on open circuit). The bridge is balanced for zero galvanometer current by adjustment of  $VR_4$  or  $VR_5$ .

To bombard the gauges,  $S_4$  must be opened, thus opening the relay  $A$ , contact 1 of which short-circuits the microammeter; contacts 3 and 4 short-circuit  $VR_4$  and  $VR_5$ , thus protecting the galvo. Contact 2 connects the 200V d.c. supply to  $S_5$  and  $S_6$ . When these switches are closed, the vacuum switches  $VS_1$  and  $VS_2$  close, thus short-circuiting the 19MΩ resistors in series with the gauges so that the full H.T. is applied across them for bombarding purposes.

This bridge unit was connected to the gauges on the pump system of Fig. 4. The leaky vessel was a 4-wire pinch, sealed into a glass bottle; the pinch was known to have a small leak along one of the wires. The system was evacuated and the bridge unit switched on and set for maximum sensitivity (see Appendix). The fluctuations at balance were of the order of 5 to 10mm of scale length on the most sensitive galvanometer range of 100mm/μA.

A jet of calor gas was played over the pinch pins and after about 10 seconds the bridge balance was disturbed; after a further 15 to 20 seconds the deflexion reached a maximum of 40 to 50mm. On removal of the gas jet,

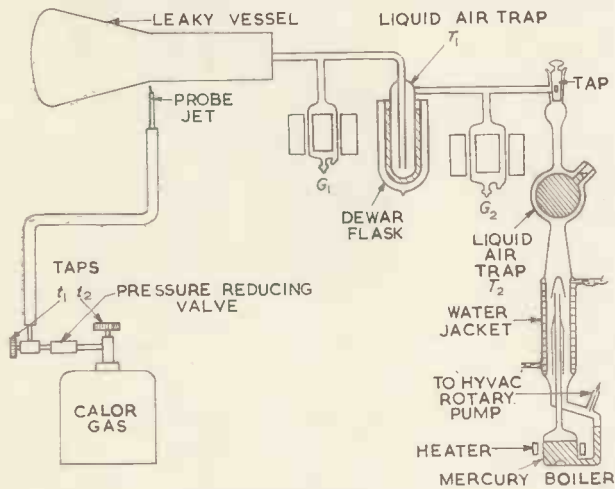

Fig. 4. First vacuum system

cuit and  $VR_2$  was adjusted to give a gauge current of 10μA.

The electrostatic voltmeter, 0–6kV, across  $G_2$ , measured the potential across the gauge and from the reading of the voltmeter, using the calibration curves of Fig. 2, the pressure in the gauge was determined. About 10 minutes after switching on the pump heater, trap  $T_2$  was filled with liquid air and, when the pumps had reduced the pressure in  $G_2$  to about  $10^{-4}$ mm Hg, the gauges were bombarded by closing  $S_2$  for a few minutes. After this bombardment, the trap  $T_1$  was filled with liquid air. When the pressure had reached its limiting value (between  $10^{-5}$  and  $10^{-6}$ mm Hg) the 300 volt electrostatic voltmeter was connected to the detector terminals and  $VR_1$  was adjusted to balance the bridge. In the best balance position the detector fluctuated continually as mentioned previously.

#### SECOND BRIDGE CIRCUIT

Further development of the first bridge circuit was abandoned and a simpler but less sensitive circuit (Fig. 5) was developed. In this circuit, an external galvanometer connected at jack  $J$  is used as the detector. A microammeter,  $M$ , which can be switched by  $S_3$  from  $G_1$  circuit to  $G_2$  circuit, indicates pressure (but is not calibrated to read pressure in mm Hg). Table 1 correlates the microam-

Table I

CURRENT (μA)	PRESSURE (mm Hg)
10	$10^{-2}$
16.5	$10^{-3}$
26	$10^{-4}$
44.5	$10^{-5}$
50	$4 \times 10^{-6}$

the system started to recover slowly, but the original balance position was not reached within about half-an-hour. After bombarding the gauges and re-balancing the bridge, a deflexion was again obtained on applying calor gas.

#### SECOND VACUUM SYSTEM

As the leak in the pinch was one which could not be detected with a commercial apparatus the above results were thought to be sufficiently promising to justify further work. In view of this, a second pump system for use with cathode-ray tubes up to 21 inches in diameter was constructed as shown in Figs. 6 and 7. The equipment is so designed that the tube under test is surrounded with an atmosphere of calor gas in order to determine whether the tube contains a leak of sufficient magnitude to be detected. If a leak is found during this preliminary test, the probe jet is then used to determine the position of the leak.

The cylindrical aluminium gas holder is removable and is held down to the base with spring clips. To avoid the necessity of making a gas tight seal at the bottom of the holder, this is surrounded by a skirt as shown, and thus any gas which leaks from beneath the cylinder is trapped in the space between it and the skirt and is removed by an exhaust fan via four vents. The exhaust gases from the fan are conveyed outside the building by a length of 3in hose.

The pump system consists of a 3in diffusion pump, a "Speedivac" rotary pump and two cold traps. Two magnetically-operated butterfly valves  $V_1$  and  $V_2$  are also included in the system; they are opened to allow the system to be evacuated, and are closed for leak detection. The valves increase the detector sensitivity by cutting down the pumping speed and causing the gas to "pile up" in

the gauges. When the valves are completely closed the pumping aperture is a 1/32in annular gap between the fixed and moving vanes of the valve.

On completion of the test, the calor gas is released from the cylinder by raising valve  $V_3$ .

The sensitivity of the new system was checked using the same leak as before. The leak was found to be only just detectable, thus showing that this system is less sensitive than the original one.

### Conclusions

The apparatus has been used to detect leaks in various types of cathode-ray tubes, with reasonable success. Leaks of sufficient magnitude to cause the pressure in a 10-in tube to rise between  $10^{-3}$  and  $10^{-2}$ mm Hg within a week of manufacture can be detected in nearly all cases. From this it would appear that the detector will locate leaks of the order of 1 to 0.1 micron-litres/hour.

The sensitivity could be increased if the cause of the fluctuations in the detector could be found and removed. There are at least two possible causes. One is fluctuations

this article and Messrs. R. H. Colborne, L. A. Woodbridge, W. J. Hoskin and R. E. Smith for their assistance.

### APPENDIX

#### INSTRUCTIONS FOR USE OF THE DIFFERENTIAL LEAK DETECTOR

The following instructions should be read with reference to Figs. 5, 6 and 7.

Seal the suspected leaky tube to pump. Close glass tap ( $t$ , Fig. 7) connecting the vacuum pump to the outer air and then open the butterfly valves. Switch on vacuum pump and, when a suitably low pressure is obtained, turn on the water supply to the diffusion pump and switch on its heater. Ten minutes later, fill the pump trap  $T_2$  with liquid air. After a further five minutes fill  $T_1$ . Check that the gauges are connected to the bridge unit then switch on the bridge unit (switch  $S_1$ ). If the galvanometer is in circuit, switch it to its least sensitive range, then switch  $S_1$  on, leaving  $VR_3$  at its minimum position. Set  $S_2$  in position  $B$ . Turn  $VR_1$  and  $VR_2$  to maximum resistance, then adjust  $VR_6$  so that the micro-

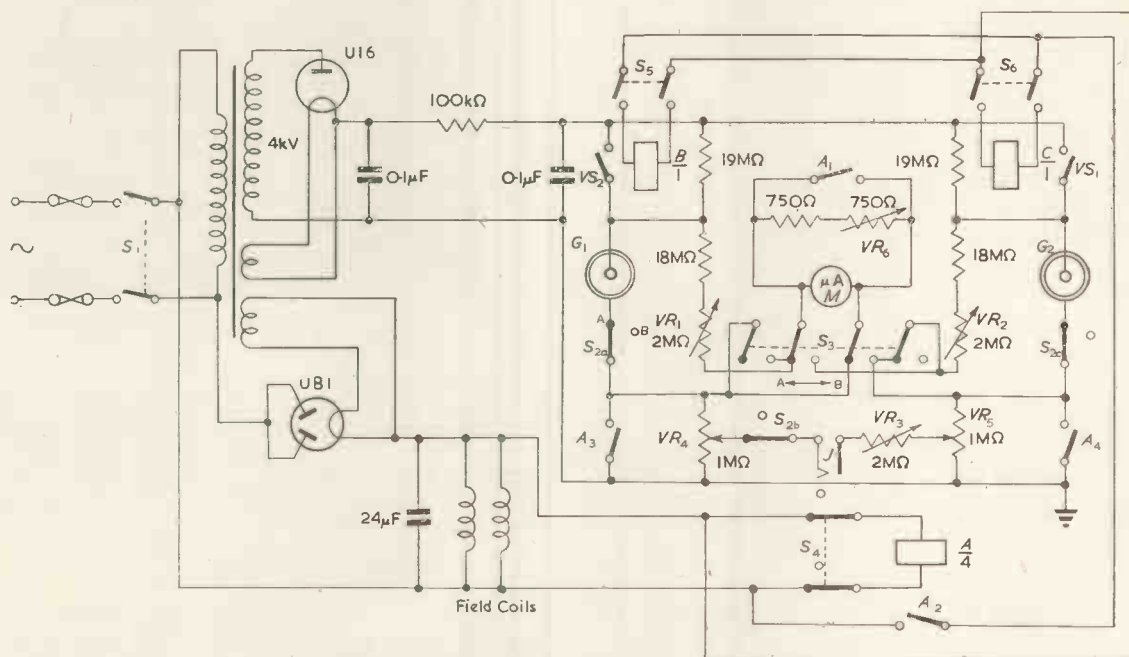

Fig. 5. Second bridge circuit

in the pumping speed of the diffusion pump; the effect of these could be determined by operating two similar gauges in an evacuated, sealed-off system in which pressure conditions are static. If the fluctuations are reduced under these conditions it may safely be concluded that pumping speed fluctuations are at least a partial cause of the trouble. These effects may possibly be reduced by incorporating a large reservoir between the diffusion pump and the ionization gauge  $G^2$ . The other possible cause of these fluctuations is the inherent instability of a cold cathode ionization tube at low pressure. This could possibly be reduced by activating the gauges with a more powerful radio-active source than the uranium oxide which is used at present.

If the fluctuations could be removed, then a D.C. amplifier could be used in the bridge circuit and the sensitivity considerably increased.

#### Acknowledgments

The author wishes to thank the Directors of E.M.I. Engineering Development Ltd. for permission to publish

ammeter reads  $49\mu A$ . Set  $S_3$  to position  $A$  adjust  $VR_1$  to give a meter reading of  $50\mu A$ , similarly with  $S_3$  in position  $B$  adjust  $VR_2$ . Return  $S_2$  to position  $A$ . The microammeter now indicates pressure in gauges 1 or 2 according to whether  $S_5$  is in position  $A$  or  $B$ .

To bombard the gauges, switch  $S_4$  off and press the spring-biased toggle switches  $S_5$  and  $S_6$  one at a time. (If both gauges are bombarded at the same time the transformer and rectifier valves may be overloaded.) The gauges should not be bombarded until the pressure is such that the microammeter reading is greater than  $15\mu A$ .

The system should be left pumping for at least one hour to allow the pressure to stabilize at its minimum value, before attempting to locate leaks.

#### Location of Leaks

Close both butterfly valves and switch the galvanometer to its least sensitive range and connect it via the jack plug. Set  $VR_1$  and  $VR_5$  with the sliders at the top position, then balance circuit for zero galvanometer current by altering either  $VR_4$  or  $VR_6$ . (Greatest sensitivity is obtained when

one of these controls is at its upper position. Set galvanometer to its most sensitive range ( $1\mu\text{A}$  F.S.D.) and adjust  $V/R_3$  to zero for maximum sensitivity, readjust balance if necessary.

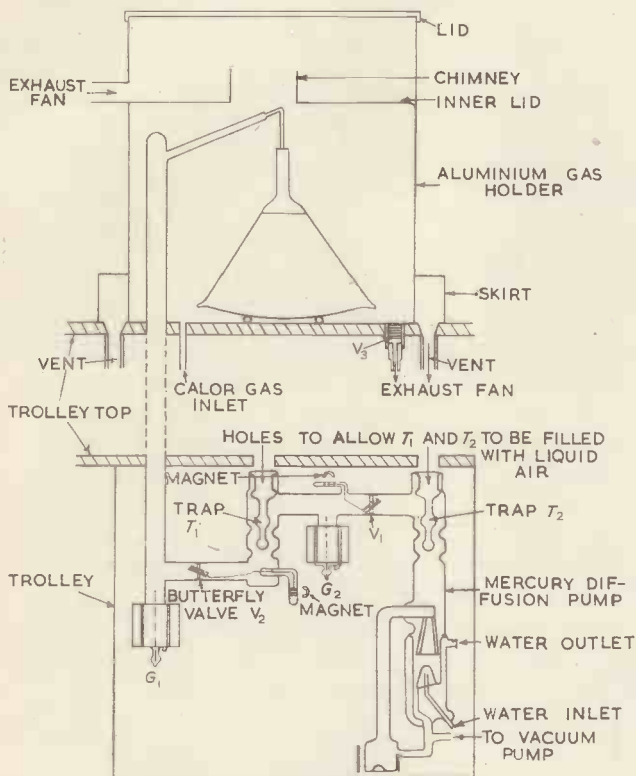

Fig. 6. Second vacuum system

The system is now set to maximum sensitivity and is ready for leak detection. Note that the bridge balance may drift slowly and it may also fluctuate (about  $\pm 0.05\mu\text{A}$ ) about its mean position. These fluctuations cannot be

eliminated but the steady drift will slow down and eventually cease when the system settles down. This may, however, take about 3 or 4 hours.

Leaks are located by probing suspected parts of the tube with a fine jet of calor gas. This probe should be moved slowly as the response time of the detector circuit is of the order of 5 to 10 seconds. When the jet

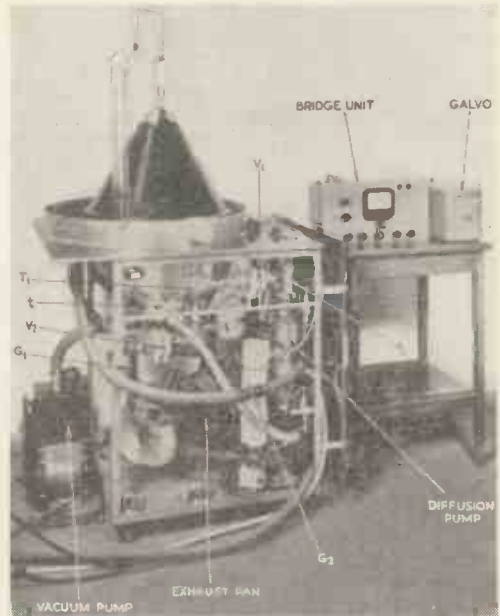

Fig. 7. Leak detector (gas holder removed)

passes over a leak the galvo will be deflected in the opposite direction to the steady drift. After a deflexion has been obtained and the probe jet has been removed, the deflexion should slowly return to zero. The gauges should be bombarded and, if necessary, the balance reset before continuing the search for further leaks or checking leaks already located.

## Cheaper Industrial Television

Production is announced by Marconi's Wireless Telegraph Co. Ltd. of a new Industrial Television Equipment which is smaller, lighter and cheaper than any other at present available in this country.

The new camera measures only  $5\frac{1}{2}$ in by 4in by  $11\frac{1}{4}$ in. Some idea of the miniaturization achieved may be gauged from a comparison of weights with an average studio camera. The latter averages about 140lb. The Marconi Industrial TV camera weighs  $4\frac{1}{2}$ lb only.

Of equal importance is its simplicity of operation. The camera itself houses only the tube, three valves and associated components, so that the likelihood of faults is reduced to a minimum. After initial setting-up it works unattended, simple control being effected from the remote control point.

The camera is merely set up to view a desired scene. The picture signals are fed by a cable to a control unit, and thence to a monitor screen, or screens, up to a distance of 2000ft away from the picture-source.

In this way, for example, a continuous watch may be kept, from a central control office, on various instruments located in widely separated points of a factory. Boiler-gauges, thermometers, revolution counters and power control-board meters, may now all be monitored from one place, with consequent economy of man-power. The checking of water-levels and flow-meters in hydro-electric projects can similarly be carried out.

Many industrial processes which have hitherto been too dangerous to view at close quarters may now be subjected to minute scrutiny. Innumerable applications suggest themselves; tests-to-destruction, the study of the combustion conditions in a boiler, or even assessment of the amount of smoke coming from a factory chimney can now all be viewed from the security of a remote point.

The equipment comprises two units, the Camera and the Control Unit, which are used with the required number of monitors.

### The Camera

A Vidicon pick-up tube is employed, the signal from which is capacity-coupled to a three-stage video amplifier and thence fed to a mixer stage. In this circuit the outputs of the vision and sync. pulse circuits are combined, and the resultant signal further amplified. This combined signal is then fed through a sync. clipper stage which keeps the horizontal and vertical sync. pulses equal in amplitude regardless of varying signal conditions, thereby maintaining stable monitor synchronization.

### The Control Unit

This contains the horizontal and vertical deflexion circuits for the pick-up tube, and a circuit which prevents burning of the video target coating in the event of scanning failure. In addition, it includes circuits for providing the necessary wave-forms for vertical scan, horizontal scan, vertical and horizontal blanking and sync. pulses.

# A Nomogram for Hartree's Threshold Voltage Criterion for Magnetrons

By J. D. Harmer\*, B.Sc.

Hartree's threshold voltage criterion is used to predict the operating conditions or identify from test results the mode of operation of a cylindrical multi-resonator magnetron. A nomogram for this criterion is presented. It includes a scale giving the upper limit to the electronic efficiency of the magnetron.

HARTREE'S threshold voltage criterion<sup>1</sup> for cylindrical multi-resonator magnetrons can be conveniently written in the practical form<sup>2,3</sup>

$$V_t = 10100 (r_a/n\lambda)^2 \left\{ \frac{n\lambda \cdot B}{10 \cdot 7} \left\{ 1 - (r_c/r_a)^2 \right\} - 1 \right\} \dots \dots (1)$$

where  $r_a$  is the anode radius (cm),  
 $r_c$  is the cathode radius (cm),  
 $B$  is the magnetic field strength (kG),  
 $\lambda$  is the oscillator free space wavelength (cm),  
 $n$  is the mode number of the oscillation in the anode resonators,  
 $V_t$  is the threshold voltage, below which the given oscillation cannot occur (kV).

on the other two scales are related by Hull's cut-off criterion for cylindrical magnetrons,

$$V_t = 22 \cdot 1 r_a^2 B^2 [1 - (r_c/r_a)^2]^2 \dots \dots \dots (3)$$

### SCALING

The scales of the nomogram can be adjusted to cover other ranges by multiplying all values by suitable factors. If all scale values of  $n\lambda$  are divided by  $x$ , then those of  $V_t/r_a^2$  must be multiplied by  $x^2$ , and of  $B(1 - (r_c/r_a)^2)$  multiplied by  $x$  to maintain equation (1). The values of electronic efficiency are unchanged.

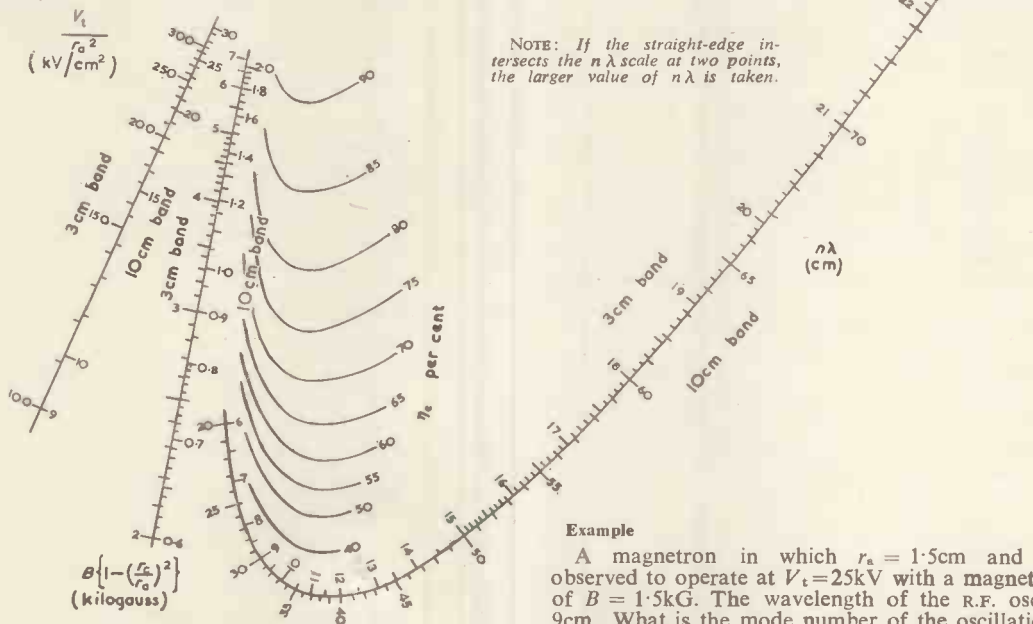

NOTE: If the straight-edge intersects the  $n\lambda$  scale at two points, the larger value of  $n\lambda$  is taken.

### Example

A magnetron in which  $r_a = 1.5$ cm and  $r_c = 1.0$ cm is observed to operate at  $V_t = 25$ kV with a magnetic field strength of  $B = 1.5$ kG. The wavelength of the R.F. oscillation is  $\lambda = 9$ cm. What is the mode number of the oscillation in the anode resonators, and what is the upper limit to the electronic efficiency when the magnetron operates in this mode?

From the above data, calculate  $V_t/r_a^2 = 11.1$  and  $B(1 - (r_c/r_a)^2) = 0.835$ . Lay a straight edge through the nomogram scales intersecting them at these points (given by the right-hand scale ranges). Read the value, from the right-hand scale range of  $n\lambda$ , which gives  $n\lambda = 54$ . Since we know that  $\lambda = 9$ , then  $n = 6$ , i.e. the mode number of the oscillation is 6.

The straight edge does not quite touch the curve marked 70 per cent, and the upper limit to the electronic efficiency,  $\eta_e$ , is therefore estimated to be 69 per cent.

### Acknowledgments

This nomogram was derived in the course of work carried out for the Department of Physical Research, Admiralty. The author wishes to thank the Admiralty and also Mr. L. J. Davies, the Director of Research of The British Thomson-Houston Company Ltd., for permission to publish this article.

### REFERENCES

- HARTREE, D. R., Mode Selection in a Magnetron by a Modified Resonance Criterion. C.V.D. Report Mag. 17.
- BOOT, H. A. H., RANDALL, J. T. The Cavity Magnetron. *J. Instn. Elect. Engrs.* 93, Pt. 3a, 935 (1946).
- WILLSHAW, W. E., et al. The High Power Pulsed Magnetron—Development and Design for Radar Applications. *J. Instn. Elect. Engrs.* 93, Pt. 3a, 991 (1946).
- COLLINS, G. B. *Microwave Magnetrons*, p. 238 (McGraw-Hill, 1948).

\* British Thomson-Houston Co., Ltd.

# A Large Magnetically-Deflected Oscilloscope

By P. E. K. Donaldson\*, M.A.

*A large-screen oscilloscope was required for demonstrating biological electrical phenomena—such as nerve action potentials—in a large lecture theatre. The instrument was to act as a “slave” to a Cossor type 1049 oscilloscope—which would be operated by the lecturer—so that the trace would be similar in appearance to that on the screen of the 1049 oscilloscope and as near a copy of it as conveniently possible. The slave time-base was to follow the master time-base over at least the range 150msec to 5msec, and if possible should handle the  $\frac{1}{2}$ sec and  $1\frac{1}{2}$ msec trace lengths as well. The Y deflexion should be able to handle the transients occurring in biological work without appreciable lag or overshoot; D.C. coupling was considered unnecessary, but the time-constant should be kept reasonably long.*

FROM the outset it seemed that within the none too stringent specification given above there lay a very good case for employing, if possible, magnetic focusing and deflexion using a television type of cathode-ray tube, television deflexion assembly, and so on. On the scores of cheapness, ease of obtaining replacements, the possibility of using non-lethal E.H.T., the convenient physical shortness of the magnetic type of tube, and the interest which lay in departing from conventional oscilloscope practice, it was decided to proceed with development of the magnetic instrument.

The expected difficulties were those of (1) securing a linear relation between the signal and sawtooth waveforms derived from the master oscilloscope, and the currents flowing in the appropriate deflector coils, and (2) getting a linear relation between deflector coil current and spot movement produced. It was felt that (2) was best solved by using a modern Ferroxcube-cored wide-angle deflexion assembly. It seemed that (1) was best attacked by, in the case of the time-base, a straightforward two-stage RC coupled amplifier with heavy current feedback, the amplifier and the feedback to be operative over as wide a frequency range as possible. In the case of the Y deflexion circuits, the difficulty was what to do about the considerable back E.M.F. which is liable to be generated across the deflector coil when handling a big step-function, for example. If this back E.M.F. is allowed to react back on, and upset, the working conditions of the valve or valves driving the deflector coil, there is clearly going to be distortion. Part of the solution is to put the coil in the anode circuit of a pentode, the anode current of which will be fairly independent of the back E.M.F. provided the latter is not allowed to become too large.

Since the deflecting field due to the coil depends on the product of current and turns, whereas the back E.M.F. depends, roughly, on the product of current and turns squared, it is better to keep the number of turns down and to supply a large current. Thus a low-impedance winding is indicated, which is convenient as being much easier to wind, and the problem is then how to supply the large current. A step-down transformer even if it could be designed would not solve the difficulty because the small deflector coil impedance would be reflected into the primary circuit as a large one. It was therefore decided to use ‘brute force’ and supply the current direct from large valves. The power consumption will then be heavy, but can be minimized by using two valves in push-pull, and biasing them as far into class B as is compatible with getting the resulting two halves of the trace to fit together properly.

Preliminary experiments with a Mullard 17in rectangular tube, a “Duomag Focalizer”, and an Allen D.C. 300/C deflexion assembly were encouraging. Despite

an E.H.T. of only 11kV—3kV less than that recommended—a bright and well-focused spot was secured. With the Allen yoke turned through a right-angle so as to use the line coils for Y deflexion and the frame windings for the time-base, an alternating current of 100mA R.M.S. in the line coil deflected the spot from top to bottom of the screen, and about 110mA deflected it from one extreme edge to the other.

The Cossor 1049 oscilloscope is a convenient one for acting as a master, as the connexions to its  $X_1$  and  $Y_1$  plates are brought to a terminal board situated behind a small sliding panel. It is thus very easy to bring out the required time-base and signal potentials and, provided these are not led into too low an impedance, with remarkably little effect on the master trace. Screened cable is used for the signal, but ordinary flex has been quite satisfactory for the time-base. The wires are 6 ft. long.

## The Complete Instrument

### THE E.H.T. SUPPLY

This uses a unit supplied as a spare part for an Ultra television receiver having a line transformer with flyback E.H.T. winding, rectifier valve and smoothing components packed together in an insulating case. This is re-arranged as a self oscillator with a Mazda 6P28 beam tetrode and produces some 11kV. Some trouble has been experienced with corona, and no attempt has been made to secure a higher voltage than this.

### THE DEFLEXION AMPLIFIER

An R.M.S. current of 100mA means about 280mA peak-to-peak, and this swing has to be supplied by each valve. Mullard EL37's have proved quite satisfactory, and although they are run at their maximum rating, there has been no falling-off in performance of the instrument in a year's use. The standing current is adjusted to 60mA, and under these conditions there is no visible cross-over distortion, and the anode dissipation per valve is 24 watts. At peak deflexion this rises to over 100 watts for one valve and is, of course, zero for the other. Fortunately, with the low-energy waveforms associated with biological recording, this state of affairs holds for only a small proportion of the time. In any case, the valves are protected by deliberately poor regulation in the H.T. supply (the 500 $\Omega$  resistor); should the instrument be required to display a high-energy waveform such as a large sine or square wave, all that happens is that it becomes impossible to use the full height of the screen, as the wave undergoes clipping as the gain control is advanced. The signal input is taken via a blocking capacitor (in general the signal leaves the master oscilloscope at 325 volts above earth) to the gain control. The value chosen is a compromise; if a higher resistance is used, there is trouble from loss of high frequencies and phase shift when the gain is lowered. If a lower value is

\* Physiological Laboratory, Cambridge.



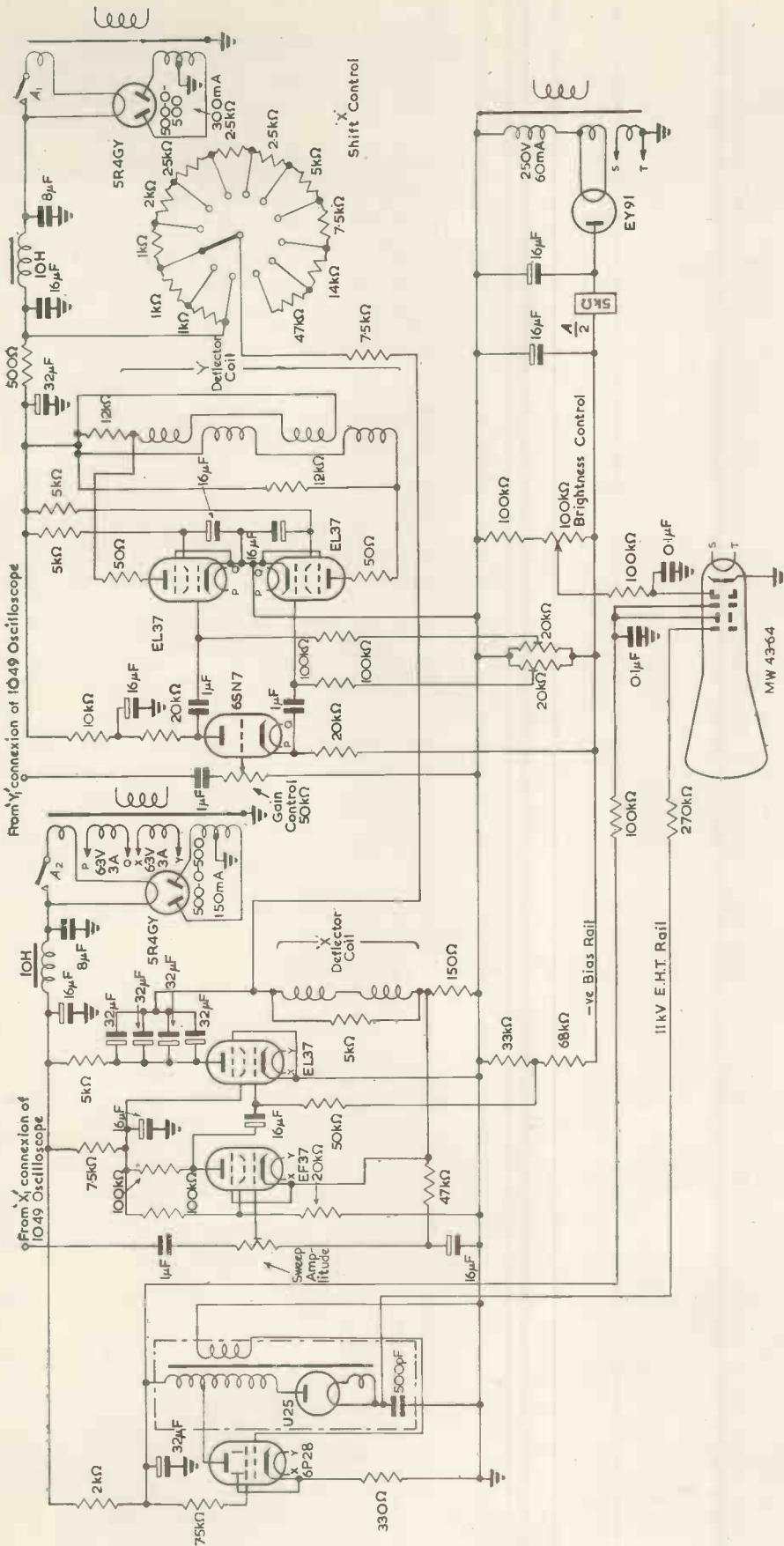

Fig. 1. The Oscilloscope circuit

employed the frequency response is excellent, but there is severe loading of the 1049 oscilloscope. Where exceptional high-frequency response is required it is intended that the spare half of the 6SN7 be arranged as a cathode-follower between input terminal and a low-resistance potentiometer. For our purposes, this has not been necessary. Some kind of gain control is necessary, otherwise a picture which fits nicely into the screen of the master screen undergoes severe "lopping" by going off the top and bottom of the slave screen. On the other hand there are times when it is quite useful to have the excess amplification. The deflexion sensitivity of the slave alone is about 70 volts peak-to-peak to fill the whole screen.

Since the two coils of the line winding have their centre-tap brought out, it was originally hoped to take this to H.T. and to take the "outers" to the EL37 anodes. When this scheme was tried, it was found unsatisfactory because in the case of a train of, say, positive-going pips, since the valves are in class B, only one is operative. The deflecting field is therefore produced by one coil only instead of two, with the result that it is not uniform. There is thus a variation in deflexion sensitivity along the trace. It is therefore necessary to replace each line coil with two others which, together, have the same number of turns, and connect them as shown in the circuit diagram. Two windings of 75 turns each of 26 s.w.g. enamelled wire go to form each new coil. They should be scramble wound on a flat former, taped, bent into shape, and fitted into the yoke.

The response of the Y deflexion circuits to a step-function can be varied from vigorous ringing to a very sluggish follow-up according to the amount of resistance shunted across each half of the deflector coil. The optimum damping resistance is best discovered by trial and error; the value of 1.2kΩ used here provides just about critical damping.

### THE TIME-BASE AMPLIFIER

The circuit of this is quite straightforward, and uses another EL37 valve in a single-ended output stage. This gives a peak-to-peak output of the order of 10mA, and as the existing frame winding on the deflexion yoke requires over 300mA peak-to-peak, it is necessary to take it out and replace it with one having three times as many turns. Each of the two new coils should comprise 1000 turns of 36 s.w.g. enamelled wire. After taping up, some care is necessary with these coils to avoid breakage during the bending-up and fitting process.

The only components in the circuit requiring any explanation are the 47kΩ resistor between the cathode of the EF37 and the bottom of the "sweep amplitude" preset potentiometer, and the associated 16μF capacitor. Were it not for the X shift control the bottom of the "sweep amplitude" potentiometer could be earthed. But the shift current flows down the 150 ohm feedback resistor and produces a voltage drop across it, so that the average cathode potential of the EF37 is not earth but anything up to 10 volts positive. This cuts off the valve unless the grid return is also taken to the average cathode potential. It is the function of the 47kΩ and the 16μF to do this averaging.

### THE X SHIFT CONTROL

When the master oscilloscope is set to "repetitive" time-base, the charge on the bank of four 32μF capacitors automatically adjusts itself so that there is an equal peak current flowing in the deflector coil in each direction, and the trace sits symmetrically on the face of the screen. But on changing over to triggered operation, when the sweep time is probably much shorter than the interval between sweeps, the bank of capacitors has time to discharge, with the result that the spot sweeps from somewhere near the middle of the screen to somewhere off the screen to the right. It is therefore necessary to supply a standing shift current of anything between zero and that required to deflect the spot halfway across the screen, some 60mA. Furthermore, the current must come from a source having

a high enough impedance not to absorb too much power from the time-base output.

These requirements are satisfactorily met with the simple arrangement shown, in which the shift current can be varied in 12 steps, the switched resistors being chosen so that all the steps produce roughly equal amounts of X shift.

### POWER SUPPLIES

The current consumption of the apparatus is heavy—about 450mA at 500V. This is rather beyond the capacity of easily-obtained transformers and chokes, and, furthermore, it ought to be stabilized to prevent coupling through the power pack of the four functions; shift, Y deflexion, time-base, and brightness (E.H.T.). In particular, the E.H.T. generator is very sensitive to changes in H.T., and it is tiresome to have the trace brilliance fall away when a large signal input causes the Y-deflexion output valves to decrease the H.T.

Both difficulties are circumvented by having two smaller independent power packs, one rated at 300mA and the other at 150mA, the former supplying Y-deflexion and shift current, and the other the E.H.T. generator and time-base amplifier.

In addition there is a small third power pack for providing the fixed bias. It employs an indirectly heated rectifier valve, so that after switching the apparatus on (energizing all three transformers) there is a delay while the valve heaters warm up. Then, if all is well with the bias, the P.O. relay closes and brings on the main H.T. supplies. In this way there are no surges of H.T., hence many of the decoupling and other capacitors can be rated for lower voltages. There is also a measure of protection for valves and cathode-ray tube.

### Conclusion

The instrument fulfils the requirements laid down, and has been kept simple. The time-base does not depart noticeably from linearity, and the rise-time on step function of the Y deflexion is less than 10 microseconds. The simplicity and operational efficiency have been obtained at the cost of rather low power efficiency, but this is not felt to be any great disadvantage.

## New Null Transmission Networks

By E. M. Reid\*

*Three new frequency sensitive null networks are shown and the operating conditions determined. Two employ CR sections, and their relative merits are discussed in terms of the off-null output voltages. The third introduces a non-linear element into the network and one application is suggested.*

**F**REQUENCY sensitive null or minimum transmission networks, using CR sections, are widely used in oscillators and selective amplifiers. In the exact null condition, however, the fundamental component of the source is entirely removed by the network and the output voltage consists of the harmonic, intermodulation, hum, noise and flutter effects which may be present in the source. For this application, the network should be capable of infinite rejection at one frequency, and have a low transfer ratio  $E/V_0$ , at all other frequencies.

### Tapered Sections

It can be shown that the output voltage from two tapered-L sections is slightly larger than from two similar sections. It was anticipated that a null network, using

tapered sections, would have rather higher off-null output than one with identical sections. The disadvantages of a high output impedance from the last section can be overcome by using a cathode-follower (Fig. 1).

Fig. 1. A 4-terminal tapered network in a balanced, constant impedance system

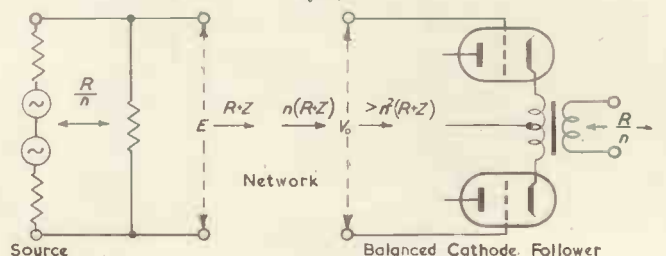

\* W. H. Sullivan, Ltd.

### Balanced Null Network

In Fig. 2, the "bolted" lattice (or "egg-timer") arrangement is shown. Each element of the first section,  $R$  and  $Z$ , is shunted by the tapered- $L$  section so that the output voltage:

$$V_o = i_2(n+1)R + i_3nZ \dots\dots\dots (1)$$

where  $n$  is the taper value, and is  $> 1$ .

Using the normal 3-mesh analysis and solving for  $V_o$ ,

$$V_o = E \left[ \frac{(n^2 - 1)R^2 + n^2Z^2}{n(n+1)(R+Z)^2 - (n+1)R^2 - nZ^2} \right] \dots\dots\dots (2)$$

from which the null condition,  $V_o=0$ , is when  $(n^2 - 1)R^2 = -n^2Z^2$ . Also, if  $R/Z = j\omega CR = jx$ , then  $R^2/Z^2 = -x^2$  and the null value,

$$x_o = \frac{n}{(n^2 - 1)^{1/2}} \dots\dots\dots (3)$$

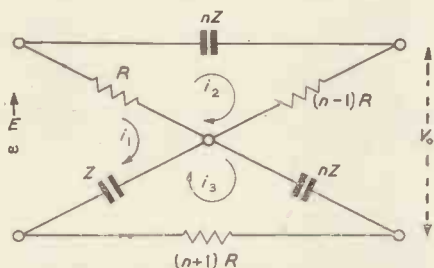

Fig. 2. The "bolted" lattice network  
If  $Z$  is a capacitor of  $0.100 \mu F$ , and  $R = 5.55k\Omega$ , with  $n=10$ , then the null occurs at  $286c/s$ .

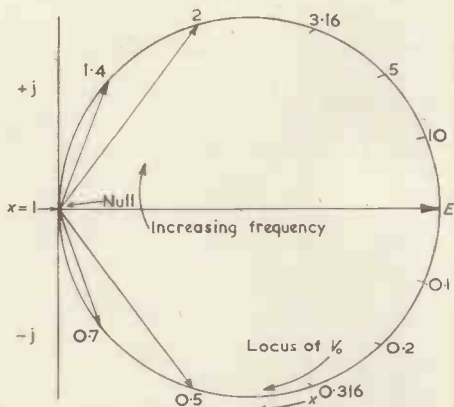

Fig. 3. Showing the locus of the output voltage vector-head

Thus with a taper value of 10 or more,  $x_o = 1$  to within 1 per cent, or:

$$f_o = \frac{1}{2\pi CR} \dots\dots\dots (4)$$

At null, the network is reasonably balanced with respect to the centre "bolt", and the input and output impedances being  $1.4R \angle -45^\circ$  and  $1.4nR \angle -45^\circ$  approximately.

### OFF NULL CONDITIONS

The response of the network at any other frequency is shown by equation (2), which may be simplified if  $n \gg 1$ , so that:

$$V_o = E \frac{1}{1 + j 2x/(1-x^2)} \dots\dots\dots (5)$$

and the locus of the vector head, over a wide frequency range above and below null, is a circle of diameter  $E$  cutting the origin at the null frequency when  $x = 1$  (Fig. 3). The normalized transfer ratio  $E/V_o$  for the network is given in Fig. 4, together with the results obtained in a practical network when  $n = 10$ .

### CONCLUSIONS

The practical figures fall slightly below the predicted response curve from the simplified equation (5). Nevertheless, the off-null response shows a second harmonic factor of 0.6 ( $-4.5db$ ) as compared with 0.35 for the parallel- $T$ , or 0.14 for the Wien bridge network.

### The Variable-T

A null network should be easily adjustable to the required frequency. The variable- $T$  network (Fig. 5) has two phase-lagging or low-pass  $RC$  sections in parallel with

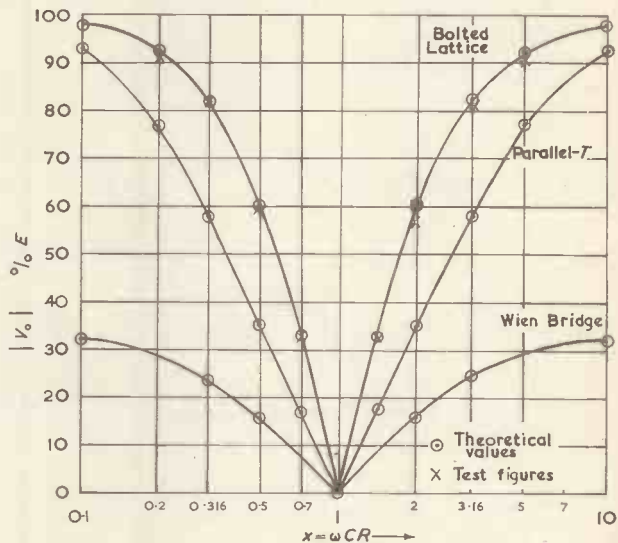

Fig. 4. Normalized response of network No. 1 compared with existing null networks

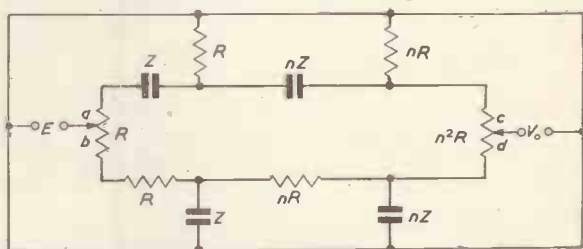

Fig. 5. The variable-T.

If  $R = 12k\Omega$ ,  $C = 0.25\mu F$ ,  $n = 10$ , the frequency range is 15 to  $75c/s$ . Smaller capacitors may be switched in to extend the range to  $15kc/s$ .

two leading, or high-pass  $CR$  sections. The input potentiometer controls relative magnitudes and phases of the two voltages acting in the output loop. The output potentiometer adjusts the magnitudes to equality without affecting the angles.

In a simplified proof,  $n \gg 1$ , the open-circuit voltage across  $nZ$ , (lower section):

$$V_{nz} = E \frac{1}{1 - x^2(1 + a/R) + jx(2 + a/R)} \dots\dots\dots (6)$$

and, since  $b = R - a$ , the open-circuit across  $nR$  (upper

section):

$$V_{NR} = E \frac{-x^2}{1 + x^2(a/R - 2) + jx(3 - a/R)} \dots (7)$$

If these voltages are equal and opposite,  $V_{nz} = -V_{NR}$ , equating real and imaginary terms:

$$a/R (1 + x^2) + x^2 + 1/x^2 = 3 \dots (8)$$

and

$$a/R (1 + x^2) = 3 - 2x^2 \dots (9)$$

and thus  $x^4 = 1$ , or  $x = 1$  and  $a/R = 0.5$ .

In the output loop  $d = c$  for  $V_o = 0$ .

The mid-band null conditions occur in the mid positions of both potentiometers at a frequency  $f_o = 1/2\pi CR$ .

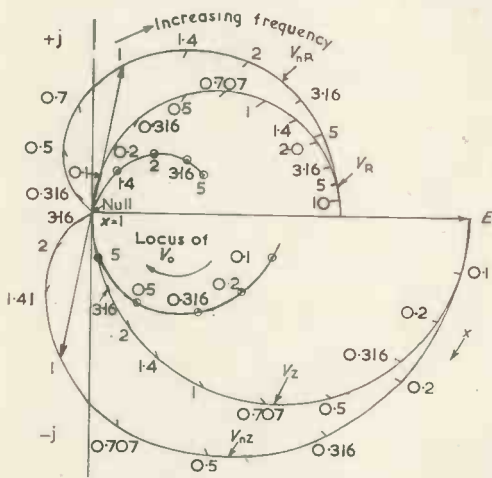

Fig. 6. Locus of  $V_o = \frac{1}{2} (V_{nz} + V_{NR})$  showing the reduced response due to the frequency control potentiometers

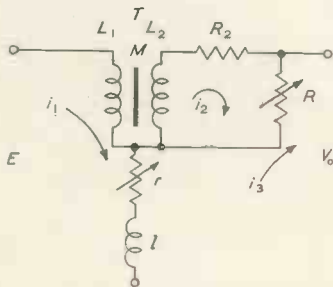

Fig. 7. The mutual-T.

If  $L_2 = 1.5H$ ,  $M = 9H$ ,  $l = 4.5H$ ,  $r$  and  $R$  are  $50k\Omega$  to cover 20 to 1000c/s.

### FREQUENCY RESPONSE

Some indication of the response at other frequencies is given in Fig. 6. This assumes the network conditions previously derived, with a constant voltage variable frequency source. In the lower section, the lower semi-circle, of diameter  $E$ , represents the locus of the voltage across  $Z$  at all frequencies. Using equations (6) and (7)  $V_{nz}$  and  $V_{NR}$  have been plotted. These two rotate  $\pi/2$  rad. apart, and the output voltage is half the sum, if the impedance looking back, in both cases, is neglected.

This output voltage locus diagram shows lower off-null outputs than the previous network, especially at the higher frequencies ( $x > 1$ ).

### Mutual-T Network

The null method of analysis can include the harmonic distortion products produced by the network itself. In

Fig. 7, the low frequency iron distortion of the transformer  $T$  produces a large 3<sup>rd</sup> harmonic component in the output of the network at the null frequency. This type of distortion is a function of frequency and of the input power level, and limits the useful range of a transformer.

As an example, an output transformer with a flat frequency response from 10c/s to 10kc/s may handle the rated power output without introducing distortion only above 50c/s. The maximum undistorted power at 10c/s may be as low as  $1/10^{th}$  of the rated value. The mutual-T network can be used to investigate this effect.

The transformer  $L_2, M, R_2$  is an integral part of the network, and is used with an air-cored inductor,  $l$ , and the two frequency controls,  $r$  and  $R$ .

### NULL CONDITIONS

The solution for  $V_o$  may be expressed in the form,

$$V_o = E M_{13} Z / D$$

where  $Z$  is the termination,  $D$  the determinant of the network, and  $M_{13}$  the minor. The null occurs when  $V_o = 0 = M_{13}$ , or

$$-(r + j\omega l)(R + R_2 + j\omega L_2) = j\omega MR$$

and if  $M$  itself is made negative, by suitably connecting the transformer windings, the two null equations become:

$$r(R + R_2) = \omega^2 l L_2 \dots (10)$$

and

$$l(R + R_2) = MR - L_2 r \dots (11)$$

Normally  $R_2$  is small compared with  $R$ , except perhaps at the lowest null frequency; with this simplification the equation for the null frequency becomes:

$$\omega^2 = rR / lL_2$$

and the ratio of the variables,

$$r/R = \frac{M - l}{L_2}$$

These show that the two variables,  $r$  and  $R$  are dependent frequency controls, and that the frequency scales on both will be linear. Also, the mutual inductance must always be greater than the fixed inductor,  $l$ , although it can be shown that the off-null response is proportional to  $l$ .

### RESPONSE CURVE

This is a function of the transformer constants, and a typical response is similar to that of the Wien bridge network, shown in Fig. 2. The response curve is reasonably constant over a wide range of null frequencies, and thus a fixed harmonic factor might be used with a given network. It may, however, be more accurate to consider that the self generated distortion products are produced in the  $L_2$  winding of the transformer, and are present at the output without further attenuation. As with other networks, the maximum output voltage at any frequency occurs when the output terminals are effectively open-circuited.

### Summary

Three null networks have been given, and the null conditions derived.

The balanced form has largest off-null outputs, but cannot easily be adjustable over a range of frequencies. The variable- $T$  network is more convenient in practice although the shape of the response varies slightly over the frequency range. This can be a slight advantage in cases where the unwanted components are lower than the source, for example hum, or flutter. One application of the mutual- $T$  network for transformer testing has been shown.

### Acknowledgments

Thanks are due to the Chief Engineer, W. H. F. Griffiths, for permission to publish this article.

# The Voltage Ratio and Output Impedance of a Ladder Network Composed of $n$ Similar Elements

By T. S. Fox\*, B.Sc., and K. R. Sturley\*, Ph.D., M.I.E.E.

THE complex voltage ratio and output impedance of a ladder network with a finite number of sections may be calculated by using Kirchhoff's Laws<sup>1</sup>, but the method is tedious. Analysis of the voltage ratio or attenuation,  $A_n$ , due to  $n$  similar elements of a ladder network connected to a generator of internal impedance,  $Z_g$ , shows that a comparatively simple expression for  $A_n$  can be developed.

For the first section (Fig. 1), the attenuation and output impedance are:

$$A_1 = \frac{Z_2}{Z_g + Z_1 + Z_2} \dots \dots \dots (1)$$

$$Z_{01} = \frac{Z_2 \cdot (Z_1 + Z_g)}{Z_1 + Z_2 + Z_g} = Z_2(1 - A_1) \dots \dots \dots (2)$$

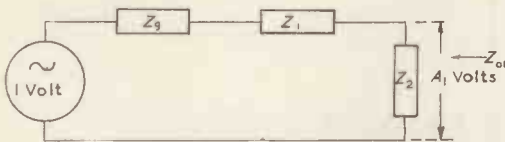

Fig. 1. First section of a ladder network

The addition of a second section gives with the aid of Thévenin's Theorem (Fig. 2):

$$A_2 = \frac{A_1 Z_2}{Z_1 + Z_2 + Z_{01}} = \frac{A_1 Z_2}{Z_2(2 - A_1) + Z_1} \dots \dots (3)$$

$$Z_{02} = \frac{Z_2(Z_1 + Z_{01})}{Z_1 + Z_2 + Z_{01}} = Z_2 \left[ 1 - \frac{Z_2}{Z_1 + Z_2 + Z_{01}} \right] \\ = Z_2(1 - A_2/A_1) \dots \dots \dots (4)$$

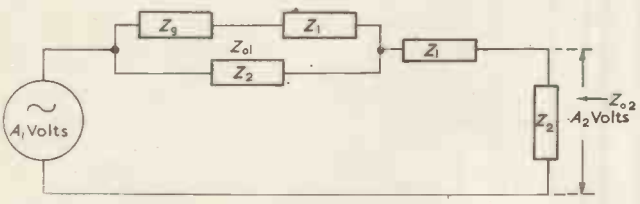

Fig. 2. Second section with the Thévenin equivalent of the first section

Repeating the procedure for a third section we have:

$$A_3 = \frac{A_2 Z_2}{Z_1 + Z_2 + Z_{02}} = \frac{A_2 Z_2}{Z_2(2 - A_2/A_1) + Z_1} \dots (5)$$

$$Z_{03} = Z_2(1 - A_3/A_2) \dots \dots \dots (6)$$

Examination of equations (5) and (6) indicates the form of the general expressions; thus for  $n$  sections:

$$A_n = \frac{A_{n-1} Z_2}{Z_2(2 - A_{n-1}/A_{n-2}) + Z_1} \dots \dots \dots (7a)$$

and

$$Z_{0n} = Z_2(1 - A_n/A_{n-1}) \dots \dots \dots (8)$$

If expression (7a) is inverted we have:

$$(2 + Z_1/Z_2) 1/A_n = 1/A_{n-1} - 1/A_{n-2}$$

and replacing  $1/A_n$  by  $a_n$ , etc., and  $(2 + Z_1/Z_2)$  by  $B$  (a constant for a given ladder network) gives the result in a much more manageable form:

$$a_n = Ba_{n-1} - a_{n-2} \dots \dots \dots (7b)$$

The reciprocal attenuation of up to 6 sections is calculated by successive applications of expression (7b), thus:

$$a_0 = 1 \\ a_2 = Ba_1 - 1 \\ a_3 = B^2 a_1 - B - a_1 \\ a_4 = B^3 a_1 - B^2 - B2a_1 + 1 \\ a_5 = B^4 a_1 - B^3 - B^2 3a_1 + B2 + a_1 \\ a_6 = B^5 a_1 - B^4 - B^3 4a_1 + B^2 3 + B3a_1 - 1$$

An example of the use of this method is to be found in the solution for the oscillatory condition in a CR oscillator. Thus for a 3-section oscillator (Fig. 3) having  $Z_1 = -j/\omega C$ ,  $Z_2 = R$  and  $Z_g = R_o$ , the output resistance of the valve, i.e., the parallel combination of  $r_a$  and  $R_a$ :

$$B = 2 - jX/R = 2 - jQ$$

where  $Q = X/R = 1/\omega CR$

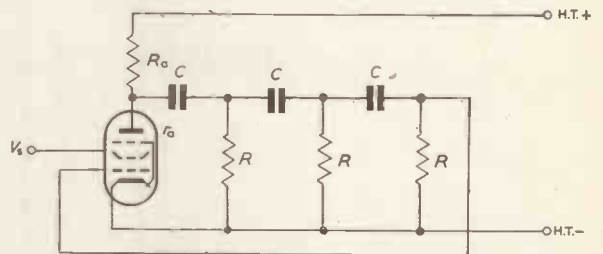

Fig. 3. A three-stage CR oscillator

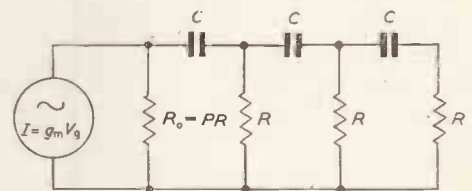

Fig. 4. Equivalent circuit for the three-stage oscillator

$$\text{and } a_1 = \frac{R - jX + R_o}{R} = 1 + P - jQ$$

where  $P = R_o/R$ .

$$\text{Then } a_3 = B^2 a_1 - B - a_1 \\ = (2 - jQ)^2(1 + P - jQ) - (2 - jQ) - (1 + P - jQ) \\ = (3 - Q^2 - 4jQ)(1 + P - jQ) - 2 + jQ \\ = (3 - Q^2)(1 + P) - 4Q^2 - 2 - jQ[4(1 + P) + 2 - Q^2]$$

The condition for oscillation is a zero imaginary term, i.e.:

$$Q = 1/\omega CR = \sqrt{4P + 6} \dots \dots \dots (10)$$

$$\text{whence } f = \frac{1}{2\pi CR \sqrt{4P + 6}} \dots \dots \dots (11)$$

Substituting  $Q$  in equation (9):

$$a_3 = -[29 + P(4P + 23)] \dots \dots \dots (12)$$

The negative sign indicates phase reversal.

It is worth noting in connexion with equation (12) that variation of  $P$  not only varies  $a_3$ , but also varies the gain of the valve. The equivalent circuit is that of Fig. 4 and

\* British Broadcasting Corporation.

increase of  $R_a$  increases  $R_o$ , the voltage output of the valve, and the attenuation.

Amplification of valve unshunted by CR network

$$= g_m R_o$$

$$= g_m P R$$

The condition for oscillation is:

$$g_m P R = -a_3$$

$$= 29 + P(4P + 23) \dots \dots \dots (13)$$

A suitable valve must therefore have:

$$g_m = (29/P + 4P + 23)/R \dots \dots \dots (13a)$$

For a given value of  $R$  the lowest  $g_m$  is found by differentiating and equating to zero:

$$dg_m/dP = (-29/P^2 + 4)/R \dots \dots \dots (14)$$

$$\therefore P_{\text{optimum}} = \sqrt{29/4} = 2.69 \dots \dots \dots (15)$$

Substituting in equation (13a):

$$g_m = (29\sqrt{4/29} + 4\sqrt{29/4} + 23)/R$$

$$= 44.6/R \dots \dots \dots (16)$$

In designing a 3-stage RC oscillator the following procedure may be followed, when using a valve of known constants:

(a) Determine  $R$  from equation (16),

(b) Find  $R_o = 2.69R$ ,

(c) Since  $R_o$  and  $r_a$  are known,  $R_a$  may be calculated from

$$R_o = \frac{R_a r_a}{R_a + r_a}$$

(d) Determine  $C$  from equation (11)

(Putting  $P_{\text{optimum}}$  in (11) gives  $f = 1/26.6CR$ )

The method can be applied to oscillators with more sections, though the calculations are more complicated.

Thus for a 5-section oscillator:

$$Q^2 = (4P + 14) \pm \sqrt{[(4P + 14)^2 - (20P + 15)]}$$

the two possible solutions represent phase shifts of 180° and 360°. The lower value for  $Q^2$  (the higher frequency) represents the oscillatory 180° condition.

The attenuation is:

$$a_5 = 1 + 5P - Q^2(35 + 21P) + Q^4(9 + P).$$

#### REFERENCE

1. TRIGG, R. D. Simplified Solution of Phase-Shift Oscillators. *Electronic Engng.* 25, 331 (1953).

## A Simple Direct Reading Thermistor Bridge

By D. C. Cooper\*, B.Sc.

*A large number of widely differing circuits have been developed for use with thermistors in the measurement of microwave power. This article describes the design of a simple circuit which gives a direct reading of power and does not require calibrating.*

THE large negative temperature coefficient of resistance of the thermistor makes it very suitable for use as the power sensitive element in a microwave power measuring instrument. The thermistor is almost invariably associated with some type of bridge circuit which is supplied with an adjustable current for the purpose of obtaining a balance. The portion of this current which flows in the thermistor is generally termed the "bias current" and the power which is dissipated in the thermistor the "bias power".

Since the resistance of the thermistor is a function of the total power dissipated in it, the application of microwave power to the thermistor element will cause the bridge circuit to become unbalanced and the methods for obtaining the value of the microwave power from this unbalance fall into two main groups.

The first group contains the circuits in which the balance is restored either manually or automatically by adjustment of the bias power, and the change in bias power is then used as an indication of the microwave power. Low frequency or direct currents are used to supply the bias power and the change of bias power made to restore balance can therefore be measured by conventional methods. Direct substitution of microwave power for bias power is desirable in order that the measured change in bias power will be equal to the microwave power. The bead type thermistor has been developed to give this one to one correspondence, this being achieved by making the bead of such small dimensions that it is uniformly heated by currents at microwave frequencies.

It should be noted that with the above method of measurement the resistance-temperature-power charac-

teristic of the thermistor does not enter into the result since the thermistor is operated at only one power level.

Circuits in which the unbalance of the bridge is used as an indication of microwave power form the second group. The indication is a function of the resistance-temperature-power characteristic of the thermistor, and since thermistors are not generally reproducible to the required extent some selection of thermistors may be necessary.

The circuit described in this article is a direct current bridge belonging to the first group and is therefore not dependent, for its indication, on the characteristics of the thermistor.

#### A Simple System

The basis of the circuit to be described is the simple direct current Wheatstone bridge shown in Fig. 1(a). The thermistor element forms one of the arms of the bridge and the remaining three arms are equal. The balance of this bridge is obtained by adjusting the total current flowing through it, thus changing the power dissipated in the thermistor until its resistance is at the required value.

If the microwave power to be measured is now applied to the thermistor the bridge may again be balanced by adjusting the total bridge current. Let the initial total bridge current be  $I_0$  and the total bridge current at balance with microwave power applied be  $I_1$ .

Since the thermistor is in each case maintained at a constant resistance equal to  $R_A$  the bridge arm resistance, the total power dissipated in it must be constant. In a properly designed thermistor mount all the microwave power applied to the thermistor will be absorbed by it, and therefore the applied microwave power  $P$  is given by the difference between the two bias powers required for balancing the bridge.

\* Metropolitan-Vickers Electrical Co., Ltd.

Thus

$$P = (I_0/2)^2 R_A - (I_1/2)^2 R_A = R_A/4 \cdot (I_0 + I_1) \cdot (I_0 - I_1) \dots (1)$$

For the measurement of small powers  $I_1$  will be approximately equal to  $I_0$  and we may write:

$$P = 1/2 I_0 R_A (I_0 - I_1) \dots (2)$$

The error introduced by this approximation will be considered later.

Equation (2) shows that the value of the current difference  $I_0 - I_1$  is linearly proportional to the microwave power for small values of this power. It is possible to indicate the current difference by supplying the bridge with a constant current and applying a circuit of adjustable resistance in parallel with the bridge to obtain a balance when the microwave power is applied. An instrument placed in the parallel circuit will indicate the current difference and its reading will therefore be directly proportional to the microwave power. Fig. 1(b) shows the arrangement with the parallel circuit connected across the bridge.

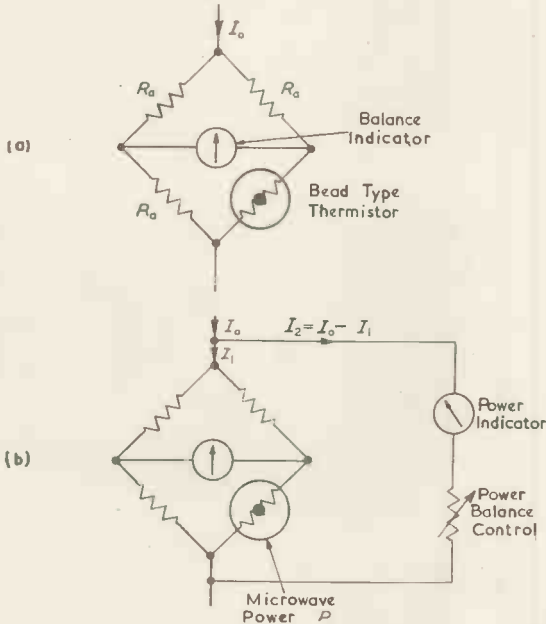

Fig. 1(a). Simple thermistor bridge circuit; (b) parallel bridge circuit

With this arrangement we have an instrument which indicates microwave power directly. However, equation (2) also contains the factor  $I_0$  which is a function of the ambient temperature for any particular thermistor and cannot be considered constant over any useful temperature range. The power indicating instrument is therefore correctly calibrated for only one value of  $I_0$  unless some provision is made for adjusting the sensitivity to compensate for changes in  $I_0$ .

A circuit with the provision for making this adjustment with the initial balancing operation is shown in Fig. 2.

The constant current supply to the bridge circuit is provided by a high stabilized voltage  $V$  and the swamping resistance  $R_1 + R_2$ . Part of this swamping resistance  $R_1$  is variable to permit the adjustment of current for the initial balance. The parallel circuit includes switch  $S_1$ , and variable resistor  $R_s$ , for the adjustment of the current to obtain the balance after the application of the microwave power to be measured.

In this circuit the sensitivity of the power indicating instrument is adjusted by  $R_V$  in such a manner that:

$$\frac{\text{Instrument current}}{\text{Difference current}} = I_m/I_2 = \frac{R_F}{R_V + R_F + R_M} \dots (3)$$

Substituting in equation (2) for  $I_0$  and  $I_2$  the values  $\frac{V}{R_1 + R_2 + R_A}$  and  $\frac{I_M(R_V + R_F + R_M)}{R_F}$  respectively gives:

$$P = R_A \cdot \frac{V}{(R_1 + R_2 + R_A)} \cdot \frac{I_M(R_V + R_F + R_M)}{R_F}$$

and on rearranging we have:

$$P = \left\{ \frac{VR_A}{2R_F} \right\} \cdot \left\{ \frac{R_V + R_F + R_M}{R_1 + R_2 + R_A} \right\} I_M \dots (4)$$

In equation (4) the first term of the expression for the microwave power  $P$  is a constant, and the instrument current  $I_m$  is therefore strictly proportional to  $P$  provided that the values of  $R_1$  and  $R_V$  are adjusted together in such a way that the value of the second term of equation (4) is maintained constant.

This is achieved by coupling together mechanically the variable resistors  $R_1$  and  $R_V$  and choosing their values such that:

$$\frac{R_V}{R_F + R_M} = \frac{R_1}{R_2 + R_A} = k \text{ a variable } \dots (5)$$

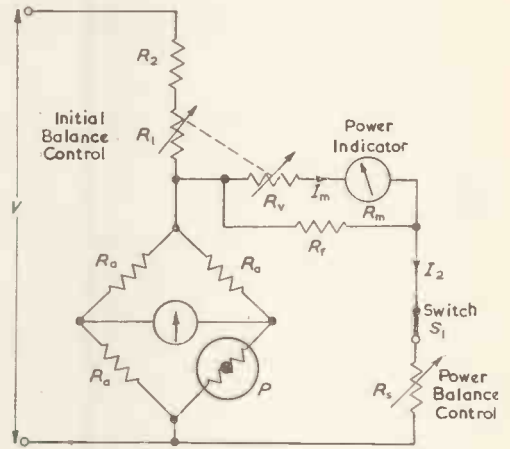

Fig. 2. Compensated bridge circuit

This means in effect that  $R_V$  and  $R_1$  are linear potentiometers whose maximum values are proportional to  $R_F + R_M$  and  $R_2 + R_A$  respectively. The second term of equation (4) now becomes:

$$\frac{(R_F + R_M)(k + 1)}{(R_2 + R_A)(k + 1)}$$

which is a constant for all values of  $k$ .

Since  $I_0$  is a function of  $k$  the instrument will indicate directly the microwave power applied to the thermistor for all values of the initial bridge current. If the instrument is to indicate correctly over a large ambient temperature range it is also necessary that the components of the circuit have negligible temperature coefficient of resistance. In the case of the instrument resistance  $R_M$  this is impracticable and to compensate for changes in  $R_M$  due to ambient temperature changes, a resistance of equal temperature coefficient must be included as a part of  $R_2$ . The value of this resistance  $R_0$  must satisfy the relationship:

$$\frac{R_M}{R_F + R_M} = \frac{R_0}{R_2 + R_A}$$

#### Choice of Component Values

Having selected the type of thermistor to be used and fixed the temperature range throughout which the

thermistor bridge is required to operate satisfactorily, one can obtain from the characteristic curve of the thermistor, at a selected operating resistance  $R_A$ , the range of the initial total bridge current  $I_0$ . Taking a suitable value of the stabilized supply voltage  $V$  now fixes the values of  $R_2$  and  $R_1$  the fixed and variable parts of the swamping resistance. The value of  $V$  should be large enough to ensure that  $R_2$  is much greater than  $R_A$ .

The maximum power to be indicated and the errors introduced in this indication are interdependent as is shown by a suitable rearrangement of equation (1):

$$P = (1/2) I_0 R_A (I_0 - I_1) \left[ 1 - \frac{(I_0 - I_1)}{2I_0} \right] \dots \dots (6)$$

The percentage error introduced by considering the last term to be unity is:

$$\text{Percentage error} = 100 \times \left[ \frac{(I_0 - I_1)/2I_0}{1 - (I_0 - I_1)/2I_0} \right]$$

and by using equation (2) an approximate expression for

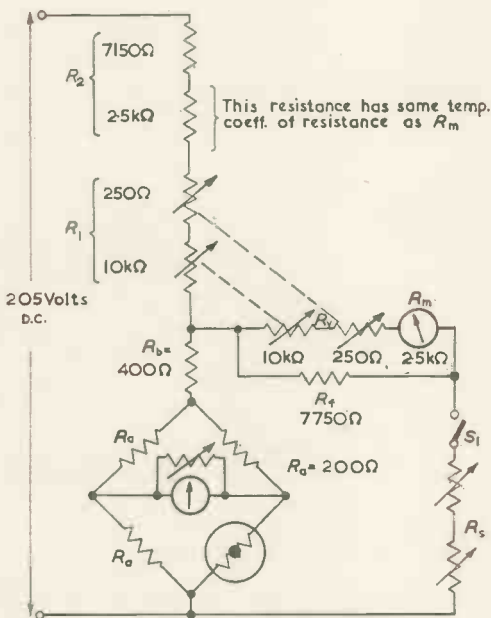

Fig. 3. Complete circuit of thermistor bridge

this error is obtained in terms of  $P$  and  $I_0$  giving:

$$\text{Percentage error} = 100P/I_0^2 R \dots \dots (7)$$

The maximum error will thus occur when  $P$  is a maximum and  $I_0$  is a minimum, and since the minimum value of  $I_0$  has been fixed a suitable compromise must be effected between the maximum power to be indicated and the maximum error to be tolerated. In practice this error can be reduced by a factor of the order of two by choosing a value other than unity as the assumed constant factor. This will be obvious when the errors of a particular arrangement are examined in detail and will be shown later.

There is now sufficient information to enable the compensating circuit for the power indicator to be designed.

Unfortunately the compensating circuit reduces the sensitivity of the indicating instrument so that an instrument of rather high sensitivity, and therefore of high resistance if it is to be robust, will be required. The reduction of sensitivity is reduced when  $R_V$  is increased, but this will lead to large values of the total compensating circuit resistance.

This can be demonstrated in the following manner. The

total resistance of the compensating circuit is:

$$\frac{R_F (R_V + R_M)}{R_V + R_F + R_M} \dots \dots (8)$$

and from equation (5) is obtained  $R_V = k (R_F + R_M)$  which when substituted in equation (8) gives for the total compensating circuit resistance:

$$\frac{R_F [k R_F + (1 + k) R_M]}{(1 + k) (R_F + R_M)} \dots \dots (9)$$

This will be seen to increase with increase of  $R_F$ .

A limitation exists on the maximum value of the total resistance of the compensating circuit, since this corresponds to the minimum possible resistance of the parallel circuit and thus fixes the maximum value of the current which can be bled from the bridge.

This current must certainly be no less than that required to balance the bridge circuit when the chosen maximum power has been applied to the thermistor. It will be seen from equation (2) that the shunt current  $I_2$  attains a maximum for the given maximum value of  $P$  when  $I_0$  is a minimum and therefore when  $R_1$  is a maximum.

Since  $R_V$  is a maximum when  $R_1$  is a maximum the total resistance of the compensating circuit, which is given in equation (8), is also a maximum and so these conditions are the most stringent which must be satisfied by the design.

From the foregoing discussion it will be seen that the



Fig. 4. The mains operated instrument incorporating the circuit of Fig. 3

design of the compensating circuit is a compromise to be effected between several conflicting requirements.

It may be found useful to place the parallel circuit across a fixed small resistor  $R_B$  as well as the bridge circuit since this permits a higher compensating circuit resistance to be used. This will, however, increase the error in the power indication, but the increase is exceedingly small for small values of the resistor placed in series with the bridge.

It may sometimes be useful to return to the initial stages of the design and change the chosen value of  $V$ , the stabilized supply voltage. This may make possible the incorporation in the circuit of more readily obtainable components than those which evolved from the first choice of  $V$ .

This has been done in the design of the circuit of Fig. 3 which uses the S.T.C. Type E2361 thermistor operating at 200Ω resistance in the ambient temperature range  $-10^\circ\text{C}$  to  $+60^\circ\text{C}$ . The corresponding range of the bridge current is 10 to 20mA.

In this design the value of  $V$  has been chosen so that the mechanically coupled potentiometers  $R_1$  and  $R_V$  are of equal and of standard value. Each potentiometer has



been split into two parts in order to provide coarse and fine adjustments.

This circuit will indicate powers up to one milliwatt and has been designed so that the indicating instrument current is  $400\mu\text{A}$  when the power level is  $1\text{mW}$ .

A photograph of a mains operated instrument incorporating the circuit of Fig. 3 is shown in Fig. 4. It will be seen that the mains switch is operated by the balance indicator sensitivity control, and the switch  $S_1$  is operated by the coarse control of the power balance control  $R_8$ . This ensures that on switching on the mains supply the balance indicator has low sensitivity, and also means that the switching and adjustment of the parallel circuit is simplified. Provision is also made for using an external balance indicator.

### Accuracy of the Complete System

In order to determine the errors introduced by assuming a linear relation between microwave power and current change, and also by measuring the parallel circuit current which is not precisely equal to the current change; an exact expression for the microwave power may be obtained. This is somewhat laborious, but quite straightforward and therefore only the result will be stated.

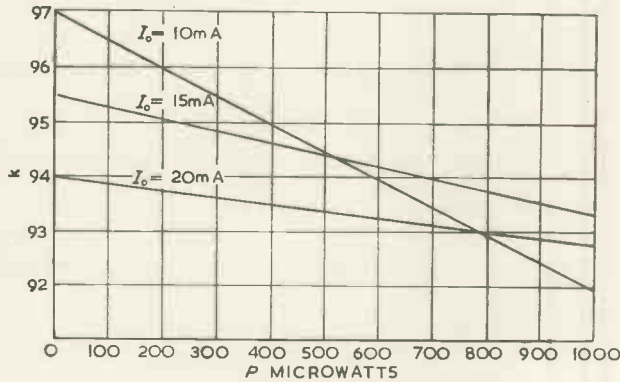

Fig. 5. Design factor of the circuit

This is:

$$P = (R_A/4) \left[ 1 + \frac{1}{1 + (R/R_D)(R'/R + R')} \right] \frac{R'}{R + R'} I_0 \cdot I_2 \quad (10)$$

where  $R = R_A + R_B$

$R' = R_1 + R_2$

and  $R_D$  = total resistance of the parallel circuit.

This expression can be used by inserting values for a particular design and considering it as

$P = K \cdot I_0 \cdot I_2$  where  $K$  is some factor.

The values of the factor  $K$  can best be calculated for a range of powers  $P$ , when  $I_0$  has a particular value, by assuming values for  $R_D$  and calculating the corresponding values of  $I_2$  and hence the corresponding powers. A curve can thus be obtained of  $K$  versus  $P$ . A set of curves for a range of values of  $I_0$  will give the percentage variation of the factor for this range.

If it is desired to incorporate the resistance  $R_B$ , several sets of curves will be required, each for a different value of  $R_B$  in order that a permissible maximum value of  $R_B$  may be determined.

For the circuit of Fig. 3 the value of  $R_B$  is the maximum which can be used without appreciable increase in the percentage change of the factor  $K$  and the appropriate set of curves for this value of  $R_B$ ,  $400\Omega$ , is shown in Fig. 5. The design is based on the assumption that the factor is a constant equal to 94.5 and the curves of Fig. 5 show

that the maximum error introduced by this assumption is  $\pm 2.7$  per cent.

Curve 1 of Fig. 6 shows the maximum error due to the difference between the factor of Fig. 5 and the assumed constant value of this factor. This is presented as a function of the initial bridge current  $I_0$ . Temperatures which correspond to the values of  $I_0$  for the average thermistor are also shown.

All further errors are due to the inaccuracy of the various components and this in the circuit considered is  $\pm 1$  per cent for the indicating instrument resistance, the corresponding temperature compensating resistance, and the tracking accuracy of the coupled potentiometers, and  $\pm 0.1$  per cent for the remaining components. Curve 2 of Fig. 6 shows the errors due to these components and curve 3 shows the resulting maximum possible error of the system, that is the sum of curves 1 and 2.

The error due to the indicating instrument calibration is eliminated by setting the supply voltage  $V$  with the aid of this instrument. Thus if the instrument reads low the voltage will be set high by a corresponding amount and so provide the correct compensation.

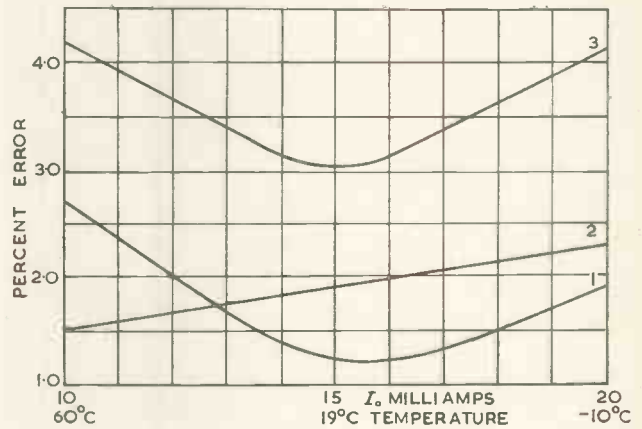

Fig. 6. Errors in power indication

High stability of the supply voltage is necessary in order to avoid introducing further errors. These will arise if there is a change of the supply voltage after the initial balance has been made, but before the final balance. The change in voltage causes a corresponding change in the total current supplied and the current in the parallel circuit when the final balance is made will differ from the correct value by approximately the amount of this change. Since the total supply current is at least ten times that in the parallel circuit for the design of Fig. 3, the percentage change in the total current will be increased by a factor greater than ten.

For the circuit of Fig. 3 a change of 0.01 per cent in the total current corresponds to a maximum error in the indicated power of approximately 4.4 microwatts. If a stabilized voltage referred to a discharge type reference tube is used, the variation due to mains voltage changes can be made less than 0.01 per cent. However, the short term stability of the reference tube may be somewhat worse than this and may therefore become the limiting factor.

At power levels of the order of 1 milliwatt this error is not appreciable, but in the measurement of much smaller powers it may be necessary to take several readings to ensure an accurate result.

### Acknowledgment

Acknowledgment is made to Metropolitan-Vickers Electrical Company Limited for permission to publish this article.

# The "Least Squares" Criterion Applied to Linear Servos

By R. Voles\*, B.Sc.

*The "least squares" criterion of curve-fitting can well be applied to the transient response analysis of servomechanisms or similar filters. The approximate value of the integral of the square of the error in the output of the system over one transient can be derived from any form of the response-vector locus and superimposed contours may be used to reduce the calculation. Consequently, it is not necessary to know the actual transient response when ascertaining the optimum system parameters. To illustrate the calculation, the integral of squared error of a given simple servo over a step transient is obtained.*

IN determining the optimum values of the variable parameters of a servo, final attention is given usually to the system response to a step in the input. Various criteria, such as the number of overshoots or the amplitude of the first overshoot, are then applied to this response. These criteria are empirical and are often only a measure of the extent to which the servo transient output fits the input. The "least squares" criterion of curve-fitting can be used in this analysis, and it is apparent that the method is not restricted to step transients. The optimum values of the system parameters then correspond to the minimum integral of squared error over the transient.

With a knowledge of the system transfer function, the integral of the square of the error over a transient,  $R$ , can be calculated either by direct integration of the squared error time function or by integration in the complex plane<sup>1</sup>. While these calculations give explicit solutions for the optimum system parameters, they are very lengthy in all but the simplest cases. Also, these methods cannot be applied to experimental systems where the transfer characteristic is known only in the form of a frequency response diagram.

The method outlined below quickly yields the approximate value of  $R$  for a system defined by its response-vector locus and may thus be applied in both design and experiment. The approximate optimum system parameters can be found by plotting response-vector loci for various values of these parameters and, by interpolation, selecting that combination which gives the least value of  $R$ .

## Principle of the Method

### THE INPUT TRANSIENT TREATED AS A FOURIER SERIES

The applied transient may be written as a half-range Fourier series of fundamental pulsance  $\Omega$  having a half-period equal to, or greater than, the servo settling time. Thus, the integral of the square of the error of the system over a half period of this Fourier series is substantially equal to that over the transient.

Suppose that the Fourier series representing the input transient is:

$$a = \sum_{p=1}^{\infty} |a_p| \frac{\sin(p\Omega t)}{\cos(p\Omega t)}$$

where  $p$  is an integer,  $t$  time, and  $|a_p|$  the modulus of the harmonic component  $a_p$  having pulsance  $p\Omega$ .

To each component  $a_p$  of the input will correspond an output  $b_p$  with an error  $c_p$  of modulus  $|c_p|$  and phase  $\phi_p$ .

By the principle of superposition, the system error is:

$$c = \sum_{p=1}^{\infty} |c_p| \frac{\sin(p\Omega t + \phi_p)}{\cos(p\Omega t + \phi_p)}$$

Then, the integral of squared error over a half-period of the fundamental is:

$$R = \int_0^{\pi/\Omega} c^2 dt = \pi/2\Omega \sum_{p=1}^{\infty} |c_p|^2 \dots \dots \dots (1)$$

### CALCULATION OF $R$

Since the component terms  $a_p, b_p, c_p$ , are related in the system response-vector plots, the value of:

$$|c_p/a_p|^2 \equiv S_p$$

may be derived for any given pulsance  $p\Omega$ . The product of  $S_p$  and  $|a_p|^2$  gives the required term  $|c_p|^2$  which is used in the summation for  $R$ .

For servo systems,  $|c_p/a_p| \rightarrow 1$  as  $p \rightarrow \infty$ . Thus, the series  $|c_p|^2$  is often slowly convergent, and a large number of terms must be taken to achieve worthwhile accuracy. However, the series:

$$|a_p|^2 (1 - S_p) \equiv |a_p|^2 \cdot T_p$$

Fig. 1. Closed-loop response-vector plot for the servo analysed in the example, with superimposed  $T$  loci

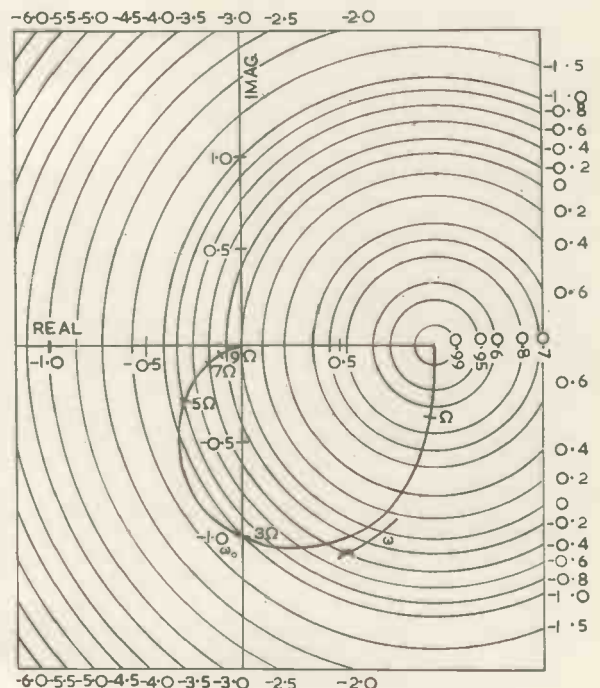

\* E.M.I. Engineering Development Ltd.

is more rapidly convergent, and then:

$$\sum_{p=q}^{\infty} |c_p|^2 = \sum_{p=1}^{\infty} |a_p|^2 - \sum_{p=q}^{\infty} |a_p|^2 \cdot T_p \dots\dots (2)$$

**T Loci**

The values of  $T$  may be derived from the response-vector plots directly, but the computation is reduced if "constant- $T$ " loci are superimposed so that  $T$  is then obtained by direct reading from the curves. The loci of  $T$  for the various response-vector presentations are given below.

- (a) Closed-loop;  $T$  loci are concentric circles about (1,0) as shown in Fig. 1.
- (b) Nyquist diagram;  $T$  loci are concentric circles about (-1,0), as shown in Fig. 2.
- (c) Inverse Nyquist diagram;  $T$  loci are a system of non-intersecting co-axial circles having centre  $((1 - T) T, 0)$  and radius  $|\sqrt{(1 - T)/T}|$ .

Of the two open-loop presentations, the Nyquist diagram is to be preferred, since there the superimposed  $T$  loci are more widely spaced at the important low frequencies and consequently allow more accurate interpolation.

**THE ERROR IN  $R$  DUE TO RESTRICTED SUMMATION**

An estimate of the error  $E_q$  produced in the calculated value of  $R$  by terminating the summation of  $|a_p|^2 \cdot T_p$  after  $(q - 1)$  terms, can be obtained by choosing a series  $U_p$  whose sum to infinity is of a simple form and such that:

$$\sum_{p=q}^{\infty} U_p > \sum_{p=q}^{\infty} |a_p|^2$$

by a sufficiently small amount.

Then, if  $T_{q(\max)}, T_{q(\min)}$  are the maximum and minimum values of  $T$  in the range  $q \leq p$ ,

$$T_{q(\max)} \sum_{p=q}^{\infty} U_p < E_q < T_{q(\min)} \sum_{p=q}^{\infty} U_p \dots\dots (3)$$

Fig. 2. Nyquist diagram for the servo analysed in the example, with superimposed  $T$  loci

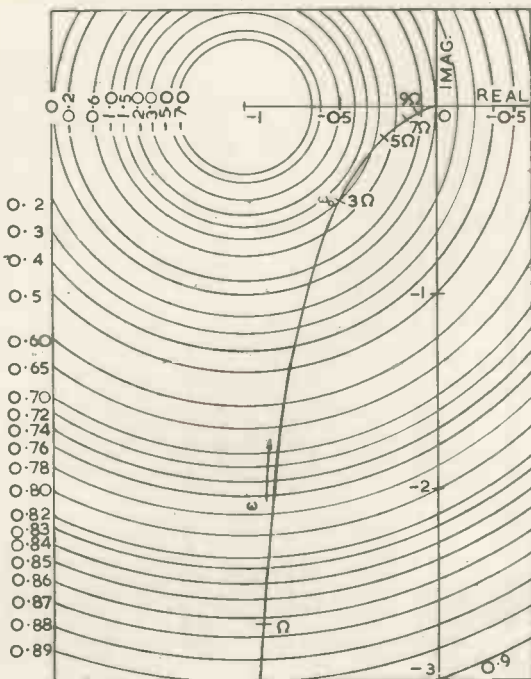

**CHOICE OF  $\Omega$**

As has been stated,  $\Omega$  should be so chosen that its half period is equal to, or greater than, the servo settling time. In the case of a step transient, the approximate time taken by a lightly damped system to settle to any desired fraction of the step can quickly be estimated from the response-vector locus by a method due to West and Potts<sup>2</sup>. Generally, however, an assumed value of  $\Omega$  can be checked for validity by comparing the obtained value of  $R$  with that computed from a fundamental of lower frequency; if the first value of  $\Omega$  was sufficiently large, the two values of  $R$  should be approximately equal.

**ILLUSTRATION**

Consider a step of unit amplitude to be applied to the input of a simple servo system defined by the differential equation:

$$(D^2 + 2\delta\omega_0 D + \omega_0^2) b = \omega_0^2 a$$

where  $\delta, \omega_0$  are the damping ratio and undamped natural pulsance, respectively.

By considering the equation of the transient error, it may be shown that for  $\delta = \frac{1}{2}$ ,  $R$  is a minimum and equals  $1/\omega_0$ . This value of  $R$  corresponding to  $\delta = \frac{1}{2}$  will now be obtained by the method given above.

The system closed-loop response-vector and Nyquist diagrams are shown in Figs. 1 and 2.

It may be shown that in a time  $3\pi/\omega_0$  the system settles to within 1 per cent of the step, which is sufficiently small for the above approach to give a reasonably accurate result. Thus:

$$\Omega = \omega_0/3$$

The applied step may be written:

$$a = 2/\pi \sum_{p=1}^{\infty} \frac{(1 - \cos \cdot p\pi)}{2p} \cdot \sin \cdot p\Omega t$$

where

$$\sum_{p=1}^{\infty} |a_p|^2 = 2\Omega/\pi \int_0^{\pi/\Omega} (\frac{1}{2})^2 dt = (2/\pi)^2 \cdot \pi^2/8$$

and a suitable form for  $U_p$  is

$$U_p = (2/\pi)^2 \cdot \frac{1}{2(p - 1)p}$$

so that: 
$$\sum_{p=1}^{\infty} |a_p|^2 < (2/\pi)^2 \cdot \frac{1}{2(q - 1)}$$

Summing  $R$ , by reading from either graph the values of the intersecting  $T$  loci at component frequencies up to  $\omega = 8\Omega$ , gives:

$$R = \pi/2\Omega \cdot (2/\pi)^2 \left\{ \frac{\pi^2}{8} - \left( \frac{0.86}{1^2} - \frac{1.0}{3^2} - \frac{0.8}{5^2} - \frac{0.4}{7^2} \right) \right\} = \frac{0.99}{\omega_0}$$

with 
$$E_9 < \pi/2\Omega \cdot (2/\pi)^2 \cdot \frac{0.25}{2(9 - 1)} = 0.03/\omega_0$$

This derived value for  $R$  of  $0.99/\omega_0$  ( $E_9 < 0.03/\omega_0$ ) compares favourably with the theoretical figure of  $1/\omega_0$ .

**REFERENCES**

1. HALL, A. C., The Analysis and Synthesis of Linear Servomechanisms, p. 15. (M.I.T., 1943).
2. WEST, J. C., POTTS, J. A Simple Connection Between Closed-loop Transient Response and Open-loop Frequency Response. Proc. Instn. Elect. Engrs, 100, Pt. 2, 201 (1953).

# A Simple Stable Capacitance Operated Relay of High Sensitivity

(On/off control for a Capacitance Change of 0.004pF)

By W. V. Dromgoole\*

THE circuit described below can be constructed entirely from standard equipment and no critical adjustments are required. The capacitance sensing probe may be attached to the end of a double-screened cable the length of which is governed by the sensitivity required.

It will be seen from Fig. 1 that the fundamental circuit consists of a simple capacitance bridge which functions as a controlled feedback path from the anode to grid of a simple oscillator, and, since  $L_1, L_2, L_3, L_4$  are all wound in the same direction, it can be seen that if  $C_0 > C_1$  the induced current in the  $L_2C_0$  arm of the bridge is greater than that in the  $L_3C_1$  arm and in such a direction in  $R$  as to produce positive feedback and oscillation; but if  $C_0 < C_1$  the bridge is unbalanced in such a direction that the phase conditions produce the equivalent of negative feedback and no oscillation takes place.

In passing the balance there is a reversal of phase and therefore a sharp transition from oscillation to non-oscillation. A change of 0.004pF is sufficient to achieve full on/off operation.

The complete circuit is shown in Fig. 2. The bridge and oscillator stage is an EF42, and the coils  $L_1, L_2, L_3, L_4$  consist of a simple 4-coil pie-wound 2.5mH choke, the intersections of which are cut to provide connexion to the bridge section and the EF42 anode section.  $L_5$  and  $L_6$  are two coil sections of a similar 2.5mH choke mounted adjacent and axially with  $L_1, L_2, L_3, L_4$  and connected as shown in Fig. 4. Spacing between the two chokes is not critical, but should be maintained constant by rigid mounting.

It will be noticed that no attempt has been made to tune the circuit to a particular frequency. The frequency determining factors are those arising from the inductances and capacitances in the anode-grid bridge circuit and other constant stray capacitances.

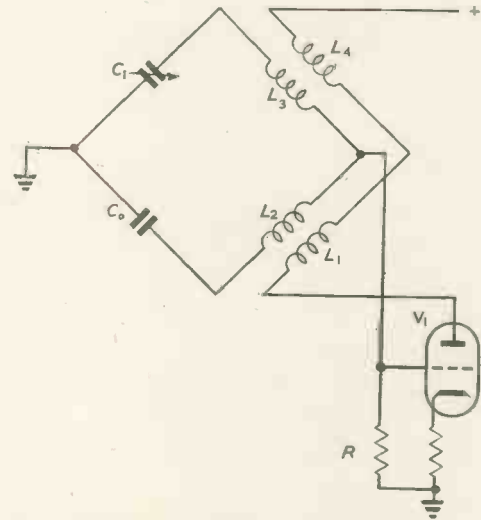
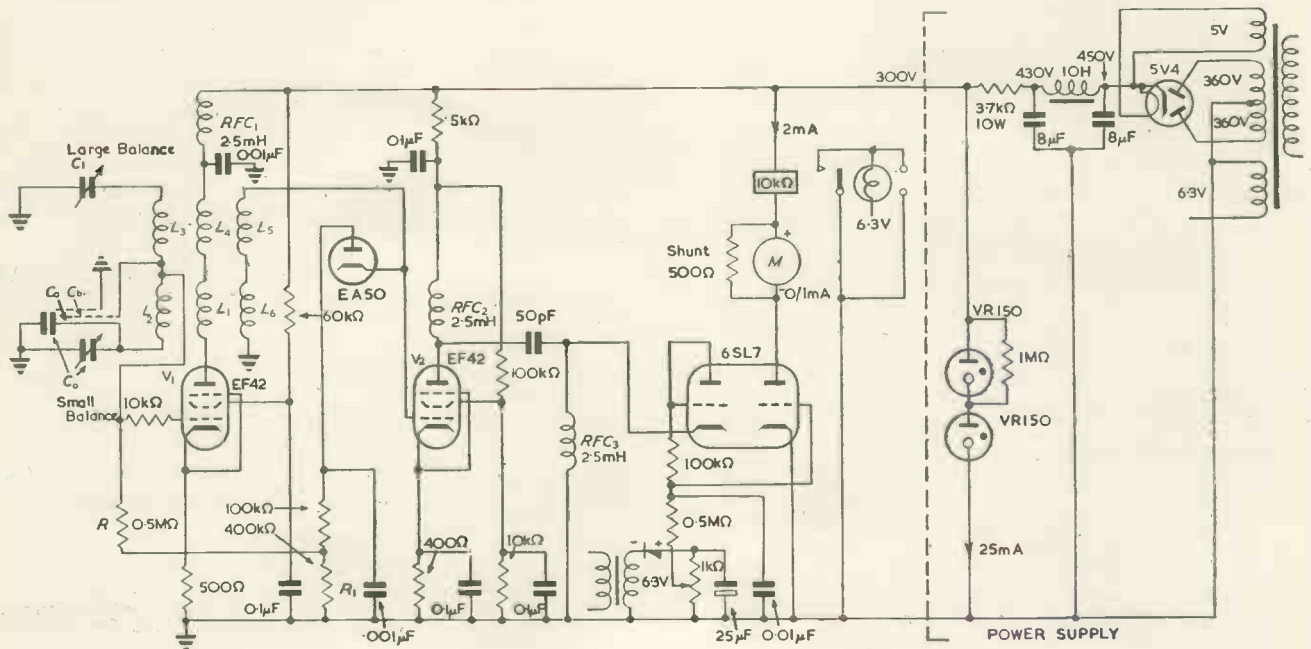

Fig. 1 (above). Fundamental bridge circuit

Fig. 2 (below). Complete circuit of capacitance operated relay



\* Canterbury University College, New Zealand.

The reason for not tuning other portions of the circuit is that the capacitance sensing device may represent, in its quiescent condition, a fixed capacitance of say, 100pF, and in some other application, may be of the order of only a few pF, with consequent changes in the oscillator frequency and response of the following R.F. amplifier if tuning was incorporated.

#### OSCILLATOR STABILIZATION

The oscillator output is fed to an EF42 R.F. amplifier stage, and also to an EA50 diode, which develops a negative voltage across a 500kΩ resistor. A portion of this negative voltage is fed to the grid of the oscillator valve

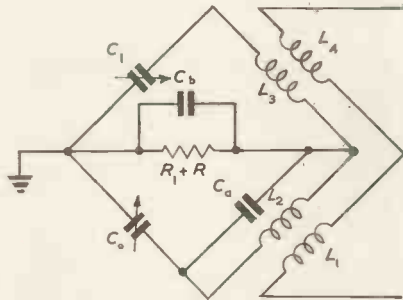

Fig. 3. Modified bridge circuit

to stabilize its gain. A certain amount of negative feedback is also provided by the unshunted cathode bias resistor.

#### R.F. AMPLIFIER AND RECTIFIER

This stage is operated at a lower screen potential than normal, since only sufficient voltage is required from half of the 6SL7 connected as a rectifier to cut off the plate current of the remaining half of the 6SL7 as a relay stage.

#### RELAY STAGE

This half 6SL7 contains a 10kΩ P.O. relay in its anode circuit, which operates on approximately 1.5mA. When the oscillator is off, a preset control (1 000Ω) in the chassis is adjusted so that the anode current of the half 6SL7

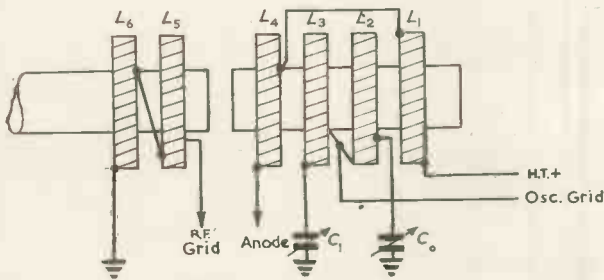

Fig. 4. Assembly of coils  $L_1-L_6$

relay stage is 2mA (full scale on meter). From the circuit of Fig. 2 this is seen to consist of 6.3V A.C. from the grounded heater supply, which is rectified and applied as negative bias to the grid of the 6SL7 by the potentiometer.

When the oscillator is on, the voltage developed across the half 6SL7 rectifier and load is negative, and is added to that already existing at the relay valve grid, resulting in cut-off.

#### POWER SUPPLY

The H.T. supply is adequately stabilized at 300V with two VR150 tubes, as shown.

#### BALANCING

It will be seen from Fig. 2 that one section of the bridge is  $L_3C_1$  and the other is  $L_2C_2$ .  $C_1$  is a preset 15 to 115pF

air trimmer mounted in the chassis.  $C_2$  consists of a 15pF balancing capacitor mounted on the front panel and also includes the capacitance sensing element, which may be terminated at the end of a double-screened cable if required.

With the capacitance sending section connected, and the panel balancing capacitor  $C_2$  (15pF) set at mid scale, turn the preset capacitor  $C_1$  until the meter shows on or off for a small capacitance change, then put chassis in cabinet, screw up and then set final balance with  $C_2$  on the panel until the meter just reads zero.  $T_6$  set is now oscillating and a small increase of capacitance at the sensing element should cause the relay to operate and the meter to read 2mA.

The capacitance device may be arranged to work with either an increase or decrease of capacitance; by reversing the junctions of  $L_3C_1$  and  $L_2C_2$ .

#### USE OF DOUBLE-SCREENED CABLE

If it is desired to sense a change of capacitance to ground at the end of a cable, a double-screened type Telcon Type PT11 M.J.M. is suitable, and when used in this connexion the bridge becomes the circuit shown in Fig. 3.

It will be seen that some sacrifice in sensitivity must be tolerated as the outer screen capacitance  $C_6$  becomes a shunt to ground to the R.F. voltage across  $R_1$  and  $R$  feeding the grid of the oscillator stage. The intermediate screen capacitance  $C_4$  merely represents a change in the balance point of the bridge and can be compensated for by a change of  $C_1$ .

#### SENSITIVITY

The sensitivity was measured by using the Dielectric Test Jig supplied for use with the Marconi Magnification Meter. The incremental capacitor had a capacitance change of 0.83pF per 0.1 inch, which represents a change of 0.0083pF per thousandth of an inch. On/off operation is accomplished with a change of 0.5 thousandths of an inch (i.e. 0.004pF).

#### Acknowledgments

The circuit was developed in the Industrial Development Department, Canterbury University College, and the permission of the Director, Mr. T. R. Pollard, to publish this paper, is gratefully acknowledged.

## New Television Detector Cars

Nine new television detector cars have just been brought in operation by the General Post Office and their main purpose is to detect the presence of television receivers in operation.

The detector equipment utilizes the magnetic induction field set up by the line-scanning coils of the television receiver; this field contains strong harmonics of the fundamental line-scanning frequency of 10.125kc/s and these can be picked up by the sensitive receiver used in the detector equipment at distances of up to 100ft or more in many cases. Three horizontal loop aerials are employed; these are tuned to the second harmonic (20.25kc/s) of the line frequency and are mounted on the roof of the detector car in an "L" formation. The outputs of the loops can be switched in turn to the input of the radio receiver and its audio output heard on a loudspeaker or indicated on an audio level meter.

The cars are also provided with a portable set of detector equipment, which can be carried into blocks of flats or other buildings where a number of television sets may be installed, and which enables the enquiry officer to pin-point each set more conveniently than can be done from the car in the street.

The fixed and portable equipment of the television detector vans, based on designs by the Post Office, was manufactured and installed by G. A. Priecheufried and Associates of Lammas Park Gardens, Ealing.

# ELECTRONIC EQUIPMENT

At the Society of British Aircraft Constructors' Exhibition at Farnborough, Sept. 6 — 12.

(Based on information supplied by the manufacturers)

## Air Trainers

### General Purpose Radio Aid Unit

(Illustrated)

THIS unit provides simulation of radio and navigational aids for instrument flying trainers. It may be used in conjunction with any flight trainer or simulator, and requires only inputs corresponding to aircraft heading, airspeed, and altitude for the operation of all the basic facilities, and inputs of pitch and roll for the zero reader.

The following are some of the basic facilities provided:—

- (a) Computation of ground position.
- (b) Semi-permanent record of flight track.
- (c) Permanent record of landing procedures on a 3-pen graphical recorder.
- (d) Facility for setting height of aerodrome at any level between 0 and 10 000ft above M.S.L.

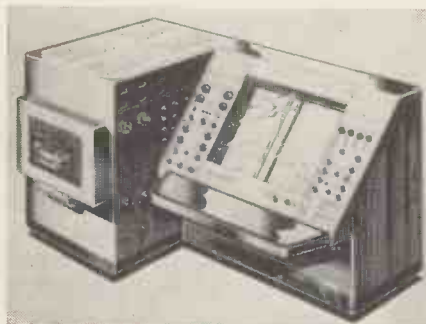

- (e) Automatic simulation of radio compass operation.
- (f) Automatic simulation of I.L.S. localiser and glidepath operation.
- (g) Simulation of VHF communication facilities, embracing communication on two 10-channel VHF TX/RX equipments.
- (h) Provision of all aural facilities through the normal crew's intercom. installation.
- (i) Provision of intercom. facilities between the crew and the instructor.

Air Trainers Ltd,  
Aylesbury, Bucks.

## Boulton Paul

### Automatic Self-Balancing Strain Gauge Bridge

(Illustrated)

THIS bridge has been designed to give an automatic indication of mechanical strain when used with suitable strain gauges in structural research, wind tunnel measurements, etc. It can be used to measure any physical variable which can be converted into a mechanical strain. Both bonded and unbonded wire gauges can be used in conjunction with this instrument.

In operation in the laboratory, the sensitivity exceeds  $2 \times 10^{-8}$  strain on the smallest range of  $1 \times 10^{-4}$  strain. On all ranges the maximum sensitivity is 0.02 per cent of full span. Any number of switched ranges of mechanical strain up to six can be provided between  $0.5 \times 10^{-4}$  and  $50 \times 10^{-4}$  full span.

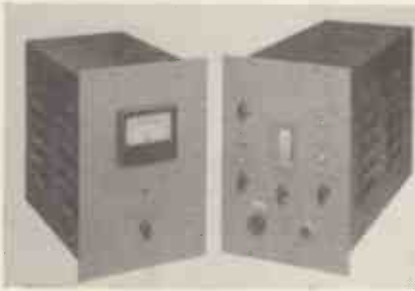

Simple control and initial setting up is provided by readily accessible controls. Bridge balance is obtained by means of a 3in centre-zero meter.

#### Brief Specification

Sensitivity: Normally less than 0.02 per cent full span on all ranges with 4V. R.M.S. applied to the strain gauge bridge.

Linearity: Lowest range better than  $\pm 0.1$  per cent of full span. Highest range better than  $\pm 1.5$  per cent of full span.

Response: Time to travel full span less than 5 seconds. Frequency response at small amplitudes of strain extends to several cycles per second.

Bridge Balance: Indicator, 3in centre zero meter. Controls, Coarse zero (resistance); fine zero (resistance); capacity balance.

Full Span Adjustment: This is provided by means of a potentiometer.

Boulton Paul Aircraft Ltd,  
Electronics Department,  
Wolverhampton.

## Elliott

### Automatic Balancing Three-Channel Strain Gauge Bridge

THIS instrument combines a sensitivity better than 0.00001 per cent strain with an input stability better than  $3 \times 10^{-7}$  volts. It has been developed and manufactured to R.A.E. specifications.

Load Cell. (Illustrated.) Load cells



provide a new means of measuring forces and weights ranging from 5 cwt to 200 tons. The force to be measured is caused to stress a high-tensile steel member carrying bonded resistance wire strain gauges connected as a bridge circuit. The load carrying member is housed in a hermetically sealed cylindrical container provided with a cable entry gland. The bridge is excited from a low voltage source, and provides an out-of-balance signal of 2mV per volt input to the bridge for capacitance load. The out-of-balance signal is linear with respect to the applied load.

Load cells are self-compensating for temperature variations. Calibration accuracy is within  $\pm \frac{1}{4}$  per cent of full range at all points from 0-100 per cent of capacity. The recommended maximum operating temperature is 150°F. The cells are conservatively rated in respect of overload, impact loading and sustained loading. Means are employed to maintain internal insulation resistance.

The present range of cells for compressive loading includes maximum ratings of  $\frac{1}{2}$  ton,  $2\frac{1}{2}$ , 15, 50, and 200 tons.

Elliott Bros. (London) Ltd,  
Lewisham, London.

## Ferranti

### New D.M.E. Interrogator

FERRANTI LTD has been closely associated with 1000Mc/s distance measuring equipment and are showing for the first time an entirely new airborne interrogator. In the new version every attempt has been made to reduce size and weight while retaining all the facilities required by the I.C.A.O. specification. The resulting equipment comprises a single main unit (mounted in standard S.B.A.C. racking) containing transmitter, receiver and timing circuits. A remote control unit (illustrated) is provided together with either one of two indicators for remote presentation of the distance information. In addition the Ferranti interrogator has facilities for the incorporation of "Homing" circuits in



the same unit. The homing display is incorporated with the distance presentation.

### New Packaged Computer F.P.C.1

The Computer Group of Ferranti Ltd is showing in pictorial form the Ferranti packaged computer F.P.C.1, a new electronic digital computer. This is a medium-sized general-purpose machine suitable for carrying out a very wide variety of calculations of the type and magnitude which arise in industry, research and management.

This machine, like other machines of its type, can

1. Do arithmetical operations exceedingly rapidly.
2. Remember a great many numbers and very rapidly find any number in its store.
3. Perform a sequence of operations automatically.
4. Make decisions; that is to say, at any stage in the calculation, it can decide between several courses of operation according to which of various contingencies has arisen.

The F.P.C.1 is a packaged computer. It is built up from a range of standardized plug-in units, so that maintenance can be quickly carried out by replacement of the standard package without the computer having to be taken out of service.

**Ferranti Ltd,  
Hollinwood, Lancs.**

### Goodman Vibration Oscillator

(Illustrated)

A NEW addition to the range of vibration equipment is an oscillator with a 5 watt amplifier, covering the frequency range; 10-10 000c/s. This unit is primarily intended for use with Model V.47 vibration generator and develops up to 5 watts into a 3 ohm load. This compact combination provides a self-contained variable frequency power supply and can be used for a wide variety of vibration investigations.

The circuit consists basically of an oscillator and amplifier sections with the necessary built-in power supplies.

The oscillator is a resistance-capacitance coupled two-stage circuit employing automatic amplitude control by means of a thermistor in a feedback loop.

The tuning is effected by a continuously variable double potentiometer, which in conjunction with a range switch selects appropriate values of fixed



capacitance. Calibration adjustment is by pre-set potentiometers.

The drive to the amplifier is taken from a continuously variable potentiometer across the oscillator output and this acts as a gain control.

One half of a double triode valve operates as an amplifier and this feeds into the second half of the same valve which operates as a phase splitter driving a conventional push-pull output stage.

Overall feedback is applied from the secondary of the output transformer to the cathode of the first amplifier stage.

A rectifier meter connected across the output winding indicates the output level and is calibrated 0.5 volts.

**Goodmans Industries Ltd,  
Wembley, Middx.**

### Marconi High Power Transmitter-Receiver

(Illustrated)

PRIMARILY designed for pilot-operated radio telephony service, the Type AD.307 equipment is a multi-channel high-power transmitter/receiver. Unit construction is employed and the main units are built to fit the standard aircraft racking. The equipment conforms to SBAC standards throughout and meets all British Civil Airworthiness requirements.

Two hundred crystal-controlled channels are available on the basic equipment, but alternative drive circuits, using crystal economiser techniques, will provide 44 000 channels in the frequency band 2-24Mc/s. Remote control is from one or two positions and the selection of a channel results in complete automatic frequency changing and self-tuning of all units, including the aerial tuning unit. Provision is made in the receiver for use of the muting system "Carrier Operated Device Anti-Noise" (CODAN). The equipment has primarily been designed for operation from A.C. supplies, but in aircraft where there are limitations in this respect, D.C. sources provide the major portion of the necessary power. Valves are directly replaceable by equivalents from the ARINC range. Potted circuit techniques, unit construction and the design of units to fit standard aircraft racking, contribute to reliability, ease of maintenance and simplified installation.

The photograph shows the complete AD307 unit as follows:

Top: (left to right) Drive and Receiver Unit, Power Amplifier Unit, Modulator and Power Unit (D.C. supply version).

Lower: (left to right) Remote Control Unit (Pilot's Controller), Aerial Tuning Unit, Remote Control Unit (Master Controller).



Other new exhibits include:

**AD7092C Radio Compass.** Primarily designed for use by airlines on the American continents, all valves have direct equivalents in the ARINC range. A special feature of this radio compass is the tuned sense aerial amplifier, which has been developed to increase the attenuation of unwanted signals in areas where numbers of closely sited broadcast stations exist.

**AD801 VHF Transmitter (50 watt).**

**AD818 VHF Receiver.**

Both of these are specifically designed for air traffic control use.

**Marconi Wireless Telegraph Co Ltd,  
Chelmsford, Essex.**

### Marconi Instruments

AMONG the recent additions to this range of communications measuring instruments are the following:—

#### F.M./A.M. Signal Generator TF 995A

This instrument retains all the features of the original TF 995, including the frequency range of 13.5Mc/s to 216Mc/s, but certain operational improvements have been introduced—particularly the revised switching and monitoring arrangements which permit simultaneous frequency and amplitude modulation with the ability to read both frequency deviation and amplitude modulation depth.

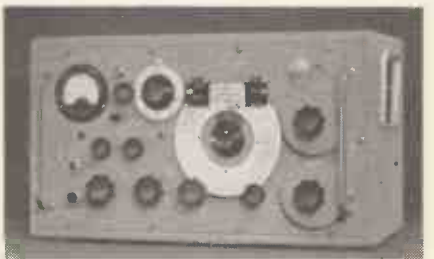

#### VHF Test Set TF 982

Specially designed for use in connexion with mobile transmitters and receivers, this V.H.F./I.F. signal generator and test set has main frequency ranges in the band 60-184Mc/s.

#### Signal Generator TF 801A/1

(Illustrated)

A general purpose instrument for the carrier range 10 to 310Mc/s, incorporating a patented contactless waveband selector which eliminates the variable factor of R.F. contact resistance.

**Marconi Instruments,  
St. Albans, Herts.**

### Murphy

#### Control Monitor Type SM.252

(Illustrated overleaf)

THIS unit has been designed to work in conjunction with the Murphy Radar Transponder Beacon RB.110. In addition to on/off switching, it provides remote indication of power output, receiver sensitivity and code operation.

The equipment comprises monitoring circuits and a signal generator mounted on a 19in panel in a separate steel case, for installation adjacent to the beacon,



together with probe fittings for the aerial array.

At the remote control station, a switch and indicator unit SU.253 is provided, housing a relay and a mains transformer for the indicator lamp.

The signal generator provides a constant low level signal pulse modulated at 50c/s, which interrogates the receiver via an aerial probe. The resultant transmitter output, via a similar probe, is gated and used to initiate an audio signal at 1 000c/s which is fed along the control line. At the remote station this audio signal is rectified and used to energize a relay which lights an indicator lamp.

The receiver performance may thus be monitored by suitable adjustment of the signal generator. Similar adjustment of the monitor detector bias circuit ensures that any fall in transmitter power output below a pre-determined level is also immediately indicated. Trigger sensitivity and power output are discriminated within very close limits, and a reliable indication of the beacon performance is continuously maintained.

A separate plug-in sub-chassis is normally incorporated which monitors the beacon code output pulse. The presence of the code pulse causes the remote indicator lamp to be extinguished so that the correct operation of the coding cycle may be observed.

The distance over which the monitor will operate will vary with the characteristics of the line in use, but a range of at least nine miles (15 km) may be expected. The maximum d.c. loop resistance must not exceed 3 000 ohms and the maximum attenuation at 1 000c/s must not exceed 15db.

The signal generator employed provides stable signals between 180 and 240Mc/s, with pulse or c.w. modulation and with a calibration accuracy of  $\pm 0.5\text{Mc/s}$ .

A calibrated piston attenuator is fitted which, in conjunction with the meters provided on the monitor, enables the beacon receiver sensitivity to be measured on the site without the aid of additional test gear.

**Electronics Division,  
Murphy Radio Ltd,  
Welwyn Garden City,  
Herts.**

#### Plessey

#### Aerial Multi-Coupler (Type PV 95)

(Illustrated)

**T**HIS equipment is intended for use in VHF receiving stations operating in the band 116-134Mc/s and enables up to six receivers to be operated from one aerial. An insertion gain of 17db is

achieved with a noise factor of 8db. Thus if the multicoupler is used with receivers of average or indifferent noise factor, the result is an improvement in the overall noise factor of the combination compared to the receiver alone. The coupling between any two output sockets is lower than 40db down relative to the insertion gain, and the linearity is such that cross-modulation effects are negligible over the range of signal strengths normally experienced. The input and output circuits are arranged for use with 75 ohms coaxial cable.

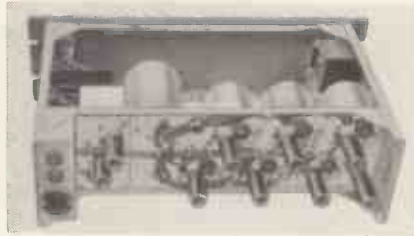

#### 5 Channel H.F. Preselector Type PV 98 and PV 98A

The preselector is intended to be used in combination with a fixed frequency single channel H.F. receiver such as the Plessey PR.53, the two units forming a five channel pre-set double superheterodyne. It may be fitted with a BFO stage for injection into the receiver for telegraphy working, and can be used with internal HFO crystals or external highly stable HF oscillators. Facilities are available for cross-coupling two preselectors for diversity working, and in conjunction with the corresponding facilities in the PR.53 receivers. Considerable economy in the number of crystals required is obtained.

#### Two-Tone Generator Type PG 96

The principal application for this unit is in connection with tone modulated line of VHF telegraphy. It converts keyed dc to two tone signals or vice-versa. The tone outputs are in the audio frequency range 300-3 000c/s. The unit can be supplied with the tone output adjusted in conformity with the British Post Office standard tones.

**The Plessey Co Ltd,  
Ilford, Essex.**

#### Pye Gliderphone (Illustrated)

**A** SMALL very lightweight set has been designed for gliders and small aircraft, and to meet this requirement



the Pye "Walkiephone" has been used as a basis for a new design. Its size is much reduced by separating the batteries from the set and stowing these away into a convenient space. The very small radio set can then be sited for easy access by the pilot.

In the case of wooden gliders a whip aerial with suitable ground plane straps can be installed within the fuselage, resulting in a very neat installation.

Using an efficient ground plane with a whip aerial, remarkable ranges are possible with airborne Gliderphones operated in conjunction with 15-watt fixed or mobile stations, and distances of 80 miles and more have been reported.

With its own power supply the Gliderphone has obvious advantages in aircraft as an emergency set or in light aircraft for radio-telephone contact with airfield control towers. Gliders can maintain contact with their recovery crews by means of this set, and also receive messages regarding weather conditions.

**Pye Ltd,  
Cambridge.**

#### Redifon G143 Transmitter (Illustrated)

**T**HE G.143 has been specially designed to meet the ever-increasing need for rapid frequency changing over a wide range, particularly in ground-to-air communication.

It provides telephony, m.c.w. and c.w. service over the frequency range 2-26Mc/s. The main feature of the equipment is the ability to select from a distance any one of ten channels, each of which can be preset to any frequency in the entire band. The average time required for frequency changing is five seconds.

The two main parts of the channel selection system are the step-by-step motor-driven frequency band selector switches, and the tuning elements, which





are driven by Servo-operated 2-phase AC motors.

Tuning is preset by selecting each channel in turn, setting the band switches (one each for oscillator driver and power amplifier units) and adjusting the driver tuning, power amplifier tuning and power amplifier loading by the appropriate setting potentiometers. Selection of a channel automatically switches in the relevant crystal.

Full facilities are provided for remote control up to 25 miles. The system includes a small push button unit for mounting close to the operator and a larger unit containing the microphone amplifier and keying oscillator, and step-by-step switches and relays.

#### G142 Transmitter

This is a medium-frequency transmitter with a coverage of 200-420kc/s which has been specifically designed as an economical locator beacon and route marker for aeronautical navigation.

For continuous unattended operation a dual installation is available with automatic monitoring, change-over switching and remote indication of serviceability.

The equipment can be supplied in a weatherproof, ventilated kiosk-type of housing, which eliminates the need for a building.

#### Brief Technical Details

The modulation frequency is 1020  $\pm$  50c/s the power amplifier being modulated to a depth of 80 to 95 per cent at all output powers without requiring adjustments. The normal method of keying is by switching on/off modulation with continuous carrier (i.e. keyed tone), alternatively, normal c.w. on/off keying up to 20 bauds. An automatic code sender for a two- or three-letter call sign, sent eight times per minute at 7 w.p.m. in accordance with I.C.A.O. requirements, is incorporated.

The R.F. unit is crystal controlled, the tolerance being  $\pm$ 0.02 per cent of the radiated frequency in accordance with International Radio Regulations (Atlantic City, 1947). This stability is maintained over an ambient temperature range of 30°C and with supply voltage variations of  $\pm$ 6 per cent.

**Redifon Ltd,**  
Broomhill Road,  
London, S.W.18.

#### Salford

#### FM Radio Altimeter

(Illustrated)

THE altimeter operates on a similar principle to that used in radar devices, but instead of a series of pulses being sent out, a continuous wave is radiated, the frequency of which varies repeatedly in a sawtooth manner. The time delay of the reflected wave enables a direct measurement of height to be made.

The altimeter is designed so that two height indicators are available, one for the pilot and one for the navigator. The instrument is accurate to  $\pm$ 10ft at 200ft and to within 3 per cent of the indicated height up to 5000ft. Where required, a height can be preselected and a visual indication is given of any deviation from this height. The power consumption is approximately 130 watts, the nominal input voltage being 24 volts



D.C. The transmitter/receiver unit and indicators are pressurized.

The presentation consists of single pointer with one revolution per 1000ft, numbers of thousands being shown on a single figure revolution counter.

Preset heights may be selected manually on a limit height unit and indicator lamps provide warning when flying on, above or below any present height.

The illustration shows the power unit and the indicator and control units.

**Salford Electrical Instruments,**  
Salford, Lancs.

#### Saunders Roe

#### Computing Amplifier

THIS amplifier has been designed for use in high-accuracy, slow speed D.C. analogue computers and those employing repetitive operation where the solution is displayed on a cathode ray tube.

The control panel is fitted with three zero-setting controls, which are suitably guarded to prevent accidental disturbance after adjustment, and a "Set/Use" switch flanked by two jack sockets also used for zero setting purposes.

The unit, which is of robust construction, is designed to be mounted on a main panel and supported by web-type brackets.

The amplifier is a triple-circuit unit comprising a high-gain drift-corrected channel which can be converted to a lower gain circuit by the operation of a relay. A separate drift-compensated unity-gain amplifier is provided for sign reversal.

The main amplifier has been designed to provide highly accurate computation when the change-over relay is in the high gain position, in which condition the frequency response is adequate for slow speed computation where the solution is presented on a pen recorder.

In the low gain circuit the frequency response is approximately eleven times that of the high gain circuit and is suitable for repetitive solution presentation on a cathode ray tube, e.g., a 10c/s phenomenon is presented fifty times per second giving a fundamental frequency of 500c/s to be accepted by the amplifier.

The main amplifier will perform the

operations of summation, differentiation and integration, and will provide any desirable transfer function when used in conjunction with suitable computing impedances.

**Saunders Roe Ltd,**  
Electronics Division,  
East Cowes,  
Isle of Wight.

#### Standard Telephones and Cables Ltd.

#### Precision Approach Airfield Radar

THIS equipment provides the ground controller on an airfield with visual three-dimensional information relating to an aircraft approaching the runway in use, i.e., distance, azimuth, and elevation. This information, vital during inclement weather, enables the controller to convey to the pilot over the normal radio telephone all instructions necessary to fly the aircraft to the approach end of the runway from where a safe visual landing can be made.

The radar section of the equipment is installed in an unattended vehicle normally positioned at the side of the runway facing down-wind. Two 50kW radar transmitters operating in the 3cm band radiate a pulsed fan beam from two aerials in the direction of the descent path. At the 10 mile working range of the equipment this represents a swept space of approximately three miles by one mile in which an aircraft can be detected. The aircraft is directed into this area by normal navigational aids. Radar echoes from the aircraft are duly interpreted by the receiving equipment in the vehicle and passed over a radio link to the control tower where they are presented to the controller on azimuth/range and elevation/range cathode-ray tubes.

#### STR.20 560/623-Channel VHF Airborne Communication Equipment

The STR.20 is an entirely new equipment specifically designed for use in military aircraft, and is exhibited for the first time.

This equipment provides 560 channels at 100kc/s channel spacing, or 623 channels at 90kc/s channel spacing. A frequency synthesis system using built-in crystals is used. Any 20 channels can be made available for selection by the pilot.

#### STR.12D 140-Channel VHF Airborne Communication Equipment

The STR.12D is the latest type of VHF aircraft equipment designed specifically for the world's air lines. It provides 140 channels in the International Civil Aviation Organisation's band of 118-132Mc/s. The transmitter has a power output of some 10 watts and the equipment is provided with full pilot remote control.

The equipment, incorporating crystal saving circuits, uses only 34 crystals although providing crystal control on each channel.

The STR.12D is fitted as the standard VHF communication equipment on such aircraft as the Vickers "Viscount," the Bristol "Britannia" and the De Havilland "Comet."

**Standard Telephones and Cables Ltd,**  
Connaught House,  
Aldwych, London, W.C.2.

## Relays for Electronic and Industrial Control

By R. C. Walker. 303 pp., 65 figs. Demy 8vo. Chapman & Hall Ltd. 1953. Price 42s.

THE author's preface states that the object of this book is to bring together in collected form for handy reference the principal features and potentialities of relays as switching devices.

Certainly the author has assimilated an immense mass of previously scattered material and, so far as the present reviewer knows, this is the first book wholly devoted to the subject. The material is too diverse to give more than a hint of the context but, with some astonishing omissions to be noted later, most aspects of relay operation and use have been dealt with, while descriptions are given of many little known and comparatively seldom used types and circuits.

## ELECTROPHYSIOLOGICAL TECHNIQUE

By C. J. Dickinson, B.A., B.Sc.  
(Magdalen College, Oxford)

Price 12/6  
(Postage 6d.)

The author describes the use of electronic methods as applied to research in Neurophysiology. Chapters are devoted to amplifying, recording and stimulating techniques used in physiology and medicine (e.g. electrocardiography, electroencephalography, etc.)

Order your copy through your bookseller or direct from

## Electronic Engineering

28 ESSEX STREET, STRAND, W.C.2

The book shows many evidences of failure in careful revision and editing due, presumably, to the regretted death of the author while the book was in the press. Unfortunately, an honest reviewer cannot take *de mortuis nil nisi bonum* as his motto and it is impossible to pass over the many omissions, pieces of careless writing and downright misstatements which the book contains. Also it must be stated that the assemblage of the vast amount of material is somewhat unsystematic.

As an example of careless expression, on page 83 occurs the phrase "If a large capacitor, normally shorted, is connected across the relay contacts on a direct current circuit, opening the contact provides

# BOOK REVIEWS

a sink into which the energy of the collapsing magnetic field can pass instead of appearing across the contacts. . . ."

On page 174 it is stated "If the coil is assumed to be devoid of resistance its inductance will be proportional to the square of the number of turns . . . ." What has the resistance to do with the inductance? The paragraph goes on "and since the number of turns is in general higher for higher voltages the time element will be relatively greater for relays used on higher voltages." This is, of course, quite untrue.

The whole of the next paragraph and the curve, Fig. 71, to which it applies also shows completely muddled thinking. While correctly indicating that the current in a circuit of a higher R/L ratio will rise more quickly than one in which this ratio is less, the fact that fewer turns will produce a smaller magnetizing effect for a given current is disregarded so that the whole argument is invalidated.

There are some astonishing omissions. Although the design of non-polarized relays is dealt with at considerable length, that of polarized relays—which, because of their much higher sensitivity are usually to be preferred for use in connexion with valves—is not even mentioned. The Western Electric 209F.A. relay, known in this country to the B.P.O. as the 299A.N., which was until recently probably by far the most widely used polarized relay in the world, is not even referred to, nor are those made by Siemens & Halske, of Munich.

The Gulstad relay with its enormously valuable ability to replace missing dots in telegraph circuits is not referred to by name and the principle is only very incompletely described in the description of the Creed relay and even here no circuit diagram is given.

On page 162 the treatment of filters, which are frequently of importance in connexion with relay working, is inadequate and confused.

In spite of the foregoing criticisms and they are only some picked at random, the book is worth buying for the information it contains but it is scarcely to be recommended to the beginner who will be frequently puzzled and sometimes misled.

R. E. H. CARPENTER.

## Cathode Ray Tubes

Edited by M. G. Say. 216 pp., 50 figs. Demy 8vo. George Newnes Ltd. 1954. Price 25s.

THIS book, which is one in the Newnes Electrical Engineering Progress series, is written by a group of authors each an expert on the particular subject he covers.

It covers a wide range and each chapter is concluded by a useful list of references.

After a brief survey of the types and uses of C.R.T's, Electron Optics are dealt with and the effects of varying the various

parameters are discussed. This is followed by a chapter on the actual construction of C.R.T's. These early chapters are extremely thorough and although most of the theoretical aspects are dealt with, the practical problems are also discussed in a manner which reflects the author's familiarity with the subject.

Chapter V is entitled "Television Tubes and Control Circuits" and covers the television application of C.R.T's and the particular problems involved. It is a most useful chapter, but it is a pity that overlapping of the previous chapters should occur. In particular the problem of ion burn is described all over again including illustrations of typical ion traps. Electromagnetic focusing is also repeated including almost exact copies of previous illustrations. The advantages and disadvantages of projection equipment are listed in a most unbiassed way and many interesting features of the system are mentioned. Several items such as neutral filters and oil filled lens are also mentioned. A typical modern television receiver circuit is shown, including all values, and the functions of the various valves are briefly described. The chapter includes a most interesting list of British C.R.T's and gives their more important characteristics.

Radar tubes and some of their associated circuits are described in the following chapter. Various displays such as the "A" and "B" type and P.P.I. are described and illustrated and the Skiatron is also mentioned. This chapter also includes a list of C.R.T's, but this one is concerned with those particularly developed for radar purposes.

Chapters VII and VIII deal with some of the problems which occur in the use of C.R.T's for measurements and investigation of various waveforms. Some of the uses of the oscilloscope technique are listed and described.

Camera tubes are dealt with in the following chapter. It contains a most interesting description of the main features of the various camera tubes including the basic principles upon which they operate. This chapter is also well illustrated.

The book concludes with a chapter on special tubes and their uses. It includes switching tubes, storage tubes, monoscopes and the image converter and its application to high speed photography.

The book is printed on good quality paper and is well illustrated throughout. The only error noticed by this reviewer was in Chapter V where a graph, showing the variation of spot size, plotted against anode voltage of a C.R.T., is illustrated. It is headed "Variation of spot size with final anode voltage," but it should obviously read ". . . . first anode voltage." It is not likely to cause confusion to the average reader as the anode voltage only ranges from 100 to 400 volts.

C. H. BANTHORPE.

## Introductory Circuit Theory

By E. A. Guillemin. 545 pp., 85 figs. Demy 8vo. John Wiley & Sons, Inc., New York. Chapman & Hall Ltd., London. 1954. Price 68s.

IT is sometimes claimed that G. B. Shaw's preface is more important than his play. The student will doubt whether this can apply to a textbook, but the teacher may well feel that the preface to this book is an important contribution to teaching aims. When reading it, he will often find himself saying "hear! hear!" To quote only one or two sentences: "Circuit theory is the electrical engineer's bread and butter" (yes, even the "heavy" electrical engineer). "He (the student) should be started off with the same basic concepts and process of analysis that he will be using in his professional work four or five years later." So we find Guillemin tackling impulsive excitation before sinusoidal. He warns us of the relativeness of the terms elementary and advanced in "We refer to things as being advanced only as long as we understand them insufficiently well ourselves to be able to make them clear in simple terms." While appreciating the partial truth of this, we should want to qualify the statement. Surely there is some absoluteness about the terms, too. For example, dealing with F.M. sideband theory involves more advanced work than dealing with A.M. sideband theory, even when both are sufficiently well understood to be made clear in simple terms. He rightly stresses the value of 1 volt or 1 amp as the starting point and refers to the importance of promoting flexibility in the student so that he can solve the slightly unorthodox problem.

And now to the book itself: the first chapter sets out how best to represent a network and to arrange the variables so as to reduce the task of solution. It is in effect an argument in favour of adopting Maxwell's circulating or loop current rather than Kirchhoff's branch current method. Next there is a discussion on Kirchhoff's laws and the equivalent voltage and current generators. Those who have had much to do with determinants will agree with the author's statement in Chapter III, that it is easier to adopt a method of systematic elimination with simultaneous equations. The application of symmetry to solve the resistance across the ends of a diagonal in a uniform wire cube is a good example of the author's commonsense approach. Thévenin's and Norton's theorems are fully explored. The reaction of circuit elements to various voltage or current sources of different amplitude-time characteristics is considered in Chapter IV. In dealing with the inverse circuit concept the author is prepared to use term "daraf" as the unit of inverse capacitance but avoids "yrneh" in favour of "reciprocal henry." Perhaps the author is not partial to Welsh! Simple circuits containing RL and/or C are employed in the next three chapters in order to examine impulse and sine wave response, and to develop the significance of impedance and the complex frequency plane. The importance of knowing the differential and integral forms of standard amplitude-time waveforms is stressed. In Chapter VIII we have the analysis extended to more com-

plicated circuits including mutual inductance. There are many examples to illustrate the general solution of a finite lumped-constant circuit in Chapter IX. The last chapter emphasizes the value of matrix representation in circuit theory and concludes with a note on duality and reciprocal circuits.

The quality of the book reaches the standard we would expect of the author and its style, a little less formal than is common with English technical writers, is quite refreshing. There are some criticisms one could offer. There is no bibliography or list of references to aid the student who wishes to go further, and a 3½-page index is hardly adequate to facilitate search through 550 pages. It would be helpful, too, if the answers were given to the many problems, which are an excellent feature of every chapter. The book can be confidently recommended to lecturers, to undergraduates, and to Higher National Certificate students in Electrical Engineering.

K. R. STURLEY.

## Industry and Science

188 pp. Demy 8vo. Manchester University Press. 1954. Price 12s. 6d.

THIS is a report by the Manchester Joint Research Council based on a survey of some 225 firms in the greater Manchester area between 1950 and 1953. The idea was to take a well-selected cross-section of firms in the thickly populated area of greater Manchester, and to appoint a small team of qualified investigators to hold confidential conversations with leading industrialists and their staffs. The scheme was given the support of the Department of Scientific and Industrial Research throughout. Individual industrialists should find in the report something which will help them make the best use of scientific knowledge in their own particular field.

## Electrical Contractor's Annual

Edited by J. Rosslyn-Stuart. 358 pp., 80 figs. Demy 8vo. 2nd Edition. E. & F. N. Spon Ltd. 1954. Price 18s.

THIS edition contains a number of entirely new articles written by specialist contributors. The existing features, trade names and trade addresses, together with other reference data, have been revised and brought up to date.

## Data and Circuits of Television Receiver Valves Book III C

By J. Jager. 225 pp., 226 figs. Demy 8vo. Philips Technical Library, Holland. Elsevier Press Inc., New York. Cleaver Hume Press Ltd., London. 1953. Price 21s.

THIS book provides the television technician and those who wish to qualify as such with useful data on the application and operation of valves which have been specially developed for television.

In the first section, each type of valve is treated individually, with full information on applications and correct operating conditions. The second section deals at some length with typical circuits, and the third contains short descriptions of a number of measuring instruments suitable for testing, fault-tracing, and so forth.

CHAPMAN & HALL

## ELECTRONIC MEASURING INSTRUMENTS

by

E. H. W. Banner

M.Sc., M.I.E.E., M.I.MECH.E., F.INST.P.  
416 pages 253 figures 45s. net

## ELECTRONICS

by

George F. Corcoran

and

Henry W. Price

(Both of the University of Maryland)

A modern introduction, including complete chapters on graphical methods, transistors, feedback circuits, and oscillators.

459 pages 326 figures 56s. net

37 ESSEX STREET, LONDON, W.C.2.

## Smith's for Technical Books



Books on the theory and practice of electronics, new developments, circuit design, and other specialized subjects can be quickly supplied through your local Smith's shop or bookstall.

Your copies of *ELECTRONIC ENGINEERING* can be bound into attractive volumes; and all your stationery and printed matter supplied through our local branch.

**W. H. Smith & Son**

for **SPECIALIST BOOKS**

HEAD OFFICE:  
STRAND HOUSE, LONDON, W.C.2

## Automatic Voltage Regulators and Stabilizers

By G. N. Patchett. 335 pp., 195 figs. Demy 8vo. Sir Isaac Pitman & Sons Ltd. 1954. Price 50s.

THIS book deals with all types of voltage regulator from those having a few watts output, which generally supply electronic equipment, to those, employed on large power systems, controlling thousands of kilowatts.

The introductory chapter briefly mentions methods of obtaining a constant voltage, the distinction between an automatic voltage regulator and a voltage stabilizer, the types of automatic voltage regulator and automatic current and power regulators.

Chapter II first deals with design specifications and methods of expressing performance. The principles of regulators in which it is impossible to distinguish the measuring and regulating units are then given. Descriptions are included of the many non-linear devices, such as glow-discharge tubes and magnetically-saturated elements, which can be arranged in potential-divider or bridge circuits. Detailed classification of regulators according to the positions and types of measuring and regulating units appears in Chapter III.

Chapter IV is devoted to regulators in which the regulating unit consists of a motor driving some variable element. Suitable elements, such as moving-coil and induction regulators, are described together with contact-making voltmeters and voltage-sensitive relays as measuring units. Chapter V gives an account of carbon-pile, rocking-sector, multiple-contact, vibrating-contact and moving-loop regulators.

The next two chapters include data on D.C. reference-voltage sources, valves and transducers, the theory of non-linear bridges, more detailed information on barretters, silicon-carbide materials, thermistors and incandescent lamps, descriptions of bridges using saturated diodes, a mention of D.C. and A.C. generators, and the principles of the metadyne generator and magnavolt and rototrol exciters. Some omissions are evident here, e.g. some details of the stability of standard cells might have been given, there are several other types of saturated diode apart from the Sorensen and 29C1 (given as 29CI at bottom of p. 184) and the saturated-diode bridge is now commonly used in this country.

Chapter VIII describes arrangements based on units covered in Chapters VI and VII, including thermionic-valve and generator-type regulators, while the final chapter considers special topics such as parallel running of machines and hunting.

The book is written in an attractive manner, is clearly illustrated with many diagrams and is easy to follow throughout because of careful arrangement of the material. There is some repetition, however, and a number of minor errors in Chapters II and VI.

The book can be thoroughly recommended to advanced students and research engineers. It is undoubtedly a valuable source of general information and reference with its excellent bibliography of 610 references and an additional list of 137 items for further reading.

In spite of this the bibliography is incomplete and, because the subject is expanding so rapidly, there are at least 150 more recent papers than those listed.

F. A. BENSON.

## Physics and Applications of Secondary Emission

By H. Bruining. 178 pp., 70 figs. Demy 8vo. Pergamon Press Ltd. 1954. Price 25s.

THIS book gives a survey of secondary emission phenomena and their uses. It covers the subject well in the sense that sections are included on all relevant topics, and will be welcomed for this reason. However, as there are so few books on the subject, it seems to the writer that a more detailed treatment of some topics would have been justifiable. The section on the theory of secondary emission is rather condensed, but more important, attention to the work of the last few years is inadequate. For example, although there is an excellent list of references to early work, only 16 papers are quoted in the list for 1950-52. Nine papers of considerable importance published in this period are omitted, and several other less important ones. Moreover, there are several papers since 1949 which are listed, but whose significance is not referred to in the text. This applies especially to the work of H. Jacobs and collaborators on the enhanced secondary emission from magnesium oxide, which should have been included in the section on the Malter effect. On page 66 Johnson's work of 1947 on the oxide cathode is described, but there is no mention of his continued work published in 1951, and in this case the reference is one of those missing from the list. The list of secondary emission coefficients of metals omits Farnsworth and Lun's values for Re and Ni-Ba, and also Brophy's values for liquid and solid Ga, Hg, Pb, and Bi. All this work was published in 1951. Brophy's work, dealing with liquid metals, should also have been referred to in section 3.4.5. His values for Pb and Bi differ from the values quoted in the book, obtained by Morozov.

The book is on the whole written clearly, but there are a few passages where the degree of condensation makes the meaning rather difficult to follow. Examples are section 3.6, the second paragraph on page 61, and the final sentence on page 127. There are several mistakes, thus on page 47 it is stated that  $\delta$  true is inversely proportional to the density of the element, which is not so. On page 59 a conductivity is quoted in ohm-cm., and one cannot deduce what value is intended; moreover, a value for the conductivity of caesium-antimony has already been published, by the present writer. On page 60 the field emission is described as falling instantaneously to zero, which is not the case, and in fact contradicts Fig. 4.5.

Thus while this book will be acceptable in so far as it serves to correlate a wide range of phenomena, and because it deals adequately with their applications, it seems likely to disappoint those who are actively engaged in the subject, and who are interested in recent developments in its physical aspects.

D. A. WRIGHT.

## Rocket Propulsion

By Eric Burgess. 235 pp., 56 figs. Demy 8vo. Chapman & Hall Ltd. 2nd Edition. 1954. Price 21s.

THE second edition of this book follows the original material very closely and only a modest amount of fresh information has been added, notable here, being several excellent illustrations of more recent origin.

It would seem that the new version has been printed largely for the purpose of correcting the many errors which marred the first edition. Assuming this to be the main object, it can be said that this has been satisfactorily achieved, but nonetheless it seems a pity that the revision has not been more widespread. It is the reviewer's opinion that the chapters concerning rocket control and long range rockets are still written at a low technical level, and from the point of view of the considerable number of engineers actively engaged in this field, the book loses some of its appeal. In a future edition it is felt that these chapters should be re-written completely, or dropped altogether from the book.

However, in defence of the author, it must be remembered that he has been unable, for obvious reasons, to draw upon the great body of material under security classification. Largely because of this, workers in combustion research and missile dynamics laboratories will no doubt smile wryly when pursuing some parts of the book. Even so, it is considered that the book manages to "put across" the general problems of rocketry with a considerable success and is consequently worthy of a place on the bookshelf belonging to anyone with an interest in this fascinating subject.

A. E. MAINE.

## The Principles of Physical Optics

By Ernst Mach. 324 pp., 280 figs. Demy 8vo. Dover Publications, Inc., New York. 1954. Price \$2.75 (paper cover), \$3.50 (cloth cover).

THIS new Dover edition is an unabridged republication of the English translation by Dr. J. S. Anderson and Dr. A. F. A. Young, first published in 1926. Like most great classics of science, this book is studied today more for its valuable philosophical and historical approach than for its "up-to-dateness." For the student of science this treatise offers a classical examination of the propagation of light, theory of colour, polarization, etc.

## Electrical Engineers' Reference Book

Edited by E. Molloy, M. G. Say and R. C. Walker. 7th Edition. 1,000 pp., 200 figs. Demy 8vo. George Newnes Ltd. 1954. Price 70s.

THIS new edition has been extended to include several new sub-sections. Each of the main technical sections is a self-contained treatise on a specific branch of the subject written by a recognized authority. There are thirty-two sections in all and it is a comprehensive work of reference, providing a summary of latest practice in all branches of electrical engineering.

# Meetings this Month

## THE BRITISH INSTITUTION OF RADIO ENGINEERS

Date: 27 October. Time: 6 p.m.  
Held at: The London School of Hygiene and Tropical Medicine, Keppel Street, Gower Street, W.C.1.  
Annual General Meeting of The Institution, followed at 7 p.m. by the Presidential Address of Rear Admiral Sir Philip Clarke.

**South Wales Section**  
Date: 6 October. Time: 6.30 p.m.  
Held at: Cardiff College of Technology, Cathays Park, Cardiff.  
Lecture: The Design of Switching Circuits.  
By: Emrys Williams.

**Scottish Section**  
Date: 7 October. Time: 6.30 p.m.  
Held at: The Institution of Engineers and Ship-builders, Elmbank Crescent, Glasgow.  
Annual General Meeting followed by a debate: Does Industry Want Electronics?

**Merseyside Section**  
Date: 7 October. Time: 7 p.m.  
Held at: Liverpool University Buildings, Liverpool, 1.  
Lecture: The Cyclotron.  
By: M. J. Moore.

**North Eastern Section**  
Date: 13 October. Time: 6 p.m.  
Held at: Neville Hall, Westgate Road, Newcastle-upon-Tyne.  
Lecture: Radio Production.  
By: H. G. Wood.

## THE BRITISH KINEMATOGRAPH SOCIETY

Date: 6 October. Time: 7.15 p.m.  
Held at: The Gaumont British Theatre, Film House, Wardour Street, London, W.1.  
The Presidential Address by H. S. Hind.

## THE INSTITUTION OF ELECTRICAL ENGINEERS

All London meetings, unless otherwise stated, will be held at the Institution, commencing at 5.30 p.m.

Date: 7 October.  
Inaugural Presidential Address.  
By: J. Eccles.

**Education Discussion Circle**  
Date: 12 October. Time: 6 p.m.  
Discussion: The teaching of the subject of Electro-magnetism.  
Opened by: K. J. R. Wilkinson.

**Radio Section**  
Date: 13 October.  
Chairman's Address.  
By: C. W. Oatley.  
Date: 25 October.  
Discussion: Whether Compatibility is necessary for a Colour Television System in Great Britain.  
Opened by: E. P. Wethley.

**Supply Section**  
Date: 27 October.  
Chairman's Address.  
By: J. D. Peattie.

**East Midland Centre**  
Date: 12 October. Time: 6.30 p.m.  
Held at: Loughborough College.  
Chairman's Address and Annual General Meeting.

**Cambridge Radio Group**  
Date: 12 October. Time: 6 p.m.  
Held at: The Cambridgeshire Technical College.  
Chairman's Address.

**Mersey and North Wales Centre**  
Date: 11 October. Time: 6.30 p.m.  
Held at: The Liverpool Royal Institution, Colquitt Street, Liverpool.  
Chairman's Address: Cables—Some Post-War Trends.  
By: P. R. Dunn.

**North-Eastern Centre**  
Date: 11 October. Time: 6.15 p.m.  
Held at: The Neville Hall, Westgate Road, Newcastle-upon-Tyne.  
Chairman's Address.

**North-Eastern Radio and Measurements Group**  
Date: 4 October. Time: 6.15 p.m.  
Held at: King's College, Newcastle-upon-Tyne.  
Chairman's Address.

**Tees-Side Sub-Centre**  
Date: 6 October. Time: 6.30 p.m.  
Held at: The Cleveland Scientific and Technical Institution, Middlesbrough.  
Chairman's Address.

**North Midland Centre**  
Date: 5 October. Time: 6.30 p.m.  
Held at: The offices of the British Electricity Authority, Yorkshire Division, 1 Whitehall Road, Leeds.  
Chairman's Address.

**North Midland Utilization Group**  
Date: 19 October. (Time and place as for North Midland Centre.)  
Lecture: Electricity in the Wool Textile Industry.  
By: A. J. Francis and T. H. Carr.

**Sheffield Sub-Centre**  
Date: 20 October. Time: 6.30 p.m.  
Held at: The Grand Hotel, Sheffield.  
Chairman's Address.

**North-Western Centre**  
Date: 5 October. Time: 6.30 p.m.  
Held at: The Engineers' Club, Albert Square, Manchester.  
Chairman's Address.

**North-Western Measurements Group**  
Date: 26 October. Time: 6.15 p.m.  
Held at: The Engineers' Club, Albert Square, Manchester.  
Discussion: Will it be Possible to Abolish Meters Entirely?  
Opened by: H. S. Petch and M. Whitehead.

**North-Western Radio Group**  
Date: 20 October. Time: 6.45 p.m.  
Held at: The Engineers' Club, Albert Square, Manchester.

Lectures: The Measurement of the Small-Signal Characteristics of Transistors.  
By: E. H. Cooke-Yarborough, C. D. Florida and J. H. Stephen.  
A Versatile Transistor Circuit.  
By: E. H. Cooke-Yarborough.  
The Transistor Regenerative Amplifier as a Computer Element.  
By: G. B. B. Chaplin.

**North-Western Supply Group**  
Date: 19 October. Time: 6.15 p.m.  
Held at: The Engineers' Club, Albert Square, Manchester.  
Lecture: The Possibilities of a Cross Channel Power Link between the British and French Supply Systems.  
By: D. P. Sayers, M. E. Laborde and F. J. Lane.

**North Scotland Sub-Centre**  
Date: 13 October. Time: 7.30 p.m.  
Inaugural Dinner at the Caledonian Hotel and Chairman's Address.  
Date: 14 October. Time: 7 p.m.  
Held at: The Electrical Engineering Department, University College, Dundee.  
Chairman's Address.

**South-East Scotland Sub-Centre**  
Date: 5 October. Time: 7 p.m.  
Held at: The Carlton Hotel, North Bridge, Edinburgh.  
Chairman's Address.  
Date: 19 October. (Time and place as above.)  
Lecture: An Analogue Computer for use in the Design of Servo-Mechanisms.  
By: E. E. Ward.

**South-West Scotland Sub-Centre**  
Date: 6 October. Time: 7 p.m.  
Held at: The Institution of Engineers and Ship-builders, 39 Elmbank Crescent, Glasgow.  
Chairman's Address.

**South Midland Centre**  
Date: 4 October. Time: 6 p.m.  
Held at: The James Watt Memorial Institute, Great Charles Street, Birmingham.  
Chairman's Address.

## THE TELEVISION SOCIETY

Date: 8 October. Time: 7 p.m.  
Held at: 164 Shaftesbury Avenue, London, W.1.  
Lecture: The "Roving Eye" O.B. Unit.  
By: P. Worswick and G. Larkby.  
Date: 28 October. (Time and place as above.)  
Lecture: An Unconventional Television Wire Distribution System.  
By: E. J. Gargini.

## THE RADIO SOCIETY OF GREAT BRITAIN

Date: 22 October. Time: 6.30 p.m.  
Held at: The Institution of Electrical Engineers, Savoy Place, London, W.C.2.  
Lecture: Transistors and Crystal Valves in Radio.  
By: B. R. Bettridge.

# PUBLICATIONS RECEIVED

THE ORGANIZATION OF APPLIED RESEARCH IN EUROPE, THE UNITED STATES AND CANADA have recently published, in three volumes, a report of the Technical Assistance Missions. Volume I is a comparative study between the United States and Canada on the one hand, and Europe on the other. Volume II is a review of applied research in Western Europe and Volume III gives the position on applied research in the United States and Canada. Printed by the O.E.E.C. these volumes may be obtained from 2 rue André-Pascal, Paris 16e, at 6s., 12s., and 8s. respectively.

VALVES FOR A.C. MAINS OPERATED F.M./A.M. RECEIVERS is a brochure which gives details of the characteristics, performance and special applications of six 89A (Noval) based valves. Mullard Ltd, Century House, Shaftesbury Avenue, London, W.C.2.

RADIO RESEARCH 1953 includes the report of the Radio Research Board and the report of the Director of Radio Research and describes the work carried out during the year. It is prepared by the Department of Scientific and Industrial Research and published by Her Majesty's Stationery Office. Price 1s. 9d.

DECIBEL TABLES POWER AND VOLTAGE RATIOS is a paper reprinted from the British Sound Recording Association's official journal of January, 1954. Copies may be obtained from the Hon. Librarian, British Sound Recording Association, 3 Coombe Gardens, New Malden, Surrey. Price 1s. 2d.

TV MANUFACTURERS' RECEIVER TROUBLE CURES, VOLUME 5, HIGHLIGHTS OF COLOUR TELEVISION, TECHNICIAN'S GUIDE TO TV PICTURE TUBES, INTRODUCTION TO COLOUR TELEVISION AND HOW TO LOCATE AND ELIMINATE RADIO AND TELEVISION INTERFERENCE are recent publications of John F. Rider Publisher, Inc. 480 Canal Street, New York, 13, U.S.A. They apply to American practice and should prove of interest to the television enthusiast.

WHAT EVERY ENGINEER SHOULD KNOW ABOUT RUBBER is a book published by the British Rubber Development Board. Over half is devoted to specific engineering uses of rubber. In the remainder, the sources, properties, manufacture and testing of rubber are covered. The author, W. J. S. Naunton was formerly in charge of the Rubber Laboratories of Imperial Chemical Industries Ltd. The British Rubber Development Board, Market Buildings, Mark Lane, London, E.C.3. Price 3s. 6d.

SOME ASPECTS OF INDUSTRIAL NOISE AND VIBRATION MEASUREMENT is a paper which discusses the necessity for noise and vibration measurements in industry, and continues with an explanation of sound radiation fundamentals. The desirable features and types of vibration pick-ups are mentioned. A. E. Cawkell, 6-7 Victory Arcade, The Broadway, Southall, Middx.

MEMORANDUM ON GAMMA-RAY SOURCES FOR RADIOGRAPHY is the second edition of one which was first published in 1952. The subject matter has been brought up to date and has been extended in many respects, particularly as regards the number of radioactive materials that receive consideration. The preparation has again been in the hands of a Committee of the Non-destructive Testing Group (formerly the Industrial Radiology Group) of the Institute of Physics. The intention has been to provide a brief statement on gamma-ray sources for radiography, particular reference being made to the products of the Atomic Energy Research Establishment and the Radiochemical Centre, The Institute of Physics, 47 Belgrave Square, London, S.W.1. Price 3s. 6d.

# Short News Items

The Radio Industry Council announces that it plans to hold a radio and television exhibition, the second Northern Radio Show since the war, at the City Hall, Manchester, in May next.

The Council of the Institution of Electrical Engineers has arranged for the jubilee of the thermionic valve to be celebrated by the Institution on 16 November, fifty years exactly from the date of the application by Sir Ambrose Fleming for the British patent for his thermionic valve. The proceedings will be opened by the Lord President of the Council, the Marquess of Salisbury, and three lectures will be delivered, one each by Sir Edward Appleton, Professor G. W. O. Howe and Dr. J. Thomson, dealing with valves from the earliest developments to the present day. An exhibition of historical apparatus will be held at the Institution in association with the Celebration.

The Manchester Municipal College of Technology is organizing Post Advanced lectures in electrical and mechanical engineering in the forthcoming session. The courses include lectures on Transistor Electronics, Automatic Control in Industry, Transient Electrical Phenomena and Information Theory. Details of these courses may be obtained from the Registrar, College of Technology, Manchester, 1.

The Isotope School, Harwell, has arranged a special course on Autoradiographic Techniques lasting four days, to be held from 13-16 December, under the direction of Dr. S. R. Pelc of Hammersmith Hospital. The course will comprise lectures, demonstrations and practical work. The fee for the course is £8 and applications should be made to the Isotope School, A.E.R.E., Harwell, near Didcot, Berkshire.

Borough Polytechnic announce courses on the following subjects: The Fundamentals of Pulse Techniques, Crystal Valves and Transistors, Nucleonic Circuitry. Details may be obtained from the Department of Electrical Engineering and Physics, Borough Polytechnic, Borough Road, London, S.E.1.

Guest, Keen and Nettlefolds Ltd and the Mercast Corporation of New York have formed a company under the name of Mercast (Great Britain) Ltd to license firms in the United Kingdom and the British Commonwealth, excluding Canada, to use the Mercast process. This is a method of investment casting in which patterns of frozen mercury replace the more usual wax patterns, permitting closer tolerances, smoother finish and the ability to make more complicated and larger castings than are practicable with the lost wax method. The chairman of the new company is Mr.

G. R. Sankey of Joseph Sankey and Sons Ltd, Bilston, Staffordshire.

The BBC, following the announcement by the Minister of Agriculture giving his consent to the construction of a television and sound broadcasting station at North Hessary Tor, Dartmoor, will proceed immediately with the construction of a permanent television and V.H.F. transmitting station which will include a 750ft mast. It is hoped that the television station can be completed by the end of 1955 and the V.H.F. station during 1956.

Mullard Ltd. announce that Mr. A. W. Welton has been appointed to the board of directors. Mr. Welton has been continuously associated with the Mullard group of companies since he joined the Mullard Radio Valve Co Ltd in 1923. He is already a director of Mullard Overseas Ltd and Mullard Wireless (Near East) Ltd.

Mr. B. C. Fleming-Williams has been appointed general manager of Sylvania-Thorn Colour Laboratories Ltd. This is a new company jointly owned by Sylvania Electric Products Inc of the United States of America and Thorn Electrical Industries Ltd. The new company is engaged on research and development work on colour television, including the design of cathode-ray tubes and upon problems arising from the application of semi-conductors to the electronics industry.

United Marine (1939) Ltd, international transport and export packers, have installed a temperature and humidity control plant at their Sidcup, Kent, works. This has been installed as a result of constant research carried out in the improvement of methods and processes employed in the preservation and tropic proofing of vulnerable electronic equipment. Previously it had been found that, despite all protective precautions, a certain amount of corrosion had affected delicate parts of equipment prior to the pre-packing stage.

Giannini Ltd is a newly formed company, an affiliate of G. M. Giannini & Co Inc, the American instrument and control manufacturers of New York. The new company intends to negotiate licenses for the manufacture of equipment to Giannini designs for the British Commonwealth and Empire, excluding Canada. Any inquiries should be sent to Mr. Dykes, 31 Pembroke Gardens, London, W.8. Telephone Western 9493.

The Ministry of Supply announces that Dr. W. H. Penley has been promoted to the rank of Deputy Chief Scientific Officer and has been appointed Senior Superintendent, Guided Weapons, Radar Research Establishment, Malvern.

Hadley Sound Equipments Ltd have installed a twelve point loudspeaking intercommunication system in the Fleet Street, London, headquarters of the Press Association.

The Physical Society and Institute of Physics are holding a Joint Colloquia Electron Physics Meeting at 2 p.m. on Thursday, 21 October, at the Research Laboratories of the General Electric Co Ltd, Wembley. Accommodation is limited and should be reserved primarily for those who have a specialized interest in the subject. Those wishing to attend should apply to the Secretary, Electron Physics Colloquia, Physical Society, Prince Consort Road, London, S.W.7, as soon as possible, and by not later than 10 October.

Mr. J. S. Clark, joint managing director of A. C. Cossor Ltd, has been elected vice-chairman of the British Radio Equipment Manufacturers' Association.

Scope Laboratories, Melbourne, Australia, have appointed Enthoven Solders Ltd as sole distributors of the Six Second Scope Soldering Iron for the whole of the British Isles.

The Atomic Energy Authority announces that Mr. W. R. J. Cook, Chief of the Royal Naval Scientific Service, has been released from his present post to take up that of Deputy Director of the Atomic Weapons Research Establishment, Aldermaston.

Marconi's Wireless Telegraph Co Ltd announce that, following upon a contract signed in 1952 for the supply to Italy of Marconi Band III television transmitters, together with studio and outside broadcasting equipment, they have now received a substantial repeat order. The new contract, placed by Radio Audizione Italiana through Marconi Italiana, orders complete equipment for two further television outside broadcast units, the equipping of another two-camera studio, and a large quantity of monitoring apparatus.

The Radio Trades Examination Board and the City and Guilds of London Institute have recently announced the results of the Radio and Television Servicing Certificate Examinations held in 1954. Candidates sat the Radio Servicing Certificate Examination at 24 centres throughout the United Kingdom and the examination was held for the first time in Dublin. Of the 367 candidates, 143 passed, 96 were referred and 128 failed. The Television Servicing Certificate Examination was taken by 104 candidates at seven centres. Fifty-five candidates were successful and 20 referred in the practical test.