

Electronic Engineering

Vol. XXV

DECEMBER 1953

No. 310

Commentary

WHILE it has become all too clear that the Ministry of Supply is not the most suitable authority to control the development of atomic energy in this country, the recent Government White Paper on the Future Organization of the United Kingdom Atomic Energy Project (*HMSO Cmd. 8986*), does little to clarify the important issue of inheritance.

A committee was set up in April of this year under Lord Waverley "to devise a plan for transferring responsibility for atomic energy from the Ministry of Supply to a non-Departmental organization and to work out the most suitable form for the organization, due regard being paid to any constitutional and financial implications," and it now recommends that an Atomic Energy Corporation be set up, under the control of the Lord President of the Council, and with a board of directors under the chairmanship of Sir Edwin Plowden, which will be responsible for all research and production other than the supply to the services of "complete atomic weapons."

The development of atomic energy in this country has had a chequered history in which political issues have loomed very prominently. It will be remembered that it was decided during the war to entrust the production of atomic bombs to the United States and, to assist in this undertaking, most of our leading scientists in this particular field had been sent across the Atlantic. With the cessation of hostilities and the changing political outlook in the post-war years there was an abrupt end to the interchange of information with the result that this country had to make an almost completely fresh start. It was not, therefore, until October, 1952, that the first British designed and British made atomic weapon was tested—and tested successfully—at Monte Bello.

While the main effort on both sides of the Atlantic is still largely concentrated on the development of atomic weapons, the more peaceful applications of atomic energy have not been overlooked and a good deal of attention has been given in this country to the large scale production of radioactive isotopes for medical and other purposes.

But by far the most important non-military application of atomic energy is the nuclear reactor—the power house of the future—and many are the forecasts that have been made of the new atomic era. While many of these predictions have been highly coloured and often over optimistic, it does now seem that the generation of elec-

trical energy with the nuclear reactor is a practical possibility and that the time has come in consequence for an organization other than the Ministry of Supply to exploit its possibilities to the full.

However, it is difficult to see how the development of atomic energy can be divided into two separate and distinct channels—the production of atomic weapons by the Ministry of Supply on the one hand and the building of nuclear reactors by the Atomic Energy Corporation on the other, and the White Paper's case for "a form of control of the project which is more akin to the structure of a big industrial organization than to that of a Government department" can only lead to confusion.

The setting up of such a Corporation does not imply, of course, that the production of abundant and cheap electrical energy by nuclear reactors is just round the corner. It is true that one or two small reactors are being built which will produce limited quantities of electrical energy, but the Committee is right in emphasizing that "there is still a long way to go and much work to be done" before any worthwhile quantities of energy are generated in this way.

It is not yet known in any great detail just what form the nuclear reactors will take, but it seems that with our present state of knowledge, the reactor will do no more than replace the coal fired boiler of the electricity generating station.

In making any forecasts of the new age it is well to bear a few facts in mind, and the first is that the initial cost of a nuclear power house may well be higher—much higher—than that of the equivalent coal fired station. Equally important is the fact that the cost of fuel as fuel is not the predominating factor in determining the price of the kilowatt-hour. By far the major items are capital depreciation of equipment, cost of transmission and distribution, wages and salaries and so on, and whatever the shape and size of the future power house, its electrical energy will still continue to be conveyed to the industrial and domestic user by cables and overhead lines.

What is of paramount importance to the prosperity of this country is that the nuclear reactor could make us independent of coal and indeed our very survival may well depend on this, for our coal reserves are rapidly dwindling and coal is becoming more difficult and costly to mine.

Selective Calling for Radio-Telephone Systems

By J. R. Pollard*, M.A., A.M.I.E.E., M.I.R.E.

Three types of apparatus are described which enable individual, group, or general calls to be made in radio-telephone systems of the type which use common communication frequencies for a large number of stations. Each method makes use of a counting circuit, together with a discriminator to produce the response appropriate to the particular combination of digits dialled by the calling station operator. The counting circuit uses either a dekatron tube, or a group of cold-cathode trigger triode tubes; discrimination can be effected by circuits using hot- or cold-cathode tubes. The particular combination of tube types and circuit arrangements to be adopted is influenced largely by the power supplies available.

IN radio-telephone systems consisting of a master station from which messages are sent out to various subsidiary stations, an operator at the master station may wish to transmit a message to one only of the subsidiary stations, to a certain group of subsidiary stations, or to all the subsidiary stations simultaneously. A typical example of a system where such a facility would be desirable is in police patrol work. The apparatus described below† allows the operator at the master station to call the subsidiary station operators selectively, as required for each type of call mentioned above.

Necessarily, most of the additional apparatus required for providing this facility is situated at the subsidiary stations. Since the selective calling apparatus represents an addition to the equipment required for the reception of messages at the subsidiary stations, it must be kept as simple as possible; it should also consume as little power as possible, since subsidiary stations of the kind under consideration are often part of mobile equipment. For this reason, attention has been directed to the use in the receiving apparatus of cold-cathode valves, which require no heater power.

The operator at the master station requires a telephone dial and an oscillator, so arranged that when a number is dialled, a train of pulses of tone is transmitted from the oscillator, the number of pulses in the train being equal to the number dialled. The master station apparatus need not be considered in greater detail.

Three circuits are described below for obtaining the selective calling facility; in each circuit there is a counting section which counts the impulses sent by the master station operator, and a discriminating section. These are arranged to give a control signal which indicates whether or not the digits dialled by the master station operator are those for a call to that particular subsidiary station. The differences between the three circuits lie in the types of components used in the counting and discriminating arrangements, and their relative advantages and disadvantages are discussed in a later section.

Numbering Schemes

In the form described, the selective calling apparatus will respond to two-digit numbers; the only exception to this is the case of a general call to all subsidiary stations, which is obtained by dialling 9 only. Apart from this, the first digit of a two-digit number corresponds to a particular group of subsidiary stations, and the second digit to a certain station within that group. The group digit followed by digit 9 will call up all stations of the particular group.

For example, the number 47 will call up one particular station of group 4, and the number 49 will call up all the stations of group 4. This means that the selective calling apparatus at each subsidiary station is required to respond to three separate numbers, corresponding to the three types of call required. In the above example these would be 47 for the station call, 49 for the group call, and 9 for the general call.

Further description is confined to the two-digit scheme outlined above, but it will be seen that by appropriate changes in the functioning of the discriminating circuits, the systems described could be applied equally either to simpler or to more ambitious numbering schemes.

Dekatron and Relay Circuit

This arrangement uses a dekatron valve in the impulse counting section, discrimination being obtained by hot cathode valves which operate relays. The circuit diagram is shown in Fig. 1.

A train of pulses of 1 000c/s tone is transmitted whenever a digit is dialled by the master station operator, and the corresponding tone pulses from the radio receiver are applied to the input terminals xx of the counting circuit. The pulses of tone are applied to the grid of V_1 via the A.F. transformer TR_1 . In the normal state, V_1 is biased to cut-off by a negative voltage derived from the -150V line. The anode circuit of V_1 contains two relays and the primary of the A.F. transformer TR_2 , this primary being tuned to 1 000c/s by the 0.002 μ F capacitor C_1 . When a pulse of tone arrives at the grid of V_1 , the positive half-cycles of tone cause the valve to conduct, and a component of tone-frequency appears across the primary of TR_2 . The signal from the secondary winding of TR_2 is rectified by MR_1 , smoothed by C_2 , R_1 , and C_3 , and fed back, as a positive voltage, to the grid of V_1 . This removes the bias from V_1 , and its anode current increases to a value corresponding to the limiting grid voltage set by the onset of grid current in V_1 . When the pulse of tone is removed V_1 returns to its normal non-conducting state after a time depending on the discharge time-constant of the network C_2 , R_1 , C_3 , R_1 , which is about 8 milliseconds. The relays in V_1 anode circuit, which are normally unoperated, are energized by the D.C. component of the anode current, the A.C. component being by-passed by C_4 . Relay A is a high-speed relay which responds to each separate pulse of a train; B is a 3 000 type relay which has a rectifier MR_2 connected in parallel with it so that B does not release after each individual impulse, but only after the last pulse of the train has ended.

The use of a regenerative circuit of this type ensures that V_1 will operate satisfactorily for a wide range of amplitudes

* Erlsson Research Laboratories, Beeston, Notts.

† Patent applied for.

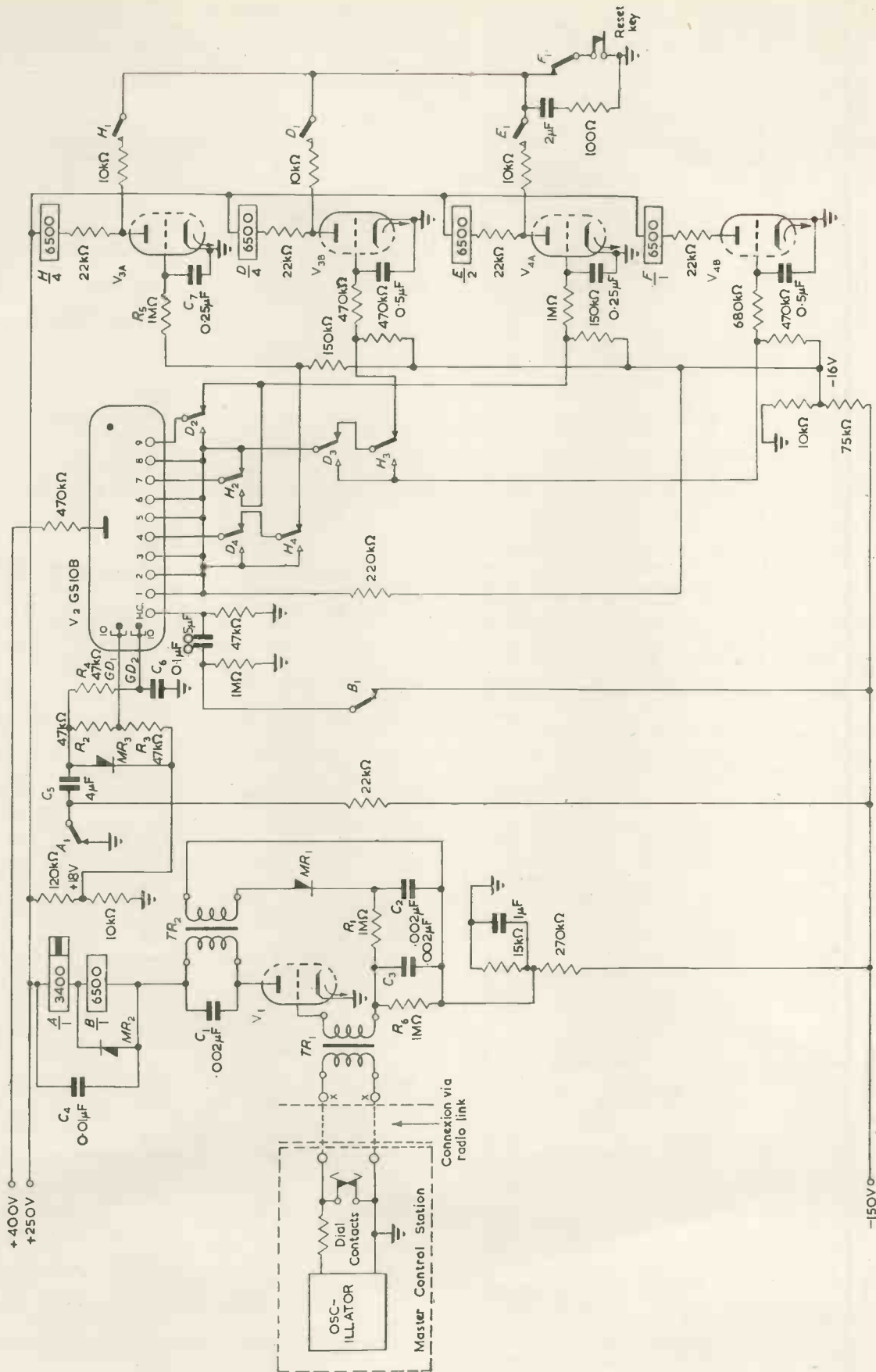

Fig. 1. Dekatron and hot-cathode valve circuit

of the received tone pulses, so that the system is reasonably independent of transmission conditions. In practice elaborations of the circuit may be necessary to guard against spurious operation by interference or speech; the techniques involved are well known and form a normal feature of voice-frequency signalling apparatus.

The dekatron V_2 in which the discharge is initially on the home cathode, is driven¹ by the operation of the contacts of relays A and B . Contact A_1 applies pulses of approximately $-100V$ through the $4\mu F$ capacitor C_5 to the dekatron guide drive circuit consisting of MR_3 , R_2 , R_3 , R_4 and C_6 and thus the discharge is driven round the appropriate number of cathodes. After a short pause, the discharge is brought back to the home cathode by the application of a $-150V$ pulse to this cathode via the relay contact B_1 . The time during which the discharge remains on the dialled cathode before being returned to the home cathode is about 260 milliseconds, corresponding to the release lag of relay B shunted by MR_2 . The output of the discrimination circuit is taken from the appropriate dekatron cathodes. For example, the circuit shown is designed to accept digits 9, 47, and 49; for this purpose, outputs are taken from cathodes 4, 7, and 9, and the remaining cathodes are joined together to form a common output.

Each output is fed through various relay contacts to the grid circuit of valves V_{3a} , V_{3b} , V_{4a} and V_{4b} . These valves are all normally cut-off by the application of a negative voltage to their grids. When the dekatron discharge is driven from the home cathode on to any other of its cathodes, the cathode to which the discharge is driven rises in potential to about $+18V$, and charges the grid capacitor of the appropriate valve; for example, when the discharge is on cathode 4, C_7 charges through R_5 , raising the grid potential of V_{3a} . However, if a digit greater than 4, say 7, is dialled, then in driving round to cathode 7 the discharge will pause on each of the intervening cathodes in turn, among them cathode 4, for a period of approximately 33 milliseconds. V_{3a} is required to conduct only when the discharge remains on cathode 4 for 260 milliseconds; it must not conduct during the 33 milliseconds pulse which appears as the discharge is driven over cathode 4 to some greater number. To fulfil this requirement, the time-constant R_5, C_7 of V_{3a} grid circuit is made such that in 33 milliseconds the grid voltage of V_{3a} does not rise above the cut-off potential, so that the valve remains non-conducting, but in 260 milliseconds it rises sufficiently above cut-off to cause the valve to conduct heavily. Similar grid-circuit arrangements are used for the other discriminator valves V_{3b} , V_{4a} and V_{4b} . In each of the anode circuits of the three valves V_{3a} , V_{3b} and V_{4a} there is a 3000 type relay, and in the anode circuit of V_{4b} there is a high-speed relay. Each relay operates when its appropriate valve conducts.

Suppose the "correct" first digit is dialled (i.e. that corresponding to the station being called, in this case the digit 4). This causes V_{3a} to conduct as explained above, operating relay H . When H operates, contact H_1 closes and holds the relay operated after V_{3a} ceases to conduct as the discharge is returned to its home cathode. Contact H_2 switches cathode 7 to V_{4a} grid. Dekatron cathode 9 is already connected to V_{4a} grid through relay contact D_2 , and so if either digit 7 or 9 is now dialled, V_{4a} conducts, and the "accept" relay E operates and is held by its own contact E_1 . Extra contacts on this relay can be used to switch on a loudspeaker, or in some other way attract the local operator's attention. When relay H operates on receipt of the correct first digit, contact H_4 switches dekatron cathode 4 to the common cathode line, since 4, as a second digit, is incorrect. Contact H_3 switches the dekatron common cathode line from V_{3b} grid to V_{4b} grid. If any digit other than 7 or 9 is now dialled, V_{4b} conducts, relay F is operated for a short time and contact F_1 opens, releasing relay H without attracting the attention of the local operator. The circuit is thus restored to its initial condition.

Suppose a wrong first digit is initially dialled. Since the

dekatron common cathode line is normally connected to V_{3b} grid via relay contacts D_3 and H_3 , V_{3b} conducts, relay D operates, contact D_1 closes and holds the relay operated. (Since digit 7 is also a wrong first digit, dekatron cathode 7 is normally connected to the common cathode line via contact H_2). When relay D operates, contacts D_2 and D_4 switch dekatron cathodes 9 and 4 respectively to the common cathode line; this line is now switched through contact D_3 to the grid of V_{4b} . Thus, when any second digit is dialled, V_{4b} conducts, relay F operates, contact F_1 opens, relay D is released, and the circuit is cleared down.

If the general call digit 9 is dialled, since cathode 9 is normally connected via contact D_2 to V_{4a} grid, V_{4a} conducts and the "accept" relay E operates and holds through its own contact E_1 .

After a call has been set up and concluded, the local operator operates the "reset" key to release relay E and so restore the circuit to normal in readiness for the next call.

The connexions shown in Fig. 1 are suitable for a subsidiary station having the number 47, and required to respond to the dialled numbers 9, 47 and 49. By connecting cathodes 4 and 7 of the dekatron to the common cathode line, and connecting two other cathodes in the way that cathodes 4 and 7 are shown connected in the figure, the circuit can be adapted to be suitable for a subsidiary station having any other number; further modifications of the dekatron connexions would enable different types of numbering schemes to be used.

Dekatron and Trigger Triode Circuit

This section describes a development of the previous circuit which is designed to eliminate the hot-cathode valves used in the discriminating part of the circuit of Fig. 1.

In the circuit shown in Fig. 2, the discrimination is carried out by selenium diode coincidence circuits and sub-miniature cold-cathode trigger triodes. A dekatron is still used as the counting element, and the circuit as far as this point is similar to that shown in Fig. 1, except that in this case there is no need to return the dekatron cathode resistors to a $-16V$ bias point, and they are returned to earth. The outputs of the counting section are taken from the appropriate dekatron cathodes, which in the circuit shown are cathodes 4, 7, and 9; the remaining cathodes are connected to a common cathode line from which a further output is taken. Each output goes to two separate coincidence circuits; the common cathode line goes to CC_1 and CC_3 , cathode 4 to CC_2 and CC_6 , cathode 7 to CC_3 and CC_7 , and cathode 9 to CC_4 and CC_5 . The other inputs to these coincidence circuits are taken from the cathodes of the trigger triodes V_4 and V_6 ; CC_1 , CC_2 , CC_3 and CC_4 from V_4 cathode, and CC_5 , CC_6 , CC_7 , and CC_8 from V_6 cathode. The operation of the coincidence circuits will be explained with reference to the first of the circuits, indicated at CC_1 in Fig. 2.

When V_4 is not conducting, and the discharge in V_2 is not on any of the "commoned" cathodes, a small current will pass through the rectifiers MR_1 and MR_2 , raising the potential of point A only slightly above earth. If now V_4 is struck, the potential of its cathode rises to about $+50V$. MR_1 will still be conducting, so that A will still be held at a low potential, but the cathode of MR_2 is raised to a higher potential than its anode, so that MR_2 is cut-off. Thus the potential of V_4 cathode will not be applied to point A . Only when the appropriate cathode of V_2 also rises in potential will the potential at A rise appreciably. The trigger resistor of V_5 is connected to A via a blocking diode MR_3 , so that V_5 is only "primed" when V_4 is conducting at the same time as a discharge is present on the appropriate cathode of V_2 . The operation of the remaining coincidence circuits is similar to that of CC_1 .

In the initial state of the circuit, V_4 is struck. Thus the diodes MR_2 , MR_6 , etc., in coincidence circuits CC_1 to CC_4 have their cathodes at about $+50V$. In this condition the circuit is ready to accept a dialled number.

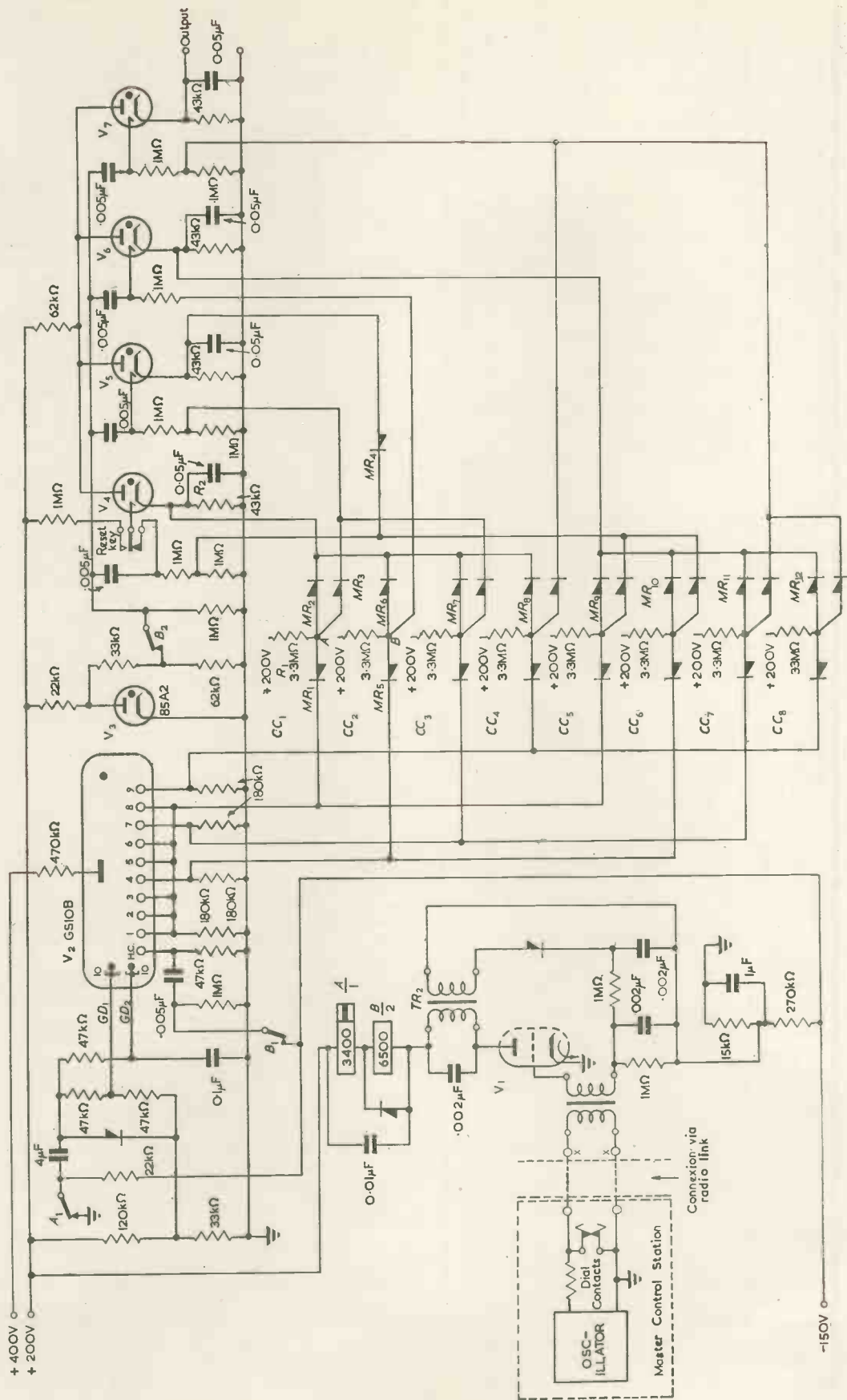

Fig. 2. Dekatron and trigger-triode circuit

Suppose now that the correct first digit 4 is dialled. The cathode side of MR_2 rises to about +50V, so that the point B also rises to this potential. This primes the trigger of V_6 . To strike V_6 a trigger pulse must be applied on the common trigger line of the valves V_4 to V_7 . This pulse is derived from contact B_2 on the relay B in V_1 anode circuit. During the train of dialled pulses relay B is operated, so that contact B_2 is open; when relay B releases, shortly after the end of the pulse train, contact B_2 closes and applies a step of about +50V to the trigger line. This step causes a positive pulse at the triggers of all the valves V_4 to V_7 , but the amplitude of this pulse is only sufficient to strike the valve which has been primed in the way described above. It is important to ensure that this trigger pulse is applied to the trigger line while the trigger triode is still primed, i.e., before the reclosing of relay contact B_1 has returned the dekatron discharge to its home cathode. If contacts B_1 and B_2 are normal "break" contacts, they are unlikely to reclose absolutely simultaneously as B releases. If B_1 were to close before B_2 , the priming voltage on the trigger of V_6 would be removed before the trigger pulse arrived, and to prevent this a "late-break" contact is used for B_2 . Thus when the correct first digit 4 is dialled, the end-of-train step on the trigger line strikes V_6 . V_4 is extinguished, in the same way as in the well-known trigger triode ring circuit, since V_4 to V_7 have a common anode resistor and the cathode resistor of each of these valves has a capacitor in parallel with it. This means that the cathodes of MR_6 to MR_{12} in coincidence circuits CC_5 to CC_8 are now raised to +50V, and the cathodes of MR_2 , MR_6 , MR_7 and MR_8 in CC_1 to CC_4 are returned to zero potential. If now either the correct second digit 7, or digit 9, is dialled, an output will be obtained from CC_7 or CC_8 respectively. These outputs are joined together and are connected so as to prime V_7 . The end-of-train step on the trigger line then strikes V_7 and V_6 is extinguished. V_7 is the "accept" valve; when struck, a positive voltage appears on its cathode, and this voltage can be used to operate a local circuit to indicate the incoming call. If, however, a wrong second digit is dialled, either the dekatron common cathode line or cathode 4 will rise in potential, so that either CC_5 or CC_4 respectively will give an output to prime V_4 . The end-of-train step then strikes V_4 , V_6 is extinguished so that the circuit is restored to its initial condition without an output voltage being obtained from the discriminator.

If a wrong first digit is dialled, either the dekatron common cathode line or cathode 7 will rise in potential, so that CC_1 or CC_3 respectively will give an output which primes V_5 . The end-of-train step on the trigger line then strikes V_5 and V_4 is extinguished. When V_5 is struck, its cathode potential primes V_4 trigger directly via MR_4 , so that the end-of-train step from any second digit dialled will strike V_4 and extinguish V_5 , the circuit then being cleared down.

If the general call digit 9 is initially dialled, CC_4 gives an output which primes V_7 trigger. The end-of-train step then strikes the "accept" valve V_7 and V_5 is extinguished. After V_7 has been struck to indicate a call, the circuit can be cleared by depressing the reset key at the conclusion of the call. This applies a +200V pulse to V_4 trigger, which strikes V_4 , extinguishing V_7 , and removing the output voltage. The stabilizer tube V_3 , to provide a supply for the end-of-train voltage step, is needed to obtain a sufficiently close tolerance on the trigger striking voltage pulse, in the absence of a closely regulated H.T. supply.

All Trigger Triode Circuit

In this circuit (Fig. 3), a ring of trigger triodes is used in the impulse counting section of the apparatus, and this removes the necessity for an additional H.T. supply line to operate a dekatron valve. The trigger triodes used are all sub-miniature types. The input circuit is similar in some respects to that used in the previous circuits, but with certain modifications. V_1 is again made to conduct heavily

on the application of tone pulses, but no relays are included in the anode circuit. They are replaced by a resistive load, across which a negative square pulse is obtained for each pulse of tone. A separate negative supply is not required to bias V_1 completely to cut-off; sufficient bias is obtained, by using a fairly large cathode resistor, for V_1 to be near cut-off in the quiescent state.

The negative pulses from V_1 anode circuit are fed to two valves: to V_2 , to provide positive pulses for the ring counting circuit, and to V_3 , to provide a positive end-of-train pulse. V_2 is a trigger triode operating in a self-quenching circuit, and in its normal state is non-conducting. The valve is fired by the trailing edges of the negative pulses on V_1 anode; the differentiating circuit C_1R_1 in V_2 trigger circuit applies a positive pulse to the trigger at the end of each pulse of current through V_1 . When V_2 is not conducting, its anode is at the full H.T. voltage of +200V and C_2 is charged. The positive pulse appearing on the trigger strikes the valve, which remains conducting until the potential across C_2 has fallen sufficiently for the current through V_2 to decay to a value insufficient to maintain a stable discharge; V_2 then ceases to conduct. The time-constant of the anode circuit R_2C_2 is such that the anode of V_2 has recovered substantially to +200V before the next pulse of the train arrives. A positive output pulse is obtained across the cathode resistor of V_2 , the required pulse amplitude being obtained from a tapping on this resistor.

The negative pulses from V_1 anode circuit are also applied to V_3 trigger. In its normal state V_3 is conducting, due to the large positive bias on its trigger. When the first negative pulse occurs, V_3 trigger voltage falls rapidly to below its burning value and V_3 ceases to conduct, due to the self-quenching action of its anode circuit, which operates in a manner similar to that of V_2 . The trigger capacitor C_3 is rapidly discharged by conduction through the selenium rectifier MR_1 . However, when the negative pulse ends, C_3 charges fairly slowly, since the time-constant C_3R_3 is fairly long, so that V_3 trigger has not reached its striking voltage before the next negative pulse of the train again discharges C_3 . In this way, V_3 trigger will only rise to its striking voltage after the last negative pulse of the train has ended: V_3 will then restrike, and its cathode potential will rise, giving a positive step of voltage across its cathode load resistor.

The trigger triode ring circuit used for impulse counting consists of the valves V_4 to V_{11} . It uses the well-known arrangement in which only one tube is conducting, and the discharge is driven along the number of valves corresponding to the number of the digit dialled. The trigger line pulse for this purpose is taken from a tapping on V_2 cathode resistor. Shortly after each digit has been dialled, the discharge is returned to the "home" valve V_4 by the positive step of voltage applied to the trigger of this valve from V_3 cathode resistor. Output voltages are taken from the cathodes of the appropriate valves, all cathodes corresponding to unused digits being connected via isolating diodes to a common output load. The outputs are used to operate eight coincidence circuits and four trigger triodes forming a discrimination network exactly as in the dekatron and trigger triode circuit shown in Fig. 2 and described above. The end-of-train pulse applied to the trigger line is taken from a tapping on the cathode resistor of V_3 , but apart from this the operation follows closely that of the previous discriminating circuit. In this case the discriminator output is the positive voltage across V_{11} cathode resistor.

In either of the circuits shown in Figs. 2 and 3, the rise in potential at the discriminator output terminals can be used directly, for example to open a "gate" circuit in the A.F. stages of the receiver or to perform some other simple control function for which a change of potential will suffice. If a more complex switching operation is necessary, it could be carried out by a sensitive relay associated with the "accept" trigger triode.

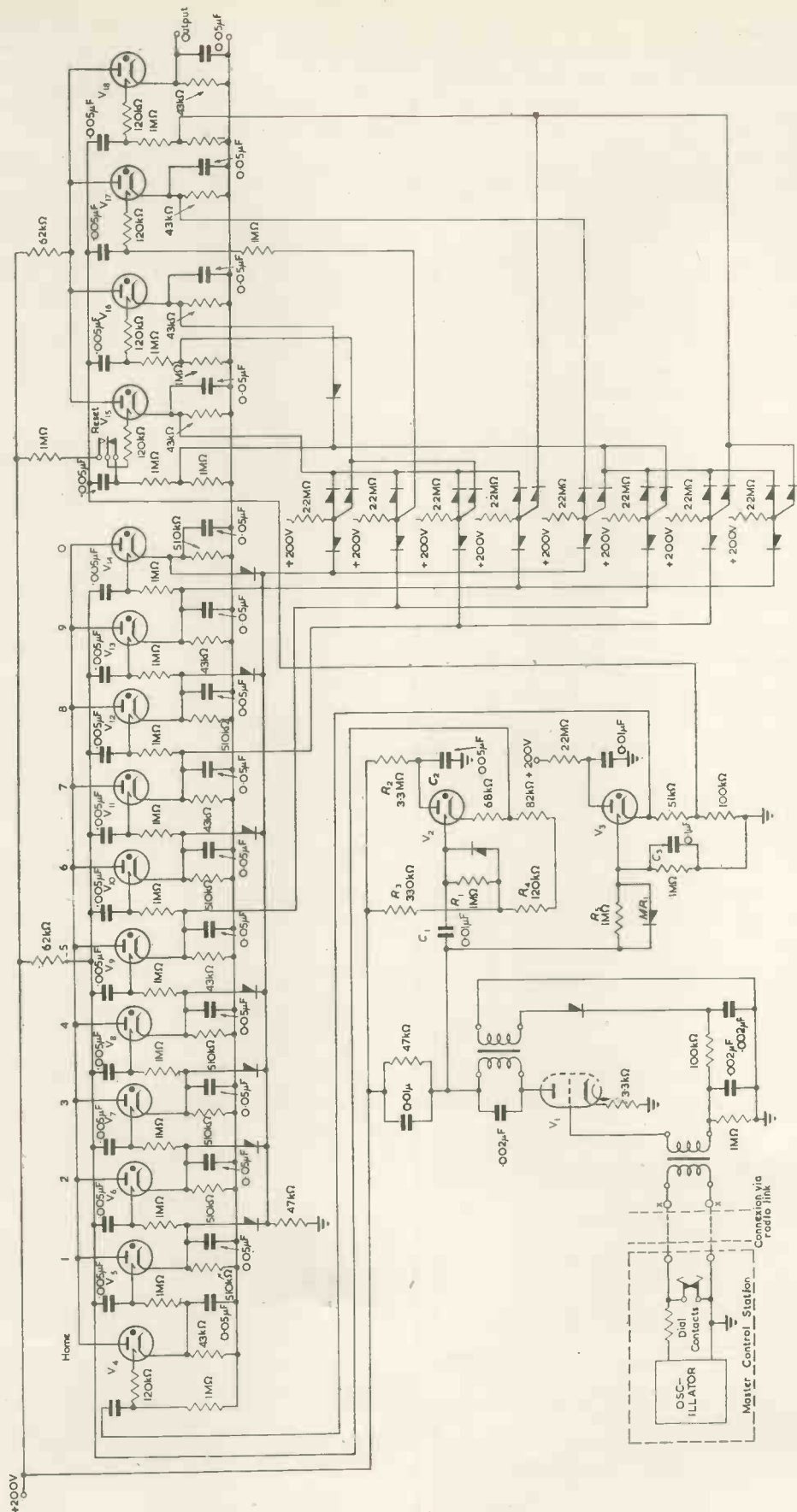

Fig. 3. All trigger-triode circuit

Comparison of the Three Circuits

Apart from overriding considerations of reliability, the requirements for the selective calling apparatus considered here are compactness, light weight, and low power consumption.

Power consumption for the three circuits is listed in Table 1. It appears that the all-trigger-triode circuit is superior in this respect to the other circuits considered. A single H.T. supply of +200V regulated D.C. is required, with a maximum current of 10mA, whereas additional supplies are required for the circuits using a dekatron valve as the counting element. The use of a trigger triode ring circuit as the counting element necessitates the use of a substantial number of extra components, of which details are given in Table 2. The extra components should

TABLE 1
Power Consumption

Supply	Circuit		
	DEKATRON and RELAY	DEKATRON and TRIGGER TRIODE	ALL TRIGGER TRIODE
H.T.	+400V 0.5mA +250V 16mA -150V 10mA	+400V 0.5mA +200V 20mA -150V 10mA	+200V 10mA
L.T. 6.3V	0.9A	0.3A	0.3A

TABLE 2.
Components and Tolerances.

Component	Circuit		
	DEKATRON and RELAY	DEKATRON and TRIGGER TRIODE	ALL TRIGGER TRIODE
Resistors ..	34 (10% tol)	42 (5% tol)	65 (5% tol)
Capacitors ..	13 (20% tol)	14	38
Hot cathode valves ..	3*	1*	1*
Cold cathode valves ..	1	6†	17‡
Selenium rectifiers§ ..	4	28	34
Relays ..	6	2	0

* Miniature types. † Sub-miniature. ‡ Small wire-end types.
 † Some miniature, some sub-miniature.

not add greatly to the size of the apparatus, so that the disadvantage of their extra number may possibly be outweighed by the advantage of a single power supply. In cases where appropriate power supplies are already available, the dekatron-and-trigger triode circuit might be more suitable.

The dekatron-and-relay circuit makes more extensive use of hot-cathode valves, and these require heater power continuously; nearly 1A at 6.3V is required for this circuit, in contrast to 0.3A for the other two circuits. Some objection can also be made to the use of relays, in view of the extra weight they involve. The main advantage in their use is the simplicity of the switching facilities which result; for example, a "make" contact on relay E, Fig. 1, could be included in series with the loudspeaker circuit; no calls would be heard at that subsidiary station unless preceded by the correct digits.

In the present state of development, no final conclusions can be reached as to the "best" circuit. It seems that a version of the all-trigger-triode circuit is ultimately most likely to be favoured, and development work is in hand on valves having characteristics particularly suitable for this type of application. The valves used for the experimental work described above, in common with other low-voltage trigger triodes at present available, show a variation in

trigger sensitivity with the intensity of ambient illumination, and this feature is clearly undesirable for a mobile application unless the valves can be enclosed in a light-tight box containing a local illuminant.

Summary of Facilities

For all the circuits described, the apparatus has been designed to respond to two-digit numbers. With this arrangement nine groups of stations are possible, with "group" (first) digits from 0-8; up to nine stations can be included in each group, with "station" (second) digits from 0-8. This allows selective calling of up to 81 stations, if allowance is made for the fact that a slight modification is required of the discriminator circuits shown to allow the use of "double" numbers such as 44. In fact, the ten-cathode dekatron type GS10B does not easily lend itself to the use of the digit "0" (ten impulses from a telephone dial), and so the circuits of Figs. 1 and 2, using a GS10B, would only serve for 64 subsidiary stations. An alternative 12-cathode version, type GS12C, has become available since this experimental work was completed and this, by allowing the digit "0" to be used, permits a complete numbering scheme to be employed. The all-trigger-triode circuit shown in Fig. 3 will in any case accept the digit "0".

Acknowledgments

Thanks are due to the Directors of Ericsson Telephones Ltd, and to Dr. J. H. Mitchell, Head of Research of that Company, for permission to publish this article.

REFERENCE

1. BACON, R. C., POLLARD, J. R. The Dekatron. *Electronic Engng.* 22, 173 (1950).

MINIATURE TEST PROBES *

Two types of miniature test probes have recently been devised at the U.S. National Bureau of Standards. Light and compact, the probes are designed to cling to the test point without danger of contacting adjacent leads and are intended particularly for use with miniaturized equipment.

One of the probes is a push-on type, with a very small tapered jaw that is simply pressed on to the wire under test. The jaw is of hardened beryllium copper, silver-plated. It grips the wire with a slight spring action until sufficient pull is exerted to remove it. The jaw screws into an insulating handle, made of lucite or of material like fibre having greater mechanical

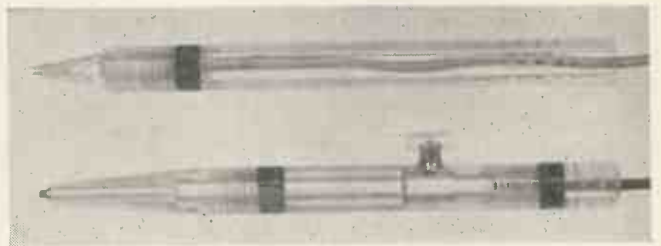

The two types of Test Probe

strength and heat resistance. The handles are 1/4 in in diameter and 3/4 in long. Colour-coding of transparent-handled probes is accomplished by using coloured lead wires, while coloured bands are placed in grooves in the fibre-handled probes. Only about 1/16 in of the metal jaw protrudes from the insulating handle, so that the danger of shorting to nearby components is minimized.

The other probe is a lock-on type, designed so that it cannot be removed from the wire until a release button on the side of the probe is pressed. A small hook mechanism at the end of the probe remains open only while the button is pressed, and tightens on the wire when the button is released. In other respects, including size, the lock-on probe is similar to the push-on model.

* Communication from M. Lorant.

Radio and Television in Germany

BEFORE the war there had been developed in Germany a sound broadcasting system, which from the technical and organizational points of view had many features in common with its British counterpart.

Moreover, a television service operating on a 441 line standard with transmitters at Berlin and Hamburg had been inaugurated shortly after the opening of Alexandra Palace in this country.

However, with the cessation of hostilities what remained of the pre-war broadcasting system was controlled by the occupying powers so that it was some time before the reorganized post-war pattern for broadcasting began to emerge. Progress was delayed to a considerable extent by the loss of some of the medium wave channels under the Copenhagen Plan and matters were not improved by the division of Germany into Eastern and Western Zones. The entire radio manufacturing industry had been otherwise engaged during the war and no new domestic radio receivers had been put on the market since 1939.

of pre-war origin and reaction to this new form of sound broadcasting on the part of the listening public was favourable due no doubt to the extremely high quality interference-free transmissions.

There are, it is estimated, some 16 million households in Western Germany, of whom about a quarter possess no receiver at all, and of the remainder nearly 5 million are in possession of v.h.f. receivers.



A simple v.h.f. adaptor made by Graetz Radio for use with broadcast receivers. It consists of a 9-stage 3-valve circuit with 2 germanium diodes and a metal rectifier power supply. The price is 109DM (about £9).

As a result, Germany faced the post-war years with no organized broadcasting system, few available channels in the medium and long wave bands, her radio industry either destroyed or dismantled and with a domestic receiver market in urgent need of replacement. But as is well known, great strides have been made in the economic recovery of Germany and this is particularly evident in the radio industry which staged its second post-war exhibition at Dusseldorf in the summer of this year.

The loss of channels in the medium waveband was not the ill wind that was first supposed, for it enabled the Federal Republic of Western Germany to model her post-war broadcasting on the higher frequency bands. Plans were evolved for v.h.f. transmission using frequency modulation with a network of low power stations to cover the whole of Western Germany, and by the time the first post-war exhibition was held in 1950 the network had begun to take some practical shape.

A modest programme of some half million v.h.f. receivers was laid down and in order to keep prices low these sets were at first of the simplest design with seldom more than four valves, and a range of adaptors was also introduced to enable existing medium wave receivers to be used. There was, of course, a large potential domestic market to be filled since practically all the receivers were



A Telefunken portable mains-battery receiver with an incorporated v.h.f. band. An extensible tape aerial is provided for v.h.f. reception.



A luxury type radio and television receiver made by Nora. This instrument contains a 40-valve television receiver with a 21in tube, a four-band receiver including v.h.f., tape recorder, microphone and an automatic three-speed recorder player. There are six loudspeakers. (Price 4900DM-£410).

Progress has therefore been rapid and the network of v.h.f. transmitters is, to all intents, complete.

Consequently, many of the ills which still afflict British broadcasting such as interference from foreign stations and unsatisfactory reception in some areas have been avoided by this bold stroke and at the same time both the broadcasting authorities and the radio industry have acquired an

unrivalled knowledge of this latest aspect of broadcasting.

Broadcasting in Western Germany is controlled by five organizations and the ninety or so V.H.F. transmitters operating under their control are grouped as shown in the Tables 1 to 8.

TABLE 1
NORDWESTDEUTSCHER RUNDFUNK
PROGRAMME : VHF "NORTH"

CHANNEL NO.	FREQ. Mc/s.	SITE	POWER (kW)
3	87.9	Bungsberg	0.25
5	88.5	Hamburg I	10.0
6	88.8	Göttingen	1.0
8	89.4	Flensburg	3.0
10	90.0	Heide	3.0
10	90.0	Berlin NWDR	3.0
13	90.9	Braunschweig	1.5
14	91.2	Oldenburg	10.0
18	92.4	Lingen	3.0
20	93.0	Hannover I	10.0
21	93.3	Osterloog	3.0
22	93.6	Osnabruck	1.5
24	94.2	Kiel	1.0
29	95.7	Lubeck	0.25

TABLE 2
NORDWESTDEUTSCHER RUNDFUNK
PROGRAMME : V.H.F. "WEST"

CHANNEL NO.	FREQ. Mc/s.	SITE	POWER (kW)
6	88.8	Bonn	0.25
7	89.1	Aachen	1.0
9	89.7	Cologne I	0.75
16	91.8	Siegen	1.5
23	93.9	Nordhelle	3.0
25	94.5	Münster	3.0
29	95.7	Langenberg	10.0
31	96.3	Hamburg III	0.1
38	98.4	Monschau	0.05
40	99.0	Teutoburger Wald	3.0

TABLE 3
NORDWESTDEUTSCHER RUNDFUNK
PROGRAMME - MEDIUM WAVE NWDR

CHANNEL NO.	FREQ. Mc/s.	SITE	POWER (kW)
6	88.8	Berlin NWDR II	0.1
17	92.1	Hamburg II	0.04
21	93.3	Cologne II	0.25
36	97.8	Hannover II	1.8

TABLE 4
SÜDWESTFUNK
PROGRAMME : V.H.F.

CHANNEL NO.	FREQ. Mc/s.	SITE	POWER (kW)
3	87.9	Blauen/Schwarzwald	3.0
4	88.2	Raichberg/Alb	3.0
7	89.1	Mainz	0.05
8	89.4	Hornisgrinde	10.0
8	89.4	Betzdorf/Westerw.	0.25
10	90.0	Haardtkopf/Hunsr	3.0
11	90.3	Weinbiet/Neutsadt Weinstrasse	6.0
13	90.9	Coblenz	1.0
14	91.2	Potzberg	3.0
14	91.2	Witthoh/Hegau	1.0
18	92.4	Waldburg/Ober-Schwaben	3.0
19	92.7	Hochrheinsender b/Waldshut	0.1
22	93.5	Baden-Baden	0.25
30	96.0	Linz/Rhein	3.0
41	99.3	Wolfshiem	10.0

TABLE 5
SÜDWESTFUNK
PROGRAMME : MEDIUM WAVE

CHANNEL NO.	FREQ. Mc/s.	SITE	POWER (kW)
10	89.9	Baden-Baden	0.25
20	93.0	Hornisgrinde	10.0
21	93.3	Betzdorf/Westerw.	0.25
22	93.6	Haardtkopf/Hunsr.	3.0
28	95.4	Potzberg/Westpfalz	3.0
36	97.8	Linz/Rhein	3.0

TABLE 6
HESSISCHER RUNDFUNK
PROGRAMME : V.H.F.
* (MEDIUM WAVE)

CHANNEL NO.	FREQ. Mc/s.	SITE	POWER (kW)
2	87.6	Biedenkopf	10.0
5	88.5	Feldberg*	10.0
9	89.7	Hoher Meissner	10.0
9	89.7	Hardberg	0.25
16	91.8	Würzburg	0.25
17	92.1	Feldberg	10.0

TABLE 7
SÜDDEUTSCHER RUNDFUNK
PROGRAMME : V.H.F. WÜRTEMBERG
(b V.H.F. BADEN * MW)

CHANNEL NO.	FREQ. Mc/s.	SITE	POWER (kW)
2	87.6	Geislingen-Oberbohringen	0.25
3	87.9	Heidelberg-Königstuhl I ^b	10.0
6	88.8	Muhlacker ^b	1.0
6	88.85	Mergentheim	0.1
7	89.1	Aalen I	3.0
9	89.6	Stuttgart	0.25
13	90.9	Degerloch I	10.0
15	91.5	Heidelberg-Königstuhl II	0.25
15	91.5	Ulm-Wilhelmsburg	0.25
19	92.7	Aalen II	3.0
21	93.3	Stuttgart	0.25
22	93.6	Waldenburg	10.0
25	94.5	Degerloch II*	3.0

TABLE 8
BAYERISCHER RUNDFUNK
PROGRAMME : V.H.F.

CHANNEL NO.	FREQ. Mc/s.	SITE	POWER (kW)
4	88.2	Ochsenkopf (Fichtelgebirge)	10.0
5	88.5	Gelvelse (Eichstatter Aln)	3.0
6	88.8	Burgstall (Hoher Bogen)	3.0
7	89.1	Traunstein (Hochberg)	1.0
8	89.4	Rothbühl (b. Hirschau)	3.0
9	89.7	Berchtesgaden	0.25
10	90.0	Wendelstein	5.0
10	90.0	Coburg (Etkartsberg)	1.0
11	90.3	Bad Reichenhall	0.25
12	90.6	Grunten/Allgau	10.0
13	90.9	Bamberg (Altenburg)	1.0
14	91.2	Würzburg (Frankenwarte)	1.0
15	91.5	Brotjacklriegel (Bayerischer Wald)	10.0
15	91.5	Nürnberg	0.25
16	91.8	Munich	0.25
20	93.0	Passau (Kuhberg)	0.25
20	93.0	Kreuzberg (Rhön)	10.0
20	93.0	Kreuzeck (b. Partenkirchen)	0.25
23	93.9	Moritzberg	3.0
24	94.2	Augsburg--Göggingen	0.25
24	94.2	Pfaffenberg (b. Aschaffenburg)	3.0
25	94.5	Keilberg (Regensburg)	3.0
32	96.6	Buttelberg-Frankenhohe	5.0
36	97.8	Hohenpeissenberg	3.0
37	98.1	Huhnerberg (Harburg)	5.0

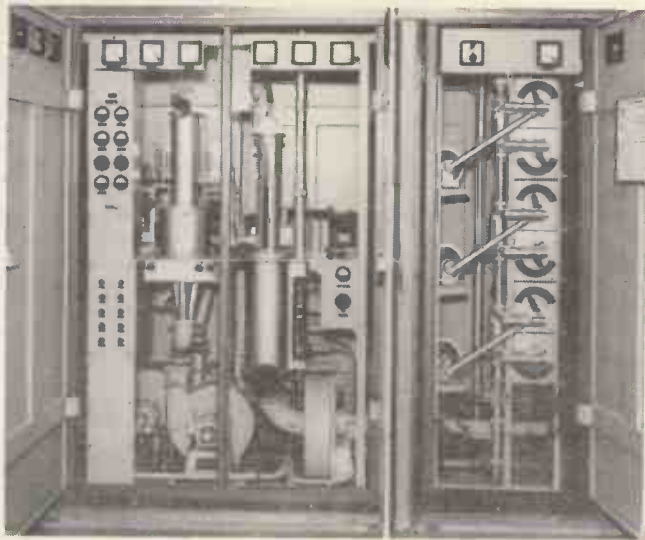

The vision output stage of a Band III Television Transmitter.

There were comparatively few pre-war television receivers in existence at the end of the war, and as practically nothing remained of the television transmitters at Berlin and Hamburg, the whole of the pre-war 441 line system was written off and the European 625 line system was adopted in its place.

Microwave radio relay transmitter for the television link. The complete transmitting and receiving equipment is housed at the top of a 120ft tower and is completely automatic in operation.

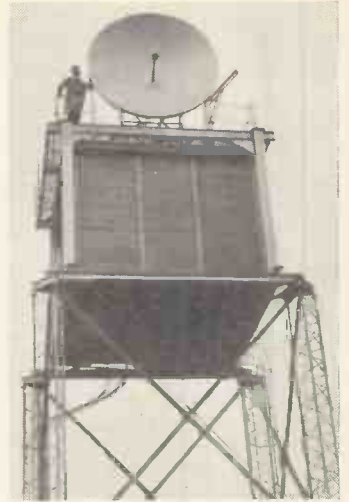

Lack of finance handicapped the development of the new television service, but recently studios have been erected at Berlin, Hamburg and Cologne, and a chain of television transmitters connected by microwave radio links was brought into operation at Berlin, Hamburg, Cologne, Hannover, Langenburg, Weinbeit and Frankfurt in time for the relaying of the Coronation ceremonies this year.

But high production costs limit the local daily programmes to about two hours, and there is as yet only a small audience of some 3 000 licensed viewers.

Practical Calibration Adjustments for Apparatus which Obeys a Theoretical Law Imperfectly

By J. W. Head*

Various empirical methods of adjustment are considered. The nature of the adjustment achieved is fully explained. The object throughout has been to obtain easily a calibration curve which is sufficiently smooth and sufficiently near the observed values to satisfy practical requirements, rather than to find the unique curve which satisfies a least-squares or other mathematical criterion of goodness of fit.

THE methods to be described were devised for the calibration of a tone source¹ in which theoretically the position ϕ° of the calibrated dial was related to the frequency f c/s by a law of the form:

$$\phi = A + B \log_{10} f \dots \dots \dots (1)$$

but in practice the law (1) was not sufficiently accurately obeyed for it to be possible to obtain least-squares values of A and B from about 25 well-distributed observations of ϕ in the range 20c/s to about 20kc/s for f . Although in what follows the theoretical law (1) will be used, the technique could easily be extended to cases in which $\log f$ in (1) was replaced by any other function of f .

Detailed Calculation for a Particular Case

For a particular tone source, values of frequency f are tabulated in column 1 of Table 1, and the associated observed dial readings ϕ are tabulated in column 2. If f_r, ϕ_r are the r^{th} associated pair of values, first calculate:

$$A_r = (\phi_r - \phi_{r-1}) / \log_{10} (f_r / f_{r-1}) \dots \dots \dots (2)$$

and this quantity, which would be constant if the observed ϕ_r obeyed equation (1) exactly, is tabulated in column 3. The values of A_r differ appreciably, but except at extreme frequencies they do not differ from their mean by more than a few per cent. For practical purposes it is wished to replace the observed value ϕ_r by a calculated value ϕ'_r where:

$$\phi'_r = A_s + B_s \log_{10} f_r \quad (f_s \leq f_r \leq f_{s+1}) \dots \dots \dots (3)$$

that is to say, a law of type (1) but only operating for a limited frequency range. Assume that ϕ' is given by:

$$\phi' = A_s + B_s \log_{10} f \quad (f_s \leq f \leq f_{s+1}) \dots \dots \dots (4)$$

for values of f other than those at which ϕ_r was observed. But it is, of course, necessary to determine the frequencies f_s at which the law for ϕ' changes, and the associated A_s, B_s , subject to the following requirements which are conflicting and are different in kind from those usually postulated when curve-fitting problems are solved mathematically:

- (a) There must be as few changes of law as possible.
- (b) The differences $\phi'_r - \phi_r$ must be kept as small as possible. Normally it is estimated that ϕ_r can be read to within $\pm 0.3^\circ$. Hence, if $|\phi'_r - \phi_r| \leq 0.3^\circ$ it is not

* BBC Research Department.

necessary to attempt to reduce it further. In some cases, especially at very low frequencies, greater values of $|\phi_r - \phi_r'|$ may have to be accepted.

- (c) ϕ_r' must be continuous at the frequencies f_s where changes of law take place. These will usually be associated with a discontinuous change in B_s which can normally be tolerated; when this is not possible, a "smoothing" technique is discussed below.

It is not necessary for the solution to be unique; any two solutions which satisfy the requirements completely can be regarded as equally good; differences between the two solutions will exist, but will have no practical significance.

It will be noticed that the value of A for 20-30c/s is very low. It is to be expected, from the physical nature of the tone source, that extra large values of $|\phi_r' - \phi_r|$ may be unavoidable at very low frequencies, and it is necessary therefore to seek to obtain the first law (3) by least-squares from the first few observed values. As A is very steady in the range 30c/s to 80c/s, it is assumed that the first law operates for the range 20-80c/s. The first law is then found to be:

$$\phi' = 198.1721 \log_{10} f - 258.4906 \dots (5)$$

and this gives the values for ϕ_r' tabulated in column 4 of the Table as far as $f = 80$ c/s. For the first law, these are regarded as entirely satisfactory; discrepancies $|\phi_r - \phi_r'|$ of the order $\frac{2}{3}^\circ$ occur, but this is only twice the normal tolerance of 0.3° . If the first law had involved discrepancies over 0.75° , least-squares equations would have been formed without the 80c/s reading and a second law taken for 60c/s to 100c/s.

For the second law, there must be continuity at 80c/s. The A 's above 200c/s are somewhat higher than those below 200c/s so it is decided arbitrarily that the second law shall operate from 80c/s to 200c/s. If this decision proves unsatisfactory it can be corrected later; the calibration obtained by making a satisfactory and different decision would be different from that obtained with a satisfactory

second law extending to 200c/s, but this difference would, as has been seen, be without practical significance.

A first approximation ϕ'' to the law for 80c/s-200c/s is obtained by assuming that ϕ in equation (4) has the value 118.6487 when $f = 80$ c/s (to secure continuity) and 201.9 when $f = 200$ c/s. The formula for ϕ'' is:

$$\phi'' = 209.2057 \log_{10} f - 279.4886 \dots (6)$$

and the values of ϕ'' are then tabulated in column 5, while the differences $\phi'' - \phi$ (with due regard to sign) are tabulated in column 6 for values of f other than 80c/s where it is compelled to ensure continuity. These differences are so small that in equation (6) ϕ' can be written instead of ϕ'' and the values of ϕ'' copied in column 4. In general the next step is to change the coefficient of $\log_{10} f$ in equation (6) to:

$$209.2057 + \xi \dots (7)$$

and choose ξ so that the algebraic sum of the differences $\phi'' - \phi$ in column 6 is reduced to zero. For the range 80c/s-200c/s this would yield as the equation for ξ :

$$(-0.0778 - 0.0382) + \xi [\log_{10}(100/80) + \log_{10}(150/80) + \log_{10}(200/80)] = 0 \dots (8)$$

so that $\xi = 0.1160/0.76785 = 0.1510$. The formula for ϕ' is then obtained as a formula of type (4), satisfied by the point $f = 80$, $\phi' = 118.6487$, and having the coefficient (7) for $\log_{10} f$. This formula is:

$$\phi' = 209.3567 \log_{10} f - 279.7759 \dots (9)$$

As shown, for the present purpose in this particular case (9) is not a significant improvement upon (6) as the law for the frequency range 80-200c/s; (6) is therefore used. If, however, in other cases the formula corresponding to (9) is significantly better than that corresponding to (6) because it reduces all of the discrepancies $\phi' - \phi$ below 0.3° , (9) is used. The procedure in awkward cases where even (9) does not reduce all the discrepancies below 0.3° is discussed below.

TABLE 1. Original Calibration Readings and Subsidiary Calculations

(1) f	(2) ϕ	(3) A	(4) ϕ'	(5) ϕ''	(6) $\phi'' - \phi$	(7)
20	0	—	-0.6628			
30	33.6	190.8	34.2334			
40	58.7	200.9	58.9930			(5)
50	78.0	199.2	78.1979			
60	93.9	200.8	93.8891			
80	119.1	200.9	118.6487			
100	139.0	205.3	138.9228	138.9228	-0.0778	
150	175.8	209.0	175.7618	175.7618	-0.0382	(6)
200	201.9	208.9	201.9000	201.9000	0	
300	239.0	210.7	239.1098	239.1098	+0.1098	
400	265.6	212.9	265.5109	265.5109	-0.0891	
500	286.0	210.5	285.9891	285.9891	-0.0109	(10)
600	302.6	209.7	302.7207	302.7207	0.1207	
800	329.1	212.1	329.1219	329.1219	0.0219	
1 000	349.6	211.5	349.6000	349.6000	0	
1 500	387.6	215.8	387.7923	387.7923	0.1923	
2 000	414.9	218.5	414.8905	414.8905	-0.0094	
3 000	453.3	218.1	453.0828	453.0828	-0.2172	(11) or (20)
4 000	480.2	215.3	480.1812	480.1812	-0.0188	
5 000	501.2	216.7	501.2000	501.2000	0	
6 000	518.2	214.7	518.0048	517.9614	-0.2386	
8 000	544.9	213.7	544.5379	544.4095	-0.4905	(15) or (21)
10 000	565.5	212.6	565.1134	564.9241	-0.5759	or (23)
15 000	602.2	208.4	602.5	602.2000	0	
20 000	626.2	192.0	626.2	(626.2)	(0)	(22) or (23)

In Column 7 is given the number of the equation finally used as the law appropriate to each frequency range. In some cases alternative numbers are also mentioned. Columns 1-6 are explained in the text.

It will be noticed that the variation in A is very small over the frequency range 200-1 000c/s, so that an attempt is made to obtain a law of the type (6) or (9) for this section. The equation corresponding to (6) is:

$$\phi'' = 211.3109 \log_{10} f - 284.3327 \dots (10)$$

and the differences $\phi'' - \phi$ are again given in column 6 of the table: they are small enough to make it unnecessary to derive the equation corresponding to (9). Once more therefore ϕ' is obtained in column 4 by copying the value of ϕ'' in column 5.

The next law is taken as applying to the range 1-5kc/s, where the values of A are relatively high and reasonably constant. The equation corresponding to (6) is now:

$$\phi'' = 216.8906 \log_{10} f - 301.0718 \dots (11)$$

and again the discrepancies $\phi'' - \phi$ in column 6 are entirely satisfactory. For the next range an attempt is made to obtain a single law for 5-15kc/s, since clearly the value of A in the range 15-20kc/s is so much lower that this section will have to be taken separately; this fall in A over the last section is expected from the physical nature of the tone source. The equation corresponding to (6) is now:

$$\phi'' = 211.6868 \log_{10} f - 281.8231 \dots (12)$$

and in this case it can be seen from Table 1 that it is clearly necessary to obtain the equation corresponding to (8), which is:

$$(-0.2386 - 0.4905 - 0.5759) + \xi[\log_{10} 1.2 + \log_{10} 1.6 + \log_{10} 2 + \log_{10} 3] = 0 \dots (13)$$

so that $\xi = 1.2295$, and the equation corresponding to (9) becomes:

$$\phi' = 212.9163 \log_{10} f - 286.3710 \dots (14)$$

This law is not entirely satisfactory, because although it reduces the discrepancies at 6, 8 and 10kc/s below 0.3° , it introduces a discrepancy of $+0.5866$ at 15kc/s. Three courses are now possible, namely:

- (a) to divide the range 5-15kc/s into two parts and have separate laws in each, say 5-8kc/s and 8-15kc/s,
- (b) to replace (14) by the law which would be obtained if the 15kc/s reading was increased by 0.3° ,
- (c) to adjust the coefficient of $\log_{10} f$ in the previous range, 1-5kc/s, as well as in the range 5-15kc/s, so that the maximum discrepancy is as low as possible.

Course (a) reduces the discrepancies at the expense of an undesirable increase in the number of separate laws. If course (b) is taken here, (14) has to be replaced by:

$$\phi' = 212.3156 \log_{10} f - 284.1490 \dots (15)$$

It is considered that this is the most satisfactory course to take in this particular case (the resulting values of ϕ' are tabulated in column 4) since the maximum discrepancy is 0.3856° at 8kc/s and this does not greatly exceed 0.3° . Course (c) will, however, also be applied as an illustration.

If for the range 1-5kc/s the coefficient of $\log_{10} f$ is increased by k , equation (11) must be replaced by:

$$\phi'' = (216.8906 + k) \log_{10} f - (301.0718 + 3k) \dots (16)$$

so that the 5kc/s reading becomes $501.2 + 0.69897k$.

It is known from (15) that the coefficient of $\log_{10} f$ for the 5-15kc/s range is about 212, so let it be $212 + l$. The law for this range is then:

$$\phi'' = -282.9816 + 0.69897k - 3.69897l + (212 + l) \log_{10} f \dots (17)$$

From (16) and (17), the discrepancies at 1.5, 2, 3, 4, 5, 6, 8, 10 and 15kc/s can be expressed as linear functions of k and l . If k is plotted against l , the lines can be determined along which each of these discrepancies has the value ± 0.3 and hence can be found either (a) a region P containing points (k, l) such that all the discrepancies are less than 0.3 , or (b) there is no such region unless the maximum permitted discrepancy is increased. The

particular case taken here is one of type (a); if the discrepancy at r kc/s be called E_r , then there is a small triangular region including the point:

$$k = 0.42, l = 0 \dots (18)$$

for which all the E_r are within the limits $\pm 0.3^\circ$. The three E_r 's nearest the limits are E_5 (positive) E_{10} (negative) and E_{12} (positive), and a unique point near (18) could be found such that:

$$E_5 = -E_{10} = E_{12} \dots (19)$$

and the maximum discrepancy would then be slightly less than at (18). In the case (b), either k can be replotted against l allowing a larger maximum for the discrepancies, and k and l chosen so that (k, l) is a central point of the area within which all the E_r are within the larger maximum, or k and l can be obtained direct from an equation similar to (19) in which the three largest discrepancies are equated; it will usually be clear from the (k, l) diagram which discrepancies are the largest when the greatest discrepancy is as small as possible. Care must be taken that the signs of the E_r equated are appropriate.

For this particular case equation (18) is regarded as giving the best value of k, l , so that in the range 1-5kc/s, the law

$$\phi' = 217.3106 \log_{10} f - 299.8118 \dots (20)$$

is perhaps slightly preferable to (11), and for the range 5-15kc/s the law

$$\phi' = 212 \log_{10} f - 282.6880 \dots (21)$$

is equally preferable to (15). But for practical purposes (11) and (15) are regarded as adequate, and this has been emphasized by tabulating the values of ϕ' from (11) and (15).

It remains to consider the range 15-20kc/s. Here the only obvious law to choose is:

$$\phi' = 189.6911 \log_{10} f - 189.6671 \dots (22)$$

Unfortunately this law has such a sharp drop in the coefficient of $\log_{10} f$ that the scale would appear noticeably discontinuous, and a smoothing procedure is required. The simplest would appear to be to replace the two laws (15) and (22) by:

$$\phi' - 212.3156 \log_{10} f + 284.1490 \\ (\phi' - 189.9611 \log_{10} f + 189.6671) = \beta \dots (23)$$

where β is an adjustable positive constant. $\beta = 0$ would give the original laws (15) and (22). $\beta = 0.09$ would cause the original reading 602.2 at 15kc/s (altered to 602.5 when the law (15) was selected for the frequency range 5-15kc/s) to become the value of ϕ' once more. Note that for most relevant values of $\log_{10} f$, one factor (A) of the left-hand side of (23) is small compared with the other (B). B can then be calculated with adequate accuracy by substituting for ϕ' the value which makes A zero. For the tone-source calibration it was not thought necessary to consider using (23) unless the change in the coefficient of $\log_{10} f$ was about 20.

Conclusions

Three processes of calculable adjustment have been described (in addition to the well-known least-squares process) designed to express adequately for practical calibration purposes the behaviour of an instrument which obeys a theoretical law imperfectly, and full details have been given of calculations involved for a suitable particular case. The adjusted curves are not unique; the conflicting conditions they are designed to satisfy are not those usually imposed when considering adjustment processes from the mathematical point of view. But these conditions do appear to be in accord with practical requirements, and it is therefore hoped that the methods described may have general application.

REFERENCE

1. MAYO, C. G., BEADLE, D. G. Equipment for Acoustic Measurements, Pt. 2. *Electronic Engng.* 23, 368 (1951).

A Comparison of the Properties of Certain Materials used in Low-power Microwave Attenuators

By F. A. Benson*, M.Eng., Ph.D., A.M.I.E.E., M.I.R.E. and R. M. Pearson*, B.Eng.

The results of some investigations made to determine the relative merits of certain materials used as microwave attenuators are given and discussed. The materials which have been tested are Morganite, anti-static gutta percha and three grades of carbon-loaded Bakelite. It is concluded that, if suitably sealed to prevent ingress of moisture, Morganite is the most satisfactory of these materials from the point of view of stability.

THE materials tested have all been used in the past as low-power attenuators at microwave frequencies. It has been noted that attenuators using these and similar materials change their properties from day to day and have to be calibrated immediately before use if any reliance is to be placed on the attenuation produced.

The materials examined are:

- (a) Morganite†, which is a sheet of plastic material coated with graphite, or some other power-absorbing material, and which is produced specially for use in microwave attenuators. The samples used had a resistivity of 200 ohms per square.
- (b) Anti-static gutta percha sheet‡. This is gutta percha having some conducting material, probably graphite, dispersed in it. This material was not developed specially for the present application, but has, in fact, been used for a considerable time for other purposes.
- (c) Carbon-loaded Bakelite** which is moulded from bakelite powder containing a percentage of carbon. This material also was not produced specially for the present application. Three grades of the material have been examined, the first containing 5 per cent carbon, the second 10 per cent carbon and the third 20 per cent. Further materials of this kind are obtainable which are moulded from powders containing other percentages of carbon. The effect of the carbon content on the attenuation of microwave power produced by carbon-loaded bakelite has already been shown by Miller, Crowley-Milling and Saxon¹.

All the materials were in sheet form and the attenuators consisted of suitably-shaped strips placed in the waveguide in the plane of the *E* vector. The measurements have been carried out at frequencies near 10 000Mc/s.

An attenuator of given physical dimensions placed in a fixed position in a waveguide should extract, without reflexion, a given amount of power from the incident wave. In practice reflexion does occur and, in general, an attenuator can be matched into a waveguide only at one frequency, although it is desirable that it should function satisfactorily over a frequency band of some hundreds of Mc/s. Secondly, an attenuator of given physical dimensions of a particular material at a certain position in the waveguide does not, as a general rule, extract a constant amount of power from an incident wave. The amount of power extracted, or more simply, the attenuation varies with the condition of the atmosphere, in particular with the ambient temperature and relative humidity. Also with

certain materials it varies with age; two identical attenuators subjected to different ageing processes will often give different attenuations.

The desirable properties of waveguide attenuators are²:

- (1) High attenuation for a given size.
- (2) Low reflexion.
- (3) Chemically stable.
- (4) Unwarped by heat.
- (5) Should conduct heat from inside to outside of guide (important for high-power use only).
- (6) Characteristics must be reproducible for quantity production.
- (7) Should permit compact designs.

A complete investigation of all the factors involved would be a time-consuming job. The present work was limited to a study of the following aspects:

- (a) A comparison of the attenuating properties of the materials for given physical dimensions.
- (b) Variations of the attenuating properties with time (ageing tests) and humidity.
- (c) A comparison of the reflecting properties of the materials for given physical dimensions.
- (d) Variations of the reflecting properties with frequency.

Experimental Procedure

A block diagram of the apparatus used for the measurements is shown in Fig. 1.

To measure attenuation the power down the waveguide was fixed at a suitable value and recorded by means of the thermistor bridge with the attenuator under test omitted. A second reading of the power was then obtained from the thermistor bridge with the attenuator under test in position, thus giving the attenuation. The attenuation measurable in this way, in practice, is determined by the oscillator power and the sensitivity of the detector. With the apparatus used in the present investigations this was limited to about 20db.

Voltage-standing-wave ratio tests which determined the power reflexions caused by the attenuators were carried out by replacing the thermistor mount with a matched load and using the standing-wave indicator in the usual way.

The attenuator containing a vane of the sample materials under investigation was one of standard design where the

Fig. 1. The measuring apparatus

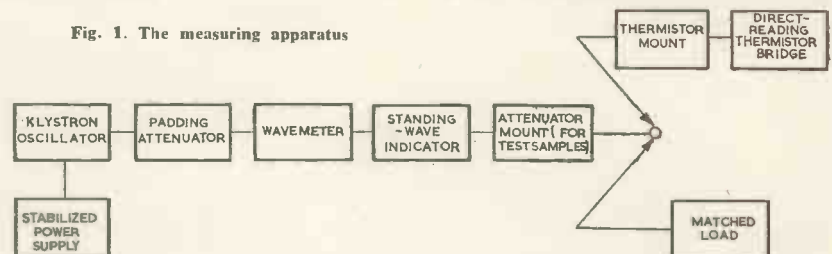

* The University of Sheffield.

† Supplied by The Morgan Crucible Co. Ltd.

‡ Supplied by The Telegraph Construction and Maintenance Co. Ltd.

** Supplied by The Engineering and Lighting Equipment Co. Ltd.

vane is fitted into the waveguide parallel to the small waveguide dimensions. The vane is mounted on two rods in the attenuator mount and can be moved across the guide by means of a micrometer drive.

ATTENUATION, AGEING AND HUMIDITY TESTS

One vane of each of the five materials to be tested was made according to the dimensions of Fig. 2 and the attenuations produced by these were measured at a fixed frequency of 9 437Mc/s for various positions in the waveguide. The specimens were then left lying on a shelf in the laboratory for about three months and re-examined. To determine the effects of humidity on the attenuating properties of the materials the specimens were placed on a rack a few inches away from the surface of a dish of cold water. The dish and rack were then surrounded by a framework supporting damp cloths. The specimens were left in this condition for 14 hours and then re-tested.

POWER REFLEXIONS FOR DIFFERENT VANE POSITIONS

A series of measurements of the voltage-standing-wave ratio produced by a vane of each material for varying guide positions was made at a constant frequency of

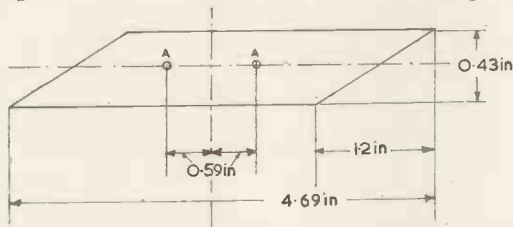

Fig. 2. Dimensions of the test vanes

9 437Mc/s. The vanes were again made according to the size and shape given in Fig. 2.

VARIATION OF POWER REFLEXION WITH FREQUENCY

Measurements were made of voltage-standing-wave ratio over a frequency range of a few hundred Mc/s for the various materials with the vane in each case at the same given position. The vanes used were again of the parallelogram shape shown in Fig. 2. The tests were repeated after the specimens had been left lying in the laboratory for about three months. Unless very high-grade test gear is employed for this work voltage-standing-wave ratio measurements are difficult to reproduce exactly.

Results

It will be seen that there are three groups of results, from the above tests, which compare the properties of the materials in various ways. These results are not, unfortunately, independent. There are a large number of interdependent variables and careful examinations of all the results are necessary before any deductions can be taken as correct. It is particularly important not to confuse reflected power with the power absorbed by the attenuator since both have the same effect on the power measuring device at the end of the waveguide run.

AGEING AND HUMIDITY TESTS

Morganite

Fig. 3(a) shows attenuation plotted against vane position as measured from one wall of the waveguide. The results of the ageing and humidity tests are shown on the same figure.

From Fig. 4(a), which shows voltage-standing-wave ratio plotted against vane position it is seen that the voltage-standing-wave ratio does not fall below 0.875 in the range considered in Fig. 3(a). Thus, if ρ is the coefficient of voltage reflexion, then in the worst conditions for reflexion:

$$0.875 = (1 - \rho)/(1 + \rho)$$

Hence $\rho = 0.0667$.

The power reflected is proportional to ρ^2 , so the error

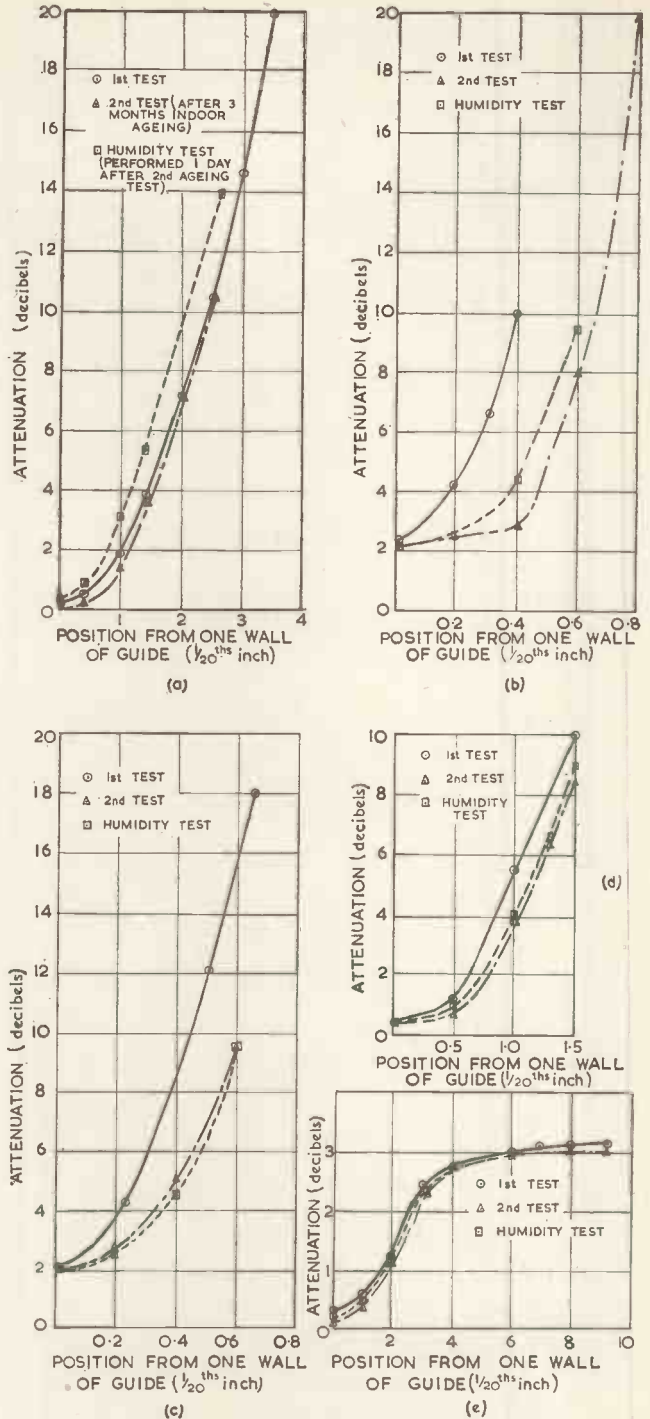

Fig. 3. Ageing and humidity tests (9 437M/cs)

- (a) Morganite.
- (b) Anti-Static Gutta Percha.
- (c) Carbon Loaded Bakelite (Grade 20 per cent carbon).
- (d) Carbon Loaded Bakelite (Grade 10 per cent).
- (e) Carbon Loaded Bakelite (Grade 5 per cent).

in attenuation reading due to reflexion is slightly less than 0.5 per cent at the very worst. Further, the conditions in the waveguide were the same for each test, and the object of the work was mainly to find the effects of ageing and humidity, thus the absolute accuracy of the observed attenuation is not so important as the accuracy of comparison between the various sets of readings. It may be assumed that the error in comparison is probably considerably less than 0.5 per cent. The curves shown then

may be said to give the true attenuation and errors due to reflexion are negligibly small.

The material is not appreciably affected by ageing, but attenuates more on being subjected to a humid atmosphere, there being an average increase of 10 per cent for any one guide position.

Anti-Static Gutta Percha

The attenuation results are shown on Fig. 3(b). Fig. 4(b) shows that the voltage-standing-wave ratio does not fall

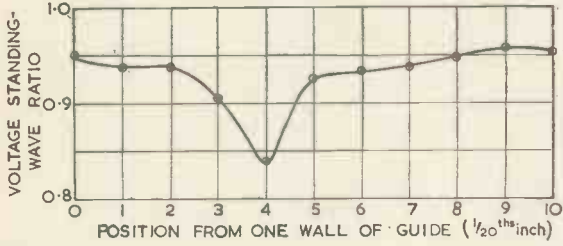

(a)

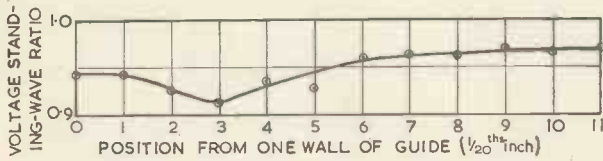

(b)

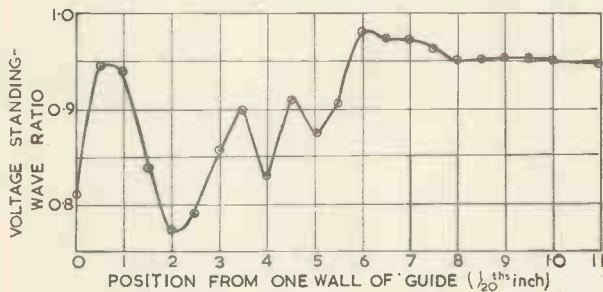

(c)

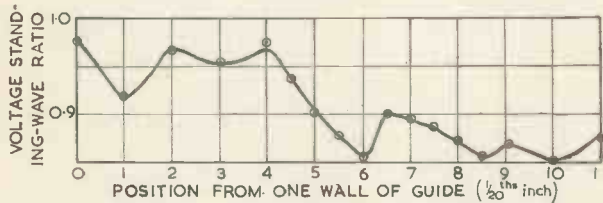

(d)

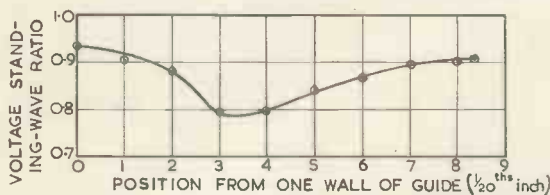

(e)

Fig 4. Voltage standing-wave ratio against guide position. (9 437Mc/s)

- (a) Morganite.
- (b) Anti-Static Gutta Percha.
- (c) Carbon Loaded Bakelite (Grade 20 per cent carbon).
- (d) Carbon Loaded Bakelite (Grade 5 per cent).
- (e) Carbon Loaded Bakelite (Grade 5 per cent).

below 0.9 for any vane position, thus, as with Morganite, the errors due to reflexions are negligibly small.

This material is appreciably affected by ageing. For a given size of vane and guide position the material gives approximately 25 times greater attenuation than Morganite. The material is not affected much by water. The second ageing tests and the humidity tests were carried out on adjacent days and it is seen that they agree fairly closely.

Carbon-Loaded Bakelite (Grade 20 per cent)

Fig. 3(c) shows the attenuation results and Fig. 4(c) gives voltage-standing-wave ratio plotted against vane position.

From Fig. 4(c) it is seen that this vane is not matched into the guide as well as for the two previous materials. The voltage-standing-wave ratio varies a good deal as the vane is moved across the guide reaching a low value of 0.76 at one point. It is presumed that these effects are due to the vane acting as a phase shifter. This, in conjunction with inevitable reflexions from the support rods is liable to produce a violently-fluctuating voltage-standing-wave ratio, since on moving the vane across the guide, the reflexions from the front and back edges of the vane and the support rods are constantly going in and out of phase and are thus producing maxima and minima of reflected power.

It is often stated that to make a reflexionless attenuator mount of this type the rods should be placed an odd number of quarter guide wavelengths apart so that reflexions from the front rod will be "cancelled out" by reflexions from the rear rod. In practice, using materials which produce both attenuation and phase shift, this simple rule is rather difficult to apply since:

- (a) the guide wavelength at the attenuator mount is unknown and in any case changes as the vane is moved across the guide.
- (b) the incident power on the rear rod is less than that on the front rod due to the attenuating effect of the material between the rods.

It is probably impossible to overcome small variations of voltage-standing-wave ratio as the vane is moved across the guide, but suitable shaping of the vane should ensure that these variations will occur about a high mean value of voltage-standing-wave ratio.

Readings of attenuation for this material were taken as the vane was moved up to about 0.03in across the guide. It is to be expected that phase-shift effects will be small when the vane is near the wall of the guide and Fig. 4(c) shows that in the region considered the voltage-standing-wave ratio is always greater than 0.8. Reflected power is thus 1.25 per cent approximately and may be neglected. The errors in comparing the various curves will be lower than this since the same guide conditions prevailed in each case.

For a given vane size and position this material produces about 20 times more attenuation than Morganite, but the material is not stable, and ageing tests show an appreciable falling off in attenuation. The results of the second ageing test and the humidity test agree fairly well showing that the material is not much affected by water.

Carbon-Loaded Bakelite (Grade 10 per cent)

The results for this material are shown on Figs. 3(d) and 4(d). As with the previous bakelite, there is considerable fluctuation of voltage-standing-wave ratio as the vane is moved across the guide and this is, no doubt, due to phase-shift effects. The voltage-standing-wave ratio over the range of vane position for which attenuation has been measured is always greater than 0.9, and so errors in the attenuation curves due to reflexions can be neglected. This material is slightly affected by age, but not appreciably by humidity.

Carbon-Loaded Bakelite (Grade 5 per cent)

No sharp phase-shift effects were observed with this material. The curves of attenuation and voltage-standing-wave ratio against vane position, Figs. 3(e) and 4(e) respectively, are smooth and regular. The voltage-standing-wave ratio over the range of movement considered is always above 0.79, there being a gradual dip to this value at 0.175in from the guide wall. At the worst the reflected power is less than 1.5 per cent and again the accuracy of comparison between curves is the important factor. The error in such comparisons will be less than 1.5 per cent.

This material attenuates much less than any of the others for a given vane size and guide position. Variations of attenuation with age and humidity are small, but the percentage values are as great as for other materials.

VARIATIONS OF REFLECTING PROPERTIES WITH FREQUENCY

The voltage-standing-wave ratio/frequency curves are shown in Figs. 5(a) and 5(b). Fig. 5(b) shows the results after the specimens had been aged in the laboratory for three months. It should be emphasized that these curves are useful for showing general trends only, because, as pointed out previously, voltage-standing-wave ratio measurements are not precisely repeatable.

With all the materials large fluctuations of voltage-standing-wave ratio are found as the frequency is varied over the band. These are due to phase-shifting properties

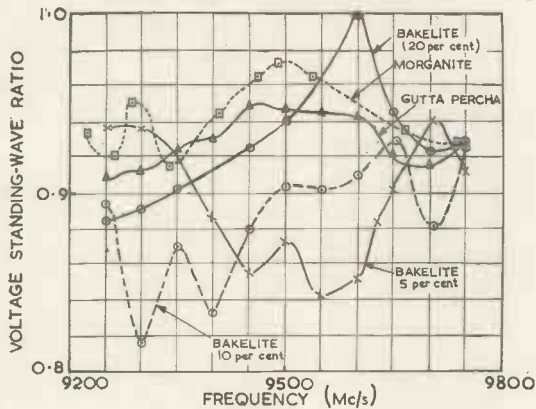

(a)

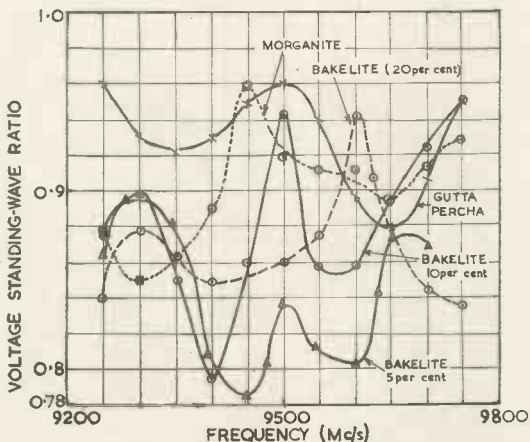

(b)

Fig. 5. Voltage-standing-wave ratio/frequency curves
(a) First Test. (b) Second Test.

of the materials coupled with the varying amounts of reflexion obtained from the support rods as frequency is varied. The reflexions from the rods and the vane go in and out of phase as the frequency is changed and produce good and bad figures for voltage-standing-wave ratio accordingly. The important thing is that these variations must be about a high mean value if a successful attenuator is to be constructed. It will be seen that Morganite and anti-static gutta percha are the only specimens for which the voltage-standing-wave ratio curves lie totally above the 0.9 value.

Conclusions and Recommendations

In the design of waveguide attenuators the aim is to produce an element whose attenuation and reflexion characteristics do not change with age, temperature or humidity. From the results of the ageing and humidity tests it is evident that Morganite has good reflexion characteristics, while its attenuation remains constant with time. Its attenuation, however, alters with humidity. It is possible to exclude moisture by coating the vanes with varnish or an adhesive.

With regard to the other materials the one giving the most attenuation for a given vane size and position is anti-

static gutta percha. This material also has extremely good reflexion characteristics. The ageing test shows that it is not a stable attenuator, but is affected very little by humidity. The material slowly oxidizes in air and so the ageing effect may be due to this. A coat of protective varnish would probably help to arrest this. Another more serious difficulty with this material is that it is very pliable and if used as a variable attenuator where it is moved across the guide on rods, it tends to change its shape once it is away from the guide wall. It would be satisfactory as a fixed attenuator fastened to one wall of the guide. Also, in view of its high attenuation and its low-reflexion properties it would be excellent for use in low-power matched loads.

Attempts by the manufacturer to produce stiffer samples were not successful and had to be abandoned. Two stiff samples (types 5347 and 5347A) were made, but the stiffening process had a disastrous effect on the reflexion characteristics reducing the average value of voltage-standing-

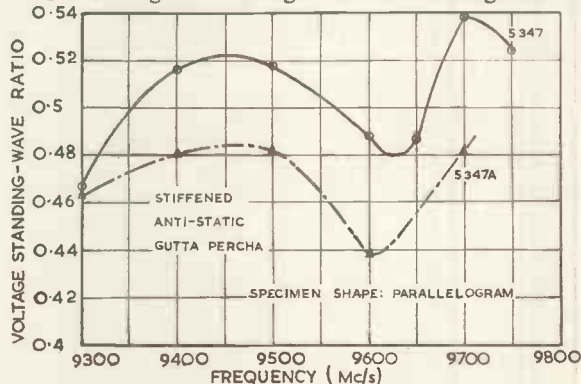

Fig. 6. Voltage standing-wave ratio over frequency band

wave ratio from 0.9 to around 0.5 as can be seen from the curves of Fig. 6. The electrical properties of later samples produced were not sufficiently reproducible for precision work. Even if they had been, or requirements could have been met by selection, it seemed doubtful whether the characteristics would be permanent.

With regard to the various Bakelite materials the higher grades have greater attenuation than Morganite. They are also mechanically rigid. They are affected by ageing, but not appreciably by humidity. They have poorer reflexion characteristics than other materials and the power reflected fluctuates rather violently with frequency and vane position due to phase-shift effects.

Makers of microwave test equipment at the present time seem to favour the metallized-glass attenuators. There is no doubt that these are more stable than vanes of carbon material. They are, however, fragile and rather difficult to make, an expensive plant being required. The final product is, as a result, very costly. More work needs to be done in the field of carbon-material attenuators. This includes the variation of attenuation with ambient temperature and the effects on the electrical properties of protective varnishes. Probably, if a suitable protective coating could be found, the performance of Morganite vanes could be made equal to that of metallized-glass attenuators.

Acknowledgments

The work recorded in this article has been carried out in the Department of Electrical Engineering at the University of Sheffield. The authors wish to thank Mr. O. I. Butler, M.Sc., M.I.E.E., A.M.I.Mech.E., for facilities afforded in the Laboratories of this Department and also Professor H. M. Barlow, B.Sc., Ph.D., M.I.E.E. for many helpful criticisms.

REFERENCES

- MILLER, C. W., CROWLEY-MILLING, M. C., SAXON, G. Notes on Wave-Guide Attenuators. *J. Inst. Electr. Engrs.* 93, Pt. IIIA, 1477 (1946).
- TEAL, G. K., RIGTERINK, M. D., FROSCHE, C. J., Attenuator Materials for Microwaves. *Elect. Engg. N.Y.*, 67, 753, (1948).

A Remote Control and Telemetry System for a Van De Graaff Generator

(Part 2)

By B. Millar*, B.A.

Telemeter Transmitter

INPUT CIRCUITS

It has been found essential to have the currents in the meter coils very well filtered, and this is attained by inserting RC filters in the leads to the metering coils. Because of the requirement that the coils should be fed from a high

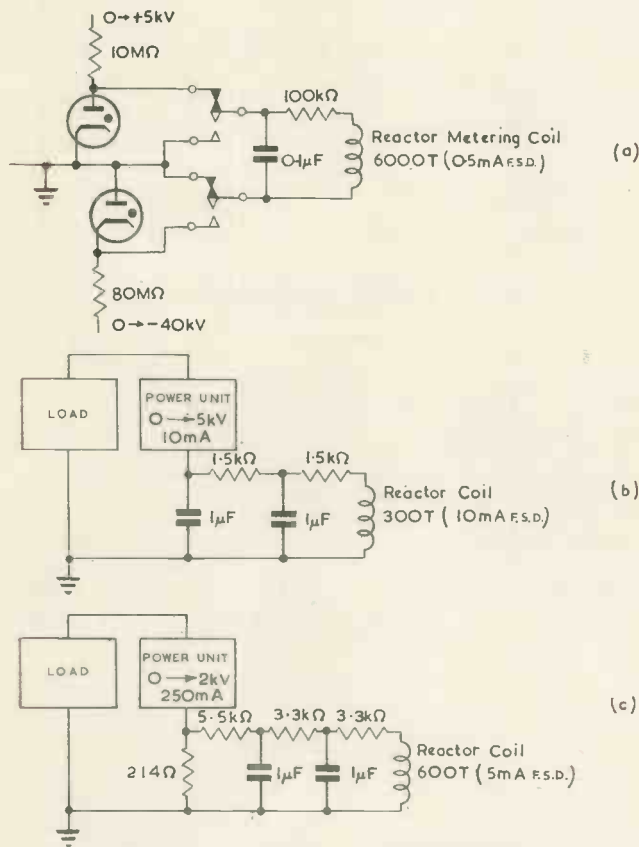

Fig. 10. Telemeter transmitter—Input circuits

impedance, the element of any filter nearest to the coil should be a series resistor, and not a shunt capacitor. Fig. 10 shows some of the circuits which are used. Fig. 10(a) is the circuit of a coil which normally indicates a voltage which may vary between 0 and 5kV positive. The coil can be switched by the relay contacts shown (operated by the control system) to indicate another voltage which may vary between 0 and 40kV negative. The protective neons prevent either power unit from producing large voltages across the relay contacts when the metering coil is switched to measure the voltage of the other. Fig. 10(b) shows a circuit for measuring a moderate current, while Fig. 10(c) shows a method of connecting a shunt in cases

* Research Laboratory, Associated Electrical Industries Ltd.

where the use of the previous circuit would result in either inconveniently great power dissipation in the filter resistors or inconveniently large filter capacitors.

There is only one case in which a more complex circuit has been found to be necessary. That is to indicate the gas pressure in the ion source discharge. The arrangement adopted uses two Pirani gauges in a bridge circuit with a simple D.C. amplifier inserted between the bridge output and the saturable reactor meter coil.

(a)

(b)

(c)

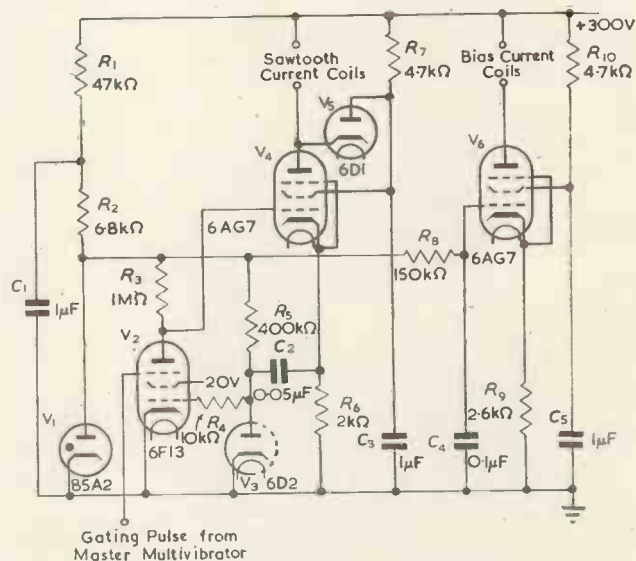

Fig. 11. Sawtooth current generator and bias current supply

TIME-BASE AND BIAS DRIVE

The circuits of the telemeter transmitter are controlled by a master multivibrator which is asymmetric, having periods 16msec and 1.5msec. The linear current sweep in the saturable reactor coils occurs during the 16msec period. In the 1.5msec period this current returns to its initial value, and also the group marker pulse in the transmitter output is produced. The multivibrator is designed so that its two periods shall be as nearly constant as possible, regardless of supply voltage variations and changes of valve characteristics.

The sawtooth current generator circuits are shown in Fig. 11. A Miller circuit is used, and the basic valve in it, V_2 is controlled by pulses from the master multivibrator applied to its suppressor grid. V_4 serves a dual purpose, firstly as a cathode-follower included in the Miller circuit, and secondly as a driver valve for the sawtooth current coils which are connected in series with one another in its anode circuit. The grid charging resistor R_5 of V_2 is fed from the 85A2 neon V_1 , which acts as a simple shunt stabilizer.

Taking the Miller feedback from the cathode of V_4 instead of the anode of V_2 has several advantages. It enables R_5 to be made rather small in value, so that it can

be made up from wire wound resistors, thus improving the stability of calibration of the system. It enables R_3 to be made large in value, so that it can be fed from V_1 , thus stabilizing the initial value from which the sawtooth current sweep starts. Finally, it reduces the dependence of the calibration on the characteristics of V_4 .

The diode V_5 , connected from anode to screen of V_4 , limits the voltage across the sawtooth current coils at the flyback of that current.

V_6 provides a constant current for the bias coils of the saturable reactors.

As was pointed out previously, the only factor in the transmitter affecting the calibration of the telemeter system is the rate of the sawtooth current sweep.

This is given by:

$$dI/dt = \frac{(E + E_0)}{R_3 C_2} \cdot \frac{M}{M + 1} \cdot \frac{1}{R_6} \cdot \frac{1}{1 + k}$$

where E = potential of the nominal 85V line,

E_0 = working bias voltage of V_2 ,

M = voltage gain from grid of V_2 to cathode of V_4 without feedback.

k = (screen current/anode current) in V_4 .

Component numbers refer to Fig. 11.

The potential E is obtained from the 85A2 neon stabilizer. It is not run under constant current conditions, but the variations in its current should be fairly small. E_0 is small compared to E , so that variations in it have only a small effect. R_3 is made up from four 100k Ω wire wound resistors, and C_2 from five 0.01 μ F mica capacitors. M is large, and so variations in it have only a small effect. R_6 has to dissipate about 1.5W, and to ensure that its value remains as stable as possible it has been made up from two wire wound resistors rated at 5W each. The probable variations in k are rather uncertain, but the operating conditions of V_4 are such that its value is determined chiefly by the valve geometry, and further, since k is about $\frac{1}{3}$, it would have to change by about 5 per cent to change the calibration of the system by 1 per cent.

From a consideration of the likely variations in all these quantities, and of possible drifts in the telemeter receiver it is concluded that over a long period the calibration of the system should be accurate to 2 per cent.

PULSE AMPLIFIER

The pulse amplifier circuit is shown in Fig. 12. The signal pulses from the saturable reactor output coils, which have an amplitude of about 20mV are amplified by V_1 and then fed to the control grid of V_2 . The short (50 μ sec) coupling time-constant between V_1 and V_2 ensures that the amplifier recovers rapidly after being overloaded by the large reverse pulses produced in the reactor output coils at the flyback of the sawtooth current sweep. V_2 operates with zero bias, and so is normally conducting. Its anode

Fig. 12. Telemeter transmitter pulse amplifier

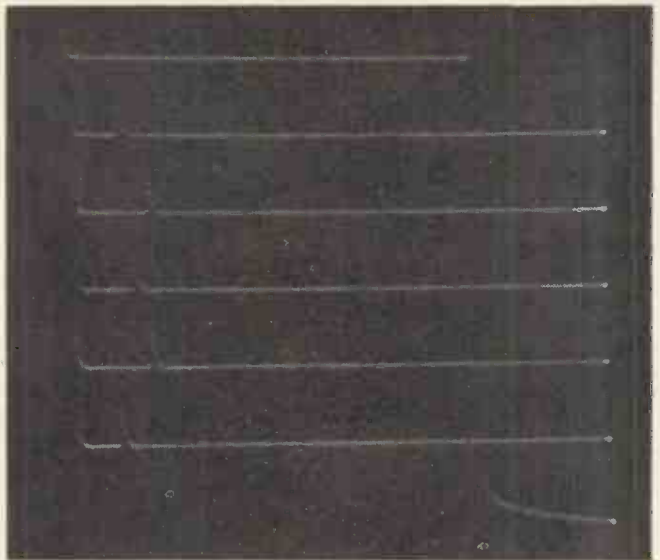
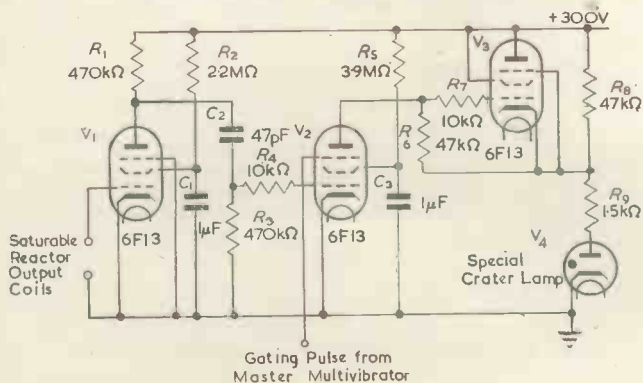

Fig. 13. The Telemeter Receiver display

current is cut off by the signal pulses applied to its control grid when the saturable reactors produce their output pulses, and also during the 1.5msec period of the master multivibrator by a negative pulse applied to its suppressor grid. The output of V_2 is coupled to V_3 which in turn controls the current in the crater lamp, so that this current is normally small, but increases when the anode current of V_2 is cut off.

Telemeter Receiver

The signal from the crater lamp is received by a 9-stage electron multiplier photocell situated immediately below the generator and is then fed by a head amplifier to the telemeter receiver.

The form of the C.R.T. display produced by this receiver has been described; it is sketched in Fig. 6 and photographed in Fig. 13.

To produce this display, the following operations are needed.

- (a) A linear time-base, of sweep time rather less than the interval between two marker pulses and triggered by the marker pulses, must be applied to the X plates of the C.R.T.
- (b) The incoming pulses must be applied to the Y plates, so that the intervals between marker and pointer pulses may be observed.
- (c) At each flyback of the X time-base, the beam must be shifted in the Y direction, so that the traces corresponding to different inputs to the transmitter are not superposed.
- (d) On receipt of the long group marker pulse, the Y shift circuit mentioned in (c) must be reset to its initial condition so that the whole display is repeated.
- (e) The beam should preferably be cut off between sweeps of the X time-base.

A block diagram based on these requirements is shown in Fig. 14.

The only point in the block diagram not mentioned above is the slicing or double limiting circuit⁵. This reduces the effects of noise by not passing any pulses below a certain size. Further, the output pulse amplitude is independent of the input pulse amplitude, provided the latter is above another critical size. Thus the pulses passed to the main receiver circuits are more uniform than those fed into the input.

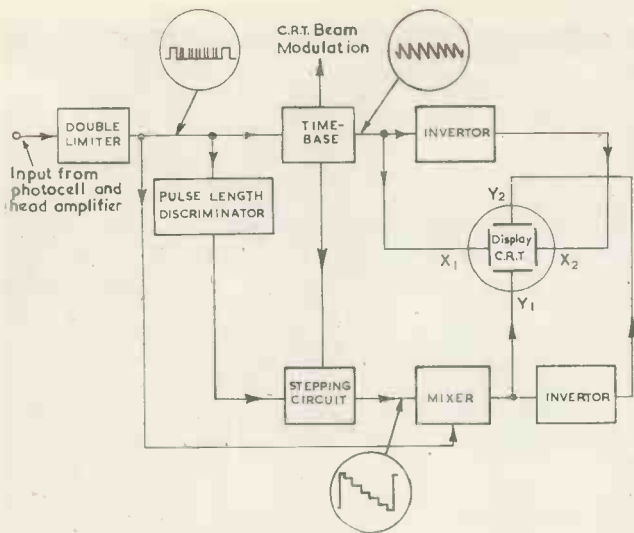

Fig. 14. The telemeter receiver

The time-base used is of the sanatron type⁶. It has the virtue that pulses applied to its trigger point during a sweep have no effect on its action. This is essential in the present case for the pointer pulses are always so applied. The Y stepping circuit uses a Miller integrator circuit of the type described by Oxford⁷. This circuit is reset by a pulse derived from the group marker pulse and applied to the suppressor grid of the Miller valve.

The receiver circuits are not very easily upset by noise pulses, for the majority of these are small, and so do not pass the limiter circuit, and of the larger ones which do pass the limiter, most come during a sweep of the X time-base, and so have no effect except to cause a momentary deflexion of the C.R.T. trace in the Y direction which the operator recognizes as spurious, since it is not repeated in successive repetitions of the display.

If the X time-base does get out of step with the trans-

mitter pulses, either by triggering on a noise pulse coming just before a marker pulse, or by failing to trigger on one of the marker pulses, then the action of the circuits is such that both the X time-base and the Y stepping circuit are brought back into synchronism with the transmitter not later than at the time of the first marker pulse of the next pulse sequence.

Thus the operator can easily detect any spurious effects, and since the system is restored to normal operation within 1/50 second he can still interpret the display even if such effects occur quite often.

Conclusions

The system described provides remote control of equipment in the high voltage electrode of an electrostatic generator without any mechanical connexions between the base of the machine and the high voltage electrode, and continuous indication, at several points if desired, of the values of five variables in the high voltage electrode with an accuracy of about 2 per cent. It has been found to be reliable in use.

Acknowledgments

The author desires to thank many of his colleagues for their assistance and in particular Mr. D. R. Chick who suggested using modulated light beams and outlined in general form the method of control and metering described. He also wishes to thank Mr. E. K. Inall, now of the Australian National University, who introduced the idea of using the saturable reactors in the telemeter transmitter, and Mr. F. C. Prescott of Metropolitan-Vickers Electrical Co., Ltd, who was responsible for the manufacture of the telemeter receiver. The author is also indebted to Dr. T. E. Allibone, F.R.S., for permission to publish this article.

REFERENCES

5. SOWERBY, J. MCG. Electronic Circuitry. *Wireless World* 54, 283 (1948).
6. WILLIAMS, F. C., MOODY, N. F. Ranging Circuits, Linear Time Base Generators, and Associated Circuits. *J. Instn. Electr. Engrs.* 93, Pt. IIIA, 1188 (1946).
7. COOKE, D., JELONEK, Z., OXFORD, A. J., FITCH, E. Pulse Communication. *J. Instn. Electr. Engrs.* 94, Part IIIA, 83 (1947).

EDGE GLUING WOOD

The use of radio frequency dielectric heating to accelerate the setting of glue is well known in the wood working industry. Better joints can be produced, valuable floor space saved and economies effected in the cost of clamps and jigs. Two years ago the G.E.C.-Fielding 5kW radio frequency edge gluing machine, probably the first of its kind in this country, extended the application of R.F. heating to the manufacture of block board or panels by edge gluing strips of wood. Hitherto the main applications had been in jointing, (as in furniture manufacture), and the production of plywood, curved laminated sections and materials from waste wood. Now Fielding & Platt Limited and The General Electric Co., Ltd., has enlarged the range of R.F. edge gluing machines to include a 25kW model which speeds the operation to give at least three times the output.

Like the 5kW machine the 25kW model is a complete unit. It comprises a pneumatically operated press, with feed table and automatic loader, to which R.F. power is applied through a suitable load matching unit from a G.E.C. 25kW R.F. generator.

The machine has been designed for the production from wood strips (after the glue has been applied in a glue spreader) of boards of the following dimensions: length 36in to 80in, width up to 40in, and thickness $\frac{1}{2}$ in to 2in (finished size). In any board the stock must be of uniform thickness but need not be cut accurately to length before treatment. Boards of any width up to the maximum can be produced by using packing pieces of the same thickness as the stock being glued. The wood strips may be of any convenient width and single boards can be made up of strips of different widths. The special radio frequency load matching device ensures the most efficient use of the generator at all times and enables the most rapid heating rates to be obtained in the manufacture of boards of any dimensions within the range of the machine.

Production rates of 6 000 square inches of glue line set hard in three minutes can be achieved, the actual rate depending to some extent on the nature of the wood and the precise type of synthetic glue used. This means, for example, that boards of the maximum dimensions 80in by 40in by 2in made up from wood strips 1in wide can be glued in about three minutes. Due to the selective heating of the glue the panels remain comparatively cool and can be handled as they leave the press immediately ready for the next production process. The necessity for expensive tongued and grooved joints between strips is entirely eliminated.

Operation of the machine has been made as simple as possible. The entire process is controlled by two operators, one assembling panels on the table and the other feeding the glue spreader and stacking completed panels. Once a panel has been assembled on the feed table the remainder of the cycle is carried through automatically in the correct sequence, on pressing a single push-button.

To start the machine the operator switches on the mains switch on the front of the R.F. generator and presses the compressor motor push-button switch on the main control panel. After a delay of about 2 minutes the generator is ready to deliver power and the requisite pressure is established in the air reservoir. The operator next receives stock from the glue spreader and assembles it on the feed table which, having a stainless steel top and stops along two edges, serves as the lay-up table. The operator then presses the "start" push-button and a pneumatically operated loading arm pushes the assembled stock direct into the press. As a precautionary measure the "start" button is inoperative if pressed before the previous cycle has been completed. The remainder of the cycle is fully automatic and the operator is able to assemble the next panel while it is in progress.

High Frequency Resistance-Capacitance Oscillators

By G. W. Holbrook*, M.Sc., A.M.I.E.E.

This article discusses the relative merits of shunt capacitance and shunt resistance oscillators with particular reference to their performance at higher frequencies. The conditions of oscillation are analysed and limiting cases for oscillations at high frequencies are quoted.

THE growing popularity of resistance-capacitance oscillators has been brought about largely by their simplicity of design, flexibility of operation and their remarkably low harmonic content. This class of oscillator functions by virtue of the specific phase shift that can be realized in a network of resistors and capacitors at any given frequency. A broad classification can be made on the basis of the relative positions of the resistive and reactive components within this network. This classification is illustrated in Fig. 1 which shows typical networks, each of three sections, and each associated with an amplifier whose phase shift is assumed to be 180 degrees. Oscillations are maintained when the gain of the amplifier is greater than the loss of the network and at a frequency

In the limit the maximum value of frequency achieved depends on the minimum value of capacitance that can be realized in the phase shifting network.

With normal circuit parameters the value of capacitance required for high frequencies becomes of the same order as the interelectrode capacitances of the valve. For this reason the use of the CR oscillator has been restricted to audio and sub-carrier frequencies. However, the RC oscillator, by virtue of its inherent shunt capacitance can be employed at much higher frequencies. At the upper limit of frequency the final shunt capacitor becomes the grid-cathode capacitance of the tube. The minimum value of resistance employed is then dictated by the value of mutual conductance that can be realized in the amplifying valve. The following paragraphs examine and compare the performance of both classes of resistance-capacitance oscillator at high frequencies and also include an illustrative design of the RC type.

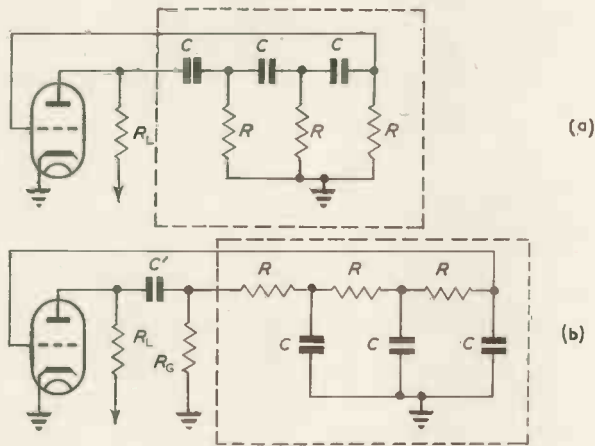

Fig. 1. (a) CR oscillator
Series capacitance, shunt resistance.
(b) RC oscillator
Series resistance, shunt capacitance.

Conditions of Oscillation

The circuits shown in Fig. 1 depict the oscillator as con-

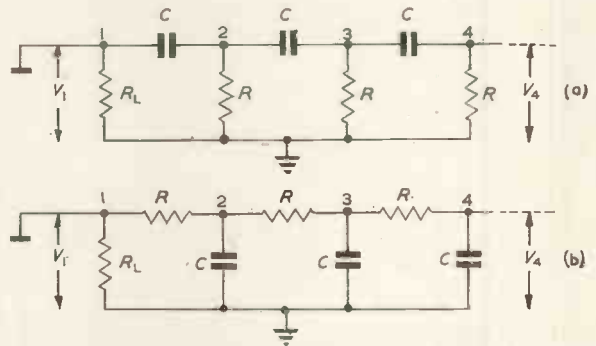

Fig. 2. RC and CR oscillators arranged for nodal analysis

which produces a further 180 degrees of phase shift in the network.

Although three sections of resistance and capacitance are required as a minimum it has been shown^{1,2} that four or more sections may be employed in the network. It can also be shown that if all the resistors are of equal value and all the capacitors are of equal value in the network then the frequency of oscillation is given by:

$$f_0 = k/CR \dots\dots\dots (1)$$

where k depends on the number and configuration, either RC or CR, of the resistors and capacitors. Under the same conditions it can be shown that, for an oscillator with a single stage of amplification, the minimum possible value of mutual conductance in the amplifying tube is inversely proportional to the value of resistance employed in the network. Thus the minimum value of resistance employed depends on the realizable gain of the amplifying valve.

sisting of an amplifier and a phase shifting network. For purposes of analysis it is more convenient to consider both parts as a single entity. It has already been indicated that a high value of mutual conductance is desirable for high frequency oscillators, thus a pentode valve is the inevitable choice for such a case. Assuming the use of a pentode it is expedient to employ nodal analysis and to treat the valve as a constant current source of power. This is illustrated in Fig. 2 which shows both RC and CR oscillators set up for nodal analysis. In both cases it has been assumed that the interelectrode capacitances are, for the moment, negligibly small compared with the size of the phase shifting capacitor.

Considering the case of the CR oscillator, let the admittances of the various elements be given by:

$$g = 1/R = \text{conductance of phase shifting resistor.}$$

$$b = j\omega C = \text{susceptance of phase shifting capacitor.}$$

* Department of Electrical Engineering, Royal Military College of Canada.

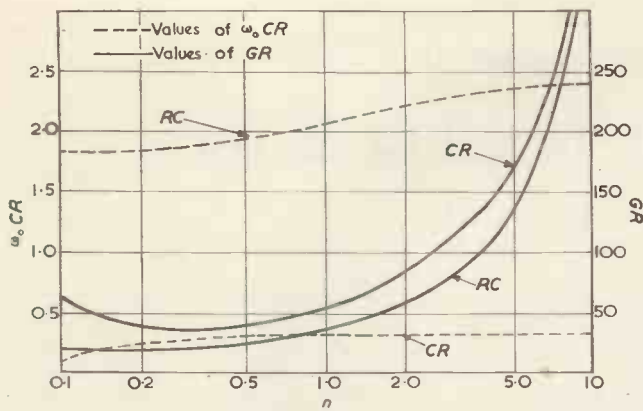

Fig. 3. Conditions of oscillation

$ng = n/R =$ equivalent conductance of the anode impedance of the valve in shunt with the anode load resistor R_L .

If G is the mutual conductance of the valve then the voltage developed on node 1 can be written as:

$$V_1 = -GV_4/Y_1 \dots \dots \dots (2)$$

where Y_1 is the admittance of node 1 to earth.

Solving this equation for real and imaginary quantities (for details see the appendix) the following expressions are obtained:

Frequency of oscillation—

$$\omega_0 = \frac{1}{CR\sqrt{4/n + 6}} \dots \dots \dots (3)$$

Minimum value of mutual conductance—

$$G = 1/R(5n + 1)(4/n + 6) - (n + 3) \dots \dots (4)$$

In the corresponding analysis of the RC oscillator the coupling capacitor C' shown in Fig. 1 is assumed to have negligible reactance and R_L now represents the resultant resistance of the anode impedance, the anode load resistor and the grid leak resistor R_g all in shunt to earth.

Developing the conditions of oscillation as before the following equations are obtained:

$$\omega_0 = 1/CR \sqrt{\frac{6n + 3}{n + 1}} \dots \dots \dots (5)$$

$$GR = \frac{(6n + 3)(5n + 4)}{(n + 1)} - n \dots \dots \dots (6)$$

A graphical illustration of these results is given in Fig. 3 which shows corresponding values of $\omega_0 CR$ and GR plotted against n for both types of oscillators. This shows clearly that for a given value of CR the frequency of oscillation in the RC oscillator is between four and ten times as great as in the corresponding CR oscillator. It will also be noted that the value of GR required in the RC oscillator is always less than that of the CR arrangement. In the latter case the required value of GR reaches a minimum for a value of n of about 0.3.

Over the range considered in Fig. 3 the value of GR required in the RC oscillator diminishes continually as n is decreased in size. A reduction in the size of n can be brought about by increasing the value of the anode load resistance R_L . The optimum value of R_L is, however, closely related to the value of H.T. supply voltage available. For any given supply voltage the effective anode voltage diminishes as R_L is increased. This, in turn, results in a reduction of the dynamic mutual conductance of the tube and a consequent reduction in the product of GR . Thus an intended reduction of the required size of GR brought about by increasing the value of R_L may well

be offset by a reduction of mutual conductance as indicated above.

From these considerations it can be seen that the design of high frequency single stage resistance capacitance oscillators is controlled by the following factors:

- (a) The RC oscillator gives a higher frequency than the corresponding CR circuit.
- (b) The upper limit of frequency is controlled by the minimum value of GR required for oscillation.
- (c) The realizable value of G is a function of H.T. supply voltage and the value of R_L employed.

Interelectrode Capacitance

When the value of the phase shifting capacitors is reduced to the same order as that of the interelectrode capacitances the performance of the RC oscillator is somewhat modified. The grid cathode capacitance of the tube can be considered as part of the final phase shifting capacitor. In the case of pentode valves, where the grid-anode capacitance is small compared with the grid-cathode capacitance, it can be shown that the effect of this capacitance can be ignored. The anode-cathode capacitance, which is effectively shunted across the anode load resistor, must be taken into consideration. This is done most conveniently by assuming the ratio:

$$m = \frac{\text{Anode-cathode capacitance}}{\text{Phase shift capacitance}}$$

Using the analysis previously employed, the following conditions of oscillation are obtained:

$$\omega_0 = 1/CR \sqrt{\frac{6n + 3 + m}{n + 1 + 5m}} \dots \dots \dots (7)$$

$$GR = \frac{(6n + 3 + m)(5n + 4 + 6m)}{n + 1 + 5m} - m \left[\frac{6n + 3 + m}{n + 1 + 5m} \right]^2 - n \dots \dots \dots (8)$$

These equations indicate that a slight reduction of frequency is obtained when compared with the case where the value of m was assumed to be negligible. At the same time there is an equivalent reduction in the required value of GR due to the smaller loss in the phase shifting network at this lower frequency.

In order to assess these results it is expedient to consider a limiting case. If a 6AH6 valve is selected, the following interelectrode capacitances are present:

$$C_{gk} = 10\text{pF} \quad C_{ak} = 2\text{pF} \quad C_{ag} = 0.03\text{pF}$$

The extreme case will occur when the grid-cathode capacitance is used as the entire value of the final phase shifting capacitor. Under these conditions $C = 10\text{pF}$ and $m = 0.2$. The effect of C_{ga} can be ignored as it is less than 1 per cent of the value of C . Assuming a value of $n = 0.5$ the condition of oscillation is that $GR = 18$. If a value of $R = 5000$ is selected, which is more than ample to fulfil this condition, the resulting frequency is given by:

$$\omega_0 = 3.14 \times 10, \text{ or } f = 5.0\text{Mc/s}$$

Fig. 4. A wideband oscillator

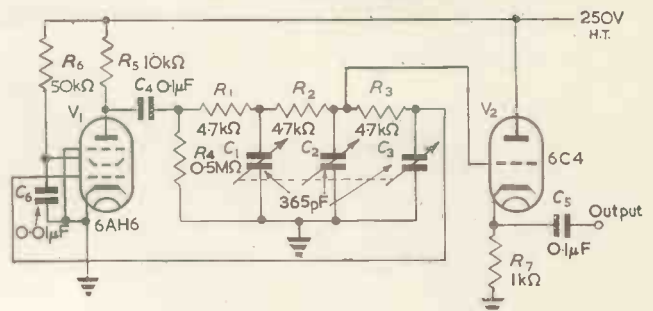

This, of course, is a limiting case and would be difficult to realize in practice. Frequencies of this order can, however, be achieved if care is taken to eliminate stray wiring capacitances.

Wide Band Operation

One of the more valuable features of the CR oscillator is, that providing that all the phase shifting capacitors remain equal, the amplification required for oscillation is almost independent of the frequency. This feature is illustrated in Fig. 4, which shows the circuit of a wide-band oscillator operating up to a maximum frequency of 2.0Mc/s. The three capacitors C_1 , C_2 and C_3 are provided by a three-gang variable capacitor. V_1 is the oscillator valve and V_2 is connected as a cathode-follower so that the output impedance of the oscillator is reasonably low. Under these conditions the anode-grid capacitance of V_2 is effectively shunted across the second phase shift capacitor C_2 . The individual sections C_1 , C_2 , C_3 are trimmed so that at the position of minimum capacitance the added interelectrode capacitances in shunt with C_1 and C_2 are absorbed and the effective values of C_1 , C_2 and C_3 are equal for all position of the gang. Using a conventional 365pF three-gang capacitor a frequency range of from 160kc/s to over 2Mc/s can be realized in a single band. This frequency range is achieved with less than 5 per cent change in output amplitude and the waveform is sinusoidal over the whole range. By employing smaller values of ganged capacitors, with lower minimum capacitances, it is clear that higher frequencies can be realized approaching the limit already discussed.

APPENDIX

(A) CR OSCILLATOR

From Equation (2):

$$-G = \frac{V_1 Y_1}{V_4} = \frac{\Delta}{\Delta_{14}}$$

where these determinants are given by:

$$\Delta = \begin{vmatrix} ng + b & -b & 0 & 0 \\ -b & g + 2b & -b & 0 \\ 0 & -b & g + 2b & -b \\ 0 & 0 & -b & g + b \end{vmatrix}$$

$$\Delta_{14} = \begin{vmatrix} -b & g + 2b & -b \\ 0 & -b & g + 2b \\ 0 & 0 & -b \end{vmatrix}$$

Thus:

$$\Delta/\Delta_{14} = - \left[ng^4/b + \frac{g^3(5n+1)}{b} + \frac{g^2(6n+4)}{b} + g(n+3) \right]$$

Substituting for g and b and taking real and imaginary parts then:

$$\text{Imaginary Part} = - \frac{(6n+4)}{\omega CR^2} + \frac{n}{\omega^3 C^3 R^4}$$

Crystal Palace Television Transmitting Station

As already announced, the BBC is to build a new London television transmitting station on the Crystal Palace site in south London. Contracts have now been placed with Marconi's Wireless Telegraph Company Limited for two vision transmitters of 15kW each and two sound transmitters of 4.5kW each for the new station. The two vision transmitters will be operated together, thus ensuring greater reliability, because if a fault should develop on one the service can be maintained on the other without interruption. By the use of a high-gain aerial system, the station will be capable of producing an effective radiated power of approximately 250kW. This compares with 100kW for each of the four post-war high-power stations and 34kW for Alexandra Palace. The sound transmitters will also

and this must equate to zero and thus the frequency of oscillation is given by:

$$\omega_0 = \frac{1}{CR\sqrt{4/n+6}} \text{ rad/sec}$$

The real part of the expression must equate to the mutual conductance and thus:

$$G = \frac{(5n+1)}{\omega^2 C^2 R^3} - \frac{(n+3)}{R}$$

and substituting for, ω_0 the second condition of oscillation is given by:

$$GR = (5n+1)(4/n+6) - (n+3)$$

(B) RC OSCILLATOR

The determinants for this case are given by:

$$\Delta = \begin{vmatrix} g(n+1) & -g & 0 & 0 \\ -g & 2g+b & -g & 0 \\ 0 & -g & 2g+b & -g \\ 0 & 0 & -g & g+b \end{vmatrix}$$

$$\Delta_{14} = \begin{vmatrix} -g & 0 & 0 \\ 2g+b & -g & 0 \\ -g & 2g+b & -g \end{vmatrix}$$

Developing the conditions of oscillation as before, the following equations are obtained:

$$\omega_0 = 1/CR \sqrt{\frac{6n+3}{n+1}}$$

$$GR = \frac{(6n+3)(5n+4)}{n+1} - n$$

(C) CR OSCILLATOR INCLUDING ANODE-CATHODE CAPACITANCE

Here the determinants are as follows, where:

$$m = \frac{\text{Anode-cathode capacitance}}{\text{Phase shift capacitance}}$$

$$\Delta = \begin{vmatrix} g(n+1)+bm & -g & 0 & 0 \\ -g & 2g+b & -g & 0 \\ 0 & -g & 2g+b & -g \\ 0 & 0 & -g & g+b \end{vmatrix}$$

$$\Delta_{14} = \begin{vmatrix} 2g+b & -g & 0 \\ -g & 2g+b & -g \\ 0 & -g & g+b \end{vmatrix}$$

These result in the following conditions of oscillation:

$$\omega_0 = 1/CR \sqrt{\frac{6n+3+m}{n+1+5m}}$$

$$GR = \frac{(6n+3+m)(5n+4+6m)}{n+1+5m} - m \left[\frac{6n+3+m}{n+1+5m} \right]^2 - n$$

REFERENCES

1. ARTZT, M. *Proc. Inst. Radio Engrs.* 32, 409 (1944).
2. BUTLER, F. *Elect. Eng. N.Y.* 21, 140 (1943).

be operated together. The Crystal Palace station is being designed so as to make it possible to raise the power still further should this be required at a later stage.

The aerial system will be erected at the top of a self-supporting steel mast 640ft high which will raise the aerial to a height of approximately 1000ft above sea level. The higher power of this station will not greatly increase the area already served by Alexandra Palace, but it will give a much stronger and therefore more interference-free signal in those parts of London and the suburbs where the level of interference is high.

Transmissions from the new station will be vertically polarized and on the same frequencies as those used at Alexandra Palace, namely, 45Mc/s for vision and 41.5Mc/s for sound.

Glass in the Electronic Industry

By M. Manners*, B.Sc.Tech., Ph.D.

The many glasses available to the electronic industry are summarized and the applications for which they were developed are described, with special reference to the problems of sealing. The composition and properties of the more commonly used glasses are tabulated.

THE specification of the requirements for the envelope of an electronic tube generally limits the choice of material to glass. The envelope must contain a vacuum or a specific gas, it must have high, sometimes very high, electrical insulating properties, it must often be transparent or of desirable colour. Very few alternatives to glass are therefore available, except the infrequently used silica.

In spite of the obviously desirable features in the use of glass for an envelope there are equally obvious limitations in the material itself. Glass is generally brittle and breaks easily, and it is often susceptible to thermal shock. Its tensile strength is low, and fractures may occur after long periods under sustained loads that are only one third of the normal breaking stress. While these limitations are relatively easy to overcome by suitable mechanical design, other considerations are more difficult. Glass is the product of the high temperature fusion of a mixture, the main constituent of which is sand. The fusion produces a very viscous liquid, molten glass and, as it cools, its viscosity increases continuously. During this cooling period, the glass is formed by hand, or by machine, into the desired shape. The skill of the glass technologist lies in providing molten glass which is homogeneous, free from small bubbles, stones and inclusions from the refractory container in which the glass is melted, while having the correct expansion and electrical properties. Before a uniform finished product is available there must be added the skill of the craftsman, whether machine engineer or hand worker, in converting this molten mass into components of the correct shape and size.

The purpose of this article is not to describe the actual production process, but rather to summarize the many and varied glasses available to the electronic industry today, and the applications for which they were developed.

Before specific types of glass are mentioned however, it is first desirable to say a little about the use of fused silica.

Fused Silica

Although glasses are available which have softening points in the region of 800°C this is still too low for some valve and electronic applications.

Fused silica is therefore used for a few transmitting valves and high efficiency lamps. This material can be operated to 1000°C and has a low thermal expansion (0.5×10^{-6}) so that it is resistant to thermal shock. Because of its low expansion, it is difficult to seal metallic leads through the silica, and many methods are used to overcome this problem.

Early silica valves consisted of a fused silica envelope with the electrodes supported on silica insulators fused on to the inside of the envelope at appropriate positions. The electrical connexions were made via molybdenum rods passing through silica tubes fused on to the outside of the envelope. The seal was made with a lead plug and to prevent the lead from melting during the operation of the valve, it was necessary to have very long seals, in some cases as much as 8 inches long, which added to the fragility of the valve and limited the maximum frequency of

operation. Considerable development work resulted in the modern improved form of silica valve shown in Fig. 1 where a graded seal technique is used to overcome the great difference in thermal expansion which exists between fused silica and the various glasses. The technique has many scientific and technical applications and aims at the production of a seal, with the stresses uniformly distributed, so that nowhere do they reach a magnitude which could cause mechanical failure.

In some cases as many as ten intermediate sealing glasses may be required, but a typical seal in a silica valve con-

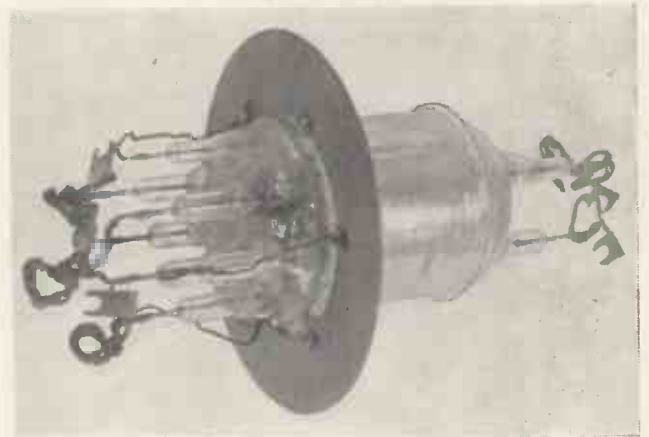

Fig. 1. Modern silica transmitting valve

sists of a tungsten rod sealed to the silica envelope through a special hard glass, which reduces the seal length considerably. The tungsten lead, 3mm in diameter, is sheathed with a thin layer of a special glass (WQ31) which was developed having a very high softening point to act as an intermediary between fused silica and tungsten. (Note: the above type classification as with all others mentioned in this article, refers to glasses made by The General Electric Co., Ltd.)

A bead is formed around the middle of the sheath covering the tungsten wire and is joined to a silica tube by a dome of WQ31 glass. Fig. 2 shows this seal photographed between crossed Nicol prisms to show the stress. Although the seal is highly stressed, it is successful because the stresses are symmetrical and compressive, and glass is very strong in compression. The corresponding tensions are proportional to the thickness of the sheathing, which is purposely kept small. Further, since the seal is made at very high temperatures (in the region of 1800°C) in air, any tungsten oxide formed volatilizes rapidly, and the little that remains, dissolves in the glass. The oxide-free seal obtained in this way is very strong, and in conjunction with the graded seal technique, has done much to increase the ruggedness of silica valves.

In a similar way, high pressure mercury vapour lamps using fused silica envelopes have been improved by the development of improved seals and an arc brightness of 100 000 stilb is now permissible. This corresponds to a

* Formerly Research Laboratories of The General Electric Co. Ltd., now Lemington Glass Works Ltd.

loading of about 30 watts/sq cm and has made available, relatively small high-intensity light sources.

In the case of these special lamps, a graded seal is not necessary and molybdenum ribbon of lenticular cross-section is commonly used for the leads. In this way the severity of the stress between metal and silica, caused by expansion differences, is reduced by distortion of the metal and by the preferential stress distribution around a thin ribbon. Leads for carrying currents of more than a few amperes are made up of a number of ribbons connected in parallel. Fig. 3 shows a lamp rated at 10kW in which the seals are of the multiple ribbon type and capable of carrying 150 amperes continuously.

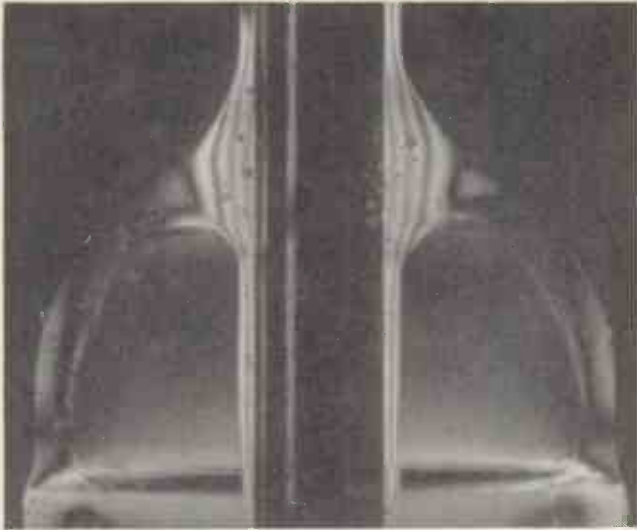

Fig. 2. Graded seal between tungsten and fused silica using WQ31 glass

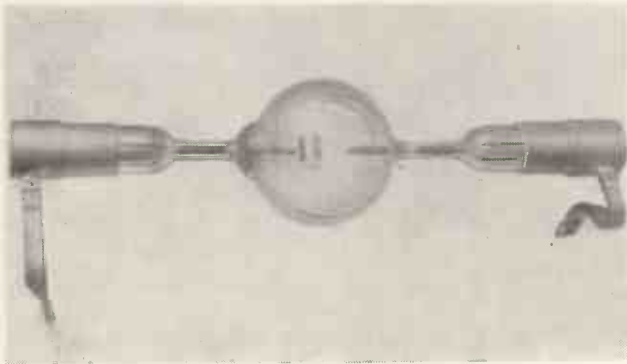

Fig. 3. 10kW high pressure mercury vapour lamp showing 150A multiple ribbon, silica-molybdenum seal

Glasses for Seals or High Temperatures

For lower power discharge lamps, borosilicate glasses with a high softening point can be used. Type H26X is one of these, and providing that the iron content is kept very low, can transmit substantial amounts of ultra-violet light. Other glasses in the borosilicate group are types W1 and HH, which are standard glasses for sealing to tungsten and molybdenum respectively. The use of a tungsten/W1 glass seal is illustrated in Fig. 4. In this, a 3cm magnetron, tungsten leads several millimetres in diameter have to be used to support the cathode structure with considerable rigidity. There is a potential difference of 20-30kV between the cathode structure and the anode, and glass is

chosen as an excellent insulator between them. Because the softening point of W1 glass is over 500°C, the use of this glass enables the assembly to be taken to the high baking temperature of 450°C (or higher) during the exhausting process, and so facilitates degassing of the glass and other components of the tube.

The W1 type has also found application in X-ray tubes, for it has been found to minimize the building up of electrostatic charges on the envelope. Interelectrode voltages range from under 70kV to over 250kV, and bulb diameters from 1½in to 5in. The use of W1 glass also enables an area of controlled thinness to be formed in the bulb to minimize the absorption of X-rays. Since this "window" is necessarily outside the hottest part of the target area of the anode, the temperature/hardness relationship of the glass is of particular importance and value.

A tungsten wire seal in W1 can be used for connexions to the cathode assembly in X-ray tubes, but in view of the relatively large anodes in many types of X-ray tube, a more robust construction is necessary for the anode connexions. In such cases a collar of nickel-cobalt-iron alloy is brazed to the copper anode and is sealed to a special glass, type FCN, which will be described below. This in

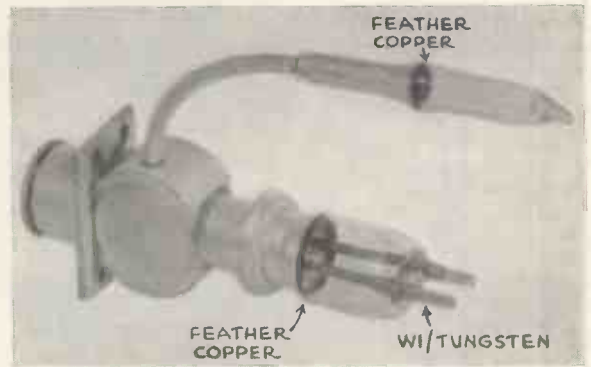

Fig. 4. 3cm magnetron showing standard sealing techniques with W1 glass

turn is sealed to type HH glass and completes the graded glass-to-metal seal.

HH glass is not widely used at present because in many applications W1 and tungsten have now replaced the use of HH and molybdenum. This is mainly due to the disadvantage introduced by the heavy oxide film formed on the molybdenum when it is being sealed to the glass. The thick oxide film formed on molybdenum is molten at glass working temperature and does not adhere to the metal as well as the corresponding oxide film does to tungsten. The W1/tungsten seal is therefore more satisfactory than that between HH glass and molybdenum, and is used to replace it wherever practicable. Some cases, however, still remain for which HH is desirable, usually on account of its slightly higher softening point.

In addition to all the above there are various other glasses made for joining glasses which have widely differing softening points.

Glass for Iron Alloy/Glass Seals

Type FCN glass is a medium softening point, low-expansion glass specially made for sealing to nickel-cobalt-iron alloys of the Kovar, Fernico or Nicosil type. These alloys are often used to replace the more expensive tungsten and molybdenum and have additional advantage in that they are not readily oxidized and can be welded and soldered. This glass represents a compromise between low-expansion glasses with a high softening point and high-expansion glasses with low softening points, and it is becoming increasingly important in a number of electronic devices.

An application of FCN glass is illustrated in Fig. 5 which shows a form of high-voltage insulator used in mercury arc rectifiers. Because these seals have to operate in the presence of mercury vapour, the metal used must be immune to attack by mercury. This limits the choice of the metal to iron, nickel-iron or nickel-cobalt-iron, and the last-named is chosen on account of its low expansion and its poor thermal conductivity. This enables a smaller seal to be made than would be possible with nickel-iron, while also making it possible to weld the metal component at points relatively close to the seal itself. Fig. 5 shows a double insulator in which four FCN glass to metal seals are made.

A germanium rectifier has been developed in which FCN glass is used for the envelope in a design made as simple as possible so that the unit can be soldered directly into the circuit. The construction chosen gives a small, robust hermetically sealed unit with high electrical and mechanical stability and low electrical capacitance. The FCN glass envelope is sealed to two nickel-cobalt-iron tubes, one slightly larger than the other. The tungsten "whisker" is welded to a nickel stub of diameter equal to the internal diameter of the smaller tube and the germanium crystal is soldered to a stub that just fits into the larger tube. When the correct contact between the whisker and the germanium has been established, the two stubs are spot welded into their respective tubes to hold them rigidly in position. Finally, the device is sealed hermetically by applying solder round the ends of the tubes.



Fig. 5. Double insulator used in mercury arc rectifiers

The cathode disk is 0.05 inches thick and has disk seals on either side of the flat portion, while the heater seal is of thinner metal (0.3mm) and has an edge seal. All nickel-iron parts are copper-plated before being sealed to the glass, in order to give good high frequency conductivity in the finished valve.



Fig. 6. Envelope for the ACT25 U.H.F. disk seal triode

Glasses for Valves and Cathode-Ray Tubes

On account of its good electrical resistivity and ease of working, a lead glass type L1 is very widely used in receiving and transmitting valves. The sealing problems connected with the use of L1 glass are solved relatively easily. Copper can be used to form a seal with the glass, provided that the metal is suitably shaped to give feather edges, so that the distortion of the copper relieves any stress set up. 50/50 nickel-iron can also be used, either with or without copper-plating.

A good example of the use of L1 glass is given in the ACT25 valve which is a U.H.F. disk-seal triode. In designing the metal-glass envelope shown in Fig 6, it was necessary to provide glass-to-metal seals with high thermal conductivity for the anode and grid, and seals with low thermal conductivity for the cathode and heater. The high conductivity seals consist of copper disks joined to the glass by the feather-edge technique which is not critical as to the kind of glass used. The low conductivity seals are made from nickel-iron of approximately 50/50 composition, the metal being in the form of a shallow disk for the cathode seal and a thimble for the heater seal. This metal is chosen since its expansion is compatible with that of L1 glass, which is used on account of its very satisfactory high frequency properties.

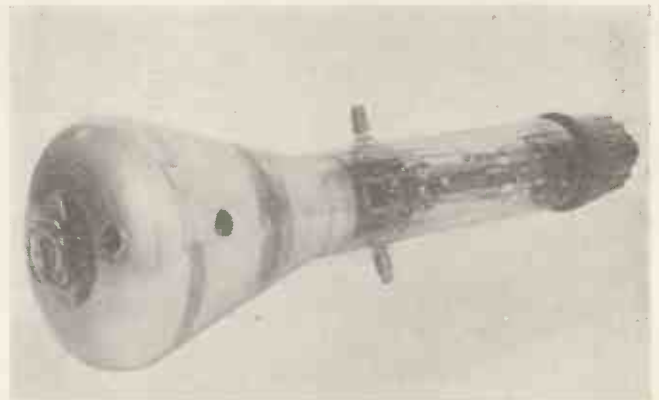

Fig. 7. Two-gun storage tube VCRX280. showing chrome-iron/X8, copper-plated nickel-iron/X8 and copper/L1/X8 seals

Another glass which finds application in electronic tubes when the highest electrical characteristics are not required is a soda glass, type X8. This glass is usually sealed to chrome-iron, as in the two-gun storage type cathode-ray tube VCRX280 shown in Fig. 7. Two chrome-iron-to-X8 glass seals are used to obtain contact with the inner metal band which acts as a collector for secondary electrons liberated from the target surface. There are also five copper-plated nickel-iron-X8 seals in the neck of the tube, of which four can be seen in the illustration. The connexion to the target storage plate in the face of the tube is made by means of a feather-edged copper-L1-X8 seal.

Sodium-Resistant Glass

Although sodium discharge lamps are on the fringe of the electronic field they represent an interesting use of three quite different types of glass. The Na10 glass used was specially developed to resist the attack of sodium

TABLE 1
The Composition and Properties of the More Common Glasses Used in the Electronic Industry

		X8	SS3	Na10	L1	FCN	HH	H26X	W1
		SODA GLASS	HIGH ELECT. RESISTANCE SHEATHING GLASS	SODIUM VAPOUR RESISTANT GLASS	SOFT LEAD GLASS	SEALING GLASS FOR FERNICO NICOSIL KOVAR	MOLYBDENUM SEALING GLASS	MOLYBDENUM SEALING GLASS FOR HIGH PRESSURE MERCURY VAPOUR LAMPS	TUNGSTEN SEALING GLASS
CHEMICAL	SiO ₂	70.12	66.0	8.0	56.0	66.0	72.0	54.25	75.5
	Al ₂ O ₃	2.58	0.72	24.0	1.0	2.0	4.0	22.0	2.2
	B ₂ O ₃	0.78	2.0	48.0	—	24.0	13.0	7.5	16.3
COMPOSITION	Na ₂ O	16.82	6.3	14.0	5.2	4.0	3.5	—	4.0
	K ₂ O	0.35	9.9	—	7.5	3.5	4.0	—	2.0
	PbO	—	—	—	30.0	—	—	—	—
	BaO	—	15.0	—	—	—	—	3.0	—
	CaO	5.40	0.44	6.0	0.5	0.5	3.0	13.25	—
	MgO	3.60	—	—	0.3	—	0.5	—	—
LINEAR EXPANSION × 10 ⁻⁶ between temperatures t ¹ & t ²		20°-350° 9.65	20°-400° 9.40	To match X8 on stress measure- ment	20°-320° 9.05	20°-350° 5.15	20°-450° 4.7	20°-580° 4.6	20°-350° 3.75
SOFTENING TEMPERATURE (°C.)		550	555	Very low	470	550	625	780	600
ANNEALING RANGE (°C.)		520-450	530-480	—	435-360	530-460	590-500	750-700	570-510
log ₁₀ (SPECIFIC ELECTRICAL RESISTANCE) at—100°		10.00	—	—	13.7	—	—	—	13.5
150°		8.8	11.8	—	12.35	12.65	11.7	—	12.23
200°		7.8	10.5	—	10.94	10.95	10.3	13.0	11.04
300°		—	8.3	—	—	8.95	8.3	11.4	—
400°		—	—	—	—	—	—	10.0	—

TABLE 2
Glass and Metal Combinations for Seal Making

METAL	LINEAR EXPANSION (× 10 ⁻⁶ between 20° and 350°C.)	GLASS	LINEAR EXPANSION (× 10 ⁻⁶ between 20° and 350°C.)	COLOUR OF SEAL	LONGITUDINAL STRESS WITH NORMAL ANNEALING	REMARKS	MAXIMUM TENSILE STRESS AFTER NORMAL ANNEALING (kg./sq. cm.)
Tungsten	4.4	W1	3.75	Straw to light brown	Slight compression	—	48 (radial)
Molybdenum	5.5	HH	4.70	Light brown	Slight compression	Normally heat treated to avoid high stress	40 (radial)
		H26x	4.60	Light brown	Severe compression		260 (radial)
Kovar Nicosil Fernico }	4.5-4.8	FCN	5.15	Grey	Slight compression	—	0-50 (radial)
Red Plat. Dumet Copper-clad 43% Ni. Fe.	7.8 L 9.0 R	L1	9.05	Red	Severe tension	Not normally annealed in production	310 (circumferential)
No. 55 alloy 26% Cr. Fe.	10.2	L1 X8	9.05 9.65	Grey-green	Compression Slight compression	—	50-100 (radial) 20- 60 (radial)
50/50 Ni. Fe. and copper-clad 50/50 Ni. Fe.	9.5	L1	—	Grey Red	Slight tension Slight compression	—	34 (circumferential) 30 (radial)
Fe. 52 Ni. 2 Cr. 6	8.9	L1	—	Grey	Slight compression	—	30 (radial)

vapour. This glass is very corrosive when molten and must be kept as free as possible from contamination by iron. The Na10 glass is therefore melted in large platinum crucibles of about 50lb capacity. Because the glass is not durable when in contact with the atmosphere, it must be used in the form of an internal coating on X8 glass, and this combination is then drawn into tubing. But X8 does not possess a sufficiently high electrical resistivity to prevent electrolysis taking place between the glass immediately

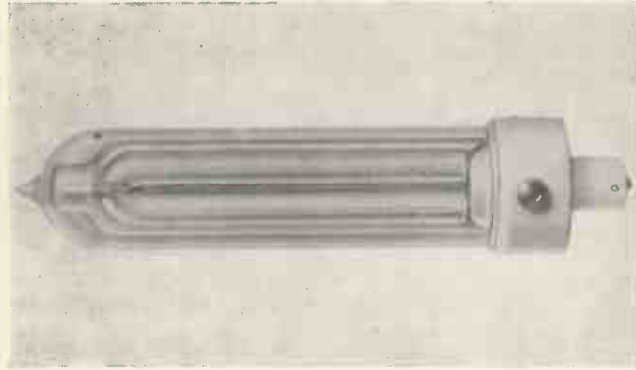

Fig. 8. Sodium lamp

opposite the cathode and the lead-in wires, a sheathing glass of high resistivity and reasonably resistant to attack by sodium vapour is sealed round the lead wires. This third glass, known as SS3, has again been specially developed for use in sodium lamps. The construction of the lamp is shown in Fig. 8. The whole assembly is mounted in a vacuum flask for two reasons. It is desirable that the lamp be lagged thermally so as to attain the optimum lamp characteristic and maximum brightness. At the same time, it is necessary to maintain the discharge tube at a uniform temperature so that migration of sodium to cool spots, which would reduce the vapour pressure in the lamp, is avoided. These two requirements are met in practice by enclosing the lamp in a vacuum flask, the circu-

lation of the air within the flask ensuring a uniform temperature on the wall of the inner envelope, while thermal losses are reduced to a minimum by the usual double-walled construction.

Conclusion

The examples outlined above give some indication of the importance of the glass technologist to the electronic industry. It is clear that progress in the design and development of valves and other electronic tubes is closely linked with, and sometimes dependent on, progress in the development of new glasses capable of meeting specific requirements.

TABLE 3
Sealing glasses

SEALING GLASS	COEFFICIENT OF LINEAR THERMAL EXPANSION ($\times 10^{-6}$)	SOFTENING TEMPERATURE (°C.)
WQ31	1.0	750
WQ34	2.1	700
H428	3.2	840
W1	3.75	600
HH	4.7	625
GS1	5.2	625
GS2	5.8	625
GS3	6.6	620
GS4	7.2	625
GS5	7.8	560
GS6	8.4	515
L1	9.05	470
X8	9.65	550

The composition and properties of the more common glasses are given in Table 1. Data on the glass-to-metal sealing combinations are given in Table 2, and in Table 3 are listed the graded sealing glasses.

SELECT BIBLIOGRAPHY

COMPREHENSIVE SURVEY
MONACK, A. J. Theory and Practice of Glass/Metal Seals. *Glass Ind.* 27, 389, 446, 502, 550 (1946).
DESIGN
SCOTT, W. J. Glass to Metal Seal Design. *J. Sci. Inst.* 23, 193 (1946).
GENERAL
PARTRIDGE, J. H. Glass-Metal Seals. *Soc. Glass Tech.*

HIGH TENSION SAFETY TEST PROD *

This article describes a prod for connecting a circuit or component to a high tension source for the purpose of measuring either its insulation resistance or its breakdown potential. If the component is a capacitor it may be dangerous to leave it in a charged condition. For this reason, a prominent feature of the test prod is that the circuit under test is discharged before the prod is removed.

The figure shows the prod, which is designed for use with a screened cable, the screening of which is connected to the earthed case of the source. The cable is passed, through a screwed cap, into the end of the prod; the centre conductor is connected to the fixed contact (1) and the braiding to the earthing rod (2). When the cap is screwed down, a clamp compresses a rubber washer and thus the cable is clamped firmly at the end of the prod.

The earthing rod is silver-soldered to a brass collar which contains a spring-loaded pin (3) whose movement is limited by a head. This pin presses against the contact of the movable portion of the prod and connects it to earth.

The movable portion of the prod consists of a spike (4), a PTFE housing (5), a spring and the contact. When the prod body is pressed forward against the action of the spring, the spike and the contact move into the body and, after travelling about two-thirds of the way through the cavity (6), the contact leaves the earthed pin. Further pressure on the body causes the

moving contact to meet the fixed contact and thus connect the source to the component or circuit under test.

On completion of the test, the pressure is released while maintaining the spike in contact with the component. The moving contact leaves the fixed one and the component is disconnected from the source; when the moving contact reaches the pin, the circuit is discharged.

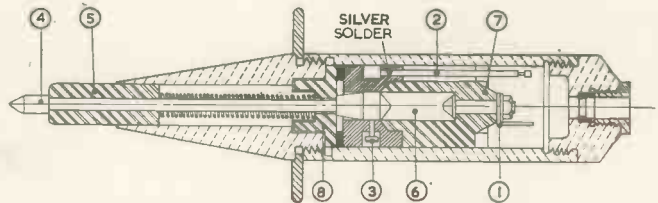

Cross-section of the Test Prod.

The prod has been designed for use with an insulation tester capable of measuring up to 5×10^{11} ohms and therefore the materials used in the prod must have an insulation resistance which is considerably better than this, together with reasonable mechanical strength. For these reasons, PTFE is used for the spike housing (5), the fixed contact support (7) and for the moving contact stop (8). The remaining insulated sections of the prod are made from "Carp" Brand, Tufnol.

* Communication from E.M.I. Engineering Development Ltd.

A Harmonic Synthesizer with Visual Display

By H. Sutcliffe*, M.A., A.M.I.E.E.

A synthesizer is described which operates by the production and summation of interrupted trains of audio frequency sine and cosine waves, the sum being displayed on a cathode-ray tube with a linear time-base. Results obtained with an eight term model are assessed, the general conclusion being that the system is excellent for demonstration purposes and has an accuracy limitation imposed by the cathode-ray tube display.

MANY branches of engineering and science make use of Fourier series equations in one or other of the following two forms.

$$f(x) = c_0 + c_1 \sin(2\pi x/\lambda + \phi_1) + c_2 \sin(2 \cdot 2\pi x/\lambda + \phi_2) + \dots \quad (1)$$

$$f(x) = \left. \begin{aligned} &a_0 + a_1 \cos(2\pi x/\lambda) + a_2 \cos(2 \cdot 2\pi x/\lambda) + \dots \\ &+ b_1 \sin(2\pi x/\lambda) + b_2 \sin(2 \cdot 2\pi x/\lambda) + \dots \end{aligned} \right\} \dots \quad (2)$$

$f(x)$ is a periodic function of x which repeats as x increases through successive multiples of λ . Fourier or harmonic synthesis is the process of summing the terms on the right-hand side of equation (1) or (2) and determining $f(x)$. It can be done directly by using sine and cosine tables, but even a simple case involving only three or four terms can be a tedious operation. For this reason a variety of computing mechanisms and circuits have been devised for the specific purpose of harmonic synthesis¹⁻⁵.

The synthesizer described here is of the analogue type. It was constructed primarily for demonstrating the principles of harmonic synthesis and operates by adding trains of audio frequency sine waves and displaying the sum on a cathode-ray tube. The interest of the design lies in the accuracy which can be achieved without resort to excessively complicated circuits.

A description of the principles of the machine is given rather than a detailed description of the actual circuits used.

General Description

The graph of $f(x)$ in equations (1) and (2) is to be traced on a cathode-ray tube screen. The variable x is to be established by a linear time-base and so the equations can be re-written:

$$f(t) = c_0 + c_1 \sin(\omega_0 t + \phi_1) + c_2 \sin(2\omega_0 t + \phi_2) + \dots \quad (3)$$

$$f(t) = \left. \begin{aligned} &a_0 + a_1 \cos \omega_0 t + a_2 \cos 2\omega_0 t + \dots \\ &+ b_1 \sin \omega_0 t + b_2 \sin 2\omega_0 t + \dots \end{aligned} \right\} \dots \quad (4)$$

The problem then is to design a circuit to produce a sinusoidal P.D. and its harmonics, each with adjustable amplitude and phase, accurately timed in conjunction with a sawtoothed waveform to provide a time-base.

One method considered was to generate continuous waves, derived either as harmonics of a fundamental by frequency multiplying, or as sub-harmonics by frequency dividing. Such a method would require the use of filters, in which the maintenance of the correct phase would be very difficult. It was felt that a circuit which established the correct phase by a basic principle of its operation would give better results. Such a circuit is shown in diagrammatic form in Fig. 1.

L and C are pure reactances, their original small resistive losses being compensated by an external circuit to be described later. The position of the linked switches S_1

and S_2 determines the type of behaviour of the circuit. In the position shown the circuit is non-resonant and has been storing energy via a current in the inductor and a charge on the capacitor. This condition of the circuit will be referred to as that of the reset period. Suppose now that the switches operate together at the instant $t = 0$. This will be called the instant of start and initiates the ringing period. The LC circuit is isolated and the stored energy will oscillate between L and C in such a manner that the potential difference $v(t)$ across the inductor terminals will be the sum of a sine and a cosine wave.

$$v(t) = V_a \cos \omega t + I_b \sqrt{L/C} \sin \omega t \quad (5)$$

where V_a = original P.D. across C ,

I_b = original current in L ,

ω = natural angular frequency of the LC circuit.

The current of I_b is supplied through a resistance R_b

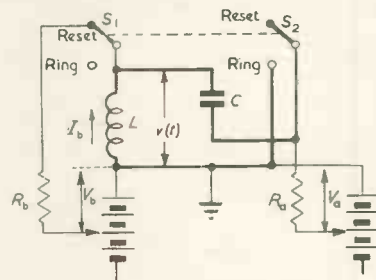

Fig. 1. Basic ringing unit

from a potential source V_b . The value of R_b is $\sqrt{L/C}$, in which case:

$$v(t) = V_a \cos \omega t + V_b \sin \omega t \quad (6)$$

Thus the cosine and sine terms of $v(t)$ have amplitudes which are determined by steady P.D. These are obtained from a stabilized supply via calibrated potentiometers.

A number of circuits such as that shown in Fig. 1 are operated in parallel, with all the switches changing simultaneously. The individual $v(t)$ signals are summed in a simple resistance network to provide the $f(t)$ of equation (4).

It is, of course, impossible to have absolute accuracy of the values of L and C , nor can the loss compensating circuit be perfect. These factors cause small but progressive changes of phase and amplitude from the original correct values. The ringing period is therefore restricted to a little more than a single period of ω_0 . The switches then return the circuit to reset conditions. This return takes place at the stop instant. The reset persists long enough for transients to subside and for energy storage to be virtually complete, and is followed by start, ring, stop, and

* University of St. Andrews, Dundee.

so on. The operation is cyclical, with a total period of about three times that of ω_0 .

It will be shown that practical considerations result in ω_0 having a value of about 10^4 . Then if the change-over of the switches is to be small compared with the period of, say, the 20th harmonic of ω_0 , the switches must make and break in less than a microsecond. Vacuum diodes are therefore used as switch elements and are operated by switching waveforms derived from a driving unit.

The synthesizer thus has a form shown diagrammatically in Fig. 2, with waveforms at various points in it as illustrated in Fig. 3.

The driving unit uses conventional hard valve circuits. An 807 valve provides symmetrical switching waveforms

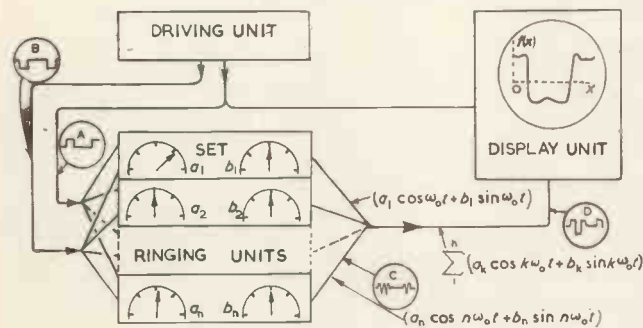

Fig. 2. The synthesizer

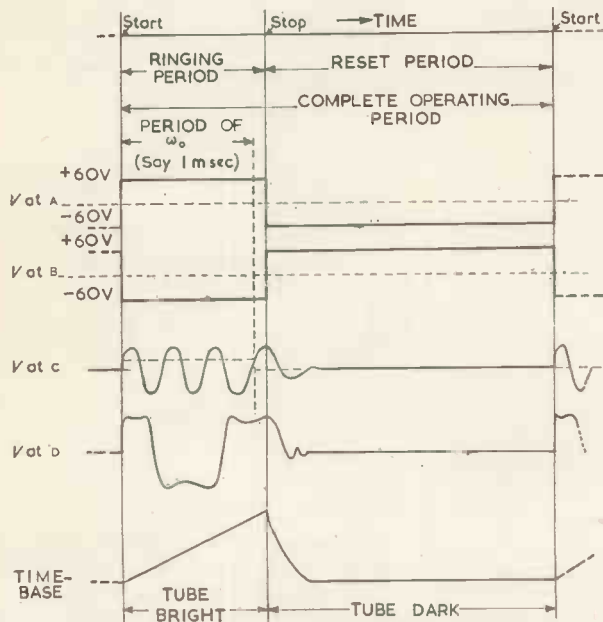

Fig. 3. Waveforms at points indicated in Fig. 2

A and B which feed the ringing units and initiate the time-base of the display unit.

The display unit contains the cathode-ray tube, a time-base and brightening circuit whose duration is the ringing period, and an amplifier for the fluctuation $f(t)$. The amplifier frequency response is level from zero to 1Mc/s or so, since it must retain the constant term of $f(t)$ and must also pass the step which occurs at the start instant.

The ringing units comprise a set of circuits of the type shown in Fig. 1. A detailed description will be given in the next section.

The driving and display units will not receive any further

description here, since they are composed mainly of well-known conventional circuits.

Circuit Details of Ringing Unit

Reference should be made to Figs. 1 and 4.

The resonant LC circuit is in heavy line. Its inevitable losses are restored by controlled positive feedback via the cathode-follower V_5 in a manner suggested by Harris⁶. The amount of feedback is adjusted by the set growth control until the circuit is just on the margin of self-oscillation during the ringing period. This being so, L and C may be regarded as the pure components of Fig. 1.

The switch S_1 in Fig. 1 is, in Fig. 4, the pair of double diodes V_1 and V_2 , in conjunction with the switching waveforms A and B. This arrangement requires the duplication of the current supply resistor R_b .

The switch S_2 in Fig. 1 is, in Fig. 4, the diode clamping circuit comprising V_3 , V_4 and the switching waveforms. The resistance of S_2 when closed is about 1 000 ohms using VR 54 (EB34) type valves.

The type of LC circuit used was determined in the light of the following considerations. A high L/C ratio gives economy in the power required to energize the circuit, but must not be too extreme in order to keep the stray capacitances within a small fraction of the total tuning capacitance. A high LC product will give a long natural

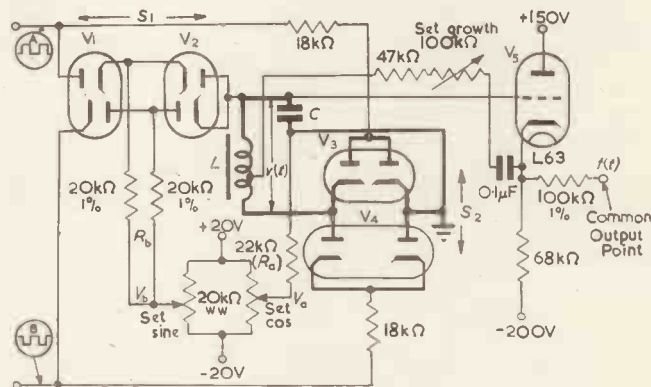

Fig. 4. The ringing unit

Diodes are type EB34 or equivalent.

period, which is an advantage in view of the finite, though small, change-over time of the diode switches. Both these considerations point to a rather large inductance value for the lowest frequency. Care must then be taken that distortion and losses due to hysteresis in the iron of the inductor have a negligible effect and that the winding resistance is not so great that it causes complications during the reset period.

With the above considerations in mind, and after some experiment, the tuned circuits were made up as follows:

$\sqrt{L/C} = 20\ 000$ ohms in all cases.

Peak $v(t) = 20$ volts in all cases.

Natural frequencies in the eight term model which was built were: 1, 2, ..., 7, 8kc/s, but the type of inductor used is satisfactory in the range 500c/s to 16kc/s. This allows 32 terms in possible extensions of the machine.

The inductors used I.S.C. type 458 radiometal 5 mil laminations, each core having a stack of $\frac{1}{8}$ in. Winding—2 100 turns 36 s.w.g. enamelled wire in each case, the inductance value being adjusted by setting the gap. A jig was made which allowed this to be done with the inductor coupled to a bridge. This method of determining the inductance allows each inductor to have a gap giving the best power factor at the particular frequency at which it is working.

All capacitors were fixed, except for a small trimmer which is used to make a final fine adjustment of frequency.

TABLE OF COMPONENT VALUES

Harmonic number	1	2	3	4	5	6	7	8
Natural frequency (kc/s)								
L(Henries)	3.2	1.6	1.07	0.8	0.64	0.53	0.46	0.4
C(Farads $\times 10^{-9}$)	8	4	2.7	2	1.6	1.3	1.14	1

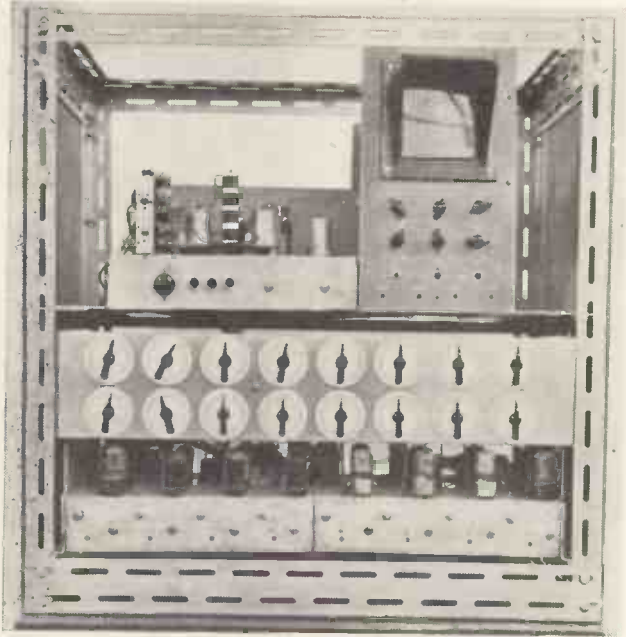

Eight-term Synthesizer with covers removed.

Assessment of Performance

As regards speed of operation, the machine supplies the answer in a time such that the operating time per synthesis is effectively the time taken to set the calibrated dials and read the answer on the screen. The question as to how accurate is this answer requires further discussion.

The cathode-ray tube display has a basic source of error in the curvature of the screen. This curvature can be the cause of much greater errors by making it difficult for the operator to avoid parallax. The operator will also

have difficulty in setting the dials, which are continuously variable, to a very high degree of accuracy. These effects introduce errors of about 5 per cent, for which the basic cause is the requirement that the machine shall be operated rapidly and shall be vivid in its method of display.

Another possible source of error arises in the tendency of the trace position to drift. This would result in incorrect zeros for x and $f(x)$, amounting to about 5 per cent of maximum amplitude per hour after the initial warming up time of the valve heaters. The error is negligible if the operator notices the drift and readjusts X and Y shift controls.

Remaining errors are present in the actual waveforms produced by the machine. These are due in part to faulty dial calibration, but also to inherent weaknesses of the circuit, too numerous to discuss in detail. One example will be given. The closed circuit resistance of the clamping circuit S_2 is not constant, but depends on the incremental slope resistances of the diodes which compose it. In the VR54 this slope is dependent to a slight extent on the working point of the characteristic, which in turn will depend on the amplitude of the switching waveforms. These amplitudes are affected, to a small extent, by the setting of the various amplitude setting dials. The closed circuit resistance of S_2 , then, is a function of the waveform to be synthesized. Variations of the resistance will result in the tuned circuit being under or over compensated and so will cause decay or growth in the amplitude of $v(t)$ during the ring period. A host of such points must be considered, their individual errors being rather difficult to assess. The total error, however, from this type of effect is of the order of 1 per cent of maximum amplitude and is thus considerably less than the probable errors in setting and reading.

Acknowledgment

The author is indebted to Miss S. M. Weir, B.Sc., for much of the early experimental work on the machine and to Mr. D. Dorward who transformed the collection of circuit boxes into a handsome piece of laboratory furniture.

REFERENCES

1. BOWEN, J. H., BURNUP, T. E. A Simple Analogue Computer for Fourier Analysis and Synthesis. *Electronic Engng.* 23, 67 (1951).
2. LEHMAN, J. *Electronics* 22, 107 (Nov. 1949).
3. ROBERTSON, J. H. A Simple Machine capable of Fourier Synthesis Calculations. *J. Sci. Instrum.* 27, 267 (1950).
4. SHIMIZU, H., ELSEY, P. J., MACHLAN, D. A Machine for Synthesising Two-Dimensional Fourier Series in the Determination of Crystal Structures. *Rev. Sci. Instrum.* 21, 779 (1950).
5. BEEVERS, C. A., LIPSON, H. The Use of Fourier Strips for Calculating Structure Factors. *Acta. Cryst.* 5, 673 (1952).
6. HARRIS, H. E. A Q Multiplier. *Electronics*, 24, 130 (May 1951).

Differentiating Circuits

By R. L. Ford*, B.Sc.

Although the use of differentiators is avoided wherever possible owing to their unfavourable response to noise, they are often employed in analogue computers and automatic controllers. Differentiating circuits are therefore of practical interest and it is the purpose of this article to discuss briefly three ways in which the time-derivative of a voltage may be obtained and to compare the performances of two of these methods which employ feedback techniques.

THE fundamental limitation in all practical differentiators, whatever the principle used, is the requirement that the frequency characteristic must rise at a rate of 6db/octave. In practice this cannot be maintained indefinitely so that the basic criterion for a differentiator is the frequency range over which its output is proportional to the frequency of a sinusoidal input.

The Passive Network Differentiator

It is well known that the series RC circuit shown in Fig. 1(a) gives an output which is approximately proportional to the time-derivative of the input voltage. The transfer function for the circuit is given by:

$$e_o/e_i = \frac{pCR}{1 + pCR} \quad \text{where } p \equiv d/dt$$

* R.R.E., Ministry of Supply.

This shows that it is equivalent to a perfect differentiator giving an output $e = CR pe_1$ followed by an RC smoothing circuit as in Fig. 1(b). The latter has the effect of attenuating the high frequency components in the derivative of the input voltage so that large errors are produced when the input voltage is changing rapidly, i.e. when the frequency spectrum of the input is large. When e_1 is sinusoidal $|e_o/e_1|$ will be 3db down on the value ωRC at an angular frequency given by $\omega = \omega_o = 1/RC$

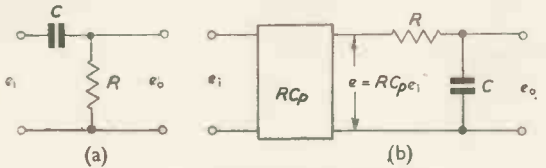

Fig. 1. The passive network differentiator

and this represents the useful frequency range of the circuit. Clearly, ω_o can be made as large as desired by making RC small enough, but this results in a very small output.

The Feedback Amplifier Differentiator

The conflicting requirements of accuracy and a reasonably large output voltage which arise in the case of the passive network could be overcome by using a small time-constant and amplifying the voltage across R , but a more satisfactory result is achieved with the feedback amplifier circuit of Fig. 2(a). If the amplifier output impedance is very small and its input impedance high, then the circuit is equivalent to that shown in Fig. 2(b) (see Appendix I). From this equivalent circuit the transfer function is seen to be:

$$e_o/e_1 = \frac{-CRp}{1+m} \cdot \frac{m}{1 + \frac{CRp}{1+m}}$$

As $m \rightarrow \infty$; $e_o/e_1 \rightarrow -CRp$. Hence by making m large high accuracy can be obtained and, within limits, the values of C and R merely affect the magnitude of the output voltage. If the simple RC circuit, using a very small value for R (say R'), had been followed up by the amplifier the result would have been

$$e_o/e_1 = -\frac{mCR'p}{1 + CR'p}$$

When $R' = R/(1+m)$ the two transfer functions become identical showing that, in theory, there is nothing to choose between the two circuits. In practice, however, this is not the case. The feedback amplifier circuit enjoys all the advantages of negative feedback, the output being indepen-

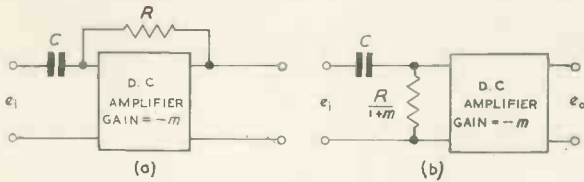

Fig. 2. Feedback amplifier differentiator

dent of m as long as the latter is large enough. The other system gives an output which is proportional to m (since R' cannot be maintained equal to $R/(1+m)$ if m is variable) so that any change in m is reflected in the output.

An Alternative Feedback Circuit*

An alternative feed-back amplifier circuit (hereafter referred to as "differentiator B") whose output contains

* This circuit originated at T.R.E. during the war

a component proportional to the time-derivative of the input waveform and which has certain advantages over the one already considered ("differentiator A") is shown in Fig. 3. When m is very large the transfer function is given by (see Appendix II):

$$e_o/e_1 = -\left(\frac{R_2 + R_3}{R_1} + \frac{R_2 R_3 C}{R_1} p\right)$$

Thus as well as the derived component $-R_2 R_3 C pe_1/R_1$, there is a direct component, $-(R_2 + R_3) e_1/R_1$, both of

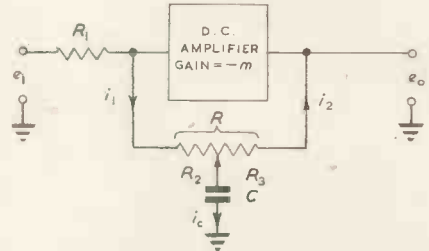

Fig. 3. Alternative feedback amplifier differentiator

which can be varied; the former independently by means of C . The circuit therefore performs two functions and in many applications its use could eliminate the need for an additional D.C. amplifier.

It is of interest to compare the performances of the two feedback circuits with regard to input impedance, overload characteristics and frequency response.

Input Impedance

Owing to the action of the feedback the input to the first stage of the amplifier is held in each case very nearly at earth potential. Therefore the input impedance of differentiator A is approximately $1/\omega C$ while that of differentiator B is approximately R_1 . It is clearly preferable to feed into the constant impedance R_1 , which can be made large. A capacitive load, even on a cathode-follower, can be troublesome.

Overload Characteristics

When the input waveform contains discontinuities or near-discontinuities, overloading of the feedback type of differentiator can occur and in automatic control applications it is important to know how the circuit will behave under overload conditions. Such conditions can conveniently be studied by considering the responses of

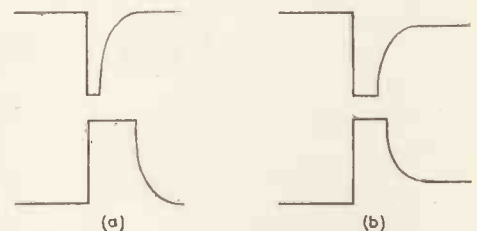

Fig. 4. Overload responses produced by positive and negative going step function inputs

(a) Differentiator A, (b) Differentiator B.

differentiators A and B to a step function input of sufficient amplitude to cause the first stages of the D.C. amplifiers to draw grid current. The responses of the two circuits to positive and negative-going step functions are shown in Fig. 4. It is assumed that the amplifiers contain no lags and have characteristics which change abruptly from linear operation to saturation at the overload limits.

When a positive-going step is applied to differentiator A it is immediately transmitted to the amplifier input and the output is driven to its lower overload limit while C begins to charge fairly rapidly, due to the grid current which flows. The amplifier remains overloaded until C charges sufficiently to allow the grid voltage to come within the range of linear operation. C is then charging through R only and the output voltage falls to zero at a rate determined by the time-constant $CR/(1+m)$. A negative going step does not draw grid current so that C can only charge through R . Consequently the amplifier remains overloaded for a much longer period and we see that the overload characteristic of differentiator A is unsymmetrical. In certain circumstances this could be a very undesirable property.

Differentiator B, while not having a perfectly symmetrical response, gives output pulses under similar conditions which are more nearly equal in duration. A positive-going step of sufficient amplitude again causes grid current to flow, but in this case the voltage drop across R_1 makes the amplifier input small so that C receives very little current from this source and is charged mainly through R_3 . It should be noticed that the small amount of current which does flow in R_2 delays the charging of C and therefore increases the period for which the amplifier is overloaded. When the step function is negative-going more current flows in R_2 than before, since no grid current is taken, and once again the direction of this current is such as to delay the charging of C . The time for which the amplifier is overloaded is therefore somewhat longer in this case. However, the current in R_2 is limited by R_1 and R_2 , so that the disparity between the lengths of the pulses is not so great as it is for differentiator A.

Stabilization of the Feedback Loop

Owing to inter-electrode and stray capacitances the D.C. amplifier will not maintain its phase shift of -180° indefinitely over the frequency band and it is necessary to ensure that the loop gain is less than unity at a lower frequency than that at which the loop phase shift becomes -360° . In this connexion it should be pointed out that an additional lag occurs in the feedback loop of differentiator B due to R_1 , R_2 and the input capacitance, C_i , of the amplifier, thus making it more difficult to stabilize than differentiator A. In the case of the latter circuit C_i is swamped by C and its effect is negligible.

Frequency Response

A further disadvantage possessed by differentiator B is the limitation of the frequency range over which it will work accurately due to the nature of the feedback network. Assuming a perfect amplifier with no lags the frequency characteristic of differentiator A rises at a rate of 6db/octave almost to the value m , the amplifier gain without feedback. In the case of differentiator B; at high frequencies C short-circuits the junction of R_2 and R_3 to earth so that R_1 and R_2 form a potential divider across the input and the maximum gain which can be attained is

$$\frac{R_2 m}{R_1 + R_2}$$

This fact determines the optimum arrangement for varying the derived component in the output when the direct component must be maintained constant and when it is not practicable to have a variable C . We then have $R_2 + R_3 = R$, a constant, so that the derived component

is given by:
$$\frac{R_2(R - R_2)C}{R_1} \cdot \frac{de_1}{dt}$$

The maximum value of this term is obtained when $R_2 = R_3$, and for all other values there are two possible positions for the potentiometer slider. By working over the right-

hand half of R , R_2 is always as large as possible and the reduction in maximum gain is least. It should be ensured, however, that R_3 never becomes small enough to overload the amplifier output stage.

APPENDIX 1

Consider the circuit shown in Fig. 5. If the amplifier input impedance is high all the current taken from the

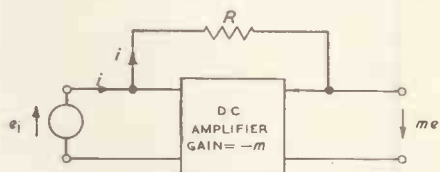

Fig. 5. Input impedance

generator of voltage e_1 will flow through R , and if the output impedance of the amplifier is negligible compared to R the following is the equation for the system:

$$e_1 - iR = -me_1$$

$$\therefore e_1/i = \frac{R}{1+m}$$

That is, the effective input impedance of the amplifier with feedback is $\frac{R}{1+m}$.

APPENDIX 2

Referring to Fig. 3, if e_o = voltage across capacitor

i_c = current through capacitor

e_g = amplifier input voltage

then the following equations hold for the circuit under linear operating conditions:

$$-me_g = e_o \dots \dots \dots (1)$$

$$e_g = e_1 - R_1 i_1 \dots \dots \dots (2)$$

$$e_o = e_g - R_3 i_1 \dots \dots \dots (3)$$

$$e_o = e_o - R_3 i_2 \dots \dots \dots (4)$$

$$i_o = Cpe_o \dots \dots \dots (5)$$

$$i_2 = i_1 - i_o \dots \dots \dots (6)$$

From equations (4) and (6):

$$e_o = e_o - R_3(i_1 - i_o)$$

$$= e_o - R_3(i_1 - Cpe_o) \text{ from equation (5)}$$

$$\therefore e_o = e_o(1 + CR_3p) - R_3 i_1$$

Substituting for i_1 from equation (3):

$$e_o = e_o(1 + CR_3p) - (e_g - e_o)R_3/R_2$$

Substituting for e_g from equation (1) and rearranging terms:

$$e_o = \frac{e_o(1 - R_3/mR_2)}{1 + R_3/R_2 + CR_3p} \dots \dots \dots (7)$$

From equations (1) and (2):

$$-e_o/m = e_1 - R_1 i_1$$

Substituting for i_1 from equation (3):

$$-e_o/m = e_1 - (e_g - e_o)R_1/R_2$$

Rearranging terms and writing $e_g = -e_o/m$ we have:

$$e_o = -e_1 R_2/R_1 - (1 + R_2/R_1)e_o/m \dots \dots \dots (8)$$

Equating the two expressions for e_o from equations (7) and (8) and rearranging we obtain:

$$e_o/e_1 = - \frac{1}{(1 + R_1/R_2)/m + \frac{R_1(1 - R_3/mR_2)}{R_2 + R_3 + R_2R_3Cp}}$$

As $m \rightarrow \infty$

$$e_o/e_1 \rightarrow - \left(\frac{R_2 + R_3}{R_1} + \frac{R_2R_3Cp}{R_1} \right)$$

An Alternating Current Stabilizer

for Supplying Valve Heaters

By P. A. V. Thomas* B.Sc.

After reviewing the existing methods of stabilizing an A.C. supply, details are given of a simple transducer controlled system, giving control better than ± 1 per cent of the output voltage.

THE stabilizer described was developed to supply power to valve heaters of a multichannel recorder in which it was found that large scale drift was taking place due to mains voltage variations.

The requirements of the stabilizer were as follows:

Output: 240 watts (at approximately U.P.F.) at 240 volts with a maximum variation of ± 1 per cent R.M.S.

Input: 190-270 volts, 48 - 52c/s.

Existing Methods

Several methods already exist for stabilizing valve heater supplies.

(1) Constant voltage transformers are manufactured commercially, but, though simple in construction and hence reliable, have a limited range of use and are susceptible to mains frequency variations.

(2) Electro-mechanical stabilizers are manufactured commercially and one was also described recently by Long¹ followed by an alternative arrangement given in a letter in the same journal². A stabilizer similar to that described by Long was built³ and has the advantage that it is independent of frequency and does not distort the waveform of the output. It was found, however, that the observed signals of the recorder tended to jitter at each operation of the stabilizer due to its transient nature of operation; it also suffered from its bulkiness and noisy operation which can become very annoying.

(3) A transducer-controlled stabilizer was recently described for use where loads of several amperes at low voltage were required⁴. The output of this form of stabilizer being D.C. would have meant operating at the valve heater voltage (6.3V) instead of mains voltage, as transformers obviously cannot be used on the output side; this would have meant a very high value of current which might have given much trouble in the smoothing circuit. Another point is the fact that several of the valve cathodes were at D.C. levels far from earth potential and the advantage of using isolated heater supply windings is lost. The last two points might have been overcome by using a number of transducers and transformers, i.e. a number of individual stabilizing units.

(4) Valve stabilizers have been built of which two will be mentioned. An ingenious method in which a multi-vibrator using two power valves producing square waves which when rectified requires no smoothing was described recently⁵ and another in which series valves were used similarly to a conventional D.C. stabilized power supply was described in 1950⁶. The first

type is somewhat limited in its power output (about 20 watts) and the second was more in the nature of a precision unit and hence elaborate, though simplifications might have been possible.

Of all the above methods the most promising appeared to be number (3) and a suitable transducer stabilizer was developed.

Principle of Operation of Stabilizer

As with most stabilizers, it consists of two parts, an error detector and a controller as shown in Fig. 1 and in the



Fig. 1. Arrangement of the stabilizer

present arrangement these are a diode valve operating with a low heater voltage and a transducer respectively. As is well known, a transducer introduces harmonic distortion and thus the ratio of R.M.S./peak value does not remain constant and therefore the error detector must be sensitive to the R.M.S. value and not the peak value as is usual; for this reason a diode operating at low voltages seemed to be the obvious detector as, under these conditions, the anode current is extremely sensitive to the heater temperature and hence the R.M.S. value of the voltage.

Fig. 2. The complete circuit

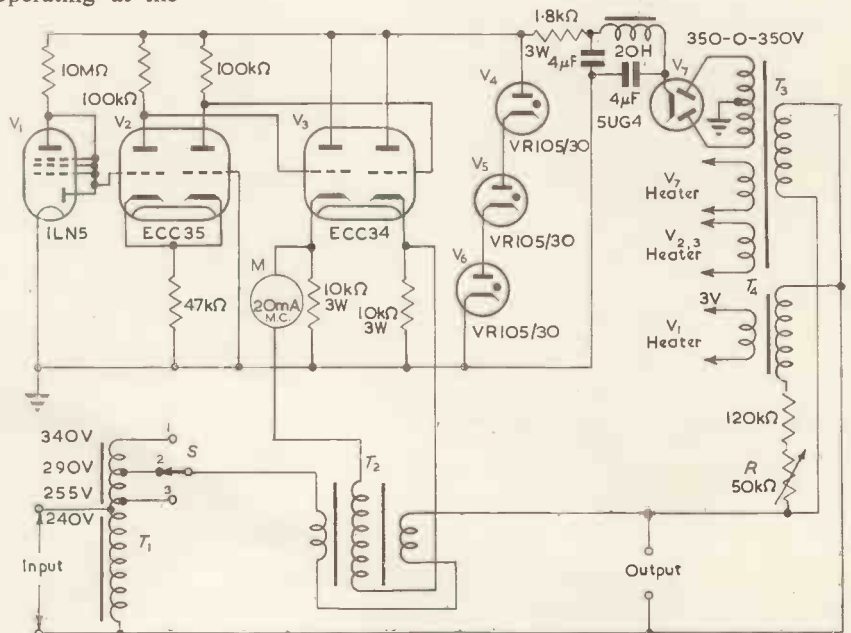

* D. Napier & Son, Ltd.

Thus the method of operation is to allow the diode to vary the D.C. controlling current through the transductor which in turn varies the reactance of the A.C. windings which are connected in series with the load across the input supply. Thus the output voltage R.M.S. value is maintained constant irrespective of the mains voltage, frequency and load current over the range of the transductor inductance variation from D.C. saturation to unsaturation conditions.

The Complete Stabilizer

The complete stabilizer circuit is shown in Fig. 2 in which V_1 is the diode detector whose heater is supplied from transformer T_1 , the heater voltage being adjusted by means of the resistor R to operate V_1 about its most sensitive heater voltage which from Fig. 3 is seen to be about 0.35V; in practice R is used to adjust the output voltage as the balance condition is altered by adjustment of the diode heater voltage. An 1LN5 battery pentode was used, being immediately available, but no reason can be seen for not using any directly heated valve, a low nominal heater power being the better, as with a fine heater the thermal capacity is small, thus keeping the time-constant of the system to a minimum.

V_2 is a comparator stage in which the second grid was originally taken to a small positive potential, but it was eventually found better to connect it to earth potential as shown, in which case V_2 really becomes a phase splitter giving equal and opposite changes in the two anode potentials.

V_3 is a double cathode-follower to supply the power to the transductor control winding; originally a single cathode-follower was to have been used, the transductor winding being the cathode load, but as it was necessary to be able to reduce the control current almost to zero this would have necessitated the use of a negative supply as an A.C. coupling could obviously not be used; thus the two cathode-followers were used, the transductor control current being supplied by the one, the other supplying the balancing current when the control current is zero.

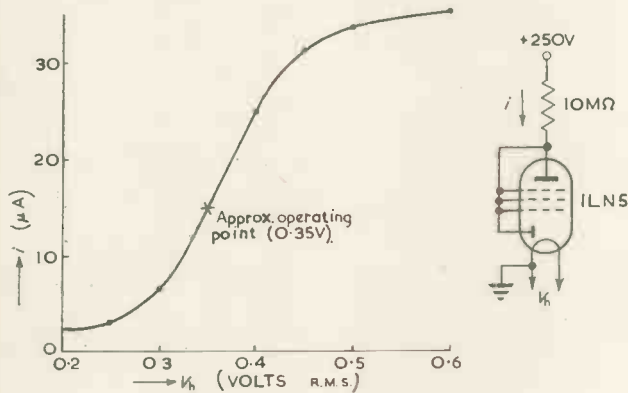

Fig. 3. Diode current/heater voltage

As was mentioned earlier the transductor causes waveform distortion, so that the peak value varies in maintaining the R.M.S. value constant; for this reason the H.T. supplied by the rectifier V_4 would vary and this in turn would cause instability, so that the neon stabilizers V_{4-6} are included to overcome the difficulty.

A meter M is incorporated to indicate that the stabilizer is operating satisfactorily and the switch S is used for exceptionally bad mains conditions which unfortunately occur. Normally the mains supply is within the range 220-240 volts, so that the switch is used in position 2; this is clearly indicated by the graph (Fig. 4), but when the voltage is exceptionally high or low the other two ranges are used. As an alternative a transductor with a larger control range

could be used, but it was felt better to use a small control range giving a higher sensitivity and use the switch for the occasional bad conditions, hence the use of the meter as an indicator.

Transductor design has already been dealt with fully in the past^{4,7,8,9} and suffice to say here that the design depends entirely on the power to be controlled, the materials avail-

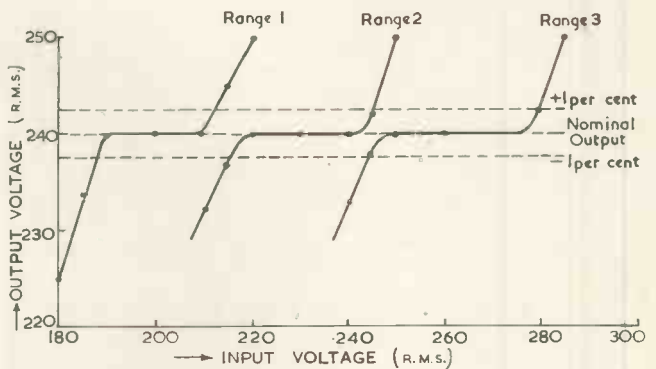

Fig. 4. Output voltage/input voltage

able and the mode of construction; however, for completeness sake the design details of the transductor used are given below.

Transductor Details

The core was of the three legged type made of Stalloy laminations butt jointed, and having the following cross-sectional dimensions:

Centre leg = $1\frac{1}{4} \times 1\frac{1}{4}$ in

Outer legs = $1\frac{1}{4} \times \frac{7}{8}$ in

Windings: 1 D.C. winding having 13 500 turns of 30 S.W.G. wire.

2 A.C. windings having 135 turns each of 18 S.W.G. wire.

Current: A.C. winding = 1A approx.

D.C. winding = 18mA MAX.

Conclusions

The results obtained are given in graphical form in Fig. 4 and it is seen that providing switching is used the output voltage is maintained within ± 1 per cent, and over most of the range the departure from the nominal value is negligible.

Acknowledgment

The author expresses his thanks to the Royal Technical College, Glasgow, for permission to publish this paper.

REFERENCES

- LONG, J. V. P. A Simple Electro-Mechanical Voltage Stabilizer. *Electronic Engng.* 24, 26 (1952).
- MCCASH, J. Electro-Mechanical Voltage Stabilizer. *Electronic Engng.* 24, 135 (1952).
- THOMAS, P. A. V. A Simple Electro-Mechanical Voltage Stabilizer. *Electronic Engng.* 25, 37 (1953).
- SMITH, H. G. A Transductor-controlled Stabilizer. *Electronic Engng.* 24, 173 (1952).
- BROWN, D. E. An Emission Stabilizer with D.C. Heater Supply. *Electronic Engng.* 24, 171 (1952).
- PATCHETT, G. N. Precision A.C. Voltage Stabilizers. *Electronic Engng.* 22, 424 (1950).
- MILNES, A. G. Magnetic Amplifiers. *J. Instn. Elect. Engrs.* 96, Pt. II, 329 (1949).
- GALE, H. M., ATKINSON, P. D. A Theoretical and Experimental Study of the Series-Connected Magnetic Amplifier. *J. Instn. Elect. Engrs.* 96, Pt. II, 339 (1949).
- Magnetic Amplifiers. Technical Publication G.068A. (Elliott Bros. (London) Ltd.)

D.C. Restoring of Variable Width Rectangular Pulses

By J. Van Bladel*, M.Sc., Ph.D.

The purpose of this article is to determine the quantitative importance of the deviations which occur when a rectangular waveform is D.C. restored.

IT is often desired to change the voltage level of a repetitive rectangular waveform so that one of its peaks is clamped to a fixed voltage, e.g. zero. The D.C. restoring circuit of Fig. 1(a) is the classical answer to that problem. With the indicated polarity, the output should ideally be

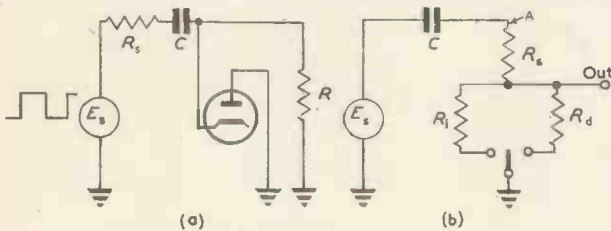

Fig. 1. General circuit of a D.C. restorer

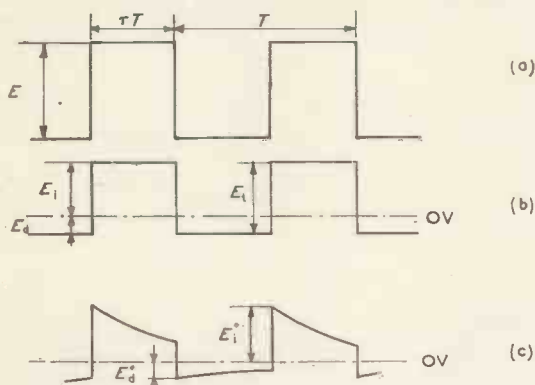

Fig. 2. (a) Input wave
(b) Output wave when C is infinite
(c) Output wave when C is finite

a rectangular waveform restored between 0 and +E volts, E being the peak-to-peak amplitude of the input. This, however, is never perfectly realized. If, in particular, the output to a waveform of constant E, but variable ratio τ of the inverse period to the repetition period (Fig. 2(a)) is observed on an oscilloscope, it will be noticed that:

- (1) the rectangle is distorted,
- (2) the clamping occurs at a value $-E_d$ lower than zero voltage,
- (3) the value $+E_i$ of the positive peak decreases continuously from +E to zero when τ varies from zero to one.

The purpose of the present note is to determine the quantitative importance of these deviations, in view of the technical interest of this particular type of input.

The above-mentioned behaviour arises because three factors do not attain their ideal value, viz: the source

impedance R_s and the diode forward resistance R_d , which should both be zero, and the coupling capacitance C, which should be infinite. Assume for the moment that the latter factor has its ideal value, in order to ensure a rectangular output. It is desired to determine the levels $+E_i$ and $-E_d$ between which this output is restored. It is convenient¹ to redraw the basic circuit as in Fig. 1(b). The average charging current of C must be zero as soon as a steady state is obtained. Let $+E_i'$ and $-E_d'$ be the peak values of the voltage in A (Fig. 1(b)). The total charge per period on C:

$$q = \frac{E_i'}{R_s + R_1} \cdot \tau T - \frac{E_d'}{R_s + R_d} (1 - \tau) T \dots (1)$$

must vanish. The peak amplitude $E_d' + E_i'$ is still equal to E, because C is infinite, so that:

$$E_i' = E - E_d' = E \cdot \frac{(1 - \tau)(R_s + R_1)}{R_s + \tau R_d + (1 - \tau)R_1} \dots (2)$$

The output voltage is obtained by mere division of the voltage in A giving:

$$E_i = E \cdot \frac{(1 - \tau)R_1}{R_s + \tau R_d + (1 - \tau)R_1} \dots (3)$$

$$E_d = E \cdot \frac{\tau R_d}{R_s + \tau R_d + (1 - \tau)R_1} \dots (4)$$

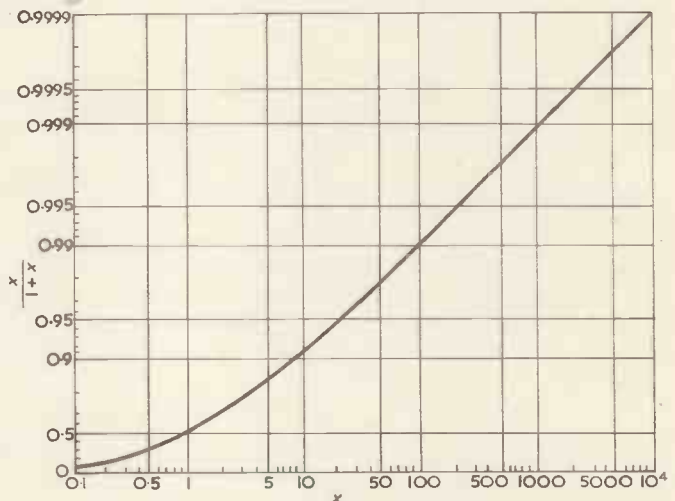

Fig. 3. General curve for $\frac{F_t}{E}$.

The dependence of E_d/E and E_i/E_d on three parameters makes plotting on a graph a difficult task. One might, of course, draw a nomograph with multiple scales for that purpose, but any overall view of the phenomenon would be lost by such a method. A better procedure consists in finding first the peak-to-peak amplitude E_t .

$$E_t = E_d + E_i = E \cdot \frac{\tau R_d + (1 - \tau)R_1}{R_s + \tau R_d + (1 - \tau)R_1} \dots (5)$$

The interesting feature of the ratio E_t/E is that its three parameters can be combined into one by putting:

$$\bar{x} = R_1/R_s + \tau \cdot \frac{R_d - R_1}{R_s} \dots (6)$$

The ratio E_t/E is now simply equal to $\frac{x}{1 + x}$, which is

plotted in Fig. 3. The inverted log scale of the ordinate axis is used to cover the region in the vicinity of 1 more clearly. It is of interest to notice that x is a linear function of τ , varying between two extreme values, R_1/R_s and R_d/R_s , reached for $\tau = 0$ and $\tau = 1$ respectively. If it is required to obtain the values of x for $\tau = 0.1, 0.2,$

* Manufacture Belge de Lampes et de Materiel Electronique S.A. Brussels, Belgium.

... 0.9 for instance, it suffices to divide the numerical interval $R_1/R_s, R_d/R_s$ in ten equal parts.

From the knowledge of E_t values of E_d and $E_i = E_t - E_d$ are easily deduced from the formula:

$$E_d/E_t = \frac{\tau}{\tau + (1 - \tau)R_1/R_d} \dots \dots \dots (7)$$

which is plotted in Fig. 4. This expression is independent of R_s . Thus once it has been calculated for a given diode, it is permissible to use it irrespective of the source impedance.

The average output voltage E_{av} , which should ideally be

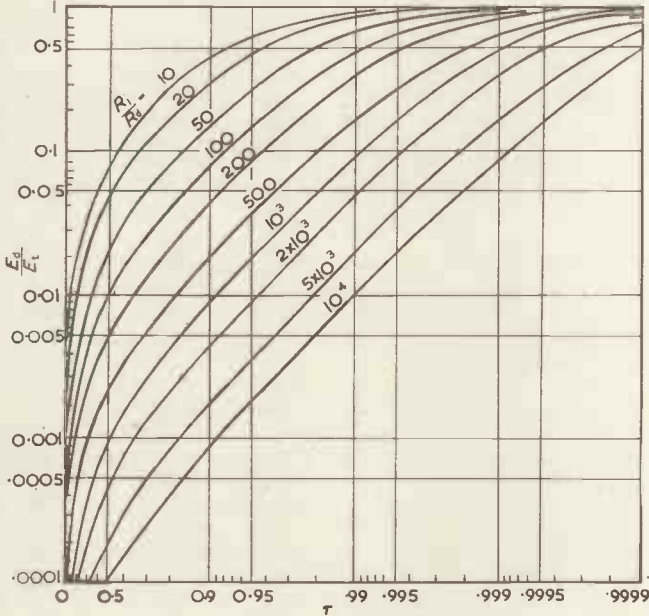

Fig. 4. Plotting of E_d/E_t .

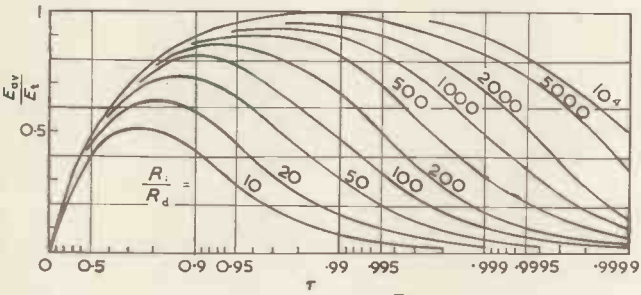

Fig. 5. Plotting of E_{av}/E_t .

proportional to τ , is often of interest in applications. E_{av} may, for instance, be a measure of the duty cycle of a certain phenomenon which can be "on" or "off", these two states being respectively characterized by the upper and the lower level of the input waveform. It is easily established that:

$$E_{av} = E \cdot \frac{\tau(1 - \tau)(R_1 - R_d)}{R_s + R_d \cdot \tau + R_1(1 - \tau)}$$

$$= E_t \cdot \frac{\tau(1 - \tau)(R_1/R_d - 1)}{\tau + R_1/R_d(1 - \tau)} \dots \dots (8)$$

The ratio E_{av}/E_t is plotted in Fig. 5.

The introduction of a finite coupling capacitance distorts the rectangular output, where the flat tops are now replaced by parts of exponential curves (Fig. 2c). It is a simple matter to find E_d'' , E_i'' and E_{av}'' by expressing that the average charging current on C is zero, but the results will

be given only for the particular case where time-constants $C(R_s + R_d)$ and $C(R_s + R_1)$ are much larger than the period T . It is then found that E_d'' , E_i'' , E_{av}'' can be obtained by multiplication of E_d , E_i , E_{av} respectively by the correcting factor F .

$$F = \frac{1}{1 - E_{av} \cdot \frac{T}{C(R_1 - R_d)}} \dots \dots \dots (9)$$

The practical example of Fig. 6 will illustrate the analysis.

There the output valve of a bi-stable multivibrator furnishes a rectangular anode voltage of 120V peak-to-peak at the frequency of 1000c/s, the width of the negative impulse being proportional to the phase difference ϕ

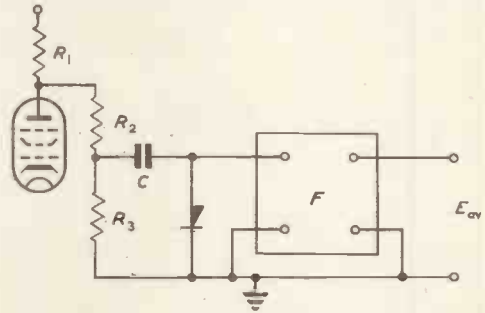

Fig. 6. Circuit of the illustrative example

$R_1 = 22k\Omega$ $R_2 = 150k\Omega$ $R_3 = 8k\Omega$ $C = 1\mu F$

Diode: germanium OA50 with $R_d = 800\Omega$ and $R_i = 100k\Omega$.

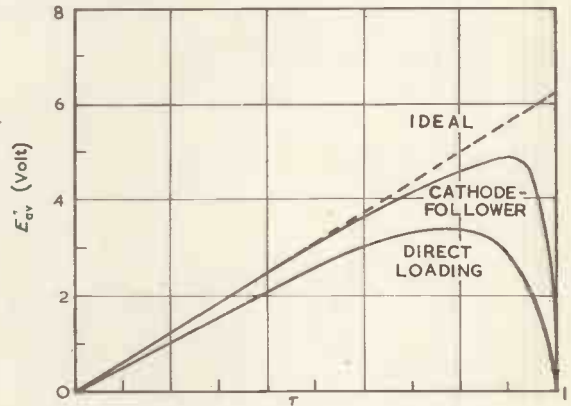

Fig. 7. Mean values E_{av}'' of the illustrative example

between the two triggering voltages. It is desired to obtain a negative D.C. potential proportional to ϕ , i.e. to τ , and not larger than -6V. The average output voltage of an ideal D.C. restorer, detected by a low-pass filter F , is the answer to the problem, provided the diode restores on the negative edge of the input. The circuit of Fig. 6 is not ideal. Voltage divider (R_2, R_3) furnishes an input voltage of $E = 6.2V$ from a source resistance of 7680Ω . The preceding analysis, taking the new diode polarity into account, allows of finding how much E_{av} differs from its ideal value. The resulting "direct loading" curve is plotted in Fig. 7. It is far from the expected linear variation. An obvious way to minimize this effect is to decrease the source impedance. This can be done with a cathode-follower buffer stage for instance. The corresponding curve of Fig. 7 has been obtained by assuming a stage output impedance of 100Ω . The deviations from the ideal values are still far from negligible for the higher values of τ .

BIBLIOGRAPHY

1. LEVELL, D. A. The Theory and Applications of D.C. Restoring Circuits. *Electronic Engng.* 23, 182 (1951).

A Portable Low Resistance Measuring Set

By P. Huggins, A.M.Brit.I.R.E.

The apparatus, as described is for the measurement of very low resistance (range 0-100 $\mu\Omega$) such as is found in lengths of conductors, interfacial contacts, etc. A moving-coil meter, having a microampere scale, is read directly in microhms.

A MICROAMMETER, whose internal resistance is some 10^5 times that of the unknown resistance to be measured, is paralleled with this resistance, by a pair of leads of known resistance.

A low voltage D.C. source, capable of supplying some 10 amperes, is connected across the microammeter. The circuit is then as in Fig. 1.

If I_m is the current through the meter (whose resistance is R_m) I_L the current through the unknown resistance R_L , I_s the D.C. supply, and R_1 the total lead resistance (all resistances in ohms, all currents in amperes) then:

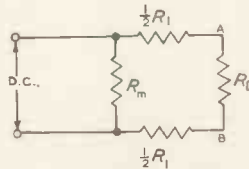

Fig. 1. The principle employed

$$I_L = I_s - I_m \dots \dots \dots (1)$$

$$\text{Also } I_m / I_L = \frac{(R_L + R_1)}{R_m} \therefore I_m = \frac{I_L(R_L + R_1)}{R_m} \dots \dots (2)$$

By substituting expression (1) for I_L in equation (2) it can be manipulated into:

$$I_m = \frac{I_s(R_L + R_1)}{R_m + (R_L + R_1)}$$

But since R_m is some 10^5 times greater than R_L , and

points A and B (Fig 1) as then the resistance of the leads is negligible compared with that of the microammeter, and consequently the microampere scale could be read directly in microhms without subtracting the lead resistance. However, this is only practicable in certain instances. (If so desired the resistance of the leads can, of course, be measured on the equipment itself by simply shorting the contact pads together.)

Practical Circuit

The meter used is a heavily damped moving-coil type having a 6in linear scale. Its internal resistance is 7.5 Ω . This, and the two 25 $\mu\Omega$ leads are constructed into a portable unit.

The D.C. source of power supply is separate from the measuring head and could well be a 6V car battery.

However, as the equipment is also designed for factory test measurement of interfacial contacts, it is felt that an alternative A.C. mains power pack is desirable. It will be appreciated that because of the sensitivity of the meter a considerable amount of smoothing is required. The circuit as outlined in Fig. 2 has proved satisfactory; the ripple on the meter used being barely perceptible. This is probably due to the fact that the optimum circuit resistance for critical damping is about 170 Ω , and using the meter in

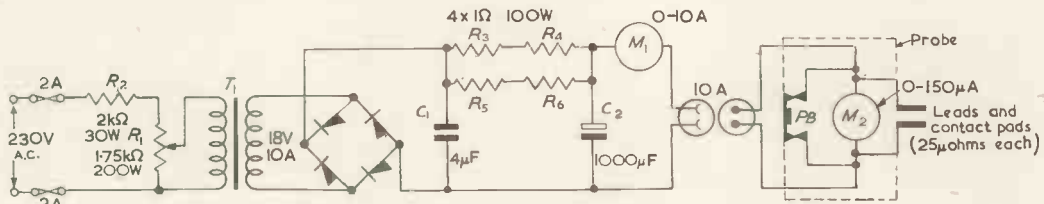

Fig. 2. The complete equipment

suppose in practice it is ensured that R_1 is of the same order of magnitude as R_L , it can be said that $(R_L + R_1)$ in the denominator is negligible compared with R_m .

Hence the equation becomes:

$$I_m = \frac{I_s(R_L + R_1)}{R_m} \dots \dots \dots (3)$$

and if I_s (in amperes) is made numerically equal to R_m (in ohms) the expression becomes:

$$I_m = R_L + R_1 \dots \dots \dots (4)$$

Since, in practice, I_m is current indicated on a microammeter, it follows that R_L and R_1 in the above equation will be in microhms.

Hence numerically:

Unknown resistance (μ ohms) = meter reading (in μ A) - total lead resistance (in μ A).

Then by having two leads of total resistance 50 $\mu\Omega$ and using a 0-150 μ A movement, it is possible to read directly off the microampere scale, resistance values of 0-100 $\mu\Omega$.

Ideally, it would be better to inject the D.C. source at

such a low resistance circuit results in considerable overdamping.

Potentiometer R_1 provides a means of adjusting the current to a value numerically equal to the internal resistance of the microammeter (i.e. 7.5A).

The microammeter is short-circuited by a normally closed push-button. This is to safeguard the moving-coil against accidental overloading, which might otherwise occur if the gear was switched on while the contact pads were disconnected.

The procedure for using the apparatus is therefore as follows:

1. Connect the contact pads.
2. Switch on mains and adjust R_1 .
3. Press push-button to obtain resistance measurement.
4. Switch off mains.
5. Disconnect contact pads.

The IR drop of the inter-unit connecting leads does not, of course, affect the measurements: the length of such leads are therefore unimportant.

An Electrometer Valve Voltmeter

By B. G. Knowles*, Ph.D.,

and D. G. A. Thomas*, M.A., A.M.I.E.E.

An electrometer intended for voltage measurements between 50mV and 100V is described, having a low input capacitance and rapid response. An electrometer valve is followed by a two-stage amplifier with overall feedback. The rate of response is 20V/ μ sec for positive signals, and grid current with transient inputs is minimized.

THE electrometer circuit suggested by Farmer¹, and used with pocket ionization chambers, has found many applications in other fields, as may be judged from the numerous references to it in the literature. Recently, modifications have been suggested^{2,3} to increase the effective gain, hence improving the efficacy of the guard rings, and to give greater power for the operation of the indicating meter.

The circuit described below, although more elaborate, is

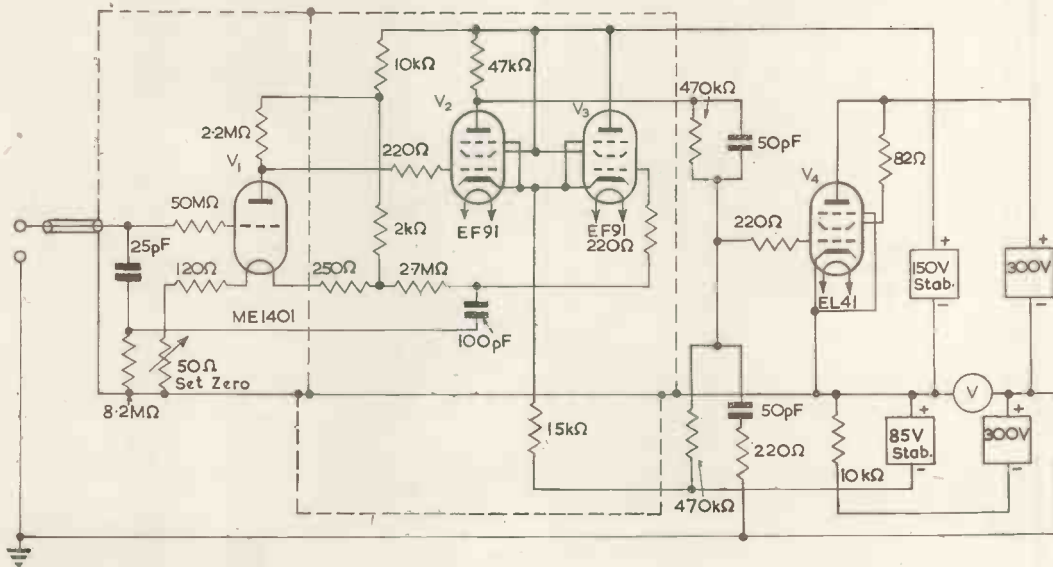

Fig. 1. The circuit described

of a similar type, and has been developed for use in experiments on static electrification. Here, a rapid response was required. In addition, it was anticipated that with positive-going transients, grid current might flow in the electrometer valve before the feedback had operated, so introducing errors in the measurement of charge. Attempts were therefore made to obtain a very rapid response and at the same time minimize grid current, by providing an alternative path for the high frequency component of the input signal.

The circuit diagram, with power supplies in schematic form, is shown in Fig. 1. V_1 is an electrometer valve (Mullard ME1401), the output from which is applied to the amplifier valves V_2 and V_3 which are arranged as a "long tailed pair". The amplified signal at the anode of V_2 is applied to the cathode loaded amplifier V_4 , the cathode of which is connected to the cathode of V_1 , to the indicating meter, and to the floating power supplies for V_1 , V_2 and V_3 . An examination of the circuit shows that

the cathode of V_4 follows the voltage applied to V_1 grid.

The high frequency component of the input signal is prevented by the 50M Ω resistor from passing through V_1 , which has a high impedance anode circuit, but is coupled to the grid of V_3 by means of a capacitor of high insulation resistance. Thus, improved high frequency response is obtained, and at the same time the 50M Ω resistor prevents any significant charge due to grid current appearing at the grid circuit during the short period before the feedback becomes effective on transient inputs.

The effective gain of the system, before closing the feedback loop, is about 300. Owing to unavoidable phase lags, in particular that due to the stray capacitance of the floating power supply, the high frequency amplification has been reduced to avoid oscillation. This is achieved by the filter in the grid circuit of V_4 . Careful shielding, connected as shown, is necessary to avoid stray pick-up; for example, capacitance from the grid of V_2 to earth would give positive feedback, with consequent oscillation.

The overall speed of response is limited for positive-going signals by the peak current available from V_4 , and for negative-going signals by the standing current of V_4 . With the circuit values shown, together with capacitances to earth of the floating power supply and internal screening, the maximum rate of change of the output voltage is 20V/ μ sec and 4V/ μ sec for positive and negative signals

respectively. For sine waves of small amplitude, the output was 6db down at 2.5Mc/s. The minimum detectable signal, determined by the zero drift of the circuit, is about 50mV over a period of hours, or 20mV over a period of 10 minutes. The maximum D.C. signal which may be handled without overloading depends on the operating conditions of V_1 , and in the circuit shown is about 150V positive or negative. The effective input capacitance is about 0.2pF at low frequencies, and the leakage current of the order 10^{-14} A.

Acknowledgments

Thanks are due to the National Coal Board for permission to publish this note. The views expressed are those of the authors, and not necessarily those of the Board.

REFERENCES

1. FARMER, F. T. An Electrometer for Measurement of Voltage on Small Ionization Chambers. *Proc. Phys. Soc.*, 54, 435 (1942).
2. ALLEN-WILLIAMS, D. J. The Development of the 30MeV Synchrotron. Cambridge University Dissertation, (Sept. 1952).
3. BREWER, A. W. An Electrometer Valve Voltmeter of Wide Range. *J. Sci. Instrum.* 30, 91, (1953).

* National Coal Board, Central Research Establishment.

ELECTRONIC EQUIPMENT

A description, compiled from information supplied by the manufacturers, of new components, accessories and test instruments.

Close Controlled Temperature Coefficient Capacitors

(Illustrated below)

THESE close controlled temperature coefficient capacitors are available with a wide selection of temperature coefficients and capacitance values, and are intended mainly for use for temperature compensation in oscillator and I.F. circuits. The range includes a temperature

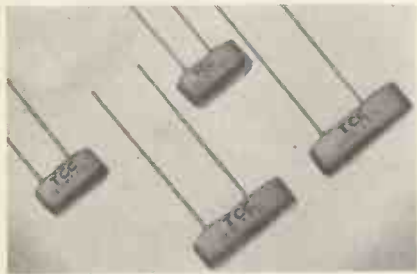

coefficient of zero and a choice of five different tolerances for each of the remaining four temperature coefficients.

The working voltage is 500V D.C. and the test voltage 1 500V D.C. The capacitance range is from 2 to 110pF and the temperature coefficient range is from $-750 \times 10^{-6}/^{\circ}\text{C}$. to $+125 \times 10^{-6}/^{\circ}\text{C}$.

The Telegraph Condenser Co., Ltd,
North Acton,
London, W.3.

General Purpose Potentiometer

(Illustrated below)

AN improved version of the Doran E4248 precision general purpose

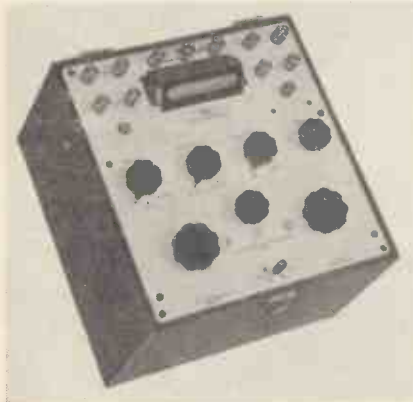

D.C. potentiometer is now being produced. It has three ranges covering E.M.F. measurements from $1\mu\text{V}$ to 1.8V, the value of the measured E.M.F. being read in a straight line of figures through the three windows provided in the panel. The reflecting galvanometer forms part of a compact removable unit which includes the light source and reflecting mirrors and is readily withdrawn through a hinged door provided at the back of the

instrument case. The galvanometer has a sensitivity of approximately 2mm deflexion for applied E.M.F. of $10\mu\text{V}$ through an external resistance of 10Ω on the lowest range, and a sensitivity control is provided to prevent excessive deflexion occurring.

The accuracy is 0.02 per cent of maximum reading on each range and the resistance 100Ω per volt.

Doran Instrument Co., Ltd,
Stroud,
Gloucestershire.



Probe and Delay Amplifier

(Illustrated above)

THIS unit is designed for use where it is desired to view or measure the leading edge component of a short duration waveform or transient. Although primarily intended for use in conjunction with the E.M.I. waveform monitor type 3794 it may also be used with other high speed oscilloscopes.

It incorporates a low input capacitance cathode-follower probe head with interchangeable capacitive and capacitive-resistive attenuators; a delay cable affording 0.5 μsec signal delay, and a wideband pre-amplifier.

When used with the waveform monitor type 3794 the probe and delay amplifier delays and amplifies the viewed signal so that the leading edge component of short duration pulses or transients can be displayed and measured in detail. Under these conditions the time-base is triggered from, or synchronized with, the displayed signal. The pre-amplifier bandwidth extends to 16Mc/s and the

waveform monitors measured pulse time of rise is not degraded.

E.M.I. Factories Ltd,
Hayes,
Middlesex.

Control Desk

(Illustrated below)

THE standard control desk manufactured by Alfred Imhof Ltd has a formica top, 10 gauge steel panels on

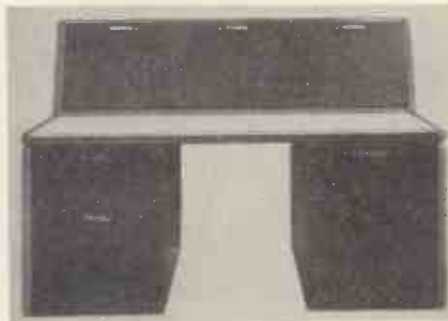

$2 \times 1 \times \frac{1}{4}$ in mild steel angle frames. The frame width is $19\frac{1}{2}$ in, drilled with standard G.P.O. drillings, taking standard 19in panels. The centre frame can be set either 19in from the front or 19in from the back, so that either front or back frame can be used with standard chassis runners, telescopic runners, etc. Drawer units and castors are available. The casework is available in two types, either $15\frac{1}{2}$ in or $10\frac{1}{2}$ in panel space \times 19in in single units, or triple unit taking up the full width.

Alfred Imhof Ltd,
112-116 New Oxford Street,
London, W.C.2.



Voltage Booster

(Illustrated above)

THIS is a single-step voltage booster designed for use with equipment which might fail to operate, or suffer damage, in the event of a substantial fall in the supply voltage, but where the accurate control provided by a constant voltage transformer is unnecessary.

The Advolt is completely automatic in operation, and when the supply falls to

a predetermined voltage the boost is immediately added. When the supply voltage rises again the boost is removed.

The equipment consists of a boost transformer, switched by means of a relay which is controlled by a voltage sensitive device designed to ensure accurate placing of the operating points.

A 2kW model is at present in production and it is anticipated that a 5kVA version will also shortly be available.

Advance Components Ltd,
Back Road,
Shernhall Street,
London, E.17.

Multi-turn Precision Dial
(Illustrated below)

THE Microdual type 57-360 is basically a special purpose version of the standard type 57. In addition to the normal features of the type 57, including two speed operation, the type 57-360 allows an unlimited number of 360° rotations to be made. Up to 20 revolutions of the operating shaft being recorded on the inset turn-counting dial. The main

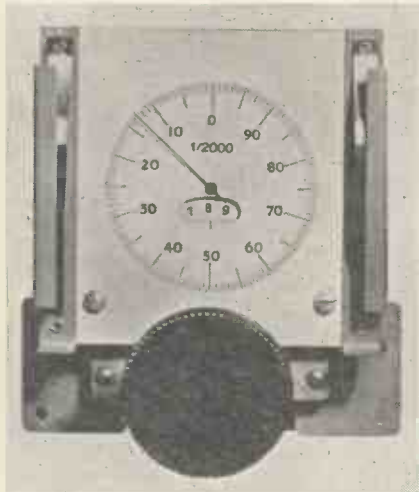

dial shows 200 divisions. This, in combination with the turn counting dial enables positioning to 1 in 4000 divisions with a resetting accuracy of better than 2.7 minutes of arc.

Transradio Ltd,
138a Cromwell Road,
London, S.W.7.

Soldering Iron Busbar Installation
(Illustrated top right)

THE Elremco low voltage soldering iron installation consists of busbar sections, usually 6ft long, so constructed that a soldering iron can be plugged in at any point along their length. Each busbar unit is provided with links to facilitate connexion between adjoining units. The units consist of a U-shaped steel channel, which protects two solid copper bars supported on Bakelite insulators. The current carrying capacity of the busbars is 160A, so that any reasonable numbers of irons may be used on a section.

Mains units can be supplied in any size from 40VA upwards, the normal output voltage being 20V centre-tapped to earth, so that the maximum busbar to earth voltage is 10V.



This firm also manufactures a soldering iron suitable for use with this installation. It is 9½in long and has a maximum diameter, apart from the handle, of 5/16in; the heating time is 35 to 50 seconds and the power consumption 35W at 20V.

Electrical Remote Control Co. Ltd,
East Industrial Estate,
Harlow New Town,
Essex.

Audio Output Transformer
(Illustrated below)

THE A.F. output transformer type P3064 is built on a grain oriented C



core and has a power rating of 20W at less than 1 per cent distortion, the maximum d.c. per half primary being 100mA. The anode to anode load is 10kΩ while the secondary is brought out as four separate sections thus providing for loudspeaker impedances of 0.95, 3.8, 8.5 and 15Ω.

Partridge Transformers Ltd,
Roebuck Road,
Tolworth, Surrey.

Ceramic Capacitors
(Illustrated below)

A NEW range of ceramic capacitors has recently been introduced by Dubilier Ltd. They are of the conventional tubular type with fired silver electrodes and wire tail terminations. The capacitance range is 300pF to 0.0047μF;



they are all 3mm in diameter and either 10 or 16mm long. The capacitors are supplied in an uninsulated form with a non-hygroscopic enamel finish. They have a low temperature coefficient while the power factor decreases with increasing temperature.

Dubilier Condenser Co. (1925) Ltd,
Victoria Road,
London, W.3.

Vitreous Enamelled Resistors
A COMPREHENSIVE range of vitreous enamelled resistors is manufactured by Jones and Tait and distributed by Radelec Ltd. They are available with a maximum power rating between 9W and 180W and with a resistance up to 100kΩ, the normal tolerances are ±5 or ±10 per cent. The smaller sizes have tinned copper wire terminations while the larger sizes are fitted with end bands. Resistors with tapings, up to a maximum of eight on the larger sizes, can also be supplied.

Radelec Ltd,
63 High Street,
Cheltenham,
Gloucestershire.

New Valves

SEVEN new valves have recently been added to the range manufactured by The General Electric Co. Ltd. The Osram Z719 has been developed primarily for use as a signal frequency and I.F. amplifier in television receivers; in addition it can be used as a video amplifier and sync separator. It is an internally-screened high slope short base r.f. pentode on a B9A (Noval) base. It has a slope of 7.4mA/V. The heater is rated at 6.3V, 0.3A, and the low operating anode voltage of 170V makes the valve of particular interest for transformerless television receivers.

The U43 is a miniature high voltage E.H.T. rectifier of the wire-in type with an indirectly heated cathode. The heater rating is 6.3V, 90mA. With a uni-directional impulse input the peak input voltage is 17kV and the rectified current 0.35mA.

The B9A based N329 output pentode is intended for use as a frame and sound output in transformerless television receivers. The heater rating is 16.5V, 0.3A. When used in the sound output stage a maximum audio output of 4W can be obtained with an anode voltage of 170V.

Also on a B9A (Noval) base is the Osram U709 full-wave indirectly heated rectifier. The heater rating is 6.3V, 0.95A. The maximum r.m.s. input voltage is 350V and the rectified current is 150mA.

The other three new valves are chiefly intended for use in broadcast and car radio receivers. All have a heater rating of 6.3V and are mounted on a B7G base. They are direct replacements for their American equivalents. The X727/6BE6 is a heptode frequency changer with a conversion conductance of 0.425mA/V. The W727/6BA6 is a variable-mu r.f. pentode with a mutual conductance of 4.4mA/V. And the N727/6AQ5 is a beam tetrode with a maximum audio output of 4.5W.

The General Electric Co. Ltd,
Magnet House, Kingsway,
London, W.C.2.

Signal, Noise and Resolution in Nuclear Counter Amplifiers

By A. B. Gillespie, 155 pp., 58 figs., Demy 8vo. Pergamon Press Ltd. 1953. Price 21s.

REGARDED as a textbook or more properly a handbook, this is undoubtedly a useful work containing much valuable information brought together in a convenient form. It is most suitable, as the author states, for young graduates about to enter the field of nuclear science and for experienced physicists who, while not specifically interested in pulse amplifiers as such, frequently require to use them in their work.

The first three chapters are devoted mainly to a discussion of the nature of signals produced by ionization chambers, and the noise and signal components appearing at the input of a counter amplifier.

Chapter IV then deals with the principal design problem of these amplifiers

ELECTROPHYSIOLOGICAL TECHNIQUE

By C. J. Dickinson, B.A., B.Sc.
(Magdalen College, Oxford)

Price 12/6

The author describes the use of electronic methods as applied to research in Neurophysiology. Chapters are devoted to amplifying, recording and stimulating techniques used in physiology and medicine (e.g. electrocardiography, electroencephalography, etc.)

Order your copy through your bookseller or direct from

Electronic Engineering

28 ESSEX STREET, STRAND, W.C.2

namely, that of maximizing signal to noise ratio under the constraint of a specified minimum resolving power. The analysis relates to an amplifier whose bandwidth is bounded by one differentiating and one integrating time-constant.

Chapter V deals with amplifier sensitivity which is defined as the ability to resolve nearly equal energy levels, and the book concludes with a discussion of the necessary modifications to conclusions previously reached, when proportional or scintillation counters are used.

The author is to be congratulated on presenting the subject in a manner which is both readable and plausible to the type of reader envisaged.

BOOK REVIEWS

It is to be regretted that a work of such undoubted merit invites criticism by virtue of the claims made for it in the prefaces.

Although for the purpose of this review it has been regarded as a textbook, we are informed by the editor that it is a "Research Monograph" and that publication has been hastened in order to make available quickly an account of new work. This is a pity because very little new work is described, and one is bound to inquire whether it would not have been fairer to the author if a little more editorial care had been exercised even at the expense of some delay in publication. For instance, in the light of the claim that "Chapters III, IV and V . . . contain much theoretical and experimental data which has not been published before," it is necessary to point out that the whole of the material of Chapter III, without exception, has been covered by publications prior to 1940.

The same criticism to a lesser extent can be applied to Chapter IV, the greater part of which, as stated, is devoted to the problem of securing the maximum value of pulse signal to noise ratio under specified conditions. It is rather surprising to find that no reference has been made to the work of Dwork (*Proc. I.R.E.* July, 1950) who has achieved a complete and elegant theoretical solution of the same problem.

In Chapter V on page 87 we read that, in shot noise, each event is the transfer of an electron from cathode to anode, and on page 88 that each noise event is the transit of an electron from the anode to the cathode. If the latter statement is not merely an error, some explanation is called for. Also Fig. 45 on page 89 and its associated text are rather ambiguous; obviously the second step function must have a value $-e/gm\gamma$ for the pulse depicted in Fig. 45 to be produced and for the caption to be true.

It is gratifying to note that, generally speaking, mathematical manipulations are removed from the text to form the subject of an appendix where they are usually dealt with in a lucid if somewhat lengthy fashion. In this connexion one would have appreciated elucidation of the steps leading from expression (46) to (47) on page 91 which are extremely difficult to follow.

A misleading statement occurs on page 28 where it is stated that, as the amplifier pass-band moves higher in the frequency spectrum, the shot noise output will increase. It is not made clear that this is only true because the stated condition $T1/T2 = \text{Constant}$, fails to keep the bandwidth constant.

Misprints occur on page 4 and page 91. In the former case recombination time should be given as $300\mu\text{Sec.}$ not 300Sec. , and in the latter where in expression (46) the exponent should be squared.

A further minor criticism is that the

author uses the term "capacity" in place of the nowadays more usual "capacitance."

The publishers are to be congratulated on the pleasing appearance and legibility of both the text and mathematical expressions. One would have liked to see more modern methods of analysis used where appropriate, but despite this, and the weaknesses to which reference has already been made, the book can be recommended.

M. G. HAMMETT.

The Living Brain

By W. Grey Walter. 216 pp., 23 figs. Demy 8vo. Gerald Duckworth & Co. Ltd. London. 1953. Price 15s.

THIS book is difficult to review since it consists of two independent and unrelated parts. In one the author, who is one of the outstanding exponents of electroencephalographic theory and practice in this country, explains the historical background, the scope and the possible meanings of compound electrical potentials from the brain. In the other he feeds us with the products of his fertile imagination and tells us how the brain may work.

In the reviewer's opinion the first part is the most satisfactory, as it is bound to be. We are taken through all the developments of the EEG culminating in the most ingenious "toposcope" by means of which records of surface electrical activity of the brain may be made from many parts simultaneously.

In the second part the author illustrates his theories of brain functions—learning in particular—by the use of models. On their own merits the models are remarkable examples of skilful economical electronic design; and there is no doubt that many of Dr. Grey Walter's readers will build some of his animal models from the circuit diagrams that he includes in the book. I trust that they will not be carried away by his infectious enthusiasm so far that they look upon the models as illustrations of brain function. To do him justice, the author does several times emphasize that models are nothing more than models, but it is felt that sometimes his convictions are not perfect. He uses one particularly specious reasoning. He designs a model to be capable of predetermined activities; then he finds that it exhibits behaviour which he has not envisaged; then he suggests that the model is an accurate one *because* it exhibits this or that behaviour which he regards as characteristic of living things. In another chapter, the author arbitrarily divides the learning process into seven components without inquiring whether the process could be split up in any other way (although I admit his system is simple and economical). Then he devises a seven-process electronic model and finds that it works. The machine also exhibits some kinds of unplanned behaviour, tempting the

author again to suggest that the close parallel with animal behaviour signifies that animal learning follows the same pattern as his model. I consider that much the most valuable contribution his models have made is to show that a very limited number of elements only might be required to operate a human brain; and that the brain may not be quite as complicated as the number of its cells suggests.

The greater part of the author's theories of brain rhythms derive from his assumption that the alpha rhythm is a "scanning system." There is no proof that the scanning effect is anything other than fortuitous; and I believe it is mistaken to build theories too high on this rather shaky foundation.

However, forgetting the theories, the matter of the book is presented in a lucid and often picturesque way; and Dr. Grey Walter may congratulate himself on having written a readable, absorbing and stimulating book on a subject which can hardly fail to interest the layman as well as the scientist.

C. J. DICKINSON

Tensors in Electrical Machine Theory

By W. J. Gibbs, 238 pp., 36 figs., Demy 8vo. Chapman and Hall Ltd. 1952. Price 30s.

THOSE engineers who have attempted to understand the papers of Gabriel Kron and others in which the tensor calculus is applied with conspicuous success to electrical problems, will probably have been keenly aware of their own lack of training in the fundamentals of the subject and of the pressing need for a suitable text written especially for engineers. In this country, no better person than Dr. Gibbs could have been selected to write such a book. He has a well established reputation in this field; in fact the book has its origins in lectures he has given to post graduate students at King's College, University of London, and at the British Thomson-Houston Co., Ltd.

The first five chapters are devoted respectively to mathematical fundamentals (determinants, matrices, invariance, group properties, transformations, connexion tensors, etc.), applications to electrical circuits, applications to rotating machines, reduction of arrays and equivalent circuits and to non-linear transformations (required for a certain class of inductor machines). As the tensor calculus owes its origins and most of its nomenclature to the fields of differential geometry and dynamics, Dr. Gibbs accordingly devotes three chapters to these subjects. The next two chapters deal with rotating machines in which holonomic and non-holonomic reference frames are required; the final chapter deals with oscillating machines.

It can with confidence be said that this book completely meets the needs of the electrical engineer; there is sufficient rigour to satisfy without boredom, and there is a concise and orderly treatment throughout. For a first edition, the book is singularly free from misprints and errors. No examples have been included; from a teaching point of view these would have been welcome.

J. E. PARTON.

Leitfaden der Funkortung (A Guide to Radiolocation)

By Walter Stanner. 163 pp., 85 figs. Demy 8vo. Elektron-Verlag, Garmisch-Partenkirchen (Bavaria). 1952. Price, paper covered, DM.8.50; bound, DM.12.

THIS little book, written by the editor of *Elektron*, a German contemporary of *Electronic Engineering*, is a valuable contribution to the rapidly increasing literature on radiolocation. It is meant as an introduction to this field and constitutes a technological survey and systematic review of the whole subject. The review is based on the author's notion of the "path triangle," i.e. the triangle having as its corners the primary radiator, the secondary or parasitic radiator and the point of observation. Three basic methods may be applied depending on which of these three points is movable while the other two are fixed in space. With movable primary radiator or point of observation the isodromes, i.e. the curves of equal transmission time difference, will be hyperbolas, with movable secondary radiator they will be ellipses. If the distance between the movable point and the fixed points becomes very large compared with that between these two points the hyperbolas may be replaced by their asymptotes and the ellipses by circles.

A further distinction is made depending on whether the methods comprise direction finding and short time measurement or only one of these two. Thus what the author calls a "morphological box" is obtained into which by suitable combinations the bewildering number of British, German and American methods for radiolocation are packed in a systematic order. This is explained in a very attractive manner in the first chapter of the book. The mode of approach is similar to what Professor F. Zwicky, Pasadena, advocates as "morphological thinking" and what he has applied successfully, e.g. to jet propulsion.

The second chapter deals with the equipment for reception, the third with transmitters, the fourth with "chains of hyperbolas" where particular attention is paid to the Loran, the Gee and the Decca systems. In the fifth chapter the equipment for distance measurement is dealt with and the Oboe system is treated in greater detail. The sixth chapter is devoted to radio measurement or radar proper. Of the numerous systems developed the Freya and Egon systems are described at some length and some radio maps are reproduced. In the concluding chapter the application of the methods to geo- and astrophysical problems is briefly discussed.

A few minor suggestions may be made for a second edition. Occasionally expressions are used which are explained only later in the book and a brief page reference to that explanation would be desirable. For instance "open and tactical radiolocation" is mentioned on page 20 and explained on pages 23-24; "direction finding by A-N keying" is mentioned on page 41 and the explanation is given on page 48 and in greater detail on page 51. Also a subject index would be desirable.

The illustrations are well chosen and the book is well produced.

R. NEUMANN.

CHAPMAN & HALL

Just Out

RELAYS FOR ELECTRONIC AND INDUSTRIAL CONTROL

by

R. C. Walker

B.SC., A.M.I.MECH.E., A.M.I.E.E.

321 pages 187 figures 42s. net

PRINCIPLES OF TRANSISTOR CIRCUITS

Edited by

Richard Shea

With Nine Contributors.

585 pages 476 figures 88s. net

37 ESSEX STREET, LONDON, W.C.2.

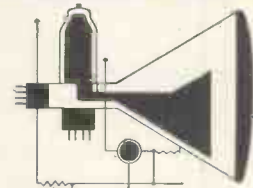

Smith's for current "know how"

From Smith's shops and book-stalls you can quickly obtain technical books on the latest developments in circuit design, new components, methods and new theories. Books not actually in stock can usually be supplied within a day or so. Smith's Postal Service can send books to any address at Home or Overseas. Lists of the standard works on any subject supplied upon request.

W. H. Smith & Son

FOR TECHNICAL BOOKS

HEAD OFFICE: STRAND HOUSE, W.C.2

BOOK REVIEWS (Continued)

Communication Theory

Edited by Professor Willis Jackson. 532 pp., 60 figs. Royal 8vo. Butterworths Scientific Publications. 1953. Price 65s.

A SYMPOSIUM on "Applications of Communication Theory", which was organized by Professor Willis Jackson and the staff of the electrical engineering department of Imperial College, was held at the Institution of Electrical Engineers in September 1952. The papers which were read at the Symposium have now been published in this book edited by Professor Jackson. Some of the papers have already appeared in various journals but these are now collected in a single volume together with others hitherto unpublished and the accompanying discussions.

The book contains thirty-eight papers. Many of them are of a mathematical nature and none are intended for the beginner. Although the first paper, by Dr. Gabor, is entitled "A Summary of Communication Theory", it is not an elementary introduction but rather, as he says, a "refresher" for those who already have some knowledge of the theory.

Thirteen of the papers deal with transmission systems, multiplexing and coding. These include a general comparison of existing systems by Z. Jelonek, a paper by F. de Jager on delta-modulation and C. W. Earp's paper on twin-index P.P.M. Eight papers deal with the extraction of signals from a noisy background and include three papers on integration methods for increasing the accuracy of pulse radar systems.

Another group of papers deals with television and methods of reducing the channel capacity it requires. These include a paper by E. C. Cherry and G. C. Gouriet on the use of variable-velocity scanning and a paper by G. Valensi on a method of coded colour transmission.

Another group of papers deals with speech and hearing. These include papers by Fry and Denes and by Davis, Biddulph and Balashek on the mechanical recognition of speech and papers by Richards and Swaffield on the performance of telephone circuits and their effects on the user. A paper by W. Lawrence describes a machine for synthesizing speech from controlling signals having an information rate less than one fiftieth of that of normal telephone signals.

The final group of papers deals with some applications of communication theory to topics outside communication engineering including optics, the statistical structure of language and a paper by Bar-Hillel and Carnap outlining a theory of semantic information.

Telecommunication engineers had devised many efficient information transmission systems long before the mathematical theories of Shannon and Wiener provided a quantitative measure of "information." Many of the studies to

which the theory has led have shown that some existing modulation methods approach very closely to the theoretical ideal and this has led some engineers to minimize the importance of modern theory. It is premature, however, to expect a large number of applications from a fairly new body of knowledge. The task of applying the theory is made more difficult because the human operator, either as transmitter or receiver or both, is an essential part of most communication links. A better understanding of the principles of communication and the limitations involved will facilitate the eventual development of new systems and the gradual improvement of existing systems. The papers contained in this book show some of the progress which has been made.

J. E. FLOOD

Luminescence and the Scintillation Counter

By S. C. Curran. 219 pp., 93 figs. Demy 8vo. Butterworths Scientific Publications. 1953. Price 32s.

THE detection and counting by electrical means of energetic particles and electromagnetic quanta is one of the most important techniques used in nuclear physics and associated investigations. It is interesting that one of the earliest methods, used by Rutherford to detect alpha particles in his pioneering experiments on the structure of the atom, has been revived in recent years in an improved form and, aided by modern advances in electronics, has become perhaps the most powerful and versatile of the particle counting techniques. Using a low power microscope Rutherford counted the minute flashes of light produced by alpha particles falling on a zinc sulphide screen. Today the microscope and the human eye have been replaced by the sensitive photomultiplier while a wide range of scintillating substances has come into use to meet diverse requirements of response and of speed.

Dr. Curran, of Glasgow University, first realized the modern possibilities in 1944 when working at the University of California. He has now performed a valuable service by collecting together, in one readable volume, scientific and technical material relating to all aspects of the subject. Some may feel that the treatment of particular aspects is too summary, but it is difficult to see how this could be much improved in a short book of this scope. For those who wish to follow up special topics there is a large number of references to original sources of information.

Systematically dealt with are the interactions of particles and quanta with matter, the secondary emission of electrons and the electron-multiplier, the properties and preparation of luminescent solids and liquids, applications of scintillation counters and, lastly, electronic circuits for use with scintillation counters.

There is also a chapter on the use of electron-multipliers in a more direct fashion where low energy particles eject electrons directly from the first electrode of the multiplier without the interposition of a scintillator and photocathode as in scintillation counting.

The book will fulfil a need felt by many for a compact and authoritative volume covering a field which has expanded with enormous speed.

D. WALKER

Wave Propagation in Periodic Structures

By Leon Brillouin. 255 pp., 120 figs. Demy 8vo. Dover Publications Inc., New York. 1953. Price \$1.75.

ANALOGIES are always attractive—whether one be the humble engineer who is relieved to find that some necessary piece of mathematics has already been done for him elsewhere, or the mathematical physicists who can point out with a slightly superior air that the problem has already been solved. Not that electronic engineers can grudge credit to the author of this book whose other published work includes a detailed derivation of the formula for Johnson noise from the mechanism of metallic conduction (*Helvetica Physica Acta*, 7, Supplement p. 47, 1934) and a contribution to the argument about information and negative entropy (*J. App. Phys.*, 22, p. 33, 1951). Most engineers will need the lure of analogy to get them into this book since it is closely mathematical, though the mathematics is not of a difficult kind. The real difficulty to the engineer is rather in the new mode of thought required to work in wave-numbers instead of wavelengths and to allow that there may be different values of wave-number for a given frequency. The reward for studying the simplest case—wave propagation in one-dimensional lattices—is the analogy with electric wave filters; and Mathieu's equation describes, among other things, the excitation of oscillations in a resonant circuit by the periodic variation of one of the reactances.

But the most important aspect of this work is that it covers the more complicated case of wave propagation in a three-dimensional lattice, leading to the theory of the "zones" which are named after the author. Their engineering importance is less explicit in the book than is the one-dimensional analogy with the filter, but it might well be said that they are the mathematical physics of the transistor and of all other semi-conductor devices. In combination with the wave description of the electron, this theory of zones provides the rationalization (some would even say the explanation) of the system of forbidden and permitted energy levels for conduction electrons in a solid, given which one can construct the machinery of holes, donors, acceptors, traps. This book can certainly be recommended to those who have the patience to study the fundamental physical background of some of the recent developments in electronics; the reader will have to look elsewhere for many applications of the theory, but the Appendix indicates the relevant literature.

D. A. BELL

NOTES FROM THE INDUSTRY

The Radio Industry Council announces that the National Radio Show will be held at Earls Court, London, from 25 August to 4 September, 1954, with a pre-view for overseas and other special visitors on 24 August. Her Majesty The Queen has consented to be patron of the exhibition, this being the first time that the reigning monarch has accepted the patronage.

The Physical Society is arranging a conference on The Physics of The Ionosphere to be held at The Cavendish Laboratory, Cambridge, from 6-9 September, 1954. The Conference will follow immediately after the meeting of the International Scientific Radio Union in Holland and it is hoped that a number of overseas delegates to that meeting will be present at the Cambridge Conference. Details will be published later in the Physical Society Bulletin and, in the meantime, Mr. J. A. Ratcliffe, Cavendish Laboratory, Cambridge, may be consulted for further information.

The British Institution of Radio Engineers, at their Annual General Meeting held recently in London, presented a Certificate of Honorary Membership to Sir Noel Ashbridge. The citation of the award referred to Sir Noel's outstanding work as Director of Technical Services of the British Broadcasting Corporation and paid tribute to his notable contributions to the whole field of radio engineering. Also at the Annual General Meeting Mr. W. E. Miller was elected President for a second year.

British Insulated Callender's Cables Limited have opened a new 80 000 sq. ft. extension to their Anchor Works at Leigh, Lancs. All BICC rubber-insulated cables will now be manufactured at Leigh and the new production area will be devoted to lead-covered and armoured cables for colliery, shipping and general industrial purposes.

Professor Arnold Tustin, head of the Department of Engineering at the University of Birmingham has been invited by the Massachusetts Institute of Technology to occupy the Webster Chair of Electrical Engineering as a visiting professor at the Massachusetts Institute of Technology for the academic year 1953-54. The Webster Chair of Electrical Engineering was established in 1952 under a grant of \$400 000 from the Edwin Sibley Webster Foundation in memory of the late Mr. Webster, one of the Institute's most distinguished members.

Westool Limited of St. Helen's Auckland, Bishop Auckland, County Durham, are now manufacturing Warner Electromagnetic brakes and clutches under licence from the Warner Electric Brake and Clutch Company, Beloit, Wisconsin.

The Television Society's Annual Exhibition will be held at the Electrical Department of King's College, Strand, London, W.C.2, on the following days: Thursday, 7 January, 6 p.m. till 9 p.m. (Members and Press only); Friday, 8 January, 12 noon till 9 p.m. (Members and ticket holders); Saturday, 9 January, 10 a.m. till 9 p.m. (Members and ticket holders). Approximately 40 companies are exhibiting a wide range of television equipment for both commercial and industrial application. Admission tickets are obtainable, free, from The Television Society, 164 Shaftesbury Avenue, London, W.C.2.

Midland Silicones Limited are to hold an exhibition of silicone rubber on their premises at 19 Upper Brook Street, London, W.1, from 2-10 December. Invitations will be supplied on application.

The Polytechnic have recently issued a prospectus of their evening courses in Telecommunications, including Television and Radio Servicing, for the 1953-1954 session. Inquiries should be addressed to The Polytechnic, Electrical Engineering Department, 309 Regent Street, London, W.1.

Dr. A. Rosen has been appointed Telecommunications Consultant in the Engineering Organization of British Insulated Callender's Cables Ltd, in succession to the late Dr. Hans Carsten.

Sir Roger Duncalfe, Chairman of British Glues & Chemicals Ltd, has been elected President of the British Standards Institution to succeed Lord Waverley, whose three-year term of office has ended.

Marconi's announce that Mr. George Millington, research engineer, has been appointed International Vice-Chairman of Study Group number IV (which investigates problems of ground wave propagation) of the International Radio Consultative Committee (CCIR). His appointment was made at the closing session of the Seventh Plenary Assembly of CCIR, which was held recently in London.

Mr. R. Clements, formerly Public Relations Officer with the Exide Battery Company, The Hymatic Engineering Company and The United Ebonite & Lorival Company, has been appointed Press Relations Officer with Messrs. Roles & Parker, advertising consultants.

The Department of Scientific and Industrial Research has appointed Dr. R. O. Jones to be the first resident Liaison Officer of the Department in Wales. His task will be to study the industrial position in Wales with a view to assisting in the identification of industrial problems amenable to research and in the application of existing knowledge and research facilities to meet Welsh needs.

The BBC announces the following new appointments in the Engineering Division. Mr. H. Walker, O.B.E., becomes Assistant Superintendent Engineer, Television Studios. Mr. W. D. Richardson becomes Assistant Superintendent Engineer, Television Outside Broadcasts.

The Tannoy Group of Companies have formed a new company in Canada called Tannoy (Canada) Ltd with headquarters in Toronto. The resident executive in charge of this project is Mr. F. A. Towler, who was for many years Sales Manager in London.

The Ministry of Supply announce that a Radioisotope Conference arranged by The Atomic Energy Research Establishment, Harwell, is to be held in Oxford during the week 19-24 July, 1954. This will be similar to a Conference arranged by Harwell in 1951 in Oxford and will discuss methods and results obtained using radioisotopes in all fields of science.

The Electronics Group of the Institute of Physics is organizing a conference on Luminescence, with particular reference to solid inorganic phosphors, from 7-10 April, 1954. All communications should be sent to Dr. S. T. Henderson, The Institute of Physics, 47 Belgrave Square, London, S.W.1.

Leicester, Lovell and Co. Ltd, North Baddesley, Southampton, manufacturers of CASCO synthetic resin and casein glues, announce that they are now in a position to supply a range of furane resins.

BINDING OF VOLUMES

Arrangements for the binding service are being continued this year, and the 1953 volume can be bound at an inclusive charge of £1.

Copies will be bound, complete with index and with advertising pages removed, in a good quality red cloth covered case blocked in gold on the spine.

Home and Overseas readers who wish to have their copies bound are asked to comply with the following instructions:—

- (1) Tie the twelve issues (January to December, 1953) securely together before parcelling.
- (2) Enclose a remittance for £1 and a gummed label bearing the sender's name and address.
- (3) Enclose the copies, remittance and label in a closed parcel and address to:—
The Circulation Dept. (E.E. Binding),
28, Essex Street, Strand, London, W.C.2.
(No other correspondence is necessary.)

* * * * *

The following are also available from our Circulation Dept. :—

A limited number of Bound Volumes for 1952. Price, Two Guineas, post free.

Binding Cases for twelve issues. Price 5s., postage 6d.

The Index for Volume XXV (1953) free.

LETTERS TO THE EDITOR

(We do not hold ourselves responsible for the opinions of our correspondents)

The Equivalent Q of RC Networks

DEAR SIR,—With reference to Mr. D. A. H. Brown's article and Mr. Tenger's subsequent letter on this subject, an exact expression for the rate of change of phase angle ϕ with frequency at the resonant frequency ω_0 may be obtained as follows:

$$\text{Starting from } \tan\phi = \frac{\omega L(1 - \omega^2 LC) - \omega CR^2}{R}$$

and substituting $\omega_0^2 = 1/LC - R^2/L^2$, $Q = \omega_0 L/R$, $\alpha = \omega/\omega_0$, we get:

$$\tan\phi = \frac{\alpha Q^2(1 - \alpha^2)}{1 + Q^2} \dots (1)$$

Differentiating and putting $\alpha = 1$, we obtain:

$$-d\phi/d\alpha(\alpha=1) = \frac{2Q^3}{1 + Q^2} \dots (2)$$

For $5 \gg Q \gg 1$ (i.e. $10 \gg -d\phi/d\alpha(\alpha=1) \gg 1$), Q is given to an accuracy of better than 2 per cent by the following equation:

$$-d\phi/d\alpha(\alpha=1) = 0.2(11Q - 6) \dots (3)$$

Applying Equation (3) to the 3-stage isolated RC network treated by Mr. Brown, for which $-d\phi/d\alpha(\alpha=1) = 3\sqrt{3}/4 = 1.3$, we find that $Q = 1.13$: this differs appreciably from the previous estimates of 0.65 and 0.87.

For values of Q near unity, $\omega_0^2 \approx 1/2LC$, i.e. about one-half of the high- Q value of ω_0^2 used in the previous approximations.

Yours faithfully,
L. A. WYATT
Fluid Motion Laboratory,
University of Manchester.

The author replies:

DEAR SIR,—By his neat approximation (his Equation 3) Mr. Wyatt has combined both simplicity with good accuracy for the low Q case. All values in my article should be corrected accordingly. The general conclusions, however, are not affected; the equivalent Q of most networks is still of the order of unity and the relative values for the various groups of networks are not greatly altered.

Your faithfully,
D. A. H. BROWN
R.R.E.,
Great Malvern, Worcs.

DEAR SIR,—I have read both Mr. D. A. H. Brown's article and the correspondence which followed it. I feel, however, that Mr. Tenger's correction and Mr. Brown's reply thereto miss the point. The low Q case of the LC network is admittedly complex—the resonant frequency depending on the distribution of resistance between the two arms. Let us for a moment follow Mr. Brown's lead, and examine the case when the resistance is wholly in the inductive arm.

It is then that

$$\omega_0^2 = 1/LC - R^2/L^2 \dots (1)$$

when resonance is defined as the condition when generator current and voltage are in phase.

Now $\tan\phi = \omega L(1 - \omega^2 LC)/R - \omega CR$.
Put $Q_0 = \omega_0 L/R$, $x = \omega/\omega_0$. Then:
 $\tan\phi = xQ_0(1 - x^2(1 - CR^2/L)) - x(1 - CR^2/L)/Q_0 \dots (2)$

From (1): $\omega_0^2 LC = 1 - CR^2/L \dots (3)$

Multiplying by L/CR^2
 $\omega_0^2 L^2/R^2 = Q_0^2 = L/CR^2 - 1$
or: $Q_0^2 + 1 = L/CR^2$

whence:
 $1 - CR^2/L = 1 - \frac{1}{Q_0^2 + 1} \dots (4)$

Substituting (4) in (2) and expanding we obtain finally:

$$\phi = \tan^{-1} - (x^3 - x) Q_0^3/Q_0^2 + 1$$

Differentiating w.r.t. x :
 $d\phi/dx = \frac{-3x^2 - 1}{1 + (x^3 - x)^2 Q_0^6/(Q_0^2 + 1)^2}$

At resonance $x = 1$ and
 $A \equiv (d\phi/dx)_{x=1} = \frac{-2Q_0^3}{Q_0^2 + 1}$
i.e. $2Q_0^3 + AQ_0^2 + A = 0 \dots (5)$

This equation is exactly true for the LC resonant circuit for the conditions mentioned—i.e. all resistance in the inductive arm, Q_0 defined as $\omega_0 L/R$, and resonance as defined above. In Fig. A it is shown compared with Mr. Tenger's and Mr. Brown's equations. Note that Equation (5), like Mr. Tenger's, is asymptotic to the value $A = -2Q_0$ for large values of Q_0 .

There seems, however, little virtue in using this equation to define an effective Q_0 since it departs considerably from the asymptote around $A = 1$. To illustrate, suppose we have two networks, the values for A of which are 1 and 10. From the point of view of frequency stability (Brown's main interest) we would expect the second to be ten times as stable as the first. Brown's criterion gives effective Q_0 values of 0.5 and 5, a ratio of 10. Tenger's modified expression gives 0.73 and 5.1 approximately, a ratio of 7, while the expression derived above gives Q_0 values 1 and 5.2, a ratio of 5.2.

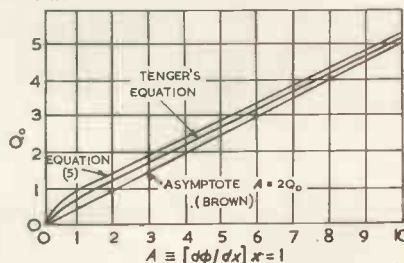

Fig. A. A comparison between Tenger and Brown's equations.

It is clear that Mr. Brown's equation, giving a parameter linearly related to $(d\phi/dx)_{x=1}$ is much preferable. The

choice of the constant making the effective Q_0 coincide with the Q_0 value of an LC resonant circuit for large values may well prove useful.

A similar situation exists when defining Q_0 in terms of bandwidth. The exact expression relating the two is very complicated, certainly not linear, and tends to the value of $2Q_0 = 1/\delta x$ when Q_0 is large (δx is the mistuning either side of resonance on a normalized frequency scale). This equation is generally used to define Q_0 for RC networks.

Finally, Mr. Brown's statement that his "approximations therefore have the virtue of simplicity until experimental work determines the absolute accuracy of the equivalent Q " seems quite meaningless. The parameters voltage gain ($d\phi/dx$); and bandwidth are experimentally obtainable and Q can then be calculated accordingly to any definition you may please. A Q -meter, of course, relies on such definitions. What it measures is usually voltage gain or bandwidth. Q as such cannot be measured.

Yours faithfully,
D. W. R. WHEELER,
Staines, Middlesex.

A Band Pass Filter for Low Frequencies

DEAR SIR,—In the article by G. W. Morris and P. G. M. Dawe in the September, 1953, issue, there appears to be an error.

The differential equation for the grid voltage of valve V_1 of Fig. 2(a) takes no account of the input signal. Since this circuit is used as an amplifier, this is apparently incorrect.

A more correct analysis is as follows (Fig. B):

Grid voltage of V_1 is $V = V_1 + V_2 \dots (1)$

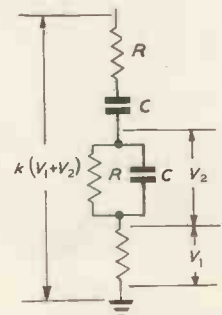

Fig. B. Input of V_1 .

If $V_1 = E \sin(\omega t + \alpha)$, V_2 is given by

$$\frac{dV_2}{dt} + \frac{3-k}{RC} V_2 + \frac{V_2}{R^2 C^2} = \frac{k-1}{RC} E \omega \cos(\omega t + \alpha) \dots (2)$$

The solution of this is

$$V_2 = e^{-\frac{(3-k)t}{RC}} \left[A e^{j \frac{\sqrt{(6k-k^2-5)t}}{2RC}} + B e^{-j \frac{\sqrt{(6k-k^2-5)t}}{2RC}} \right] + \frac{(k-1) E \cos(\omega t + \alpha - \phi)}{\sqrt{X^2 + (3-k)^2}} \dots (3)$$

where $X = \frac{1}{RC\omega} - RC\omega$
 $\phi = \tan^{-1} \frac{3-k}{X}$

The first term of this solution is oscillatory if $1 < K < 5$ and if $K < 3$ it represents a damped oscillation. The frequency of this oscillation is $\sqrt{(6k - k^2 - 5)}/4\pi RC$. This term of the solution will rapidly die away and we are left with

$$V_2 = \frac{(k-1) E \sin [\omega t + \alpha + (\pi/2 - \phi)]}{\sqrt{[X^2 + (3-k)^2]}} \dots\dots\dots (4)$$

Substituting for V_1 and V_2 in equation (1)

$$V = E(\sin(\omega t + \alpha) + \frac{(k-1) \sin (\omega t + \alpha + (\pi/2 - \phi))}{\sqrt{[X^2 + (3-k)^2]}})$$

$$\therefore V = E \sqrt{\left[\frac{X^2 + 4}{X^2 + (3-k)^2} \right]} \sin (\omega t + \alpha + \delta) \dots\dots\dots (5)$$

where $\sin \delta = \frac{X(k-1)}{\sqrt{[X^2 + (3-k)^2] [X^2 + 4]}}$

From equation (5) it can be seen that resonance occurs when $X=0$.

i.e. $\frac{1}{RC\omega_0} = RC\omega_0$
 $\therefore \omega_0 = \frac{1}{RC}$

Thus resonant frequency $= \frac{1}{2\pi RC} \dots\dots\dots (6)$

Putting $X = 0$ in equation (5)

$$V = \frac{2E}{3-k} \cdot \sin(\omega t + \alpha)$$

when $K \rightarrow 3$ $V \rightarrow \infty$ until limited by valve characteristics. For this gain the first term of equation (2) also represents

a continuous oscillation with $f = \frac{1}{2\pi RC}$

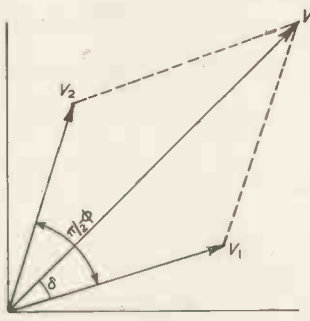

Fig. C. Vecton analysis

From band width considerations it can be seen that

$$Q = \frac{2 + \sqrt{\left[\frac{2(3-k)^2}{6k - k^2 - 7} \right]}}{2 \sqrt{\left[\frac{2(3-k)^2}{6k - k^2 - 7} \right]}} \dots\dots\dots (7)$$

$Q \rightarrow \infty$ as $k \rightarrow 3$

It is to be noticed that using a value of $K=2.8$, $Q=5.5$ and the expression for resonant frequency given by Messrs. Morris and Dawe reduces to $f = \sqrt{(3.96)}/4\pi RC \approx 1/2\pi RC$ which is given by the correct equation (6).

Yours faithfully,
 ALAN H. SILCOCKS.
 3 Trg. Bn. R.E.M.E.
 Arborfield, Berks.

The Author replies:—
 DEAR SIR,—We are interested in the

further analysis that Lance-Corporal Silcocks has given for the zero phase RC valve resonant circuit, and agree that the input voltage to the grid should certainly be included when the circuit is being considered strictly as an amplifier. The theory seems to bring out the interesting point that the resonant frequency of this circuit is constant for any particular values of R and C, whereas its frequency of natural oscillation is not, since this varies with the stage gain k. However, for values of k close to k=3, the two frequencies will be approximately the same.

Yours faithfully,
 G. W. MORRIS,
 P. G. M. DAWE,
 Biophysics Unit,
 Crichton Royal,
 Dumfries.

Ten-Volt Effect with Oxide-Coated Cathode

DEAR SIR,—I would like to add a note on the "ten-volt effect," which was discussed by Mr. Fowler on page 443 of the October issue. The effect appears to have first been noted by Van der Pol and Weijers¹ in 1934. Later, Jonker² found that it occurs only in valves whose anodes are contaminated with barium and its compounds.

A possible explanation of the effect is to be found in some noise measurements which I carried out several years ago at the Engineering Laboratory, Cambridge University. The effect of electron reflexion and secondary emission at the anode was one of the subjects under investigation.

It is known that when current in a valve is space-charge limited, any reflected primary electrons or secondary electrons will cause an increase in the space charge density and hence in the height of the potential barrier outside the cathode. The anode current will thus have a lower value than would be the case if the reflected and secondary electrons were absent.

If the reflexion and secondary emission are random processes, as is to be expected, these electrons will cause fluctuations in the height of the potential barrier and therefore increased fluctuations of the main electron current.

At the values of anode voltage in which we are interested ($\approx 10V$) the number of reflected electrons and secondary electrons will be of the same order. The former, in view of their higher energy will be able to approach far closer to the potential barrier, and so exert a greater influence on it. To a first approximation, therefore, the true secondary emission at low voltages may be neglected.

The effect of the reflected electrons on the anode current and noise has been calculated. It was only possible to carry this out for the case of parallel plane electrodes because of the extreme mathematical difficulty of dealing with the cylindrical case. However, it appears from the experiment described below that the results may be applied to cylindrical structures with a good degree of accuracy. The change in anode current was

found to be given by $\frac{\Delta I}{I} \approx -0.53 \alpha \dots\dots\dots (1)$

where ΔI is the change in anode current,

I the anode current in the absence of reflected electrons,

and α the coefficient of reflexion of the anode surface.

The increase in the space-charge reduction factor was found to be given by

$$r^2 - r_0^2 \approx 0.6\alpha \dots\dots\dots (2)$$

where r^2 is the space charge reduction factor in the presence of reflected electrons,

and r_0^2 the reduction factor with no reflexion taking place.

To determine how far it was possible to apply equation (2) to the practical case of cylindrical electrodes, noise measurements were made on a valve with an uncontaminated nickel anode; the valve used a pure tungsten cathode and zirconium getter. The values of α deduced from them showed good agreement with those obtained by Farnsworth⁴ from direct measurements.

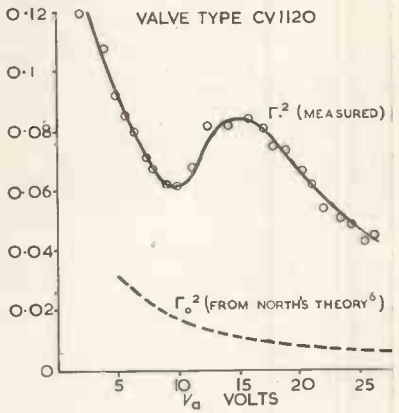

Fig. 1. Typical measurements

Noise measurements were then carried out on a number of valves with oxide-coated cathodes and barium getters; the anodes of such valves are invariably contaminated through evaporation of the getter and cathode material. A typical set of readings is shown in Fig. 1 from which it may be deduced that α decreases to a minimum at 10V, increases to a peak at 15V and thereafter decreases steadily. Measurement of the anode current/anode voltage characteristic clearly showed a local increase in current at $V_a = 10V$ corresponding to the trough in the reflexion characteristic. The current increase was of the same form as that shown by Mr. Fowler and by earlier workers in this field⁵.

It appears then, that the "ten-volt effect" is due to a reduction in the reflexion coefficient of barium-contaminated nickel occurring at this voltage. Such irregularities have been found to occur for various contaminated surfaces⁵, but unfortunately, no sufficiently detailed measurements of α are available for the type of surface under consideration. This

data will be needed before the origin of the ten volt effect can be determined with certainty.

Yours faithfully,
D. M. TAUB,
Nottingham.

REFERENCES

1. VAN DER POL, B., WEIERS, T. J. *Physica*, 1, 481 (1934).
2. JONKER, J. L. H. *Philips Res. Rep.* 2, 331 (1947).
3. TAUB, D. M. *M.Sc. Dissertation, Cambridge University* (1950); *Research* 4, 391 (1951).
4. FARNSWORTH, H. E. *Phys. Rev.* 31, 405 (1928).
5. KRENZLEN, O. *Wiss. Veröff. aus den Siemenswerken* 20, Pt. 2, 91 (1942).
6. NORTH, D. O. *RCA Rev.* 4, 269 and 441 (1940).
7. MATHESON, R. M., NERGAARD, L. S. *RCA Rev.* 12, 258 (1951).
8. BRUINING, H. *Physica*, 5, 913 (1938).

The Author replies:—

DEAR SIR,—Mr. Taub's letter throws more light on this problem. It appears that Matheson and Nergaard' (1951), to whom I referred in my note, were aware of the additional effect of reflected electrons, but they used the reflexion coefficients found by Bruining³ in 1938. His curves of a versus V_a were smooth, making it appear that the reflected electron contribution could not produce such a "kink."

The later work of Jonkers² (1947), to whom Mr. Taub refers, demonstrated that reflexion coefficient curves may have several minima for values of V_a up to 15 volts, depending markedly on the contaminating traces on the anode. Mr. Taub's results confirm this. Indeed, his paper³ provides a more complete ex-

planation of the ten-volt effect than I had hitherto seen.

It is apparent that anomalies of this kind may occur in valve characteristics between $V_a = 0$ and $V_a = 15$ or 16 volts, depending upon the anode contamination. The voltage of onset is therefore likely to be constant for a given type of valve.

In practice, this limitation becomes of importance in the use of electrometer valves and also in "starved current" stages. It is this aspect of the effect with which I am concerned, and I am grateful to Mr. Taub for providing further information.

Yours faithfully,
J. F. FOWLER,
Radiotherapy Department,
Royal Victoria Infirmary,
Newcastle-upon-Tyne.

MEETINGS THIS MONTH

THE BRITISH INSTITUTION OF RADIO ENGINEERS

Date: 9 December. Time: 6.30 p.m.
Held at: The London School of Hygiene and Tropical Medicine.

A Symposium on Vibration Methods of Testing.

Scottish Section

Date: 3 December. Time: 7 p.m.
Held at: The Institution of Engineers and Ship-builders, Glasgow.

Lecture: The BBC Television O.B. Unit.
By: Member of Staff of Regional Studio, Glasgow.

North Western Section

Date: 3 December. Time: 7 p.m.
Held at: The College of Technology, Manchester.
Lecture: The Monitoring of High-Speed Waveforms using a Sampling Technique.
By: J. G. MacQueen.

Merseyside Section

Date: 3 December. Time: 7 p.m.
Held at: The Electricity Service Centre, White-chapel, Liverpool, 1.
Discussion: Education in The Radio and Electronics Industry.

North Eastern Section

Date: 9 December. Time: 6 p.m.
Held at: Neville Hall, Westgate Road, Newcastle-upon-Tyne.
Lecture: The Effects of Aural Disturbances on Audio Production.
By: M. Anderson.

THE INSTITUTE OF NAVIGATION

Date: 18 December. Time: 5 p.m.
Held at: The Geographical Society, 1 Kensington Gore, London, S.W.7.
Lecture: A description, by members of the Admiralty Signal Radar Establishment, of some recent developments in Marine Radio Aids.

THE INSTITUTE OF PHYSICS

Electronics Group

Date: 15 December. Time: 5.30 p.m.
Held at: The Institute's House, 47 Belgrave Square, London, S.W.1.
Lecture: Electrical Breakdown in Liquids.
By: K. MacFadyen.

THE INSTITUTION OF ELECTRICAL ENGINEERS

All London meetings, unless otherwise stated, will be held at The Institution, commencing at 5.30 p.m.

Radio Section

Date: 2 December.
Lecture: Telegraph Codes and Code Converters.
By: T. Hayton, C. J. Hughes and R. L. Saunders.
and: Code Converters for the Interconnexion of Morse and Teletprinter Systems.
By: R. O. Carter and L. K. Wheeler.

Date: 14 December.
Discussion: Will Transistors Oust Receiving Valves?
Opened by: E. H. Cooke-Yarborough.

Ordinary Meeting

Date: 3 December.
Lecture: Technical Arrangements for the Sound and Television Broadcast of the Coronation Ceremonies.

By: W. S. Procter, M. J. L. Pulling and F. Williams.

Informal Meeting

Date: 7 December.
Discussion on The Ridley Report.
Opened by: C. T. Melling.

Measurements Section

Date: 8 December.
Lectures: (1) The Determination of Optimum Process-Controller Settings and their Confirmation by means of an Electronic Simulator.

By: R. L. Ford.
(2) The Effects of the Addition of some Non-Linear Elements on the Transient Performance of a Simple R.P.C. System Possessing Amplifier Saturation.
(3) The Step Function Response of a R.P.C. Servo Mechanism possessing Torque Limitation.
By: J. C. West and I. R. Dalton.

East Midlands Centre

Date: 3 December. Time: 7.15 p.m.
Held at: De Montfort Hall, Leicester.
Faraday Lecture on Process Heating.

By: O. W. Humphreys.
Date: 10 December. Time: 6.30 p.m.
Held at: Leicester College.

Lectures: The Industrial Application of X-rays.
By: T. E. Tufton, and
The Industrial Application of Radioactive Isotopes.
By: Sydney Jefferson.

Cambridge Radio Group

Date: 1 December. Time: 8.15 p.m.
Informal Lecture: Electronics in Aircraft
Held at: The Cambridgeshire Technical College.

North Eastern Radio and Measurements Group

Date: 7 December. Time: 6.15 p.m.
Held at: King's College, Newcastle-upon-Tyne.
Lecture: The Electricity Division of the National Physical Laboratory.
By: R. S. J. Spilsbury.

North Midlands Centre

Date: 8 December. Time: 6 p.m.
Held at: The University of Leeds.
Lecture: Some Applications of Electronics.
By: T. G. Bridgwood.

North Scotland Sub-Centre

Date: 9 December. Time: 7.30 p.m.
Held at: The Caledonian Hotel, Aberdeen.
Lecture: Design Features of Certain British Power Stations.

By: S. D. Whetman and A. E. Powell.
The above lecture to be repeated on 10 December at 7 p.m. at the Royal Hotel, Dundee.

South-East Scotland Sub-Centre

Date: 1 December. Time: 7 p.m.
Held at: The Heriot-Watt College, Edinburgh.
Lecture: Special Effects for Television Studio Productions.

By: A. M. Spooner and T. Worswick.
Date: 15 December.
(Time and place as above.)
Lecture: Voltage Transformers and Current Transformers associated with Switchgear.
By: W. Gray and A. Wright.

South-West Scotland Sub-Centre

Date: 2 December. Time: 7 p.m.
Lecture: Special Effects for Television Studio Productions.

By: A. M. Spooner and T. Worswick.

South Midland Centre

Date: 7 December. Time: 6 p.m.
Held at: The James Watt Memorial Institute, Birmingham.

Lecture: Radio Aids for Airport Control.
By: E. J. Dickie.

(Joint meeting with the South Midland Radio Group and the Supply and Utilization Group.)

North Staffordshire Sub-Centre

Date: 18 December. Time: 6.30 p.m.
Lecture: The Co-ordination of Insulation of High Voltage Electrical Installations.

By: J. S. Cliff.

Southern Centre

Date: 9 December. Time: 7.30 p.m.
Held at: The R.A.E. Technical College, Farnborough.

Lecture: Colour Perception and Colour Television.
By: J. H. Mole.

West Wales (Swansea) Sub-Centre.

Date: 10 December. Time 6 p.m.
Held at: The Central Public Library, Alexandra Road, Swansea.

Lecture: Economic Aspects of Overhead Equipment for D.C. Railway Electrification.
By: O. J. Crompton and G. A. Wallace.

Maidstone District

Date: 7 December. Time: 7.30 p.m.
Held at: "The Wig and Gown," Maidstone.
Lecture: Electronics in Industry.
By: B. Kellet and E. R. Davies.

Norwich District

Date: 7 December. Time: 7.30 p.m.
Held at: The Royal Hotel, Norwich.
Lecture: The Basic Principles of Electronic Digital Computing Machines and their Uses.

By: R. L. Grimsdale.

THE INSTITUTION OF POST OFFICE ELECTRICAL ENGINEERS

Date: 11 December. Time: 5 p.m.
Held at: The Institution of Electrical Engineers, Savoy Place, Victoria Embankment, London, W.C.2.

Lecture: Maintenance of Television Links.
By: C. E. E. Clinch and L. Thomas.

THE SOCIETY OF INSTRUMENT TECHNOLOGY

Date: 15 December. Time: 6.30 p.m.
Held at: Manson House, Portland Place, London, W.1.

Lecture: Section Paper Machine Drives with Electronic Control.
By: T. E. Barany.

THE TELEVISION SOCIETY

Date: 17 December. Time: 7 p.m.
Held at: The Cinematograph Exhibitors' Association, 164 Shaftesbury Avenue, London, W.C.2.

Lecture: Information Theory and Television.
By: E. C. Cherry.