

Electronic Engineering

MAY 1951



*multi-unit cables
made to suit your
requirements*

Here's a unique opportunity for radio - equipment manufacturers needing special multi-unit low-loss cables . . . ! Let BICC design and manufacture them to meet your requirements. Our engineers have had extensive experience in this field and can also place at your disposal the vast research and production facilities of the BICC organisation.

BICC have designed and produced numerous multi-unit cables to meet specialised needs including flexible cables for electronic equipment. Some of these are shown below.

Write to us and let us assist you with your problems.



Multicore polythene-insulated and sheathed T/V Camera Cable.



Double-quad polythene-insulated audio-frequency cable.



Multicore polythene-insulated P.V.C. sheathed flexible T/V Camera Cable



Polythene-insulated P.V.C. sheathed multicore cable for film studio use.



multi-unit

LOW-LOSS CABLES

BRITISH INSULATED CALLENDER'S CABLES LIMITED
NORFOLK HOUSE, NORFOLK STREET LONDON, W.C.2

TWO SHILLINGS

a better baby...

The Walter Type B.T. Switch is a mighty midget. It takes up small panel space, and is just the switch for simple switching. Recently we have made some big improvements in it too. Here they are:

A new method of fixing contact blades. This ensures that they are completely rigid all the time. **Definite positioning of the drive spindle in the wafer, providing double bearing.**

There are other improvements as well—positive contact and steady contact resistance, better insulation between contacts, and a self-cleaning action. What does all that add up to? A sensible, reliable and lasting switch, which we feel will give you first class service and complete satisfaction.

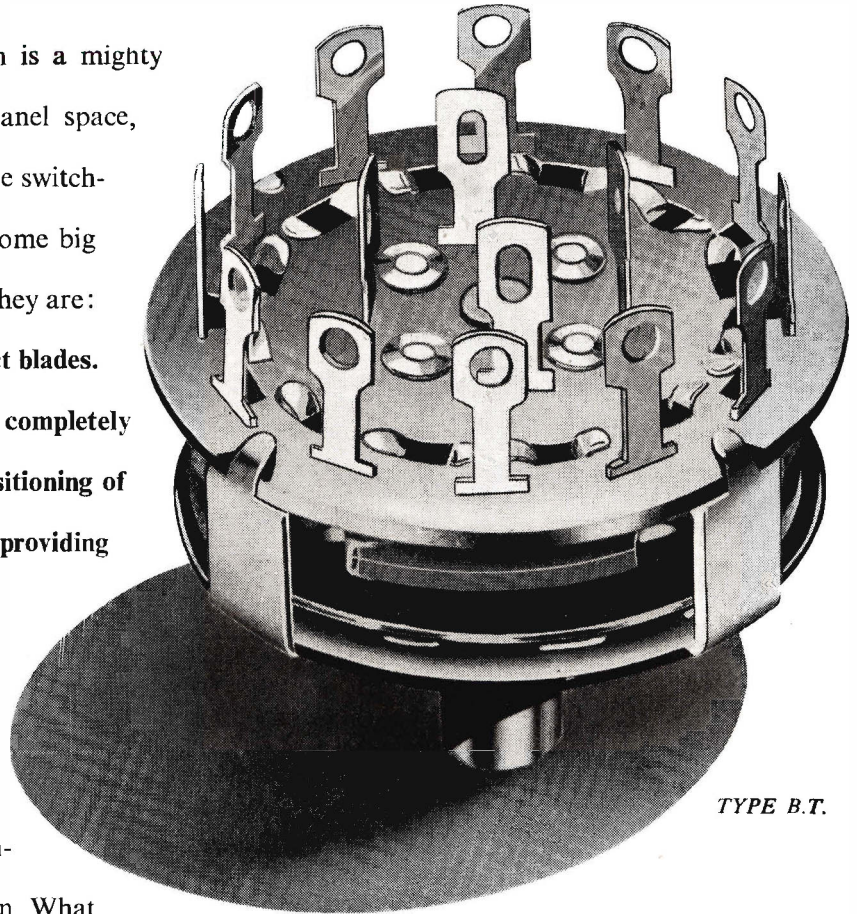

TYPE B.T.

Walter Instruments
LIMITED

**WALTER
SWITCHES**

**MADE
FOR LIFE**

GARTH ROAD, LOWER MORDEN, SURREY.

TELEPHONE: DERWENT 4421-2-3
CRC 48

CLASSIFIED ANNOUNCEMENTS

The charge for these advertisements at the LINE RATE (if under 1" or 12 lines) is : Three lines or under 7/6, each additional line 2/6. (The line averages seven words.) Box number 2/- extra, except in the case of advertisements in " Situations Wanted," when it is added free of charge. At the INCH RATE (if over 1" or 12 lines) the charge is 30/- per inch, single column. Prospectuses and Company's Financial Reports £14 0s. 0d. per column. A remittance must accompany the advertisement. Replies to box numbers should be addressed to : Morgan Bros. (Publishers), Ltd., 28, Essex Street, Strand, London, W.C.2, and marked " Electronic Engineering." Advertisements must be received before the 14th of the month for insertion in the following issue.

OFFICIAL APPOINTMENTS

ADMIRALTY. Vacancies exist for Electrical and/or Mechanical Engineering Draughtsmen in Admiralty Research and Development Establishments located in the vicinity of Weymouth, Portsmouth, Teddington (Middlesex) and Baldock, Herts. Draughtsmen experienced in light current, electro-mechanical precision mechanical and electronic equipment are particularly needed. Candidates must be British subjects of 21 years of age and upwards, who have had practical workshop experience (preferably an apprenticeship) together with Drawing Office experience. Appointments will be in an unestablished capacity, but opportunities may occur for qualified staff to compete for established posts. The salaries offered, depending on age, experience, ability and place of duty, will be within the range £283-£510 p.a. Exceptionally well qualified candidates may be considered for appointment in a higher grade within the salary range £470-£610 p.a. Hostel accommodation is available at some Establishments. Applications, stating age and details of technical qualifications and apprenticeship (or equivalents) and Workshop and Drawing Office experience, should be sent to Admiralty (C.E.11, Room 88) Empire Hotel, Bath. Original testimonials should not be forwarded with application. Candidates required for interview (at London or Bath whichever is nearer) will be advised within two weeks of receipt of application. W 2780

ROYAL AIR FORCE—Education Branch Permanent and Short Service Commissions. Applications are invited for Permanent Commissions (age limit 23-33 years) or for Short Service Commissions for 3, 4 or 5 years (minimum age 21 years). University graduates in Physics, Engineering (Mechanical, Aeronautical, Electrical, Electronic or Radio) or Mathematics are mainly required. Candidates for Permanent Commissions should ordinarily be first or second class honours graduates in one of these subjects. Pay on appointment depends on qualifications, experience and war service. Thus a first class honours graduate aged 25 may receive pay of £529 a year and, if married, marriage allowance of £338. Single officers receive free furnished accommodation. All officers draw rations in kind, or a tax-free allowance of £60 a year in lieu. There is time promotion to Squadron Leader, in which rank pay and marriage allowance rise to £1,232 a year (plus rations or ration allowance). Promotion to Wing Commander and higher rank is by selection. Retired pay for Permanent officers varies with rank (e.g. £625 for Wing Commander, £825 for Group Captain). Some Short Service officers will be selected annually for permanent commissions. Those not so selected receive a gratuity on completion of service. Short Service in the Education Branch can be treated as contributory for teachers' superannuation purposes. Women's Royal Air Force. Vacancies exist for Education Officers on Permanent and Short Service Commissions. Qualifications and conditions as for men except that pay rates are about three-quarters and retired pay rates about two-thirds of those for men. Free furnished accommodation and rations are provided. Full details and application forms for all the above appointments from Air Ministry A.R.1, Kingsway, London, W.C.2. W 2772

CROWN AGENTS FOR THE COLONIES. Electrical Engineer (Electronic) required for the Headquarters staff at the London Office. Salary scale £750 a year rising to £1,000 a year. Extra duty allowance of 8 per cent of annual salary also payable at present. Engagement will be on unestablished terms with a prospect, after satisfactory service, and as vacancies occur, of appointment to the established and pensionable staff and promotion to a higher grade. Candidates should preferably hold an Honours Degree in Electrical Engineering (Telecommunications and Electronics) or be corporate members of the Institution of Electrical Engineers. They should have served an apprenticeship with a firm of electrical engineers manufacturing radio or associated equipment and have had subsequent experience on the manufacturing and technical side of the in-

dustry. The appointment will, in the first instance, be to the Inspection Department and candidates should be capable of dealing with the problems arising from the inspection of a wide variety of electronic equipment by a staff of Inspecting Engineers. Apply at once by letter stating age, full names in block letters, and full particulars of qualifications and experience, and mentioning this paper, to the Crown Agents for the Colonies, 4 Millbank, London, S.W.1, quoting M.28544.B on both letter and envelope. The Crown Agents cannot undertake to acknowledge all applications and will communicate only with applicants selected for further consideration. W 2854

APPLICATIONS are invited by the Ministry of Supply for the following unestablished appointments at the Royal Aircraft Establishment, Farnborough, Hants: Physicists or Mathematical Physicists. (1) Principal Scientific Officer. Candidates should have experience of radar systems analysis and war-time operational research. A strong mathematical bias is desirable, ref. A.133/51A. (2) Senior Scientific Officer for theoretical investigations. A knowledge of statistical methods is desirable, ref. A.134/51A. Aeronautical Engineer. (3) Senior Scientific Officer with experience in planning and analysis of flight trials and application of results to project design. A knowledge of servo mechanisms theory and practice is required, experience of liaison with industrial firms an advantage, ref. C.217/51A. Physicists, Mathematicians or Engineers. (4) Senior Scientific Officer, with research experience involving arithmetical applications of mathematics in the analysis of physical data, and the formulation of problems for solution by automatic computing machinery. A knowledge of aerodynamics an advantage, ref. A.135/51A. (5) Senior Scientific Officer with wide experience of methods of measurement in physics or engineering research, experience and up-to-date knowledge of electronics, ref. A.136/51A. Candidates should have a 1st or 2nd Class Honours Degree in the appropriate subject and at least 3 years' post-graduate research experience is necessary. For the P.S.O. post, candidates must be at least 31 years of age, for the S.S.O. posts at least 26 years. Salary will be determined on age and on an assessment of the successful candidates' qualifications and experience within the ranges: Principal Scientific Officer £960-£1,295. Senior Scientific Officer £670-£860. Rates for women somewhat lower. Posts carry benefits of F.S.S.U. Application forms obtained from Ministry of Labour and National Service, Technical and Scientific Register (K), York House, Kingsway, W.C.2, quoting appropriate reference number. Closing date 24th May 1951. W 2858

TELECOMMUNICATIONS Engineers and Physicists are invited by the Ministry of Supply to apply for unestablished appointments in the grade of Principal Scientific Officer or Senior Scientific Officer at the Royal Aircraft Establishment, Farnborough, Hants. Candidates should have a 1st or 2nd Class Honours Degree in Physics or Telecommunications and upwards of 5 years' experience of research and development in one of the following: R.F. techniques at centimetric wavelengths; centimetric radar, preferably for airborne application; servo systems or telecommunication networks and feedback amplifiers. For the P.S.O. grade, candidates must be at least 31 years of age and for the S.S.O. grade at least 26. Salary will be determined on age and on an assessment of the successful candidates' qualifications and experience within the ranges: Principal Scientific Officer £960-£1,295. Senior Scientific Officer £670-£860. Rates for women somewhat lower. Posts carry benefits of F.S.S.U. Application forms obtainable from Ministry of Labour and National Service, Technical and Scientific Register (K), York House, Kingsway, W.C.2, quoting D.158/51-A. Closing date 24th May 1951. W 2859

ELECTRONIC ENGINEERS required by Government Department for unestablished post. Experience of development work including circuit design in telecommunications and of pulse techniques an advantage. Higher National Cer-

tificate or equivalent essential. Pay: £325 at 21 with increments of £25 to £425 at 25. Applicants over the age of 25 start at the 25 age point. Satisfactory performance of duties leads after age 25 and at least a year's service to a grade with salary £425-£600. London rates are quoted; provincial rates are rather less. Further prospects of advancement on merit to a grade with maximum of £700. Apply for application form to M.L.N.S., Technical and Scientific Register (K), York House, Kingsway, W.C.2, quoting D85/51-A. Closing date 14th June 1951. W 2873

ELECTRICAL ENGINEERS and Physicists are invited by the Ministry of Supply to apply for unestablished appointments in the grade of Senior Scientific Officer at the Royal Aircraft Establishment, Farnborough, Hants. Candidates should be at least 26 years of age and have a 1st or 2nd Class Honours Degree in the appropriate subject and at least 3 years' post-graduate research experience. They should also have a wide knowledge of communications work and H.F., V.H.F. or display techniques for research work associated with design and development of airborne and ground equipments. Salary will be determined on age and on an assessment of the successful candidate's qualifications and experience within the S.S.O. range £670-£860. Rates for women somewhat lower. Posts carry benefits of F.S.S.U. Application forms obtainable from Ministry of Labour and National Service, Technical and Scientific Register (K), York House, Kingsway, W.C.2 quoting D.159/51-A. Closing date 24th May 1951. W 2860

RADAR and Electrical Control Equipment Technicians wanted for work of national importance. Vacancies exist in various locations in the London and Home Counties area. Good prospects exist for advancement. Salary scale £400 p.a. rising to £525 p.a. Apply with full details of qualification, experience and area preferred to I.A.A. Group Wksps., Shrapnel Bks., Woolwich, S.E.18. W 2847

ELECTRONIC MECHANICS. Wanted for employment in various Establishments of the Ministry of Supply, Craftsmen experienced in the installation, operation, repair and maintenance of Radio, Radar, Signal, Fire Control and other electronic equipment. Applicants must have had wide experience of such work. Wages according to skill and experience from 139s. to 155s. with opportunities for advancement up to 173s. 6d. (London), 171s. (Provinces) for 44-hour 5-day week. Applications giving full particulars of age, apprenticeship, training, experience and qualifications to: Assistant Director, T.P.A.2, Ministry of Supply, Ivybridge House, John Adam Street, London, W.C.2. W 2851

ADMIRALTY. Temporary Assistant Overseers experienced in all Electrical Engineering techniques are required for temporary service in the Overseeing service of the Electrical Engineering Department, Admiralty. Vacancies exist at Glasgow, Belfast, Manchester, Newcastle, Nottingham, Gainsborough and Edinburgh, and further vacancies are expected to arise in other towns. Candidates must be British subjects of 21 years of age and upwards who have had practical workshop experience and preferably an apprenticeship. Salary will be assessed according to age, qualifications and experience on a range with a London maximum of £625 p.a. For candidates of 30 years of age salary will normally be related directly to age, i.e., £500 p.a. (London), and for younger candidates will be approximately £20 p.a. less than the age 30 rate for each year of age they are under 30. The London rates are reduced by from £10 to £15 p.a. at intermediate centres such as Belfast, Glasgow, Manchester and Newcastle, and by from £20 to £30 p.a. at other towns in the provinces. Applications stating age, details of technical qualifications and of apprenticeship (or equivalent) and of workshop experience should be sent to the Admiralty, Empire Hotel (C.E.II Room 83), Bath. Candidates will be interviewed locally as soon as possible after receipt of their applications. W 2857

SITUATIONS VACANT

SPERRY GYROSCOPE CO. LTD., Great West Road, Brentford, Middlesex, require Electro-Mechanical Engineer. Good academic qualifications and recognised apprenticeship desirable. Experience in electrical and electro-mechanical methods of computation; servo theory, and instrument design preferred. Apply with full details of experience and salary required to the Personnel Manager. W 124

SPERRY GYROSCOPE CO. LTD., Great West Road, Brentford, Middlesex, require Electronic Engineer. Good academic qualifications and recognised apprenticeship desirable. Required for development work on control systems. Experience of D.C. amplifiers and computing devices an advantage. Apply with full details of experience and salary required to the Personnel Manager. W 126

SPERRY GYROSCOPE CO. LTD., Great West Road, Brentford, Middlesex, require Mechanical Engineer. Good academic qualifications and recognised apprenticeship desirable. Preferably experienced in one or more of the following: precision mechanical design; hydraulics or pneumatic servo systems; servo theory, aerodynamics. Apply with full details of experience and salary required to the Personnel Manager. W 128

PROMINENT AIRCRAFT firm in Greater London area, commencing new project of great National importance, offers unique opportunity for advancement. High salaries with monthly staff status and Pension Scheme offered to suitably qualified applicants. Electronic Engineers with 1st Class Honours Degree in Mathematics or Engineering preferably with several years' practical experience, though not essential. Apply, stating age, nationality and experience, to Box Ac.58212, Samson Clarks, 57-61, Mortimer Street, W.1. W 131

FERRANTI LIMITED, Moston Works, Manchester, have staff vacancies in connexion with long term development work on an important radio tele-control project. (1) Senior Engineers or Scientists to take charge of research and development sections. Qualifications include a good degree in Physics or Electrical Engineering and extensive past experience in charge of development work. Salary according to qualifications and experience in the range of £1,000-£1,500 per annum. Please quote reference R.S.E. (2) Engineers and Scientists for research and development work in the following fields:—Radar, radio and electronic circuits, microwaves, high-power centimetric valves, vacuum and/or high voltage techniques, servo-control and electro-mechanical devices. Qualifications include a good Degree in Physics or Electrical Engineering or Mechanical Science, or equivalent qualifications. Previous experience is an advantage but is not essential. Salary according to qualifications and experience in the range, £420-£1,000 per annum. Please quote reference R.T.E. (3) Technical Assistants for experimental work in the fields listed in (2) above. Qualifications required: A Degree or Higher National Certificate in Electrical or Mechanical Engineering or equivalent qualifications. Salary in the range of £260-£550 according to age and experience. Please quote reference R.T.A. The Company has a Staff Pension Scheme, and will give housing assistance in special cases. Application forms from Mr. R. J. Hebbert, Staff Manager, Ferranti Limited, Hollinwood, Lancs. W 2764

E. K. COLE, LTD. (Malmesbury Division), invite applications from Electronic Engineers for permanent posts in Development Laboratories engaged on long-term projects involving the following techniques:—(1) Pulse Generation and Transmission. (2) Servo Mechanisms. (3) Centimetric and v.h.f. Systems. (4) Video and Feedback Amplifiers. (5) v.h.f. Transmission and Reception. (6) Electronics as applied to Atomic Physics. There are vacancies in the Senior Engineer, Engineers and Junior Grades. Candidates should have had at least 3 years industrial experience in the above types of work, together with educational qualifications equivalent to A.M.I.E.E. examination standard. Commencing salary and status will be commensurate with qualifications and experience. Excellent opportunities for advancement are offered with entry into a Pension Scheme after a period of service. Forms of application may be obtained from Personnel Manager, Ekco Works, Malmesbury, Wilts. W 2800

ELECTRONIC MECHANIC required by Oil Refinery for maintenance work on Process Controllers. Applicants must have experience of automatic electronic control. Industrial experience preferable but not essential. Apply Box No. W 1283.

TELECOMMUNICATIONS Research and Development Engineers are required by British Telecommunications Research Ltd., a Company associated with The Automatic Telephone & Electric Co. Ltd. and British Insulated Callenders Cables Ltd., for work on long term development projects. Applicants should preferably have a good University Degree in physics or light electrical engineering and have had experience of some aspect of development work in any of the following fields: (a) Wide-band line transmission systems and apparatus, or (b) v.h.f. and U.H.F. radio communication systems and apparatus, or (c) Electronic switching computing and control systems and apparatus. Applications for a number of more junior posts are also invited from Hons. Graduates in physics or electrical engineering who have an interest in the above fields. Salaries in accordance with experience and qualifications. Successful candidates will be required to join the B.I.C.C. superannuation scheme after an initial probationary period of 3 months. Application forms obtained from the Director of Research, British Telecommunications Research Ltd., Taplow Court, Taplow, Buckinghamshire. W 2795

McMICHAEL RADIO, LTD., require Senior Project Engineers in their Equipment Division Laboratory at Slough. Training and experience in the field of Applied Electronics (including Communications) and experience of working with Government Departments are the chief qualifications required. Salary will be commensurate with ability. Write stating age, and full details of training, qualifications and experience to the Chief Engineer, Equipment Division, McMichael Radio, Limited, Slough, Bucks. W 2799

PROMINENT AIRCRAFT FIRM in Greater London area commencing new project of National importance offers unique opportunity for advancement. High salaries with monthly status and pension scheme offered to suitably qualified applicants. Engineers required with good theoretical and practical experience in design and research in any of the following specialist groups:—(a) Radar, Marine or Aircraft, (b) U.H.F. Radio, (c) Low Frequency Amplifiers, (d) Electro-mechanical measurement techniques. City & Guilds qualification or University Degree desirable though not essential. Apply stating age, nationality and experience to Box AC60194, Samson Clark & Co., Ltd., 57-61 Mortimer Street, London, W.1. W 2790

ATTRACTIVE and interesting opportunities are available in an independent research group located in West London on important radar projects. Applications are invited from experienced Physicists or Electronic Engineers. Give full particulars of age, education, qualifications, experience and salary required to Box A.E. 283, Central News Ltd., 17 Moorgate, E.C.2. W 2783

SENIOR DEVELOPMENT ENGINEER. A large Engineering establishment in the North Kent area are requiring the services of Senior Development Engineers with technical and practical experience in electronics. Applicants should possess a good Degree, the minimum qualifications being the Higher National Certificate in Electrical Engineering. A good knowledge of Servo Mechanisms would be an advantage. Reply, stating age and giving full particulars of experience and salary required to Box No. W 2785.

DESIGN ENGINEER required by unit of English Electric Co. Ltd., working on important defence project, to undertake detailed design and layout of electromechanical analogue computing devices. Degree or H.N.C. essential and experience of Anti-Aircraft predictors, Magslip applications or the like desirable. Write giving full details and quoting Ref. 862 to Central Personnel Services, English Electric Co. Ltd., 24-30 Gillingham Street, London, S.W.1. W 2793

DIGITAL COMPUTERS: Ferranti Limited, Moston, Manchester, are engaged upon the long term development and exploitation of digital computers. This interesting work covers vacuum physics, the electronic and electrical properties of materials, computing and pulse circuit techniques, electrical and mechanical recording, electromechanical mechanisms, precision mechanical engineering and power supply equipment. In the course of this work there are occasional vacancies for senior engineers with wide experience from whom enquiries will be welcomed at any time. There are immediate vacancies for: (1) Engineers and Scientists for research and development work in the above fields. Qualifications include a good Honours Degree in Physics or Engineering, or equivalent experience. Salary according to qualifications and experience in the range £450 to £1,000 per annum. Please quote Ref. D.C.E. (2) Technicians Assistants for experimental work in the above fields. Qualifications are a Degree or Higher National Certificate in Engineering, or equivalent. Salary according to age and experience in the range £350 to £650 per annum. Please quote Ref. D.C.A. The Company has a Staff Pension Scheme and will give housing assistance in special cases. Application forms from the Staff Manager, Ferranti Limited, Hollinwood, Lancs. W 2825

A NUMBER of Senior and Junior vacancies for Radio, Radar, Electronic, Television, etc., Development, Service Engineers, Draughtsmen, Wiremen, Testers, Inspectors, etc. Urgently required, 30 Television Service Engineers. Write in confidence: Technical Employment Agency, 179 Clapham Road, London, S.W.9. (BRIxton 3487.) W 113

BELLING & LEE LTD., 540 Cambridge Arterial Road, Enfield, Middlesex, wish to engage a specialist to conduct aerial research and development, particularly at television frequencies. Applicants must possess scientific qualifications together with considerable experience in the field; must be imaginative and original, and able to work with minimum supervision. Excellent research facilities are available and an attractive salary will be offered to the right applicant. W 134

E. K. COLE, LTD., have vacancies in their Electronic Division at Malmesbury, Wilts., for senior and Intermediate Draughtsmen in the Development Drawing Office, for work on Radar, Communications, and Electronic Projects. Previous experience in this field desirable, but not essential. Apply in writing to the Personnel Manager, Ekco Works, Malmesbury, Wilts. W 2808

EXPERIENCED Electrical Testers and inspectors required for factory in Harrow area. Applicants should have sound theoretical knowledge of valve amplifiers. Salary dependent on ability and experience. Box No. W 2880.

CLASSIFIED ANNOUNCEMENTS continued on Page 4

FINE

RESISTANCE WIRES

Nickel - chromium

Copper - nickel

Minalpha

Mancoloy 10

FOR INSTRUMENT MANUFACTURE

Other JMC Products

PRODUCTS FOR PRESSURE
RESPONSIVE ELEMENTS

THERMOCOUPLES

CAPILLARY TUBES

INSTRUMENT POINTER TUBES

INSTRUMENT HAIR SPRING
STRIP

GALVANOMETER SUSPENSION
STRIP

Whenever an instrument depends for its accuracy upon a resistance wire, and particularly when that wire is of small diameter, uniformity of characteristics is vital. Long specialist experience of fine wire drawing enables us to guarantee extremely close tolerances on the nominal resistance per unit length and—equally important—consistency from batch to batch.

JMC resistance wires in nickel-chromium, copper-nickel, Minalpha and Mancoloy 10 and in other alloys for specialised requirements are normally available in sizes down to .0005 inch. Finer sizes can be produced if necessary.

A series of technical data sheets descriptive of our materials and products for instrument manufacture is available on request.

Specialised Products of

Johnson 
Matthey

JOHNSON, MATTHEY & CO., LIMITED, HATTON GARDEN, LONDON, E.C.1.

Telephone : HOLborn 9277.

GD 180

MAY 1951

3

ELECTRONIC ENGINEERING

SITUATIONS VACANT (Cont'd.)

EXPERIMENTAL ASSISTANT (Instrument Engineer) required. Duties include installation of thermocouples, etc., and maintenance of temperature recorders and similar equipment. National Certificate in Chemical Engineering or Matriculation standard essential. Salary range £420-£520. Pension scheme. 5-day week. Apply in writing to the Assistant Secretary, Ref. A.18, B.C.U.R.A., Randalls Road, Leatherhead, Surrey. W 1294

TECHNICIAN for electro-physiological research (E.E.G./E.M.G.) wanted by University Department in Medical School. Duties to operate and maintain multi-channel amplifying and recording equipment, and to assist with development of new research apparatus. Wide knowledge of electronics techniques and cathode ray oscillography desirable, preferably with experience of Ediswan or similar ink-writing E.E.G. equipment. Salary in range £390-£465, according to experience. Family Allowance and Superannuation. Apply, in writing, to the Secretary, Department of Physiology, Middlesex Hospital Medical School, London, W.1. W 1292

ELECTRONIC ENGINEERS required by Airmec Laboratories, Limited, Cressex, High Wycombe, Bucks, to be employed on interesting Government and commercial development work. Salary according to experience. Write giving full details to Personnel Officer. W 2870

ELECTRONIC ENGINEER required by Capacitor Manufacturers (E. London) for development work on test instruments and electrical research. Opportunity for young engineer with some years' experience. Write Box No. W 1291.

REQUIRED. Senior Draughtsman, preferably with experience of electronic engineering. Must be able to work on own initiative. Good prospects. Apply: Personnel Manager, Dynatron Radio, Limited, Ray Lea Road, Maidenhead, Berks. W 2866

A **SENIOR** Electronic Development Engineer and two Junior Engineers required by firm in Watford area. The work covers a wide field including L.F., R.F. and centimetric equipment, servo mechanisms and pulse circuits. Write stating age, qualifications, experience and salary required to Box No. W 2865.

AN **ELECTRONICS ENGINEER** is required by a scientific instrument company for the development stages of new spectroscopic equipment. Familiarity with layout and testing of electronic apparatus is desirable. Commencing salary £500 to £600 per annum according to qualifications and experience. Write Box No. W 2856.

LIBRARIAN required for E.M.I. Technical Library. Qualifications: Good general scientific background with practical experience, preferably in the field of Light Electrical Engineering, coupled with a keen interest in librarianship, though actual experience of this work is not essential. Knowledge of technical German and French would be an advantage. Age over 24 years. Please write giving full details of experience and salary required, etc., to ED/36, E.M.I. Engineering Development, Ltd., Blyth Road, Hayes, Middlesex. W 2855

DESIGN DRAUGHTSMAN (Senior), experienced in Instrument Design, required by large light engineering company, East London district. Apply in writing giving age, previous experience and salary required to Box No. W 2852.

ELECTRICAL and Electronic Engineers required in connexion with expanding work on new projects. Applicants should have at least Higher National Certificate in Electrical Engineering, or an equivalent qualification, and experience in one or more of the following: small motors, instruments, servo-mechanisms, pulse techniques, computer circuits. Write, stating experience and qualifications, to Employment Manager, Vickers-Armstrongs, Ltd. (Aircraft Section), Weybridge. W 2861

JUNIOR ENGINEERS interested in radio/radar and servo-mechanisms are required in special English Electric Company Laboratory working on new defence project. Preference given to applicants with Ordinary or Higher National Certificates in Electrical Engineering. Progressive position, commencing salary £400-£600 p.a. according to qualifications. Write, giving full details of age, qualifications and experience and quoting ref. 815A, to Central Personnel Services, English Electric Co., Ltd., 24-30 Gillingham Street, London, S.W.1. W 2864

DESIGNER-DRAUGHTSMAN aged 28/35. Sound knowledge light electro-mechanical apparatus. Used to handling detailing draughtsmen. Education at least H.N.C. standard. Old established and highly reputed firm of instrument and telegraph engineers, S.E. area. Applications with full particulars of age, experience and salary required to Box No. W 2848.

DRAUGHTSMAN aged 21/26 for Instrument and kindred Electro-mechanical apparatus design and detailing. Workshop experience. Education to O.N.C. standard or higher. Good opportunity for young man to gain wide experience. Beckenham area. Applications giving full particulars of age, experience and salary required to Box No. W 2849.

WOOLWICH POLYTECHNIC, London, S.E.18. The Governing Body invite applications for the post of Lecturer in Physics from men or women who possess Honours Degrees in Physics. Candidates should be prepared in the first place to teach Physics to the standard of the London Intermediate B.Sc. Examination. Opportunities for more advanced teaching may arise. Burnham Technical Scale Salary: £300-£15-£555, plus London allowance of £36-£48, plus the following where applicable: (i) Graduate allowance £30 above minimum and maximum; (ii) First Class Honours Degree—£15 above minimum and £30 above maximum; (iii) training allowance £15 for each year, up to three for full-time study or training beyond two years—above minimum and maximum; (iv) increments for industrial experience up to 12 years above minimum; (v) increments for full-time teaching experience. These scales will be revised as from 1st April 1951. Full particulars of the post and application forms may be obtained from the Clerk to the Governors, to whom they should be returned not later than 10th May 1951. W 2853

ENGINEERS required for development, servicing and instruction on electronic equipment. National Certificate standard. Previous experience on electronics or radar desirable. Remuneration according to experience and qualifications. Apply Construction Department, The British Thomson-Houston Co., Ltd., Rugby. W 2850

ELECTRONIC MOTOR CONTROL-DESIGN Engineer required. Applicants should have had previous experience in this field and have a power engineering background. Apply Staff Manager, General Electric Co., Ltd., Witton, Birmingham 6. W 2843

ELECTRONIC ENGINEER REQUIRED to handle 250 Kilowatt high frequency Induction Heater. Knowledge of Metallurgy and familiarity with high power Radio components essential. Please write stating age, experience and salary sought to Personnel Manager, De Havilland Propellers, Ltd., Manor Road, Hatfield, Herts. W 2789

SENIOR ENGINEER wanted for experimental work on radar, radio and/or electronics for modern high-speed project with special English Electric Company laboratory. Honours Degree preferable. Commencing salary £700/£900 p.a. Write giving full details, and quoting ref. 456D, to Central Personnel Services, English Electric Co., Ltd., 24/30 Gillingham Street, London, S.W.1. W 2869

DEVELOPMENT ENGINEER required, with Degree or equivalent in Telecommunications, Electrical Engineering or Physics and experience in design of Audio and Carrier Frequency Measuring Instruments. Knowledge of design of Noise Measuring Apparatus and/or Bridges an advantage. Salary according to qualifications and experience. Write giving full details to Personnel Manager, Standard Telephones & Cables, Ltd., Newport, Mon. W 2868

ELECTRICAL TESTER required. Preference given to man with experience of high frequency generators as used for high frequency heating. Apply: Applied High Frequency, Limited, 52a Goldhawk Road, London, W.12. W 1290

DESIGNER-DRAUGHTSMEN with Higher National Certificate, University Degree or similar qualifications and with 2-4 years' experience are required for work with experimental research teams in mechanical and radio engineering. Applications giving age and record should be sent to the Personnel Officer (Ref. GBLC/474), Research Laboratories of The General Electric Co., Ltd., East Lane, North Wembley, Middlesex. W 2867

ELECTRONIC TECHNICIAN with minimum five years' experience required North London to start department involving maintenance and operation of geophysical equipment. Box 266, Allardyce Palmer, Limited, 109 Kingsway, London, W.C.2. W 2872

REQUIRED. Electronics/Electrical Designer, take charge design and development wide range covering electronic welding and process controls. Small spot welders, rectifier units up to 50kW. Valve and relay circuitry experience essential. Should have Degree or equivalent with practical outlook. State age, experience and salary required. Hirst Electronic Development, Ltd., Dermody Road, London, S.E.13. W 1287

WANTED, an experienced Electronics Engineer to take charge of investigations into effect of anti-vibration measures in special English Electric Laboratory. Starting salary £500-£600 p.a. according to qualifications. Write, giving full details and quoting ref. 850A, to Central Personnel Services, English Electric Co., Ltd., 24-30 Gillingham Street, London, S.W.1. W 2862

PATENTS ENGINEER required for Patent Investigation work in connexion with Electronic Circuits. Applicants must have a University Degree in Electrical Engineering (Light Current) or Physics. Some previous practical experience on Research or Design advantageous or, alternatively, suitable technical experience in the Services. Write giving age, fullest details of education and experience, together with salary required, to Personnel Department (PDB), Electric & Musical Industries, Limited, Blyth Road, Hayes, Middlesex. W 2871

SENIOR ENGINEER wanted for experimental work on servo-mechanisms for modern high-speed project in special English Electric Company Laboratory. Good experience in servo loop design essential. Honours Degree preferable. Progressive position, with commencing salary £700-£900 p.a. Write, giving full details and quoting ref. 844B, to Central Personnel Services, English Electric Co., Ltd., 24-30 Gillingham Street, London, S.W.1. W 2863



The Metrovick Stabilised D.C. Power Unit

IN laboratories and meter testing stations there is often a demand for a highly stable d.c. voltage supply. The Power Unit, Type 222, has been produced to satisfy this demand.

SPECIFICATION

- Supply :** 200/250V, A.C., 50 c/s., single-phase.
- Output :** Between 660 and 680 volts D.C. (fixed) at up to 250 mA.
- Stability :** Maximum drift over 10 min-4 parts in 100,000.
Maximum drift over 1 hr-1.5 parts in 10,000.
These figures apply for mains input changes not exceeding $\pm 5\%$ after warming up period of two hours.
- Output Impedance :** Better than 0.1 ohm.
- Output Ripple :** Approximately 2mV r.m.s.

Stabilised D.C. Power Unit, complete with Voltage Divider Type 292

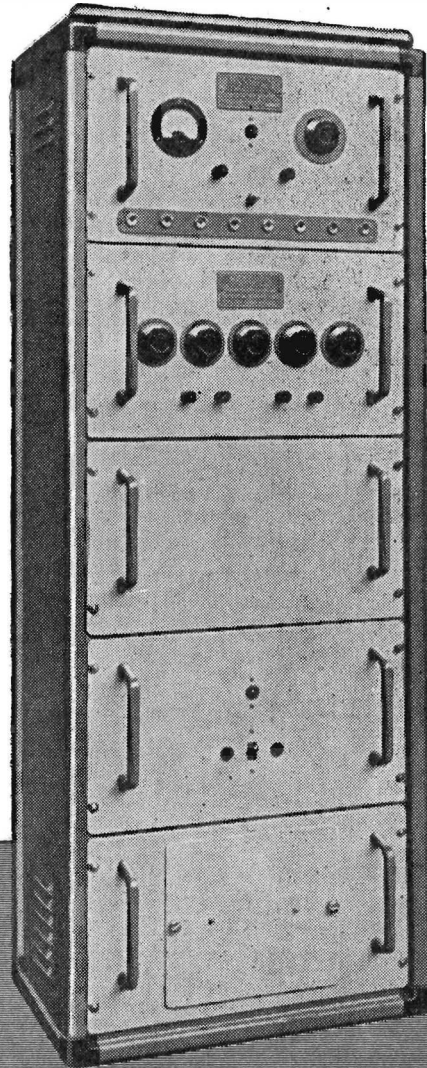

TYPE 222



METROPOLITAN-VICKERS ELECTRICAL CO. LTD.

TRAFFORD PARK, MANCHESTER 17

Member of the A.E.I. group of companies

R/E 904

SITUATIONS VACANT (Cont'd.)

YOUNG ELECTRONIC ENGINEER required by a Research Laboratory of a large Engineering Firm in the Midlands to work on specialized strain gauge testing equipment. Applicants should be 21 or 22 years of age, and should have had very sound training in radio or electronic engineering, together with some experience of practical development work. Box No. W 2846.

ELECTRONIC ENGINEER, graduate, with several years' production experience, required for development work on electronic and electrical apparatus. Write giving particulars of age, qualifications and salary required to the Personnel Officer, Aeronautical and General Instruments, Ltd., Purley Way, Croydon.

W 2845

DEPARTMENT OF COLLOID SCIENCE, Cambridge University. Applications are invited for a departmental Research Assistantship. The holder of this post will be expected to devote his time to the operation and maintenance of an air-driven ultracentrifuge. This requires the use of electronic, photographic and general laboratory techniques. Salary £300-£400 p.a. according to qualifications. Tenure—two years (in the first place). Please communicate with Dr. P. Johnson at the above address.

W 2844

SENIOR DEVELOPMENT ENGINEER required in the Test Gear Department of large Radio Manufacturer. Applicants must have technical knowledge of a high order and should have experience of development work in connexion with Electronic Circuits. Kindly state full details, including salary required, to Box No. W 2841.

RADIO DESIGNER-DRAUGHTSMEN for work in the field of radio communications, including airborne and V.H.F. equipment, are required by the G.E.C. Research Laboratories, North Wembley, Middlesex. At least 3 years' experience in a drawing office is essential. Apply by letter to the Personnel Officer (Ref. GBLC/189), giving age, record and qualifications.

W 2840

A GRADUATE ENGINEER is required by Marconi's Wireless Telegraph Co., Ltd., Chelmsford, for work on development and installation of high power transmitting aerials and associated equipment. A good salary will be offered to suitable applicant. The Company operates a staff superannuation scheme. Please write, giving full details and quoting ref. 874, to Central Personnel Services, English Electric Co., Ltd., 24-30 Gillingham Street, London, S.W.1.

W 2875

ASSISTANT required for Design Office of electronic navigational instrument manufacturers in Ilford district for maintenance of records and technical files. Young man with good knowledge of electronic and electrical components, preferably experienced in Drawing Office procedure and coding systems. Apply giving details of previous experience, age and salary required to Box No. W 2876.

TECHNICAL WRITER required by manufacturers of navigational, industrial and electronic instruments, in Ilford district, for preparation of instrument specifications, installation and maintenance instruction books and technical reports. Applicants should be familiar with Ministry and Inter-Services specifications, must have an ability for this form of writing and be accustomed to working closely with engineers and design staff. Design experience of small mechanisms and knowledge of materials essential. Knowledge of electronic and electrical components desirable. Apply giving details of previous experience, age and salary required to Box No. W 2877.

A SENIOR Sales Executive required by large old-established Engineering Company. Must have first-class technical knowledge, preferably with University Degree in Electrical Engineering. Extensive experience of Electronics essential. Position offers wide scope for really live man possessing initiative and sales ability of high order. Apply giving full details of age, education and positions held to Box No. W 2878.

TECHNICAL ASSISTANT with considerable experience of the wire and cable industry is required for light current and electronic engineering. The position involves a wide knowledge of specifications, the ability to prepare and maintain a classified index of cables, and the experience to assist designers in choosing cables. Applicants should write, giving full details, to the Personnel Department, E.M.I. Engineering Development, Ltd. (ED/40), Hayes, Middlesex.

W 2879

WANTED, competent engineer familiar with use of telemetry in the field. Salary £500-£700 p.a. according to experience. Please write, giving full details and quoting ref. HHE, to Box No. W 2874.

SITUATIONS WANTED

ABLE EXECUTIVE with technical knowledge and training. Radar experience in charge of installation and maintenance party during the war (R.A.F.). Now in retail television and electrical trade as buyer/manager, wishes to join manufacturer in sales or liaison capacity. Earning four figure salary. Box No. W 1293.

EDUCATIONAL

CITY AND GUILDS, (Electrical, etc.) on 'No Pass—No Fee' terms. Over 95 per cent Successes. For full details of modern courses in all branches of Electrical Technology send for our 176-page handbook—Free and post free. B.I.E.T. (Dept. 337c), 17 Stratford Place, London, W.1.

W 123

NORWOOD TECHNICAL COLLEGE, W. Norwood, London, S.E.27. Full-time, part-time day and evening courses in Radio and Television (Technology and Servicing), Radar and Line. Preparation for following examinations: C. & G. Full Technological, R.T.E.B., Amateur Transmitting Licence, P.M.G. Free Telecom. Prospectus (D) from the Secretary. (170.) W 2775

E.M.I. gave the world electronic television; E.M.I. is now giving the finest home study television courses; moderate terms—facilities for easy payment. Free brochure giving full details on application to the Registrar, Dept. EE.7, E.M.I. Institutes, 10 Pembridge Square, London, W.2. BAYswater 5131/2.

W 2791

FOR SALE

SELENIUM RECTIFIERS. FW, 12V, 1A, 5s. 6d. 4A, 14s. HW 250V, 70 MA, 4s. Sliding resistances, 1 ohm 12A, 4 ohm 6A, 6s. Fixed 1 ohm 12A, 3s. 6d. Vitreous, 800, 30W, tapped 2s. 2,000 30W, 1s 3d. 1,500 15W, 10d. 50 200 5W, 5d. 25, 1,000, 1,500, 3W, 4d. 45, 100, 1,200 2W, 3d. Tone controls 15,000, 6d. Voltmeters AC/DC 0-15, 5s. Motors squirrel cage, 24V, 3ph, 5s. Reduction quantities. Letters answered: Parker, 3, Longdene Road, Haslemere, Surrey.

W 1271

MERCURY SWITCHES are made by Hall Drysdale & Co. Ltd., of 58 Commerce Road, Wood Green, London, N.22. Phone BOWes Park 7221-2.

W 107

MAGSLIPS at 1/10th to 1/20th of list prices. Huge stocks. Please state requirements. K. Logan, Westalloy, Hitchin, Herts.

W 116

AMERICAN MAGAZINES. One year post free. "Radio Electronics," 32s. 3d.; "Audio Engineering," 28s. 9d.; "Radio and Television News," 36s.; "Popular Science," 28s. 6d. S.A.E. for full list from Willen Ltd., (Dept. 9), 101 Fleet Street, London, E.C.4.

W 101

GLASS-TO-METAL SEALS and High Vacuum by Hall, Drysdale & Co. Ltd., of 58 Commerce Road, Wood Green, London, N.22. Phone: BOWes Park 7221.

W 117

WEBB'S 1948 Radio Map of World, new multi-colour printing with up-to-date call signs and fresh information; on heavy art paper. 4s. 6d., post 6d. On linen on rollers, 11s. 6d., post 9d.

W 102

FIRST BOOK about transmitters "Radio Communication Transmitters" by J. J. Hupert, Prof. de Paul University, Chicago, USA, published by ATA Scientific Progress Ltd., 19, Effra Road, S.W.2, price, 24s.

W 133

PURE BERYLLIUM FOIL, 0.005 in. thick, for X-Ray Tube Windows. Elgar Trading Limited, 240 High Street, London, N.W.10.

W 132

RF COILS, 10kc/s to 100Mc/s, Singly or Quantity. Bel Sound Products Co., Marlborough Yard, Archway, N.19. ARC. 5078.

W 2794

ELECTRONIC ORGAN Construction Data; component values, practical layout, etc. Further details—C. & S., 10 Duke Street, Darlington, Durham.

W 1284

POLYSTYRENE SHEET and Rod. Sheets 28" x 20" and 22" x 18" in varied thicknesses. Rod various diameters in 6' lengths. Miltoid, Ltd., 34-5 Royal College Street, London, N.W.1. Phone EUSton 6467.

W 1289

RECORDING WIRE. Stainless Steel, 3,600ft. reels, 4s. 9d. 12 Rosendale Avenue, Blackley, Manchester 9.

W 1286

AMERICAN "ELECTRONICS", 36 monthly issues ending March 1951. Excellent condition. Cost approximately 10s. per issue. Offers for the lot. Box No. W 1296.

SERVICE

YOUR COPIES BOUND, handsome volumes. imit. Blue Leather, Gold Lettering, 10s. 6d. each, post free. C.W.O. Jerome Alcock, Cheadle, Stoke-on-Trent.

W 1272

METALWORK. All types cabinets, chassis, racks, etc., to your own specifications. Write Dept. "T," Philpott's Metal Works, Ltd., Chapman Street, Loughborough.

W 2731

GLASSBLOWING, repetition and scientific, by Hall Drysdale & Co. Ltd., of 58 Commerce Road, Wood Green, London, N.22. Phone BOWes Park 7221-2.

W 109

SHEET METALWORK. Chassis, cabinets, instrument cases made to your own specification. Prototype and one off a speciality. Beauclerc Metalworks, 30 Beauclerc Road, London, W.6.

W 1288

BUSINESS OPPORTUNITIES

REPRESENTATIVE leaving for South Africa in May desirous of contacting British Manufacturers. Box No. W 1295.

FOR DISPOSAL as a going concern, Limited Company, world wide reputation, good profits record, profitable contracts, adequate supplies of raw material, well introduced to Government Departments, manufacturing components for the electronic and electrical industries, essential to the defence programme, housed in modern factory in west country town with ample room for expansion. Director who is approaching retiring age would (a) sell all shares outright for cash about £30,000, buildings on lease or could be purchased, (b) sell portion of shares for cash and exchange remainder for shares in reputable public company, (c) take in as co-director, energetic individual with knowledge of the electronic industry prepared to invest at least £10,000 and eventually to take entire charge.

W 1300



Partridge News

precision

TRANSFORMERS

"TO SPECIFICATION" or STANDARD, if the problem is Transformers or Chokes, none are more experienced to find the solution than Partridge. Nearly two decades of specialised research and production have prompted leading industrial concerns and Government Experimental Stations consistently to use the unequalled Partridge service. Your need, too, can be adequately met for transformers ranging from 5VA to 50 kVA —power or A.F. Send for catalogue and data sheets.

* Note: All Partridge components are now available HERMETICALLY SEALED IN OIL



PARTRIDGE
TRANSFORMERS LTD

ROEBUCK ROAD, KINGSTON-BY-PASS
TOLWORTH SURREY
Telephone ELMbridge 6737-8

BECKENHAM • KENT • ENGLAND Telephone: Beckenham 0041 Telegrams and Cables: MURHEADS ELMERS-END

MURHEAD & CO. LTD.

MURHEAD PRECISION ELECTRICAL INSTRUMENTS

Please send me, free of charge, your 1951 CATALOGUE advertised in "Electronic Engineering"

NAME _____
ADDRESS _____

48K

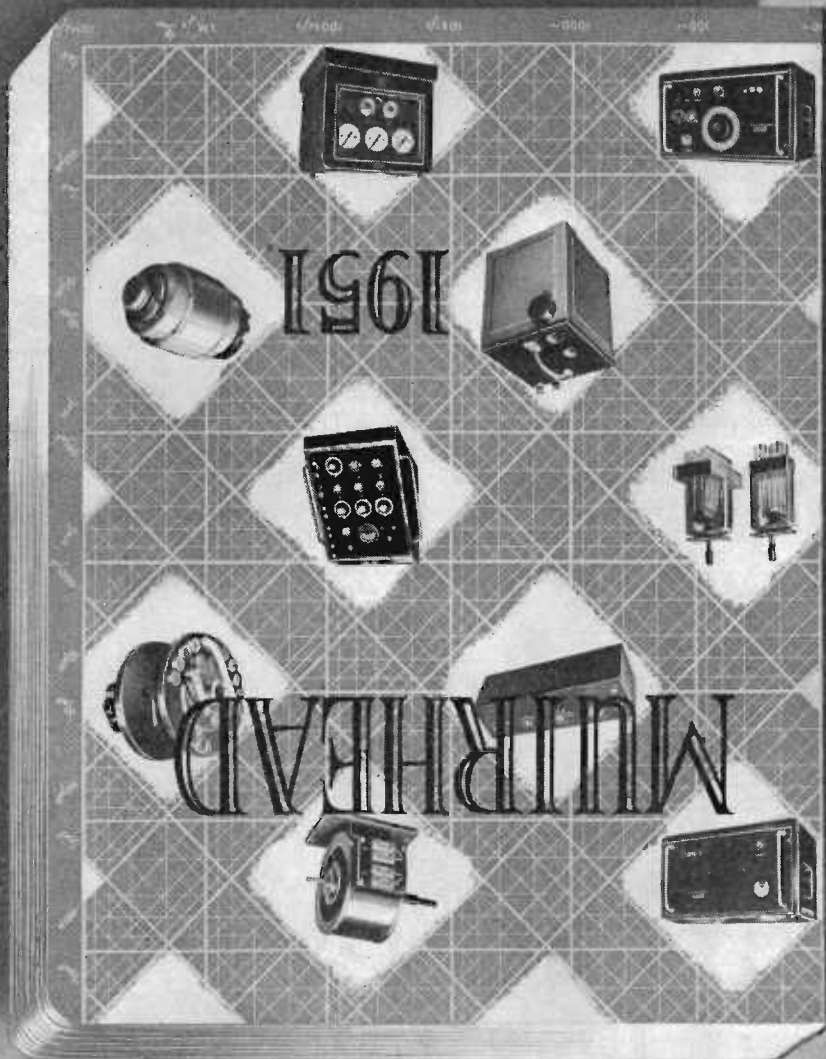

MURHEAD 1951 CATALOGUE



HIGH QUALITY REPRODUCTION

"FIFTY and THIRTY WATT" CINEMA AMPLIFIERS

as illustrated for single or double P.E.C. input with separate adjustable bias. Full range of tone controls to suit all needs with built-in Exciter Supply if required.

PRICES range from 34½ gns. to 42½ gns.

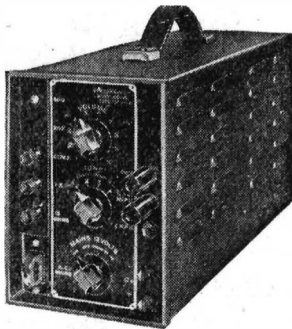

TYPE C.P. 20A AMPLIFIER

For AC Mains and 12 volt working giving 15 watts output, has switch change-over from AC to DC and "Stand-by" positions. Consumes only 5½ amperes from 12 volt battery. Fitted with mu-metal shielded microphone transformer for 15 ohm microphone, provision for crystal or moving iron pick-up with tone control for bass and top. Outputs for 7.5 and 15 ohms. Complete in steel case with valves.

PRICE £28 . 0 . 0.

FOUR-WAY ELECTRONIC MIXER

This unit has 4 built-in balanced and screened microphone transformers, normally of 50-30 ohms impedance. It has 5 valves and selenium rectifier supplied by its own built-in screened power pack, consumption 20 watts. Suitable for recording and dubbing, or large P.A. installations since it will drive up to six of our 50 watts amplifiers whose base dimensions it matches. The standard model has an output impedance of 20,000 ohms or less, and any Impedance can be supplied to order.

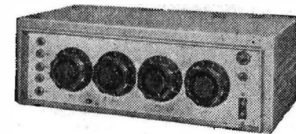

PRICE £24 . 0 . 0.

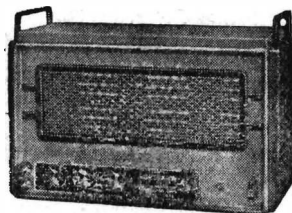

OTHER MODELS IN OUR RANGE OF AMPLIFIERS

- "SUPER-FIFTY WATT" - - - - - PRICE 36½ gns.
- "THIRTY WATT" - - - - - " 30½ gns.
- "10-15 WATT RECORD REPRODUCER" .. 25½ gns.

These are fitted in well-ventilated steel cases with recessed controls, as illustrated.

Full details upon request
EXPORT ENQUIRIES INVITED

VORTEXION LIMITED, 257-261 THE BROADWAY, WIMBLEDON, LONDON, S.W.19.

Telephones : LIB 2814 and 6242-3

Telegrams : "Vortexion Wimble, London"

Laminations

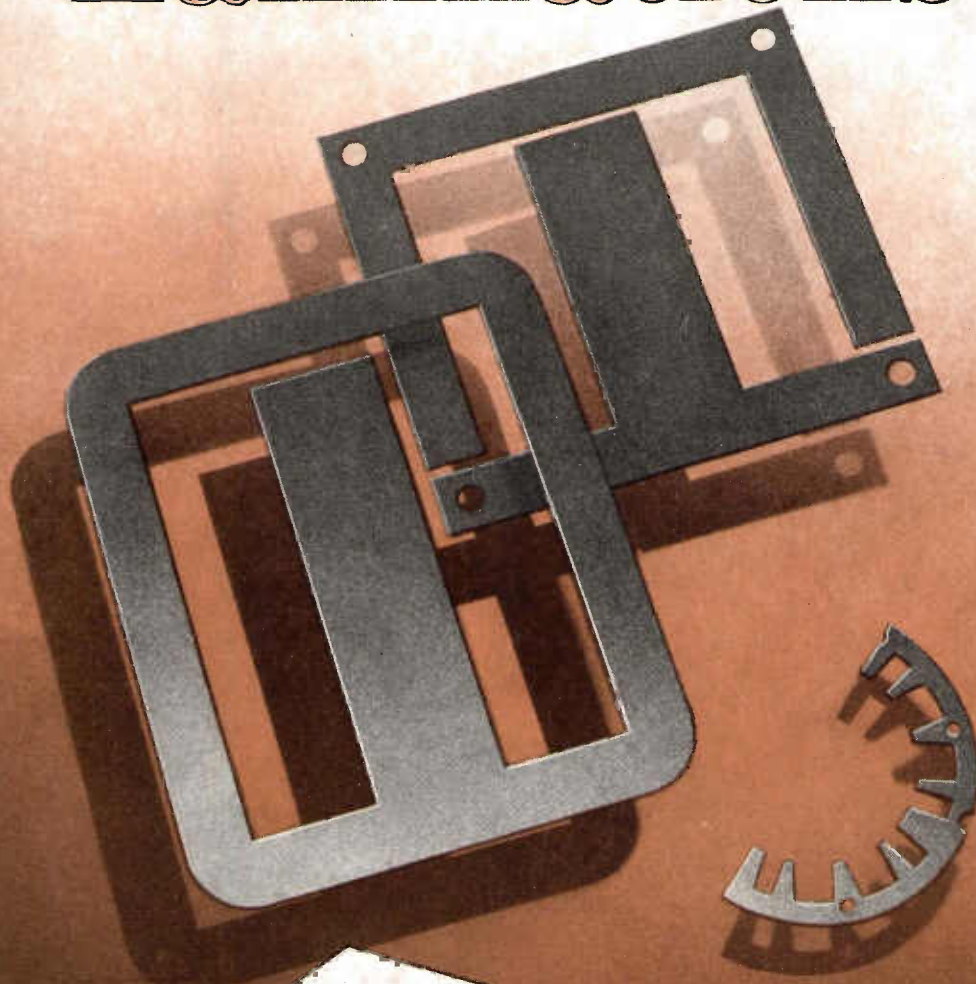

*Richard Thomas
& Baldwins Ltd.*

WILDEN IRON WORKS, STOURPORT-ON-SEVERN

LONDON OFFICE: 47 PARK STREET, W.1

'ENGLISH ELECTRIC'

electronic insulation tester



Designed for industrial electrical testing

It provides for the first time **10-kV D.C.** in a truly portable equipment having the following outstanding features :

Non-lethal output adjustable from 500 to 10,000-volts.

Measurement up to 250,000 megohms.

High accuracy on comparative tests.

Rejection of surface leakage current.

Aural indication of ionisation.

Price **£55** · Size : 16" × 10" × 6" · Weight : 23 lbs.

The **ENGLISH ELECTRIC** Company Limited

QUEENS HOUSE, KINGSWAY, LONDON, W.C.2

Industrial Electronics Dept. Stafford

Works : STAFFORD · PRESTON · RUGBY · BRADFORD · LIVERPOOL

EIN. 1.

MODERN CAPACITOR ENGINEERING

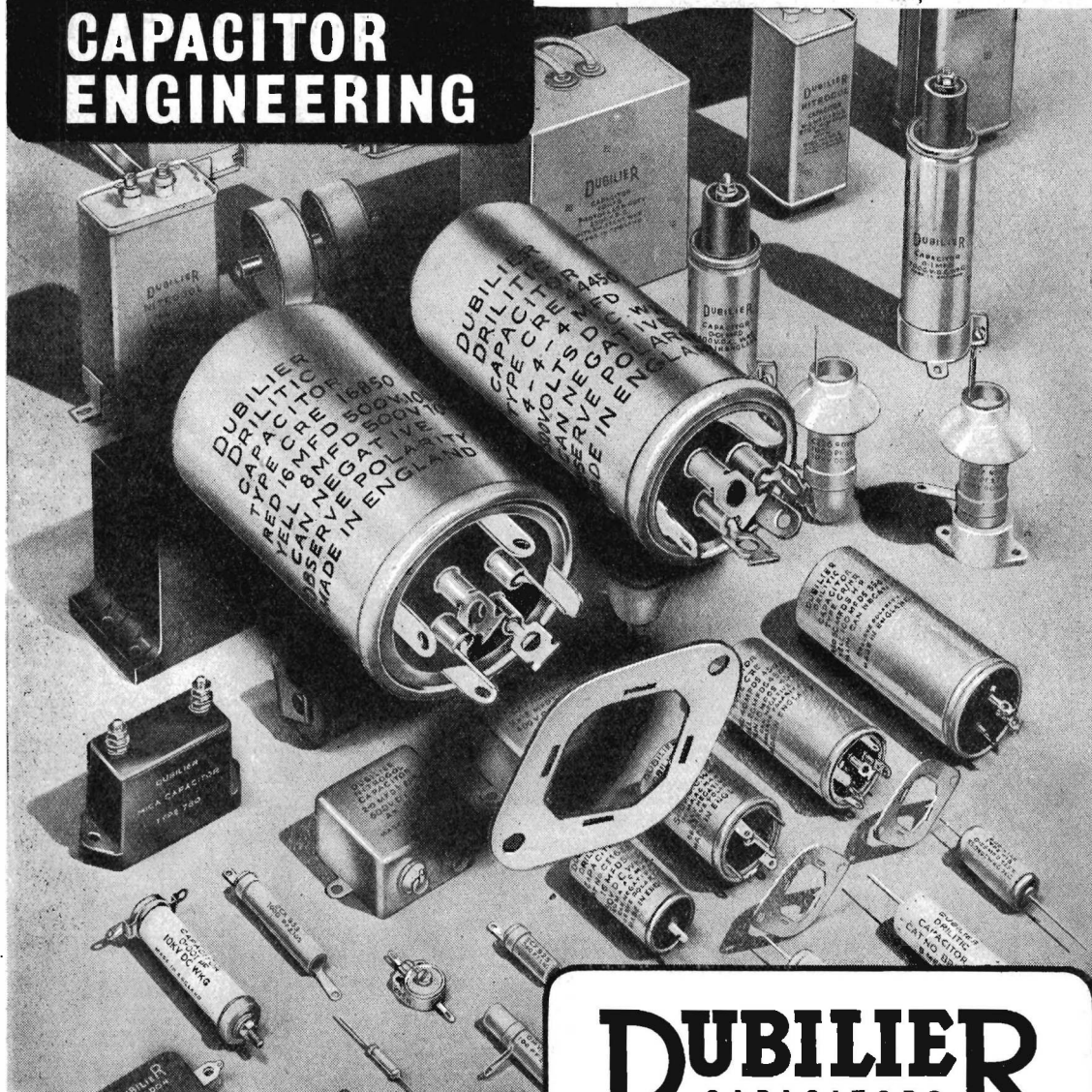

DUBILIER CAPACITORS

THIS modern method of mounting Dubilier Drilitic Capacitors enables the maximum advantage to be secured from the improved electrical characteristics and size reductions, and is one instance of modern capacitor engineering.

No loose parts, clamps, screws or rivets are necessary—a slight twist of the mounting ears and the capacitor is fixed. For chassis capacitor isolation, bakelite mounting plates are supplied; metal plates are available with identical centres

for general replacement purposes of the older type capacitors and for interim tooling period. Ear Mounting Drilitic Capacitors type C.T.E. and C.R.E. have hermetically sealed seamless drawn aluminium containers, have solder tags and are supplied in the usual capacitances and voltages.

Comprehensive catalogues giving detailed information of Dubilier capacitors and technical service are available upon request.

DUBILIER CONDENSER CO. (1925) LTD., DUCON WORKS, VICTORIA ROAD, N. ACTON, LONDON, W.3
 Phone: Acorn 2241 (5 lines) Cables: Hivolcon, London. Marconi International Code. Grams: Hivolcon, Wesphone, London

D48A

Light . . . robust . . . durable

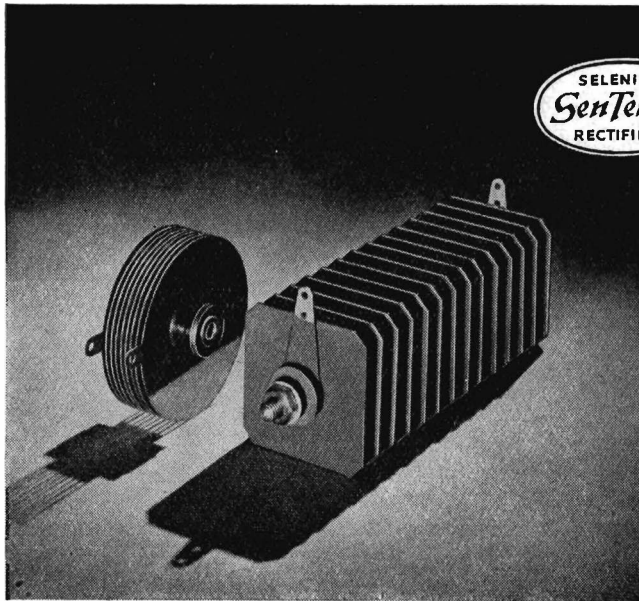

miniature H.T. Rectifiers

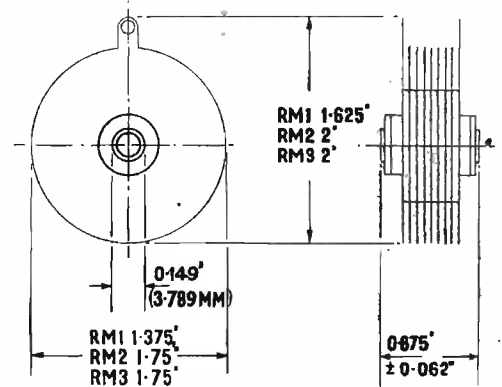

SenTerCel miniature H.T. Selenium rectifiers offer these unique features :

- Instant starting — no warming-up period
- Unlimited instantaneous overload
- No limit to size of reservoir capacitor
- Withstand overloads such as charging current of deformed electrolytic capacitors.
- Low heat dissipation
- Practically indestructible in service
- Simple mounting — no valve holder
- Simple wiring — two connectors only
- Small size . . . low weight
- Low cost

Ratings

TYPE	RM1		RM2		RM3		RM4		
	35°C	55°C	35°C	55°C	35°C	55°C	35°C	40°C	55°C
Maximum ambient temperature	35°C	55°C	35°C	55°C	35°C	55°C	35°C	40°C	55°C
Maximum output current (mean)	60mA	30mA	100mA	60mA	120mA	90mA	275mA	250mA	125mA
Maximum input voltage (r.m.s.)	125V		125V		125V		250V		
Maximum peak inverse voltage	350V		350V		350V		700V		
Max. instantaneous peak current	Unlimited		Unlimited		Unlimited		Unlimited		
Weight	1 oz.		1.4 oz.		2 oz.		4.5 oz.		

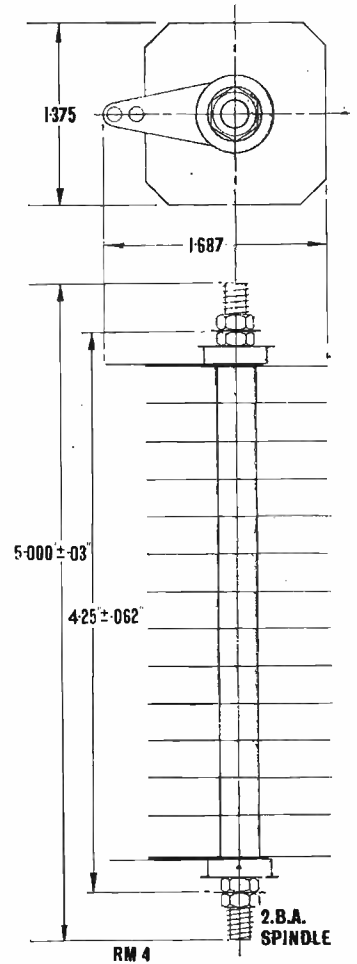

Standard Telephones and Cables Limited

Registered Office : Connaught House, Aldwych London, W.C.2

RECTIFIER DIVISION : WARWICK ROAD, BOREHAM WOOD, HERTS.

Phone : Elstree 2401

Grams : SenTerCel Borehamwood

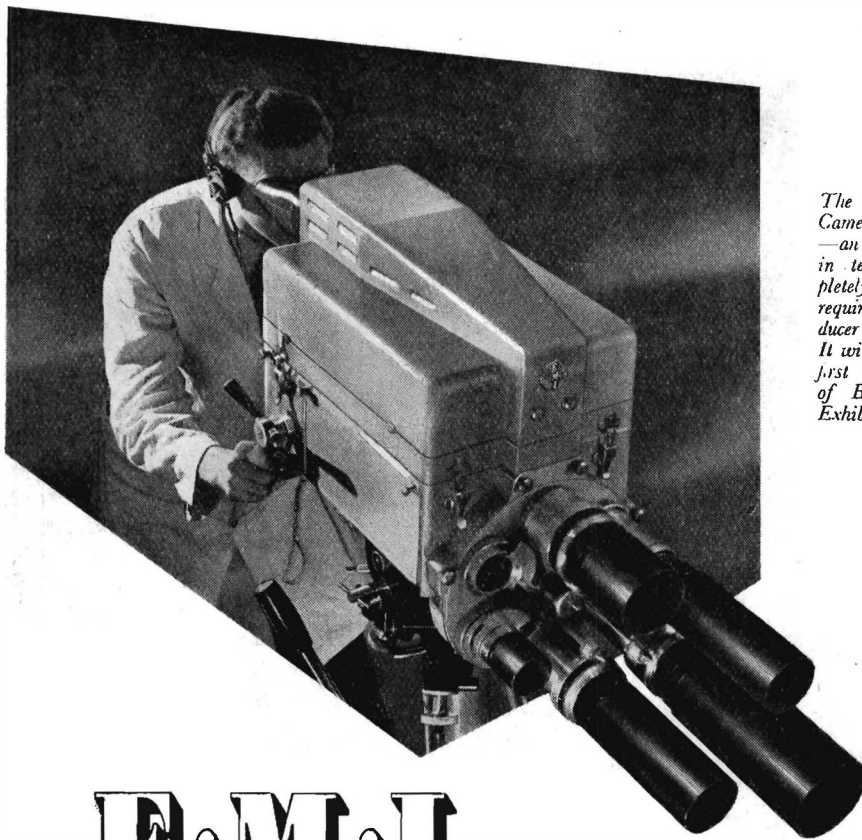

The latest C.P.S. Emitron Camera with 6 lens turret — an entirely new conception in television which completely satisfies the exacting requirements of both producer and operator. It will be in action for the first time at the Festival of Britain, South Bank Exhibition.

E·M·I

The leading British organisation for the Design, Development and Manufacture of Electronic equipment of all kinds.

COMPLETE TELEVISION TRANSMITTING STATIONS INCLUDING STUDIO EQUIPMENT, FILM CHANNELS, EMITRON CAMERAS, SOUND EQUIPMENT, AERIALS, TRANSPORTABLE AND MOBILE TRANSMITTERS • TELEVISION RECEIVERS • RADIO TRANSMITTERS • BROADCAST AND COMMUNICATIONS RECEIVERS (A.M. & F.M.) • RADIO AND TELEVISION RELAY EQUIPMENT • EMISCOPE CATHODE RAY TUBES • AIRBORNE RADAR (BEAM APPROACH EQUIPMENT) • VELOCITY MODULATED OSCILLATORS • MULTIPLIER PHOTO-TUBES • ELECTRONIC MEASURING EQUIPMENT • R.F. INDUCTION AND DIELECTRIC HEATERS • ELECTRONIC DICTATION MACHINES • RECORDS • DISC AND MAGNETIC TAPE RECORDERS • DOMESTIC ELECTRIC APPLIANCES.



ELECTRIC & MUSICAL INDUSTRIES LTD. HEADQUARTERS: HAYES : MIDDLESEX • ENGLAND

E 209



Pointers for Designers AND CONSTRUCTORS

TELEVISION SOUND RECEPTION



One of the main requirements of a television sound receiver is a high attenuation of the adjacent vision carrier frequencies. This attenuation should not be less than 30-40 db and is normally effected by the use of several tuned circuits used in conjunction with RF pentodes having high mutual conductance which, however, usually have an input resistance of under 10 k Ω .

It is apparent that the required attenuation may be achieved with fewer tuned circuits if the associated valves have a higher input resistance - resulting in less damping of the circuits. The Osram W 77 meets this requirement, having approximately three to four times the input resistance of the normal RF Pentode. This is only one of many applications of the W 77 miniature valve.

Write for a copy of the data sheet on the W77 to: Osram Valve and Electronics Dept., Magnet House, Kingsway, W.C.2.

W77

MADE IN ENGLAND

W77 PENTODE

DESCRIPTION
Type W77 is an indirectly heated variable-mu pentode in the miniature range and suitable for R.F. and I.F. amplifiers.

RATINGS

Heater Voltage	6.3	volts
Heater Current	0.5	approx. max.
Anode Voltage	250	max. volts
Anode Dissipation	7.5	max. watts
Screen Voltage	150	max. volts
Screen Dissipation	0.5	max. watts
Impedance*	9.5	approx. megohm
Mutual Conductance*	25	max./volt

* measured at $V_a = V_g = 200$; $V_{g1} = -2.5$

Capacitances (taken on valve with external screening cap.)

Control Grid to AF	4.6	approx. pF
Anode to AG	8.5	" "
Anode to Control Grid	0.300	" "

OPERATING CONDITIONS

R.F. Amplifier, Class A

Anode Voltage	200	200	volts
Screen Voltage	200	200	volts
Suppressor Voltage	0	0	volts
Anode Current	8.0	7.7	mA
Screen Current	2.8	1.9	mA
Cathode-Base Resistance	150	270	ohms
Control Grid Voltage	-2.5	-2.7	volts

The effective external grid to cathode resistance should not exceed 1 megohm.

DIMENSIONS

All dimensions are in mm and are max. except where otherwise stated.

BASE

Pin 1	Control Grid, pt
2	Cathode
3	Heater
4	Heater
5	Anode
6	Suppressor Grid, pt and Shield
7	Control Grid, pt

An internal shield is fitted to this valve and pinned to pin 6.

THE GENERAL ELECTRIC CO. LTD., MAGNET HOUSE, KINGSWAY, W.C.2.

The "Belling-Lee" page for Engineers

"MINIFUSE" MINIATURE FUSES

U.K. patent 647049

LIST No. L.562

Ratings
10, 15, 25, 50, 100,
250 and 500 mA
1 and 2.5 amp.

Ideal where space is a limiting factor. A miniature fuse with a wire element only $\frac{5}{8}$ in. by $\frac{1}{16}$ in.

The results of long development enable such a fine element to be handled in production to give reliable results from 10mA to 50mA.

Useful in the protection of small meters, test and laboratory gear, etc.

Ratings from 50mA comply with R.C.L. 261.1.

Fusing time with 120 per cent overload=1 second.

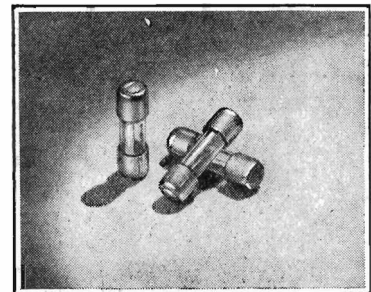
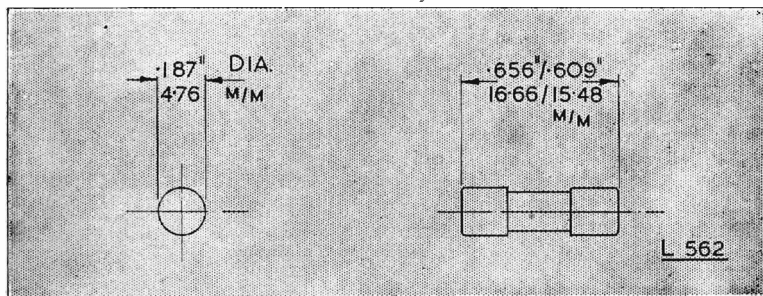

May be obtained
tropically finished
to service requirements

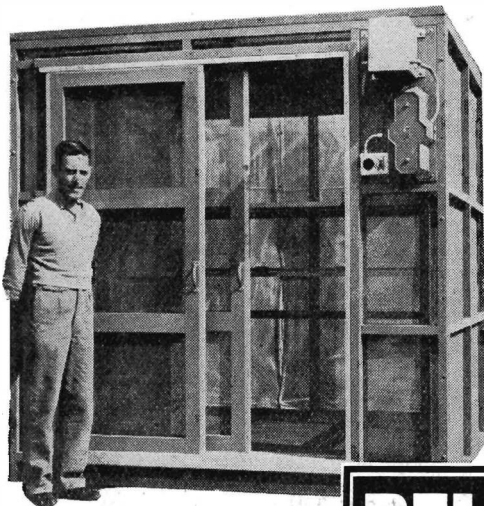

Illustration shows a typical screened compartment, designed to customer's special requirements. Design and prices submitted on request.

SCREENED COMPARTMENTS — SECTIONALISED

A screened compartment has two purposes, to provide an interference free space in which to test, calibrate or use high gain electronic equipment; to surround equipment known to be creating radio interference.

In the first instance very great care and experience is required in design, and invariably a double screen is necessary.

Where electric power supply is required inside a compartment, interference filters of the correct current rating can be supplied and fitted, and the effectiveness of the screen is limited by the efficiency of such filters. We can now provide suppression from 150 Kc/s to 300 Mc/s.

With the inclusion of these mains filters the screening attenuation at the very high frequencies is in the order of 55 db.

Screened power transformers, additional electric fittings, benches, shelves, etc., can be provided to customers requirements.

To allow access to the site, and to facilitate easy transportation the compartments are sectionalised, adequate provision being made for bonding. An important feature of design is sliding doors which operate in steel channels and, when closed, maintain multi-point electrical contact all round.

The screening requirements for the second category are not so severe, nor are the limits yet laid down under the Wireless Telegraphy Bill.

We invite you to inspect our stand No. C. 710 at the B.I.F., Birmingham.

BELLING & LEE LTD
CAMBRIDGE ARTERIAL RD., ENFIELD, MIDDX., ENGLAND



PHOTO-ELECTRIC RELAY

for 'ON' or 'OFF' control
of ELECTRIC POWER

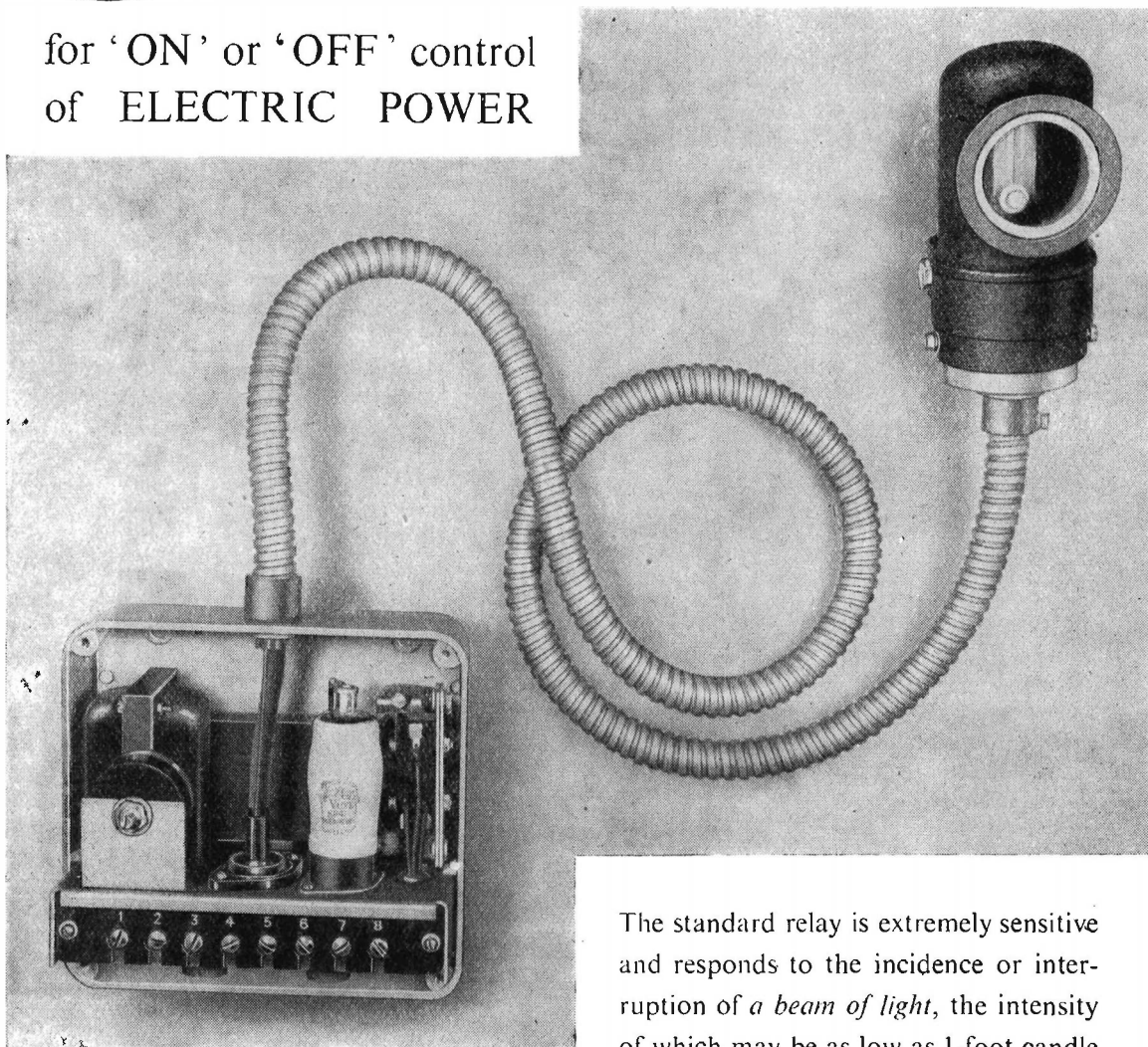

The standard relay is extremely sensitive and responds to the incidence or interruption of a *beam of light*, the intensity of which may be as low as 1-foot candle and the duration as short as one-tenth of a second.

Applications to industrial processes include:— Control of lighting, liquid level, register, side-play, dimension, weighing, counting, etc; also alarm devices.

THE
—BRITISH THOMSON-HOUSTON—
COMPANY LIMITED, RUGBY, ENGLAND

Member of the AEI group of companies

A4254

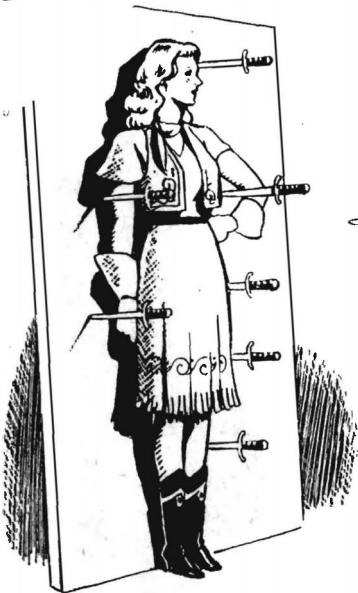

WHEN ACCURACY COUNTS

There are many times when a frequency source is required, the accuracy of which can be relied upon.

THE 'CINTEL' R.C. OSCILLATOR AND FREQUENCY MONITOR

provides any frequency in the range 10c/s to 100Kc/s with an accuracy of $\pm 0.005\%$, $\pm 0.1c/s$ and indicates the exact value by means of an electronic monitor. This monitor samples the frequency every 5 seconds, measures it against a crystal and indicates the result on five panel meters each scaled 0 — 9. This operation continues automatically and thus the exact output frequency is always known. Full technical details are available in publication No. RCI/1.



CINEMA-TELEVISION LIMITED

A Company within the J. Arthur Rank Organisation

FOREMOST IN THE MANUFACTURE OF

Counters & Chronometers • Metal Detectors • Oscilloscopes • Photo-Electric Cells • Cathode Ray Tubes • Geiger-Muller Tubes • Electronic Instruments

WORSLEY BRIDGE ROAD · LONDON · S·E·26

Telephone: Hither Green 4600

F. C. Robinson & Partners Ltd.,
287 Deansgate, Manchester, 3.

SALES AND SERVICING AGENTS:
Atkins, Robertson & Whiteford Ltd.,
100 Torrisdale Street, Glasgow, S.2.

H. Hawnt & Co. Ltd.,
59 Moor St., Birmingham, 4



VALVES For **SPECIAL PURPOSES**

For stabilised power supplies

A typical example of the use of Ediswan Mazda 12E1 valves is illustrated in these photographs of a standard rack-mounted unit as supplied by All-Power Transformers, Ltd., for Government Communication and G.P.O. use. These units supply a stabilised D.C. output up to 5 amps. The Ediswan Mazda 12E1 is an indirectly heated Beam Tetrode designed for use as a series or shunt control valve in stabilised power packs.

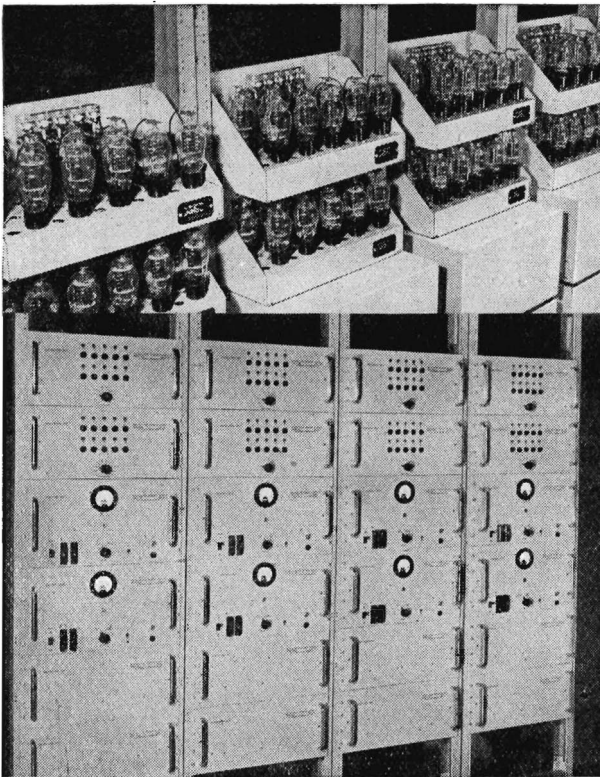

RATING

Heater Voltage (volts)	V_h	6.3
Heater Current (amps.)	I_h	1.6
Maximum Anode Voltage (volts)	$V_a(\text{max.})$	800
Maximum Screen Voltage (volts)	$V_{g2}(\text{max.})$	300
Maximum Control Grid Voltage	$V_{g1}(\text{max.})$	-100
Maximum Voltage between g1 and g2 (volts)	V_{g1-g2}	400
Mutual Conductance (mA/V)	g_m	* 14
Maximum Anode Dissipation (watts)	p_a	35
Maximum Screen Dissipation (watts)	p_{g2}	5.0
Maximum Cathode Current (mA)	$I_k(\text{max.})$	300
Maximum Potential Heater/Cathode (volts DC)	$V_{h-k}(\text{max.})E^\dagger$	300

* Taken at $V_a = V_{g2} = 150v$, $I_a = 200 \text{ mA}$.

† Provided the cathode is positive.

Base — International Octal.

EDISWAN

MAZDA

VALVES AND CATHODE RAY TUBES

THE EDISON SWAN ELECTRIC CO. LTD., 155 CHARING CROSS ROAD, LONDON, W.C.2

Member of the A.E.I. Group of Companies

R.V. 95.

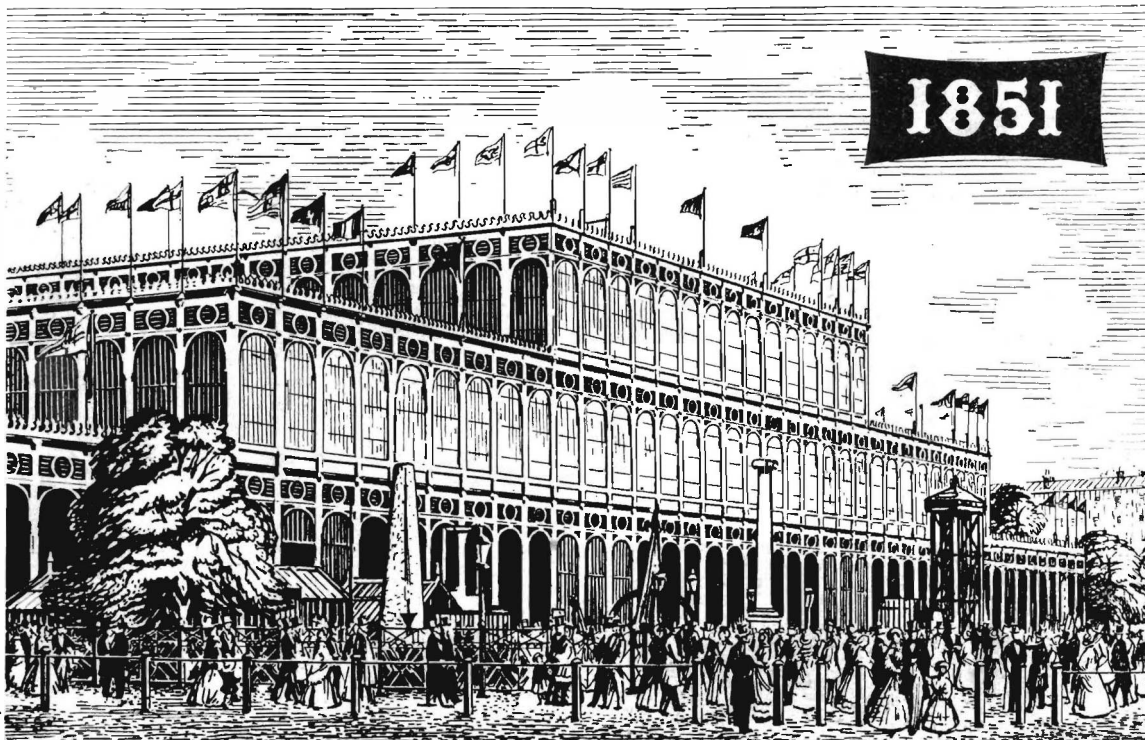

TELCON at the 1851 EXHIBITION

Telcon's founder, The Gutta Percha Company, exhibited at the Crystal Palace in Hyde Park and was awarded one of the coveted Council Medals of the Exhibition. In 1850 it had made the first submarine telegraph cable to be laid between England and France, the centenary of which was celebrated last year. From such adventurous beginnings has grown the present Telcon organisation, the activities of which now cover a wide field in engineering and industry at home and overseas. Again, in 1951, the Festival of Britain Exhibition includes some examples of the outstanding Telcon developments of the present century.

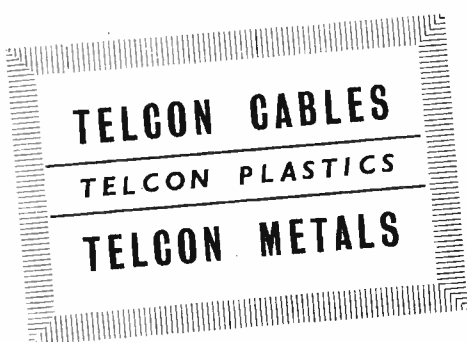

THE TELEGRAPH CONSTRUCTION & MAINTENANCE CO. LTD
 Head Office: 22 Old Broad Street, London, E.C.2. Telephone: LONDON Wall 7104
 Enquiries to: Telcon Works, Greenwich, S.E.10. Telephone: GREENWICH 3291



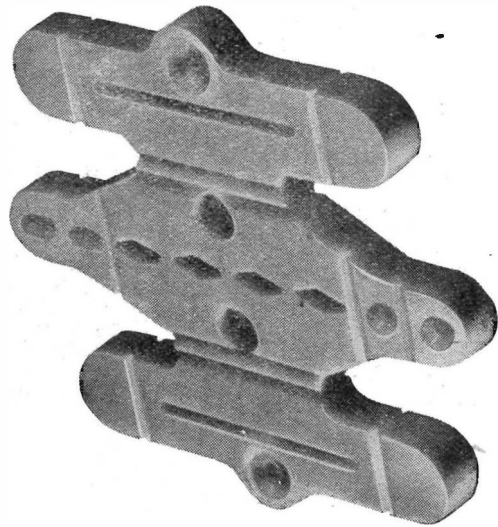
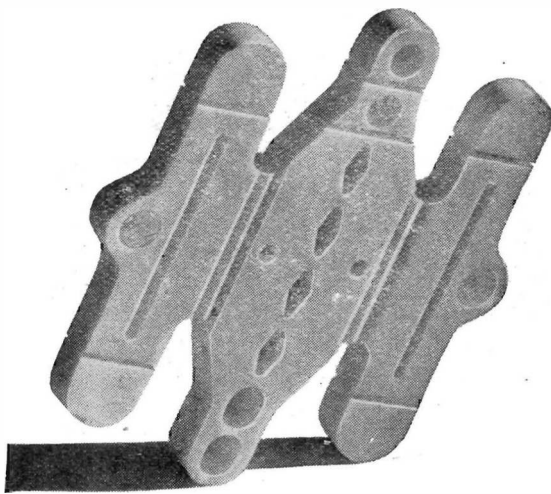

**from every
point of view**

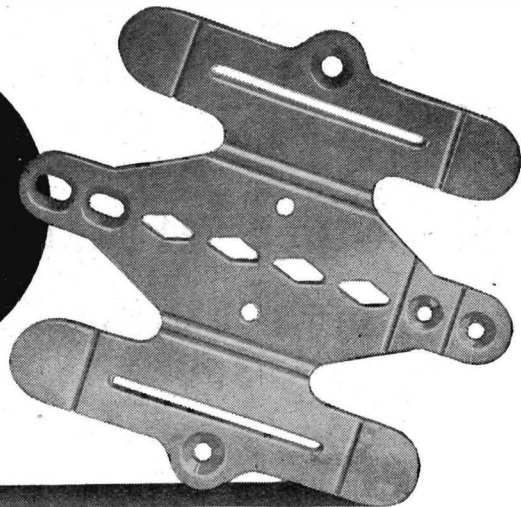

Frequentite is the most suitable insulating material for all high frequency applications. Seventeen years ago we introduced the first British-made low-loss ceramic, and consultation with us before finalising the design of new components is a wise precaution.

STEATITE & PORCELAIN PRODUCTS LTD.

Head Office: Stourport-on-Severn, Worcestershire. Telephone: Stourport 111. Telegrams: Steatins, Stourport



S.P.66

EVERSHED

**SPECIAL DUTY
F.H.P. MOTORS**

**TYPICAL
A.C. MOTORS**

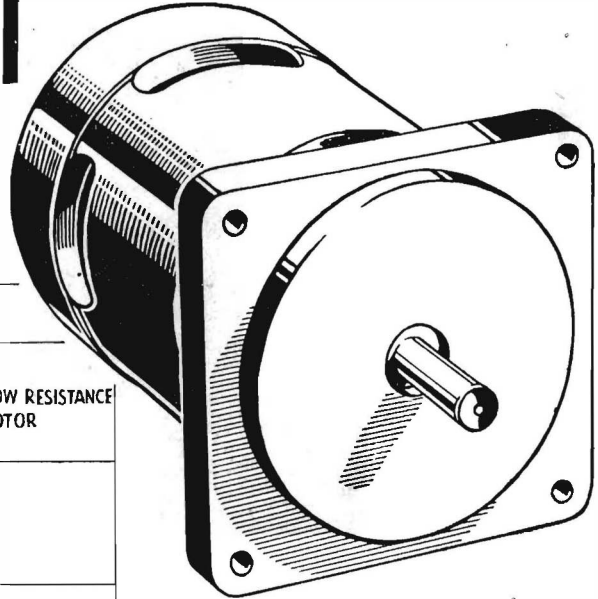

CHARACTERISTIC CURVES FOR
ASYNCHRONOUS MOTORS

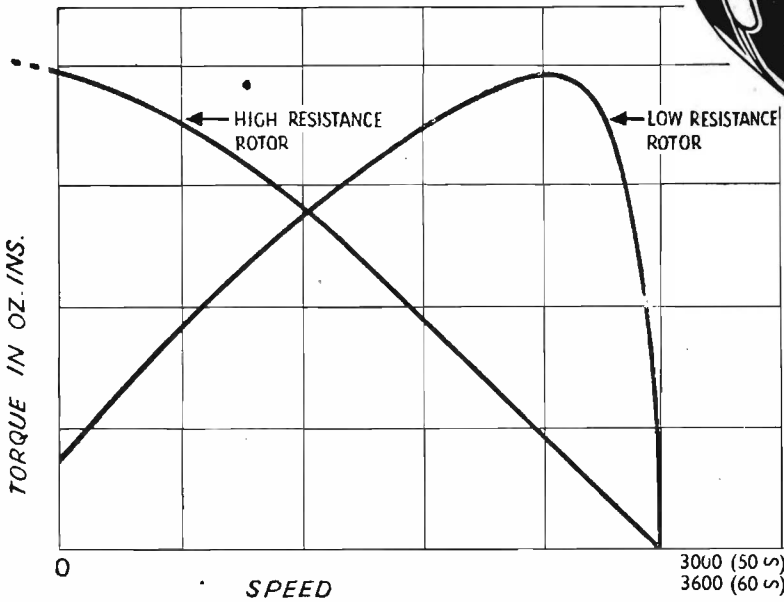

- 1) The motors may be supplied wound for 60 C.P.S. and other voltages.
- 2) The asynchronous motors can be supplied with high resistance rotors giving high starting torques.

Frame Size and Symbol	Type	Voltage	Phase	Frequency C.P.S.	No Load Speed r.p.m.	Torque	
						Starting oz. ins.	Running oz. ins.
FCI/O	Asynchronous	230	1	50	2900	2.5	2
FCI0/O	Synchronous	230	1	50	3000	0.75	0.75
FEI6/C	Synchronous	230	1	50	3000	6	6
FEI7/A	Asynchronous	50	3	50	3000	30	9
FEI8/C	Asynchronous	230	1	50	2950	11.5	10

*Send for the
Evershed Small Motors'
Data Book EE 22*

EVERSHED AND VIGNOLES LIMITED

ACTON LANE WORKS · CHISWICK · LONDON · W.4

Telephone: Chiswick 3670

Telegrams: Megger, Chisk, London

Cables: Megger, London



STABILISED POWER SUPPLIES

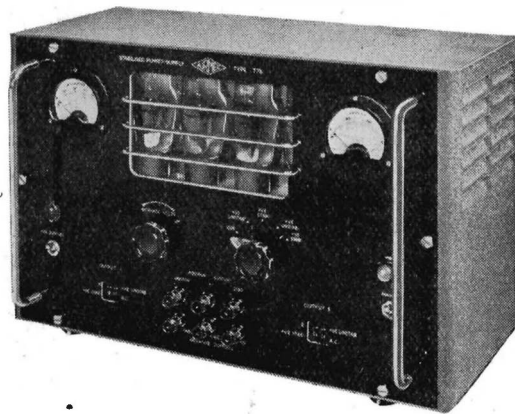

Type 705

THIS unit provides a stabilised direct voltage, continuously variable from 200-350 volts, which may be used with either the positive or negative lines earthed, or with the output floating. An unstabilised alternating supply of 6.3 volts, the centre tap of which may be strapped to earth, is also available.

- Stabilised output continuously variable from 200-350 volts at maximum currents of 200-100 mA.
- Output change is less than $\pm 0.5\%$ for $\pm 10\%$ input change.
- Output change from full load to no load is $+0, -0.5\%$.
- Source impedance of 5 ohms.
- Both voltage and current meters incorporated.
- Suitable for operation on 100-130 and 200-250 volts 50 c/s mains.

Type 776

POSITIVE and negative stabilised direct voltages, positive and negative unstabilised direct voltages, and an unstabilised supply of 6.3 volts are all provided by this Unit. Both voltage and current meters are included, and a meter switch enables any of the four direct outputs to be monitored.

- Stabilised positive output continuously variable from 200-350 volts at maximum currents of 200-100 mA.
- Positive output change is less than $\pm 0.5\%$ for $\pm 10\%$ input change.
- Stabilised negative output of 85 volts at 5 mA.
- Unstabilised positive output of 500 volts at 200 mA.
- Unstabilised negative output of 500 volts at 5 mA.
- Suitable for operation on 100-130 and 200-250 volts 50 c/s mains.

Illustrated descriptive leaflets of these Stabilised Power Supply Units, or any other Airmec instruments, will be forwarded gladly upon request.

AIRMEC LABORATORIES LTD

HIGH WYCOMBE · BUCKINGHAMSHIRE · ENGLAND

TEL: HIGH WYCOMBE 3060

CABLES: AIRMEC HIGH WYCOMBE

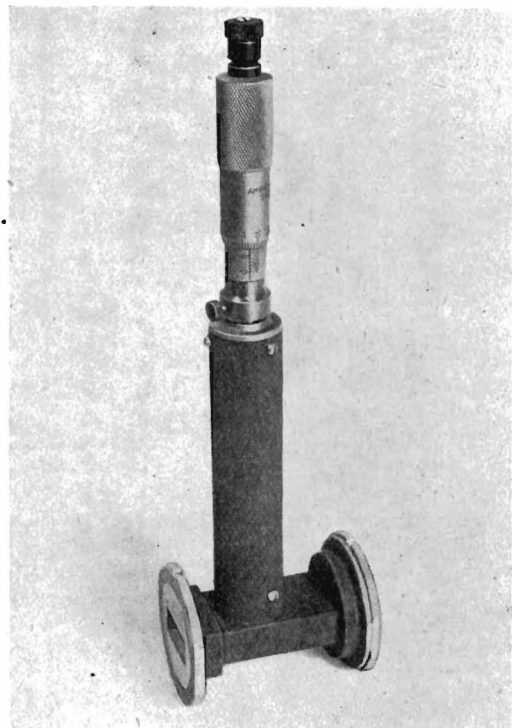

WAVEMETER TYPE 32/800
CO-AXIAL, SELF CALIBRATING
RANGE 8,800 Mc/s to 10,000 Mc/s

The above Wavemeter is one of a Range of "X" Band Instruments available for early delivery.

OUR RANGE INCLUDES:—

- CAVITY WAVEMETERS
- DIRECTIONAL COUPLERS
- VARIABLE ATTENUATOR
- STANDING WAVE METERS
- KYLSTRON MOUNTS, ETC.

Let us quote you for waveguide Systems. R.F. Heads Aerial Feeds, etc.

A RANGE OF "S" BAND TEST BENCH EQUIPMENT WILL BE AVAILABLE SOON.

MICROWAVE INSTRUMENTS LIMITED

WEST CHIRTON INDUSTRIAL ESTATE
 NORTH SHIELDS - NORTHUMBERLAND.

PHONE : 2817

Electronic Engineering

Incorporating
ELECTRONICS, TELEVISION
and SHORT WAVE WORLD

Managing Editor, H. G. Foster, M.Sc., M.I.E.E.

Vol. XXIII

MAY 1951

No. 279

In This Issue

Commentary	161
Portable Repeater used for Broadcast Programmes	162
By F. A. Peachey, M.I.E.E., G. Stannard, B.Sc., A.M.I.E.E. and C. Gunn-Russell, M.A.	
Daventry Third Programme Transmitter	166
A New Modulated Light Source	167
By James A. Darbyshire, M.Sc., Ph.D., F.Inst.P.	
Screening of TV Cabinets	169
A D.C.-A.C. Amplifier for Use in Physiology	170
By H. Asher.	
Radio Link Testing of Jet Engines	172
Piezo-electric Crystal Devices (Part 3)	173
By S. Kelly.	
Recalibration of G.C.A. Precision Aerial Systems	176
Visual Observation Equipment—A Brief Review of the Operating Principles of Stroboscopic Tachometers and Allied Equipment	177
By C. A. H. Pollitt, M.I.E.D., A.M.I.Ac.S.	
Design of Input (Regulation Control) Chokes	179
By N. H. Crowhurst, A.M.I.E.E.	
The Theory and Applications of D.C. Restoring Circuits (Part 1)	182
By D. A. Levell, B.Sc.(Hons.), Grad.I.E.E.	
Television by Co-axial Cable	185
R.E.C.M.F. Exhibition	186
Rediffusion Television Service	191
The 35th Physical Society Exhibition	192
Letters to the Editor	196
Book Reviews	198
Notes from the Industry	200
Meetings this Month	200

Published Monthly
 on the last Friday of the preceding month at
 28 Essex Street, Strand, London, W.C.2.
 Telephone CENTRAL 6565
 Telegrams 'LECTRONING, ESTRAND, LONDON'

Subscription Rate:
 (Home or Abroad) Post Paid 12 months 26s. or \$3.75 (U.S.)

Classified Advertisements, Page 1.
 Index to ADVERTISERS, Page 48

DATA ON THE MT57 TRIODE MERCURY VAPOUR RECTIFIER, ONE OF THE RANGE OF MULLARD THYRATRONS

LIMITING VALUES (ABSOLUTE RATINGS)

Maximum Peak Anode Voltage	
Inverse	1000V *
Forward	1000V
Maximum Cathode Current. 25c/s and above.	
Peak (for general control service)	15A
Peak (for ignitor firing service)	40A
Average (for general control service)	2.5A
Average (for ignitor firing service)	1.0A
Maximum averaging time	15 secs.
Surge (maximum duration 0.1 secs.)	200A
Maximum Grid Voltage.	
Before conduction	-500V
During conduction	-10V
Maximum Grid Current.	
Average (Averaging time 15 secs.)	0.25A
Maximum Grid Resistor	0.1M Ω
Min. Cathode preheating time.	300 secs.
Condensed Mercury Temperature Limits.	40 to 80°C

CHARACTERISTICS.

Heater Voltage	5.0V
Heater Current	4.5A
Capacitance Anode-grid	4 μ F
Deionisation Time (approx.)	1000 μ secs.
Ionisation Time (approx.)	10 μ secs.
Anode Voltage Drop	18V
Control.	
Anode Voltage	60 100 1000V
Critical grid Voltage (approx.)	0 -1.75 -6.5V

Base 4-pin UX.

* 1500V for condensed Mercury temperature up to 75°C



THYRATRONS

for fixed and

mobile applications



Mullard

The Mullard range of Thyratrons has now been extended to include types suitable for use in both fixed and mobile equipments.

For fixed power and motor speed control applications, a selection of Mercury Vapour tubes is available providing maximum average anode current ratings from 0.5 to 6.4 amperes.

For relay, switching and motor control applications in aircraft, ships and industry where movement is encountered, a selection of rare-gas-filled tubes is also available. Important among these is a series of xenon-filled tubes with anode current ratings from 0.1 to 6.4 amperes. On account of the small variations-with-temperature of xenon gas, these tubes are ideal for use in equipments operating over a large ambient temperature range.

The Thyatron illustrated and described here is the 2.5 amp. MT57. Full details on the complete range of Mullard Thyratrons will be supplied on request.

INDUSTRIAL POWER VALVES · THYRATRONS · INDUSTRIAL RECTIFIERS · PHOTOCELLS
FLASH TUBES · ACCELEROMETERS · CATHODE RAY TUBES · STABILISERS AND
REFERENCE LEVEL TUBES · COLD CATHODE TUBES · ELECTROMETERS, ETC.

MULLARD LTD., CENTURY HOUSE, SHAFTESBURY AVENUE, LONDON, W.C.2

MVT96 (REV).

Electronic Engineering

Vol. XXIII.

MAY 1951

No. 279.

Commentary

ON Friday, May 4, after a Service of Dedication in St. Paul's Cathedral by their Majesties the King and Queen on the previous day, the much-publicized and much-criticized Festival of Britain Exhibition will open its doors to visitors from home and overseas who will then throughout the summer be able to assess for themselves Britain's achievements in the arts and sciences, technology and industrial design.

For some time past, the Exhibition has had a severely critical Press and has been the subject of much comment, both inside and outside Parliament, mainly on the grounds of excessively extravagant expenditure of money and materials at a time when the unsettled state of the world makes it very doubtful what we are trying to celebrate. Its most severe critics allege that we are celebrating in a festive manner—to the tune of at least £12 million for the South Bank Exhibition alone—the achievements of the post war years in Britain and if this is the case the last six years have provided nothing whatsoever to be festive about in so expensive a manner.

It is most unfortunate that the Festival should have been so overshadowed by political controversy. The scheme was originally announced in December 1947 by Mr. Herbert Morrison, the Lord President and was intended to mark a hundred years progress by this country since the Great Exhibition of 1851. This is indeed a laudable project but final judgment must be deferred until the Exhibition is closed in September and the final balancing of accounts completed. We shall then be able to judge whether the Exhibition was a success and whether the cost was worth while.

Up to the time of going to Press we have had but one opportunity of a preview of the Exhibition which presented, as all exhibitions have a habit of doing before opening day, a disorderly spectacle of packing cases and half completed stands, but we were most impressed with the general theme and we are sure that our readers will be proud of the many contributions which our particular industry has made to the achievements which the Festival celebrates.

It may not be out of place, therefore, to defer comment on the several other topics of importance this month and to give instead a brief description of those items at the Festival which are likely to be of the greatest appeal.

The main contributions of radio, radar, television and electronics will be found in the "Transport and Com-

munications" Pavilion and here they will be divided according to the subject and displayed on four floors.

On the ground floor will be shown the development of the postal services with the growth of electrical communication from the primitive methods of telegraphy by Cooke and Wheatstone to the modern high speed teleprinter and facsimile systems, while in an adjacent section dealing with point-to-point radio communication emphasis will be laid on world wide communication with a working demonstration of the latest type of time sharing pulse multiplex system as the principle exhibit. The first floor will be given over to radar navigational aids of all kinds, where there will be a working model scanning ships on the Thames. An interesting large scale working model of a cross section of a magnetron on this floor should not be missed, while on the second floor will be found the British story of television from the early mechanical scanning methods to the present latest practices.

Sound broadcasting and recording are not omitted and the fourth floor houses a comprehensive display of this branch of communications.

The Dome of Discovery where electronic exhibitions of a more fundamental character will be on display, and the Exhibition of Science to be held concurrently at South Kensington should not be overlooked and mention should also be made of the many valuable contributions which are to be made by the various research organizations and learned societies. There will be a Joint Engineering Conference of the Institutions of Civil, Mechanical and Electrical Engineers from June 4-15 and an International Radio Conference will be held under the auspices of the British Institution of Radio Engineers. The National Physical Laboratory at Teddington is combining by holding a number of Open Days by invitation throughout the session.

Our more musically minded readers should not fail to visit the Concert Hall of the South Bank Exhibition, where the largest and most comprehensive electronic organ will be installed. Only preliminary details of this instrument have so far been announced, but it is stated that it will have a complete tonal appointment and will be equipped with every aid to registration. The power output will be of the order of 250 watts provided by double channel amplifiers, and will be distributed throughout the Concert Hall by twenty loudspeakers.

Portable Repeater

used for Broadcast Programmes

By

F. A. Peachey, M.I.E.E., G. Stannard, B.Sc., A.M.I.E.E. and C. Gunn-Russell, M.A.*

IN sound broadcasting, whether accompanied by vision or not, it is the aim of a broadcasting organization to give the highest grade of technical service economically possible.

If the broadcast originates from any place other than a normal studio centre, it is known as an "outside broadcast" (O.B.). Programme signals from an O.B. point have to be conveyed to a main centre for distribution on the permanent broadcast line network. Post Office lines are normally used for this purpose and it is fortunate that in this country such facilities exist to even the most remote places. Such lines, however, intended primarily for telephone purposes, are not usually suitable for good quality programme transmission unless special treatment is applied.

The special treatment involves careful selection of suitable circuits in co-operation with the G.P.O., equalizing to give a wider frequency response than that normally

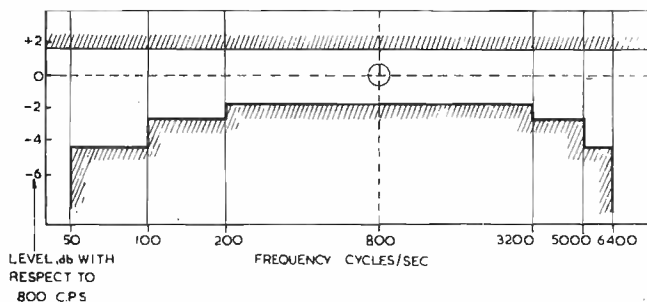

Fig. 1. Permissible variations of level with frequency

required for telephone purposes and, in some cases, the insertion of intermediate amplifiers so that the programme signal-to-noise ratio of the line is kept within the limits required for good technical quality in broadcasting.†

As such intermediate amplifiers will frequently be required at remote telephone exchanges at which the G.P.O. do not normally provide such equipment, the B.B.C. is expected to provide suitable portable apparatus and set it up in co-operation with the G.P.O.

This article gives a description of repeater apparatus used in this way. As the details of its design are dependent on the type of line circuits in which it is used, a brief description will be given of such circuits and their transmission characteristics.

The Characteristics of Typical Line Circuits Used for O.B. Purposes

The attenuation in db per mile of a pair of wires in a telephone cable is approximately equal to $6.14\sqrt{RC\omega}$, where R is the loop resistance in ohms per mile, and C

* Design Department, British Broadcasting Corporation.

† The Comité Consultatif International has laid down that "music channels" on telephone circuits in existing types of cables, should have a minimum bandwidth of 50-6,400c/s and quotes the limits between which the levels of all frequencies with respect to 800c/s must lie. These are shown in Fig. 1.

the capacitance between wires in farads per mile. Thus the attenuation increases as the gauge of the wire decreases and also increases as the frequency increases. The attenuation frequency characteristic is modified by terminal effects at both ends. The modified characteristic is known as the insertion loss characteristic.

Circuits to which inductance has been added (loaded circuits) in order to decrease their attenuation over the wanted band of frequencies, have an attenuation in db per mile approximately equal to

$$4.343 [RV(C/L) + GV(L/C)]$$

where G is the conductance in ohms per mile and L is the overall inductance in henries per mile. This approximation is only true where ωL is large compared with R . At low frequencies the attenuation becomes the same as for non-loaded circuits. Cables are loaded by adding series inductance coils at regular intervals. A loading section may be considered therefore as a mid-shunt terminated low pass filter section, the inductance being that of the loading coil and the shunt capacitances, half the capacitance of each loading section. The cut-off frequency of such a filter section is $1/\pi\sqrt{LCS}$, where L is the value of the loading coil inductance, C the capacitance per mile, and S the distance in miles between loading coils. The attenuation given by the above formula is therefore further modified at frequencies approaching cut-off, and at cut-off it is infinite.

The insertion loss characteristics of loaded and non-loaded circuits with resistive terminal impedances are shown in Fig. 2, and an inspection of the above formulae will account for the shapes shown.

Quite frequently a mixture of loaded and non-loaded

Fig. 2. Insertion loss characteristic

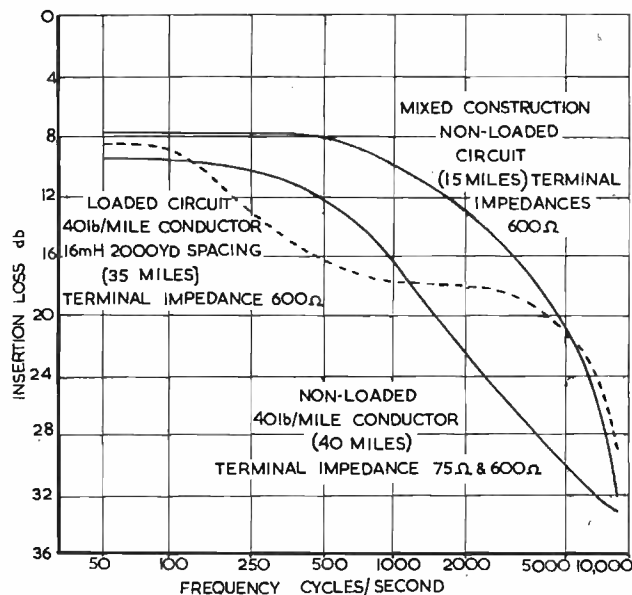

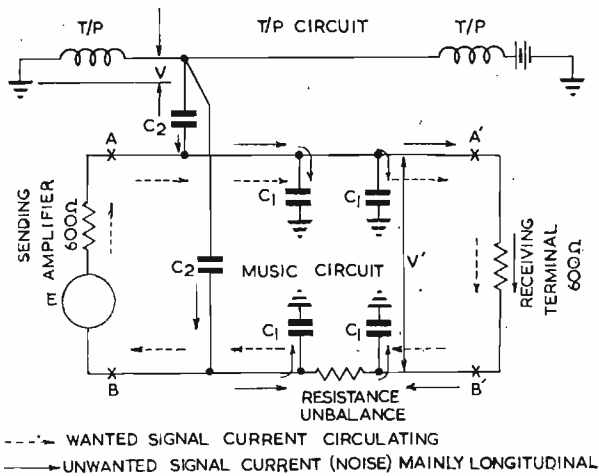

Fig. 3. Noise on a cable pair due to unbalance

circuits has to be employed and the resulting frequency response characteristic is of a more complicated nature, but in general the attenuation is highest at high frequencies. So it follows that signals at the higher frequencies are likely to approach nearer to the noise level, as will be seen from the following brief study of the introduction of noise on such circuits.

LINE NOISE

Referring to Fig. 3, the two wires *AA'* and *BB'* represent the programme circuit, the circulating programme currents being represented by the broken arrows. The two wires have nominally the same resistance, but a resistance unbalance, such as may be caused by an indifferent joint is shown. Suppose also, for example, that in the same cable there is a teleprinter circuit. The teleprinter circuit will have distributed capacitances C_2 and C_2 , assumed to be equal, to each of the wires *AA'* and *BB'*. The A.C. potential difference between the teleprinter circuit and earth will drive a current through each C_2 , *AA'* and *BB'* and back to earth through the earth capacitances C_1 of *AA'* and *BB'*.

If there is no resistance unbalance these longitudinal currents will be equal and there will be no potential difference from the teleprinter signal across the terminal impedance, and therefore no interference on the programme transmission. With a resistance unbalance, however, or if the capacitances C_2 or C_1 are unbalanced, a potential difference V' will be introduced, resulting in a circulating current through the terminal impedance and consequent interference from the teleprinter circuit. Unbalanced insulation resistances can also cause interference. The degree of interference will depend on the relative strength of the interference and wanted currents.

Resistance and insulation unbalances in the programme circuit can be detected by D.C. tests and in most cases eliminated before the broadcast. Auxiliary apparatus is provided as a part of the repeater for this purpose.

Capacitive unbalances cannot be dealt with in this way but steps are taken in the design and laying of cables to keep such unbalances to a practical minimum. A certain amount of capacitive coupling between adjacent circuits is inevitable and high frequency interference currents will be present on the programme circuit. Experience has shown that, with the types of circuit under consideration, these currents will cause objectionable interference unless the programme currents are amplified before the higher frequencies become attenuated by more than about 40db. In these circumstances the low frequency loss would be about 5 or 6db.

It is obvious, therefore, that the signal must be

equalized at the repeater point. Equalization not only restores the frequency amplitude response to its original form, but it ensures that the repeater does not overload at low frequencies and that the following section of line is worked at the proper level at all frequencies. An excessive level of signal for the following section of line would give crosstalk and consequent disturbance to other circuits in the same cable.

TYPE OF EQUALIZATION USED

The circuits involved often contain a mixture of gauges and types of cable and the resultant frequency amplitude response characteristic is of a complicated nature. A variety of equalizer types and settings must be available.

Typical equalizers used for such purposes at B.B.C. main centres are shown in Fig. 4. Two types cover most of the requirements to be met with on O.B. lines. They are constant resistance equalizers as this type simplifies manipulation, their insertion loss being known and independent of the cable impedance. The derivation of the required settings has been facilitated by the use of specially constructed transparent masks which may be

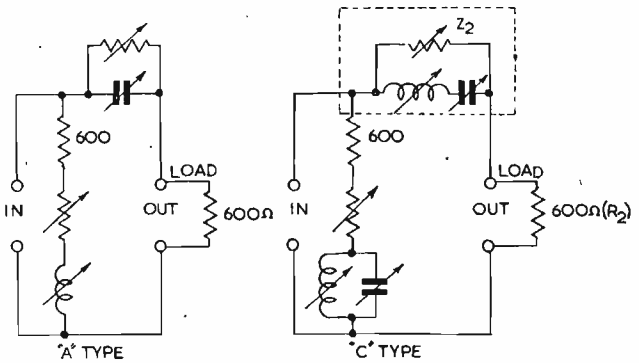

Fig. 4. Typical constant resistance equalizer used on O.B. lines

fitted over the plotted frequency response characteristic of the unequalized line and show straight away on the margins of the paper the required equalizer setting. Obviously any facility such as this which is desirable at the base is even more valuable in the field and the aim in the design of this repeater has been to include in its circuits, equalizers which simulate in performance and settings those used at the main terminal points. This has had a considerable influence on the repeater design.

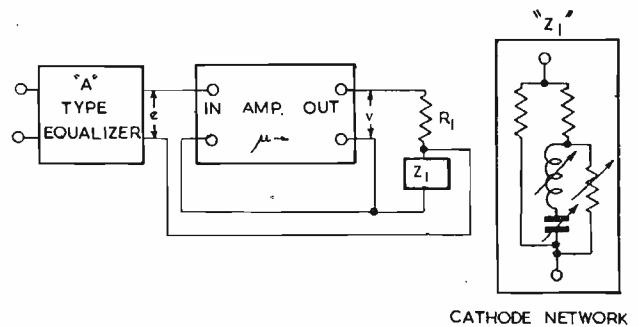

Fig. 5. Basic negative feedback arrangement of the repeater

The Repeater

THE REPEATER AMPLIFIER AND EQUALIZER UNIT

The repeater amplifier and equalizer unit is basically as shown in Fig. 5. A constant resistance equalizer similar to that shown in Fig. 4 ("A" type) is provided at the input of the amplifier and another equalizer which, in

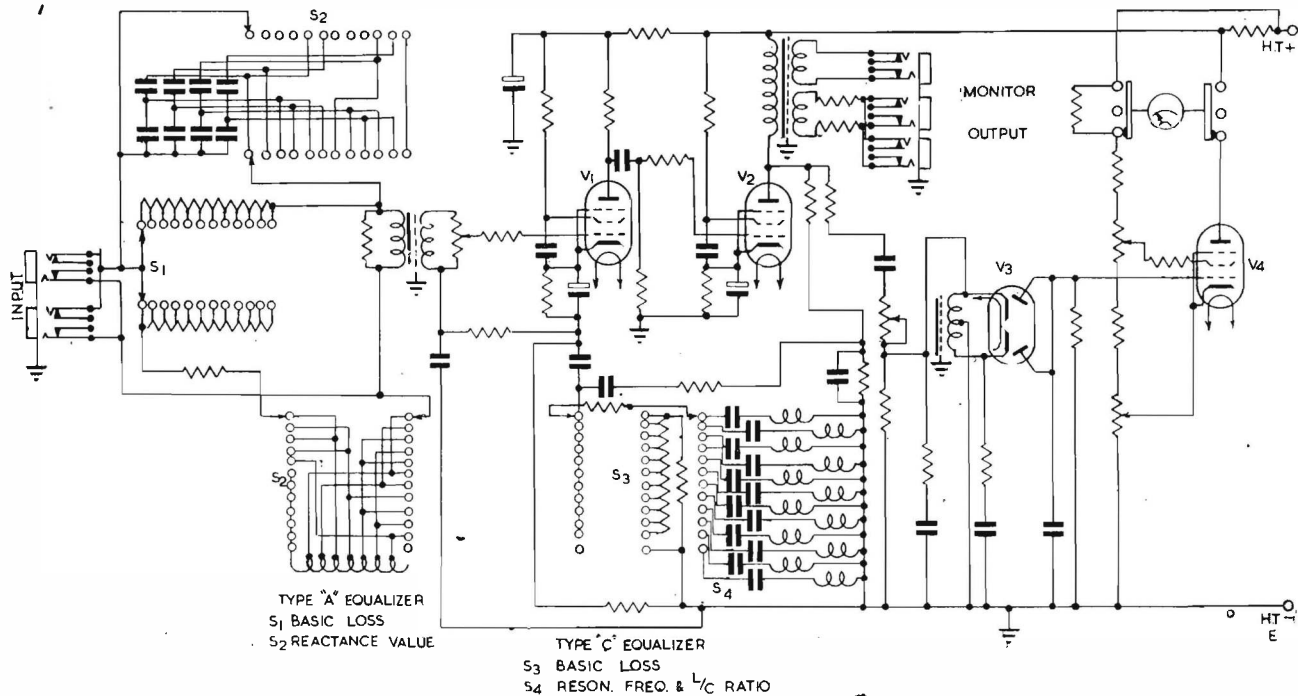
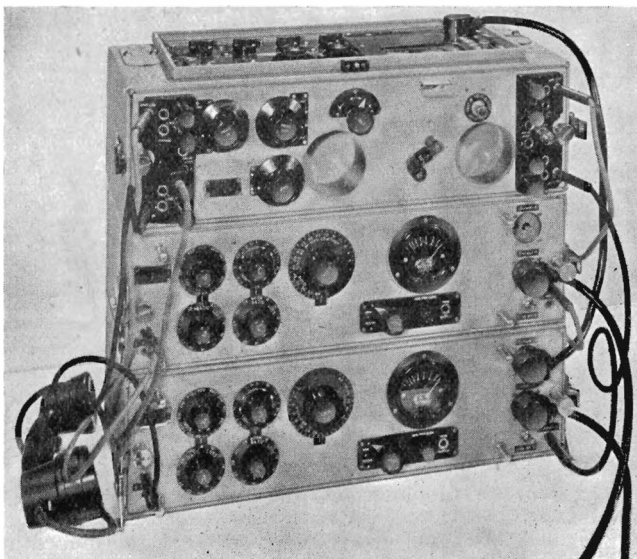

Fig. 6. Schematic of portable repeater

performance is similar to that shown in Fig. 4 ("C" type), is in the negative feedback path. The use of the negative feedback path for this purpose was desirable for the following reasons.

If two equalizers, which may be set to have a substantial basic loss, were connected before the input to the amplifier, the input level handled by the amplifier would be extremely low and difficulty would arise from amplifier noise, valve microphonicity, etc. Although this particular type of equalizer, built as a constant resistance equalizer, with its series and shunt elements has a large number of variable components, quite a considerable economy can be made by using it as a two-terminal network in the feed-

Fig. 7. Portable repeater gear showing two repeater units and one control unit stacked for operation



back path. This also has the advantage that the low frequency loss inserted by the equalizer operates at low frequencies as increased negative feedback on the amplifier. This amplifier has a gain without feedback of 95db which is reduced by negative feedback (without equalization) to 66db at full gain setting. The equalizer in the feedback path reduces the gain at low frequencies by another 28db. This, of course, gives excellent amplifier performance and stability in gain, against battery supply variations. It should be mentioned that the equipment is driven from a portable battery unit of a compact nature and in which the H.T. supply may be anything from 300-230 volts according to the age and condition of the battery.

The need for stability in gain will be realized not only from the above point of view, but because in the tests which have to be made some days before the broadcast to establish proper equalizer and gain settings, reliable results must be obtained. One set of equipment may be used for the test and another for the transmission.

Referring to Fig. 5, it may be shown that the performance of the two terminal networks in the negative feedback path of the amplifier is very similar to that of the constant resistance network showing in Fig. 4 ("C" type). It will

be seen that $V = \mu \left(e - \frac{Z_1 V}{Z_1 + R_1} \right)$ where Z_1 is the cathode network shown also in Fig. 5.

Therefore:

$$e/V = \frac{Z_1}{R_1 + Z_1} + 1/\mu$$

If μ is large

$$e/V = \frac{Z_1}{R_1 + Z_1}$$

The gain of the repeater is therefore

$$\text{Gain } (G_1) = \frac{R_1 + Z_1}{Z_1}$$

The constant resistance equalizer shown in Fig. 4 has a

loss ratio of

$$L = \frac{R_2 + Z_2}{R_2}$$

If in considering the amplifier, we put
 $Z_1 = z_1 + r_1$
 then

$$G_1 = \frac{R_1 + r_1 + z_1}{r_1 + z_1}$$

When $z_1 = 0$,

$$G_1 (\text{max.}) = \frac{R_1 + r_1}{r_1}$$

(this is the condition of maximum gain).

$$= 1 + \frac{z_2}{r_2 + R_2} \dots \dots \dots (4)$$

Comparison of Equations (3) and (4) shows that if $r_1 + z_1$ is small compared with R_1 and

$$z_1/r_1 = \frac{z_2}{r_2 + R_2}$$

the expressions for relative loss are approximately equal.

This is actually the case as R_1 is in the feedback path and large in value compared with $r_1 + z_1$, and z_1/r_1 may be made equal to $\frac{z_2}{r_2 + R_2}$. If in the design either of these conditions is not quite complied with, a deviation between

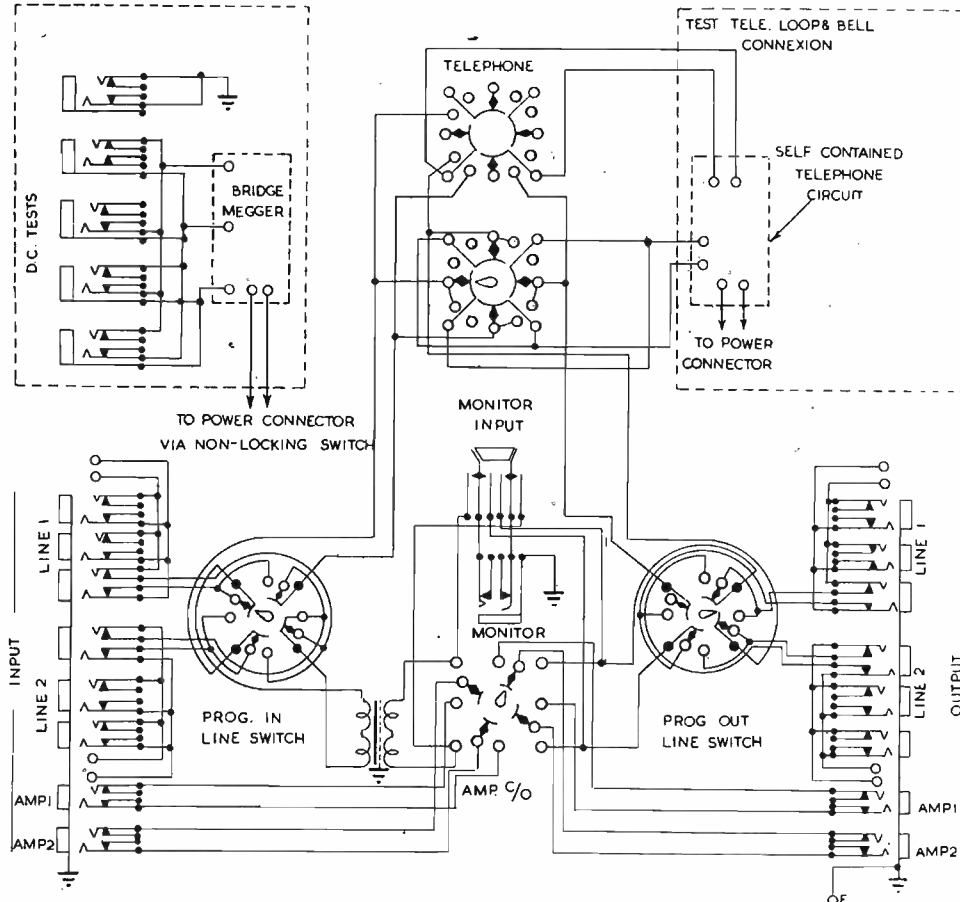

Fig. 8. Repeater switch unit

The relative loss is then

$$\frac{G_1 (\text{max.})}{G_1} = \frac{R_1 + r_1}{r_1} \times \frac{r_1 + z_1}{R_1 + r_1 + z_1} = 1 + \frac{z_1 R_1}{r_1 (R_1 + r_1 + z_1)}$$

$$= 1 + \frac{r_1 + z_1}{r_1 \left(1 + \frac{r_1 + z_1}{R_1} \right)} \dots \dots \dots (3)$$

If the constant resistance equalizer is treated in a similar way, i.e., let $Z_2 = z_2 + r_2$,

$$L_1 = \frac{z_2 + r_2 + R_2}{R_2} \text{ (this is a minimum when } z_2 = 0 \text{),}$$

i.e.,

$$L_1 (\text{min.}) = \frac{r_2 + R_2}{R_2}$$

The relative loss is given by

$$\frac{L_1}{L_1 (\text{min.})} = \frac{z_2 + r_2 + R_2}{R_2} \times \frac{R_2}{r_2 + R_2}$$

the characteristics will be evident at small loss values and for practical purposes may be corrected by a slight adjustment of the resonant frequencies.

Fig. 6 shows the general schematic of the equalizer unit, and negative feedback arrangements of $V1$ and $V2$ will be understood from the foregoing remarks. The *Input Gain* control has a range from 0-66db in 2-db steps. This means that the output level may be set to the nearest 1db.

The unit also includes a volume meter which has a logarithmic scale and has a similar electrical performance to the peak programme meter commonly used on the main B.B.C. transmission system.

The output transformer has a monitoring winding, so that quality at the output of the repeater may be checked and is not impaired by the line impedance shunted across the output terminals.

COMPLETE ASSEMBLY.

The assembly is shown in Fig. 7. It comprises two equalizer amplifier units (one of these operating as a spare),

one switching, telephone and D.C. testing unit, and a small satchel containing the L.T. and H.T. batteries (not shown in Fig. 7). The chassis of the equalizer amplifier unit is shown in Fig. 9.

Two lines are normally employed on an O.B. of the type in which this apparatus is used. One is for the programme transmission and the other for telephone purposes between the O.B. point, the repeater point and the main B.B.C. centre. Sometimes this latter circuit is also suitable

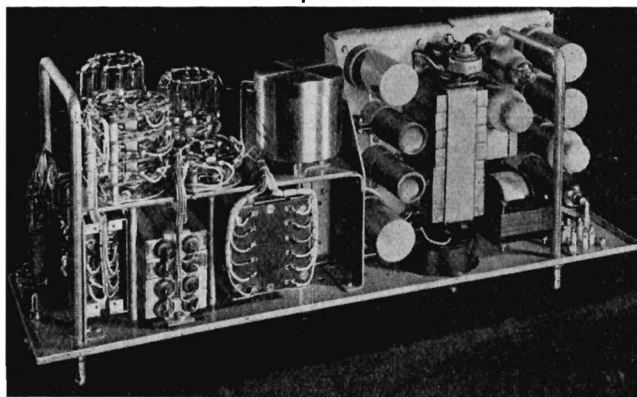

Fig. 9.—Rear view (upper side) of the portable repeater

for programme transmission and for this reason the control unit contains quick changeover switches so that the equalizer amplifier unit may be connected to either of the lines at its input or at its output. The need for this arises if one line section should become noisy or disconnected during the actual transmission. Either equalizer amplifier unit may be selected by a similar switch, so that if the one unit fails, a quick changeover may be made to the other. The control unit contains telephone apparatus including a hand 17c/s ringing generator; and a switch enables telephonic communication to be established either to the O.B. point, to the receiving station, or to both simultaneously. A convenient push button enables the engineer at the repeater to discover whether his telephone loop is complete to either one end or the other. The control unit also includes a full bridge megger with jack arrangements so that a line may be tested by merely successively plugging it to the various jacks. The bridge megger unit is powered from the H.T. supply and reasonable economy is maintained by a push button switch so that power is consumed only at the moment of the test. The circuit diagram of the switching unit is shown in Fig. 8.

This D.C. test facility is extremely useful as it not only saves carrying auxiliary apparatus for this purpose, but it means that the equipment can be installed at the appropriate Post Office exchange, set up with its lines and supplies connected to it in preparation for the broadcast and nothing has to be dismantled when the lines are checked for their suitability just before transmission. The units shown in Fig. 7 are extremely compact, light and portable. The boxing and chassis are made of duralumin throughout, fitted with sprung-on lids, and are carried in close fitting canvas cases with grip handles. The weight of the total equipment, which includes one control unit, two repeater equalizer units and two battery packs, is approximately 1cwt. This replaces equipment which had far fewer facilities and weighed approximately 3cwt. The reduction in weight and size not only eases the handling of the gear, but also provides, of course, a great economy in travelling cost as this apparatus is continually travelling by car and train to various towns in the British Isles.

Daventry Third Programme Transmitter

APRIL 8, 1951, marked the opening of a new high-power transmitter and mast radiator at Daventry for the Third Programme on the present wavelength of 464 metres (647kc/s). Originally this programme was broadcast from Droitwich, but last year it was transferred to a temporary 60-kilowatt transmitter at Daventry at the time when the Copenhagen Wavelength Plan came into force. Shortly afterwards the installation of the permanent transmitter at Daventry was begun, and now that this is complete the service is being transferred to it.

With a power of 150 kilowatts the new transmitter is not only more than twice as powerful as its predecessor, but has also been provided with a more efficient aerial, specifically designed to give as large a fading-free service area as possible. It is expected that the average radius of the service area will be about 100 miles—indeed towards the north and east it will be rather more than this—and that the number of listeners able to receive the Third Programme will be increased to about 70 per cent of the population.

The new Third Programme transmitter, which has been designed and manufactured by Marconi's Wireless Telegraph Co., Ltd., is in the building that originally housed the 5XX transmitter. It consists of two identical transmitter units which can work in parallel, each complete in itself and each capable of an unmodulated carrier output power of 100 kilowatts, but to conform with the Copenhagen Wavelength Plan the actual power used will be limited to 150 kilowatts. Another feature of the transmitter is that all the valve filaments are supplied with alternating current, so that there is no rotating machinery, other than the air blowers, associated with it. A third feature, and one of particular interest, is that the transmitter is designed so that it will ultimately be possible to operate it from a remote point—from another building at Daventry or from Broadcasting House, London, for example—by means of signals sent over a single telephone channel.

There are three stages of radio-frequency amplification in the transmitter. The first stage consists of two tetrodes in push-pull, the input for which is taken from a standard quartz-crystal drive unit of B.B.C. design, which is separate from the transmitter. Next comes the penultimate stage, having a BR124 triode valve in a push-pull circuit with a dummy valve to balance it. The output is applied to the final stage, which is anode modulated and consists of four BR126 triode valves arranged in parallel push-pull with fixed neutralizing capacitors.

The modulator chain has four stages, with push-pull circuits throughout. Pentodes are used in the first stage, and tetrodes in the second, with resistance-capacitance coupling between them. The third stage consists of four ACM3 triode valves connected as cathode followers, an arrangement which provides a sufficiently low output impedance to supply the grid current required by the main modulator without causing distortion. Each ACM3 drives one of the four BR126 valves that make up the final stage of the modulator, the output circuit of which is conventional.

There are two negative feedback paths in the modulator. About 18db of feedback is applied to the input of the first stage from the primary of the modulation transformer. In addition an audio-frequency signal is derived from the transmitter output and applied as feedback to a pre-amplifier, which precedes the first modulator stage.

About a mile and a quarter to the east of the transmitter building on a site 460ft above sea level a mast radiator has been erected to serve as an aerial for the new transmitter. With a height of 725ft, this is the tallest mast yet erected by the B.B.C. for a medium-wave transmitter. It was designed and erected by British Insulated Callender's Construction Co., Ltd., to the B.B.C.'s specification.

A New Modulated Light Source

James A. Darbyshire, M.Sc., Ph.D., F.Inst.P.

THERE are many problems in applied electronics in which it is essential to have a device which will convert variations in the value of an electric current into corresponding variations in the intensity of a source of light. This device will, in general, have to satisfy some special conditions. Thus it will have to respond to certain ranges of frequency and there will have to be a certain degree of correspondence between the current input and the light output. Also the light may be required to have some particular colour which may render it suitable either for visual or for photographic purposes.

A number of lamps of this description are on the market already and are known as glow tubes and sometimes as crater lamps according to the nature of the internal assembly of the lamp. Some of these tubes operate with cold cathodes and others with hot cathodes.

Cold Cathode Glow Discharge Tubes

The w3 is a cold cathode neon filled glow discharge tube with an operating voltage of 250 and a mean operating current of 30mA. Also the NGD is a cold cathode neon filled glow discharge tube operating at a rather lower voltage than the w3 and striking at a considerably lower voltage. Both the w3 and the NGD are manufactured by the General Electric Co. Ltd.

A cold cathode tube of rather different design is manufactured by Sylvania. This is a neon filled cold cathode tube and is known as R.1130B.

A directly heated hot cathode tube, made by Philips, was also available prior to 1939.

The early crater lamp manufactured by Ferranti Limited was known as the MAC4 and it was similar to that manufactured by Philips. The MAC4 had three electrodes, the hot cathode, the striker and the anode. The anode consisted of a tungsten rod fused into a piece of pyrex tubing in such a manner that the tip of the tungsten rod was approximately 5mm down from the edge of the glass tubing. The tungsten rod was therefore at the bottom of a small cup formed from the 3mm dia. glass tubing. This pyrex glass tube, holding the tungsten rod, was mounted vertically along the axis of the assembly. The striker consisted of a nickel cap having a hole 4.0mm in diameter at the centre and this cap was mounted over the anode in such a manner that the tungsten rod was visible through the hole in the striker cap when viewed from a point anywhere along the axis of the assembly. The cathode consisted of an oxide coated nickel tube having a tungsten heater and the cathode was mounted inside the cap and close to the edge of the pyrex tube which held the tungsten anode rod. This lamp was struck by applying a potential of approximately 100 volts between the anode and the cathode. The striker was connected through 20,000 ohms to the anode. The discharge actually took place, first of all, from cathode to striker and then passed rapidly over to the anode. This lamp had a four volt heater; a photograph of it is given in Fig. 1. In nearly all applications this lamp is now replaced by the GMC6 which will be described in more detail later. In certain particular instances operators still find the old MAC4 to be more useful than the GMC6 and therefore stocks of the MAC4 are still available.

The new lamp GMC6 was developed in response to the requests for greater light output and more accurate

linearity. Also, because of the rather close proximity of the hot cathode to the glass viewing window at the top end of the MAC4 it was found that the glass tended to become slightly coated with evaporated barium from the cathode after several hundred hours' life. This effect has been completely eliminated on the GMC6 because the hot cathode is far removed from the viewing window. A drawing of the assembly of the GMC6 is given in Fig. 2. It consists of an indirectly heated oxide-coated cathode mounted in a bulb at the lower end of a straight glass tube of approximately 3mm diameter and 40mm long. There is a striker electrode (S) mounted just above the cathode (C) and the anode (A) consists of an inverted nickel cup having a central aperture of 3mm diameter. This inverted nickel cup is attached to the upper end of the glass tube and is situated at a distance of 40mm from the cathode.

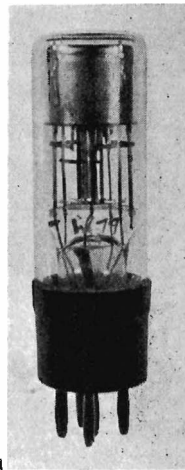

Fig. 1. Early Ferranti crater lamp, type MAC4

Circuit Arrangements

The MAC4 and GMC6 can be operated in a considerable number of different circuit arrangements. In general principle, any circuit which will enable the current through the lamp to be controlled over the range 2 to 100mA is suitable for controlling the modulation of these lamps provided that sufficient voltage (approximately 300) is available to ignite the lamp.

A typical circuit which had been found suitable, both for steady running and for modulation, is shown in Fig. 3.

The current through the crater lamp (and therefore the brightness) is controlled by means of adjustment of the bias on the modulating valve 6V6G. The value of the grid voltage on this tube is controlled by means of the 1 megohm potentiometer. The normal range of current control is 0.55mA.

If the switch A is closed, the 2k resistance is shorted out and the bias is reduced. The range of current control is then changed so that it covers the region of 30mA to 90mA. The switch B is incorporated in the 1 M Ω brightness control in such a manner that when the circuit is first switched on, the bias on the 6V6G valve has a minimum value and so the lamp is sure to ignite because the settings correspond to maximum brightness at that instant.

Any modulation signal can be applied across the terminals points marked X and Y.

The rating of the various components are as follows:—

Resistors	Recommended rating
1M Ω	1 watt
25k Ω	5 watts
20k Ω	1 watt
2k Ω	20 watts
1000 Ω	1 watt
Capacitors	
8 μ F	Electrolytic 500V
0.1 μ F	Paper 500V

Warming Up

When a new lamp is inserted it is necessary to allow the heater to run for five minutes before any current is passed through the lamp. The lamp should then be

* Physical Laboratory, Ferranti Ltd.

ignited and the current adjusted to a value of approximately 50mA and the lamp should be allowed to run at this value of current for another fifteen minutes before it is actually put into operation.

When the lamp has been run in as described above, it can be brought into action more quickly when switched on in subsequent operations. It is essential, however, even then, to allow the lamp to warm up with the heater alone for a period of approximately two minutes before current is passed through the lamp. After the current has been switched on, the current should be adjusted to approximately 50mA and left at this value for approximately ten minutes before the lamp is considered to be ready for active service.

The heater rating of the MAC4 is 4 volts 2 amps and that of the GMC6 is 6.3 volts 1.2 amps. The striking voltage of the MAC4 is below 100 volts whereas the striking voltage of the GMC6 is considerably higher and is usually about 250 volts. The striking voltage of the GMC6 is always less than 300 volts and therefore no difficulty will

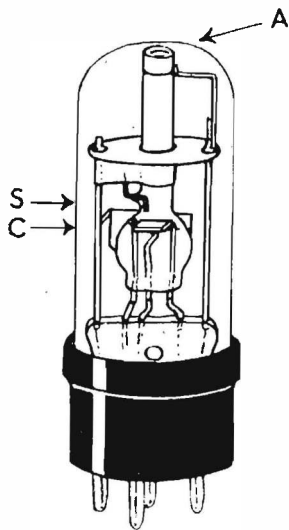

Fig. 2. Assembly of the newer-type lamp, type GMC6

be encountered in striking this lamp if 300 volts are available from the power unit. To cover various losses in the circuit it is desirable to design the unit so that it has an output of 350 volts.

Light Output

The MAC4 and the GMC6 are both filled with a mixture of mercury and argon and the resultant light is of very high actinic value for purposes of photographic recording. It is difficult to give a measure of light output in terms of academic units, but using a selenium photocell with normal eye correction filter (Ilford 827) the figures for intensity of illumination in foot candles at a distance of 10cm are given in table I.

TABLE I

Current in Milliamperes	MAC4	GMC6
10	0.13	0.18
20	0.29	0.39
30	0.46	0.60
40	0.62	0.80
50	0.79	1.00
60	0.95	1.20
70	1.10	1.38
80	1.24	1.56
90	1.35	1.72

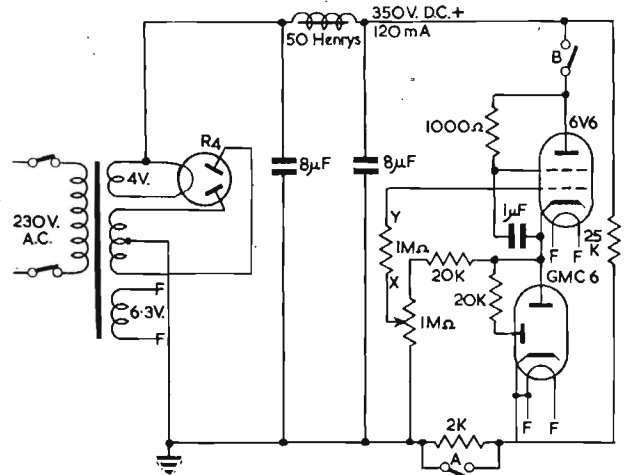

Fig. 3. Typical circuit for modulating a glow tube or crater lamp

Also it can be stated that satisfactory sound film tracks can be recorded photographically using the GMC6 modulated $\pm 15\text{mA}$ from a mean current of 30mA (for more complete details see the section on Applications).

Both types of crater lamp may be modulated at frequencies from 0 to 12,000c/s, but there is an appreciable fall in response for frequencies above 8,000c/s. Measurements of this reduction in response for the higher audio frequencies have not yet been taken, but it is hoped to publish more details about this later. The loss of response at the higher frequencies enables the lamp to be used as a very effective needle scratch filter when playing gramophone records and there is no appreciable loss of brilliance due to the attenuation of the higher frequencies.

The current through the MAC4 can be varied over the range 1 to 100mA. The current through the GMC6 cannot usually be reduced below 6mA otherwise the lamp will become extinguished and it will have to be ignited again. The current through the GMC6 may be varied over the range 6 to 100mA. The GMC6 will not operate at values of current as low as the MAC4 (about 1mA), nevertheless it has the advantage of giving more light output for any given value of the current and also the characteristic curve of light output against current is considerably more linear than that of the MAC4. The characteristic curve of the GMC6 over the range 6 to 100mA is shown in Fig. 4 and the linearity is often within 1.5 per cent. The test limits are at present arranged so that the characteristic curve must be linear to within 3 per cent, but special selection can be made, if necessary, in order to obtain lamps with linearity within 1.5 per cent.

The special collimated construction of the GMC6 has enabled a degree of linearity to be obtained which, as far as we are aware, is an outstanding feature of this design of modulated discharge tube. The MAC4 is inherently a tube of the crater type, but the GMC6 is not, strictly speaking a tube of crater type at all; however, for want of a better description, it is often referred to as a crater lamp. A more correct, but more cumbersome expression would be "a gas filled hot cathode variable intensity arc discharge tube."

Life

There is no evidence of any blackening of the window on the GMC6 for period up to 3,000 hours of life. A life of 1,000 hours may be considered to be normal for a lamp of this type, but there is likely to be a progressive decrease of light output as the lamp continues in service. There is not sufficient evidence available at present to enable statistical figures to be given, but the effect over the first 1,000 hours is not considered to be sufficient to give concern in most of the applications of this lamp. In Table 2

some figures are given which indicate the results of our life test observations as far as we have carried them out, up to the present time.

TABLE 2
Change of Brightness during life of the GMC6 Crater Lamp
(measured in relative units)

Time (hours)	Current through lamp		
	30 mA	60 mA	90 mA
0	1.0	1.9	2.6
100	0.95	1.9	2.6
200	0.95	1.8	2.6
300	0.9	1.8	2.5
400	0.9	1.8	2.4
500	0.85	1.7	2.3
700	0.8	1.6	2.2
1000	0.8	1.6	2.0
1500	0.7	1.5	1.9

The brightness for a current of 30mA at the beginning of life test is taken as unity. The lamps had been run at a steady current of 35mA throughout life test except during the period when their light output was measured at 30, 60 and 90mA as indicated in the above table.

Applications

The crater lamp is used in a variety of different ways in various forms of electronic equipment. Many of these applications are quite orthodox, whereas some applications are of an unusual nature and new methods of using the lamp are frequently being devised. The following list of applications of the crater lamp incudes most of those which have been brought to our notice directly by the users of these lamps.

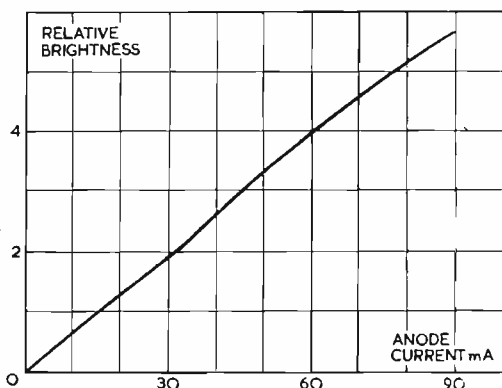

Fig. 4. Characteristic curve of GMC6 lamp over the range 6 to 100mA

Facsimile Reproduction of Photographs

In this application the lamp is used as a modulated source of light at the receiving end and so replaces the considerably more elaborate light modulating equipment such as the loop galvanometer. The crater lamp has certain disadvantages as well as advantages over the loop method. These matters are discussed in more detail in the literature (Facsimile Reproduction).

The lamp is readily adapted for sound-on-film recording by the variable density method. Typical conditions would be:

Mean current	30mA
Modulated current from mean (typical)		15mA
Speed of film	36ft per minute
Type of film	Kodak positive
Minimum current to give measurable blackening	15mA

Just after switching on the current, the lamp may register a certain amount of noise owing to oscillation of the light column. This noise dies away to a negligible amount after

the lamp has been allowed to run for approximately ten minutes.

The GMC6 which has a linearity curve such that the departure from linearity is not more than ± 3 per cent is very satisfactory for the photographic recording of sound by the variable density method.

Interval Marking

The lamp can be used to give interval markings on a strip of moving film or photographic paper. The lamp is pulse driven at the required frequency and so prints a series of dots or strips on the film. The time intervals associated with any other traces on the film can then be readily estimated by reference to these timing marks. Typical operating conditions would be:

Pulse of current	.. 40 to 80mA
Frequency of pulse	.. Between 0 and 2,000c/s
Duration of pulse	.. 100m.sec. to 50m.sec.
Type of film or paper	.. Ilford B.P.1 recording paper
Optical reduction ratio	4:1
Speed of film or paper	.. 15-120cm per sec.

Telecontrol

The lamp may be used instead of a radio link for remote control of equipment over considerable distances. It has been used in this manner for the control of apparatus operating at very high voltages. Also the lamp may be used to transfer information from a remote point to the ground station.

Encephalograph

Recording on film by the variable density method enables higher frequencies to be investigated than would be possible by the pen recorder.

Spectroscopic Source

The normal mercury-argon lamp gives an intense spectrum of mercury, typical of low voltage and low pressure excitation, in which the singlet combinations are unusually strong. The lamp gives ample light output to enable it to be of use as a light source for interferometric measurements.

In conclusion, I must thank Mr. H. Brown and Mr. W. Birtwistle for very considerable assistance in the preparation of this paper.

Screening of T.V. Cabinets

Extensive tests carried out to determine the screening efficiency of coatings formed on the inside of wooden and bakelite television cabinets with "dag" Dispersion 479 have shown that the E.H.T. and line time base generator radiation are greatly attenuated.

The sets, after treatment, are well within the specification suggested by B.R.E.M.A. with regard to radiated signal strength, attenuation of the order of 20 to 30db being obtained. An actual case concerns a set which before treatment showed a field strength of 200 microvolts per metre at a distance of 21ft. (210kc/s signal). After cabinet treatment with "dag" Dispersion 479 the field strength was reduced to 31.5 microvolts per metre at a distance of 9ft.

Further tests were carried out to show the efficiency of the screening as compared with copper mesh of the order of 36 strands sq. inch. These tests showed that at 120kc/s the screening efficiency of the Dispersion 379 coating was the same as that of the copper mesh and although the efficiency of the graphite coating decreases at higher frequencies, the screening efficiency is of the order of 60 per cent at 210kc/s, which means that the time base radiation is effectively suppressed.

A D.C.-A.C. Amplifier for Use in Physiology

By H. Asher

Physiology Dept., Birmingham University

AFTER reading much of the literature about building direct coupled amplifiers, some people may be deterred by the number of precautions which have been described as necessary. The amplifier described here has a simple circuit and is built almost entirely out of standard components readily obtainable from government surplus stores. It has been used for several years, chiefly for recording human and animal electro-retinograms.

An electro-retinogram is the voltage change generated by the retina in response to a flash of light falling on the eye. It is usual to take one lead from the cornea (the front of the eye) and another from the forehead near the eye. These are the two input leads shown in Fig. 1. The body of the animal is connected to earth by a separate lead not shown in the diagram.

Switches convert from direct coupling to capacitor coupling so that the amplifier may have a wide range of applications.

Fig. 1 shows a simplified diagram of the amplifier. The usual arrangement of push-pull stages with cathode degeneration of in-phase voltages is used. The gradual stepping up of the H.T. voltages allows the simple method of connecting the anode of one stage to the grid of the next.

In any D.C. amplifier there must be some system of "setting up" whereby the couplings are adjusted so that each valve is correctly biased. There must also be a system for backing off any large applied potential difference so that small variations of it may be examined. These two problems are solved together by the shift control in the cathode follower circuit, V_1 , Fig. 1. By operating this control a balanced D.C. voltage change is fed into the first amplifier stage, where it is amplified and fed to the remaining stages. This control acts therefore as a Y shift. Clearly there is one setting of this control which will result in the two anodes of the output stage being at the same potential. This is shown by the trace being central on the C.R.T., and the operator sets it to this position. If we now argue backwards from the output stage it follows from the symmetry of the circuit that there is no difference in potential between the two grids of stage 4, and the same is true of the anodes and grids of all the previous amplifying stages. There will be a departure from this condition only in so far as the components may differ from their nominal values. The bias conditions are now determined by the resistances R_A , R_k and the H.T. voltages. Owing to the use of the resistors R_k to produce degeneration of in-phase voltages, the grid bias of any one pair of valves is affected but little by considerable changes in the H.T. voltages of the preceding stage. Thus operating the shift control so as to bring the trace on the C.R.T. to the centre does two things. Firstly, it backs off any potential difference in the animal, and, secondly, it establishes correct bias conditions throughout the amplifier.

The gain control is a variable resistance connected between the anodes of stage 2. If no precautions are taken, operation of this control will cause an unwanted vertical movement of the trace. This trouble arises as follows. Suppose the shift control in the cathode follower circuit is set so that the trace is central, i.e., the two output anodes are at the same potential. Then if there is a slight divergence from equality of the anode loads of the two output valves V_8 and V_9 , it will follow that there will be a slight difference between the potentials of the grids of these two valves. If we now argue backwards as before we find that there is a small difference in potential between the grids of the valves of stage 3 (V_6 and V_7). Asymmetry of any of the pairs of components between V_6 and V_7 and the output may contribute to the potential difference between the grids of this stage. It is convenient to look on this difference of potential as a signal fed into V_6 and V_7 . Operation of the gain control will amplify this signal, and will thus result in an unwanted Y shift. This trouble is avoided by use of an equalizer in stage 3. This compensates for any asymmetry of the components by adding an equal and opposite asymmetry. It is set by trial and error so that operation of the gain control does not affect the shift. Various arrangements of the shift control and equalizer are possible. The essential condition is that the shift control must come

before the gain control and the equalizer must come after it. Further details of the circuit are shown in Fig. 2. The input is by ordinary thin braided screened cable to the cathode follower stage. These leads are about 6 ft. long. The cathode followers are mounted in the same box as all the other valves. The switch S_1 allows for direct or capacitor input. The purpose of the cathode followers is

Fig. 1. Basic circuit diagram of the amplifier

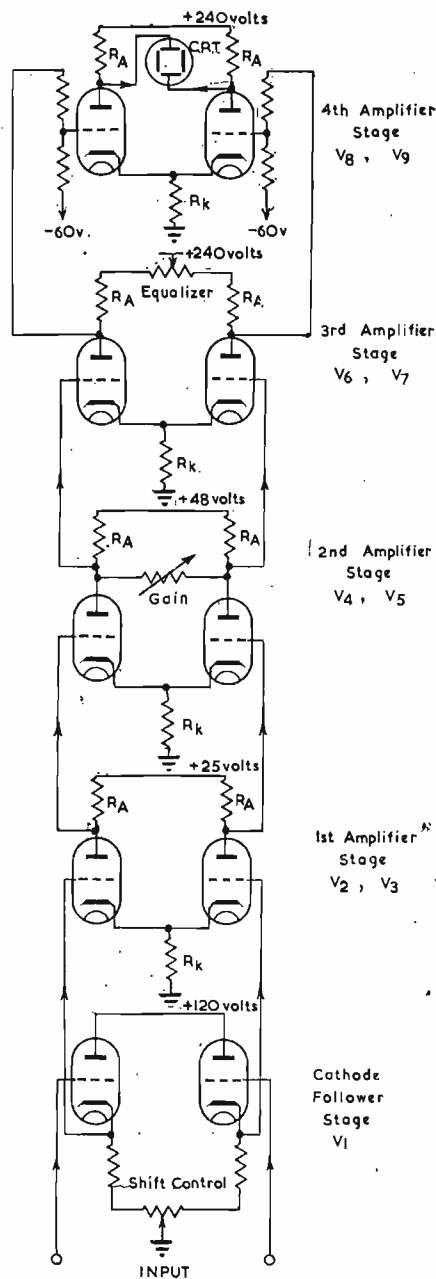

to provide the grid current which is drawn by the first stage. When working from a source of very high output impedance this simple arrangement would not be satisfactory and a more elaborate cathode follower arrangement such as that described by Attree¹ or Bishop² should be employed.

The first amplifying stage differs from the basic circuit only by the inclusion of the 250 ohm potentiometer and the 50 ohm and 5 ohm variable resistors. These all act as shift controls of progressively increasing fineness. The extent to which the shift controls affect the gain of the amplifier was investigated. A floating potential of 0.2 volts was inserted in series with the lead from the calibrating signal, which was set to 200 micro-volts. This was backed off, using the shift controls, and the 200 micro-volt signal recorded on the moving paper. The floating potential was now reversed and again backed off, and again the 200 micro-volts signal was recorded. No difference could be detected.

For a separate test the 250 ohm potentiometer was operated over its full extent and compensated by a suitable variable floating potential in series with the lead carrying the 200 micro-volt signal. Again, no difference could be detected. Thus, although the gain is theoretically affected by a change in the cathode resistance, in this case the cathode resistance is so small compared with the anode load that the change in gain is not appreciable.

For those who like to reduce the number of controls to a minimum it may be pointed out that the 250 ohm potentiometer and the 5 ohm variable resistor may be omitted altogether, the full shift is now controlled by the 1k and 50 ohm shift controls, but now more care is required to operate them. It has been found that the triode connexion of the first stage effects no improvement in signal-to-noise ratio. The values are therefore used as pentodes.

The second stage differs from the basic circuit only by the inclusion of the gain control. This consists of 50k (coarse) and 5k (fine) variable resistors. With the 50k resistor at zero and the 5k at maximum the overall gain of the amplifier is 4×10^5 . With both resistors set at maximum the gain is 2.5×10^6 . A higher value of resistance would give more gain, but this is not required.

A.C. Couplings

When using the amplifier direct coupled there is a gradual drift of the base line. Using a separate 4 volt battery for the heaters of the first stage, the drift due to the amplifier is about 30 micro-volts per minute or less. The drift is mainly due to slow changes in the potential of the heater battery. There may, however, be a drift which is considerably greater than this from the eye. For many purposes it is more convenient to use an A.C. coupling, particularly for use with a human subject. For this purpose C-R couplings of various time constants can be switched in. With the arrangement shown the switching is on

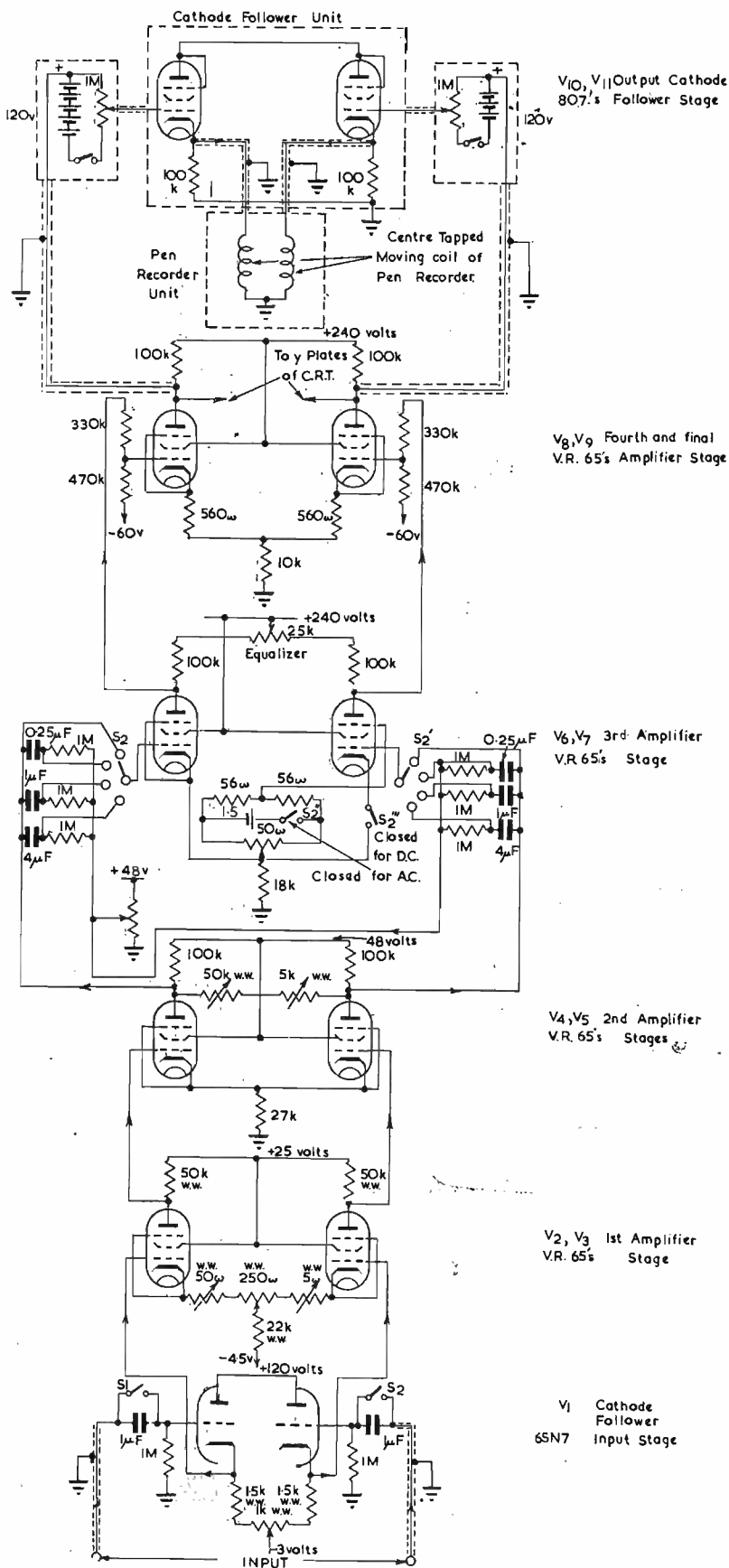

Fig. 2. Complete circuit diagram of the amplifier

the grid side, and the capacitors are always charged to the same potential whether they are in use or not. This involves the use of a few extra resistors, but it avoids delay due to capacitor charging when switching from one time constant to another. The grid leaks are returned to the slider of a 100k potentiometer. This is preset so that the mean grid potential of V_6 , V_7 is the same whether the coupling is direct or via the capacitors.

A.C. Shift Control

With the A.C. couplings in circuit the shift controls in the cathode circuits of V_1 , V_2 and V_3 , are ineffectual, so that an additional shift control is included for use in this case. This is a 50 ohm potentiometer in the cathode circuit of the third amplifier stage (V_6 , V_7). The cathode of V_6 is joined to this slider, and is made either positive or negative with respect to the cathode of V_7 , which is always joined to the mid point of the potential divider across the 1.5 volt dry battery.

The final amplifier stage (V_8 , V_9) is straightforward. The two 560 ohm resistors in the cathode circuit effect current negative feedback. This output stage feeds the cathode ray tube.

For driving a pen recorder (Henry Hughes), power is required, and this is supplied by two 807 valves connected as cathode followers. With the low value of H.T. used for

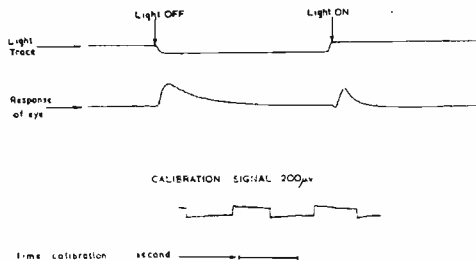

Fig. 3. Shows the response of the eye of a frog to switching off and on the normal room lighting. An upward deflexion signifies the front of the eye is positive with respect to the back. Amplifier A.C. coupled

the amplifier (240V) it was found that the full output was required to drive the pens. Consequently, the old-fashioned type of D.C. coupling was used, as it does not lose any volts. Each of these couplings consists of a 120V battery shunted by a 1 megohm potentiometer. These potentiometers are set so that when the C.R.T. trace is central the cathodes of V_{10} and V_{11} are each at 50 volts above earth. Then each valve is passing 20mA through each half (2.5k) of the 5k centre tapped coil of the pen recorder.

Screening and General Construction

Input and output leads are screened. In the amplifier the valves are well spaced, and there is a single partition separating the one half which contains valves V_1 - V_5 from the other half which contains valves V_6 - V_9 . The cathode followers V_{10} and V_{11} are mounted in a separate unit because the requirement for a pen recorder only arose after the main amplifier had been built. The V_{R65} valves for the first stage must be selected for low microphonic effect. To insulate the amplifier from vibration it is placed on a shelf above the bench and mounted on four rubber sponges. The heater leads to the first amplifier stage are soldered directly to the pins of the valves. Holes are drilled through the heater sockets of the valve holder to allow this. The resistors in the input cathode follower stage and the first amplifier stage should be wire wound. Carbon resistors cause both noise and drift.

Power Supplies

The output cathode follower stage is supplied by a

power pack delivering 40mA at 300V H.T., and 2 amps at 6.3V for the heaters.

The H.T. for the amplifier is from batteries, the total H.T. consumption being 5mA. The heaters are supplied from a 6 volt car type accumulator of 105 amp-hour capacity.

A description of a stable mains H.T. and heater supply for direct coupled amplifiers has been given by Miller³.

Fig. 3 shows the trace obtained from a frog's eye in response to switching on the normal room lighting. The amplifier is A.C. coupled, the time constant used is one second. The eye responds both to the onset and the cessation of light.

Fig. 4 shows a trace taken from the same eye with the

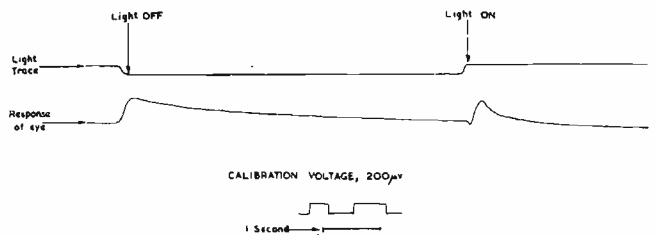

Fig. 4. Same as in Fig. 3, but amplifier direct coupled

amplifier direct coupled. For the "off" response there is a considerable difference between this wave and that shown in Fig. 3, showing that a time constant of 1 second introduces an appreciable amount of distortion.

Calibration

Calibration signals of 50, 100 or 200 micro-volts from a dry battery, tapping key, and potential divider can be fed into the input.

REFERENCES

- Attree, V. A., *Electronic Engineering*, 21, 100, 1949.
- Bishop, P. O., *Electronic Engineering*, 21, 469, 1949.
- Miller, *Electronics*, 1941.

Radio Link Testing of Jet Engines

Some interesting tests on jet turbine engines in flight have recently been undertaken by Rolls Royce, Ltd., at their Development Aerodrome at Hucknall, Nottinghamshire. Turbine blades were given comprehensive strain tests; as far as is known the first time that such tests have been made while the engine is actually propelling an aircraft in flight. The method used was as follows.

Electrical resistance elements are built into the turbine blades and electrical connexions made to a radio transmitter in the aircraft by means of special mercury slip-ring contacts. When the jet engine is running, any strains which are set up will appear as an electric signal which is transmitted to the ground, where it is recorded on magnetic tape, so that it may be examined and analysed under laboratory conditions. Due to the impracticability of using a high-speed camera for a flight period of about $\frac{1}{4}$ hour it was found that magnetic tape recording was the only suitable method for obtaining an accurate record of these signals, which may include frequencies up to 20kc/s. A standard E.M.I. studio type Tape Recorder has been used by Rolls Royce, Ltd., for the purpose. The recorded signals are examined so that it can be determined at what speeds any dangerous strains occur, and for this purpose a special Frequency Analyser is used to examine the recording. Both the recording and its analysis and a visual indication on a cathode-ray tube were demonstrated at the Muirhead Stand at the Physical Society's Exhibition.

The Muirhead-Pametrada Wave Analyser used to analyse these recordings was designed and is manufactured by Messrs. Muirhead & Co., Ltd., of Beckenham, Kent.

Piezo-electric Crystal Devices (Part 3)

By S. Kelly *

Ancillary Apparatus

When piezo-electric transducers are used for measurement purposes certain precautions must be taken to ensure that the overall stability of the system has the best optimum value. In particular, care must be used in the method of connecting the crystal transducer to its amplifier. The input circuit, while not being extremely critical, requires that certain requirements be observed.

The piezo-electric co-efficient of most crystal transducers is independent of temperature, but the capacitance does vary slightly, so that the overall sensitivity of the transducer can in certain circumstances become temperature dependent, especially if the electrical load impedance which is connected across the transducer has a low value. Where possible, it is advisable to mount the amplifier as close as possible to the transducer. It will be appreciated that, even though the input resistance of the amplifier is infinite, any capacitance introduced by connecting cables will form a capacitance potential divider with the source

be used. In this case, a cathode follower input is used and double shielded co-axial cable for connexion between the transducer and the amplifier. It will be seen that the inner shield of the coaxial cable is connected to the cathode of the cathode follower, the outer shield of course going to ground and the centre conductor connected to the control grid, the transducer being from the centre conductor to the ground. It can easily be shown that the effective capacitance of the cable will be reduced by the amount of degeneration introduced by the cathode follower. The output from the cathode follower is coupled into a two-stage feed-back amplifier and the output of the amplifier can then be connected to the main amplifier. The nominal gain of either of these amplifiers can be adjusted between 30 and 60db by the adjustment of the feed-back resistance and no special comments are needed here.

These amplifiers are nominally flat within 1db from 20-20,000c/s. and if the frequency response is required

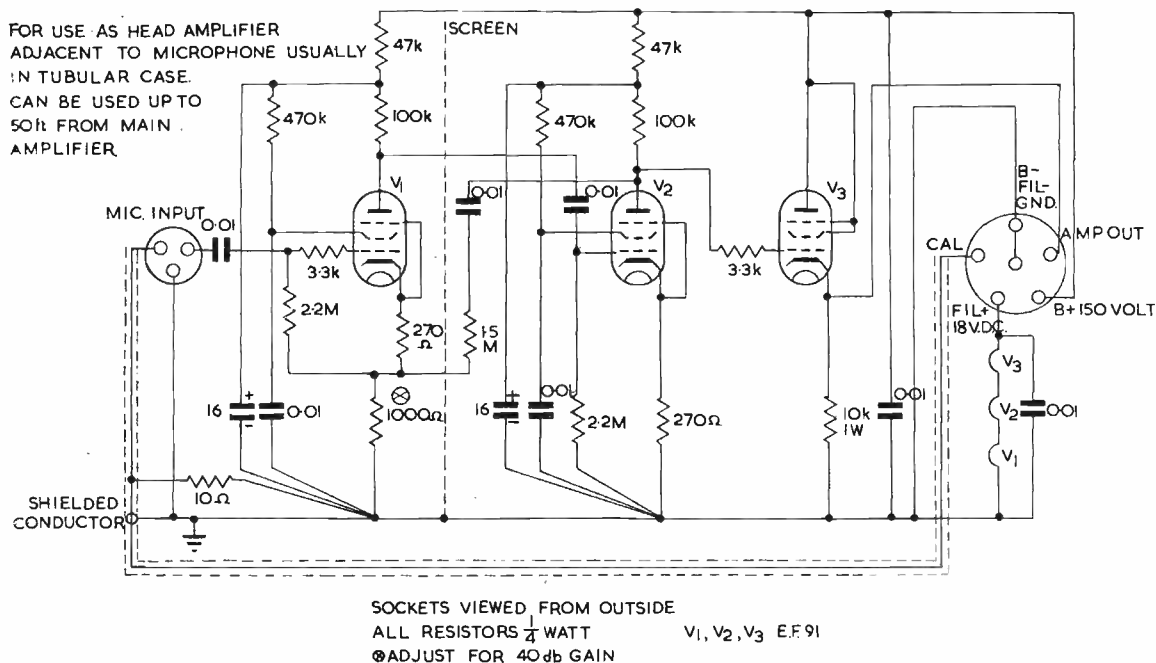

Fig. 14. Microphone head amplifier

capacitance of the transducer, and if the transducer capacitance is temperature dependent, a variable loss (which will also be temperature dependent) will be introduced by the cable capacitance.

Fig. 14 shows the circuit schematic of a suitable amplifier for direct connexion to a transducer. It has a nominal gain of 40db and a cathode follower output system is used in order approximately to match the co-axial cable used to connect the head amplifier to the main amplifier. If a low capacitance cable (say, 15pF per foot) is used the amplifier may be separated from the main amplifier by a distance up to 50ft.

Where it is not convenient to have the amplifier adjacent to the transducer, the system shown in Fig. 15 may

to be extended in the upward direction, it is suggested that the anode and screen feed resistance be reduced by an amount dependent on the upper frequency limit, i.e., reducing the anode resistance to 10,000 ohms and the screen resistance to 50,000 ohms will increase the upper frequency limit to values in excess of 100kc/s.

Where it is desired to use a very wide frequency range, some form of selective tuning should be introduced into the main amplifier in order to reduce noise caused by thermal agitation in the input circuit. Specific details for this cannot be given as each case must be treated on its merits.

The power supplies for these amplifiers must be very well smoothed and we recommend that electronic stabilization be used for the high tension supply and the filament

* Chief Engineer, Cosmocord, Ltd.

be supplied either from a storage battery or a well smoothed rectified a.c. The psophometric noise on the high tension should not exceed 100 microvolts and on the low tension 5/10 millivolts. If these precautions are observed and attention is paid to the layout and shielding of the amplifier, no interference caused by hum should be experienced. It may be found necessary to shock mount the valves individually and in extreme cases the whole amplifier may have to be spring mounted. Again, these are points to be taken care of by the individual designer.

Vibration Pick-ups

Vibration pick-ups are devices designed for industrial use in converting the motion of vibrating objects into electrical potentials that may be observed and studied by means of an oscilloscope or other indicating device. Under certain conditions, it may be desired to use the output of the pick-ups in the operation of relays or other equipment.

These pick-ups use piezo-electric crystal elements as the generating members.

INERTIA TYPE

The inertia type pick-up shown in Fig. 16 delivers a voltage that is approximately proportional to the acceleration it receives when applied to a vibrating body. For a sinusoidal vibratory motion, the acceleration is proportional to the product of the amplitude and the square of

amplitudes) this rising characteristic of the inertia type pick-up is especially desirable for applications where the high frequency components are to be indicated.

An important feature of inertia type pick-ups is the fact that there are no moving parts to actuate the crystal generator. Instead, vibratory motion which the pick-up case receives by contact with a vibrating body causes the crystal element to bend because of its inertia with respect to the motion of the case.

When studying vibrations with low harmonic content, the order of magnitude of the voltage output can be found in Fig. 17. However, in many applications, measurements are desired on systems of varying frequency or on vibrations of high harmonic content on which a linear response curve is essential. A simple filter network consisting of two R-C differentiating networks will give essentially uniform response over large portions of the spectrum between 4 and 1,000 cycles per second.

It should be borne in mind that when using such a network the signal is attenuated at the rate of 12db per octave to compensate for the square law response of the pick-up proper. Hence, greater amplitudes of vibration or greater signal amplification must be provided than when using the pick-up alone, particularly at the high frequencies.

DISPLACEMENT TYPE

The displacement pick-up delivers a voltage which is

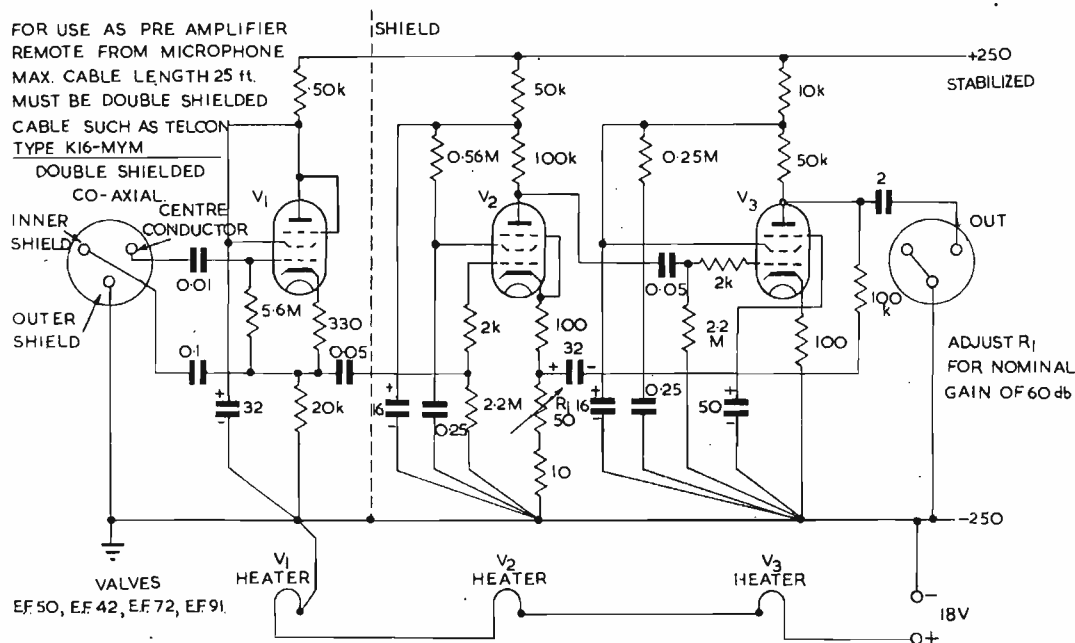

Fig. 15. Microphone pre-amplifier

the frequency. The approximate general equation for the frequency range embraced by the straight portion of the curve is:

$$V = KAF^2$$

- V = a voltage generated by pick-up.
- K = a numerical constant determined by sensitivity of pick-up.
- F = frequency of vibration observed.
- A = amplitude of vibration observed.

If the vibration is complex, the harmonics will be magnified in a manner expressed by the response curve. Thus a 200 cycle vibration having a 400 cycle component of 2 per cent will cause a voltage to be generated of 200 cycles fundamental and an 8 per cent 400 cycles component.

Inasmuch as vibratory amplitudes in the high frequency range may be quite small (compared to lower frequency

directly proportional to the displacement of the pick-up probe and which is independent of frequency in its linear range. Consequently, the frequency and harmonic content of the generated voltage is identical with that of the observed vibration. To achieve this type of response, the crystal element is actuated by a suitable drive pin which bears against the vibrating body. A fixed stop is provided to protect the element.

The displacement pick-up is preferred for low frequency work because of its type of response and its relatively greater sensitivity at these frequencies.

ARTIFICIAL EARS

In order to assess the performance of telephone receivers two methods of measurement are possible. One is for the observer to listen to the telephone receiver and attempt to

judge the sensitivity versus frequency characteristic by subjective means. This would be a simple procedure providing that the acuity of everyone was the same. Unfortunately, this very desirable requirement is not the case. The alternative is therefore to provide some form of "artificial ear" in order that the measurement of the telephone receiver may be carried out objectively. The artificial ear is used to couple the receiver under test to a standard microphone by means of which the pressure developed by the receiver under test can be determined and plotted against the E.M.F. driving to the receiver. The design of the acoustic network coupling the receiver to the microphone is of utmost importance. It is obvious that the acoustic load impedance which the telephone receiver works into will affect the response of the instrument. Therefore, the impedance of the artificial ear should approximate to that of an average human ear. Much work was carried out during the 1920's by the British Post Office and Bell Telephone Laboratories, and, based on the early work of Mr. West, of the British Post Office in 1929-30, the Medical Research Council issued a report in 1947 on the requirements of artificial ears for the objective calibration of telephone receivers. Their recommendations were:—

- (a) For use with external telephone receivers. The artificial ear should consist of a cavity in hard material of volume 3cc, combined with an acoustic resistance in the range of 100-150 acoustic ohms. The construction should be such that the acoustic capacitance of the cavity and the acoustic resistance element are effectively connected in parallel.
- (b) For use with insert receivers. The artificial ear should have the same general characteristics as (a) except that the volume of the cavity should

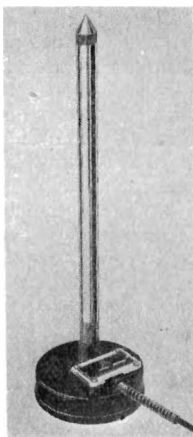

Fig. 16. Inertia vibration pick-up

be 1.5cc and the value of the acoustic resistance should be 200-300 ohms. The above definitions do not give an exact analogy of the human ear because both the reactance and the resistive components are subject to wide variations with frequency in addition to individual variation, but the analogy is sufficiently close to give a close representation of the actual performance of telephone receivers over a range of about 200 to 4,000c/s.

The American requirements are somewhat different, being 6cc for the external receiver and 2cc for the internal receiver, with no acoustic leakage resistance. These differences between the American and British practice can be explained to a large extent by the different methods of performing the tests. Fig. 18 shows an artificial ear which has been designed primarily to meet the requirements of the Medical Research Council in their report No. 261—Hearing Aids and Audiometers.

The cavity is normally 3cc with an acoustic resistance of 100 ohms in parallel. This resistance is obtained by

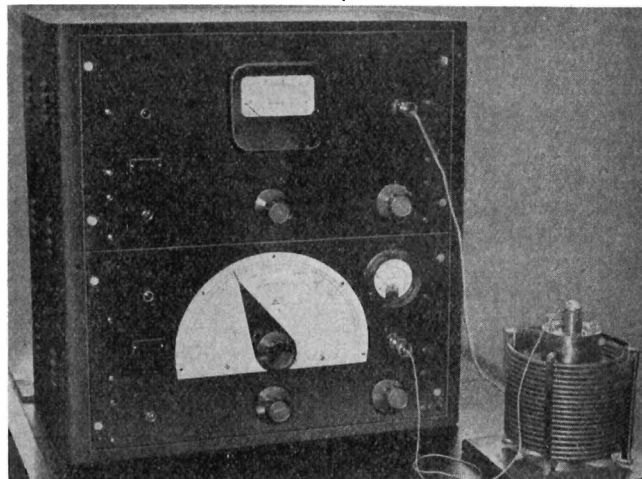
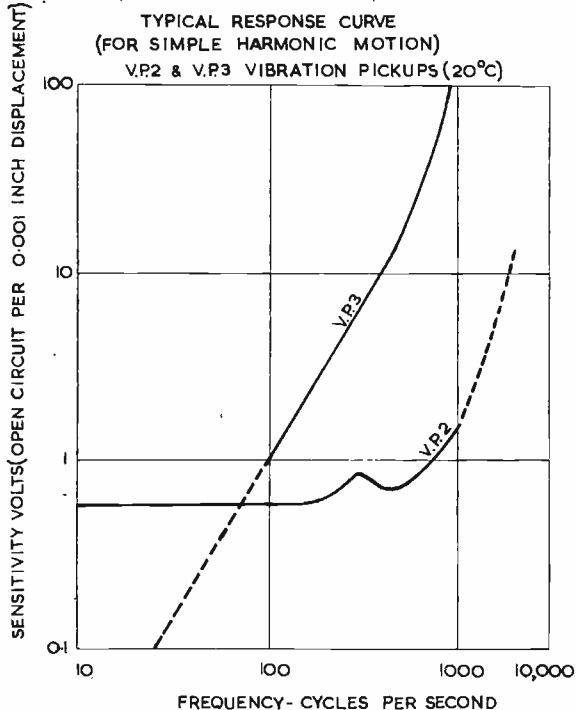

Fig. 18: Artificial ear test set.

Fig. 17. Frequency response vibration pick-ups



connecting two semi-infinite tubes of suitable cross-section and terminated with an acoustic damping network. An adaptor is arranged to reduce the volume of the cavity to 1½cc and at the same time to remove one of the resistance tubes from the circuit. This has the effect of maintaining the resistance-reactance ratio constant over the band of frequencies for which the unit is designed. The cavity is terminated with a crystal microphone of specialized design. The acoustic impedance of the microphone is sufficiently high that it may be considered infinite for all practical purposes and the response is maintained to well beyond 15kc/s, although because of absence of information of the impedance of real ears at the higher frequencies, the artificial ear is not calibrated above 4kc/s.

The unit should be kept at a fairly constant temperature, preferably between 18°C and 20°C, which is the temperature at which calibration is made. The pre-amplifier should follow the general lines outlined earlier and the following precautions should be taken:

Particular attention must be paid to the screening and layout of the amplifier in order to reduce hum and extraneous noises. It should preferably be resiliently mounted against mechanical shocks and the power supply for both the filament and high tension should be very well smoothed. The microphone behaves as a generator in series with a nominal capacitance of 500pF, and while the microphone response is flat to below 10c/s the effective response will be modified by the input impedance of the pre-amplifier. If the input impedance of the amplifier is low compared to the series impedance of the microphone a suitable correction must be applied for the effective

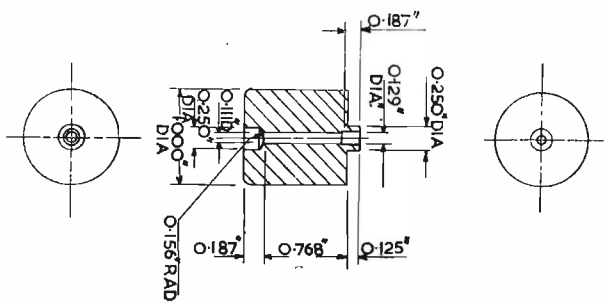

Fig. 19. Acoustic coupler for insert type receivers and 1½cc artificial ear

attenuation introduced. This will be further complicated by the variation in capacitance of the microphone with temperature.

It is essential that adequate acoustic seal be provided between the receiver under test and the acoustic coupler and the artificial ear. Fig. 19 gives details of a coupler used by these laboratories; but because of the wide divergence in the design of these anatomical fittings it is better for the user to make up a model with the same general configuration as the one normally used with the receiver under test. It is most important that the shape and volume of the cavities inside the anatomical fitting be accurately reproduced in the coupler. In the case of the external receivers it is only necessary to clamp the receiver to the artificial ear and seal the junction with petroleum jelly, or equivalent substance. Failure to effect a good acoustic seal will usually result in attenuated low frequency

response and the introduction of spurious resonances. When it is desired to use the 3cc cavity the adaptor is removed by first unscrewing the four machine screws which fix the adaptor to the body, and then turning the two knurled screws simultaneously in a clockwise direction. This will enable the adaptor to be withdrawn and ensure that the sealing between the two units is maintained when it is replaced.

Normally the sensitivity response of receivers is specified in terms of a constant voltage across the input and the pressure developed in the cavity; the input voltage being equated to 1 volt, and the necessary correction added to the response curve. The unit can be used with equal facility for measuring overall electrical to air performance tests on hearing aids, etc. Where overall air to air tests are to be made, precautions must be taken to ensure that adequate acoustic shielding is provided between the input section of the hearing aid and the receiver-cum-artificial ear. It is recommended that a box about 2ft cube with a lining of 6in. thick glass wool or equivalent substance be used to contain the artificial ear.

Acknowledgment is made to Cosmocord Limited and the Brush Crystal Company Limited, in whose laboratories the above work was carried out.

BIBLIOGRAPHY

- Medical Research Council Report No. 261—Hearing Aids and Audiometers.
- Elements of Acoustical Engineering—H. F. Olson.
- Electro-Mechanical Transducers and Wave Filters—W. P. Mason.
- Crystal Growth—The Faraday Society.
- Dynamical Analogies—H. F. Olson.
- Design of Crystal Vibrating Systems—W. J. Fry, J. M. Taylor and Bertha W. Hervis.
- Piezoelectricity—W. G. Cady.

Recalibration of G.C.A. Precision Aerial Systems

THE precision (talk-down) system of the G.C.A. equipments used in the Ministry of Civil Aviation depends upon a pair of mechanically complex aerial systems, one for the azimuth beam and the other for the elevation beam.

These aerial systems require frequent attention, necessitating complete dismantling, and once dismantled it is almost impossible to reassemble them to give exactly the same characteristics, i.e., beam angle to wave guide width, and it is necessary for each reassembled antenna to be recalibrated. This is effected by mounting the antenna system on a specially designed turntable and

- (a) determining the beam angle/guide with characteristics of the array, and
- (b) adjusting these characteristics until the curve of their ratio is a hyperbola.

This turntable is mounted on a low four-wheeled trailer fitted with levelling jacks, and consists of a robustly constructed framework, accurately machined to take the antenna systems and capable of being turned through 360° under the control of handwheels. A vernier calibration scale is fitted so that the degree of rotation of the framework relative to the base may be measured to within one minute of arc, a degree of accuracy necessitated by the fact that the beam width of the azimuth and elevation antennæ in their scanning planes are 0.6° and 0.4° respectively. A brake is also fitted to control the movement of the framework while certain measurements are being made.

The method by which these antennæ are calibrated is briefly described below:—

Firstly the antenna is directed at a transmitter situated a few hundred yards away and a power indicating device is connected to the end of the antenna remote from the absorber. The antenna is rotated (at 1° intervals for the azimuth and at 0.5° intervals for the elevation) and the

power readings recorded. From these readings the polar diagram of the antenna is determined and it is essential for this polar diagram to be symmetrical over the entire scanning range.

Once the required symmetry has been obtained, it is necessary to determine the normal to the array, which is effected by reversing the absorber and power indicating device and, in effect, using the "split lobe" thus formed to D/F upon the source of signal.

Only when these preliminary checks have been completed can the main task of calibrating the antenna begin.

The equipment is manufactured by Research Engineers, Ltd., of Canonbury, London, N.1.

The azimuth antenna in position on the turntable, with the feeder to the power indicating device on the left and the absorber on the right

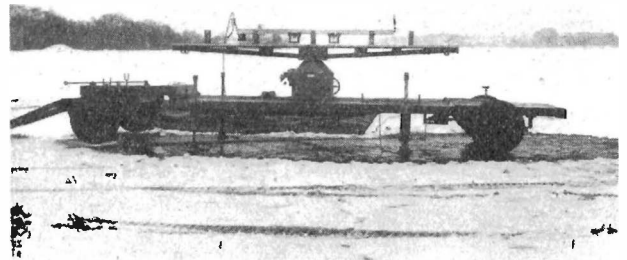

Crown Copyright Reserved

Visual Observation Equipment

A brief review of the operating principles of Stroboscopic Tachometers and allied equipment

By C. A. H. Pollitt, M.I.E.D., A.M.I.Ac.S.

THE measurement of speed and the study of rotating and oscillating machinery in slow motion presents many difficulties. The application of high-speed photography, controlled by mechanical means, has done much to simplify matters, but such methods have certain inherent limitations such as the difficulty of attaching a tachometer, or other apparatus, to the spindle of the rotating body.

While it is true that these difficulties can be circumvented in the laboratory they are not so easily surmountable when applied to everyday industrial practice. For instance, it may be necessary to measure the speed of rotation of a shaft which is clearly visible but to which it is impossible to apply any mechanical means of external transmission such as might facilitate observation.

In these, and other, cases the advent of the electronic stroboscope has opened up a new and widely extended field of development in which it is no longer necessary to

cal and the body will appear to be at rest. Hence, since the speed of flashing is synonymous, under these conditions, with R.P.M., a specially-calibrated R.P.M. scale on the instrument promptly establishes the speed of rotation of the body.

Fig. 1 illustrates a standard commercial pattern electronic stroboscope capable of measuring directly speeds between 600 and 14,500 R.P.M. and by indirect methods, speeds up to 100,000 R.P.M.

The circuit of this instrument, shown in Fig. 2, consists of a multi-vibrator V_2 , the output of which is applied to the discharge lamp V_1 , causing a series of short duration flashes. The frequency of the multi-vibrator, and therefore the flashing rate of the lamp, is controlled by the setting of the potentiometer R_{13} , and an engraved scale covers the two speed ranges corresponding to the two sets of coupling capacitors selected by the rotary switch S_3 . Preset potentiometers R_{11} and R_{14} permit standardization of the scale against mains or any other known frequency.



Fig. 1. Standard commercial pattern Electronic Stroboscope

make mechanical contact with the object under observation. Considerable progress has been made in the use of these instruments for checking speed, and timing adjustments of mechanisms which need to be controlled within close limits.

The theory upon which the operation of these instruments is based is contained in the elemental fact that an identifiable point on a body rotating at a constant speed can be viewed by a flashing light of controllable frequency, and the conditions of motion thus observed will be a function of the speed of rotation relative to the rate of flashing of the light. If the speed of flashing of the light is less than the speed of rotation of the body, consecutive flash-views will reveal the object to be rotating slowly in its true direction of rotation. By the same token, therefore, if the speed of flashing of the light is precisely that of the rotating body, consecutive flash-views will be identi-

Standardizing

Projecting through the lamp reflector is a vibrating reed and by means of this the stroboscope may be standardized in terms of the a.c. mains frequency. This reed is driven from the a.c. mains 50 cycle supply, and vibrates 6,000 times per minute, or twice for each cycle of mains voltage. When the flashing rate of the instrument corresponds to this reed vibration rate, or a multiple or sub-multiple of it, the reed will appear to stand still. The points on the scale at which this occurs can then be used to standardize the calibration.

High-Intensity Lighting

In order to provide an increased light output for photographic purposes, and also for floodlighting large areas, an accessory instrument known as the Stroboflood is used. Three types of Stroboflood are available and may be classified as follows:

Type 1201 B. Operates as a high intensity multiple flash stroboscope in conjunction with the one shown in Fig. 1.

Type 1201 C. Incorporates a torque tube so that it will operate directly from a Contactor Unit with-

Fig. 2. Circuit diagram of standard commercial pattern Electronic Stroboscope

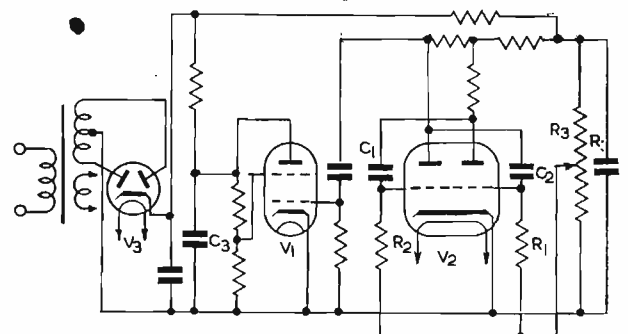

out the need for the previously-mentioned stroboscope.

Type 1201 D. This is a dual-purpose equipment. It can be triggered by the stroboscope shown in Fig. 1 for high intensity stroboscopic work or, when used with a capacitor, develops a single intense flash of light, particularly suitable for high-speed photographic work.

The circuit of all three models employs a capacitor charged to a high voltage from a self-contained power supply and connected directly across a gas-filled discharge lamp. The gas pressure in the lamp is such that the voltage does not produce a spontaneous discharge, and the gas is ionized by applying a high voltage to a third electrode, which thereby causes the capacitor to discharge through the lamp in a single brilliant flash.

The ionizing or triggering potential is obtained from the secondary of a high ratio step-up transformer, the primary of which can be connected either to the output socket of the stroboscope or to the "plug-in" trigger lead and push switch. In the case of the type 1201 C the primary of the step-up transformer is energized from a gas-filled relay valve built into the instrument. One grid of this valve is connected via a coupling capacitor to a socket marked "Input."

For multiple flash work, the capacitor across the discharge tube must be fully discharged before the next triggering pulse arrives and therefore the value of the discharge capacitor can be varied by a selector switch to cover the full flash speed range of the stroboscope. Fig. 3 illustrates the stroboflash in operation.

The Stroboloom

Fig. 4 illustrates one of the most recent stroboscopic instruments to be developed. This is a high intensity stroboscope specifically designed for viewing the moving shuttle of a textile loom. It enables the lay of the thread from behind the shuttle to be accurately determined at each stage of its progress through the loom, whereby the operator is enabled to quickly locate the development of a broken thread, or other weaving defect due to shuttle faults.

In contrast to the stroboscopes previously described, the Stroboloom equipment is contained in a mobile trolley with the lamp unit arranged as a separate item embody-

Fig. 3. The illustration below gives some indication of the general proportions and method of using the Electronic Stroboscope

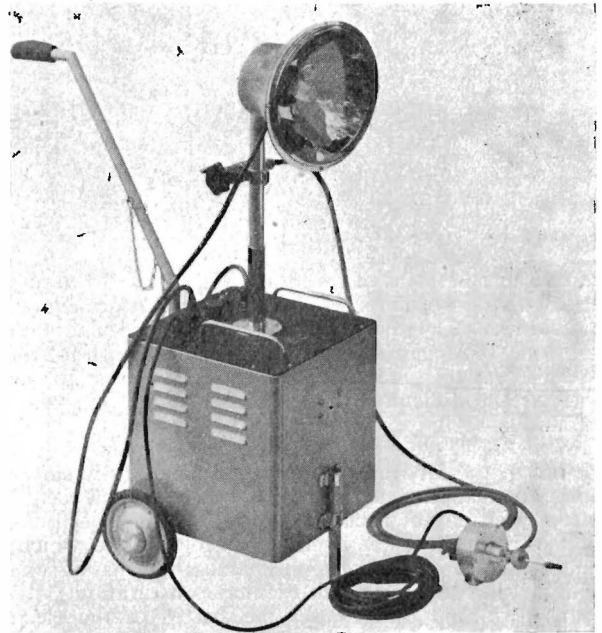
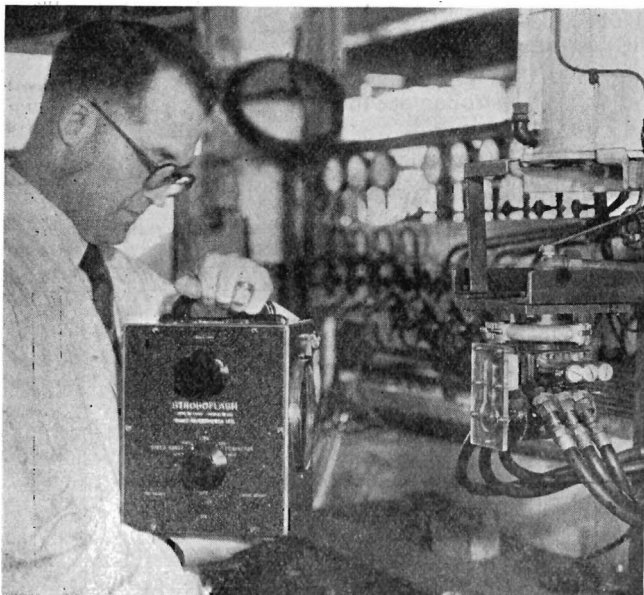

Fig. 4. High intensity stroboscope developed for viewing the moving shuttle of a textile loom

ing a phase control. This arrangement has manifold advantages, not the least of which is the greater freedom of movement it imparts to the operator, which in turn reduces the possibility of accidents often associated with experiments on moving machinery. It is not these considerations alone, however, which have influenced the adoption of a mobile trolley arrangement, but rather the weight of the equipment, which is 75lb and therefore too great for single-handed manual movement.

The flash tube of the Stroboloom gives a very brief but intense flash of white light, the timing of which can be adjusted to synchronize exactly with each cycle of the mechanism under investigation up to a maximum of 220 flashes per minute. The intensity of flash is sufficient to permit direct inspection under well lighted factory conditions and the duration of flash is about 50 microseconds.

General Conclusions

The uses to which electronic stroboscopes have been applied are as diverse as they are numerous and embrace, on the one hand, the study of vibration in rotating mechanisms, including non-recurrent transient phenomena and, on the other hand, industrial maintenance and the checking of the operation of gears, cutters, drills, and cams. In the manufacture of small electric motors stroboscopes have been used to locate vibrations and, by the use of smoke in the air stream, have also facilitated the study of air currents around propeller blades. A novel and highly successful experiment, concerning vacuum cleaner design, was that in which a stroboscope was used to study the vibration of a carpet when a cleaner was being used on it.

The motor car industry has applied stroboscopes to the study of valve springs in conjunction with the use of a contactor unit for synchronizing from the engine crankshaft. This unit is designed to control flash speed, and enables direct synchronism to be obtained with the mechanism being studied. Its function is to interrupt the light source at the same frequency as the rate of revolution of the mechanism, and consists of a small commutator that can be coupled to the shaft under examination by a friction pad or other suitable means.

The author wishes to acknowledge the co-operation of Messrs. Dawe Instruments, Ltd., who have made available the information and illustrations on which this article is based.

Design of Input (Regulation Control) Chokes

By N. H. Crowhurst, A.M.I.E.E.

THE preceding data sheet (published in *ELECTRONIC ENGINEERING*, December, 1950) provided for the design of iron cored inductances carrying D.C., producing the maximum inductance at some specified current value by the use of an appropriate air gap. The type of choke here considered requires an inductance value that varies over a specified range of current values so as to improve the regulation of the rectified supply. This design chart determines the optimum specification for a choke intended to cover a specified range of currents and output voltage, from which specification the preceding data sheet may be employed to produce the complete design.

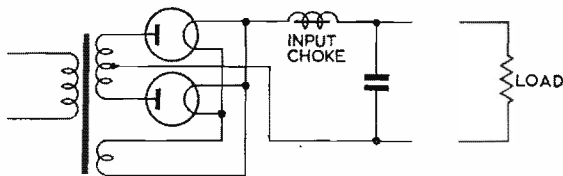

Fig. 1. Input or swinging choke used to improve regulation

The Principle of Input Choke Action

Fig. 1 shows the essential circuit, employing an input or swinging choke for the purpose of improving regulation. At zero load current the first capacitor charges up to peak A.C. input voltage. As soon as a small load current is drawn the input choke makes the smoothing circuit essentially a choke input filter, the conditions for which are illustrated in Fig. 2.

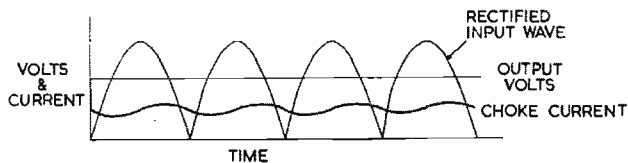

Fig. 2. Conditions of working when a small direct current is being taken

The load current is still so small that the first capacitor has sensibly constant voltage across it, due to the action of the choke in reducing current variations during the cycle. The voltage across the choke will be the difference between the full wave rectified waveform and the steady D.C., and since the average voltage across the choke must be zero (except for the drop due to D.C. resistance), the D.C. output voltage will be equal to the mean value of the A.C. waveform. The instantaneous variation of current through the choke from its mean value will be proportional to an integration of the voltage across the choke, provided the inductance can be regarded as constant during the cycle. The air gap in the magnetic circuit of the choke will be larger than the optimum for this current value, so that the iron will be operating below saturation, and the assumption of constant inductance throughout the cycle is reasonably accurate owing to the stabilizing effect of this relatively large air gap.

At a higher current the conditions in the iron change,

so that saturation takes place during part of the cycle, and the inductance falls in value during this period. Fig. 3 shows the voltage and current waveforms associated with the circuit for a partially saturated condition, while Fig. 4 represents a condition where the choke is fully saturating. This last condition closely approximates a capacitance input smoothing filter, the waveforms for which are illustrated at Fig. 5. In this case the output D.C. voltage approaches the peak A.C. value.

As with all inductances carrying D.C., an input choke is subject to two forms of magnetization: a polarized one, due to the steady D.C. component of magnetizing

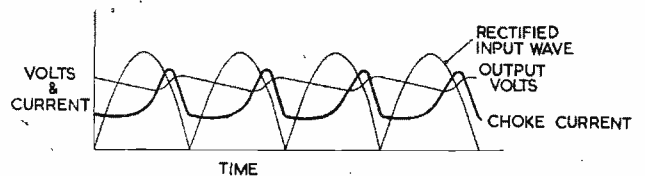

Fig. 3. Conditions of working with the input choke partially saturated

current; and an A.C. magnetization necessary to produce the back E.M.F. corresponding to the A.C. voltage across the choke terminals, which will cause a fluctuation in current. The instantaneous magnetization will depend upon the instantaneous current, according to the composite magnetization characteristic of the magnetic circuit. The steady polarized component of the magnetization has no effect upon the electrical circuit voltages, but the A.C. component

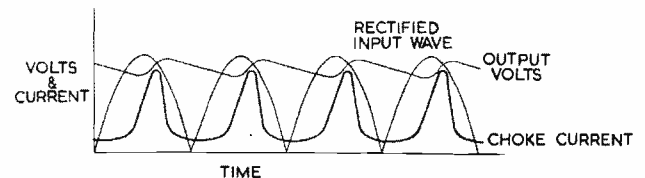

Fig. 4. As Fig. 3, but with choke fully saturating

will produce an E.M.F. across the choke proportionate to the instantaneous rate of change of flux.

By using a swinging choke in which the core saturates at high current values, a rising output voltage regulation characteristic would be obtained if the circuit were loss-free. A choke input filter employing a loss-free inductance that never saturates would maintain a constant output voltage after the first drop due to change-over from initial capacitance input effect when the inductance value is inadequate to produce choke input conditions for very low currents. A capacitance input filter produces a falling characteristic as shown, the rate of fall being dependent upon the capacitance value relative to the output current and voltage. By using a swinging choke, a change-over from one condition to the other can be effected, producing a rising section in the ideal characteristic. In practical circuits, this rise may be used to offset losses due to rectifier resistance, and choke and transformer winding resistances.

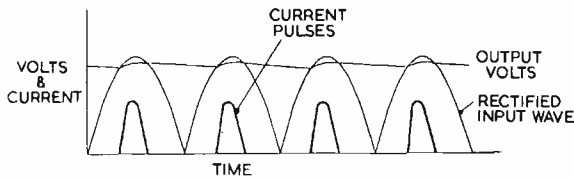

Fig. 5. Waveforms for capacitance input filter

Change of Inductance Required

An ideal choke for this purpose would have an inductance value falling according to some linear law relative to current, as shown by the straight line between *A* and *B* in Fig. 6. In practice a choke that varies between the values of inductance and current represented by these points has to serve, giving the best approximation to a linear regulation characteristic. A practical choke will have an inductance-current characteristic as represented by the curve connecting *A* and *B* in Fig. 6. The operating condition of such a choke corresponding to the optimum design produced by the previous data sheet is represented by the point *C* on this curve.

Examination of a number of typical cases in which the current variation ratio varied up to between 10:1 and 20:1, the following law for determining the point *C* from points *A* and *B* was found to give a close approximation, where the ordinates of point *A* are I_a, L_a , and those of point *B*, I_b, L_b :

$$I_c = I_a^{0.35} I_b^{0.65} \dots \dots \dots (1)$$

$$L_c = L_a^{0.65} L_b^{0.35} \dots \dots \dots (2)$$

The present design chart is based upon these formulae. It will be noted from the ideal characteristics of Fig. 6

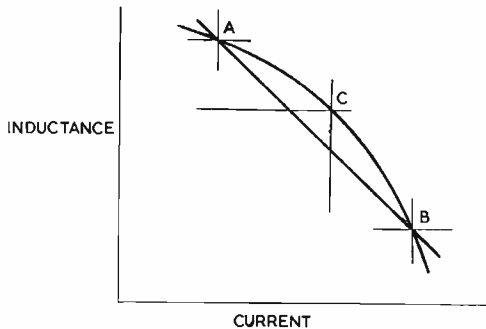

Fig. 6. Ideal choke's linear-law inductance/current characteristic

that such a swinging choke will not hold the output voltage within the required range below a certain minimum current. Where the supply is called upon to handle very wide ratio changes in current it is advantageous to cut down this ratio by the use of a current bleeder. As a potential divider is often required for other purposes, a suitable current can be chosen to provide a good minimum load value. Assuming that the various losses are arranged so that the regulation from minimum to maximum load is zero, there will be slight variations in output voltage at intermediate values of output current. These variations will be reduced by reducing the ratio between maximum and minimum current.

The capacitance value of the first capacitor is important. Increase above the required minimum will improve the regulation, and may even make it negative, by over-compensating for the losses. The minimum value, in the first place, is set by the requirements of a capacitance input filter operating at maximum current on a full wave rectifier. There is, however, a further condition that usually dictates a somewhat higher value of minimum capacitance. It must not resonate with the inductance at any current value to a frequency as high as 50c/s, as a form of resonance can then be set up that takes an unbalanced load

from the rectifier sections, imposing a very severe overload on one half, while the other is almost if not quite inoperative.

The values of inductance given by the chart are for full wave rectification on 50c/s supply only. The chart can be adapted for supplies of other frequencies by modifying the inductance in inverse proportion to the frequency.

Choice of Core Shape

For this type of choke to achieve its full effect, the core must not saturate due to the A.C. flux alone, or at low values of D.C. polarizing. This means that the core must be proportioned to allow for a relatively high component of A.C. flux. The ideal arrangement employs the largest possible iron cross section or volume, and a correspondingly small proportion of winding space. The best way to build up the necessary volume is with a shape approximating to the "Wastefree" lamination, using a stack about twice the dimension across the centre limb of the laminations. A stack up to three or four times this dimension is theoretically ideal, but involves increased difficulty in the practical problem of winding, so that the available space in the winding window is less efficiently utilized in bigger stacks, for which reason a stack of about twice the centre limb cross-dimension is usually a practical optimum.

Use of Chart

Fig. 7 illustrates the method of using the reference lines of the chart, while the following examples will serve as an exercise in the use of the chart:

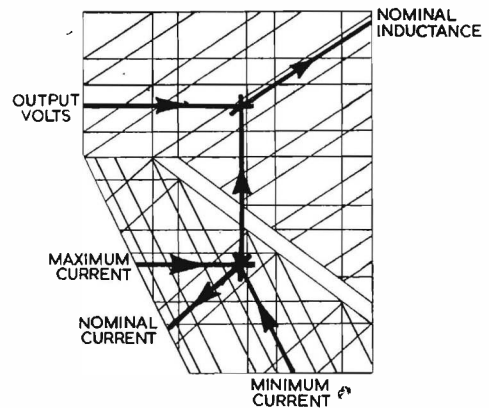

Fig. 7. Guide lines for using chart on the opposite page

Example 1

Output requirements: voltage 400, minimum current 50mA, maximum current 500mA.

Reference along the appropriate scales for minimum and maximum current find a point of intersection corresponding to a nominal current of 0.22A, or 220mA, and to a reference position on the vertical lines corresponding to 110mA on the three current scales where they coincide at the 45° line forming the top right-hand boundary of the lower portion of the chart. Referring up these vertical lines to intersect with the 400 volt reference line on the horizontal scale, the required nominal inductance is found to be 5.5 Henry. The required specification is thus 5.5 Henry, 220mA.

Example 2

Output requirements: voltage 6.3, minimum current 1A, maximum current 4A.

Following the same procedures as in Example 1, except that the reference scale for voltage is in the slanting space across the chart, the specification is found to be 5.8mH, 2.45A.

INPUT (REGULATION CONTROL) CHOKES

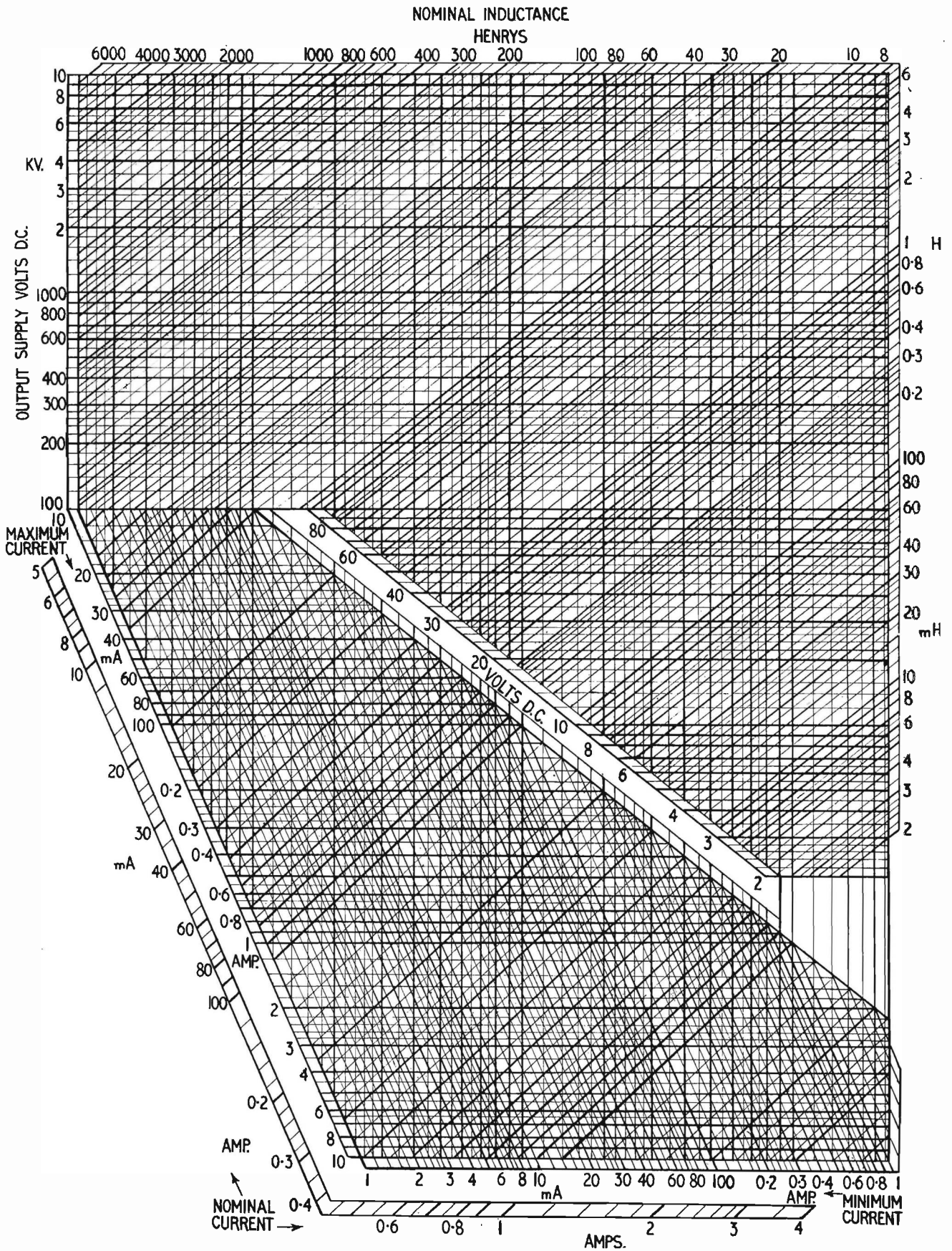

The Theory and Applications of D.C. RESTORING CIRCUITS

Part I

By D. A. Levell, B.Sc. (Hons.); Grad. I.E.E.*

THE general principles of D.C. restoring circuits are discussed and design data is given with particular reference to the D.C. restoration of television signals. The use of "partial" D.C. restoration on the grid of a pentode "double slicing" synch. separator is considered and the necessary design data is given. A method of automatic D.C. restoration at the black level of video signals is described, the design requirements of the circuit are discussed in detail and a practical design is evolved. The article is concluded by discussing the advantages of black level restoration and considers how an A.G.C. voltage can be derived from a black level restored circuit.

General Theory of a D.C. Restoring Circuit:

When a repetitive waveform is passed through a simple A.C. coupling, the D.C. component of the output of the coupling, after the initial transient state, is independent of the amplitude of the A.C. input. For a simple C-R coupling the D.C. component of the output will be zero. By introducing a valve into the simple circuit R can be made a non-linear function of the input potential and the D.C. component of the output signal can then be made to depend upon the A.C. input.

During one cycle of the repetitive input waveform the capacitor of the A.C. coupling gains or loses quantities of charge at the rate $dq/dt = i_c$, where i_c is the current flowing through the capacitor at any instant.

After the initial transient state the circuit will attain a

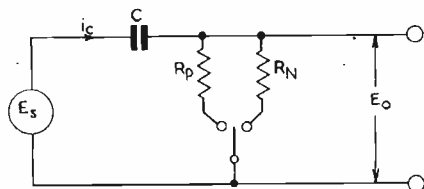

Fig. 1. A general circuit of a D.C. restoring network. When the output E_o is positive the switch connects R_p into the circuit; when E_o is negative the switch connects R_N in the circuit

state of equilibrium in which the capacitor gains and loses equal quantities of charge during one cycle, or stated mathematically:

$$\oint dq = 0 \dots\dots\dots (1)$$

$$\oint i_c dt = 0 \dots\dots\dots (2)$$

where the integral sign \oint denotes integration throughout one cycle.

Let the symbol E_o denote the output voltage of the C-R coupling at any instant, therefore,

$$R \cdot i_c = E_o \dots\dots\dots (3)$$

so that we have,

$$\oint E_o/R dt = 0 \dots\dots\dots (4)$$

The circuit given in Fig. 1 represents a general D.C. restoring circuit. The circuit depicts the passing of a repetitive potential E_s through an A.C. coupling of time constant CR_p when the output E_o is positive and time constant CR_N when E_o is negative.

Let $E_o = E_p$ when E_o is positive

Let $E_o = E_N$ when E_o is negative

and also specify that $E_p = 0$ when E_o is negative

$E_N = 0$ when E_o is positive

then the integral of Equation (4) can be split up into the sum of two integrals thus,

$$\oint E_p/R_p dt + \oint E_N/R_N dt = 0 \dots\dots\dots (5)$$

During the times of integration R_p and R_N may be considered as constant so that,

$$\oint E_p dt / \oint E_N dt = -R_p/R_N = A_p/A_N, \text{ say } \dots\dots (6)$$

This equation shows that the output waveform will be restored to zero at a level such that the areas enclosed by the positive and negative portions of the output voltage against time curve are in the ratio of R_p to R_N .

Let it be assumed that the capacitor has been chosen so large in value that the variation of potential drop across the capacitor is negligible in comparison with the variation of output potential during one cycle, then the waveform of the potential E_o will be approximately identical in amplitude and phase with the input waveform E_s . It is thus apparent from the preceding discussion that the D.C. component of the output waveform can then be evaluated by a graphical construction. One cycle of the input waveform is plotted against time as shown

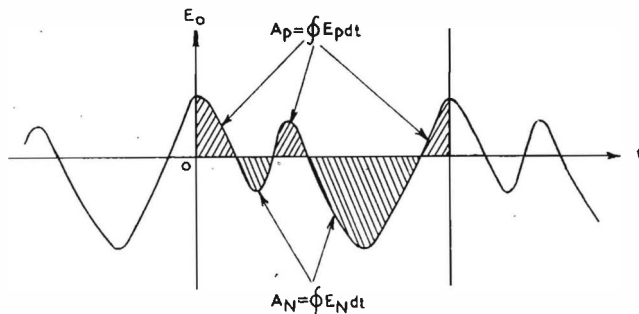
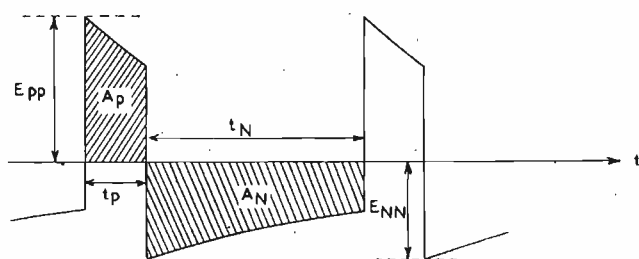

Fig. 2. One cycle of the input voltage waveform plotted against time. To find the D.C. component of the output waveform, the y axis is chosen so that the ratio of the areas shaded satisfies Equation (6)

Fig. 3. General shape of the output from a D.C. restorer when the coupling capacitor capacitance is finite and the input is a repetitive rectangular waveform



* Messrs. A. C. Cossor, Ltd.

in Fig. 2. The y axis of the curve is then found by inspection in order to satisfy Equation (6).

In practice the capacitance of the capacitor C will be necessarily finite in value and the effects of the periodic variation of potential across the capacitor must then be considered. If C is chosen suitably small in value the circuit can be made a differentiator of time constants CR_p on positive output and CR_N on negative output. The calculation of the output waveform will then depend upon the complexity of the input waveform.

D.C. Restoration of Repetitive Rectangular Waves Through a Finite Coupling Capacitor :

Fig. 3 shows the general shape of the output waveform when repetitive rectangular waves are passed through the D.C restoring network of Fig. 1. Let E_{pp} and E_{nn} be the values of the positive and negative peaks of the output waveform E_o , and let t_p and t_N be the total times during which the output is positive and negative respectively in one cycle. Then during the positive period of each cycle the output can be represented by the equation,

$$E_o = E_v = E_{pp} \cdot e^{-t/CR_p} \dots\dots\dots (7)$$

where $t = 0$ at $E_o = E_{pp}$
hence,

$$A_p = \int_0^{t_p} E_{vp} \cdot e^{-t/CR_p} dt \dots\dots\dots (8)$$

$$= -CR_p E_{pp} (e^{-t_p/CR_p} - 1) \dots\dots\dots (9)$$

Similarly,

$$E = E_{NN} e^{-t/CR_N} \dots\dots\dots (10)$$

and,

$$A_N = -CR_N E_{NN} (e^{-t_N/CR_N} - 1) \dots\dots\dots (11)$$

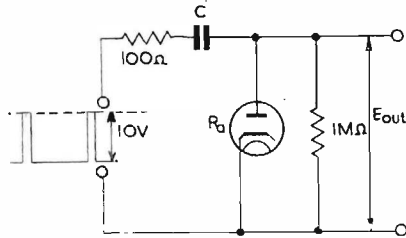

Fig. 4. Circuit of a typical D.C. restoring network for clamping the peaks of positive input pulses to zero

thus,
$$\frac{E_{pp}}{E_{NN}} = \frac{A_p}{A_N} \frac{R_N}{R_p} \frac{e^{-t_N/CR_N} - 1}{e^{-t_p/CR_p} - 1} \dots\dots\dots (12)$$

but,
$$\frac{A_p}{A_N} = - \frac{R_p}{R_N} \text{ from (6)}$$

so that,
$$\frac{E_{pp}}{E_{NN}} = - \frac{e^{-t_N/CR_N} - 1}{e^{-t_p/CR_p} - 1} \dots\dots\dots (13)$$

The following interesting cases arise from this equation
(a) $CR_p \gg t_p$ and $CR_N \gg t_N$
By expanding the exponential terms of Equation (13) and neglected high order terms, it follows that,

$$\frac{E_{pp}}{E_{NN}} = \frac{-t_N}{t_p} \frac{R_p}{R_N} \dots\dots\dots (14)$$

Since this equation applies to conditions often met in radar circuits, a simple example of its application will be given. Suppose that it is desired to clamp to zero the positive peaks of a signal of positive repetitive pulses each $1\mu S$ wide and repeated at intervals of $1mS$. Suppose that the pulses are of 10 volts amplitude and are generated at a source impedance of 100 ohms. The proposed circuit of the D.C. restoring network is given in Fig. 4. The shunt resistance of 1 megohm across the diode will be assumed to be

the maximum value which may be used due to the circuit which the restorer is required to drive. It is required to know the minimum value of conduction resistance R_a that the diode must have for satisfactory restoration of the pulses.

For the purpose of the analysis let the positions of the capacitor C and the 100 ohm resistor be interchanged as in the equivalent circuit of Fig. 5. Then E_o will be a waveform of the same shape and peak to peak amplitude as the pulse source voltage if C is chosen sufficiently large in value. It will be seen that when E_o is positive,

$$E_{out} = \frac{R_a}{R_a + 100} \cdot E_o \text{ if } R_a \ll 1 \text{ megohm} \dots\dots (15)$$

and that when E_o is negative,

$$E_{out} = E_o \dots\dots\dots (16)$$

as the diode resistance is then very much greater than 1 megohm. For the waveform considered $t_p = 1\mu S$, $t_N = 1mS$, so that substitution in Equation (14) gives,

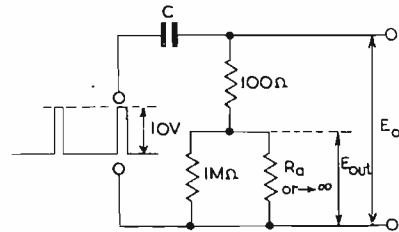

Fig. 5. Equivalent circuit of Fig. 4 for determining E_o

$$E_{pp}/E_{NN} = -1000 \cdot \frac{(100 + R_a)}{10^6} \dots\dots\dots (17)$$

where R_a is measured in ohms.

Thus, if $R_a = 150$ ohms, $E_{pp}/E_{NN} = -1/4 \dots\dots (18)$

and as $E_{pp} - E_{NN} = 10$ volts $\dots\dots\dots (19)$

it follows that $E_{pp} = 2$ volts and $E_{NN} = -8$ volts.

The corresponding values of E_{out} show the positive peak output of the restored potential is 1.2 volts and the negative peak output is -8 volts.

However if $R_a = 1000$ ohms

$$E_{pp}/E_{NN} = -1.1 \dots\dots\dots (20)$$

so that $E_{pp} = 5.24$ volts and $E_{NN} = -4.76$ volts, and the positive and negative peak values of E_{out} are 4.76 and -4.76 volts respectively.

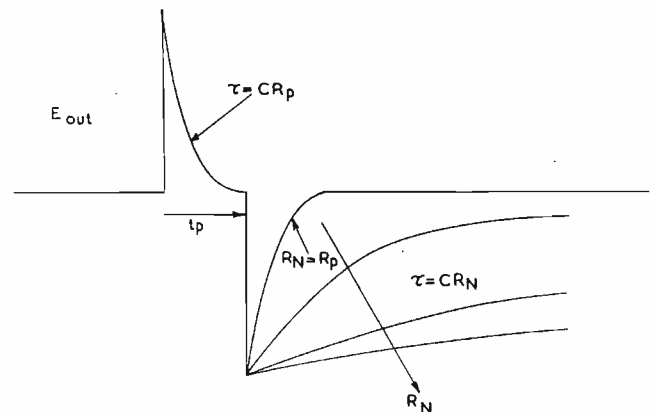

Fig. 6. Differentiation of positive pulses when $CR_p \ll t_p$ and $CR_N \ll t_N$

It is thus quite apparent that a low resistance diode is preferable for the above application. It can also be seen that if the diode has a back resistance less than 1 megohm the efficiency of D.C. restoration is seriously affected. The back resistance of a hard valve diode is normally many

times greater than 1 megohm and may be neglected in calculations; however, the back resistance of germanium crystal diodes is of the order of 50k ohms, and it is this low back resistance which makes the crystal diode virtually useless for many D.C. restoring applications of diodes.

(b) $CR_p \ll t_p$ and $CR_N \ll t_N$

Substitution in Equation (13) gives,

$$E_{pp}/E_{NN} = -1 \dots \dots \dots (21)$$

This case corresponds to the differentiation of repetitive rectangular waves with the aid of diodes. The advantage of using a diode for differentiation is shown by Fig. 6, in which it is seen that a short positive pulse may be "stretched" to produce long negative pulses of leading edge coincident with the trailing edge of the positive pulse.

D.C. Restoration of Television Video Signals

Fig. 7 shows a typical clamping circuit used in television receivers. The circuit clamps on negative peaks of the input and works with a positive-going video input of amplitude E_s at any instant. R_s is the output resistance of the driving stage, R_z is the leak across the diode, including any loading due to the following stage, and R_a is the conduction resistance of the diode when the output waveform E_{out} is negative. The diode back resistance will be assumed to be much greater than R_z .

Except for the frame synchronizing period, the video signals will lie between the limits of an all white (Fig. 9) and all black picture (Fig. 10). For simplicity the equalizing levels before and after a line synchronizing pulse will be ignored and the waveforms of all white and all black signals will be assumed to be repetitive rectangular waves of relative amplitudes 100 to 30. The time occupied by one line including synch. pulse will be referred to as t_L . The minimum ratio of circuit resistances which can be tolerated for effective D.C. restoration will now be found.

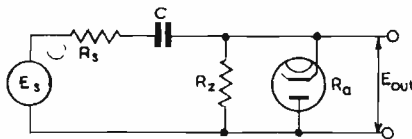

Fig. 7. A typical D.C. restoring circuit used in television receivers

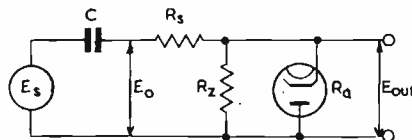

Fig. 8. Equivalent circuit of Fig. 7 referred to in the analysis

When the ratio of positive to negative resistance paths of the circuit shown in Fig. 8 is reduced below infinity, the effect is to reduce the amplitude of the positive peak output. If the output on peak white is referred to as 100 per cent when the positive to negative resistance ratio is infinite, it will be fairly obvious that a fall to not less than 90 per cent will be tolerable when the resistance ratio is finite. The corresponding reductions of the black level and negative synch. pulse peak of an all white picture for this limiting condition are given in Fig. 11. An all black picture will be restored with the black level 10 per cent below the amplitude corresponding to black level. Since this amplitude would be 30 per cent of peak white, i.e., reduced by 10 per cent of 30 per cent. The percentage ratios indicated on the left of Figs. 11 and 12 refer to the relative signal amplitudes of the waveform E_o where 0 per cent corresponds to zero D.C. output and 100 per cent corresponds to the amplitude which peak white would attain if the restoration were perfect, i.e., $R_z/R_a = \infty$. The percentage ratios indicated on the right of these figures refer to the relative

signal amplitudes of the waveform E_o where 100 per cent corresponds to peak white signals and 0 per cent corresponds to peak negative signals.

Referring to Fig. 8 it will be obvious that,

$$E_{out} = \frac{R_z}{R_z + R_s} \cdot E_o \text{ on positive output } \dots \dots (22)$$

and,

$$E_{out} = \frac{R_z \cdot R_a}{R_s(R_z + R_a) + R_a R_z} \cdot E_o \text{ on negative output } \dots (23)$$

as generally, $R_a \ll R_z$ and $R_z \gg R_s$ these equations become,

$$E_{out} = E_o \text{ on positive output } \dots \dots \dots (24)$$

and,

$$E_{out} = \frac{R_a}{R_s + R_a} \cdot E_o \text{ on negative output } \dots \dots (25)$$

The corresponding resistance ratio for this limiting case is given by,

$$\begin{aligned} R_p/R_N &= -A_p/A_N \\ &= \frac{90\% \times 90\% t_L}{10\% \times 10\% t_L} \\ &= 81 \dots \dots \dots (26) \end{aligned}$$

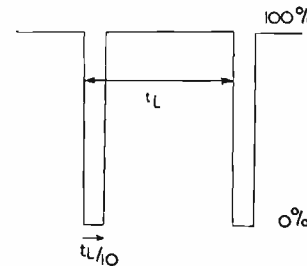

Fig. 9. Assumed all white signals

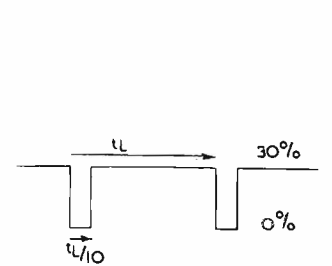

Fig. 10. Assumed all black signals

When the resistance ratio is 81 it has been shown that peak white level corresponds to 90 per cent of the value for perfect restoration on all white signals and 97 per cent of the value for perfect restoration on all black signals. The peak white level will thus fluctuate between these two limits on normal video signals. Hence it follows that,

$$\frac{\text{fluctuation of picture level}}{\text{peak white level—black level}} = 7\%/70\% = 10\% \dots (27)$$

This ratio shows that the fluctuation is probably just on the limit of discernibility and it can thus be concluded that to effect satisfactory D.C. restoration of video signals it is necessary to make,

$$R_p/R_N \geq 81 \dots \dots \dots (28)$$

Assuming $R_z \gg R_a$ and $R_z \gg R_s$, it follows that, for the circuit of Fig. 7,

$$R_p = R_z \dots \dots \dots (29)$$

$$R_N = R_a + R_s \dots \dots \dots (30)$$

Fig. 11. Restored all white signals when resistance ratio is taken to the minimum tolerable

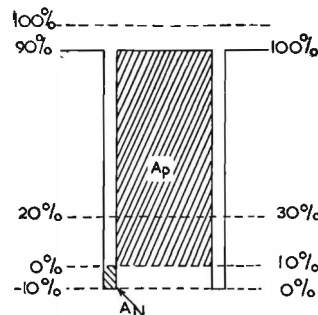
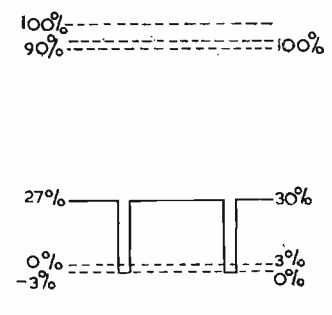

Fig. 12. Restored all black signals when resistance ratio is taken to minimum tolerable



therefore, the requirement becomes,

$$\frac{R_z}{R_a + R_s} \geq 81 \dots\dots\dots (31)$$

In practical cases R_a will generally be less than 1k ohm and R_s will generally be less than 6k ohms, so that the condition for satisfactory D.C. restoration becomes,

$$R_z \geq 560k \text{ ohms} \dots\dots\dots (32)$$

In this discussion the capacitor C has been assumed to be infinitely large. In practice it is generally desirable to use the minimum value permissible in order to keep down stray capacitances to earth. It will be assumed that a maximum change of potential corresponding to 2 per cent of peak white during a line scan of $90\mu\text{S}$ duration is quite tolerable, then it follows that the time constant CR_p must be $50 \times 90\mu\text{S}$, i.e., 4.5mS . Thus if R_p is 560k ohms, C should be greater than or equal to $0.008\mu\text{F}$.

Double Slicing Synch. Separator for Television Signals

The circuit shown in Fig. 13 is a typical double slicing pentode synch. separator as used in many television receivers. The grid and cathode of the pentode form a D.C. restoring diode which conducts on the positive peaks of the input signal. If the grid-cathode conduction resistance is assumed to be much less than $R_1 + R_s$ and also $R_z \gg R_1 + R_s$ it follows that,

$$R_p/R_N = \frac{R_1 + R_s}{R_z} \dots\dots\dots (35)$$

Let it be assumed that the voltage corresponding to 10 per cent peak white is equal to the grid base of the pentode under chosen operating conditions. If $R_N \gg R_p$, restoration will be perfect and the output at the anode of the pentode will be an amplified and inverted replica of the

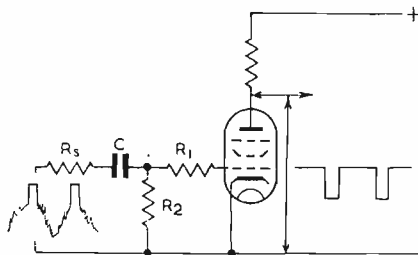

Fig. 13. A typical pentode television synch. separator

signal contained between the limits 0 per cent and 10 per cent.

If $R_p/R_N = 81$ it follows from the earlier analysis that the slicer will cut signals below 10 per cent on an all white picture and below 3 per cent on an all black picture. Thus the double slicer will then operate between the limits 10 per cent and 20 per cent or 3 per cent and 13 per cent according to the mean picture content.

The advantage of double slicing over the simple slicing action obtained when $R_N \gg R_p$ can be seen by considering Fig. 14, which shows a video signal with noise voltage superimposed. It will be seen that noise pulses of amplitude less than 10 per cent of peak white are not present on the output of the synch. separator when the signal is an all white picture and $R_p/R_N = 81$. Noise pulses near the leading edges of line synch. pulses introduce distortion into the waveform which results in modulation of the repetition period of the line time base. Thus double limiting of synch. signals ensures more stable operation of the line time base.

The value of R_p/R_N must not be chosen too low or the limiter will not cut below the black level, and picture modulation will pass through into the time base circuits. The calculation of the required value of R_p/R_N for most efficient double limiting under given conditions can be

made on the assumption that the grid cut-off limit corresponds to black level of an all white signal of the minimum amplitude with which the circuit is required to work. Let $V_B =$ measured grid base of the limiter.

$V_s =$ peak to peak amplitude of the minimum all white signal.

100*m* per cent = percentage of peak white corresponding to black level of the signal.

Although the B.B.C. transmits black level at 30 per cent, non linearity of the receiver detector and video stages may easily compress black level to 20 per cent or lower.

$V_B/V_s \cdot 100$ per cent is the percentage of peak white corresponding to the grid base of the limiter, so that 100 ($m - V_B/V_s$) per cent is the level corresponding to the grid current limit of the slicer.

Thus, it is required that,

$$R_N/R_p = -A_N/A_p = \frac{9(1 - (m - V_B/V_s))}{m - V_B/V_s} \dots\dots\dots (34)$$

combining Equations (33) and (34) the design condition becomes,

$$\frac{R_z}{R_1 + R_s} = 9 \left(\frac{1}{m - V_B/V_s} - 1 \right) \dots\dots\dots (35)$$

In a typical circuit the signal fed into the slicer will also be the signal fed into the cathode of the cathode-ray tube. The required value of V_s for most cathode-ray tubes is not less than 20 volts. The screen of the synch. separator is generally run at a low voltage so that V_B is approximately 2 volts. Substituting these values and taking 100*m* per cent = 20 per cent, Equation (35) gives,

$$\frac{R_z}{R_1 + R_s} = 81 \dots\dots\dots (36)$$

Fig. 14. Typical video signal in the presence of noise modulation

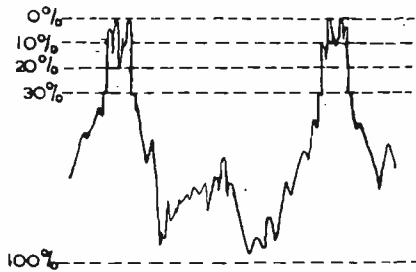

(To be continued)

Television by Co-axial Cable

When delegates to the recent C.C.I.F. (International Consultative Committee on Telecommunications) conference in London visited Sutton Coldfield they saw the transmitter being fed by programme signals sent from London over a Standard Telephones and Cables, Ltd., co-axial cable. Later, at Telephone House, Birmingham, the delegates saw a special demonstration showing television signals transmitted over co-axial cables from London, through Birmingham to Stoke, and back to Birmingham, a total distance of over 200 miles.

The London-Birmingham cable incorporates two 0.975in. and four 0.375in. co-axial tubes. The larger tubes are used, with repeaters at 12-mile spacing, for two-way transmission of 405-line television signals requiring a video bandwidth of approximately 3Mc/s. Ultimately these tubes may be required for very-high-definition or colour television and frequencies up to 26Mc/s may be involved with repeaters at three-mile spacing. The 0.375in. tubes are used for broadband telephony purposes, each pair being capable of carrying 600 speech circuits. On the Birmingham-Stoke cable, 0.375in. tubes are used for the 405-line television transmissions, the repeater stations being at six-mile spacing.

R. E. C. M. F. Exhibition

A Selection of New Equipment and Components shown at Grosvenor House, Park Lane, London, W.1. from 10th to 12th April, 1951

A.B. "Minibank" Switch (Illustrated below)

A. B. METAL Products, Ltd., have developed a miniature one bank switch, the "Minibank," with overall dimensions, including wire soldering terminals, of $\frac{1}{4}$ in. diameter by $\frac{13}{16}$ in. long, inside the panel, thus occupying one-third of a cubic inch of space.

The combinations obtainable and the efficiency are not impaired, claim the makers. The single pole type has up to 12 positions, two-pole six positions, three-pole four positions, and four-pole three positions. "Make before break" and "break before make" contacts are available as required.

Insulation resistance, contact resistance, current carrying capacity, etc., meet the requirements of the Service specification for equipment to withstand extreme tropical conditions.

An interesting feature is that all moving parts and contact mechanism are totally enclosed and the switch hermetically sealed, rendering it impervious to dust and atmospheric conditions.

A. B. Metal Products, Ltd.,
Great South West Road,
Feltham, Middx.

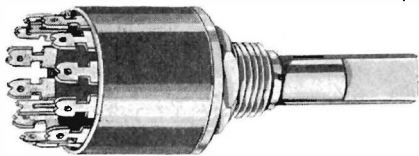

Combined Aerial for Television and F.M. Reception

THIS new type of aerial is designed primarily for use with combined Television and F.M. receivers. It consists of a vertical dipole tuned to the Alexandra Palace Television transmission, and a horizontal dipole tuned to the F.M. transmission from Wrotham. The latter is horizontally polarized at a frequency of 91.4Mc/s and the length of the horizontal dipole is therefore approximately one half that of the vertical one.

The horizontal F.M. dipole is bi-directional, the maximum response being obtained from directions broadside to the aerial elements. When erecting the aerial it must therefore be oriented to suit the direction of the F.M. transmitter. The vertical dipole is omni-directional, and television reception will, therefore, be unaffected by the turning of the aerial.

Both dipoles are mounted in a common junction unit of moulded Bakelite. Two pairs of terminals are provided inside a weather-proof compartment for attaching the lead-in cables to the receiver. These may be of coaxial or balanced twin feeder in accordance with the requirement of the receiver. The aerial rods can be attached to the junction unit after erection if

required and when in position their connexions are completely waterproofed.

The aerial is supplied with a chimney lashing or wall mounting bracket complete with a 5ft mast and although rigid in construction is light in weight and easily handled.

Antiference, Ltd.,
67 Bryanston Street,
London, W.1.

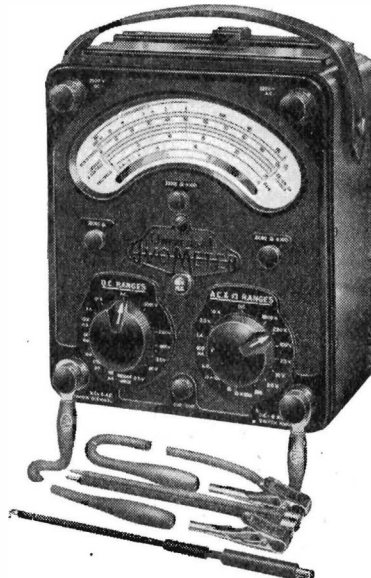

Model 8 Universal Avometer (Illustrated above)

THIS multi-range instrument is a high sensitivity version of the Avometer. It has the additional features of: a movement reversing press button, for use when current and voltages polarities reverse with respect to the basic test position; a wide range of resistance measurements which can be made by means of the internal batteries; an ability of the instrument to measure high voltages and a.c. current, and provision of external accessories to extend further the range of the meter.

All the D.C. voltage ranges are 20,000 Ω /V and the A.C. ranges 1,000 Ω /V from the 100V range upwards. The 25, 10 and 2.5V A.C. ranges consume 4, 10 and 40mA respectively at full scale deflexion.

Four scales are provided, the outermost being marked for use with the resistance ranges. This is followed by two uniformly divided scales marked 0-100 and 0-25 which are used in all current and voltage ranges. The innermost scale is marked in db from -15 to +15. An anti-parallax mirror is provided to facilitate accurate readings.

The accuracy of both the D.C. current ranges and A.C. current and voltage are to B.S.I. limits. The resistance accuracy is taken to be 3 per cent at the centre and 10 per cent at deflexions correspond-

ing to 10 per cent and 90 per cent full-scale deflexion.

An automatic cut-out protection is included to interrupt the main circuit in the event of the instrument being overloaded.

Automatic Coil Winder and Electrical Equipment, Ltd.,
Winder House,
Douglas Street,
London, S.W.1.

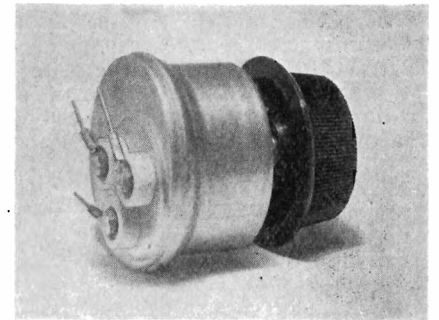

Hermetically Sealed Potentiometer (Illustrated above)

A NEW hermetically sealed wire-wound potentiometer which has been designed for use in Services equipment under arduous tropical conditions is an interesting development of the British Electric Resistance Co., Ltd. All the electrical parts are hermetically sealed in an aluminium case and the spindle is of stainless steel. The connexions are brought out through specially designed porcelain pressure sealing rings.

Values from 5 to 25 ohms are wound with 44/56 per cent nickel copper tape; 50 to 1,000 ohm windings are wound with 44/56 per cent nickel copper wire and 2,500 to 50,000 ohm windings with 80/20 per cent nickel chromium wire. The turns are accurately spaced and give minimum residual and hop-off resistances. Variation of the resistance law with rotation can be obtained by the use of tapered formers and windings of variable pitch to suit individual requirements. The normal overall resistance tolerance is ± 10 per cent, but closer tolerances can be obtained. Linearity is of the order of ± 3 per cent. The rating is 5 watts and the maximum working voltage is 500 volts.

The British Electric Resistance Co., Ltd.,
Queensway,
Ponders End,
Middx.

Largest British Plastic Moulding (Illustrated top right)

PROBABLY the largest plastic moulding in production in Great Britain is a console television cabinet made for Sobell Industries, Ltd., by British Moulded Plastics, Ltd. The cabinet costs less to produce than a conventional wooden cabinet. Its weight is only 32 lb.

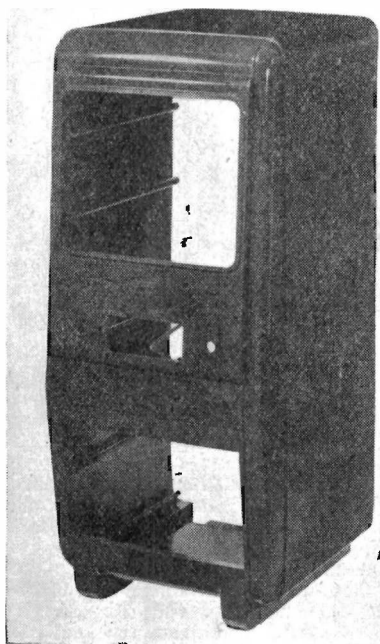

and it will accommodate a 12 in. tube. The mould is of nickel-chrome alloy steel in heat treated condition forged and rough machined by the English Steel Corporation. It is machined from rough to finished stages by British Moulded Plastics, Ltd. It is moulded by a 1,500-ton hydraulic down stroke press, and heated by steam. The powder used is a general purpose phenol formaldehyde by Bakelite, Ltd. The cabinet is pre-heated by a Radyne six kilowatt r.f. heater, and cooled at air temperature in two fixtures. It is moulded throughout, and there is no drilling.

British Moulded Plastics, Ltd.,
Avenue Works,
Walthamstow Avenue,
London, E.4.

BICC Television Camera Cables and "Polypole" Multi-Way Couplers
(Illustrated below)

THE Television Camera Cables manufactured by B.I.C.C. are multi-way cables designed to meet customers particular requirements. Specially developed for the arduous conditions encountered in television outside broadcasts, the television camera cables are insulated with Polythene and sheathed with P.V.C. They are normally supplied in 200-ft. lengths with B.I.C.C. "Polypole" couplers to enable up to 1,000-ft

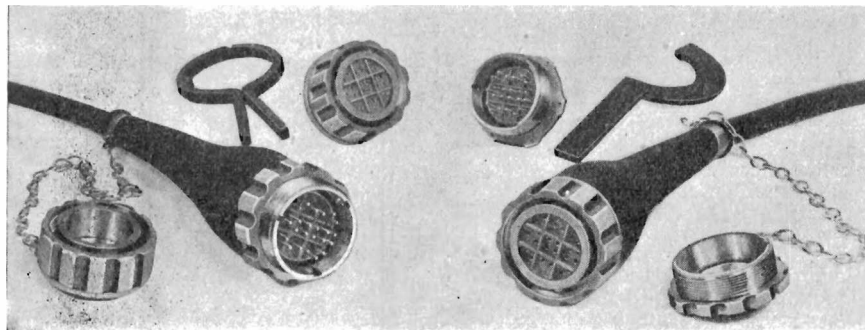

of cable to be inter-connected. These cables are available in two types, one—already extensively used by the B.B.C.—having 6 screened twins, 1 quad and 6 single insulated conductors, and the other containing 4 coaxials and 24 single conductors. This latter type has been developed for use with both Marconi and Pye Television Cameras.

Associated with the range of multi-unit cables are the "Polypole" multi-way couplers. These consist of a robust cast gunmetal body enclosing a homogenous polythene moulding, and are used for terminating or inter-connecting cables in a reliable union with all the circuits correctly disposed and screened. **British Insulated Callenders Cables, Ltd.,**
Surrey House,
Embankment,
London, W.C.2.

Ten-turn Helical Potentiometer

THE Colvern helical potentiometer is capable of 3,600° mechanical rotation, and is obtainable in resistance ranges from 100 ohms to 100,000 ohms, at 5 watts rating.

Housed in a light alloy case, the potentiometer is completely sealed, and terminations are brought out through ceramic terminals. Two neoprene rings interspaced with a grease-packed groove in the spindle-bush assembly ensure almost hermetical sealing.

Colvern, Ltd.,
Mawneys Road,
Romford, Essex.

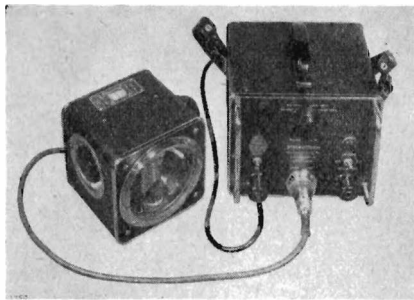

Dawe Strobotorch and Frequency Meter and Photo-electric Pick-up
(Illustrated above)

THE Dawe Strobotorch is a high-intensity type strobotorch employing a separate hand lamp with built-in speed control.

The lamp is constructed as a separate unit, which is consequently light in weight and easily handled. In addition the speed control has been embodied into the lamp unit so that the difficulty of adjusting the

flash rate control from a separate power unit is avoided.

The practical upper limit of speed measurement is around 50,000 r.p.m. As the flash duration of the lamp is only about 40-50 microseconds, sharp images are obtained even at the highest speeds. The scale calibration can be standardized at the mains frequency by means of a vibrating reed contained within the lamp unit. The strobotorch has an accuracy of ± 2 per cent ± 5 r.p.m. and has direct reading over a range 120 to 14,400 r.p.m.

The flash can be synchronized with an external oscillator. A square wave of approximately 200 volts peak-to-peak is required, or with a sine wave input 75 volts r.m.s. at 200c/s rising to 150 volts r.m.s. at 50c/s. is necessary. It is also possible to link the flashing rate of the strobotorch to an electrical contactor, such as the Type 1200/1, fitted on the mechanism.

Dawe Instruments, Ltd.,
130 Uxbridge Road,
Hanwell,
London, W.7.

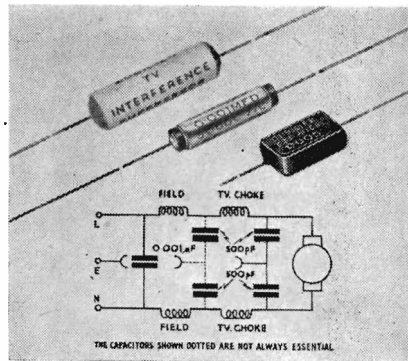

Dubilier Television Suppressors
(Illustrated above)

DUBILIER Condenser Company (1925) Ltd., have developed a small choke, Type BPC.514, for use in conjunction with the special suppressor capacitors detailed below, for suppression of television interference caused by domestic and other electrical appliances. These chokes have a high impedance over the television band 40-70Mc/s, and with suitable capacitor values will give a high degree of suppression on appliances to which they are fitted. The choke is housed in an insulated tubular container measuring 1 3/16 in. by 3/4 in. diameter, and is supplied with tinned copper connecting leads. The rated current of the choke is 1 ampere max.

The associated capacitors are—Moulded Silver Mica Capacitors, Type S.635, 470pF ± 20 per cent, 2,250V d.c. test and Metal Minicap Capacitors 0.001 μ F, ± 20 per cent, 1,500V d.c. test.

Dubilier Condenser Co. (1925), Ltd.,
Ducon Works,
Victoria Road,
North Acton, London, W.3.

Power Vibrator—Type 101
(Shown top overleaf)

THIS vibrator is of the permanent magnet moving coil type and is specifically designed for determining the dynamic modulus of rubber-like materials.

The moving coil has a brass rod which

is suspended by a system of leaf springs and has a special attachment to house samples of material under test. The unloaded system has a resonance of approximately 40c/s which may be varied by the addition of weights. The rod operates in a horizontal position so that variation of mass does not cause displacement of the coil in the gap.

The apparatus exhibited is based on a design of the Goodyear Tire and Rubber Co. of America, and was constructed for the Distillers Co., Ltd.

**Electro Acoustic Industries, Ltd.,
Stamford Works,
Broad Lane,
Tottenham, London, N.15.**

Valve Retainers

(Illustrated below)

ELECTROTHERMAL Engineering, Ltd., have developed a type VRA valve retainer for B7G and B9A based valves. It is of all-metallic construction and by virtue of its design takes up the minimum of space, and valves can be mounted with bases adjoining.

**Electrothermal Engineering, Ltd.,
270 Neville Road,
London, E.7.**

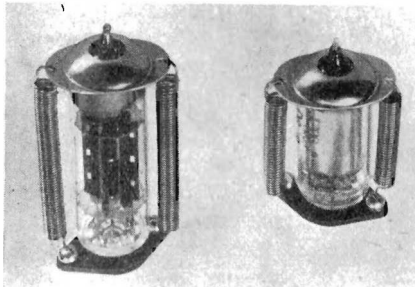

English Electric Tube and Transformers

WELL-KNOWN as the first British all metal tube, the English Electric Co., Ltd., exhibited their type T901, a 16-inch steel C.R.T. This was described in the February, 1951, issue of **ELECTRONIC ENGINEERING** on page 72.

Also exhibited was an attractive display of the firm's C-core transformers, designed to show an exploded view. Among the advantages of C-cores are the reduction in size, increase in permissible flux density, reduced flux leakage, and better magnetic properties.

**The English Electric Co., Ltd.,
Television Department,
Queens House,
Kingsway,
London, W.C.2.**

Coloured Cored Solder

SUPER SPEED solder with a coloured rosin core in red, blue, green and yellow was shown for the first time.

Enthoven's new cored solder not only avoids the difficulties associated with the use of lacquer, but it also reduces the inspection time. During the soldering process the coloured flux core is substantially dispersed to the extremities without appreciably colouring the main surface of the joint, and it can be easily examined as the essential parts are not coloured.

**H. J. Enthoven & Sons, Ltd.,
89 Upper Thames Street,
London, E.C.4.**

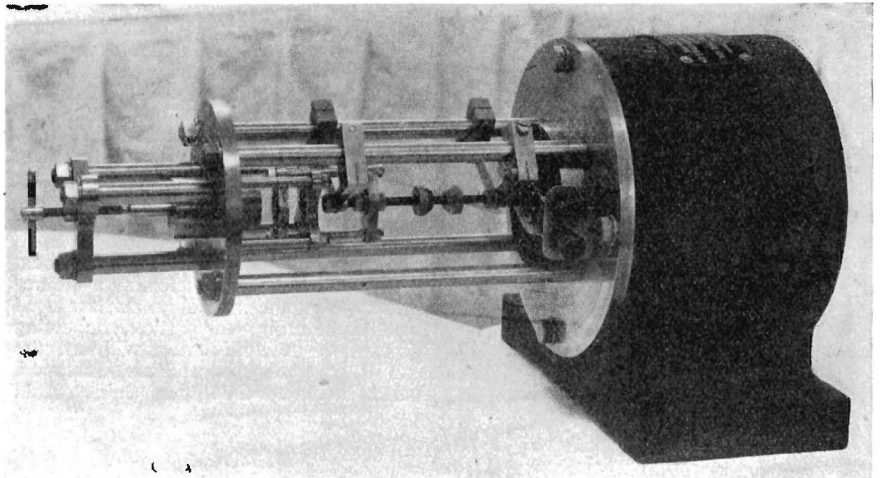

Rectangular Cathode Ray Tube

FERRANTI, LTD. exhibited a 14in. diagonal rectangular C.R. tube which they have, at the moment, in the course of development. In most respects it is similar to the current Ferranti C.R. tubes except that it is designed to operate at 9kV and will be aluminized. Also the semi-scan angle is about 3 degrees greater than in existing circular types.

**Ferranti, Ltd.,
Hollinwood,
Lancs.**

Widney-Dorlec "Circuit" Cabinet Lock

THE demand for a combined lock and circuit breaker has led to the development of the Widney Patent "Circuit" Lock, which consists of two visible chromium plated outside handles, the outer one being fixed and forming a safety bar. The inner handle controls the microswitch connexion and the locking mechanism which is fixed to the inside of the cabinet wall.

When the inner handle is drawn forward by the action of squeezing both handles together, the switch control is first disengaged and all electrical current disconnected from the cabinet. The cabinet lock is then released to allow the drawer to be opened.

Similarly, when the drawer is closed the lock is actuated before the circuit is re-made.

A separate control can be incorporated to allow the current to be connected for testing purposes while the drawer is open, but which is automatically cancelled when closing the drawer.

**Hallam, Sleight & Cheston, Ltd.,
Widney Works,
Birmingham 4.**

Self Bonding Wires

THE London Electric Wire Co. and Smiths, Ltd., have developed self-bonding wires called "Lewmexbond" and "Lew-en-Bond." The former consists of the standard Lewmex wire, in either of four grades of thickness, with an additional covering of a thermoplastic material.

The latter has the same thermoplastic covering superimposed on standard, oil-based enamelled wire.

The increase in diameter due to the additional covering is usually of the order of from half to one mil., according to wire size. For the present, the conductor

sizes to which this treatment is applied are limited to the range 0.024 in. and finer.

Self-supporting coils of almost any required shape may readily be produced with these wires by the simple application of heat to the coil while still on the former. After cooling, the coil is removed from the former and will be found to be firmly bonded into a rigid unit by the welding of the thermoplastic coating on adjacent turns.

Any convenient form of heating may be employed, but the most effective method is undoubtedly to pass a sufficient current through the coil to raise the temperature momentarily to 130-150°C.

The heat dissipation throughout the coil is practically uniform, and the bonding operation is both simple and rapid.

**London Electric Wire Co. and
Smiths, Ltd.,
24 Queen Anne's Gate,
London, S.W.1.**

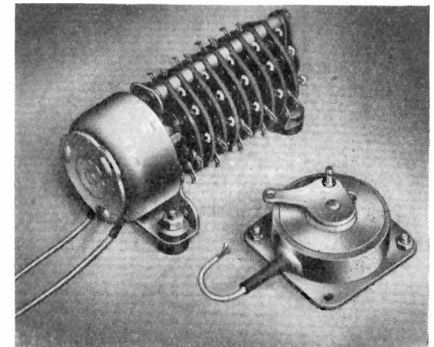

N.S.F. Ledex Rotary Solenoids and Circuit Selectors

(Illustrated above)

THE N.S.F. Ledex rotary solenoid is a compact, robust electro-mechanical device which provides a powerful snap-action rotary movement of substantially constant torque over the whole of the angular stroke.

Following the development of the rotary solenoid came the Ledex circuit selector, which employs the rotary solenoid in conjunction with "Oak" switch sections.

It is a snap action switch operated by a solenoid which can be used to rotate banks of conventional-type contacts. It

can be converted into a rapidly oscillating motor by means of a commutating switch and return spring. The switch breaks the winding circuit at the end of the stroke, and the spring then returns the armature to the starting position.

This process is repeated automatically as in the case of a "homing" circuit selector until the desired circuit is selected.

**N.S.F., Ltd.,
Keighley,
Yorks.**

Painton's New Components

(Illustrated above right and below)

AMONG Painton's new products was a miniature edgewise fader of very small dimensions which facilitates a most compact design of audio frequency control desk. It is shown centre and right below. Features of this instrument are: plug-in arrangement to facilitate removal; readily accessible contact studs for easy cleaning; change-over contacts to operate at any predetermined position, in addition to auxiliary contacts to operate at both ends of the wiper travel; single or double assemblies, requiring minimum panel space, and it has 21 or 30 steps available—suitable for bridged T networks.

Also on display was a hermetically sealed 5 watt wirewound potentiometer available up to $50,000\Omega$ (illustrated centre top.) Another new component was a heavy duty 15 amp. 8 point plug and socket (shown top right) that permits the complete and rigid connexion of the cable form before attaching the cover.

Other items included a compact high voltage 6 point plug and socket and a quick action D.P.D.T. 3 amp. 250 volt toggle switch (illustrated bottom left). Both these units conform to the standards laid down in R.C.S. 1000. A shrouded spring loaded terminal which can safely be used with mains voltages was another feature.

**Painton and Co., Ltd.,
Kingshorpe,
Northampton.**

New Pullin Voltmeter

(Illustrated centre)

EXHIBITED at the stand of Measuring Instruments (Pullin), Ltd., was a new contact voltmeter which is designed for controlling auxiliary circuits. This instrument operates on a new principle whereby the contacts are floating on an

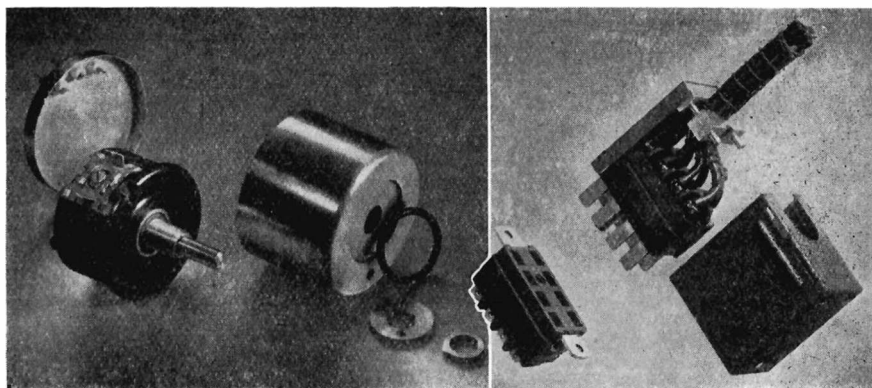

adjustable pointer which can be set to any pre-determined scale value. The contacts are completely isolated from the moving coil system and will carry up to 50 milliamps at 10 volts A.C. or D.C.

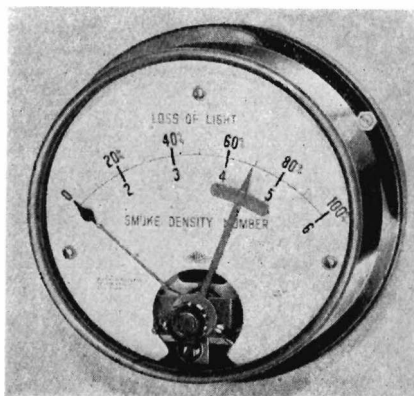

A device is employed which overcomes the inertia of the contacts and nullifies contact chatter on A.C., thus reducing any tendency to stick. These contacts can be fitted on all moving coil voltmeters or ammeters with a sensitivity down to 1 milliamp for full scale deflexion.

**Measuring Instruments (Pullin), Ltd.,
Electrin Works,
Winchester Street,
Acton, London, W.3.**

C-Core Transformers

THE Parmeko "Neptune" series of C-core hermetically sealed transformers and chokes has been developed to provide the electronic industry with smaller, lighter and more efficient components. If compared with standard shell core types they offer up to 30 per cent saving in volume and weight. Embodying new developments in both mechanical and electrical design, these components are designed to conform with and operate under the conditions specified in R.C.S. 214 Grade I and RCL 215. By using a high efficiency core and steel container, external magnetic field is reduced by approximately 50 per cent when compared with a normal shell transformer. Further magnetic screening may be obtained on Models 6000/31 to 6000/35 by the use of high permeability nickel steel containers. All components of this range are provided with fixing bushes at the top and bottom—(except Models 6000/31 and 6000/32 which have fixing bushes at the top only) to allow for inverted mounting, and are supplied with one set of slotted hexagon headed steel fixing bolts and lock washers.

The high efficiency C-core employed is specially manufactured from a continuous strip of grain-orientated high permeability steel and is up to 30 per cent more efficient than the normal built-up lamination core.

**Parmeko, Ltd.,
Percy Road,
Aylestone Park, Leicester.**

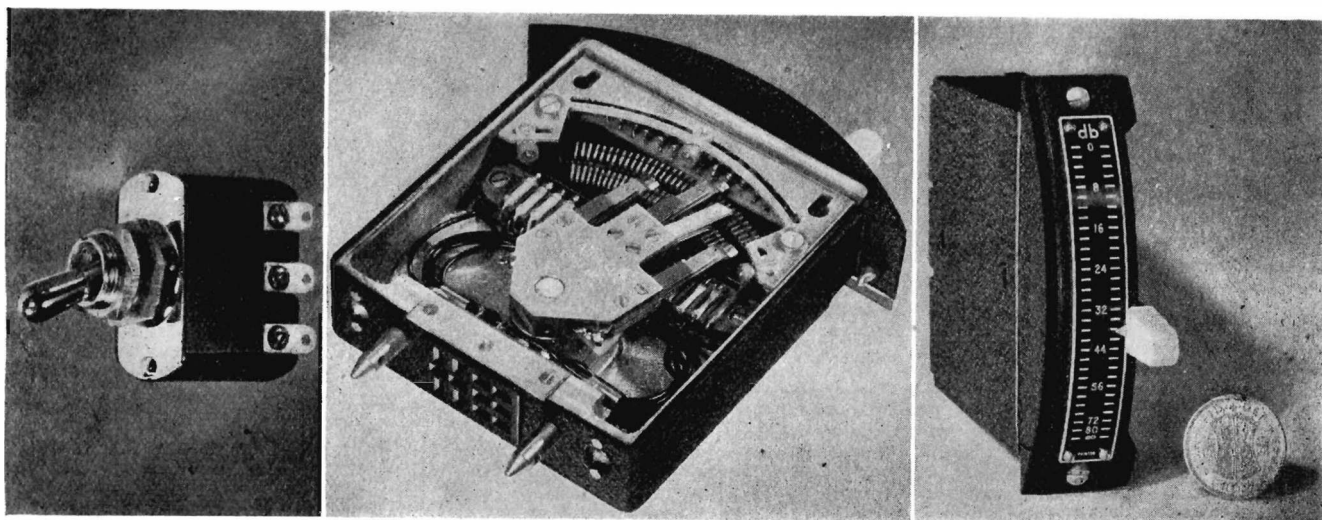

Partridge Audio Transformer

(Illustrated below)

THE C.F.B. range represents an improvement of the Williamson transformer by the use of new materials and technique, including the latest grain orientated strip wound "C" cores. The components are intended for equipment reproducing the full audio band width with a distortion of 0.05 per cent at 16 watts 50c/s. The characteristics are such that considerable negative feedback voltage can be taken from the secondary winding and injected into the circuit at a point three or four stages back.

The D.C. resistance per half primary is 88 ohms, and it weighs (potted) 10 lb. It has a power rating of 60 watts from 30c/s to 30,000c/s with less than 1 per cent distortion and no negative feedback. The transformer insulation is adequate for a 500 volt supply line with a full class B swing.

Partridge Transformers, Ltd.,
Roebuck Road,
Tolworth, Surrey.



Permanent Magnet Exhibit

THE exhibit of the Permanent Magnet Association included a collection of sectioned columnar crystal magnets. Columnar crystal magnets have the same chemical composition as other types of magnets but their structure comprises a single group of long crystals extending from one end of the magnet to the other, instead of the usual structure of crystals growing inwards from all surfaces with a random arrangement at the centre. Columnar crystal magnets have a performance between 25 and 50 per cent better than that of normal magnets. Although these magnets are not yet available for sale, it is nevertheless considered that the time is rapidly approaching when they will be in normal production, and it was therefore appropriate to show them at the R.E.C.M.F. Exhibition.

Another development is a magnetic sheet floater. Manufacturers are well aware of the difficulties of handling steel pressings and laminations, etc., in press shops and assembly shops. By arranging magnets to magnetize the sheets similarly to one another, the sheets are caused to repel mutually so that the top one

floats in the air and can easily be lifted off by the fingers or by automatic machinery.

Permanent Magnet Association,
301 Glossop Road,
Sheffield 10.

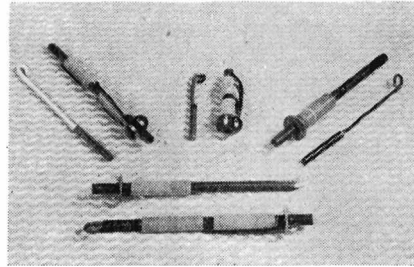

Plessey Developments

AMONG the exhibits shown on the stand of the Plessey Company, Ltd., was a new and comprehensive range of television components, embracing wide controls (illustrated above), scanning coils, focusing units and control resistances in addition to filter coils, scan output transformers and a multi-station tuner.

The permeability tuned gang multi-station-tuner (shown below) permits the manufacture of a single television receiver model to cover all five B.B.C. frequencies, and is of particular interest as being the first unit tuner for the British stations to be made commercially available.

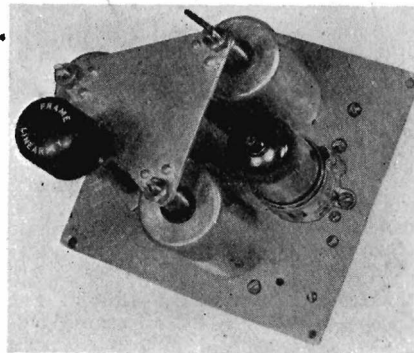

A new capacitance law has been evolved for the Plessey "E" gang capacitor, which has the effect of providing a satisfactory re-distribution of the B.B.C. stations, and of improving short wave performance for export requirements. On the Copenhagen plan, two-thirds of the B.B.C. stations are on frequencies higher than 1,000k/cs, which frequency, with the "E" law, normally occurs at approximately one-third of the scale length from the high frequency end. The new law both shifts the 1,000k/cs point further to the centre, and also considerably alters the position of the stations at the extreme end. The rate of change of capacitance at the high frequency end is much reduced, and thus the comparative station widths become more even, and greater trimming accuracy at this end is possible as the scale movement is more apparent.

The range containing the "B" type glass based valve, and the B8A ceramic valveholder has been extended to include

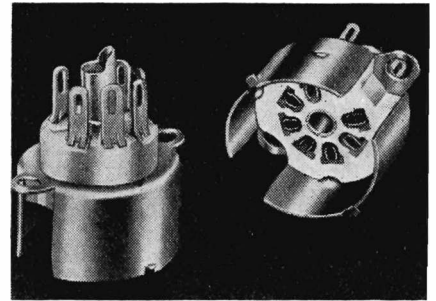

valveholders for both B7G and B9A valves. With body formed from low-loss unglazed ceramic moulding with high insulation resistance, with low pin-to-pin and pin-to-earth screen capacitance values, and with high operating stability, these will be found to be particularly advantageous in television and H.F. applications. The valve holders are illustrated above.

The Plessey Co., Ltd.,
Ilford, Essex.

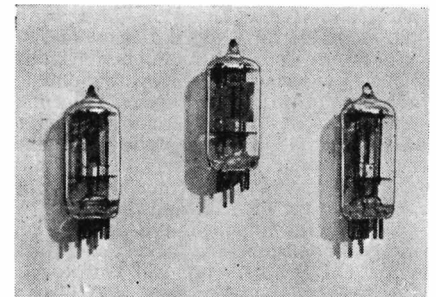

Pye Quartz Unit

(Illustrated above)

PYE, Ltd., have produced a new type 7G and 7G2 quartz unit, which is contained in an evacuated glass bulb case with maximum dimensions of 1.88 by 0.75in. diameter, excluding pins. The base is the standard B7G type, with connections to pins 1 and 5 in a single crystal unit; pins 3 and 7 are used for a second crystal.

Its frequency ranges are: 200-1000 kc/s, 4-14Mc/s and 14-20Mc/s, which are all fundamental modes. The unit can be supplied to accuracies of ± 0.01 , ± 0.005 , ± 0.003 per cent at a stated temperature and input capacitance.

The operating temperatures, with optimum stability, are 25°C., 45°C., and 65°C. The normal temperature range is -20 to -70°C.

These units have increased stability and activity associated with gold-plated elements operating in a vacuum. They can be supplied containing either one or two crystals.

Pye, Limited.
Crystal Department,
Radio Works,
Cambridge.

Low Current Tubular Rectifiers

S.T.C. have developed recently high-voltage SenTerCel rectifier plates which enables less plates to be used for a given voltage. The "K" and "N" type tubular rectifiers which incorporate these plates show considerable advantages in size and weight as compared

with other types. Also they can be produced much more cheaply.

The "K" type is provided with wire ends and may be connected directly into the circuit, whereas the "N" type has screw ends for use when a more secure fixing is required. Both types are suitable for oil immersion and can be supplied for tropical use.

For television receivers the "K" type is especially useful to provide an E.H.T. voltage derived from the fly-back pulse which appears at the line scanning transformer. The duration of the peak inverse voltage in this circuit is much less than occurs with a sinusoidal wave form and special ratings for rectifiers used in this circuit are therefore available.

Standard Telephones & Cables, Ltd.,
Connaught House,
Aldwych,
London, W.C.2.

T.M.C. Polystyrene Capacitors

POLYSTYRENE Capacitors are now showing promising commercial applications and a filter was exhibited using these in a novel way.

Small Powder Cored Toroidal Coils are placed inside the appropriate capacitor, which circuit element takes the form of an annular ring some $\frac{1}{2}$ in. to $\frac{3}{4}$ in. wide. A number of these rings may be fixed together and the capacitor and coil assembly cast in a cold setting resin.

Telephone Manufacturing Co., Ltd.,
Sevenoaks Way,
St. Mary Cray,
Orpington, Kent.

Weymouth New Components

THIS firm exhibited a number of interesting new components, brief mention of which is given below.

Transformers—power and audio-frequency in an extremely wide range, from hearing-aid types to 500 watt P.A. system output transformers, including a variety of chokes. All these in open and shrouded types. "C" cored transformers, oil filled and hermetically sealed, using the standard range of cores and cans.

The B.M. range of coil packs for set manufacturers use in several types for mixer input. Coverages 16-50 metres, medium wave and long wave, of 11-35 metres, 33-100 metres and medium wave.

A novel oscillator circuit frees one section of the miniature switch used, thereby providing gram pick-up switching with radio muting.

Conversion units for this range of coil packs for easy conversion to R.F. type packs, the R.F. stage coils being switched by what were normally the gram pick-up contacts. The fourth switch position still gives ratio muting for pick-up operation.

A miniature two-wave coil pack for medium wave and long wave using a slider type switch, size $2\frac{1}{2}$ in. by $1\frac{1}{2}$ in. This unit is ideal for the small lower priced receiver in view of its very low cost.

Also shown was a permeability tuning unit using screw thread drive. Basically for medium wave, an attachment unit complete with switch provides long wave coverage from 1,200-1,950 metres. The use of two separate units allows

flexibility of control layout where two wave operation is necessary.

Weymouth Radio Manufacturing Co., Ltd.,
Crescent Works,
Weymouth,
Dorset.

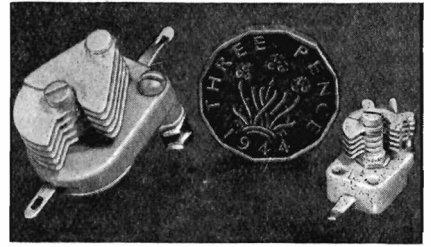

Miniature Air-spaced Trimmer Capacitors

PROBABLY the smallest conventional air-spaced variable capacitor yet produced is the Wingrove and Rogers Type C32-01. This, as can be judged from our photograph above, is roughly one-eighth of a cubic inch, and is available in three sizes, 4.5, 5 or 10pF maximum values, all having the same minimum at 1.25pF.

The C31-23 type is rather larger physically and gives a higher range of maximum values from 20 to 30pF, with minima of 3.5 or 4pF. This model is the larger of the two shown in the photograph above.

Wingrove and Rogers, Ltd.,
Mill Lane,
Old Swan,
Liverpool.

Rediffusion Television Service

The television relay service at Margate is operated briefly as follows: an aerial 65 ft. above ground level receives the television signals from Alexandra Palace. The television sound is then taken by cable to Relay House for monitoring, amplification and general distribution. For the section of Margate which is now receiving television relay the vision signal is carried through 2,000 yards of cable to a kiosk near the Tivoli Railway Bridge, where the vision signal is boosted and repeated. The vision signal is then carried 700 yards by a main feeder cable to the Rediffusion showrooms. During this distance there can be up to 25 spurs taken from the feeder at intervals, each spur capable of serving ten or twelve subscribers.

Fig. 1. The high-gain aerial array which has a gain of 10 db. The signal is passed to a low-noise amplifier, then to a frequency changer to convert the 45 Mc/s vision carrier into an intermediate carrier frequency with asymmetrical side-band. The equipment also includes a master sound receiver whence the sound is transmitted to Relay House.

Fig. 2. The control desk in the Control Room at Relay House where the sound is monitored.

Fig. 3. A view of the opened repeater kiosk, where the vision is received from the aerial receiving site. The television signal is boosted automatically and joins one of the feeders for its journey of 700 yards to the Rediffusion showrooms.

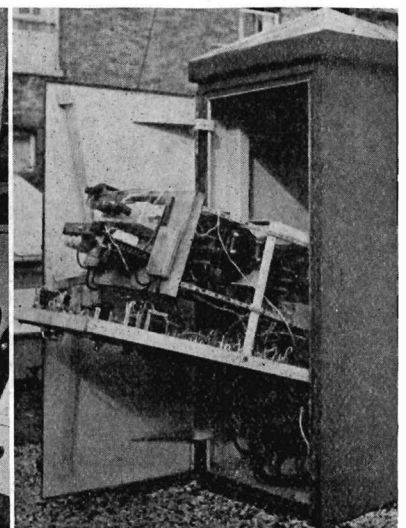
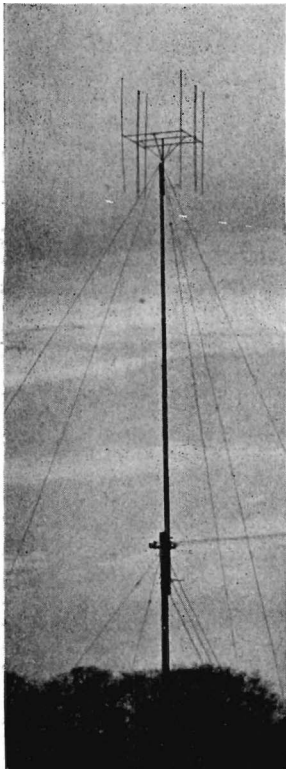

The 35th Physical Society Exhibition

A selection of some of the more interesting exhibits of new research items and electronic equipment at the Physical Society's Exhibition held at the Imperial College and the Huxley Building, South Kensington, London, from April 6 to 11.

New Research Results

The ATOMIC ENERGY RESEARCH ESTABLISHMENT displayed four new methods for the detection and measurement of nuclear particles by:—

- (1) the vibrating reed electrometer.
- (2) a germanium point rectifier.
- (3) a scintillating gamma-ray spectrometer.
- (4) high current, halogen-quenched Geiger Muller tubes.

The ARMAMENT RESEARCH ESTABLISHMENT showed:—

- (1) A high-speed camera, taking a sequence of 80 photographs at a rate of 400,000 per second, in which a Kerr cell was used to control the duration and timing of exposures.
- (2) A method of overcoming bearing-friction in high-speed rotating equipment by magnetically suspending a rotor in a vacuum, motion being produced by a rotating magnetic field. In the model demonstrated at the Exhibition, a speed of 100,000 R.P.M. was obtained.
- (3) A gauge enabling the thickness of a slab of non-metallic material to be measured in terms of its dielectric properties.

The RADAR RESEARCH AND DEVELOPMENT ESTABLISHMENT showed:—

- (1) A high-speed oscilloscope for analysing the waveshape of voltage pulses. Pulses ranging from 1/10 microsecond to 50 microseconds are displayed across two-thirds of a three-inch C.R.T.
- (2) Apparatus demonstrating the principles of operation of pulsed servos.
- (3) A cathode-ray tube position indicator for direction finding systems.
- (4) A quick-response phase sensitive detector, intended for use in servo-mechanisms where an A.C. error signal is used to control a D.C. motor.

The ROYAL AIRCRAFT ESTABLISHMENT displayed:—

- (1) A resistance gauge for continuous automatic recording of creep strain, capable of being used at temperatures up to 900°C.
- (2) A 2,000-channel frequency generating unit, covering the band 33-66Mc/s. in which, by the use of 32 crystals, 2,000 discrete frequencies are obtained.

The TELECOMMUNICATIONS RESEARCH ESTABLISHMENT demonstrated:—

- (1) The application of lead telluride cells to spectroscopy and pyrometry.
- (2) Optical techniques for operation in the 8 to 9 millimetre wavelength band.
- (3) The Wollaston wire bolometer, for rapid measurement of low microwave powers in the decimetre-centimetre region.
- (4) A very low frequency sinusoidal oscillator covering the range 0.16c/s to 50c/s.

Ministry of Supply,
Shell Mex House,
Strand, London, W.C.2.

Ediswan Recording Equipment

ELECTRO-PHYSIOLOGICAL RECORDING EQUIPMENT (photo centre, below). A 5 stage push-pull R-C coupled amplifier with a time constant of 1 second and a voltage gain of 2×10^6 . High discrimination against in-phase inputs. Noise level $2\mu V$ peak to peak under E.E.G. conditions. Response 0.3-5,000c/s. Power Pack Type EPP. Input 200-250V 40-100c/s. Highly stabilized outputs to feed one or two amplifier units Type EPA.

Other interesting exhibits on this stand were:—

EDISWAN MICROFILM READER (WITH AUTOMATIC FILM-GATE). The Ediswan Model II Microfilm Reader was shown for the first time with an automatic film feed mechanism. This is integral with the film-gate and can be supplied as an alternative to the standard gate.

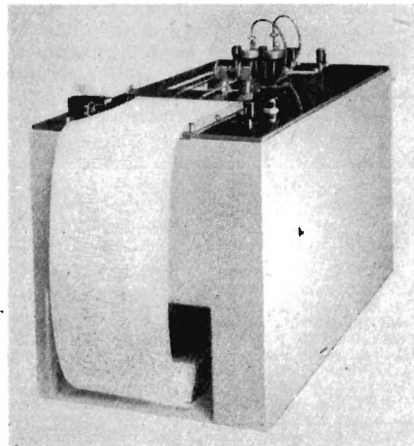

SPECIAL APPLICATION VALVES. Valves exhibited included the latest developments in trigatrons, photo-electric cells, high vacuum rectifiers and heavy duty industrial valves.

The Edison Swan Electric Co., Ltd.,
155 Charing Cross Road,
London, W.C.2.

Mullard Electronic Products, Ltd.

Important among the instruments exhibited were a Wide Band Oscilloscope for the observation and measurement of the waveforms of high-speed transients, an Electronic Polarograph for the rapid determination of the concentration of metallic ions in solution; and an Electronic Temperature Controller providing an accuracy of $\pm 0.02^\circ C$.

Other exhibits included a range of Radiation Counter tubes, and a completely new precision variable capacitor which can be used in measuring equipment demanding the highest possible accuracy. (Photo above right).

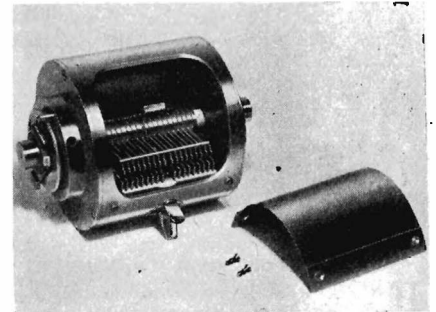

A special demonstration was also given illustrating the ultraviolet transmission of synthetic mica. It was shown that the U.V. transmission in this material is appreciably higher than in any samples of natural mica available. This property of synthetic mica suggests its use for windows of ultraviolet lamps, electron multipliers, photocells and other electronic tubes. The mechanical properties of this material enable it to be used for thin windows. It can also be readily fuse-sealed to glass. These features constitute an advantage over the use of quartz.

Mullard Electronic Products, Ltd.,
Century House,
Shaftesbury Avenue,
London, W.C.2.

Vibrating Reed Electrometer

(Photo at top of page 193)

A new instrument exhibited was the model 32 Vibrating Reed Electrometer, which is a direct development of the Type 1086A designed by A.E.R.E. at Harwell. This instrument, which is intended for the measurement of very small ionization currents, or wherever the use of an ultra stable D.C. amplifier is required, has excellent long-term stability; the zero drift does not exceed ± 100 microvolts over some days, and a figure around ± 20 millivolts may be expected for periods of several hours.

Also shown was the Betaray Thickness Gauge, which follows conventional practice, but special attention has been paid to producing a robust and factory-proof equipment. A well engineered detector head is connected by steel reinforced flexible cable to a totally enclosed wall-mounting amplifier. A large meter situated on the front of the amplifier indicates the deviations in thickness, and the controls are visible through a glass panel and can only be reached by opening the front of the instrument, which is normally locked to prevent unauthorised interference.

A direct reading mains driven milliohm-meter, covering from a fraction of a milliohm up to 1200 ohms, has recently been added to the firm's standard range

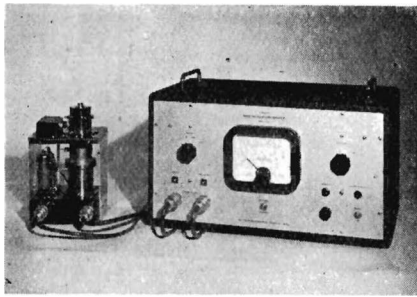

Valve Voltmeter
(Photo below)

A new instrument in the field of high frequency measurements shown for the first time was a mains-operated valve voltmeter suitable for use on D.C. or on A.C. between 50c/s and 150mc/s, and with ranges of 1.5, 5, 15, 50 and 150 volts. The circuit is of the bridge type, with the unknown voltage indicated in terms of the out-of-balance current. An interesting feature of the circuit enables the zero to be set for one range and to hold good for all the others.

Other electrical exhibits on this stand included a representative display of the many types of quartz crystal units made by the Company, also precision test equipment associated with the manufacture of crystals. In addition there was a new emergency lighting unit, embodying a selenium rectifier and an Exide battery; also a display of "Gecalloy" iron dust core material for use in television components.

of instruments. This is very simple to use and has an overall accuracy of ± 2 per cent.

Electronic Instruments, Ltd.,
17 Paradise Road,
Richmond.

Dawe Instruments

The company's display included the following instruments:

TYPE 706 PANORAMIC ANALYSER: A scanning heterodyne type of instrument which automatically separates the frequency components of a complex audio wave, and simultaneously measures their frequencies and magnitudes.

TYPE 1001 RACEND-OMEGA TIMING CAMERA: (Illustrated below) provides a photographic record of the finish and the exact duration of a race to 1/100th of a second on 35mm film. The finished picture can be in the judges hands approximately 15 seconds after the conclusion of the event.

TYPE 1406 HIGH SPEED LEVEL RECORDER: An entirely new design with greatly extended frequency response extending from 30c/s to 150kc/s, employing a synchronous motor for the chart and servo mechanisms. Three chart speeds and a fast writing speed giving full scale movement in 0.15 second are incorporated.

TYPE 1501 PEAK STRAIN GAUGE: Enables peak strain readings to be indicated on a pointer-type meter from signal pulses as short as $\frac{1}{2}$ millisecond. The meter indication can be held with a fall-off of only 2 per cent in 10 minutes until released by a spring-loaded toggle switch.

Dawe Instruments, Ltd.,
Hanwell, London, W.7.

Magnetic Materials

The T.C.M. company's exhibits showed the application of high magnetic saturation alloys in electrical equipment where a high power/weight ratio is required. Examples of aircraft generators and starters were displayed in which a weight saving of 1/5th is achieved by the use of iron cobalt alloys instead of iron. Even greater reductions in weight are envisaged.

The company has developed special apparatus to facilitate the comparison of hysteresis loops of magnetic materials. This apparatus was exhibited and used to demonstrate the improved characteristics of recently developed alloys. The apparatus is adaptable to rapid routine testing.

The Telegraph Construction & Maintenance Co., Ltd.,
Telcon Works,
Greenwich.

Elliott-Petch Electrical Pressure Detector

(Illustrated below)

This detector is a portable device for providing a positive indication whether or not a high-voltage conductor is alive. It consists of a type of insulating material containing an indicating cell, visible through an aperture in the tube. The cell depends for its action on the fact that if an electrostatic field is applied to mixed dielectrics of differing permittivities the dielectric of high permittivity will displace that of lower value, if free to move to the strongest part of the field. When the detector makes contact with a live A.C. conductor the red fluid in the cell "humps" in a characteristic manner. Similarly, if a D.C. charge is present the fluid gives a definite momentary agitation.

A particular advantage of the detector is that, unlike devices employing gas-filled tubes, it cannot give the operator a false sense of security since accidental breakage of the cell will cause an immediate and obvious loss of the volatile red fluid.

The detector will give good indication down to 1,500 volts A.C.

Elliott Bros. (London), Ltd.,
Century Works,
Lewisham,
London, S.E.13.

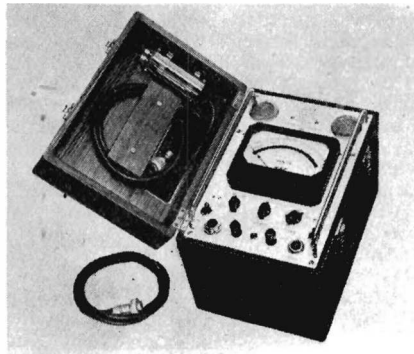

One non-electrical instrument shown at the exhibition was a new miniature layer thickness meter. This is a pocket sized magnetic gauge for the measurement of non-ferrous layers on ferrous bases. The instrument is contained in a moulded case and is entirely independent of any electrical supply. It is available in ranges of 0.5, 0.10 and 0.30 thousandths of an inch.

Salford Electrical Instruments,
Silk Street,
Salford,
Lancs.

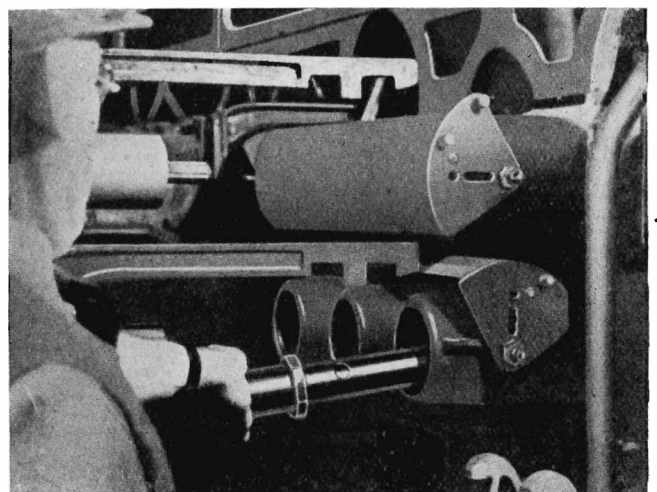
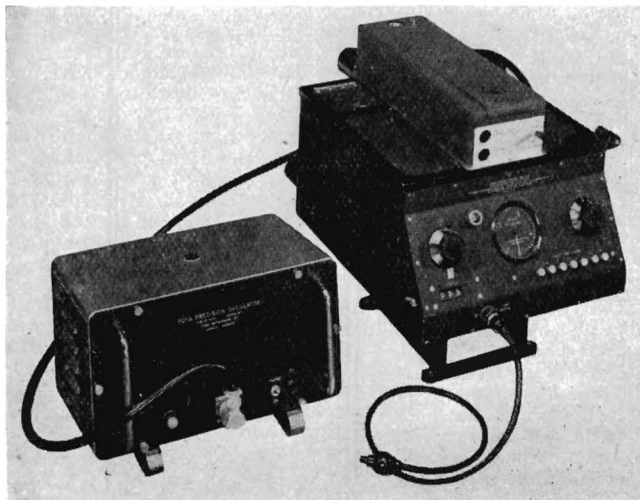

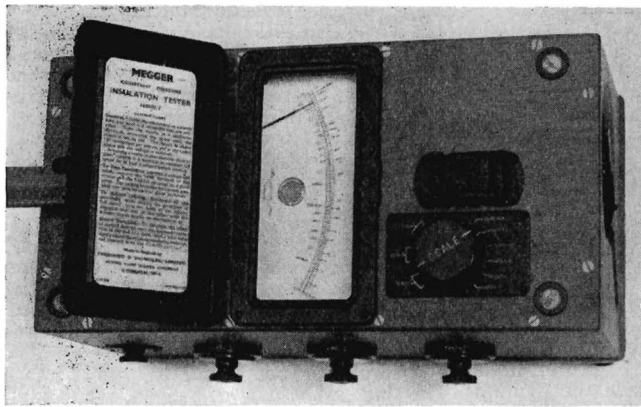

A Six Range "Megger" Tester

A new "Megger" Insulation Tester having three voltage and six megohm ranges was on view. In outward appearance the new instrument is very similar to the ordinary Series 1 instrument. It includes, however, a six position range switch facilitating tests at pressures of 500 volts (ranges 0-50 and 3-10,000 megohms), 1,000 volts (0-100 and 5-20,000 megohms) and 2,500 volts (0-200 and 15-50,000 megohms).

A new quick response Recorder having a maximum sensitivity of ± 1 millivolt A.C. or D.C. was also on view. Its recording movement incorporates a two-phase induction motor instead of the moving coil movement used in previous instruments, which had a sensitivity of only ± 10 volts D.C. A drag-cup generator coupled to the movement facilitates variable damping. The new recorder, which will follow frequencies up to 10c/s, is intended for working from high-speed thermo-couples or from strain gauges.

Other exhibits included a selection of special fractional horsepower motors for D.C. and A.C. operation, and examples of the Series 4 ranges of "Megger" insulation, earth and earthometer testers introduced about a year ago.

Evershed & Vigno's, Ltd.,
Acton Lane Works,
Chiswick,
London, W.4.

The Measurement and Control of the Thickness of Thin Metal Films

This apparatus is used for the quick determination of the thickness of thin metal films on insulating surfaces, for example the aluminium backing on a cathode ray tube screen (illustrated below). The instrument is built around a thermionic oscillator, the frequency of

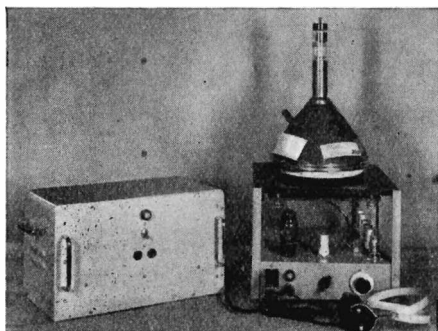

which is determined partly by the presence of the metal film. Adequate sensitivity in the determination of this frequency is obtained by causing the output of the oscillator to beat with the output from a standard oscillator. The frequency of this is chosen so that a zero beat frequency is obtained when the variable oscillator assumes a frequency corresponding to the required thickness of metal.

DEVELOPMENTS IN CRYSTAL VALVES.

(a) Silicon Crystal Valves.

A new coaxial type crystal for use at frequencies up to 10,000Mc/s was shown. This crystal is intended for use in pretuned mixers, which are now extensively used in high frequency radar receivers. This new valve has a markedly superior performance to the now obsolete capsule type. A large scale model was also shown, together with a typical holder and charts indicating the electrical characteristics.

(b) Germanium Crystal Valves.

Diodes.

Among the germanium diodes shown was a new type capable of working satisfactorily as a frequency changer up to about 1,000Mc/s. This diode has the low forward resistance characteristic which is required for use in telephone modulators. It is of the glass bead, wire-ended, construction which makes for low cost in manufacture.

Triodes.

The design of the crystal triode has now been modified to obviate the use of a valve holder. The new design, which is hermetically sealed, is of a wire-ended form of construction so that it may be soldered directly into a circuit.

The General Electric Co.,
Kingsway,
London, W.C.2.

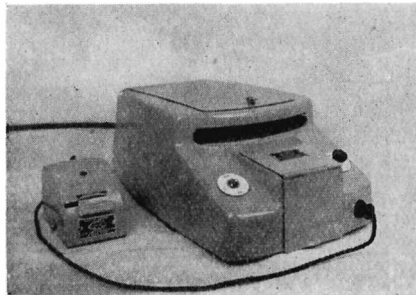

"Eel" Exhibits

"EEL" REFLECTANCE SPECTROPHOTOMETER (Illustrated above). Using this it is possible to draw a curve which illustrates the percentage of reflectance from the surface in various regions of the spectrum, and from the shape of this curve to investigate and record the colour of the surface. The filter wheel is readily removable and may be replaced by a three colour wheel if it is desired

to record the colour, in terms of percentages of red, green and blue, or in terms of the C.I.E. co-efficients.

"EEL" GLOSS HEAD is a recent production in line with a specification laid down by the Paints Division of the Imperial Chemical Industries. This instrument incorporates a precision lens system which is designed to give reproducible results and to yet detect small differences in samples of very high gloss.

"EEL" OPACIMETER designed for the routine assessment of the capacity of paper or other translucent materials. Measurements are made, by means of a photocell and a small integrating cube, of the reflected light from the sample, first self-backed and then backed by a black cavity.

The Gloss Head and Opacimeter have been designed as interchangeable units to operate from the same galvanometer employed with the reflectance spectrophotometer.

Evans Electro Selenium, Ltd.,
Bishop's Stortford,
Herts.

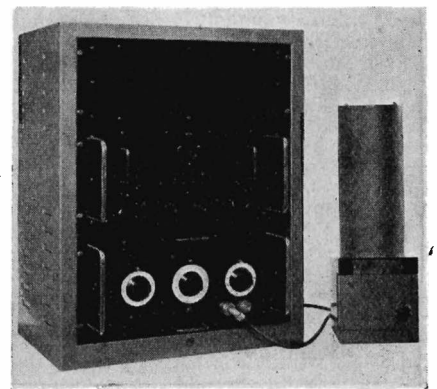

Ekco Exhibits

Shown for the first time was the Ekco Aerial Polar Diagram Measuring Equipment. This has been developed to provide accurate automatic recording of the polar diagrams of centimetric antennae. The antenna under test is mounted on a rotatable trailer and illuminated by a fixed transmitter, while the amplitude of the received signal is continuously plotted against the angular traverse of the trailer and antenna. As shown, the equipment covered a frequency range of from 8,500Mc/s to 9,500Mc/s, but any convenient range can be covered by the substitution of two units.

Another new Ekco exhibit was a working model of the latest industrial type Thickness Gauge. Using radioactive Thallium 204, it is capable of measuring from 0.0005in. up to 0.10in. of paper, or the equivalent weights of other materials.

The new Ekco Scintillation Counter (illustrated above) uses the E.M.I. Photomultiplier Tube 5032, which is contained in a cylindrical lead shield with the amplifier mounted on top. One demonstration showed the Counter working with a ratemeter, and another showed the Scintillation Counter, a Scaler and power unit as a complete counting equipment.

E. K. Cole, Ltd.,
Southend-on-Sea.

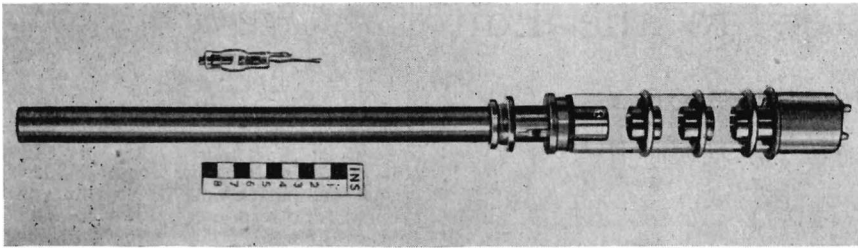

X-Ray Equipment

This exhibit comprised a selection of Newton Victor X-ray tubes and rectifying valves for industrial, medical and scientific purposes. At one extreme was the 54in. long, multi-section, sealed-off "Resomax 300" deep X-ray therapy tube designed for operation at 300kV at 20mA continuously in oil—at the other, the "NVX-3" diagnostic medical X-ray tube of only 4½in. overall length, as used in portable and mobile apparatus. (Both tubes are illustrated above.)

A special exhibit was the sectioned X-ray tube-casing showing the internal arrangement of the oil insulation chamber and expansion bellows, etc., and the mounting of the high-vacuum insert with its inbuilt protection against high voltage, and internal shielding which restricts the emission of X-radiation to the required half-angle.

Other X-ray tubes displayed were the new, continuously-evacuated, rotating-anode unit for crystallography, a medical tube for operation up to 85kV at 30mA intermittently and a double-focus diagnostic tube rated for 100kV working.

Both air and oil insulated types of X-ray rectifying valves were exhibited, the former up to 230kV maximum inverse voltage and 195mA maximum filament emission, and the latter up to 140kV and 180mA. There were also shown two special types of valve designed for use in electron microscopes, one of which is the recently developed type MV012 which has a filament emission of 30mA with the exceptionally low voltage of 1.75.

Newton Victor, Ltd.,
15 Cavendish Place,
London, W.1.

"Atomat" Beta-ray Thickness or Weight Gauge, Industrial Model (Illustrated below)

A radioactive isotope with a useful life of four years is used with an ionization chamber operat-

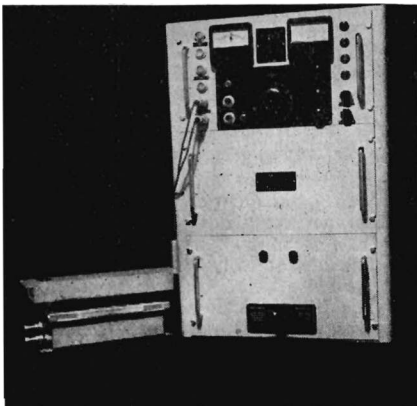

ing an indicating instrument calibrated in units of thickness or weight, and another showing deviation from a pre-set quantity. It may be used with paper, board, plastics, metal foil, etc., and is now being extensively applied in industry. A.C. mains operation.

Other exhibits were a gamma-ray thickness or weight gauge, a Baldwin-Farmer sub-standard X-ray dosimeter and a tuned visual null indicator for A.C. bridges.

Baldwin Instruments Co., Ltd.,
Brooklands Works,
Dartford,
Kent.

Cintel Products

SQUARE WAVE AND PULSE GENERATOR. Square Waves of 1:1 Mark/Space Ratio at the following maximum voltages: 5V peak to peak in 100 ohms, 15V peak to peak in 300 ohms, 50V peak to peak in 1,000 ohms.

Repetition rate continuously variable from 5c/s to 250kc/s. Rise time 0.015μs in 100 ohms. Pulse widths of 0.05, 0.1, 0.2 and 0.3μs available in 100 ohm load.

WIDE RANGE CAPACITANCE BRIDGE. Capacitance range 0.002 picofarads to 100 microfarads. Resistance range 1

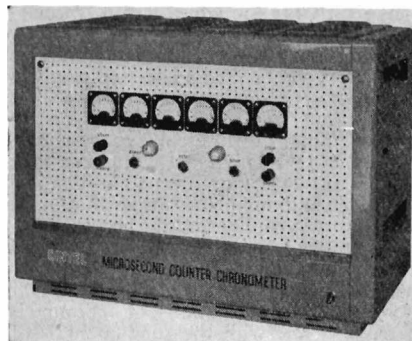

ohm to 100,000 Megohms. Accuracy ±1 per cent. Frequency 1592c/s.

MICROSECOND COUNTER CHRONOMETER (Illustrated above). For time measurement in range 1 microsecond to 1 second. Accuracy ±0.005 per cent ±1μs and 10μs to 10 seconds accuracy ±0.005 per cent ±10μs.

ELECTRONIC FREQUENCY METER. For measuring frequencies in range 0-150 kc/s. Accuracy ±2 per cent of full scale. Input amplitude range 0.25 to 30 volt R.M.S.

CK. DOSIMETER. A personal monitor giving a direct indication of radiation dose received. Calibrated from 0-500 milli Roentgens in 25mR steps.

HIGH VOLTAGE SURGE TESTING EQUIPMENT. For performing surge tests on any suitable impedance (e.g.

motor stator windings, etc.). Comparison made on oscilloscope between a test and standard winding. Voltage pulse for testing, variable from 500 volts to 10 Kilo volts. Peak short circuit current 75 amps.

Cinema Television, Ltd.,
Worsley Bridge Road,
London, S.E.26.

The Ferranti Radiation Pattern Recorder

In the case of an aircraft aerial the radiation pattern may be appreciably modified by the presence of the aircraft, especially when aircraft size exceeds one wavelength. The shape and positioning of the wings, engine nacelles, tailplane, etc., and asymmetry in the fore and aft direction all contribute in varying degrees to produce a distorted radiation diagram. Thus, since the complex character of the aircraft surface must be taken into account, mathematical computation of aerial behaviour becomes very difficult; and experiment using a "life-size" aeroplane, is generally impracticable.

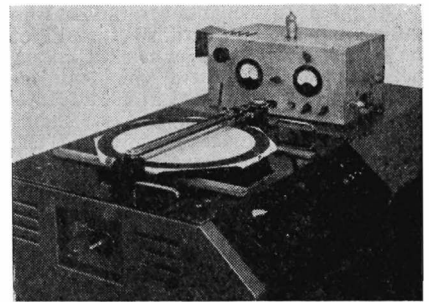

The solution to these difficulties lies in the use of models, reducing both aircraft dimensions and operating wavelength by the same scaling factor. The radiation pattern recorder was designed primarily for this purpose, though the apparatus is flexible and may be adapted if required to other problems.

As initially developed, the equipment is intended to cater for the aircraft installation of L-band aerials (30cm) in connexion with the Ferranti-developed Distance Measuring Equipment. The model acts as a transmitter, but results thus obtained are equally valid whether the full-scale aerial is to be used either as a transmitting or as a receiving element.

The recording equipment (illustrated above) consists essentially of two separate servomechanisms. The first, the rotational system, produces motion of the plotting table in sympathy with the remotely controlled rotation of the aircraft model. The second, the translational system, determines the deflection of a pen according to the instantaneous value of the power radiated by the aerial under test. Plots may be taken either in Cartesian or polar coordinates, for a maximum variation in signal power of 40db, and for a writing speed normally between 1.5 and 2 minutes per pattern.

Ferranti, Ltd.,
Hollinwood,
Lancs.

Letters to the Editor

(We do not hold ourselves responsible for the opinions of our correspondents)

Electronic Colorimetry

DEAR SIR,—In his article on "Electronic Colorimetry" in the March 1951 issue of ELECTRONIC ENGINEERING Mr. Thomasson would appear to have seriously confused additive colorimetry with spectrophotometry. In his opening paragraphs he points out the deficiency of a colour specification giving the intensity at three selected wavelengths in the red, green and blue parts of the spectrum, and goes on to suggest that it would be much better to divide the spectrum into 10 parts and evaluate the intensity for each of these 10 regions. As far as I am aware, no one has ever suggested that the intensity at three wavelengths could be regarded as a description of the spectral curve and no system of specifying colour in this manner exists.

The three wavelengths Mr. Thomasson has chosen are the cardinal stimuli of the C.I.E. trichromatic system of colour measurement—the system which was internationally standardized in 1931. However, the way in which those wavelengths are used is completely different. The C.I.E. system is based on the facts of additive colorimetry. While this is not the place to attempt a full description of the system, one may say very briefly that any unknown colour can be matched by adding suitable intensities of illumination of those three wavelengths in a mixing device (additive colorimeter) and judging the result with the eye. A specification of the amounts of the three primaries necessary to produce a match is then a complete and unique colour specification. Three figures only are quoted, but the eye in making the match has been using the spectral responses of the retinal receptors, which extend over the whole of the visible spectrum. Hence, a trichromatic colour specification giving the intensities of the three cardinal stimuli is completely different from a specification merely quoting the intensities at three isolated wavelengths in the spectrum and giving no information about the remainder of the visible spectrum.

The other approach to colorimetry is via spectrophotometry. This method is the analytical one and consists of measuring the relative intensity of reflexion or transmission of the colour throughout the visible spectrum. In theory, an infinite number of measurements would be required to specify the spectrophotometric curve, but in practice 40 measurements from 380 to 770m μ , taken at 10m μ intervals, will constitute a very satisfactory record. This spectrophotometric curve is not in itself a colour specification, although it contains all the information required for calculating the trichromatic co-ordinates (i.e., the three stimuli values quoted in the C.I.E. system). To evaluate the trichromatic co-ordinates the following integration must be performed:

$$X = \int_{380}^{770} E \cdot \bar{x} \cdot R \cdot d\lambda \quad Y = \int_{380}^{770} E \cdot \bar{y} \cdot R \cdot d\lambda$$

$$Z = \int_{380}^{770} E \cdot \bar{z} \cdot R \cdot d\lambda$$

where X , Y and Z are the required trichromatic co-ordinates,

E is the spectral energy distribution of the illuminant,

\bar{x} , \bar{y} and \bar{z} are the three standard functions relating to the red, green and blue receptors of the eye and tabulated in the literature,

R is the spectrophotometric curve of the colour specimen,

λ is the wavelength in millimicrons.

If the absolute value of the luminance (brightness) of the colour is not required, then the trichromatic co-ordinates can be normalized, giving the chromaticity co-ordinates x , y and z . Thus:

$$x = \frac{X}{X+Y+Z} \quad y = \frac{Y}{X+Y+Z} \\ z = \frac{Z}{X+Y+Z}$$

As $z = 1 - (x + y)$ it is unnecessary to specify z .

A complete colour specification on the C.I.E. system consists of the values of X , Y and Z or alternatively, x , y and Y .

One consequence of the above calculations is that although a given spectrophotometric curve produces one and only one chromaticity (i.e., one particular set of values of X , Y and Z) in a given illuminant, the converse is not true. A given colour can be produced by an infinite number of different spectrophotometric curves. The name metameric pair is given to two colours which are identical in a given illuminant, although they have different spectrophotometric curves.

Hence the suggestion that an abridged spectrophotometric curve based on 10 spectral regions should replace a proper trichromatic specification of colour is scarcely in line with the fundamentals of colour physics. However, in all fairness, one may add that a record of the type suggested by Mr. Thomasson may have useful applications in industry.

One or two minor points of instrumentation may be added in conclusion. The adjustable mask shown in Fig. 4 has equal horizontal divisions. Owing to the way in which a prism disperses light, this will spread out the information at the blue end of the spectrum and compress the information at the red end. Unequal divisions should be used to compensate for this and the time base of the scope operated to give a linear wavelength scale.

The numerical example of identification in terms of graticule readings ends with three 0s. This is a little perplexing as the curve (see Fig. 6) is still above the black level. Is the level marked 0 in-

tended to imply some sensation level greater than black and yet to which the eye makes no response? From the point of view of easily transferring the curve on the oscilloscope to C.I.B. readings a linear vertical scale would be preferable.

W. N. SPROSON.

B.B.C.,
Kingswood Warren, Surrey.

Mr. Thomasson replies:

DEAR SIR,—The main subject of the article was the application of electronic methods to the measurement and identification of colour. I therefore avoided a detailed exposition of existing colorimetric technique, but gave a much simplified outline of the trichromatic principle in order to indicate the possible ambiguities of such a method, which are not removed by the additive technique. Mr. Sproson states that a "complete and unique colour specification" can be obtained by additive colorimetry, but later refers to "metameric pairs" which are examples of possible ambiguities. He does not comment on the fact that variations of up to 15 per cent may be observed between readings taken by different operators.

By connecting my remarks on visual colorimetry with later remarks regarding a spectrophotometric method, Mr. Sproson deduces that I have confused colorimetry with spectrophotometry. He states himself that a trichromatic colour specification can be obtained from a spectrophotometric curve, i.e., that the spectrophotometer can be used as a colorimeter. I differ only in that I suggest an alternative method of specifying the colour which is more suitable for the purpose.

Concisely, to use Mr. Sproson's terms, I stated a preference for the spectrophotometric approach to colorimetry, but with a modified method of deriving a colour specification. This method would not involve the user in complicated integration processes, and would therefore be more suitable for work outside the confines of a laboratory.

The key to Mr. Sproson's dissension is that he regards the trichromatic system as essential and irreplaceable. It is primarily an academic method, however, and is not well adapted to the needs of commerce and industry. The method I propose is intended to provide a practically useful means of colour identification.

It would be desirable to complicate the method by using a perfectly linear wavelength scale and other features, but these would not be of great practical value. The light gate suggested by Mr. Sproson is academically correct, but is neither necessary nor practicable.

Mr. Sproson's last suggestion shows that he has entirely missed the point of the whole article. I have no desire to arrange the graticule so that C.I.E. readings can be taken. I have arranged the graticule so that the necessary information can be obtained more readily and in a more useful form. The anti-logarithmic

"sensation" units ensure the maximum possible differentiation between different colours with a given number of ordinates. The "O" level is above the "black" level because the latter corresponds to zero illumination. The region between the two levels has been found to contribute little to the appearance of coloured surfaces of average reflectivity. If a precise identification is required for a surface of low general reflectivity, it is possible to expand the vertical scale and read a set of negative intensity values below the nominal zero. This will rarely be necessary in practice.

A colorimeter of the type described would not be of any use to an operator desiring to read C.I.E. values. It is not intended to be. Equally, the visual colorimeter could not be used by a completely unskilled shop-assistant for the purpose of matching fabrics, whereas the colorimeter described would be very suitable for this purpose. The readings are independent of ambient illumination, and are in a convenient form for transmission by telegram or other means.

Mr. Sproson is justified in expressing his disapproval of my cavalier treatment of an accepted method of colour specification. Unfortunately, the "fundamentals of colour physics" have become divorced from the requirements of practical colour matching, and academic matters have tended to become of purely academic interest. The real test is the practical utility of a method, not its academic correctness.

Yours faithfully,
D. W. THOMASSON,
Exeter.

A Simple Frequency Comparison Circuit (Circuit shown below)

Dear Sir,—In the laboratory, the measurement of an unknown frequency by comparison with a variable source of known frequency can be carried out by a number of methods. The use of a cathode-ray oscillograph to produce Lissajous figures is perhaps the simplest to set up and operate and yet capable of a very high order of accuracy. Variations of 1/5th of a cycle per second can be easily distinguished, representing an accuracy of 2 parts in 10⁴ at 1000c/s. In the limit, the accuracy is determined by the calibration and freedom from drift with time of the comparison frequency source.

The same order of frequency measurement can be achieved, however, with the aid of a cathode-ray tuning indicator or "magic eye"; thus obviating the need for a bulky and expensive cathode-ray oscilloscope, while enabling the comparison facility to be readily incorporated in such test equipment requiring it.

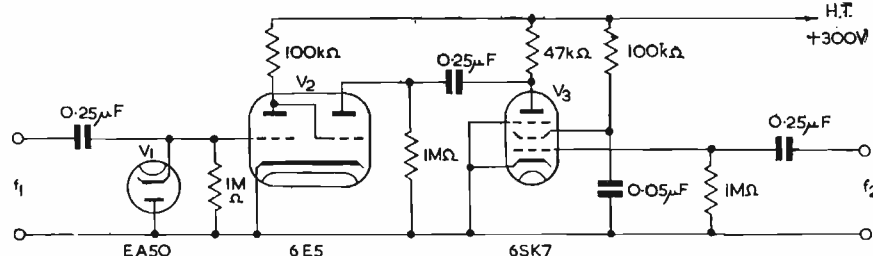

The principle involved is to modulate the target grid with one frequency, f_1 , of sufficient amplitude to swing the grid beyond cut-off potential on negative half cycles, while the other frequency, f_2 , is applied to the target anode.

When the two frequencies are equal and of opposite phase the target current is at a minimum, due to the anode being negative whenever the grid is positive, and the grid negative beyond cut-off, when the anode is positive. Thus as f_1 approaches f_2 , the "eye" will begin to flicker and zero beat can easily be observed when $f_1 = f_2$, where n is an integer.

A suitable circuit is shown below, and in operation this will enable frequencies to be compared up to a maximum of $n = 10$, the clearest indication being obvious when $f_1 = f_2$.

In order to sharpen the null point for values of n other than unity it is desirable to introduce a measure of "squaring" of the input waveforms. This can be obtained by operating both f_1 and f_2 amplifying valves with zero grid bias, allowing limiting action by grid current to take effect. In addition the positive half cycle applied to the target grid may be attenuated by diode V_1 ensuring target current cut-off during the positive grid excursions.

K. G. BEAUCHAMP,
G.E.C., Coventry.

Measurement of Noise in Resistors

DEAR SIR,—I am surprised at the reply in your February issue to my letter on the above topic, for if Mr. Oakes cares to analyse the circuit in question in the same way as he analyses another input circuit earlier in his article he should obtain the expression:

$$e_G = \frac{R'e_N}{R' + kR + R_X}$$

where $R' = \frac{R_B R_G}{R_B + R_G} \div R_B$

and where:

R_B = battery internal resistance,

k = fraction of potentiometer resistance in circuit,

and

R_G, R_Y, e_G, e_N are used by Mr. Oakes.

The expression shows that $e_G \ll e_N$, and that e_G depends very much on the internal resistance of the battery.

I have no explanation to offer for the "successful" tests carried out with this circuit, except to suggest that the tests are regarded as successful because the results have not been checked against different tests.

Yours faithfully,
A. M. ANDREW,
Glasgow.

Mr. Oakes replies :

DEAR SIR,—On looking again at the Figure 10 in question, I find that, in fact, this is not drawn correctly, and quite possibly was my mistake in the first place. Obviously this should be as illustrated below.

Yours faithfully,
FRANCIS OAKES,
London, N.W.3.

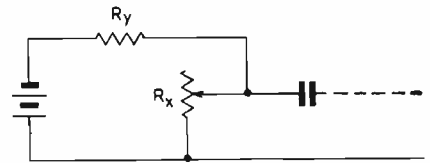

The Grounded Grid Amplifier

DEAR SIR,—It was interesting to read Mr. J. Roorda's article on "The Grounded Grid Amplifier" in the November 1950 issue of your journal. The mathematical analysis, leading to a number of useful derivations, was impressive. But may I point out that a few mathematical steps are rather confusing.

For, I feel that the equation just preceding relation No. (12) on pp. 479 ought to be expressed as:

$$(g + 1/\rho)[\omega_0(C + C_{ac} + C_{ag}) - 1/\omega_0 L] = \omega_0 C_{ac}(1/\rho + 1/r)$$

instead of:

$$(g + 1/\rho)\omega_0(C + C_{ac} + C_{ag}) - 1/\omega_0 L = \omega_0 C_{ac}(1/\rho + 1/r)$$

The results derived by Mr. J. Roorda can be arrived at only if the former expression is utilized. Personally, I do not know if the error is one of misprint, but as it appears in your journal, it requires, I think, rectification.

Then again, following the steps suggested by Mr. Roorda, the maximum amplification works out to be:

$$A_{max} = \frac{2(1 + \mu)}{1 + \sqrt{1 + (\rho\omega C_{ac})^2}}$$

in place of half this value, as expressed in relation No. (22).

Yours faithfully,
K. C. CHADHA, M.Sc. (Hons.)
Simla, India.

Mr. Roorda replies:

DEAR SIR,—Replying to Mr. Chadha's letter, I can only thank him for pointing to the mistakes of two of the equations appearing in my article on "The Grounded Grid Amplifier."

The expression just preceding relation No. (2) on page 479 should read exactly as Mr. Chadha corrects. The subsequent analysis makes this clear. I suppose that the method of printing of the formula has defied my attention in the correction of the proofs.

As to the expression for A_{max} , I have traced out, that the factor 2 in the denominator appears correctly in my original notes on the subject. In some mysterious way it has dropped out in the manuscript for the article. The formula for A_{max} , as given by Mr. Chadha is entirely correct.

Yours faithfully,
J. ROORDA,
Voorburg, Holland.

H. K. LEWIS & Co. Ltd.

Invite Inspection of their stock of books on all branches of

RADIO and ELECTRICAL ENGINEERING

FOREIGN BOOKS. Select Stock. Books not in stock, obtained under Board of Trade Licence.

Secondhand Department

140 Gower Street, W.C.1

A constantly changing large stock of scientific and technical literature on view.

Books sought for and reported free of charge

Large or small collections bought

LONDON: H. K. LEWIS & Co. Ltd.
136 GOWER STREET, W.C.1

Telephone: EUSton 4282

Established 1844

Business hours: 9 a.m. to 5 p.m. Sats. to 1 p.m.

CATHODE RAY TUBE TRACES

by H. MOSS, Ph.D.

Price 10s. 6d. Postage 6d.

This Monograph is based on a series of articles published in *Electronic Engineering* and contains the elementary theory of common types, with notes on their production.

"This book has considerable general educational interest,"—*Electrical Review*.

"The photographs of c.r.-tube traces are excellent and in both their quality and their number they form an outstanding feature of the book."—*Wireless Engineer*.

A HOME-BUILT TELEVISOR

For Sutton Coldfield Reception

by W. I. FLACK

Price 4s. 6d. Postage 3d.

This booklet fully describes the design and construction of a high quality receiver for the reception of the Sutton Coldfield transmission.

Reprints of the article by W. I. Flack on suitable pre-amplifiers for use with either the Alexandra Palace or Sutton Coldfield models of the Home-Built Televisor (originally published in the April, 1950, issue of *Electronic Engineering*) are now available on application to the Circulation Department.

Price 9d.

Post Free 10d.

PUBLISHED BY

Electronic Engineering

28, ESSEX STREET, STRAND,
LONDON, W.C.2

BOOK REVIEWS

Practical Television Engineering

By Scott Holt. 708 pages. 1st Edition. Murray Hill Books Inc. 1950. Price \$7.50.

THIS is a neatly written and presented book which is of most value to the engineers interested in the transmission end of television. Although there is an excellent chapter on receivers, it comprises approximately 1/6th of the volume only. The writer of the book has obviously not only an intimate knowledge of the subject, but presents his knowledge in a logical and easy manner.

The book deals only with television of American standards, but each chapter has a lengthy bibliography of works on the subject of the chapter and many authors outside the U.S.A. are listed.

The first chapter deals with fundamentals of picture transmission and is concerned with the characteristics of light, light sources, lens, and the principles of scanning.

Chapter 2 carries on with C.R.T.'s, their properties and manufacture, methods of deflexion and focusing, and includes, like all the others, excellent illustrations and photographs. Electromagnetic focusing and deflexion is, in some places, referred to as magnetostatic. This is a word not much used by others, and it would be tidier if it were not used here. It is a very useful chapter and contains a wealth of theory and very practical up to date information.

The next chapter is about cathode ray oscillographs and is full of interest. Circuits of commercial equipment which include some particular feature, are discussed in the text, such as frequency compensation, shift circuits, power supplies, and so on. A cathode follower circuit is shown as a means of increasing the response of systems, but no reason is given why the circuit is "improved" if the cathode load is returned to a negative potential, nor is it mentioned that there is a loss of signal if the cathode load is of low value, which is recommended, but cathode followers are treated in more detail in Chapter 6.

Pick-up tubes are treated in Chapter 4 in an interesting and authoritative way. No mention is made of any tubes outside the U.S.A., and it is specifically stated that only four have general use. The iconoscope, Orthicon, Image Dissector and Image Orthicon. In the bibliography however, a paper of McLee and Lybszyustic on E.M.I. tubes published in the *J. Am. Electrical Eng.* is listed.

Chapter 5 is a long chapter dealing with sync. generators, mixing, timing, shaping and deflexion circuits, and the treatment is very thorough. Complete circuits of dividing chains, etc., are given, and it is particularly useful to have waveforms shown at so many points in circuits.

Some of them could be explained more clearly however. For instance the stepped waveform of a counter circuit on p. 244 does not follow the general shape of an exponential curve, some steps being too big and others too small, and what

is worse large ones come after small ones in several places. In another on p. 270, when describing the action of a circuit to re-form the equalizing pulses, it is not pointed out that owing to the relative complexity, it is necessary to generate pulses of a different width, and displaced in time from the input. As shown it looks as if the output is merely the same as the input but inverted. No controls are shown to indicate width or delay adjustment. The chapter is full of practical information, but none of the precision delay or divider circuits developed during World War II is mentioned.

Chapter 6 is on the video amplifier and cathode follower, and although this contains material which is now well known, it is very useful and complete. This chapter is followed by a short one on stabilized power supplies, and the same remarks apply.

Chapter 8 on the television receiver is well balanced, and squeezes into the 125 pages a useful summary of current practice in American receivers. Chapter 9 and 10 are about the camera chains and the transmitter and contain details of mixers, monitors, attenuators, faders and anti-bounce circuits, as well as of purely transmission problems such as aerials and aerial filters. Again there are numerous photographs and drawings.

The final chapter is on television broadcasting techniques, and shows a number of block diagrams of complete television transmitters, photographs of equipment, relay stations, and has a section on maintenance.

As the book is primarily intended for engineers who wish to know more about the transmission side of the business, and assume they are of rather more than average technical standard, this reviewer found the list "Review Questions" at the end of each chapter a waste of space, and rather irritating.

If it is intended to leave them in, it is suggested that at the end of each question there should be a note of the page on which the answer can be found.

C. H. BANTHORPE

Electronics: Experimental Techniques

By W. C. Elmore and Matthew L. Sands (National Nuclear Energy Series, Division V, Volume 1). XVIII + 417 pp. McGraw-Hill Book Company, Inc. 1949. Price 32s.

THIS book is a laboratory manual which arose from the work in electronic instrumentation done during the years 1943 to 1945 by the Electronics Group in the Los Alamos Laboratory of the U.S. Atomic Energy Commission. The material of the book is drawn from a large stock of electronic circuits devised for specific requirements in nuclear research work. In the authors' words: "... the circuits chosen for inclusion in the volume were judged on the basis of their general usefulness as proved at the laboratory, and of their probable usefulness in other laboratories. Some special-purpose circuits

were chosen which have no general utility but which illustrate some particular method or technique. For reasons of security no circuits having a special application to weapon technology were included."

The subject is divided into the following chapters, viz:

1. Circuit components and construction practice (brief discussion of components suitable for constructing the various electronic circuits).

2. Circuit elements (description of the different elements constituting the complete electronic circuits).

3. Voltage amplifiers (discussions of linear voltage amplifiers that are useful in nuclear physics investigations).

4. Electronic counters (practical circuits that record the occurrence of a large number of electrical pulses of restricted properties of amplitude and of time of occurrence).

5. Oscillographs and associated equipment (cathode-ray oscillographs).

6. Test and calibration equipment, and

7. Power supplies and control circuits.

The book is essentially descriptive with a large number of clear and well-designed diagrams, well written and excellently printed.

R. FEINBERG

The Principles of Television Reception

By A. W. Keen, M.I.R.E., A.M.Brit.I.R.E.
319 pp. Pitman, 1950. Price 30s.

THIS book is intended for technicians and service engineers, as a qualitative introduction to the theory underlying the design of television receivers, and for students taking examinations which involve television principles.

The subject is dealt with in four main parts. The first two chapters comprise the first part and deal with the general outline of a television system and the necessary basic circuit theory. The second part, which forms the main body of the book, examines the receiver stage-by-stage and gives several examples of commercial practice including four complete receiver circuits. The third part deals with aerials and test equipment, while the fourth reviews the problems of colour television.

In broad conception and scope the book is very well suited to its declared purpose and there is little doubt that this is the best English introduction to the subject at present available. American books, while often of a very high standard, are not at all suitable as an introduction to the techniques in use in this country.

The treatment is almost entirely non-mathematical, the argument being carried on in physical terms and illustrated with a very large number of diagrams. The physical conception is, of course, vitally important in an introduction to any electronic subject. Full understanding only comes, however, when both mathematical and physical interpretations are given, and are linked together. In this sense the book is deficient, especially for the student. Moreover the explanations tend to become so involved that they may be more difficult to follow than the mathematics. The author must himself

have been aware of this because he has added eight pages of "Mathematical Notes" to which reference is occasionally made by means of footnotes. This does little to remedy the defect.

Valuable features of the book include the extensive bibliographies given after each chapter, the balanced presentation of British and American practice, and the references to original patent applications which appear in footnotes.

In an introductory work it is inevitable that the author should avoid difficult or controversial subjects. It is surprising, however, to find the important subject of staggered tuning dealt with in a single page which includes a badly drawn diagram. Later on we learn that "band-pass couplings, when employed, are nearly always optically coupled"—a very doubtful statement. Again "In Britain the most popular sawtooth driver is the thyatron" which is surprising, since it cannot be used in the most popular type of receiver, the A.C./D.C. type. A heroic attempt is made on p. 75 to explain magnetic focusing, during which one tries to imagine a velocity component moving perpendicularly to its own direction! The treatment of energy recovery line scanning systems is totally inadequate, if not misleading, and this is quite unnecessary, since they are best explained in physical terms, the mathematical treatment being sketchy and inaccurate, at least when this book was written. The same criticisms apply to the treatment of linearity, both in line and frame circuits. On page 198, in dealing with single sideband techniques we are told that "if the carrier is placed higher up the sloping side of the response curve the H.F. portion of the accepted band will predominate over the lower frequencies and vice versa" which is the reverse of the truth. In Fig. 3.10.c a circuit is given for providing E.H.T. supply for the C.R. tube from the line scanning circuit. Unfortunately, the potential provided by this circuit is of negative polarity, and this is not just an artist's error; the circuit needs almost complete redrawing.

There are numerous other small points which call for correction, and one or two statements which have been rendered inaccurate by the passage of time (pp. 27 and 172). Nevertheless, the book is well worth reading by anyone who requires a comprehensive introduction to the subject—comprehensive in scope rather than treatment. One must always remember that an introduction may present the truth, rarely the whole truth, and in this case occasionally something other than the truth!

EMLYN JONES

The Radio Manual

By George E. Sterling and Robert B. Munroe.
890 pp. D. Van Nostrand Co. Inc., New York, and Macmillan and Co., London. 4th (enlarged) edition 1950. Price \$12 or £4 10s.

THIS is an encyclopaedic production reminiscent of a Radio Amateur's Handbook expanded to cover additionally such subjects as broadcasting and radio navigational aids. All sections are illustrated by line and tone blocks which are commendably clear, and in addition there are several fold-in schematics.

CHAPMAN & HALL

Recently Published

TRANSFORMER ENGINEERING

A Treatise on the Theory, Operation and Application of Transformers

by

L. F. Blume, A. Boyajian,
G. Camilli, T. C. Lennox,
S. Minneci, V. M. Montsinger

Second Edition

500 pages 278 figures 60s. net

FRACTIONAL HORSE POWER MOTORS

by

Stuart F. Philpott
M.I.E.E., F.B.H.I.

380 pages 265 figures 30s. net

37 ESSEX STREET, LONDON, W.C.2

Applied Electronics

- TELECOMMUNICATION DEVELOPMENTS
by A. W. Cole, A.M.I.E.E.
- BROADCASTING EQUIPMENT
by H. D. Ellis, M.A.(Hon), M.I.E.E.
- SOUND RECORDING EQUIPMENT
by H. Davies, M.Eng., M.I.E.E.
- TELEVISION IN BRITAIN
by S. C. Hewward, B.Eng., A.M.I.E.E.
- SPONSORED v. STATE TELEVISION
by C. O. Stanley, O.B.E.
- ELECTRONICS IN HEAVY INDUSTRIES
by W. Wilson, D.Sc., M.I.E.E.

Also by leading authors: Marine Equipment, Radar in War and Peace, Microwave Physics, Electronics in Industry, Atomic Energy Control, Testing and Measuring, Education and Training ...

All included in the first edition of the

APPLIED ELECTRONICS

ANNUAL Edited by R. E. Blaise, A.M.Brit.I.R.E.

Together with a WORLD DIRECTORY of Manufacturers, Distributors of Radio and Electronic Apparatus and Component Parts, List of Trade Marks and classified Buyers Guide.

PRICE £2 POST FREE

222, STRAND, LONDON, W.C.2.

Notes from the Industry

MEETINGS
THIS
MONTH

INSTITUTION OF ELECTRICAL ENGINEERS

Unless otherwise stated, all London meetings are held at the Institution of Electrical Engineers, Savoy Place, London, W.C.2, at 5.30 p.m.

Measurements Section

Date: May 28-30.
Conference: Electrical Instrument Design.
(For full particulars see Journal I.E.E., April 1951.)

Radio Section

Date: May 9.
Symposium on: The Sutton Coldfield Television Station.
Lecture: The Sutton Coldfield Television Broadcasting Station.
By: P. A. T. Bevan, B.Sc., and H. Page, M.Sc.
Lecture: The Vision Transmitter for the Sutton Coldfield Television Station.
By: E. A. Nind, B.Sc.(Eng.), and E. McP. Leyton.
Lecture: Vestigial-Sideband Filter for the Sutton Coldfield Television Station.
By: E. C. Cork, B.Sc.(Eng.).

Utilization Section

Date: May 3.
Lecture: A New Power Stroboscope for High-Speed Flash Photography.
By: W. D. Chesterman, B.Sc., D. R. Glegg, G. T. Peck and A. J. Meadowcroft.

North Midland Centre

Date: May 8.
Held at: The Queen's Hotel, Leeds.
Lecture: Mind and Invention.
By: Professor G. P. Meredith, M.Sc.

North Western Centre

Date: May 8. Time: 6.15 p.m.
Held at: The Engineers' Club, Albert Square, Manchester.
Lecture: The Development of the Electrical System on the Bristol Brabazon Mark I Aircraft.
By: M. J. J. Cronin.

North Lancashire Sub-Centre

Date: May 9. Time: 7 p.m.
Held at: Harris Institute, Corporation Street, Preston.
Lecture: Evolution of the Lighting Art.
By: J. W. T. Walsh, M.A., D.Sc.

Northern Ireland Centre

Date: May 8. Time: 6.45 p.m.
Held at: Queens' University, Belfast.
Lecture: Impressions of the 1950 Session of the Paris High Tension Conference.
By: W. Szwander.

South Midland Centre

Date: May 7. Time: 6 p.m.
Held at: James Watt Memorial Institute, Great Charles Street, Birmingham.
Lecture: The Application of Gas-Turbine Technique to Steam Power.
By: J. F. Field, B.Sc.
(Joint Meeting with the South Midland Branch of the Institution of Mechanical Engineers.)

British Institution of Radio Engineers

Date: May 24. Time: 6.30 p.m.
Held at: London School of Hygiene and Tropical Medicine, Keppel Street, Gower Street, London, W.C.1.
Lecture: The Resistance Wire Strain Gauge in Measurement of Physical Quantities.
By: J. L. Thompson.

Date: May 24.
Held at: Birmingham.
Joint Meeting of the West and South Midlands Sections.

TELEVISION SOCIETY

Engineering Group

Date: May 10. Time: 7 p.m.
Held at: The Cinema Exhibitors Association, 164 Shaftesbury Avenue, W.C.2.
Lecture: Negative Feed-back Amplifiers of Optimal and Maximal Flatness.
By: V. J. Cooper, B.Sc., A.M.I.E.E.

BRITISH SOUND RECORDING ASSOCIATION

Date: May 19-20. Time: 10.30 a.m.—6 p.m.
Held at: The Waldorf Hotel, Aldwych, London, W.C.2.
Exhibition: Sound Recording, Reproducing and Audio Frequency Equipment.
Admission: Free to members. Non-members by catalogue available at door, price 1s., or 1s. 3d. post free from Secretary, "Wayford," Napoleon Avenue, Farnborough, Hants.

"British Standards"—the Measure of Industrial Progress. This year the British Standards movement attains its Golden Jubilee, and as a part of the celebrations an Exhibition supported by practically the whole range of British Industry will be held at the Science Museum, South Kensington, during the two weeks beginning June 18, 1951.

As Britain was the first country to put industrial standardization on an organized basis nationally through the British Standards Institution, it is fitting that the first exhibition devoted to this subject should be staged in London—and during the national Festival year.

The benefits derived from standards, standardization and simplification will be graphically presented, and each industry will show how standards have simplified production, reduced costs and maintained quality, and how in turn they have benefitted the users of that industry's products.

The Exhibition will also show how research at one end of the production chain and quality control at the other are linked with and helped by standardization. Other special features will include apparatus used in testing for compliance with British Standards.

The Exhibition will be opened at 11.30 a.m. on June 18 by the President of the Board of Trade.

Admission will be free, and opening hours will be 10 a.m.-7 p.m. each day (except Sunday) from June 18 to 28 inclusive.

New Commonwealth Apprentice Training Scheme. Engineering graduates from universities all over the Commonwealth will now be able to apply to join a new scholarship scheme for apprentice training in Britain.

The scheme, which provides a thorough engineering training at the Brush Aboe group of factories, has now been announced by the group's chairman, Sir Ronald Matthews. It will allow for two years study of the products and methods of production of the group and will provide technical experience of considerable value to the Commonwealth as a whole, and to the under-developed areas in particular. In addition to enlarging the scope of the engineering profession, it is hoped that the scheme will help to strengthen the ties between the U.K. and Commonwealth countries.

A brochure describing the scheme is available from the Brush Electrical Engineering Co., Ltd.; Loughborough, Leicestershire.

Royal Society Fellowships. Among those persons elected to Fellowship of the Royal Society were Herbert Frohlich, Professor of Theoretical Physics at Liverpool University, and John Ashworth Ratcliffe, O.B.E. Professor Frohlich was distinguished for the application of quantum theory to the physics of the solid state, and Mr. Ratcliffe, who is a reader in physics at Cambridge University, for his contributions to the development of the scientific basis for radio communications.

1951 Brit. I.R.E. Radio Convention is to be held in six separate sessions at intervals during the Festival of Britain. It is thus hoped to cover almost the whole field of radio and electronic engineering. In addition to the formal papers and ensuing discussions, there will be informal discussion meetings during each session and nearly all the papers will be accompanied by demonstrations. In order that a considerable portion of each session may be devoted to discussion and demonstration, advance copies of the papers will be available prior to the commencement of each meeting. Visits to places of technical interest will also be arranged.

The first session will take place at University College, London, on July 3 and 4, and is on "Electronic Instrumentation in Nucleonics." The second session is on "Valve Technology and Manufacture," and will take place on July 5 and 6. Session three, on July 24-25, on "Radio-Communication and Broadcasting" will take place at University College, Southampton. The fourth session will also be held there, this time on July 26 and 27, and the subject matter will be "Radio Aids to Navigation." The fifth session takes place in Cambridge on August 21-24, and is on "Television Engineering." The last session, on "Audio Frequency Engineering," is on September 4-6, and will take place in the Richmond Hall, Earls Court, during the Radio Show. Applications for meeting tickets and reservations for accommodation at Connaught Hall, University College, Southampton, or King's College, Cambridge, should be lodged with the Secretariat by April 30, 1951. Full particulars can be obtained from the British Institution of Radio Engineers, 9-Bedford Square, London, W.C.1.

The Electro Physiological Technologists' Association will hold their annual general meeting at Hurstwood Park Hospital, Haywards Heath, Sussex. The meeting will include lectures and demonstrations of electro physiological interest. Full particulars are available from G. Johnson, Esq., Honorary Secretary, at the above address.

Reader in Electrical Engineering, London University. Mr. B. Adkins, M.A.(Cantab.), M.I.E.E., A.M.Inst.C.E., Assoc.A.I.E.E., has been appointed to the University of London Readership in Electrical Engineering, Imperial College of Science and Technology, and will take up his duties on October 1, 1951.

As a design engineer with the British Thomson-Houston Co., Ltd., Rugby, from 1928 to 1947, and from 1947 as a senior lecturer for the B.T.H. Advanced Engineering Course, he has been in close contact with student apprentices and graduates.

Television Society Summer Meeting. An all-day summer meeting will be held at the Norwood Technical College on Saturday, June 2. Full particulars from the Honorary Secretary, Mr. G. Parr, 68 Compton Road, London, N.21.

THE COSSOR DOUBLE BEAM OSCILLOGRAPHS

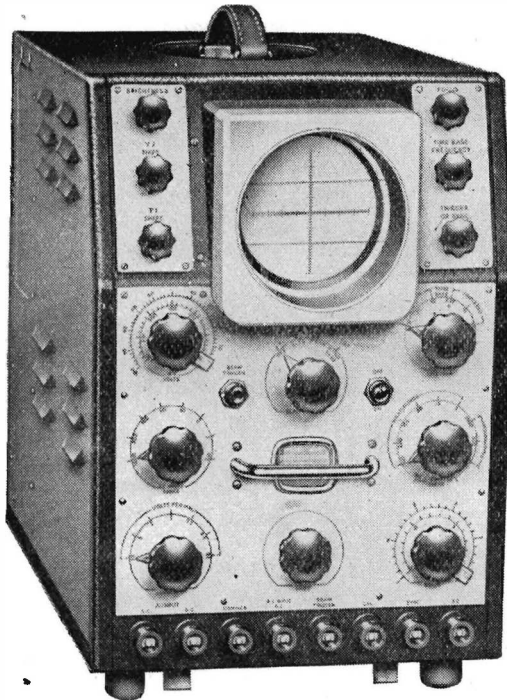

***Can this
Instrument
solve a
problem
for you?***

Here are some details of Model 1049 as illustrated: The Double Beam Tube presents two simultaneous independent traces over the full diameter of a 90 mm. screen, and provision is made for the measurement of both input voltage and time upon the calibrated dials of the instrument. The Oscilloscope is particularly suitable for obtaining permanent photographic records using the Cossor Model 1428 Camera for which a Motor Drive Attachment Model 1429 is available.

Widely different industries are daily finding new uses for the COSSOR Double Beam Oscilloscope. Sometimes it provides the answer to an industrial problem of long standing. The tracing and measurement of noise, strain and vibration are typical everyday applications of this versatile instrument which is already helping engineers in industries as far apart as brewing and the manufacture of jet engines. Call on our technical advisory staff if you have a problem. They will quickly let you know whether the Oscilloscope can help you.

This Instrument has been selected for demonstration in the Dome of Discovery (research feature) and will also be shown in the Floating Exhibition on S.S. Campania.

COSSOR

Double Beam OSCILLOGRAPHS

Please address enquiries to:

A. C. COSSOR LTD., INSTRUMENT DIVISION (Dept. B), Highbury Grove, London, N.5.

Telephone: CANonbury 1234 (30 lines)

CI.21

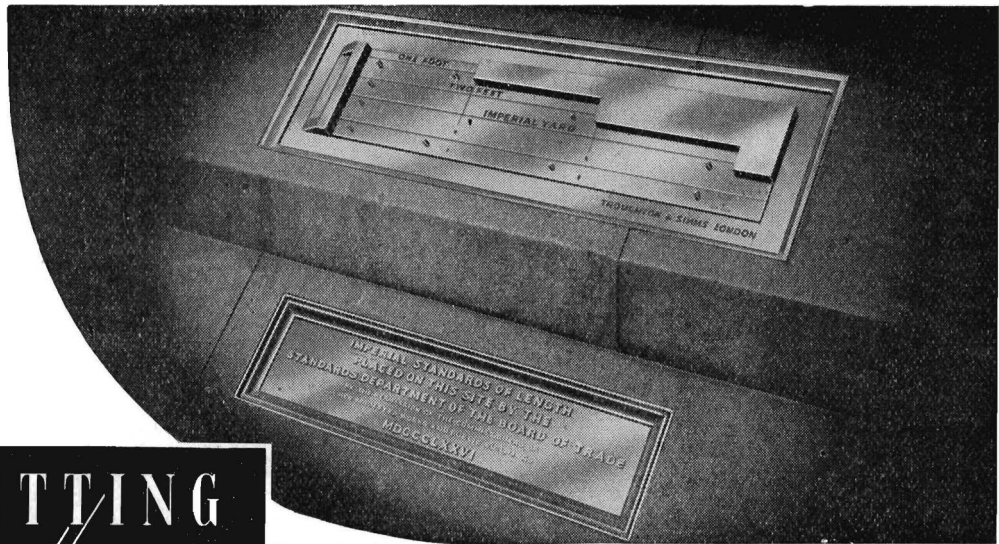

Imperial Standards of Length
—Trafalgar Square, London.

SETTING *the* STANDARD

In every branch of industry, in laboratories and scientific research establishments, in the services and in fact, wherever electrical maintenance and measurement are of prime importance, "AVO" Electrical Testing Instruments maintain a reputation unexcelled for robustness and dependable accuracy. They are frequently used as a standard by which other instruments are judged.

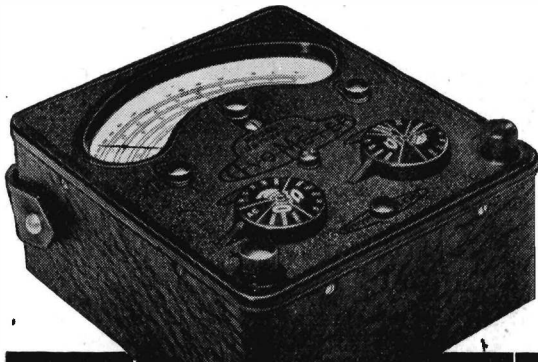

The Model 7 Universal Avo Meter is a typical example of a modern "AVO" multi-range meter. It is a combination AC/DC instrument providing on a 5-inch hand calibrated scale 50 ranges of readings of Current, Voltage, Resistance, Capacitance, Power Output and Decibels. The total resistance of the instrument is 500,000 ohms, and its small power consumption and precision accuracy make it the choice of radio, television and electrical engineers throughout the world.

Write for a FREE copy of the Comprehensive Guide to "Avo" instruments.

THE STANDARD OF *Dependable* **ACCURACY**

THE AUTOMATIC COIL WINDER & ELECTRICAL EQUIPMENT CO., LTD.
WINDER HOUSE • DOUGLAS STREET • LONDON • S.W.1 Telephone: VICTORIA 3404/9

SS.1.



**.. THAT
CAN'T
BE
WORN**

When we are asked to state occasions where Tufnol's endurance has proved superior in action to more conventional materials, we bow our heads in modest confusion—since engineering and industry can show innumerable examples. This ball-race housing has

several advantages due to Tufnol's unique qualities alone: though extremely light in weight it stands up to impact, shock and grinding wear: and above all it's slight natural resilience means that it works 'sympathetically' with metals and substantially reduces wear

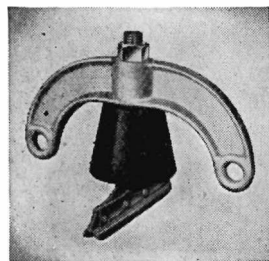

A Bell Insulator supporting overhead conductors on a Coke Oven Plant. Hot and dusty conditions have no ill-effects on Tufnol.

on the bearings. Tufnol, in fact, displays a balance of the virtues of both hardwood and metal—with few of their defects. Besides impressive shear, tensile and compressive strengths, good electrical

insulating qualities, and resistance to corrosion and moisture—add the fact that it machines easily and quickly and can be lubricated with water! Small wonder that Tufnol is gaining loyal allegiance from engineers everywhere.

NEW KINGDOMS TO CONQUER . . .

Supplied in standard sheets, tubes, rods, bars, angles and channels, or to order in specially moulded blanks or finished parts, Tufnol's field of application is so vast that engineers are only just beginning to realise its possibilities. Literature is available dealing with its conquests up to the present date. Our technical staff will co-operate enthusiastically on any NEW use for Tufnol you may find.

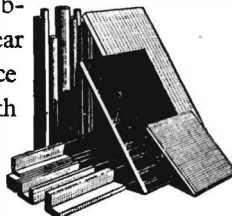

TUFNOL
REGISTERED TRADE MARK
An ELLISON Product

TUFNOL LTD • PERRY BARR • BIRMINGHAM • 22B

256

new valves



CHARACTERISTICS

	3B/240M	3B/241M
Heater	6.3 V 1.1 A.	9 V 0.37 A.

CAPACITANCES

Anode to grid	4.3 pF
Anode to cathode	0.15 pF
Grid to cathode	11.0 pF

RATINGS

Va (max.)	325 V
Ia (max.)	120 mA
VWa (max.)	15 W (without cooling) 24 W (with cooling)

Amplification factor	Measured at	90
Mutual conductance	Ia = 50 mA	27 mA/V

DIMENSIONS

Maximum overall length	3.5/32 inches
Maximum seated height	2.5/8 inches
Maximum diameter	1.3/16 inches
Base	B8B

for **AIRBORNE** and **MOBILE**
V.H.F. Communication Equipment



Recently added to the *Standard* range are two Grounded Grid Triode Valves types 3B/240M and 3B/241M, which have been specially developed to meet the need for reliable, low priced transmitter output valves capable of giving an output of at least 12 watts at frequencies up to 200 M/cs.

Standard Telephones and Cables Limited

Registered Office: Connaught House, Aldwych, London WC2

RADIO DIVISION Oakleigh Road, New Southgate, London N.11

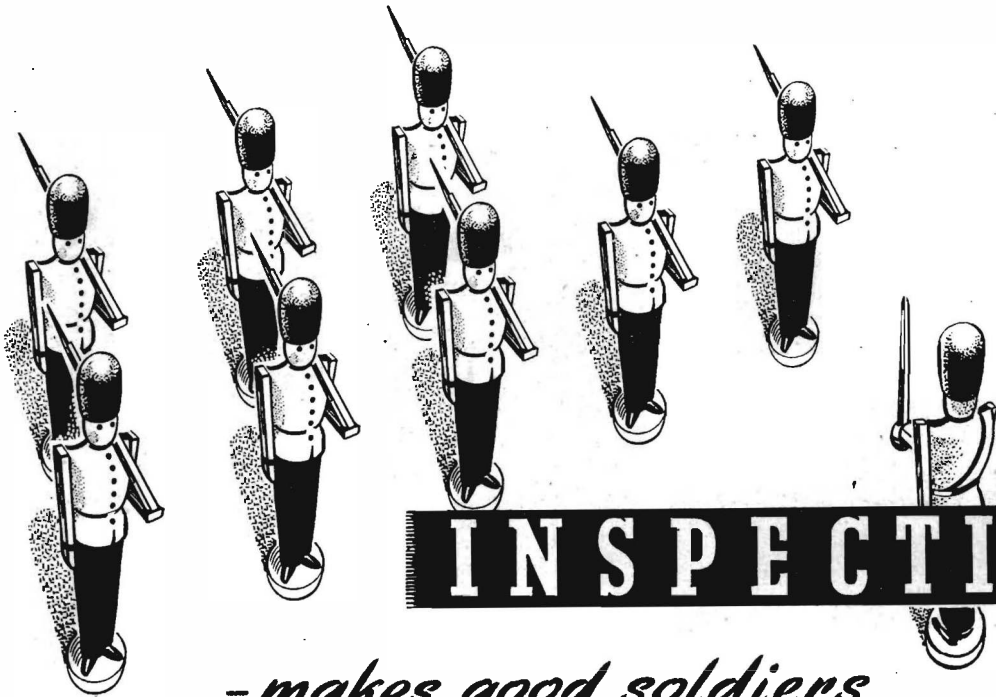

*- makes good soldiers
- and good switches!*

Men and machines are not, as yet, infallible — output that is 100% perfect is only a factory manager's dream. Until that Utopian vision can become a reality, we must continue to safeguard our reputation — and yours — by a most rigorous standard of inspection at every production stage from raw materials to finished product.

Only by so doing can we be assured that every Cutler-Hammer switch you buy from us will worthily uphold the reputation that has been so laboriously built up over many years. Only by so doing can we look forward to retaining your goodwill. Only by so doing can we increase still further the already long list of appliance manufacturers standardising on Cutler-Hammer Switches.

Let us know your problems: we are specialists in switchcraft.

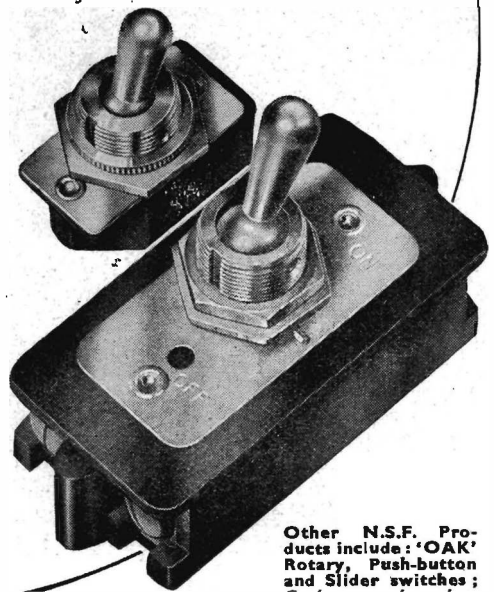

"THE SWITCH PEOPLE"



Other N.S.F. Products include: 'OAK' Rotary, Push-button and Slider switches; Carbon and wire-wound potentiometers for Television and Radio applications.

Certain types of Cutler-Hammer switches have been granted limited Type Approval by R.C.S.C. to R.C.S/151.

N. S. F. LIMITED · KEIGHLEY · YORKS

Phone: Keighley 4221/5. Grams: ENESEF, Keighley. LONDON OFFICE: 9 Stratford Place, W.1. Phone: Mayfair 4234

Licenses of Igranic Electric Co. Ltd. for the above products of Cutler-Hammer Inc. Milwaukee, U.S.A

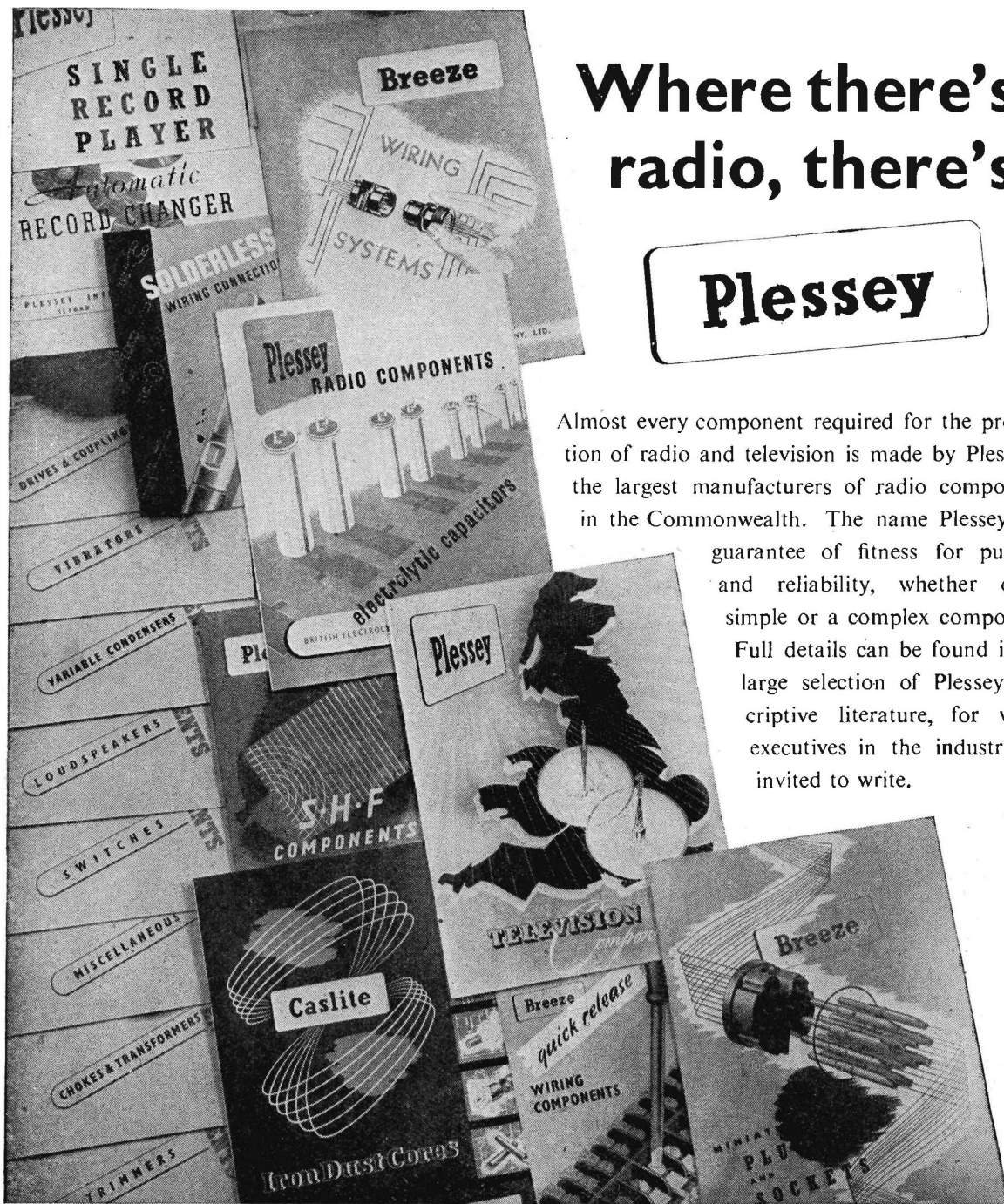

Where there's
radio, there's

Plessey

Almost every component required for the production of radio and television is made by Plessey—the largest manufacturers of radio components in the Commonwealth. The name Plessey is a guarantee of fitness for purpose and reliability, whether on a simple or a complex component. Full details can be found in the large selection of Plessey descriptive literature, for which executives in the industry are invited to write.

THE PLESSEY COMPANY LIMITED

ILFORD · ESSEX

TELEPHONE: ILFORD 3040

Overseas Sales
Organization
**PLESSEY
INTERNATIONAL
LIMITED**

VARIAC voltage – regulating infinitely variable transformer

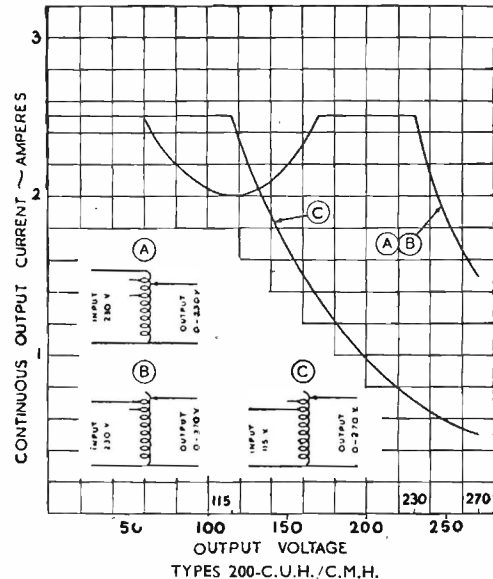
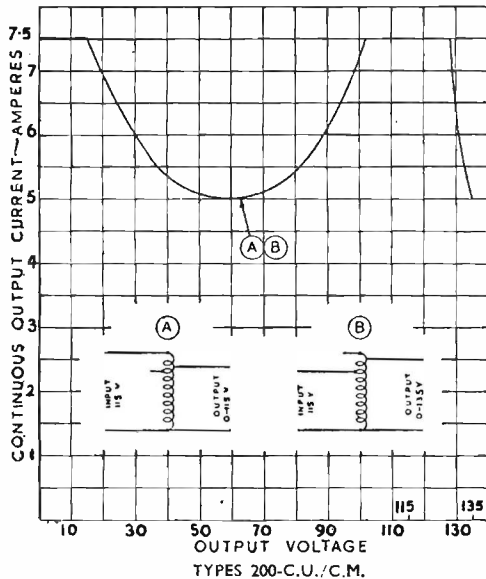

SERIES "200" VARIAC TRANSFORMERS

With a VARIAC, voltages are instantly and minutely adjustable from O-Line Voltage. On some patterns, such as 200-C.U.H. there is even an "over voltage" feature. This can provide over line voltage, or compensate for low lines. Many other suggestions on the use of Variac Transformers are contained in Catalogue V549 which will gladly be sent on request.

- 1. Infinitely variable voltages.
- 2. Smooth, precise adjustment.
- 3. Dial calibrated in output voltage.
- 4. Large current-handling ability.
- 5. Excellent voltage regulation.
- 6. Low temperature rise.
- 7. Catalogue V549 (32 pages) gives full details of all available patterns, from 580 va to 7,000 va.



TYPE 200-C.U.H.

CL 2

CLAUDE LYONS LTD.

ELECTRICAL AND RADIO LABORATORY APPARATUS, ETC.
180 Tottenham Court Road, London, W.1, and 76 Oldhall Street, Liverpool, 3, Lancs.

BALDWIN

DUNLOP

STATIGUN

FOR THE MEASUREMENT OF
ELECTROSTATIC CHARGES

A self contained battery operated instrument for the direct indication of voltage gradient : reads on three ranges with full scale values of 2 kilovolts per foot to 200 kilovolts per foot.

In use it is pointed at the charged surface and if necessary adjusted for range.

It will indicate if the charge is positive or negative.

OF PARTICULAR APPLICATION TO ALL PROCESSES IN WHICH ELECTROSTATIC CHARGES ARE DEVELOPED AND MAY BE A NUISANCE OR SOURCE OF DANGER.

It will also measure charge and resistance to earth with extra accessories.



Weight 3½ lb.
Write for Leaflet EE 123

BALDWIN INSTRUMENT CO. LTD., DARTFORD, KENT

Northern Agents : F. C. Robinson & Partners, 287 Deansgate, Manchester, 3.

Telephone : Dartford 2989 & 2988

TOUGH little chap! HUNTS W99

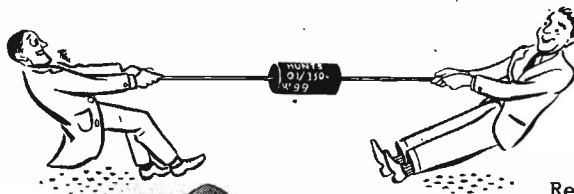

LEADS THE WAY TO
**MINIMUM SIZE WITH
MAXIMUM RELIABILITY**

Really strong end connections are one of the features of the rugged construction of the W99 Midget MOLDSEAL Metallised Paper Tubular. Others are:—

1. Complete reliability — wire leads soldered *directly* to the capacitor unit, giving strength and freedom from intermittence.
2. Self healing.
3. Special moisture-proof moulded casing, developed by Hunts.
4. Insulation resistance : 20,000 megohms or better for all values at working voltage at 20°C.
5. Temperature range. —40°C to +71°C (types also available for higher temperatures.)

Hunts will be pleased to send you full details.

A. H. HUNT LTD., WANDSWORTH, LONDON, S.W.18
Telephone : BATersead 3131 Established 1901



Wkg. Voltage	Cap. Range. µF	★Size
150 D.C.	0.004 to 0.01	A
	0.02 to 0.04	B
350 D.C.	0.001 to 0.003	A
	0.004 to 0.01	B
600 D.C.	2.5pF to 0.001	A
	0.002 to 0.004	B
300 A.C.	0.00005 to 0.001	A
	0.002 to 0.004	B

★A. 3/16" x 7/16" B. 1/4" x 9/16"

REGISTERED TRADE MARK

HUNTS
CAPACITORS

THE TRADE MARK OF RELIABILITY

Miniature Vacuum Coating Unit

*... with the facilities of
a production plant !*

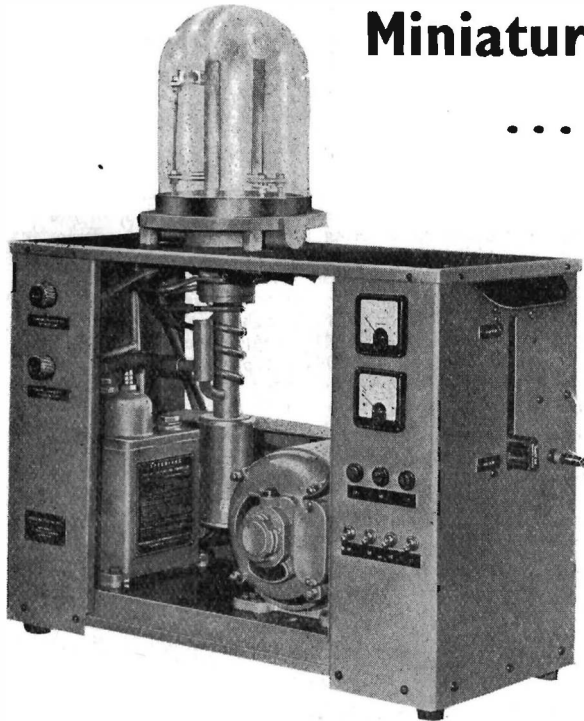

The Model 6E unit incorporates the facilities of the larger production plant on a reduced scale and is suitable for laboratory experiment coating and demonstration of High Vacuum phenomena.

also . . .

- ★ *Shadow casting and cathodic etching for Electron and optical microscopy.*
- ★ *Multiple Beam interferometry*
- ★ *Optics, plastics, quartz-crystals, photo-cells, Radiation detectors, precision resistors, etc.*

W. EDWARDS
 & CO. (LONDON) LTD.
 LOWER SYDENHAM · LONDON · S·E·26

... For better vacuum service
 30 YEARS VACUUM EXPERIENCE

Telephone: SYDENHAM 7026 (8 lines)

Telegrams: Edcohvaco. Souphone. London.

AN ULTRASONIC SOLDERING IRON

Can be used for soldering aluminium, magnesium, duralumin and other metals which form refractory oxides

THE problem of soldering metals which form refractory oxides has now been overcome.

A new soldering iron, developed by Mullard, destroys oxide film by ultrasonic stimulation and provides a "clean" metallic surface.

This means perfect soldering of aluminium, magnesium, duralumin, etc. can now be achieved without scraping or brushing molten metals.

Standard soft solders can be used. And no flux is needed.

A small electronic amplifier supplies the ultrasonic power.

There are no controls, apart from the mains switch, to operate. Unskilled workers can use the apparatus without discomfort, since the ultrasonic frequency used is inaudible to the human ear. Full information about the Mullard Ultrasonic Soldering Iron — the only commercial model in the world — is available on request.

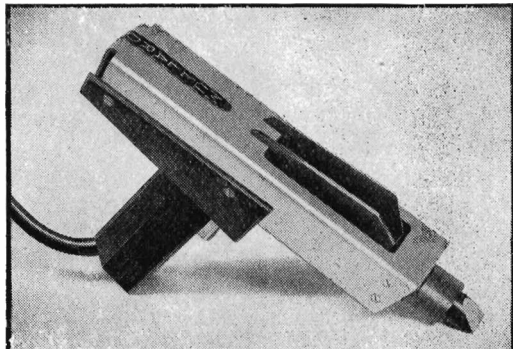

The soldering iron has a nickel silver bit driven by a magnetostriction transducer. The transducer is arranged to run at its natural resonant frequency by a feed-back system. A conventional low voltage winding heats the soldering bit.

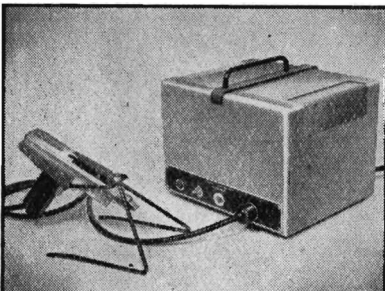

The Mullard Ultrasonic Soldering Iron and Amplifier. The unit operates from A.C. mains and is robustly made to suit workshop conditions.

Mullard 

MULLARD LTD., EQUIPMENT DIVISION, CENTURY HOUSE,
 SHAFTESBURY AVENUE, LONDON, W.C.2. TELEPHONE: GERRARD 77

(1.340)

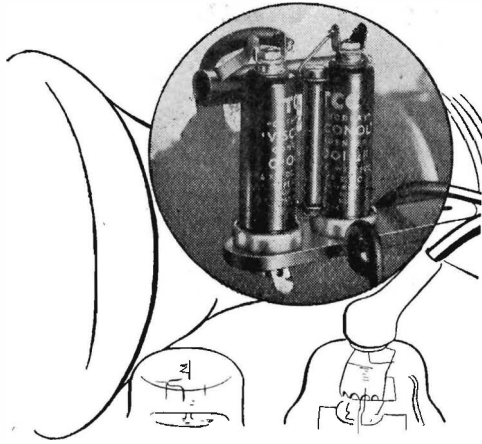

BOOST YOUR EXISTING E.H.T. SUPPLY

You have a television receiver that is now not so new. No doubt you would like to substitute a modern tube and obtain a brighter and improved picture. Of course, you want to retain the existing E.H.T. supply, but it is insufficient for the higher anode voltage required. A problem with an easy solution. A Flyback E.H.T. Booster, which can be incorporated in your receiver, either commercial or home constructed, without disturbing or over-stressing the existing E.H.T. components. Easily and cheaply constructed, the only components required are one $2M\Omega$ 1 watt resistor, two 0.001 mFd 6kV capacitors and a 36EHT miniature high voltage rectifier.

For further details of the Flyback E.H.T. Booster and also methods of obtaining E.H.T. supply using

WESTINGHOUSE
WESTALITE

36 E.H.T. MINIATURE HIGH VOLTAGE RECTIFIERS

send 6d in stamps for a copy of "The All Metal Way"
(which also includes details of H.T., L.T. and H.F. rectifiers)
to Dept. E.Eng.5.

WESTINGHOUSE BRAKE & SIGNAL CO. LTD., 82 York Way, King's Cross, London, N.1

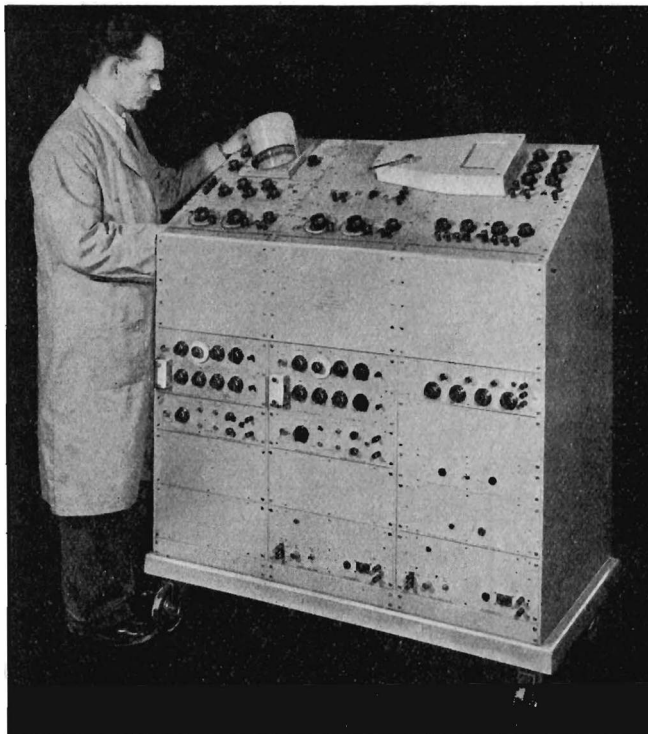

OSCILLOGRAPHS FOR ALL PURPOSES

The ME24 Type illustrated has F.M. Pre-amplifiers for capacity pick-ups, D.C. Pre-amplifiers for strain gauges, two recording tubes with a built-in recording camera, a large monitor tube, a time-base and a time-marker oscillator. This is a high-quality instrument capable of making a wide range of measurements. Write for our new catalogue.

S O U T H E R N I N S T R U M E N T S L I M I T E D

HAWLEY, CAMBERLEY, SURREY. Telephone: Cambarley 1883/4. Telegraphic Address: "Minrack, Camberley, England."

P 514

Man-hours cost money — so does *The* **HYDRACLAMP**

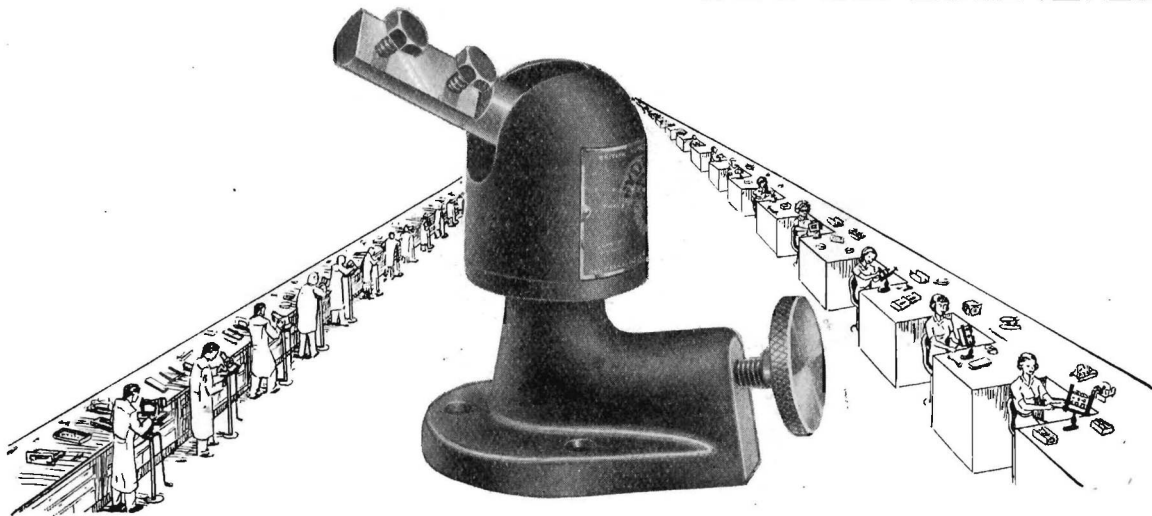

but it pays you back — by saving them! Ten per cent can be easily saved by "Hydraclamping" your radio assemblies for production line build up, also for inspection, maintenance and in the research laboratory. Our catalogue will show you how.



SPENCER, FRANKLIN LTD.

292 HIGH HOLBORN, LONDON, W.C.1. TEL: HOLBORN 1436/7
TELEGRAMS: SPENKLIN, HOLB, LONDON CABLES: SPENKLIN, LONDON

"COLVERN" HIGH ACCURACY PRECISION POTENTIOMETERS

For Electronic Computing, Radar, Communications and Laboratory apparatus.—Incorporating the unique COLVERN CAM-CORRECTION DEVICE—the finest and most accurate potentiometers in the world.

A guaranteed law accuracy of better than $\pm 0.1\%$ is maintained in all standard COLVERN CAM-CORRECTED POTENTIOMETERS, whilst in the type CLR. 9101 illustrated the law tolerance can be held as low as 0.04% and even lower dependent on resistance value.

There is a "COLVERN" Potentiometer to suit every circuit an Electronic Engineer is likely to devise.—Write for illustrated brochures to :—

COLVERN LIMITED

MAWNEYS ROAD

ROMFORD · ESSEX

Telephone: ROMFORD 8881/2/3

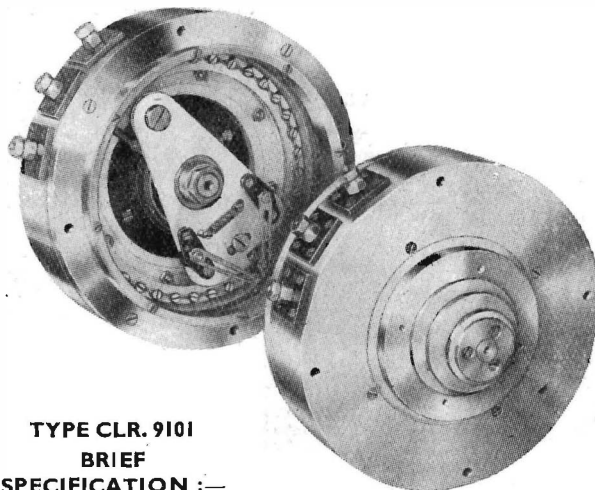

TYPE CLR. 9101
BRIEF
SPECIFICATION :—

Rating	10 watts
Resistance values	1000 Ω to 150,000 Ω
Law accuracy	$\pm 0.04\%$
Working voltage (between spindle and track)	1000 V D.C.
Effective angle of resistance	315° plus 0.25°—0°
Angle of spindle rotation	360°

The AUTHORITY ON *Power Equipment* for **ELECTRONICS**

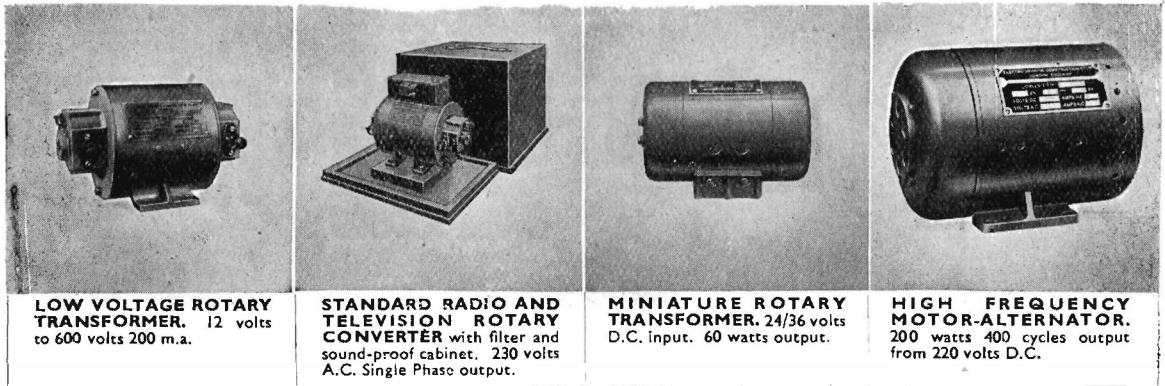

LOW VOLTAGE ROTARY TRANSFORMER. 12 volts to 600 volts 200 m.a.

STANDARD RADIO AND TELEVISION ROTARY CONVERTER with filter and sound-proof cabinet. 230 volts A.C. Single Phase output.

MINIATURE ROTARY TRANSFORMER. 24/36 volts D.C. input. 60 watts output.

HIGH FREQUENCY MOTOR-ALTERNATOR. 200 watts 400 cycles output from 220 volts D.C.

For details and technical specification of Power Equipment for all Electronic purposes including the equipment illustrated, write for fully illustrated and descriptive lists 3 R.C. and 16 H.F. In prototype stages let your designers meet ours.



ELECTRO DYNAMIC CONSTRUCTION COMPANY LIMITED
 Head Office and Works: **ST. MARY CRAY · KENT**
 Phone: **ORPINGTON 2560-3**
CONTROL GEAR WORKS: BRIDGWATER · SOMERSET

E.D.C. 19

NAGARD OSCILLOSCOPE & WAVE FORM MONITOR

6" C.R.T.
SIMPLE CONTROLS

CALIBRATED OSCILLOGRAMS

The illuminated graticule and single shot camera attachment gives clear records and accurate measurements.

STABLE TRACES

The exceptional synchronising properties of the Time Base, and stability of the D.C. Amplifiers aids measurement and photography.

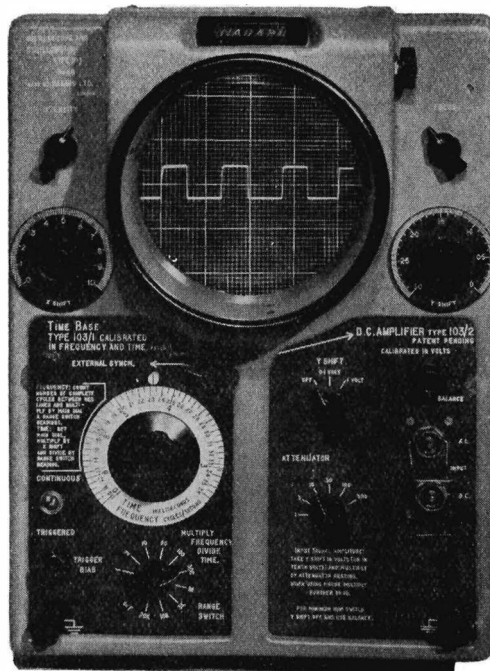

CALIBRATED IN TIME, FREQUENCY AND VOLTAGE

TIME BASE RANGES

Calibrated sweep velocities from 2 in. per sec. to 2 in. per μ sec. Triggered or continuously running.

D.C. AMPLIFIERS

Voltage calibrated and fully stable Response, Maximum Gain and Sensitivity

0-20 K/cs.	0-2 Mc/s	0-10 Mc/s
100,000	20,000	300
0.12mV/inch	0.60mV/inch	40mV/inch

Phase to frequency ratio constant. Perfect square wave definition within the limitations of each frequency range.

These are available as self contained units with power supply and stabiliser for use apart from the oscilloscope.

NAGARD LTD

245, BRIXTON ROAD, LONDON, S.W.9.

Phone: **BRixton 3550** Grams: **Intertel, Claproad, London.**

SEE TRULY
what you measure!

Control by

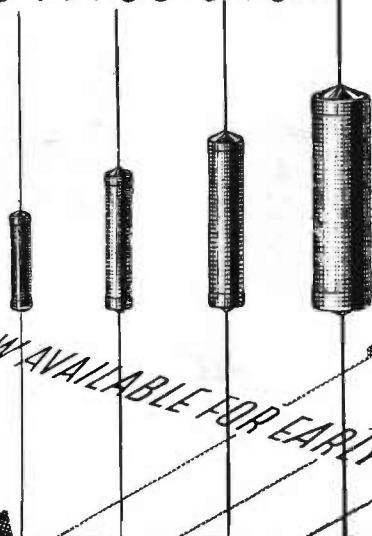

PAINTON

**HIGH STABILITY
CARBON RESISTORS**

NOW AVAILABLE FOR EARLY DELIVERY

Swedish Agents:
Messrs. Elektrotensilier,
Rasundavägen 101,
Stockholm-Solna, Sweden.

PAINTON & CO. LTD · KINGSTHORPE · NORTHAMPTON TELEPHONE 2820

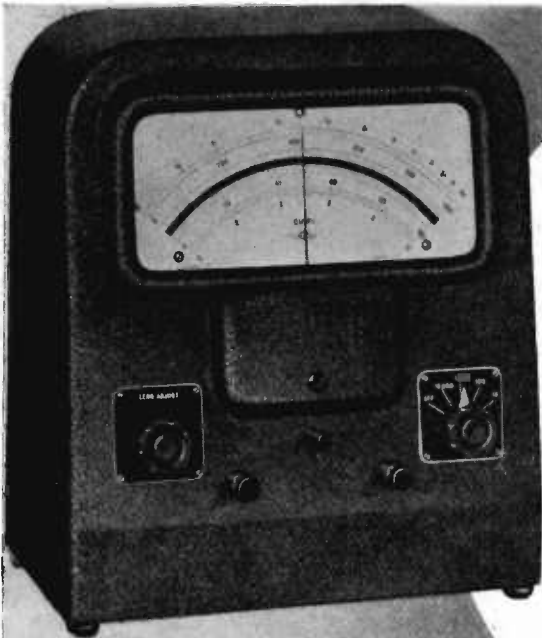

*Pullin industrial Bench type
Ohmmeter gives accurate
readings independent of
supply voltage variations
of plus or minus 20%.*

Rapid

PRODUCTION TESTING

With its almost linear 8" scale the Pullin Bench Ohmmeter is the ideal instrument for rapid production testing of a wide range of resistance values.

A selector switch gives an immediate choice of 4 range-scales on the one instrument, 0-10, 0-100, 0-1,000, 0-10,000.

Calibration accuracy on all scales being plus or minus 1% full scale deflection.

**PULLIN BENCH TYPE
OHMMETER**

**MEASURING INSTRUMENTS (PULLIN) LIMITED,
Electrin Works, Winchester Street, W.3. ACO rn 4651.**



WEBB'S *Radio*

The map which offers
the right approach to

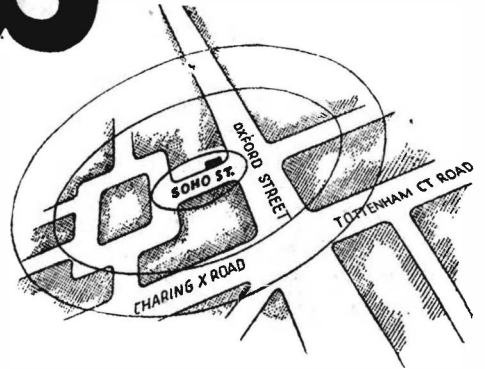

-Communication Receivers

G.E.C. "BRT400," famous 14 valve high-performance receiver, from stock—£120. Please enquire for manufacturers' details and best possible delivery on EDDYSTONE RECEIVERS "750," "740" and "680."

-Test Apparatus

A wide range always available.

ADVANCE SIG. GEN. "E2"	£23 10 Od.
AVOMETER "7"	£19 10 Od.
AVO ELECTRONIC TEST METER	£35 0 Od.
APPARATUS BY AVO — TAYLOR — WAYNE KERR, ETC.	

-High Fidelity

A most comprehensive selection of gear can be demonstrated to your pleasure.
ACOUSTICAL : LEAK : CHARLES : BARKER
SOUND SALES : WHARFEDALE : DECCA :
CONNOISSEUR — in fact all leading makes in this field are represented at Webb's.

LET WEBB'S UNRIVALLED STOCKS HELP YOU — DESPITE SUPPLY SHORTAGE

WEBB'S *Radio*

14 SOHO ST., OXFORD ST.,
LONDON, W.1. GERRARD 2089
Hours: — 9 - 5.30. Saturdays, 9 - 1.

BARE & INSULATED RESISTANCE WIRES

Eureka (Regd.) and Nickel-Chrome



'Eureka' (Regd.) and Nickel-Chrome Resistance Wires can be supplied BARE or with STANDARD COVERINGS of cotton, silk, rayon, enamel and glass.

These wires have been used for many years for winding resistances for instruments, control apparatus, etc.

'Eureka' with its low temperature coefficient is always in demand for precision work, while Nickel-Chromes are used where a high resistance is required in a limited space.

Full details gladly supplied upon request — please address your enquiries as follows:

INSULATED WIRES:
The London Electric Wire Company
and Smiths Limited.

BARE WIRES:
Vactite Wire Company
Limited.



THE LONDON ELECTRIC WIRE COMPANY
AND SMITHS, LIMITED
LEYTON, LONDON, E. 10.

VACTITE WIRE COMPANY LTD.
75 ST. SIMON STREET,
SALFORD 3, LANCs.

ELECTRONIC ENGINEERING

More than interesting . . . more than inspiring . . .

it will be profitable to you . . . because here you will see the latest types of instruments designed for producing maximum efficiency economically in all spheres of production.

This is the first Exhibition devoted entirely to the British Instrument Industry. You will see here the latest products of over 150 of the leading British manufacturers engaged in designing and making instruments for use in industry, medicine and education.

OPEN DAILY 11 a.m. to 8 p.m., EXCLUDING SUNDAY. Closes 6 p.m. Saturday, 14th July, 1951

Be sure to visit this Exhibition—and, remembering the crowds that will be pouring into London for the Festival of Britain, it will be as well to book your hotel accommodation as early as possible.

Organised by **F. W. BRIDGES & SONS LTD.**
GRAND BUILDINGS, TRAFALGAR SQ., LONDON, W.C.2
Phone: Whitehall 0568 Telegrams and Cables: Segdirb, Rand, London



SULLIVAN-GRIFFITHS DUAL DIAL NON-REACTIVE DECADE RESISTANCES

FOR D.C. AND A.C.
OF ALL FREQUENCIES
NOVEL AND PATENTED
ACCURACY BETTER THAN 0.1%

Screened Resistances of guaranteed accuracy exactly similar to our well-known Decade Resistances but specially arranged so that one box of a given number of dials gives many different values of maximum resistance. Thus a three-dial box (as illustrated) may be used, for instance, for

three decades of **Thousands, Hundreds** and **Tens**
or three decades of **Hundreds, Tens,** and **Units**
or three decades of **Tens, Units** and **Tenths**
or three decades of **Units, Tenths** and **Hundredths**

H. W. SULLIVAN
— LIMITED —
LONDON, S. E. 15

Telephone: New Cross 3225 (P.B.X.)

Electrical Standards for Research and Industry

Testing and Measuring Apparatus
for Communication Engineering

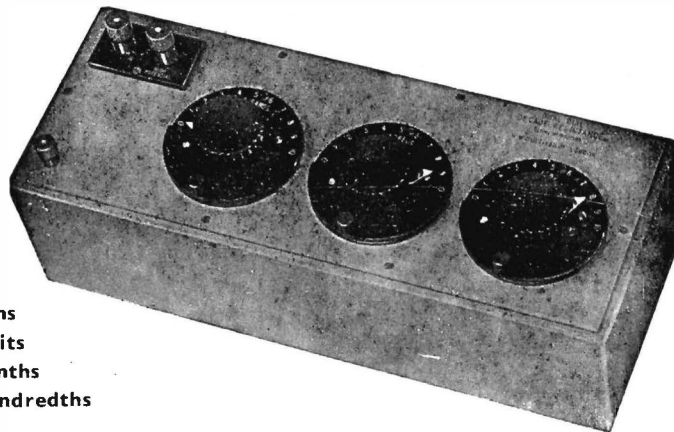

The advantages of such a system will be obvious, for in addition to the economy involved much space is saved and the residual resistance and inductance is much reduced.

The resistances are available in 3-dial, 4-dial and 5-dial types, with subdivision of 0.001% to 0.1% depending, of course, on the number of dials incorporated.

Also available in the simple multi-decade series and in unit form for panel mounting.

HIGH, WIDE AND HANDSOME

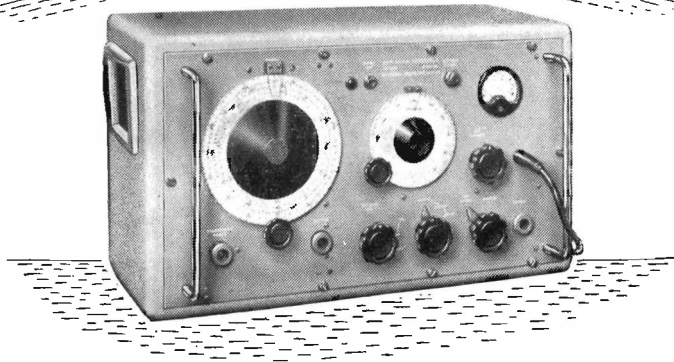

A wide coverage over high frequencies is of negative value unless coupled with a long, open scale for effective frequency selection. In the U.H.F. Signal Generator, TF 762C, more than five feet of continuous scale provides exceptional discrimination and accuracy over its entire range (300-600 Mc/s). Effective also are the many other features which contribute to

the handsome behaviour of this Marconi instrument. With a maximum output of 1 mW into 75 ohms the level is variable by piston attenuator over 100 db. Internal pulse and 50-50 squarewave modulation at 1000 c/s are incorporated together with an externally available synchronising signal and provision for external modulation.

MARCONI INSTRUMENTS LTD St. Albans, Herts. Phone: St. Albans 6161/7

London Office: Marconi House, Strand, W.C.2. Midland Office: 19 The Parade, Leamington Spa. Northern Office: 30 Albion Street, Hull.

TOROIDAL POTENTIOMETERS 10-1000 WATTS

Ceramic Insulation only—and approved for Tropical conditions. Complete Ceramic Rings for strength. Approved by all Government Departments. Reasonable Delivery.

Also precision Toroidal-wound Potentiometers (including 360° of winding with up to eight tapping points) and Helical wound Potentiometers of 3600° of winding. All are available with sealed spindles and glass or ceramic terminal seats.

Specialists in ALL TYPES OF TOROIDAL WINDINGS

P. X. FOX LIMITED
HORSFORTH · YORKSHIRE · ENGLAND
 Telephone: Horsforth 2831
 Telegrams: Toroidal, Leeds

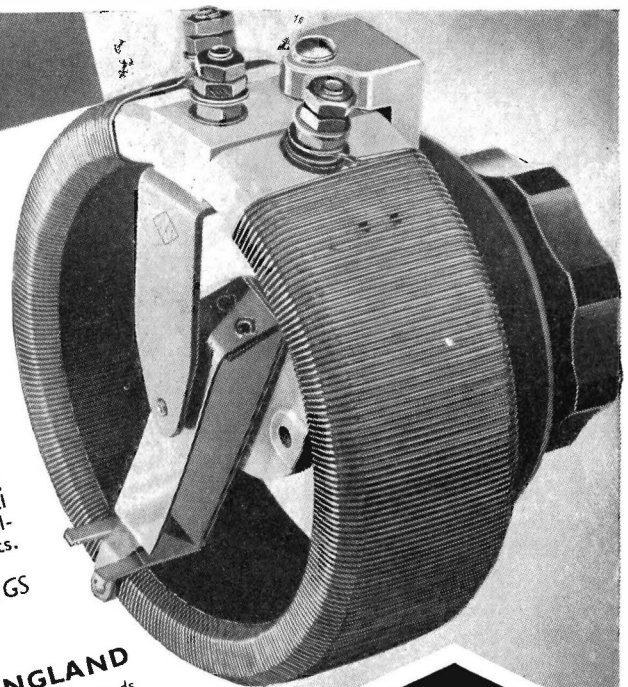

*24 x 30 amps
at 250 volts a.c.*

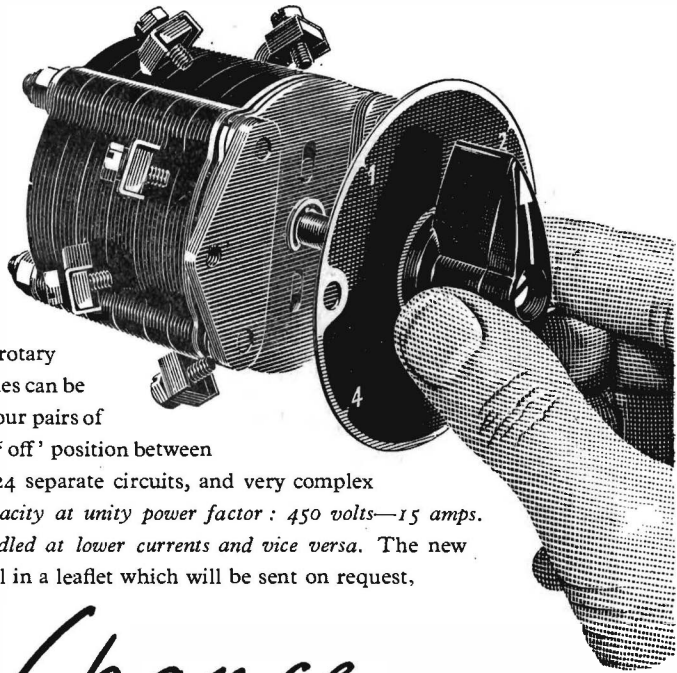

The Austinlite 'Thirty' is an entirely new switch designed on the same lines as the larger Austinlite 'Fifty'. It is a robust, compact rotary switch built for long life and heavy duty. Switches can be made up containing 1 to 6 cells and each cell has four pairs of fixed and up to four moving contacts. There is an 'off' position between each contact. A six-cell switch can thus switch 24 separate circuits, and very complex sequence switching can be easily handled. *Capacity at unity power factor: 450 volts—15 amps. 250 volts—30 amps. Higher voltages can be handled at lower currents and vice versa.* The new Austinlite 'Thirty' switch is described in detail in a leaflet which will be sent on request.

A *Chance* PRODUCT

AUSTINLITE LIMITED, DEPT. A5, LIGHTHOUSE WORKS, SMETHWICK 40, BIRMINGHAM.

ALWAYS "FIT"



CASTORS

Loads up to 30 tons each
Wheel diameters up to 40"

OVER 6,000 TYPES
and sizes from which to select the best
castors manufactured

Specify: quantity, load per fitting, type of head fitting,
size and type of wheel preferred, and running conditions.

ASK FOR BROCHURE

Engineers, Patentees, and
Sole Manufacturers:—

AUTOSET (PRODUCTION) LTD.,
Stour Street, BIRMINGHAM 18.

Established over 30 years.



B.I.F. Stand
No. D. 426
Castle Bromwich

LTD., Dept. 0,

'Phone: EDG 1143/4.

Please mention "Electronic Engineering"

NILO ALLOYS

for
Vacuum-tight

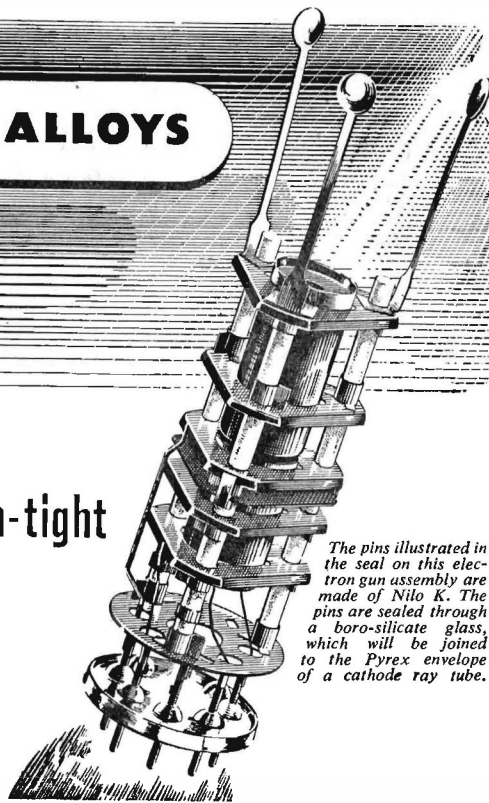

The pins illustrated in the seal on this electron gun assembly are made of Nilo K. The pins are sealed through a boro-silicate glass, which will be joined to the Pyrex envelope of a cathode ray tube.

GLASS-TO-METAL SEALS

Single and multiple seals for a wide variety of purposes can be readily produced with the Nilo Series of alloys with controlled coefficients of thermal expansion.

- Nilo K has a coefficient of thermal expansion closely matching that of medium hard boro-silicate glasses over the range 20-500°C. These glasses are used in the construction of electronic equipment.
- Nilo 42 is the alloy used for cores of copper-covered wires for vacuum seals in lamps and radio valves.
- Nilo 48 and Nilo 50 are employed for seals with the softer glasses.
- Another alloy, marketed under the name B.T.H. No. 12 Alloy, is designed for use with soft lead and lime glasses.

For further information write for free copies of our publications "Glass-to-metal Seals" and "The Nilo Series of Low-Expansion Alloys".

HENRY WIGGIN & COMPANY LIMITED

WIGGIN STREET, BIRMINGHAM, 16.

Nilo is a registered trade mark.

56/NILO

The tricky ones are fun!

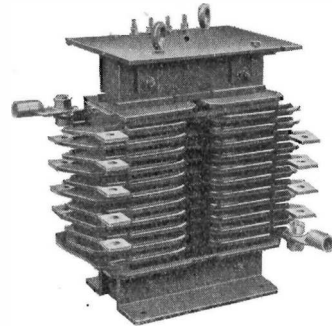

Thanks to 25 years experience in design and manufacture of transformers, we can face most transformer 'headaches' with equanimity. If you want instruments which you can fit and forget, which will give you trouble-free service for years, write or telephone us.

Telephone **SAVAGE TRANSFORMERS OF DEVIZES LIMITED** Devizes 536

SAVAGE TRANSFORMERS LTD. NURSTEED RD., DEVIZES, WILTS.

B.P.L. TEST SETS

NOW AVAILABLE

AT NET PRICES

B.P.L. UNIVERSAL TEST SET

£5 - 18 - 6

B.P.L. SUPER RANGER 1,000Ω/v.

£13 - 10 - 0

B.P.L. SUPER RANGER 20,000Ω/v.

£15 - 10 - 0

Prices include postage and packing, and are applicable to Home Market only.

Send your order direct to:

British Physical Laboratories

HOUSEBOAT WORKS, RADLETT, HERTS.

Tel.: Radlett 5674-5-6

"Cyldon" Variable CAPACITORS

from **MINIATURE TRIMMERS** to
HIGH VOLTAGE
TRANSMITTER CAPACITORS

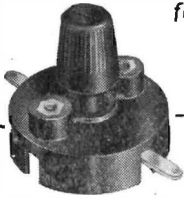

No. 26. A new Mica Compression Trimmer

For use in Television circuits. High stability with constant, wide capacity swings and long life at high voltage. Blade resilience not affected by continual setting. Low loss Rockite base and best Mica di-electric give very efficient Power Factor. Location method prevents flash-over from blade movement. Capacities up to 1,000 pF. at 1,500 or 3,000 v. D.C. test and up to 3,000 pF. for 250 v. D.C. test. 1.225" diam. 1 1/8" high.

Full details of the complete "Cyldon" range and list of Agents for Home and Overseas available from the manufacturers:

No. 18/5.

Air Di-electric Trimmer

Of high stability and excellent Power Factor. High but smooth operating torque. Metal parts silver plated. First-grade ceramic base. Single-hole fixing. Split stator and locking versions also available. Max. capacities from 10-30 pF. Base size 1" x 3/8".



SYDNEY S. BIRD & SONS, LTD.

CAMBRIDGE ARTERIAL ROAD, ENFIELD, MIDDX.
Phone: Enfield 2071-2. Grams: Capacity, Enfield.

HANDBOOK OF INDUSTRIAL ELECTRONIC CIRCUITS

By J. Markus & V. Zeluff

11 x 9 272 pages Illus., 46/6

An exact facsimile of the American edition, this text is now published in London, making it available at the favourable price quoted. An invaluable reference manual on 433 industrial electronic circuits for immediate practical use with all circuits cross-indexed for quick location. The values of all the important components are given to facilitate conversion of the theoretical circuit to actual practice.

AVAILABLE FROM ALL BOOKSELLERS

McGRAW-HILL

Publishing Co., Ltd.
Aldwych House, London, W.C.2.

AUDIGRAPH DEMONSTRATE



RECORDING EQUIPMENT AT THE BRITISH SOUND RECORDING ASSOCIATION EXHIBITION

Waldorf Hotel, Aldwych, London, W.C.2.

MAY 19th & 20th

VISIT OUR STAND—HEAR OUR RECORDING EQUIPMENT—SEE OUR RANGE OF RECORD, PLAYBACK and ERASE HEADS, AMPLIFIERS, OSCILLATOR COILS and UNITS, TAPE MECHANISMS, CONSTRUCTORS, ENVELOPES, and BOOKS ETC.

E.M.I. On Standard
TAPE G.E.C. WIRE 1/2, 1/4 and 1/8
Durex Spools

5", 7", 11" Spools. Write for latest price list.

We specialise in :
HIGH ACCURACY COUNTING DEVICES
and development of Electronic applications to Industry.



Dept. MR. 7. 74, Gt. Hampton Street, Birmingham 18.

from the range of  instruments

Model 44 SUBSTANDARD MULTI-RANGE METER

A self-contained precision instrument for general laboratory use and for calibrating first grade single and multi-range meters. The accuracy on the 44 ranges is Substandard on d.c. and within $\pm 0.5\%$ on a.c. These meters are made with the greatest care and have been supplied for a number of years to the leading laboratories at home and abroad.



ELECTRONIC INSTRUMENTS LTD
17 PARADISE ROAD · RICHMOND · SURREY





COMPOUND FILLED TRANSFORMERS & CHOKES

for **UTMOST**

RELIABILITY

Woden Compound Filled transformers have been developed for use in exacting industrial and climatic conditions and have the following features:—



- Complete moisture-proof filling compound
- Universal fixing for above or below chassis wiring
- Constant fixing centres and overall size
- Occupy minimum space and ensure clean and compact layout

Send for latest catalogue

WODEN TRANSFORMER CO., LTD.,
MOXLEY ROAD, BILSTON, STAFFS.

J.T.L.

THE BRITISH NATIONAL RADIO SCHOOL

ESTD. 1940

Now in our eleventh year and still—

NO B.N.R.S. STUDENT HAS EVER FAILED

to pass his examination(s) after completing our appropriate study course. Nothing succeeds like SUCCESS and what we have done already for so many of your colleagues, we can do again for YOU.

All our courses are conducted by correspondence, on INDIVIDUAL lines and our Syllabus includes preparation for the following examinations: A.M.Brit.I.R.E.; City and Guilds, Radio, Telecommunications, Mathematics and P.M.G. (theory only). Other courses include what we believe to be the finest RADAR course available anywhere.

Free Booklet and specimen lessons (please mention this advt.) from

STUDIES DIRECTOR

BRITISH NATIONAL RADIO SCHOOL
66 ADDISCOMBE ROAD, CROYDON

Phone Addiscombe 3341

Choose the Solon for the job

Write for Folder Y.10 to:—
W. T. Henley's Telegraph Works Co. Ltd.
51-53 Hatton Garden, London, E.C.1.

HENLEY SOLON MARK
ELECTRIC SOLDERING IRONS

FOR INDUSTRIAL USE

Only with **CO-AX** R.F. CABLES
AIR-SPACED ARTICULATED
4mm/ft

Patents. Regd. Trade Mark.

THE LOWEST EVER CAPACITANCE OR ATTENUATION

IMMEDIATE DELIVERIES

SPECIALISTS IN AIR-SPACED ARTICULATED CABLES SINCE 1929

TRANSRADIO LTD.
CONTRACTORS TO H.M. GOVERNMENT
138A CROMWELL ROAD, LONDON SW.7
ENGLAND

LOW CAPAC. TYPES.	CAPAC. $\mu\text{m}/\text{ft}$	IMPED. OHMS	ATTEN. dB/100ft	LOADING $\mu\text{H}/100\text{ft}$	Q.D.
A 1	74	1.7	0.41	0.36	
A 2	74	1.3	0.24	0.44	
A34	73	0.6	1.5	0.88	
LOW CAPAC. TYPES.	CAPAC. $\mu\text{m}/\text{ft}$	IMPED. OHMS	ATTEN. dB/100ft	LOADING $\mu\text{H}/100\text{ft}$	Q.D.
C 1	7.3	150	2.5	0.36	
PC1	10.2	132	3.1	0.36	
C11	6.3	173	3.2	0.36	
C 2	6.3	171	2.15	0.44	
C22	5.5	184	2.8	0.44	
C 3	5.4	197	1.9	0.64	
C33	4.8	220	2.4	0.64	
C44	4.1	252	2.4	1.03	

HIGH POWER FLEXIBLE

PHOTOCELL CABLE

VERY LOW CAPACITANCE

SEAMLESS ONE-PIECE METAL BELLOWS

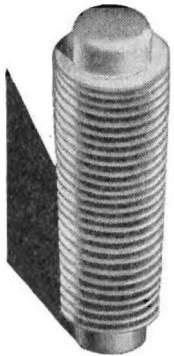

- Combining the properties of:
- 1 A compression spring capable of repeated flexing
 - 2 A container which can be hermetically sealed
 - 3 A packless gland

Hydraulically formed by a process unique in this country

for Automatic coolant regulation. Movement for pressure change. Packless gland to seal spindle in high vacua. Reservoir to accept liquid expansion. Dashpot or delay device. Barometric measurement or control. Pressurised couplings where vibration or movement is present. Dust seal to prevent ingress of dirt. Pressure reducing valves. Hydraulic transmission. Distance thermostatic control. Low torque flexible coupling. Pressure sealed rocking movement. Pressurised rotating shaft seals. Aircraft pressurised cabin control. Refrigeration expansion valves. Thermostatic Stream Traps. Pressure amplifiers. Differential pressure measurements. Thermostatic operation of louvre or damper. Write for List No. M. 800-1

by **DRAYTON**

B10
Drayton Regulator & Instrument Co. Ltd., West Drayton, Mdx. · W. Drayton 2611



Antenna Theory and Design

(2 vols.)

By H. Paul Williams, Ph.D., A.M.I.E.E., Sen.M.I.R.E. This important two-volume work gives a complete account of the theoretical basis of antenna design followed by comprehensive guidance on the practical aspects of this work. Profusely illustrated. Vol. I (Foundations of Antenna Theory) 142 pages. 21/- net. Vol. II (The Electrical Design of Antennae) 522 pages. 63/- net.

"A most comprehensive treatment of the theory and practice . . . can be confidently recommended to all engineers concerned with aerial design, no matter in what part of the frequency spectrum."—
ELECTRONIC ENGINEER.

Pitman,

Parker Street, Kingsway, London, W.C.2.



Electrolytic Iron Powder

'SINTREX' BRAND

Its exceptional purity makes it especially suitable for electrical and magnetic applications. Supplied in a wide selection of mesh gradings.

GEORGE COHEN
SONS & CO. LTD

BROADWAY CHAMBERS
TELEPHONE:



LONDON . . . W 6
RIVERSIDE 4141

EE/501/P20

Quantity production of small automatically made pieces in Steatite, Porcelain, and Rutile materials for electric cooking and heating equipment, and telecommunication apparatus.

BRAY

GEO. BRAY & CO. LTD., Leicester Place, Leeds 2.
Tel: 20981/8. Grams: "Bray, Leeds 2"

**REPETITION WORK
IN ALL METALS
MACHINING AND
LIGHT ASSEMBLIES
BROCHURE ON REQUEST**

**THE CASTLE
ENGINEERING
COMPANY (NOTTINGHAM) LIMITED**
 HASLAM STREET · CASTLE BOULEVARD · NOTTINGHAM
 Telephone: Nottingham 40008 (3 lines) · Telegrams: "Copston" Nottingham

5329 B

D

**DONOVAN ACCESSORIES—
FOR THE ELECTRONIC
APPARATUS MANUFACTURER!**

TYPE J.96 TERMINAL BLOCKS. Made in 15, 30 and 60 amp. sizes.

Type C.30 PUSH-BUTTON UNIT arranged for mounting on customers' own cover plate.

Type A.11 A.C. POWER RELAY — 4-pole with N.O. or N.C. contacts.

THE DONOVAN ELECTRICAL CO. LTD.
 Safuse Works · Stechford · Birmingham 9

*Precision
miniature
steel balls
and bearings*

AT THE B.I.F.

We shall be glad to welcome Home and Overseas Buyers visiting the B.I.F. in Birmingham, where we shall be exhibiting Miniature Steel Balls in a range of sizes from .006" diameter —

Grade A.25 being held to a tolerance of plus/minus .000025" (.0006 mm.)

Grade A.1 to a tolerance of plus/minus .0001" (.0025 mm.) for sphericity and diameter.

We shall also exhibit synthetic jewel balls, as well as a range of Precision Miniature Ball Bearings from 5/64" to 3/16" bore diameter — (Metric sizes from 1 mm. bore) — all products of British Manufactured Bearings Co. Ltd., Crawley, Sussex.



**BIRMINGHAM
STAND No.
D.137**

Quotations and literature may be obtained on request to: Sole Selling Agents for British Manufactured Bearings Co. Ltd.

B · M · B (Sales) Ltd

2 BALFOUR PLACE, MOUNT ST., LONDON, W.1
 TELEPHONE: GROsvenor 3155 (3 lines)

ACRU FINGER TOOLS

are a blessing to the RADIO ENGINEER

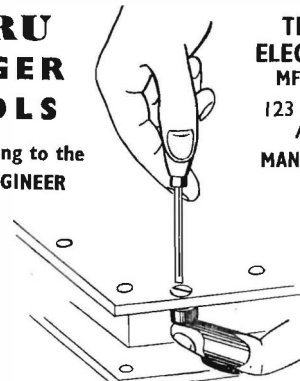

THE ACRU ELECTRIC TOOL MFG. CO. LTD.
123 High Road, Ardwick, MANCHESTER 12

Available in all B.A. sizes

Write for new leaflet.

B.I.F.
Visit our Stand Olympia C.29

SAVES TIME and assembly and avoids fatigue

Three piece lead wires — for hard glass seals

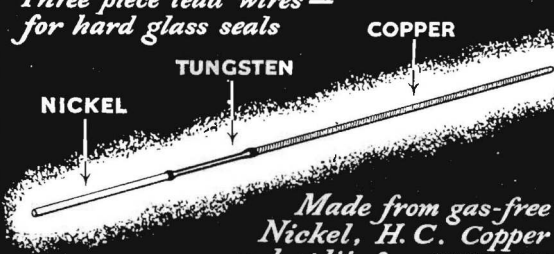

NICKEL TUNGSTEN COPPER

Made from gas-free Nickel, H. C. Copper and split-free TUNGSTEN

ELECTRO-ALLOYS LTD 12 Brunel Rd. London, W.3
Makers of TUNGSTEN and MOLYBDENUM Products

A MINIATURE MAGNETIC LIGHTWEIGHT EARPHONE



Developed primarily for hearing aid use, the Amplivox E3 earphone is adaptable to many purposes where a highly sensitive, lightweight receiver of small size is needed. Available in D.C. resistances 2-2000 ohms; frequency 100-4000 c.p.s.; diameter .835", depth .420"; weight 1/4 oz.

AMPLIVOX LTD.
2 Bentinck Street, London, W.1

AMBITIOUS ENGINEERS

HAVE YOU HAD YOUR COPY OF "ENGINEERING OPPORTUNITIES"?

Whatever your age or experience—you must read this highly informative guide to the best paid engineering posts. The handbook contains particulars of A.M.I.C.E., A.M.I.Mech.E., A.M.I.M.J., A.M.Brit.I.R.E., and other important Engineering Examinations, and outlines home-study courses in all branches of Civil, Mechanical, Electrical, Automobile, Radio and Aeronautical Engineering, Government Employment, Draughtsmanship, Building and Plastics, Matriculation, etc. We Guarantee "NO PASS - NO FEE"

If you are earning less than £12 a week you cannot afford to miss reading "Engineering Opportunities". It tells you everything you want to know to secure your future. Write for this enlightening guide to well paid posts NOW—FREE and without obligation.

BRITISH INSTITUTE OF ENGINEERING TECHNOLOGY

337a Shakespear Hse., 17/18 Stratford Place, London W1 **BIET**

MAGNETIC RELAYS

LARGEST STOCK IN GREAT BRITAIN OF RELAYS, KEY SWITCHES AND UNISELECTORS

Government Contractors

RELAYS P.O. 3000 - 600 - HIGH SPEED
Also 230v. A.C. 50cy.

ALL NEW EX-MINISTRY GOODS

JACK DAVIS (Relays) LTD. DEPT. E.E.
36 PERCY STREET, LONDON, W.1.

Phones: MUSEum 7960 LANgham 4821



MICA

DISCS
DIAPHRAGMS
ELEMENT STRIPS
CONDENSER PLATES
SPECIAL SHAPES
RAW MICA
WASHERS
Etc

BRITISH MICA CO LTD - BEDFORD.

THE "J.B." SERVICE
5 MAYPLACE RD., WEST. BEXLEYHEATH. KENT

OFFER

"RACON" EQUIPMENT NAVAL MODEL YJ-1. This equipment is a two-channel automatic responding "Racon" for installation aboard ship or on shore. It will receive and answer an interrogating signal at a frequency near 176 m/cs., and receive and answer another interrogating signal near 515 m/cs. A plane or ship equipped with suitable Radar on these bands can receive a reply to its interrogating signal from YJ-1 "Racon" within range. Pulse Power at 400 pps is 15 watts on A Band and 75 watts on B Band. Power supply 115 or 230 volts 50 to 60 cps. Brand new in packing case.

GALVONETERS MIRROR TYPE. Permanent magnet field. Sensitivity 30 microamps per standard scale 20° sweep.

SLOTTED LINE TEST EQUIPMENT TYPE TS/56A/AP. Frequency range 360-675 mcs. Characteristic impedance 51 ohms. Contains a fine 3 1/2". Westinghouse 0-100 microammeter. Brand new in robust metal carrying case with handbook of instruction. Your specific Radar requirements are invited.

Lists sent on request.

"TECHNICAL EXCELLENCE"



—combines with beauty and soundness of DESIGN in the

OXLEY
AIR DIELECTRIC TRIMMER

Width: 16.5 mm. Length: 22 mm. Height: 1.5 to 8pF—7.5 mm. 1.8 to 20pF—18 mm. 2 to 26pF—11 mm. 2 to 32pF—12 mm. Law: Straight line capacity. Power Factor: Less than .001. Insulation: Over 2,000 megohms. Voltage: 500 D.C.

OXLEY DEVELOPMENTS CO. LTD.
ULVERSTON. NORTH LANCs. TEL: ULVERSTON 3386

Type approved Cal. A No. 464.

INDEX TO ADVERTISERS

Acru Electric Tool Manufacturing Co., Ltd., The	47	Davis (Relays) Ltd., Jack	47	Muirhead & Co., Ltd.	7
Air Control Installations	Cover iii	Donovan Electrical Co., Ltd., The	46	Mullard Ltd.	24 & 33
Airmec Laboratories Ltd.	22	Drayton Regulator & Instrument Co., Ltd.	45	Multicore Solders Ltd.	Cover iv
Amplivox Ltd.	47	Dubilier Condenser Co. (1925) Ltd.	11	Murex Ltd.	48
Audigraph Ltd.	43	Ed'son Swan Electric Co., Ltd., The	18	Nagard Ltd.	36
Automatic Coil Winder & Equipment Co., Ltd., The	26	Edwards & Co. (London) Ltd., W.	33	N.S.F. Ltd.	29
Autoset (Production) Ltd.	41	Electro-Alloys Ltd.	47	Oxley Developments Co., Ltd.	47
Baldwin Instrument Co., Ltd.	32	Electro-Dynamic Construction Co., Ltd.	36	Painton & Co., Ltd.	37
Belling & Lee Ltd.	15	Electronic Instruments	43	Partridge Transformers Ltd.	6
Bird & Sons Ltd., Sydney S.	43	E.M.I. Parent Co.	13	Pitman & Sons Ltd., Sir Isaac	45
Bray & Co., Ltd., George	45	English Electric Co., Ltd., The	10	Plessey Co., Ltd., The	30
British-Continental Trade Press Ltd.	199	Evershed & Vignoles Ltd.	21	Radiospares Ltd.	4
British Institute of Engineering Technology	47	Fox Ltd., P. X.	40	Savage Transformers Ltd.	42
British Instrument Industries Exhibition	39	General Electric Co., Ltd., The	14	Southern Instruments Ltd.	34
British Insulated Callender's Cables Ltd.	Cover i	Henley's Telegraph Works Co., Ltd., W. T.	44	Spencer, Franklin Ltd.	35
British Manufactured Bearings Co., Ltd.	46	Hunt Ltd., A. H.	32	Standard Telephones & Cables Ltd.	12 & 28
British Mica Co., Ltd.	47	Johnson, Matthey & Co., Ltd.	3	Steatite & Porcelain Products Ltd.	20
British National Radio School, The	44	"J.B." Service, The	47	Sullivan Ltd., H. W.	39
British Physical Laboratories Ltd.	42	Lewis & Co., Ltd., H. K.	198	Telegraph Construction & Maintenance Co., Ltd., The	19
British Thomson-Houston Co., Ltd.	16	London Electric Wire Co. & Smiths Ltd.	38	Thomas (Richard) & Baldwins Ltd.	9
Castle Engineering Co. (Nottingham) Ltd., The	46	Lyons Ltd., Claude	31	Transradio Ltd.	44
Chance Bros.	41	Marconi Instruments Ltd.	40	Tufnol Ltd.	27
Chapman & Hall Ltd.	199	McGraw-Hill Publishing Co., Ltd.	43	Vortexion Ltd.	8
Cinema-Television Ltd.	17	Measuring Instruments (Pullin) Ltd.	37	Walter Instruments Ltd.	Cover ii
Cohen, Sons & Co., Ltd., George	45	Metropolitan-Vickers Electrical Co., Ltd.	5	Webb's Radio	38
Colvern Ltd.	35	Microwave Instruments Ltd.	23	Westinghouse Brake & Signal Co., Ltd.	34
Cossor Ltd., A. C.	25			Wiggin & Co., Ltd., Henry	42
				Woden Transformer Co., Ltd.	44

Tungsten and Molybdenum

ROD · WIRE · SHEET · STRIP

This Transmitting Triode with 400 W Anode Dissipation shown by courtesy of the English Electric Valve Co. Ltd. is made with Tungsten and Molybdenum supplied by Murex Ltd.

MUREX LTD.

(Powder Metallurgy Division)
RAINHAM, ESSEX
Telephone : Rainham, Essex 240



London Sales Office : Central House, Upper Woburn Place, W.C.1. Telephone : EUSTON 8265

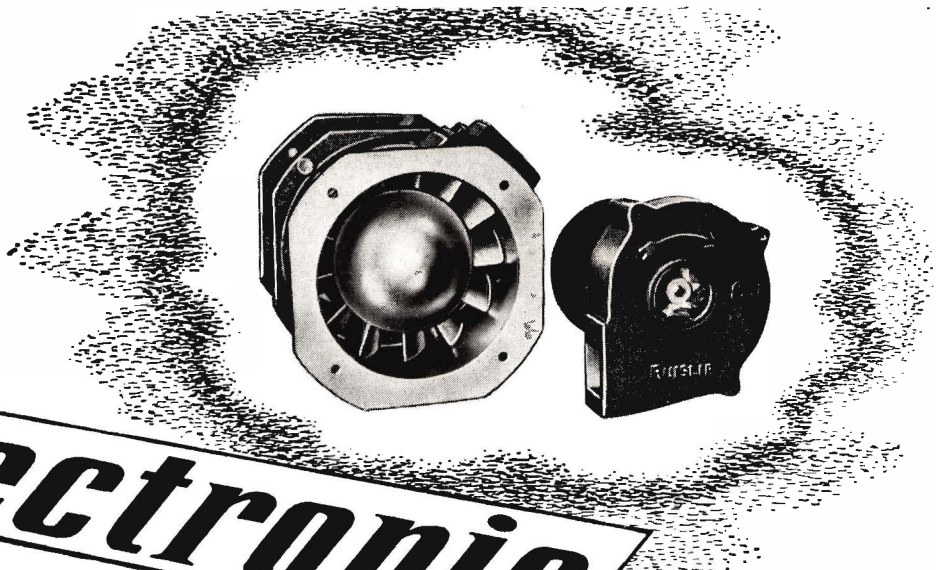

electronic COOLING

The wide range of blowers for force-cooling of valves and maintenance of desired temperature levels in electronic and general electrical apparatus is typical of the progress maintained by **ACI**. The illustration shows the smallest of the blowers (4" Axial Flow type and 2½" Centrifugal type), but our range covers duties from 5 c.f.m. up to many thousands of c.f.m. at pressures up to 45 or more inches w.g. These blowers are used in MARINE & AERODROME RADAR INSTALLATIONS, AIRCRAFT AUTOMATIC PILOTS, COMMUNICATION AND BROADCASTING STATIONS, R.F. HEATING EQUIPMENT, Etc. Let us know your application—we shall be pleased to put forward our proposals.

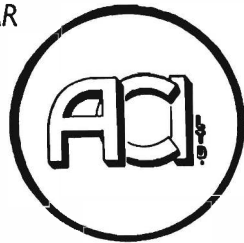

Complete
Air Treatment
Plant

AIR CONTROL INSTALLATIONS LTD.

Manchester

RUISLIP, MIDDX.

Glasgow

Telephone : Ruislip 4066 (8 lines)

Telegrams : Controlair, Ruislip

THE FINEST CORED SOLDER IN THE WORLD SPECIFIED ALL OVER THE WORLD BY LEADING MANUFACTURERS OF RADIO & TELEVISION EQUIPMENT

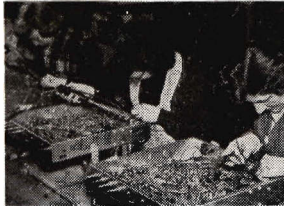

*DuMont Factory,
Newark, U.S.A.*



*Canadian Admiral
Corporation,
Malton, Ontario.*



*Philips Argentina S.A.
Saavedra, Buenos Aires*

It is impossible for us to show illustrations of all the manufacturers who use Ersin Multicore Solder. We apologise to those who are not included in this advertisement.



*Bang & Olufsen, Struer,
Denmark.*



*Luxor Radio Factory,
Motala, Sweden.*



*Tandberg Radiofabrikk,
Oslo, Norway.*

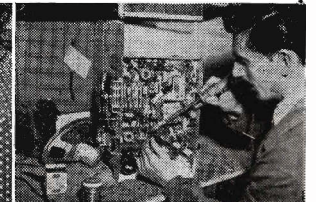

*H. Karayannis & Co.,
Athens, Greece.*



*Philips Radio Factory,
Calcutta, India.*



*Invictus Radio Works,
Brazil.*

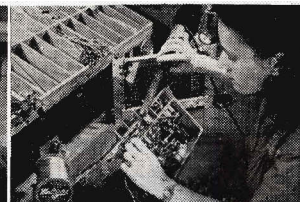

*Amalgamated Wireless Ltd.,
Sydney, Australia.*



*Collier & Beale, Wellington,
New Zealand.*

FOR THESE EIGHT GOOD REASONS

- The 3-cored construction guarantees flux continuity and prevents "dry" or H.R. joints.
- Multiple core composition means thinner walls of solder, which result in instant melting.

- The correct proportion of flux to solder is always assured - no extra flux is required.
- Soldered joints made with Ersin Multicore remain free from corrosion even after prolonged exposure.

- The flux residue is impervious to moisture, hard, non-sticky, non-toxic, and avoids accumulation of dirt.
- For more than a decade the same unvarying and consistently high quality.

- Ersin Flux reduces surface tension of molten solder, causing it to wet metals rapidly. It also cleans oxidised metallic surfaces.
- Fully approved by A.I.D. and G.P.O. and complies with U.S. Govt. specification B.S.S. 219 & 441 and M.A.P., D.T.D. 599.

ERSIN
Multicore
THREE CORE SOLDER WIRE

SIZE 1 CARTONS 5/- RETAIL.

Catalogue Ref. No.	Alloy Tin/Lead	S.W.G.	Approx. Length per Carton
C.16014	60/40	14	13 feet
C.16018	60/40	18	37 feet
C.14013	40/60	13	13 feet
C.14016	40/60	16	26 feet

MULTICORE SOLDERS LTD., MELLIER HOUSE, ALBEMARLE STREET, LONDON, W.1 • REGent 1411