

PROPRIETORS :

HULTON PRESS, LTD.

EDITOR

G. PARR.

# Electronic Engineering

EDITORIAL, ADVERTISING AND PUBLISHING OFFICES, 43-44, SHOE LANE, LONDON, E.C.4

TELEPHONE:  
CENTRAL 7400

Monthly (published last day of preceding month) 2/- net. Subscription Rates :  
Post Paid to any part of the World—  
6 months, 13/- ; 12 months, 26/-.  
Registered for Transmission by  
Canadian Magazine Post.

TELEGRAMS  
HULTONPRES, LUD  
LONDON.

## Strato-Television

FROM the Westinghouse Electric Corporation of Baltimore comes a novel idea which should solve most of the problems of wide area television coverage. It is nothing less than the continuous broadcasting of programmes from aeroplanes hovering in the stratosphere.

In a paper by C. E. Nobles, of the Industrial Electronics Division, the disadvantages of the recognised methods of television relay—coaxial cable or relay links—are emphasised and the advantages of aeroplane broadcasting are shown to be very real from all points of view.

One of the principal savings is in the amount of power required. It is estimated that 50 kW are required to give a useful signal at 50 miles from a ground station, whereas, owing to the increase in path difference between the direct and reflective wave, only 1 kW is required to give the same signal over a distance of 200 miles from an altitude of 30,000 feet.

This reduction in power makes the installation of transmitters in an aeroplane a practical proposition, and we have already had the experience of portable transmitting equipment from war uses. Relaying between planes is correspondingly easier, owing to the increased line-

of-sight distance, and if the frequency is increased to the order of 2,000 Mc/s. the power requirements are absurdly low.

In collaboration with the Westinghouse Corporation the Glenn Martin Company have made a study of aeroplane design for the purpose, and have produced an experimental model which will accommodate four television transmitters, five F.M. transmitters, monitoring equipment, and sufficient relay equipment to carry four television programmes and five F.M. programmes. Each plane has a service range of 200 miles in every direction.

At 30,000 feet it is considered that the aeroplane will not be affected by winds or storms to any great extent,

and with de-icing equipment it should operate reliably for long periods. To guard against interruption of the service, four aeroplanes will operate, taking off at staggered four-hour intervals and remaining at 30,000 feet for eight hours each, two being in the air at all times.

These planes would also serve a valuable purpose in providing meteorological data and in abnormal conditions there would be plenty of time to put extra aircraft near storm areas. It is estimated that the probability of complete interruption of the programme by the forcing down of both planes at once is 1 in 30,000,000, and the frequency of interruption due to engine failure is put at once every 82,000 years. As the Glenn Martin report says: "This eased our minds a great deal, and we are not very worried about engine trouble any more."

The operating cost is put at \$1,000 per hour, which is about 1/13th of that of an equivalent ground station.

Although the problem of television coverage in this country is not comparable with that in the United States, the whole scheme makes very interesting reading, and the outcome of the suggestion will be awaited with interest.

### ELECTRONIC ENGINEERING MONOGRAPH

The third Monograph, which has been unduly delayed owing to printing and paper difficulties, is now in press and will be issued shortly. It is entitled:

#### THE ELECTRON MICROSCOPE

BY DR. D. GABOR

(Research Laboratory, B.T.-H. Co.)

Dr. Gabor is one of the foremost authorities on Electron Optics, and his monograph deals fully with the present developments in electron microscopes and their future possibilities.

Copies will be available through technical booksellers, or direct from the Circulation Dept., Hulton Press, 43, Shoe Lane, E.C.4, price 4/9, post free.

Orders should be placed early as the number of copies is limited.



# STEADY

your A.C. SUPPLY WITH A



# STABILISTOR

the only constant voltage equipment giving a constant UNDISTORTED output with changes in mains voltage and load.

Write for literature to Dept. E.E.

**WESTINGHOUSE BRAKE & SIGNAL CO. LTD.,**  
Few Hill House, Chippenham, Wilts.

## A TAYLOR FAMILY

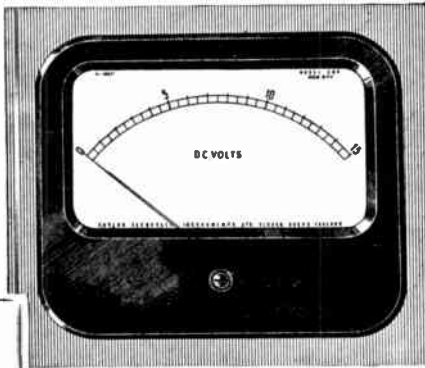

These moving coil instruments are very soundly constructed, and are accurate and dependable in use. A very large number of ranges are available in moving coil, Rectifier and Thermocouple type instruments. Model 400 and 500 instruments are also available with illuminated dials. All models are supplied in black moulded insulated cases, and Alnico magnets and stainless iron polepieces and cores are used.

We also manufacture several other sizes of moving coil instruments with scales of 2" and up.



- MODEL 500  
5" scale.  
Size 6½" x 5½"
- MODEL 400  
4" scale.  
Size 4½" x 4½"
- MODEL 350  
3½" instrument type.  
Flush or Projecting.

**IMMEDIATE DELIVERY.**  
For some time past we have been carrying a small varied stock of most ranges of moving coil instruments. We are able to give immediate delivery for urgent orders.

Send your enquiries to

**TAYLOR ELECTRICAL INSTRUMENTS, LTD.,**  
419-424 Montrose Avenue, Slough, Bucks.

Telephones: "Slough 21381 (4 lines).

"Grams" "Taylins, Slough."

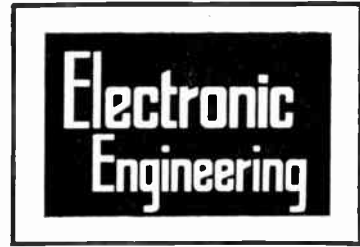

OCTOBER, 1945

Volume XVII.

No. 212

## CONTENTS

	PAGE
Editorial : Strato-Television ... ..	711
GEE—A New Method of Radio Navigation	713
Industry's Contribution to Radar ... ..	717
A Radar Glossary ... ..	719
Frequency Measurement at U.H.F. ... ..	720
Post-War Television Ideas from U.S. ... ..	722
Cathode-Ray Tube Traces—Part III ... ..	723
A Modified Inverted Triode-Valve Voltmeter ... ..	731
Radio Beacons ... ..	735
The Recording of Strain by the "Parallel Resonance" Method ... ..	737
October Meetings ... ..	738
Book Reviews ... ..	740
Correspondence ... ..	742
Abstracts of Electronic Literature ... ..	744
Notes from the Industry ... ..	746

**CONDITIONS OF SALE.**—This periodical is sold subject to the following conditions, namely, that it shall not without the written consent of the publishers first given, be lent, re-sold, hired out or otherwise disposed of by way of Trade except at the full retail price of 2/- and that it shall not be lent, re-sold, hired out or otherwise disposed of in a mutilated condition or in any unauthorised cover by way of Trade, or affixed to or as part of any publication or advertising, literary or pictorial matter whatsoever.

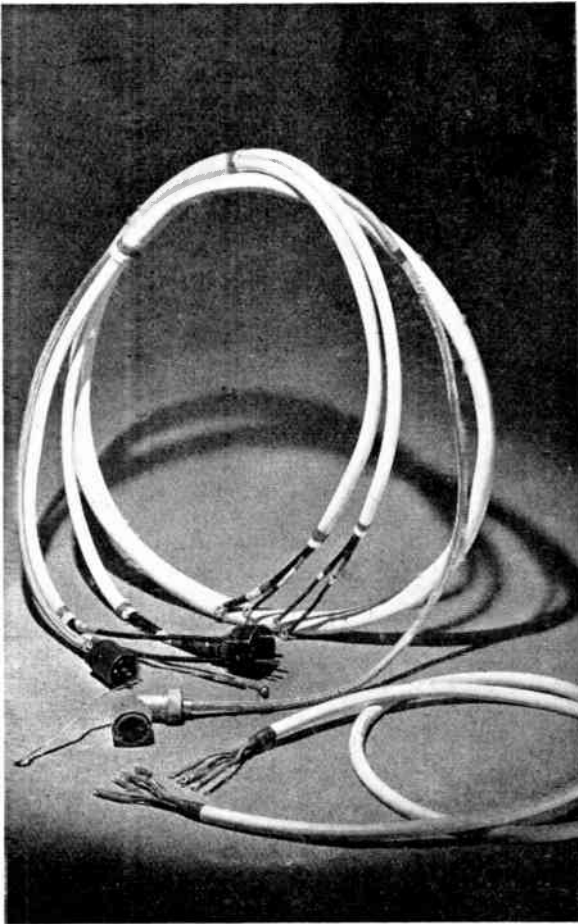

## *Pardon our extrusion!*

Tut, tut! What are we saying? What we meant to say was, please pardon this intrusion, but we have been making plastics since 1877, and thus have nearly seventy years of research and experience behind us.

In fact, we know a very great deal about plastics, particularly in the form of P.V.C. extrusion compounds made to G.D.E.S. 18 and all other specifications, and can supply the answer to many an unusual problem.\* In addition, BX P.V.C. is made in the form of paste or dough for coating, and in calendered sheets.

Why not send for full information and the advice of our technical experts?

*\* This material can only be obtained on allocation from Plastics Control.*

# **BX PLASTICS LTD**

LARKSWOOD WORKS · LONDON E. 4

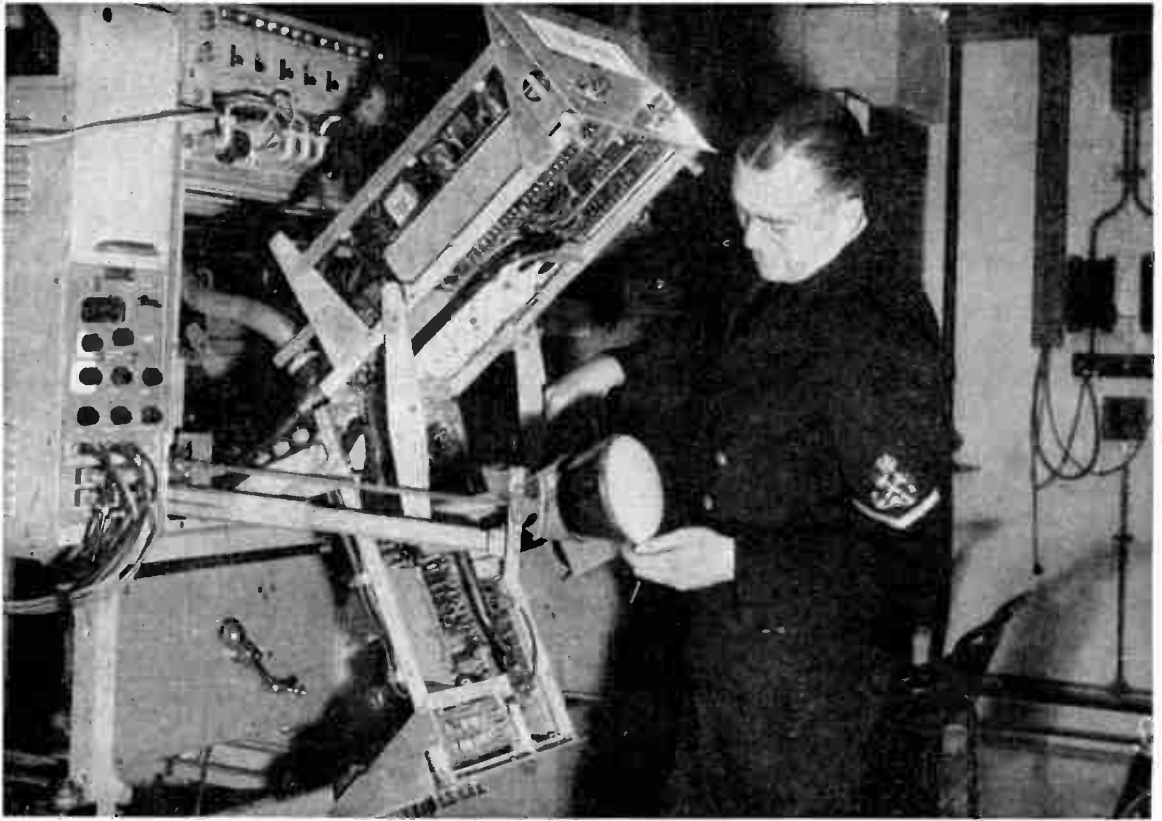

**Two Aspects of Radar Construction :** Above, "Crocodile Jaw" construction of centimetric A.A. equipment, giving ease of access to every part of the chassis. Below, Sealing U.S.W. dipoles and reflectors into alkathene spheres at the B.T.-H. works.

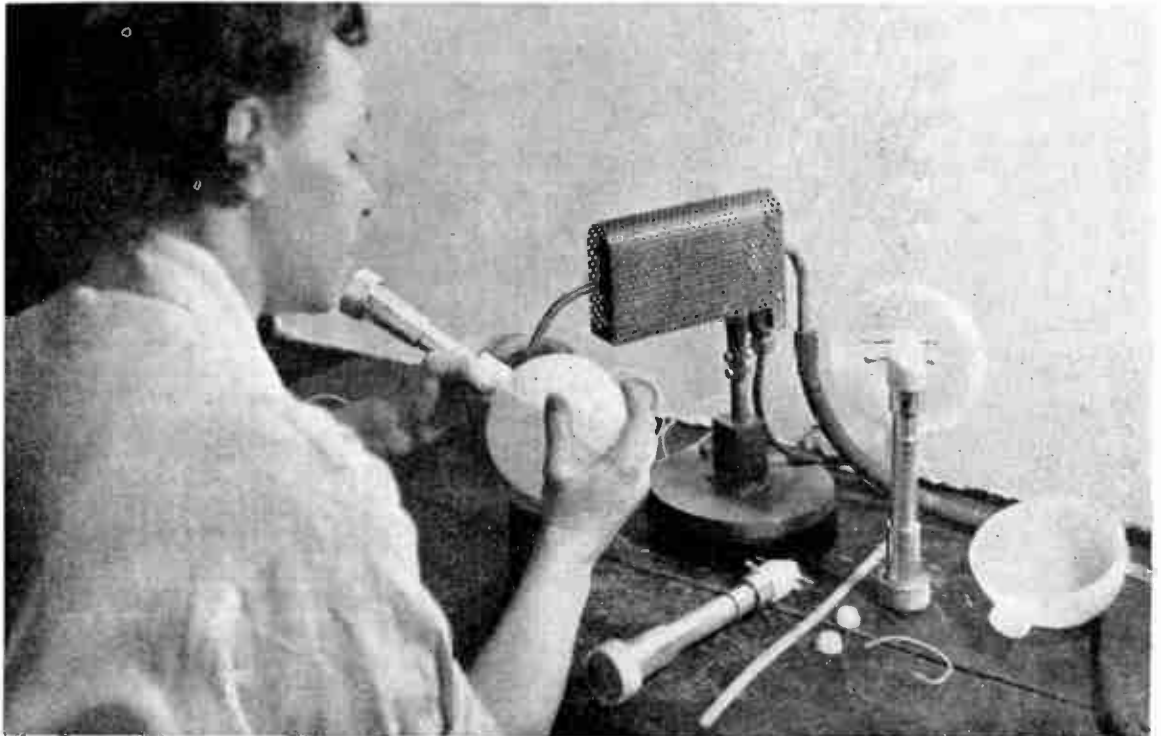



## A New Method of Radio Navigation

By L. S. HARLEY

The name "G" or "Gee," as it is more often spelt, is an abbreviation for "Grid," relating to the grid map references in use by R.A.F. navigators

In order to overcome the difficulties of navigation in all weathers on bombing flights over Germany, it became necessary to devise a method to give the accurate location on the map at all times during the flight, utilising for the purpose the known speed of propagation of radio waves

THE essence of the new method is this: if two pulse transmitters send out synchronised pulses, that is to say, the pulses of energy leave the transmitters at the same moment of time as judged by an observer at rest relative to them, then a suitable receiver, P (see Fig. 1), situated anywhere on the perpendicular bisector of the straight line joining the two transmitters, will receive the two pulses simultaneously, because any point on this bisector is equidistant from both transmitters. At any other point, for example P, there will be a time difference in the receipt of the pulses, because the pulse from the nearer transmitter will get there earlier.

In early practice, the operational need was so urgent that existing radiolocation transmitters were modified to give extra high-power pulses; it was found more convenient to let one act as the "Master" station and then arrange that the second, or "Slave," station received the Master pulse, which triggered the Slave transmitter into action. This meant that the inevitable but constant time-delay in the link between Master and Slave was added to the time-difference characteristic of the geometrical relations between P and A and B (see Fig. 2).

Sets of lines can be drawn, joining all the points having the same time-differences, and it has been agreed to call these lines "isochrones," analogous to the "isobars" of a weather-map. In general, these "isochrone" lines are hyperbolae (see Fig. 3).

The received pulses are displayed on a cathode-ray tube connected with the aircraft receiver, in the now-familiar radiolocation technique. The "time-bases" (there are two, one under the other) are marked to provide a calibration scale for measurement of the time-differences, by a constant-frequency oscillator which brightens or deflects the traces at suitable small time intervals.

If the observer notes, for example, that the pulses from stations A and B arrive 20 millionths of a second apart (in addition to the delay in the A-B link), he can say (if he is mathematically inclined) that he must be situated on one of a family of confocal hyperbolae having A and B as foci, but what he probably *does* say is that he is somewhere on "BLUE 20," A and B being the "blue" pair of stations.

Repeating the observation on the pulses from a second pair of stations, A and C (C being another "Slave" of A), he may observe that he is also somewhere on "RED 16." Now, his

map or chart will have printed on it intersecting families of confocal hyperbolae, coloured blue and red respectively, and numbered at intervals with their characteristic time-differences. The navigator has but to follow "BLUE 20" with his pencil until he comes across "RED 16" when (subject to an unimportant ambiguity which will never mislead him) he can fix within a mile or so the position of his receiver. It will be at the intersection of the two isochrones, on both of which he is situated at the moment of observation (see Fig. 4).

As the distance between the aircraft and the GEE stations increases, the isochrone intersections occur at ever more acute angles and the error of "fix" naturally becomes greater; moreover, the "radio horizon" is eventually reached, since "metre" waves are being used. The ambiguity referred to above arises from dual intersections of the relevant isochrones on opposite sides of the median line between the stations, but error from this cause cannot arise in practice, except very near the GEE stations.

The possibility of confusing the two slave pulses can be made negligible over areas of operational importance by suitably adjusting the

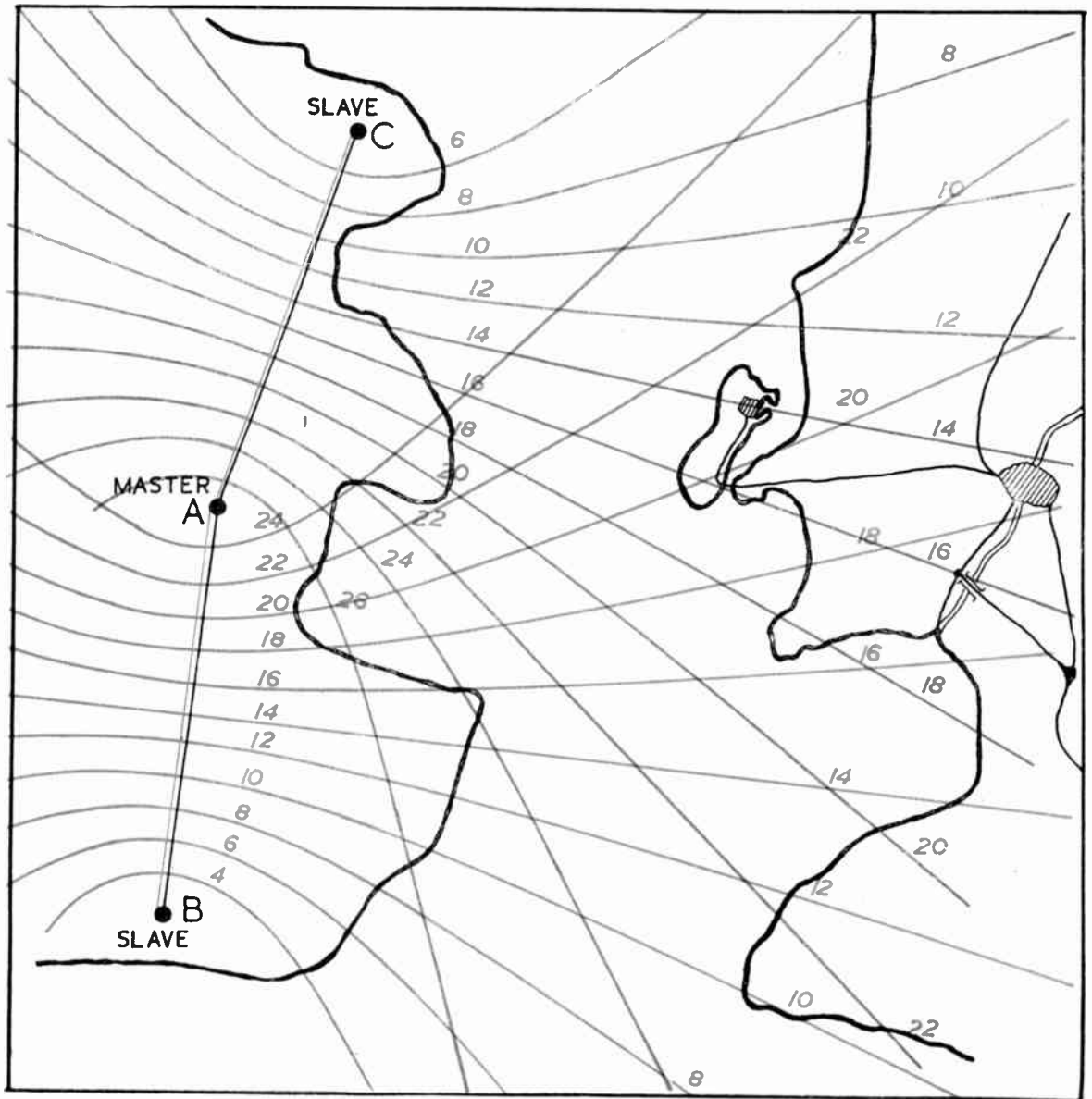

Fig. 4. Fictitious chart showing GEE "lattice" covering enemy naval installations and supply centres.

time-delay in the links between Master and Slaves, and by attention to the siting of the stations.

This, then, is the basic method of radio navigation which in its British form (proposed in 1937 at the Air Ministry Research Station, Bawdsey, Suffolk) is called "GEE" and which, using longer wavelengths, has been developed in the U.S.A. as "LORAN" (Long Range Navigation). The LORAN system has this advantage over GEE, that its greater wavelength pulses are propagated over wide stretches of the earth's surface by multiple reflexions from

the ionosphere, but it suffers from the corresponding disadvantage of all such reflected propagations, that the path lengths are not precisely determinate, and the errors of position-finding may, in consequence, be somewhat greater.

It is important to observe that here are systems using all the pulse techniques developed for radiolocation, but that no "echo" is used: it is a straightforward reception of pulses which started out at predetermined intervals from their respective transmitters.

Since the time-delays in the A-B

and A-C links can be increased by suitable circuitry, and the total time-difference thereby altered for any isochrone fixed in space, the enemy can be denied the immediate use of the altered GEE system in making his sorties; a last-moment change, made known to our navigators and easily allowed for, would necessitate remeasurement by the enemy before his aircraft could use the system.

With this preliminary technical explanation, the operational notes which follow may be of greater interest to readers.

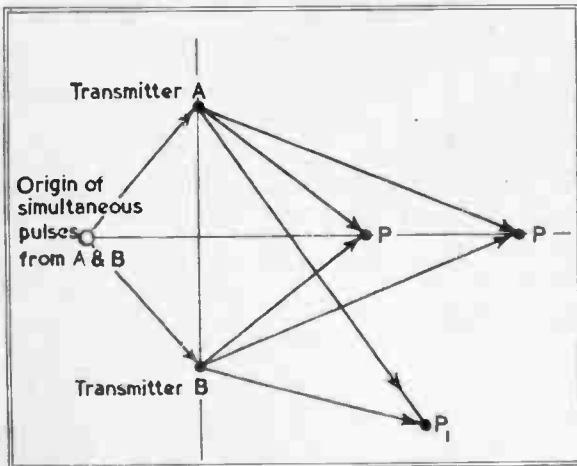

Fig. 1. GEE: The theoretical idea.

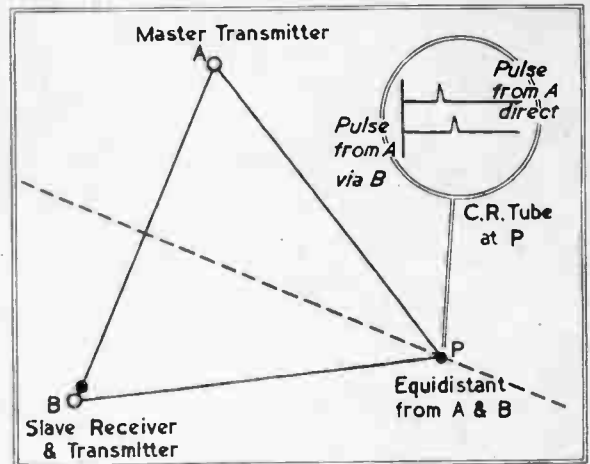

Fig. 2. GEE: The practical arrangement.

From experience gained between the outbreak of war and the early summer of 1940, British R.A.F. Bomber Command realised that although their aircraft were able to navigate over large distances to target areas in Germany and German held territory, the methods of navigation in use in that period were not sufficiently accurate to enable bombers to find and identify specific targets with any degree of certainty under bad weather conditions, when the target was obscured by cloud. The expectation of effective bombing was remote, apart from their inability to find their targets in such conditions. The bomber crews were confronted also with serious difficulty in finding their way back to base. Wireless direction finding systems were in use to help bombers to return to base but these relied on radio communication from ground stations to aircraft in order to pass D.F. information and were necessarily cumbersome and unable to handle large numbers of aircraft in a short time. Moreover, maintenance of "wireless silence" was impossible in these circumstances and the enemy had undesirable warning of our operations.

The first small-scale test flights were carried out in the autumn of 1940; by means of two very low power ground stations situated some fifteen miles apart on the South Coast, it was found that an aircraft could obtain "position lines" up to distances of about 100 miles, even with the experimental equipment. As explained earlier, position lines only can be obtained from one pair of stations, but many flights along such lines were successfully made at the end of 1940.

During the time the small-scale tests were being carried out plans were made for setting up a full-scale three-station system with high-power transmitters and accurate monitoring equipment to give 24-hour-a-day coverage over W. Germany. At the same time an efficient aircraft receiver was under development. Test flights were carried out over this country during the spring and summer of 1941 and by July of that year all the ground station equipment had been thoroughly tested and modifications made where necessary. Air crews had been trained in the use of GEE in flights over the British Isles and twelve aircraft were fitted and ready for operational flights over Germany.

The operational service trials over Germany took place during August, 1941, and the results, which were of outstanding success, were enthusiastically received by Bomber Command. Not only were navigators able to find targets within range of the ground stations but they were able to obtain accurate information on wind velocity which enabled them to navigate more accurately than before to places outside the GEE coverage area. In navigational language, they had from GEE a new "point of departure" and up-to-date local wind corrections at the limit of GEE coverage. It was also found that the GEE system was of inestimable value in enabling aircraft to home right back to base without breaking radio

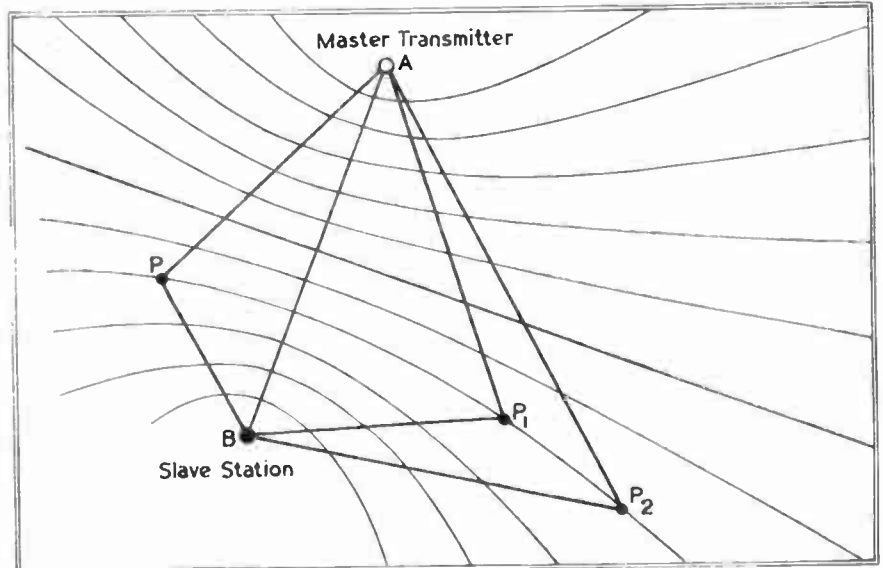
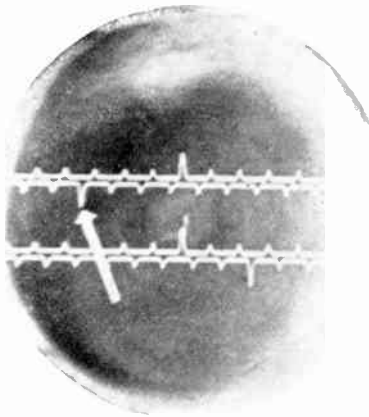

Fig. 3.  $PP_1P_2$  is a hyperbola such that  $AP - BP, AP_1 - BP_1, AP_2 - BP_2$  are all equal differences of path length, with corresponding equal differences of reception time.



## STROBE



## MAIN

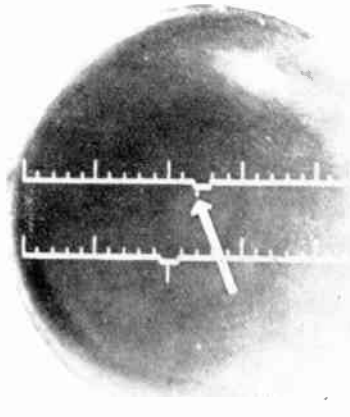

Photographs of the cathode-ray tube face, showing (right) the main display and (left) the "magnification" of a portion of the time-base by electrical methods, analogous to the mechanical stroboscope and called the "Strobe," in consequence. Note the calibration scales, in this case formed of small and larger "blips," not bright dots.

silence by asking for D/F information.

The first GEE raid was made on the night of March 8, 1942, when about 350 aircraft made a heavy attack on the Ruhr. Approximately one-quarter of these were equipped with GEE and they were used mainly as fire raisers. The raid was highly successful compared with previous attacks, as were others mounted on a similar scale on succeeding nights. Reports showed that the aircraft equipments were behaving satisfactorily with only a small percentage of failures, the ground stations proved to be reliable and aircrews were unanimous in their praise of the new system.

At the same time a new chain of ground stations was erected by the Air Ministry along the South Coast in order to give cover over France, including the then most important naval ports of Brest and Lorient and St. Nazaire. Later, two further chains were designed, mainly for use by Coastal Command in the South Western Approaches and off the coast of Northern Scotland.

By March, 1943, the Mark II airborne receiver had successfully passed its operational trials and had been introduced into R.A.F. Bomber Command on a massive scale. Practically all heavy bombers and also certain squadrons of light bombers had been fitted. From this time onwards the whole Bomber Command system of mass raids involving control of large numbers of aircraft and the very complicated problems associated with routing of both outgoing and returning bomber streams was based on the use of GEE. It was found possible for aircraft to operate

under much worse weather conditions since if the weather had closed in at some bases on their return it was a simple matter for them to navigate to others which were known to be clear.

In the summer of 1942 the Navy began to install GEE in their light naval craft and by utilising the facilities offered by the Southern Gee Chain they were able to navigate accurately in all weathers in the English Channel. Since then, naval craft have been fitted in ever-increasing numbers and the use of GEE has been found of inestimable help in many directions; for instance, it enabled minesweepers to sweep definite lanes with precision. Coastal Command aircraft also use GEE very

extensively for patrol and strike aircraft against both U-boats and surface craft. It has been used for accurate minelaying from both ships and aircraft.

When plans for the invasion of Europe on D-Day were made, it was decided that GEE should be the main system of navigation. It was planned that the general navigation of all aircraft (British and American) of the bomber and troop-carrier types should be by means of GEE, and also that surface craft should make use of this method of navigation. In the case of troop-carrier aircraft, the actual landing was to be carried out using "Radio Beacons" dropped in advance, but GEE was to be used wherever possible in the approach to the area of the landing zones.

The GEE system was the most important of all the new radio contributions to the offensive. In its application to Bomber Command it permitted those close concentrations in time and space which were essential to the defeat of the enemy ground defences, and the special tactics required to defeat his fighter defences; it was essential to the "thousand-bomber raid" by night; it made practicable great elaborations in the close relative timing of separate attacks, real and feint; and it gave invaluable aid in bringing back the great bomber formations, and their individual aircraft, by the most suitable routes in any weather, and under close time control.

A great achievement, of which Britain should be justly proud.

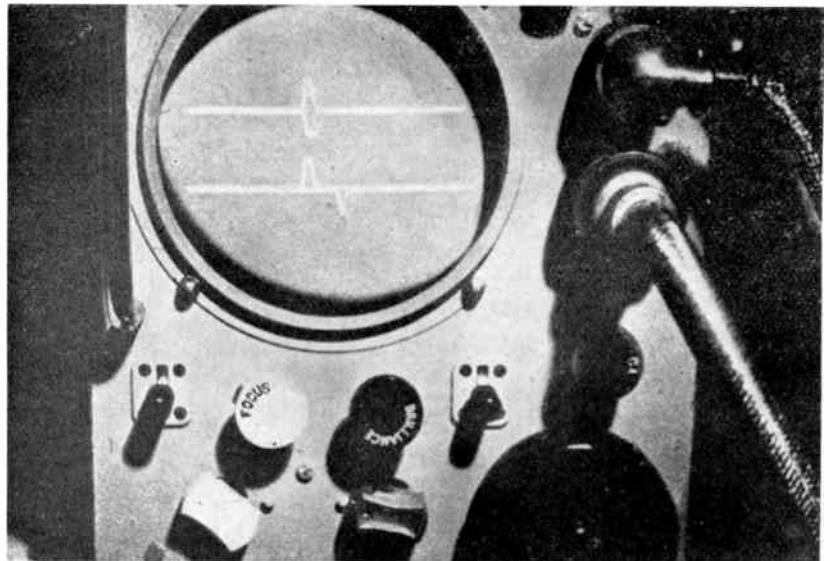

What the GEE navigator sees when he is comparing the time of arrival of pulses direct from the Master A and via the Slaves B and C.



# Industry's Contribution to Radar

Extracts from a speech by Sir Stafford Cripps to the Radio Industries Council on Friday, August 31

**I**N a speech which I made two weeks ago I paid tribute to some of those in the Service and Supply Departments, the Government Research Establishments and the Universities to whom we are specially indebted for making this great invention of Radar possible. To-day I want to speak about the no less remarkable achievement of the other great partner in this teamwork of research and development, the scientists in the laboratories of the industrial firms who by their ingenuity and resourcefulness first turned the rough models, and even in some cases the ideas, of the Government scientists into devices which could be quickly and economically produced in the factories and which, in the exacting conditions of military service, were capable of giving good and continued performance.

The intimate intermingling of research and development minds was followed up by a corresponding co-operation of development and production minds, which can only be fully achieved within the industrial plant itself. From this interweaving of effort we derived our greatest single advantage in war achievement. Not only did we far outstrip the enemy, but I can confidently say that we outstripped all others in the art of carrying the research project into battle with the least possible delay. Our line production performance was creditable; our "crash programme" performance was unparalleled. And the crash programme for something between fifty and two hundred sets—the bane of the production engineer's existence—was carried through, and in every one of the many cases, by the workers from Government and industrial laboratories borrowing one another's pencils.

If examples are needed, the final defeat of the U-boat springs to mind. A hundred centrimetric ASV sets in aircraft, a couple of hundred Type 271 sets in destroyer and corvette, ensured the defeat. The Type 271 went as a request to the contractor on March 14, 1941, as a rough model on April 15, as a set of incomplete sketches on April 24, and emerged as a successful model on June 4, to be

followed by 250 sets within the following seven months. And anyone who knows or has seen that set can judge how remarkable was that production performance.

So far I have referred only to the part played by the industrial research scientists, but while their work was the necessary first step after the initial designs and models, often of the very roughest, had been given to the factories by the Government scientists, the great job of producing these varied and intricate equipments was going on ceaselessly day and night. Every radio firm in Britain, and many firms which before the war had never made a radio valve in their lives, devoted their resources entirely to meeting the endless demands of the Services. And, though I am talking to-day only of Radar, we must never forget that, insistent though the demand was for Radar, the Services' requirements for ordinary radio communications for signalling were on a prodigious scale.

By the peak of the European war, a quarter of a million workers, men and women, were engaged on the production of Radar and radio equipment. Some idea of the wonderful job which these men and women did can be realised when I tell you that, whereas before the war we produced in this country only a few million valves a year, in 1944—invasion year—we produced no less than 38 million valves, of 600 different types, for the three Services. This vast production was achieved under the constant threat of aerial bombardment, and since a great proportion of the production capacity had pre-war been established in the London area, a great deal of it was in fact carried out under almost continuous bombardment by Vis and V2s. I should like to take this opportunity of paying a special tribute to the gallant men and women who worked continuously night and day throughout the periods of even the heaviest bombing.

As with valves, so with components. With each new development an entirely new range of components was demanded. Industry was responsible for its own development of these and

it is a great tribute to the innumerable firms concerned that even with the rapid changes in types and designs, requirements were always met.

It is impossible for me to mention the names of all the firms in the radio industry who have contributed to this great achievement. My main object to-day has been to pay a tribute to the industry as a whole and to put on record certain aspects of a story which have been so long cloaked by security demands. I feel, however, with full recognition of my foolhardiness, that I must mention the names of a few firms whose contribution has been particularly marked. Not because I am unappreciative of the many others, great and small, who have also played their part, but because it is right that some at least should not have their blushes spared.

In the field of scientific research in the laboratories, I should mention the following firms for their outstanding contribution:

**Metropolitan-Vickers Electric Co., Ltd.**  
**A. C. Cossor, Ltd.**  
**Pye, Ltd.**  
**General Electric Co., Ltd.**

Outstanding, too, for their contribution in scientific research as well as in development to the production stage were:

**Dynatron Radio, Ltd.**  
**Ferranti, Ltd.**  
**Electric and Musical Industries, Ltd.**

In developing to the production stage the designs and models that came from the laboratories the following made particularly notable contributions:

**E. K. Cole, Ltd.**  
**Murphy Radio, Ltd.**  
**Bush Radio, Ltd.**  
**Allan West.**  
**British Thomson-Houston Co. Ltd.**

All these firms also played their full part in actual production of the vast quantities of Radar equipment required by the Services, but in the production field I must also add for particularly honourable mention the names of Standard Telephones & Cables, Ltd., and the Philips organisation.

There can, I think, be little doubt that the day will come when ships of all nations will be fitted with Radar, just as to-day they carry wireless; and once that day has come, which cannot be far distant, delays to shipping due to fog, and perils of the deep like icebergs, will have gone for good.

So far as commercial air lines are concerned, we can, I think, already see the shape of "things to come." While still many miles from the ground station, the airliner will be given by Radar a particular track on which to come in to the airport and will be guided along that track all the way in. If, on arrival over the airport, weather conditions should be so bad that the pilot cannot see the runway, this will make no difference because a special "blind-landing" installation will enable him to guide the aircraft on to the runway automatically. It may be a year or two more before this is finally perfected, but already the pilot can be guided down to within 40 feet of the runway.

In planes flying the Atlantic and making other long hops over the sea, the pilot will be able to fix his precise position within a margin of error not exceeding 10 miles even when he is hundreds of miles from the shore. In the event of the plane approaching thunder and other clouds of a dangerous nature or, if it is over land, approaching high ground, the pilot will be warned by Radar of what is ahead of him. Crossing the Alps or the Atlantic by air will shortly be robbed by Radar of its special dangers.

Such is the prospect of the future and if our great radio firms continue to show the ingenuity, initiative and resourcefulness which they have shown in the war, and if the close working partnership which has been developed between the Government Research Establishments, the Universities and the scientists, the laboratories of the industrial firms can be continued into peace—as it must be—then I for one look forward to a great future for your industry in both the home and foreign markets. And speaking now for one final moment as President of the Board of Trade, I am indeed most anxious that our friends in other countries should appreciate to the full what a magnificent industry we have built up during the war so that they will flock to you with their orders knowing that they will get the very best that human skill and ingenuity can produce.

## Some Individual Achievements

**I**N his speech at the Radio Industries Club, Sir Stafford Cripps mentioned by name a few of the firms who played a major part in the war. It is our intention to do justice to all those companies whose work was of vital importance in this field, and we publish below the first summary of the reports which have been supplied by individual firms.

### British Thomson-Houston Co., Rugby

The first Radar contract was received in 1940, when this company was asked to develop and build centimetric equipment for A.A. fire control. The successful trials in 1941 led to the development of the G.L.3, which is independent of terrain and contains the whole transmitting and receiving equipment in one cabin with the maximum of comfort for the operator.

In collaboration with Messrs. A. C. Cossor and Messrs. Nash & Thompson equipment was built for the automatic following of aircraft by Radar, code-named "Glaxo." In this, the operator selects the target to be followed from those within range, and, once set, the Radar beam follows it automatically in bearing and range and transmits the information to the predictor.

A small Radar unit, "Cupid," was developed in 1944 to counter the flying-bomb attack on London.

The B.T.-H. industrial high-voltage thyatron BT.9 was used in the earlier days of the war as a high-power pulse modulator in Radar equipments, and special valves of this type were continually designed and improved for greater power outputs. Including smaller thyatrons for control purposes, the total output was over 200,000.

In the production of special magnetrons a total of 4,000 per month was achieved in 1944—the highest production rate reached in this country.

Among the sub-contractors for G.L.3 equipment mentioned in the report are:

The Garraud Eng. Co., Swindon; Scientific Projections, Ltd., London; Joseph Adamson & Co., Hyde; Tilling-Stevens, Ltd., Maidstone.

### A. C. Cossor, Ltd.

This company can claim to be the true pioneers of Radar development, since the Government first ap-

proached them in 1936 on the project of developing an "early warning" system of detecting approaching aircraft. The work was in the hands of L. H. Bedford and O. S. Puckle and the first production model was put in hand in 1937. When, after the Battle of Britain, night bombing started, the electronic gun-laying equipment then in use could only give accurate range and approximate bearing, leaving the elevation to be obtained by optical means. An attachment was designed by L. H. Bedford to enable the existing receivers to obtain the elevation electrically in addition to the other data.

This equipment was produced in the factory working 24 hours a day, and Cossor engineers installed it as fast as it was produced and trained Army personnel in its use.

The Radar navigation device "Gee" was developed in the shadow factory at Chadderton and the first prototype model was delivered to the Air Ministry within six weeks of the start of the work—a record in high-speed production.

The more exact target-finder, Gee II, was developed and produced in 1943 from the original Gee units, and finally the shadow factory and a "daughter" factory produced 100 prototype sets of Oboe equipment by August, 1943.

For his work on the A.A. equipment, Mr. L. H. Bedford was awarded the O.B.E. in the Birthday Honours of 1943.

### Metropolitan-Vickers Co., Manchester

Early in 1937 Sir Robert Watson Watt approached Sir Arthur P. M. Fleming, Director of Research at Metropolitan-Vickers Electrical Company, in connexion with R.D.F. transmitters. Sir Arthur arranged that some of the best men among his research workers should devote their time exclusively to the technical problems to be solved, and when this had been successfully done, to proceed with the design and production of the required equipment. The investigator who, with the assistance of a remarkably small team of researchers, ultimately found the answer required, was Dr. J. M. Dodds. In recognition of his work on the chain transmitters and many subsequent developments, Dr. Dodds was awarded the O.B.E. in 1944.

By the time the technical solution had been found, war appeared to be

so imminent that the constructional facilities of the Metropolitan-Vickers Research Department were obviously inadequate to complete these large transmitters at the rate required, and a new assembly shop building of 25,000 sq. ft. area was erected, equipped, and some assembly work started in seven weeks. The erection of this building and the production of transmitters was carried out on a basis of 24 hours a day and seven days a week.

All the high-power transmitters were designed around the Metropolitan-Vickers continuously evacuated demountable valves developed several years before as the result of original research work carried out in the research laboratories by Dr. C. R. Burch, F.R.S., and his brother, Francis Burch—since deceased—who in 1930-33 demonstrated the considerable powers which could be transmitted on short waves.

#### Erskine Laboratories, Ltd., Surbiton

After working on Service communication equipment for two years, this company became primarily concerned with Radar test gear, but also specialised in small "crash" programmes for D.R.F. necessitating high-speed development and production of equipment to bridge the gap between the initial model and the mass production by larger firms.

The company was closely connected with airborne and test gear for Oboe from its inception, and at the termination of the war had completed development of the Mk. III G-H airborne receiver.

Among the special jobs handled were test gear for the American Radar altimeter, developed in the Surbiton laboratories, and the P.R.F. selector, a device for sorting out the received pulses in the Oboe system and converting them into audio-frequency signals.

#### Masteradio Ltd., Watford

In May, 1942, Masteradio, Ltd., undertook the development of 100 prototype units of the complete Rebecca-Eureka equipment, comprising an airborne transmitter-receiver and indicator unit and portable transmitter-receiver beacon with vibrator-operated power unit, trickle charger and collapsible aerial system. Further deliveries of prototype approved equipment commenced in October, 1942, and by May, 1943, the whole contract of 100 complete equipments had been delivered.

## A Radar Glossary

- A.I.** Air Interception. Airborne Radar equipment carried by fighters to locate bombers at close range at night. First successful use reported on night of July 22-23, 1940. From November, 1940, to autumn, 1941, the main night fighter using A.I., Mk. IV, was the Beaufighter, with an interception range of 20,000 to 600 ft.
- A.S.E.** Admiralty Signal Establishment.
- A.D.R.D.E.** Air Defence Research and Development Establishment (now R.R.D.E.).
- Babs.** Beam Approach Beacon System of aircraft guidance while landing.
- C.A.** Form of early ranging and warning equipment for Coastal Artillery.
- C.D.** Ditto for Coastal Defence.
- C.H.** Chain of early warning stations set up round the coast ("Chain—Home") to detect the approach of aircraft. The first chain comprised Dover, Dunkirk (Kent), Canewdon, Gt. Bromley, and was in operation continuously from September, 1938.
- C.H.L.** "Chain—Home, Low-flying." Variant of C.H. for the detection of aircraft flying at heights of a few hundred feet.
- C.O.** }  
**C.O.L.** } Overseas variants of C.H. and C.H.L.
- Elsie.** Elided form of S.L.C. : Searchlight Control. Equipment mounted on searchlights to give accurate bearing and elevation, enabling the light to be opened up directly on the target.
- Ge** (**G**). Code name for system whereby time differences in the receipt of signals emitted from 3 or more stations are used to fix the position of the receiving station.
- G-H.** System for measuring the range of an aircraft from two fixed ground beacons.
- G.C.I.** Ground Controlled Interception. Equipment for directing night fighters to their targets, used in conjunction with the P.P.I.
- G.L.** Gun Laying. Application of Radar to rangefinding by the measurement of interval between pulse and echo on the time base of the C.R. tube. The Mk. I G.L. had an accuracy of 50 yards up to 15,000 yards. A later addition enabled both range and elevation to be measured and in addition provided for the selection of a particular target to the exclusion of others.
- G.L.T.** }  
**A.G.L.T.** } Gun Laying Turret. Automatic Gun Laying Turret.
- H<sub>2</sub>S.** Code name for device which reproduces a form of map of the terrain over which an aircraft is flying. By scanning the landscape continuously by a beam of short-wave radiation it is possible to distinguish between reflexion from buildings and objects which give a strong echo and weak echoes from scattering by water and open land.
- I.F.F.** Identification : Friend or Foe. For short account of this system see *Electronic Engineering*, August, 1945.
- M.B.** Mobile Base early warning equipment.
- Maggie.** Original code name for ranging unit fitted to S.L.C., now obsolete.
- Oboe.** Code name for the system of directing bombing aircraft to their targets. The position of the aircraft is fixed by range measurements from two ground stations and the correct moment for releasing bombs is given by signals from another station.
- P.P.I.** Plan Position Indicator. A method of indicating the target by means of a rotating beam aerial, the echo from which is shown on the C.R. tube by the brightening of the trace which is swept round in synchronism with the aerial. The position of the target is given by the distance of the bright spot from the centre of the tube and its bearing is given by the angular bearing of the line trace.
- Rebecca.** }  
**Rebecca-Eureka.** } Radio Beacon systems responding only to a code interrogation by the I.F.F. system.
- R.R.D.E.** Radar Research and Development Establishment.
- S.L.C.** Searchlight Control—see "Elsie."
- T.R.E.** Telecommunications Research Establishment.

# Frequency Measurement at U.H.F.

The use of a communication superhet as an accurate wavemeter for frequencies up to 250 Mc/s.

By G. A. HAY, M.Sc., Assoc.Brit.I.R.E.\*

**M**ETHODS available for the measurement of frequency in the range 30 to 300 Mc/s. can be broadly divided into three classes. The least accurate method is that employing an absorption wavemeter, which works at the frequency concerned, and must therefore be calibrated against an external standard. This method is ideal for rough measurements and does not give any ambiguity due to the presence of harmonics, but suffers from the defect that the position of maximum response is not well defined due to flatness of tuning.

Alternatively, we may use standing waves on a transmission line as a wavemeter; this, of course, measures the actual wavelength, and has the advantage that calibration is easily done with a metre rule. The apparatus, however, is bulky, and the accuracy of measurement is not comparable with methods in use at lower frequencies. This may be due to the difficulty of determining nodal and antinodal points accurately, and also to the disturbing influence of objects of dielectric constant greater than unity.

The absorption wavemeter can be greatly improved by the addition of a valve which will provide the necessary energy to maintain the tuned circuit in continuous oscillation—this is the familiar heterodyne frequency meter. The meter can now be set very accurately to the unknown frequency, as any difference between the two results in an audio-frequency beat note which reduces to zero without difficulty. The accuracy of this method is limited mainly by the stability of the oscillator and its tuned circuit with regard to temperature changes, and an important modification is to provide check points at regular intervals by means of a crystal oscillator and harmonic generator. A wavemeter using this principle has been described recently (Beattie and Knight, *Wireless World*, March, 1944) and the method is undoubtedly one of the most satisfactory available.

Instead of making the variable oscillator tune over the whole range

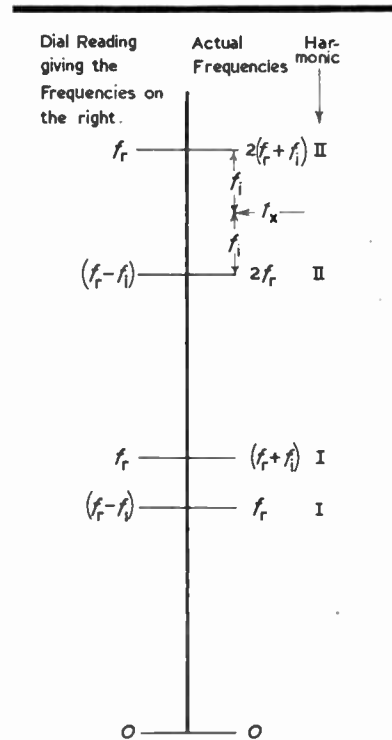
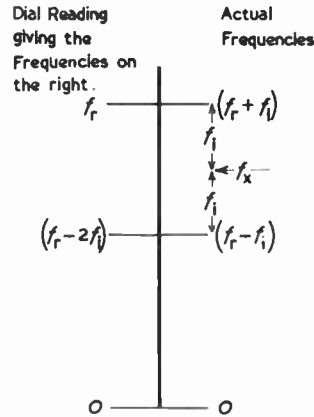

Fig. 1 (above). Frequency relationships when oscillator fundamental is being used.  $\Delta f = 2f_i$ .

Fig. 2 (below). Oscillator second harmonic in use.  $\Delta f = 2f_i/2$ .

of signals to be encountered, an alternative is to provide crystal harmonics, at say 1 Mc/s. intervals, and then to provide a variable low frequency oscillator of stable construction and accurate calibration to interpolate by a beat method between these harmonics. There are several variations of this, all of which can be relied on to a high degree of accuracy. A difficulty which arises in this method is the identification of the particular harmonic in use. This can be done by the laborious process of counting, or by certain other heterodyne methods (Clapp, *General Radio Experimenter*, September, 1943, and January, 1944).

In many cases the degree of accuracy given by the last two methods is not required, while something better than the simple absorption wavemeter is wanted. For example, in the measurement of the radio-frequency resistance of a tuned circuit by capacitance variation, the final calculation involves the resonant frequency to the first power. Now as the results of this sort of measurement are rarely better than  $\pm 5$  per cent. at these frequencies, it is quite sufficient to determine the frequency to  $\pm 0.5$  per cent. This can be done simply and effectively by a method developed by the author, using a conventional communication superhet receiver.

For use in this way, the receiver must have the following characteristics: (a) a range covering 10 to 30 Mc/s. or thereabouts; (b) a known or measurable intermediate frequency, with as high a value as possible; (c) preferably a good band-spread scale which can be used to indicate roughly frequency differences of the order of 100 to 1,000 kc/s.; (d) a beat frequency oscillator. The method depends on the use of harmonics of the receiver oscillator, and thus the percentage accuracy is the same no matter which harmonic is in use. The calibration of a good receiver is usually reliable to about  $\pm 1$  per cent., and if a crystal calibrator is available as an accessory this figure can be greatly improved.

The signal whose frequency  $f_x$  is to be measured is injected into the mixer

\* Rutherford Technical College, Newcastle-on-Tyne.

section of the frequency changer. For this it is necessary to by-pass the R.F. stages, if any, and it is usually sufficient to attach a short pick-up lead about a foot long to the mixer grid, leaving the signal frequency tuned circuit connected. For weak signals it would be an advantage to substitute an external circuit tuned to the unknown frequency, but in practice this has not been found necessary.

Harmonics of the unknown frequency originally present are unlikely to cause any trouble, but harmonics generated by overloading of the mixer may be troublesome, and this condition must be avoided.

The selectivity of the receiver is then set to minimum to facilitate tuning, and the beat frequency oscillator switched on. Suppose that  $f_x$  lies within the highest band on the receiver, and is tuned in on this band. There will be two tuning points, as there is no pre-selection, and if, as is usual, the oscillator frequency in the receiver is designed to be higher than the signal, the dial reading  $f_r$  will be equal to the unknown  $f_x$  if the higher tuning point is used. The repeat point will appear at a dial reading less than  $f_r$  by twice the intermediate frequency, *i.e.*, at a point  $(f_r - 2f_i)$  on the scale, where  $f_i$  is the intermediate frequency (*see* Fig. 1).

Now if  $f_x$  is of the order of twice its former value, it will heterodyne the second harmonic of the oscillator. Assuming that it is still tuned in at the higher repeat point  $f_r$  on the scale, its frequency will *not* be  $2f_r$ . For if the receiver dial is set to  $f_r$ , the oscillator frequency will be  $(f_r + f_i)$  and its second harmonic  $2(f_r + f_i)$ . Now this will be higher than the unknown  $f_x$  by  $f_i$ , and so  $f_x$  will be equal to  $2(f_r + f_i) - f_i$ , and as  $f_x = 2(f_r + f_i) - f_i$ , the oscillator second harmonic will be

$$[2(f_r + f_i) - f_i] - f_i = 2f_r$$

Hence the two repeat points will be found at scale readings  $f_r$  and  $(f_r - f_i)$ , and the difference between them is  $f_i$ . This is shown diagrammatically in Fig. 2.

In the general case, where the unknown  $f_x$  beats with the  $n$ th harmonic of the oscillator, and is received at the higher tuning point on the scale  $f_r$ , the oscillator fundamental is again  $(f_r + f_i)$ . The harmonic in use is  $n(f_r + f_i)$ , and  $f_x$  is then equal to  $n(f_r + f_i) - f_i$ . The lower possible oscillator harmonic is  $(f_x - f_i)$ , which on substituting for  $f_x$  gives

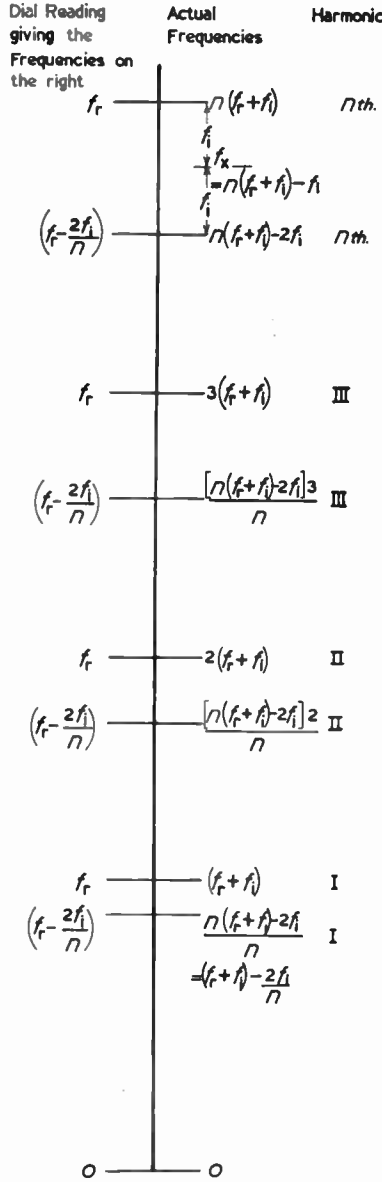

Fig. 3. Representation of the general case where the  $n$ th harmonic of the oscillator is in use.  $\Delta f = 2f_i/n$ .

$n(f_r + f_i) - 2f_i$ , and its fundamental is therefore

$$[(f_r + f_i) - 2f_i]/n = (f_r + f_i) - 2f_i/n$$

Thus the difference in scale readings between the two alternative settings is

$$(f_r + f_i) - \left[ (f_r + f_i) - \frac{2f_i}{n} \right] = \frac{2f_i}{n}$$

It appears, therefore, that two separate operations will determine fully the frequency of an unknown signal: (1) the tuning in of the signal at the higher alternative setting on the dial  $f_r$ ; (2) the measurement of the

frequency difference  $\Delta f$  between the two possible settings. Then

$$f_x = n(f_r + f_i) - f_i = nf_r + (n - 1)f_i \dots \dots \dots (1)$$

$$\text{and } \Delta f = \frac{n}{2f_i}$$

$$\text{or } n = \frac{\Delta f}{2f_i} \dots \dots \dots (2)$$

In calculating  $n$  from Equation (2) an integral value will probably not be obtained, due to errors in measurement, and the nearest whole number must be used.

**Example**

A numerical example will make the application of the method clear. Suppose that an unknown signal  $f_x$  is injected into the mixer, and the higher tuning point  $f_r$  is 20 Mc/s. The lower tuning point is found to occur at a setting of 19.7 Mc/s., and the I.F. is 450 kc/s. The oscillator frequencies corresponding to settings of 20 and 19.7 Mc/s. are 20.45 and 20.15 Mc/s., and these have harmonics of 40.9 and 40.3 Mc/s., 61.35 and 60.45 Mc/s., 81.8 and 80.6 Mc/s., etc. Now for one of these pairs of harmonics to represent a pair of tuning points for a single signal frequency, they must differ by twice the intermediate frequency. This condition is satisfied by the third harmonics, 61.35 and 60.45 Mc/s., which are 0.9 Mc/s. apart. Hence  $f_x$  must be less than 61.35 Mc/s. by the intermediate frequency, and therefore has a value of 60.9 Mc/s. In using the method in practice, of course, it is unnecessary to follow the above reasoning in each case, as the result can be easily obtained by substituting in Equations (1) and (2):

$$\text{from (2) } n = \frac{2f_i}{\Delta f} = \frac{2 \times 0.45}{0.3} = 3$$

$$\text{from (1) } f_x = nf_r + (n - 1)f_i = (3 \times 20) + (2 \times 0.45) = 60.9 \text{ Mc/s.}$$

The accuracy is limited mainly by the accuracy of calibration of the receiver, and use of the higher harmonics conditioned by (1) the strength of the harmonic in the oscillator output, (2) the minimum frequency difference measurable with reasonable accuracy. For as  $\Delta f = 2f_i/n$ , if  $n$  increases,  $\Delta f$  decreases, and it becomes more difficult to discriminate between adjacent harmonics. Using a non-standard receiver with a fairly good mechanical band-spread dial, measurements have been made without ambiguity up to the sixth harmonic of 30 Mc/s., and further harmonics could have been used with a little care in adjustment.

# Post-War Television Ideas from U.S.

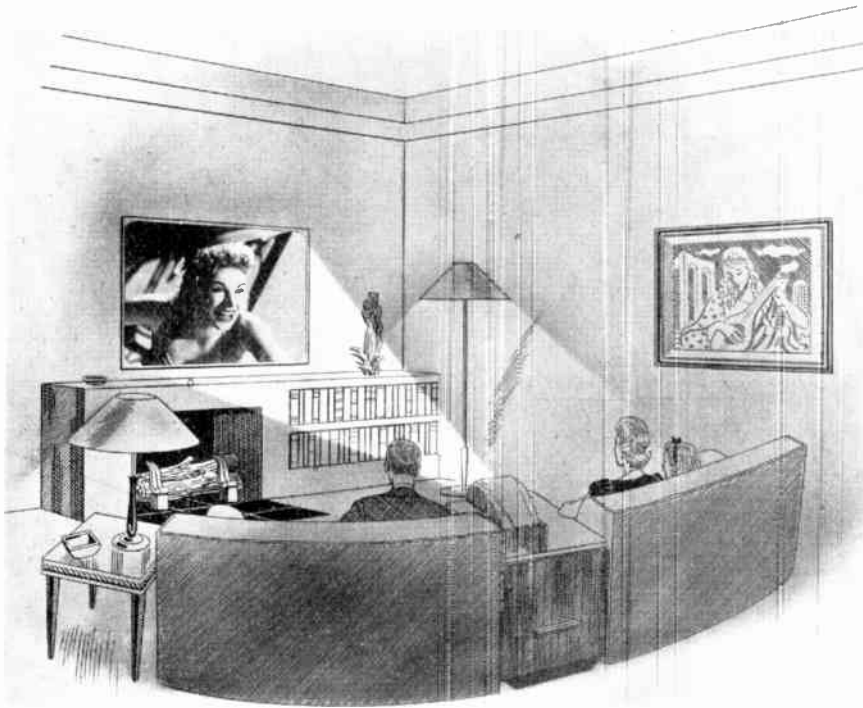

THE Du Mont Laboratories (Passaic, N.J.) gave a pre-view of their post-war designs for television receivers earlier in the year and the accompanying photographs show two of the models demonstrated.

The de luxe projection installation (left) is capable of giving a picture 4 ft. by 3 ft., and is shown in conjunction with settees for family viewing.

One of the modern style "teletesets" shown below has a 20-in. tube for direct viewing and is housed in a cabinet 60 in. by 24 in. deep by 48 in. high—approximately the dimensions of an ordinary radiogram cabinet. Push-button controls automatically open the door in front of the tube and tilt the tube into the viewing position (see drawing on left). The cabinets were specially designed by Herbert Rosengren, one of America's leading industrial designers, and are available in classic and modern styles. Station selection is by means of push-buttons, and the controls will be pre-set as far as possible when the receivers are installed.

—Photographs by courtesy of Du Mont Laboratories.

De luxe projection installation and (below) cabinet with 20-in. tube.

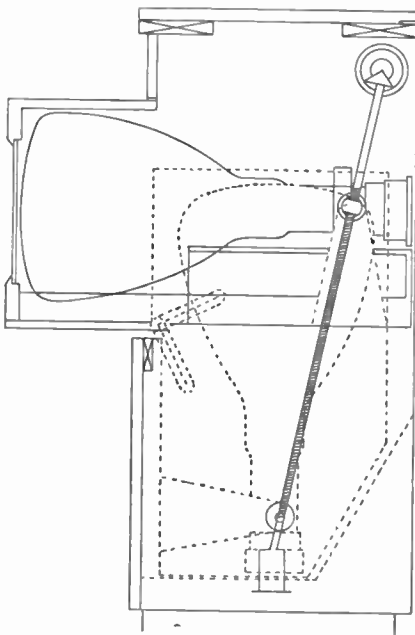

# Cathode-Ray Tube Traces

## A Series to Illustrate Cathode-Ray Tube Technique

### Part III.—Circular and Spiral Time Bases

By HILARY MOSS, Ph.D., A.M.I.EE.

**General**

**I**N Part II, when discussing straight line time bases, attention was directed to the advantages of using simple sinusoidal time base waveforms. The superiority of the discontinuous time base wave, in respect of linearity and occupancy,\* is obtained only at the expense of increased difficulty in the attenuation and amplification of such wave-shapes. In addition the problem of synchronisation of the time base to the period of the phenomenon under examination presents more difficulty than might be supposed, unless we choose to be rather uncritical about "jitter." There is little doubt that "linear" time bases are used too often in applications where their complications are unjustified, and where sinusoidal waveforms would be simpler and more satisfactory.†

The primary drawback of the sinusoidal time base is its low occupancy rather than poor linearity, for the latter can be made very good by sweep expansion (Fig. 3, December, 1944). This drawback can be eliminated by an interesting development, in which two sine waves in phase quadrature are used to produce not a straight line, but a circular trace. This time base waveform in a sense has also perfect linearity, since the speed of the spot traversing the circle is absolutely constant.

Suppose we apply to the X-plates a voltage  $A \cdot \cos \theta$ , and to the Y-plates a voltage  $B \cdot \cos(\theta - \pi/2) = B \cdot \sin \theta$ . The amplitudes of  $A$  and  $B$  are adjusted so that the maximum spot displacements along the two axes are equal. Then the parametric equation of the spot locus is:

$$\begin{aligned} x &= R \cdot \cos \theta \\ y &= R \cdot \sin \theta \end{aligned} \quad (39)$$

Squaring these two equations and adding, results in the elimination of the parameter  $\theta$ , and gives the expression of the locus in the familiar Cartesian form:

$$x^2 + y^2 = R^2 \quad (40)$$

\* "Occupancy"—an expressive term meaning the ratio of the useful forward tracing time of the fluorescent spot to the total time for one complete cycle on the tube face.

† This statement may require modification in the light of very modern unpublished time base developments.

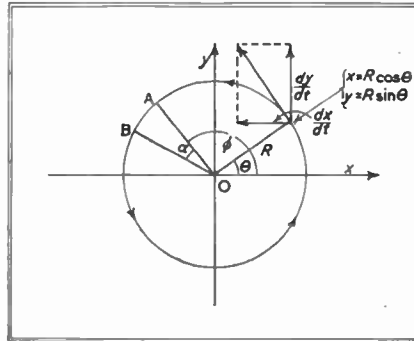

Fig. 1.

which is the equation of a circle, centre at origin, and of radius  $R$ , as shown in Fig. 1.

We now prove that the speed with which the spot traces the circle is constant. Differentiating each equation (39) in turn, with respect to  $t$ , and squaring, yields the two equations:

$$\left(\frac{dx}{dt}\right)^2 = R^2 \cdot \sin^2 \theta \left(\frac{d\theta}{dt}\right)^2 \quad (41)$$

$$\left(\frac{dy}{dt}\right)^2 = R^2 \cdot \cos^2 \theta \left(\frac{d\theta}{dt}\right)^2$$

These two equations define the components of the velocity of the spot along the X and Y axes. Adding the two left-hand sides together gives the square of the spot speed round the circle (using the velocity parallelogram, Fig. 1). Performing the same operation on the right-hand side gives

$$R^2 \cdot \left(\frac{d\theta}{dt}\right)^2, \text{ which is obviously constant, since as usual } \theta = \omega t, \text{ where } \omega = 2\pi \cdot f.$$

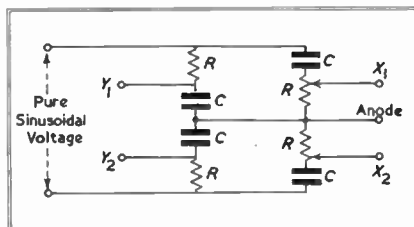

Fig. 2. Production of L.F. circular time base. (Passive circuit giving balanced deflector plate voltages in phase quadrature.)

Note.— $R$  adjusted to be approximately equal to  $1/\omega C$ .

It will be noted that the circular locus defined by (39) or (40) is merely a special case of the Lissajous figure with one-to-one frequency ratio. (Refer to June issue, 1944.)

Here, then, is a remarkable type of time base wave. It has absolutely uniform speed, employs only pure sine waves, gives 100 per cent. occupancy, and requires no flyback mechanism. It is indeed unfortunate that this perfection is so marred by the difficulty of modulating the circular trace with the signal under examination. Before considering the various methods available, we shall treat the production of the circular time base wave itself.

**Production of Circular Time Base Trace**

**All-Electrostatic Method**

(a) *At Audio-Frequencies.*

The simplest method uses the condenser-resistance phase-splitting circuit shown in Fig. 8, September, 1944, but this has the drawback of providing asymmetrical deflecting potentials. A modification of this arrangement which gives symmetrical deflecting potentials (*i.e.*, potentials balanced to anode) is shown in Fig. 2. It is usually most convenient to feed this network from an isolating transformer, and it is desirable that the secondary winding of the latter should be electrically balanced to ground.

Consideration of Fig. 2 will show that the shunt capacities of the Y deflector plates of the C.R.T. merely slightly increase the value of the condensers  $C$ , and have therefore no effect on the operation of this arm of the network. However, the X-plate capacities shunt the resistances  $R$ , and in general, unless the latter are made inconveniently low in value (with consequent heavy loading on the driving circuits), it is not possible to obtain accurate phase splitting, and the circular trace degenerates into an ellipse.

This difficulty may be conveniently avoided by modifying the network of Fig. 2, as shown in Fig.3(a). The modification consists merely of joining the slider of *one* of the potentiometers  $R$  to the end of the track, thus converting it into a variable resistance.



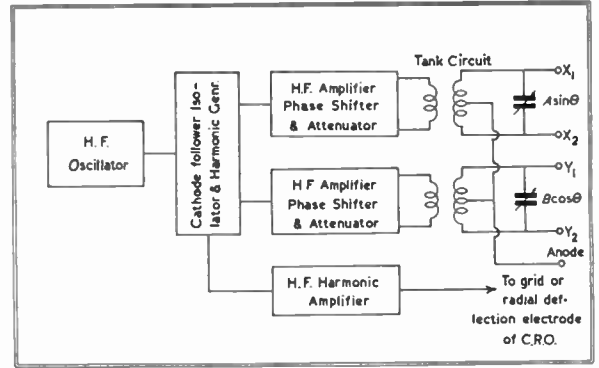
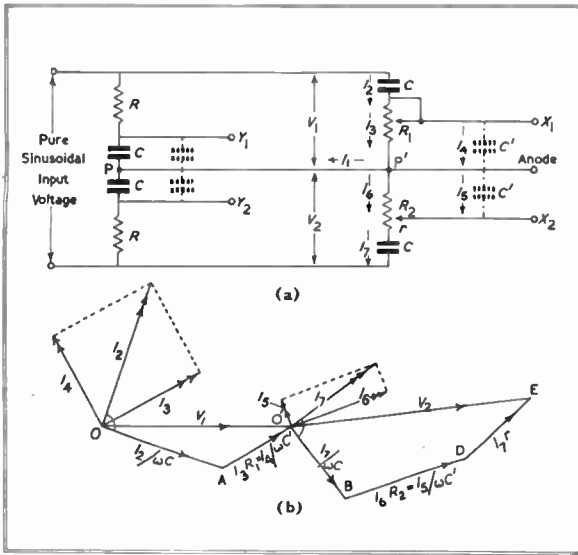

Fig. 5 (above). Production of H.F. circular time base with auxiliary synchronised voltage for radial modulation.

Fig. 3 (left). (a) Circuit of Fig. 2, but modified to allow compensation for deflector plate capacities  $C'$ .

(b) Vector diagram for right-hand portion of network of Fig. 3(a)

A rigorous analysis of the resulting network is far too involved to be treated here, but some general idea of how the compensation is obtained can be seen from the following considerations. The left-hand portion of the network is symmetrical about the point P, and P is joined to the nominal symmetry centre of the right-hand portion at P'. Thus, in spite of the lack of symmetry of the right-hand portion (except at full X-plate voltage), the point P' tends to be held at roughly the mid point of the two rails, and the voltages  $V_1$  and  $V_2$  are substantially equal in phase and magnitude. This condition could be closely approximated by making the impedance of the left-hand portion of the network low in relation to the impedance of the right-hand portion.

With this simplification in mind we can construct the vector diagram for the right-hand portion, as in Fig. 3(b). The effect of the deflector plate capacitances is to introduce a displacement current  $I_3$  which retards the current through  $R_2$ , and causes the voltage between anode and  $X_2$  (equal to vector BD) to lag, thus upsetting the phase split. Compensation is introduced since on reducing  $R_1$ , the current  $I_2$  increases in magnitude, and becomes more leading in phase. Thus the anode to  $X_1$ -plate voltage (equal to vector AO') is advanced in phase, and by suitable adjustment of  $R_1$  and  $R_2$ , the resultant inter-X-plate voltage (vector sum of BD and AO') can be made to be exactly  $90^\circ$  out of phase with the Y-plate voltage. The price paid for this facility is a lack of perfect balance between the plate

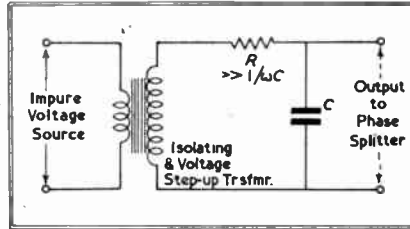

Fig. 4. Simple harmonic filter.

voltage and anode, but for many purposes this does not matter much. In any case the conditions are better than when completely unsymmetrical deflecting potentials are used, and, in fact, unless the capacities are so large that their reactance is of the same order as  $R_1$  and  $R_2$ , fair balance is obtainable.

(a) At Audio-Frequencies (cont.)—Harmonic Filters.

For general use the most important audio source is the supply mains, usually of 50 c/s. Unfortunately, this source has usually a very appreciable harmonic content, and attempts to produce a circular trace by phase splitting give rise to a distorted circle, of the form shown in photo No. 100. (See also September issue, 1944.)

To overcome this difficulty Dye<sup>1</sup> suggested 20 years ago the use of L.F. resonant circuits. This technique is a little difficult at frequencies as low as 50 c/s. where it is not easy to construct high Q passive circuits, and the author prefers a simpler solution shown in Fig. 4. Provided  $R$  is appreciably larger than the reactance of  $C$  at the frequency considered then the current waveform through the circuit has sub-

stantially the same shape as the impressed voltage wave. But the reactance of the condenser varies as  $1/n$  where  $n$  is the order of the harmonic, so that the voltage wave developed across it has its harmonics attenuated in proportion to their order. The inner circle of photo No. 100 shows the improvement effected by this method. Circuit values were  $R = 10,000$  ohms, and  $C = 1 \mu F$ . The technique is naturally wasteful in power, but this is seldom of importance when using the supply mains as a source.

(b) At Radio Frequencies.

At high frequencies it is easy to construct resonant circuits of high Q, and the obvious source of sinusoidal waves is clearly a tuned circuit. Such a driving network has the following important advantages: (1) low D.C. resistance to anode, (2) excellent discrimination against unwanted harmonics, (3) balanced deflecting voltages readily obtained by centre tapping inductance, (4) deflector plate circuits easily isolated from driving oscillator circuit in a D.C. sense, by using H.F. transformer with primary in anode circuit of driving valve, (5) deflector plate capacitances merely augment tuning condensers of resonant circuit. In fact, such a driving network is perfect in all respects.

Fig. 5 shows a block diagram of a suitable circuit incorporating these features. Tuned circuits (not shown) are also used between the cathode follower isolating stage and the H.F. amplifier. The required phase split is obtained by slightly mistuning the resonant circuits

In practice some care is necessary to provide sufficient discrimination against harmonics when only two sets of tuned circuits are used, since the requirement of phase splitting necessitates these being somewhat mistuned. It is helpful to provide variable coupling between the primary and secondary coils of the tuned transformers. If this is not done there is some risk of harmonics being transmitted through the circuits due to excessive coupling, or, at the other extreme, of insufficient coupling resulting in heavy voltage attenuation. Some effects of harmonics of higher order than the time base frequency have been discussed in the September, 1944, issue. Photo No. 101 shows the results of sub-harmonics. In this case the master oscillator frequency was 100 kc/s., while the time base frequency was 200 kc/s., but with a superposed component at 100 kc/s. due to excessive coupling in the tuned circuits. This forms a double loop as shown.

This defect often displays itself, in more insidious form, as a thickening of the circular trace, which might be mistaken for the results of mains interference.

**Semi-Magnetic Method**

Although the all-electrostatic methods discussed are the most generally convenient, it is necessary to appreciate that the beam locus thereby generated is not conical. It is a somewhat similar but more complex form with two apexes, one at the deflection centre of each of the two sets of plates. As a result the angle at which the beam strikes the screen is not constant round the circle, and with several of the methods of radial modulation employed this causes a variation of radial sensitivity round the trace. (See photos Nos. 103-108). This is not usually a serious defect, since only rarely is it necessary to make radial deflection measurements. In any case it is bad practice to attempt such a form of display for most quantitative work, since the task of producing radial deflections which are propor-

tional to voltage is far from easy, except for small displacements.

If, however, for some special reason, *uniformity* (although not necessarily linearity) of deflection is essential, then the time base circle should be produced from coincident electric and magnetic fields. This has been described by Von Ardenne.<sup>2</sup> By this technique the beam locus can be made conical. Fig. 6 shows the essence of the method. It is clear that if the coil resistance is zero, then the phase splitting is automatically obtained, since the current through the coil will lag behind the voltage by 90°.

A spiral time base is merely a special case of a radially modulated circular base, in which the radial modulation period is long in relation to that of the tracing time of one revolution. The generating methods follow therefore to the next section.

**Modulation of Circular Time Bases**

We here use the term "modulation" in its most general sense, to imply the impressing of signal intelligence on the circular trace.

*(a) Grid Modulation.*

This is the simplest and most direct method. The obvious drawback is that it gives only the crudest idea of the *shape* of the modulating signal, this estimate being based on the variation of beam brilliance round the circle (see photo No. 102).

There are, however, two types of measurement where this limitation is of no consequence—firstly, in the measurement of frequency in terms of the frequency of the sinusoidal oscillator driving the time base circle, and secondly, the measurement of the phase difference (or time interval) between two or more sharp pulses.

Attention must be drawn to the ambiguity of these measurements. In Fig. 1, A and B represent the positions of two pulses. If A has co-ordinates  $(R, \phi)$ , then B has co-ordinates  $(R, \phi + \alpha + 2\pi.k)$  where  $k$  is any integer, so that there are an infinite number of solutions to the phase difference or time interval.

An exactly analogous ambiguity arises when making a frequency comparison. The photo No. 102, for instance, illustrates the pattern obtained when the grid modulation frequency is 17 times that of the time base, but this is not a unique solution, for we are not justified in assuming that adjacent arcs are formed during the same revolution of the spot. This will be better appreciated by supposing that frequencies having non-integral ratios with the time base frequency are used to modulate the grid. Typical patterns thus produced are shown in photos Nos. 107 and 108. A little consideration will show that if the number of arcs present is  $n$ , then the frequency of the signal modulating the grid is  $n/k$  times the time base frequency, where  $k$  can have all values from 1 to infinity, excluding those values which give  $n$  and  $k$  a common factor.

This ambiguity may be of no account in some cases, since the *approximate* frequency ratio may be known from other data. Otherwise, and if  $k$  is not large, it is possible to disentangle the wanted solution by making the whole pattern move laterally across the screen, and watching the way the arcs break up into rows. The number of rows so formed is equal to  $k$ . This technique is hardly elegant.

When the ratio of grid modulation frequency to time base frequency is not expressible in the form  $n/k$ , where  $n$  and  $k$  are integers, the pattern rotates. Let  $f$  be the time base frequency, and  $p$  the "slip" frequency, i.e., the number of times per second that the pattern rotates. Then it can be shown that the grid modulation frequency is  $n \left[ \frac{f}{k} \pm p \right]$

where the positive sign is taken when the slip is in the opposite direction to the direction of spot traverse, and the negative sign when they are in the same direction. Methods of determining the direction of spot traverse were discussed in the September issue, 1944.

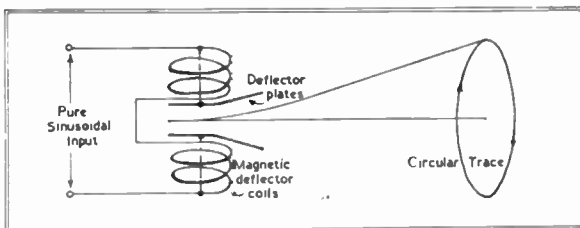
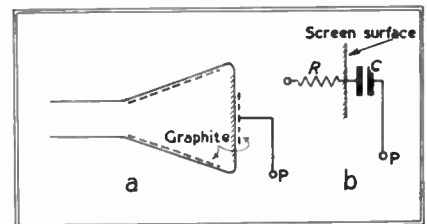

Fig. 6 (left).

Fig. 7, a & b (right).



## Patterns relating to Circular



100

Two separate records. L.F. circular time base, at 50 c/s. Outer trace obtained direct from mains (via transformer) and phase-splitting circuit of Fig. 3. Inner trace with addition of harmonic filter as Fig. 4.



101

R.F. circular time base, 200 kc/s. with superimposed 100 kc/s. subharmonic.

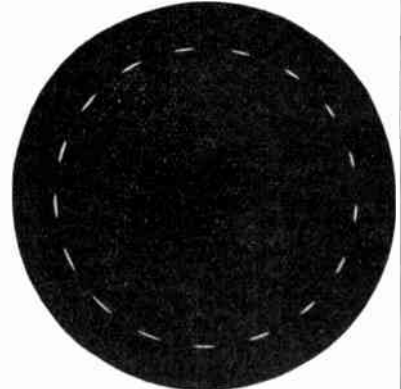

102

Modulation of circular time base by grid injection. Time base frequency, 100 kc/s. Grid frequency, 1.7 Mc/s.

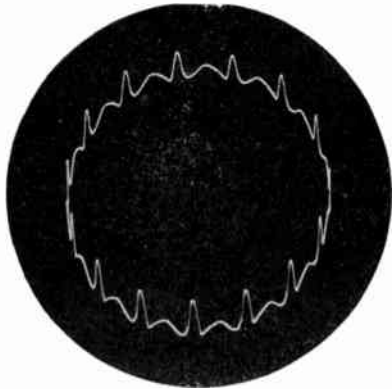

103

Modulation by series injection of signal into Y-plate.

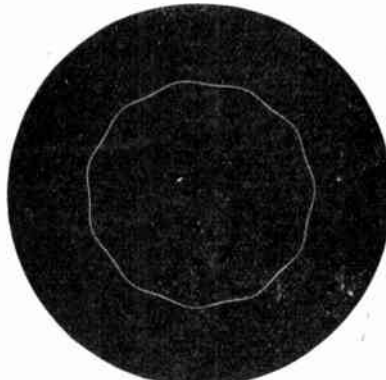

104

Radial modulation by screen induction. Anode voltage 2.4 kV. Radial signal voltage approx. 250 at 1.1 Mc/s.



105

Radial modulation pattern with radial frequency twice time base frequency. Circle is time base alone without radial signal (double exposure).



106

Sinusoidal radial signal of frequency 10 times that of time base.

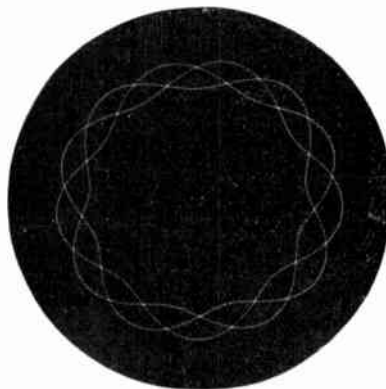

107

Sinusoidal radial modulation with radial frequency  $13/3$  times that of time base. Actual frequencies: Time base, 300 kc/s. Radial signal, 1.3 Mc/s.

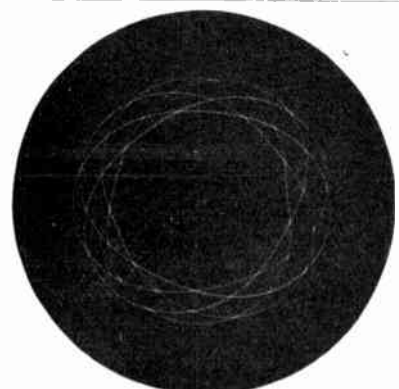

108

As 107, but radial frequency  $9/5$  times that of time base.

## and Spiral Time Bases



109

Radial deflection on special tube with centre spike electrode. D.C. voltages of +120, +80, +40, 0, -40, -80, -120. H.T. voltage, 2 kV. Note distortion of circle due to all-electrostatic time base.

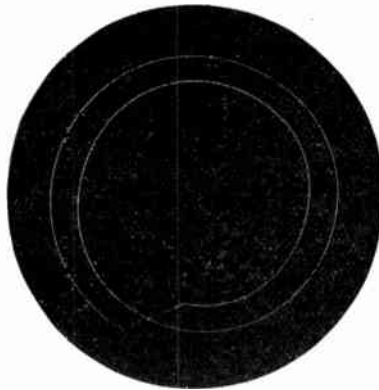

110

Short spiral trace obtained on special radial deflection spike tube, with linear time base connected to spike. Time base repetition rate half that of circular trace frequency.



111

As 110, but time base repetition rate one-sixth that of circular trace frequency.



112

As 110, but time base repetition rate three times that of circular trace frequency.

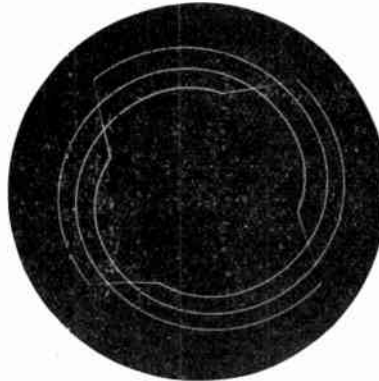

113

As 110, but time base repetition rate  $\frac{4}{3}$  that of circular trace frequency.



114

Determination of duration of damped oscillation produced by sharp pulses from squared sine wave (two pulses per sine wave cycle). Time base circular trace produced by phase splitting same sine wave, thus ensuring perfect synchronisation.



115

Radial modulation by sinusoidal wave of one-third frequency of circular trace. Circular trace wave amplitude modulated before phase splitting.

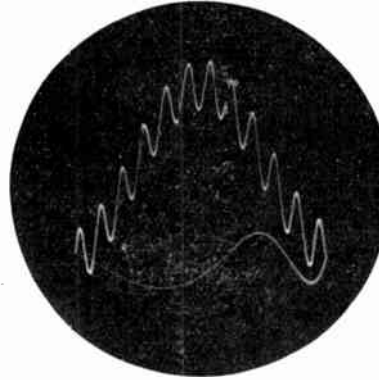

116

Sine wave with very strong twelfth harmonic content, as applied to phase splitter, producing circular trace of photo 117.

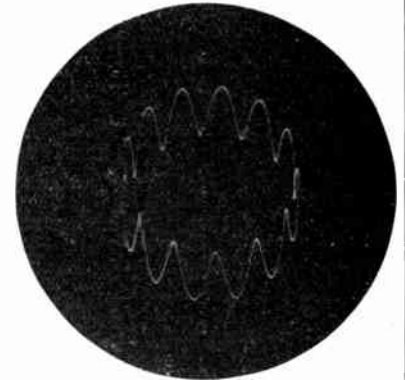

117

Pattern resulting from application of wave of photo 116 to phase splitter. Horizontal axis fed from plates across condenser. Note there is some radial modulation in horizontal direction. Cf. photos Nos. 76 and 103.

(b) *Deflectional Modulation by Superposition of Signal on one pair of Deflector Plates.*

Here the signal is merely injected in series with one of the time base voltage components. Photo No. 103 shows a typical resulting pattern. It is clear that many of the advantages of a circular trace are nullified by this method of modulation.

**True Radial Deflectional Methods**

(1) *Radial Modulation by Variation of Anode Voltage.*

The sensitivity of a cathode-ray tube varies inversely as the final anode voltage. Thus the radius of the circular time base trace is inversely proportional to the anode voltage. One interesting advantage is that the radial sensitivity is constant all round the circle, even for large deflections. This feature is not easy to obtain by any other method, even if we generate the circular time base by crossed electric and magnetic fields, so that the beam locus is a cone with a common apex for the X and Y scans.

To avoid defocusing of the beam for large deflections it is necessary to modulate the focusing anode voltage in phase with the final anode voltage. To ensure proper phasing, the two halves of the supply potentiometer feeding the second (focusing) anode should be shunted by frequency compensating condensers. Omission of these condensers may result in loss of uniformity of focus quality. The main drawback to the method is the loading imposed on the modulating source which is in series with the power supply to the tube.

(2) *Radial Modulation by Screen Induction.*

This is a little-known method which has occasional uses, and which does not require a special tube. A circular metal plate perhaps 1-2 inches in diameter is brought up close to the screen of a normal cathode-ray tube, so that the centre of the plate and the screen coincide. The radial modulating voltage is applied between this plate and the final anode or wall coating of the tube. Alternatively (and preferably on account of somewhat increased sensitivity), the screen centre is painted over with a roughly circular patch of colloidal graphite to which electrical connexion is made (Fig. 7(a)). Equally good results can be obtained by painting on the graphite in the form of a ring round the periphery of the bulb face, and this has the advantage of not obscuring the screen centre.

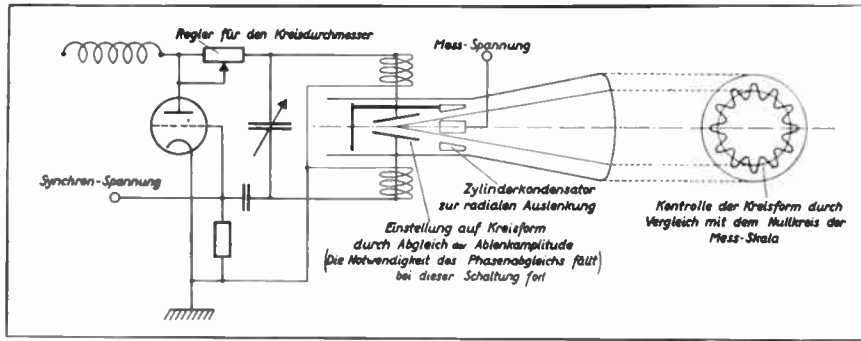

Fig. 8. Von Ardenne's radial deflection tube.

Some idea of the mode of operation of this arrangement can be obtained by consideration of the equivalent circuit shown in Fig. 7(b). Here  $C$  represents the capacitance between the graphite coating and the interior of the screen surface. The resistance  $R$  represents the "leakage resistance" between this interior surface and the final anode. In the absence of any electron beam,  $R$  is almost infinite, but its value falls greatly as soon as the screen is scanned, on account of secondary emission effects. It would be reasonable to assume that  $R$  varies roughly inversely as the beam current. Again it is apparent that  $R$  will be much higher when the screen is driven positive, since in the latter case secondary electrons are rapidly attracted to neutralise the charge. Measurements made by the author on a typical tube gave time constant values of about  $1/2$  second on negative pulses and some  $1/10$  sec. on positive ones, with beam currents of the order of 15 microamperes. This indicates that the method is suitable down to quite low audio-frequencies. The order of sensitivity obtainable is 30 V/mm. per volt. This is low, but it should be remembered that the load imposed on the driving circuit is virtually zero, being mainly that due to the capacity of the connecting lead. Photo No. 104 shows a trace obtained by this technique.

Tubes which possess separate connexions to the wall coating (or better still—post-accelerator types) are easily modulated radially on these electrodes. Although the sensitivity is often not much higher than with the screen induction method, an advantage is gained for some work, since the radial deflection is "D.C." connected.

(3) *Special Radial Deflection Tubes.*

Various tubes have been designed from time to time which incorporate

specially shaped electrodes to give radial deflections at reasonably high sensitivity.<sup>2,3</sup> (Fig. 8.) A common method is to insert a rod-shaped electrode through the screen end of the tube to within a few cms. of the deflector plates. With such construction a sensitivity of the order of 200/V and an input capacitance of about  $4 \mu\text{F}$  are obtainable. Fair deflectional linearity (see photo No. 109) is also obtained provided the deflection is small. This latter restriction is generally enforced from consideration of deflection defocusing, which tends to be severe in this class of tube. It is very doubtful whether the manufacture of such tubes is justified, having regard to their limited application.

**Radial Modulation by Circuit Methods**

It is apparent that all the methods so far described fall short of the ideal for various reasons, except perhaps the method using a special form of radial deflection tube not generally available. It is therefore necessary to consider carefully how radial deflections might be imparted to the beam by purely circuit techniques.

First, we proceed to dispel any possible illusion that the radial modulating signal can be injected before the phase-splitting stage. Suppose, for example, we sinusoidally amplitude modulate the voltage applied across the ordinary series condenser/resistance phase-splitting network. (Fig. 8, September, 1944.) On superficial consideration this might be expected to yield a circle of the required sinusoidally varying radius, but it is easily shown that it does so only when the frequency of the modulating wave is low in relation to that of the time base.

Suppose that the applied voltage has the familiar amplitude modulated

orm  $e = (1 + B \sin \phi t) \sin \omega t \dots\dots (42)$

Rigorous analysis shows that the steady-stage voltage then developed across the condenser is given by

$$e_c = \frac{1}{\sqrt{1 + \omega^2 C^2 R^2}} \sin(\omega t - \alpha) + \frac{B}{2V \{1 + (\omega - \phi)^2 C^2 R^2\}} \sin \{ (\omega - \phi)t + \beta_1 \} - \frac{B}{2V \{1 + (\omega + \phi)^2 C^2 R^2\}} \sin \{ (\omega + \phi)t + \beta_2 \} \dots\dots (43)$$

while the steady-stage voltage across the resistance is:

$$e_r = \frac{\omega CR}{\sqrt{1 + \omega^2 C^2 R^2}} \cos(\omega t - \alpha) + \frac{(\omega - \phi)BCR}{2V \{1 + (\omega - \phi)^2 C^2 R^2\}} \cos \{ (\omega - \phi)t + \beta_1 \} - \frac{(\omega + \phi)BCR}{2V \{1 + (\omega + \phi)^2 C^2 R^2\}} \cos \{ (\omega + \phi)t + \beta_2 \} \dots\dots (44)$$

where  $\tan \alpha = \omega CR$ ,  $\tan \beta_1 = 1/CR(\omega - \phi)$ ,  $\tan \beta_2 = 1/CR(\omega + \phi)$ . Inspection of these expressions shows that beam will not undergo the required radial deflection, since the relative modulation components across the condenser and resistance change with modulating frequency  $\phi$ . But in the special case when  $\phi \ll \omega$ , the method works, because now (43) and (44) reduce to:

$$e_c = \frac{1}{\sqrt{1 + \omega^2 C^2 R^2}} (1 + B \sin \phi t) \sin(\omega t - \alpha) \dots\dots (43A)$$

and

$$e_r = \frac{\omega CR}{\sqrt{1 + \omega^2 C^2 R^2}} (1 + B \sin \phi t) \cos(\omega t - \alpha) \dots\dots (44A)$$

$R$  is adjusted so that the amplitudes of the last two equations are equal (i.e., for equal deflector plate sensitivities  $R = 1/\omega C$ ). (43A) and (44A) then show that the spot locus is a circle of sinusoidally changing radius, so that the circular trace has become radially modulated as required. Photo No. 115 shows some practical results obtained.

Photos Nos. 116 and 117 show the results of attempted radial modulation by merely superimposing the signal in series with the time base voltage before the phase-splitter. Reference should here be made to the September, 1944, issue, including photo No. 69.

From the foregoing considerations it is apparent that the proper technique is to amplitude modulate each of the two separate phase-split components so as to produce terms of the

form of (43A) and (44A). This method was originally due to the Radio Research Board, and is illustrated in Fig. 9. Each of the push-pull stages can be regarded as a circuit which permits its gain to be controlled by the magnitude of the signal applied to both the control grids via the centre-tap on the driving transformers. The use of a symmetrical push-pull stage, however, prevents the gain-controlling signal from itself modulating the output, as would inevitably occur if only a single valve were used. Thus, suppose that the valves are perfectly matched, and that the circuit is perfectly symmetrical. At the instant

when the secondary voltage of transformer  $T_1$  is zero both grids are at the same potential, the current through  $R_1$  equals that through  $R_2$ , and since  $R_1 = R_2$  it follows there is no P.D. across the X deflector plates. But any arbitrary signal applied at P affects the potentials of both grids equally, and since the valves are perfectly balanced, the change of current through  $R_1$  is exactly balanced by an equal change through  $R_2$ . Hence the potential across the X-plates remains zero. When the secondary potential of  $T_1$  is not zero, the curvature of the  $V_g/V_a$  characteristic makes the current changes in  $R_1$  and  $R_2$  resulting from a signal at P unequal, so that an output is obtained. Notice that it is the non-linearity in

Fig. 9.

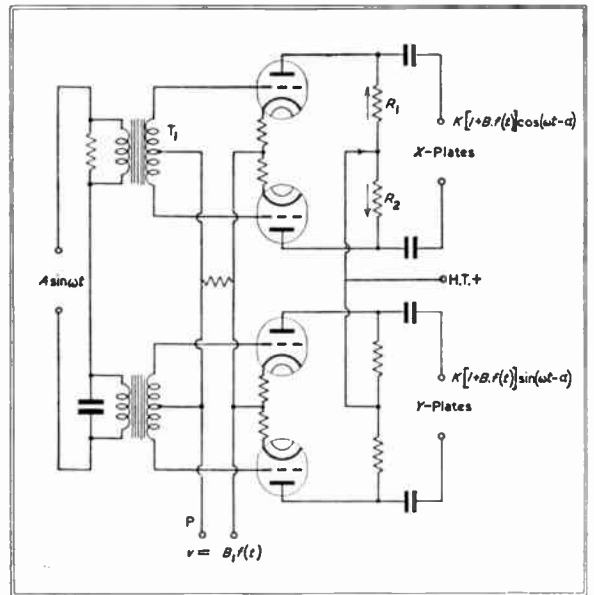

the valve characteristic which provides the output. Modulated waves which by definition contain product terms, as (43A) and (44A), cannot arise from wholly linear networks.

The phase splitting is done before gain modulation. It is instructive to compare this circuit with one due to Stevens.<sup>5</sup>

REFERENCES

- 1 "Improved Cathode Ray Tube Method for the Harmonic Comparison of Frequencies," *Proc. Phys. Soc.*, 1925, 37, p. 158.
- 2 Von Ardenne, W. *Eng.*, 1937, Vol. 14, p. 5.
- 3 Dowling and Bullen, *Proc. Royal Irish Academy*, 1937, Section A, 44, p. 1.
- 4 "The Cathode Ray Tube in Radio Research," I.L.M. Stationery Office.
- 5 "Variable Slope with Constant Current," W. H. Stevens, *W. Eng.*, January, 1944.



# CONDENSERS

## MINIATURE AND TROPICAL RANGES

It has long been known that to rely upon wax coating in components for tropical use was, at the best, only a compromise. Wax merely delays and does not prevent the entry of moisture, and moreover the temperature operating limits of wax-coated components are too restricted.

No alternative was available until T.C.C. engineers again pioneered the way with the tropical sealing technique described below. Now most radio engineers and set designers are familiar with the T.C.C. range of metal-cased miniature and super-tropical capacitors. Without them important equipment used in the Far

East campaigns would not have functioned. We shall be pleased to supply technical data and samples to those on essential work who have not already received them. For the present, however, the use of these capacitors is restricted to purposes laid down by the Supply Ministries.



**'METALMITE'**  
PAPER dielectric. Synthetic rubber end plugs. Wire end connections.

D.C. Working Volts		Capacity	
at 71° C.	at 100° C.	Mfds.	
500	350	.001 to .05	
350	200	.005 to .1	
200	120	.05 to .1	



**'METALPACK'**  
PAPER dielectric. Synthetic rubber-faced end discs. Wire end connections.

D.C. Working Volts		Capacity	
at 71° C.	at 100° C.	Mfds.	
1000	600	.005 to .1	
750	500	.02	
500	350	.05 to .25	
350	200	.1 to .5	



**'MICROPACK'**  
Plain foil ELECTROLYTIC. Temp. range -30° C. to +71° C. Synthetic rubber-faced end discs. Tag connections.

Peak Working Volts		Capacity	
at 60° C.	at 71° C.	Mfds.	
6 to 450	6 to 350	2 to 100	
(With standard intermediate voltage steps)		(With standard intermediate capacity values.)	



**'PICOPACK'**  
Plain foil ELECTROLYTIC. Temp. range -30° C. to +71° C. Synthetic rubber end plugs. Tag connections.

Peak Working Volts		Capacity	
at 60° C.	at 71° C.	Mfds.	
12 to 350	12 to 275	1 to 20	
(With standard intermediate voltage steps.)		(With standard intermediate capacity values.)	



**'METALICON'**  
CERAMIC dielectric. Synthetic rubber end plugs. Wire end connections.

Capacity Ranges	Temperature Coefficient
10 to 1000 Mmfd.	-800 × 10 <sup>-6</sup> per 1° C.
5 to 150 Mmfd.	+120 × 10 <sup>-6</sup> per 1° C.

**CONSTRUCTION:** In all of the ranges illustrated above a thin wall metal case is employed. "Metalpacks" and "Micropacks" are sealed by spinning the ends over on to synthetic rubberised discs. "Metalmites," "Picopacks" and "Metalcons" are sealed by reducing the ends on to synthetic rubber bungs, which in turn seal themselves on to the connecting wires.

The above ranges deal with Paper, Electrolytic and Ceramic capacitors; later it is hoped to offer a range known as "Micamites," which will deal with stacked Mica and Silvered Mica capacitors. These will be in flat rectangular cases following the shape of the capacitor element.

**IMPORTANT:** The proprietary names used to identify these capacitors refer exclusively to components developed and produced by T.C.C. Other products bearing similar names and not manufactured by us should not be confused with the genuine and original T.C.C. super-tropical condensers.

All of the Capacitors described above can be supplied fitted with P.V.C. Insulating Sleeving.

# THE TELEGRAPH CONDENSER CO. LTD.

RADIO DIVISION

NORTH ACTON · LONDON · W 3      TELEPHONE: ACORN 0061



# A Modified Inverted Triode-Valve Voltmeter

By H. G. FOSTER, B.Sc.(Eng.), A.M.I.E.E.\*

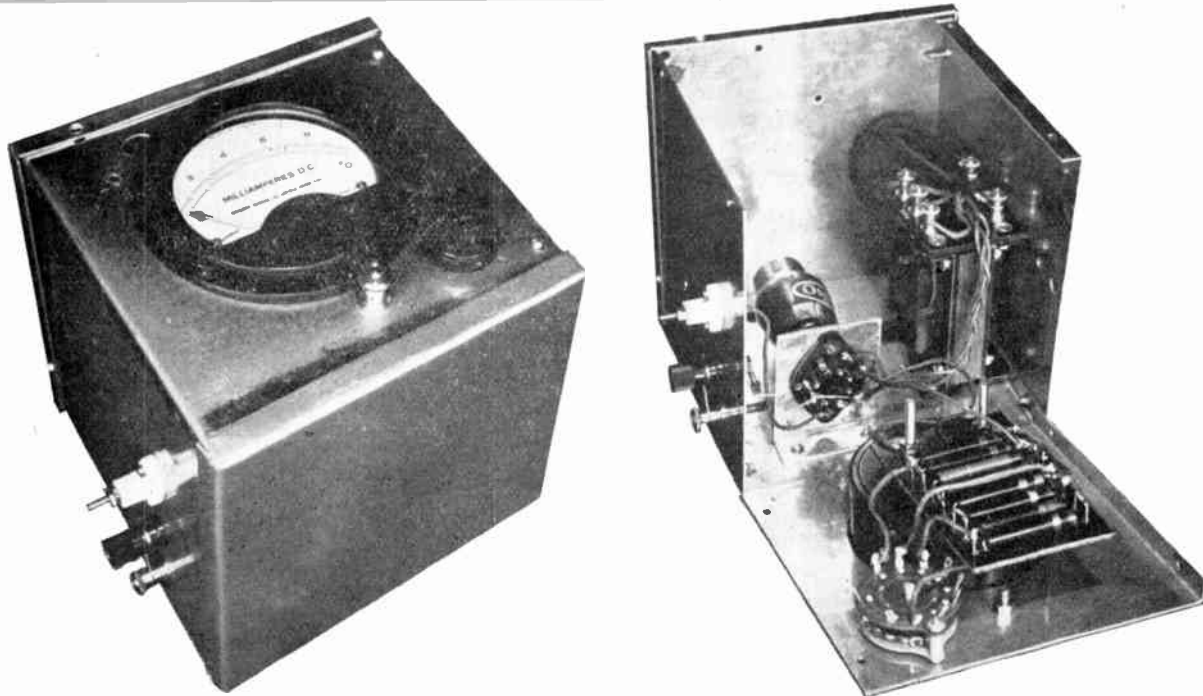

(Above) : Assembly of experimental valve voltmeter.  
 (Right) : View showing mounting of resistances on the milliammeter. The valve is mounted in a horizontal position, together with the small heater transformer on the base of the box.

CONSIDERABLE attention has been given to methods for increasing the frequency range of valve voltmeters, and numerous articles have appeared in technical periodicals on the theory and design of valve voltmeters which will maintain their 50 c/s. calibration up to frequencies as high as 100 Mc/s. with a reasonable degree of accuracy.

The two main types of such instrument are (a) the diode, and (b) the triode, although the modern tendency is towards the diode on account of its superior performance at the higher frequencies, but in both types the maximum voltage which can be applied directly is of the order of 150 volts. Where voltages greater than this are required to be measured, resort is usually made to different types of valve voltmeter circuit or to potentiometer methods in conjunction with a standard diode or triode valve voltmeter circuit.

There are several "null" reading methods which lend themselves to the

measurement of voltages beyond the range of the ordinary valve voltmeters, and two of which might be mentioned are the slide-back diode and the inverted triode. These valve voltmeter circuits, which are essentially peak voltmeters, are shown in Fig. 1, and in each case the voltage to be measured is balanced against another voltage until a null reading is obtained.

In the slide-back diode circuit, the unknown alternating voltage is connected in series with a D.C. voltage which can be varied until there is no current through the diode and when this condition has been reached, the voltage as read by the D.C. voltmeter is (very nearly) equal to the peak value of the alternating voltage.

The inverted triode voltmeter<sup>1</sup> is similar in operation to the slide-back diode but avoids the necessity for a high voltage source by employing grid control of anode current. With this circuit the unknown voltage is connected in series with a D.C. voltage and is applied to the anode

circuit, and measurement of voltage is carried out as follows:—

The input terminals are first short circuited and with an anode voltage of  $E_B$ , the grid-bias voltage is adjusted until the anode current is just reduced to zero or to a small standing value. The short circuit across the input terminals is then removed and the unknown voltage is applied. The grid-bias voltage is readjusted until the anode current is again zero or reduced to the initial standing value and if  $E_1$  and  $E_2$  are the two values of grid-bias voltage, it can be shown that the peak value of the alternating voltage

$$= E = \mu(E_1 - E_2) = \frac{E_B \cdot E_2}{E_1} - 1$$

While no calibration is necessary, except for precise measurements, these circuits have the disadvantage that they require two meters, and in the case of the slide-back diode, a high-voltage D.C. supply is necessary and which must be commensurate with the peak value of the alternating voltage to be measured. Both

\* Electrical Engineering Dept., The University, Birmingham.

circuits, too, are not direct readings in as much as a null balance must be obtained before the peak voltage can be read from the D.C. voltmeter.

### Measurement of Current

It is often possible to determine the voltage in a circuit by the measurement of the current instead of the voltage and the various methods of current measurement are equally methods of voltage measurement. Ammeters of the thermo-couple type are subject to frequency error to a very small degree and are made to read from a few milliamperes upwards, so that if the circuit constants are known, the voltage can be calculated.

It is perhaps worth while at this stage to point out that a valve voltmeter can be adapted as an ammeter<sup>2</sup> by shunting its input terminals with a condenser of known capacity. If the condenser is included so that the current in the circuit flows through the condenser, the valve voltmeter will read the voltage across the condenser, and a simple calculation enables the value of the current to be found.

### Potentiometer Methods

Of the potentiometer methods, the condenser potentiometer is probably the best known and it consists of applying the high voltage to be measured across two condensers,  $C_1$  and  $C_2$ , in series as shown in Fig. 2. If a valve voltmeter is connected across the condenser  $C_2$ , then the ratio of the voltages  $E_1/E_2$  is equal to  $C_2/C_1$ , from which it follows that

$$E_1 = E_2 \frac{C_2}{C_1}. \text{ Ideally, any voltage}$$

greater than the maximum input voltage to the valve voltmeter itself can be measured merely by a suitable choice of the ratio  $C_2/C_1$ , but this ratio cannot be extended indefinitely, for, if the reactance of the condenser potentiometer is to be kept high so as not to disturb unduly the circuit conditions when the valve voltmeter and potentiometer are applied, the capacities of  $C_1$  and  $C_2$  must be kept small. This means that for a high ratio of, say, 50/1 or 100/1, the capacity of  $C_1$  will be of the order of a few micro-microfarads and in consequence the ratio  $C_2/C_1$  cannot usually be determined with accuracy unless precision bridge or other apparatus is available.

Moreover, it has been assumed so far that the input impedance of the valve voltmeter is high and does not

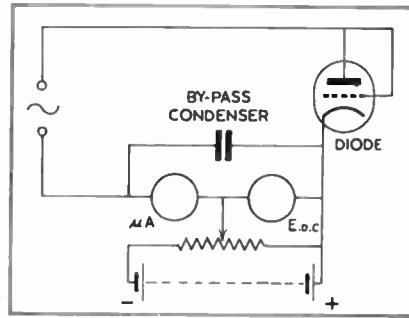

Fig. 1. High range valve voltmeter. (Above): Slide back diode circuit. (Below): Inverted triode circuit.

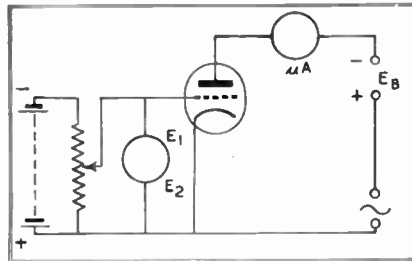

Fig. 2. Condenser potentiometer circuit.  $E_1$  is the high voltage to be measured.  $E_2$  is the voltage applied to the voltmeter.

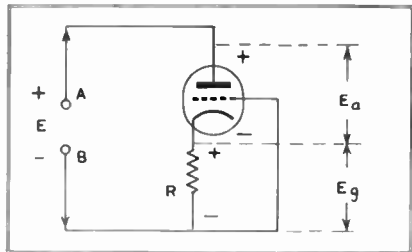

Fig. 3. Inverted triode circuit with anode supply voltage removed and with self-bias resistance  $R$ .

produce any shunting of the condenser  $C_2$ . If the input impedance of the valve voltmeter is high compared with the reactance of  $C_2$ , then a low-frequency calibration of the potentiometer and valve voltmeter—say 50 c/s.—may be obtained which will hold at high frequencies, assuming, of course, that the valve voltmeter itself is not subject to any

frequency error. However, if care is taken in the design, this method enables high voltages at high frequencies to be measured<sup>3</sup> and reference to a design for a condenser potentiometer with integral diode valve voltmeter with a range of 10,000 volts at 50 Mc/s. was recently made in this journal.<sup>4</sup>

### Modification of Inverted Triode

It would be advantageous, however, if the direct reading range of a valve voltmeter could be extended, and a simple modification of the inverted triode circuit suggests a method whereby this can be achieved, at the same time dispensing with battery supplies.

Suppose that the anode supply  $E_a$  is removed, and that self-bias is provided as an alternative to the grid-bias battery. The latter can be done by the inclusion of a resistance  $R$  in the cathode circuit and the arrangement becomes that shown in Fig. 3. The circuit now resembles the cathode follower<sup>5</sup> in as much as the whole of the load is in the cathode circuit and the input voltage is applied between grid and anode. The circuit is similar, too, to the infinite impedance detector.

The behaviour of this modified triode when a steady voltage is applied between the points A and B may be readily understood by reference to the anode characteristics of a typical triode which are shown in Fig. 4. Suppose that the resistance  $R$  has a value of 1,000 ohms and that the polarity of the steady voltage is such that the point A is positive with respect to the point B. Under these conditions anode current will flow and a bias voltage will be developed across the 1,000 ohms resistance. The voltage applied across the points A and B will then consist of two voltages in series—the anode-cathode voltage, and the bias or cathode-grid voltage.

If now the anode current is 2 mA then the bias developed across  $R$  will be 2 volts, which condition will be indicated by the point P on the  $I_a/E_a$  curve for a grid voltage of  $-2$ . This  $I_a/E_a$  curve shows that for an anode current of 2 mA and a bias voltage of 2, the anode-cathode voltage is 60, and hence the applied voltage must be the sum of the anode-cathode and bias voltages, i.e., 60+2, or 62 volts. Let this condition be represented by the point P'. If the applied voltage is increased until a steady anode current of 4 mA is obtained, a bias voltage of 4 will be

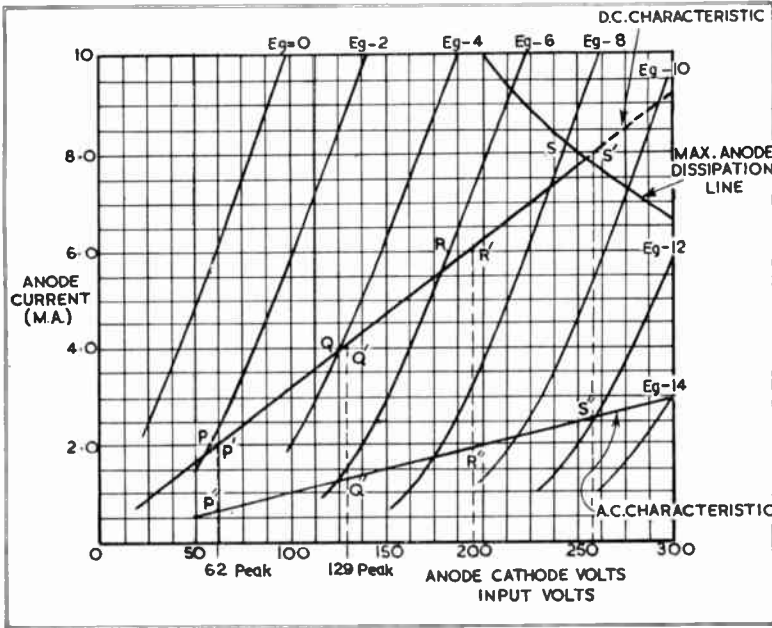

Fig. 4. Static characteristic curves of typical triode showing construction of D.C. and A.C. characteristics.

developed across  $R$  and conditions will now be indicated by the point  $Q$  on the  $I_a/E_a$  curve for a bias voltage of  $-4$ . The required anode-cathode voltage is now 125, the total voltage is  $125+4$ , or 129 volts, and the point  $Q'$  is thus obtained. Points  $RS$  and  $R'S'$  can be obtained in a similar manner for currents of 6 and 8 mA and if  $P'Q'R'S'$  are joined up they will be on a line which, except for the lower portion, is straight. This line represents the static characteristic of the modified triode and the reciprocal of the slope of this line  $\delta E_a$

is the forward or slope resistance.

If now an alternating voltage (assumed sinusoidal) is applied between  $A$  and  $B$ , there will be no anode current through the valve on the half-cycle during which the anode is negative. On the forward half-cycle the valve will conduct and there will be half-cycle pulses of anode current for each complete cycle of applied voltage.

The performance of the modified triode under alternating voltage conditions can also be determined from reference to the D.C. characteristic just obtained. Suppose the alternating voltage has a peak value of 62 volts. Then on the forward half-cycle the peak value of anode current is 2 mA, and the peak value of bias voltage is 2. Now a milliammeter in

series with the resistance  $R$  will read the average value of these half-cycle pulses, the peak value of which is 2 mA in this particular case. The average value of the half-cycle of anode current over a whole cycle is  $2/\pi$  or .64 mA when the applied alternating voltage has a peak value of 62 volts.

Similarly for a peak current of 4 mA the milliammeter will indicate  $4/\pi$  or 1.28 mA for an applied peak voltage of 129 and, if the current and voltage scales in Fig. 4 were average and peak values respectively, a line similar of  $P'Q'R'S'$  could be drawn which would give the A.C. perform-

ance. However, since the milliammeter reads the average value of the current pulses, the peak values of applied voltage must be converted into average values in order to give the true slope resistance in ohms under alternating conditions. The input voltage will be read by a voltmeter which will be calibrated in r.m.s. values so that the voltmeter readings must also be converted into average values. Now for a sinusoidal voltage, the r.m.s. value is  $1/\sqrt{2}$  of the peak value, and the ratio of the average r.m.s. values (known as the Form Factor) is 1.11, so that the average value of the applied voltage

$$\text{will be } \frac{\text{Peak value}}{1.11 \times \sqrt{2}} \text{ or } \frac{\text{Peak value}}{1.57}$$

Hence the average values of the applied voltage for average currents of .64 and 1.28 mA are therefore  $\frac{62}{1.57}$  and  $\frac{129}{1.57}$  or 39.5 and 82.2 volts respectively and thus the two points  $P''$  and  $Q''$  on the A.C. characteristic are obtained. Similarly, for average anode currents of  $6/\pi$  and  $8/\pi$  mA the points  $R''$  and  $S''$  can be obtained and the A.C. characteristics of the line  $P''Q''R''S''$ .

**Calculation of Slope Resistance**

It is possible to derive a simple expression for the relationship between the anode current and applied voltage when the triode is connected as in Fig. 3. Suppose a steady voltage  $E$  of correct polarity is applied to the triode. This will give rise to anode current  $I_a$  and there will be developed across  $R$  a bias voltage of  $E_x = I_a \times R$  while the anode-cathode voltage will be  $E_a$ . These two voltages  $E_a$  and  $E_x$  are in series and we can write:—

$$E = E_a + E_x$$

If the anode voltage  $E$  is now changed by an amount  $\delta E$ , there will be corresponding changes in anode current and grid voltage of  $\delta I_a$  and  $\delta E_x$  which can be related by:

$$\delta E = \delta E_a + \delta E_x = \delta E_a + \frac{\mu}{\mu + 1} \delta E_a = \delta E_a \left( \frac{\mu + 1}{\mu} \right) \dots \dots (1)$$

where  $\mu$  is the amplification factor of the triode.

If  $r_a$  is the A.C. resistance of the triode and  $g_m$  its mutual conductance, the change of anode current can be expressed as:—

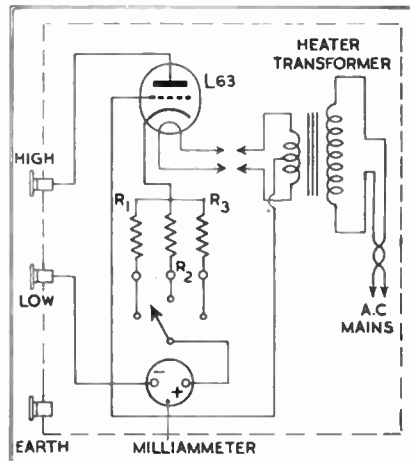

Fig. 5. Wiring diagram of valve voltmeter.

**Modified Triode as a Valve Voltmeter**

From the foregoing, a triode connected as in Fig. 3 will act as a half-wave rectifier, and there will be a linear relationship between the applied voltage and the rectified current, so that the milliammeter can be calibrated in terms of applied voltage—in other words the modified triode can be adapted as a valve voltmeter.

Since it is desirable to have as high an input impedance as possible for the valve voltmeter, it appears on first sight that a valve with a high  $\mu$  should be chosen and biased with a high value of  $R$ , but high  $\mu$  triodes when operating with high bias are not linear and if a linear calibration is required the high  $\mu$  triode is precluded. However, if high input impedance is important a high  $\mu$  triode can be used with a high  $R$ , and the valve will work satisfactorily as a square law rectifier.

After obtaining the experimental curves of a number of triodes, it became apparent that the most suitable type of triode for use in the proposed circuit was a power triode with a  $\mu$  of about 20 and an A.C. resistance of about 10,000 ohms. The maximum permissible input voltage which can be applied to the triode is governed by several factors. On the forward half-cycle the peak voltage should be such that the peak power does not exceed the safe anode dissipation of the valve, and on the backward half-cycle the maximum input voltage will be limited by the safe peak inverse voltage. However, provided the anode current is such that the safe anode dissipation is not exceeded, it will be quite safe to set the r.m.s. value of the maximum input voltage at *twice* the anode voltage of the triode when operating as a normal Class A amplifier. If the maximum input is restricted to 500 volts r.m.s. a power triode of the broadcast receiver type can be used and from previous considerations an Osram L63—or its equivalent—appears a satisfactory type. This valve has a  $\mu$  of 20, an A.C. resistance of 7,700 ohms and an anode dissipation of 2 watts.

Making the peak power at maximum voltage equal to the anode dissipation results in a peak current on the conducting half-cycle of 2.8 mA, the average value of which is .9 mA. The average current of .9 mA conveniently allows the use of a 1 mA D.C. milliammeter as the indicating instrument.

Having chosen a suitable type of valve and determined its operating characteristics, the next consideration is the value of the biasing resistance  $R$ . This can be done experimentally, or by simple calculation if the static characteristics of the valve are available. Referring to Fig. 4, which represents the static characteristics of a typical triode for a particular range of voltage and current, the A.C. characteristic can be predicted, and since the A.C. Slope Resistance is  $2 \mu R$ , the bias resistance  $R$  is therefore:—

$$\text{A.C. Slope Resistance} \div 2 \mu$$

and as an approximation we can write

$$\text{A.C. Slope Resistance} = \frac{\text{Maximum input volts (average)}}{\text{Current at max. input (average)}}$$

For the L63 valve the A.C. Slope Resistance at maximum input will be

$$\frac{500}{.11} \div 20 = 2,272 \times 10^3 = 2,272,000 \text{ ohms}$$

and with a nominal amplification factor of 20, the value of the bias resistance is obtained from

$$\frac{2,272,000}{20} = 113,600 \text{ ohms}$$

The power dissipation in this resistance will be quite small and a resistance of the ordinary metallised type will be satisfactory.

**Constructional Details**

The valve voltmeter is assembled in an aluminium box of 6 in. cube with a Western Model E.643 1-milliamp instrument mounted horizontally on the top of the box, together with a three-way wafer-type range switch. Ranges of 125, 250 and 500 volts (r.m.s.) are provided and the calculated values of resistance for each range, based on a nominal  $\mu$  of 20 are 3,125, 6,250 and 12,500 ohms respectively.

These resistances were obtained by a series combination of resistances, the arrangement and values of which are shown in Fig. 5, and full-scale deflection on each range was reached with input voltages of 110, 240 and 522 volts respectively. Closer agreement with the nominal 125, 250 and 500 volts could, of course, have been obtained by further selection of resistance values and combinations, or by the addition of semi-variable resistances of low value of the volume-control type.

These resistances, all of the 1-watt insulated type, are mounted on a

$$\delta I_a = \frac{\delta E_a}{r_a} - g_m \delta E_g$$

$$= \frac{\delta E_a}{r_a} - g_m \delta I_a R$$

from which

$$\delta I_a = \frac{\delta E_a}{r_a} \left( \frac{1}{1 + g_m R} \right) \dots \dots \dots (2)$$

Hence

$$\frac{\delta E}{\delta I_a} = \frac{\delta E_a \left( \frac{\mu + 1}{\mu} \right)}{\frac{\delta E_a}{r_a} \left( \frac{1}{1 + g_m R} \right)}$$

$$= \frac{\mu + 1}{\mu} \left\{ r_a (g_m R + 1) \right\} \dots \dots \dots (3)$$

Remembering that  $g_m r_a = \mu$  and that  $\mu R \gg r_a$ , the expression simplifies to

$$\frac{\delta E}{\delta I_a} = (\mu + 1) R \dots \dots \dots (4)$$

$$= \mu R \text{ if } \mu \gg 1 \dots \dots \dots (5)$$

So that, providing the valve is operating on the linear portion of its characteristics and  $R$  is not zero, there is a linear relationship between the change of applied voltage and of anode current, and this value of  $\mu R$  is the slope resistance of the modified triode.

If  $R$  is zero, then the slope resistance is  $\frac{\delta E_a}{\delta I_a}$  which is the slope

of the  $I_a E_a$  characteristic for zero grid bias and is nominally the  $r_a$  of the valve itself.

It can be easily shown that the slope resistance of A.C. characteristic is twice that of the D.C. characteristic. It has already been stated that

$$\frac{\text{R.M.S. value}}{\text{Average value}} = 1.11$$

for a sinusoidal waveform and that the r.m.s. value is  $1/\sqrt{2}$  of the peak value, also that the average value of a half-cycle of anode current over a whole cycle is  $1/\pi$  of the peak value so that

$$\text{A.C. Slope Resistance} = \frac{\text{Average value of applied voltage}}{\text{Average value of anode current}}$$

$$= \frac{E}{I_a} \div \frac{E}{I_a} \times \frac{\pi}{1.57}$$

$$= \sqrt{2} \times 1.11 \times \frac{\pi}{1.57} \times \text{D.C. Slope Resistance.}$$

## Radio Beacons

THE conception of I.F.F. at the very beginning of radiolocation in 1935 gave time for the development and production of numerous valuable consequent devices while the other applications of the R.D.F. principle were being brought to maturity.

Once it was established that pulses from a transmitter could be received and used to "trigger" automatically another pulse transmitter with uniformly negligible time-delay (not necessarily repeating the original pulse, or even the original frequency) it became clear that such a "transponder" (as it was later called) could set up at any convenient place and would act as a beacon; a beacon which would normally keep "wireless silence," only speaking when spoken to, capable of being made to respond only to certain coded sequence of pulses on a given frequency, and giving accurate information of the distance between beacon and interrogator.

The response could itself be coded, so that such a beacon could be identified among other, or distinguished from spurious enemy, transmissions made to mislead the inquirer.

Thus, not only were there I.F.F. equipments in our aircraft and later in ships and other vehicles, which would respond to questioning pulses from our ground stations, but aircraft and other moving vehicles could now carry small questioning transmitters ("interrogators") and obtain replies from "responder" beacons on land or sea, in addition, of course, to those in other friendly aircraft. Moreover, by use of selective frequencies, response could be limited to any particular beacon, or groups of beacons.

The earlier beacon signals were presented to the pilot of the questioning craft as fluctuating "blips" on his range scale, with whatever indication of azimuth (or "bearing") the apparatus might be capable of displaying. Since the introduction of the P.P.I. presentation (Plan-Position Indicator), the beacons show up as "winking" spots or arcs of light in their positions relative to the P.P.I. interrogator on the scale of the maplike P.P.I. picture.

As in the case of I.F.F. equipment, and indeed because the beaconry and identification are allied both technically and operationally, it has been found necessary to standardise the coding and responses throughout the civilised world (that is, among the Allies).

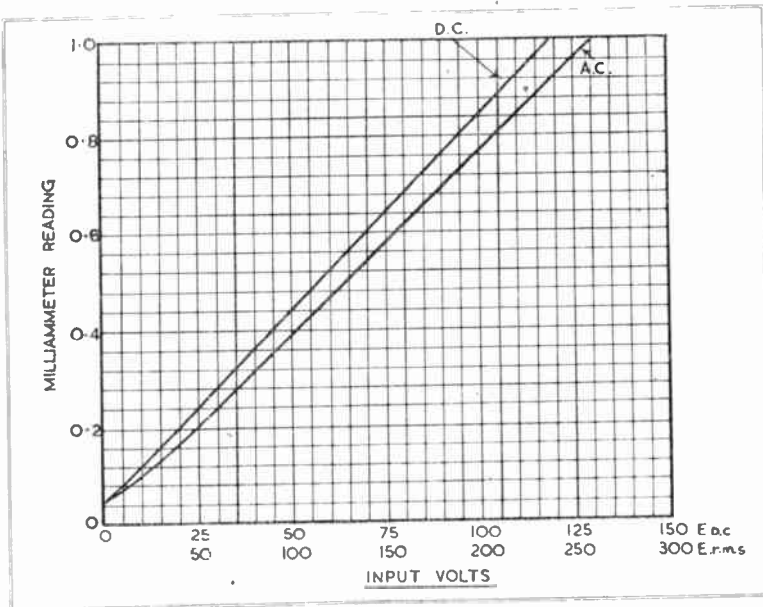

Fig. 6. D.C. and A.C. calibrations on range 2.

bakelite strip which is supported directly on the main terminals of the milliammeter itself. With this arrangement, the resistances, milliammeter and range switch can be assembled and wired as a complete unit, and two wires only, the cathode lead and the negative lead from the milliammeter, are all that are required to connect the top unit to the voltmeter circuit. The remainder of the wiring of the valve voltmeter is very simple and the constructional details can be seen from the two photographs.

The high-voltage terminal is made from a small Eddystone stand-off insulator while the "earth" terminal is a shrouded insulated terminal which is connected to the earth terminal of the case when the voltage being measured has one side earthed.

### Calibration

The instrument was calibrated on all three ranges on D.C. and 50 c/s. supplies—the latter being of good waveform—and a typical calibration curve is shown in Fig. 6. With regard to the A.C. calibrations, it is more convenient to calibrate the instrument in terms of r.m.s. volts rather than average volts so that the slope of the A.C. calibrations is not the true A.C. slope resistance. Converting the A.C. calibrations into A.C. slope resistances, however, shows that the latter are twice their respective D.C. slope resistances within 1 or 2 per cent.

The pointer of the milliammeter vibrates a little at low frequencies of the order of 50 c/s. and less and can be cured by the use of a milliammeter with a pointer system of greater mass. As the particular instrument was required to work at the higher frequencies, this was not considered a serious defect. Calibration of the A.C. ranges was extended at intervals up to 2 Mc. and the error on the 50 c/s. calibration was not excessive.

It should be remembered that the milliammeter reads average values and is calibrated in r.m.s. volts on a pure sinusoidal supply, so that if voltages with high harmonic content or of complex waveform are applied, the instrument will not read correctly. The valve voltmeter just described, however, becomes a useful instrument for the measurement of voltages of the order of 125 to 500 which are above the direct range of most valve voltmeters and below those where potentiometer methods are more applicable. Its input impedance is not high compared with valve voltmeters of the anode bend or slide-back type although it does compare with that of the diode, and the instrument has the merit of extreme simplicity in construction and calibration.

### REFERENCES

- 1 *Hind, High Frequency Measurements.*
- 2 *G.R. Experimenter*, August-September, 1938.
- 3 *G.R. Experimenter*, May, 1940.
- 4 *Electronic Engineering*, June, 1943.
- 5 *Electronic Engineering*, November, 1940.

# PULSE CIRCUITS



Whether or not this treatment is good for his pulse circuit we do not know, but we do know that for radio pulse circuits MYCALEX is just what the doctor ordered.

Power Factor (1 meg & over) .002	Tensile Strength (lbs./sq. in.) 5,800
Permittivity ... .. 6.7	Water Absorption NIL.
Electric Strength (volts mil.) .550	Plastic Yield ... 450°C.

*Send for illustrated brochure.*

**MYCALEX COMPANY LIMITED • CIRENCESTER • GLOS.**

MY8



## PAINTON VITREOUS RESISTORS

Painton Vitreous Resistors are available in values from 1 ohm to 100,000 ohms; from 10 watts to 150 watts rating, and are made in a wide variety of fittings. The Resistors consist of a fully vitrified porcelain tube, which carries a winding of high-grade resistance alloy wire. The ends are electrically welded to the copper terminal leads. This winding is held firmly in position by a coating of extremely durable vitreous enamel, rendering the unit absolutely impervious to the effects of moisture, and ensuring absolute stability of value under all conditions of service. Type approval of these Resistors has been given for use under the most severe tropical conditions.

**PAINTON & CO. LTD**  
KINGSTHORPE NORTHAMPTON

THE following experiments were carried out by the writer on a method of measuring and recording photographically small changes in the physical dimensions of materials, due to strain, temperature changes, etc.

The principle is briefly as follows: Two metal plates, placed in close proximity to form a condenser, are caused to vary their relative distance by a force exerted on one of them. The consequent variation of capacity is sufficient to alter the normal conditions existing in a parallel resonant circuit, of which the condenser "gauge" is the capacitive element.

The varying potential difference developed across the circuit as a result is applied to a cathode-ray oscilloscope after rectification and amplification, the resultant deflection being photographed on a moving film. The arrangement may be calibrated by noting the spot deflection on the oscilloscope for a given depression of the condenser gauge.

It is well established that a parallel resonant circuit consisting of an inductance  $L$  and a capacitance  $C$  will present an impedance of a very high order to voltages applied externally of the same frequency to which  $L$  and  $C$  are tuned.

This high impedance may be used as a "load" and the I.R. drop across it applied to the deflector plates of an oscilloscope, as will be seen later.

It follows, then, that if this resonant circuit  $LC$ , Fig. 1, be so designed that it possesses a high  $Q$ , and also a high degree of selectivity, the potential difference across it will also vary considerably with small changes of capacitance, as the further the departure from  $\omega L$  being equal to  $1/\omega C$  the less will be the impedance due to phase opposition of  $L$  and  $C$ . The arrangement therefore becomes a virtual short-circuit, passing a heavier current and thereby reducing the potential difference across it. Conversely, the nearer conditions become to complete phase opposition, the greater is the total impedance, with a resultant increase in the P.D.

If an alternating voltage of predetermined frequency were applied to an oscilloscope *via*  $LC$  it would result in a straight line on the screen.

It is desirable, however, that a D.C. change only is applied to the C.R.O., giving rise to a deflection of the beam with changes of potential, and not a repetitive sweep.

## The Recording of Strain by the "Parallel Resonance" Method

By  
H. J. BEACH

This may be effected (see Fig.) by rectification in a tetrode ( $V_1$ ), which also acts as an amplifier.

It was found that a frequency of 15,100 c/s. was most convenient, supplied from a commercial beat-frequency oscillator.

The values of  $L$  and  $C$  were  $0.933 \mu H$  and  $0.00012 \mu F$  respectively, the frequency quoted above being governed by the inductance used, which was not specifically designed for the experiment.

The capacity gauge ( $C$ ), Fig. 1, consists of two brass plates mounted suitably at their outer edges on rubber or other resilient material of thickness approximately 0.1 in. This separation between the plates allowed ample clearance for variation of relative distance when subjected to compression. The greatest movement imposed during tests was of the order of 0.05 in.

### Tuning and the Oscillator

It is desirable that a reasonably high frequency be used in order to attain a steep-sided resonance curve, but this must not be so high that it impairs the magnification of the circuit.

As the voltage developed across  $LC$  is dependent on the difference between the frequency of the applied voltage and the frequency to which  $LC$  is tuned, the oscillator should be detuned slightly with respect to  $LC$  during operation. Any changes in capacitance brought about by the gauge  $C$  will tend to tune  $LC$  to the applied frequency, thereby altering the dynamic impedance, with a resultant change in P.D. across the circuit, which is applied to the control grid of  $V_1$ .

The diagram shows the connexions to the oscilloscope, but one or two

points of importance should be stressed.

The "earth" connexion to the cathode ray oscilloscope should be joined to all other points at earth potential as shown. The tube should be used with the deflector plates directly coupled to the output terminals of the unit, as the use of shift networks renders the recording of a D.C. change impossible (owing to the fact that the spot will drift back to the centre position in a short time, dependent on the constants of the network).

A small condenser ( $C_3$ ) should be connected across the deflector plates in order to bypass any residual alternating voltages. The value of this should not exceed about  $0.001 \mu F$ .

### Results

For a depression of the condenser gauge of approximately 0.002 in., a deflection of 2.5 centimetres was recorded on the C.R.O. and even smaller changes were capable of a readable significance, especially if photographed on a ciné film. This runs at right angles to the "work" voltage deflection, thereby serving as a time base.

A Cossor-type 402 tube was used. The oscillator output voltage was 20 V R.M.S.

A final point worth comment is that the spot will be permanently deflected during operation, but this was found not to be detrimental provided it is not allowed to depart from the "flat" portion of the screen.

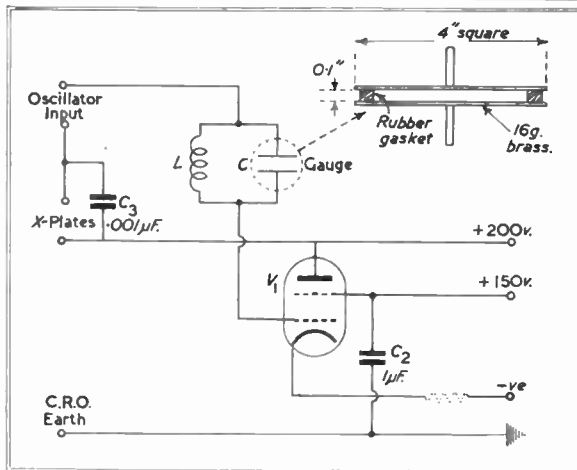



# OCTOBER MEETINGS

**NOTE.**—In general, visitors are admitted to the meetings of scientific bodies on the invitation of a member, or on application in writing to the Organising Secretary at the address given. In certain cases (marked \*) tickets may also be obtained on application to the Editorial offices of this Journal.

## Institution of Electrical Engineers

All meetings of the London Section will be held at The Institution of Electrical Engineers, Savoy Place, Victoria Embankment, London, W.C.2.

### Ordinary Meeting

Date: October 4. Time: 5.30 p.m.  
Inaugural Address as President.

By:

P. Dunsheath, O.B.E., M.A.,  
D.Sc.(Eng.).

### Radio Section

Date: October 10. Time: 5.30 p.m.  
Inaugural Address as Chairman.

By:

A. H. Mumford, B.Sc.(Eng.).

### Informal Meeting

Date: October 17. Time: 5.30 p.m.  
Discussion:

"Should Engineering Concerns be  
Managed by Engineers?"

Opened by:

The President (P. Dunsheath,  
O.B.E., M.A., D.Sc.(Eng.)).

*The Secretary:*

*The Institution of Electrical Engineers,  
Savoy Place, Victoria Embankment,  
London, W.C.2.*

### Cambridge Radio Group

All meetings of the Cambridge Radio Group will be held in the Cambridgeshire Technical College.

Date: October 9. Time: 6 p.m.  
Inaugural Address as Chairman.

"Notes on Measurements at Very  
High Frequencies."

By:

L. B. Turner, M.A.

Date: October 20. Time: 6 p.m.

Lecture:

"Frequency Modulation."

By:

K. R. Sturley, Ph.D., B.Sc.

*Group Secretary:*

*D. H. Hughes, c/o Pye Ltd., Radio  
Works, Cambridge.*

## The Television Society \*

All meetings are held at the Institution of Electrical Engineers, Savoy Place, London, W.C.2.

Date: October 23. Time: 6 p.m.

Lecture:

"The Simplification of C.R. Tube  
Design by the Application of the  
Theory of Similitude."

By:

H. Moss, Ph.D., A.M.I.E.E.

*Lecture Secretary: G. Parr, 43 Shoe  
Lane, E.C.4.*

## Institute of Physics

### Electronics Group

Date: October 23. Time: 5.30 p.m.

Held at:

The Reid Knox Hall of the British  
Institute of Radiology, 32 Welbeck  
Street, London, W.1.

Lecture:

"Recent Work on the Theory of  
the Latent Image."

By:

Professor N. F. Mott (Bristol  
University).

*Group Secretary:*

*A. J. Maddock, M.Sc., F.Inst.P.,  
Messrs. Standard Telephones and  
Cables, Ltd., Oakleigh Road,  
London, N.11.*

## NOTICE

### Instruments Conference

The Institution of Chemical Engineers, the Society of Chemical Industry (Chemical Engineering Group) and the Institute of Physics announce that the one-day Joint Conference on

"Instruments for the Automatic  
Controlling and Recording of  
Chemical and other Processes,"

which was postponed in September last, will take place in the Royal Institution, London, on Friday, October 19, 1945.

## The Association for Scientific Photography\*

Date: October 25. Time: 6.30 p.m.  
Held at:

Alliance Hall, Westminster, London, S.W.1.

Lecture:

"The Organisation of an Industrial  
Photographic Unit."

By:

C. W. Bradley, A.I.B.P., F.R.P.S.  
(The British Cotton Industry Research Association)

*The Secretary: A.S.P., 34 Twyford  
Avenue, Fortis Green, London, N.2*

## Bradford Electronics Society

Date: October 11. Time: 7 p.m.

Held at:

The Technical College, Bradford.

Lecture:

"The Future of Television."

By:

G. Parr, A.M.I.E.E.

*Hon. Secretary:*

*G. N. Patchett, The Technical College, Bradford.*

## Kingston-upon-Hull Electronic Engineering Society

Date: October 12. Time: 7.15 p.m.

Held at:

Electricity Showrooms, Ferenway

Lecture:

"High Frequency Currents."

By:

C. H. Nicholson, M.I.E.E.,  
M.I.Mech.E. (I.N.E.R.)

*The Secretary:*

*C. H. Hyman, 2 Lockton Grove,  
Hull.*

## British Kinematograph Society

Both meetings held at the Gaumont British Theatre, Film House, Wardour Street, W.1.

Date: October 24. Time: 6 p.m.

Symposium on Sound by:

J. S. Croydon and F. Williams.

### Theatre Division

Date: October 21. Time: 11 a.m.

Lecture:

"Electronics in the Cinema."

By:

G. Parr, A.M.I.E.E.

*Secretary:*

*C. H. Cricks, Dean House, Dean Street, W.1.*

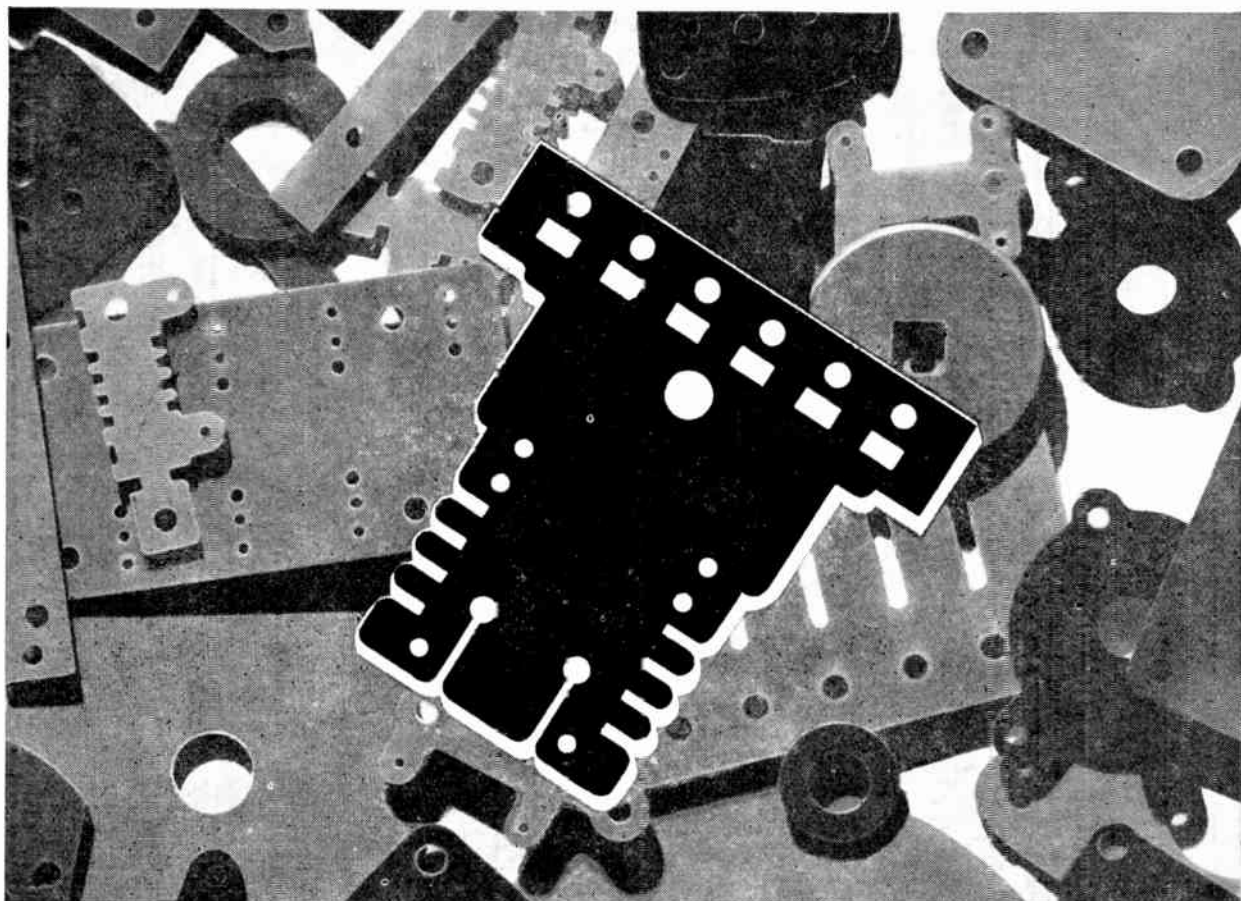

**A ROUTINE PIERCING AND BLANKING TEST**

**BAKELITE LAMINATED**

The piercing and blanking properties of Bakelite Laminated are checked as a matter of routine. Above is illustrated a piece of the material which indicates the design of tool used. Note the clean edges and the close proximity of the holes. The design generally represents a critical test of practicability. Samples and data of special punching grades for a variety of purposes will be furnished upon request.

**BAKELITE**  **PLASTICS**  
REGD. TRADE MARKS

*Pioneers in the Plastics World*

T.28

**BAKELITE LIMITED · 18 GROSVENOR GARDENS · LONDON S.W.1**

# BOOK REVIEWS

## Waveform Analysis

R. G. Manley. (Chapman and Hall, Ltd. 21s. net.) 275 pp., 103 figs.

The subject of waveform analysis is necessarily a mathematical one, and the book under review is no exception to this rule. A fair knowledge of trigonometry and the calculus is essential on the part of the reader if he is to read the book intelligently, but this is unavoidable. The author approaches his subject by the opposite process of synthesis, building up waves of various types, before taking the resultant waves and analysing them into their several components. This has been tried elsewhere and, indeed, is the obvious line of attack, having various merits.

Many waveforms encountered in vibration records consist of individual waves the peak values of which change rhythmically, and a knowledge of the manner of the variation of these peaks is of more importance than a knowledge of the shape of the individual waves. The envelope of this record is thus of first importance and the present book deals in detail with the envelope method of analysis, after having dealt with the general properties of sine waves in combination. Another chapter is devoted to "Mechanical and Other Aids to Analysis," one section dealing with electrical waveform analysers of the filter-circuit type. This chapter could, with advantage, have been expanded since these aids are of very great importance to the engineer who wishes to substitute mechanical processes for human effort.

The author states that the title "Waveform Analysis" was deliberately chosen in preference to the more familiar "Harmonic Analysis," since many hundreds or thousands of recorded waveforms may require to be interpreted, these themselves varying in a periodic manner. This is emphasised by the sub-title of the book which is "A guide to the interpretation of periodic waves including vibration records." Nevertheless, it is felt that the title is a little unfortunate since to many it will suggest the harmonic analysis of electrical waveforms. These are dealt with in very cursory fashion, this side of the subject being to all intents and purposes disregarded. This may appear

natural on the part of the author, who is a vibration engineer, but it is not so obvious to the reader who may pick up the book expecting to find information on the subject of electrical waveforms. On the other hand, it must be stated that the book gives a very clear exposition, although necessarily mathematical, as has already been mentioned, of a subject that is rather abstruse and complicated to most of those not immediately connected with it in actual practice. The author obviously is a master of his subject and has succeeded in presenting it in an acceptable way. He is to be congratulated on having written a book which can be highly recommended for the purpose for which it was produced.

P. KEMP.

## The Life and Work of John Tyndall

Professor A. S. Eve, F.R.S., and C. H. Creasey, O.B.E. (Macmillan, 21s. net.)

Those who have read Professor Eve's "Life of Lord Rutherford" will need no spur in welcoming another biography from the same pen. After a protracted interval, as related by Mr. Granville Proby in the Preface, the work was begun by Professor A. S. Eve and ably completed by Mr. C. H. Creasey, while Lord Schuster has contributed a fascinating chapter on Tyndall's exploits as a mountaineer.

This is a record of a stubborn fighter, who rose from obscurity as a poor Irishman from County Carlow to become head of the Royal Institution, in succession to the great Michael Faraday and the brilliant Cornishman, Humphrey Davy.

It is probably true to say that Tyndall's contemporary fame has not been sustained; this is because his reputation was partly based on his wonderful gifts and eloquence as a lecturer, and partly due to the nature of his experimental researches which, although conducted with infinite resource and patience, by no means always led to clear-cut theoretical conclusions. It is interesting that Preston, "Theory of Heat," 1804 edition, still gives the conflicting results of Tyndall and of Magnus on heat absorption in gases as of somewhat equal value twenty or thirty years after Tyndall's experiments on the subject.

Tyndall's interests in science were wide and varied, as the record given in this biography shows; it is perhaps of pertinent interest to physicists that his excursions into the realms of biology were markedly successful, and his researches were as decisive as those of Pasteur in annihilating the theory of "spontaneous generation." It was, however, as a masterly expositor that Tyndall, as head of the Royal Institution, achieved world-wide fame, and his lecture tour in America in 1872 was a triumphant success.

Tyndall was a merciless smiter of humbug wherever it appeared, and his zeal as champion of the neglected Mayor redounds entirely to his credit. The echoes of his religious and political controversies resounded throughout the land, especially the storm evoked by his Belfast address in 1874, in which he virtually declared that "Matter carries in it the promise and potency of all terrestrial life."

Tyndall was fortunate to mingle with so many eminent Victorians—Faraday, Spencer and Carlyle, together with his friend Hirst, all add to the interest of these pages. He was fortunate, too, and very happy in his marriage, which rendered doubly tragic the manner of his death in 1893.

In some ways this biography just falls short of re-creating a living portrait of the man of dynamic and combative personality that Tyndall evidently was, but it is a book which should be of intense interest to every scientist.

S. RODDA.

**Books reviewed on these pages or advertised in this Journal can be obtained from**

**H. K. LEWIS & Co. Ltd.**

136 Gower Street, W.C.1

*If not in stock, they will be obtained from the Publishers when available*

## Industrial Electronic Control

W. D. Cockrell. (McGraw-Hill, 1944.)  
242 pp. 175 figs. (Price in Britain, 17s. 6d.)

This slim volume is another pointer to progress in the application of electron tubes to industrial purposes. The author is on the staff of the General Electric Company of America, with the advantage that his work carries a convincing practical outlook and is illustrated by various examples of that company's technique in electronic control. The photographs of tubes, components and devices are excellent.

The book is addressed to electrical engineers with no previous electron tube experience. It will also contain much that is novel to the radio man who is interested in this new field. The text is non-mathematical, since it stresses the operational rather than the design aspects, but useful references are given for wider reading.

The introduction contains an interesting electro-mechanical analogy for both the triode and thyatron, in terms of a voltmeter and rectifier, with a variable resistance for the triode and a latch-in relay for the thyatron. The first section of the book deals with the operation of vacuum and gas tubes, including mercury-arc rectifiers and ignitrons, the latter being particularly important for heavy AC power control. Section 2 deals with measurements and components, including transient as well as steady-state behaviour, magnetic saturation and non-linear resistance elements. Simple combinations with a rectifier, for peaking and other circuits, are described as the basis of later applications. Section 3, "Basic Electronic Circuits," covers Rectification, Amplification, Oscillators, Timing Circuits and Phase-Shift Circuits. Many unusual but valuable aspects are here described, including among amplifiers the "long-tailed pair" (descriptive term for the common-cathode-coupled twin amplifier), the "cascade," "cathode follower" and an AC-powered amplifier. Section 4 describes complete "Industrial Electronic Circuits." After some very commonsense remarks about circuit diagrams (layout, lettering and usage), practical details are given of PE relays, thyatron motor control, AC relays (electronic switches), AC power control, e.g., for theatre light-

ing, resistance furnaces, etc., by thyatron-controlled saturable reactors, follow-up or servo-control, and lastly, the important field of welding control.

The scope of the book is limited to electric and photo-electric control, so that the use of auxiliary devices whereby many industrial factors such as temperature, expansion, moisture, gas pressure, vibration and acidity are measured and controlled is not suggested. The basic circuit theory and the use of relays, etc., will, of course, apply throughout.

There are two criticisms which are to be made of this work. The symbols, unfortunately, follow American industrial practice (as may be seen in journals such as *Electrical Engineering*), with the confusing result that to the average engineer chokes or contactor coils appear as resistors, contacts as condensers and resistors as general impedances. This is extremely irritating, and is another indication that proper co-ordination between power and radio engineers is long overdue. Another feature, which is a general weakness of much commercial electronic equipment, is the wiring. The nightmare assembly of many a domestic receiver will not suffice for industrial control, where reliability supersedes cheapness as the most important factor. Neat layout, sub-panel mounting of small resistors and capacitors, and tidy wiring to give easy access to all components, are essentials of industrial practice and entirely in keeping with the author's dedication. Some lapse might be understood, if not condoned, in a firm which had specialised entirely in radio receivers. It is all the more regrettable, then, that a company which has taken a progressive international lead in all matters electric should produce a back-panel such as Fig. 141 (wiring of the famous "Thymotrol" motor-control unit). This is evidently a field in which traditional British craftsmanship would find a healthy and appropriate expansion.

J. C. FINLAY.

## Introduction to Short Wave Therapy

*Correction.*—The price of this book was given in the review last month as 7s. It should be 21s.

**MELTON**  
**METALLURGICAL**  
**LABORATORIES**  
LTD.

## AVOID WHISKERS!

You cannot afford to take chances by using a soldering flux that will eventually cause corrosion on your electrical connections.

**MELTON Non-Corrosive Liquid Flux, grade N21 (A.I.D. approved) conforms with Air Ministry Specification D.T.D. 599 and may be used with confidence on all electrical and other work, where corrosion would be injurious.**

Sold in 4 oz., ½ pt., 1pt., tins and in bulk.

IPSWICH ROAD  
TRADING ESTATE  
SLOUGH, BUCKS.

Phone : Slough 20992

## Improved Germinal CLIPS

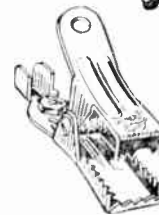

Well made of steel, double ridged for strength. Teeth on three sides of lower jaw and special design of upper jaw ensure firm grip and good contact.

Wingard products are always equal to the job they have to do. For our own sakes—as well as yours—they bear our name, because the reputation of the maker is, in the last analysis, the best guarantee of the product.

**Wingard**  
LTD.

CHURCH ROAD · HENDON · LONDON · N.W.4

# CORRESPONDENCE

## Electronic Musical Instruments

DEAR SIR,—Referring to Dr. Saraga's article in the issue of ELECTRONIC ENGINEERING for July, I feel that I should like to make a few remarks on Mr. Hobson's letter in the August issue criticising Dr. Saraga's views.

I do not propose to deal in detail with Dr. Saraga's proposals but, as an engineer, to refer to some basic principles in artistic and scientific development relevant to this discussion.

Surely music developed experimentally in its early stages and many types of instrument were probably discovered accidentally and were then perfected as the needs of musicians grew.

To claim that musicians should state their needs and that electronic engineers should then fulfil them is to narrow unduly the possible fields of artistic growth in music.

The main advantages of a scientific study of problems of sound and musical production are to provide unexpected and hitherto unknown aids to musical development. If new means or methods are provided, artists can use them, reject them or ask for them to be modified, and by such co-operation it conceivable that great good can result. To use an analogy illustrating this relation between a science and an art, penicillin was the product, at first, of bio-chemists rather than of medical men, but the medical world now asks for it to be provided in forms most useful to it.

Again, the sulphonamide drugs arose out of dye chemistry. They could not be specified until they had been produced.

Yet further examples can be shown in the production of improved pigments and plastic materials by chemists for use by artists and sculptors.

Progress is many sided and unceasing, and all creative workers may co-operate to the advantage of all the arts.—Yours faithfully,

W. J. RICKETS.

DEAR SIR,—I have read with great interest Mr. Hobson's letter dealing with my article, "An Electronic Musical Instrument," in your August issue.

I should like to say at the outset that I agree with Mr. Hobson that my "instrument" is not—I should prefer to say "not yet"—an instrument. I was careful to point this out at the meeting of the Electronic Music Group in May, but in the abstract published in ELECTRONIC ENGINEERING this is probably not sufficiently emphasised—hence Mr. Hobson's remark—though I said in the first sentence of the article that a "first model" of an instrument will be described.

Mr. Hobson says, further, that my instrument "presents no new features over and above those known for many years, apart from my method of pitch control." I submit that every unbiased reader of the article in question will agree that nowhere in it is anything else claimed; on the contrary, it is emphasised that "the object in designing the new instrument was to obtain experience with the new method of playing made possible by employing a photo-electric cell as playing manual."

Mr. Hobson further reproaches me for presenting my instrument—not being a musician myself—to players and composers for study of its musical features, and he asks electronic engineers to prepare designs of new instruments with the requirements of musicians in view. Though I agree that this is a possible attitude of electronic engineers, I most emphatically disagree with Mr. Hobson's opinion that this is the only permissible one. After all, the requirements of musicians—as the requirements of any other group of persons—are bound to be based on known, or at least anticipated, possibilities. They cannot be expected to be based on the technical possibilities of the future, particularly in a period where their range increases rapidly and unexpectedly. A limitation of the development of electronic musical instruments to such channels which have previously been specified by musicians would stifle at the very start any chance of genuine technical development—as distinct from pure

technical design work to prepare specifications. Therefore I think there is room and need for experimental development work which is not based on any previously agreed requirements. This experimental attitude advocated by me would, of course, leave musicians the right to reject the results of the development work if they do not like it, but it would not exclude the possibility that one or the other musician might find some of these results interesting and stimulating. Mr. Hobson seems to imply that musicians are not interested in such "delightful jobs." I do not believe that this is true of *all* musicians, but if it were, *they* should be blamed, not the electronic engineers.

I should like to conclude my remarks by assuring Mr. Hobson that I have no wish to "introduce" my instrument, but I think that the method of pitch control described may be of some interest, particularly after further development, and I should be delighted to have any comments regarding this method from him which, unfortunately, I was unable to find in his letter.—Yours faithfully,

W. SARAGA.

### Radar Anticipated ?

The following is an extract from Pat. 292,185 of June 21, 1928 (Television, Ltd., and J. L. Baird): "... this invention comprises a method of viewing an object by projecting upon it electromagnetic waves of short wavelength adjacent to the infra-red radiation in the spectrum but of longer wavelength than the infra-red rays, exploring the object or the image thereof by a device sensitive to such rays . . . and traversing a spot of light across a screen in synchronism with the exploration of the object."

### These German Professors

After Professor Czerny has eaten his frugal breakfast, he sets to work to clear away a few more yards of rubble. Every day he salvages a few bits of apparatus—perhaps parts of a spectroscope or a voltmeter. These he cleans with a piece of rag dipped in paraffin.

—*Evening Standard*, 17.9.45.

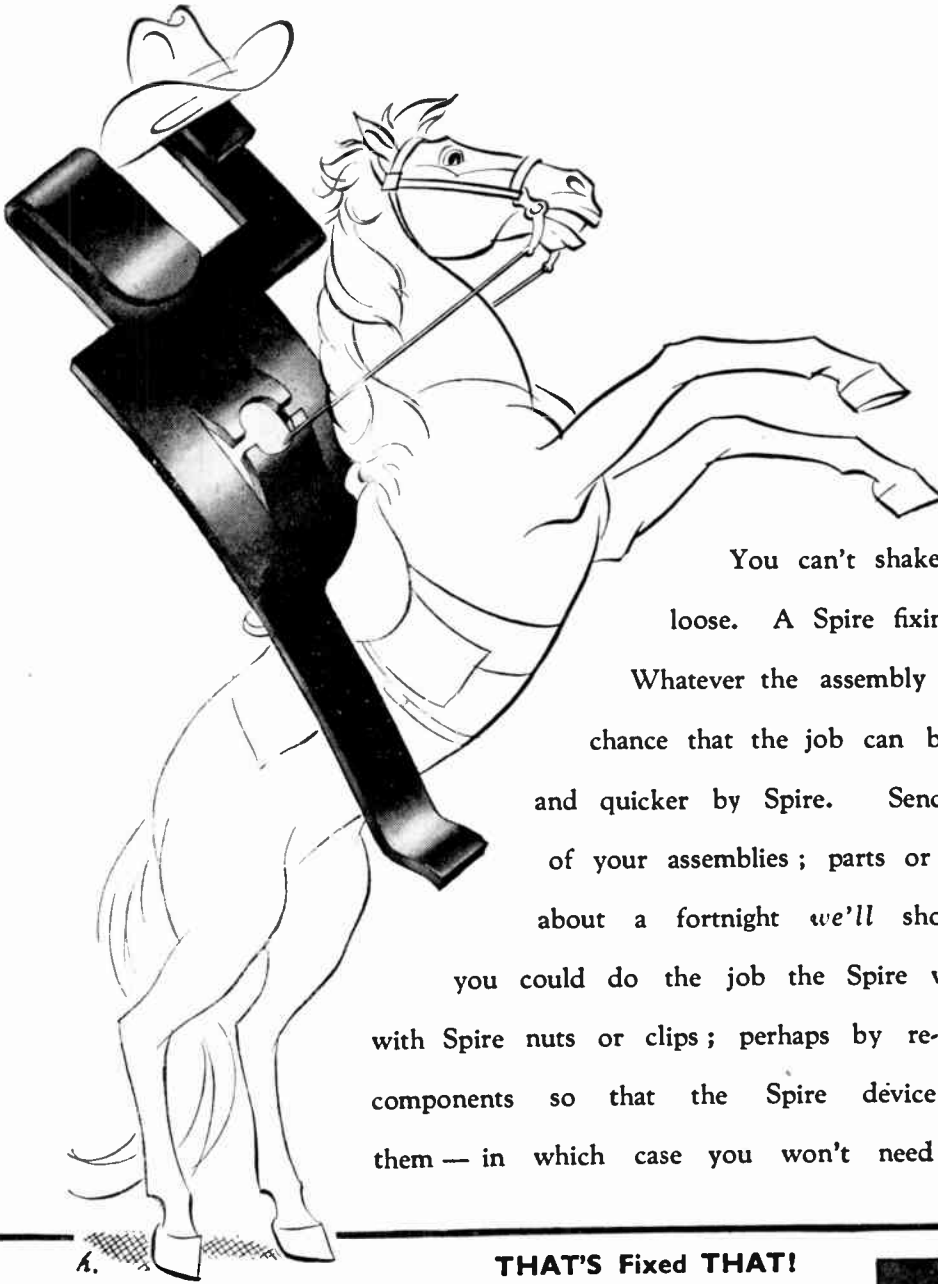

You can't shake a Spire Nut loose. A Spire fixing locks itself. Whatever the assembly there's a good chance that the job can be done better and quicker by Spire. Send us examples of your assemblies; parts or drawings. In about a fortnight we'll show you how you could do the job the Spire way — perhaps with Spire nuts or clips; perhaps by re-designing your components so that the Spire device is part of them — in which case you won't need nuts at all.

**Spire**

**\* A BETTER way of fixing**

**THAT'S Fixed THAT!**

This is a typical case of intelligent use of Spire fixing. This was originally a spring clamp which was screwed to its base with screw, washer and nut. Now the clamp is redesigned to incorporate its own Spire fixing, and the nut and washer have disappeared. Apart from the saving in material it is a much quicker and simpler assembly job, the clamp is 'zipped' on to the screw and tightened firmly home.

Designed as a fuse holder this fixing NS 1307 is suitable also for securing any cable, rod or circular equipment from  $\frac{1}{8}$ " to  $\frac{1}{4}$ " diameter.



# ABSTRACTS OF ELECTRONIC LITERATURE

## CIRCUITS

### Survey of D.C. Amplifiers (M. Artzt)

Analysis of causes of drift in direct-current amplifiers, descriptions of methods used to neutralise or prevent drift, and typical industrial applications.

—*Electronics*, Aug., 1945, p. 112.

### Curved Quartz Crystals as Supersonic Generators (L. W. Labaw)

The supersonic beam radiated from a one-centimetre radius X-cut quartz disk is examined experimentally as a function of the spherical curvature of the crystal, at a frequency of 1,110 kilocycles. The crystals of large curvature produce a definite focusing action as has been reported. Experimental data show that it is possible to obtain a much greater excess pressure amplitude close to the generator from a curved crystal than is possible from a flat crystal having the same area and thickness using the same input power. The quartz plates of small curvature do not produce a marked focusing action but give a larger supersonic amplitude at large distances from the generator. The flat crystal gives the smallest angle of spread of the supersonic beam. The resonant frequency for any of the five crystals studied did not differ by more than 20 kilocycles (2 per cent.) from that to be expected from the thickness.

—*Jour. Acous. Soc. Am.*, April, 1945.\*

### Crystal Filters (3)—Quartz Crystal Resonators (R. L. Corke)

A brief description is given of the X-cut quartz crystal resonator with a simple explanation of its operation as an element of a filter.

—*P.O.E.E.J.*, July, 1945, Part 2, p. 39.

### Reflex Oscillators (J. R. Pierce)

This paper discusses qualitatively the behaviour of reflex oscillators. Power production, electronic tuning, variation of frequency with resonator voltage, effect of modulation coefficient, and influence of load are considered. Two brief mathematical appendices are included.

—*Proc. I.R.E.*, Vol. 33, Feb., 1945, p. 112.

## INDUSTRY

### Induction and Dielectric Heating Equipment

Tabular comparison of technical characteristics and initial cost per kilowatt of output power for commercially available induction and dielectric heating equipment as reported by manufacturers. Both electronic and non-electronic types are covered.

—*Electronics*, Aug., 1945, p. 110.

### Electronic Control of Cloth-drying Machinery (N. H. Chamberlain)

Electronic control appears to be almost completely unknown in the textile industry. In this article the author endeavours to show the necessity for controlled drying and to indicate the basic principles along which such control may be effected by electronic means. Any device to control the moisture content of the delivered fabric must comprise a detector unit and a control unit. The detector unit converts moisture variations into variations of current or voltage. The control unit responds to these electrical variations by affecting the running of the machine to offset the original detected variations. Various types of detector and control units employing vacuum tubes and thyratrons are described.

—*Text. Mfr.*, April, 1945, p. 163.\*

### Electronic-type Instruments for Industrial Purposes

(P. S. Dickey and A. J. Hornfeck)

The authors discuss the use of electronic equipment in fields of measurement where mechanical or electro-mechanical instruments have previously been employed. A new type of measuring and controlling instrument for general process work is described. Equipment for automatic computation of results obtained from several primary measurements is described and typical measuring circuits for different problems are illustrated, including a circuit for the measurement of differences, and several bridge circuits. Simplification and standardisation of instruments for process control through the use of electronic devices is stressed as the important advantage of the equipment described.

—*Trans. A.S.M.E.*, July, 1945, p. 393.\*

### Dielectric Heating by the Radio-frequency Method

(L. Grinstead)

After a brief reference to some of the applications of radio-frequency energy to the heating of dielectric materials, the general theory of the method is outlined. The heat and power relations governing all such uses are discussed in some detail with special reference to sources of electrical and thermal loss in the generator and the work. It is shown that, for minimum losses and a reasonably good temperature distribution, fast heating is desirable. A family of curves is included enabling relative performances of various generators in terms of power and time to be rapidly determined. The basic circuits for dielectric heating equipments are briefly reviewed and the need for correct loading of the transmitting valves is explained.

Two of the more usual load coupling circuits are analysed so that the effects on loading and efficiency of varying circuit parameters may be studied. It is shown that the series-capacitance type of circuit can, under certain conditions, maintain nearly constant power in the work during a heating cycle. For transformer circuits, the conclusions reached show that a proper value of coupling coefficient is desirable in the interests of circuit efficiency.

—*Jour. Brit. I.R.E.*, Vol. 5, No. 3 (1945), p. 128.

### Phototube-controlled Flame Cutter (D. S. Walker)

A method of electronic control applied to a flame cutter is described which makes possible the accurate cutting of large steel sheets on a mass production basis. The outline to be cut is determined by reflecting spots on four black bakelite drums, two controlling the action of the longitudinal drive motor and the other two controlling the transverse drive motor. A photo-electric cell system is used to observe the reflecting spots on the rotating drums and translate their effect into electrical impulses. The scanning apparatus, circuit and power supplies for the apparatus are discussed with reference to diagrams and the advantages of the electronic flame cutter over machines performing a similar function are reviewed.

—*Electronics*, July, 1945, p. 100.\*

\* Abstracts supplied by the courtesy of Metropolitan Vickers Electrical Co. Ltd., Trafford Park, Manchester



# *The* **MULLARD** *all-glass technique*

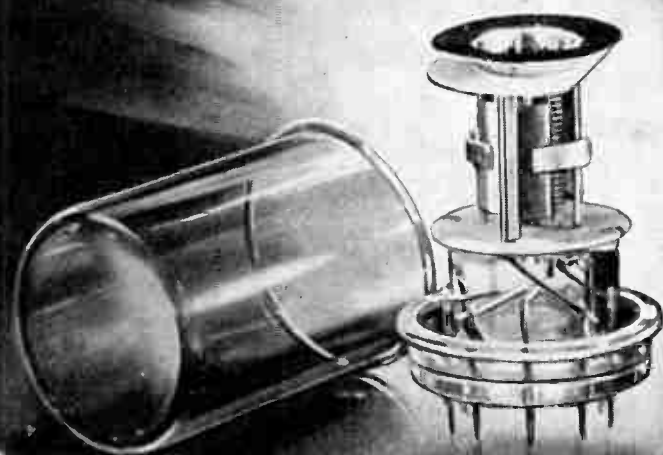

By a complete departure from the conventional form of valve construction, Mullard have effectively reduced the losses due to H.F. resistance, inductance and capacity effects within the valve itself and in the leads coming from the electrodes. The all-glass technique makes use of an almost flat circular glass pressing for the base of the valve, into which short pins are sealed, the electrodes being welded directly to the pins. By thus reducing the length of the lead-out connections, considerably improved efficiency at the higher radio frequencies has been achieved.

A  
DEVELOPMENT  
OF THE  
MULLARD  
LABORATORIES

## NOTES FROM THE INDUSTRY

### Air Commodore Leedham

Air Commodore H. Leedham, C.B., O.B.E., Director of Research and Development at M.A.P. from 1943 to 1945, has been appointed managing director of Ericsson Telephones, Ltd.

From 1940 to 1943 he was in charge of radio production at M.A.P. and was responsible for the Radar equipment for the R.A.F. and the Army. His many friends in the radio industry will wish him success in his new position.

### Cable and Wireless, Ltd.

A new direct radio-telephone circuit has been opened between Canada and Barbados operated by the Canadian Marconi Co. in Canada (an associated company) and Cable & Wireless, Ltd., in Barbados.

### Neon Tester

The Acru Electric Tool Manfg. Co., makers of the "Pyrobit" soldering irons, announce the introduction of a small neon tester in moulded plastic case for the pocket. It operates on 100-400 V A.C. or D.C. and is priced at 12s. 6d.

### Modern Instrument Cases

From October 1 to 13, Alfred Imhof, Ltd., of 112-116 New Oxford Street, W.C.1, will hold an exhibition of instrument cases. The complete process of manufacture, as well as the preliminary design work, will be demonstrated. The first range of post-war standard instrument cases will be shown, in addition to the first designs of a range of ornamental handles for a variety of applications.

The exhibition will be open daily from 11 till 6. Saturdays 10 till 1.

### High Frequency Heating

Rediffusion, Ltd., have just concluded a successful exhibition of Redifon H.F. heating equipment at Dorland Hall, W.1.

The primary aim of what is claimed to be the world's first exhibition of radio frequency heating was to explain its operation and what it can do for industry. It was arranged in four sections:

Examples of products suitable for heating.

Simple explanatory story of H.F. heating.

Practical demonstrations showing how the more important materials can be treated.

Lecture theatre for introductory talks and films.

The company also exhibited specimens of their other activities, including radio transmitters, navigational trainers and communication equipment, and their associated company, Small Motors, Ltd., showed a new abrasive saw for cutting laminated board and metals.

### Metallised Ceramics

Ceramic materials may be coated with a firmly adherent film of metal, e.g., silver, by firing on at red heat, and the thickness of the metal may be increased by subsequent plating.

Such a coating can be soldered to metal and forms a reliable and permanently gas-tight joint.

Steatite and Porcelain Products, Ltd., publish a leaflet of standard designs of terminals and bushings and welcome inquiries for special applications which cannot be met from the existing range.

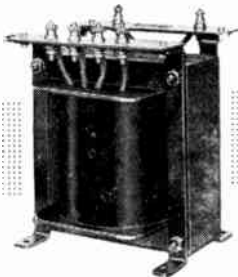

For the past 15 years we have devoted our energies exclusively to the manufacture of Transformers and Chokes. Although we continue to be very active in the field of Research and Development, we are nevertheless giving much of our attention to increasing our range of mounting facilities.

Illustrated above is one of the varied range of styles shown in our Catalogue which is now in preparation. If you would like a copy, please write to us (enclosing 1d. stamp) and we will send you one immediately it is ready.

Telephone:

Abbey 2244

**PARTRIDGE**  
**TRANSFORMERS LTD**  
76-8, PETTY FRANCE. LONDON, S.W.1

*Critical users*

AMPLIFIERS FROM  
5 to 500 WATTS FOR  
PRIORITY WORK.

*Trust*  
**TRIX**

*Quality SOUND Equipment*

**THE TRIx ELECTRICAL CO. LTD.**  
1-5 MAPLE PLACE - TOTTENHAM COURT ROAD,  
LONDON, W.1.  
Phone: MUSEUM 5817 *Grams & Cables* TRIXADIO - WESDO - LONDON.

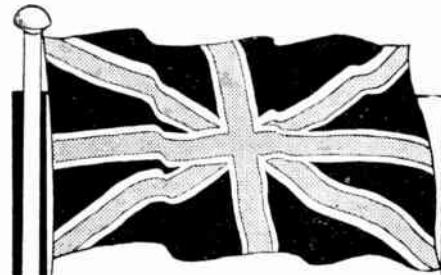

We have pleasure in announcing that limited quantities of RELIANCE Potentiometers are now available for trade purposes.

All orders will be dealt with in strict rotation.

**RELIANCE**

Manufacturing Co. (Southwark) Ltd.  
Sutherland Rd., Higham Hill,  
WALTHAMSTOW - E.17

Telephone : : Larkwood 3245