

Electronic Engineering

INCORPORATING ELECTRONICS, TELEVISION AND SHORT WAVE WORLD

**PRINCIPAL
CONTENTS**

' PHOTO-ELECTRIC NUMBER '

The Sound Head

The Spectral Response of Photo-electric Cells

Data Sheet — Spectral Response Curves (In Colour)

Smoke Density Measurement

The Electrical Activity of the Human Brain

21-MAY, 1943

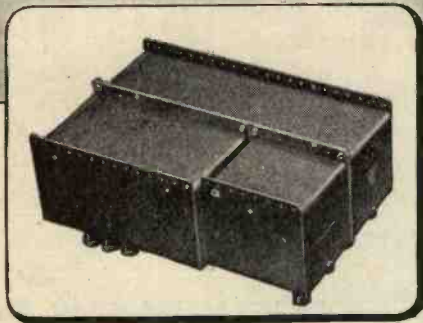

“Munit”

Muirhead instruments bearing this registered name are assembled in a special form of metal case enabling them to be rapidly assembled into many types of permanent measuring equipment, and as readily dismantled when this is no longer required. The illustration of a Wheatstone bridge, assembled in a few minutes from Munit instruments, is typical of the way in which they “go together.” Many of our instruments are available in Munit form,

The following are some useful Munit instruments :

Bridge Multipliers
Galvanometer Units
Variable Air Condensers 2 types
Decade Condensers..... 1 to 3 dials
Decade Resistance Boxes 1 to 5 dials, 2 types

Munit construction is described in Bulletin B-500-B, a copy of which will gladly be sent on request.

MUIRHEAD

MUIRHEAD & COMPANY LTD., ELMERS END, BECKENHAM, KENT. TEL: BECKENHAM 0041-2

FOR OVER 60 YEARS DESIGNERS AND MAKERS OF PRECISION INSTRUMENTS

C.R.C.48

The fact that goods made of raw materials in short supply owing to war conditions are advertised in this magazine should not be taken as an indication that they are necessarily available for export.



Going one better
IN COMMUNICATIONS

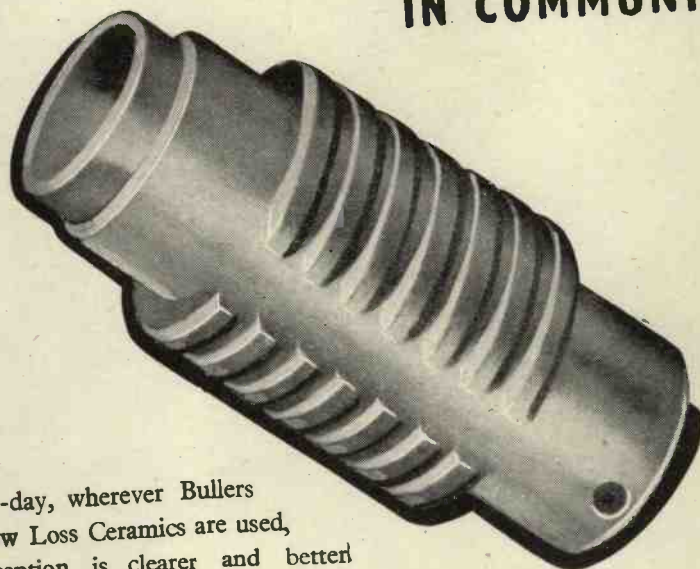

To-day, wherever Bullers Low Loss Ceramics are used, reception is clearer and better than ever before.

Years of research in Bullers Laboratories have developed these materials to such a high level of efficiency that Dielectric Loss is virtually eliminated. Bullers Ceramics are now playing a vital part in maintaining communications under all conditions.

BULLERS LIMITED
 THE HALL, OATLANDS DRIVE, WEYBRIDGE, SURREY
 Telephone : Walton-on-Thames 2451
 Manchester Office : 196 Deansgate, Manchester

Made in Three Principal Materials:

FREQUELEX. An Insulating material of Low Dielectric Loss. For Coil Formers, Aerial Insulators, Valve Holders, etc.

PERMALEX. A High Permittivity Material. For the construction of Condensers of the smallest possible dimensions.

TEMPLEX. A material of medium permittivity. For the construction of Condensers having a constant capacity at all temperatures.

Bullers

LOW LOSS CERAMICS



S.S. White

FLEXIBLE TORSIONAL REMOTE CONTROL

*further examples of
end-fittings*

THE S. S. WHITE COMPANY • BRITANNIA WORKS • ST. PANCRAS WAY • CAMDEN TOWN • LONDON N.W.1.
Cable Address : WHICODENTA, WESDO, PHONE, LONDON Telephone : EUSTON 4758-4759

COMMUNICATIONS DEPEND....

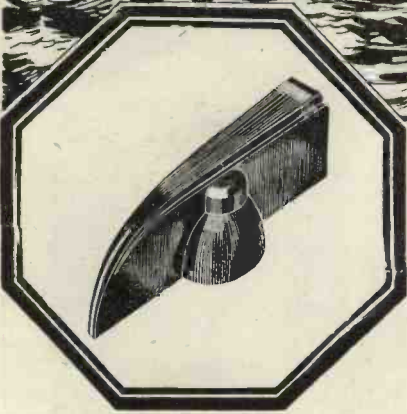
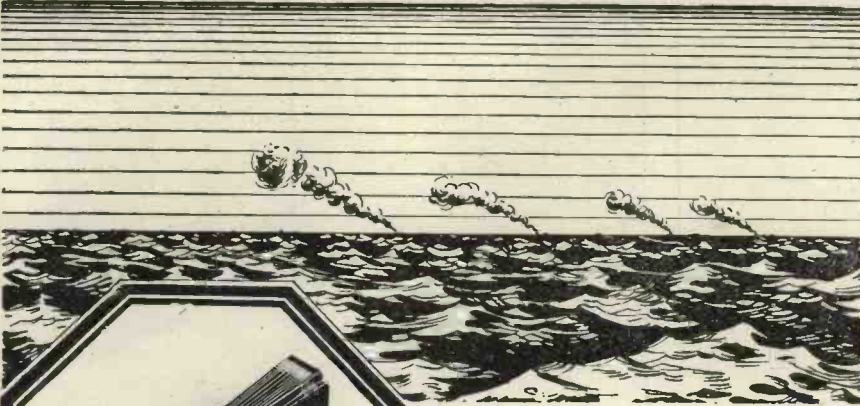

ON SMALL PARTS....

In countless instances quite intricate pieces of apparatus are wholly dependent on the proved reputation and reliability of their component parts.

All products from the House of Bulgin are pre-eminent for superior design and workmanship, and every article bearing our Trade Mark has to pass exacting and exhaustive tests during the course of its production.

We ask the kind indulgence of the public on delivery until peaceful conditions return.

The Choice of Critics

**BULGIN
FOR
KNOBS**

The largest and most extensive range in the World. Over fifty models from which to choose. All sizes and shapes, for different classes of work or operation. Nearly every type has brass-insert, steel grub-screws are fitted, well sunk. For 0.25" dia. shafts and other sizes. Finely moulded and highly polished. The highest class instruments use Bulgin Knobs exclusively.

ALWAYS DEPEND ON

BULGIN

REGISTERED • TRADE • MARK

A. F. BULGIN & CO. LTD., BY-PASS RD., BARKING, ESSEX

Tel. Rippleway 3474 (4 lines)

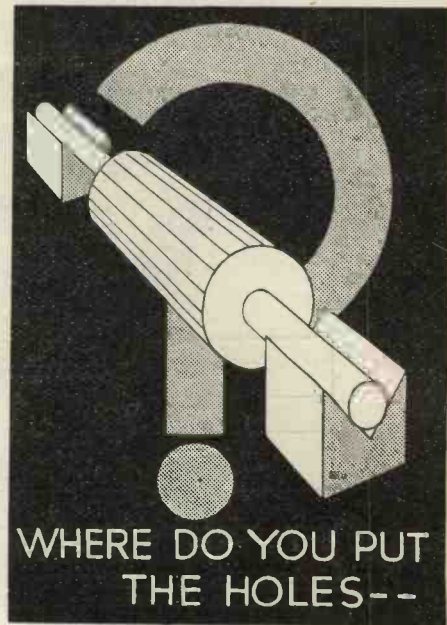

WHERE DO YOU PUT THE HOLES--

The diagram above represents a rotor. If this is not dynamically balanced, forces will be generated in the journal causing vibrations which may well be serious.

To balance the rotor, metal is removed from suitable portions, but the problem is to know where these portions lie. The vibrations produced can be detected without difficulty, but the complete information involves a knowledge of the phase as well as the magnitude.

This information can be obtained electronically by mounting a seismograph head on the journal and thereby transforming vibrations into electrical voltages which are amplified and presented on an oscillograph screen. If the time base of the oscillograph is then synchronised with the revolutions of the rotor, the amplitude and phase of the out of balance forces, can be determined simply and accurately.

It is all a matter of knowing how. Furzehill Laboratories Ltd. have made it their business to know how. Perhaps your problem is capable of an electronic solution.

FURZEHILL
LABORATORIES LTD.
BOREHAM WOOD
HERTS
TELEPHONE • ELSTREE 1138
ELECTRONIC EQUIPMENT ENGINEERS



ELECTRO-MEDICAL EQUIPMENT

DRAWING OFFICE EQUIPMENT

SPECTROGRAPH
ANALYSIS EQUIPMENT

H.F. ELECTRIC FURNACES

Interference created by above is suppressed by H.F. mains filters and screened rooms.

We supply screened rooms of any dimensions and H.F. mains filters 15 and 300 amperes maximum loadings.

AERIAL SYSTEMS
DESIGNED & INSTALLED

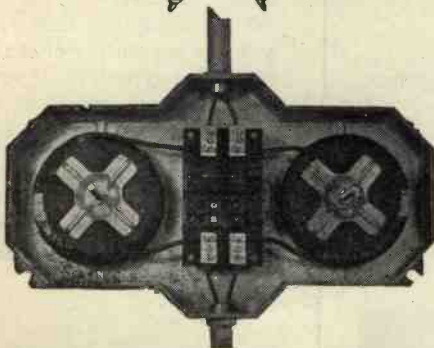

A Typical H.F. Filter.

BELLING & LEE LTD
CAMBRIDGE ARTERIAL ROAD, ENFIELD, MIDDX

◀ 18773

STABILITY
in all your Electrical Instruments

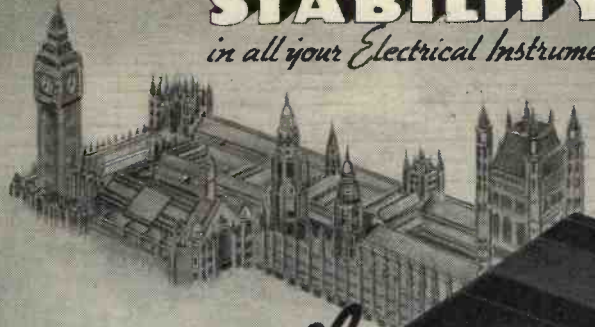

Advance
**CONSTANT
VOLTAGE
TRANSFORMERS**



ADVANCE COMPONENTS LTD.
BACK RD. SHERNHALL ST. LONDON, E.17. Tel: LARKwood 4366-7

**POWER PACKS
TRANSMITTERS
RECEIVERS** *for
priority
contracts*

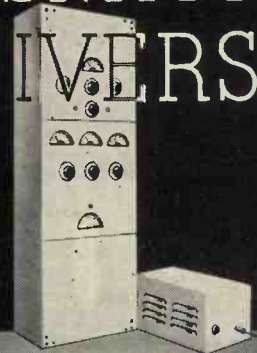

built to specification,
with precision, on time - by

WODEN
TRANSFORMER CO.

THORNLEY ST., WOLVERHAMPTON · PHONE. 22629

SPECTRUM ANALYSIS OF GASES

The exact composition of materials used in manufacture of WESTINGHOUSE METAL RECTIFIERS is determined by analysis of the spectrum, and recorded by spectrograms photographed by the apparatus shown. The gas discharge method of excitation is being used in this instance.

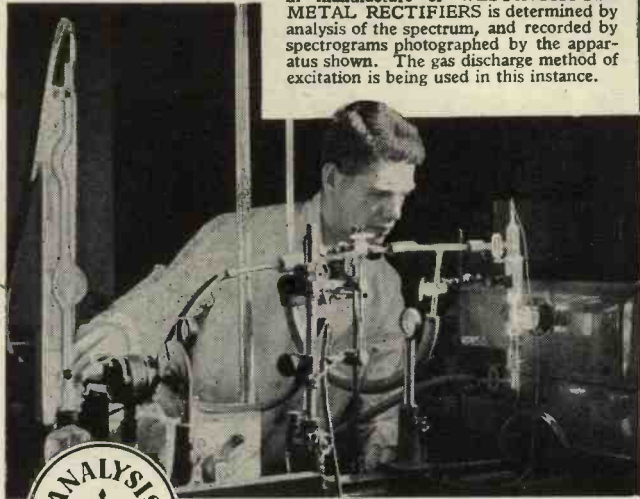

In spite of greatly increased production we are unable to supply Westinghouse Rectifiers as freely as we would wish. We hope customers will understand and accept our assurance that the constant research now going on in our laboratories and designing departments, is resulting in Rectifiers of remarkably advanced design which will be available after the war.

Westinghouse Rectifiers

WESTINGHOUSE BRAKE & SIGNAL CO. LTD.
PEW HILL HOUSE, CHIPPENHAM, WILTS.

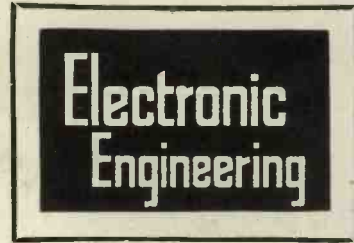

MAY, 1943

Volume XV.

No. 183.

CONTENTS

	PAGE
Editorial	495
The Sound Head	496
The Spectral Response of Photo-electric Cells	501
Some Measurements on Selenium Photocells	505
Smoke Density Measurement using Photocells	507
Data Sheet—Spectral Response Curves (Colour)	509
A Photo-electric Voltage Control Gear ...	516
Amplifying and Recording Technique in Electro-Biology—Part 2	519
Method of Determining Biological Inter-Electrode Impedances	524
Table of R.C.A. Photocells	525
Notes from the Industry	526
Book Reviews	528
R.C.A. 931 Photocell	530

PAINTON

**COMMUNICATION
COMPONENTS**

**MINIATURE WIRE
WOUND RESISTANCES**

PAINTON & CO. LTD.

NORTHAMPTON

CONDITIONS OF SALE—This periodical is sold subject to the following conditions, namely, that it shall not without the written consent of the publishers first given, be lent, re-sold, hired out or otherwise disposed of by way of Trade except at the full retail price of 2/- and that it shall not be lent, re-sold, hired out or otherwise disposed of in a mutilated condition or in any unauthorised cover by way of Trade; or affixed to or as part of any publication or advertising, literary or pictorial matter whatsoever.

SYMBOLS OF PRECISION

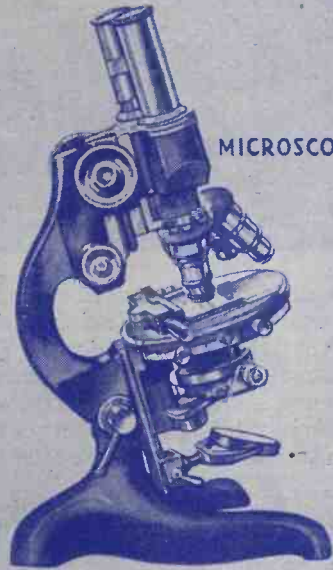

MICROSCOPE



MAZDA

RADIO
VALVES

THE EDISON SWAN ELECTRIC CO. LTD.



155, CHARING CROSS RD., LONDON, W.C.2

For full particulars write to Technical Service Department

PROPRIETORS :

HULTON PRESS LTD.,

Electronic Engineering

EDITOR :

G. PARR.

EDITORIAL, ADVERTISING AND PUBLISHING OFFICES, 43-44, SHOE LANE, LONDON, E.C.4

TELEPHONE:
CENTRAL 7400

Monthly (published last day of preceding month) 2/- net. Subscription Rates :
Post Paid to any part of the World—
3 months, 6/6; 6 months, 13/-; 12 months, 26/-. Registered for Transmission by Canadian Magazine Post.

TELEGRAMS :
HULTONPRES LUD
LONDON.

NOTICE BOARD

Completion of Volume

THIS issue completes Volume XV, the first volume of this journal in its new format. The Editor and Publishers again thank those readers who have written to express their appreciation of the Journal and will continue to make every effort to provide up-to-date information on all electronic and allied subjects.

Suggestions for articles on special subjects are always welcomed, but readers will appreciate that it is not always possible to include all items of interest owing to the paper restrictions and the difficulty of packing a quart into a pint pot.

As stated at the completion of the previous volume, the Publishers feel that under present circumstances they cannot recommend the permanent binding of issues, as materials for a high quality binding cover are not available, nor is the labour for binding.

A standard binding cover will be designed and issued as soon as conditions permit, and in the meantime it is recommended that readers procure a "self-binder" in which copies can be kept safely and conveniently for reference.

This self-binder is made in stiff blue cloth-covered board and is fitted with strings through which copies can be slipped to keep them in place. It holds a maximum of 24 copies, and can be obtained from

the Circulation Department at this Office, price 3s. 6d. post free.

Binding Covers for *Electronics*, *Television and Short Wave World*, as this journal was formerly known, are still in stock and can be supplied at 2s. 3d. post free.

Applications should be addressed: Circulation Dept., Hulton Press, 43 Shoe Lane, E.C.4, and be accompanied by a postal order for the amount.

Index

An index for Volume XV is in preparation, and will be available shortly. The index for Volume XIV is still obtainable, price 6d. post free.

Data Sheets

A number of readers have taken advantage of our Data Sheet Service, by which extra copies of Data Sheets are posted quarterly to hold-

ers of the Data Sheet Binder, the charge for a year's supply being 7s. 6d. including postage.

Binding Covers for the Data Sheets are available, price 2s. 6d., post free.

The Publishers regret that extra copies of the earlier Data Sheets are no longer in stock and that it will not be possible to issue reprints at the present time. Readers are advised to make application for the Data Sheet Service as early as possible if they wish to obtain extra copies.

Electronic Engineering Monographs

Copies of the monograph "Frequency Modulation" by Dr. K. R. Sturley are still available, price 2s. 8d., post free. The demand for this monograph has exceeded expectations and it may not be possible to print a further supply when the stock is exhausted.

The second monograph in the series, entitled "Plastics in the Radio Industry" is now in preparation and a further announcement will be made in due course.

Back Copies

There is a steady demand for back copies of ELECTRONIC ENGINEERING, particularly the 1941 and 1942 issues. Will any readers who have copies for disposal in good condition write to the Circulation Department stating the month and year of issue.

SALVAGE

Catalogues, Instruction Sheets, and Circuit Diagrams which are collected and filed for reference, mount up to a surprisingly large quantity in a comparatively short space of time.

There are probably catalogues in your files which are now out of date together with obsolete circuit diagrams. These would play a vital part in the war effort as paper salvage helps to make munitions.

Will you help by sorting your files at the earliest opportunity and add all you can to the salvage sack?

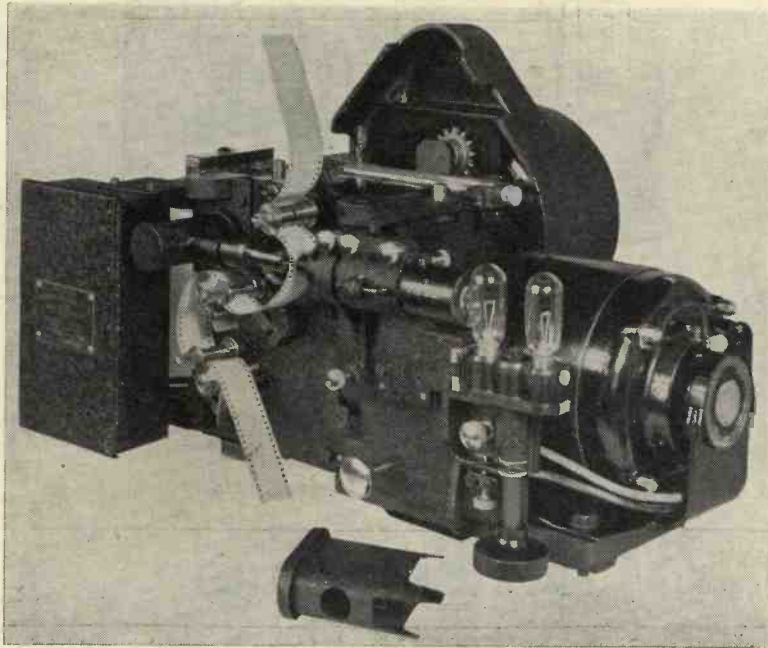

B.T.H. Magnetic Sound Head. Note the dual exciter lamps, a safeguard against burn-out. The magnetically coupled flywheel is mounted on the scanning drum shaft. The optical system, which projects a narrow slit of light on the film, is by Taylor-Hobson. The resilient motor supports can be seen, which not only isolate the vibration of the motor, but also absorb the abrupt starting torque.

The Sound Head

By R. HOWARD CRICKS, F.R.P.S.*

IF the patient searcher of Patent Office records delves through the British specifications for the year 1906, he will come across a remarkable specification, which may set him wondering why he had to wait until some 12 or 15 years ago to hear acceptable sound reproduction from film.

For the patent in question, No. 18,057, in the name of Eugene Lauste, describes fully the basic essentials of sound-on-film recording and reproduction. Lauste's work was briefly mentioned in the *Kinematograph and Lantern Weekly* in the following year, and again three years later, while in 1912 and 1913 further British patents were filed.

What then is the answer to the question posed by our searcher of specifications? The answer can be given in one word: electronics. If Lauste had had modern amplifiers and—equally important—the modern photo-electric cell, there is little doubt that the sound film would have appeared some twenty or thirty years before it actually did. For it is a fact that in the early days, recording was far ahead of reproduction, as can be demonstrated by running an early De

Forrest phono-film of some 20 years ago through a modern reproducer.

I. FUNDAMENTALS OF THE SOUND HEAD

Fundamentally the sound head is a very simple piece of apparatus. It comprises an exciter lamp and optical unit, which project a beam of light upon the film; means for moving the film past the scanning point; and a photo-cell which translates the light modulations due to the sound track into corresponding current modulations.

Lauste insisted upon two essentials for the reproduction of film-recorded sound: a constant film motion past the scanning point; and the scanning of the film at that point by a narrow bar of light. These remain the principal essentials for reproduction, and modern sound heads have advanced chiefly in their manner of achieving these ends.

Relation of Sound and Mute Heads

First there was the basic question to answer: where is the sound head to be situated in relation to the picture projector? And correspondingly, where in relation to a particular pic-

ture on the film is its sound record to be located?

It is obvious that while intermittent motion of the film is necessary for picture projection, sound and picture records cannot be alongside one another; the separation between picture and its corresponding sound record must be equal to the separation between picture gate and the scanning point in the sound head, if synchronism is to be maintained. (As a matter of interest, the film may be so threaded as to differ slightly from its correct separation, to allow for the time taken by the sound waves to travel back from the loud-speakers, but this difference amounts to only one or two frames of film).

Lauste, De Forrest, Grindell Matthews and others favoured the positioning of the sound head above the mute head; the argument was that in that position it would be less likely to get oily due to drippings from the mute head. But in America, mechanical considerations dictated that the sound head should be below the projector, and this is the existing standard. Its advantage is that the heavy flywheel needed is better situated below the projector; also,

* Secretary, British Kinematograph Society.

that, instead of driving this flywheel from the projector mechanism, it is the projector mechanism that is driven from the sound head, and the driving motor is most conveniently situated either below the sound head, as in earlier types, or; as in most modern types, is actually built integrally with the sound head.

Separation between Picture and Sound

The standard separation of 20 frames (15 in.) between picture and sound on the 35 mm. film (25 frames, or 7½ in. on 16 mm.) was actually fixed by convenience of design of the sound head in conjunction with the leading American projectors. Actually it proved to be difficult to obtain this separation with certain European projectors, which had consequently to be modified to comply with standards originated in America.

The sound head represents a combination of mechanical, optical, and electronic devices. It will be convenient to consider it under these three headings.

II. MECHANICAL DESIGN

Mechanically there are three essentials of sound head design:

1. The film must run at constant speed at the scanning point.
2. The film must be maintained in the correct focal plane at the scanning point.
3. Mechanical vibrations which may be transmitted to the exciter lamp or optical unit, and may cause spurious modulation of the light reaching the photo-cell, must be suppressed.

The engineer maintains, with some justness, that one of the most difficult things to achieve is a perfectly constant speed. If this is true of components made of unyielding metal, it is doubly true when an unstable material such as film is concerned. The problem is still further aggravated by the fact that the film is required to have perforations and is required to run not at a given linear speed of so many inches per second, but at so many perforations per second.

Wow and Flutter

Film speed fluctuations tend towards one of two types, dependent upon the frequency of fluctuation. Such fluctuations are known respectively as *wow* and *flutter*.

Wow is an imitative word, which may be defined as speed variations giving rise to audible variations in pitch. It is the objectionable sound heard when a gramophone motor changes its speed, or when the motor is switched on or off with the needle on the record: a gradual raising or lowering of the pitch.

Flutter differs from wow primarily in its effect upon the ear. It may be defined as speed fluctuations causing pitch variations too rapid to be heard as individual pitch variations. If for instance a film contains a frequency of 100 c/s., and is run with a flutter of 2 per cent., then the rapid succession of speed changes will cause this frequency to be reproduced at all frequencies between 101 and 99 c/s. The resultant tones will naturally be dissonant, and will furthermore give rise to sum and difference tones.

The matter is worsened by the fact that flutter rarely has a sinusoidal characteristic, but is generally rather of a saw-tooth form; one effect of this is that some of the high frequencies contained in the track may be lost. The audible effect of flutter is then harsh sound, frequently unintelligible speech (due to the distorted wave-forms of consonantal sounds) and "sour" music.

Elimination of Flutter

The most obvious cause of wow is variations in speed of the driving motor. The point is nowadays commonly overcome simply by the use of a repulsion induction type of motor, carrying a heavy flywheel.

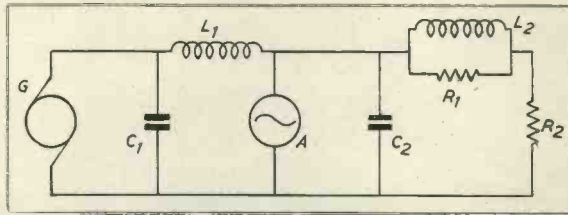

Fig. 1. Equivalent Electric Circuit of Mechanical Smoothing System of Sound Head.

The case is otherwise with flutter, which still presents considerable difficulties. The causes of flutter may be listed as follows:

1. Ripple imparted by mechanical components, e.g., gears and chains between the motor and the point at which the film is driven, and projector components, notably the Maltese cross with its 24 c/s. vibration.
2. Eccentricity or other inaccuracy of film driving sprockets, commonly at 6 c/s.
3. Sprocket ripple due to difference in pitch between the film and sprocket teeth, having a frequency of 96 c/s.
4. Random modulations due to variations in film stiffness, film "weave," etc.

Electrical Equivalents

For two reasons the problem is of interest to the television engineer: first, he encounters similar, if less difficult, problems in mechanical systems

of television scanning; and secondly, the method nowadays employed to solve such problems is based on electrical calculations.

The smoothing out of mechanical speed variations may be likened to the smoothing of electric currents; thus, in the example given, we have a task analogous to designing a circuit for smoothing out an A.C. ripple of ± 1 per cent. superimposed upon a D.C. supply.

The method was first set out by the B.T.-H. Company,¹ but has since been much elaborated by RCA.² The relation between the electrical and mechanical forces may be stated as:

- E—Volts = Force in lbs. of disturbance to be filtered.
- L—Henries = Mass in lbs./g.
- C—Farads = Resilience of spring in feet extension per lb. loading.
- R—Ohms = Damping in lbs. per foot per second.
- I—Ampères = Amplitude in feet per second of the disturbance to be filtered.

The filtering effect of a circuit is given by:

$$\frac{I_2}{I_1} = \frac{1}{1 - \omega^2 LC}$$

To prevent self-oscillation if the circuit is excited by a transient, resistance is added in series with the inductance, such that

$$R = \frac{1}{\sqrt{LC}}$$

Then

$$\frac{I_2}{I_1} = \frac{1}{1 - \omega^2 LC + j\omega CR}$$

Mechanical Application of Electric Circuits

The translation of these results into mechanical design has led to much ingenuity being applied. The general basis of design may be regarded as a mechanical translation of the circuit shown in Fig. 1. The generator G producing a current with a certain degree of ripple is the equivalent of the motor and its gear drive to the sound sprocket. Some form of resilient coupling (the condenser C₁) is introduced prior to the flywheel L₁.

The alternator A injecting A.C. into the circuit represents the sprocket

teeth ripple and other disturbances due to the film. For the condenser C_2 the resilience of the film loops generally suffices. The film may be scanned upon a flywheel drum, or it may drive such a drum prior to reaching the sound sprocket, the flywheel is represented by L_2 and its damping by R_1 . The resistance R_2 may be of quite low value, provided solely by the friction of the drum shaft bearings, or, if the flywheel drum and scanning drum are separate, it may consist of an actual friction drum upon which the film is scanned. In any case, the old idea of a friction gate is quite out of date.

Chief ingenuity has been employed in regard to the damping represented by R_1 . Obviously any form of static damping would be unsatisfactory, because it would vary according to the absolute speed, whereas it should vary according to the change in speed.

In one particularly efficient system, due to RCA, the flywheel runs freely within a light casing mounted on the scanning drum shaft, the only coupling being by means of oil of low viscosity.² In place of the flywheel, a

quantity of mercury may be used, as by British Acoustic.

The magnetic drive used by B.T.-H. and RCA is particularly interesting. In this, field magnets are driven by the mechanism, and form a narrow gap in which a copper annulus carried on the flywheel shaft turns. The magnetic drag, due to currents induced in this annulus, provides a driving torque enabling a drive to be transmitted without mechanical contact, and hence with a very considerable filtering effect.²

III. OPTICAL DESIGN

The need for a narrow scanning line on the sound track will be evident. Since the optical system producing this line of light will generally produce a converging beam, it is first essential that the film should be maintained in the correct focal plane.

Maintenance of Film in Focal Plane

The early types of sound gate, which were virtually identical with the picture gate, offered a serious objection on optical grounds. Film has an inherent tendency to buckle across

its width; the tendency is difficult to overcome in a flat gate.

The first improvement was the use of a curved gate; if the film is curved longitudinally, it cannot buckle laterally. But to-day practically every maker has abandoned this principle in favour of a scanning drum. The mechanical advantages of this principle have already been referred to. The drum may be smooth, or it may be knurled or etched with acid in order to provide an adherent surface for the film. It generally extends across the width of the film only as far as the inner edge of the sound track, so that the scanning light can pass through the film and can be transmitted to the photo-cell through a small prism.

A difficulty is, however, encountered even on this type of equipment. As one might expect, the film has less stiffness in the region of the perforations; thus when it is placed upon a drum it will tend to take up a polygonal form, so departing at intervals from the focal plane.

It is obviously impossible to provide any means of restraining the film

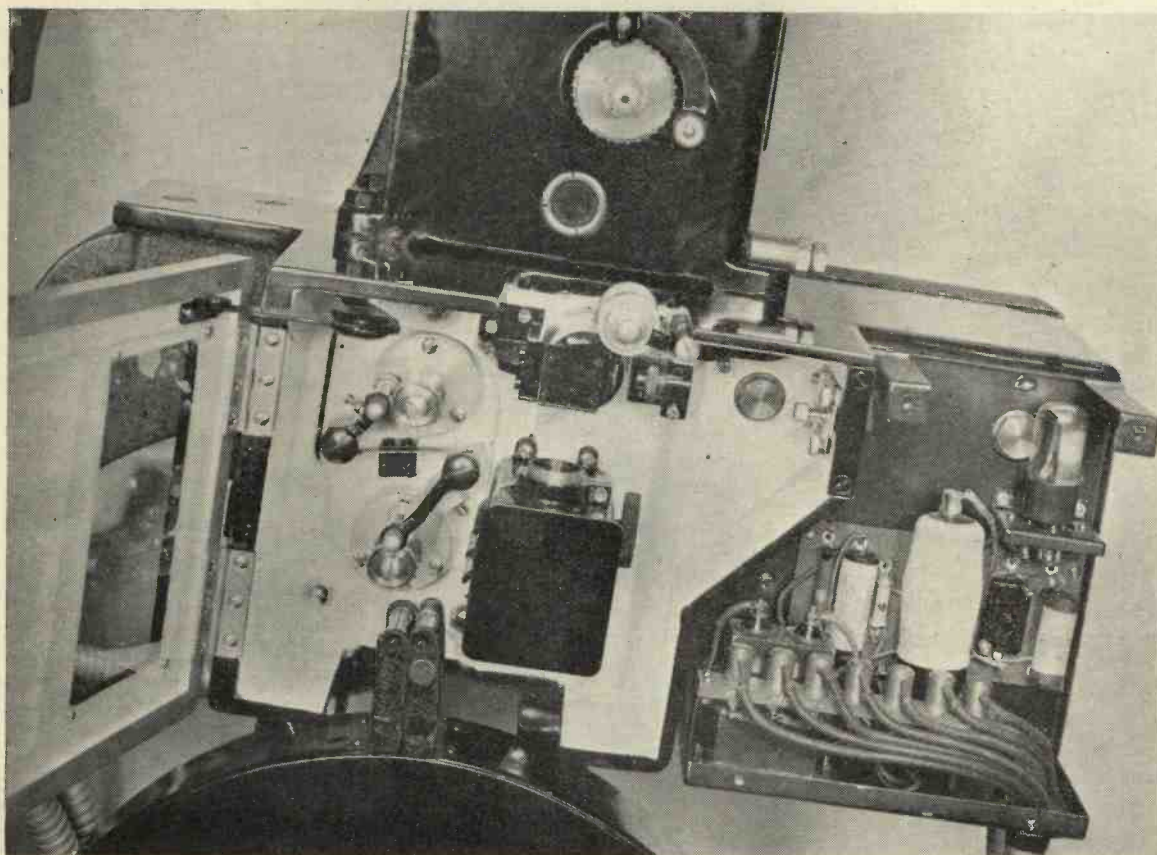

British Acoustic G.2 Sound Head. The drum upon which the film is scanned is connected to a fluid flywheel, consisting of a hollow aluminium shell filled with fluid of high specific gravity. Light from the 8v. 4a. exciter lamp (in housing below scanning drum) is condensed through a prism upon the sound track; an image of the track, magnified $7\frac{1}{2}$ diameters, is projected upon the light bridge and through to the photo-cell (in right-hand compartment). Below the cell is the pre-stage amplifier.

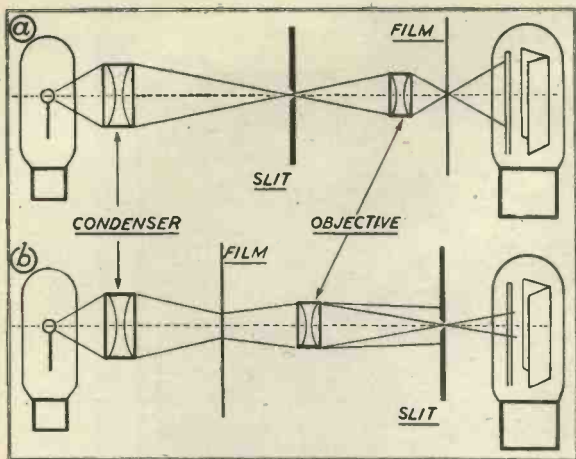

Fig. 2. Two types of Sound Head Optical System.

upon the drum. As the useful frequency range is extended, this point may be expected to raise difficulties in securing sufficiently accurate focus for the high-frequency waves to be scanned without undue loss.

Light Source

The source of light for the scanning of the film is a low-voltage exciter lamp; various types range from 10v. 7.5a. to 6v. 1a. The lamp is of the bar filament type, with A.S.C.C. cap; a number of types are standardised in B.S. specification No. 1,015 of 1942.

The use of a low-voltage lamp is essential for several reasons. In the first place, it enables a single bar filament to be used, which functions most efficiently in conjunction with the optical system. The heavier filament (as compared with higher voltage lamps) is less subject to mechanical vibration; it also has a greater thermal inertia thus permitting the exciter to be run on A.C. without serious fluctuation of light at mains frequency (although D.C. operation is in fact more general). These advantages tend to be lost in the case of the smallest type of lamp, rated at 6v. 1a.

Optical System

Two basic types of optical system are used, illustrated in Fig. 2. In (a), the light from the exciter is condensed upon the slit (constructed generally of two knife-edges very closely separated); the slit is then imaged upon the film by means of a highly corrected objective. The light, modulated by the sound track, passes to the photo-cell.

A system adopted in recent years by several manufacturers is shown in (b). Here the light is condensed upon the film, and a magnified image of the track is thrown upon the slit member, behind which is the photo-cell.

It will be evident that the effect is precisely the same in either case; their relative merits are a matter of

argument. The former type has the advantage that the whole of the optical components—condenser, slit, and objective—are enclosed in the one tube, and are protected from dirt and from careless handling. On the other hand, focusing is possibly easier in the second type (in one model the film is actually focused upon a piece of opal glass in which the slit is formed). It appears also that the second type is rather more efficient in regard to light transmission, due probably to its greater mechanical dimensions.

Slit Losses

The effect of slit losses in sound scanning is analogous to aperture losses in television scanning. Fig. 3 shows the calculated value of slit loss for a given value of slit width/wave-length ratio. It will be seen that up to the point where the slit width is half the wave-length, losses are negligible, but they increase rapidly thereafter.

In practice, recordists adopt a recording characteristic having an abrupt drop between 6,000 and 8,000 c/s., primarily because of the difficulty of printing the higher frequencies. However, years ago a number of manufacturers proudly claimed a standard of reproduction extending up to 10,000 c/s.; it will be of interest to consider slit width in relation to this frequency.

The running speed of 35 mm. film is 18 in. per second, and the wave-length of a 10,000 c/s. note is therefore .0018 in. Standards frequently adopted for the theoretical width of the slit on the film are .0005 in. or .001 in., either of which would appear to provide an adequate standard of definition for the 10,000 c/s. note. Practical difficulties however complicate the situation; in the first place, it is not easy to be sure that the optical unit is perfectly focused, and secondly, the photographic image on the film has a finite thickness, and the converging beam of light diverges

and scatters within the emulsion, while halation also occurs. Thus in practice, it is probable that few sound heads have much scanning power above 6,000 c/s.

Evenness of Slit Illumination

A point urged in favour of the variable density track is that unevenness of illumination along the length of the scanning slit will not affect the quality of sound. On the variable area track, serious distortion may, of course, result from this cause.

The most common fault is, as one would expect on optical grounds, an increased intensity in the centre of the slit, falling off towards either end. In the case of the unilateral track, spurious odd harmonics may be produced, but the effect will be less serious with a bilateral or multilateral track.

Push-Pull Reproducers

The push-pull track is increasingly used in the original studio recording. In this system the track is divided into two halves, one being a negative replica of the other (Class A) or alternatively (Class B) one carrying the positive half-cycles and the other the negative. Its advantages are very similar to those of the corresponding valve circuit: ground noise due to the film is virtually cancelled out, while

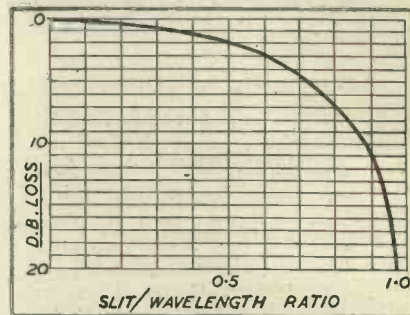
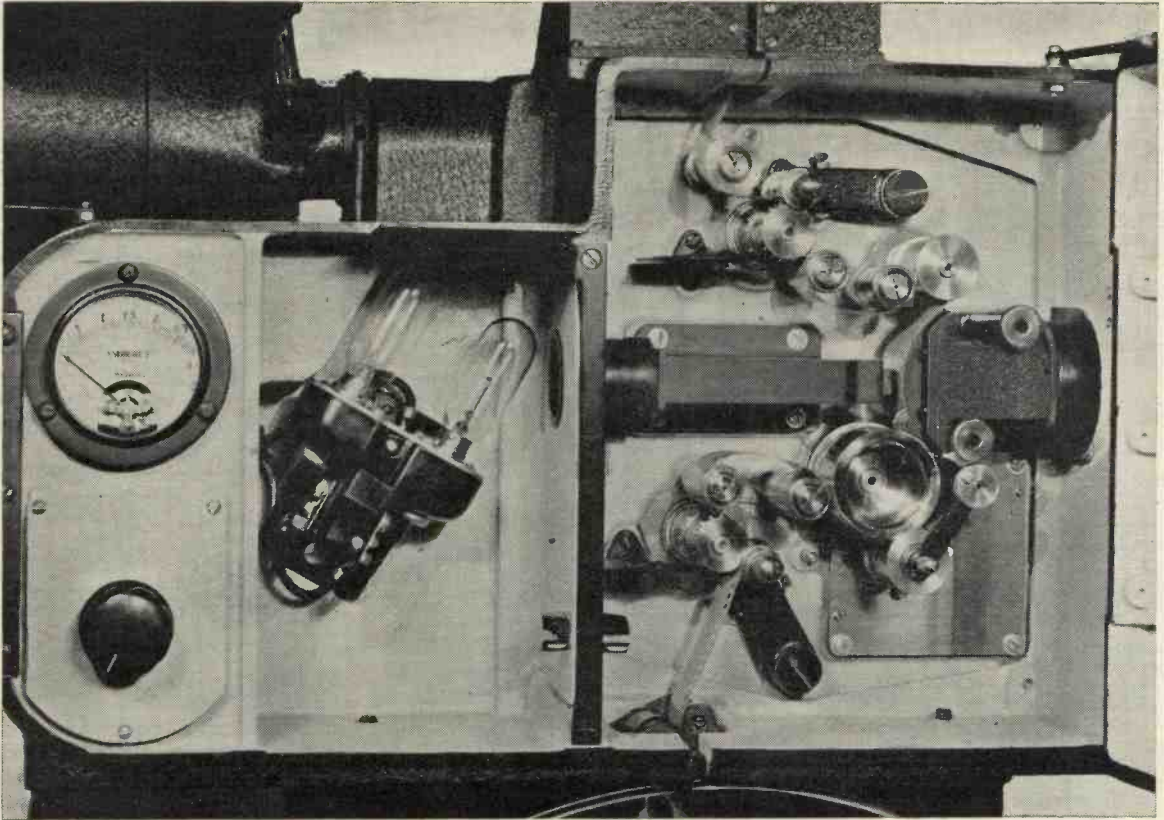

Fig. 3. Calculated Losses due to finite width of Scanning Slit.

photographic non-linearity is practically eliminated, the track thus having a higher signal/noise ratio.

The method of reproducing such a track comprises separate optical systems which enable each half-track to influence a separate photo-cell, the two cells being connected in push-pull. In order that normal tracks may also be run, switching arrangements are provided whereby the two cells can be connected in parallel.

The push-pull track has not yet reached the kinema, all release copies being re-recorded to a single track. One obvious reason for this is that a special sound head is needed. Another practical difficulty is that of securing perfect balance, optically and electronically, between the two channels.



RCA Fantasound Head. The quadruple optical system scans the three sound tracks and the control track. Since the Fantasound system employs separate picture and sound films, the sound head is a "dummy" (i.e., has no picture head) and is electrically interlocked with the Picture Projector.

IV. ELECTRONIC REQUIREMENTS

Electronically, the chief essential of the sound head is that it shall produce a sufficiently high output level for the signal to be transmitted through screened low-capacity cable to the main amplifier rack, which may be situated at a distance of some feet from the projectors. Generally, therefore, a pre-stage valve is embodied in the sound head, close to the photo-cell, which raises the level of the photo-cell output sufficiently for it to be transmitted to the amplifier without undue loss, and without risk of pick-up.

Alternatively, the impedance of this line may be stepped down by means of a transformer in the sound head, and stepped up again before feeding into the first stage of amplification.

Colour Sensitivity of Cells

The possibility of dispensing with any such complications by an increase in photo-cell output has been constantly borne in mind. Needless to say, gas-filled cells are invariably used, originally with potassium

cathode, but nowadays invariably caesium, owing to the fact that the sensitivity of the latter more nearly corresponds with the colour of the light emitted by the exciter.¹

Considerable progress has been made recently in this direction by Cinema Television, who have produced a new series of cells whose colour sensitivities are shown on page 501.

An alternative recently demonstrated is the use of an electron multiplier type of cell, providing in the one tube a magnification equal to that of several stages of thermionic amplification.²

A point of interest is that practically every system of colour cinematography produces a black-and-white track, hence variations in colour sensitivity of different cells will not appreciably alter the output as compared with that of a black-and-white film.

Equality of Response of Cathode

It will be gathered from the sketches of the optical units that there is generally no diffusion provided be-

tween the film and the photo-cell, hence it is essential that the sensitivity of the cathode should be fairly constant over its surface.

The modulated light usually reaches the photo-cell in the form of a diffused circle. Any variation of sensitivity across the horizontal diameter of this circle will probably give rise to wave-form distortion, at least in the case of the variable area track.

Balancing Output

It is obviously essential that the output from the two sound heads should be accurately balanced, so that no appreciable change in volume will occur when changing over from one projector to the other.

This is commonly effected by adjusting the voltage applied to the two cells by means of potentiometers. Alternatively, a resistance network equaliser may be provided in the speech circuit.

REFERENCES

- 1 *Proc. B.K.S.*, No. 39.
- 2 *J. Soc. Mot. Pic. Eng.*, October, 1935, p. 289.
- 3 *J. Soc. Mot. Pic. Eng.*, August, 1940, p. 138.
- 4 *J. Soc. Mot. Pic. Eng.*, July, 1937, p. 20; February, 1938, p. 158.
- 5 *J. Brit. Kine. Soc.*, January, 1943, p. 6.
- 6 *J. Brit. Kine. Soc.*, October, 1942, p. 102.

The Spectral Response of Photo-electric Cells

By T. M. C. LANCE*

ACCORDING to the present day theory of atomic structure the atoms of all elements consist of systems of smaller particles, protons, neutrons and electrons. The protons and neutrons form a central nucleus, while the electrons circulate around the central mass, the obvious analogy to the planets circulating around the sun in the solar system having given them the name of planetary electrons. The planetary electrons, though free to move in their orbits, are closely restrained when they approach the boundary of the atomic structure. If, however, energy is communicated to them from outside, one or more of these planetary electrons may approach the boundary with sufficient energy to break loose from its solar system. Light falling on the surface of certain metals imparts the required energy to the planetary electrons of the atoms and in consequence some of them escape from the parent atoms nearest the surface of the metal and pass into the surrounding space.

The rate of liberation of electrons from the atoms, prior to their passage through space to constitute the photo-

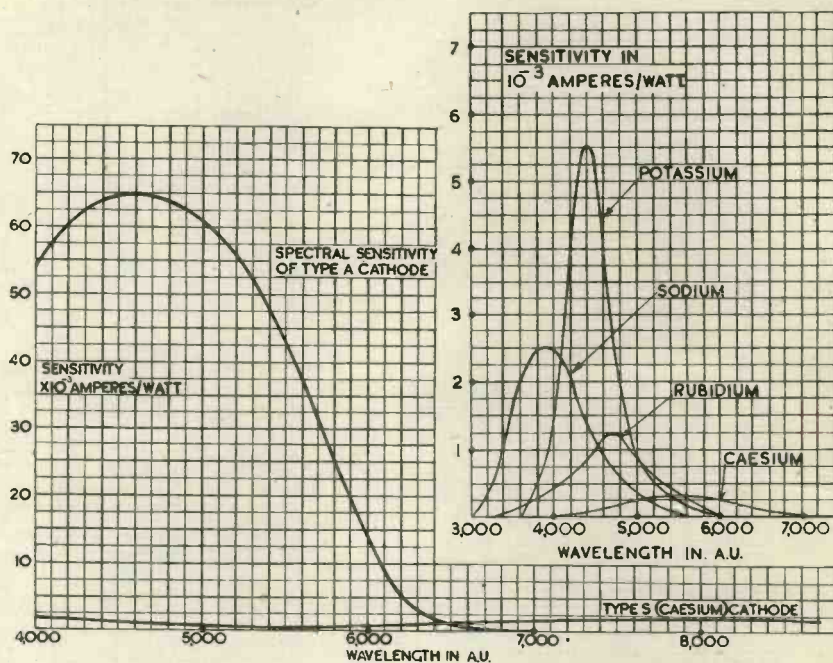

Fig. 1 (top right). Spectral sensitivities for thick film cathodes of certain metals.

Fig. 2 (left). Characteristics of cathodes specially developed for monochrome spotlight scanning or multi-channel colour television transmission.

* Cinema Television, Ltd.

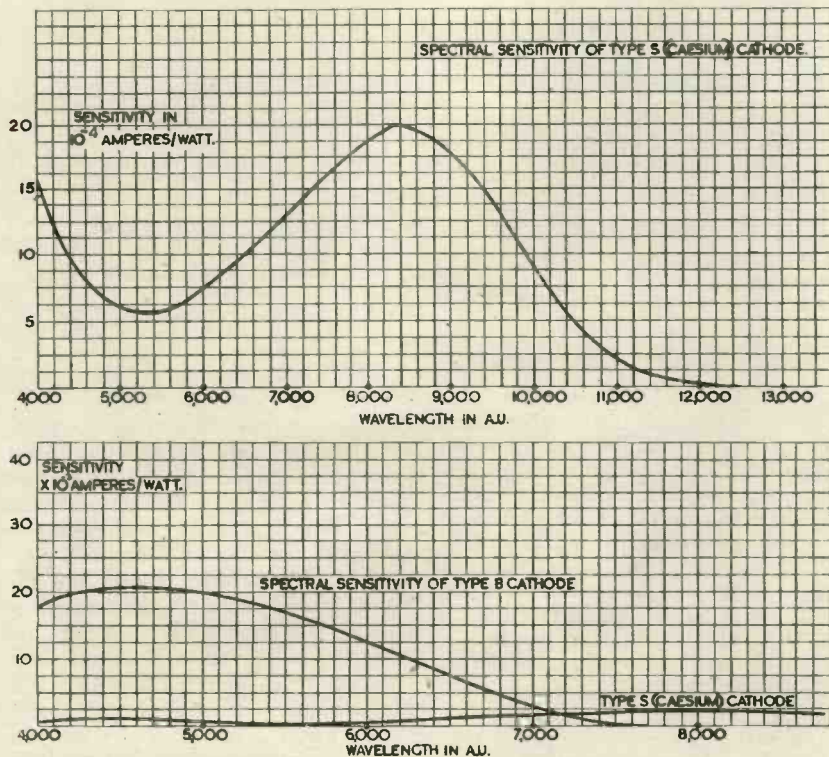

Fig. 3 (above). Characteristic of CsAg-O cell. Compare with that of caesium in Fig. 1.

Fig. 4 (below). Characteristic of new type of cathode (Baird Television Ltd.)

electric current, determines the strength of the photoelectric current flowing.

The photoelectric effect is a perfectly general one exhibited by all elements for radiant energy of suitable frequency. For example, if we consider radiations of the highest frequencies, *i.e.*, X-rays or γ -rays a photo emission is always produced when the surface of any metal is irradiated. On the other hand, radiations of the lowest frequencies, *i.e.*, radio waves, are incapable of producing an electron emission from the surface of any substance. Between these extreme limits of high and low frequency which embrace the photoelectric band there is a comparatively narrow band of frequencies which have the power of exciting the sense of sight, and radiations in this band convey to the human brain, through the optic nerve, the impression of light and colour.

Although the above remarks refer to frequency bands, in dealing with spectroscopy the wavelengths are always used and the band of frequencies constituting the visible spectrum, and the corresponding wavelengths, range from 7,500 AU for deep red light to 4,000 AU for deep blue light.

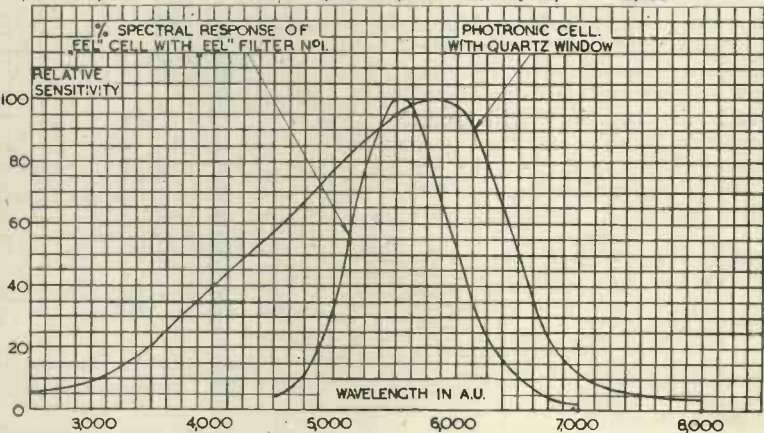
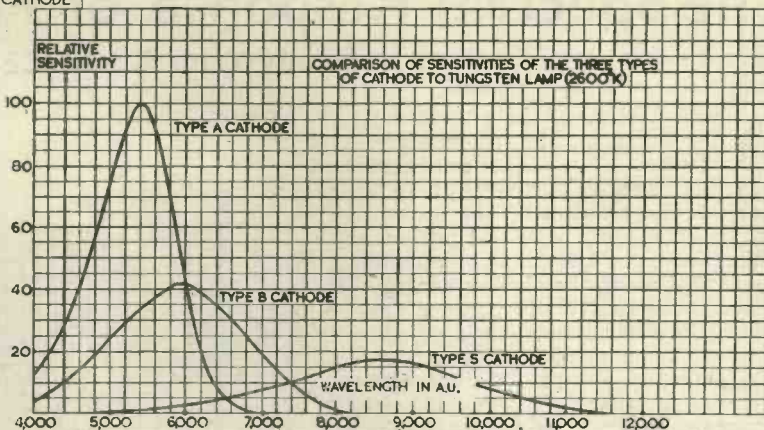
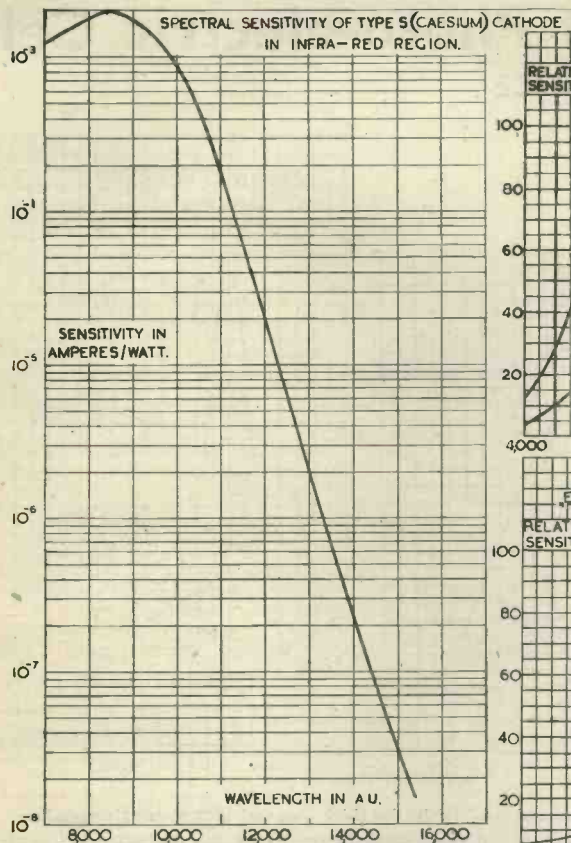
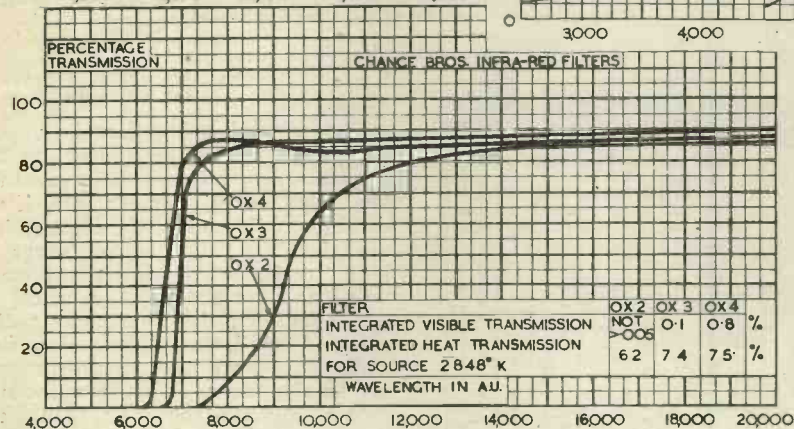

Fig. 8 (top). The sensitivity to tungsten lamp of the three cathodes: A, Antimony B, Bismuth, and S, Caesium-Silver.

Fig. 5 (underneath). Spectral response of selenium barrier layer cell.

Fig. 7 (top left). Response of caesium silver type cathode to infra-red.

Fig. 6 (left). Effects of infra-red filters (Chance Bros.)



The units in common use for specifying wavelengths of radiation are:

- (1) The Micron (1μ) = 10^{-3} mm.
- (2) The Millimicron ($1m\mu$) = 10^{-6} mm.
- (3) The Angström Unit (AU) = 10^{-7} mm

Immediately above and below this band lie respectively the infra-red and the ultra-violet radiations of which considerable use is made in some photoelectric applications.

All the metals exhibit a photoelectric effect and it can be proved that the total number of electrons released in unit time by unit intensity of absorbed light energy depends on the wavelength and polarisation of the light and the nature of the surface

being illuminated.* This quantity is called the spectral distribution function. Different metals show different values and it is the purpose of experimenters by their skill in the photoelectric field to produce the maximum yield for given energy inputs at different wavelengths. The spectral sensitivity or photoelectric yield is the factor of principal interest and is a quantity very naturally expressed in electrical terms as amperes per watt at any wavelength.

Cell Characteristics

The early experimenters found that seven of the elements showed appre-

cial photoelectric emission for radiation within the visible spectrum, *vis.*, lithium, sodium, potassium, rubidium, caesium, strontium and barium. The cells they manufactured had thick films of one of these metals as the light sensitive surfaces and since these metals oxidise rapidly the surfaces were enclosed in evacuated bulbs. Subsequent developments and research have shown that the most satisfactory cells are those in which the cathodes consist of monatomic alkali metal films or alloys on suitably prepared bases. Occluded gases in the metal surfaces influence the efficiency of the surfaces either adversely

* See *Photoelectric Phenomena*; Hughes and Du-bridge, (McGraw Hill, 1932). Chapter III, page 39.

or beneficially and therein lies part of the photoelectric art.

The spectral sensitivity to wavelength curves in the visible spectrum for thick film cathodes of certain metals are illustrated in Fig. 1. Since none of these materials is now used in photocells in the thick film form, this series of curves is really only of interest when considered in comparison with the improved monatomic thin films. Compare for example the characteristic of the thick caesium surface with the caesium-silver - oxygen cathode illustrated in Fig 3. It will be noticed that the peak of the curve has shifted from about 5,600 AU to 8,400 AU, while the value of the maximum spectral sensitivity has increased roughly ten times.

Figs. 2 and 4 are the characteristics of two new cathodes which were developed by Baird Television, Ltd., primarily for use in monochrome spotlight scanning with mercury lamps or cathode-ray tubes, and in multi-channel colour transmissions.

All the cathodes considered so far have been prepared in photocells of the alkali metal vacuum type wherein the free electrons leave the surface of the cathode and traverse an evacuated space towards a collecting anode, or into a secondary emission multiplier.

Reference should also be made to the barrier layer type of cell in which the electron emission is confined within the surface structure of the photoelectric and adjacent surfaces. The spectral sensitivity of one of these is shown in Fig. 5. It will be noticed that the characteristic of this cell is carried further into the ultra violet than in the curves of all the other types due to the fact that a quartz protecting window can be fitted if required to these cells.

The vacuum cells, on the other hand, under commercial manufacture, have to be enclosed in glass vessels which absorb the short wave radiation and although photocells have been made with bulbs entirely of quartz or with vacuum tight quartz windows facing the cathode, this is rather an impractical arrangement and has not been used except for a few particular applications. The influence of the glass is therefore included in the spectral characteristics illustrated in these notes.

Infra-Red

The fact that the caesium-oxygen-silver cell has a response to radiation in the infra-red or the long wave invisible range of the spectrum has been the basis of many inventions, practical and impractical, such as burglar alarms, Noctovision, secret signalling and so on. Unfortunately, it is not always realised by the inventors that

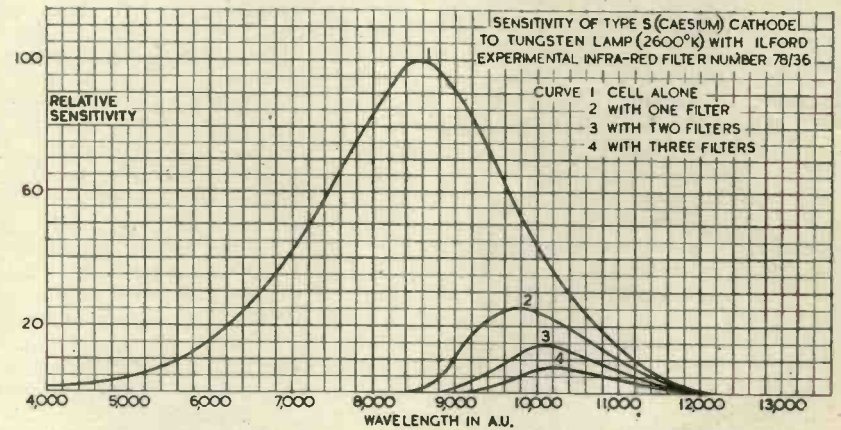
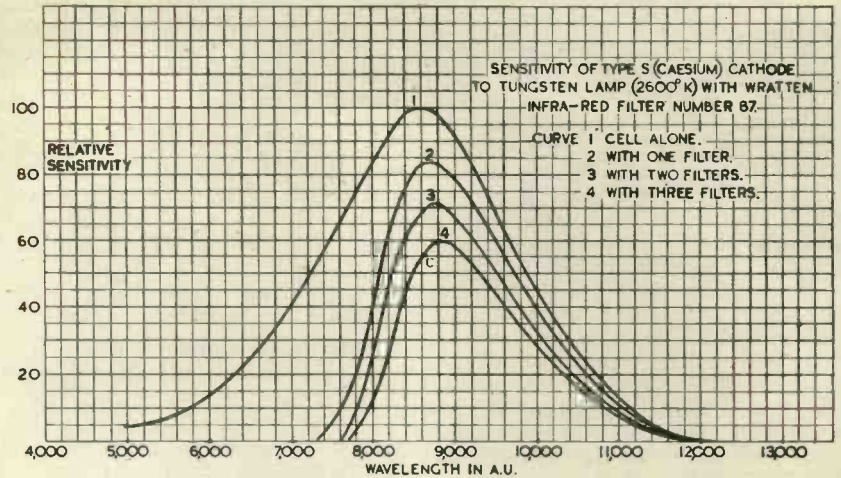

Figs. 9 and 10. Characteristics of caesium cathodes with Wratten and Ilford filters.

there are considerable difficulties to be surmounted before the desired effects can be obtained.

Firstly, strong infra-red radiation cannot be obtained from a practical source without the generation of visible radiation which it is usually proposed to obscure by the use of coloured filters of gelatine or glass, or by thin ebonite sheets. While some of these filters can be made very effective it must be remembered that no perfect filters can be obtained and that while obscuring visible radiation and passing the long waveband quite a high attenuation of the infra-red always occurs.

Secondly, although the spectral response of the caesium cathode extends into the infra-red region further than other surfaces, the response actually falls off very rapidly as shown in Fig. 7 partly because the energy associated with each wavelength band decreases as the wavelength increases. The scale of this curve should be carefully observed for then the detrimental effect of imperfect filtering of the light source becomes more apparent.

For example, if it is proposed to operate an application, such as fog penetration, with an invisible light of a wavelength of 12,000 AU and a filter has been obtained for the light source which produces the required operating condition with a photoelectric relay, then the relay will also be 200 times more sensitive to the energy from any random illumination or light passing through the filter at a wavelength of 8,500 AU which is the peak sensitivity of the photocell.

Thirdly, the ratio of dark current to photoelectric current increases as the energising band selected by the filter approaches the long wave heat radiations because dark current is largely composed of thermionic emission and in most applications where amplification is employed the background noise introduced by these currents completely masks the photoelectric signals. This is particularly true for caesium cathodes where the thermionic emission at room temperatures is of the same order as the photoelectric current.

With "A" type (Antimony) cathodes where the thermionic work

function is very different than for the caesium-oxygen-silver cathode, the thermionic currents are extremely small but then, of course, the cells are not responsive to the infra-red.

For burglar alarms where only the visible light to be reduced is say the band above 7,500 AU, commercial gelatine filters can be used in front of the lamp and the overall response of such a system using caesium cells, projection lamps and either Ilford or Wratten filters is shown in Figs. 9 and 10.

When planning such a system it may be found necessary to use more than one filter dependent on the degree of dark accommodation of the eye which may be searching for the light source and for this reason the Ilford filters are more suitable, although they introduce greater overall attenuation in the lamp-photocell system.

Incandescent Lamps

For photoelectric work the most efficient and convenient sources of radiation are Tungsten gas-filled lamps of the projection type wherein the filaments are bunched and accurately located for focusing and quick replacement in optical systems, and so the curves given in these notes (Fig. 8) cover the sensitivity to wavelength characteristics of different cathodes, the curves having been modified to include the characteristic of the lamp.

It will be noticed that because the

energy radiation of the lamp increases towards the red end of the spectrum and there is only a very small emission in the blue part, the ratio of maxima for the antimony and caesium-oxygen-silver cathodes is reduced from 33 times to 5 times under these conditions.

However, this improvement of 5 times makes it worth while to use the "A" type cell with an unfiltered lamp, particularly as the noise level is lower than the "S" type caesium-oxygen-silver cathode.

Simulating the Eye Response

For photometric and other purposes it is very useful to have a photocell-filter combination which simulates very closely the spectral response of the human eye, particularly since the introduction of coloured light sources such as discharge tube and fluorescent lighting, make direct comparisons difficult.

The usual cells have their maxima too far removed from the peak response of the eye (5,500 AU) to enable a simple correction to be made without serious attenuation, but the bismuth cathode (Type B in Fig. 4), the photronic and the selenium barrier layer types approach the desired result so closely that very simple filters can be attached which give a reasonably close approximation. Since the latter two types, being low impedance devices, do not lend themselves readily to valve amplification the bismuth cathode, being high impedance,

is most convenient under these circumstances. This cathode, as explained, was originally developed for colour television and is best suited for such purposes as light integrators, peak indicators, and similar devices.

Colour Combinations in the Visual Range

The use of specially designed combinations of filters and photocells can often solve quite difficult problems. For example in the photoelectric control of chemical titration testing where the addition of a reagent to a water-clear solution produces a colour change, the sensitivity of the photo-relay can be increased by using a cell and filter which produce a steep change in spectral response for the colour change anticipated. The sensitivity can sometimes be increased three or four times by this method using gelatine filters selected from the large range illustrated in the Kodak Wratten catalogue. In fact the photocell can be made to operate with certainty with colour changes hardly visible to the naked eye.

Sunlight

For applications associated with sunlight or skylight the antimony cell is definitely to be preferred as the sensitivity is on the average 15 times superior to the caesium-oxygen-silver cell for the total radiation because the peak emission of the sun is much nearer to the blue end of the spectrum than that of an incandescent lamp.

A "Pea" Photo-electric Cell.

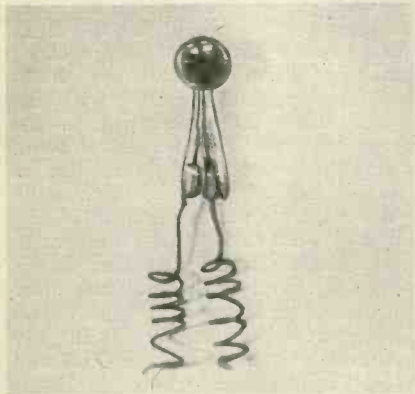

The photograph shows a miniature photocell of the Antimony type specially made for biological research work by Messrs. Cinema Television Ltd.

Its spherical envelope and small electrode give it omnidirectional characteristics. Sensitivity to a tungsten lamp is $20 \mu\text{A}/\text{lumen}$.

Photocell Photometer Unit.

The illustration shows a complete photometer unit, manufactured by the General Electric Co., which incorporates a photocell and electrometer triode with a high value coupling resistance. The whole assembly is contained in an evaporated bulb fitted with a standard valve base and the construction eliminates variations in grid circuit resistance due to surface leakage. The grid connexion between the photocell and triode is short, giving high stability.

Characteristics

1. Overall length, including pins: 35 cms.
2. Diameter of bulb: 4.5 cms.
3. Sensitivity of KMV.6 Photocell (approx.) $2\text{mA}/\text{lumen}$ when receiving radiation from a tungsten source operating at 2360°K .
4. Grid Leak (normally 50 or 100 megohms).

Units fitted with higher values of grid leak resistances—up to 10,000 megohms—can be supplied to order at an extra charge.

Electrostatic screening of this unit is desirable, and where serious electrical disturbances are present, the controlling apparatus in the anode and filament circuits should also be screened. If it is not convenient to house the unit in the same screened cabinet as that occupied by the control gear, the unit can be accommodated in a metal tube closed at both ends, but provided with a suitable aperture in the side to admit light to the photocell. In such an arrangement a 5-way flexible screened cable can be used to connect the unit to the control cabinet.

For full details of the use of this unit see G. T. Winch and C. F. Machin: *G. E. C. Journal*, Vol. vi, No. 4, November, 1935.



Some Measurements on Selenium Photo-Cells

By Dr. G. A. VESZI*

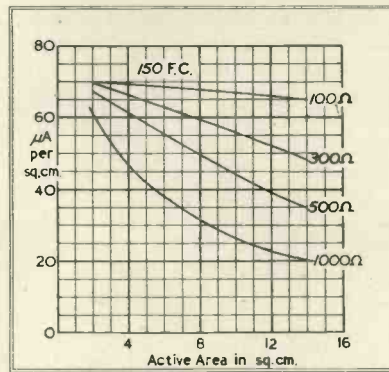
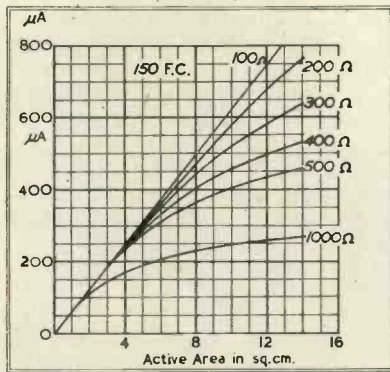

Fig. 1. (right) Current output against active area of cell for various loads.
 Fig. 2. (left) Current per unit area as a function of cell area for various loads.

SOME time ago the author published† a few diagrams showing the current output obtainable from a selenium photo-cell through a given load resistance as a function of the active cell area. The measurements were made on commercial cells of different shapes and sizes. This method was adequate for the practical purpose in mind at that time. It is obvious, however, that the results are bound to be influenced by variations in cell quality and by secondary effects due to differences in the arrangement of contact strips.

In order to obtain results more free from accidental and secondary influence, a different procedure has now been adopted.

A number of 37 mm. x 50 mm. cells, with contact strips parallel to the long sides (Type C "EEL"), were cut up into ten equal slices, each 5 mm. wide. Each part cell had an active area of 1.75 sq. cm. with two contact strips parallel to the short sides. The part cells were now measured with different circuit resistances at different illumination intensities and those eight selected the characteristics of which nowhere differed more than 10 per cent. In this way it was made possible to increase the cell area in identical steps by adding one more part cell at a time to the others.

Some of the results, obtained at 150 F.-C., are reproduced in Fig. 1, in which the current output in microamperes is plotted against the active cell area in sq. cms. Along each curve the load resistance is constant, its

value being indicated at the top end. For 100 ohms the curve is practically a straight line. But for higher load resistances the current output begins to lag behind the linear relation and the magnitude of the lag increases with the resistance and the cell area. The higher the resistance the smaller the area at which the lag begins to be noticeable.

Fig. 2 shows the current yield per sq. cm. as a function of the cell area. The load resistance again constant along each line, is indicated as before. This diagram is self explanatory.

Diagrams showing (in analogy to Fig. 1) the watt output as function of the active area are not very instructive. The picture is that of an embarrassing tangle of intersecting lines without any apparent order. A more satisfactory presentation of the results is to plot watt output against load resistance for constant cell size. This is done, again for 150 F.-C., in Fig. 3. The magnitude of the active area is given at the end of the curves. The majority of the curves show distinct maxima, the height of which is increasing with increasing cell size. The smaller the cell size the less sharp the maximum and the larger the value of the load resistance to which it belongs. For 3.5 sq. cm. it is just inside the edge of the diagram, but for 1.75 sq. cm. it is already beyond it.

From Fig. 3 it is clear that for

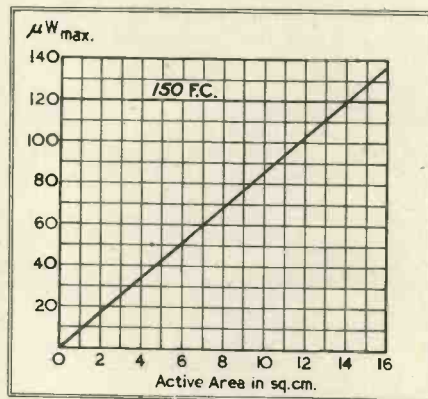

Fig. 4. Maximum watts output against cell area.

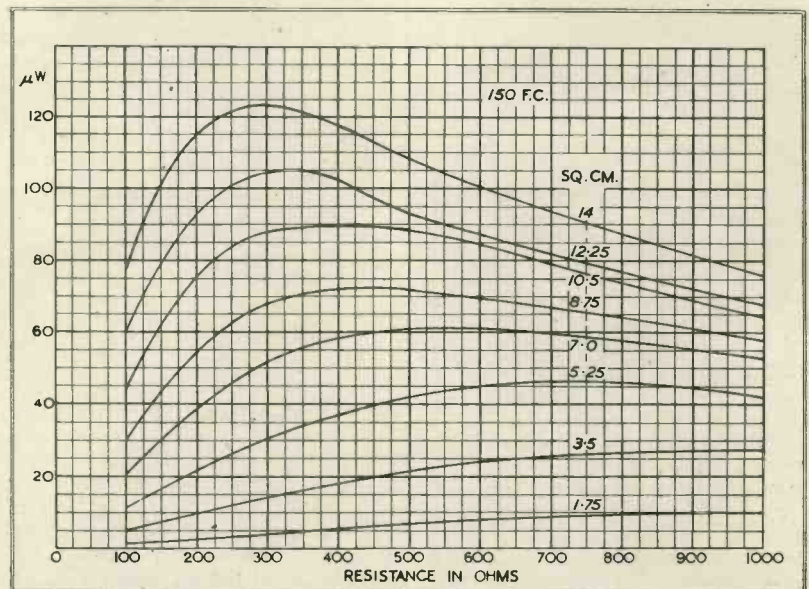

Fig. 3. Output in microwatts for various values of load resistance with varying active areas of cell.

* Laboratory of Evans Electro Selenium, Ltd.
 † The Selenium Barrier Layer Photo-Cell, Dr. G. A. Veszi, *Electronic Eng.*, October 1941, p. 436.

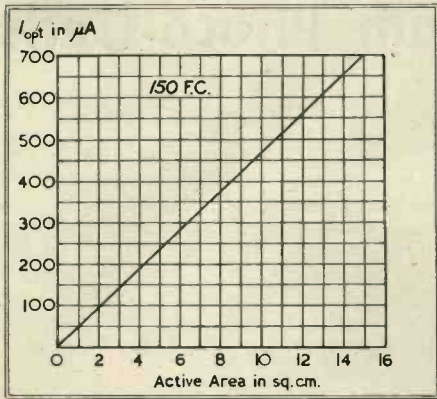

Fig. 5. Optimum current against cell area.

every cell size there is one load resistance (R_{opt}) with which the watt output is largest.

In Fig. 4 the height of the maxima (maximum watt output in microwatts W_{max}) is plotted against the area. The result is a straight line along which, of course, the value of the resistance is not constant. Thus, the maximum number of microwatts obtainable from a cell is proportional to its active area, provided the circuit resistance is adapted properly.

Fig. 5 shows that the current at which maximum watt output is obtained (I_{opt} , measured in microamperes) is proportional, too, to the cell area.

How the magnitude of the optimum load resistance depends on the cell size is shown in Fig. 6. The experimentally found values are represented by points marked \circ . The fully drawn line is the hyperbola:

$$R_{opt} \cdot S = 4,000,$$

where S is the active cell area in sq. cms. The close agreement between a hyperbola and the points found experi-

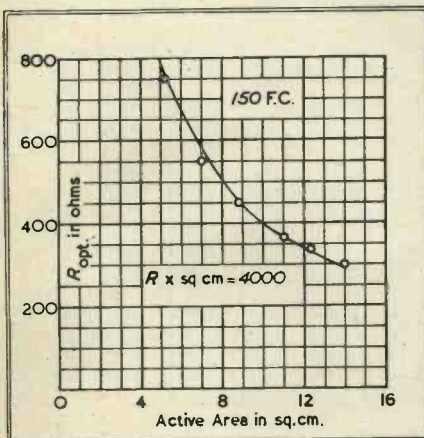

Fig. 6. Optimum load resistance for a given cell area.

mentally shows that the optimum resistance is inversely proportional to the cell area and its value for a cell of 1 sq. cm. at 150 F.-C. is 4,000 ohms.

From the above it is clear that we can define three basic quantities which should guide us in the choice of either the most suitable cell for a given circuit, or the most suitable circuit for a given cell. These three basic quantities are: the maximum watt output per sq. cm. (W_{max} in microwatts), the optimum current per sq. cm. (I_{opt} in microamperes) and the optimum resistance for unit area (R_{opt} in ohms). Of course, only two of these are independent of each other because of the relation:

$$W_{max} = R_{opt} \cdot I_{opt}^2$$

If these three quantities are known as functions of the illumination intensity, the total maximum watt output and the total optimum current are obtained by multiplying and the total optimum resistance by dividing with the cell area.

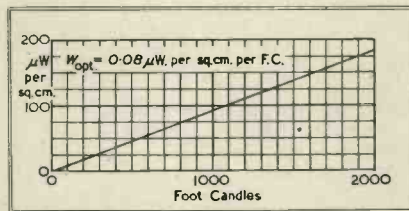

Fig. 7. Optimum watts per unit area against illumination for a given cell of 12 sq. cm. active area.

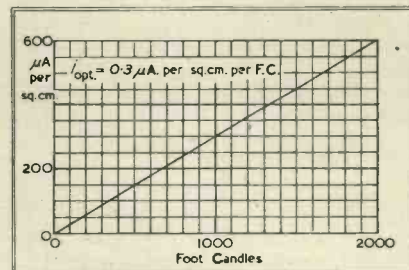

Fig. 8. Optimum current against illumination for the same active area.

To determine these three functions measurements were made on a 45 mm. diameter circular cell of average quality, with an active area of 12 sq. cm. The method was to measure the current output at given illumination intensities with different circuit resistances. Plotting watt output against load resistance, curves were obtained similar to those shown in Fig. 3. The co-ordinates of the maximum could be taken directly from the diagrams and the current was found by interpola-

tion. The illumination intensity ranged from 10 to 2,000 F.-C.

A summary of the results is shown in Figs. 7, 8 and 9. Fig. 7 shows that the maximum watt output per sq. cm. is, with a good approximation, proportional to the intensity of illumination. The maximum output per sq. cm. per F.-C. is about 0.08 microwatts. Thus we obtain for the total maximum watt output of a cell of S sq. cm. at L foot candles:

$$W_{max} = 0.08 L \cdot S \text{ (microwatts).}$$

Fig. 8 demonstrates the proportionality of the optimal current with illumination intensity. The factor here is about 0.3 microamps per sq. cm. per foot candle. With this value we obtain for the total optimum current:

$$I_{opt} = 0.3 L \cdot S \text{ (microamperes).}$$

In Fig. 9 the points marked \times are the values found experimentally. The fully drawn line represents once more a hyperbola. The agreement with the experimental values is quite satisfactory.

The equation of the hyperbola being:

$$R_{opt} = \frac{7.5 \times 10^5}{L + 30}$$

we may write now for the optimum resistance for a cell of S sq. cm. at L foot candles:

$$R_{opt} = \frac{7.5 \times 10^5}{S(L + 30)}$$

If we assume that maximum watt output is obtained when the load resistance is equal to the internal resistance of the cell, the last formula gives us the internal cell resistance as a function of the light intensity. Under this assumption the value of I_{opt} should be half the value of the short circuit current of the unit area cell, which, indeed, is very nearly the case.

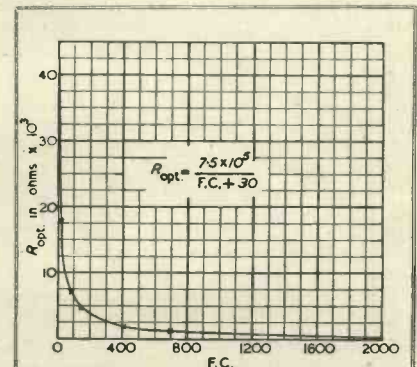

Fig. 9. Optimum load resistance (in thousands of ohms) against illumination (foot candles).

Smoke Density Measurement using Photo-Cells

By R. J. WEY, A.M.I.E.E.*

Introduction

AN interesting and important industrial application of photo-electric cells is that of smoke density measurement. During the last decade much attention has been directed towards the problem of reducing the atmospheric pollution of our cities, caused mainly by excessive smoke emission. At the present time under the Public Health Acts, local authorities are empowered to decide a limit of smoke emission applicable to industrial concerns. Generally, this is that "black" smoke may not be emitted for more than two minutes in each half hour.¹ This definition is naturally incapable of accurate quantitative interpretation, since it involves the human element in the judgment of what constitutes "black" smoke. Very often estimation of the smoke density is made by visual comparison of the smoke issuing from the stack with a series of five shaded cards, known as Ringelmann charts.

The use of a photo-electric method offers many advantages over visual estimation, and consequently many power stations and industrial plants have adopted such a scheme. The absorption principle is practically always used, in which a beam of light is projected across a space, through which the smoke-laden flue gases pass, on to a photo-electric cell.² The illumination of the cell thus decreases due to absorption of light as the smoke becomes more dense, finally becoming zero when the smoke is "black." In some cases, a portion of the flue gas is by-passed from the chimney stack or duct through a measuring chamber, but in the great majority of cases the measurement is made directly on the stack. Such an arrangement is illustrated schematically in Fig. 1, in which A—A represents the walls of the stack, the photo-cell B and the light source C being mounted in similar housings D and E on opposite sides of the stack. The lens F enables a substantially parallel beam of light to be projected across the stack through suitable apertures G and H, whilst the lens I concentrates this beam on to the active surface of the photo-cell. The photo-electric current may be amplified and fed to a milliammeter J calibrated in

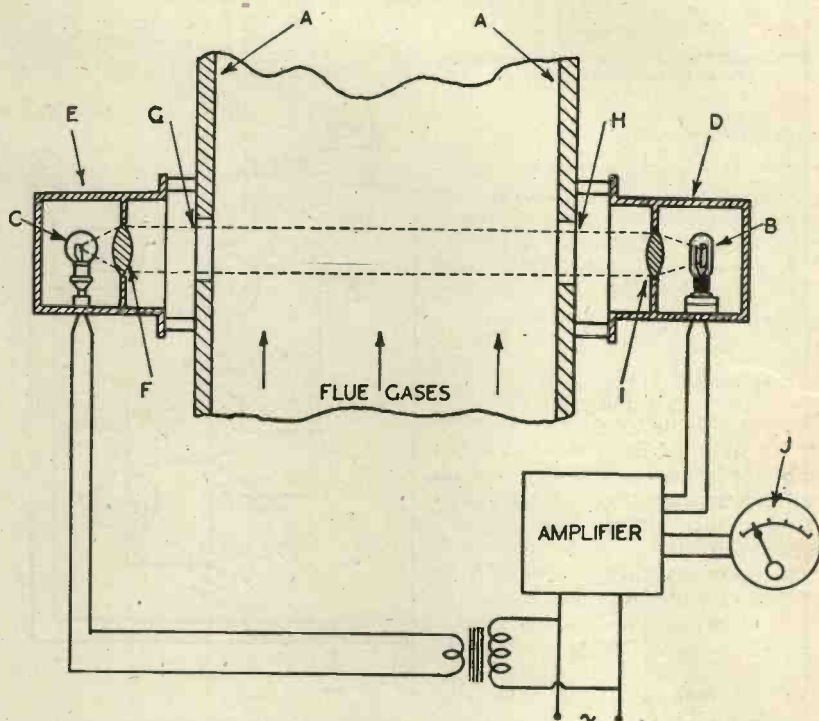

Fig. 1. Arrangement of Absorption type Smoke Meter.

terms of smoke density. The photo-cell current is naturally at its maximum value when no smoke is present, but the amplifier is generally arranged so that this corresponds to zero anode current, thus enabling a standard left hand zero instrument to be used.

The use of the absorption principle for smoke density measurement dates from 1906, a thermocouple being then employed as the radiation detector.³ To obtain the necessary rise in temperature a powerful light source must be used, accurately focused upon the couple. A slight mis-alignment of the optical system arising perhaps from the distortion of the stack walls due to heat, may affect the focusing to an extent sufficient to cause a considerable reduction in output from the thermocouple. These disadvantages are overcome by the use of a photo-electric cell, so that nowadays the thermocouple is seldom employed.

Some early smoke density meters made use of photo-conductive cells of the selenium type, but, as is well

known, this type of cell possesses a high temperature coefficient, often 5 per cent. per °C, so that special methods are necessary for successful operation. One of the author's early designs utilised a rotating shutter interposed between the light source and selenium cell thus producing an alternating component in the cell current.⁴ It has been found that the alternating component is much less dependent upon temperature than the steady component, hence, by means of a resistance capacity coupling the alternating component could be filtered out and then amplified, rectified and applied to a moving coil indicator. A suitable circuit is shown in Fig. 2 in which A represents the selenium cell, coupled by means of R and C to the grid of the triode B. The cell and the valve anode are supplied with about 200 volts D.C. from the rectifier and smoothing circuit D, E, F, G of conventional design, and the valve is coupled to the rectifier H and indicator I by means of a step down transformer J.

* Electroflo Meters, Ltd.

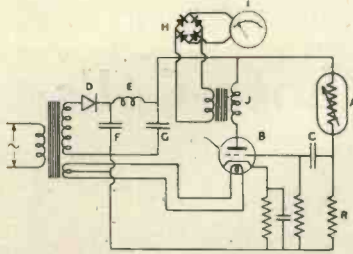

Fig. 2. Circuit for use with Photo-conductive cell and light interrupter.

Circuit Arrangements

The use of photo-emissive cells enables a considerable simplification to be made, since these are very stable and unaffected to any appreciable extent by temperature within reasonable limits. Gas-filled cells are generally used on account of their sensitivity. A type of circuit often used is shown in Fig. 3 and is suitable for either A.C. or D.C. mains supply. In operation, an increase in illumination of the photo-cell P causes the grid potential of the valve V to drop due to the passage of current through R, thus reducing the anode current. Adjustment of the amplifier is carried out by means of D which controls the grid bias and hence the anode current, so that full scale deflection is produced on the indicator M when the photo-cell is in darkness. With maximum illumination, *i.e.*, complete absence of smoke, the photo-cell voltage is adjusted by means of L so that the anode current is reduced to zero. Thus it will be seen that the anode current will rise from zero in accordance with the smoke density, until with complete absorption of light the indicator will stand at full scale. If desired, a relay N of the telephone type may be included in the anode circuit, the contacts controlling an audible or visual alarm signal Q. The

relay should be provided with an adjustable spring tension device to enable the point of operation to be set as desired.

The circuit just described is very suitable for D.C. supply, but with A.C. supply the anode current will be greatly reduced and difficulty may be experienced in obtaining full scale current. It is better to use a circuit designed for A.C. operation such as that shown in Fig. 4. It will be seen that the anode, grid and photo-cell

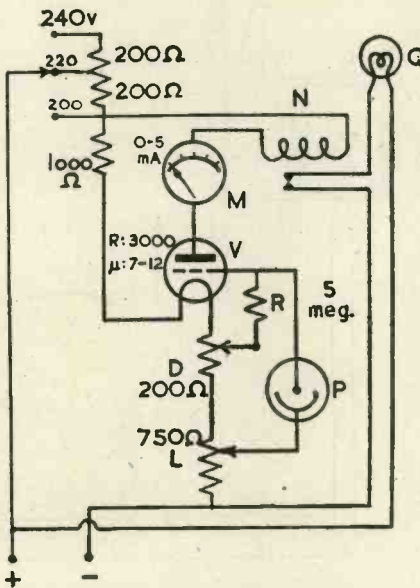

Fig. 3. Typical circuit for use with Photo-emissive cell.

voltages are supplied from the windings of the transformer T, thus enabling a sufficiently high anode voltage to be employed to give the requisite anode current. The choice of valves is much wider as the filament or heater is not limited in its current consumption as in Fig. 3. A smoothing condenser C should be employed to by-pass the alternating component

of the rectified current, which otherwise might cause chattering of the relay and vibration of the indicator pointer.

A photo-voltaic type of cell may also be employed and its use is accompanied both by advantages and disadvantages. No amplification by thermionic valves is necessary or indeed practicable, the photo-cell being connected directly to a sensitive moving coil indicator having a full scale deflection of 100 to 150 micro-amps. This is provided with a right-hand zero to give the conventional direction of pointer movement, *i.e.*, from left to right with increasing smoke density. When an indicator only is required the arrangement is thus very simple, but when the operation of an alarm is required a special relay must be used, since the small power output of the photo-cell prohibits the use of a telephone type relay. Usually a moving coil relay is used having magnetised contacts to ensure positive closure and absence of chattering. The relay must, of course, be reset by hand after each operation or mechanically reset by a small motor or similar device.⁵

When a continuous record of smoke density is required a dotting or depressor type of millivoltmeter recorder is necessary, again on account of the small power output of the photo-cell. As an alternative, however, an operation recorder may be used, connected to the alarm relay to give a record on the chart of those periods during which the smoke density exceeds a predetermined value. A schematic diagram of such an arrangement is shown in Fig. 5, in which the cell A is connected in series with the indicator B and relay C. The relay contacts D and E are connected to control the audible alarm F and the operation recorder G. The relay should be of the automatic resetting type, to ensure correct records. The

(Continued on page 513).

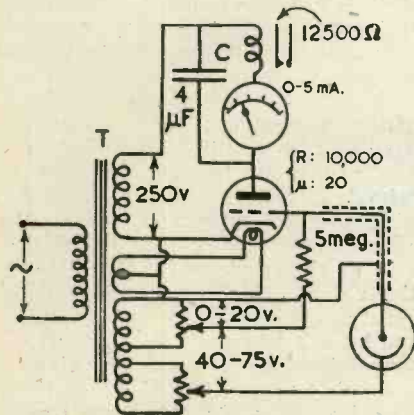

Fig. 4. Circuit for A.C. mains supply.

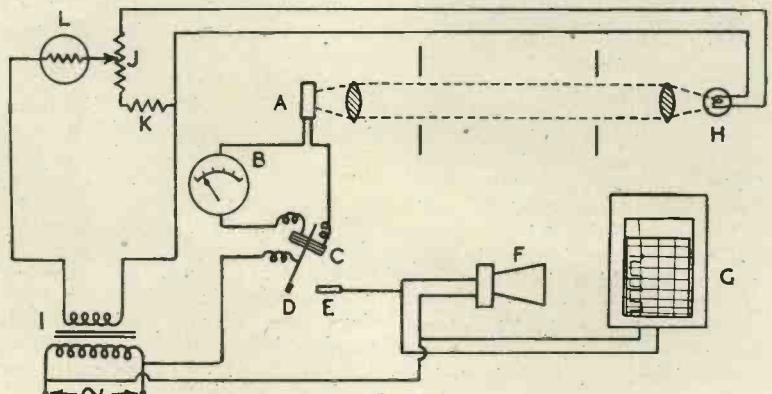
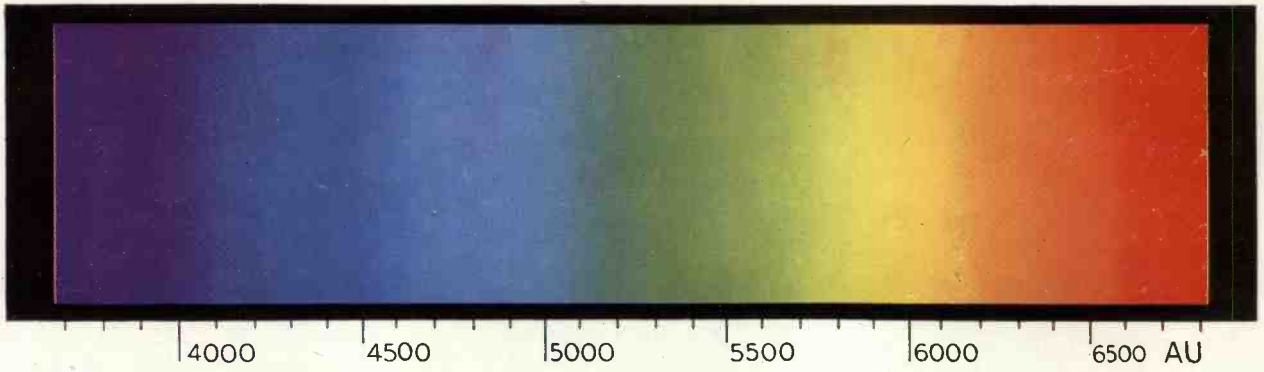
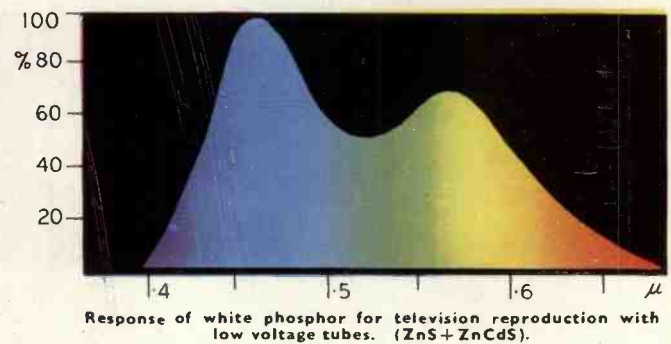
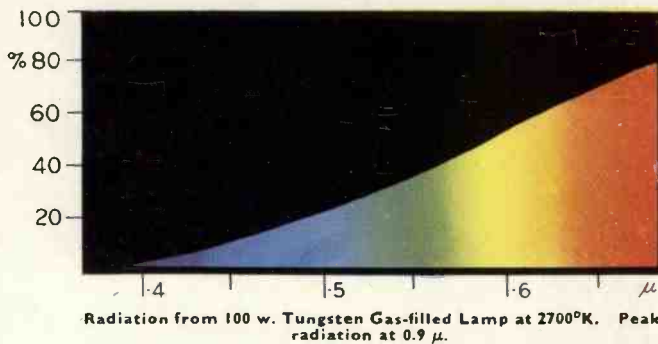
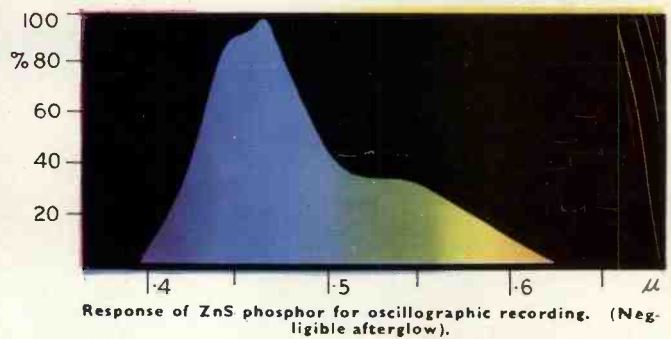
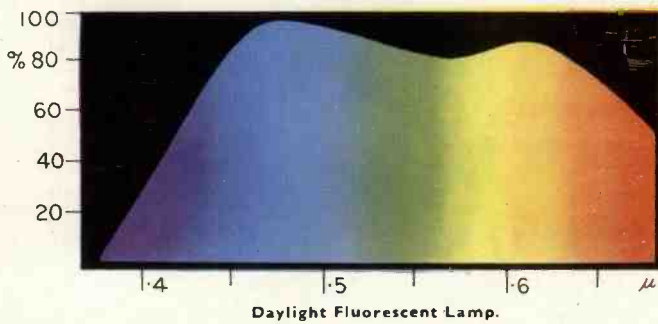
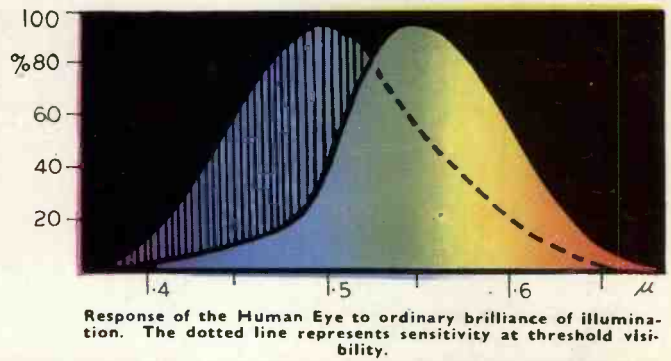
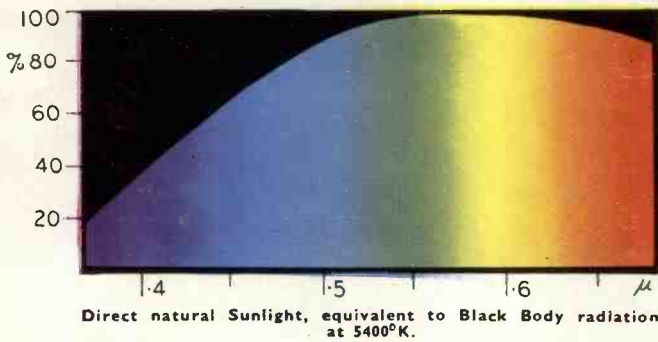

Fig. 5. Use of Photo-voltaic cell with moving coil relay.



The Visible Spectrum, showing the relation between colour and wavelength in Angstrom Units.



(Wavelength scales in microns.)

Examples of Two- and Three-Colour Reproduction of Pictures



Three-colour Print.

These pictures are analogous to those obtained in television by means of two- or three-colour filters, due allowance being made for the limitations of reproduction by coloured inks.

In order to indicate the relative proportions of the colours passed by the filters the monochrome pictures have been printed from reversed blocks, i.e., the pure colours are lightest in tone on the prints.

The response curves of the filters used are shown on the opposite page.

For a theoretical comparison between filters refer to the paper by Dr. Goldmark, "Electronic Engineering," October, 1942.

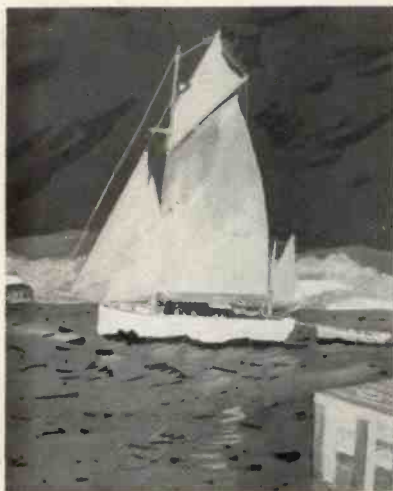

Indicating the yellow, red, and blue content of the above picture.



Two-colour Print.



Red and blue content of the picture on the left.



SPECTRAL RESPONSE CURVES—contd.

PHOTO-SENSITIVE MATERIALS AND FILTERS.



Response of Cs-Ag0 Photo-Cell for infra-red work 100% = 2×10^{-3} amps/watt. Peak response to 0.85 μ .

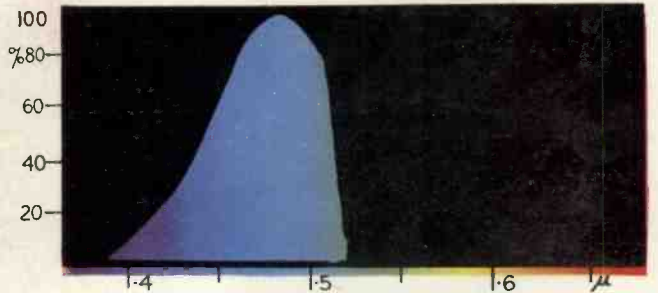

Relative sensitivity of Ilford Blue-sensitive photographic emulsion to equal energy spectrum.

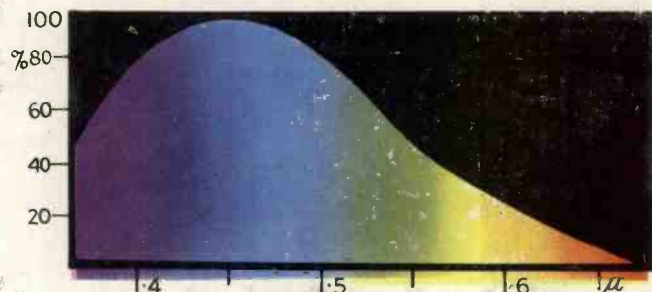

Response of Cs-Sb Photo-Cell for daylight. 100% = 65×10^{-3} amps/watt.



Transmission band of red filter for 3-colour photography or television.

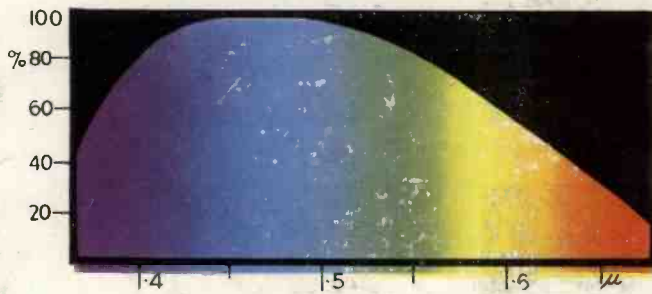

Response of Cs-BI Photo-Cell for colour television. 100% = 20×10^{-3} amps/watt.

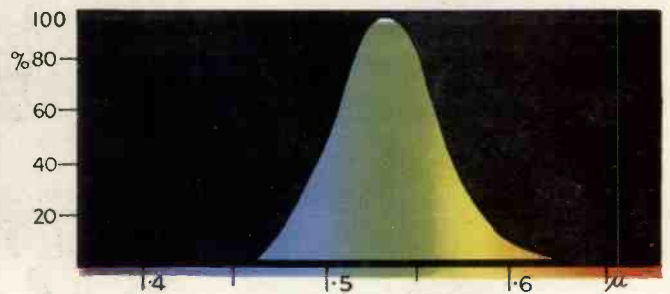

Transmission band of blue-green filter for 3-colour photography or television.

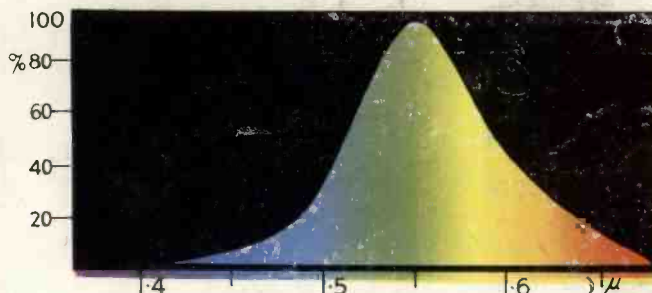

Response of Selenium Barrier Layer Cell with correcting filter to simulate normal eye.

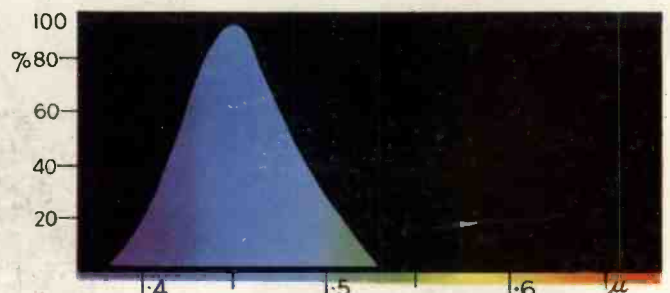

Transmission band of blue filter for 3-colour photography or television.

ON BRITAIN'S

Lifelines

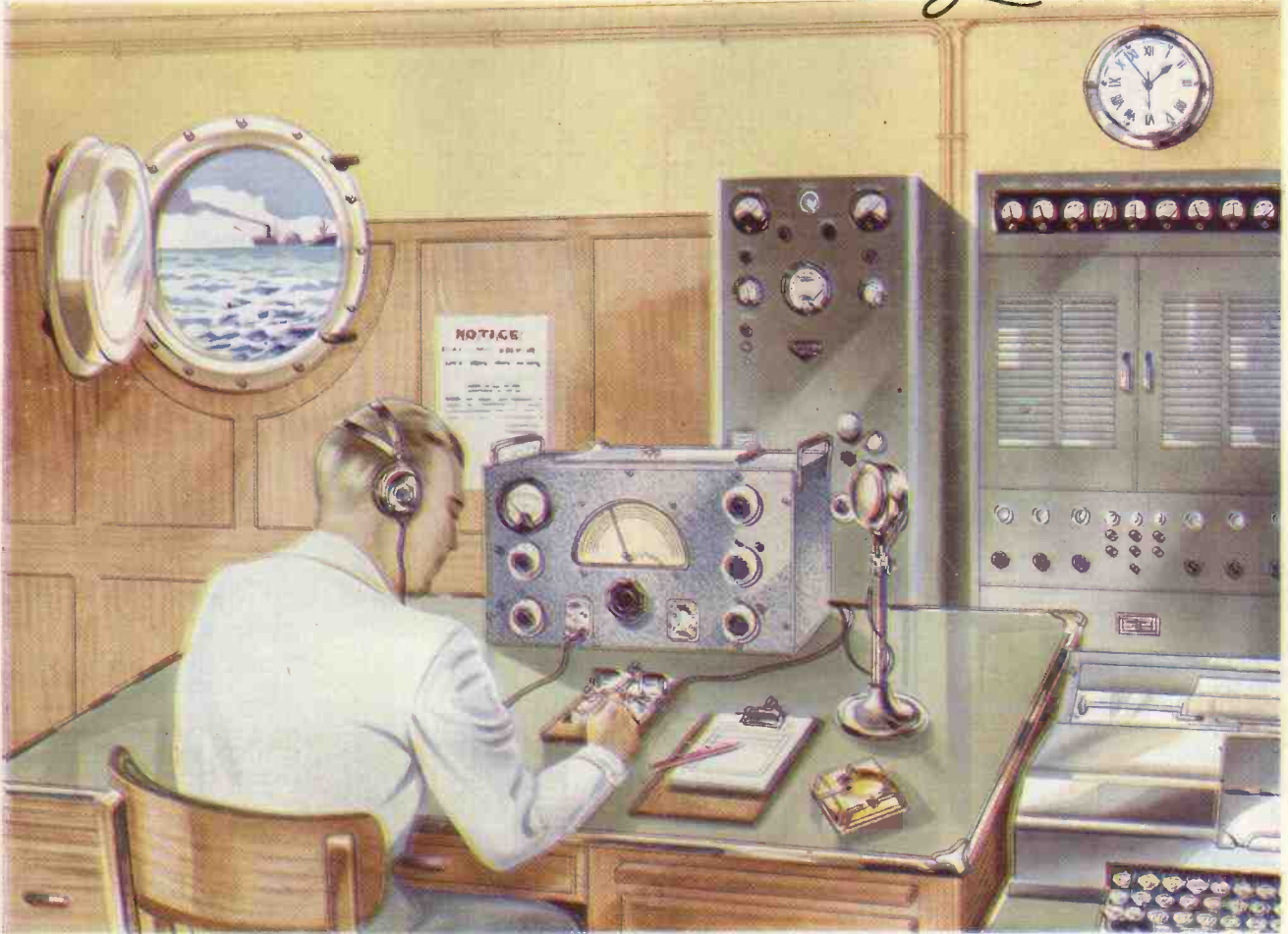

Eddystone

358 X

COMMUNICATION

RECEIVER

WEBB'S RADIO

14, SOHO ST., LONDON, W.1.

PHONE : GER. 2089

Smoke Density Measurement—
(Continued from page 508)

projector lamp H is fed from the transformer I, through a voltage regulating network, to which reference will be made later.

Performance

It will be evident that the performance of a photo-electric device of this nature will depend mainly upon the constancy of the photo-cell and amplifier characteristics, the constancy in brilliance of the light source, and the cleanliness of the optical system. Photo-cells and thermionic valves are now very stable in characteristics, and any variation in output due to ageing can be easily compensated by a periodic adjustment of the amplifier potentials as explained previously. The chief source of error apart from that due to deposition of soot upon the optical system, is due to supply voltage fluctuations, which can cause a considerable variation in brilliance of the light source. The effect upon the amplifier is much less serious and may be neglected. Referring to Fig. 6 it will be seen that a 1 per cent. variation in projector lamp voltage is sufficient to cause between 3.5 per cent. and 4.5 per cent. variation in light output, and hence in the indicated density of the smoke. Since voltage fluctuations of the order of 5 per cent. are common, an error of up to 22 per cent. may be introduced. The difference in the two curves shown in Fig. 6 is, of course, due to the differing spectral response of the eye and the photo-cell. Obviously, some means of compensating for the changes in brilliance of the projector lamp is necessary, or alternatively, the voltage supply must be stabilised.

Various methods of compensation have been used, most of them involving a second or "balancing" photo-cell exposed directly to the projector lamp and connected differentially with

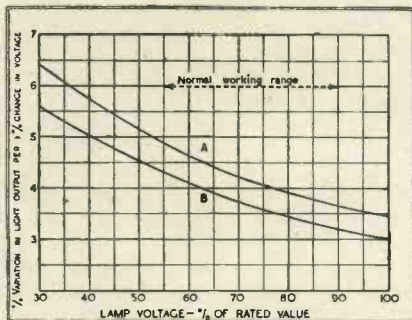

Fig. 6. Effect of Supply Voltage Variation on 12 v. 48 w. gasfilled projector lamp. (A) Measured by visual photometer. (B) Measured by selenium photo-voltaic cell.

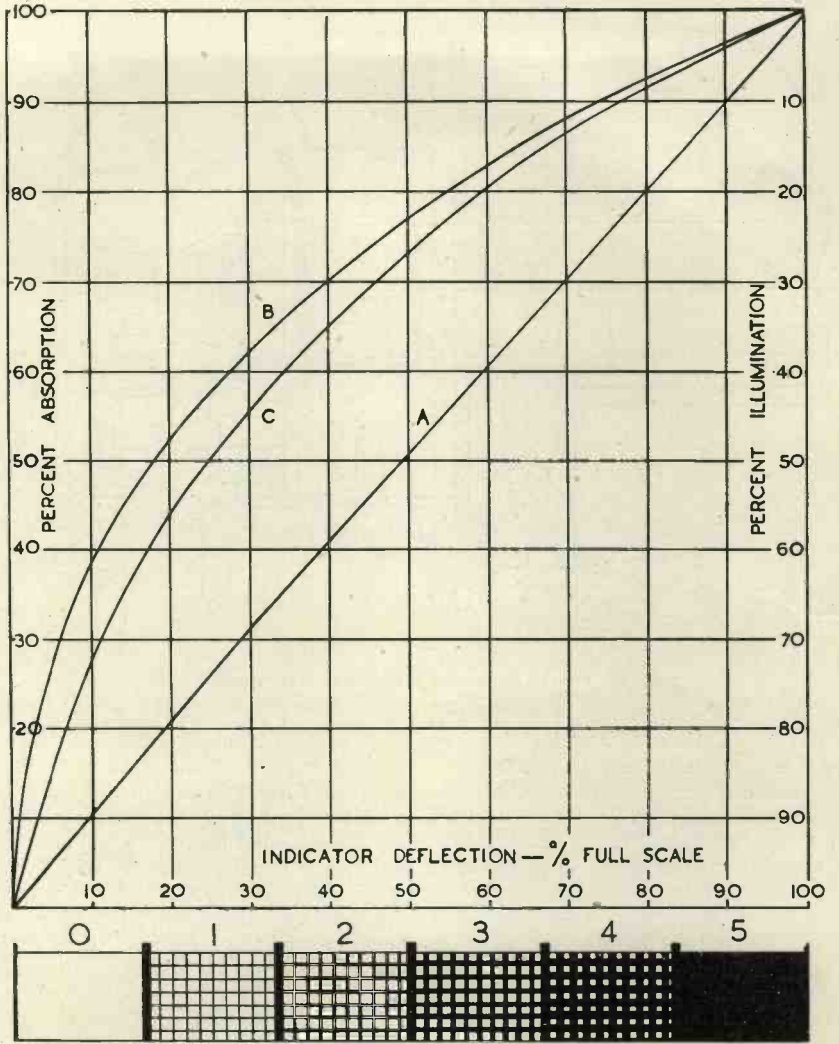

Fig. 7. Photo-cell Illumination in relation to indicator pointer movement and Ringelmann Scale. (A) Photo-voltaic cell, 100 Ω load. (B) Photo-emissive cell circuit, Fig. 4. (C) Photo-voltaic cell, 1,000 Ω load.

respect to the "operating" photo-cell. Such methods suffer from the obvious disadvantages of increased cost and complication and also that the compensation is exact at one particular value of smoke density only. It is, therefore, general to use the orthodox single photo-cell arrangement, and employ some form of voltage stabiliser for the projector lamp, and perhaps also for the amplifier, e.g., a battery floated across the supply, a saturated core transformer device, or barretter. When using barretters it must be remembered that the current output of these is constant, and therefore any adjustment of lamp current must be made through a constant-current network. A suitable network is shown in Fig. 5, from which it will be seen that the projector lamp H is fed from one end of the potentiometer

J, a biasing resistance K being connected to the other end of the potentiometer. By suitable choice of values the total current taken by the lamp and resistance K can be made sufficiently constant at all positions of the slider to ensure that the barretter L is not overloaded.

In considering the performance of a smoke density meter due regard must be taken of the nature of the measurement and the purpose for which the measurement is required. Bearing this in mind it will be evident that reliability is of greater importance than accuracy. Indeed, the majority of instruments of this kind are not calibrated in the strict sense of the word but merely serve to show the relative density of the smoke at any moment. The generally accepted use of the Ringelmann scale in the

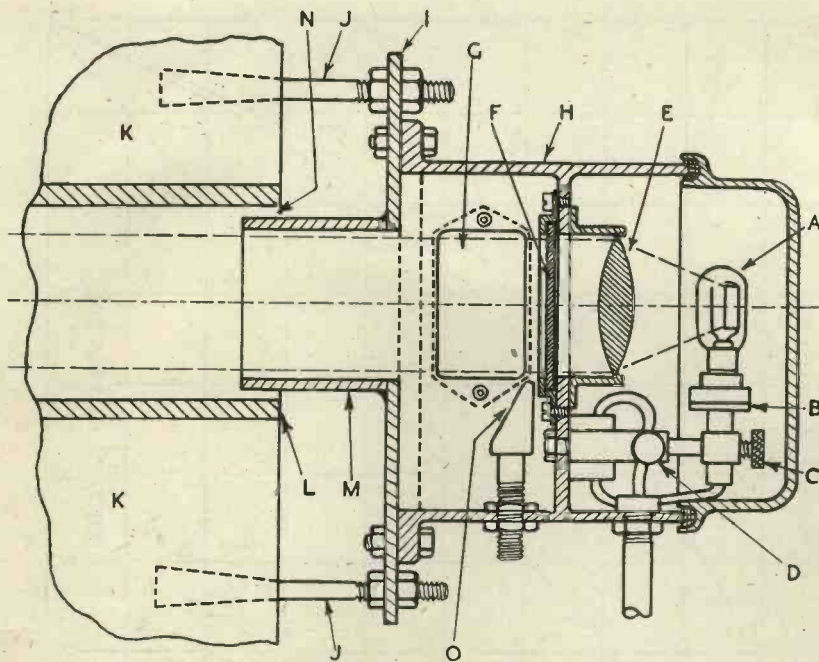

Fig. 8. Photo-cell housing attached to brick stack.

visual estimation of smoke density has often caused users of photo-electric smoke meters to stipulate that the indicator be marked in terms of the Ringelmann scale. However, a scale of smoke densities based upon the absorption of light cannot, in general, correspond with one based mainly upon the reflected light as in the visual method. When an indicator scale is marked in this way it is generally divided into six equal divisions, shaded as illustrated in the lower part of Fig. 7. The shading of divisions 1 to 5 corresponds in appearance with the shading of the Ringelmann charts in which the relative area covered by the black lines increases in steps of 20 per cent. In spite of the arbitrary nature of this calibration, instances have been found where the indications of the smoke density meter correspond closely with the visually estimated density.

In most cases to obtain reasonable agreement, it is necessary to modify the scale shape of the instrument so that it is less sensitive at low values of smoke density and more sensitive at high values, *i.e.*, when the illumination of the photo-cell is low. This is illustrated in Fig. 7 which shows the relationship between pointer deflection and illumination. Curve A refers to a simple photo-voltaic cell instrument having a substantially linear characteristic; whilst curve B refers to a typical gas-filled

photo-cell with triode amplifier which gives a curved characteristic of the required form. When using photo-voltaic cells, however, the scale shape may be modified by the inclusion of a high resistance in series with the photo-cell (*see* curve C), or by the use of a moving coil indicator having pole pieces shaped to give a non-linear flux distribution. A further advantage of the curved characteristic is that it provides a degree of apparent voltage stabilisation, by lessening the pointer movement at high illuminations where the effect of voltage fluctuations would normally be most apparent.

Constructional Features

Because of the conditions under which the apparatus has to operate it is necessary that the housings of the photo-cell, projector lamp and amplifier be of substantial construction and as dust-proof as possible. Generally, the projector lamp and photo-cell housings are each provided with a glass window upon which any deposits of soot may form, thus avoiding risk of damage to the optical system during cleaning. A typical design of photo-cell housing is shown in Fig. 8 from which it will be seen that the photo-cell A is mounted upon an adjustable holder B which can be locked in any position by means of the thumbscrews C and D. The lens E is mounted behind the window F

which is readily accessible for hand cleaning through a removable door G in the side of the housing H. The housing is attached to a steel plate I, which is held in position by means of bolts J set in the brickwork K forming the stack wall. A refractory or metal tube L lines the hole cut in the wall, and a short length of tube M prevents the entry of a large volume of air into the stack (generally the natural draught is equal to a head of several inches of water). An annular gap N is left to allow the entry of some air to assist in keeping the tube L clear of smoke and soot deposits. Also, to minimise the deposition of soot upon the window F an air jet O, generally of fish tail form is often provided, and may either be left open to the atmosphere or connected to a source of compressed air at low pressure.

When the walls of the stack are of steel it is desirable to adopt a modified method of mounting the projector lamp and photo-cell housings, to prevent the passage of heat from the stack to the housings and to reduce the effect of local distortion of the stack walls upon the focusing. A good plan is to mount the housings upon frames entirely separated from the stack or duct or clamped to this at widely separated points. Sometimes the amplifier is incorporated in the photo-cell housing thus eliminating any possible trouble due to the wiring between the photo-cell and valve.

It is hoped that this brief review will prove of interest to those concerned with photo-cell applications, but for more complete information, reference should be made to published works on the subject, a selection of which is included in the following bibliography.

BIBLIOGRAPHY

- "Smoke Abatement Exhibition Handbook" (Science Museum, October, 1936), p. 7. Published by The National Smoke Abatement Society, London.
- (a) *Power Plant Engineering*, Vol. 34, 1930, p. 447.
(b) British Patent No. 337,212.
- British Patent No. 25,266/1906.
- The Engineer*, Vol. 155, 1933, p. 606.
- British Patent No. 440,665.
- "Methods and Standards of Smoke Measurement." By J. F. Shaw and T. F. Hurley, *Fuel Economy Review*, 1930, p. 97.
- "Smoke Density Measurements." By H. E. Bumgardner, *The Engineer*, Vol. 166, 1938, p. 372.
- "Photo-Electric Smoke Meters." By R. J. Wey, *The Engineer*, Vol. 173, 1942, p. 283, 300, 320, 342.

No nine o'clock news-

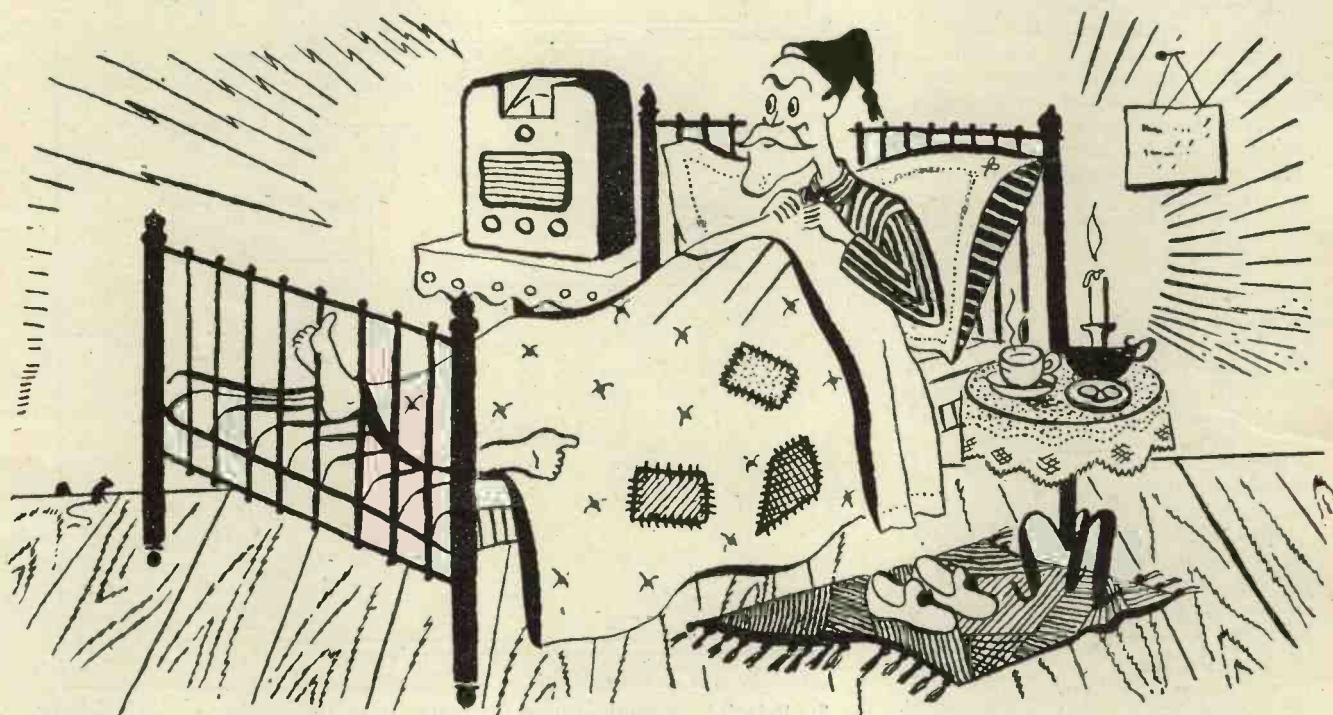

without **David Hughes?**

David Hughes died in 1900, yet without him broadcasting might never have been possible. In 1878, Hughes invented the microphone—which is his own word; from the principle on which it worked he also determined the phenomena affecting the action of coherers. In the opinion of "The Electrical Review" (Jan. 2, 1899), he "discovered the Hertzian waves before Hertz . . . and the wireless telegraph before Lodge, Marconi, and others."

David Hughes would have appreciated Distrene for its outstanding insulating qualities. The brief data below suggest something pretty unusual in electrical properties; working samples will confirm the figures. Distrene (Regd.) is made in sheets, rods and tubes, and also as moulding powder for use on all types of injection machines. It is available in glass clear and most colours.

COMPRESSION STRENGTH	7 tons per sq. in.
SPECIFIC GRAVITY	1.06
WATER ABSORPTION	Nil
COEFFICIENT OF LINEAR EXPANSION0001
SURFACE RESISTIVITY (24 hours in water)	3×10^6 megohms
DIELECTRIC CONSTANT 60—10 ⁶ CYCLES	2.60—2.70
POWER FACTOR UP TO 100 MEGACYCLES0002—.0003

BX PLASTICS LIMITED



LONDON E4 AND ELSEWHERE

A Photo-electric Voltage Control Gear

By K. A. R. SAMSON, Dr. Phil.*

A RISING out of a practical requirement the writer found occasion to design a voltage control gear which could be assembled quickly from more or less common components, and which would be able to maintain the voltage on a small load of about 1 kilowatt constant to within at least ± 1 volt at 240 volts. The resulting gear has proved so satisfactory during one year of operation that it seems justifiable to give a short description of it despite the fact that the fundamental idea may not be entirely new.

Working Principle

The principle of the method used for controlling the mains variations is illustrated in Fig. 1a for the case of a nominal mains voltage of 240 volts and a constant load. It is generally accepted that variations of ± 5 per cent. (± 12 volts) are likely to occur, and to be on the safe side a controlling range of ± 15 volts was adopted for the control gear described. The adjusting voltages are taken from transformer 1 which can be adjusted (in a way described later) to cover a continuous range on the output side from zero to 30 volts, this being connected in series between the mains input and the controlled output. Assuming for a moment that the mains voltage is at its upper limit of $240 + 15 = 255$ volts, the output voltage of transformer 1 will be reduced to zero leaving 255 volts. If, on the other hand, the mains voltage drops to its lowest value of $240 - 15 = 225$ volts the maximum output voltage of transformer 1 of 30 volts will be added, producing again 255 volts. Intermediate cases will be treated accordingly, so that a constant voltage of 255 volts is available behind the transformer. If the output voltage is to be the same as the input voltage this excess of 15 volts must be taken away. In Fig. 1a this is done by the insertion of resistance 2 which, of course, has to be adjusted according to the load. If a constant voltage has to be provided for a widely varying load this method would be inconvenient, and Fig. 1b shows the method to be adopted for such a load. In this figure a step-down transformer is used instead of the resistance 2, and this circuit will provide controlled voltage independent of variations of the input voltage and of the load.

General Layout

The working principle of the whole

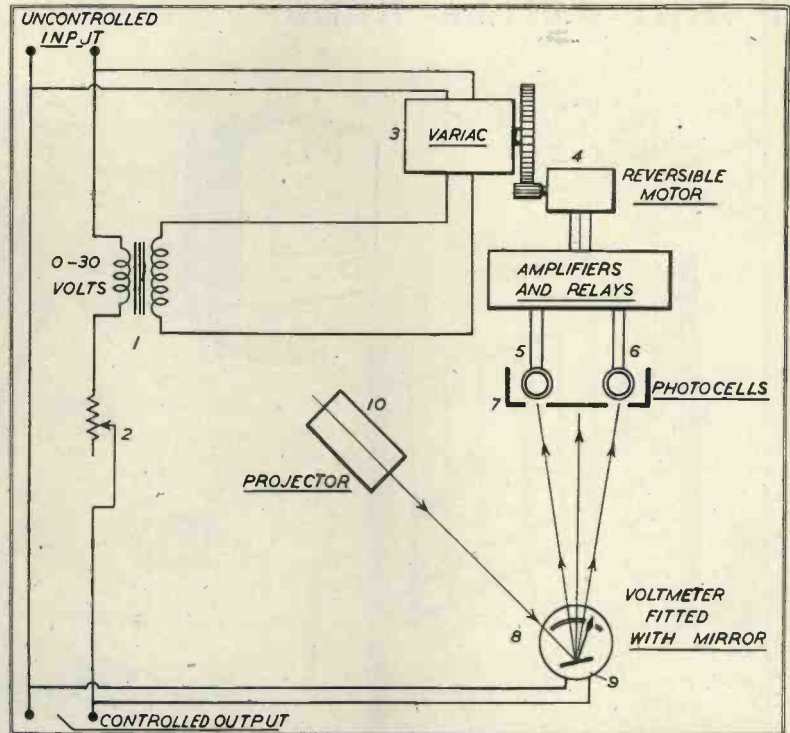

Fig. 2. Principle of method used for maintaining the output voltage constant.

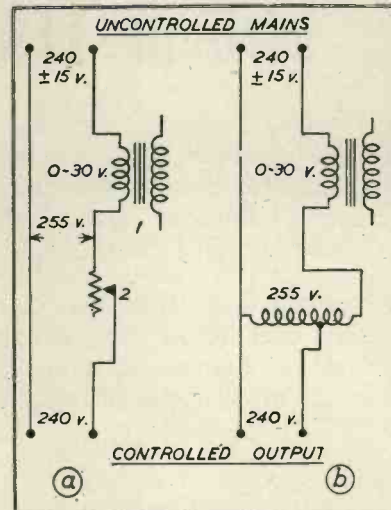

Fig. 1. Schematic diagram of photo-electric control gear.

gear is illustrated in Fig. 2, the transformer 1 and resistance 2 being the same as those shown in Fig. 1a. The control from zero to maximum of transformer 1 is effected by the Variac 3, which is a well-known type of auto-transformer having a sliding

contact for allowing continuous regulation from zero to maximum by turning a handle through an angle of approximately 320 degrees. The input side of the Variac is connected to the mains, the output to transformer 1; consequently, according to the position of the sliding contact on the Variac, the output voltage of transformer 1 can have any value between zero and 30 volts.

The movement of the sliding contact on the Variac is effected by a small reversible motor 4, which is of the type used for remote control or remote tuning of wireless sets and similar devices. This motor has two windings which cause the armature to rotate in opposite directions and is designed for an operating voltage of 20 volts. It has a small reduction gear embodied, and a further reduction gear is inserted between its driving shaft and the Variac shaft. The ratio chosen for the latter gear is such that the Variac contact moves through the whole range from stop to stop in about 5 seconds.

The impulses used to control the position of the Variac are derived from two photocells 5 and 6 which are arranged side by side behind a

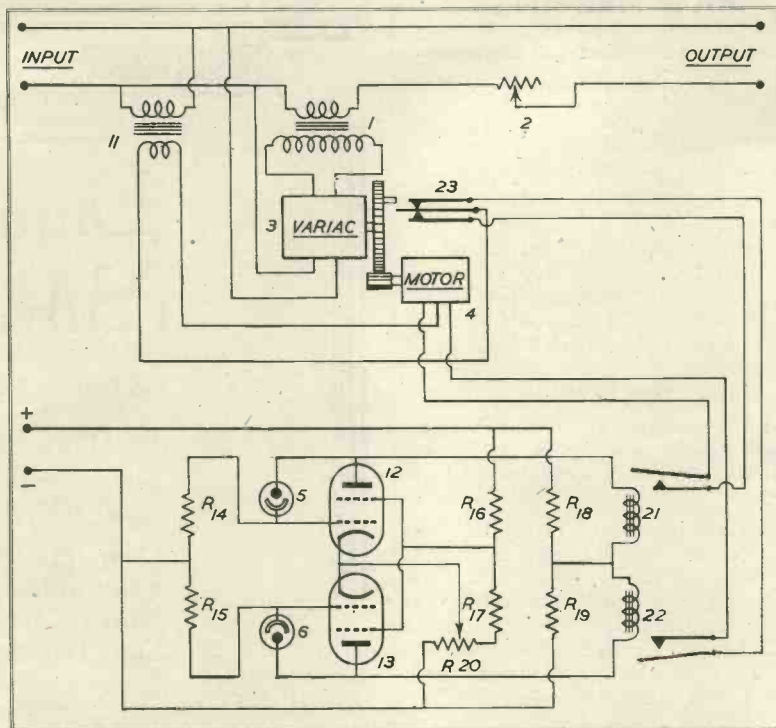

Fig. 3. Circuit diagram of amplifier and relays for controlling Variac transformer

screen 7. The screen contains two windows separated by a distance of three-quarters of an inch. A voltmeter 8 is connected to the terminals of the load to be kept on constant voltage, and a mirror 9 (consisting of a thin microscope cover glass of 15 mm. diameter, silvered and coated with a protective layer of varnish) is fixed to its moving system. Almost any ordinary voltmeter can be adapted in this way. A small light projector 10 is provided, consisting of an 8 volt, 32 watt lamp with straight spiralled filament and a lens of a focal length of 4 inches. The lamp filament is arranged in a vertical position, and the lens is adjusted to form an enlarged image of the filament in the plane of the screen 7 after reflection from the mirror 9. The projector and the voltmeter plus mirror are arranged in such a manner relative to each other that, provided the output voltage is at its correct value, the image of the filament is incident on the dividing space between the windows in front of the photoelectric cells.

If the mains voltage drops below the correct value, the moving system of the voltmeter 8 will be displaced and the light beam reflected from the mirror 9 will move from the neutral space between the windows and will fall on the photocell 5. The electron current thus produced will, after amplification, operate a relay which in turn closes the circuit for the ap-

propriate winding of the reversible motor, that is the winding which will lead to an increase of the output voltage of the Variac. The motor will drive the Variac until the increase in the output voltage is sufficient to restore the moving system of the voltmeter whereupon the light beam will leave photocell 5 and return to the neutral space. The relay will now release and disconnect the current to the motor. A similar but opposite controlling effect will take place when the mains voltage rises above the correct value. With the gear ratios mentioned the correcting action takes only a small fraction of a second.

Complete Circuit Diagram

Fig. 3 shows the complete circuit diagram of the apparatus in which transformer 1, resistance 2, Variac 3, motor 4 and photocells 5 and 6 are the same as those illustrated in Figs. 1a and 2. A transformer 11 provides the operating voltage of 20 volts for motor 4. The lower part of Fig. 3 gives the connexions of the amplifier and relay part of the gear. Photocells 5 and 6 are "Baird" Vacuum Cells, Type VA.26, manufactured by Cinema-Television Limited; the valves 12 and 13 are TSP4 tetrodes. These valves are coupled to the photocells by means of resistances 14 and 15 each of which has a value of 2 megohms. The values of the resistances 16-19 (to provide the appro-

propriate anode and screen grid voltages to the valves) depend on the D.C. source available. This may vary from case to case and is therefore not shown in the drawing. A potentiometer 20 of 300-500 ohms resistance permits the adjustment of the negative grid bias for the valves 12 and 13, the exact value of this bias depending on the valve characteristics and on the intensity of the room light. The best adjustment for the potentiometer is such that the anode current is kept well below the value where the relays pull in; on the other hand the slightest amount of light from the projector entering one window should cause an immediate rise in the anode current.

The relays 21 and 22 which are inserted in the anode circuits of the valves, are ordinary Post Office telephone relays which respond to a current of approximately 3 milliamps. With accurate adjustment of the grid bias and with the full light on one photocell, an anode current of 10 milliamps or more can easily be obtained so that there is ample current to make the response of the relays quite certain. The operating contacts of the relays are inserted in circuits which also contain the 20 volt source 11, the two windings of the reversible motor 4 and the contact system 23; the purpose of the last mentioned will be discussed later.

Safeguarding Measures

It is hoped that from the foregoing description the working principle of the whole apparatus has been made quite clear. There remain two points to be mentioned which though not essential from the point of view of the working principle are, nevertheless, important for the reliable working and the protection of the apparatus. Firstly, returning to Fig. 2, the light beam must be prevented from leaving the outside edges of the two windows in screen 7 as otherwise a particularly violent surge of the mains voltage might flick the beam across one cell before the mechanism had time to correct the surge. This purpose is easily achieved by fixing two little stops on either side of the voltmeter pointer to restrict the swing of the mirror in such a way that the light beam is definitely arrested on the outer edges of the two windows.

Another possibility to be provided for is that the mains voltage may accidentally exceed the ± 5 per cent. tolerance for an appreciable length of time. If this happens the Variac will be rotated until it comes up against the stop at the respective end of the winding, and the motor which is still being supplied with current via the relay contact, will be left on volt-

age and be damaged by overloading. The purpose of the contacts 23 is to prevent this overloading. They are operated by one or, preferably, two studs fixed to the toothed wheel on the shaft of the Variac and are arranged in such a way that the appropriate winding of the motor is interrupted by the stud just before the sliding contact of the Variac reaches the end of the winding. The contact serving the other winding of the motor must, of course, be left closed so as to keep the appropriate circuit ready for the reversing movement as soon as the mains voltage returns to normal conditions.

Accuracy of Control and Reliability

The aim set out in the first paragraph of this article (to keep voltage variations within ± 1 volt at 240 volts) was achieved immediately with the described apparatus and without any particular refinement. The length of the light beam or, in other words, the distance between photocells 5 and 6 and mirror 8 was 18 inches. If a greater accuracy of regulation is required, two main ways of improvement are open: firstly reduction of the neutral space between the windows in front of the photocells, and secondly increase of the distance between mirror and photocells. The difficulty arising in both cases, without special precautions, is that the gear may start "see-sawing." This is mainly controlled by the damping constant of the voltmeter which, in the gear described above, was not suitable for higher accuracy. With a voltmeter of nearly aperiodic damping, however, and possibly a slight alteration in the gear ratio between the motor and the Variac, an accuracy of ± 0.1 per cent. for the controlled voltage seems easily within reach.

Controllable Output

In conclusion, a few words about the amount of power it is possible to control with the apparatus. The type of Variac used gave an output of about 500 watts, and as this power appears in the output at a voltage of 30 volts, a current of 16.5 amps can be handled. This current, in conjunction with the output voltage of 240 volts, means that a load of 4 kilowatts can be controlled by the described gear (which, incidentally, covers a space of not more than 5 square feet). The largest type of Variac available has an output of 2 kilowatts, and accordingly an output of 16 kilowatts could easily be controlled with the gear substantially in the form described.

Acknowledgments are given to Messrs. Cinema-Television, Ltd., for permission to publish the above information.

MAY MEETINGS

Institution of Electrical Engineers

Ordinary Meetings

The annual general meeting (Corporate Members and Associates only) will be held on May 13 at 5.30 p.m.

Measurement Section

The next meeting of the above section will be held on May 21 at 5.30 p.m. A lecture will be given by Dr. E. H. Reyner, M.A., on "Measurement of small quantities."

Wireless Section

At a meeting to be held on May 5 a paper will be read by H. J. Finden, entitled "The Frequency Synthesiser."

An extra informal meeting has been arranged and will take place on May 11. This will be in the form of a discussion on "Factors determining the choice of Carrier frequency for an Improved Television System." The discussion will be opened by Mr. B. J. Edwards of Messrs. Pye Radio.

British Kinematograph Society

On May 12 at the Gaumont British Theatre, Film House, Wardour Street, W.1, at 6 p.m., the annual general meeting of the above Society will be held.

This will be followed by a paper on "Developments in Projector Design" by the Organising Secretary, R. Howard Cricks, F.R.P.S.

Brit. I.R.E.

At a meeting to be held on May 28 at the Institution of Structural Engineers, 11 Upper Belgrave Street, London, S.W.1, an address will be given by S. Hill, A.M.I.E.E., on "Cathode Coupling and Decoupled Amplifiers."

Verb. Sap.

The successful man, whether industrialist, merchant or engineer, is successful because he is curious about the things around him and is continually striving to satisfy that curiosity by reading, thinking, and cooperating with his fellow-men in discussion and in action. If one builds a wall about himself which keeps valuable knowledge from getting out, that same wall keeps valuable information from coming in.

Co-operation, curiosity, knowledge, and action, individually and collectively, lead to success.—A. F. Dixon (slightly modified) (Bell Lab. Record).

MELTON METALLURGICAL LABORATORIES LTD.

Liquid Silver

& Platinum Solutions

For Metallising
Mica Ceramic
Quartz etc.

Low Melting
Point Solder and
Non - Corrosive
Liquid Flux (A.I.D. Approved)

IPSWICH ROAD
TRADING ESTATE
SLOUGH, BUCKS.

'Phone: Slough 20992

Agents for Australia:

A. F. HARRISON & CO. PTY. LTD.
85 CLARENCE STREET, SYDNEY

"Eenie, Meenie, Miney, Mo—"

When it comes to horses, 'picking-em out with a pin' is probably as good a method as any. And the 'Eenie, Meenie' way is the only way in children's games. But in the choice of transformers, taking chances is not worth the risk. It is an element that has no place in the manufacture of any Gardner product and its absence is particularly noticeable in the range of Small Power Transformers up to 4 kva. So when next you need this type of component and the specification says, in effect, "no 'Eenie, Meenie'" please ask for our co-operation.

We regret that at present Small Power Transformers are available for highest priority orders only.



GARDNERS RADIO LIMITED
SOMERFORD · CHRISTCHURCH · HANTS.

Amplifying and Recording Technique in Electro-Biology

Part II: The Electrical Activity of the Human Brain

A paper read before the Wireless Section of the Institution of Electrical Engineers, March 3rd. 1943

By G. PARR, A.M.I.E.E.,* and W. GREY WALTER, M.A.†

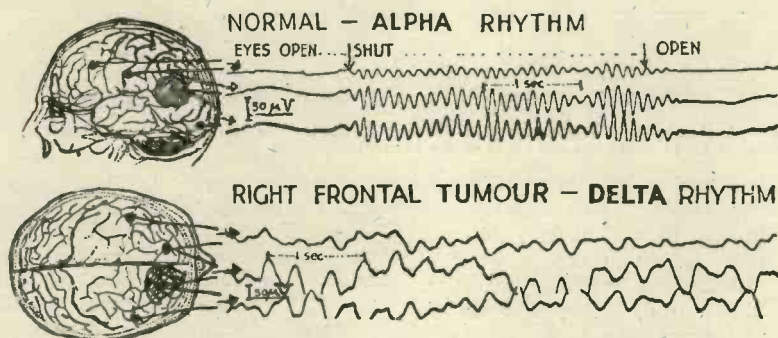

Fig. 14. Records showing the wave forms obtained from typical normal and abnormal conditions.

THE electrical activity of the human brain, first recorded by Berger and confirmed by Adrian, has provided a field of research which is becoming increasingly important, not only from the clinical aspect (in the diagnosis of disease) but in giving an indication of the psychological fitness of the individual for particular work. Both in this country and America the records of brain activity are taken in a number of cases to confirm the findings of the more usual psychological tests for ability, and recently the evidence given by an abnormal record from a subject was accepted in a legal case.

In 1936 one of the authors undertook the study of the electrical potentials originating in the brain with special reference to abnormalities such as tumours, and from that date an immense amount of data has been accumulated by various workers¹⁷ correlating the electrical record with mental conditions, normal and abnormal.

The magnitude of the potentials produced by the brain varies between 5 microvolts and 1.0 millivolt under certain conditions.

The average potential measured in the human electro-encephalogram is about 50 microvolts. The waveform is alternating, irregular, and of very low frequency, compared with audio frequency practice. The periodic time may vary from one second to 20 milliseconds, and may also vary from cycle to cycle. Further, the quasi-

sinusoidal nature of the wave may be interrupted at intervals by abrupt transients or "spikes."

In the normal human adult the electroencephalogram takes the form of a series of irregular waves of about 10 c/s, varying in amplitude from zero to about 100 microvolts. This regular discharge, or rhythm, is termed the "alpha rhythm" and is indicative of the normal brain at rest. The most striking characteristic of the alpha rhythm is that it is inhibited by visual activity or by mental concentration. In Fig. 14 the upper record shows a

typical alpha rhythm from the human brain which is suppressed when the eyes are opened. In certain people (of whom the author* is one) an active mental condition prevents its occurrence except under certain special circumstances. The suppression of the alpha rhythm by mental exercise is shown by the record of Fig. 15 in which the subject was asked to perform a sum in mental arithmetic, the eyes being shut. The break in the regular wave-form during the working out of the sum can be seen clearly.

The above facts suggest that the alpha rhythm is a sign of physiological rest or inactivity, and it may possibly be due to the same cause as that producing slow bio-electric rhythms in other organs—the electrical summation of slightly asynchronous volleys of action potentials. The rhythm of these volleys may be set by some pacemaker or master oscillator in the cortex. The electrical discharge has a focus, or point of origin, in the occipital region of both hemispheres of the brain, the two foci being nearly always symmetrical and giving rise to waves of the same frequency and phase relationship. This

* W.G.W.

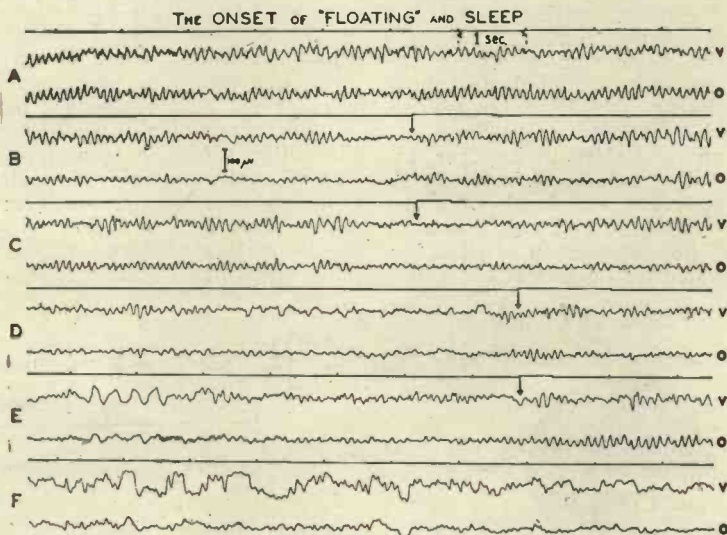

Fig. 16. Records taken from a subject of the onset of sleep: (a) Normal record of subject awake. (b), (c), (d), (e) Period of "floating," the arrows indicating when the subject roused. Drowsiness is increasing throughout the series. (f) Real sleep with waves at 14-12 c/s in addition to large delta waves. (From Davis, Loomis, et al., *Jour. Neurophysiol.*)

* Editor: *Electronic Engineering*.

† The Burden Neurological Institute, Bristol.

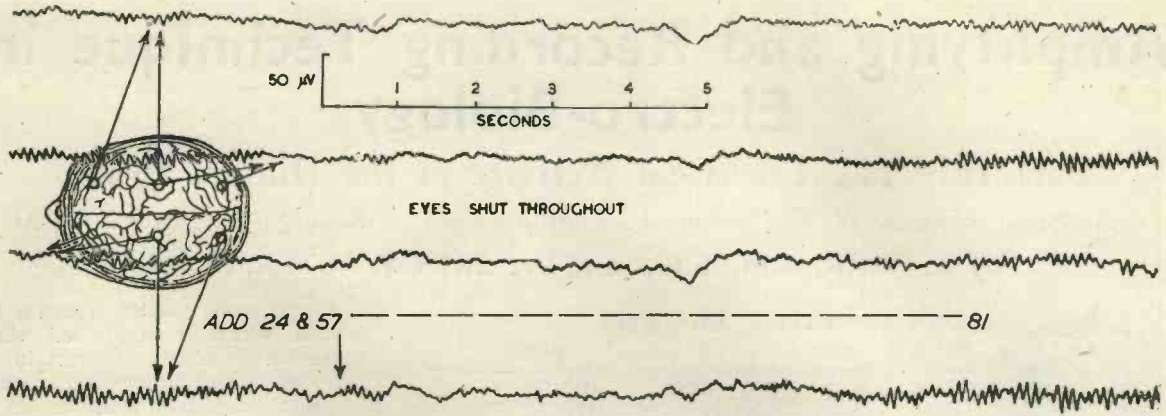

Fig. 15. Records showing the suppression of the alpha rhythm by mental exercise (addition of 24 and 57). The resumption of the rhythm when the answer is given is seen at the right of the record.

tends to support the hypothesis of the master oscillator, but very little is known about the resonance conditions in the central nervous system and it is possible that the two hemispheres have a common natural frequency and that one drives the other by a small amount of coupling.

More recently, C. A. Beevers¹⁸ has attempted to explain the origin of the potentials in terms of the distribution of the electric field surrounding a dipole. Such dipoles are considered to be placed with their axes parallel with the surface of the cortex.

The distribution of potential in the anterior-posterior direction of the skull can be explained by the assumption that there exist chains of linked synchronously oscillating dipoles which gradually diminish in strength from the occipital to the frontal region. This hypothesis cannot be said at present to be in accordance with all the observed facts, but is nevertheless worthy of attention as a physical approach to the study of the electroencephalogram.

The conditions under which the alpha rhythm is found are those which imply the least degree of stimulation, interest, or anxiety.

The onset of sleep is, however, accompanied by a decrease in frequency of the waveform and finally by a disappearance of the alpha rhythm altogether. The phenomenon of sleep has been studied by Loomis *et al.*¹⁹ and a

typical record is shown in Fig. 16. The onset of sleep is characterised by a diminution in the rhythm, followed by a stage in which the record contains intermittent bursts of waves at 14-15 per second, followed again by the appearance of waves of much lower frequency which gradually increase in size. It has also been observed that dreams are accompanied by a burst of alpha waves.

The very low frequency (less than 8 c/s) rhythm is also characteristic of abnormalities in the brain of the waking subject.

The lower record of Fig. 14 shows a waveform of much lower frequency which is characteristic of a cerebral tumour. The name delta rhythm has been given to this wave which usually has a frequency of 3 c/s or lower.

It was noted by Berger (1931) that the records of the potentials from the brain of patients suffering from various forms of epilepsy were of a lower frequency than that of the normal alpha rhythm. These observations have been confirmed by several later workers who have established that the rhythm obtained during seizures is distinctive for three main types and that it is also possible to predict the onset of an epileptic attack several hours before it occurs. Fig. 17 shows the potentials produced in cases of petit mal which in this case are char-

acterised by sharp "spikes" occurring at intervals in the delta rhythm.

In 1936 one of the authors found that slow frequency waves were almost invariably associated with the presence of cerebral tumours and that it was possible to locate the tumour with considerable accuracy by a systematic search over the surface of the skull to find the focus of the potentials.

Before describing the method of localisation in detail some brief notes on the actual technique are added:

To record the potentials two electrode systems are available; they give different results and serve different purposes. The simplest method of observing the potential of a point on the scalp is to place one electrode on a reference point, such as the ear, and the other at any point on the scalp, previously cleaned and moistened with saline. (It is not necessary to shave the subject!)

If the ear electrode is earthy, the voltage recorded will be that existing at the given point on the scalp with reference to earth and will be proportional to the actual potential of the cortex underneath, allowing for attenuation by the overlying tissue.

In the other method, two electrodes are used, connected to the inputs of a balanced amplifier and placed a convenient distance apart on the scalp. The voltage in this case will be the potential difference between

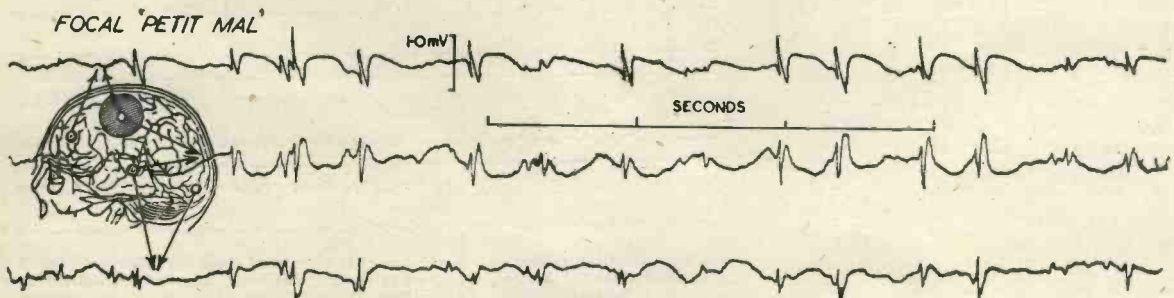

Fig. 17. 'Wave and spike' record from epileptic patient.

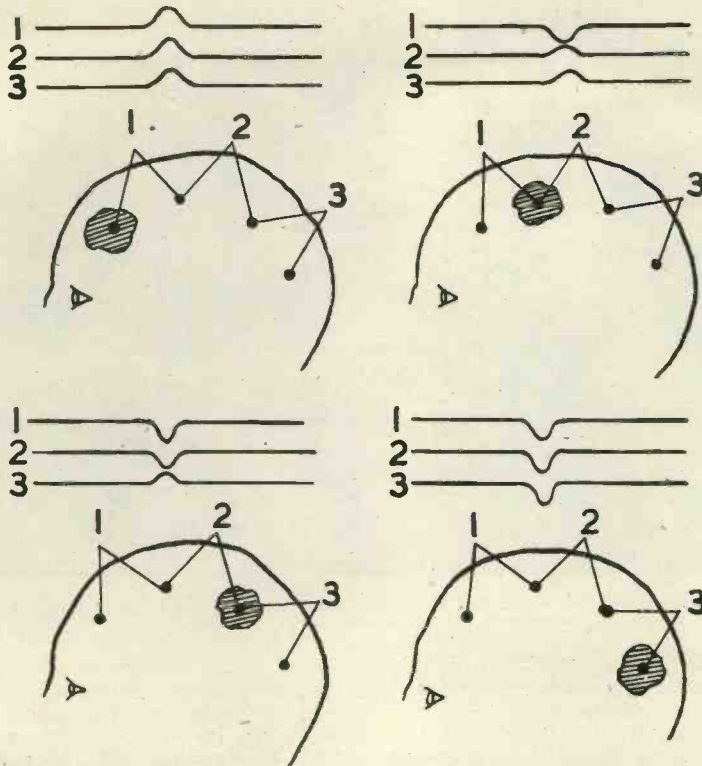

Fig. 18. Showing the method of localisation of the focus by a series of paired electrodes.

the two points, irrespective of their potential with respect to earth. A convenient analogy, which also illustrates the meaning of the word "focus" applied to the potentials, is to consider the potential gradient from any point on the scalp as a hillock. The single electrode then records the height of the hillock above ground level, while the paired electrodes indicate the difference between two points on the hillock.

If a series of electrodes are placed on the scalp in line from front to back, the first being at a focal point (Fig. 18a) the instantaneous values of potential under each electrode will be in phase and will diminish in amplitude slightly as the gradient decreases towards the last electrode. On the other hand, if the focus is under one of the intermediate electrodes, the potential gradient will fall off in both directions from that point and the amplifiers will record the potential changes as 180° out of phase (Fig. 18b).

In practice it is only necessary to use four electrodes as shown in the figure, instead of six separate ones, one electrode of each pair being commoned.

If in such an arrangement a difference in phase of 180° is found between two records it indicates that the focus lies between the pairs of elec-

trodes concerned (Fig. 18b and c). It is thus possible to locate accurately the focus of low frequency waves, which in the majority of cases coincides with the site of a tumour.

The electrodes are held in place on the scalp either by collodion or preferably by means of an elastic cap such as is used in wave setting. The subject need not be lying down. Fig.

19 shows the electrodes in position and the leads connected to a three channel amplifier of the recording apparatus.

Although this method of location of tumours has given remarkably successful results, it should be pointed out that no worker has claimed that it can completely displace the more conventional methods of diagnosis. Tumours below the hemispheres cannot be located with accuracy, although they give rise to the characteristic delta discharge rhythm. Benign tumours seldom have a marked effect on the electroencephalogram, and therefore a normal record cannot always be taken as a certificate of good health.

An important factor which affects the accuracy of the record is introduction of extraneous potential changes, either by radiation from an external source or due to the patient. The general term "artefacts" is given to spurious waves appearing from these causes, and the most common are:

(a) *Radiated Interference.* This may vary from high frequency interference from diathermy apparatus to mains frequency ("hum pick-up") interference. Although the balanced input circuit minimises the pick-up it is sometimes essential to enclose the patient in a screened cubicle.* Any movement of an electrostatically charged body in the neighbourhood of the input leads (such as celluloid ruler, rubber shoes, etc.) will produce large deflections if the subject is not earthed.

(b) *Photo-electric potentials.* Silver chloride electrodes are photo-sensitive,

* See E. F. Gould, *P.O.E.E.J.*, April 1942 for a suitable design.

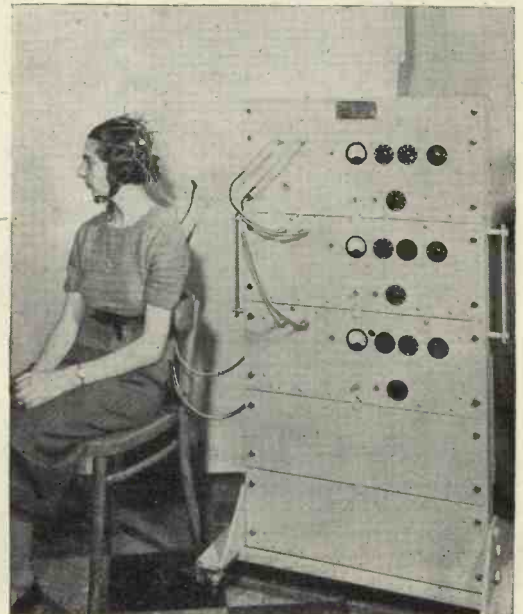

Fig. 19. Patient with electrodes in position for location of brain tumour. The amplifier rack contains three identical channels with a variable gain and filter controls.

(Edison Swan Co.)

and spurious potentials may be produced by the action of sunlight or intense light on the patient. These are seldom found, as under normal conditions it is convenient to take the records in subdued light.

(c) *Eyeball movements.* The commonest cause of artefacts is movement of the eyelids or eyeballs. These can be recognised owing to their magnitude and the fact that they appear to originate from the frontal electrode.

(d) *Skin potentials.* A small steady e.m.f. exists between two points on the scalp due to differences in ionic concentration in the tissues and the electrolyte used on the electrodes. These potential changes will generally give trouble if the electrodes become dry or alter their resistance appreciably.

Interference from the electro-cardiogram is seldom seen in electroencephalographic records, but pulsation from the arteries of the head can sometimes be seen in records from the frontal region.

Analysis of Records

Although the record in most cases shows a waveform of a main predominating frequency it is frequently interrupted by irregular groups or bursts of waves or even random single waves of a frequency differing from the dominant frequency.

These irregularities have a definite clinical significance in addition to the variations which may occur in the dominant frequency, and it is therefore of importance to analyse the record accurately to determine the frequencies present.

As is well known, this problem presents some difficulties and various methods have been suggested based on standard procedures.

A method of analysing the low frequency record and automatically plotting the amplitude of the various frequencies has been devised by Grass.²⁰ A specially selected record is made on a cine film in the form of a variable area trace. A representative length is selected from the record and is spliced to form a continuous band which is then driven past a light source and photo-cell at 100 times the recording speed. The frequencies are thus increased a hundredfold and are brought within the range of a wave analyser. Automatic plotting of the frequency spectrum is done by coupling a recording drum to the frequency control of the analyser to obtain a frequency scale as a base. The output of the analyser is then fed to a mirror galvanometer which traces out the amplitude at each frequency on to the recording drum.

It has been pointed out by the users of this method that it cannot replace

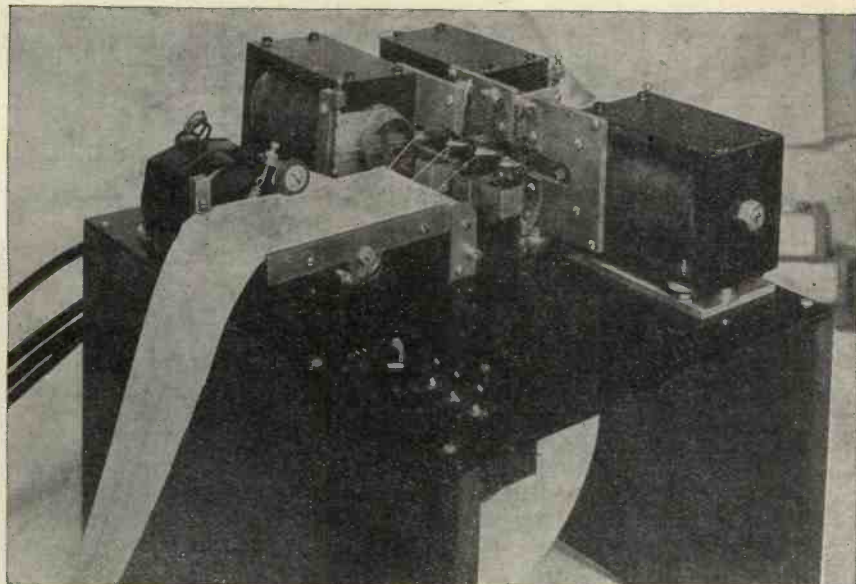

Fig. 18. Three-channel ink writer for biological recording developed by A. M. Grass (U.S.A.). See also Fig. 12 in the first part of the paper.

a detailed examination of the encephalogram, since a transient wave occurring once in the record is lost in the average over the whole period. As such transients have a definite significance, the method can only be used with success on a limited number of records.²¹

One solution which has given promising results is the use of tuned reeds as frequency indicators, the reeds being extended into pens to trace on the same record as the electroencephalogram. For example, three of the pens in the Grass ink writer were loaded to resonate at 10, $9\frac{1}{2}$, and 8 c/s respectively and thus traced the dominant frequency during the recording of a normal electroencephalogram. The change of the dominant frequency between these three values can

be seen as the trace proceeds. Exact quantitative measurements are governed by pen friction and other factors, but the method is simple and satisfactory for rapid analysis of the dominant rhythms. (Fig. 19).

Further work on a simple apparatus for automatic analysis of low frequency waves is in progress and this will be described in a forthcoming article.

BIBLIOGRAPHY

- ¹⁷ See Walter, *J. Neuro & Psych.*, 1938, Vol. 1, No. 4, p. 359, for bibliography.
- ¹⁸ Beavers, *To be published.*
- ¹⁹ Loomis, *et al.*, *Jour. Neurophysiol.*, 1, 1, p. 24, 1938.
- ²⁰ Grass & Gibbs, *Jour. Neurophysiol.*, 1, p. 521, 1938.
- ²¹ Dawson, *Electronic Engineering*, Vol. 15, p. 34, 1942

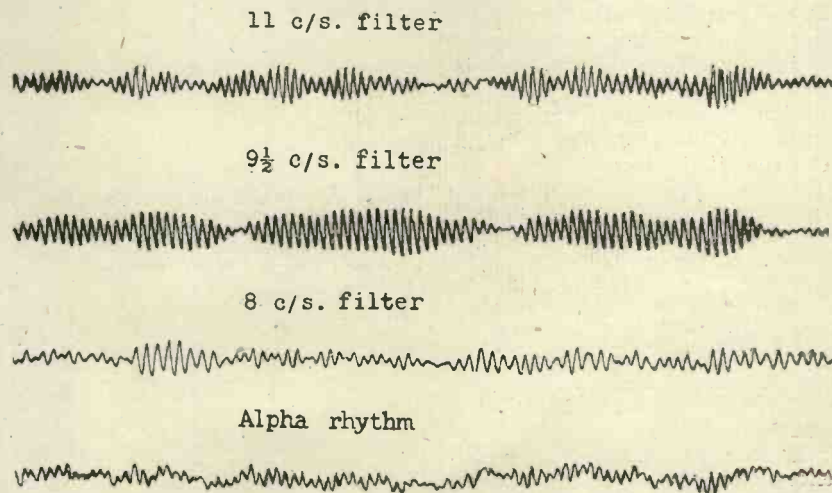

Fig. 19. Analysis of alpha rhythm by tuned pens, showing changes in the dominant frequencies.

Callender

RADIO FREQUENCY CABLES



Part of our High Frequency Test Laboratories

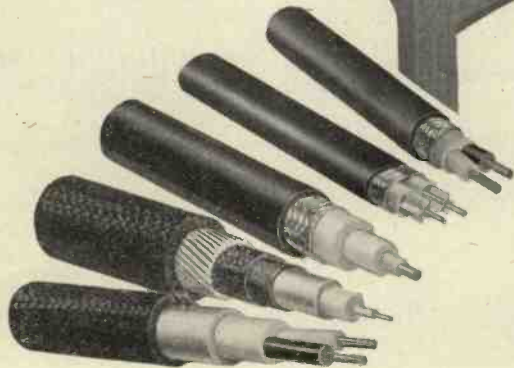

We are fully engaged on war production and are manufacturing all types of low loss and low capacity cables for use at high frequencies.

We shall be pleased to make available the experience of our extensive research and technical organisations in connection with special cable problems directly related to the war effort.

CALLENDER'S CABLE & CONSTRUCTION CO. LTD. HAMILTON HOUSE, VICTORIA EMBANKMENT, E.C.4

All over the World

A Method of Determining Biological Inter-Electrode Impedances

By M. G. SAUNDERS, B.Sc.*

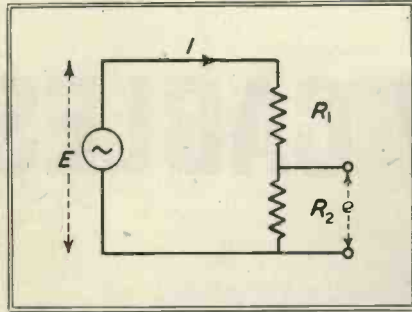

Fig. 1. Circuit for producing constant current in R_2 .

WHEN recording bio-electric phenomena it is often desirable to determine the impedance between any pair of electrodes in use, and, although the value of this inter-electrode impedance is often ignored, its determination is essential in many quantitative investigations.

There are two general methods of determining an interelectrode impedance. In the one, a simple ohmmeter is used, and in the other some bridge system. Both these methods have disadvantages, the most important being the necessity for using an alternating current across the electrodes to prevent polarisation giving rise to incorrect readings; it is this complication which makes the apparatus both more elaborate and more expensive. Instead of using alternating current, non-polarisable electrodes might be employed, but this frequently introduces a complication which is greater than that of the use of the alternating current itself.

As an alternative to these methods, a constant current device may be used to determine the inter-electrode impedance; this method has the advantages of simplicity, cheapness, and the utilisation of an alternating current source with little extra complication. Furthermore, using it in conjunction with existing amplifying and recording apparatus, it is possible to record results directly on to the tracing.

To produce a constant current across a load, which will in this case be the impedance of the material between the electrodes, the circuit in Fig. 1 may be used. R_2 represents this inter-electrode impedance, and R_1 is a fixed resistance of very much greater value than R_2 . A potential E drives an alternating current I through the resistances R_1 and R_2 . Making R_1 very much greater than R_2 enables quite large changes in the

value of R_2 to be made with negligible change in the current I passing through the two resistances. For example, with $R_1 = 10,000 \times R_2$, a hundredfold increase in the value of R_2 produces a one per cent. change in the value of I . Under these conditions, the potential across R_2 will be almost directly proportional to the value of R_2 itself.

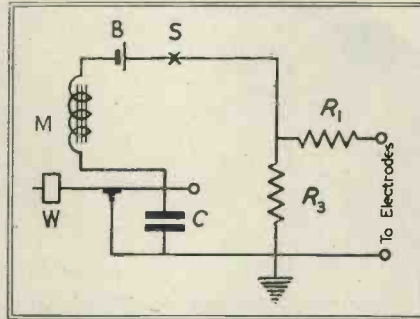

Fig. 5. Circuit of constant current device.

As has been mentioned, the resistance R_1 represents the impedance across the electrodes, so that by incorporating the electrode system in the circuit (Fig. 2) and switching on, there is superimposed on the tracing of the phenomena under investigation, the waveform from the alternating current source of the device (Fig. 3), the amplitude of this waveform bearing a direct relation to the impedance across the electrodes (Fig. 4). Although knowing circuit constants, it is possible to calculate the values of R_2 in terms of amplitude, it is, in practice, simpler to cross check against standard resistances.

The circuit of a simple constant current device is shown in Fig. 5.

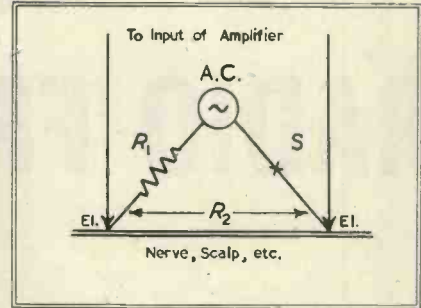

Fig. 2. The circuit of Fig. 1 in practice.

It consists of an ordinary bell mechanism, with its period of oscillation altered by the addition of a length of rod and a sliding weight. The bobbin M is connected in series with the battery B and a short length of resistance wire R_3 of value about an ohm. The high resistance R_1 (50 megohms) is connected in series with electrodes and R_3 .

For use with differential input amplifiers, R_3 is earthed at a centre tap and a resistance of value equal to R_1 inserted in the lead going to the other electrode.

Three points in connexion with this system of measuring impedances which must be borne in mind are (1) the necessity for keeping all amplifier settings standardised when determining impedance values, (2) of making frequent cross reference to standard resistances, and (3) of allowing for the parallel effect of the input impedance of the amplifier itself. Apart from these, however, the simplicity and cheapness of the device, together with its permanent record on the tracing, have much to commend it.



Fig. 3. Calibrating voltage superimposed on electroencephalogram.

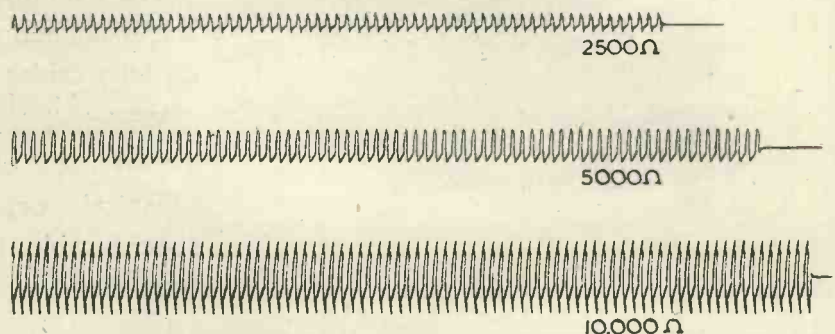

Fig. 4. Showing variation of amplitude with impedance.

* Department of Electroencephalography, Manchester Royal Infirmary.

A Table of American Photocells (R.C.A.)

TYPE	Gas-filled or Vacuum (G. or V.)	Luminous Sensitivity (μ A) lumen 1,000 c.p.s. ³	Spectral Sensitivity (max. response)	Gas Amp. Factor ⁴	Max. Anode Supply (D.C. or peak A.C. volts)	Max. Anode Current (μ A) ¹	Cathode Areas. (sq. ins) (approx)	Bulb Dia. (ins.)	Capacity C-a (μ F)	Cathode	Base	Remarks
868	G.	61	3,500 & 7,500 AU	7	90	20	1	1 $\frac{1}{8}$	2.5	Cs	Ux	
917	V.	20	3,500 & 8,000 AU	—	500	30	1	1 $\frac{1}{8}$	2.0	Cs	Ux	Top Cap—Anode
918	G.	104	3,500 & 8,000 AU	10	90	20	1	1 $\frac{1}{8}$	2.5	Cs	Ux	
919	V.	20	3,500 & 8,000 AU	—	500	30	1	1 $\frac{1}{8}$	2.0	Cs	Ux	Top Cap—Cathode
920	G.	70	3,500 & 7,500 AU	10	90	10	0.3	1 $\frac{1}{8}$	1.5	Cs	Ux	Twin Cell
921	G.	94	3,500 & 8,000 AU	9	90	20	0.4	0.89	1.0	Cs	Special	
922	V.	20	3,500 & 8,000 AU	—	500	30	0.4	0.89	0.5	Cs	Special	
923	G.	94	3,500 & 8,000 AU	9	90	20	0.4	1 $\frac{1}{8}$	2.0	Cs	Ux	
924	G.	<55	3,500 & 7,500 AU	8.5	90	15	0.2	1 $\frac{1}{8}$	2.5	—	Screw	
925	V.	15	3,500 & 7,500 AU	—	250	20	0.4	1 $\frac{1}{8}$	1.0	—	Octal	
926	V.	6.5	4,500	—	500	20	0.4	0.89	0.5	—	Special	
927	G.	70	3,500 & 7,500 AU	7.0	90	2	0.4	23/32	2.0	—	3-pin	
928	G.	<65	3,500 & 7,500 AU	10.0	90	15	0.7	1 $\frac{1}{8}$	3.0	—	Ux	
929	V.	45	3,750	—	250	20	0.6	1 $\frac{1}{8}$	2.5	—	Octal	
930	G.	94	3,500 & 8,000 AU	9.0	90	20	0.6	1 $\frac{1}{8}$	2.5	—	Octal	
934	V.	30	3,750	—	250	10	0.4	23/32	1.5	—	3-pin	
935	V.	30	U.V. to 2,000	—	250	20	0.9	1 $\frac{1}{8}$	0.6	—	Octal	Top Cap—Anode

¹ On basis of the use of a sensitive cathode area $\frac{1}{8}$ " in diameter;

² Between cathode and anode of each unit. Capacity between cathodes—1.6 μ F; between anodes—0.36 μ F.

³ These sensitivity values are measured with a light input varied sinusoidally about a mean value from zero to a maximum of twice the mean. The sensitivity values shown are the ratio of the amplitude of variation in the current output to the amplitude of variation in the light input. The light source was a Mazda projection lamp operating at a filament colour temperature of 2,870 deg. K. Sensitivity of the gas photocells was measured with a 90 volt supply, a 1 megohm load, and a mean light input of 0.015 lumen. Sensitivity of the vacuum photocells was measured with a 250 volt supply, a 1 megohm load, and a mean light input of 0.1 lumen.

⁴ Ratio on sensitivity at maximum anode voltage to sensitivity at a voltage sufficiently low (approximately 25 volts) to eliminate gas ionization effects. Values given are maxima.

General Note.—The Ambient Temperature is 100 deg. C. in all cases except the 929, which is 50 deg. C.

B.S.I.

The British Standards Institution announce that Part III of the Glossary of Technical Terms and Definitions was issued in March (Switchgear and Instruments) and that Part IV is now ready (Transmission and Distribution). Copies may be obtained from the Institution at 28 Victoria Street, S.W.1, price 2s. per part.

B.S. Code on Radio Valves

A Code of Practice relating to the use of radio valves in equipment has been drawn up in collaboration with the B.R.V.M.A. and is available, price 1s. This should be read by all engaged in the design and operation of new radio equipment and contains important recommendations for preserving valve life and efficiency.

B.S. 1082—Fixed Capacitors

This specification extends the scope of B.S. 271 of 1926 which dealt with small capacitors for radio receivers, and now includes all fixed capacitors for general purpose.

In addition to the standard tests for insulation, voltage, temperature rise, etc., the booklet also contains details of colour-coding and some definitions. Price 2s. 3d. post free.

A Compact Oscillator

The illustration shows a neat valve oscillator developed by Webbs Radio for morse practice or any work requiring a fixed frequency source of moderate voltage. The unit only requires a 2 v. cell and 9 v. bias battery for operation, but can be worked from the cell alone if necessary. The sockets shown are for the insertion of a key. The workmanship is robust and the

**NOTES FROM THE INDUSTRY**

Mr. S. R. Mullard, Sir Ian Fraser and Mr. M. M. Macqueen at the opening of the Brit. I.R.E. headquarters.

unit is in a moulded case with fixing lugs. Price 27s. 6d. from Webbs Radio, Soho Street, W.1.

The Brit. I.R.E.

The new premises taken over by the British Institution of Radio Engineers at Bedford Square, W.C.2, were formally opened on March 30. As the date coincided with the Radio Industries Club luncheon, a large number of well-known names in the radio industry visited the Institution's headquarters during the afternoon, including Sir Louis Sterling, Lord Brabazon, Mr. S. R. Mullard, Mr. J. L. Baird, Mr. E. E. Rosen, and many others.

The new headquarters have been necessitated by the steady growth in membership and expansion in the Institution's activities during the past few years. Membership is confined to qualified radio engineers, and particulars of the Institution's examinations and requirements can be obtained from the Secretary, Mr. G. D. Clifford, at the address above.

Improved Unipivots

The Cambridge Instrument Company announce the production of a new range of Unipivot galvanometers with increased sensitivity. The new instruments have sensitivities equal to those of many suspended coil galvanometers while at the same time retaining the portability and robustness of the Unipivot construction.

The pattern LX is 2.4 times as sensitive as the pattern L, and the LY is 4 times as sensitive, but slightly less robust. Full details are given on leaflet No. 160 from the Cambridge Instrument Co., 13 Grosvenor Place, S.W.1.

Quartz Crystals

The Minister of Supply has appointed Mr. R. L. Prain to be Controller of Quartz Crystals.

On and from March 17 all communications relating to the supply of quartz crystals should be addressed to the Controller at Portland House, Tothill Street, London, S.W.1. Telephone No. : Abbey 7788.

Radio Industries Club

Over 200 members and guests of the Radio Industries Club on Tuesday, March 30, heard the views of Mr. C. O. Stanley, O.B.E. (Pye, Ltd.), on the subject of the radio industry after the war.

Mr. Stanley made two concrete suggestions: First, that for six or nine months after the war the manufacturers should make and sell the type of sets they had just before the war; and, secondly, that during that period they should discuss the future system of broadcasting. The industry did not want new theories foisted on it without consultation, and it must have some say in the future system to be adopted.

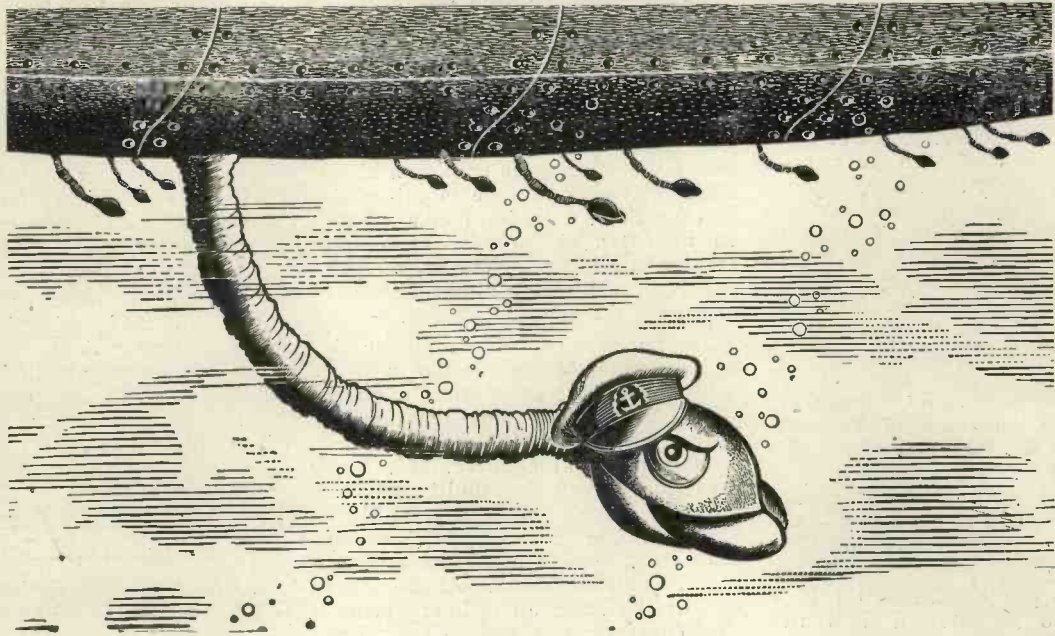

No passengers

SCIENCE is discouraging the barnacle. There is no room for "passengers" on the smooth surface of the stream-lined age.

Industry, too, distinguishes an AEROCESSORY from an accessory. It knows the AEROCESSORY as a revolutionary product which, far from being an adjunct, is conceived and designed specifically to solve a vital need of production and is blue-printed as an integral part of the whole.

The AEROCESSORY, moreover, is a product sired by the high limits of precision engineering essential to the exacting needs of aeronautics—standards which are becoming every day equally appreciated by all industry in this the Air Age.

S I M M O N D S

The Creative Impulse in
AERONAUTICAL, INDUSTRIAL & MARINE
Construction

THE SIMMONDS NUT · PINNACLE NUT · SPIRE NUT
 SIMMONDS GAUGES, INSTRUMENTS AND CONTROLS
 FRAM OIL & ENGINE CLEANER

SIMMONDS AEROCESSORIES LTD.
 GREAT WEST ROAD, LONDON

A COMPANY OF THE SIMMONDS GROUP

LONDON, MELBOURNE, PARIS, NEW YORK.

BOOK REVIEWS

Radio Receiver Design

Part I. K. R. Sturley, Ph.D. 436 pp. 2 appendices. (Chapman & Hall, 28/- net.)

A large number of textbooks are available on Radio Engineering, a few of them excellent. Most of them endeavour to cover the very wide scope embraced by the many branches of radio engineering and perforce have to leave out a lot of detail in order to treat thoroughly the fundamental principles involved.

The book under review falls into an entirely different category: firstly it is the only book written on Radio Receiver Design from the point of view of the radio engineer; secondly, by thus limiting the scope of the book the author has been able to treat a considerable proportion of the subjects covered with greater thoroughness, and in more detail than in any other book in the English language.

Owing to war conditions the book has had to be divided into two volumes, the first part now published starts with a brief review of modulation methods, amplitude, frequency and phase modulation being considered. This is followed by a chapter on valves and their equivalent circuits, the subject of the input admittance of a valve as affected by electrode reactances is extensively treated. It is, however, surprising that the pioneer work by Strutt on this subject is not referred to.

The third chapter covers aerials and aerial coupling circuits and typical performance curves of a large number of coupling arrangements are included. On page 85 the expressions 3.20 for maximum aerial transformer gain do not include the most useful form, *i.e.*, $\frac{1}{2}\sqrt{R_D/R_a}$ or $1/(2\sqrt{R_a G_D})$. The use of the latter expressions would simplify calculations of the type given on page 173.

Chapter 4 covers a very wide scope under the title of Radio Frequency Amplification. Starting with the properties of the parallel resonant circuit and the characteristics of coils, it carries on to deal exhaustively with the theory of R.F. valve coupling circuits including band-pass filters. The question of modulation distortion and cross-modulation is treated in considerable detail and reminds one of the author's past association with the valve industry.

Limits of amplification both from the point of view of stability and noise and the problems of U.S.W. amplification are then considered. The author discusses a modern development in all-

wave receivers, *i.e.*, the use of H.F. couplings pre-tuned for each band to be received (including the television band), but surprisingly enough only considers the use of a medium slope pentode or acorn in the H.F. stage. The tendency in the latest receivers before the war was to employ a high-slope television pentode in this position (on S.W. only) in order to obtain an improved signal-noise ratio and greater amplification. The use of such a valve considerably alters the magnitudes of the effects discussed.

The reviewer considers the unqualified definition of the effective "band width" for noise calculations on page 165 unsatisfactory and the figures shown for the equivalent noise resistance not representative. The lowest figure given for multi-electrode valves is $4,000 \Omega$, while a good high-slope pentode (7 to 9 mA/V) would have an equivalent noise resistance of the order of 800 ohms. At the other end of the scale an ordinary pentagrid convertor has a noise resistance of the order of $200,000$ ohms. The phenomena of induced grid noise is not mentioned.

An excellent treatment of Frequency Changers follows in chapter four which covers all forms of mixing from diode to push-pull. The causes of interference whistle production are analysed and the measurement of Harmonic Responses, Conversion Conductance and Signal Handling discussed. The chapter concludes with the analysis of some image suppression circuits. The reviewer would have liked to have seen more space devoted to the comparison of the input admittances and noise resistances as the provision of a high signal to noise ratio is one of the most important problems of short wave reception.

The oscillator of the superhet receiver and its ganging problems are treated in Chapter 6, while Chapter 7 covers the I.F. amplifier. Such items as the design of I.F. transformers, signal handling, variable selectivity and the variation of valve input admittance are all treated at length. In fact this is one of the very few books that considers in detail the effect of the variation of input admittance on the frequency response.

An excellent and very detailed treatment of detection is given in the last chapter and a wealth of information is provided which will benefit even the experienced engineer. The importance of the demodulation of a weak signal by a strong one justifies a more extensive treatment.

To appreciate this book a reasonably good knowledge of mathematics is essential, though for the majority of the text it need not be of an advanced nature.

In a volume of this type which is likely to be used to a considerable extent as a reference text, the provision of a list of symbols used for the whole volume or for each chapter would be of great benefit.

This book is unreservedly recommended and the reviewer is looking forward to the publication of the second volume which will deal with audio frequency amplifiers, power supplies, receiver measurements, television and frequency modulated receiver design, etc.

C.L.H.

The Amplification and Distribution of Sound

A. E. Greenlees. (2nd Edition.) 255 pp. (Chapman & Hall, 12/- net.)

The book is divided into 16 chapters covering fundamentals, components, amplifiers and their performance; associated equipment such as radio receivers, microphones, loudspeakers, etc.; and discusses the planning of an installation, with notes on distribution methods, operation and maintenance of complete installations.

Although, as shown above, this book outlines the main principles governing sound amplification and distribution, it does not cover modern industrial systems, including the use of remote control facilities.

The fundamental mathematics are clearly presented for the beginner, and would be useful as a "refresher" to those more advanced in the subject.

The author's description of the operation of push-pull output stages is clear, but would nowadays be considered incorrect, particularly his description of "Class B" stages. Engineers today tend to give this title to zero bias positive grid drive stages, and Fig. 11 on page 56 would be usually taken to illustrate a "Class A.B.2" circuit.

On page 208, the statement is made that an electrolytic condenser depends on an insulating film of gas, but present-day opinion is that a chemical film of molecular thickness is formed on the surface of the aluminium foil.

One printer's error on the bottom of page 14 was noticed, but apart from this, the printing and layout are very clear, as one would expect from a Chapman and Hall publication.

F.P.

The glory of the future..

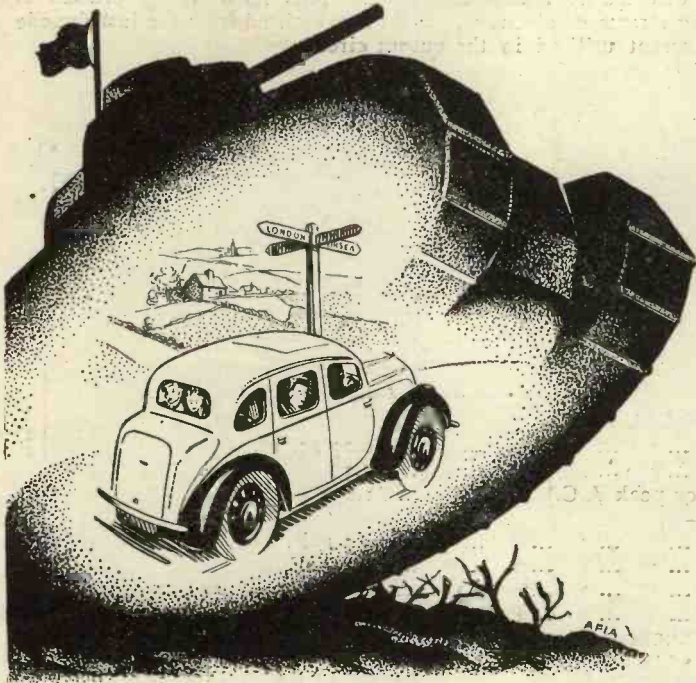

..when the tank gives pride of place to the "family 'bus" and engines of war to the instruments of peace, Goodmans will be able, once more, to give the connoisseur Loudspeakers that open up new possibilities in high fidelity reproduction.



GOODMANS

Makers of

HIGH GRADE LOUDSPEAKERS

Priority Orders only can be accepted

GOODMANS INDUSTRIES, LTD., LANCELOT ROAD, WEMBLEY, MIDDLESEX



On every battlefield

Condensers are at work

Perfect communication by radio is essential in all modern war operations, from grand strategy down to the smallest tactical manoeuvre. Nothing but the very best of apparatus is good enough.

TRADE **HUNTS** MARK
The

Home of Condensers

R.C.A. 931 MULTIPLIER CELL

The 931 is a high vacuum multiplier photocell in which the electrons emitted from the illuminated photo-cathode are directed by the fixed electrostatic fields along curved paths to the first dynode (secondary emitter). The electrons impinging on the dynode surface produce many other electrons, the number depending on the energy of the impinging electrons. These secondary electrons are then directed to a second dynode. This multiplying process is repeated in each successive stage, with an ever increasing stream of electrons, until those emitted from the last dynode (No. 9) are collected by the anode and constitute the current utilised in the output circuit.

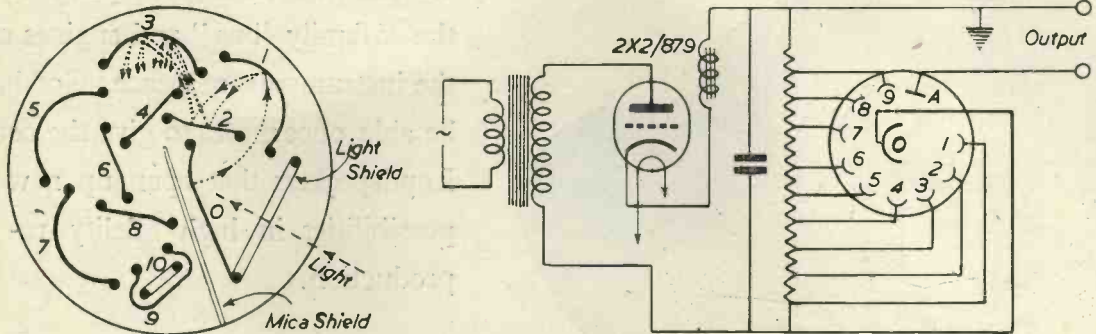

TECHNICAL DATA

Cathode window area	0.25 sq. in.
Anode Current (mA) (max.)	2.5
Anode-supply voltage (max.) (D.C. or peak A.C.)	1,250
Inter-electrode Capacities (approx.)—					
Anode to Dynode No. 9	3.5 μ F.
Anode to all other electrodes	6.5 μ F.
Maximum Overall Length	3 $\frac{11}{16}$ "
Maximum Diameter	1 $\frac{5}{16}$ "

REFERENCES

J. A. Rajchman and R. L. Snyder, "An Electrically Focused Multiplier Phototube," *Electronics*, Vol. 13, p. 20, Dec., 1940.
 V. K. Zworykin and J. A. Rajchman, "The Electrostatic Electron Multiplier," *Proc. I.R.E.*, Vol 27, p. 558, Sept., 1939.

SAVE PRECIOUS TIME—USE PRECIOUS METALS

ELECTRICAL CONTACTS IN PRECIOUS METALS OR PRECIOUS METAL ALLOYS

JMC electrical contacts are in demand for war service in all types of electrical equipment in all theatres of war, but we endeavour to maintain our advisory service to customers and give the benefit of our wide experience in the application of precious metals and their alloys to all kinds of contact requirements.

- SILVER.
- PLATINUM
- PALLADIUM-COPPER
- GOLD.
- GOLD-SILVER
- SILVER-COPPER-
- PLATINUM-GOLD-SILVER
- PLATINUM-IRIDIUM
- PALLADIUM-SILVER
- AND OTHER ALLOYS

Enquiries should be headed "Contact Enquiry" and addressed to Head Office.

**JOHNSON, MATTHEY
 & CO., LIMITED.**

**73/83, HATTON GARDEN,
 LONDON, E.C.1**

Telephone: HOlborn 6989

71/73, Vittoria Street,
 Birmingham

Oakes, Turner & Co., Ltd.
 75/79, Eyre Street, Sheffield, 1

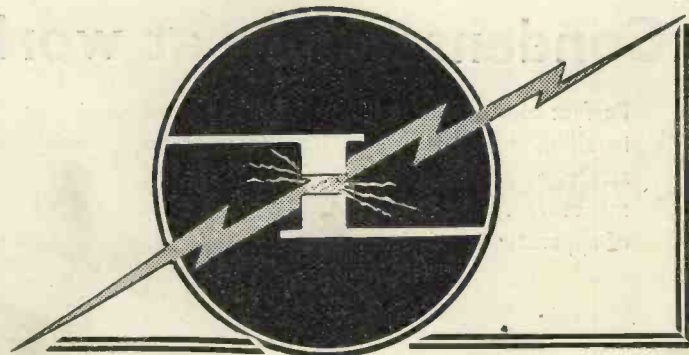

Ensure the most successful results



USE
BI CONDENSERS

BRITISH INSULATED CABLES LTD.,
Head Office: PRESCOT, LANCs. Telephone: PRESCOT 6571.

WHAT BIT TEMPERATURE SHOULD BE USED FOR 40/60 ALLOY?



This and numerous other queries are answered in reference sheet 2 of "Technical Notes on Soldering," published by the manufacturers of Ersin Multicore—the A.I.D. approved solder wire with three cores of non-corrosive Ersin activated flux.

Firms engaged on Government contracts are invited to write for a reference sheet and samples of ERSIN MULTICORE SOLDER wire.

ERSIN MULTICORE

The Solder Wire with 3 cores of Non-corrosive Ersin Flux

MULTICORE SOLDERS LTD., BUSH HOUSE, LONDON, W.C.2. Temple Bar 5583/4

GALPINS ELECTRICAL STORES

"Fairview" London Road, Wrotham, Kent.

PLEASE NOTE CHANGE OF ADDRESS
This business is now transferred permanently to the above address where all mail orders will receive strict personal attention.

TERMS: Cash with order. No C.O.D.
(Ire and Northern Ireland orders cannot be accepted.)

HEADPHONES, 120 ohm, Secondhand, complete with headband and cords, in perfect working order. Price 7/6 per pair, post free.

INSTRUMENT METAL RECTIFIERS, by famous makers, 10 M/A full load working. Price 15/- each, post free.

TUNGSTEN CONTACTS, 3/16 in. dia., a pair mounted on spring blades also two high quality pure silver contacts, 3/16 ins. dia., also on spring blades, fit for heavy duty, new and unused, there is enough base to remove for other work. Price the set of four Contacts, 5/-, post free.

POST OFFICE RELAYS, Small type high resistance, twin blade, very low milliamps operation, as new Price 7/6 each, post free.

ELECTRIC LIGHT CHECK METERS, well-known makers, first-class condition, electrically guaranteed, for A.C. mains 200/250 volts 50-cy. 1 phase 5 amp. load 10/- each; 10 amp. load, 12/6, carriage 1/-.

I.K.W. FIRE ELEMENTS, mounted, size 16 x 1 1/2 x 1 ins., for 220 volts A.C. or D.C., as new 6/-, post free.

ROTARY CONVERTOR, D.C. to D.C., Input 12 volts; Output 1,100 volts at 30 M/A, Ex R.A.F., new. Price 50/-, carriage paid.

1/2 WATT WIRE END RESISTANCES, new and unused, assorted sizes (our assortment), 6/6 per doz., post free.

VOLTMETERS, 2 1/2 in. dia., panel mounting, moving coil, range 0-120 volts, F.S.D., very low, modern meters by famous makers. Price, 32/6 post free.

AMPMETERS, description as above, range 0-1 1/2 amps., Price, 25/- post free.

KLAXON MOTORS, for 220 volts D.C., shunt wound, ball bearing, fitted reduction gear giving speed of 700 r.p.m. High-grade job. Condition as new. Price, 50/- carriage paid.

D.C. MOTORS, shunt wound, ball bearing, 1/2 h.p., high grade. Condition as new. Can be offered for 110 volts or 220 volts as required. Price either voltage, 40/- carriage paid.

Classified Announcements

The charge for miscellaneous advertisements on this page is 12 words or less 3/-, and 3d. for every additional word. Single-column inch rate displayed, £1. All advertisements must be accompanied by remittance. Cheques and Postal Orders should be made payable to Hulton Press, Ltd., and crossed, and should reach this office, 43, Shoe Lane, London, E.C.4, not later than the 15th of the month previous to date of issue.

FOR SALE

IN STOCK, Rectifiers, Accumulator Chargers, Rotary Converters, P.A. Amplifiers, Mikes, Mains Transformers, Speakers of most types, Test Meters, etc., Special Transformers quoted for.—University Radio, Ltd., 238, Euston Road, London, N.W.1. Ger. 4447.

200 G.E.C., P.M. SPEAKERS with Transformer in stock, complete in metal cabinets, £2 5s. each, c.w.o. plus 1/- carriage and packing. Brand new in maker's carton. A. Imhof Ltd., 112 New Oxford Street, W.C.1.

LITERATURE

7,000 MEMBERS of the Scientific Book Club believe that Knowledge is Power. Are you a member? Particulars from 121, Charing Cross Road, London, W.C.2.

LOUDSPEAKERS

3,000 SPEAKERS P.M. and energised 4" to 14" including several Epoch 18". Sinclair Speakers, 170, Copenhagen Street, N.1.

LOUDSPEAKER repairs, British, American, any make, 24-hour service; moderate prices.—Sinclair Speakers, 170, Copenhagen Street, N.1.

MISCELLANEOUS

WE WILL BUY at your price used radios, amplifiers, converters, test meters, motors, pick-ups, speakers, etc., radio and electrical accessories. Write, phone or call, University Radio Ltd., 238, Euston Road, London, N.W.1. Ger. 4447.

MORSE EQUIPMENT

FULL range of Transmitting Keys, practice sets and other equipment for Morse training.—Webb's Radio, 14, Soho Street, London, W.1. Phone: GERrard 2089.

RADIO MAP

WEBB'S Radio Map of the World enables you to locate any station heard. Size 40" by 30" 2 colour heavy Art Paper, 4/6, post 6d. Limited supply on Linen, 10/6, post 6d.—Webb's Radio, 14, Soho Street, London W.1. Phone: GERrard 2089.

WANTED

WE OFFER cash for good modern Communication and all-wave Receivers.—A.C.S. Radio, 44, Widmore Road, Bromley.

DIRECTOR OF RESEARCH and development, to take complete charge of these departments, required by a London firm of Electrical Engineers manufacturing radio frequency, acoustic and electrical instruments. First class qualifications in Physics or Electrical Engineering essential, coupled with wide industrial experience. Write, stating full particulars, to "Electronic Engineering," Box No. 652.

CHIEF DESIGNER (mechanical) required for development department of a firm of Communication Engineers. Good experience in the design of electrical instruments and apparatus essential. Write giving full details to "Electronic Engineering," Box No. 653.

ASSISTANT RESEARCH ENGINEER required by London firm engaged on essential work for development of radio frequency and/or audio frequency apparatus. Training to B.Sc. standard in Physics or Electrical Engineering. Some experience desirable but not essential. Write stating full particulars to "Electronic Engineering," Box No. 656.

RADIO

ENGINEERING AND TELEVISION

Complete Postal Courses of Instruction. Recommended to all who desire to obtain a thorough technical and practical knowledge.

Apply —

BRITISH SCHOOL OF TELEGRAPHY LTD
179, Clapham Road, London, S.W.9.
(Estd. 1906)

Varley

Quality Components

- I.F. TRANSFORMERS
- WIRE WOUND RESISTANCES
- L.F. CHOKES & TRANSFORMERS
- MAINS TRANSFORMERS
- DELAY SWITCHES

Varley (Prop. Oliver Pell Control Ltd.)
Cambridge Row Woolwich, S.E.18

LONDEX for RELAYS

for A.C. and D.C.

TWO STEP RELAY LF/FS (Heavy Silver Contacts)



First Impulse "ON" Second Impulse "OFF"

Also Aerial Change - over Relays.

Ask for leaflet 88a/EO

LONDEX LTD

MANUFACTURERS OF RELAYS

207 ABERLEY ROAD - LONDON S.E.20

Classified Announcements (cont.)

HANK BUSHES and screws to your specifications (Repetition Work). Quick deliveries. D.T.Co., "Electronic Engineering," Box No. 654.

COPIES wanted. Television & S.W. World, Electronic Engineering, 1939-1942. However few. Murfitt, 17 Ravenscroft Drive, Chaddesden, Derby.



EDWARD Wilcox & CO LTD
Sliding-Interlocking and vibration-proof contacts and comprehensive adaptability are characteristics of interest to designers of unusual schemes in these unusual times.
Edward Wilcox & Co., Ltd., Sharston Road, Wythenshawe, Manchester.

PANILAX

REGISTERED TRADE MARK

BONDED PAPER INSULATION OF HIGH MECHANICAL STRENGTH AND MOULDED RESIN WITHOUT FILLER. BOTH HAVE EXCELLENT ELECTRICAL PROPERTIES.

the **MICANITE & INSULATORS COMPANY LIMITED**

WALTHAMSTOW LONDON E.17

Telephone: LARkwood 1044 (Ptc. Br. Exch)

BASICALLY BETTER...

Air Insulation is the basic principle of

CO-AX

LOW LOSS CABLES

Unequaled

H.F. PROPERTIES

From the complete range MAY BE QUOTED:

Character impedance ohms	Capacity microfarads per foot
100	2.61
150	3.2
200	3.7
300	4.2
400	4.7
500	5.2

TRANSRADIO LTD. Inc. TELEQUIPMENT CO. 16 HIGHWAY, BEACONSFIELD.

**TUCKER
EYELETS**



AND TAGS

GEO. TUCKER EYELET CO. LTD.

WALSALL ROAD, BIRMINGHAM, 22

Phone: BIRchfields 5024

SHAW'S

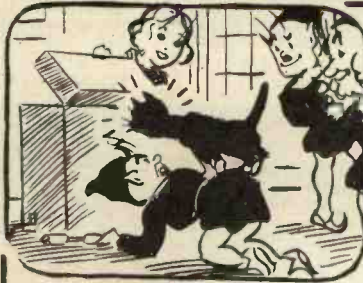

**THE "FLUXITE QUINS"
AT WORK**

"Music? Well, I'll eat my hat!
FLUXITE'S a grand cure for that
Those squeaks—they're not
mice
They'll be gone in a trice
But for goodness sake call off this
cat!"

For all **SOLDERING** work—you need **FLUXITE**—the paste flux—
with which even dirty metals are soldered and "tinned." For
the jointing of lead—without solder; and the "running" of
white metal bearings—without "tinning" the bearing.

It is suitable for **ALL METALS**—excepting **ALUMINIUM**—and
can be used with safety on **ELECTRICAL** and other sensitive
apparatus.

**With Fluxite joints can be "wiped" success-
fully that are impossible by any other method**

Used for over 30 years in Government Works, and
by leading Engineers and Manufacturers, OF **ALL
IRONMONGERS—IN TINS—8d., 1/4 and 2/8.** Ask
to see the **FLUXITE SMALL SPACE SOLDERING
SET**—compact but substantial—complete with
full Instructions, 7/6.



The "**FLUXITE
GUN**" puts
FLUXITE where
you want it by a
simple pressure.
Price 1/6, or
filled 2/6

ALL MECHANICS WILL HAVE

FLUXITE

IT SIMPLIFIES ALL SOLDERING

Write for Leaflets on **CASE HARDENING STEEL** and **TEMPERING TOOLS**
with **FLUXITE** also on "**WIPED JOINTS.**" Price 1d. each.

FLUXITE LTD. (Dept. T.V.) Bermondsey Street, London, S.E.1

HEWLETT-PACKARD

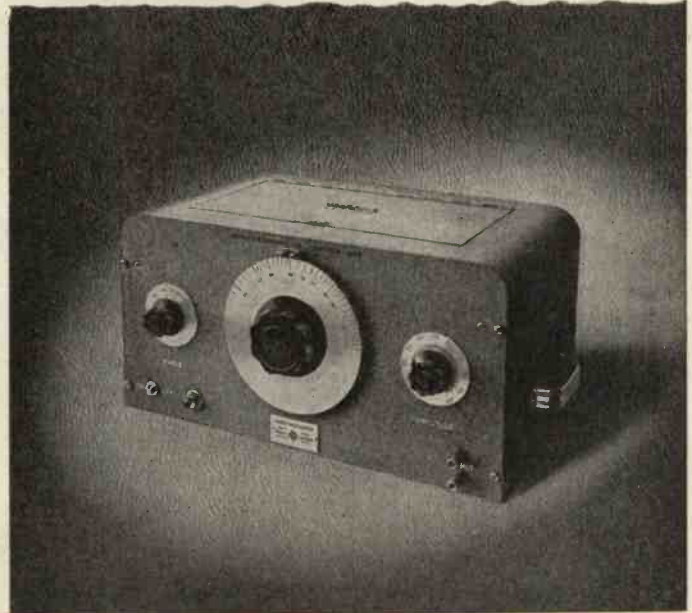

**LELAND
INSTRUMENTS LTD.**

**Resistance Tuned Oscillators
Model 200, covers the Frequency
Range of 7-200,000 cycles per second
Write for full details of the series.**

**21, JOHN ST., BEDFORD ROW,
LONDON W.C.1.
TELEPHONE: CHANCERY 8765**

CLOUGH-BREngle • BOONTON • FERRIS • BALLANTINE • HEWLETT-PACKARD

Parke

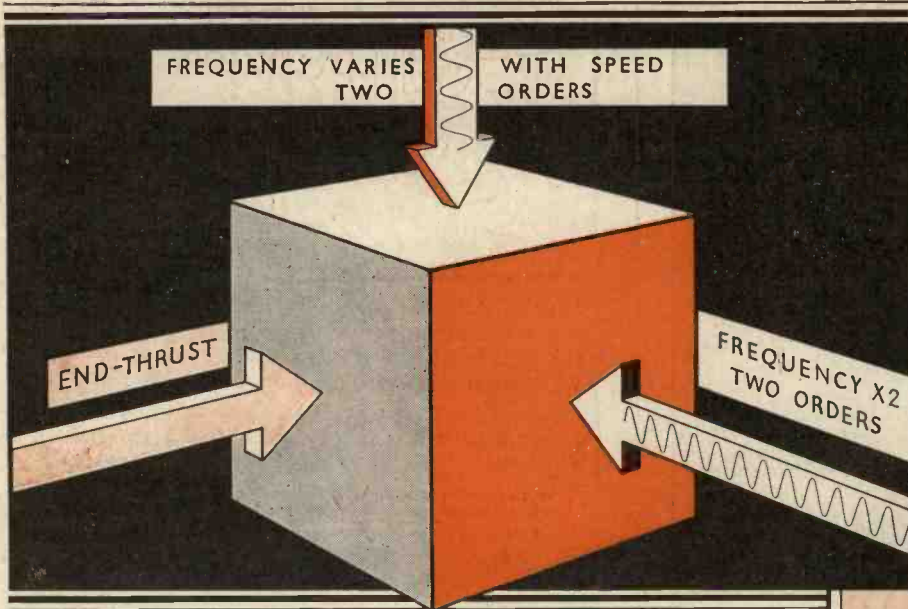

Vibration problems that we solve [No.2938]

Vibration problems are rarely simple; here is a typical one. A Diesel-engine-driven generator set, mounted in a vehicle, produced vibrations damaging to pipe work and mechanical connections, and extremely irritating to the occupants of the vehicle.

An unsuccessful attempt to insulate had already been made before we were called in.

Testing with vibration meters and cathode-ray oscillograph we found a large amplitude half-order harmonic of engine speed, also a third-order harmonic—both in a vertical plane—and a smaller component parallel to the axis of rotation.

Our accumulated experience in design enabled us to solve this problem completely, introducing special mountings which provided effective insulation and also the necessary constraints against shock and acceleration.

*Our experience is likewise at your disposal
Metalastik Ltd., Leicester.*

The 'Cross'-type anti-vibration Mounting; ingenious construction gives equal areas of rubber-to-metal weld on both elements. Used for a great variety of frequencies and sizes, and for loads ranging from 1 lb. to 1 ton.



Double 'U' mounting using rubber in shear. Very simple to install, slips under bolt heads. Used in great range of frequencies and sizes.



The Equi-Frequency mounting is a patented Metalastik design giving equal spring rates and natural frequencies along all axes. It is especially useful for complex cases with vibrations in several planes. Made for a range of loads and stiffnesses.



METALASTIK

SPECIALISTS IN CONTROLLING MOVEMENT IN THREE DIMENSIONS