

Vol. 3 OCTOBER 1930 No. 32 <sup>10<sup>00</sup></sup> 25 CENTS MONTHLY

# TELEVISION

A  
**VISION  
WIRELESS  
RECEIVER**

See Inside



THE WORLD'S FIRST TELEVISION JOURNAL.

**VOLUME II**  
*WE CAN SUPPLY*  
**“TELEVISION”**  
**VOL. II**

Handsomely Bound in rich brown imitation leather,  
morocco finish, lettered in gold on front and spine,  
complete with index

**PRICE 12/6 post free**

**BOUND VOLUMES**

are preferable to a loose collection of well-thumbed  
and worn individual copies of a magazine.

This is a unique opportunity for you to  
obtain a *handsome* and *permanent* record  
of the second volume of the

**WORLD'S FIRST TELEVISION JOURNAL**

ALSO AVAILABLE for those who wish to  
have their own copies bound :

*Brown Cloth Binding Cases*, lettered in gold on  
front and spine, and index

**PRICE 4/6 post free.**

There are a few Bound Copies of Vol. I “Television”  
still available. Secure yours by ordering immediately.



*Apply to* TELEVISION PRESS, LIMITED  
505, CECIL CHAMBERS, STRAND, LONDON, W.C.2

# Principal Contents

	PAGE
THIS MONTH'S CAUSERIE . . . . .	315
MY FIRST TELEVISION IMAGE . . . . .	By H. J. Barton Chapple 316
THE KERR CELL . . . . .	By Colin P. Garside 319
A VISION WIRELESS RECEIVER . . . . .	By William J. Richardson 322
TELEVISION AT THE BERLIN RADIO EXHIBITION . . . . .	By Dr. Alfred Gradenwitz 327
TELEVISION FOR THE BEGINNER.—PART X. . . . .	By John W. Woodford 329
THE ENTHUSIAST SEES IT THROUGH . . . . .	332
SELECTIVITY AND MODULATION RESPONSE.—PART II. . . . .	By R. S. Spreadbury 336
THE EXHIBIT OF THE FERNSEH A.G. . . . .	338
THE CRYSTALLISATION OF SELENIUM.—PART I. . . . .	By James Scott 342
TELEVISION BELOW 100 METRES . . . . .	By B. Marshall 345
LETTERS TO THE EDITOR . . . . .	348



**Cut out this Order Form and hand it to your Newsagent.**

To Mr. ...., Newsagent.

Address .....

*Please deliver to me at the address given below a copy of TELEVISION for November, and monthly thereafter until countermanded.*

Name .....

Address .....

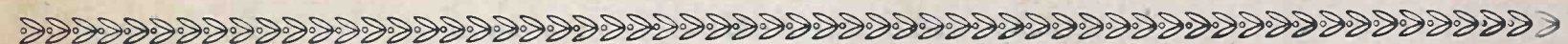

# The following is a LIST of some of the PRINCIPAL STOCKISTS of Baird "Televisor" Receivers and Branded Components.

- "Aldertons"**  
8, Bank Parade, EDGWARE, MIDDLESEX.
- Bannister & Fitton,**  
27, Milnrow Road, ROCHDALE.
- Barbrook Bros. & Co.,**  
St. Peter's Street, IPSWICH, SUFFOLK.
- Barnsley British Co-Op. Society, Ltd.,**  
New Street, BARNSELY.
- The Battery & Dynamo Co.,**  
124, North End Road, LONDON, W.14
- T. Beadle & Co.,**  
3/5, Castle Street, HULL.
- F. T. Bennett,**  
Rue de Pre, Park Street, CONTREE MANSELL, GUERNSEY.
- H. Binns, Son & Co., Ltd.,**  
SUNDERLAND.
- "B.N.B." Wireless, Ltd.,**  
80, Castle Street, BELFAST, N. IRELAND
- "B.N.B." Wireless, Ltd.,**  
65, Renshaw Street, LIVERPOOL.
- Brown Bros.,**  
Great Eastern Street, LONDON, E.C.2,  
and all Branches.
- Fred. Burris & Sons, Ltd.,**  
7/16, Redcliffe Street, BRISTOL.
- R. Cadisch & Sons,**  
50/58, Eagle Street, W.C.
- Messrs. Caversham Motors,**  
CAVERSHAM, READING, BERKS.
- Cole Bros., Ltd.,**  
Church Street, SHEFFIELD.
- Colwyn Charging Works,**  
OLD COLWYN, NORTH WALES.
- Consulting & Radio Service, Ltd.,**  
47, Hope Street, GLASGOW.
- J. H. Cook,**  
49/51, Monks Road, LINCOLN.
- Frank Crocker,**  
Wireless Corner, TORQUAY.
- R. Darbyshire (Wholesale), Ltd.,**  
2, St. John's Walk, BLACKPOOL.
- A. J. Dew & Co.,**  
34, Rathbone Place, Oxford Street, W.1.
- Downes & Davies,**  
1/3, Stanley Street, LIVERPOOL.
- J. Dyson & Co., Ltd.,**  
5/7, Godwin Street, BRADFORD.
- The East Ham Wireless Supplies,**  
427, Barking Road, East Ham, E.6.
- J. J. Eastick & Sons,**  
Eelex House, 118, Bunhill Row, LONDON, E.C.1.
- Ecco Radio,**  
Ecco House, Princes Street, Edgware Road, N.W.8.
- Economic Lighting Stores,**  
24, Fulham Palace Road, W.6.
- S. Evans & Sons, Ltd.,**  
King Street, MAIDENHEAD.
- F.A. Wireless Co.,**  
11, Market Row, GT. YARMOUTH.
- Flinders (Wholesale), Ltd.,**  
East Stockwell Street, COLCHESTER, ESSEX.
- A. Franks (Wholesale), Ltd.,**  
3, South Kings Street, MANCHESTER.
- Galliers, Ltd.,**  
167, North Street, BRIGHTON.
- A. W. Gamage, Ltd.,**  
Holborn, LONDON, E.C.1.
- The Guaranteed Accumulator Co.,**  
7, Station Road, WEALDSTONE.
- Harrods, Ltd.,**  
Knightsbridge, LONDON, S.W.1.
- Henshall Bros.,**  
89, Lower Hillgate, STOCKPORT, LANGS
- Hobday Bros., Ltd.,**  
Turner Street, MANCHESTER.
- Henry Hollingdrake & Sons,**  
STOCKPORT, LANGS.
- Houghton, Butcher, Ltd.,**  
High Holborn, LONDON, W.C.
- Lampitt & Elliott,**  
8, Stratford Road, WOLVERTON, BUCKS.
- L. Leaman,**  
97, Northfield Avenue, LONDON, W.13.
- Lipton,**  
614, Oldfield Road, Bow, E.
- Messrs. F. Llewellyn & Co., Ltd.**  
CLACTON-ON-SEA, ESSEX.
- B. W. McCallum,**  
8, Scots Street, PERTH.
- H. R. Moore, Ltd.,**  
Northgate End, BISHOPS STORTFORD.
- Mullard Radio Valve Co.,**  
Nightingale Lane, BALHAM.
- Mundy,**  
45, Eastcheap, LONDON, E.C.3.
- Major W. H. Oates, London Lagonda Service Depot,**  
195, Hammersmith Road, LONDON, W.6.
- The Palmers Green Radio Service,**  
15, Melbourne Parade, Palmers Green, N.13.
- Partridge & Mee,**  
26, Dover Street, LEICESTER.
- C. A. Paterson & Son,**  
Hornchurch Road, ROMFORD.
- Payne & Hornsby, Ltd.,**  
7, St. Andrew's Buildings, Gallowgate, NEWCASTLE-UPON-TYNE.
- J. N. Piper,**  
118, Union Street, ABERDEEN, N.B.
- Pulford Bros., Ltd.,**  
102, Whitechapel, LIVERPOOL.
- Frank Riddiough & Son,**  
Simes Street, Westgate, BRADFORD.
- The Saxon Radio Co.,**  
Henry Street Works, BLACKPOOL, LANCs.
- Messrs. Selfridges,**  
Oxford Street, W.1.
- Sellers,**  
Standard Buildings, LEEDS.
- Shrosbury & Bakewell, Ltd.,**  
Crouch Street, COLCHESTER.
- Singer,**  
397A, Edgware Road, LONDON, N.W.
- The South Wales Installation Co.,**  
Edward Street, CARDIFF, WALES.
- Messrs. J. H. Sparkes,**  
55, High Street, GUILDFORD.
- J. H. Taylor & Co.,**  
Macaulay Street, HUDDERSFIELD, YORKS.
- Thompson's,**  
Radio House, St. Helier, JERSEY, CHANNEL ISLANDS.
- Thomson & Brown Bros., Ltd.,**  
20, King Street, DUNDEE.
- Tomlinson's,**  
Egyptian House, PENZANCE.
- Victors (Cambridge), Ltd.,**  
36, Petty Cury, CAMBRIDGE.
- Walker & Sons,**  
1/2, Marine Terrace, MARGATE.
- Walker's Wireless,**  
Northumberland Street, NEWCASTLE-UPON-TYNE.
- Messrs. Whiteley, Ltd.,**  
Queen's Road, LONDON.
- Wilrose & Co.,**  
42, Church Street, BIRMINGHAM.
- Wycombe Electrical & Radio Supplies,**  
51, Oxford Street, HIGH WYCOMBE, BUCKS.

## BAIRD TELEVISION, LTD.

133, Long Acre, W.C.2

# TELEVISION

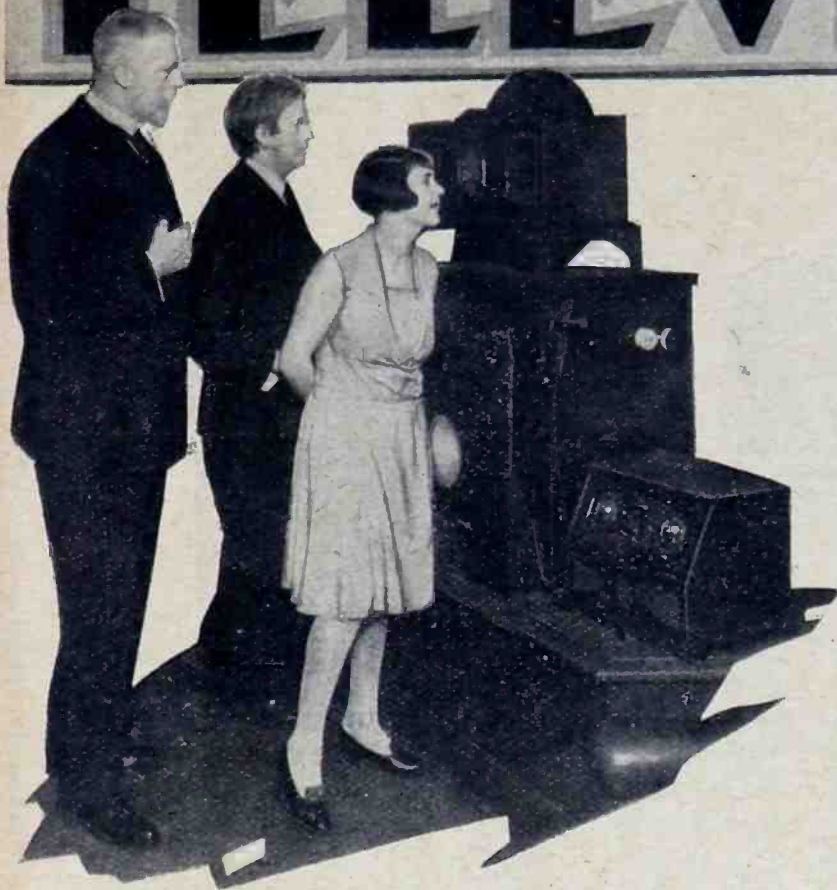

## THE OFFICIAL ORGAN OF THE TELEVISION SOCIETY

SYDNEY A. MOSELEY, *Managing Editor.*

Consultants { C. TIERNEY, D.Sc., F.R.M.S.  
W. J. JARRARD, B.Sc., A.R.C.S., A.I.C.

VOL. III] OCTOBER 1930 [No. 32

## THIS MONTH'S CAUSERIE

THE optimistic references which we made in the last issue of the magazine relative to the screen demonstration at the Coliseum are fully justified, judging not only by the unanimous chorus of approval, but by something more concrete.

The Baird Company informs us that it has received offers for the exhibition of this screen both in this country and abroad, and it has decided to accept the offers made from Germany and France.

As we go to press we understand that the Exhibition in Berlin is as great a success as the London demonstration. Early in October the screen is to be sent to Paris, and, after that, it is a matter for the Baird Company to decide which other country shall have the privilege of witnessing one of the most remarkable scientific demonstrations ever given to a public audience in any part of the world. We repeat that it is highly gratifying

that this invention is a British invention, but no achievement is ever made public without a counter-claim being received from our energetic "cousins," the Americans.

There comes a report to us from Schenectady that a similar demonstration was given in that part of the country. We have made full enquiries into this claim, and discover that the statements are very much in dispute. These enquiries were instituted in many quarters, and the strange thing is that the reports are so varied and contradictory as to leave one in doubt as to what actually happened. This certainly cannot be said regarding the demonstration at the London Coliseum. Here, tens of thousands of people saw for themselves, in their own time and under their own conditions

—from the gallery—from the stalls—and from the boxes—the television transmission that was so widely advertised and acclaimed throughout the world.

(Continued on page 340.)

*Editorial, Advertisement & Publishing  
Offices :*

Television Press Ltd.,  
505, Cecil Chambers, Strand,  
London, W.C.2.

Telephone: Temple Bar 8169.

Subscription Rate, 7/6 per annum, Post Free.

American Rate, \$2.50 per annum, Post Free.

MSS. and other material for Editorial consideration should be accompanied by a stamped addressed envelope, and should be typewritten.

*Entire Contents of this Journal copyright in the U.S.A., 1930, by Television Press Ltd.  
Foreign Translation Rights Reserved.*

# My First Television Image



A RETROSPECTION

BY

*H. J. Barton Chapple,*

Wh.Sch., B.Sc. (Hons.), A.C.G.I.,  
D.I.C., A.M.I.E.E.

“OFF with the old love, on with the new,” is an expression which in its literal sense savours somewhat of the rash action of irresponsible youth. In a modified form, however, say rather as a *bringing together* of the old love and the new, I think it will describe my attitude towards that newest of wonders—television.

For years my interest was centred in radio, and in those days this was accepted as implying “sound radio.” When I heard the first wireless signals that I managed to pick up I was thrilled, for it marked the culmination in practical form of the theories I had studied and taken to heart. Of course at that time we had valves with bright filaments and component parts which, although boasting of an exorbitant price, suffered badly from a low efficiency. The progress of sound radio could not be arrested, and inefficiency (coupled with thrills and pioneering efforts) gave way to efficiency (and for many a relegation into the commonplace).

## *Still a Wide Interest*

This present feeling is attributable, I suppose, to the simplification of wireless, in so far as the reception of, say, alternative broadcast programmes is concerned. To the keen radio man there is still an enormous amount of work which he can undertake and thus retain his early interests. These were my feelings on the matter, and that interest has never wavered and is as much to the fore to-day as it was several years ago.

There is a modification, however, and this has been brought about through the satiation of my desire to become conversant with a subject which ultimately may alter the whole aspect of our everyday life just the same as sound wireless. When I first read in the press of Mr. Baird’s exploits I must admit that I felt somewhat sceptical, but in 1928, a year in which Baird achieved so many epochal performances, I decided to investigate matters for myself.

I felt convinced that the wedding of sight and

sound was of paramount importance, for by its aid one could convey complete intelligence. One without the other was only half the story, and whether viewed from the educational, utilitarian, commercial or entertaining angle the whole scheme had everything in its favour. Of course, while I appreciated that sound broadcasting had reached a wonderful state of perfection I realised that it would be some time before this sister science of vision broadcasting could, with honesty, claim to be on a similar level. One fact was perfectly clear. The amateur pioneers of sound broadcasting had, as a band of enthusiastic workers, rendered untold service and expedited the day when wireless was made available to a public counted in millions.



*The McMichael “Dimic Three” receiver which was used by the author when receiving his first television image.*

## *Initial Experiments*

Surely the same co-operation could be effected with television was the thought that came to my mind. One manifestation has shown itself in the growth of the Television Society, and there is now ample evidence of the interest which television has aroused amongst amateurs not only in this country but abroad.

Let me get back though to my acquaintance with television made early in 1928. The details concerning

suitable apparatus were scant, while the type of wireless receiver necessary to pick up the Baird experimental broadcasts made through their own station had to be found out by actual testing. Far from being a deterrent, this situation merely served as a stimulus, and I set to work. The television apparatus that I employed was of a rather bulky character, but that did not matter so long as it was capable of delivering the goods.

At the time I had been conducting some special tests on a McMichael Dimic Three Receiver, and since it had given such excellent results I decided to use this receiver for my first vision tests. The set consisted of a screened grid stage of high frequency, a leaky grid detector, and a pentode output valve coupled to the detector by a first-class low-frequency transformer. While appreciating that this set was in the first rank for receiving sound broadcasting, I knew it would be necessary to modify the low-frequency side for handling the television signals.

### *Special Amplifier*

I therefore made up a resistance capacity coupled low-frequency amplifier and joined this to the detector valve. While this arrangement was essentially an experimental hook-up, I was keen to make my first try-out a successful one if at all possible, and I spared no effort in adopting every precaution. The apparatus was arranged so that I could tune-in the television signals on the loud-speaker—in those days it was called the "Stookie Note," since an immortal dummy generally served as the first "artist" in these experimental broadcasts—and then switch over to the vision apparatus.

At long last I had everything ready. I was aglow with excitement, but while waiting for the scheduled transmission to commence my mind ruminated on several points which bid fair to upset my equanimity. "Were the batteries likely to give out at the crucial moment?" "Had I joined up all my leads correctly, for they looked a veritable maze of wires?" "Was there any likelihood of local interference from neighbouring oscillators?" etc. Subsequent events proved that my fears were unfounded, but how was I to know that?

"Zero hour" arrived, and I switched on my Dimic Three Receiver, amplifier, and vision apparatus. Yes, the signals were there and, as far as my ear could judge, were coming through splendidly. Over went the switch and my eyes became glued to the aperture through which I watched the neon being scanned by the rotating disc. A whirl of reddish orange dots greeted me, so I at once adjusted the motor speed. These rapidly moving dots began to take on a more definite shape, and as the motor approached the proper speed—namely, 750 revolutions per minute—I could detect images moving downwards.

### *Like Archimedes*

The drift gradually slowed down, and I became aware of the fact that a weird-looking face was gazing at me from the back of the viewing tunnel. My excitement was now at fever pitch, and after careful adjustments on both the motor and receiver controls I was rewarded with my first television image. It would be

foolish to say that it was perfect; no one realised that more than I did, but that in no way detracted from the feeling of intense satisfaction which I felt at that moment. Archimedes is quoted as having said "Eureka, I've found it," when in his bath he established one of the well-known principles associated with his name. I felt like shouting "Eureka, I've done it," when I saw my first television image.

Subsequent experiments showed where improvements could be effected in the receiving apparatus and far superior images thereby obtained, but I shall



*Experimental television apparatus as used by the Baird engineers in those earlier days such as referred to by the author in his article.*

always cherish the memory of that grinning dummy's face that served as my formal introduction to Baird television. I am sure that readers of this journal experienced similar sensations when they saw their first image, and the earlier one's association with the work the greater is the progress that can be noted.

Pioneering work of any description provides one with a wonderful experience, and in the case of television one is rewarded by the knowledge that the results will be of far-reaching importance. Even now there is comparatively little material available on which to base efforts, so that it is incumbent upon the individual to keep a very true record of all his experiments in a log book.

Note the effects of every alteration made in either the wireless or the vision apparatus, for in this way your work will become of more value not only from a personal motive, but from the collation of results in different districts, when television workers congregate together to discuss the science in all its aspects.

Undoubtedly, television has come to stay, and while not wishing to prognosticate it is to be hoped that every avenue will be explored for its use, both nationally and internationally.



# Our Competition Prizewinner is presented with his "Televisor"

ON September 4th a happy little ceremony took place, for Mr. H. J. Jeakings was presented with the Baird "Televisor" which he won in our recent competition. So that Mr. Jeakings could be televised for a few moments the function was staged in the Baird Company's offices at Long Acre, and Mr. Moseley, in a few well-chosen words, handed over the "Televisor" and congratulated the recipient on his splendid efforts. They then passed into the studio, and Mr. Jeakings had the experience of knowing that his image was broadcast into space for all to see.

We print below a letter as received by us from the gentleman in question, together with an extract from the local newspaper:—

"I wish to thank you for the 'Televisor' which you kindly presented me with on Thursday last, also for the interesting time spent at the Baird Studio. It certainly is a very interesting experience to be televised, and I am pleased to say that all my friends in Bedford were able to see and recognise me quite easily.

"Since my visit I am more than ever convinced that television has definitely come to stay; all that is needed now are longer transmissions to make it as popular as ordinary broadcasting.

"I am enclosing a cutting from the *Bedfordshire Times and Independent*, which I think will be of interest to you. Again thanking you for your kindness."

"TELEVISION IN BEDFORD.

"Mr. H. R. Jeakings wins a Competition and is Televised.

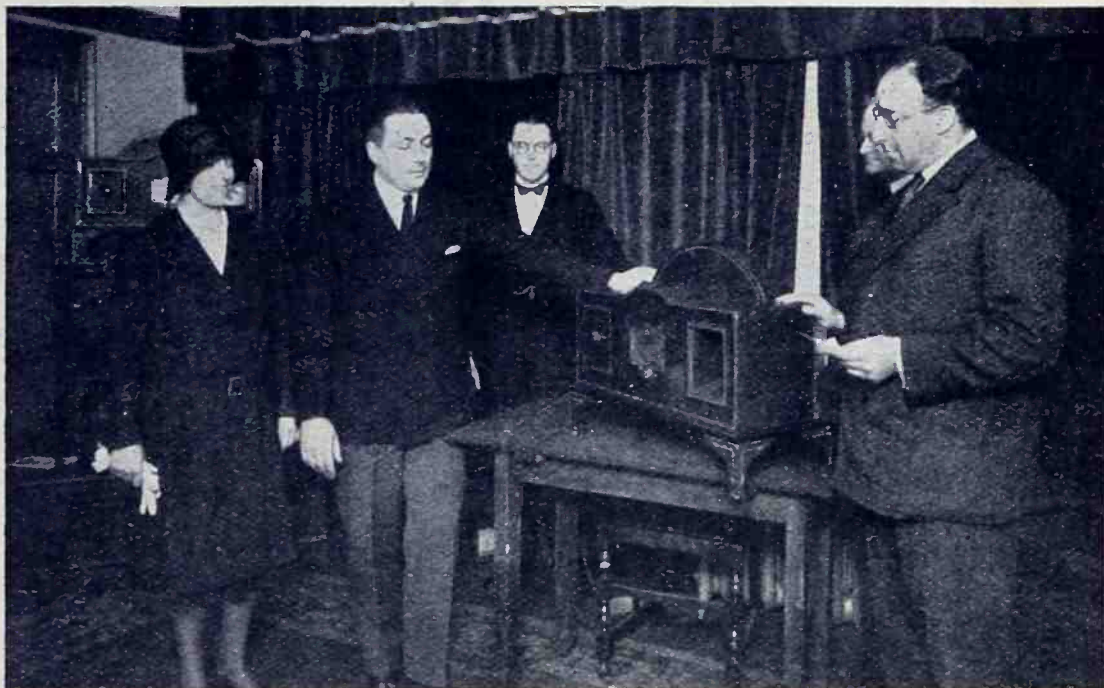

Mr. H. R. Jeakings being handed the Baird "Televisor" which he won in the successful competition we organised in our August issue.

"On Thursday morning a small gathering of the friends of Mr. H. R. Jeakings assembled in the wireless studio of Messrs. Jeakings and Son, Mill Street, Bedford, and saw Mr. Jeakings, by means of television, in London. Mr. Jeakings was the winner of a competition organised by TELEVISION which was broadcast during one

of the Baird Company's experimental transmissions on August 12th. He was presented with a Baird "Televisor" on Thursday, and after the announcement of the presentation had been made he came before the screen and made a short speech. His features were clearly recognised by his friends.

"Mr. Jeakings is one of the pioneers of television in Bedford, and in the short time in which he has been giving demonstrations to the public a marked improvement has been made in the clarity of the persons and objects broadcast."



# The Kerr Cell

By *Colin P. Garside*, Stud.I.E.E.

**N**OBODY will deny that one of the greatest problems to be faced in a television system lies at the receiving end, in the re-conversion of the luminous signal into light pulses.

By this time in the history of the development of television we must all be well aware of the limitations of self-luminous surfaces as light sources in the reproducer, where, for small scenes, the neon lamp has sufficed to give a sufficiently bright image, brighter perhaps than it is possible to secure by the illumination of a screen by a single light source which can be rapidly controlled as to its intensity, and distributed by a similar scanning mechanism.

There are two general methods by which the necessary modulation of the light can be brought about. The first is by applying the signal directly to the light source, where the power input actually produces the light, so that the intensity of the illumination effected is proportional to the amplitude of the luminous signal; or, secondly, the signal can be applied to a shutter of some sort intercepting a beam of light from a source of constant intensity; it is with the latter method that we are mainly concerned in this article.

## Requirements

The requirements of the light source or valve may be briefly set forth as follows:

First, and most important, it must have the necessary rapidity of response; secondly, the light produced or allowed to pass, respectively, must be adequate; and, thirdly, its characteristic must at least approximate to a linear one.

Fig. 1 gives the voltage illumination characteristic of a Kerr cell, while Fig. 2 shows the corresponding curve for a typical neon lamp—the ordinates plotted in milliampere units of current may be taken as representing intensity of illumination produced, this being a function of the current producing it.

It is known that the speed of response of both devices is, for all practical purposes, instantaneous, thus fulfilling the first requirement.

Referring to Fig. 1, it is seen that no light passes until the potential difference across the cell reaches some 300 volts. After this we have a fairly rapid rise in the light passed, strictly linear conditions being reached at the point *P* at about 700 volts, and obtain until the point *Q* is reached at 1000 volts. Then the light increases less rapidly with a maximum at about 1300 volts, and any further increase in voltage begins to reduce the light passed. From the foregoing it is evident that if we wish to operate over the full

length of the linear part, which for most purposes could be taken from *O* to *Q*, a D.C. bias will have to be applied, or, alternatively, as is done in picture transmission, a correction made elsewhere in the circuit.

Fig. 2 shows by way of comparison the well-known voltage-current characteristic of the neon lamp. The break-down potential of the gas for this particular lamp is reached at about 210 volts with a current of 2.8 m.a. From this point on the current, and therefore the intensity of illumination produced, increases linearly with respect to voltage up to the maximum of 300 volts. The curve shows that the current values depend to some extent upon the direction in which the voltage is changing, but for all practical purposes it may be taken as single valued.

## A Comparison

Summing up, we may make an interesting comparison between two fundamentally different devices

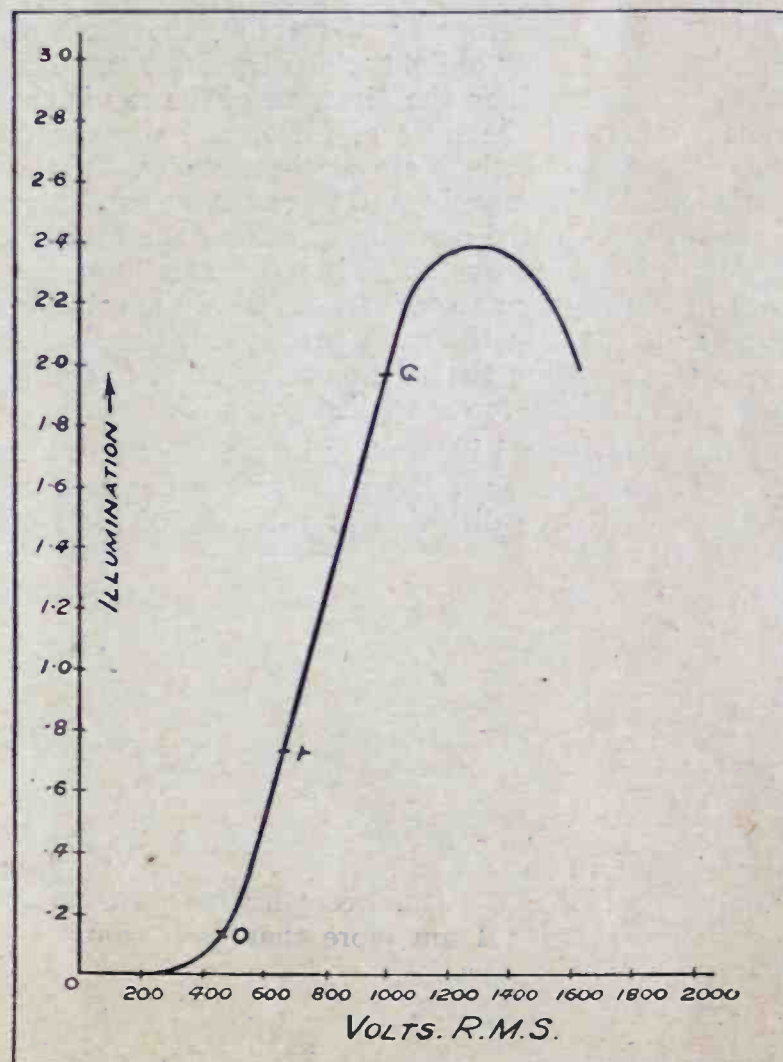

Fig. 1.—The voltage illumination characteristic of a Kerr cell.

performing the same function. In the transmission of an image the direct current component of the picture due to the general illumination of the subject, upon which the general tone value of the received image depends, is eliminated in the process of amplification from the photo-cell onwards, and therefore has to be reinserted at the receiver; both methods readily lend themselves to this requirement.

Referring back to the curves in Figs. 1 and 2, it is seen that the voltages required for the Kerr cell are of a much higher order than in the case of the neon lamp. These comparatively high voltages may be obtained conveniently from a suitably designed step-up transformer, for it is essentially a voltage-operated device, the only current which would be taken from the secondary being a very small capacity current due to the plates of the cell forming a small capacitance. In the neon lamp one is limited to the characteristic colour of the discharge through neon gas, which varies from orange to pink according to the purity and pressure of the gas, whereas in the Kerr cell the light projected through it may be varied at will, thus making it adaptable for colour television.

### Principles of Operation

It is now convenient to examine in some detail the principle by which the Kerr cell may be made to modulate a ray of light of constant intensity.

The operation of the Kerr cell depends upon the fact, fundamentally, that any substance, whether solid, liquid or gaseous, when placed in a magnetic field acquires the property of rotating the plane of polarisation of a ray of light which traverses it. The effect is greatest when the direction of the ray is the same as that of the lines of force, and disappears when the two directions are at right angles. If the ray is reflected back again, and traverses the substance a second time in the opposite direction, the rotation is doubled. Thus by increasing the length of the path of the ray by successive reflections the rotation can be increased in the same proportion, the significance of this being that the same rotation can now be obtained with a lower applied potential.

If an electric field be used as in the Kerr cell, the effect is greatest when the path of the beam is at right-angles to the direction of the lines of force of the electric field.

In practice the angle of the plates by which the electric field is applied (mentioned later) to the plane of polarisation of the ray is set at  $45^\circ$ , or, what is the same thing, the angle between the lines of force of the electric field and the plane of polarisation is  $45^\circ$ . This is because the voltage applied to the cell through the transformer being alternating, the maximum value of the positive half-cycle of the wave will rotate the plane the maximum possible amount in one direction, *i.e.*,  $45^\circ$ , and the negative half-cycle of the wave will rotate the plane of polarisation through  $45^\circ$  in the opposite direction.

Of the substances which show the Kerr effect in an especial degree perhaps the following are the best known: Faraday's heavy glass (borosilicate of

lead), certain sugar solutions, carbon bisulphide, and nitrobenzene. The latter is the substance used in the Kerr cell. It is prepared by the action of concentrated

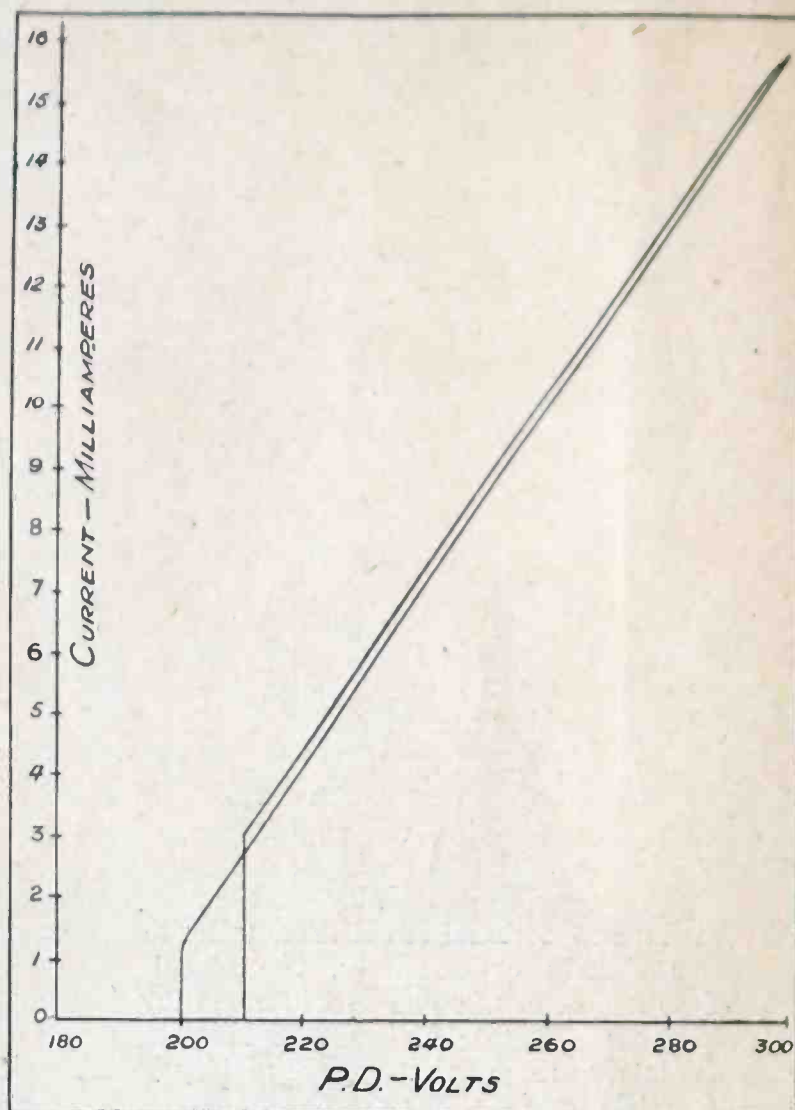
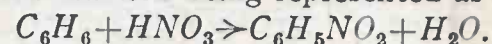

Fig. 2.—Compare this curve of a typical neon lamp with that for the Kerr cell.

nitric and sulphuric acids upon benzene ( $C_6H_6$ ) in the cold, the reaction being represented as follows:—



It has the peculiar smell of bitter almonds, and is pale yellow in colour. As it has been found that the liquid discolours in use, probably owing to the presence of impurities, it is contained, in the Kerr cell shown in the photograph, in a sealed tank, thus ensuring absolute cleanliness.

### A Light Valve

Let us now see how this property of substances to rotate the plane of polarisation of a ray of polarised light is applied in practice.

It is well known that certain substances possess the property of polarising light, that is, of being transparent to light vibrating in one plane only, and cutting out all the rest, thus it is clear that a ray of light, whose constituent waves are vibrating in every plane, will after passing through such a substance emerge polarised. These substances owe their property to their peculiar layer-like structure; tourmaline, a gem, is one such substance. Iceland spar, cut into a special form, and known as a Nicol prism, is another which has often been described in these pages.

Imagine a ray of light traversing a Nicol prism, it emerges polarised, and passes through a tank of nitrobenzene between two immersed metal plates to which the alternating voltage is applied, and strikes, on emerging from the liquid, a second similar Nicol prism, termed the analyser. The ray will now be able to pass through the analyser freely only if the polarising plane of the analyser coincides with that of the polariser. If now the analyser be rotated slowly about its polarising axis, it is evident that the light emerging from it will be gradually cut off, until, when the polarising plane of the analyser has been rotated through  $90^\circ$  no light at all will emerge. The Nicols are now "crossed," giving a dark field. Now when this condition obtains it is clear that any rotation of the plane of polarisation of the ray passing through the solution will bring about the same effect as rotating the analyser back towards its original position,

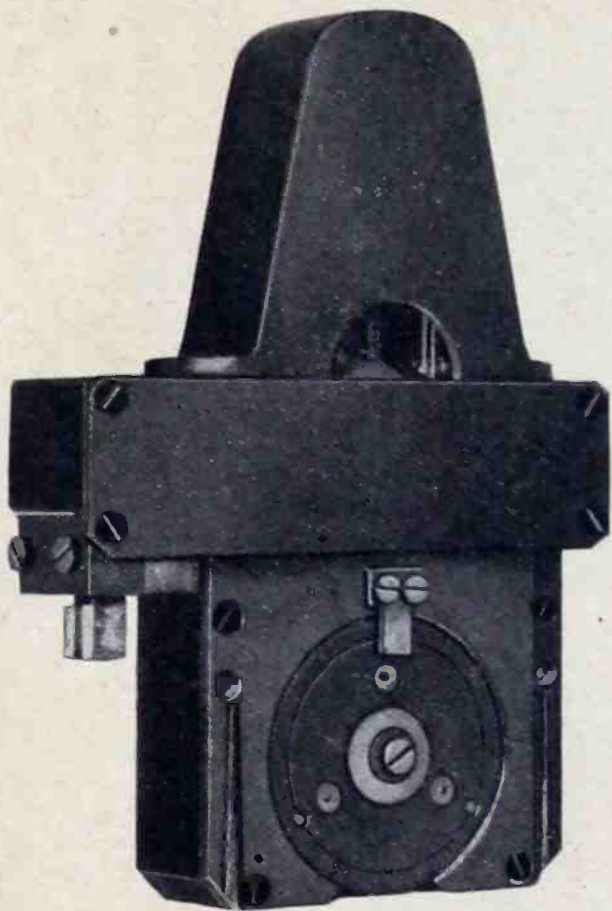

Photo. by courtesy of Siemens-Shuckert.

*A Kerr cell which acts as a light shutter at the receiving end.*

and this is brought about as we have seen by applying a potential to the plates. Let it be noted here that the rotation is not the same for all wavelengths of light for a given potential, but varies nearly as the inverse square of the wavelengths.

### *Electrodes*

The electrodes or plates of the cell have, of course, to be constructed of some metal which does not react chemically with the nitrobenzene in which they are immersed.

In the Simplex type of Kerr cell the electrodes take the form of two round metal rods separated by a

very small distance, between which the light is projected. The voltages applied to this cell are necessarily higher than that required in the multiplex type, where the electrodes consist of several interleaved metal plates of very small dimensions, rather like the plates of an accumulator. The light is projected endwise through the plates.

With respect to the power of the light available for projection through the cell for photo-telegraphy purposes for which the cell is extensively used, one may state 30 watts as being a fair average input to the incandescent lamp.

### *A Kerr Cell for Television*

In the designing of a suitable cell for television it is assumed that, as a beginning, a Nipkow disc will be used as affording perhaps the simplest means of image reconstruction.

Take as a basis of comparison the amount of light passing through the cell as that produced by the 30-watt incandescent lamp used in photo-telegraphy, and a cross-sectional area of the light path between the electrodes equal to  $.3 \times .3$  cms. =  $.09$  sq. cm.

The power input to a neon lamp giving sufficient illumination for a picture  $1$  in.  $\times$   $2\frac{1}{4}$  in. =  $2.25$  sq. in. is of the order of 5 watts. Let us suppose that the received image is to be  $6$  in.  $\times$   $10$  in. =  $60$  sq. in., then for the same illumination we shall need a power of some 500 to 1000 watts, assuming that only 20 per cent. of the total light produced emerges from the analyser. Now it is here that we see the very big gain of the Kerr cell over the neon lamp, for were a neon lamp used to illuminate this large screen, a large percentage of this power would have to be produced by the amplifier, whereas it is merely supplied by an incandescent or other lamp of constant intensity.

With respect to the electrodes, it is easily seen that, assuming, as indicated above,  $.09$  sq. cm. is adequate for the passage of the light produced by the 30-watt lamp, the cross-sectional area of the path between the electrodes will have to be increased some 20 times, giving us a path of  $1.5 \times 1.5$  cms., for equal densities of light.

If we wish to use light of various wavelengths for colour television, by interposing some such device as a synchronously rotating colour filter between the light source and the Kerr cell, it must be remembered, as indicated above, that the rotation is not the same for all wavelengths, but varies practically as the inverse square of the wavelength. It is seen, therefore, that the rotation of a ray of wavelength  $450$  m. $\mu$  is about twice that of ray of wavelength  $650$  m. $\mu$  for a given applied potential. Hence the rotation is greatest for the shorter wavelengths (violet).

The maximum operating potential generally used is of the order of 700 volts R.M.S., giving a peak voltage of about 1000 volts.

In conclusion, it is hoped that these few remarks may prove useful to readers, and inspire them to experiment with the Kerr cell themselves. Expense should be no barrier—there are other ways of polarising light than by the use of expensive Nicol prisms.

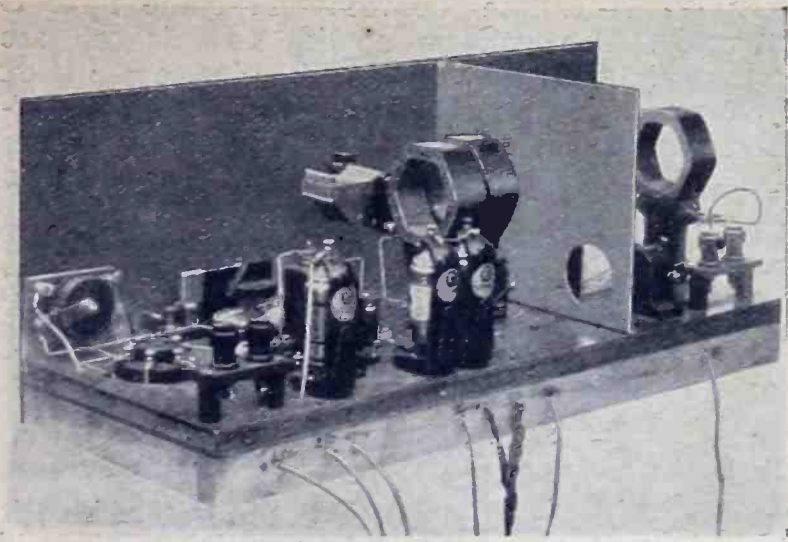

# A Vision Wireless Receiver

By *William J. Richardson*

**T**HE design and construction of wireless sets which have for their main object the successful reception of television signals so that they may be handed on to the vision apparatus for transformation into first-class images, has always been a fascinating hobby of mine. I have carried out numerous experiments both with mains and battery-driven receivers, and the pages of TELEVISION testify to some of the fruits of my labours, and I should like to thank those readers who have been good

enough to write and express their appreciation of the designs which have been described.

## *Within a Definite Radius*

Not long ago a case arose in which a friend of mine was anxious to receive the Baird television transmissions with only one stage of low frequency after his detector valve. From the standpoint of economy this had everything in its favour, and I determined

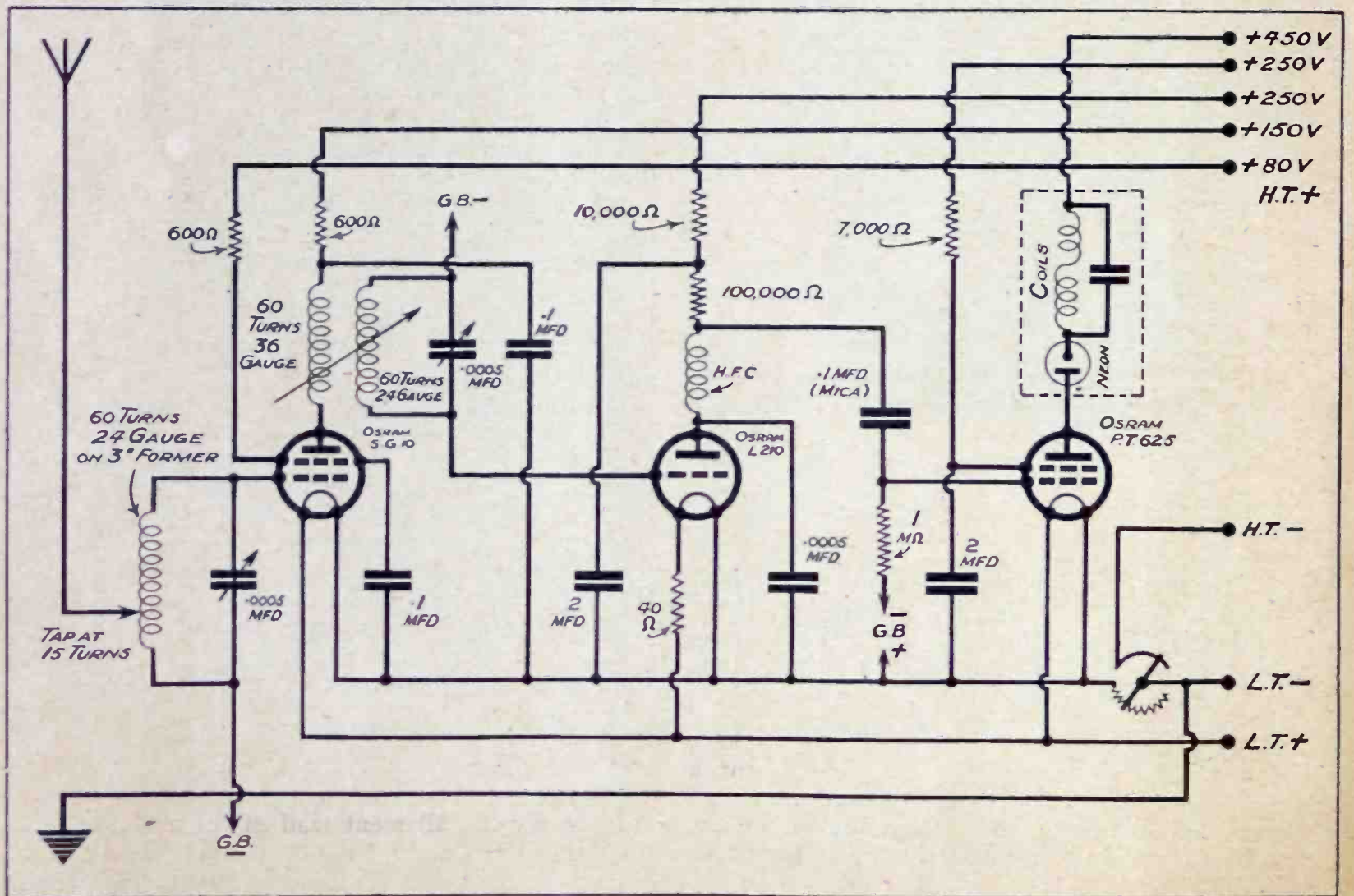

Fig. 1.—This is the theoretical diagram of the three-valve vision receiver which has given good results in the Baird television transmissions.

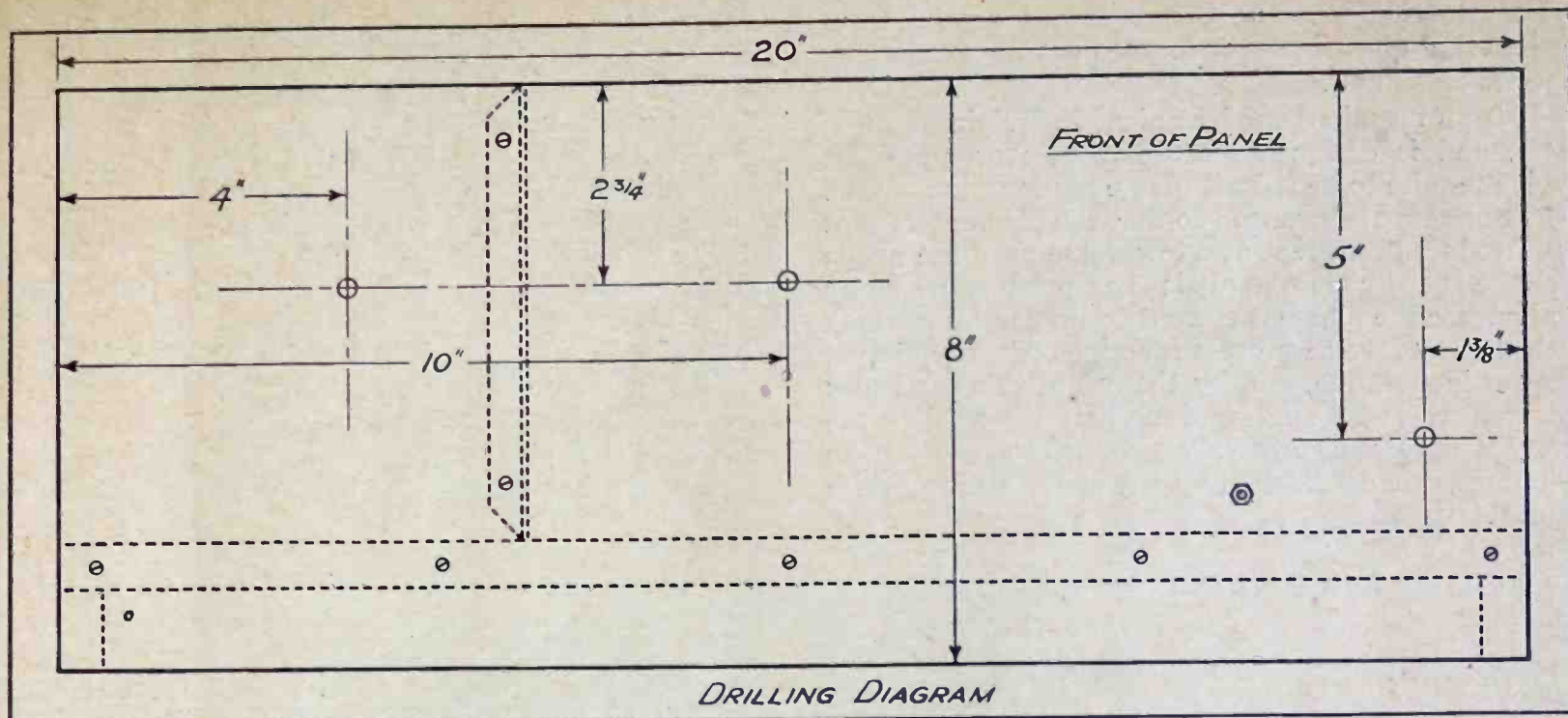

Fig. 2.—Only a few holes require to be drilled in the front metal panel, and these are shown above.

to put the matter to a test. Out of curiosity I lodged an inquiry with the Baird Company, and was furnished by them with a blue print of a three-valve battery-driven receiver in theoretical form. I learned that within a radius of twenty to thirty miles of the Brookman's Park station this set was capable of delivering an output power sufficient to work a "Televisor," not only to produce good images but also ensure the satisfactory operation of the synchronising mechanism when both the neon and synchronising coils were placed in series.

This met the needs of the case, and I proceeded to examine with care the diagram that had been placed in my hands. Except for the device for switching on and off the set, the schematic diagram is reproduced in its entirety as Fig. 1. Readers will see that all refinements have been cut down to a minimum in order to cheapen costs, while the specification of a pentode for an output valve was most interesting.

### The Circuit Analysed

Let us examine the circuit carefully. You will notice that three coils of 60 turns are specified, but since I had by me a stock of plug-in coils of the two-pin variety so popular two or three years ago, I thought I would use them as a trial and thus keep down cost still more. The tap on the aerial coil is to provide a measure of selectivity, while a negative bias is impressed on the grid of the high-frequency valve, simply by tapping into the grid bias battery provided for the low frequency end.

Personally, I do not favour this practice, as generally it entails long grid leads, which are likely to bring about unwanted oscillation. I prefer to mount a small  $4\frac{1}{2}$  volt battery close to the grid connection and bias from this. However, the scheme as shown did not give rise to instability and, as was stressed originally, economy without undue loss of quality is represented in this particular set. Both the high-

tension feeds to the screening grid and the plate of the S.G. valve are decoupled through 600 ohm resistances and .1 mfd. by-pass condensers.

### By-passing and Decoupling

The coupling to the detector valve is provided by an H.F. transformer arrangement and, in the set shown, this was carried into effect by the two plug-in coils, which are visible in the photograph included with the title. Anode bend rectification is, of course, employed.

In the plate circuit of the detector valve there is a high-frequency by-pass operating through the medium of the H.F. choke and .0005 mfd. fixed condenser. Next we come to the resistance capacity coupling to the output valve. A 100,000 ohm resistance is specified with a mica coupling condenser of .1 mfd. capacity, and a grid leak of 1 megohm. Decoupling is effected by the 10,000 ohm resistance and the 2 mfd. fixed condenser.

It is essential to include these refinements, as any tendency to feed back from the high-tension battery side would only cause motor-boating, and this would evidence itself in the resultant television image as thick vertical lines passing across the field of vision. Proceeding to the pentode valve we meet another safety decoupler in the 7,000 ohm resistance and 2 mfd. fixed condenser, the resistance being in the H.T. lead to the high potential grid. The dotted rectangle encloses the pictorial representation of the neon and synchronising coils belonging to the "Televisor."

### A Special Rheoswitch

Notice that a 40 ohm filament resistance is included in the positive filament lead of the detector valve. This is to cut down the voltage to that valve as a two-volt valve is specified for this position, whereas 6-volters are employed in the H.F. and L.F. stages.

Also attention must be drawn to the special rheo-switch that I have included for the purpose of switching the set on and off.

It is an ingenious product of A. F. Bulgin and Co., Ltd., and is designed for use in sets or amplifiers which require to be fed with large high-tension values. The contacts are arranged so that the filament current is introduced but kept at a low value until the anode voltage is switched on. It is then possible gradually to increase the filament current to its normal working value. The reverse process functions when rendering the set inoperative, and by the use of this particular component large surges of electrical potential are prevented. Damage to valves, transformer or choke windings, condensers, etc., therefore, cannot arise and this is an important factor of safety.

### Components Required

We come now to actual constructional details, and for the benefit of those readers who desire to duplicate the set in the form illustrated, I append below a list of the components employed, together with the manufac-

turers' names. If substitutes are preferred, then be sure that they are of good quality and can be accommodated in the panel and baseboard space allotted in the layout.

One Aluminium Panel, 20 in. by 8 in. by  $\frac{1}{16}$  in. (British Aluminium Co., Ltd.).

One Aluminium Cross Screen,  $7\frac{1}{2}$  in. by  $6\frac{1}{4}$  in. by  $\frac{1}{16}$  in., with two  $\frac{1}{2}$  in. lips (British Aluminium Co., Ltd.).

Two .0005 mfd. De Luxe Variable Condensers (Formo).

Two Vernier Dials (Formo).

One S.G. Valveholder and one Five-socket Valveholder (Whiteley Boneham).

One Anti-phonic Valveholder (Benjamin).

Three fixed Coil Holders (Burne-Jones).

Two 600 ohm Decoupling Resistances (Wearite).

One Binocular H.F. Choke (McMichael).

One .0005 mfd. Clip-in Condenser and Base (McMichael).

One 40 ohm Baseboard Resistance (Igranic).

One .1 mfd. Mica Condenser (T.C.C.).

Two .1 mfd. Mansbridge Condensers (T.C.C.).

Two 2 mfd. Mansbridge Condensers (T.C.C.).

One 1 meg. Dumetohm Resistance and Holder (Dubilier).

One Rheoswitch, Type A (Bulgin).

Three Wirewound Anode Resistances and Holders, 100,000 ohms, 10,000 ohms, and 7,000 ohms (Varley).

Four Insulated Terminals—Aerial, Earth, Output+, Output— and one S.G. Valve Safety Connector (Belling Lee).

Three Plug-in Coils (see text) (Lissen).

Quantity Glazite and Flex Wire.

Three Osram Valves—S.610, L.210, and P.T.625 (G.E.C.).

One Wooden Baseboard, 20 in. by  $7\frac{1}{2}$  in. by  $\frac{1}{2}$  in., with four Side Battens,  $1\frac{1}{4}$  in. deep.

### Making a Start

First of all screw the four battens to the underside of the baseboard, as shown in the illustration on this page. Then mark out and drill the panel according to the dimensions shown in Fig. 2. There is a hole in the cross screen to allow the screened grid valve to pass through and lay horizontal with its legs held in the sockets of the vertical valveholder. This should now be

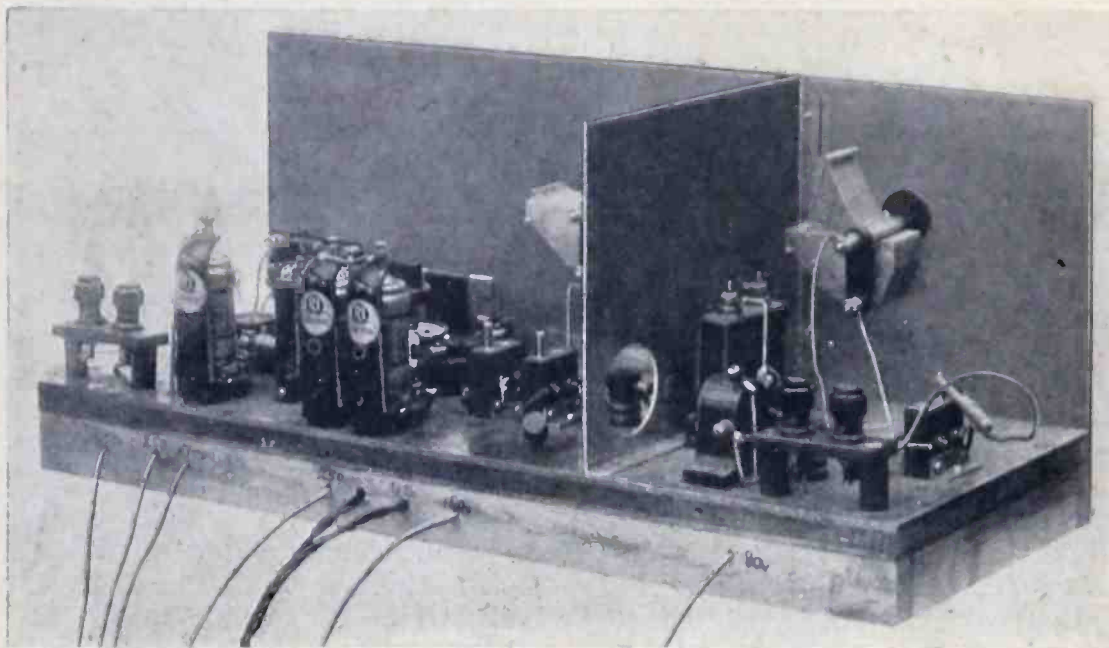

The general appearance of the set can be gathered from this illustration and it should be used in connection with the wiring diagram when laying out the components in position.

cut according to the following dimensions: diameter of hole  $1\frac{3}{4}$  in., distance of hole centre from baseboard edge of screen  $1\frac{3}{8}$  in., distance of hole centre from outside edge of screen  $1\frac{1}{2}$  in.

If suitable cutters are not available in order to cut out the hole direct then a circle should be scribed, and small holes drilled just within the circumference so as to cut away the centre. Then finish off with a half-round file. Having mounted the panel components in place, noting that the two tuning condensers are bushed with insulating washers, lay this on one side, together with the cross screen, and turn your attention to the baseboard.

The positioning of the components should not be a difficult matter if you keep before you the wiring diagram of Fig. 3 and the two photographs accompanying the article. Each item is marked carefully, and the reader is advised to adhere rigidly to the layout shown, as this will reduce the amount of wiring and ensure the satisfactory working of the receiver.

In the case of the S.G. valveholder, it will be necessary temporarily to fix the cross screen in place, pass the valve through the hole prepared, and push the legs firmly home into the sockets. Now hold the valve so that the screen just coincides with the

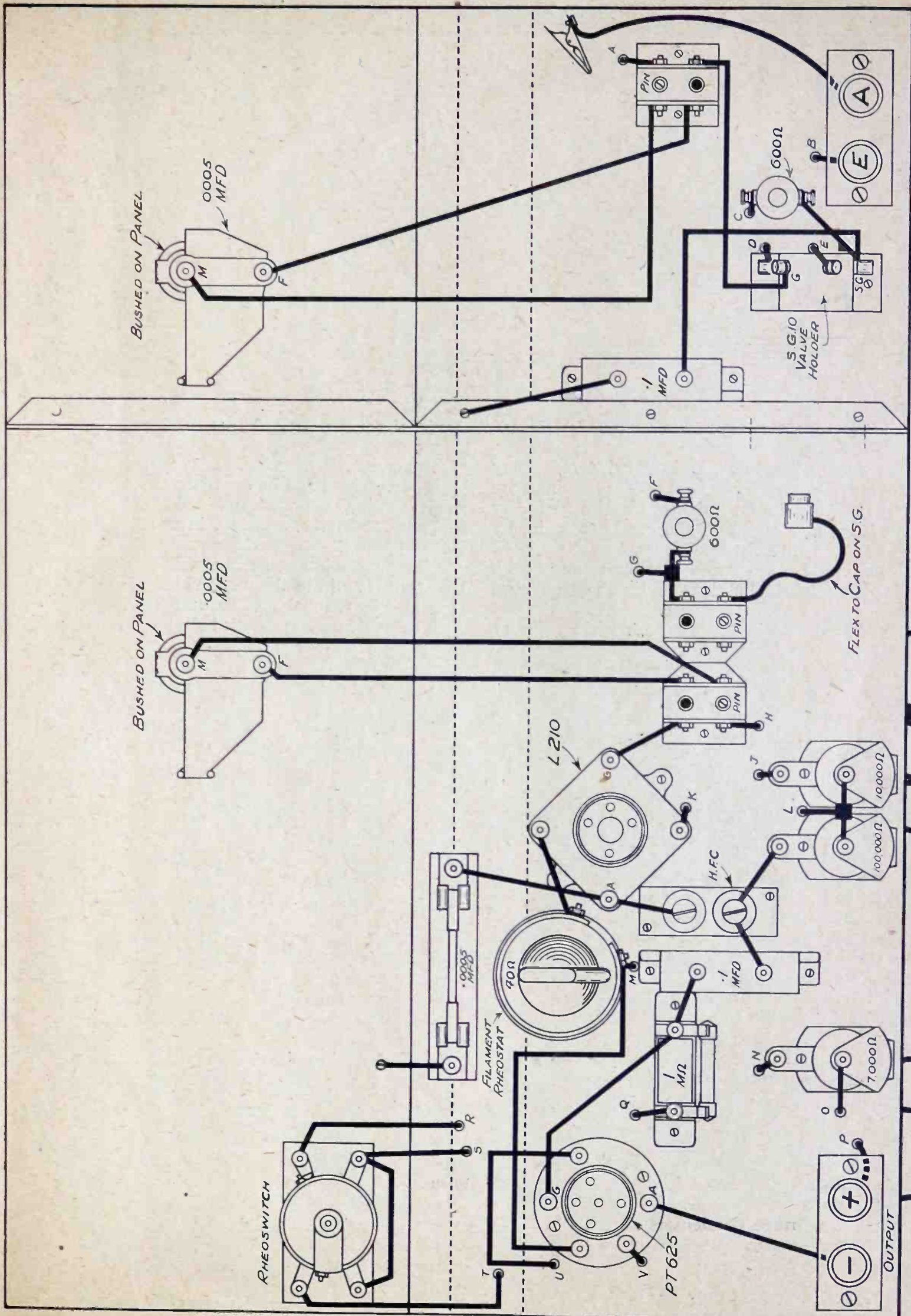

Fig. 3.—Complete back of panel and above baseboard wiring details.

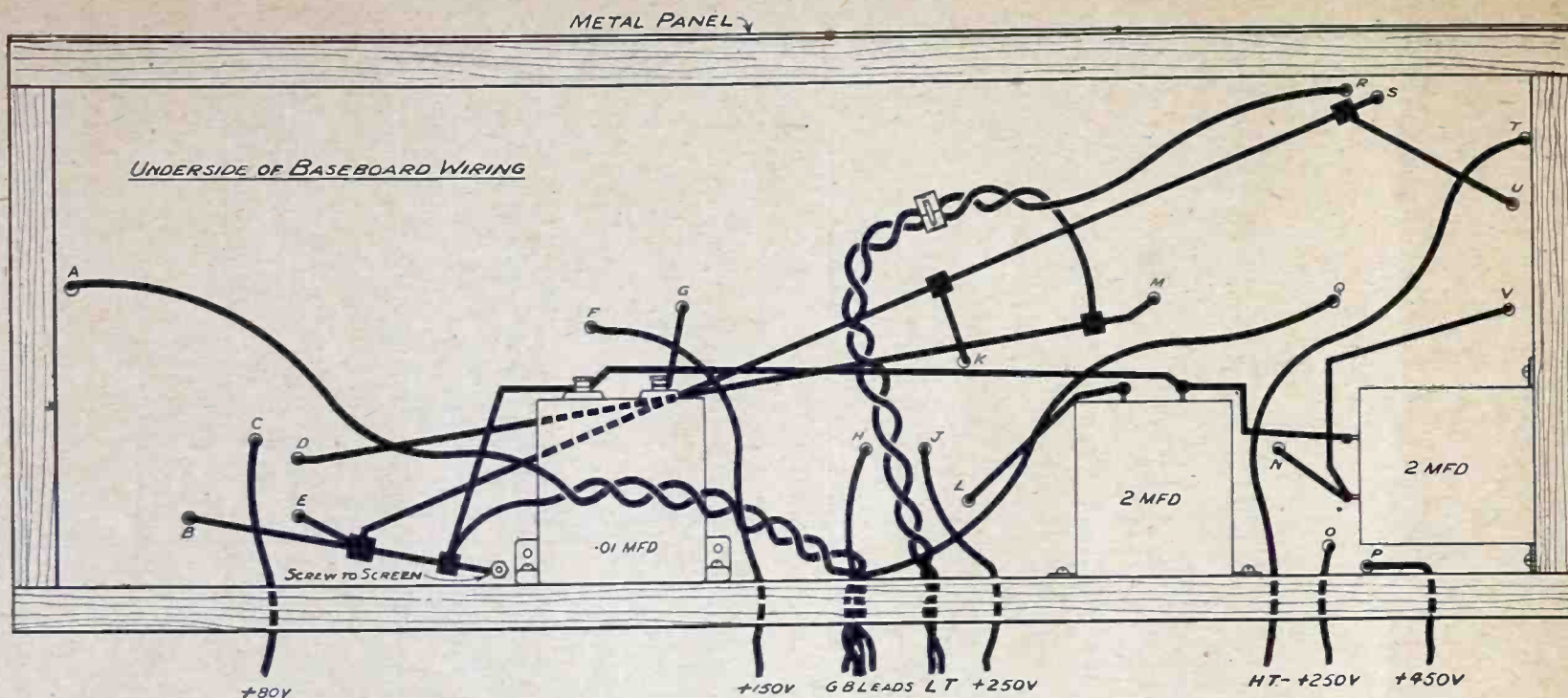

Fig. 4.—Several of the connecting wires pass right through the baseboard and these are all shown clearly in the diagram.

screening grid of the valve, and the valveholder may then be fixed down to the baseboard. The terminals are mounted in two pairs on strips of ebonite  $2\frac{1}{2}$  in. by 1 in. by  $\frac{1}{4}$  in., and raised off the baseboard 1 in. by means of four ebonite distance pieces.

Notice that there are two 2 mfd. and one .1 mfd. fixed condensers held in place under the baseboard by screws passing into the side battens.

All should now be in readiness for wiring. Carry out as much of this as possible on the baseboard alone before fixing on the panel and cross screen. Remember that there are a number of wires which pass right through the baseboard to connections underneath, the lettered holes indicating this in both Figs. 3 and 4. See that you do not damage any of the insulation on the Glazite wire, or if you prefer to use bare wire sheath it with Systoflex, where there is a danger of it touching other leads or the baseboard.

Since you are going to use fairly high voltages with this set it is as well to guard against any possibility of short circuits. All the flexible leads for connecting to the batteries are shown clearly in Figs. 3 and 4 and the illustrations, and can terminate in suitable plugs for insertion into the batteries. Make a real neat job of your wiring, and you will find the quality of your workmanship reflecting itself in the resultant "Televisor" image.

Before making any connections to the batteries check over your wiring to see that no leads have been omitted, and then prepare for a try-out of the receiver on the aerial. Set the detector filament resistance at 40 ohms and place the anode resistances, grid leak, and .0005 mfd. fixed condenser in place as Fig. 3. For the aerial position I used a No. 60 Lissen "X" coil with its two tappings, a No. 40 (or 60) coil in the plate of the screened grid valve, and a No. 60 coil in the grid of the detector valve. The three specified G.E.C. valves—S.610, L.210, and P.T.625—can now be inserted in their respective valve holders.

For grid bias I would suggest the following values:  $1\frac{1}{2}$  volts for the screened grid valve,  $4\frac{1}{2}$  to 6 volts for

the anode bend detector, and 12 to 15 volts for the pentode. These will be approximately correct for the high tension voltages specified in the theoretical diagram of Fig. 1, and also in the wiring diagrams, Figs. 3 and 4.

The 7,000 ohm resistance will drop the value on the pentode grid to about 200 volts, which is the value specified by the makers. Naturally slight adjustments can be made on test to suit individual conditions, but a plate current of at least 20 milliamperes is necessary in the output valve plate circuit.

It is advisable, first of all, to try out the set on a loud-speaker, and this is always quite straightforward. There are only two condensers to tune, the set being switched on and off through the special rheoswitch mentioned earlier. If the signals from the Brookman's Park Regional Station are strong and of good quality, then the loud-speaker may be replaced with the "Televisor," and the usual instructions followed for the vision apparatus.

I have tried out this set and been rewarded by some particularly good images when working in conjunction with the "Televisor" made up from a kit of Baird parts. It must be understood that the receiver has a limited range, as was mentioned in the opening paragraphs, but for a cheap set to work within the area specified then it has everything in its favour and, being so simple, is not liable to get out of order.

**60**  
Pages.

**2D.**  
Post-  
age

EVERY KEEN RADIO CONSTRUCTOR SHOULD  
SEND FOR A COPY OF OUR NEW  
ILLUSTRATED CATALOGUE

A. F. Bulgin & Co. Ltd. 9-10-11 CURSITOR ST.  
CHANCERY LANE,  
LONDON, E.C.4.



# Television at the Berlin Radio Exhibition

By Dr. Alfred Gradenwitz

**F**OLLOWING a tradition of three years' standing, the Research Department of the German Post Office, or Reichspost-Zentralamt, as it is styled, had arranged a comprehensive television show illustrating recent developments and the present status of visual broadcasts in Germany.

In 1928, it will be remembered, the Telehor Company, working under Mr. v. Mihály's patents, had been allowed, under the auspices of the German postal authorities, to exhibit their apparatus side by side with a demonstration of Telefunken-Karolus television, both systems showing lantern slides and the like. Last year, a third competitor, the Fernseh A.G., sole licensees of Baird patents in this country, had stepped in, and the German Post Office, having assumed the control of television broadcasts and the promotion of television generally, likewise had a receiver of their own to show.

This year's exhibits have been even more varied and many-sided, although the Telefunken people, strikingly enough, refrained from showing their system. A recent press demonstration having given a summary idea of their recent results, this reserve, of course, was not indicative of any lack of interest.

The Reichspost-Zentralamt, then, figured at the Exhibition both as exhibitor and patron of private exhibitors. The Witzleben television transmitter, which for the last eighteen months or so had been sending out experimental television broadcasts, was, in connection with a small valve-type wireless transmitter on a 115-metre wave, used to transmit television films that could be received by all television sets on show.

In addition to this transmitter, which, of course, was working on German television standards (1200

picture elements,  $12\frac{1}{2}$  images per second), there was exhibited a light-spot transmitter for actual television—as opposed to the tele-cinema transmissions to far exclusively resorted to. This transmitter, constructed by the Fernseh A.G. for the Post Office Research Department, is described elsewhere in this issue and is shortly to be taken into operation for the Witzleben experimental broadcasts.

Readers are referred to page 338 for complete details of the Fernseh A.G. stand.

One Baird standard receiver for combined visual and acoustic reception was on show, but, owing to the difference in standards, was not exhibited in actual operation.

Television receivers exhibited by the Telehor Company comprised apparatus of a commercial type,

designed to be installed in connection with any battery-less wireless receiver. The firm are of the opinion that television transmissions now taking place both in Germany and England supply sufficient variety of programmes to warrant the purchase of television receivers. A synchroniser independent of the frequency of the mains enables a remarkable stability to be obtained, any fluctuation of

images being eliminated. In fact, a satisfactory long-distance reception within the whole range of the transmitter is thus secured, even in continuous-current mains or, without any mains, merely by the use of accumulators.

Interesting particulars of the Telehor apparatus comprise the newly invented "image adjuster," i.e. a novel device for adjusting pictures in their proper phase, by a swift and simple manipulation, further overhung phonic drums and discs and two lamp sockets, for rapidly exchanging the discs for German and English television reception respectively,

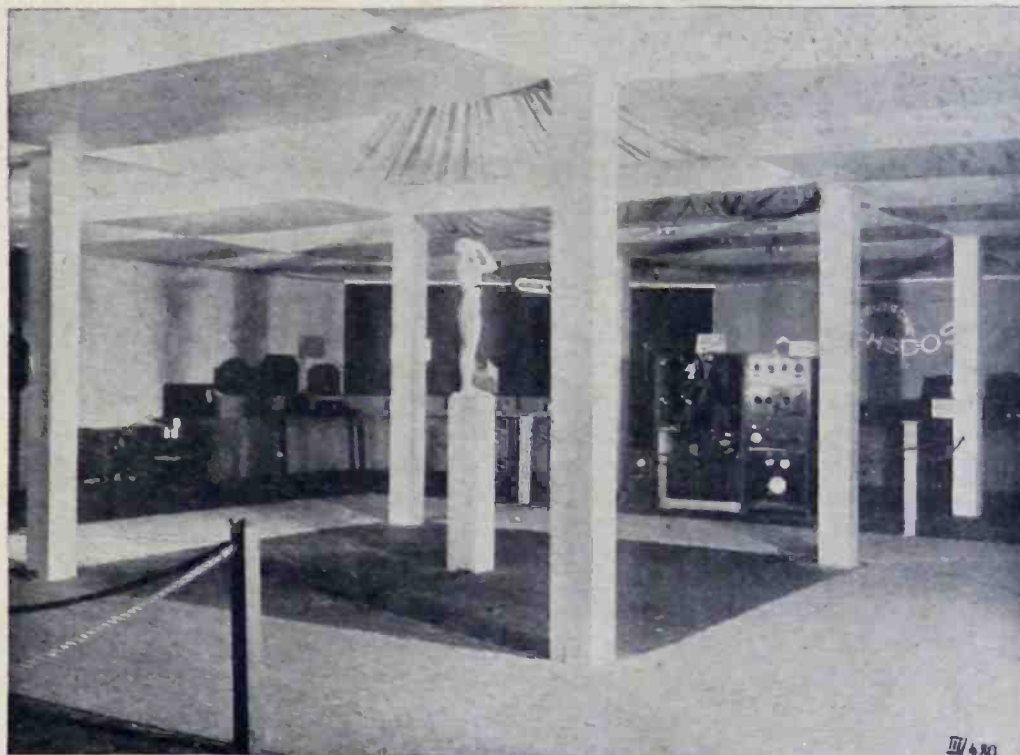

[Photo. by courtesy of German P.O. Research Dept.]  
The stand of the Reichspost-Zentralamt (German P.O. Research Dept.) showing Television apparatus.

A box of components for building up a complete television receiver has been perfected for the Telehor people by a Nuremberg radio firm, which also supply complete television receivers.

A small lens-disc projection receiver was likewise shown by Telehor. This is destined for projection on a frosted glass of images of about 15 by 20 centimetres. A further enlargement should be possible

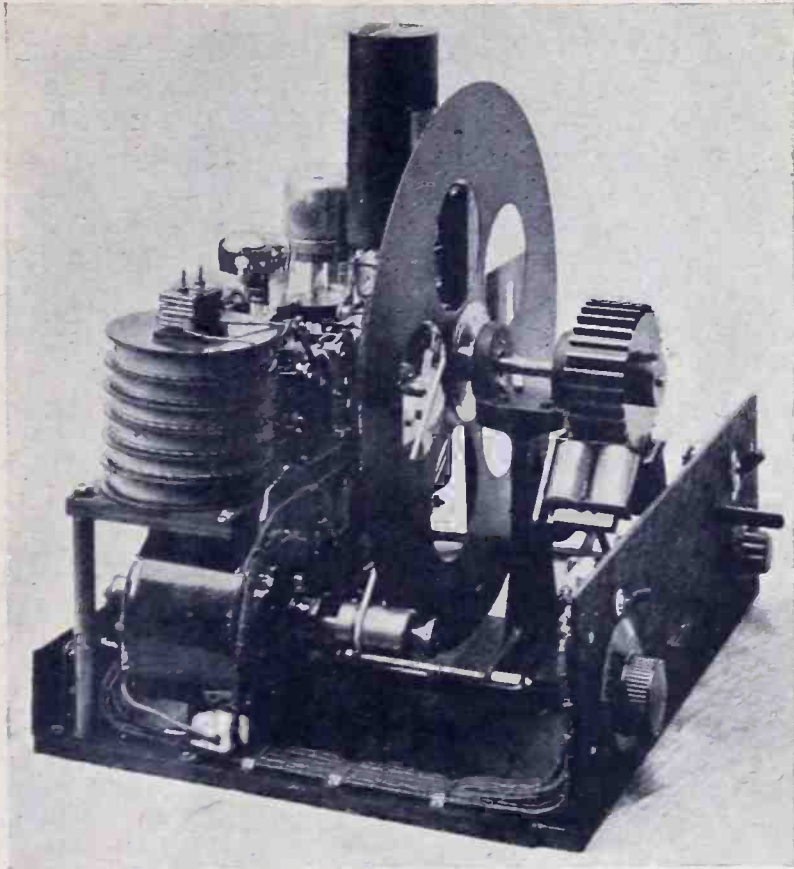

*The Telehor A.G. Universal Receiver, for receiving English and German television transmissions, with image adjuster.*

as soon as attempts now being made to improve the source of light have led to a definite result.

The great improvement obtained in general appearance and wealth of detail on passing from 30 holes to 42 holes was illustrated by two receivers designed for this increased frequency. Inasmuch as no wireless broadcasts at a higher frequency are possible for the time being, these receivers were demonstrated in connection with a special transmitter of the Telehor Company, by means of line conductors.

---

## *A Book Review*

*Television for All.* By Charles G. Philp. Published by Percival Marshall & Co., Ltd., at 1s.

We have read this little book with great interest, and naturally take a certain pride in the compilation, since the author has stated in his Foreword that he has relied mainly for his subject-matter upon articles which have appeared in TELEVISION. He has translated into simple language the gist of technical articles so as to make his book appeal to the non-

technical reader. Furthermore, the author expresses his gratitude to Television Press, Limited, for their kind permission to use the information he has thus obtained.

Undoubtedly the book fills a need in the literature on television which is now available to the public in book form. Mr. Philp has spared no pains in his endeavour to express the principles of television in everyday language, and for this alone he is to be congratulated. He assumes that the reader has no technical knowledge on the subject, but naturally does not imagine that he knows nothing about anything else. Where possible, he draws simple analogies in order to impress his theory on the minds of the reader, and we are sure that the book will make a good appeal and stimulate in the mind of the "man in the street" an interest in this newest of sciences.

Every endeavour has been made to refute the impressions made in certain quarters by false criticism of the Baird process, and, while the bulk of the book is devoted to the Baird system, since it is the only one operative in England, it has given due mention to the work carried on in America and on the Continent.

As this book is designed essentially for the non-technical reader, it would be unfair to criticise some of the remarks made by the author, where he has unfortunately slipped in his mode of simplification. There are just a few points, however, to which we should like to draw attention.

First of all, the cover design has obviously been inspired by the paper jacket on "Television To-day and To-morrow," by Sydney A. Moseley and H. J. Barton Chapple, published by Sir Isaac Pitman & Sons, Ltd. The similarity, we would suggest, is rather too pointed. Then, on page 23, although vertical scanning is described in the context, the diagram of Fig. 1 illustrates horizontal scanning, and is thus liable to mislead the reader. On page 44, where the author is describing scanning, we fail to see his purpose for assuming scanning in a direction opposite to the correct one, although he states that it makes the explanation easier. This is not so.

Synchronism, admittedly, is a difficult subject to deal with, and on page 47 the author, after starting out on a rather elaborate explanation, dismisses the problem very summarily, and goes on to say, incorrectly, that the receiver motor is set to run slightly faster than the transmitting motor in order to ensure satisfactory functioning.

When dealing with noctovision, the terms noctovisor and noctovision are confused slightly. On page 64, colour television is being described, but it would appear that the colours have got somewhat mixed, especially when yellow is spoken of in place of green. In his efforts to refute the stories of the adverse television critics, the arguments become rather loose when dealing with the frequency question, while his picture dimensions are wrong.

Apart from the few points mentioned, we have no hesitation in recommending this book to our readers, feeling that the perusal of its pages, both by the technical enthusiast and the non-technical layman, will prove of interest and value.

# Television for the Beginner

PART X

By *John W. Woodford*

**W**E dealt fairly fully last month with the important problem of synchronism, and saw how certain peculiarities can be introduced into the received image, their causes and cures being explained. Before proceeding to the vision wireless receiver let me mention one or two other effects which can arise under certain circumstances, as it is only by being forewarned that one can be forearmed.

I have stressed repeatedly in this series that the correct scanning operation at the receiving end and, of course, at the transmitting end, is for the disc holes to move from bottom to top while the light strips travel from right to left. For this to be carried into effect we must have the aperture spiral, as indicated in Fig. 1(x), the disc rotating in anti-clockwise direction, and the neon placed so that the flat plate is on the right hand side behind the disc, as shown by the dotted rectangle. The image then appears quite normal with all movement portrayed correctly.

## *A Backward Movement.*

Suppose, now, that in error you mounted your disc the wrong way round on the motor shaft, what effects will you notice, assuming that everything else is unchanged? This is portrayed simply in Fig. 1(y),

and you can see at once that while the glowing neon plate is scanned by the disc holes from bottom to top just the same as previously, the strip movement will be from left to right. All movement in a horizontal plane would therefore be reversed, and while one may overlook this with an artist performing his or her turn, the error will be thrown into bold relief when moving printed script in the form of a news bulletin or an announcement of the next day's programme is transmitted.

All the letters will be moving in the wrong direction, namely, from right to left instead of from left to right, and it will be impossible to read the message. Of course the remedy for this trouble is quite obvious, for it is necessary only to reverse the disc on the motor shaft.

## *The Image Upside Down.*

Another possibility arises, and, although rather remote, it is as well to record it for the benefit of readers. You will remember that I mentioned earlier in this series, that the neon lamp should be mounted on the right-hand side of the "Televisor," behind the disc. Supposing now, that in error, this neon was placed on the left-hand side, the disc rotation being normal.

Obviously the image would appear upside down, since all upward movements of the disc apertures at the transmitting end would be reproduced as downward movements at the receiving end. Then again, if the phasing had been set as normal for straightforward working, the image, when seen on the left, would not only appear upside down, but also split down the centre. Fig. 2 shows this effect quite well.

We are now in a position to study the wireless receiver for television signals, but before leaving the "Televisor" itself, it is opportune to run over, briefly, the series of operations which must be undertaken in order to ensure the reception of a good image.

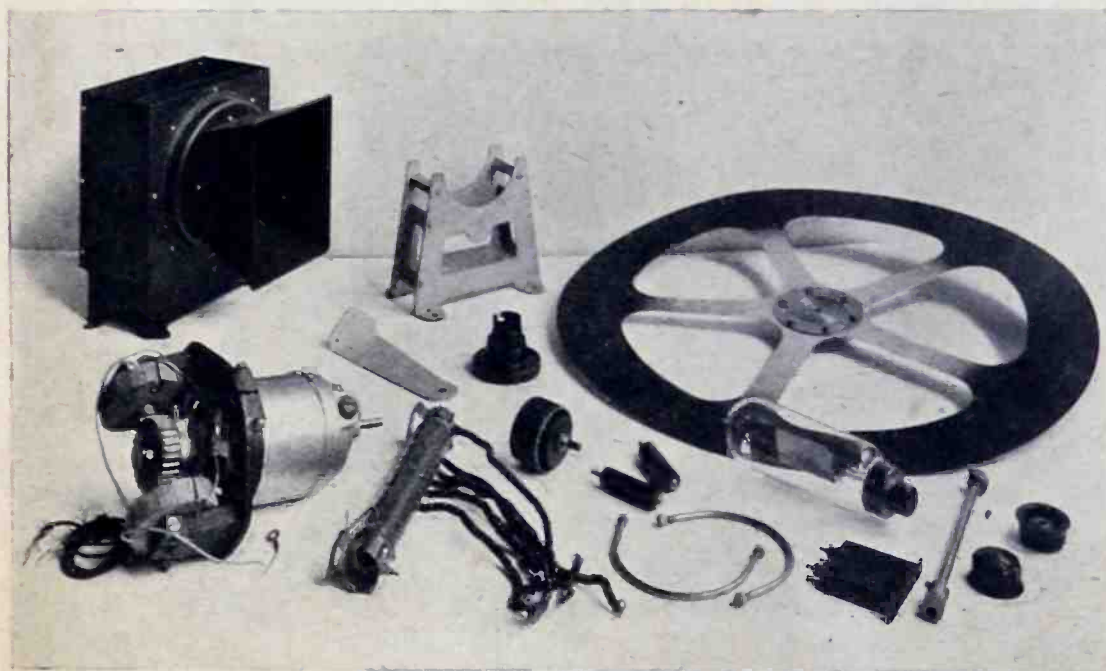

*A complete kit of branded components as supplied by the Baird Company for making up a "Televisor" at home.*

## Jogging your Memory.

First of all, tune in your wireless receiver to the station broadcasting the vision signals, and listen to the note on your loud speaker. It may, perhaps, be appropriately described as a high-pitched steady note, with another high-pitched chirrup superimposed on it.

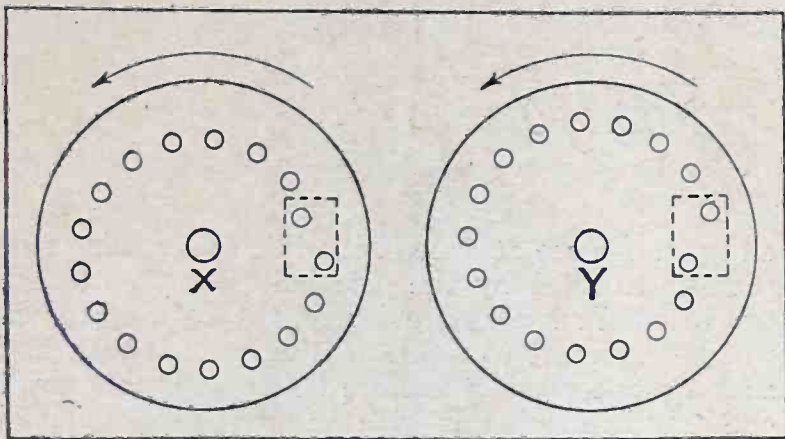
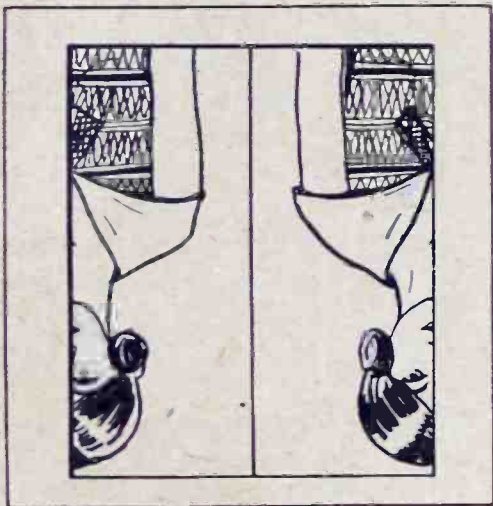

Fig. 1.—Notice how the light strip movement is reversed when the disc is mounted the wrong way round on the shaft.

Now start up the motor of your "Televisor" and switch over from the loud speaker to the vision apparatus, and watch through the viewing tunnel. First of all you will see some form of image, and, as the motor speed is increased, a series of black lines will appear and sweep downwards across the lens. These will be inclined slightly from the vertical, but they will slowly, with the increasing motor speed, assume a more horizontal inclination, the image meantime appearing between them.

## Image Drift.

The speed of the motor must be increased until the lines lie horizontally, and the image will then be plainly visible. Bear in mind that lines sweeping downwards signify that the motor is running too slow, while an upward sweep proves that the motor



\* \* \*  
Fig. 2.  
A weird result  
will be seen if the  
neon is on the  
wrong side of  
the motor  
shaft.

is running too fast. Adjustments on the speed control must be made accordingly, and if handling a standard Baird mechanism and the image is stationary, turn the extreme left-hand knob slightly in the same direction as the image drift until this drift ceases.

Framing and phasing have been dealt with, and if these one or two instructions are followed carefully good reception will be the reward of your enterprise, with perfect synchronisation.

Any troubles that may arise will be due chiefly to difficulties in the wireless receiving apparatus, for the vision apparatus is a simple mechanical device and unlikely to get out of order when handled intelligently. That being the case, let us now proceed to deal with this final side of our problems.

## The Wireless Receiver.

The impression has got abroad in some quarters that one wireless receiver only is necessary to receive the dual transmissions of sound and vision, which are

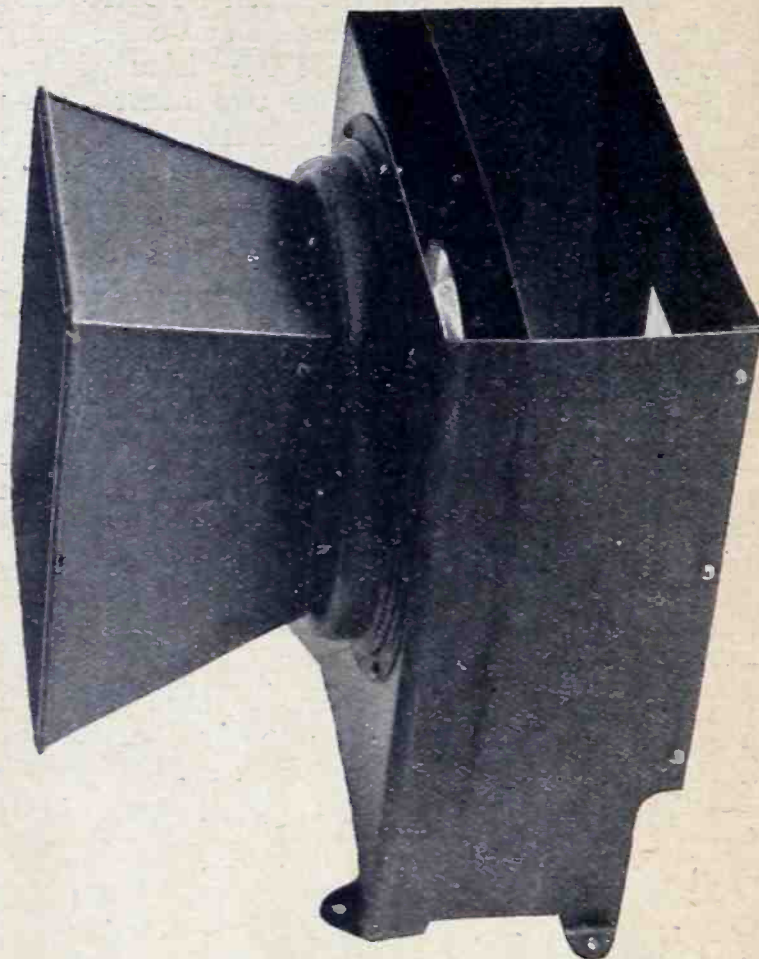

Here we have the viewing tunnel and lens assembly through which the received image is watched.

now being broadcast. A moment's reflection should suffice to show that this idea is mythical. Just the same as it is impossible to receive two normal broadcasting stations on one receiver and listen intelligently to each programme separately without interference, so it is out of the question at the present stage of development to expect one set to handle both the vision and sound signals and pass them over individually to the loud-speaker and "Televisor."

Two distinct sets are required, one for sound and one for vision. In the case of the former, a portable is satisfactory with the home outside aerial used in conjunction with the vision set, but, if preferred, the same outside aerial will serve for both receivers, provided certain precautions are taken in the methods of coupling the sets to the aerial.

## Following a Similar Process.

The item which needs the most careful consideration is the type of wireless set *best* suited to handle the television signals. We have seen that, to all intents and purposes, the signals, when broadcast, resemble electrically those sent out as a result of sound transmissions. They must be detected, rectified, and amplified in a similar manner, but owing to their special nature certain rules must be observed if the best results are to be achieved.

Hard and fast regulations cannot be laid down in a general elementary article of this character, for so much depends on environment and the local nature of signal reception, coupled with the distance from the Brookman's Park National and Regional Stations, which send out the dual programmes.

First of all, then, let us investigate the quantity factor or, in other words, judge signal volume. To work the commercial models of "Televisors" and also the home-made replicas of this apparatus your vision receiver should be capable of delivering good quality output of the order of 1.5 watts on optimum load. This figure can be arrived at if you are in possession of suitable measuring instruments, but for those not so happily placed we can assess the volume as *strong* loud-speaker strength.

### Output Strength.

By this I mean a volume above that required to listen to in comfort in an average room, but nothing approaching that of a public address equipment. This latter statement is included because so often have I heard it expressed that the power necessary is far beyond the capabilities of any well-designed set. The enthusiastic reports of amateurs, which are published in the columns of this magazine, should be sufficient to dispel any thoughts of this nature.

What must be borne in mind is that the amplified signals, passed on from the last valve of your receiver, are required to make a neon flicker in sympathy with the signal pulsations, and also make the automatic synchronising mechanism function in an efficient manner.

The stronger the signals the better will be the resultant image up to a point, but against this must be registered the warning that *too great* an output will "over cook" the image, that is, over-emphasise the light and shade formation. Obviously, this will detract

from picture quality, just the same as overloading the loud-speaker will bring about an "unpleasant noise" instead of a pleasing reproduction.

I think the remarks which have just been made will dispose of the question of quantity, and we must accordingly turn our attention to that which is perhaps even more important, namely, quality. This factor is wrapt up entirely in the wireless receiver itself;

the high frequency side, the detector, and the low frequency side all contribute in their own measure towards the ultimate end of a first-class image.

These items must be treated in order, and next month I shall endeavour to explain, in the simplest possible manner, the outstanding details to which due regard must be paid.

It is quite erroneous to imagine that drastic alterations must be made to the wireless receiver, but since, in order to receive the dual transmissions, two wireless receivers must be employed, it should follow quite naturally that the existing home set will suffice for the reception of the sound transmissions, and the new set, which will be required for vision working, can then be made to conform to all these quality factors.

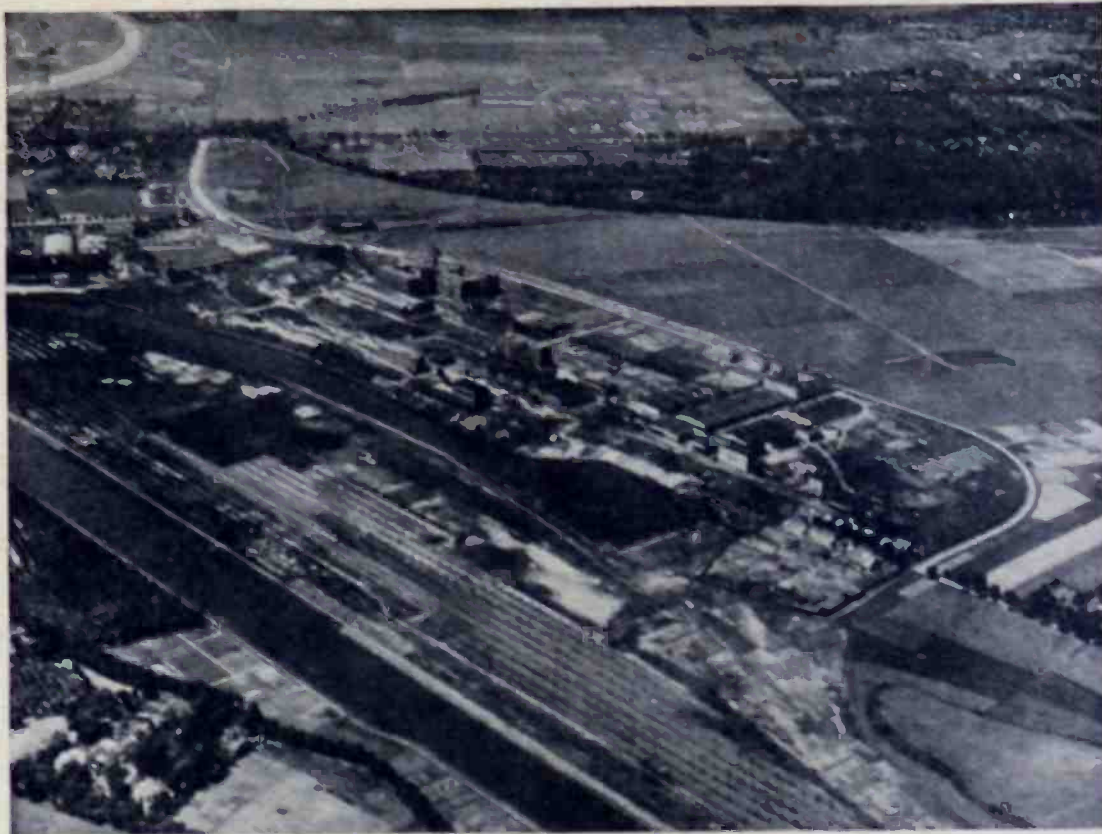

An aerial view of the Goerz Works at Zehlendorf, Berlin. The laboratories and offices of the Fernseh A.G. are situated here, and, as shown elsewhere in this issue, their television activities are most marked.

## L. LEAMAN

97, NORTHFIELD AVENUE  
WEST EALING, LONDON, W.13

For Radio and Television

DEMONSTRATIONS  
DURING TELEVISION TRANSMISSIONS

Baird Components Supplied

PHONE: EALING 5394 (MEMBER, TELEVISION SOCIETY)



# The Enthusiast Sees it Through

OUR post bag this month has been unusually heavy and we feel justified in assuming, therefore, that the "holiday spirit" is almost past. With the promise of dark evenings to come, there is sure to be a concerted attack on the television front. That the enthusiast will overcome all obstacles is a foregone conclusion, and we shall welcome reports of "action" for inclusion in these series, which is proving such a popular feature in our magazine.

## Interesting Observations from Leigh-on-Sea

Mr. A. R. Knipe, of 5, Southsea Avenue, Leigh-on-Sea, has sent us a very interesting description of his experiences in the reception of Baird television. He has included one or two ingenious ideas in order to improve his work, and, since the whole of his apparatus is home constructed, we are sure that readers will welcome the information which Mr. Knipe imparts. He writes as follows:—

"Since forwarding you the first reports of my reception of the Baird television transmissions, I have entirely rebuilt my receiving equipment.

"The receiver I now use for the vision signal consists of one stage of H.F. (SG) amplification transformer coupled to an anode bend rectifier, which is followed by either two or three stages of R.C.C. L.F. amplification, the complete receiver being designed solely for television reception.

"While engaged in experimenting with the above I have had to overcome several difficulties, the results of which I hope may be of interest to other readers.

"Although I know that the best results generally are obtained when the neon is placed directly in the anode circuit of the output valve, I am at present limited to a mains supply of 230 volts D.C. I therefore have to 'choke feed' the neon, although the television signals as at present being radiated give a positive image with a receiver having anode rectifica-

tion followed by three stages of R.C.C. L.F. amplification, the neon, of course, being *in the plate circuit* of the final valve.

"With the normal connection of choke-fed neon (Fig. 1) a positive image is obtained only when using two stages of R.C.C. L.F. amplification (unless transformer coupling between output valve and neon is resorted to).

"As I have purposely kept the stage gain low in my amplifier, sometimes the addition of a third stage of R.C.C. is used, and the result is, of course, a negative

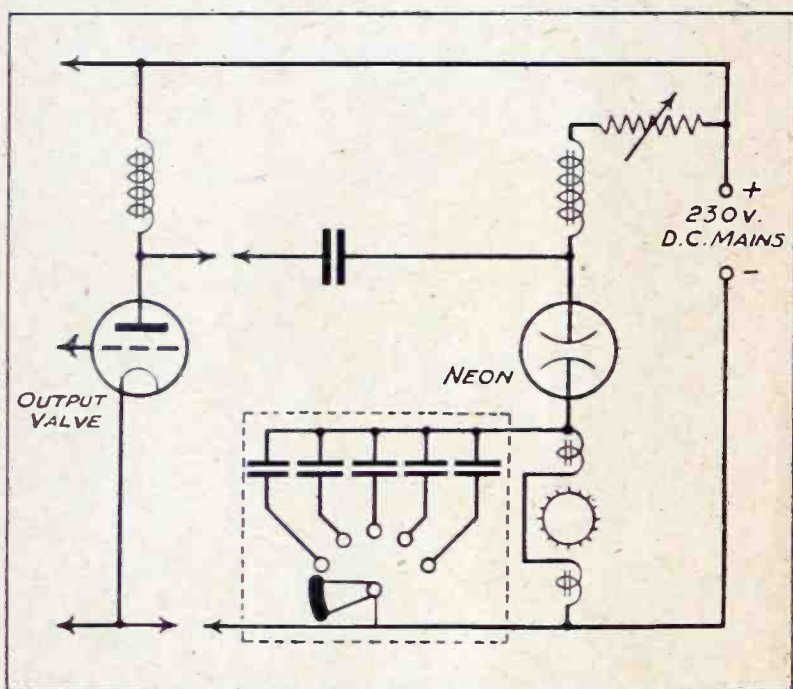

Fig. 1.—The normal connections for a choke-fed neon in the television receiver. Note the special bank of condensers inside the dotted lines.

image. However, by altering the neon connections, as shown in Fig. 2, a positive image is again obtained.

"The bank of condensers shown enclosed by dotted

lines I find of great value, as whilst observing the image, if the switch is *slowly* rotated, dark patches and 'seaweed effect' on the received image can be removed without disturbing synchronisation. Of course, on consideration one realises that the condenser shunting the fields coils of the magnetic corrector, although primarily serving to by-pass the A.C. component, the inductance of the field coils in combination with the capacity shunting them will form an L.F. filter circuit, and by making this shunt capacity variable I find a nice control of the density and high lights of the received image is obtained.

"Unfortunately, I am only able to look in, or should I say 'telegaze,' to the midnight transmissions, and to save precious minutes of the half hour I have adopted the following method of tuning in.

"I constructed a rough tuning fork which I adjusted by ear to the pitch of the television signals, and when about to look in to a transmission of vision I switch on the motor driving the disc a few minutes before the transmission commences and adjust the speed of the motor until the slight audible hum of the synchronising device is in unison with the note emitted by the tuning fork. As the television signal comes in, the image floats into the field of view and, provided the voltage of the mains is fairly constant, the synchronising device will 'hold' the picture for the remainder of the transmission.

"Although the whole of my apparatus is home constructed and mostly built from 'scrap,' and also that I am still using an ordinary Nipkow disc, by the above arrangement I obtain a very good picture.

"I trust these notes may be of interest to other experimenters."

### A Suggestion for Mr. Richardson

Our correspondent, Mr. S. G. Foord, of 229, High Road, Willesden Green, N.W. 10, appears to be in

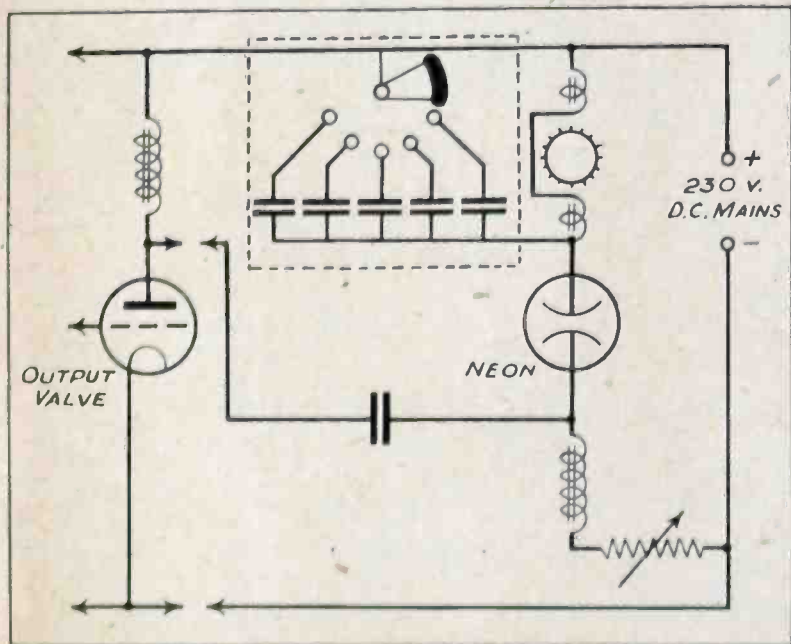
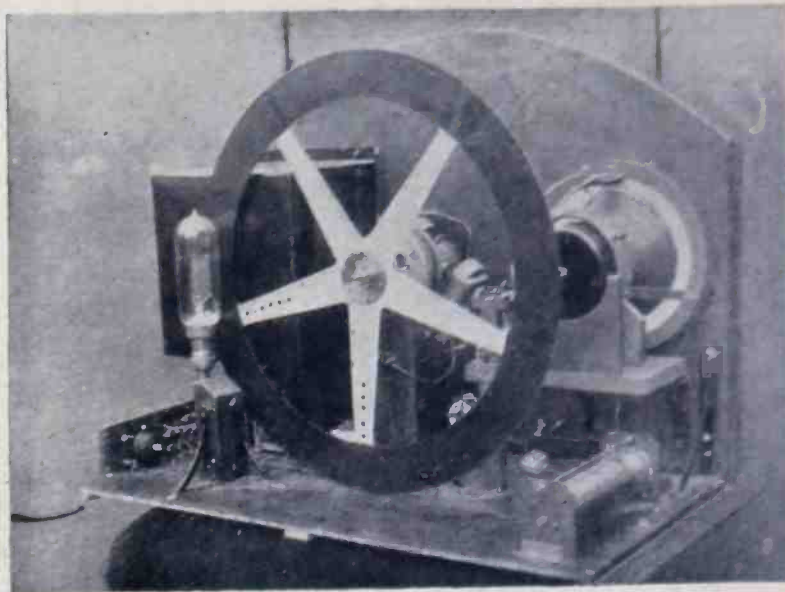

Fig. 2.—Mr. Knipe changes over to these connections if his original circuit produces a negative image.

difficulties over the dual reception of speech and vision. Apparently he receives good images from the vision signals alone, but only when he employs

a crystal set can he receive the two Brookman's Park transmissions. He has made an interesting suggestion in the letter which we print below, and we



The apparatus as made up by Mr. Knipe from "scrap." Very good images are secured, and our correspondent is to be congratulated on his keenness.

have no doubt that our well-known contributor, Mr. William J. Richardson, will be able to solve the troubles experienced by Mr. Foord. This is what our reader states in the course of his letter:—

"I have for some time past been receiving quite good images on my 'Televisor,' using a three-valve receiver, namely, anode-bend detector followed by one R.C. and one transformer coupled stage, a combination I have found by trial to be the most satisfactory. Synchronism is maintained by hand, using a knob controlled friction brake. An ordinary Phillips neon lamp is used as a light source, and scanning is done by a disc with square holes arranged to give a length-breadth ratio of 2/1.

"I have deferred writing to you of my results in the hope of being able to report the simultaneous reception of the sound accompaniment, but although I have been able to accomplish this by using a crystal set, all attempts at using a one-valve receiver have been of little value for reasons I will explain. It is necessary to feed the filaments of all four valves from the same accumulator, and H.T. to be provided from the same mains (240 D.C.). The same aerial was originally used, using the arrangement shown in the accompanying sketch. But even with two aerials unsatisfactory results were obtained. With one circuit tuned to the vision signals, the same signals would be heard all round the dial on the other tuned circuit of the one-valver.

"It is suspected that the trouble is due to the necessary use of a common L.T. negative, since my positive main being earthed, the H.T. smoothing choke is in the negative lead. This would result in the supplying of unsteady H.T. to the one-valve, due to fluctuations of current taken by the three-valve.

"I do not see how to overcome this difficulty, and I note that the excellent articles by Mr. William J. Richardson only deal with vision reception. I trust that in the near future you will arrange with him to

describe a dual receiver, which may be worked from mains, which will solve my little quandary. If the need of such a receiver is not universal I should be obliged if you or any of your readers having more

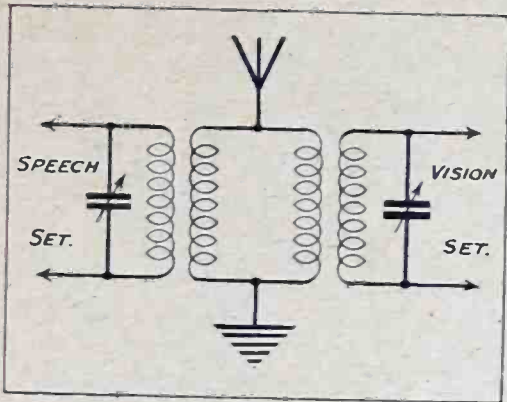

\* \* \*

*The scheme adopted by Mr. Foord to couple his vision and speech sets to the aerial.*

\* \* \*

technical ability than myself would tender a suggested solution of my problem.

"P.S.—I have made a new scanning disc from the data given in your April number, but on test it would seem that although the  $7/3$  length-breadth ratio is about right, the outer and inner three holes should still be square and not rectangular, as stated in TELEVISION. This is easily seen by observing the rate at which lettering passes across the screen, being much faster over the first and last holes than the middle ones."

### *Baird Television Reaches Jugo-Slavia*

Jugo-Slavia is a very long way from London, but not too far for the Baird television signals sent out via Brookman's Park to reach that country. We have received a communication from Professor Dr. Jos. Lončar (honor. Dozent an der Technischen Fakultät Zagreb), Zagreb, Klaićeva ulica II./III, Jugo-Slavia, in which he records his successful reception of television both from London and Berlin. Undoubtedly this is a first-rate achievement, and we congratulate Dr. Lončar on his efforts. Naturally, we should be pleased to record any further efforts



*Dr. J. Lončar, who has been successful in receiving the Baird television images in Jugo-Slavia.*

made by this gentleman in the columns of our magazine, and meanwhile give extracts from his letter as received by us:—

"I am pleased to inform you that on the night of August 7th to 8th, 1930, I succeeded in receiving the television transmissions from Berlin-Witzleben with a home-constructed set. In spite of very considerable disturbances that night, due apparently to a thunderstorm in the vicinity, I was able with this set to receive part of a transmission from Berlin on the first night experiments were carried out. On account of the atmospherics, it was impossible to observe the images continuously, but when the unusually great interference (which at the same time almost completely cut out ordinary radio reception) was modified, comparatively good images were observed. Reception was particularly good at the time when the word 'Pause' appeared on the screen and later when the word 'Ende' was to be seen.

"Reception of the television transmission from London was not possible on the first night, but

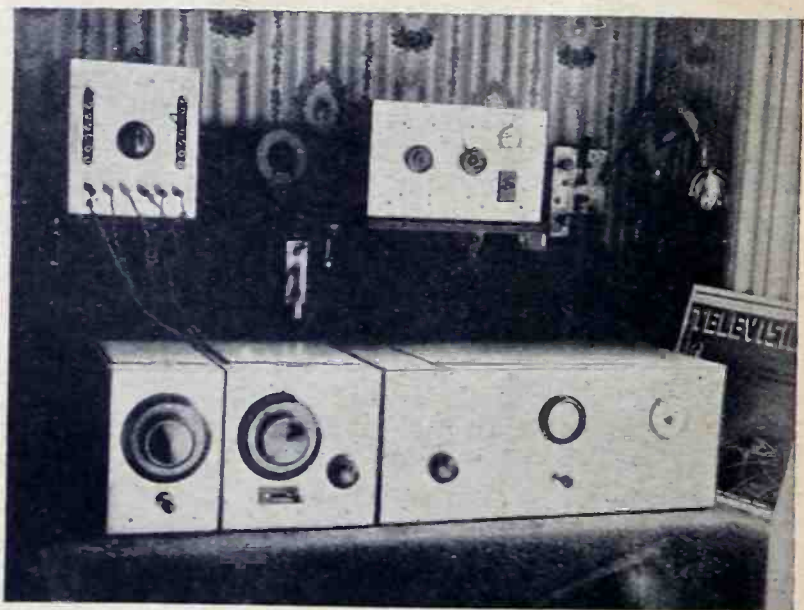

*Neatness and efficiency would appear to be the keynote of the receiving apparatus used by Mr. Knipe.*

success was obtained on the night of August 12th-13th, under considerably better conditions.

"Possibly this is the first reception of television in Jugo-Slavia, and the results obtained up till now indicate that we may rely with certainty on very good reception in this district in winter time when conditions for wireless reception are much better."

### *A Dumbartonshire Reader's Efforts*

Mr. P. F. Carmichael, of Claddoch, Gartocharn, Dumbartonshire, has been carrying out some interesting television experiments during the course of his reception of the midnight Baird television transmissions. The apparatus, which he has made up himself, has been so designed that it serves the dual purpose of being suitable for both the London and Berlin transmissions. The method employed by our reader to carry this into effect is very ingenious, and we print below extracts from his letter, which we are sure will make interesting reading to our friends:—

"The television receiver has four valves—S.G., det., R.C., and trans.—while its selectivity can be altered at will. The leaky grid detector has 120 volts H.T. and the grid-bias can be varied from 1-5 volts



by a potentiometer. The last stage consists of an A.F.5 transformer and a small power valve of about 3000 ohms impedance. When ordinary sound programmes are received, only 120 volts H.T. are applied to the power valve, and a choke output is used for the loud-speaker. For television, however, the neon is in series with the valve, and 190 volts are generally used. The extra 70 are supplied by a dry battery in the 'Televisor.' An on-and-off switch is used to make the change-over, as shown in the diagram.

"The 70 volts cannot light the neon when the loud-speaker is on, although, when the neon is switched on, enough power is left over to tune-in with the loud-speaker or 'phones. As will be seen, only a low power 110 volt Beehive neon is used.

"The 'Televisor' has four controls: on-and-off switch for lamp, volume control, combined switch and resistance for bringing motor up to correct speed, and a friction control for holding it in synchronism.

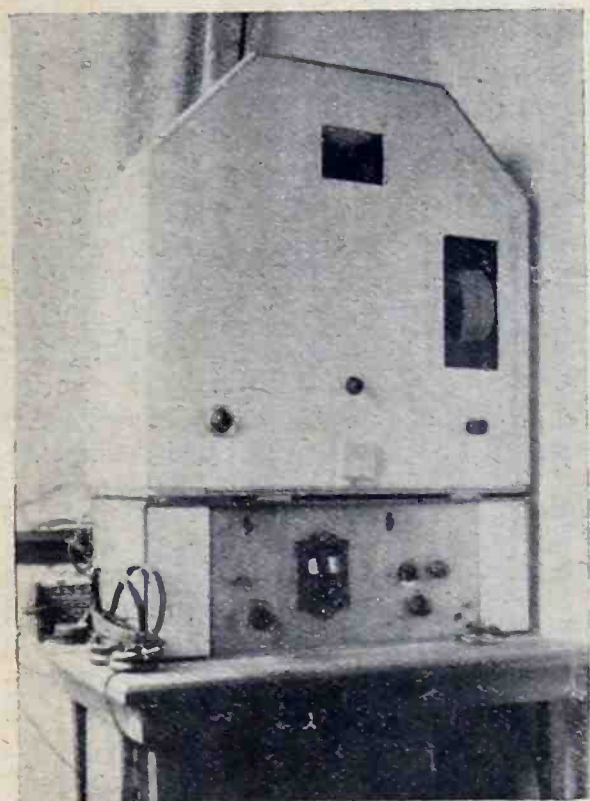

\* \*  
Both the London and Berlin television transmissions are received by Mr. P. F. Carmichael on this apparatus which is entirely home made.  
\* \*

The disc has both a London and a Berlin spiral. An even field of illumination is directed on them at their corresponding apertures from the same neon by means of mirrors and lenses. A water lens is used at the London aperture, but the Berlin one has a plain receiving tunnel. The disc is made of thick black paper.

"It is difficult to give you an idea of the results, because of the lack of comparisons with a really good set in the Brookman's service area and because of the fading and distortion due to distance which is in evidence here. The writing, however, can be read easily, and a week ago, when conditions were good, I recognised an artiste from a photograph which appeared in TELEVISION for June.

"At this distance from the transmitter, where fading is bad, it is necessary to have full control of the sets. You can see from the photograph how this is done. The reaction and potentiometer controls are below the volume control on the 'Televisor.' The

phase reversal control for negative images is at the extreme right bottom corner of the set, next the wall. It is even possible to adjust the reaction of the two-

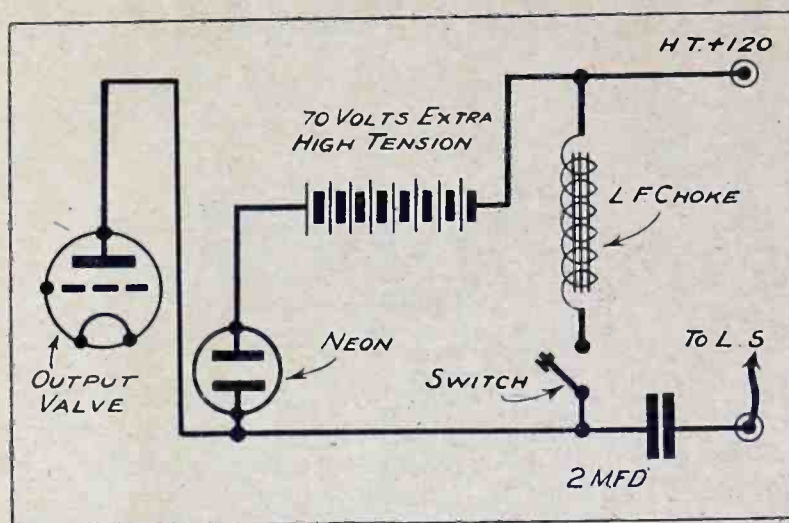

Here you have the arrangement used by Mr. Carmichael for working either loudspeaker or neon.

valve 'sound' set (below the table, on the left) while looking at the image.

"The phase reversal control is raised up for London, but left down for Berlin (Königswusterhausen), which can be received imperfectly on Saturday mornings. I have, however, been able to make out indistinct faces. Witzleben, which transmits on Friday nights, is not strong enough yet. I expect to receive both these transmissions better in a short time.

"I have no proper synchronism control, but the shunt-wound motor can be made to run fairly steadily after a little practice with the friction control.

"The transmissions up to now have afforded many good examples of light and shade. If I might make a suggestion, would it not be a good idea to introduce more movement? This might be done by transmitting subjects with bold outlines such as cartoon films, say Felix-the-Cat or something similar to Micky Mouse."

## STOP PRESS

We have just heard of the great triumph of Baird Screen Television at the Scala, Berlin. The following cabled extracts from German newspapers tell their own story:—

*Berliner Lokalanzeiger*.—"Gigantic and endless possibility, astounding achievement. Epoch making, remarkable."

*Uhrblatt*.—"Magnificent invention. Baird's photo received tumultuous applause."

*Berlin am Morgen*.—"One holds one's breath."

*Vorwärts*.—"The miracle has happened. Perfectly synchronized."

*Berliner Illustrierte*.—"Immensely interesting, immensely instructive."

*Lichtbildbuehne*.—"Miracle realized, all faces plainly visible, perfectly synchronized. Baird photo had long, well-merited applause; an epoch-making hour."

# Selectivity *and* Modulation Response

## PART II

(Concluded from the August Issue)

By *R. S. Spreadbury*

THE term "Selectivity," as applied to tuned oscillatory circuits, implies the acceptance of one particular frequency and the exclusion of all other frequencies, but as no circuit has so far been invented which will select a single frequency, this definition must be modified to imply the acceptance of a band of frequencies, to the exclusion of all frequencies outside the band, and the smaller the range of frequencies within this band, the more selective is the circuit said to be. In present-day receivers the unwanted frequencies are not excluded, however, but only reduced, the reduction in most cases rendering them inaudible. In this case, then, even the above definition is inaccurate, selectivity being a loosely applied term for relative acceptance. A circuit can be designed giving absolute selectivity over a limited frequency range, however, and the description of such a circuit was given in the first part of this series.

### *A Mixed Blessing?*

The selectivity and sensitivity of a receiver may be improved by applying reaction, but the modulation response suffers thereby, resulting in distortion, the cause of this being an abnormal reduction in the decrement portion of the modulation response. Ordinary reaction is then a mixed blessing, being less than useless during decrement, but extremely useful during increment. Conversely, negative reaction is useless during increment, but useful during decrement. The question thus arises as to whether some means can be found to apply positive reaction while the oscillations in the tuning circuit are increasing, the reaction phase reversing, and applying negative reaction when the oscillations commence to die out. Is there any portion of the circuit giving the requisite phase reversal from which the initial energy for the reaction can be drawn?

### *Phase Reversal*

Referring to the action of a direct coupled oscillatory circuit (Fig. 1), oscillations are applied from the input, which in the case of a receiver is the aerial, resulting in the building up of an oscillatory current in the circuit *C*, which opposes the applied oscillations. If the applied oscillations decrease in amplitude, or cease altogether, the circuit *C* returns oscillatory current to the input, the phase of which is reversed. The arrow, *T*, indicates the direction of a transient of the oscillatory current in *C*, the corresponding transient currents in the input for increment

and decrement being given. The phase reversal required to energise the reaction may be obtained by indirect coupling with *L*, but reaction from such a source is useless, as full reaction would be applied to unwanted frequencies.

In the circuit which follows, no reaction of any kind is applied to any but the required frequencies. The circuit (Fig. 2) is similar to Fig. 3 of Part I., but with the addition of the special differential reaction. As explained in Part I., the oscillations from *L*<sub>1</sub> and *L*<sub>2</sub> are applied to the tuned circuit *T* in opposition, and since the impedance of *L*<sub>1</sub>, *C*<sub>1</sub>, *C*<sub>3</sub> is equal to the impedance of *L*<sub>2</sub>, *C*<sub>2</sub>, *C*<sub>4</sub>, the tuned circuit *T* will not respond, except at the required frequency, at which frequency the wavetrap *W* becomes operative, suppressing one phase, thus allowing the other phase to affect *T*. The energy for the differential reaction is derived from *L*<sub>1</sub> and *L*<sub>2</sub>, so it would be advisable first to examine the conditions given by these coils.

### *Current Direction*

The direction of transient currents in *L*<sub>1</sub> and *L*<sub>2</sub> for unwanted frequencies, and for the increment and decrement of the required frequency, are given in Fig. 3. In the first case unwanted frequencies produce currents of equal strength in *L*<sub>1</sub> and *L*<sub>2</sub>, and produce no response in *S*<sub>1</sub> and *S*<sub>2</sub>, since the voltages induced are equal and opposite. Taking the second case, the increment of the required frequency results

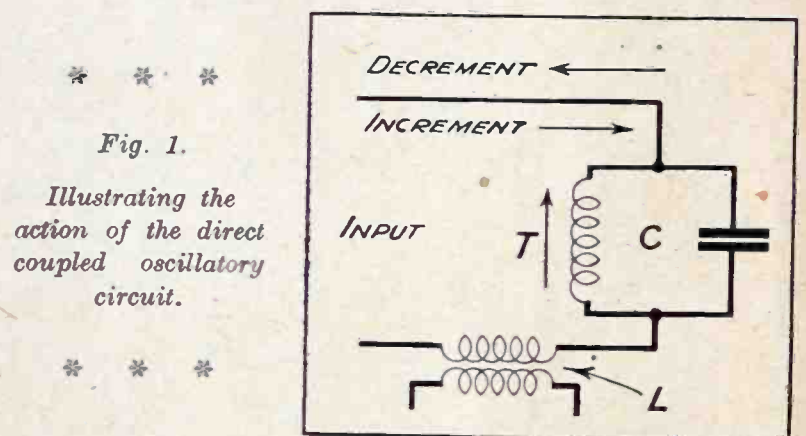

Fig. 1.  
Illustrating the action of the direct coupled oscillatory circuit.

in a current in *L*<sub>2</sub>, but little or no current in *L*<sub>1</sub>, thus inducing a voltage in *S*<sub>2</sub> of such phase relation as to produce positive reaction. Lastly, the decrement of the required frequency results in a reversal of the phase in *L*<sub>2</sub>, but also a current in *L*<sub>1</sub> in the direction indicated, inducing voltages in *S*<sub>1</sub> and *S*<sub>2</sub>, these

voltages assisting each other and having such phase as to produce negative reaction. The induced voltages in each case are fed to the grid of a special reaction valve, *RV*, the anode circuit of which supplies the requisite amplified oscillations for the reaction.

Next comes the problem as to where and how the reaction can be applied to the greatest advantage. It must, of course, be applied to the tuning circuit *T*, and a little thought here will show that no means are necessary to regulate the reaction strength, since local oscillations cannot form. The most im-

portant point of application is not the tuning circuit, however, but the wavetrap, the inductance of which is a variometer, and the best method here is to wind the reaction coil outside of, and on top of, the outer coil, forming a very close coupling between the two. Now a consideration of this point of application will show that local oscillations result if the reaction be excessive, yet no control for limiting the reaction is shown in the circuit diagram, the reason for which must be looked for in the last point of application, which is the aerial circuit, where the two inductances perform the double duty of aerial and reaction coils.

In this circuit again excessive reaction will result in the formation of local oscillations, and here a limiting control is needed, taking the form of a .0005 mfd. variable condenser, the capacity range of

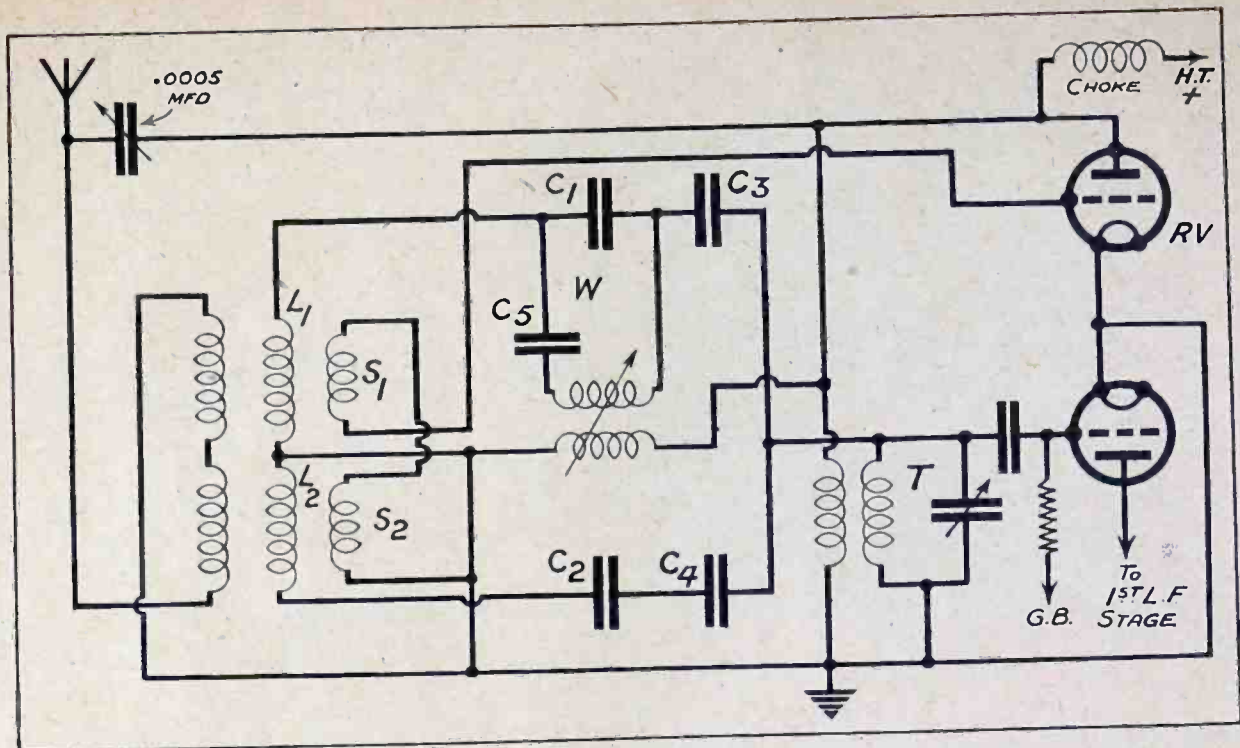

Fig. 2.—In this circuit no reaction of any kind is applied except at the required frequencies.

and effectively damped out by the reaction applied to the aerial, provided the latter be not unduly reduced.

### Still Experimental

No specific values for the components can be quoted, as the circuit is still in the experimental stage, but one or two necessary precautions can be given. The wavetrap is the most important point, and the components here must be of the highest quality. As the low-loss qualities of commercial variometers are often conspicuous by their absence, this part can be rewired, slightly spacing the turns, and if possible using a stouter gauge of wire. The condenser *C*<sub>5</sub> should have a very small capacity in comparison with that of *C*<sub>1</sub>, so as not to offer an alternative path to *C*<sub>1</sub> and vary the impedance of this side of the circuit. The inductance, resistance and self-capacity of *L*<sub>1</sub> and *L*<sub>2</sub> must be perfectly matched, and this also applies in a lesser degree to the coils *S*<sub>1</sub> and *S*<sub>2</sub>, and the aerial coils. As regards the condenser pairs, *C*<sub>1</sub>, *C*<sub>2</sub>, and *C*<sub>3</sub>, *C*<sub>4</sub>, they should be especially tested for accurate matching. The two condensers, *C*<sub>2</sub> and *C*<sub>4</sub>, may of course be replaced by a single condenser of the same capacity as the two in series.

A necessary precaution is to ensure that the natural frequency of the circuit *L*<sub>2</sub>, *C*<sub>2</sub>, *C*<sub>4</sub> be slightly greater than the highest frequency to which the receiver will tune, otherwise negative reaction may not take place. Another rather obvious precaution, if the reaction coils are to be connected in parallel as shown, is to make them of approximately the same values.

The addition of straight reaction applied to the tuning circuit *T* greatly improves results, and both differential and straight reaction controls may be adjusted to the oscillation point without distortion.

The circuit as described is admittedly complicated, but it is hoped to simplify as well as improve it in other ways.

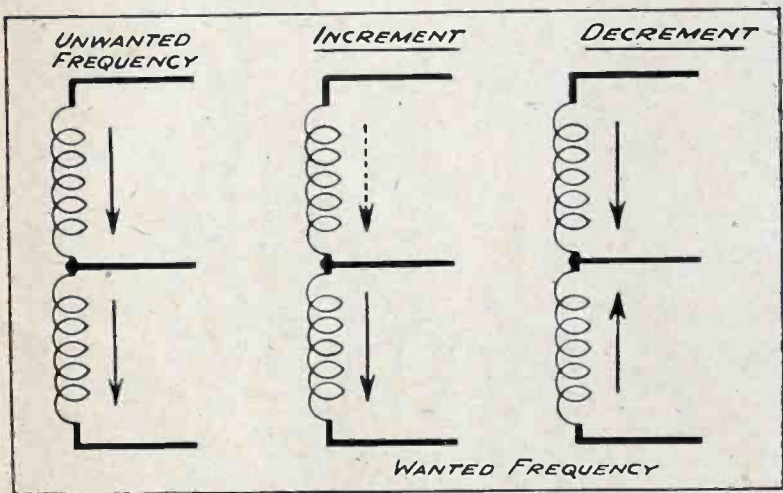

Fig. 3.—Showing the direction of transient currents under certain frequency conditions.

which will be found suitable in most cases. The reason for the omission of any reaction control in *W* can now be explained. Excessive reaction in *W* tends to set up oscillations in *L*<sub>1</sub>, which, however, are opposed



# The Exhibit

*of the*

## Fernseh A.G.

*as shown at the*

### Berlin Radio Exhibition

AS last year, the Berlin Radio Exhibition (Funkausstellung, as it is known in Germany) was held under the shadow of the Witzleben Tower from 22nd to 31st August. It proved a huge success, and undoubtedly the exhibit which attracted the greatest attention was that staged by the German Post Office (Reichspostzentramt), which showed television in all its aspects. The Fernseh A.G. again participated in this special exhibit and showed several different types of television transmitters and receivers. We felt that our readers would be particularly interested in the details of these exhibits and have pleasure, therefore, in furnishing them.

With regard to the transmitters, there was a special apparatus which had been built by the Fernseh A.G. for the German Post Office. This particular scanning device served the purpose of transmitting moving images of living persons, and we append a description of the method of working.

The object which has to be transmitted is illuminated by means of a light source interposed by a Nipkow disc, so that illumination is in the form of scanning strips. These light rays are then reflected from the object and are caught up on the sensitive surface of a number of photo-electric cells, arranged in the form of a ring. These photo-electric cells serve the purpose of transforming, in known manner, the light variations into current variations, these being amplified by means of a special amplifier. The light ray comes from a projection lamp of 900 watts and is reflected by means of a parabolic mirror, which is precision work, and also through a projection objective, and is then thrown on to the Nipkow disc. Every single hole in the Nipkow disc is focussed sharply on the object to be scanned.

As the objects to be scanned vary in size and height,

the projection system, together with the analysing system, is placed on a stable metal casting, which is adjustable vertically and horizontally, thus enabling the subject always to be in a correct focus. The photo-electric cells are also adjustable in the same manner, so that they will always catch the light from the object which is being scanned. These photo-cells are fitted in a brass housing screened by means of wire gauze. The efficiency of the photo-electric cells is increased owing to the fact that they embody a particular type of mirror. The sensitive surface has a size of, roughly, 450 by 600 mm., and thus it is possible to transmit two heads beside each other.

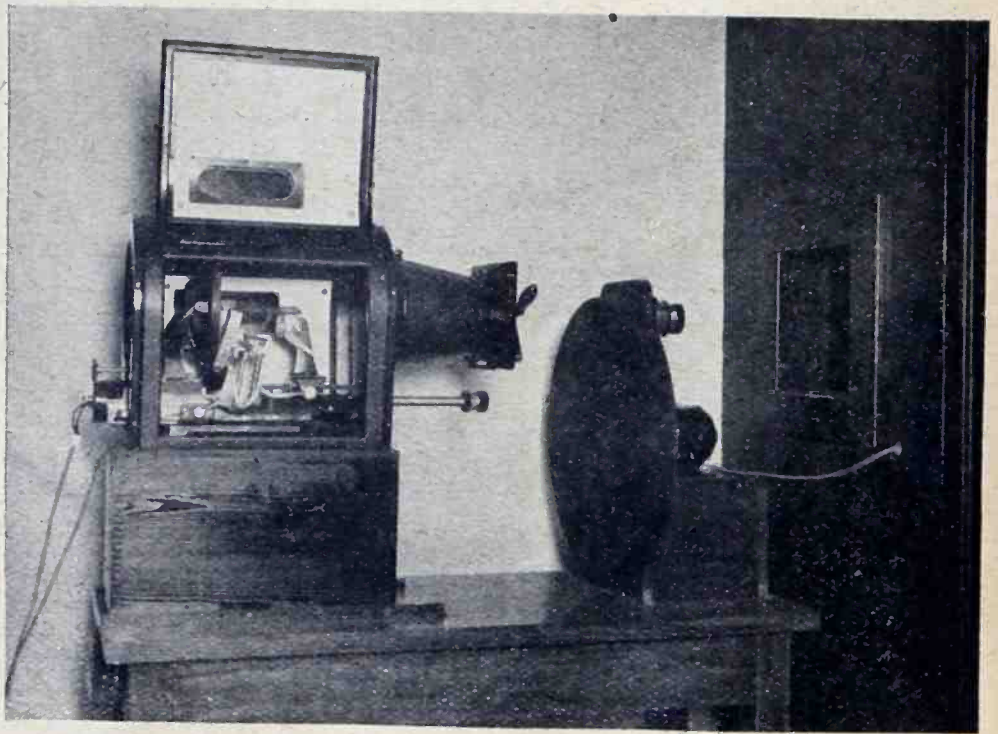

*The special transmitter designed by Fernseh A.G., images from which can only be seen through the medium of the Company's receivers.*

Furthermore, it is possible to increase the surface of the picture scanned in accordance with the size of the object to be transmitted, without spoiling the results. The transmitter is fitted out for 1200 as well as for

1750 picture elements. For the transmitter, special photo-cells are provided which can also respond to infra-red light and which, in the province of the visible spectrum, are twelve times as sensitive; they also possess a very high sensitivity in the infra-red spectrum. It is thus possible to scan the object through an infra-red filter, the stopping-down of the light then being unnecessary. The space occupied by the person who is being scanned may be illuminated by visible light of a short wavelength, as the special photo-electric cells are not responsive to the short waves and it is thus possible to read a book during the process of scanning.

The amplifier shows one or two new improvements. It is driven solely from the mains, and the main connections, as well as the amplifier itself, are placed in a long housing of 1.50 metres length. Many precautions had to be taken in constructing the amplifier, such as eliminating as far as possible any disturbance caused by the mains, which would certainly occur if the construction were too compact. In order to ensure the least possible danger, a number of special measuring instruments are included in the eliminator. These instruments are placed on one side of the amplifier.

The transmitter described above is to be used by the German Post Office. Pictures of the transmitter were shown on the stands of different firms, as well as by the Post Office.

The Fernseh A.G. also exhibited a scanner, almost similar to that above, in its own transmitting case. It is provided with a Nipkow disc having 67 holes,

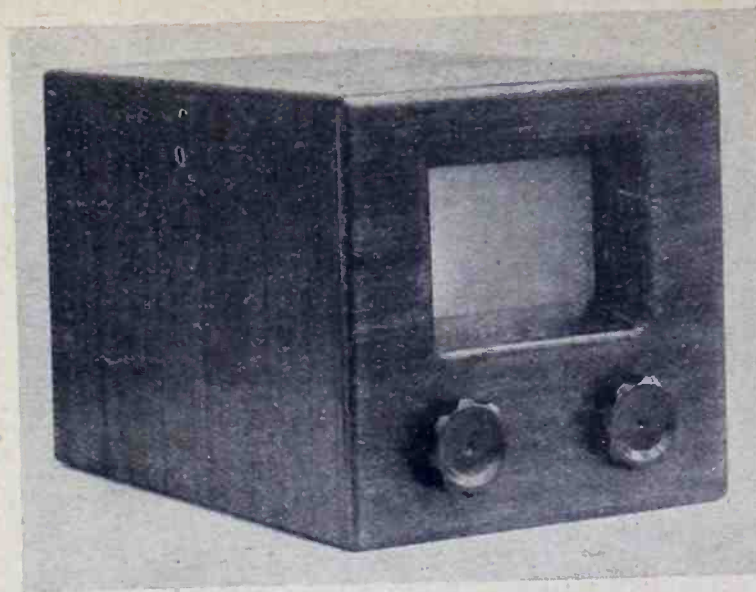

*A mirror drum receiver made by Fernseh A.G., which is most ingenious in its working.*

a talking film, this being accomplished by combining the talking film apparatus of the Zeiss Ikon A.G. and the Fernseh A.G. The speech is received by a special television receiver constructed for this purpose with a loud-speaker. This transmission of talking films is certainly in advance of the transmission of silent films, and is particularly advantageous in that it lends a certain liveliness to the reception, and recognition of what is taking place is thereby simplified. The image is much better than the films hitherto transmitted by the Post Office, as the transmission is not  $12\frac{1}{2}$  pictures per second but 25 pictures, and the speed is thus doubled.

With regard to receivers, the Fernseh A.G. are fitting up two normal types which give a picture of about 60 by 90 mm. In both types the Nipkow disc is driven by a special synchronous motor working through a particular type of valve generator. This valve generator consists of two normal, indirectly heated amplifier valves, R.E.N.804 and R.E.N.1104. The frequency of the valve generator is in sympathy with the frequency of the picture current and thus it is possible to maintain a picture in perfect synchronism.

Furthermore, the glow lamp of the television receiver is connected to the last valve of the radio receiver in series, the disadvantages of the usual type of switching thus being avoided. A further advantage is that, in case of necessity, the last valve of the radio receiver can be replaced by one with

higher rating. Generous dimensions are given to the mains eliminator of this television receiver and from this eliminator can be taken off grid bias voltages of the valves as well as voltage for the glow lamp.

The synchronous motor which is employed by the Fernseh A.G. is of a special type and is self-synchronous. The correct speed can be attained by two different

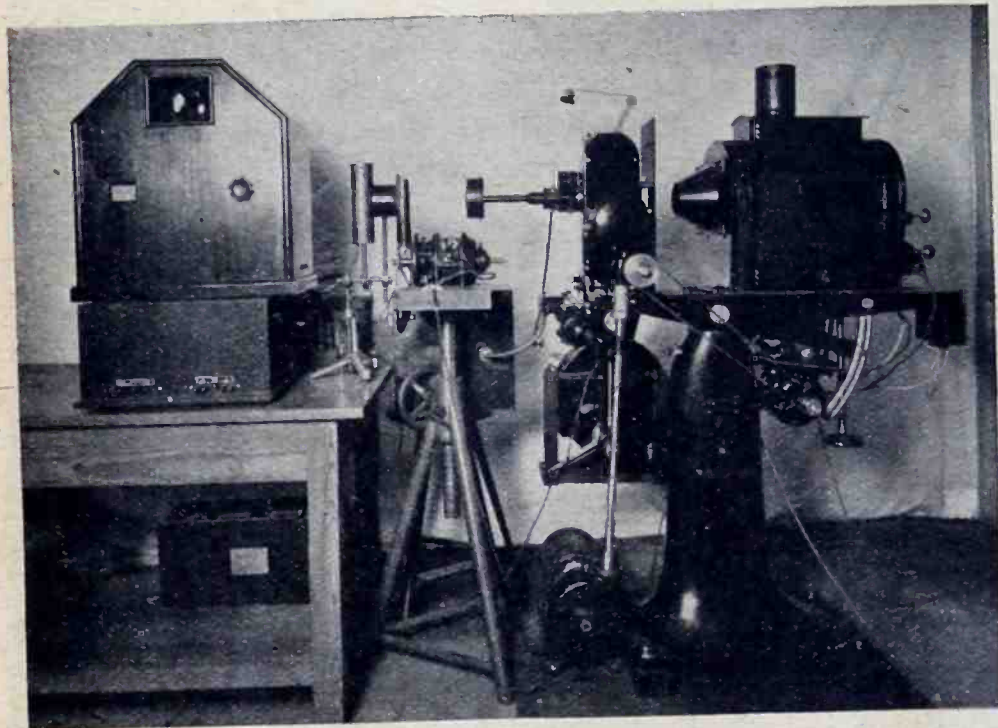

*The Fernseh have produced this "movie-tone" television transmitter, and excellent images are obtained*

and in the case of a picture of 3 by 4 cm. the number of elements will be 3350. This number of elements is about three times that which is usual in the Post Office experimental transmissions. This transmitter also will be put into use, but the pictures can only be received by the Fernseh A.G. receiver.

Particular attention is drawn to the transmission of

methods, either by the application of a hand-wheel or by the use of a small auxiliary motor mounted on the same spindle as the synchronous motor. In the latter case the synchronising of the motor is brought about simply by pressing a knob. This receiver is shown at the head of the article.

Particular attention is drawn to the fact that perfect synchronism is attained which, in the case of transmitters and receivers working from the mains, has hitherto been impossible. The Fernseh A.G. have succeeded in constructing a mirror-drum receiver having the same synchronising methods, and the whole is kept in step, using the same amount of energy as that consumed in the case of a Nipkow disc of about 300 mm. diameter. The whole apparatus is fitted into an elegant mahogany case, the image thrown by the mirror-drum being projected on to a matt screen, size 90 by 120 mm., on the front of the case. The mirror-drum is driven by the same synchronous motor as used in other models. This motor is coupled

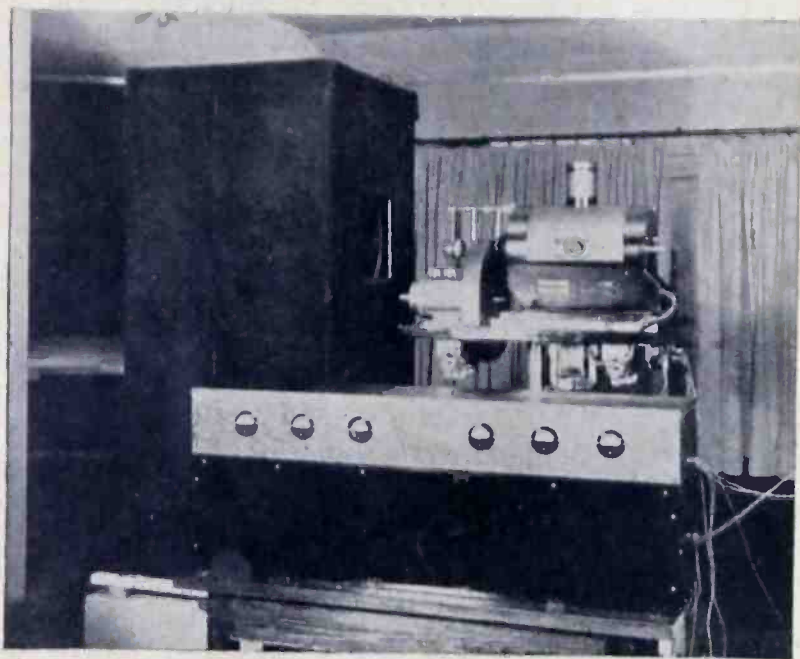

*A light spot transmitter suitable for 1,200 or 1,750 picture elements as made by Fernseh A.G. for the German post office.*

to a small auxiliary motor, which is switched out of the circuit as soon as synchronism has been effected. It is really surprising what small rating this possesses, this being of the order of 4 watts for the synchronous motor. A special point-light type of glow lamp is used as light source, this having a heated cathode.

Thus the Fernseh A.G. have succeeded in introducing a small apparatus of the projection type with simple synchronising.

The Fernseh A.G. also exhibited apparatus constructed by the Baird Company. As these receivers are built according to different standards from those prescribed by the German Post Office, they unfortunately could not be used for the demonstrations.

In order to enable the amateur radio enthusiasts to build their own television receiver, the Fernseh A.G. have decided to supply component parts, details of which are given in the Company's prospectus. Schemes of connections, together with price lists, are also found in the prospectus. The component parts were also seen on the stand.

## Bristol Calling

USING a Baird "Televisor," the simplicity of which is marvellous, I have for many months been a viewer of the television transmissions which are daily broadcast from the Baird studio through the National and Regional Stations, at Brookman's Park.

No words can express the additional pleasure it gives one to see the actual actions of living people at the same time as hearing them. J. I. Baird, the British inventor, who was the first to demonstrate true television to the world, and has since made possible television broadcasts as a feature of our daily radio programmes, deserves not only our congratulations but assistance and help from all real experimenters.

During the months that I have been viewing these transmissions great improvements have taken place. Clearer and better defined pictures, more steady synchronisation, screen news more easily read, and programmes are most pleasing. The transmission of plays, competition, etc., have shown most forcibly that the synchronisation of sound and action is the most wonderful achievement in radio, and that in the future one cannot possibly go without the other.

Reception at Bristol has been such that within fifteen seconds synchronisation has been obtained in 95 per cent. of transmissions received, and unless distorted by atmospheric or other outside disturbances the results received are remarkably good.

The play, "The Man with the Flower in His Mouth," and your novel competition, were both demonstrated to the press, photos were taken and published by them, together with complimentary remarks about transmissions (see page 351 for photograph). Ghost or echo images have been noted and data obtained, and forwarded to Professor E. V. Appleton for his address on Wireless Echos before the British Association.

Television is an accomplished fact, and I add my congratulations to TELEVISION Magazine.

Radio G 6QW of Bristol.

W. B. WEBER.

### This Month's Causerie.

*(Concluded from page 315.)*

The demonstration in America fails under any of these conditions. It does not appear to have been extensively advertised, nor does there appear to have been a daily transmission, nor in fact was an independent jury of the public permitted to witness a demonstration under the same conditions as those which obtained in London. We are content, then, to leave it to posterity.

There is, however, a British claim which does not appear to have had even the ghost of opposition. The first teletalkie by television ever shown anywhere in the world was given in London by Mr. Baird on Saturday, August 9th, 1930. We shall be interested if any enterprising inventors can state a counter-claim.

Meanwhile the race for television proceeds, and if Mr. Baird maintains the lead he has at present, the prestige of British television is in no imminent danger.



*Look out for  
these artistes on your Television  
screen during October*

~ ~ ~

1. Mr. **BRET HAYDEN**, one of the first artistes to broadcast from Marconi House. Has a fund of good stories to relate, and is a clever mimic.
2. Miss **MABEL ADEANE**, "The Versatility Girl," is effective both in comedy songs and monologues.
3. Mr. **JOHN MOREL**, the well-known baritone, who appeared in the operette, "The Damask Rose," at the Savoy Theatre, London, and also at the Queen's Hall "proms."
4. Miss **CECILE FORBES**, soprano. Another artiste from musical comedy, who recently toured as leading lady in "The Vagabond King."
5. Mr. **WILL RUSSELL** will recall to lookers-in his humorous character cameo, "The Headmaster."
6. Miss **JANE LEE**, a gifted soprano with a delightful style of her own.
7. Miss **DOROTHY VERNON**, soprano, knows the value of facial expression when televising.
8. Miss **PHILIPA HERON**, a comedienne with personality, who possesses a unique repertoire of songs.



# The Crystallization of Selenium

PART I.—GENERAL REMARKS

By *James Scott*

Fellow of the Television Society ; Member of the American Chemical Society

A FEW months ago Mr. G. P. Barnard gave a lecture on "The Photo Conductivity of Selenium and various other Substances" before the Members of the Television Society. During the course of his remarks the crystallization of selenium was dealt with, and since it is such an interesting topic it is hoped that this additional information will prove helpful.

My article on "Selenium" in TELEVISION for May, 1928, dealt chiefly with its origin, physical properties and modifications, or polymorphism.

Until the subject of this remarkable light-sensitive element has been fully studied by competent men, it will still hinder operations during its use in a selenium cell owing to the heterogeneous massing together of its minute crystals. There appears to me, however, no more reason why selenium could not be rendered into a homogeneous film like glass. Window panes of good quality are practically entire, yet, essentially, they are crystalline. Take a piece of plate-glass, for instance; and light, whether it be sunlight, electric light, or gas light, passes freely and uninterruptedly through the substance; there being no analogy between the transmission of light rays through it and a film of selenium. In the latter substance the light waves are refracted, and otherwise distorted, hence the faults noted when it is used in a selenium cell, due to the crystal planes.

A few words on the general topic of crystallization may be welcome. An individual, separate, crystal of any element, or compound, consists of symmetrically arranged atoms, molecules, or units, so disposed of that the external form of the mass has a definite, constitutional series of planes and points. In other words, it has geometrical shape; and this is as a rule fixed for the particular material being considered.

The atoms may be conveniently compared with invisible "bricks." Just as a builder may so arrange his bricks as to make a square, oblong, or other kind of wall, or lay them to produce a set of steps, a pyramidal mound, and so on, so does the inscrutable law of crystallization erect the atoms of an element into a

perfect crystal, capable of being altered during its growth into another pattern, apparently quite different, yet belonging to the same fundamental system.

Formerly, crystals were arranged into six systems, viz., Isometric, Tetragonal, Hexagonal, Orthorhombic, Monoclinic, and Triclinic. There are now considered to be something like thirty-odd systems; but since most of them can be resolved into the primary half-dozen types I will continue my remarks on these latter. The Isometric, into which we really ought to introduce Selenium, is also spoken of as the Regular, and Cubic, system. But since selenium is capable of crystallizing into minute hexagonal forms, it can also be said to

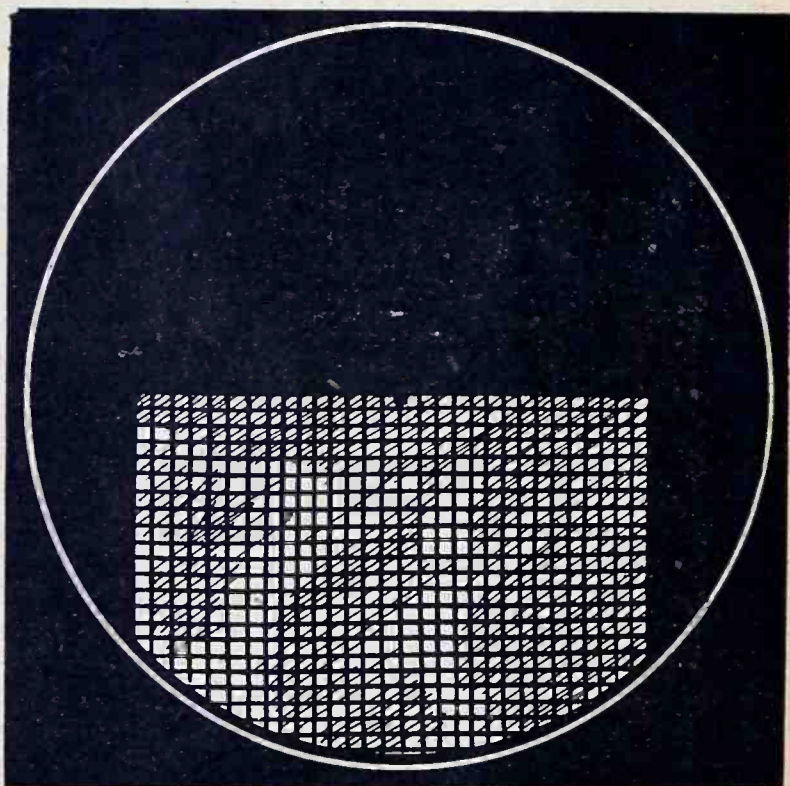

Fig. 1.—Ultra-magnified view of a cubic crystal showing how it is built up of smaller cubic units. By the modification of these units the larger crystal formed can become octahedral.



belong to the Hexagonal system. It is here where selenium proves to be so extremely puzzling. Although its name signifies that it is regarded as a member of the group of metals, it certainly is not a true metal, and is more appropriately considered as a metalloid.

Selenium can be altered, without in any way changing its constitution, into three distinct varieties, these being the lustrous, brilliant kind, giving conchoidal fractures; the metallic or crystalline kind; and the amorphous. The first named looks like bright brown porcelain, the second like dull-polished steel, and the third like lustreless sealing wax.

By the way, it is the "um" in the name Selenium that distinguishes it as a metal—e.g., sodium, potassium, cuprum, stannum, ferrum, argentum, aurum, &c. The first indicates soda, the second potash, third copper, fourth tin, fifth iron, sixth silver, and seventh gold. All these metals are minutely crystalline.

Beginning with a molten metal, a salt solution, or fused selenium, the soft mass, or fluid, is of course shapeless. As it cools, microscopic nuclei, or particles, separate out, and around them are systematically and symmetrically arranged other particles, or atoms. A molecule is an arrangement of elemental atoms in a compound manner—still perfectly geometrical. But I am really trying to confine my notes to elements, as they yield the purest and best crystals; and selenium is an element.

As the substance is transposed from its fluid, or plastic, state into a solid one the units are laid down side by side in perfect order; and if it belongs to the cubic, or octahedral style, these invisible "bricks" will yield either a tiny cube or octahedron. If the nucleus starts as a cube it may, later on, give rise to a larger octahedron. If it starts as an octahedron it may, later on, give rise to a larger cube. Such changing is usually accomplished on a minute scale so is commonly unobservable.

In "The Outline of Science," Vol. 2 (edited by Professor J. Arthur Thomson), in the section under "The Romance of Chemistry," it is stated that "Little is known of the determining causes of the formation of crystals." Seeing that these books were published only a year or so ago, it is obvious that more knowledge on the subject is desired. Professor Sir William H. Bragg has lately been undertaking some unique researches into the structure of crystals from the electronic point of view; and a study of his writings should be of great service to "televisionists." I am avoiding, at present, much reference to electrons, and kindred phenomena, though they are so closely related to the causes of crystallization, and the light-sensitiveness, in particular, of selenium. Once manage to produce thin films of homogeneous, instead of heterogeneous, selenium (that is in a glossy rather than a crystalline state) and its possible use for television purposes may arise. It possesses unique capacities.

In Fig. 1 is shown a magnified aggregation of crystal units (or "bricks") diagrammatically. Whatever is the actual cause of the first unit, nucleus, or atom, solidifying out; it is stamped with the creative power of its type. Common table-salt (chloride of sodium)

will give the reader—and not all the readers are professional men and women—a good idea of the subject. This handy substance crystallizes in the cubic (Isometric) system; though this fact is seldom noticed.

Make a strong solution of the salt—a so-called brine—by dissolving in some hot water as much as this will absorb. When this saturated solution is obtained, filter it in its cooled condition, pour it into a shallow glass jar, cover the latter and leave all alone

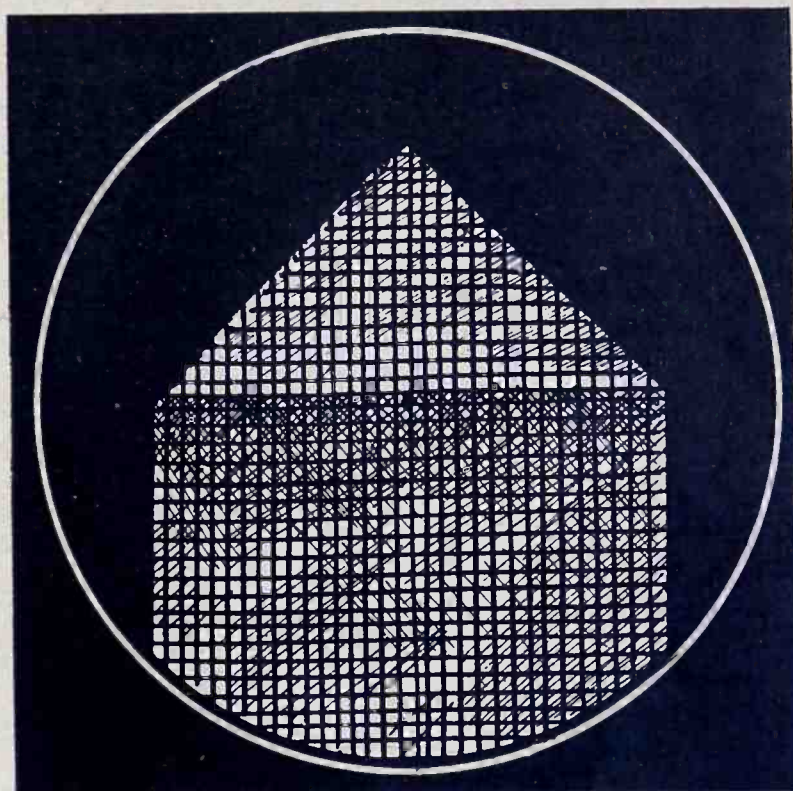

Fig. 2.—A cubic crystal (greatly magnified) being resolved into one with quadratic plane summit. When both halves are similar an octahedron is produced; and this may become a larger cube.

for a few weeks in a warm cupboard. At the end of that time excess water will have evaporated, and a beautiful mass of glistening cubic crystals, of small yet noticeable sizes, will be found. These contain "water of crystallization," and if the salt crystals are heated to drive it out, only a shapeless heap of opaque white salt is left.

Now each little salt cube has been built up on the plan of cubic units, the cube thus being a collection of smaller cubes; right away down to invisibility even under a powerful microscope.

We can get a better idea of the truth if we place a few drops of a strong salt solution on a glass slide, leave it for a few hours to evaporate, and then magnify the film. Very minute scattered square slabs will be found, crossed at right angles internally with fine lines (ultra-minute, particules, or unit boundaries) which divide each crystal into tinier cubes. The whole crystal is divided across the middle diagonally.

Many years ago I had sent to me a mass of salt cubes, about a foot in diameter, by the manufacturers of a branded class of table salt. Some of the cubes were six inches wide, and one could see that they were made of smaller cubes. A few of the large cubes had

sunken middles, the depressions going down four sets of steps with cubic blocks! The masses were called "Saggars."

This cubic plan persisted right into every part of the crystal; a piece chipped off and dissolved in water; the solution then being evaporated, yielded microscopic cubic crystals.

I have digressed into this side issue because of the importance of making the minute method of crystallization understandable. The fundamental cause for such definite formation is less explicable. But you can always rely on the fact that salt water will crystallize in little cubes. Other substances, including selenium, obey kindred laws, but selenium is comparatively new to us, whereas salt has been known to mankind for ages.

Selenium is one of those elements which, for some reason, crystallizes in what would popularly be called different ways. But the variations are actually related very closely to one another. I will deal with them in my next article. Meantime, reference must be made to Fig. 2, which shows how, by nature mysteriously solidifying out from a fluid, or paste, in the original number of units, gradually reduces them; so that instead of a cubic crystal (say) having a flat, square, plane or face, when its size has been increased, will disclose a double four-sided pyramid—an octahedron, really.

In Fig. 3 are shown some minute salt crystals (which anyone can obtain within a few hours) for the purpose of elucidating my previous remarks. Naturally as the internal crystalline units get smaller, their lines of junction, or boundaries, are revealed, magnified, fainter and fainter, to the observer until finally none can be seen.

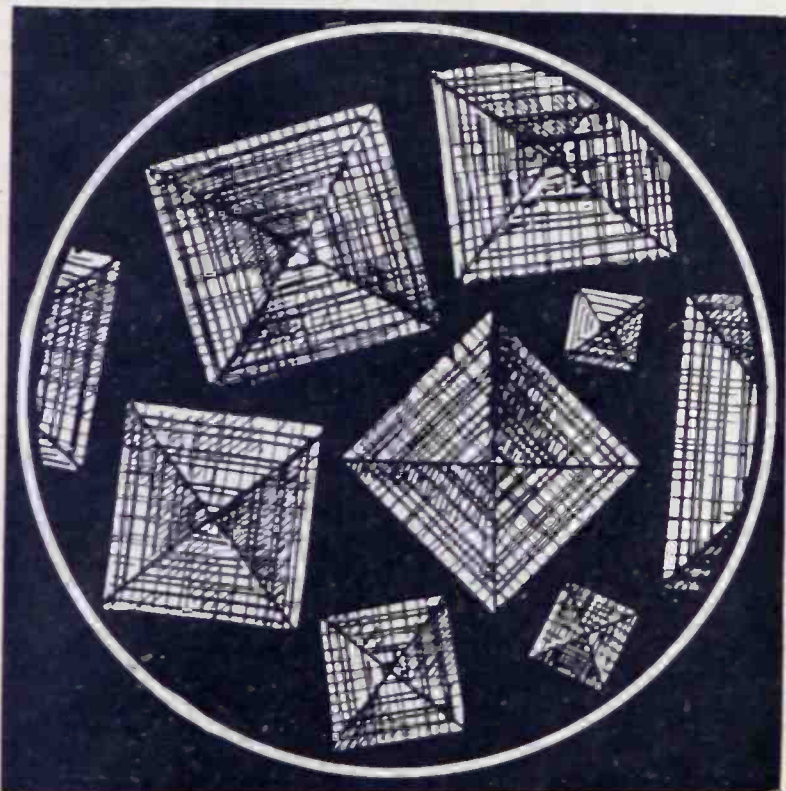
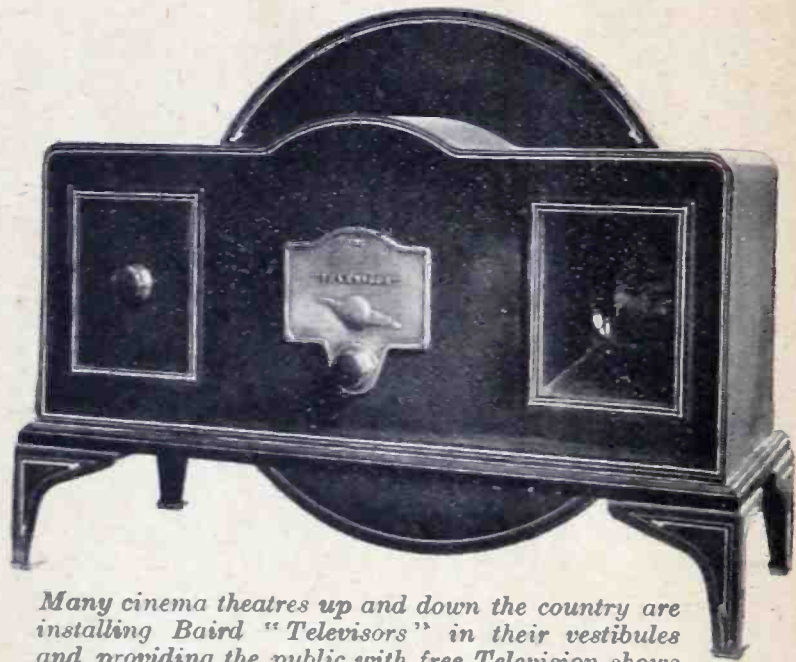

Fig. 3.—Greatly magnified transparent crystals of table salt (sodium chloride) deposited after evaporating a solution of the salt on glass. Note the internal units responsible for external formation.

## History—and a Symbol

(Extract from Editorial of "To-day's Cinema" dated 12th August.)

WITH the presentation in public in a London theatre of a "televised" talking film, television takes one step forward towards history. Crude as may yet be its condition, primitive its effects, it has arrived as a calculable force in the entertainment world.



Many cinema theatres up and down the country are installing Baird "Televisors" in their vestibules and providing the public with free Television shows in the mornings from 11 to 11.30.

The Coliseum demonstration is a significant event. For the first time on a public stage a film has been seen as it has been broadcast in sound and vision from a central studio. The practicability of the new entertainment is thereby established. Though the Coliseum was alone in this event last week, it is surely the forerunner of a new day when one film will be broadcast from a central studio and received and televised on a multitude of screens throughout the country.

It is true that the picture as seen at the Coliseum was small and none too clear. Criticism of its æsthetic and technical deficiencies would be easy. But it must not be forgotten that it is a newly born infant. It compares surely with the early silent films in their embryonic state. Yet the cinema has developed to a state of maturity and technical perfection far beyond the dreams of the most confident pioneer. If the cinema could reach this state of perfection there is every reason, considering the rapid rate at which technical science develops, and the resources of modern machinery and mechanics, to believe that television will follow suit.

It needs no stressing that at this stage television presents no menace to the film. It will be some little time before it becomes a practical force. But the Coliseum demonstration proves that it can be done, and showmen must be alive to the fact. For, as we have already said, it is of little use to wait the *fait accompli*, and then groan. The logical process is to get wise to it and to use it to our own ends before the groaning stage arrives.

# Television Below 100 Metres

By B. Marshall

WHEN arrangements are made for television broadcasts on short waves there will be a wonderful opportunity to prove what a small band in the ether can be taken up by a television transmission.

Some of the American stations are now giving experimental tests on wavelengths below 100 metres, but the reception of these is beyond the capabilities of most amateurs in this country, at least at sufficient strength for the operation of a "Televisor." Most of the American and Continental transmissions are put out on wavelengths above 200 metres, however, and this has partly to do with the difficulty of "holding" below-100-metre signals for long periods without fading setting in—which results in lack of synchronism.

## A Suggested Circuit

There are plenty of amateurs with short-wave sets which could easily be added to a good L.F. amplifier for operating a "Televisor," but experience shows that something special in the way of "wavelets" sets is needed.

A good circuit is shown by the accompanying diagram. It shows only the high-frequency side, and would need two or three L.F. stages to bring the output current up to a sufficient value for the "Televisor," but it is to the H.F. side that attention must be turned if television reception below 100 metres is to be made practicable.

This little short-wave receiver could be made up in a metal box and connected, when needed, to the L.F. side of the broadcast receiver. It would be equally suitable for ordinary 'phone reception on the short waves, but it has been arranged specially for television reception. Just what this means will best be appreciated by an analysis of the circuit.

A striking thing is that a screen-grid H.F. stage is employed, which is a thing many people still declare to be impossible below about 150 metres, no matter how much screening is used. In this circuit *no screening between the stages is needed*, although it is advisable to put the whole set in a metal box. This is more than can be said of many broadcast-band screen-grid sets, in which elaborate screening is needed to secure stable working.

The stability of this receiver is the result of doing away with coils in the aerial circuit. A high resistance is, instead, placed across the grid and earth

terminals. This is a good way of using an S.G. valve below 100 metres, although it is not very efficient on broadcast wavelength. The resistance should have a value of about 100,000 ohms, and need not be wire-wound, for it has to carry no heavy current. A 1½-volt dry cell, shunted by condenser C<sub>6</sub>, 1 mfd., applies the small amount of grid bias which most S.G. valves need for proper working if their impedance is not too high.

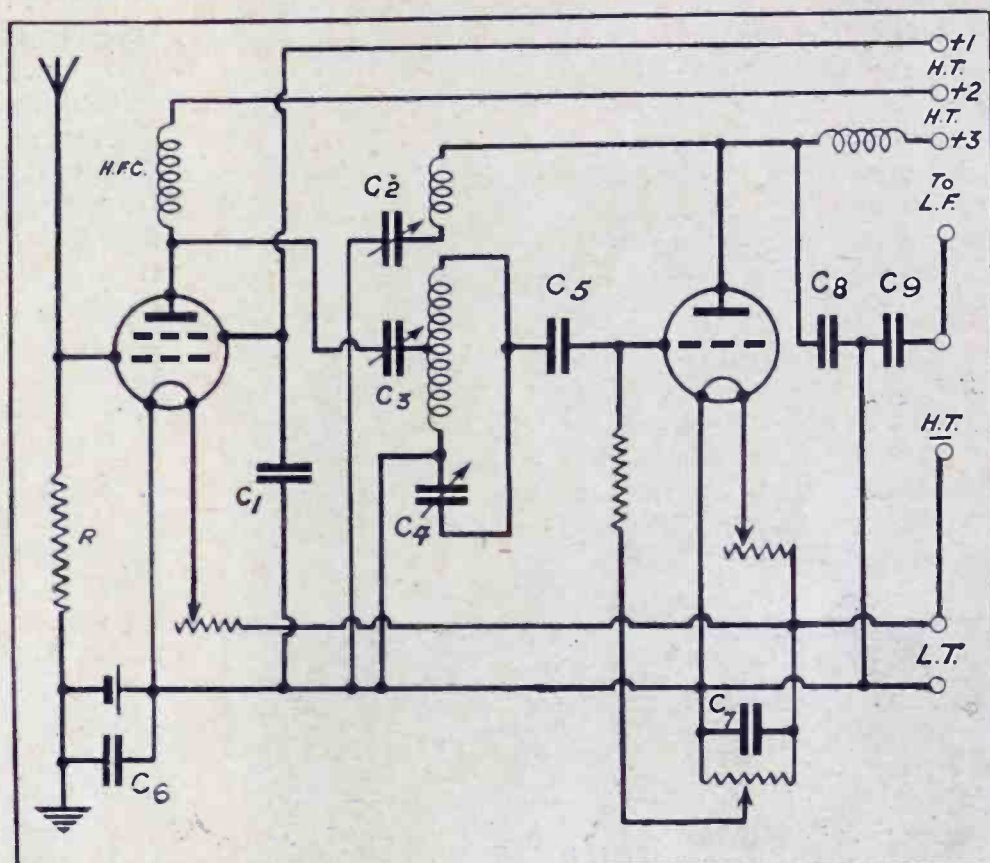

The short-wave circuit suggested by the author as being very suitable for working below 100 metres.

## Component Details

The H.F. chokes both in the H.F. and detector stages should be of the low-capacity special short-wave type as ordinary H.F. chokes for working up to 2,000 metres have too much wire and too great a self-capacity.

Most of the condensers have conventional values, C<sub>1</sub>, the screen-stabilising condenser being, together with C<sub>7</sub> (shunting the potentiometer) of 1 or 2 mfd. The tuning condenser, C<sub>4</sub>, need not have a maximum larger than .0003 mfd., and the reaction condenser, C<sub>2</sub>, should be .0001 mfd. The coupling condenser, C<sub>3</sub>, is a small pre-set (type J, maximum .0003), although a fixed condenser of this value could be used, but it is generally better to have a variable control here.

The grid condenser should, for most valves, have a

capacity of .0001 mfd., and a leak of slightly higher resistance than usual, say 5 megohms, is best to use. The by-pass condenser,  $C_8$ , may be .0001 mfd., while the shunt condenser across the output is given as .001 mfd.

### Operation

For television working this circuit would be very satisfactory, for there is a minimum of control needed. Before a station is tuned in the potentiometer arm should be set to the mid-point and the reaction control tried. If there is any threshold howl or plopping as the set goes into oscillation then the arm can be moved one way or the other—generally towards the positive end.

Set the coupling condenser,  $C_3$ , at maximum, with the knob screwed right in, and tune with the main  $C_4$  and reaction  $C_2$  condensers in the usual way. A loud-speaker can be placed across the output terminals for a first test, and once the proper tuning point has been found the L.F. stages and the "Televisor," can be connected up.

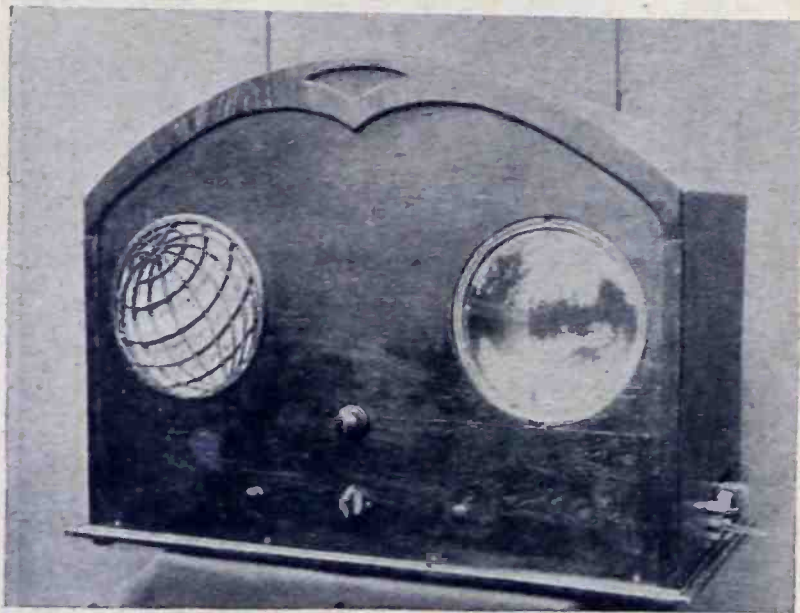

*Mr. A. R. Knipe is naturally proud of his home-made vision apparatus, a reference to which is made on another page of this issue.*

The writer has had an amplifier made up to this circuit working satisfactorily for some months now, and all the large American and Canadian stations can regularly be logged, although short-wave conditions have not been any too good recently.

Television enthusiasts would be well advised to make up a short-wave amplifier similar to the foregoing, no matter how roughly it is "hooked-up," for tests of television below 100 metres are a distinct possibility of the future, according to announcements which have appeared in the Press from time to time.

It is known that the Baird Co. have a short-wave station in course of erection, and this will do much to extend the value of their television broadcasts.

---

**SCANNING DISCS.**—Special parts made. Models for inventors. Experimental work of all kinds.—JOHN SALTER, Featherstone Buildings, High Holborn, W.C.1.

## Television at Wrexham

*(Extract from "The Leader," dated July 25th, 1930).*

"What is possible and what is impossible, can anyone say? Going back a hundred years or so a great philosopher says "Man might as well try to find out what the stars are made of." Kant would be very surprised to learn that the chemistry of the stars and the sun is as well known as that of the earth itself.

"Sir Norman Lockyer discovered helium in the sun 30 years before we knew we had it on earth.

"Caruso, the great singer, is no longer with us, but as far as he entered into most of our lives he is still here. We can still hear him sing, and this achievement of the gramophone stirs up no more than passing interest. It is possible now to converse with anyone in almost any part of the world. Wireless has given wings to voices and sounds, it bears them everywhere. The cinematograph and the aeroplane are other things that have helped to achieve the impossible. There are, in fact, so many wonderful things that wonder has become a commonplace. We are suffering from such a surfeit of scientific achievement that some marvel or another may even now be passing quite unnoticed. Late the other evening I walked into the den of an enthusiast. It brought joy to my heart, the table was covered, the floor was covered, everything was everywhere. It was a man's room, and although it was almost necessary to push the tobacco smoke out of the way to get in, once inside neither time nor anything else seemed to matter.

"Our enthusiast moved through the maze of apparatus with the skill of an acrobat. On goes a switch near the fireplace, two or three clicks on the near table, down goes another switch on the far table, something hums, and keeps humming. Three or four lamps light on the near table. 'Put out the lights, please.' From the far table the hum still continues, and a luminous glow spreads out from the apparatus on it. We draw near, and we gaze on to a small screen across which light and dark bands are flickering. Our enthusiast, Mr. A. Hughes, Electrical Engineer, 21, Charles Street, and 11, Smithfield Road, Wrexham, is now turning knobs; it wants skill and it wants care, and he has them both—but stop, what is this? Am I dreaming, or is it a trick? I see a man's face as perfectly as if I were looking at a photograph. He is speaking; I see every movement of his mouth and all the rapid changes in his features. It is truly a living picture. It slowly moves off the screen. Our enthusiast finds some difficulty in achieving synchronisation. We chase the picture on and off for half an hour, and at its best one sees something wonderful in the way of achievement.

"It is really possible to see by wireless, and like all things of its kind, television has not been born perfect.

"At present it is subject to many limitations, but the seed of television has been planted, and is sprouting.

"Enthusiasts like Mr. Hughes are the people who are going to help to bring this marvellous invention of television to a state of maturity." (J.J.)

# Feminine Reflections

## Tell a Woman by Television

### Eve's Latest Career

By *Nancy Debenham*

I LAID up a spot of bother for myself when in a recent article I hinted that television might open up new careers for women; since then I have been bombarded with enquiries as to "What exactly did I mean?" "How is it possible to become a television artiste?" etc., etc.

To all these aspiring Eves I might say that my remark about hairdressing demonstrations, lessons in beauty culture, manicure, dressmaking and all the other subjects dear to the heart of women was just a hint of the future; although the not-too-distant future, we hope.

I also hope that every one of them will take the very first opportunity of studying the matter at first-hand; "Televisors" are now on sale, and can be attached to any really good wireless set. Soon your seven-valve set with no "aural sister," as Mr. Moseley so agreeably put it, will be as out of date as a silent "custard-pie" film comedy.

#### *Eve Unadorned*

Looking ahead again, I feel that we shall soon be searching for the woman with a perfect television face; I have seen the faces of dainty ladies, in period dress and head-dresses, on the screen, and their clarity of detail has been amazing.

Here's a funny thing: we all know that "make-up" enhances the charms of the stage and movie star, but there will be no gilding—or rather rouging—the lily in the television studio. Eve has to appear quite unadorned as to facial make-up, because of the red and infra-red colours in the light itself (aren't we learned!). So there is a lovely chance for the truly beautiful, clear-skinned daughter of nature. She may be employed to demonstrate "How to deal with growing hair"; "How to cure falling ditto"; or "Massage without tears." Anyway, when the B.B.C. get busy with their programmes let us hope they keep my words in mind, and give us subjects of vital interest to women.

#### *For Sports Girls*

And what a chance for the girl with the perfect golf swing, the world's wonder swimmer, or the tennis champion!

We have paid our one-and-tuppences and seen fleeting impressions of many of them on the pictures; we have heard a few of them on the sound films, but a picture-house is not intimate and cosy like a television screen; let us hope that the champions in sport will give us their television turns slowly, smoothly, and very simply, so that we can take it all in.

With golf-club or tennis-racket in hand we might follow the movements of the "star" with much advantage to our game, although I have an idea that the household furniture of a breakable character might suffer.

There, the television student has a great advantage over the mere cinema-goer; I have *never* seen film-goers taking advantage of film sports lessons in that manner.



*The interest in television reception is not confined to the male sex. On every side we find the ladies expressing keenness in this new addition to the home.*

# LETTERS TO THE EDITOR

The Editor does not hold himself responsible for the opinions of his correspondents. Correspondence should be addressed to the Editor, TELEVISION, 505, Cecil Chambers, Strand, W.C.2, and must be accompanied by the writer's name and address.

## SIDEBAND INTEREST STILL UNABATED.

To the Editor of TELEVISION.

DEAR SIR,—The letter of Merlin Jones in the July issue is a good example of the extent to which mathematics is a substitute for thinking. We are told that mathematics is an integral part of all *theoretical* structures, which may be very true, but we are more interested in *actual* broadcasting than we are in *theoretical* broadcasting. Mr. Bailey, in the June issue, gives seven clauses stating the equivalence, seven times over, between a modulated single frequency  $MC$ , and three unmodulated frequencies  $A$ ,  $B$  and  $C$ . Yet both he and Mr. Jones turn right around and argue *against* the equivalence of the two theories of modulation suppression. In his conclusion to his second paragraph it is suggested that he extend the italics to include the word "known." Just because the resolutions into the components  $A$ ,  $B$  and  $C$  permits of the *only known* solution to the differential equation, is no proof that nature does not solve it physically by opposing the inertia of the tuner to the rise and fall in resonance. In the expression,  $MC=A+B+C$ , either side of the equation is a correct representation

as we pass from the left-hand side of the equation to the right-hand side; and, if it does, why do not the triple frequencies change back into a single modulated frequency as we pass back again?

If mathematics regulates the sun, moon and stars, as Mr. Jones would have us believe, instead of merely describing their motions, then surely the physical structure must vary with the mathematical structure as we shift back and forth between the two members of the equation, and one moment we have a single modulated frequency and the next moment three unmodulated frequencies. It is surprising how many can be found who are able to solve differential equations who do not know the meaning of the words "equivalent" and "component."

According to his fourth paragraph the sidebands are so unequal that though one is very strong the other has negligible strength. I suggest that Mr. Jones try the numerical solution to the sidebands. The solution for the sideband currents gives fairly unequal amplitudes, but the inequality is almost unmeasurable at the rates of modulation he argues for in his eighth paragraph. When each component current (which was obtained by dividing each

component of the modulated impressed voltage by the impedance of the circuit to each) is in turn multiplied by the condenser reactance to each in order to obtain the voltage impressed on the grid—that is, to obtain the potential drop across the condenser—the sideband voltages which are now found to be suppressed are likewise practically equalised, if not exactly so.

Thus, if equal sideband voltages are impressed in series equal sideband voltages will be taken off across the condenser, though the sideband currents through the condenser are slightly unequal. Since it is voltage that is utilised on the grid and not current, what good is all the mathematical hocus-pocus on the inequality of the sidebands as given in his illustration and text?

Paragraph 7 calls attention to trouble that might arise from the *tenth* harmonic of the modulation when it should be the *eleventh* harmonic. It suggests the remedy by shifting the modulation to 600 kc., but does not say what would happen

to the *ninth* harmonic of 600 kc. or, if there were no odd harmonics, the *eighth* harmonic. The fact is, this is stretching the argument a little too far in an attempt to refute the facts as found by Mr. Spreadbury.

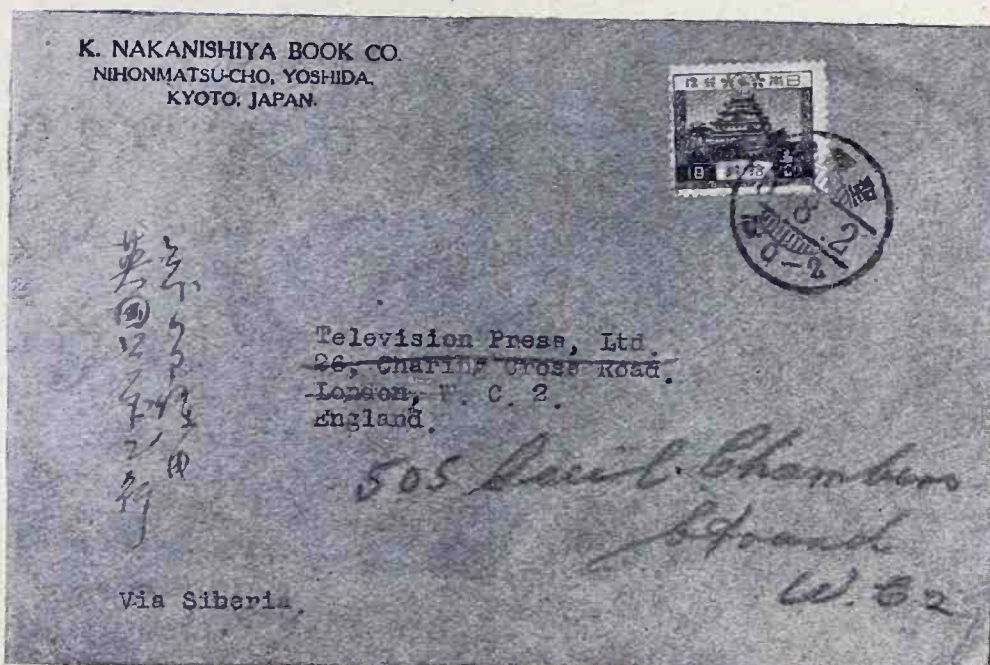

That our journal stretches to the very ends of the earth is borne out by the letter we received from Japan a few days ago. It will also serve to remind readers of our change of address in case they have failed to notice this important fact.

of a modulated carrier wave. If mathematics is such an integral part of all theoretical structures, does the modulated single frequency  $MC$  change over to the unmodulated triple frequencies  $A$ ,  $B$  and  $C$

Paragraph 8 calls for the observation that there is no fundamental difference between a radio frequency and an audio frequency, any more than there is any fundamental difference between "hot" and "cold." Set a pan of hot water on the right and a pan of cold water on the left, and a pan of lukewarm water in the middle. Place the hands in the two outside pans for a few moments, and then place them in the middle pan. It will be found that the middle pan of water is both "hot" and "cold." I do not know what the "mathematical and integral structure" of this theory is, but the question readily arises as to how "hot" is "hot"?

Paragraph 9 suggests the possibility that a "certain circuit" behaves at variance with all the known fundamental principles. I have noted that certain circuits do this generally when they refute the theory of the reality of sidebands. It depends somewhat on which side of the argument the circuit is on as to how it behaves.

If Mr. Jones cares to he may note the following about Dr. Colebrook's discussion, and compare it with Mr. Bailey's letter. Mr. Bailey keeps the valve on the *linear* portion of the curve to obtain sidebands, while Dr. Colebrook takes care to operate on the *square-law* portion of the curve. It appears, therefore, that it is possible to make the sidebands appear or disappear at will, depending on whether the operation is on the *linear* or the *parabolic* portion of the curve, and that different investigators have different ideas about which part of the curve produces the sidebands.

Most potent is the argument that the sideband theory has been in about ten years now, yet in the hands of the most capable investigators it is still unconfirmed experimentally. If it were the principle of the induction motor under consideration there would not be the slightest difference of opinion. This is because there are no known components to the theory of the induction motor. As soon as the *components* of the modulated carrier wave sprang up ten years ago the confusion started.

Yours faithfully,

VERNE V. GUNSOLLEY.

116 So. 4th Street,  
Minneapolis, Minn., U.S.A.

#### A CURIOUS POINT. CAN READERS EXPLAIN?

To the Editor of TELEVISION.

DEAR SIR,—I have not written you for some time regarding reception here of the transmissions from the 356-metre station, as you will no doubt fully understand that hardly anything is receivable here at this period of the year owing to the extreme weakness of the station in question and also the predominance of static.

However, in the August number of TELEVISION the remarks made by your correspondent "Uncle Tom" in his letter to you, extracts of which you publish, have confirmed certain views which have been puzzling me for some time. I am referring to the relative signal strengths of speech and music as compared with television transmissions.

In my own case I am referring to the 356-metre station only. As I have already mentioned, although this period of the year is hopeless for receiving this station, every Tuesday and Friday night will find me ready for the transmission as a matter of interest. The last strains of dance music and the chimes of Big Ben, followed by the B.B.C. announcer announcing the Baird transmission to follow, we can state as being just audible when one's head is glued tight

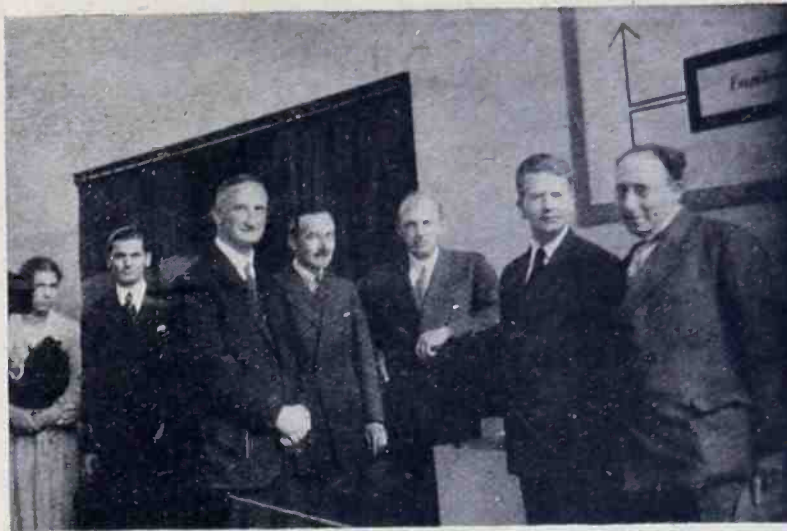

An interesting group at the Berlin Radio Exhibition. Mr. Baird is second from the right, with Mr. S. A. Moseley on his left. Then we have on Mr. Baird's right Dr. P. Goerz, Managing Director of Fernseh A. G., Mr. L. P. Napier, General Manager of Baird Television Ltd., and Dr. Banneitz of the Reichspost-Zentralamt.

against the loud speaker. A quick switch over to the "Televisor" will find no impression on the screen whatsoever beyond static flashes. Precisely what the last tune was one could not say, and I have had people present who could not even tell that Big Ben was striking. This will give you an idea of what the strength is. Now the curious thing is that as soon as the Baird motor and transmission commenced signs of the image transmitted are immediately apparent on the screen in the form of the characteristic lines and black masses moving up and across the screen. It is generally too weak to make anything of, as you will understand, but the main point is there is something there which, if stronger, could be held, whereas the music and speech made no impression whatsoever. I am quite sure that the signal does not increase in intensity. I thought at first that increased power was being used.

I trust that I am not wasting your time in writing you of this, but your correspondent's remarks certainly intrigued me, coming from England where I should have thought such a thing would not have been noticed. Here, 1,600 miles away, anything of such a nature is immediately noticed, but with so many varying factors to contend with, one is apt to let them slide by. I shall take particular notice of the transmissions from now on during the next twelve weeks, during which time strength of all stations should gradually improve, until they reach the maximum period in December.

I may say I have had no television reception that could be called fair since April last, but this has not deterred me from keeping an eye on the Tuesday

and Friday transmissions, as it is intensely interesting to study the reception even at this time of the year. I trust I have not unduly bored you in writing you of this, but I thought you might find it interesting yourself, and perhaps the technically minded persons of the Baird Company can offer an explanation.

Your magazine is always very welcome and interesting, but I think the subject deserves a plainer cover, more space given to it (increased price of course understood), and, especially now, more frequent publication.

Yours faithfully,

W. L. WRAIGHT,  
*Associate, Television Society.*

c/o The Madeira Electric Lighting Co., Ltd.,  
Campo do Almirante Reis,  
Funchal, Madeira.

August 5th, 1930.

#### INTERESTING EXPERIENCES.

*To the Editor of TELEVISION.*

DEAR SIR,—I think you and your readers may be interested to know of my adventures with television during the last few months. I have been a reader of your magazine since the appearance of the first number, and saw that here was something to revive my interest in radio work, which has extended over the last eight years. My first "Televisor" would have given Mr. Heath Robinson a nightmare; the scanning disc was of cardboard, and though marked and cut with great care gave very streaky images. It was rotated by hand through friction gearing, the cost of a motor proving too much for my pocket. The neon lamp was a Phillips' 130 volt, and was connected in

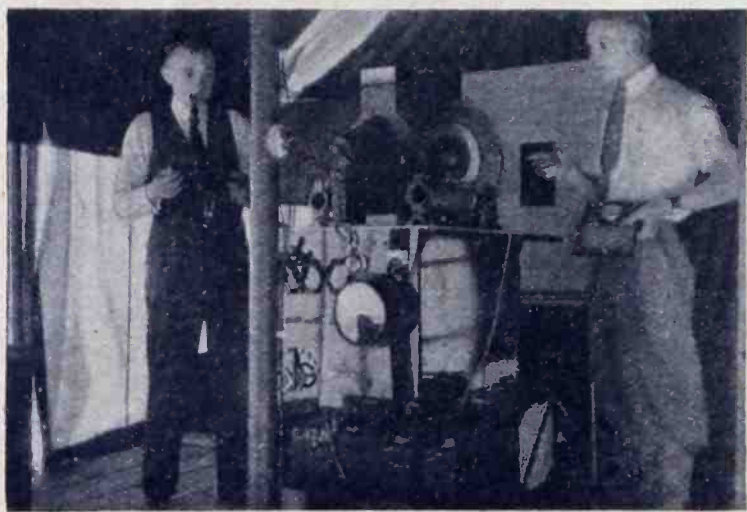

*A rather unconventional picture of the Baird transmitter as installed in a tent at the recent Colchester Exhibition.*

the anode circuit of a two-valve resistance coupled set, with 150 volts H.T. By exerting myself to the utmost, I was able to turn the disc at half speed, which gave me four small images in the field of view! The joy with which I gazed at this abortion was reminiscent of the days of 1922 when I first heard speech from 2LO. Needless to say, most of the defects have now been overcome, and I have now been

receiving good images for some weeks, using an aluminium disc driven by an A.C. motor, a 100-volt neon, and 200 volts H.T. The speed of the motor is controlled by a series resistance which can be short-circuited at will by a push-button held in the hand; this enables the image to be held quite steady after a little practice.

Yours faithfully,

J. A. I. ROYDS.

The Lawn, Gills Hill Road,  
Radlett, Herts.

#### MR. GUNSOLLEY AGAIN.

*To the Editor of TELEVISION.*

DEAR SIR,—Over in this country, when two stations get as close together as indicated by Mr. Jones' illustration in his August letter, there is hardly any interference that could be called negligible. Millions of Americans will attest to that, and mostly they possess multitube receivers, that have "knifelike" selectivity; that is, if we are to believe the advertisers.

When two stations first begin to interfere (according to Mr. Jones) the lower sideband of the upper station comes in contact with the upper sideband of the lower station. These two interfering sidebands are unmodulated, according to the theory, but by the act of heterodyning produce modulation in their resultant. As long as the modulation of both stations does not vary in frequency, this heterodyning will give off a note of steady pitch, the same as if two unmodulated carrier waves were interfering. As soon, however, as the modulation pitch changes with every change in melody, the heterodyning will also vary in pitch, so that the first thing we hear when two stations begin to interfere is a heterodyning of variable pitch. When the stations are brought closer together, finally the carrier wave components interfere and since, by the sideband theory, they are unmodulated, the two carrier waves will set up a steady heterodyne whistle regardless of the modulation, since they do not change frequency with change in modulation as the sidebands do. If! If Mr. Jones' curves are correct representations of the selectivity curve of the broadcast station as checked by an extremely selective wave meter, then we hear audio interference between stations *before* we hear carrier wave interference. Now as a matter of fact it is common experience that the heterodyne whistle comes through clearly at the same instant the audio interference starts as the stations are brought closer and closer together, and, furthermore, much to our dismay on certain very desirable programs, the interference cannot be tuned out by working on the upper sideband region of the upper station, or the lower sideband region of the lower station. A receiver so selective as to permit that would be of little use in telephone transmission.

It would be interesting to know by what mathematical expression Mr. Jones or anyone else obtains the depressions between the sidebands in his illustration. A wave meter gives them due to periodic partial resonance, but this is a peculiarity of the meter



and not a function of the modulated carrier wave in the fundamental tuned circuit. Will Mr. Jones kindly give us the formula by which he calculates that the selectivity curve of the three components is as represented in his illustration?

Yours faithfully,

VERNE V. GUNSOLLEY.

116 So. 4th Street, Minneapolis, Minn.

August 24th, 1930.

### A SUGGESTION ARISING FROM OUR COMPETITION.

To the Editor of TELEVISION.

Dear Sir,

I note from your recent communication that this time I was not successful in your competition, and thank you for wishes of success on a future occasion.

Without wishing to run a future competition that I alone could win, I think that you will welcome some ideas from a competitor's point of view.

First of all, I am sure all competitors would like to know what apparatus the winner used. We amateurs care very little for traders running on Baird "Televisors," and would like the next competition on one of the midnight transmissions. This is also a test for enthusiasm, and the competition might even be limited to amateur built "Televisors."

I think you would find plenty of us quite keen to enter for a much smaller prize. Personally I do not want a Baird "Televisor," but I would like to win a Baird disc to compare with my own, or even a pair of lenses would be useful.

I should like even to suggest that we amateurs make our own prize or prizes each month with a 6d. entrance fee. Other periodicals do it, and I am sure we already get full value for 6d. in TELEVISION, without expecting to get a 25 guinea prize thrown in.

## STAFF OUTING of Baird Television Limited.

"WE'RE off! Our coach is full; we have just been snapped from one of the office windows and the first Annual Staff Outing of Baird Television Limited has begun." The event took place on Saturday, September 6th, when a score of the office and laboratory staff, some with attachments, had a most enjoyable trip to Eastbourne.

Leaving Long Acre at midday, the first event of importance, according to the excellent programme with which we had been provided on starting, was to take place thirty minutes later, the programme informing us that—"You may start feeding!"

Our programme told us that at 3.31 p.m. precisely we should be at Eastbourne pier and our driver saw to it that we were there to time. Out of the coach we jumped, armed ourselves with bats, stumps, and balls, and proceeded to a vacant pitch on the beach where we prepared for an "exhibition" game of rounders. At least, that was the impression gathered from the size of the audience on the promenade above.

There are many more ideas and suggestions; perhaps you will have an editorial on the subject next month.

I wonder if you heard Mr. Lloyd James talk on "Mind and Machines" on September 2nd. He made some very pleasing references to television.

When next you are addressing some remarks to



Mr. W. B. Weber of Bristol is an enthusiastic television experimenter and here we see him demonstrating his "Televisor" from which he has obtained excellent results.

Captain Eckersley (to give him his military title) please quote Mr. Lloyd James: "Don't think that the world comes to an end with you."

Thank you very much, Mr. Editor, for TELEVISION, and carry on with the medicine for the folk who are weak.

Yours faithfully,

H. E. CHRISTIE.

94, Suffolk Road,  
Milton, Southsea.

September 4th, 1930.

After a strenuous game, which resulted in only one casualty calling for first-aid (Miss L. would not take off her stockings as the programme instructed the ladies to do, and naturally, when one crawls (?) on a shingly beach, it does not preserve the silk or the knee) we proceeded back to the coach which speedily took us to Wannock where we sat down amidst a maze of flowers to an excellent tea, to which everybody did justice, including Sonny Jim, our O.B., who found his pockets very useful when his belt would not expand any further.

I am not aware of all that went on during the succeeding hour—in the tea gardens there is a Wishing Well, a Witch's Circus, a Kissing Gate, and the Wannock Stile, and much of what took place must be left to imagination.

Seven o'clock came too soon and once more we clambered back into the coach and started for dear old London Town. Things got a bit mixed among the passengers—the Patents Department especially, and the "Hello" girl managed things very nicely by securing the whole of the back row for herself, the crate of bottles (some full—some empty) and one other.

R. E. L.

# The Utilitarian Aspect of Television

By *Alfred S. Reeve* (Assoc. Television Society)

THE year 1930, so far as it has already progressed, has been one likely to prove historic in the annals of television, the subject having passed from the realm of fugitive contributions in scientific journals to the great kingdom of "news" in the daily Press, not only of Great Britain but of the United States.

It is the desire of one who has watched the growth of Mr. J. L. Baird's wonderful system from its infancy to now express his concern lest television, and all that it stands for, should find itself cornered in that realm, a wide one, admittedly, which we term amusement or entertainment. For while television may well prove to be all that, quite as much as the cinematograph or the gramophone, it is something more. It is to be earnestly hoped that the many backers and friends of television will not devote the major portion of their research and energy into this, the most fascinating of optical studies, with the idea of giving television to the world merely as another, if more attractive, form of the singing and talking picture, or even as an extension of wireless telephony and broadcasting. Television must rise above that conception and enter the field of utility.

Imagination has played a great part in the advance of television. Mr. Baird dreamed big things—and that is why he was subsequently able to accomplish them—but many of those who have this year been letting their imaginations run as well, merely visualise television progress in the form of bigger screens, or as a competitor of the "movies," or the home cinema. Over and above these stands utilitarian television as a field of endeavour and, ultimately, commercial values.

The instantaneous transmission of newspaper copy from headquarters to branch producing offices, the facsimile transmission of long-distance telegrams or other form of written messages, and the possibilities opened up by flashing through the ether the actual form and semblance of loved ones, one to the other. Conceive television transmission stations working in our big Colonial and Dominion cities and those with whom we have family ties, but who have had to leave old England to seek fortune elsewhere, entering these stations on high festival days, or birthdays, or in moments of domestic trouble, and being able to see their loved ones at home and be seen of them, by the payment of a fee as one now pays for a long-distance telephone call, or a cable to Wall Street. To conjure this up is to visualise the forging of yet another sentimental link between the Motherland and her sons and daughters the Empire over.

The use of television by the forces of law and order in this country is another phase that leaps to the

mind. The instant transmission from police station to station of the picture of the wanted motor bandit who has just taken to the high road after his latest "job," or the circulation of images of missing persons. In following the advice of TELEVISION to "make people television-minded" these aspects seem to the writer to be the ultimately valuable ones. By its very popularity and instant appeal the entertaining value of television is bound to make the more rapid progress. Anyhow, big financial interests will doubtless see that it does, but if the friends of British television elect to make headway on that ground alone it may find itself in the same predicament as the silent films when they had to make way for their more lively successors. Several other analogies will occur to the reader.

But when the battle is carried into the field of utility then, and only then, will the triumphs for which television is obviously destined be ultimately won. Rich, too, will be the reward of the far-seeing pioneers. "Talk television," but talk of it as one talks of telegraphy or transport, as something the public MUST have, not merely MAY have if it likes.

Remember, the locomotive was an amusing toy to some of the "knowing" ones in Stephenson's time; a rocket was only a firework, but later it helped to save lives at sea; Edison's phonograph was a peep-show for a nickel in New York, but now we preserve the living accents of the mighty dead. Television, too, will similarly justify itself in the eyes of mankind.

---

## Television Temptations

Under the above heading our contemporary, *Amateur Wireless*, makes the following very interesting remarks, which we heartily endorse:

"What do you think is one of the greatest inducements to lead the average listener to television? In our opinion that eerie, monotonous buzzing heard when one picks up the Baird tests on the speaker is a wonderful advertisement. It makes one long to be handling the 'televisor' controls, and resolving that buzzing into pictures. The speech accompanying the pictures is, too, rather fascinating. One longs to see as well as hear."

In the same issue our contemporary also comments very favourably on the quality of the Baird Company's programmes, especially those given after midnight. Up to the present the standard of the artistes who have appeared is extremely high.

# BAIRD BRANDED COMPONENTS for HOME CONSTRUCTION

In addition to the "Televisor" Home Reception Set we can supply a complete range of Baird branded parts for the home constructor. We can also provide any single part of the apparatus, thus enabling the experimenter to build his own experimental apparatus.

We feel that all those who are keenly interested in television should know and definitely realise that Baird branded products are the *only* genuine television components. The successful reception of the Baird transmission is dependent upon the use of *Baird* instruments only.

What the great Marconi has done for wireless, Baird has done for television. We, as producers of his apparatus, wish to ask our public to join us in furthering the cause of television by co-operating with us to ensure longer hours and better programmes, to which end all television enthusiasts must work.

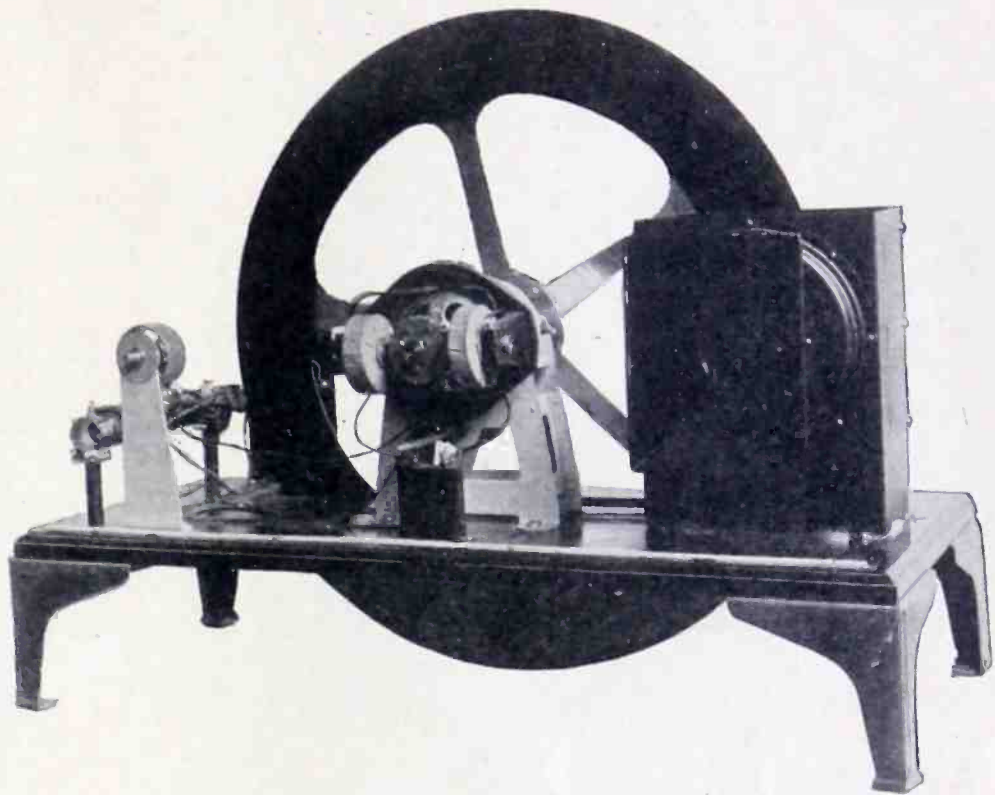

## Price List

	£	s.	d.
<b>Complete KIT OF PARTS for the Home Constructor (as under)</b> .. ..	<b>16</b>	<b>16</b>	<b>0</b>
Motor and Synchronising Gear .. ..	7	7	0
Motor Bracket, Clamping Bolts and Nuts	1	14	0
Lens—Large .. ..	0	13	6
„ Small .. ..	0	7	6
„ Box Assembly, with Viewing Tunnel (6 pieces) .. ..	1	4	0
Neon Lamp .. ..	1	5	0
„ „ Holder .. ..	0	6	3
Disc .. ..	2	2	0
Zenite Resistance and Supports .. ..	0	17	0
Resistance, with Bracket and Control Knob	0	6	3
Spindle Assembly, with Control Knob and Screws .. ..	0	5	9
T.C.C. Condenser .. ..	0	8	0

## The following are other Spare Parts not included in the Kit of Parts :

	£	s.	d.
Main Casing .. ..	4	10	0
Well Casing .. ..	1	1	0
Neon Casing .. ..	0	2	6
Terminal Casing .. ..	0	3	4
Wood Base .. ..	0	18	6
Feet for Base (4) .. ..	0	11	0
Terminal Board .. ..	0	9	6
Screws and small Parts for Base Assembly	0	3	0
Screws, &c. (various) .. ..	0	3	0
Flexible Lead and Adapter .. ..	0	5	6

USE  
BAIRD BRANDED COMPONENTS  
for best reception

**BAIRD TELEVISION LIMITED**  
133, LONG ACRE . . . . . LONDON, W.C.2

Telegrams : "TELEVISOR, RAND, LONDON"

Phone : TEMPLE BAR 5401

# "Television To-day and To-morrow"

## SOME PRESS OPINIONS

### DAILY NEWS

"Many secrets of the apparatus used are revealed in detail for the first time in this book, together with full technical information about the system, put in simple language specially for the wireless amateur."

### ELECTRICAL TIMES

"This book is of very considerable general interest. It sets out very clearly the outstanding developments and achievements in the evolution of television broadcasting."

### YORKSHIRE POST

"The book is neither dull nor formidable for the non-technical reader; in addition to the diagrams, this book is excellently illustrated by almost fifty photographic plates."

### ELECTRICAL REVIEW

"The illustrations are good, well chosen and interesting, while the diagrams and sketches are numerous and clear. It is well worth careful perusal by anyone interested in this entertaining subject."

### ABERDEEN PRESS AND JOURNAL

"The subject of television is dealt with in an admirable and non-technical manner, and we are led through essentially intricate phases to a clear appreciation of what has been done, what takes place, and the possibilities for the future."

### SUNDAY GRAPHIC

"Every branch of the subject is simply but exhaustively dealt with, and both principle and practice are made abundantly clear; it is a book for the expert or the beginner."

### BIRMINGHAM DAILY MAIL

"It is at once one of the most authoritative books on the subject yet published in this country, both as an historical outline of the research and the many demonstrations that have been given during the past few years, and as an exposition of the technical processes involved in this new and astonishing development in the science of wireless."

### NOTTS GUARDIAN

"The authors have kept in mind the fact that many persons interested

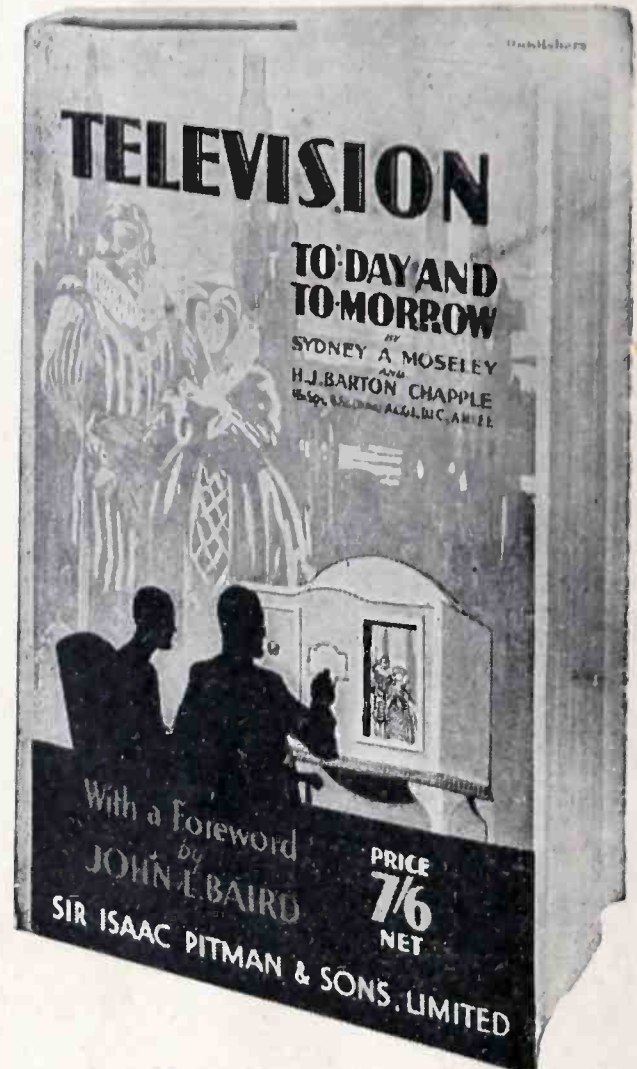

in wireless have no very deep knowledge of electrical matters, and have written a book which the amateur will readily understand."

### BIRKENHEAD NEWS

"It is essentially a book for the person who knows little or nothing about television, and is so simply written, so free from those technical terms which often mar a book otherwise good, that even the most untechnically minded of us are able to understand it."

PRICE  
**7/6**

POSTAGE  
SIXPENCE  
EXTRA

By SYDNEY A. MOSELEY

and H. J. BARTON CHAPPLE, B.Sc.(Hons.), A.M.I.E.E.

Obtainable from

TELEVISION PRESS, LTD.  
505, CECIL CHAMBERS, STRAND, LONDON, W.C.2.