

SIMPLEST WAY TO HEAR SHORT-WAVE STATIONS

# TELEVISION

THE FIRST TELEVISION JOURNAL IN THE WORLD

and **SHORT-WAVE WORLD**

MONTHLY 1/-

APRIL, 1935

BERNARD JONES PUBLICATIONS LTD.,  
CHANSITOR HOUSE, CHANCERY LANE,  
LONDON, W.C.2.

## Television

*Cheap and Novel Receiver*

*Why Ultra-short Waves are  
Necessary for Television*

*The Electron-image Camera*

*Germany's New Television—  
Transmission Times*

*A B C of Cathode-ray Tube*

## Short Waves

*The Beginners' Two-valver*

*Modulation with Single Stage*

*Making Short-wave Chokes*

*Short-wave Radio World*

*Listen to the World*

*Many Other Features*

*a Novelty.*

## THE PAPER DRUM RECEIVER

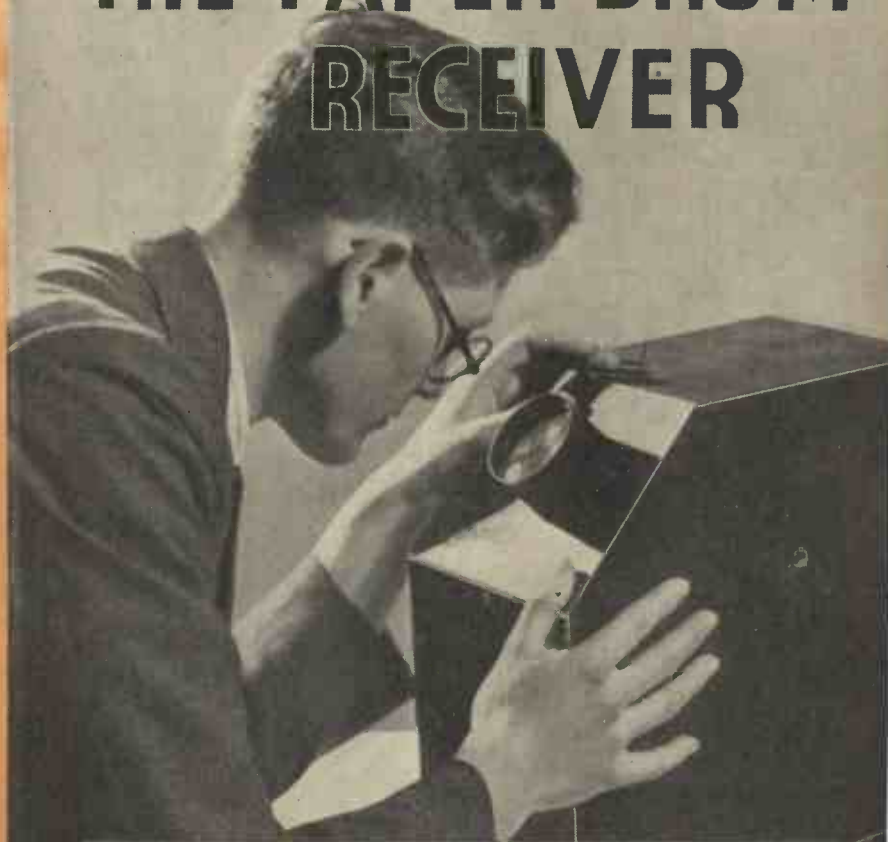

**CHEAP AND PRACTICAL**

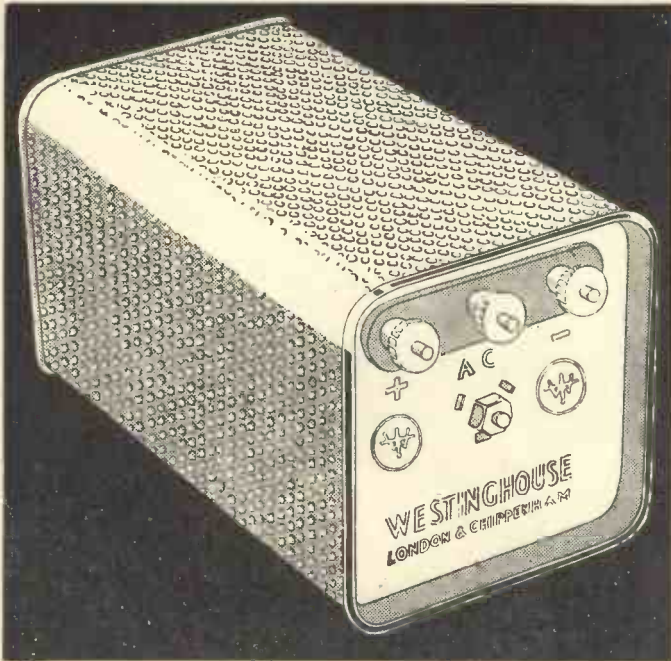

## RELIABILITY..

How many worries would be removed if you COULD depend on your high tension supply? and yet you CAN . . . if you use a Westinghouse Metal Rectifier. No danger of break-down. No renewals or maintenance. Just a constant high tension supply for as long as the set itself is in use . . . and longer.

Full particulars of, and circuits for use with Westinghouse Metal Rectifiers are given in "The All Metal Way, 1935." Use the attached coupon to get a copy.

# WESTINGHOUSE METAL RECTIFIERS

### COUPON

Westinghouse Brake & Signal Co. Ltd.,  
82 York Road, King's Cross, London, N.I.

Please send me "The All Metal Way, 1935," for which I enclose 3d. in stamps.

Name.....

Address.....

T.I.4.35.

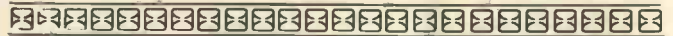

For a good job  
well done  
Use *Belling-Lee*  
Connections

<p>"Wanderfuse" complete, 1/-</p>	<p>Television INDICATIONS</p> <table border="0"> <tr> <td>SYN</td> <td>MOD</td> </tr> <tr> <td>ANODE</td> <td>GN</td> </tr> <tr> <td>X1</td> <td>X2</td> </tr> <tr> <td>Y1</td> <td>Y2</td> </tr> <tr> <td>A1</td> <td>A2</td> </tr> <tr> <td>B1</td> <td>B2</td> </tr> </table>	SYN	MOD	ANODE	GN	X1	X2	Y1	Y2	A1	A2	B1	B2	<p>"B" Type Terminal, 6d. each.</p>
SYN	MOD													
ANODE	GN													
X1	X2													
Y1	Y2													
A1	A2													
B1	B2													
<p>Screened Plug Top Valve Connectors, 8d. each.</p>	<p>Spade Terminals, 2d. each.</p>	<p>"Bow-Spring" Wander Plugs, 1½d. each.</p>												
<p>Fused Mains Input Connector.</p> <p>3/6 Without Plug and Socket, 2/6</p>		<p>Single Open Fuseholder, Complete, 9d.</p>												

Write for a copy of the 32-page  
"RADIO CONNECTIONS"  
and keep it by you.



APRIL, 1935

**SOUND SALES**

TELEVISION IS THE ELECTRICAL "OPPORTUNIST'S" OPPORTUNITY TO MAKE MONEY. THE USE OF COMPONENTS OTHER THAN THOSE PRODUCED BY SPECIALISTS MAY PROVE EXPENSIVE ECONOMY.

Most connoisseur experimenters realise that the name of SOUND SALES is synonymous with Power Transformers, Audio Transformers and Chokes of the highest quality. One has only to look through the specified lists of parts appertaining to the most famous sets designed by the "WIRELESS WORLD" and it is apparent that SOUND SALES components hold the "KEY" to the situation from the designer's choice.

As in Radio, so in Television, we have the honour to supply the leading authorities in the science, and since the early days of the Cathode-Ray tube have concentrated on the production of transformers and associated equipment, which not only uphold our zealously guarded reputation, but gives just the results that laboratory equipment demands. Whether you need an L.T. Transformer or an H.T. Transformer up to 30,000 volts; from 6 watts to 6 KVA. to our standard or to your own specification, the fact remains—SOUND SALES are anxious to show you how well such a component can be produced.

May we send you further particulars of our "BETTER THAN THE ADVERTISEMENT" components and guaranteed straight line amplifiers?

**SOUND SALES LTD.,** CONTRACTORS TO G.P.O., ETC., — TREMLETT GROVE WORKS, JUNCTION RD., LONDON, N.19. Telephone: ARchway 1661/2.

**CLIX "AIRSPRUNG"**  
Chassis Mounting Valveholders

These Anti-microphonic Valveholders

- Damp out actual physical shocks to the valve.
- Insulate the valve from consistent vibration set up by the transformer on the chassis.
- Counteract and absorb the air pulsations set up by the increased acoustic output of modern receivers.

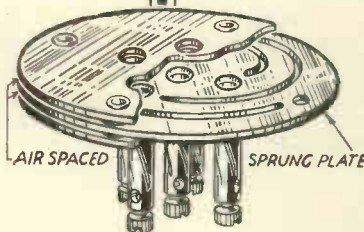

**ANTI-MICROPHONIC**  
The CLIX patented resilient sockets embrace the valve pins both moving together as integral parts in contrast to the chafing movement resulting from badly designed pressed sockets or springs which cause microphonics.

**IDEAL FOR S/W WORK**  
With the absence of metal springs and the minimum amount of material employed, the sockets are practically air insulated, thus embodying the essentials of a super short wave valveholder that cannot be surpassed

"AIRSPRUNG"

4-pin,...1/2 ; 5-pin,...1/3 ;  
7-pin,...1/4

All fitted with terminals.

Supplied without terminals for 3d. less.

Illustrated Folder "F" and Leaflets free on request.

**LECTRO LINX LTD.**

79a ROCHESTER ROW, LONDON, S.W.1

WHEN "Only the BEST is good enough"

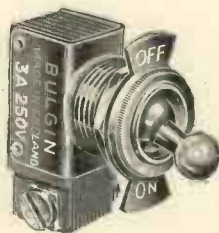

Toggle On-Off Switch.

World famous for reliability and years of service. Nickel-plated finish, for sets, radiograms, eliminates, etc.

List No. S.80, 1/6 each.



Skeletonised Short Wave Plug-in Coils.

Low loss. Aerial and reaction windings in addition to grid-coil. In three models:  
No. mH Metres  
S.W.15 0.54 7.5-17  
S.W.16 2.4 16-36  
S.W.17 12.0 35-80

3 6 each.

Screened Midget H.F. Choke.

Small, neat. Inductance approximately 198,000 M.H. Smooth choking from 200 to 1,750 metres. Can be mounted in any position. List No. H.F.8

2 3 each.



**BULGIN**  
is the inevitable choice

Their reputation for unflinching quality is the proudest possession of the House of Bulgin. Never, by even the minutest divergence, will they permit any departure from the standards they themselves have set. Meticulous manufacturing methods and ruthless factory tests before the goods are issued ensure that every Bulgin product is as near perfection as man can attain.

And that is why Bulgin components are so insistently specified where every other requirement is subservient to quality and dependability. You'll get the best out of any Televiser when you build with Bulgin parts.

**BULGIN**

POST THIS COUPON TO-DAY.

Please send, post free, 80-page catalogue No. 154. I enclose 3d. in stamps.

NAME .....

ADDRESS .....

(Use block letters)  
A. F. BULGIN & CO., LTD., Abbey Road, Barking, Essex. Phone: Grangewood 3266.

**SPECIFIED FOR THE BEGINNERS "SW" 2**

---

# BAIRD TELEVISION LTD.

PIONEERS & MANUFACTURERS OF ALL  
TYPES OF TELEVISION EQUIPMENT

---

HIGH - DEFINITION "TELEVISORS"

IMMEDIATELY THE HIGH - DEFINITION SERVICE FROM THE FIRST LONDON STATION COMMENCES "TELEVISOR" RECEIVERS AND COMPONENTS WILL BE AVAILABLE ON THE MARKET.

LOW-DEFINITION "TELEVISORS"

A LIMITED QUANTITY OF USED DEMONSTRATION DISC AND MIRROR-DRUM "TELEVISOR" RECEIVERS ARE AVAILABLE AT £5 AND £25 RESPECTIVELY.

*FULL DETAILS SUPPLIED ON APPLICATION.*

*PARTICULARLY USEFUL FOR EXPERIMENTAL AND EDUCATIONAL PURPOSES.*

ADMINISTRATION OFFICES.

58 VICTORIA STREET,  
LONDON, S.W.1.

SALES DEPARTMENT.

CRYSTAL PALACE,  
(Anerley Rd. Entrance)  
LONDON S.E.19.

TELEGRAMS : "TELEVISOR, SOWEST, LONDON."

'PHONE : VICTORIA 7238.

'PHONE : SYDENHAM 8400.

# TELEVISION

## and SHORT-WAVE WORLD

### Special Features in this Issue

	PAGE
Artificial Aerials for Station Checking	180
The Paper-drum Receiver	181
A Short-wave Two for Beginners	185
Listen to the World on Morse	188
Projecting the Image	189
Volume Control in Vision Receivers	191
Why Ultra-short Waves are Necessary for Television	192
The Electron-image Camera	195
A High-definition Service for Germany With Other Listening Posts	197
The Simplest Way to Hear Short-wave Stations	199
ABC of the Cathode-ray Tube	201
Modulation with a Single Stage	204
Scannings and Reflections	205
Making a Synchroniser	207
An Experimental Oscillator Tone Source	209
Making Short-wave H.F. Chokes	212
Modulation Monitoring	212
Studio and Screen	213
Short-wave Radio World	218
High-definition Mechanical Scanning	219
Television in the Cinema	221
Ray Focusing in C.R. Tubes	223
Trade Notes	224
Recent Developments	225
Modern Physics and Television Research	227
Improving the Light Modulation of Neons	229
Heard on the Short Waves	231

## COMMENT OF THE MONTH

### *The Need for Representation*

WE have heard the criticism very freely expressed that there is no body in existence representative of real television interests. This, no doubt, is due to the comparatively small number of concerns engaged in the development of television and the necessity hitherto of working more or less secretly. The time for this isolation has now surely passed and unless some definite steps are taken there is danger of the actual control of television passing into hands which may not have its best interests at heart. At present the Postmaster-General's Advisory Committee is taking advice and evidence from various organised bodies, which are only indirectly connected with television, but those who are almost wholly responsible for its development are only able to approach the Committee individually and their views, divergent as they must be when expressed in this manner, cannot have the same influence that would be ensured by joint representation. We suggest that it is now desirable that the concerns which are *actually* engaged in television should meet on common ground in order to further their mutual interests.

### *Short-waves and the Morse Test*

THERE seems to be a growing tendency for amateurs in this country to decry the morse test. From time to time we hear rumours to the effect that definite action will be taken to try and induce the Post Office to remove the morse test on the higher-frequency bands.

Again we seem to be following the Americans, for over there amateurs are already divided into two distinct camps, for and against code test. The theory is put forward that a code test for the 5-metre experimenter is rather a waste of time and that a good many men are deterred from applying for a radiating licence because of it. This theory seems all very well, but we feel that a really good man who wants to do serious experimental work would not be put off by the morse test. In fact we go as far as to say that the morse test keeps off all those frivolous amateurs who want a licence for the fun of the thing.

Morse code is going out of general use in official circles, but a lot of good DX work is still being done by amateurs in all parts of the world. A genuine amateur knows that with the B.B.C. on the air almost all day a powerful amateur station is almost bound to cause bad interference to local listeners. The use of C.W., however, does to a certain extent enable the amateur to radiate almost all day long on the low wavelength bands without causing trouble. This is without question one of the strongest arguments for the continuance of the code test otherwise B.C.L. interference will soon be greatly on the increase.

Incidentally, do not lose sight of the fact that commercial transmitters still use code, making it imperative for the amateur to know it as well in case of interference. The commercial station will soon tell an amateur to close down if interference is being caused. So what would happen if the operator of an amateur station could not read the C.W. call telling him to close down? We do feel that the number of amateur experimenters lost through the code test are greatly outnumbered by the real experimenters who take the test and advance the cause of amateur radio.

### TELEVISION AND SHORT-WAVE WORLD

#### Proprietors :

BERNARD JONES PUBLICATIONS, LTD.

#### Editor-in-Chief :

BERNARD E. JONES.

#### Editor :

H. CORBISHLEY.

Editorial, Advertising and Publishing  
Offices :

Chansitor House, 38, Chancery Lane,  
London, W.C.2.

Telephones : Holborn 6158, 6159

Telegrams : Beejapee, Holb., London.

Subscription Rates : Post paid to any  
part of the world—3 months, 3/6 ;  
6 months, 6/9 ; 12 months, 13/6.

Published Monthly—1/- net.

(Last Wednesday in every month for  
following month).

Contributions are invited and will be promptly considered. Correspondence should be addressed according to its nature, to the Editor, the Advertisement Manager, or the Publisher, "Television and Short-wave World," Chansitor House, Chancery Lane, London, W.C.2.

# Artificial Aerials for Station Checking

By Arthur Weston.

*This article is for the B.R.S. listener and the A.A. licence holder. It is bad form to test a station on an elevated aerial when you know that interference will be caused to local broadcast listeners.*

THE intermediate stage between the B.R.S. listener and the fully-licensed transmitting operator is rather an interesting one. I believe that this is the only country in the world where amateurs are able to obtain a three-letter call-sign and construct transmitting apparatus without actually broadcasting any signals.

If it is desired to check the modula-

A much closer check on the actual R.F. output can be obtained if the resistance is replaced with a small hot-wire or thermal ammeter. Hot-wire meters can be obtained from Leslie Dixon quite cheaply, while, of course, everyone knows of the Ferranti thermal ammeters.

A less expensive way of checking the amount of R.F. in the output stage is

All types of valves can be used in the various stages and it is an easy matter to tell which are the most efficient. The individual stages can be tuned and neutralised so that the transmitter is working at maximum efficiency before it is ever connected to an elevated aerial.

If more amateurs were to use an artificial aerial for testing and so actually check the efficiency of their stations, there is no question but that the results obtained would be greatly improved and, at the same time, interference with local broadcast listeners would be decreased.

In America it is considered bad form to connect a transmitter to an elevated aerial before it has been completely checked and adjusted by means of an artificial aerial. There are several points which cannot be checked until the transmitter has been on the air, but all of the more usual tests can be made without radiation.

B.R.S. listeners who intend to obtain full transmitting licences will be well advised to apply for a three-letter call-sign, make up their apparatus, and get it going in the most efficient manner as suggested.

As a radiating transmitter will cause interference to B.C.L.'s even when the

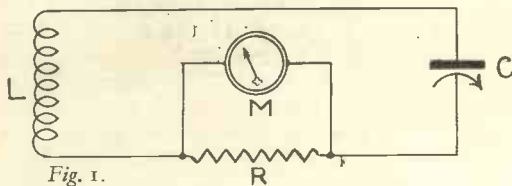

*A complete test of a transmitter can be made with this type of artificial aerial. Either the resistance R or the meter M should be left in circuit, not both at the same time.*

tion or different types of valve, in fact, most of the problems one comes up against in the transmitting circuit, a three-letter call-sign can be obtained from the Post Office, that is, providing the desire to experiment is perfectly genuine.

## Using the Dummy Aerial

With this licence one can have a most interesting time making up a complete transmitter and actually making tests with it in the same way as one does with a fully-licensed station. To do this, however, the output of the transmitter must be linked with what is called a dummy or artificial aerial. This type of aerial should have similar characteristics to an elevated aerial. Normally, it consists of a non-inductive resistance having a value between 10 and 100 ohms, a small .00035 mfd. tuning condenser and an inductance which will cover the wavelength for which the transmitter has been designed.

## The Simplest Artificial Aerial

Fig. 1 gives the fundamental circuit of such an aerial. The inductance of the coil should be the correct value to cover which ever amateur band is required. It can be of the plug-in type if necessary. The resistance R is usually about 50 ohms, but this depends entirely on the frequency and must be adjusted when necessary.

to use a small 6-watt, 12-volt bulb in place of the resistance or meter. The amount of output as it increases or decreases can readily be seen by the amount of illumination.

In Fig. 2 is shown an artificial aerial for use with a P.A. stage using push-pull valves. Here again the meter and resistance have been omitted and a lamp used. For preliminary tests the lamp is quite effective.

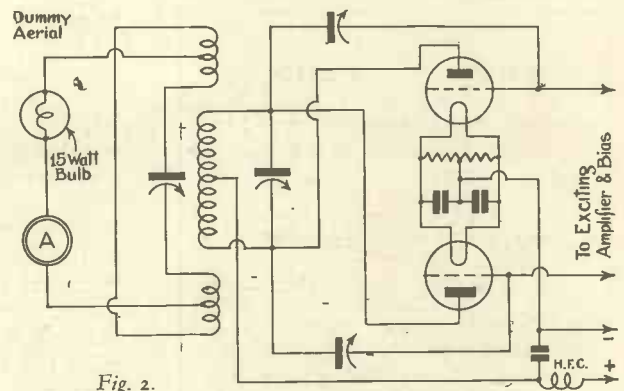

*This arrangement is a little more complicated, but more closely approximates a full elevated aerial. The wattage of the bulb depends on the type of transmitter being tested. For the A.A. licence holder 15 watts will be about right.*

## Couple to the Tank Coil

These aerials should be coupled to the tank coil in the P.A. circuit. After adjustment to give the correct degree of coupling the coil should be fixed, as if it is moved the amount of R.F. present in the aerial will vary and so upset any measurements made.

carrier is unmodulated it becomes very important to see that the transmitter is off the air during broadcasting hours. This will restrict the use of the transmitter to only a few hours a day unless an artificial aerial is used. Why not give this type of aerial a trial? It will be useful even though external contacts cannot be made and it will provide a lot of experience.

# THE PAPER-DRUM RECEIVER

By J. Sieger

CHEAP TO BUILD, EFFICIENT,  
SIMPLE AND PRACTICAL

*Here are details of a novel type of scanner employing a drum instead of a disc. A great feature is the absolute simplicity of construction.*

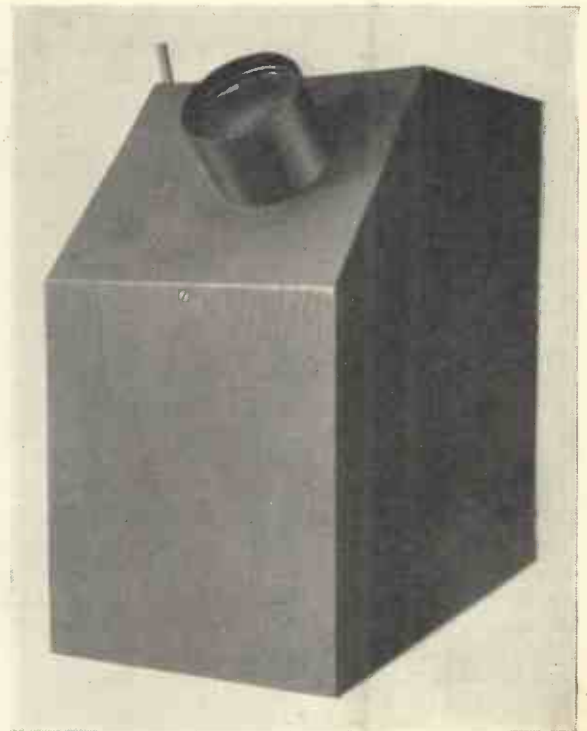

*This is a photograph of the complete scanner.*

IT seems strange that after nearly five years of 30-line television broadcasts, there has not been any simple home-constructor receiver other than the disc type which has been popular. The receiver about to be described is just as simple as the disc type and has the additional feature that it can be entirely home-constructed, including even the scanning device. It

can, therefore, be made by the veriest novice.

A mirror-drum is used at Broadcasting House for transmission and scans the picture in vertical straight lines. The usual simple type of receiver in use to-day utilises the Nipkow disc in which a series of holes in spiral formation reproduces the picture.

## Straight-line Scanning

Owing to the spiral formation an arc-shaped picture results. But the shaping is not sufficient to cause actual distortion of the reproduced picture. With this receiver, with a drum scanner, the scanning follows the same path as that of the transmitter. This overcomes the shaping of the picture due to arc scanning. Actually the image is produced in vertical straight lines by means of a drum around which is a series of staggered holes, the light source being inside the drum.

In the conventional disc receiver the scanner is usually made from sheet aluminium, which must remain perfectly flat when revolving at speed. In addition to this the 30 holes have to be accurately spaced in two dimensions, that is, radially and angularly.

With this drum receiver the position for the holes can be obtained by using only a ruler, and accurate spacing with two dimensions is easy to obtain.

Owing to the design of the scanner constructors will find it particularly simple to make. Ordinary drawing paper will possess considerable strength owing to the circular formation of the drum.

## A Compact Instrument

Perhaps one of the biggest advantages of this drum receiver as far as the home constructor is concerned is its compactness. Normally with a disc receiver a con-

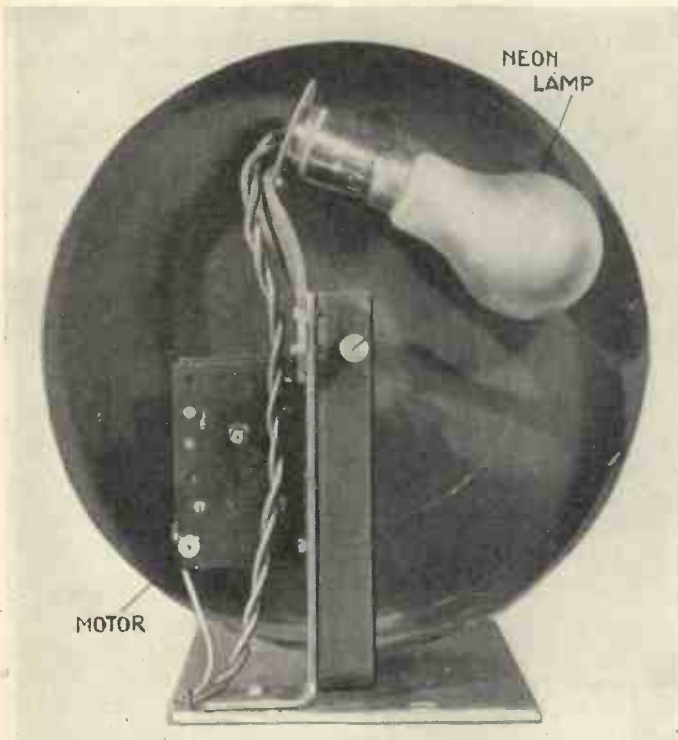

*This photograph shows the arrangement of the lamp and motor within the paper drum.*

siderable amount of space is required to allow for the fast-rotating disc, speed regulator, lenses and neon.

As the drum is only  $8\frac{3}{8}$  ins. in diameter and the motor, lamp and speed regulator are all within that diameter the actual size of the completed instrument is reasonably small. Also it is a distinct advantage to have all movable parts completely self-contained.

### Home-made Scanner

The most important section of the instrument that will have to be home-constructed is the drum scanner. For this scanner obtain a sheet of Whatman's drawing paper and very carefully cut out a piece 27 ins. long by 4 ins. wide. This must be carefully cut, preferably using a T-square so as to make sure that both edges are absolutely parallel.

Then draw two parallel straight lines on this drawing paper; these must be drawn very accurately. The first line is drawn 2 ins. from one edge of the paper, the second line being drawn  $1\frac{1}{8}$  ins. from the opposite side of the paper. Then, of course, if the paper has been accurately cut four inches in width, it will give a

space between the two parallel lines of  $\frac{3}{8}$  of an inch.

At  $\frac{1}{2}$  in. from one end of the paper, draw a vertical line with the aid of a set-square—don't do it by eye. In Fig. 1 is shown just where this line and the two parallel lines just mentioned are drawn.

After this little operation has been successfully completed draw 29 vertical lines  $\frac{7}{8}$  in. apart, the final line finishing up at B in Fig. 1. Finally draw a single vertical line  $\frac{7}{8}$  in. after the point marked B in Fig. 1. For guidance the final line is marked C on Fig. 1.

A diagonal line must then be drawn between the two parallel lines joining up the point marked A and the point marked B.

If these lines are drawn accurately the vertical lines should cross the diagonal line in 30 places. Where these lines cross represents the exact positions for piercing the 30 scanning holes, which is done by means of an ordinary pin. A pin is suggested because it will not make too large a hole.

### Fixing the Drum

The surplus paper should then be cut off the strip when it will be all ready to be bent round in the form of a cylinder. A wooden disc  $8\frac{3}{8}$  ins. in diameter should then be made. This disc must be fairly thick, say, a minimum of  $\frac{1}{2}$  in. otherwise difficulty may be experienced in sticking the drum to it, owing to lack of surface area. Make a very careful job of sticking the drum on to the wooden disc and make sure that the thick vertical line at the point C in Fig. 1 coincides exactly with the first line A, also of Fig. 1. Fig. 3 explains this fully. That finishes the drum for the moment except that it must be coated with indian ink or spirit black, so that it has a dull black finish.

Any television motor will have sufficient power to rotate the drum at the correct speed. But remember that if the wooden disc is too heavy then trouble may be experienced in getting the drum to revolve at the right speed.

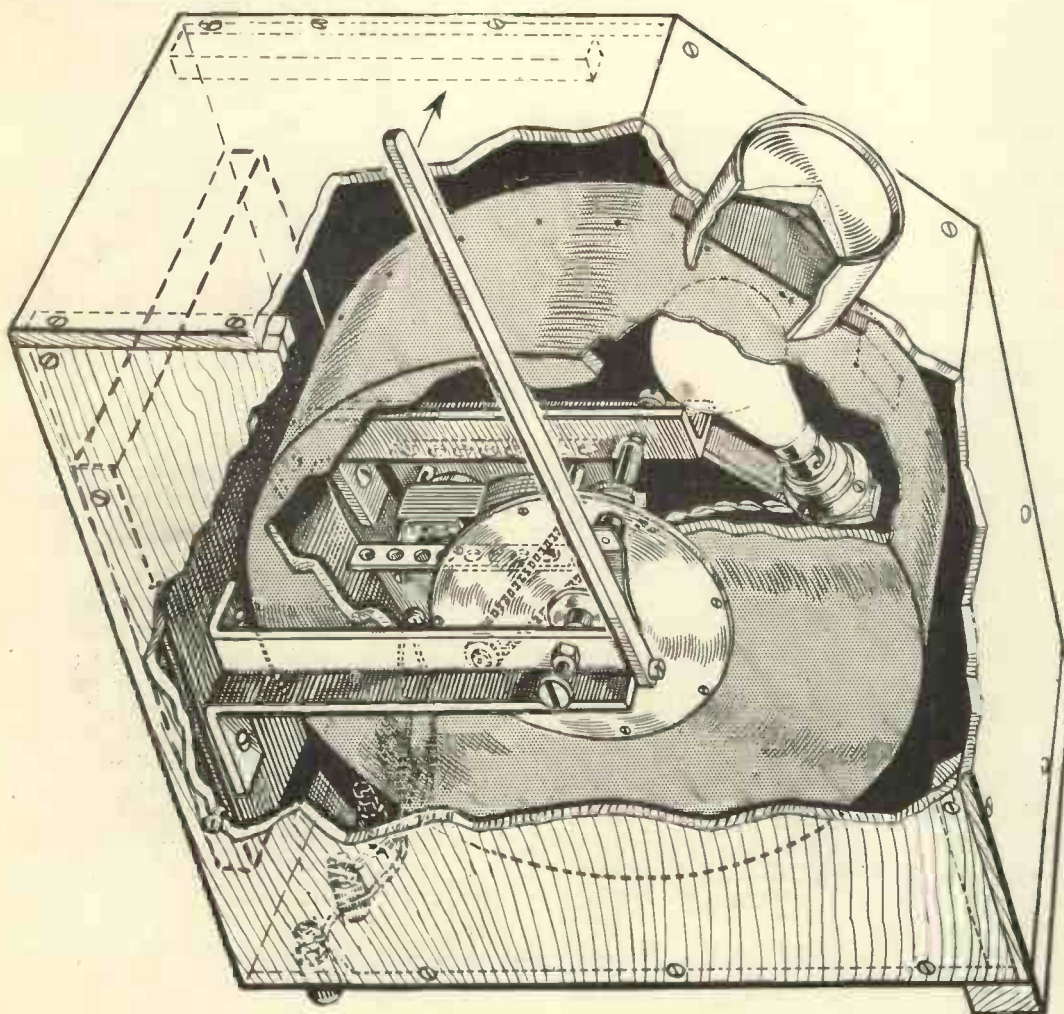

*All the constructional details are apparent from this perspective sketch. The drum is driven by means of a coiled wire or rubber belt. The perspective has been exaggerated in order that the internal construction will be clear.*



CUT OFF BEFORE STICKING

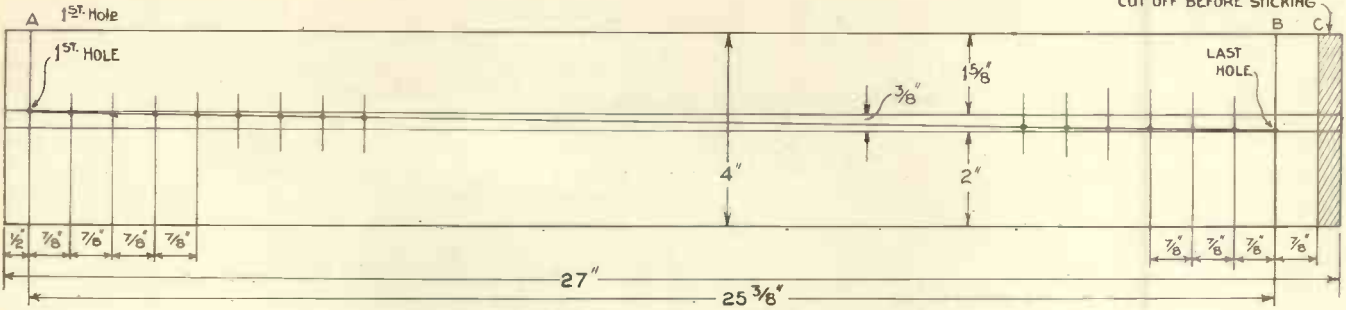

Fig. 1.—Details of the paper strip of which the scanner is made.

Elaborate methods of synchronising have not been used. Actually speed regulation is obtained by means of a rubbing contact on the side of the disc. This contact is a small piece of felt fitted to a spring which is in turn soldered on to a brass rod protruding through the top of the cabinet.

**Speed Regulation**

If a little care is taken with this regulator the pictures can be held in frame without any difficulty. The slightest movement of the brake causes the motor either to increase or decrease in speed and it is simply a matter of finding the best position to give the required 750 revolutions to the minute. Incidentally, it is advisable to let the motor run at speed for a few minutes before each transmission in order to warm up.

The light source recommended is a standard Osglim type of neon lamp, in which the resistance from the base has been removed. If, when ordering the neon lamp from the makers it is specified that the lamp is required for television work, it will be supplied without the resistance.

**Distortion-free Pictures**

Naturally in view of the size of the drum, the picture is on the small side, but this is enlarged by means of the lenses. To obtain pictures free

6d. each. The frames must be removed from these glasses after which they are mounted as shown. Two of these lenses are required, the first one being mounted about 1 in. above the surface of the drum. Then the second lens must be fixed two inches above the first

Fig. 3.—Method of joining the paper to form the scanner.

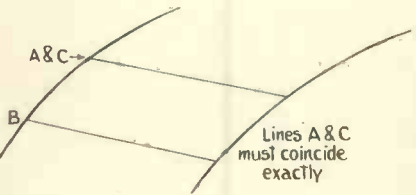

lens. Slight variation in the distance between the lenses should be tried.

These lenses magnify the picture three or four times, but it will be realised that the better the lens the better will be the picture both as regards size and clarity. In Fig. 4 it has been shown just how the lenses are fixed while the lamp inside the drum is held in position by means of a small bakelite lamp holder clamped on to a

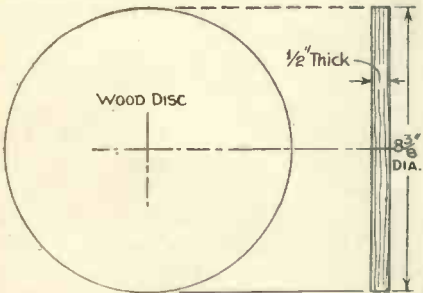
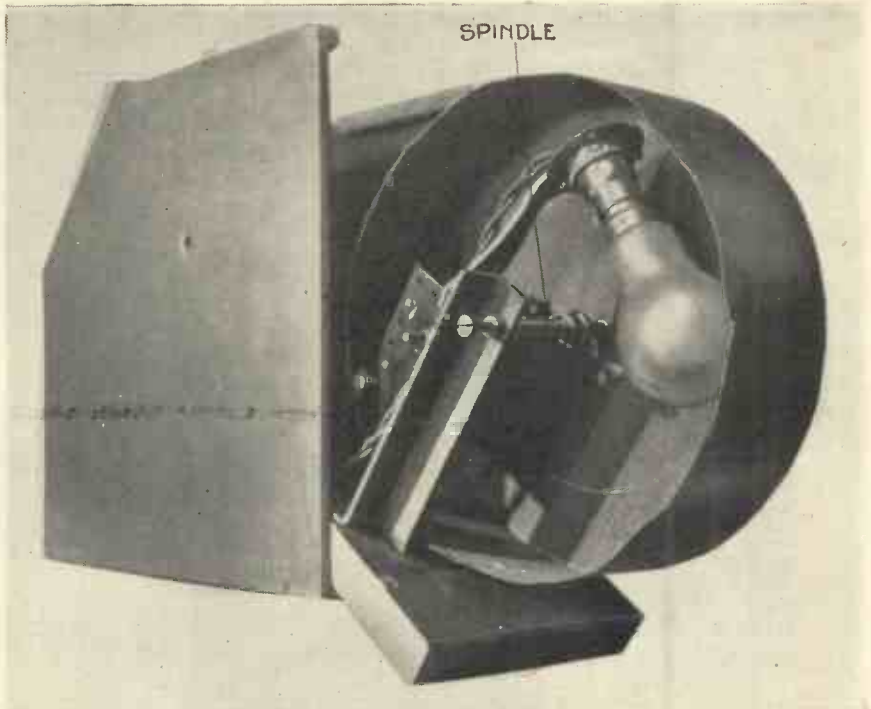

Fig. 2.—The wood disc supporting the paper drum; this is mounted on a spindle which is centred between two pointed screws in the iron frame.



The drum is mounted in a U-shaped metal frame and the motor is secured to this also.

from distortion it is essential that the lenses give natural reproduction without introducing any curvature. Quite satisfactory lenses can be obtained from Woolworths where they are actually sold as reading glasses and cost

bracket. The photographic illustrations clearly show how this is done.

**Cabinet Construction**

Construction of the actual cabinet should not present any difficulty and in Fig. 5 the dimensions of a side are

base removed if one can be found that is the correct size.

Ingenious home constructors will no doubt be able to devise other means of fixing the lenses.

This type of drum receiver gives very satisfactory results and not for one moment should readers consider that anything is lost by virtue of the small drum. Even though the picture may be a little smaller than that

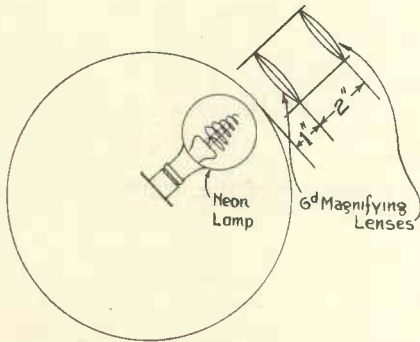

Fig. 4.—Diagram showing the arrangement of the neon lamp and lenses.

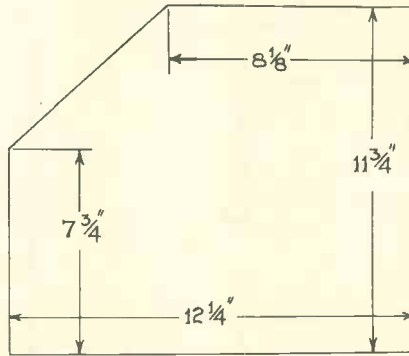

Fig. 5.—Dimensions of side of case.

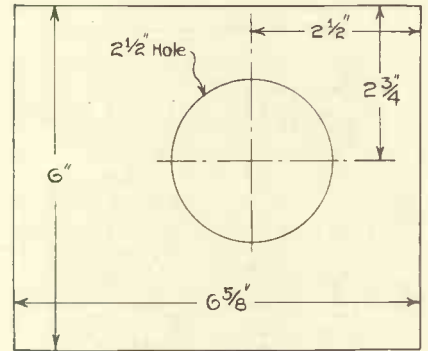

Fig. 6.—Details of lensboard.

given. Across the sloping side is clamped the holder for the two lenses. This holder can be made from a piece of circular cardboard or an ordinary tin with the

given by a standard flat disc this is more than compensated by means of the vertical straight-line scanning employed.

**When to Listen for Short-wave Stations**

Here is a concise guide indicating when the short-wave stations should be heard during April. It has been pre-

pared by 2BWP, C. J. Greenaway, who has been making a study of reception conditions for a number of years.

**A NEON LAMP HINT**

**I**N every television receiver, no matter what its type, it is essential that none of the brilliance of the received picture is lost.

In a disc receiver, probably the greatest source of waste is the neon lamp, for less than a third of the illumination it gives is utilised for the production of the picture, as all of the light given out at the sides and back of the lamp is wasted.

It is possible, of course, by gumming pieces of tinfoil on these parts, to reflect some of the light to the front, but this procedure, although it does help a little, does not improve results to any great degree owing to the comparatively low reflective power of the tinfoil.

However, by coating the sides and back of the lamp with a small quantity of what is known as liquid chromium, which has a high reflective power, greatly improved results will be obtained. This liquid chromium is sold in tubes. It is applied with a small brush, and, after it is dry, has just the appearance of the metal chromium itself.

When applied to the neon lamp, it reflects practically all the light, that otherwise would be wasted.

G.M.T.	3.5 mc.	7 mc.	14 mc.
0100	W4		
0200	W1, 2; YI		
0300	W1, 2, 3, 4, 8; VE1	LU	
0400	W1, 2, 3, 4, 8; VE1	W2, 3, 4, 8, 9	
0500	W1, 2, 3, 8	HC; W1, 3, 4, 8; ZL	
0600	W1, 3, 8	CN; VK; ZL	
0700		VK; ZL	
0800		VK	
1000			FM8
1400			VE1
1500			SU; W8
1600			PK; VE1; W1, 8
1700			KA; SU; W1, 8; ZS
1800			FM4; SU; W1, 8
1900			PY; W1, 2, 8
2000			CN; K5; PY; VO;
			VO4; W1, 8
2100	YI	CN	CN; CX; HC; K4;
			LU; PY; VE1;
			VP6; W1, 2, 8, 9;
			YV
2200		CN; FM4, 8; SU;	CE; CM; CX; K4;
		VO; VP6; W1	LU; PY; VE1, 4;
			VP6; W1, 2, 3, 8, 9
2300		CM; CN; HP; W2,	PY; W1, 2, 3, 8, 9
		3, 4, 8	
2400			CM; W4

# A Short-wave Two for Beginners

*Here are some details of a simple receiver designed by Norman Brandon, who is obtaining some remarkable captures with this actual set. Some of the components can be home constructed, and the total cost of the receiver is less than £2 15s.*

*Operation will not present any difficulty. There is only the main tuner in the centre to consider, for the reaction control on the right is almost constant.*

**F**ROM time to time readers have asked for details of the sets used by correspondents who claim reception of short-wave stations from all over the world.

Just recently one of our readers with a simple two-valver, situated at Barnet, has been logging South American, Australian and other real DX stations with remarkable ease. We have verified his logs and, in view of the simplicity of the receiver, we feel sure readers will welcome the opportunity of making it up for themselves.

## For the Beginner

For the beginner, at least, the most suitable receiver is the two-valver with a minimum number of controls, smooth reaction and complete stability. This little set embodies all of these features, and, in addition, is very cheap to build.

It consists of a conventional leaky-grid detector using a triode valve which, in turn, is transformer-coupled to a small power output valve. The efficiency is not due to the circuit chosen, but to little points which will be enumerated later and the clean layout and care of long leads.

First of all the panel. The movable components are fixed to this and make automatic negative contact. This simplifies wiring and obviates hand capacity. Then with the chassis. All the fixed condensers and resistances are connected by short leads. The grid bias battery is fitted under the chassis, again reducing the length of the leads.

Battery leads are brought out to a three-way socket. This obviates having straggling leads. When the set is

ready for testing all that is necessary is to plug in the three-way socket.

## Simple Construction

Construction should not present any difficulty. On the top of the chassis are bolted the low-frequency transformer, three valve holders, high-frequency choke, sockets and the tuning

condenser. Actually the tuning condenser is bolted down by means of a bracket, which is part of the tuning dial.

On the underside of the chassis there are three fixed resistances, three fixed condensers and the bias battery clip. The actual position for these components can be seen from the illustrations or the blue-print. Incidentally, a full-size print can be obtained from

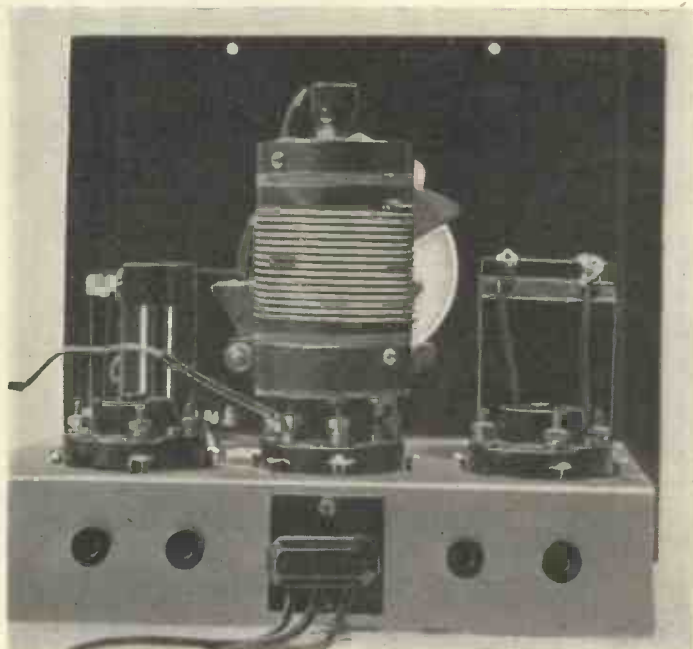

*The centre valve holder is actually a coil mount. On the right hand side of the coil is the output valve holder. So make quite sure that the valves are inserted in the correct holders.*



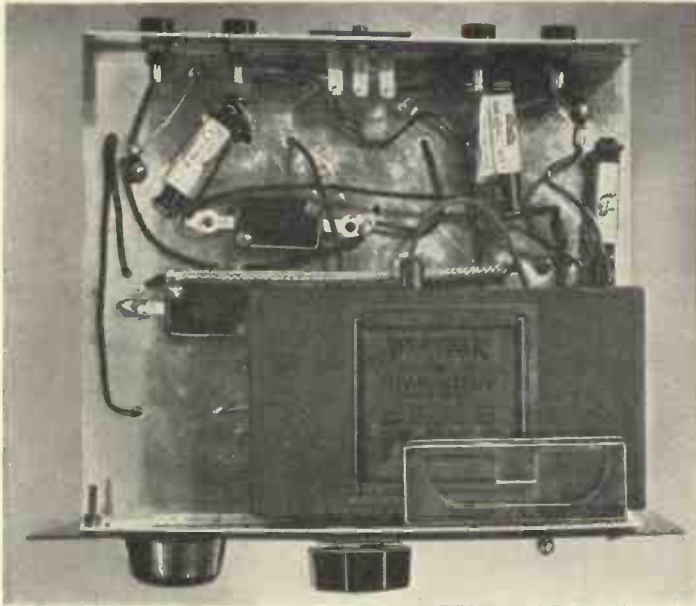

An underside view of the chassis.

**Wiring**

When wiring up this receiver make the connections as short and tight as possible. Often home-built sets have long wires which are quite unnecessary.

With a 120-volt high-tension battery the average anode current will be about

As there are only two controls to worry about, operation is very simple.

**Using the set**

It is important to use the set at the proper time of the day and on the correct wavelengths. For example, with the smallest coil in circuit there would not be very much heard during the dark evenings. The lower wavelengths are most productive during the morning and early afternoon.

In the early evening the second coil bringing in the 31-metre band should be used. Sometimes the 19-metre band will be quite good as late as 6 p.m., but as a general rule the later the hour the higher should be the wavelength. As the conditions change quite rapidly, make use of the notes in other pages of this issue which give full details of conditions in other parts of the country.

No special aerial is required with this type of receiver. As long as it is clear from the house and gutterings and the lead-in wire does not sway in the wind, any type of aerial will do quite well. It is not advisable at this stage to go in for specially-tuned short-wave aerials.

A good average length is 40 to 50 feet, including the lead-in wire, but if

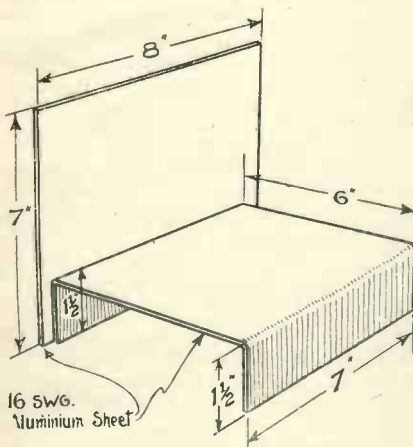

The metal chassis is made up of two bent pieces of aluminium.

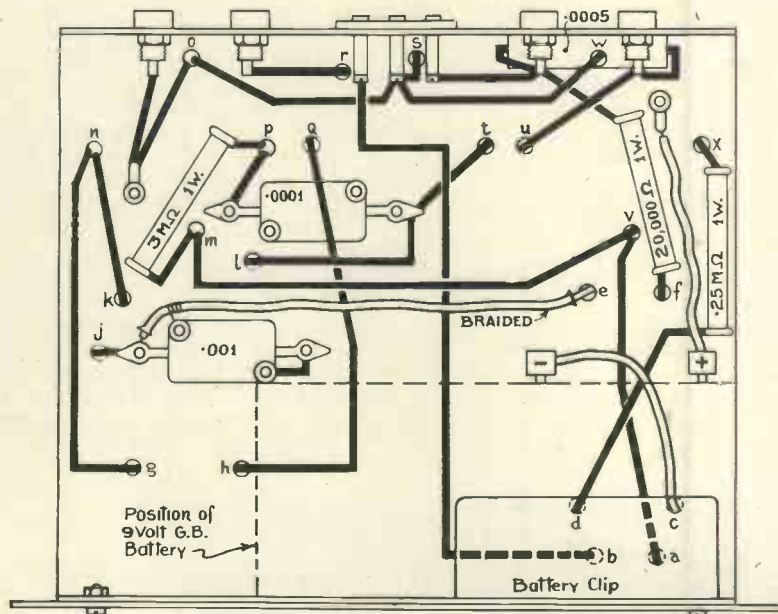

The wiring diagram of the underside of the chassis.

9 milliamperes. This is low for a set that will bring in American stations on the loudspeaker.

The volume, and, of course, the anode current as well, will be increased if a pentode valve is used. But the alterations are quite simple. In place of the four-pin output valve holder substitute a five-pin holder and join the extra or fifth pin to high-tension positive.

Actually, all that is necessary is to turn the main condenser to zero, adjust the reaction control until the receiver is gently oscillating and then operate the tuning condenser until a healthy chirp is heard in the loudspeaker. After that the amount of reaction applied is decreased until the chirp is resolved into a signal. After that, a slight re-adjustment to the main tuning condenser may be necessary.

the present aerial is longer than this it may cause the receiver to stop oscillating on the shorter wavelengths. To overcome this, simply connect a small fixed condenser of about .0001 mfd. in series with the lead-in wire.

If carefully handled, this receiver will bring in stations from all over the world and will provide a welcome change from the conventional broadcast receiver.

# Listen to the World on Morse

**T**O the uninitiated morse code is merely a confused jumble of dots and dashes not having any real significance. But for those who can read morse, even slowly, a new field of interest in the receiving of messages of all descriptions from every part of the world is opened up.

With the simplest of apparatus it is quite usual consistently to receive messages from New Zealand, Australia, America, etc. References to letters from correspondents published on other pages will confirm this. Even when the conditions for reception are bad a two-valver will bring in upwards of a hundred C.W. stations, while the log of phone stations heard during the same period might not reach a dozen.

Amateurs who are keen on DX reception and can read morse at speeds of 12 words per minute regularly log 300-400 stations during the course of a week-end. A one-valve receiver and a pair of headphones are all that are required to listen to the world with morse.

Press messages, time signals, transmissions from ships, and, of course, the thousands of amateur stations the world over can all be received at different times of the day.

No longer is it necessary to wait until the conditions are suitable or for the correct time of the day to hear stations situated perhaps a thousand miles away.

## Learn the Code in Two Months

Spend an hour or so each evening for about two months learning the alphabet, numerals, and some of the abbreviations. At the end of that time you will be able to make out some of the call signs that are not sent too quickly. Then it is merely a matter of practice

to increase the speed at which signals can be read.

As a general rule it is a good idea to listen on the amateur channels for it is on these bands that slow morse can be heard. Incidentally, every Sunday morning, slow morse transmissions are sent for beginners by several amateur stations. G2DQ, for example, at 10 a.m. on Sundays on the top band.

correctly and so recognise the sounds of the different letters.

When learning the code do not think of the letters as dots and dashes but rather as they sound when you hear them via your radio set. For example, do not think of the letter B as a dash and three dots but rather as dah-dit-dit-dit, or the letter O as dah-dah-dah, and so on.

THE MORSE CODE.			
A ..-	L ...	X -..	9 ----
B ...	M --	Y -.-	0 ----
C -.-	N -. -	Z ---	
Ch ---	O ---		(.) . . . .
D -..	P ---	1 .----	(0) . . . .
E . . .	Q ---	2 .----	(1) . . . .
F . . .	R ---	3 .----	(2) . . . .
G . . .	S . . .	4 .----	(3) . . . .
H . . .	T . . .	5 .----	(4) . . . .
I . . .	U . . .	6 .----	(5) . . . .
J . . .	V . . .	7 .----	(6) . . . .
K . . .	W ---	8 .----	(7) . . . .
			(8) . . . .

Apply to the Secretary of the Radio Society of Great Britain, 53 Victoria Street. He will tell you all about these transmissions. They are sent out very slowly indeed and the matter sent is usually a section of the current bulletin. This is rather a good idea for when a few words are missed the whole sense of the matter need not be lost.

At first it is advisable to listen to the slow transmissions with the copy of the bulletin without making any attempt to take down the message. After a while several words will be recognised and later the whole of the transmissions will be recognisable when sent slowly.

It is useless attempting to listen to these transmissions until the entire alphabet has been completely mastered. This is easier than perhaps might be imagined. A good plan is to tap out paragraphs in the newspaper until you are able to space the words and letters

## Formation rather than Speed

Of course, two people learning code at the same time are at a great advantage for then it is possible to check the sending, and if a small buzzer is used the letter formations will sound similar to the genuine morse signals through the radio receiver.

Never make the mistake of trying to tap out letters too quickly. It is far more important to obtain correct formation and proper spacing otherwise nobody will be able to read the messages.

From our correspondence it seems that most amateurs wishing to learn code have to do it entirely without help. We have just been trying a little gadget marketed for such readers with which morse can be sent automatically or by means of a key as you wish (see photograph).

This gadget consists of a brass plate connected to one side of a battery over which is fitted a cardboard template. This template is cut so as to form the proper dots and dashes. A metal pencil is connected to the other side of the battery and when it is drawn across the template, say, beneath the letter A, an automatic dit-dah is sent. Of course, the whole alphabet is arranged in order from A to Z with numerals from 0 to 9, so even the beginner can send simple messages without knowing anything about morse code at all.

With such a gadget it is a much more simple matter to pick up the correct dots and dashes with perfect spacing. Letters can be formed automatically, and then after the alphabet has been memorised they can be sent by hand with the key supplied and checked up by means of the automatic sender.

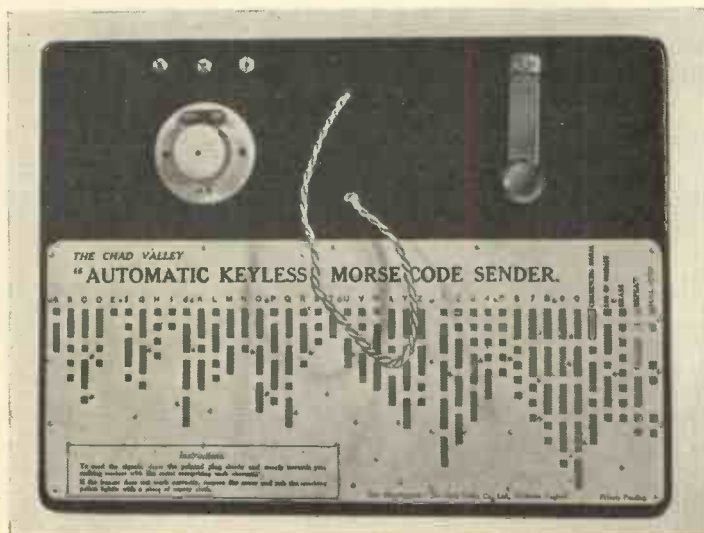

*An easy way to learn morse code. Messages can be sent with out any knowledge of the code. This is the Chad Valley Co's automatic code sender. It costs 7/6.*

APRIL, 1935

# PROJECTING THE IMAGE —HOW TO MAKE THE BEST USE OF THE LIGHT

By A. H. Berry, M.Sc.

*This article explains how the best use can be made of the available light in apparatus for screen projection.*

THE clarity of the picture which is produced on a television screen depends directly upon the amount of modulated light that can be directed there. With a relatively small amount of such light available it is necessary to use it in the most economical fashion, i.e., the whole projector system must be as efficient as possible.

Suppose we place an eye in such a position that the light from the projector falls upon it. An "Electric

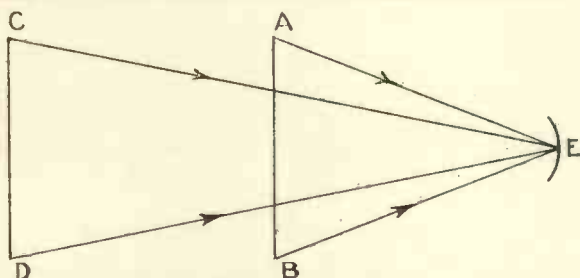

Fig. 1.—Diagram explaining the inverse-square law of light. E is the retina or sensitive surface of the photo-cell.

Eye" or photo-cell would be better than a human eye because of the action of the iris in "stopping down" the lens of the eye, and thus making comparable observations difficult. The brighter the front of the projector appears to this eye, the brighter must be the appearance of the spot of light on the screen.

To this eye the *brightness* of a source always appears the same no matter from where it is viewed, and the amount of light entering the eye is proportional to the apparent size of the source, which in turn depends upon the "visual angle" AEB or CED of Fig. 1. If we double the distance away, we divide the apparent size by four in accordance with inverse-square law. Thus the intensity of the light spot projected on to our screen depends only upon the brightness and the apparent size of the source as seen by our electric eye.

## Brilliance of Light Sources

Apart from reflection and refraction losses the brightness of the light seen by our eye is not affected by its passage through the projection system. The intrinsic brightness or number of candle per square inch of the source used is evidently of prime importance; the following table gives the relative intrinsic brightnesses of some ordinary light sources:—

Paraffin oil lamp with glass chimney .....	10
Acetylene burner .....	36
Vacuum tungsten lamp .....	960
Gasfilled tungsten lamp .....	7,500
Gasfilled tungsten lamp "overrun" so as to give 2½ candle-power per watt ...	17,000
"Pointolite" lamp .....	16,000

Carbon arc .....	110,000
Equatorial sun at zenith .....	1,000,000
Neons have low values, generally below	10

The carbon arc, as will be seen, has the greatest intrinsic brightness of the artificial sources, but in its simple form is subject to flickering, and the carbons have to be fed forward as they burn away. If one of the glass-enclosed type in which the carbons burn away slowly is made use of, neither of these defects need be considered as serious for experimental television purposes, and the arc can be modulated directly.

The "Pointolite" or tungsten arc is in very general use (for satisfaction and long life it must be used as recommended by the makers). Overrunning a gasfilled lamp shortens its life considerably, but, as suitable lamps can be purchased quite cheaply, it may be found more economical to use this method rather than either of the arcs. It will be found that an ordinary 12-volt motor headlight bulb run at 14 to 15 volts, gives a very efficient source. It will last at least 50 hours, before

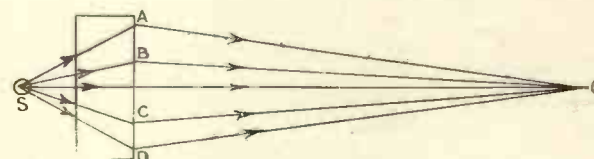

Fig. 2.—The effect of magnifying the source of light.

any great deal of blackening takes place. In the writer's experience the cheapest lamps costing six-pence each, when overrun in this manner appear to last as long as better quality ones similarly treated.

The apparent size of the source is the greatest when

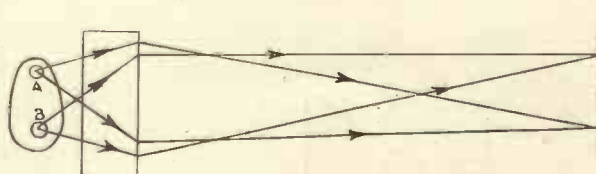

Fig. 3.—Diagram showing a source of light greater than the focal sphere.

the whole of the front of the projector appears to our eye to be filled with the light, or "completely flashed" with it. The effect of the projector in this case is simply to magnify the source so that it appears to be as large as the projector front. Suppose AO and BO, etc. (Fig 2), are rays from the front of the projector to the light spot where our eye is placed. It is a well-known axiom that a ray can always be traced backwards from receiver to source without violating any optical principles.

Suppose that on tracing the rays back from O through the projector, bearing in mind that the ordinary laws of reflection and refraction must be obeyed, they all pass through a very small region at S, called the focal sphere, then we can have the front of the projector completely flashed with a very small source of the size of the focal sphere.

This is the most efficient arrangement. It is interesting to inquire what happens if the size of the source is greater than the focal sphere. In Fig. 3, A and B represent two regions of a large source, each of the size of the focal sphere. They both produce their own light spots on the screen, of the same size and intensity as in the projector illustrated in Fig. 2. Regions intermediate between A and B produce like results, and the whole effect is to increase the size of the light spot, without however increasing its intensity. We have assumed here that the projector would be completely flashed at all such points as A and B on the source. This is most unlikely, many of these regions would only produce "partial flashing" which is less efficient. This increase in the area of the light spot is opposite to what is required for television purposes; stops or masks have in general to be used to reduce the size of the spot, so that a large source is always inefficient.

The purpose of any projecting device is to collect the light from the source which would in the ordinary way spread out in all directions, and send it in one desired direction. The most important projection systems

are shown diagrammatically in Fig. 4. A is the parabolic reflector and is probably the best known, being used for motorcar headlights. Its action depends upon the fact that rays from a point S (the focus) are rendered parallel to the line OX (the axis) after reflection, so that theoretically a parallel beam is obtained in one direction whose intensity remains constant at all distances from the source. The amount of light thus collected and directed depends upon the

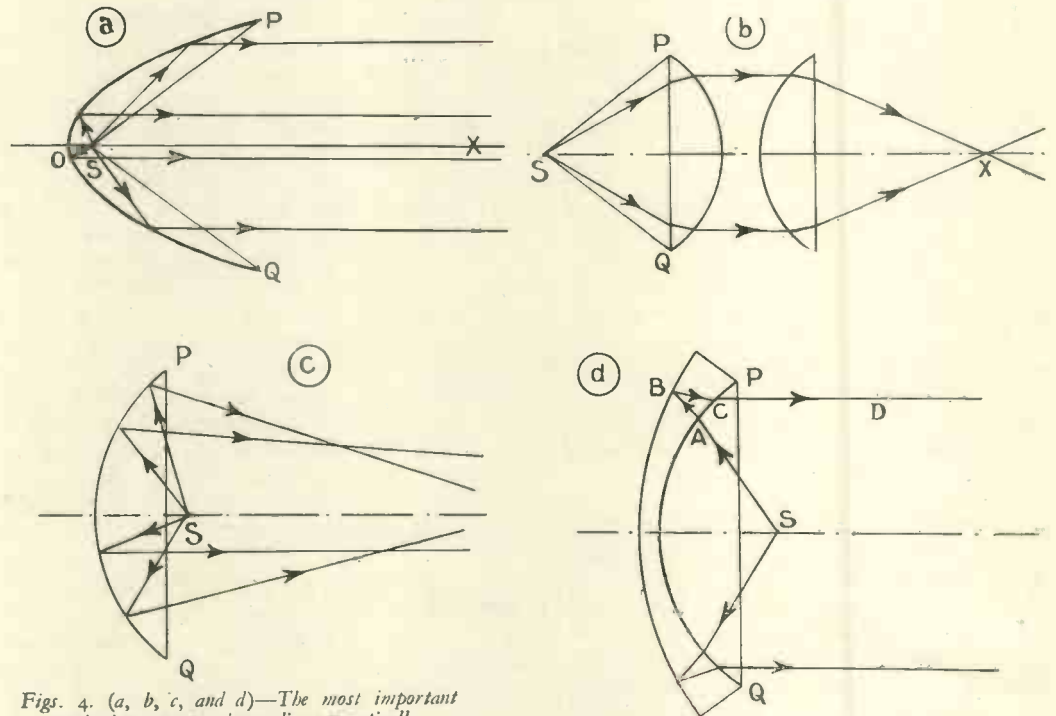

Figs. 4. (a, b, c, and d)—The most important projection systems shown diagrammatically.

size of the "angle of collection" PSQ, and may be anything up to three-quarters of the total light emitted.

**Reflectors**

In practice this ideal state of affairs is not realised, light striking the cap of the lamp is not efficiently reflected; commercially-produced parabolic reflectors suffer from many geometric defects, a point source of light does not exist, and some light is reflected by the glass of the bulb, e.g., SABC of Fig. 5. In spite of these defects efficient light sources for televisors using Kerr cells can be made from old motor headlamps, obtainable very cheaply from a car breaker's, used in conjunction with the overrun lamp mentioned above.

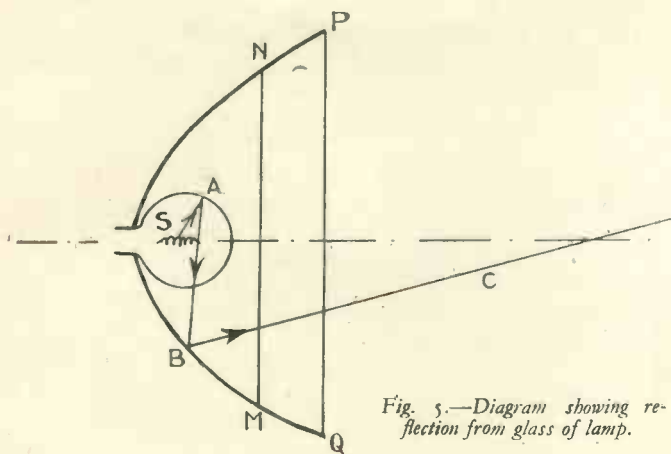

Fig. 5.—Diagram showing reflection from glass of lamp.

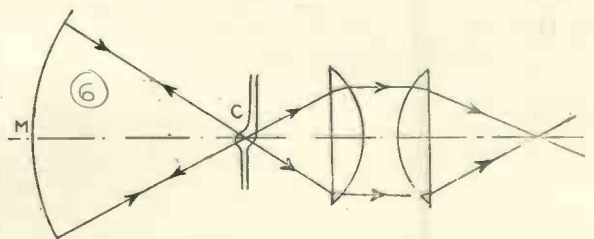

Fig. 6.—An effective arrangement using a curved mirror and lenses.



The condenser B of Fig. 4 consists generally of two plano-convex lenses arranged as shown with the source at S. It will be seen that the angle of collection must always be less than about 90 degrees, corresponding to the collection of one quarter of the light.

The focal sphere of a condenser is relatively large as can be tested with cigarette smoke, and hence a very small source does not give a complete flash, but on the other hand it is fairly easy to fix the lamp so that its parts cause little obstruction to the light.

C represents the simple spherical mirror, which can be made reasonably accurately by ordinary commercial processes, but it is impossible to obtain a truly parallel beam with it; unless the aperture or diameter PQ is very small the effect is similar to the spherical aberration produced by a simple lens. This type of mirror can, however, give very efficient service in conjunction with a condenser when used with the neon or neon-mercury lamps, which are specially made for television projection and concentrate most of the light in a relatively small space.

The part of the tube in which the light is most intense is placed at the centre of curvature C of the mirror. This is situated twice as far from the mirror as is the focus. All rays from the intense portion at C strike the mirror normally and are reflected back along their own paths, as shown by the arrows. From C we thus obtain, travelling towards the condenser, a percentage of the light which began by travelling in

the opposite direction, so that an effective doubling of the angle of collection is produced. It is evident that for best results the light should not be reflected back exactly along its own path, but the reflected image of the source should be formed just alongside the source itself. Because of the relatively large size of the focal sphere of a condenser, the larger effective source thus produced is not in general detrimental; it makes the flash more complete.

### The Mangin Mirror

The Mangin mirror (D, Fig. 4) consists of a concavo-convex lens with the outer surface silvered. The path of the light from the focus S is as shown by SABCD, etc., and a truly parallel beam can be obtained. The spherical surfaces of the lens can be more accurately made commercially than can parabolic ones, but the angle of collection cannot be made so large, although it is greater than that of the condenser. It can be shown that the focal sphere is very small, i.e., a small efficient light source can be used and little of the light falling upon the mirror need be allowed to spread. It will be noticed that the focus S lies outside the plane of the mirror so that the light from S perpendicular to the plane of the paper cannot be collected. It is peculiarly suitable for small flat sources, such as acetylene flames, and can be used very effectively in television for some kinds of neons.

**V**OLUME control in a radio receiver, be it for vision or sound reception, can be applied before or after the detector, in both cases they can produce undesirable effects when the volume is not at maximum, though this note will only deal with the post-detection type.

Fig. 1 shows a conventional volume-control circuit, C being the coupling condenser and R the volume-control potentiometer, which is, of course, the grid leak. The dotted condenser CV represents the valve capacity. This circuit is redrawn at Fig. 2 as a network of capacity and resistance. The voltage applied across E is divided into two parts EX and EZ, of which the latter is applied to the valve grid. In this circuit, as the frequency of E is raised

## VOLUME CONTROL IN VISION RECEIVERS

the impedance becomes less, but the proportion EX to EZ is for all practical purposes constant, assuming normal values of resistance and capacity are used.

Now consider the volume turned down, Fig. 3, redrawn at Fig. 4. Again assuming normal values, the impedance C over 1,000 cycles will be negligible. At high frequencies (in the low-frequency range) the impedance will be RU and RL of the resistance R. But RL will be virtually shorted by CV, which will be

practically non-existent to lower frequencies. Therefore the volume-control will have a selective effect to frequency once one begins to turn it down, which, of course, is very undesirable in television, though often unnoticeable on sound; this effect is generally worst at about the midway position, the effect on the picture being to reduce sharpness.

Grid stoppers also produce a selective effect on frequency, though normal values on grid stopper resistance generally produce a less injurious effect, though it is always present, to some extent. The obvious cure in both cases is to keep the value of CV as low as possible, a rule which holds good from every point of view in the design of television amplifiers.

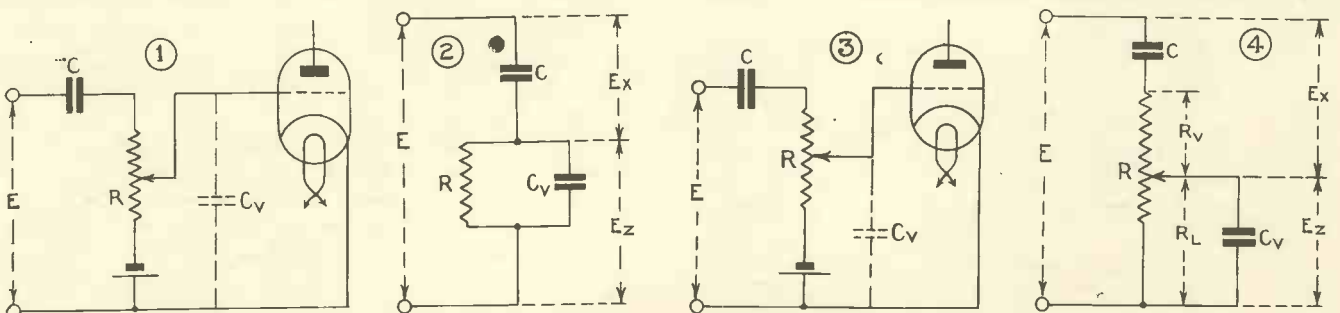

Diagrams of volume-control systems described in the accompanying text.

# WHY ULTRA-SHORT WAVES ARE NECESSARY FOR TELEVISION

By "Microwave"

*This article is an exhaustive analysis of the frequency requirements of television explained in as simple a manner as possible.*

THE ultimate sphere of usefulness of the very short waves (under 10 metres) has for a long time been a matter of controversy. Doubt has sometimes been expressed as to whether they would occupy a commercially useful niche in the edifice of

television, does not occupy greater band widths than these. Television comes in a different category.

## How Television is Transmitted

Consider the way in which television is usually transmitted. Fig. 1 represents the picture "frame" at the receiver or the field of view at the transmitter. In either case this is usually scanned in the manner to be described. The active field of view from moment to moment is represented by a small element of the picture colloquially termed the "spot," usually square in shape. This spot follows a perfectly straight path across the picture parallel to one of the pairs of sides of the picture, for convenience generally parallel to the longest side. This path is termed a "line." For the first line the spot moves from a to b (Fig. 1): for the second line from c to d, and so on. The width of each line is equal to the width of the spot, so that after a certain number of lines has been traversed, the whole area of the picture or field of view has been covered.

A little consideration will show that in the case of a square picture ("picture ratio" = 1) the number of elements in the picture would be equal to the square of the number of lines. In the case of the picture of

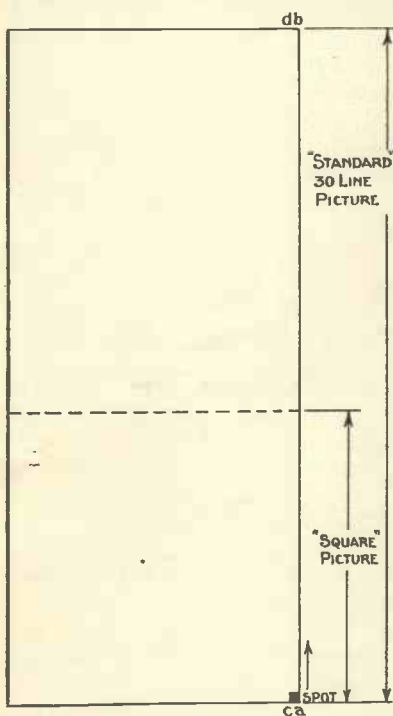

Fig. 1.—"Standard" picture (30-line):  $r = 7/3$ , No. of elements = 2,100,  $f_s = 26.3$  kc. Square picture (30-line)  $r = 1$ , No. of elements = 900,  $f_s = 11.1$  kc

electrical communication, especially in view of the fact that they have proved useful in the medical sphere in certain applications.

The suggestion that they might be particularly useful in connection with television is by no means new. This was suggested even before the technical problems confronting television were as well understood as they are now.

Let us consider the situation in the light of known facts.

From a bare recollection of "Hartley's Law" one infers that the transmission of moving pictures involves the passage of a relatively enormous amount of information—from moment to moment—in a very small space of time. Consequently the "band width" of frequency required must be very great—much greater than any band width required for broadcasting or commercial telegraphy. It is well known that the band width commonly used for broadcasting may extend to about 15 kc., for the highest quality, but is usually restricted to 9-10 kc. for commercial reasons. Telegraphy, even of the highest speed commercially prac-

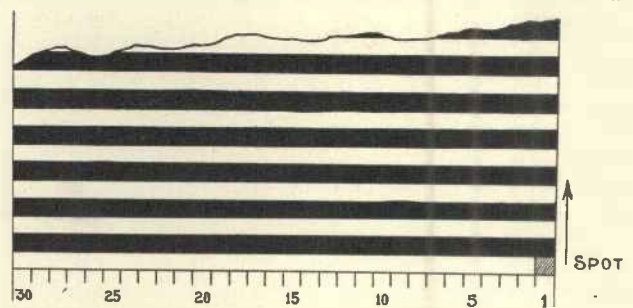

Fig. 1a.—Portion of field of view of 30-line picture composed of strips alternately black and white in colour, and of width of the spot. This gives rise to the limiting frequency =  $f$ .

shape other than square, the number of elements is equal to the square of the number of lines multiplied by the "picture ratio," which is itself defined as the ratio—length of picture parallel to the lines/breadth of picture (normal to the lines).

In the present standard "30-line" picture as broadcast by the B.B.C. the constants would be as follows:

No. of lines = 30. Picture ratio =  $7/3$ .  
No. of elements = 2,100.

Now consider (Fig. 1a) the case of a picture consisting of a number of alternate black and white strips arranged in a direction normal to the lines, the strips being each of the same width. Suppose further that

# FREQUENCIES REQUIRED FOR TELEVISION

the width of the strips is equal to the width of the spot. In this case each adjacent element of the picture will have the opposite signal value to that of its neighbour, and this alternation of signal current will be transmitted because each successive position of the spot (supposed for the present to move in jerks) discloses a complete spot area either white or black.

But the spot does not move in jerks; its motion is steady, so the transition from light to dark is gradual. Since neither the white portion nor the dark portion of the field is in the spot completely for more than an infinitesimally short period of time, the total variation of light values is beginning to be cut down as compared to the case where the widths of the strips is large compared with the width of the spot.

If the width of the strips is further decreased the variation and therefore the value of the signal current representing this variation decreases until when the width of two strips (one black

“ standard ” transmission these frequencies are:—  
( $f_1$  and  $f_2$  lie outside normal audible frequency limits).

$$f_1 = 12\frac{1}{2} \text{ c.p.s.}$$

$$f_2 = 375 \text{ c.p.s.}$$

$$f_3 = 26,300 \text{ c.p.s. (26.3 ks.)}$$

In forthcoming developments  $f_1$  is not very likely to be a limiting factor, since it is now well within the capacity of communication channels and apparatus, and will tend to be slightly raised (to, say, 25 or 30), still further reducing the difficulty due to bottom “cut-off” in the apparatus.  $f_2$  is not at all important, since it lies well inside the band of frequencies to be transmitted. But  $f_3$  is the real limiting factor; any attempt to utilise a channel with a cut-off frequency much below this value will result in an obvious deterioration in the quality of the picture.

A good broadcast transmitter on frequencies of the order of 1,500 kc. can only just pass a band (one of the sidebands, in this case) of width approaching this frequency (say, 20 kc.) for the case of standard 30-line pictures. The limitation is beginning to be felt even under such comparatively “ easy ” conditions as these.

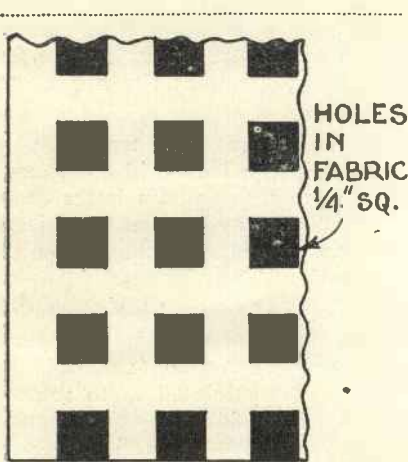

Fig. 2 (left).—Portion of special “talkie” cinema screen. (Two-thirds actual size.)

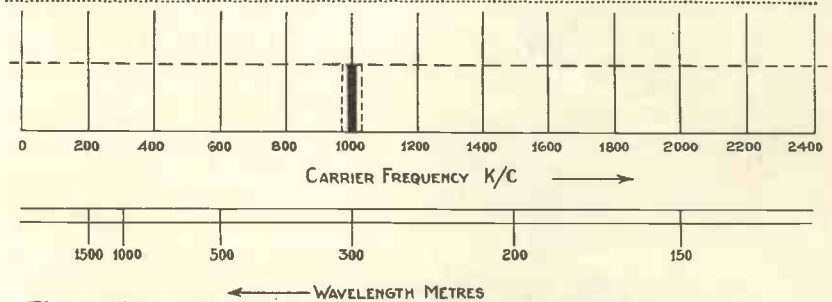

Fig. 3.—Transmitter carrier frequency=1,000 kc.; pass-band for broadcasting=dark band (20 kc.); pass-band for 30-line television=dotted space (56 kc.); pass-band for high-definition television extends beyond limits of paper (1.33 mc.)

and one white) is equal to the width of the spot the signal current in zero. In this latter case the spot “ cannot see ” the strips, so to speak. Such a picture would appear at the receiver as a uniform grey field. The signal-current frequency at which this occurs represents the highest frequency component of the signal current. This frequency is given (in cycles per second) by the number of elements transmitted per second, i.e., number of elements in picture multiplied by the number of pictures per second (“ framing frequency ”).

Adopting the use of a formula to find the limiting frequency this becomes:—

$$f_3 = A^2 B C,$$

where A = number of lines in picture

B = “ picture ratio ”

C = picture frequency.

Incidentally there are three “ landmark ” frequencies in every picture scanned by this or similar systems:—

$f_1$ —the picture frequency (No. of pictures per second).

$f_2$ —the “ line ” frequency (No. of pictures per second  $\times$  number of lines).

$f_3$ —the limiting frequency, as defined above.

Listening orally to the 30-line transmissions,  $f_2$  is the most noticeable component of the signal. For a 30-line

Let us now examine the case of the so-called “ high-definition ” pictures. Take the following:—

$$\text{Picture frequency} = 25 \text{ per second (} = f_1 \text{)}$$

$$\text{No. of lines} = 200 \quad (f_2 \text{ will} = 5,000 \text{ c.p.s.)}$$

$$\text{Picture ratio} = 4/3$$

(Note that the picture ratio is rather more favourable than in the 30-line case.) Here  $f_3$  works out at 1,333 kc. !

The picture-ratio given in the last example corresponds with the standard cinema screen, which represents a ratio that has been found after many years’ experience to be the most “ comfortable ” to view, at least for long periods. This picture, in the television case, would be scanned horizontally (i.e., along the length of the picture) in order to make best use of the number of lines available. Note in passing that if the picture were to be scanned in a direction parallel with its minor dimension, the definition would be inferior (assuming the same number of lines, of course) owing to the greater breadth of each line.

But there would be compensation, from the transmission point of view, in the fact that the picture-ratio would in this latter case become 3/4 instead of 4/3, and the band-width of communication be reduced to 750 instead of 1,333 kc. Thus we see that the band-

## TELEVISION AND CINEMA COMPARISONS

width of communication and the "quality" of the picture are directly related.

### *Desirable*

#### *Definition*

Whilst a 200-line picture may at the present time be considered a great advance upon the 30-line transmissions, it cannot be considered as the *ultima thule* in regard to quality. Nevertheless it may happen that the necessary compromise between desirable quality of picture, technical complication and expense (especially the latter, if television is to become at all popular) will stabilise the number of lines at somewhere between 200 and 300.

### *Cinema*

#### *Standards*

With good apparatus and technique the results in practice always seem to be at least a little better than one would expect from theory. The amount of definition in the best modern cinemas is equal to not more than 600 lines, and leaves nothing to be desired. Perhaps it may be of interest to explain how this figure was arrived at by the writer. A certain special cinema screen was developed for use in connection with "talkies," to enable the loudspeakers to be situated directly behind the screen, and at the same time avoid "blanketing" the speakers. This screen consisted of meshed fabric with symmetrically placed holes  $\frac{1}{4}$  in. square (Fig. 2). *This did not in the least affect the definition of the picture as viewed from the auditorium.* The holes in the screen correspond with a  $\frac{1}{4}$  in. "spot" in the television case. Such a cinema screen would have dimensions of, say, 16 ft. by 12 ft. The number of spot widths contained in the minor dimension is therefore 576, = number of lines in the television case.

It would seem that 600 lines would meet all reasonable requirements, but on working out the value of the limiting frequency ( $f_s$ ) with a  $\frac{4}{3}$  picture-ratio the band-width comes out at 12 megacycles!

For an immediate start on a compromise at 200 lines the band-width is  $1\frac{1}{3}$  megacycles (1,333 kc.).

Amplifier and control circuits can be designed to deal with band-widths of between 1 and 2 megacycles, but the question of communication channels is much more difficult. Screened cables will be essential if land-line channels are to be used, and though it is not at all technically impossible to *design* cables capable of passing such wide band-widths, their production and installation would probably be prohibitively expensive, even for short routes.

The alternative to sending the composite band of picture-frequencies through the cable is to use the carrier ("wired wireless") system, by sending a modulated carrier along the route. By this means the difficulty of making the cable with flat frequency characteristics over such a relatively wide band is avoided, but other complications are introduced, the discussion of which we must defer until later. The question of carrier-current working is no different from that of

radio, except in regard to the actual channel (line or "ether") used. In either case the essential "terminal apparatus" is the same.

### *High-Frequency*

#### *Difficulties*

The modulation of radio transmitters with currents representing wide frequency bands is a problem of some complexity. To obtain high efficiency at the transmitter, high-frequency circuits of very low resistance must be used. This implies that such circuits respond only to the carrier-frequency and frequencies which differ very little from it. Such high-efficiency transmitters, such as are used for continuous-wave telegraphy, only emit a band-width of a few cycles on either side of the carrier. Telephony transmitters, for "good commercial" speech, must emit a band-width of about 2,500 cycles on each side of the carrier. This involves a slight sacrifice of efficiency owing to the necessary increase in resistance in the high-frequency circuits in order to "flatten the tuning," so that the necessary band-width may be passed.

Requirements in high-quality broadcast transmitters are more difficult to meet, since a band-width of, say, 10,000 cycles has to be passed. In this latter case efficiency is deliberately thrown away in order to achieve the necessary flatness of tuning of the resonant circuits in order to pass the band-width.

Take as an example the case of a broadcast transmitter working on a wavelength of 300 metres. The carrier-frequency is therefore 1 megacycle (1,000 kc.). With good design, this can be modulated up to 10,000 p.p.s. This means that the two sidebands to the carrier will be each 10,000 cycles in breadth, i.e., 1 per cent. of the carrier. The total frequency range is then  $1,000 \pm 10$  kc. (Fig. 3), that is to say, a total channel width of 20 kc., from 990 to 1,010 kc., and a corresponding wavelength band of from 297 to 303 metres. This seems to be the utmost limit that can be tolerated, both on account of the reduction in efficiency at the transmitter and on account of the space (channel width) occupied in the ether.

It will be seen at a glance that it is quite impossible usefully to modulate a radio transmitter with a carrier-frequency of 1 megacycle with a band of frequencies up to  $1\frac{1}{3}$  megacycles. If we accept as the standard a band-width equal to 1 per cent. of the carrier, the lowest carrier-frequency we can hope to use will be  $1\frac{1}{3} \times 100 = 134$  megacycles. This corresponds to a maximum wavelength of 2.25 metres. This is with reference to the 200-line picture.

In the case of the 600-line picture the minimum carrier-frequency comes out at 1,200 megacycles, giving a maximum wavelength of 25 centimetres! However, it seems possible that owing to the somewhat different nature of high-frequency circuits at these very short wavelengths (below 3 metres) it might be feasible to modulate with a band-width of perhaps up to 5 per cent. of the carrier-frequency, and so obtain figures of 12.5 metres and 1.25 metres for the maximum wavelengths for the 200- and 600-line pictures respectively.



The dissector-multiplier camera for direct electronic scanning.  
(From the Journal of the Franklin Institute.)

OF the many systems of electron-scanning which have been proposed for television transmission, only two have so far come into practical prominence: the cumulative photo-electric mosaic of Campbell-Swinton, and the electron-phalanx of Farnsworth. As a matter of prior publication in this country, it is true that Farnsworth can lay no claim to the electron-phalanx principle, for this was originally disclosed by C. E. C. Roberts\* in 1929; nevertheless, the invention may justly be attributed to him, since he applied for his first United States patent† in 1927, well before Roberts' application date, and has an even earlier date of conception.

### The Principle of the Electron-image Camera

The principle itself is more readily explained with the aid of a diagram. Referring to Fig. 1, this shows a vacuum tube of cylindrical shape, one end of which is coated on the interior surface with photo-electric material and is connected to the negative pole of a source of potential. Upon this coating, which is in the form of a diaphanous layer upon a translucent conducting backing, there is focused an optical image, by means of a lens, of the object or scene to be scanned. At the other end of the tube there is an anode punctured with a small aperture Q, and electrons given off by the photo-electric material on the cathode are drawn off towards this anode under the influence of electrostatic acceleration.

For the moment, let us consider that all electrons are emitted from the cathode at right-angles to its surface; under the influence of the electric field, these will be accelerated in straight lines towards the anode and will preserve their relative density-configuration all the way to it. That is to say, if we were to place a fluorescent screen anywhere in the path of the electrons, or upon the anode, we would observe it to light up with the same tone distribution as that existing in the original optical image. The electrons come off, as it were *en bloc*, in phalanx formation, and can be deflected as shown in Fig. 1, by suitably placed deflector plates

# THE ELECTRON-IMAGE CAMERA

By J. C. Wilson of the Baird Laboratories.

The details of the Farnsworth Image Dissector have been kept secret until recently. This article, which is published by kind permission of Baird Television Ltd., provides a complete explanation of the device which has very great importance.

fed with scanning potentials via the leads A, B, in exactly the same way as the electron beam in a receiving cathode-ray tube.

It will be seen therefore that those electrons which would normally strike the anode at Q now rush through the aperture, and these can be collected on an additional electrode, behind the anode, to yield an electrical signal corresponding with an elemental area of the image.

### Practical Considerations

The broad principle described above is common to both Roberts and Farnsworth, but when the system is reduced to practice, there are a number of major modifications required before the system will work at all, and detailed refinement is necessary before it will produce satisfactory pictures. These major modifications and refinements Farnsworth alone has supplied‡, and these we will now briefly describe.

In the first place, with real photo-electric surfaces,

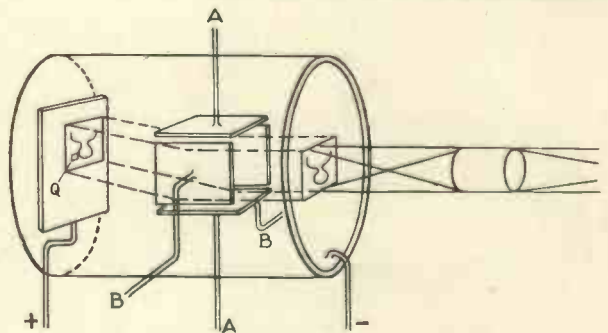

Fig. 1.—Diagram showing the principle of the electron camera.

no matter how carefully prepared, the electrons are not shot out absolutely at right angles under the influence of light; in other words, they have in general a component of initial velocity parallel with the surface so that they are somewhat dispersed by the time they

\* British Patent No. 318,331 (June 22nd, 1928).  
† U.S. Patent No. 1,773,980 (January 7th, 1927).

‡ "Radio Industries," vol. 5, No. 7, pp. 386-389 *et seq.*  
"Fernsehen," vol. 2, No. 2, pp. 123-128, 1931.  
"Journ. Frank. Inst.," p. 411, vol. 218, No. 4, Oct., 1934.

reach the anode and no sharp electron-image results.

This may be minimised by using very great accelerating potentials, or by forming the optical image with light which is very close to the critical frequency for the particular photo-electric material employed so that the initial expulsion velocities are all very nearly zero; but the dispersion and blurring of the image cannot be avoided altogether. To overcome the difficulty, Farnsworth focuses a real electron image in the plane of the anode by means of a magnetic field, and the

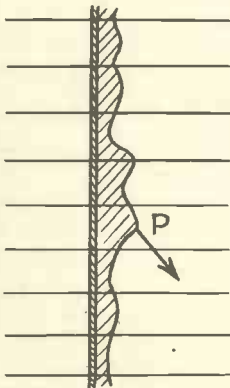

Fig. 2.—A section of the photo-electric surface shown diagrammatically on a large scale.

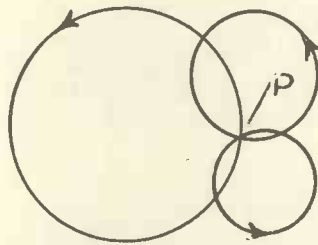

Fig. 3.—Diagram explaining the travel of an electron.

manner in which this is accomplished is shown in Figs. 2, 3 and 4.

A section of the photo-electric surface is represented on a very large scale in Fig. 2, showing the kind of

The straight parallel lines through the surface represent lines of magnetic force passing right down the tube.

Now, in a magnetic field a moving electron behaves just as a current-carrying conductor: if its direction lies absolutely parallel with the field there is no force on it, but if it tends to move sideways, crossing the field as shown in Fig. 2, a force proportional to its sideways velocity acts upon it in such a way as to make it tend to curl around the lines without altering its velocity down the tube. This is shown in an end-on view in Fig. 3, in which three electrons are represented as springing from P in different directions and with different sideways velocities; each experiences a force acting at right angles to its direction of motion at any instant and to the magnetic lines, so that it actually travels round in a circle, or rather what would be a circle if it were not moving down the tube as well.

The size of the circular path is dependent upon the initial sideways velocity and on the strength of the magnetic field, but the time which an electron takes to complete one convolution is the same whatever its initial velocity because the larger the velocity the larger the circle and *vice versa*. All the electrons from P thus complete their particular circular paths together and converge to a point farther down the tube.

This is shown more clearly in Fig. 4, where PQ represents the shortest distance from the cathode to the anode-aperture, whereas an electron actually travels over the helical path represented by the undulating line from P to Q. In order to obtain the axial magnetic field, the tube is surrounded with a solenoidal winding

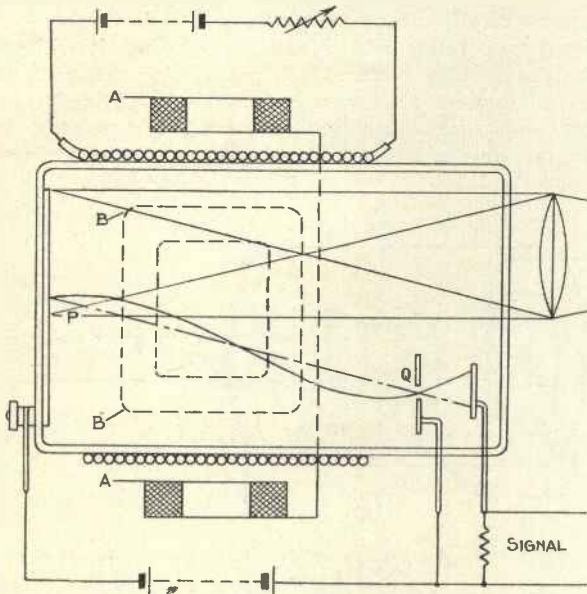
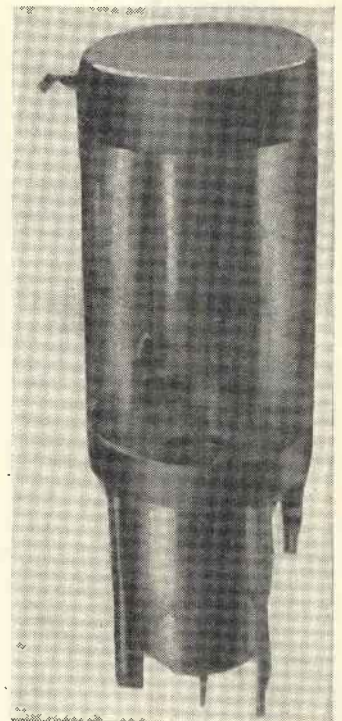

Fig. 4.—Diagram explaining how the electrons travel in the Farnsworth tube.

direction in which an electron emitted from the point P may be thought of as emerging from the material.

§ See another article, p. 227 of this issue, for explanation of "critical frequency."



The Farnsworth image dissector and electron multiplier tube. From the Journal of the Franklin Institute.

(shown in section) supplied by a battery through an adjustable resistance. For anode accelerating potentials in the neighbourhood of 500 volts the distance of the target upon which the electrons are concentrated

APRIL, 1935

by this method is about 8 inches; the radii of electron helices is given by

$$r = 0.66 V/\sqrt{v},$$

where  $V$  is the transverse electron velocity, and  $v$  is the anode accelerating potential.

### Scanning Motion

The scanning motion is imparted to the electron-phalanx by Farnsworth not with electrostatic deflector-plates, but with magnetic coils in pairs on opposite sides of the tube. One such pair is shown in section in Fig. 4, the connections A being fed with currents from an oscillator of suitable wave form; the coil shown in broken lines behind the tube, with connections at B, is one of the second pair for supplying the other component of traversal.

The resultant of the fields from these coils and that of the axial solenoid actually provides a two-dimensional scanning motion for the electron-phalanx, but the effect of any one pair of coils is not simply a motion at right angles to the line joining them as might at first be supposed. The matter is too complex to be dealt with in the present article, however,

It will be seen that the optical image in Fig. 4 is focused on the photo-electric surface from the front instead of the back. This gives greater efficiency, although it means that the anode and collector-electrode are eccentric.

The second necessary modification concerns the amount of signal-strength developed by the electron-current passing through the aperture  $Q$  and striking

the collector. This is exceedingly small, especially for high-definition television, where the aperture is minute, and the signal would be below the noise level of the amplifying valves unless some kind of artificial multiplication of the available number of electrons took place. Roberts, it is true, recognised this difficulty and provided a gas-multiplier in which the original electrons are multiplied by collision with gas-molecules as in ordinary soft photo-cells, but this is no good for high-definition work, as the ionisation process introduces lag. Farnsworth solved\* the difficulty by making use of secondary emission† of electrons from the collector under the impact of the primaries passing through the aperture  $Q$ .

To do this, he introduced two refinements: he made the collector slightly negative with respect to the anode, and coated its surface with a material of "low-work value," that is, a material such as caesium or strontium oxide which gives off a large number of electrons, under suitable conditions, per electron striking it. By this means, the electrons passing through  $Q$  are made to impinge upon and release more electrons from the collector, which then pass to the anode and so generate a larger reverse signal current in the load-resistance.

There is no space in the compass of a short article to go into the details of the electron-phalanx system, but it is hoped that sufficient information has been given to enable those interested to pursue their inquiries by reading the original publications to which reference is made.

\* U.S. Patents Nos. 1,941,344 and 1,969,399.

† See, for instance, papers published by A. W. Hull, Phys. Rev., vol. 18, p. 31, 1921.

## HIGH-DEFINITION TELEVISION SERVICE FOR GERMANY

THE German Post-Office laboratories have been broadcasting high-definition television pictures ever since August, 1933. These test transmissions, to which the accompanying sound was added in 1934, were limited to reception by scientists and television amateurs.

The German Broadcasting Company have now decided to open a public experimental high-definition sight and sound television broadcasting service. Broadcasts, which will be in addition to the ordinary Post-Office test transmissions, take place three times weekly from 8.30 p.m. to 10.00 p.m. C.E.T. Programmes will consist of excerpts from topical films and of one complete all-star entertainment film. Vision is broadcast on 6.7 metres and sound on 6.985 metres.

It will be remembered that the aerials of these ultra-short-wave transmitters are situated on the top of the Berlin broadcasting tower, 430 feet above ground level. The power of each of these transmitters is rated at 16 kW, although a certain amount

of power gets lost owing to the long feeder line up the tower.

As forecast in TELEVISION of December, 1934, the German Broadcasting Company will, after a short preliminary period, make its own topical films and broadcast these under the title: "Mirror of the Day." The intermediate-film television van will also be made use of to supply programmes.

Meanwhile, work on the transportable high-power ultra-short-wave transmitters, which are first to be tested on the Brocken mountain in the Harz in the early summer, is continuing and it is understood that they will be completed some time in May.

One German firm is already able to supply the necessary ultra-short-wave all-mains television sight and sound receivers. The price, it is stated, will be RM. 600.

The German picture is 180 lines and 25 frames per second. Work is at present in hand further to increase the definition and the German Post-Office laboratories are preparing a

system of electrical scanning together with a number of private firms. It is understood that the first public demonstrations of this new system will take place in August at the radio exhibition. The Germans are of opinion that until electrical scanning has reached the necessary standard of quality and reliability for everyday operation it is better to start out with the present 180-line picture.

### Scophony, Ltd.

Scophony, Ltd., propose marketing television receivers to receive the television broadcasts which are to be inaugurated. It is too early to give details of apparatus. The company are awaiting the decision of the Television Advisory Committee on the nature and characteristics of the signals which are to be radiated.

The general features of the Scophony system will be employed in the apparatus marketed, affording as they do optically-projected pictures of ample size and brilliancy by means of compact apparatus, which is simple to operate, of low power and low voltage, capable of long and efficient service.

# With Other Listening Posts

These reports from amateur receiving stations are a good guide to current conditions. In addition to logs of amateur transmitting stations a complete list of South American broadcasters is given.

HERE is an ever-growing listening circle to the news summary sent out by G5MM on the 160-metre band on Tuesday evenings at 11.0 p.m. Those who have heard this summary will be familiar with the name of John Preston, of Muirskirk, Ayrshire, whose reports form the basis of the news.

We have received a report from Mr. Preston telling of the conditions in Scotland, which is so comprehensive that we have reprinted it in full. Owing to the exceptional local conditions, nothing of importance is missed at this listening-post so the reports will be of interest to both short-wave listeners and transmitters alike.

Here is his report covering all wavebands and we feel sure listeners will appreciate it.

"To begin, the 1.7 band has been very poor for reception during the last three weeks, and the few stalwart 'G's' who keep at it have not been coming in at their usual QRK's. Trawler and land station QRM has been worse than usual. 2VQ, 5NW, 6SR, 2KT, 6KV, 6GO, 2PO, 5MM, 5RD, 5HO, 2LZ, 6RQ, 2DQ, 6AU, 2JG, 6TY, 5TQ, 6OM, 2LD, 5PB, 2LH, have all provided good



Good components are essential for reliable short-wave reception. Here are some Eddystone parts we can recommend. (1) Low-loss plug in coil; (2) Steatite valve holder; (3) Single contact fixed condenser; (4) 7-metre tuning coils; and (5) a typical I.F. coil.

reception in the late evening at QRK's ranging from R9 to R6 and mostly QSA5. Daylight reception on 1.7 has been very disappointing. Two Scottish stations 6UU and 5GK, which have been dormant for some time are now back on the air, but so far their 1.7 transmissions have not been heard here. No W phone has been heard on this band this last three weeks, but on Monday night, March 4, 6SR was heard relaying C.W. from W1FOV. Rapid fading has been noticed on many nights on 1.7.

"The outstanding events on 3.5 have been the VE and W contacts made by G5VL. Both ends of these QSO's have been heard exceptionally well up here. Almost every night after 23 hours 5VL can be heard working either a W or a VE as if they were locals, and some of them, particularly, W1ADM, W1EF,

W1BCP, W3DQ, W3UD, W2KR, W4ACZ, VETEI, VE1AS, W1AS, VE1DT, W2FFY, W3XR, W1CCJ, W1BR, W1DI, W1BES, W2VO, W3ALC, W2FLO, have provided me with splendid reception on a simple 0-V-2. I have been able to listen to a number of duplex transmissions in America and hear both speakers as if they were working in my own district.

"I have heard PAOSLB working W1EF and W1ADM and making a 100 per cent. contact. So far 5VL is the only G to make regular schedules and keep them. I understand that many transatlantic contacts are made round about 5 a.m. on Sunday morning, but I am asleep then. The best W heard has been W1ADM portable at Hyannas, Mass., who on Saturday night, March 9, was R9 when working 5VL. There is great excitement across the pond over these G contacts and the W's can be heard discussing their chances of getting over. There is a regular line-up when 5VL is on the air. 6LL has been heard in America and in Canada. 2XS has been reported by VE1EI. 5SY has been heard cutting DX VE and W, but I have not heard any contact made by him. 2LZ was heard one night calling W4ACZ. I could hear them both but they could not make contact. Frequencies above 3,550 are best for W contacts as lower frequencies are subject to C.W. interference.

"CT1AJ has been heard on Wednesdays and Saturday nights on 75 metres round about R6, QSA5 between 23 and 24 hours.

"OZ's, PAO's, SP's, HAF's, HB's, CT's, F's, ON's, OK's, and occasionally LY's, have all been good during the past month. A few D's have been heard.

"G's heard on 3.5 have included 2VQ, 5VL, 6LL, 5VM, 5MM, 6KV, 2KT, 2SA, 5SY, 2XS, 21P, 5AK, 5OG, 6PY, 6OM.

"5NW has been reported R4 to 5 in Rotterdam on 1.7.

"On 20 metres W2AND, W1CND and CT1BY were all heard between 18 hours and 18.30 on phone, R6 to 7, QSA5, QSB.

"On 40 metres reception is good during daylight and on Sunday mornings it is a regular thing to log 40 to 50 stations between 11 a.m. and 1 p.m. all

between R6 and R9. From Aberdeen in the north, to Newport, I.O.W., they all roll in, and many continentals besides. It is a very poor signal which is not heard up here, and I could fill pages about them."

\* \* \*

A record is claimed by B.R.S. 1,353, S. Bradbury, of Bradford, Yorkshire. During a period of 8½ hours' listening the number of stations heard totalled 181. All stations heard were using phone and the receiver used is a four-valver with an H.F. Pen. in the high-frequency stage with leaky grid detector and two low-frequency stages. 125 were on 40 metres, and 56 on 20 metres.

\* \* \*

A late report has just come in from F. A. Beane, of Ridgewell, Essex. His report is of a different type and includes only commercial broadcasters. He says: "At the time of writing the South American stations are 100 per cent. f.b., and with a 0-V-2 receiver I have heard amongst others:

HP5B	Panama City	49.75 ms.	R6-7
PRA8	Penambuco	49.45 "	R9
TIEP	Costa Rica	44.71 "	R6
TIGPH	" "	51.5 "	R5
OAX4D	Lima, Peru	51.9 "	R5
HI4D	Santo Domingo	45.5 "	R4-5
PRF5	Rio de Janeiro	31.58 "	R9
COH	Havana, Cuba	31.8 "	R3
COC	" "	49.92 "	R8
HJ4ABB	Manizales	42. "	R5
HJ1ABB	Barranguilla	46.5 "	R6-7
HJ5ABD	Cali	46.3 "	R4
HJ1ABG	Barranguilla	49.65 "	R6
HJ4ABE	Medellin	50.42 "	R7
YV6RV	Valencia	46. "	R8
YV3RC	Caracas	48.78 "	R6
YV2RC	" "	49.08 "	R5-6
YV5RMO	Maraycaibo	51.28 "	R5
HJ4ABN	Manizales	49.15 "	R5

Others heard include JVP 39.95 ms. relaying JOAK of Tokio, VUB, VK3LR, VK2ME, VQ7LO, VE9GW, etc., etc.

"The 20 metres amateur band is good here up till 22.00 G.M.T., W2DC seems to be the best here. The 40 metres band is good, but QRM is terrific and wipes out the real DX. The G's are plentiful, so too are the EA's, CT's and F's.

"The University of Heidelberg operates a station D4AEG on 40 metres, and it is well heard here. LX1AS, of Luxembourg, is good too.

"VE9AS, 46.69 metres approximately, of the University of New Brunswick, sent me a verie in the form of their newspaper called *The Brunswickian*, with my report reproduced therein. Incidentally, I was the only one in England who had reported this station, up to the time of printing the number sent.

3/6 per Quarter  
6/9 per Half-Year  
13/6 per Annum  
will ensure "Television and Short-wave World" being delivered to you regularly each month.



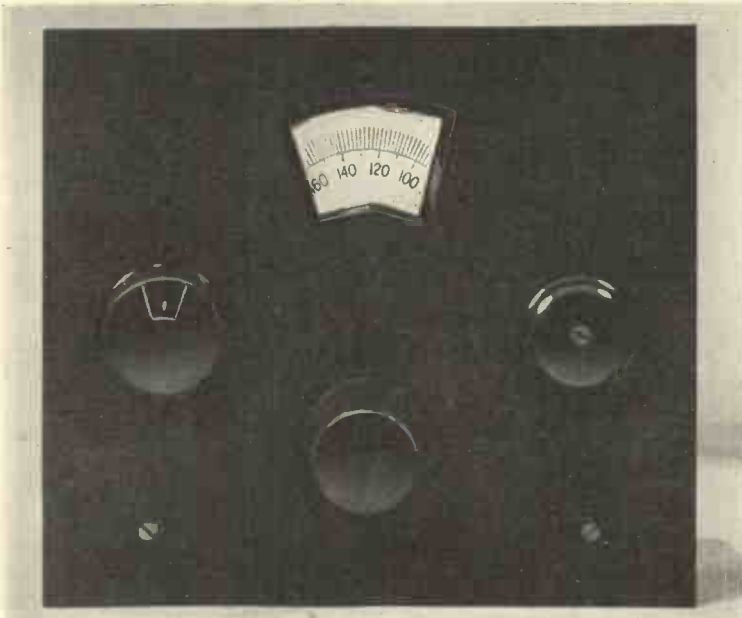

The three controls on this simple converter are from left to right—wavechange switch, main tuner and an oscillator-cum-reaction condenser.

# The Simplest Way to Hear Short-wave Stations

Here are the details of a simple Autodyne super-het converter of the very simplest kind. It can be constructed for less than 45 shillings, and will enable any owner of a broadcast set, with one or more high-frequency stages, to receive programmes from all over the world.

ALMOST any broadcast set can be used to receive world-wide short-wave stations if a super-het converter is connected in front of it. The only qualification is that the receiver must either have one or more high-frequency stages preceding the detector or else be of the super-het type. Even though we have tried to convince readers that a good short-wave set is a real investment, there are still numerous broadcast listeners who will not spend more than a few shillings to find out whether or not short-wave reception is all that it is claimed to be or whether short-wave enthusiasts are inclined to exaggerate.

Providing a converter is well designed and equally well constructed, a standard broadcast receiver can be converted into a short-wave super-het and a highly efficient one at that. There is no reason at all for a broadcast receiver

plus super-het converter not being as good as a genuine short-wave set except that of convenience. Quite a number of correspondents mention that they either use a converter or else were introduced to short-wave listening by means of a converter.

For those who would like to listen to America on the short waves, or perhaps to Sydney on Sundays, but as yet are sceptical as to whether this can be done, we have designed this little inexpensive converter.

## How the Converter Works

Fundamentally it is an oscillating one-valve detector circuit having its output fed into the grid circuit of the broadcast receiver tuned to approximately 1,800 metres.

As a general rule these converters are

supplied with plug-in coils, but knowing that readers dislike coil changing we have designed the unit around a special triple-range coil which tunes between 12 and 86 metres.

Actually the coil is three coils in one, all series linked together. The amount of inductance or the number of turns wanted can be obtained by means of a D.P.D.T. switch.

The first coil covers all wavelengths between 12 and 25 metres, the second 19 and 43 metres, and the third 38 to 87 metres.

In this way most of the amateur bands and all of the broadcast bands can be tuned in when using the standard .00016 condenser for tuning.

The first wave range is most suitable for the reception of 13- and 16-metre broadcast stations, such as W8XK Pittsburgh and W3XAL Boundbrook, New Jersey.

It is better to receive the 19-metre band on the second coil. This ensures

## COMPONENTS REQUIRED

### CHASSIS.

- 1—Aluminium 6 in. by 5½ in. by 1½ in. (Peto Scott)
- 1—Aluminium panel, 6 in. by 5½ in. (Peto Scott)
- 1—Ebonite Panel 6½ in. by 5½ in. (Peto Scott)

### CONDENSERS, FIXED.

- 1—.0001 mfd. type 665 (Dubilier)
- 1—.0002 mfd. type 665 (Dubilier)

### CONDENSERS, VARIABLE.

- 1—.0001 mfd. reaction type 1054 (Jackson)
- 1—.0005 mfd. pre-set type 1087 (Jackson)
- 1—.00016 mfd. type 942 (Stratton)

### COIL.

- 1—Three range S.W. coil (Lissen)

### CHOKE, HIGH-FREQUENCY.

- 1—HF8 Screened (Bulgin)
- 1—Eddystone type 948 (Stratton or home made)

### DIALS, SLOW MOTION.

- 1—Disc drive type No. R365 (Ormond)

### HOLDERS, VALVE.

- 1—4 pin type baseboard (W.B.)

### PLUGS, TERMINALS, ETC.

- 3—Wander plugs marked H.T.+1, H.T.+2, and H.T.— (Belling-Lee)
- 2—Spade terminals marked L.T.+ and L.T.— (Belling-Lee)
- 1—Insulated socket, red, type 1070 (Belling-Lee)
- 1—Terminal type R marked E (Belling-Lee)
- 1—Insulated socket black, type 1070 (Belling-Lee)

### RESISTANCES, FIXED.

- 1—3 meg-ohm type 1 watt (Erie)

### SUNDRIES.

- 1—length paxolin former 2½ in. by ½ in. (Peto Scott)
- 1—length paxolin 5 in. by ½ in. (Peto Scott)
- Quantity thin flex (Ward and Goldstone)
- Connecting wire and sleeving (Ward and Goldstone)
- 24-6 B.A. nuts and bolts (Peto Scott)
- ½ oz. 36 enamelled wire (Peto Scott)

### SWITCH.

- 1—DPDT rotary change over (Wright and Weaire)

### VALVE.

- 1—Marconi S.23

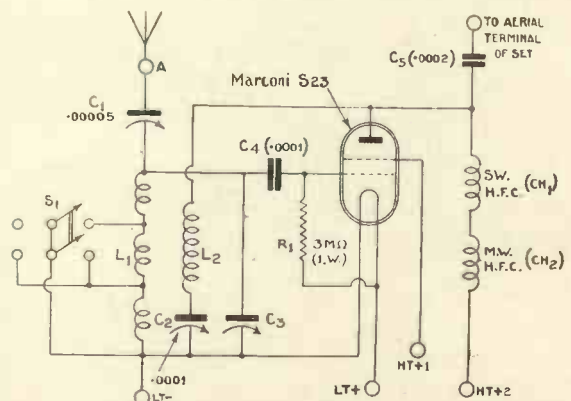

A screened grid valve is used as a combined detector oscillator on the Autodyne principle with this simple converter.

that the capacity-to-inductance ratio is correct. There is no need for us to explain the L/c formula here, but remember if the station wanted can be heard at the bottom of the tuning dial it will be louder than if it is tuned in with all the condenser vanes in mesh.

The second coil tunes in the 19-metre broadcast band, the 20-metre amateur band and the 31-metre broadcast band.

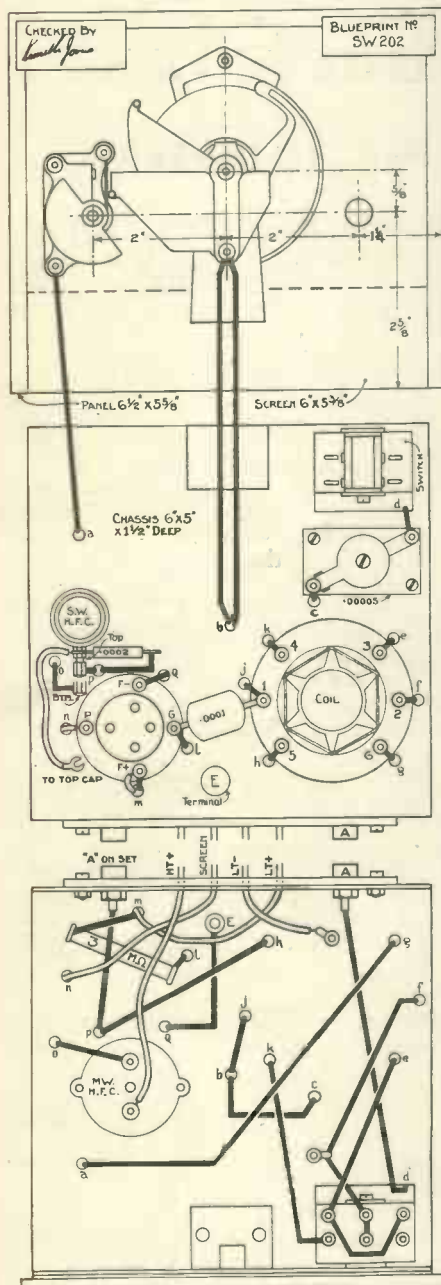

The layout and wiring diagram. A full-size blueprint is available, price 1/-

The third coil covers the 40-metre amateur band, the 50-metre commercial bands and finally the 80-metre amateur band.

All the components are mounted on a metal chassis, some on top and the

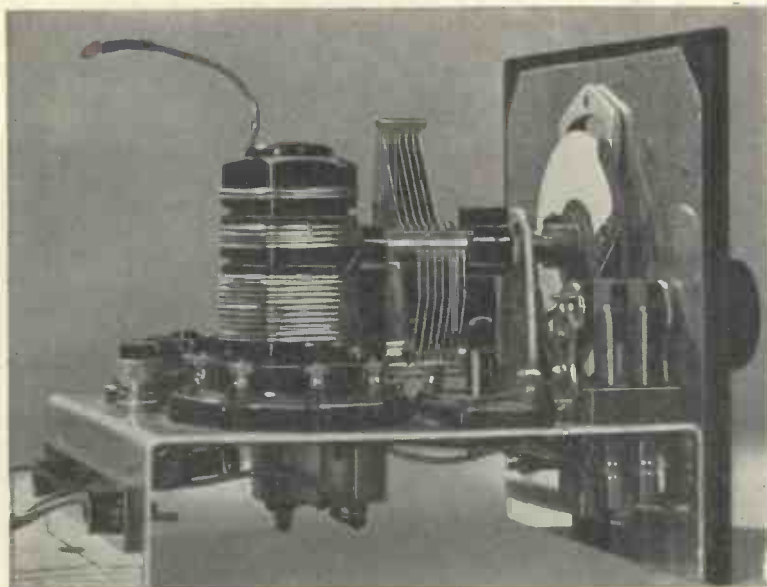

The layout of the components can be seen quite clearly. Make a special note that the ebonite panel is shielded by means of a second aluminium panel behind it.

balance beneath. The coil unit, valve holders, series aerial condenser, high-frequency choke, etc., are all on the top of the chassis.

Beneath will be found another high-frequency choke and a fixed resistance. On the panel are the tuning and oscillator condensers and the switch.

The blue-print explains the connections to the various components.

### Using the Converter

No additional power supply is needed. The existing accumulator and high-tension battery can be used to energise the unit. In the event of the broadcast receiver being of the mains type then, of course, a battery will be wanted for both anode and filament supply.

When connecting up remember that there is not any high-tension negative connection. There are four leads; one for low-tension negative and one for low-tension positive. The third must be plugged into the 120-volt tapping of the battery, and the fourth into the 60-70 volt tapping.

Also there is no need for an earth connection if a common battery supply is used. The aerial lead-in wire is removed from the broadcast set and plugged into the red terminal on the back of the chassis. The black terminal is then linked with the aerial terminal of the broadcast set.

The high-frequency choke can be home-constructed and consists of a piece of paxolin former wound with 150 turns of 36 d.s.c. wire as a plain solenoid. The two ends are anchored under 6 B.A. terminals.

Although the unit is virtually a single-valve detector unit, the oscillator must not be regarded in the same light as a

reaction condenser. The maximum point does not come with the maximum condenser capacity. As a general rule the unit will begin to work as a super with the condenser somewhere near the central position.

There is not any need to vary the condenser as one does a reaction condenser. In practice after the proper position has been obtained only very slight adjustments have to be made to keep the volume at maximum level.

Tuning will be very sharp, but there will not be any need to touch the broadcast set. Leave this tuned to about 1,800 metres on the long waves, with the volume control full on and, if it is a straight set, the reaction control slightly advanced.

For reception of C.W. stations the detector must be made to oscillate, otherwise the receiver can be left alone. For those about to delve into the supposed mysteries of short-wave reception a converter of this kind can be recommended. After it has been decided that short-wave listening is worth while all the components can be used again to make a more ambitious receiver.

## The Simplest Cathode-ray Receiver

We regret that a draughtsman's error in the wiring diagram of the "Simplest Cathode-ray Receiver" on p. 100 of the February issue made it appear that the 1/2-ohm resistance is connected to the accelerator, instead of to the cathode. The lettering "ACCEL" on the print refers to the terminal marked E and not to the 1/2-ohm resistance.

# THE A B C OF THE CATHODE-RAY TUBE—I

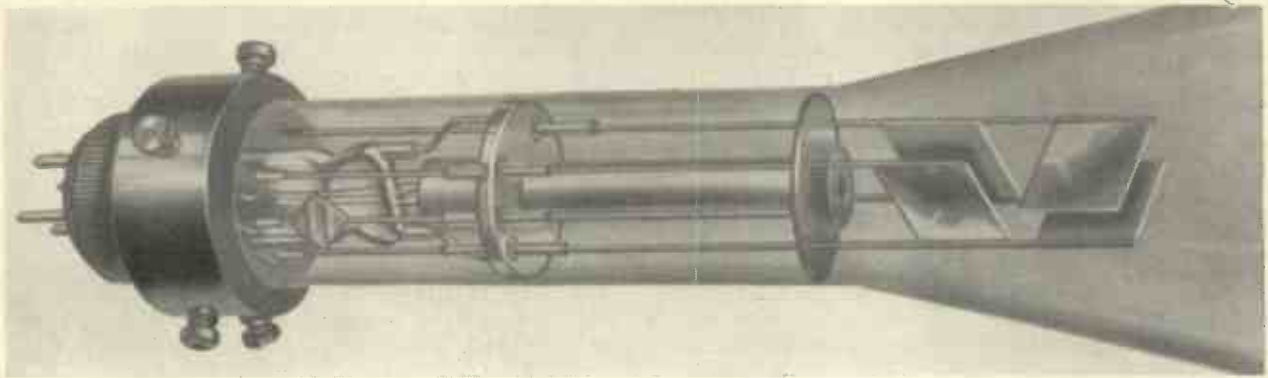

## ELECTRONS AND THE CATHODE-RAY TUBE

By G. Parr

*Since the impetus given to Television by the recent P.M.G. Report a number of new readers are taking up the study of this fascinating subject for the first time. This, the first of a series of articles, will explain in detail the theory of operation of the Cathode-ray Tube on which most of the new Television receivers will be based. The ground will be covered fully from the start and the articles written in such a way that the beginner is not confused with technical terms introduced without explanation.*

**T**HERE is a hoary old story, almost forgotten now, about a professor examining his class who noticed a sleepy student in the back row. He called out to him, "You, sir, there, what is electricity?" The student blinked and stammered, "I did know, sir—but I'm sorry to say I've forgotten."

The professor turned to the class and said, "There! The only man in the world who knew what electricity is has forgotten all about it!"

In the early years of the century this story had a great deal of point, as the exact nature of electricity was largely a matter of speculation, but nowadays a student taxed with the same question would merely say "It is the movement of electrons under the influence of some external or internal force," and he wouldn't be so far wrong. But he could easily be caught out by being asked, "What is an electron?" and the answer might not be given so glibly. For although we have weighed electrons and counted them and done all sorts of things with them, no one can say that they have seen them. And what can't be seen is always difficult to describe.

That there is such a thing as an electron is quite definite, but until someone discovers a way of seeing it we have to take it on trust and try to explain it by referring to something that we already know. What do we know? That everything is built up of minute particles. Most people know that, when they stop to think about it. In the case of concrete it is quite easy to see that it is made up of innumerable tiny grains of sand and cement, but in the case of air it is not so easy to imagine that it is made up of even tinier particles.

It is the old problem again—it is difficult to imagine something that can't be seen. But it does not require a great effort to argue from one case to the other. If we can see that an aggregate of tiny particles can form a solid mass like concrete, it is not a big step to visualise a gas as made up of similar particles, but of a dif-

ferent nature. If the particles were of the same nature it wouldn't be a gas! Think that out!

### The Atom

The name of the tiny particle is the *atom*, and we can here jump to a very quick statement which can be accepted at once—All matter is made up of atoms. Actually there is a little more in it than that—it is not only the nature of the atom which is concerned but also its arrangement in the substance, but we can leave that for the moment. How can atoms differ in their nature? Does not this imply that there is something which goes to the make-up of the atom itself? Ebonite differs from bakelite because of the different make-up of the substance, and in turn the atoms of ebonite differ in make-up from the atoms of bakelite.

So the next step is to investigate the atom itself and

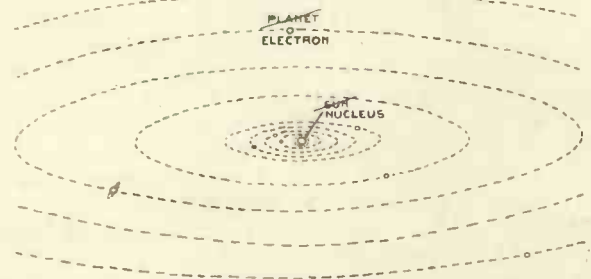

Fig. 1.—The solar system, which is almost an exact representation of an atom and its components.

try to find out what it is that makes the difference—the little something the others haven't got, to use a phrase that has passed into the language. The atom, in consequence, has been explored by the best brains,

1,000,000,000,000,000,000,000 TO THE CUBIC CENTIMETRE!

examined with the closest attention, and even split!

And the net result of the work is this: So far from being a minute particle, the atom is a most complicated arrangement of even tinier particles! The reader is probably saying, "What, more particles? I'm getting tired of reading about particles." All right, call them by their proper name—ELECTRONS.

**The Electron**

Look at the drawing of Fig. 1, which is a diagram of the solar system. In the centre is the sun and round it, revolving on their definite paths are various planets, each having a definite place and a definite track to follow, and revolving at a definite speed.

What has all this to do with the atom? Only this—instead of the word planet write "electron." Instead of "sun" write "nucleus," and we have a very fair idea of how an atom is made up. And the spacing isn't so far out either. In proportion there is almost as much space between the electrons and the nucleus as there is between the planets

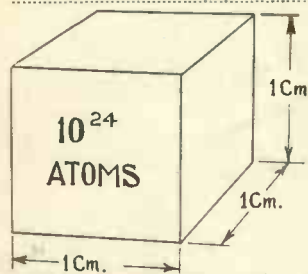

Fig. 2.—A cube of 1 cm. side, i.e., 1 cubic centimetre. This will hold 1,000,000,000,000,000,000,000 atoms.

and the sun. Another very nice analogy was put forward by, I think, Professor Andrade.

He imagined a plum on a tree, and round it were circling dozens of gnats, each keeping station at a certain distance away from the plum. On a proportionate scale to the electron and the nucleus, the outermost gnat would be at a distance of two or three large fields away! In fact the atom contains considerably more empty space than solid matter!

But we need not go further into the make-up of the atom. Sufficient for the moment we can visualise a centre core, round which are revolving numbers of electrons, each in its own orbit held to the centre of the system by a form of gravitational attraction.

The next thing is to get hold of an electron. It is not so firmly fixed in the tiny universe of the atom that it cannot be dislodged—in fact we are dislodging millions of electrons every day without knowing it. A kick to the atom, and away goes an electron, shaken out of its regular appointed path.

What happens to the electron which has been moved out of its routine track? It becomes a "free electron" and can be coaxed into any path by the application of a suitable persuasion. If we dislodge innumerable electrons and persuade them to move as a body in any direction we have a steady flow of exiles from the atom, all moving according to the influence of the force we apply, and we have in effect, a current! Just like that! Current of what?

Electricity, of course. So electricity is produced by the movement of electrons under some persuasive force in such a way that a flow is steadily maintained. The strength of the current is, of course, dependent on the number of electrons involved, in fact we could measure our current in terms of electrons, but the numbers are so big that a more convenient way is to stick to the good old units and speak of "an ampere of current," which is really only another way of saying "so many million electrons passing per second."

Incidentally there are two units which are used in speaking of the electric current—the ampere, which most of us have heard of, and the coulomb, which is seldom used. The difference between them is that the coulomb is equivalent to so many electrons in bulk and the ampere refers to their rate of flow. The difference is the same as that between the "gallon" and the "gallon per second." A milliampere is much more common in radio, or even the microampere, which is one-millionth of the ampere.

Talking of numbers, it is interesting to have a few definite figures which have been established. Sir Oliver Lodge gives them in his book "Electrons," which although published thirty years ago covers the whole subject in a thorough way and would be difficult to supersede. He says: "In the solar system the diameter of the earth is 1/24,000th part of the diameter of its orbit round the sun. If the earth represented an electron, an atom would occupy a sphere with the sun as centre and four times the distance of the earth as radius." Again: "The volume of an atom is 10<sup>-24</sup> cubic cms.\*; the aggregate volume of all the electrons composing the atom is 10<sup>-31</sup> cubic cms. and consequently the space left empty is 10<sup>-10</sup> or ten thousand million times the filled space! And as a final thought, in an atom of mercury there are 100,000 electrons. Surely the mercury atom can lose a few without noticing it!

**Weight and Size of Electrons**

The weight and size of the electron are important in some ways and we shall probably have to refer back to these figures at some future time. For the present, let us go on to ways and means of moving electrons. The one that most concerns us with reference to the subject is *heat*. If a substance is heated there is immediately a violent agitation among the atoms of which it is made up.

They move about in all directions, collide, rebound, and even leave the material altogether and go off into the surrounding air.

This is not so extraordinary as might be supposed—would you stay still for long if you sat on a hot plate? Anyhow, this movement among the atoms is bound to have an effect on the electrons and some inevitably get dislodged in the general confusion. So one simple

\* For those who have forgotten their mathematics, these signs are merely abbreviations to save writing strings of o's. So 10<sup>6</sup> means 1 followed by six o's, and 10<sup>-24</sup> means a fraction with a denominator of 1 followed by 24 noughts! As this is the same as a million million million million, you can imagine (or, rather, can't imagine) how small these things are!

## WHAT HAPPENS TO "FREE" ELECTRONS

method of providing a general exodus of electrons is to heat the substance of which they form a part. The sketch of Fig. 3 shows them migrating at the surface of the metal when it is heated.

Actually, electrons which are ejected from atoms by "thermal agitation" as it is called do not go very far in the surrounding air for the reason that they meet other atoms and find their progress impeded. The majority make a short excursion into the neighbourhood and then return to their original home or to another home which has lost its occupant. The net result of heating a metal in air is therefore to produce a violent agitation in electron circles which makes them jump off the metal spasmodically and then return.

If, however, the air is removed, then a different state of affairs exists. The outside area round the metal is comparatively free from impeding atoms and the electrons are encouraged to make longer excursions. In the scientific sense we now have a metal surrounded by

a vacuum and heated. This then gives off a steady outflow of electrons which travel a longer or shorter distance into the empty space surrounding the metal. The proper name for this is "thermionic emission," which in very crude language means chucking out electrons from atoms by warming up the metal! Next time we shall capture the electrons as they leave the metal and make them do something useful.

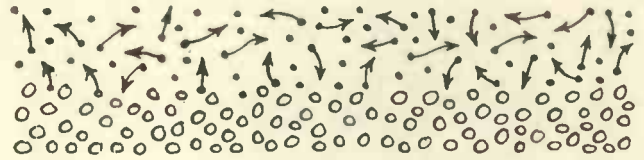

Fig. 3.—What happens when a metal is heated. The agitation among the atoms frees electrons, which go off into the surrounding air.

A "DE LUXE" CATHODE-RAY  
TELEVISION RECEIVER

IT is generally understood that although the Television Committee's Report is published, some considerable time will elapse before the recommended high-definition television transmissions take place on a regular basis.

In the meantime the regular 30-line transmissions are of sufficient interest to be received, but many are deterred from investing in apparatus by the thought that it will be obsolete in a short time. This, however, is not the case with a cathode-ray tube, which can be adapted to reproduce low- or high-definition television with equal clarity.

Accordingly we make no apology for introducing a second design for a cathode-ray receiver for the home constructor, believing that a great deal of valuable experience will be obtained from its assembly, which will leave the user free to devote time to the short-wave side of reception when this is established.

A Complete  
Receiver

The "De Luxe Viewer" will be a complete sound and vision receiver in a handsome cabinet and will make use of one of the new high-vacuum tubes of a large diameter which is capable of accommodating both the low-definition and high-definition picture without loss of detail. The present picture ratio is 7-3, which

means that a picture approximately 14 by 6 cms. can be accommodated. The new proposed picture ratio is 4-3, which will yield a picture approximately 12 by 9 cms. This is equivalent to an increase in size of picture of nearly 30 per cent., which can only be effectively realised on a large-diameter tube without loss of clarity.

Both sound and vision receivers will be accommodated in the cabinet,

## "TELEVISION'S" NEW ADDRESS

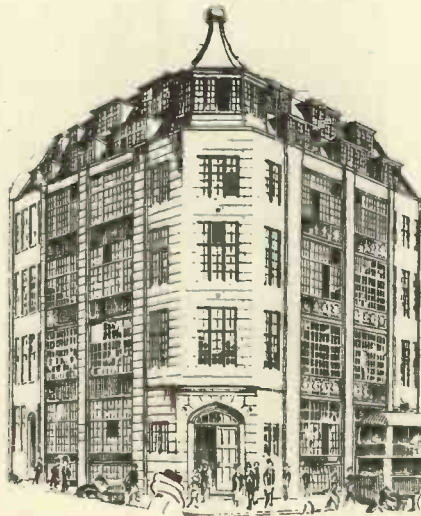

Television and Short-wave World,  
Chansitor House, 38, Chancery Lane,  
London, W.C.2.

{Telegraphic Address BEEJAPPE, HOLB., London  
Telephones HOLBORN 6158, 6159.

which is of the standard radio-gram pattern.

Mains equipment is housed in the bottom of the cabinet in a shock-proof safety box and the whole receiver will be ready for use at the touch of the switch.

High or Low  
Definition

The circuits will be assembled on baseboards which can easily be replaced when alterations to the scanning circuit and receiver are required. As far as possible, components will be used which can be of service in both the low- and high-definition circuits and the receiver section for the medium waveband will be of a standard pattern, which can be used for broadcast reception when it is ultimately replaced with a short-wave chassis. It is realised that our provincial readers require a more elaborate receiver with one or more H.F. stages, although the use of the cathode-ray tube helps to a great degree by the low signal input required for modulation. Accordingly it is proposed to give an alternative receiver design which will be suitable for local conditions only and which will have as high a frequency response as possible.

In each case a detailed price list of components will be given in order that the constructor can judge the total outlay before undertaking the work.

Next month the general layout of the receiver will be discussed and the principal dimensions of the cabinet and baseboards.

# Modulation with A Single Stage

By E. L. Gardiner, B.Sc.

*Details of a new pick-up which will load the modulator valve without intermediate amplification. This pick-up gives an output of 25 volts R.M.S. which can be applied to the grid of a large power valve.*

**A**T most amateur transmitting stations the gramophone pick-up is found very useful as a source of reliable and reproducible modulation while carrying out tests. In conjunction with a constant frequency record it provides the cheapest and simplest means of carrying out the simpler forms of modulation adjustment.

A new type of pick-up which has just made its appearance in America as a

milliamps is required. The main advantage of the pick-up lies in the exceptionally large voltage-swing which can be obtained from it. This naturally depends on the magnitude of the external potential used, and, in fact, variations of this form a good system of volume control. With an applied voltage of 200 to a single

the pick-up so handy for use in amateur transmission. Ordinarily, an amplifier of one stage, or sometimes two, is essential between a pick-up and the modulator valves of a transmitter, but the Amperite pick-up gives sufficient output to be coupled direct to the grid of many valves of the types used as modulators. It also has, of course, a

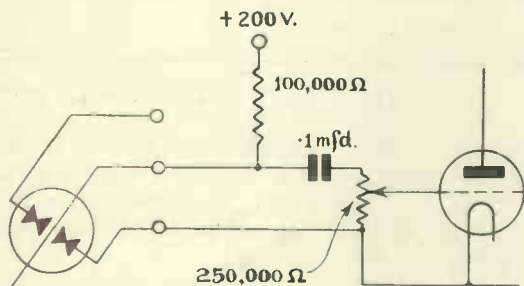
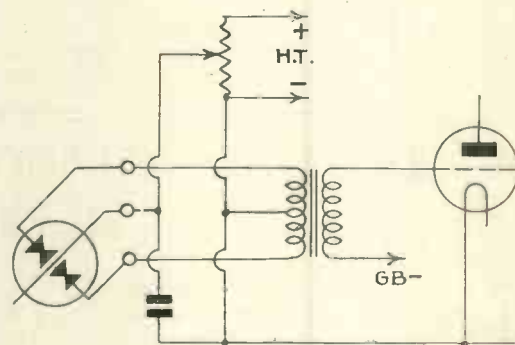

Fig. 1 (left).—The simplest circuit for use with the copper-oxide rectifier.

Fig. 2 (right).—A high-output arrangement.



product of the Amperite Company, and which is now becoming available here through the usual dealers who import American components, is of special utility for this work, as well as being of considerable technical interest.

## A New Principle

The pick-up operates on a new principle, relying for its action upon the variations in resistance of copper oxide buttons with changes of pressure. Actually, two such buttons are used in the construction of the device, mounted in such a way that the movements of the gramophone needle carrier increase the contact pressure on one of them, while simultaneously decreasing that on the other.

The changes in resistance of the two buttons is thus reciprocal, and, whereas one only can be employed, "push-pull" connection between the two is also possible. The action of the pick-up is closely analogous to that of a double-button carbon microphone.

Clearly the pick-up is not self-generating; it acts rather as a variable resistance. An external potential is therefore necessary, but this is no disadvantage, since the H.T. voltage of the amplifier may be used for this purpose. The resistance of the buttons is of the order of 100,000 ohms each, and hence a current of only one or two

milliamps is required. The main advantage of the pick-up lies in the exceptionally large voltage-swing which can be obtained from it. This naturally depends on the magnitude of the external potential used, and, in fact, variations of this form a good system of volume control. With an applied voltage of 200 to a single

large field in the production of inexpensive commercial electric gramophones.

In other respects the pick-up conforms to accepted practice. The bass response is very good, rising to below 60 cycles. A very good response to high frequencies is also shown in the



The Amperite copper-oxide pick-up.

centre-tapped step-up input transformer, it should be possible to apply up to 100 volts swing at the grid of a power valve without additional amplification.

## Large Output

It is this large output which makes

maker's published curves, but the sample tested by ear did not sound exceptional in this respect, although the brilliance of reproduction was not below that expected from good commercial pick-ups. The device is well and strongly made from light and well-designed metal castings and has a pleasing appearance.

# Scannings and Reflections

By THE LOOKER

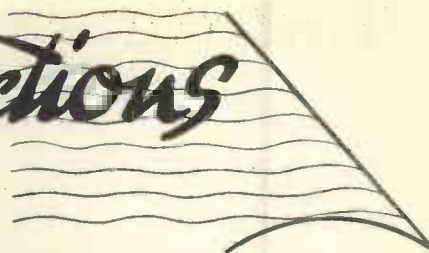

**N**OW that the future of television is linked, hand in glove so to speak, with the ultra-short waves we may expect designers to get busy with a fresh crop of circuits specially designed for 7-metre working. The superhet has had a very good innings during the last few years for broadcast reception—on all waves—but it does not necessarily follow that it will hold its own in the new field.

## Short-wave Circuits

One possible rival is our old friend the super-regenerator, with the "quenched" valve. Although this circuit has been out of fashion for some time, it may yet stage a comeback on its merits as a short-waver. Another interesting development in short-wave technique is the new method of working a valve with a high positive voltage on the grid, and none on the plate. It is usually referred to as the Barkhausen-Kurz circuit, though a good deal of work has been done on it by Gill and Morrell.

The results obtained are rather fascinating. The electron stream does not flow straight from the filament to the plate, in the ordinary way, but is kept oscillating at a very high speed in and out of the grid windings. As they leave the filament the electrons speed up towards the positively-charged grid, the bulk of them passing clean through. Once past, however, they find nothing to attract them towards the plate, and so turn back again towards the grid. Those that pass through only find themselves, as before, moving away from the electro-static centre of attraction. Back they go again, and in this way are kept continually dancing in and out of the grid windings.

The point of it all is that every time the stream crosses the grid it induces a current in the external circuit. Since it takes less time to oscillate to and fro across the grid than it does to cover the whole dis-

tance between filament and plate, one can get more impulses into (or out of) the aerial per second in this fashion than when using the valve in the ordinary way. After all, it takes a certain definite time for each electron to pass right across the valve, and as 7-metres waves come in (or go out of) the aerial at the rate of over 40 million a second, any scheme which helps the electron stream inside the valve to keep pace with the signals is all to the good.

## The Farnsworth Tube

Apropos of my reference last month to the Iconoscope, I am reminded that the "mosaic cell" type of transmitter mentioned in the recent Television Report might be taken to apply equally well to the Farnsworth tube. In a sense this is so, since in the Farnsworth tube the image to be televised is focused as a whole on to a photo-electric cathode surface. The action is, however, different in the two cases.

In the Iconoscope the electrostatic image formed on the mosaic cell electrode does not contribute to the main electron stream, though it is scanned by it. On the other hand, the Farnsworth picture actually produces a dense stream of electrons, which preserves a constant density throughout its length. That is to say, if one could take a cross-section through the stream at any point along the tube, the relative densities of the electrons found there would represent the relative light-and-shade values of the original picture.

This is a most ingenious arrangement though it naturally depends for its efficiency upon an accurate focusing of the whole stream. Should the electrons, for instance, be allowed to lose step with each other, once they have left the cathode, the picture will be blurred. Scanning is effected by traversing the stream bodily, both up and down, and to and fro, past a small aperture at the anode of the tube.

A notable development of the

Farnsworth transmitter is the new "electron-multiplier," which boosts up the strength of the photo-electric emission by passing it to and fro between a pair of sensitised anodes. Each anode contributes a fresh quota of secondary electrons which go to strengthen the original discharge current, and so greatly increase its volume.

## British First

As a nation we have the reputation of being rather easy-going in our ways, preferring as they say, to "make haste slowly." That may be so, but the report of the Television Committee has certainly taken the rest of the world by surprise. Rumour has been eloquent for some time concerning the progress made in television elsewhere—particularly in America and Germany—though the precise details have not generally been forthcoming.

Finance is the excuse given in America for not launching out into television on a large scale some two years ago. So far as the technical side is concerned, they claim to have been waiting for the word go, even before the great depression. But as they could not see how it was going to pay it was decided to close down until the prospects looked more favourable. Of course, if this is true, it only goes to show that it is better to pay 10s. a year for a licence than to depend upon the tender mercies of the advertiser. If every listener in America paid a yearly tax for his broadcast service as we do, there would have been plenty of reserve funds available to nurse television through the preliminary stages.

## A Relay Problem

One of the problems we shall soon have to face is the relaying of television programmes. As the effective range of a 7-metre wave is at present limited to about 25 miles, it is obvious that a large number of local

stations will be required to cover the whole country. It is equally clear that it will be quite out of the question—on the score of expense alone—to provide a separate studio for each centre.

One suggestion is to link up a master studio to a number of distant transmitters, through as many short-wave radio beams, each concentrated in the required direction. Another is to use the special type of high-frequency cable which has recently been developed to carry a frequency band of over a million cycles. This consists of a tubular outer conductor having an inner core so as to act as a two-wire transmission line, the space between the two wires being filled with a solid dielectric. Incidentally such a cable could be used to run a television service on wired-wireless lines.

### **Not Buying Big Sets**

Really, the public mind is a strange thing, and the misconceptions that the Television Report has given rise to are absolutely astonishing. It is a fact that the sales of large broadcast sets have fallen off drastically since the report was published.

Those who can afford anything from fifty to a hundred guineas for their receivers seem to think that they might just as well wait a few months and get a radio-cum-television receiver. What they obviously overlook is the fact that, if the sound as well as the vision is put out on the ultra-shorts, a television set will not be suitable for any medium- or long-wave reception.

In the meantime I gather that several makers of big sets are seriously scratching their heads.

### **Tele-ma Possibilities**

Did you notice an item of news in your paper recently saying that a super cinema equipped for television is to be built at Everton Valley, Liverpool? Now, what do such announcements mean?

A trade paper called *The Cinema* tells its readers that Capt. A. G. D. West, of the Baird Company, has assured its representative that in all likelihood television would be seen in at least one cinema this summer.

### **"Something Worth While"**

And then I see that Mr. F. Walton, of Scophony, also told *The Cinema* that he expected to be able to give a demonstration of television suitable for the cinema this year—and it would be "something worth while." The Scophony people have projected a newsreel by *television apparatus* (please note the italics) on a large screen and have achieved what are described as "arresting results," though, it is a far cry from experimental work to what the public understands by "the television cinema."

### **Showmen's Problems**

Cinema people generally are very interested in the possibilities of television, of course. The showmen are all for it as a new attraction to their patrons, but others are wondering how far it will lead them into additional expense—as did sound apparatus when talkies came along.

There is also the political problem as to how far the picture-making industry will be prepared to have its productions transmitted through the ether, which will be as free to all lookers as it is to all listeners. Indeed, this seems as if it is going to be one of the greatest difficulties.

### **Killing Films by Television**

Super productions may cost anything up to £100,000 to make and only the fact that each picture can be shown a good many times in cinemas in all parts of the world enables the producers to get their money back.

Once a film is televised it will be past history as far as the lookers are concerned; and the B.B.C. could not afford to pay for one performance anything like what the film would earn in one week if shown in the usual way in picture houses. Equally, of course, the B.B.C. can hardly afford to go to the expense of making a picture that will be shown only once through its television service.

So where *are* the television programmes coming from? No doubt Mr. Gerald Cock, the Director of Television at Broadcasting House, has by now a good idea of what he is going to do when the time comes, but he is keeping silent for the time being—wise man!

### **Regular German Service**

After much talk the Germans have at last started a regular and official television service. Quite a lot of British radio people who went over to Berlin for the last radio exhibition there were under the impression that the demonstrations they saw were part of a regular service, but apparently they were mistaken.

Anyway, there seems to be no doubt that the announcement of a regular service has been inspired by the British Television Report; the Germans do not want anybody to get the impression that we are further ahead than they are.

### **Teething Troubles**

The site for our transmitter is not yet fixed; nobody seems to know any technical details of the service at all (actual number of lines, frames, etc.); and it will take a good many months for a transmitter to be built and—equally important—for receiver manufacturers to get down to some sort of production. That, of course, is the trouble about television in Germany; there is a transmission, but there are practically no receivers.

It is reported that the German broadcasting authorities are buying television machines and planting them free of charge in the homes of certain chosen people so that they can get some sort of line on what the public thinks of the new art.

### **German 180-line Standard**

These German television pictures are of 180 lines, 25 frames, and are transmitted on 6.7 metres; accompanying sound is on 6.985 metres. Of course, the effective range is not expected to be much more than thirty miles or so, as we are aiming at over here.

Still, the Germans have the advantage of a pretty good tower in the grounds of the radio exhibition buildings that is used for erecting the aerial.

READ TELEVISION  
& SHORT-WAVE WORLD  
REGULARLY



APRIL, 1935

# MAKING A SYNCHRONISER

The following details of the construction of a synchronising apparatus are given in response to a number of requests from readers who wish to make their own.

THE construction of a synchroniser for disc or mirror-drum is within the ability of the amateur who is used to metal working, though it should be borne in mind that if it is to be efficient some rather accurate work is called for. Although one or two turned parts are required these can easily be obtained if a lathe is not available, and the remainder of the work can be accomplished by means of the usual metal-working tools which are in the possession of most amateur metal workers.

## Material Required

The materials required are as follows:

Eighteen pieces of 22 s.w.g. sheet iron about  $2\frac{3}{8}$  in. square.

One piece of 1-16-in. sheet iron or mild steel about  $2\frac{5}{8}$  in. square.

$3\frac{1}{4}$  ins. of  $\frac{1}{2}$ -in. dia. mild steel rod.

One piece of brass 2 ins. dia. and about 1 in. long.

One piece of mild steel or wrought iron  $1\frac{1}{2}$  in. wide by  $\frac{3}{8}$  in. thick. (This can be procured from the local blacksmith and bent to the shape shown in Fig. 2 for about one shilling.)

One brass bush to fit the end bearing of the motor in use (or alternatively a piece of rod for making a bush).

$\frac{1}{2}$  doz. rivets, 3-16 in. by  $\frac{3}{4}$  in.

The construction of the thirty-tooth rotor is the most difficult part of the work, for this must be exactly circular and the teeth must be accurately spaced. This, as will be seen, is built up from a number of sheet iron laminations riveted together and secured to a boss; this boss is the only part which requires to be turned.

The rotor teeth are formed by drilling and then cutting the surplus metal away. If a lathe or drilling machine is available then the plates can be drilled after being riveted together, but if a hand drill is to be used then it will be essential to drill the plates separately or at the most in threes.

Even with this method it is not possible to make an accurate toothed-wheel; some of the teeth will be slightly broader than others, due to the difficulty of drilling 30 equidistant holes. However, this difficulty may be overcome in the following manner:

It will be noticed that six rivets are passed through the assembly; as each plate is put into position it should be turned one hole past the original drilling position. If each plate is assembled in this manner it will be found that the errors more or less cancel each other out, and this is the reason for marking the plates before removing from the drilling jig as is explained later.

The first procedure is to mark out very carefully the 1-16-in. mild steel plate as shown in the left-hand side of Fig. 1; this forms the template or jig from which the 18 iron plates for the rotor are drilled.

An outer ring of 30  $\frac{5}{32}$ -in. dia. holes is drilled on a diameter of 2 ins. and an inner ring of 6  $\frac{3}{16}$ -in. dia. holes is drilled on a smaller diameter of  $1\frac{1}{4}$  in. The hole in the centre of the plate must be drilled to be a good fit on the motor shaft to which the rotor is to be fixed.

A good way of making the jig is to mark out as carefully as possible, on a piece of tin or aluminium (using a large protractor and a fine pointed scribe) the 30 radial lines 12 degrees apart. Then drill the centre hole and the outer holes with a small drill. This template may now be clamped to the 1-16-in. plate, and a small drill put through all the holes. The template is next removed, and all the holes very carefully enlarged to their correct size.

While the holes are being enlarged, any small errors made in the marking-out process may be corrected. The steel jig from which the 18 iron plates (which form the laminations of the toothed wheel) are to be drilled is now finished, and should appear as the left-hand side of Fig. 1.

The 18 iron plates are next dealt

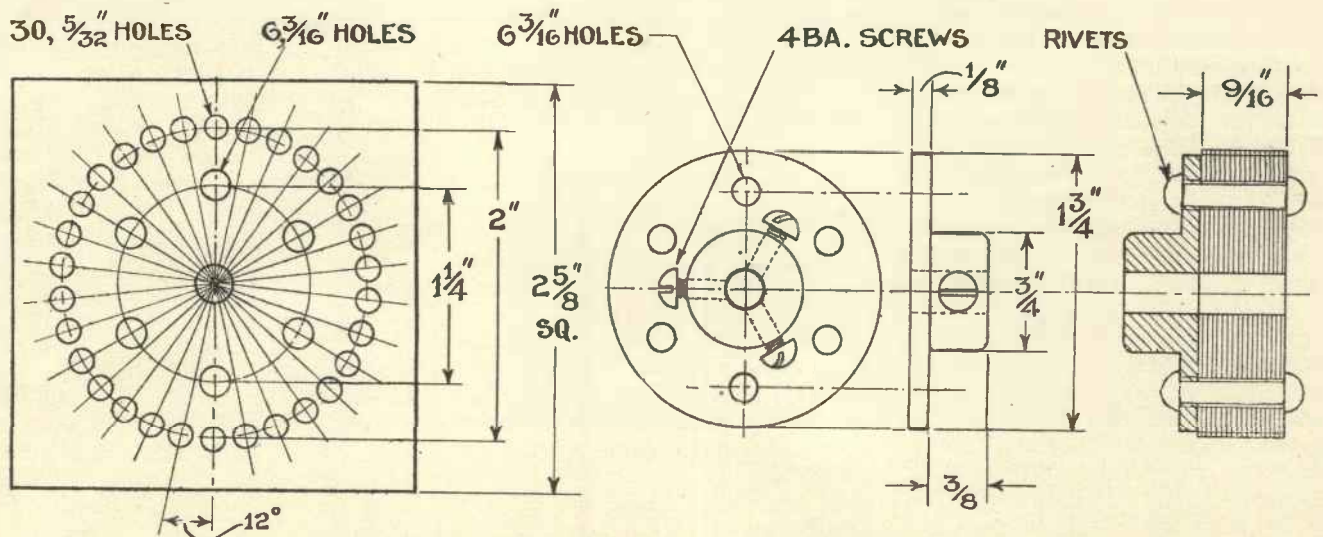

Fig. 1.—These diagrams give the details of the toothed wheel and the method of assembly.

with, a hole being drilled in the centre of each, and a short bolt obtained which is a good fit in the centre hole. Three of the iron plates may now be taken and placed underneath the steel jig, the bolt being passed through the centre hole and the nut tightened. The assembly of plates and jig is then clamped with a hand-vice, and all the holes drilled.

The three iron plates may now be removed and another group of three

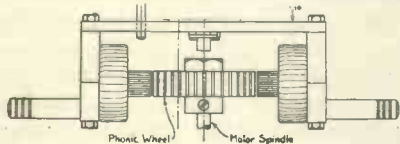

Fig. 2.—Details of magnet yoke and pole pieces.

clamped up and drilled as before, and so on until all the 18 are drilled. Before each group is removed from the jig, each plate must be marked in some way so that its position on the drilling jig is known. The reason for this will be clear from what was said earlier.

Having drilled all the plates and filed off the burrs, the plates may be placed in a dyeing fire and allowed to cool down very slowly to soften them.

Next a 2-in. dia. circle of tin is cut, having a centre hole to suit the short bolt. The bolt is now passed through the tin disc, and one of the plates put on and a scribe run round the circumference of the tin disc. After all the plates have been treated thus, they may be each cut out with shears round the 2-in. scribed line, i.e., through the centre line of the outer ring of holes. We have a set of 18 more or less rough thin-toothed wheels.

The brass boss for mounting the plates should now be obtained or made. It is shown in Fig. 1, and is simply turned up from the 2-in. dia. brass given in the list of materials, or alternatively built up from a disc of brass riveted and screwed to a short length of  $\frac{3}{4}$ -in. dia. brass rod. Whichever course is adopted, the centre hole must be a good fit on the motor spindle, and the six holes shown drilled to register with the inner ring of holes on the jig.

One of the iron plates is now given a coat of shellac varnish on one side, and rivets passed through the six inner holes, another plate varnished and laid on top and so on until all the plates are assembled. When this is done the rivets are hammered over.

The assembly of plates and boss may now be slipped on to a man-

drel and the tops of the teeth trued up, the gaps between the teeth being trimmed up with a small round file. The toothed wheel is now complete.

The pole pieces are made from the piece of  $\frac{1}{2}$ -in. dia. iron according to the dimensions given in Fig. 2, the pole faces being cut away to a width of about 3-64 in., taking care to keep the faces quite square.

### The Magnet Yoke

The field magnet yoke is shown by Fig. 2; this can either be built up as shown or made from a forging. A brass bush is driven into a hole in the back of magnet, thus enabling the field magnet to be moved round on the motor for "framing" the image.

When the field magnet is assembled on the motor, the two-pole pieces should approach the toothed wheel as closely as possible without actually touching it. The pole pieces are, of course, finally locked in position by

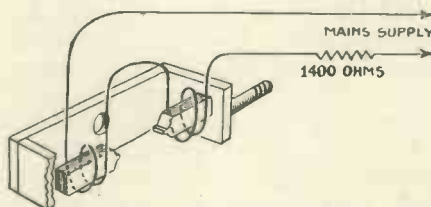

Fig. 3.—Diagram showing the direction of winding the coils.

the screws in the slotted ends of the field magnet.

### The Coils

There now remain the coils. Each of these consists of 3,000 turns of No. 36 enamelled copper wire wound on cardboard formers, which can be fitted on the pole pieces. These formers can easily be made by glueing end cheeks on a paper tube and finally coating with shellac varnish. The winding is best done by rigging up some simple arrangement or mounting the formers in a breast drill held in a vice. The connection of the two coils is shown by Fig. 3, the object being to obtain poles of opposite polarity.

With the normal current through the neon lamp and field coils, on turning the scanning disc by hand a distinct pull should be noticed as the teeth pass the pole pieces, the pull should be sufficient to move the scanning disc should the wheel have stopped with the pole pieces between the teeth.

## A New Use for Neon Tubes.

According to *Electronics* watch repairers in U.S.A. are now making use of amplifiers and stroboscopic neon tubes to diagnose watch troubles and to adjust timekeepers rapidly, without waiting to determine the accumulated errors of several days.

The watch is placed on a crystal microphone, enclosed in a case to shut out room noises. Volume is then turned up to bring out all the sounds of the watch. Many troubles developing in watch mechanisms have characteristic sounds that are too weak to hear with the unaided ear. An amplifier brings these sounds up to a level where they may readily be detected and a more rapid diagnosis of the trouble may thus be made.

The neon lamp provides a visual means of comparing the watch under test to a tuning-fork frequency standard.

A stroboscopic disc is driven by the amplified tuning-fork frequency, and rotates at one revolution per second. The amplified watch tick is switched to "Time" position and will then flash the neon lamps behind this stroboscope disc. These flashes will occur 4, 5 or 6 times per second, depending on the watch, but as the stroboscopic disc has only one hole, only one flash per second will be seen.

The disc and lamp are first lined up so that flash occurs each time the disc hole passes before the lamp and observations may then be taken at intervals to determine the "drift" of the watch as compared to the tuning-fork. This drift will be seen by the flash gradually shifting from the starting position and occurring earlier or later than the arrival of the disc hole.

The Bennett Television Co., of Station Road, Redhill, Surrey, have published a simple 16-page handbook on television.

This handbook has been written for the beginner who wishes to assimilate in a simple way the fundamental principles. The construction and operation of a disc machine are given and brief details of mirror-drum equipment. The price of this booklet is 1s. 2d. post free.

THE AMATEUR TELEVISION EXPERIMENTER

# AN EXPERIMENTAL OSCILLATOR TONE SOURCE

*A very desirable piece of apparatus for an experimenter is some form of generator of A.C. volts at different frequencies in order to find out what happens to a signal of an individual frequency after passing it through amplifiers, etc.*

FOR television work an oscillation generator should have a range from at least 10 to 1,000,000 cycles; from 25,000 cycles upwards is required for the high-definition television recommended by the Committee.

General requirements of such apparatus are constant calibration, ease of manipulation over the working range and reasonably constant output. The simplest arrangement would be a valve oscillator such as Fig. 1a, the frequency depending on the values of L and C. Such an arrangement in practice requires a very large number of inductances for L and  $L_1$ , so many as to make it not sufficiently flexible; also the calibration will vary according to output load, though this can be practically eliminated by using a buffer valve as in Fig. 1 b.

Communication engineers generally use a beat frequency oscillator signal generator or tone source, covering ranges from 50 to 20,000 cycles; these

are made commercially in America at very reasonable prices, and judging from the last radio exhibition are coming into favour in this country.

The principle of the beat oscillator is to generate two frequencies, one, say, 100,000 cycles and the other, say, 99,000. Now if we mix these signals and rectify we shall get their difference, namely, 1,000. The action is shown diagrammatically in Fig. 2. The great advantage of such an oscillator is that a relatively small change in one of the oscillators causes a wide frequency variation in the output or beat frequency.

In practice the turning from minimum to maximum of a 500 u.f. variable condenser will cover the whole range of the apparatus. Now the range for television as previously pointed out, is from 10 to 1,000,000, which in practice is extremely hard to get from two oscillators, for reasons which we will try to explain briefly.

Supposing we make the A oscillator, Fig. 2, 1,000,000, and beat it

with the B oscillator at 120,000, giving rectified signal of 20,000 which is 1/50 of the lower A frequency. The two frequencies A and B appear in the detector circuit, but can be easily

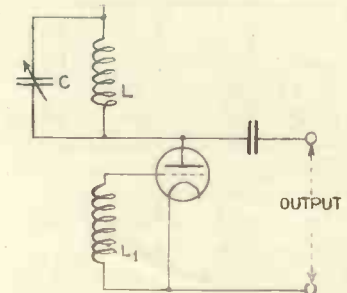

Fig. 1a.—Circuit of simple valve oscillator.

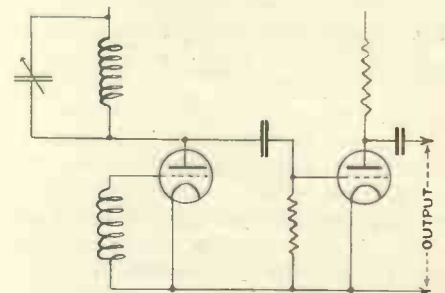
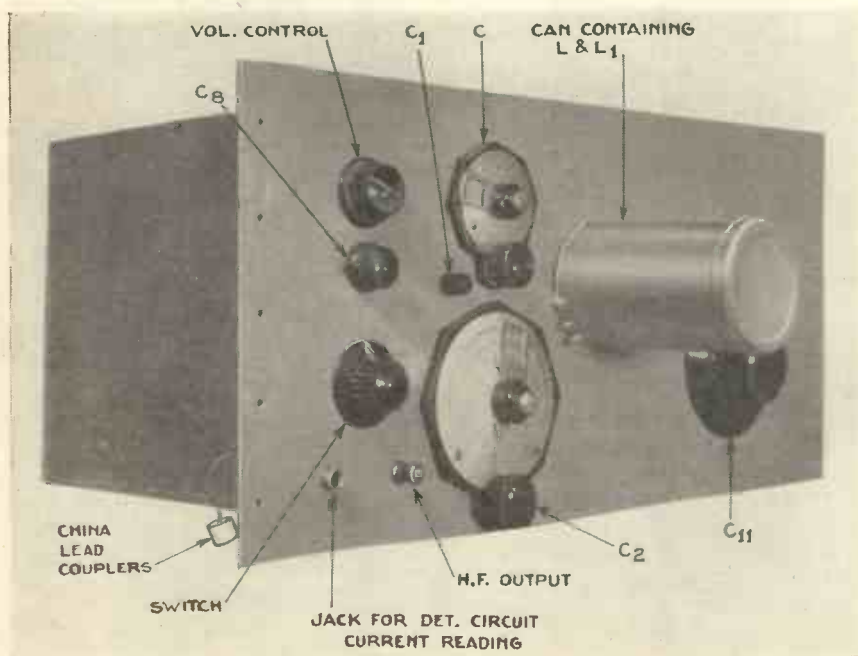

Fig. 1b.—Valve oscillator circuit incorporating buffer valve.



The complete oscillator ready for operation.

filtered out, leaving only the 20,000 signal. Now suppose we want an output signal of 80,000, A still remains at 1,000,000 but B is increased to 1,800,000 (or decreased to 20,000). Under such conditions the frequencies in the detector circuit are 1,800,000 (or 20,000), 1,000,000, and 80,000, and the problem of filtering out the 80,000 wasted signal becomes so difficult that it is not worth while. So if we want 80,000 we must increase both the A and B oscillator frequencies, so much so, that in practice the lower frequencies of the two oscillators should be at least ten times greater than the highest wanted frequency.

Therefore to produce 1,000,000

cycles by such a method A should produce 10,000,000 and B 11,000,000. So much for the higher range. Let us examine the lower.

To produce, say, 100 cycles under the conditions of A at 10,000,000, B must be 10,000,100, which is an accuracy of 1 in 100,000, which is not, for the home experimenter, anyway, possible to obtain.

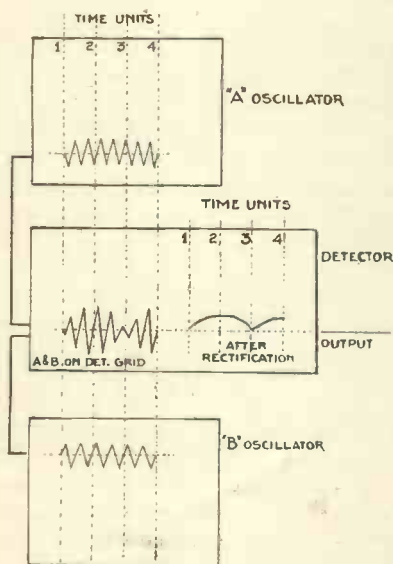
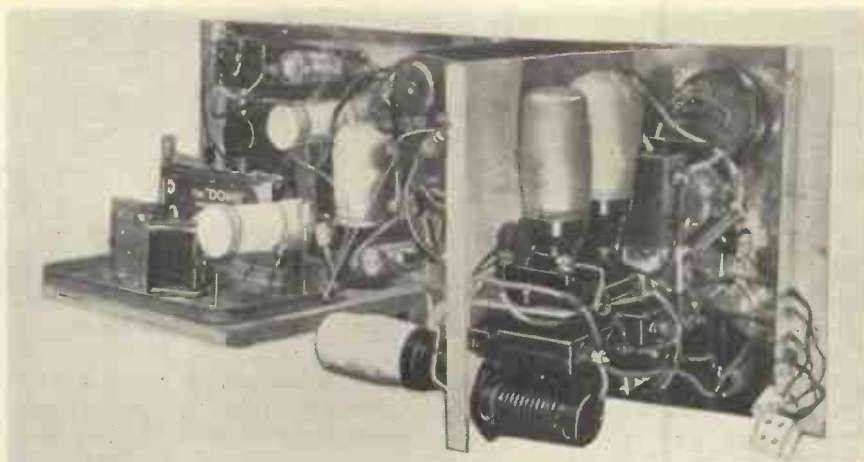

Fig. 2.—Diagram explaining the action of a beat oscillator.

The writers have found in practice that three generators are really necessary, though two can be built into one as will be described. The theoretical circuit is shown in Fig. 3, the apparatus being intended for use between 50 and about 1,500,000 cycles.

Starting with the bottom left-hand corner the valve  $V_4$  represents the A oscillator of Fig. 2. The values of  $L_3$  and  $C_{11}$  determining the frequency with  $L_4$  the grid exciting coil. The H.F. choke and  $C_{12}$  filter out the H.F. from the H.T. supply, while  $R_{10}$  is a voltage dropping resistance with  $C_{13}$  as an extra H.F. by-pass. Coupled to  $L_3$  is  $L_2$  which goes to make up part of the inductance in the filter circuit  $L_6$  and  $C_{14}$ . This filter is most important. It is enclosed in its own special screen. The function of this filter is two-fold. Firstly it secures constant calibration and secondly largely eliminates the harmonics from the oscillator reaching the detector as it is very loosely coupled via  $L_2$ , which in practice is only one turn.  $L_5$ , which is also fairly loosely coupled to  $L_6$  brings the signal to the grid of



General back view with screens removed; (left) fixed oscillator and filter (with filter screen removed); (right) detector and amplifier sections; variable oscillator is hidden behind wood panel.

the detector  $V_2$  via  $R_8$ . In practice it should be stated that one oscillator must be much weaker than the other, which in this case is the oscillator just described; at least the resulting signal is when applied to the detector grid.

$L$  with  $C$ ,  $C_1$ ,  $C_2$ , in parallel fixes the frequency of the B oscillator (Fig. 2),  $L_1$  being the grid exciter coil. The signal generated is fed via  $C_7$  to a resistance-coupled valve, which acts as a buffer, inasmuch as it prevents any signal from the other oscillator

getting fed into the tuning circuit of the valve  $V_1$ ; also it acts as an output valve for the higher frequency output, according to the position of the switch.  $V_3$  is an anode-bend detector for which is biased via  $R_5$  and  $L_5$ , the rectified output being amplified by  $V_4$ , which is a normal resistance-coupled amplifier.

The H.F. choke in the detector circuit in conjunction with  $C_9$  by-passes the unwanted oscillator's frequencies. Anode-bend rectification is used as it produces less "damping" in the in-

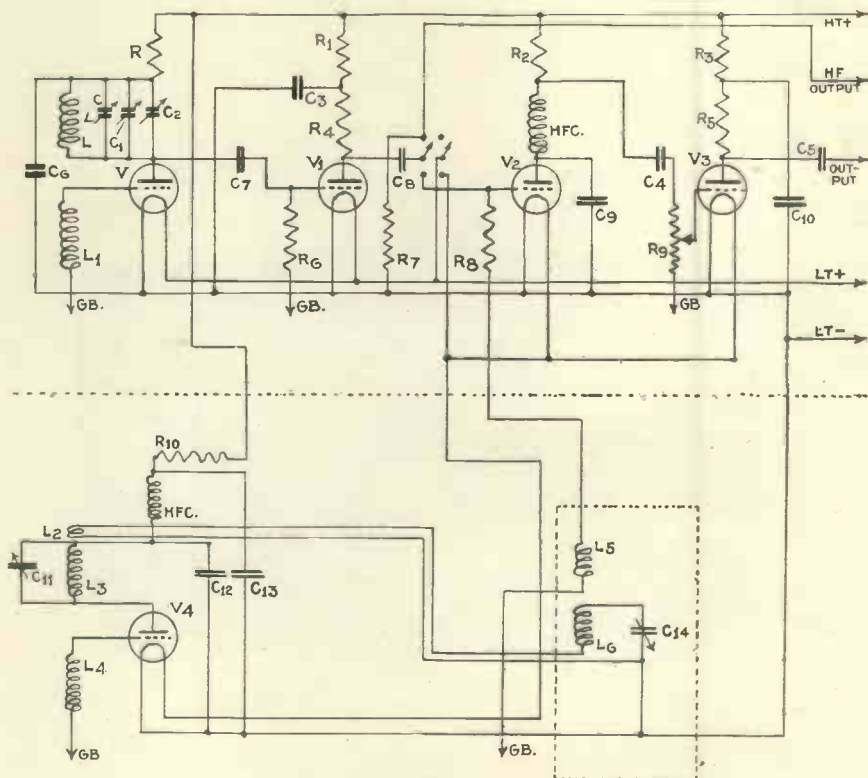

Fig. 3.—The theoretical circuit of the oscillator.

APRIL, 1935

put circuit.  $C_9$  is variable so as to act as a volume control, while  $R_7$  is of such a value as to be about .1 of the lowest impedance which the H.F. output is likely to work into. This helps to keep the calibration constant.

$R_4$  (see Fig. 3) is and should definitely be of the metalised type. A list is given of the components and values, all of which were in the writers' workshops; no special make is necessary. The voltage dropping resistances are

**Resistances.**

- $R = 30,000$  ohms.
- $R_1 = 25,000$  ohms.
- $R_2 = 60,000$  ohms.
- $R_3 = 20,000$  ohms.
- $R_4 = 7,500$  ohms.
- $R_5 = 10,000$  ohms.
- $R_6 = .25$  megohm.
- $R_7 =$  As required.
- $R_8 = 50,000$  ohms.
- $R_9 = 500,000$ -ohm potentiometer.
- $R_{10} = 30,000$  ohms.

**Inductances.**

- $L$  } = 45 turns.
- $L_3$  }
- $L_6$  }
- $L_1$  } = 20 turns.
- $L_4$  }
- $L_2 =$  one turn.
- $L_8 =$  ten turns.

**Valves.**

- $V$
- $V_1$  } Mazda L2
- $V_3$  }
- $V_4$  }
- $V_2$  Mazda H2.

**The Eye as a Scanner**

It is not generally appreciated that the human eye scans. It moves quickly and takes in the whole of a picture in a series of rapid glances, and the memory retains these pictures, each piece in its proper place, and the effect seems to be a whole, complete picture.

In television the same thing takes place, the television camera rapidly scanning a scene, which in turn is reproduced in the same order by the television receivers. Of course, this scanning is much more rapid than the human eye, as the scanning spot cannot pick up as much detail as the human eye will register correctly at one instant, and so must travel faster to get in all the points.

Another point of difference is that the human eye needs no definite routine to follow in scanning a scene, for it may move across the top, then down to the bottom and across there, then up to an angle from the lower left to the upper right corner, etc. In television, as in anything mechanical or electrical, an accurate pattern must be followed to be repeated in rapid succession in order that at the receiver the same pattern may be followed and a picture reproduced which will be the same as the picture picked up at the transmitter.

While television may seem far removed from any human parallel, it actually follows the human eye more accurately in its procedure than does a camera, which takes in all at once a completed picture.

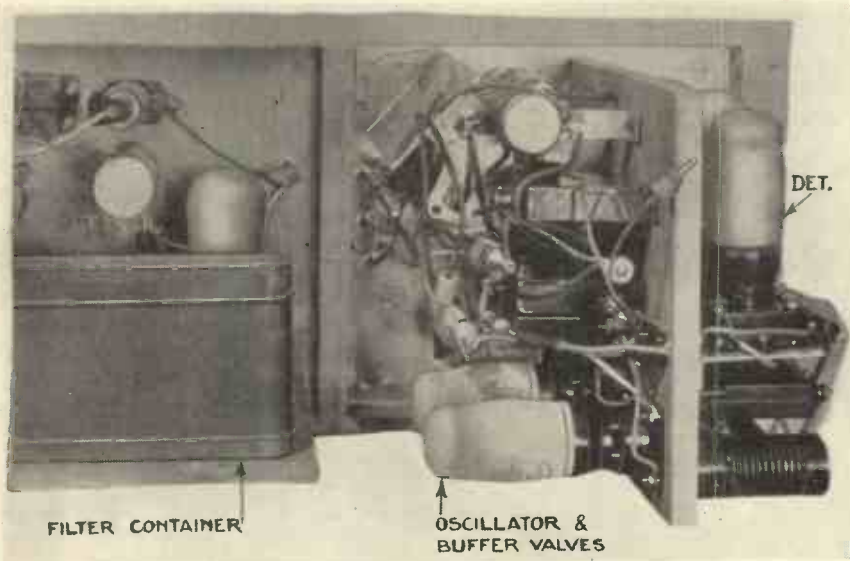

Back view with screens removed showing variable oscillator and detector section.

As to the actual construction the various illustrations probably give more information than many written words.

Designed for rack mounting it consists of a  $\frac{1}{4}$  in. ply-wood panel 22 ins. by 10 ins. on which two large biscuit box lids are mounted. One tin contains the fixed oscillator and the filter, which is further screened, the other the variable oscillator, buffer valve, detector and note amplifier. The inductances,  $L$  and  $L_1$  are mounted on the front of the panel in a round tin, so that they can be interchanged for different ranges. The H.F. output terminal is brought out on the front of the panel, as ordinary screened wiring would be inclined to attenuate it too much. Connection terminals are not fitted, but the leads are brought out to china connecting links, which connect up with the general wiring.

The coils  $L$  and  $L_1$  are plug-in on a special former fitted into an old valve base. All the inductances are wound on the same size wooden former, which was turned up out of some old broom handle, the dimensions of which are given in Fig. 4.

The variable condensers are all fitted with fibre spindles as this was found easier than making insulated bushes. Metalised and wire-wound resistances have been used, though

calculated for an H.T. of 300 volts. Calibration and actual operation will be dealt with next month.

**LIST OF COMPONENT VALUES.**

**Condensers.**

- $C = .001$  mfd.
- $C_1 =$  N.C. type.

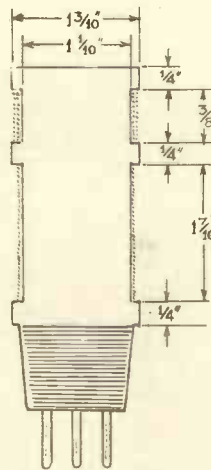

Fig. 4.—Details of inductances.

- $C_2 = .0001$  mfd.
- $C_3 = 1$  mfd.
- $C_4 = 1$  mfd.
- $C_5 = 1$  mfd.
- $C_6 = 1$  mfd.
- $C_7 = .0003$  mfd.
- $C_8 = .0001$  mfd.
- $C_9 = .0002$  mfd.
- $C_{10} = 1$  mfd.
- $C_{11} = .0005$  mfd.
- $C_{12} = .1$  mfd.
- $C_{13} = .1$  mfd.
- $C_{14} = .0005$  mfd.

# Making Short-wave H.F. Chokes

By 2BHN.

**I**NTERFERENCE to local listeners is often increased by the use of a high-frequency choke peaking in the broadcast band. The commercial component is generally designed to avoid this resonating, but I have found it advisable to make chokes specially tuned to a little under 200 metres so as to make quite sure. Incidentally it is a lot cheaper.

A glass test tube  $1\frac{1}{2}$  ins. in diameter and complete with cork can be obtained from any chemist. Add to this the cost of half an ounce of 30 gauge d.c.c. wire and that is all that is required for a really good choke. As a general rule 150 turns of this 30-gauge wire will tune to the correct wavelength, but it is quite simple to look after any variation.

Unless a little care is taken difficulty may be experienced in winding the wire on the smooth surface of the glass tube. After having wound several chokes I have found a simple way of properly doing this little winding job. With a small smooth file, rough the ends of the tube so that a spot of Chatterton's compound for fixing the wire can easily be seen. As a general rule 30 gauge wire will occupy  $2\frac{1}{2}$  inches of former.

When winding on the wire keep it taut, so that it cannot become loose.

Put on 150 turns, then if any trouble is experienced with harmonics experiment by taking off 25 turns. With a transmitting circuit in particular it is advisable to adjust the choke not

TEST-TUBE



The Chatterton's compound for fixing the wire can easily be seen. As a general rule 30 gauge wire will occupy  $2\frac{1}{2}$  inches of former.

only to prevent B.C.L. interference but to gain the maximum R.F. in the power amplifier stage. A choke resonating to the 150-metre band, for example, will completely upset the functioning of the associated stage.

On the receiving side although a poor choke should not affect other listeners, the receiver will probably start oscillating or suffer from dead spots. A 1-in.

test tube wound with 300 turns of 36 gauge enamel-covered wire is suitable. This gauge wire is easy to handle and the whole 300 turns will just about fill a 1-in. tube. To make quite sure that the windings stay in position and that the Chatterton's compound will not break away from the glass, wind a single turn of Empire tape round the top and bottom turns of the wire and stick the tape both to the glass former and the wire. Celluloid cuttings dissolved in amyl acetate will hold the Empire tape to the glass.

Fixing the tube to the baseboard will not present any difficulty. Put a large wood screw through the centre of the cork and fix this to the baseboard. The test tube can then be pushed down on top of it. In this way several chokes can be tried with the minimum amount of trouble. Simply unsolder the two connecting wires and the new choke can then be joined in circuit.

If space is of importance a smaller test tube can be used. With a  $\frac{1}{2}$ -in. diameter tube 38 or 40 gauge enamel-covered wire can be used, but it is not advised owing to the difficulty in handling the wire.

# Modulation Monitoring

**A** MODULATION monitor consists of three essential sections. A linear diode rectifier which gives an instantaneous output voltage proportional to the carrier envelope, a peak voltmeter to measure the peak modu-

the desired phase for either positive or negative peak is applied to a peak voltmeter, designed to be quite independent of tube characteristics and to put an entirely negligible load on the first detector. This voltmeter circuit makes it

Over-all tests on the equipment show that a pulse lasting only 0.1 second will make the meter throw to within about 90 per cent. of the true value. This is the most rapid meter as yet available, but it is not instantaneous and, even if it were, it would not be possible for the eye to follow it with any accuracy. In fact, in making dynamic tests on the meter, it was necessary to use screens to be sure of the maximum throw.

In order to avoid this difficulty, a warning lamp circuit has been provided. After determining the permissible level of modulation by means of the distortion meter, a dial is set in the lamp circuit controlling the percentage modulation at which it will flash. An automatic biasing arrangement used in conjunction with a thyatron flashes a light whenever the percentage modulation exceeds the value at which the dial is set. This method is essentially an automatic null arrangement which requires no attention or adjustment.

A plug has been provided so that additional percentage meters and flashing lamps can be used externally. Connection is also made by this plug to provide an audio-frequency voltage proportional to the modulation for recording purposes.

The modulation meter provides a pointer which gives a direct reading, dynamic measure of the modulation and provides a warning signal when the modulation is exceeded.

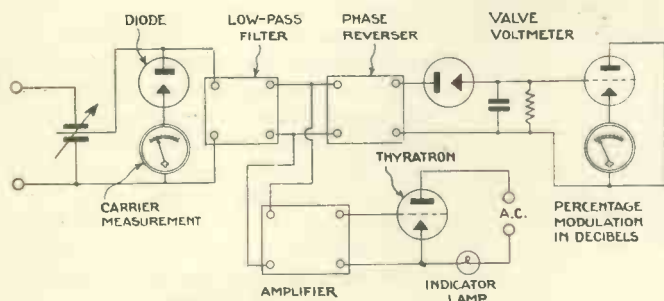

This modulation tester has been designed for amateur or commercial use. G.R. components are used throughout.

lation, and a trigger circuit to flash a light whenever the modulation momentarily exceeds a predetermined value. The output of the carrier and is set at the start to 100, as shown in the diagram. This meter will then indicate carrier shift as the station is modulated.

As will be seen, the audio-frequency component of the carrier envelope in

possible to combine the accuracy of the older type of null method instrument with a direct-reading, rapid-movement meter. The peak voltmeter reads directly in percentage modulation from 0 to 110 per cent. and has a superimposed decibel scale for monitoring purposes.

The meter movement is arranged to follow speech and music very rapidly.



REVIEWS OF THE PROGRAMMES AND RECEPTION REPORTS

FOR lookers in the South of England the substantial increase in power of Midland Regional is more than offset by the attenuation of a lower wavelength, the effect of the directional aerial in use at Droitwich, and the greater distance from the station. Although Midland Regional must be used for sound by all lookers within range of the vision signals from London National, it is evident that the transmitter at Droitwich is primarily designed to give a broadcasting service to listeners in the Midlands.

An ideal arrangement would be to transmit vision and sound signals from the same point, but no wavelength is available, and lookers who now get a weak signal in their sound receivers are victims of the international wavelength situation. It is rough luck, but the B.B.C. can offer no hope of an adjustment.

I have yet to learn how the change in wavelength is affecting foreign

lookers, but I doubt whether experimenters in Bologna, Capri and Nuremburg will report as enthusiastically as in the past.

\* \* \*

Artists with a reputation for good looks should not televise, says a writer in a stage paper, and it is unfortunate that such advice should be given at a time when many famous artists are thinking of facing the projector. Let us hope that they will decide to discover studio conditions for themselves. After all, if Margaret Bannerman, Mathea Merryfield, Jane Carr and Lucienne Herval are content to entrust their looks to the scanner others need feel no anxiety.

At the same time, "what shall I look like?" is the usual reaction of an actress when first approached by the producer. Elizabeth Pollock wondered whether she should appear or not, and was advised to come to Portland Place and watch a friend in

the visor. This she did, finding that there was no distortion, and that the likeness was unmistakable even in the most distant shot. Elizabeth was converted and later faced the flickering beam herself.

\* \* \*

For many lookers the event of the month was undoubtedly the first appearance of Margaret Bannerman before the scanner. The novice should study the movements of this graceful artist, who, like other good actresses, never stops acting, yet never over-acts. With her in a snappy programme to be repeated on March 30 were Hermione Gingold, effective as a giraffe-necked woman in a costume copied from a Bertram Mills' Circus poster, Max Kirby, who sounds like Jack Buchanan, but looks like himself, Charlotte Leigh, a competent commere, Georgie Harris and Mathea Merryfield, fan dancer, from the Palladium.

Altogether a bright programme inspired in parts by the recent Gate Theatre revue and well worth repeating. A snow scene provides the essential contrast and one of the most successful pictures was formed by tiny Georgie Harris, in the character of an Eskimo, emerging from his igloo. For better definition black plumes were placed in the yellow ostrich fans carried by Mathea Merryfield in her fan dance. Even so, some of the beauty of her dance was lost as her figure flitted before the inevitable whiteness of the backcloth.

In a novel opening to this programme artists introduced themselves with a few words spoken in close-up. It seemed odd to hear a dancer talk.

\* \* \*

In acrobatic and fan dances when artists are not overlaid, a black back-screen would undoubtedly provide a greater contrast, as suggested by the television correspondent of *The Daily Telegraph*, and it is unfortunate that a dark backcloth can never be used



The Farnsworth electron-multiplier. A full description of this new tube is given on page 195.

as the synchronising pulse would be nullified.

Pictures have even suffered when darkly-clad artists have appeared too close to the scanner and occasionally when the producer in search of a novel effect has grouped his characters in such a way that it has been difficult to "hold" the picture.

I recall an instance during a ballet when the dark costumes of the dancers formed a second synchronising band and the picture slipped. Then there was another case in which a comedian with a black face and a black top hat left so little white background in a close-up that it was difficult for the synchronising gear to discriminate.

It is no good being obstinate about

for the eyebrows. Eyelashes must always be beaded and false ones as used for the film camera can be added when a devastating effect is required.

Sometimes the situation requires that a woman should appear to be "made-up," and in such cases the paint must never be spared. By an ingenious arrangement of scanner, lights, check receiver and mirror it is possible for an artist to get an impression of her own appearance on the screen, but if an actor doubts the wisdom of making-up, despite the expert's advice, his best course is to bring a friend to the studio and let him be the judge.

Sandy Powell chose to appear in his Honeymoon sketch which he had

cellent pictures. Stage training undoubtedly helps in the studio and neither of these artists would make the mistake of singing *away* from the audience.

It has been suggested that artists should appear at an angle from the lens to relieve the monotony of a full face picture, but I cannot agree that such a trick would help. An artist is either singing to his audience or to someone else. If he is addressing an audience it is natural that he should face them, and if he is singing to someone else we expect to see her, in which case he will not appear in close-up at all.

Croquet is a game that often rouses the worst instincts of its players, and the malice of the mallet was cleverly portrayed by Elinor Shan in a sketch on March 6. Fast work with the scanner was needed to keep pace with this miming, as the artist moved backwards and forwards about the "lawn" until finally she struck her own foot with the mallet.

Hevkite and her dances made equally good pictures. This is an act which satisfies when seen and not heard, as I proved by switching off my sound receiver in the middle of a dance—an exacting test with a thirty-line picture.

Although the Television Committee used the term "television looker" in its official report to the P.M.G., there are signs that the B.B.C. favours the word "televiever" or its abbreviation "viewer" to describe our kind.

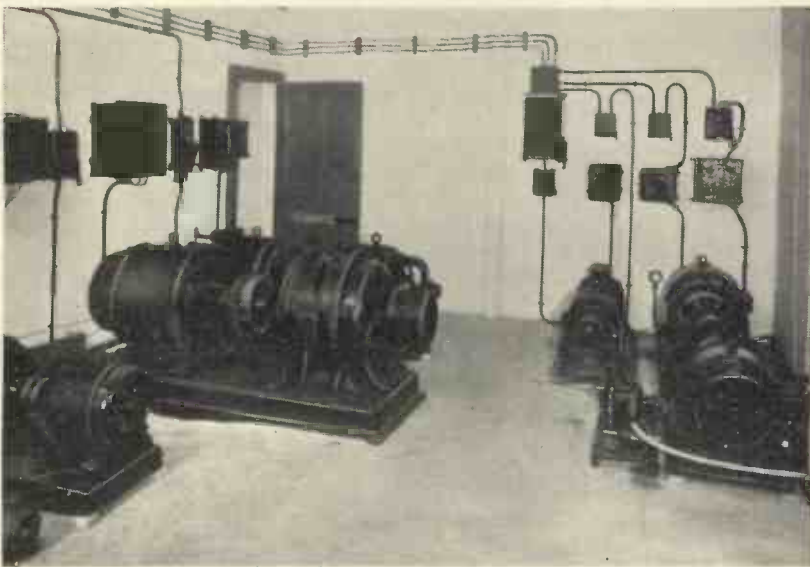

The generators at the laboratories of the Baird Company at the Crystal Palace.

this make-up—the producer always knows best. Make-up is necessary for television, as it is for the films, if the best results are to be obtained, but the colour and thickness of paint to be used depend upon various conditions. For instance a black fur collar call for an abnormally heavy make-up if an artist is not to appear anæmic, and for the same reason an actor appearing with a coon must slightly darken his face. On my visitor Donald Peers seemed to have a beard, just because he had not applied enough fleshing. Some artists need more than others. It depends on features and colouring and without make-up a dark man usually appears to have a beard.

The usual treatment consists of white fleshing for the features, blue for the lips, and dark brown or black

broadcast in the previous week and his act gained a lot from being seen. It is difficult to indicate the passage of time in an ordinary broadcast. Striking gongs, recounting the months or the season and other means have been tried, and I was interested to see that Eustace Robb adopted a cinematic method in Sandy's sketch. A drawing of a clock face in the caption machine showed the time while a gong in the studio struck the hour.

Comedians can get a laugh by raising an eyebrow, and Sandy knows the value of facial expression. Both he and Violet Victoria made ex-

Our Policy  
"The Development of  
Television."

## Television Transmissions from France

Radio Lyon-La-Doua claims the honour of being the first French station to transmit television programmes. Quite recently a demonstration was given at the studios of P.T.T. in the Rue de Marseille under the direction of M. Chauvierre.

The wavelength of Radio Lyon is 463 metres and the power 15 kilowatts. A low-definition system is being employed using a Nipkow disc for both transmission and reception. There are 30 scanning lines with a picture-ratio of 4 to 3.

A regular programme is to be instituted in the near future so we advise readers to listen from time to time on this wavelength to Radio Lyon. Some readers have already reported reception of this transmission.





# Correspondence

Correspondence is invited. The Editor does not necessarily agree with views expressed by readers which are published on this page.

**The Double-image Kerr Cell :: 30-line Transmissions for the Provinces :: The Thames Valley Amateur Radio and Television Society :: Three-dimensional Television.**

### Double-image Kerr Cell

SIR,  
In your February issue on pages 53-56 there is published an article mentioning *double-image Kerr cells*. As presented in the said article, the impression is given that there are no proprietary rights on double-image Kerr cells and that anyone is at liberty to manufacture, sell and use such light-control devices.

In order that the public should not be misled in this matter, we should like to point out that *double-image Kerr cells* were invented by G. W. Walton and described in his Patent Specification No. 407,385 and other patent applications pending in this and other countries. Scopphony, Ltd., have the sole right to exploit the inventions of G. W. Walton and alone are entitled to manufacture, sell and use apparatus according to those inventions.

SCOPHONY, LTD.,  
S. SAGALL, Managing Director.

### 30-Line Transmissions for the Provinces

SIR,  
Now that a definite programme of development has been announced, I find that I, in common with some 70 or even 80 per cent. of the television enthusiasts of this country, shall be deprived of any form of transmission for a period of a year at the minimum.

Although I am in agreement with the Committee as to the uselessness of the 30-line transmissions for a public service, I do think that regular 30-line broadcasts from the new Midland Regional transmitter would be of very great service, as many of the enthusiasts have, as yet, been unable to receive any transmission, and therefore have been prevented from acquiring any practical knowledge which would be of use in popularising the new high-definition trans-

missions when they become available. I should be very interested to know if any of your other readers are in agreement with me.

E. K. M. BIRD.

\* \* \*

### Thames Valley Amateur Radio and Television Society

SIR,  
We feel that we should offer you our congratulations upon your excellent publication, which has met with great success in its first issue among the members of the above Society. This new magazine fills a long-felt want and we wish you every success with your effort to cater for the hundreds who have long passed the "B.C.L." stage.

Whilst writing we are taking the liberty of informing you of our activities and trust that you may find space in your journal to give us a little publicity.

This Society was formed in 1933 with a membership of about a dozen enthusiasts and has grown very quickly as the membership list now stands at 55. We have, among our members, many keen amateur transmitters who are always willing to assist the newcomer. The committee, without exception, is composed of fully-licensed transmitters. The annual subscription is only 3s. 6d. and we hold meetings at least once a month when interesting lectures are held. During the summer months we hold field days and numerous visits are arranged to places of interest. New members are invited and are advised to communicate with Mr. Smith, at 303 Staines Road, Twickenham, Middlesex.

The only qualifications necessary are a "bona-fide" interest in short-wave radio and television: anyone with this interest is welcome.

RADIO G2VV,  
Joint Hon. Secretary.

### Three-Dimensional Television

SIR,  
With reference to the letter of Mr. Parsons published in the December issue, I beg to submit the following explanation of the phenomenon witnessed. I found it in the German journal *Kinotechnik*, Nos. 3, 5 and 6, 1933. There was printed an abridgment of a publication of Dr. Guido Jellinek, Milan (Editors: Libreria Editrice Politecnica, Milano), "Two New Systems of Plastic Cinematography." The second system, called "Three-dimensional Cinematography by Means of Central Projection," is based on exactly the same phenomena. Dr. Jellinek established its theory and showed apparatus constructed by him to demonstrate his three-dimensional (not stereoscopic) pictures.

The underlying idea of Dr. Jellinek's system is as follows: If we

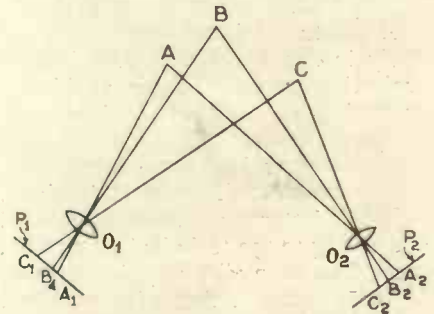

The diagram to which reference is made in the accompanying letter.

suppose A, B, C. to be three luminous points in the space,  $O_1$ ,  $O_2$  camera lenses,  $P_1$ ,  $P_2$  projection plates, then, by means of the central projection, the pictures  $A'$ ,  $B'$ ,  $C'$  respectively,  $A''$ ,  $B''$ ,  $C''$  of the spots A, B, C are obtained. If we imagine, however, that A, B, C are off, and instead of the screens  $P_1$ ,  $P_2$  the respective diapositives are placed and lighted from behind, in this case, the centres of projection (lenses) through which the rays  $A' O_1$ ,  $A'' O_2$  pass, produce at their points of intersection the spots A, B, C within the space, assuming that the whole apparatus is left unchanged.

From this short note, I suggest, we can learn the reasons of Mr. Parsons's phenomenon. Without special knowledge of the circumstances of the disposition during his reception, we must suppose that he only saw the plastic image, either on the half-transparent screen formed by the smoke (see also the answer of Mr. L. H. B., in the January issue), or

**Cathode-ray Sweep Circuits : : Mystery Transmission : : Ghost Images**

in viewing it "subjectively." For only two sets were used, the plastic naturally was restricted only on foreground and background—quite enough to get a more natural picture, e.g., of a dancer.

In order to get results in trying to repeat such phenomena it seems, according to Dr. Jellinek's theory, that certain conditions must be fulfilled, viz., the different sets must produce different pictures, which correspond to different perspective views of the scene transmitted (this may accidentally happen, e.g., as the result of a certain but different degree of distortion in each receiving set of the same picture transmitted). The different bundles of light distributed by the projecting lenses (no focusing screen anywhere), must cross each other at sharp angles, so as to produce definite light points only on the corresponding gauze screens or the like. Both receivers must run absolutely in synchronism. Only image-projecting receivers are capable of producing three-dimensional pictures in space.

ROBERT I. ROSENFELDER  
(Frankfurt (Main)).

[This letter has been translated and owing to the technical terms used there has been difficulty in arriving at the exact meaning of the writer.—Ed.]

**Cathode-ray Sweep Circuits**

SIR,

Your correspondent, Mr. F. H. Woodbridge, will find his suggested neon lamp and valve amplifier described in a paper by Appleton and Builder in the *Proceedings of the Physical Society*, Vol. 44, p. 85, 1932.

The valve used at the time was of the L.S.5A type and had an H.T. voltage of 500.

Very good results are obtained with the valve amplifier and I have more recently tried a Mazda AC/Pen with success. The principal difficulty is in the synchronising of the time-base to the incoming signal, and I doubt whether the economy effected in the cost of the mercury relay is worth while, in view of this.

With an increase in the size of cathode-ray tube and a corresponding increase in the width of traverse of the beam it is probable, however, that some form of amplification will be necessary with moderate voltage time-bases.

G. PARR, F.T.S. (London, N.21).

**A Mystery Transmission**

SIR,

I have written to ask if any of your readers could help me to identify a certain station which has been sending out television signals.

On the night of February 28 at about 9.40 I was tuning around on our set in the region 450-500 metres when I was greatly surprised to hear television signals coming through. I tuned it in accurately and switched on my televisor and, after getting the speed correct to hold the picture (I found that it was the usual  $12\frac{1}{2}$  frames per sec., by using a stroboscope from 50-cycle mains), I was able to recognise the picture as a succession of still shots, which after a while was replaced by an ordinary studio shot of what appeared to be a human figure. The picture was very bad indeed and it was very hard to distinguish anything at all. This kind of thing continued until 9.54, when the signal shut down.

I left the receiver tuned to this wavelength (having switched off the visor) and waited to see if the station would continue with a normal sound programme; however, it did not. Consequently I tried to identify it by listening to the station immediately above, which announced itself as Bucharest (although it is possible that it was Budapest), but as this station is not on or near this wavelength I concluded that it must have been a relay. The station then closed down without saying any more (approximately 10 p.m.), so I could not identify the station directly above the television station. The station below was also useless as it did not announce.

I next tried a station a few degrees on the dial away (approximately  $4^{\circ}$  above). This announced in English as the programme for the West and then spoke in Welsh (approximately 10.5 p.m.). Hoping to find what the wavelength was I looked for a western station in a station chart; I was then mystified to find that there was not an English station on this wavelength.

An order placed with your newsagent will ensure regular delivery of TELEVISION AND SHORT-WAVE WORLD

After this I gave it up as a bad job and wondered if any other of your readers received this station.

If any reader can help me I shall be obliged.

R. F. HANSFORD (Bognor Regis).

**Ghost Images**

SIR,

We are greatly interested in the remarks of N. M. Butler (Breston, near Derby) in the columns of your paper for March, 1935.

We should like to point out that we also found the same effect in the transmission on Wednesday, February 13th. We should be interested to know if anyone can account for this strange phenomenon.

As regards this afternoon's transmission (March 2) we also noticed a strange effect; the picture changed from positive to negative. The changeover occurred quite evenly, and there were no "breaks" between positive and negative pictures.

We are quite sure that it was no fault in our apparatus, and we shall be glad to know if any other readers noticed this effect.

JENSEN & BASE (Wallasey).

**The Thirty-line Transmissions**

SIR,

I was very much surprised to find that, in your March issue, only one person referred to the possibility of the present low-definition transmissions of television being discontinued before the new system is available for the greater part of the country.

According to the Television Committee's Report "they might reasonably be discontinued as soon as the first station of a high-definition service is working."

This means, of course, if the report is acted upon, that with the exception of the London area, we shall have no television whatever for some years. Surely this must call for protest as being most unfair to the large numbers outside the London area.

I wonder, can this part of the report have escaped the notice of so many of your readers, or are they just indifferent to the stopping of the present transmissions? I can hardly think that the latter reason is the case, and I trust that they will now indicate their disapproval as forcibly as possible by writing to your journal.

If we show that the present transmissions are valued it would be reasonable to expect their continuance

till such time as the new system is available over the greater part of the country.

I trust that your readers will respond to this letter, and by so doing give guidance to those on whose decision the continuation of the transmissions rests. Personally I felt very strongly that they should be continued, and that to deprive practically the whole country of programmes, which are really good, is most unjust.

As a suggestion, when the new London short-wave station is in operation, could not the low-definition transmissions be continued by, say, the North National station? The location of this station is fairly central, and its wavelength is now the same as that of the London National. There may be objections about land lines, but it would seem to be practicable to move the existing equipment to the Manchester studios. This would cost money, of course, but the apparatus in the possession of licensed receivers must represent a considerable amount of money also.

At any rate, morally we are entitled to receive explanations and reasons if we are to be deprived of television facilities for any long period.

A. GRAHAM (Dudley).

\* \* \*

**Receiver Manufacture**

SIR,

I, as you are probably aware, have been very closely associated with television developments for some time past, and possibly by personal efforts have in some degree contributed to the progress which is rapidly being made in developing this new industry.

My object in writing is to inform you that I shall, in association with a very important firm, be quite ready

to put on the market a popular-priced complete receiver, within the reach of all, as soon as high-definition transmission is available. I ask you to publish this letter, so that in the event of any London factor or dealer being desirous of receiving advance information, I will, if they communicate with me, be most happy to keep in touch with them, and arrange at a later date the question of distributorship, etc.

THOMAS HARRIS,  
No. 7 Factory, Waddon Estate,  
Croydon.

**Land Lines for Television**

Radio, television and postal engineering are so closely linked at the present time that technical advances in one branch are generally an advantage to the others. At the moment one of the most important developments is the transmission of more than one programme or conversation over a single line simultaneously. This is done by modulating H.F. with the voice-frequency currents and demodulating at the other end.

P.O. engineers are working on the design of a land line that will be able to carry the enormous frequency-band required for high-definition television without attenuation. It seems from this that the successful creation of such a land line will enable more speech channels to be accommodated on a given number of channels than ever before.

**An Opportunity for Short-wave Listeners**

All listeners who have heard the General Electric Co.'s short-wave stations W2XAD and W2XAF will be pleased to know that there is every possibility of the radiating hours being increased in the near future. It has been discovered that these stations are heard all over the world with almost complete regularity and in view of this the owners of the two stations feel that a little readjustment in operating times and perhaps a slight increase in power will enable the programmes to be heard the world over with 100 per cent. reliability.

These two stations are now coming over at great strength on the simplest of receivers so readers will not have any trouble in listening to good American programmes.

W2XAD on a wavelength of 19.56 metres is best heard during the early part of the evening between 6.30 and 8.30 p.m., while W2XAF on 31.48 does not start up until 10 p.m.

Both these stations relay the medium-wave station WGY so WGY will be the call sign heard. At intervals a special short-wave announcement is made for correct identification to be obtained.

The General Electric Co., Ltd., particularly want reports from listeners telling how these two stations are received and at what time of the day.

**PLEASE NOTE OUR  
NEW ADDRESS**

Television & Short-wave World,  
Chansitor House,  
38, Chancery Lane,  
London, W.C.2.

**GERMAN HIGH-DEFINITION TELEVISION BROADCASTS FROM WITZLEBEN**

180-lines, 25 frames-per-second. Ratio 5 : 6 (horizontal scanning). Vision on 6.7 m. Sound on 6.985 m.  
4 kW. in aerial, 16 kW. anode dissipation.

C.E.T.	SCHEDULE OF TRANSMISSIONS.						
9.00 a.m.-11.00 a.m.	Post Office television tests	..	..	..	..	..	Mondays, Tuesdays, Wednesdays, Thursdays, Saturdays.
11.00 a.m.-12.30 p.m.	Broadcasts of music on sound wave. No vision	..	..	..	..	..	Mondays, Tuesdays, Wednesdays, Thursdays, Saturdays.
3.00 p.m.- 4.30 p.m.	Post Office television tests	..	..	..	..	..	Mondays, Wednesdays.
5.00 p.m.- 8.30 p.m.	Broadcasts of music on sound wave. No vision	..	..	..	..	..	Daily.
8.30 p.m.-10.00 p.m.	Television programmes by German Broadcasting Company	..	..	..	..	..	Mondays, Wednesdays, Saturdays.
8.30 p.m.-10.00 p.m.	Post Office television tests	..	..	..	..	..	Tuesdays, Thursdays.
10.00 p.m.-midnight.	Broadcasts of music on sound wave. No vision	..	..	..	..	..	Daily.

*Broadcasts according to this schedule started on March 1st and will continue until further notice.*

# The Short-wave Radio World

## A Low-frequency Oscillator

NOW that interest in morse code is being revived in the amateur world, readers will be glad to have the opportunity of knowing how the Americans suggest one should learn morse.

In Fig. 1 we have shown a two-valve oscillator which will drive a loud-speaker. The actual oscillator valve is

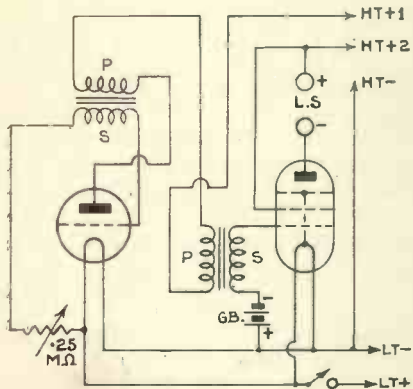

Fig. 1.—The key is connected in the L.T. positive lead, while the pitch of the note can be adjusted by altering the value of the high resistance.

the type 230 which is equal to a PM2DX. This is followed by an amplifier of the 33 type, the nearest English equivalent being a Mazda Pen22OA.

The morse key is connected in series with the positive high-tension lead to the oscillator valve while the  $\frac{1}{4}$ -megohm variable grid leak is used to control the pitch of the note. Two standard low-frequency transformers are used, which must be correctly connected.

Lack of oscillation can be cured by reversing the connections to the primary of the oscillator transformer, but this will only be necessary in the event of the transformer being incorrectly wired internally.

A .002 condenser across the key will reduce clicks and interference while the pitch of the note can be increased by connecting a .0005 variable condenser across the secondary of the transformer.

## An Unusual A.V.C. Circuit

Automatic-volume-control circuits are legion, but we have found a very interesting arrangement being used in France. The receiver embodying it consists of two stages of high-frequency amplification using pentodes. One is used for the ordinary broadcast band and the other for short waves. Then comes a heptode frequency-changer, pentode I.F. amplifier, diode-pentode second detector, triode L.F. amplifier and push-pull output.

## A Review of the Most Important Features of the World's Short-wave Literature

Added to this circuit is the anti-fading circuit shown in Fig. 2. This control is double-acting and operates upon the grid of the second high-frequency stage, the intermediate frequency amplifier and the frequency-changer. The connection to the second I.F. grid taps the grid leak resistance after the first 60,000 ohms counted from the diode-anode, the connection to the other valves being at the junction of a 185,000-ohm and a  $\frac{1}{4}$ -megohm resistances. The intermediate-frequency amplifier is less closely controlled than the high-frequency amplifier, so that frequency changing can take place at the highest possible signal level.

When the carrier fades the high-frequency amplification is the first to increase, the intermediate-frequency amplifier being second.

## An Amplifier for 30-10,000 Cycles

In a recent number of the *Australian Wireless Weekly* was an interesting article on high-fidelity amplifiers. A typical amplifier is shown which has an absolutely flat response to frequencies between 30 and 10,000 cycles. Actually the variation is less than 5db. The amplifier (see Fig. 3) consists of a type-55 valve used as a phase changer and amplifier to couple the single valve into a push-pull stage without using any low-frequency transformers which might limit or impair the frequency response. It is not claimed that the cir-

cuit is in any way novel, but it has been proved that the values of the various resistances and capacities are such that the amateur can construct his amplifier and, providing the components specified are used, obtain response of the highest order.

No power pack is shown as this is

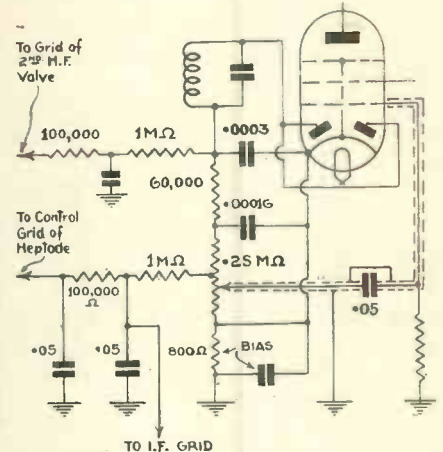

Fig. 2.—This A.V.C. circuit is more simple than perhaps it may look at first sight. It can be recommended.

quite standard, and consists merely of a transformer giving 500 volts, and a rectifying valve of the MU14 indirectly-heated type.

Adequate smoothing is essential and we suggest two low-resistance chokes, such as the Sound Sales at 215 ohms, smoothed with one 4-mfd. and two 8-mfd. electrolytic condensers.

## A Home-built Resistance Bridge

One of the most useful pieces of apparatus that the amateur is likely to need is a highly efficient resistance

(Continued on page 221.)

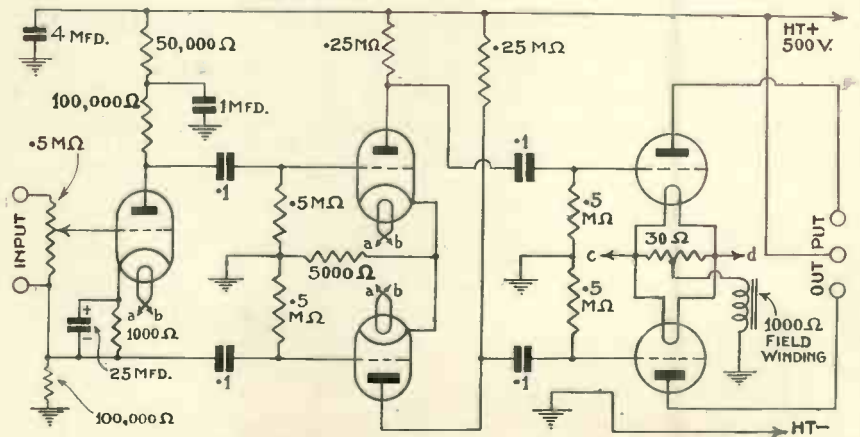
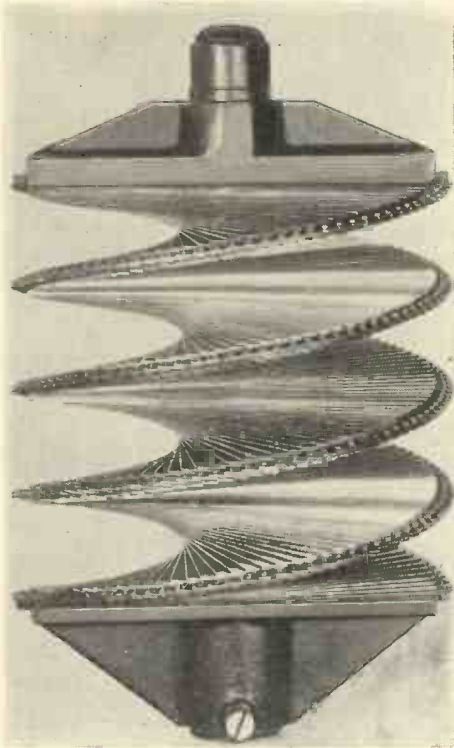

Fig. 3.—British components can be used throughout in the construction of this Australian amplifier.

# HIGH-DEFINITION MECHANICAL SCANNING

WITH PARTICULAR REFERENCE TO THE MIRROR SCREW

*This is a translation of an article by Franz von Okolicsanyi which appeared in "Funk Technische Monatshefte" recently. It is of importance in view of the problems that have arisen in connection with high-definition scanning by mechanical methods.*



The Tekade 180-line mirror screw.

WHEN, at the Radio Exhibition of 1931, 90-line images were shown for the first time, one had the impression that this was the acme of the mechanical system and could hardly be surpassed.

At the 1932 Radio Exhibition, however, Professor Karolus, with the help of the mirror-wheel system, produced images with 96 lines, while the A.G. televisior with Nipkow's spiral-hole discs produced images with 120 lines.

In 1933 no further progress with mechanical receiving was noticed, but at this year's Exhibition Tekade Co. with their mirror-screw for 180 lines, proved that an increase in the number of scanning lines was possible.

In an earlier number of the journal *Fernsehen*, the limit to the number of lines was discussed in connection with the mirror-screw. The calculations were based on the usual mirror-screw with flat mirror surfaces and the intensity of the light source, which was a glow lamp. Since then the light value has been improved by the use of filament lamps in conjunction with Kerr cells, and with the use of mirror-screws with graphite-polished mirror surfaces, the calculations must be revised to suit the new conditions of technique.

The increase of luminous intensity lowers the amount of pupil distension in the eye, and the angle of resolution is diminished, but owing to the

wide individual variations of the pupil distension, exact calculations are unnecessary. It has been empirically established that the distance between distinguishable points on a white surface illuminated by a lamp, must be three times as much in the case of Kerr cells and filament lamps, and this shows that the previously established limit of 104 lines can, by the greater clarity of the image, be increased to 180.

$$(Z = Z \sqrt{3} = 104 \sqrt{3} = 180)$$

The viewing position with the mirror-screw depends on the number of

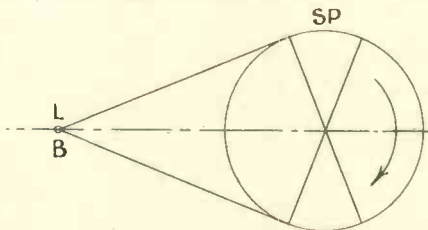

Fig. 1.—Diagram explaining the viewing position for a mirror screw.

lines and increases proportionally to the number of lines. With the construction of mirror-screws for 180 lines the viewing position should not exceed 2 metres, particularly as this distance is adaptable to the average room.

To make this point clear, in Fig. 1 the lamp and the observer are placed at the same distance, approximately coincident, and the connection between the size of the image, the number of lines and the lamp, i.e., the viewing range, is seen.

If the point of the luminous source (observer) is joined to the edge of the mirror-screw, the connecting lines will stand on two adjacent vertical segments. Moller gave the general formula, which serves for the given position of the luminous source as:

$$\frac{l}{L} + \frac{l}{B} = \frac{4}{Z \cdot B}$$

in which L and B signify the lamps, i.e., the distance for viewing, b the size of the image and Z the number of lines.

In order to shorten the viewing distance, the mirror-screw was developed in two directions in the television laboratory of Tekade.

1. As a double mirror-screw system.
2. As a screw with curved faces.

The double-mirror-screw is built up of mirror segments similar to the double spiral hole discs in which holes are distributed over an angle of 720°. To outward appearance this is a double-mirror-screw or 180 lines made up of two ordinary simple mirror-screws for 90-line images, which are set opposite to one another on the same axis, with the difference that the segments are half as thick, so that each of the 90 segments is half as high as the image.

The double mirror screw runs with twice the angular velocity of the normal mirror-screw, and effects in 50 revolutions, 25 pictures per second. Two segments are thus facing the observer at any instant. It supplies, however, only one of the two segments necessary for the desired number of lines to form the image; the other must be furnished with one or other of the known diaphragm devices. While the double-mirror-screw executes its two turns, the diaphragm opening moves only once along the mirror-screw axis, setting free in turn the segments of the upper and lower halves of the mirror-screw.

The precision of such mirror-screws for 180 lines is, on the basis of the above, the same as for the normal 90-line mirror-screw, but the advantage of the double-mirror-screw is that the turning angle of 41°, which serves for the 90-line mirror-screw, can be retained, and so the viewing distance remains unchanged at 2 metres.

In the curved mirror-screw the two

# LIGHT MODULATION AT HIGH FREQUENCIES

ends of the segments appear to be bent, and as a result the intersection of the two verticals establishes a close position for viewing, as in Fig. 2.

It was proved by experiments that such curved surfaces were most economical if a round surface, with its centre at the extension of the connecting lines of the mirror-screw lamp, was taken. In place of a circu-

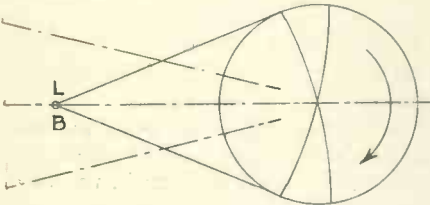

Fig. 2.—Effect of using curved mirror surfaces

lar surface a parabolic surface, similar to the known arc-lamp carbon mirror, can be introduced, but the axis of the rotating body must always be perpendicular to the middle of the mirror-screw surface.

## Curved Screws

With the flat mirror-screw the lamp and the observer are at a distance of 4 to 5 metres. On the other hand, with the curved surface screw, the distance is decreased to about 1.5 to 2 metres. Curved screws, as above described, were exhibited at the Radio Exhibition of 1934, and it was shown that old glow lamps of the year 1930, which in the course of the development of 60-line scanning had been put on the scrap-heap on account of the inefficiency of the Nipkow discs and the poor luminosity with flat mirror-screws give serviceable, if only moderately clear images, in 180-line images with the curved mirror.

With a combination of the curved, reflecting surfaces and double-screw, up to 360 image lines can be obtained from the mirror-screw system and with fourfold screws correspondingly higher number of lines.

## Light Sources for High-definition

The development of luminous sources of light for mechanical television receivers creates, with a high number of lines, more difficulties than the above-described development of the image construction itself.

By simple experiments it can be shown that the modulation of discharge tubes, in which the positive pole emits light (sodium or mercury lamp), the ordinary television frequencies of 500,000 Hertz and above is not practically possible. The control of the glow lamp discharge from negative electrode has not been sufficiently tested with high-frequencies. The previous experiments of Tekade show, however, that with this lamp a regulation of luminosity up to 500,000 Hertz is possible. In any case, the colour of the light and the poor luminosity prevent its application.

Under the above conditions, there remained for consideration as a light modulator, only the cell of Karolus, exhibited for the first time at the 1928 Radio Exhibition.

On account of the high dielectric constants of the fluids with high Kerr constants, small single-aperture cells such as are used for mirror-screws, gave a capacity of 200 cms. and above. With 500,000 Hertz the alternating current resistance is 1,600 ohms and forms with high picture frequencies a capacitive shunt. The development of a corresponding output stage has special difficulties, particularly for home receivers, since a

ance. This requires an expensive output stage of high performance, which can, however, be somewhat cheapened by the use of intermediate A.F. stages. In this case the Kerr cell can form a part of the capacity of a damped oscillating circuit whereby the need for an effective output is lessened.

That in principle perfect regulation is possible was proved by the A.G. apparatus which, with its capacity recorded 180-line images by means of a Kerr cell; this, however, was achieved with a large and expensive set. It is the task of the future to develop the Kerr cell, or the crystal light relays for the needs of the home receiver.

The writer is convinced that with improvements in controllable sources of light a large number of now neglected television systems will be revived. That such a sudden evolution is possible is proved by the example of the Braun tube, whose usefulness for television was known for years. Its importance was emphasised by F. Schroter in the first number of the first year of the journal "Fernsehen," but in spite of this it was some time before real development was undertaken, because the problem of regulating the luminosity was still unsolved and the ordinary oscillograph tubes were not suited to television. After the first productions of Von Ardenne, development started in almost all television firms.

With the substantial progress of light technique and light relays, television receivers will experience a similar advance, particularly when with small simple sets large images are projected. A backward glance on the development to the present day supports this. Apparatus up to 1930 required a large and costly equipment to show images little larger than a postage stamp, but with the introduction of the Braun tube and the mirror-screw the apparatus was improved, so that the screen of the Braun tube or the mirror-screw became the same size as the image. For the first time television images were produced the size of a postcard.

In the course of time it will be possible to project images on a wall or a screen as large as 50 cms., and the television receiver of the future will give a large image from compact apparatus. Then mechanical receivers will play a large part.

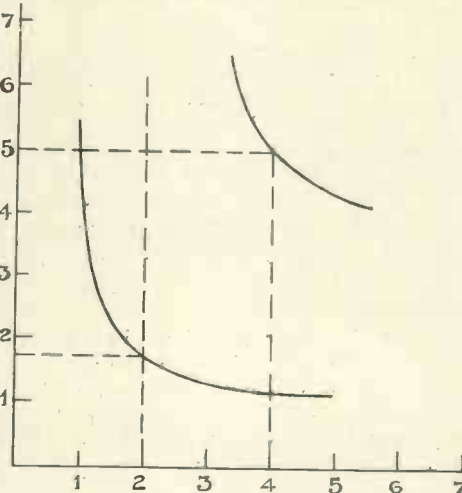

Fig. 3.—Curves showing the comparative viewing distances of curved and flat screws. The curve on the left is for the curved screw and that on the right the flat screw.

low ohm starting resistance must be considered.

For the regulation of the usual Kerr cell, low voltages of 3 to 500 volts are essential and high currents are necessary with low starting resist-

APRIL, 1935

# BRINGING TELEVISION TO THE CINEMA

An abstract from a paper read before the British Kinematograph Society by G. W. Walton, of Scophony, Ltd.

IN introducing his subject, Mr. Walton said that at the present moment the cinema industry appears to have confused ideas on television and the way in which it will affect the cinema. Some regard it as insignificant and others as a serious competitor. It is remarkable how few think of it as a possible ally. Television is very much similar to the cinema in many respects. They both have the theatre and the home aspects. In the theatre television may be quite as important as the cinema, and in the home certainly more important than the cinema.

The cinema and television are naturally complementary. Roughly it may be said that the cinema annihilates time as it applies to date of an event and as independent of the place of occurrence. On the other hand television annihilates distance and also time as connected therewith. Obviously, together they afford the greatest possible flexibility in the handling of picture entertainment.

It follows that, for the best picture entertainment, television must follow the lines of the cinema and will undoubtedly require the same kind of organisation, and it appears inevitable that the two will join up to use the existing organisation of the

cinema industry, instead of engaging in useless competition.

## In the Studio

The application of television to the production of films is likely to result in a speeding up of the process, as well as considerable reduction in cost. For instance, any number of television cameras can be operative on the same set, and the director will be able to see the picture on a screen just as it will appear to the public; by means of switch he can immediately select the best point of view and control the lighting, etc., whilst the scene is being taken.

## In Distribution

In distribution there are also many advantages. It will be possible for a cinema theatre to obtain urgent changes of programme by wire, shall we say, or to supply a particular picture at a few minutes' notice. In news and topical events, television will be used to obtain and distribute at once the latest of everything.

## Exhibitors

It appears that exhibitors will derive the greatest benefit from tele-

vision. It is probable that every cinema theatre will have television projectors as regular equipment, as well as the normal projector. They will be able to show a greater variety of entertainment with more frequent changes, surprise items, etc., all of which will encourage the public to visit the theatres more frequently. News cinemas are likely to grow in importance and number through television.

To attain the present stage, television has had to face much more than the cinema had to in its early days. From what I have seen, the average person is extremely critical and demands from television to-day as much, or more than the cinema can give. To-day television has arrived at a stage when it can be introduced into the home. So far as the cinema industry is concerned, the effect of this will be greater than that of the home cinema, though there does not appear to be any cause for alarm, for, by the time that home television has advanced to a stage which could seriously affect the cinema industry, it is highly probable that theatre television will have arrived to maintain the balance.

Passing on to technical considerations of theatre television, Mr. Walton said, the position to-day is that the definition approaches that of the cinema so that picture quality and therefore the entertaining capabilities can be regarded as established. However, present television pictures are small and there are considerable difficulties in the way before large screen pictures can be obtained. These difficulties are fundamental and it seems as though basic changes in television methods, are required. The methods of television, that is to say the ways in which signals can be obtained from a picture, or a picture can be reproduced from those signals, are well over fifty years old. There are two general methods, the mosaic and scanning. For a number of years television was held up by the necessity of amplification. This was solved by the thermionic valve and its use as an amplifier in radio. Revived interest in television followed those developments in radio, and that interest has grown steadily during the last fifteen years.

## "The Short-wave Radio World"

(Continued from page 218.)

bridge, which can be made cheaply and is simple to operate. H. C. Polson, writing in the current number of *Radio-*

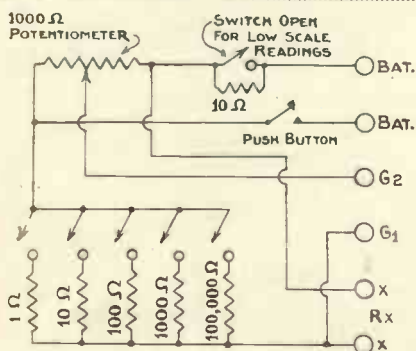

Fig. 4.—A resistance bridge is a really useful piece of apparatus for the laboratory. Here is a simple one.

Craft, tells of a new bridge that he has just constructed.

It consists of a 1,000-ohm wire-

wound potentiometer, six fixed resistances, six terminals and a simple push-button switch. After connecting the components as shown in Fig. 3, the points G<sub>1</sub> and G<sub>2</sub> are connected to a current-indicating device such as a small galvanometer or low-reading milliammeter. Across the two terminals, marked battery, a small 1½-volt dry cell is connected, and this will be ample for all resistances up to 10,000 ohms. When, however, it is desired to test low-value resistances, it is advisable to connect a series resistance in the battery circuit. For higher values of between 10,000 ohms and, say, 1 megohm, a 4½-volt battery will be necessary.

Calibration is not difficult. If a resistance-bridge is not available from which it can be calibrated, then it can be checked by means of high quality resistances that are accurate to within 1 or ½ per cent.

The standard resistance should be connected between the two terminals marked X and then the 1,000-ohm potentiometer must be adjusted until the meter reads zero.

It will be conceded that projection is necessary for theatre television to be successful, and therefore the ordinary laws of optical projection must apply, as in the cinema. The illumination at the screen, necessary to give a specified size and brilliancy of picture, depends primarily on the intrinsic brilliancy of the light source used as reduced by the transmission losses of the total optical system, including the loss due to inoperative periods; secondly, the illumination varies inversely as the square of the projection distance; and, thirdly, the illumination varies directly as the product of the area exit pupil of the optical system and the area at the screen simultaneously illuminated.

An example will show the astonishing limitation in present-day television receivers as required to project in the cinema. Taking an average cinema picture of 6 by 8 metres, a projection distance of 40 metres and the usual intensified arc as light source, the illumination at the screen is approximately 80 lux with a normal size of projector lens. In the cinema, light is not continuously active on the screen because of intermittency, the light being reduced to about 50 per cent. This can be taken as equivalent to half of the area of the picture continuously active.

Suppose with the same light source and optical transmission efficiency as in the above cinema example, a television receiver is required to project at the same distance an equal size and brilliancy of picture. We will take a picture of 300 lines and the usual 3 by 4 aspect ratio, so that the

picture element is  $\frac{1}{120,000}$ th of the

area of the picture. Using the present method of scanning with one spot of picture element size, only

$\frac{1}{120,000}$ th of the picture is active at

any instant of time, whereas in the cinema 60,000 times more, is active simultaneously. Consequently the area of the exit pupil of the television receiver must be 60,000 times greater than that of the cinema, which means that it would be about 17 sq. metres, or a projection lens of about 465 cm. in diameter.

This stubborn fact obviously must be squarely faced.

The next difficulty is that of transmission channels. Radio is not very satisfactory from a cinema point of view.

Still another difficulty, quite apart from actual transmissions, is the high picture frequencies. By the normal method a 300-line picture of 3:4 ratio at 50 pictures per sec. gives a 3 million cycle band. Such high frequencies have several nasty effects in amplifiers, such as reduced amplifiable photo-cell response, due to capacity. Similar difficulties may also apply to some light controls. Viewed in the light of television as it is to-day, theatre television may strike many as well-nigh impossible. But it appears that fundamental changes in methods of television are imminent.

The two methods of television, mosaic and scanning, are both extreme methods. The first shows all the picture simultaneously and requires such a multiplicity of channels that it is impractical for high definition, but modulation frequencies are low and light is at a maximum. The second uses only one channel, modulation frequencies are high and light is at a minimum. Hybrids of the two methods have been suggested and used; an example as a transmitter is the Iconoscope, whilst an example of a receiver is the lamp screen and commutator form of apparatus.

There have also been made attempts at something between the two extreme methods, that is to say, whilst still employing scanning, to have several picture elements simultaneously active such as zone scanning methods, the Karolus lamp screen and multiple scanning

methods. To get any light worth while, a large number of transmission channels is required and this makes some methods not very practical. Multiple methods appear to be more promising, though many types of television apparatus will not be suitable. At this point it will be as well to note that certain types of apparatus can be regarded as probably obsolete as far as the cinema is concerned, such as the Nipkow disc, the cathode-ray and certain mirror-drum arrangements.

What then appears to be necessary for cinema television?

1. A considerable portion of the picture must be active at the same instant of time and continuously. This may have to be the equivalent of several hundred picture elements.

2. A minimum of channels, say, not more than three.

3. Picture frequencies must be reduced.

There are a number of people thinking of (1), but so far no published solution has appeared. The Iconoscope to a certain extent meets (1) by storage, but not (2) or (3). Shroeter has suggested that some similar storage be used, but gave no definite solution. Alexanderson has suggested two or three apertures simultaneously active with time-delay circuits between the light-control devices of those apertures, but no indication has been given that it has proved satisfactory in practice. It appears to be rather difficult in view of the wide frequency-band utilised.

That what I have been discussing is not impossible, will be apparent from the fact that Scophony has been using for nearly one year on 120 lines the equivalent of 30 to 40 simultaneously active picture elements in receivers, all operated from the signals of only one transmission channel. On 240 lines it appears possible to use 50 to 100 elements by the method so far used without further channels, and therefore, without exceeding 3 channels, up to 300 picture elements can be active at once. Apply this to the example previously given in comparing cinema and television, and the area of exit pupil comes down to 570 sq. cm. instead of 17 sq. metres, i.e., lens diameter of about 27 cm.

The enormous increase of light so far obtained shows that this definitely is the direction of the greatest possible advance in television. So far Scophony has covered 1 and 2 practically and 3 theoretically, and it is hoped to test the theories on 3 in the very near future.



Larger cathode-ray tubes are being produced. Here is the new Cossor tube.



APRIL, 1935

# RAY FOCUSING IN C.R. TUBES

*Describing the use and application of colloidal graphite on the interior walls of the cathode-ray tube to assist in focusing the beam.*

IN cathode-ray tube manufacture, especially in those tubes intended for use in television reception, it is usual practice to apply to the interior walls of the glass envelope a conducting coating which extends from the edges of the fluorescent screen into the neck of the tube near the point where the electrons are pro-

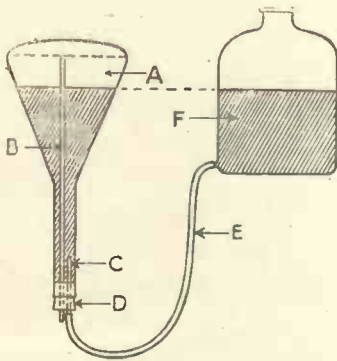

Fig. 1.—Diagram showing how the coating of graphite is applied.

jected. This conducting layer acts as a second anode and plays an important role in the focusing of the electron beam.

When the second anode is composed of silver or any similar metal, its lustrous surface acts as a mirror and impairs the brilliancy of the image by reflecting any light which may be emitted from the tube elements during operation, or which may have diffused through the translucent material comprising the screen.

The substance best suited for ray-focusing anodes is one which possesses not only opacity but a dark matt surface as well. Graphite films are especially advantageous in this connection. When formed through the agency of colloidal-graphited water of proper concentration, they show poor reflecting properties, are electrically conductive and, unlike silver, can be applied to all types of glass with equal ease.

Graphite films are highly resistant to oxidation, acquire "getter" pro-

perties when baked and have a low coefficient of expansion. The fine particle size of colloidal graphite, together with the protective colloid it carries, makes unnecessary the use of binding agents.

Films formed with colloidal-graphited water adhere equally well to metallic parts, thus making possible the formation of a good contact with lead-in wires. It may also be used to coat the metallic tube elements, i.e., deflecting plates, etc., when such a procedure is necessary or advisable.

When graphite films were first adopted, they were employed primarily for their dark colour and used in tubes which had previously been coated with silver. It has since been found that the graphite deposits are sufficiently conductive in themselves, thus making unnecessary prior treatment of envelopes with metallic elements.

## Method of Application

Colloidal-graphited water, as manufactured by E. G. Acheson, Ltd., under their trade-mark "Aquadag," contains approximately 18 per cent. or 22 per cent. graphite, by weight. Being a concentrated product, Aquadag is, in most cases, diluted with a suitable electrolyte-free water-miscible liquid, before use.

In cathode-ray tube manufacture, it is usually mixed with an equal weight of distilled water and the resulting solution carefully worked to effect a homogeneous dispersion of the graphite. Where agglomerates of concentrated Aquadag persist, it is advisable to remove them by passing the diluted solution through a piece of closely-woven cloth. The agglomerates so separated may then be further worked with a small amount of water before being returned to the original solution.

The volume of solution prepared should exceed by at least 50 per cent. that of the envelope to be treated. For example, if it is desired to coat a

number of tubes having a capacity of 1,000 c.c., not less than 1,500 c.c. of solution should be prepared.

## Apparatus Employed

The apparatus best adapted for the coating operation is shown in Fig. 1. The glass envelope A may be placed in a ring stand or in any other suitable support. Its neck is then fitted a two-holed rubber stopper, carrying long and short pieces of glass tubing, indicated in the diagram by B and C respectively. The solution of colloidal-graphited water is transferred to an aspirator bottle F connected to the inlet tube C by means of rubber tubing E.

The tube B serves as an air vent and also controls the maximum height of the coating within the envelope. Should the solution be forced higher than the uppermost end of the tube B the latter will act as an overflow pipe. It is not desirable to consistently use tube B as an overflow pipe as frequently spattering of the screen surface results, especially if the diameter is too small.

The method of coating is obvious. By raising the bottle F the solution will flow into the envelope A until the liquids in vessels F and A stand at the same level. When the aspirator bottle is lowered the direction of flow is reversed and the solution, with the exception of that adhering to the glass to form the coating, may be recovered.

If the neck of the tube is unusually narrow, it is well to employ concentric glass tubes as illustrated

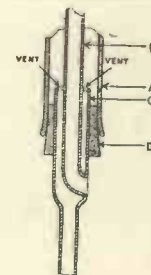

Fig. 2.—Suitable arrangement when the neck of the tube is very narrow.

in Fig. 2. As in the case of the apparatus previously described, D represents the rubber stopper, C the inlet pipe and B the combined air vent and overflow pipe.

Films of any desired thickness may be deposited in this manner, the controlling factors being the concentration of graphite employed and the number of coatings applied. In most

(Continued on page 236)

# Trade Notes of the Month

## Reports on Apparatus Tested

### A New Short-wave Transmitting Valve

Short-wave transmitters will learn with interest that a new short-wave valve is being placed on the market by the Edison Swan Co. The valve, which is known as the E.S.W.50, is of the thoriated tungsten type with a graphite anode and tungsten seals. As the photograph shows, the connections to the grid and anode are brought out at the top of the bulb with as short a connection as possible.

This construction enables the valve to be used on wavelengths as low as 4-5 metres, and the improved dissipating properties of graphite ensure a very low operating temperature and liberal margin of safety. The following are the characteristics: Filament volts 6; filament current 4 amps; max.



One of the very latest short-wave valves. This S.W. 50 has a graphite anode and a thoriated tungsten filament. Dissipation up to 40 watts at ten metres is possible.

anode voltage 1,500; amplification factor 15; impedance 10,000; maximum dissipation 50 W.

At 10 metres the valve runs comparatively cool and a dissipation of 40 watts is easily obtainable. At 5 metres we obtained 32 watts without difficulty, and from our experiments we feel that it

would be quite safe to claim a maximum 45 watts at 5 metres. The tentative price is £4 10s. 0d.

### A Valve Holder for Television and Ultra-short Waves

As the new amplifiers used in high-definition television receivers will have to reproduce up to 2 megacycles, as far as possible, all traces of grid to earth

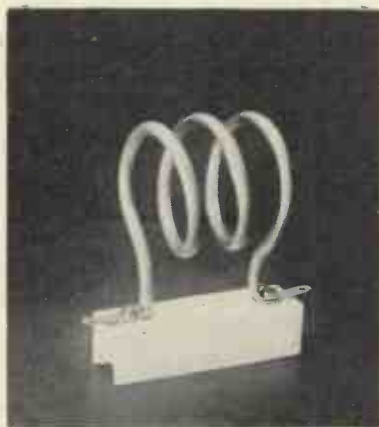

A complete set of these coils covering 5-25 metres can be obtained from Bulgin. They are wound with silver plated copper wire.

and anode to earth capacities should be eliminated. Valve makers will shortly be introducing special output valves having low inter-electrode capacities, but these valves will require special holders if they are to work at maximum efficiency.

A. F. Bulgin & Co. have just introduced a new holder mounted on a steatite base, in which losses have been reduced to a very low minimum. All metal parts are nickel plated while the holders are suitable for four- or five-pin valves. The type number is S21 and the price 1s. 6d. These holders are of the baseboard mounting type but five-pin chassis holders are available at 9d. (model No. SW41).

Tube-wound ultra-short wave coils of very low-loss construction and made of silver plated copper wire are now available. One of these is shown by the photograph. The set of three coils tunes between 5 and 25 metres.

### A Fifteen-watt Screened-grid Transmitting Valve

Screen-grid valves are not very popular in this country for transmitting use, but we feel sure that the new Mullard QZ05/15 will establish the

popularity of this type of valve. At 45 metres the QZ05/15 will give an output of 15 watts, 10 watts at 15 metres and approximately 7 watts at 5 metres. It overcomes neutralising difficulties (the anode to grid capacity is only .001-micro-microfarads) and, in addition, it only requires a very low grid excitation power.

The bulb is of cylindrical shape, 50 mm. in diameter and has been fitted with an American four-pin base. The anode connection is brought out through the top of the bulb, while the control grid is taken to a side terminal. The filament requires four volts at 1.1 amperes and is of the oxide-coated type. The total emission is 400 m/a at 500 v/a. The maximum screened voltage is 125 volts.

When used as a frequency-doubler it will deliver 10 watts at 30 metres.

Under all conditions of operation the anode current must be limited to 70 milliamps, while the normal grid current should not be more than 7 milliamps. With a valve of this type it is very important that the dissipation be checked by the following formulæ.

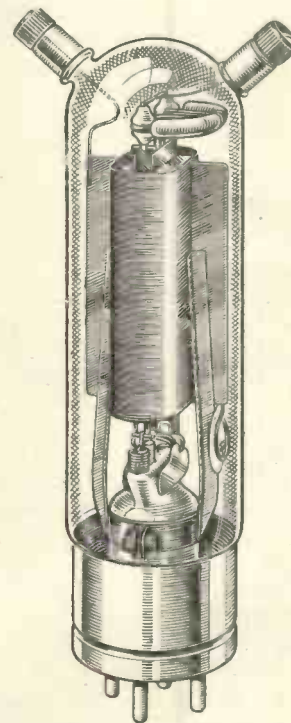

This valve will obviate neutralising. It is the Mullard 15 watt screen-grid type QZ05/15.

For screen dissipation use  
Screen dissipation (watts) = 0.6 (Screen current (amps) + Anode Current (amps)) × Screen volts.

Anode dissipation can be checked from the following expression:—  
Anode dissipation (watts) = (V<sub>a</sub> I<sub>a</sub> + V<sub>s</sub> I<sub>s</sub>) - (W<sub>s</sub> + W)

Where W<sub>s</sub> = Screen dissipation

W = Output power.

The price is £5 17s. 6d.

# RECENT TELEVISION DEVELOPMENTS

A RECORD  
OF  
PATENTS AND PROGRESS  
*Specially Compiled for this Journal*

Preventing Distortion :: Enlarging the Picture :: Cathode-ray Scanning :: Photo-sensitive Mosaics  
Light Valves :: Scanning Systems

## Preventing Distortion in Cathode-ray Tubes

(Patent No. 421,603.)

Because of the difference of potential between the deflecting electrodes of a cathode-ray tube, a current is

## Enlarging the Picture

(Patent No. 422,034.)

Under daylight conditions it is not usually possible to magnify the picture as thrown on to the fluorescent screen, on account of the resulting

loss of illumination, though at night-time or in a darkened room the same picture may be enlarged with advantage. According to the invention, a cathode-ray receiver is designed so that the picture may be viewed either directly on the screen, or through an optical magnifying system, as desired.

In the latter case the effect of the lens system is to invert the picture, or to give it a wrong-sided appearance, and in order to correct this the normal direction of the voltages applied to the scanning electrodes is re-

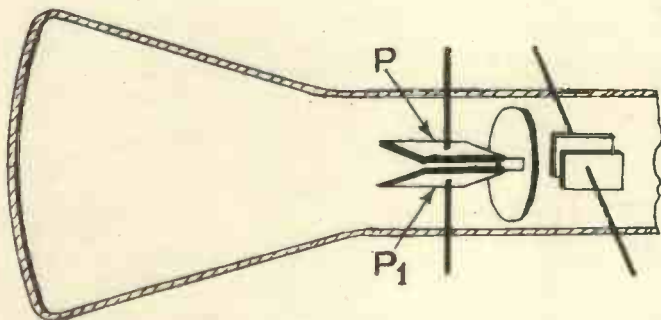

Preventing distortion in cathode-ray tubes Patent No. 421,603.

liable to be set up across the intervening space by the action of stray electrons. Its value will depend in part upon the light-intensity of the image-point projected on the screen (i.e., on the intensity of the stream passing between the deflecting plates) and in part on the strength of the applied scanning potentials. Such a leakage current naturally causes a drop in the applied scanning voltage, which in turn produces a displacement of the image-point and consequent distortion in the picture.

Various methods are described for preventing or minimising this so-called "cross-current" error. In the one illustrated in the figure the pair of electrodes marked P, P<sub>1</sub> are tilted relatively to each other, so that the spacing between them is smallest at the point where the electron stream attains its highest speed, and largest at the point where the stream travels slowest. In this way displacement of the image-point due to the presence of cross-current is automatically offset, and the correct form of the picture is maintained.—(Radio-Akt. D. S. Loewe and K. Schlesinger.)

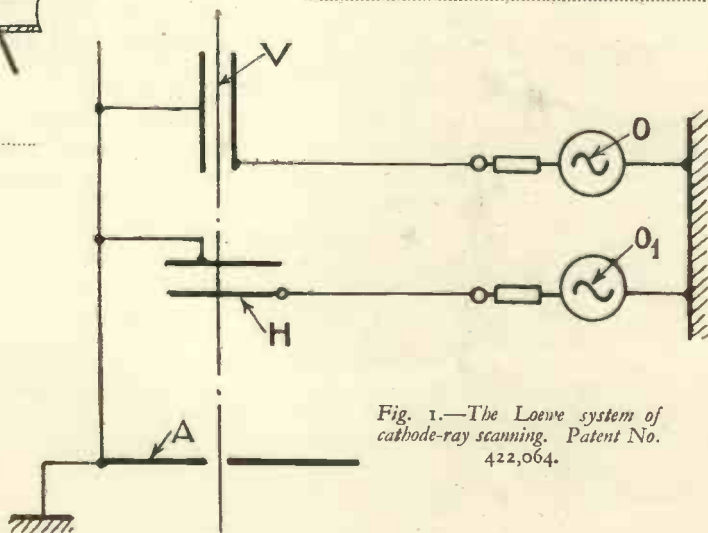

Fig. 1.—The Loewe system of cathode-ray scanning. Patent No. 422,064.

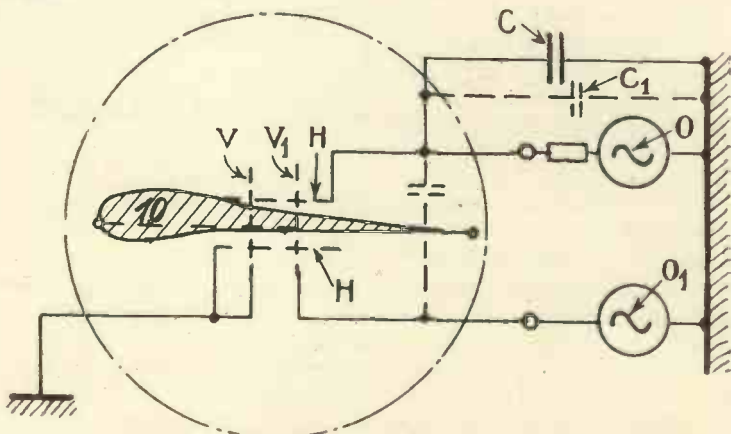

Fig. 2.—End view of tube showing track of ray. Patent No. 422,064.

The information and illustrations on this page are given with the permission of the Controller of H.M. Stationery Office.

versed by a switch when the optical viewing system is brought into use. The switch is of the snap-over type, having no stable intermediate posi-

**Photo-sensitive "Mosaics"**  
(Patent No. 421,201.)  
The photo-electric surfaces upon which the picture is focused in the

tional to the applied field; also the required control voltage is low. The crystal is arranged between the two electrodes of the Kerr cell, the other components of the light-valve being standard.—(Süddeutsche "Tekade" Co.)

**Scanning Systems**

(Patent No. 422,710.)

The invention is chiefly concerned with means for preventing "strays" or atmospheric disturbances from interfering with the proper synchronising control of a cathode-ray receiver. The line synchronising-signals are first separated out from the picture signals (which are taken off as shown) and are then passed through a filter and a rectifier, which is shunted

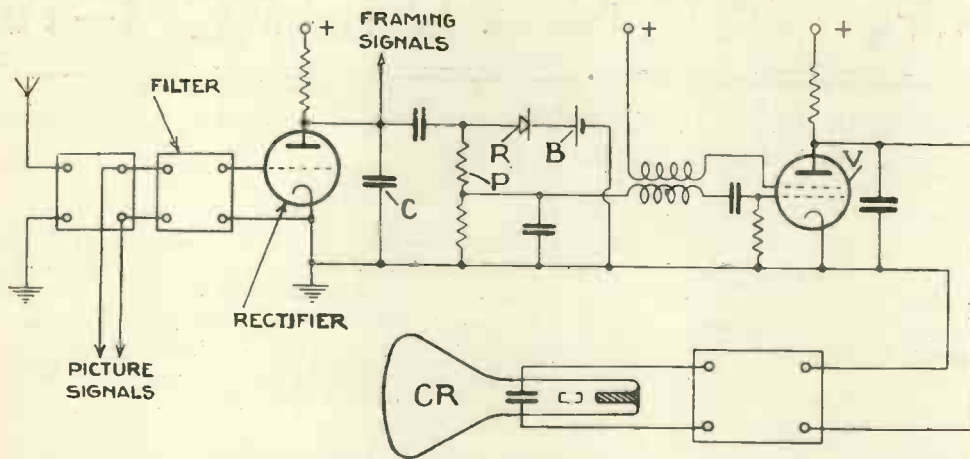

Method of preventing atmospheric disturbances interfering with the synchronising control. Patent No. 422,710.

tion, so as to prevent any possibility of the fluorescent screen being burnt out by a stationary spot.—(A. C. Cossor, Ltd.)

**Cathode-ray Scanning**

(Patent No. 422,064.)

Relates to means for preventing the effect of the leads, both inside and outside a cathode-ray tube, from affecting the straightness of the scanning lines produced by the ray on the fluorescent screen. Fig. 1 shows a typical arrangement of horizontal scanning electrodes H, and vertical electrodes V. One plate is in each case "anchored" to the voltage of the anode A, whilst the other plate is connected to the oscillators O, O<sub>1</sub> producing the scanning voltages. Fig. 2 shows the tube end-on, the shaded area representing the undesired "curved" track of the forward and return path of the ray across the fluorescent screen.

The curvature is largely due to the fact that the impedances of the leads to the scanning electrodes prevent the charging voltages from operating instantaneously. The resulting "lag" converts what should be a straight-line traverse into a curved one.

In order to remove this defect the leads are screened from each other both inside and outside the tube, and a condenser C is inserted in parallel with the "earth" capacity C<sub>1</sub>, so as to reduce the the impedance of that circuit at the picture frequency.—(Radio-Akt. D. S. Loewe and K. Schlesinger.)

"mosaic cell" type of transmitter are usually prepared by depositing silver in minute globules upon a mica backing. The silver is first oxidised, and is then coated with caesium, so as to form a series of tiny condensers upon which the picture produces an electrostatic image.

In order to ensure maximum sensitivity it is essential that the oxidised silver coating should be of the proper thickness, and the invention is concerned with the necessary means to ensure this. The mica backing, after being covered with a deposit of silver, is enclosed in a glass bulb filled with oxygen. The bulb is then subjected to the high-frequency field from an external electrode, which is moved by hand so as to regulate the degree of ionisation produced inside the bulb. This in turn controls the oxidising of the silver globules, so that a coating of any desired thickness can be obtained.—(Marconi's Wireless Telegraph Co., Ltd.)

**Light Valves**

(Patent No. 422,370.)

Nitro-benzene as ordinarily used in a Kerr cell has an uncertain insulation resistance, whilst the required control voltage is high and may at times exceed the break-down point. According to the invention the nitro-benzene is replaced by a doubly-refracting crystal, such as natural zinc blend, which is semi-transparent to the visible spectrum and is also an insulator. The double-refraction effect is without lag and is propor-

by a condenser C having low-impedance to the carrier frequency. The potentiometer P accepts the line-scanning frequencies, which are then applied to "trigger" the oscillator valve V and so control the scanning voltages applied to the deflecting electrodes of the cathode-ray tube C.R.

In order to limit the effect of stray atmospheric, a copper-oxide rectifier R is arranged in series with a biasing battery B. This normally prevents current from passing through the rectifier unless a stray of greater amplitude than the line voltages is received, in which case it is shunted away by the combination. The result is that the voltage across the potentiometer P, and therefore the voltage applied to the control grid of the valve V, is always limited substantially to the voltage of the line-synchronising impulses.—(Electric and Musical Industries, Ltd., M. Bowman-Manifold and W. S. Percival.)

**Summary of Other Television Patents**

(Patent No. 419,727.)

Cathode-ray tube fitted with an optical-electron focusing system.—(Radio Akt. D. S. Loewe.)

(Patent No. 411,540.)

Improvements in connection with television studios.—(Fernseh Co.)

(Patent No. 411,819.)

Reproducing television pictures on a bank of incandescent lamps controlled by relays which are energised

(Continued at foot of page 228.)

THE TELEVISION ENGINEER

MODERN PHYSICS  
AND TELEVISION RESEARCH—IV

By J. C. Wilson,  
of the Baird Laboratories

*This is the fourth article of a series on pure physics. It explains how the theories advanced in preceding articles are applicable to television.*

THE QUANTUM PRINCIPLES AND TELEVISION

IN one particular sphere the application of quantum principles touches very closely upon the domain of the television engineer, and this is in the region of photo-electricity. It had been observed by many workers that when light-energy falls upon a photo-sensitive surface, the maximum velocity of ejection of photo-electrons by light of a given colour depends not at all upon the intensity of the light, although

the right-hand quantity,  $h\nu$ , is at least as high as  $w$ , there will be no ejection at all, so that the frequency  $\nu$  must be greater than a certain critical value.

By means of a brilliantly beautiful series of experiments, Millikan demonstrated the absolute validity of this: he applied an opposing electric field to a photo-cell so that emission was just stopped when light of a certain known frequency was falling on the sensitive surface. From his results he was able to calculate again the value of  $h$ , finding it to be  $6.57 \times 10^{-27}$  erg.-sec., which conclusively proved the quantum-nature of whatever action is taking place during the liberation of photo-electrons by light.

Analogous Properties  
of Light and Electrons

This is not all, however. Far from simplifying the interpretation of light- and electron-phenomena in other directions, the small but highly significant quantum nearly upset the apple-cart completely. For example,

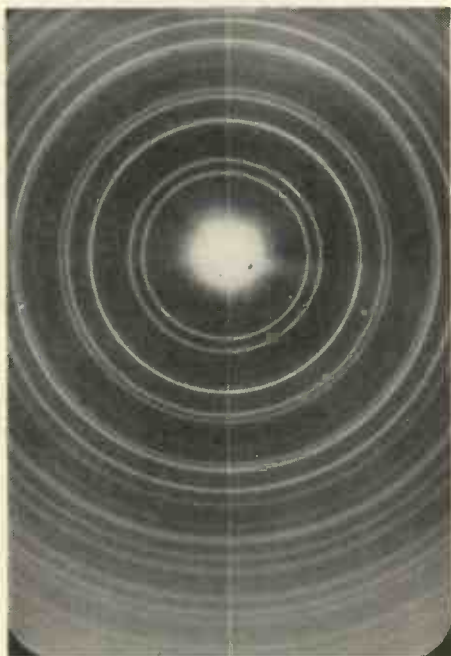

Fig. 2.—Transmission patterns of electrons diffracted through nickel film (Photograph by courtesy of Professor G. I. Finch of the Royal College of Science).



Fig. 3.—Electron-pattern from film containing an aluminium crystal (spot pattern) and scattered aluminium and aluminium-oxide (ring pattern) (Photograph by courtesy of Professor G. I. Finch of the Royal College of Science).

the number ejected is very strictly proportional to the intensity.

This phenomenon, coupled with the remarkable fact that no electrons are given off at all, however intense the light, if the wavelength is not less than a certain critical value, was discussed by Einstein (Einstein again!) in the light of Planck's hypothesis, and he was able to formulate the highly unclassical equation:

$$mv^2/2 + w = h\nu$$

in which  $m$  is the electronic mass

$v$  is its velocity of ejection

$\nu$  is the frequency of the light causing ejection

$h$  is Planck's constant

and  $w$  is a certain critical amount of work characteristic of the surface, which must be done to dislodge an electron.

From this formula it will at once be seen that unless

if light is made up of small parcels or bundles (termed photons) instead of comprising a wave-motion, what becomes of diffraction? Diffraction, it will be remembered, is the name given to the scattering of little secondary wavelets of light in the region of sharp edges. If light from a very small source, such as an illuminated

**THE TELEVISION ENGINEER**

pin-hole, falls upon two tiny apertures in an opaque diaphragm, and the two emergent pencils of light are allowed to overlap on a white screen, the screen will be seen to be crossed with dark interference fringes. Now, unless a quantum can mysteriously dissolve itself into waves in emergencies of this sort, it must, one would think, pass wholly through either one aperture or the other.

How then can separate quanta interfere with one another at some parts of the screen and not at others? Moreover, the interference pattern persists even when the light is made so weak that the passage of quanta through the apertures is a comparatively rare occurrence, and the chance of two meeting at any one point on the screen quite remote.

Before the world of science had time to assimilate this, came a further catastrophe: G. P. Thomson demonstrated the wave-properties of the electron itself by bombarding fast-moving electrons upon a very thin film of metal, by the atoms of which they were diffracted even as light-waves were by the tiny apertures.

A photograph taken by Professor G. P. Thomson and sent to Sir Ambrose Fleming has already appeared in the pages of this journal.\*

Recent photographs, taken by Professor G. I. Finch, of the Royal College of Science, and very kindly placed at my disposal for the present article, are reproduced here in Figs. 2 and 3. Of these, the first, consisting of complete rings, is a transmission pattern of an electrodeposited nickel film containing face-centred cubic crystals in nearly random array, while the second is from an aluminium film in which there is one large single crystal (giving the spot-pattern) and a large number of aluminium and oxide of aluminium crystals, minute ones, in random array (giving rise to the rings).

These photographs were obtained by projecting a stream of 60 kV electrons through a film of the metal, a few atoms thick, on to the photographic plate situated on the other side of the film at a distance of the order of 20 ins.; they show the effects of diffraction which are precisely similar to those obtained in suitable circumstances with light-waves. The diffracted rays are electrons, as is simply proved by subjecting them to a transverse magnetic field the effect of which is just to deflect the pattern on the photographic plate sideways as a whole, without any deformation, in exactly

\* Vol. 2, No. 14, at p. 55 (April, 1929).

the same way as that in which electrons themselves are deflected in a cathode-ray tube.

Is an electron a group of waves or a particle? Is light really corpuscular? Or are both of these descriptions merely mental pictures or aspects of something which is quite different from wave-motion or corpuscular light? It is not possible yet to answer these questions with certainty. But the first rosy flush of imaginative rapture at the success of the quantum of action in explaining the facts of radiation and photo-electric action has gone, and its place has been taken by a steady orderly activity, mostly mathematical, on the part of such men as Temple, Dirac and de Broglie, and tending to the elucidation of the circumstances in which quantum mechanics must be applied and of those in which classical theory cannot safely be discarded altogether at the moment.

APPENDIX.

For an electron of mass  $m$ , in an orbit of radius  $\nu$ , the centrifugal force is  $m\nu w^2$ , where  $w$  is its angular velocity round the nucleus. The electric force attracting it to the nucleus, since the electron is negative and the nucleus positive, is  $e^2/\nu^2$ , where  $e$  is the electronic charge.

But these two forces must be equal for the electron to remain in its orbit; hence:

$$e^2/\nu^2 = m\nu w^2.$$

Now the impulse of a mass  $m$  moving with angular velocity  $w$  at radius  $\nu$  is  $m\nu w^2$ , and for a complete revolution about the nucleus this comes to  $2\pi m w \nu^2$ .

But this must, on the quantum theory, be equal to  $h$ , or a multiple of  $h$ , so we may write:

$$2\pi m w \nu^2 = nh \text{ where } n \text{ is an integer.}$$

These two equations give  $\nu$  and  $w$ , viz. :-

$$\nu = n^2 h^2 / 4\pi^2 m e^2$$

$$\text{and } w = 8\pi^3 m e^4 / n^3 h^3.$$

Now the kinetic energy of a mass  $m$ , moving with velocity  $v$  is  $m v^2 / 2$ ; but  $v$  here equals  $\nu w$ , giving for the kinetic energy :-

$$m \nu^2 w^2 / 2 = m (2\pi e^2 / nh)^2 / 2.$$

But the electron also possesses potential energy which is negative and twice the kinetic energy, so that the total energy is equal to  $m(2\pi e^2 / nh)^2 / 2$ , but negative. Remembering that each integral value for  $n$  gives an electron orbit permitted by the quantum theory, a jump from the  $k$ th orbit to the  $n$ th represents a loss in

energy given by  $m \left( \frac{2\pi^2 e^4}{h^2} \right) (1/n^2 - 1/k^2)$ . Since this must equal

$h \eta$ , where  $\eta$  is the frequency of the light-wave yielded, we have:

$$\eta = (2\pi^2 m e^4 / h^3) (1/n^2 - 1/k^2).$$

Using the fact that  $\eta \lambda = c$  where  $c$  is the velocity of light, we see that in the empirical equation  $1/\lambda = R(1/n^2 - 1/k^2)$ , the value of Rydberg's constant,  $R$ , must be  $2\pi^2 m e^4 / h^3 c$ .

The known values of  $c$ ,  $e$ ,  $h$  and  $m$  satisfy this relationship.

"Recent Television Developments"

(Continued from page 226.)

by light passing through a photographic film on to light-sensitive cells.—(H. Rosenberg.)

(Patent No. 421,937.)

Method of transmitting picture, scanning, and sound signals involving the use of intermediate carrier-frequencies.—(Suddeutsche "Telegraph" Co.)

(Patent No. 422,060.)

Cathode-ray tube with supplementary magnetic field control.—(Telefunken Co.)

(Patent No. 422,041.)

Cathode-ray tube with electron-optical system for intensity control.—(Radio-Akt. D. S. Loewe and K. Schlesinger.)

(Patent No. 422,158.)

Mosaic-cell structure for the sensitive electrode of a cathode-ray transmitter.—(Marconi's Wireless Telegraph Co., Ltd.)

(Patent No. 422,481.)

Synchronising by means of a sinusoidal signal modulated on a carrier

and fed, with the picture signals, to a single transmission channel.—(Electric and Musical Industries, Ltd., E. C. Cork and M. Bowman-Manifold.)

(Patent No. 422,614.)

Electrode assembly, including a focusing member, for a cathode-ray tube.—(Fernseh Akt.)

(Patent No. 422,708.)

Improvements in the deflecting electrodes used with cathode-ray tubes.—(Radio-Akt. D. S. Loewe and K. Schlesinger.)

# IMPROVING THE LIGHT MODULATION OF NEONS

This article, by J. H. Reyner, B.Sc., A.M.I.E.E., explains the importance of constant voltage for the operation of modulated light sources and describes how the best operating conditions can be secured.

**C**ORRECT operation of the light source in television receivers involves a constant-voltage supply irrespective of the fluctuating current demand. While this can be obtained from a battery it makes a

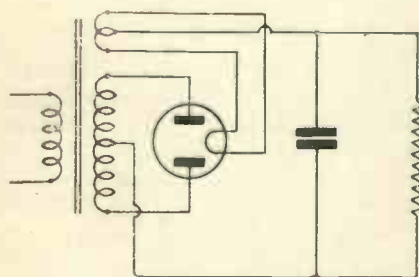

Fig. 1.—Usual rectifying circuit (smoothing omitted).

somewhat heavy demand unless a high-tension accumulator be used.

Unfortunately, the ordinary mains unit even when well constructed, has a poor regulation. The voltage falls off as the current increases, so that if the current is varying the voltage is also fluctuating the whole time.

## Effect of Varying Voltage

Let us examine first the exact effect of a varying supply voltage. Normally there is a steady voltage on the neon lamp and a steady current. Assume that the modulation decreases the voltage. The current accordingly falls. Because of this the voltage supplied by the mains unit rises so that the variation in the current is checked. In other words the change in current produced by the modulation is not as large as it should be.

An exactly similar argument can be used for an increase in the current and we find that the effect of the fluctuating supply voltage is to restrict the variation of current produced by the modulation so that in

order to load the lamp we require more modulation voltage.

The bad regulation of the mains unit does not cause distortion. The normal equation to the current for a neon or similar gas discharge lamp is  $i = k(v - V_0)$  where  $v$  is the instantaneous voltage, and  $V_0$  is the extinction voltage.

Now if the lamp is supplied from a mains unit the steady voltage is  $V - iR$ , where  $R$  is the total effective resistance of the unit. Added to this we have the modulation voltage  $V_1 \sin \omega t$ . Thus,

$$v = V - iR + V_1 \sin \omega t.$$

Substituting this in the above expression and re-writing we get

$$i = \frac{k}{1 + kR} (V - V_0 + V_1 \sin \omega t)$$

which is still proportional to the modulation.

Hence the principal result is simply the reduction in the sensitivity. This, however, is undesirable because, due to the low impedance of the customary neon or similar light source, it is difficult to obtain suffi-

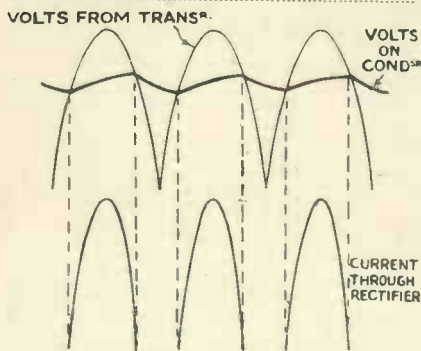

Fig. 2.—Curves showing operation of usual rectifier circuit.

cient modulation without using large power valves. A form of mains supply unit which does not suffer from the bad regulation of the ordinary type can be obtained by using a special form of smoothing circuit in conjunction with a low-impedance rectifier, preferably of the gas-filled type. Gas-filled rectifiers are similar to ordinary rectifying valves except for the fact that a small quantity of mercury vapour is introduced into the bulb. This gives a very low internal

resistance compared with the ordinary rectifying valve—a matter of a few ohms instead of several hundred ohms. Using such a valve in conjunction with a special circuit enables an almost constant output voltage to be obtained.

The special circuit required is particularly simple. It consists of the inclusion of a choke before the reservoir condenser of the ordinary smoothing filter. The action of this circuit was analysed recently by C. R.

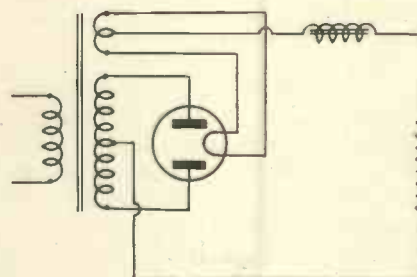

Fig. 3.—Circuit with induction instead of condenser.

Dunham\*. With the ordinary rectifier circuit the operation is as follows. The reservoir condenser is normally charged to some particular voltage and across this condenser is connected the load which is drawing current from the condenser the whole time. Consequently the voltage on the condenser is slowly falling. When the voltage on the secondary of the mains transformer exceeds the voltage on the condenser, the rectifier valve becomes conducting and a sudden pulse of current flows into the condenser, charging it up and raising the voltage by an appreciable amount. Thus the voltage on the condenser is fluctuating and it is this which constitutes the ripple which has to be smoothed out by the use of filter circuits subsequent to the reservoir condenser.

The chief point of note is that the pulse of current which flows into the condenser during the charging period must be such as to make up the loss due to the constant drain of the load on the condenser during the remain-

\* Some considerations in the design of hot-cathode mercury-vapour rectifier circuits. *Journal I.E.E.*, vol. 75, p. 278.

## CONSTANT VOLTAGE FROM MAINS UNITS

der of the time. It will be clear that this equilibrium is arrived at by an automatic adjustment of the voltage on the condenser. If the load is increased, the discharge of the condenser will be more rapid and it will fall to a lower voltage. This, however, means that the rectifier valve begins to conduct a little sooner, so that the pulse of current during the charging

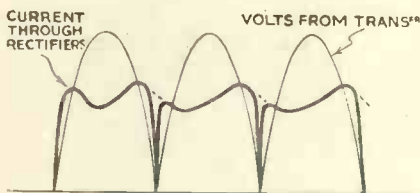

Fig. 4.—Graph showing rectifier current with Fig. 3 circuit.

period is proportionally greater and in practice the circuit automatically adjusts itself to a mean operating voltage such that the charge received in the form of a sudden pulse every time the rectifier valve becomes conducting is exactly equal to the discharge taken out by the load during the remainder of the time.

This operation involves implicitly the fact that the voltage must vary according to the load, and this is the main source of bad regulation in the ordinary rectifying circuit. However low the resistance of the smoothing circuit may be and however low the internal resistance of the rectifier, the varying voltage on the condenser is an essential feature of the operation and cannot be avoided.

If we arrange an inductance in series with the load instead of a condenser across it, as shown in Fig. 3, we get a different state of affairs. An inductance can store energy in the same way as a condenser and it is well known that the effect of inductance in a circuit is to slow up any sudden variations of current by absorbing energy from the circuit and then releasing it subsequently so that it tends to keep the current constant.

This is exactly what happens here. The rectifier valve is conducting current practically the whole time. As the voltage rises, more current can flow through the rectifier, but any marked increase is prevented by the inductance. Towards the end of the half cycle, when the voltage on the rectifier valve is falling, the current

tends to decrease but is actually maintained by the action of the inductance throughout nearly the whole cycle so that the valve supplies a more or less steady current to the load the whole time.

The action may be analysed as follows. When the rectifier first starts to conduct, the rush of current through the load develops a voltage on the inductance which opposes the voltage on the rectifier valve and therefore limits the current. As this surge dies away the current slowly increases. Ultimately the voltage on the transformer begins to fall and with it the current through the rectifier and load. This falling current, however, induces a voltage on the inductance which now assists the transformer voltage and maintains the rectifier valve in a conducting condition so that the falling off of the current is restrained. Actually the current is of the form as shown in Fig. 4. For a more complete analysis the reader should refer to the paper already mentioned.

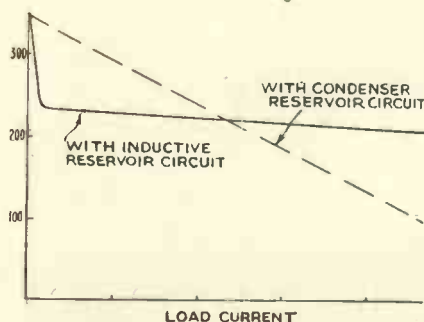

Fig. 5.—Typical regulation curves.

The advantage of this method of operation can clearly be seen. In the first place the current through the rectifier valve is much steadier and does not come in a series of pulses so that the valve itself is called upon to work under less severe conditions. There is, of course, still some fluctuation which has to be smoothed out, but it is no worse than in the case of an ordinary rectifying circuit, and in fact may be somewhat better. It is often thought that a mercury-filled rectifier valve is much more difficult to smooth than the ordinary hard rectifier. While this is so with the ordinary form of circuit it does not apply if the inductive type of circuit is adopted.

The great advantage, however, is that the current required by the load is supplied by the transformer the whole time and is not drawn from a reservoir condenser. Consequently if the transformer itself has a good regulation—the windings having a low resistance so that the transformer voltage does not vary appreciably with current—the voltage supplied to

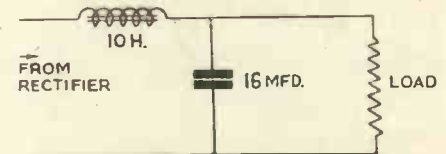

Fig. 6.—Typical values suitable for television and radio supplies.

the load is largely independent of the current. Fig. 5 shows a typical case and it will be seen that the voltage remains remarkably constant over the whole range of current.

The initial output voltage is a little less than is obtained with the conventional rectifying circuit. The effect of the reservoir condenser is to build up the voltage to a fairly high value and this action is, of course, not obtained with the inductive circuit. Under load, however, the voltage with the condenser circuit falls off rapidly whereas the voltage with the inductive circuit, after a rapid initial drop, remains practically steady. Fig. 5 shows the two types of load curve and indicates the difference quite clearly.

The ordinary smoothing choke is suitable for the purpose. It should not be of a gapped type because it is an advantage for the inductance to increase as the current falls off. The reason for this is explained in the article by Dunham, who also quotes the limiting values of the inductance to fulfil the optimum requirements. Generally speaking, however, the values quoted on the diagram of Fig. 6 will be satisfactory for the type of use indicated at the beginning of this article.

The circuit can be used with ordinary rectifier valves as I have proved by actual trial, but the full benefits are not obtained because of the relatively high internal resistance of the average vacuum rectifier valve. It does, however, give better regulation than the usual circuit, and is worth experimenting with.





*G2BL has been heard very well just lately. The complete transmitting and receiving apparatus can be seen from this photograph.*

**S**HORT-WAVE conditions show a decided improvement on all bands in practically every part of the country. Correspondence this month has been heavier than it has been at any time for over two years. Readers have obtained verifications of real DX on the 20-, 40- and 80-metre bands, while 500-mile range on the top band seems to be quite usual.

In view of the volume of correspondence I have picked out a number of letters which will more or less cover the whole country.

### A Yorkshire Report

First of all, S. Davison, B.R.S. 1,480, pulls me up about my comments on the slackness of Yorkshire listeners. Mr. Davison, writing from Scarborough, says that the best time for 20-metre reception is between 16.30 and 19.30. He finds conditions steadily improving while his star station is W2ZC, who has a directional aerial beamed on this country. Amongst phone stations heard were W6IH, W7BCU, W5GQ, W9BHT, our old friend Bill Ingersoll, W8ANN, VE2DX, VE3HC—this is the station that particularly requires reports from English listeners—VE2BG, CM2LL, CM2WZ and K4SA.

The 80-metre band has been very productive as early as 23.30 and stations heard include VE1E1, who has a Y.L. second operator, W4BCP, W2FLO, W3CQ and W1DIC. It looks as if the 3.5 megacycle band is worth a visit.

2ALX, M. B. Edwards, of Brentwood, Essex, uses an o-V-1 receiver with a screened-grid detector. With this set 175 phone stations have been logged, of which 80 per cent. have been on 14 megacycles.

From time to time I have mentioned that transmitters will not reply to reports unless these reports actually contain items of interest. In view of this let me quote a section of Mr. Edwards's letter. He says, "May I say that, providing the listener uses discretion and sends in useful information, verifications are usually received from 75 per cent. of the stations."

Amongst the more reliable stations heard in Brentwood are W2OA, W3GY, W3BJ, W4BSH, W4AQU, W4PJ, W4IX, etc., etc. W10XEA has also been logged. I am not so sure that this is correct. Should it not be W10XDA? Perhaps some reader can verify.

### Reports Wanted

Those who have heard G5HO will be interested to know that this station is owned by the Hoddesden and District Radio Society and operates on a wavelength of 168 metres (1,785 kc.) with a power of 10 watts. G5HO will shortly be operating on 40 metres. Regular transmissions are made on Sundays at 11.00, on Wednesdays at 20.00 and irregularly at 23.00. Reports will be appreciated and should be sent to G5HO, Station Road, Broxbourne, Herts.

### Carrier Hum on G5ZJ

Talking about reports, I am being troubled with a very bad carrier hum on my transmission, so I should very much like reports from readers who have noticed this. I understand that the hum is sufficiently bad to affect speech. Will any listeners hearing

transmissions from G5ZJ please drop me a line. The frequency is 1,801 kilocycles, approximately in the middle of the top band, and I am operating this station between 9.00 and 12.30 and 18.30-20.00 on Sundays, between 22.30 and 23.30 on week-days, and irregular transmissions from 07.30 to 08.30. All reports will be acknowledged.

Congratulations are due to J. V. Warner, of Oakham, Rutland, who, readers will probably remember, was 2BXC. Mr. Warner has now obtained his full ticket and is operating with the call-sign G2WR on 40 and 20 metres. He would very much like reports on his transmissions from any B.R.S. listeners; acknowledgements will be sent in every case. All reports should be sent via R.S.G.B.

The receiver in use at this station is a simple o-V-1, and in the log are included such stations as ZC6FF, F4AA, VQ4CRP, CM8YV, VE3LU, several W's and a host of Europeans.

It is quite a long way from Rutland to Exeter, but E. L. Wills, B.R.S. 1,448, also finds conditions very satisfactory. His average log of stations on the 7-megacycle band is about 30, but during the past few days he has heard various stations such as W1LZ, W3AQI, W2AND, W7EK, W7BPJ, W3CDX, VE1EA, LY1AG, YU7GG, FF8MQ, and YL2BQ.

### Iceland Calling

A call that I have not heard before is TF3M, of Iceland, so I should like to know if any other readers have logged this station. B.R.S. 1,448 also finds the 80-metre band good for W and VE reception.

2AIO, R. W. Rogers, of Southport,

uses an o-V-1 with a tuned H.F. stage. He has a criticism to make regarding these short-wave notes. He wants to know why I do not deal more fully with C.W. transmissions. The reason is that with a good receiver some 200 or 300 stations can be logged over a week-end, also from time to time readers have mentioned that C.W. is not of much interest. However, just recently there seems to have been a revival of interest in morse, so perhaps it might be advisable to devote a little more space to this side of amateur radio.

Mr. Rogers has heard some very good stations on C.W. including VQ8A, located in the Ascension Isles. This station was logged on 14 megacycles at 08.30. Other interesting stations heard using C.W. were VS8AB, ZU8AG, VS6AQ, VS6AM, TI2RC, VP5PZ, VP5AB, VU7FY, VU2BL, several ZE's, ZU's, ZS's and also K5AG.

Going a lot farther north, Oliver Derrick, of Stirling, has a shack all to himself for radio work, right away from the house. It is 50 feet long and 14 feet wide, and made of brick. A really fine radio shack. He has several receivers, including a two-valver and

a 5-7-metre receiver. During a period of one-and-a-half hours he logged over 30 stations between R7 and R9. Amongst the log were OE3FL, G5KG, G6YU, G5ML, G6KW, G6RL. He finds conditions in Stirling very poor indeed and absolutely no trace of 20-metre phone.

He wants to know when a two-valve receiver is to be described—a really hot one. I feel that the Contest Three fulfills that demand because the H.F. stage is such a help, but if readers want a two-valver then by all means let me know.

The Listening Post at Standon, Herts, operated by R. D. Everard, has again been doing some good work. By the way, here is a photograph showing some of his verifications.

Mr. Everard says that at Standon the 20-metre band has been fair to good. He goes on to say that the band remains active until 21.30, reaching peak strength at 20.00. He has sent me a log of 104 phone stations on the loud-speaker on 20 metres, which includes such real DX-ers as VP6YB, VP5PA, VE3HE, W4ZF, W1FHG, etc. He has just received verification from VP6YB on the 40-metre band, DE6DK, SM6VX, and W4LU, the latter station being on 75 metres. He tells me that VV6RV is now coming in on 46 metres a little below HJ1ABB, also, COH can be heard quite regularly on 31 metres between 22.30 and 23.00.

**The Beginner's Two-valver**

Norman Brandon, whose receiver appears in this issue, sends me a log of stations, actually heard on this set, which covers three pages of foolscap. It is obviously impossible to reproduce that colossal log, but amongst the stations heard were quite a lot of old friends, including the following G's: 6QB and 2DQ at R5, 2KT R6, 6KV R5, 6NF R4, 6NV R5, 5RD R9—this station is just around his corner—2XP and 5HO R5, 5CD R8, all on 160 metres. On 40 metres G6SR and G5ML both R9.

As early as 15.30 some 25 W stations were heard varying between R4 and R8, while during the course of the day all American districts were heard. In addition,

CT1BY, VE1DC, VE2BG, CT1BU, and VPD were also heard. His log of stations also includes 30 commercials, including Bombay, Columbia, Lisbon, Johannesburg, Kuala Lumpur, and all the usual American commercials. A very good log indeed.

B. McDougall, of Glasgow, says the conditions on 7 megacycles are very good. The most important G's heard up there were 5PB, 6ZS, 6QW, 6YU, 5CY, as well as several Dutch stations.

VE1DR, J. L. Mullin, has sent me some details of his station. He writes from Glace Bay, Nova Scotia. His phone transmitter consists of a type 47 crystal oscillator, type 47 doubler with a P.A. stage of two type 46's in push-pull with an input of 40 watts. For modulation he uses two 46's in push-pull class B, driven by a 59. Aerial is the doublet type cut for 20 metres, having a 75-ohm transmission line. So far he has worked all continents, 85 countries with C.W. and 28 countries on phone.

I had rather an interesting experience with W4ZF, it is operated by Dan Taylor, of Leaksville, North Carolina. He wrote me about his 20-metre rig and went on to ask whether or not I knew anything about a journalist who had met his niece while she was in this country last year. It does seem rather extraordinary that from all the journalists there are, the one referred to should have been my colleague in this office.

The W4ZF transmitter consists of a crystal oscillator with a frequency of 7,112 kilocycles doubled down to 20 metres. The P.A. consists of a pair of 203A carbon-anode valves in push-pull. These are driven by a pair of 210's in push-pull. The class C stage is modulated by a single 845.

**Listeners**

**Please Note**

Reports will be appreciated by W4ZF on transmissions sent out during April, from 8.30 a.m. until 12 C.S.T.

F. G. Sadler, B.R.S. 1,287, writing from Stamford Hill, sent me quite a good log of stations received on an o-V-1. This includes VK2ME at R5, and several U.S.S.R. amateurs which come in during the afternoon.

On 20 metres a multitude of OH, OK, U's, LA, SM, and HA's, and similarly on 40 metres. On 80 the best bag was VE1EI, W4BAC, and LA3K. With the exception of W4BAC all stations heard used C.W.

E. H. Fritschel, W2DC, of Scotia, New Jersey, wants reports on his 20-metre phone station. So far he has not worked any G stations, although F's and ON's seem to be getting over quite well. Transmission consists of 80-metre C.O., 80-metre buffer and then doubling down to 40 metres. The output valves consist of UV2L1's having an input of 500 watts.



Here is Bob Everard's listening post at Standon, Herts. With an eight-valve super plus short-wave converter he has logged stations from all parts of the world.

*Quick fault-tracing*  
**DEMANDS**  
**ACCURATE TESTING**



Even the smallest degree of distortion in television calls for immediate remedy. Slight faults which might pass unnoticed in radio become, in television, glaringly apparent imperfections. More than ever is an accurate testing meter of first importance—vital to perfect reception.

The world-famous D.C.

**AVOMINOR**

Regd. Trade Mark

is 10 accurate instruments in one. Circuits, valves, components, batteries and power units can all be tested quickly and easily. In handsome case, with leads, interchangeable crocodile clips, testing prods and instruction booklet.

The **UNIVERSAL AVOMINOR**

Gives 22 different ranges of readings. The best of A.C. and D.C. meters. 3-inch scale. Total resistance 200,000 ohms. Complete with leads, crocodile clips, testing prods and instruction booklet.

**THE AUTOMATIC COIL WINDER AND ELECTRICAL EQUIPMENT CO., LTD.,**

Winder House, Douglas Street, London, S.W.1.  
Telephone: Victoria 3404-7.

The **UNIVERSAL AVOMINOR**

**D.C. VOLTS**

- 0—75 millivolts
- 0—5 volts
- 0—25 "
- 0—100 "
- 0—250 "
- 0—500 "

**MILLIAMPS**

- 0—2.5 milliamps
- 0—5 "
- 0—25 "
- 0—100 "
- 0—500 "

**A.C. VOLTS**

- 0—5 volts
- 0—25 "
- 0—100 "
- 0—250 "
- 0—500 "

**RESISTANCE**

- 0—20,000 ohms
- 0—100,000 "
- 0—500,000 "
- 0—2 megohms
- 0—5 "
- 0—10 "



**£5**

Deferred Terms if desired.

● Send for fully descriptive folders, post free.

- CURRENT**  
0—6 milliamps  
0—30 "  
0—120 "
- VOLTAGE**  
0—6 volts  
0—120 "  
0—300 "
- RESISTANCE**  
0—10,000 ohms  
0—60,000 "  
0—1,200,000 "  
0—3 megohms

The D.C. AVOMINOR

**40/-**

Deferred Terms if desired.

**TELEVISION and SHORT WAVE COMPONENTS**



In the coming era of ultra short wave reception, components of the highest quality will be necessary. The trade mark Eddystone is your guide to purchase the best. Eddystone's specialised design for high frequency components is well known and Eddystone parts bought for short wave receiver construction to-day will be suitable for the ultra short wave working of to-morrow.

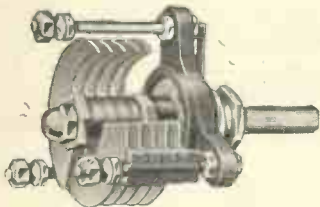

**EDDYSTONE MICRODENSER**

No. 900. DL9 Insulation.  
15 m.mfd. 3/9  
40 m.mfd. 4/3  
100 m.mfd. 5/-

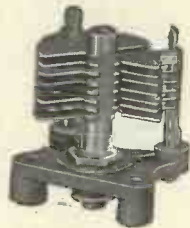

**EDDYSTONE AIR DIELECTRIC TRIMMER.**

DL9 Insulation.  
Cap. 3.65 m.mfd. No. 978. 3/6

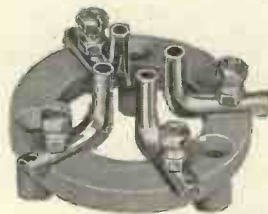

**EDDYSTONE LOW LOSS VALVEHOLDER.**

Insulation. Frequentite  
No. 949. 4-pin. 1/5  
No. 950. 5-pin. 1/8



**EDDYSTONE LOW LOSS VALVEHOLDER.**

DL9 Insulation.  
No. 985 7-pin Tags. 1/4  
No. 986. 7-pin Terminals. 1/8

**STRATTON & CO. LTD.**  
Bromsgrove Street, BIRMINGHAM.

London Service Depot:  
**WEBB'S RADIO STORES,**  
14, Soho Street, Oxford Street, W.1.

**EDDYSTONE**  
**HIGH GRADE COMPONENTS**

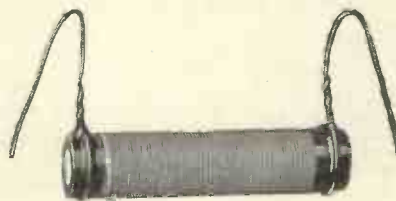

**EDDYSTONE ULTRA S.W. CHOKE.** 3-10 metres. Wound on Frequentite Tube.  
No. 947. 1/8.

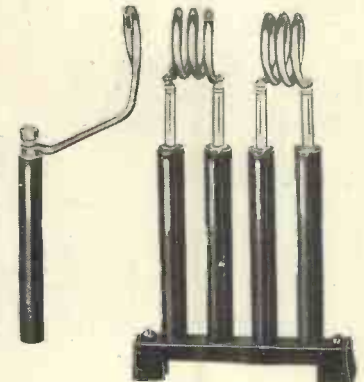

**EDDYSTONE ULTRA S.W. COILS.**  
No. 976. 5-metre coil swth stand - - 5/-  
No. 977. Set of 10-metre coils - - 2/3

There is news in the "Television and Short-wave World" advertisements.

zAZD is rather disappointed in the lack of interest in the Watford area. He tells me that the meetings organised in that area last winter received very

interest in Hertfordshire and the fact that there are several new stations working surely the time has come to revive these regular meetings. Anybody interested

Mr. Forbes, B.R.H. 1,703, of East Grinstead, Sussex, almost completes the area logs from this country. Mr. Forbes tells me that this sta-

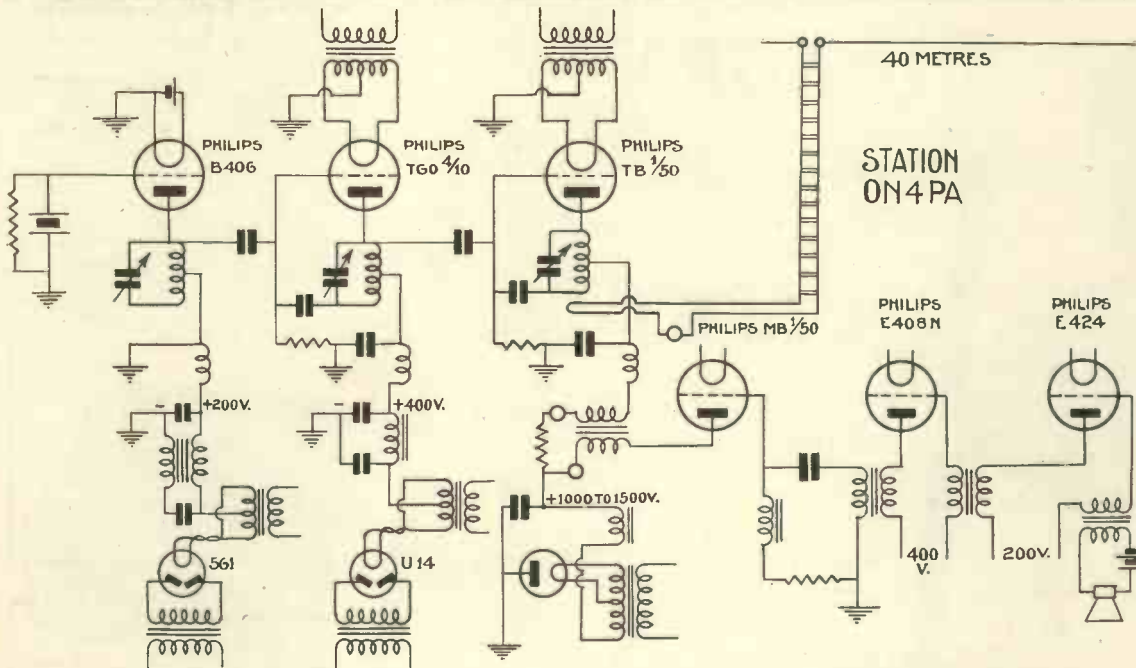

ON4PA has been breaking some more records. The American stations comment on the exceptional power of this Belgian amateur so we have reproduced his circuit for you.

little support. The only active stations appear to have been 5RD and 2TH. In view of the increase of in-

terest in Hertfordshire and the fact that there are several new stations working surely the time has come to revive these regular meetings. Anybody interested

tion puts out a very fine phone signal which would put many G stations in the shade.

## The SAFETY you want

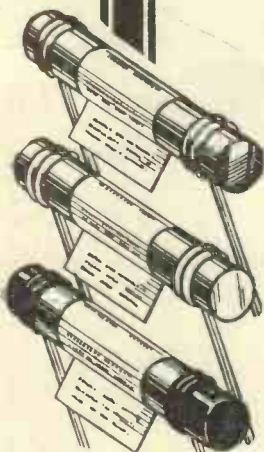

No climatic conditions or changes in temperature affect Erie Resistors. They are made of a combination of carbon and rare earth, and are specially impregnated to withstand heat and damp. Erie engineers have marched ahead in perfecting the dependable resistance. That's why the leading radio manufacturers all use Eries.

1/- PER WATT in all values. Each resistor colour coded, labelled and Guaranteed.

## ERIE RESISTORS

★ Genuine Erie Resistors are hall-marked with the Erie label. Look for this guarantee of 100% safety.

Write for the invaluable "Erie Service Instruction Booklet," post free.

ERIE VOLUME CONTROL. 3/6

Erie have produced a Volume Control that does not develop faults. The bone-hard Erie element and nickel silver contact ensure smooth and noiseless efficiency. Widely specified by designers.

or with built-in mains switch, 5/-.

THE RADIO RESISTOR CO., LTD.  
1 Golden Square, Piccadilly Circus, London, W.1.

## SPECIALISTS in HIGH VOLTAGE MAINS TRANSFORMERS for CATHODE RAY TUBES

- MAINS TRANSFORMERS
- SMOOTHING CHOKES
- AUDIO FREQUENCY CHOKES
- INTERVALVE AND LINE TRANSFORMERS
- OUTPUT TRANSFORMERS
- HIGH QUALITY AMPLIFIERS

Every component is backed by Savage's outstanding reputation for reliability

W. BRYAN SAVAGE LTD.  
56/58, CLERKENWELL ROAD, E.C.1.

CLERKENWELL 3068

**PETO-SCOTT 75/-  
DISC TELEVISION KIT**



ASSEMBLED in 30 Minutes  
Peto-Scott, Pioneers in  
Television, have, after  
considerable research,  
produced this "up-to-the-minute"  
Disc Television Receiver Kit, of  
which Efficiency and Economy  
are the Key-  
notes.

**NO SPECIAL  
TOOLS  
REQUIRED.**

**10/-  
DOWN**

Designed to work from almost any 3-valve battery or mains set. Comprises Peto-Scott Universal Television Motor and Stand; controlling resistances; laminated and ready assembled chassis; strobe and 11 monthly bosopic 16-in. scanning disc; payments of 6/6. lens and lensholder; neon lamp and holder, together with sundry small parts. Full-size Blue Print with full instructions included with every Kit. Cash or C.O.D. Carriage Paid. 75/-.

**B.T.S. 1935 SHORT WAVE  
ADAPTOR**

Make your Set an All-Wave Set... receive America direct. No alterations whatsoever. . . simply plugs into your present Battery or A.C. Mains Set. With 2 plug-in coils, 13-52 metres. Send only 7/6; balance in 10 monthly payments of 5/-. Cash or C.O.D. Carriage Paid, Extra Coils, 46-96 and 90-190 meters, 4/6.



**7/6  
DOWN**

Send for descriptive leaflet.

**PILOT AUTHOR KIT  
EXACT TO SPECIFICATION**

Build with a Pilot Author Kit and make a 100% success certain. Since 1919 the most popular Kits with Home Constructors the whole world over because they are exact to the designer's specification and are complete down to the last screw and piece of wire.

**BEGINNERS' SHORT WAVE 2 ● SHORT WAVE ADAPTOR**

Described in this month's issue

**KIT "A" CASH or C.O.D. £2 : 13 : 6**  
Carriage Paid.  
Author's Kit of first specified parts, including ready-drilled Aluminium Baseplate and Panel, with Bulgian Short Wave Coils, less Valves.  
**OR 6/6 DOWN**  
and 8 monthly payments of 6/6

**KIT "A" CASH or C.O.D. £2 : 1 : 0**  
Carriage Paid.  
Author's Kit of first specified parts, including ready-drilled Aluminium Chassis, Screen and Ebonite Panel, less Valve.  
**OR 5/- DOWN**  
and 8 monthly payments of 5/-

**KIT-BITS**

You pay the Postman. We pay post charges on all orders over 10/- GREAT BRITAIN ONLY.

	s. d.
1 Peto-Scott Ready Drilled Aluminium base-plate	2 6
1 Peto-Scott Ready Drilled Aluminium Panel	2 0
1 Set of 3 Bulgian Short Wave Coils	10 6
1 J.B. type 2043 Short Wave Condenser, .00015 mfd.	5 9
1 J.B. air spaced differential condenser, .0001 mfd.	4 3
1 set of 2 specified valves	12 6

**KIT-BITS**

You pay the Postman. We pay post charges on all orders over 10/- GREAT BRITAIN ONLY.

	s. d.
1 Peto-Scott Ready Drilled Aluminium Chassis	2 6
1 Peto-Scott Ready Drilled Aluminium Screen	1 6
1 Peto-Scott Ready Drilled Ebonite Panel	2 0
1 J.B. type 1054 reaction condenser, .0001	4 6
1 Stratton type 942, variable condenser	7 6
1 Lissen 3 range S.W. coil, type LN. 5137	4 6
1 Stratton type 948 H.F. Choke	2 9
1 Wearite rotary switch, type 1-22	3 6
1 Cosor SG220 (Met) valve	12 6

**FREE BLUEPRINT OFFER**

PETO-SCOTT CO., LTD., 77 (Dept. T.3), City Road, London, E.C.1. Telephone: Clerkenwell 9406-7. West End Showrooms: 62 (Dept. T.3), High Holborn, London, W.C.1. Telephone: Holborn 3248. Please send me descriptive literature of the Peto-Scott NEW DISCOVERER H.F.P.3, together with FREE BLUEPRINT, for which I enclose 1½d. In stamps to cover postage.

NAME .....

ADDRESS .....

T.3

**WEARITE  
COMPONENTS**

SPECIFIED for the  
**S.W. Converter**

The Wearite 1.22 Rotary  
Switch (D.P.D.T.)

A neat positive-action switch of finest materials. Low capacity. **3/6**

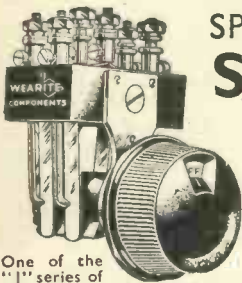

One of the "1" series of D.T. switches, with indicator window.

GENUINE PAXOLINE TUBES  
2 1/2" x 1" } **9d.** per pr.  
5" x 3/8" }  
LOOK FOR THE TRADE MARK  
M.I.C.

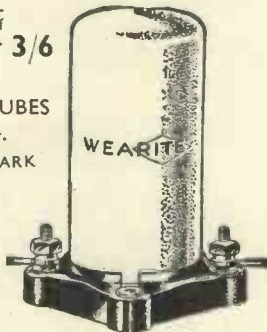

For the  
**18 WATT AMPLIFIER**

The Wearite H.F. CHOKE (H.F.P.)

Self Ca p. 4.5 m.mfd.  
Inductance 255,000 m.h. **3/6**  
D.C. Resistance, 300 ohms

FILL IN AND POST THIS COUPON TO-DAY

Please send copy of your Booklet A834 with technical data on Coils, Chokes, Transformers and Theoretical Circuit Diagrams. Please also send leaflet on NEW WAVE TRAP COILS.

To Messrs. Wright and Weare, Ltd.,  
740, High Road, Tottenham, N.17.

Name .....

Address .....

T.4/35.

6572



**A NEW  
SHORT WAVE  
TRANSMITTER**

for amateur use

Owing to the heat dissipating properties of the graphite anode, a low operating temperature is maintained up to very high frequencies. Inter-electrode capacities are reduced to an absolute minimum by bringing the anode and grid leads through the top of the bulb. The valve can in this way be used on wavelengths down to a few metres.

Filament Voltage - - - - - 6  
Maximum Anode Voltage 1,500  
Filament Current - - - 4 amps  
Impedance - - - 10,000 ohms

PRICE - £4.10.0

**EDISWAN**



THE EDISON SWAN ELECTRIC CO. LTD.  
155 CHARING CROSS ROAD, LONDON. W.C.2.

RF 241.

"Ray Focusing in C.R. Tubes."  
(Continued from page 223.)

cases only one application is required. Should it be necessary to have several layers, best results are

obtained if each film is permitted to dry thoroughly before successive applications are made.

Drying should be effected by passing filtered warm air into the tube. To prevent spattering of the screen surface the rubber tubing E is disconnected. A suction line is attached to the lower end of the tube C drawing in the clean, warm air through tube B. If there is a tendency for moisture to condense on the screen surface, the latter should be kept warm by application of slight external heat.

When it is desired to apply more than a single coating of graphite, the insertion of a third piece of tubing through D will facilitate matters. The new tube should be of approximately the same length as C and may be used in its stead during the drying operation. With the aid of this extra refinement it becomes unnecessary to dismantle the apparatus each time drying is carried on. The third tube, of course, must be sealed during the period in which the solution is being flowed into the envelope.

**Drying and Baking**

After the graphite film has been dried the envelope is baked for several hours at a temperature ranging between 400° C. and 500° C. This baking serves to drive out any occluded moisture in the layer and completely destroys an organic protective colloid contained in Aquadag. To prevent condensation and hasten the removal of water vapour and any of the decomposition products of the protective colloid, a suction line should be attached to the envelope for the duration of the baking period. Tubes prepared with colloidal-graphitized water should not receive their initial baking during assembly and

Colloidal graphite adheres equally well to all types of glass used in cathode-ray tube manufacture, providing the envelope has previously been cleansed thoroughly with such an oxidising agent as chromic acid. Being of a colloidal nature, Aquadag solutions must be kept free of electrolytes. It is important, therefore, that glass envelopes which have been treated with chromic acid or similar cleaning solutions, be rinsed not less than six times with distilled water and air-dried before being subjected to the coating operation. It is interesting to note that the process is being used by the Ediswan Co. in coating their new high-vacuum tubes.

**The B.T.S. Short-wave Unit**

WITH the new short-wave unit produced by B.T.S. the ordinary listener will be able to hear amateur phone as well as the ordinary commercial broadcasting.

With standard coils the unit will tune between 13 and 52 metres so covering the 13, 16, 19, 20, 25, 31, 40 and 50 metre bands. Two additional coils to cover the 50 to 260 metre bands are also available.

This is one of the most flexible units we have so far tried, for, in addition to being a standard short-wave adapter, to be plugged into the detector stage of straight receivers, it can also be used as a super-het unit in front of receivers having one or more high-frequency stages. When used as a convertor, however, a new valve of the PM2DX type, when used with a battery set, or an AC/HL when used with a mains receiver, will be required.

Finally, if it is used in front of a super-het receiver triple detection is obtained, so giving an extremely high degree of efficiency. Tuning is by means of a single condenser driven by a slow-motion dial geared 180 to 1. This enables the unit to be tuned very accurately without trouble.

Amongst other features that should be noted are: No alterations need be made to the existing receiver; a slow-motion reaction condenser for fine tuning; air dielectric .00016 tuning condenser with the minimum of loss, and full screening to prevent hand capacity. The effect of all the refinements is to make the receiver as simple to handle as the ordinary broadcast set.

If a little care is taken to listen on the correct wavebands or to make mental notes of the local conditions, short-wave stations can be heard from all over the world. The manufacturers are British Television Supplies, Ltd., Bush House, W.C.2, and the price is 52s. 6d.



HEAR America, hear Short Wave stations in every corner of the World. Plug the B.T.S. Short Wave Adaptor into your present Battery or A.C. Mains Set and instantly convert it to an efficient all-wave receiver with no alterations to your set whatsoever. No other adaptor at the price incorporates all the B.T.S. features. Send coupon below to-day for descriptive leaflet.

**52/6** With 2 Plug-in Coils, 13-26 and 24-52 metres. Extra coils, 46-96 and 90-190 metres, 4/6 each. From All Dealers. If any difficulty, send direc.

FREE 3 SHORT WAVE BLUEPRINTS  
Post the Coupon below to-day.



**COUPON** Short Wave and Television Specialists.

BRITISH TELEVISION SUPPLIES, LTD., Bush House, Dept. T.I London, W.C.2.

Please send me descriptive literature of the B.T.S. 1935 Short Wave Adaptor and the famous B.T.S. Short Wave Sets: A.C./D.C. 4-Valve; Battery 4-Valve; A.C./D.C. Converter, together with FREE BLUEPRINTS for same. I enclose 3d. in stamps to cover postage.

NAME .....

ADDRESS .....

**1935 EDITION... FREE!**

A New and greatly enlarged edition of "ENGINEERING OPPORTUNITIES" is just off the Press. It describes the easy way in which you may become an A.M.I.C.E., A.M.I.Mech.E., A.M.I.E.E., A.M.I.A.E., A.M.I.W.T., etc.

Under our "NO PASS—NO FEE" Guarantee and contains the world's widest selection of courses in all branches of Civil, Mech., Elec., Motor, Aero., and Radio Engineering, Television, Building, etc.

If you are earning less than £10 a week, you cannot afford to miss this unique guide to a first-class job. DON'T DELAY—send for FREE copy of the Handbook to-day. No cost or obligation of any kind.

THE BRITISH INSTITUTE OF ENGINEERING TECHNOLOGY, 337, Shakespeare House, 29/31, Oxford Street LONDON.

Sth. African Enquiries: P.O. Box 470x, Jo'burg.  
Australasian Enquiries: P.O. Box 3597S, Sydney.  
Canadian Enquiries: 219, Bay Street, Toronto.



# SPECIFIED



The Differential Reaction condenser illustrated above makes short circuit at normal voltage impossible.

Very rigid construction with wide air space between the vanes. Centre spindle insulated.

Cat. No. 2001.  
.0001.

4/3

Yet again Jackson Bros.' Condensers have been specified by the designers of prominent circuits. This time the Differential Reaction Condenser and the Short Wave "Special"—both illustrated below—are specified for the "Beginners Short-Wave Two"; and a Midget Condenser (Cat. No. 1054, .0001, Price 4/6) and Baseboard Trimmer (Cat. No. 1087, 0.00005, Price 1/-) for the Short-Wave Receiver Unit. A great tribute to the efficiency and advanced design of all Jackson Bros.' Condensers.

This condenser is designed in every way for short wave work. Absolute and permanent silence in operation is ensured. The minimum capacity is very small, and the maximum is true to rating. Easy tuning ensured by specially shaped hard brass vanes.

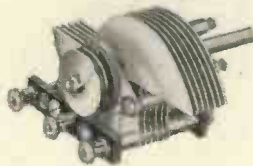

Cat. No. 2043.  
.00015

5/9



Write for our **FREE**  
**Illustrated Catalogue**

JACKSON BROS. (LONDON) LTD. 72, St. Thomas Street, London, S.E.1.  
Tel. HOP 1837.



**VALVES  
FOR  
EVERY RADIO  
PURPOSE**

Illustrated is  
VALVE LP4  
PRICE  
**16/6**



Write for  
booklet to  
**FERRANTI LTD.**  
**HOLLINWOOD**  
**LANCS.**

## The R.S.G.B.

AND THE RADIO AMATEUR.

For close on 22 years the Radio Society of Great Britain has sponsored interest in amateur and experimental radio.

**THE SOCIETY** publishes monthly its own Journal, the "T. & R. Bulletin." Up-to-the-minute information on all amateur developments and sound constructional articles are two of its main features.

**THE SOCIETY** operates a Research and Experimental section. Notes and results of original work undertaken by its members appear in the "T. & R. Bulletin" each month.

**THE SOCIETY** organises a free QSL service for its members.

**Privileges of Membership :**

Calibration Service	Local Meetings
Slow Morse Practices	Annual Conventions
Organised Tests	Tech. Information Bureau

**MEMBERSHIP** Details will be sent on receipt of a stamped addressed envelope.

"A Guide to Amateur Radio," now in its Second Edition, contains 80 pages of general and technical information. A full description is given of short-wave Transmitters, Receivers and Frequency-meters. Other chapters deal with Aerial Systems, Valves, Power Supplies, etc. etc.

A copy will be sent on receipt of 8d.

All communications to :—

**THE SECRETARY** (Dept. J S.W.3.)  
**Radio Society of Great Britain,**  
53, Victoria Street, London, S.W.1



## FOR YOUR TELEVISION SET

Use Varley Components for your television set. Remember that thirty-six years experience in specialised electrical engineering goes into the production of every Varley product.

Write for free catalogue.



E.P. 20 Mains Transformer 27/6

- Mains Transformers.
- Heavy Duty Smoothing and Output Chokes.
- High Inductive Chokes.
- Resistances. All Types.
- Power Potentiometers.
- Volume Controls.
- Nicore Flat-Gang Units.
- Duo-Nicore Coils.
- Junior H.F. Chokes.
- Nicore H.F. Chokes.

**Varley**  
PROPRIETORS:- OLIVER PELL CONTROL LTD

Oliver Pell Control Ltd., Bloomfield Road, Woolwich, S.E.18.

Tel.: Woolwich 2345

Better service results from mentioning "Television and Short-wave World" when writing to advertisers.

**Commercial Receivers for the Short-waves: No. 3.**



*The Eddystone receiver has been designed for tropical use; it is particularly selective on the broadcast bands.*

**The  
Eddystone  
All-world  
Four**

**F**IVE members of the Stratton Co.'s staff are owners of private transmitting stations. These five members incidentally have very definite ideas on receiving sets so that one really need not be surprised at the exceptional efficiency of Stratton's latest receiver, the Eddystone all-world Four.

This receiver is one of the most useful we have tried and will be equally effective when used by owners of transmitting stations, ordinary short-wave listeners, or colonial listeners who wish

to hear Empire and other long-distance stations.

**Impervious to Climatic Conditions**

It is supplied in an all-steel case, impervious to any changes in climatic conditions and all the components can be used in any part of the world.

The first impression one obtains is that the receiver is very simple to handle, in fact quite as simple as a standard broadcast set. Tuning coils have been so accurately constructed that the calibration is sufficiently accurate for short-wave stations to be identified merely by cross reference between the dial readings and the curve supplied.

These coils, incidentally, are constructed on the new Eddystone DL9 insulating material, the effect of which is to reduce all losses to an absolute minimum. As this special material is used throughout the receiver, it probably accounts for the high degree of selectivity on the broadcast band. We do not say that selectivity is in the order of 9 kilocycles, but it is sufficiently good for the set to be used as a normal broadcast receiver.

**The Valves**

Four valves are used in a more or

less conventional way. First of all comes a variable-mu high-frequency pentode which is transformer-coupled to a triode detector. This valve, by the way, is carefully picked so as to make quite sure that it is absolutely free from microphony. Next comes an R.C.-coupled stage feeding into another triode valve, with finally a transformer-coupled pentode.

All grid bias is obtained automatically and, so as to overcome the slight voltage loss, the high-tension battery must be at least 135 volts.

Four pairs of coils are supplied with the standard receiver and these are supposed to tune between 14 and 510 metres with a break between 95 and 260 metres, but in practice the minimum wavelength is 13 metres with a maximum of 560 metres. For those who wish to listen to the top band, coils can be obtained to tune between 85 and 175 metres.

**Tuning**

Ganged tuning, with a small variable balancing condenser, makes for both simple and accurate tuning. The reaction condenser, with a slow-motion drive, enables one to obtain perfectly smooth oscillation. Owing to the receiver design and the use of a steel cabinet, there is absolutely no hand-capacity even without an earth connection.

At the correct periods of the day, stations can be heard from all parts of the world. We were able to log stations from Australia, New Zealand, India, Africa and Argentine.

W8XX on its 13-metre channel was heard regularly around 14.00 every day. With this set one is able to hear stations from all over the world at almost any time of the day and, at the price, we feel that it is exceptional value for money. It can be confidently recommended for all who require a really reliable short-wave receiver.

The battery version is priced at £22 10s. od., while there is also a five-valve A.C. version costing £30. The makers of the Eddystone All-world Four are Stratton & Co., Ltd., Birmingham, 5.

**AUSTRALIA RECEIVED DIRECT ON THE UNIT RADIO CHASSIS BUILT SHORT WAVE CONVERTER-ADAPTOR**

This remarkable feat has been accomplished by satisfied users of the UNIT RADIO S.W. converter in conjunction with their own receiver. WHY NOT make your receiver all-wave and enjoy the thrills of S.W. listening? The UNIT RADIO S.W. converter is suitable for any type of receiver,

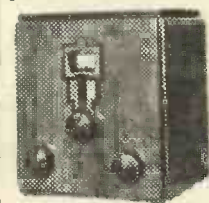

mains or battery operated, without the use of extra batteries.

**SIMPLY PLUG IN. NO ALTERATIONS**

CASH C.O.D. OR H.P. **39/6**

Send for illustrated Leaflets.

**UNIT RADIO 12 PULTENEY ST. LONDON, N.1**

TERMINUS 5382.

**AUTHORITATIVE TRAINING**

Write to-day for "The Engineer's Guide to Success"—156 pages—Free—containing the widest choice of Engineering Courses in the world, covering all branches, including **Television, Radio, Electrical, Mechanical Engineering,** etc.,—and showing how to become **A.M.I.Mech.E., A.M.I.E.E., A.Rad. A., A.M.I.W.T., B.Sc.(Eng.),** etc. The T.I.G.B. guarantees training until successful. Mention branch, post or qualification that interests you.



The Technological Institute of Great Britain, 160, Temple Bar House, London, E.C.4.

(Founded 1917. 19,000 Successes.)

**Read**

**"Television and Short-wave World" Regularly**



## THE TELEVISION SOCIETY

President: Sir AMBROSE FLEMING, M.A., D.Sc., F.R.S.

Founded in 1927 for the furtherance of Study and Research in Television and allied Photo-electric Problems.

Ordinary Fellows are elected on a Certificate of Recommendation signed by Two Ordinary Fellows, the Proposer certifying his personal knowledge of the Candidate. The Admission Fee for Fellows is half-a-guinea, payable at the time of election, the Annual Subscription is £1 payable on election, and subsequently in advance on January 1st in each year, but the Annual Subscription may be compounded at any time by the payment of Ten Guineas.

Any person over 21, interested in Television, may be eligible for the Associate Membership without technical qualifications, but must give some evidence of interest in the subject as shall satisfy the Committee. For Associate Members the Entrance Fee is 5/-, payable at the time of election, with Annual Subscription 15/-, payable in advance on January 1st in each year.

Student Members.—The Council has arranged for the entrance of persons under the age of 21 as Student Members, with Entrance Fee 2/6 and Annual Subscription 10/-, payable as above.

The Ordinary Meetings are held in London on the second Wednesday of the month (October to May inclusive) at 7 p.m. The business of the meetings includes the reading and discussion of papers. A Summer Meeting is usually held, and affords Members the opportunity of inspecting laboratories, works, etc. A Research Committee and the preparation of An Index of Current Literature are active branches of the Society's work.

### The Journal of the Television Society

is published three times a year. All members are entitled to a copy; and it is also sold to Non-Members, at an annual subscription of 15/- post free.

Forms of proposal for Membership, and further information regarding the Society, may be obtained on application to the Business Secretary, J. J. Denton, 25, Lisburne Road, Hampstead, London, N.W.3.

## TELEVISION LAMP



5 to 7 METRE  
VACUUM  
H.F. CHOKE



25/-

Regd.  
792977

### LAMP

1. The ONLY lamp for successful screen projection through discs.
2. Fluorescent glass, utilising 15% to 20% ultra-violet light which was previously lost.
3. Highest frequency-response of any gas-discharge lamp.
4. Enlarged gas-chambers and metal ends ensuring long electrical and mechanical life.



4/6

Prov. Pat.  
No. 4406/35

### CHOKE

Impervious to draughts or sudden temperature changes.  
Impervious to changes in humidity.  
Impervious to damp.  
No shellac or other damp proofing dopes.  
No climate proofing losses.  
No air dielectric losses.  
Cannot change its value. Cannot "wander." Remains stable.

## TELEVISION INSTRUMENTS LIMITED

323 1/2 CITY ROAD, E.C.1

Telephones: Clerkenwell 0686

## DO YOU WANT QUALITY RECEPTION?

If so, ask to hear on approval one of the latest models of Hyvoltstar UNIVERSAL ALL-WAVE RECEIVERS. We give you or your dealer a chance to prove our claim that these Sets are the finest on the market. Fitted with the famous Ostar-Ganz Universal High Voltage Valves, they require no transformers, breakdown resistances or barretters, as used by all other makers. Full range of

Supers, Straights, Band-Pass, Miniature Models, Transportable Radiograms, Quality Amplifiers for Television purposes and Short-Wave Adaptors.

These receivers are eminently suited for the present Baird 30-line Television System. High Definition (240-line) models are in preparation. Write for Literature "T" and particulars of our approval scheme.

UNIVERSAL  
HIGH VOLTAGE  
RADIO LTD.

28-29, Southampton  
Street, Strand, W.C.2

Telephone:  
TEMple Bar 4985.



## 50 ohms to 100,000

WIRE-WOUND  
RESISTORS



"ENTIRELY  
DEPENDABLE"

"Popular Wireless" said:  
We tested the resistances of the full range of samples sent—the whole thirty different values—and found them to be accurately rated.

As for their reliability, in our opinion constructors will find the Amplion resistors entirely dependable.

Specified for the  
"CONTEST THREE"

described in March issue.

Price 1/- each; all values.  
1-WATT WIRE-WOUND RESISTORS  
Obtainable from all Dealers

# AMPLION

AMPLION (1932) LTD.

87-84 Rosoman Street, Rosebery Avenue, London, E.C.1

## RIGIDITY OF CONSTRUCTION

The consistency of the stated characteristics of Hivac valves is safeguarded at every possible point of construction.

Molybdenum wire is employed in the construction of Hivac grids because it possesses the exceptional quality of retaining its shape during changes of temperature—thus consistent performance is maintained and an exceptionally long working life guaranteed.

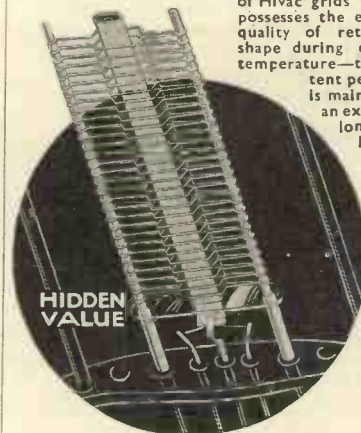

HIDDEN  
VALUE

HIVAC  
British  
Made  
Valves  
from  
3/9

For the S/W  
Receiver Unit.

HIVAC  
D210 ... 3/9  
P220 ... 5/6

# HIVAC

THE SCIENTIFIC  
VALVE

BRITISH MADE

HIGH VACUUM VALVE CO., LTD.  
113-117 Farringdon Road, London, E.C.1

# The Television Society

President: Sir Ambrose Fleming, M.A., D.Sc., F.R.S.

Hon. Secretaries: J. J. Denton, 25, Lisburne Road, Hampstead, London, N.W.5.  
W. G. W. Mitchell, B.Sc., "Lynton," Newbury, Berks.

*At the meeting of The Television Society held at the University College, Gower Street, on Wednesday, March 12th, Messrs. Parr and Price of the Edison Swan Electric Co., read a paper on "Improvements in Cathode-ray Tube, with particular reference to Television."*

THE chair was taken by A. Bennett, Esq., Chief Engineer of the North Met. Power Co., a keen television enthusiast, and the attendance, including a large number of visitors, was over 100.

At the commencement of the lecture Mr. Parr referred to the original Kerr cell, a description of which appeared in this journal (February issue) and showed lantern slides made from the photographs taken at the Glasgow University. These were presented to the Society for the use of members, and accepted by Mr. J. J. Denton, the joint hon. secretary.

Dealing with the subject of the lecture, Mr. Parr outlined the improvements which had been made in the cathode-ray tube and showed how the introduction of the high-vacuum tube had overcome the disadvantages of the gas-focused type, namely "origin distortion" and loss of focus at high traversing speeds. It was shown that in the high-vacuum tube the focusing was a function of the ratio between the first and second accelerator potentials and was independent of the negative cylinder potential. This implied that the modulation of the intensity of the beam by a signal on the negative cylinder did not produce loss of focus on strong signals as was the case in the gas-focused tube. Mr. Parr stated that these advantages of the high-vacuum tube were such that the gas-focused tube was rapidly becoming obsolete for television purposes.

The scanning arrangements for producing the line screen on the tube were explained by a lantern slide, and the lecturer pointed out that these did not differ appreciably from the original circuit described in the lecture of last year. It was their opinion that the resistance-capacity linear time-base was still the most satisfactory and economical form of scanning circuit, although it would probably be necessary to increase the value of H.T. potential applied in order to accommodate the longer travel of beam required by the larger tubes.

An important point which was of interest to the audience was that the time-base used for 30-line low-definition scanning could be adapted for 180-line

scan by an alteration in value of the charging condensers. Since the high-definition system used horizontal scanning it would also be necessary to turn the tube through a right angle in the clockwise direction, but the direction of the high-definition scan was such that no alteration to the deflector plate connections was required.

At the conclusion of the lecture, Mr. T. W. Price demonstrated the Edison Swan Co.'s new high-vacuum cathode-ray tubes on both 30-line pictures and on 180-line scanning. Two experimental tubes aroused great interest; the one showed the methods of focusing the beam by adjustment of the accelerator potential and the projection of the actual image of the emitting surface on the fluorescent screen, and the other, by an ingenious device, the movement of the beam in the tube between the deflector plates.

To show this a long tube had the standard electrode system sealed in one end, while at the other a thin stream of fluorescent material was allowed to descend in the path of the beam from a form of hour glass mounted at the top of the tube. As the particles descended, the path of the beam and the effect of the deflecting potentials were clearly visible to the audience.

## Discussion

In opening the discussion, Mr. T. M. C. Lance, of the Baird Co., expressed doubt that the time-base circuit was as truly linear as the lecturer claimed, and said that his experience was that the image tended to be cramped at one end. In reply, it was pointed out that the form of time-base described was undoubtedly the most economical for experimental work and that the linearity could be improved by an increase in H.T. potential applied. Mr. Price gave the figure of 5 to 1 as

the working ratio between the condenser potential and that applied to the time-base, but said that for the larger tubes the H.T. could be with advantage increased to 3,000.

Mr. T. H. Bridgewater, of the B.B.C., suggested that some form of "performance factor" for tubes would have to be devised, and proposed that the intensity-modulation characteristic be taken in a similar manner to the mutual conductance of a triode. The lecturers agreed that some similar factor was very desirable, but reminded the audience of the difficulty of taking exact measurements when a colour effect had also to be considered. With regard to Mr. Bridgewater's further questions regarding the life of tubes it was stated that there was no reason why the life of the high-vacuum tube should not be comparable with that of a thermionic valve, and that at least 600 hours working life could be expected under normal conditions.

In closing the meeting, Mr. Bennett reminded the members that the working voltages employed in cathode-ray tube circuits were definitely dangerous to life, and that while Messrs. Parr and Price appeared to handle the tubes with impunity, experience had shown them the safest parts! He stressed the importance of adequate shielding of live parts and reminded the members of the I.E.E. safety rules for radio receivers. After a hearty vote of thanks to the lecturers and their assistants, Messrs. Kent and Atkinson, for their trouble in arranging a most interesting demonstration, the meeting concluded, the chairman saying that Mr. Parr would attend at the next meeting to continue the discussion further if required.

## Slow Morse Test for April

For the benefit of our readers taking up morse code we are re-printing from the R.S.G.B. Bulletin the following details relating to slow morse tests during April.

Reports on the transmissions are required by the stations concerned so a check on their value can be obtained.

### SCHEDULE OF SLOW MORSE TRANSMISSIONS.

Date, 1935.	G.M.T.	Kcs.	Station.
April 7	00.00	1761.5	G2WO
" 7	09.30	1785	G5BK
" 7	10.00	1815	G2DQ
" 7	10.30	1911	G2JL
" 7	11.00	1.7 mc.	G2UV
" 7	11.30	1761.5	G2WO
" 14	00.00	1761.5	G2WO
" 14	09.30	1785	G5BK
" 14	10.00	1815	G2DQ
" 14	10.30	1911	G2JL
" 14	11.00	1.7 mc.	G2UV
" 14	11.30	1761.5	G2WO

FOR  
DISC AND MIRROR DRUM SYSTEMS  
"BAIRD" and "MERYN"  
KITS AND COMPONENTS  
L. LEAMAN, 97, Northfield Avenue,  
W. Ealing, W.13.  
Phone—EALING 5394



USE BENNETT OPTICAL UNIT (REGD.) FOR BEST RESULTS WITH DISC RECEIVERS. PRICE 10/- COMPLETE WITH SUPER LENS.

ALSO WITH 6" PLANO CONVEX LENS FOR USE WITH 10 c.m. C.R. TUBES (High Def.) 20/- High Definition Apparatus Lists Free.

Low Definition Apparatus Lists Free. "Television" Complete Specifications supplied. COMPLETE TELEVISION RECEIVER ... 70/-

See Specification in "Television" February issue. "PRACTICAL TELEVISION HANDBOOK" 1/-

Television Explained, Construction and Operation. All apparatus sent post free over 10/- or C.O.D. Trade orders executed at usual Trade Discounts. BENNETT TELEVISION CO., REDHILL, SURREY. Telephone: 720

## Constructor's Circle

### Additional Members.

Sydney W. Allcorn, 39b North End Road, West Kensington, W.14; W. H. Watts, 27 Chingford Road, Kingstanding, Birmingham; L. Oxley, 1 The Broadway, East Cosham, Portsmouth, Hants; C. Salter, 155 Botwell Lane, Hayes, Middlesex; L. Walsh, 14 Constance Road, Edgbaston, Birmingham, 5; A. E. Wilkinson, 40 Stanley Road, Woking, Surrey; A. Palmer, 21 Heath Lane, Oldswinford, Worcs.; J. Sparrow, 113 Mackintosh Place, Cardiff; A. E. Buxton, 53 Coulton Avenue, Northfleet, Kent; H. W. Dawson, 134 Market Street, Hyde, Cheshire; S. Gray, 22 St. Aidans Terrace, Deaf Hill, Trimdon Station S.O., Co. Durham; S. Wesley, 2 Cornwall, Mews West, S. Kensington; J. Wyness, 11 Howies Place, Lime Road, Falkirk, Scotland; E. Howell, 6 St. Paul Street, Chippenham; R. E. Smith, Gatton, Albert Road, Deal, Kent; P. Paterson, 5 Dewhurst Terrace, Sunnyside, Newcastle-on-Tyne; A. C. Rawlins, 20 Devonshire Road, Forest Hill, S.E.23; S. Brotherton, 22 Duncanson Avenue, Alloa, N.B.; M. D. Treleaven, 199 Snowdrop Road, Welling, Kent; J. Davidson, 38 Union Terrace, Aberdeen, Scotland; Guy Miller, 81 East Street, Prittlewell, Southend-on-Sea; H. J. Muggleton, Glenhurst, Bishops Way, Andover; W. A. H. Waddington, Holt Lane End, Bentworth, Alton, Hants; R. E. L. Saunders, 19 Barons Court Road, W. Kensington, W.14; R. Smith, 6 Abbots Nook, Liverpool Road, Chester; James Reid, 41 High Street, Fort William; N. Moor, 33 George Street, Pocklington, Yorks; H. Holroyd, 18 New Broadway, Hillingdon, Middlesex; H. D. Jones, 17 Godolphin Road, Shepherds Bush, W.12; C. Lewis, 52 Lucien Road, Upper Tooting, S.W.17; A. W. Read, 71 Montague Road, Leytonstone, E.11.

## H. E. SANDERS & CO.

SUPPLY ALL "MERVYN" AND "BAIRD" COMPONENTS

START BUILDING your apparatus for HIGH DEFINITION RECEPTION. CATHODE RAY High Vacuum Tube, £8-8-0.

RELAY TUBES for TIME BASE. Price 35/- each.

COMPONENTS for TIME BASE and EXCITER UNIT. Prices on application. SYNCHRONISING GEAR. Hold your Pictures with "SANDERS" IMPROVED PEDESTAL TYPE Complete with Coils, Price 25/6.

LOW DEFINITION APPARATUS is cheap. Why not send for DISC RECEIVER KIT with DUPLEX LAMP for Home Assembly. Price £3-0-0.

"SANDERS" NON-DISTORTING BI-CONVEX LENS, 4" 4/6, post 6d. or 5" 7/6, post 6d.

THE NEW DUO-SPHERE MIRROR DRUM. 3 1/2" dia. Ready adjusted for 30-line. 1/2" spindle. Price £3-10-0.

HANDBOOK "EASY LESSONS IN TELEVISION." 1/9 post free.

Send for Latest Illustrated List

H. E. SANDERS & CO. 4, GRAYS INN RD., LONDON, W.C.1

Telephone—Chancery 8778.

## THE CONSTRUCTORS' CIRCLE

### Application for Membership

To be filled in and sent with a stamped envelope for reply to the Editor, "Television and Short-wave World," Chansitor House, Chancery Lane, London, W.C.2.

- (1) I already subscribe to your journal at the address below.
- (2) I have placed a regular order for TELEVISION and SHORT WAVE WORLD with my book-sellers, Messrs.....

..... and desire to be enrolled as a member of the TELEVISION and SHORT WAVE WORLD "Constructors' Circle."

Please send membership badge free of charge to

Name (in block letters) .....

Address .....

\*Strike out lines not applicable.

## FOYLES FOR BOOKS

New and secondhand books on every subject. Catalogues free on mentioning your interests.

119-125, Charing Cross Rd., London, W.C.2 Telephone Gerrard 5660 (10 lines)

Mention of "Television and Short-wave World" will ensure prompt attention.

## MISCELLANEOUS ADVERTISEMENTS

The charge for advertisements in these columns is 12 words or less 2/-, and 2d. for every additional word. All advertisements must be accompanied by remittance. Cheques and Postal Orders should be made payable to Bernard Jones Publications Ltd., and crossed, and should reach this office not later than the 15th of the month previous to date of issue.

PATENTS, Trade Marks, Advice. Handbook and Consultations Free.—B. T. King, Patent Agents, G.B., U.S.A. and Canada, 146a, Queen Victoria Street, London. 48 years' references. Phone: City 6161.

A. MATHISEN, Chartered Patent Agent, F.Tel.S. Patents, Designs and Trade Marks.—First Avenue House, High Holborn, W.C.1. Holborn 8950. Telegrams: "Patam" Holb., London.

PATENTS, Trade Marks, Inventions Patented, United States.—Samuel Goldstein, Registered Patent Attorney, former Patent Examiner, U.S. Patent Office, lowest rates, 275, East Gunhill Road, New York City.

AMERICAN RADIO PUBLICATIONS. Callbooks, 6/-; Who's Who in Amateur Radio, 3/- Handbooks (1935 revised edition), 4/6, all post free.—G5KA, 41, Kinfauns Road, Goodmayes, Essex.

AMERICA'S only television publication. Benn Hall's "Television Times." All the news of America's television progress. Issued semi-monthly. Editor is a leading American authority on television, contributes to leading publications. English and Continental subscriptions, 11/6.—Benn Hall, Editor, "Television Times," 326, West 4th Street, New York City.

BE WISE! KINGSTOVISE. Complete Television Receiver £2.25.0d. Complets Synchroniser 11/-. Double-ended Meters, 15/-. Synchroniser Coils, 4/- pair. Machine Cut Tooth Wheels, 4/8d. Synchronised Meter, 27/-. Disc (20"), 7/6. Stamp for list. Kingstone & Company, 372, Essex Road, London, N.1.

DOUBLE ENDED MOTORS 200/250 AC/DC universal, 30/- type slightly used, new condition guaranteed 8/11. Shop soiled synchronisers, poles, coils, machine cut tooth wheel 3/6. Ancel Cine Television Co., 8, Highbury Terrace Mews, N.5.

## SITUATIONS VACANT

TELEVISION ENGINEER wanted to take charge of receiver development work. Good prospects for right man. Apply, Department 44, Pye Radio Limited, Cambridge.

## INDEX TO ADVERTISERS

Ampion (1932), Ltd. ....	239
Automatic Coil Winder & Electrical Equipment Co., Ltd. ....	238
Baird Television, Ltd. ....	178
Belling & Lee, Ltd. ....	Cover ii
Bennett Television Co. ....	Cover iii
British Television Supplies, Ltd. ....	236
British Institute of Engineering Technology ....	236
Bryan Savage ....	234
Bulgin, A. F., & Co., Ltd. ....	177
Edison Swan Electric Co., Ltd. ....	Cover iv and 235
Eugen J. Forbat ....	239
Ferranti, Ltd. ....	237
Foyles ....	Cover iii
High Vacuum Valve Co., Ltd. ....	239
Jackson Bros. (London), Ltd. ....	237
Leaman, L. ....	232
Lectro Linx, Ltd. ....	177
Peto Scott ....	235
Radio Resistor Co., Ltd. ....	234
Radio Society of Great Britain ....	237
Sanders, H. E., & Co. ....	Cover iii
Sound Sales, Ltd. ....	177
Stratton & Co. ....	233
Television Society ....	239
Television Instruments, Ltd. ....	239
The Technological Institute of Great Britain ....	238
Unit Radio ....	238
Varley ....	237
Westinghouse Brake & Signal Co., Ltd. ....	Cover ii
Wright & Weare, Ltd. ....	235



Proprietors of  
Electric Lamps  
By Appointment

# EDISWAN



Manufacturers  
and Proprietors  
of Electric Lamps  
By Appointment



Ediswan Ray Tube  
Price £8.8.0

Ediswan Mercury Vapour  
Relay. Price £1.15.0

Ediswan MR/AC.1 gas  
discharge triode for use  
in sweep circuits  
associated with the  
tube.

## HIGH VACUUM CATHODE RAY TUBES

This new high vacuum device supplies the need for a tube of long life and improved modulating characteristics suitable

*for*  
*and* **TELEVISION  
RADIO RESEARCH**

We invite enquiries for :

- Mercury Vapour Rectifiers.
- Grid controlled discharge tubes for time bases.
- High Vacuum Diodes.
- Transmitting Valves, low and medium powers.

Full information on the tube and its associated circuits can be obtained on application to the Technical Service Dept. at the address below.

# EDISWAN RADIO VALVES

THE EDISON SWAN ELECTRIC CO. LTD.  155 CHARING CROSS ROAD, LONDON, W.C.2

**USED BY ALL GOVERNMENT DEPARTMENTS**

R.E.237