

# TELEVISION

**SPECIAL  
CONSTRUCTIONAL  
FEATURES**

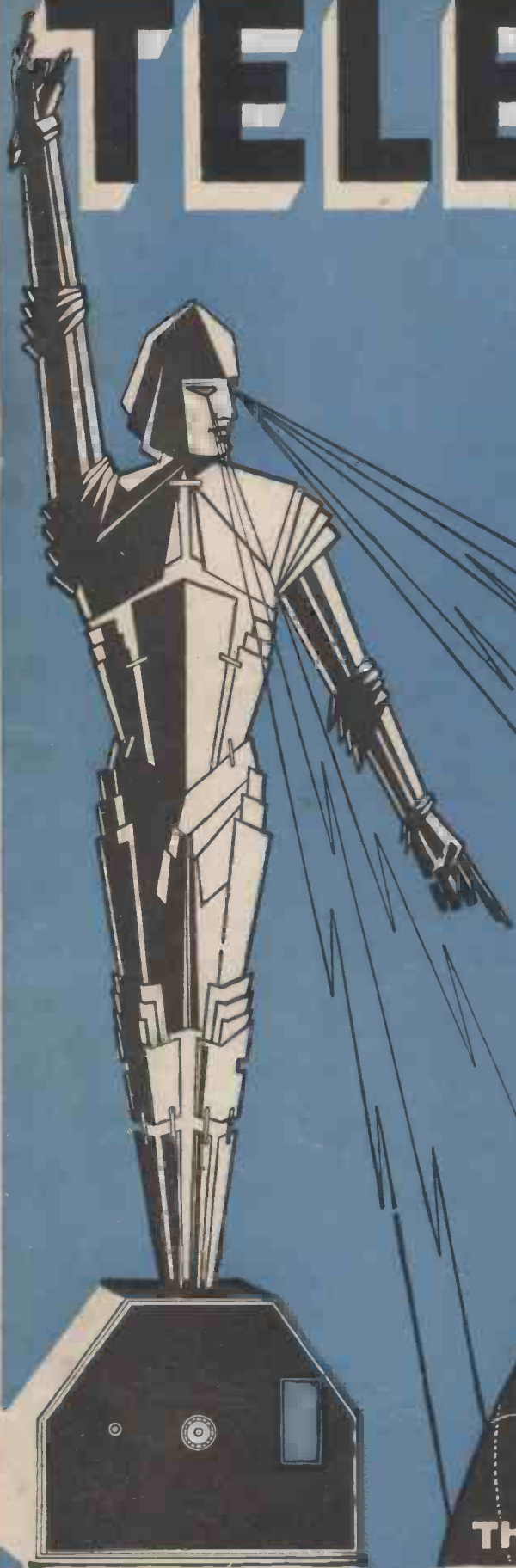

**THE WORLD'S FIRST TELEVISION JOURNAL.**

EMINENTLY  
SUITABLE  
NEW YEAR  
GIFTS

BOUND VOLUMES  
of  
"TELEVISION"

HANDSOMELY BOUND IN  
RICH BROWN IMITATION  
LEATHER, MOROCCO  
FINISH, LETTERED IN  
GOLD ON FRONT AND  
SPINE, COMPLETE WITH  
INDEX.

HANDSOME PERMANENT RECORDS  
OF THE WORLD'S FIRST  
TELEVISION JOURNAL.

VOLS. 1, 2, & 3 **12/6** EACH  
POST FREE

BINDING CASES  
for  
"TELEVISION"

AVAILABLE FOR THOSE  
WHO WISH TO HAVE  
THEIR OWN COPIES  
BOUND. IN BROWN  
CLOTH, LETTERED IN  
GOLD ON FRONT AND  
SPINE, WITH INDEX.

BOUND VOLUMES ARE PREFER-  
ABLE TO LOOSE, WORN COPIES.

EACH **4/6** POST  
FREE  
*Indexes (only) for Vols. 1, 2, & 3, 6d. each,  
postage 2d.*

TELEVISION PRESS, LTD.  
505, CECIL CHAMBERS, STRAND, W.C.2

TEMPLE BAR 8169

# TELEVISION

33922

## TELEVISION PRESS, LTD.

Editorial, Advertisement and Publishing Offices:

505, CECIL CHAMBERS, STRAND, LONDON, W.C.2

Telephone: TEMPLE BAR 8169

SUBSCRIPTION RATES  
13/6 PER ANNUM, POST FREE.  
6/9 SIX MONTHS, POST FREE.  
AMERICAN RATE:  
\$4.50 PER ANNUM, POST FREE.  
\$2.25 SIX MONTHS, POST FREE.

MS. AND OTHER MATERIAL FOR EDITORIAL CONSIDERATION SHOULD BE ACCOMPANIED BY A STAMPED ADDRESSED ENVELOPE, AND SHOULD BE TYPEWRITTEN.

## PRINCIPAL CONTENTS

	PAGE
THIS MONTH'S CAUSERIE . . . . .	411
TELEVISION RECEPTION IN MARBURG . . . . .	412
DEFINITIONS AND MISNOMERS . . . . .	414
FROM MY NOTEBOOK . . . . .	417
THE ENTHUSIAST SEES IT THROUGH . . . . .	420
"TELEVISION'S" QUERY CORNER . . . . .	424
WORKSHOP HINTS . . . . .	425
THE "TELE-POWER" JUNIOR UNIT . . . . .	427
THE TELEVISION SOCIETY . . . . .	432
SCANNING OR EXPLORING . . . . .	433
A SIMPLE MAGNETIC CORRECTOR . . . . .	434
LETTERS TO THE EDITOR . . . . .	438
TRADE NOTES OF THE MONTH AND APPARATUS TESTED . . . . .	446

### INDEX to ADVERTISERS

	PAGE
"Armchair Science" . . . . .	439
Baird Television, Ltd. . . . .	iii (Cover) & 410
Bapty, S. Lee . . . . .	443
Bound Volumes . . . . .	ii (Cover)
"Discovery" . . . . .	419
Dossett, A. . . . .	432
Dubilier Condenser Co. (1925), Ltd. . . . .	429
"Irish Radio News" . . . . .	447
Leaman, L. . . . .	419
Microfuses, Ltd. . . . .	425
Oates, W. H. . . . .	415
Partridge & Mee, Ltd. . . . .	431
Salter, J. . . . .	432
"Television To-day and To-morrow" . . . . .	iv (Cover)
Whiteley Electrical Radio Co., Ltd. . . . .	445

### ORDER FORM

CUT THIS OUT AND HAND IT TO YOUR NEWSAGENT.

To Mr. . . . . ., Newsagent.

Address . . . . .  
 . . . . .  
 . . . . .

Please deliver to me at the address given below a copy of **TELEVISION** for February, and monthly thereafter until countermanded.

Name . . . . .

Address . . . . .  
 . . . . .  
 . . . . .

# BAIRD GOLDEN POINTS

FOR TELEVISION ENTHUSIASTS TO CONSIDER

BAIRD  
BRANDED  
COMPONENTS

BETTER RESULTS!

## BAIRD

B  
R  
A  
N  
D  
E  
D



P  
A  
R  
T  
S

OBTAINABLE FROM ALL FIRST-CLASS RADIO DEALERS

**BAIRD TELEVISION Ltd., 133 Long Acre, London, W.C.2**

TEMPLE BAR 5401

# TELEVISION



## THE OFFICIAL ORGAN OF THE TELEVISION SOCIETY

SYDNEY A. MOSELEY, *Managing Editor.*

*Consultants* { H. J. BARTON CHAPPLE, Wh.Sch.,  
B.Sc.(Hons.), A.C.G.I., D.I.C., A.M.I.E.E.  
C. TIERNEY, D.Sc., F.R.M.S.  
W. J. JARRARD, B.Sc., A.R.C.S., A.I.C.

VOL. IV] JANUARY 1932 [No. 47

## THIS MONTH'S CAUSERIE

SO much has happened during the past year that it will be of special interest to readers of TELEVISION to glance backward down the months, recalling, at the threshold of the New Year, one or two of the important advances in the history of British television.

Early in the year 1931 a special demonstration of Zone television was given to the Press at the Baird laboratories, and as many as seven or eight full-sized figures were transmitted by land line.

In May, daylight television was successfully demonstrated, when street scenes were transmitted. This led naturally enough to the Epsom racecourse. Here, with the enthusiastic co-operation of the B.B.C., an actual scene of the Derby was broadcast, and those who were fortunate enough to look-in had the thrill of seeing and hearing the whole field thundering past the winning-post.

Considerable public interest was taken in the first of the B.B.C. television transmissions of artistes from the B.B.C. studios at Savoy Hill by means of a Baird portable transmitter, when Jack Payne and members of his band were successfully televised.

A hard battle has been fought to conquer prejudice and scepticism, but at long last glimpses of a happier future show themselves in the recent announcement made to the Press from the B.B.C.

itself. Closer co-operation! Magic words indeed, which bring the new science right out into the open.

The actual statement made by the B.B.C. on November 26th, was as follows: "The B.B.C. have initiated discussions with Baird Television Limited to explore the possibility of the more active participation of the B.B.C. in the production of television transmissions, both from the programme and technical points of view."

This was supported by Baird Television Limited, who stated that they welcomed the initiative of the B.B.C. in beginning these discussions. The growing volume of correspondence received by the Baird Company proves conclusively the steadily increasing public interest in television. At the same time this new move of the B.B.C. undoubtedly will be welcomed by the wireless industry—both manufacturers and traders alike. To receive the television signals which are broadcast a wireless receiver is necessary, and when installed in the home the resulting sound and vision will provide entertainment in a manner which has been desired for a long time. The stimulus to the radio industry through the development of this new industry will therefore manifest itself in every direction.

*Entire Contents of this Journal copyright in the U.S.A., 1932, by Television Press, Ltd.  
Foreign Translation Rights Reserved.*

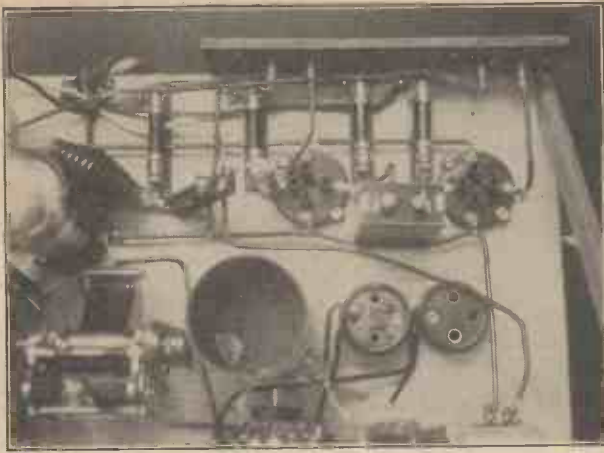

# Television Reception in Marburg

By R. Theile

**T**ELEVISION is certainly one of the most interesting branches of science for the wireless amateur. For this reason I started, at the end of last year, to interest myself in this new invention, and to construct a wireless set for receiving the signals. I have already described the

arrangement was quite satisfactory when a high aerial was used.

The aerial was coupled to the grid of the first valve, passing first through a small condenser to the coil. In difficult cases a resistive circuit can be connected to this arrangement.

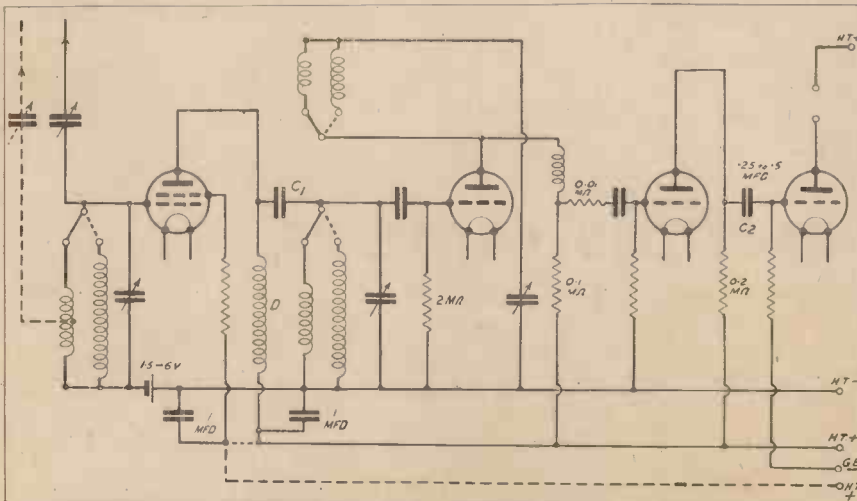

A circuit diagram of the wireless receiver used by Mr. Theile in Marburg, Germany. All the anode voltages were applied from a home-made eliminator.

results in the January, 1931, issue of this journal, and now I will report on the wireless receiving apparatus used for the experiments.

## Securing Adequate Strength

It is, of course, to be understood that any type of apparatus is not suitable for this purpose. Mistakes which in wireless reception cause little or no disturbance may interfere considerably and spoil completely the quality of the images in television.

In the construction of the apparatus the following items had to be kept in mind: Sufficient strength and reserve power for distant reception (Marburg-London), amplification free of distortion, no annihilation of the side bands of the transmitting wave, and no overloading of the last valve.

The apparatus was built in accordance with these requirements. In order to obtain sufficient power four valves were chosen—one screen-grid high-frequency, one detector, and two stages of resistance-capacity low-frequency amplification. This

## Allowing for the Long Waves

The apparatus can be switched over to long wavelengths in order to pick up the experimental trans-



Showing the detector stage, with the low-frequency amplifier.

missions from Königswusterhausen. The quality of the images from this station were, however, by reason of the bad frequency response and other unfavourable receiving conditions, not as good as those from London.

The apparatus is not very complicated, and may be seen in the illustrations. The coupling of the H.F. valve and detector is also capacitive through  $C_1$ , while the high-frequency "throttle"  $D$  prevents the transmission of the high-frequency energy to the battery.

The low-frequency section is composed of pure resistance amplification, as this method of amplification works most free of distortion. The component values deviate slightly from normal,  $C_2$  being 0.25 to 0.5 mfd. and so on, while the best value for the anode resistance proved to be 0.1 to 0.2 megohm.

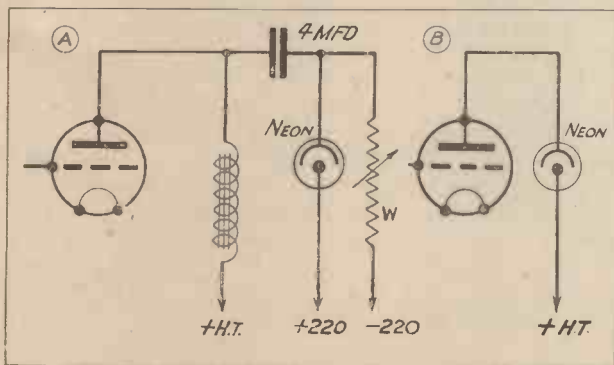

Two methods for coupling to the neon lamp. (A) Capacitive, and (B) direct.

The coupling of the neon lamp was made variable, one being direct, that is to say, the lamp in the anode circuit of the last valve, and the second capacitive wherein the necessary igniting voltage passes over a regulating resistance  $W$  (approx. 10,000 ohms). Both methods were used with good results.

Another interesting experiment in the working of the receiver must be mentioned. As we know, each oscillatory circuit has its own resonance curve, and

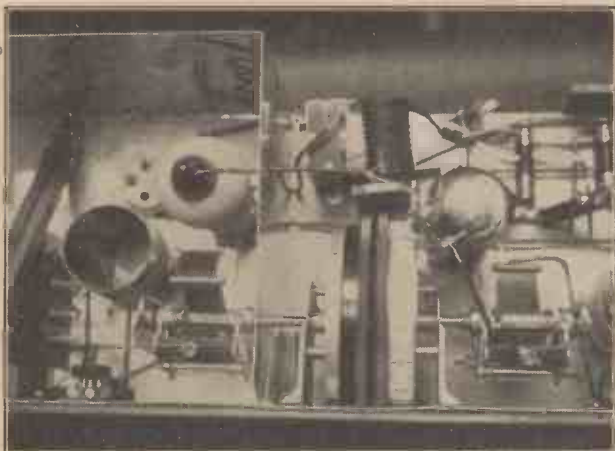

A plan view of the high-frequency end, together with a portion of the detector stage.

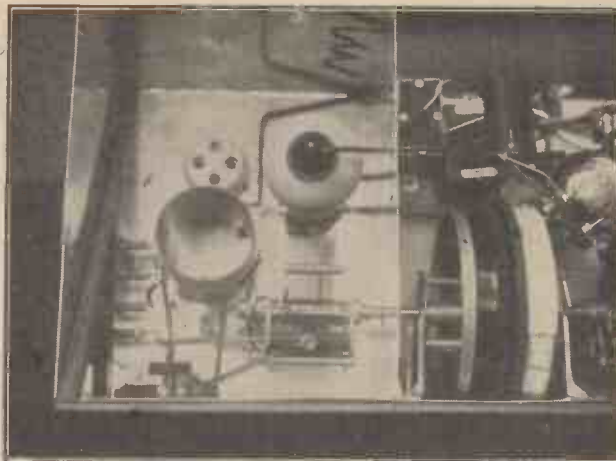

The high-frequency S.G. valve, together with the tuned aerial circuit are well screened.

the more selective, and therefore the more attenuation free, is the arrangement, the more pointed is the curve. This has, however, its own disadvantage, for the side bands are then always weaker and the high picture frequencies are destroyed. The picture is hard and loses its half tones.

The receiver must, however, also be selective, otherwise the neighbouring transmitters interfere. I helped myself out of these difficulties in the following way: The two oscillatory circuits were not equally adjusted as in the sketch but somewhat out of tune, and the curve resulting from this be-

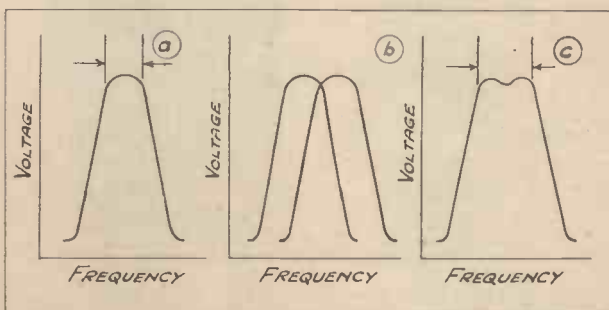

Sketches of the resonance curves referred to. (a) Equal tuning of each circuit, (b) out of tune, (c) nett result.

came right angular, that is, the side bands were well amplified and not cut off.

In working, this difference shows itself very markedly, and I succeeded in varying the quality to advantage by this method.

The enclosed photographs show the receiver which was used for the experiments in Marburg.

Unfortunately, it has not been possible for me to experiment during the last few months, as since April I have been living in Berlin-Siemensstadt, and everyone knows that it takes time to set up wireless equipment when one is far from home. In spite of this the construction of new apparatus has already been started, and I shall have pleasure in reporting on my experiments later on, for I am looking forward with keenness to being able to see-in to London again.

# Definitions and Misnomers

By *William J. Richardson*

I EXPECT all of you can remember Winston Churchill's famous definition of a lie, "a terminological inexactitude." It is a definition not to be found in the household dictionary; indeed, it is sure to lead to more confusion than the original word, and consequently may be put on one side as an inapt description for general use. Too often are we led into a maze of misunderstanding when endeavouring to fathom the true meaning of words or phrases, with the result that our brain becomes confused and we are forced to postpone or give up our quest for enlightenment.

## *Doctrine of Nomenclature*

The question of terminology as applied to television, that is, the doctrine of nomenclature and



*The term "amplification ratio" is a property of the valve itself, and the expression "amplification factor" is not used except for the complete amplifier.*

terms used in this "far-seeing" science, is being tackled, but it is to be regretted that, as is usual in these cases, any committee recommendations are taking a long time to get into print.

It happened the same way with wireless, and although as far back as 1923 the British Engineering Standards Association issued a handbook (No. 166) which contained a large number of accepted terms and definitions used in radio communication, I gather that the book is now out of print, and we must

hope that either a reprint or a new publication will rapidly become available.

At the beginning of the publication referred to the following note appeared: "Throughout the List the word *wireless* may be used in substitution for the word *radio*." For a long time efforts were made to get everyone to use radio and not wireless, but they failed lamentably. It is a curious but frequent occurrence that the first term coined to describe a process or article generally remains, and since wireless was preferred in the early days, it has remained. This is in spite of the fact that from the point of view of either the transmitting or receiving ends, wires are abundantly in evidence. It is merely the medium used for the conveyance of signals which justifies the term "wireless," and now we are becoming introduced to an apparent contradiction—wired wireless. Who knows where it will end?

## *An Erroneous Expression*

While on this question of wrong terms I should like to draw attention to a common practice whereby one of the thermionic valve constants is spoken of as the "amplification factor." This term is erroneous and should be called the "amplification ratio." Referring to the B.E.S.A. Handbook No. 166, the amplification ratio is defined as "the numerical ratio of the slope of the anode current/grid voltage characteristic curve to the slope of the anode current/anode voltage characteristic curve of the three-electrode thermionic valve, the slope in each case being that at the point representing the particular adjustments under consideration."

From this it is clear that the ratio is a definite number found by dividing the change in anode volts to produce a small change in anode current by the change in grid volts necessary to bring about the same current change. These calculations should be made on the straight part of the valve's characteristic when working at the correct filament current or voltage.

## *Inherent Property*

All valve users must realise that if a definite voltage change is effected on the grid or control electrode, it will produce a much larger alteration in anode current than would be the case if the same change was applied to the anode. This is an inherent property, and the actual magnitude of the amplification ratio is dependent mainly upon the dimensions of the three electrodes, the size of the grid mesh or closeness of the grid spiral, and also



the relative distances between the filament, grid, and anode.

Now, where is the misused term "amplification factor" applied? Referring to the handbook again, we are furnished with the following definition: "The ratio of the power, voltage, or current available at the output terminals of an amplifying device to the power, voltage, or current at the input terminals under certain specified conditions, such as given output or input. The amplification in each case must be such that no saturation or threshold effects of any kind are involved."

### A Useful Expression

When operating any amplifying device using valves, it is necessary to have some associated apparatus in the anode circuit, such as a choke, resistance, transformer, etc., and this offers a definite impedance to the flow of fluctuating current in the anode circuit. The anode to filament impedance of the valve itself cannot be neglected in comparison with this added external impedance, and consequently the total impedance of the circuit must be used for calculation purposes.

The actual mathematical expression for, say, a single-stage amplifier is expressed as:

$$\text{Amplification Factor} = \frac{\mu Z}{\sqrt{R^2 + Z^2}}$$

where  $Z$  = external impedance in anode circuit in ohms.

$R$  = internal anode to filament impedance of the valve in ohms.

$\mu$  = amplification ratio.

The amplification factor is thus dependent upon the amplification ratio, and the two quantities must be treated separately. The figure published by valve manufacturers as amplification factor should therefore be read as amplification ratio, bearing in mind that it is a valve quantity as it stands and only becomes a factor when the valve is used in an amplifier.

### Exploring or Scanning

Let us now turn for a moment to television. That word in itself has been the subject of criticism, but to my mind it sums up the situation very well. We are familiar with the telephone, which implies sound from a distance, and the telegraph, meaning messages from a distance, so what better than "television" to infer the operation whereby we transmit visual images? The word has become more or less accepted universally, but the same cannot be said of the process of exploring or scanning. The latter term is really of American origin, but, as in previous instances, there is a tendency for it to remain since it was used initially.

A Chambers's Dictionary seems to offer little solution to the difference between the two terms, for "scanning" is given "to examine carefully," "to scrutinise," and "exploring" is given "to search for

the purpose of discovery," "to examine thoroughly." We so often use the word "scan" in the relation of "a quick glance" that it is small wonder it has been applied to television, for obviously the object or subject being transmitted is disintegrated by the moving light spot at a rapid rate.

On the other hand, whereas a quick glance by a person is sure to miss detail, our television eye with its associated disc or drum controlling the spot movement must not fail in this respect, so perhaps the palm should be awarded to "exploring," which implies a thorough examination.

### Looker-in?

Another difficult case which so far has defied adequate definition is a description of the process

When an image is split in the direction of scan it is said to be "out of phase."

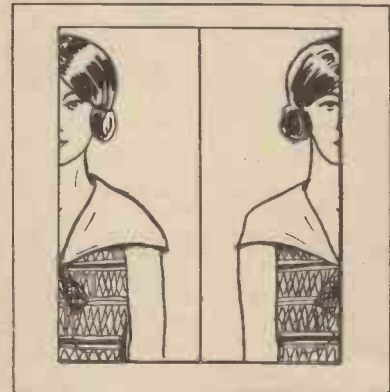

whereby one or more persons watch a television image on the screen of large or small dimensions. "Looker-in" has been used frequently and no doubt arose from the earliest models, whereby one had to get up close to the vision apparatus and look down a viewing tunnel. But does this meet the case for an image thrown on to a translucent screen? An American magazine held a competition recently to see if it was possible for the journal's readers to coin a phrase or expression, but the entries failed to provide a good solution, in fact the term which won the prize, namely, "visualist," in my opinion still falls short of the ideal. I wonder what the "definitions committee" will recommend?

There are other terms in this science of ours which are not above criticism. Take, for example,

**W. H. OATES**

**COMPLETE TELEVISION SERVICE**

Our Depot affords unique facilities to those interested in Television. Our own transmitting apparatus enables us to give callers demonstrations upon request.

**DEMONSTRATIONS**

BETWEEN 9 A.M. AND 6 P.M.

THE **BAIRD** "TELEVISOR," ALSO HOME CONSTRUCTOR'S "TELEVISOR" KITS, SUPPLIED FROM STOCK.

Only genuine Baird components are supplied by us. We have a full range available of parts and accessories.

**195, HAMMERSMITH ROAD,**  
LONDON, W.6. RIV. 3342.

the early "selenium cell," surely this would be better known as a "selenium bridge." In effect it is a light-sensitive device in which the phenomenon that selenium alters its resistance under the action of light is used. The cell really consists essentially of two separate conductors bridged by a thin film of



An image incorrectly framed will look somewhat as illustrated.

selenium, hence the suggestion for "selenium bridge."

### Phasing and Framing

"Phasing" and "framing" are confused by a vast number of people who really should know better. The two words arise in connection with the synchronising of the vision apparatus at the receiving end with the moving element at the transmitting end. An image is said to be out of phase when corresponding disc holes or mirrors on a drum, although revolving at the same speed, are not strictly in step. For example, No. 1 hole at the transmitting end may be exploring the subject at the instant when, say, No. 15 hole of the disc at the receiving end is moving across the neon glow. Under these circumstances the image is split in the direction of scan, the accompanying illustration showing what is meant in the case of a vertically scanned image.

To *phase* the image correctly the motor speed needs to be altered slightly to allow the image to drift at right angles to the direction of scanning and thus get it centred correctly. That is to say, in the case of vertical scanning, the image must be moved bodily to left or right, so that the centre of the subject scanned is seen on the vertical centre line of the viewing screen.

### Image Adjustment

That may not be sufficient to give you everything you require, however, for if you have a toothed-wheel synchroniser it may be set on the shaft in an incorrect angular position, so that although the image is "phased" it is not "framed." This is shown in another illustration and indicates how an image can be in true synchronism with the transmitter and yet the top and bottom sections are interchanged. This can be rectified by moving round the motor carcass and synchronising mechanism bodily to raise or

lower the image and bring it into frame. In the case of the Baird "Televisor" a framing knob brings this about through the medium of a pinion and toothed sprocket. Another method is to stop the motor and turn the disc round slightly on the shaft itself, but, of course, this is rather an inconvenient process.

### Isochronism and Synchronism

Speaking of synchronism recalls also another confusion of terms, namely, "isochronism" and "synchronism." Stated simply, "isochronism" infers only a state of running at the same speed, whereas "synchronism" implies running at the same speed *and* in the same phase. This is shown in Fig. 1, A and B, where A illustrates two wheels revolving in the same direction at the same number of revolutions per minute, but spoke No. 1 of the left wheel is not in the same angular position as spoke No. 1 of the right wheel. Here isochronism is established, but we must have the condition of Fig. 1 B before synchronism describes the condition. In this case not only are speeds identical, but No. 1 spoke of each wheel has the same angular position at every instant of the motion.

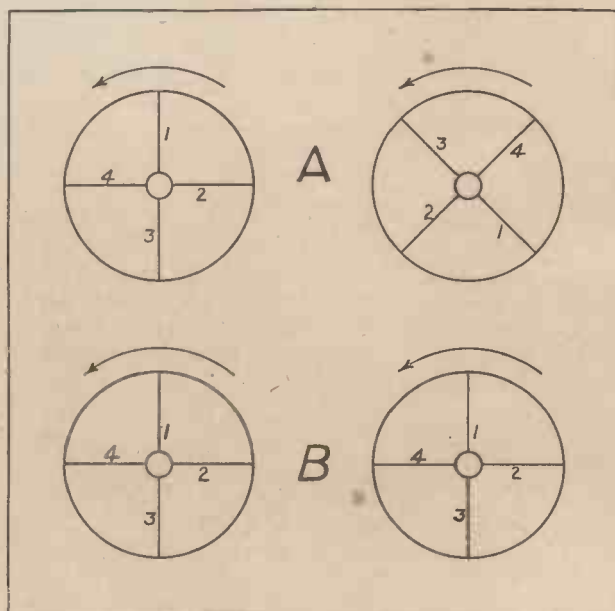

Fig. 1.—A simple diagram to explain the essential difference between isochronism and synchronism.

I could go on adding to this list of misplaced terms and looseness of expression. Why should that phenomenon whereby visual impressions are retained by the eye for a fraction of a second after the image causing them has ceased be known as persistence of vision or time-lag of the eye or visual persistence? Why not have one expression and be done with it? It would make the details of the subject so much easier to assimilate.

# From My Notebook

By *H. J. Barton Chapple*,  
Wh.Sch., B.Sc.(Hons.), A.C.G.I.,  
D.I.C., A.M.I.E.E.



## *An Interesting Experience*

I HAD a most interesting experience the other evening as, by the kind invitation of the B.B.C.'s Director of Programmes, I was one of a small audience in the studio at Savoy Hill during the course of a vaudeville programme. Seated at one end of the studio one sensed an entirely different atmosphere from that of, say, a concert hall. In fact, it would seem that the B.B.C. recognise this themselves, as a small pamphlet was issued to every member of the audience, stating that the announcer would call for silence when he made the full announcement of the programme to be broadcast.



*An unconventional study of Mr. and Mrs. Baird taken at Coney Island after the inventor's wedding.*

After that the audience could express its appreciation as it felt inclined, and it was suggested that the artistes be received in the same way as they would in a music-hall, it being emphasised that the rather curious atmosphere created in the studio should not be allowed to affect one's feelings.

The experience was certainly unique in many respects, and, curiously enough, I was able to recognise amongst some of the artistes that evening, faces of those who had broadcast on previous occasions from the Baird Television Studios in Long Acre.

This dual recognition of the artistes' qualities is a point worth noting, and, furthermore, I was con-

vinced that there were several sections of that vaudeville programme which would have proved material for a television broadcast. For example, Clarice Mayne, a comedienne of international fame, gave a turn in her inimitable manner, and I felt very strongly that those listening-in missed the full value of her microphone performance. Her mannerisms and general deportment were features that only the small "seeing" audience in the studio could appreciate, but had television been there, lookers-in would have enjoyed the same privilege.

It is to be hoped the recent announcement made by the B.B.C. will culminate in not only extended hours for the broadcasts of vision, but also in an embracing of such programme items as these, for in that way the full value of television will be appreciated.

## *Eliminating Tramcar Interference*

The study of devices for the elimination of parasitics produced by tramcars has been actively pursued in various countries, and I was therefore very interested in a fresh contribution to this study

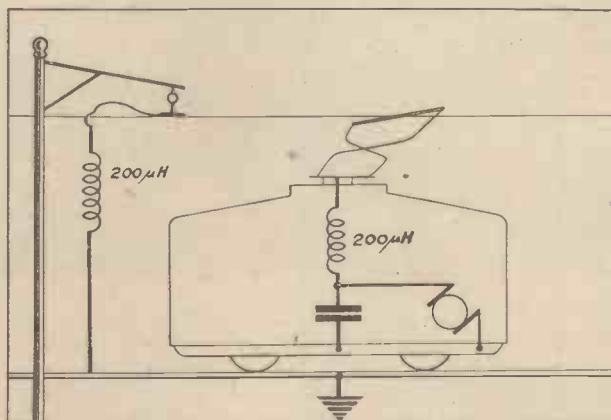

*Indicating the steps which have been taken to overcome tramcar interference on the Continent.*

which has been made by the E.I.A.R. of the Turin, Padua, and Varese tramways.

The Italian engineers have verified that the trolley

line itself has only a comparatively small interfering influence; in other words, its aerial effect for radiating disturbances is weak. As long as no tramcar is in sight, no important parasitic is detected. It has been shown in Germany that it is not the traction current which is the most troublesome, but the sparks produced by the accessory service currents—bells, lighting of carriages, compressor motor of the pneumatic brake, etc. To give some idea of this, the stopping signal alone creates disturbances at a distance of just over half a mile, whilst the trouble produced by the arc which establishes contact with the wheel and the rail can hardly be ascertained.

As the aerial line remains the principal vehicle of interference however, it is essential to prevent this radiation to as large an extent as possible by stopping the parasitics by means of shock absorbers. For this purpose, a shock absorber of 220 microhenrys, of sufficient cross-section to carry the total current, is placed in series in the circuit at the base of the pole of the trolley. A condenser of 0.02 mfd., placed between the outlet of this absorber and earth (or the bed of the wheel), shunts the motor and the controller (see accompanying diagram).

### Shock Absorbers

As applied to the metallic tramways of Turin, this eliminating system has given excellent results—so much so that the passage of a tramcar, with

disturbance is diminished by replacing the electric lamps by neon tubes, which have, moreover, the advantage of a much lower consumption. As at Varese, condenser filters can also be installed at about every 500 to 600 yards between the trolley wire and the parallel conductor of the block, placed on the ground.

These encouraging results are, of course, of no use except for tramcars fed by trolleys and not by wheels.

### D.C. Mains Valves

During the past year or so the user on A.C. mains has been specially well catered for by the rapid development and perfection of highly efficient and reliable A.C. mains valves. With the information gained from the manufacture of these A.C. valves, it has now become possible to give the user who has D.C. mains an equal opportunity of running his set from the electric light mains without the necessity for any batteries or accumulators.

In tackling the problem of D.C. mains valves the important points to be considered are:

- (1) A reasonable economy of operation.
- (2) An easy dissipation of heat in the set.
- (3) Adequate insulation between cathode and heater.
- (4) Consistency in characteristics and reliability in use.

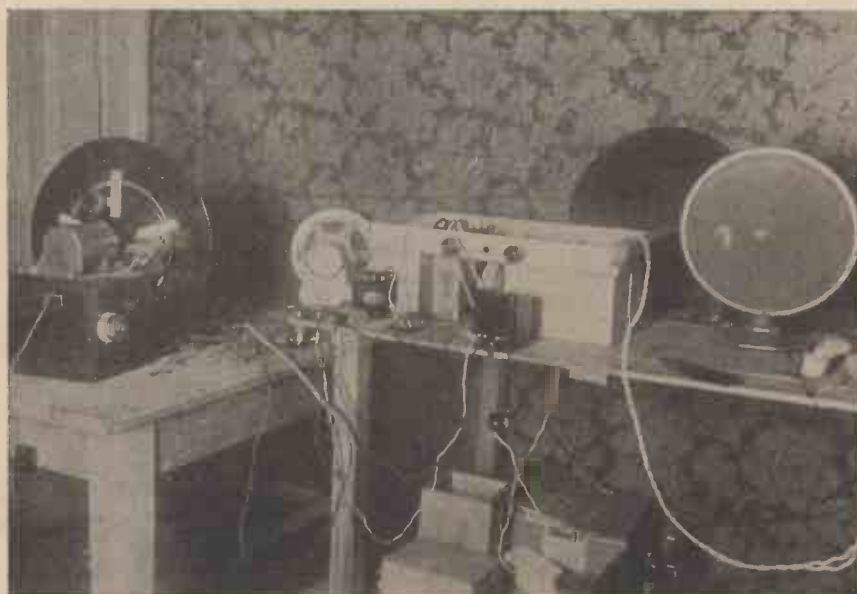

A normal radio receiver adapted for use with vision receiving apparatus in the Argentine. The vision apparatus itself is seen on the left of the photograph.

bells and compressor working, cannot be noticed in receiving apparatus placed at five yards from the lines.

It is presumed that such categoric results can only be obtained on completely metallic cars whose conductors are sheathed. As regards the line, the protection is even more improved by the installation of a shock absorber in series with the arrival of each feeder on the trolley line.

The attention of the engineers was drawn to the block systems in use at Padua and Varese. The

D.C. mains valves are run in series and, in consequence, the set design is somewhat different from those cases using parallel-fed valves. I notice that the G.E.C. have 16-volt heaters, the reason given being that this figure is not too high to prevent several valves being wired with filaments in series. It will be appreciated that the more valves which are wired in series the higher will be the voltage difference between the heater and the cathode of the valve at the end of the series. It is not practicable to make this voltage too high, owing to difficulties in

cathode design. With 16-volt heaters, however, up to six D.C. valves can be wired in series with perfect safety. Such an arrangement gives only 96 volts between heater and cathode on the end valve.

Furthermore, the "waste" voltage must be disposed of. For practical reasons it is necessary that the valve voltage should be considerably lower than the mains voltage, and even with up to six valves in series there is still a reasonable amount of external resistance required to reduce the voltage, and in practice the energy not required is dissipated in the form of heat through a breakdown resistance.

### *Ether Police for Air Crime*

An interesting experiment was carried out recently in Germany. A pseudo-criminal set out in a "stolen" aeroplane bound for an unknown destination. Five minutes after he started a description of his plane was broadcast, and listeners were asked to report any movements they saw to the transmitting station.

Meanwhile another aeroplane, containing "police" and equipped with wireless, left the aerodrome and waited in mid-air for these reports to come via the station. Reports were received so regularly that the "criminal" was captured after only an hour's freedom.

### *A "Tele-Power" Note*

Readers will notice in my article in this issue describing the "Tele-Power" Junior Unit that I have referred to the new filament rating of the Mullard D0/25 valve. Where readers have already had a mains transformer made up for the 6 volts, 1.8 amperes output as specified originally in the September issue, and yet have one of the new valves which now only require 1.1 amperes, it may be inconvenient to have that secondary winding re-wound. The matter can be rectified quite easily, however, by having a shunt resistance across either the valve holder filament terminals or across the appropriate transformer terminals.

Since the original valve filament resistance was  $\frac{60}{1.8} = 3\frac{1}{3}$  ohms and the new valve filament resistance is  $\frac{60}{1.1} = 5\frac{1}{11}$  ohms, then the paralleling resistance to balance matters must be  $8\frac{1}{11}$  ohms. This resistance must be capable of carrying a current of 0.7 ampere, and if this specification is adhered to the unit will function as originally intended, and the valve will in no way be over-run.

**L. LEAMAN**  
97, NORTHFIELD AVENUE  
WEST EALING, LONDON, W.13

*For Radio and Television*

DEMONSTRATIONS  
DURING TELEVISION TRANSMISSIONS

**Baird Components Supplied**

PHONE: EALING 5394 (MEMBER, TELEVISION SOCIETY)



# DISCOVERY

FOUNDED 1920

for everyone interested in

## SCIENCE

NEVER TOO TECHNICAL  
NEVER TOO POPULAR

BUT

AUTHENTIC ARTICLES  
BY LEADING EXPERTS

THE CONTENTS OF THE

## January Number

*include the following:*

INTERNATIONAL POLAR  
RESEARCH

By Frank Debenham

THE NEW ERA IN FARMING

By C. S. Orwin

BIOLOGY AND CIVILIZATION

By H. H. Dale

THE "REBEL" REPLIES

By Herbert Dingle

WHAT IS A VIRUS?

By A. E. Boycott

PRICE . . 1/- MONTHLY

ANNUAL SUBSCRIPTION 12/6

SEND FOR FREE SPECIMEN COPY  
NOW TO

THE MANAGER, "DISCOVERY,"

Bouverie House, Fleet Street,

LONDON, E.C.4.



# The Enthusiast Sees it Through

**A**S our magazine will be on sale just before Christmas, we should like to take this opportunity of wishing all our readers seasonable greetings for the Yuletide, coupled with a prosperous New Year in every sense of the word.

We are convinced that 1932 will see the dawn of a new era in television activities, and in a measure reward the work of our enthusiasts, who have been spending time and money in an effort to further the progress of this wonderful science.

May we hope that they will have more power to their arm and that they will continue to regard this series as one in which they can take an intimate personal interest, and thus help on fellow-experimenters in the good work.

## Rapid Progress

Rapid progress seems to be the watchword of Mr. Joseph Owers, of 130 Praed Street, Paddington,

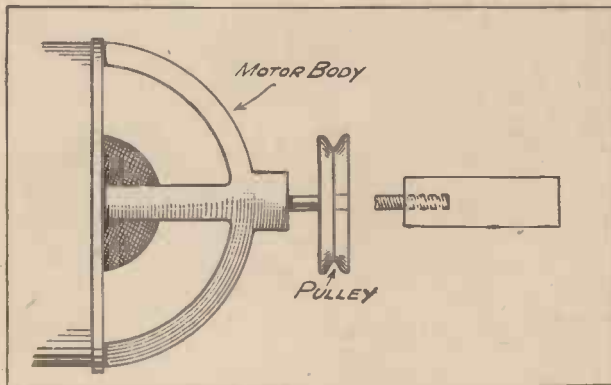

Diagram A.—Adapting the end of the motor shaft to fit the boss of the Baird disc.

W.2. Since giving him advice towards the end of October, he writes again in November giving very full particulars of the vision apparatus he has evolved,

and is enthusiastic over his results. We congratulate Mr. Owers on his handiwork, and are sure other readers will benefit by the information he has been good enough to send along. He says:

"Since writing you for advice in the latter days of October, I have made rapid strides with my television experiments. I will give you an account of these up to date, hoping that they will be of sufficient



Mr. Joseph Owers has been successful in watching good television images with the home-made apparatus illustrated above.

interest to be included in your 'The Enthusiast Sees it Through' series.

"Realising the need for a well-cut disc, I purchased one 'Baird' branded, also the necessary neon lamp. I then searched around for a good motor, and came across one which I thought would be suitable, working off 6 volts. The next job was to sweat to the end of the motor shaft a length of brass rod to take the 'Baird' disc. I unearthed a suitable rod having a threaded hole in the end, into which I screwed a short length of threaded rod (see diagram A), slightly drilling out the pulley. I forced the

rod into it, sweated them together, and thus obtained a perfectly centralised shaft for the disc.

"I soon rigged up the rest of the apparatus, and was ready for the first reception. I could not make head or tail of this at first; then I discovered that the images were coming through negative. I reversed the transformer connections in the wireless set, and next time was rewarded by wonderfully good images. Of course I was handicapped by having no synchronising gear, but managed to hold the images quite well by means of a string friction brake on the motor pulley.

"After this the motor began to give trouble, failing to give sufficient speed and vibrating badly, so I searched for one of more robust design. I was successful in obtaining an excellent Universal motor, with sliding resistance control. This had a large pulley firmly riveted to the shaft, so I fixed an extension shaft in the same manner as before.

"I eagerly tuned-in the next television broadcast. This time the order of things was reversed, the motor being much too fast, even with the resistance fully in use. Fierce use of the friction brake had to be resorted to. I found it hopeless trying to keep the image steady, so the immediate need was an extra variable resistance to bring the motor under better control. This I obtained, and also improved the friction brake, details of which may be of interest to others (see diagram B). Two pieces of wood are

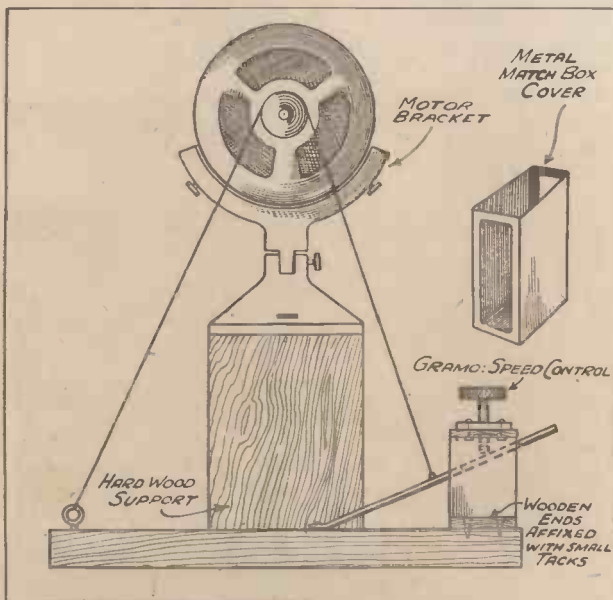

Diagram B.—An ingenious scheme for a friction brake used by Mr. Owers with considerable success.

cut to fit the end of the match-box cover, one piece being drilled to receive the gramophone control. The rod (which is U shaped so that the control bears on the groove) passes through the open sides of the box cover. The motor bracket, by the way, was pre-

viously a stand for a millimeter. I cut the upper part away, mounting the motor on the remaining half, the base being firmly screwed to the wood support. Diagram C shows the lens assembly, and needs no explanation.

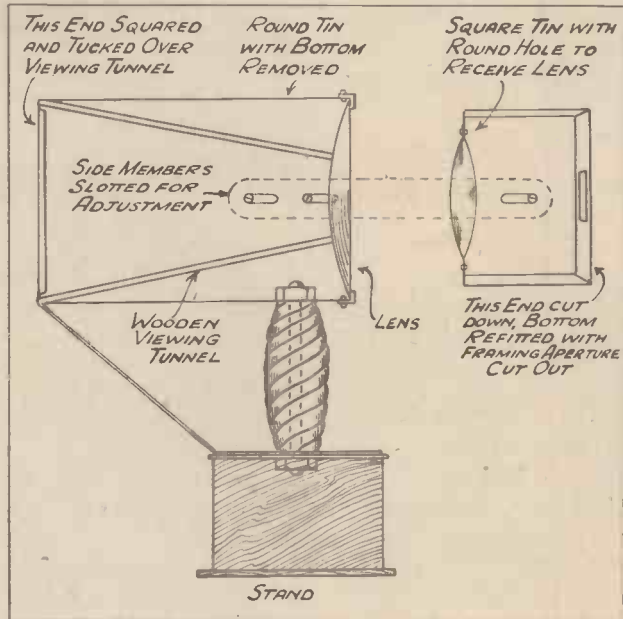

Diagram C.—Full details of the lens assembly employed for magnifying the television image.

"By running up the motor on the variable resistance and then adjusting the string brake, I can hold the image for long periods; an occasional turn on the control keeping it steady.

"I can now pay more attention to the adjustment of the wireless set, for I am able to turn away from the vision apparatus without 'losing' the motor in the process. Thus I can bring the detail out well by suitably altering the signal strength.

"My wireless set was built purely for moving-coil speaker reception—two S.G., grid-leak detector, R.C., and transformer, two L55A's in parallel. A large output eliminator supplies current to the set, so I have plenty of power to operate the neon.

"Hoping that this detailed account of my apparatus will help other TELEVISION readers, and looking forward to more and better programme periods."

### Interesting Experiences in Rugby

The reception from a television transmitting station of unknown wavelength has been the interesting experience of Mr. J. Foster Cooper, of 3 Barby Road, Rugby. Although he has made very special efforts in an endeavour to trace the origin of this station, which he presumed was American, he has not been successful, but we are sure readers

**PLEASE MENTION TELEVISION WHEN REPLYING TO ADVERTISERS**

will be glad to learn of Mr. Foster Cooper's work, and also of his hopes for the future.

We should like to congratulate our reader on his most commendable efforts, and trust that in the

"I also enclose a letter from *Jenkins Television* giving details of their transmissions.

"Since I last wrote to you in August I have completely rebuilt my vision apparatus, and have carried

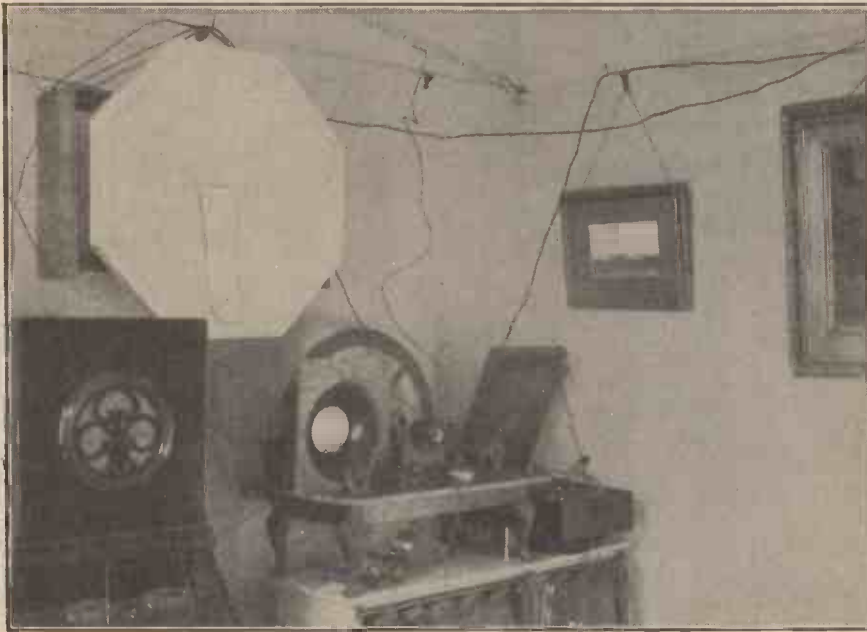

Mr. Foster Cooper's work has been featured on these pages before. Here we see his latest scheme for combined sound and vision reception.

New Year he will make rapid strides and give the benefit of his further experiences to others who are working for the television cause. In the course of his communication to us he says:

"I hope that these few details of my improved vision apparatus and circuit will be of interest.

"I have had an extremely interesting experience in the reception of television from some unknown station on short wavelengths, and I have been trying to find out the origin for some time. I enclose two letters from American publications concerning it, and there appears to be no definite answer,

out several improvements. The first of these was to cut spokes in the scanning disc. This brought up my motor speed considerably. I then decided to scrap the Pathoscope motor, and obtained a larger and more powerful one, made by the G.E.C. I have rebuilt the viewing tunnel, but it is not as yet properly fixed, for reasons which I will state later.

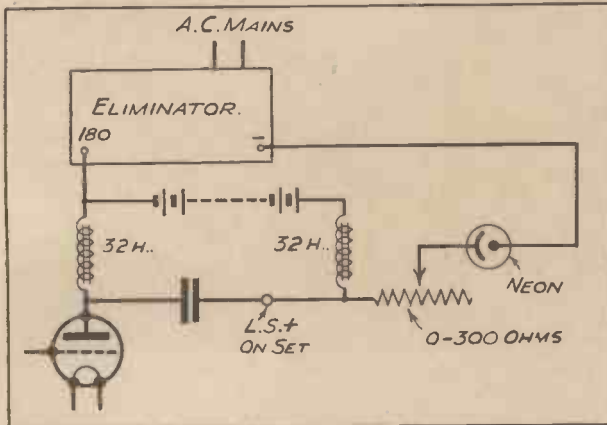

Striking the neon by the combined use of the mains and H.T. batteries.

as they both hold opposite views. Incidentally you will be interested to note that they do not agree about the details of the American standard transmissions!

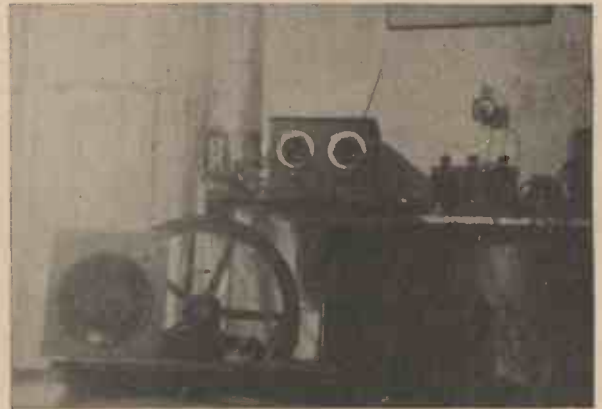

Marked improvements in reception is the claim made by yet another of our enthusiasts.

"The next job was to improve the wireless set, which is a G.E.C. World-Wide Four. This set, unfortunately, does not carry enough voltage on its last valve to be suitable for lighting the neon. It simply causes the pink light to travel up and down the plate, instead of modulating it properly.

"I have therefore struck the neon off the mains, using an eliminator plus H.T. batteries, as is shown clearly in the diagram.



"The resistance has to be adjusted very carefully to obtain results. I think the photographs show every detail. Notice that I have 'hitched' the old Pathescope motor behind the other, with a separate resistance to act as a brake for holding the picture.

"On a Friday night, after I had sat up for the Baird midnight transmission, I was working my short-wave set which I had been using with Mr. S. Falloon (details of whose apparatus you have already published), when I located apparent television signals between 30 and 40 metres. Unfortunately, as I have not calibrated my short-wave set in any way, I was unable to fix the wavelength. The time was between 1 and 2 a.m. With as much speed as was possible without waking the rest of the household, the short-waver was connected to a G.E.C. 2-valve set, and then to the amplifying portion of the 4-valve one, and so finally to the vision apparatus. Needless to say, when this was eventually

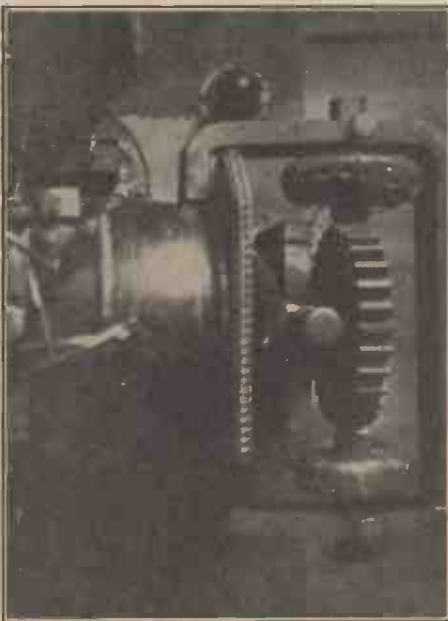

⊗ ⊗ ⊗  
*The synchronising gear is very rigid, being bolted firmly to the motor.*  
 ⊗ ⊗ ⊗

done, with a maze of wires and batteries, the station had closed down, or at any rate had stopped.

"On the following night, however, I got him again, much earlier (say 11 p.m.), and promptly switched on the television apparatus. To my surprise, however, the images, which were frightfully crude, and distorted almost beyond recognition, appeared right way up. Later they faded right away. In getting them I had to reduce motor speed to about ten pictures per second; the images were seen by three people, and appeared to be of one (or two perhaps) men who were moving about as if dancing. As I have no synchroniser, however, this may have been my motor. I have therefore the following data:

- (1) Wavelength 30 to 40 metres.
- (2) Vertical scanning.
- (3) Slower speed than Baird's; ten pictures per second approximately.
- (4) 45, 48, or 60 holes.

"I am inclined to believe that it was probably a 45- or 48-holed transmitter, which would, of course, cause very distorted images to move continually across the neon.

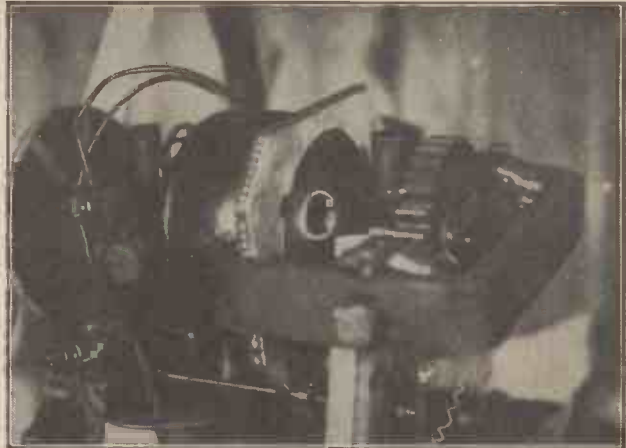

*For framing, the whole motor is rotated in the supports under its bearing bushes by a chain round the frame and a sprocket.*

"I have ascertained from Baird Television that it was no English transmitter, and the American publications seem divided in their opinions. (I wrote to *Popular Science*, *Radio News*, and *Jenkins Television*.)

"I intend soon to fit up my set for reception on the 80- to 150-metre band, and am preparing the necessary coils.

"In addition to this I am going to fit synchronising coils to my television apparatus, arrange my viewing tunnel so that it can be used either for vertical or horizontal scanning, and if necessary obtain a disc suitable for 60-hole transmissions (always supposing that I can get them first).



*A close-up of the viewing tunnel and lenses used by Mr. Foster Cooper.*

"Another possibility which has occurred to me is that of recording Baird vision transmissions on to aluminium discs, but I have not as yet attempted anything in this direction. Has anyone else? If he has, could he let me know whether he got any results?"

(Continued on page 442)



**QUERY:**

I am not exactly clear as to what is meant by a negative image. Will you kindly tell me how I can provide for this, and what steps must be taken in order to reverse the negative into a positive?

H. A. V.

**REPLY:**

A negative image is, as in photography, a condition brought about when the light portion of the image is dark and vice versa. If a negative image is obtained in the vision apparatus, then there are several methods whereby this condition can be rectified.

In some cases it is necessary only to reverse or interchange the output terminals from the receiver. Where a transformer precedes the last valve, then just reverse either the primary or secondary connections. If the wireless receiving set is R.C. coupled throughout, then change the method of rectification; that is, anode bend to leaky grid or vice versa, or alternatively add another stage of L.F.

As a general rule, it can be taken that an anode-bend detector, followed by an odd number of resistance-capacity coupled L.F. stages, will give a positive picture. In addition, a leaky-grid detector, followed by an even number of L.F. resistance-capacity coupled stages, will give a positive picture. For the fullest information on this problem may we refer you to Mr. H. J. Barton Chapple's article on page 258 of the August 1930 issue of TELEVISION?

**QUERY:**

I have just built myself some rather crude vision apparatus, and am using a three-valve set: S.G., D., and S.P. The neon lamp is a Philips beehive pattern (frosted 110 volts), and I am driving the scanning disc with a 6-volt motor with which I can get about 1,000 r.p.m.

On test I find I can get the image on the screen but cannot hold it at all. Is this due to not having synchronising apparatus on the machine?

At present I have only 120 volts with accumulators, but will be able to manage up to 300 volts

# Television's Query Corner

with same, and what voltage neon lamp will I require with 300 volts?

T. C. F.

**REPLY:**

Concerning your query with reference to the neon lamps, there is really no necessity to have another type of neon lamp when you increase your voltage, provided you include in series with that neon a resistance which will enable you to regulate the current passing through the neon. Until we know the value of the current which normally flows through your neon, we are unable to give you an approximate value for the resistance.

Your inability to "hold the image" is due entirely to the absence of any form of synchronising apparatus, and we would refer you to the current issue, and also the January and February 1930 issues, of our journal for details concerning electrical methods of working such a device.



*Not only is the neon lamp an essential part of television equipment but it can be made up into a form of tester with great ease.*

In addition, if you work this type of synchronising apparatus in series with the neon, we would point out that a current of about 20 to 25 milliamperes is generally necessary for passing through the coils. As an alternative, one can work the synchronising apparatus separately.

# Workshop Hints

By *Thos. W. Collier*

CONSTRUCTORS interested in these articles will have noticed that aluminium has been largely recommended as a suitable material for making the various parts described. This is due principally to the ease with which this metal can be worked, particularly in bending, a somewhat difficult operation with any other metal of equal

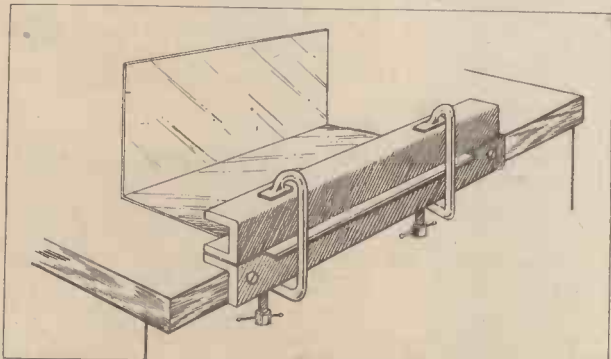

Fig. 1.—A length of angle iron and channel iron being used for the purpose of bending aluminium.

gauge. This is especially so if the length of metal to be bent is longer than the jaws of the vice, and therefore difficult to hold firmly. A convenient and inexpensive method of performing this otherwise difficult bending operation is to employ two lengths of angle or channel iron. Possibly the best arrangement would be one length of each. The angle iron

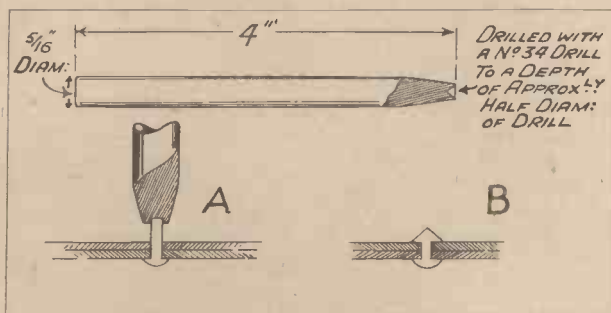
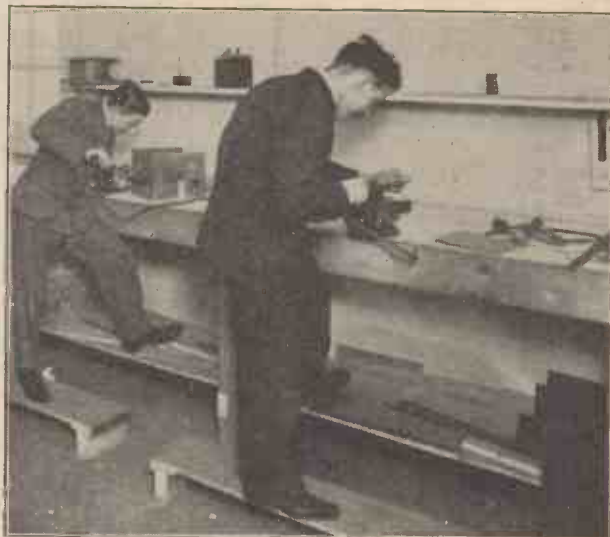

Fig. 2.—At A is shown a loose rivet about to be fastened, and B the finished job.

can be screwed down permanently to the edge of the bench, and the channel iron clamped in position when required (see Fig. 1).

It is advisable to drill only two screw holes in the angle iron for securing to the bench, and these should be near the ends, as any metal which has to be bent over a screw head, even though it may be



flush with the face of the angle, will bear an impression which may be difficult to remove.

## Soldering Difficult

The greatest disadvantage which aluminium has against other metals is the difficulty of soldering, which, although by no means impossible, cannot be accomplished with the same simplicity as with the ordinary soldering iron when used on brass, copper, or tinplate. There are, however, several other ways by which two or more pieces can be joined together more or less permanently. These are screws and nuts, riveting, and beading or seaming. Riveting is probably the most satisfactory method of the three, both from the point of view of neatness and rigidity; so perhaps the following hints may be useful.

For light work, such as screening boxes, cases for radio receivers, or metal covers for your television receiving apparatus, small aluminium rivets

## PROTECT YOUR APPARATUS AGAINST DAMAGE



The MICROFUSE is a GOLD FILM—not a wire  
The fastest-blowing fuse known

Any rating from 50 milliamps to 500 milliamps :	
Fuse and holder complete ..	12/- per dozen
Fuse only .. .. .	6/- per dozen
<b>Special Light Fuses.</b> To fuse at 25 milliamps	1/- each
.. .. . 10 ..	2/- ..
.. .. . 5 ..	3/- ..

## MICROFUSES, LTD.

36, CLERKENWELL RD., LONDON, E.C.1

Telephone : CLERKENWELL 4049

$\frac{1}{8}$  in. dia. by  $\frac{1}{4}$  in. or  $\frac{5}{16}$  in. long will do quite well, the length depending upon the thickness of the material used. The only tools required are a light hammer and a rivet set, and the latter may be purchased or made at home.

### Riveting

A short piece of iron or mild steel is required

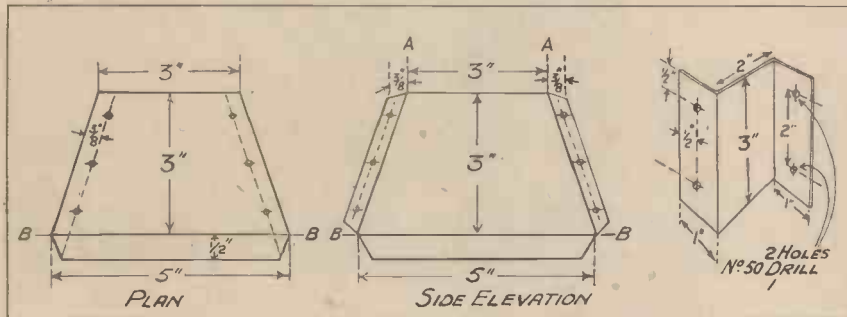

Fig. 3.—The plan and side elevations of the viewing tunnel elements. Bend on all lines marked A in the same direction, and on all lines marked B in the opposite direction.

about 4 in. long by  $\frac{5}{16}$  in. dia. File up the ends, spot off one end with a centre punch and drill down with a No. 34 drill to a depth equal to approximately

Fig. 2). Use a No. 50 twist drill for drillings where a  $\frac{1}{8}$ -in. rivet is to be used, and a larger drill for burring the holes after drilling. This is very important, and great care should be taken to ensure that no chips are left between surfaces to be riveted.

Paraffin or turps will be found a good lubricant for use when drilling or tapping aluminium; this prevents breakages due to clogging and leaves a bright clean hole or thread.

### Viewing Tunnel

A viewing tunnel is a useful component, its chief function being to screen off all the unwanted glow from the neon lamp, thereby permitting the picture to be viewed with comfort. The one described here can be arranged for fitting directly to the lens mount described in the last issue, or may be fitted permanently to the inside of a cover. The only difference will be the addition of suitable brackets for fixing to the lens mount.

Suppose we wish to make a tunnel 5 in. by 5 in. at the front, tapering to 3 in. by 3 in. at the back. The correct way to construct this, after having decided on the depth from front to back, which we will call 3 in. for the purpose of illustration, would be to mark out the whole in one piece and bend where necessary. This would be a lengthy matter to describe, however, and probably be too difficult for the amateur to accomplish. I propose describing the construction by a far simpler method. Fig. 3 shows the plan and side elevations as they should be marked out; bend on all lines marked A in the same direction, bend on all lines marked B in the opposite direction, drill the rivet holes, putting one hole and one rivet in first. This of course will help you to keep the parts in position during the further operations.

The lips or edges bent up on the 5-in. dimensions are intended for fixing the tunnel to the inside of the case, and should be drilled accordingly. If it is not desired to fit this way they should be folded right over, thus forming a rounded edge to the front. If, however, you wish to fit the tunnel to the lens mount, previously described, the brackets also shown in Fig. 3 should be made and additional riveting holes drilled in the two sides of the tunnel, using the bracket drillings as a template. Finally, a coat of dead black paint should be given.

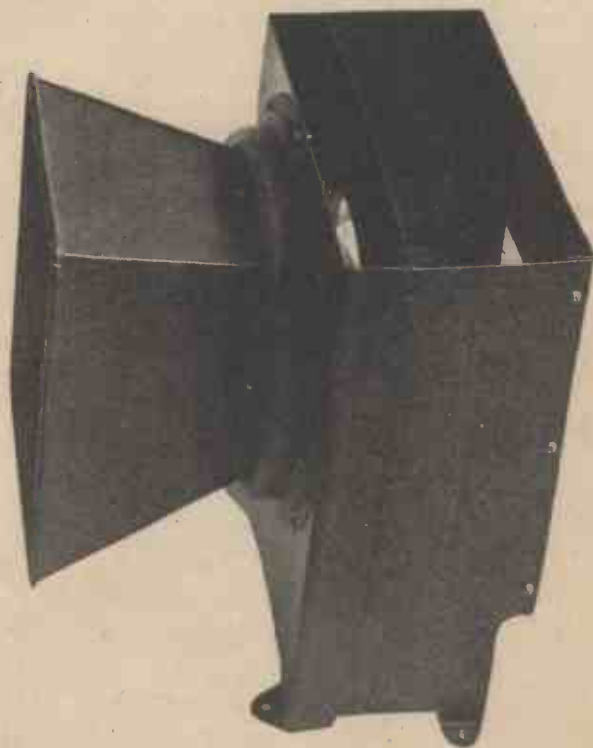

The viewing tunnel marketed with the Baird kit of components.

half the diameter of the drill. This will answer quite well for a rivet set, the form of the rivet head being taken from the drilled end of the rod (see

**PLEASE MENTION TELEVISION WHEN REPLYING TO ADVERTISERS**

# The "Tele-Power" Junior Unit

By

*H. J. Barton Chapple, Wh.Sch., B.Sc.(Hons.), A.C.G.I.,  
D.I.C., A.M.I.E.E.*

I HAVE naturally been quite gratified with the success of the "Tele-Power" Unit which I designed and described in the September 1931 issue of TELEVISION. Not only have I had several communications from readers on the subject, but the Baird Company reprinted the article in booklet form, and distributed it at the Radio Exhibition held at Olympia.

## *Economy*

Several inquiries have reached me, however, asking whether it is possible to build a unit of similar characteristics but at a somewhat cheaper price. We all realise that in these days when economy seems to be the watchword certain experimenters are working under a handicap. I have therefore been giving the matter a good deal of thought lately, and called a temporary halt in my work on the "Tele-Radio" receiver in order to evolve a piece of apparatus which would include the barest of components, and yet represent only a small sacrifice in quality when compared with the senior model referred to previously.

This has now been completed, and I have pleasure in presenting the "Tele-Power" Junior Unit, which I am sure readers will find of great utility in their experimental work. Its functions need not be gone into very thoroughly here, for they were set out in detail in the September 1931 issue, and I strongly advise readers to refer to that article in conjunction with the present one.

## *The Circuit Explained*

Referring now to the circuit connections shown in theoretical form in Fig. 1, the following observations can be made. An extra stage of low-frequency amplification is given, the coupling from the anode of the last valve in the particular set used for vision reception being via the 1 mfd. fixed condenser  $C_1$ .

It is advisable to indicate here how the connections

are made to the wireless receiver. Both commercial and home-made receivers today have one of three types of output, namely choke feed, transformer feed, or direct feed. These are illustrated simply in Fig. 2 as *A*, *B*, and *C* respectively, the usual terminals across which the loud speaker is connected being shown.

For the

choke-feed set all we have to do is to ignore the fixed condenser which normally by-passes the L.F. signal pulses to earth through the speaker, and make our flex connection from  $C_1$  direct to the junction between the anode of the last valve and the L.F. choke. The second connection is made by joining the lead marked earth in the "Tele-Power" Junior Unit to the earthed L.T. connection on the set.

## *Joining to the Receiver*

Coming to case *B*, namely transformer output, the earth connection is as before, but we now regard the primary winding of the transformer as an output choke and join the lead from  $C_1$ , exactly as indicated

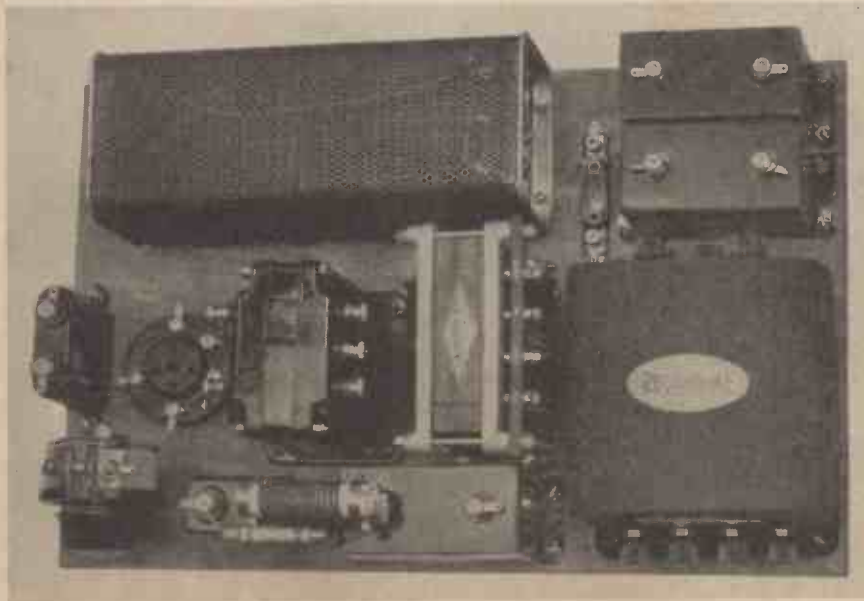

*Showing how all the components of the "Tele-Power" Junior Unit are laid out on the baseboard prior to commencing the wiring operations.*

dotted in Fig. 2 B. Finally for direct output we must make the coupling a resistance-capacity one instead of a choke-capacity one. This is done simply by adding a power resistance  $R$  (shown dotted) across the normal loud-speaker terminals and adding the connections shown dotted in Fig. 2 C. The

characteristics and data of the Mullard DO/25 have been revised. The filament is now rated to consume 1.1 amperes at 6 volts, and not 1.8 amperes as previously. This power is supplied by a special secondary winding on the mains transformer  $T_2$ , and the centre tap on this winding becomes the

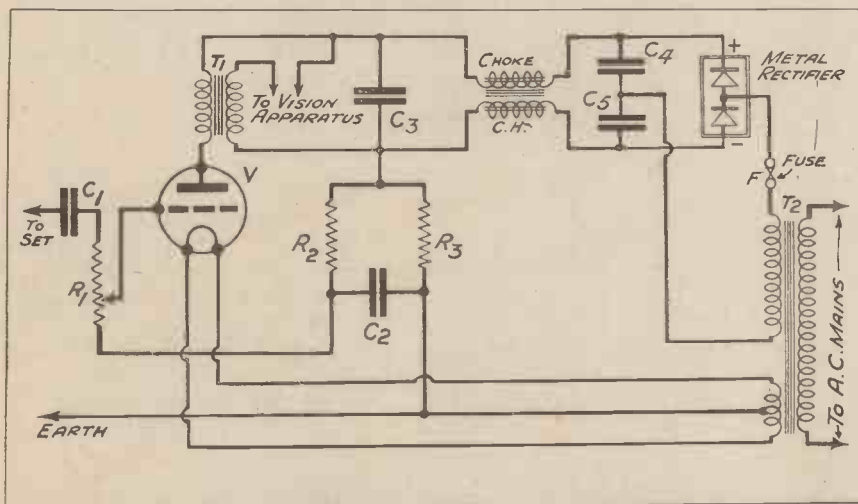

Fig. 1.—Readers are advised to study this theoretical diagram in conjunction with the text. In this way they will familiarise themselves with the working of the "Tele-Power" Junior Unit.

value of this resistance is not critical, but should be chosen according to the rated impedance of the set's output valve, being generally two to four times this value in ohms.

Reverting now to Fig. 1, the resistance  $R_1$  is a 100,000-ohm potentiometer which provides a very smooth and most effective volume control to regulate the signal strength judged finally as the television image. The valve  $V$  is of the super-power class, actually a Mullard DO/25. Grid bias for this valve is applied automatically. This saves any

common earth connection between the unit and the set used for vision reception.

Constructors of the first "Tele-Power" Unit using the new DO/25 must therefore note that the grid-bias resistance they use is of 1,500 ohms resistance, and not 1,750 ohms as originally specified, and the filament secondary winding has to be wound to suit 6 volts and 1.1 amperes and not the 1.8 amperes which was correct for the old valve.

In the plate circuit of the valve  $V$  we have a

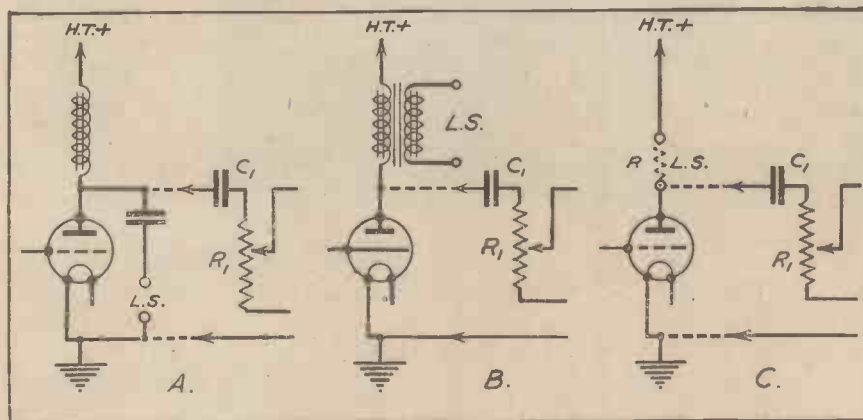

Fig. 2.—Giving three alternative methods for joining the unit to the vision wireless receiver. The method chosen depends upon the output connections of the set.

both with batteries, and incidentally is quite definite in action.  $R_3$  is the actual biasing resistance of 1,500 ohms, and must be capable of carrying the full anode current of the valve. The 2-mfd. condenser  $C_2$  and the 100,000-ohm resistance  $R_2$  constitute the "decoupling" arrangements which must always be fitted when working the valve in this way.

Ferranti OPM1 transformer  $T_1$ . The primary winding is connected up in the usual way, while the secondary on one side passes to the vision apparatus (neon and synchronising coils if the latter are incorporated and are in series with the neon), while the other side passes to H.T. —.

### An Important Point

Since I designed the last "Tele-Power" Unit the

### Rectifying and Smoothing

The voltage and current feeding both the neon of the vision apparatus and the plate of the DO/25

valve are furnished by an H.T.8 Westinghouse metal rectifier. This is very conservatively rated by the makers to give 60 milliamperes at 250 volts after smoothing when joined up in the manner shown, namely as a voltage doubler, and just suits our purpose.

The valve takes 35 milliamperes and the neon 25 milliamperes, a division that on test works well. On the other hand, the constructor who desires to vary his neon current can include a variable resistance in series with the flex leads marked "to vision apparatus," but this is largely a question of taste.

The mains transformer has been made up for me specially by the Regentone Company, and is essentially their standard W.R.8 power transformer with the addition of a further centre-tapped secondary winding giving 6 volts 1:1 amperes across the two outer terminals. One side of the main secondary winding passes to the junction of the two 4-mfd.

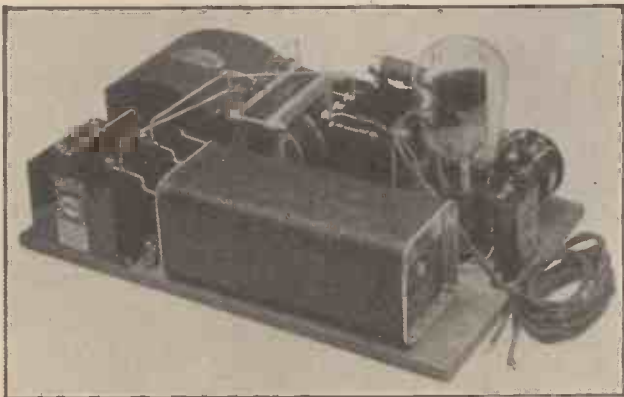

The "Tele-Power" Junior Unit wired complete and ready for test.

condensers,  $C_4$  and  $C_5$ , while the other side is connected to the A.C. terminal of the metal rectifier after the fuse  $F$  has been included. This fuse is a new flat type made by Microfuses, Ltd., and although rated at 200 mA. corresponds to their 300-mA. cartridge type as used in the previous unit. The value of a protective fuse must not be overlooked; it forms a cheap form of insurance to the expensive components if for any reason an overload occurs.

The positive and negative terminals of the rectifier are marked plainly, and care must be taken to see that it is connected the right way round. The raw but rectified A.C. is smoothed by being fed through a heavy-duty Parmeko choke ( $Ch$ ) wound in two halves so that one leg is in each side of the circuit. Join these legs up correctly, or the resulting choking effect will be materially reduced.  $C_3$  completes the circuit, and of course functions in the usual way as a reservoir condenser.

### *The Components Employed*

All the components which have been employed are detailed below, together with the names of the manufacturers. In addition the symbol representing each component, in both the theoretical and wiring diagrams, has been included to enable the

# DUBILIER

CONDENSERS  
AND RESISTANCES

are

specified

for the

"TELE-POWER"

JUNIOR



To ensure the best results, together with absolute reliability and permanent accuracy—use Dubilier Resistances and Condensers in your receivers. The name Dubilier is your guarantee of scrupulous care in manufacture and stringent testing before despatch. Your dealer will tell you—it's worth while to build with Dubilier.

# DUBILIER

CONDENSER CO. (1925) LTD.

Ducon Works, Victoria Road, N. Acton,  
London, W.3.

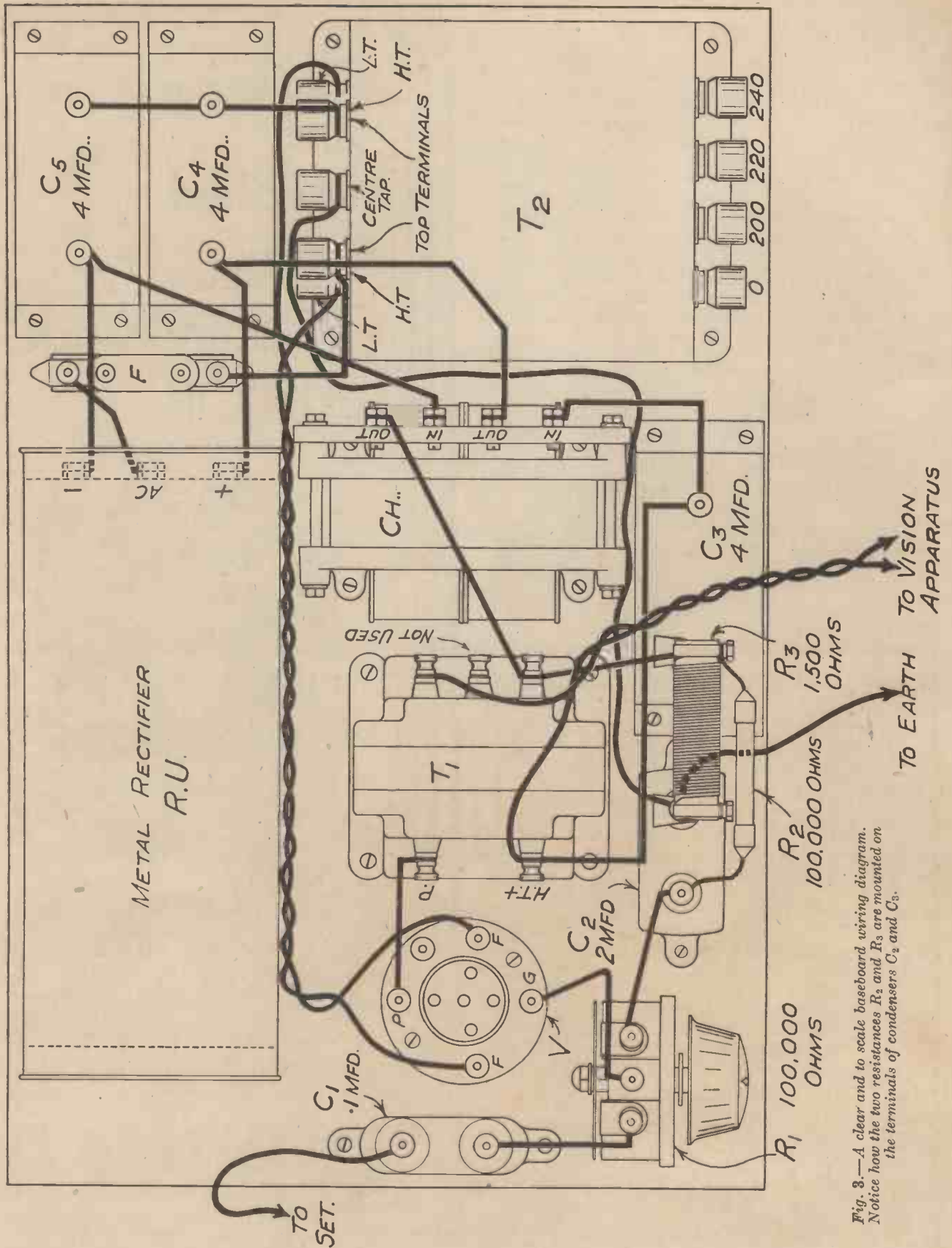

Fig. 3.—A clear and to scale baseboard wiring diagram. Notice how the two resistances  $R_2$  and  $R_3$  are mounted on the terminals of condensers  $C_2$  and  $C_3$ .



reader to see exactly where each item is placed. Since the unit is very compact, alternative components are not recommended, owing to possible difficulties arising from different component sizes. If such a course is taken however, be sure the substitutes are efficient and reliable.

One mains transformer as specified and to suit your own A.C. house mains ( $T_2$ ). (Regentone, Ltd.)

Three 4-mfd. mains type condensers ( $C_3, C_4, C_5$ ). (Formo Co., Ltd.)

One 2-mfd. type BB condenser ( $C_2$ ). (Dubilier Condenser Co. (1925), Ltd.)

One 1-mfd. type B775 mica condenser ( $C_1$ ). (Dubilier Condenser Co. (1925), Ltd.)

One heavy-duty smoothing choke, type 2 ( $Ch$ ). (Partridge & Mee, Ltd.)

One anti-phonic valve holder. (Whiteley Electrical Radio Co., Ltd.)

One volume control, 100,000 ohms ( $R_1$ ). (A. F. Bulgin & Co., Ltd.)

One metal rectifier, type H.T.8. (Westinghouse Brake & Saxby Signal Co., Ltd.)

One output transformer, type OPM1 ( $T_1$ ). (Ferranti, Ltd.)

One flat-type fuse, "Microfu," 200-mA. rating, with holder ( $F$ ). (Microfuses, Ltd.)

One 1-watt resistance, 100,000 ohms ( $R_2$ ). (Dubilier Condenser Co. (1925), Ltd.)

One power resistance, 1,500 ohms ( $R_3$ ). (A. F. Bulgin & Co., Ltd.)

One super-power valve, DO/25 ( $V$ ). (Mullard Wireless Service Co., Ltd.)

Quantity of Glazite connecting wire and twin flex. (London Electric Wire Co. & Smiths, Ltd.)

One wooden baseboard 14 in. by 9 in. by  $\frac{3}{8}$  in.

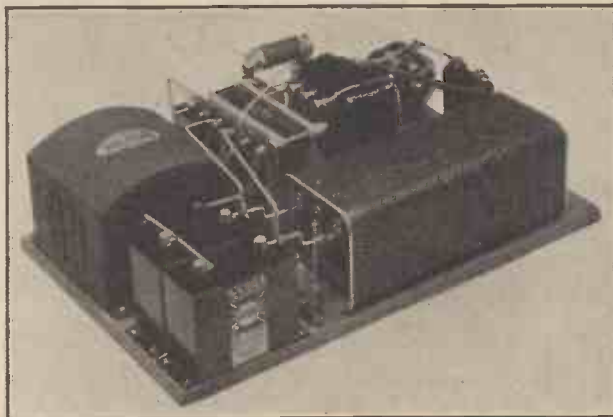

*The neat right-angled bends of the wiring are shown clearly. Note also the fuse between the rectifier and fixed condensers.*

### *The Lay-out Described*

The components which I have just listed must be laid out very carefully on the baseboard, and I advise the constructor to follow the wiring diagram of Fig. 3 and to use the accompanying illustrations to help matters still further. Note that the feet of the Ferranti OPM1 transformer have been reversed to bring the terminals to the top.

*(Continued on page 437)*

# WHEN IT'S RESULTS THEY WANT YOU WILL NOTICE THEY CHOOSE

# PARMEKO

When he designed the "Tele-Power" Junior Unit described in this issue, Mr. Barton Chapple was concerned with only one thing—PERFORMANCE. That is why a "PARMEKO" No. 2 SMOOTHING CHOKE is specified.

You will notice it all along the line—when the best results are wanted, "PARMEKO" components are used. Remember this when you are buying—and do not be tempted to save a few coppers on cheaper apparatus. The saving is soon forgotten, but the second-best results remain. Insist on "PARMEKO," and have no regrets.

## PARTRIDGE & MEE LTD.,

74, New Oxford Street, LONDON, W.C.1 (Phone: MUSEUM 5070) & Leicester (Phone: LEICESTER 22276).



# The Television Society

THE THIRD MEETING, HELD ON  
WEDNESDAY, DECEMBER 9th

ON December 9th the usual monthly meeting of the Society was held in University College, London, at 7 p.m. Preceding it, at 6.45 p.m., members met in response to the call for an Extraordinary General Meeting, in order to pass a resolution, recommended by Council, to revise the annual subscription payable by certain members. A motion to increase the subscriptions of associates to fifteen shillings and students to ten shillings per annum was passed without dissent. The Chairman, Dr. Tierney, stated that the increase was demanded by the progressive activities and the standard of work of the Society, but in spite of the voluntary work of members in connection with Lectures, Exhibitions, the Index of Literature, the Journal, and the entirely honorary services of all Officers, there were expenses of postage and printing, etc., which were unavoidable, as neither the G.P.O. nor the printers had as yet made known that their honorary services were available.

## *Echo Signals in Transatlantic Picture Telegraphy*

The meeting which followed gave rapt attention to an exceedingly thorough paper read by H. M. Dowsett, Esq., M.I.E.E., F.Inst.P., M.I.R.E. (Fellow), the subject being as above mentioned.

It is impossible in a short report to do justice to the amount of data referred to, or to the methods and results of the intensive research work of the Marconi and associated companies, who have so kindly granted their permission to publish their results through the Society.

Mr. Dowsett carefully described curves by aid of lantern slides, by way of illustrating his paper, and showed the relationship of Echo signals, both as to time-lag and intensity, in connection with day and night hours, and solar activity generally; also effects comparable when using long- or short-wave transmissions.

A physical picture of the Heaviside layer was effectively suggested, and the investigations by the Marconi Company of short-wave propagation phenomena during the period 1925-31 were described. As also were the Facsimile Echo tests at Somerton—New York on 16 and 32 metres 1928-9; Montreal, similarly 1931, and Cape Town on the same wavelengths 1931.

As the paper progressed, it became obvious that organised research on Echo signals will make available a new tool for the physicist to apply in the search for information regarding the upper layers of the atmosphere, and the relation of cosmic influences to the electrical and magnetic variations that surround us.

In conclusion Mr. Dowsett suggested the best times for transmitting Television and Facsimile signals over long distances, and forecasted the likely variations of suitable wavelengths in the future.

Dr. Tierney complimented the lecturer on his sincere and successful effort, and said that he hoped the full paper could be published in the journal of the Society.

A very hearty vote of thanks followed.

All interested in the subject should read the paper which will be published in the journal of The Television Society, and posted free to all paying members after January 1st. This is a good date for new members to join the Society, and for full particulars and conditions of membership apply to the Joint Secretaries, Television Society, 4 Duke Street, Adelphi, W.C.2.

## FORTHCOMING LECTURES

A special course of nine lectures on television will be given at the Borough Polytechnic, S.E., by Mr. J. Denton, A.M.I.E.E., commencing January 21st, 1932, at 8 p.m.

The lectures will deal with recent research, developments, and practice at home and abroad.

Full particulars can be had on application to The Principal, The Borough Polytechnic, Borough, S.E.1.

**P**ARTS for experimenters. Scanning Discs, 12/6; Baseboards with slot and four feet, 12/-; Viewing Lenses, per pair, 13/-; Motors, 35/-; Phonic Wheels, 3/6; Magnets and Bobbins (unwound), 3/- per pair. JOHN SALTER (Established 1896), Featherstone Buildings, High Holborn, London, W.C.1.

**A**DOSSETT, Commercial Artist and Draughtsman for all technical diagrams, illustrations and layouts.—HAZLITT HOUSE, Southampton Buildings, Chancery Lane, London. Holborn 8638.

# Scanning or Exploring

"SCANNING," a common term in television, believed by many people to be something new, is really as old as man. The human eye has always scanned and always will.

When we look at a picture or a scene we do not see it all at once; we see only a tiny spot. Our flexible, efficient eyes rapidly travel across and up and down a given scene, registering the various points so rapidly that a complete picture seems to be seen.

It is easy enough to test this.

Hold your hand straight out in front of you and then look at the thumb-nail.

Now, without shifting your eyes in the slightest, try to see how much else you can see, clearly, not just suggested, but vividly. You will find that the area comprising your thumb is about all that is sharp.

Now open your hand and decide you want to see all of it. As you do, notice carefully what your eyes are doing and you will see that they are swinging back and forth in various directions until they have covered every bit of your hand. Now you have a very definite picture of what your hand looks like, yet it was obtained piece-meal.

Taking something more concrete, more nearly like what a television camera must pick up, let us look at a motion picture.

As the action goes on, you seem to see what is happening on the whole screen, but if you will pick out a single spot on the screen and look at it without moving your eyes, as you did when looking at your thumb-nail, you will find you are actually seeing but a small part of the picture clearly, the rest being in sort of out-of-focus relation to the main spot of vision.

The human eye, however, moves so quickly that it takes in the whole picture in a series of rapid glances, and the memory retains these pictures, each piece in its proper place, and the effect seems to be a whole, complete picture.

In television the same thing takes place, the television camera rapidly scanning a scene, which in turn is reproduced in the same order by the television receivers. Of course this scanning is much more rapid than the human eye, as the scanning spot cannot pick up as much detail as the human eye will register correctly at one instant, and so must travel faster to get in all the points.

Another point of difference is that the human eye needs no definite routine to follow in scanning a scene, for it may move across the top, then down to the bottom and across there, then up to an angle from the lower left to the upper right corner, etc. In television, as in anything mechanical or electrical, an accurate pattern must be followed to be repeated in rapid succession, and in order that at the receiver the same pattern may be followed and a picture reproduced which will be the same as the picture picked up at the transmitter.

Thus, while television may seem to be a far cry from any human parallel, it actually follows the human eye more accurately in its procedure than does a camera, which takes in all at once a complete picture.

Eye scanning is a fascinating thing to experiment with, and should offer a lot of fun for the person who likes to contemplate television problems. Since the apparatus is already part of one's body, there is no cost involved.

## MUSIC ROOMS OF THE FUTURE

The music-room of the "gay 'nineties" may have its counterpart in the electrical home of the future.

Dr. W. E. G. Baker, Vice-President of the R.C.A.-Victor Company of Camden, New Jersey, foresees such a possibility.



*With the apparatus illustrated, scanning (or exploring) is carried out by a flying spot whose movement is controlled by a perforated disc running before an arc lamp.*

"The day is in sight when every new home costing £2,000 or more will have a room fitted up exclusively for radio-electrical entertainment," he declares.

"The 'home theatre' will become another home institution. Television and home talkies will share a room with a wireless news bulletin and talking books that read themselves aloud to those who wish to save their eyes."

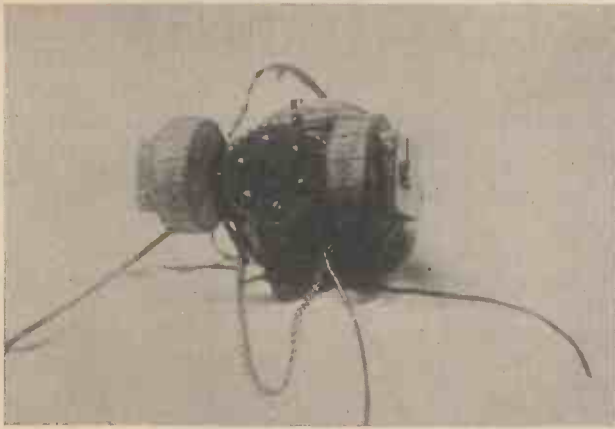

# A Simple Magnetic Corrector\*

By *A. R. Knipe*

**I**N the course of experiments with television, the writer soon realised that some sort of automatic control was necessary to keep the image in view whilst making adjustments to the receiving amplifier. Not having access to a gear-cutting machine, the method of construction described below was adopted.

If these details are followed it will be found that the magnetic corrector will comfortably hold in step a 20-in. disc when a current of 25 to 30 mA. is passing through the field coils.

Although a fair amount of patience is required in taking the job in hand, the cost of the materials is quite small.

*Materials required.*—The materials employed are briefly as follows:

Eighteen pieces of 22 S.W.G. sheet iron about  $2\frac{5}{8}$  in. square.

One piece of  $\frac{1}{16}$ -in. sheet iron or mild steel about  $2\frac{5}{8}$  in. square.

$3\frac{1}{4}$  in. of  $\frac{1}{2}$ -in. dia. mild steel rod.

Eleven No. 4 B.A. round head steel screws,  $\frac{3}{4}$  in. long.

One piece of brass 2 in. dia. and about 1 in. long.  
One piece of mild steel or wrought iron  $1\frac{1}{2}$  in. wide by  $\frac{3}{8}$  in. thick. (This can be procured from the local blacksmith and bent to the shape shown in Fig. 2 for about one shilling.)

One brass bush to fit the end bearing of the motor in use (or alternatively a piece of rod for making a bush).

The first step is to mark out very carefully the  $\frac{1}{16}$ -in. mild steel plate as shown in the left-hand side of Fig. 1; this forms the template or jig from which the 18 iron plates are drilled.

It will be seen that an outer ring of 30  $\frac{5}{8}$ -in. dia. holes are drilled on a diameter of 2 in. and an inner

\* The synchronising apparatus described in this article is covered by Letters Patent No. 336655, and publication of the article does not authorise manufacture for sale or for any other purpose than that of personal experimental use. (Ed.)

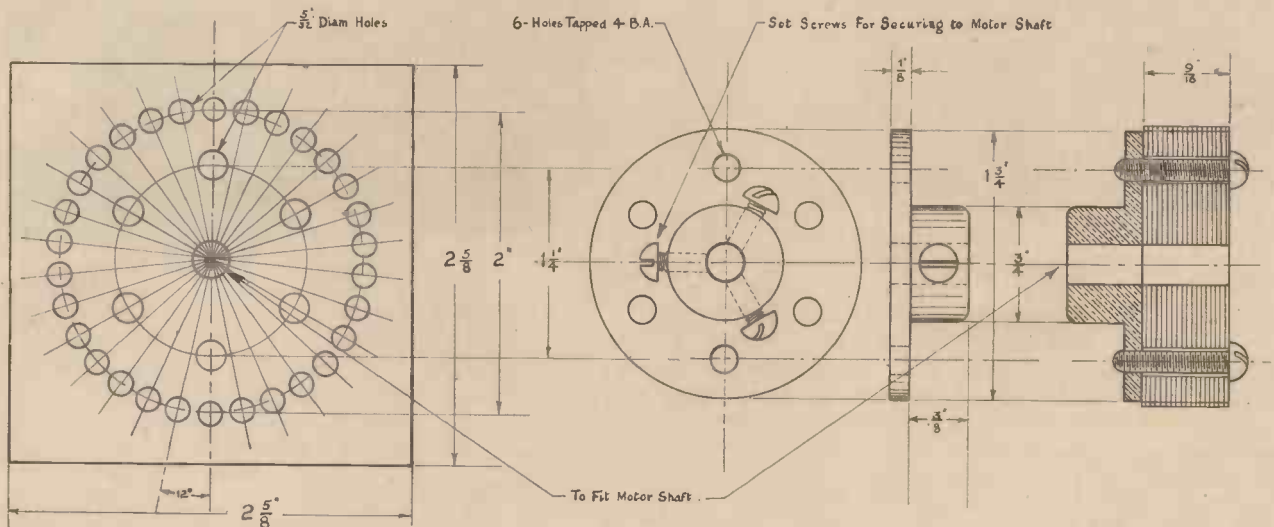

Fig. 1.—Complete details for marking out the individual pieces of sheet iron which form the toothed-wheel laminations. In addition the assembly of these plates is indicated on the right.

ring of 6  $\frac{5}{32}$ -in. dia. holes are drilled on a smaller diameter of  $1\frac{1}{4}$  in. The hole in the centre of the plate must be drilled to be a good fit on the motor shaft to which the magnetic corrector is to be fixed.

A good way of making this jig is to mark out as carefully as possible, on a piece of tin or aluminium (using a large protractor and a fine pointed scriber) the 30 radial lines 12 degrees apart. Then drill the centre hole and the outer holes with a small drill.

a centre hole to suit the short bolt. The bolt is now passed through the tin disc, and one of the plates put on and a scriber run round the circumference of the tin disc. After all the plates have been treated thus, they may be each cut out with shears round the 2-in. scribed line, *i.e.* through the centre line of the outer ring of holes.

It will now be seen that we have a set of 18 more or less rough thin-toothed wheels.

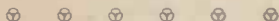

*The Baird Company hold patents dealing with the magnetic toothed-wheel synchroniser, and their own product is illustrated here together with the motor, brackets, and framing spindle.*

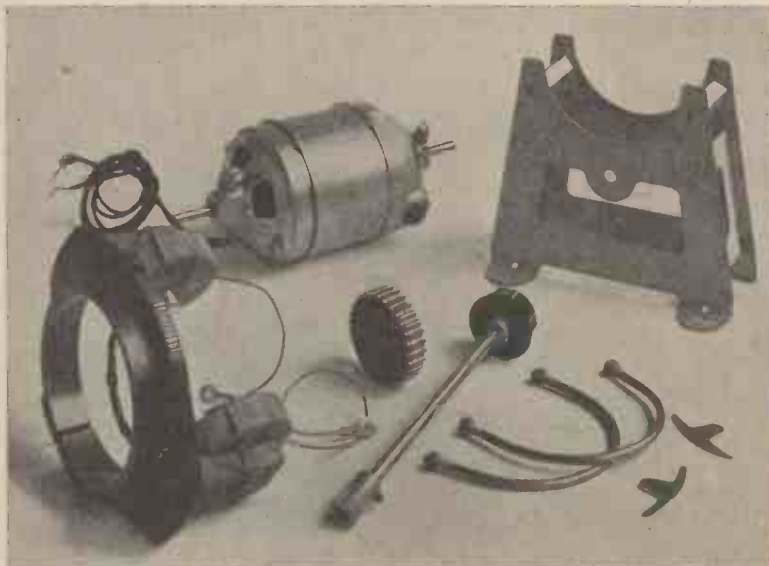

This template may now be clamped to the  $\frac{1}{8}$ -in. plate, and a small drill put through all the holes. The template is next removed, and all the holes very carefully enlarged to their correct size. (The centre one of a size to suit the motor spindle, and the two rings of holes  $\frac{5}{32}$ -in. dia.)

While the holes are being enlarged, any small errors made in the marking out process may be corrected. The steel jig from which the 18 iron plates (which form the laminations of the toothed wheel) are to be drilled is now finished, and should appear as the left-hand side of Fig. 1.

The 18 iron plates are next dealt with, a hole being drilled in the centre of each, and a short bolt obtained which is a good fit in the centre hole. Three of the iron plates may now be taken and placed underneath the steel jig, the bolt being passed through the centre hole and the nut tightened. The assembly of plates and jig is then clamped with a hand vice, and all the holes drilled  $\frac{5}{32}$  in.

### *Drilling Precautions*

The 3 iron plates may now be removed and another group of 3 clamped up and drilled as before, and so on until all the 18 are drilled. Before each group is removed from the jig, each plate must be marked in some way so that its position on the drilling jig is known. The reason for this will be seen later.

Having drilled all the plates and filed off the burrs brought about by the drilling process, the plates may be placed in a dying fire and allowed to cool down with the ashes to soften them.

Next a 2-in. dia. circle of tin is cut, having

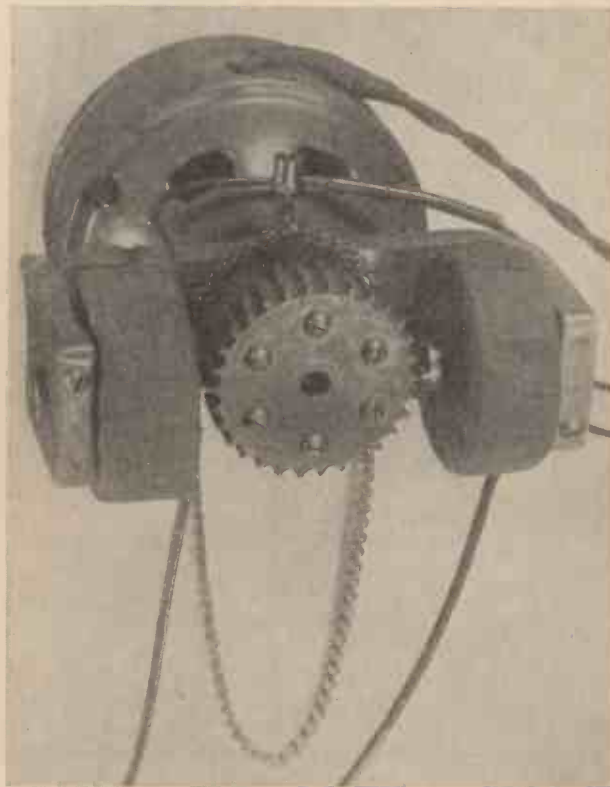

*"Framing the image" is carried out by means of a Meccano chain and sprocket wheel.*

## The Toothed-wheel Mounting

The brass boss for mounting these plates should now be made. It is shown in Fig. 1, and is simply turned up from the 2-in. dia. brass given in the list of materials, or alternatively built up from a disc of brass riveted and screwed to a short length of  $\frac{3}{4}$ -in. dia. brass rod. Whichever course is adopted, the centre hole must be a good fit on the motor spindle, and the 6 holes shown in the sketch tapped No. 4 B.A., drilled to register with the inner ring of holes on the jig.

## Assembling the Plates

One of the iron plates is now given a coat of shellac varnish on one side, and 6 No. 4 B.A. screws passed through the 6 inner holes, another plate var-

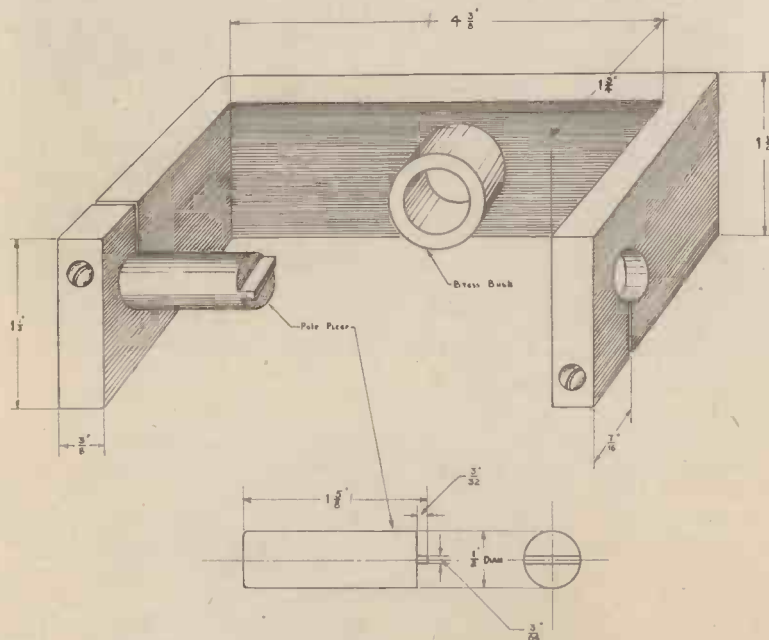

nished and laid on top and so on until all the plates are assembled.

It has no doubt been seen by now that it is not possible to make an accurate toothed wheel by the method outlined above, and some of the teeth will be slightly broader than others, due to the difficulty of drilling 30 equidistant holes. However, the writer overcame the difficulty in the following manner:

After the 6 screws are passed through the first plate, the next plate is laid on top so that the mark made in the drilling process is *one-sixth of a revolution* from the mark on the first plate. If each plate is assembled in this manner it will be found that the errors more or less cancel each other out, and this is the reason for marking the plates before removing from the drilling jig.

The assembly of plates and boss may now be slipped on to a mandrel and the tops of the teeth trued up, the gaps between the teeth being trimmed up with a small round file. The toothed wheel is now complete.

The pole pieces are made from the piece of  $\frac{1}{2}$ -in.

dia. mild steel, according to the dimensions given in Fig. 2, the pole faces being cut away to a width of about  $\frac{3}{8}$  in., taking care to keep the faces quite square.

## The Field Magnet

Little need be said about the field magnet forging, as the perspective sketch (Fig. 2) is self-explanatory, and no doubt this will have to be modified to suit existing motors. In the writer's case the outside of the end bearing of the motor was turned true and a brass bush bored to fit and driven into the hole in the back of the field magnet, thus enabling the field magnet to be moved round on the motor for "framing" the image. As will be seen from the photograph, this is accomplished in the writer's case by a

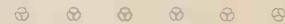

Fig. 2.—This sketch of the field-magnet forging is almost self-explanatory. Dimensions for the pole pieces are given at the bottom, these being made from  $\frac{1}{2}$ -in. dia. mild steel.



Meccano chain and sprocket wheel, the sprocket wheel being screwed to the field magnet. The coils for the field magnet are made by winding the wire on cardboard bobbins, which are then taped up and pushed on to the pole pieces.

When the field magnet is assembled on the motor, the two-pole pieces should approach the toothed wheel as closely as possible without actually touching it. If necessary, the centring of the wheel on the shaft may be slightly altered by adjusting the tightness of the three fixing screws in the boss, also the tops of the teeth may be very carefully trimmed in place with a fine flat file. The pole pieces are of course finally locked in position by the screws in the slotted ends of the field magnet.

It will be found that, with the normal current through the neon lamp and field coils, on turning the scanning disc by hand a distinct pull is noticed as the teeth pass the pole pieces, and often the pull is sufficient to move the scanning disc should the wheel have been stopped with the pole pieces between the teeth.

## The "Tele-Power" Junior Unit (Concluded from page 431)

There is no room to spare, and a great deal of time was spent before the final form was decided upon. Most of the arrangement is perfectly straightforward, but there are one or two points which call for a little additional explanation.

First of all the volume control  $R_1$  is mounted on a small right-angled bracket, so that the centre is

*The twin flex is joined to your vision apparatus, while the single rubber-covered flex is the earth lead. Note the twisted leads passing to the filament terminals of the valve holder.*

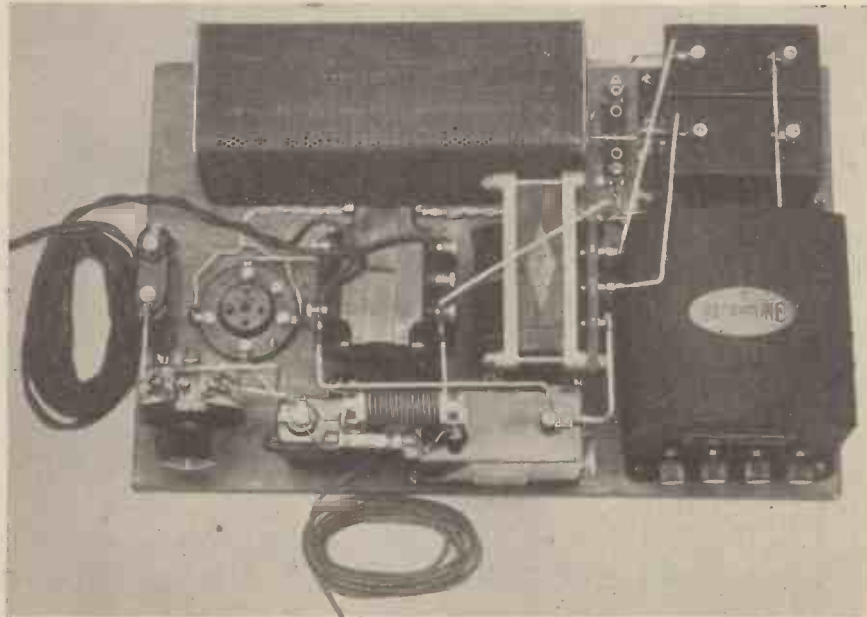

about  $1\frac{3}{4}$  in. from the baseboard. This can be made up easily by the reader, or he may be lucky enough to find such a thing in his junk-box—I was. See that the spindle is insulated from this bracket by small ebonite or fibre washers. The 1,500-ohm power resistor  $R_5$  is mounted direct between the fixed condensers  $C_2$  and  $C_3$ . This is done by removing the supports supplied with this component and holding the resistor on its porcelain tube direct on small right-angled brackets (I used old grid leak supports) held under the respective terminals of each condenser. This is shown clearly in Fig. 3 and the photographs. The 100,000-ohm cartridge resistance  $R_2$  is similarly held direct under the terminal heads, since a length of wire is fixed to each end of this Dubilier component.

### Making the Connections

All should now be in readiness for the wiring which, except for the flex leads, has been carried out with Lewcos Glazite wire to give firmness and rigidity. I prefer to make soldered joints, but the constructor not at home with the soldering-iron can loop his wire under the terminal heads. I advise you to run the filament leads first, and it is necessary to twist the pair of wires together as shown and tuck them away neatly. The rubber-covered earth lead is the next wire to run, and after this the remainder of the wires can be added as fancy dictates. Keep the leads short and straight with neat right-angled bends, and your finished work will then take on an air of professionalism.

On the secondary side of the output transformer only the outer terminals are used, giving a one to one ratio. Finally join the twin flex in place, this being the link to the vision apparatus.

### Testing

After giving the wiring a check over to ensure you have not been guilty of sins of omission or

commission, connect the earth lead to your vision wireless receiver and make your other connection according to the detailed instructions given earlier in conjunction with Fig. 2. I had my Regentone power transformer tapped for 200, 220, and 240 volts A.C. input to be suitable for experimental work, but when ordering your own component just specify the house voltage and frequency, and all will be well. Join the input terminals to your mains plug, insert the DO/25 valve, and having connected the unit to your receiver and vision apparatus, and tuned in the station broadcasting the television signals, switch on.

The neon lamp will glow and the valve light if no mistake has been made in your work and, owing to the extra stage of amplification, there should be ample power to give you good signal modulation on the neon lamp. Use the volume control judiciously, and if by chance you have a negative image, reverse either the primary or secondary connections (preferably the latter) of the output transformer  $T_1$ , and all will be well.

If the constructor so desires he can house the unit in a metal box, but that is just left to individual requirements. In any case, I am sure the constructor will be delighted with the unit's performance, and have the satisfaction of knowing that the expenditure of his time and money has been well worth while. It gives just that additional power for good television images, especially when used in conjunction with a Baird "Televisor," and, furthermore, acts as a source of H.T. to give the striking voltage and current to the neon lamp.

# LETTERS TO THE EDITOR

*The Editor does not hold himself responsible for the opinions of his correspondents. Correspondence should be addressed to the Editor, TELEVISION, 505, Cecil Chambers, Strand, W.C.2, and must be accompanied by the writer's name and address.*

## METHODS OF SCANNING

*To the Editor of TELEVISION*

DEAR SIR,—With reference to the publication in the issue of your Journal for December 1931 of two letters from Mr. G. E. Land and Mr. P. F. Carmichael respectively, I would like to say that the method of scanning proposed by Mr. Land is already contained, in essence, in the specifications of Letters Patent No. 347,435 and No. 324,949 (Provisional Specification lines 39 to 49).

The chief disadvantage of scanning apparatus of these types is the difficulty of maintaining sufficiently perfect synchronism. If in an ordinary system the receiving disc alters slightly and rhythmically in speed, the image hunts as a whole, and the eye follows it and appreciates the picture easily, though it is moving. In cross-scanning or counter-scanning systems, however, the image does not maintain its outline in hunting, and a displacement from the synchronous position of a very small fraction of a radian is sufficient entirely to remove it from all semblance of a picture.



*The new diagram submitted by Mr. Weekes in support of his theories. This should be compared with that which appeared on page 348 of our November issue.*

It seems that the special form of apparatus, in which two images formed by a disc are superposed, is further anticipated by the disclosure of Letters Patent No. 354,863.

Mr. Carmichael's invention, on the other hand, though designed with the same object in view, is not anticipated so specifically by the Patents to which I have referred as by the specifications of Patents Nos. 289,307 and 354,572.

I trust that the information afforded by these comments may prove of interest to your readers.

Yours faithfully,

J. C. WILSON.

"LINDEN,"  
NORTH HARROW.  
December 1st, 1931.



## A CORRECTION AND FURTHER VIEWS

To the Editor of TELEVISION

DEAR SIR,—On examining the reproduction of the Sketch and Curve of Light variation passing over Image, as published in November TELEVISION, I notice an error has occurred in my sketch and I am sure that you will desire me to correct this, so that the TELEVISION Magazine is above criticism. You will see by checking the curve with the scanning strip that it is not correct.

I am sending you a further sketch with more detail, hoping it will make my remarks clearer to you and also interest the readers of TELEVISION.

The point I wish to raise is the question of the radio transmitter and receiver being criticised for the shortcomings of the light converting apparatus at the transmitting and receiving ends.

Compare the response curve of the picture signal and the audio signal. Note that the variation of the audio signal is considerably more than the picture signal, even if the image subject is moving about continuously.

Note also that the audio signal must die away to zero, approximately, between each sound. This is not essential in large sections of light and shade as delivered from the anode of the output valve or valves. I admit that the grid input must be alternating, but not necessarily varying in amplitude, or be of a high value, say a frequency of 100, while these sections are being scanned. The reproduction apparatus for sound often handles and delivers several frequencies and harmonics at the same time. This shows in my opinion that the efficient wireless receiver is capable of more television reproduction than it is called upon to produce.

I am also of the opinion that if 60-hole discs were used it would be a great improvement, and a double-plate neon could be considered.

Yours faithfully,

H. WEEKES.

25 CHARTERIS ROAD,  
KILBURN, N.W.6.  
December 1st, 1931.

FROM A PRIZEWINNER

To the Editor of TELEVISION

DEAR SIR,—I am very pleased indeed to be the recipient of a copy of *Television To-day and Tomorrow*, awarded as the prize in your competition of November 12th. I very much regret that I was unable to acknowledge its receipt promptly, having been away from this address for the past week.

My interest in the subject dates from August 1928, when a copy of TELEVISION came into my hands. It is only during the last eighteen months, however, that I have had the opportunity of constructing apparatus for the reception of television images. I append herewith brief details of the apparatus I am using at the moment.

ONE SHILLING — MONTHLY

# ARMCHAIR SCIENCE

A POPULAR ILLUSTRATED  
MAGAZINE FOR THE  
AVERAGE MAN &  
WOMAN

YOU will enjoy reading this popular, brightly illustrated magazine dealing with curious and interesting discoveries and events throughout the world. Each month there is interest and instruction for every member of the family.

"Profitable and delightful reading."—*Alnwick City Gazette.*

"Well worth a monthly shilling."—*Derbyshire Advertiser.*

"Full of good things, fully and attractively illustrated."—*Northants Evening Telegraph.*

"Deserves a front place. Every copy sold will find a permanent reader."—*National Newsagent.*

- ★ Send 3d. in Stamps for
- ★ Free Specimen Copy to
- ★ address below

## JANUARY ISSUE NOW ON SALE

ARMCHAIR SCIENCE LTD.  
SUBSCRIPTION DEPT.  
56 Victoria St., LONDON, S.W.1

Receiver: One H.F. screen-grid, power-grid detector (200 volt), two low-frequency resistance-coupled stages (LS6A last stage); choke output.

Reproducer: 22-in. home-made disc, Osglim neon,  $\frac{1}{8}$  h.p. 200-volt motor, synchronising by hand (phonic wheel now being fitted).

The output from the set is on the generous side, being about  $3\frac{1}{2}$  watts, and I have had results very little inferior from previous sets of much less power, but this will probably be of considerable assistance for really steady synchronisation.

I have not been able to attempt any of your previous competitions, and hence I am all the more pleased with the measure of success attending my first effort.

Yours faithfully,  
C. C. BUCKLE.

64C MATTOCK LANE,  
WEST EALING, W.13.

### AN EARLY EXPERIMENTER

To the Editor of TELEVISION

DEAR SIR,—I have been a wireless experimenter since January 1923, quite the early days of amateur experimenting, when one had to be contented with receiving Morse and time signals from Paris, then music from Paris, while a little later on came the

think the way in which the B.B.C. announce the television programmes in *The Radio Times* and the daily papers is very discouraging to the experimenter. I prepared for an enjoyable television night as stated in *The Radio Times* a week or two ago, to commence at 10.50 p.m. from the London National station, with sound on the Regional consisting of dance music by Jack Payne's Band, and after patiently waiting for the time to roll round and starting up the motor a few seconds beforehand, so as not to lose any of the valuable half-hour, I heard the announcer say the London National station is now closing down without even saying anything about television (but the band was going on quite O.K.).

I was able to obtain the best results of all on Saturday, November 14th, but even then it was completely jammed by a ship transmitting in the harbour. I have just made up a new lot of gear, which I was hoping to try out one Saturday, but was disappointed to find the transmission not taking place according to the paper's programme. I will let you know more about my results later on.

Wishing TELEVISION every success.

Yours faithfully,  
J. J. W. STONE.

22 MINDEN ROAD,  
LOWESTOFT.  
November 23rd, 1931.

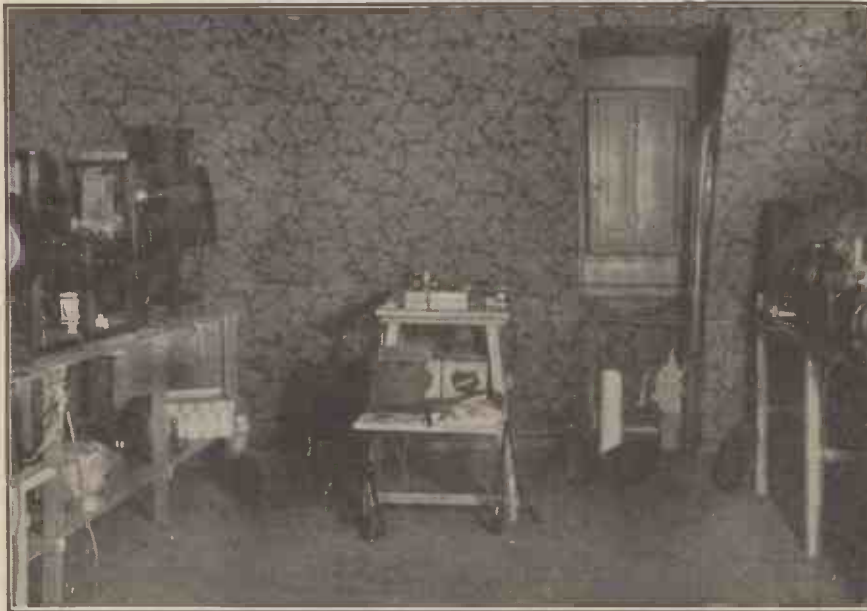

A partial view of the television laboratory of "Radio Revista" and "Popular Science," whose transmissions are carried out through the Radio Splendid Station, LRA, in the Argentine. On the left is the transmitter for stationary objects; centre, the amplifiers; and right, the cinema transmitter and transmitter for living persons.

little wooden hut at Writtle (2MT) where music sounded like tin cans rattling and a few notes of the piano were heard occasionally ringing out. But for all this they were the best and most enjoyable times for the experimenter.

Are we going to wait until television is brought to perfection by other countries before the B.B.C. gets really enthusiastic and gives us the chance of getting some of the old times back again, but in tin-pot pictures instead of music as above mentioned. I

### A WISH

To the Editor of TELEVISION

DEAR SIR,—I hope the North Regional listeners, who listened last night to the relay from the Argyle Theatre, Birkenhead, were as pleased to hear, as I was, the B.B.C. announcer close by saying "To see the camels, etc., going across the stage would only be made interesting by television."

It only makes one wish for the time when we shall be able to see as well as hear such broadcasts.

And only goes to prove that the B.B.C. will in time have to acknowledge its sister science as part of the evening's programme.

Sincerely yours,

N. M. BUTTON.

9 RICHMOND AVENUE,  
BREASTON,  
NR. DERBY.  
December 3rd, 1931.

## RECEIVING FILMS BY TELEVISION

To the Editor of TELEVISION

DEAR SIRs,—I was pleased to note in the December issue of TELEVISION that mention was again made of the hours of the television broadcasts from both Königswusterhausen and Witzleben, but I would respectfully suggest that the particulars given as regards "picture ratio" might deter enthusiasts from attempting to look-in to these stations with the standard Baird apparatus. Distortion is not so obvious, and every detail can be followed excellently, the words PAUSE and ENDE come out in block letters exactly as shown by you in the December issue of TELEVISION.

As far back as March of this year I wrote Berlin congratulating them on their sending, especially from the high-power station, and I then gave them complete details of the hour's programme. I am sending you this correspondence, and trust that it may be of interest to you.

It is some time now since I waited up till 12.45 a.m. to look-in to what to me is possibly one of the finest television broadcasts which takes place—films from Königswusterhausen.

I could not resist the temptation to look-in again this morning, and in the early hours KW gave out a complete film. I have not the space to give particulars of all I saw, nor for that matter can I remember everything in detail, but the following may give you some idea of the programme.

PAUSE. — *Achtung — Achtung — Reichsposte — Fernsehen.* (These words come through in smaller type than the film proper type.)

Lady and Gentleman.

Lady standing before a mirror—puts on hat—a dark one with white border—cuffs of costume had these white borders also—puts on gloves. Back of head shown to the camera and face reflected from mirror. The gentleman then came forward and smoothed hair with hand several times—put on a cap and overcoat—print came through in large black letters at intervals. Lady walks in front of gentleman who follows with parcel under arm—gentleman throws down large parcel—presumably tent which is now shown. Dog runs about—close-up of dog begging and obviously barking comes through good. Close-ups of both lady and gentleman—bathing suits—water scene. Close-up view of picnic table, showing the utensils (I am not quite sure of this, as recep-

tion was not too good at this particular moment). Lady winds up gramophone, places a record on same, and then they commence to dance. A few more close-ups and then PAUSE. Then the film commenced again from the beginning, and I switched off.

All that requires to be done is to change over transformer to positive, and up-end the complete apparatus.

I am now using a Varley Square Peak, which I find is a great improvement.



Another view of Mr. Owers' apparatus to which reference is made in our enthusiast series.

I often wonder whether people appreciate the tremendous stride, between televising films and the televising of actual scenes and individuals. Great credit is due to Mr. Baird surely, in not halting at films and taking the line of least resistance.

Yours faithfully,

W. S. MOWAT.

8 TULLOS CIRCLE,  
BALNAGASK, ABERDEEN.  
December 3rd, 1931.

## IMPORTANT NOTICE TO READERS

WITH the increasing interest which is being manifested in television developments and the growing numbers of amateurs who are conducting definite experiments in the science, we have had a very large number of queries sent in from readers who are seeking advice.

We are, therefore, inaugurating a query service for the benefit of these readers. Will they note that we shall be pleased to give advice on their problems, provided these are set out carefully and neatly on one side of the paper?

There will be a nominal charge of one shilling for this service, the number of queries to be answered for this sum not to exceed one. We cannot at the moment, however, undertake to supply blue prints, circuit diagrams, etc., in this service.

When space permits, we shall include one or two selected queries in our Editorial columns, so that others can reap the benefit of our advice.

**The Enthusiast Sees it Through**  
(Concluded from page 423)

**Great Improvement**

Mr. G. D. Dawson, of Penlee, Knutsford Road, Wilmslow, near Manchester, is a very ardent en-

thusiast and on several occasions has contributed to this series. As he has now returned to college, he has taken the opportunity of furnishing us with details of work he has carried out during the vacation, and, since he has built up synchronising gear and made alterations to his wireless receiver, we feel sure that readers will be interested in it.

photographs and a skeleton diagram showing alterations to the receiver circuit.  
"The synchronising gear is very rigid and bolted firmly to the motor. For framing, the whole motor is rotated, in the supports under its bearing bushes, by a chain round the frame and a sprocket. The

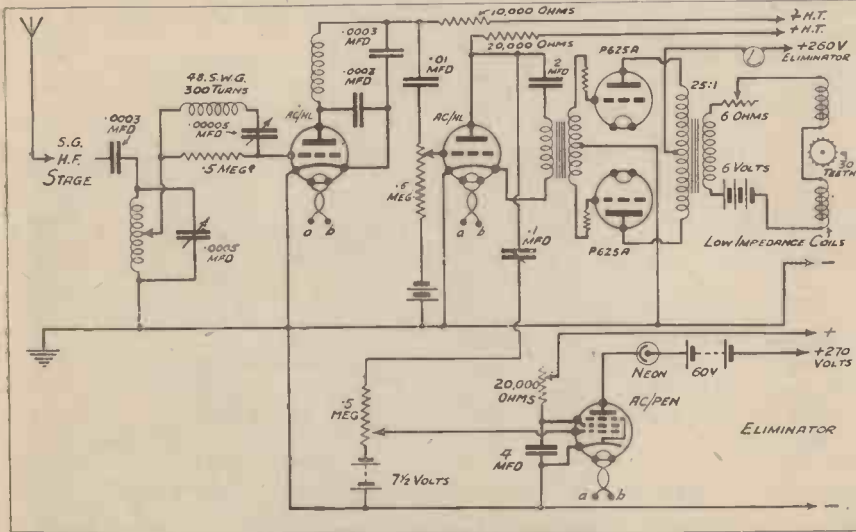

Certain changes have been made in the vision wireless receiver used by Mr. Dawson, and the diagram shows clearly where these alterations have been carried out.

thusiast and on several occasions has contributed to this series. As he has now returned to college, he has taken the opportunity of furnishing us with details of work he has carried out during the vacation, and, since he has built up synchronising gear and made alterations to his wireless receiver, we feel sure that readers will be interested in it.

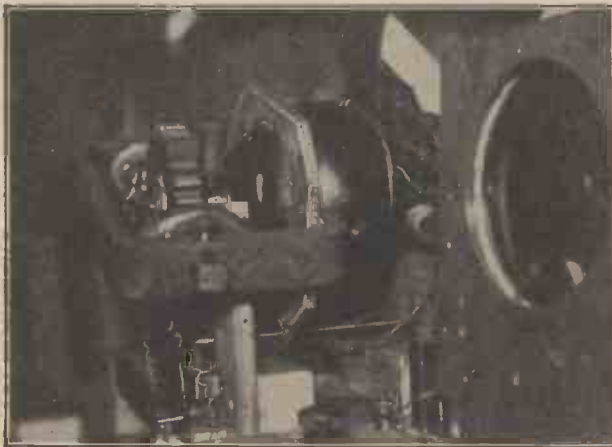

A side view of Mr. Dawson's synchronising apparatus, which on test has worked well.

We take this opportunity of once more congratulating Mr. Dawson on his pioneering work and trust that he will make good use of any further spare time he has for television purposes. He writes as follows:

"On the 14th of October the term at college began. Television experiments, therefore, had to be dropped till the next vacation. I have been very busy, but I now enclose three rather hastily taken

sprocket shaft is geared down to give smooth movement. On account of the rigidity of the main forging, the pole to wheel clearance can be reduced to under .003 in. without any pulling together of the wheel and pole piece. The synchronising coils are of low impedance and connected as in the diagram. If the mains are fairly steady, this arrangement will hold the picture quite satisfactorily on the output from the two P625A's.

"The only alterations to the receiver are as follows:

"The replacement of the detector grid circuit condenser by a tuned by-pass. This improves the higher audio-frequency characteristics of the detector considerably, as the tuning condenser value can be reduced to .00005 mfd.

"The alteration to the detector anode circuit H.F. filter with a view to decreasing high-note loss.

"The operation of the neon directly in the anode circuit of an AC/PEN (see diagram), the H.T. being 270 volts from an eliminator and 60 volts from an accumulator.

"The results obtained from this modified apparatus are really a great improvement. The greatest change seen is in the synchronising lines and other horizontal straight lines, such as the back edge of the stage in extended views. These lines now appear far sharper and clearer than when the neon was fed from the push-pull stage containing transformers."

**An Ambitious Amateur**

"That he intends making efforts to receive the television broadcasts from the United States," are the words of J. Curle, of 1A Westcliffe Terrace, Ramsgate, Kent. In giving us a few details of the work he has already carried out, he points out that he has

been an experimenter since the very first "Simple Televisor" was announced in our magazine.

We trust that Mr. Curle will be successful in his efforts, and no doubt he will advise us in due course of the results obtained. He says:

Mr. J. Curle, of Ramsgate, uses the circuit shown here to receive his television signals. He has been an experimenter since No. 1.

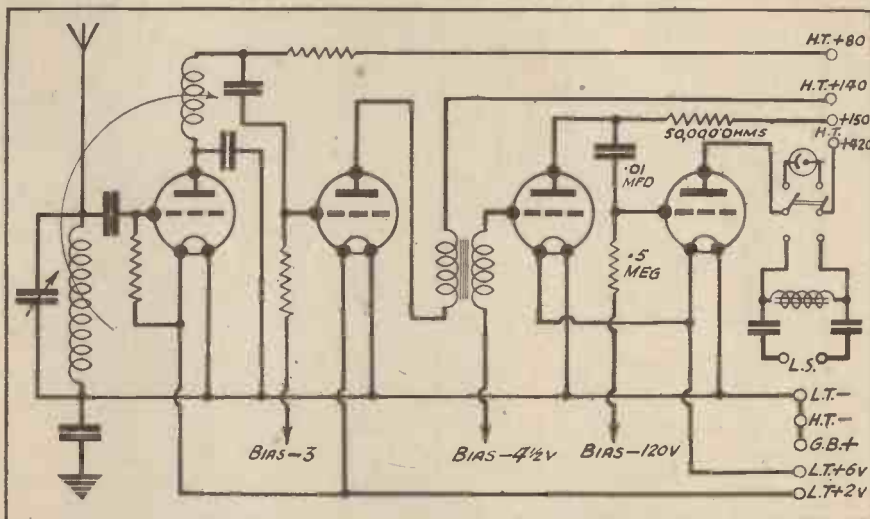

"I write to report the results I have obtained with my home-made vision apparatus, for I have been experimenting since the 'Simple Televisor' was announced.

"I am using a set containing detector and 3 L.F., the circuit of which I enclose. The valves used are PM<sub>2</sub>DX, PM<sub>2</sub>, DEL610, and LS5A. I use the D.P.D.T. switch for switching over from neon to speaker, a filter being incorporated in the speaker circuit as shown. Grid bias on the LS5A is reduced to 80 volts when the neon is in use.

"My motor is an old three-speed fan motor controlled by a Curtis resistance. I find some difficulty in holding the image. To focus and enlarge the image I use a Mangin mirror in conjunction with an old bull's-eye lens.

"I am thinking of receiving television from Schenectady, N.Y., on the short waves. I would be very grateful for information as to hours of broadcasting, number of holes used in American disc, speed of disc, etc.

"I congratulate you on the high standard of your magazine, which I have read since the first number."

### Thrilled

Mr. Vincent E. Protheroe, of Harborne Road, Edgbaston, Birmingham, is one of our ardent enthusiasts, and from time to time has supplied us with material showing the excellent progress he has made with his work. He has now gone to great pains to supply us with a very comprehensive diagram of the circuit he uses, and in addition a full description of same. We congratulate Mr. Protheroe, and trust that he will continue to be one of the pioneers for many years to come.

He says:

"Although it is a considerable time since I first wrote to you, I have by no means lost interest in television.

"The electric supply in this district has recently been changed from D.C. to A.C., and of course I have had a lot of work to do to change my wireless and television apparatus to suit this new supply.

"My 'vision' wireless set has been entirely re-

built, using the new A.C. mains valves, viz.: AC/SG for H.F., AC/HL as anode-bend detector, which is R.C. coupled to a P625, which in turn is coupled to the output valve, a P650, by means of a Ferranti AF5 transformer, parallel-feed method.

"The current for this set is derived from a Mazda

## MOTOR STAND

Complete with pinion, spindle and knob as specified by Mr. H. J. Barton Chapple in the November issue for the Tele-Radio Receiver.

5/- Postage 9d.

## S. LEE BAPTY

60, CRAVEN PARK ROAD, N.W.10

WILLESDEN 7084

## SCANNING DISCS

STANDARD - 20½-INCH

ALUMINIUM - 30-HOLE

BRASS-BUSHED

12/6

When ordering, please remit sufficient to cover postage; also please state size of motor spindle.

TRADE ENQUIRIES WELCOMED

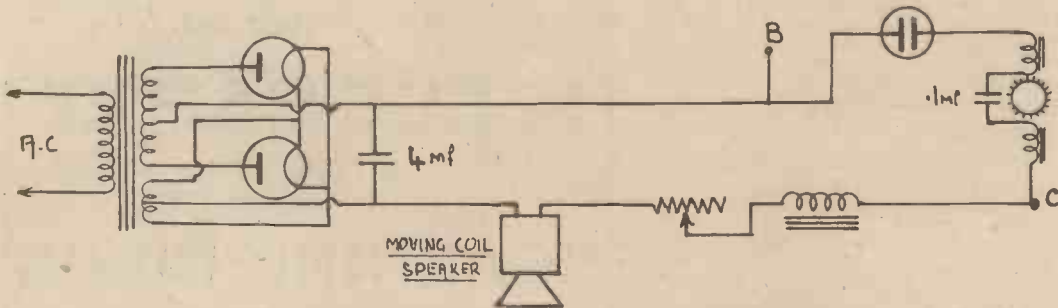
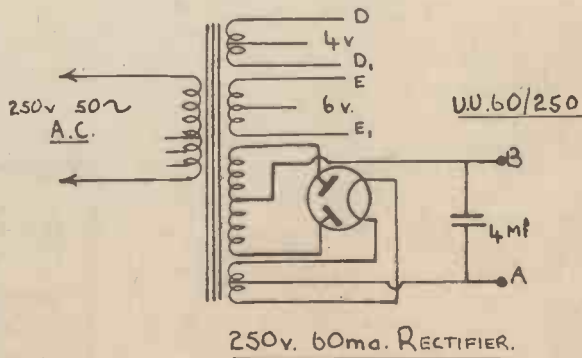
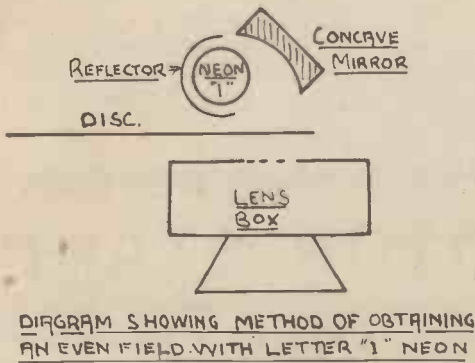
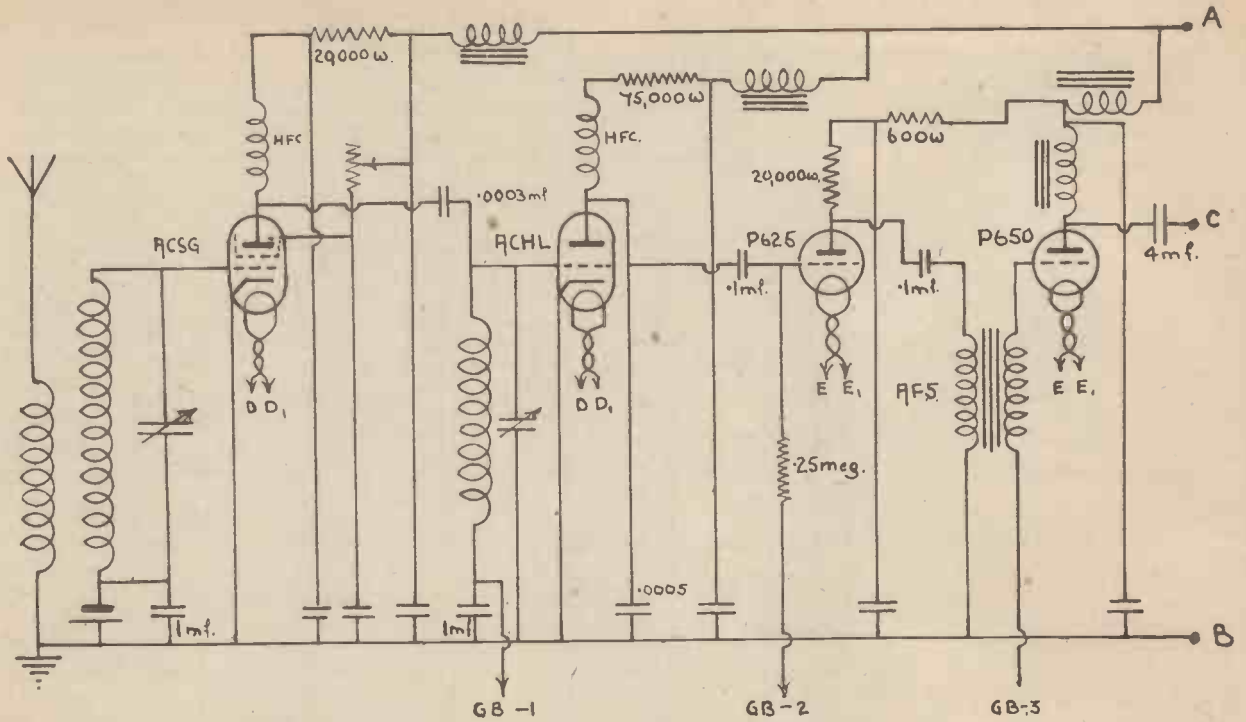

**300V. 150ma. RECTIFIER USING FIELD OF M.C. SPEAKER AS SMOOTHING CHOKE**

The very comprehensive circuit diagram which Mr. Protheroe at great pains prepared specially for this magazine. It shows quite clearly how he carries out his reception of television signals.

UU60/250 full-wave rectifying valve. This set, with the P625 cut out, is used as the house set with a moving-coil speaker; the field of the speaker is then used as a smoothing choke. Thus I am still able to use it for the sound part of the transmissions, which is received on a small 3-valve frame aerial set made from odd parts.

"The vision apparatus itself has also been entirely rebuilt, and now consists of a special G.E.C. fractional horse-power A.C. motor in lieu of the old 'fan' motor originally used which, it was found, would not work on A.C. The disc is the same as used before, made from thin aluminium, as it is particularly accurate, being constructed with the jig

described some time ago in your indispensable magazine. Synchronising is obtained with a 30-toothed wheel filed from a 3-in. diam. mild steel disc  $\frac{1}{2}$  in. thick. This was drilled centrally, and finally trued up whilst running on the motor shaft, which makes for absolute accuracy which is so essential to allow the pole pieces to clear the wheel by a few thousandths of an inch only, thus ensuring maximum pulling strength on the teeth.

"The synchronising coils consist of about 4,500 turns of 40 gauge D.S.C. copper wire wound on cardboard bobbins, which are slipped on the pole pieces. These are supported by two mild-steel 'uprights,'  $\frac{3}{8}$  in. by  $\frac{1}{2}$  in. thick, joined by a yoke of the same material. All these mild-steel parts were thoroughly softened before cleaning and assembling



Mr. Protheroe draws attention to some vertical and faint dark shadows which travel across his screen under certain conditions.

"The speed of the motor, which by the way is wonderfully steady, is controlled by one fixed and two variable resistances, one coarse, the other fine. In my first set the neon was a letter 'M' type with the resistance removed, but this has now been replaced with a letter 'I,' as I find this gives a slightly more even field in conjunction with the polished metal reflector and concave mirror, shown in diagram.

"A lens box was constructed from aluminium, whilst the lens itself was taken from an optical condenser. This serves the purpose admirably, giving an image considerably larger than a postcard.

"From the diagram it will be seen that the neon and synchronising coils are connected in series together with a choke and variable high resistance. The whole is choke coupled through a 4-mfd. condenser to the output valve, as I find this the best method.

"As for results, well, I thought they were good with the original apparatus (described in your September 1930 issue), but there is a big improvement now with this new set, and much more detail is now discernible, whilst the picture, as a whole, seems much clearer than before; also the items are far more interesting since the extended screen was put into use.

"The synchronising arrangement holds the picture steady for the whole half-hour, unless anything happens at the transmitting end to upset same. As this gear has fixed magnets, it is obvious that the picture will not always fall centrally in the viewing aperture, and this is compensated for by having a sliding opening instead of a fixed one, as is normally used. Thus if the picture is too high or too low, it is only necessary to alter the height of the opening to bring the whole of it into view.

"It is interesting to note that with the neon glowing and the motor running, but the wireless set switched off, very faint dark shadows travel across the screen. These are, no doubt, due to some very low frequency in the supply mains, and I find it impossible to eliminate them. Fortunately, however, they are too faint to interfere with the picture when it is being received.

"Several of my friends have seen the results I am getting and were rather 'thrilled' at what they termed a novel experience. May I add that the majority of them are now suffering from 'Televisionitis,' and one and all agree that it should have far more time given to it by the B.B.C., as very often there are no transmissions at all in the evenings, and as we, like many others, are not 'gentlemen of leisure,' we cannot look-in to the morning transmissions. Thus the half-hours, which seem to be getting scarcer for us, are valued nearly as much as THE magazine, which I am certain everyone is longing to see a weekly soon. Wishing you continued success in your fight for television."

## This "WB" Antiphonic VALVEHOLDER is specified in the



## "Tele-Power" Junior Unit because of its great reliability.

ONE MILLION W.B. VALVEHOLDERS ARE SOLD ANNUALLY.

Made by the makers of the famous W.B. PERMANENT MAGNET MOVING COIL SPEAKERS.

Write for complete lists, post free.

Whiteley Electrical Radio Co., Ltd., Radio Works, Nottingham Road, Mansfield, Notts.

Irish Free State Distributors: Kelly & Shtel, Ltd., 47 Fleet Street, Dublin.



## TRADE NOTES OF THE MONTH

### REPORTS ON APPARATUS TESTED

#### "Parmeko" Permanent-magnet M.C. Loud Speaker

THE "Parmeko" Loud Speaker embodies the results of two years' experimental work on moving-coil units. It is totally enclosed in a cast aluminium case, and the first impression one receives on handling this speaker is the excellence of the workmanship throughout. The field magnet is of very large dimensions, and gives a total flux



*Excellent workmanship is the first impression received with the "Parmeko" speaker. This is supported by a first-class performance.*

of 70,000 lines (neglecting leakage). This corresponds to a flux density of 9,000 lines per square centimetre in the gap itself.

The moving coil is of the low-resistance type,

having an impedance of 16 ohms at 500 cycles, being wound on a bakelite former, which is rigidly secured to the cone. The diaphragm consists of a 90-degree cone suspended at the outer edge by flexible soft leather, and the centring allows a large lateral movement.

On test we found this speaker was not only extremely sensitive, but it gave an even response over the whole of the musical scale, extending in fact from 50 to 8,000 cycles. The reproduction, both on the lower and higher register, was quite natural, and it is capable of handling a heavy input without any suggestion of overloading. Its general performance in the reproduction of both speech and music places it quite definitely in the foremost class for moving-coil loud speakers of the permanent-magnet type.

A die-cast aluminium base housing the output transformer is supplied. This transformer has a primary wound in two parts, which can, by altering small connecting links, be connected in series or parallel, giving an impedance of 2,000 ohms or 8,000 ohms, and ratios of 11 to 1 or 22 to 1. It is claimed that by this method of series or paralleling the primary to obtain these definite impedances and ratios, the undesirable dead-end effects often associated with tapped transformers are obviated.

The speaker is supplied either as a unit alone or complete with output transformer and base, the price being £6 10s. for the unit alone and £1 10s. for the base and transformer.

#### *Mullard Rapid Valve Guide, Second Edition*

Earlier in the season the Mullard Wireless Service Co. issued an abridged catalogue containing illustrations, characteristic curves, and full technical



data of the standard battery-heated and mains-operated receiving valves and also rectifier valves.

A second edition of this useful booklet has now been produced. It has been brought thoroughly up to date to include the latest revised characteristics of valves which have been modified since the first edition was printed, and extra pages have been included dealing with such new valves as the MM4V Multi-mu Valve.

The technical appendix at the end has been enlarged to include several new circuit diagrams, including battery-operated and mains-operated low-frequency amplifiers with push-pull output stages.

A useful feature in this appendix is a series of diagrams showing how to apply automatic grid bias to various types of valves and giving the correct values of the biasing resistances for standard Mullard types.

Readers desiring copies should write direct to Mullards, mentioning this paper.

### Wates Universal Testmeter

We have had an opportunity of examining and testing a small instrument of great utility, strong construction, and good accuracy. We refer to the Wates Universal Testmeter. The meter itself is



The very neat and useful Wates testmeter marketed by the Standard Battery Co., Ltd.

of the polarised magnet type, and is encased in a black bakelite case. The scale is very clearly marked in white and red lettering on a black background, being divided separately into four individual readings.

- (1) 0 to 150 volts for H.T. supply readings.
- (2) 0 to 6 volts for L.T. readings.
- (3) 0 to 30 mA. for anode current consumption.
- (4) 0 to 2,000 ohms (resistance measurement).

The battery used for testing continuity and the resistance of circuits is conveniently contained within the case. It is of the 3-cell type giving  $4\frac{1}{2}$  volts, and is easily renewable at small cost when its useful life is exhausted. Five sockets are provided on the face of the bakelite case, to which contact is made by means of flexible connections and plugs which are provided with the instrument.

We found this testmeter very simple to use and, being neat and compact, could be tucked away easily when not required. Considering that the price, complete in carton with instructions to use, is only



We should like you to see a copy of "IRISH RADIO NEWS," and therefore if you will drop us a postcard with your name and address we shall be glad to send you a specimen copy FREE of charge.

Regular Contents include:  
 OFFICIAL IRISH AND B.B.C. PROGRAMMES FOR THE WEEK  
 "BROAD TUNING," by A.Z. (Gossip)  
 HINTS FOR CONSTRUCTORS  
 GRAMOPHONE NOTES  
 NORTHERN IRELAND NEWS  
 Special Articles, News, Photos, Etc.

Why Not Become a Subscriber?  
 One Year, Post Free - 7s. 6d.  
 Six Months, Post Free - 3s. 9d.

Edited by JAMES KITCHEN, A.M.I.R.E.  
 EVERY FRIDAY

## Irish Radio News

Editorial and Publishing Offices:  
 179 PEARSE STREET, DUBLIN  
 'Phone: DUBLIN 43236

ENGLISH BRANCH:  
 RICHMOND HOUSE  
 NORTHBROOK ROAD  
 LONDON, S.E.13  
 'Phone: LEE GREEN 1059

12s. 6d., we were surprised at the accuracy of the results obtained. This type of meter, being of somewhat low resistance, is not recommended for testing all-mains receivers or eliminators, but for ordinary use we can thoroughly recommend the product as being a sound investment.

### *Amplion Moving-coil Loud Speaker*

We have recently had an opportunity of testing out one of Messrs. Amplion's Chassis Units, Type No. M.C.6. This is designed with a circular pot-type field magnet, having a pressed-metal cone chassis. A low-impedance coil is employed, and to enable the speaker to be used in conjunction with an ordinary wireless receiver, a tapped input transformer is mounted on a bracket over the pot magnet. Three ratios can be obtained from this transformer, so as to match the coil for use with pentodes, power valves, and super-power valves.

On test we found this unit very sensitive, and it was capable of handling sufficient power for normal home use. Reproduction on bass notes showed an absence of boominess, and although on the high notes the response was not quite as good as with the low notes, this effect seemed in no way to detract

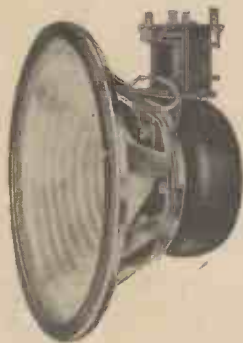

The Amplion moving-coil chassis unit M.C.6 has a tapped input transformer mounted on a bracket over the pot magnet.

from the good quality of the reproduction both for speech and music.

The speaker was reasonably free from resonance, and should go far in the sphere for which this model has been specially designed, namely normal home working with average-powered sets. The workmanship was excellent and, bearing in mind the relatively low price of the unit, namely 67s. 6d., we have no hesitation in recommending it to our readers.

### *Osram Music Magnet Conversion Kit*

Readers will no doubt remember that in our October issue we published a test report dealing with the "Music Magnet," sponsored by the G.E.C., in kit form. This was for battery operation, and it will no doubt come as news to many that this receiver can be converted quite readily to be suitable for mains operation.

A special conversion kit is marketed by the G.E.C. for this purpose. We have received one of these, but there has not been time to complete the conversion and carry out the tests for a report to be included in this issue. Next month, however, we shall give full details of this interesting work.

### *Another New Loud Speaker*

We have been informed by Messrs. Celestion Limited, that they have introduced another new permanent-magnet moving-coil loud speaker, designated the P.P.M., at the remarkably low price of 47s. 6d., this cost including a tapped transformer. They claim that the P.P.M. speaker has been designed to provide a very high sensitivity, with correct tone balance, when operated on relatively small inputs such as are obtained from the majority of sets in common use.

The speaker is housed in a strong metal chassis, and has mounted on it a dual-impedance output transformer. The speakers are supplied with three alternative types of transformers, namely "standard" for ordinary triode power valves, "pentode" for ordinary pentodes, and "special pentode" for the new high-efficiency pentodes.

It is hoped to include a test report of this speaker in our next issue.

## BOOK REVIEW

THE 1932 edition of *The Wireless and Gramophone Trader Year-book and Diary*, which we have had an opportunity of examining, should prove of valuable assistance to manufacturers and retailers of wireless and gramophone goods every day throughout the year.

In this edition the feature entitled "Practical Service Methods" deals with the broad principles involved in the service work the dealer is normally called upon to perform. It covers the most economical and up-to-date methods of dealing with repair, service, and constructional jobs in installations, accessories, and receivers. This article has been extended by the addition of further technical features of importance to service men. Two of the most useful are "Output Valve and Speaker Matching" and a suggested design for the construction of a powerful amplifier for dealers' own use. A further entirely new feature is a seven-page Directory of Mains-supply Voltages, covering Great Britain and Ireland with selected towns in the British Empire.

All the wireless and gramophone technical data and broadcasting information have, of course, been revised to date. It is presented in a new form, providing more convenient reference.

The Trade Directory portions include lists of manufacturers, manufacturers' agents, and wholesale factors—their addresses and telephone numbers; proprietary names of wireless and gramophone goods listed, with the name of their suppliers. These sections have all been brought up-to-date in accordance with the most recent trade developments and changes.

*The Year Book* is as usual issued to subscribers to "Trader" Journals at the special price of 3s. 6d., post free, the price to non-subscribers being 5s. 6d., post free. It is published by The Trader Publishing Co., Ltd., at St. Bride's House, Salisbury Square, Fleet Street, London, E.C.4.

# Is your dealer's name in this list of up-to-date Wireless Traders who are demonstrating **BAIRD TELEVISION**

ASHFORD (KENT)  
BAGSHOT  
BEACONSFIELD  
BEXLEY HEATH  
BICESTER  
BIRMINGHAM  
BIRMINGHAM  
BISHOPS STORTFORD  
BOURNEMOUTH  
BRACKNELL  
BRIDGEND  
BRIXTON  
BURNHAM  
BURTON-ON-TRENT  
CHALVEY  
CHERTSEY  
CHESTERFIELD  
COLCHESTER  
COULSDON  
COVENTRY  
DARLINGTON  
DEAL  
DOVER  
EASTBOURNE  
ERITH (KENT)  
FOLKESTONE  
GERRARDS CROSS  
GODALMING  
GRAYS (ESSEX)  
HORLEY  
KIRKCALDY  
KNEBWORTH  
LEIGHTON BUZZARD  
LLANDUDNO

## LONDON :

BAYSWATER  
BROMLEY  
CLAPHAM COMMON  
CRICKLEWOOD BROADWAY  
CROYDON  
EALING  
EALING (WEST)  
EARLSFIELD  
EAST DULWICH  
EDGWARE  
EDMONTON  
FULHAM PALACE ROAD  
HAMMERSMITH  
HENDON  
HOLLOWAY  
HOUSLLOW  
KINGSTON  
LEE  
NEW BOND STREET  
OXFORD STREET  
PIMLICO  
SOUTH NORWOOD  
THORNTON HEATH  
TOTTENHAM  
WALWORTH  
WEMBLEY  
WEST NORWOOD  
WIGMORE STREET, W.  
WOOD GREEN  
LUTON  
NEWCASTLE  
NEW MALDEN (SURREY)  
NORWICH  
PLYMOUTH  
RAMSGATE  
REDHILL  
ROCHDALE  
SLOUGH  
STAINES  
TONBRIDGE  
UXBRIDGE  
WELLING  
WEST BYFLEET  
WEST DRAYTON  
WEYBRIDGE  
WINDSOR  
WOKING  
WORTHING

C. HAYWARD & SONS  
LINDFIELDS GARAGE  
BEACONSFIELD MOTOR CO. LTD.  
J. SPENCER (LONDON) LTD.  
LAMBOURNE BROS.  
C. WEBB LTD.  
SHANNON & CAPENER  
H. R. MOORE LTD.  
J. E. BEALE LTD.  
DRAKE & MOUNT LTD.  
WRIGHT & ASHWORTH  
QUIN & AXTENS  
TIMMS & ALDRIDGE  
RADIO & CY-KAR MART  
J. D. HALLIDAY  
RADIOGRAM STORES  
G. KENNINGTON (CHESTERFIELD) LTD.  
SHROSBURY & BAKWELL CO., LTD.  
THE "VIC" WIRELESS STORES  
MAX. A. BUCH  
C. SHARP  
G. CLOUT  
DOVER RADIO STORES  
OWEN H. RELLY  
GREFFIELD ELECTRICAL SUPPLIES  
BOBBY & CO. LTD.  
R. F. CHIPPS  
H. J. CHALLEN  
GRAYS WIRELESS CO. (H. W. FRANKLIN)  
S. A. COUTTS  
GIBB & WATSON  
E. S. HEAP  
GRIFFIN BROS.  
EVANS & EVANS

HOPE, NORMAN & CO.  
UNIVERSAL ENGINEERS  
DEMPSEY & CO.  
HARDEN & CO.  
KENNARDS  
KEEN WIRELESS CO.  
L. LEAMAN  
H. HOLLIER & SONS  
RAND & BARKER  
J. F. WISSON  
E. J. HERAUD  
"ECONOMIC"  
W. H. OATES  
S. G. THAINE  
JONES BROS. (HOLLOWAY) LTD.  
SANDERS ELECTRIC & RADIO SUPPLIES  
BENTALLS LTD.  
A. BEDFORD & SONS  
KEITH PROWSE LTD.  
SELFRIDGE & CO., LTD.  
F. DOVE & SONS  
AGAR & WEBB  
D. L. KING & CO.  
B. HOGGEN, A.M. INST. B.E.  
GAS LIGHT FITTINGS LTD.  
MELODY HOUSE (J. C. MILLS)  
E. SHELDRICK  
WIGMORE RADIO SERVICE  
DISTRICT SUPPLIES LTD.  
R. J. STEARN & CO.  
PAYNE & HORNSBY LTD.  
ACORN SERVICE STATION LTD.  
E. A. PRIEST & CO.  
W. H. AXWORTHY & CO.  
J. CARMAN  
ROBERTS & SONS  
BANNISTER & FITTON  
G. CASE & SONS  
V. & D. KEALE  
A. T. LANGTON  
WILLIS & SONS  
WELLING RADIO STORES  
A. LONG  
SPRATLEY BROS.  
E. W. FARROW  
FENEMORE, HOWLETT & CO.  
C. F. ROYSTON & CO.  
E. LAMB

20/42 New Street  
Surrey  
68 London End  
127 The Broadway  
47 Market Square  
41 Carrs Lane  
13 Aston Road North  
Northgate End  
Hants  
Berks  
Kings Bldgs., Adair Street  
Brixton Road  
Bucks  
Cross Street  
Nr. Slough  
81 Guildford Street  
Victor Lane  
73 Crouch Street  
21 Chipstead Valley Road  
143 Lower Ford Street  
321 North Street  
Electrical Engrs.  
4 Townwall Street  
"Gavinwood," Willingdon  
90 High Street  
48 Sandgate Road  
6 Oak End Way  
12 Church Street  
Clarence Road  
Victoria Road  
270 High Street  
London Road  
11 High Street  
29 Mostyn Ave., Craig-y-Don

85 Westbourne Grove  
1 Chatterton Road  
69 South Side  
99 Cricklewood Broadway  
High Street  
1 Dare Road  
97 Northfield Avenue  
422 Garratt Lane  
Melbourne Grove  
2 Cheapside, Deans Lane  
78 Fore Street  
24 Fulham Palace Road  
195 Hammersmith Road  
192 Brent Street  
Holloway Road  
119 Staines Road  
Surrey  
11 High Road  
159 New Bond Street  
W.I.  
77 Pimlico Road  
287 Portland Road  
20 High Street  
272 High Road, N.15  
322 Walworth Road  
56a Ealing Road  
493 Norwood Road  
36/38 Wigmore Street  
43 High Road  
7 Manchester Street  
7 St. Andrew's Buildings  
Kingston By-pass Road  
28 St. George's Road  
106 Tavistock Road  
65 King Street  
72 Station Road  
27 Milnrow Road  
2 Grove Parade, High Street  
Kingston Road  
High Street  
278 High Street  
3 The Parade  
1 Byfleet Corner  
Station Road  
42 High Street  
14/16 Victoria Street  
Guildford Street  
Franklin Road, Durrington

Advt. of Baird Television, Ltd., 133 Long Acre, London, W.C.2.

# THE GIFT PROBLEM SOLVED

NON-TECHNICAL FRIENDS

WILL BE GLAD TO POSSESS A BOOK WHICH DEALS, IN NON-TECHNICAL LANGUAGE, WITH A SUBJECT IN WHICH THEY ARE BOUND TO BE INTERESTED IN THE NEAR FUTURE

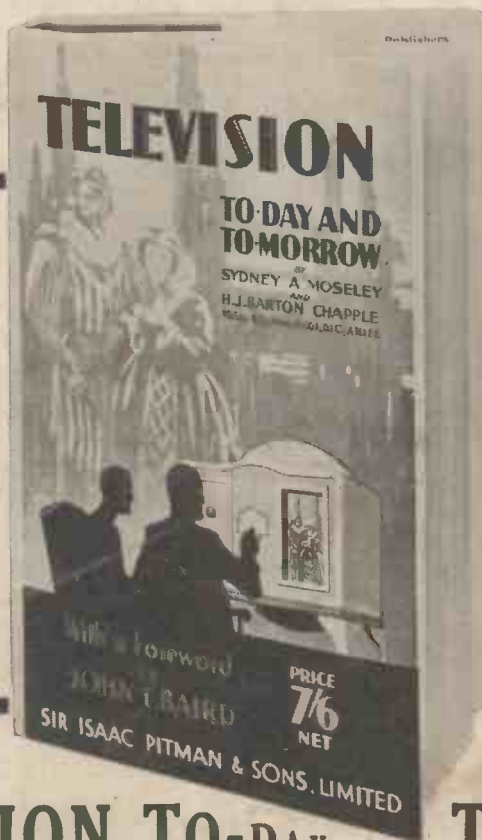

FELLOW EXPERIMENTERS

WILL BE GRATEFUL FOR AN AUTHORITATIVE BOOK WHICH WILL GIVE THEM THE UTMOST ASSISTANCE IN THEIR EXPERIMENTS AND RESEARCH

## "TELEVISION TO-DAY AND TO-MORROW"

(SECOND EDITION)

By SYDNEY A. MOSELEY and H. J. BARTON CHAPPLE, B.Sc.(Hons.), A.M.I.E.E.

All the big developments which have occurred in the Television World since this book was first printed are fully described in the New Edition. Every advance of the science is dealt with. The Second Edition is a veritable mine of the latest information.

**"DAILY NEWS"**

"Many secrets of the apparatus used are revealed in detail for the first time in this book, together with full technical information about the system, put in simple language specially for the wireless amateur."

**"ELECTRICAL TIMES"**

"This book is of very considerable general interest. It sets out very clearly the outstanding developments and achievements in the evolution of television broadcasting."

**"YORKSHIRE POST"**

"The book is neither dull nor formidable for the non-technical reader; in addition to the diagrams, this book is excellently illustrated by almost fifty photographic plates."

**"NOTTS GUARDIAN"**

"The authors have kept in mind the fact that many persons interested in wireless have no very deep knowledge of electrical matters, and have written a book which the amateur will readily understand."

**"ABERDEEN PRESS AND JOURNAL"**

"The subject of television is dealt with in an admirable and non-technical manner, and we are led through essentially intricate phases to a clear appreciation of what has been done, what takes place, and the possibilities for the future."

**"ELECTRICAL REVIEW"**

"The illustrations are good, well-chosen and interesting, while the diagrams and sketches are numerous and clear. It is well worth careful perusal by anyone interested in this entertaining subject."

PRICE  
**7/6**  
POSTAGE  
SIXPENCE  
EXTRA

ORDER NOW FROM

**TELEVISION PRESS, LTD.**

505, CECIL CHAMBERS, STRAND, W.C.2

Telephone: TEMPLE BAR 8169