

TAPE

RECORDING MAGAZINE

FEBRUARY 1962

1/6

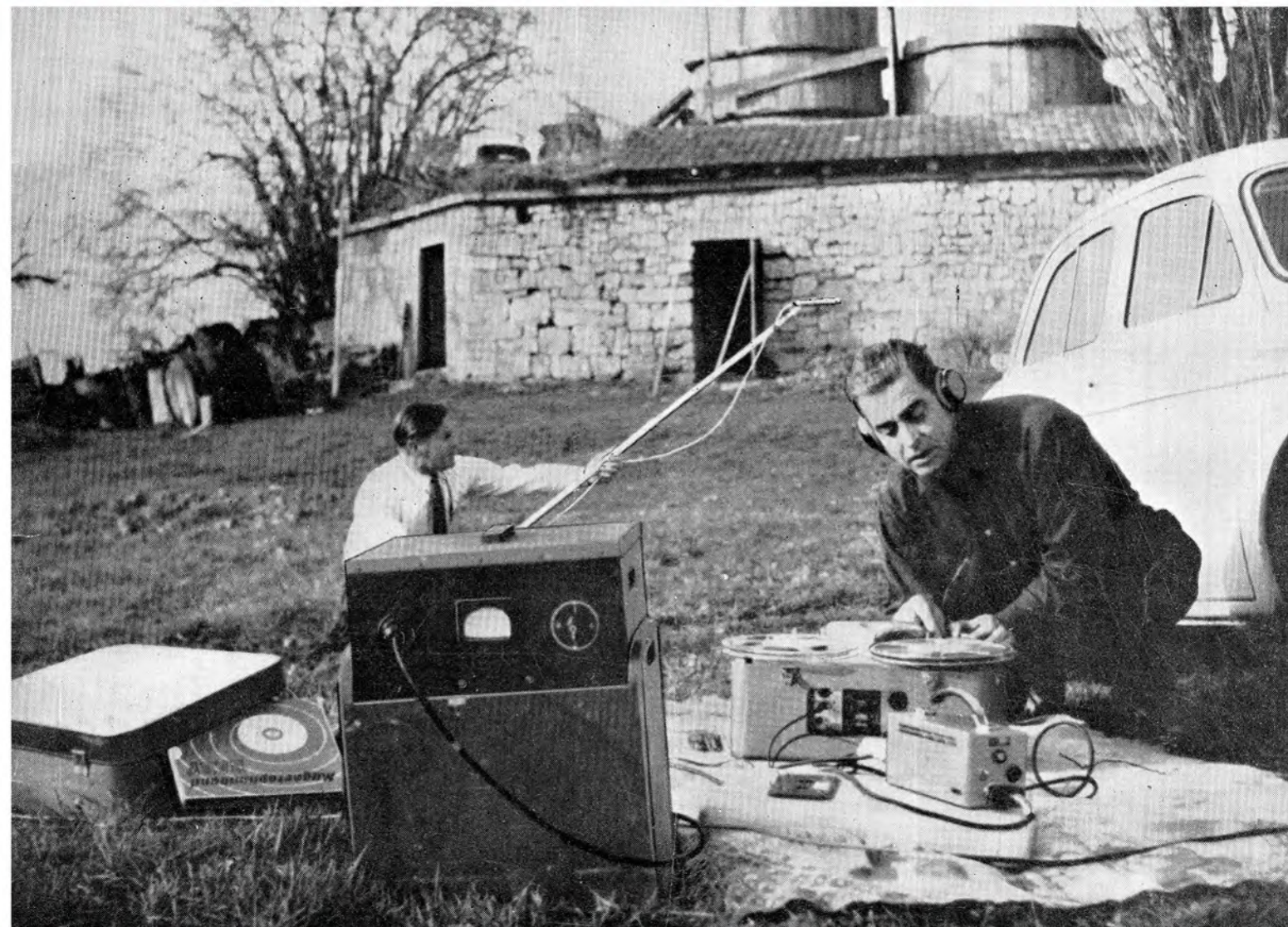

FIRST AND FOREMOST IN THIS FIELD

**British Amateur
Tape Recording
Contest
Entry form and details**



**Everybody's
listening to
The tape
that speaks
from space ***



Because everybody appreciates the new recording experience that SOUND CRAFT Magnetic Recording Tape can give. Its special FA4 formulation captures and then reproduces the full frequency spectrum, enabling you to enjoy the majesty of your favourite orchestra or the subtle musical variations of East Coast jazz. In clarity too SOUND CRAFT is remarkable—famed for its 'Background of Silence'.

Your recorder deserves the best—deserves the tape that is at this moment speaking from space. Buy SOUND CRAFT tape now and prove to yourself just *how* much difference there is. It's SOUND CRAFT tape for a new experience in high fidelity recording.

*** ASK YOUR DEALER!**
SOUND CRAFT products are chosen for the U.S. Space Satellites Tyros I and II. Tyros II is at this moment transmitting to the Earth on 108 and 108.03 m/cs. Already in use by leading professional recording studios in this country.

Your Recorder deserves
SOUND CRAFT
MAGNETIC RECORDING TAPE

On 'Mylar' (Polyester) Long Play and Double Play tensilised or SOUND CRAFT Tri-Acetate, Standard and Long Play. Each in 3" (tape mailers) 5", 5½" and 7" reel sizes. 4 spoke reels all with coloured Mylar Leaders. Packs cellophane sealed against dust. Each with colour coding for easy identification.

SOUND CRAFT MAGNETICS LTD • Haddenham • Bucks.

Manufactured by Reeves Soundcraft Corporation, Connecticut U.S.A.

2 YEARS FREE SERVICING!!

**FREE GIFTS, FREE TAPES,
COMMISSION & DISCOUNTS!!!**

If that's what you want when you buy a tape recorder then you most certainly will not come to us to purchase one. We cannot and will not give you these things for our reputation as Britain's leading tape recorder specialist company is not built on sales gimmicks but on SERVICE. What we do give you is two whole years of worry-free, trouble-free and above all cost-free servicing. Every new tape recorder over £35 carries our unique and exclusive two years' absolutely FREE SERVICING GUARANTEE, that many thousands of more than satisfied customers have found to be the best obtainable anywhere. Make your choice when buying that new tape recorder. Gimmicks or superlative free servicing by a company specialising in nothing but recorders and servicing.

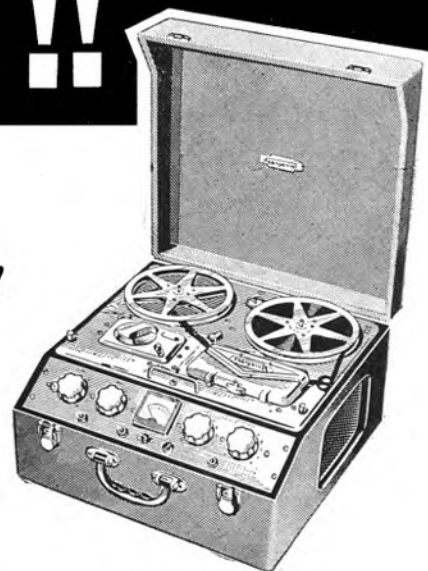

Specialists in

FERROGRAPH . VORTEXION
BRENNELL . REFLECTOGRAPH
GRUNDIG . REPS . ETC

- ★ OVER 250 NEW AND LOW PRICED SECOND-HAND RECORDERS ON DISPLAY ★
- ★ GENEROUS PART EXCHANGES ★ CASH & H.P. TERMS OVER 9-24 MONTHS ★
- ★ FREE HOME DEMONSTRATIONS ★ FREE DELIVERY ★ FREE PAMPHLETS, Etc. ★

SHOWROOMS:

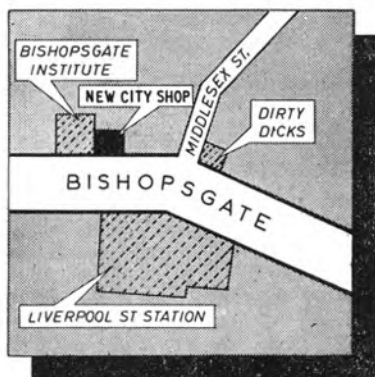

◀ CITY:

228 BISHOPSGATE, E.C.2 (Opp. Liverpool St. Station). BIS 2609
OPEN MON. to FRI. 9 to 6 p.m. CLOSED SATS. OPEN SUN. 9 to 2-30 p.m.

STRATFORD:

2 MARYLAND STATION, LONDON, E.15 (Adj. Maryland Station)
(EAST HAM & STRATFORD OPEN ALL DAY SAT.) MAR 5879

EAST HAM:

205 HIGH ST. NORTH, E.6 (Opp. East Ham Station). GRA 6543

CITY & ESSEX TAPE RECORDER CENTRES

Great newcomer to the Greatest
range of Tape Recorders

STAR
VALUE
AT ONLY

27 GNS!

*including
microphone, 4"
reel of L.P.
tape and radio
connecting lead.*

Now the world's finest range of tape recorders gets a brilliant addition – the fabulous Philips 'Starmaker'. Combining snag-free ease of operation with revolutionary design and outstanding performance, it opens up a fascinating new world of exciting entertainment for the newcomer to tape recording.

Everything the 'Starmaker' does is governed *completely* by just six error-proof controls. It's got a whole host of other advantages, too: economical mains operation, 4-track recording and playback; 4 hours playing time on a 5" reel of double-play tape; fast winding and re-winding; moving coil microphone; *plus* brilliant reproduction from the 6½" loudspeaker.

The vertical design and lightweight compactness of this sleekly styled recorder make it exceptionally *portable*.

See the Philips Starmaker in operation and hear it play at your local Philips dealer. It will convince you that no other machine in its price range can give you such a marvellous performance.

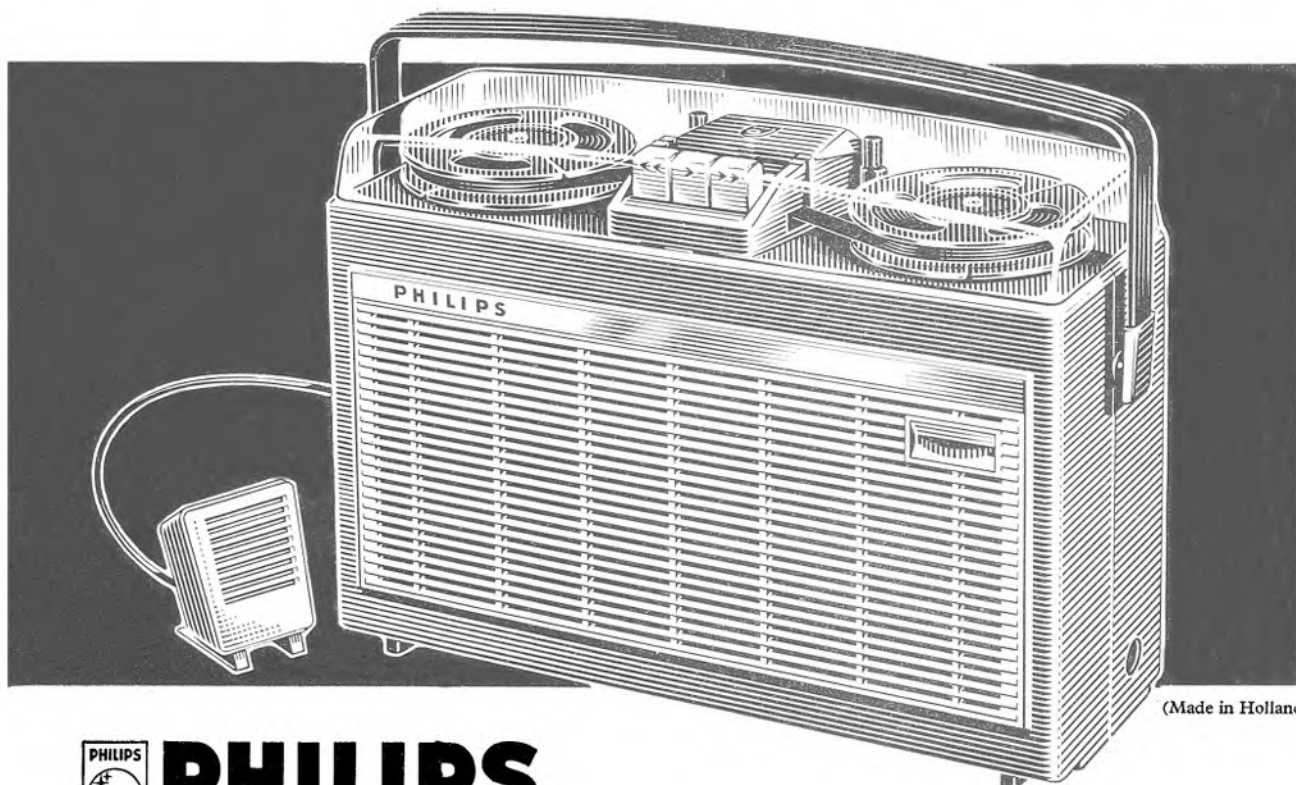

(Made in Holland)

 **PHILIPS**
STARMAKER TAPE RECORDER

... the unique new mains 4-track machine

PHILIPS – THE FRIEND OF THE FAMILY

PHILIPS ELECTRICAL LTD., CENTURY HOUSE, SHAFTESBURY AVENUE, LONDON W.C.2

(PR3897)

an absolute practical minimum of



and

That has been one of our main objectives since we started making tape decks and recorders and we feel that we have achieved this (along with many other notable features) in our present range of recorders. By the use of high quality components and fastidious precision assembly these "wow and flutter" figures are maintained:—

- Below .05% at 15 ips
- Below .1% at 7½ ips
- Below .15% at 3¾ ips
- Below .25% at 1⅞ ips

The Brenell Mark 5 deck at 28 gns. has greater precision and dependability than you are ever likely to find elsewhere at anywhere near the price.

IT'S A HEART THAT IS AS SOUND AS SOUND CAN BE

Abridged Specification:

- 3 INDEPENDENT MOTORS—
(Capstan motor—hysteresis synchronous)
- 4 RECORDING AND PLAYBACK SPEEDS—
1½, 3¾, 7½ and 15 ips.
- FAST REWIND (1,200 ft. rewind in either direction in 45 secs.)
- ACCEPTS 8½ in. reels ■ PAUSE CONTROL ■ INTER-LOCKED CONTROLS ■ DIGITAL REV. COUNTER
- PROVISION FOR EXTRA HEADS (Mono or Stereo)

TAPE RECORDERS: MARK 5 STEREO, £99.12.0.
3 STAR, 58 GNS.
3 STAR STEREO, 89 GNS.

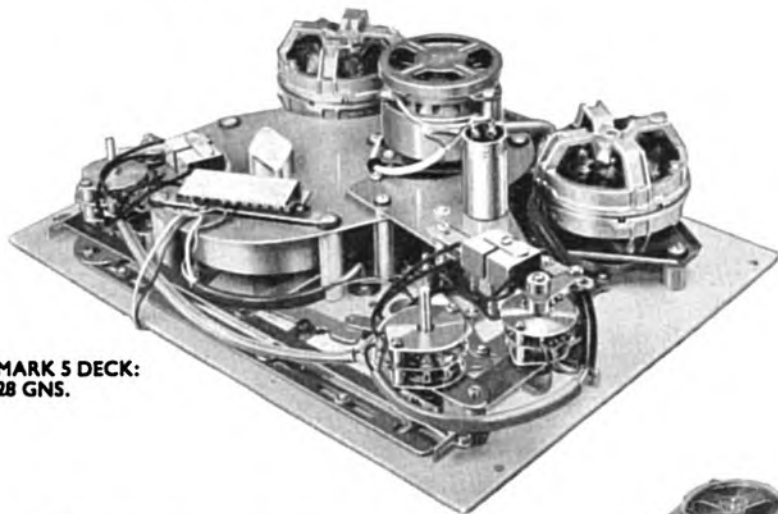

MARK 5 DECK:
28 GNS.



MARK 5 Type M:
88 GNS.



MARK 5: 64 GNS.



Full details and the address of your nearest stockist from the sole manufacturers: **BRENELL ENGINEERING CO. LTD.**,
1a DOUGHTY STREET, LONDON, W.C.1. Tel.: CHA 5809 and HOL 7358

G.D. 821

IMPORTANT NEWS

IF YOU OWN A STEREO TAPE-RECORDER

YOU NOW HAVE THE OPPORTUNITY TO HEAR THE FANTASTIC REPRODUCTION OF

STEREO 21

the newest, truest sound on tape today!

Revolutionary new STEREO 21 pre-recorded tapes (7½ ips twin-track) are issued exclusively by World Record Club. But they are offered *without membership commitments of any kind*. The first list of all-new STEREO 21 releases is now available. It features **30 superb stereophonic tapes** ranging from *Beethoven's Eroica* with Josef Krips conducting the LSO to a lavish full-cast production of *South Pacific*. As always World Record Club prices present unparalleled value — all STEREO 21 releases cost either 50/- or 60/- depending on playing time (up to 50 minutes). STEREO 21 tapes are now obtainable through leading retailers or direct, by post, from World Record Club.



Post the coupon for colour brochure with full details — Now!

STEREO 21 must be heard to be believed!

SEND FOR DETAILS NOW!

To: WORLD RECORD CLUB (Dept.STGI)
 Box 11, Parkbridge House, Richmond, Surrey

Please send me your free colour brochure showing the full range of STEREO 21 releases.

NAME

ADDRESS

.....

.....

ISSUED EXCLUSIVELY BY WORLD RECORD CLUB



WE'VE GOT WHAT IT TAPES AT THE TAPE RECORDER CENTRE

Every model, every make. Hundreds to choose from to put before you the most comprehensive selection of Tape Recorders and Hi-Fi equipments in Europe. Expert, honest advice to make sure you get exactly what you want.

Tape Recorders

Grundig
Elizabethan
Ferrograph
Vortexion
Brenell
Reflectograph
Simon
Harting
Telefunken
Philips
Spectone
Sony

H.M.V.

Veritone
Stuzzi-Magnette
Fi-cord
Truvox
Kurland
Reps
Wyndor
Audiograph
Minivox
Korting
Stella-Cossor

Hi-Fi Equipment

Microphones
Speakers, etc.
Leak
Quad
Rogers
Armstrong
Jason
Dulci
Pamphonic
Stentorian
Avantic
S.M.E.

Collaro

Goodsell
Elpico
Decca
Philips
Wright & Weaire
G.E.C.
Goodmans
C.Q.
Wharfedale
Elac
B.J.
Garrard

Connoisseur

Goldring
T.S.L.
Acos
Lustraphone
Cadenza
Reslo
Record Housing
Linear
Tannoy
Ortofon
Auriol

*All Accessories, Tapes, etc. by return of post.
All makes in stock.*

Lowther

Film Industries
Audiomaster
Tape
Emitape
Scotch Boy
BASF
Grundig
Telefunken
Irish
Philips
Agfa

THE TAPE RECORDER CENTRE

CHOOSE IN PERSON— CHOOSE BY POST

Central London: 82 High Holborn, W.C.1 CHAncery 7401

North London: 75 Grand Parade, Green Lanes, Harringay, N.4 FITzroy 2316/7/8

Only at these two Showrooms will you find the complete Tape Recorder Centre range!



YOU—ALONE WITH THE MUSIC



You will be amazed by the unique qualities of stereo through headphones. AKG's K 50 dynamic headphones will put you in a world apart—alone in the concert hall with conductor and musicians, thrilled by the new sense of realism and immediacy inherent in the K 50.

Only with binaural hearing through fine headphones can you eliminate every environmental influence outside the recording hall—only with K 50's three featherlight ounces can you listen for hours without discomfort.

The finest recordings are made with AKG microphones. Any recording, mono or stereo, sounds best through AKG's K 50 phones. Designed and handcrafted in Vienna "the Home Town of Music". K 50 costs you only £7.10.0. Z 50 earpads now available for 9 shillings per pair.



Microphones from Vienna

POLITECHNA (LONDON) LTD. 3 PERCY STREET, LONDON, W.1

Telephone: LANGHAM 6236 Telex: 23894
Cables: POLINDUST LONDON

Amalgamated Wireless (Australasia) Ltd., Sydney, Wellington—Soundrite Ltd., Singapore, Penang, Kuala Lumpur—Hind Industrial & Mercantile Private Ltd., Bombay—The China Engineers Ltd., Hong Kong—Sandbach, Parker & Co. Ltd., Georgetown.



THE METRO-SOUND RANGE OF TAPE RECORDER ACCESSORIES

KLENZATAPE—for cleaning Tape Recorder Heads—Complete kit, 12/6; Fluid Refills, 3/11. Replacement Tapes 5/- each.

METRO-SPLICER—for both Recording Tape and 8mm. Cine-Film—Complete with Film Emulsion Scraper and spare Cutting Unit, 15/-; Spare Scrapers, 1/-; Spare Cutting Units, 2/6.

The Original **METRO-TABS**—for making positive identification of Recordings **AT A GLANCE**—3/11 complete with Index.

Tape Deck Cleaning Brush—made from specially shaped feather-soft non-scratch Nylon, 2/6 each.

The above items complete with many spares making a total value of £2 4s. 9d.

NOW AVAILABLE IN THE METRO-SOUND TAPE ACCESSORIES SET LAVISHLY MOUNTED AND LUXURIOSLY PACKAGED FOR ONLY £2 2s.

Sole manufacturers:

METRO-SOUND Mfg. Co. Ltd.

19a, Buckingham Road, London, N.1. (CLIssold 8506/7)

6 Books by G.A. BRIGGS

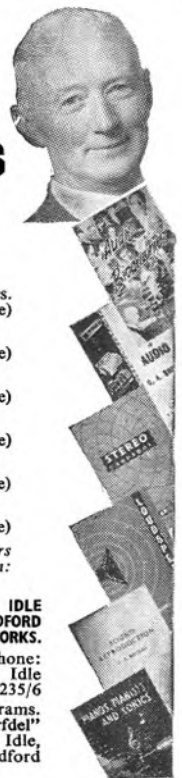

AUDIO BIOGRAPHIES

With contributions by 64 collaborators. 344 pages, 112 illustrations, 19/6 (20/9 post free)

A TO Z IN AUDIO

244 pages, 160 illustrations, 15/6 (16/6 post free)

STEREO HAND BOOK

146 pages, 88 illustrations, 10/6 (11/6 post free)

LOUDSPEAKERS, 5th Ed.

336 pages, 230 illustrations, 19/6 (20/9 post free)

SOUND REPRODUCTION, 3rd Ed.

368 pages, 315 illustrations, 17/6 (18/9 post free)

PIANOS, PIANISTS AND SONICS

190 pages, 102 illustrations, 10/6 (11/6 post free)

The above books are sold by many radio dealers and bookshops. In case of difficulty direct from:



IDLE
BRADFORD
YORKS.
Telephone:
Idle
1235/6
Grams:
"Wharfedale"
Idle,
Bradford



**YOU'LL KNOW GOOD SOUND
WHEN YOU SEE IT!**

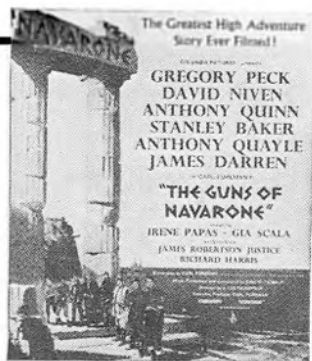

If you've seen "Ben Hur" or "The Guns of Navarone" you'll know what we mean. Both these outstanding films were recorded on Zonastripe—a fact worth remembering when you are buying tape and want to buy the best. Zonatapes are supplied in handsome case bound library containers and are obtainable from most high class radio, music and photographic shops.

ZONAL FILM (MAGNETIC COATINGS) LTD., THE TOWER, HAMMERSMITH BROADWAY, LONDON, W.6 • TEL: RIVERSIDE 8741



Stagesound produce all the right effects—with **EMITAPE**

You can still hear the rumble-hiss-whine of a London tram in Covent Garden—it's just one of the 60,000 effects on Emitape at Stagesound, Britain's largest independent effects library. But, if Stagesound keep their tabs on the past, they've also got more than half an ear on the present with a satellite's bleep to match the croak of a klaxon.

All these miles of Emitape at Stagesound keep ITV, commercial radio and film studios well supplied with any effects they may want. Incidentally, Stagesound also supply most of London's West End theatres with alarums, excursions and noises off.

There simply *must not* be any mistakes in this business. That's why Stagesound always use Emitape—the world's finest magnetic recording tape.



E.M.I. TAPE LIMITED, Hayes, Middlesex.

ET30

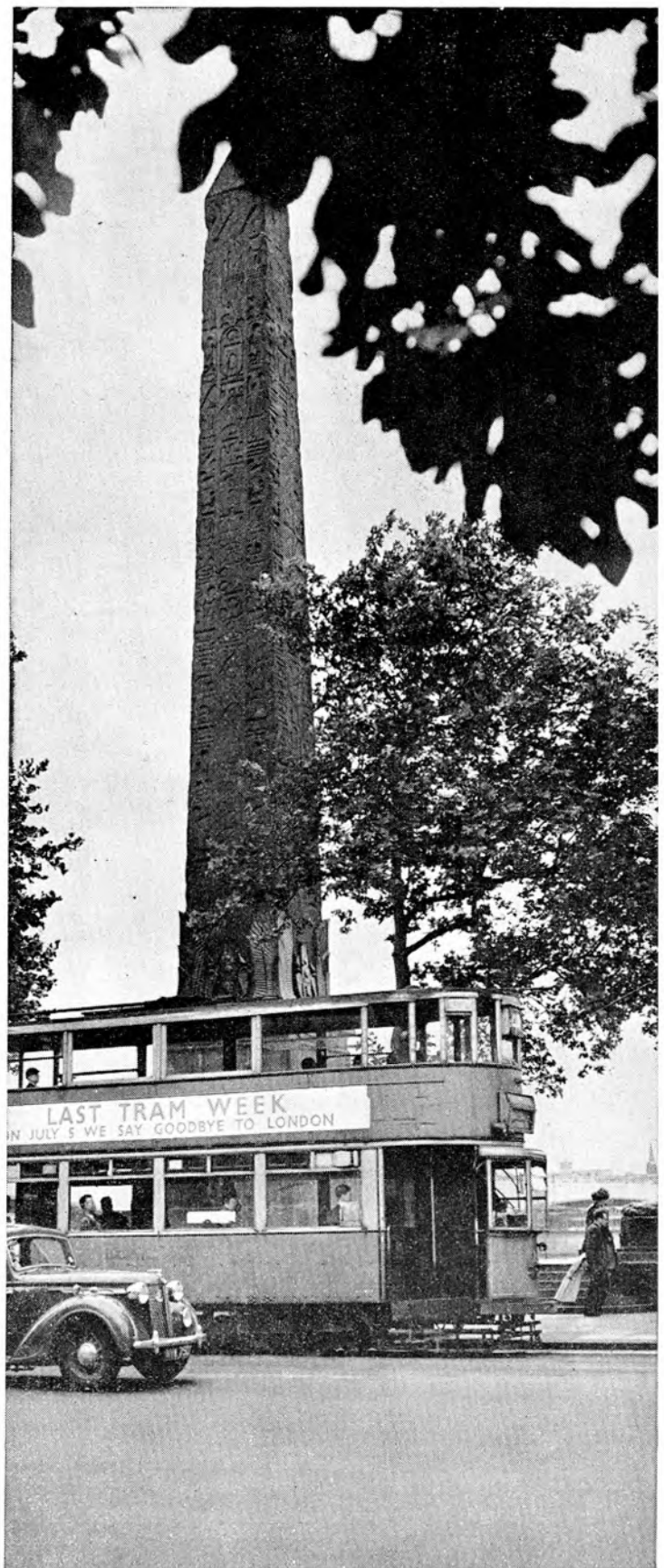

TRUVOX **SERIES 80**

a new range of

FOUR TRACK AND TWIN TRACK TAPE RECORDERS

"Technically Luxurious"

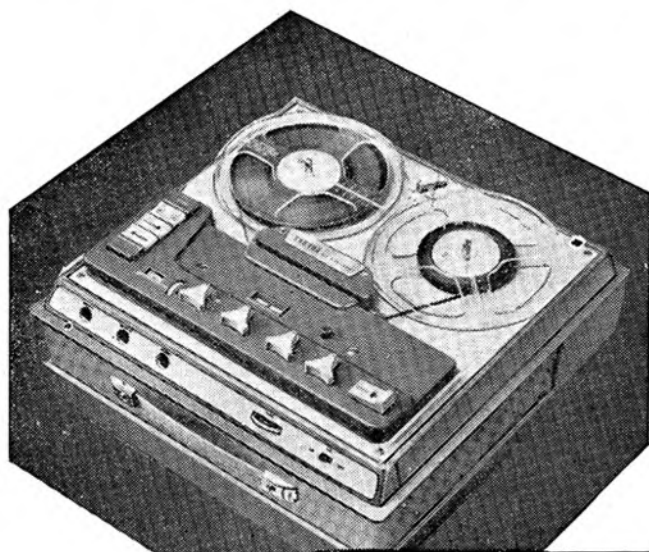

Supplied with microphone, recording lead and 7" reel of Tape. 4 watt output.

Model R82 twin-track 55 gns.
Model R84 four-track 59 gns.

Push-button controls, instant Mechanical braking, Fast Wind and Rewind, Auto-Stop, Speeds $7\frac{1}{2}$ and $3\frac{3}{4}$ i.p.s., Input mixing, Superimposition, versatile matching to other equipment. Frequency response 30—20,000 c.p.s.

also Tape Decks and Hi-Fi units*

For Technical Specification and Full Particulars write to:—

**TRUVOX LTD. NEASDEN LANE,
LONDON, N.W.10**

Telephone: Dollis Hill 8011

*Deck with pre-amplifier mounted in attractive plinth.

TAPE

RECORDING
MAGAZINE

Vol. 6 No. 2 February, 1962

IN THIS ISSUE

The Editorial view . . .	12
Special Assignment	13
Denys Killick	
Tape in the school	14
Geoffrey Hodson	
Tape Talk	15
Alan Edward Beeby	
Loudness and quality	16
James A. Moir	
Portables on parade	20
S. M. Wheatley	
British Amateur Tape Recording Contest	21
Special announcement	
Make way for the Ladies	24
Vivienne Gooding	
A recording level indicator	24
Do-it-yourself feature	
Test Bench	26
Symphony and Grundig TK14	
Stereo Notes	29
Douglas Gardner	
Letters to the Editor	31
Tape Records reviewed	32
Stanley R. White	
Practical guide to Loudspeakers	33
Peter R. Milton	
New Products	34
News from the Clubs	36
Fred Chandler	
Tape Exchanges	38

"TAPE Recording Magazine" is published on the third Wednesday in the month, by Print and Press Services Ltd., from 7, Tudor Street, London, E.C.4.

"TAPE Recording Magazine" is available by a postal subscription of 20s. per annum, including postage, or it can be obtained at newsagents, bookstalls and radio and music dealers. In the event of difficulty, write to the Publishers at 7 Tudor Street, London, E.C.4.

Back numbers, if still in print, are available at 2s. 6d. per copy for issues up to November 1959, and 2s. per copy for later numbers.

Address all communications
7 TUDOR STREET, LONDON, E.C.4 FLE 1455-6

EDITORIAL

Editor,
R. DOUGLAS BROWN

ADVERTISING

Advertisement Manager,
KENNETH P. WILSON

Cover picture—Recording in the field by Marcel Beck. See page 29.

Amateurs and professionals

WHAT is the difference between an amateur and a professional recording engineer? I think we have now reached the stage where it is true that the only real difference is that one is paid for his work and the other does it for enjoyment.

This was the conclusion reached about interviewers, too, in the recent BBC "Sound" programme in which a professional interviewer was brought face to face with three amateurs from the tape recording clubs. I suppose even that distinction has been destroyed in their cases, now that they have received fees for broadcasting!

We listened to a large number of taped interviews gathered by the Eastbourne, Coventry and London clubs—far more than we were able to use in the broadcast. Many of them were excellent. They did not all have the finesse of the BBC product, but all were exceptionally successful.

This illustrates the way in which amateur recording has progressed in recent years. The range of equipment

now available has opened up many new possibilities particularly out-of-doors, and enthusiasts who took to the hobby in the early days have acquired a vast store of knowledge and experience.

For this reason the British Amateur Tape Recording Contest, preliminary details of which are announced elsewhere in this issue, takes on a new significance. It may now be regarded as a gateway through which a talented amateur, whether interested in production, scripting, recording—or, from this year, as a would-be stage performer—can hope to step through to professional status.

Nothing would please us better at *TAPE Recording Magazine* than to see a steady stream of the most skilled amateurs moving into the world of radio, recording and entertainment. The opportunity is there.

* * *

THIS magazine has been intimately associated with the foundation and expansion of a healthy club movement in Britain from the

day it was established in February, 1957. We have consistently argued in favour of a voluntary, democratic movement, based upon local clubs in every locality with sufficient enthusiasts to make it possible.

We regard the British Federation of Tape Recording Clubs as an appropriate national expression of such a movement and it has always had our full backing. For "tapespondence" there is, of course, a need for special international organisations, and these, too, we fully support.

Many of our readers, however, may have become members of a different type of national club when the British Recording Club was established a couple of years ago. This was started as an ordinary commercial enterprise, as we pointed out at the time.

The Associated British Tape Recording Club Ltd. is now being voluntarily wound up and creditors of the company should submit details of their debts or claims to the Liquidator, Mr. Ralph M. Morris, at 8 Fulwood Place, London, W.C.1, on or before January 31.

In association with the British Recording Club, a Centre of Sound was opened by Audio Industries Club Ltd. in the West End of London. This Club has now closed. Enquiries should be addressed to Mr. E. J. Rogers, 8 Fulwood Place, Holborn, London, W.C.1.

The magazine that was published in association with the Club has passed into other hands.

* * *

SNEAK recordings are objectionable and equipment designed to make them possible is undesirable. We have, in the past, published strong criticism of recorders designed to look like ordinary dispatch cases.

But the most fantastic case of sneak recording to date is reported from the United States. Over there a security chief has resigned following an interview with a politician who had a recorder hidden in his wooden leg.

THE EDITOR

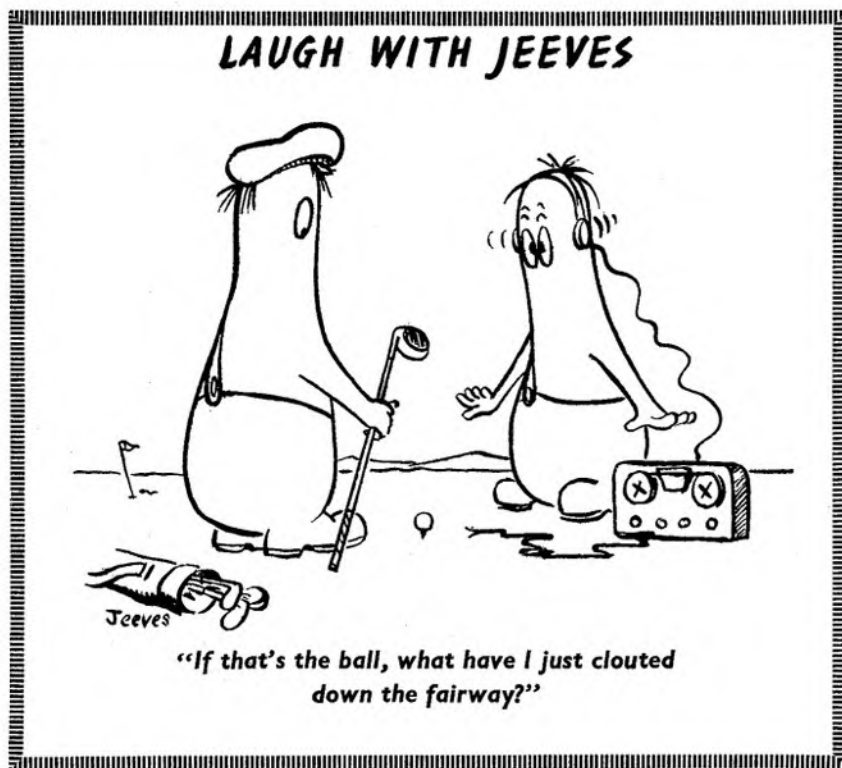

SPECIAL ASSIGNMENT

By Denys G. Killick



RECORDING IN COFFEE BARS

Readers suggest the recording assignment and if they wish, the equipment to be used. Killick does the job and reports on the problems encountered and the way they were solved. Let him have your suggestion for his next assignment.

A RECENT letter from Mr. James Walker, of Richmond, Surrey, raised an important point concerning the difficulty of achieving good recordings in a coffee bar.

His tapes, he wrote, had so much background noise from the general chatter and laughter, clatter of crockery and scraping of chairs and tables that the recordings were confused and interviews unintelligible. There are simple methods of overcoming these problems, and this article is intended to clear up some of the most troublesome.

Usually when I receive my special assignment I pack up my gear and go out deliberately to take some particular recording. This time it's different, because I've recorded so often in coffee bars that I know exactly what to expect in advance.

Before setting out on any recording expedition we must have at least some idea of the kind of thing we expect—or hope—to record. What shall we find in our coffee bar? First of all, the very sounds of which Mr. Walker complains, the noises of the coffee bar itself. There will be plenty of these background sounds, and we shall be able to record quite a lot of this general material if we wish. We shall want to speak to people as they sit and drink coffee, and perhaps we might record the bright remarks made by the waitress. If we're very lucky perhaps we might find a vocalist to sing for us. I once came across a bright-eyed, black-haired beauty from Spain who had an endless store of Spanish and Mexican folk songs which she rendered with a truly ferocious passion.

What is the best equipment to use? If you have it, a good battery portable, but if your only machine is mains operated don't despair. I know several people who have tackled this subject with mains-only equipment, although it does require greater initiative and physical effort.

The advantage over the battery portable is that the recordings are likely to be of better quality, but one must make special arrangements with the proprietor and request permission to plug-in

to the mains supply. To ignore this would not only be an abuse of the services offered to the public but would also bring disrepute to the whole recording fraternity. You would also stand a very good chance of damaging your machine by connecting to the wrong voltage—and serve you right!

What is the best microphone to use? Definitely, a moving-coil instrument on no more than six feet of cable, as little as three feet can be an advantage. Too long a cable will trail on the floor and get under people's feet. There is another reason for having a short cable. One of the recordist's gravest errors is to allow anyone to take the microphone from his hand. If foolish enough to part with it, all control over the recording is lost from that moment, and you may even lose your microphone as well. If, when presenting it to a stranger he attempts to take it from you, withdraw it firmly and indicate with your other hand that it's not to be touched. Then, equally firmly, re-present it to him. He won't try to take it a second time.

Although I've suggested using a moving-coil microphone, I always take a ribbon instrument as well on such an assignment as this. It's not really necessary, but I carry it because I like the improved quality it will give if I should happen to unearth a vocalist such as the Spanish girl. I would never use it for general interviewing work and regard it purely as an added refinement. Spare tapes and spare batteries complete the outfit, and I manage to slip the lot into the rather voluminous pockets of my top coat so that with the machine on its strap over my shoulder I have no loose bags or packages to worry about.

One last thought before we leave for our coffee bar. Does one really need an assistant? The job can be done single-handed, but it's going to be very much

easier to have an assistant by your side. This aide must be used to working with you and you must be able to hand over your machine knowing it will be handled competently in the way you want. If three or four other people decide to come along and help, develop a rapid cold-in-the-head and stay-at-home.

As soon as we enter the coffee bar we can hear all kinds of very distinctive sounds. Assuming we are using a battery machine, are we at liberty to just start recording or should we first ask the manager? If we are going to record the sounds of the staff at work, the hiss of the coffee machine and the bell of the cash register, we *must* ask before starting. If we only wanted to record a few interviews in one corner of a large and busy establishment it might be possible for us to omit this formality, but in a small, intimate kind of bar it's a matter of courtesy to say what you would like to do and to make sure the proprietor has no objection.

I've never yet been told that I can't record in places such as this, and the bar we've chosen tonight is no exception. Holding the microphone in a suitable position to pick up as much sound from the counter as possible, the machine is switched on and the record level brought up. My Fi-Cord has a numbered scale around the control knob, and when level four is reached the recording indicator is fluttering nicely to show that the tape is being fully modulated. Recording has started.

There are a couple of interesting-looking characters sitting at a table quite close to the counter, but they're in the very worst position in the room, next to the greatest source of background noise. The lift to the basement kitchen is in the wall next to their table and, as we watch, the waitress clatters in a load of dirty dishes. To add to our troubles, a party of teenagers have started laughing and shouting only a few feet away. Under these conditions can we successfully record our interview?

If the tape is going to be worth listening to, recordings of speech must be

(Continued on page 19)

TAPE IN THE SCHOOL

EDITED BY GEOFFREY HODSON

MISS HOLLINGWORTH: We have met today to discuss the use of the recording machine in the classroom. I have with me a Head Teacher of an infant school, a teacher of English from a junior secondary school and the Head Teacher of a primary school. These representatives from the various schools have all had some experience of tape recording in the classroom. First, I shall ask Miss McHaffie, infant school Head Teacher, to tell us about her school and what use she makes of the tape recorder.

MISS McHAFFIE: Kingswood school is a modern infant school in a new housing area in Aberdeen, and we find the tape recorder a great help in school work. With careful use, we are able to encourage the children to express their thoughts clearly, fluently and easily. Children in the 6-7 age group regularly compose entertainment programmes with their own announcer, without any emphasis whatever being laid on a polished performance.

These programmes are recorded on tape and later broadcast to all the classes through the school wireless system.

HOLLINGWORTH: Miss McHaffie, you have made no mention of the bilingual factor which is very important.

McHAFFIE: By the time the children are six years old they understand that there is a language which they use in school which is not the language of the playground or the home. They appreciate that there is a little more formality about it but they try to use their classroom language. Of course, there are lapses but these are not corrected. We do not mind lapses into the vernacular so long as the child can express his ideas clearly, with pleasure and with some grace.

HOLLINGWORTH: Mr. Wright, what use does your school make of the tape recorder?

MR. WRIGHT: In Ferryhill School we use the machine to try to improve the quality of the spoken work. When teachers are preparing a play or a puppet show it is very useful to be able to let the players hear their own voices. The school choir finds it helpful when learning a descant or a two-part song. Our speech therapist also uses the machine very extensively and considers that the playback is a

great incentive to the child with a speech defect.

Recently we have also held experiments of interviewing technique with children in the top classes. I feel that there are great possibilities of helping the children to be self-assured and fluent at expressing themselves to a stranger. Last week we recorded a tape to send to a school in Saskatchewan. The programme, which was prepared by my top class, consisted of a story about their school, their work

A recorded conversation between Miss Catherine Hollingworth, Superintendent of Speech Training in Aberdeen and Miss Isobel McHaffie, Head Teacher of an infant school, Miss Marian Green, English Mistress at a Junior Secondary School and John M. Wright, Head Teacher of a Primary School.

in class, and their outside activities. Each member of the class took part in this recording. We also recorded an interview between one of the class and a visiting speech therapist and finished with a short general knowledge quiz.

McHAFFIE: Mr. Wright, our children record short poems and verse. Do you do anything with poetry?

WRIGHT: Oh yes. We have successfully used the machine to record choral verse speaking. With the tape to help them the children rapidly become aware of their errors and learn to pronounce the final consonants clearly.

HOLLINGWORTH: Miss Green, perhaps you will give us some comments about how far you think this technique might be useful with the older boys and girls in the 12-15 age group. Have you anything to say about the less formal type of work one could do with a tape recorder?

MISS GREEN: Most of the points have already been made by Miss McHaffie and Mr. Wright. I have found that it gives great point and purpose to written work when the children know that they are writing for a recorded programme. When we recorded a play, complete with numerous sound effects, the playback really sounded wonderful.

HOLLINGWORTH: Do you think that it would be a good thing if the children could develop a technique in interviewing?

GREEN: Although I have not tried this technique yet I can certainly see a use for it. I think it would be an excellent idea for third-year pupils who are ready to leave school. Ahead of them are interviews with prospective employers and a good interview can help a lot to shape their future career. Listening to a record of a class debate also helps them to speak fluently and correctly.

McHAFFIE: It seems that we have all found that the use of the tape recorder can bring about improvements in many ways. I find that it certainly motivates good reading. The standard of reading has noticeably improved since the children learned to listen to themselves on the tape. There is also a great interest in and awareness of the school as a community, as a result of the different classes broadcasting their own programmes to the rest of the school. We also have many discussions on the techniques used in the BBC programmes.

WRIGHT: Could you tell us about the content of these programmes?

McHAFFIE: The classes in the 6-7-year-old age group take turns of preparing a programme which is broadcast once a fortnight. We have an announcer who keeps the programme together. There are news items—personal or class news and reports on pet animals or on interesting events. Then we have stories, singing, birthday greetings, poetry, dramatised stories and a guessing competition. The whole programme lasts about twenty minutes.

HOLLINGWORTH: Mr. Wright, one last question! What would be the reaction of the teachers on your staff if you asked them to prepare a programme of this nature?

WRIGHT: Oh, they would prepare a programme all right, but they would expect me to come and record it for them. Most of them, but not all, are rather afraid of the machine and worried lest they press the wrong knob. Time and patience and a more liberal supply of power plugs in the classrooms will, I hope, eventually overcome this difficulty.



ALAN EDWARD BEEBY'S TAPE TALK

AS a result of a background-music recommendation of mine in the October 14th issue, several of our readers called at the offices of Inter-Art Music Publishers and tried to purchase the recording concerned.

Mr. F. Benson, secretary of the Company, told me: "As publishers, we would be only too happy to sell the discs direct to your readers, but the restrictions governing the sale of these items have been placed by the Purchase Tax Authorities, and we have to abide by their ruling. This is that only members of the Institute of Amateur Cinematographers may purchase the recordings, and then only from the Institute which obtains the recording for the purchaser from the publisher." (You still with us?) "No direct transaction is permitted between a publisher and an I.A.C. member."

I then asked Mr. Benson why, if this ruling was in force, I had been able, fairly recently, to purchase several background-music discs direct from his firm's offices—and without question? "That would be at the time when our records were charged with Purchase Tax," he said, "and therefore sale to the general public was permitted. Since then, we have obtained exemption for our discs. During a short space of time the P.T. Authorities did not permit the sale of non-taxed library recordings to amateurs. Now, however, the publishers have come to an agreement with the I.A.C. which has produced the aforementioned ruling."

Note to the P.T. Authorities: Would it not be possible to dream up a more simple and straightforward scheme than one which requires the amateur tape enthusiast—who may, after all, only intend to purchase one record—to join an organisation, order the disc through that organisation, wait for it to be delivered to the organisation's office, then have the thing passed on to him from there, etc., etc., etc. . . . ? Anything rather than this ridiculous, penny-pinching pantomime!

MY recent note concerning the lack of information about the use of tape recording equipment at Buckingham Palace has brought a reply from Rear-Admiral Christopher Bonham-Carter, C.B., on behalf of the Duke of Edinburgh.

The Royal Family, it seems, has no active interest in tape recording for entertainment purposes. Wonder how The Joneses feel about it. . . .

NEW TO YOU? Ever heard of a double-decked tape recorder: one that carries two spools of tape at the same time? On-the-spot dubbing, copying and editing—all on one machine? Patience, friends, it's on the way.

Word also reaches me of backroom experiments on a record-playing unit which plays—wait for it—pictures! Mind you, the same idea was being explored as far back as 1938, but it now appears that the plans are being brought out of cold-storage as a practical possibility at long last. The drill? You simply lift the lid, and inside the lid is the screen. Put a record on and there, on the screen, is your picture.

It's a bit early to start naming names in connection with the above two projects, but when the official announcements break, remember you first read about it in *TAPE*.

... AND THINGS THAT GO 'BUMP!' ETC.: Last Saturday evening. Our sitting-room. Vortexion on table, playing back effects-tape. Stopped machine to mark-up for splice and lifted head-cover. . . "P-I-N-G!!" Small, unidentified object suddenly sprang out from beneath head-cover, went streaking across room, hit window, ricocheted fiercely between wall and ceiling for few seconds, then dropped to earth somewhere in region of settee.

For next hour, self and wife on hands and knees, searching for mysterious projectile. Had carpet up, shifted all furniture and went over floor with toothcomb. Groped down seats of armchairs and settee; found rusty tanner, two half-chewed dog-biscuits and ancient election-pamphlet proclaiming: "McPheeny Gets Things Done!"—but no projectile.

Vortexion's still working O.K. Doesn't appear to have made the slightest difference to it. Baffled! Poltergeists, shouldn't wonder! What a life!

THIS month's Star Shop Service Spot features Watford. Mr. P. Holloway, secretary of the West Herts Tape Recording Society recommends Messrs. Watford Supplies, 81 Queens Road, Watford.

"They've given our group much assistance," he tells me, "with publicity and practical help, as well as donating a silver challenge-cup which is competed for annually. I have dealt with these people for much of my own equipment and, along with my fellow society-members, have derived a great deal of benefit from the excellent service offered by this firm."

Before we leave this subject, however, I am sorry to have to report that, so far, the response to my appeal for recommendations of reputable dealers has proved disappointingly poor.

Editorial comment suggested that the time has come to end the almost-constant bickering and back-biting between manufacturers, dealers and customers in favour of a more constructive and useful relationship of equal benefit to each camp. I could not agree more. And

this is the whole idea behind our Star Shop Service Spot. High-lighting the manufacturer or dealer who gives exceptionally-good service to his customers is one of the best ways I know of quietly, but firmly, pushing the "get-rich-quick/couldn't-care-less" merchant well into the background—where he rightly belongs! But, to be able to do this effectively, we need your help.

At this very moment, literally hundreds of people in all parts of the country are thinking about purchasing their first machines . . . and wondering where to go to get the best service for their money: just as you were, once-upon-a-time—remember? How about giving them a helping hand in the shape of a friendly piece of advice? Don't forget, you're the experts here, not me! Simply jot your recommendation down on a postcard and send it to *TAPE*.

BOUGHT your set yet? HMV "Sound Effects" Disc-Series.

They are copyright-cleared for dubbing by amateur tape and cine enthusiasts, and may be reproduced without licence-fee for non-professional public performance. Record-speed: 45 rpm. Record Nos.: 7FX1-15. Price: 7s. 6d. each.

Categories: The lot! Air-raids, cars, bells, animals, birds, sea, ships, weather, trains, aircraft, space-ships, ghosts, applause, etc.

Verdict: Best thing that's happened to tape recording since the invention of tape!

"HOME TRUTHS" DEPARTMENT: Visited my local disc shop the other day to buy two new LPs. It was crowded. After twenty minutes, I was still cooling my heels in a three-mile-long queue, while the teenage bottleneck at the counter chose, rejected, finger-snapped and argued the respective merits of Richard, Faith, Shapiro & Co.

"It's Beeby, isn't it?" said the man in front of me. I looked up to find my old headmaster. "What are you doing for a living these days?" he asked. I said I was a journalist. His face registered blank amazement. "What—writing, you mean?" I nodded. "Good Lord!" He then made some remark about remembering the days when I appeared to labour under the unshakeable conviction that any word consisting of more than two syllables must invariably be written in a foreign language!

"You interested in gramophone records?" he asked. I said I wrote quite a bit about that and tape recording. His reaction to this was to remind me of the time when myself and a chap named Mullen plunged the entire school into Stygian blackness trying to connect up a faulty radiogram!

After being served, he bade me "Good afternoon" and tottered off towards the exit, visibly shaken, and muttering something about: "wonders never ceasing." Theoretically, I suppose—according to him—I should be starving in an attic, papering the walls with editorial rejection-slips and marvelling over the complex, wonderful workings of the 2.5 V electric torch!

Must keep him away from the Editor. A meeting between those two could be very nasty for the lad!

IN the first instalment it was noted that musical instruments produce sounds with components having frequencies up to perhaps 20,000 cps and that noise may include frequencies up to 100,000 cps. If the sound reproducer system is not to restrict the performance in any way it is reasonable to assume that all the equipment should reproduce frequencies of this order.

Experience shows this assumption to be wrong. The explanation is many-sided and all the facets will not be seen until later in the series. At this point, one aspect only will be discussed, though it is a very significant aspect.

Instrumental analysis of typical musical compositions reveals that the acoustical power from an orchestra is not uniformly distributed over the audio frequency band, the majority of the sound power being concentrated in the frequencies below about 2,000 cps. In fact a very high percentage of the power is contained in the band below 1,000 cps. Thus it is reasonable (though too much reliance should not be placed on reasonableness) to assume that those portions of the frequency range containing little acoustic power could be eliminated without serious loss of quality. But first of all a digression on the meaning of "acoustic power."

In a direct current circuit the power dissipated in a resistance is given almost unambiguously by multiplying the current flowing in the resistor by the voltage existing across that resistor. In the A.C. circuit familiar to the electrical power engineer, there are complications that make this simple procedure unacceptable. The instantaneous value of the voltage (and current) vary with time following the simple and familiar sinusoidal relation shown in Fig. 1.

In such conditions it may be shown that the power dissipated in a resistor is not given by multiplying the peak value of voltage V , by the peak value of current I , but is a lower value, $.707 V$, multiplied by $.707 I$. As $.707$ is $.5$, the real value of power is one half that obtained by multiplying together the peak values of current or voltage.

Unfortunately for the simple approach, music, speech and noise do not have such simple sinusoidal waveforms, a typical example being shown in Fig. 2, the waveform of an oboe. In a signal of this kind, the ratio of the peak value to the mean value changes continuously and there is no simple relation such as "multiply the peak value by $.707$ to obtain the mean value" as there was for the sinusoidal waveform of Fig. 1.

Thus there are two values of acoustic power that are significant, the peak value obtained by multiplying the peak value of voltage by the peak value of the current, and the mean or average value obtained by multiplying the "average" value of the spikey waveform by the average value of the equally spikey current waveform.

Both these powers are significant under differing circumstances but in discussion one has to be very careful to make clear which power is being quoted for the values may differ enormously for the same waveform. The spike power (or

LOUDNESS AND QUALITY

By **JAMES MOIR, M.I.E.E.**

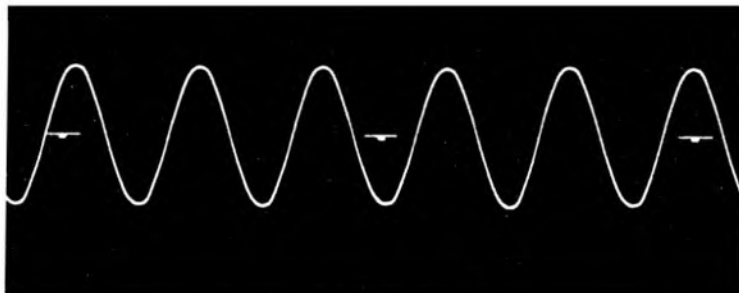

Fig. 1. The sound-curve of the simple tone from a tuning fork. The note is of frequency 256 (Middle C), and the dots indicate intervals of $\frac{1}{100}$ second.

peak power in technical circles) in music or noise may easily be ten times the average power of the same signal. The average power has substantially the same meaning as the electricity supply engineer's interpretation of the word "power" when he speaks of a 100 watt lamp, or of a motor taking 2,000 watts.

It would be very convenient to be able to forget one of these powers and always quote the other in discussion but in fact both are important and neither can be discarded. Broadly speaking the loudness of a sound is related to the average power while in the same broad terms, sound quality is related to the peak power. This statement does not have to be interpreted too literally for sound quality as we are seeing, is related to many factors other than the peak power.

After this rather long digression we can return to the primary problem of finding how the acoustic power of a musical

instrument or of an orchestra is distributed over the frequency band. There is a large amount of data available on this subject most of it due to the efforts of research workers at Bell Telephone Laboratories interested in fixing the standards to which communication equipment should be designed.

The data shows that most of the (average) power is concentrated in the frequencies below about 500 cps., though the peak values are more uniformly distributed throughout the frequency band. Even so Fig. 3 is a typical curve showing the distribution of average power over the frequency band for a large concert orchestra playing, while Fig. 4 shows the distribution of peak powers for the same orchestra playing the same music. The vertical scale is marked in some esoteric units intended to show the professional engineer the absolute levels, but for our present purpose these can be ignored and

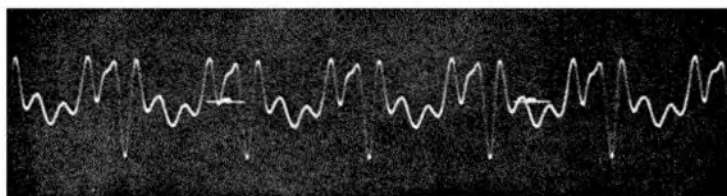

Fig. 2. The sound-curve of an oboe, played *mf*. The note is Middle C of frequency 254. The two time-scale marks halfway up the photograph are $\frac{1}{100}$ second apart.

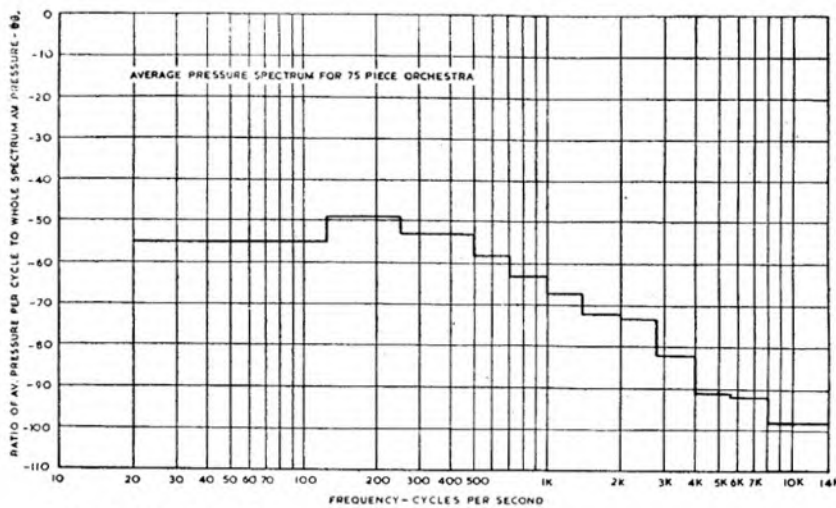

Fig. 3. Data from tests on 75 piece orchestra; average pressure spectrum.

the data used to show relative values. The spectrum, Fig. 3, indicates that the average power is falling away rapidly above a frequency as low as 500 cps and that at 10,000 cps it is about 40 dB below the value in the 500 cps region, i.e., the power per cycle in the 10,000 cps region is only about one ten-thousandths of the power per cycle of bandwidth in the 500 cps band.

The peak pressure spectrum tells a rather different story. The maximum peak levels reached in the neighbourhood of 10,000 cps are seen to be only about 10 dB below the peak levels reached in the 500 cps region i.e., the height of the peaks in the 10,000 cps region is about one third the height of the peaks in the 500 cps region. The curve provides the additional information that these peaks are those reached for one per cent of the time the orchestra is playing.

If account is taken of only those peaks that exist for twenty per cent of the playing the story is changed rather radically, for it will be seen that the peaks in the 10,000 cps region are then about 25 dB down on those in the 500 cps region. This is in fact almost the whole explanation, the peak voltages (or acoustic powers) in the high frequency end of the audio spectrum have about the same amplitude as those occurring at the low frequency end but they occur much less frequently.

This is the story for musical compositions written for concert orchestras, but it may be suspected that it does not hold for music written for Latin-American combinations where the emphasis is on the percussion section. There is not a great deal of data available on this kind of music but some measurements I have taken are indicative. As our analysing equipment differed radically from that used by the Bell Telephone Laboratories, we first of all checked a typical recording of a concert orchestra and having proved that the results were in qualitative agreement with the American figures we despatched one of the apprentices to pick out the "topiest" recordings that he could find in the stock of one of the major record dealers in the district. This excursion produced about half a dozen recordings and from these we selected the topiest sections for analysis. Five examples are illustrated on page 17 of *High*

*Quality Sound Reproduction** and need not be repeated here but they show that in extreme instances the peaks in the 10,000 cps have about the same amplitude as those occurring in the 500 cps region but that they occur much less frequently.

By this time readers may well be wondering what practical significance can be attached to these findings, a very reasonable query. The short answer is that the results show that if a recreation of the original is required, then hi-fi amplifiers and all the other parts of the system should have the same peak power handling capacity available in the 10,000 cps region as they have in the middle frequency region (say 200 to 2,000 cps). There are few amplifiers that meet this specification and I have yet to meet the domestic tape recorder amplifier that gets anywhere near the target. However readers should delay the ceremony of scrapping all their equipment until they have read a later section dealing with the results of listening tests.

* Published by Chapman & Hall, £3 10s.

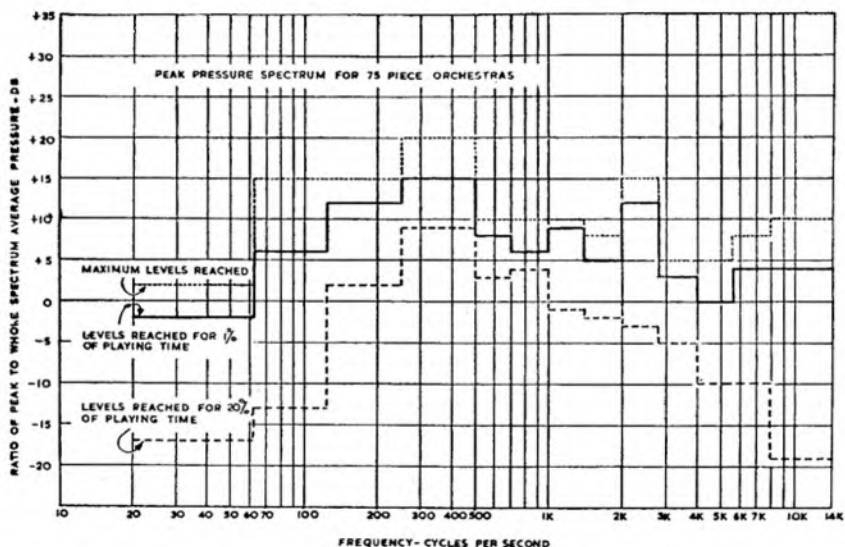

Fig. 4. Data from tests on 75 piece orchestra; peak pressure spectrum.

In a special new series we are inaugurating an authoritative but very readable explanation of the whole background of audio—theory and practice.

This is the second article in the series.

The author is one of the best-known authorities in the field. His "High Quality Sound Reproduction" is recognised as a standard work.

The actual amount of acoustic power produced by the orchestral instruments, a full orchestra and some other typical sound sources is interesting, for this has a bearing on the output of the power amplifier in a hi-fi system. Table 1 presents some information on this subject, the sound powers quoted being "peak" and not "average" values.

A large orchestra may produce peak acoustic powers in the region of 60-70 watts though this is a very exceptional result occurring for a second or so in an hour's playing. More typically the peaks are in the region of 15-20 watts and occur in the frequency band below 3,000 cps. Apart from the drums, only the trombone produces more than one watt of acoustic power, the majority of the instruments having outputs in the region of .1 watt.

These are acoustic powers and as will be seen later, the efficiency of a typical

(Continued on page 18)

PEAK POWER OF MUSICAL INSTRUMENTS

JAMES
MOIR

Loudness and quality

(Continued from page 17)

Instrument	Whole Spectrum Peak Power Watts	Band Containing Maximum Peaks	Band Peak Power Watts		
36 × 15 in. bass drum—A	24.6	250-500 c/s	9.8		
36 × 15 in. bass drum—B	1.2	20-62.5	0.24		
		250-500	0.19		
30 × 12 in. bass drum—C	13.4	125-250	1.7		
34 × 19 in. bass drum—D	4.9	20-62.5	1.2		
Snare Drum	11.9	250-500	3.7		
15 in. cymbals	9.5	8,000-11,300	0.95		
Triangle	0.050	5,600-8,000	0.017		
	0.012				
Bass viol	0.156	62.5-125	0.078		
		125-250	0.078		
Bass saxophone	0.288	250-500	0.228		
BB $\frac{1}{2}$ tuba	0.206	250-500	0.082		
Trombone	6.4	500-700	0.064		
		2,000-2,800	0.051		
Trumpet	0.314	250-500	0.047		
		500-700	0.047		
French horn	0.053	250-500	0.053		
			0.013		
Clarinet	0.050	250-500	0.0055		
			0.0045		
Flute	0.014	700-1,000	0.0045		
			1,400-2,000	0.0045	
					0.0035
Piccolo	0.084	2,000-2,800	0.021		
				0.021	
Piano—A	0.166	250-500	0.166		
				0.437	0.437
				0.198	0.198
				0.267	0.267
Piano B—Average	0.248	250-500	0.248		
15-piece Orchestra—Average of two methods	2.2	250-500	0.45		
		2,000-2,800	0.32		
18-piece Orchestra—Average of two methods	2.5	250-500	0.80		
		2,000-2,800	Not taken		
		125-250	0.82		
75-piece orchestra—A	8.2	250-500	1.03		
		2,000-2,800	1.03		
		250-500	6.7		
75-piece orchestra—B	66.5	8,000-∞	5.3		
		250-500	1.4		
75-piece orchestra—C	13.9	2,000-2,800	1.4		
		125-250	1.7		
75-piece orchestra—D	13.8	250-500	1.7		
		2,000-2,800	1.7		
		1.75			
Pipe organ—A	3.5	250-500	0.44		
			10.0		
Pipe organ—B	12.6	20-62.5	2.5		

Table 1. Data on all the instruments tested; peak power.

high fidelity speaker is in the region of only one per cent so that the driving amplifier really needs to have an electrical power output one hundred times greater if it is necessary to recreate the orchestral loudness levels in the same hall. Fortunately for his pocket the amateur enthusiast never needs to do this for the original loudness levels can be recreated in his living room by an amplifier having a power output of only a few watts.

The peak acoustic powers produced by the human voice are all remarkably low, typical conversational speech only producing about twenty microwatts (twenty millionths of a watt). A very loud shout may produce about half a watt peak. Thus the power handling capacity of a high fidelity system is determined by the power required for the reproduction of orchestral music. If this is adequate there is a very large margin when speech or singing is being performed.

Fig. 5 illustrating the distribution of peak power in speech over the audio frequency band is interesting as it illustrates a point made previously. Crooners earn their living by singing quietly (though this is becoming unfashionable) into a microphone and allowing the public address system to produce the power. When this is done, the curves show that the bass output of the singer is enhanced, his sound output in the 100 cps region being raised (relatively) by about 20 dB.

Experience indicates that there are many other factors that influence the quality of the sound from an instrument. Unfortunately most of them do not lend themselves to quantitative measurement or analysis. Kellog has shown that there are transient sounds at the commencement of each syllable and word that are characteristic of the individual speaker and have no connection with the intelligibility or meaning of the word being spoken. No doubt these starting transients are one of the factors that give the personality and character to a speaker's voice that distinguish him from any other individual making the same speech.

Bonar has shown that similar transient disturbances characterise the starting sounds of an organ pipe. These are a function of the material and construction of the pipe and not of the note being played. There can be little doubt that these transients are important in determining the quality of a sound, tests having shown that the difficulty of recognising an instrument is greatly increased if these starting transients are artificially eliminated.

The word "transient" has some peculiar mystique attached to it by the average hi-fi enthusiast, there being a feeling that an amplifier needs to have a frequency range extending to 20,000 or 30,000 cps or higher in order that it may

reproduce transients. This feeling is unfounded. When reproduction of the waveform of such noises as pistol shots is really necessary for visual reproduction on an oscilloscope such a wide frequency range is desirable. However it is well established that waveforms are almost meaningless to the hearing system.

The waveform of a complex signal such as the sounds of music is greatly affected by the relative times at which the harmonics appear. A square wave may be turned into a triangular wave by varying the relative phase (timing) of the harmonics but such a change produces no audible effect. This is fortunate for the waveform of a complex acoustic signal varies enormously at points only a few inches apart in the average living room. It would be quite impossible to create or replay music indoors if waveform changes were detachable by the ear for the music would undergo large changes in quality as a result of small changes in the listener's position.

The contents of the first two instalments may be summarised quite briefly.

1. Original speech and music contain components having frequencies between about 20 cps and 20,000 cps.

2. Noise may contain components having frequencies extending to perhaps 50-100,000 cps.

3. Practically all the power and loudness is contained in the frequency range below about 1,000 cps, but the peak amplitudes are fairly uniformly distributed over the whole audio frequency range.

4. The hearing system is almost completely insensitive to the change in the relative time of starting of all the components in a complex wave. Thus phase shift is relatively innocuous.

Objective results obtained by measurements on sources of sound do not represent the ear's opinion on the quality of the sound. A later instalment will discuss the ear's interpretation and show how the limited performance of the ear and its skill in reconstructing an image from little data makes it possible to reproduce satisfactory music under impossible conditions.

KILLICK IN THE COFFEE BARS

(Special Assignment—Continued from page 13)

intelligible. If the sense of the words is drowned in the noises-off, the recording engineer has failed in his job and the result is useless. There is, however, a very simple technique which you and I, working together as a team, could apply. We shan't get a good-quality recording, but that doesn't matter in an instance like this, because our only real concern is to get a clear voice-recording free from the background noise which is now going on all around us.

After a few introductory words the two gentlemen agree to record for us. Having the machine, you grab an empty chair and move it to one side of the table, whilst I seat myself exactly opposite my two subjects. The first thing we do is to measure the intensity of the background sound. This is done very easily with the recorder and microphone by merely turning to record and increasing the gain until the indicator shows full modulation from the ambient noise. In our case this is reached at number three on the scale, although the occasional extra loud clatters from the trays of crockery would be peaking at that level. If we go ahead and record we should have the kind of tape Mr. Walker was complaining about: a reasonably loud voice recording in the midst of equally loud, or louder, noise and confusion. So we do something rather clever. We bring the level right down at about one and a half. At this setting even the loudest of our noises-off are showing no movement on the recording indicator. We have rendered the microphone so insensitive as to cut out nearly all that unwanted background noise.

As our subjects start to speak I bring the microphone right up to them, holding it at ninety degrees so that they speak across the top of it. By pre-arrangement, you give me a sharp crack on the shins when I have brought it close enough to

show a clear movement on the indicator and I keep it more or less in that position, bringing it closer only if the subjects speak more softly.

There's no need to play back that recording to see if we have what we wanted; I'm sure we have. I'm equally sure that we also have a little distortion now and again, but that doesn't matter. The sense of what was said will definitely be there and clearly audible, with no more than a suggestion of background sounds.

By the way, this system works spectacularly well, even if you are recording under conditions where the surrounding noise is so high you literally can't hear the sound of your own voice. I demonstrated this technique with great effect to students in our local evening classes recently. About thirty of them screamed, shouted and banged chairs and tables in a cheerfully enthusiastic attempt to sabotage my experiment. In the very middle of that din I was able to record my own voice quite comfortably and their concerted din was hardly audible on playback of the tape. If you don't believe it, try it!

Our two subjects prove to be really co-operative and offer to introduce us to a lady at an adjacent table. She tells us she is from Southern Ireland and sings in Gaelic. This is excellent, so I anxiously look around for a quiet spot as I change over to the ribbon microphone. I could not use the close-talking technique for a singer, and I doubt if she would want to perform in the most public part of the room, so it suits us both to move to an alcove away from the noise.

A word of warning here. Non-professionals may perform brilliantly as they extemporise in a café or coffee bar, but under studio conditions they may well lose that natural quality which makes their recording so worth while. The "alcove" in which I recorded the Spanish girl I mentioned earlier was actually a disused coal-cellar in which she performed a thousand times better than ever she did subsequently in my studio at home.

The Irish girl gives us some very good recordings which we take without any special difficulty. The Reslo ribbon microphone has a facility for damping one of its faces but I'm using it undamped to avoid the slight loss in the lower frequencies that this can involve.

It now only remains for us to buy a coffee for these good people who have been so helpful, and with a pocket full of recorded tapes we can return to base for a playback session and a discussion on the results.

Public restaurants and coffee bars are ideal places in which to learn to really master your machine and techniques. The secret of success is to retain complete control of every situation and to use to its limits the very flexible versatility of your equipment. There may well be brilliant recordings to be taken within ten minutes' walking distance from your own home. Are you getting them, or are you missing them?

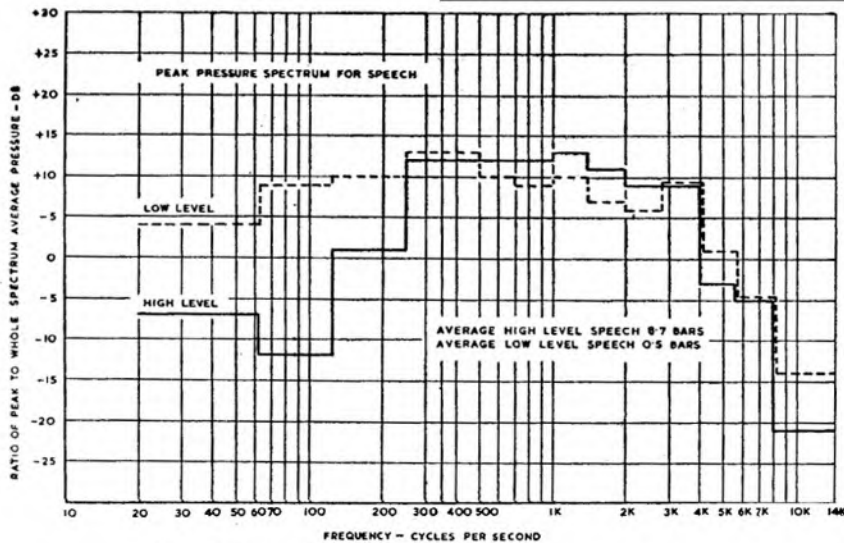

Fig. 5: Data from speech tests; peak pressure spectrum.

Im Wheatter's

BATTERY RECORDER NOTEBOOK



NOW that the Christmas rush of tape-recordings made at parties are being edited and tidied up, new owners of recording equipment may be slightly at a loss to know what next to do in the way of recording. Owners of battery portable recorders will find the field is wide open for a number of projects.

First any Tape Club or Correspondence group will welcome them because their gear can be used for many of the contributions which the Club may require for its next production or competition, the contributions that are the real "meat" of most features.

There is another aspect too which will accord with the current mood to render help to old people, both for their physical well-being and to combat the loneliness of lives cut off by reason of infirmity or distance.

One particular personal experience comes to mind, both interesting and socially very helpful.

My aid was sought by the parents of a friend of Christchurch, Hampshire who had received a tape recording from a married daughter and her family in Christchurch, New Zealand. Could I tell them what to buy in order to send messages back?

I explained that first I must know at what speed the recording was made. No written information had accompanied the tape so I took it home and played it first. I found that speech was at 3½ ips but some original pianoforte compositions, played by one of the grandchildren, were recorded at 3½ ips first and then repeated at the 7½ ips speed. When this tape was played back to the grandparents here, they clearly understood the reasons and the virtue of tape economy at the slower speed, and the improvement of the music when recorded at a faster speed. The demonstration was a delight and a thrill for the old folk as the grandchildren told of their life at school and on holidays in far off New Zealand to the grandparents they had never seen.

Altogether it was a very worth while effort and I was able to recommend a recorder in the medium price range, quite suitable for the tape correspondence which I am sure will now start and so knit these two families more closely together despite the 12,000 miles' separation.

Hospital Service

Another useful job to be done is recording or playing messages for patients in Hospitals or Nursing Homes, or the old folk in Old People's Homes. This is essentially a job for the battery portable recorder because it is so informal and prevents the need for mains plugs and trailing wires.

Permission from the Matron or Ward

Sister should always be sought. Obviously people still ill should not be worried with anything which could cause excitement or anxiety. But for those able to appreciate the facility, keeping in touch with loved ones can have a real tonic effect.

The expenditure of tape need not be a deterrent as the patient will not usually have a great deal to say at a time and 3½ ips speed should be quite satisfactory. Messages from family or friends could well be longer and the tape should have silent gaps left between items so that the machine can be stopped and started again without having to wind back to "find the place."

When recording for such a purpose

TAPE PEOPLE

In these days of high speed air travel it's not very remarkable to come across some one who has recently been recording traffic sounds in New York. The sounds of the car engines, the peculiarly American gong that clangs as the traffic lights change, the chatter of the passing pedestrians—all these things we are inclined to take for granted and the only interested comment is likely to be: "When did you arrive back?"

That was the first question I asked Mrs. Sylvia Margolis. But she looked at me blankly and said that she hadn't been away. Seeing my perplexed expression she went on to explain that she had taken her trans-Atlantic recordings with a Grundig battery portable and microphone. . . . "We were in Knightsbridge at the time—or was it Brompton Road? I've recorded from all over the world in just the same way. New Zealand, South America, Africa, Australia, and all the time my husband and I are simply driving through London!"

Even the least technical person would realise that it is only too obviously impossible to record as Sylvia described other than by direct radio contact. Yet all the time, she stressed, that her recordings were taken whilst she was out travelling in a car. Is such a thing really possible? In this case, yes, because my interviewee is an enthusiastic member of the Amateur Radio Mobile Society.

Do many people actually go to the trouble of fitting up their cars as travelling radio stations? I was told that the Society has over three hundred members and is growing rapidly. Of course, they

the messages should be spoken clearly and slowly—or perhaps I should say calmly—to suit the proper ward atmosphere. I think you would do well to use a light-weight headphone or a deaf aid for the patient to hear the message, it will be more personal and private.

When the patient records let him or her hold the microphone quite close to the face, say four inches away. Adjust the gain control of the recorder to give the correct indication and leave it then to the patient to speak their thoughts into the microphone. You will find the gain control is lower than you usually use, but this will be an advantage as all the noises in the room will be subdued.

By careful and unobtrusive operation the recording need not disturb other occupants and the joy of being able to exchange messages makes this service to the sick and elderly a very rewarding use of your equipment. If conducted as a service to the public it is only reasonable to expect incidental expenses, like postage, telephone calls or fares to be paid by the people involved. Clubs would soon find out how best to organise it in their locality, and if started in a small way with friends or relatives the best routine would soon emerge.

Sylvia Margolis



don't all have transmitting licences; many are content to operate short-wave receivers only.

To find out more about Sylvia and her friends I went along to the Radio Hobbies Exhibition at the Horticultural Hall. I found her presiding over an imposing looking stand, explaining, with the aid of colour slides, just how this seemingly impossible feat is accomplished.

The answer, of course, is that before one can transmit one must hold a licence, and before being granted a licence there's a very stiff examination to pass. The ladies of the Amateur Radio Mobile Society are content therefore to leave that more serious side of the business to their husbands while they look after the very full social side and the monitoring of broadcasts on tape.

When transmitting over the air certain controversial subjects are prohibited: politics, religion and sex to name only three. So if the Margolis' want to have a real hammer and tongs discussion with one of their radio contacts they do exactly the same as you and I. Back at home they have a Philips standard recorder, and out comes a three-inch tape and the microphone for a session of tape correspondence.

Before I left Sylvia she told me of the lectures she has given all over the country, of her broadcast in the BBC Woman's Hour, of the entertaining of people from all over the world. "Electronics," I thought, "may be marvellous, but surely no more wonderful than some of the women behind the men behind the valves!"

VIVIENNE GOODING

Talent with tape

YOU CAN WIN FAME IN THE BRITISH AMATEUR TAPE RECORDING CONTEST 1962

THE greatest-ever talent competition for British tape recording enthusiasts opens this month—the sixth British Amateur Tape Recording Contest.

Do you fancy yourself as a recording engineer, a news commentator, a script-writer, a producer of documentary and drama features or as an artist in the manipulation of electronic sound?

If so, this is your big chance.

Are you associated with a school group or a club which can produce a worthwhile team effort at production and recording?

If so, there is the opportunity now to make a hit. Do you think you have the talent to become a professional performer—as vocalist or musician or comedian?

If so, the 1962 Contest can be your passport to fame.

Talent in all these fields is at a premium. When, next year, the Pilkington Committee reports on the future of British radio and television, a big expansion of broadcasting is certain to follow. Thousands of new jobs will be created for the men and women with the right experience and ability.

You can use the British Amateur Tape Recording Contest as a means of staking your claims.

The best entries will be heard and studied by leading authorities in the world of recording, broadcasting and entertainment. They will be on the lookout for promising new talent.

In addition, there are valuable prizes to be won.

The main part of the Contest will follow the same lines as in previous years. There will be five different sections for individuals, one for schools and one for clubs. All of these will be concerned with recording technique.

In addition, we are introducing this year, for the first time, a new section for performing talent. The recording technique will be incidental; in this new section the judgment will be based on the quality of the performance. Fuller details of this new section of the Contest will be published next month. Meanwhile, we can say that it will offer a unique opportunity to the amateur to get his or her name into the bright lights.

As in previous contests, the best entries in the appropriate sections of the British Contest will automatically become the official British entries in the international Recording Contest on the Continent, and will be eligible for further valuable prizes.

The closing date for entries is Friday, June 29, 1962. There is no entry fee, but all competitors must complete the entry form printed on page 23. Further copies can be supplied on request.

The Contest will be divided into the following classes:—

1. **Compositions**—Radio plays, dramas, sketches, etc., not exceeding 15 minutes.
2. **Documentaries and "reportage"**—not exceeding ten minutes.
3. **Music or Speech**—not exceeding four minutes.

4. **Actuality**—unusual voices, historic moments, etc., not exceeding four minutes.

5. **Technical experiment**—electronic music, etc., not exceeding four minutes.

6. **Schools**—features illustrating any aspect of school life or children's interests, made with the participation of groups of children, not exceeding 15 minutes duration.

7. **Clubs**—feature tapes on any subject and of any type, not exceeding 15 minutes duration.

8. **Performing talent**—recording of amateur performers (musicians, vocalists, comedians, etc.), not exceeding five minutes.

Only the best entries in classes 1 to 6 will be sent on to the International Contest which does not have comparable sections for clubs and amateur performers.

The Contest is again being organised with the support of all the most important tape recording interests in Britain.

The Federation of British Tape Recording Clubs will be closely associated with the event. It is hoped that the best tapes will again be broadcast by the BBC.

These are the prizes . . .

THE best entry in the whole Contest (excluding Class 8) will be selected as "The Tape of the Year" and will be awarded the *Emitape Challenge Cup*, to be held for one year, with a replica to be kept permanently.

The best Schools tape will win the *Grundig Challenge Cup*, with the Grundig Shield for permanent possession.

The best Club tape will win the *Amphlett Club Trophy*, awarded by the Federation of British Tape Recording Clubs.

The best entry in either Compositions or Music/Speech sections will win the *Acos Cup*.

The best in the Documentaries and "Reportage" class will hold the *Irish Trophy* for one year, with a replica for permanent possession.

The best entry in the technical experiment section will win the *Wyndor Gold Medal*, to be kept permanently.

In addition to these awards, *TAPE Recording Magazine* offers prizes of ten guineas for the best tapes in each class.

Messrs. E.M.I. Tape Ltd. will be hosts to all the winners at a special *Emitape Luncheon* at the Savoy Hotel, London.

Grundig (Great Britain) Ltd. will organise a special social gathering for the pupils who help to produce the best schools tape.



Emitape Challenge Cup



Grundig Challenge Cup



Acos Cup



Wyndor Gold Medal

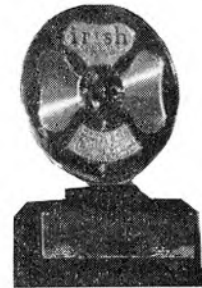

Irish Trophy

RULES OF THE 6TH BRITISH AMATEUR TAPE RECORDING CONTEST

1. Only bona fide amateur recordists may enter and the production of tapes submitted must be entirely the work of the person submitting, both as regards recording and editing.

2. If recordings are of singers, players, actors, etc., the quality of their performance in these roles will not affect judgment of tapes.

3. No tapes submitted may contain anything taken from radio transmissions or commercial recordings, nor any matter of which copyright is held by another person, and an undertaking to this effect must be signed by the entrant.

4. Only individuals may submit tapes in Groups 1 to 5 (Compositions, Documentaries, Music, Actuality, Technical Experiment); group efforts are excluded. Groups are catered for by the Clubs section for a fifteen-minute feature tape. There is also a special section for School entries only.

5. Only one tape in each category may be submitted by any single individual. (Duration: Compositions, 15 mins.; Documentaries, 10 mins.; Music or Speech, 4 mins.; Actuality recordings, 4 mins.; Technical Experiment, 4 mins.)

6. Tapes must not include any matter other than that which forms the entry. The programme must commence at the beginning of the tape and only one track may be used (when judging, there will be no reversal of spools to hear second tracks). Tape should be prepared between white or coloured "leader" tapes.

7. Recordings may have been edited in any way desired, but entry forms must give details of all equipment used.

8. Recordings must be made at either 7½ ips or 3½ ips. No other speeds can be accepted. Stereo recordings may be entered, but they must be of the "stacked-head" type.

9. All tapes will be returned to competitors, provided adequate return postage is sent with entries. But *TAPE Recording Magazine* will retain copies of the winning tape and the six runners-up tapes. Copyright of these will be the property of their owners, but *TAPE Recording Magazine* reserves the right to arrange for the publication of the whole, or parts, of any or all of them, by radio, disc or tape, or by any other means. In such event, half of all payments received will be retained by the sponsors of the contest and the other half divided between competitors proportionately to the use of their tapes.

10. The decision of the judges will be final and no appeal may be made, nor correspondence entered into.

11. The closing date for receipt of tapes will be Friday, June 29th, 1962. No entries received after that date can be considered in any circumstances. The winner and the six runners-up will be notified immediately judging is completed.

12. Every tape entered must be adequately packed and properly stamped and must be addressed "Contest," *TAPE Recording Magazine*, 7, Tudor Street, London, E.C.4. An entry form, fully completed, and return postage, must be included with the tape. Name and address should also be written on a small label firmly affixed to the tape spool and to the containers.

RULES OF THE 11TH INTERNATIONAL AMATEUR RECORDING CONTEST

ART. 1.—The Eleventh International Contest for the Best Amateur Sound Recording is organised to fit into the framework of the International Sound Hunters Federation and of the broadcast programmes reserved for such recordings (i.e., in most continental countries, but not in the U.K.) and is patronised by the following organisations:—

Austria.—Oesterreichischer Tonjager Verband.

Belgium.—Institut National Belge de Radiodiffusion. (French and Flemish Transmissions). "Chasseurs de Sons."—Federation Belge des Amateurs de L'Enregistrement Sonore.

Denmark.—Dansk Magnetone Klub.

Great Britain.—British Amateur Tape Recording Contest, 7, Tudor Street, London, E.C.4.

France.—Radiodiffusion-Television Francaise. Ministere de L'Education Nationale (Haut-Commissariat la Jeunesse et aux Sports).

Federation Nationale des Industries Electroniques et Syndicat des Industries Electroniques de Reproduction et d'Enregistrement.

Holland.—Nederlandse Vereniging van Geluidsjaegers.

Sweden.—Svenska Magnetofon Klubben.

South Africa.—T.A.C. Tonband Amateur Club.

Switzerland.—Societe Suisse de Radiodiffusion.

Radio Lausanne.

Radio Berne.

Association Suisse des Chasseurs de Sons.

International Centre of School Correspondence (France).

ART. 2.—The Eleventh I.A.R.C. takes place in Strasbourg, France, in October 1962.

ART. 3.—The I.A.R.C. is a contest between amateur recordists and not between the singers, players, actors, etc., whose performance they may have recorded.

ART. 4.—Each competitor is free to choose his own subjects. He can take part in the contest in one or more of the five categories as indicated in article seven or even in the five of them simultaneously, but he cannot enter more than one monophonic or stereophonic recording in each category. The recordings may be edited and can have already been broadcast. They can have been used in commercial records provided that the author still has the entire copyright and provided he sends the original recordings, which he himself made, for the contest. Apart from commercial records made from such originals, the only recordings which are excluded are those which have been submitted to, or awarded a prize in a previous I.A.R.C.

ART. 5.—Copies of commercial recordings and of broadcast programmes even when recorded at home, cannot be submitted.

ART. 6.—Only one recording may be submitted to the I.A.R.C. on each disc or tape, and if on tape it must commence at the beginning of the reel. With multi-track magnetic tape recordings, one track only is to be used. The other tracks must be erased or left blank. Tape must be prepared between two white or coloured editing tapes.

ART. 7.—The competitor may indicate the category in which he wishes his entry/entries to be entered, but the jury is at liberty to allocate the recordings to other categories or even to create new categories with appropriate prizes.

Categories.—

(a) Compositions (Radio plays, drama, sketches, etc.)—Maximum duration 15 minutes.

(b) Documentaries and "Reportage."—Maximum duration 10 minutes.

(c) Music or Speech (Solo singer or player, orchestras, choruses, poems, imitations, monologues, etc.)—Maximum duration 4 minutes.

(d) Actuality recordings (Unusual voices, Historic moments.)—Maximum duration 4 minutes.

(e) Technical performance—4 minutes.

In addition, a scholastic category has been included for schools or colleges using sound recording in their classes. The inter-school prize will be given for the best recording in this category. For the 1962 contest it may be on any subject and may have a maximum duration of 15 minutes.

ART. 8.—Recordings must be addressed to **The Eleventh International Contest for the Best Amateur Recording** at one of the following addresses, and must be received before 14th September, 1962.

Austria.—Oesterreichischer Tonjager Verband, Anastasius-Grungasse 25, Vienna 18.

Belgium.—Chasseurs de Sons, Maison des Arts, 147 Chaussee de Haecht, Brussels 111.

Denmark.—Dansk Magnetone Klub, Vesterbrogade 19, Copenhagen V.

Great Britain.—British Amateur Tape Recording Contest, 7, Tudor Street, London, E.C.4.

France.—Radiodiffusion-Television Francaise, 107, rue de Grenelle, Paris.

Holland.—Nederlandse Vereniging van Geluidsjaegers, Slotlaan, 154, Zeist.

Switzerland.—Association Suisse des Chasseurs de Sons, Case 1251, Berne-Transit.

ART. 9.—Each recording must be accompanied by an envelope containing a form similar to that attached herewith. **If this is not done, the entry will not be accepted.** For one recording this actual form may be used and similar forms written out for any others. **The script must also accompany all speech recordings and any others made with a script.** Competitors are invited to send photographs of themselves for publicity use in connection with the I.A.R.C.

ART. 10.—In each country taking part in the 1962 I.A.R.C. the National Jury will make a selection of a maximum of five of the best recordings (monophonic or stereophonic) in the category or categories it chooses, plus one recording (mono. or stereo.) in the schools category. Recordings from competitors of countries not taking part are grouped in one class from which the I.A.R.C. Committee will likewise select a maximum of five recordings.

For every speech recording, of whatever nature selected, the National Jury (and for entries from non-participant countries the I.A.R.C. Committee) must make a written translation in the language or languages of the other members of the International Jury. Any stereo tapes submitted will be judged separately and not with the other categories. Stereo tapes recorded on "staggered-head" machines will not be accepted.

ART. 11.—The International Jury, which consists of a maximum of four delegates from each National Jury, will only have to judge the recordings selected by the National Juries.

ART. 12.—The International Jury will choose its Chairman and make its own internal regulations at its first meeting.

The technical standard reached by the competitors in the fullest meaning of the term will have the jury's first consideration.

ART. 13.—Prizes:—

Grand Prize of the I.A.R.C. 1962 (Monophonic).

Grand Prize of the I.A.R.C. (Stereophonic).

MONOPHONIC

First Prize for Category "A"—Compositions.

First Prize for Category "B"—Documentaries and "Reportage."

First Prize for Category "C"—Music or Speech.

First Prize for Category "D"—Actuality Recordings, etc.

First Prize for Category "E"—Technical Performance.

International Prize for Inter-Schools Contest.

Other prizes may be given in all five categories, particularly a prize for the research, technical or artistic merit of a recording.

The International Jury may also give a prize for the best national selection, the first prize in Categories "A," "B," "D," "E" and the Schools Contest will be more valuable than that for Category "C."

STEREOPHONIC

Similar prizes may be awarded under this heading.

ART. 14.—All the announced prizes must be awarded, but the jury has the right to divide them and, if they are prizes in kind, to rearrange them or combine them so as to reward the competitors as fairly as possible.

ART. 15.—The best recordings will be broadcast during special programmes by the broadcasting authorities who are interested in amateur recording.

ART. 16.—Whether selected or not and whether prize winners or not all the recordings will be sent back to their owners, perhaps after having been broadcast in one or more of the programmes devoted to amateur recordings.

ART. 17.—Both the National and International Juries have the right to eliminate any recordings which do not conform to the above rules.

ENTRY FORM

**BRITISH AMATEUR TAPE
RECORDING CONTEST**

Name (Block letters)
Address
.....
.....
Age

I declare that the enclosed tape feature is entirely my own work, that I have no professional status as a sound recordist, and that I have not included on the tape any copyright material from radio, commercial recording, or any other source.

Signed:

Title of your entry

Duration of your entry

Categories in which you wish your tape entered:
.....

Make of recorder used

Recorded at a speed of inches per second.

Make of magnetic tape used

Any other equipment used (i.e., microphone, mixer unit, tape splicer, etc.). Give details and manufacturers:
.....
.....
.....

How long have you been doing amateur recording?
.....
.....

Titles of works used. Names of authors, composers, etc.
.....
.....
.....
.....

ENTRY FORM

**INTERNATIONAL AMATEUR
RECORDING CONTEST**

Name and Address (In block letters)
.....

Age Occupation

Other hobbies besides amateur recording
.....

How long have you been doing amateur recording?
.....

Special interests

Data on the attached recording:

(a) Title—If there is one

(b) Exact duration

(c) Category in which you wish it to be entered:
.....

(d) System used (i.e., tape, wire or disc, speed, make of apparatus, if tape, is it single or multi-track? *In the case of multi-track only one track may be used*):
.....

When and where was the recording made
.....
.....

Titles of words used. Names of authors or composers, duration, etc.
.....
.....

Names of any assistants and how they helped in making the recording:
.....
.....
.....

IMPORTANT NOTE.—Any competitor who has fully or in part used any literary production of which he is not the author or composer and which is still in copyright, must obtain authorisation from the author, composer or organisation owning or controlling the copyright and must produce proof of such authorisation. This proof must be submitted with this form and must state expressly that the author, composer or the organisation owning or controlling the copyright forgo any payment by the broadcasting organisations which transmit the recording. (This does not imply that, in the countries where they apply, the normal rights of payment arranged by the organisations owning or controlling the copyright are relinquished.)

Make way for the LADIES

By VIVIENNE GOODING

NINETEEN SIXTY-TWO! The first day of a new year arrived in a shimmering gown of frost and ice; houses and streets softly glittered in the bright, white light of the first day of January, 1962. It was very beautiful indeed.

By the time you are reading this the snow will have turned to dirty slush and then have swirled in muddy streams down a thousand ignominious gutters, but one can't help remembering that almost painful beauty.

When you have a spare ten minutes with your machine and microphone ready, try recording your own description of what you saw and how you felt on this first day of the year. You'll be surprised how difficult it is, and I know how you'll feel as you make your attempt—rather foolish. But don't worry, that's quite normal!

I've just done the same thing myself, and to make my recording more acceptable I included a few well-known quotations on the theme of snow and winter. "When icicles hang by the wall" from "Love's Labour's Lost" was one of them. If you're not used to it, reading poetry can easily make you feel—more foolish.

The result wasn't too bad and I was just going to put the tape back on the shelf when I had an idea. Why not send it to someone who had seen nothing of what I described? Well, why not?

In the days before the advent of the mass media of entertainment, the "good old days" of the Victorian era, every family prided itself on the virtuosity of its members. At evening gatherings in the comfortable, solid homes of the period the amateur musicians formed their trios and quartets, while the non-musical read or recited.

We have only to realise that the tape recorder and not the television set is the real centre of family interest to re-create the spirit of that past generation. Even if the quality of the performance falls far short of what we have come to expect today, as it almost certainly will, it doesn't matter. The pleasure we can find in this new year is the lost pleasure of entertaining rather than of being entertained.

Used by the family for the family the tape recorder is the perfect antidote to anti-social influences, replacing the passive acceptance of the printed programme with the healthier urge towards personal, creative effort.

DO-IT-YOURSELF

By W. PATRICK COPINGER

IT frequently occurs that the magic eye on a large number of domestic and semi-professional tape recorders cannot be seen properly from the recording position when you are both recording engineer and artiste, performer, speaker, etc.

Furthermore, if you are the recording engineer only and are using a separate mixer with a number of microphones it is not always convenient to have the mixer right beside the tape recorder so that the magic eye can be seen. Sometimes there is too much light near the magic eye so that it cannot be seen anyway.

The device described here enables the "magic eye" to be placed where you want it beside the microphone in the case of a speaker/recording engineer or on the piano for a pianist/recording engineer or on or beside the mixer when in use. It is not a magic eye but a meter and thus not affected by too much light. The device consists of a sensitive microammeter, a small one milliamp bridge rectifier, a couple of resistors, a potentiometer, a couple of capacitors and a short length of flex.

The tape recorder has to be modified and fitted with a small two-pin non-reversible socket which can be mounted quite simply on any wooden part of the case or on the deck, or it can be sunk into the case. Two wires are taken from the socket to one of the valves. It will be seen that it will be necessary to remove the tape recorder from its case and if you are not competent to do this, then this modification should not be attempted.

Find the final amplifying valve in the record section of the tape recorder. This may be an ECC83 or ECC81, EF86, 12AT7, 12Ax7 or other. Identify the second anode of the valve. Looking at the underside of the valve holder from below the valve you will see nine solder tags which are the connections to the valve pins. (Fig. 1).

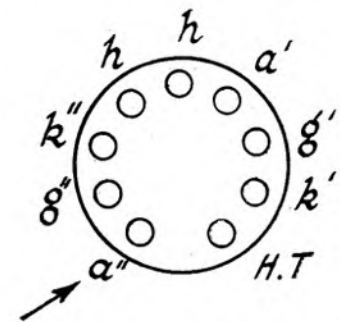

Fig. 1. Valve base from below.

You must find the second anode marked in Fig. 1 a'. This may be the point to which you solder one of the wires to the socket, but it sometimes happens that the other anode is used. This is a' in Fig. 1. In order to make sure that you have the right pin trace the wiring from a'' or a'. The correct anode will have a .1 micro F capacitor about 350-volt, fairly large size, and a small resistor 47K, 66K or similar coming from it. From the capacitor there may be one or perhaps two wires, one going through a resistor and across a capacitor possibly, to the magic eye circuit and one going to the switch for recording to the record head.

Having made quite certain that you have identified the correct valve pin, solder one wire to the most convenient tag strip which is connected to this pin. Solder the other wire to a convenient earthing point nearby and run these two wires to the outlet socket. Make sure that the earth line is identified as either the larger or smaller hole on the socket and wire the plug from the meter box similarly.

The meter can be a 300 microamp meter or less on full scale deflection. A number of different meters are advertised in the technical Press. One type particularly suitable for this job, costing £1, is a government surplus 50 microamp moving coil meter made by Sangamo

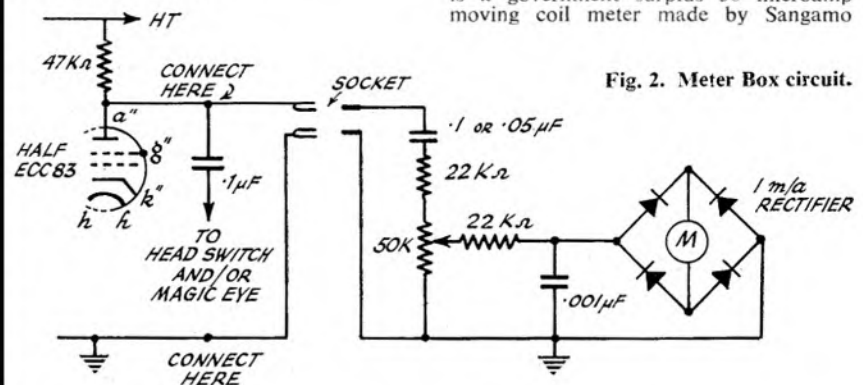

Fig. 2. Meter Box circuit.

A remote record level indicator

Weston. This can be obtained from Testgear Components (London) Ltd., 15, Arcany Road, South Ockendon, Essex.

The circuit for the meter is quite simple and needs no explanation. Make sure that the red wire (+) from the bridge rectifier is connected to the + terminal on the meter. (Fig. 2).

The components in the meter circuit should be assembled round the back of the meter which can be mounted in a box with the components. The spindle for the potentiometer should have a slot cut in the end so that it can be adjusted with a screwdriver rather than a knob which could be easily shifted accidentally so upsetting the meter reading. The potentiometer can be mounted on a small bracket in the box as shown in Fig. 3, with spindle just protruding at the back.

Run a short length of bell flex or 2 amp twin flex through a hole drilled in the back of the box to a two-pin non-reversible plug. Make sure that the earth lead is correctly identified at the plug to correspond with the earth lead from the tape recorder valve to the socket. The flex need not be longer than about four feet as it is necessary to be within reach of the recorder gain control.

To calibrate the meter, plug the meter lead into the tape recorder socket, set tape recorder to "record" and use a fairly strong radio signal to operate the magic eye and meter. A good signal from which to calibrate is the tuning signal before the start of the BBC Network Three programme.

Turn up the record gain control until the magic eye is practically closed. Just on distortion. Adjust the meter reading with a screwdriver on the pot, at the

back of the meter box so that the meter pointer is at about one o'clock. In the event of a very small meter pointer movement when a good signal is being recorded with the 50K pot. fully over, remove or short out one or both of the 22K resistors but put the full 50K pot. in the circuit first. Bring up the pot. slowly when a signal should move the meter pointer over.

Some meters have a red mark at about the one o'clock position (the recommended meter does) which can be used as a reference point for maximum gain before distortion. If there is no red mark, it should be quite a simple matter to dismantle the meter and mark the meter scale with red ink or crayon

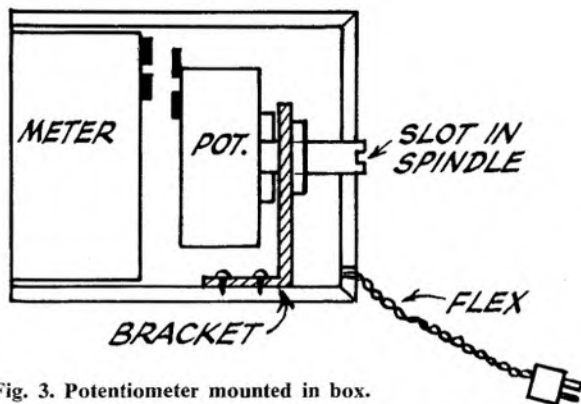

Fig. 3. Potentiometer mounted in box.

somewhere about one o'clock. If you don't want to or are unable to take the meter apart, put a red mark on the glass front with a chinagraph pencil.

A little practice will be necessary in the use of the meter at first, comparing the pointer may momentarily go right over and quickly back again. This won't upset a recording as long as it does not stay beyond your calibration mark or point of distortion.

This same remote record level indicator may be used on any number of different tape recorders which have been modified and fitted with the meter socket. I have installed this device and use it on a Simon SP/4, a Brenell with Mullard Type "C" pre-amp and the elderly Sonomag with the Collaro Mk. IV deck with every satisfaction.

In this case the potentiometer has three different settings, one for each tape recorder and the back of the meter box has been marked to indicate the correct position for the potentiometer for each tape recorder.

A more efficient system for three tape recorders would be to calculate the actual resistance required from the pot., remove it and replace with fixed resistors and a three-position switch, one position for each tape recorder.

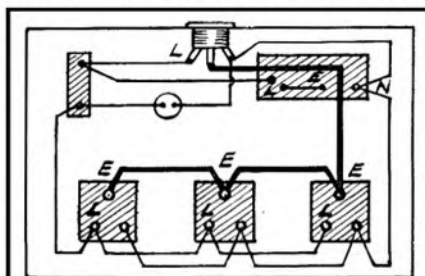

This circuit diagram is a modified version of the inaccurate drawing which appeared on page 26 of the January issue

LOW-PRICE TAPE with a REAL GUARANTEE

7" 1200 ft. Acetate 17/6
7" 1800 ft. Polyester 29/- POST FREE
7" 2400 ft. Polyester 42/6

Brand new, perfect, splice free, attractively boxed.

GUARANTEE: If you are not completely satisfied, I undertake to refund the full price plus the cost of your return postage.

A. VILLIERS, 16-20 Strutton Ground, London, S.W.1.
(Mail orders only, please)

AUDIO LEARNING

USE YOUR TAPE RECORDER OR GRAMOPHONE FOR SELF-IMPROVEMENT

Here are a few of the tapes and discs issued by Educational Recordings Ltd.

SLEEP LEARNING MIND MANAGEMENT
SELF-HYPNOSIS PRACTICAL HYPNOTISM
SAFE SLIMMING POSITIVE PERSONALITY
"PERSONAL" RECORDINGS

INTERESTING BROCHURE describing our full range of helpful recordings gladly sent post free under plain cover and without obligation.
POST THIS COUPON NOW

To EDUCATIONAL RECORDINGS LTD.

Dept. 10, 27 York Road, Ilford, Essex

NAME (block letters please).....

ADDRESS

record it on

gevasonor

magnetic tape

GEVAERT

Ask your dealer for free descriptive leaflet
GEVAERT LIMITED
BRENTFORD MIDDX.

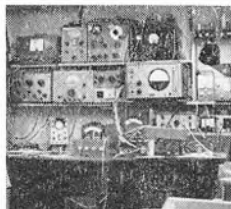

TEST BENCH



SYMPHONY AUTOMATIC

MOST tape recorder enthusiasts have at one time or another felt the need for a recorder which would automatically switch itself on and off at predetermined times, so that an item could be recorded which would otherwise be missed.

The Symphony Automatic tape recorder meets the requirements above and is distributed by Northern Radio Services Ltd. The automatic recorder consists of an electric clock which has a built in switch, a process timer, and a standard tape recorder. The model obtained for review used the Telefunken 75-15 and a description of this and some tests made will be dealt with first.

The recorder has two speeds, $1\frac{1}{2}$ and $3\frac{1}{2}$ ips, giving over six hours playing time using double play tape. The maximum reel size that can be accommodated with the lid closed is $5\frac{1}{2}$ inches.

Nine controls are fitted to the recorder and are as follows; six push button types mounted in two groups of three, with functions of: record, stop, replay and safety-erase lock, fast wind and pause. The remaining controls include a rotary switch selecting either microphone or radio, although there is no mixing facility, and a gain control which adjusts the

After the recorder had been in use for a while it was put through the usual tests, and the results of these can be seen in the accompanying table and graph. Most of the distortion was produced by the output stage of the recorder which uses an EL95.

The signal-to-noise ratio for a signal recorded 6 dB below tape saturation was better than -40 dB. Erasure was complete. The 75-15 met the claims made except for power output measured with a sine wave. On speech or music slightly higher output can be expected.

The graph shows the frequency response using the tape supplied and also a British manufactured long-play tape. It can be seen that the bias and equalising has been set for the tape supplied (BASF) and for optimum results this should be used. To test for distortion a signal was recorded at 900 cps 6 dB below tape saturation level and replayed into a dummy load connected in place of the speaker. The test also showed that the absolute maximum power was 1.6 watts, less than the claimed 2.5 watts.

The workmanship of the 75-15 is very good and should prove a reliable unit.

The recorder can be used in the normal manner without the automatic timing, but I am going to discuss only the way in which fully automatic recordings can be made.

The main part of the automatic timer is of course the clock. This is identical

It follows from this that as soon as the recorder mains supply is available it would start recording, although neither the recorder or the tuner would be "warmed up." To avoid this, a process timer is also fitted and it is connected to the automatic braking circuit of the 75-15. Now, when the mains is applied to the tuner and recorder (it is also applied to the process timer) they can have a warm-up period of from 0-30 minutes before the process timer trips the auto stop of the recorder and recording

TABLE 1

Power output RMS	Distortion
0.5 watts	2 per cent
1 watt	3 per cent
1.5 watts	14 per cent
1.6 watts	20 per cent

(Total harmonic measured @ 900 cps)

starts. This unique feature makes it necessary only to set the main auto switch to cover the time taken for the item to be recorded plus the time allowed for the warm-up.

In practice the system is very easy to operate and a few minutes should be all that is required to get the feel of it. The automatic switch fitted to the clock will handle up to twenty amps and, at no extra cost, can be supplied fitted with heavy power sockets and cable so that the timer can be used to control electric fires, etc. Many uses, both for the timer on its own and when used with the built in recorder, will be found.

On test it was found that the time of switching could be set to within about three minutes of the time required. The clock itself is very accurate.

The recommended microphone is the Lustraphone VP 64Z at 7½ guineas extra. The cost of the recorder with automatic switching is 69 guineas.

Using the Lustraphone, excellent recordings were made. Recordings from a VHF tuner were also very good. However, there was some motor noise which was audible during quiet passages. This noise was at time picked up by the microphone when the gain was set high, as it may often be, to capture distance sounds.

The operating instructions are very easy to follow and in general the complete system can be recommended.

E. A. RULE

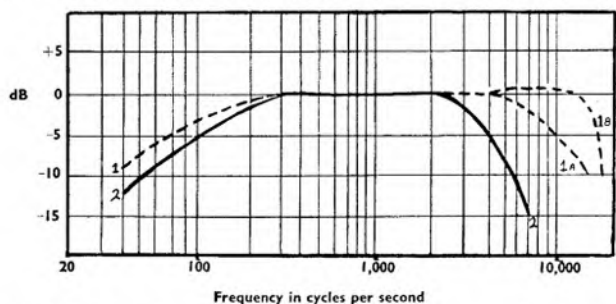

Frequency response of Symphony using Telefunken 75-15.

1a. $3\frac{1}{2}$ ips using British Long-play tape.

1b. $3\frac{1}{2}$ ips using BASF tape supplied with the recorder.

2. $1\frac{1}{2}$ ips.

record level and replay volume: speed selection is achieved by means of a switch mounted between the two tape reels. A special screw driver is supplied to activate this. Tape counter and auto stop facilities are also fitted.

The amplifier section uses three valves: EF86 pentode voltage amplifier; ECC83 double triode amplifier, EL95 output pentode which also doubles as bias oscillator when recording, and an EM84 used for recording level indicator. Negative feedback is adjusted by the speed switch to compensate the frequency response at each speed. HT supply is via a bridge rectifier and resistance capacity smoothing network.

to those fitted to some domestic electric cookers for automatic oven control and therefore will be quite familiar to many. It has three controls. One to set the right time in the normal way, a second selects either, Manual Control, Auto "on/off," or Auto "off" only, and a third sets the time required for automatically switching on and off. This clock and its auto switching controls the mains supply to the recorder and also to a power socket mounted on the back of the cabinet. At a predetermined time, therefore, the mains supply will be fed to both the recorder and whichever unit obtains its power from the socket at the rear of the cabinet, say a tuner.

THE GRUNDIG TK14

THE TK14 is the latest and cheapest recorder to come from the Grundig stable and the manufacturers are to be congratulated on producing an attractive, soundly constructed, compact instrument at such an economical price—35 guineas.

Economies have of course been made and the most obvious of these is the use of plastics for the case, deck cover and lid, the main part of the cabinet, however, has a steel lining which makes it far stronger than it appears at first sight. Also, the plastic used, is, I understand, of a shatterproof variety and capable of withstanding any knocks and bumps which are normally suffered by "portable" recorders.

The white and two tone grey fabric finish, with chrome trimming, together with the neatly arranged piano key controls make the TK14 a most attractively styled recorder.

Further economies have been made by the use of a single printed circuit board on which are mounted all the electronic components, and the use of a two-pole induction motor which is considerably less expensive than the "Papst" type synchronous motors used on earlier models. The recorder is supplied complete with a high quality moving coil microphone, a 1,200 ft. spool of long playing tape and a lead to enable the recorder to be connected directly to the extension speaker sockets of a radio or radiogram.

Tape Deck

The design of the deck is a departure from the normal Grundig style. The piano key controls are very light and positive in action and a joy to use. Six clearly identified push buttons and two variable controls provide control of all tape movements and amplifier switching. A separate "record" button is fitted which must be pressed simultaneously with the "start" key before recording can commence. On stopping after a recording session the recorder is automatically set to "replay" so that there is no chance of accidental erasure. The mechanical braking system is very efficient and operates at any point throughout a reel without any sign of tape spill. The temporary stop control also operates most efficiently. This control halts the passage of the tape through the recording and playback heads leaving the recorder in the "switched on" position. This facility enables the user to adjust the recording level, as indicated by

the magic eye, before recording actually commences. The magic eye, "Twin beam" type, gives a very clear image and is mounted in a very convenient position in the front of the dress cover. Another useful feature is the three digit tape position indicator which on test proved to be quite accurate.

During the two months in which I have been testing this recorder I am glad to be able to say that I have not been able to fault the deck or deck mechanism. Apart from the normal use the recorder has had, all the normal tests were carried out regarding wow and flutter. Although wow was audible on a pure tone at 3,000 cps this is recognised as being a very severe test and can be considered quite satisfactory for a machine in this price class. Mechanical noise is higher than one normally expects from Grundig and this is obviously due to the use of the cheaper motor. However, I do not consider it in any way excessive and consider it a small price to pay when one considers the overall performance and price of the complete recorder.

Amplifier

The amplifier follows conventional design and no extravagant claims have been made for it regarding frequency response and power output. All the claims are fully met except for one minor exception which is the figure for signal-to-noise ratio. On the machine reviewed it was found to be -47 dB. However, the difference is not significant and the figure obtained is as good as can be expected in a machine in this class.

As explained before, all the electronic components are mounted on a printed circuit board and this results in a very clean and tidy lay out as well as being an aid to maintaining consistent specification figures on the production line. On the debit side I thought that servicing accessibility might prove to be a little

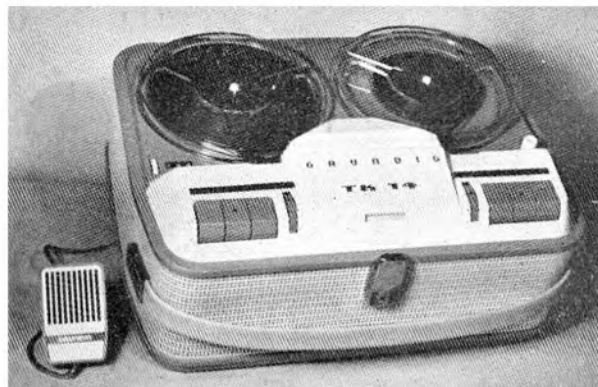

difficult, even to the extent of valve replacement.

Frequency response checks were made, using the tape supplied with the recorder to check the overall response from the radio input to the loudspeaker output and the resulting curves are shown in Fig. 1. Curve (a) shows the response with the tone control set for maximum treble, and curve (b) with the tone control set for minimum treble.

Playback only response was checked using a test tape corrected to CCIR standards and the resulting response, measured at the loudspeaker output with the tone control fully up, is shown in Fig. 2. The results obtained would seem to indicate that a recording characteristic approaching that of NARTB recommendations has been adopted. However, subjective tests using pre-recorded tapes corrected to CCIR still did not sound unpleasant. During the time in which I have had the use of this recorder I have been able to subject it to several hours of continuous use and found that the machine ran remarkably cool without any sign of overheating.

Several recordings were made using the excellent moving coil microphone supplied with the recorder and speech reproduction was surprisingly natural. Recording music via the microphone from the loudspeaker of a radio set or radiogram is not recommended. Tests were, however, carried out. The results obtained were very much better than those I have obtained when testing recorders of a similar specification, but using the cheaper type of crystal microphone. This is most certainly due to the much smoother fre-

(Continued on page 29)

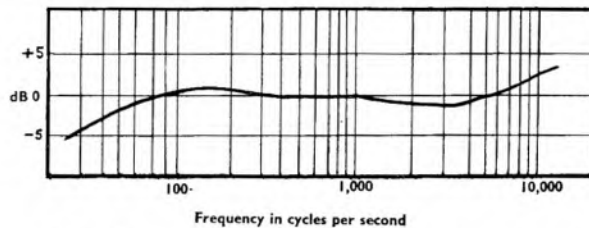
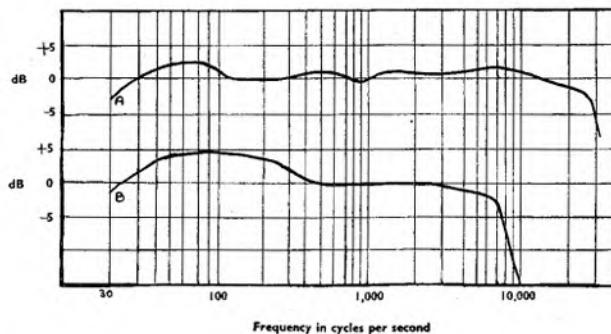

Left: Fig. 1. Record and replay frequency response of Grundig TK14. Above: Fig. 2. Playback only frequency response.



SCOTCH

BRAND

MAGNETIC TAPE

A party by any other name is just as sweet, but there's only one 'name' for recording tape—SCOTCH. And that's where the most fun lies. Its clarity of reproduction alone invites celebration:

its reliability keeps alive the party-spirit hour after hour. Whenever you're in the party-throwing mood, lay in a reel or two of SCOTCH Magnetic Tape. Every party calls for it.

Made in Great Britain by MINNESOTA MINING & MANUFACTURING CO. LTD., 3M House, Wigmore St., London, W.1 

TEST BENCH

(Continued from page 27)

quency response obtained from moving coil microphones.

Further test recordings were made direct from the output of a high quality amplifier and when played back through the recorder, the reproduction, considering the small size of the speaker and cabinet, was very good. When these same recordings were reproduced through a wide range extension speaker, the results were excellent.

The TK14 is a pleasure to handle. I give full marks for frequency response, general styling and all-round performance. The manufacturers are to be congratulated on producing a recorder at a reasonable price with a down to earth specification, and what is more important, a specification (apart from two minor points as mentioned) that is lived up to. Within the limitations of the 3½ ips speed, I would say that this machine is as good a value for money that can be found on the market today.

D. ALLEN

MANUFACTURER'S SPECIFICATION

Frequency response, 40-12,000 cps +3 -5 dB.

Wow and flutter, Less than 0.2 per cent.

Signal-to-noise ratio, Better than 50 dB.

Recording sense, Top track, left to right, two tracks.

Playing time, One hour per track using 1,200 ft. of long-play tape (Type TLP 2).

Rewind speed, Approx. 2½ minutes for 1,200 ft. of tape.

Maximum spool size, 5½ inches.

Inputs, Microphone (2mV at 0.5 M Ohms); and Radio/pick-up (80 mV/1 M Ohm).

Outputs, High impedance (500mV/15 K Ohms), and Low impedance (5 ohms).

Power output, 2½ watts.

Loudspeaker, Multi-Octave elliptical, 5½ x 4½ inches with ceramic magnet.

Recording level meter, Magic eye.

Dimensions, 14½ x 11½ x 6½ inches.

Weight, Approx. 20 lb.

Microphone, GDM 18, high performance moving coil.

Manufacturers: Grundig (Great Britain)

Limited, 39-41, New Oxford Street,

London, W.C.1.

B.B.C. "Sound" Programme

A magazine for radio and recording enthusiasts

2.40 p.m. January 21

MORE ABOUT INTERVIEWING

A further instalment of discussion between BBC interviewer Leslie Smith and three amateurs: Dee Harris, Henry Hopfinger and Ronald Tucker; with examples from interviews they have recorded.

CORDELL ON RECORD

Frank Cordell talks to Steve Race about some of his records and the way they were made.

The next programme is on February 4th

OLD IDEALS FOR NEW

I HAVE noticed recently a number of references to the "discovery" of what is referred to as reflected stereo sound. This might be allowed to pass without serious comment but for the fact that it is put forward as possibly the ideal form of stereo.

There is still much that we do not know about sound and sound reproduction, but one of the things that has been established beyond reasonable doubt is that reflections are the enemy of perfect stereo. The directional information that comes from the speakers must have only a single source in each case if the ear is not to be confused.

The confusion may be slight if the reflected sounds come from points very near to that of the true source but if, as the "reflected stereo" advocates suggest,



the speakers are not only turned to face the wall but are also moved away from the wall so that the true and reflected sounds jointly occupy a substantial width, the chances of localising any particular instrument more than vaguely are very slim indeed. And the evil is aggravated if use is also made of the side walls to produce yet more reflected sounds.

The only qualification that needs to be made about all this is that there does come a point where the reflected sounds are so far away from the original source—the loudspeaker cone—that the hearing mechanism automatically discounts them from the point of view of directional clues. However, unless the room in which the equipment is installed has been rigged up as a perfect sound studio there are going to be enough of such reflections without devising a system to produce more of them.

Of course, the suggestion is made that these extra reflections give roundness and naturalness to the performance—or words to that effect. Such suggestions can only be made in complete forgetfulness of the fact that in a stereo recording all the environmental sounds are built in. The logic of the reflection advocates that it is desirable to hear—or try to hear—the music in two rooms at once, the concert hall or the studio and the drawing room.

Only a full understanding of the actual nature of stereo can prevent this false thinking which assumes that anything which "spreads" the sound must make for more perfect "stereo." So long as true stereo is the subject of discussion then it must be accepted that crude spreading achieved by the introduction of reflected sounds is retrograde.

I have some sympathy for people who cannot manage to detach themselves from the old conception of perfect reproduction as well-spread mono, but they should not broadcast the myth that stereo is at its best when it remains faithful to this outdated ideal.

I have sympathy, also, for people who find perfect stereo difficult or impossible to attain with the available equipment and room conditions; but the fact that some compromise is forced upon them, or that they may deliberately sacrifice true stereo in a limited area to provide poorer stereo over a wider area, does not entitle them to claim that they have discovered better stereo than has been obtainable before.

Unless we are clear-headed about this thing we shall have a lot of people going out of their way to produce inferior results although their own particular circumstances are such that first-class stereo is within their reach.

FRONT COVER PHOTOGRAPH

MARCEL BECK of Zurich works as a sound recording specialist for Swiss and foreign film companies. He has developed various methods of recording which are currently helping sound technicians to make film sound tracks even more effective.

Beck's profession has involved him in a laborious, but truly enchanting activity: the collecting of sounds. He captures them all "live" and is therefore frequently off sound hunting. A storm with thunder and lightning, the winch of a ski lift, a ship's siren, breakers on the shore or bird song—Beck has simply everything in his files. To date he has recorded over 100,000 ft. of BASF magnetic recording tape. This is a lot when one considers that only from 17 to a maximum of 160 ft. of recording tape are required for one recording.

Since Beck's sounds are of value primarily for television, radio and film studios, they have all been recorded at a tape speed of 15 ips. Foreign sound technicians are often sent to Beck for sounds which are rare or which cannot be obtained in their countries; standard film enthusiasts too, are often supplied from Beck's sound library.

Our front cover photograph, supplied by courtesy of BASF Chemicals Ltd, shows Beck and his assistant at work. The car battery, working in conjunction with a vibrator, provides the power for the tape recorder.

When writing to manufacturers for information about new products, please mention that you saw it in "TAPE Recording Magazine."

FREE H.P!

**YOU PAY THE
CASH PRICE
ONLY—OVER
24 MONTHS!**



WE HAVE THE BIGGEST SALES IN THE COUNTRY!

WHY? BECAUSE WE GUARANTEE YOU THE BEST TERMS

They include:

DEPOSITS FROM ONLY 10% ★ 2 YEARS TO PAY ★ SPECIAL FREE OFFERS AND CUSTOMER DISCOUNTS ★ 12 MONTHS FREE SERVICING—NO CHARGES ★ FREE DELIVERY ANYWHERE IN U.K. ★ NO PURCHASE TAX ★ COMMISSION PAID ON SALES YOU MAKE FOR US ★ 15% INTEREST PAID ON YOUR DEPOSIT ★ and lots more besides.

As **THE APPOINTED MAIN AGENTS** for **ALL** the best makes, our Mail Order Department specialises in orders by post with thousands of sales throughout the whole of England, Scotland, Wales & N. Ireland—order from us wherever you live—you get cheaper terms, faster delivery, better service from us.

Nearly 500 machines in stock—dozens of different mains, battery and stereo models—both new and second-hand on permanent demonstration in our showrooms. Open until 6 p.m. Saturdays.

If you want proof of how you can actually save money by buying from us, write, phone or call in **NOW** for free brochures and full details of our terms:

**OPEN TO
8 PM FRIDAY NIGHT**

**HOWARD
TAPE RECORDERS**

Please rush me full details of your Terms and Tape Recorder brochures:

Name.....

Address.....

Name below any models or price range you are particularly interested in:

TG:J

218 HIGH ST., BROMLEY, KENT · RAVensbourne 4477 & 4000

No fuss — No argument!

THE bouquets to Messrs. Philips and Wellington Acoustics in the November 29 issue prompts me to write in support of Recording Devices Ltd.

Some years ago, having purchased one of their original Stuzzi Magnettes, I paid a call on them to tell them how pleased I was with the performance of the machine. At that time a modification was being carried out, to cut out the internal speaker when dubbing, etc. Their service engineer took great trouble to explain it fully to me, so that I could effect this change on my model.

Some months later, the Stuzzi developed a ticking sound which was picked up on recording. I blamed the motor. Having stripped, cleaned and re-assembled this motor without curing the fault, I rang up the works and contacted the same service engineer. Over the phone he courteously and fully explained a second modification which was then being done to the wiring loom of the motor, and which I was then able to carry out myself with great improvement to the running and sound of my Stuzzi.

Having done an amazing amount of good recording on this machine, I eventually sold this Magnette, and purchased one of their latest models. This one, how-

ever, soon developed an intermittent fault.

As I cannot expect a service engineer to travel to Devon to service my machine, and not liking the idea of sending my machine by post, I took it personally to their works, after 'phoning them first.

Without any fuss or argument, and rather than keep me there while the fault was rectified (with the chance of me missing my return train), they replaced the entire machine. I can now once more look forward to many years of trouble-free and excellent recording.

It is the after-sales service of firms such as these that fully deserve the support of the serious amateur tape-recordist.

As an ardent reader, from the first issue of *TAPE*, may I wish you success with the new monthly magazine, and I look forward to seeing more "Do-it-Yourself" items in the coming months.

KENNETH LINGARD,

Honiton, Devon.

TAPE TALK

WITH the coming of the darker nights and more time spent indoors, I looked around for a really worthwhile hobby that could also be shared with my wife. At first I thought that this would present some difficulty—my wife wasn't cut out to wield hammer and chisel and I didn't feel inclined to embark upon delicate embroidery.

However, at last I believe that we have found the ideal hobby that other couples would do well to imitate—we have joined "World Wide Tape Talk", which was advertised in your columns, and through the medium of this excellent organisation, look forward to the exchange of tapes with folk from all walks of life from far and near.

In this age, when it is fast becoming the accustomed thing to see newspaper headlines scream "Fall-out from the Skies" and possible "Fall-in for the Troops", I think that "Tapetalkers" the world over can, in a modest but most decisive way, make a great contribution to the promotion of peace, fellowship and understanding amongst the peoples of all nations.

PAUL HORTON.

Neasden, London.

MORE KIND WORDS

SORRY your magazine is going to be monthly as I used to look forward to reading it every fortnight. However, so long as it maintains the same standard as before, I can wait.

M. D. ROBINS,

Kingswinford, Staffs.

* * *

May I congratulate you on your excellent magazine.

IAIN W. DONALDS.

Grimsby.

"I DIG THIS THE MOST"

REGARDING the spread of *TAPE Recording Magazine* (November 29 issue), I personally send off twelve copies of each issue to various parts of the world—four to America, two to Canada, and one each to friends in San Salvador, Columbia, Australia, Germany, Switzerland and Norway. Checking among my fellow club members, I discovered we send no less than 37 copies of each issue to people all over the world.

As a result of your "Tape Exchanges" column members have found that several of their tape contacts know each other already. Typical reaction to a copy of "Tape Recording Fortnightly," as it then was, is given in a letter from Bill Orman, the well-known American tape-stretcher. He wrote: "Thanks for the magazines, that's quite a selection you have over there, but I dig this Recording Fortnightly the most. Your magazines have a really technical flavour, but the characters that make the fortnightly seem to have a real sense of humour to back it up. Can you fix me a regular order for this?"

We agree with Bill, for the strongpoint of *TAPE* is the sense of humour and relaxed attitude, even when dealing with technical subjects. The other magazines are too stiff and formal. As far as this club is concerned, its official organ is *TAPE*. Regardless of what appears in other journals, it is only accepted if you publish it. The average clubman has a pretty good sense of humour, and wants his paper written that way. So far only you are doing this, and proof of this is that the number of copies we send of your magazine outnumbers the rest seven-to-one.

DAVE WISEMAN.

Acton, London, W.3.

More tape in the classroom, please!

BOTH as a member of the South Birmingham Tape Club and as a schoolboy of 14, I disagree with Mr. Gordon Pemberton's article in your magazine (Nov. 29) on Tape in Schools. As is the case with most schools, ours has no recorder or television.

I feel that in this day and age tape recorders should be part of a school; this generation of school-folk are apt to take tape recorders, television and radios for granted. We are modern people in a modern age and should, therefore, be taught in a modern way.

Radio has brought about a new way of teaching and now television is playing its part; why is the tape recorder so rarely seen in schools?

Is it just that teachers are "old fashioned"?

JAMES TETLOW,

Hall Green, Birmingham.

Finding the position

IN L. G. Brown's article on tape position indicators (*November 1 issue*), he mentioned the complications of finding a position on the Simon SP/4. This he described as being due to the automatic tape reversal transport system used in this machine.

In fact, the method of finding one's place on a tape described in that article would not apply to the Simon SP/4 which has a digital counter of the linear law variety.

It is not driven from the take-up spool hub, but from a rotating tape guide pulley. It therefore shows numbers directly related to the amount of tape which has passed the heads—in either direction. Each digit equals two feet of tape. With this information, it is simple enough to read off the digits and estimate the length of tape which has run through, and also how long it has taken to do so.

The following formula can then be used to construct a simple table or graph:—

Digits x .0534—minutes.

First decimal place of the above answer x 6—seconds.

Digits x 3.2—seconds.

Feet x .0267—minutes.

Providing the spring belt driving the counter is kept free of oil, this method is accurate to within ten seconds for 2,400 feet of tape, and even better on shorter lengths.

Wishing you success with your excellent magazine.

R. E. OXLEY.

Maidstone, Kent.

TAPE RECORDS REVIEWED

By Stanley R. White

Sentimental Journey. Jackie Brown at the Mighty Wurlitzer Theatre Organ. Esoteric. Dual $\frac{1}{2}$ track. $3\frac{3}{4}$ ips. 30 minutes. (Stereo on request.)

THIS Tape of the Month Club release is possibly the finest commercial recording of one of the larger Wurlitzer organs ever made in England. The instrument itself has four manuals and sixteen ranks of pipes, and has been recorded by many famous organists in the past.

In this case it is played by one of the finest popular organists in the country, Jackie Brown, who is often heard playing an electronic pipeless organ with his group on the BBC Light Programme.

He has, however, kept his hand in with the mighty pipe organs. He is also well known as an arranger.

Sentimental Journey features Jackie at the large theatre pipe organ in a selection of tunes with a sentimental flavour, both in the titles—and in the playing, and the arrangements are his own.

His superb control over the large organ makes this tape a joy to hear. Some of the numbers are moving, for instance, the lovely signature tune of the late Tommy Dorsey, *I'm Getting Sentimental Over You*. Other numbers include *Sentimental Me*; *Slow Boat to China* and *Love is the Sweetest Thing*.

The initial release of this tape will be a monaural version, but a stereo version is on its way. This firm is anxious to oblige with stereo recordings, but response so far has been poor.

* * *

Bryan Rodwell at The Organ. Music On Tape. D/1127. Dual $\frac{1}{2}$ track. $3\frac{3}{4}$ ips or $7\frac{1}{2}$ ips. Monaural only.

THIS tape features Bryan Rodwell, the celebrated "modernist" of the theatre organ, playing the Wurlitzer instrument in the Granada, Clapham Junction, except for one number, *After The Rain*, which was recorded at the Tooting Granada Wurlitzer.

This is an hour-long session, providing a variety of popular, jazz and light orchestral music, dressed in the exotic modern style arrangements of Bryan Rodwell.

Rodwell's style of organ playing is unique, and recordings by him are used to illustrate the teaching of modern popular organ playing in at least one famous American music college. Rodwell was given a very thorough musical training early in life, aimed at giving him the background as a classical pianist; however, an accident which broke both of his

wrists robbed him of this ambition by slowing him down for some time; he turned to the organ, which did not call for such speed.

As he recovered, he regained his former ability, but concentrated on organ and piano. In fact, Mr. Rodwell has often broadcast serious music on theatre organs suitable for the purpose, although his first love seems to be his fabulous modern style of popular playing, which often incorporates more serious music dressed up in his own modern arrangements.

It is not possible to compare his playing with any other organist. Rodwell goes it entirely alone, his footwork on the pedals is faster than a double bass, if called for, and his ability to control the organ in fast music is fantastic. Even when playing fast, Rodwell produces a very clear sound, every note played as he wishes. His slower music contains the same care and control.

What appeal this music will have depends upon the listener's musical knowledge; whether you like the style of playing or not, no musical person can help admire the sheer ability of this organist.

Numbers include *Sophisticated Lady*; *When Somebody Thinks You're Wonderful* and *Jet Ride*, *Puppet Suite*, and *Toy Trumpet*. For me the whole tape is a joy to listen to.

* * *

Giant Wurlitzer Vol. 3, Leon Berry. Audio Fidelity. Four track Stereo. $7\frac{1}{2}$ ips. AFST 1844.

THIS recording features organist Leon Berry, an American who plays a Wurlitzer theatre organ in the Hub Skating Rink in Chicago. Leon is a sort of American Reginald Dixon, but his style is tailored to suit the needs of his skating audience, just as Dixon's is tailored for his ballroom dancers.

The jaunty rhythm of this organist is unique to this country, and he makes a lot of noise with percussion effects, quite apart from the use of the pipes. On this particular tape he is not using the organ in the Hub Rink (which is available on an Audio Fidelity tape), but the Wurlitzer theatre pipe organ which he has installed in his Chicago home.

Mr. Berry is a good organist in his own field, and his playing is strictly in a popular style. His arrangements and rather unorthodox style could even make the "top twenty," if released as pop singles, I imagine.

The playing is noisy, easy to listen to, and full of life. The reproduction quality is superb.

The presentation of this tape—labeling and packaging will certainly help sales. A person is bound to feel proud when buying such a product.

The infinite baffle enclosure

P. R. Milton continues his practical guide to loudspeakers

THE primary object in having an enclosure at all is to prevent the radiation from the rear of the cone cancelling that from the front. The easiest way of achieving this is to seal the back of the cabinet.

As far as an observer at the front is concerned, the effect is exactly the same as if the loudspeaker were mounted upon a baffle of infinite dimensions since in neither case does the sound from the back of the cone reach him.

The similarity ends here, however, because the completely closed cabinet has an important snag. The air which is trapped in the enclosure cannot be moved as a whole but it is compressed and expanded by the action of the cone. When it is compressed it stores energy, and this is released when the applied force is removed. Mechanical oscillations are then set up between the air acting as a spring and the mass of the moving system.

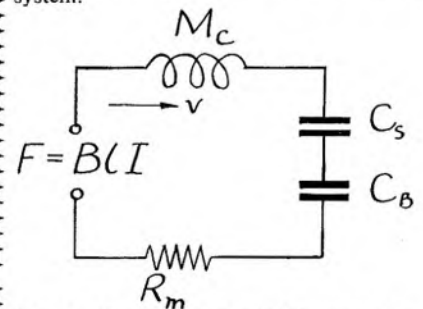

Fig. 1. Equivalent circuit diagram of a loudspeaker mounted in a completely closed cabinet. M_c =Mass of cone and air moving with it. C_s =Compliance of suspension. C_b =Compliance of air in cabinet. R_m =Sum of mechanical losses and radiation resistance.

The ability to store energy makes the compliance of the air analogous to a capacitor in an electrical circuit and in the mechanical network this appears as a compliance in series with that of the suspension of the cone and coil, **Fig. 1**.

The net effect is that the stiffness of the complete system is increased and the fundamental resonance is raised. The radiation resistance is proportional to the square of frequency up to the value of ultimate resistance as in the case of the loudspeaker on an infinite baffle, and the output is independent of frequency down to the fundamental resonance. There is usually a slight peak in this region depending upon the amount of damping existing in the system and thereafter the bass falls at a rate tending towards 12 dB per octave.

Fig. 2 is a graph of final resonance frequency plotted against various enclosure volumes. The stiffness due to the

The infinite baffle enclosure

air in an enclosure depends upon its volume, the area of the cone and the amplitude of the cone movement. If the frequency were very low so that during the process of compression and expansion the temperature were allowed to remain at the same level at all points in the gas, *isothermal conditions* would apply and the relationship between pressure and temperature would be in accordance with Boyles Law, i.e., $P \times V = K$ at a constant temperature.

Under normal conditions the variations take place so rapidly that there is no time for a flow of heat throughout the entire gas and any particular portion of it neither gains nor loses heat. In this case the pressure changes are said to take place under *adiabatic conditions* and the pressure and volume vary according to the law $P \times V^{\gamma} = a$ constant.

Here the volume is raised to the power γ which is known as the gas constant and has the value of approximately 1.4 for air.

Thus the change in pressure brought about by the movement of the cone will not be strictly proportional to the amplitude of movement. This amount of non-linearity is very slight and can be controlled by the correct selection of volume and piston diameter.

The stiffness of an enclosure is given approximately by the formula:—

$$S_B = \frac{\rho c^2 A^2}{V} \left[1 + \frac{1}{2} (x+1) \frac{A \cdot d}{V} \right]$$

where S_B is the stiffness, ρ the density of air, c is the velocity of sound in air, V is the volume of the enclosure, A is the area of the piston, and d is the displacement of the piston.

In the mechanical equivalent circuit we use the inverse of stiffness, compliance, and the resonant frequency is given by:—

$$f_0 = \frac{1}{2\pi \sqrt{M(S_B + S_s)}}$$

From this we deduce that the final resonance of the system is always above that of the loudspeaker itself and that for reproduction down to low frequen-

Goodman's Model IB3 MkI showing internal arrangement. Note the robust construction of this unit. The magnetic system of the bass loudspeaker weighs 22 lb!

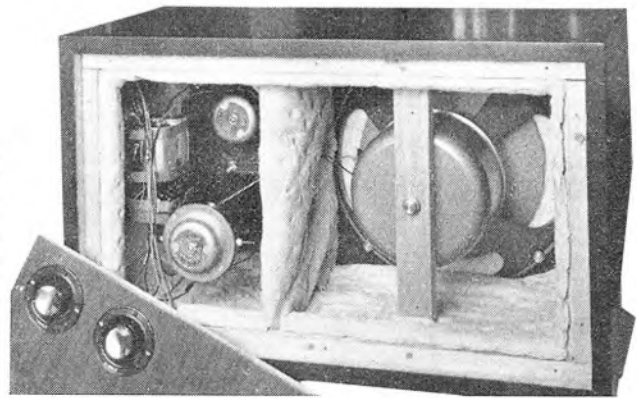

cies the cabinet should be as large as possible.

The spacious age is past and the question posed to the designer is "Given a small box, what sort of loudspeaker is required to give a reasonable extent of bass?"

From Fig. 2 it can be seen that a normal loudspeaker in a 2,500 cubic inch box would have a final resonance of 96 cps, an increase of approximately 61 cps. Allowing for wood and trim, a cabinet of this volume would be roughly 24 x 15 x 12 inches. At 30 cps the power would be over 20 dB down on the mid-range power which is an unsatisfactory state of affairs. In order to provide a reasonable bass response it is usual to place the final resonance below 60 cps.

With a given piston area we can either decrease the stiffness of the system or increase the moving mass. In the small enclosure mentioned, the stiffness of the air swamps that of the cone suspension and even if this were removed completely, the resonance would only be reduced from 96 to 90 cps.

Stuffing the box with fibre glass changes the condition of operation from *adiabatic* to *isothermal* reducing the velocity of sound to 291 metres per second. In this case the resonance is 84 cps, but the extra damping introduced tends to lower the amplitude, cancelling any advantage gained. This could be regained by adjustment of the tone controls since it is a smooth roll off, but there seems to be some prejudice against that.

The last and most drastic way of lowering the resonance is to add extra mass to the moving parts. Taking the same loudspeaker, Fig. 3 shows the final resonance to be expected when various

amounts of mass are added to the cone. Unfortunately, the efficiency of the loudspeaker decreases according to the square of the ratio of the new to the original weight and the transient response deteriorates, so more powerful magnetic systems have to be used.

Loss of efficiency is the price to be paid for a compact wide range reproducer. It is reasonable to make a virtue of necessity by emphasising other advantages of this type of loading. First of all, the greater part of the stiffness is contributed by the enclosure and providing the distortion due to this is kept within reasonable bounds, the effect of non-linearities in the suspension is reduced considerably. Secondly, by using a heavier and stiffer cone, the resonances within the cone structure are brought under control and a very smooth frequency response can be obtained.

One example of the infinite baffle, the IB3 Mk. II, once produced by Goodman's Industries, had a fundamental resonance of 42 cps, was tested at 60 cps, with an input of 12 watts. The total harmonic distortion, including the oscillator and ancillary equipment, was only 2.5 per cent.

In the class of very compact loudspeaker systems, a correctly-designed infinite baffle enclosure is capable of giving the most accurate reproduction. Unfortunately, the method of construction makes its price rather high, and attention has been directed towards other methods of mounting which might offer a more satisfactory compromise between price and performance. In the next issue we will introduce the subject of acoustic mass and go on to discuss vented enclosures.

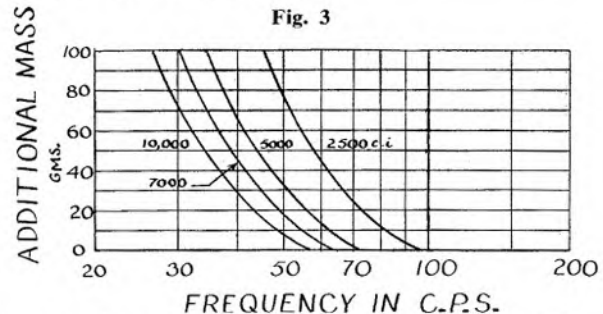
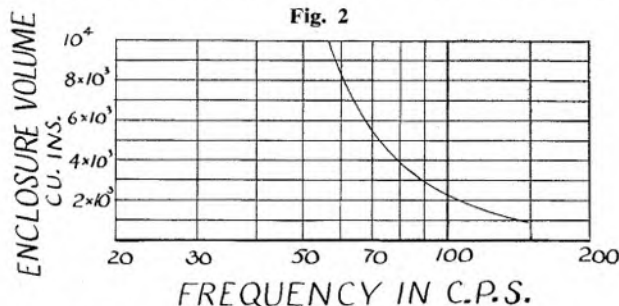

Left: Fig. 2. Effect of the enclosure volume on the resonance frequency of a twelve-inch loudspeaker (Resonance of baffle: 35 cps). Right: Fig. 3. The effect on the final resonance of adding weight to the cone of a twelve-inch loudspeaker in sealed cabinets of various volumes (volume in cubic inches).

YOUR LOCAL DEALER

LONDON

Lee Electronics

THE TAPE RECORDER &
HI-FI AUDIO SPECIALISTS

400, EDGWARE ROAD, LONDON, W.2

London's leading Stockists of High-Fidelity and Audio Equipment. Many Bargains in new and reconditioned Equipment.

SEND FOR FREE LISTS OF RECORDING TAPES, RECORDERS, AMPLIFIERS, ETC

All Machines demonstrated for performance on Record and Playback. All leading makes of Hi-Fi equipment from stock

PADDINGTON 5521

Leonard G. Francis presents—

SHEEN

TAPE RECORDER CENTRE LTD.

Specialists in Tape Recorders and Accessories etc.

—THE CENTRE FOR—

FRIENDLY HELP — SALES — SERVICE
HOME DEMONSTRATIONS ANYTIME

—MODELS FROM 19 GNS.—
PRE-RECORDED TAPE: LANGUAGES
DANCE CLASSICS JAZZ

CALL—WRITE—PHONE

8 Station Parade, Sheen Lane, Sheen,
London S.W.14 (next to Mortlake Station, S.R.)
Showrooms: PROSPECT 0985 10 a.m.—7 p.m.

- ★ TAPE RECORDER HIRE
- ★ TAPE TO DISC 78 & LP
- ★ RECORDING STUDIO
- ★ TAPE RECORDER REPAIRS
- ★ SALES—EXCHANGES

MAGNEGRAPH

1, Hanway Place, London, W.1.
Tel.: LANgham 2156

THE SOUTH

PORTSMOUTH and SOUTHAMPTON

Tape Recorder Specialists

APPROVED AGENTS FOR—
PHILIPS GRUNDIG - FERROGRAPH
VORTEXION, ETC.

- ALL MAKES OF TAPE RECORDERS SUPPLIED
- ACCESSORIES AND HI-FI EQUIPMENT
- PART EXCHANGES AND SECOND-HAND MACHINES
- PROMPT AND SKILLED SERVICING

RECORDING MACHINES LTD.

299 Commercial Road, Portsmouth
Telephone: 23097
4 New Road, Southampton
Telephone: 27092

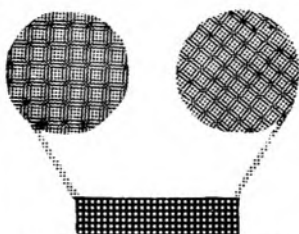

NEW PRODUCTS

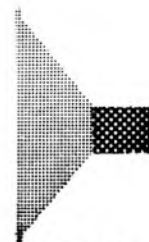

NEW PHILIPS MODEL-27 GUINEAS

LAATEST of the Philips tape recorders was introduced at a special press gathering at Century House, London, at the beginning of January. The new machine, the Starmaker, price 27 guineas, is described as designed to meet the demand of a large section of the public which wants a low-priced, four-track mains tape recorder giving high-quality reproduction with simple operation.

Among the many features is a vertically styled cabinet with a restricted base area, and accommodation for a 6½-inch loudspeaker; choice of input sockets to facilitate use with continental plugs. Another feature which enhances the machine's versatility is the ease for adaptation for use on a 60 cycles mains supply.

Quoted frequency response is 80-10-000 cps ±3dB at the single speed of 3½ ips, with signal-to-noise ratio given as better than 40 dB. Maximum spool size is 5 inches (with lid removed) providing a total playing time of one hour per track using double-play tape, or 4 inches allowing 22 minutes per track with long-play tape. Rewind time is given as 130 seconds for 600 feet of tape.

Power output is rated at 1½ watts, and the microphone supplied is an omnidirectional moving coil with 500 ohms impedance. Input sockets are provided for microphone (0.2 mV at 3 K ohms,

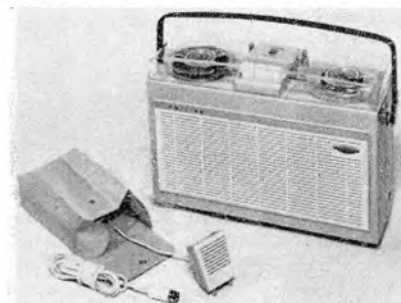

5-pole DIN); radio (3.0 mV at 50 K ohms, 5-pole DIN); and gramophone (130 mV at 2.2 M ohms connected in parallel for 5-pole DIN or IEC). The output sockets are for radio (1V, variable by volume control, at 30 K ohms, 5-pole DIN), and for extension loudspeaker 1½ watts, 3-7 ohms, 2-pole 4 mm.

Valve line-up includes one transistor, AC107, ECC83, EL95, DM71, plus selenium rectifier, and the mains supply is 110-127 and 200-250 V, AC, 50 cycles. The consumption is rated at 25 watts.

Dimensions of the light grey Polystyrene cabinet are 13 x 9¼ x 4¼ inches, and it weighs 10½ lb.

Philips Electrical Limited, Century House, Shaftesbury Avenue, London, W.C.2.

BASF INTRODUCE ACCESSORY KIT

RECENTLY introduced by BASF are two items of practical use for the tape enthusiast. First is an attractive

Tape Library Box offered to purchasers of BASF long-play tape.

It consists of three smoothly-swivelling cassettes in a durable Polystyrol plastic case. Designed in the traditional BASF red, white and black and available in three spool sizes—5, 5½ and 7 inches—they are the newest and most effective way to store and protect valuable film or tape.

The box supplied is free if three BASF long-play tapes are purchased. If only one tape is bought, the price for the three spool sizes is respectively 35s., 43s. 9d. and 62s. 6d.

Their second recent introduction is a comprehensive tape editing kit, the BASF Cutter Box. This handy accessory includes a semi-automatic tape splicer with spare knife and groove, fifty automatic stop foils, a 35-foot roll of splicing tape, three 80-foot rolls of red, green and white leader tapes, four tape clips, and a supply of spool labels.

Housed in an attractive rigid plastic box, the complete kit costs 52s. 6d., and is in the dealers' shops now.

BASF Chemicals Limited, 5a, Gillespie Road, London, N.5.

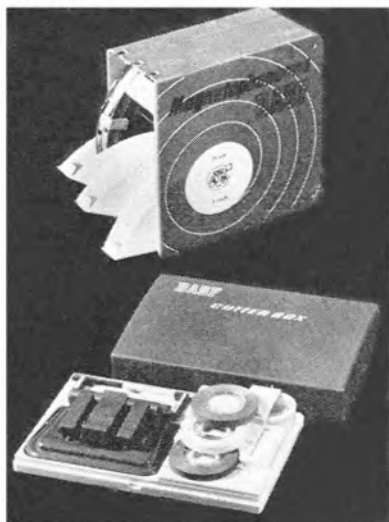

PHILCO ENTER TAPE FIELD

A SINGLE-SPEED, 3½ ips, half-track tape recorder, illustrated below, is Philco's introduction to the tape market. Incorporating the BSR Monardeck with a maximum spool size of 5½ inches, their Model 5200 provides a playing time of 90 minutes per track using double-play tape. The rewind time is approximately 3 minutes for 850 feet of tape.

Among the features are a quoted frequency response of 50-10,000 cps, a 7 x 3½ inch P.M. loudspeaker providing

an output of 2½ watts, and inputs for microphone (2 mV into 10 M ohms), radio (2 mV into 22 K ohms), and pick-up (100 mV into 1 M ohm). Also provided is a radio output (500 mV at 22 K ohms source impedance, minimum load 50 K ohms), and an extension loudspeaker socket (2½ watts at 3 ohms), with automatic muting of the internal speaker.



Saga announce more tapes

SAGA RECORDS LTD. announce that their large, new, fully-equipped recording studio is nearing completion. It is expected to be in action during the first weeks of the new year. Further, considerable streamlining is being carried out in chemical departments and pressing shops, and extensive new tape-duplicating equipment is being installed in newly-acquired premises.

The new studios will enable them to keep up with the demands for their tape-records. Further negotiations are being carried out for the extension of the present Kensal Road offices.

A substantial increase is also forecast in all ranges of their products. Saga disc productions will be stepped up to carry the American Concert-Disc, Audio-ophile, French Pretoria and two other major labels now available to them. The same repertoire will be issued on Saga tapes (3½ and 7½ ips, mono and stereo) with the addition of material from the Storyville jazz catalogue. Many new additions to the Dandy label are planned and releases will be made regularly throughout the year. Special attention will be given to these tapes recently launched at 9s. 11d.

All Dandy titles will be available in both disc and tape form.

Saga Records Ltd., 127, Kensal Road, London, W.10.

New Sugden units

TWO speakers have been introduced by A. R. Sugden, in their Craftsman range. Designated the Major and Minor, both are available in two separate forms; as complete speaker units or as speaker enclosures only. Both have omnidirectional characteristics and as such suitable for stereo reproduction.

The Major has a quoted frequency response of 30-17,000 cps with a power rating of 5 watts, and impedance of 15 ohms at 400 cps. The weight is 25 lb. The price as a complete speaker unit is £19, plus £7 1s. 10d. tax. Enclosure only is £14 15s.

Quoted frequency response of the Minor is 40-12,000 cps, power rating 4 watts, and impedance 15 ohms at 400 cps. The weight is 17 lb., and the price of a complete unit is £12, plus £4 14s. tax. Enclosure only is £9 18s. 9d.

A. R. Sugden & Co. (Engineers) Limited, Market Street, Brighouse, Yorkshire.

Other features include "ribbon" type recording level indicator, combined tone control, safety button to prevent accidental erasure, removable lid, and a storage compartment for microphone, recording and mains lead.

The valve line-up is an ECC83, ECL82, and an EM84, and the power consumption is rated at 60 watts on record and replay.

Housed in a strong wood cabinet covered in leathercloth, dark grey with red front panel, it measures 13¼ x 11¼ x 6¼ inches and weighs 18¼ lb. including accessories.

A crystal microphone and radio connecting lead is included in the price of 25 guineas.

Philco (Great Britain) Limited, 21, Cavendish Place, London, W.1.

Optacord price announcement

A CHANGE in price for the Optacord recorder (below), announced in our December 13 issue. The Optacord 404 is reduced to 53 guineas from £61 19s. The portable model, Optacord 412, for which no price was available at the time, is to retail at 45 guineas.

Highgate Optical Manufacturing Company Limited, 71/3, Great Portland Street, London, W.1.



YOUR LOCAL DEALER

SCOTLAND

GLASGOW

Tape Recorder Specialists

APPROVED AGENTS FOR:—
PHILIPS - GRUNDIG - FERROGRAPH
VORTEXION, ETC.

- ALL MAKES OF TAPE RECORDERS SUPPLIED
- ACCESSORIES AND HI-FI EQUIPMENT
- PART EXCHANGES AND SECOND-HAND MACHINES
- PROMPT AND SKILLED SERVICING

RECORDING MACHINES LTD.

60 ST. VINCENT STREET, GLASGOW, C.2

Telephone: City 3847/8

Tape-to-Disc Services

SSS Private gramophone record made from your own tape

Microgroove LPs from 12/6
Mobile Unit available for Weddings, Receptions
Choirs, Meetings, etc. S.A.E. for full details:—
John Leviss, Sunderland Sound Services,
28, Viewforth Terrace, Sunderland 57032
■ If you can hear it—We can record it! ■

RAPID Recording Service

78's and L.P's from your own tapes

Master Discs and Pressings

Recording Studio
equipped with Bechstein Grand

Practising studios
with or without accompanist

Mobile Recording Van
"Off the Air" Service

21 Bishop's Close, Walthamstow, E.17. COP 3889

TAPE TIME CALCULATOR

The TAPE Recording Magazine accessory, gives playing times for any size reel or length of tape.

A simple, read-at-a-glance device for any speed from 15/16ths to 15 ips. Orders can now be accepted at the address given below.

Price 2/6d

(3/- including postage)

7, Tudor St., London, E.C.4

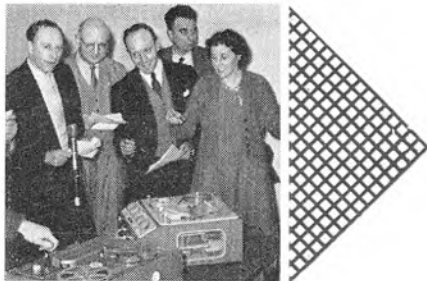

News from the Clubs

EDITED BY FRED CHANDLER

CHESTERFIELD

Another AGM for the Chesterfield club was held at the end of last year. This was their fourth, and it was decided to continue to hold meetings every third Monday.

Among their final activities for the old year were a playback of "Fireworks" tapes recorded by members; a demonstration of echo effects by Geoff Foster; a quiz tape and a *Look after your recorder* talk presented by Dave Baldwin, and a demonstration of the recently-issued EMI Guides. A competition night with a free-for-all to test members' recording skill and including a session of producing sound effects made an ideal prelude to their final meeting of the year. For this members produced a Christmas Extravaganza with everybody working together to prepare a script and take play-acting parts in a hilarious farce.

HALESOWEN

A tape club is to be formed in Halesowen, Worcestershire. Instigator is Roy Finch, a newsagent, of the High Street, who, with a few friends, would like to hear from interested persons. Contact him c/o Mrs. D. Hollyoak, 20, Honeyborne Road, Sutton Coldfield, Warks.

KETTERING

One of the final exercises of 1961 for the Kettering club was the production of a play on tape. With a script written by member Ray Joyce, who also acted as producer with Maurice Thornton, the members were certainly put through their paces. Each member was occupied in some way, although the busiest man was said to be John Potter, the club's librarian, who had to locate a number of sound effects.

The latest recorded meeting, on November 22, was their AGM. This was the third for the club, and it was held at their newly-decorated clubroom at the "Rising Sun." Mr. A. M. Webb regrettably resigned as Secretary and Mr. M. York, 31, Green Land, Kettering, was elected in his place. During the customary report, the treasurer, Mr. J. Bull, declared the club's financial position to be the best ever.

KIDDERMINSTER

A recent meeting of the Kidderminster society could easily have been called a "Spanish Night" when members were visited by a local musician who allowed them to record his renderings of this country's guitar music. Excerpts from six typically Spanish dances were played, including *Malagueñas* and *Soleares*, both widely played in Spain as a song and dance. These were followed by the *Alegrias*, one of the most colourful and fastest of Spanish tunes, and the evening concluded with a collection of old Flamenco melodies from Andalusia.

LONDON

A demonstration of the Veritone Sixteen tape recorder was the highlight of one of the closing meetings for 1961 at the London club headquarters. Twenty-three members were present to hear Mr. Alan Wakeford demonstrate the machine on behalf of the manufacturers, and hear Messrs. Breed and Brownlee provide the piano and trumpet music for a live recording session.

Members' tape time provided a few laughs when Michael Avel failed to locate a particular tape he wished to demonstrate. Chairman, Alan Stableford, then offered to play a tape *How to Index and File Tapes*, but unfortunately he couldn't find it, and instead he gave a short talk on how to wire jack plugs.

The evening was rounded off with a presentation to Michael Avel of a Certificate in Class "A" Section of their internal competition for the MacManus Cup.

NORTH-WEST LONDON

A recent letter from D. Pansey, of 37, Rupert Road, Holloway, London, N.19, provides the news that a tape club is in formation in the Islington-St. Pancras area. Anyone interested is invited to write direct to Mr. Pansey.

NOTTINGHAM

News of another proposed society in the Nottingham area is received from S. Streets who, with a few friends, is currently seeking to start a club. Interested persons should write direct to 23, Bracken Close, Long Eaton, Nottingham.

RUGBY

The Rugby members have been trying their hand at play production, and at a meeting on November 16 Alec Lovett presented some of the material already recorded by this specialised group.

Sound effects recorded on a local market day were among those heard.

Mr. Lovett outlined the work of the group, and announced the preparation of a new script. Work on the next production was to have begun in the new year.

Two delegates have been appointed by the club to the Rugby Town Twinning Committees—who have regular contact with Evreux in France.

VOICESPONDENCE

A new service has been started by the UK representatives of the Voice-spence Club. It entails sending out a *Welcome to Voicespence* tape to prospective members, dispatched by Robert "Skip" Shipman, of 3, Marina Gardens, Weymouth, Dorset. He is the latest addition to the trio responsible for the UK members of this international tape correspondence club. Robert Coote, responsible for the society's publicity, is the second member. He lives at 57, Corelli Road, London, S.E.3.

The third member is Fred Gazeley, who operates the blind services side from his home at 12, Bromley Road, Beckenham, Kent.

WALSALL

Members of this club have also been preparing a tape play production. Their subject was the pantomime *Aladdin*, and if it turned out satisfactorily they had hopes of sending it to other clubs to hear. The club has also held its first AGM, and are looking forward to an equally prosperous forthcoming twelve months after a fairly hectic close of the past year, during which they have moved headquarters a number of times. They are now comfortably settled in the "New Inn," John Street, and look like staying put for some while.

They held a social gathering on



☆
Left: Members of the Cambridge Tape Society seen during an instructional evening with three popular tape recorders. No points for identifying the machines.
☆

December 13, and spent a relaxing evening listening to tape music. The previous evening a number of members had attended at an organist's home to hear his recordings, which included tapes of the local Amateur Operatic Society's recitals and carol-singing, and performances by the Borough Organist in the Town Hall.

WEST MIDDLESEX

First meeting in their new headquarters at the Dormers Wells Primary School was described as an unqualified success by members of the West Middlesex club. The hall, forty feet by twenty feet with a parquet floor and acoustic tiling on the walls and ceiling is ideal for their purpose and the meeting developed into a demonstration of the facilities and acoustic possibilities. A large stage, plus a piano for the asking, makes the hall at 2s. 2d. an evening, an economic venue for this most active club.

The following meeting, at the Railway Hotel for the last time, was devoted to a discussion on forming a Sound and Vision Group. A talk on echo and reverberation by Dave Lloyd using the HMV DSR1 was also included.

On November 23 the first of the sound/vision programmes was held when Phil Mead used his Ferrograph to play back a taped commentary for a slide show with photographs taken during his Austrian holiday.

Their December 14 meeting was turned over into a social occasion being their last gathering before the end of the year.

Snags have been met regarding an internal competition for the Chairman's Trophy, and the closing date has been put back to March 1.

YORK

Yet another AGM, this time by the York Society, was held at the close of the old year. Miss J. Hare was elected secretary in favour of Mr. H. C. Edwards. During the annual report which followed the election, members reconsidered the year's activities. Heaviest months had been the final two when, among their regular exercises, the members had been called upon to record the first taped service of St. Helen's Church, and a service of carols at St. Lawrence's Church. The recordings achieved were played in local hospitals and children's homes at Christmas. Other recordings made include the Lord Mayor's annual message to Münster in Germany, a wedding and reception, and two further carol services, including one around the York Station Christmas tree.

On top of all this they had embarked on a documentary about York. Recordings so far obtained have been made at the Fire Station, of some popular massed bands of York, and on a bus-tour of the city. In all, some 45 recordings are proposed, and permission has already been given for the members to eavesdrop on a bingo session. Just cannot get away from it, can you?

Inter-club contacts continue, the latest exchanges being with the clubs in Keighley and Wakefield.

Looking ahead to the New Year, they have already planned visits to the BBC and ITV Studios, and in March they have another wedding to record when the secretary and chairman get married.

CLUB MEETING DIARY

Is your club included in this list? If not, send details, on a postcard please, including date of the next meeting.

ABERDARE: Alternate Wednesdays at Cwman Institute, Cwmanan, (Jan. 17.)

ABERDEEN: 1st Tuesday in every month at 8 Deer Road, Woodside.

ACTON: Alternate Fridays at the King's Head, Acton High Street. (Jan. 19.)

BARNSELY: Every Tuesday at YMCA, Eldon Street.

BATH: Every Wednesday at 24, Green Park.
BATH (2): Alternate Wednesdays at 41, Herbert Road, Oldfield Park. (Jan. 24.)

BEDFORD: Final Tuesday in month at 131, London Road.

BELFAST: Every Thursday at 44, Dublin Road, Belfast 2.

BETHNAL GREEN: Every Friday at Shoreditch Tabernacle, Hackney Road, E.2.
BIRMINGHAM: Every Monday at the Chapel Tavern, Ludgate Hill.

BIRMINGHAM (SOUTH): Alternate Mondays at Stinchley Institute, Hazlewell Street, Stinchley. (Jan. 29.)

BLACKBURN: 1st and 3rd Tuesdays at Blackburn YMCA.

BLACKPOOL: Alternate Wednesdays at the Albert Hotel, Lytham Road. (Jan. 17.)

BOURNEMOUTH: Alternate Tuesdays at the Queen's Hotel, Queen's Road, Bournemouth West. (Jan. 23.)

BRIDGWATER: Every Tuesday at Evis' Radio Shop, West Street.

BRIGHTON: Every Wednesday at The Brunswick Arms, 38, Ditchling Road.

BRISTOL: Alternate Wednesdays at Redcliffe Church Hall, Guinea Street, Redcliffe. (Jan. 24.)

BRIXTON: Every Tuesday at The White Horse, 94, Brixton Hill, S.W.2.

BROMLEY: 2nd and 4th Thursdays at St. Mary's Church Hall, College Road.

CAMBRIDGE: Every Wednesday at the Mitre Hotel, Bridge Street.

CARDIFF: 1st and 3rd Tuesdays at 46, Caroline Street.

CATFORD: Every Thursday at the Black Horse, Rushey Green, Catford, S.E.6.

CHESTERFIELD: Every 3rd Monday at the Yellow Lion Inn, Saltergate. (Jan. 29.)

COTSWOLD: Fortnightly, alternating Monday and Thursday at Bayshill Hall, Royal Well Lane, Cheltenham (Jan. 25.)

COVENTRY: Alternate Wednesdays at Holy-Park Hotel. (Jan. 17.)

CRAWLEY: 1st and 3rd Mondays at Southgate Community Hut.

DARTFORD: Every Thursday at 41, Winsor Drive.

DERBY: Alternate Wednesdays at Osmaston Park Hotel. (Jan. 17.)

DONCASTER: Alternate Thursdays at Lancaster House, Westlathie Gate. (Jan. 18.)

DOVER: Alternate Mondays at the Priory Hotel, Dover. (Jan. 22.)

DUBLIN: 1st Monday at "Hardy House," 6, Capel Street.

DUNDEE: Alternate Mondays at the Salvation Army Hostel, 31, Ward Road. (Jan. 29.)

EASTBOURNE: Alternate Saturdays at Hartington Hall, Bolton Road. (Jan. 20.)

EAST HERTS: Alternate Mondays at 3, Chadwell, Ware. (Jan. 29.)

EDINBURGH: 1st and 3rd Fridays at 22, Forth Street, Edinburgh 1.

FRIERN BARNET: 2nd Friday at 7, Harmsworth Way, N.20, and 4th Thursday at 146, Friern Barnet Lane, N.20.

GLASGOW: Fortnightly, alternating Tuesday and Thursday at the Highlands Institute, Berkeley Street Glasgow, C.3, (Feb. 1.)

GRIMSBY: 1st Monday at 21, Langton Drive, Nunthorpe, Grimsby.

HARROGATE: Every Wednesday at 4, Belford Road.

HARROW: 1st and 3rd Thursdays at St. George's Hall, Pinner View, North Harrow.

HASTINGS: Every Tuesday at the Citizens' Advice Bureau, Cambridge Gardens.

HINCKLEY: Alternate Wednesdays at The Wharf Inn, Coventry Road. (Jan. 17.)

HOVE: Every Thursday at 44, Hogarth Road, Hove.

HUDDERSFIELD: 1st and 3rd Wednesday and last Monday at the Public Library, Ramsden Street.

HULL: Alternate Tuesdays at 281, Hessle Road, (Jan. 30.)

ILFORD: Every Tuesday at the RAFA Rooms, Cranbrook Road.

IPSWICH: Alternate Thursdays at the Art Gallery, High Street. (Jan. 18.)

JARROW: Alternate Mondays at Jarrow Central School. (Jan. 22.)

JERSEY: 1st and 3rd Mondays at "Santa Barbaba," Maufant, St. Saviour.

KEIGHLEY: Alternate Wednesdays at the Spencer Street, School Rooms. (Jan. 24.)

KETERING: 2nd and 4th Wednesdays at the Rising Sun, Silver Street.

KIDDERMINSTER: Alternate Wednesdays at the Town Hall. (Jan. 17.)

LEEDS: Alternate Fridays at 21, Wade Lane, Leeds 1. (Jan. 19.)

LEICESTER: Alternate Fridays at the Newark Girls' School, Imperial Avenue. (Jan. 19.)

LONDON: 4th Thursday at the Abbey Community Centre, Marsham Street, S.W.1.

LUTON: 2nd and 4th Tuesdays at Flowers Recreation Club, Park Street West, Luton.

MAIDSTONE: Every Wednesday at the Ex-Services Club, King Street.

MANCHESTER: Every Saturday, 6 p.m., at 20, Naylor Street, Hulme, Manchester 15.

MEDWAY: Every Monday at 23, Edward's Close, Rainham, Kent.

MIDDLESBROUGH: Every Wednesday and Friday at 130, Newport Road.

MILLOM: Every Wednesday at Millom Centre.

NORTH LONDON: Alternate Wednesdays at Bush Hill Park School, Main Avenue, Enfield. (Jan. 17.)

NORTHAMPTON: Every Tuesday at the Peacock Room, Grand Hotel.

NOTTINGHAM: Alternate Thursdays at the Co-operative Educational Centre, Heathcote Street. (Jan. 25.)

NORWICH: 4th Tuesday at "Lady Chamberlin Hall," 38a, St. Giles' Street.

PETERBOROUGH: Alternate Thursdays at The Youth Centre.

PONTYPOOL: Every Monday at the Hospitality Inn, Crumlin Road.

PLYMOUTH: Alternate Wednesdays at Virginia House, Plymouth. (Jan. 24.)

READING: Every Monday at Abbey Gateway.

REDDITCH: 4th Thursday at The White Hart Hotel, Headless Cross.

RHYL: Alternate Tuesdays at Studio A, Bedford Street. (Jan. 30.)

ROTHERHAM: Alternate Thursdays at St. John's Church Hall, Masbro'. (Jan. 25.)

RUGBY: Alternate Thursdays at the Red Lion, Sheep Street. (Jan. 25.)

SHEERNESS: Alternate Fridays at Arthur Gisby's, 136, High Street. (Jan. 19.)

SOUTHALL: Every Monday at Southall Community Centre.

SOUTHAMPTON: Alternate Thursdays at Southampton University. (Jan. 25.)

SOUTH DEVON: Alternate Wednesdays at the YMCA, Castle Circus, Torquay. (Jan. 17.)

SOUTH-WEST LONDON: Every Wednesday at Mayfield School, West Hill, S.W.15.

STAFFORD: Alternate Tuesdays at The Grapes, Bridge Street. (Jan. 23.)

STEVENAGE: 1st and 3rd Tuesdays at the Tenants' Meeting Room, Myrmead.

STOCKPORT: 1st Friday at the Unity Hall, Greek Street.

STOKE NEWINGTON: Every Wednesday at 53, Londesborough Road, N.16.

SWANSEA: Every Thursday at the YMCA Buildings, St. Helen's Road.

URMSTON: Alternate Thursdays at Davyhulme Scout Hut, Barton Road. (Jan. 18.)

WAKEFIELD: Alternate Mondays at York Street Hotel. (Jan. 22.)

WALSALL: Every Wednesday at the New Inn, John Street.

WALTHAMSTOW: Alternate Fridays at 22, Orford Road, E.17. (Jan. 19.)

WARWICK & LEAMINGTON: 1st and 3rd Wednesdays in Room 18 of the Royal Leamington Spa, Town Hall.

WEST HERTS: Fortnightly alternating at the Cookery Nook, High Street, Watford (Jan. 24) and Heath Park Hotel, Hemel Hempstead. (Feb. 7.)

WEST MIDDLESEX: 2nd and 4th Thursdays at Dormers Wells Primary School, Dormers Wells Lane, Southall.

WEST WALES: 1st and 3rd Fridays at The Meeting House, New Street, Aberystwyth.

WEYMOUTH: Alternate Wednesdays at The Waverley Hotel, Abbotbury Road. (Jan. 24.)

WINCHESTER: Every Friday at 45a, St. Swithen's Street.

WINDSOR: Every Thursday at The Guildhall.

WOOLWICH: Alternate Mondays at the North Kent Tavern, Spray Street, Woolwich. (Jan. 29.)

YORK: Every Thursday at 62, Micklegate.

Unless otherwise stated, meetings start between 7 and 8 p.m.

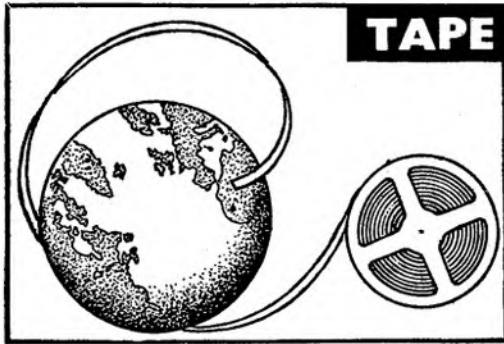

TAPE EXCHANGES

Tape goes round the world! There is no comparable means—except costly travel—to form friendships with men and women in other countries and continents. Every month, in this feature, we list enthusiasts who are seeking tape contacts.

Bailey, F. C. (Male 53). 18a, Booths Farm Road, Birmingham 22a. Colour photography, stamps, Esperanto. 3½ ips. 5-inch spools. Male contacts anywhere, letters first please.

Boothroyd, H. (male, 50). 54, Norwood Avenue, Shipley, Yorkshire. 1½, 3½, 7½ ips. 2- or 4-track. English speaking contacts anywhere.

Cox, John B. (35). 4, Leigh Crescent, New Addington, Croydon, Surrey. Electronic organ music, light modern orchestras. 3½ ips. 5½-inch spools. Contacts anywhere.

Dewitt, David, A. (15). 42, Addison Road, London, W.14. Philosophy, psychology, gymnastics, microscopy. 1½, 3½, 7½ ips. 7-inch spools. Contacts anywhere welcome.

Dickens, John (31). 1, Pilgrim's Way, Bedford, Bedfordshire. All music, motoring. All speeds. 8¼-inch spools. Contacts anywhere.

Foster, G. D. 152, Mead Lane, Caravan Park, Chertsey, Surrey.

Germann, Gerhard (28). 8, Hartmann Strasse, Stuttgart-Feurbach, Germany. Model railways, short-wave radio, jazz, opera and folk music. 3½, 7½ ips. 7-inch spools. Can speak a little English.

Griffiths, D. J. (male, 40). 10 Woodland Crescent, Merry Hill, Wolverhampton. Fiction writing, "pop" music. 1½, 3½, 7½ ips. 7-inch spools. English-speaking contacts anywhere, letter or tape.

Hayes, H. T. (male, 57). "Avondale," EThorpe Close, Gerrards Cross, Buckinghamshire. All music, especially modern jazz. All speeds, 2- or 4-track. Male contacts anywhere.

Healey, Ken (43). 33, East Elloe Avenue, Holbeach, Spalding, Lincolnshire. Piano, accordion and organ music, and stereo. 3½, 7½ ips. 2- or 4-track. Contacts anywhere.

Holding, Bruce S. (25). 164, Chiswick Village, London, W.4. New Orleans Jazz. 5½-inch spools. Continental or USA contacts preferred.

Jennings, Dan (25). 26w, Juniper Street, London, E.1. Travel, people, "off-beat" subjects. 3½ ips. 7-inch spools. Anyone, anywhere. New Zealand preferred.

Kenyon, L. W. (male, 49). Melville Farm, Shenley Road, Bletchley, Buckinghamshire. Fishing, printing, sailing, music (not "rock"). 3½ ips. 5½-inch spools. Anyone, anywhere.

Kerr, G. (Male 23). Block A, 4, Waterloo Square, Camberwell, London, S.E.5. Pop music and films. Any speed. 7-inch spools. Anyone, anywhere.

Keszei-Koch, Janos (25). 48, Allen Park, Stillorgan, Dublin, Ireland. 35 mm. photography, 8 mm. colour cine, any music except rock'n'roll. 3½, 7½ ips. 8¼-

inch spools. Anyone, anywhere, English or Hungarian language.

Knight, Michael. 220, Ringland Circle, Newport, Monmouthshire. Classical music, instrumental rock. 3½, 7½ ips. 5-inch spools. Female contacts preferred.

Knowles, R. J. (male, 25). 11, Greenfield Avenue, Springboig, Glasgow, E.2. 8mm cine and 35mm, colour photography. 3½ ips. 5½-inch spools.

Lansbury, Basil. 6, Granville Road, North Hillingdon, Middlesex. Photography, all music, travel. 1½, 3½, 7½ ips. 2- or 4-track. 7-inch spools. Anyone, anywhere.

Lawson-Smith, P. (23). 4, Fisherman's Way, Bourne End, Buckinghamshire. Brass bands, catering and stereo. 1½, 3½, 7½, 15 ips (7½ ips for music). 8¼-inch spools.

Madden, William F. (33). 170, Daiglen Drive, South Ockenden, Romford, Essex. Perry Como records. All speeds. 8¼-inch spools. Contacts in all countries required, particularly New York.

Maguire, William. 13, Arthur Avenue, Whitewell Road, Newton Abbey, N. Ireland. Country and western music. 3½ ips. 5¼-inch spools. Contacts anywhere welcome.

Marwitz, Klaus (23). 28, Bremen 17, Am Rickmers Park 19, Germany. "Pop" music, literature, linguistic problems, travel. 3½ ips. 6-inch spools. Female contacts required, can speak English and French.

McLean, R. T. (32). 20, Beaconsfield Road, Fareham, Hampshire. Fishing, boating, travel. 3½ ips. 5½-inch spools. 2- or 4-track. Overseas contacts preferred.

Messenger, Margaret (Mrs). 5, Beaulieu Park, Wellington Road, St. Helier, Jersey, Channel Islands. 1½, 3½ ips. 5½-inch spools. Family exchanges wanted.

Moorhouse, T. (49). Grange Villa, 39, Warren Road, Rhyl, North Wales. Motoring, fishing, stereo and mono. 3½, 7½ ips. Contacts required in Commonwealth countries and USA.

Petrie, Ron S. T. (33). 330, King Street, Broughty Ferry, Angus, Scotland. People and general interests, light classi-

cal opera and show music. 1½, 3½, 7½ ips. 7-inch spools. Anyone, anywhere, overseas preferred.

Platts, Dorothy Miss (20). "The Bungalow," Mansfield Road, Heath, Nr. Chesterfield, Derbyshire. Records, dress-making, cars, films. 3½ ips. 5½-inch spools. Grundig TK14. Contacts required in America, Canada and Jersey, C.I.

Robins, Mostyn Douglas (33). Photography, chess, brass band music. 1½, 3½, 7½ ips. Grundig TK35 and Ferrograph 4AN. English-speaking contacts anywhere.

Seaden, Edwin (37). 11, Hereward Road, Footing, London, S.W.17. Country and western music. Contacts anywhere welcome.

Sparkes, Bernard. Flat C, 5, Brynderwen Road, Maindee, Newport, Monmouthshire. General interests, organ and unusual sounds. 1½, 3½, 7½ ips. 2- or 4-track. 7-inch spools. Stellaphon ST455, RGD Mk 104. Prefers message spools to start. Contacts anywhere welcome.

Spring, H. A. M. (Male). 16, Newquay Avenue, South Reddish, Cheshire. General interests, all tastes in music. 1½, 3½, 7½, 15 ips. 8¼-inch spools. Anyone, anywhere.

Stern, Bernhard (18) and sister (15). Darmstadt-Arheilgen, Schliebfach 14, Western Germany. General interests, electronics, jazz and classical music. Contact with English teenagers required.

Tepfers, Sulamite Miss (24). 51, Hendon Way, London, N.W.2. Stamps literature, music, films, German and Latvian languages. 3½ ips. 5¼-inch spools. Contacts anywhere welcome.

Thomas, Klaus (29). Wurzburg, Am Dicken Turm 4, Germany. Books, photography, travel. 1½, 3½, 7½ ips. 7-inch spools. Wish to exchange language conversations.

Thompson, H. (Male). 4, Priory View, Priory Road, Hastings, Sussex. Light classical music. 3½, 7½, 15 ips. 7-inch spools.

Wales, Joy Miss (21). 39, Olive Road, New Costessey, Near Norwich, Norfolk. 8mm cine and colour photography. 5½-inch spools. Contacts anywhere welcome, especially France.

Tape recorder owners wishing to make contact with others of similar interests are invited to complete and return the form below.

Name Age
Address
(BLOCK LETTERS PLEASE)

Other interests
Speeds to be used Pool size
Recorder owned
Special areas to be contacted



Alive to every sound

Like the ears of a wary fox, the Gramplan DP4 microphone is sensitive to an extremely wide range of sounds. With its uniform frequency response from 50 to 15,000 c/s, the reliable, medium-priced DP4 will greatly improve the standard of your recordings.



Gramplan DP4

—also for broadcasting, public address and call systems

Low Impedance microphone complete with connector and 18 ft. screened lead **£8.0.0**
 Medium and high impedance models **£9.0.0**

A complete range of stands, swivel holders and other accessories is available.

GRAMPIAN—sounds like the real thing!

Write or phone for illustrated leaflets:

GRAMPIAN REPRODUCERS LTD
 Hanworth Trading Estate, Feltham, Middlesex. Feltham 2657



be an angel

write to us for a free specimen copy of RECORDS AND RECORDING —the illustrated monthly magazine which is *absolutely devoted* to classical records

HANSOM BOOKS LTD • 7 AND 8 HOBART PLACE • LONDON SW1

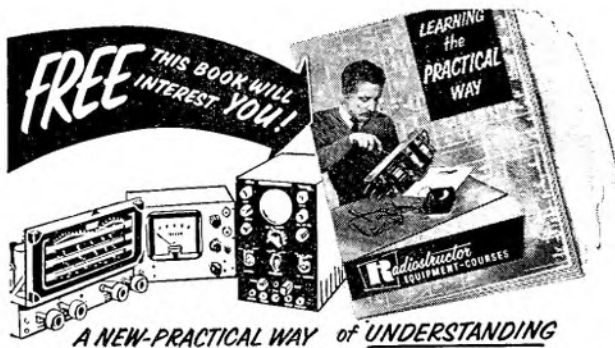

FREE THIS BOOK WILL INTEREST YOU!

A NEW-PRACTICAL WAY of UNDERSTANDING

RADIO • TELEVISION • ELECTRONICS

including: Transistors; VHF/FM; Hi-Fi equipment; Computers; Servomechs; Test Instruments; Photo-electrics; Nucleonics; etc.

FOR ... Your Career ... Your Own Business ... An Absorbing Hobby

Radiostructor—an organisation specialising in electronic training systems—offers a new self-instructional method using specially designed equipment on a “do-it-yourself” basis. You learn by building actual equipment with the big kits of components which we send you. You advance by simple steps, performing a whole series of interesting and instructive experiments—with no complicated mathematics! Instructional manuals employ the latest techniques for showing the full story of electronics in a practical and interesting way—in fact, you really have fun whilst learning! Fill in coupon below, for full particulars.

POST NOW

To RADIOSTRUCTOR (Dept. G35)
 READING, BERKS.

Please send brochure, without obligation, to:

Name:
 Address:

**BLOCK
 CAPS
 PLEASE**
 2/62

**RADIOSTRUCTOR LEADS THE WORLD
 IN ELECTRONICS TRAINING**

SOUTH LONDON TAPE RECORDER and HI-FI CENTRE

The Largest Selection of Highest Quality Recording and Reproducing Equipment on Show. 200 Machines Displayed.

FERROGRAPH 4AN	...	81 gns.
FERROGRAPH Stereo 422U	...	110 gns.
BRENELL Mk. V "M"	...	88 gns.
PHILIPS Stereo	...	92 gns.
REFLECTOGRAPH Type 'A'	...	105 gns.
REPS. R.10. 4 Track	...	69 gns.
SIMON S.P.5	...	93 gns.
TANDBERG Stereo 6	...	110 gns.
TRUVOX Twin Track	...	82 gns.
VORTEXION WVA	...	£93.13.0
SONY Stereo 521	...	124 gns.
AMPEX 971 Stereo	...	225 gns.

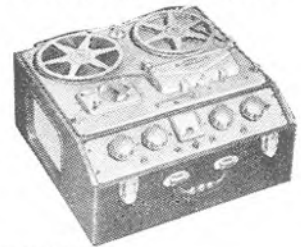

AMPLIFIERS BY

LEAK ROGERS QUAD
 ARMSTRONG DULCI JASON

TUNERS

DULCI LEAK QUAD FM and AM
 ARMSTRONG ROGERS

MICROPHONES

GRAMPIAN DP4 RESLO
 FILM INDUSTRIES CADENZA

SPEAKERS

LEAK SANDWICH QUAD ELECTRO-
 STATIC LOWTHER GOODMAN'S
 WHARFEDALE

Large stock of shop-soiled and used Tape Recorders at bargain prices.

THE LEADING TAPE-RECORDER AND HI-FI MAIL SPECIALISTS

- No interest terms on tape recorders over 12 months (18-24 months available).
- Generous allowance on your Tape-recorder, Hi-Fi equipment.
- Immediate delivery (normally waiting time on above machines is 12-16 weeks).
- Tape recorders for hire from 45/- weekly.

CALL IN PERSON OR WRITE TO OUR MAIL ORDER DEPT. FOR IMMEDIATE ATTENTION

REW EARLSFIELD LTD. TELEPHONE:
 BALHAM 7710
 266, UPPER TOOTING ROAD, LONDON, S.W.17

You'll find it
at

**FRANCIS OF
STREATHAM**

**RECORDERS—
ACCESSORIES AND HI-FI
WITH NO EXTRA CHARGES FOR CREDIT**

**BRENELL
BUTOBA
COSSOR
ELIZABETHAN
FERROGRAPH
FIDELITY
GRUNDIG
PHILIPS
REFLECTOGRAPH
SONY
TELEFUNKEN
etc., etc.**

FRANCIS OF STREATHAM have long been known to readers of tape recording journals as one of the foremost and liveliest suppliers of tape-recorder and high-fidelity equipment in the country. This is the reflection of a policy of customer confidence gained from service and attention to detail no matter how large or how small your requirements. There are two well-stocked centres at your service—169-171 for recorders and everything for recording; 181 for hi-fi where you can choose from the best of everything from a stylus to stereo gramophone/recorder/radio set-up.

QUAD, LEAK, ROGERS, WHARFEDALE, DECCA, ORTOFON, SHURE, GARRARD, Lenco, ARMSTRONG, MORDAUNT, THORENS, etc.

Hire-Service Tape-Disc and Disc-Tape Copy Service

Recorders at 169-171, STREATHAM HIGH RD., LONDON, S.W.16
Hi-Fi Dept. at 181, STREATHAM HIGH RD., LONDON, S.W.16
Between STREATHAM STN. and St. Leonard's Church ● STREATHAM 0466/0192

**NOW
HEAR
THIS!**



**A MUST FOR EVERY TAPE
RECORDING ENTHUSIAST**

THIS unique recording gives spoken and audio examples of the principles of tape recording; acoustics; cycles per second; decibels; frequency response; equalisation; balance and distortion.

It demonstrates right and wrong microphone positioning; mixers; feed-back; gagging; hiss; hum and overload; wow and flutter; signal-to-noise ratio and many other aspects of recording.

The final section provides examples of typical recording sessions and a signal for use when adjusting azimuth alignment of tape heads.

Tapecraft plays at 3½ i.p.s. Playing time 45 mins.
If your retailer cannot supply, send us his name and address, or P.O. 35/- and we will send direct to you.

**PRICE
35/-**

ESOTERIC PRODUCTIONS LTD., 22 COASTAL CHAMBERS,
BUCKINGHAM PALACE ROAD, LONDON, S.W.1.

Trade enquiries invited

**Whether You Prefer
Twin Track or Four Track
You're Bound to Prefer**

ELPICO

Two tape recorders we are proud to produce. Many years of tape recorder manufacturing experience have gone into the production of these machines, and all the very latest developments in printed circuitry have been utilized, to give you many years of trouble-free use. Expert styling, wonderful clarity of reproduction, with all the extra refinements such as separate inputs for microphone and gramophone with separate gain controls on each channel, separate tone control and separate switch with warning light for superimposing that are only found in equipment at a much higher price. Ask your dealer to demonstrate . . . you will be convinced that ELPICO offers the finest value in tape recorders today.



MODEL TR 500 (Twin Track)
Supplied Complete with microphone, 5½" spool 850' Standard Tape, Recording lead.

Retail Price **28** GNS.

MODEL TR 600 (Four Track)
Supplied Complete with microphone, 5½" spool 1200' L.P. Tape, Recording lead.

Retail Price **33** GNS.

Send for full technical details

LEE PRODUCTS (Gt. Britain) LTD.

10-18 Clifton Street, London, E.C.2

Telephone: B1Shopsgate 6711 (all lines)

**Technical Details
(Both Models)**

Power Supply:
200-250v 50 c/s

Tape Speed:

3½ i.p.s.

Frequency Range:
80-8000 c.p.s.

Internal Speaker:
8" × 2½"

Spool Size: 5½"

Microphone: High Impedance Crystal Hand/Desk Type



4 REASONS THAT MAKE THE **Garrard** TAPE SYSTEM SO SIMPLE

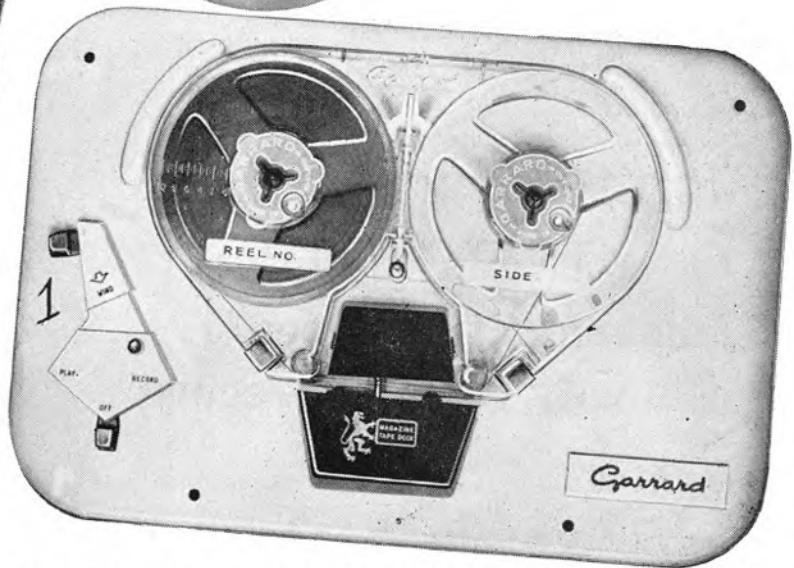
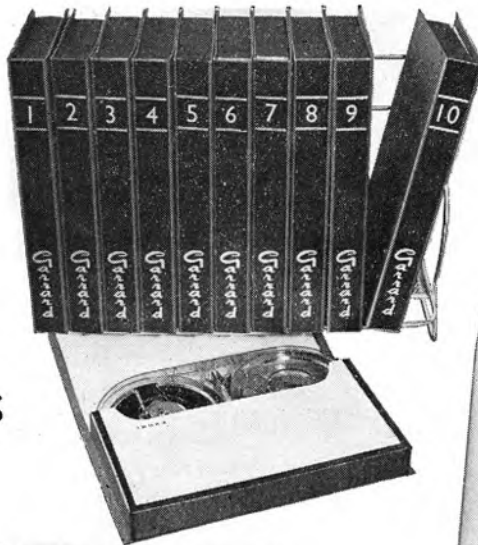
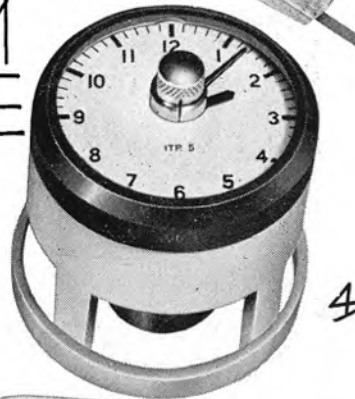
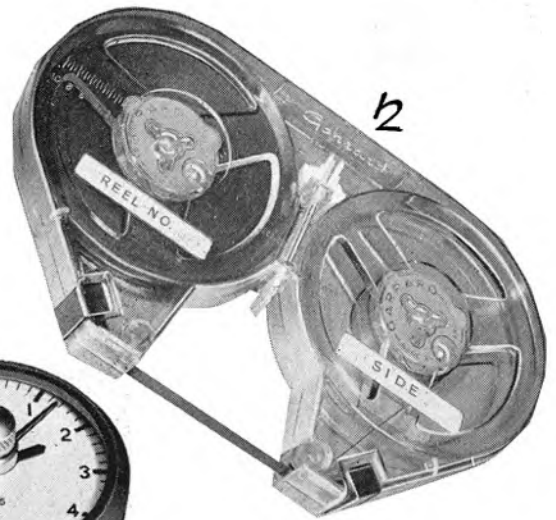

- 1 SIMPLE TO OPERATE**
Anyone can operate the Garrard system. Controls have been simplified. There are three positions only. PLAY · RECORD · WIND.
- 2 MAGAZINE LOADING**
No tape threading. No spilling. No anchoring of tape. Just place the magazine on the deck and it's ready to operate.
- 3 EASY STORAGE**
The Magazine is the same size as an average book. It fits neatly on a bookshelf using the Library Storage Unit.
- 4 GARRARD TAPE POSITION INDICATOR**
Gives precise and accurate indication of recordings on the tape.

CONTINUOUS—EASY TAPE RECORDING & PLAYBACK WITH THE GARRARD MAGAZINE METHOD

MAGAZINE TAPE DECK ACCESSORIES

	£	s.	d.
Magazine containing 650 ft. Double Play Tape in container	1	13	4
Magazine only with one empty spool	8 0
Reel of 650 ft. Double Play Tape	1 4 0
Garrard Spool only	3 3
Library Storage Magazine Container	3 6
Tape Position Indicator	1	19	6

THE GARRARD ENGINEERING & MANUFACTURING CO. LTD.
SWINDON · WILTSHIRE

**ORDER TO NEWSAGENT FOR
"TAPE RECORDING MAGAZINE"**

Published on the third Wednesday
in every month. Price 1s. 6d.

To

(Newsagent's name and address)

Please deliver me one copy of
"TAPE Recording Magazine"
each month until further notice.

(Signed)

Address

TAPE Recording Magazine is published by
Print & Press Services Ltd., 7, Tudor Street,
London, E.C.4, and distributed by Trans-World
Circulation Co., Park Royal Road, N.W.10.

**ORDER FOR ANNUAL
SUBSCRIPTION TO
"TAPE RECORDING
MAGAZINE"**

Please post me one copy of
"TAPE Recording Magazine"
monthly for one year. I enclose
£1 in payment.

(Signed)

Address

**REQUEST FOR
IMPROVED
DISTRIBUTION**

Will you please contact the
newsagent(s) named below, who
report difficulty in obtaining
copies of "TAPE Recording Maga-
zine" for sale.

(Name of newsagent(s))

(Name of informant).....

**Classified
advertisements**

**Rate—Sixpence per word (minimum 5s.);
Trade, ninepence per word (minimum
10s.); box numbers, one shilling extra.
Payment with copy. Copy should be sent
to Advertisement Department, "Tape
Recording Magazine," 7, Tudor Street,
London, E.C.4.**

MISCELLANEOUS

FRIENDLY FOLK ASSOCIATION,
Torquay (Est. 1943). Social Introduc-
tions, Pen-friends, Book-lovers, Stamps,
Photography, Tapesponding. Members
100 Countries.

50 per cent BELOW USUAL PRICES.
Highest grade standard recording tape.
Brand new. 7 in. reels 17s. 6d., 5 in. reels
12s. 6d., 5½ in. reels 15s. Post and pack-
age free if four or more ordered, other-
wise 1s. per tape. Genuine offer carry-
ing money-back guarantee. W.S.L. (Tape
Dept.), 106, Greyhound Lane, London,
S.W.16.

"BRAND FIVE" American Tape.
Standard Play, 5 inch (600 feet) 16s.;
7 inch (1,200 feet) 25s.; Long Play 5
in. (900 feet) 18s. 6d.; 5½ in. (1,200 feet),
23s. 6d.; 7 in. (1,800 feet), 35s. Sent by
return. Post Free! Watts Radio, 54,
Church Street, Weybridge, Surrey.

PRE-RECORDED TAPES

Unique complete catalogue listing all
makes, Mono, Stereo, 7½ and 3½ ips,
including World Record Club tapes.
Call for FREE copy or send 1s. mailing
fee. Dept. T.R.1, Teletape Ltd., 33,
Edgware Road, W.2. PAD 1942.

RECORDING TAPE. See my adver-
tisement on page 32. Nobody has yet
asked for his money back. Villiers.

ASK YOUR DEALER for American
Ferrodynamics "Brand Five" recording
tapes—the best tape value!

TAPE-TO-DISC

TAPE TO DISC RECORDING
Reduced prices. Finest professional
quality. 10-in. L.P.—30s. (32 mins.),
12-in. LP—35s. (45 mins.). 7-in. EP
17s. 6d.

48-HOUR POSTAL SERVICE
S.a.e. for leaflet to Deroy Sound Service,
52, Hest Bank Lane, Hest Bank,
Lancaster. Tel.: H.B. 2444.

**TAPE-TO-DISC RECORDING SER-
VICE.** All speeds. Photographic sleeves
with all records. Details from E.R.S.,
162, Shirland Road, London, W.9.

JOHN HASSELL RECORDINGS.
Tape/Discs. All speeds. CCIR Studio,
21, Nassau Road, London, S.W.13.
Riverside 7150.

J. & B. RECORDINGS. Prompt tape
to disc and sound effects service. 14,
Willows Avenue, Morden, Surrey. Tele-
phone: Mitcham 9952 any time.

MISCELLANEOUS

Recording Tape. Save up to 30 per
cent. Send for list. Also 50 secondhand
Recorders in stock. E. C. Kingsley & Co.,
132, Tottenham Court Road, London,
W.1. EUS 6500.

Make **WORLDWIDE, WORTH-
WHILE** friendships. Join in
"WORLDWIDE TAPETALK." S.A.E.
for particulars: "WWTT4," 35, The
Gardens, Harrow.

EASYSPLICE SPLICER makes tape
splicing easy. Patented, guaranteed.
3s. 6d. and 5s. P. & P. 6d. Thousands
sold.—Easysplice, 30, Lawrence Road,
Ealing, London, W.5.

FOR SALE

1960 HMV MODEL D.S.R.1. Com-
plete as new £40. Owner going overseas.
—Dodd, Cotesbach Hall, Rugby.

**WITH CABINET:—2 QUAD II AM-
PLIFIERS, 22 Control Unit, FM Tuner,
AM II Tuner and Jason JTV/2 FM and
AM/TV Tuner. Also Ferrograph 808
and 2 Cotswold speakers. All mint con-
dition. £170—£175. Offers considered.
Box No. 433, TAPE Recording Maga-
zine, 7, Tudor Street, London, E.C.4.**

**AMERICA'S ONLY
TAPE RECORDING
MAGAZINE**

Since 1953, this magazine has
totally been devoted to tape
recording.
In addition to its timely
articles, our columns also
feature:

- Tape Reviews
- New Products
- Industry News
- Questions & Answers
- Feedback (letters from
readers)
- Crosstalk (an edi-
torial)
- Club News (tape
correspondence
clubs)
- Tape in Education
- Book Reviews

A one year subscription,
including overseas postage,
\$4.75



**SEVERNA PARK,
MARYLAND, U.S.A.**

exciting
new
idea
in tape storage



BASF Tape Library Box

Here's the new, easy and inexpensive way to store and protect recording tape—the BASF way! BASF Tape Library Boxes will house three tapes (or 8mm films) in swivel-open cassettes. Made from tough, rigid Polystyrol plastic, the boxes not only provide a perfect quick reference library, they protect your tapes from dust and damage. BASF Tape Library Boxes are only obtainable containing either 1 LP tape or 3 LP tapes. The boxes come in 3 sizes—for 5", 5½" and 7" spools.

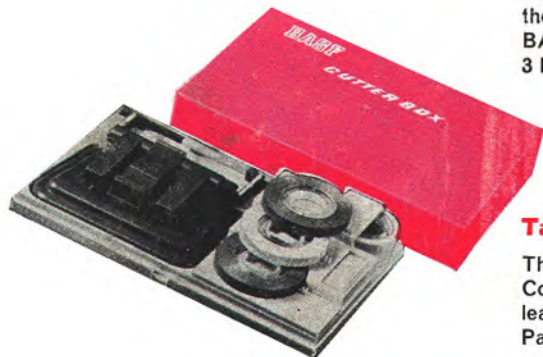

Tape Editing Made Easy

The BASF Cutter Box is an accessory kit to delight every tape enthusiast. Contents include—semi-automatic splicer, tape clips, splicing tape, leader tape, automatic stop foils, etc. Packed in attractive, rigid plastic boxes. Only 52/6.

If you have difficulty in getting either the Library Box or Cutter Box, ask your usual dealer to order these for you.



Magnetic Recording Tape
for **Authentic Sound**

BASF CHEMICALS LTD 5A Gillespie Road London N5