

2/6

*The*  
**SHORT WAVE**  
*Magazine*

VOL. X

MARCH, 1952

NUMBER 1



WORLD WIDE COMMUNICATION

# H. WHITAKER G3SJ

10 YORKSHIRE STREET, BURNLEY Phone 4924

**RESISTORS.** New and Unused Erie and Dubilier. We have secured another fine parcel of these and offer as follows:  $\frac{1}{2}$  watt 8/6 per 100,  $\frac{1}{4}$  watt 12/6 per 100, 1 watt type 9 insulated 15/- per 100, 1 watt standard type 15/- per 100, 2 watt 20/- per 100, 5 watt 25/- per 100. All well assorted values between 100 ohm and 6.8 Meg. Or sample 100 as follows, 20  $\frac{1}{2}$  watt, 25  $\frac{1}{2}$  watt, 20 1 watt insulated, 20 1 watt standard, 10 2 watt, 5 5 watt, with a range of least 30 different values at 14/- post free.

**WIRE WOUND.** 5 watt. Values in ohms. 15, 20, 25, 50, 75, 100, 150, 175, 200, 250, 500, 750, 1000, all with wire ends at 6/- per doz. assorted.

**OSCILLOSCOPES.** By well known British Manufacturer. In black crackle steel cases, size 12 x 8 x 6 in. For A.C. mains 230/200v 50cy. Tube size 3in. (green). Hard valve time base continuously variable from 5 to 250,000 c.d.s. Push-pull "X" deflection circuit with T.B. wave form brought out to separate terminal for wobulator work or synchronising. Provision for fly back suppression. Push-pull "Y" deflection circuit, level from 15 to 300,000 c.d.s. All usual controls and provision for using a D.C. volt-meter to measure the amplitude of an A.C. waveform. Separate synchronised amplifier and no control interaction. Complete with all test leads and instruction manual. They are brand new and boxed in original cartons, and represent an un-repeatable bargain at £19/10/0. Carr. paid.

**ELECTRONIC KEYS.** 230v 50cy. A.C. Mains. Our own production. Grey crackle steel case 9 x 7 x 6 in. Employs in all 5 valves. Controls for dot, dash, and spacing with, speed control continuously variable from below 10 wds. per minute to 60 wds. per minute, with perfect formation of characters. This is precision first class operating made easy. Carr. paid £12/10/0.

**CRYSTALS.** 1000 kc Valpey, Bliley or Somerset; standard  $\frac{1}{2}$  in. pin spacing, 20/-, R.C.A. 100kc sub-standards 20/-, Western Elec. 500 kc Ft 243 holders with  $\frac{1}{2}$  in. pin spacing, 7/6. Full range of Western I.F. freqs. 450, 465 kc, etc., 12/6 each. Amateur and Commercial bands. G3 SJ Xtals are precision lapped, and acid etched to final freq. Are available in either Ft 243 holders,  $\frac{1}{2}$  in. British,  $\frac{1}{2}$  in. U.S.A. or  $\frac{1}{2}$  in. P.5 holders. Your own choice of frequency 2 Mc to 10 Mc inclusive. We will despatch to within 1 Kc of your chosen frequency at 15/- each, accurately calibrated with freq. clearly marked. Slight extra charges for decimal point freqs. We also undertake the calibration, or re-grinding of your own crystals at extremely reasonable and nominal charges.

This month's special offer. 7290 Kc  $\frac{1}{2}$  in. 10x type standard British holders, G.E.C., Standard, etc. at 7/6 each.

**CONNOISSEUR LIGHT WEIGHT PICK-UP.** Connoisseur standard light weight pick-up complete with input transformer, brand new and boxed. List price £4/10/5 inc. tax. To clear £1/6/10 each. Available in quantity for export.

**U.S. SIGNAL CORPS.** Light weight speed Keys. J.38 with cranked arm. 3/9. Ditto with short circuiting lever 5/-. U.S. Signals J5a Flame proof 3/-. R.A.F. Mk2 Nr2 2/-.

**ATKINS 465 Kc I.F. TRANSFORMERS.** Dust core tuned 4/6 each. Ditto Wearite 552 type, 465 Kc 6/- each. Weymouth P2 miniature I.F. 465 Kc 4/- each. Wearite coils P type. The following only now available at 2/- each, PA, 4, 5, 6, and 7. PHF4, 5, 6, and 7. PO4, 5 and 6. AF, RF, BFO. Weymouth Coils. The following at 2/6 each, DA1, DA3, DA6, KA1, KH1, KO1, DH6, DO1, DO3, DO6, HO1, HO4, KO2, KA2, HA4, MSC3, Q1 IF filter, CS3 W3 Three wave super het, per pair with circuit 4/-. Weymouth and Wearite coil packs are also available, details on receipt of enquiry.

**U.S.A. GROVES, UEI.** Vitreous. 25 ohm 5 watt, 175 ohm, 200 ohm and 3k, 7 watt, 175 ohm 10 watt, 2k 20 watt, 5k, 8k, 10k, 15k, 25 watt all at 1/6 each. Groves. 11  $\frac{1}{2}$  in. vitreous 25k and 50k 80 watt, at 3/- each. R.C.A. 8k and 16k 120 watt at 3/- each. U.S.A. screw in type element for 4336 Tx 5/6 each.

**7B TX.** G.E.C. INPUT 230V 50cy. Crystal Osc. and Doubler, Det 19, Push Push Doubler Det 19, Push Push Doubler Det 19, Power Amp. Det 19, KT66 Modulator. Standard rack and panel complete with power supply. 2 U52 Rectifiers. All stages tuned Grid and anode. Link coupled throughout. Completely enclosed, weight approx. 80lb. Relay for push to talk. Provision for remote HT switch. Frequency coverage approx. 100 to 120 Mc. Easily adapted for 144. Oscillator will function on 8 mc xtals. All stages are meter jacked. Filament and HT pilot lights. Microphone jack. This is a complete Tx with all valves, and beautifully built. Input about 50 watts. Tune/Operate switch for tuning up on low power. This is a really exceptional bargain at £8 Carr. Paid. 30/- extra Ireland.

**POWER SUPPLY UNIT TYPE 45.** 1200 volts D.C. at 200 Mills input 230v 50cy. in ventilated steel case. Metal rectification, fully smoothed and bleedered. This is the HT Unit for the 1154 TX. £7/10/0 carriage paid. Weight 60lbs.

**POWER UNIT TYPE 46.** The low tension unit for the 1154 TX. Ventilated steel case, metal rectification throughout, input 230v 50cy. output 6.3v at 12 amp. Price £3/15/0 carriage paid. The pair of the above units £10/10/0 carr. paid.

**SMOOTHING CHOKES.** Parmeko. 15 hy 400 mills. 30/- Carr. paid.

**SPEAKERS.** P. Mag. 8in. at 20/-, 6 $\frac{1}{2}$  in. at 18/6.

**THIS MONTH'S BARGAIN.** R.C.A. 4C 27 VALVE. BRAND NEW AND BOXED. Rarely seen in this country. 6.3v 150 watt anode dissipation. Full rating at 750 Meg. Anode radial fin cooled. Surplus price of this valve in the States 58 dollars 75c. Our price 75/-.

**VALVES.** RG3 1250 note the price £3. 836 vac equivalent to the 866 20/-, 813 £4/10/0, 805 27/6, 826 UHF Triode 7.5v heater 4 amp., 1250v plate, 125 Mills, maximum frequency full rating 250 mc. 30/-, Taylor T200 £6. 450TH £6. VU111 HV rectifier 4v heater 4.5 Kv. at 50 Mills, 4/-, Cossar VS110 voltage stabilizer 6/6. 6SG7 met. 6SA7, 6L7, 6K7G. 5Z4, 80, all at 8/-, 6H6, 3/6. 12SR7, 12SF7 6/-.

**HAMMERLUND.** Variable 00047, solid brass construction with quartz insulation. Rotor on dual ball bearings,  $\frac{1}{2}$  in. spindle extended for front or back mounting. Brand new, 7/6 each. A.R. Car Battery Chargers 230/50cy. 6 or 12v output at lamp. Metal rectification 39/6, carriage paid.

**STATION LOG BOOKS.** A quality production, 300 pages cream laid paper, section sewn, opens completely flat like a ledger. Stout heavy cover, 18/- post free. Sample leaves on request.

**POWER SUPPLY UNIT. TYPE 247.** Input 230v 50cy, output 550v at 300 mills, plus 6.3v at 3 amp. In grey steel cases 11in. x 10in. x 9in., with pilot light. 5U4 rectifier required. £3/19/6. Carr. paid.

**1154TXZ.** Brand new and boxed, complete with all valves in original transit cases. Carriage paid £5.

**when ship speaks to ship**



A COMPREHENSIVE RANGE OF UNITS IS AVAILABLE COVERING ALL COMMUNICATION REQUIREMENTS. WRITE FOR LEAFLET Q.C. 5012

**SALFORD ELECTRICAL INSTRUMENTS LTD · SALFORD 3 · LANCs**  
 A SUBSIDIARY OF THE GENERAL ELECTRIC CO LTD OF ENGLAND

# An introduction to Magnetic Recording by M · O · S

Our new series of announcements in this magazine will bring to your notice the latest in magnetic recording components and kits in which we specialise. In addition we will present our range of high fidelity audio equipment into which field this journal is entering. All our equipment is available on unrivalled H.P. facilities. Send S.A.E. for Lists.

## B·S·R INDUCTION MOTORS for MAGNETIC RECORDING

FOUR POLE MOTOR · MODEL FP.10  
 Precision Engineered

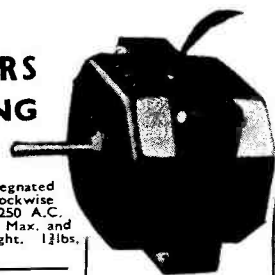

Fully protected. Negligible external magnetic field. Oil impregnated self aligning bearings. Silent running. Speed constancy. Both clockwise or anti clockwise rotation available. Voltage 100/125-200/250 A.C. Consumption at 230v. 14 watts. Speed (light) 1,400 R.M.P. Max. and Starting Torque 3inch ozs. Shaft dia. .1875 inches. Weight. 12lbs. Size 3 x 2 1/2 x 2 1/2 ins. External shaft length. 1 inch.

Price 38/-

### OTHER B.S.R. GRAMOPHONE AND RECORDING MOTORS

SR1	High Torque Motor, two pole	£1 12 0
SR2	Low Torque Motor, two pole	£1 5 0
TP1	Two Pole Motor	£1 2 0

All from Stock

### The COLLARO 4-Pole Recording Motor

Supplied with cooling fan. Speed 1400 RPM, Torque 4ins./03, 42/-  
 Clockwise or anti clockwise rotation available.

Matched Pair 84/- (Clock and anti-clock) or 24/- deposit and 12 monthly payments of 8/4.  
 1 Pair MATCHED COLLARO MOTORS WITH 1 BSR FP10 MOTOR £6 2s. 0d. CASH OR 42/- DEPOSIT AND 12 MONTHLY PAYMENTS OF 10/-.



### BURGUYNE Magnetic Recording Heads

Distributed exclusively by M.O.S. For Superior Performance at Lower Costs.—Record/Playback and Erase Heads giving first class frequency response. High Impedance Positive fixing Method. Half Track width. Totally enclosed with Tape Guide wide frequency Range.

39/6 each. Record/Playback or Erase, or Set of 2 for 23/- deposit and 12 monthly payments of 8/-, or Set of 3 for 38/6 deposit and 12 monthly payments of 10/-.

### QUALITY HEADPHONES FOR THE AMATEUR AND MAGNETIC RECORDING ENTHUSIAST

S. G. BROWN	Cash	12 Monthly Deposit Payments of
Type A. Adjustable reed movement.	77/6	17/6 8/4
Type F. Featherweight General purpose	35/-	—
Type K. Moving coil for high fidelity	£5/5-	25/- 10/-

**MAGNETIC RECORDING** by S. S. Begun. a comprehensive book on all you need to know about magnetic recording. 25/- Post/Packing 1/6.

**ANNOUNCEMENT** We have been appointed sole distributors for the London area and leading agents for **HARTLEY-TURNER** High fidelity equipment

**M·O·S** MAIL ORDER SUPPLY COMPANY, Dept. SWM The RADIO CENTRE, 33 Tottenham Court Rd., London, W.1 COME TO THE RADIO CENTRE THE HEAD-QUARTERS FOR MAGNETIC RECORDING

# RADIO CLEARANCE LTD.

27, TOTTENHAM COURT ROAD, W.1

MUS 9188

## SPECIAL LINE TELEVISION COMPONENTS

Comprising, Line Transformer with E.H.T. winding (gives 7KV using E.Y.51), Scanning Coils (low imp line and frame), and Focus Coil (res 10,000 $\Omega$ , current approx. 20 mA). Special offer at 42/- the set. Post 1/6, while they last.

## MEDIUM-WAVE PERSONAL RECEIVERS

3-valve medium-wave dry battery operated receiver, housed in smart bakelite box, size 7" x 6 $\frac{1}{2}$ " x 5", with plastic carrying handle. T.R.F. circuit, using 3-1.T.4 valves, with reaction. Output to pair of lightweight H.R. phones, self-contained. Frame aerial in lid, provision for external aerial, S.M. dial. Powered by self-contained dry batteries, 1-W1435 and 2-U2's. Supplied brand new, with valves and batteries. Open the lid and it plays. Covers whole M.W. band. Purchase Tax paid £4/4/0. Not ex-Govt. surplus. Postage paid.

## MOVING COIL METERS

2 in. Square bakelite cased 0/5mA, 6/6; 0-50mA, 7/6; 0-300v, D.C. with series res., 8/-

## ELECTROLYTIC CONDENSERS

500 + 500 MF 6v 1" x 2" Lug 2/6. 250 - 250 MF 6v 1" x 2" Lug 2/6. 700 + 700 MF 6v 1" x 3" Lug 2/9. 1500 MF 6v 1" x 2 $\frac{1}{2}$ " Clip 2/11. 30 + 50 MF 150v 1 $\frac{1}{2}$ " x 2" Clip 3/6. 40 + 40 MF 150v 1 $\frac{1}{2}$ " x 2" Clip 3/6. 400 MF 6v 1" x 2" Lug 2/3. 16 + 32 MF 275v 1" x 2" Lug 4/3. 20 + 20 MF 275v 1" x 2" Lug 4/3. 100 + 200 MF 275v 1 $\frac{1}{2}$ " x 4 $\frac{1}{2}$ " Clip 5/6. 64 + 120 MF 275v 1 $\frac{1}{2}$ " x 4 $\frac{1}{2}$ " Clip 5/6. 32 + 12 MF 350v 1 $\frac{1}{2}$ " x 2" Clip 5/6. 50 MF 350v 1 $\frac{1}{2}$ " x 2" Clip 3/6. 32 MF 450v 1 $\frac{1}{2}$ " x 2" Clip 4/6. 16 + 8 MF 450v 1 $\frac{1}{2}$ " x 2" Clip 5/6. 16 + 16 MF 450v 1" x 3" Lug 5/6. 16 MF 450v 1" x 2" Clip 3/3. 10 MF 450v 1" x 2" Lug 2/9. 20 MF 450v 1" x 2" Lug 3/3. 20 + 30 MF 150v 1" x 2" Clip 3/6. 40 MF 150v 1" x 2" Clip 2/9. 12 MF 50v 1" x 1 $\frac{1}{2}$ " Wire End 1/6. All conds. are ali can, some have cardboard sleeve, all voltages working, all prices post paid, all guaranteed fresh stock.

## ROTARY POWER UNITS

Type 104. 12v D.C. input, outputs 250v 65mA, 2.5A, D.C. P.M. rotary on chassis with cover, size 8 $\frac{1}{2}$ " x 4 $\frac{1}{2}$ " x 6 $\frac{1}{2}$ ", 7/-, post paid. Type 87, input 24v, output as Type 104, 6/6 post paid.

## P.M. LOUDSPEAKERS

6 $\frac{1}{2}$ in. P.M. New and Boxed, 12/6 post paid. 10in. P.M. with Trans. 4500  $\Omega$ , 33/6 P.P.

## SMOOTHING CHOKES

5H. 200mA, 100  $\Omega$  5/6 8H. 250mA, 50  $\Omega$  Potted 10/-

## MANSBRIDGE CONDENSERS

4mf. 1000v. wkg., 3/6 each, 6/- pair, post paid.

The efficiency of your  
equipment depends on  
the solder that you use

Just a single faulty connection may interfere seriously with reception or transmission. Make sure that every joint is sound by using Ersin Multicore—the 3-core solder that ensures complete freedom from "dry" or H.R. joints.



This is the Handyman (Size 2) Carton, specially made for use in the home. Contains enough solder for 200 average joints. Price 6d.



Illustrated above is the Size 1 carton for Service Engineers and maintenance use. Price 5/-. Both sizes are obtainable at most radio and electrical shops.

MULTICORE SOLDERS LTD., MULTICORE WORKS, MAYLANDS AVENUE,  
HEMEL HEMPSTEAD, HERTS. Telephone: BOXMOOR 3636 (3 lines)

## TRANSFORMERS

All 230 volt primaries 6.3 volts 4 amps 7.5 volts 3 amps (twice) ... ..	15/- each carr.	5/-
" " " " 350-0-350. 200 M/A ... ..	15/-	" " 5/-
" " " " 4VCT + 4VCT for GU50, RG1-240A rectifier. 5000 volt insulation ...	12/6	" " 5/-
" " " " 500-0-500 170 M/A (Admiralty rating) + 4v 4 amps, shielded primary	25/-	" " 5/-
" " " " as above, with damaged end terminals ... ..	17/6	" " 5/-
Driver P.P. 6L6 to TZ40 grids ... ..	10/-	" " 1/6
Intervalve shielded PP6C5 to 6L6 grid ... ..	7/6	" " 1/6
Single 6C5 to P.P. class A 6C5 ... ..	7/6	" " 1/6
Microphone 100/I shielded GPO type ... ..	4/6	" " 1/6
Chokes LF. Type N approx. 1H 2 amps suitable for fil. smoothing ... ..	7/6	" " 1/6
Chokes double wound RAF type, make good 1/I mains transformer for isolation purposes	8/6	" " 1/6
Modulation trans. ex T1131, PP class B TZ40 to RF load ... ..	25/6	" " 5/-

**SPECIAL Power Transformers 230v. Primary 500-0-500 @ 170 M/A and 5v. 4A., 6.3v. 4A. secs. £2 carr. paid.**

## SUNDRIES

Cabinets by RCA. Black crackle 35in. high, complete with sides and back, take standard 19in. panels, louvred ventilation sides and top. Grand for your new TV proof TX £3 ea. carr. 15/-. Steel tool chests 36in. x 12in. x 8in. grey finish 25/- ea. carr. 10/-. Mains Suppressors. 230 volt working, in screened case 5 amp 7/6 ea. carr. 1/6. Mains Suppressors, 230 volt working, in screened case 10 amp 12/6 ea. carr. 1/6. Muirhead S.M. Dials, similar to Eddystone brass dial 5/- ea. carr. 1/6. Metal Rectifiers, 240 volt 3 amp. ex. T1131 for relay circuits 17/6 ea. carr. 1/6. Transformers to suit above, 230 volt in 30/24 volts output 12/6 ea. carr. 1/6. Pye Plugs 6/- per doz. Fuse Wire 33 gauge 2 oz. reels 2/6 per reel. Fuse Wire 24 gauge 2 oz. reels 2/6 per reel. Fuse holders 5 amp 2 way Porcelain 2/6 ea. Telephone cords 1/- ea. Telephone jumpers with 2 P/O plugs 2/- ea. Indicators Type 6 with VCR97 Cathode Ray tube 67/6 ea. carr. 7/6. Switches 15 amp. DP. Panel mounting 2/6 ea. carr. 1/-. U.X. bases for 866 2/6 ea. carr. 1/-. U.X. bases Jumbo for 805 etc. 3/6 ea. carr. 1/6. Panel lights ex. T1131 1/6 ea. carr. 6d. Tuning Units. TU7 and TU10 15/- ea. carr. 5/-. Contactors, 24 volt coil Make/break 230 volt 5 amp, for H.T. switching in your relay circuit 7/6 ea. carr. 1/6. Headphones LR with cords, new and boxed 5/6 p. pair carr. 1/6.

## PANDA RADIO CO.

58 School Lane, Rochdale, Lancs. :: Telephone 47861

**HIGH RESISTANCE HEADPHONES** :- Ericsson's first grade, 4,000 ohms per pair, Brand New, boxed. **ONLY 17/6.**

**LOW RESISTANCE HEADPHONES 5/11.**

**THE NEW 1355 CONVERSION**, Data for all five T.V. Channels 3/-

**RECEIVER P40** Tunes 85—95 mc/s; crystal controlled oscillator, with subsequent frequency multiplication ensures stability. With 4 EF54's (RF, mixer and multipliers) 1 EC52 (LO.), 2 EF39's (2.9 mc/s IF's) EB34 (det) and 6J5 and 6V6 (audio), these may be easily converted for "2" or the new BBC UHF transmissions from Wrotham. **BRAND NEW** with circuit 69/6, post 1/8 (circuit only 1/3). **MODULATION TRANSFORMERS** to match class B 211's to a class C 221 final, these may be used as 2 : 1 mains auto-transformers handling some 75 watts. **ONLY 6/6.** (1/- post). Input transformers, to drive class B 221's 4/6. (1/- post).

**POWER UNIT S41B** 300v at 200mA D.C., 12v 3A AC and 5v DC provided from 200/250v 50cps input. These, in attractive grey crackle finish cases, use separate HT and LT transformers, with individual switching and indicator lights, the HT being also relay controlled if desired. **IN SEALED MAKER'S CARTONS. 65/-** (5/- carr.).

**HAND MICROPHONES**, in flat cases, with switch and carbon insert, 4/6 (9d. post).

**TRANSMITTER 2I** Covering 4.2—7.5 mc/s, and 18-31 mc/s, sending speech, CW or MCW, and complete with valves, key, control box and circuit, the PA coils (not formers) and relays have been stripped by the MOS, but may easily be replaced by following our data. Complete with front panel for mounting receiver and vibrator pack. **25/-**.

**VIBRATOR PACK 2I** Delivers approx 140v at 40mA from 6v input. **ONLY 17/6.**

**POWER PACK**, Complete with one 5Z4, one SU2150A (2v indirectly heated filament) 5KV rectifier, three condensers, two high cycle transformers, choke, relay, etc. measures 7 x 6½ x 3½ ins. **OUR PRICE 16/6** in new condition. Our 50 cps EHT and HT conversion data, to supply approx. 1,800v EHT or approx. 450v at 50 mA, 2/3.

**CARBON MICROPHONES**, in black hemispherical cases with switch, **NEW** and boxed, 5/5.

**NON-SPILLABLE ACCUMULATORS** Multi-plate, in celluloid cases (approx 4 x 3 x 1½ ins.). 2v, 7AH. **OUR PRICE 5/11.** (6d. post).

**MIDGET AMPLIFIERS** : with 2 x 12 SH7's and 1 x 12SJ7. measures only 5 x 3 x 3½ ins. **15/-**.

**MALLORY VIBRATORS** (4 pin), 6v. or 12v. 5/- (9d. post.).

**H.T. BATTERIES** recent manufacture : 60v 4/9, two for 8/11. (post 1/8).

**RADIO EXCHANGE CO.** 9 CAULDWELL ST., BEDFORD  
Phone 5568

# RELIABILITY

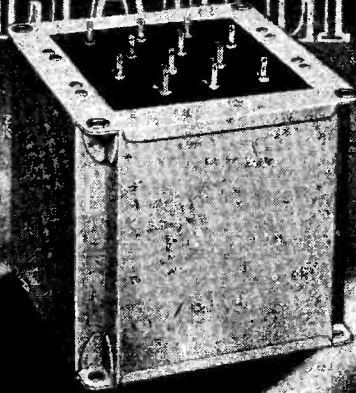

## TRANSFORMERS FOR RADIO · TELEVISION AND ELECTRONICS

The Reliability factor is one of the outstanding reasons for the continued demand by discerning Manufacturers for WODEN transformers. Quality is paramount and every precaution is taken to ensure that the reputation, which has been established over many years, is safeguarded. For example, apart from the usual rigid inspection, every transformer leaving our Works is fully impregnated by the latest vacuum and pressure process.

The need for competitive prices has not been overlooked. Our long experience and modern facilities enable us to keep production costs down to the lowest possible level. If, then, your requirements are for transformers with assured reliability at reasonable cost, we are at your service.

Our comprehensive catalogue is available on request.

**WODEN TRANSFORMER CO. LTD.**  
MOXLEY ROAD BILSTON · STAFFS · PHONE: BIL. 41959

G2AK

### This Month's Bargains

G2AK

**COMPLETE NOISE LIMITERS:** Wired on a small sub-chassis with 6H6 type valve, boxed, with circuit and instructions. Only 5/- post free.

**SPECIAL VALVE OFFER:** To transmitting hams only. Not more than 2 of any type to any one person. 813-70/-, 829-80/-, 832-30/-, 866a-17/6, 807-10/-.

**HEAVY DUTY CHOKES, Fully Potted:** 30 H. 100 mA. 150 ohms (weight 14lb.) Price 13/6. 20 H. 126 mA. 100 ohms. (weight 14 lb.), Price 15/6. 30 H. 150 mA. 150 ohms (weight 18lb.) Price 17/6. All carriage paid. Eire 5/- extra.

**20 H.** 120 mA. unshrouded chokes, new goods. Price 15/9. Packing and postage, 1/6.

**HEAVY DUTY POTS:** 500 ohms only. Toroidal type by P. X. Fox, worth 15/- . Our Price 3/6 each.

**MORSE PRACTICE SETS,** with double-action buzzer, output for phones, excellent key, Requires only 4½ V. battery. As new. 7/6, postage & packing 1/-.

**TWIN FEEDER:** 300 ohm Heavy Twin Ribbon Feeder 5d. per yard. Standard K25 300 ohm. Twin Ribbon Feeder 9d. per yard. K24, 150 ohm 9d. per yard. Co-ax. Cable ½ in. dia. 70 ohm 8d. per yard; ¼ in. dia. 1/3 per yard. Post on above feeder and cable 1/6, any length.

Carriage paid on all orders over £1 except where stated. Please include small amount for orders under £1. Please Print Your Name & Address

**HEADPHONES.** DLR.2., B.A. type L.R. 9/6 per pair, postage and packing 1/-.

**TANNOY POWER MIKES:** Few only, 7/6 each. Post 1/-.

**AMERICAN** Single Button Carbon Breast Mikes with aluminium diaphragm. Beautiful job. Only 5/- each. Packing and postage, 1/-.

**R.F. CHOKES:** Pie wound, 2.5 mH., 100 mA., receiver type, 9d. each, or 7/6 per doz.; 250 mA., transmitter type, 1/- each, 10/- per doz.

**PARMEKO H.D. SHROUDED CHOKES.** 8H or 250mA., weight 11lb. Beautiful job. Only 16/6 each, postage and packing 1/6.

**METERS:** 2½ in. Flush Mounting M.C. 100 mA., 12/6 each. 2in. Flush M.C. 500 µA., 10/-; 5 mA., 7/6; and 0.5 A. Thermo, 5/- . Special offer 2½ in. Flush 0-1 mA. Rectifier Meter, scaled 0-10 V., 22/6 each. Few only.

**TEST PRODS** for Test Meters, Red and Black, 4/6 Pair.

**CRYSTAL DIODES,** 3/9 each. **GERMANIUM DIODES,** 5/6 each.

**EDDYSTONE 704 & 750** Receivers & components from stock.

**CHAS. H. YOUNG, G2AK**

ALL CALLERS TO

110 Dale End, Birmingham · Central 1635

MAIL ORDERS TO 102 Holloway Head, Birmingham Midland 3254



## R.C.A. TRANSMITTER ET4336.

### UNUSED AND RECONDITIONED

THIS MAGNIFICENT TRANSMITTER IS COMPLETE IN ONE TOTALLY ENCLOSED RACK AND INCLUDES AERIAL TUNING PANEL.

**TUBE LINE UP :** 807 C.O./Buffer. Two 813 P.A. Two 805 P.P. Class B Modulator. Four 866A Rectifiers. **CONTROLS :** Manual or Remote. **POWER OUTPUT :** Normal 350 watts. **FREQUENCY COVERAGE :** Normal 2 to 20 mcs continuous. **FREQUENCY CONTROL** THE TRANSMITTER HAS A DETACHABLE FRONT PANEL FOR INSERTION OF WILCOX GAY V.F.O. OR CRYSTAL MULTIPLIER.

20 page manual and circuit diagram with each equipment. Every Instrument is Air Tested and Guaranteed perfect.

**WILCOX GAY** Crystal Multiplier for use with above transmitter.

**WILCOX GAY VFO** for use with above transmitter. **SPEECH AMPLIFIER** British made with 500 ohm output, suitable for use with EF4336B.

**R.C.A. ET4336 SPARES.** Very large stocks of essential maintenance spares available.

## McELROY - ADAMS Manufacturing Group Ltd.

(Sole concessionaries U.K. for Hallicrafter Communication Equipment)

Phone Fulham 1138/9. 46 GREYHOUND ROAD, LONDON, W.6. Cables Hallicrafter London.

## THE RADIO & ELECTRICAL MART OF 253-B PORTOBELLO ROAD · LONDON · W.11

Phone: Park 6026

**Valves.** 1S5, 1R5, 12/6; 1T4, 1S4, 3S4, 3V4, 10/6; 6AG5, 10/6; 117Z6, 12/6; 6SH7, 6/6; EF50, 8/6; 9003, 6/6; 9001, 9002, 7/6; 955, 954, 6/-; 6G215, 6/6; Pen 220A, 6/6; 6V6GT, 11/6; TT11, 8/6; 6Q7G.T., 10/6; 6SN7G.T., 12/6; 5Y3GT, 10/6; Y63, 10/6; MU14, 10/6; VR150, 10/6; SZ4, 10/6; VP4B, 11/6; 42, 10/6; 25L6GT's, 35L6GT's, 11/-; 6K8GT's, 14/6.

**Selenium Rectifiers.** 120mA, 9/-, F.W. 6-12 3A, 14/6, 4A, 26/-, 12v ½ amp., 5/6. Post paid.

**New and Boxed P.M. Speakers.** Rola 8ins. 21/6.

**New Type 1N34 Germanium Crystal Diodes** with wire ends, 5/6, P.P.

**Mains Transformers.** Input, 200/240v. output 6.3v. 1.5A, 8/-, 350-0-350v. or 250-0-250v. 80mA, 4v. and 6.3v. 4A and 4v. and 5v. 2A, 21/6. Trans.: 200/240v. output 3, 4, 5, 6, 8, 9, 10, 12, 15, 18, 20, 24, 30 volts at 2 amps, 21/3. One Year's Guarantee. Post paid

**RF24 Units.** Converted to 28 mcs band variable tuned with 100-1 geared SM. dial. Complete with plug and leads for immediate use. £3. Post paid.

**Deaf Aid Miniature Valves.** DL72 and CK512AX. New, 9/-, P.P.

**Army Morse Key and Buzzer Practice Set.** 6/6 New and Boxed.

**0-500 Microammeters** 2in. 14/6, P.P.

**Type 18.** 2 volt Transmitter/Receivers 6 — 9 mcs. New Condition £16/10/-, Carriage Paid.

**2 volt Battery Receivers** 190/200 Mcs. Complete with 2 valves. Unused 14/-.

**M/C Microphone with Switch,** 6/6, P.P. Transformer to match, 5/-, P.P.

**New odd Freq. Crystals** between 6 to 8 mcs 5/6 each P.P. Amateur band 12/6.

**Army Morse Keys,** 2/-, P.P.

**200/240 volt A.C. Alarm Bells,** 3/6, P.P.

**10H-120MA. Brass Shrouded Chokes,** 7/6, P.P.

**6 volt Vibrator Units.** Complete in black steel case 7½ x 5½ x 3½ins. Output 200 volts, 40 mA., 22/6, P.P.

**D.P.D.T. Relays.** Operate at 200/300 volts D.C., 6mA., 13/-, P.P. D.P. Change over make and break, 8/6. We can supply any combination and voltage at varying prices.

**Type 22.** (Similar to 19 sets) 12 volt Transmitter/Receivers 2 to 8 mcs. 12/14 watts output. New condition, complete £22. Carriage Paid.

Please add postage when writing.

# CLYDESDALE

Bargains in Ex-Services Radio and Electronic Equipment

## ELECTRONIC IGNITION TESTER

Type V.E.D. Patt 563562 made by English Electric. In Original Maker's Case.

A Cathode Ray tester employing an entirely new technique in ignition testing of internal combustion engines. Enables the electrical performance of the entire ignition system to be observed on the screen of the Cathode Ray Tube, while the engine is running. Will operate from 6, 12, and 24 volts D.C. or 230v. A.C. Built into a black crackle case, with hinged front and carrying handle, mid. 15½ x 8½ x 11½ ins. CLYDESDALE'S PRICE ONLY

£35

CARRIAGE PAID

## BATTERY CHARGER

Rectifier Type 42A. Ref. 10DB/1630.

A compact battery charger, Output 4 amps at 6 or 12 volts D.C. Input 230v. AC. 30c/s with amp-meter, removable fuses, control switch for each circuit, input and output points, contained in well ventilated black crackle metal case for wall or bench mts. CLYDESDALE'S PRICE ONLY

£5 19 6

CARRIAGE PAID

## POWER SUPPLY UNIT NO. 7. Ref. ZA17571.

For charging 6 volt Accumulators by hand. Designed for the W.S.21, could be used for many other purposes. Consists of a stout metal case, diam. 17 x 10½ x 7½ ins., with detachable lid, containing hand driven generator, with gearing mechanism, hand driven generator, with gearing mechanism which delivers 6 volts D.C. at 4 amps., also 6 volt cut-out and battery clamp.

CLYDESDALE'S PRICE ONLY

£2 5 0

CARRIAGE PAID

## METAL (MINE) DETECTOR NO. 4.

Of Cdn. design and construction, using 1T4 pentodes. Comprising —TC Amplifier, Search Coil, Sweep Pole, Control Box, Headphones, Test Unit and Rucksack. Complete less batteries in fitted transit case. CLYDESDALE'S PRICE ONLY

£6 19 6

CARRIAGE PAID

## CRYSTAL OVEN. (Few only).

Brand new, extremely sensitive with adjustable thermostatic control and thermometer. Built into a cork lined metal box 12 x 6½ x 6½ ins. Weight 5½ lbs. CLYDESDALE'S PRICE ONLY

£4 19 6

POST PAID

## MOVING COIL METERS

Ammeters. E784 Range of 1 Amp. 2½ in. round flush mtg., drilled flange. Price 12/6 ea. Post Paid. E785 Range of 10 Amps 2½ ins. Round flush mtg., plug-in. Price 12/6 each Post Paid.

## D.C. VOLT METERS.

E729 Range of 750 volts, 200 ohms. per volt. 25/-  
E730 Range of 1500 volts, 250 ohms. per volt. 26/-  
E731 Range of 3000 volts, 200 ohms. per volt. 27/6  
All 2½ ins. round flush mtg. drilled flange. Post paid

NEW LIST OF EX SERVICE and other Items No. 8. Price 1/6. Price credited on purchase of 10/- value or over.

## No. 9 SET MK. I. RECEIVER UNIT, with Power Supply Unit.

A Ten valve 7AP3, 2125C7, 12Y4, Band-Pass, superhet Receiver frequency range, 2 to 5 mcs.; with built in calibrator, switched HT and 5 meter, HF and LF gain, B.F.O. etc. etc. Separate Power Unit, operates from 12v. D.C. or 115v or 230v A.C. OZ4 cold cathode rectifier, with spare kit, all valves, Aerial, Insulators, Headphones. CLYDESDALE'S PRICE ONLY

£10

CARRIAGE PAID

Order Direct from :—

Phone : SOUTH 2706/9

**CLYDESDALE SUPPLY 2 BRIDGE ST. Co. Ltd. GLASGOW G5**

BRANCHES IN SCOTLAND, ENGLAND AND NORTHERN IRELAND

## Benson's Better Bargains

**VALVES**: IS4, IS5, IT4, IR5 at 9/-; 2X2, VR65, VR66, 7V7, 900A, 900B; VR21, CV6, VU120, CV54, 6H6, at 3/6; 6AG5, 6B8M, 6C4, 617M, 6J5M, (GT), 6N7M, 12S17, 6X5, 12SR7, 12A6, EFP4, EC52, EBC33, EL32, CV66, AC6/Pen, SG215, Pen 46, 1625, ATP4, 9002, 6K7, SP4, KT2, 3Q5, 6L7M, 12SC7, EK32, PM256, 7MA, 721A, VSI10A, NGT1 at 7/6; Pen 25, 524M, 6L6G, 210VPT, 1C5 at 8/6; 5U4G, KT66 at 10/-; 6AC7, 12SK7, 954, 955, 956B, 9D2, EF39, EF50, ARP12, AR8, 9003, 65H7, 9001, ML6, 77, 78, RK34, NT37, V570 at 5/6; EA50, 7193, 12H6, EB34 at 2/6; Over 2000 BVA type valves at below list prices. (Enquiries, S.A.E. Please). B.V.A. types at 10/-; EL41, UF141, UCH42, UY41; ECL80, EZ40, EF41, PM240, 6SN7, 6AG6, EBC41, UAF42, UBC41, 35L6GT, 6F6G, ECH35, NEONS, SBC/DCT. 80/100v. 2/-; MOBILE RXS (ex Police) Xtal controlled, 95mcs. Grey met. case approx 11 x 8 x 6 ins. Valves: Det 19, 954/3, D63/2, KT63, at 52/6; TXS similar to RXs. Valves: RK34/4, 6L6G, 52/6. Both above less xtal and power supplies. Good used condition. **VAR CONDENSERS**: Twin .0005 5/-; with drive 6/-; Single .0005 3/6; 4 gang .0005 8/6; 3 gang 25pf 3/6; 2 gang 75 pf 4/-; single 2/-; single 50pf. 1/6; 150pf TX type D, spaced 3/6. Single 25pf 1/3; CRT's 3BP1 with base 25/-; VCR97, crated 37/6.

**MAINS TRANS.** New, std. inputs 50c. Outputs, 230v. (S.E.) 20ma., 6v. IA 16/-; 350v. 80ma., Univ. Lts 18/6; similar 250v. 18/6. Cellulose Cement 1/- bot. Condensers, block, 6Mf. 440VAC wkg. 5/-, 4mf. 750v 3/-. Sprague tub., 01 IKV 6d., Fuseholders, single 6d., twin 8d., Panel, single 1/-; Fuse clips 3d. pr., Fuses 1½in. cartridge 4½d. each. Terminals B/Lee, black, insulated 9d.; METERS: 500 ma RF 2in. 5/6; 40/120ma 2in. 6/6. Mine Detector Amp with 3 x IT4 etc. 28/6, chassis only 3/6. IFTS, canned, new 10/13mcs 2/-, 10mcs for G2IG WB Couplers, 2/9. Coilformers 2in. x ½in. 4 for 1/-. Morse keys, small, brass 2/6. Vibrapacks, Mallory 12v synch, 150v. 30ma 12/6; Vibrators

2v. synch. 7pin UX, 6/- Cable, 5 core rubber, 2yd. lengths 1/6. Spindle couplers, brass; concertina or insulated 9d. each; Eddystone type 1/3. Chokes, RF 4 pie Rx 9d., TX 1/-; LF 5H 150ma 120u 5/3, 10H 250ma 12/6. Muirhead Dials (black) 7/6. Ferranti 30w Mod. Trans. 2: 1 ratio 10/-, ET4336 Driver Trans. 1: 1, 8/6. Dynamotors 9v. to 450v. 9/-; 24v. to 250v/6v 6/6; 28v. to 285v. 7/6. CO-AX: Plugs/Skts. Pye 5/- doz., D.E. Skts. 1/-, Triple skts. 1/-, 3-way skt/plugs 1/-. Vitreous resistors: 20k, 120w. 350u, 20w. 20u, 35u, 65w, 75, 20w, 20k, 15w, 3k, 30w, 30k, 25w, 400u 25w, 65k 10w, 9k Tap 2k 25w, 21k Tap 3k 15w, 15k, 25w, 3k 12w, 30u 30w, each 1/-. **AERIAL c/o RELAYS** 12v. balanced, 4/6; Price Bros SP c/o, 28vdc 12/6. **HAND-DRIVEN GENERATORS.** outputs 28/300v 9/-, RXS R-3/ARR-2X. 234/258 mcs. Valves-3/6AK5, 79001, 1/12A6. New condition, each £4 less valves, 21/6. R78, less valves, xtal, tuning knob, 10/6.

**HANDSETS**, Self-energised, with bracket, 25/- pr. **LINECORD**, 3 way. 3A (60u p.f.) 1/- yd. **VALVE-HOLDERS**, English, pax asstd. doz. 5/- **INSULATORS**: Beehive 2½in. ceramic 9d. ribbed 3ins. glass, 1/6. Single standoff chassis, 4 for 6d. Glass lead-thru' chassis type, 6 for 1/-. Thru' chassis, double cone 4in. 1/-. Aerial, 4in. metal ends, 1/-. Aerial double "U" cer. 6d. Chassis thru' double ½in. cones, cer. 9d. Pillars, 2in. cer. 6d. Double-cones with skirt 6d. Aerial spreaders, cer. 9in. 9d., Aerial insulators, black torpedo, 3d., Cable 3 core, braided non-kink, 9d. yd. Perspex CRT windows 5½ins. x 5½ins. 1/-; Lampholders, panel, ruby (Bulgin) metal, 1/6; bakelite, 1/-. 3pin (sunken) mains Pl/skt 3/6, 2pin, chassis type, 1/3. R3132, soiled, 65/- **YAXLEYS.** 3P3W2B, 2P5V2B, 1P11W2B, each 2/9; 4P2W1B, 1/3; 3P4V1B (cer) 3/6. Headphone cords, with plug, 18ft. 2/6; Toggles, rotary SP 1/3. Alltan ½in. Formers 9d.

LISTS AVAILABLE 1½d. S.A.E.

Terms: C.W.O. CARR. PAID OVER 12/6. S.A.E. enquiries please

**W. A. BENSON, 308 Rathbone Rd., Liverpool, 13 STONEYCROFT 1604**



# Create your own Reference Library OF RADIO JOURNALS

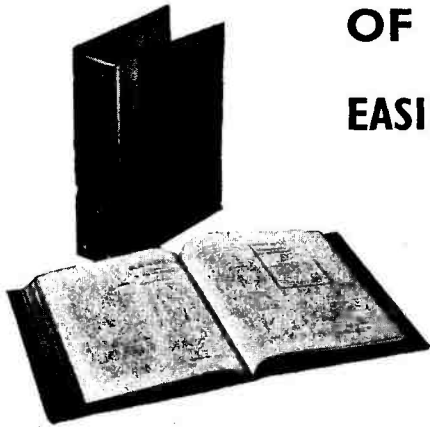

## EASIBINDERS for the . . .

### “SHORT WAVE MAGAZINE”

Bind your issues in the Easibinder. By a simple operation the journals are inserted with a steel wire, and at once become a neatly bound volume for the Bookshelf.

The Easibinder is bound in green cloth, and gold-blocked with title and year on the spine. It will hold 12 issues. (One volume).

Now available for Vol. 10 (new size) 13/- each (Post paid). Also available for all previous volumes at 11/9 each (Post paid).

Easibinders can also be supplied for all other Radio Journals, including, Wireless World. (for one Vol. at 13/-) Q.S.T. (for one Vol. at 13/-) R.S.G.B. Bulletin (for two Vols. at 13/-) Electronic Engineering. (for one Vol. at 13/-) Short Wave Listener. (for two Vols. at 11/9) Short Wave News. (for two Vols. at 11/9).

# EASIBIND Ltd. 84, NEWMAN STREET LONDON W.1.

## RADIO SUPPLY CO

15 WELLINGTON STREET, (City Square End) LEEDS, 1

Post Terms C.W.O. or C.O.D. No C.O.D. under £1. Postage 1/3 charged on orders under £3. Open to callers 9 a.m. to 5.30 p.m. Sats. until 1 p.m.

### R.S.C. MAINS TRANSFORMERS

Fully Guaranteed, Interleaved and Impregnated. Primaries 200-230-250v 50 c/s Screened.

Top Shrouded Drop Through		
260-0-260v	70ma., 6.3v 2a., 5v 2a	13/9
260-0-260v	80ma., 6.3v 2a., 5v 2a	14/11
350-0-350v	80ma., 6.3v 2a., 5v 2a	16/11
260-0-260v	90ma., 6.3v 3a., 5v 2a	19/9
350-0-350v	90ma., 6.3v 3a., 5v 2a	19/9
250-0-250v	100ma., 6.3v 4a., 5v 3a	21/9
350-0-350v	100ma., 6.3 v-4 v 4 a.	21/11
C.T. 0-4.5 v 3 a		
350-0-350v	120ma., 6.3v 4a., 5v 3a	25/9
350-0-350v	150ma., 6.3v 4a., 5v 3a	27/11
Clamped Upright Mounting		
250-0-250v	80ma., 6.3v 3a., 5v 2a	18/9
250-0-250v	100ma., 6.3v 6a., 5v 3a., for 1355 conversion	25/9
350-0-350v	100ma., 6.3 v 3a., 5v 3a	21/6
350-0-350v	150ma., 6.3v 4a., 5v 3a	27/9
Fully Shrouded Upright		
250-0-250v	60ma., 6.3v 2a., 5v 2a.	16/9
Midget type 2½-3-3in.		
350-0-350v	70ma., 6.3v 2a., 5v 2a	18/9
250-0-250v	100ma., 6.3-4v 4a C.T.	24/9
0-4.5v 3a		
300-0-300v	100ma., 0-4-6.3v 3a., 0-4-5v 3a.	24/9
350-0-350v	100ma., 6.3 v-4 v 4a., C.T., 0-4-5v 3a.	24/9
350-0-350v	150ma., 6.3v 4a., 5v 3a	31/9
350-0-350v	250ma., 6.3v 6a., 4v 8a	31/9
0-2-6 v 2a., 4 v 3a., for Electronic Eng. Television		
425-0-425v	200ma., 6.3 v-4 v 4 a., C.T. 6.3 v-4 v 4a., C.T., 0-4-5 v 3 a., suitable Williamson Amplifier	49/9
325-0-325v	20ma., 6.3v 0.5a., 6.3 v. 15a., for Williamson Pre-amplifier	17/6

Filament Transformers	
All with 200-250v 50 c/s primaries;	
6.3v 2a., 7/6; 0-4-6.3v 2a., 7/9; 12v 1a., 7/11; 6.3v 3a., 10/11; 6.3v 6a., 16/9	
0-2-4-5-6.3v 4a., 16/9; 12v 3a., or 24v 1.5a.	16/9
Charger Transformers.	
All with 200-230-250v 50 c/s Primaries	
0-9-15v 1.5a., 12/9; 0-9-15v 3a., 15/9	
0-9-15v 6a., 21/9; 0-4-9-15-24v 3a., 21/9	
0-9-15-30v 3a.	22/9
Smoothing Chokes	
200ma. 5 h. 100 ohms	7/6
100ma. 10 h. 100 ohms	7/6
90ma. 10 h. 100 ohms	5/9
80ma. 10 h. 350 ohms	5/6
Auto Transformers	
100 watts 110-200-230-250v	19/9
Eliminator Transformers	
Primaries 200-250v 50 c/s. 120 v 40 ma	7/11
120-0-120v 30ma., 4v ½a.	12/9
Output Transformers	
Midget Battery, Pentode 66: 1 for 3S4, etc.	3/6
Small Pentode, 5,000 ohms to 3 ohms	3/9
Standard Pentode 8,000 to 3 ohms	4/9
Multi ratio 40ma., 30: 1, 45: 1, 60: 1, 90: 1 Class B Push-Pull	5/3
Push-Pull 8 watts 6V6 to 3 ohms	8/9
Push-Pull 10-12 watts 6V6 to 3 or 15 ohms	15/11
Push-Pull 10-12 watt to match 6L6, PX4, 6V6, etc., to 3-5-8 or 15 ohms	16/11
Push-Pull 15-18 watts to match 6L6, etc., to 3 or 15 ohm Speaker	21/9

New Ex-Govt. Valves. DI 1/3; EA50, 954, VU120A, 2/9; 12H6 Met. 1/11; 9D2, 2/11; MS/PEN, 4/6; 12SG7 Met. 6/5GT, 12SH7 Met. 5/9; 6SG7 Met. 6SS7 Met. 6C5 Met. 12C8 Met. 12SK7 Met. 12SQ7 Met. 12SR7 Met. 6/9; 6K7G, 6J7G, KTZ63, EF39, 6K6GT. 8/9; 5U4G, 6X5GT, VP4B, PEN46, SP4B, MHL66, 9/6; 5Y3G, KT66, EB91, 10/6; 6Q7G, 10/11.
Valves. Ex New Equip. VT61A, 1/11; EB34, 2/11; VR126, SP41, 1/11, EF50, 6/6.
Special Offers. Mains Trans. 200-230v Primaries, 6.3 v 1.5 a. small 5/9
Auto 0-200-230-320 v 70ma, with separate 6.3 v 3 a L.T. 7/6
P.M. Speakers. All 2-3 ohms, Sin. F.W., 11/9; Sin. Rola with Trans., 15/9 6in. F.W., 14/11; Bin. Plessey, 14/11; Bin. Rola, 17/6.
M.E. Speakers R.A. (2-3 ohms) Field 600 ohms, 12/9. Plessey 10in. (Field 1,000 ohms) 21/9
Receiver Chassis. Undrilled, 16 s.w.g. aluminium 10-5½-2in., 3/6; 11-6-2½in. 3/11; 12-8-2½in., 4/11; 16-8-2½in., 6/9
Amplifier Chassis. Undrilled 16 s.w.g. aluminium, 12-8-2½in., 7/11; 16-8-2½in. 10/11; 20-8-2½in., 13/6.
Selenium Rectifiers. Ex New Equipment. 230 v 50 ma. (small), 4/9; 120-0-120 v 60 ma., 4/6; 250-500 v ma. 6/9; 600 v 30 ma., 6/9.
Misc. Items. Ex Govt. Chokes 50ma., 50 h 1000 ohms, 4/6; Philips Chokes 90ma., 8 h 100 ohms, 4/6; Pye Coax Plug and Sockets, 7/6 doz. prs.



**D77.** Double-diode.  
Vision detector and sync  
separator.

**KT61.** High sensitivity  
output tetrode. Frame T.B.  
output and sound output.

**DH63.** Double-diode-  
triode. Sound detector and  
A.F. amplifier.

# Osram VALVES

*are recommended for  
the 'VIEW MASTER' television receiver*

Only by using the valves specified can you be sure of the best results from your "View Master."

The designers have found that the valves illustrated are the best for the job.

Use Osram valves for their proved consistency of performance.

*Also specified: G.E.C. 9-inch cathode ray tube 6504A, or alternatively, the 12-inch tube 6705A may be used without circuit alteration.*

INDEX TO  
ADVERTISERS

	<i>Page</i>
Adcola	62
Alpha Radio Service	60
Altham Radio	59
Anglin, J. T.	63
Ashworth, H.	60
Bensons	6
Brookes Crystals, Ltd.	58
Brown, S. G.	58
Bull, J.	10
Candler System	61
Clydesdale Supply Co., Ltd.	6
Cook Furnishing	64
Easibind	7
Electrad Radio	62
Electradix Radios	59
E.M.I.	63
Field, N. H.	57
Gage & Pollard	<i>cover iii</i>
G.E.C.	8
Henry's	<i>cover iv</i>
Hoile, A. C.	62
H.P. Radio Services, Ltd.	61
Johnson's	63
Lyons Radio	59
McElroy Adams	5
Mail Order Supply Co.	1
Multicore	2
Panda Radio	3 & <i>cover iv</i>
P.C.A. Radio	57
Pullin (M.I.)	57
Read & Ford	64
Radio & Elect. Mart	5
Radio Clearance	2
Radio Exchange	3
Radio Servicing Co.	58
Radio Supply Co.	7
Rollett, H.	62
Salford	1
Sallis, A. T.	64
Samsons Surplus Stores	58
Small Advertisements	60-64
Smith, H. L.	57
Southern Radio	59
Southern Radio and Elec- trical Supply	63
Whitaker	<i>cover ii</i>
Woden	4
Young	4

# SHORT WAVE MAGAZINE

Vol. X

MARCH 1952

No. 104

## CONTENTS

	<i>Page</i>
<b>Editorial</b>	11
<b>A Magnetic Tape Recorder, Part I</b> , by E. P. Harris (G3GFN)	12
<b>Multi-Band Ground Plane System</b> , by P. Pennell (G2PL)	18
<b>Two-Metre Portable</b> , by J. H. Jowett (G3CFR)	21
<b>The R9'er Again</b> , by N. P. Spooner (G2NS)	25
<b>DX Commentary</b> , by L. H. Thomas, M.B.E. (G6QB)	28
<b>Audio Frequency Amplifiers, Part I</b> , by J. N. Walker (G5JU)	34
<b>Random Jottings</b> , by <i>The Old Timer</i>	39
<b>Constructing the Cascode</b> , by R. H. Webb (G6XY)	40
<b>Yagi Made Easy</b> , by J. H. Hum (G5UM)	44
<b>VHF Bands</b> , by E. J. Williams, B.Sc. (G2XC)	47
<b>New QTH's</b>	51
<b>The Other Man's Station</b> — G3HQU	52
<b>The Month with the Clubs</b> — <i>From Reports</i>	53

*Managing Editor* : AUSTIN FORSYTH, O.B.E. (G6FO)

*Advertisement Manager* : P. H. FALKNER

*Assistant Editor* : L. H. THOMAS, M.B.E. (G6QB)

*Published the Friday following the first Wednesday each month at 55 Victoria Street, London, S.W.1.*

*Telephone : Abbey 2384*

*Annual Subscription : Inland 30s. Abroad 30s. post paid.*

**Copyright Reserved throughout the World.**

### AUTHORS' MSS

*Articles submitted for Editorial consideration must be typed double-spaced with wide margins on one side only of quarto or foolscap sheets, with diagrams shown separately. Photographs should be clearly identified on the back. Payment is made for all material used, and it is a condition of acceptance that full copyright passes to the Short Wave Magazine Ltd. on publication.*

THE SHORT WAVE LISTENER ASSOCIATED WITH THIS  
MAGAZINE IS SPECIALLY FOR THE RECEIVING ENTHUSIAST

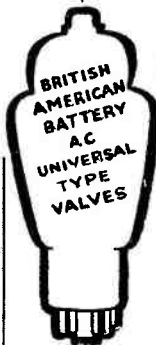

“DEMOBBED VALVES”

MANUAL

2/3

Post Free

giving equivalents of British and American Service and Cross Reference of Commercial types, with an appendix of B.V.A. Equivalents and comprehensive Price List. We have still some valves left at PRE-BUDGET rates which are actually sold at the old price.

EXPORT

to all parts of the Commonwealth and beyond—safely packed fully insured (no C.O.D.) and free of tax.

★—If yours is a (Rare) Valve problem BULLS are the people most likely to solve it.

Table listing vacuum tube types and prices, including OZ4, IA5, IB4, ID5, IG4, IC6, ILA4, ILD4, IN5, IP5, IQ5, IR4, IRS, IS4, IT4, IT5, IV, 2A6, 2X2, 3V4, ST4, SY3, SZ3, SU4, SX4, SZ4, 6A3, 6AC5, 6AC7, 6AG5, 6AJ7, 6B4, 6B7, 6B8, 6C4, 6C5, 6C6, 6C8G, 6D6, 6F6, 6F6G, 6F8, 6G6G, 6H6, 6J5, 6J6, 6J7, 6K6, 6K7G, 6K7, 6K8G.

Table listing vacuum tube types and prices, including 6L5G, 6L6, 6L7, 6N7, 6P5, 6P8, 6Q7, 6S17, 6R7, 6U7, 6V5, 6X5, 6SA7, 6SG7, 6SH7M, 6SK7, 6SL7, 6SN7, 6SS7, 6T7, 6V6G, 6ZY5, 7B7, 7B8, 7C7, 7A7, 7D6, 7V7, 12A6, 12B8, 12C6, 12J5, 12F5, 12Q7, 12SA7GT, 12SR7, 12SG7, 12SH7, 12SJ7, 12SK7, 12SR7, 12SQ7, 14F6, 15, 18, 19, 25A6, 25AC5, 25L6, 25Y5, 25Z5, 25Z6, 28D7, 31, 32, 33, 37, 41, 43, 45Z5GT, 46, 50L6GT, 52, 58, 62, 72, 73, 76, 77, 803, 805, 807B, 807m, 813, 860, 866A, 84/6Z4, 900, 9003, 9004, 954, 955, 956, 1299A, 1625, 7193, T240, VR150, VR105.

MULLARD

Table listing Mullard tube types and prices: CBLI, CBL31.

Table listing vacuum tube types and prices, including 8/6, CL4, CL33, CCH35, CY32, CY31, DL2, EBC35, ECC35, ECC31, ECL80, EF36, ECH33, EF91, EL2, EL3, EL33(BVA266), EL50, TH3OC, TH62, UBC41, UCH42, UF41, UL41, UL41.

MARCONI/OSRAM.

Table listing Marconi/OSRAM tube types and prices, including D43, D53, DH73, DL63, DL74, H63, HD24, KT2, KT32, KT44, KT61, KT72, KT74, KTW61, KTW62, KTW63, KTW74, KTW74, MH4, U52, U71, U74, U76, X63, X73, X76, X77.

BRIMAR.

Table listing Brimar tube types and prices, including 4D1, 8A1, 9D2, ID6, IOD1, I1D3, 15D2.

COSSOR.

Table listing Cossor tube types and prices, including 41MPT, SU2150A, OM4.

MAZDA.

Table listing Mazda tube types and prices, including AC6PEN, ACTH1, ACPI, AC2HL, AC5P3, HL23, HL23DD, HL133DD, HL120, HL41, HL41DD, PEN1340, PEN3B3, PENDD1360, PEN45, PEN25.

Table listing vacuum tube types and prices, including PEN46, PENDD2530, QP25, OP230, SP61, SP41, TH233, TP1340, TP25, TP2620, VP23, SP42, UU7, U21, CI, CIG, VA26, XP (1.5), XH (1.5), ACDD, TX21, U21, VP2, SG215, 210LF, 210HF, 230XP, PM22A, LP2, QP22B, TDD2A (HD24), PD220 or equivalent, DDT4, VMP4G or equivalent (KTZ41), MU12(VU39), U12, BVA, 216, HL13C or equivalent, 354V (HL4), ML4 or equivalent, MSPEN (SP4) or equivalent, MX40 (FC4, MH4105), AC2 PEN (APP4B), FW4/500, AC5PENDD (AC2PENDD), TDD130 or equivalent, FC13C, TH2321, VP130 (9D2), 8D2 or equivalent, UR30, Z220, QP21, EB34, EF39, EBC33, EF36, EF36(N), EK32, SP61(N), SP61, SP41, P41, L63, MHLD3, BL63, 9D2, KTW62, EFB, DI, EA50, EF50(N), EF50, RL16, EF54, V1907, V950, EL32, KT66, U17, HL23DD, PEN46, VP23, ATP4.

MISC. TYPES.

Table listing miscellaneous tube types and prices, including CI, CIG, VA26, XP (1.5), XH (1.5), ACDD, TX21, U21, (replaces FC4 etc.).

POSTAGE 1/-

Subject to Stock

Kindly Mark Envelope (S.W.3.) Postage 1/-.

CONDENSER TESTERS and Rectifier Units. Plugs straight into A.C. mains 200/240V. and is indispensable for examination of condensers. Very slight and intermittent leakages which cannot be discovered by conventional instruments can be traced by this unit. Complete 39/6. Post 1/-.

TAYLOR 7 Range multimeters AC/DC 0-6-30-150-300V. 0-30 mA-300mA-3 Amperes Precision M/I movement. 50/-

Easy Terms 28pp. Illust. Catalogue 5d. Stamps.



FOR THE EXPERIMENTER AND THE RADIO ENGINEER

# The SHORT WAVE Magazine

## E D I T O R I A L

**Prelude** This issue, No. 1 of Volume X, sees SHORT WAVE MAGAZINE in what we hope readers will agree is much improved style and layout. To the casual glance the changes will appear to be no more than in size and appearance. But in fact a great deal of planning and preparatory work—which started as long ago as October last year—has been called for to get this issue into your hands in its new guise. There are considerable detail changes, which we hope are improvements, and in their turn they have involved a number of problems on what is purely the production side.

All this effort notwithstanding, the appeal and the success of SHORT WAVE MAGAZINE will still entirely depend, not on what we say in this space, but on what goes into the MAGAZINE itself. Hence, plans are in hand for a wider coverage of the radio field and as time goes on readers will find articles on topics which previously have been outside our usual range.

As always, we shall welcome readers' own comments and criticisms—though, as we have said before, opinions on this or that point always tend to cancel themselves out! If one reader wants more DX news, it is easy to find another who wants less; if one says SHORT WAVE MAGAZINE is too technical, the next letter complains that it is not nearly technical enough. If another asks for more articles on VHF construction, someone else is certain to say we are already devoting far too much space to VHF. And so it goes on!

Nevertheless, we sincerely hope that as many readers as possible will continue giving us their considered and candid opinions on SHORT WAVE MAGAZINE and its policies. Only thus can we hope to meet the views and satisfy the needs of the majority of our readers.

Austin Foster  
G.F.O.

# A Magnetic Tape Recorder

## MECHANICAL CONSIDERATIONS, AND THE DESIGN OF AN AMATEUR-BUILT UNIT

### PART I

E. P. HARRIS (G3GFN)

*The subject of Recording is attracting increasing attention not only among amateur transmitters, but is also of much interest to home constructors generally. A properly designed and built recording equipment has considerable practical possibilities, useful as well as amusing, and is as popular as the cine camera in the home and the dictating machine in the office. Some excellent tape table units are now available as foundation for the complete recorder, the necessary equipment on the audio side being a matter of no great difficulty to the radio amateur, already experienced in the construction of LF amplifiers. This series of articles will deal in detail with the home-construction of a complete Recording Unit. Later, some of the equipment and parts commercially available will be discussed.—Editor.*

THE advent of magnetic tape recording as a commercial proposition places at the disposal of the amateur a very useful adjunct. Like all other things, however, the use of such apparatus is open, like VFO's, to abuse—but sensibly handled, a tape recorder can provide more information concerning transmission characteristics in three minutes than all the talking of thirty minutes. Apart from this specific application — which is obviously of interest to the transmitting amateur — tape recording, because of the fidelity of reproduction possible, the ease with which recordings can be made (and if not required, eradicated) and the low running costs, opens to the home constructor a fascinating and absorbing field of study and experimental interest.

Contrary to general opinion, magnetic recording has its roots deeper in the past than disc or cylinder records. It is only of recent date that, with the availability of satisfactory tapes and heads, it has become possible to make recordings which excel in quality those possible on a standard pressed, or cut, disc. It is worth mentioning that the tremendous advance in magnetic recording is due, in the main, to the fact that during the last war Germany found herself short of the waxes and esters required for the production of discs. Concentrated scientific effort developed the magnetic recording system to its present high level, starting from the initial efforts of the Dutch scientist Van Poulsen (who first patented a magnetic recorder in 1898) and the subsequent work of Stille and Blattner; the latter, as a showman, saw possibilities in Stille's machine, and

popularised it under the name of the "Blattner-phone," which will be remembered by many pre-war readers of *Short Wave Magazine*.

The magnetic tape recording system is, as is well-known, a method of leaving a magnetic impression on a storage medium, the impression being electrical, as distinct from the mechanical method of cutting a disc, as in a gramophone record. In a tape recorder, the storage medium consists of a paper or plastic base tape which is coated with a specially treated form of iron oxide, the treatment being designed to make the oxide particles as small as possible, and to increase the coercivity of the oxide.

In recording, the tape is passed in front of what is virtually an electro-magnet, excited by the output from an amplifier. The electro-magnet at the point of contact with the tape is fitted with a gap. This gap, having a high resistance to the magnetic circuit within the head, makes the magnetic field choose the easier path, which is *via* the coating on the tape, rather than across the gap, in order to complete the circuit. In playback the converse occurs.

This very brief outline description of the fundamental operation of the system will, it is hoped, enlighten those who have no knowledge of the way in which the magnetic tape recording system operates.

Frequency response depends on several factors, which includes tape speed past the head(s), gap width, characteristics of the tape, construction of the head, and so on. Since this article is intended to aid those contemplat-

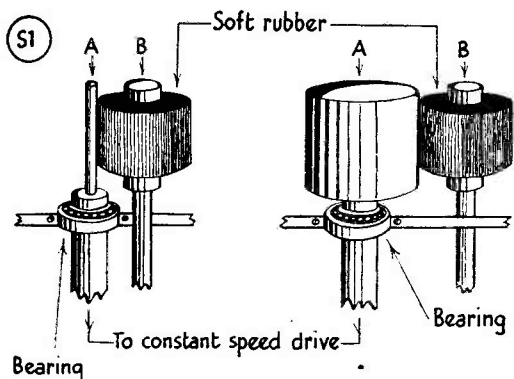

Fig. 1. Section through high- and low-speed capstans. The points regarding choice, in practice, of diameters A and B in each case are explained in the text.

ing the actual home-construction of a Magnetic Tape Recorder, it is not proposed to go deeply into the complete theory of operation. For those interested in the bibliography, the writer recommends *Magnetic Recording*, by S. J. Begun, which contains a full and detailed account, and *Magnetic Tape Recording*, by P. A. Tarry.

Following on to further work since the end of the last war, it is possible to effect economies. The greatest single economy is the use of twin tracks on a single tape. In this, the magnetic head is designed to occupy less than half the width of the tape, and consequently after passing the heads, if it is turned through 180 degrees, a further recording can be made on the same tape, but on "the other half," in the other direction.

The great advantage of the tape recorder is that, by subjecting the recorded material to the field of a 45-60 kc oscillator, fed to another head similar in design to the recording-playback head, the existing matter can be erased and the tape used again. Alternatively, the material can be stored indefinitely and played indefinitely. Wear normally associated with disc records just does not happen in the magnetic system. Indeed, the original recordings made by Van Poulsen are reputed to be as good today as the date on which they were made.

In one of the following sections, mention is made of HF bias. It is necessary to feed to the recording head a small amount of the HF oscillator output while a recording is being made. This is in order to overcome the tape's initial sluggishness in accepting recorded material.

In the first paragraph mention was made of

the use of a tape recorder as far as the amateur is concerned. That is, in the play-back of another station's transmission. The writer would like to give a little advice on the use of recorders in this way. The advice is intended to prevent indiscriminate use of recorders and consequent misleading reports, and also confusion! It will be obvious that as, so far, the GPO do not lay down specific conditions (beyond the note appearing on p. 740 of the February, 1952, issue of *Short Wave Magazine*) concerning the use of such machines, it is up to every operator who is in the position of being able to use a tape recorder to put it on the air in such a way that the GPO is not forced to regulate their use.

Operated correctly, recorders can be classed as a scientific aid, but used incorrectly they are a nuisance and the cause of much bad feeling. Here are some points:

- (1) Never record a signal less than S9 unless perfectly clear from QRM and, on a quiet receiver.
- (2) Always use electrical and *not* acoustical patching between receiver/recorder, recorder/modulator.
- (3) Never record call-signs.

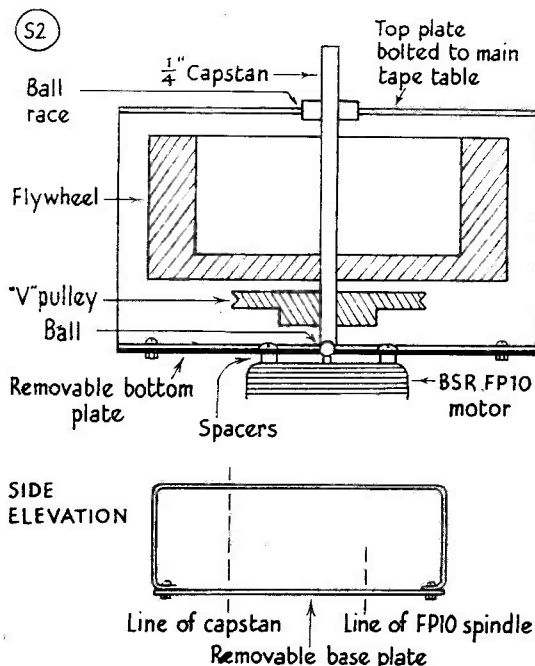

Fig. 2. Sectional detail of capstan unit. Mechanism for withdrawing pressure roller for tape loading, for fast forward and rewind also incorporated in this unit but not shown. Capstan speed 600 r.p.m.

(4) Always play back a recording immediately. Never store it and play it back days later.

(5) Qualify the recording verbally after play-back if, after monitoring, it sounds in any way different from the received signal.

(6) After play-back *announce* that "it was a recording of G.....'s previous transmission, by G....., played back to G....."

### Mechanical Design

It is proposed in this first part of this series of articles, to deal at some length with the mechanical considerations affecting the design of a tape mechanism.

It will be obvious from initial considerations that the achievement of a constant tape speed is of prime importance. As with the gramophone record, any speed variation will show as undesirable "wow" and "flutter" during reproduction. It is in the design and construction of the mechanical assembly that the average constructor (the writer included, be it said) usually has the greatest difficulty, and it must be admitted that unless one has access to a machine shop, the construction of an actual tape table should not be envisaged. A rider is added to this, however. If the machine is only required to record and reproduce voice, then ordinary hand tools can be used to produce a machine which will be satisfactory.

Prior to considering the design in any detail, thought should be given to the facilities required of the tape mechanism. Fast Rewind is obviously required, and in the writer's opinion, Fast Forward is equally important since it allows any particular part of the tape to be selected rapidly. The question of tape speed also arises.

With the tapes generally available today, a tape speed of seven and a half inches per second, coupled with recording and play-back heads having gaps set to 1/1,000 inch or better, will give excellent musical reproduction—reproduction which, in fact, will excel that associated with the normal disc record. As a result of this, 7½ inches per second has become one of the standard tape speeds. For voice reproduction, alone 3¾ inches per second can be used, giving a total of playing time of one hour single track, or two hours on twin track, with a standard 1,200ft. reel of tape. Music of reasonable quality can also be recorded at this speed, but the top frequency limit will be well below that of the faster speed.

From an economical point of view it would seem desirable to have facilities to allow the tape speed to be set at 7½ or 3¾ inches per

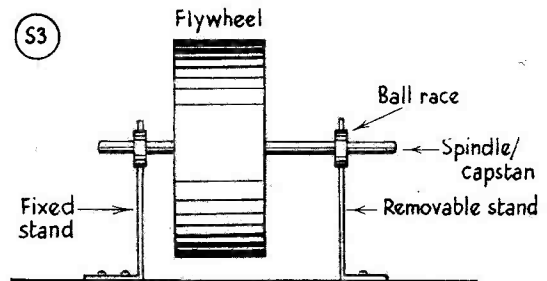

Fig. 3. Mounting of the flywheel for balancing, which can be done experimentally by the method described in the article. Absolutely true running of the flywheel is essential if "wow" and "flutter" are to be avoided on playback.

second, dependent on the material to be recorded. From a design standpoint, however, the simpler mechanism is to be preferred. Moreover, as far as the home constructor is concerned, the fewer variables which can cause cyclic speed variations, the better. Considered as a whole, the writer thinks that the amateur is well advised to concentrate on a single speed unit, and having found the snags, and their cures, venture on a multi-speed unit at a later date.

### Motors

The problem of motors was, until comparatively recently, a very real one. Constant speed motors are *essential*, which rules out the use of brush type motors which are liable to considerable speed fluctuations. The synchronous motor is the only type suitable for consideration, and even here caution must be exercised in selection. Large stray magnetic fields are to be avoided since the play-back head will be found to be prone to hum pick-up, even when screened, as is sometimes commercially said, "carefully." Fortunately for the constructor, Messrs. Birmingham Sound Reproducers (B.S.R.) and Collaro, produce motors eminently suitable for inclusion in tape mechanisms—motors which have been found to be free from all unwanted traits.

### Capstan Units

The capstan unit is that part of the tape table which ensures that the tape passes the magnetic heads at a constant speed. In general, there are two main types, high or low speed.

Fig. 1 shows the fundamental design of a capstan, and its associated pressure roller. The tape is under pressure between capstan A and the pincher or pressure roller B. If A, the capstan, is rotated at a constant speed, then all things equal, the tape should pass through at a constant speed. It will be realised



that the tape speed in inches per second can be determined by:—The diameter of A multiplied by 3.14, multiplied by the speed of A in revolutions per second.

With a high speed capstan, the diameter of A becomes very small, and due to the pressure exerted on it by B, it is difficult to prevent the capstan whipping, or alternatively being bent due to the pressure of B. Another difficulty arises, and this is due to the small area of tape that is under the influence of A. With a small capstan, a great deal of pressure has to be exerted by B, in order to grip the tape tightly and prevent any slip.

With a large diameter capstan, revolving at relatively slow speed, difficulty has been experienced with cyclic "wow" due to the capstan not running absolutely true. The difficulty was experienced despite the fact that the capstan had, to all intents and purposes, been "precision" made in a lathe. The use of a large diameter capstan does have one advantage, in that it permits the use of a low pressure between A and B, by virtue of the increased area of contact. It would seem that if a large diameter capstan is used, the rest of the capstan unit, including flywheel (which is not shown in Fig. 1) must be turned up as one, after assembly.

Inasmuch as experiments with high and low speed capstans did not prove very successful, the writer took the middle course and found success.

The capstan A was made from  $\frac{1}{4}$ -inch material (and to the horror of purists is steel), and revolves at a speed of the order of 600 r.p.m., giving a tape speed of 7.6 inches per second. Despite the fact that in the author's machine the tape is in direct contact with a steel capstan, no detrimental effects have been observed over a period of some nine months, during which time certain recordings have been played through more than a hundred times in the course of tests. Steel was chosen since  $\frac{1}{4}$ -inch stub steel was readily obtainable, and is produced to a very high order of accuracy.

The complete capstan unit is shown in Fig. 2 which also introduces a flywheel.

### Flywheels

It is perhaps not untrue to say that the biggest single headache was provided by the search for a really good flywheel, and a system to drive it.

Originally, a small 2in. flywheel turned up from brass rod was used, the flywheel being rim-driven by a soft rubber idler from the motor spindle. The flywheel was mounted in

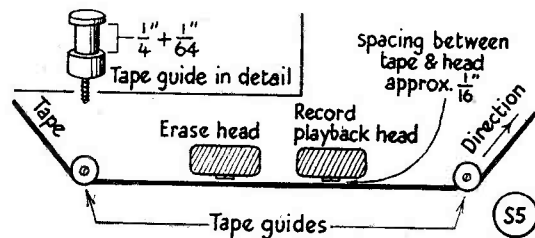

Fig. 4. Tape layout and tape guide in detail. Factors affecting tape routing and rewind are explained in the text.

two ball races, to ensure complete freedom of movement. The system, while seeming satisfactory on voice tests, proved useless on music and audio oscillator tests. Attempts to "jockey mount" the idler, and at the same time true it up, did not prove satisfactory. It was surmised that there was insufficient elasticity in the drive system to allow the flywheel to do its job properly, and moreover, that the inertia of the flywheel was inadequate.

A second assembly utilised a flywheel  $3\frac{1}{2}$ ins. in diameter, and  $1\frac{1}{2}$ ins. thick. This was mounted on a quarter inch stub steel shaft, which formed the capstan. On this shaft was also mounted a V pulley, and on the motor shaft another V pulley, the ratio between them being such that the capstan and flywheel rotated at 600 r.p.m. The capstan/shaft was set in a ball race at the top, and on a single ball at the bottom, and the drive between the two pulleys effected by a soft rubber belt.

Results using this system were infinitely better, but cyclic wow at 600 cycles menaced the unit. The fluctuations were traced to unbalance in the flywheel, and this in turn was due to the fact that brass varies considerably in density. Much patience and time was spent in locating and drilling out the heavy spots on the flywheel, and eventually the speed was found to be absolutely constant.

While obviously dynamic balancing is the best way of correcting the flywheel, the writer was unable to find anyone who could undertake such work. The method illustrated in Fig. 3 was employed and was found satisfactory. The flywheel on its shaft was mounted in two ball races and set up as shown. The circumference of the flywheel was divided off into a number of equal parts, each part being given a reference letter. The flywheel was spun by hand, and when it came to rest a note of the section at the bottom was made. This procedure was repeated several times until the heavy spot was determined, i.e., at the bottom. With a hand-drill part of the heavy spot on the flywheel was drilled out, and the process

repeated. Eventually the flywheel would stop at random, showing more or less complete balance. This was confirmed in performance.

Investigation has since shown that the ideal material for a flywheel would be fine grain cast iron, since when this is poured, a large head of metal is invariably used, making for the minimum of density variation. One manufacturer, who utilises cast iron flywheels, has proved to the writer that a cast iron flywheel needs only skimming and clocking in a lathe prior to use.

Mention has been made of elasticity in the drive system, and the use of a rubber belt drive. It is the writer's opinion that a spring belt drive similar to that used on home ciné projectors, would in fact be superior to a rubber belt, but so far, this has not been tested.

### Other Considerations

The foregoing has dealt at some length with the major parts of a tape mechanism, in order that the constructor may benefit from the experiences of the writer, and appreciate the difficulties liable to be encountered. It is now proposed to cover more briefly the remaining parts of a tape mechanism.

The actual route taken by the tape is of considerable importance, relative to the desire to be able to wind on, and rewind, at high speed. The minimum of friction is essential, not only to avoid wear on the tape, but also to ensure that motors of limited torque are able to handle the tape as required. This essential of minimum friction necessitates the minimum number of tape guides, coupled with a virtually straight run for the tape.

In some machines the faces of the heads are set in such a way that the tape automatically makes contact with the heads. While this method brings simplification of the mechanical design, it does mean that either the tape has to be re-routed during wind-on or rewind, or that a gearing ratio (or more powerful motor) has to be used. If the tape is not re-routed, then the tape is subjected to additional wear. Moreover, considerable tension in the reverse direction to that in which the tape is progressing has to be used in order to ensure good contact between tape and heads to avoid loss of top frequency response.

If the system of tape routing shown in Fig. 4 is used, the tape need not be re-routed for wind-on or rewind. However, a method must be found to bring the tape in contact with the heads during the record or play-back positions. This can best be achieved by the use of light pressure pads, as are shown in Fig. 5.

The main advantage is that once the tape is placed in the tape gate, it need not be handled, other than when changing spools. In addition, only small back tension is required.

The operation of the pressure pad unit is as follows: Normally the pads are held in tight contact with the heads by the transfer of energy from the spring which lightly retains the operating bar to the right. The energy of the spring is transferred by the transfer stops fitted to the operating box. The pressure arms being fitted to the same pivots as the transfer levers, move in sympathy with them, thus exerting light pressure on the heads. (The pivot units are merely drive spindles from full-vision type radio dial assemblies pressed into this service.) The operating bar should be mechanically linked to a switch which selects record play, fast forward or rewind, and this linking should not provide any difficulty.

The fact of having a straight run of tape makes loading the tape a simple and quick operation. Moreover, it can be made even simpler, by building up a small platform, so that when the tape is dropped into position, it automatically comes to rest at the correct height. This in turn means that the heads and the pad mechanism can be completely enclosed, except for a slot into which the tape can be dropped.

Mention has been made of back tension on the tape. It is not satisfactory, even with

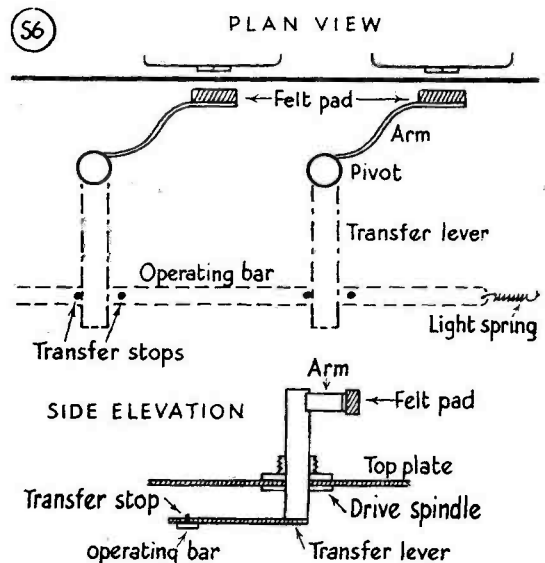

Fig. 5. Pressure pad mechanism; in the position shown, the pads should be holding the tape against the heads (for clarity a gap appears). To release the pads, the operating bar is moved to the left.

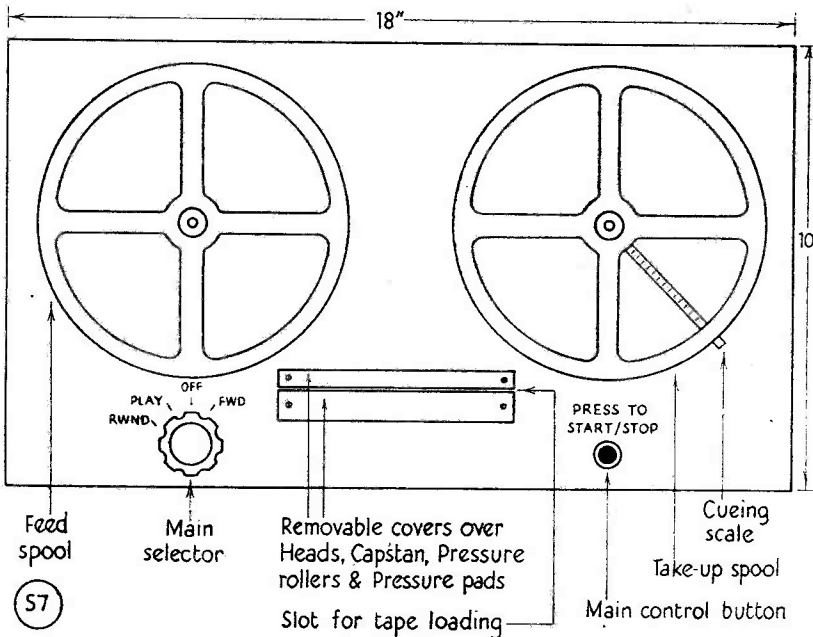

Fig. 6. Spool layout and controls for the Recorder as described by G3GFN. Full details are given in the text.

pressure pads, to let the feed spool run free for a variety of reasons, such as adhesion between layers of tape as the tape leaves the feed spool, the danger of a full reel of tape "spilling," and so on. To overcome such difficulties is, in a three-motor mechanism such as is envisaged, simple.

A moment's thought will reveal that in the Rewind position, the motor which drives the original feed spool, drives it in such a way that the direction of the tape is the reverse to the recording or play-back direction. If this motor is run in series with a resistor during recording or play-back, it will automatically provide the required back tension, and hence keep the tape taut as it passes through the head mechanism. The amount of back tension can be varied by changing the value of the series resistor, and the value of resistor chosen should be such that minimum back tension is used consistent with smooth passage of the tape, through the head (maximum series resistor possible).

During Recording or Playing Back, the motor to which the take-up spool is fitted is also run with a series resistor. In this case, the value chosen should be such that a reasonably tight wind-on is secured.

Despite the apparent simplicity of the method of securing satisfactory wind-on, and back tension, there are difficulties which must be overcome. It will be obvious that if the motor which is providing the back tension (feed spool) does not rotate smoothly, but suffers from cogging (rotates in jerks from one pole to the other), then the operation will be unsatisfactory. The alternative to a motor providing back tension, is the use of a mechanical brake. However, since for Fast Rewind this spool is driven from a motor, if it is possible to use the motor to provide the necessary back tension, then a further simplification will have been effected. In the

author's experience, the motors produced by Messrs. Collaro do not suffer from the effect of "cogging," and can be used with success. The alternative to this motor is the B.S.R. type FP 10, which when run with a suitable resistor, exhibits negligible cogging effect.

Figs. 6 and 7 show the layout of a tape mechanism which is easily constructed, and

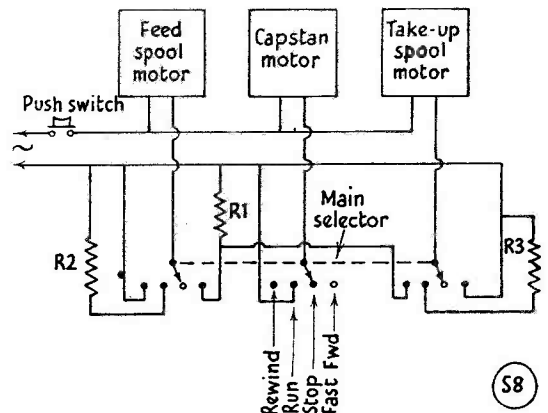

Fig. 7. Switching control layout—for details see text. The values of R1, R2 and R3 must be determined experimentally, since they depend upon the friction in the tape system and the torque of the motor employed.

also the motor wiring circuit. No mention has been made of spool brakes in the Stop position and this is left to the ingenuity of the constructor. If a tape mechanism is made without brakes fitted to the spool, it is essential to remember to stop the spool from which the tape is coming when switching off the mechanism. Tape can become very tangled if it spills off the spool, particularly if it spills at any speed.

### Summary

It may be as well, in conclusion of this part, to survey the requirements and functions of a tape table in order to provide good tape handling facilities.

- (1). **Fast Forward.** Allowing rapid selection of any particular portion of the tape. Brakes, if any, off. Take-up spool motor fully energised. Pressure Pads off. Pressure Roller off. Capstan motor off. Feed spool motor lightly energised.
- (2). **Fast Rewind.** Giving speedy re-play. Brakes, if any, off. Feed spool motor fully energised. Pressure Pads off. Pressure Roller off. Capstan motor off. Take-up spool motor lightly energised.
- (3). **Stop.** Brakes, if any, on. No motors energised. Pressure Roller off. Pressure Pads off.
- (4). **Play.** Brakes, if any, off. Pressure Roller on. Pressure Pads on. Capstan motor energised. Take-up and Feed spool motors lightly energised.

(To be continued)

---

## Multi-Band Ground Plane System

FOR TEN, TWENTY AND FORTY

P. PENNELL (G2PL)

*The author of this article is one of the world's most consistent and successful DX operators, whose results are well-known on the communication bands. He describes here an interesting low-angle radiating system, having a wide frequency coverage, and capable of giving excellent DX working from a confined space.—Editor.*

**M**ANY amateurs who live in large cities or their suburbs, where space is restricted, must feel that they would like to erect a simple aerial for DX work on the 7, 14 and 28 mc bands. A compact rotary beam can be used on 28 mc, of course, but it is often impossible to erect one for 14 mc and for size alone a rotary 7 mc system is totally impracticable. Dipoles, or full wave aerials, exhibit marked directional properties and are high angle radiators, unless they are suspended at a considerable height (e.g., 66 ft., or 2 wavelengths, in the case of a 14 mc dipole). Furthermore, their success is largely dependent on the nature of the sub-soil.

A vertical dipole, if suspended at a height of a quarter-wave from its centre to the ground, is a low angle radiator, but again this assumes perfectly conducting soil.

A Ground Plane system is, however, almost entirely dependent on its radials, or earth mat, and accordingly the height above earth is not important for low angle radiation; also, the base may be raised above any nearby obstacles which would screen it. The radiation pattern is omni-directional, more ideally so than a vertical dipole, whose feeder must pass through the radiated field; the coaxial feeder to a ground plane system should be run *below* the radials, thus ensuring that there is a negligible effect on the field pattern.

In a particular case, a satisfactory performance has been achieved with the base of a 7 mc ground plane aerial only *two feet* from the ground, and on 14 and 28 mc with the base 23 feet from the ground. In both instances, there was screening in the form of trees, with other systems within a radius of 30 ft. The Ground Plane can be used equally successfully by the flat dweller who has access to a flat roof-top, or at a suburban location with a small garden.

There are many different ways of building a Ground Plane system. The one to be described uses four radials only, each radial having link patch boards to allow a change in its length, together with three easily changed whip radiators, for change in vertical height. No one should be deterred because he is unable to duplicate the system rigidly; many varieties are possible.

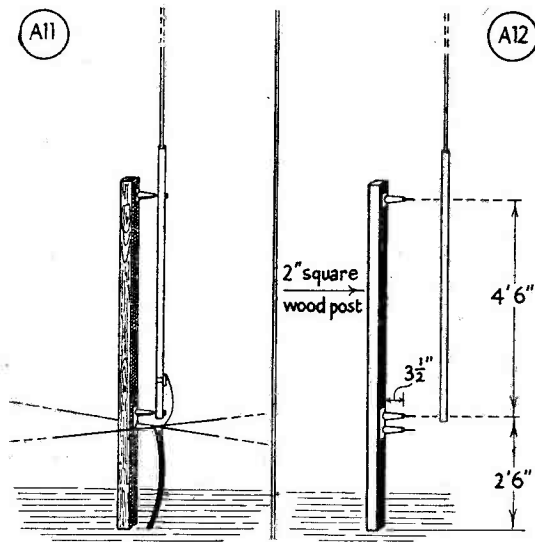

Fig. 1. Base arrangement of simple ground plane system, with detachable vertical section. The outer conductor of the coaxial feeder is taken to the junction of the radials, the inner conductor going to the base of vertical radiating member.

### Selection of Site

First, it is necessary to choose the site. If possible, the four radials should be run at  $90^\circ$  angular displacement from each other, around the main mast which supports the whip; if this is impossible, a certain amount of bending can be tolerated and the system has been operated successfully with the radials occupying only a semi-circle. In such circumstances the radiation pattern may exhibit slightly directional characteristics.

The radials can be run horizontally, or down from the base at no greater than an angle of  $45^\circ$ . In the case of the horizontal radials the feed impedance will be approximately 25 ohms. But, where the radials slope downwards, the impedance may rise to approximately 50 ohms. There are several varieties of coaxial cable available with characteristic impedances ranging from 50 to 100 ohms, and adequate power rating for the British maximum input of 150 watts DC to the RF power amplifier. The lower value of impedance is better, however, as a good match can be obtained by tapping the centre conductor up along the whip section, as described later. A standing-wave-ratio of less than 1.5-to-1 has been obtained by this method. For short feeder lengths, an SWR of 2.5-1 may be tolerated.

The writer has used this system equally successfully in the centre of the garden (Fig. 1

shows the base view) and at the side of the house; individual circumstances will determine the best position for locating the array.

### Constructional Details

Having selected the site, a wooden post should be erected for the centre of the proposed system; one of two forms may be used as shown in Figs. 1 and 2. One is a suitable support for use where space is restricted and it is necessary to carry the whip in a vertical position before attaching it to the appropriate insulators. (The height of the two insulators above ground is limited by the stature of the individual!) The other arrangement (Fig. 2) shows a support which can usefully be employed where there is sufficient space to permit the length of the vertical radiator to extend from the base in the horizontal state before erection (minimum 50 ft.). One bolt is used as a pivot and the other as an anchoring device. The insulators are of porcelain and have an O BA screw for retaining the tube, wing nuts being used to facilitate a quick change of radiators. When fixing the insulators, cork or fibre washers should be used between the heads of the wood screws and the porcelain. The same applies to the centre fixing screw; it is surprising how easily insulators crack without some form of resilient packing!

The top two insulators are used for fixing the whip sections and the bottom insulator is for anchoring the radials, together with the outside of the coaxial feeder. The radials may be conveniently terminated in O BA soldering lugs.

The overall length of each radial (which is preferably of 14 SWG enamelled copper wire) from insulator to O BA lug is 33ft. 10ins. At 8ft. 6ins. and 17ft. from the lug, patch boards are inserted (see Fig. 3). The patch boards should be opened according to the frequency,

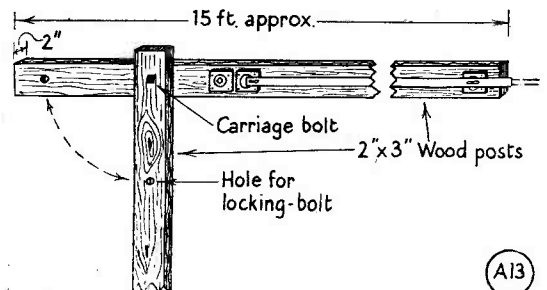

Fig. 2. Another method of mounting the vertical section, suitable where increased height is called for and there is sufficient space to lay out the radiating member.

*i.e.*, for 7 mc the complete radial is used ; for 14 mc 17ft. of radial is required, and for 28 mc 8ft. 6ins. is used. When the wire has been made fast around the insulator it should be soldered at the end and the distance measured from the centre of the loop to the lug. The unused sections appear to have no ill-effect on the performance of the system on different bands. In certain circumstances it may not be possible to have easy access to the patch boards, in which case—if the radials are near to the ground, *i.e.*, the capacity to earth is high—the aerial can be used on all *three* bands with the 33ft. 10in. radials; only a slight reduction in performance will be noticed on the two higher frequencies.

The vertical portion of the aerial is made in sections from duralumin tubing, the outside diameter of which is reduced from 1½ins. at the base to ½in. at the top. Fig. 4 shows measurements for the writer's system, but the diameters and lengths of the individual sections are not critical, provided that the overall length is maintained. The flexibility of these whips is surprising ; the full 7 mc length reacts the most to any high winds and in a recent gale it bowed to an alarming angle, but always returned to the vertical position. An increase



Fig. 3. Patch board or strip connector in series with the radials, for altering their length (see text).

in base diameter to 1¼ins. or 1 5/16th ins. would make this section still more rigid. At no time did the PA current change by more than 1%. The gauge of the tubing is not critical. 18 SWG is very satisfactory for the bottom section and 20 SWG for the intermediate and top sections. The 14 and 28 mc lengths are more rigid and the top displacement is small.

Where it is not easily possible to obtain telescopic sections of tubing the joints may be made quite satisfactorily by packing the small diameter tubing with half sections of tube, four to five inches long and cut from the same section. When sufficient layers have been sprung on to the inner tube it should be forced into the larger tube. After the sections have been united, a fixing bolt can be driven through them and the edges sealed with a good sealing compound. (Bostik is quite suitable.) It cannot be stressed too greatly that all joints

and untreated metal *must* be sealed ; the ravages of corrosion can be very serious. The ends should be blocked with bungs of cork or wood and the whole vertical section carefully treated with at least two coatings of aluminium paint, unless the tubing is already proofed when purchased.

At the appropriate points, spaced the same distance as the two insulators, drill two holes for fixing the vertical section. If the tubes are

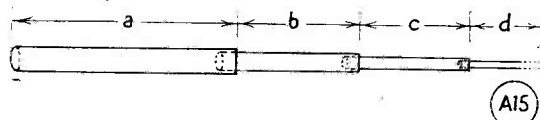

Fig. 4. Vertical section of the ground plane aerial. Suitable tube lengths would be, for 7 mc : A, 12ft. ; B, 10ft. ; C, 7ft. ; D, 4ft. 10ins. For 14 mc : A, 10ft. ; B, 4ft. ; C, 2ft. 11ins. For 28 mc : A, 6ft. ; B, 2ft. 5½ins. These lengths, while producing the necessary quarter-wave for each band, also give the best mechanical compromise between tube section and length.

telescopic, split the outer sections for one inch and fix a clip on the outside ; this will bind the sections together firmly. It is, of course, essential to ensure a low resistance connection between the individual sections.

#### Matching Feed Line to Aerial

A simple clip can be used to provide contact between the inner conductor of the coaxial cable and the bottom of the radiator. The wire should be run approximately three inches from the main whip and the exact tapping may be determined experimentally by measuring the standing wave ratio on the feeder and adjusting the tap until it is less than 2.

The coaxial feeder should be run straight down the main support and kept as near the ground as possible ; if the system is mounted, say, on the roof of a block of flats, the cable must be brought below the radials before turning at right angles.

#### Operating Experience With the Ground Plane

Results with this system have been most interesting. On 7 mc in the mornings, stations in W6 and ZL report an increase of 1 to 2 S-points (3 to 6 dB) over a full-wave horizontal aerial with the optimum lobe in that direction. This is particularly noticeable when these parts of the world are first audible or just fading out—as would be expected with a low angle radiator. If conditions are at a peak, only a slight superiority is noticed ; presumably, under these circumstances the optimum angle of radiation is high. Without doubt, if the base of the aerial could be raised from two to ten feet, the performance would be even better, as

certain local obstacles in the close vicinity would be cleared. On 14 mc the performance has been similar. For a short period the aerial was tried at the side of the house, and with the base 23ft. from the ground and the radials in a semi-circle, radiation seemed to be almost the same in all directions. The low angle of radiation was apparent, and in comparison with a two-element horizontal beam, aimed in the wanted direction, the reports were only one S-point less. Similar results have been obtained on 28 mc. The effects of screening are more pronounced than on the other two bands, and it seems that, ideally, the aerial should be as high as possible for this band.

### Broadcast Interference

Fears are occasionally expressed that any vertical system can cause greater interference to nearby broadcast receivers than a horizontally polarized aerial. No trace of such QRM could be detected on either of two broadcast receivers operated in close proximity to the transmitter. The local field seemed to be no greater than that from a two-element beam.

Normal loose coupling between the PA tank circuit and aerial, together with lagged keying circuits, should be employed at all times.

### Future Experiments

In the future, it is proposed to examine the possibilities of using the 7 mc whip on 3.5 mc and 1.7 mc over a narrow frequency range. This could be achieved by using a loading coil, mounted at the base of the vertical section, with link coupling to the coaxial feeder. A weatherproof housing would have to be provided for the coil and a system of plugs and sockets would allow a rapid connection when desired.

In describing the system, the intention has been to encourage the reader to use the information which applies to his own particular requirements and not necessarily to duplicate the system as described here. Although there seems to be no immediate prospect of the long-promised and now almost forgotten 21 mc amateur band being issued, the general principles discussed in this article of course apply to that band as well.

---

## Two-Metre Portable

EXCITER / TRANSMITTER  
FOR STATION OR FIELD  
USE

J. H. JOWETT (G3CFR)

*Here is a nice design for operation either in the station as an exciter for the full-power PA on Two, or by itself as a portable 144 mc transmitter. Full attention has been given to points of detail for both services, and the RF output obtainable should be about 5 watts.—  
Editor.*

**T**HIS transmitter was designed with two purposes in view: For possible portable operation, and for use as the standard exciter in the permanent rig, to drive an 829 PA. For the first purpose, a compact, low consumption design was needed, as space and power supply are usually at a premium under portable condition: also, it was required to operate at 12 volts, this being generally the most convenient

to give a reasonable weight-capacity ratio for the batteries. Furthermore, for 12 volts a number of suitable vibrators or rotary converters are available on the surplus market. One such "rotary converter"—or more strictly speaking, voltage changer—is the Type 104, rated to give 250 volts from a 12-volt supply, with full electrical suppression; it may also be used for the receiver. It is available even now from *Short Wave Magazine* advertisers at an exceptionally moderate price.

With the valve arrangement in the transmitter as given, it is possible, by changing over a couple of connections, to run the heaters on 12 volts or 6 volts. The 832 itself will run at either 12 volts or 6 volts, while the heaters of the EF91's are each rated at 0.3 amps., and so two in parallel may be placed in series with the heater of the QV04-7 to run at 12 volts. The heater inter-connection is then as shown in Fig. 1. It need hardly be said that 6 volts is much more convenient in the station, for most purposes.

### Circuit Details

The 5-watt RF output fulfils the second purpose, to provide ample drive for an 829. The complete circuit of the transmitter is given in Fig. 2. The values and circuit arrangement

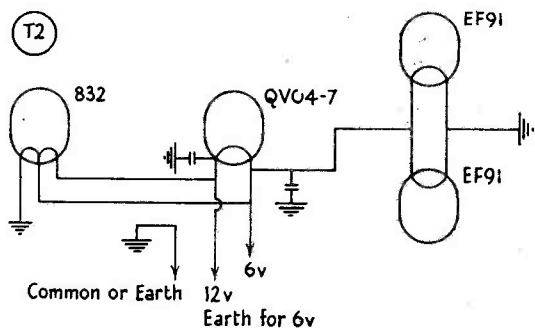

Fig. 1. Heater arrangement for the 144 mc Exciter/Transmitter, to give either 6v. or 12v. working with the valves used.

follow fairly conventional practice. In the oscillator a cathode resistance is omitted as it was found to have a negligible effect on the performance. The oscillator valve V1 has an 8 mc crystal, and the output is extracted at 24 mc. V2 operates as a tripler to 72 mc, and V3 was made to be a QV04-7 in order to ensure sufficient drive for the 832 and also for convenience with the heater circuit, as already described. The coupling between the 832 and the final doubler is arranged inductively; the grid circuit of the 832 is of such a size as to be resonant and to ensure maximum transfer of energy. These dimensions should be

followed as closely as possible from Fig 3, and a certain amount of trimming of the coil and adjustment of coupling is advisable to ensure best results.

The final doubler of V3 runs with a low screen voltage, which was found to be best; a cathode resistance is not used, as it is not to be expected that V3 will be operated without drive and, in any case, it is most unlikely that the maximum anode dissipation will be exceeded. Keying is effected in the screens of V2-V3 to ensure a complete cut-off of drive to the PA, so that a spacer wave will not be obtained. This system was used in preference to cathode keying, as the key need not break such a large current, and it also avoids difficulties with heater-to-cathode insulation when the key is up. In the system described, the insulation of the key and associated wiring

### Table of Values

Fig. 2. Circuit of the Two-Metre Exciter/Transmitter

R1, R3,	C5 = 30 $\mu$ F air trimmer
R5, R6, = 47,000 ohms, $\frac{1}{2}$ watt	C5 = 2.8 $\mu$ F concentric trimmer
R2 = 57,000 ohms $\frac{1}{2}$ watt.	C7, C10 = 200 $\mu$ F.
R4 = 620 ohms $\frac{1}{2}$ watt.	C8 = 400 $\mu$ F.
R7 = 100,000 ohms $\frac{1}{2}$ w.	C11 = 20 $\mu$ F. air trimmer
R8 = 1,000 ohms $\frac{1}{2}$ watt.	C12, C13 = 150 $\mu$ F.
R9 = 250 ohms $\frac{1}{2}$ watt.	C14 = 10 $\mu$ F. per section
R10 = 20,000 ohms 3 watt.	
C1 = .001 $\mu$ F.	V1, V2 = Mullard EF91.
C2 = 35 $\mu$ F.	V3 = Mullard QVO4-7
C3, C4, =	V4 = 832.
C9 = 50 $\mu$ F.	

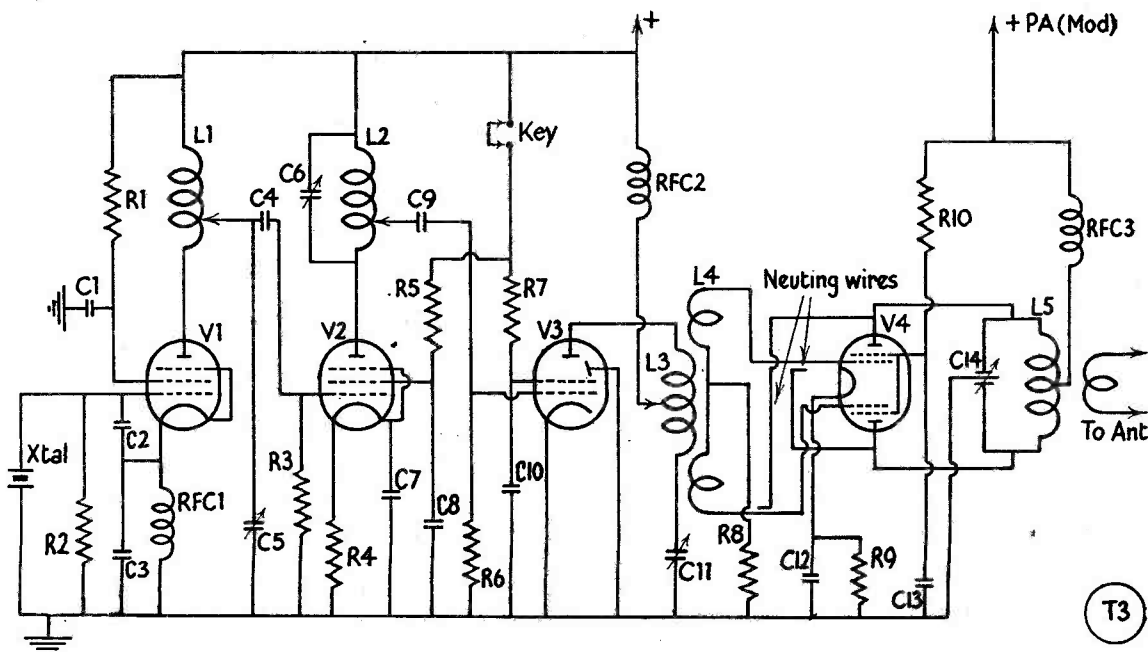
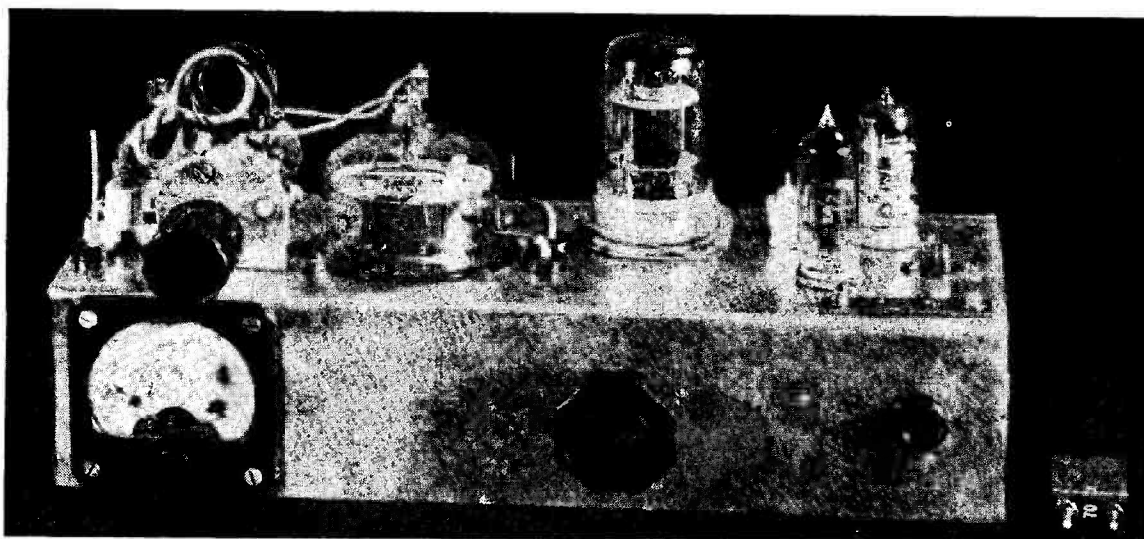

Fig. 2. Circuit complete of the Two-Metre Transmitter Unit, which can be operated either as an Exciter for the QRO PA or as a self-contained portable giving about 5 watts RF out. All values are given in the accompanying table.





Neat appearance of the 144 mc Exciter/Transmitter described by G3CFR. The PA stage is on the left, the CO drive to the right and the crystal insert is at the right front edge.

should be good to avoid a spacer wave.

The 832 PA is partly cathode biased to limit the current in the key-up condition, and partly grid-leak biased; fixed bias was not provided owing to difficulties of supply during portable operation. The small wire seen protruding vertically from the chassis at the left-hand front end, near the tank coil, is used to take off a small amount of RF which is applied to a separate rectifier and meter circuit, indicating when the final tank is correctly tuned. It was decided that this single meter would be used rather than a grid or anode current meter, as the RF output is, after all, the criterion for the correct functioning of the transmitter, and indicates when the complete transmitter is tuned. The circuit of the RF indicator unit is shown separately in Fig. 4. Some may prefer to meter all the circuits, in which case the same instrument could be used with a switch and the necessary shunts. In this case, the chassis arrangements would have to be modified to accommodate the selector switch.

#### COIL VALUES

- L1 = 14½ turns 18g., ½in. i.d. close wound tapped 1 turn from anode end.
- L2 = 5 turns 16g., ½in. i.d. spaced ½in. tapped 2 turns from anode end.
- L3 = 7 turns 16g., ½in. i.d. centre-tapped, spaced ½in.
- L4 = Each side 1-1/3rd. turns, ½in. i.d. (See dimensions given in Fig. 3).
- L5 = 3 turns, 16g., ½in. i.d., spaced ½in.

#### Chassis Layout

For the sake of completeness, drilling details for the chassis are given in Fig. 5; the holes for the 832 plate condenser mounting are omitted. The material used was tinned steel and the corners of the chassis were soldered.

The transmitter was tested on an AC mains power pack giving some 250 volts with 6 volts for heaters, and also with heaters supplied from a 12 volt DC source, with HT from the Type 104 Unit. In the latter case, with key down, the PA took 47 mA at 230 volts (about 10½ watts) and the RF output was estimated to be 4½ or 5 watts. The whole rig consumed 88 mA. With the key up the voltage rose to

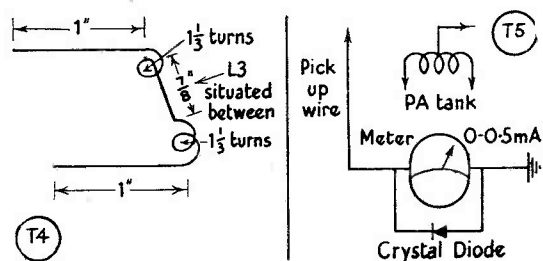

(T4) Fig. 3. shows the dimensions of L4, in the grid of V4, in detail; slight bending will be necessary to obtain resonance. (T5) Fig. 4. is the circuit of the RF indicator, coupled to the output end of the Exciter, which enables the unit to be tuned for full output without the need for intermediate meter indications. The pick-up between the indicator and the tank coil L5 should be adjusted so that readings are obtained within the range of the microammeter.

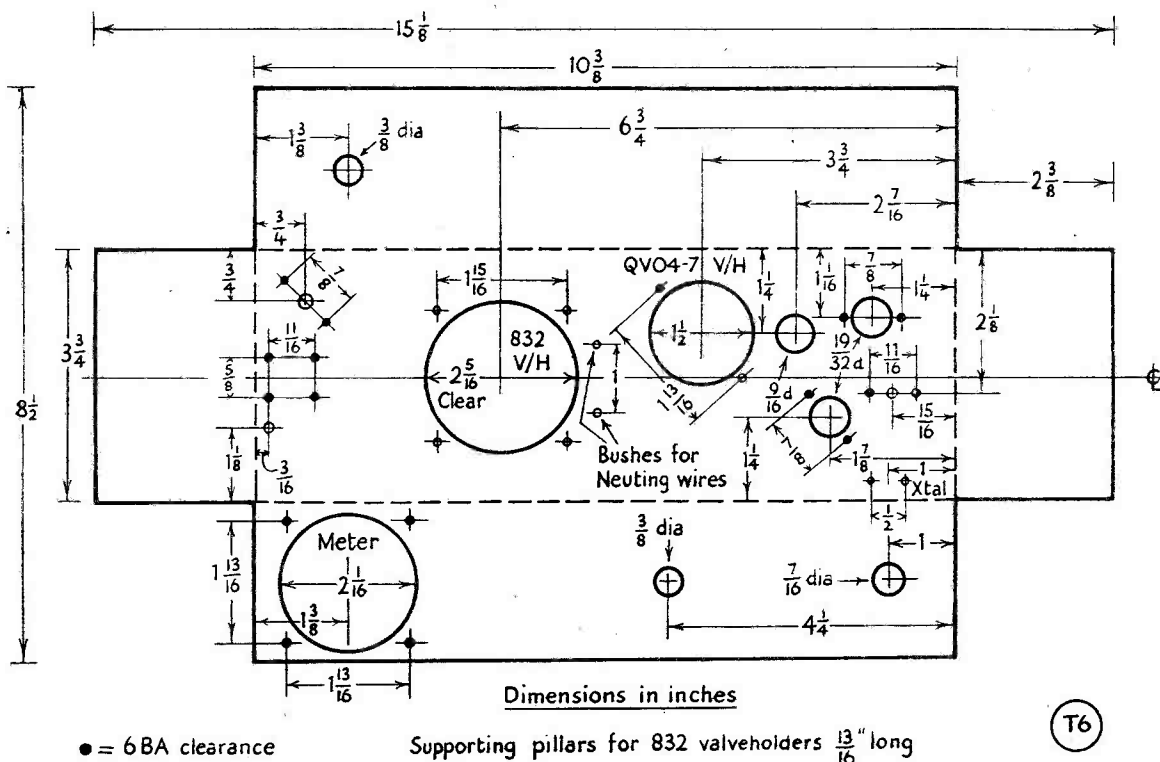

Fig. 5. Chassis drilling detail for the form of construction adopted by G3CGR for his 144 mc Exciter/Transmitter. This sketch should be related to the photograph and circuit diagram Fig. 2. before work is commenced.

260 volts and the current fell to 50 mA. The current of 90 mA taken from the 104 Unit may be considered to be excessive, as it is rated at 250 volts, 60 mA. However, the converter has a separate 6.3 volt, 2.5 amp. winding, brought out to a commutator, and if the brushes to this commutator are taken out, some of the load is removed from the unit. This is partly the reason why this winding was not used for the heater supply to the transmitter, as well as for reasons of flexibility, *i.e.*, so that the rotary could be disconnected from the 12-volt supply if necessary, and still leave the heaters ready on the transmitter. That the machine is not then overloaded was apparent at a recent field event, when the writer's 104 Unit ran continuously for a long period with no signs of heating or distress of any kind, under a full-load current consumption of about 100 mA.

**Setting Up**

The transmitter is best tuned with the PA HT first disconnected. The advice of G2NS (page 734, Jan., 1951 *Short Wave Magazine*)

cannot be too strongly recommended: an absorption wave meter is necessary before attempting to tune up.

First of all, listen on the 8 mc crystal frequency, to ascertain that the CO is oscillating. Then tune the oscillator anode circuit to 24 mc, indicated by grid current in the next stage, the frequency being measured with the appropriate absorption wave meter; with the values given it should *not* be possible to tune to other harmonics. This process is continued stage by stage until 144 mc output appears at V3, and is detected by grid current in the 832. Upon rotating the 832 anode condenser (with HT still disconnected), a point will very likely be found which affects the magnitude of the grid current. This indicates that the neutralising is incorrect and it is as well, at this point, to adjust it by bending the neutralising wires nearer to, or farther from, the 832, or by adjusting their length until this grid current variation upon rotation of the tank circuit through resonance becomes zero. Then the grid circuit coil of the 832 can be pruned to give maximum grid current, as explained

previously, and the neutralisation upon applying HT to the PA will be found to be almost exact. Modulation may be applied to the plate and screen of the final, but as this is not usually required for field events, it was decided to have a separate modulator.

There is sufficient room underneath the chassis at the left hand end to mount a small change-over relay if desired, but the writer prefers to use a separate relay. The Type 78 coaxial relay is quite successful, and although it is designed for 24 volts, in general it will pull satisfactorily on 12 volts providing that the auxiliary contacts (which place a resistance

in series with the coil to limit the current when the armature has moved a certain distance) are shorted. Some may be found uncertain in operation, in which case, it will be necessary to rewind the coil with slightly thicker wire, as removing turns will not usually be effective.

To conclude, a plea for *your* interest in portable operation on 2 metres this coming season, to swell the activity.

Even though you may not work the best GD<sub>X</sub>, you will find it quite good fun. *Now* is the time to get your rig into action and that which has been described will enable you to do this, with a minimum of trouble.

---

## The R9'er Again

### DESIGN FOR THE 14 MC BAND

N. P. SPOONER (G2NS)

*The "R9'er" is well-known as an effective RF pre-amplifier design for improving the performance of receivers which are not as lively as they might be at the HF end of the tuning range. It has been widely used for this purpose on the 28 mc amateur band. This article discusses in detail the "R9'er" application to Twenty, and thus will be of interest to many DX operators.—Editor.*

OVER five years have elapsed since the General Electric Co. of America introduced their R9'er design. Any operator who would today welcome a minimum increase of about five S-points added automatically to every weak DX signal he hears should spare the short time needed for building this remarkable one-valve RF amplifier. With it he will be made aware of signals that he previously could not even hear, and while its originators secured gains as high as 60 dB on 28 mc (with lesser but very considerable increases on 14 mc), the average constructor should obtain at least some 30 dB even if the former desirable figure is not approached. This minimum means that an S1 burble about to be abandoned as barely perceptible can be snatched up out of the noise and suddenly transformed into a fair S5 signal. DX-despondent amateurs harassed by present-day operating difficulties will surely agree that this is too good to be foregone — and that no

apologies are needed for reminding owners of receivers that behave poorly on 28 mc of an article about the R9'er by G5UX that appeared in the April, 1948, issue of *Short Wave Magazine* under the title of "Wide-band RF Pre-amplifier."

Constructors who would like the original American details and photographs will find that by agreement with the G.E.Co., to whom full acknowledgment is paid, they have been re-printed over here by Bernards in their *Ham Notes* No. 2. In both descriptions the emphasis, of course, is on 28 mc working and there the gain is the most marked for the simple reason that the mismatch between aerial and receiver is invariably the greatest on that particular band.

### Function

The purpose of the R9'er is to avoid such a serious loss and give to all weak incoming signals the highest possible boost by virtue not only of the special characteristics of the valve in use but also by correctly matching the aerial into the receiver. It may be open to argument, but in the writer's opinion it is the 14 mc band that will perhaps prove to be the DX hunting-ground and mainstay of interest during the present sunspot cycle.

The lazy version of the original unit now to be described caters therefore only for that band and instead of striving to obtain wide coverage with its attendant inductance and damping-resistor experimentation the suggested fixed coils cover only half the band at a time. This allows full amplification only across that portion in which the individual CW or Phone operator happens to be the most interested; should a later change from one to the other be desired it takes only a few seconds to alter the position of the iron cores and resonate

the coils for maximum response in the other section of the band. Construction may be along miniature lines with the unit completely shielded and tucked away inside the receiver, from which in many instances it might draw its power; alternatively, an external unit could be built with its own power pack giving 6.3v., 0.175a. and 180v., 8 mA.

Although the original and probably most subsequent versions of the R9'er used a 6AK5 valve, excellent results have been obtained by P. J. Towgood, a local constructor and VHF contributor to *Short Wave Listener*, using an EF91, which has an equivalent in the CV138.

### Design Points

In every case, the valve is shielded and as the grid and the plate circuits are both tuned attention should be given to shielding one from the other. Trouble should not arise if both are separated by an above-deck shield and by one below deck that sits across the valve holder itself and hides the grid pin from the anode pin, with the centre spigot earthed as usual. The simplified construction suggested allows any desired lay-out to be followed, and it avoids the need for carefully shielding an aerial wafer switch that has one portion in the grid circuit and another in the plate circuit.

On bands other than 14 mc the receiving aerial is, in the absence of this switch, simply transferred manually from one stand-off to another. The advantage of fixed coils is that they avoid the complications of a shielded plug-in coil-box, but the degree of gain achieved will nevertheless still depend on the efficiency of the coils themselves. To obtain high-Q properly insulated wire should be wound on formers of good quality in one single layer only. Enamelled wire can be used, but the ideal, of course, is silk-covered, of which very little indeed is needed; failing favourite sources this can be obtained reasonably on two-ounce reels in many standard gauges from Post Radio Supplies of Bourne Gardens, London, E.4. Excellent polystyrene formers are stocked by Stern Radio, Ltd., of Fleet Street, London, E.C.4: those specially recommended for the R9'er are  $\frac{3}{8}$ " diameter Neosid, complete with iron cores, for one shilling each. (In shape only they are similar to those found with wire-anchoring discs in the RF26 and 27 Units.) Neosid formers have simpler anchoring holes and slots provided in the base; if the beginning of the wire is fed down through, say, the rear left-hand hole, laid in its slot and brought up through the front left-hand hole, sufficient can be left protruding for a good

soldered connection. The winding of the coil can be proceeded with and the final top turn secured by a narrow strip of cellophane or similar tape. The end of the wire can be finally passed down through the rear right-hand hole, laid in its slot and brought up through the front right-hand hole for a soldered connection.

### Construction

The former bolts down in the usual manner by means of the fixing holes provided in the base and a spot of Durofix or Polystyrene solution will effectively secure the upper coil-turns. The lay-out, assembly and wiring of the unit is normal and requires very little description. In the present case a flat square of thick tin was first cut and the components assembled on it so that coil L1, stand-off A and the spindle-head of pre-set C2 appeared above-deck on one side of a central upright shield. On the other side of this shield appeared coil L2, spindle-head of pre-set C7, stand-off B, shielded 6AK5 valve and spindle-head of the potentiometer R4. Below deck C1, C2, C3, R2 and pins 1, 2 and 7 of the valve holder were separated from pins 3 to 6, C8, C4-C7 and R3, R4 and R6 by the shield that sat across the valve holder itself. The centre spigot was earthed and a glance at the original circuit showed that the plug-in coil-box, aerial switch and damping-resistors R1 and R5 had been duly dispensed with.

When wired up the whole assembly was simply dropped into a lidless metal box, inside which it came to rest about half-way down on two narrow ledges of wood beading fixed along the sides. The open top allowed easy adjustments to be made to the cores and the potentiometer R4, while at the same time giving free access to the stand-offs A and B.

### Operation

Putting the unit into operation takes only a few minutes. It should first be connected to the receiver by a length of coaxial cable, although other methods may be tried. With only LT on the unit the receiving aerial is clipped to stand-off B and a signal near the centre of the desired CW or Phone portion of the 14 mc band tuned in on the receiver and there left at a comfortable volume. The aerial is then removed from B and transferred to stand-off A, whereupon the signal will probably be heard again on the receiver at the same setting, but more faintly. The potentiometer R4 is now set at about half-way, the HT to the unit is switched on and the setting of C2 and the position of the iron core in L1

are both adjusted until the signal on the receiver becomes greatly increased. By alternative adjustments of C2 and the core of L1 the signal is peaked to its maximum strength. Having accomplished this exactly, the same process is then repeated with C7 and the iron core in L2 until the signal is at its increased and maximum possible strength *without any adjustments having been made to the main receiver in the meanwhile.*

If the HT to the unit is then switched off the settings of C2 and C7 can be examined and if C2 has matched the aerial (already indicated by maximum signal strength having been obtained) with its vanes at full maximum or minimum capacity a more satisfactory meshing may be obtained if desired by altering the length of the aerial. The same can be done with C7 by altering the length of the connection between unit and receiver. Once these points have been settled no further adjustments are needed beyond fixing the potentiometer R4 to give the lowest screen voltage consistent with the highest output. If an auto transformer is already in use in the station for boosting the AC mains up when they drop below normal, R4 might well be replaced by a fixed resistor of the correct value. If the unit has its own power pack, two closed contacts of a "de-energised upon receive" relay may be conveniently wired across a manual switch placed in the pack centre-tap line, so that the unit is automatically switched with the rest of the station and HT is removed from the 6AK5 during transmitting periods.

In conclusion, acknowledgments are due to G5UX and Bernards (Publishers), Limited, both of whom in turn have paid due acknow-

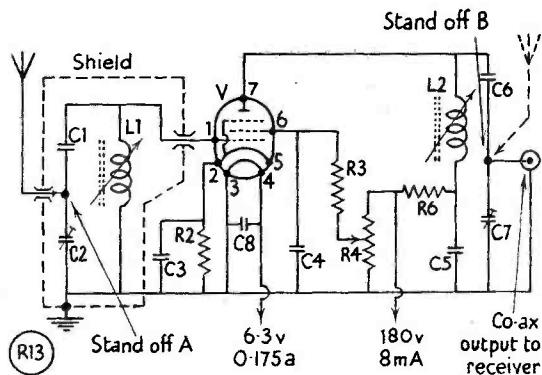

Fig. 1. Circuit of the simplified R9'er for Twenty, after G2NS. This design differs from the original in that the plug-in coil box, the aerial switch and the damping resistors R1, R5 have been discarded. For "straight-through" operation, the receiver aerial is tapped to point B. With the aerial at point A, R9'er action is obtained.

### Table of Values

#### The Simplified R9'er for 14 mc Operation

C1, C6 = 100 $\mu$ F fixed ceramic	R2 = 200 ohms, 1-watt
C3, C8 = 500 $\mu$ F mica	R3 = 15,000 ohms, $\frac{1}{2}$ -watt
C2, C7 = 100 $\mu$ F air-spaced preset	R4 = 25,000 ohms, 3-watt
L1, L2 = For 14mc: 30 turns 24g. DSC close-wound on 3/8in. iron-cored formers (see text)	R6 = 10,000 ohms, 1-watt
	V = 6AK5 (see text)

A, B = Midget stand-off insulators.

(Note: Resistors R1, R5 of original circuit not used.)

ledgment to the General Electric Co., of America. So re-juvenating is the effect of the R9'er on most receivers that in an "empty" band unheard stations are suddenly endowed with life and each springs up to readable strength. Try it and see!

### NEW QTH's

Readers are reminded that all new call-signs and changes of address should be sent to us for appearance in "New QTH's" and the *Radio Amateur Call Book*. We are sole European agents for the *Call Book*, and it is the objective both of the American publishers and ourselves that the G listings in the *Call Book*—which is the world directory of amateur stations—should be as complete, as accurate and as up-to-date as possible.

### DIRECT SUBSCRIBER RATE

With the regrettable but necessary slight increase in cover price, the direct subscription rate for *Short Wave Magazine* becomes 30s. for a year of 12 issues, posted on the day of publication each month. Existing direct subscribers are not affected until their

next renewal falls due, and readers outside the United Kingdom can subscribe at the old rate of 24s. until March 31. Gift subscriptions from home readers for friends overseas can also be accepted at this rate until the same date. Subscriptions can be paid in any currency exchangeable with sterling, and should be addressed to: The Circulation Manager, Short Wave Magazine, Ltd., 55 Victoria Street, London, S.W.1.

### • PHOTOGRAPHS

These are always wanted, and are paid for immediately on publication. Photographs should be clear and sharp, identified on the back, and accompanied by brief notes describing the subject. They can be of either general or amateur interest and can be of equipment, stations or personalities.

# DX COMMENTARY

L. H. THOMAS, M.B.E. (G6QB)

Now and then something annoys us so much that we have to direct our monthly moan, not against our old enemy, "conditions," but against some of the much newer and much more insidious enemies of Amateur Radio—those within the ranks.

Seldom have we been annoyed so intensely and so often as during this past month. The target of our wrath, this time, is not the Spiv, the Grabber, the VFO-Swisher or even the Ordinary Clot, who should no more be allowed to foul the bands than a lunatic should be allowed to drive on the roads.

We refer to the owners of some of these indescribable notes, who add to their loathsome noises a complete lack of elementary knowledge about **How Radio Works**, and proceed to lacerate large slices of our narrow bands with their obscene cacophony. We have in mind a certain EA5 station, whom we heard calling CQ with a wobbly T2 note and an almost unreadable effort at Morse; in the middle of such a three-minute call he paused, held down the key for what we thought was a long dash, but, to our horror, proved to be an attempt to *modulate* the stuff. Unfortunately, it succeeded, to the tune of 500 per cent. or so.

The modulation of an *unstable* carrier wave with an AC component of about 80 per cent. produces results which are not describable in print, and this menace proceeded to whistle and shout "Hola" for ten minutes or so on 14070 kc. completely smearing the band from the bottom

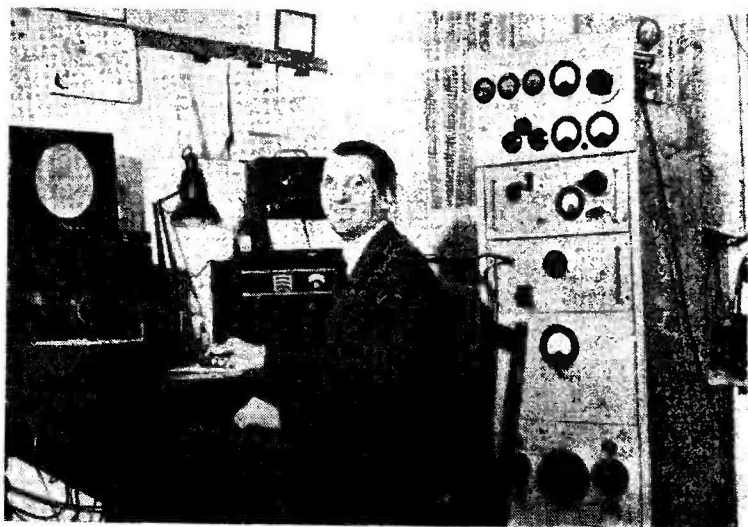

## CALLS HEARD, WORKED AND QSL'd

edge to about 14200 with slimy projectiles of all sorts.

### How to Stop Them

We have dealt with this at some length because it is an extreme case of what is going on all the time. There is only one way to stop these pests, and that is to ensure that they never make a QSO. Then, surely, after a year or so, they would discover that there was something wrong, and proceed to learn the simple facts of radio. Unfortunately, there seem to be people who are quite eager to work them. After the EA mentioned above had given up his "phone" and called a long CQ on the key, back came a well-operated, T9 station from SM, calling "EA?" We hung on, thinking that a monumental ticking-off was coming, but all he wanted was just a nice cosy QSO. This left us wondering which of the two was the bigger Clot.

We have, in a way, a state of anarchy within our ranks, when it

is possible for manifestations like this to take place without swift retribution. It is most important that the law-abiding amateurs themselves should not be passive about it, but should do all they can to suppress these triumphs of ignorance and inability. Don't work them—or, if you must, be as rude as you know how. It's not a question of lending a helping hand to a struggling beginner: it's a matter of suppressing a nuisance who should never have been allowed to begin.

On behalf of ourselves and all fellow-sufferers, we thank you for your forbearance, and will now pass to the more pleasant topics of the month's DX, band by band.

### The DX on Twenty

Despite the usual patchiness of conditions, there has been some good DX about, and even the high-scorers have been able to add a few brand-new ones. One such was 4U-AJ, said to be United Nations Radio, Jammu, Kashmir.

He was worked by G2PL (Wallington) and G5BZ (Croydon). The odd call-sign is accounted for by the fact that the 4U block is allocated to United Nations, but he should have put a figure in the call-sign itself. His country-status is, as yet, uncertain.

No one has reported hearing YA3UU, but G2PL heard YA3MJ (14120, phone) and called him, but had no luck. G5BZ's other catches were VK9XK, MP4BBD, EL2R, FB8BD, TI, FF8, FQ8, ZD1 and the like. 'BZ says he will continue to bind about the phones on 14 mc who come below 14100—including an increasing number of G's, who ought to know better. (Those who sit on 14100 and over-modulate are just as bad).

G6QX (Hornchurch) worked TA3QZ and found G6ZO on the key. Others were FQ8AE, EL2R, VP6IN, TF3AB and—UA1BQ, who replied to a CQ. (One more for the salt mines, but an extra Zone for 'QX, who should be one up on all of us at the end of the year!)

G3FXB (Hove) worked EL2R, FB8ZZ, JA2IM, KV4AA and W3JAK/AR, to mention only a few. Gotaways were EA0AD, VK1BS, VK9XK, VQ8CB and ZS2MI. 'FXB draws attention to the new HA short-wave listener cards, complete with remarks such as "Pse rite mit poste"! No more Russians for a while, but a spate of HA, OK, LZ and even JA cards seem to be coming out.

G5FA (London, N.11) raised VS6BA and 1CZ, PY7LJ, SP1IL and 5A2TP (Tripoli) for new ones this year. G3FPQ (Bordon) found CR7CN, FB8ZZ, ZD1SD and ZA1AA. He awaits a card from the latter! Since raising one end of his long wire to 55 ft., 'FPQ finds it easy to work ZS, which was difficult before. Now they come back to his 24 watts with S7-8 reports.

G2VD (Watford) comes in nicely with KR6HB, EL2R, TI2AG (1300), 3A2AH, VK1BS (1500), FB8BD (1830), KG4AF, ZS3E and many others. He is the highest country - scorer in the Marathon at present, but G5BZ leads him by one Zone. 'VD lists the following Gotaways: FR7ZA,

ZD6HN, EA0AC, CE5AW, YS1O, FK8AB, F18YB, VK9GM and ZS2MI.

G2BW (Walton-on-Thames) lists Gotaways only! They were HS1WL, FB8BD, CR7CK and EL2R. G3A1M (Speke) works most of his DX off the end of his dipole. He lists VU2JV, VS7ES, VK9XK and a whole load of Africans. G6TC (Wolverhampton) has a new aerial, on which his 75 watts raised FF8AC, EL2R, EA6AM, KV4AA and sundry W6, W7 and ZL.

GD3FBS sends in a welcome report from Douglas, I.O.M. He says that most GD stations are confined to one sector for their DX, except GD3UB, whose location permits operation over about 270 degrees. 'FBS seldom hears ZL's, and he can hear ZS's but can't raise them. He could do with both those countries! Although a "rare DX man" himself, 'FBS says he insists that replies should come on his own frequency. He picks a quiet spot and takes what comes, remarking that anyone who can't read more than one signal at a time shouldn't be on the DX bands, anyway. He worked TI2AG, who was using "induction coil HT" of the type associated with CR4SS and other

phoneys; but, strangely enough, we happen to know that this TI2AG is genuine, in spite of his terrific signal at mid-day.

GW3FSP (Skewen) managed to raise VK1WO (Macquarie) and also VQ3BM and 3CP, but spent very little time on the band. G3FXA (Bexhill) worked FQ8AE, FM7WF, KG4AF, VS7GQ, VE8ML (all during the afternoon) and KL7PB and VK3GU around 0930.

G2NS (Bournemouth), in his usual afternoon spells, collected F9JD/FC, MD2DW, 9B3AA, FF8AE and VS7XG. Other things heard on the band were 9A3AR, XU2AB ("Hankow"), F18YB, EA0AB and a very long list of the more usual DX.

G8KP (Wakefield) has at last broken silence, and apparently to some purpose! His DX on Twenty includes HS1UN, FK8AC, ZS7C, F18RO, ZD6DU, FR7ZA, FB8BB, TT2KBC, VQ8CB, FD8AA and quite a few more. It looks like our own list of Gotaways!

G3TR (Southampton) joins the Phone list as support for GM2BDX. His most interesting contact was ZD9AA at 5 and 9 on 14150 kc. Others include FF8, PJ, EA6 and lots of routine DX.

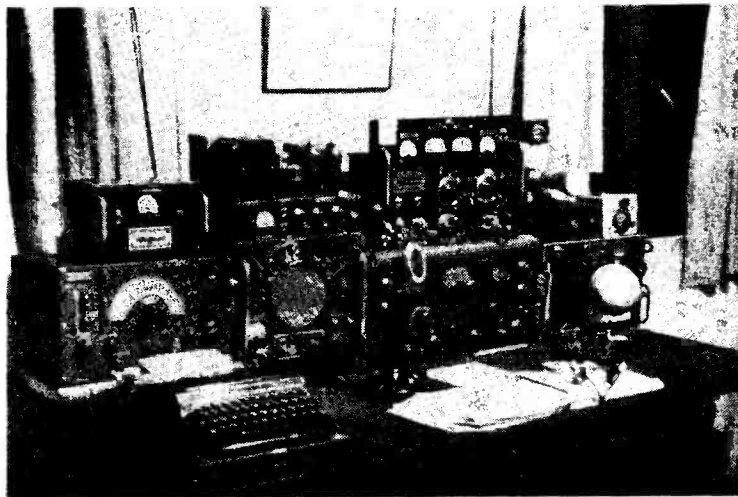

The knobs and dials at GM3ASM, Paisley, Renfrewshire, who on CW and phone has worked 118 countries in 33 zones. The main receiver is an SX-28, with a Hambander as stand-by, and a TCS-12 outfit for the Top Band. The transmitter is VFO control and band-switched for Ten, Twenty and Forty with a pair of 807's in the PA. Plate-and-screen modulation is used, with (unusually) two pairs of 6L6's in push-pull-parallel. Aerials are two 68ft. wires, one connected "VS1AA."

GM3ASM (Paisley) has had more time on the band than usual, owing to an illness, and has collected VK1WO (1430), KR6HB (1015), CR9AF (1115), VE8PS, KG4AF and a lot of other nice ones. He also had a phone contact with KL7ADR, S9 plus at both ends for over an hour. Stuff that he missed, suffering, was FB8BB, FB8ZZ, VP9F, FM7WF, FE8A1, F18YB, EA0AB—but why go on? It's bad enough already! Two queer ones were CU3YY and CU2AH—who the heck?

That just about sizes up the Twenty-Metre news; quite a lively band at times, with short-skip (or is it our fancy?) just a little less troublesome than of late.

**The Forty-Metre Band**

There are not many constant followers of this band, which is too much of a madhouse for any but the most patient and hardened cases. Why is it, though, that everyone still tries to cram in between about 7020 and the band edge? While doing a job in the shack the other night, we monitored a clear spot between 7055 and 7058 kc, and not a soul came near it for the forty minutes between 2230 and 2310. There are some much better spots in between the B/C stations, right up to 7200, than the small areas around 7000-7010 and 7015-7020 kc into which everyone tries to squeeze. If you work DX on

Forty, pass them on the word to use a bit more of the band; goodness knows, we are short enough of kc's without wasting them like this.

The Confirmed Clot is also in evidence on this band. The one we have in mind replies to a "CQ DX" call with an S9 signal bang on your frequency, and a three-minute call at about 5 w.p.m. He turns out to hail from F, DL, PA or somewhere similarly exciting. Any DX that does reply, of course, is just obliterated by the Clot. We called "CQ W6" one afternoon and actually heard one come back, very weak; but on top of him was a European calling us and saying "No W6 on this band." We bet there weren't —on *his* receiver; jolly decent of him to tell us so, wasn't it?

GM3ASM raised 3A2AH, PY4AMG and 4X4DK, but missed VS7NG and a VS6 at 1930. G3FXA managed ZL3OX and SU1DV. G5GK (Burnley) rang the jackpot bell by working VU5AB (Nicobar Is.) for his first G contact. VU5AB was a steady 449—no time given. Others have mentioned hearing him on Forty, although he said in his letter to us that he would be on Twenty only (*see* last month).

G2BJN (Loughborough) did well with W6DFY (0800), VQ4AQ (2000), VE1PA (2035). BJN has a dipole and two fixed reflectors on USA; on this W6DFY was

RST 599, and 'BJN's report 569. G6TC reports ZL's, W's and a ZB1.

G3CFG (Harpenden) worked KT1WH and wonders whether he is a different country from EK. Unfortunately, no. KT1 is the prefix for U.S. personnel in Tangier (corresponding to KP4, KH6 and the like). EK is, and always was, unofficial.

G2VD raised ZS1CX (1800), OX3EL and EA6AM (1900), VK3CP (2000) and KZ5CW (2300). Gotaways were HE9LAA, PX1A and ZA1A.

G2BW thought the band better than Twenty; with his new TVI-proof rig he was on between 2000 and 2200 and worked SU, VQ4, EA6, ZS, PY, ZL and VK. His parallel 807's with a Pi-coupler tank circuit give him 15 per cent. more amps. up the aerial than before, so there's quite a lot to be said for his TVI-proofing.

G3GVY (Buxton) emerged on Forty with 15 watts and one crystal. However, as he says, this gets a bit trying when a BC station gets a replica of one's crystal, so he built a VFO. 'GVY has very sportingly entered his score in the 1952 Marathon Table, as he says "To enable absolutely *anyone* to send in a score without the least fear of being the lowest."

G5FA worked LX1DG, EQ3FM, KP4KD and sundry ZL, VK and W stations. G2HKU (Sheerness) heard a station signing LU0DDH, who has since turned out to have been a ship off the Cape Verde Is. G3FXB thinks conditions have definitely been better, with VQ4AQ and 4HJP a couple of outstanding signals. Best DX was CR5AE, EA8BF, FF8AC, KP4UW, KZ5CP and ZS5FY. Among some good Gotaways were EQ3FM, MP4BAM, M13SL and VP8AK.

G6QX collected one new one—VQ4CM. G5BZ worked VQ4, ZL (morning and evening), EA9, VP4, ZB1 and SU. G8KP says "Can't stick this band for more than a few minutes at a time, but have worked VQ4AQ, 4CM and 4HJP, also SU's, ZL's, EA9 and VS7." Well!

**Eighty—No Mean DX Band**

Following our remarks about G8KP, he has come forward with full particulars of his 80-metre

**FOUR BAND DX TABLE**  
POST WAR

Station	Points	3.5 mc	7 mc	14 mc	28 mc	Countries	Station	Points	3.5 mc	7 mc	14 mc	28 mc	Countries
W2QHH	495	90	90	209	106	209	G6YR	255	16	33	105	101	152
G6QB	480	49	92	204	135	220	G8VG	253	31	74	122	26	140
G2AJ	433	42	81	192	118	211	G2YS	246	38	45	123	40	136
G5BZ	397	48	88	200	61	204	G2BW	238	21	53	133	31	139
G2VD	397	42	79	170	106	178	GM2DBX	217	5	31	101	80	121
G5FA	363	33	110	147	73	162	G6TC	213	17	58	110	28	118
G3FXB	318	40	92	147	39	156	G3GUM	208	28	38	141	1	152
G6QX	311	46	81	129	55	155	GM3EDU	197	37	41	96	23	116
G6BB	306	36	80	136	54	147	G2HKU	181	3	46	118	14	128
HC2JR	293	3	15	143	132	183							



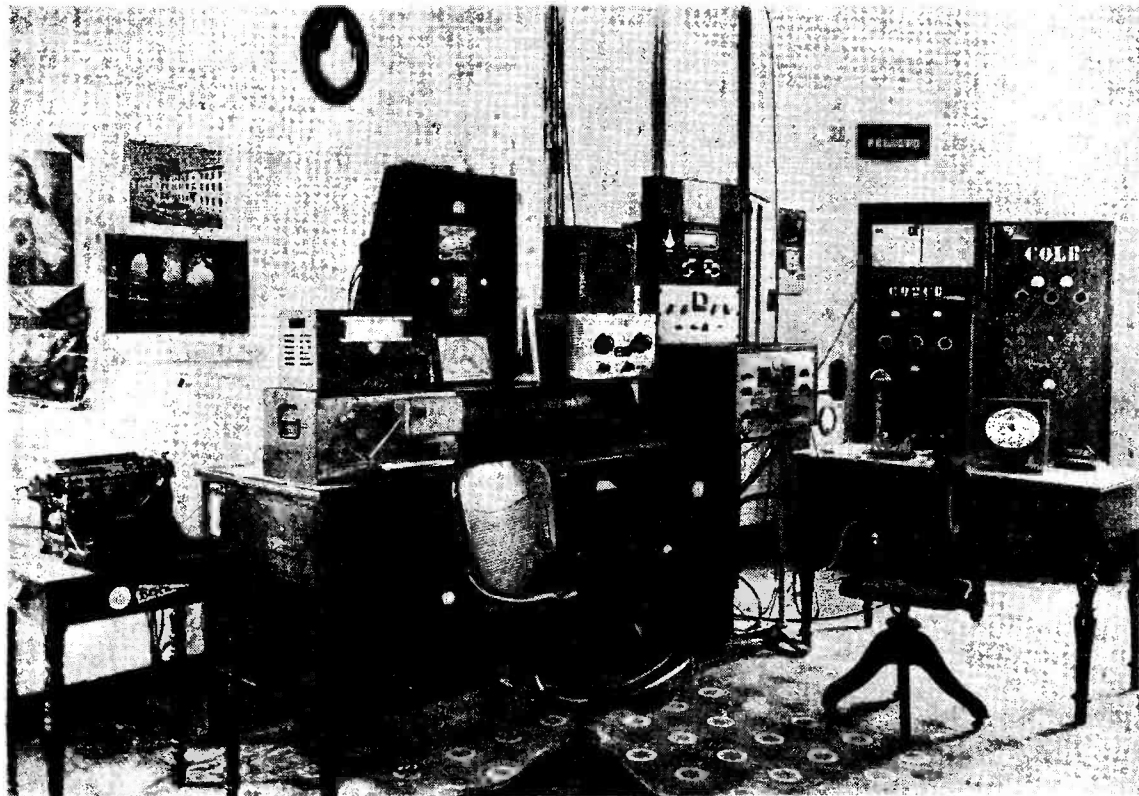

The very fine station of CO2CB, Havana, Cuba. Among many other nice things, he has complete recording equipment. Note the remote reading beam direction indicator.

DX. He started as a novice on the band eight months ago, since when he has worked 52 countries. Among them are PY, ZL, KP4, VQ4, CE, KV4, 4X, EK, VS7, VP8, VP4, OX, W6, OY and many more. He has managed WAC several times—and has got the cards. This just shows what can be accomplished on this band with the necessary patience and operating skill (but you do need some good gear as well!)

G6QX caught 3V8AB for a new one, and heard what he calls a "doubtful" ZB2A. G3FXB had two new ones—EK1AO and SU1FX—and tells us that EI9J now has 70 worked and 59 confirmed on the band. G3FPQ winkled out 4X4BX for his first Asiatic contact on Eighty, and also worked "CK8FB," CT3AB and I1BCB/Trieste. G2VD's offerings are CT3AE and SU1FX.

We hear, *via* the grape-vine, of

all sorts of interesting stations likely to appear on 80. Among them are PK4DA, EL2R and a possible VS6. It's a pity that G stations who have worked so much on this band maintain such a modest silence.

#### Top Band Topics

Although the Trans-Atlantics, up to the present, have been very uninspiring this year, all sorts of good DX *has* been showing up. G3PU (Weymouth) reports a contact with OH7OH on January 26 at 2018 GMT. The QSO was held for 34 minutes, with G3PU's signals S6 and the OH's S4/5.

GW3FSP tells us that TF5TP listened on One-Sixty on February 4. In 25 minutes, from 2230 onwards, he heard G2HW/A, GW3KY (Phone), GW3FSP and 3ZV, G2JF, 2AOP, 6ZR, 3GRL, 3AKW and GW2CUT, in that order. Most of them were S7 or

thereabouts. Dewi also informs us of ZC4XP's schedule, which shows that he is QRX on the band on Wednesdays from 1800 to 2200 GMT, and on Saturday nights from 1800 right through to sunrise on Sunday morning. ZC4XP's frequency is 1850 kc.

G5FA is busy chasing the various brands of WAE (*see* later paragraph) and so he has had to go on the Top Band for the first time in his life in order to get QSL's from GD, GI, GM and GW! He finds it quite fun operating on a new band for the first time, but hasn't worked any DX yet.

G2DMT (Bristol) is an exclusive Top-Band user, and sends us a leaflet disproving the commonly-held notion that Bristol is in the county of Gloucester. Bristol became a county by Royal Charter granted in 1373! Just why this undoubted and authen-

ticated fact is not recognised by authority, nearly 600 years after the event, we are unable to state—but probably someone can enlighten us on the subject. Don't start counting Bristol as a Top Band County until further light is shed, please!

G5JU (Birmingham) sends for our inspection a very interesting report on his Top Band signals from ZD2—Lagos, to be precise. This would seem to be a new one. JU also tells us that VE1EA suddenly appeared recently, having changed his aerial system after a futile spell—so that's why we haven't been hearing him on Sunday mornings. Further QSO's with W9NH are also reported. G2NJ (Peterborough) says he and G6AB both called SM7BNU, calling CQ at 2215—are the SM's licensed for this band?

#### Worked All Europe

The WAE Award, which should give the pot-hunters something to go for while conditions are generally poor, has now expanded itself somewhat. We are indebted to G5FA and G8KP for the following details: The original WAE (40 countries and 100 points) is now known as WAE III. A score of 50 countries and 150 points brings a diploma known as WAE II, and carries a year's free sub. to the German magazine *QTC*. The premier award, WAE I, implies 55 countries and 175 points and carries a free sub. for life! For this you also get an "Honor Metal Sticker" with engraved call-sign. Full details are obtainable from DL7AA, new rules having come into force from December 1, 1951. A substitute list for USSR Zones is given.

G8KP adds that he has more than enough cards for the French award "DUF 4," and has a copy of the full rules; but can anyone tell him how to get 700 francs out of the country? He also suggests that although G2PL holds the only *Magazine DX Award*, it might be an idea to run a table showing how other people are faring with the collecting of the 405 cards necessary for it. His own total is 377. If enough people send their figures in, we will certainly publish them in tabular form.

#### The L.A.B.R.E. Award

This time it is G5JU and G8KP who come to the rescue. This Brazilian "Worked All America" Certificate requires the forwarding of confirmations from 45 countries on or around the American continent, ranging from KL7 and OX in the North to VP8 in the South. Cards and list should be sent to LABRE HQ, Box 2353, Rio de Janeiro. G8KP holds Certificate No. 53, but there are only six others in Europe.

#### General Gen.

G6QX says it was himself who persuaded W2QHH to join our Four-Band Table again—and look where he sits! QX adds that as G6QB seems to be the only one with a hope of catching Howy, we should do lots of hard work on 80 and 20 with that in view. We might, at that—although we don't like sitting on the top of our own tables! There are at least six 'G stations with much higher scores than G6QB, but they refuse to show themselves for some reason or other.

Latest addition to the series of Comic Calls is this collection of 5A's. Those beginning with 5A2C hail from Cyrenaica, and those with 5A2T from Tripolitania.

GD3FBS sheds a sidelight on TVI troubles in the Isle of Man, where, he says, the locals are blamed for the noises emanating from trawlers on 1700 kc, ships on 484 kc, aircraft and airport services near the IF's, and the terrific QRM level from all the electrical installations on the island.

G3GEN (Gloucester) refers to our recent note from VK5WO, and asks if he can help, as he lives about halfway between Staverton and Moreton Vallance. GW3FSP is another one who refers to the use of phone on 14150 kc or below; he adds that if he ever has any aerial or keying tests to carry out, he always looks for a spot in the CW band occupied by one of these phones and performs on that frequency. He confirms that many of them are G's, with some well-known call-signs among them, too.

G3DXC (Watton) nobly owns up to giving us "Duff Gen." on ZB2C (see expostulation from

ZB2I last month). Calling himself "our misinformed informant," he wants to apologise on behalf of ZB2I. DXC adds that, during eight months, he spent roughly seven days in each of these countries: ON, EA, LX, ZB1 and ZB2. He would like to learn from some old hand such as HZ1KE, just how to go about acquiring a licence for use on such occasions with the minimum of delay. Can anyone help him—we can't!

GM2DBX (Methilhill) is now the proud possessor of DXCC Phone No. 418 (No. 4 for Scotland). He worked eighteen months for it and was delighted finally to make it. By the way, the ARRL also sent him an ordinary DXCC, No. 1412; he wonders if this is the first case of receiving a DXCC without asking for it! This year's work from up

#### WAZ MARATHON, 1952

Station	Zones	Countries
G5BZ	26	64
G2VD	25	81
G6QB	25	50
G6QX	21	57
G3FXB	20	51
G3FXA	19	36
G5FA	18	54
G5GK	17	24
G2AJ	16	45
G2BW	16	36
GM2DBX (Phone)	13	33
G3TR (Phone)	12	31
G3BDQ	12	29
G6YR	12	24
G6TC	9	26
G2BJN	9	26
G2VJ (Phone)	7	8
G3GUM	6	14
G3GVY	1	3

*NOTE: New entries in this table must not include QSO's dating back more than two months from the time of entry. Regular reporters should send in their score month by month — three months' failure to do so will be taken to indicate loss of interest and the score will be deleted.*

there includes phone contacts with YI, MP4KAC, OX, CR4, 5A2TN, TA2EFA and VP1CN.

The former ZE3JQ is now stationed at St. Mawgam, Cornwall, and is all set for the day his G licence arrives. He tells us that ZE3IX is QRT and home, and that ZE3JL expects to pack up in April. 'JQ finished up in ZE-land with 113 worked and 93 confirmed.

G3CRY, who was also VP9K, tells us that he is QRT and *en route* for Ceylon on Admiralty service, so he hopes to meet the gang again as a VS7. As soon as his call arrives he will let us know.

### Another Moan

The Department of Low Moans, started off by our own, continues with this one from G2CBN (Hayes). He has found an increasing number of cases in which someone working a rare DX station is "wanted on the telephone" and pauses. After this he goes back and says, "Say, o.m., would you please listen for G . . . on my frequency when we finish?" This seems a childish procedure—getting QSO's by telephone. Do they get their QSL's the same way? (Personally, we wouldn't dream of answering the telephone, or anything so unimportant, during a real rare DX contact.)

'CBN has been taking his DX as it comes since 1926, and he was VU2BM from 1930-34. Now, he says, "If I don't get the DX man, I'm just as happy working a local. He probably has something more interesting to say than the DX station, who is so fed-up with repeating his remarks that you can hear him yawning with boredom."

### News From Overseas

DL6MU (Konstanz) tells us that he has resigned from his position of Test Manager of the DARC since hearing that the latter body are struggling for higher power for the DL amateurs. He has heard figures of 600 watts quoted. He says: "I write to ask you if you can support our fight contra Superwatts; we mean that the bands are full, so it is necessary to hold discipline, not to go to commercial-watts, so catastrophic for the latter develop-



One of the world's leading low-power stations. W2QHH, Hamilton, New York, in his attic shack—and he has got nothing round the corner! Never running more than 35 watts, he has a long list of "firsts" and most of the DX certificate awards. W2QHH has been particularly successful on Eighty, using an end-fed 270ft. wire.

ment of our hobby in all the world."

We entirely agree; the effect of shoals of DL's with the best part of a kilowatt would be "catastrophal" for us. The Italians, with their kilowatt of phone, are already a solemn warning of what can happen. Personally, we should like nothing better than to see a world-wide limit of 100 watts—and some efforts to enforce it.

The genuine ZK2AB (Niue Island) writes to say that when he returned there from ZL in July, 1951, he found a terrific pile of QSL's acknowledging contacts on Twenty. He had never worked on any band but Eighty and naturally can't QSL all these cards. Will the owners please take this as official notice that they worked a pirate? (We heard that guy many times and can't imagine anyone being taken 'n. He used to come in at RST-577 late at night!)

VS6HR is another overseas stalwart shortly to close down

He is also G3CDR, but doesn't tell us whether he is coming home or going somewhere else.

An old friend who crops up with the call ZC4RX is none other than G3FNJ—the former SV1RX. Norman is now comfortably installed in Cyprus, having had some hectic times in the Canal Zone. He says that Cyprus has two main mountain ranges (up to 5,600 ft.) but the centre of the island is a rhombic man's paradise and as flat as a pancake. His nearest neighbour will be ZC4KN, 14 miles away, so ZC4 might well turn out a "paradise" for ZC4RX.

And that just about takes care of this month's mail, so we will wish you everything good until next time. The deadline for April is first post on March 12, and the one after that will be first post on April 16. Address all your gen. to "DX Commentary," *Short Wave Magazine*, 55 Victoria Street, London, S.W.1. Until it arrives, 73, Good Hunting, and BCNU.

# Audio Frequency Amplifiers

## DESIGN AND CONSTRUCTION

### PART I

J. N. WALKER (G5JU)

*Though the ideal of "hi-fi" for amateur band phone working is to be severely discouraged—due to the much greater band widths it requires than are needed when transmitting speech which is merely of good communication quality—there is nevertheless ample scope for high-grade audio equipment in many non-transmitting applications. It is the intention in this short series of articles to discuss in detail the design and construction of a self-powered Audio Amplifier capable of giving 5 watts output with negligible distortion over a wide frequency range.—Editor.*

**T**HIS is the first of a series of articles which will culminate in the description of a relatively inexpensive quality type audio amplifier, capable of delivering five watts or so of audio power with very low distortion and suitable for use with radio, pick-up or microphone. The design points discussed are taken care of in the final equipment, but it is not proposed to treat every point in minute detail — to do so, and provide alternative circuits, would call for almost a full length article on each subject. Sufficient is said to indicate the importance of the many aspects which it is necessary to bear in mind when designing and constructing an amplifier to give really good quality.

Interest is increasing in the high quality reproduction of gramophone records, of radio programmes and in home-recording applications. Whilst the quality provided by the average medium-priced broadcast receiver is reasonably good to the uncritical ear, the single pentode valve output stage usually found in such a receiver can introduce quite a degree of distortion, and the discerning listener will obtain much improved reproduction by employing a separate and properly designed amplifier.

When extreme high fidelity combined with a rather large power output is desired, the equipment becomes somewhat expensive, but a simpler unit, capable of giving excellent quality

at a level adequate for a room of average size, can be constructed at no great cost. Such a unit then becomes available directly for the playing of gramophone records; it comes in useful at times for reproducing speech from a remote source and/or to an assembly of people; for "PA" on speakers round the house; and, with the addition of a radio feeder unit, which can be of a simple type, local broadcast transmissions can be received at the utmost the B.B.C. can give in terms of quality.

### General Design

Quite a number of factors are involved in the design of an audio amplifier if it is to work really well, whilst a number of refinements are generally desirable to cater for individual tastes. These factors are absence of distortion, overall gain, power output, noise and hum level, introduction of negative feedback, tone controls and choice of valves. Physical size, cost and ease of construction also call for consideration whilst other links in the chain such as type of pick-up, microphone, radio feeder unit and, last, but by no means least, the speaker into which the output is fed, can make or mar the final results.

### Power Output

It may seem a little unusual to discuss first the stage which, when running one's eye over a circuit diagram, comes last, but for all that the power output stage is relatively the most important and affects the design of the amplifier as a whole. When assessing the audio power output, two points must be borne in mind. The first is that whilst the *average* power called for may be quite low, there must be ample reserve in hand to take care of the loud passages of music (and distortion must still remain low at the higher level). Secondly, the human ear is insensitive to bass notes relative to the middle and upper register, and to obtain what appears to the ear as a proper balance, the output stage must be capable of delivering a fair amount of power at low frequencies. Therefore, although for normal domestic use two watts average output is ample, it is desirable to employ an amplifier capable of delivering five or six watts over a wide range of frequencies—say from 30 or 40 cycles up to 12,000 cycles. It may be noted here that an ordinary domestic receiver will give little or no output below 60 cycles (often 100 cycles) or above 5,000 cycles.

There are a number of ways of producing the requisite amount of power. A single valve, of the heavy duty beam power pentode type, will deliver it at a pinch, with quite high anode

efficiency, but distortion will be marked on loud passages, when it may rise to as much as 10%. Two such valves in push pull are better, and second (and even) harmonic distortion will be reduced; but third and uneven harmonic output will still be undesirably high. Unquestionably, the use of triodes is much more satisfactory and the fact that the efficiency is lower and also that a greater voltage swing on the grids may be required, simply mean that one cannot get something for nothing.

Another benefit conferred by the use of triodes is the broader matching to the speaker which results. Pentodes tend to emphasise the higher register—not, as many think, because this type of valve amplifies high notes more than low (it does not), but because the high output impedance makes difficult correct matching for maximum output with minimum distortion, and, unless a very special output transformer is used, matching improves at the higher frequencies. But this state of affairs is modified when negative feedback is employed, as mentioned later.

With either triode or pentode output valves there are definite advantages to a push-pull circuit. Ripple present in the HT line is cancelled in the output and smoothing requirements are thereby simplified. More important, the direct current through the windings of the output transformer causes the static magnetic field to be cancelled out and the transformer operates under true alternating current conditions. The risk of the core saturating at high signal levels—and such saturation introduces intolerable distortion—is practically eliminated. The output valves must, however, be truly balanced to achieve this in full degree.

### Operation of Output Valves

Space does not permit a full explanation of the Class-A, Class-AB and other modes of operation. Class-A (no change of anode current) gives the least degree of distortion, constant matching and lowest efficiency. It is the one most desirable for quality work, and, in actual fact, any amplifier with normal or near normal bias operates in this mode when the input voltage and output power are low. At greater levels, it is usual to allow the valves to operate in Class-AB, which means that the anode current rises somewhat with signal but grid current does not flow. Efficiency is thereby increased and smaller valves can be used than would otherwise be possible, whilst distortion remains reasonably low except when the valves are driven unduly hard.

### Output Valves

There are a number of readily obtainable valves suitable for the purpose. Most of them are of the pentode type, but they can easily be connected and used as triodes. Of the octal types, the Osram KT63 and KT66 and Brimar 6V6 are good and, in the miniature range, the Mullard EL91 and Osram N78 are recommended.

The power output is dependent on the anode voltage and the latter may need to be 300 volts or more, but this is quite permissible, provided the operating conditions are correctly chosen.

### The Output Transformer

Something has already been said about the output transformer, but it should be emphasised that this is a most important component. It is pointless—and false economy—to design an amplifier to give the highest possible quality and then to employ a small transformer which will not adequately handle the load. The transformer should be of good manufacture, wound to match correctly the stated output impedance of the valves into the speaker impedance, rated to handle at least the maximum peak output and preferably a little more, and with windings capable of easily carrying the anode currents of the output valves.

### Loud Speaker

Distortionless output can only be converted satisfactorily into sound by a speaker which in itself has a linear response and which is capable of reproducing the full range of frequencies fed into it. This is a tall order in a single speaker. In expensive high fidelity equipment, twin speakers are often employed, one designed to respond to the lower frequencies and the other to the higher frequencies. The situation is then complicated by the necessity of inserting units to give proper matching and will not be dealt with further here.

Preferably a 10-inch speaker, of reputable manufacture and mounted in a large cabinet or baffle, should be chosen. In any case, the speaker diameter should not be less than 8 inches—a smaller one may prove satisfactory for initial tests but overloading on peaks will produce distortion and cross-modulation. The cone will gradually lose its correct stiffness and the coil, which makes large movements on the lower notes, will probably suffer.

The actual impedance is not of great moment. In the smaller sizes, 3 ohms is an average figure but in a speaker rated to handle a fair amount of power, it is common to

employ 15 ohms. The important point is that the output transformer must match the speaker impedance and a tapped winding is often provided for the purpose. The connection between speaker and transformer, if long, must be made of wire of moderately heavy gauge, to minimise voltage drop.

### Overall Gain and Input

Having discussed the output stage, it is time to go back and consider the earlier stages. These are required to provide voltage amplification only, finally delivering a truly balanced voltage, with low distortion content, to the grids of the output valves, the amplitude at maximum reaching that required for full output.

The necessary voltage can be secured with one or two high gain stages or with a greater number of low gain stages. But the overall gain and the means of obtaining it cannot be divorced from two other factors—voltage swing at each stage and distortion. A valve will accept a certain maximum AC voltage at the grid, according to type, grid bias, anode voltage, and so on (generally termed the parameters). The greater the *ratio* of actual input voltage to maximum permissible input voltage, usually the greater the degree of distortion introduced at that point, and if, say, two high gain stages are operated at or near full *output* (the gain remains the same irrespective of output), quite considerable distortion will be introduced. Although negative feedback (of which more later) can be employed to minimise such distortion, it is obviously desirable to keep it to a minimum at the start. It therefore pays to keep the grid swing on each valve relatively low, even though so doing involves the use of one or more additional valves.

The voltage available from a pick-up will generally be 0.25 volts or more, from a radio unit something of the same order and from a microphone (direct if crystal and *via* a step-up transformer if moving coil) much less, possibly only some 0.05 volts. Sufficient gain must be provided to deal with the latter, but, in any case, this range of voltage is easily handled by the first valve, which, for best signal-to-noise ratio, is allowed to accept the full voltage. In certain cases, when a radio unit or pick-up delivers an unusually high voltage, a fixed attenuator may be necessary as otherwise the volume control will be operative only over a small portion of its traverse and will consequently be difficult to adjust satisfactorily.

The tone control circuits can well be associated with this valve, and, to have a reserve of gain in hand, it is well to use a pentode valve which can be expected to give an amplification of the order of 80 to 100 times. In many cases, however, adequate gain will be secured from a triode valve giving an amplification of about 40. The next stage is arranged for moderate gain, the valve used being capable of accepting a fair grid swing (10 to 15 volts) without distress. A proportion of the voltage appearing across the secondary of the output transformer is injected into the cathode circuit of this valve.

### Penultimate Stage

The unbalanced voltage appearing across the anode load of the second valve must be converted into a balanced voltage for application to the output valves. Also as feedback will reduce the normal gain, it is desirable that the penultimate valve or valves give a certain amount of amplification, although this need not be high.

An intervalve transformer could, of course, be used and that possibly without additional valves, but it is bad policy to do so because transient response will be poor and also because instability over the feedback loop is likely to occur at some frequencies.

Then there is the method of using a single valve with equal load resistors in anode and cathode circuits. Because of the cathode follower action, gain is low and a high grid swing must be applied, which is a disadvantage. The method recommended is to use two triode valves (which may in practice be a double triode in a single envelope), one being driven directly from the preceding stage, the other taking its input from a potential divider in the anode circuit of the first of the pair, to give the requisite phase reversal. Means must be provided to adjust for correct balance, but this is not difficult.

### Noise and Hum

The degree of noise in the output will depend to some extent on the magnitude of the input voltage. When this is low, as with a microphone, a little noise may show itself, but it can be reduced by careful choice of valves (triodes are better in this respect than pentodes) by adequate screening and by using only good quality resistors and other components.

The securing of a low hum level calls for good smoothing of the high tension supply, proper by-passing where called for and careful positioning of the components, particularly the

iron-cored ones. In a stubborn case of hum, it may be necessary to adopt balanced heater wiring, and the latter is, of course, essential when directly heated output valves are employed.

### Distortion

The word "distortion" has occurred many times, but nothing has so far been said about the various kinds of distortion which may be introduced by an amplifier. The first is amplitude distortion—which simply means that the whole frequency range applied to the input is not being amplified equally. Usually the middle register is emphasised compared to the low and high notes. It is therefore necessary to take care that *all* frequencies are amplified equally, although the insertion of tone control circuits will, of course, affect the response, but in a deliberately intended manner.

Then there is harmonic distortion, which means the introduction, through incorrect operation of a valve or transformer, of harmonic components which were not present originally. Second, and even harmonic components, if of low amplitude, can easily pass unnoticed, but third and following odd harmonics are distressing to the ear. For true fidelity, *all* harmonics must be reduced to the absolute minimum.

Finally, there is phase distortion, caused by the time constants of the intervalve couplings changing the phase of some frequencies relative to others. Fortunately, the ear is tolerant of this form of distortion within moderation.

Proper reproduction of transients and avoidance of inter-modulation effects are other points coming under the heading of distortion, but if all the valves are working well within their limits and the output stage properly matched to the load, no difficulties will be experienced in these directions.

### Negative Feedback

Reasonably good quality will be secured on the lines indicated earlier without the use of negative feedback, but the application of this confers several advantages and has but one disadvantage (if not applied excessively)—the necessity of ensuring that the overall gain is sufficiently high originally to permit the considerable reduction which occurs when feedback is used.

Negative feedback increases the linearity of an amplifier and tends to correct the falling-off at the low and high ends of the frequency spectrum applied to the input. It also decreases harmonic distortion and, properly applied, it

lowers the *apparent* impedance of the output valves (wrongly applied it can increase the impedance). The matching impedance remains the same and the benefit obtained is due to the heavy damping factor reflected into the speech coil of the loud speaker. This damping reduces the natural resonances of the speaker—or rather the build-up of sound at these natural resonances is prevented to a large degree, which factor in itself leads to more faithful reproduction.

Much of any non-linearity found in an amplifier is due to the output transformer—the power is not transferred to the secondary at equal efficiency throughout the frequency range—and it is therefore most desirable to take the feedback voltage from the secondary of this transformer, so that it is included in the overall feedback chain.

The feedback can be applied to the output valves only or be made to include some of the earlier stages. From the linearity angle, the more stages included the better, but, at the same time, the greater the number of stages covered, the greater must be the overall gain and also the greater the likelihood of instability through phase changes in a number of intervalve couplings.

There is an important point to consider here. Tone control circuits must not be included in the feedback loop—a little thought will show why. The action of negative feedback is to level up the amplitude of all frequencies appearing at the output to the ratio at which they were applied *at the input to that part of the amplifier where feedback is introduced*. It will therefore tend to nullify the action of the tone control circuits, which must therefore take effect prior to the first valve taking feedback.

In some cases it will be found that feedback is applied over the amplifier as a whole, but then an external tone control unit has to be added. For the present, it is simpler (and performance is excellent) to include the tone control circuits in the first stage and apply feedback to the remaining stages.

Incidentally, the voltage from the output transformer must be taken in the correct phase to oppose the original signal—otherwise the feedback will be positive, a state of affairs which will be quickly indicated by instability (probably a howl), severe distortion and poor quality.

### Tone Control

There are several reasons why some measure of tone control is desirable. During the disc

recording of music, restriction of the amplitude of low notes has to be introduced as the grooves in the record simply will not accommodate the actual range of amplitudes generated at the microphone. When reproduced, bass boost is necessary to compensate for the loss.

The intelligibility of speech (or at least of male speech) is improved if the bass tones are reduced in strength relative to the remainder. With radio, and to some extent with records also, individual tastes differ, and, whilst initially the amplifier should possess a flat characteristic, variation of the bass and treble response, relative to the middle register, is usually a requirement.

There are many ways of causing the frequency response to be affected, some of

them being quite complex and calling for several valves, but most needs can be adequately met by switching various combinations of resistance and capacitance in the first stage and this is the system adopted in the amplifier to be described. One point about this should be mentioned—there must be some amplification in reserve if the tone control circuits are to work properly (special valve operated circuits excepted). For example, bass boost comes about by arranging for the valve to amplify the low tones to a degree greater than the other frequencies which, in the converse, means that full gain is then no longer available for these other frequencies. This is another reason why the use of a pentode valve was recommended earlier as the actual available gain is reduced by the tone control circuit.

*(To be continued)*

### **HIS LATE MAJESTY KING GEORGE VI**

The melancholy event which fell upon the Nation with such shocking suddenness on February 6, 1952, recalls the fact that the King was himself greatly interested in radio practice and technique — as indeed he was in all branches of science. Having been brought into contact with "Signals" during his early days in the Royal Air Force, his interest was a practical one; in the middle 20's, when still Duke of York, like many other people at that period, he was a keen constructor of BC receivers. This led to an interest in the short waves then in process of development, and at one time there was an expectation that he might come on the air himself with an EG callsign, though this never actually materialised.

The Nation has indeed lost not only a King, but a man of great intellectual stature and wide practical knowledge, whose unmistakable contribution to our times will be told in the pages of history. It is from his example that the young Queen, his daughter, Her Majesty Queen Elizabeth II, will derive not only deep inspiration, but also the loyalty and devotion of countless millions — which, with Her Majesty's own true qualities, promises to make the new reign one of the greatest and most fruitful in all our long history.



IT has been a very pleasing thought, since this feature began, that every kind of enthusiast for our common hobby can contribute an idea or two. This has, in fact, been happening, and your elderly rambler's post-bag has included some interesting reminders of past glories from even older Old Timers than himself. This month's best idea emanates from one who started in 1911 and would like to build a replica of his original station. As, however, this would be far from pleasing to the authorities, he proposes to collect the necessary pieces for recreating his station of 1922-23, which worked on the "150-200 metre band." Such a station, working with 10 watts on 160 metres, will be able to hold its own with any 1952 model and should bring its owner lots of forgotten thrills from the past.

---

### UNINTELLIGIBILITY

As the trawler skipper is to phone, so are some ex-Service operators to CW; and let us hasten to add that there are many exceptions on both sides. But the Chinese or Japanese variety of Morse seems more common these days than ever before. Much of it would be very hard to read off an undulator or a siphon recorder—one wouldn't know which were dots and which were dashes. On one side we have a certain French prescription: "Dots equal dashes equal spaces." This brand sounds like someone operating a straight key with the aid of a long-handled broom, probably in his left hand. On the other we have the squeezed-out dot, nearly (or quite) as long as a dash, suggesting the handling of a straight key, on the edge of the bench, with a 7-lb. weight tied to the wrist. Once upon a time this was supposed to be good for getting through static, or something. Then we used to have "DX Swing," which, by the way, has passed out now. This consisted of giving a false rhythm to practically any character one wished to maltreat, thereby showing individuality or something.



Are any of these curious things as easy to copy as ordinary auto or the output of an electronic bug properly handled?

---

### IMPROVEMENTS ?

This prompts the rather sad thought that so many of these modern improvements, judging by *what you hear* (and what fairer way of judging could there be?) are perhaps not so clever after all. We still hear speech quality that would have disgraced us in the 1920's, and the fact that it emanates from super-modulation or Clamper or what-is-it circuits makes it no better. To hear, once again, the telephony put out by some of the well-known stations 25 years ago would be as a breath of fresh air. The gear? Probably a smallish triode in the PA (or oscillator!) and a slightly bigger one as modulator, running Class-A and driven by two or three more smaller triodes. Possibly the origin of it all was a good carbon microphone, carefully fringed to give "BBC quality." At all events, the quality was there, and, for all the absence of compressors, expanders, clippers and whisker removers, it didn't spread as much as a lot of the phone one hears today.

---

### PIRATES

Are we amateurs such a powerless lot that we cannot raise a

concerted squeal any more? We know that the 7 mc band, above 7100 kc, is "shared" (what an idea!) with broadcasting stations. In fact, we resign ourselves to accepting that what was once a fine band of 700-7300 kc is now reduced to one-third of its width. But by whose authority or mandate do these wretched broadcast stations operate on 7015 and 7025 kc, or thereabouts? And who *listens* to them? They seem to be grinding out gramophone records of scratchy quality throughout most of the day, presumably for someone's edification. What a pity we are not licensed for a kilowatt over here; a concerted onslaught by ten or a dozen amateurs would make these pirates move. We even concede that there is a certain usefulness about *some* short-wave broadcasting; but what is to be gained by this continual drip, drip of sawn-off music in a part of the band where broadcasting is not normally found, is not legalised, and is certainly not wanted? Does *anyone* listen to the stuff?

---

### CANDOUR

It seems that all outgoing reports from some stations are consistently optimistic. We have heard a well-known DX operator handing out S9's to stations barely readable to us; we have heard another station giving a T8 report to a man who was honestly no better than T3 but would have richly deserved a T1. Is it that the DX-urge and the QSL-complex makes cowards of us all? In contrast to such timidity, we will recall a rare DX type (3A2AB, to be precise) boldly replying to a PA station by saying "You should be ashamed to go on the air. Your note is a disgrace to you." (Or words to that effect). But then *he* was at the sending end for QSL purposes, and our euphemistic friends are, or hope to be, at the receiving end thereof. Can't we have a little more honesty and a few outspoken criticisms of bad notes, bad phone and bad operating?

# Constructing the Cascode

BROAD-BAND CONVERTER FOR TWO METRES

R. H. WEBB (G6XY)

*Many excellent VHF converter designs have been discussed in these pages during the past few years, but this is the first detailed description of the building of the Wallman Cascode—a design originating in the States, and now widely used in many commercial VHF applications. All who have ever constructed a VHF converter of any kind will find the information given here ample for obtaining successful results with the Cascode—Editor.*

**T**HIS article is prompted by the considerable interest shown by VHF operators in the Wallman Cascode circuit as applied to signal frequency amplification and also by the lack, in this country, of any essentially practical information on the construction of a converter or receiver embodying this circuit and the results which may be expected from it.

Originality is not claimed for either circuit or layout. The unit to be described represents the writer's best effort to combine desirable features, based on all available information, in a unit which may be readily constructed by the amateur of average skill using components which can be had at reasonable cost.

The converter to be described is for operation in the 144-146 mc band, but highly satisfactory results may be realized at 28-30 mc, using the same circuit and layout with suitable adjustment of the various component values.

## Signal-Noise Ratio

Before proceeding to the actual construction of the converter a few words concerning the results to be expected may not be out of place. First and foremost, it must be fully realised that the object of the Cascode circuit is the reduction of noise-level as distinct from the increase of signal strength—do not expect the signals which were S6 on your old converter to be S9 or even S8 on the new one; if they are your old converter was not much good! Rather, look forward to being able to resolve, with the Cascode, those weak signals which were previously down in the noise. Disappointment has been expressed by some users of the Cascode circuit that there has been no increase in the strength of average signals and it is, therefore, most essential to direct attention to the advantage of improved signal-noise ratio rather than to the level of audio output at the

loudspeaker—which could be all noise. Once this is fully appreciated, the Cascode converter, properly constructed and adjusted, should give better results than most types of converter in current use on the two-metre band.

It is not the purpose of this article to discuss the theory of the Wallman circuit in detail. This is already known to most interested readers, and several excellent articles dealing with the theoretical aspect have already appeared, but it may be as well to clear up one or two less well-understood points before dealing with the actual construction of the converter.

## Circuit Arrangement

The basic circuit consists, as will be seen from Fig. 1, of two triode stages in cascade, a neutralized grounded cathode stage followed by a grounded grid stage. This combination has the desirable effect of giving the gain of a pentode stage and the inherent noise level of a triode, a state of affairs much sought-after by all VHF operators.

It can be shown that, using the circuit constants given herewith, the bandwidth of the RF stages of this converter is around 5 mc, and thus it will be seen that there is no point in trying to peak the tuned circuits L1, L2 (and to a lesser extent L3) by means of variable condensers—if the coils are constructed in accordance with the table and set up as described later the response of the converter will be uniform over the whole of the 144-146 mc band. Once again, it must be emphasised that it is signal-noise ratio we are after and not merely gain. This circuit will show a small advantage over the popular push-pull 6J6 RF stage as we only have the noise factor of one valve to contend with as compared with two.

The Wallman circuit, if laid out as shown, also offers extreme simplicity of construc-

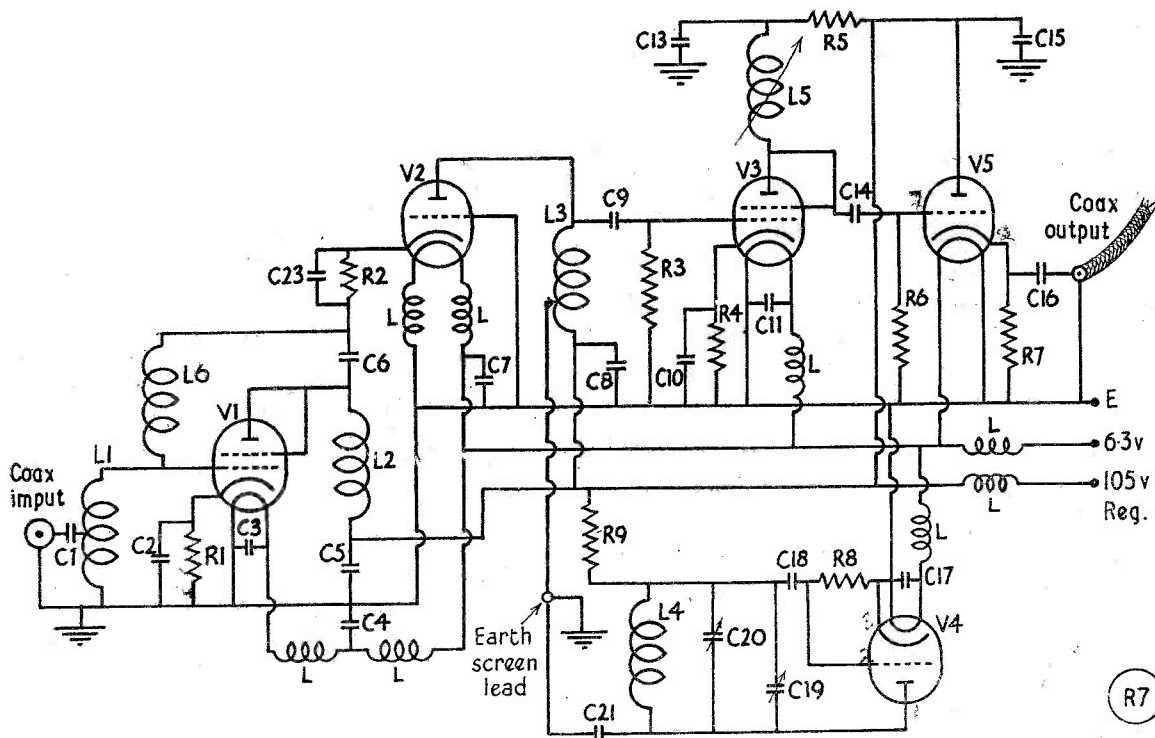

Fig. 1. Circuit complete of the Cascode Converter for 144 mc, as described by G6XY. All values are given in the table.

tion and complete freedom from neutralizing difficulties, something which cannot always be said of the push-pull 6J6 design, although this latter can be extremely good if carefully adjusted. The writer has built many converters of both types and there is no doubt that the Cascode is much simpler to get going and every one of the several in use in his area has worked satisfactorily from the word "Go," the only critical adjustment being the setting-up of the local oscillator to the correct frequency.

**Construction**

Proceeding now to the actual construction of the converter, the physical layout will be readily seen from the photographs. It would be hard to improve upon this layout arrangement as only two leads in the RF stages exceed a fraction of an inch in length, all earths are short and direct, and all voltage carrying leads are below the sub-chassis, being by-passed where they go through the chassis.

Decoupling is very thorough indeed in order to prevent any possibility of undesired feedback or unintentional coupling.

The five parts of the assembly are cut out

**Table of Values**

Fig. 1. Circuit of the Wallman Cascode Converter. ]

- C1, C2, C3, C4, C6, C9, C10, C23 = 220  $\mu$ F. ceramic.
- C5, C7, C8, C11, C17 = 500  $\mu$ F, TCC Micadisc.
- C13, C14, C15, C16 = 1000  $\mu$ F. ceramic.
- C18 = 100  $\mu$ F. mica.
- C19 = 3/30  $\mu$ F. Philips trimmer.
- C20 = 5  $\mu$ F. variable.
- C21 = 2  $\mu$ F. ceramic.
- R1 = 68 ohm  $\frac{1}{2}$ w.
- R2 = 100 ohm  $\frac{1}{2}$ w.
- R3 = 4300 ohm  $\frac{1}{2}$ w.
- R4 = 2200 ohm  $\frac{1}{2}$ w.
- R5, R9 = 1000 ohm  $\frac{1}{2}$ w.
- R6 = 47000 ohm  $\frac{1}{2}$ w.
- R7 = 1000 ohm 1w.
- R8 = 22000 ohm  $\frac{1}{2}$ w.

- L1. 5 turns 16 SWG. 3/8in. inside dia., tapping point 3 turns from ground end.
- L2. 4 turns 16 SWG. 3/8in. inside dia.
- L3. 3  $\frac{1}{2}$  turns 16 SWG. 3/8in. inside dia., oscillator input tapping at 2/3 turn from cold end.
- L4. 2 turns 16 SWG. 3/8in. inside dia.
- L5. Coil wound on 3/8in. dia. slug-tuned former to suit IF.
- L6. 28 turns, spaced one wire diameter, on 1/8in. polystyrene rod. (28 SWG.)

(Coils L are suitable RF chokes).

of 20 SWG tinplate as shown in the drawing Fig. 2 (copper or brass may, of course, be used, but tinplate is every bit as satisfactory and enables really sound soldered earth connections to be made with ease). The extra  $\frac{3}{8}$ -in. hole "X" in one of the interstage screens is to accommodate the neutralizing coil which may be seen in one of the photographs. The

two holes A,A, in the panel register with the similar holes A,A, in the turned-down lip of the sub-chassis, the two parts being bolted together with 6 BA bolts and nuts. The third hole A in the sub-chassis is of suitable size to enable the earthy end of L1 to be pushed in and soldered very firmly to the tinplate; a good joint at this point is most important.

The valve line-up comprises a neutralized, triode-connected 6AK5 followed by one half of a 6J6 in the grounded grid stage, a triode connected 6AK5 as mixer and a 9002 as local oscillator. V5 is a 6C4 connected as a cathode follower, the function of which is to provide an output impedance suitable for connection to the input of most communications receivers; this latter stage may be omitted and the output taken from a link around the cold end of L5 if so desired.

There is room above the local oscillator valve for a 6J6 oscillator/multiplier and crystal if it is thought necessary to use a crystal-controlled local oscillator. In this case, V4 becomes the final multiplier and all tuning is done on the main receiver, there being then no variable controls on the converter itself.

Looking at the back of the panel as shown in the photograph, the upper left-hand  $\frac{3}{8}$ -in. hole accommodates the coax input socket and the valve-holders are mounted in the remaining holes as follows: Left to right, V1, V2, V3, V4, with V5 above V3 and the holders orientated as follows: V1, pin 1 at bottom, pins 3 and 4 on left. V2, pin 7 at bottom, pins 3 and 4 to right; V3, pin 1 bottom left and pins 5 and 6 top right; V4, pins 3 and 4 at bottom, pins 6 and 7 on left; V5, directly above V3, has pins in the same positions as V4. This

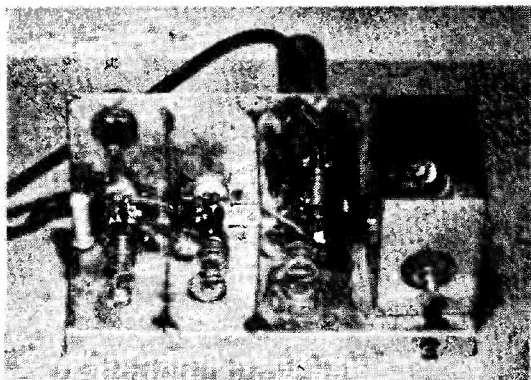

Sectional layout view of the G6XY version of the Cascode Converter for Two Metres.

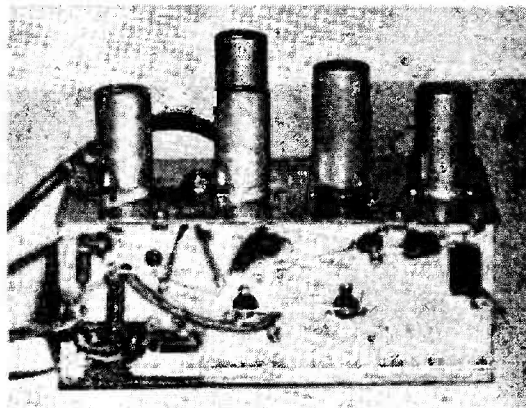

The valve layout in the 144 mc Cascode Converter as constructed by G6XY and fully described in the article.

arrangement makes for direct earths and short leads.

#### Assembly

The panel and chassis may now be bolted together as shown and all wiring carried out with the exception of the anode leads to V1 and V2 and the mounting of the neutralizing coil, L6, before the oscillator and interstage screens are placed in position. These screens are then soldered in place, the interstage screen with two  $\frac{3}{8}$ -in. holes being between V1 and V2. The anode leads and the neutralizing coil are then passed through these holes, which may be fitted with rubber grommets if desired, and soldered into place. The screened lead carrying the injection voltage from the local oscillator to the mixer is taken below the sub-chassis to a point just below L3, the braiding being securely soldered to the sub-chassis at several points. The cold ends of L2 and L3 are supported by the Micadisc feed-through condensers C3 and C8. C1 is soldered directly to the coax input socket and the correct point on L1. It will be appreciated that throughout it is necessary to use the physically smallest components available in order to achieve a neat layout and to avoid stray capacities.

The local oscillator components must be rigidly mounted and wired with heavy gauge wire, the tuning condenser C20 being mounted on an insulated bracket, as its spindle is at HT potential.

L5 is wound, to suit the IF selected, upon a  $\frac{3}{8}$ -in. slug-tuned former and is located between V3 and V5. The IF in the writer's case is 14 mc; a fairly high IF is desirable in view of the wide acceptance of the input circuit to avoid swamping of the RF stages by the out-

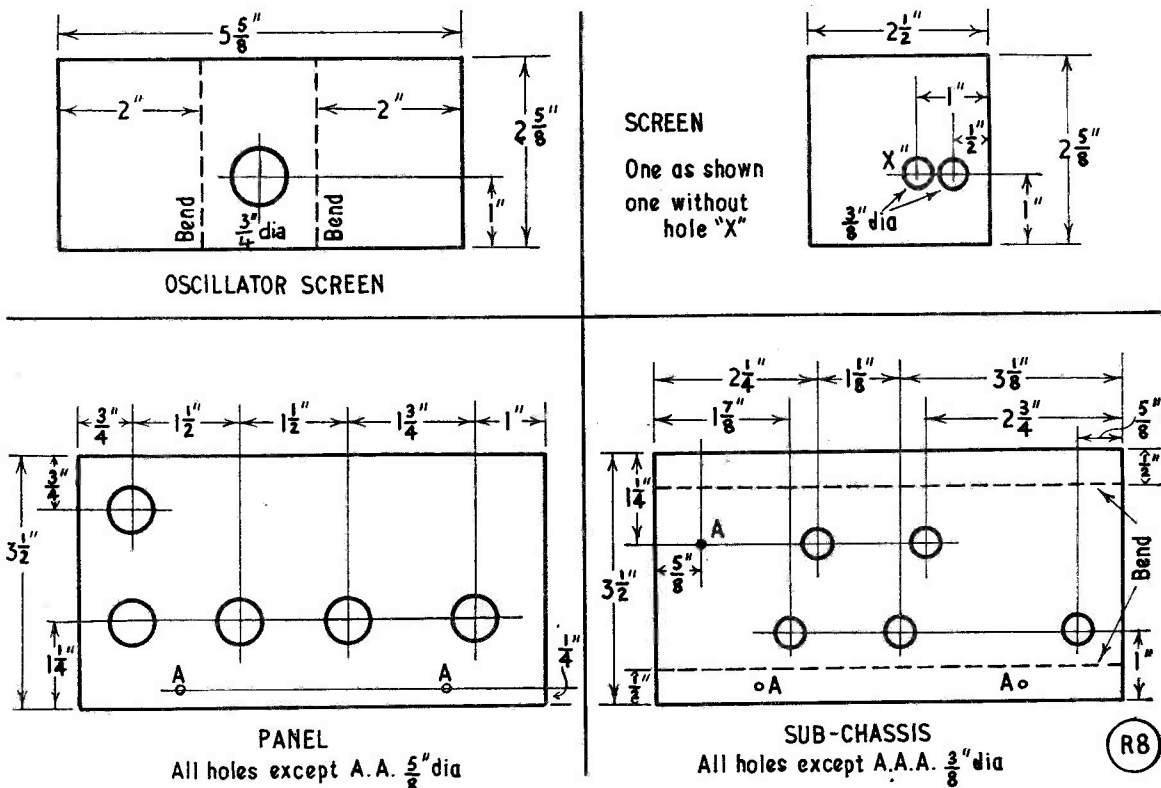

Fig. 2. The necessary details for the mechanical construction ; all metal-work is in 20g. tinplate, or as may be convenient.

put from the local oscillator ; an IF of 8 mc has, however, been used successfully.

When the wiring has been completed and tested, the converter can be connected to a power supply giving 6.3v. and 105v. regulated HT, and the local oscillator set at 131 mc by means of the Philips trimmer C19, with C20 at mid-scale. (This, of course, for 14 mc IF). The output of the converter may now be connected to the aerial terminals of the main receiver, which is set at 14 mc, and L5 adjusted for maximum noise. The aerial may now be connected to the input socket of the converter and the tuned circuits L1, L2 and L3 aligned to 145 mc by means of a local signal or a signal generator. This is done with the aid of a "Magic Wand" (a piece of insulating material with a dust-iron slug attached to one end and a brass slug to the other). Due to the bandwidth of the converter a strong signal will be heard even if the tuned circuits are not spot-on and exact alignment is effected by squeezing or opening the coils. Starting with L3, the "Magic Wand" is advanced towards the end of the coil first with one end and then the other ; if the signal increases when the

brass slug is placed near the coil the turns need to be squeezed together, and *vice versa*. This procedure is repeated with L2 and then L1. This completes the alignment of the converter, the response of which should now be constant over the whole band. It will, of course, be necessary to use a slow-motion drive for the oscillator tuning condenser, C20, but individual requirements in this respect will vary considerably. In the writer's case the converter, together with power supply, is mounted in a small metal cabinet, an insulated flexible coupling being used to take the spindle of C20 to the slow-motion dial which is calibrated in the usual manner.

### Conclusion

When searching for signals, the audio gain control on the main receiver should be fairly well up and the RF gain advanced until a barely perceptible hiss is heard in phones or speaker : these conditions will give optimum signal-noise ratio and no weak signals will be missed.

If it is desired to use 300-ohm feeder from the aerial, a simple balun should be used be-

tween this feeder and the input of the converter, as it is possible to obtain better signal-noise ratio with 75-ohm input to L1.

A 6J4 or EC91 may be used as V2, to give a very slight improvement over the  $\frac{1}{2}$ -6J6; in this case it may be necessary to re-orientate the valveholder for optimum placement of leads and components. If the 6J6 is used, pins 1, 5 and 6 should be bent inwards and soldered to the tubular metal screen in the centre of valveholder and a stout lead connected from this point to the sub-chassis directly below.

If the layout given is followed there will be no tendency to self-oscillation even if the neutralizing coil L6 is omitted entirely; the

omission of this coil will, however, cause a slight deterioration of the signal-noise ratio. This coil and also L1 should be as high Q as possible.

The input tapping point on L1 may be varied slightly to obtain best results, bearing in mind that slight overcoupling gives the maximum signal-noise ratio; exact adjustment at this point is almost impossible without a noise generator, but the position given is near enough for all practical purposes.

Finally, the writer wishes to acknowledge the valuable assistance of G4RK and G8QK in connection with the construction and testing of this and other converters.

## Yagi Made Easy

PRACTICAL TWO-METRE.  
BEAM

J. H. HUM (G5UM)

*While the best possible beam array, both electrically and mechanically speaking, is the objective of all determined VHF operators, the fact remains that something much simpler is quite good enough for a beginning. The 3-element Yagi is the easiest thing of the kind for those who are making a start on Two, and this useful practical article gives all the necessary information for building, mounting and turning the array.—Editor.*

TO the uninitiated the title of this article may seem to have some connection with those curious demonstrations of the human body in a state of oscillation which BBC television once thought fit to put out. But the initiated will know that the reference is to Mr. Yagi, of VHF aerial fame, and not to Oriental physical culture.

When at the end of 1948 the 2-metre band became available to British amateurs the writer—and many others—flung together the necessary equipment with almost indecent haste in an attempt to get going on this new band as quickly as possible. Repentance at leisure duly followed, and the various pieces of equipment were gradually replaced and improved. Last to receive attention was the aerial, due mainly to a natural reluctance to lower the mast which bore it until the operation was absolutely necessary.

The original Yagi erected for 2-metre operation was a folded dipole of the usual trombone slide type, plus one director and one reflector consisting of nothing more than an appropriate length of 10-gauge solid wire, with low impedance feeder at the centre of the dipole, which itself consisted of small gauge copper tubing.

When the time came to replace this aerial the writer was exhorted from many quarters to "go in for something much more ambitious." Nevertheless, he steadfastly stuck to his intention to go in once again for a three-element Yagi, but this time very much better built. It was thought that the advantage of a fourth element was so slight as not to be worth while; and the adoption of a stacked array hardly seemed justified at a location which happens in any case to be particularly good for VHF working—400ft. up, no obstructions and land sloping away in all directions. (No, the QTH was not hand-picked!)

So a three-element it was to be. It was thought undesirable, too, to sharpen up the beam too much. A three-element Yagi combines the virtues of quite a wide field of search and reasonable gain—and of course simplicity of construction. In its design the primary aim was to attempt to make it if possible at "no cost" (as with the writer's design of a "No Cost Five" transmitter three years ago), so much favoured by those with deep junk boxes but shallow purses.

### Aerial Assembly

The first encouraging step in the "no cost" direction came when the writer was presented with a number of ex-Government copper rods  $\frac{1}{2}$ -in. in diameter. One of these was cut down

to  $40\frac{1}{2}$  ins. in length to make a reflector, another to  $36\frac{1}{2}$  ins. for the director, while a third length was cut to  $38\frac{1}{2}$  ins. to form the top section of the trombone element. For this element it is desirable that the other segment—to the centre of which the low impedance feeder is attached—should be of slightly smaller gauge than the unbroken segment. Some  $\frac{1}{4}$ -in. copper tubing happened to be on hand. Two  $19\frac{1}{4}$  in. lengths were brazed (not welded—for brazing gives better electrical continuity) to each end of the unbroken element. Its centre was supported in holes in a polythene block, on top of which the unbroken section rested, securely bolted down. The polythene block was then mounted at the centre of a 40 in. wooden batten, the director  $16\frac{1}{2}$  ins. in front and the reflector  $16\frac{1}{2}$  ins. behind. All these dimensions conform to those which have been published many times in *Short Wave Magazine*.

The reflector and director were each mounted on small mahogany blocks to bring them level with the radiator, but no special pains were taken to insulate them. After all, if the thing had been a plumber's delight all the elements would have been in metallic contact, and the insulation of the parasitic elements is not vitally important. Each parasitic element was secured to its mahogany block with a pair of those little semi-circular holding-down brackets used for securing fixed condensers to chassis.

### Feeder Line

A feeder line of characteristic impedance of 70-100 ohms will give a reasonable match when connected in the centre of an aerial such as this. The whole set-up will work extremely well with none of that laborious "checking for standing waves" which deters so many would-be aspirants to VHF working from ever trying Two Metres at all.

So much for the completed aerial. It was mounted on a 10ft. pole and given a preliminary "airing" on the 144 mc band, and it functioned so satisfactorily that consideration was next given to the rotating mechanism. Here again it was decided to do the job in a way most amateurs would do it—that is, in the simplest way possible and at the expenditure of very few of those precious man-hours.

First of all the completed aerial on its beam was secured by means of two coach bolts to one surface of a large wooden reel. This reel originally contained wire for winding coils. It measures about a foot in diameter and similar reels can be obtained at almost any place where transformer rewinding and trade repairs are

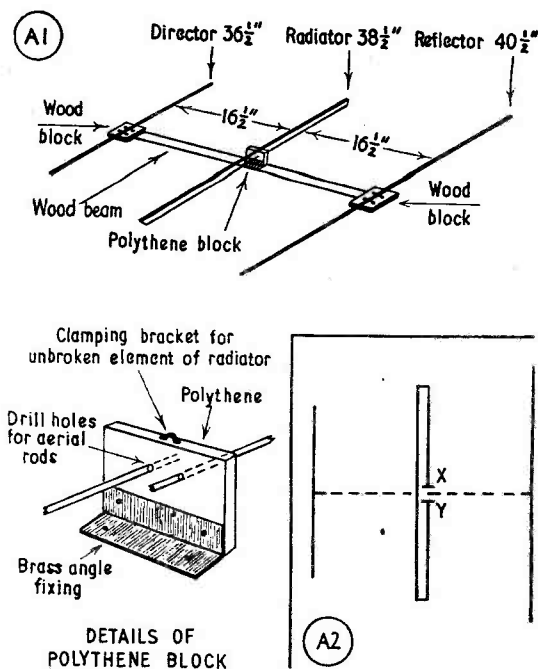

Fig. 1. Mechanical construction of the Yagi 3-element beam. The radiator consists of a  $38\frac{1}{2}$  in. length of  $\frac{1}{4}$  in. copper rod bolted to the top of the polythene block, and two  $19\frac{1}{4}$  in. lengths of  $\frac{1}{4}$  in. rod secured in the centre of this block, thus forming the folded dipole. The "grip" can be obtained by forcing the rods into an under-sized hole under heat; if necessary, they can be further secured by cementing with heated polythene. In the electrical layout, the feeder line is connected at points X, Y.

done. It is one of the most practical "beam turners" that the writer knows. But being made of laminated wood it must be creosoted or painted before it is put into operation, otherwise the weather will soon penetrate and disintegrate it.

### Rotating Gear

The spindle on which this reel was to rotate consisted of a 4 in. length of electrical conduit screwed into one of those two-hole fixing base plates which are widely used by electricians for ceiling fittings and so forth. This base plate was firmly fixed to the cap at the top of the mast. The conduit was then screwed into it, but before the reel and its Yagi were dropped over it a liberal application of the weekly lard ration was given to it. Also, a brass disc was slipped over it to act as a bearing for the reel.

A minor snag was encountered here; the electrical conduit was found to be a very tight fit inside the reel, but it was soon turned down in a lathe so that the reel revolved freely on it.

The only thing that now remained to do was

to drill a hole in the upper and lower surface of the reel to allow the feeder cable to pass through. These holes were drilled so that the feeder was quite a tight fit in them. By leaving a certain amount of slack the danger of breaking the feeder from its soldered joints to the dipole was obviated.

To prevent the aerial on its reel from rotating beyond  $360^\circ$  a simple stop can be devised consisting of a long bolt attached vertically to the lower surface of the reel. A nail driven into the mast an inch or two below will act as a buffer to it and prevent the feeder from windng round the mast.

It will be obvious from the foregoing that no elaborate form of turning motor is visualised in this simple VHF aerial arrangement. The method of rotating the beam is simplicity itself; a length of weather-proofed cord is attached to each end of the aerial boom so that the device can be rotated by hand at ground level—not so convenient on a wet night as a push-button electrical system, but vastly easier and cheaper to complete.

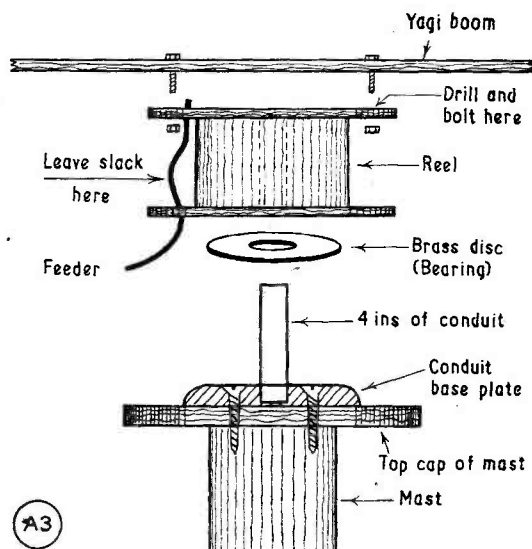

Fig. 2. The suggested method of mounting and rotating the completed three-element beam for Two Metres. The feeder line is passed through holes drilled in the top and bottom surfaces of the wooden reel, enough slack being left in the space to prevent the feeder being twisted off when rotated.

#### "THE PATTERN OF PREFIXES"

This is the title of an interesting article in the March issue of our *Short Wave Listener & Television Review*, discussing the system (or lack of it) on which international amateur prefixes have been allotted. The same issue also contains a useful TRF 1-V-1 design for the Top Band, and a number of other features and items of particular interest to SWL's. Copies are available at 1s. 7d. post free, of The Circulation Manager, Short Wave Magazine, Ltd., 55 Victoria Street, London, S.W.1.

#### "LETTERS TO THE EDITOR"

Readers are reminded that we welcome letters, controversial or otherwise, suitable for publication. They should be marked "For the Attention of the Editor."

#### "THE OTHER MAN'S STATION"

We are always glad to see offerings for this feature, which has appeared almost without a break since *Short Wave Magazine* was first published. The requirements are: A clear, sharp print or negative, and a detailed account in "own words" describing the equipment, the interests of the operator, the results achieved, and brief historical notes such as the date of the licence, and for how long the operator has been interested in Amateur Radio. We write the story from these notes, and pay a fee for the material immediately on publication.

#### THE WINTER CALL BOOK

The Winter 1951-52 edition of the *Radio Amateur Call Book* is now available, listing a larger G Section than ever before, and giving the call-signs, names and addresses of amateur stations throughout the world. All British call-signs appearing in our "New QTH" feature up to and including the November 1951 issue of *Short Wave Magazine* are published in the latest edition of the *Call Book*. The price is 21s. post free, of Gage & Pollard, Publishers' Agents, 55 Victoria Street, London, S.W.1.

#### THE RADAR ASSOCIATION

We are asked to mention that the sixth annual Reunion Dinner and Dance of the Radar Association will take place on Saturday, March 15, at "Chez Auguste," Frith Street, London, W.1. Tickets are 15s. each and can be obtained on application to the Honorary Secretary, Radar Association, 83 Portland Place, London, W.1.

#### MULTICORE — CHANGE OF ADDRESS

The construction of their factory and offices in the new town at Hemel Hempstead having been completed, the address of Multicore Solders, Ltd., is now Multicore Works, Mayland Avenue, Hemel Hempstead, Herts. (Tel.: Boxmoor 3636).



**M**ORE than one reader has suggested that an outline of the Two-Metre Zone Plan should be given once again, as many newcomers to VHF work are unaware of the reasons for its existence, and possibly of its details. With news at a low level this month, it is proposed to take the opportunity to act on this suggestion.

The Plan was the outcome of an article by G3CYY in the May 1949 issue of *Short Wave Magazine*. In his introductory remarks, G3CYY made the point that after a CQ call it was extremely difficult to tune over the whole 2 mc of the 144 mc band with sufficient care to ensure that no reply was missed. The directional beam aerials in use at most stations still further complicated the matter and made searching a tedious task. He then suggested that it would be much easier if operators knew the part of the band in which to look for stations from a given direction. Accordingly, he divided the British Isles into ten zones, and to each zone allocated 200 kc of the two-metre band. Realising that activity was greater in some parts of the country than others, the suggested zones varied in size (*i.e.* area) somewhat, being smaller in areas of high activity.

At the time this suggestion was put forward, most stations were operating between 144.95 and 145.3 mc in all parts of the country, so that DX signals were, more often than not, lost in strong local QRM. To your conductor it appeared that the scheme would do much to alleviate such QRM. Most of our correspondents agreed "in principle" with the idea, and it was also discussed at two largely attended Fiveband Club meetings. As a result, the original scheme was modified to overcome one or two points of criticism, and, with the knowledge that the majority were in favour, the Plan was launched on October 1, 1949.

From the start we have emphasised that there is nothing obligatory about it, and it is entirely a matter for each individual operator to decide for himself whether or not to operate in accordance with the Zone Plan. Several well-known operators have not

# VHF BANDS

E. J. WILLIAMS, B.Sc. (G2XC)

---

## Discussing the Band Plan—

Conditions Patchy and  
Activity Low—

Individual Reports and  
Station News—

The Tables and Calls Heard—

---

complied with the frequency divisions—some due to an objection to what is called "regimentation," and others through a sincere disagreement with the principles of the Plan. There are some who genuinely like to fight for their DX through QRM and feel it is unfair to make the going too easy. There have been others who have felt that the frequency which they were asked to use was too far from the centre of the band and that, as a result, they would obtain very few contacts. Still others have been of the opinion that the frequency range allocated to their own Zone was already so filled by existing signals that there was no room for their own signal in that part of the band.

Personally, your conductor considers the Zone Plan has succeeded very largely in achieving its purpose, in spite of the lack of co-operation of certain stations. Success might have been even greater had more use been made of the high-frequency end of the band. From 145.65 mc upwards

was allocated to Wales and Ireland. Activity has been at a very low level in these two zones, and in many cases the few stations that have been active have not used the correct frequency area. Thus, 350 kc. of the band has been rather wasted, and there has been much congestion, at times, in other Zones. There would appear to be little objection to the use of this 350 kc by stations in *any* zone, particularly for local contacts. Stations in Zones D and F, whose correct zone frequency is in this 350 kc, may prefer to shift frequency under these circumstances. It is suggested that such a shift should be to the nearest geographical Zone; that is, C, E, H or I, according to position.

For the benefit of newcomers, we are printing the details of the scheme as it has operated from October 1, 1949, and would ask all who are about to choose a frequency in the band to give careful consideration to the possibility of falling in with the suggestions of the Zone Plan. The area/frequency groupings are shown in the accompanying table.

## VHF Century Club

The membership of the VHF Century Club has now reached 100. The hundredth certificate goes to G3BYY (Homerton, London, E.9). Congratulations to him and to all the other 99!

Complaints continue to come in regarding the failure of members of the Club to honour their promise to continue to reply to all VHF QSL's received. Many of these complaints are doubtless justified, and all members are reminded of the promise they made. On the other hand, it is as well to point out that the promise only referred to QSL's received. Within the past month your conductor has received two complaints regarding his personal failure to send a QSL, but in neither case has he yet received a card from the complainant! In addition, in both these cases, no address appears in current call-books, although the calls were issued to their owners at least two years ago. Like many other VHF operators, G2XC prefers to send cards direct. Many VHF stations

do not collect cards at a quick rate, and the QSL Bureaux are a slow method of delivery. May we suggest to all whose correct QTH's do not appear in the Call Books that they remedy that state of affairs promptly. It would help many of us.

A list of members of the VHF Century Club is given this month. Members of VHF CC must first of all be members of the Five Band Club. Membership of this Club is granted to active VHF transmitters, who send us a signed guarantee of their interest in VHF work, and their intention to encourage, by all possible means, VHF activity. Applicants for the VHF Century Club must send in for verification 100 post-war QSL's confirming contacts on frequencies of 50 mc and above. These certificates are issued on an operator basis and not a station basis, so that if you move QTH the cards referring to contacts from the original location can still be included. To make this quite clear, suppose you operate from location "A" and work from there and receive QSL's from G3XYZ, G7ABC and G9ZZZ; then you move to location "B" and work and receive cards from G5ABC, G8XZY and G9ZZZ. This gives you five eligible cards (G9ZZZ cannot be counted twice, unless you work him on another band). Similarly, if you go /A or /P or even /MM.

The above is in the hopes of clearing up some queries which have reached us in recent weeks.

#### Around the Stations

In the London area G8LN, after a lapse of activity during December and January, is back on Two. Using only 10 watts and a dipole, he has had some good phone contacts with G5TP. He comments that only the same few regulars are heard, and most of these do not beam east. Conditions, on the other hand, seem to have been quite good, and he suggests another contest to end the hibernation. He thinks present indications are that VHF propagation should be better during 1952 than 1951. In the calls heard list, he asks for emphasis to be placed on the

## TWO-METRE ACTIVITY REPORT

### G3HAZ, Birmingham, Warwick.

WORKED: G2AOK/A, 2ATK, 2BFT, 2COP, 2DTP, 2FNW, 2FWW, 2HCG, 2HIF, 2XS, 2XV, 3BPL, 3CHY, 3DJQ, 3DUP, 3FGT, 3FUW, 3FZL, 3GHC, 3GZM, 5BM, 5DS, 5LJ, 5ML, 5SK, 6CI, 6NB, 6SN, 6TA, 6XM, 6XY, 6YU, 8DV/A, 8KL, 8MZ.  
HEARD: G2ANL, 3ABA, 3EHY, 3ELI, 3GHI, 3HAZ, 3IAI, 4NB, 5RW, 8IK, 8QY. (January 1 to February 11)

### G2HDZ, Pinner, Middlesex.

WORKED: G2AIW, 2AVR, 3ENI, 3FAN, 3FSG, 3FTR, 3GHI, 3HZK, 3MI, 5DS, 5QL, 6BO, 6NB, 6RH, 8DV/A, 8OU.  
HEARD: G3BK, 3BUZ, 3EDD, 3FGT, 3GZM, 3HAZ, 4GR, 4MW, 5YV. (January 8 to February 10).

### G3HXO, Shefford, Beds.

WORKED: G2XV, 3BPL,

3CGO, 3EDD, 3FFX, 3FUL, 3HBW, 3HXS, 3IAI, 3VW, 4HT, 5UM, 6NB, 6YP, 8DV/A.  
HEARD: G2ANT, 2BN, 2FKZ, 2FNW, 2FVD, 2FZU, 2HIF, 3ABA, 3CCP, 3DIV/A, 3EHY, 3FGT, 3FUW, 3FZL, 3GHI, 3GHO, 3VM, 5TP, 5UF, 6XM, 6XY, 6YU, 8OU, 8QY. (December 7 to February 11).

### G3FKO, Bath, Somerset.

WORKED: G3FIH, 4AP.  
HEARD: G3EHY, 8DM.

### G2HIF, Wantage, Berks., NGR 41/404885.

WORKED: G2BZ, 2FOP, 2HCG, 2XV, 3AVO/A, 3CCP, 3CWW, 3FD, 3GHC, 3GHI, 3GZM, 3HAZ, 4AP, 4HT, 5HB, 5ML, 6JK, 6KB, 6XM, 8DM, 8DV/A, 8KL, 8VZ.  
HEARD: G2BN, 2FKZ, 3BPL, 3GHO, 5TP, 6NB.

### G3FEX, Bramber, Sussex, NGR 51/180104.

WORKED: G2AIW, 2BN,

2DTP, 2KF, 2MQ, 2TP, 3ENI, 3GDR, 3HCU, 3HXS, 4HT, 5NF, 6NB, 8DV/A.  
HEARD: G6TA. (January 1 to 31).

### G5DS, Surbiton, Surrey.

WORKED: G2AIW, 2BN, 2HCG, 2TP, 3BRQ, 3BYV, 3ENI, 3FD, 3GXO, 3HAB, 3HAZ, 3HBW, 3HXS, 3HZK, 3SM, 5TP, 6NB, 6RH, 8HK, 8HY, 8OU, 8VZ.

HEARD: G2BZ, 2CUA, 2DD, 2DGY, 2DTP, 2FKZ, 2FNW, 2FOP, 2HDZ, 2HIF, 2KF, 2MQ, 2MV, 2UQ, 2XV, 2VC, 3ABA, 3ASG, 3AUS, 3BPL, 3BOB, 3BVG, 3CCP, 3CDJ, 3CHF, 3DUP, 3EHY, 3EYV, 3FEX, 3FGT, 3FSD, 3FSG, 3FUL, 3FZL, 3GBO, 3GDR, 3GHI, 3GHO, 3GHS, 3HCU, 3IAI, 3MI, 4AP, 4HT, 4MW, 5BM, 5DT, 5LC, 5LK, 5LQ, 5QB, 5QL, 5UF, 5UM, 6QN, 6TA, 6WU, 6XM, 6YU, 8DV/A, 8KL.

(January 12 to February 10)

lesser-known stations. (With the present low level of activity, all lists of Calls Heard are printed). Regarding height above sea-level, he remarks that although he is 200 feet a.s.l., he cannot even hear the Cambridge stations, due to still higher land to his north. His conclusion is that height above sea-level does not mean very much. He is active most evenings and would welcome any reports.

G3HBW (Wembley) has been rebuilding and hence somewhat inactive. Having got his input up to 150 watts, he is now hopeful of working more than 10% of the stations he hears. The PA uses a QQVO7/40 and can be modulated by a pair of 807's in Class-B. In the past he has been running an 832 at 60 watts! (G3HBW assures us he does not use a wind-tunnel). He says a good 832 will take 550 volts on anode, 300 on screen and, with 11 mA drive through a 3.9 kilohm resistor, runs without any signs of overheating. The input is reduced to 40 watts when the 832 is used as a driver for the new PA.

G3GBO (Denham) writes to say he is still alive and occasionally on Two Metres. He is endeavouring to work an "impossible county" from his location, namely, Northants. A schedule has been arranged with G3DUP for Saturday evenings, and already

G3GBO has heard what he is certain is a weak signal from G3DUP. So when conditions look up a bit, there seems to be a good chance of them making it!

A list of calls worked and heard by G5DS (Surbiton) during four weeks of January and February suggests that activity is higher in the London area than some people think. G3EYV (S.W. London) is not on the band after 10 p.m., but one evening recently managed to work G5UF and G5BM in succession. He is in favour of dropping competitive tables such as "Reliability," "Best Ten" and so

## TWO METRES

COUNTIES WORKED SINCE SEPTEMBER 1, 1950

Starting Figure, 14

Worked	Station
43	GW5MQ
42	G3EHY
37	G3BK, G3WW, G5YV
36	G4HT
34	G2XC, G5MA
33	G4SA, G5DS
32	G2NH, G3FAN
27	G2HDZ
26	G8IL
25	G2AHP, G3VM, G6YU
21	G2FVD, G2OI, G3BNC, G6CB
20	G2FOP
19	G3AVO/A, G3CWW, G3GHO
18	G4MR, G8VR
17	G3HCU, G5ML
16	G3EGW
15	G6CI

Note: This table will run for one year until August 31, 1952.

## TWO METRES

## ALL-TIME COUNTIES WORKED LIST

Starting Figure, 14  
From Fixed QTH Only

Worked	Station
54	G2OI
53	G3BLP (500)
52	GW5MQ (188)
51	G3EYJ (310)
48	G2AJ (408)
47	G2NH, G3BW, G5WP, G6NB, G8SB
46	G4HT (478), G5BY
45	G5YV, G6XM (356)
44	G3ABA (222), G5MA
43	G2SC, G3WW, G3COJ, G5DF
42	G5BI
41	G3BA, G3DMU (192)
40	G3BK, G3CGQ, G5BM, G5DS (297), G8OU
39	G2IQ, G4SA, G5LI (285)
38	G3APY, G3VM (208)
37	G6YU
36	G2FNW, G3CND, G6CB (312), G8IP
35	G2POP, G3FAN, G8IL (212)
34	G3HAZ (113), G4RO, G5JU
33	E12W, G2HDZ (238), G3FZL
32	G3AVO/A, G6CW, G8QY
31	G2AHP (249), G5RP
30	G2HIF, G5NF
29	G5UM (218), G6CI
28	G2DLJ/A
27	G3DAH, G3GSE, G3HBW, G3HCU
26	G2FVD, G3BNC, G3CFR (125), G3FIH
25	G4MR (155), G5SK, G8VR
24	G3FD, G3FXG, G3GBO (246), G8KI
23	G5PY, G6GR
22	G3AEP, G3BPM, G3CWW (221), G8IC, G3BDA
21	G3AGS, G5MR, G6XY
20	G3EYV
19	G3SM, G5LQ (176)
18	G4LX
16	G2AOL, G3FRE, GC2CNC, G3EGW
15	G2DVD
14	3CYY, G3FEX

Note: Figures in brackets after call are number of different stations worked. Starting figure, 100.

forth, as they do not maintain the friendly spirit which has been such a feature on Two in the past. He feels this spirit has become somewhat strained recently.

G3FZL (East Dulwich) joins the Five Band Club and has been forecasting conditions on VHF by watching the weather. A certain measure of success has been obtained. G3ENI (Richmond) has been checking on QSL returns and finds that 44% of pre-war licensed stations do not QSL; 12% of three-letter G2's and 27% three-letter G3's fail. These figures allow 2 months' grace. G3HZK (Hayes, Middx.) is active for at least a couple of hours per week, but studies are taking up much of

his time. He is using 23 watts to an 832, and a dipole in the roof. On the receiver side, he has a 6J6 pre-amplifier working into a very much modified RF27 unit which feeds into an S640 on 5.8 mc. He is one of the few who report activity as "pretty good." He is in favour of a QRP contest on Two. His frequency is 144.83 mc and he joins the Five Band Club.

G2HDZ (Pinner) has little to report, his log for the past month occupying less than one page. Conditions, he feels, have been fairly good on more than one occasion. He mentions the evenings of January 27 and 31, and February 1 as instances. Due to an oversight (for which your conductor is deeply apologetic), G2HDZ was missed from the Activity List published in the December 1951 "VHF Bands." He agrees with us that height above *surrounding country* is what matters, but feels that, as this is so difficult to assess, it would be better to use height a.s.l. (with reservations) in assessing. (Personally, we propose to use *neither*, as any contest scoring based on such ideas is likely to produce a state of affairs just as unfair as that which it replaces).

G3FEX (Worthing) has worked 83 stations to date. He is using a CC converter with 6AK5 RF stage, 9003 mixer and output on 28-30 mc into an AR88D. The transmitter is an SCR522 with 20 watts input. A close-spaced 4-element Yagi at 40 feet completes the line-up.

G2HIF (Wantage), once again in argumentative mood, criticises our remarks in January "VHF Bands." He rises in defence of the man who is active every evening, whom he feels we condemned rather harshly last month. He says that the regular operator shows more of the right spirit than the boys who need good conditions before they think it worth while switching on the rig. They are, he contends, more ready to ragchew, discuss technical points and give help, and they can and do make a serious study of propagation. Were it not for the regulars, it would be difficult to find a signal on the band with

which to test out a new converter. G2HIF continues by making the point that, because of his regular operation, the gear of such an operator is reliable, and he usually QSL's 100% without worrying about returns. Summing it up, he says: The regular guy is a "regular guy." (He does not put himself in this category.)

G2HIF also jumps on your trembling conductor for saying that it takes a 600-mile QSO to produce a VHF thrill these days. He says: "Surely there is more in VHF work than just the thrill of DX?" (Most certainly there is, but we doubt if the word *thrill* could be accurately used to describe these other activities. Surely the fact that 600-miles is now the criterion of DX achievement says something for progress?) Regarding current conditions, G2HIF has found them average for winter months. A change from cold to warm weather often produces a limited opening. He also notices that good two-metre conditions are often accompanied by fading on TV in the fringe areas.

G3FKO (Bath) is active once in every 3 weeks. He has worked G4AP, who is using NBFM successfully. G3HXO (Shefford) writes to give his QTH, which is in Bedfordshire. He is 30 feet

## THE TWO-METRE ZONE PLAN

(This is reproduced here for the benefit of newcomers to the band. Further comments on the plan will be found in this month's "VHF Bands").

<b>Zone A &amp; B: 144.0 to 144.2 mc.</b>	All Scotland.
<b>Zone C: 144.2 to 144.4 mc.</b>	All England from Lancs. Yorks. northward.
<b>Zone D: 145.8 to 146 mc.</b>	All Ireland.
<b>Zone E: 144.4 to 144.65 mc.</b>	Cheshire, Derby, Notts., Lincs., Rutland, Leics., Warwick and Staffs.
<b>Zone F: 145.65 to 145.8 mc.</b>	Flint, Denbigh, Shrops., Worcs., Hereford, Monmouth and West.
<b>Zone G: 144.65 to 144.85 mc.</b>	Northants, Bucks., Herts., Beds., Hants., Cambs., Norfolk, Suffolk.
<b>Zone H: 145.25 to 145.5 mc.</b>	Dorset, Wilts., Glos., Oxon., Berks., and Hants.
<b>Zone I: 145.5 to 145.65 mc.</b>	Cornwall, Devon, Somerset.
<b>Zone J: 144.85 to 145.25 mc.</b>	London, Essex, Middlesex, Surrey, Kent, Sussex.

a.s.l. and uses a pair of TT11's with 20 watts. A 3-element indoor Yagi and a 6J6 converter are also in use. G3WW, writing from "The Mountain," Wimblington, sends a list of stations which have not replied to his QSL's. The list includes a number of very well-known 2-metre operators who are also VHF CC members, and it is noteworthy that these same calls appear in many other lists that are sent to us from time to time for the same reason. Perhaps we had better start a "Black List," after all.

G3VM (Norwich) has worked PE1PL twice, but fails to hear any but local G's. G3AJP (Great Yarmouth) runs 24 watts to an SCR522 with controlled carrier modulation, although CW operation is more usual. The present 4-element Yagi will be replaced by a 4-over-4 as soon as weather permits. He is active most evenings. G3CFK and G4PV are also active in the same area, but G2CPL is temporarily QRT, while changing QTH.

G3HAZ (Birmingham) finds conditions typically wintry. January 14 was an exception, with London signals workable, but fading badly. January 5 and 24 also produced DX, but otherwise little was heard outside the local area. He agrees 100% with our remarks last month on one-way transmissions.

GC2CNC (Jersey) is still active, particularly on Sundays, when he has a schedule with G8IL. Regarding the height above sea-level controversy, he says that at high tide his garden wall is also the sea wall!

ON4BZ (Brussels) sends news of VHF doings in Belgium. December was quite good for DX, but January poor. ON4BZ uses the winter months to build new converters, measuring their noise level, etc., with noise generators. The noise factor obtainable with all the better-type circuits is very much the same, he says, and so his conclusion and advice is to adopt the circuit that is simplest to build and operate, and cheapest. So far as he is concerned, this is the grounded-grid using a 6BQ7 and a 12AT7, the former acting as GG RF mixer, and the latter as overtone oscillator and multiplier.

## VHF CENTURY CLUB

### List of Certificated Members

G2AHP	G3APY	G3WW	G6HD
G2AJ	G3BBA	G4AP	G6KB
G2ANT	G3BLP	C4AU	G6LX
G2AOK	G3BNC	C4CI	G6MN
G2AOL	G3BOB	G4DC	G6NB
G2AXG	G3BTC	G4IG	G6OS
G2BN	G3BW	G4RO	G6UH
G2CIW	G3BY	G5BD	G6VX
G2CPL	G3CFR	G5BM	G6XM
G2D2O	G3CGO	G5BY	G8GX
G2FVD	G3COJ	G5DS	G8IC
G2HDY	G3CVO	G5GX	G8IL
G2HDZ	G3CWW	G5JU	G8KL
G2KI	G3CXD	G5LO	G8LY
G2MR	G3DA	G5MA	G8OX
G2MV	G3DCV	G5MR	G8SM
G2NH	G3EHY	G5NF	G8TS
G2NM	G3EYV	G5PP	G8UZ*
G2OI	G3FAN	G5PY	G8VR
G2OY	G3FD	G5RP	G8WV
G2RI	G3GBO	G5TP	GM3OL
G2XC	G3GHI	G5UD	GW2ADZ
G2XS	G3GSE	G5UM	GW5MQ
G3ABA	G3IS	G5YV	ON4BZ
G3AEX	G3VM	G6CB	PA0ZQ

Total VHF CC membership, 100. List correct to February 16, 1952.

\*Deceased.

He comments that best performance is obtained with this circuit when both cathode and plate tuning are peaked. This can be achieved *without* using noise generators and so is easy to set up. At ON4BZ there is a new 16-element wide-spaced beam with exceptional gain.

### Seventycems

GC2CNC is constructing a transmitter for 70 cm, using an 832 PA, while a converter should be coming along soon. G3AQC and G3IEE (Kingston) work on 70 cm every Tuesday and Thursday evening from 2100. Transmissions are beamed in a N/S line. Receivers are ASB8's modified as per *Short Wave Magazine*.

G3HBW (Wembley) is in agreement with G2OI regarding restricting the width of the band used for CC transmissions. He further suggests that 1296 to 1300 mc also be reserved for CC working; he hopes to have a stable receiver for that band soon. On 70 cm, G3HBW considers fundamental injection is an essential.

G3FZL (Dulwich) worked G8DM/A during December, while G2FKZ has had several contacts with GW2ADZ. G2FKZ is 200 feet up with a clear view of 30 miles to the north-west. However, this is still excellent going over a 160-mile path.

G3HAZ (Birmingham) reports an increase in both interest and activity in his area, while G3GBO (Denham) is at work on a converter.

### Sayings of the Month

"Some stations would be surprised to know how far their frequency wanders during a 10-minute phone transmission" (G3HAZ) . . . "Re G2OI last month, I'm not so old, but I do enjoy TV and slippers" (G3GBO) . . . "I have yet to hear G2HIF" (G2FVD) . . . "For contests, recommend that serial number should consist of 3 different digits, not three the same, like 777" (G8LN) . . . "I assume that the continued omission of my call from the Activity List has no deep and sinister significance" (G2HDZ) . . . "The operator who is never will find the time, no matter what other activities he has, and find time without seriously curtailing those other activities" (G2HIF) . . . "Seemingly there is no return path on some semi-DX signals" (G3HXO) . . . "G3VM has something up his sleeve. I think, as have heard very little of him" (G3AJP) . . . "GC2CNC is *not* dead — yet" (GC2CNC) . . . "I am waiting Spring with hot receivers, transmitters and beams on 144" (ON4BZ).

### In Conclusion

Reports have been rather few this month, but many thanks to those who sent along news and views, all of which were read with interest. Next month's reports should be addressed to E. J. Williams, G2XC, *Short Wave Magazine*, 55 Victoria Street, London, S.W.1, to reach us by **March 12** at latest.

# NEW QTH's

This space is available for the publication of the addresses of all holders of new U.K. call signs, as issued, or changes of address of transmitters already licensed. All addresses published here are reprinted in the quarterly issue of the "RADIO AMATEUR CALL BOOK" in preparation. QTH's are inserted as they are received, up to the limit of the space allowance each month. Please write clearly and address on a separate slip to QTH Section.

- EI9E**, R. F. Law, Shamrock Place, Blackrock Road, Cork.
- G2DYY**, W. C. Longman, Broomfield House, Cleckheaton, Yorkshire.
- G3APS**, A. F. Shergold, 49 Beatrice Street, Swindon, Wilts.
- G3CBV**, C. S. Styler, 15 Dalkeith Avenue, Old Bilton, Rugby, Warwickshire.
- GM3DZB/A**, A. I. Duncan, Gordon Castle Farm, Fochabers, Morayshire.
- G3FEI**, L. W. Willoughby, 136 Stapleford Lane, Toton, nr. Beeston, Notts.
- G3FSG**, C. Pegg, 165 Clapham Park Road, Clapham, London, S.W.4.
- GM3GOL**, Kirkcaldy and District Amateur Radio Society, c/o The Pharmacy, Methilhill, Leven, Fife.
- G3HQK**, E. Dales, 105b, Barrowgate Road, Chiswick, London, W.4 (Tel.: Chiswick 2771).
- G3HQT**, P. J. Ball, 74, Dalycell Road, Stockwell, London, S.W.9.
- GM3HSB**, R. I. Coutts, 41 Princes Street, Perth.
- G3HTM**, W. Ellis, 5 Kingwell Crescent, Ward Green, nr. Barnsley, Yorkshire.
- G3HTV**, E. Wollen, 15 Woodside Road, Richmond Road, Kingston, Surrey.
- G3HTX**, W. F. H. Hipwell, 138 St. Albans Road, Seven Kings, Ilford, Essex.
- G3HTY**, S/Ldr. E. M. Kerr, The Bower, Far Forest, nr. Kidderminster, Worcs. (Tel.: Rock 214).
- G3HWQ**, J. Hawkins, 1 Hey Heads, Meltham Road, Marsden, nr. Huddersfield, Yorkshire.
- GW3HWR**, H. W. Rees, 18 St. Peter's Road, Newton, Mumbles, Swansea, Glam.
- G3HWR/A**, H. W. Rees, Army Camp, nr. Reading, Berks. (QSL to GW3HWR).
- G3HWU**, D. Littlewood, 200 Quarmby Road, Lindley, Huddersfield, Yorkshire.
- GM3HXT**, R. Innes, 40 Castle Street, Fochabers, Morayshire.
- G13HXV**, R. R. Parsons, 134 Benmore Drive, Finaghy, Co. Antrim.
- G3HXZ**, F/Lt. Ritter, c/o Officers Mess, R.A.F. Station, Compton Bassett, Wilts.
- G3HYF**, W. J. Jones, Flat 10, 16 Tavistock Place, Holborn, London, W.C.1.
- G3HYJ**, O. F. Simkin, 15 Hillside Road, Thorpe - next - Norwich, Norwich, Norfolk.
- G3HYM**, W. Savage, 27 Pinewood Drive, Bletchley, Bucks.
- CHANGE OF ADDRESS**
- EI6X**, B. Fogerty, c/o Power Station, Ardnacrusha, Co. Clare.
- G2AMV**, B. O'Brien, 1 Waterpark Road, Prenton, Birkenhead, Cheshire.
- G2BGA**, R. Graham, 5 Steep Close, Findon, nr. Worthing, Sussex.
- G2CHL**, J. E. Bassett, 81 Abbots Road, Abbots Langley, Herts.
- G2DRK**, A. J. Herridge, 44 Wolfe Close, Winchester, Hants.
- G2HKT**, L. R. Hawkesford, 190a Icknield Street, Hockley, Birmingham, 18.
- G2HLU**, H. Owen, B.Sc. (ex-ZD4AM), 23 St. Anne's Road, Caversham, Reading, Berks.
- G3AKA**, W. N. Stevens, 25 Lawrence Road, London, E.6.
- G3AYM**, G. Reily, 4. Brackloonagh, Lindsay Road, Bournemouth, Hants. (Tel.: Westbourne 63114).
- G3BBD**, J. L. Townend, 424 Bradley Road, Bradley Bar, Huddersfield, Yorkshire.
- G3BMX**, G. H. Greenwood, 55 Greenwood Mount, Leeds, 6, Yorkshire.
- G3BYW**, W. M. Dunell, 15 The Gardens, Monkseaton, Whitley Bay, Northumberland.
- G3CAL**, D. B. O'Donoghue, 25 Ardwyn Estate, Wellington, Somerset.
- G3CDE**, Dr. G. A. Jackson (ex-GW3CDE), 44 Fairpark Road, Exeter, Devon.
- G3CNM**, F. Armstrong, 23 The Circuit, Cheadle Hulme, Stockport, Cheshire.
- G3CVB**, J. P. Hannifan, 79a High Street, Bridgnorth, Shropshire.
- G3DCJ**, J. E. Wootton, Beachfield House, Sennen Cove, Lands End, Cornwall.
- G3DO**, D. A. G. Edwards, Brook House, Ladywood Road, Four Oaks, Warks. (Tel.: Four Oaks 269).
- GM3DZB**, A. I. Duncan, Drumduan, Bellevue Road, Banff, Banffshire.
- G3EAG**, O. Gunnill, 10 Charlton Road, Wantage, Berks.
- G3ELB**, A. R. Tugate, (ex-Y12AT), 59 Vicarage Lane, Ilford, Essex.
- G3FDE**, D. W. Lilley, Grad.I.E.E., 23 Melton Road, Asfordby Hill, nr. Melton Mowbray, Leics.
- GW3GCZ**, Rev. F. C. Dorken (ex-G3GCZ), 3, Saithaelwyd Park, Holywell, Flintshire.
- G3GZN**, E. Buckingham, 208 Twyford Avenue, Portsmouth, Hants.
- G3IN**, C. J. Moore, Penistone Villas, St. John's Road, Saxmundham, Suffolk.
- G3JD**, W. H. Baker, 1 Mincent Hill, Torquay, Devon.
- G3ZY**, J. R. Tweedy, 4 Whitton Terrace, Rothbury, Northumberland. (Tel.: Rothbury 4).
- G4QK**, J. B. Roscoe, 2 Chichester Road, Croydon, Surrey.
- G5OW**, W. O. Wigg, 83 Parkside, Beeston, Nottingham.
- G5QI**, W. S. Carter, The Ards Lodge, Dorridge Road, Dorridge, nr. Birmingham, Warks.
- G16WG**, R. Carlisle, 22 Hopefield Avenue, Portrush, Co. Antrim.
- G8DM**, L. G. Stoodley, Danes House, Great Coxwell, Faringdon, Berks.

## CORRECTION

- G3EVE**, Brighton and District Radio Club, The Eagle Inn, Gloucester Road, Brighton, 1, Sussex.

## G3HQU

PICTURED here is one of the newer G3-plus-three's; the station of G3HQU, owned and operated by J. G. Jackson, at 1 Highfield Road, Barrow-in-Furness, Lancs. Though only licensed comparatively recently, he has been actively interested in experimental short-wave radio for twenty years or more.

Equipment now in use includes three transmitters—a 6SK7 VFO-807 PA for 7 and 14 mc. running 25 watts; a 6V6-6V6 rig for 3.5 mc; and (at the moment) a self-excited transmitter and super-regenerative receiver for the 430 mc band.

The station main receiver is an Eddystone 504, and the aerial system a Zepp-fed roof 137-ft. long, for the communication bands, with dipoles for 430 mc.

Apart from constructional work, one of the main operating interests at G3HQU is QRP, with which very satisfactory coverage is being achieved, though no great DX

## The Other Man's Station

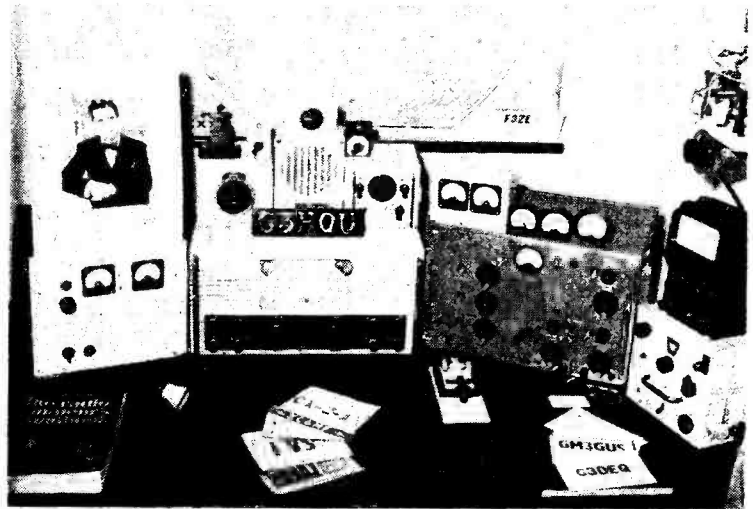

successes can yet be claimed. G3HQU is himself also one of those who labour in the cause of Amateur Radio—he is honorary secretary of the Barrow Amateur Radio & Television Society, and is

greatly interested in club activities generally, believing that work of this nature is the best way of helping the newcomer to develop a practical interest in Amateur Radio. And so say we.

### THE INDEX TO VOLUME IX

Every copy of the March issue of *Short Wave Magazine* should have been found to contain, as a loose supplement, a detailed index to Volume IX, free of charge. Any reader who did not get an index with his copy should apply to the Office, though the supply of spare copies is limited.

### "STRUCTURE OF A NATIONAL SOCIETY"

The correspondence arising from this article, which appeared in our February issue, has not (at the moment of writing) yet had time to assume the proportions which would enable a fair opinion to be formed as to the general feeling. So far, the reaction is about equally divided For and Against the principles put forward, qualified in some cases by violent opinions which have no bearing on the main theme. We look forward to hearing a great deal more upon this particular subject.

### AUSTRALIAN JUBILEE RELAY

The results of this Contest—held during the periods October 13-14 and October 20-21, 1951, in connection with the Jubilee Celebrations of the

Commonwealth of Australia—are announced in the January 1952 issue of the *Australian Amateur Radio*. The winner was VK9XK, Papua, with 27,440 points derived from 343 contacts with 80 countries, using three bands; the runner-up was VK4KS, Brisbane, who made 26,480 points from 331 contacts, also with 80 countries, but using only two bands. The total number of VK entrants was apparently 35 only, though, as usual in contests, a great many more stations took part than sent in logs. The ZL entry totalled six, with ZL3JA, Akaroa, leading with 22,592 points. Scores ranged down to less than treble figures at the tail end.

### FOREIGN SUBSCRIPTIONS

We are asked to remind readers that subscriptions to all foreign technical periodicals—including *QST* and the American radio press generally—can be paid in sterling through Gage & Pollard, Publishers' Agents, 55 Victoria Street, London, S.W.1. When you get your reminder, send them the notice with the sterling equivalent. Lists of American technical journals, covering all trades, industries and professions, with the subscription rates quoted in sterling, can be obtained on application.

# The Month With the Clubs

## Co-op. Radio Society Belfast

This Club, after being re-formed last October, now has a membership of 60 and is still expanding. Listeners, the greater proportion of the members, are helped out by local amateurs with lectures, Morse classes and so on. A large hall is available on Tuesdays and Saturdays, and a Club station, G13BC, is very active and was described last month. The station was opened in the course of a Social Evening on December 1st, 1951.

## Benghasi Amateur Radio Club

This overseas Club, to which we give a special welcome in this space, was inaugurated on January 13, with an opening attendance of 24. Membership is around the 30 mark, including five active transmitters. Naturally, the majority are Service personnel. Lectures on Radio Theory have been arranged, Morse classes are under way, and a talk on the History of Amateur Radio has been given by 5A2CA.

## Barnsley & District Amateur Radio Club

The Annual Dinner and Dance, in January, was attended by nearly 100 members and friends from a radius of some twenty miles. The President, G2BH, welcomed the visitors and paid a tribute to Mr. J. J. Rose, the retiring Secretary, who is leaving the district. Note new Secretary's QTH, in panel.

## Eccles & District Radio Society

At the AGM, held on January 21, Mr. G. Gray was elected

Last month we commented on the increase in the number of broadsheets, News Letters and Club Circulars in existence. This month we have received only three—from Wirral, Romford and Brighton. May we once more ask all Clubs who publish their own journal, however humble, to put us on the circulation list? They are always appreciated, and we constantly marvel at the amount of work put into them by the one or two members responsible.

It is also time for a reminder that photographs of Club events, meetings, social occasions, Club stations and gear constructed for contests will always be welcomed for publication.

Next month's deadline is **FIRST POST ON MARCH 12** (for the following month it will be **APRIL 16**). All reports should be addressed to "Club Secretary," **SHORT WAVE MAGAZINE**, 55 Victoria Street, London, S.W.1.

And here are this month's reports, from 41 Clubs, almost a record number . . . . .

Secretary—note QTH in panel. Mr. E. Rayson, the former Secretary, is off to Australia, where we wish him well.

## Edinburgh Amateur Radio Club

Weekly meetings continue in Unity House, Hillside Crescent, Edinburgh, the next after publication being March 12 (Clamp Modulation), March 19 (Visual Receiver Alignment). Intending members and visitors are always welcome, and should either turn up at a meeting or contact the Secretary. All meetings are at 7.30 p.m.

## Gateshead & District Amateur Radio Club

Meetings are now held every Monday, 7.30 p.m., at the Mechanics' Institute, Whitehall Road, Gateshead. All interested in Amateur Radio will be welcomed to the lectures, demonstrations and classes which have been arranged.

## Hastings & District Amateur Radio Club

This newly-formed Club is now flourishing with a membership of some 25, of whom 12 are licensed amateurs. Talks, Film Shows, Junk Sales and similar events are arranged for the future, and meetings are on alternate Tuesdays, the next being March 11 and 25. The rendezvous is the Saxon Café, Hastings, and the time 7.30 p.m. (See panel for Hon. Sec.'s QTH.)

## Spenn Valley Radio & Television Society

Forthcoming events are lectures on March 12 and 26: the former on "Z." by G6XT, and the latter on the Germanium Crystal Valve, by Mr. Henderson, of the G.E.C.

## Torbay Amateur Radio Society

Recent meetings have included lectures on Aerial Couplers, by G2GK, and on Links in the High-Quality Chain, by Mr. R. J. Whittall. On March 17, G3AUS will give a talk on Propagation. Meetings are at 7.30 p.m. in the YMCA, Castle Road, Torquay, on the third Saturday of the month.

## Worthing & District Amateur Radio Club

At two recent meetings members have seen the Mullard film strips on the Cathode Ray Tube and Amplifier Valve Construction, and have heard a talk on Radio Anaesthesia, by Mr. Atkinson. New members will be heartily welcomed, and are asked to contact the Secretary—name and address in panel.

## East Surrey Radio Club

Monthly meetings are now running at the new Hq. in the Old County Police Station, 19 London Road, Reigate. G3BLP and G6LX, both of Croydon, were welcomed to a recent meeting, at which they lectured on Basic

Valve Circuits. New members are invited either to the meetings or by application to the Secretary.

#### Albany Radio Club

Expansion continues, and recent activities have covered lectures on Modulation Systems, Wire Recording, and "Behind the CR Tube." Future talks are on VFO's, QRP and Twenty Questions. The Club Tx, G3HPI, is knocking a hole in the Top Band with a very nice signal.

#### Birmingham & District Short Wave Society

The Annual Dinner, held on January 17, was a very successful event and was followed by a visit to the theatre. It is hoped to expand the Club's social activities to include more events for the (long-suffering) YL's, XYL's and friends. Three coach outings are being planned with this in view. The April 14 meeting will be one of the ever-popular Mock Auctions.

#### Wirral Amateur Radio Society

Meetings are held on alternate Wednesdays at the YMCA, Whetstone Lane, Birkenhead, the March dates being the 12th and 26th. Lectures have been given on Aids to Constructional Work, and "Japanese Morse," the latter illustrated with an electronic key! A symposium on aeriels and matching systems, and the annual Constructional Contest, have also been held. Membership is on the increase, particularly among the juniors, although the Club now has 30 licensed amateurs in its ranks.

#### Coventry Amateur Radio Society

Membership increases steadily and attendances are high. The "Nights on the Air" have caused much interest and look like becoming a regular feature. Recent items have been the showing of the Mullard CRT and Valve Film Strip, a full-dress debate on S-Meters and the RST Code, and a Transmitting Contest. On March 17 the Chairman, G5GR, will talk on "25 Years of Amateur Radio"

and on the 31st G3FAB will continue his lectures on Aeriels.

#### Warrington & District Radio Society

At the AGM, Mr. G. Leigh, G2FCV, was elected Chairman. Usual meetings are on the first and third Tuesdays, 7.30 p.m., at the King's Head Hotel, Warrington. The first Tuesday is normally the lecture evening. On April 1 the talk, on Radar Principles, will be given by an overseas visitor, W7OFU.

#### East Grinstead & District

A Club embracing all aspects of Amateur Radio is being formed in East Grinstead. Everyone in that locality who is likely to be interested is asked to get in touch with G3GVZ, the organiser—name and address in panel.

#### North Kent Radio Society

The AGM was held in January

and a new Secretary elected (see panel). The new Chairman is G3HOZ, of Erith. Meetings are held in the second and fourth Mondays, and features for the near future include a demonstration of Tape Recording and a lecture, "Sound on Film." The Club station G3ENT is frequently active on the Top Band.

#### South Manchester Radio Club

This Club is now settled in new premises at Ladybarn House, Mauldeth Road, Manchester, 14, and G3FVA, the Club Tx, is on the air. The winter session is in full swing, forthcoming items being Fault Finding, by G3FTD (March 14); Receivers, by G2AIN (March 28). Membership is flourishing and now numbers 60 to 70, which is impressive.

#### Brentwood Amateur Radio Society

A new Secretary has been

#### NAMES AND ADDRESSES OF SECRETARIES OF CLUBS REPORTING IN THIS ISSUE.

**ALBANY:** A Meyers, G3EYE, 33 Old Kent Road, London, S.E.1.  
**ARMY APPRENTICES SCHOOL:** A/T B. C. Stocker, "A" Coy., A.A.S., Arborfield, Reading.  
**BARNET:** M. R. Jenkins, G3EIM, 1193a High Road, Whetstone, Ldn. N.20.  
**BARNESLEY:** P. Carbutt, King George Hotel, Peel Street, Barnsley.  
**BELFAST:** (Co-Op. Radio Society)—W. F. Jordan, Husband Memorial Hall, Frederick Street, Belfast.  
**BENGHASI:** E. Angell, 5A2CB, No. 5 Forces B/C Stn., Benghasi, MELF 6.  
**BIRMINGHAM:** A. O. Frearson, 66 Wheelwright Road, Birmingham 24.  
**BRENTWOOD:** C. A. Nightingale, 39 Westwood Avenue, Brentwood.  
**BRIGHTON:** R. T. Parsons, 14 Carlyle Avenue, Brighton 7.  
**COVENTRY:** K. Lines, G3FOH, 142 Shorncliffe Road, Coventry.  
**EAST GRINSTEAD:** F. J. Glynn, G3GVZ, The Mount, 13 Station Road, East Grinstead, Sussex.  
**EAST SURREY:** L. Knight, Radiohme, Madeira Walk, Reigate.  
**ECCLES:** E. Rayson, 11 Hartington Road, Winton, Lancs.  
**EDINBURGH:** C. L. Patrick, 19 Montgomery Street, Edinburgh.  
**EDINBURGH (Lothians):** I. Mackenzie, 41 Easter Drylaw Drive, Edinburgh 4.  
**GATESHEAD:** J. Kennedy, 11 Lanthwaite Road, Low Fell, Gateshead 9.  
**GRAFTON:** W. H. C. Jennings, G2AHH, Grafton LCC School, Eburne Road, London, N. 7.  
**HASTINGS:** G. W. Spray, G3FXA, 255 London Road, Bexhill, Sussex.  
**ILFORD:** C. E. Lorgan, 44 Trelawney Road, Barkingside, Ilford.  
**ISLE OF MAN:** H. Grist, GD3FBS, Broadway House, Douglas, I.O.M.  
**LEICESTER:** A. L. Milnthorpe, G2FMO, 3 Winstler Drive, Thurmaston, nr. Leicester.  
**MID-CHESHIRE:** W. Howarth, G3AHF, 2 Mervyn Road, Owlsey Wood, Northwich.  
**NORTH KENT:** K. Chapman, G3HOZ, 327 Bexley Road, North Heath, Erith, Kent.  
**PONTEFRAC:** W. Farrar, G3ESP, Stanton, Hensworth Road, Ackworth, Pontefract.  
**PORTSMOUTH:** M. W. Pearce, G3BSR, 58 Hollam Road, Milton, Portsmouth.  
**ROMFORD:** D. L. K. Coppendale, G3BNI, 9 Morden Road, Chadwell Heath, Essex.  
**SHEFFIELD:** E. Walker, G2LT, 11a Welwyn Close, Sheffield 12.  
**SLADE:** C. N. Smart, 110 Woolmore Road, Birmingham 23.  
**SOUTH MANCHESTER:** F. H. Hudson, 21 Ashbourne Road, Stretford, Manchester.  
**SPEN VALLEY:** N. Pride, 100 Raikes Lane, Birstall, nr. Leeds.  
**STOKE-ON-TRENT:** K. H. Parkes, G3EHM, 159 Belgrave Road, Longton, Staffs.  
**TEES-SIDE:** H. Walker, G3CBW, 64 Ayresome Street, Middlesbrough.  
**TORBAY:** W. A. Lauder, B.Sc., G3FHL, 15 Cambridge Road, St. Marychurch, Torquay.  
**WANSTEAD:** J. Binning, G3AJS, 150 Upton Park Road, London, E.7.  
**WARRINGTON:** S. Wood, G3EZX, 12 Thelwall Lane, Latchford, Warrington.  
**WATFORD:** J. A. Kane, 23 Oaklands Avenue, Oxhey, Herts.  
**W.F.S.R.A. (Bedford Club):** J. Beavan, G3GBL, 296 Fore Street, Edmonton, London, N.9.  
**WIRRAL:** A. H. Watts, G3FXC, Woodend, 14 Grange Crescent, Hooton, Wirral.  
**WORCESTER:** J. Morris-Casey, G8JC, 4 Kennels Road, Station Road, Fernhill Heath, Worcs.  
**WORTHING:** F. H. Bettelley, 42 Annweir Avenue, Lancing, Sussex.  
**YORK:** G. R. Foggin, G3GRF, 10 MacLagan Road, Bishopthorpe, Yorks.



appointed (see panel for details), and he promises us regular reports in the future. G2CIW, who was one of the leading lights and the foremost Two-Metre man in the area, is now EK1CW in Tangier.

#### **Tees-Side Amateur Radio Club**

Visits have been paid to the local Police Radio Department, and to the *Kemsley Evening Gazette*. A Junk Sale was recently held, and lectures have been given on Meters and on Receiver Noises. Meetings every Thursday, 7.30 p.m., at the Joe Walton Boys' Club, Feversham Street, Middlesbrough.

#### **Pontefract Area Transmitting Group**

Fortnightly meetings at the Fox Inn continue, with regular support. The next are on March 6, 20 and April 3. G3US is the new President. Various visits to electronics firms and radio installations have been planned, and a dinner is also in the offing. Listeners to the Sunday Slow Morse transmission (1030 on 1990 kc) are asked to drop a card to G3ESP. On March 20 there will be a Dinner at the Darrington Hotel—the usual meeting is cancelled.

#### **Bournemouth Radio & Television Society**

Meetings are held on the first and third Fridays at the Cricketers' Arms Hotel, Windham Road, 7.30 p.m. On March 21 there will be a visit to the Central Fire Station, followed next evening by a Ladies' Night. G3FVU is on Top Band CW. Friday evenings.

#### **Barnet Amateur Radio Society**

On February 8 a talk and demonstration on GDO's was given by G4OO, and on March 9 Mr. J. R. Turner (GPO Engineering Branch) will lecture on TVI. As accommodation is limited and this lecture is likely to attract a crowd, members are asked to be there early. All meetings are held at 7.30 p.m. on the second Saturday—Bunny's Restaurant, Station Road, New Barnet.



A Leicester occasion. Capt. H. V. Thomas, G2CUR (right) presenting the "Thomas Trophy" to G2RI, president of Leicester Radio Society. The trophy is for "Outstanding receiving achievement during the year" and was awarded to G2RI for his work on the VHF bands.

#### **Grafton Amateur Radio Society**

The current programme of lecture-demonstrations includes a Colour Film Show, Selenium Rectifiers, Tape Recorders, Test Instruments, "Any Questions" and so on. Meetings continue every Monday, Wednesday and Friday at 7.30 p.m., and G3AFT, the Club Station, welcomes contacts with other Club stations on the Top Band—Phone or CW.

#### **Sheffield Amateur Radio Club**

The Hallam Trophy prizes for 1952 were presented at the Annual Dinner. G3DRE was the winner, with a Top Band transmitter; G3CGF (TVI-proof PA) and G3HTE (Frequency Meter) were second and third. The officers for the forthcoming season were also elected.

#### **Isle of Man Amateur Radio Society**

The monthly meetings (first Wednesday) attract good support, and a few new members have been elected. Meetings continue until May, with a recess until

October. The last two gatherings have brought problems of BCI and TVI to the fore; they are acute in the I.O.M. owing to poor sig/noise ratio, old-fashioned receivers and badly-designed modern BC sets. The Club will doubtless do a useful job in the direction of helping its members to combat these troubles.

#### **Romford & District Amateur Radio Society**

The March programme includes a talk on Radio Fundamentals (March 11), a TV Lecture (March 18) and a visit and talk by G8TL (March 25). The talks on Radio Fundamentals are given by a member for the benefit of the beginners, and the TV lectures by a member who is interested in the transmission side and already has a camera standing by for demonstration purposes.

#### **Slade Radio Society**

A recent lecture on "Coil Q" was very interesting, as also was the "Open Night." Intense discussion was also aroused on a D-F Night. On March 14 there will

be a talk on Home-Built Tape Recorders, and on the 28th a Film Show. As always, visitors will be welcomed at any meeting.

#### **Worcester & District Amateur Radio Club**

The Annual Dinner, in February, was well supported, the usual Prize Draw being an attraction. For the second year in succession the Secretary drew first prize and returned it to the Club for use in a future "swindle"! Local SWL's are asked to listen regularly to the Top Band QSO's for the latest news of the Club's activities. Those who have not yet shown up in person are invited to call on any Thursday night, 7.30 p.m.

#### **Army Apprentices' School Radio Club**

This Club's station, G3HOS, has been active on four bands on Club nights, at which attendances have been good, with membership still on the increase. Morse instruction continues, and it is hoped to produce sufficient good operators to take part in the year's contests.

#### **Brighton & District Radio Club**

Officials for 1952 were elected, and past and future activities discussed at the AGM held late in January. Several new members joined, but there is room for still more. Meetings continue every week on Tuesday evenings at the Eagle Inn, Gloucester Road, Brighton.

#### **Ilford & District Radio Society**

Activities continue unabated, as they have done for nearly 30 years, since 1922. Visitors are always welcome to the meetings at the St. Alban's Church Hall, Alvert Road, Ilford, at 8 p.m. Next after publication are on March 13 (Gramophone Demonstration by Mr. H. T. Stott), March 20 (Talk by Mr. A. J. Tyrrell) and March 27 (Junk Sale). On the afternoon of March 8 a party of 12 are visiting the GPO Trunk Telephone Exchange.

#### **Mid-Cheshire Radio Society**

The AGM was held on February 8 and the officers elected for 1952. As the lease of the Shack has expired, Mr. B. Poole has consented to the holding of meetings over his radio store until new premises have been organised to accommodate the Club. Meetings are therefore on the first and third Mondays, 7.30 p.m., at Poole's Radio Shop, Davenham, next after publication being on March 17.

#### **Leicester Radio Society**

The programme for the next four months includes a talk and demonstration on the "Mini-Four" Portable, a Junk Sale, Field Day preparations and a talk on VHF Tuned Circuits. Several contests are also being organised. Members and visitors welcome at all meetings—first and third Mondays, 7.30 p.m., at the Clubroom, Holly Bush Hotel, Belgrave Gate, Leicester.

#### **Wanstead & Woodford Radio Society**

Activity is increasing, particularly in the VHF line, and a VHF lecture is being put on for the benefit of younger members. On March 11 there is a practical evening; on the 18th a talk on Weak-Signal Receivers; and on the 25th a Transmitting Night. Four members have passed the Morse test and are awaiting their licences.

#### **W.F.S.R.A. ("Bedfast Club")**

The Book and Magazine Distribution Centre is flourishing but causing the manager much trouble for want of shelves and racks! All reading matter of any kind should be sent to him—John Gill, 30, Sholebroke View, Leeds, 7. More and more is needed, as the number of Bedfast members is growing daily. Any transmitter or SWL requiring a 10in. by 7in. "Shack Display Card" with call-sign or SWL number hand-painted thereon may obtain one from Mr. W. Harris, Bridge Cottage, Great Bealings, Woodbridge, Suffolk, by writing to him and enclosing a contribution to the Club's funds, no matter how small.

#### **Portsmouth & District Radio Society**

Meetings continue every Tuesday, 7.30 p.m., in the R.M. Barracks, Eastrey (Sig. School), and new members will be welcomed thereat. Recent lectures have covered Navigational Aids, Superhets and their Tuning, and other subjects. On March 11 there will be a talk on Television by Mr. Fenn, of Southampton University—an open invitation is extended to all interested. The last Tuesday in March will be devoted to the General Meeting.

#### **Edinburgh-Lothians Radio Society**

Meetings are held fortnightly at 25 Charlotte Square, the March dates being the 13th and 27th—7.30 p.m. Coming events include talks on Microphones, Tape Recorders, ZD4AE on DX and a Question Night. The Annual Social is being held on March 7.

#### **Stoke-on-Trent Radio Society**

Meetings are on Thursdays at the rear of the Cottage Inn, Oakhill, and membership is steadily growing. Forthcoming meetings are: March 13, Filmstrip on Theory of Valves; March 20, Transformer Winding, by G3UD; March 27, AGM; April 3, Social Evening. The Club Tx, G3GBU, is shortly being raised to its 150-watt status, and will then be going full blast.

#### **Watford Amateur Radio Society**

On February 5 the AGM was held at Cookery Nook, Watford. A successful year's activity was reviewed, and the Chairman stressed the need for more active participation by licensed amateurs, many of whom live locally but are not members. The name of the Society has been changed to the above, and meetings will continue on the first and third Tuesdays throughout the coming year.

#### **York Amateur Radio Society**

This Club has now been granted a licence and will be active on Wednesday evenings with its new call, G3HWW, on the 80- and 40-metre bands.

## P.C.A. RADIO

**R.C.A. TRANSMITTERS.** Type ET-4336. Complete with matched speech amplifier, crystal multiplier and VFO Units; brand new. (Export only).

**AMERICAN ULTRA** High Frequency Transceivers UFI, UF2, 60-75 mc.

**TRANSMITTERS No. 12.** With coupling units, remote control, microphone, etc.

**COLLINS** Navy Model TCS 9 transmitters and receivers 1.5—12 Mc.

**NAVY MODEL TBY-8 TRANSMITTING RECEIVING EQUIPMENT.** Output 0.7 Swatts on M.C.W. telegraphy and 0.5 watts on telephony. Frequency range 28-80 mc.

**AR.77s NC.45** (540 kc-30 mc AC/DC supply). **HRO**s and others.

All above items in excellent working condition with new valves, working demonstration on request.

**TX VALVES.** 803, 805, 807, 814, 861, 866A.

**RX VALVES.** 1T4, 1S4, 1S5 and many others.

Large stock of transmitting condensers, crystals and other components. Alignment and repair of communication receivers and all other amateur equipment undertaken.

## P.C.A. RADIO

Transmitter Div.: Cambridge Grove, The Arches, Hammersmith, W.6. Tel. RIV 3279.

Receiver Div.: 170 Goldhawk Road, Shepherds Bush, W.12. Tel SHE 4946.

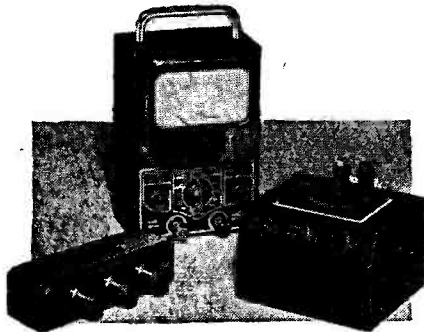

## PULLIN SERIES 100

### MULTI-RANGE TEST SET

**Sensitivity 10,000 ohms per volt, with A.C./D.C. Voltage Multiplier for 2,500 v. and 5,000 v. Volts A.C. and D.C. range: 10, 25, 100, 250, 500, 1000. Milliamps D.C. only: 2.5, 10, 25, 100, 500. Ohms: 0/10,000 and 0/1 megohm. A.C. Current Transformer range: 0.025, 0.01, 0.5, 1.0, 5.0, 25.0 amps. Early deliveries**



### MEASURING INSTRUMENTS (PULLIN) LTD

Electrin Works, Winchester Street, W.3.

Tel.: ACORn 4651/3.

## "SENSITIVE TRF RECEIVER"

(Amos & Johnstone W.W. November Issue)

# SMITHS

## of EDGWARE ROAD

THE COMPONENT SPECIALISTS

Can supply ALL the parts as used by the designers, for this amazing receiver.

**TOTAL COST about £7**

Send for Complete Priced List of Parts

## H. L. SMITH & CO., LTD.

ELECTRONIC COMPONENT SPECIALISTS

287/9 Edgware Road, London, W.2.

Tel. Paddington 5891. Hours 9 till 6 (Thurs. 1 o'clock)

Near Edgware Road station, Metropolitan and Bakerloo

## NORMAN H. FIELD

68 HURST STREET, BIRMINGHAM 5

Mail Order Dept.

64-65 Church Lane, Wolverhampton

### VALVES

At 11/6 6K8G, 5R4G, ECC32, 5Y3/5Z4, 6Q7, 6I, 6SN7, KT66, 6F6, 807, 6K6, At 10/-: 1616, 6SQ7, PEN46, 50YG/GT. At 9/-: 6F7, ARP6, 6X5, KT63, 1T4, 1S4, 1R5, 1S5, At 8/6: VT52, EL32, VR55, 12SL7, At 7/6: 7R7, 7T, 6K7, 6J7, VR150, 6G6/GT, 7C7, VR119, 6Y7/G, 7C5, OZ4, 12A6, 12AC7, VR136, At 7/-: 6B8, 6B8G, 1G6/GT/C, 1A5/GT, 6K7G, VR53, EF39, EF36, At 6/6: 6AB7, ARP12, VP23, At 5/6: GSS7, 12J5, 6SH7, VR91, EF50, 3D6, TT11, VT501, At 5/-: 6J5, 12SK7/GT, 2A3, VU133, 1625, VT51, PEN220A, V118, KT2, At 4/6: 6J5/G, 6J5GT, 12SH7, 12H6, VU120, A5, At 3/6: RR72, ARP3, 9D2, 6H6, At 3/3: VR18, 21SSG, VU111, HL2, VR21, VR66, P61, VR65, SP61, VR65A, SP41, At 2/6: V54, EB34, VR92, EA50, VR78, D1, CV6.

### Special Offer

**VIEWMASTER VALVE KIT at Half Price £6/4/-**

Aircraft Instruments marked OIL and AIR Moving coil basic movement 200m/a 2 1/2 in. square. Very sensitive 7/6. Similar marked RAD lower sensitivity 2 1/2 in. Moving Coil 5/-. Meters R.F.O.- Amp Thermo couple 2 in. square, 5/6, All above meters New and Boxed. Amplifiers, Battery All34 with 2 Valves VR35 and VR21. Can be modified easily for Gram amplifier or input preamp. New and Boxed, 17/-. with Carrying Case, 18/6. Headphones B/A, Brand New 12/6. Crystals 500KCs, 7/-. Loop Aerials 1155 D.F., 8/6. Rotary Convertors Approx 6V input and 220V at 80m/a output 12/6. Condensers 8 mfd. 500v. wkg. Screw-hole fixing, 2/-.  
Please Include something for Postage  
Money Back Guarantee.

# BROOKES FOR CRYSTALS



with a World-Wide  
Reputation for Quality

## TYPE "SM"

Range 3 to 17 mc/s

Hermetically sealed metal  
can 1.125" high under pins,  
0.825" wide, 0.457" thick,  
with 3/32" diameter pins at  
0.490" centres

**BROOKES** CRYSTALS  
LIMITED

10 Stockwell St., Greenwich, London, S.E.10

Phone : Greenwich 1828.

Grams : Xtals Green, London Cables : Xtals. London

YOU CAN RELY ON US FOR BRAND NEW  
CLEAN COMPETITIVE COMPONENTS.

VALVE MANUALS.

BRIMAR, OSRAM, MULLARD, 5/- each

### VALVES

In addition to our large stock we again have a few of the following:  
6C5gt., 7/-, 12K8gt., 10/6, 6SN7gt., 10/6, 6X5gt., 8/-, 6K8GT.,  
10/6, 77, 7/6, KT61, 10/6, KT41, 10/6, KT66, 12/6, EF50, 7/6,  
50L6gt., 10/6, 6K6, 8/6, 6B4, 10/6, KT63, 10/6, 12SG7, 6/-,  
EF54, 7/6, 757, 10/6, 6AK6, 8/6, 5Y3gt., 10/6, 12J5gt., 6/-.

**MINIATURE SHORT WAVE TUNING CONDENSERS.**  
25 Pf. Single Section, Ceramic, Size 1 1/4 x 1 1/4 x 1 1/4 ins. Spindle  
3/16 in. 2/6. 25 Pf. do 1 1/2 x 1 1/2 x 1 1/4 ins. Spindle 3/16 in. 2/6. 30 Pf. do.  
1 1/2 x 1 x 1 1/4 ins. Spindle 3/16 in. 2/6. 65 Pf. do 1 1/2 x 1 1/4 x 1 1/4 ins. Spindle  
3/16 in. 2/6. 25 Pf. Split Stator, Ceramic, Size 1 1/4 x 1 1/4 x 1 1/4 in. Spindle  
1/16 in. 2/6. 5 x 5 pf. ganged 2/6.

### FILAMENT TRANSFORMERS

Finished in green crackle and of very small dimensions 210/240v  
to 6.3v at 1.5a 8/6 ; 210/240v to 6.3v 3a 12/6.

### SELENIUM RECTIFIERS

RM1, 4/6. RM2, 5/-, RM3, 6/-, EHT50, 22/6, EHT45, 20/6.  
12v.5ma meter rectifiers, 1/- each. WX6, WX3, new midget  
type 3/5. 36EHT 100, 27/10. 1 m/a meter rectifier Westinghouse,  
11/4. 14 D36, 11/-, 14 A86, 18/6.  
LT51 2v. 1/2 amps. Westinghouse 5/9.

### SPEAKER TRANSFORMERS

Elstone 8 Ratio 7/6 ; standard pentode, 4/6 ; super midget  
for personals to match 354, DL92, 5/-.

### TWIN-GANGS

.0005 mfd New, Complete with slow-motion drive and drum,  
rubber mounting, standard size, 10/6.

### YAXLEY

6 pole, 3 way 4/6. 4 pole, 3 way 3/6. 1 pole 12 way 4/-.

### ELSTONE

MR7, 18/9, SR/250, 28/6, SR/350, 28/6. MR30, 49/6. MR15, 41/6.

Don't forget some postage, chaps.

## RADIO SERVICING CO.

Dept. M/0 444 Wandsworth Road, Clapham, S.W.8.  
MACaulay 4155

CATALOGUE No. 11 available 2 1/2d. stamp

# SAMSONS SURPLUS STORES

**MASTER VOLTMETER.** 0-20v AC 50cy. 6 inch  
mirrored scale by Metro-Vickers. Brand new in  
makers carton 27/6. Post 1/6.

**ALKALINE CELLS.** 2.5v 10 AH. by Britannia  
Battery Ltd. 12/6. Post 1/-. 2.5v 21 AH 15/- Post 1/6.

**THERMOSTATS** Adjustable type 37-85° F. 5/6  
post 6d.

**HEAVY DUTY SLIDING RESISTORS.** 5 ohm  
10amp 22/6. post 1/6 ; .4 ohm 25 amp knob control  
22/6 Post 1/6. ; 50 ohm 1 amp S.M., Control 10/6  
Post 1/- ; 6.5 ohm. 2.5 amp 15/- Post 1/6 ; 1 ohm  
12 amp 12/6 Post 1/-.

**M.C.R.I. POWER PACKS.** Input 100-240v AC/DC  
output 90v and 7 1/2v. 37/6 Post 1/6.

**30ft. LENGTHS CO-AXIAL CABLE** with Pye  
sockets on each end. 8/6 Post 1/6.

**PANEL MOUNTING OVERLOAD SWITCHES**  
15 amp American Make 7/6. Post 1/-.

169/171 EDGWARE ROAD

LONDON, W.2. Tel : PAD 7851

125 Tottenham Court Road, W.1. Tel : EUS 4982

Hundreds of Bargains for Callers.

Edgware Road Branch Open All Day Saturday.

All orders and enquiries to our Edgware Rd. branch please

# S. G. Brown



A  
TYPE  
HEADPHONES

The first choice of  
RADIO OPERATORS  
throughout the world

These headphones feature a  
High Permeability Reed tuned to  
1,000 c/s. and coupled to a  
conical aluminium diaphragm.  
Earpieces individually adjustable  
while in use for sensitivity and  
power-handling characteristics.  
D.C. Resistance : 4,000 ohms.  
Impedance : 16,000 ohms at  
1,000 c/s.

The S. G. Brown range of head-  
phones covers types for many  
specific requirements. Details of  
the full range are available in  
the illustrated Brochure "S."  
—sent on request.

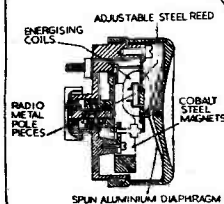

ENERGISING  
COILS  
ADJUSTABLE STEEL REED  
RADIO METAL  
POLE  
PIECES  
COBALT  
STEEL  
MAGNETS  
SPUN ALUMINIUM DIAPHRAGM

S. G. Brown Ltd

TRANSFORMER DIV. 444 WANDSWORTH ROAD, LONDON, S.W.8.

# TO HAMS & DEALERS WE WANT TO BUY AMERICAN SURPLUS EQUIPMENT OF EVERY KIND

FOR RADIO HAM SHACK—  
NEW YORK'S LEADING DEALERS

RECEIVERS · TRANSMITTERS  
TEST SETS · SIGNAL GENS  
EVERYTHING · ELECTRONIC

We are interested in any quantity, from one upwards.

\*Phone us immediately, transfer charge

SOLE AGENTS IN GT. BRITAIN

ALTHAM RADIO CO BRAZENNOSE ST.  
MANCHESTER 2 Tel: DEAnsgate 5387

## SOUTHERN RADIO'S WIRELESS BARGAINS

**WALKIE-TALKIE (TRANSMITTER-RECEIVER).** Type 38 Mark II. Complete with 5 valves, Throat Microphone, Headphones and Aerial. 7 mc/s Amateur Band suitable for field use. Powerful Superhet Receiver. Modulated Transmitter. Guaranteed ready for the Air, less batteries £3/10/-.

**R.3515 TELEVISION UNITS.** Complete with 21 valves. 6 stage 14 mc/s I.F. Strip. Ideal for T.V. Conversion. Brand new in original wooden cases. £3/10/-.

**G.E.C. "MINISCOPE" M861B. MINIATURE CATHODE RAY OSCILLOSCOPES** 1½in. Tube. Time Base etc., etc. Brand New in Makers Sealed Cartons with Leatherette Carrying Case—£15/10/0 plus 5/- carriage.

**LUFBRA HOLE CUTTERS.** Adjustable from ½in. to 3½in. for use on Wood, Metal, Plastic, etc., 5/9. LUFBRA FLY CUTTERS 14/6.

**LIONEL "BUG" KEYS.** Genuine U.S.A. Automatic Morse Key, Type J36. Few only, £3/7/6.

**THROAT MICROPHONES.** Magnetic type complete with long lead and plug, 4/6.

**HAND GENERATORS.** 6 volts at 5 amps. With Crank, 21/-.

**PLASTIC TRANSPARENT MAP CASES** 14 inches by 10½ inches. Ideal for Maps, Charts, Display, Photographs, etc., 5/6.

**STAR IDENTIFIERS.** With Hydrographic Office Modifications A-N Type 1. Complete in case 5/6.

**MOVING COIL D/C METERS.** Brand new, 2in. 0-2 mA., 0-5 mA., 0-30 mA., 0-20 volts, 9/6 ea.

**WESTECTORS.** Type WX6 and W112. 1/- ea. 11/- doz.

**MARCONI AERIAL FILTER UNITS.** Type "916" in conformity with P.O. Specification. Full instructions for fixing 4/-.

**CONTACTOR TIME SWITCHES.** 10-hour movement 2 impulses per second. Thermostatic Control in soundproof Cases 11/6.

**VISUAL INDICATOR UNIT Type 3 (10Q/4).** Contains two Moving Coil movements, two Neons, etc. Easily convertible to very efficient M.C. Meters, 11/-.

Conversion fully described in "W.W." Sept. 1951.  
Full list of Radio Publications, 2½d.  
**SOUTHERN RADIO SUPPLY LTD.,**  
11, LITTLE NEWPORT STREET, LONDON  
W.C.2. GERrard 6653.

## LYONS RADIO LTD.

**AERIAL MASTS.** Consist of four sections of stout all-weather resisting paxolin tubing (3½ins. max. dia. 3/16ins. wall. Min. dia. 1½ins.). Each section fits together with metal ferrules forming a mast 28ft. high. Very light weight and can easily be raised by one man. Guy ropes etc. are not supplied. PRICE 42/-, carriage 4/-.

Top two sections only to form a mast 14ft. PRICE 18/6, carriage 2/6.

**ELECTRIC MOTORS.** These useful motors operate from 12v. AC. or DC. Dimensions are 2½in. dia. x 4ins. long. Spindle length ½ins. and ¾ins. dia. In new condition. PRICE 14/-, post 1/-.

**HAND GENERATORS Mk. 2.** A manually operated generator originally designed to provide the operating voltages for the American trans./Rcvers. types 18 Mk. 3 and 48. but of course suitable for a variety of other purposes. Nominal rating is HT. 162v. DC. at 60mA. and LT. 3.1v. DC. at 0.3A. The generator includes a built-in smoothing unit designed to filter out ripple and voltage irregularities. Size 5¼ x 5½ x 6½ins. In brand new and unused condition supplied complete with connector, two crank handles, seat for operator and instruction book. PRICE 25/-, carriage 7/6.

**MOVING COIL SPEAKERS.** A large purchase of a Radio Manufacturers surplus stock enables us to offer these speakers made by famous makers at much less than normal list price. All brand new. 8in. lightweight (Only 5½ozs.) employs high perm. magnet. PRICE 17/6 : 6½ins. PRICE 15/6 : 3ins. PRICE 14/-.

Postage all types 1/-.

**SUPPLY UNITS TYPE LPI.** Contain a rotary converter for 12v. DC. input and 230v. DC. output at 30mA., many wire-wound resistors, condensers, chokes etc. Slightly damaged externally but in good condition internally. Circuit diagram pasted inside dust cover. Overall size. 11 x 8½ x 4½ins. PRICE 10/-, carriage 3/9.

**RECEIVERS TYPE R3515.** Adaptable for TV. sound or vision details of which were given in last May's issue of the Short Wave Listener. Fitted with 10-VR65's, 1-VR92, 5-VR56's, 1-VR54, 1-VR53, 3-VR55's, 13 Mc. I.F. amplifier strip and a wealth of useful components. In good condition PRICE £3/17/6. or less valves 30/-.

Carriage 7/6.

**MAGNETRONS TYPE 725A.** Brand new by Western Electric. PRICE 75/- post free.

3 GOLDHAWK ROAD (Dept. MS),  
SHEPHERDS BUSH, LONDON, W.12  
Telephone: Shepherds Bush 1729

## Good Investments

**RECORDING METERS** by Evershed & Vignoles, in iron case, wall type Murday system, 3-0-3 or 10-0-10 m.a. full scale. chart 12in. per min. as new.

**ELECTROSTATIC VOLTMETERS** Everett Edgcumbe 2½in. flush 1500 volts 65/-. Voltmeters 2in. flush D.C. m.c. 0-20 volts 8/6 post 9d. Ammeters to match 0-50 amps. 10/- plus 9d. post.

**RESISTANCES,** variable sliders, 152 ohms 2 A., 30/-, post 2/-; 5 ohms 10 A., 27/6; 6½ ohms 5 A., 25/-; 3000 ohms ½ A., 15/- post 1/-; 1.2 ohms 15 A., 12/6.

**METAL RECTIFIER UNITS** Westinghouse, 50 v. 5 A. £9/10/-, 50 v. 1½ A. £6. 50 v. ½ A. £4/10/-, all for 230 v. A.C. 50 c/s input. Battery chargers for all sizes made to specification.

Hewlett Type Rectifier by E.C.C. 365/440 v. 3-ph. 50 c/s. input 110 v. 18.2 A. 2 kW. output ammeters, voltmeter, in ventil. metal case with new Hewlett type valve.

**PANORAMIC RADIO ADAPTORS.** Navy Model R.B.W.B. CPN 55090/A max. sweep width 100 kc/s. input frequency 5.25 Mc/s. Power source 115/230 v. A.C. 50/70 c/s sweep frequency adjustment 30 c/s. complete with tubes and cathode ray tube, £55, ex. London stores.

**MOTORS.** ½ h.p. 230v., 1,425 r.p.m. £8/10/-; ½ h.p. 400 v. 3-ph., 1,425 r.p.m., £9, carriage extra at cost.

D.C. Motors, 230 v. ½ h.p. shunt wound, 1,425 r.p.m. £4/10/-; 24 v. starter motors, new, 25/-; 12 v. ½ h.p. high speed, 55/-, carr. 5/-.

**TRANSFORMERS** double wound 230/110 volts 50 cycles £6/10/-, carr. 5/- Auto Transformers 230/110 volts Met-Vic. 500 watt £4/10/- carr. 5/-.

Dynamos, Alternators, Pumps, Battery Chargers, Microphones, Telephones, Test Equipment, Lighting Plants, etc.

Send us your enquires.

## ELECTRADIX RADIOS

Dept. B. 214 Queenstown Road, Battersea, London, S.W.8

Telephone: MACaulay 2159

**ALPHA OFFERS**

**WAXED TUBULAR CONDENSERS.** .002 mfd. 400v., .003 mfd. 1000v., .005 mfd. 1000v., .01 mfd. 500v., .05 mfd. 500v., .01 mfd. 500v., 25 mfd. 1000v., 5 mfd. 450v., all to clear at 4½d each ... 4/- doz.

**P.M. FOCUS RINGS.** Latest Type R20 and R25 ... 19/6 each.

**VITREOUS ENAMELLED RESISTORS.** 10K/2 20 watt clip-in-Type 1/6 each. 3 mains dropper 717.1 tap at 600V 1/3 each.

**FLEXIBLE COUPLINGS.** Small metal type 6d. each. Large 9d. ea.

**BAKELITE CASE H.V. CONDENSERS.** .02 mfd 5kV 1/6 each. .001 mfd 4kV 1/- each. .25 mfd 800v 1/- each. .1 mfd 600v 1/- each.

**FUSE HOLDERS. CARTRIDGE TYPE** Ideal for amplifiers and T.V. complete with 2.3 amp fuses 1/9 each.

**EA50 DIODE HOLDERS.** Cradle type 2 for 9d. 3 for 1/-.

**CONSTRUCTORS' BARGAINS** Partly dismantled 3170A chassis. Leaving all valve holders, Resistors, Condensers, Pvc type co-axial plugs, H.V. Anode cap. Complete with case 9/- each. 3/- carriage. Small Sub Chassis with EF50 ceramic valve holder and locking ring 10K wire wound control, Philips 3:30 IF trimmer, Alladin Coil formers and slugs Resistors and Condensers ... 4/6 each.

**MOULDIED MICA CONDENSERS.** .01, .001, .002, .003, .005, .0001, .0002, .00027, .0004, .0008, all 5/6 doz.

**ALLADIN COIL** Formers and Slugs: ex equipment 7/- doz.

**TINNED COPPER WIRE** 1lb. Reels 26 SWG ... 1/6 each.

**INSULATED SLEEVING** Bright colours. 1mm 2mm, 3mm, 4mm, 1/- doz. yards.

5mm, 6mm, 8mm, 10mm ... 1/6 doz. yards.

**Valves all Guaranteed. Majority in Makers Cartons.**

6C6GT	9/6	3Q4	9/-	1625	4/-
6H6	4/-	3V4	9/-	807	11/6
6SH7	7/-	354	10/6	954	2/9
6F6M	9/-	42	9/6	955	5/-
6AC7	6/9	78	9/-	956	2/9
6K7G	6/6	5U4G	9/-	AT40	8/6
6CSGT	7/6	VU133	6/-	AC6/Pen	7/9
6D6	8/-	VU39	9/6	VR150/30	9/-
6C6	7/6	5Z4	9/-	MS/PEN	5/9
12A6	5/9	5Y3GT	9/-	2155G	4/-
6SL7	9/6	SP41	4/-	EB34	3/-
IT4	9/-	SP61	4/-	KT263	7/9
IR5	9/-	EF50	6/6	80	9/6
IS4	9/-	VU111	4/6	12K8	9/-
IS5	9/-	VU120A	4/6	688	7/9

Thousands of parts for the constructor in stock send for list 3d. Stamp. Terms Cash with order or C.O.D. Mail order only. Please add postage 1/- under £1. 1/6 under £2.

**ALPHA RADIO SUPPLY CO.**  
5/6 VINCES CHAMBERS, VICTORIA SQUARE, LEEDS 1.

**MAINS, TRANSFORMERS, SCREENED, FULLY INTERLEAVED AND IMPREGNATED**

**Half Shrouded—**

H.S.63. Input 200/250v. Output 250/0/250v. 60 m/a  
6.3v 3 amps, 5v 2 amps ... 18/6

H.S.40. Windings as above, 4v 4 amps, 4v 2 amps ... 18/6

H.S.2. Input 200/250v. Output 250/0/250v. 80 m/a ... 21/-

H.S.30. Input 200/250v. Output 300/0/300v. 80 m/a ... 21/-

H.S.3. Input 200/250v. Output 350/0/350v. 80 m/a ... 21/-

H.S.2X. Input 200/250v. Output 250/0/250v. 100 m/a ... 23/-

H.S.30X. Input 200/250v. Output 300/0/300v. 100 m/a ... 23/-

**Fully Shrouded—**

F.S.2. Input 200/250v. Output 250/0/250v. 80 m/a ... 23/-

F.S.30. Input 200/250v. Output 300/0/300v. 80 m/a ... 23/-

F.S.3. Input 200/250v. Output 350/0/350v. 80 m/a ... 23/-

F.S.2X. Input 200/250v. Output 250/0/250v. 100 m/a ... 23/9

F.S.30X. Input 200/250v. Output 300/0/300v. 100 m/a ... 25/9

F.S.3X. Input 200/250v. Output 350/0/350v. 100 m/a ... 25/9

All above have 6.3-4-0v at 4 amps. 5-4-0v at 2 amps.

F.S.43. Input 200/250v. Output 425/0/425v. 200 m/a 6.3v  
4 amps C.T. 6.3v 4 amps C.T. 5v 3 amps ... 51/-

H.S.6. Input 200/250v. Output 250/0/250v. 80 m/a 6.3v  
6 amps C.T. 5v 3 amps. Half-shrouded ... 29/3  
For Receiver R1355.

**Framed, Flying Leads—**

F.30X. Input 200/250v. Output 300/0/300v. 80 m/a, 6.3v  
7 amps, 5v 2 amps ... 31/9

HS150. Input 200/250v. Output 350/0/350v. 150 m/a 6.3v  
3 amps C.T. 5v 3 amps. Half-shrouded ... 30/9

FS120. Input 200/250v. Output 350/0/350v. 120 m/a, 6.3v  
2 amps C.T. 6.3v 2 amps C.T. 5v 3 amps Fully  
shrouded ... 33/-

FS150. Input 200/250v. Output 350/0/350v. 150 m/a, 6.3v  
2 amps C.T. 6.3v 2 amps C.T. 5v 3 amps Fully  
shrouded ... 34/9

**FILAMENT TRANSFORMERS**

F5. Input 200/250v. 6.3v at 10 amps or 5v 10 amp or  
10v at 5 amp or 12.6v at 5 amp. Framed Flying  
Leads ... 37/9

F.U.6. Input 200/250v. 0-2-4-5-6.3v at  
2 amps ... 11/-

F.29. Input 200/250v. 0-2-4-5-6.3v at  
4 amps ... 20/9

F.6. Input 200/250v. 6.3v 2 amps ... 9/-

F.12. Input 200/250v. 12.6v. Tapped at 6.3v 3 amps ... 18/6

F.24. Input 200/250v. 24v. Tapped at 12v, 3 amps ... 26/-

C.W.O. (add 1/3 in the £ for carriage). All orders over £2 carr. paid.

**H. ASHWORTH (Dept. S.W.)**  
676 Great Horton Road, Bradford, Yorks.

**SMALL ADVERTISEMENTS**

9d. per word, minimum charge 12/-. No series discount; all charges payable with order. Insertions of radio interest only accepted. Add 25% for Bold Face (Heavy Type). No responsibility accepted for errors. Replies to Box Numbers should be addressed to The Short Wave Magazine, 55 Victoria Street, S.W.1.

**TRADE**

**QSL'S** and LOGS by MINERVA. The best there are.—Samples from Minerva Press, 46 Queen's Road, Brentwood, Essex.

**WANTED.** RCA speech amplifiers, type MI-11220 W J or K and Aerial Tuning Units for BC-939A.—Offers, stating quantity and price, to PCA Radio, The Arches, Cambridge Grove, W.6.

**WANTED.** BC-610 Hallicrafters, ET-4336 transmitters, SX-28's, AR-88's. Receivers and spare parts for above. Best prices.—Write Box 864, c/o Spiers Service, 82 Centurion Road, Brighton, Sussex.

**QSL CARDS AND LOG BOOKS. APPROVED G.P.O. SAMPLES FREE.** — ATKINSON BROS., PRINTERS, ELLAND, YORKS.

**ROTARY-BEAM** Antenna indication. Magslip transmitters from 10/-. (Listed £16).—Stamp for circuit and full details: Engineering Facilities Ltd., 29 Rea Street, Birmingham, 5.

**QSL CARDS.** Neat, attractive. Reasonable price. Samples—Lovedee, BRS. 15642, Mill Street, Barwell, Leicester.

**REQUIRED Urgently:** AR88's, SX27-28's, S38's, BC221's. All Test Equipment, Tape and Disc Recorders. Contact us before selling. Highest prices paid.—Universal Electronics, 27 Lisle Street, Leicester Square, London, W.C. 2. (GER. 8410).

**TRANSmitters** required urgently: types ET4336, BC610, etc. Also spares. Highest prices paid.—Pype-Hayes Radio, 606 Kingsbury Road, Birmingham. (Erdington 4942).

**CRYSTAL** Microphone Inserts (Cosmocord Mic-6). Guaranteed brand-new, 15/6 post free.—Radio-Aid Ltd. (Retail Dept.), 29 Market Street, Watford.

**ATTRACTIVE** QSL's at reasonable prices; also Club Headings. Send for samples.—Rowe, 101 Fawnbrake Avenue, Herne Hill, S.E.24.

**WANTED.** Valves, small or large quantities; 6K8, 6V6, 5Z4, 6AC7, IR5, IS5, FW4/500, 6Q7, 12K8, 80, VU39, EBC33, 354, etc., etc. **PROMPT CASH.**—WM. CARVIS, 103 NORTH STREET, LEEDS, 7.

**QSL CARDS;** attractive designs. Samples on request.—Sandhurst Press, 67 Upper Sandhurst Road, Brislington, Bristol, 4.

**APOLOGY:** Due to urgent defence work, shortage of materials and labour, a number of our private orders have been seriously delayed; will those whom we have kept waiting accept our sincere apologies for the delays? We are doing our best to catch up, and hope to have deliveries back to normal in a few weeks.—E. J. Philpotts, Metalworks, Chapman Street, Loughborough.

SMALL ADVERTISEMENTS, TRADE—*continued*

**WANTED URGENTLY:** Any test equipment with T.S. prefix: TS47/AP. 34, 174, etc. VHF gear; BC221's; Klystrons; APR4 units. Receivers AR88, SX28, S27/CA. HRO's, etc.; also any other type of good equipment. The very top paid... cash. Write, telephone or bring along.—Universal Electronics, 27 Lisle Street, Leicester Square, London, W.C.2. (GERRARD 8410).

**SITUATIONS VACANT**

**LEADING** Manufacturers of Electronic Medical Instruments require service man with experience of electronic equipment; must have good presence and be mobile.—Apply, giving full particulars of age, training and experience, to Box No. 1062.

**READERS' ADVERTISEMENTS**

3d. per word, min. charge 5/-. payable with order. Box Numbers 1/6 extra. Replies to Box Numbers should be addressed to The Short Wave Magazine, 55 Victoria Street, S.W.1.

**R.103A** MAINS Communication Receiver; internal speaker, plus new Eddystone 28 mc converter built Webbs. £10 pair.—17 Asquith Road, Rainham, Kent.

**CLASS D W/M.** £4. American testmeter, 2000-ohm/Vt., 0/6000v AC/DC, 0/600 mA DC, 0/5/500K/5M ohm, £5; 500v 150 mA, 4v4A (3) P/P, £2. Offers? Valves: Cossor 09J D/B CRT, £3; 829B, 60/-; 35L6GT, 10/-; 6SA7, 12SN7GT, 6SC7GT, 5U4G, 6V6G, 5Z3, 6SN7GT, 6L6G, 807, GTIC, X61M, 6SQ7, 80, X65, VR150, 45Z3, 26A6, 6K8G, 7/6; 6X5GT, 6N7G, VU39, 12SR7, N14, EF50, EF54, 3Q5GT, VT52, KTZ41, PENA4, 5/-; 955, 6J5G, 28D7, VR137, VU133, 6SJ7, 6SK7, 6J7G, 3/-; VR54, QP21, HL41DD, VU111, 2/-.—Box No. 1047.

**EXCHANGE** Leitz 3.5 CM F3.5 wide-angle chrome Elmar lens, for good communications receiver, Offers for Thermador Modulation Transformer Type CS-2160 and BC-454-B. Both new and unused.—Taylor, 103 Mill Street, Macclesfield.

**FOR EXCHANGE:** Hambander Receiver, as new.  
**WANTED:** Miniature QRP phone transmitter with power pack for 160 and 80 metres; must be in good condition.—Box No. 1048.

**R.107** RECEIVER; output, RF stage modified (6SG7-SP61). S-meter. New Sprague condenser. Not original case. AC mains only. Price £9 15s. 0d.—G3IKY, 58 Flaxton Road, Plumstead, S.E.18.

**FOR SALE:** Complete SCR-522 VHF Tx/Rx. BC348 converted to mains. Unused 813's.—Offers to 183 Princes Gardens, London, W.3.

**WANTED:** Propeller Pitch Motor, 24 volt AC, with reversible 9750:1 reduction box; splined shaft.—G3AAG, Ferndale, Gipsy Lane, S.W.15.

**EXCHANGE:** Cossor DB Scope 339, Mullard Universal Bridge, manuals, good condition; for TV receiver. Sutton Coldfield frequency.—123 Hamill Road, Burslem, Stoke-on-Trent.

**WANTED:** AR77E Handbook.—R. Poppi, 265 Kent House Road, Beckenham.

# Dits and Dahs!!

THIS IS THE LANGUAGE OF THE AIR THAT EVERY RADIO AMATEUR, PILOT, SHIP'S OPERATOR, ETC., MUST BE ABLE TO READ AND SEND. IT IS EASILY AND QUICKLY LEARNED BY THOSE WHO TAKE UP

A

**CANDLER CODE COURSE**

THE CANDLER SYSTEM not only teaches you the **right way to send** but the **right way to read** code sound just as easily as you read print.

The **Special Course** covers all the Code training necessary to pass the G.P.O. test for an **Amateur Transmitting Licence**.

The **Junior Course** is a complete Code Course for the **Beginner** who desires to secure the G.P.O. Certificate in which he is interested.

The **Advanced Course** is for those with a consistent sending and receiving speed of not less than 15 w.p.m. who desire to improve their speed and accuracy in code work.

**Touch-Typing Course.** A series of interesting and easily followed lessons which enable one to record messages at high speeds.

Courses supplied on Cash or Monthly Payment Terms.

You are invited to send for a copy of the **CANDLER "BOOK OF FACTS,"** it gives full details of the above training.

**THE CANDLER SYSTEM CO.**

(55SW) 52b, ABINGDON RD., LONDON, W.8.

Candler System Company, Denver, Colorado, U.S.A.

• **Special Offer** •

G.E.C.



MR SERIES

**V.H.F. RECEIVERS**

The receiver uses 10 valves as follows. HF and 1st det stages. ZA2's, 954's or EF50's. Local oscillator, Det 19, three IF stages KTW63's. Det and AVC D63 Double diode, LF H63, Output KT63. Noise Suppressor D63. Technical data. Frequency Range (A) 128-131 Megacycles. (2134-2.29 metres). Frequency Range (B) 95.5-100 Megacycles (3.14-3.0 metres) Frequency Range (C) 78.5-82 Megacycles (3.82-3.66 metres) Intermediate Frequency 8.3 to 9.8 mcs. Oscillator Crystal Controlled. Sensitivity 3 microvolts for 50 MW audio output. 30% modulation at 130 mcs. Input impedance 72 ohms. Band Width 9.8 mcs, 8.3 mcs, at 6DB down 105 kcs., 90 kcs., at 40db down 295 kcs., 215 kcs. Maximum power output, 2 watts. May be operated entirely from a 6 volt or 12 volt source of DC (with suitable motor generator to supply anode voltage) or with external source of 6 volts and 270 volts. Houses in a Grey enamel steel case 10in. x 8in. x 7in. Total weight 22lbs. We consider these are the best bargain in Govt. Surplus obtainable anywhere. Note the Price. £2/9/6, plus 5/- carr.

**H.P. RADIO SERVICES LTD.**

55 County Road, Liverpool 4

Est. 1935.

Tel.: Aintree 1445

## RADIO G200 ANNOUNCES

**VALVES** : 12A77 500mcs double Triode frequency changer, 12AX7, 866A, 6J6, EC91, EC53-RL18, CV2 Radio control thyatron, 1S/-, 6AM6, Z77, EF91, EB91, DH77, D77, 6D2, 6AV6, W77, EF92, 9D6, 8D3, 6F12, IR5 DK91, X17, IT4, DF91, W17, 1S5, DAF91, ZD17, DL92, 35A, N17, N18, 3Q4, N19, DL94, DL93, 3A4, 6K8gt, X61, X76, 12K8gt, 524G, 6A7G, 6B6G, 6SN7, 6SL7, 3B7/1291, 12K7gt, KT66, 6L6, 6L6G, 6B6G, 6L7, 6CSgt, 6J7, 6V6gt, 6Q7gt, 6B8, 12SN7, 6AB7, 12C8, 10/6, 6AC7, 6C4, 6K6gt, 12A6, KT41, 2A3, 6U5G, 6X5gt, 35Z4, 35L6, 50L6, KT33c, 6I7G, 6SK7gt, 8/6, NGT1, GDT4C, DPQ, CV18, E1148, 12SH7, 6SH7, 4/9.

Post 6d. Reg. post 10d. extra

TRADE & OVERSEAS ENQUIRIES INVITED.

### ARTHUR HOILE

55 UNION STREET, MAIDSTONE, KENT.

Phone 2812

**BRASS, COPPER, BRONZE,  
ALUMINIUM, LIGHT ALLOYS**  
IN ROD, BAR, SHEET, TUBE, STRIP, WIRE

3000 STANDARD STOCK SIZES

### H. ROLLET & CO., LTD.

6, CHESHAM PLACE, LONDON S.W.1.

SLOane 3463

WORKS

36, Rosebery Ave.,  
London E.C.1.

Kirkby Trading Estate,  
Liverpool

"No Quantity too Small"

### ELECTRAD RADIO GUARANTEED BARGAINS

Marconi CR100, very good condition, £27. Eddystone 640, unmarked, as new, £20. R1224A 5 valve Battery Superhet, good order, £6. BC221 with Power Pack, perfect, £20. B.P.L. Signal Generator, 100 Kcs to 3 Mc/s, complete with aerials, Leads, etc., good order, £8/10/-, Wilcox-Gay V.F.O., complete, as new, £5. Carriage extra on all above items. Lighthouse Tubes, 2C40, few only, brand new, £2. Brand new 813 valves £3/10/-, 829B valves £4. VCR97 C.R.T.'s brand new, 35/- plus 10/- carriage. Photo Electric Cells, type GS16, a snip at 25/-, VALVES: 815, 30/-; 803, 6/6, 3A5, 20/-; 1616, 884, 12/6; Z77, KT61, 11/6; 6AG5, 6F6, 6SC7, VR105/30, 10/-; 807, 801A, 5X4, 5Y4, 6SF5, 6T1C, VR 150/30, 8/6; 1L4, 3A4, 1LC6, 7/6; 6C4, 1LN5, 3D6, 1LH4, 6/6; S130, 6AC7, 5/-; EA50, 2/6.

S.A.E. for Free List. Post 9d. on orders under £1.

**ELECTRAD RADIO**  
69 High Street, Belfast, N.I.

### ADCOLA (Regd. Trade Mark) SOLDERING INSTRUMENTS



Reg. Design No. 860302  
British, U.S. and Foreign Patents

Supplied for all volt ranges from 6/7v-230/250v. Meets every requirement for radio assembly, maintenance, telecommunications, etc. High Temperature. Quick Heating, Low Consumption, Light Weight

3/16in. Dia. Bit Standard Model  
1/4in. Dia. Bit Standard Model  
3/16in. Dia. Detachable Bit Type

Sole Manufacturers: **ADCOLA PRODUCTS LTD.**  
General Offices and Works: **Cranmer Court, Clapham High Street,  
London, S.W.A. (MACaulay 4272)**

SMALL ADVERTISEMENTS, READERS—continued

**WANTED:** B2 Tx/Rx complete P/P, coils, etc. £10 given for FB job.—Brelsford, 150 Bramall Lane, Sheffield.

**URGENTLY Wanted:** CNY1 transceiver, 230 AC.—G3ESG, 83 Rock Avenue, Gillingham, Kent.

**Q** MAX B 4/40 Tx and B 5/10 Rx for sale or exchange for wavemeter and or what-have-you?—G3ESG, 83 Rock Avenue, Gillingham, Kent.

**WANTED:** Small AC petrol generating plant, about 300 watts, in good order; also TBY transceiver.—30a Fore Street (Saltash 2395), Cornwall.

**OPERATION Removal.**—Must sell immediately: Sender 12; Wilcox-Gay VFO; 60-watt transmitter; power packs; transformers; valves; racks; cases; vibrators; portable gear; receivers; turntables; etc.—GM2FZT, 3 Berridale Avenue, Glasgow, S.4.

**WANTED for Army Type 12 transmitter:** Power Transformer T/230; also any information on receiver RU-19.—Price, details, to GM2CQI, 166 Kingswood Drive, Glasgow, S.4.

**SALE:** National 1-10, complete power pack, six sets coils, and two spare valves, £15; or exchange BC221, mains operated.—Box 1051.

**CANADIAN 58MK1 Tx/Rx,** power pack, accumulators, aerial, phones, spare valves, vibrator, new; £12 10s. 0d. Two available.—S.A.E., Wyatt, F2, Odeon Parade, Croydon Road, Beckenham, Kent.

**R.1155** modified for 230v AC, complete with internally-fitted speaker, and power pack; in very good condition; £10 10s. 0d.—Box 1049.

**VALVES** (limited quantity 954). 2/6; 955, 3/6; 9003, 3/6; 6SH7, 5/-. All above prices include postage. C.W.O. only. Stamped addressed envelopes with enquiries.—G3AAU, 30 Churchbury Road, Enfield, Middlesex.

**FOR SALE:** HRO Senior with power pack and coils 10 to 160, perfect; used 5 months since new; £25. Weston industrial tester, 20,000 O.P.V., £10. Q.Max B/4/40, complete with 4 xtals and xtal mike, £45. Combination valve and circuit tester, ESPEY model 104 T.C. (new), complete with charts and booklet, £12. 58 set—(new) complete spare valves—power pack and batteries, £10.—Box 1052.

**SALE:** Canadian 58 MK.1 walkie-talkie complete, S new, in original packings, £8.—Nelson, Olivet, Norwood Lane, Nr. Gravesend, Kent.

**HALLICRAFTERS SX24,** 9 valves, 550 kc; 43 mc; S-meter, xtal filter, manual; £15. 807's, 5/6 each.—9 Hill Crescent, Bexley, Kent.

**WANTED:** HRO with bandsread coils, or Collins 75A or SX28.—Elm Tree Inn, Bridge Street, Mansfield.

**BOXED and guaranteed Valves;** 6SN7 and 6SL7 at 7/6 each; 6H6, 2/3 each.—Hall, 129 Buckstones Road, Shaw, Lancs.



## SMALL ADVERTISEMENTS, READERS—continued

**SELLING-UP:** Army 19 Set. Power unit (Rx only working), 20 octal mains, and 10 battery valves, chokes, coils, condensers, valve-holders, etc. Bargain, £5.—Sallows, 1 Shaftesbury Avenue, Dovercourt, Essex.

**SALE:** *Short Wave Magazine*, Vols. 5, 6, 7, 8 and 9; perfect condition.—Cornfield, 50 Cologne Road, London, S.W.11.

**FOR SALE:** 522 Tx unmod, with choke mod, transf., and switch, 25/-; Set of Valves for 522 Tx: 6G6 (1), 12A6 (3), 832 (2), £3. Power Unit, Type 3, 300v 150 mA, fully metered, £2 15s. 0d. Monitor-Crystal, Type 4A, with valves and P/Pack, £3. Complete manual 522 equip., £1. 15 American Metal 2 mF 600v. Cond., 7/6. Odd crystals, 5-7 mc, 2/6 each. Many 1.4v valves; state wants. S.A.E. enquiries.—Box No. 1053.

**WANTED:** SX28A, S29. Must be in good condition. Sell PCR1, £10 (or near offer).—Wise, 81 Albany Road, Reading, Berks.

**UNIVERSAL** Avomitor, perfect, £5; Marconi 14A pickup, unused, £2; Collor centre-drive motor, AC47, unused, £3; Pickup, 15/-.—Wood, 118 Moscow Drive, Liverpool 13.

**CR.300** RECEIVER, in working order, wanted. —N. Smith, 69 Essex Road, Leyton, E.10.

**CLEAR-OUT:** Ardente 6v portable loud-hailer, less speaker, weight 10 lbs., £4; R.C.A. 100 kc crystal and base, 18/-; 460 kc crystal unit, with phasing and 2 IF's, German, £2; 6v R.C.A. vibrator pack, 25v 80 mA, superb, 30/-; Sound Sales AC Power unit, 250v 80 mA double-choke filter, 6.3v, cabinet, 50/-; AC power unit, S.441B, 300v 200 mA, 12.5v 3A, cabinet, £2; 12v converter unit S.455B, 180v 60 mA, cabinet, 30/-; CNY1 power unit, 35/-; Driver unit, 20/-; Valves, TZ40, 805, 866, 15/-; EF50's, 2/6; Command 12v dynamotor, £2. Carriage extra.—G2AC, Sleepy Hollow, Headley, Bordon, Hants.

**EDDYSTONE** 750 for sale; little used; perfect condition. Offers?—26, Townsend Drive, St. Albans, Herts.

**SCR.593** FOR SALE, complete and unmodified field with BC728 Rx (Emerson), vehicle mountings, aerial, charging cable, set of spare valves and vibrators, two manuals; packed in original cartons and crate. Rx and accumulator slightly used. Offers over £10. Wanted: BC746 tuning units, with or without xtals; lower half of BC1000 case.—Box 1056.

**AR88** (D) in unmarked condition; also BC221 with power pack; also 221 with two extra driver stages as VFO, perfect with P/Pack. Offers?—Box 1055.

**WANTED:** Collins TCS12 motor generator; also one or two sets of harness; also 3 Cannon sockets to fit same.—82 Framingham Road, Sale, Cheshire.

**RCA** ET4336; excellent condition; unmodified with Wilcox Gay VFO. — Offers to: G3DMO, 18 Cattle Street, Great Harwood, Blackburn, Lancs.

**PMG CERTIFICATE**

*Prepare now for next exam.*

Take our special POSTAL COURSE. Many former students testify that our tuition was invaluable in ensuring their success in previous examinations.

Full details in FREE BROCHURE from

**E.M.I. INSTITUTES, Dept. 14**

(Postal Division)

43 Grove Park Road, Chiswick, London, W.4

Phone CHiswick 4417

I.C.7

**G4GZ's BARGAINS**

**VALVES.** 810, 813, 70/-, 829, 65/-, 803, 805, 45/-, 866, 22/6. 6AC7M, 6C4, 6N7GT, 6J5GT. 6/6. 12A6M, 6J7G, 6F8G, 6J5M 6K7GT, 6C5GT, 7Z1A, 7/6. 2A3, 6AG5, 6SG7M, 8/6. 1RS, 1T4, 1S5, 1S4, 8012, 6SA7M, 9/6. 5Z4M, 5Y3G, 5Z4G, VR150/30, 6X5GT, 25L6GT, 5U4G, 6SQ7M, 10/6. 2C26, 2D21, 1642, KT66, 1622, 6F6M, 6L6G, 6V6M, 6K8G, 6AG7M, 6SL7GT, 6SN7GT, 12/6. 6AK5, 6J6, 17/6.

**NEW BOXED MC METERS.** 3in. rd. fl. mtg. (2 1/2in. dial) 0-30mA, 0-500mA, 0-15v AC (MI cal at 50 cps) 2in. sq. 0-200mA, 0-300v, 2in. rd. 0-500 microamps (scaled 0-10V) all 12/6 ea. 400 watt PARMEKO Mod. Transformers. CT prim. 4500, 5000, 5500 ohms twin secs for sc. and pl. of PP 813's. NEW CRATED, only 47/6 ea. (plus 7/6 carr.)

**ONE ONLY PARMEKO HT Trans.** wt. 100 lbs. input 110/250v. sec. 2000-0-2000v conservatively rated 500mA. Fully shrouded new crated, £10.

**ONE ONLY AR7E** in perfect condition. £27/10/0. Silver mica 200, 300pf, Ceramic 1000, 220pf, 500v, 5/- doz.

All goods despatched per return of post.

**J. T. ANGLIN**

160, CLEETHORPE ROAD, GRIMSBY, Lincs. Tel. 56315.

Amateur enthusiasts should send for free catalogue and literature—stamp for postage

THE INCOMPARABLE

**GLOBE - KING**

**SINGLE VALVE S.W. RECEIVER**

- WORLD-WIDE RANGE 11-100 METRES
- CRYSTAL-CLEAR NOISE-FREE RECEPTION
- ELECTRICAL BAND-SPREAD TUNING
- EXTREMELY LOW RUNNING COSTS
- KITS OR READY-BUILT SETS FROM 27/6

Direct from Makers. Home and Overseas Sales

**JOHNSONS (RADIO)**

46 FRIAR STREET, WORCESTER

**G2ACC OFFERS YOU —**

- PROMPT SERVICE
- FIRST CLASS CATALOGUE
- GUARANTEED GOODS

Illustrated Catalogue No. 8—54 pages printed on fine art paper listing over 2,000 radio and television lines. Replaceable price revision sheet service. Price 9d. post free.

**Southern Radio & Electrical Supplies**

85 FISHERTON STREET, SALISBURY, WILTS.

Telephone: Salisbury 2108

SMALL ADVERTISEMENTS, READERS—continued

**S**ALE or Exchange: 150w Tx (not W.D.), professionally built in 6ft. rack; 35T in final TZ40's in mod., covering 10, 20, 40 and 80-metre bands; in superb condition; cost £125. Sell £45, or exc. for shot gun (DB Hammerless) and cash, or anything good (not radio).—Box 1054.

**B36** RECEIVER, 2 RF stages, 1-20 mc; brand-new; less valves; £10, carriage 10/-. R109 receiver, £4 10s. 0d., complete with 6v P/Pack, BC221 handbook, £1.—W. Robertson, 8 Byron Street, South Shields.

**S**ALE: Unfinished Ham B7G/Denco coil receiver. £5; 19in. 450v. (twice) power pack, £5. Many other items. S.A.E.—Wells, Atickwa, Salvington Gardens, Worthing.

**W**ANTED: ASB8; also petrol generator, 115 or 230 volts AC, 500/1500 watts output. Good prices paid.—G5ML, Miles, 28 Cannon Park Road, Coventry. (TEL. 67237).

**BC221** modulated, original condition, £30; "Supreme" Tube Tester-Analyser, £15; Hammarlund HQ129X, £60. All are in perfect condition. Manuals included.—Box No. 1057.

**F**OR SALE: Avo Battery-operated signal generator, good condition, £7; RF25 unit, 15/-; 6-volt vibrator pack, 15/-.—Teychenne, 37 Greenwood Drive, Watford.

**ET4336**, SINGLE 813 PA; VFO, home-built speech amp.; manual; spare valves 813 (3), 805 (3), 807 (2); £55. Buyer collects. R107, £10.—2 Leewood Road, Trent Vale, Stoke-on-Trent.

**W**ANTED: Pair 35T; also Hi-Fi gram amplifier.—J. A. Hunt, 2 Parkhill Road, Chingford, E.4.

**C**OMMUNICATION Receiver, built-in speaker; excellent condition. Set of spare valves. Price £14 0s. 0d. Buyer collects.—Fawkes, St. Chloe Green, Amberley, Stroud, Glos.

**W**ANTED: Post-war American transmitter (not ex-Services); Collins 32V2 preferred. Willing to pay good price.—Box 1035.

**R.1155** (new) with kit for power and output stage, including valves. Price £12.—Telephone *Edgware* 2581.

**S**ALE: Hallicrafters SX28; first-class condition and correctly aligned; £38. Also "Leak" TL/12 audio amplifier with special pre-amp, in brand-new condition, £29 inclusive. Large quantity of other radio gear.—Ellis, 1 Station View, North Tawton, Devon.

**F**OR SALE: HRO, Mod. RF stages, 9002, 9001. NL, breadspread coils 3.5, 7, 14, 28 mc; GC1.7 mc P/Pack; 10-inch loudspeaker in black crackle cabinet. EXC. DX'er, £30. Two-metre converter, 35/-. 6F12's, IT4, IR5, 5/- each.—Box No. 1050. 24, Ostersund, Sweden.

**W**ANTED: BC348, 640, 1359 and a personal portable Rx (in order or not); also BC611 (SCR536) Handie Talkie, and handbook for same; also 1625 valves. —G3GZT, 31 John Street, Brighton 7.

SMALL ADVERTISEMENTS, READERS—continued

**F**OR SALE: Three 250TH's, brand-new, and boxed, 150/- each; or near offer?—G3BOT, 14 Station Road, Histon, Cambridge.

**B**RAND-NEW Boxed Valves, ECC91, 12AT7, 6AM6, B7W7, UCH42, 6K8GT, 10/6; UF41, UF42, EL91, 5Z4, 8/6. Several others. Would part-exchange for good test gear, communication Rx, or what-have-you?—Box 1059.

**S**ALE: Collins TSC Tx and power supply; ready for the air; incorporated improved modulator and speech amplifier; 40w Phone, 80w CW. Three equipments in mint condition. £20.—Further details. S.A.E.. Box No. 1061.

## EX-GOVERNMENT BARGAINS

Vibrator Packs for 12 volt supply complete with vibrator, OZ4A valves, smoothing, etc. 250v. 50 m.a. 15/6. Postage 2/-. Chassis Clean. 10 x 5 1/2 x 3 drilled for 5 valves. Volume control, switch, and drop through transformer, 2/-. Postage 6d. Aerial Switches, 10FB/168 solenoid operated, 24v. Heavy duty with silver contacts, 3/6. Post. 1/3. Telephone Hand Sets. P.O. type 10/6 Postage 9d. Chokes L.F. 60 m.a. 15 h. 4/9 Postage 1/-. 50 m.a. 6 h. 2/-. Postage 8d. T/R. No. 19 Chassis. Part stripped by B.O.T. but containing dozens of resistances and condensers, 4 gang, 1 gang, and split stator condensers, 12 octal valve holders, 3 I.F.T.s, 465 KCS., potentiometers 6 mic. transformers, intervalve and output transformers, etc. 15/6. Postage 7/6. Brass Terminals. 4 BA 6 for 1/6. Postage 6d. Chassis. 5in. x 3in. x 11in. with cover, 5in. x 5in. x 11in. ideal for power packs, amplifiers, etc. 4/6. Postage 2/-. Receivers 1125. Complete with 2 valves, 10/6. Postage 2/-. Our New List No. 8, containing 300 ex-Government items is now available price 6d. inland, 1/6 Overseas Air Mail.

A. T. SALLIS

93, North Road, Brighton, Sussex. 'Phone Brighton 25806

## FOR FURNISHINGS

for your

## STAND

at the forthcoming

## EXHIBITION

consult

CHARLES COOK'S

Furnishing Stores Ltd

71 HAMMERSMITH ROAD, LONDON, W.14

Opposite Olympia.

Tel. FULham 0084.

## BRAND NEW EX-GOVERNMENT VALVES

The following valves are Brand New and in the original cartons:—954, 7193, 3/6; 2C25, 2X2, 4/9; 6H6, 5/6; 6J5GT, 6/3; 7V7, 6/6; 6J5, 6K7GT, 6SH7, 6/9; 6B8, 7/-; 6K7G, 7/3; 6K7, 7/9; 6K6GT, 8/6; 6F6G, 9/6; 6R7, VR150, 10/-; 6V6GT, 12/6; 6Q7GT, 13/-. The following are new, but in plain or Services cartons:—EB34, 2/-; 12H6, 2/9; EA50, 3/6; 2C26, 2X2, 4/3; EC31, 5/6; 6B8, 6/-; 6K7GT, EF36, 6/3; 6J5, 6J7G, 6/6; 6K7, 6/9; 6J7, KTZ63, 7/-; KTW61, 8/6; 80, 8/9; VPI33, 9/-; HLI33DD, 9/6; 6V6GT, 10/-; 6Q7GT, 11/6; TH233, 12/6; AR60 (Tungar Type rectifiers) 14/6 each.

## ELECTROLYTIC CONDENSERS

8-8 mfd.	350 volt	tag fixing	2/6 each.
8 mfd.	450 volt	clip-fixing	2/9 each.
32-16 mfd.	350 volt	clip-fixing	5/- each.
32-32 mfd.	350 volt	clip-fixing	5/9 each.
32-32 mfd.	450 volt	clip-fixing	6/9 each.

Clips for the above 6d. each.

Ceramic 6in. Spacers for aerial feeders etc., 6d. each or 5/- a dozen.

Please allow postage on orders for less than £1.

REED &amp; FORD

2a Burnley Road, Ainsdale, Southport

# AMERICAN PUBLICATIONS



### RADIO HANDBOOK (11th Edition)

The standard work on practical and theoretical aspects of all radio communication, both amateur and commercial. 26/2

### RADIO HANDBOOK (12th Edition)

Detailed constructional information on a wealth of radio communication equipment: all brand-new equipment, none from prior editions. 25/11

### RADIO HANDBOOK (13th Edition)

The 13th is a large volume of more than 700 pages, covering in 28 chapters the Fundamental Principles the Generation of RF Energy; Modulation, including FM and SSB; Transmitter Design, Construction and Adjustment; Aerials, in five separate chapters discussing Theory, Construction, Matching and Feeding, Directive Arrays of every type, and VHF and UHF designs; BCI and TVI, to which some 24 pages are devoted. Further information on many other subjects. 49/6



### ANTENNA MANUAL

Design and Construction of Aerials of every kind for Radio Amateurs, Engineers and Technicians. Aerials for all bands, with many tables and diagrams. 300 pages cloth covers. 27/11

### A.R.R.L. RADIO AMATEUR HANDBOOK

The latest Edition of the A.R.R.L.'s standard manual on Amateur Radio, known throughout the world. Revised and brought up to 1952 and covering Theory, Design, Construction and Practice. An essential buy for every amateur. Orders now being taken for delivery Feb./March. 30/-



### ANTENNA HANDBOOK

Latest edition of the A.R.R.L.'s own publication on Aerial Theory and Installation. Written to be of practical value to amateurs and engineers engaged on the design of all types of receiving and transmitting aerials. Immediate delivery. 11s. Post 7d.



### RADIO AMATEUR CALL BOOK

is a large volume of 400 pages, published four times a year: Spring, Summer, Autumn and Winter. The callsign lists and addresses are under constant revision and each issue is right up-to-date with hundreds of new callsigns and changes of address. Single copy post free 21/- or for any two issues to choice 36/- or for a year of four quarterly issues, delivered on publication 64/-



### QST

The leading American monthly on Amateur Radio, established over 30 years ago as the official journal of the American Radio Relay League. Subscribers become associate members automatically. For a year of 12 issues. 36/-

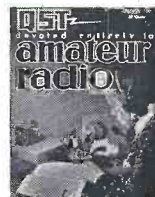

### CQ

An independent American magazine for Radio Amateurs, published monthly. Full of general-interest and sound constructional articles, with special activity sections. CQ is successor to the well known pre-war magazine Radio. For a year of 12 issues. 29/-

### AUDIO ENGINEERING

A monthly of quite unusual value and interest to all concerned with the design, construction and operation of audio equipment of every kind. For a year of 12 issues. 29/-



### RADIO AND TELEVISION NEWS

One of the large American general-interest monthlies, covering television and including regular articles on design and construction for radio amateurs. An average issue runs to about 170 pages, profusely illustrated. For a year of 12 issues. 36/-

### HINTS AND KINKS

Useful collection of technical ideas and practical workshop data, with plenty of diagrams, written up in shortened form. Latest edition of a recommended A.R.R.L. publication. Immediate delivery 11/- Post 5d.



### HOW TO LISTEN TO THE WORLD

Containing information suitable for beginners, for it deals with the mechanism of short wave propagation, gives advice on how to use the short wave bands, and explains how to prepare a log-book and how to write up a report, using the appropriate international abbreviations. 1/11

### WORLD RADIO HANDBOOK

Revised and enlarged to include the Copenhagen Wavelength allocation and giving essential information covering the World's Broadcasting Stations. World Radio Handbook is recommended by such authorities and organisations as UNO I.R.U. and UNESCO. 1952 Edn. 9/-

### HAMS INTERPRETER

This booklet gives lists of selected words and phrases used in Amateur Radio in English, French, Spanish, Italian, German, Swedish and Finnish. Compiled by OH25Q. 5/-

## MAGAZINES BY SUBSCRIPTION

ONE YEAR		ONE YEAR	
Radio Electronics ...	33/-	Popular Science ...	32/-
Popular Mechanics ...	32/-	Proc. I.R.E. ...	152/-
Radio Electronic Engineering ...	56/-	RCA Review ...	20/-
Service ...	24/-	Tele-Tech ...	40/-
F.M. and Television ...	32/-	Television ...	48/-
Electronics ...	160/-	Television Engineering ...	32/-

## GAGE & POLLARD 55 Victoria Street • London S.W.1

Suppliers of Technical Books and Publications to Schools, Universities, British and Colonial Government Departments  
Telephone: ABBEY 5034

# PANDA RADIO CO.

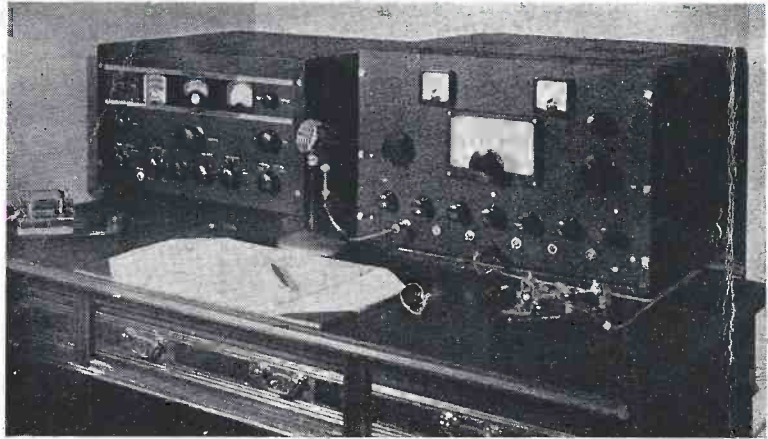

**AS A MATTER OF FACT—yes it is a fact that PANDA'S NEW PR-120-V enables its owner to :**

- (1) Forget T.V.I. troubles (the hours of T.V. are already extending).
- (2) Make the XYL happy. (No more MESS—No more WIRES—No more SEPARATE POWER PACKS, AMPLIFIERS, V.F.O.'s, etc.).
- (3) Operate 150 watts of C.W. with full break-in facilities on all bands.
- (4) Change bands merely by tuning a switch. No messy re-tuning required. 3.5-7-14-21—and 28m/cs available.
- (5) Rapidly QSY using the CALIBRATED HIGH STABILITY V.F.O. without annoyance to other operators.
- (6) Work locals on reduced power.
- (7) Use 120 watts of 100% modulated phone without bawling into the mike.
- (8) Operate with complete safety as circuits are interlocked and power circuits are individually fused.
- (9) Have ALL the above advantages in one neat, compact cabinet—in FACT—the PERFECT PANDA "TABLE-TOPPER" the PR-120-V.

We specialise in Export and do own Packing and forwarding to all parts of the world.

**58 SCHOOL LANE, ROCHDALE.**

Tel. 47861

Cables : Panda Rochdale

## ★ A COMBINED SIGNAL TRACER AND AUDIO OSCILLATOR ★

An easy-to-build unit that can be used for I.F. and Audio signal tracing, without any switching or tuning, including variable output oscillator, for amplifier checking. Highly sensitive, responds to signals picked up from an ordinary receiving aerial. The circuit is that of a high-gain 2-stage, resistance-coupled audio frequency amplifier, employing 3 miniature 1.4 valves, with a 3-inch speaker in the output of the Power Amplifier Stage. An added advantage being that as this Unit is "All-Dry" it can be used with safety on AC or AC/DC mains and Battery sets. The complete Kit with portable cabinet (size 6in. x 7in. x 6in.) and battery weighs only 4 lbs. We shall be pleased to supply a complete Kit for the construction of the above, right down to the last nut and bolt, including 2-1T4 and 1-1S4 Valves, 3in. Speaker and Portable case and All-Dry Battery for £4/19/6. Concise instructions and circuits supplied. If preferred, circuit and instructions only can be supplied for 1/6d. If required this Unit will be assembled and tested for an extra charge of 15/-. This is a highly efficient instrument, and a MUST for every radio man.

**CATHODE RAY TUBES.** VCR97 Brand new in original crates. Guaranteed for full picture on Television. 45/-.  
**3BP1.** Complete with base, holder and shield in metal case. Ideal for Scope. 25/-, 2/6 carriage.

**POWER UNIT.** Complete with 5Z4G, VU120, 1mfid 2,500vW Relay and 80c input Trans. 15/-, New condition. (Post 1/6).

**RECEIVER UNIT TYPE 159.** Containing VR91, VR92, VR65 and 24v Selector Switch, New condition 15/-, (Post 1/6).

**E.H.T. TRANSFORMER for VCR97.** Input 230v Output 2,500v 4v, 2-0-2, 39/6.

**E.H.T. TRANSFORMER for 5CPI.** Input 230v Output 3,250v, 6.3v @ 0.6am, 2-0-2v, 39/6.

**OSCILLOSCOPE TYPE 3BP1.** We have pleasure in offering a scope designed primarily for simplicity and low cost at the same time giving reliable and consistent results. The Service engineer will find this an invaluable instrument due to its compactness, simplicity and speed of interpreting faults in radio receivers, checking transmitters, modulation, depth, etc.

**SPECIFICATIONS. Amplifier :** Max. Gain, Peak to Peak = .3 volts per cm. Frequency response 10 c/s—100 k/c. Flat = 100 c/s to 50 k/c. Time base : frequency range 5 c/s—30 k/c. Dimensions : 8½ x 6½ x 11½. Weight 17½lb. Black crackle finish. PRICE : Brand new, £14/14/-, carr. pd.

**WALKIE-TALKIE TYPE 46.** Containing 6 Valves 2 of VP23, HL23/DD, QP25, TP25, ATP4, 3 I.F.T.'s 1.6 Mcs. Mike and Interval Trans. Aerial Rods etc. Metal case size 12in. x 6in. x 4in. In new condition but less transmitting components removed by the MOS. Price including carriage 35/- Limited quantity.

**FREQUENCY CONTROL CRYSTALS.** By American G.E. Co. Octal base fixing. Following frequencies only : 2,500 kc/s., 3,500 kc/s., 4,600 kc/s., 6,200 kc/s., 8,000 kc/s., 7/6 each.

**No. 38 "WALKIE-TALKIE" TRANS./RECEIVER.** Complete with throat mike, phones, junction box and aerial rods in canvas bag. Freq. range 7.4 to 9 mc/s. All units are as new and tested before despatch. As supplied to Overseas Police Forces. £4/19/6. carriage 2/6

**PUSH-PULL OUTPUT TRANSFORMER.** U.S.A. potted type primary 10,000 n sec., 2 n 8 n, 15 n, 15 watts, 21/-.

**GERMANIUM CRYSTAL DIODES,** complete with full wiring circuit and diagram, 4/6.

**METAL RECTIFIERS.** S.T.C. 300 volts, 75 m/a., 6/- ; G.E.C. 6 volts, 1 amp., 4/- ; Westinghouse 12 volts, 2 amp., 12/6 ; Pencil Type E.H.T. 600v. 1 m/a., 4/7 ; Pencil Type E.H.T. 1,000 v. 1 m/a., 6/- ; 12v. 3½ amps 17/6.

**S.T.C.R.M.2.** 125v. 100 m/a., 4/6.

# HENRY'S

## 5 HARROW ROAD W.2

We are situated at the junction of Edgware Road and Harrow Road facing Edgware Rd. Tube Station. OPEN ALL DAY SATURDAY

Telephone—PADDINGTON 1008/9 and 0401