

# RADIO & ELECTRONICS CONSTRUCTOR

DECEMBER 1976

35p

## Constant Current AUDIO AMPLIFIER



MEDIUM WAVE

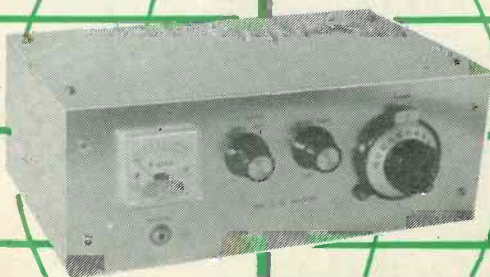

D'x SUPERHET

**ALSO  
FEATURED**

**WIDE RANGE A.C. MILLIVOLTMETER**



## Each £3 unit of Home Unit Insurance gives you protection up to the limit shown

This is the simplified insurance you have been waiting for. Not just cover on the contents of your home but a package of personal protection you and your family need. And it's how we save you so much money: just ONE policy to issue instead of nine! You can build up to the cover you need by additional units

(or 1/2 units after the first) up to a maximum of five. So simple. So easy. Apply to your Broker, Agent or local office of a General Accident company. The Home Unit Policy can replace your existing insurances And remember - as you buy more possessions just add more Home Units at any time. *Quote Ref. 20/9468*

## THE GENERAL ACCIDENT FIRE & LIFE ASSURANCE CORPORATION LTD

Metropolitan House, 35 Victoria Avenue,  
Southend-on-Sea, Essex, SS2 6BT

It pays to be protected by a **General Accident** company

Please send me further particulars of the Home Unit Insurance.

Name .....

Address .....

20/9468

# RADIO & ELECTRONICS CONSTRUCTOR

DECEMBER 1976  
Volume 30 No. 5

Published Monthly (1st of Month)  
First Published 1947

*Incorporating The Radio Amateur*

Editorial and Advertising Offices  
57 MAIDA VALE LONDON W9 1SN

Telephone                      Telegrams  
01-286 6141                      Databux, London

© Data Publications Ltd., 1976. Contents may only be reproduced after obtaining prior permission from the Editor. Short abstracts or references are allowable provided acknowledgement of source is given.

**Annual Subscription:** £5.00 (U.S.A. and Canada \$11.00) including postage. Remittances should be made payable to "Data Publications Ltd". Overseas readers please pay by cheque or International Money Order.

**Technical Queries.** We regret that we are unable to answer queries other than those arising from articles appearing in this magazine nor can we advise on modifications to equipment described. We regret that such queries cannot be answered over the telephone; they must be submitted in writing and accompanied by a stamped addressed envelope for reply.

**Correspondence** should be addressed to the Editor, Advertising Manager, Subscription Manager or the Publishers as appropriate.

**Opinions** expressed by contributors are not necessarily those of the Editor or proprietors.

**Production.**—Web Offset.

MEDIUM WAVE DX SUPERHET—Part 1 by A. P. Roberts	270
WIDE RANGE A.C. MILLIVOLTMETER by B. S. Wolfenden	276
NEWS AND COMMENT	280
OCTAL AND BINARY by D. Sheffield	282
MAINS CURRENT MONITOR (Suggested Circuit 313) by G. A. French	284
TRADE NOTE — New Compact Satellite Navigator	285
SHORT WAVE NEWS—For DX Listeners by Frank A. Baldwin	286
CONSTANT CURRENT AUDIO AMPLIFIER —A Quality Battery Design — by R. A. Penfold	288
NOVEL L.E.D. STEREO BEACON by R. N. Soar	292
THE CA3130 COS/MOS OP-AMP by J. B. Dance	294
PHASE LOCKED LOOP F.M. TUNER —Part 2 by R. A. Penfold	297
IN YOUR WORKSHOP—ELECTRONIC DICE	300
NOTES FOR NEWCOMERS—PINS AND LEAD-OUTS by F. T. Jones	306
WORKSHOP AIDS	308
MOMENTARY POWER FAILURE INDICATOR by J. Knapp	309
RADIO TOPICS by Recorder	312
ELECTRONICS DATA—No. 17 (For the Beginner—Germanium and Silicon)	iii

Published in Great Britain by the Proprietors and Publishers, Data Publications Ltd, 57 Maida Vale, London W9 1SN

The *Radio & Electronics Constructor* is printed by Swale Press Ltd.

THE JANUARY ISSUE WILL BE  
PUBLISHED ON 2nd JANUARY

# TRADE COMPONENTS

JUST A FEW BARGAINS ARE LISTED - SEND STAMPED ADDRESSED ENVELOPE FOR A QUOTE ON OTHER REQUIREMENTS. PAY A VISIT. OVER 90% OF STOCK BELOW QUANTITY WHOLESALE PRICE. RETURN POSTAL SERVICE UNLESS CHEQUE. ALL PRICES INCLUDE THE ADDITIONAL DISCOUNT IN LIEU OF GUARANTEE.

Goods sent at customer's risk, unless sufficient payment for registration (1st class letter post) or compensation fee (parcel post) included.

VALVE BASES	
Printed circuit B9A-B7G	5p
Chassis B7-B7G	9p
Shrouded chassis B7G-B9A-B8A	10p
B12A tube	9p

Speaker 6" x 4" 5 ohm ideal for car radio **£1.25**

TAG STRIP	5 x 50pF	2 x 220pF
6 way 3p		
9 way 5p	Single 1p	trimmers 20p

**BOXES** — Grey polystyrene 61 x 112 x 31mm, top secured by 4 self tapping screws **32½p**  
Clear perspex sliding lid, 46 x 39 x 24mm **10p**

**ABS**, ribbed inside 5mm centres for P.C.B., brass corner inserts, screw down lid, 50 x 100 x 25mm orange **48p**; 80 x 150 x 50mm black **70p**; 109 x 185 x 60mm black **£1.10**

ALUMINIUM		8" x 6" x 3"	£1.02
3" x 2" x 1"	39p	4" x 2½" x 2"	44p
2½" x 5½" x 1½"	45p	10" x 4½" x 3"	£1.02
4" x 4" x 1½"	45p	12" x 5" x 3"	£1.20
4" x 2½" x 1½"	45p	10" x 7" x 3"	£1.22
		12" x 8" x 3"	£1.50

SWITCHES			
Pole	Way	Type	
4	2	Sub. Min. Slide	18p
6	2	Slide	20p
2	2	Slide	14p
1	3	13 amp rotary	6p
2	2	Locking with 2 to 3 keys	£2.00
2	1	2 Amp 250V A.C. rotary	28p
Wafer Rotary, all types <b>30p</b>			
S.P.S.T. 10 amp 240v. white rocker switch with neon. 1" square flush panel fitting <b>46p</b>			
S.P.S.T. dot 13 amp, oblong, push-fit, rocker <b>20p</b>			

**AUDIO LEADS**  
5 pin din plug 180° both ends 1½ Mtr., **80p**  
3 pin din to open end, 1½ yd twin screened **35p**  
Phono to Phono plug, 6ft. **35p**

**COMPUTER AND AUDIO BOARDS**  
VARYING PANELS WITH ZENER, GOLD BOND, SILICON, GERMANIUM, LOW AND HIGH POWER TRANSISTORS AND DIODES, HI STAB RESISTORS, CAPACITORS, ELECTROLYTICS, TRIMPOTS, POT CORES, CHOKES ETC.  
3lb for **85p** + **85p** post and packing  
7lb for **£1.95** + **£1.20** post and packing

Skeleton Presets	3" Tape Spools	3p
Slider, horizontal or vertical standard or submin. 5p	1" Terry Clips	4p
	12 Volt Solenoid	30p

**KNOBBS**  
SILVER METAL PUSH ON WITH POINTER, OR WHITE PLASTIC, GRUB SCREW WITH GOLD CENTRE **8p EACH**

ENM Ltd. cased 7-digit counter 2½ x 1½ x 1½" approx. 12V d.c. (48 a.c.) or mains **75p**

**ZM1162A INDICATOR TUBE**  
0-9 Inline End View. Rectangular Envelope 170V 2.5M/A **£1**

**REGULATED TAPE MOTOR**  
9v d.c. nominal approx 1½" diameter **60p**

12v 8 amp Transformer **£2.50 (p&p 85p)**  
Ferric Chloride, Anhydrous mil. spec. 1lb bag **40p**

Car type panel lock and key **60p**  
18 volt 4 amp charger, bridge rectifier **79p**  
GC10/4B **£3.00**

**Telescopic aerial**  
Closed 9½", open 38½"  
Fitted right angle TV plug, **50p**

JAP 4 gang min. sealed tuning condensers **New 35p**

ELECTROLYTICS MFD/VOLT. Many others in stock		70-	200-	300-	450-
Up to 10V	25V	50V	75V	100V	250V 350V 500V
MFD					
10	4p	5p	6p	8p	10p 12p 16p 20p
25	4p	5p	6p	8p	10p 15p 18p 20p
50	4p	5p	6p	9p	13p 18p 25p —
100	5p	6p	10p	12p	19p 20p —
250	9p	10p	11p	17p	28p — 85p £1
500	10p	11p	17p	24p	45p — — —
1000	13p	22p	40p	75p	— £1.50 — —
2000	23p	37p	45p	—	— — — —

As total values are too numerous to list, use this price guide to work out your actual requirements  
8/20. 10/20. 12/20 Tubular tantalum **20p each**  
16-32/275V. 100-100/150V. 100-100/275V **30p**;  
50-50/385V. 12,000/12V. 32-32-50/300V. 20-20-20/350V **60p**; 700 mfd/200V **£1.00**; 100-100-100-150-150/320V **£2.00**.

RS 100-0-100 micro amp null indicator  
Approx. 2" x ¾" x ¾" **£1.50**

**INDICATORS**  
Bulgin D676 red; takes M.E.S. bulb **30p**  
12 volt or Mains neon, red pushfit **18p**  
R.S. Scale Print, pressure transfer sheet **10p**

**CAPACITOR GUIDE - maximum 500V**  
Up to .01 ceramic **3p**. Up to .01 poly **4p**.  
.013 up to .1 poly etc. **5p**. 12 up to .68 poly etc. **6p**. Silver mica up to 360pF **8p**, then to 2,200pF **11p**, then to .01 mfd **18p**.  
**8p**. 1/600; **12p**. .01/1000, 1/350, 8/20, 1/900, 22/900, 4/16. 25/250 AC (600VDC) 1/1500 **40p**. 5/150, 9/275AC, 10/150, 40/150.

Many others and high voltage in stock.

**FORDYCE DELAY UNIT**  
240 volt A.C./D.C. Will hold relay, etc., for approx. 15 secs after power off. Ideal for alarm circuits, etc. **£1**

**CONNECTOR STRIP**  
Belling Lee L1469, 4 way polythene. **6p each**  
1½ glass fuses 250 m/a or 3 amp (box of 12) **6p**  
Bulgin, 5mm Jack plug and switched socket (pair) **30p**  
Reed Switch 28mm. body length **5p**

**MAINS DROPPERS**  
36+79 ohm **25p**  
66+66+158 ohm, 66+66+137 ohm  
17+14+6 ohm, 266+14+193 ohm **30p**  
50+40+1k5 ohm }  
285+575+148+35 ohm } **40p**  
25+35+97+59+30 ohm }

5½" x 2½" Speaker, ex-equipment **3 ohm 30p**  
2 Amp Suppression Choke **8p**  
3 x 2½" x 1½" } **PAXOLINE 4p**  
4½" x 1½" x 1½" } **1p**  
PCV or metal clip on MES bulb Holder **4p**  
**VALVE RETAINER CLIP**, adjustable **2p**

**OUTPUT TRANSFORMERS**  
Sub-miniature Transistor Type **25p**  
Valve type, **40p**

Transformers 6 volt ½A **25p**  
Whiteley Stentorian 3 ohm constant impedance volume control way below trade at **80p**  
RS Yellow Wander Plug Box of 12 **25p**  
18 SWG multicore solder **2½p foot**

## THE RADIO SHACK

161 ST. JOHNS HILL, BATTERSEA, LONDON S.W.11

Open 10 a.m. till 7 p.m. Monday to Saturday. VAT receipts on request

Terms: Payment with order Telephone: 01-223 5016

**SEMICONDUCTORS**

Fill spec. marked by Mullard, etc. Many other types in stock

AC107	16p	BC557	9p	BFW10/11 F.E.T.	40p
AC128/176	8p	BCX32	12p	BFW30	£1
ACY28	19p	BCY40	50p	BFW57/58	17p
AD149	40p	BCY70/1/2	12p	BFX12/29/30	20p
AD161/2	33p	BD112/3	50p	BFX84/88/89	17p
AF116	16p	BD115/6	31p	BFY51/52	13p
AF124/6/7	25p	BD131/2/3	35p	BFY90	50p
AF139	20p	BD135/7/9	30p	BR101	30p
AF178/80/B1	30p	BD142	30p	BRY39/56	26p
AF239	30p	BD201/2/3/4	70p	BSV64	30p
ASY27/73	30p	BD232/4/5	49p	BSV79/80 F.E.T.s	80p
BC107/8/9 + A/B/C	6p	BDX77	£1	BSV91 Mosfet	90p
BC147/8/9 + A/B/C/S	5p	BF115/167/173	15p	BSX20/21	14p
BC157/8/9 + A/B/C	6p	BF178/9	20p	BSY40	27p
BC178A/B, 179B	12p	BF180/1/2/3/4/5	15p	BSY95A	12p
BC184C/LC	9p	BF194/5/6/7	6p	BU105-01	50p
BC186/7	20p	BF194A, 195C	6p	CV7042 (OC4/44 ASY63)	5p
BC213L/214B	10p	BF200, 258	20p	GET111	40p
BC261B	8p	BF202/3	30p	OC35	45p
BC327/8, 337/8	8p	BF336	27p	ON222	20p
BC547/8/8A	10p	BFS28 Dual Mosfet	£1	TIP30/3055	45p

**BRIDGE RECTIFIERS**

Amp	Volt	Part No.	Price
1	1,600	BYX10	30p
1	140	OSHO1-200	20p
1.4	42	BY164	46p
0.6	110	EC433	15p
5	400	Texas	90p

**RECTIFIERS**

Amp	Volt	Part No.	Price
IN4004/5/6	1	4/6/800	5p
IN4007/BYX94	1	1,250	5p
BY103	1	1,500	18p
SR100	1.5	100	7p
SR400	1.5	400	8p
REC53A	1.5	1,250	14p
LT102	2	30	10p
BYX38-300R	2.5	300	40p
BYX38-600	2.5	600	45p
BYX38-900	2.5	900	50p
BYX38-1200	2.5	1,200	55p
BYX48-300R	2.5	300	26p
BYX49-600	2.5	600	35p
BYX49-900	2.5	900	40p
BYX49-1200	2.5	1,200	52p
BYX48-3UUR	6	300	40p
BYX48-600	6	600	50p
BYX48-900	6	900	60p
BYX48-1200R	6	1,200	80p
BYX72-150R	10	150	35p
BYX72-300R	10	300	45p
BYX72-500R	10	500	55p
BYX42-300	10	300	30p
BYX42-600	10	600	65p
BYX42-900	10	900	80p
BYX42-1200	10	1,200	95p
BYX46-300*	15	300	£1.00
BYX46-400*	15	400	£1.50
BYX46-500*	15	500	£1.75
BYX46-600*	15	600	£2.00
BYX20-200	25	200	60p
BYX52-300	40	300	£1.75
BYX52-1200	40	1,200	£2.50

\*Avalanche type

Amp	Volt	Part No.	Price
6	800	Plastic RCA	£1.20
25	900	BTX94-900	£4.00
25	1200	BTX94-1200	£6.00
12-0-12 50M/A Min. Txmfr. 90p			
RS 2mm Terminals			
Blue & Black		5 for 40p	
Chrome Car Radio fascia 15p			
Rubber Car Radio gasket 5p			
DLI Pal Delayline 50p			
Relay socket 25p			
Take miniature 2PCO relay			
B7G or B9A valve can 5p			
0-30, or 0-15, black pvc, 360° dial, silver digits, self adhesive, 4 1/2" dia. 10p			

**OPTO ELECTRONICS**

BPX40	50p	Photo transistor	
BPX42	80p	BPX29	80p
BPY10	80p	OCPT1	44p
(VOLTAGE)			
BPY68	80p	BIG L.E.D. 0.2"	
BPY69		2v 50m/A max.	
BPY77		RED 10p	
		ORANGE 17p	
		GREEN 14p	
		YELLOW 14p	
		CLIP 2p	
Diodes			
TIL209 Red	10p		

**PHOTO SILICON CONTROLLED SWITCH**

3" red 7 segment L.E.D.	14
D.I.L. 0-9+D.P. display	1.9v
10m/a segment, common anode	61p
DL747.6"	£1.25
Minitron 3" 3015F filament	£1.10

CQY11B L.E.D.	£1
Infra red transmitter	£1
One fifth of trade	

Plastic, Transistor or Diode Holder 1p  
 Transistor or Diode Pad 1p  
 Holders or pads 50pper100

Philips Iron Thermostat	15p
McMurdo PP108 8 way edge plug	10p

**TO3 HEATSINK**

Europlec HP1 TO3B individual 'curly' power transistor type. Ready drilled 12p

Tested unmarked, or marked ample lead ex new equipment

ACY17-20	8p	OC71/2	5p
AS220	8p	OC200-5	20p
AS221	30p	TIC44	24p
BC186	11p	G240	£1
BCY30-34	10p	2G302	15p
BCY70/1/2	8p	2G401	15p
BF115	10p	2N711	25p
BY126/7	4p	2N2926	4p
HG1005	10p	2N598/9	6p
HG5009	3p	2N1091	8p
HG5079	3p	2N1302	8p
L78/9	3p	2N1907	£1
M3	10p	Germ. diode	1p
OA81	3p	GET120 (AC128 in 1" sq. heat sink)	25p
OA47	3p	GET872	12p
OA200-2	3p	2S3230	30p
OC23	20p		

2N2401	30p
2N2412	70p
2N2483	23p
2N2904/5/6/7/7A	15p
2N3053	14p
2N3055 R.C.A.	50p
2N3704	8p
2N3133	20p
2N4037	34p
2N5036 (Plastic 2N3055)	30p
2SA141/2/360	31p
2SB135/6/457	20p
40250 (2N3054)	30p

**NEW B.V.A. VALVES**

6BW7	60p
EB91	34p
ECH81	34p
ECL80	36p
EF80	34p
EF183	34p
EY86/7	34p
PC86	53p
PC88	53p
PC97	36p
CC84	34p
PCC89	45p
PCC189	45p
PCF80	34p
PCF82	34p
PCF801	46p
PCL82	34p
PL81	35p
PY500A	80p
RY81/800	38p
R20/U26	50p

**OTHER DIODES**

1N916	6p
1N4148	2p
BA145	14p
Centercel	24p
BZY61/BA148	10p
BB103/110 Varicap	15p
BB113 Triple Varicap	37p
BA182	13p
OA57/7/10	15p
BZY88 Up to 33 volt	7p
BZX61 11 volt	15p
BR100 Diac	15p

**INTEGRATED CIRCUITS**

TAA700	£2.00
723 reg (TO99)	45p
741 8 pin d.i.l. op. Amp	20p
TAD100 AMRF	£1
CA3001 R.F. Amp	50p
CD4013 CMOS	36p
TAA300 1wt Amp	£1
NE555v Timer	35p
TAA550 Y or G	22p
TAA263 Amp	65p
7400/10	9p
7402/4/20/30	12p
7414	56p
7438/74/86	24p
7483	69p
LM300, 2-20 volt	£1
74154	90p

**THYRISTORS**

Amp	Volt	Part No.	Price
1	240	BTX18-200	30p
1	400	BTX18-300	35p
1	240	BTX30-200	30p
15	500	BT107	£1
6.5	500	BT101-500R	90p
6.5	500	BT109-500R	£1.00
20	600	BTW92-600RM	£3.00
15	800	BTX95-800R Pulse Modulated	£8.00
30	1000	28T10 (Less Nut)	£3.00

**PAPER BLOCK CONDENSER**

0.25MFD	800 volt	30p
1MFD	250 volt	15p
2MFD	250 volt	20p
10MFD	500 volt	80p
4MFD	250 volt	20p

I.C. extraction and insertion tool 32p

**CHASSIS SOCKETS**

Car Aerial 9p, Coax 3p, 5 pin 180° 9p, 5 or 6 pin 240° din 6p, speaker din switched 5p, 3.5 mm switched 5p, stereo 1/2" jack enclosed 10p.

**CRAZY OFFERS**

4700 mfd. 40v	35p
2500 mfd. 40v	30p
2200 mfd. 25v	30p
2200 mfd. 64v	40p
10000 mfd. 15v	12p
1250 mfd. 35v	10p
6800 mfd. 10v	6p
32+32 mfd. 275v	8p
16+32 mfd. 350v	12p
8+8 mfd. 350v	8p

Philips electronic engineer kits add on series, E1004 75p each

G.E.C. 5% Hi-stab capacitors .073, .056, .061, .066, .069, .075, .08, .089, .095, .1 2p each  
 3.5mm metal stereo plug 20p

Push-to-Break or Push-to-Make Panel Switch 24p

ENAM. COPPER WIRE SWG. PER YD.  
 20-24 3p  
 26-42 2.5p

GARRARD GCS23T or GP93/1 Crystal Stereo Cartridge £1.50

HANDLES Rigid light blue nylon 6 1/2" with secret fitting screws 8p

Belling Lee white plastic surface coax outlet box 35p

Miniature Axial Lead Ferrite Choke formers 2p

RS 10 Turn Pot 1%. 250, 500 Ω, 1K, 50K ..... £1

Copper coated board 10" x 9" approx 25p

TIE CLIPS Nylon self locking 7" or 3 1/2" 2p

Geared Knob 8-1 ratio 1 1/2" diam, black 70p

1lb Mixed bolts; nuts, washers etc. 45p

SMALL ORDERS, ENCLOSE SUITABLE STAMPED ADDRESSED ENVELOPE  
 LARGE ORDERS, ADD SUFFICIENT FOR POSTAGE, INSURANCE, ETC.  
 TOTAL GOODS PLUS CARRIAGE, ADD V.A.T.

MAIL ORDER CUSTOMERS ONLY ADD 8% VAT-I PAY BALANCE ON 12 1/2% ITEMS  
 ALL ENQUIRIES, ETC., MUST BE ACCOMPANIED BY A STAMPED ADDRESSED ENVELOPE

# Sparkrite Mk2

Capacitive discharge  
electronic ignition kit

VOTED BEST  
OF 8 SYSTEMS  
TESTED BY  
'POPULAR  
MOTORING'  
MAGAZINE



- \* Smoother running
- \* Instant all-weather starting
- \* Continual peak performance
- \* Longer coil/battery/plug life
- \* Improved acceleration/top speeds
- \* Up to 20% better fuel consumption

Sparkrite Mk. 2 is a high performance, high quality capacitive discharge, electronic ignition system in kit form. Tried, tested, proven, reliable and complete. It can be assembled in two or three hours and fitted in 15/30 mins.

Because of the superb design of the Sparkrite circuit it completely eliminates problems of the contact breaker. There is no misfire due to contact breaker bounce which is eliminated electronically by a pulse suppression circuit which prevents the unit firing if the points bounce open at high R.P.M. Contact breaker burn is eliminated by reducing the current to about 1/50th of the norm. It will perform equally well with new, old, or even badly pitted points and is not dependent upon the dwell time of the contact breakers for recharging the system. Sparkrite incorporates a short circuit protected inverter which eliminates the problems of SCR lock on and, therefore, eliminates the possibility of blowing the transistors or the SCR. (Most capacitive discharge ignitions are not completely foolproof in this respect). All kits fit vehicles with coil/distributor ignition up to 8 cylinders.

### THE KIT COMPRISES EVERYTHING NEEDED

Ready drilled pressed steel case coated in matt black epoxy resin, ready drilled base and heat sink, top quality 5 year guaranteed transformer and components, cables, coil connectors, printed circuit board, nuts, bolts, silicon grease, full instructions to make the kit negative or positive earth, and 10 page installation instructions.

### OPTIONAL EXTRAS

Electronic/conventional ignition switch. Gives instant changeover from "Sparkrite" ignition to conventional ignition for performance comparisons, static timing etc., and will also switch the ignition off completely as a security device, includes: switch connectors, mounting bracket and instructions. Cables excluded. Also available RPM limiting control for dashboard mounting (fitted in case on ready built unit).

CALLERS WELCOME. For Crypton tuning and fitting service - phone (0922) 33008.

PRICES INCLUDE VAT, POST AND PACKING.

Improve performance & economy NOW

POST TODAY!

Quick installation  
No engine modification  
required

Electronics Design Associates, Dept., REC/12  
82 Bath Street, Walsall, WS1 3DE. Phone: (0922) 33652

Name .....  
Address .....

Mk. 2 DIY Ass. Kit @ £11.80	QUANTITY REQUIRED
Mk. 2 Ready Built Negative Earth @ £14.97	
Mk. 2 Ready Built Positive Earth @ £14.97	
Ignition Changeover switches @ £4.30	
R.P.M. Limit systems in above units @ £2.42	

I enclose cheque/PO's for £

Cheque No. ....

Send SAE if brochure only required.

BULK PURCHASE - EXCLUSIVE TO HENRY'S  
ALLOWS US TO SELL AT SUCH FANTASTIC PRICES!

AS USED IN BRAUN  
DIGITAL CLOCKS

QUALITY ITEMS Compare  
performance and specification with  
units costing 3 times as much!

## DIGITAL 24 HOUR CLOCK

WITH BUILT-IN ALARM

- SILENT RUNNING
- LARGE ILLUMINATED NUMERALS
- AC MAINS • SIZE 6 1/2" x 2 1/2" x 2 1/2"

NORMALLY  
£24 WITH CASE

Assemble, fit in an evening!  
MECHANISM ONLY inc. assembly instructions  
MECHANISM AND CASE  
Modern styling  
COMPLETE UNIT

MECHANISM ONLY P&P 25p	£6.00 +VAT 48p	MECHANISM AND CASE P&P 25p	£7.99 +VAT 64p	COMPLETE UNIT P&P 25p	£8.99 +VAT 72p
THREE FOR £16.50 +VAT £1.32 POST FREE		THREE FOR £22.00 +VAT £1.76 POST FREE		THREE FOR £25.00 +VAT £2.00 POST FREE	

1 1/2" digit height, bright red LED 7 segment displays for calculators, digital watches, miniature clocks, DVMS, timers etc.  
\* Fairchild FND-10, single digit common cathode £1.00 (+vat 8p) 6 for £5.00 (+vat 40p)  
\* HP 7414 4 digit, common cathode 12 pin d.i.l. pin out 99p (+vat 8p) 6 for £5.00 (+vat 40p)  
\* Bowmar 8 1/2 digit, common cathode with pc connector, and red bezel £1.85 (+vat 15p) 6 for £10 (+vat 80p)  
\* Texas 3 digit common cathode 12 pin d.i.l. pin out 85p (+vat 7p) 6 for £4.00 (+vat 32p)  
\* Texas 4-5 digit, common cathode 2x14 pin d.i.l. £1.85 pair (+vat 15p)  
\* 30 pin termination board for all types except FND-10 20p (+vat 2p)  
\* Texas calculator keyboards, 19 gold plated "snap" type key contacts on gold plated pcb, 75p (+vat 6p) p & p on all the above 25p.

BX12E343 TRACK ERASE HEAD - £1.25 (+vat 15p)  
BX12RP63 WITH BX12E343 - £2.95 (+vat 36p)  
STEREO CASSETTE R/RP HEAD (200 ohm) - £2.25 (+vat 28p)

GX11 E388 ERASE 675 ohms 2 mA - £0.88 (+vat 11p)  
GX12 E387 ERASE 675 ohms 2 mA - £0.88 (+vat 11p)  
GX20 E382 ERASE 90 ohms 90 mA - £0.88 (+vat 11p)  
R/RP1/3 TAPE HEAD 1/2 TRACK - £0.65 (+vat 8p)  
XRPS17 1/2 TRACK - £3.25 (+vat 40p)  
XRPS18 1/2 TRACK RED - £3.25 (+vat 40p)  
XRPS36 1/2 TRACK - £6.75 (+vat 79p)  
XES11 1/2 TRACK ERASE - £1.25 (+vat 15p)  
BX/RP/63 1/2 TRACK - £2.25 (+vat 28p)

MULLARD TUNER MODULES  
LP1171 combined AM/FM IF strip - £4.29 (+vat 53p) \* LP1179 FM front end with AM tuning gang, used with LP1171 - £4.29 (+vat 53p) \* LP1171 & 79 pair - £8.00 (+vat £1.00) \* LP1157 complete AM strip - £2.05 (+vat 26p) \* Ferrite Aerial - 95p (+vat 7p) p & p all modules 25p each

### HENRY'S GREAT NEW CATALOGUE

★ OVER 5,000 ITEMS  
★ OVER 200 PAGES  
★ DISCOUNT VOUCHERS  
★ OFFERTY DISCOUNTS ON MOST ITEMS  
FREE - (to educational establishments and manufacturers when ordered on official headed notepaper)  
We will be pleased to quote for parts for circuits in this magazine. Send your list for quotation in S.A.E.

Henry's RADIO  
All mail to: Henry's Radio 303 Edgware Rd. London W2  
LONDON W2: 404/6 Edgware Road. Tel: 01-402 8381  
LONDON W1: 231 Tottenham Ct Rd (above sales floor) Tel: 01-636 6681

DESIGNED BY TEXAS  
30,000 ALREADY SOLD!  
TEXAN AMPLIFIER featured by PHACTICAL WIRELESS still the best selling amp in the UK  
★ Can be built Stage by stage. Ask for leaflet 20.  
★ Everything necessary supplied. Full after sales service and guarantees.

Build the Texan stereo amplifier, and be doubly proud! You'll own a superb home entertainment unit. And the pleasure of doing it yourself. Look at the Texan specification! Fully integrated stereo preamp and power amp, 6 IC's, 10 transistors, 6 rectifiers and zener diodes. Plus stabilised, protected circuitry, glass fibre pcb; Gardener's low-field low-line mains transformer; all facilities and controls. Slim design, chassis 14 1/2" x 6" x 2" overall. 20 watts per channel RMS.

The natural follow on!  
TEXAN FM TUNER KIT £20.95 +VAT £2.62  
Built and tested £25.95 +VAT £3.24

Build the matching Texan stereo tuner Features advanced varicap tuning. Phase lock loop decoder. Professionally designed circuit. Everything you need is in the kit. From the glass fibre pcb to the cabinet itself. Excellent spec. 2.5 uV aerial sensitivity. 500 mV output (adjust). Tuning range 87-102 MHz. Mains powered.

NEW HENELEC Mullard AM/FM TUNER MODULE  
£21.95 +VAT £2.74 p&p £1.00  
MAY BE ASSEMBLED IN AN EVENING. FEATURES \* Built-in AM Ferrite aerial \* LW coverage 150KHz-250KHz \* MW coverage 530KHz-1.6MHz \* FM coverage 97-104MHz \* 75 Ohm aerial for FM \* 150mV output \* Size 8(L) x 6(W) x 2(H)

This new AM/FM tuner kit incorporates 2 Mullard modules. Supplied as a pre-aligned and tested printed circuit, the constructor only has to build the PCB into the chassis, connect the power, aerial and output leads. Styled to match the Texan amp, mains operated. Easily adapted for stereo, using the Henelec IC stereo decoder kit, high performance modular design, phase lock loop principle. Low pass filter, or opt perior. Price £8.75 +VAT £1.02 p&p 50p.

HENELEC RADIO CONTROL SYSTEM  
\* INCLUDING PROPORTIONALLY CONTROLLED SWITCH  
\* FEATURING COSMOS DIGITAL LOGIC to minimise power consumption and extend battery life.  
Specially designed to provide aircraft and boat modelmakers with a low-cost, easy-to-use radio control, the Henelec system gives you everything from single channel, up to sophisticated 7-channel Digital Proportional System! Buy the components you want. Ideal for any radio control application. \* Simple transmitter - £11.75 (+vat £1.47p) \* Single-ch. add-on for receiver - £2.95 (+vat 37p) \* PC board for above - 75p (+vat 6p) \* Case for transmitter - £1.25 (+vat 16p) \* Basic receiver - £6.95 (+vat 87p) Send now for leaflet No. 8 (35p) for full details. Post etc. 50p each. Ask for FREE leaflets and lists on our kits projects.

Specialized to provide aircraft and boat modelmakers with a low-cost, easy-to-use radio control, the Henelec system gives you everything from single channel, up to sophisticated 7-channel Digital Proportional System! Buy the components you want. Ideal for any radio control application. \* Simple transmitter - £11.75 (+vat £1.47p) \* Single-ch. add-on for receiver - £2.95 (+vat 37p) \* PC board for above - 75p (+vat 6p) \* Case for transmitter - £1.25 (+vat 16p) \* Basic receiver - £6.95 (+vat 87p) Send now for leaflet No. 8 (35p) for full details. Post etc. 50p each. Ask for FREE leaflets and lists on our kits projects.

# RETURN OF POST MAIL ORDER SERVICE

## NEW BSR HI-FI AUTOCHANGER STEREO AND MONO

Plays 12" 10" or 7" records  
Auto or Manual. A high  
quality unit backed by BSR  
reliability with 12 months  
guarantee. AC 200/250V.  
Size 13 1/2 x 11 1/2 in.  
Above motor board 3 1/2 in.  
Below motor board 2 in.



With STEREO/MONO CARTRIDGE **£11.95** Post 75p  
Single player version with cueing device **£13.50**

## PORTABLE PLAYER CABINET £4.50

Modern design. Size 16" x 15" 7" approx. Post 50p  
Large front grille. Hinged Lid. Chrome fittings.  
Motor board cut for Garrard or 8SR deck.  
Recline covered, in red or black or blue.

## HEAVY METAL PLINTHS

With P.V.C. Cover. Cut out, for most  
B.S.R. or Garrard decks. Silver grey  
finish. Size 12 1/2 x 14 1/2 in.  
Size 16 x 13 1/2 x 7 in. £7.50

**£6.50**  
Post 75p

## EXTRA LARGE PLINTH & COVER

Size: 20in. x 19 1/2 in. x 9in. TEAK FINISH

CALLERS ONLY

**£19.50**

## TINTED PLASTIC COVERS

Post 75p  
Sizes: 'A' 14 1/2 in. x 12 1/2 in. x 4 1/2 in. £2.50. 'B' - 20 1/2 in.  
x 12 1/2 in. x 4 1/2 in. £3. 'C' - 17 1/2 in. x 13 1/2 in. x 3 1/2 in. £3.25.  
19 in. x 14 1/2 in. x 4 1/2 in. £3.50  
Ideal for record decks, tape decks, etc.

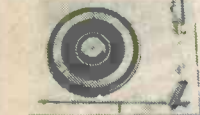

**R.C.S.  
DISCO  
DECK  
SINGLE  
RECORD  
PLAYER**

Fitted with auto stop, compatible cartridge. Base-  
plate. Size 11 in. x 8 1/2 in. Turntable. Size 7 in. diameter. A/C  
mains. 220/250V motor has a separate winding 14 volt to  
power a small amplifier.  
3 speeds plays all size records.  
Two for £13.

**£6.95** Post 45p

## COMPLETE STEREO SYSTEM

Two full size loudspeakers 13 1/2 x 10 x 3 1/2 in. Player  
unit clips to loudspeakers making it extremely compact.  
Overall size only 13 1/2 x 10 x 8 1/2 in. 3 watts per channel.



plays all records  
33 rpm 45 rpm.  
Separate volume  
& tone  
controls 240V  
A.C. mains.

Attractive  
Trunk finish  
Weight 13lbs. **£22.50** 85p carriage

Bargain Price

## GARRARD MINICHANGER

Plays all size records. 3 speed.  
Size 12 x 8 1/2 in. Complete with  
stereo/mono cartridge.

**£9.95** Post 75p.

CASSETTE RECORDER MOTOR ONLY. 6 Volt.  
Will replace many types. Ideal for models. £1.25

BLANK ALUMINIUM CHASSIS, 18 s.w.g. 2 1/2 in. sides  
6 x 4 in. 70p; 8 x 6 in. 90p; 10 x 7 in. £1.15;  
14 x 9 in. £1.50; 16 x 6 in. £1.45; 12 x 3 in. 87p;  
16 x 10 in. £1.70. All boxes, many sizes in stock.

ALUMINIUM PANELS 18s.w.g. 6 x 4 in. 15p; 8 x 6 in. 25p;  
10 x 7 in. 30p; 12 x 5 in. 30p; 12 x 8 in. 40p; 16 x 6 in.  
45p; 14 x 9 in. 50p; 12 x 12 in. 65p; 16 x 10 in. 75p.

ALUMINIUM ANGLE BRACKET 6 in long x 1/2 x 1/2 15p.

1 1/2 inch DIAMETER WAVELENGTH SWITCHES 45p. EA.  
2 p. 2-way, or 2 p. 6-way, or 3 p. 4-way.  
1 p. 1 1/2 2-way, or 4 p. 2-way, or 4 p. 3-way.

TOGGLE SWITCHES, sp. 20p. dp. 25p. dt. 30p.

1 p. P.I.F. CENTRE OFF 65p. S.P.C.D. CENTRE OFF 45p.  
Many types TOGGLE SWITCHES in stock

## R.C.S. GENERAL PURPOSE TRANSISTOR PRE-AMPLIFIER BRITISH MADE

Ideal for Mike, Tape P, Guitar, etc. Can be used with Battery  
9-12v. or H.T. line 200-300V. D.C. operation. Size 1 1/2" x 1 1/2" x  
1". Response 25 cps. to 25 Kc/s, 26 db gain.  
For use with valve or transistor equipment. Post  
Full instructions supplied. Details S.A.E. **£1.45** 30p

## NEW ELECTROLYTICS CONDENSERS

2/350V 20p	250/25V 18p	16+16+16/275v 45p
4/350V 20p	500/25V 20p	50+50/300V 50p
8/350V 22p	100+100/275v 85p	32+32/450V 75p
16/350V 22p	150+200/275v 70p	100+50+50/350V 85p
32/500V 50p	8+8/450V 50p	32+32/350V 75p
25/25V 10p	8+16/450V 50p	30.00/25V 95p
50/50V 10p	16+16/450V 50p	4700/63V 95p
100/25V 10p	32+32/350V 50p	

## LOW VOLTAGE ELECTROLYTICS CONDENSERS

22, 25, 50, 68, 150, 470, 500, 680, 1500, 2200, 3300.  
mfd all 6 volt 10p ea.  
22, 25, 68, 100, 150, 200, 220, 330, 470, 680, 1000,  
1500, 2200, mfd all 10 volt 10p ea.  
220, 330, 1000, 4700 mfd all 4v. 10p ea.  
1, 2, 4, 5, 8, 16, 25, 30, 50, 100, 200mF 15v 10p.  
500mF 12v 15p.; 25v 20p.; 50v 30p.  
1000mF 12v 20p.; 25v 35p.; 50v 47p.; 100v 70p.  
2000mF 6v 25p.; 25v 42p.; 50v 57p.; 4700/63V 95p.  
2500mF 50V 62p.; 3000mF 25V 47p.; 50V 65p.  
5000mF 6V 25p.; 12V 42p.; 35V 85p.; 50V 95p.  
500V-0.001 to 0.1-10p; 0.25 12p; 0.47 25p  
CERAMIC 1pF to 0.01mF. 5p. Silver Mica 2 to 5000pF. 5p.  
PAPER 350V-0.1 7p; 0.5 18p; 1mF or 2mF 150V 15p.  
MICRO SWITCH single pole changeover 20p.  
MICRO SWITCH sub min 25p.  
TWIN GANG. "0-0" 208pF + 176pF £2. TWIN 365pF 50p.  
Slow motion drive 365pF + 365pF with 25pF + 25pF 65p.  
500pF standard twin gang 75p. 120 pF twin gang 50p.

ELAC 9 x 5 in. HI-FI SPEAKER. TYPE 59RM.  
THIS FAMOUS AND WIDELY USED UNIT  
NOW AVAILABLE AT BARGAIN PRICE  
10 WATT, 8 OHM, CERAMIC MAGNET. **£3.45**

NECIN PANEL INDICATORS, 250V Red or Amber, 30p  
RESISTORS, 1/4w, 1/2w, 1w 20%, 2p; 2w, 5p, 10 to 100M.  
HIGH STABILITY, 1/2 w, 2% 10 ohms to 10 meg., 12p.  
OHME 5%, Preference values, 10 ohms to 10 meg., 5p  
WIRE-WOUND RESISTORS, 5 watt, 10 watt, 15 watt,  
10 ohms to 100K, 12p each; 2w 0.5 ohm to 8.2 ohms 15p.  
TAPE OSCILLATOR COIL. Valve type 35p.  
FERRITE ROD 6" x 1/2" 30p; 6" x 1/4" 20p; 3" x 1/4" 10p.

## MAINS TRANSFORMERS

ALL POST 50p each  
250-0-250V 80mA, 6-3, 2A £2.95  
250-0-250 80mA, 6-3v 3-5a, 6-3v 1a or 5v 2a £4.60  
350-0-350 80mA, 6-3v 3-5a, 6-3v 1a or 5v 2a £5.80  
300-0-300 120mA, 6-3v 4a C.T., 6-3v 2A £7.00  
220v 45mA, 6-3v 2a £1.75  
HEATER TRANS. 6-3v 3 amps. £1.45 jump. 95p  
GENERAL PURPOSE LOW VOLTAGE. Tapped outputs  
2 amp 3, 4, 5, 6, 8, 9, 10, 12, 15, 18, 24, 30v £4.60  
1 amp 6, 8, 10, 12, 16, 18, 20, 24, 30, 36, 40, 48, 60, £4.60  
2a, 6, 8, 12, 16, 18, 20, 24, 30, 36, 40, 48, 60 £7.00  
3a, 6, 8, 10, 12, 16, 18, 20, 24, 30, 36, 40, 48, 60 £8.70  
5a, 6, 8, 10, 12, 16, 18, 20, 24, 30, 36, 40, 48, 60 £11.25  
5, 8, 10, 16v, 1a £2. 6-0-6v 500mA £1. 9v 1a £1  
12v 300mA £1. 12v 500mA £1. 12v 750mA £1.  
40v 2a tapped 10v or 30v £2.95. 20v 3a £2.  
40v 2a £2.75 30v 5A and 34v 2A ct. £3.50  
20-0-20v 1a £2. 30v 1 1/2a £1.75. 20v 1 1/2a £1.75. 1a £2  
1 amp Transformer, mounted on panel with input and  
output fuses supplied. 6-3v 4a, 6v 4a, 8v 4a, 20-0-20v £3.50  
AUTO TRANSFORMERS, 115v, to 230v or 230v to 115v  
150w £5, 250w £6, 400w £7, 500w £8.  
CHARGER TRANSFORMERS, Input 200/250v  
for 6 or 12v 1 1/2a £2.75 4a £4.60.  
FULL WAVE BRIDGE CHARGER RECTIFIERS:  
6 or 12v outputs 1 1/2a 40p, 2a 55p, 4a 85p.

## R.C.S. STABILISED POWER PACK KIT

All parts including printed circuit and instructions to  
build this unit. Voltages available: 6v, 7.5v, 9v, 12v.  
Up to 100mA output. Post  
Please state voltage required. **£2.95** 45p

## STEREO FM/AM TUNER AMPLIFIER CHASSIS BY KUBA



This all transistor chassis has push button selection for long,  
medium, short and V.H.F. wave bands. Features A.F.C. on  
V.H.F. band with automatic stereo beacon light. Volume tone  
and Balance controls with push button mains on/off switch.  
Amplifier accepts ceramic cartridge and has record playback  
socket fitted. Four watts per channel output.  
Chassis size 17 x 4 x 5 in. **£33.50** POST £1.50

## E.M.I. 13 1/2 x 8 in. SPEAKER SALE!

With tweeter  
Aid crossover, 10 watt **£5.95**  
State 3 or 8 ohm Post 45p  
15 watt version **£8.50**  
8 or 15 ohm  
20 watt version **£9.50**  
8 or 15 ohm  
as illustrated **£7.50**  
Bass units only 20W **£6.50**  
Bass units only 15W **£4.95**  
Bass units only 10W **Post 65p**



## Bookshelf Cabinet

Teak Veneer. For above units **£7.50** Post 75p

## R.C.S. 10 WATT AMPLIFIER KIT



This kit is suitable for record players, tape play back,  
guitars, electronic instruments or small P.A. systems.  
Two versions are available. A mono kit or a stereo kit.  
The mono kit uses 13 semiconductors. The stereo kit uses 22  
semiconductors with printed front panel and volume,  
bass and treble controls. Spec. 10 watts output into 8  
ohm, 7 watts into 15 ohms. Response 20 cps to 30K/cps.  
Input from 20mV high imp. Size 9 1/2 in x 3 in x 2 in.  
Mno kit **£11.25** Stereo kit **£17.50** post 45p

LOUDSPEAKERS P.M. 3 ohms, 7 x 4 in. £1.25; 6 1/2 in. £1.50;  
8 x 5 in. £1.60; 8 in. £1.75; 10 x 6 in. £1.90; 10 in. £2.50.  
SPECIAL OFFER LOUDSPEAKERS! All Brand New.  
3 ohm, 2 1/2 in. 2 1/2 in. 5 in. 8 ohm, 2 1/2 in.; 5 x 3 in.  
5 in. 15 ohm, 3 1/2 in.; 5 in. 6 x 4 in.; 5 x 3 in.; 7 x 4 in.;  
7 1/2 ohm, 2 1/2 in. 3 in. 5 x 3 in. 7 x 4 in. 35 ohm, 3 in. 5 in.  
80 ohm, 2 1/2 in. 2 1/2 in. 120 ohm, 3 in. **£1.25** EACH

TWEETER VOLUME CONTROL 15 ohm 10 watt  
with 1 in. long threaded bush for wood panel  
mounting. Will suit all tweeters **75p**

RICHARD ALLAN TWIN CONE LOUDSPEAKERS, 8 in.  
diameter 4W £2.50, 10 in. diameter 5W £2.95; Post 25p.  
12 in. diameter 6W £3.50; 3 or 8 or 15 ohm models.  
SPEAKER COVERING MATERIALS. Samples Large S.A.E.  
Horn Tweeters 2-16Kc/s. 10W 8 ohm or 16 ohm £3.60.  
De Luxe Horn Tweeters 2-18 Kc/s. 15W, 8 ohm £6.80  
TWO-WAY 3,000 cps CROSS OVERS 3, 8 or 15 ohm £1.90  
3-WAY CROSSOVER 850 cps and 3,000 cps (25 watt) £2.20

GOODMANS CONE TWEETER **£3.25**  
18,000 cps. 25 watts, 8 ohm.  
6 1/2 in. Woofer 10 watt. Price £4.95.

## ELECTRO MAGNETIC PENDULUM MECHANISM

1-5v d.c. operation over 250 hrs continuous on SP2 battery.  
Fully adjustable swing and speed. Ideal displays teaching  
electro magnetism or for metronome, strobe etc. 95p. Post 20p

## WEYRAD TYPE COILS

P50/1AC 60p	RA2W 85p	Twin Gang £2
P50/2CC 40p	OPT1 65p	Printed Circuit 85p
P50/3CC 40p	LFDT4 65p	

COAXIAL PLUG 10p. PANEL SOCKETS 10p. LINE 18p.  
OUTLET BOXES, SURFACE MOUNTING 40p

BALANCED TWIN RIBBON FEEDER 300 ohms, 5p. yd.  
JACK SOCKET 1 Std. open-circuit 20p, closed circuit 25p.  
Chrome Lead Socket 45p. Phono Plugs 10p. Phono Socket 8p.  
JACK PLUGS Std. Chrome 30p; 3.5mm Chrome 15p. DIN  
SOCKETS Chassis 3-pin 10p; 5-pin 10p; DIN SOCKETS  
Lead 3-pin 18p; 5-pin 25p; DIN PLUGS 3-pin 18p; 5-pin  
25p. VALVE HOLDERS 5p. CERAMIC 10p; CANS 5p.

## R.C.S. 100 WATT VALVE AMPLIFIER CHASSIS



Professional model. Four inputs, Treble, Bass, Master  
Volume Controls. Ideal disco, P.A. or groups. 5 speaker  
outputs, very robust job **£85** plus £2.50 carr.  
S.A.E. for details

## NEW MIXER/AMP 150 WATT

PROFESSIONAL TRANSISTOR AMPLIFIER **£68**  
4 inputs, 3 outputs, separate volume treble Carr. £1.50  
and bass controls. Ideal disco or group. P.A. amplifier  
Suit for Judds or Disco Gear.

# RADIO COMPONENT SPECIALISTS

Minimum post 30p.

Components Lists 10p.

DECEMBER 1976

Access and Barclaycard welcome

Cash price includes VAT

Open 9-6 Wed. 9-1 Sat. 9-5 (Closed for lunch 1.15-2.30)

Rail Selhurst.

Tel. 01-684 1665

337 WHITEHORSE ROAD,  
CROYDON, SURREY.

# PAKS — PARTS — AUDIO MODULES

## PANEL METERS

### 4" RANGE

Size 4 1/4" x 3 1/4" x 1 3/8"

Value	No.	Price
0-50UA	1302	£4.50
0-100UA	1303	£4.50
0-500UA	1304	£4.50
0-1MA	1305	£6.00
0-50V	1306	£6.00

### 2" RANGE

Size 2 3/8" x 1 3/4" x 1 1/2"

Value	No.	Price
0-50UA	1307	£3.50
0-100UA	1308	£3.50
0-500UA	1309	£3.50
0-1MA	1310	£3.50
0-50V	1311	£3.50

### MR2P TYPE

Size 42 x 42 x 30mm

Value	No.	Price
0-50UA	1313	£4.80
0-1MA	1315	£3.20

### EDGEWISE

Size 3 1/2" x 1 3/8" x 2 1/4"  
Cut out 2 3/4" x 1 1/4"

Value	No.	Price
0-1MA	1316	£4.05
0-500UA	1317	£4.05

### MINIATURE BALANCE/TUNING METER

Size 23 x 22 x 26mm

Sensitivity 100/0/100MA

No.	Price
1318	£1.95

### BALANCE/TUNING

Size 45 x 22 x 34mm

Sensitivity 100/0/100UA

No.	Price
1319	£2.00

### MIN. LEVEL METER

Size 23 x 22 x 26mm

Sensitivity 200UA

No.	Price
1320	£1.95

### Vu METER

Size 40 x 40 x 29mm

Sensitivity 130UA

No.	Price
1321	£2.00

## MINI

### MULTI-METER

Size 60 x 24 x 90mm

Sensitivity 1000 ohms/V

AC Volts 0-10, 50, 250, 1000  
DC Volts 0-10, 50, 250, 1000  
DC Current 0-1 100mA  
Resistance 0-150k ohms

No.	Price
1322	£5.95

P&P

Postage and Packing add 25p unless otherwise shown. Add extra for air-mail. Minimum order £1.

## TRANSISTORS

BRAND NEW — FULLY GUARANTEED

TYPE	PRICE	TYPE	PRICE	TYPE	PRICE	TYPE	PRICE	TYPE	PRICE	TYPE	PRICE
AC126	0.16	BC109C	0.08	BC550	0.14	BFY52	0.14	TIP42C	0.95	2N3708	*0.07
AC127	0.14	BC147	*0.09	BC556	*0.14	BIP19	0.38	TIP2955	0.95	2N3708A	*0.07
AC128	0.26	BC148	*0.09	BC557	*0.13	BIP20	0.38	TIP3055	0.95	2N3709	*0.07
AC128K	0.26	BC149	*0.09	BC558	*0.12	BIP19/5	0.38	TIS43	0.22	2N3710	*0.07
AC132	0.15	BC157	*0.12	BC559	*0.14	20MP	0.80	TIS43	0.22	2N3711	*0.07
AC134	0.15	BC158	*0.12	BD115	0.50	BRY39	0.45	UT46	0.20	2N3711	*0.07
AC137	0.15	BC159	*0.12	BD116	0.60	BU105	1.90	ZTX107	*0.10	2N3820	0.40
AC141	0.18	BC167	*0.12	BD121	0.65	BU105/	1.90	ZTX108	*0.10	2N3821	0.60
AC141K	0.18	BC168	*0.12	BD123	0.65	BU2	1.95	ZTX109	*0.10	2N3823	0.40
AC142	0.18	BC169	*0.12	BD124	0.70	BU204	1.70	ZTX300	*0.12	2N4058	*0.14
AC176	0.12	BC199C	*0.12	BD131	0.35	BU205	1.70	ZTX500	*0.10	2N4059	*0.14
AC176K	0.26	BC170	*0.10	BD132	0.38	BU208	2.40	2N1613	0.20	2N4060	*0.14
AC178	0.26	BC171	*0.10	BD131/	0.38	BU208/	2.40	2N1711	0.20	2N4061	*0.12
AC179	0.26	BC172	*0.10	132 MP	0.80	/02	2.95	2N1889	0.45	2N4062	*0.12
AC180	0.20	BC173	*0.12	BD133	0.36	JE2272	0.38	2N1890	0.45	2N4062	*0.12
AC180K	0.30	BC177	*0.12	BD135	0.36	MJE2955	0.88	2N1893	0.30	2N4284	*0.18
AC181	0.20	BC178	0.16	BD136	0.36	MJE3055	0.60	2N2147	0.75	2N4285	*0.18
AC181K	0.30	BC179	0.16	BD137	0.36	MJE3440	0.45	2N2148	0.70	2N4286	*0.18
AC187	0.16	BC180	0.25	BD138	0.45	MP8113	0.45	2N2160	0.80	2N4288	*0.18
AC187K	0.26	BC181	*0.25	BD139	0.54	MPF102	0.35	2N2192	0.38	2N4289	*0.18
AC188	0.16	BC182L	*0.10	BD140	0.60	MPF104	0.39	2N2193	0.38	2N4290	*0.18
AC188K	0.26	BC183	*0.10	140 MP	1.20	MPSA05	*0.20	2N2217	0.22	2N4291	*0.18
AD140	0.60	BC183L	*0.10	BD155	0.80	MPSA06	*0.20	2N2218	0.22	2N4293	*0.18
AD142	0.85	BC184	*0.10	BD175	0.60	MPSA55	*0.20	2N2218A	0.20	2N4921	*0.55
AD143	0.75	BC184L	*0.10	BD176	0.60	MPSA56	*0.20	2N2219	0.20	2N4923	*0.65
AD149	0.60	BC207	*0.11	BD177	0.68	OC22	1.50	2N2219A	0.20	2N5135	*0.10
AD161	0.36	BC208	*0.11	BD178	0.68	OC22	1.50	2N2902	0.18	2N5136	*0.10
AD162	0.36	BC209	*0.12	BD178	0.68	OC22	1.50	2N2904	0.21	2N5138	*0.10
AD161/	0.36	BC212	*0.11	BD179	0.75	OC24	1.40	2N2904A	0.21	2N5194	0.56
162 MP	0.75	BC212	*0.11	BD201/	1.70	OC25	0.60	2N2905	0.18	2N5244	*0.28
AF115	0.20	BC213	*0.11	BD202 MP	1.70	OC26	0.60	2N2905A	0.21	2N5294	0.34
AF116	0.20	BC213	*0.11	BD203	0.80	OC28	0.90	2N2906	0.16	2N5296	0.35
AF117	0.20	BC214	*0.12	BD204	0.80	OC29	1.00	2N2906A	0.19	2N5296	0.35
AF117	0.20	BC214L	*0.12	BD203/	0.80	OC35	0.90	2N2907	0.20	2N5457	0.32
AF118	0.40	BC237	*0.16	204 MP	1.70	OC36	0.90	2N2907A	0.22	2N5458	0.32
AF124	0.30	BC238	*0.16	BDY20	0.80	OC70	0.15	2N2926	*0.09	2N5459	0.38
AF125	0.30	BC251	*0.15	BDX77	0.37	OC71	0.15	2N2926Y	*0.08	2N5551	*0.30
AF126	0.30	BC251A	*0.15	BF511	0.37	TIC44	*0.29	2N2926B	*0.08	2N6027	0.32
AF127	0.32	BC301	0.30	BF458	0.37	TIC44	*0.29	2N2926R	*0.08	2N6122	0.70
AF139	0.58	BC302	0.28	BF459	0.38	TIP29A	0.44	2N3053	0.16	2N6122	0.70
AF180	0.58	BC303	0.32	BF594	*0.15	TIP29B	0.52	2N3054	0.40	4031	0.36
AF181	0.58	BC304	0.38	BF596	*0.17	TIP29C	0.62	2N3055	0.40	4031	0.36
AF186	0.58	BC327	0.16	BF840	0.25	TIP30A	0.60	2N3414	*0.16	4031	0.58
AF239	0.38	BC328	0.15	BF840	0.25	TIP30B	0.60	2N3415	*0.16	4031	0.58
AL102	0.95	BC337	*0.15	BF879	*0.28	TIP30C	0.70	2N3416	0.29	4032	0.36
AL103	0.95	BC338	*0.15	BF879	*0.28	TIP31A	0.54	2N3417	*0.29	4032	0.36
AU104	1.00	BC440	0.30	BFX29	0.25	TIP31B	0.66	2N3614	0.55	4034	0.66
AU110	1.00	BC441	0.30	BFX30	0.30	TIP31C	0.68	2N3615	0.90	4034	0.55
BU113	1.00	BC460	0.38	BFX84	0.24	TIP32A	0.64	2N3616	0.90	4034	0.70
BC107A	0.08	BC461	0.38	BFX85	0.24	TIP32B	0.76	2N3646	*0.09	4036	0.38
BC107B	0.08	BC477	0.20	BFX86	0.25	TIP32C	0.80	2N3702	*0.08	4036	0.38
BC107C	0.08	BC478	0.19	BFX87	0.22	TIP41A	0.66	2N3703	*0.08	4036	0.38
BC108A	0.08	BC479	0.20	BFX88	0.22	TIP41B	0.70	2N3704	*0.07	4040	0.40
BC108B	0.08	BC547	*0.20	BFX90	*0.55	TIP41C	0.80	2N3705	*0.07	4040	0.28
BC108C	0.08	BC548	*0.12	BFY50	0.14	TIP42A	0.72	2N3706	*0.08	4040	0.48
BC109B	0.08	BC549	*0.12	BFY51	0.14	TIP42B	0.78	2N3707	*0.08	4049	0.52

## 74 SERIES TTL IC's

FULL SPECIFICATION, GUARANTEED, ALL FAMOUS MANUFACTURERS.

TYPE	PRICE	TYPE	PRICE	TYPE	PRICE	TYPE	PRICE	TYPE	PRICE	TYPE	PRICE
7400	0.14	7409	0.15	7441	0.64	7482	0.85	7493	0.40	74122	0.50
7401	0.14	7410	0.14	7442	0.64	7483	0.95	7494	0.88	74123	0.70
7402	0.15	7411	0.23	7445	0.90	7484	0.98	7495	0.75	74141	0.80
7403	0.15	7412	0.23	7446	0.90	7485	1.20	7496	1.00	74154	1.30
7404	0.15	7413	0.23	7447	0.90	7486	0.90	74100	1.00	74180	1.10
7405	0.15	7414	0.58	7448	0.80	7489	2.90	74110	0.50	74181	2.00
7406	0.30	7415	0.28	7475	0.48	7490	0.42	74118	0.90	74190	1.50
7407	0.30	7417	0.28	7480	0.50	7491	0.75	74119	1.85	74198	2.00
7408	0.15	7440	0.15	7481	0.95	7492	0.45	74121	0.30	74199	1.90

## C.M.O.S. IC's

TYPE	PRICE	TYPE	PRICE	TYPE	PRICE	TYPE	PRICE	TYPE	PRICE	TYPE	PRICE
CD4000	0.14	CD4012	0.18	CD4022	0.95	CD4031	2.20	CD4046	1.30	CD4071	0.28
CD4001	0.18	CD4013	0.50	CD4023	0.18	CD4032	0.95	CD4047	1.10	CD4072	0.28
CD4002	0.18	CD4015	0.90	CD4024	0.72	CD4037	0.95	CD4048	0.55	CD4081	0.18
CD4006	0.98	CD4016	0.50	CD4025	0.18	CD4040	0.95	CD4050	0.55	CD4082	0.28
CD4007	0.18	CD4017	0.90	CD4026	0.98	CD4041	0.82	CD4054	1.20	CD4510	1.30
CD4008	0.95	CD4018	1.00	CD4027	0.60	CD4042	0.82	CD4055	1.20	CD4511	1.60
CD4009	0.55	CD4019	0.52	CD4028	0.98	CD4043					



# SEMI-CONDUCTORS—COMPONENTS

## DIODES

TYPE PRICE	TYPE PRICE	TYPE PRICE	TYPE PRICE
AA129 0.08	BY100 0.16	BYZ11 0.31	OA91 0.07
AA30 0.09	BY107 0.12	BYZ12 0.31	OA95 0.07
AA213 0.10	BY105 0.18	BYZ13 0.26	OA182 0.07
AA217 0.10	BY114 0.12	BYZ16 0.41	OA200 0.08
BA100 0.10	BY124 0.12	BYZ17 0.36	OA202 0.08
BA102 0.32	BY126 *0.15	BYZ18 0.36	SD10 0.06
BA148 0.15	BY127 *0.16	BYZ19 0.28	SD19 0.06
BA154 0.12	BY128 0.16	OA10 0.35	IN34 0.07
BA155 0.14	BY430 *0.17	OA47 0.07	IN34A 0.07
BA156 0.14	BY133 *0.21	OA70 0.07	INR14 0.06
BA173 0.15	BY164 0.61	OA79 0.07	INR16 0.06
BA184 0.15	BY176 *0.75	OAB1 0.07	IN4148 0.06
BAX13 0.07	BY206	OAB5 0.09	IS44 0.05
BAX16 0.0*	BY210 0.36	OA90 0.07	IS920 0.06

## SILICON RECTIFIERS

TYPE PRICE	TYPE PRICE	TYPE PRICE	TYPE PRICE
IS920 0.06	IN4003 0.07	IS020 0.10	IS031 0.25
IS921 0.07	IN4004 0.08	IS021 0.11	IN5400 0.13
IS922 0.08	IN4005 0.09	IS023 0.13	IN5401 0.15
IS923 0.09	IN4006 0.10	IS025 0.14	IN5402 0.16
IS924 0.10	IN4007 0.11	IS027 0.16	IN5404 0.17
IN4001 0.05	IS015 0.09	IS029 0.20	IN5406 0.21
IN4002 0.06			IN5407 0.25

## TRIACS

2 AMP VOLTS	T05	CASE PRICE	10 AMP VOLTS	T048	CASE PRICE
100	TR12A/100	0.31	100	TR110A/100	0.77
200	TR12A/200	0.51	200	TR110A/200	0.92
400	TR12A/400	0.71	400	TR110A/400	1.12

6 AMP VOLTS	T066	CASE PRICE	10 AMP VOLTS	T0220	CASE PRICE
100	TR16A/100	0.51	400	TR100A/400P	1.12
200	TR16A/200	0.61		DIACS	
400	TR16A/400	0.77	BR100	0.23	D32 0.23

## THYRISTORS

600ma TO18 CASE	7 Amp TO48 CASE
Volts No. Price	Volts No. Price
10 THY600/10 £0.13	50 THY7A/50 £0.48
20 THY600/20 £0.13	100 THY7A/100 £0.51
30 THY600/30 £0.19	200 THY7A/200 £0.57
50 THY600/50 £0.22	400 THY7A/400 £0.62
100 THY600/100 £0.25	600 THY7A/600 £0.78
200 THY600/200 £0.38	800 THY7A/800 £0.92

10 Amp TO48 CASE
Volts No. Price
50 THY10A/50 £0.51
100 THY10A/100 £0.57
200 THY10A/200 £0.62
400 THY10A/400 £0.71
600 THY10A/600 £0.99
800 THY10A/800 £1.22

16 Amp TO48 CASE
Volts No. Price
50 THY16A/50 £0.54
100 THY16A/100 £0.58
200 THY16A/200 £0.62
400 THY16A/400 £0.77
600 THY16A/600 £0.90
800 THY16A/800 £1.39

30 Amp TO44 CASE
Volts No. Price
50 THY30A/50 £1.18
100 THY30A/100 £1.43
200 THY30A/200 £1.63
400 THY30A/400 £1.79
600 THY30A/600 £3.50

No. Price
BT101/500R £0.80
BT102/500R £0.80
BT106 £1.25
BT107 £0.93
BT108 £0.98
2N3228 £0.70
2N3525 £0.77
BTX30/50L £0.33
BTX30/400L £0.46
C106/4 £0.60

## ORDERING

PLEASE WORD YOUR ORDERS EXACTLY AS PRINTED, NOT FORGETTING TO INCLUDE OUR PART NUMBER.

V.A.T.

ADD 12½% TO PRICES MARKED\*  
ADD 8% TO OTHERS EXCEPTING THOSE MARKED†. THESE ARE ZERO

## SUPER UNTESTED PAKS

Pak No.	Order No.	Price
U50 100 Germ. Gold bonded OA47 diode	16130	£0.60
U51 150 Germ. OA70/81 diode	16131	£0.60
U52 100 Silicon Diodes 200mA OA200	16132	£0.60
U53 150 diodes 75mA 1N4148	16133	£0.60
U54 50 Sil Rect Top Hat 750mA	16134	£0.60
U55 50 Sil Rect Stud Type 3 Amp	16135	£0.60
U56 50 400mV Zeners D07 Case	16136	£0.60
U57 30 NPN Trans BC107/8 Plastic	16137	£0.60
U58 30 PNP Trans BC177/178 Plastic	16138	£0.60
U59 25 NPN TO39 2N6972/1711 sil	16139	£0.60
U60 15 Plastic Power 2N3055 silicon	16140	£0.60
U61 30 NPN TO18 2N706 silicon	16141	£0.60
U62 25 NPN BFY50/51	16142	£0.60
U63 30 NPN Plastic 2N3906 silicon	16143	£0.60
U64 30 PNP Plastic 2N3905 silicon	16144	£0.60
U65 30 Germ. 0071 PNP	16145	£0.60
U66 15 Plastic Power 2N3055 NPN	16146	£1.20
U67 10 T03 Metal 2N3055 NPN	16147	£1.20
U68 20 Unijunction trans IIS43	16148	£0.60
U69 10 1 amp SCR TO39	16149	£1.20
U70 8 3 amp SCR TO66 case	16150	£1.20

Code No. mentioned above are given as a guide to the type of device in the pak. The devices themselves are normally unmarked.

## COMPONENT PAKS

PACK NO QTY	ORDER NO	PRICE
C1 200 Resistor mixed value approx. (Count by weight)	16164	*0.80
C2 150 Capacitors mixed value approx. (Count by weight)	16165	*0.80
C3 50 Precision resistors. Mixed values.	16166	*0.80
C4 80 ¼W resistors mixed preferred values.	16167	*0.80
C5 5 Pieces assorted ferrite rods.	16168	*0.80
C6 2 Tung ganging capacitors.	16169	*0.80
C7 1 Pack wire 50 meters assorted colours single strand.	16170	0.80
C8 10 Reed switches.	16171	*0.80
C9 3 Micro switches.	16172	*0.80
C10 15 Assorted pots.	16173	*0.80
C11 5 Metal Jack sockets 3 x 3.5mm.		
C12 30 2 x standard switch types. Paper condensers preferred types mixed values.	16174	*0.80
C13 20 Electrolytics trans. types.	16175	*0.80
C14 1 Pak assorted hardware—Nuts/bolts, gromets etc.	16177	0.80
C15 5 Mains slide switches ass.	16178	*0.80
C16 20 Assorted tag strips and panels	16179	0.80
C17 15 Assorted control knobs.	16180	*0.80
C18 4 Rotary wave change switches.	16181	*0.80
C19 2 Relays 8-24V operating.	16182	*0.80
C20 1 Pak, copper laminate approx. 200 sq. ins.	16183	0.80
C21 15 Assorted fuses 100mA-5amp.	16184	0.80
C22 50 Metres PVC sleeving assorted size and colour	16185	0.80
C23 60 ½ watt resistors mixed preferred values.	16188	*0.80
C24 25 Presets assorted type and value.	16186	*0.80
C25 30 Metres stranded wire assorted colours.	16187	0.80

## SLIDER PAKS

PACK NO QTY	ORDER NO	PRICE
S1 6 Slider potentiometers, mixed values.	16190	*0.80
S2 6 Slider potentiometers, all 470 ohms	16191	*0.80
S3 6 Slider potentiometers, all 10k	16192	*0.80
S4 6 Slider potentiometers, all 22k	16193	*0.80
S5 6 Slider potentiometers, all 47k	16194	*0.80
S6 6 Slider potentiometers, all 47k log.	16195	*0.80

## CERAMIC PAKS

Containing a range of first quality miniature ceramic capacitors. Unrepeatable value.

PACK NO QTY	ORDER NO	PRICE
MC1 24 Miniature ceramic capacitors, 3 of each value—22p, 27p, 33p, 39p, 47p, 68p, 82p.	16160	*0.80
MC2 24 Miniature ceramic capacitors, 3 of each value—100pf, 120pf, 150pf, 180pf, 220pf, 330pf, & 390pf, 270pf.	16161	*0.80
MC3 24 Miniature ceramic capacitors, 3 of each value—470pf, 560pf, 680pf, 820pf, 1,000pf, 1,500pf, 2,200pf & 3,300pf.	16162	*0.80
MC4 21 Miniature ceramic capacitors, 3 of each value—4,700pf, 5,800pf, 0.01µf, 0.033µf, 0.047µf, 0.022µf.	16163	*0.80

## LINEAR PAKS

Manufacturers "Fall Outs" which include Functional and part Functional Units. These are classed as "out-of-spec" from the maker's very rigid specifications, but are ideal for learning about I.C.'s and experimental work.

U721 30 Assorted Linear Types. 709-741-747-748-710-588 Etc.

ORDER NO. 16227 PRICE \*£1.50

U76SD FM STEREO DECODER  
5 I.C.'s 76110 Eqp. to MC1310P-MA767.  
Data supplied with pak.  
ORDER NO. 16229 PRICE \*£1.50

U78A AUDIO POWER OUTPUT AMPLIFIERS  
8 Assorted types SL403 76013 76003 etc  
Data supplied with pak.  
ORDER NO. 16228 PRICE \*£1.00

## 74 SERIES PAKS

Manufacturers "Fall Outs" which include Functional and part Functional Units. These are classed as "out-of-spec" from the maker's very rigid specifications, but are ideal for learning about I.C.'s and experimental work.

74G 100 Gates assorted 7400-01-04-10 50-60 etc.

ORDER NO. 16224 £1.20

74F 50 Flip-Flops assorted 7470-72-73-74 78-104-109

ORDER NO. 16225 £1.20

74M 30 MSI Assorted Types. 7441-47-90-154 etc.

ORDER NO. 16228 £1.20

## VEROBOARD PAKS

VB1 Approx 30 sq. ins. various sizes, all 1" matrix.

ORDER NO. 16199 £0.80

VB2 Approx 30 sq. ins. various sizes, 1.5" matrix.

ORDER NO. 16200 £0.80

## ELECTROLYTIC PAKS

A range of paks each containing 18 first quality, mixed value miniature electrolytics. EC1 Values from 47mFD to 10mFD.

ORDER NO. 16201 \*£0.80

EC2 Values from 10mFD to 100mFD.

ORDER NO. 16202 \*£0.80

EC3 Values from 100mFD to 680mFD.

ORDER NO. 16203 \*£0.80

## C280 CAPACITOR PAKS

75 Mullard C280 capacitors, mixed values ranging from 0.1µf to 2.2µf complete with identification sheet.

ORDER NO. 16204 \*£1.20

## CARBON RESISTOR PAKS

These paks contain a range of Carbon Resistors, assorted into the following groups:

R1 60 mixed ¼w 100ohms-820ohms

ORDER NO. 16213 \*£0.80

R2 60 mixed ¼w 1kohms-8.2kohms

ORDER NO. 16214 \*£0.80

R3 60 mixed ¼w 10kohms-82kohms

ORDER NO. 16215 \*£0.80

R4 60 mixed ¼w 100kohms-820kohms

ORDER NO. 16216 \*£0.80

R5 40 mixed ¼w 100ohms-820ohms

ORDER NO. 16217 \*£0.80

R6 40 mixed ¼w 1kohms-8.2kohms

ORDER NO. 16218 \*£0.80

R7 40 mixed ¼w 10kohms-82kohms

ORDER NO. 16219 \*£0.80

R8 40 mixed ¼w 100kohms-820kohms

ORDER NO. 16220 \*£0.80

R9 60 mixed ¼w 1 Meg-10Meg ohms

ORDER NO. 16230 \*£0.80

R10 40 mixed ¼w 1 Meg-10Meg ohms

ORDER NO. 16231 \*£0.80

## WORLD SCOOP!

## JUMBO

## SEMICONDUCTOR PAK

Transistors-Germ and Silicon Rectifiers - Diodes - Triacs - Thyristors - I.C.'s and Zeners. ALL NEW & CODED. Approx. 100 Pieces. Offering the amateur a fantastic bargain PAK and an enormous saving identification and data sheet in every pak.

ORDER NO. 16222 £2.25

SEE OUR 1977 CATALOGUE Order Now ONLY 50p + 15p P&P

**BI-PAK**  
P.O. BOX 6, WARE, HERTS.  
SHOP 18 BALDOCK ST, WARE, HERTS.  
AT OPEN 9 to 5.30 Mon/Sat. Tel: 61593

# LATEST BOUND VOLUME No. 29



of  
"Radio & Electronics  
Constructor"

FOR YOUR LIBRARY

NOW AVAILABLE

Comprising  
776 pages  
inc. index

AUGUST 1975  
to JULY 1976

PRICE £3.10 P&P 75p

BOUND VOLUME No. 27 (August 1973 to July 1974)  
BOUND VOLUME No. 28 (August 1974 to July 1975)

PRICE £2.40 p. & p. 75p  
PRICE £2.75 p. & p. 75p

Limited number of these volumes still available

We regret all other volumes are now completely sold out.  
Available only from

DATA PUBLICATIONS LTD., 57 MAIDA VALE, LONDON, W9 1SN

## 1. Understand electronics.

Step by step, we take you through all the fundamentals of electronics and show you how easily the subject can be mastered using our unique Lerna-Kit course.

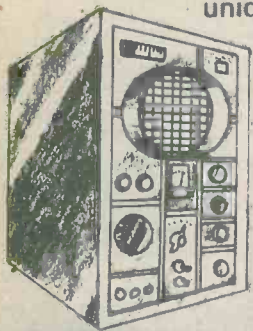

- (1) Build an oscilloscope.
- (2) Read, draw and understand circuit diagrams.
- (3) Carry out over 40 experiments on basic electronic circuits and see how they work.

## 2. Become a radio amateur.

Learn how to become a radio-amateur in contact with the whole world. We give skilled preparation for the G.P.O. licence.

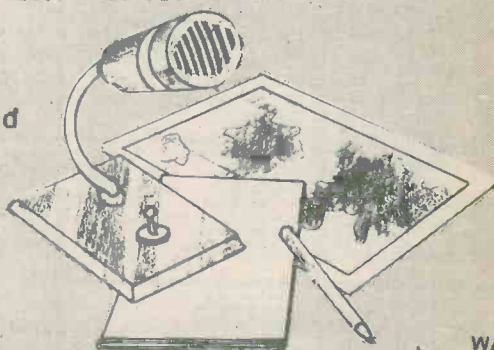

Free!

Brochure, without obligation to:  
BRITISH NATIONAL RADIO & ELECTRONICS SCHOOL,  
P.O. Box 156, Jersey, Channel Islands.

NAME \_\_\_\_\_

ADDRESS \_\_\_\_\_ Block caps please

REC126



# WILMSLOW AUDIO

## THE Firm for speakers!

### SPEAKERS

Baker Group 25, 3, 8 or 15 ohms  
 Baker Group 35, 3, 8 or 15 ohms  
 Baker Group 50/12.8 or 15 ohms  
 Baker Group 50/15.8 or 15 ohms  
 Baker Deluxe 12" 8 or 15 ohms  
 Baker Major 3, 8 or 15 ohms  
 Baker Superb 8 or 15 ohms  
 Baker Regent 12" 8 or 15 ohms  
 Baker Auditorium 12" 8 or 15 ohms  
 Baker Auditorium 15" 8 or 15 ohms

Castle BRS/DD 4/8 ohms  
 Celestion G12M 8 or 15 ohms  
 Celestion G12H 8 or 15 ohms  
 Celestion G12/50 8 or 15 ohms  
 Celestion G12/50TC 8 or 15 ohms  
 Celestion G15C 8 or 15 ohms  
 Celestion G18C 8 or 15 ohms  
 Celestion HF1300 8 or 15 ohms  
 Celestion HF2000 8 ohms  
 Celestion MH1000 8 or 15 ohms  
 Coles 4001 Gek

Decca London ribbon horn  
 Decca London CO/1000/8 Xover  
 Decca DK30 ribbon horn  
 Decca CO/1/8 Xover (DK30)

EMI 14 x 9 Bass 8 ohms 14A770  
 EMI 8 x 5, 10 watt, d/cone, roll surr.  
 EMI 6 1/2" d/cone, roll surr. 8 ohms  
 Elac 59RM109 (15) 59RM114 (8)  
 Elac 6 1/2" d/cone, roll surr. 8 ohms  
 Elac 10" 10RM239 8 ohms  
 Eagle FR4  
 Eagle FR65  
 Eagle FR8  
 Eagle FR10  
 Eagle HT15  
 Eagle HT21  
 Eagle MHT10  
 Eagle FF28 multicell. horn

Fane Pop 15, 8 or 16 ohms  
 Fane Pop 33T, 8 or 16 ohms  
 Fane Pop 50, 8 or 16 ohms  
 Fane Pop 55, 8 or 16 ohms  
 Fane Pop 60, 8 or 16 ohms  
 Fane Pop 70, 8 or 16 ohms  
 Fane Pop 100, 8 or 16 ohms  
 Fane Crescendo 12A, 8 or 16 ohms  
 Fane Crescendo 12BL, 8 or 16 ohms  
 Fane Crescendo 15/100A, 8 or 16 ohms  
 Fane Crescendo 15/125, 8 or 16 ohms

### SPEAKERS

£9.00 Fane Crescendo 18, 8 or 16 ohms  
 £10.25 Fane 910 Mk.II horn  
 £14.00 Fane 920 Mk.II horn  
 £18.62 Fane HPX1 crossover 200 watt  
 £13.38 Fane 13 x 8, 15 watt dual cone  
 £10.69 Fane 801T 8" d/c, roll surr.  
 £16.31 Goodmans Axent 100  
 £9.00 Goodmans Audiom 200 8 ohms  
 £14.65 Goodmans Axiom 402 8 or 15 ohms  
 £19.41 Goodmans Twinaxiom 8, 8 or 15 ohms  
 Goodmans Twinaxiom 10, 8 or 15 ohms

£9.28 Goodmans 8P 8 or 15 ohms  
 £12.95 Goodmans 10P 8 or 15 ohms  
 £15.95 Goodmans 12P 8 or 15 ohms  
 £18.00 Goodmans 12PG 8 or 15 ohms  
 £20.00 Goodmans 12PD 8 or 15 ohms  
 £26.95 Goodmans 12AX 8 or 15 ohms  
 £39.95 Goodmans 15AX 8 or 15 ohms  
 £6.98 Goodmans 15P 8 or 15 ohms  
 £8.55 Goodmans 18P 8 or 15 ohms  
 £13.50 Goodmans Hifax 750P  
 £5.90 Goodmans 5" midrange 8 ohms

£29.95 Gauss 12"  
 £6.95 Gauss 15"  
 £19.95 Gauss 18"  
 £4.75 Jordan Watts Module, 4, 8 or 15 ohms

£11.92 Kef T27  
 £3.75 Kef T15  
 £3.93 Kef B110  
 £3.95 Kef B200  
 £3.95 Kef B139  
 £3.95 Kef DN8  
 £3.95 Kef DN12  
 £5.51 Kef DN13 SP1015 or SP1017  
 £8.95 Lowther PM6  
 £11.95 Lowther PM6 Mk.I  
 £14.06 Lowther PM7  
 £3.96 Peerless KO10DT 4 or 8 ohms  
 £4.95 Peerless DT10HFC 8 ohms  
 £4.00 Peerless KO40MRF 8 ohms  
 £5.95 Peerless MT225HFC 8 ohms

£5.50 Richard Allan CA12 12" bass  
 £9.75 Richard Allan HP8B  
 £12.50 Richard Allan LP8B  
 £16.75 Richard Allan DT20  
 £19.95 Richard Allan CN8280  
 £21.75 Richard Allan Super Disco 60W 12"  
 £33.95 Coles 4001 G&K  
 £42.95 Tannoy 10" Monitor HPD  
 £44.95 Tannoy 12" Monitor HPD  
 £54.95 Tannoy 15" Monitor HPD  
 £64.95 Wharfedale Super 10 RS/DD 8 ohms

### SPEAKER KITS

£75.95 Baker Major Module 3, 8 or 15 ohms each  
 £15.75 Goodmans DIN 20 4 or 8 ohms each  
 £45.95 Goodmans Mezzo Twin kit pair  
 £2.50 Helme XLK 20 pair  
 £5.50 Helme XLK 30 pair  
 £8.96 Helme XLK 35 pair  
 £8.50 Helme XLK 40 pair  
 £14.95 KEFkit 1 each  
 £22.00 KEFkit III pair

£10.60 Peerless 1060 pair  
 £10.95 Peerless 1070 each  
 £6.50 Peerless 1120 pair  
 £6.95 Peerless 2050 pair  
 £16.50 Peerless 2060 pair  
 £17.75 Richard Allan Twin assembly each  
 £18.75 Richard Allan Triple 8 each  
 £44.00 Richard Allan Triple 12 each  
 £49.00 Richard Allan Super Triple each  
 £24.00 Richard Allan RAB Kit pair  
 £39.95 Richard Allan RAB2 Kit pair  
 £16.00 Richard Allan RAB2L Kit pair  
 £4.05 Wharfedale Linton II Kit pair  
 £95.00 Wharfedale Glendale 3XP Kit pair  
 £110.00 Wharfedale Dovedale III Kit pair  
 £121.00 Denton 2XP Kit pair

£15.36 Wharfedale Linton 3XP Kit pair

### HI-FI ON DEMONSTRATION

In our showrooms:  
 Akai, Armstrong, Bowers & Wilkins, Castle, Celestion, Dual, Goodmans, Kef, Leak, Pioneer, Radford, Richard Allan, Rotel, Tandberg, Trio, Videotone, Wharfedale, etc.

—Ask for our HiFi price list—

### THIS MONTH'S SPECIALS (Carr. £2.00)

ROTEL RA 412 £77.95  
 ROTEL RX 202 Mk. II £97.50  
 VIDEDTONE MINIMAX II £43.00  
 VIDEDTONE SAPHIR II £49.00  
 PIONEER SX 450 £116.00  
 SANSUI SC 2000/2002 £149.70

We stock the complete Radford range of amplifiers, preamplifiers, power amplifiers, tuners etc., and also Radford Audio Laboratory equipment, low distortion oscillator, distortion measuring set, audio noise meter etc.

ALL PRICES INCLUDE VAT  
 (Prices correct at 19/10/76)

Send stamp for free 38-page booklet "Choosing a Speaker"

All units guaranteed new and perfect  
 Carriage and insurance  
 Speakers up to 12" 60p; 12" £1.00; 15" £1.75;  
 18" £2.50; Kits £1.00 each (£2.00 per pair);  
 Tweeters & Crossovers 33p each.

# WILMSLOW AUDIO

DEPT REC

LOUDSPEAKERS, MAIL ORDER AND EXPORT:  
 SWAN WORKS, BANK SQUARE, WILMSLOW  
 HIFI, RADIO & TV: SWIFT OF WILMSLOW, 5  
 SWAN STREET, WILMSLOW CHESHIRE  
 PA, HIFI & ACCESSORIES: WILMSLOW  
 AUDIO, 10 SWAN STREET, WILMSLOW  
 CHESHIRE

TELEPHONE: LOUDSPEAKERS, MAIL ORDER  
 AND EXPORT WILMSLOW 29599  
 HIFI, RADIO ETC., WILMSLOW 28213

Access & Barclaycard Orders  
 accepted by phone

### COMPLETE KITS IN STOCK FOR

**RADFORD STUDIO 90, RADFORD MONITOR 180,  
 RADFORD STUDIO 270, RADFORD STUDIO 360,  
 HIFI ANSWERS MONITOR (Rogers), HIFI NEWS NO  
 COMPROMISE (Frisby), HI FI NEWS STATE OF THE  
 ART, WIRELESS WORLD TRANSMISSION LINE  
 (Bailey), PRACTICAL HIFI & AUDIO MONITOR (Giles),  
 PRACTICAL HIFI & AUDIO TRIANGLE (Giles),  
 POPULAR HIFI (Colloms) ETC.**

**On Dem. Answers Monitor, State of Art, etc.  
 Construction leaflets for Radford, Kef, Jordan Watts,  
 Tannoy, HIFI Answers Monitor, Free on request  
 PA Amplifiers, microphones etc. by  
 Linear, Shure, Eagle, Beyer, AKG etc.**

**FREE with orders over £10**

**"Hi-Fi Loudspeaker Enclosures" Book**

# Stirling Sound

## QV\* MODULES FOR COST-CONSCIOUS CONSTRUCTORS

STIRLING SOUND policy is to ensure customer satisfaction by designing and making their products in their own factory in Essex and selling direct. Production control-checked throughout. All QV Modules are compatible within the range and with much other equipment.

### PRE-AMP CONTROL MODULES UNIT ONE

Combined pre-amp with active tone-control circuits.  $\pm 15\text{dB}$  at 10Khz treble and 30Hz bass. Stereo. Vol./balance/treble/bass. 200mV out for 50mV in. Takes 10-16V. **£7.80**

**SS.100** Active tone control, stereo.  $\pm 15\text{dB}$  on bass and on treble **£1.60**

**SS.101** Pre-amp for ceramic cartridges, etc. Stereo. Passive tone control details supplied. **£1.60**

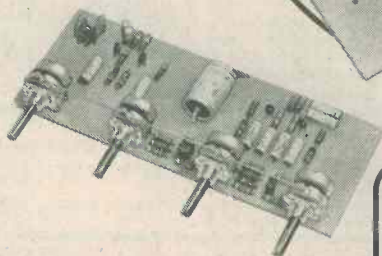

**SS.102** Stereo pre-amp for low output magnetic P.U.s. R.I.A.A. corrected. Linear feedback facility. **£2.65**

### POWER AMPLIFIERS

**SS.103** 3 watt r.m.s. mono, I.C. short, **£1.75**

**SS.105-3** Stereo version of above using two I.C.s **£3.75**

**SS.105** 5 watts r.m.s. into 4 ohms, using 12V **£2.25**

**SS.110** 10 watts r.m.s. using 24V and 4 ohm load **£2.75**

**SS.120** 20 watts r.m.s. into 4 ohms, using 34V **£3.25**

The above all measure 89 x 50 x 19mm ( $3\frac{1}{2}$  x 2 $\frac{1}{4}$ in). Suitable power supplies available.

### FM TUNING MODULES

**SS.201** Front end tuner, slow geared drive, two gang. A.F.C. facility. Tunes 88-108 MHz **£5.00**

**SS.202** I.F. amplifier. Metering and A.F.C. facilities **£2.65**

**SS.203** Stereo Decoder for use with the above or other FM mono tuners. A LED may be fitted **£3.85**

### ★ THE BUILT-IN QV FACTOR

means Stirling Sound's guarantee of QUALITY AND VALUE to give you today's best value all round.

# Stirling Sound

A member of the Bi-Pre-Pak group

220-224 WEST ROAD, WESTCLIFF-ON-SEA, ESSEX SS0 9DF

Telephone Southend (0702) 46344

Personal callers welcome



**SS.140** 40 watts r.m.s. into 4 ohms using 45V supply such as SS345. Ideal for small disco and P.A. 101 x 76 x 19mm (4" x 3" x  $\frac{3}{4}$ ") **£3.95\***

## TODAY'S BEST VALUE IN POWER SUPPLY UNITS

with 13-15V take-off points

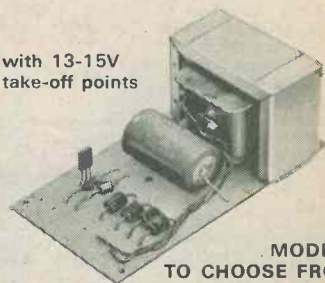

7 MODELS TO CHOOSE FROM

Complete with mains transformers and low volt take-off points (except SS.300). All at 8% V.A.T. rate. Add 50p for p/p any model.

**SS.312** 12V/1A **£3.75\***

**SS.318** 18V/1A **£4.15\***

**SS.324** 24V/1A **£4.60\***

**SS.334** 34V/2A **£5.20\***

**SS.345** 45V/2A **£6.25\***

**SS.350** 50V/2A **£6.75\***

**SS.300** Power stabilising unit 10-50V adjustable for adding to unstabilised supplies. Built in protection against shorting (p/p 35p) **£3.26\***



Built-in protection against shorting

**SS.310/50** Complete stabilised power supply with variable output from 10 to 50V/2A **£11.95**

### WHEN ORDERING

add 35p for p/p unless stated otherwise. V.A.T. add 12 $\frac{1}{2}$ % to total value of order unless price is shown\* when the rate is 8%. Make cheques, etc. payable to Bi-Pre-Pak Ltd. Every effort is made to ensure correctness of information at time of going to press. Prices subject to alteration without notice.



# Announcement

## Electronic Construction Kits for 1976/77

AF 25	Mixer	£ 2.50
AF 30	Pre-amplifier	2.30
AF 300	3 Watt audio amplifier	6.10
AF 310, 3	Power amplifier	5.90
AF 340	40 watt AF power amplifier	8.95
AF 380	2 Watt IC universal amplifier	3.25
AT 5	Automatic light control	3.10
AT 30	Photo-cell amplifier	5.25
AT 30	Triac AC regulator up to 440W	3.70
AT 56	Triac AC regulator up to 2200W	5.55
AT 320	All-round AC/DC regulator	10.75
AT 325	Interval and flasher unit	7.20
AT 347	Electronic Roulette	8.75
AT 365	Light show	17.00
AT 405	Low-cost light/heat control	2.75
AT 460	Monolite	10.80
AT 465	Superlite	17.10
AT 466	Strobolite	20.45
AT 468	Quadrrolite	19.45
GP 304	Main circuit unit	4.55
GP 310	Hi-Fi pre-amplifier	24.80
GP 340	Hi-Fi pre-amplifier	29.10
GU 330	Guitar tremolo	5.65
HF 61	Diode medium wave receiver	4.30
HF 65	FM transmitter/testing signal generator	2.50
HF 305	Amateur band 2 metre VHF 144 MHZ converter	6.70
HF 310	FM tuner	11.50
HF 325.2	FM tuner module	19.85
HF 330	Stereo decoder	6.70
HF 375	Mini FM receiver	2.95
HF 385	VHF/UHF aerial amplifier	5.80
HF 395	Aerial amplifier AM-FM	1.50
LF 380	4d-stereo	8.45
MI 310	Stereo VU module	4.30
MI 350	S-meter module/amplifier	2.95
MI 360	Multivibrator/signal generator	1.40
MI 390	Dial module (meter not included)	2.55
MI 391	VU module (meter not included)	1.60
MI 392	Balance module (meter not included)	2.10
MI 393	Tuning module (meter not included)	2.60
MI 402	Semi-conductor tester for diodes/transistors	4.50
NT 300	Power pack (transformer not included)	10.15
NT 305	Voltage converter	4.40
NT 311	Voltage converter	2.80
NT 315	Power pack	8.75
NT 330	Power pack	4.70
NT 400	Power supply (transformer not included)	17.15
NT 410	Power supply	4.50
NT 415	Power supply (transformer not included)	8.45

Please enclose 25p for p&p with order

All prices include V.A.T.

### Send for free Catalogue to:

JOSTYKIT (UK) LTD., Mail Order Division  
P.O. Box 68, Middlesbrough, Cleveland  
TS1 5DQ

NAME .....

ADDRESS .....



### "I MADE IT MYSELF"

Imagine the thrill you'll feel! Imagine how impressed people will be when they're hearing a programme on a modern radio you made yourself.

## Now! Learn the secrets of radio and electronics by building your own modern transistor radio!

Practical lessons teach you sooner than you would dream possible.

What a wonderful way to learn - and pave the way to a new, better-paid career! No dreary ploughing through page after page of dull facts and figures. With this fascinating Technatron Course, you learn by building!

You build a modern Transistor Radio... a Burglar Alarm. You learn Radio and Electronics by doing actual projects you enjoy - making things with your own hands that you'll be proud to own! No wonder it's so fast and easy to learn this way. Because learning becomes a hobby! And what a profitable hobby. Because opportunities in the field of Radio and Electronics are growing faster than they can find people to fill the jobs!

So fast, so easy, this personalised course will teach you even if you don't know a thing today!

No matter how little you know now, no matter what your background or education, we'll teach you. Step by step, in simple easy-to-understand language, you pick up the secrets of radio and electronics.

You become somebody who makes things, not just another of the millions who don't understand. And you could pave the way to a great new career, to add to the thrill and pride you receive when you look at what you have achieved. Within weeks you could hold in your hand your own transistor radio. And after the course you can go on to acquire highpowered technical qualifications, because our famous courses go right up to City & Guilds levels.

No soldering - yet you learn faster than you ever dreamed possible.

Yes! Faster than you can imagine, you pick up the technical know how you need. Specially prepared step-by-step lessons show you how to read circuits - assemble components - build things - experiment. You enjoy every minute of it!

You get everything you need. Tools. Components. Even a versatile Multimeter that we teach you how to use. All included in the course. AT NO EXTRA CHARGE! And this is a course anyone can afford. (You can even pay for it by easy instalments).

Send now for FREE 44-page book - see how easy it is - read what others say!

Find out more now! This is the gateway to a thrilling new career, or a wonderful hobby you'll enjoy for years. Send the coupon now. There's no obligation.

POST TODAY FOR FREE BOOK

To: ALDERMASTON COLLEGE  
DEPT. CRE 24, READING RG7 4PF

CRE 24

Also at our London Advisory Office, 4 Fore Street Avenue, Moorgate, London, EC2Y 5EJ Tel: 01-628 2721. Yes, I'd like to know more about your course. Please send me free details - plus your big, 44-page book that tells about all your courses.

NAME .....

ADDRESS .....

POSTCODE .....



HOME OF BRITISH INSTITUTE OF ENGINEERING TECHNOLOGY



**PRECISION PETITE LTD**  
**119a High Street**  
**Teddington, Middx.**

**Tel: 01-977 0878**  
**(24hr. Tel: Enquiry Service)**

Have pleasure in introducing  
 their Precision Tools from  
 France for all types of  
 electronic design and  
 development, professional  
 or amateur

**THE ABOVE KIT IS AVAILABLE  
 AS SEPARATES**

	£ p	p&p
● Kit Complete as above .....	33.48	1.15
● Mk.II Drill Stand .....	4.40	35
● Mk.II Drill Only .....	8.79	35
● Flexible Shaft.....	5.46	25
● Transformer .....	6.00	70
● S.30 Kit (30 tools).....	17.62	85
● S.10 Kit (10 tools).....	13.74	65

*Postage for spares (any quantity) 15p*

Replacement accessories ....40p each  
 Circular Saw Blade Sets (4)..... £2.00  
 Spare Collets..... £0.40  
 Spare Chuck & 3 Collets..... £2.50

**ALL ABOVE PRICES INCLUDE V.A.T.**

**S.A.E.** FOR ILLUSTRATED LEAFLET  
 & ORDER FORM

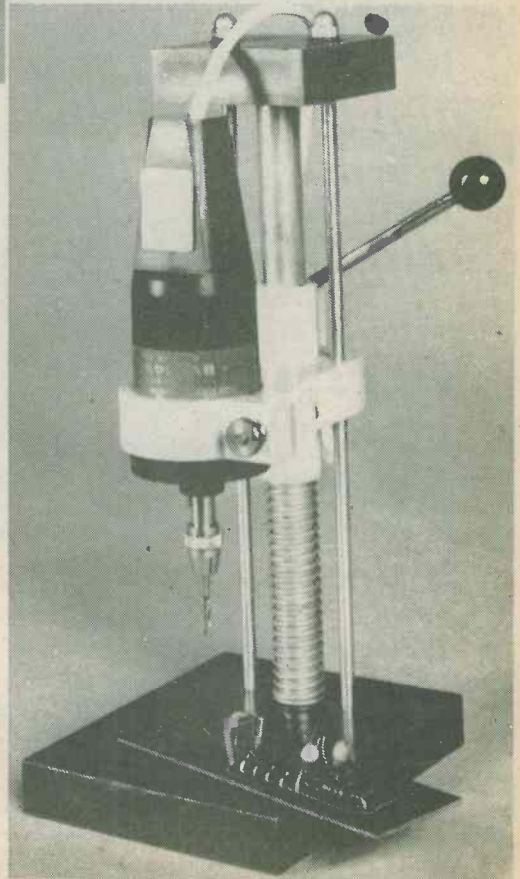

# ONLY TESTING?

FOR SAFE, POSITIVE INDICATION OF THE DYNAMIC GAIN OF BIPOLAR TRANSISTORS — BATTERY OPERATED

FOR ONLY £6.50 + V.A.T.

## BE SURE — GET A SEESURE!

Available from

**FORESIGHT ELECTRONICS**  
57 Mungo Park Way, Orpington, Kent  
MAIL ORDER ONLY

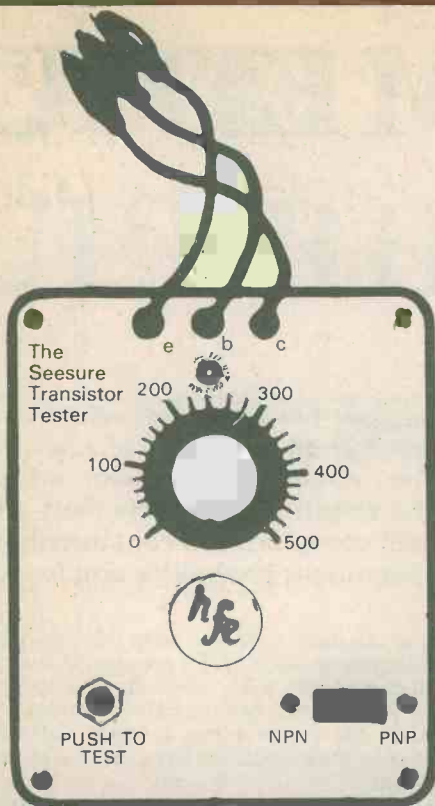

A Happy Christmas to all our readers

Of course, by 'Santas' I mean Dads, Grandads and Uncles who, at this time of the year, are often desperate for inspiration! Well, if your son, grandson or nephew is keen on electronics, may I make a suggestion? Buy a Home Radio Catalogue. In it you will find dozens of wonderful presents. When you give him the present you have chosen you can double his pleasure by giving him the catalogue as well!

This is the one catalogue every electronic enthusiast must have. Its 200 pages are crammed with over 5,000 items, well over 1,000 of them illustrated. It's a present that will last for years, because it can be updated with new price lists, supplied free on request. With every catalogue comes a free bargain list — another worthwhile bonus. At the price of £1 plus 40p for postage and packing it's certainly wonderful value; so send off the coupon with a cheque or PO for £1.40 ... and become the Santa of the year!

Please write your Name and Address in block capitals

NAME .....

ADDRESS .....



**POST THIS COUPON**  
with cheque or p.o. for  
**£1.40**

HOME RADIO (Components) LTD., Dept. RC  
234-240 London Road, Mitcham, Surrey CR4 3HD

Regd No 912966 London

**HOME RADIO (Components) LTD. Dept. RC, 234-240 London Road, Mitcham, CR4 3HD. Phone: 01-648 8422**



# MEDIUM

Medium wave DX listening requires a receiver having a high selectivity, and in this superhet design the selectivity is achieved by the use of a narrow band mechanical filter in the i.f. amplifier stages. The present article describes the circuit and gives details of the construction of the case and chassis. Next month's concluding article will complete the constructional details and will then deal with the simple alignment procedure employed.

Receiver designs for the medium wave DX enthusiast are something of a rarity, and the number of medium wave DX receiver articles which have been published in the past is extremely small. In consequence, anyone wishing to embark on this form of reception usually has to use either one of the more expensive transistor portables or a communications receiver which has the medium wave band included in its range.

Neither of these alternatives is completely satisfactory. Transistor portable receivers are intended for entertainment use, and even the better of these do not have the level of sensitivity and selectivity which is needed for serious DX listening. A communications receiver is likely to give better results, especially if some form of directional aerial is employed. It is unnecessarily expensive, though, and has some features, such as a b.f.o., which are not required.

This article describes a receiver which has been designed specifically for medium wave DX reception and which is capable of an extremely high performance level. A later article will describe a preselector which is intended for use with the receiver. The preselector has an integral ferrite aerial and no other aerial, or an earth connection, are required.

Although these two items of equipment have been designed to work together, the receiver can be used on its own with other types of aerial, such as a long wire. Similarly, the preselector can be used to feed a communications receiver that is being employed for medium wave DX reception.

## DESIGN BASICS

A block diagram, showing the basic stages and the semiconductor complement of the receiver is given in Fig. 1. It will be seen from this that the receiver uses five bipolar transistors, a dual gate MOSFET, a diode and an integrated circuit a.f. amplifier. The preselector uses a dual gate MOSFET as its only active device.

As with any high performance set, cross modulation

is one of the main problems with this type of receiver. In consequence, MOSFET's are used in the mixer and preselector stages since these have a better performance than bipolar devices in this respect. It is found also that the receiver has a lower noise level and higher gain than would be the case if a bipolar mixer were used.

Good selectivity is obviously as important a requirement in this type of receiver as it is in an ordinary communications set. A mechanical i.f. filter is employed and this ensures excellent selectivity. Indeed, it gives a level of selectivity which is too high for normal domestic listening, with the treble and high middle frequencies of an accurately tuned transmission being virtually eliminated. The bandwidth is adequate for perfectly intelligible speech, however, and its narrowness gives a good signal to noise ratio and a low level of adjacent channel interference.

The circuit after the mechanical filter is quite conventional except for the inclusion of the S-meter. This can be omitted if it is not required.

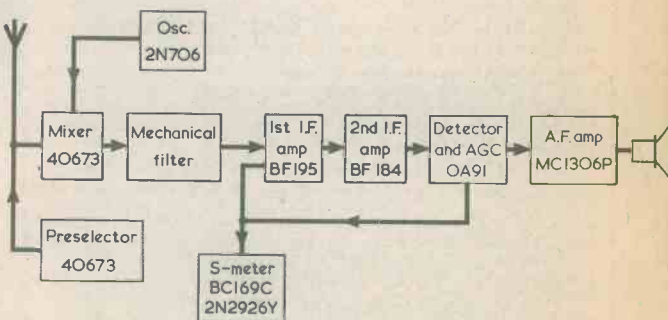

Fig. 1. The stage line-up of the medium wave DX superhet. The preselector is a separate unit and is not part of the receiver proper



# WAVE DX SUPERHET

Part 1

By A. P. Roberts

## COMPONENTS

### Resistors

R1 560k $\Omega$   
R2 2.2k $\Omega$   
R3 12k $\Omega$   
R4 10k $\Omega$   
R5 100 $\Omega$   
R6 390 $\Omega$   
R7 56 $\Omega$   
R8 2.7k $\Omega$   
R9 120k $\Omega$   
R10, 39k $\Omega$   
R11 680 $\Omega$   
R12 390 $\Omega$   
R13 470k $\Omega$   
R14 680 $\Omega$   
R15 1.8k $\Omega$   
R16 270 $\Omega$   
R17 1k $\Omega$  pre-set potentiometer, standard skeleton, horizontal  
R18 5.6k $\Omega$   
R19 56k $\Omega$   
R20 220k $\Omega$   
R21 1k $\Omega$   
R22 2.2 $\Omega$   
R23 27k $\Omega$   
R24 68k $\Omega$   
VR1 5k $\Omega$  potentiometer, log, with switch S1  
VR2 5k $\Omega$  potentiometer, linear

### Capacitors

C1 10-40pF ceramic trimmer (see text)  
C2 125 $\mu$ F electrolytic, 10 V. Wkg.  
C3 47pF polystyrene  
C4 0.047 $\mu$ F type C280 (Mullard)  
C5 0.1 $\mu$ F type C280 (Mullard)  
C6 0.047 $\mu$ F type C280 (Mullard)  
C7 0.022 $\mu$ F type C280 (Mullard)  
C8 350pF silvered mica or polystyrene (see text)  
C9 10-40pF ceramic trimmer (see text)  
C10 5 $\mu$ F electrolytic, 10 V. Wkg.  
C11 0.1 $\mu$ F type C280 (Mullard)  
C12 0.01 $\mu$ F type C280 (Mullard)  
C13 0.022 $\mu$ F type C280 (Mullard)  
C14 0.01 $\mu$ F type C280 (Mullard)  
C15 0.1 $\mu$ F type C280 (Mullard)  
C16 82pF ceramic or silvered mica  
C17 0.1 $\mu$ F type C280 (Mullard)

C18 200 $\mu$ F electrolytic, 10 V. Wkg.  
C19 200 $\mu$ F electrolytic, 10 V. Wkg.  
C20 470pF polystyrene  
VC1,2 365+365pF, variable 2-gang type 'O' (Jackson)

### Inductors

L1 Transistor tuning coil, Blue, Range 2T (Denco)  
L2 Transistor tuning coil, Red, Range 2T (Denco)  
IFT1 I.F. transformer type IFT.13 (Denco)  
IFT2 I.F. transformer type IFT.14 (Denco)

### Filter

MF1 Mechanical filter type MFH41-T (Ambit)

### Semiconductors

TR1 40673  
TR2 2N706  
TR3 BF195  
TR4 BF184  
TR5 BC169C  
TR6 2N2926Y  
IC1 MC1306P  
D1 OA91

### Meter

M1 S-meter, 1mA f.s.d. (see text)

### Switch

S1 s.p.s.t. (part of VR1)

### Sockets

SK1 3.5mm. jack socket  
SK2 Coaxial socket

### Miscellaneous

Tuning reduction drive, type T.502 (Eagle)  
2-off B9A valveholders  
2-off Knobs  
9 volt battery (see text)  
Battery connector  
Loudspeaker or headphones (see text)  
Plain perforated board, 0.1 in. matrix  
Plain board, 0.15 in. matrix  
Veropins (see text)  
Materials for case (see text)  
Wire, nuts, bolts, etc.

## CIRCUIT

The complete circuit diagram of the receiver appears in Fig. 2. The aerial is coupled by the low impedance primary winding of L1 to the tuned winding, this connecting to g1 of TR1. The tuned winding also provides the gate bias for TR1. L1 has a third winding (not shown in the diagram) which is intended for coupling to the base of a transistor, but in the present circuit it is the tuned winding which is coupled to the gate of the transistor. This does not impair the input selectivity as TR1 imparts a very low level of loading on the tuned circuit. R2 and C4 are the source bias resistor and bypass capacitor, and the g2 of TR1 is held slightly positive of the negative supply rail by being connected to the source via R1.

The oscillator transistor, TR2, is used in the grounded base mode, and positive feedback is provided between its collector and emitter by L2. VC2 is the oscillator tuning capacitor and is ganged with VC1, the tuning capacitor for the aerial tuned circuit.

Oscillator harmonics can be troublesome in any receiver, but tend to be especially so in a sensitive medium wave design. The practical result of these harmonics is the breakthrough of short wave transmissions with consequent heterodynes on medium wave stations. The basic oscillator design showed a very high harmonic content when the output waveform was viewed on an oscilloscope. In consequence, R6 and R7 have been included and they very greatly reduce the harmonic content.

C3 couples the output of the oscillator to g2 of TR1. The voltage at g2 controls the gain at g1, and the oscillator signal thus modulates the aerial signal, producing the required mixing action. The difference signal is at the intermediate frequency of 455kHz, and is coupled to the primary of the input i.f. transformer of the mechanical filter. No integral tuning capacitor is included for this winding of the filter, and C20 is required to perform this function. The manufacturer's data for the filter specifies the tuning capacitance needed as 500pF total, and the 470pF capacitor employed for C20 was found to be adequate in practice.

The mechanical filter has a typical bandwidth of 4kHz at the -6dB points, and less than 10kHz at the

-40dB points. The result is a very noticeably sharper bandpass than can be achieved using ordinary i.f. transformers at the same frequency, and the bandwidth is really about as narrow as can be employed for normal a.m. reception.

A high gain two stage i.f. amplifier is used, and this is entirely conventional. Single-tuned i.f. transformers are employed, as there is little point in using double-tuned ones when the selectivity is mainly determined by the mechanical filter. With the very narrow bandwidth of the mechanical filter, having a subsequent i.f. amplifier with a relatively wide bandwidth helps to keep i.f. alignment simple and straightforward. The i.f. transformers have a nominal frequency of 470kHz, but they will tune down to 455kHz (and lower) comfortably.

D1 is the detector diode, and C13, R14 and C14 are i.f. filter components. VR1 is the volume control, and from here the signal is fed to the audio amplifier. This uses a single integrated circuit type MC1306P, which is capable of offering 0.5 watt into an 8Ω load.

R19 and R20 bias an internal pre-amplifier stage in the i.c. and set its voltage gain and input impedance at 12dB and 56KΩ respectively. C16 rolls off the high frequency response and helps to maintain good stability. R21 couples the output of the pre-amplifier to the input of the i.c. power amplifier stage, and sets the voltage gain of the latter at 20dB. R22 and C17 form an output Zobel network. Typical total harmonic distortion is only 0.5% at 250mW output.

Turning to components, the mechanical i.f. filter type MFH41-T is available from Ambit International, 25 High Street, Brentwood, Essex. The oscillator padding capacitor, C8, requires a value of 350pF in silvered mica or polystyrene. If difficulty is experienced in obtaining a single component in this value, two capacitors may be connected in parallel. In the prototype the author employed a 200pF capacitor in parallel with a 150pF component, both polystyrene. An alternative combination could consist of two 100pF and a 150pF capacitor. The ceramic trimmers, C1 and C9, are specified at 10-40pF. If this value cannot be obtained it is in order to employ 10-60pF trimmers, which are available from Doram Electronics.

## S-METER AND A.G.C.

The S-meter circuit is fed from the a.g.c. voltage applied to the first i.f. amplifier transistor. An a.g.c. bias is produced across VR1 and is the d.c. component of the received transmission. Its amplitude is proportional to the strength of the received signal.

TR3 receives its base bias current, via R10 and the output winding of the mechanical i.f. filter, from a potential divider consisting of R9, R23 and VR1. When a weak signal is received very little bias is produced across VR1, and the biasing of TR3 is not significantly affected. On stronger signals, however, the negative d.c. bias due to the signal reduces the positive voltage across VR1, and on very strong signals a negative voltage of about 0.5 volt is produced across VR1. In consequence the bias current for TR3 is reduced.

This reduction in bias current causes the gain of TR3 to fall, and thus the transistor has a lower gain on strong signals than it has on weak ones. In consequence an automatic gain control system is set up which has the beneficial effects of producing similar

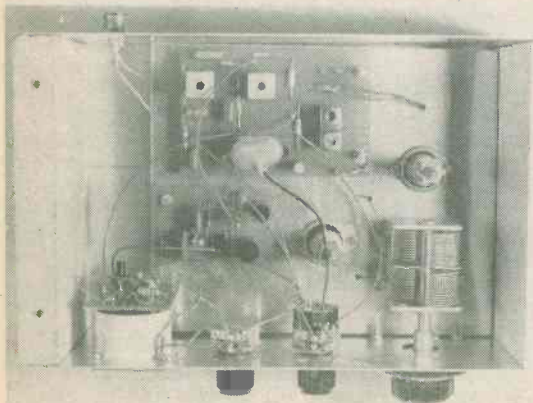

*The use of separate component boards for the i.f. and a.f. amplifiers results in a neat layout with adequate spacing*

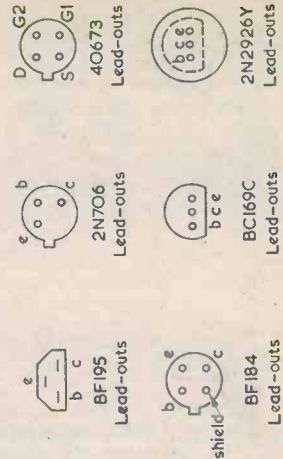
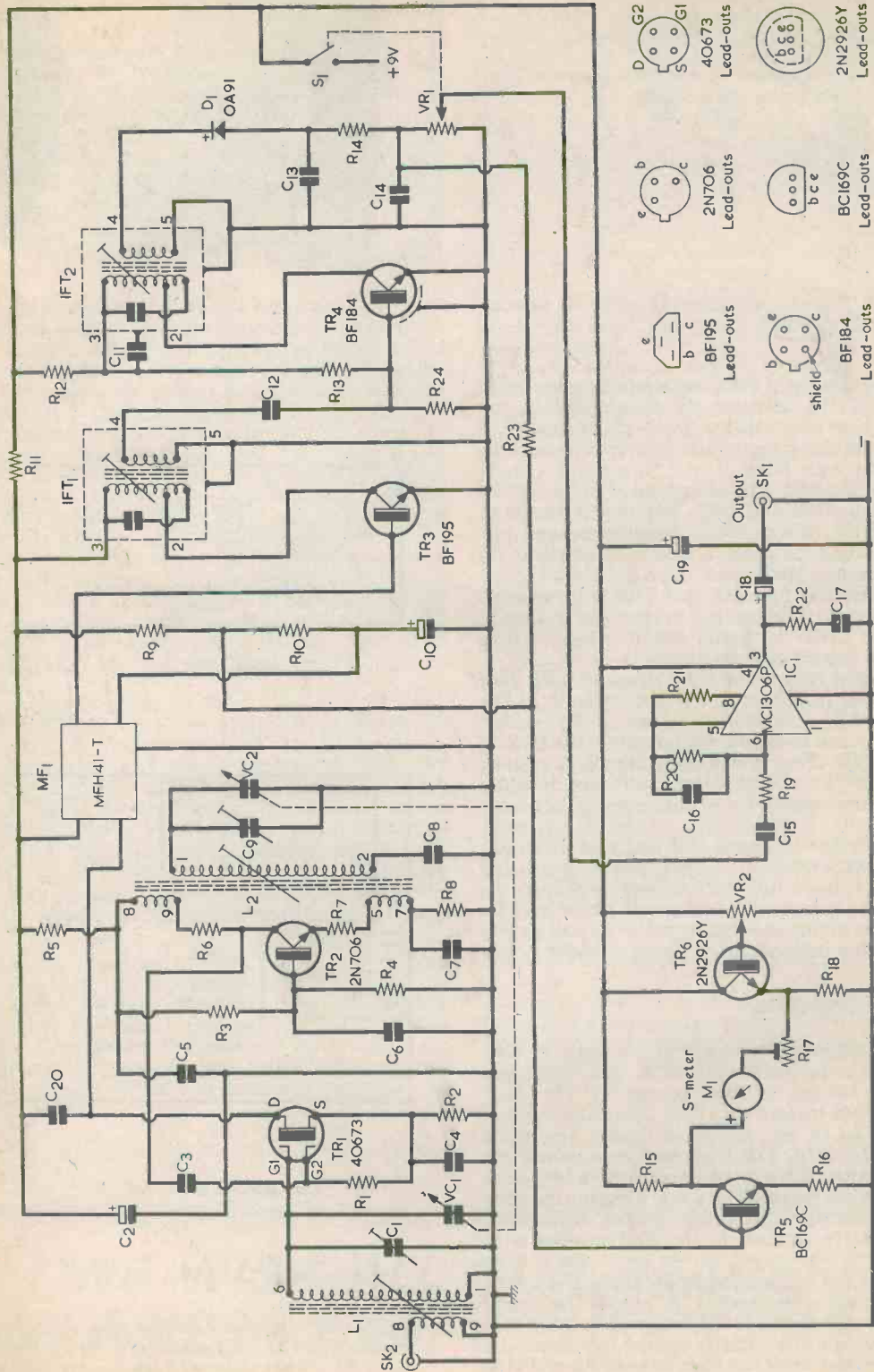
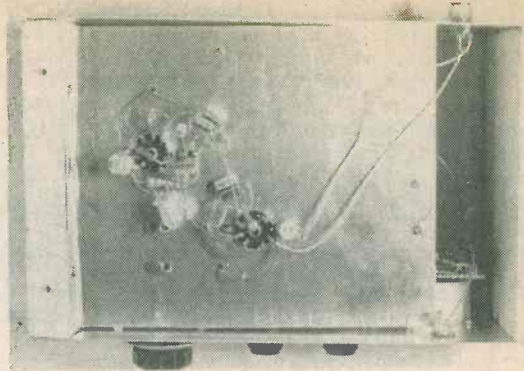

Fig. 2. Complete circuit diagram for the receiver

The mixer and oscillator components are wired up below the chassis



volumes from signals of differing strength, preventing overloading of the detector on strong signals and minimising the noticeable effects of fading. C10 bypasses the audio signal which would otherwise be present on the a.g.c. bias.

TR5 is the S-meter amplifier, and is fed from the junction of R9, R10 and R23. The emitter resistor, R16, gives TR5 a high input impedance and low voltage gain. The high input impedance ensures an insignificant level of loading on the a.g.c. circuit.

TR6 is an emitter follower, and VR2 is adjusted so that the voltage at TR6 emitter is identical to that at TR5 collector under no-signal conditions. VR2 thus acts as the S-meter set zero control.

When a signal is received the voltage at TR5 base will be reduced in proportion to the strength of the received signal. This causes the voltage at TR5 collector to increase and so produce a forward deflection of the meter needle. The level of deflection is, of course, proportional to the amplitude of the received signal. R17 enables the sensitivity of the S-meter to be adjusted.

The S-meter has the same size as panel meters in the Henelec '38 Series', with a square front measuring 42 by 42mm. It has a full-scale deflection of 1mA. As an alternative a standard 0-1mA panel meter may be employed, this acting as a tuning meter as well as giving comparative indications of signal strength.

## CASE AND CHASSIS

The construction of the case and chassis is very simple but is nevertheless effective. The front and rear panels consist of two pieces of 18 s.w.g. aluminium sheet measuring 10 by 3 3/4 in. The sides of the case consist of two pieces of timber 3/4 in. thick measuring 6 by 3 3/4 in. The front and rear panels are fixed to the timber sides by two woodscrews near each edge. Two further pieces of 18 s.w.g. aluminium, each measuring 10 by 6 1/8 in., form the top and the bottom, and are similarly secured to the timber sides with woodscrews.

Fig. 3 shows the drilling required for the front panel. The two small holes marked 'X' are for the tuning drive and are not drilled at this stage. The large hole for the S-meter may be initially cut out by means of a fretsaw. The meter itself can then be used for marking out the four small holes around the large hole.

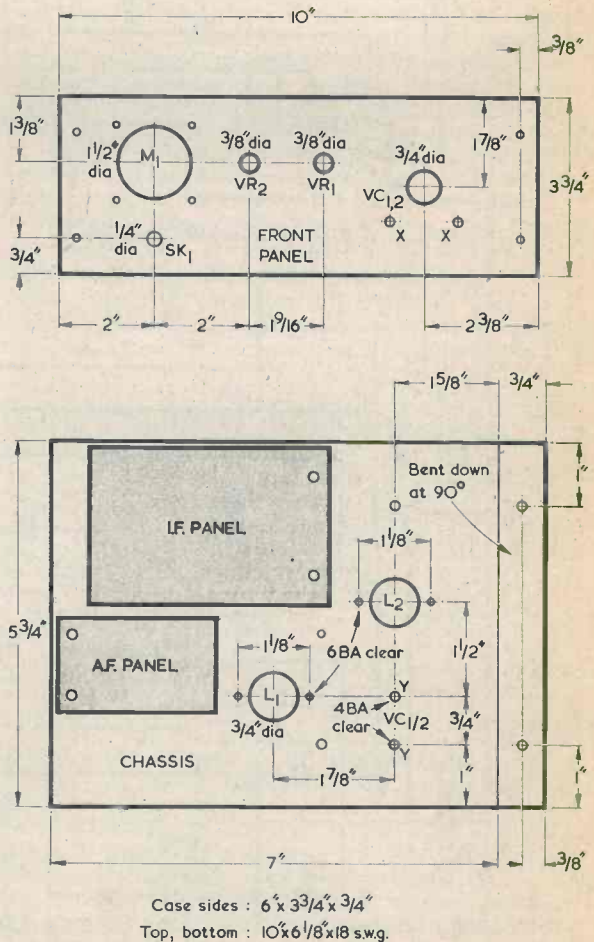
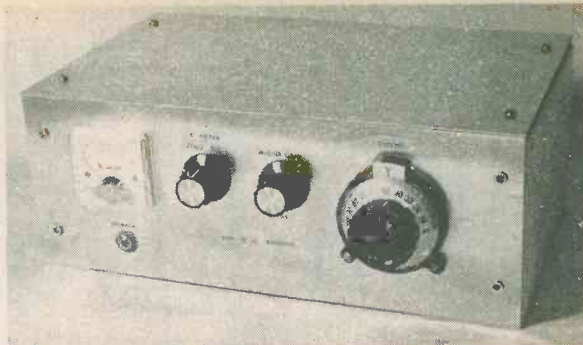

Fig. 3. Drilling details for the front panel and the chassis. The front panel holes for the meter and VR2 are not required if the S-meter facility is to be omitted

Another view of the completed receiver. The legends on the front panel are taken from 'Panel Signs' Set No. 4, available from the publishers of this journal



The only item mounted on the rear panel is a coaxial socket. It is fitted towards the left hand edge of the panel, as seen from the front, and a solder tag is secured, on the inside, under one of its mounting nuts. The positioning of the socket is not critical, and can be judged from the accompanying photographs.

When the drilling, apart from the two 'X' holes, has been completed, the front and rear panels are mounted on the side panels, using four woodscrews for each panel. The top and bottom panels are then temporarily mounted in the same way to check that the case fits together properly. Although it is not essential for the top and bottom panels to be in electrical contact with the front and rear panels, it should in practice be found an easy matter to have the edges of the top and bottom touch the edges of the front and rear panels at several points. If desired, four small rubber feet may be fitted near the corners of the bottom panel.

The chassis is made up from a piece of 18 s.w.g. aluminium measuring  $7\frac{1}{2}$  by  $5\frac{1}{2}$  in. This is also shown in Fig. 3. The two holes marked 'Y' are for the 2-gang tuning capacitor and they correspond with two 4BA tapped holes in the bottom of the tuning capacitor frame. As these tapped holes do not appear in the normal specification of the capacitor listed, it is advisable to check the positions of the chassis holes with the capacitor itself before drilling. The capacitor should take up a position which will allow its spindle to engage correctly with the tuning drive on the front panel.

L1 and L2 are fitted in B9A valveholders. Each valveholder has two solder tags secured below the chassis under its mounting nuts. Both valveholders are mounted with pins 1 and 9 nearer the front. The mounting holes for the i.f. panel and the a.f. panel are not drilled yet. There are three further holes with no apparent purpose as yet, and these will later allow the

passage of wires through the chassis. Their precise positioning is not important, and they should be fitted with grommets.

When the chassis drilling as so far described has been completed and the 90 degree bend has been made, the chassis is mounted as low down as possible on the right hand side of the case by means of two woodscrews. The  $\frac{3}{4}$  in. flange is below the mains chassis surface.

The tuning capacitor is next mounted to the chassis by means of two  $\frac{3}{4}$  in. 4BA bolts. Several 2BA nuts, or similar, are used to space the capacitor slightly away from the chassis. If this is not done, projecting parts below the capacitor frame will bear against the chassis; also the screws would pass too far through the capacitor frame with the risk of consequent damage to its vanes.

The tuning drive can then be placed in position on the front panel. The mounting screw which is supplied with the drive and which fits into the hole at its top rear has been found to be unnecessary, and is discarded. With the drive in position it is possible to use the drive itself as a template to find the positions of the two small mounting holes marked 'X' in Fig. 3. The tuning capacitor is then removed so that these holes can be drilled. After this, the capacitor and tuning drive are finally mounted. Two 1 in. 6BA round-head screws with nuts are used to mount the drive at the holes 'X'.

#### NEXT MONTH

In next month's concluding article, details will be given of the remaining constructional steps required, together with the alignment. Any queries concerning components or parts will be cleared up in the concluding article.

(To be concluded)

WE WISH ALL OUR READERS  
— A VERY HAPPY CHRISTMAS —

# Wide range A.C. millivoltmeter

By B. S. Wolfenden

**This simple but effective design requires only one operational amplifier i.c. and two transistors, and it draws an extremely low current from its battery supply.**

A very useful piece of apparatus when dealing with audio equipment is undoubtedly an a.c. millivoltmeter. The design to be described can claim no great advance in performance, but it is very simple and the performance it has is very acceptable. An a.f. oscillator or signal generator is required for setting it up.

## CIRCUIT DETAILS

The circuit, which is shown in Fig. 1, can be split into two parts. The meter drive section incorporating

TR1 and TR2 is a simple design following normal practice. The meter and rectifiers are included in the feedback loop and the resistor, R11, in the emitter of the first transistor determines the input sensitivity for full-scale deflection on the meter. In this case f.s.d. is approximately 20mV.

D1 and D2 are gold bonded germanium diodes which are specially suitable for high speed switching applications. Since the 0-100 $\mu$ A meter is included in the feedback circuit its resistance can have any value within reason. The meter employed in the prototype had a resistance of 675  $\Omega$ .

In order to produce an instrument with a sensitivity of 1mV f.s.d., and also to provide a reasonably high input impedance, the driver stage is preceded by a pre-amplifier making use of the 709 integrated circuit. The output from this stage is attenuated by the resistors R7, R8 and R9 to give a X1, X10 and X100 scale. For maximum accuracy these resistors should be as accurate as possible and with the prototype were selected by measurement on a universal bridge. R9 was given by a parallel combination of a 27  $\Omega$  and a 10  $\Omega$  resistor.

In order to save complicated switching and produce 10dB (3.162 voltage ratio) steps between obtainable scales, the gain of the first stage is adjusted by means of RV1, RV2 and S2 to obtain 1mV and 3.162mV f.s.d. on the meter. In the prototype the meter only had a 0-10 scale and therefore a suitable 0-3 scale was added. The correlation between this scale and the 0-10 scale to obtain the required 10dB step is given in

## SPECIFICATION

Range: From 1mV f.s.d. to 300V f.s.d. in 10dB steps (12 ranges).

Frequency Response: Within 1dB from less than 10Hz to approx. 250kHz on the 1mV range, falling to approx. 100kHz on the 100mV range.

Linearity: Within approx. 0.5% of f.s.d. (as checked against a digital voltmeter).

Input Impedance: 150k $\Omega$  typ. on mV scale, 10M  $\Omega$  approx. on V scale.

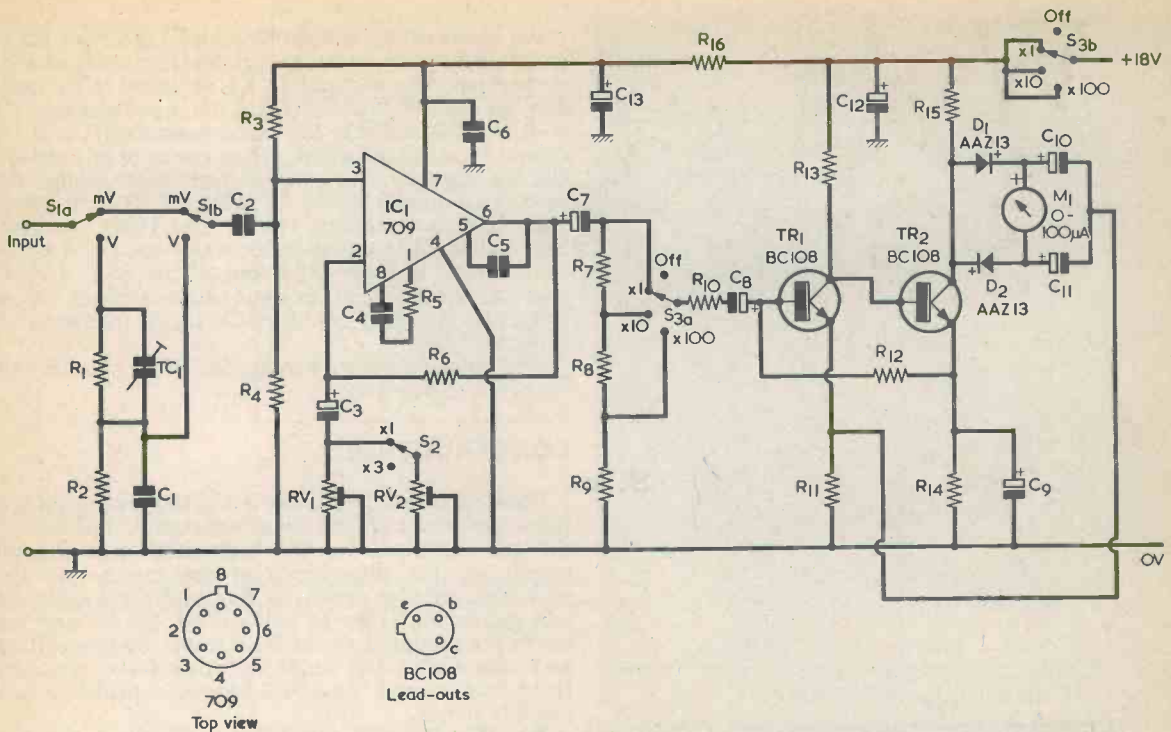

Fig. 1. The circuit of the wide range a.c. millivoltmeter. This has 12 ranges, from 0-1mV to 0-300V

## COMPONENTS

### Resistors

(all fixed values  $\frac{1}{4}$  watt 5% unless otherwise stated)

- R1 10m  $\Omega$  high stability (see text)
- R2 10k  $\Omega$  high stability (see text)
- R3 470k  $\Omega$
- R4 470k  $\Omega$
- R5 1.5k  $\Omega$
- R6 22k  $\Omega$
- R7 680  $\Omega$  high stability (see text)
- R8 68  $\Omega$  high stability (see text)
- R9 7.55  $\Omega$  high stability (27  $\Omega$  and 10  $\Omega$  in parallel — see text)
- R10 1k  $\Omega$
- R11 100  $\Omega$
- R12 10k  $\Omega$
- R13 47k  $\Omega$
- R14 1.8k  $\Omega$
- R15 15k  $\Omega$
- R16 1.8k  $\Omega$
- RV1 4.7k  $\Omega$  pre-set potentiometer, miniature skeleton 0.1 watt, horizontal
- RV2 4.7k  $\Omega$  pre-set potentiometer, miniature skeleton 0.1 watt, horizontal

### Capacitors

- C1 0.0068 $\mu$ F plastic foil
- C2 1 $\mu$ F plastic foil
- C3 100 $\mu$ F electrolytic, 15 V. Wkg.
- C4 470pF silvered mica or polystyrene
- C5 10pF silvered mica or ceramic
- C6 0.1 $\mu$ F ceramic

- C7 100 $\mu$ F electrolytic, 15 V. Wkg.
- C8 80 $\mu$ F electrolytic, 10 V. Wkg.
- C9 250 $\mu$ F electrolytic, 6 V. Wkg.
- C10 22 $\mu$ F electrolytic, 15 V. Wkg.
- C11 22 $\mu$ F electrolytic, 15 V. Wkg.
- C12 50 $\mu$ F electrolytic, 25 V. Wkg.
- C13 100 $\mu$ F electrolytic, 25 V. Wkg.
- TC1 20pF trimmer

### Semiconductors

- IC1 709, in round TO99 case
- TR1 BC108
- TR2 BC108
- D1 AAZ13
- D2 AAZ13

### Meter

- M1 0-100 $\mu$ A, moving-coil

### Switches

- S1(a)(b) 2-pole 2-way, toggle or rotary
- S2 s.p.d.t., toggle or rotary
- S3(a)(b) 2-pole 4-way, rotary

### Miscellaneous

- Input socket or input terminals
- Metal case (see text)
- 2-off 9V batteries with connectors
- Perforated s.r.b.p. board, 0.1in. matrix
- Control knob or knobs (as required)

TABLE 1  
0-3 Scale Calibration

Reading on 0-3 scale	Corresponding reading on 0-10 scale
0.2	0.64
0.4	1.27
0.6	1.90
0.8	2.52
1.0	3.15
1.2	3.78
1.4	4.42
1.6	5.05
1.8	5.68
2.0	6.32
2.2	6.95
2.4	7.58
2.6	8.22
2.8	8.85
3.0	9.50

Table 1. A dB scale was also included and a similar correlation for this scale is given in Table 2. This table shows the dB calibration points against the 0-10 markings on the original scale. The reference level is taken as 1mW into 600Ω, corresponding to 775mV.

TABLE 2  
dB Scale Calibration

Reading on dB scale	Corresponding reading on 0-10 scale
+2	9.75
+1	8.69
0	7.75
-1	6.90
-2	6.15
-3	5.48
-4	4.89
-5	4.36
-6	3.88
-7	3.46
-8	3.08
-9	2.75
-10	2.45
-11	2.18
-12	1.95

An input attenuator employing S1, R1 and R2 to enable the unit to measure high level inputs is also incorporated. The value of TC1 is adjusted to compensate for the self-capacitance of the input resistors. As with R7, R8 and R9, the input resistors R1 and R2 should have values which are as accurate as possible. (In the absence of a suitable resistance bridge, the resistors required for R2, R7, R8 and R9 are listed in 1% tolerance by Home Radio. The 10MΩ resistor, R1, is difficult to obtain in close tolerance as a single component, but it could consist of four 2.2MΩ resistors and a 1.2MΩ resistor in series, these values being also listed by Home Radio in 1% tolerance. — Editor.)

The total current consumption from the 18 volt supply is 2½mA only.

## CONSTRUCTION

Constructional details are left to the reader but the following points should be of assistance. The size of the case required for the instrument will depend largely on the dimensions of the meter and the switches, and the prototype was built into a diecast box measuring 7¼ by 4¼ by 2¼in. S1, S2, S3 and the meter are mounted on the front panel. S3 is specified as 2-pole 4-way, but could be 3-pole 4-way with the third pole unused. Two PP3 batteries inside the box provide power.

R1, R2, R7, R8 and R9 are wired on the appropriate attenuator switches, as also are C1 and TC1. The remaining components are assembled on a plain perforated s.r.b.p. board of 0.1in. matrix having 17 by 42 holes. This is illustrated in Fig. 2. The board is mounted directly to the meter terminals whose centres, with the author's meter, are spaced by 1.3in. Other 0-100μA meters will probably have different terminal spacing, but the general wiring layout of Fig. 2 can still be followed. Meter terminal spacing may also necessitate the use of a larger board than that shown in the diagram.

## CALIBRATION

If no better alternative is available the unit may be calibrated with the aid of a mains transformer having a low voltage secondary and an ordinary moving-coil multimeter set to an alternating voltage range. Arrange the transformer, a 5kΩ potentiometer and the multimeter as in Fig. 3. Adjust the potentiometer so that it offers a low voltage. Next adjust RV1 and RV2 so that they insert maximum resistance into circuit, set the millivoltmeter controls to correspond to an f.s.d. of 3 volts and connect it in parallel with the multimeter. Adjust the potentiometer so that the multimeter reads 3 volts and then adjust RV1 so that the millivoltmeter gives f.s.d. on the 0-3 scale. Reduce the voltage so that the multimeter reads 1 volt and, with the millivoltmeter now set to read 1 volt full-scale, adjust RV2 to give f.s.d. The millivoltmeter is now calibrated for all ranges to an accuracy dependent upon that of the multimeter and the attenuators in the millivoltmeter.

Whatever method is used to calibrate the millivoltmeter, the X3 scale must be calibrated before the X1 scale. This is because RV1 determines the gain of the pre-amplifier in the X3 position, whilst the parallel combination of RV1 and RV2 determines the gain in the X1 position.



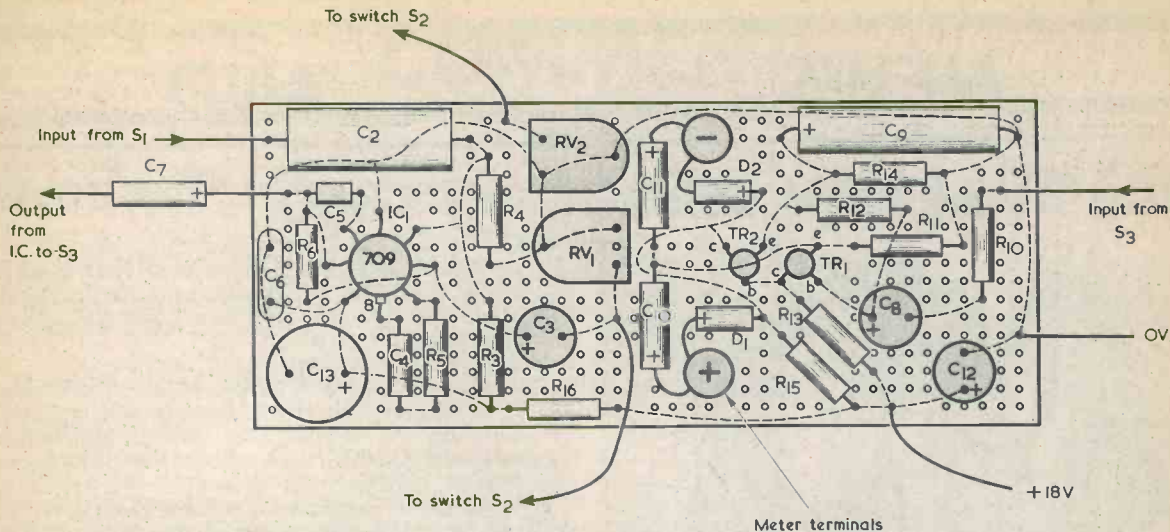

Fig. 2. Layout of the component board employed in the prototype. Two holes are drilled in this to accommodate the meter terminals. The layout is modified as required to suit the terminal spacing of the particular meter used

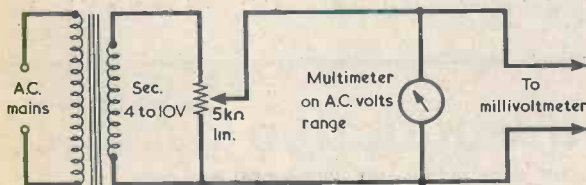

Fig. 3. A simple circuit which may be used for setting up RV1 and RV2

To adjust TC1 an audio oscillator having a constant or monitored output is required. Set the oscillator to a low frequency (say 500Hz) and adjust the output to

give f.s.d. on the 1 volt range of the millivoltmeter. Reset the oscillator to 100kHz and adjust TC1 to give f.s.d. again. Check that the response is reasonably flat over the frequency range and if necessary readjust TC1 for maximal flatness.

## CONCLUSION

Despite the fact that this millivoltmeter employs only two transistors and one operational amplifier the performance it offers is very adequate for the testing of audio equipment. The current consumption is low, enabling small batteries to be used for a power supply and allowing the complete instrument to be made up as a small, easily portable unit.

## BACK NUMBERS

For the benefit of new readers we would draw attention to our back number service.

We retain past issues for a period of two years and we can, occasionally, supply copies more than two years old. The cost is the cover price stated on the issue, plus 11p postage.

Before undertaking any constructional project described in a back issue, it must be borne in mind that components readily available at the time of publication may no longer be so.

We regret that we are unable to supply photo copies of articles where an issue is not available. Libraries and members of local radio clubs can often be very helpful where an issue is not available for sale.

# NEWS . . . AND . . .

## Big screen TV sales reach 1000



Crown Cassette Communications recently announced the sale of their 1000th VideoBeam projection television unit. This big screen television is able to display a picture almost 6 feet wide.

Our photo shows Henry Oliver, Marketing Director of Crown Cassette Communications, making a special presentation to Edward Gillespe, Racecourse Manager of United Racecourses, for the purchase of the 1000th machine. He presented, on behalf of Crown Cassette Communications, a Philips N1501 VCR in front of a large crowd in the Grandstand at Sandown's prestige Variety Club meeting.

United Racecourses purchased the VideoBeam system to replace a number of smaller monitors at both Kempton and Sandown Park racecourses. This is the second time VideoBeam projection television from CCC has been seen by Sandown Park's regular racing enthusiasts. In June a large crowd watched live transmission of the Wimbledon tennis finals in between races.

## Loctite Super Glue-3 introduction

Loctite Super Glue-3 is a type of adhesive virtually unknown, until recently, outside of industry for which it was especially developed to meet the most stringent bonding needs. Ordinary adhesives require solvents, catalysts and a lengthy period of time before the treated parts can be handled. Loctite Super Glue-3 claims it has none of these disadvantages.

Fast action allows almost instant bonding of a wide variety of materials with non-porous surfaces: rubbers, metals, ceramics and most plastics. This enables the making and repair of many items which were previously either very difficult and time-consuming or virtually impossible. It is ideal for repairing plastic toys, mending and making jewellery, restoring and repairing ceramic items such as ornaments and fine display china, and for many other tasks.

Loctite Super Glue-3 is very economical to use, only the smallest drop is needed to make a repair or join with a virtually invisible bondline. Applying too much of this adhesive will actually retard its high-speed action. There is need for neither the mixing of resins and hardeners nor the use of clamps. A small droplet of Loctite Super Glue-3 and firm finger-pressure are all that is needed to make an amazingly strong joint in seconds.

Loctite Super Glue-3 is obtainable from Woolworths, W. H. Smith, Halfords and most hardware and DIY departments and stores. Each 3 gramme tube contains approximately 190 drops and

retails at a recommended price of 99p, including VAT. Due to its speed of action and strength the product should not be sold to or used by children. Each tube of Loctite Super Glue-3 is fitted with a special applicator nozzle to ensure accurate and controlled use of the adhesive.



# COMMENT

## Oracle Teletext specification

A new edition of "Broadcast Teletext Specification" — the document that describes the technical parameters of the Teletext signals transmitted in the United Kingdom by Independent Television and the BBC — has recently been published jointly by the IBA, BBC and BREMA.

This edition, dated September 1976, includes a number of minor changes, designed primarily to make the displayed pages of information visually more attractive by the use of double height characters where required and providing more flexible use of colour backgrounds ("contiguous colour background"). These new facilities have been incorporated in the system in such a way that the transmissions will remain suitable for Teletext decoders based on the earlier Specification issued in January 1976, although such decoders will not, of course, display the information in exactly the same way. The ORACLE teletext transmissions put out by Independent Television already incorporate the new facilities.

## Professional drilling machine

P.B. Electronics of 57 High Street, Saffron Walden, Essex, has introduced a new drilling machine called the P.B. SuperDrill. It is British made and has been designed specifically for the professional drilling of PCBs. It is ideal for prototype and medium production use.

The case is of solid, all steel construction and the P.B. SuperDrill has a throat clearance of 150mm. Height under the chuck is a big 44mm. Maximum chuck capacity is 4mm.

The motor is rated at 100W and the P.B. SuperDrill runs at 18,000 rpm off load.

The unit has additional features, such as fan-assisted swarf removal and a high intensity lamp to illuminate the drilling area without discomfort to the operator — even after long periods of use. The P.B. SuperDrill also has a spring plunger which makes stack drilling easy and untiring, even on medium production runs.

The P.B. SuperDrill is available in the U.K. at a special introductory price of £125 complete with stand.

## Tape gifts



A thousand Scotch High Energy cassettes were given away by 3M at Audio 76 in Harrogate. Scotch cassette girls toured the show distributing lucky number cards, the recipients of which were invited to the 3M exhibition room where those with the lucky numbers received a free Scotch High Energy cassette — 3M's new small-particle "super ferric" product that is compatible with all cassette machines and yet can show an improvement of up to 9dB in performance over some standard ferric tapes it is claimed.

## Death of radio pioneer

It was with great sadness that The Marconi Company recently announced the death of Mr. E. Green M.Sc, M.IEE, at the age of 86. Mr. Green was one of the pioneers of transmitter engineering, responsible for many developments in this field.

From 1919-1929 he assisted C. S. Franklin in the development of the Marconi Short Wave Beam System, which led to the establishment of the Imperial Wireless Scheme. Under his supervision the world's first 100kW Short Wave Broadcast sound transmitter was developed for the BBC.

In the field of television, Mr. Green was responsible for the design of the high-definition vision transmitter installed at Alexandra Palace in 1935.

He had more than fifty patents to his credit and was author of numerous technical articles.

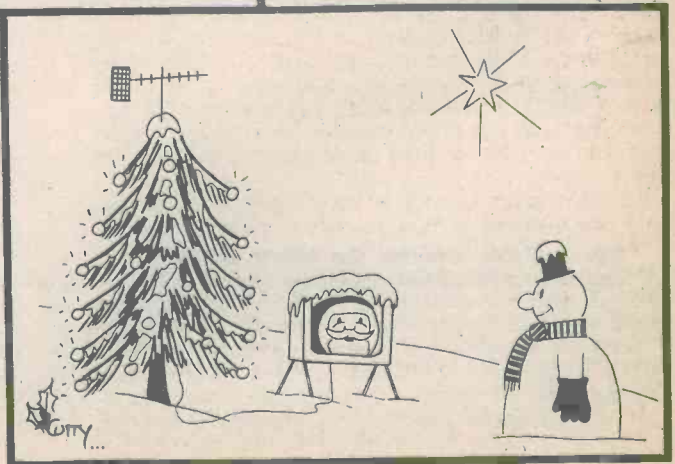

# OCTAL AND BINARY

by

D. Sheffield

One of the first numbering systems encountered when starting work with digital logic is binary notation. This is normally followed by the octal numbering system.

Binary is easy to understand because all that has to be remembered is that it has no digit higher than 1. If we add 1 to binary 1 we get binary 10. With octal there is no digit higher than 7. Adding 1 to octal 7 gives us octal 10.

These relationships fit readily into place when we remember that in our familiar decimal notation there is no digit higher than 9. When we add 1 to decimal 9 we get decimal 10.

A table giving binary and octal equivalents of decimal numbers up to decimal 16 is given in Fig. 1.

## CONVERTING NUMBERS

Converting binary or octal to decimal is not difficult, but can be rather time-consuming. However, the newcomer to binary and octal can be encouraged by the fact that converting binary to octal, and vice versa, is delightfully easy. Fig. 2(a) shows the binary number 10111001. To convert this to octal, first space out the binary digits in groups of three starting from the right, as illustrated in Fig. 2(b). When necessary,

The conversion of binary to octal, or octal to binary, is a very simple process.

add a 0 or 0's at the extreme left to complete the left hand group of three. Then, as in Fig. 2(c), write down the octal (or decimal) equivalent of each group of three binary digits. The resulting number, shown in Fig. 2(d), is the octal equivalent of the binary number.

The reason for this ease of conversion can be inferred by examining the table of Fig. 1. Here, the first seven binary numbers have three digits or less. On proceeding to the eighth number, the binary numbers hop from the three digit 111 to the four digit 1000, and the octal numbers hop from the single digit 7 to the two digit 10. The binary numbers lower down in the table can then be converted to octal by the process shown in Fig. 2. Binary 1001 is the same as octal 11, binary 1010 is the same as octal 12, and so on. If the table progressed to seven digit binary numbers, the hop from six to seven digits in binary would be accompanied by a hop from two to three digits in octal.

## BINARY POINT

The decimal point becomes a binary point with binary notation and an octal point with octal notation. The same method of conversion is employed

Fig. 1. Table showing the binary and octal equivalents for decimal numbers from 1 to 16

DECIMAL	BINARY	OCTAL
1	1	1
2	10	2
3	11	3
4	100	4
5	101	5
6	110	6
7	111	7
8	1000	10
9	1001	11
10	1010	12
11	1011	13
12	1100	14
13	1101	15
14	1110	16
15	1111	17
16	10000	20

- Fig. 2(a). A binary number which is to be converted to octal  
 (b). The binary number is split into groups of three digits  
 (c). The groups are converted to octal digits  
 (d). The final answer in octal

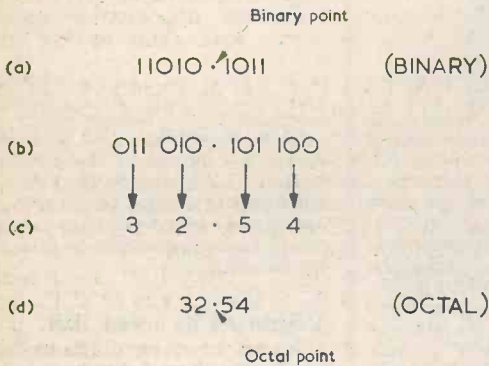
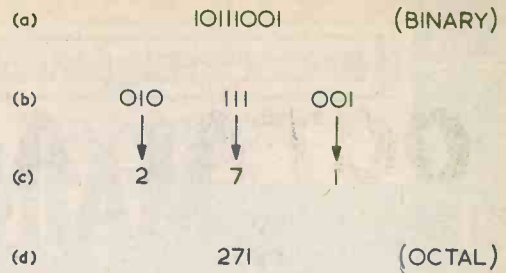

- Fig. 3(a). This time the original number has a binary point  
 (b). The number is once more broken up into three digit groups  
 (c). Again, the octal equivalents are taken  
 (d). The octal number, with octal point, is then given

- Fig. 4(a). An octal number for conversion  
 (b). The equivalent for each octal digit is written in groups of three binary digits  
 (c). The binary number finally obtained

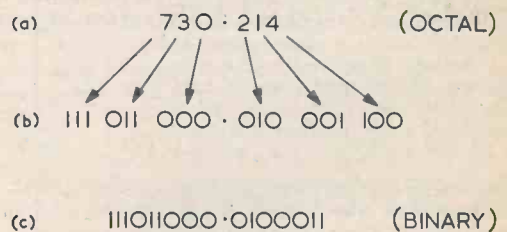

with binary expressions which include the binary point, as is illustrated in Fig. 3. First, break up the binary number into groups of three digits to the left and right of the binary point. If necessary, add a 0 or 0's at the ends to complete the outside groups. Then write down the octal equivalents of each group. The result is the octal version, complete with octal point, of the binary number.

The reverse process is carried out when converting octal into binary. Fig 4 shows the procedure. Each octal digit is converted into a group of three binary digits, and the outcome is the binary equivalent. If required, a 0 or 0's is inserted in each group to make it up to three digits. Any 0's appearing at the extreme ends of the binary number can be discarded.

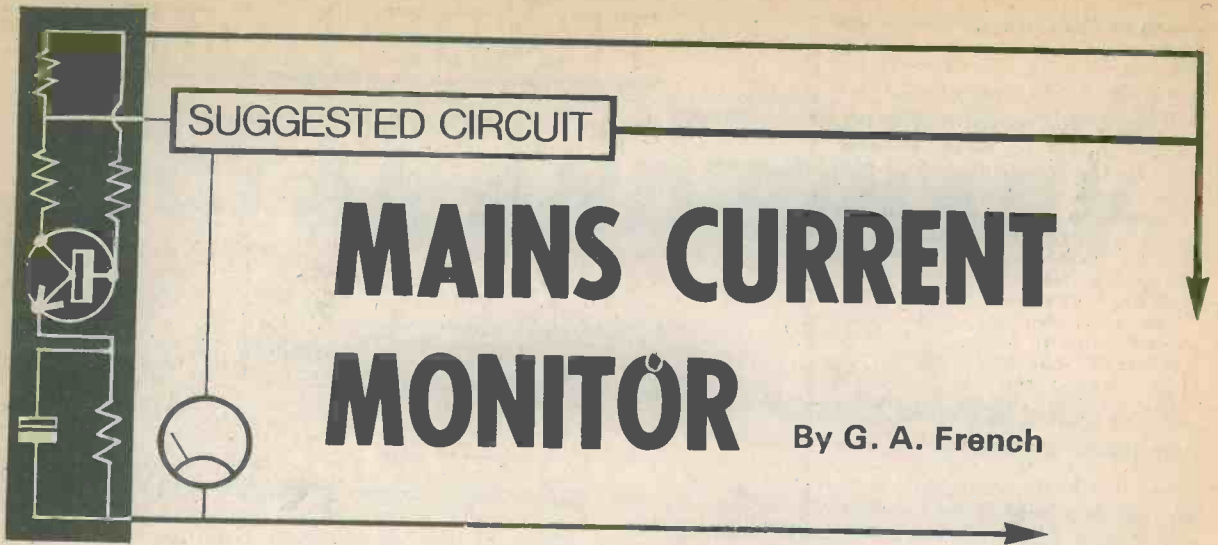

Many experimenters and service engineers have quite a wide array of mains operated test equipment on their benches and it is quite possible, after an intensive session of work, to accidentally leave at least one item switched on after finishing. The mains current monitor described in this article is intended to cater for this situation; it is inserted in the mains supply to the work bench and it causes an l.e.d. to light up when even a very small mains current is being drawn. The l.e.d. will only extinguish when all items drawing current from the mains have been switched off.

end of the 6.3 volt transformer secondary is negative as well, and no current flows through D1. At the same time the base of TR1 is taken slightly negative of its emitter by way of R3, and the transistor is non-conductive. All that happens is that the load current passes through D4.

On half-cycles when the live input is positive so also is the upper end of the transformer secondary, and D1 is able to conduct. The mains current flows through D2 and D3, with the anode of D3 becoming approximately 1.3 volts positive of the emitter of TR1. Base

current flows via R3, TR1 is turned on and the l.e.d. lights up, l.e.d. current being limited by resistor R1.

Thus, as soon as a load is connected across the output of the circuit the l.e.d. is illuminated on the half-cycles when the live input is positive. Persistence of vision in the eye then gives the impression that the l.e.d. is glowing continuously.

### COMPONENT VALUES

Mains transformer T1 is a small heater transformer having a 6.3 volt

### MONITOR CIRCUIT

The circuit of the monitor appears in the accompanying diagram. The primary of the transformer T1 is connected permanently across the mains supply and its secondary offers an r.m.s. voltage of 6.3 volts. The windings are phased such that, on half-cycles which cause the upper end of the primary to go positive the upper end of the secondary goes positive also.

The mains current to the supplied equipment on the bench passes through diodes D2 and D3 on half-cycles when the live mains input is positive, and through D4 on half-cycles when the live mains input is negative. These three diodes are all silicon rectifiers, and cause a voltage drop of about 1.3 volts when D2 and D3 conduct and a voltage drop of about 0.65 volt when D4 conducts. These low voltage drops will have no effect on normal mains equipment.

Let us assume next that a load is connected across the output of the circuit at the right, causing current to pass through D2 to D4. On half-cycles when the live input is negative the circuit does not operate. The upper

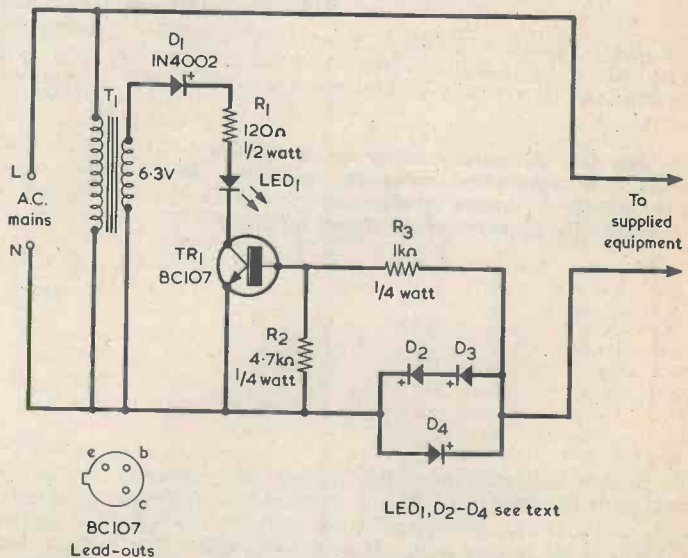

*The circuit of the mains monitor. This is extremely sensitive, and the l.e.d. glows for mains currents which are lower than 1mA*

secondary. Most transformers of this type have a secondary current rating of 0.5 amp or more, which is well in excess of the current requirements in the circuit.

Rectifiers D2, D3 and D4 require a forward current rating which is adequate for the mains driven equipment to be supplied. Rectifiers rated at 3 amps will, for instance, be adequate for loads up to 720 watts. They can have low inverse voltage ratings since the reverse voltages applied across them are very small.

The i.e.d. requires a maximum forward current rating of at least 60mA and that employed by the author was a red i.e.d. Type 4, available from Doram Electronics, which is rated at 80mA. The maximum current flows in the i.e.d. when the voltage at the upper end of the transformer secondary is at its positive peak value of 6.3 multiplied by 1.414, or 8.9 volts. Assuming a total voltage drop of 2.5 volts in D1, the i.e.d. and TR1, the remaining 6.4 volts appears across R1. The consequent current is then 53mA. This current only flows, of course, at one instant in the a.c. cycle, and the intensity of illumination in the i.e.d. is about the same as would be given if a direct current of around 17mA flowed through it.

The circuit is very sensitive and, indeed, R2 is connected between the base and emitter of TR1 to keep the sensitivity at a reasonable level. In the author's circuit the i.e.d. lit up when a load of  $1M\Omega$  was connected across the output points, and gave a glow which was just discernible with a load of  $2M\Omega$ . A load of  $1M\Omega$  corresponds to a current of 0.24mA, and so the circuit is capable of detecting insulation leakage in the bench wiring and mains connectors. The sensitivity will vary somewhat in different units made up to the circuit, because of gain spread in TR1, but it should still be of the same order as that obtained with the prototype.

As has already been mentioned, the mains transformer primary is connected permanently across the mains supply, and it will draw a negligibly low current. If, as is probable, the phase relationship between the transformer primary and secondary is not known it will be necessary to find the correct method of connection experimentally. The circuit should be initially checked out with a load connected, after which the mains should be turned off, the connections to the secondary transposed and the circuit checked again. The incorrect method of connection is that in which either the i.e.d. does not light up or it glows at very reduced brilliance.

The circuit should be assembled in a completely enclosed box with only the i.e.d. visible, and all precautions against accidental shock must be observed. If a metal case is employed this must be reliably connected to the mains earth. ■

# TRADE NOTE

## New compact satellite navigator



*The MX 1102, a new precise positioning satellite navigator, introduced by S. G. Brown*

S. G. Brown of Greycaine Road, Watford, Herts, a Hawker Siddeley company, and principal European agents for Magnavox, announce the introduction of the MX 1102, a new precise positioning satellite navigator.

The MX 1102 is the first satellite navigation system incorporating a microprocessor in place of a separate minicomputer. With its advanced, permanently stored programme, the MX 1102 is easy to use and requires only a few hours training for operation and maintenance.

The receiver, microprocessor and CRT data display are housed in a single unit which is no larger than a portable TV set, and may be chart table, bulkhead or deckhead mounted. The only other item, a small antenna/preamp, is mast mounted in any relatively unobstructed location.

Continuous navigation information is clearly displayed, requiring no special charts or manual computations. Latitude, longitude, and Greenwich Mean Time (GMT), are supplemented by such information as distance travelled, heading to steer, Great Circle and Rhumb Line courses, distance to destination, and time of next (and future) satellite fixes, all of which may be displayed upon operator command. A feature never before offered in shipboard satellite navigation systems is Programmed Tracking. This feature enables the new system to distinguish between different satellites, and to only lock on signals from the satellite offering the best navigation fix. This results in more usable fixes than available from any other equipment. Between fixes, the system automatically dead reckons and compensates for set and drift.

Specifications for Class Nav N certification by Det Norske Veritas have been met in the design and testing of the MX 1102. These include demonstrated accuracy — static accuracy to 0.05 nautical miles (rms), and underway to 0.1 nautical mile (rms) — comprehensive environmental testing, failure mode effects and reliability analysis. In addition, the system selftests every two hours and, in the event of failure, identifies the easily replaced module responsible for the malfunction. With the exception of the microprocessor and mechanical packaging, the MX 1102 utilises circuits proven in service on over 700 ships, ensuring the highest system reliability.

As the result of a decade of satellite systems development, the MX 1102 with its reliability, simplicity of operation and ease of maintenance should prove attractive to shipowners and operators.

# SHORT WAVE NEWS

## FOR DX LISTENERS



By Frank A. Baldwin

Times = GMT

Frequencies = kHz

Short wave listeners on the higher frequencies may find some of the following transmissions of interest to them — and we commence with two clandestine loggings.

“Radio Espana Independiente” on a measured 14479 at 1915, YL and OM alternate in Catalan with news and a talk on Catalan affairs; also heard in parallel on 12140. These pro-communist, anti-Spanish Government programmes are radiated from Bucharest and, possibly, Sofia. The programme logged here is in the schedule 1800 to 2245 on 10110, 12140 and 14485. These are all Bucharest frequencies but they are, as you may have already noted from the above, subject to variation (10kHz in the present case). Most broadcasts are in Spanish but Galician is included on Wednesdays, Basque on Fridays and irregularly in Catalan.

“Voice of the Communist Party of Turkey” on 6200 at 0810 when opening with a choral version of the Turkish party anthem, repeated identification by OM in Turkish, then anti-Turkish Government propaganda. Closes at 0840 with a choral version of the “Internationale”. At the time of writing this programme is radiated on Sundays and Tuesdays only.

“Radio Andorra” on 6230 at 0800, identification by OM then a programme of U.K. pop records.

Jerusalem on a measured 15512 at 1910, YL in Hebrew in a relay of the Domestic 2nd Service to Europe and the Middle East, the schedule being from 0600 to 1800 and from 1830 to 2000 on this channel.

### CURRENT SCHEDULES

Whilst the schedules published here are correct at the time of writing, readers are reminded that some of them are subject to alteration at short notice, either with respect to frequencies, times, or both.

#### ● VATICAN CITY

“Vatican Radio” has an External Service in which English transmissions are directed to the U.K. and Eire from 1445 to 1500 on 6190, 7250, 9645 and on 11740; from 2030 to 2045 on the first three channels mentioned above.

#### ● INDIA

“All India Radio”, Delhi, in the Domestic Service, presents a series of five minute news bulletins in English at various times throughout the day. Two popular times for listeners here in the U.K. would probably be as follows — from 1430 to 1435 on 3255, 3925, 4860, 6015, 7125, 7195, 9645, 9950, 10335 and 11840; from 1530 to 1545 on all the foregoing channels with the addition of 9705.

#### ● IRAN

“Radio Iran”, Tehran, has a Domestic Service First Programme which, of course, operates throughout the day. Listeners here in the U.K. may care to listen on 9022, 9765 or on 15085 from 2030 to 2100 when a newscast in Farsi (Persian) is radiated.

#### ● ALGERIA

“Radio Algiers” operates an External Service in English from 1900 to 2000 on 7245 (also announced on 9610 and 15420 but not heard by the writer on these channels despite many attempts). According to the BBC Monitoring Service, the following transmissions are also made from Algiers — from 1800 to 1900 in Arabic, “Voice of Palestine, Voice of the Palestine Revolution,” presented by the Palestine Liberation Organisation on 6145, 6160, 7195, 7245, 9685, 11810, 15160 and on 17825. From 2100 to 2200 in Arabic/Spanish and/or French or vernaculars, “Voice of the Free Sahara” presented by the Polisario Front, the Popular Front for the Liberation of the Sahara and Rio de Oro. From 2200 to 2300 in Spanish, “Voice of the Free Canary Islands” presented by the Movement for the Self-determination and Independence of the Canaries Archipelago.

### AROUND THE DIAL

#### ● ZAMBIA

Lusaka on 4911 at 1755, OM in vernacular then station identification and a newscast in English at 1800. This is the Home Service which operates in both English and vernaculars from 1400 to 2105 weekdays (2nd transmission period) and from 1400 to 2005 on Sundays, the power being 50kW.

#### ● SAUDI ARABIA

Riyadh on 15245 at 1845, chants from the Quran in a transmission from the “Holy Quran Station” to North and Central Africa, the schedule of this programme being from 1700 to 2000 daily.

#### ● U.S.S.R.

Baku on 4785 at 0203, music in the local style, OM in dialect. This is the Baku Relay in Azerbaijan S.S.R. which relays Baku 1 from 0157 to 2200 in Azerbaijani/Armenian, this transmission period also including a relay of Moscow 1 from 2100 to 2200. Baku is a port of the Caspian Sea and is noted for its oil wells. The power is 50kW and the relay may also be heard in parallel on 9840.

Yerevan on 4990 at 2036, YL in Armenian in a



programme directed to the Near and Middle East, the schedule of which is from 1900 to 2100. The full schedule of this Armenian S.S.R. transmitter is as follows — from 1300 to 1630 and 1730 to 2200 with the Foreign Service, from 2200 to 0100 relaying the Moscow 2 programme, from 0200 to 1300 with the Home Service 1.

#### ● CHAD

Radio Ndjamana on 4904.5 at 0426, interval signal on a Balafon (native musical instrument) until identification and a newscast in French at 0430. This is a transmission in the Home Service which has a schedule from 0430 to 0630 and from 1740 to 2200 (Saturdays 2300) and the power is 100kW, making it quite the easiest African to receive on the 60 metre band. Which reminds me, why do some short wave listener journals published in the U.K. consistently print metre as meter — the latter being the spelling used in the U.S.A.? Perhaps tonite my S-Metre will liven-up on 60 meters. Oh dear!

#### ● NORTH YEMEN

Sana'a on a measured 4853 at 1752, OM in Arabic with a programme for the local police force. This transmission is in the Domestic Service which is also radiated on the parallel channels of 7235 and on 9780. The schedule is from 0300 to 0700 (on Fridays to 1000 approx.), from 1100 to 2015 on 4853, 7235 and 9780 (the 4853 channel signs off at 0700 except on Fridays). From 2015 to 2200 sign-off on 7235 and on 9780. Sana'a is the capital city of North Yemen, it is walled and is 7,270ft above sea-level.

#### ● TANZANIA

Dar-es-Salaam on 5050 at 1848, when radiating a programme of local orchestral music with announcements in Swahili. This transmitter operates the Commercial Service in Swahili and the schedule is from 0300 to 0500 and from 1400 to 2015, the power being 10kW. Dar-es-Salaam is the seaport capital of Tanzania, situated on the shores of the Indian Ocean, the main activity is that of oil refining.

#### ● CENTRAL AFRICAN REPUBLIC

Bangui on a measured 5038 at 1852, local pops on records, announcements in French. Schedule is from 0430 to 0730 and from 1630 to 2300, the power is 100kW. -Bangui is on the banks of the river Ubangi near the border with Zaire (formerly Republic of the Congo).

#### ● MALAWI

Blantyre on 3380 at 1828, OM and YL alternate with a local newscast in English. Schedule is from 0257 to 0520 and from 1750 to 2215 (from April to September the first period extends to 1100 and the latter commences at 1300); the power is 100kW. Blantyre is in the Shire Highlands and is the capital city of Malawi. Being linked to Beira (Mozambique) by rail, Blantyre is the commercial centre of the country, tobacco is one of the main exports.

#### ● PAKISTAN

Islamabad on a measured 4737.5 at 0118, YL with a mournful song in vernacular, no accompaniment — all very sorrowful! This is Islamabad relaying PBC Rawalpindi Home Service from 1300 to 1810 from November to February according to the published schedule — obviously now very much amended. Islamabad is the capital of Pakistan and lies below the Himalayas, just to the north of Rawalpindi, it boasts a nuclear power station.

#### ● CHINA

Radio Peking on 4460 at 2014, YL with a talk in Standard Chinese in a programme of the 1st Domestic Service. The schedule is from 2000 to 2335 and is also in parallel on 7935.

Radio Peking on 4500 at 2025, OM in Russian to the U.S.S.R., jammed by a relay of Moscow 1. Schedule is from 2000 to 2055.

Radio Peking on 4800 at 2050, YL with songs in Chinese in the 1st Domestic Service, schedule from 2000 to 0100.

Radio Peking on 9020 at 2118, orchestra and chorus with local music and songs in the 2nd Domestic Programme, schedule from 2100 to 1600.

Radio Beijing on 3920 at 2008, YL with a talk in Chinese in the 1st Domestic Programme, schedule from 1100 to 1735 and from 2000 to 0100.

PLA Fuzhou on 3900 at 1820, programme of Chinese orchestral music. This is the Fukien Front station with Network II programmes in Amoy scheduled from 1115 to 1900. The programmes are intended for the offshore islands and Taiwan. Be careful however when listening on this frequency, the Radio Peking Foreign Service in Mongolian is relayed by Hailar from 1400 to 1500 as is the Radio Peking Domestic Service in minority languages (in this case Mongolian) from 2230 to 2325.

#### ● AUSTRALIA

ABC Brisbane on 4920 at 1907, local and U.K. pop records, OM announcer. The schedule is from 1900 to 1402 (Sundays from 1930) and the power is 10kW. The town of Brisbane is a port and the capital of Queensland, it has a university and extensive docks, main exports being meat, wool, hides and skins. Oil refining is another commercial venture.

#### ● EQUATORIAL GUINEA

Radio Equatorial, Bata, on a measured 4926 at 2050, guitar and drums, OM's in chorus. The schedule of this one is from 0430 to 0630, 1000 to 1600 and from 1700 to 2140, the power is 5kW. Sometimes identifying as "La Voz del Partido", the station has been reported closing as late as 2300 at weekends.

#### ● ALBANIA

Gjirocaster on a measured 5057 at 0436, a programme of typical local music in a relay of the Home Service. The schedule is from 0430 to 1830 and the power is 50kW.

#### ● SWAZILAND

TWR (Trans-World Radio) Mpangela on 3240 at 1829, U.K. pop records programme with announcements in English. This station broadcasts in English and Afrikaans according to the following schedule — 0515 to 0700 (Mondays and Wednesdays from 0445; Thursdays and Sundays from 0500); in local vernaculars from 1700 to 1830 (Sundays from 1800); in English from 1800 to 2100 and the power is 30kW.

#### NOW HEAR THIS

#### ● COLOMBIA

La Voz del Caqueta, Florencia on 5035 at 0445, local music programme, OM with song in Spanish, three long drawn-out chimes followed by a chord on a Hawaiian guitar before and after identification with echo-effect at 0452, followed by announcements with several mentions of Bogota then off after a trumpet fanfare at 0457, without National Anthem. ■

# CONSTANT CURRENT AUDIO AMPLIFIER A quality battery

The output quality of many battery operated audio power amplifiers is not very high, and often the level of distortion is so great that anyone using the amplifier is very much aware of its presence. Some simple output stages have total harmonic distortion levels of up to about 50% at high outputs.

The distortion is due to the simple designs employed in most of these circuits, which are usually kept fairly basic in order to keep their cost low. It is not necessary to tolerate such poor quality though, and it is possible to produce a reasonably simple design that is capable of quite acceptable output quality.

Such an amplifier forms the subject of this article. The amplifier was intended as a simple add-on unit for an f.m. tuner (such as the 'Phase Locked Loop F.M. Tuner' described in this and last month's issues. — Editor) but it will have many other applications. It has an output power of about 300mW r.m.s. at 1kHz into a 15Ω speaker, and the t.h.d. level is no more than a few per cent for output powers up to this level. At higher outputs the signal is clipped, and in consequence distortion rises rapidly. Satisfactory operation can be obtained using any speaker impedance in the range of 8 to 80Ω. The maximum output power will be significantly reduced, however, if a load of more than 25Ω impedance is used. An input level of approximately 30mV r.m.s. is required for full output. The input impedance of the amplifier varies with changes in the setting of the volume control, but is generally in the region of 10kΩ.

A simple top-cut tone control is incorporated in the circuit.

Provided the amplifier is used with a reasonably good speaker the sound quality obtained is very pleasant, and the unit certainly achieves its main design aim.

## CONSTANT CURRENT LOAD

Normally an audio power amplifier relies upon the use of quite large amounts of negative feedback to reduce distortion. Simple battery powered circuits do not always employ much feedback, and can use a configuration like that shown in the skeleton circuit of

This battery operated a.f. amplifier uses a constant current load for the output stage to provide improved quality.

Fig. 1(a). This is really just an ordinary common emitter amplifier driving a complementary emitter follower stage.

There is another method of obtaining a low level of distortion from an amplifier, although this technique is mainly encountered in high quality stereo amplifiers. This second approach consists of using constant current loads in voltage amplifier stages. In the present amplifier the only voltage amplifying stage is the driver, and the general scheme of things is shown in Fig. 1(b).

In this diagram the silicon transistor TRA provides

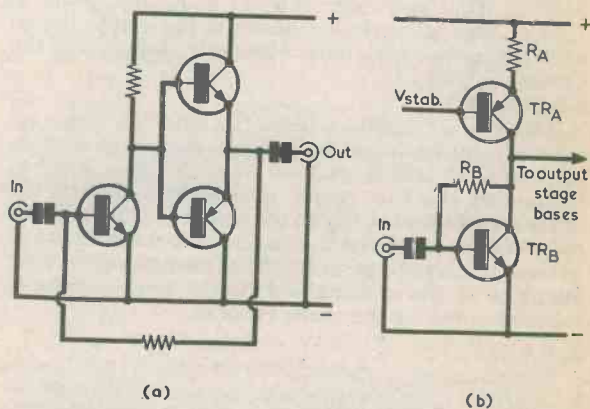

Fig. 1(a). Skeleton audio amplifier circuit representative of a simple driver and output stage

(b). Here, the collector load for the driver transistor is a constant current source

# CURRENT AMPLIFIER Circuit design

Amplifier incorporates a constant current source driver transistor to give improved reproduction.

the constant current. A stabilized voltage of about 1 volt negative of the positive supply rail is applied to its base, whereupon the voltage at its emitter is positive of this by about 0.65 volt. In consequence, what is effectively a stabilized voltage appears across the emitter resistor RA. Since the value of this resistor is constant, the current flowing in it will be constant as well. The emitter and collector currents of a high gain transistor are virtually identical, the only difference being that that the proportionally very small base current flows additionally in the emitter. Thus, the collector current of TRA can also be considered as a constant current, and this current will flow in the collector load if the latter has a sufficiently low impedance.

In Fig. 1(b) the load is the common emitter amplifier, TRB. RB biases this transistor so that its collector voltage is mid-way between the negative rail and the emitter of TRA.

Input signal currents at the base of TRB are amplified and fed to the bases of the output stage transistors. There are consequent voltage excursions at TRB collector but the standing collector current is unaffected by these, whereas the standing collector current of the driver transistor in Fig. 1(a) varies with voltage since the collector load is a fixed resistor.

The fact that TRB operates with a constant current source as load allows its hfe figure to remain unaltered. The hfe of a transistor varies with collector current and, in Fig. 1(a), the fixed resistor load causes such changes and hence introduces distortion.

In a practical version of the circuit of Fig. 1(b) there is still a degree of distortion, because no constant current generator is perfect and because the output transistors will themselves introduce some distortion. Nevertheless, amplifiers incorporating a constant current load give appreciably lower levels of distortion than do amplifiers with simple resistive load circuits.

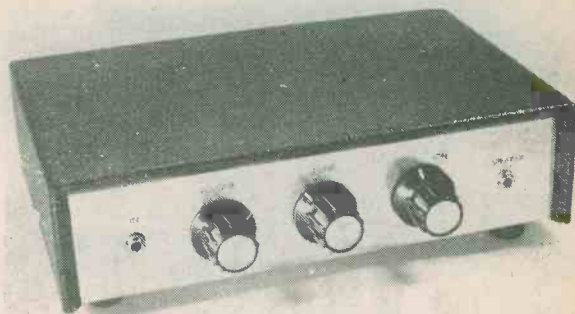

By R. A. Penfold

## COMPONENTS

### Resistors

(All fixed values  $\frac{1}{4}$  watt 5% unless otherwise stated)

- R1 5.6k  $\Omega$
- R2 4.7k  $\Omega$
- R3 10k  $\Omega$
- R4 22k  $\Omega$
- R5 220  $\Omega$
- R6 220  $\Omega$  pre-set potentiometer, 0.1 watt horizontal
- R7 100k  $\Omega$
- R8 2.2  $\Omega$   $\frac{1}{2}$  watt
- R9 2.2  $\Omega$   $\frac{1}{2}$  watt
- VR1 22k  $\Omega$  potentiometer, log
- VR2 1M  $\Omega$  potentiometer, log

### Capacitors

- C1 100 $\mu$ F electrolytic, 10 V. Wkg.
- C2 10 $\mu$ F electrolytic, 10 V. Wkg.
- C3 470 $\mu$ F electrolytic, 10 V. Wkg.
- C4 0.001 $\mu$ F polystyrene

### Semiconductors

- TR1 2N3703
- TR2 2N3703
- TR3 BC109C
- TR4 AC176
- TR5 AC128

### Sockets

- SK1 3.5mm. jack socket (see text)
- SK2 3.5mm. jack socket (see text)

### Switch

- S1 s.p.s.t. rotary (see text)

### Miscellaneous

- Instrument case type BV1 (Bi-Pak)
- Veroboard, 0.15in. matrix
- Veropins, 0.15in.
- 3 control knobs
- 9-volt battery (see text)
- Battery connector
- Nuts, bolts, wire, etc.

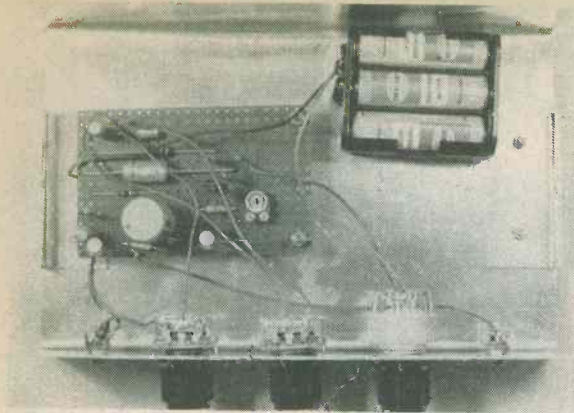

The controls and input and output sockets are mounted on the front panel. All the remaining components are assembled as a Veroboard module

## PRACTICAL CIRCUIT

The complete circuit of the 'Constant Current Audio Amplifier' is shown in Fig. 2. The input signal is applied to the volume control, VR1, and from here it is fed to the base of the driver transistor, TR3, via d.c. blocking capacitor C2. TR2 is the constant current source transistor, and its base is stabilized at about 1.2 volts below the positive supply rail by the circuit incorporating R1, R2, R3 and TR1. TR1 is employed as an amplified diode. It is necessary to have a low voltage here since the greater the voltage across the emitter resistor, R5, the less the maximum peak-to-peak output voltage available from the amplifier.

R6 provides the usual small forward bias to the output transistor bases in order to reduce crossover distortion to an insignificant level. Using a resistor to provide this bias voltage in a circuit with a resistive load can result in quite large variations in the standing current in the output transistors, as the bias voltage tends to change with variations in the battery voltage. This does not occur here because the resistor appears in a constant current circuit, and the voltage dropped across it is therefore stabilized.

TR4 and TR5 are the complementary emitter follower output transistors. Germanium devices are used here as these have lower base-emitter threshold voltages than have silicon types, and they thus provide a greater peak-to-peak output voltage swing. R8 and R9 are current limiting resistors and help to guard against thermal runaway in the output transistors. C3 is the output d.c. blocking capacitor.

R7 and R4 bias the amplifier and also provide negative feedback. If VR2 is adjusted to insert minimum resistance into circuit, C4 is effectively shunted across R7. The reactance of C4 becomes significant at the higher audio frequencies and it reduces as frequency increases. In consequence, C4 causes negative feedback to increase and amplifier gain to reduce at these frequencies, producing a treble cut. C4 has an increasingly reduced effect as VR2 is adjusted to insert more resistance into circuit, and it has no effect at all when VR2 inserts maximum resistance. VR2 thus acts as a simple top-cut tone control.

S1 is a rotary on-off switch, and C1 is the only supply bypass capacitor used in the circuit.

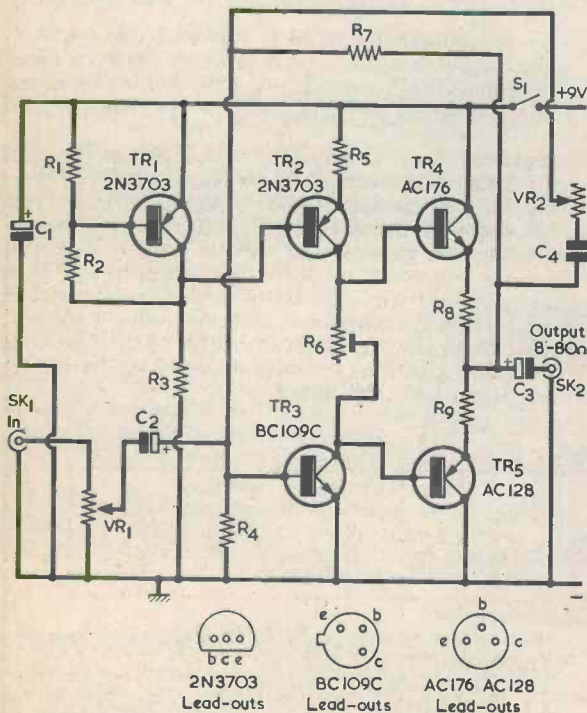
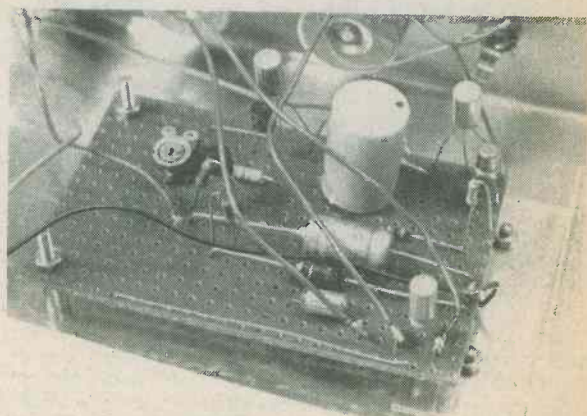

Fig. 2. The circuit of the constant current audio amplifier. TR2 provides the constant current collector load for TR3



The Veroboard panel mounted in position on the bottom of the case

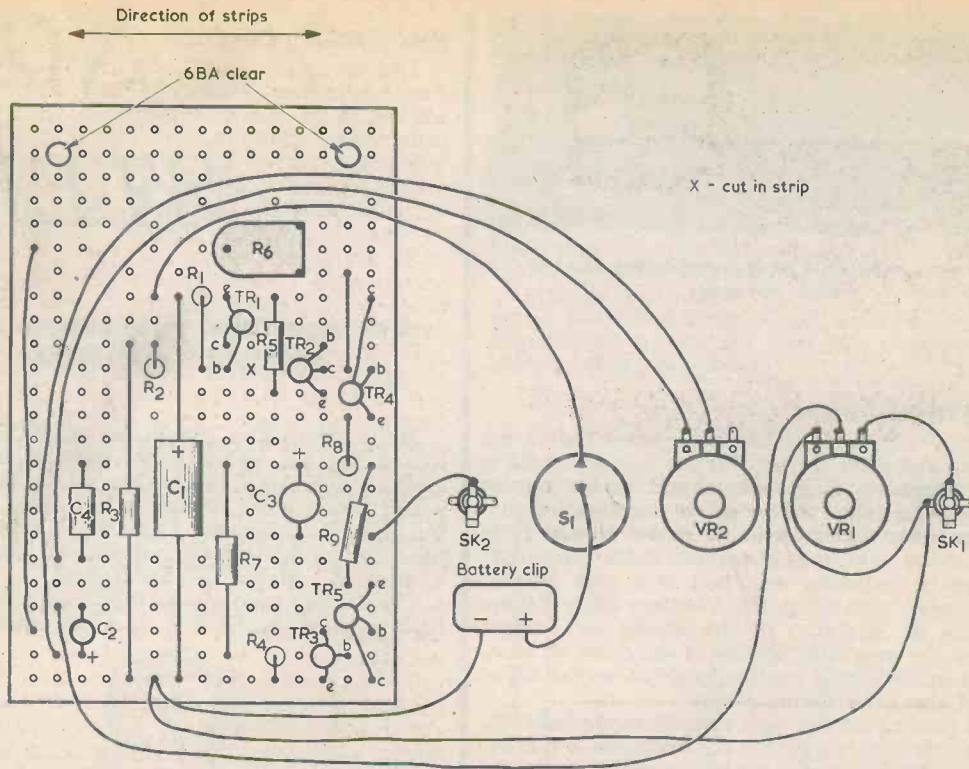

Fig. 3. Component assembly on the Veroboard and the wiring to the front panel controls and sockets

### CONSTRUCTION

Apart from those which are mounted on the front panel, the components are assembled on a piece of Veroboard of 0.15in. matrix having 15 holes by 24 strips. Details of this board are given in Fig. 3.

First cut out the board from a larger piece, then drill out the two 6BA clear mounting holes. A single break in the strips is required and this is made with the aid of a Vero spot face cutter or a small twist drill.

The components and link wires are then fitted and soldered into circuit. 0.15in. Veropins are employed at the points where external connections are made to the board. R6 is a miniature pre-set potentiometer having 0.2in. spacing between track tags, and 0.4in. spacing between the slider tag and the track tags. These tags will need to be spread out slightly to fit into the holes in the board.

The amplifier is housed in a case type BV1, available from Bi-Pak. This measures approximately 8 by 5½ by 2in. (203 by 133 by 51mm.) and the drilling required in its front panel is shown in Fig. 4. As may be seen from the photograph of the case interior, the component board is mounted inside the case to the left, as seen from the front. The two 6BA mounting screws are near the centre of the case, and ½in. spacers are fitted to ensure that the underside of the Veroboard is well clear of the case bottom.

The front panel components are next fitted. SK1 and SK2 are jack sockets of open construction, giving an automatic chassis connection to the sleeve contact by way of their mounting bushes. S1 can be any 2-way rotary switch. The author used a multi-pole switch

with no connections made to the unused poles.

Wiring between the Veroboard and the front panel components is now completed. Thin flexible insulated wire is employed and there is no need to use screened leads anywhere.

There is plenty of space for the battery on the right hand side of the case, and in the interests of good economy it is advisable to use a high capacity type. The author employed six HP7 cells in series, these being contained in a plastic battery holder. However, any fairly large 9 volt battery, such as the PP6 or PP7, can be used. The battery may be secured in place with a simple clamp. Alternatively, a piece of plastic foam may be glued to the lid of the case over the battery position, and this will hold the battery in place when the lid is fitted.

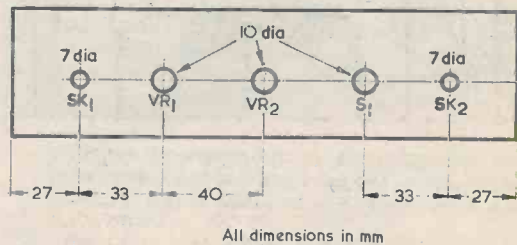

All dimensions in mm

Fig. 4. Drilling details for the front panel of the amplifier

# NOVEL STEREO

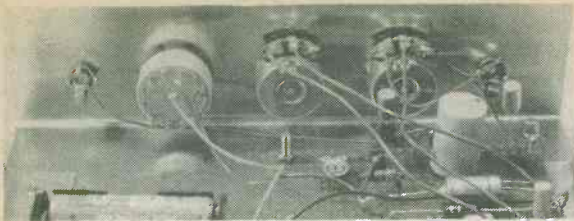

This view shows the front panel wiring as seen from the rear

## ADJUSTMENT

The only adjustment that is required before the completed amplifier is ready for use is to set up R6 to give the requisite quiescent current in the output transistors. Initially, R6 is set to insert minimum resistance into circuit, with its slider turned fully anti-clockwise. No input is applied to the amplifier.

Connect a testmeter switched to a high current range in series with the positive battery lead. If there have been no mistakes in the wiring the current drawn by the amplifier will be of the order of 3mA. Should a much higher reading be given, switch off at once and check for wiring errors.

If the reading on the high current range indicates that it is safe to do so, switch the testmeter to a lower current range which will enable currents of around 10mA to be measured.

The quiescent current required in the output transistors is about 4mA. R6 is next slowly adjusted to insert increasing resistance into circuit until the meter gives an indication which is 4mA greater than the initial reading. Thus, if the first reading was 3mA, R6 is adjusted for a current of 7mA. Avoid setting R6 for current readings above this level as this will result in a shortened battery life. There could even be a risk of thermal runaway in the output transistors if the potentiometer were grossly over-adjusted.

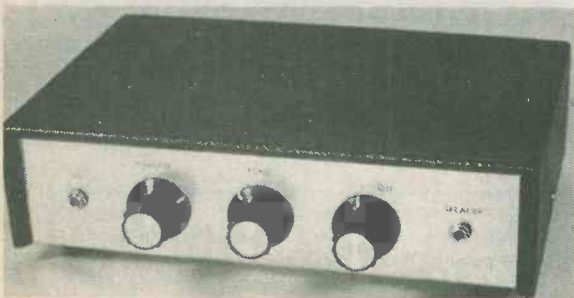

An alternative view of the completed amplifier, emphasising the neat appearance imparted by the instrument case in which it is assembled

After R6 has been set up the testmeter is removed and the normal battery connections completed. The amplifier is then ready for use.

## An ingenious application for a 7-segment I.e.d. display.

Many stereo f.m. tuners use an MC1310P phase locked loop i.c. as the stereo decoder, with a light-emitting diode as the stereo beacon. It occurred to the writer that a more striking effect could be obtained by using a 7-segment I.e.d. display as the stereo beacon. The figure 5 when displayed looks more like a letter "S", giving "S" for Stereo!

The display used was an 0.3in. red common anode type, such as the DL707, SLA7 or equivalent.

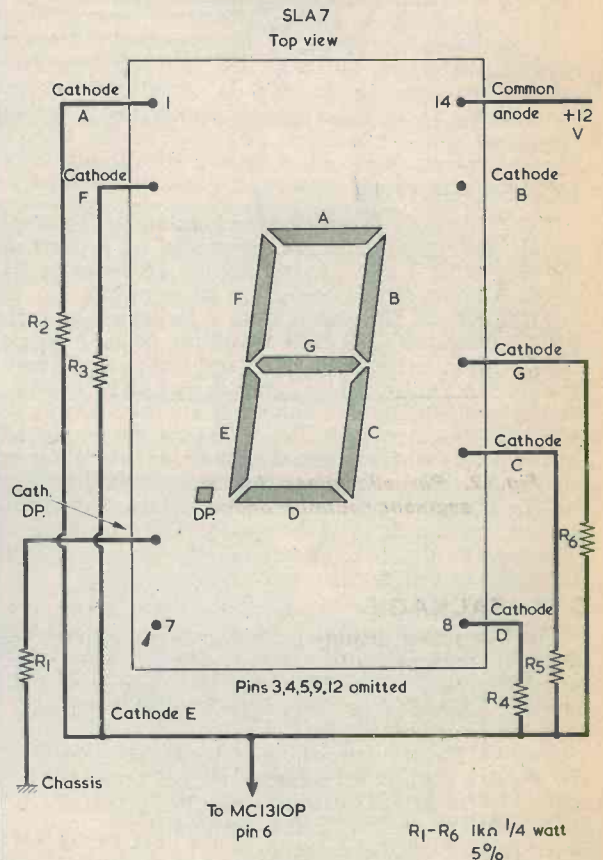

Fig. 1. Connecting up the 7-segment display to function as a stereo beacon

# L.E.D. BEACON

By R. N. Soar

proximately 10mA to flow in each segment and this is sufficient to give a bright display. For a 9 volt supply the resistor values may be reduced to 680  $\Omega$ . Incidentally, the maximum stereo beacon current rating for the MC1310P is 75mA.

If the display is a TIL302 or equivalent it is necessary to connect pins 3 and 9 to the positive supply in addition to pin 14. This is because the TIL302 has three common anodes. For the record, Fig. 2 shows the pin connections for a TIL303, which has the decimal point on the right.

In the author's tuner a rectangular hole was filed out in the metal front panel, and the display was glued in place with the pins and connecting wires hidden behind the panel.

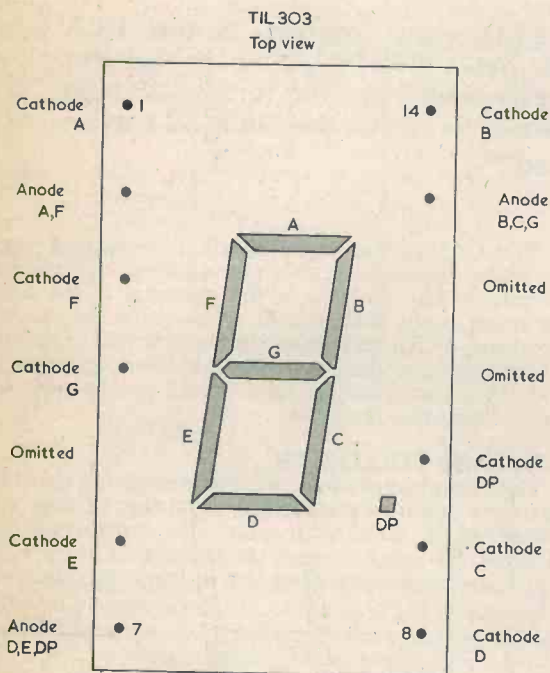

Fig. 2. Pin allocations for the TIL303 7-segment common anode display

## D.I.L. PACKAGE

The 7-segment display is housed in a modified 14 pin d.i.l. package with unused pins omitted. The remaining pins are numbered to correspond with a normal 14 pin d.i.l. package. Fig. 1 shows a top view with the pins underneath.

Pin 14 is for the common anode and is connected to the positive supply. Pins 1, 2, 8, 10 and 11 are taken to pin 6 of the MC1310P via current limiting resistors R2 to R6. The decimal point, pin 6 of the display, is taken to chassis, the negative rail, by way of R1.

When the tuner is switched on and is receiving a mono signal the decimal point is illuminated. When a stereo signal is being received the "S" display lights up. The series resistors allow a current of ap-

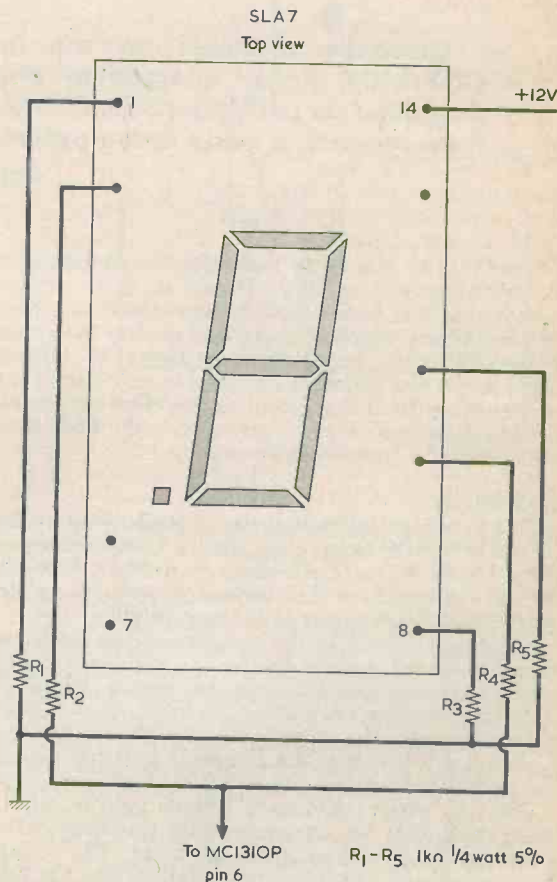

Fig. 3. An alternative method of presentation. Three horizontal bars indicate that the tuner is switched on, these changing to the letter "S" when receiving a stereo signal

An alternative method of presentation could consist of having segments A, G and D light up when the tuner is switched on and receiving a mono signal. Segments F and C are coupled to pin 6 of the MC1310P, as in Fig. 3. No connection is made to the decimal point. Three horizontal bars are then given for a mono signal, these changing into the letter "S" when a stereo signal is tuned in. ■

# The CA3130

## COS/MOS OP-AMP

By J. B. Dance

Currently available on the home-constructor market is the RCA COS/MOS linear operational amplifier type CA3130. Our contributor describes its performance and then gives working circuits for two voltage followers and a wide range pulse generator in which the CA3130 can be employed.

The CA3130 is a fairly new operational amplifier i.c. manufactured by RCA. One of its main advantages is that it is one of the few high impedance, high gain amplifiers which is cheap and readily available. It has an input impedance of about  $1\frac{1}{2}$  million megohms; if one connects its input to any circuit the current taken from that circuit is therefore very small indeed. A typical input current is only 5pA (five millionths of a microamp).

### COS/MOS

This very high input impedance is obtained by the use of COS/MOS techniques; that is, Complementary Metal Oxide Silicon field-effect transistors. One can connect the inputs of this device into almost any circuit without loading the latter appreciably.

Although COS/MOS devices are used in the input stage the second stage of the i.c. is a high gain circuit employing conventional bipolar transistors. However, COS/MOS devices are used in the third, output, stage and these enable the output voltage of the i.c. to swing to within a few mV of the potential of either supply line if the load impedance is fairly high.

The first stage provides a voltage gain of only 5 times, and acts as an impedance transformer by providing an output of low impedance. The second stage provides a voltage gain of 6,000, whilst the output stage gives a typical gain of about 30 times. Thus, the total gain is well over 100dB.

### CONNECTIONS

The CA3130 is available only in circular metal packages with eight leads, the connections being as shown in Fig. 1. The package is similar to a TO-5 type transistor encapsulation. The CA3130T has straight leads, whilst the CA3130S has its leads formed into a dual-in-line pattern so that it can fit into an 8-pin dual-in-line socket. More expensive types are available which have the suffix 'A' or 'B' in their type number. These have more closely controlled input circuit specifications, but the normal CA3130T is suitable for most purposes.

The CA3130 has the normal inverting and non-inverting connections of a conventional operational amplifier. Any increase in the potential of the non-inverting input produces an increase in the output potential, whilst an increase in the potential of the inverting input produces a decrease in the output potential. Thus the inverting input is used for the application of negative feedback.

### VOLTAGE FOLLOWER

High input impedance devices such as the CA3130 are very useful as voltage followers; that is, they are employed in circuits in which the output voltage 'follows' the input voltage, the impedance at the output being much lower than that at the input. One can

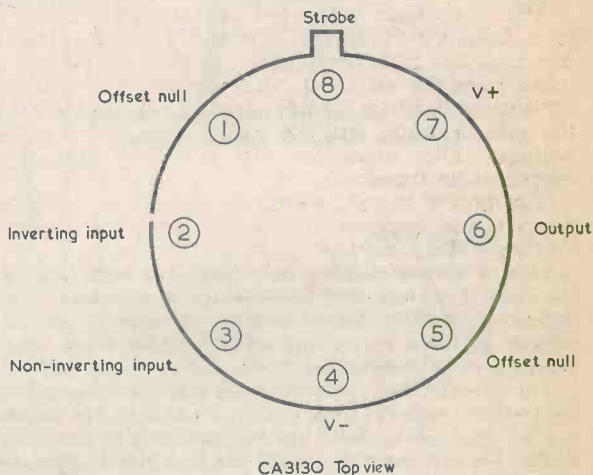

Fig. 1. Pin connections for the CA3130



therefore measure the voltage at the input by connecting the output to a voltmeter or other circuit which requires an appreciable current. The CA3130 output can supply or accept a current of up to 20mA, this being enormously greater than the input current required by the device.

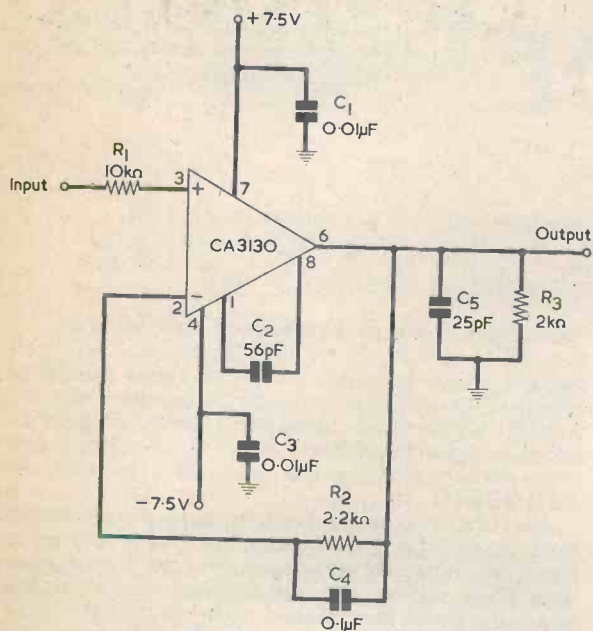

Fig. 2. A voltage follower circuit incorporating the CA3130

A typical voltage follower circuit is shown in Fig. 2. The non-inverting input of the CA3130 is connected via a protective 10kΩ resistor to the source of voltage. A 56pF capacitor connected between pins 1 and 8 gives frequency compensation and prevents possible instability at high frequencies. Negative feedback is taken from the output at pin 6 through R2 to the inverting input. Since the full output voltage is fed back the gain is unity, and the output follows the input voltage. The capacitor C4 prevents excessive overshoot on transients.

The power supply shown in Fig. 2 is 7.5 volts positive and negative of ground, this being slightly less than the maximum permissible voltage for the device of 8 volts positive and negative. Although the device will operate with positive and negative supplies as low as 2.5 volts, the use of a supply voltage near the maximum enables a fairly wide range of input voltages to be catered for. If the output is not delivering a current, the power supply current required is typically 10mA when the output is near ground potential or 2mA when the output is near the potential of either supply line. C1 and C3 are included to prevent possible instability.

In the circuit shown, the input may be connected to any voltage to be measured which has a value between the two supply line potentials. A voltmeter connected between the output of the device and ground will then read the input voltage.

## SINGLE SUPPLY

A somewhat similar circuit is shown in Fig. 3, in which a single supply line is used instead of the split positive and negative supply lines of Fig. 2. The potentiometer VR1 connected between pins 1 and 5 enables the offset voltage to be adjusted. Setting up VR1 enables the output voltage to be made equal to the input voltage. The maximum permissible supply voltage is 16 volts and the input voltage should be kept between zero volts and the positive supply voltage.

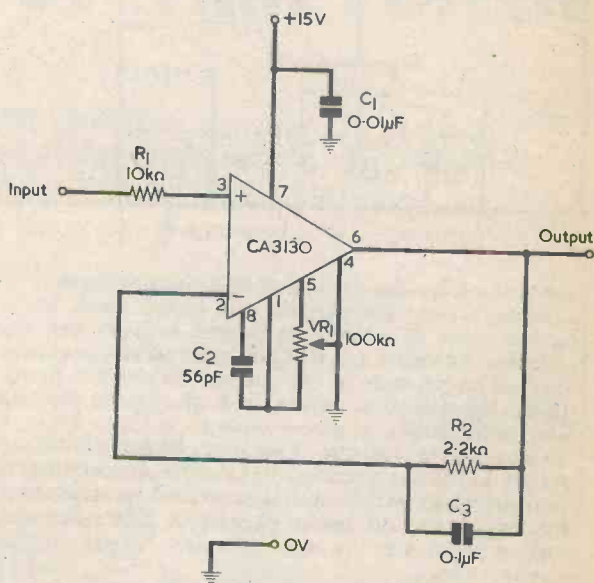

Fig. 3. Another voltage follower with a single supply rail

## PULSE GENERATOR

The exceptionally high input resistance of the CA3130 is an attractive feature for pulse generator circuit design because it permits the use of high values of resistors and, therefore, correspondingly low values of capacitors. One cannot use electrolytic capacitors if one requires a stable frequency, so the use of a high input impedance device enables reasonably small capacitors to be employed for generating low frequency outputs.

A CA3130 square wave generator circuit is shown in Fig. 4. Four frequency ranges are provided and are selected by S1. When C2 is switched into circuit the pulses have a duration of 4μS to 1mS according to the settings of VR1 and VR2. The pulse duration with C3 is 40μS to 10mS, with C4 400μS to 100mS and with C5 4mS to 1S.

The times during which the output pulses are in their high and low voltage states (the 'duty cycle') can be independently controlled by VR1 and VR2. At a time when the output voltage is high, the potential at the inverting input will be low and the capacitor selected by S1 will be charging through VR1, R4 and D1, the charging rate being controlled by the setting of VR1.

When the potential at pin 2 rises above that at pin 3, the voltage at the output will suddenly be switched to a low value. The same timing capacitor now discharges through VR2, the rate of discharge being

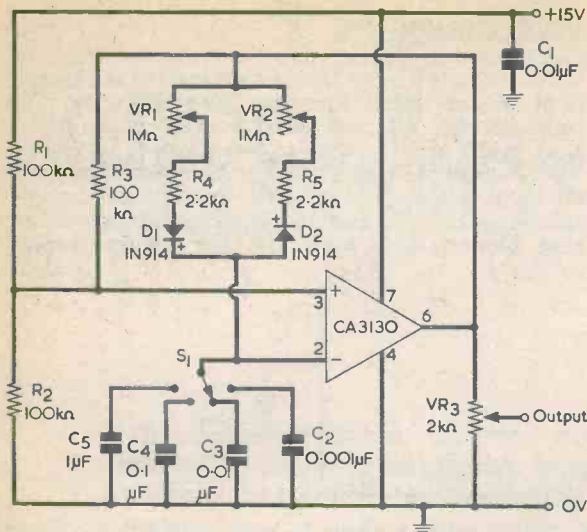

Fig. 4. Wide range pulse generator in which the length of positive and negative pulses can be adjusted independently

determined by the setting of this potentiometer.

After a time the circuit will switch back to its former state in which the output is high and the capacitor selected by S1 will commence to charge again. The polarity of the diodes D1 and D2 determines the direction of the flow of current through VR1 and VR2.

An output attenuator, VR3, may be included if required. It should be noted that the output potential is not centred about ground; a capacitor in series with the output may be used if necessary. The maximum output amplitude is approximately equal to the supply voltage.

### PRECAUTIONS

The very high input impedance of all COS/MOS devices renders them liable to damage by electrical transient pulses. Although the CA3130 is protected by means of internal zener diodes which become conductive when the input voltage exceeds a certain limit, the manufacturers recommend that reasonable precautions should still be taken. In particular, all soldering iron tips used for soldering the CA3130 connections should be earthed.

It is wise not to solder the devices whilst power is

being applied to them. No input signal should be applied unless the power supply is connected, and the possible input current should be limited to 1mA by a suitable series resistor.

### STROBING

Apart from its use for frequency compensation, pin 8 of the CA3130 can also be used for strobing the amplifier. When this pin is connected to the negative supply line at pin 4, the output potential at pin 6 rises to a value which is very close to the positive supply at pin 7. The amplifier remains in this quiescent state for as long as the potential of pin 8 is kept low.

This strobing of the amplifier into the off state can be effected by a mechanical switch or by electronic means. The strobing pulses may be synchronised with changes in the input circuit, such as input switching. Alternatively, the strobing facility may be used as an On-Off facility.

When the CA3130 is strobed into the quiescent state, a condition of almost zero current drain can be attained if the ohmic load resistance presented to the amplifier output is very high, as occurs, for example, when it is used to drive COS/MOS digital circuits in comparator applications.

## Mail Order Protection Scheme

The publishers of this magazine have given to the Director General of Fair Trading an undertaking to refund money sent by readers in response to mail order advertisements placed in this magazine by mail order traders who fail to supply goods or refund money and who have become the subject of liquidation or bankruptcy proceedings. These refunds are made voluntarily and are subject to proof that payment was made to the advertiser for goods ordered through an advertisement in this magazine. The arrangement does not apply to any failure to supply goods advertised in a catalogue or direct mail solicitation.

If a mail order trader fails, readers are advised to lodge a claim with the Advertisement Manager of this magazine within 3 months of the appearance of the advertisement.

For the purpose of this scheme mail order advertising is defined as:

"Direct response advertisements, display or postal bargains where cash has to be sent in advance of goods being delivered."

Classified and catalogue mail order advertising are excluded.

# PHASE LOCKED LOOP F.M. TUNER

Part 2 By R. A. Penfold

In this concluding article, outstanding details of construction are dealt with, after which a description is given of the single setting up operation that is required to bring the tuner into operational order.

The article which appeared in last month's issue described the circuit functioning of this rather unusual f.m. tuner. Also dealt with were the drilling of the receiver chassis and the assembly of the main component board, these being illustrated by Figs. 5 and 6, both of which were published last month. We now carry on to the mounting of the board in the case.

## FITTING THE BOARD

S1, VR1 and sockets SK1 and SK2 are fitted to the chassis as shown in Fig. 5. The main component board is next mounted in the approximate position indicated in that diagram. It is fitted by means of two 1½ in. 6BA bolts with nuts, metal spacers being used to hold the board about 1 in. clear of the bottom of the case.

The board is then wired to the external components by means of ordinary thin flexible p.v.c. covered wire. The lead from the aerial socket centre conductor passes direct to the tap in L1, and does not require coaxial cable. The outer conductor of the aerial socket connects to chassis via its own mounting. The lead from the board to SK2, VR1 and battery negative connects first to the tag of SK2 which, by way of its mounting bush, is common with chassis. The appropriate socket tag may be identified by visual inspection or by means of a continuity tester or ohmmeter. A further lead then travels from this tag to the tag of VR1 which is at the track end corresponding to maximum anti-clockwise rotation of the potentiometer spindle. Also connected to this tag of VR1 are the negative battery lead and, later, the earthy lead from the oscillator board. The connection to the main component board from the oscillator board is made when the latter has been assembled and mounted in position inside the case.

## OSCILLATOR BOARD

The oscillator transistor and its associated components are mounted on another plain perforated panel of 0.1 in. matrix, this having 23 by 17 holes. Details are given in Fig. 7.

This board is cut out and assembled in a similar manner to the main component board. Coil L2 is identical with L1, the only exception being that there is no tap on L2. The positions of the connection points for trimmer TC1 may vary slightly from those shown in Fig. 7 according to the dimensions of the actual

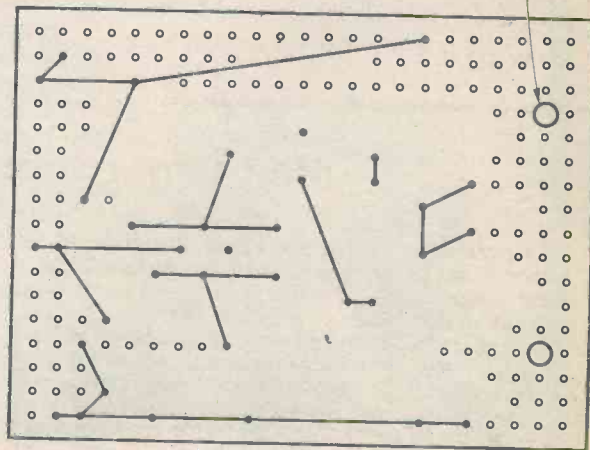
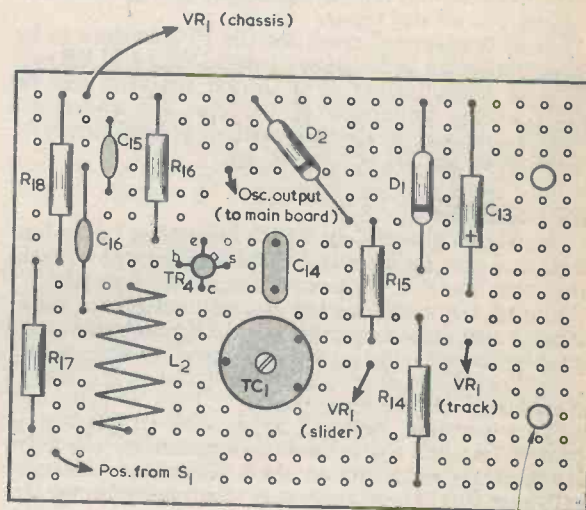

Fig. 7. Two views showing the component layout and the underside wiring on the oscillator board

trimmer employed. When mounted, the board is spaced off from the case bottom in the same way as is the main component board. The approximate positioning of the board is shown in Fig. 5.

The oscillator board obtains its positive supply from the same tag of S1 which supplies the main component board. The positive battery lead then connects to the remaining tag of S1. As a final touch, four rubber feet are secured to the underside of the case near the corners, either with adhesive or by means of nuts and bolts passed through holes already drilled for them.

All the wiring should next be given a thorough visual check. When all is ready, the conductive foam or metal foil may be taken from the pins of the integrated circuit and it is then carefully plugged into the i.c. holder. Ensure that it is fitted right way round. It should be remembered that the i.c. used in the tuner is a COS/MOS device which can be damaged by high static voltages. As a precaution, it can be removed from the holder if any subsequent soldering work is carried out on the tuner.

There is plenty of room for the PP3 battery to be fitted vertically in the space behind SK2 and VR1. A piece of foam rubber or a similar material can be glued to the underside of the case lid above the battery position, so that the battery is held firmly in place when the lid is screwed on.

## ADJUSTMENT

One single adjustment has to be carried out before the lid can be finally fitted. This adjustment consists of setting up TC1 for correct frequency coverage.

During the initial testing and adjustment an aerial of some sort must be connected to SK1 and the output from SK2 applied to an amplifier and speaker or to a crystal earphone or crystal headphones. A few feet of connecting wire terminated in a coaxial plug will make a suitable aerial in areas where reception is good or fair, but a proper outdoor or loft aerial will be required in poor reception areas. When using a simple wire aerial, the positioning of the aerial inside the room will greatly influence results. It will be



*A view showing the front panel components from the rear*

necessary to experiment a little with the placing of the aerial in order to find the position that corresponds to the strongest signal. This point should be kept in mind when the following adjustment is being carried out.

Initially set TC1 well towards minimum capacitance, and then switch the tuner on. The characteristic high level of background noise should be produced by the tuner when it is not tuned to a transmission. Adjusting VR1 should enable a few stations to be heard, but if none can be picked up TC1 should be adjusted for increased capacitance in order to increase the frequency coverage of the tuner. Also, L2 can be slightly stretched out or compressed to shift the tuning range slightly.

TC1 is given a setting that provides coverage of the required stations. Adjusting TC1 for increased capacitance greatly increases the low frequency range, but at the expense of the high frequency coverage. If adjusting TC1 for sufficient tuning range causes stations to be lost at the high frequency end of the band, L2 can be slightly stretched out. This will shift the frequency coverage towards the high frequency end of the band, and bring the lost stations back into the range of the tuner. Do not adjust TC1 for greater coverage than is really needed, as this will only make the tuning unnecessarily sharp.

It will be possible to tune each station twice, once with the oscillator frequency just above the signal frequency, and once with it just below. F.M. stations are well spaced out in terms of frequency and so this does not have any undesirable effects. One simply tunes to whichever tuning position is reached first.

In a normal superhet the r.f. tuned circuit would be used to accept one of these responses and reject the other. This is not feasible here as the very low i.f. brings the responses too close together for the r.f. tuned circuit to reject one and yet still accept the other one. In consequence, a broadband r.f. tuned circuit is used, which considerably simplifies the setting up of the tuner. Theoretically, L1 could be stretched out or compressed to peak the r.f. response at the centre of the tuning range. However, in practice this tuned circuit has a very wide bandwidth, and the inductance of L1 is not at all critical.

As is the case with any f.m. tuner, the stronger the aerial signal the lower the noise level that is obtained. It is therefore important that the aerial be orientated for the best signal, and hence also for the maximum signal to noise ratio. ■

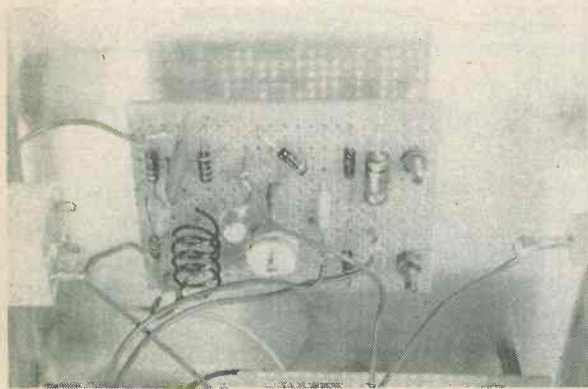

*Illustrating the components mounted on the oscillator board*

**NOEL M. MORRIS**

**SEMICONDUCTOR  
DEVICES**

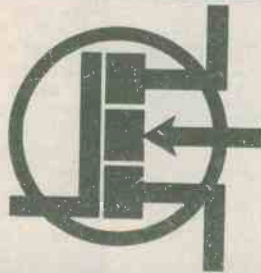

MACMILLAN BASIS BOOKS IN ELECTRONICS

# ANOTHER SPECIAL OFFER

*For a limited period*

By arrangement with Messrs. MacMillan we are able to offer the above book at a special low price to readers of RADIO & ELECTRONICS CONSTRUCTOR.

Normal Price .....£4.35

**SPECIAL OFFER PRICE..... £3.50**

*Saving 85p*

Both prices include postage and packing

In this introduction to semiconductor devices, the author provides a comprehensive survey of modern active and non-active semiconductor technology. Without leaning too heavily on device physics, he explains device functions and then illustrates their use with typical circuits and applications.

Following a summary of the physical basis of semiconductor elements — in non-mathematical terms — a study of bipolar and field-effect transistors leads to considerations of monolithic integrated circuits. More advanced charge-coupled devices, semiconductor memories and optoelectronic devices are studied in some detail.

#### CONTENTS

1. Semiconductors
2. Basic Semiconductor Devices
3. Semiconductor Diodes and the Unijunction Transistor
4. Bipolar Junction Transistors, Amplifiers & Logic Gates
5. Field-Effect Transistors, Amplifiers and Logic Gates
6. Monolithic Integrated Circuits
7. Charge-coupled Devices
8. Semiconductor Memories
9. Thyristors and other Multilayer Devices
10. Optoelectronics

To: Data Publications Ltd., 57 Maida Vale, London W9 1SN  
Please send me within 21 days ..... copy/copies of

**SEMICONDUCTOR DEVICES**

I enclose Postal Order/Cheque for £.....

Name .....

Address .....

(Block Letters Please)

*(We regret this offer is only available to readers in the U.K.)*

# In your work-shop

This month we find Dick and Smithy at a Christmas Eve when, for once, they are not engulfed in an ocean of urgent repairs. Smithy takes advantage of the situation to demonstrate to his assistant the operation of his latest creation, an electronic dice.

"Christmas," grunted Dick. "Huh!"  
The Serviceman's assistant flopped, scowling, on his stool.

"Dear, oh dear," said Smithy from his bench, "what's wrong with you? This is Christmas Eve and you're supposed to be happy. What's upset you now?"

"Everything!"

"Such as?"

"Well, for a start, we're usually dead busy on Christmas Eve. You feel really ready for Christmas when you've cleared out a good bit of work on Christmas Eve."

"We were lucky this year," stated Smithy. "We got everything cleared up nice and early. In fact, there's a good three hours to go before we officially pack in for the day."

"Huh!"

"Dash it all," remonstrated Smithy, "tomorrow's Christmas Day. Aren't you even looking forward to your Christmas dinner?"

"No."

## DINNER AT EFF'S

Smithy sighed and glanced at his assistant's brooding features.

"When you get the blues," he remarked irritably, "everybody else has got to get out and push. Where will you be having your Christmas dinner?"

"That's part of the trouble," replied Dick morosely. "I've got to have it at my Auntie Eff's. Ye gods, I'm dreading it. I bet she'll have her cats walking all over the kitchen table when she's stuffing the turkey."

A gleam came into his eye.  
"She's so short-sighted that one day she might stuff one of the cats instead. Hah!"

"Oh, come on," snorted Smithy. "As it happens, I'd been looking forward to this quiet period just before Christmas to show off my latest electronic gadget to you. But you're so darned grouchy that I don't think you'll even appreciate it."

"Gadget? What gadget?"

"It's a gadget I've been making up in the evening as a little exercise in logic."

"Oh yes?"

It was obvious that Dick was already beginning to forget his qualms about the morrow. Whenever his avid curiosity concerning electronic matters was aroused all other emotions faded into limbo.

"It's an electronic dice," stated Smithy proudly. "When you turn a switch it displays any number from 1 to 6."

Smithy got off his stool, reached inside the cupboard under his bench and produced a small aluminium box. As he placed it on the bench Dick walked over eagerly to examine it.

"Now, let's have a look at this," he remarked keenly. "There don't seem to be many things on the top panel."

"There aren't," said Smithy. "There's just an on-off toggle switch, a two-way rotary switch and a TIL302 seven-segment i.e.d. display. I'll turn on the toggle switch."

Smithy clicked the switch on. At once, all the segments of the i.e.d. display lit up, to indicate the figure 8. There was a slight but just noticeable flicker in the segments.

"Turn that rotary switch to the right," said Smithy.

Dick reached forward and turned the switch. The flickering 8 gave way to a steadily illuminated figure 4. He turned the switch back, to produce the 8 again, then turned it to the right again. This time the display showed the number 2.

"Hey," he chuckled, "you can get hooked on this thing. Let's try it again."

He operated the switch back and forth once more. On this occasion the i.e.d. display extinguished completely.

"What's happened here?" queried Dick. "It's gone out."

"I know," grinned Smithy. "I should have told you that the random generator circuit in this gubbins of mine offers eight options instead of six. Six of the options give the figures 1 to 6 and the other two cause the i.e.d.

segments to extinguish. It's rather the same as you get when you're playing with an ordinary dice and it hops off the table."

"How," asked Dick, switching off the dice, "do you get eight options?"

"By combining the outputs of three 50:50 multivibrators," replied Smithy. "Bring your stool over and make yourself comfortable, and then I'll explain it all to you."

As Dick walked back to his bench, Smithy pulled his note-pad towards him and started to make up a sketch. (Fig. 1).

"Now," said Smithy, pointing to his note-pad after Dick had returned and settled himself on his stool. "Here are the three multivibrators, and I've drawn them in block form. The first multivib has two outputs which I've labelled T and V. When output T is at a low voltage output V is at a high voltage, and vice versa. We want the multivib outputs to light up individual segments in a common anode i.e.d. display, and they are able to do this when they are in the low state."

"So output T is only of use," questioned Dick, "when it is in the low condition?"

"That's right," confirmed Smithy. "We'll be using some of the outputs when they're in the high state later, but for the time being we are only interested in a multivibrator output when it's low."

"Fair enough. Do the three multivibrators run at different frequencies?"

"They do."

"And what are those disabling switches?"

"They disable the multivibrators when they're opened, whereupon each multivib remains in the state it had at the instant of opening. The three switches are all ganged together in a single 3-pole component so that, when this is operated, all three mul-

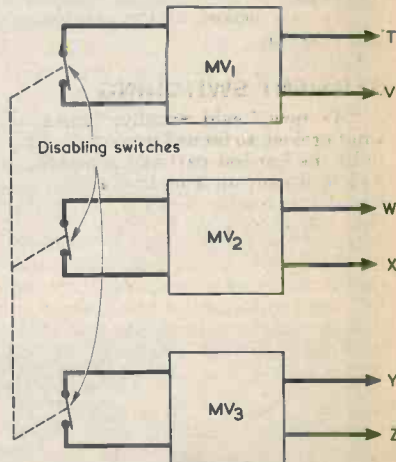

Fig. 1. The random factor in Smithy's electronic dice is provided by three multivibrators running at different frequencies

TWY
TWZ
TXY
TXZ
VWY
VWZ
VXY
VXZ

Fig. 2. The three multivibrators offer eight output combinations

tivibrators stop running at the same time. Since they're 50:50 multivibrators, the three sets of outputs can then produce, in completely random manner, one of eight combinations."

"Eight combinations, eh," repeated Dick thoughtfully. "Well, for a kick-off you could have T, W and Y in the low state after the switch opens. After which you could have T, W and Z."

"You've got the idea," stated Smithy, pleased with Dick's immediate grasp of the situation. "Let's write down all the possible combinations. You've already given me two, and these can be followed by TXY and TXZ. The next two can be VWY and VWZ."

"And," chimed in Dick, "the last two would then be VXY and VXZ. And that's the lot."

"It is, indeed," confirmed Smithy, writing down the last two combinations.

The pair looked at the completed list. (Fig. 2).

### SEGMENT SWITCHING

"We now," said Smithy, "come to what proved, so far as I was concerned, to be the hardest part of the design. I had to dream up a method of having six of the combinations light up the segments to form the numbers 1 to 6. I accepted the fact that two of the combinations would be redundant, and that it would be a very simple matter to have them operate a NAND gate which would extinguish the display. I could have routed the remaining six combinations through standard gates to the various l.e.d. segments but I wanted to see if I could control the segments with nothing more complicated than simple diodes. As it happened, I was able to work out a method which enabled the combinations to directly control the numbers 2 to 6, and I only had to call in another NAND gate to give me the figure 1."

Smithy reached in his cupboard again and produced a sheet of paper on which he had jotted down several columns of letters as well as the lettered outline of a seven-segment display. (Fig. 3).

"Let's take a look at the display first," he went on. "This is pretty well-known, of course, with each segment being identified in clockwise order by the letters A to F. The middle segment is then identified as G."

"That explains something that's been puzzling me a little."

"What's that?"

"Why you chose to give the multivibrator outputs letters which are at the end of the alphabet. You didn't want to get these confused with the segment letters."

"You're really with it today," commended Smithy. "If you're as bright as this today, your Christmas dinner tomorrow should be no trouble at all."

Dick's brow furrowed as he contemplated his immediate future.

"Christmas Day is going to be bad enough," he said morosely. "What I'm really dreading is Boxing Day. That's going to be murder."

Smithy's eyebrows rose.

"What's happening on Boxing Day?"

"I don't," said Dick firmly, "want to even talk about it. Let's get back to this gadget of yours."

"Okay," said Smithy, allowing his interest in Dick's Yuletide activities to abate for the moment. "Where were we?"

"We'd got to the point where you'd used letters from the end of the alphabet to identify the multivibrator outputs. Incidentally, why didn't you include the letter U?"

"Because," replied Smithy, "it tends to get muddled with letter V if you're trying to work out combinations. Now this is the final solution I arrived at for having the combinations turn on the segments."

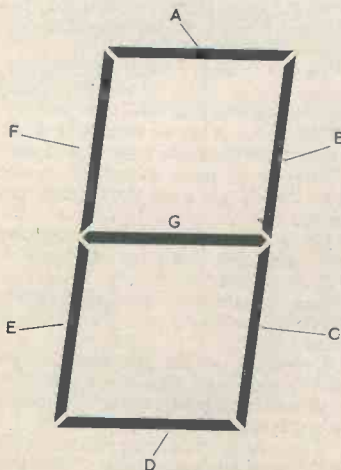

Fig. 3. The segments of a seven-segment display with identifying letters

## Your Local Supplier

LONDON

### THE MODERN BOOK CO.

Largest selection of English & American radio and technical books in the country.

19-21 PRAED STREET,  
LONDON, W2 1NP

Tel: 01-723 4185/2926

ESSEX

### GLASS FIBRE P.C.B.'s

From your own tape, films or in master. Send S.A.E. for quotation.

### RADIO ELECTRONICS AND CONSTRUCTOR P.C.B.'s

Send S.A.E. for details.

Dept. RE

PROTO DESIGN

4 Highcliffe Way,  
Wickford, 8LA.

Essex, SS11 8LA.

SUSSEX

## JEFFRIES

For  
Hi-Fi Equipment  
Tape Recorders  
Television  
Transistor Radios

6A Albert Parade  
Victoria Drive,  
EASTBOURNE SUSSEX

EIRE

### PEATS for PARTS ELECTRONIC COMPONENTS RADIO & TELEVISION

For the convenience of Irish enthusiasts we supply  
Radio & Electronics  
Constructor  
Data Books and  
Panel Signs Transfers  
Also a postal service

Wm. B. PEAT & Co. Ltd.  
25/26 PARNELL STREET  
DUBLIN 1

T	—	CFG
V	—	ADG
W	—	C
X	—	E
Y	—	B
Z	—	AD

(a)

TWY	—	BCFG	—	4
TWZ	—	ACDFG	—	5
TXY	—	BCEFG	—	1
		(Inhibit EFG)		
TXZ	—	ACDEFG	—	6
VWY	—	ABCDG	—	3
VWZ	—	INHIBIT ALL		
VXY	—	ABDEG	—	2
VXZ	—	INHIBIT ALL		

(b)

Fig. 4(a). The multivibrator outputs turn on the segments in the manner shown here

(b). Six of the multivibrator output combinations light up segments in the form of figures

(c). The figures produced by the combinations

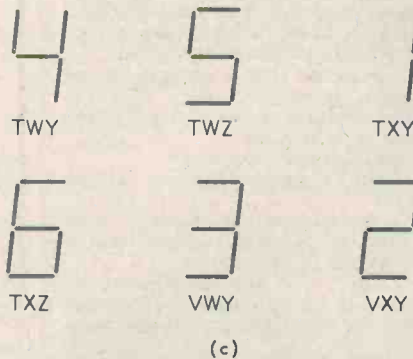

(c)

Smithy pointed to a column of letters in the centre of the piece of paper he had taken from his cupboard. (Fig. 4(a).)

"I don't quite get this," commented Dick, puzzled.

"You'll see the idea soon," replied Smithy. "First of all, let's go down the column. When multivibrator output T is low, segments C, F and G are lit up. Similarly, when V is low, it is segments A, D and G which turn on. Output W turns on segment C, output X turns on segment E and output Y turns on segment B. The last output, Z, causes segments A and D to light up."

"Some of the segment letters," objected Dick, "appear opposite more than one output."

"That doesn't matter," said Smithy. "A segment can be lit up by one output, or by two outputs if the segment is controlled by both."

He pulled his note-pad towards him and proceeded to add further letters to the column of multivibrator output combinations he had compiled earlier. (Fig. 4(b).)

"Right," he said briskly, "as you can now see, combination TWY causes segments B, C, F and G to light up. You'll notice that segment C appears twice but, as I said just now, this doesn't matter."

"Segments B, C, F and G," repeated Dick slowly. "What does that give us, Smithy?"

"Draw them out on my pad," invited Smithy, handing Dick his pen.

Dick drew the segments in their appropriate positions. (Fig. 4(c).)

"Why," he exclaimed, "it's the number 4."

"It is," confirmed Smithy. "Let's get on to the next combination, which is TWZ. This gives us segments A, C, D, F and G. Okay?"

"Sure," said Dick, drawing out the segments. "Well, these segments correspond to figure 5."

"That's right," agreed Smithy. "Now, we'll skip the next combination for the moment and proceed to TXZ. This gives us segments A, C, D, E, F and G. Quite a lot this time."

"They're all there except B" stated Dick. "And, ah yes, they form the number 6."

"Good show. They are followed by VWY, and this lights up segments A, B, C, D and G."

"Just a minute," remarked Dick, busy with Smithy's pen. "This one is figure 3."

"Correct," stated Smithy. "Now VWZ is next and this doesn't form a recognisable number. So it inhibits all the segments and turns them off."

"The following combination is VXY," said Dick excitedly. "This will turn on, let me see now, segments A, B, D, E and G. And it's quite easy to see that these make up the number 2."

"Very good," stated Smithy. "The

last output combination, VXZ, is another redundant one, and this also turns off all the segments."

"That's the lot, then," remarked Dick cheerfully. "No, it's not! We haven't done TXY yet."

"Ah yes," said Smithy. "This gives figure 1. TXY produces B, C, E, F and G, and I had to add a NAND gate and external transistor to inhibit E, F and G, leaving B and C to form the figure 1. This is the only number which raises the control circuitry above simple diode level."

## MULTIVIBRATORS

"Well," said Dick, "you definitely did a man-sized job sorting out those combinations. Now, how about those 50:50 multivibrators which provide the outputs? Do these use two transistors with cross-coupling capacitors in the usual multivibrator configuration?"

"They could do," said Smithy, "if they had a disabling switch circuit added. However, I felt it would be easier and that there'd be a small saving in components if I used 555 integrated circuits instead. Here's the circuit of one of the multivibrators."

Smithy quickly sketched out the multivibrator circuit on his note-pad. (Fig. 5.)

"Apart from the disabling switch and the external transistor," commented Dick, gazing at the circuit, "that seems to be pretty standard to me."

"It is quite standard," agreed Smithy, "when the disabling switch is closed the circuit runs as a standard 555 multivibrator. The capacitor C1 charges via R1 and R2 and discharges via R2, with the output voltage, at pin 3, going high when the capacitor charges and low when it discharges."

"If," said Dick critically, "the capacitor charges via two resistors and discharges via only one resistor, the output can't be a true 50:50 waveform, can it?"

"It can be as near to 50:50 as dammit," retorted Smithy. "The value of R2 is 1MΩ whilst R1 is only 1kΩ, which is one-thousandth of 1M. So the charge and discharge paths for the capacitor are virtually identical in terms of resistance."

"Yes, I see that now," remarked Dick. "What frequency does the multivibrator run at?"

"At a little under 100 Hertz."

"Blimey, that's low, isn't it?"

"It's high enough for the present job. The other two multivibrators run at even lower frequencies."

"Why's that, Smithy?"

"Because," replied the Serviceman, "there's no point in having the multivibrators run at unnecessarily high frequencies. With frequencies as low as I've used here the risks of capacitive couplings between circuits are lower and you don't have to worry too much about general layout. The only high impedances in the circuit are at the disabling switch, and you do, in fact,



have to be a bit careful with the wiring there."

"What," asked Dick, "does the disabling switch do?"

"It disconnects the capacitor from the comparators inside the 555," explained Smithy. "If the capacitor happens to be charging when the switch is opened it continues to charge and the 555 output stays high. Similarly, if the capacitor is discharging when the switch opens it continues to discharge and the output stays low. The 555 will only start oscillating again when the disabling switch is closed."

"I'm with it," said Dick. "Why is the output of the 555 coupled to the external transistor?"

"To give you two outputs of opposite polarity. When the 555 output is high the transistor is turned on and its collector voltage is low. And when the 555 output is low the transistor is turned off and its collector voltage is high. The circuit I've just drawn is the one which gives the T and V outputs in the complete circuit."

"Ah," said Dick eagerly, "you haven't shown me that yet."

A glint appeared in Smithy's eye. "All in good time," he said. "But first of all you must tell me what it is that you're worried about on Boxing Day."

"Oh, come on, Smithy. I'm doing my best to forget about it."

"Boxing Day," stated Smithy firmly, "or no circuit."

"Hey," snorted Dick indignantly, "this is blackmail."

Smithy looked at him impassively. "Oh all right then," stated Dick reluctantly, "I'll tell you. It's all to do with the local T.C.P."

"The local what?"

"The local T.C.P.," repeated Dick. "That's the Thespians and Casual Players, and they're putting on an amateur pantomime on Boxing Day. It's going to be Cinderella."

"How does that affect you?"

"They're making me do one of the Ugly Sisters," wailed Dick. "A right nit I'll feel out there dressed in drag, and with the blokes in the audience all whistling at me."

"I didn't even know you had any

aspirations towards acting."

"I haven't," said Dick aggrievedly. "I've just been going along with them as a sort of stage electrician and scene shifter. Last night they had their first proper rehearsal for the pantomime and it resulted in them calling me in to replace the chap who was going to do one of the Ugly Sisters."

"What happened?"

"Well, you know the scene near the end where the Prince, and he's a woman if you get me, tries to fit the glass slipper on the Ugly Sisters' feet."

"Go on."

"Well, the Prince came to this chap who I'm going to replace, and he put out his foot."

"Yes?"

"How can I put this?" said Dick, dubiously. "Well, now, have you seen that TV ad where the bloke takes off his shoes and everybody falls down?"

"I've seen it several times," said Smithy. "In fact I've been trying to buy a pair of shoes like those in the ad, but whenever I go into a shoe shop and ask about them they all carry on as though I'm a nut."

Dick looked suspiciously at the Serviceman, but the latter's face bore its familiar guileless expression.

"Well," continued Dick uncertainly, "it was the same with this bloke. When the Prince knelt down to try on the slipper, she pretty well fell down, too. There was no end of a row after that with the Prince refusing to continue with the part. So they either had to replace the Prince or the Ugly Sister. They couldn't find anyone else to play the Prince and, even if they could, no one would have done the slipper fitting bit with that cheesey geysir. And so they had to replace the Ugly Sister. Which is now me."

Smithy inspected his assistant's woebegone visage. "I think," he remarked encouragingly, "they made an excellent choice. To start off with, you've got the physical attributes."

"Come off it, Smithy," said Dick indignantly. "Anyway, I've told you all about Boxing Day, so you now show me the full circuit of this electronic dice of yours."

"All right," grinned Smithy. "I've

## MORSE MADE EASY

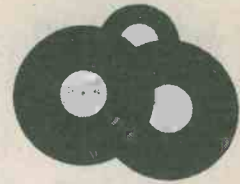

### BY THE RHYTHM METHOD!

These courses, which have been sold for over 23 years, have been proved many times to be the fastest method of learning Morse. You start right away by learning the sounds of the various letters, numbers, etc., as you will in fact use them. Not a series of dots and dashes which later you will have to translate into letters and words.

Using scientifically prepared 3-speed records you automatically learn to recognise the code RHYTHM without translating. You can't help it. It's as easy as learning a tune. 18-W.P.M. in 4 weeks guaranteed.

The Complete Course consists of three records as well as instruction books. For Complete Course send £5.00 including P.P.I. etc. (overseas surface mail £1 extra).

#### THE MORSE CENTRE

Box 8, 45 Green Lane, Purley, Surrey.  
I enclose £5.00 or large s.a.e. for explanatory booklet.

Name.....

Address.....

## GAREX

### Modulation transformer

Valve type 747, for 30W Tx **£2.60**

Mains transformer (multitap primary) 250 0-250V 200mA, 6.3V 5A, 5V 2A, fully shrouded. (suitable for 30W Tx - matching style to mod. transf.) **£5.95**

Connection data supplied with transformers.

H.T. chokes 5H 80mA, 1.8H 125mA **£1.25**

Relays GPO type 2400. 12V coil, 8A contacts.

4PCO or 2P make 40p each; 5+ : 25p

Neons min. wire end. 55p/10; **£4/100**

Slide Switches min. DPDT 15p ea; 5+ : 12p

2 pole, 3 positio. 22p each; 5+ : 18p

PL259 UHF Plug & Reducer 65p; 5+ : 55p

SO239 UHF Socket panel mtd. 50p; 5+ : 40p

BNC cable mtg Socket 50Ω 15p; 5+ : 12p

Resistor Kits E12 series, 22Ω to 1MΩ

57 values. 5% carbon film, 1/4W or 1/2W.

Starter pack, 5 each value (28s) **£2.40**

Mixed pack, 5 each 1/4W + 1/2W (570) **£4.65**

Standard pack, 10 each (570) **£4.65**

Giant pack, 25 each (1,425) **£11.65**

Numericators ZM1080 75p each; 5+ : 63p

I.C.'s (new, full spec.) CD4001AE 20p

SN76660 **£1.12**, 723 (T05) 90p

NE555 Timer 75p

709 (T05); 741 (DIL-8) Op. amps 30p each

5+ I.C.'s (any mix) at 20% discount

Nicad rechargeable cells HP7 size **£1.05**

each; 4+ : 95p; 10+ : 88p. Brand new.

We stock amateur V.H.F. equipment and mobile aerials, s.a.e. details.

Distributors for J. H. Associates Ltd. (switches and lamps)

Prices include UK Post. Packing & VAT

Mail order only Sole Address:

**GAREX ELECTRONICS**

7 NORVIC ROAD, MARSWORTH.

TRING, HERTS HP23 4LS

Cheddington (STD 0296) 668684

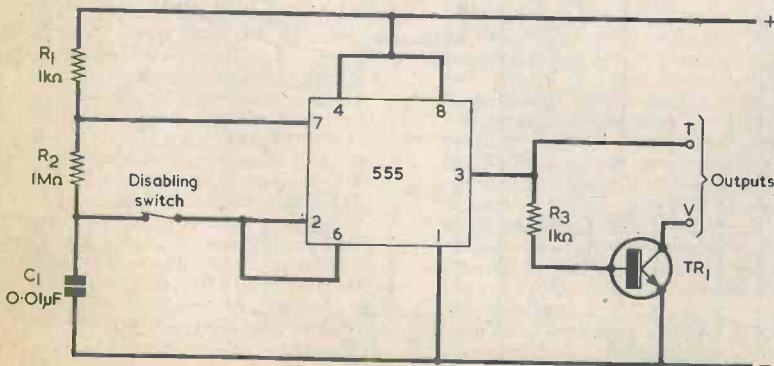

Fig. 5. One of the multivibrators in the electronic dice

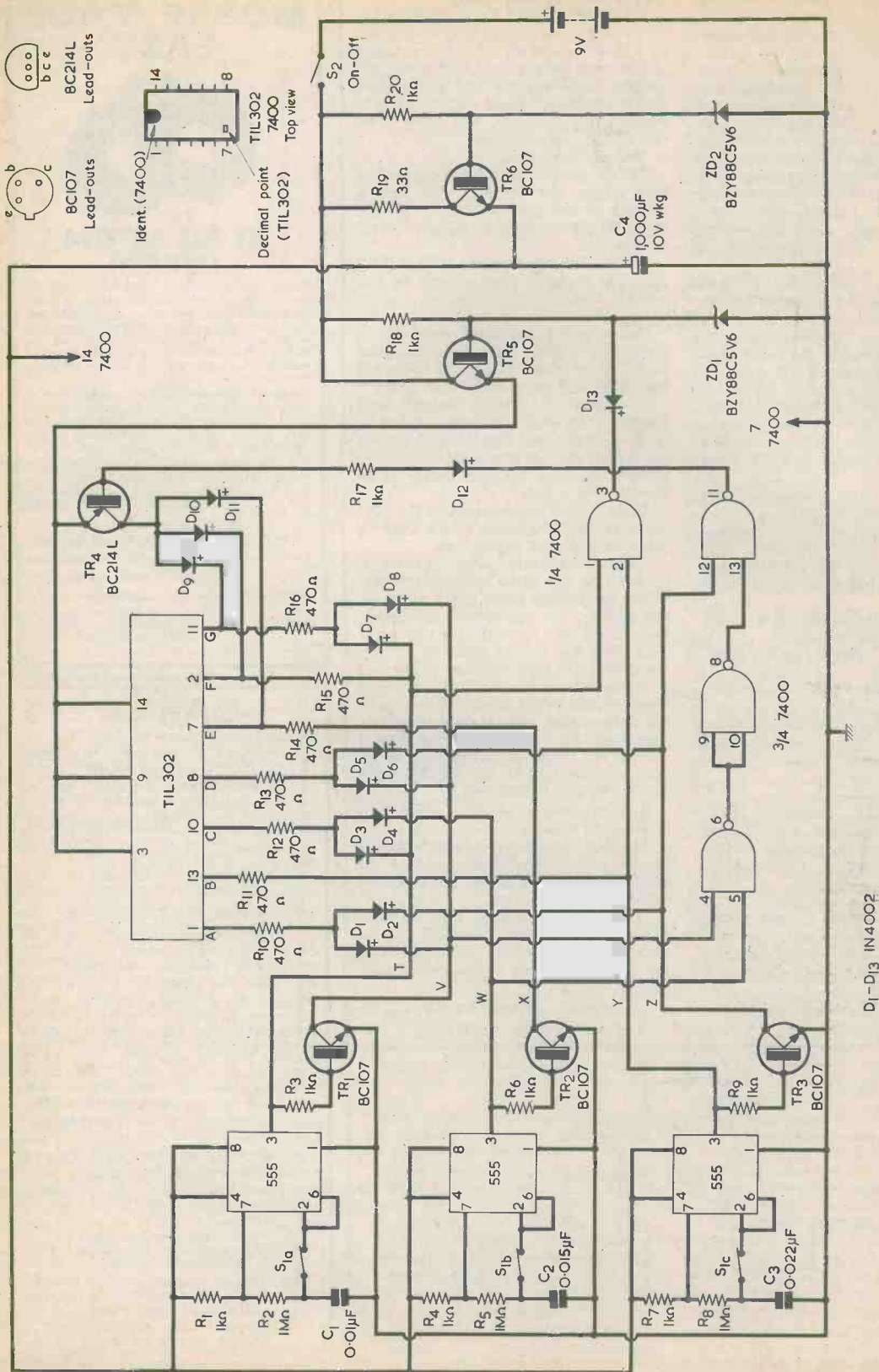

Fig. 6. Complete circuit of the device. The TIL302 is a seven-segment common anode display with a nominal character height of 0.3in. and the decimal point on the left. Some alternatives, such as the SLA7, have the same segment pinning and a single common anode at pin 14. The display plugs into a 14-way d.i.l. integrated circuit holder

got it all drawn up, so I'll bring it out."

He reached yet again into the cupboard under his bench and produced a large piece of paper, which he laid out on the bench surface. (Fig. 6.)

## COMPLETE CIRCUIT

"Here we are," he announced. "This is the complete circuit. At the left hand side there are the three multivibrators, giving the outputs from T to Z. They run at different frequencies because the capacitor in each has a different value. The outputs couple to a TIL302 seven-segment display. This has three common anodes, at pins 3, 9 and 14, and all the other pins shown are for the segments. If you trace out the circuit lines you'll see that the multivibrator outputs connect to the appropriate segments via 470Ω resistors, so that the segments concerned light up whenever the corresponding outputs go low in voltage. It two outputs go to one segment a diode is inserted in series with each so that one output can go low without interfering with the other. The three multivibrators and the diodes from D1 to D8 are the only logic components required for displaying the numbers from 2 to 6."

"There seem," said Dick, "to be two stabilized supplies."

"There are," confirmed Smithy. "One of these is given by TR5 and ZD2, and it offers 5 volts stabilized for the 555's and a 7400 integrated circuit. This, incidentally, has four 2-input NAND gates. The second supply is for the seven-segment display. This is also 5 volts but it doesn't have to be stabilized, and the supply circuit's main function is to provide a simple means of inhibiting the display when the redundant output combinations from the multivibrators are given. If you check back on the list we made up, you'll see that these are VWZ and VXZ."

Dick looked at the column of combinations they had discussed earlier.

"That's right," he said. "How do those combinations inhibit the display?"

"Well," said Smithy, "they're the only combinations with V and Z in them, so all we have to do is to inhibit the display when V and Z are low. A 2-input NAND gate is an excellent device to use here but it must be remembered that the output of a NAND gate goes low when both its inputs are high. When V and Z are low T and Y are high, so we connect T and Y to the NAND gate inputs at pins 1 and 2 of the 7400. The result is that, for all combinations except the two redundant ones, the output of the NAND gate, at pin 3, is high and a full 5.6 volts appears across zener diode ZD1. When the redundant combinations appear, the NAND gate output goes low, pulling down the voltage across ZD1 to less than a volt and thereby extinguishing the seven segment display."

"Gosh," said Dick, "that's really

neat. What do the other NAND gates do?"

"They cause segments E, F and G to be inhibited for the combination TXY. Again we use the opposite multivibrator outputs, and the inhibiting action takes place when V, W and Z are high. We could use a single 3-input NAND gate here, but I've chosen the three remaining NAND gates in the 7400 instead. When V and W are high the output of the first NAND gate, at pin 6, goes low. The second NAND gate inverts this, passing a high to pin 13 of the third NAND gate. Output Z goes to pin 12, with the consequence that pin 11 goes low when V, W and Z are high. Pin 11 allows a current to flow into the base of TR4 via R17 and D12. This transistor then turns on and pulls the pins for segments E, F and G up close to the positive rail via diodes D9, D10 and D11. The final outcome is that E, F and G cannot be illuminated and the display shows B and C only."

"Hell's teeth," remarked Dick, supremely impressed by the sequence of events described by the Serviceman. "That really is something. Are there any possible potential snags in the circuit, Smithy?"

"I didn't encounter any myself," said Smithy. "In fact the whole circuit worked just like a text-book demonstration. There is, however, a very slight risk that the output of a 555 might not go sufficiently low to fully turn off the transistor connected to it. Should this occur, the cure is to add a 470Ω resistor between the base and emitter of the transistor concerned. A 470Ω resistor can also be added between the base and emitter of TR4 if the NAND gate output, at pin 11 of the 7400, doesn't go sufficiently high to allow this transistor to turn off. If the output at pin 3 of the 7400 doesn't go high enough to allow the full 5.6 volts to appear across ZD1, then one or more extra silicon diodes can be added in series. I had none of these difficulties with my own circuit and I'm only mentioning them now to cover all possible angles."

"Perhaps," suggested Dick, "it might be a good idea to run the multivibrators at a slow speed after the circuit has been assembled."

"That's an excellent idea," agreed Smithy. "If something like 4μF is temporarily across C1, 6μF across C2 and 8μF across C3, the circuit will run quite slowly with individual numbers and display inhibiting occurring in random fashion. If all the numbers from 1 to 6 appear properly then the circuit is all right and the temporary capacitors can be removed. These can be electrolytic, incidentally."

Dick leaned over, switched on the electronic dice again and turned the rotary switch. The number 6 appeared.

"This is certainly a crafty gadget," he remarked. "How much current does it draw?"

"It's rather high," replied Smithy.

## AN AUDIO SIGNAL GENERATOR for only £14.95!



### STAR FEATURES:

- ★ 15Hz-150KHz
  - ★ Sine/Square Wave Output Variable 0-3V PKPk
  - ★ Very Low Current Consumption, 9V Btty
  - ★ One IC Plus 4 Transistor Circuit
  - ★ Smart ABS Case, drilled and screen printed
  - ★ KIT includes All Components, Drilled PCB, Controls, etc.
  - ★ Unbeatable Value:
- KIT.....ONLY £14.95 (pp 70p)  
READY BUILT £19.70 (pp 70p)  
CWO To:

**WELTEX MFG. CO.,**  
9 Sirdar Strand, Gravesend  
DA12 4LP  
(C.O.D. orders accepted)

## PADEC COMPONENTS (Dept. REC2)

### STOCK UP NOW, QUANTITY PURCHASE OF QUALITY COMPONENTS

- 250 CARBON FILM RESISTORS 5% (at least 40 different values per pack).....£2
- 20 1 AMP DIODES (1N4000 series).....£1
- 10 ZENER DIODES (all different values).....£1
- 40 metres PVC EQUIPMENT WIRE (2 amp, 7/0.2)
  - 10 metres of red
  - 10 metres of black
  - 10 metres of green
  - 10 metres of white.....£1
- 3 BRIDGE RECTIFIERS (mixed: 1-3 amp/50 volts).....£1
- 2 PLASTIC TRIACS 1.6 amp/400v (ideal for experiments, lead details given).....£1
- 10 GLASS WIRE ENDED NEONS (require a 220K resistor for mains operation).....70p

#### Also available:

Capacitor-Discharge (car) ignition transformers (FREE CIRCUIT)  
Limited number of Stereo Headphones

S.A.E. with enquiries please  
Quoted prices include post, etc.

P.O. BOX 71,  
SOUTHEND-ON-SEA,  
ESSEX SS2 5DZ.

"It's about 45mA when the l.e.d.'s are lit up, dropping to about 30mA when they're inhibited. So you need a fairly large battery. Or, of course, you could use a small mains supply instead of the battery. There's one thing I've just remembered, too. The 555 comparator inputs at pins 2 and 6 are a little susceptible to ripple pick-up when the disabling switches are open, so it's best to keep the wiring here reasonably short and clear of mains fields. It helps in this respect to have the complete circuit in a metal case."

### CHRISTMAS CHEER

"Well," said Dick, brightening. "This little session has cheered me up no end. I'm beginning to almost look forward to Boxing Day, even."

But Smithy was once more investigating the interior of his cupboard and as he rose again there came the musical clink of glass against bottle. He charged two glasses and handed one to his assistant.

"A Merry Christmas, Dick."

"And a Merry Christmas to you too, Smithy."

They both stood and held their glasses high.

"Let us now," stated Smithy, "wish a very Merry Christmas and a truly Happy New Year to all the readers who've put up with our antics over the last year."

They drank deeply.

"And let us end," concluded Dick, "as on so many previous Christmasses, by saying 'God Bless us, every one!'"

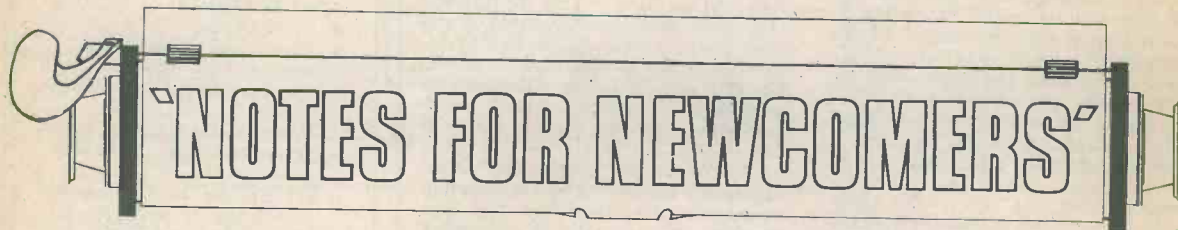

# PINS AND LEAD-OUTS

By F. T. JONES

A brief survey of the methods employed for identifying pins and lead-outs in electronic diagrams.

The identification of pins and lead-outs can be a little confusing for the newcomer to electronics. Fortunately, however, only a little time is needed to become familiar with the methods of presentation employed in technical magazines and in manufacturers' literature.

### VALVE PINS

Valves hardly ever appear in constructional projects these days, except perhaps in amateur transmitter designs, but it is still desirable to be able to repair radio and television receivers incorporating these devices. Indeed, with the current rocketing prices of transistor radio batteries, a few people may be thinking quite seriously of blowing the dust off any old mains-driven valve radios they have and seeing

whether they can be brought back into working order again.

There are three main types of valve base, these being the octal, the B7G and the B9A types. The 8-pin octal valve base has the pins protruding from a bakelite moulding, the latter also having a circular centre piece with locating spigot. The pins are equally spaced and are numbered from 1 to 8 in a clockwise order, as in Fig. 1(a). With the B7G base, the pins protrude directly from the glass of the valve envelope. There are 7 pins, these being numbered 1 to 7 in a clockwise order, number location being provided by a gap between pins 1 and 7. See Fig. 1(b). The B9A base is slightly larger and uses 9 pins, but is otherwise similar to the B7G base. As can be seen in Fig. 1(c), there is a gap between pins 1 and 9.

Fig. 1. Pin numbering for (a) an octal valve base, (b) a B7G base and (c) a B9A base

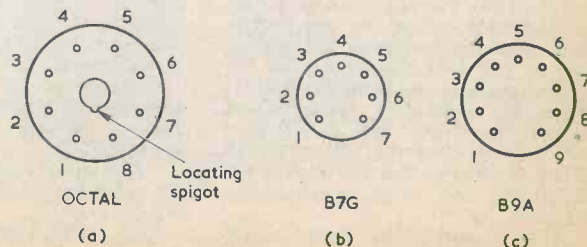

In the diagrams of Fig. 1, all the valve pins are pointing towards the reader. The B9A base is of especial interest to the home-constructor because the popular Denco miniature dual-purpose coils have pins with the same spacing and numbering as those of a B9A valve. These coils can, in fact, be plugged into B9A valveholders.

## TRANSISTOR LEAD-OUTS

Transistor lead-outs are normally shown as parts of circuit or wiring diagrams, appearing in insets alongside the main section of the diagram. Unless otherwise stated, they are always drawn with the lead-outs pointing towards the reader. A typical example is shown in Fig. 2(a), in which "e" stands for emitter, "b" for base and "c" for collector. Fig. 2(b)

Fig. 2(a). A typical transistor lead-out inset  
 (b). With a power transistor the metal case provides the collector connection  
 (c). A transistor with centre lead offset  
 (d). How the transistor with offset lead is shown in the lead-out diagram

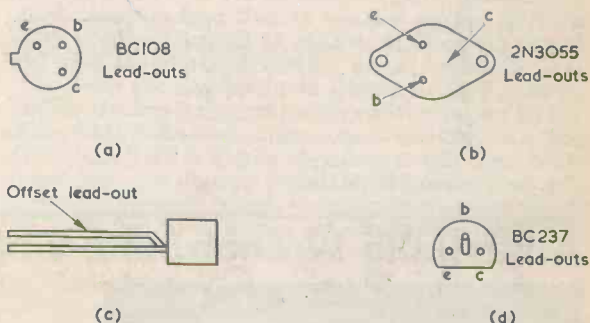

shows a power transistor in the familiar diamond-shaped case. The emitter and base lead-outs are displaced to one side of the case centre to permit identification. The collector arrow points to the case. This is because the collector connection is provided by the metal case itself.

Occasionally, transistors have the centre lead offset, as in Fig. 2(c). The lead-out diagram then appears as in Fig. 2(d). The idea behind the offset is

the pins which appear above the printed board or Veroboard to which the integrated circuit is soldered.

Fig. 3(b) shows an integrated circuit in a circular can with locating lug and 8 wire lead-outs. Again this is a top view, with the lead-outs pointing away from the observer. As can be seen, the lead-out numbering also proceeds in an anti-clockwise direction. In this instance the easing of trouble-shooting procedures is not very evident, but the method of presentation

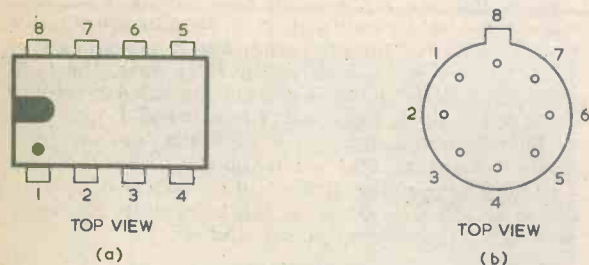

Fig. 3(a). Pin numbering for an 8-pin dual-in-line integrated circuit  
 (b). Lead-out numbering for an 8-lead i.c. housed in a circular can

that the transistor lead-outs then conform to a triangular pattern similar to that in Fig. 2(a), but this is a matter of academic interest only so far as the home-constructor is concerned.

## I.C. PINS

All the pin and lead-out diagrams discussed up to

shown is nevertheless that which has been adopted by the industry for integrated circuits in cans.

Returning to Fig. 3(a) to raise a final point, the abbreviation for dual-in-line is d.i.l., but an alternative abbreviation, d.i.p., may also be encountered. This is applied to dual-in-line integrated circuits having plastic housings. ■

# WORKSHOP AIDS

## Novel diagnostic aid

The Pantec "Usijet" is a small and light universal signal injector made in the form of a pen for clipping into the pocket. The circuit consists of two signal generators, one operating at audio frequency and the other at radio frequency. The impulsive waveform derived from a blocking oscillator-type circuit produces a signal with a wide range of harmonic frequencies up to 500 MHz.

By injecting the signal at various points in an amplifier circuit, the Usijet is an effective dynamic analyser for tracing breaks and component failure. The fundamental frequencies are 1 kHz and 500 kHz with an output voltage of 20V peak-to-peak. Maximum permissible voltage at the probe tip is 500V D.C. Powered by a self-contained 1.5V cell, the current consumption is about 25 mA.

The Usijet can be applied to fault finding in AF, IF and RF amplifier stages, radio in the LW, MW, SW, USW and FM wavebands and TV VHF and UHF channels up to 500 MHz.



## Adjustable wrench with ratchet action

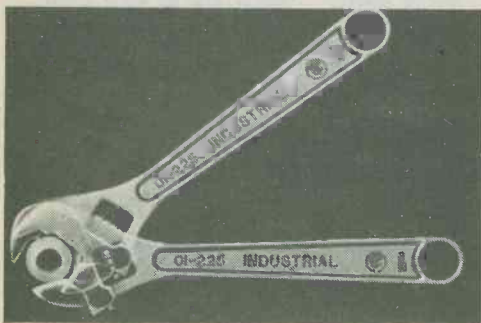

Complementing the successful range of V-Cut ratchet action combination spanners is this

new adjustable wrench. This tool can be used as a normal adjustable wrench, or it can be used as a ratchet. The operator turns the wrench as far as space permits and then slips it back again to its original position without removing it from the nut. Further torque is then applied and the process repeated. The tool is simple and fast to operate saving time and money. The wrench is 8in. long with a maximum opening of 1in., individually walled for display purposes and with a R.R.P. of £3.51 each excluding V.A.T.

Details from Thunder Screw Anchors Ltd., Industrial Estate, Southwater, Horsham, Sussex.

## Wow and flutter meter

The new addition to the Leader range of Wow & Flutter Meters is designed for accurate, simple and rapid determination of the wow & flutter characteristics of tape recorders, phonoplayers and other playback recording apparatus. It also includes a drift meter measuring the drift simultaneously with wow flutter.

The four important characteristics, namely weighted (in accordance with DIN CCIR and JIS specifications) and wow and the flutter, separately or combined, are indicated on the meter calibrated in terms of effective values in percent (JIS specifications). Moreover, this wow & flutter meter is capable of measuring centre frequency of 3.15KHz in accordance with DIN specifications in addition to weighted measurement. Five full scale ranges, 0.03%, 0.1%, 0.3%, 1% and 3% are used in the measurements. The 0.03% range is convenient in testing high grade tape equipment.

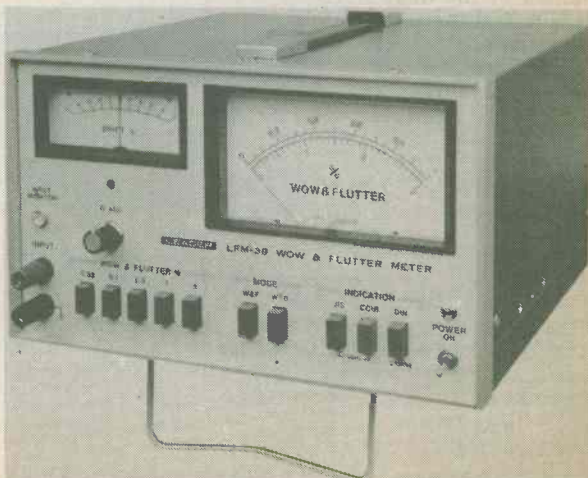

# MOMENTARY POWER FAILURE INDICATOR

By J. Knapp

This neat little circuit detects short power failures in t.t.l. equipment which would otherwise pass unnoticed.

In items such as digital frequency counters a brief power supply failure (due to a momentary mains power cut or a faulty plug, etc.) can cause incorrect readings without being noticed. This is particularly the case if the failure is very short, say of the order of 0.01 second.

The circuit to be described detects these short power cuts, and indicates that they have taken place by turning on an l.e.d. until re-set by a front panel push-button. Operation is very simple and, as will be seen, the circuit can employ the odd one or two gates that are left over in a complicated t.t.l. circuit. Even if the i.c. to be used has to be purchased, its cost is very low.

## CIRCUIT FUNCTIONING

The basic circuit is shown in Fig. 1 and incorporates one gate of the quadruple AND gate type 7408. Since this is an AND gate, the output is low, at 0, when both its inputs are at 0, and is high, at 1, when both the inputs are at 1.

When the 5 volt supply is initially turned on a charging current flows to C1 via R2, LED1 and D1. However, before any appreciable voltage can be developed across this capacitor the gate output becomes 0 because of the low voltage at the input. No further charging current flows to C1 and it is maintained in the discharged condition by R1. Both the inputs and the output are stable at 0, and the l.e.d. is illuminated.

The circuit is set by pressing S1. This takes the gate inputs up to 1 and causes C1 to charge to the full 5 volts of the supply. The output also rises to 1 so that, when S1 is released, C1 is maintained in the charged condition via D1, which is now forward biased. The initial surge of charging current to C1 is borne by the switch, and so no excessive current is drawn from the gate output. Both inputs and output are at 1 and the l.e.d. is extinguished.

Should the power supply be cut for a short period, C1 discharges very quickly into R1 whereupon, when the power returns, both the inputs and the output are at 0 and the l.e.d. is illuminated, indicating that a power supply failure has taken place. The circuit can then be re-set by pressing S1 once more.

In the diagram, LED1 is shown as a TIL209. Any other similar type of light-emitting diode can, of course, be used.

## TIME OF DISCHARGE

For very short power cuts C1 may not discharge sufficiently, and the gate will return to the state where the inputs and output are at 1, with the l.e.d. extinguished, when the supply reappears. Hence the circuit will not detect breaks shorter than a particular time period which is dependent on the value of C1. It has been found by observation that the minimum time, in milliseconds, which the circuit can

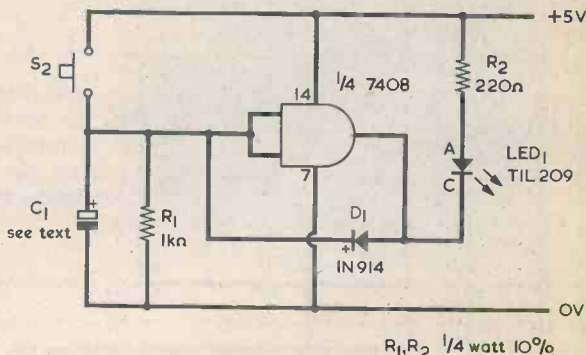

R<sub>1</sub>, R<sub>2</sub> 1/4 watt 10%

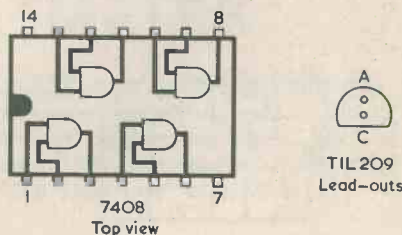

Fig. 1. Basic circuit of the power failure indicator. This is set up by pressing S1, and it causes the l.e.d. to be illuminated after a short power failure

detect is approximately equal to 1.25 times the value of C1 in microfarads. Thus, if the circuit is to disregard breaks of less than 1 millisecond C1 requires a value of  $0.6\mu\text{F}$ . The exact value will vary with different gates, but an approximate choice of minimum time period may be obtained by giving C1 the appropriate value. This component is shown in the diagram as an electrolytic capacitor, but for the lower values a plastic foil capacitor is used instead.

The circuit has been checked with values of C1 giving time periods from 10 microseconds to 1 second and has functioned correctly in every case. If C1 is to have a value larger than, say,  $10\mu\text{F}$  it would be preferable to add a  $10\Omega$   $\frac{1}{4}$  watt surge limiting resistor in series with S1 to prevent sparking at the switch. The resistor may be inserted between S1 and the positive rail.

### OTHER GATES

Instead of a 7408 gate, the circuit can use a quarter of a 7432 quadruple OR gate, as in Fig. 2. This is connected in the same manner as the 7408.

Another variation is shown in Fig. 3 where two gates of a 7400 quadruple NAND gate are connected in cascade. Each gate acts as an inverter, giving an output which is the same as the input. Two gates of a quadruple NOR gate type 7402 could be cascaded in a similar manner.

In Fig. 4, two inverters from the 7404 hex inverter are used and produce the same result. As may be

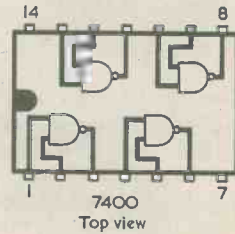
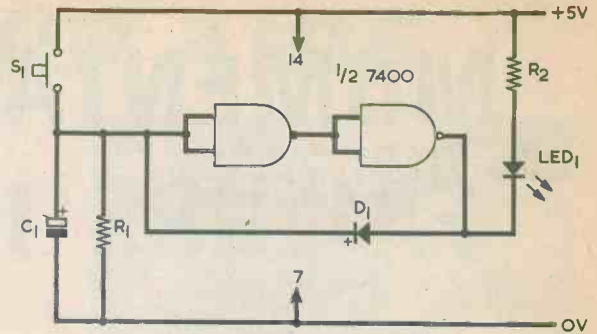

Fig. 3. Using two gates of the 7400 quadruple NAND gate

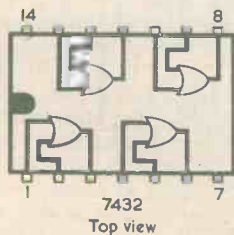
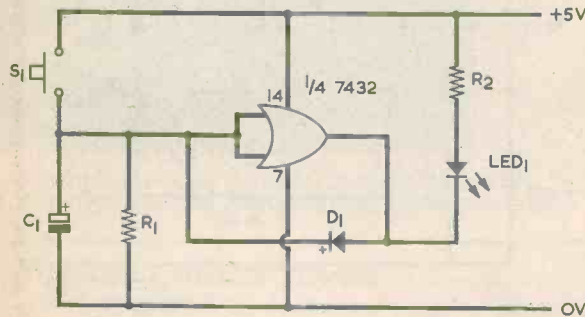

Fig. 2. The circuit may also employ one gate of the 7432 i.c.

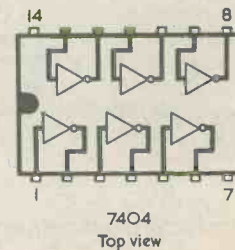
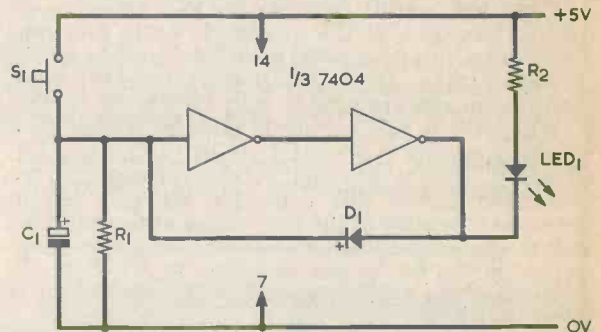
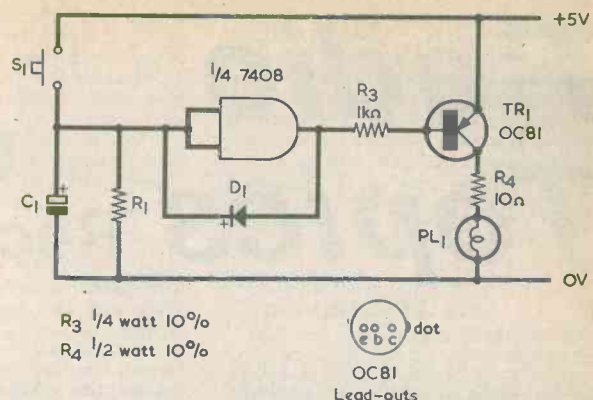

Fig. 4. Another version of the circuit incorporates two 7404 inverters



Fig. 5. The addition of a small power transistor allows the failure indicator to light a bulb instead of an l.e.d.



gathered, the basic circuit can employ a wide range of individual gates.

The output of the circuit does not have to be connected to an l.e.d., and it could be used to blank the display or carry out another function when it trips.

Again, it could illuminate a bulb by way of a small power transistor, as illustrated in Fig. 5. The bulb can draw a current of the order of 200mA, and R4 limits the surge current which can flow through its filament in the cold state to 500mA.

# NEXT MONTH IN

## SPECIAL FEATURES

# RADIO & ELECTRONICS CONSTRUCTOR

## SIMPLE REGENERATIVE S.W. RADIO

This little receiver employs an unusual regenerative f.e.t. detector circuit and covers 1.5 to 36 MHz by means of three plug-in coils. The output is at headphone level, and it may alternatively be applied to an a.f. amplifier. A particular attraction is the low current which is drawn from the 9 volt supply battery.

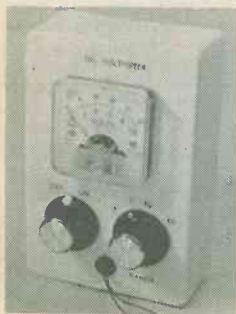
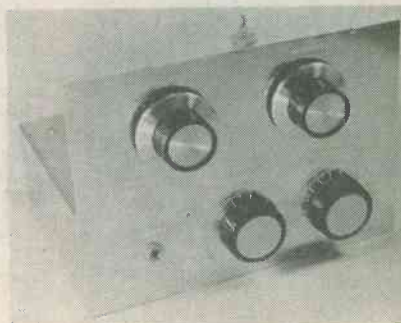

## CMOS VOLTMETER

The introduction of the CMOS linear operation amplifier type CA3130T allows the construction of very simple circuits which take advantage of its extremely high input resistance. This article describes an electronic voltmeter incorporating the CA3130T and offering ranges of 0-1 volt, 0-5 volts and 0-50 volts.

**ORDER NOW!**

ON SALE 2nd JANUARY

# Radio Topics

## By Recorder

I have been doing quite a bit of design work recently for projects which are finally assembled on Veroboard. This is a fascinating process, particularly if d.i.l. integrated circuits are employed because connection layout is then governed by the i.c. pins themselves. If, for instance, pin 3 of an i.c. provides an input function, then the discrete component lead-outs and wiring associated with that input have to be soldered to the strip connecting to pin 3.

Everybody has their own ideas on making up designs on Veroboard, but my own approach may perhaps still be of interest.

### INITIAL STEPS

If the project incorporates a new and previously untried circuit, I first of all check it out in lash-up form. This is really a debugging exercise and it ensures that resistor and capacitor values are correct and that there are no little errors that have been overlooked. Believe me, there are many circuits conceived in the lofty fastnesses of theory which fail very dismally when tried out in the hard world of practice!

Wiring can be kept quite short in even the most hastily assembled of lash-ups, but it will still almost inevitably be longer than occurs in the final Veroboard version of the circuit. In general, this is nearly always to the good as the longer wiring encourages any tendency in the circuit towards instability due to unwanted feedback from an amplifier output to its input. A fairly common trap here is given in circuits intended for d.c. or for switching operation and which have two or more transistors connected in cascade. A typical example occurs when a constant current transistor feeds the base or emitter of another transistor. You may fondly imagine that the base of the constant current transistor is firmly tied to its supply rail by the voltage reference diode or diodes, but this point cannot be banked on. If an apparently stable circuit starts to act unpredictably as your hand approaches any of the components or if, alternatively, it will only work properly when your hand is close to the components, then there's almost definitely r.f. instability due to a hidden amplifier chain and feedback path. The solution is normally quite

simple. To start with, should the circuit require a bypass capacitor across the supply rails ensure that this connects to the circuit with short leads and do not rely on any bypass capacitors inside, say, a bench power supply. If the instability continues with the supply bypass capacitor connected, find the amplifying chain and kill it by adding a bypass capacitor of around 0.01 $\mu$ F between one of the supply rails and any collector, emitter or base in the middle of the chain.

When the circuit is stable in the lash-up form it will almost certainly, provided certain rules are followed, be even more stable in its final Veroboard layout where the wiring will be shorter.

### CROCODILE CLIP LEADS

Crocodile clip leads can offer a considerable saving of time when trying out lash-up circuits. These leads consist of thin flexible insulated wires about 16in. long terminated at each end by a miniature crocodile clip having a flexible p.v.c. cover which allows only the extreme ends of the clip jaws to be visible. These leads are well worth the trouble of making up, and it is a helpful idea to use wire of a different colour in each lead. Obviously, crocodile clip leads cannot be employed for high impedance signal paths, but they can be used for quick low impedance connections.

When the lash-up circuit has proved to be satisfactory, the next process consists of working out a Veroboard layout. My procedure here is to use a piece of paper marked up with faint squares taken from a school exercise book. These books can be obtained in most stationers or from a Woolworth store and are about 6 $\frac{1}{2}$  by 8in. If the exercise book staples are opened out, a good supply of squared sheets is available, each sheet measuring 12 $\frac{1}{2}$  by 8in. The squares have a side of  $\frac{1}{16}$ in. or 5mm. depending on when the stock was last changed.

The procedure then is to regard the square corners as Veroboard holes and work out the project layout in pencil assuming that one is looking at the component side of the board. Breaks in the Veroboard strips are shown by crosses. If it is necessary to make a change in the layout then the first attempt is simply erased and a fresh start made. This is probably the most

engrossing part of the procedure. The process will also show the size of Veroboard that is required. Incidentally, I prefer myself to use one of the standard size pieces of Veroboard with edges neatly cut by the manufacturer, but this is just a personal choice.

The only main rules to observe in the Veroboard layout concern high impedance input points. If an amplifier input and an in-phase output are at high impedance it is desirable not to connect them to adjacent Veroboard strips in case the capacitance between them (admittedly very small) allows positive feedback to occur. Again, a strip connecting to a sensitive high impedance amplifier input should be kept short and should be cut, after all the input connections have been made to it, rather than allow it to traverse the width of the board.

When the pencil layout has been completed, the components, connections and link wires are drawn more permanently in blue or black ink, and the crosses which indicate breaks in red ink.

The design is now complete and all is ready for making up the actual Veroboard assembly. The preliminary work will then show its value because, after its initial test in lash-up form, the circuit is almost certain to work first go. And the pencil design step will also ensure that the layout looks neat, clean and uncluttered.

Before concluding on this topic, there is another dodge which some may find helpful. If a typewriter is available, set it to single line spacing, insert a sheet of paper and type out a series of small letter 'o's' with a space between each. The result is a sheet of paper with rows of evenly spaced circles on it. This can then be used for working out a Veroboard layout instead of the squared pages of school exercise books.

### MEGGER — 1976 STYLE

Those of you who, like me, have fond Service memories of the Wee Megger and its larger brother will be more than interested in the accompanying photograph of this instrument in its latest form. For the benefit of readers who have not previously encountered the Megger, I should add that this is a unique resistance-measuring instrument capable of indicating extremely high resistance values. The energising voltage is obtained by turning a crank coupled to an internal generator.

The instrument illustrated is the Megger model SL15, which has been introduced in 1976. It continues the tradition of high range insulation resistance testers, robustly designed for the rigours of maintenance work and sensitive to the advanced development of insulating materials.

The a.c. generator in the SL15 can be hand driven or mains operated by way of an internal motor. Stepped test voltages from 500 to 5,000 volts d.c.



*The latest instrument in the Evershed and Vignoles Megger range. This is the model SL15, and is capable of measuring resistance up to 250,000MΩ*

are stabilized to 0.1 per cent by precision electro-mechanical engineering. The discharge of external circuit capacitance is achieved by manual switching on the voltage selection switch.

An amplifier-assisted Evershed cross-coils movement is incorporated, providing a sensitivity of 250,000MΩ at 2,500 volts. Each instrument is

assembled in a hard wood case fitted with a hinged lift-off cover for top panel protection, a carrying handle and levelling feet. Accessories supplied comprise a mains lead and three test leads.

The Megger model SL15 is manufactured by Evershed and Vignoles, Ltd., Archcliffe Road, Dover, Kent, CT17 9EN.

### COIL WINDER

Avo Limited, also of Archcliffe Road, Dover, Kent, do not only produce high grade test equipment, and they have been well-known for many years as manufacturers of coil winding machines. The coil winder shown in the photograph is the type CW63 Mk 3, and has been very recently added to the Avo range. This winder is the most versatile Avo machine, and it is particularly suitable for in-house coil winding by the electronics manufacturer who requires a moderate output of a wide diversity of coil designs.

All the machine controls for the coil winder are housed in the electronic controller fitted above the headstock. The newly designed foot control is interlocked with a "fail safe" latch-on system. This allows the machine to be left running on the set maximum speed, and enables the operator to control two or even more machines when the coils to be wound have a large number of turns.

Two important new features are

reverse winding spindle rotation and "end-of-layer" stopping. The "Reverse Rotation" switch in the electronic controller allows coils having bi-directional winding to be easily produced. "End-of-layer" stopping is particularly useful when coils having single layer windings are being produced. It is also essential when hand interleaving between layers is necessary.

### OFFSHORE COMMUNICATIONS

Marconi Communications Systems Limited, a GEC-Marconi Electronics company, are undertaking an important study in communications for the European Space Agency Headquarters in Paris. The study is concerned with the use of the European Communications Satellite System (ECS) and the Maritime Orbital Test Satellite (MAROTS) in the 1980's to provide telecommunication facilities supporting installations engaged in offshore oil and gas exploitation.

The communications requirements of such installations will be met with the use of many small earth terminals. Since the major role of ECS will be in large earth terminal applications, like International Trunk Telephony and the exchange of television programmes, there is an obvious need to study the problems of sharing a single satellite between large and small earth terminal users. In the case of MAROTS there is the different problem of sharing the satellite's capacity between ships and exploration rigs.

Marconi Communications Systems have been involved since 1972 in a series of studies which have shown that there are no fundamental technical obstacles to using ECS and MAROTS type satellites to satisfy the communication requirements of oil companies engaged in the exploitation of the hydrocarbon resources in the European sea areas. The present study will result in a detailed definition of the space and earth sectors of such systems, compatible with the requirements of the trunk sector of ECS and the requirements of the mercantile shipping sector of MAROTS.

In the case of ECS, Marconi Communication Systems are also identifying those aspects of the trunk services which might be modified to achieve integration. In addition, account will be taken of the development of alternative communications media such as tropospheric scatter (which, to date, has been entirely provided by Marconi for the oil fields in the North Sea) to ensure all-round compatibility. Further, means are being examined for achieving a smooth transition to an ECS-based system via the interim satellite OTS which is planned for a 1977 launch.

Things are certainly moving these days in the field of communications.

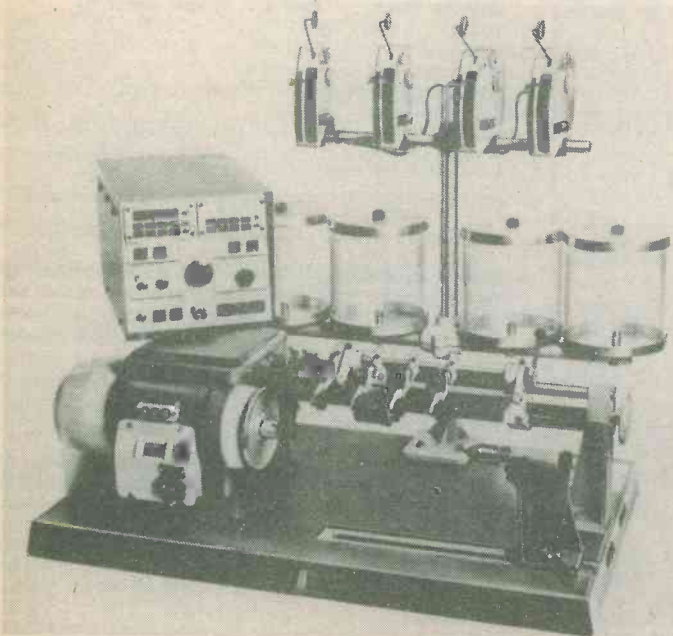

*This highly versatile Avo coil winding machine, the type CW63 Mk3, is capable of winding coils in either direction and of providing an automatic stop at the end of a layer. Other features include a foot control system which enables several machines to be controlled by a single operator*

# THE MODERN BOOK CO

## 110 ELECTRONIC ALARM PROJECTS FOR THE HOME CONSTRUCTOR

BY R. M. Marston

Price £3.20

**ELECTRONIC CALCULATOR USERS HANDBOOK**  
by M. H. Babani PRICE: £1.20

**PROJECT PLANNING & BUILDING**  
by M. A. Colwell PRICE: £2.25

**SIMPLE CIRCUIT BUILDING**  
by P. C. Graham PRICE: £2.25

**PRACTICAL ELECTRONIC PROJECT BUILDING**  
by A. C. Ainslie PRICE: £2.25

**TRANSISTOR POCKET BOOK**  
by R. G. Hibberd PRICE: £4.40

**110 OPERATIONAL AMPLIFIER PROJECTS FOR THE HOME CONSTRUCTOR**  
by R. M. Marston PRICE: £2.75

**STEREO F.M. RADIO HANDBOOK**  
by P. Harvey PRICE: £3.00

**RADIO SERVICING PROBLEMS**  
by W. A. L. Smith PRICE: 85p

**THE HANDBOOK OF ELECTRONIC TABLES**  
by M. Clifford PRICE: £1.70

**TEST INSTRUMENTS FOR ELECTRONICS**  
by M. Clifford PRICE: £2.10

**ILLUSTRATED TEACH YOURSELF RADIO**  
by D. Gibson PRICE: £1.85

**THE CATHODE-RAY OSCILLOSCOPE & ITS USE**  
by G. N. Patchett PRICE: £4.00

**PRINCIPLES OF TRANSISTOR CIRCUITS**  
by S. W. Amos PRICE: £4.45

**COLOUR T.V. WITH PART. REF. TO THE PAL SYSTEM**  
by G. N. Patchett PRICE: £5.40

**COLOUR T.V. PICTURE FAULTS**  
by K. J. Bohlman PRICE: £2.75

**PRINCIPLES OF PAL COLOUR T.V. & RELATED SYSTEMS**  
by H. V. Sims PRICE: £2.50

**THE OSCILLOSCOPE IN USE**  
by I. R. Sinclair PRICE: £2.80

**ELECTRONICS & RADIO**  
by M. Nelkon PRICE: £3.10

**ELECTRONIC SYSTEMS FOR RADIO, T.V. & ELECTRONICS MECHANICS**  
by R. Lewis PRICE: £3.45

PRICES INCLUDE POSTAGE

We have the Finest Selection of English and American Radio Books in the Country

**19-21 PRAED STREET (Dept RC) LONDON W2 INP**

Telephone 01-723 4185

## NEW STYLE SELF-BINDER

for

"Radio & Electronics  
Constructor"



The "CORDEX" Patent Self-Binding Case will keep your issues in mint condition. Copies can be inserted or removed with the greatest of ease. Rich maroon finish, gold lettering on spine.

Specially constructed Binding Cords are made from Super Linen of great strength, very hard twisted and twice doubled. They are attached to strong RUSTLESS Springs under tension, and the method adopted ensures PERMANENT RESILIENCE of the Cords. Any slack that may develop is immediately compensated for and the Cords will always remain taut and strong. It is impossible to overstretch the springs, as a safety check device is fitted to each.

PRICE

**£1.20**

including V.A.T.

P. & P. 30p

Available only from:—

**Data Publications Ltd.**

**57 Maida Vale London W9 1SN**

# SMALL ADVERTISEMENTS

Rate: 8p per word. Minimum charge £1.00  
Box No. 20p extra

Advertisements must be prepaid and all copy must be received by the 4th of the month for insertion in the following month's issue. The Publishers cannot be held liable in any way for printing errors or omissions, nor can they accept responsibility for the *bona fides* of Advertisers. (Replies to Box Numbers should be addressed to: Box No. —, **Radio and Electronics Constructor**, 57 Maida Vale, London, W9 1SN.

**WANTED TO PURCHASE:** All early books on radio, preferably before 1925. Box No. 282.

**WANTED TO PURCHASE:** large and small quantities of transistors, diodes, I.C.s, etc. Immediate requirement for 10,000 BC109 transistors. Send samples/lists of any surplus components. Elekon Enterprises, 224a St. Paul's Road, Highbury Corner, London N1 2LJ. Telephone: 01-359 4224.

**TREASURE HUNTERS!** Construct, inexpensively, metal detector giving £300 performance. 10 pages, illustrated plans, £1. C. H. Lucas, 241 Upminster Road South, Rainham, Essex.

**FAST SERVICE** for resistors, capacitors, transistors, din plugs, jack plugs, audio leads. Special Offer: AC128 12p, post extra. S.A.E. list. Callers welcome. Torbay Electronic Components, 185 Higher Union Street, Torquay, Devon. Telephone: 211086.

**FOR SALE:** AD162 32p, BC107 8p, BC108C 8p, BC109 8p, 2N3819 28p, 1N4001 5p, 1N5401 17p, 400mW zeners BZY88 5V6 7p, BZY88 6V8 7p. Aluminium chassis co-ax aerial socket 8p, and co-ax aerial plug 14p. Sub.min. toggle switch 2 pole 2 way 85p. Jack plug ¼in. plastic (mono) 18p, chrome (stereo) 50p, jack socket ¼in. (mono) 25p, stereo 35p. Din socket 3 way 10p, 5 way 12p. Min. main transformer 2 x 6.3V, ¼A, £1.60, P&P 25p extra. Other types stocked. Please write stating requirements. For parts list send s.a.e. Box No. G308.

**COMPONENTS OBTAINED ON REQUEST** for projects in this and other magazines for constructors in the Coventry area. Barras Electronics, 11 North Street, Coventry. Telephone 441141.

**SERVICE SHEETS** for Radios/TV's etc. 50p and s.a.e. Catalogue 20p and s.a.e. Hamilton Radio, 47 Bohemia Road, St. Leonards-on-Sea, Sussex.

**THE RADIO AMATEUR INVALID & BEDFAST CLUB** is a well established Society providing facilities for the physically handicapped to enjoy the hobby of Amateur Radio. Please become a supporter of this worthy cause. Details from the Hon. Secretary, Mrs. Rita Shepherd, 59 Paintain Road, Loughborough, Leics., LE11 3LZ.

**FOR SALE:** Heathkit oscilloscope Model 10-18U, 4.5MHz bandwidth. Assembled and working but otherwise not used £15.00. Two c.r.t. 3BP1 for new transistorised oscilloscope, £5 each. L. Wade; Telephone: Epping 75899, office hours only.

(Continued on page 317)

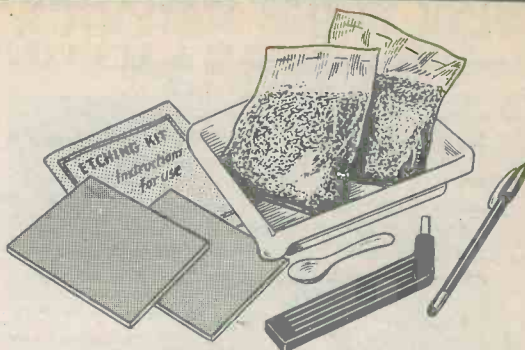

## ETCHING KIT

All you need to make your own  
**PRINTED CIRCUITS**

Full instructions, Copper Clad Board, Ferric Chloride, Dish and Pen

Price incl. VAT & Postage .....**£4.75**

Send cheque or P.O. today to:  
**HOME RADIO COMPONENTS LTD.**

240 London Road, Mitcham,  
Surrey, CR4 3HD

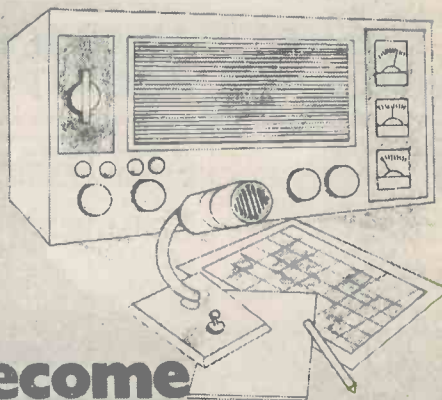

## Become a radio amateur.

Learn how to become a radio-amateur in contact with the whole world. We give skilled preparation for the G.P.O. licence.

WAA

Free!

Brochure, without obligation to: **REK126**  
**BRITISH NATIONAL RADIO & ELECTRONICS SCHOOL,**  
P.O. Box 156, Jersey, Channel Islands.

NAME \_\_\_\_\_

ADDRESS \_\_\_\_\_ (Block caps please)

## NEW FROM AMERICA

### Superbly Styled Liquid Crystal Display Watches

#### FROM FAIRCHILD TIMEBAND

5+4 functions. Continuous readout of hours, minutes, and pulsating seconds. Single command button, push once for month/date — auto reset; twice for seconds — manual reset.

#### PLUS —

Programmed 4-year calendar, backlight for night viewing, optional continuously alternating time/date display, am/pm setting indicator.



High contrast L.C.D. display visible in bright sunlight. Supplied in presentation boxes, these slim, quality watches sell in jewellers' shops for up to £80.

TC411	White	£29.50
TC410	Gold	£32.50

On leather strap

TC413	White	£34.50
TC412	Gold	£37.50

Matching adjustable bracelet.



#### OUR SPECIAL L.E.D. OFFER —

GALA 6+3 functions.

At the touch of a button, hours, minutes, seconds, Alpha Day, month and date.

#### PLUS —

Programmed 4-year calendar, auto hold and fadeout, am/pm setting indicator. Available in S/S or Gold Plated with S/S back and matching adjustable bracelet. Sold elsewhere at £22.90

OUR PRICE £17.50

No moving parts to wear out, clean or oil. Accuracy to a few seconds/month. We believe our prices are the lowest anywhere and include VAT at 8% and P&P. Free battery/s. No quibble 1-year guarantee.



Send Cheque/Money Order to:

## TEMPUS

Dept. REC, 5-7 Norfolk Street, CAMBRIDGE CB1 2LD

Telephone 55094

A LOT OF TIME FOR THE MONEY

## VALVE BARGAINS

Any 5-54p, 10-£1.00, 50-£4.50. Your choice from the list below.

ECC82, EF80, EF183, EF184, EH90, PCF80, PCF802, PCL82, PCL84, PCL85, PCL86, PCL805, PL504, PY81/800, PY88, 30PL-14, 6F28.

Large stock of older types of TV Valves. Brand new 35p each.

Colour Valves—PL508, PL509, PL519, PY500/A. All tested. 30p each.

Press Button UHF Tuners—4 Button Transistor—British made—£2.50 each.

## 50p BARGAIN PACKS

All Packs Un-used Parts—PK1-40-C280 (Mullard) Axial Lead Capacitor mixed values from .01µF to .47µF (250V/W). PK2-30-C281 (Mullard) Radial Lead Capacitors mixed values from .015µF to 1.5µF (250V/W). PK3-6 Co-ax. plugs. PK4-6 Co-ax connectors. PK5-8-5m/m formers with slugs. PK6-25-AC128 Transistors. PK7-3 BF200 (VHF) Transistors. PK8-2 BF182 (UHF) Transistors. PK9 Any 6 Transistors BC108, BC113, BC135, BC153, BC171, BC172, BF194, BF195, BF196, BF197. PK10 8-1 amp 400 volts rectifiers. PK11 4-5 pin din plugs (180°). PK12-5 PP3 Battery Connectors.

All prices include VAT. P&P 20p per order. Please send uncrossed P.O. or Cheques for returning if we are out of stock of Bargain Packs or older types of new valves.

## ELECTRONIC MAILORDER LTD.

62 BRIDGE ST., RAMSBOTTOM, BURY, LANCS. TEL. RAMS. (070 682) 3036

## AERIAL BOOSTERS

Aerial boosters can produce remarkable improvements on the picture and sound, in fringe or difficult areas.

B11 For TH stereo and standard VHF/FM radio.

B12—For the older VHF television—Please state channel numbers.

B45—For Mono or colour this covers the complete UHF Television band.

All boosters are complete with battery with Co-ax plugs & sockets. Next to the set fitting. £3.60

# PLAIN-BACKED NEW STYLE SELF-BINDERS

for your other magazines

(max. format 7½" x 9½")

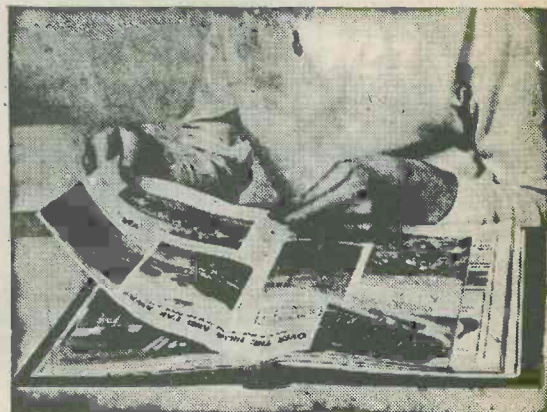

The "CORDEX" Patent \* Self-Binding Case will keep your copies in mint condition. Issues can be inserted or removed with the greatest of ease. Specially constructed Binding cords are made from Super Linen of great strength, very hard twisted and twice doubled. They are attached to strong RUSTLESS Springs under tension, and the method adopted ensures PERMANENT RESILIENCE of the Cords. Any slack that may develop is immediately compensated for, and the Cords will always remain taut and strong. It is impossible to over-stretch the springs, as a safety check device is fitted to each.

COLOURS: MAROON OR GREEN

(If choice not stated, colour available will be sent)

PRICE **£1.15** P. & P. 30p

Available only from:—

**Data Publications Ltd.**  
57 Maida Vale London W9 1SN

## SMALL ADVERTISEMENTS

(Continued from page 315)

**BOOKS TO CLEAR.** *Television Engineering* by Amos, Birkinshaw & Green, 1969, £2.00; *Radio & Line Transmission* by Danielson & Walker, 1969, £1.50; *Electric Model Car Racing* by D. J. Laidlaw-Dickson, 1965, 60p; *Radio Communication* by J. H. & P. J. Reyner, 1962, £2.00. All prices include Postage and Packing. Box No. G316.

**ANTIQUA RADIO BOOKS.** Newnes "Television & Short Wave Handbook" by F. J. Camm, 1935, £3.00. News Chronicle "Wireless Constructor's Encyclopaedia" by F. J. Camm, 3rd edition, circa 1930, £3.50. Prices include postage and packing. Box No. G318.

**FOR SALE:** Telford Communications 2m. converter, G8AEV MKII. £10. G2UK, 21 Romany Road, Oulton Broad, Lowestoft, Suffolk.

**COLLECTORS' ITEMS.** Bound Volumes of "The Wireless World" (which was then published weekly) for 1929, 1930, 1931, 1932, 1933, 1934, 1935, 1936, 1937, 1938, and 1939 (nine months only for this year due to outbreak of war). Two volumes per year, total of 22 volumes. All in very good condition. Offers invited. Box No. G319.

**ABS BOXES** - Black with lids, brass corner inserts. 80 x 60 x 42mm. 35p. 100 x 75 x 42mm. 40p. 120 x 100 x 42mm. 45p. Please add 8% VAT and P&P. Nortek Engineering Ltd., 41a Harrowby Street, Farnworth, Lancs.

**FOR SALE:** Books on Communications: Electronics: I.E.R.E. Journal Vol. 43: List. Transistor Checker. Transistor 2-Metre pre-amp. Wanted: "Microwave Journal" Hughes, 11 Henley Road, Ludlow, Salop.

**WANTED:** "Practical Television" issues: October '68, February '68. Also "Television" issues: December '73, January '76. Box No. G320.

**JOIN THE INTERNATIONAL S.W. LEAGUE.** Free services to members including Q.S.L. Bureau, Amateur and Broadcast Translation, Technical and Identification Dept. - both Broadcast and Fixed Stations, DX Certificates, contests and activities for the SWL and transmitting members. Monthly magazine, *Monitor*, containing articles of general interest to Broadcast and Amateur SWLs, Transmitter Section and League affairs, etc. League supplies such as badges, headed notepaper and envelopes, QSL cards, etc., are available at reasonable cost. Send for League particulars. Membership including monthly magazines, etc., £3.75 per annum. (U.K. and British Commonwealth), overseas \$10.00 or £4.00. Secretary ISWL, 1 Grove Road, Lydney, Glos., GL15 5JE.

**MULLARD COMPONENTS.** Send s.a.e. for free list to P.M.S. Dept. REC3, P.O. Box 6, Crawley, Sussex, RH10 6LH.

**WANTED TO PURCHASE:** American "Popular Electronics" magazine for January, 1973. Good price paid. Box No. G314.

**NINE 7-SEGMENT DISPLAYS, £1.** Postage 15p. Two lots post free. In arrays of nine. With clock circuit. (For AY51224A clock I.C.). Mr. Bobker, 29 Chadderton Drive, Unsworth, Bury, Lancs.

(Continued on page 319)

## PRECISION POLYCARBONATE CAPACITORS

ALL HIGH STABILITY - EXTREMELY LOW LEAKAGE

440V AC (+10%)	63V DC Range	+1%	+2%	+5%	
0.1µF (1" x 1/2")	68p	0.47µF	£1.32	7p	51p
0.22µF (1" x 1/2")	86p	1.0µF	£1.56	9p	60p
0.25µF (1" x 1/2")	92p	2.2µF	£1.98	£1.32	£1.23
0.47µF (1" x 1/2")	£1.10	4.7µF	£2.82	£1.88	£1.47
0.5µF (1" x 1/2")	£1.16	6.8µF	£3.48	£2.32	£2.14
0.68µF (2" x 1/2")	£1.25	10.0µF	£4.98	£3.32	£2.01
1.0µF (2" x 1/2")	£1.37	15.0µF	£7.14	£4.78	£2.88
2.0µF (2" x 1/2")	£1.95	22.0µF	£9.66	£6.44	£3.90

\***TANTALUM BEAD CAPACITORS** - Values available: 0.1, 0.22, 0.47, 1.0, 2.2, 4.7, 6.8µF at 15V/25V or 35V; 10.0µF at 16V/20V or 25V; 22.0µF at 6V/10V or 16V; 33.0µF at 6V or 10V; 47.0µF at 3V or 6V; 100.0µF at 3V. ALL AT 12p EACH: 10 for £1.10; 50 for £5.00.

### TRANSISTORS:

BC107/8/9 9p    BC183/183L 11p    BF194 12p    BFY51 20p  
 BC114 12p    BC184/184L 12p    BF196 13p    BFY52 20p  
 BC147/8/9 10p    BC212/212L 12p    BF197 13p    OC71 20p  
 BC157/8/9 12p    BC547 12p    AF178 10p    2N3055 50p  
 BC182/182L 11p    BC558A 12p    BFY50 20p    2N3702/4 11p  
 1N914 6p; 8 for 45p; 18 for 90p. 1N916 8p; 6 for 45p; 14 for 90p.  
 IS44 5p; 11 for 59p; 26 for £1.00, IN4148 5p; 6 for 27p; 12 for 48p.

**LOW PRICE ZENER DIODES:** 400mW; Tol. +5% at 5mA. Values available: 3V; 3.6V; 4.7V; 5.1V; 5.6V; 6.2V; 6.8V; 7.5V; 8.2V; 9.1V; 10V; 11V; 12V; 13V; 13.5V; 15V; 16V; 18V; 20V; 22V; 24V; 27V; 30V. All at 7p each; 5 for 33p; 10 for 65p. SPECIAL: 100 Zeners for £6.00.

\***RESISTORS:** High stability low noise carbon film 5%, 1/2 W at 40°C; 1/2 W at 70°C. E12 series only - from 2.2Ω to 2.2MΩ ALL AT 1p EACH; 8p or 10 of any one value; 70p for 100 of any one value. SPECIAL PACK: 10 of each value 2.2Ω to 2.2MΩ (730 resistors) £5.00.

**SILICON PLASTIC RECTIFIERS** - 1.5 Amp - Brand new wire ended DO27: 100 P.I.V. - 7p (4/26p); 400 P.I.V. - 8p (4/30p).

**BRIDGE RECTIFIERS:** 2 1/2 Amp, 200V - 40p; 350V - 45p; 600V - 55p.

**SUBMINIATURE VERTICAL PRESETS** - 0.1W only: ALL AT 5p each; 50Ω, 100Ω, 220Ω, 470Ω, 680Ω, 1K, 2.2K, 4.7K, 6.8K, 10K, 15K, 22K, 47K, 100K, 220K, 680K, 1M, 2.5M, & 5M.

**PLEASE ADD 8% VAT TO ALL ITEMS EXCEPT THOSE MARKED WITH \* WHICH ARE 12 1/2%. PLEASE ADD 20p POST AND PACKING ON ALL ORDERS.**

Send S.A.E. for lists of additional ex-stock items. Wholesale price lists available to bona-fide companies. ALL EXPORT ORDERS PLEASE ADD COST OF SEA/AIR MAIL.

## MARCO TRADING

Dept. P1, The Old School, Edstaston, WEM, Salop. Tel: WHIXALL (Salop) 464/5 (STD 094872) (Props: Minicost Trading Ltd.).

# REVOR OPTICAL & TECHNICAL

42 TAVISTOCK STREET  
 LONDON W.C.2  
 Tel. 01-836 4536



£10.00

POST FREE

FLEXIBLE  
 MAGNIFIER

WITH CAST IRON BASE,  
 PRECISION GROUND AND  
 POLISHED LENS, CHROME PLATED  
 FRAME AND FLEXIBLE TUBE.  
 IDEAL FOR HOBBIES, AND  
 DETAILED WORK WHICH REQUIRES  
 BOTH HANDS FREE.

CALLERS WELCOME

(Subject to price ruling at the time of issue)

# THE OPEN DOOR TO QUALITY



This catalogue — Electrovalue Catalogue No. 8 (Issue 2, updated) offers items from advanced opto electronic components to humble (but essential) washers. Many things listed are elsewhere very difficult to obtain. The company's computer is programmed to expedite delivery and maintain customer satisfaction. Attractive discounts are allowed on many purchases. Access and Barclaycard orders are accepted. **+FREE POSTAGE** on all C.W.O. mail orders over £2.00 list value (ex. V.A.T.) in U.K. If under, add 15p handling charge.

**144 pages**  
Post paid  
**40p**  
inc. refund voucher worth **40p**

All communications to Dept. REC 12  
28 St Judes Rd, Englefield Green, Egham, Surrey TW20 0HH  
Phone: Egham 3603. Telex: 264475. Shop hours 9-5.30, 9-1 pm Sats.  
Northern Branch: 680 Burnage Lane, Burnage, Manchester  
M19 1NA. Phone: (061) 432 4845. Shop hours 9-5.30, 9-1 Sats.

## ELECTROVALUE LTD

**MULLARD FERRITE CORES** — LA3 100 to 500 kHz, 54p; LA5 30 to 100 kHz, 81p; LA7 <10 kHz, 81p; LA13 for W.W. Oscilloscope, £1.50.

**SPECIAL OFFER** — Metallised Polyester Capacitors by Erie, Mullard, etc. Values include: .01/160V, .01/250V, .015/160V, .022/160V, .033/160V, .047/160V, .068/160V, .1/160-250V, .22/160V, etc. This is a bargain not to be missed. 100 for £2.00.

1N4148 **SWITCHING DIODES**, 10 for 30p; 50 for £1.25; 100 for £1.50; 1,000 for £12.50.

**TRANSISTORS** — All branded BC147, BC148, BC149, BC157, BC158, BC159, BF194, BF195, BF196, BF197, 8p each or 100 for £8.00.

Please note all prices include UK Postage and appropriate VAT @ 8% or 12½%

MAIL ORDER ONLY  
**XEROZA RADIO**  
1 EAST STREET, BISHOP'S TAWTON, DEVON

OVER 2,000 ELECTRONIC COMPONENTS IN A

# BIG NEW FREE

## 100 PAGE CATALOGUE



**YOURS BY POSTING TODAY**

Please send me the 100 page Tandy catalogue

Name \_\_\_\_\_

Address \_\_\_\_\_

REC/5

# TANDY

Nationwide supermarket of sound!

Tandy Corporation (Branch UK), Bilston Road, Wednesbury, W Midlands WS10 2JN

Denco Coils, Tuning Gangs, TTL C'MOS, Quartz Crystal, Vero, DVM Chips, Clock Chips, LED's, LCD's Displays, Transformers, Boxes, Cases, Knobs and millions of R's and C's, Transistors and Diodes. Oh, I forgot... Audio IC's.

It's all in our brand new illustrated catalogue. With every copy are 36p worth of vouchers absolutely **FREE!**

Send 35p inc. Free p&p to:  
**DEPT 6, CHROMASONIC ELECTRONICS**  
56 Fortis Green Road, London, N10 3HN  
Telephone: 01-883 3705

### BINOCULAR MAGNIFIER

FOR PRECISION CLOSE-UP WORK - LEAVES BOTH HANDS FREE

2, 2½ or 3x Model with Winged Lens Mount

See close-up work with less eye strain. Lightweight adjustable headband. Powerful optically ground lenses. Can be worn over normal glasses. Essential Industry, Home Workshop, Collecting, Modelling, Jewellery, Watchmakers. Any fine work. DE LUXE model with superior quality lens. PLUS hinged lens mount. 2x model £9.95 + 75p p. & p., 2½x model £10.50 + 75p p. & p., 3x model £10.95 + 75p p. & p.

**£9.95**

### MICROJET WELDER

A TINY FLAME UP TO 5,000°F

WELDS BRASS & SOLDER

INC. FLAME TIPS

Precision tool using combination of butane and compressed oxygen or micronox. A pencil lead thin flame size, adjustable to 5,000°F. Cuts metals, welds, brazes and solders gold, silver. Ideal electricians, opticians, dentists, silversmiths, modelling, jewellery, clockmakers, electronic and computer servicing. Up to 40 minutes use on fuel supplied. Replacement set of 2 micronox. 1 butane cylinder: £1.65 extra inc. post. Our price £16.95 + 90p p. & p.

**£16.95**

**JOHN DUDLEY & CO. LTD., Dept RC8, 301 Cricklewood Lane, London NW2. Tel: 01-458 5917 Access accepted (Callers welcome)**

	ENAMELLED	COPPER	WIRE
swg	1 lb	4 oz	2 oz
14-19	2.40	.69	.59
20-29	2.45	.82	.69
30-34	2.60	.89	.64
35-40	2.85	1.04	.75

Inclusive of p & p and VAT

S.A.E. brings Catalogue of copper and resistance wires in all coverings.

**THE SCIENTIFIC WIRE COMPANY**  
PO Box 30, London E4 9BW

### H.M. ELECTRONICS

275a Fulwood Road, Broomhill  
SHEFFIELD S10 3BD Tel: 0742-669876

### BEC CABINETS (Book End Chassis)

Standard Cabinet	GB2 14" x 7" x 3"
GB1 14" x 6" x 2"	GB3 14" x 9" x 4"
GB1A 9" x 6" x 2"	GB4 14" x 9" x 6"

Send 15p for wallet of leaflets.

A beautifully designed modern cabinet with simulated black leatherette top (PVC bonded to metal) solid wooden end cheeks, with room at the back for Output Sockets etc, felt pads are fitted on bottom of cheeks for non-scratch.

### NO LICENSE EXAMS NEEDED

To operate this miniature, solid-state TRANSMITTER-RECEIVER kit. Only **£8.25** plus 20p p&p.

'Brain-freeze' 'em with a **MINISTROBE** kit, pocket-sized lightning flashes, vari-speed for discos and parties. A mere **£3.80** plus 20p p&p. Experiment with a psychedelic **DREAM LAB**, or pick up faint speech/sounds with the **BIG EAR** sound-catcher; ready-made modules. **£4.75** each plus 20p p&p.

LOTS MORE! Send 20p for lists. (Prices include V.A.T.) (Mail Order U.K. only).

Boffin Products (RC), 4 Cunliffe Rd, Stoneleigh, Ewell, Surrey

### EXPLORED VLF?

SEE WHAT'S ON 10-150 KHz with a VLF TUNER. Listen to CW weather forecasts, time signals, DX beacons etc. AF output. EASY to make, all parts, printed circuit, case etc, instructions, money back assurance, **ONLY £9.70 inc. post, £11.20 airmail.**

### CAMBRIDGE KITS

45(EM) OLD SCHOOL LANE,  
MILTON, CAMBRIDGE.



## SMALL ADVERTISEMENTS

(Continued from page 317)

**POSTAL ADVERTISING?** This is the Holborn Service. Mailing lists, addressing, enclosing, wrapping, facsimile letters, automatic typing, copy service, campaign planning, design and artwork, printing and stationery. Please ask for price list. - The Holborn Direct Mail Company Capacity House, 2-6 Rothsay Street, Tower Bridge Road, London, S.E.1. Telephone: 01-407 6444.

**FOR SALE:** Avo electronic multimeter £10.00. Avo Minor £7.00. Super 8 projector £5.00. Stereo cassette mechanism £10.00. Closed circuit television camera, not working £40.00. Video recorder, not working £50.00. Box No. G322.

**SPECIAL OFFER:** Limited number of Bound Volume No. 25 "Radio Constructor" (1971/1972) which were only slightly damaged in a fire at our warehouse. Price £1.25 each plus 75p postage and packing. Data Publications Ltd., 57 Maida Vale, London W9 1SN.

**FOR SALE:** 4½ in. reflector telescope, f/1900mm. Wooden tripod. 6mm. and 20mm. eyepieces. £50 o.n.o. Tony Weatherley, G3WDL, 16 Beverley Court, Carlton Colville, Lowestoft, Suffolk.

**FREQUENCY LIST TRANSFERS.** We have a limited supply of sheets of Dial Frequency Transfers in black. Short Wave frequencies 1.8Mc/s to 32Mc/s and 144Mc/s and 146Mc/s. Includes amateur band marker frequencies at 100kc/s points and other short wave frequencies from 2 to 32 Mc/s at every 500Kc/s points. Each frequency is repeated. Two sheets for 5p., five sheets for 10p., postage 7p. Data Publications Ltd., 57 Maida Vale, London, W9 1SN.

**WANTED:** Weymouth HH3 CMR1 coils, Jackson Dilemin variable capacitor ganged 192/78pF. Repanco I.F. trans. XT6. RA1, RA2 coils. FS3 slab aerial. J. H. O. Cull, 35, Belmont Road, Taunton, Somerset.

## PERSONAL

**JANE SCOTT FOR GENUINE FRIENDS.** Introductions to opposite sex with sincerity and thoughtfulness. Details free. Stamp to: Jane Scott, 3/Con North St. Quadrant, Brighton, Sussex, BN1 3GJ.

**SPONSORS** required for exciting scientific project. Norwich Astronomical Society are building a 30" telescope to be housed in a 20' dome of novel design. All labour being given by volunteers. Already supported by Industry and Commerce in Norfolk. Recreational. Educational. You can be involved. Write to: NAS Secretary, The Manse, Back Lane, Wymondham, Norfolk.

**IF YOU HAVE ENJOYED A HOLIDAY** on the Norfolk Broads, why not help to preserve these beautiful waterways. Join the Broads Society and play your part in determining Broadlands future. Further details from: - The Hon. Membership Secretary, The Broads Society, "Icknield," Hilly Plantation, Thorpe St. Andrew, Norwich, NOR 85S.

**ESSEX GARDENERS.** Buy your Bedding and rock plants, shrubs, etc., also cacti from May's Nurseries, 608 Rayleigh Road, Hutton, Brentwood, Essex. Callers only. Monday to Saturday.



**Random Flasher Unit**  
Wired ready for use  
Complete with three  
100 watt coloured lamps  
that flash independently  
at random  
**£18.95**



**TWIN BANK 6 LIGHT UNIT**  
(less lamps) LENGTH 14½ inches  
B.C. Fitting **£9.55**  
E.S. Fitting **£10.35**  
EACH



**Sound to Light MASTER UNIT** 600 WATTS PER CHANNEL  
**£30.95**  
INCLUDING CHANNEL OUTPUT PLUGS AND MAINS INPUT SOCKET



**TYPE A SPOT**  
(less lamp)  
B.C. Fitting **£1.95** EACH  
E.S. Fitting **£2.12** EACH



**TYPE B 3 BANK UNIT**  
(Less Lamps)  
B.C. Fitting **£6.90** EACH  
E.S. Fitting **£7.26** EACH



**TWIN BANK 12 LIGHT UNIT**  
Length 31¾  
(less lamps)  
B.C. Fitting **£15.60** EACH  
E.S. Fitting **£17.00** EACH

ALL PRICES INCLUDE V.A.T. and POST & PACKING (These prices apply to the United Kingdom only)

**ALBEN ENGINEERING CO. LTD.,**  
DEPT. RE THE CRESCENT, WORSTHORNE,  
BURNLEY, LANCS. Tel: Burnley 20940

Send 20p for illustrated leaflet & price list

Still the simplest, fastest way of constructing your electronic circuits. Vero Electronics Ltd manufacture boards to suit most of your requirements; including, Verostrip; Dual in line I.C. boards, Plain Boards, etc. A new catalogue is available (price 10p + S.A.E. at least 7" x 9")

# VERO BOARD

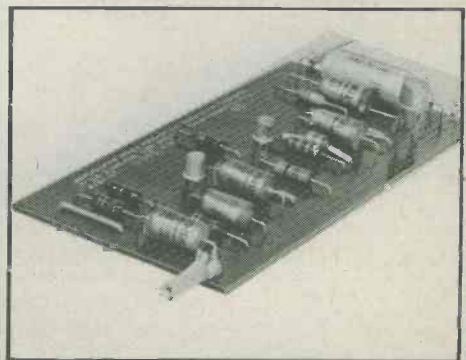

Vero Electronics Limited, Retail Dept.,  
Industrial Estate, Chandler's Ford, Hants., SO5 3ZR  
Telephone: Chandler's Ford 7956 (STD 04125)

# RADIO & ELECTRONICS CONSTRUCTOR

## Single Copies

Price 35p each, postage 11p

Issue(s) required .....

## Annual Subscription

Price £5.00, post free, commence with ..... issue

## Bound Volumes:

Vol. 27. August 1973 to July 1974	Price £2.40, post & pkg 75p
Vol. 28. August 1974 to July 1975	Price £2.75, post & pkg 75p
Vol. 29. August 1975 to July 1976	Price £3.10, post & pkg 75p

## CORDEX SELF-BINDERS

With title, 'RADIO & ELECTRONICS CONSTRUCTOR' on spine,  
maroon only Price £1.20, post & pkg 30p

With no title on spine, maroon Price £1.15, post & pkg 30p

With no title on spine, green Price £1.15, post & pkg 30p

*Prices include V.A.T.*

## DATA BOOK SERIES

DB5 TV Fault Finding, 132 pages Price 90p, P. & P. 18p

DB6 Radio Amateur Operator's Handbook,  
88 pages Price 70p, P. & P. 12p

DB17 Understanding Television, 504 pages Price £3.25, P. & P. 60p

DB19 Simple Short Wave Receivers  
140 pages Price 80p, P. & P. 18p

## STRIP-FIX PLASTIC PANEL SIGNS

Set 3: Wording — White Price 75p, P. & P. 7p

Set 4: Wording — Black Price 50p, P. & P. 7p

Set 5: Dials Price 38p, P. & P. 7p

*Prices include V.A.T. on Panel Signs*

I enclose Postal Order/Cheque for.....in payment for .....

NAME .....

ADDRESS .....

(BLOCK LETTERS PLEASE)

*Postal Orders should be crossed and made payable to Data Publications Ltd.*

*Overseas customers please pay by International Money Order.*

*All publications are obtainable through your local bookseller*

**Data Publications Ltd., 57 Maida Vale, London W9 1SN**

**PLEASE MENTION THIS MAGAZINE WHEN WRITING TO ADVERTISERS**