

THE
RADIO CONSTRUCTOR

Vol 20 No 6

JANUARY 1967
2/6

A DATA PUBLICATION

RADIO · TELEVISION
ELECTRONICS · AUDIO

Linear Scale Audio Frequency Meter

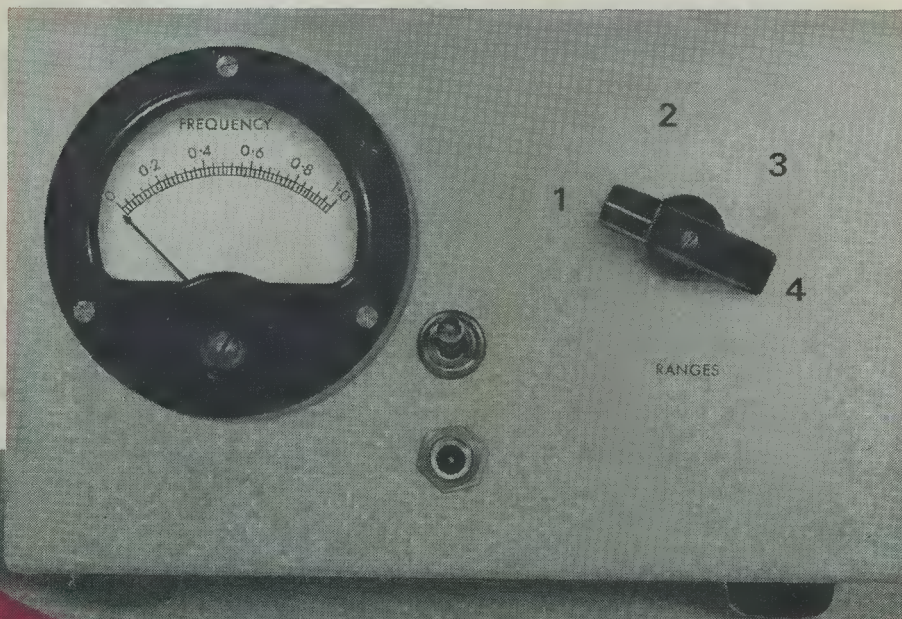

- WIDE BAND PHOTOPHONE
- TELEPHONE BELL REPEATER
- TRANSISTOR CURVE TRACER
- ELECTRONIC FLASHER UNIT

Scottish Insurance Corporation Ltd

66-67 CORNHILL · LONDON · EC3



*TELEVISION
SETS,
RECEIVERS
AND
TRANSMITTERS*

Television Sets, Receivers and Short Wave Transmitters are expensive to acquire and you no doubt highly prize your installation. Apart from the value of your Set, you might be held responsible should injury be caused by a fault in the Set, or injury or damage by your Aerial collapsing.

A "Scottish" special policy for Television Sets, Receivers and Short Wave Transmitters provides the following cover:

- (a) Loss or damage to installation (including in the case of Television Sets the Cathode Ray Tube) by Fire, Explosion, Lightning, Theft or Accidental External Means at any private dwelling-house.
- (b) (i) Legal Liability for bodily injury to Third Parties or damage to their property arising out of the breakage or collapse of the Aerial Fittings or Mast, or through any defect in the Set. Indemnity £10,000 any one accident.
- (ii) Damage to your property or that of your landlord arising out of the breakage or collapse of the Aerial Fittings or Mast, but not exceeding £500.

The cost of Cover (a) is 5/- a year for Sets worth £50 or less, and for Sets valued at more than £50 the cost is in proportion. Cover (b) (i) and (ii) costs only 2/6 a year if taken with Cover (a), or 5/- if taken alone.

Why not BE PRUDENT AND INSURE your installation—it is well worth while AT THE VERY LOW COST INVOLVED. If you write to the Corporation's Office a proposal will be submitted for completion.

Write for full details, quoting reference 5304, to:—

**THE MANAGER
SCOTTISH INSURANCE CORPORATION LTD.,
66-67 CORNHILL, LONDON E.C.3**

NEW FROM SINCLAIR

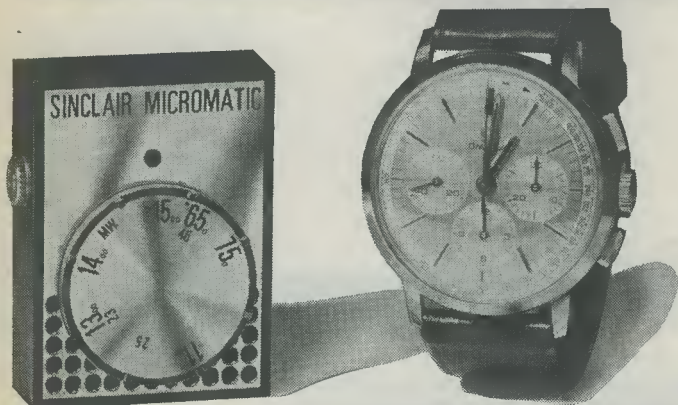

*The
World's
smallest
radio*

ACTUAL SIZE

- * ONLY ONE CONTROL
- * CALIBRATED DIAL
- * SIZE — $1\frac{1}{2}$ " x $1\frac{1}{8}$ " x $\frac{1}{2}$ "
- * POLISHED ALUMINIUM FRONT PANEL WITH SPUN ALUMINIUM DIAL
- * AMAZING RANGE POWER & SENSITIVITY
- * NEW CIRCUITRY
- * BANDSPREAD FOR EASY RECEPTION OF 'POP' STATIONS
- * A.G.C.
- * IN KIT FORM OR READY BUILT
- * 5 YEAR GUARANTEE

SINCLAIR MICROMATIC

Here is a brand new design from an organisation world famous for its production of micro electronic equipment for the constructor. This new set, the SINCLAIR MICROMATIC reaches fantastically high standards of performance. In it, we have combined new circuitry with new elegance to make this set professionally right in every detail whether you build it yourself or buy it ready built. It is the perfect personal radio, ready to serve wherever and whenever required. Reception from a wide range of stations is assured with excellent selectivity and quality. The MICROMATIC is a set you will be proud to be seen using—and it makes an excellent gift too.

Six stage transistor circuit of remarkable power and sensitivity. Two R.F. stages are followed by double diode detector and 3 stages of audio-amplification A.G.C. counteracts fading from distant stations. Ferrite rod aerial and two Mallory cells type ZM. 312 are contained in the minute case. Tunes over M.W. Dial marked in Kc/s and metres. Inserting plug of earpiece switches set on.

Complete Kit inc. Case, Transistors, earpiece, and instructions.

59/6

Ready built in presentation case with earpiece

79/6

Guarantee
Should you not be completely satisfied with your purchase when you receive it from us, your money will be refunded in full and at once without question. Please quote RC167 should you prefer to write your order instead of cutting out this coupon.

FULL SERVICE FACILITIES AVAILABLE TO SINCLAIR CUSTOMERS.

SINCLAIR MICRO FM 7 Transistor FM superhet for use both as tuner and independent pocket radio. Easy to build. Needs no alignment. With telescopic aerial. Case size less than $3"$ x $2\frac{1}{2}"$ x $\frac{3}{8}"$. Complete kit inc. earpiece and instructions.

£5.19.6

SINCLAIR Z-12 AMPLIFIER Measures only $3"$ x $1\frac{1}{2}"$ x $1\frac{1}{2}"$ including integrated pre-amp. 12 watts R.M.S. output continuous sine wave. Ready-built with manual of input matching and control circuits.

89/6

SINCLAIR STEREO 25 De Luxe pre-amp/control unit for use with two Z.12s or any high quality stereo amplifier. Size $6"$ x $2\frac{1}{2}"$ x $2\frac{1}{2}"$ with brushed and polished aluminium front and solid aluminium knobs Ready built.

£9.19.6

sinclair

SINCLAIR RADIONICS LIMITED
22 NEWMARKET ROAD, CAMBRIDGE
Telephone: OCA3-52731

SINCLAIR RADIONICS LTD., 22 NEWMARKET ROAD, CAMBRIDGE

Please send

NAME

ADDRESS

for which I enclose cash/cheque/money order
value £.....s.....d.

RC167

HI-FI AMPLIFIERS ~~~~~ TUNERS ~~~~~ RECORD PLAYERS

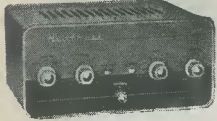

**3+3W
STEREO
AMP.
S-33H**

10W POWER AMPLIFIER. Model MA-12. 10W output, wide freq. range, low distortion. For use with control unit. Kit **£12.18.0** Assembled **£16.18.0**

3 + 3W STEREO AMPLIFIER. Model S-33. An easy-to-build, low cost unit. 2 inputs per channel. Kit **£13.7.6** Assembled **£18.18.0**

DE LUXE STEREO AMPLIFIER. Model S-33H. De luxe version of the S-33 with two-tone grey perspex panel, and higher sensitivity necessary to accept the Decca Deram pick-up. Kit **£15.17.6** Assembled **£21.7.6**

HI-FI STEREO AMPLIFIER. Model S-99. 9 + 9W output. Ganged controls. Stereo/Mono gram., radio and tape inputs. Push-button selection. Printed circuit construction. Kit **£28.9.6** Assembled **£38.9.6**

TRANSISTOR PA/GUITAR AMPLIFIER, PA-2. 20W amplifier. Four inputs. Variable tremolo. New Low Price Kit **£39.19.0** Assembled **£54.10.0**

50W VALVE PA/GUITAR AMP., PA-1. Kit **£54.15.0** Assembled **£74.0.0**



**10W
POWER
AMP.
MA-12**



**GARRARD
PLAYER
AT-60**

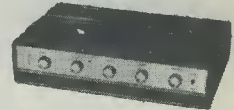

**20+20W
STEREO
AMP.
AA-22U**

TRANSISTOR MIXER. Model TM-1. A must for the tape enthusiast. Four channels. Battery operated. Similar styling to Model AA-22U Amplifier. With cabinet. Kit **£11.16.6** Assembled **£16.17.6**

20+20W TRANSISTOR STEREO AMPLIFIER. Model AA-22U. Outstanding performance and appearance. Kit **£39.10.0** (less cabinet). Assembled **£57.10.0** Attractive walnut veneered cabinet **£2.5.0** extra.

GARRARD AUTO/RECORD PLAYER. Model AT-60. less cartridge **£13.1.7** With Decca Deram pick-up **£17.16.1** incl. P.T. Many other Garrard models available, ask for Lists.

HI-FI MONO AMPLIFIER. Model MA-5. A general purpose 5W Amplifier, with inputs for Gram., Radio. Attractive modern styling. Kit **£11.9.6** Assembled **£15.15.0**



The World Leader in Quality Kitsets

Easy-to-follow instruction manuals show you how to build the models

INSTRUMENTS

3" LOW-PRICED SERVICE OSCILLOSCOPE. Model OS-2. Compact size 5" x 7 1/2" x 12" deep. Wt. only 9 1/2 lb. "Y" bandwidth 2 c/s-3 Mc/s ± 3dB. Sensitivity 100mV/cm. T/B 20 c/s-200 kc/s in four ranges, fitted mu-metal CRT Shield. Modern functional styling. Kit **£23.18.0** Assembled **£31.18.0**

5" GEN-PURPOSE OSCILLOSCOPE. Model 10-12U. An outstanding model with professional specification and styling. "Y" bandwidth 3 c/s-4.5 Mc/s ± 3dB. T/B 10 c/s-500 kc/s. Kit **£35.17.6** Assembled **£45.15.0**

E LUXE LARGE-SCALE VALVE VOLT-METER. Model IM-13U. Circuit and specification based on the well-known model V-7A but with many worth-while refinements. 6" Ernest Turner meter. Unique gimbal bracket allows operation of instrument in many positions. Modern styling. Kit **£18.18.0** Assembled **£26.18.0**

AUDIO SIGNAL GENERATOR. Model AG-9U. 10 c/s to 100 kc/s, switch selected. Distortion less than 0.1%, 10V sine wave output metered in volts and dB's. Kit **£23.15.0** Assembled **£31.15.0**

VALVE VOLTMETER. Model V-7A. 7 voltage ranges d.c. volts to 1,500. A.c. to 1,500 r.m.s. and 4,000 peak to peak. Resistance 0.1Ω to 1,000MΩ with internal battery. D.c. input resistance 11MΩ. dB measurement, has centre-zero scale. Complete with test prods, leads and standardising battery. Kit **£13.18.6** Assembled **£19.18.6**

MULTIMETER. Model MM-1U. Ranges 0-1.5V to 1,500V a.c. and d.c.; 150μA to 15A d.c.; 0.2Ω to 20MΩ. 4 1/2" 50μA meter. Kit **£12.18.0** Assembled **£18.11.6**

R.F. SIGNAL GENERATOR. Model RF-1U. Up to 100 Mc/s fundamental and 200 Mc/s on harmonics. Up to 100mV output. Kit **£13.18.0** Assembled **£20.8.0**

SINE/SQUARE GENERATOR. Model IG-82U. Freq. range 20 c/s-1 Mc/s in 5 bands less than 0.5% sine wave dist. less than 0.15μ sec. sq. wave rise time. Kit **£25.15.0** Assembled **£37.15.0**

TRANSISTOR POWER SUPPLY. Model IP-20U. Up to 50V, 1.5A output. Ideal for Laboratory use. Compact size. Kit **£35.8.0** Assembled **£47.8.0**

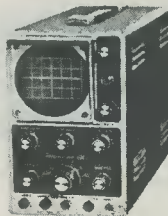

OS-2

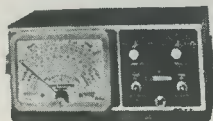

IM-13U



V-7A



RF-1U

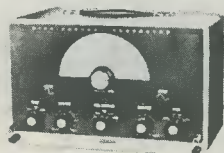

IG-82U

Prices and specifications subject to change without notice

Complete your motoring pleasure with this outstanding CAR RADIO, Model CR-1



Will give you superb LW and MW entertainment wherever you drive. Tastefully styled to harmonise with any car colour scheme. Available for your convenience in two separate parts, RF Amp. Kit **£1.13.6** incl. P.T. IF/AF Amp. Kit **£1.13.6**

Total Price Kit (excl. Loudspeaker) £12.17.0 incl. P.T. 8" x 5" Loudspeaker **£1.16.1** incl. P.T.

TRANSISTOR RADIOS

"OXFORD" LUXURY PORTABLE. Model UXR-2. Specially designed for use as a domestic, car or personal portable receiver. Many features, including solid leather case. Kit **£14.18.0** incl. P.T.

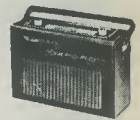

UXR-2

TRANSISTOR PORTABLE. Model UXR-1. Pre-aligned I.F. transformers, printed circuit. Covers L.W. and M.W. Has 7" x 4" loudspeaker. Real hide case. Kit **£12.11.0** incl. P.T



UXR-1

JUNIOR EXPERIMENTAL WORKSHOP Model EW-1. More than a toy! Will make over 20 exciting electronic devices, incl: Radios, Burglar Alarms, etc. 72 page Manual. The ideal present! Kit **£7.13.6** incl. P.T.

STEREO TRANSISTOR FM TUNER. (Mono version also available)

Designed to match the AA-22U Amplifier. Available in separate units, can be built for a total price.

Kit (Stereo) **£24.18.0** incl. P.T.

Kit (Mono) **£20.19.0** incl. P.T.

Cabin extra **£2.5.0**.

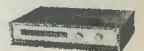

FM Tuner

WELCOME TO OUR LONDON HEATHKIT CENTRE 233 Tottenham Court Road, W.1

We open MONDAY - SATURDAY 9 a.m. - 5.30 p.m.
THURSDAY ... 11 a.m. - 2.30 p.m.

Telephone No: MUSEum 7349

WHEN YOU ARE IN TOWN, WE HOPE YOU WILL VISIT US THERE

TAPE AMPLIFIERS ~~~~~ TAPE DECKS ~~~~~ CONTROL UNITS



**FM
TUNER
FM-4U**



**MAGNAVOX
DECK**

HI-FI FM TUNER. Model FM-4U. Available in two units. R.F. tuning unit (£2.15.0 incl. P.T.) with I.F. output of 10.7 Mc/s, and I.F. amplifier unit, with power supply and valves (£13.13.0). May be used free standing or in a cabinet. Total Kit **£16.8.0**
(Multiplex adapter available, as extra.)

HI-FI AM/FM TUNER. Model AFM-1. Available in two units which, for your convenience, are sold separately. Tuning heart (AFM-T1—£4.13.6 incl. P.T.) and I.F. amplifier (AFM-A1—£22.11.6). Printed circuit board, 8 valves. Covers L.W., M.W., S.W., and F.M. Built-in power supply. Total Kit **£27.5.0**
(Multiplex adapter available, as extra.)

MAGNAVOX "363" TAPE DECK. The finest buy in its price range. Operating speeds: 1½", 3¼" and 7½" p.s. Two tracks, "wow" and "flutter" not greater than 0.15% at 7½" p.s. **£13.10.0**
MAGNAVOX deck with **TA-IM** Kit **£31.5.6**

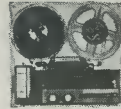

**TRUVOX
DECK**

TRUVOX D-93 TAPE DECKS. High quality stereo/mono tape decks. D93/2, ¼ track, **£36.15.0** D93/4, ¼ track, **£36.15.0**

TAPE RECORDING/PLAYBACK AMPLIFIER
Mono Model TA-IM kit **£19.18.0** Assembled **£28.18.0**
Stereo Model TA-IM kit **£25.10.0** Assembled **£35.18.0**

HI-FI CABINETS. A wide range available for example: Malvern Kit **£18.1.0** incl. P.T.

MONO CONTROL UNIT. Model UMC-1. Designed to work with the MA-12 or similar amplifier requiring 0.25V or less for full output. 5 inputs. Baxandall type controls. Kit **£9.2.6** Assembled **£14.2.6**

STEREO CONTROL UNIT. Model USC-1. Push-button selection, accurately matched ganged controls to ±1dB. Rumble and variable low-pass filters. Printed circuit boards. Kit **£19.19.0** Assembled **£27.5.0**

First in dependability - first in performance

Convenient credit terms available in U.K. over £10



SSU-1

SPEAKER SYSTEMS

HI-FI SPEAKER SYSTEM. Model SSU-1. Ducted-port bass reflex cabinet "in the white". Two speakers. Vertical or horizontal models with legs, Kit **£12.12.0**, without legs, Kit **£11.17.6** incl. P.T.

THE BERKELEY Slim-line SPEAKER SYSTEM, fully finished walnut veneered cabinet for faster construction. Special 12" bass unit and 4" mid/high frequency unit. Range 30-17,000 c/s. Size 26" x 17" x only 7½" deep. Modern attractive styling. Excellent value. Kit **£19.10.0** Assembled **£24.0.0**

COTSWOLD SPEAKER SYSTEMS. Outstanding performance for price.

MFS: Size 36" x 16¼" x 14" deep. Kit **£25.12.0** Assembled **£33.17.0**

STANDARD: Size 26" x 23" x 14¼" deep. Kit **£25.12.0** Assembled **£33.17.0**



Berkeley

MULTIPLEX DECODER, SD-1

for receiving Stereo FM.
Convert your existing FM Mono receiver to stereo with this low-cost, self-powered unit. Fully transistorised. Styled to match Heathkit models FM-4U and AFM-1 Tuners.

Kit **£8.10.0** Assembled **£12.5.0**
Styled to match British Heathkit models.

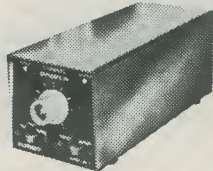

SD-1

SEND FOR THE LATEST FREE CATALOGUE

INSTRUMENT AND AMATEUR RADIO BROCHURES
AVAILABLE ON REQUEST

Prices quoted are Mail Order prices.

DAYSTROM LTD DEPT. RC.1
GLOUCESTER

"AMATEUR" EQUIPMENT

THE "MOHICAN" GENERAL COVERAGE RECEIVER. Model GC-1U. With 4 piezo-electric transmitters, variable tuned B.F.O. and Zener diode stabiliser, this is an excellent fully transistorised general purpose receiver for Amateur and Short wave listeners. Printed circuits, telescopic aerial, tuning meter and large slide-rule dial. Kit **£37.17.6** Assembled **£45.17.6**

AMATEUR BANDS RECEIVER. Model RA-1. To cover all the Amateur Bands from 160-10 metres. Many special features, including: half-lattice crystal filter; 8 valves; signal strength "S" meter; tuned R.F. Amp. stage. Kit **£39.6.6** Assembled **£52.10.0**

160-10M TRANSMITTER. Model DX-100U. Careful design has achieved high performance and stability. Completely self-contained. Kit **£81.10.0** Assembled **£106.15.0**

COMMUNICATIONS TYPE RECEIVER. Model RG-1. A high performance, low cost receiver for the discriminating listener. Frequency coverage: 600 kc/s-1.5 Mc/s and 1.7 Mc/s-32 Mc/s. Kit **£39.16.0** Assembled **£53.0.0**

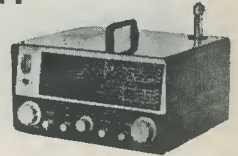

GC-1U

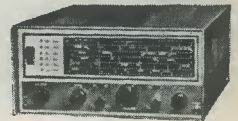

RG-1

NEW! Hi-Fi Models. 'AVON' The Mini Speaker System with Hi-Fi performance.

Only 7¼" wide x 13¼" high x 8¼" deep. Specially designed Walnut veneered finished cabinet kit **£8.18.0**.
Two speaker system and crossover network **£4.18.0**.
Total price kit **£13.16.0**.

Low-cost 3 + 3W Transistor Stereo Amplifier, TS-23
Has all the essential features for good quality reproduction from gram, radio and other sources.

Kit (less cabinet) **£17.15.0**.
Kit (with handsome finished cabinet) **£18.19.0**.

Without obligation please send me
FREE BRITISH HEATHKIT CATALOGUE.....

(Tick here)

FULL DETAILS OF MODEL(S).....
(Please write in BLOCK CAPITALS)

NAME

ADDRESS

DEPT. RC.1

A Mullard inspiration
**10 + 10
 STEREO**

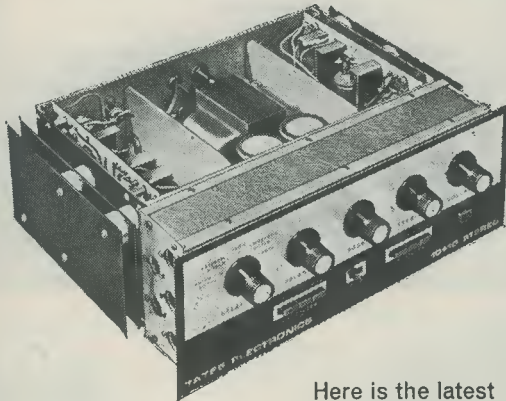

Here is the latest
 from Mullard's
 top designers
 — the 10 + 10 Stereo

This remarkable pi-mode stereo amplifier has been engineered by Bates to very high standards. Gain experience and enjoyment in the thrill of constructing this superb amplifier. Undoubtedly a piece of electronic precision, the Mullard designed 10 + 10 costs no more than ordinary equipment and building can commence for as little as £3 7 6d (Total kit price 38 guineas). Circuits, parts lists and assembly procedure are fully detailed in the 10 + 10 Construction Manual.

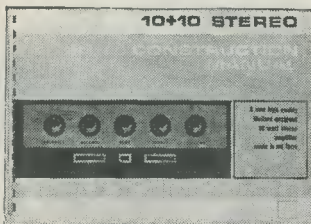

**Construction
 Manual.**
 Send for your
 copy today,
 12/6d. post paid.

Tates Electronic Services Ltd., Waterloo Road, Stockport,
 Cheshire. Telephone: Stockport 7301

**TATES
 ELECTRONICS**

BOUND VOLUME No. 19
 of "The Radio Constructor"
FOR YOUR LIBRARY

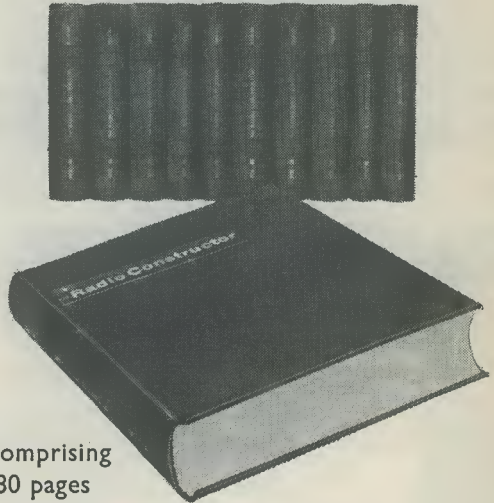

Comprising
 780 pages
 plus index

Volume 19

August 1965 to July 1966

PRICE 30/- Postage 4/6

Special discount of 10/- for regular readers

Where the 12 monthly issues making up the
 volume are returned, the price is only 20/-
 plus 4/6 postage

Available only from:—

Data Publications Ltd.
57 Maida Vale London W9

T.R.S. BARGAINS IN KITS, COMPONENTS AND EQUIPMENT

2 FAMOUS MULLARD AMPLIFIERS

Mullard design with T.S.R. kits for value

MULLARD "3-3" 3-valve Hi-Fi quality at reasonable cost. Bass Boost and Treble controls, quality sectional out-put transformer (3 and 15 ohms), 40 c/s.-25 kc/s.+ 1 dB. 100 mV. for 3W., less than 1% distortion. Bronze escutcheon panel. Complete Kit only £7 10s.0d. Carr. 5/-. Wired and tested £9 10s.0d.

MULLARD "5-10" 5 valves 10 W., 3 and 15 ohms output. Mullard's famous circuit with heavy duty ultra-linear quality output transformer. Basic amplifier kit price £9/19/6. Carr. 7/6. Ready built 11½ gns.

7 VALVE AM/FM RADIOGRAM CHASSIS

3 wave-band L/M/FM. Permeability tuning on F.M. Large clear dial A.V.C., good neg. feedback. Magic eye. 3 w. output. A.C. 200/250 v. Circuit diagrams available. Aligned, tested and ready for use £13/19/6 (Carr. and ins. 7/6). S.A.E. brings full details.

GARRARD UNITS AND PLINTHS. LM3000 with 9TA 8gns. Stereo Cartridge AT.60 De Luxe-12" Cast Turntable less cartridge 9½gns. SP.25 De Luxe, less cartridge 9gns. Packing and Carr. 7/6 each.

GARRARD PLINTHS to take any of above, with plastic cover £3 15s.0d. C/P/5/-. Garrard Cartridges—Mono from 15/- Stereo from 25/- Post free.

MISCELLANEOUS—continued

VOLUME CONTROLS. LOG and LINEAR.—5K-2 MΩ 3" Spindles Morganite Midget Type 1½" diam. Guar. 1 year. LOG or LIN ratios less Sw., 3/6. DP. Sw. 5/-. Twin Stereo less Sw., 7/6. D.P. Sw., 9/6 (100k to 2 Meg. only).

RESISTORS—Modern ratings full range 10 ohms to 10 megohms, 20% ±½ w. 3d. ea., ditto 1 w. 6d. ea., 2 w. 9d. ea., 10% ±½ w. 4d. ea., 5% Hi-stab., ±½ w. 6d. ea. (below 100 ohms and over 1 meg. 9d. ea.) 2% Hi-stab., ½ w. 1/6 ea. (below 100 ohms. 2/- ea.).

ERSIN MULTICORE SOLDER. 60/40 4d. per yard. Cartons 6d., 1/-, 2/6, etc.

WIREWOUND RESISTORS. 25 ohm to 10 K. 5 w. 1/3, 10 w. 1/6, 15 w. 2/-. **CONDENSERS** Silver Mica. All values 2 pf. to 1,000 pf. 6d. ea. Ditto ceramics 9d. Tub. 450 v. T.C.C., etc. .001 mfd to .01 10d. and .1/350 v. 10d. .02 MF to 0.1MF. 500 v. 1/-. .25 T.C.C. 1/9. .5 T.C.C. 2/-.

ENAMELLED COPPER WIRE—2 oz. reels 14 g.-20 g. 3/-; 22 g.-28 g. 3/6; 30 g.-34 g. 4/3; 36 g.-38 g. 4/9; 39 g.-40 g. 5/-. etc..

TINNED COPPER WIRE. 16-22 g. 4/- 2 oz.

BONDACOUST Speaker Cabinet Acoustic Wadding (1" thick approx.) 18" wide, any length cut, 6/- yd.

VEROBOARD—All sizes including 24" x 5", 3/8; 24" x 3½", 3/-; 33" x 5", 5/4; 32" x 3½", 3/8; 3½" x 17", 12/6. All accessories and tools in stock.

TYGAN FRET (Contem. pat.) 12" x 12", 2/-; 12" x 18", 3/-; 12" x 24", 4/- etc.

SEND 3d

FOR COMPREHENSIVE LISTS SHOWING FULL RANGES OF OUR VERY LARGE STOCKS AT BARGAIN PRICES.

★★★ T.R.S. F.M. STEREO DECODER

Based on Mullard design and produced by T.R.S. Built-in stereo indicator. 6-transistor model, readily adaptable for use with valve tuners as well. For 9-15v. operation. Complete kit with Mullard specified inductors already aligned. £5 5s.0d. (p.p. 2/6).

WE ARE SINCLAIR SPECIALISTS

We carry full stocks of these world-famous all-British designs as advertised and give prompt delivery.
MICRO-6 Six stage vest-pocket rcvr. (Kit)... 59/6
MICRO-FM 7 transistor FM tuner-rcvr. (Kit) £5 19 6
Z.12 combined 12w. amp and pre-amp, built 89/6
STEREO 25 de luxe pre-amp/control unit (stereo) built£9 19 6

"CIR-KIT" INSTANT CIRCUITS

Indispensable for constructors. Enables you to produce "printed circuits" quickly and cleanly. Kit No. 3 inc. baseboard, processed copper scrip and sheet as advertised.

15/-

6 VALVE A.M./F.M. TUNER UNIT

In Kit Form with or without Power Pack

Med. 190 m. 550 m. V.H.F.—86 Mc/s-103 Mc/s. 6 valves and metal rectifier. Self-contained power unit. Magic-eye, 3 push-button controls, on/off, Med., V.H.F. Diodes and high output sockets with gain control. Illuminated 2-colour perspex dial 1½" x 4" chassis size 1½" x 4" x 5½". Strongly recommended for use with Mullard amplifiers below. For A.C. mains 200/250 v. Unbeatable value. Complete kit, inc. Power Pack as illustrated, 11gns. Carr. 7/6. Ditto less Power Pack 10gns. Carr. 7/6. Circuit and Const. details 4/6. Free with kit.



TRANSFORMER MANUFACTURING SERVICE

We manufacture all types Radio Mains, Transformer, Quality O/P Trans., etc. Enquiries invited for specials, prototypes for small production runs. Quotations by return.



Established 1946
RADIO COMPONENT SPECIALISTS
70 Brigstock Rd, Thornton Heath, Sy

Telephone THO 2188. Hours 9.0 a.m.—6.0 p.m. daily, 1.0 p.m. Wed.

THE MODERN BOOK CO

Radio Valve Data. Compiled by "WW" 8th ed. 9s. 6d. Postage 1s.

Transistor Pocket Book. By R. G. Hibberd. 25s. Postage 1s.

Questions and Answers Audio. By C. Brown 8s. 6d. Postage 8d.

Pick Ups the Key to Hi-Fi. By J. Walton 10s. Postage 6d.

Guide to Broadcasting Stations. Compiled by "WW". 6s. Postage 6d.

Wireless for Beginners. By C. L. Boltz revd. by T. Roddam. 18s. Postage 1s.

Rapid Servicing of Transistor Equipment. By G. J. King. 30s. Postage 1s. 6d.

Tape Recorder Servicing Manual. By H. W. Hellyer. 63s. Postage 2s. 6d.

Amateur Radio Call Book 1967 ed. By RSGB. 6s. Postage 9d.

Guide to Amateur Radio. RSGB. 5s. Postage 9d.

Transistor Transmitters for the Amateur By D. L. Stoner. 21s. Postage 1s.

Questions and Answers Electronics. By C. Brown. 8s. 6d. Postage 8d.

Basic Digital Computer Concepts. By D. Whitworth. 25s. Postage 1s.

Questions and Answers Transistors. By C. Brown. 8s. 6d. Postage 8d.

Radio Servicing Vol. 4. By G. N. Patchett 8s. 6d. Postage 6d.

Introduction to Lasers and Masers. By A. Lytel. 16s. Postage 1s.

Wireless Servicing Manual. By W. T. Cocking. 25s. Postage 1s. 6d.

Basic Oscillator Handbook. By N. H. Crowhurst. 21s. Postage 1s.

Circuits for Audio and Tape Recording. By F. C. Judd. 7s. 6d. Postage 1s.

Valve and Cathode Ray Tube Manual No. 10. By Brimar. 7s. 6d. Postage 1s.

We have the Finest Selection of English and American Radio Books in the Country

19-21 PRAED STREET (Dept RC) LONDON W2

Telephone PADdington 4185



IMPROVE YOUR HOME RECEPTION

For 1967

UNBEATABLE VALUE FOR YOU, AS A READER OF THE RADIO CONSTRUCTOR
 Something for the womenfolk! 'Dull radio bits and pieces' represent junk to most of the fairer sex, but now this **INTRODUCTORY OFFER** puts YOU and your hobby on a new plane

**THE NEW
 TOLTEC
 Debutante
 HAIR DRYER**



SPECIFICATION

Moulded in beautiful symmetrical pastel blue impact resisting thermoplastic casing.

Quiet in operation.

Hot or cold air.

No radio or T.V. Interference—meets British standard specification.

Fitted with safety cut-out.

12 months & money refund guarantee. 230-250 volts A.C. only.

Value 80/9 in the shops

Send the coupon below with the sum of only 52/6 (plus 4/6d to cover postage, packing and insurance, unless you are collecting personally) to:—

**THE TOLTEC ELECTRONIC & TRADING CO. LTD.,
 HATTON HOUSE, HURST GREEN, SUSSEX**

If you are not delighted with your purchase, its price will be refunded if the appliance is carefully replaced in its mail-order pack and returned safely within seven days.

GET YOUR APPLICATION AWAY TODAY

**THE RADIO CONSTRUCTOR
 TOLTEC HAIR DRYER OFFER
 INTRODUCTORY VOUCHER WORTH 28/3**



ESTABLISHED

1865

Savings in this old established Building Society combine sound investment with an attractive return

THE DUCHESS OF KENT PERMANENT BUILDING SOCIETY

Member of the Building Societies Association

Shares are in units of £25 each (maximum investment £5,000) . . . BUT, for the smaller saver, Subscription Share accounts may be opened with any sum from 1/- upwards. Interest is payable half-yearly on Fully Paid Shares—credited annually on Subscription Shares—all interest accrues monthly

Withdrawals at short notice

INTEREST IS AT 4% PER ANNUM

(There is NO DEDUCTION FOR INCOME TAX, as this is paid by the Society)

For further information apply to
**DUCHESS OF KENT
 PERMANENT BUILDING SOCIETY
 289/293 Regent Street London W1
 Telephone MUSEum 4876-9**

Please send to me, without obligation, free brochure and a copy of the audited statement of accounts. (I understand that I shall not be troubled with calls by representatives)

Name
 (If lady, please state Mrs. or Miss)

Address

.....R.C.
 (Please use Block Capitals for both name and address)

BI-PAK SEMICONDUCTORS

8 RADNOR HOUSE
93/97 REGENT STREET
LONDON, W.1

★ **VALUE PAKS for '67**
NEW, UNTESTED

LOW COST SILICON CONTROLLED RECTIFIERS (THYRISTORS) FACTORY TESTED
 1 AMP (TO-5 can) 7 AMP (STUD) 16 AMP (STUD) Free SCR Literature including
 PIV EACH PIV EACH PIV EACH Circuit Diagrams for Light
 508/6 10016/6 40030/- Dimmers, Speed Controllers,
 1009/6 40035/- 40030/- A.C. Motor Switch, etc., with
 20022/6 40045/- 60055/- SCR orders or on request.
 40022/6 400 PIV Power SCR 30 Amp. Special Price.....80/-

FREE One 10/- Pack of your own choice free with orders valued £4 or over **FREE** LOGIC MODULES and/or, Gates, Memory Units, Timer Units, etc., details free **FREE**

VALUE PAK 50	TRANSISTORS MIXED UNTESTED	10/-	10SCR's	UNMARKED UNTESTED VOLTAGE RANGE 1 Amp 50-400 PIV	20/-
3 OC139 Trans. NPN Mullard	10/-	3 High vit. AF Trans. PNP ACY17	15/-	5 Sil. Rect. 750mA 100 PIV TEXAS	15/-
2 Drift Trans. 2N 1225 100 M/Cs PNP	10/-	3 BSY95A Sil. Trans. STC	15/-	3 Sil. Trans. OC200 Mullard	15/-
6 Matched Trans. OC44/45/81/BID	10/-	2 Sil. Power Rect. 6 Amp. 200 PIV BYZ13	15/-	1 AF139 GERM. Trans. 1500 M/Cs	15/-
4 OA10 Diodes Mullard	10/-	1 Sil. Power Trans. 100 M/Cs TK201A NPN	15/-	6 Zener Diodes 3-15 Vts. Mixed 400mW	15/-
15 Red Spot AF Trans. PNP	10/-	5 OA5 Gold Bonded Diodes Mullard	15/-	1 2N1132 PNP PLANAR Trans. Sil.	15/-
5 White Spot RF Trans. PNP	10/-	2 2N697 NPN PLANAR Trans. Sil.	15/-	4 GERM. Power Trans. eqvt. OC16 Mullard	15/-
4 Sil. Rects. 3A 100/400 PIV	10/-	1 UNIJUNCTION Trans. 2N646 G.E.	15/-	2 Sil. Trans. 60VCB 200 M/Cs. ZT83/84	15/-
4 NPN Trans. OC139 ZN1302, ETC.	10/-	1 Sil. PLANAR Trans. BSY25 NPN 1000M/Cs	15/-	1 Sil. Trans. IS104 150 M/Cs HFE 200 NPN	15/-
2 10 Amp. Sil. Rect. 50/100 PIV	10/-	2 SCR's 50 PIV 1 Amp. TO-5 can	15/-	1 Tunnel Diode IN370 (TD-5) G.E.	15/-
8 Diodes 4 OA70, 4 OA79	10/-	1 2N2160 UNIJUNCTION Trans. TO-5 can	15/-	2 Sil. Rect. 5 Amp. 400 PIV Stud	15/-
1 5 Amp. SCR 100 PIV	10/-	1 Tunnel Diode AEY11 STC. 1050 M/Cs	15/-	2 GERM. Power Trans. OC28/29	15/-
3 Sil. Trans. 2S303 PNP	10/-	2 Zeners 25 Watt 18 & 22 Vts.	15/-	6 Sil. Rect. Type BY100 800 PIV 550mA	20/-
5 GE1884 Trans. Eqvt. OC44	10/-	8 Sil. Rect. 400 PIV 500mA	20/-	1 Transistor Manual by G.E. 648 pages	30/-
10 Assorted Computer Diodes	10/-	1 Silicon Controlled Rect. Manual G.E.	30/-	25 Mixed Sil. & GERM. Trans. New Marked	30/-
4 Zeners 5, 6.8, 10, 12 Vts	10/-	40 Mixed Semiconductors New Marked	40/-	1 Logic Module Handbook & Catalogue	17/6
4 2G417 Trans. Eqvt. AF116/117	10/-				
2 200 M/Cs 5 l. Trans. BSY26/27	10/-				
2 Bi-directional Trans. ASY66	10/-				
4 High Current Trans. OC42	10/-				
2 Power Trans. OC26/35	10/-				
5 Sil. Rects. 400 PIV 250mA	10/-				
3 OC71 Trans. Mullard	10/-				
3 OC75 Trans. Mullard	10/-				
3 NPN Sil. Trans. 70 M/Cs	10/-				
1 Power Trans. OC20 100 Vts	10/-				
5 OA47 Gold Bonded Diodes	10/-				
4 OA202 Sil. Diodes CV448	10/-				
3 OC77 Trans. Mullard	10/-				
8 OA81 Diodes Sub-min	10/-				
3 Sil. Rects. 400 PIV 500 mA	10/-				

Our vast stocks change daily with hundreds of Semiconductor bargains becoming available. Just send 2/6 to cover 3 months mailing of our latest stock lists, eqvt. charts, circuits, etc.

Minimum Order 10/-. CASH WITH ORDER PLEASE. Add 1/- postage and packing per Order. GUARANTEED by return postal service. Overseas add extra for Airmail.

120 Germ. Sub-min. **Diodes** 10/-

20 All types Mixed Volts. **Zeners** 10/-

25 Transistors 10/-
Silicon N.P.N. 200 m/cs.

20 Rectifiers 10/-
1 amp. Germ. up to 300 PIV

60 Silicon 200 mA **Diodes** 10/-

16 Rectifiers 10/-
Silicon 750mA Top-Hat

NEW — SILICON BRIDGE RECTIFIERS — TESTED
 600 PIV 2 Amp at 55°C 25s. each.
 800 PIV 2 Amp at 55°C 30s. each.

A complete range of Sil. Rect. 750mA to 25 amp 50-1000 PIV now in stock. Ask for Price List.



MIDLAND AGENTS FOR
★ **EDDYSTONE**
Receivers & Components

TRANSMITTERS, RECEIVERS and SUNDRY EQUIPMENT BY
KW ELECTRONICS
GREEN E.C.E.
T.W. ELECTRONICS
CODAR RADIO

H.P. Facilities Part Exchanges

At your service
G2AK, G3LAY, G3VFW

AERIAL EQUIPMENT

TWIN FEEDER. 300 ohm twin ribbon feeder similar K25, 8d. per yard. 75 ohm twin feeder, 6d. per yard. Post on above feeders and cable, 2/- any length.

COPPER WIRE, 14G, H/D, 140ft, 30/-; 70ft, 16/-. Post and packing 3/3. Other lengths pro rata.

FEEDER SPREADERS. 6" Ceramic type F.S., 10d. each. Postage 2/6 up to 12.

CERAMIC CENTRE PIECE for dipoles, Type AT, 1/6 each. P. & P. 1/-.

2 METRE BEAM, 5 ELEMENT W.S. YAGI. Complete in box with 1" to 2 1/2" masthead bracket. Price 56/-. P. & P. 4/-.

SUPER AERAXIAL, 70/80 ohm coax, 300 watt very low loss, 2/3 per yard. 50 ohm 300 watt, 2/6 per yard. P. & P. 2/6.

TOUGH POLYTHENE LINE, type ML1 (100lb), 2d. per yd. or 12/6 per 100 yds. Type ML2 (220lb), 4d. per yd. or 25/- per 100 yds., ML4 (400lb), 6d. per yd. Ideal for Guys, L.V. Supports, Halyards, etc. Postage 1/6 on all line.

ABSORPTION WAVEMETERS. 3.00 to 35.00 Mc/s in 3 Switched Bands. 3.5, 7, 14, 21 and 28 Mc/s. Ham Bands marked on scale. Complete with indicator bulb. A MUST for any Ham Shack. ONLY 25/- EACH. Post free.

BANDCHECKER MONITOR, 3.00-35.00 Mc/s in 3 switched Bands. 0-1mA Indicator. Monitor Socket. Very sensitive, £3.13.6. P. & P. 3/6.

VARIABLE CONDENSERS. All brass with ceramic end plates and ball race bearings. 50pF, 5/9; 100, 6/6; 160, 7/6; 240, 8/6; and 300pF, 10/6. Extension for ganging. P. & P. 2/-.

SEALED RELAYS. 12v. 105 Ohmcoil Type A, 4 Pole c.o. 15/- Type B, 2 Pole c.o. + 2 Pole Norm. ON. 12/6 P. & P. 1/6

FEW LEFT ONLY!
 ★ **10 WATT MOD TRANS.** Approx. 1-1 8/10K P to P 15/-
 Driver to suit 10/- P & P 3/-

For Immediate Delivery
 WITHERS 2MTR. COMMUNICATOR
 £75
 WITHERS 2MTR. NUVISTOR CONVERTORS £17

CHAS. H. YOUNG LTD
170-172 Corporation St., Birmingham 4
 Please print your address. No C.O.D. under £1. 'phone 021-236-1635

**GET A HOME RADIO CATALOGUE NOW!
PREVENTS THAT "THINKING FEELING"**



Dr. Killem "Now then Mr. Sparks what seems to be the trouble?" (*smiles encouragingly*).

Patient "I get these awful headaches doc!"

Dr. K. "Oh yes! Well now let me see—have you a hobby?"

Patient "Yes ham radio"

Dr. K. "Does it give you any worries?"

Patient "Well, yes and no as far as the actual construction goes NO—but where to get hold of all the components I needYES".

Dr. K. "Oh I see, this is obviously another case of catalogue starvation. Now just send this prescription along to Home Radio of Mitcham, and they'll soon get you perfectly in tune." (*Exit patient jubilant!*)

THE PRESCRIPTION *Take one Home Radio catalogue annually.*

Are you tired, listless, dispirited, headachy and unable to get all your components easily and quickly? Then follow Dr. K's advice and send today for the Home Radio Catalogue. (We regret it cannot be obtained on the National Health). All the same you do get 218 pages, 6000 items, 1000 illustrations for 7/6 plus 1/6 postage & packing. Every catalogue contains 5 vouchers each worth 1/- if used as directed, which makes it wonderful value. For a quick cure send the coupon today, enclosing your cheque or P.O. for 9/-.

Please write your Name and Address in block capitals

Name

Address

Home Radio Ltd., Dept. RC, 187 London Rd., Mitcham, Sy.



Vol. 20, No. 6

Published Monthly (1st of month)

Editorial and Advertising Offices
57 MAIDA VALE LONDON W9

Telephone CUNningham 6141
Telegrams Databux, London

21st Year of Publication

© Data Publications Ltd., 1967. Contents may only be reproduced after obtaining prior permission from the Editor. Short abstracts or references are allowable provided acknowledgement of source is given.

Annual Subscription 36s. (U.S.A. and Canada \$5) including postage. Remittances should be made payable to "Data Publications Ltd". Overseas readers please pay by cheque or International Money Order.

Queries. We regret that we are unable to answer queries other than those arising from articles appearing in this magazine nor can we advise on modifications to equipment described. Queries should be submitted in writing and accompanied by a stamped addressed envelope for reply.

Correspondence should be addressed to the Editor, Advertising Manager, Subscription Manager or the Publishers as appropriate.

Opinions expressed by contributors are not necessarily those of the Editor or proprietors.

Production.—Letterpress/contact litho.

Published in Great Britain by the Proprietors and Publishers
Data Publications Ltd. 57 Maida Vale London W9
Printed by A. Quick & Co. (Printers) Ltd.
Clacton-on-Sea England

Simple Variable Frequency Test Oscillator, <i>by A. Bryan</i>	330
Can Anyone Help?	333
Modified Transistor Curve Tracer, <i>by D. Burn, Ph.D.</i>	334
Simple Neon Lamp "Voltmeter" (Suggested Circuit No. 194), <i>by G. A. French</i>	337
Recent Publications	339
News and Comment	340
Electronic Flasher Unit for a Direction Indicator System, <i>by D. J. Rayner</i>	342
Modifying Published Designs, <i>by Sir Douglas Hall, K.C.M.G., M.A.(Oxon)</i>	343
Telephone Bell Repeater, <i>by A. Thomas</i>	348
Recent Publications	350
Linear Scale Audio Frequency Meter, <i>by M. Harding</i>	352
Quality Power Pack for the Beginner, Part 2, <i>by James S. Kent</i>	358
Understanding Radio (Practical Project—Completing the 3- Stage Receiver), <i>by W. G. Morley</i>	361
Wide-Band Photophone, Part 1, <i>by D. Bollen</i>	365
In Your Workshop	372
Radio Topics, <i>by Recorder</i>	376



SIMPLE VARIABLE FREQUENCY TEST OSCILLATOR

by
A. BRYAN

An inexpensive test oscillator which has particular applications in the checking of radio control equipment

A TRANSISTOR AUDIO OSCILLATOR IS ONE OF THE simplest devices to build, provided the specification is not too severe. For most applications in connection with radio control, for which the present oscillator is primarily intended, a straightforward design will usually suffice.

The main requirements of the oscillator are:

1. Reasonable output.
2. A degree of flexibility.
3. A control of attenuation.
4. A choice of sine or square wave output.
5. Suitable output impedance.
6. Low current consumption.
7. Level output over the frequency range.

Twin-T Oscillator

A phase shift twin-T oscillator was built and the component values adjusted to provide, without switching, a frequency coverage of below 200 c/s to 1 kc/s. This type of oscillator can give an excellent sine wave and is very stable. The circuit is given in Fig. 1.

To extend the coverage it would have been necessary to switch several ranges, and this would have complicated the unit. The 200 c/s to 1 kc/s range decided on covers most audio and reed requirements. If frequencies higher than 1 kc/s are required, without the lower frequencies, the requisite change can easily be carried out as described later.

The collector load of the oscillator, TR₁, is provided by the primary of transformer T₁. The voltage swing at this part of the circuit approaches the supply voltage. There is no change in the waveform with supply voltages between 6 and 18; the output is therefore dependent on the battery used and 18 volts is recommended. Also, with a reduced

supply voltage the higher frequencies suffer.

Should extreme frequency stability be required a zener diode can be incorporated to hold the supply voltage steady. This will, of course, necessitate the use of a higher supply voltage and the appropriate dropping resistor.

A degree of flexibility is introduced in the oscillator by making one arm of the phase shift network variable, and this helps to take care of slight differences in transistor parameters. The variable resistor can also be used to narrow the frequency band, should this be desired, whereupon oscillation at, for instance, 100 c/s can be obtained at the expense of the upper range.

To enable a satisfactory output to be obtained, the oscillator is followed by the amplifier, TR₂. The output from this amplifier gives 2mW into 1,000Ω with the 18 volt supply.

A transformer may be used in the collector circuit of TR₂ if different output impedances are called for. A small degree of feedback is introduced by C₄, which maintains the sine wave shape.

Resistor R₄, between the oscillator and amplifier transistors, serves a dual purpose. With S₁ in the "sine wave" position, R₄ is in circuit and prevents overdrive. For square waves, R₄ is short-circuited by S₁, whereupon TR₂ is driven into saturation. The result is a square wave output with a mark-space ratio of 2 : 1.

In parallel with the collector load resistor of TR₂ is the attenuator control VR₃. This taps off the output level which is required.

Construction

Construction is straightforward and the layout is not critical. A printed circuit is not called for and

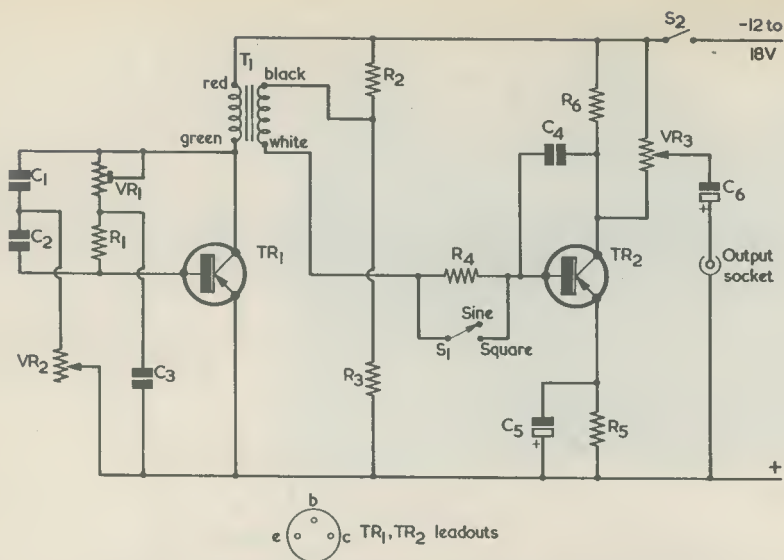

Fig. 1. The circuit of the oscillator. VR_2 is the panel frequency control

the use of perforated board and Radiospares turret tags makes for easy and neat assembly. The only error that can be introduced is a loss of the extreme frequencies, this being shown by the fact that the frequency control, VR_2 , is effective over a limited part of its range only. This shortcoming will be the result of maladjustment of VR_1 .

The frequency control, VR_2 , should be effective over the whole of its range except for a small section at the high frequency end. When the resistance inserted by VR_2 is about $2k\Omega$ (this corresponding

to maximum frequency) the oscillator will stop. The effective range offered by VR_2 is, therefore, from its maximum resistance of $50k\Omega$ for the low frequencies down to approximately $2k\Omega$ for the high frequencies. It will be a simple matter to mark the dial accordingly. The addition of a fixed resistor in series with the control was considered, but as its value will tend to vary for different units made up to the circuit, the idea was discarded. Nevertheless, if the constructor feels it to be worthwhile, he may set VR_2 to the lowest resistance which allows the

COMPONENTS

Resistors

(All fixed values $\frac{1}{4}$ watt 10%)

- R_1 1M Ω
- R_2 12k Ω
- R_3 10k Ω
- R_4 100k Ω
- R_5 1k Ω
- R_6 1.5k Ω
- VR_1 250k Ω potentiometer, skeleton preset
- VR_2 50k Ω , potentiometer, lin track
- VR_3 25k Ω , potentiometer, lin track

Capacitors

- C_1 0.005 μ F paper
- C_2 0.005 μ F paper
- C_3 0.005 μ F paper
- C_4 0.001 μ F ceramic
- C_5 250 μ F electrolytic, 12V wkg.
- C_6 250 μ F electrolytic, 18V wkg.

Transformer

- T_1 A.F. transformer type TR5001 (Teleradio Co. (Edmonton) Ltd., 325-327 Fore Street, Edmonton, London, N.9.).

Transistors

(The types specified here are available from Teleradio Co. (Edmonton) Ltd.)

- TR_1 NKT212
- TR_2 NKT217

Switches

- S_1 s.p.s.t., toggle
- S_2 s.p.s.t., toggle

Miscellaneous

- 2 knobs
- Coaxial output socket
- Perforated board, turret tags, panel, case, etc.

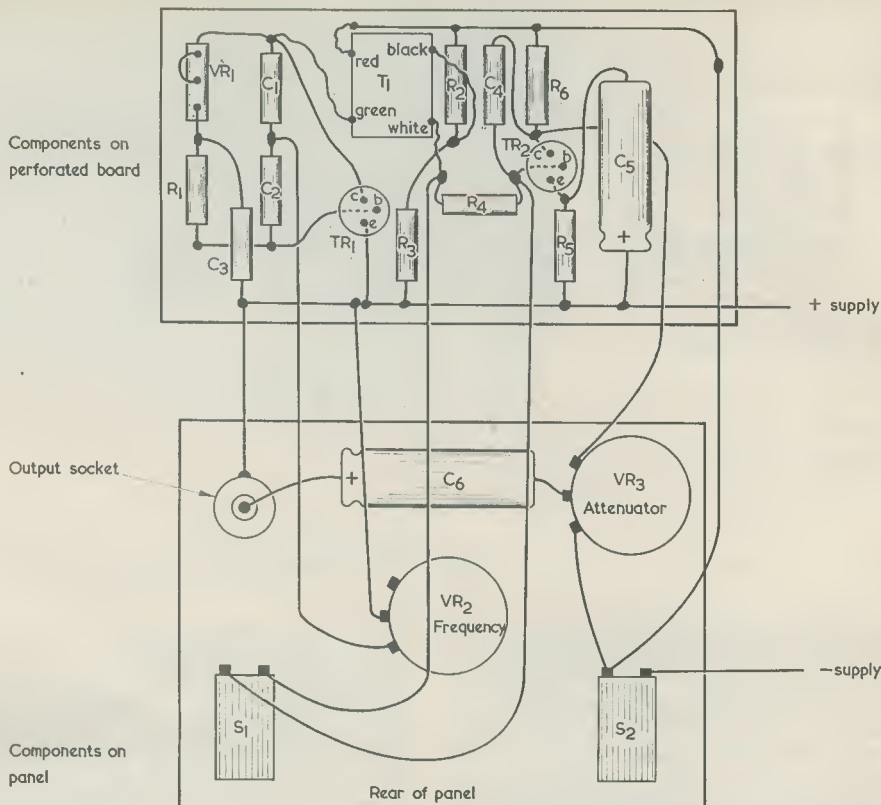

Fig. 2. The layout of components in the prototype. The transistor cans are towards the reader, with the lead-outs on the underside

oscillator to function, measure the value given by VR₂ at this setting, and insert a fixed resistor of the same value between VR₂ and the junction of C₁ and C₂. Oscillation will then be given at all settings of the frequency control.

The simplest way of checking the oscillator consists of connecting a crystal earpiece across the output. Alternatively, a loudspeaker may be used. This will need to be matched by a suitable transformer to about 1kΩ. Most transistor output transformers will function satisfactorily here.

The ideal method of adjusting the oscillator is

with an oscilloscope. This should first of all be coupled to the collector circuit of TR₁, the frequency control being at mid-position. Set VR₁ initially to 120kΩ and then adjust slightly so that a full output is obtained throughout the sweep of the frequency control (except at the extreme high frequency end, as previously mentioned). The setting in VR₁ tends to be critical. It could be made less critical by connecting a fixed resistor of 100kΩ in series with VR₁, whose value is then reduced to 50kΩ. The output amplitude should be level from 200 to 800 kc/s

The control offered by VR₂ becomes rather cramped at the extreme high frequency end, but is reasonably well spread out over reed frequencies. A slight reduction in frequency may be encountered when attenuating the square wave output. The accompanying Table shows sine wave outputs given by the prototype. An increased output is available with square waves.

Current consumption, at the battery voltages specified, lies between 5 and 10mA.

The instrument is primarily intended for testing the sensitivity and efficiency of the audio sections of radio control receivers. If the receiver is a super-

Table		
Output Voltages (sine wave r.m.s.)		
Output load	Supply voltage	Output
600Ω	12V	0.6V
1,000Ω	12V	0.8V
5,000Ω	12V	1.5V
600Ω	18V	1V
1,000Ω	18V	1.5V
5,000Ω	18V	3V

The internal assembly of the prototype frequency meter. The front panel and base are made of a single sheet of metal, with an angle of 80° at the bend to form a sloping panel. The perforated board, on which most of the components are mounted, has a 0.25in matrix

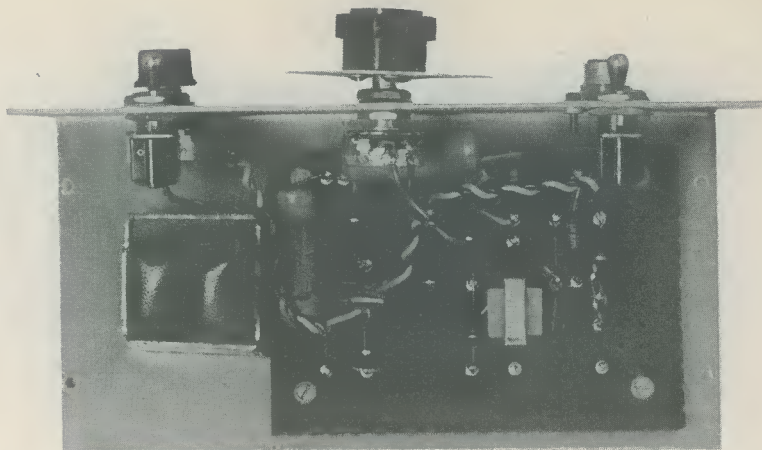

regenerative type, connect the output to the first a.f. amplifying stage. With a superhet receiver, the output may be applied to the diode load. By sweeping the frequency control, reed bank performance can be checked. The amount of drive needed for reed or relay operation can also be determined by measuring (with an a.c. voltmeter) the minimum input from the oscillator that is required for triggering, and then comparing this with the amount of drive available from the r.f. side of the receiver.

Alternative Ranges

The experimenter with suitable test gear will be able to convert the basic design to one covering 50 c/s to 10 kc/s by changing the values of VR₁, R₁, C₁, C₂ and C₃, and introducing a suitable switching circuit. An improvement could consist of feeding the output of the unit (as a sine wave generator) into a Schmitt trigger for the square wave output, but this would complicate what is otherwise a very simple device.



CAN ANYONE HELP ?

Requests for information are inserted in this feature free of charge, subject to space being available. Users of this service undertake to acknowledge all letters, etc., received and to reimburse all reasonable expenses incurred by correspondents. Circuits, manuals, service sheets, etc., lent by readers must be returned in good condition within a reasonable period of time

Jennings Model D1 Organ.—L. Szeneszi, Avenida Grace Aranha, 182-4, Rio de Janeiro, GB, Brazil, S. America—service manual or any other information.

* * * *

VHF Transmitter Tx64.—M. Towers, 45 Huntingdon Road, London, N.2—details of circuit, valve line-up, power supplies, frequency coverage, or any other information.

* * * *

RA10(DA).—D. Smith, 10 Hill Ley, Hatfield, Herts.—circuit diagram and 240V conversion details of this ex-U.S.A.F. receiver.

* * * *

Monitor 56.—P. Pauling, Department of Chemistry, University College London, Gower Street, W.C.1—circuit diagram and manual for Indicator Unit Type 248 (ref. 10QB/6325) and Power Unit Type 675 (ref. 10KB/6295), both part of Monitor 56.

W1081 Wavemeter.—W. Bourke, 96 Rowan Drive, Bearsden, Glasgow—any information or manual—which will be quickly returned.

* * * *

R1475 (Receiver Type 88).—R. Nettleship, 145 Milton Road, Cambridge—loan or purchase handbook or circuit.

* * * *

31 Set.—C. T. Cowley, 15 Willow Walk, Dog in Tree Estate, Huntingdon, Cannock, Staffs.—any information or manual of this Tx/Rx which is fitted with 15 valves (1.4V) and 2 crystals. Believed akin to BC1000.

* * * *

Transmitter Type T-19/ARC-5.—R. Burrows, 33 Worth Beck House, Westgate Gardens, Keighley, Yorks.—loan or purchase of circuit diagram of this unit (valve line-up 1625, 1625, 1626, 1629 with 3265 kc/s crystal).

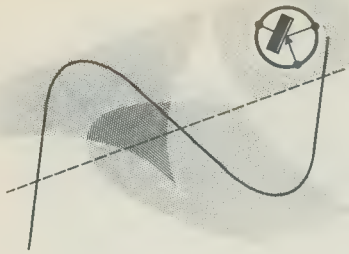

Modified Transistor Curve Tracer

by D. Burn, Ph.D.

Readers may recall the very successful automatic transistor curve tracer design, by R. J. Barrett, which appeared in our June 1966 issue. The present short article describes a modification to this design which, at the expense of some added complication, enables critical frequency adjustments to be obviated. Following the principles outlined here, a family of 4, 6 or 8 curves may be displayed.

the grounded base or grounded emitter mode was selected, of the transistor being examined. At the same time an oscillator provided a continually increasing collector voltage once each cycle, enabling an oscilloscope to display collector voltage against collector current with emitter or base current, as applicable, as parameter. Since the step waveform was derived from the same oscillator that produced the increasing collector voltage the result was that a family of transistor curves, each curve corresponding to an individual step, was displayed by the oscilloscope. The circuitry was such that both p.n.p. and n.p.n. transistors could be accommodated.

The duration of the overall step waveform was controlled by a free-running multivibrator. The oscillator was then set up to a multiple of multivibrator frequency, whereupon the number of curves displayed could be controlled. The oscillator and multivibrator were not synchronised.—Editor.

Introductory Note

In a previously published article describing a transistor curve tracer*, a staircase waveform was available for application to the emitter or base, according to whether

* R. J. Barrett, "Transistor Curve Tracer", *The Radio Constructor*, June, 1966.

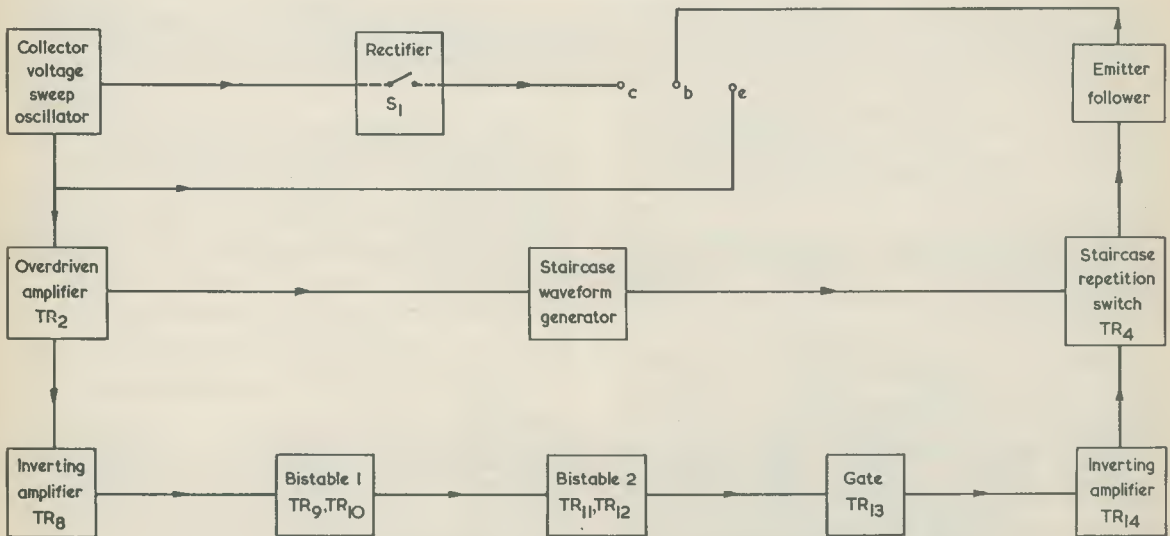

Fig. 1. The stages introduced by the modification are in the lower row of "blocks", corresponding to TR₈ to TR₁₄. This diagram may be compared with Fig. 2 of the article in the June 1966 issue

HAVING BUILT THE VERY USEFUL CURVE TRACER described by R. J. Barrett in the June issue, the writer was rather disturbed to find that the preset control VR₁ needed fairly frequent adjustment to maintain a steady trace. In order to be able to concentrate on obtaining the desired results, the instrument itself should ideally need no adjustments, and so it was decided to see whether the circuit could be modified so as to eliminate this adjustment.

Initial attempts to synchronise the multivibrator (TR₆ and TR₇) with the pulse present at the collector of TR₂ were not successful, and so the multivibrator was removed altogether and replaced by a divide-by-4 counter triggered from the collector of TR₂. A block diagram of the new arrangement is shown in Fig. 1.

Circuit Operation

A portion of the output from the overdriven amplifier TR₂ is amplified and inverted by TR₈ (in order to avoid confusion, the transistor numbering continues from the previous article) and the resulting positive pulses are applied to the divide-by-4 counter formed by the two bistables (TR₉ to TR₁₂) and the gate TR₁₃. The gate output, which consists of one pulse for every four cycles of the oscillator, is again amplified and inverted and applied to the switch TR₄. The waveforms are illustrated in Fig. 2.

Now, no matter how much the oscillator frequency

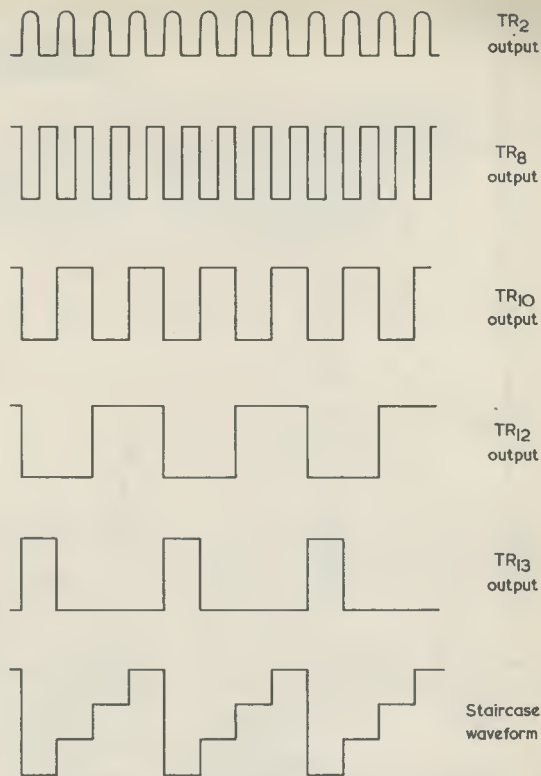

Fig. 2. The waveforms resulting from the modification

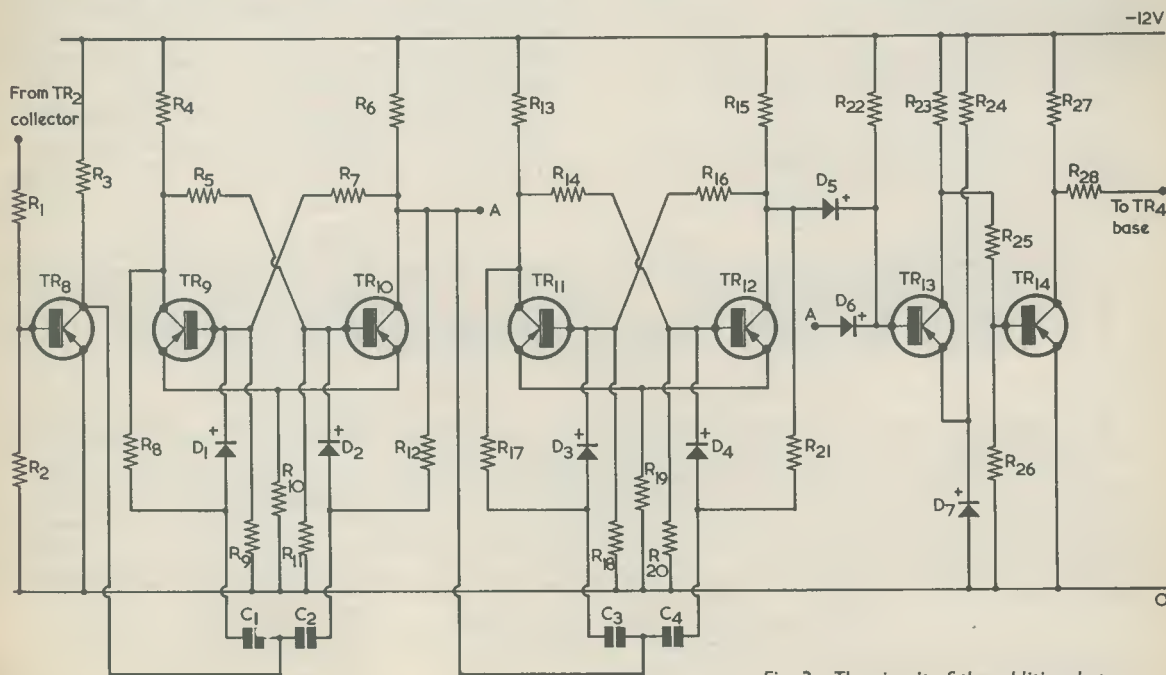

Fig. 3. The circuit of the additional stages

COMPONENTS

Resistors

(All $\frac{1}{4}$ watt 10%)

R ₁	33k Ω
R ₂	2.2k Ω
R ₃	3.9k Ω
R ₄	2.2k Ω
R ₅	10k Ω
R ₆	2.2k Ω
R ₇	10k Ω
R ₈	10k Ω
R ₉	10k Ω
R ₁₀	100 Ω
R ₁₁	10k Ω
R ₁₂	10k Ω
R ₁₃	2.2k Ω
R ₁₄	10k Ω
R ₁₅	2.2k Ω
R ₁₆	10k Ω
R ₁₇	10k Ω
R ₁₈	10k Ω

R ₁₉	100 Ω
R ₂₀	10k Ω
R ₂₁	10k Ω
R ₂₂	33k Ω
R ₂₃	3.9k Ω
R ₂₄	2.2k Ω
R ₂₅	22k Ω
R ₂₆	820 Ω
R ₂₇	3.9k Ω
R ₂₈	15k Ω

Capacitors

C ₁	0.01 μ F
C ₂	0.01 μ F
C ₃	0.01 μ F
C ₄	0.01 μ F

Semiconductors

TR₈ to TR₁₄ OC44 or equivalent
D₁ to D₇ OA47 or equivalent

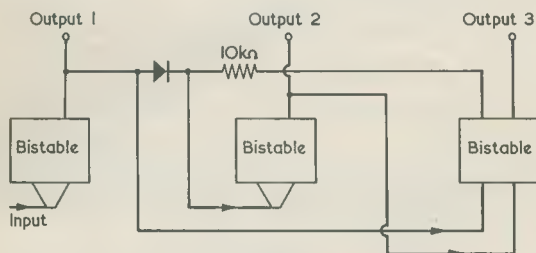

Fig. 4. A divide-by-6 counter, which enables a family of 6 curves to be presented

may drift, the switch TR₄ will always operate in exact synchronism.

The modified circuit is shown in Fig. 3. It will trace a family of four curves, although this can easily be extended if desired. For example, the addition of a third bistable will give a divide-by-8 counter, and a family of 8 curves will be obtained. Three bistables connected as shown in Fig. 4 will give a divide-by-6 counter.

While the writer's version is rather more complicated than the original, he thinks it is well worth considering.



New Mazda Semiconductor Booklet

The second edition of the popular MAZDA Semiconductor Data Booklet for dealers has recently been published. The number of pages, now 64, is double that of the first edition.

Abridged data, using a new format, is given on the range of MAZDA germanium transistors and silicon rectifiers. "Comparables" and "Device Identification", useful reference sections introduced by MAZDA in 1964, have been greatly enlarged. These cover all device makes used in British-made entertainment equipment and the "Device Identification" section covers 370 different types. Industrial devices have been purposely excluded since MAZDA transistors are intended solely for the entertainment market.

Copies of the MAZDA Semiconductor Data Booklet are available (to the trade only) from MAZDA representatives, MAZDA Wholesalers or direct from:

MAZDA Publicity Department,
Thorn-AEI Radio Valves & Tubes Ltd.,
7 Soho Square,
London W.1.

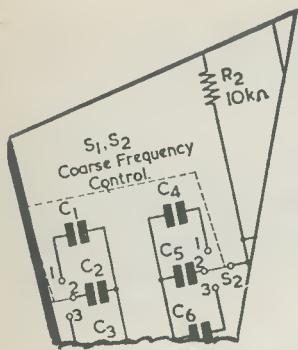

SIMPLE NEON LAMP "VOLTMETER"

SUGGESTED CIRCUIT No. 194

By G. A. FRENCH

NEON LAMPS LEND THEMSELVES to many interesting applications in electronics, this being largely due to their three main characteristics. These are that a neon lamp draws no current until it strikes, that it becomes illuminated when it strikes, and that it then maintains a regulated voltage across its terminals.

In this month's Suggested Circuit all three characteristics are taken advantage of in a simple voltage indicating device. The circuit offers voltage indications up to some 360 volts d.c. or 250 volts a.c., but it does not offer the same resolution in reading as would be given by a conventional voltmeter with a needle and scale. On the other hand it can be made up in a form which is very much more robust than a normal voltmeter. Also, it can be assembled at fairly low cost in a case which is not much larger than a packet of ten cigarettes. Typical uses would be given by checks for h.t. voltage in TV and mains radio receivers, and for checking a.c. mains connections and the like. Indeed, a unit built up to the circuit would probably be an extremely helpful instrument for the field service engineer who wants to carry out simple fault-finding voltage tests on a domestic receiver in a customer's house before returning it, if necessary, to the service workshop for more detailed examination. Other applications may readily suggest themselves to the reader.

The Circuit

The circuit of the "voltmeter" is shown in Fig. 1. In this diagram the six neon lamps are miniature wire-ended types having striking and burning voltages which are of the order of 60. For the explanation which immediately follows we shall

presume that burning voltage is only slightly lower than striking voltage.

Let us assume that a direct voltage is connected to the Test Terminals of Fig. 1, this voltage being made to increase in value from zero volts. When the direct voltage reaches 60 volts, neon lamp NE₁ strikes and commences to glow. In consequence, a regulated voltage of slightly less than 60 appears across the terminals of NE₁. The direct voltage applied to the Test Terminals continues to increase until it approaches 120 volts. Some 60 volts are then applied to neon lamp NE₂, which similarly becomes illuminated. A regulated voltage of about 120 now appears

across lamps NE₂ and NE₁ in series, both of these being illuminated. When the increasing direct voltage applied to the Test Terminals approaches 180 volts, some 60 volts are applied to neon lamp NE₃, which also becomes illuminated. The process continues in a similar manner for higher direct voltages at the Test Terminals. At around 240 volts NE₄ lights up; at around 300 volts NE₅ lights up; and at around 360 volts NE₆ lights up. It will be seen that no neon lamp can become illuminated unless the lamp immediately below it in the chain has already struck and is passing current. Thus, to take an example, neon lamp NE₄ cannot light up with

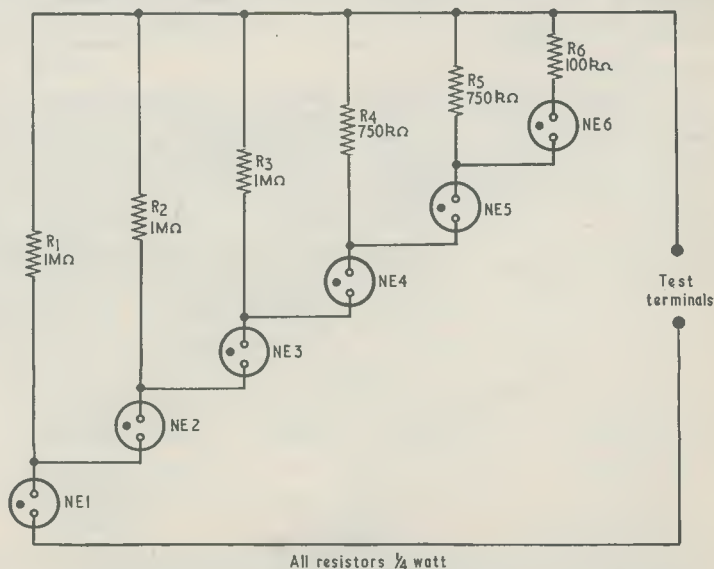

All resistors 1/4 watt

Fig. 1. The circuit of the neon lamp voltage indicator. The neon lamps employed are discussed in the prototype

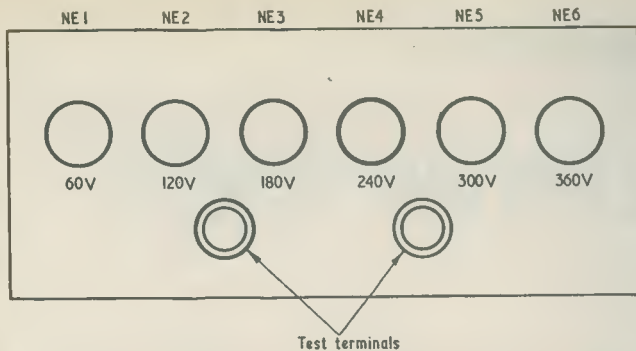

Fig. 2. A suitable panel layout for the "voltmeter". The voltage figures are marked on the front panel surface

NE₃ non-conductive because, in this state, the lower terminal of NE₄ is at the same potential as its upper terminal.

The polarity of the direct voltage applied to the Test Terminals is, of course, unimportant.

The neon lamps can be mounted in a small case having the front panel layout illustrated in Fig. 2. In this diagram, voltage figures from 60V to 360V are marked on the panel below each lamp. If, when the Test Terminals of the instrument are applied to an unknown direct voltage, only neon lamp NE₁ lights up, it is then obvious that the direct voltage lies between 60 and 120 volts. If, say, lamps NE₁, NE₂ and NE₃ light up, then the voltage must be between 180 and 240 volts. If all six neon lamps light up, then the voltage is 360 or higher.

Practical Points

The voltage figures shown on the front panel layout of Fig. 2 are somewhat idealised, since the small neon bulbs employed exhibit slightly varying striking voltages. The author made up a prototype circuit to check operation, the results given by this being shown in the accompanying Table. The applied direct voltages shown in this Table were obtained from a potentiometer connected

across a 400 volt supply, as illustrated in Fig. 3. The applied voltage was increased from zero, the voltage at which each successive neon lamp became illuminated then being read from the monitoring voltmeter. It will be noted that, with this practical circuit, the voltages at which the neons became illuminated differs

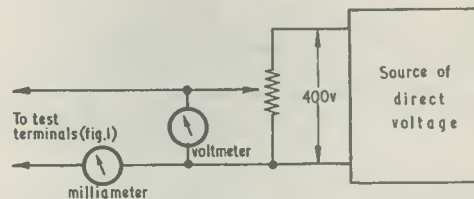

Fig. 3. How the prototype circuit was calibrated. The polarity of the applied voltage is unimportant. The potentiometer may have a value of the order of 25 to 50kΩ and should be a wirewound component

slightly from the figures shown for the front panel of Fig. 2. In the preceding explanation it has been assumed that the burning voltage at which each neon lamp runs is only slightly lower than its striking voltage. In practice, the striking voltage of the neon lamps was of the order of 65 to 70, with a burning voltage about 10 volts less. This slight complication raises no problems in practice if

calibration is carried out in the manner shown in Fig. 3, which is concerned only with the actual illumination of each lamp.

The constructor is advised to carry out a similar calibration operation with his own unit and then to inscribe the front panel of the completed instrument with the actual figures obtained. The calibration process will also provide a useful check of the circuit after it has been constructed.

The neon bulbs employed may be either Hivac 16L or 34L (obtainable from Henry's Radio Ltd.) or the lamps listed under Cat. No. PL32A in the catalogue of Home Radio (Mitcham) Ltd. Both types were checked by the author and offer equivalent performances. Since the glow, on initially striking, is rather low the lamps should be mounted below the front panel surface, preferably with cylindrical surrounds having a matt black inner surface.

The accompanying Table also shows the currents drawn by the neon lamp circuit at the voltages

listed, these being read from a milliammeter connected as illustrated in Fig. 3. At the highest voltage of 355, the current drawn is less than 1mA, which would seem reasonable for an instrument of this type. When a voltage of 355 or more was suddenly applied to the Test Terminals of the prototype, there was a very short period during which the current exceeded 1mA. This is due to successive striking currents as each neon lamp along the chain becomes illuminated, and the period lasted for less than a second. If a voltage slightly lower than 355 was suddenly applied, neon lamp NE₆ became momentarily illuminated by these charging currents after which it extinguished. With the prototype circuit the same effect was noticeable, to a much lesser extent, in NE₅ for voltages slightly below 295 volts, but it was absent with the preceding neon lamps in the chain. This point does not detract from the usefulness

Table

Neon Lamps Illuminated	Minimum Direct Voltage Required for Illumination	Current Drawn By Voltmeter
NE ₁	65V	<0.05mA
NE ₁ , NE ₂	120V	0.1mA
NE ₁ to NE ₃	185V	0.25mA
NE ₁ to NE ₄	235V	0.4mA
NE ₁ to NE ₅	295V	0.6mA
NE ₁ to NE ₆	355V	0.9mA

of the unit, but it indicates that it would probably be impracticable to employ a chain of more than six neon lamps with the circuit principles involved.

The resistors shown in Fig. 1 are not at all critical in value and may readily have a tolerance of 20%. Should it be likely that direct voltages in excess of some 470 volts might be applied to the instrument it would be preferable to increase R_6 to a value of the order of 300k Ω .

Alternating Voltages

The instrument can be employed to measure low frequency alternating voltages, whereupon the figures given for illumination by direct voltage correspond to the *peak* value of the alternating voltage. However, it is normally desirable to find the r.m.s. value of an alternating voltage, whereupon the peak voltage figure should be multiplied by 0.7. Thus, the 120 volt direct voltage figure in the Table corresponds to an alter-

nating r.m.s. voltage of 120×0.7 , i.e. 84 volts. If desired, r.m.s. values may be added to the front panel figures shown in Fig. 2. The writer checked the prototype circuit with 50 c/s a.c. voltages, and found that the 0.7 relationship held good in practice.



RECENT PUBLICATIONS



A GUIDE TO AMATEUR RADIO. By J. Pat Hawker, G3VA. 88 pages, $7\frac{1}{4} \times 9\frac{3}{4}$ in. Published by the Radio Society of Great Britain. Price 5s. 0d.

This revised twelfth edition includes the important changes introduced in recent years in the U.K. amateur regulations which make it possible to obtain a form of amateur (Sound) licence without passing a Morse test. The far greater use of single sideband techniques and semiconductor devices is also reflected in this new edition, guidance on these developments and new constructional projects—including an economical transistorised h.f. receiver, transistorised converter and a transistorised crystal calibrator—have been included.

This publication is intended to assist those who wish to learn more about the hobby and to obtain a transmitting licence. It also contains much information on amateur receivers, transmitters, and technical information of interest to all engaged, or about to engage, in radio amateur and short wave listener activities.

RSGB AMATEUR RADIO CALL BOOK 1967 Edition. Compiled by John Clarricoats, O.B.E., G6CL. 96 pages, $7\frac{1}{4} \times 9\frac{3}{4}$ in. Published by the Radio Society of Great Britain. Price 6s. 0d.

This edition of the Call Book records the many changes that have taken place since the 1966 edition closed for press in September 1965. More than 1,600 changes of address, reissued calls and cancellations have been recorded, in addition to more than 900 new calls. These include about 600 in the G3AAA series and 200 in the G8AAA Amateur (Sound) Licence B series. Also listed are a number of new calls in the G6AAA/T Amateur (Television) series.

During 1966 the Post Office entered into reciprocal licencing agreements with the United States and other administrations and this has resulted in the issue of another new series of calls in the G5AAA series followed by the home call sign of the licensee, 110 of such calls being listed.

THE RADIO AMATEURS' EXAMINATION MANUAL. By B. W. F. Mainprise, B.Sc.(Eng.) G5MP. 64 pages, $7\frac{1}{4} \times 9\frac{3}{4}$ in. Published by the Radio Society of Great Britain. Price 5s. 0d.

This fifth edition includes some additional information of help to those wishing to obtain a transmitting licence and an important addition is some excellent advice on tackling the Radio Amateurs' Examination. The Manual contains specimen answers to actual examination papers and Chapters dealing with licence conditions, transmitter interference, radio calculations, circuits and valves, receivers and transmitters, aerials and propagation, etc.

GUIDE TO BROADCASTING STATIONS—15th edition. Compiled by the Staff of *Wireless World*. 136 pages, $7\frac{1}{4} \times 4\frac{3}{4}$ in. Published by Iliffe Books Ltd. Price: 6s. net (by post, 6s. 9d.).

The information given in this fifteenth edition of *Guide To Broadcasting Stations* has been completely revised and brought up to date although it must be remembered that some stations make frequent changes in operating characteristics.

Authorized and unauthorized long- and medium-wave stations operating in the European Broadcasting Area, which includes the Western part of the U.S.S.R. and territories bordering the Mediterranean Sea, are listed both in order of frequency and geographically. The details have been checked against the latest information available from the European Broadcasting Union. Also included are a list of the stations outside Europe which are heard under favourable conditions.

There are nearly 4,000 entries in the list giving frequencies, wavelengths and power of the world's broadcasting stations operating the short-wave bands.

In this edition are included lists giving a selection of the more powerful European television stations and v.h.f. sound broadcasting stations. All British stations, irrespective of power, are included in both these lists.

Contents

Long- and Medium-Wave European Stations: Some L.W. and M.W. Stations outside Europe: Short-Wave Stations of the World: Map of Broadcasting Regions: European Standard Frequency Transmitters: Short Wave Broadcasting Bands: Wavelength and Frequency Conversion: European Television Stations: European V.H.F. Sound Broadcasting Stations: Internationally Allocated Call Signs.

NEWS . . . AND .

1966 INTERNATIONAL RADIO COMMUNICATIONS EXHIBITION



The accompanying photograph shows His Royal Highness, the Prince Philip, Duke of Edinburgh, during the making of his speech opening the 1966 International Radio Communications Exhibition, reported in last month's issue.

The following two quotations demonstrate the lively interest shown by His Royal Highness.

From *Mobile News* the journal of The Amateur Radio Mobile Society:

"What do you do?"

"We proceeded to give the Prince the ordeal-by-fast-talk . . ., when we spoke about "Mobile Operation from cars" he asked "Why just cars? why not aeroplanes?"

From *Radial* the journal of the Radio Amateur Invalid and Bedfast Club:

"It is understood on good authority that when the Patron of the Radio Society of Great Britain had opened the exhibition and was going round the hall he stopped in front of an amateur wearing a clerical collar and asked him who he intended communicating with. . . ."

A Cool Light On The Work Bench

A new miniature bench or desk light from Henri Picard & Frère of 34/35 Furnival Street, London, E.C.4. gives high-intensity lighting, concentrated, glare-free, and cool. It is the 12-volt "Beam-lite", mains-supplied through a built-in transformer. The bulb—an ordinary headlight bulb will serve—is mounted in a 2½in shade on a 16in adjustable and jointed arm. With these dimensions it can be brought right over the work without interfering with vision, and with none of the heat generated by a standard bulb.

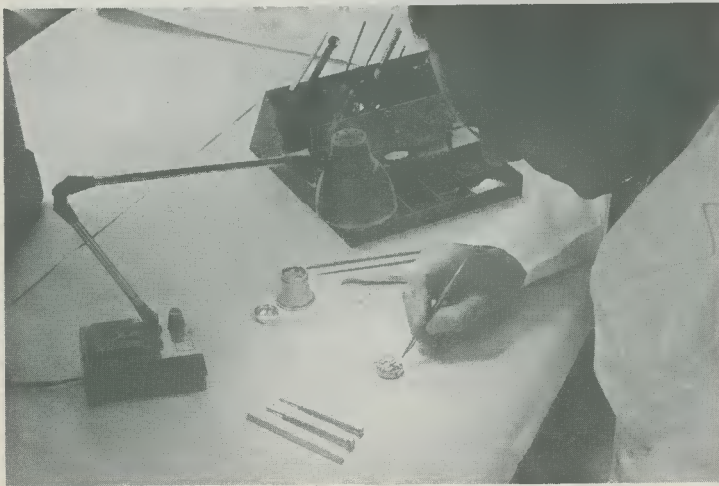

Adjustable miniature high intensity lighting for bench or desk

Laser Beams Create Eye Hazards

Although there are no statutory regulations governing the safe operation of lasers, a recently published booklet provides a good general guide to their safe use.

The emphasis is on hazard to vision, but laser devices often use high voltages and all normal precautions must also be taken against electric shock.

To enable laser machines to be operated safely in a factory, the beam should be entirely enclosed. For instance in a laser drilling or welding machine, the output of the laser should be confined in a box made of opaque material which is thick enough to resist penetration under the most unfavourable conditions.

The booklet *A General Guide to the Safe Use of Lasers*, published by the Electronic Engineering Association, costs 2s. per copy. It can be obtained from the Association, Berkeley Square House, Berkeley Square, London, W.1.

COMMENT

U.S.A. Buys From Britain

Major American Order For Colour Television Cameras

The Columbia Broadcasting System, has placed a new order with The Marconi Company for 27 of the latest Mark VII colour television cameras. This order, which includes colour coding equipment using the American NTSC system, follows an earlier one for six cameras which have already been delivered.

The Mark VII is a fully transistorised colour television camera which was introduced in December 1965. It employs four photo-conductive camera tubes, which provide high quality colour or black-and-white pictures which are less dependent on accurate tube registration than with three tube cameras. Very advanced "thin film" circuits are used to provide sufficient stability for "hands-off" operation, using only a simple control panel mounted in the studio suite. This simplicity of control has been a major feature of Marconi black-and-white cameras for some years.

Large Resistor Order From U.S.A.

Morganite Resistors Limited, of Bede Trading Estate, Jarrow, one of last year's winners of the "Queen's Award to Industry" for export achievements, has just received a record order from U.S.A. for 42 million carbon resistors worth approximately £120,000. The order, secured through the company's agents, Collins and Hyde Incorporated, of Palo Alto, California, is almost double the size of any previously obtained in America.

Since 1962, when Collins and Hyde were appointed, sales of resistors have rocketed, mainly due to the rapidly increasing demands for electronic and colour television equipment.

Quote

"... So this stereo illusion, even on the best stereograms, fell far short of being breathtaking. Some of the claims in the brochures might take your breath away though."

From the *Which* report on Stereo radiograms.

New Plessey 3in Deep Chassis Speaker

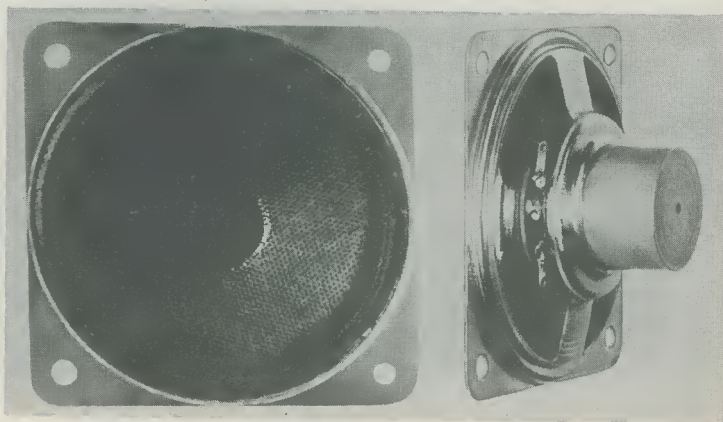

Front and side views of the new Plessey 3in deep type loudspeaker

The Plessey Components Group have introduced a new 3in deep chassis loudspeaker for use under severe climatic conditions. The more common applications of this speaker will be in taxi, ambulance and police radios, where the unit is exposed to conditions of high temperature and humidity.

Investigations during the development of this speaker indicate that temperatures of up to 80°C are found in these applications during the summer months in the U.K. These high temperatures are frequently accompanied with conditions of high humidity, and can be followed by periods of low temperature and high humidity.

The new 3in speaker has been designed to withstand these conditions without any loss of sensitivity and, at the same time, the size has been kept to a minimum. Chassis height is 0.6in and when fitted with the 6,500 line motor unit the total height becomes 1.22in.

New Elite Moving Coil Hand Microphone

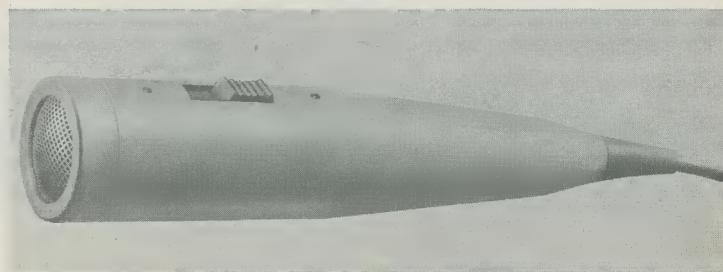

Amplivox Ltd., announce the release of a new high fidelity moving coil microphone—the Elite.

This quality microphone has been introduced to meet a wide variety of applications in the fields of recording and communications. The Elite is available with or without switching arrangements and a variety of circuits are available to suit customer's requirements. The switched version may be supplied as a single pole or double pole type with a choice of either press-to-talk or press-to-talk and slide-to-lock.

This new microphone has a very smooth response (from 50–15,000 c/s) and it has many attractive features which would certainly appeal to manufacturers and users of modern communications and recording equipment.



Electronic Flasher Unit for a Direction Indicator System

by D. J. Rayner

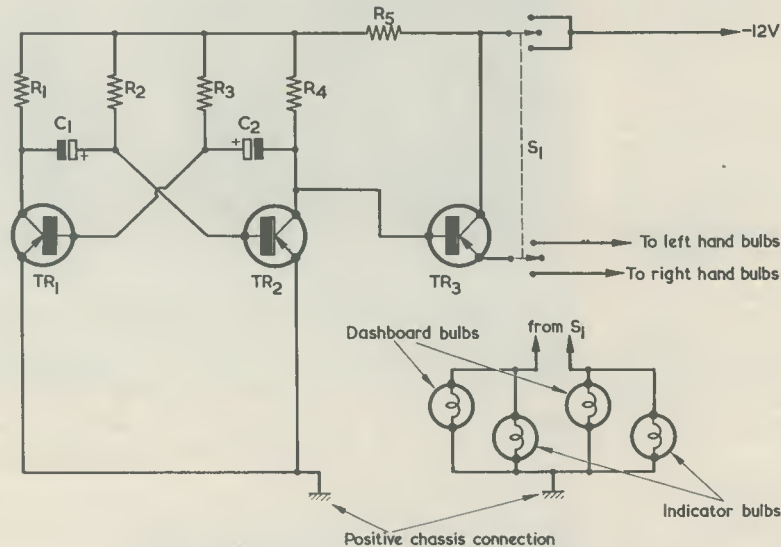

The circuit of the direction indicator flasher unit.
The dashboard bulbs may be small m.e.s. types

HAVE YOU EVER HAD TROUBLE WITH THOSE OLD semaphore direction indicators on your car? Here is an interesting little circuit the writer built as a flasher "unit" for an indicator system which was made to replace the troublesome semaphores on his car. It could also be used to replace the flasher on a more conventional system.

Operation

The circuit comprises two parts, these consisting of a slow speed multivibrator which drives a power transistor used as a switch for the indicator bulbs.

The multivibrator operates in the normal way and the collector of TR₂ alternately goes from almost zero volts to a value determined by the leakage current of TR₂ and the base current of TR₃.

When TR₂ saturates, TR₃ is cut off and the indicator bulbs go out. When the collector of TR₂ rises again TR₃ conducts, and the bulbs come on.

COMPONENTS

Resistors

- R₁ 360Ω 1 watt
- R₂ 180kΩ ¼ watt
- R₃ 150kΩ ¼ watt
- R₄ 360Ω 1 watt
- R₅ 100Ω ½ watt

Capacitors

- C₁ 10μF electrolytic 25V wkg.
- C₂ 5μF electrolytic 25V wkg.

Transistors

See text

Switch

- S₁ 2 pole, 3 way

The emitter of TR₃ is switched to whichever set of bulbs are required.

When the unit is fitted to the car, the constructor will find that the speed of operation when supplied from the battery alone is different from when the engine is running. This is because the voltage is not pure d.c. when the engine is running with the generator and regulator working. However, the unit will never be used without the engine running, so the effect is not noticed.

Components

The component values are not critical and the values could easily be altered slightly to suit the spares box. The circuit values given are those used by the author and, as it stands, the bulb flashes about 100 times a minute.

The transistors used were OC42's for TR₁ and TR₂, but practically anything in the range with a V_{ce} max of 16 volts or more, and an I_c max of 45mA or more, should do for these. For TR₃ an OC35 was used, but an OC36, OC28 or OC29 will cope. All components can be purchased fairly cheaply.

Construction

The circuit is very simple and no trouble should be experienced whilst making the unit. The layout is not at all critical, the main thing in the author's mind being compactness. Everything, except the switch, was mounted in a small plastic box measuring 2×3×1in. This was fitted on the rear of the dashboard next to the switch. In the author's unit TR₃ was mounted on the outside of the box, its leads protruding into the box.

Editor's Note

Flashing indicators fitted to cars should provide not less than 60 or no more than 120 flashes per minute. If, due to component tolerances, the unit described here offers a flashing rate outside this range the values of C₁ and C₂ should be adjusted accordingly. Also, the total rated wattage of the bulb or bulbs illuminating any indicator should be not less than 15 watts or more than 36 watts. The transistors specified will control bulbs up to 20 watts, and it would be preferable to provide a small heat sink of some 2×2in for TR₃. There should be a visible (or audible) warning for the driver when the indicator is switched on, this being given here by the dashboard bulbs shown in the circuit diagram.



THE OBJECT OF THIS ARTICLE IS not to suggest drastic alterations to published designs of which the end result would be something quite different; but rather to suggest that minor changes can often be made which will result either in the performance intended by the designer and obtained with his prototype, or in some useful additional benefit. The author has drawn largely on his own designs for purposes of illustration—not because the suggested alterations are peculiar to them—but because he is most familiar with his own circuits.

Correct biasing is of great importance with transistors, though in the majority of cases it is possible to employ negative feedback of direct current in such a way as to permit considerable variation in resistor values. This applies particularly with frequency changers and i.f. stages in transistor superhets, and with any design likely to be published in this magazine it can be assumed that no modification is necessary or desirable with these stages unless a specific suggestion is made by the designer in question. The same applies with many small-signal audio frequency amplifiers (though these represent one of the parts of a circuit which can sometimes benefit from changes in the recommended values of resistors) and also with some simple reflex circuits and

Modifying Published Designs

by SIR DOUGLAS HALL, K.C.M.G., M.A. (Oxon)

Our contributor is well-known for his ingenious and highly successful receiver and amplifier designs. In this article he refers to the design problems which all home-constructors encounter from time to time, and he offers some useful tips on how these may be satisfactorily overcome.

detector circuits especially when reaction is used. Small alterations can frequently benefit either quality or economy with Class B and other economy circuits.

Audio Frequency Input Bias

Fig. 1(a) shows a single stage audio frequency amplifier. Full stabilisation is employed by means of a potentiometer feed to the base, and a resistor in the emitter circuit. Any tendency for current to increase is checked by a rise in voltage across R₁. Even greater stabilisation

is obtained with a circuit of the type shown in Fig. 1(b) where the negative feedback of direct current takes place over two stages. With both these circuits there is compensation for considerable variations in transistor characteristics and resistor values, and in most cases no changes in values will be called for.

Sometimes, however, it is desired to provide a high input impedance to accommodate, for example, the input from a crystal pick up or to follow the high output impedance of a common base amplifier. In

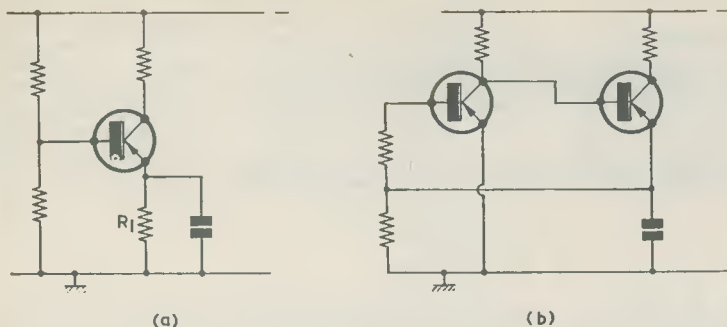

Fig. 1 (a). A commonly encountered a.f. amplifier stage which offers a high degree of stabilisation
 (b). Even greater stabilisation is given with a circuit of this type

this case the circuit may appear as in Fig. 2. R_1 will have a relatively high value of $150k\Omega$ or more—it may be several megohms in some cases—and R_2 will either be non-existent, the internal resistance of the transistor forming the lower arm of the potentiometer, or of such high value as to provide very little stabilising effect. These high values are required to preserve the high input impedance which is needed, and which can be provided by a common collector amplifier. Examples of circuits of this type appear around TR_2 in the author's 4-transistor "Spontaflex" circuit (published in the June 1964 issue) where the upper arm is $150k\Omega$ and the lower arm non-existent, and around TR_1 in his short wave "Spontaflex" design (published in the August 1964 issue) where the upper arm is shown as $470k\Omega$ and the lower arm as $100k\Omega$. Although in many cases the values specified will prove satisfactory, it can be seen from Fig. 2 that if TR_1 were a specimen offering unusually high amplification the voltage drop across R_3 would be larger than required and TR_2 would draw too much current for proper functioning. Because of the lack of a suitable potentiometer feeding the base of TR_1 there is no negative feedback of direct current to provide compensation. In any design incorporating a stage such as is shown in Fig. 2 it is well worth while trying alternative values for R_1 . If a milliammeter is available it should be inserted in the collector lead of TR_1 . The approximate current will probably have been mentioned by the designer. If not, something of the order of 0.5 to 1mA may be assumed. If no milliammeter is available, R_1 should first be increased in value and results

noted. If an improvement has taken place, R_1 may be increased again. If results have deteriorated, a smaller value for R_1 may be tried, and so on. With unusual specimens of transistor the optimum value can prove considerably different from that specified. The author has found an increase from $150k\Omega$ to $330k\Omega$ to be beneficial with one example of TR_2 used in the 4-transistor "Spontaflex" receiver.

Detector Stage Modification

Fig. 3 shows a detector stage which may be encountered in simple short wave and all-wave receivers. With such a circuit the optimum current passing through TR_1 is fairly critical. If the current is too large, detection efficiency will suffer; if the current is too small amplification will fall and reaction may prove impossible to obtain. The best compromise is usually about $100\mu A$. The possibility of error arises from the lack of resistance in the emitter lead. One possible solution is to insert a resistor of about $1k\Omega$ between L and chassis, shunted by an electrolytic capacitor of about $50\mu F$ to

bypass audio frequency currents. In this event it will be necessary to considerably reduce the value of R_1 to compensate for the voltage drop across the new emitter resistor. However, because of the d.c. negative feedback it will be found that circuit values are now much less critical. A possible disadvantage is that the electrolytic capacitor may cause motor-boating on the threshold of oscillation, in which case it is better to leave the circuit as it stands and make sure that R_1 has the exact value for best results.

Output Stage Bias

Fig. 4 (a) shows a typical Class B output stage and Fig. 4 (b) shows a Class A economy stage designed by the author for his 4-transistor "Spontaflex" receiver already mentioned. With both these circuits it is necessary that there should be a small standing current passed by the output transistor or transistors which increases as the signal increases. Once again, the bias for the base is critical. If it is too small there will be serious distortion. If it is too large there will be unnecessary extravagance in quiescent current. R_3 is very low in value—never more than 15Ω and often less—as it is necessary for a large current to be passed on reception of a large signal. This small resistor gives little stabilising effect at low current values. It is often worth-while trying variations in the value of R_1 to make sure that the circuit is functioning properly. With a small Class B stage, about 3 or 4mA should flow through R_3 with no signal being received, and about half that current with the circuit in Fig. 4 (b).

Trimmers

A word about trimmers might be useful. Those found across ganged tuning capacitors, or used as tuning capacitors in miniature receivers, normally have a very low minimum

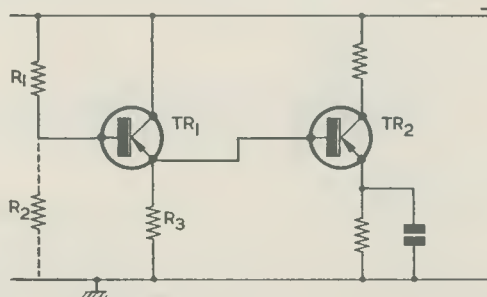

Fig. 2 A circuit with high input impedance which provides little stabilising effect. Sometimes, performance may be improved by adjusting the value of R_1

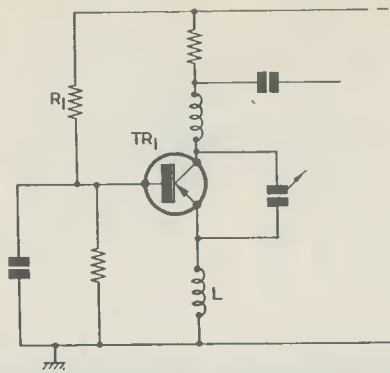

Fig. 3. Some simple detector circuits may employ a coil and feedback capacitor configuration such as that illustrated here. It may be beneficial to insert a bypassed emitter resistor between L and chassis. (This diagram is only intended to show basic feedback and bias circuitry, and tuning components are not included)

capacitance. But sometimes a trimmer with a maximum capacitance of about 500pF is specified as occurring, for example, in the author's super-regenerative circuit (published in the May 1965 issue) where it is used to control quench oscillation amplitude. To take this receiver as an example, it might be found that best results are obtained with the trimmer fully unscrewed. This does not mean that *no* capacitance is required but, merely, the need for substitution by a smaller trimmer of say 250pF which might well be the minimum capacitance of the 500pF trimmer). Alternately, if best results are obtained with the 500pF trimmer fully screwed up, a fixed capacitor should be wired in parallel with it. The value of this fixed capacitor should not, in the first instance, be 500pF but about 250pF, to provide sufficient trimming range, bearing in mind the minimum capacitance of the trimmer. If the addition of a 250pF capacitor improves results, but the trimmer still requires screwing right up, a larger fixed capacitor could be tried.

Instability

It will sometimes be found, after the most careful following of a published circuit, together with any necessary checking of values along the lines suggested above, that there is distortion or instability present. This is most likely to happen when there are several low frequency stages and no suggested layout plan has been given. One common cause of the trouble is interaction between the ferrite rod or frame aerial and the output transformer. This can soon be tested by trying various positions and angles for the transformer.

The trouble may alternatively be due to high frequency currents finding themselves in the wrong

places in other parts of the circuit. Fig. 5 shows a representative audio frequency circuit where this difficulty may arise, and capacitors C_1 to C_5 are shown (in dotted lines) as suggested cures. Some of these capacitors may already appear in the circuit. Others can be tried out, one by one. All except C_3 connect across low impedance circuits and can be about $0.1\mu\text{F}$ in value, but C_3 should be restricted to about $0.01\mu\text{F}$ in the interests of the higher audio frequencies. C_5 may be tried either as a shunt (C_{5a}) or to give a degree of negative feedback (C_{5b}). In the latter position it should be restricted in value or high notes will be lost. C_6 , an electrolytic capacitor of about $1,000\mu\text{F}$, 12V. wkg., may well cure a tendency towards instability as the resistance of the battery rises with age.

A similar large electrolytic capacitor may improve bass response if substituted for a smaller capacitor specified as an emitter resistor bypass

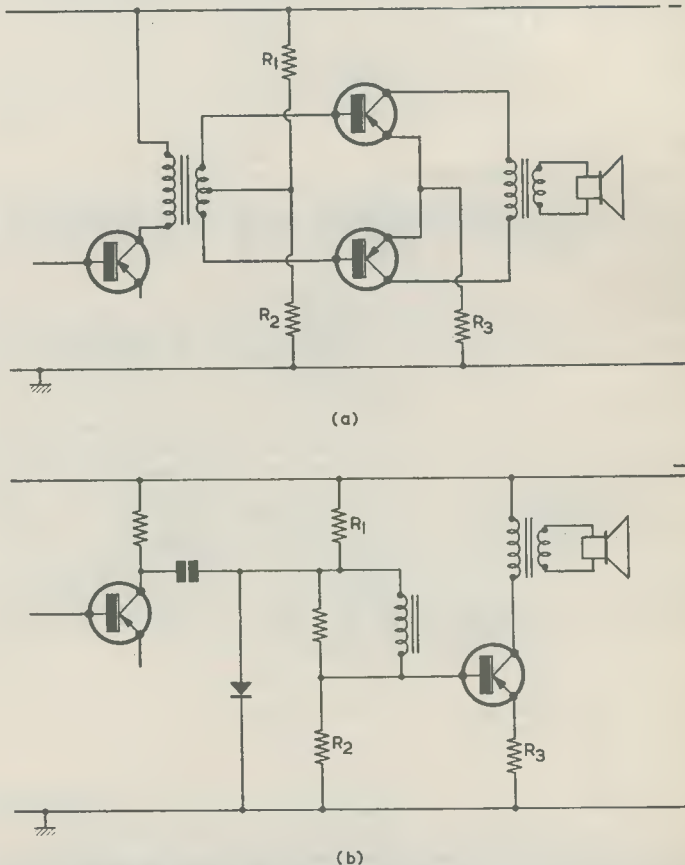

Fig. 4. A class B output stage (a), and (b) an economy Class A output stage designed by the author. In both instances, improvements in performance can sometimes be given by adjusting the value of R_1

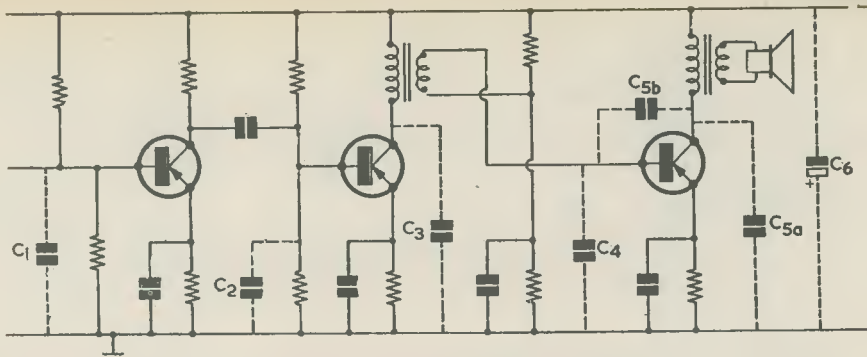
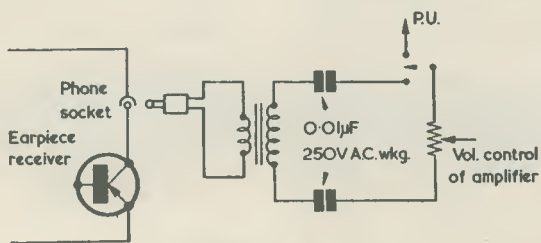
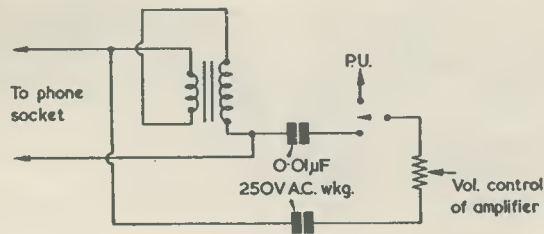

Fig. 5. A representative transistor a.f. amplifier. If distortion or instability is present it may sometimes be cleared by adding one of the capacitors shown in dotted line



(a)



(b)

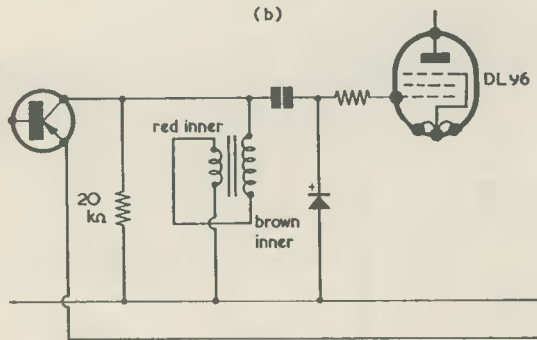

(c)

Fig. 6 (a). A suitable method of coupling a small transistor receiver to a valve amplifier. The transformer is an intervalve component
 (b). An alternative approach, in which the transformer is connected as a choke
 (c). Employing the transformer as a choke in the author's "Economical Hybrid Amplifier", which was described in the December 1964 issue

especially when direct coupling is employed and a good quality loud-speaker is used. It is well worth trying this substitution for the capacitor between emitter and battery positive in the output stage of the original Spontaflex 3-transistor design (published in the June 1964 issue), and the later super-regenerative version.

Coupling To A Valve Amplifier

A problem which puzzles some constructors is how to modify a simple low amplification valve operated amplifier, as used in simple record players, so that it will give good loud results when it is coupled to a transistor receiver of the personal earpiece type. It is assumed that the reception area is not very good, that results have proved disappointing, and that major changes are not contemplated.

In these circumstances the use of a suitable intervalve transformer can provide a big increase in amplification. Not only will the impedance in the output of the transistor tuner be higher with a transformer primary instead of an earpiece, with a consequent increase in voltage amplification, but there will be a further increase of voltage due to the step-up effect in the transformer. The primary (small winding) should be plugged into the earpiece socket of the tuner, and two capacitors of $0.01\mu\text{F}$ connected between the ends of the secondary and the ends of the volume control in the amplifier. Both the transformer and the capacitors should be mounted in the amplifier in the interests of safety. A single pole changeover switch will also be needed for changing from gram to radio, and vice versa. See Fig. 6 (a).¹

Assuming a straightforward common emitter output stage in the

tuner, its output impedance may be expected to be about 20k Ω . In order to obtain good amplification of bass with an inductive load, this load should be approximately equal to the output impedance at 50 cycles. We know that $Z=2\pi fL$ where Z is the impedance in ohms, f the frequency in cycles, and L the inductance in Henries. In this case, therefore, it can be shown that L needs to be 64H approximately for best results.

Many of the intervalve transformers available at present have a primary inductance very much lower than 64H. If, therefore, the suggestion which has just been made gives results which are disappointing in quality it may be helpful to use the two windings of the transformer connected in series to form a choke, thereby greatly increasing the inductance and consequently the load for the transistor output stage. The correct phase for connecting the windings of the transformer can be tested by ear, if this is not evident from an examination of the component. Bass will be better when the windings are series-aiding.

With choke coupling the step-up effect of the transformer will be lost, but the large impedance in the

collector load of the output transistor will result in much higher amplification of voltage than would be possible with resistance coupling, because of the need to avoid undue voltage drop from the battery which would take place with a resistor of high value. Fig. 6 (b) shows the choke arrangement.²

The author used transformer coupling between a transistor and a valve in his hybrid amplifier described in the issue for December 1964, and he has since found that it is well worthwhile reconnecting the transformer as a choke in this circuit, as in Fig. 6 (c). The transformer originally specified is easily obtainable and is suitable in many ways for this circuit, where low d.c. resistance is needed for the windings. But its inductance is too low, for best quality, unless connected as a choke. It might be mentioned that many transformers would not be suitable connected as a choke in this circuit partly because the overall resistance of the windings would be too high for the economy circuit to function correctly, and partly owing to saturation trouble with the comparatively large current flowing with large input signals. But the specified component does not appear

to become saturated due, no doubt, to its comparatively small windings. An alternative arrangement which works well with this circuit is to use the whole of the primary of a multi-range valve output transformer, such as the Elstone MR/T.

It may prove useful to shunt the winding with a resistor of about 22k Ω to smooth out any tendency for some frequencies to be over-amplified.

¹ The two 0.01 μ F capacitors in Fig. 6 (a) are required to provide isolation if the amplifier is of the a.c./d.c. type with a live chassis. The insulation between primary and secondary of the transformer should not be considered adequate for mains voltages (because the transformer is not designed to provide such insulation) whereupon the two 0.01 μ F capacitors *must* be rated at 250 volts a.c. working. If connection to the receiver results in hum, the mains connections to the amplifier should be reversed. If the amplifier has a double-wound mains transformer and its chassis, is in consequence, isolated from the mains supply, the 0.01 μ F capacitors may be omitted.—Editor.

² If the amplifier has a live chassis, the two 0.01 μ F capacitors in Fig. 6 (b) *must* be rated at 250 volts a.c. working. As with the circuit of Fig. 6 (a), if connection to the receiver results in hum, the mains connections to the amplifier should be reversed. Also as in Fig. 6 (a), the two 0.01 μ F capacitors may be omitted if the amplifier has a double-wound mains transformer and an isolated chassis.—Editor.



New Mobile Radio System Developed by Pye Telecommunications Ltd

Pye Telecommunications announces today that they have successfully developed and demonstrated a new system of mobile radio communication which overcomes the limitation of range inherent in all present systems.

The new development enables an unlimited number of relay stations to extend the range of transmission over any distance without alteration to the frequency or any other characteristic of the original transmission.

Mr. J. R. Brinkley, Managing Director of Pye Telecommunications Ltd., stated that the new development was a most significant one. Radio engineers and scientists have been trying to achieve this result since the earliest days of wireless and it was the first time that a fully practicable system had been demonstrated.

The system will be applied shortly to some of the many pocket radio telephone systems now being installed by Pye Telecommunications throughout Britain and the world for police and other purposes. It will be also applied widely to communications with vehicles of all kinds, as well as ships.

There was no limit to the range that the new relay system could achieve and there seems to be no limit to the possibilities which have opened up for mobile radio, now the range restriction has been overcome.

Mr. Brinkley stated that a pocket radio telephone service over an entire metropolitan area was now possible and for the first time radio telephone communications would become really practicable on long trunk roads and railway lines.

The new development, an entirely British one, was to be known by the letters S.S.R. (Synchronous Stable Relaying). The first demonstration system which had been set up in Cambridge operated on Ultra High Frequency (UHF) in the 450 megacycle band.

The system is particularly suitable for ultra high frequency transmissions.

"Untuned R.F. Pre-Amplifier"

In the article appearing under this title in the November 1966 issue it is, of course, assumed that the conventional aerial isolating capacitor is inserted between the aerial and the pre-amplifier input terminal when the preamplifier is used with a receiver whose chassis connects to one side of the mains. This capacitor may be the aerial isolating capacitor already fitted to the receiver, or may consist of an additional 2,000pF 250V a.c. wkg. component.

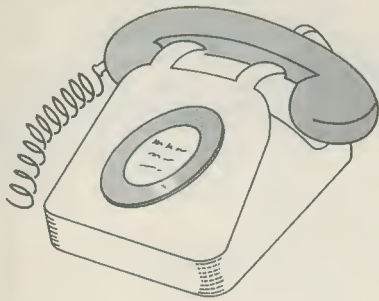

Telephone Bell Repeater

by A. THOMAS

Ingenious circuit design in this telephone bell repeater results in a battery current in the quiescent condition of 70 μ A only. Thus, the unit may be left permanently switched on with negligible battery drain

WHEN THE AUTHOR'S TELEPHONE WAS MOVED from the hall into the lounge, it was found that the bell was inaudible in the kitchen. The circuit described in this article was then devised to enable the bell to be heard in one or more remote places. A necessary feature was that the system used must not interfere in any way with the telephone circuit and must be capable of being left with the current switched on permanently. The current

drawn from the battery must be negligible to give long life.

Description

The circuit of Fig. 1, shows output connections to two rocking armature receivers. However, only RX₁ is essential, and RX₂ may be replaced by a 150 Ω resistor.

The search coil is a P.O. type 3,000 or 600 relay coil, and it is placed underneath the telephone receiver not further than $\frac{1}{2}$ in away from the bottom plate. Coil resistance is not critical, provided it is 1,000 Ω or greater.

When the telephone rings, the 16 $\frac{2}{3}$ c/s ringing waveform is induced into the relay coil. This is amplified by TR₁ and TR₂. TR₁ is held in a partially conducting state by the 1M Ω base resistor R₁, the collector current being approximately 60 μ A. TR₂ is held in the non-conducting state by the 100k Ω resistor, R₃, from base to emitter.

The output from TR₂ collector is a 16 $\frac{2}{3}$ c/s square wave which is approximately 7 volts peak-to-peak. This is d.c. restored and fed to the compound emitter follower TR₃ and TR₄ as a negative-going 7 volt square wave. The emitter follower is thereby switched on, and the square wave appears at the emitter of TR₄, where it is used as the power supply for a free running multivibrator, TR₅ and TR₆.

When the negative waveform appears at TR₄ emitter the multivibrator runs at approximately 1.5 kc/s and this is emitted from the receivers as a warbling tone similar to that on the new style telephone known as the Deltaphone.

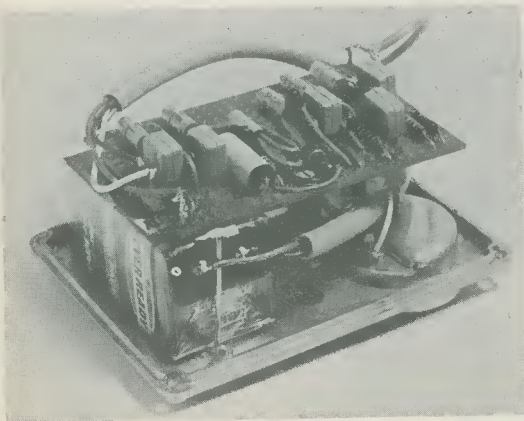

How the writer's unit is fitted in the Eddystone diecast box. The rocking armature receivers are mounted on the front panel of the box

(Continued on page 351)

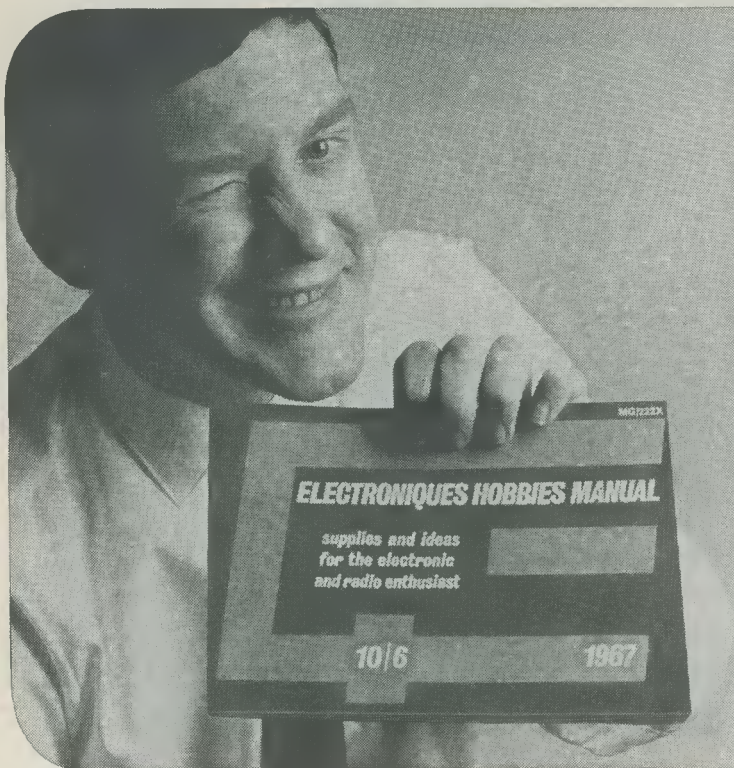

*I should like a copy of the Electronics Hobbies Manual.
Enclosed is a cheque/P.O. for 10/6.*

NAME

ADDRESS

R.C.Z.

Available now!

The enthusiasts' greatest-ever components guide!

Over 600 pages packed full of tips, kits and details of over 11,350 different parts from 85 leading manufacturers!

Whatever your particular interest in electronics, you'll find the **Electronics Hobbies Manual** a first-class investment.

It saves you time. No searching around for the parts you need. Every type of equipment—from stock components to sophisticated professional items—is here. Supplied by over 85 leading manufacturers, this equipment is *all* available by mail order on fast despatch.

It aids your projects. Complete designs, and details of kits available for beginners and experts, are all contained in the Manual. Inside, too, there's a wealth of technical data, practical tips and formulae to help you build with confidence.

It costs just 10/6 post free. And it puts the whole electronic industry at your service, including the specialised knowledge of Electronics. Behind this brilli-

ant new venture are the vast resources of STC and ITT, so you're assured of a first-class service!

Be sure of your Electronics Hobbies Manual. Clip the coupon, and send today—while stocks last!

Electronics (Prop. STC Ltd.)
Edinburgh Way, Harlow, Essex.
Telephone: Harlow 26777.

High-grade components for amateur communications



electronics

RECENT PUBLICATIONS



ELECTRONIC SYSTEMS FOR CONVENIENCE, SAFETY AND ENJOYMENT. By Edward A. Altshuler. 261 pages, $5\frac{1}{2} \times 8\frac{3}{4}$ in. Published by W. Foulsham & Co. Ltd. Price 30s.

This book, which appears in the Foulsham-Sams Technical Books series, comprises an American text with a short introductory chapter for English readers. It is mainly aimed at the *non*-electronically minded reader, as its function is to present to business men, architects, builders and home-owners the manner in which electronic devices may be employed to speed business activities and provide increased entertainment in the home. The author's theme is that people tend to look upon the more advanced electronic equipment as a luxury, whereas the advantages offered by the equipment should make it, instead, a necessity.

Part I of the book gives a detailed description of current (1965) American equipment in the entertainment, communications and business fields. Part II continues the story under the title "You Live And Work Best Electronically", dealing with computers and home and office equipment, then carrying on to electronics in education, government and medicine. Part III is devoted to the marketing and selling of electronic systems.

All the electronic equipment and systems referred to are American, and the background is the present American commercial scene. The book offers a factual description of the way Americans deal with electronics and should be of particular interest to Englishmen in business, ranging from the retailer and wholesaler to the manufacturer.

ELECTRONICS FOR YOUNG EXPERIMENTERS. By W. E. Pearce, B.Sc. 159 pages, $5 \times 7\frac{3}{4}$ in. Published by G. Bell & Sons, Ltd. Price 18s. 6d.

This book sets out to demonstrate the basics of electricity and electronics for the young schoolboy. The demonstrations are made almost entirely by means of experiments, and very nearly all of the text is devoted to no less than 72 practical experiments. Of these, 43 are described as "Things To Make", 16 come under the heading "Research" and 13 are listed as "Measurements". The experiments are specifically designed to suit a shallow pocket and, apart from several transistor components needed for experiments at the end of the book, most of the component parts are made up from such things as tinfoil, small pieces of Perspex and Sellotape. The reader may, perhaps, have to hunt around for some of the parts required, a typical example consisting of transformer laminations to provide a soft iron U-core which features in many of the experiments. But this will not deter the youngster, especially when it is remembered that some people are only too keen, these days, to be able to dispose of an unwanted radio set which can be easily stripped down of its parts.

The experiments themselves are exceptionally imaginative. Out of the many items which may be made one finds a miniature Van der Graff machine, a moving iron meter, a relay, d.c. and a.c. motors, a reaction timer, an "oscilloscope" (in which a torch vibrates vertically and a lens moves horizontally to provide an X timebase), a transistor receiver and a multivibrator toy electronic organ. Where required, power is obtained from dry cells or the secondary of a bell transformer. The reviewer was particularly impressed by the simple manner in which LC resonance is demonstrated. The experiments are illustrated by 92 diagrams and 20 photographs.

Electronics For Young Experimenters is an excellent book, and can be warmly recommended for any boy who is just starting to take an interest in electrical matters and who is capable of carrying out simple wood-working and metal-working operations.

INTRODUCTION TO RADAR AND RADAR TECHNIQUES. By Denis Taylor, M.Sc., Ph.D., M.I.E.E., F.Inst.P. 135 pages, $4\frac{1}{2} \times 7\frac{1}{4}$ in. Published by George Newnes Ltd. Price 10s. 6d. (cut flush) or 15s. (cased).

The author of this book was formerly Head of Electronics Division, Atomic Energy Research Establishment, Harwell and, during the war, Superintendent Scientist, Telecommunications Research Establishment (now known as the Royal Radar Establishment), Malvern. With a background of this nature one may confidently expect an authoritative book and to this can be added an economic and extremely readable style, the whole making the present work virtually compulsory reading for those who have had any experience of radar equipment or who are interested in radar as part of aircraft instrumentation.

As its title indicates, the book is intended as an introduction to radar, and it does not carry on to circuit diagram level or introduce complex mathematics. But the book does give excellent operating and functional descriptions of the radar equipment referred to, with complete details of frequencies, p.r.f., range and the like.

The first chapters of the book refer to wartime radar equipment and provide, incidentally, a fascinating narrative of the development and improvisation which took place during World War II. Systems covered include C.H., G.C.I., A.S.V., H₂S and Gee. Also dealt with are radar altimeters, A.T.C. radar systems, radar spectroscopy, radar astronomy, Doppler systems, and radar detection of clouds. The subjects dealt with in the final chapters include satellite tracking, nucleonics and current military radar systems.

This book has clear diagrams together with 11 plates and, as may be seen from the heading to this review, is available at two prices according to the finish required.

Telephone Bell Repeater

(Continued from page 348)

TR₁ to TR₄ are silicon transistors, these being required to enable the low leakage current to be obtained. TR₅ and TR₆ may be almost any germanium type. The total current drain in the

It should be mentioned that the rocking armature receiver may also be described as a "balanced armature" unit. The type employed by the writer had an impedance of 150Ω and a d.c. resistance of 20Ω.

Layout

The circuit diagram of Fig. 1 also shows the

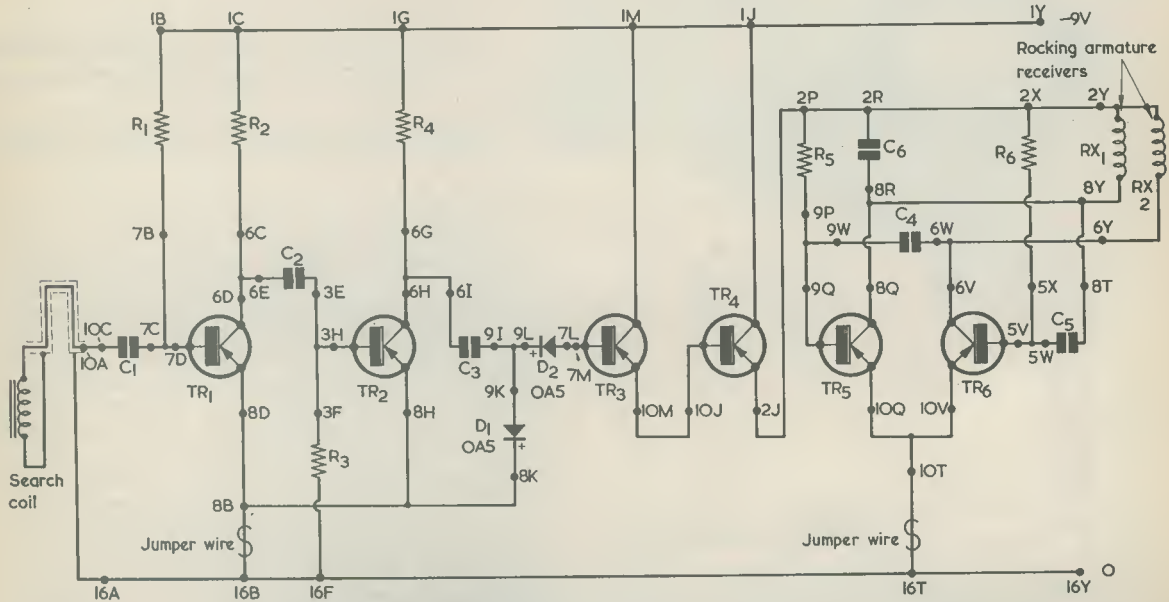

Fig. 1. The circuit of the repeater. This diagram also shows the points on the Veroboard to which each component connects

COMPONENTS

Resistors

(All resistors 5% ½ watt high stability)

R ₁	1MΩ
R ₂	47kΩ
R ₃	100kΩ
R ₄	47kΩ
R ₅	3.3kΩ
R ₆	3.3kΩ

Capacitors

C ₁ to C ₅	0.1μF Radiospares miniature polyester, or equivalent
C ₆	0.47μF Radiospares polyester, or equivalent

Semiconductors

TR₁ to TR₄ silicon p.n.p. transistors. OC200 or similar

TR₅, TR₆ germanium p.n.p. transistors. ACY18 or similar

Battery

9-volt battery type PP6 (Ever-Ready)

Miscellaneous

Veroboard sheet type VB1504, 0.15in hole matrix, 16 strips by 25 holes

2 Rocking armature receivers (see text)

P.O. 3,000 or 600 relay coil, 1,000Ω or greater

Battery Clips

Eddystone diecast box, Cat. No. E650 (Home Radio (Mitcham) Ltd.)

Single screened flexible cable

quiescent condition is 70μA, this rising to 10mA when the telephone rings. The battery life should exceed 9 months. If a rocking armature receiver is unobtainable, then a loudspeaker of about 2¼in diameter and a matching transformer can be used. The transformer ratios required are shown in the accompanying Table. As mentioned above, RX₂ may then be replaced by a resistor.

connection points for all the components when mounted on a Veroboard sheet with a 0.15in hole matrix. This should have 16 copper strips, each with 25 holes, and the figure/letter coding is illustrated in Fig. 2. Some of the strips require breaks, and the positions of these breaks are also given in Fig. 2. The Veroboard assembly is fitted in an

(Continued on page 375)

Linear Scale Audio Frequency Meter

by M. J. ...

This instrument displays frequencies from 10 c/s to 100 kc/s and can be an invaluable aid to the experimenter.

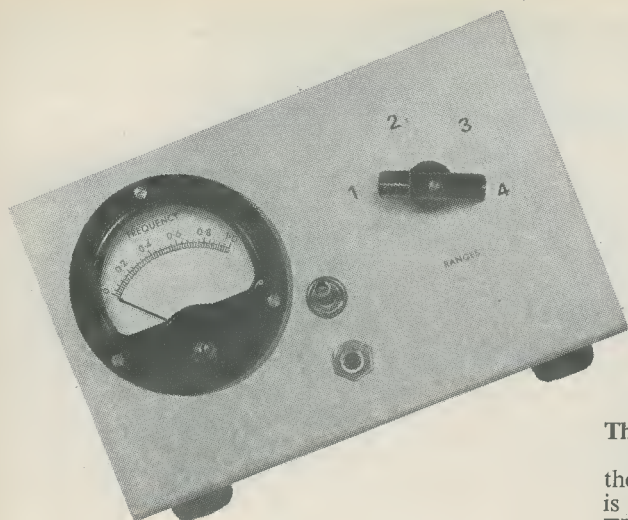

THE AMATEUR TAPE ENTHUSIAST IS INTERESTED in frequencies from 10 c/s to 100 kc/s. This range covers all the audio frequencies as well as the usual bias oscillator frequencies, and an instrument which will measure and display them on a moving-coil meter is an invaluable addition to the normal audio test gear. Such an instrument considerably simplifies the performance evaluation of, say, the playback amplifier.

A gliding tone test tape may be prepared by sweeping the audio generator over the range of frequencies of interest, and then on playback the frequency may be monitored at the same time as the output is being measured.

The instrument to be described has the great advantage of a perfectly linear scale over its entire range, and employs a robust 1mA moving-coil meter. The heart of the circuit may also be used as a built-in frequency meter for an audio oscillator, thereby replacing the conventional calibrated dial. The circuit will accept a sine or square wave drive within the amplitude range of 200mV to 5V peak-to-peak. Above this voltage an input attenuator will be required. The lower amplitude limit was considered adequate for most purposes.

The Circuit

Looking now at the circuit shown in Fig. 1, the signal whose frequency it is desired to measure is applied to the base of TR₁ via capacitor C₁. TR₁ acts merely as an emitter follower and serves to present the input signal with a reasonably high input impedance. The voltage gain of the TR₁ stage is nearly one, and so virtually the whole of the input signal is presented to the base of TR₂. TR₂ acts as a straightforward voltage amplifier offering a gain of some 25 times.

The next two transistors, TR₃ and TR₄, are arranged as a Schmitt trigger circuit, the purpose of which is to provide the output stage with constant amplitude rectangular pulses from the waveform appearing at the collector of TR₂. In the steady state without any input signal applied, the potential divider circuit formed by R₅, R₇ and R₈ is arranged so that the potential on the base of TR₃ is more negative than that on its emitter, thereby ensuring that TR₃ conducts heavily. Hence the potential

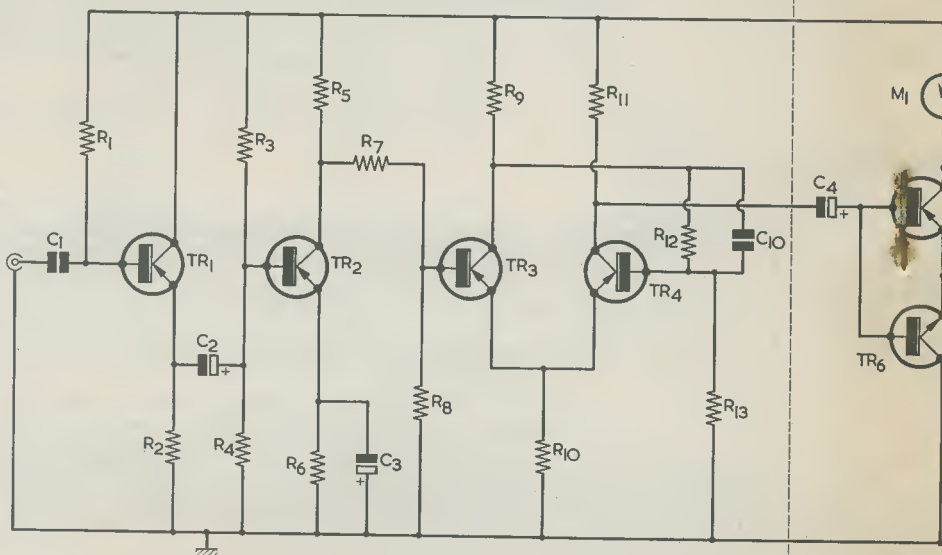

Fig. 1. The circuit of the frequency meter. Input frequency is in kc/s.

Audio Frequency Meter

M. HARDING



Cover Feature

... up to 100 kc/s on a moving coil meter, and
... the keen tape recording enthusiast

at the collector of TR₃ is so low that insufficient base current is available via R₁₂ and R₁₃ to bring TR₄ into conduction. When an input signal is applied, the positive-going half-cycle of the waveform appearing at the collector of TR₂ is communicated to the base of TR₃ via R₇ and R₈ and, eventually, a point is reached in the half-cycle when the base potential goes positive of the emitter potential, thereby cutting off TR₃. The collector potential of TR₃ promptly returns to the full supply voltage. A fraction of this potential is now communicated to the base of TR₄ via R₁₂ and R₁₃, this being sufficient to bring TR₄ from its original cut off condition to full conduction.

The circuit so far described provides at the collector of TR₄ a train of constant amplitude pulses occurring at a repetition rate equal to the frequency of the original input signal. Input amplitude variation from 200mV to 5V peak-to-peak merely alters slightly the width of the pulses, but since the meter driving stage tolerates this, it is

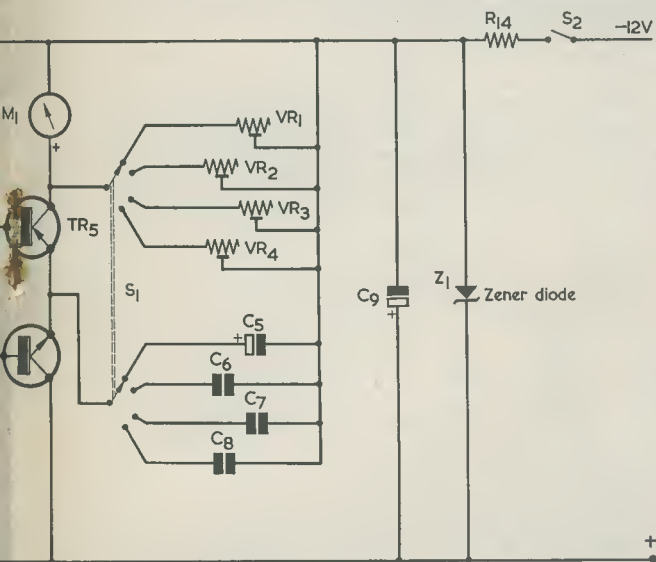

... is indicated directly by M₁

Resistors

(All fixed values ½ watt 10% carbon.)

R ₁	220kΩ
R ₂	5.6kΩ
R ₃	27kΩ
R ₄	3.3kΩ
R ₅	4.7kΩ
R ₆	1kΩ
R ₇	2.2kΩ
R ₈	47kΩ
R ₉	2.7kΩ
R _{10,11}	2.2kΩ
R ₁₂	6.8kΩ
R ₁₃	15kΩ
R ₁₄	270Ω

VR_{1,2,3,4} 100Ω preset, linear, carbon (see text)

Meter

M₁ 1mA f.s.d., moving-coil, (100Ω internal resistance)

Capacitors

C ₁	1μF, paper, 150V wkg
C _{2,3,4}	50μF, electrolytic, 15V wkg
C ₅	5μF, electrolytic, 15V wkg
C ₆	0.5μF, paper, 150V wkg
C ₇	0.05μF, paper, 150V wkg
C ₈	0.005μF, paper, 150V wkg
C ₉	50μF, electrolytic, 15V wkg
C ₁₀	10pF, ceramic

Semiconductors

TR _{1,2,3,4}	OC45
TR ₅	OC42
TR ₆	OC140
Z ₁	OAZ207

Switches

S ₁	2-pole, 4-way
S ₂	on/off

Miscellaneous

12V battery
18-way groupboard
Coaxial plug and socket
Metal case, nuts, bolts, wire, etc.

COMPONENTS

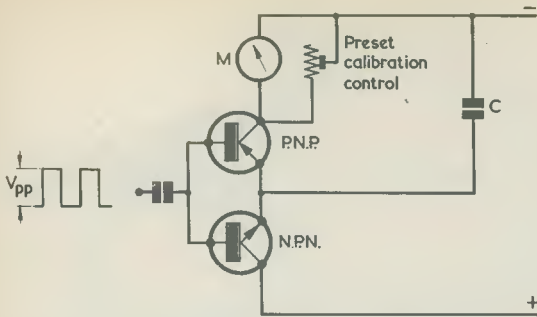

Fig. 2. Basic circuit of the meter driving section

of no consequence. Signals below 200mV peak-to-peak have insufficient amplitude to trigger the Schmitt circuit.

Let us next consider the meter driving circuit comprising transistors TR₅ and TR₆. It is this circuit which is the heart of the instrument, providing a current which is linearly related to frequency. It uses a technique which the valve boys simply did not have, that of complementary symmetry, i.e. a symmetrical arrangement of p.n.p. and n.p.n. transistors. The basic circuit is shown in Fig. 2. If the circuit is driven from a pulse train, the positive-going edges cause the n.p.n. transistor to conduct and charge the capacitor C. On the negative-going edges the p.n.p. transistor conducts, and the n.p.n. transistor is cut off. The result is that the capacitor is effectively short-circuited and hence discharges through the meter M. One of the fundamental definitions of electrical engineering tells us that the discharge current of a capacitor is equal to the rate of change of its charge. Numerically, this is the product of frequency (f) × charge (Q)

$$\therefore \text{Current } I = fQ \dots 1.$$

If the peak-to-peak amplitude of the input pulse wave-form is V_{pp} then by emitter follower action virtually the whole of this amplitude appears across the capacitor.

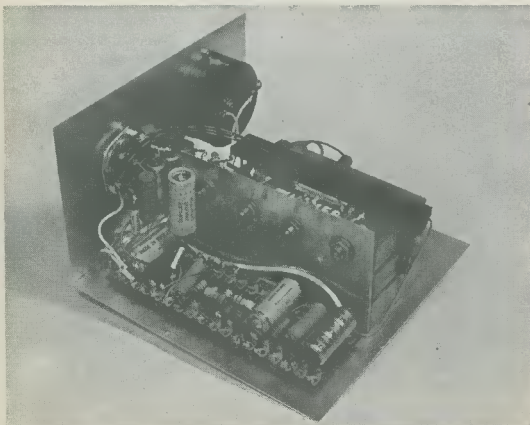

The neat internal layout of the frequency meter is readily apparent from this illustration of the prototype

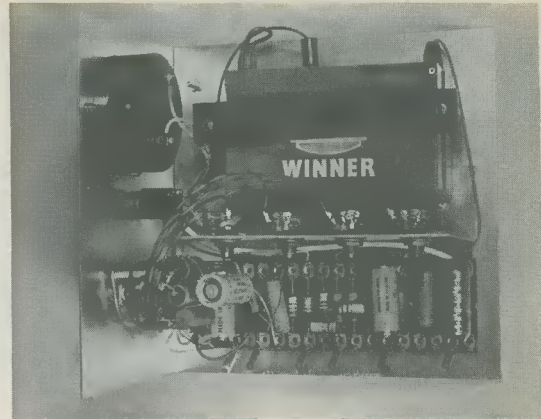

Top view of the chassis. The "speed-up" capacitor, C₁₀, was added to the groupboard after this photograph was taken

By definition the charge on a capacitor equals the product of applied voltage (V_{pp}) × capacitance (C)

$$\therefore \text{Charge } Q = V_{pp}C$$

Substituting for Q in 1, we get

$$\text{Current } I = fV_{pp}C \dots 2.$$

Convenient units for this equation are: I in mA, V_{pp} in volts, C in μF and f in kc/s.

The Value of C

From equation 2 it can be seen that, for a given value of C, the current that the meter measures is proportional to frequency and also to the applied peak-to-peak voltage. It should be noted that the current does not depend on the mark-space ratio of the waveform, and this explains the circuit's tolerance of varying pulse widths. Therefore, if we give C a suitable range of values and maintain V_{pp} constant, we have the basis of a wide-range linear scale frequency meter.

As was shown above, the first part of the circuit comprising transistors TR₁ to TR₄ provides the necessary constant amplitude pulse drive waveform. The amplitude of the latter is some 4V peak-to-peak and the moving-coil meter requires 1mA for full-scale deflection (f.s.d.). Therefore, direct substitution in equation 2 would yield a value for C. In practice,

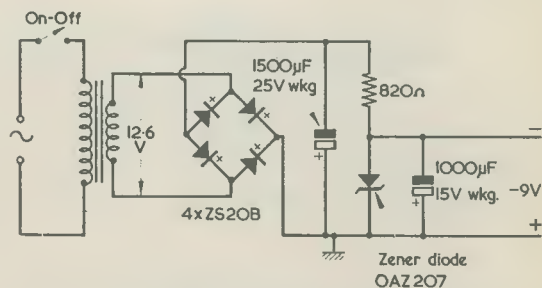

Fig. 3. A mains power supply, such as that shown here, can be employed instead of a 12V battery

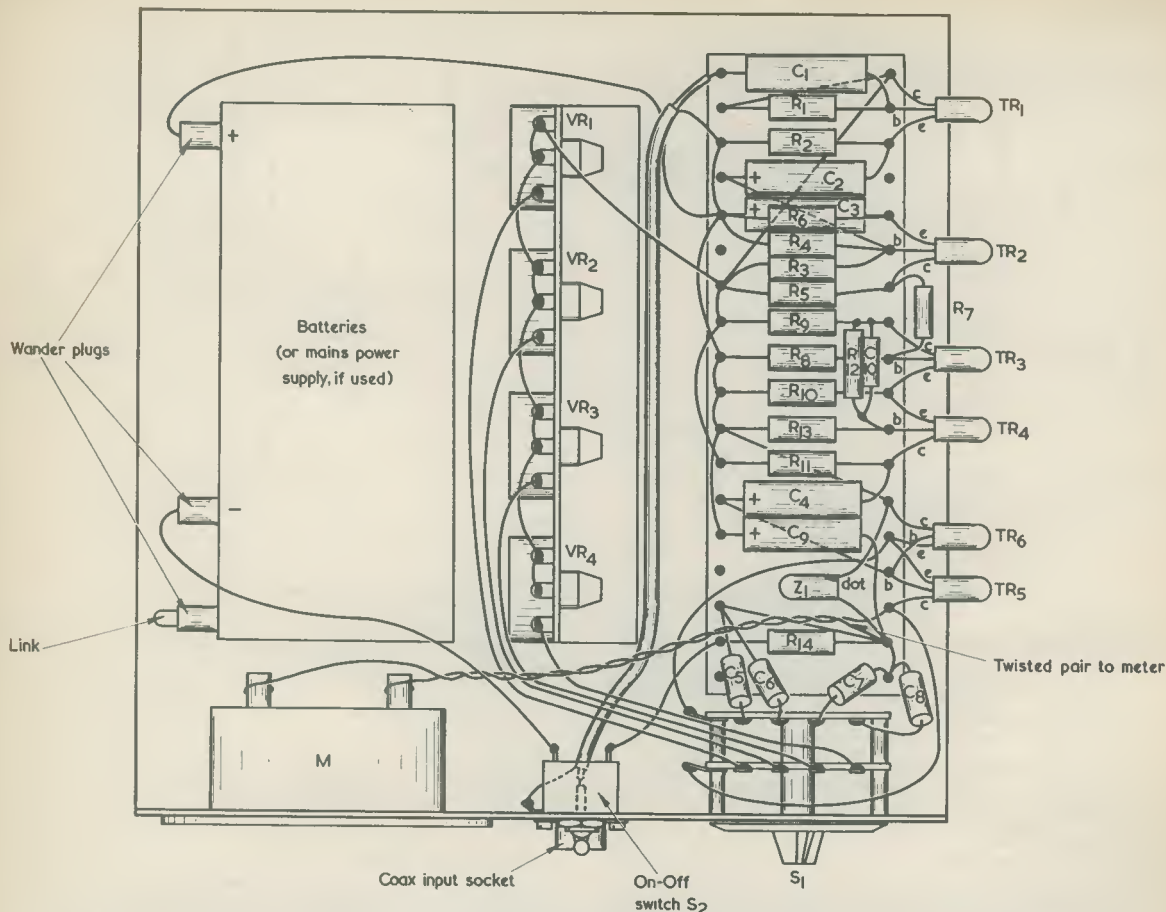

Fig. 4. Layout employed in the prototype. The batteries consist of two 9-volt grid bias batteries, one above the other, and series-connected by way of the link

however, a convenient, larger, value of C than that calculated is selected. This provides more current than the meter needs at the frequency corresponding to f.s.d., whereupon it becomes possible to incorporate a variable shunt resistor on each range as a very convenient preset calibration control. These variable resistors appear as VR_1 to VR_4 in Fig. 1. The values given for C provide coverage as follows: (1) 0–100 c/s, (2) 0–1 kc/s, (3) 0–10 kc/s and (4) 0–100 kc/s.

As to the transistors employed, OC45's were chosen for TR_1 to TR_4 to ensure a reasonable waveform at 100 kc/s. The meter driving stage uses an OC42 and an OC140. These were chosen for good frequency response and because they are virtually opposite polarity versions of each other.

The power requirements are 12V at about 11mA, which can be provided by two 9V grid bias batteries suitably tapped. Other battery types will of course do just as well. The circuit is sensitive to supply line variations and therefore a nominal 9V zener

diode has been included to provide a stabilised supply line. This takes care of voltage drop due to battery ageing, and enables the instrument to hold its calibration throughout the useful life of the battery. Alternatively a "bench-bound" version could be supplied from a mains-derived supply. A suitable power supply is shown in Fig. 3. In this diagram the OAZ207 occupies the same circuit position as Z_1 of Fig. 1. and C_9 and R_{14} of Fig. 1 are not required. Also, the on-off switch is now in series with the mains supply.

Construction

The construction is not very critical provided that a logical layout is adopted. The layout and type of construction used by the writer is shown in Figs. 4 and 5. The size of the front panel is dictated primarily by the size of the moving-coil meter, that employed in the original being a fairly conventional 3½in round flush mounting type. A word of warning about the preset calibration potentiometers. Carbon

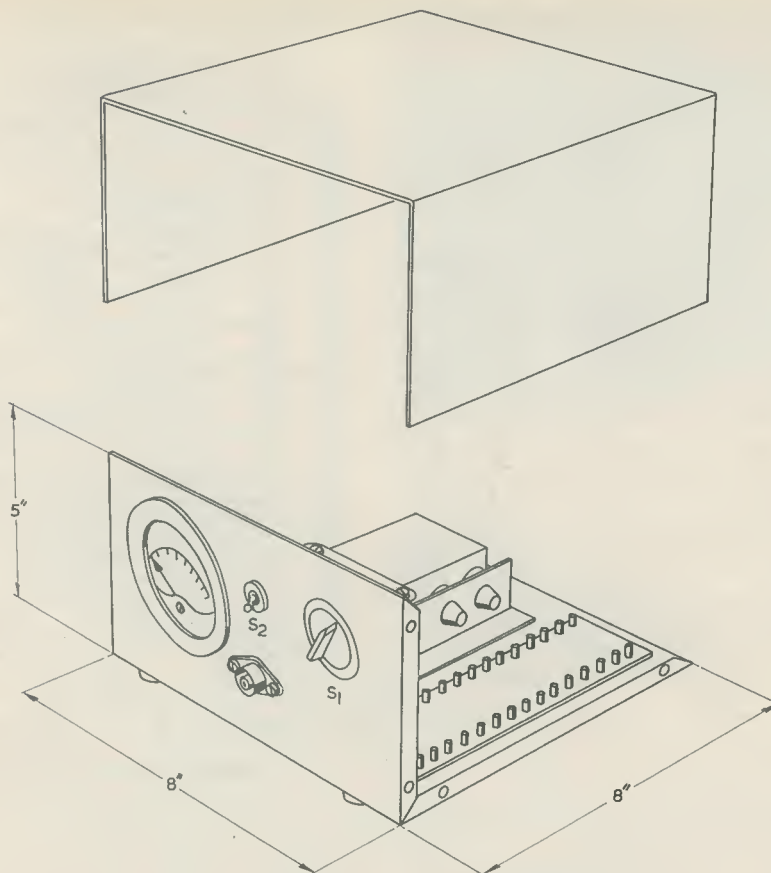

Fig. 5. Another view of the prototype, giving outside chassis dimensions

types *must* be used and wirewound types avoided. This is particularly important on ranges 3 and 4. The inductive reactance of a wirewound variable resistor rises with frequency, forcing a greater fraction of the discharge current through the meter as the frequency rises and resulting in a non-linear scale, the very thing we are trying to avoid. All the components were mounted on an 18-way groupboard except the frequency determining capacitors, which were wired directly between the tags of the board and the tags of the 2-pole 4-way switch, S_1 .

Calibration

For the calibration of the instrument a calibrated oscillator is required covering preferably 10 c/s to 100 kc/s, although a coverage of 50 c/s to 20 kc/s should prove satisfactory. The higher the upper limit of the oscillator the more accurately will range 4 be calibrated. The procedure is very straightforward. The calibrated generator is set to a frequency corresponding to a mid-scale value of one of the ranges of the frequency meter, and its output amplitude is best set to some 1 or 2 volts

peak-to-peak. The preset calibration controls are all set to maximum resistance. With the frequency meter set to a suitable range the calibrated generator is connected to the input and the appropriate preset calibration potentiometer is adjusted until the meter reads mid-scale. Finally the generator should be set to the frequency corresponding to the full-scale value of the range being calibrated, and the preset calibration control readjusted as necessary. This completes the calibration for one range and the procedure is simply repeated for the remaining ranges.

A point worth noting on the calibration of range 1 (0-100 c/s) is that it is best to use frequencies removed from multiples of the mains frequency in order to avoid beating effects. Frequencies of 40 c/s and 80 c/s are quite suitable. At frequencies below about 15 c/s the meter pointer has a noticeable tremble. This is unavoidable, and once the user becomes accustomed to it accurate readings are quite possible.

Built-in Frequency Meter

As was mentioned earlier, the basic circuit to the

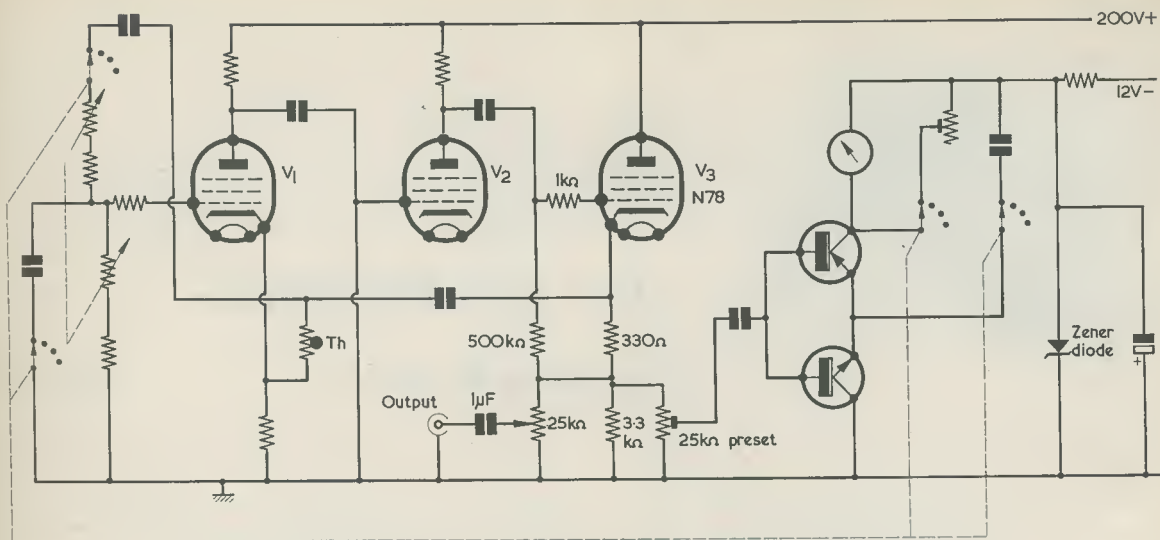

Fig. 6. Using the frequency discriminator section with a typical Wien Bridge oscillator

right of the dotted line in Fig. 1 may be employed as a built-in frequency indicator in a variable frequency oscillator. Since the circuit is independent of waveshape, it works just as well with a sinewave drive of constant amplitude as with a fixed amplitude rectangular pulse drive. A typical Wien Bridge valve design is shown in Fig. 5. V_3 is the usual cathode follower driving the Wien network. The amplitude of the sinewave appearing across the cathode load resistor remains virtually constant by means of the conventional thermistor feedback arrangement, and is typically some 40 volts peak-to-peak. A fraction of this voltage is tapped off by means of the $25k\Omega$ potentiometer, and used to drive the frequency meter circuit. The frequency determining capacitors are best selected by means of an additional wafer ganged to the main frequency selector switch of the oscillator. The setting-up procedure simply involves advancing the $25k\Omega$ potentiometer from its earthy

end until the sinewave amplitude on the slider is roughly 4V peak-to-peak.

The calibration now follows the same procedure as outlined above except that this time a calibrated generator may not be available since the constructor is making his own. An oscilloscope with a 50 c/s sinewave sweep and an auxiliary oscillator, which may be set to 1 kc/s, is this time required. With the uncalibrated oscillator connected to the Y amplifier, the low frequency end of the oscillator's coverage is calibrated using the 50 c/s sweep and observing the Lissajous figures which result. The higher frequency end, up to 10 kc/s, may be calibrated using the 1 kc/s auxiliary oscillator as a replacement for the 50 c/s sweep.

As will be found, this instrument, once set up, is perfectly stable, and it forms a very useful addition to the usual audio test equipment.



The M20 Static Inverter

With the ever increasing interest in boating, caravanning and "camping-with-the-car", there is a demand for a small a.c. current supply of modest wattage for various purposes. One such unit capable of supplying such a voltage is that produced by the Lowestoft firm of J.A.C. Electronics shown in the accompanying illustration. This is a well made unit that is intended primarily for running a.c. and universal electric razors aboard ship. Its use is equally applicable in caravans and cars.

Input can be either 6, 12, or 24 volts, giving an output of 240V a.c. single-phase; 50 c/s rated at 20 watts into a non-inductive load. As its load is normally inductive, it is fitted with a small amount of power factor correction in order that it can attain its full output, and this may be disconnected if not required.

Further particulars, price, etc., may be obtained from J.A.C. Electronics, 14 Yarmouth Road, Lowestoft, Suffolk.

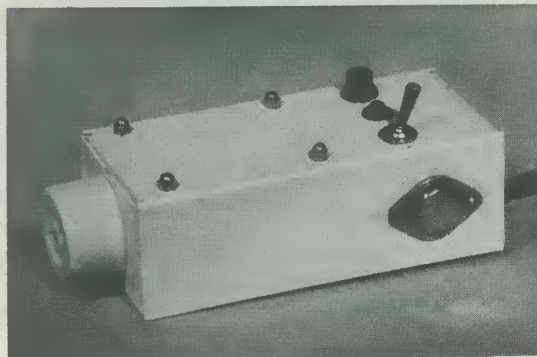

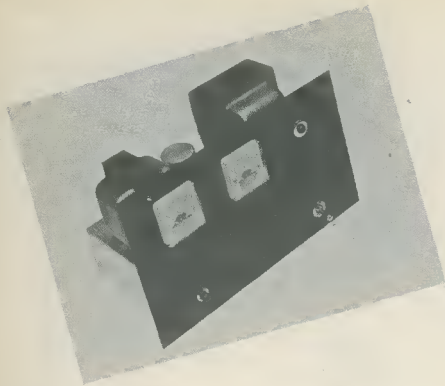

Quality Power Pack for the Beginner

by James S. Kent

Part 2

The power pack design presented here contains all those features that are desirable in a unit of this nature—fully metered h.t. output, stabilised h.t. output, visual indications of both heater and h.t. voltage and a double-smoothing circuit. The author has paid particular attention to safety with beginners in mind, a fully-shrouded mains transformer and a fused a.c. input being features of the design. For the benefit of beginners, the construction of this power unit is fully described. A point-to-point wiring diagram, together with the illustrations, provides all details for an interesting practical project which is ideal for those about to commence the hobby of radio construction

Wiring-up

The best method of wiring-up is to first connect the mains transformer wiring into circuit. Commence with the leads passing through grommet B. The two thin red wires are cut to length (save the cut off portions of wire—these will be used later) and soldered, one to pin 1 and the other to pin 7 of the rectifier V_2 . It does not matter which way round these two wires are connected. The black wire is next soldered to the rear earth tag (5) of the tagstrip, having first been cut to a suitable length. The thick green and white wires, after having been cut to length, must first have the covering enamel removed and the underlying copper wire tinned before connections are made. This is best done either by means of scraping with a penknife or by lightly filing the enamel. Connect the white wire to pin 5 and the green wire to pins 3 and 4 of V_2 . The mauve wire is not required and this should have its end securely taped with insulating tape such that it cannot make contact with the chassis. It is then tucked away to one side.

Deal next with the wires passing through grommet C. The black/yellow wire, the green wire, and the thin yellow wire are not required and they should be taped up in the same way as the mauve wire passing through grommet B. The red wire should next be soldered to tag A of the fuseholder and a left-over

length of red wire connected from tag B of the fuseholder to switch tag 1. (This method of connection assumes a 240V mains supply. If the mains supply is 220 or 200V, the red lead is taped up and the green or thin yellow lead—as shown in Fig. 1—connected to tag A of the fuseholder). The brown wire is now soldered to tag 1 of the tagstrip. The two thick yellow wires must next be cut to length and have the enamel removed from the copper wire as previously described. One yellow wire is soldered to tag 1 of the tagstrip, the other yellow wire being connected to pins 2, 3 and 4 of power outlet socket B. A further length of this thick wire, the ends of which have been similarly cleaned, should next be soldered at one end to pin 4 of socket B and at the other end to pins 2, 3 and 4 of socket A. The black wire passing through grommet C should now be soldered to on/off switch tag 4.

To complete the switch wiring, the a.c. mains input cable should now have one wire connected to tag 2 and the other wire connected to tag 3 of the switch having first, of course, fed the cable through the grommet on the rear apron of the chassis.

Complete the wiring to V_2 valveholder by soldering one bared end of a length of left-over red p.v.c. covered wire to pin 3 and the other end of this wire to the red tag of C_2C_3 .

Dealing now with the capacitors C_2 and C_3 ,

solder a length of black wire to the black tag, the other end of this wire being soldered to tag 5 of the tagstrip. To the red tag of C_2C_3 solder one end of R_3 , the other end of which connects to the yellow tag of C_2C_3 . To the yellow tag of C_2C_3 connect one of the l.f. choke wires passing through grommet A, the other wire from the choke connecting to the insulated stand-off tag adjacent to V_1 . It does not matter which way round the l.f. choke wires are connected.

The valveholder for V_1 (150C2 stabiliser) should next be wired-up. Pins 2, 4 and 7 are connected together, the other end of the wire being soldered to the chassis tag associated with outlet socket B. Pins 1 and 5 of V_1 are next connected together, and thence to pins 8 of both the outlet sockets. The resistor R_1 should next be connected between pin 1 of V_1 and the adjacent insulated tag.

The power outlet sockets should now have their wiring dealt with. Pins 5, 6 and 7 should be connected together, and to the respective earth tags as shown in Fig. 3. Both pins 1 should be connected together by a suitable length of p.v.c. covered wire. Before proceeding further, and for ease of wiring, it is now necessary to mount the front panel to the chassis,

ensuring of course that the paint or cellulose is thoroughly dry.

Mount to the panel the two meters and NE_1 . M_2 should have a solder tag fitted under one securing nut. The neon assembly is a push-fit whilst the meters are secured individually by means of integrally mounted bolts (4 off) and the associated nuts. The meters themselves may be used as templates when drilling the required holes ($\frac{3}{32}$ in). Remove the fixing nut of the on/off switch and PL_1 , place the panel into position and, having fed both these latter components through the appropriate panel holes, secure into final position by means of the two nuts.

Continue the wiring as follows. One wire from the mains neon NE_1 (it does not matter which one) is connected to tag 1 of the tagstrip and the other to tag 4 of the tagstrip. Both wires pass through grommet F. From tag 4 of the tagstrip solder a length of wire, the other end of which connects to the yellow tag of C_2C_3 . (The original wire fitted to the neon is not of sufficient length to reach the capacitor direct.) The positive tag of meter M_1 is next connected via a length of p.v.c. covered wire passing through grommet D to the insulated tag

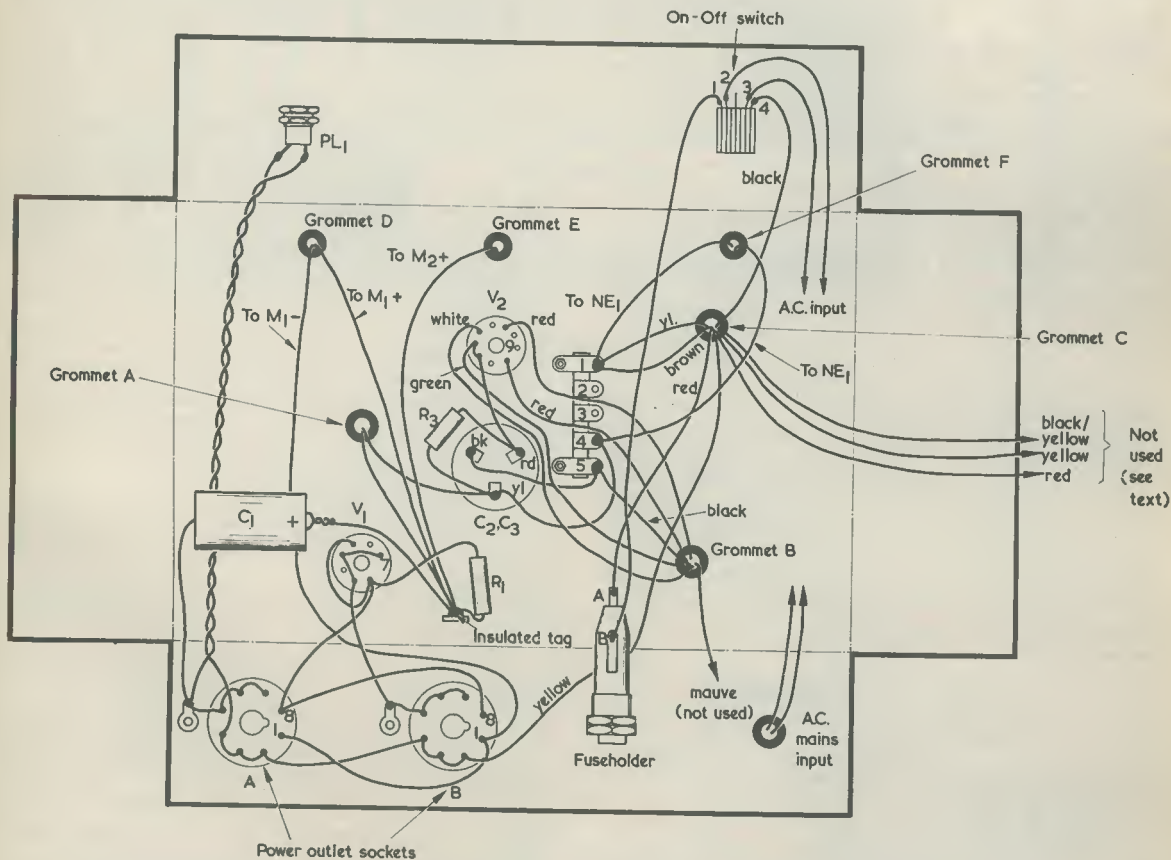
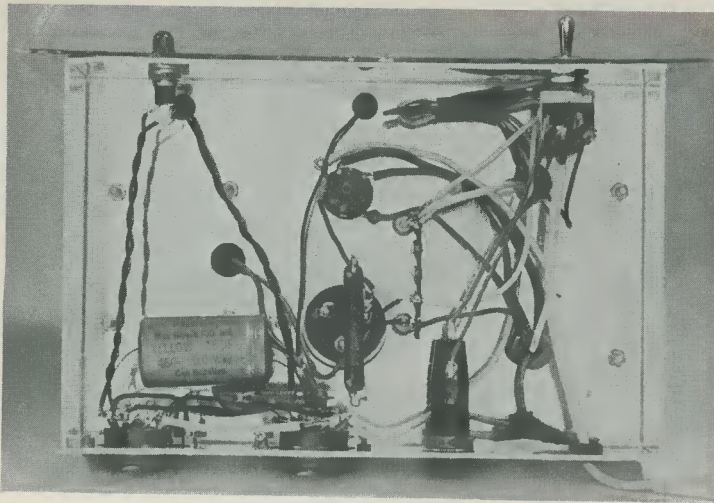

Fig. 3 Point-to-point wiring diagram of the power pack. This diagram is opened out for clarity and the actual wiring should be as short and direct as possible—see illustration of the below-chassis view



Below-chassis view of the completed power unit—compare with the point-to-point wiring diagram of Fig. 3. The single insulated tag is directly under R_1

adjacent to V_1 . The negative tag of M_1 , also passing through grommet D, connects pin 1 of outlet socket B. The positive tag of meter M_2 is next connected by way of grommet E to the insulated tag adjacent to V_1 . The negative tag of M_1 is connected to the chassis tag mounted under one of the meter securing nuts.

The two wires required for PL_1 are now dealt with, one being connected from a tag of this component to pin 4 of outlet socket A and the other, from the remaining tag of PL_1 , to the chassis tag adjacent to output socket A. It does not matter which way round the tags of PL_1 are connected.

The last item to be dealt with is the capacitor C_1 . This component is, in fact, two capacitors within one can, each having a value of $16\mu\text{F}$ and giving a total capacitance of $32\mu\text{F}$. The two lead-out wires should be tinned, twisted around each other and then soldered together. These are the positive wires. Cut to a suitable length and solder these twisted wires to the insulated tag adjacent to V_1 . The other wire of this capacitor is the one rivetted to the metal case and provides the negative connection. This wire should be soldered to the earth tag associated with outlet socket A. The wiring of the power pack is now complete.

TABLE
(Mains Voltage—240 a.c.)

Circuit	Volts (d.c.)
Junction R_3, C_3	315
Junction R_3, C_2	288
Junction $C_1, \text{LF Choke}$	280
Junction $R_1, \text{Pin 1 } V_1$	150

Readings taken with no load connected and with 150C2 in circuit.

Testing the Power Unit

Assuming the power unit has been constructed as described and using the 150C2 stabiliser, it may be switched on for a short period without any external load being connected, and tested. The 150C2 stabiliser consumes (off load) approximately 23mA but if this stabiliser has been dispensed with from the completed unit, a $27\text{k}\Omega$ 5 watt resistor should be temporarily connected from the junction of C_1 and the 1.f. choke (the insulated tag adjacent to V_1) and chassis (tag 5 of the tagstrip), before switching on the unit and testing. In the prototype such a resistor was fitted with the stabiliser tube withdrawn from its holder and the current then drawn was 9.2mA. Without this resistor, the voltage output could rise to a high level and this is not entirely desirable. Additionally, if the voltmeter

is omitted from the circuit, the capacitors would remain charged for a long period of time after switching off and unpleasant shocks would result. If the stabiliser tube has been permanently omitted, then the $27\text{k}\Omega$ 5 watt resistor *must be fitted as a permanent component within the circuit*, this being of particular importance when the power unit is to be used with an external unit having a low current consumption, i.e. a one or two-valve preselector or receiver. The output current is then limited to about 65mA.

Fit the fuse into the fuseholder, the valves into their respective sockets and a mains plug to the a.c. mains input lead. Stand the unit on the bench such that the underside of the chassis is uppermost. If a meter is available, make an insulation test from the h.t. positive line to chassis, to ensure that an h.t. short-circuit to chassis does not exist. If a meter is not available, a simple continuity device as given by a battery and a torch bulb will at least indicate direct short-circuits. Make completely certain, by visual examination and a meter, if available, that there are no short-circuits between the mains wiring and the chassis.

Connect to the mains and switch on. If all is well, the heater of the EZ80 will glow and, after a period neon NE_1 will become illuminated.

Having completed the tests, obtain a length of insulating tape and wrap this, lengthwise, around the mains on/off switch—having first removed the plug from the mains socket—several times such that the four switch tags are completely covered. In this manner, the accidental touching of these tags, whilst the unit is switched on and connected to the mains, will not result in the operator receiving a shock.

Voltage reading on the prototype, for a mains voltage of 240, are given in the accompanying table.



IN LAST MONTH'S ISSUE WE COMMENCED A DESCRIPTION of the three-stage receiver which forms the second constructional project in the "Understanding Radio" series. Heavy pressure on magazine space made it necessary, however, to hold over the final wiring steps until this present issue. Also described this month are the testing and operation of the receiver.

Final Wiring Steps

Much of the receiver wiring has now been carried out, and the final steps are illustrated in Fig. 5, which should next be consulted.

43. The next step consists of fitting potentiometer R_1 to the front Chassis Rail U-slot which is adjacent to L_1 valveholder. The potentiometer will normally have a locating pip or lug on the surface it presents to the rear of the Chassis Rail. Since the pip or lug will probably not coincide with a hole in the Chassis Rail it may need to be

45. Connect tag 10 to pin 7 of V_2 . Solder at tag 10 and pin 7.

46. Connect tag 9 to pin 9 of V_2 . Solder at tag 9 and pin 9.

47. Fitting sleeving over its lead-out wires, connect C_8 between pin 2 of V_2 and tag 16. Solder at tag 16.

48. Fitting sleeving over its lead-out wires, connect R_{10} between pin 2 of V_2 and tag 18. Solder at pin 2.

49. Connect R_7 between tags 18 and 19. Solder at tags 18 and 19.

50. Fitting sleeving over its lead-out wires, connect C_3 between pin 1 of V_1 and pin 3 of L_1 valveholder. Keep lead-out length as short as possible. Solder at pin 1 of V_1 and pin 3 of L_1 valveholder.

51. Connect and solder R_2 between the centre spigot of V_1 and pin 2 of V_1 . Keep lead-out wires short. The best approach here consists of soldering one end of R_2 to the spigot and then positioning

UNDERSTANDING RADIO

Completing the 3-Stage Receiver

$$f = \frac{1}{2\pi\sqrt{LC}}$$





by W. G. Morley

filed or cut off (in the case of a pip) or bent outward (in the case of a lug) so that the potentiometer can sit squarely. When mounted, the potentiometer shaft length should be such that, when one of the smaller K402 knobs is fitted to it, the rear of the knob is in the same plane as the rear of the tuning drive knob. Thus, the potentiometer has to be temporarily fitted to find the required shaft length, then removed so that the excess shaft material can be cut off with a hacksaw. (Remember the point made last month that it may be necessary to apply a file to the inside of the knob bush to remove proud metal from the grub screw holes). When the potentiometer is finally mounted, its tags should project away from the Chassis Plate, as illustrated in Fig. 5. After mounting, fit the knob.

44. Similarly mount R_8 in the front Chassis Rail U-slot adjacent to C_{10} (see Fig. 4), after having attended first to the locating pip or lug and shaft length. Fit the remaining K402 knob to its shaft.

it so that it lays over the spigot, with its remaining lead close to pin 2, to which it may then be soldered. It will be noted that all previous connections to V_1 centre spigot have already been soldered. In consequence, only a small amount of heat needs to be applied to the spigot to solder R_2 which might otherwise, because of its short lead-out connection, become excessively heated.

52. Connect C_5 between tags 12 and 13. Solder at tag 12.

53. Prepare one end of a length of screened lead, connect its centre conductor to pin 7 of V_1 , and its braiding to the chassis tag adjacent to V_1 . Solder at pin 7 and the chassis tag.

54. Following the route shown in Fig. 5 and keeping it close up against the underside of the chassis, run the screened lead to R_8 . At R_8 , connect the centre conductor to the centre tag of R_8 . Solder at this tag. Connect the braiding to the right hand tag (potentiometer shafts pointing towards the reader).

55. Prepare one end of a further length of

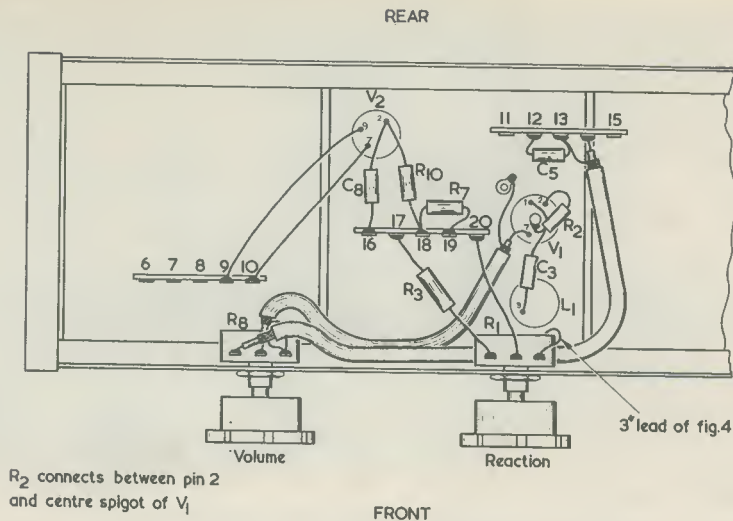

Fig. 5. Completing the under-chassis wiring

screened cable, connect its centre conductor to tag 14 and its braiding to tag 13. Solder at tags 14 and 13.

56. Following the route shown in Fig. 5 and keeping it close up against the underside of the chassis, run this second screened lead to R₈. Connect its centre conductor to the left hand tag of R₈, and solder at this tag. Connect the braiding to the right hand tag of R₈.

57. Examine the potentiometer fitted in the R₈ position. If this has a rear metal plate which, due to the construction of the potentiometer, is *not* automatically connected to chassis via the mounting bush, solder a short length of bare tinned copper wire to this plate and connect its other end to the right hand tag of the potentiometer. Solder at the right hand tag. This connection ensures that the rear plate is at chassis potential. If the rear plate of the potentiometer is already connected to chassis via the potentiometer metalwork and the mounting bush, this additional lead is not needed. All that then has to be done is to solder the connection of the two screened lead braidings to the right hand tag.

58. Fitting sleeving over its lead-out wires, connect R₃ between tag 17 and the left hand tag of R₁. Solder at tag 17 and the tag of R₁.

59. Connect tag 20 to the centre tag of R₁. Solder at tag 20 and the tag of R₁.

60. Shortening as necessary, connect the 3in lead of Fig. 4 (fitted in Step 41) to the right hand tag of R₁. Solder at this tag.

Wiring up is now complete and the receiver is ready for test.

Testing

The wired receiver should be given a visual examination to ensure that all-joints are well made.

Check, in particular, for possible short-circuits to chassis from the smoothed h.t. positive line and the anode circuit of V₂. These, if they exist, are likely to cause damage, whereas other faults are more likely to give incorrect operation only. The h.t. positive and output anode circuit wiring appears at tags 5, 6, 10 and 17, the two lead-through insulators connecting to tags 6 and 10, and pins 7 and 8 of V₂. The needle of an ohmmeter connected between the h.t. positive line and chassis should give an initial kick as C₁₁ charges, after which it should indicate a high resistance.

Connect a loudspeaker to the appropriate output terminals of the receiver. Also, connect an aerial to the aerial terminal. Some eight yards of lighting flex, or similar wire, will give sufficiently good results for testing. If a long outdoor aerial is used, insert a 200pF fixed capacitor in series with the aerial input connection, as shown in Fig. 6(a), to reduce loading on L₁. If the long aerial is to be used permanently, the 200pF capacitor can be incorporated later on the chassis, as shown in Fig. 6(b).

In some localities, it may be found that a particular aerial capacitance to earth causes the coupling winding of the long wave aerial coil to resonate at a medium wave frequency, whereupon the medium wave signal is heard at all points over the long wave band. This difficulty may be cleared by connecting a capacitor of around 100 to 300pF between aerial and earth connections to detune the interfering signal. The effect will be absent when the r.f. stage is added.

Fit valves V₁ and V₂, and rest the chassis on its back, knobs uppermost, so that the underside is in view.

Insert the receiver octal plug into the power

supply socket. If an ohmmeter or continuity tester is available, there should then be zero resistance between the two chassis.

Switch on the power unit. The heaters of V_1 and V_2 in the receiver should commence to glow. After a short period, the neon lamp in the power supply unit will become illuminated, indicating the presence of h.t.

Turn the reaction control, R_1 , fully anticlockwise. With the finger, touch the tag of the volume control, R_8 , which connects to the non-earthed end of the track. (This is the extreme left-hand tag in Fig. 5). A hum should be heard from the loudspeaker, varying in intensity as the volume control is operated. This "grid hum" test is very well known to service engineers and is frequently employed in rough checks of valve a.f. amplifier stages. The inexperienced should not use this test in equipment employing chassis which are connected to one side of the mains and, obviously, care should be taken not to touch h.t. points.

Set both the volume control and the reaction control fully clockwise. This adjustment of R_1 will allow an h.t. voltage to be applied to the anode of $V_{1(a)}$ which, without a coil plugged in, will function as a straightforward a.f. voltage amplifier. An audible hum (whose level depends upon the mains wiring in the room in which the receiver is being tested) may now be evident and it should increase considerably if the finger is brought close to C_2 (see Fig. 4). If pin 5 of the L_1 valveholder is short-circuited to chassis with a screwdriver, any residual hum should drop to negligible proportions. The intensity of the residual hum may vary if the mains input connection to the power supply unit is reversed.

This exercise demonstrates the fact that the grid circuit of the first valve in an a.f. amplifier having a relatively high degree of gain, as occurs here, is susceptible to hum pick-up. The fact that the residual hum clears when pin 5 of L_1 valveholder is short-circuited to chassis indicates that this hum is being picked up by the wiring to the tuning capacitor fixed vanes, and by the vanes themselves, and is being passed to the grid of V_1 via the low capacitance in C_2 . When a coil is inserted the residual hum will clear in the same manner as when pin 5 of L_1 valveholder is short-circuited to chassis, because the tuned winding between pins 5 and 2 offers virtually zero impedance to hum signals.

Turn the chassis to its correct operating position and insert the Range 2 (medium wave) coil into the L_1 valveholder, remembering that the projection on the coil base corresponds to the gap between pins 1 and 9 of the valveholder. Turn the reaction control so that it is nearly fully anticlockwise. Rotate the tuning capacitor. It should be possible to pick up a local medium wave station under these conditions, and its volume will increase as the reaction control is advanced until oscillation occurs. Oscillation will be shown by an increased hiss as R_1 is advanced or by the appearance of

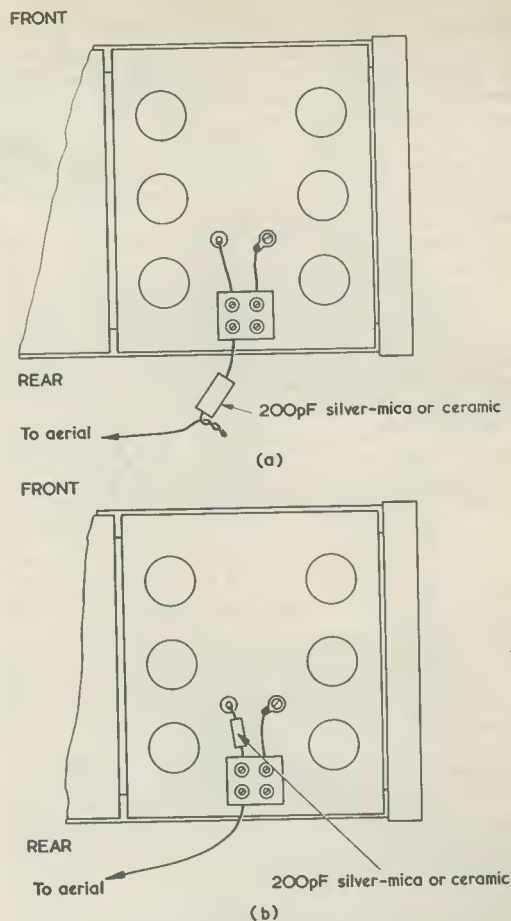

Fig. 6 (a) If a long aerial is used with the receiver, a 200pF fixed capacitor should be inserted in series with the aerial lead

(b) When permanent connection to the long aerial is intended, the 200pF capacitor may be fitted on the chassis, as shown here

heterodynes ("whistles") on either side of the station. A little practice will soon enable the correct setting to be found. The receiver should not be left in the oscillating condition for any length of time as the oscillation will be radiated by the aerial and may cause interference with neighbouring receivers.

Tune in other signals on the medium wave band, remembering that the setting in R_1 for optimum reaction varies according to the frequency of the tuned circuit. Best results with weaker signals will be given by adjusting R_1 for optimum reaction, since this allows the single tuned circuit in the receiver to exhibit maximum sensitivity and selectivity, and then adjusting R_8 for the desired volume level.

Insert the Range 1 (long wave) coil. It should

be possible to pick up the Light Programme transmission on 1500 metres at good volume when the tuning capacitor vanes are about three-quarters enmeshed. Some breakthrough of medium wave signals may be evident at the extreme high frequency end of the band, and this effect would be less pronounced if trimming capacitance were present across the tuned circuit. The breakthrough does not indicate a fault condition.

Remove the Range 1 coil and insert the Range 4 (short wave) coil. It should be possible to pick up a number of short wave stations, and it will be noticed that tuning is more critical and that it is desirable to keep reaction just below oscillation level whilst searching for signals. The slow motion drive specified offers very good control for short wave tuning.

All that finally remains is to set the iron dust cores of each coil for maximum inductance. Due to the absence of trimming capacitance the high frequency end of each band extends beyond the nominal figures quoted for each range; increasing the inductance in L_1 will bring the high frequency end of each band fairly close to the nominal figure with a somewhat extended response at the low frequency end.

Commence with the Range 2 (medium wave) coil and tune in a signal near the low frequency end of the band (tuning capacitor vanes fully enmeshed). Adjust the dust core of the coil in the direction which necessitates reduced tuning capacitance to retain the signal. Repeat this process, whilst continually adjusting the tuning capacitor, until no further increase of inductance is possible. The setting for maximum inductance corresponds to the core being fully in the tuned winding and is quite "broad" and non-critical. The core is, of course, adjusted by way of the threaded brass stem protruding from the top of the

former. This may be turned with a screwdriver or, even, just with the fingers.

Repeat the process for the Range 1 (long wave) and Range 4 (short wave) coils. The receiver is now ready for use.

Voltage Readings

H.T. Voltage at C_{11}	245V
Pin 8 V_2	245V
Pin 7 V_2	237V
Pin 3 V_2	10.5V
Pin 6 V_1	105V
Pin 8 V_1	4.3V
Pin 1 V_1^*	0—12V
Slider R_1^*	0—58V

* Voltage varies as R_1 is adjusted, no coil inserted

Voltage Readings

Voltage readings obtained with the prototype are given in the accompanying Table. These were obtained with a 20,000 Ω per volt meter switched to a 250, 100, 25 or 10 volt range as applicable for maximum deviation on the scale. Roughly similar readings should be given with receivers built to the circuit. Some small differences will be given by component tolerances and slight variations in valve performance, and do not indicate a fault.

Next Month

In next month's issue we shall review one or two points arising from experience of operation with this receiver, after which we shall turn to the subject of r.f. amplification.

Marconi Television Equipment for Sweden

Against international competition, The Marconi Company recently won two important export orders for television broadcasting equipment from organisations in Sweden. Marconi Mark V cameras have been ordered by Sveriges Radio for their studios in Stockholm, while a u.h.f. transmitter, which will be the most powerful in Scandinavia, is to be supplied to the Swedish Telecommunications Administration.

The order for cameras follows another, received earlier last year, from Norsk Rikskringkasting, Norway, for five Mark Vs intended for their new Oslo Headquarters.

The Mark V camera is the latest in the Marconi range. In Sweden these cameras will be used with Marconi monitoring equipment which is already installed at the Circus studio in Stockholm. This studio is mainly used for producing light entertainment programmes.

The 40kW u.h.f. transmitter, one of the most powerful ever proposed, is due to be installed this year. It is designed for remote control operation and is equally suitable for broadcasting colour or black-and-white signals. Three similar transmitters were recently ordered by the B.B.C., to extend the coverage of B.B.C.-2.



WIDE-BAND PHOTOPHONE, PT. I

by D. BOLLEN

Transmission of high quality audio signals over a very wide frequency range is feasible with ordinary fluorescent lighting tubes. In this, the first of a 2-part series, our author introduces the circuit techniques employed at the transmitter and gives a full description of the transmitting lamp reflector. Next month's concluding article gives further details concerning the transmitter and then describes the receiver circuits.

It should be noted that some of the equipment described in these articles is the subject of a provisional patent application

THE USE OF A MODULATED LIGHT BEAM FOR THE transmission of signals has a history as long as that of the telephone. Graham Bell's original Photophone consisted of a thin sheet of silvered glass attached to a mouthpiece, which became alternately concave and convex when sound waves acted upon it, thus affecting the intensity of a reflected light beam. His receiver used a selenium cell as a light sensitive device. An account of his experiments states that "Speech can be transmitted to a considerable distance by the simple agency of a beam of light", but there was no suggestion that this method would seriously rival the wired telephone.

Although the agency is simple, results depend a great deal upon what one means by "speech" and "a considerable distance". Tests carried out by the writer with torch bulb transmitters indicated that muffled tones were sometimes to be heard at distances not further than 100 yards, and the quality of the transmission was poor, even by the standards attainable with wired links in the days of Graham Bell. Perhaps such discouragements are to blame for the meagre interest shown, during the intervening 80 years, in systems employing light as a carrier of modulated signals.

Now, with the radio spectrum fast becoming crowded, together with the development of lasers and other optoelectronic devices, it is possible that light links will be used where radio, wires, and inductive loops are unsuitable. Short range car-to-car communication on the move, talking traffic lights and road signs, ship-to-shore harbour links, private communications networks across streets, and pulse operated remote control systems are a few of the potential uses for a modern Photophone. The fact that interest in such transmissions is very much alive is well demonstrated by the number of interesting articles on the subject that have appeared in *The Radio Constructor*.

Prototype Experiments

Some time ago the writer experimented with an ordinary fluorescent lamp tube fed from an output valve anode of an a.f. amplifier as an alternative to the filament bulb with its restricted frequency range. Results were not initially promising. The tube gave a severely distorted signal over a range of a few tens of yards when used with a simple phototransistor receiver. It was realised later that the light from such a tube peaks at the blue end of the visible spectrum, to which a phototransistor is insensitive. A blue sensitive caesium antimony photocell was then purchased, at somewhat more cost than an OCP71, and this worked well when coupled to a high input impedance transistor amplifier at a photocell anode potential of less than 9 volts. A marked increase in range resulted, and early experiments resulted in speech which was just intelligible at around 200 yards in daylight. Further tests revealed that the distortion of the transmission could be very much reduced if the fluorescent tube was biased with a d.c. standing current of about 50mA, but the tube then generated a fair amount of noise. This was presumed to be caused by low level self-oscillation due to a

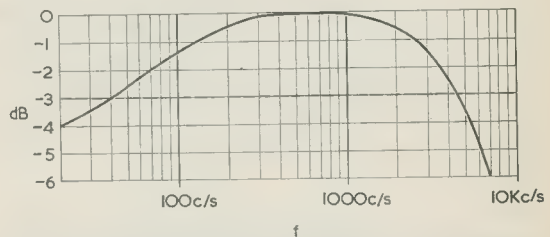

Fig. 1. The overall uncorrected frequency response offered by the Photophone system. By means of suitable compensating circuits, this can be changed to the response shown in Fig. 8

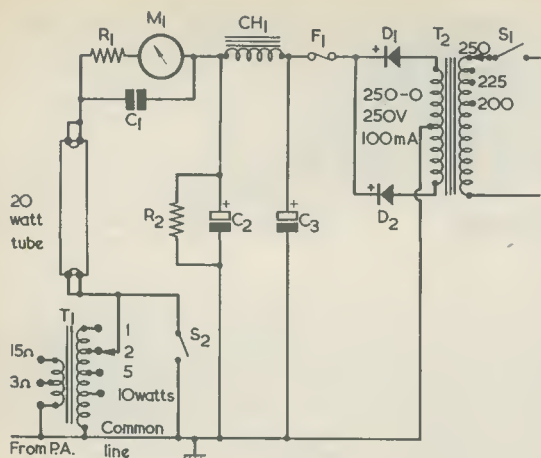

Fig. 2. The power supply for the tube. The modulating signal is applied via transformer T_1

negative resistance portion of its slope, and vibration of the discharge striations or rings visible along the length of the tube at the lower audio frequencies. The noise tended to disappear with a high frequency audio signal, and it was found that introduction of a supersonic bias, similar in principle to bias in a tape recorder did much to reduce the noise.

With the fluorescent tube coupled to a suitable modulation transformer driven by a valve amplifier, the overall uncorrected frequency response was plotted as shown in Fig. 1, and was within 3dB from 40 kc/s to 4 kc/s. Although this response is much better than that obtained with torch bulbs and a 15 watt mains bulb, and is adequate for speech communication, it was thought that better results were possible. A small residual signal as high as 60 kc/s, shown on an oscilloscope, prompted attempts to extend the frequency range by compensation, so that music signals could be evaluated. Eventually, with suitable pre-emphasis, a response of 20 c/s to 25 kc/s, within 2dB, was obtained. The maximum range at full modulation was also extended to better than 400 yards in bright daylight. Good treble response was well in evidence on music signals, quality was crisp.

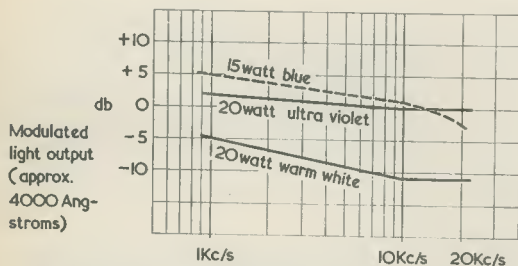

Fig. 3. Uncorrected responses of three fluorescent tubes using a "flat" amplifier characteristic and constant power input

Resistors

- R_1 1k Ω -3k Ω wirewound, 20 watts (see text)
- R_2 100k Ω 1 watt

Capacitors

- C_1 4 μ F paper, 350V wkg.
- C_2 100 μ F electrolytic, 350V wkg.
- C_3 60 μ F electrolytic, 350V wkg.

Inductors

- CH_1 8H, 100mA
- T_1 "100V Line" Matching Transformer (Radiospares)
- T_2 250-0-250 volt, 100mA, mains transformer

Diodes

- D_1, D_2 BY100

Fuse

- F_1 0.5 amp fuse

Meter

- M_1 f.s.d. 100mA

Switches

- S_1 s.p.s.t. toggle
- S_2 s.p.s.t. toggle

Tube

- 24 in 20 watt fluorescent, Daylight or Warm White (see text)

COMPONENTS

and percussion instruments such as the triangle came through unimpaired.

Tube Unit

With ease of working in view, the tube unit—incorporating d.c. supply and modulation transformer—was designed to match the 3 or 15 Ω output of a standard amplifier, either valve or transistor. The circuit can be modified for portable car battery working by substituting a 15 watt transistor 50 cycle inverter for the mains transformer supply.

It will be seen, in Fig. 2, that the fluorescent tube is directly modulated by the transformer T_1 , and that the tube starting heaters are not used. After switching on the equipment the tube will strike on a high level audio peak, attaining full brightness almost immediately. Dropper resistor R_1 limits tube current which is monitored by a 100mA meter, to a safe value, and it may be adjusted to suit the fluorescent tube and supply voltage. The correct value of resistor will lie within the range 1k Ω to 3k Ω (start with the high value and reduce this until the desired results are obtained). On no account should the tube ever be connected straight across the 250 volt d.c. supply, as this will quickly ruin the tube, and could have spectacular if short-lived results. Capacitor C_1 presents a low impedance path to the a.c. drive which is developed across the secondary winding of the modulation transformer.

T₁ is a readily available 100 volt line transformer wired in reverse. The tag markings—1 to 10 watts—do not refer to the power rating of the transformer, but to the sound volume given by a loudspeaker when the transformer is employed normally in a public address system. Although not considered an ideal component for this particular application, the transformer specified for T₁ effectively removes the need for a “difficult” special component. The existing tapping points do provide a correct match to the tube under varying conditions and, despite the high level d.c. standing current in its windings, this small transformer performs surprisingly well with a good frequency range, and it never even ran warm throughout long-period tests.

The original prototype tube consumed 60mA with a 2kΩ dropper resistor for R₁, and the voltage across the tube when struck was only 75 volts. Neglecting losses in the dropper resistor, this means that the tube power is only 4.5 watts, and yet the light output is roughly equivalent to that given by a pearl 60 watt mains filament bulb. It is recommended by manufacturers that a low pressure mercury vapour discharge lamp should have its connections reversed periodically when run on a d.c. supply, to prevent blackening of one end of the tube. As the tube ages, its internal d.c. resistance will rise, and so will its striking voltage. Old tubes were tried, but they proved reluctant to start and gave a poor light output. Fortunately, because of their mass application, new tubes are relatively inexpensive, and will give a long life.

Construction of the tube supply unit followed standard practice, components being mounted on a small aluminium chassis. C₁ was a 4μF paper block capacitor and was situated underneath the chassis, with the mains transformer, rectifiers, electrolytic capacitors, choke and modulation transformer on top. A later version of the unit made provision for switched values of R₁ for experimental purposes and to suit cascaded tubes, but this refinement has only a small effect on performance. A terminal block on the back of the chassis is useful for making external connections to the unit. The 100mA meter and switches may be mounted on a front panel, and it is convenient to arrange for sockets to select tappings on the modulation transformer. By closing S₂, it is possible to vary the taps without extinguishing the tube.

The tube may be mounted on its own, remote from the amplifier and power supply, but long runs of cable will cause some attenuation of high frequency response, even at the fairly low impedance at which the tube is fed. If the tube is not visible to the operator, the meter will tell him when the tube is passing current, and will give a useful indication of modulation level.

It is quite possible to use larger fluorescent tubes, or batteries of small tubes, if a power amplifier of sufficient power to modulate them is available. There seems to be no limit on transmitter size. Components will, of course, have to be re-rated to suit the heavier working currents, but the in-

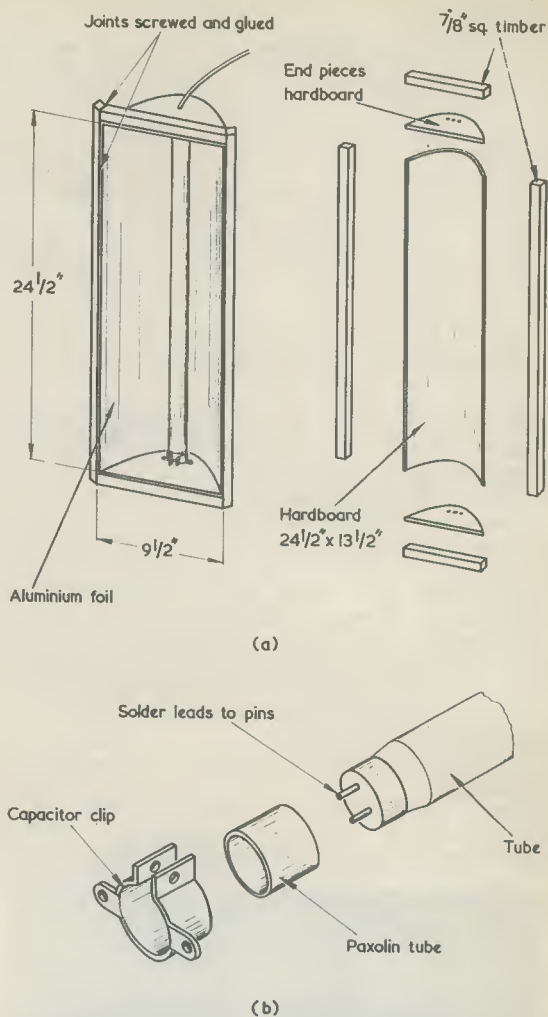

Fig. 4 (a). The assembly of the tube reflector unit (b). Detail showing the method of securing the tube at each end

creased output should result in a considerable extension to the range of operation. For modest installations, a smaller 6 watt tube is available, and its use would enable a very compact layout to be arrived at for instances where long range is not so important. Tubes can also be supplied with a variety of powder coatings, to emit light at different parts of the spectrum, including ultra-violet.

As a guide to readers, the following three tubes may be considered as representative.

Philips Warm White TLA 20w/35, 20 watt 24in.

Atlas ultra violet 20 watt 24in.

Ekco blue 15 watt 18in.

Fig. 3 gives a comparison of the performance of these three tubes, from 1 to 20 kc/s. The small

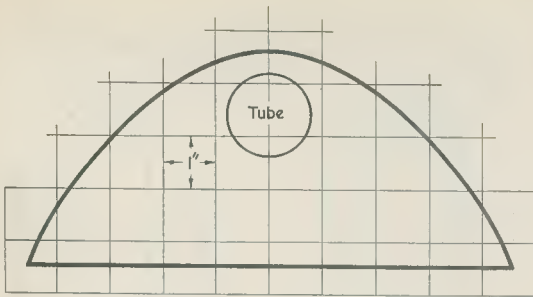
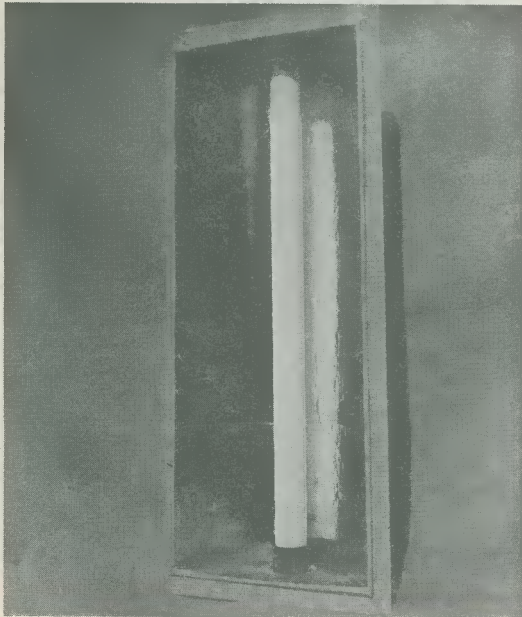

Fig. 5. The end pieces for the reflector. This may be drawn full size on 1 in graph paper to the proportions given here

blue tube is the most efficient (its phosphor output matches closely the response of the photocell), giving the longest range for a given input power, but the high frequency response is poor compared to the other types of tube. The ultra violet is the best all-round tube, with a good output and a very flat response, and the added advantage that its small visible light output makes it inconspicuous in daylight. However, for economy and general working, the much cheaper normal lighting tubes such as the Warm White are satisfactory. There is only a very slight difference between tubes of different manufacture thus far encountered, mainly with regard to noise levels.

Reflectors

When unmounted, the tube will allow 360° transmission of a signal, but a parabolic reflector was constructed to give concentration in one direc-



A 20 watt transmitter tube mounted in its reflector

tion and, at the same time, a fairly big light source to make optical receiver alignment simpler. Rather than use large, expensive sheets of polished aluminium, a hardboard and cooking foil method of construction was preferred. In this way, a light source measuring 24 x 9 in was obtained, and contacts at several hundred yards were quite simple, without a long search time and erratic reception due to hand shake. In fact, an appreciable deviation of the receiver from true centre can be tolerated without loss of signal, this being better than $\pm 2^\circ$ of arc.

Constructional details for the reflector are given in Fig. 4 (a), and the parabolic shaped end pieces may be copied from the drawing of Fig. 5. The large piece of hardboard forming the body of the reflector is first soaked in a bath of hot water for about an hour to make it pliable. It is then bent roughly to shape and the end pieces are held in place with several windings of string. String is also spirally wound along the body to hold the sides in, and the whole is left to dry. All joints are then screwed and glued and the timber frame is fitted. Details of the tube mountings are given in Fig. 4 (b). Electrolytic capacitor clips were employed to grip Paxolin tubing, into which the fluorescent tube was then fitted. Finally, a layer of bright cooking foil is glued and smoothed on to the reflector body, and the wood frame and hardboard externally painted.

When viewed from a distance, the reflected image of the tube should fill the frame of the reflector. Wires soldered to the tube pins are taken out, top and bottom, to a suitable socket or connector.

Power Amplifier

The approximate impedance of the fluorescent tube is $1,000\Omega$, this being matched to the output of a 3 or 15Ω valve amplifier by means of the modulation transformer, as described earlier. An amplifier of 15 watts or more is recommended as

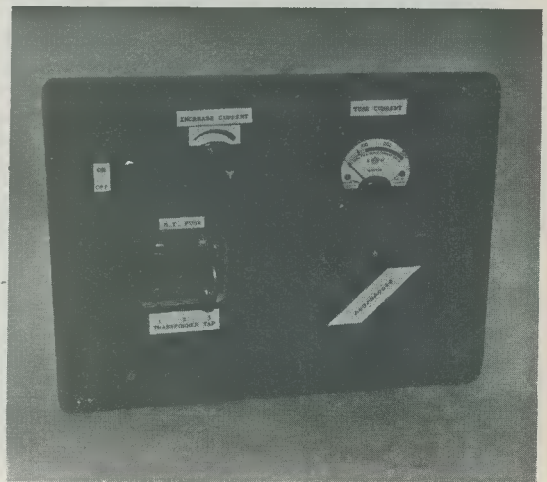

One of several tube h.t. supply units made up by the writer

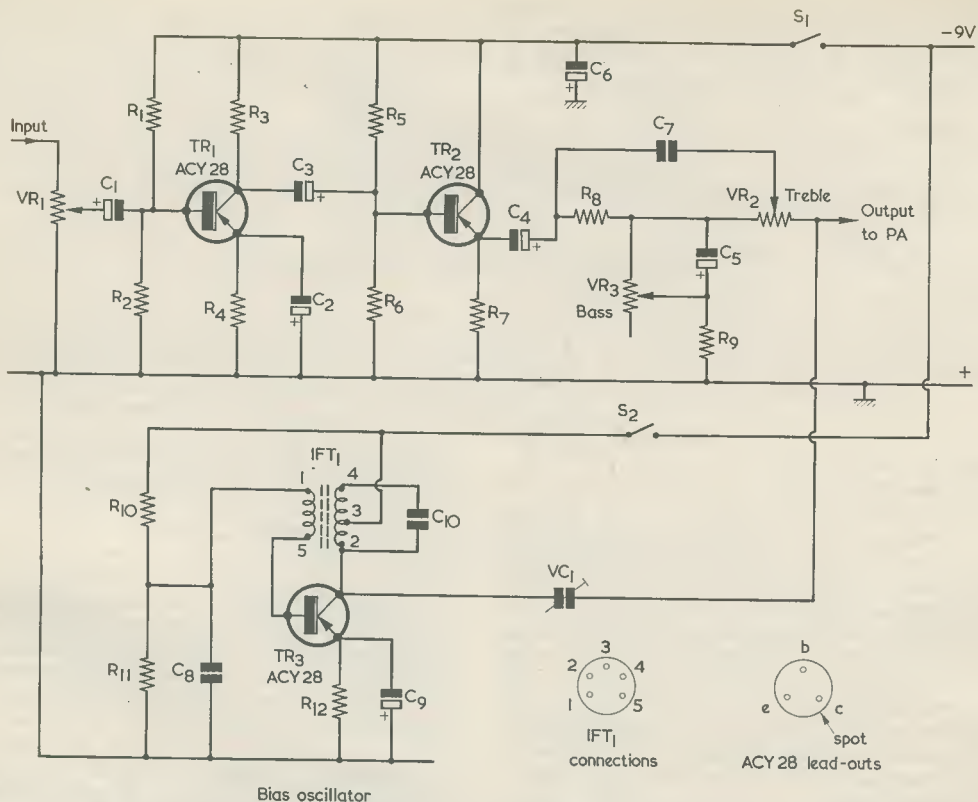

Fig. 6. The circuit of the transmitter pre-amplifier and compensation unit. The internal low-value capacitor between pins 2 and 4 of IFT₁ is not shown here

COMPONENTS

Resistors

(All fixed values $\frac{1}{4}$ watt 10%)

R ₁	27k Ω
R ₂	4.7k Ω
R ₃	4.7k Ω
R ₄	1k Ω
R ₅	12k Ω
R ₆	10k Ω
R ₇	1k Ω
R ₈	1k Ω
R ₉	150 Ω
R ₁₀	27k Ω
R ₁₁	10k Ω
R ₁₂	1k Ω
VR ₁	25k Ω potentiometer, log track
VR ₂	1k Ω potentiometer, linear track
VR ₃	1k Ω potentiometer, linear track

Capacitors

C ₁	15 μ F electrolytic, 9V wkg.
C ₂	100 μ F electrolytic, 6V wkg.
C ₃	15 μ F electrolytic, 9V wkg.
C ₄	100 μ F electrolytic, 6V wkg.
C ₅	2 μ F electrolytic, 6V wkg.
C ₆	100 μ F electrolytic, 12V wkg.
C ₇	0.01 μ F paper
C ₈	0.01 μ F paper
C ₉	1 μ F electrolytic, 6V wkg.
C ₁₀	0.02 μ F paper
VC ₁	100pF pre-set

Transformer

IFT₁ I.F. transformer type P50/2CC (Weymouth)

Transistors

TR_{1,2,3} ACY28 (or equivalent)

Switches

S ₁	s.p.s.t. toggle
S ₂	s.p.s.t. toggle

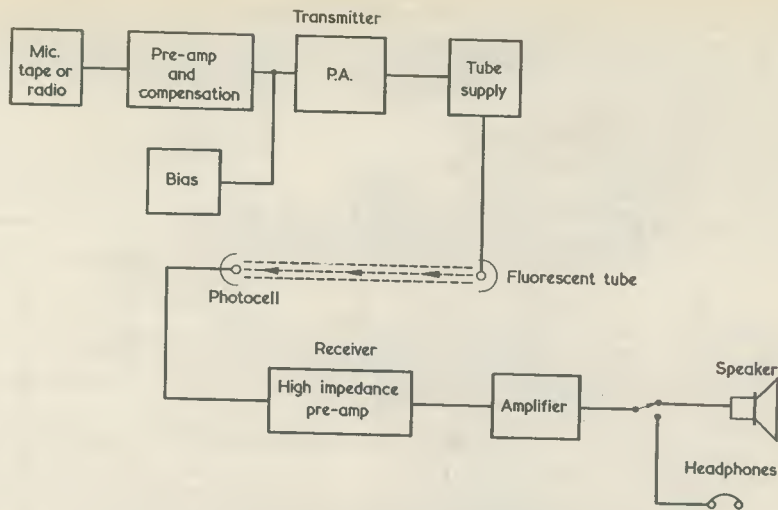

Fig. 7. Block diagram representing the complete installation

this will give an ample reserve of power and prevent amplifier abuse during experiments. The actual power required, including losses, will not be more than 7 watts at full drive. The amplifier should also be capable of handling a small 45 kc/s signal if bias is to be used. Most Hi-Fi amplifiers made today have a response extending well into the supersonic region and are able to handle such a signal at low levels.

Points to watch while setting up the equipment is that the power amplifier is not grossly overloaded, and that it does not become unstable. An oscilloscope is invaluable for modulation tests, but if one is not available an output meter may be connected to the p.a. output to monitor signal level and

check for self-oscillation. A useful pointer to overloading is when the modulation transformer starts to "sing" loudly: another is the fluorescent tube itself. When overmodulation occurs the tube will flicker. At normal levels of modulation the flicker is scarcely perceptible.

Compensation and Bias

To correct for a fall in frequency response at the extremes of the audio range and beyond, bass and treble boost were included for convenience along with the pre-amplifier and bias circuits in a single unit. There is enough boost to give treble emphasis on transmit and, by introducing a similar amount of treble cut at the receiver, thus improve

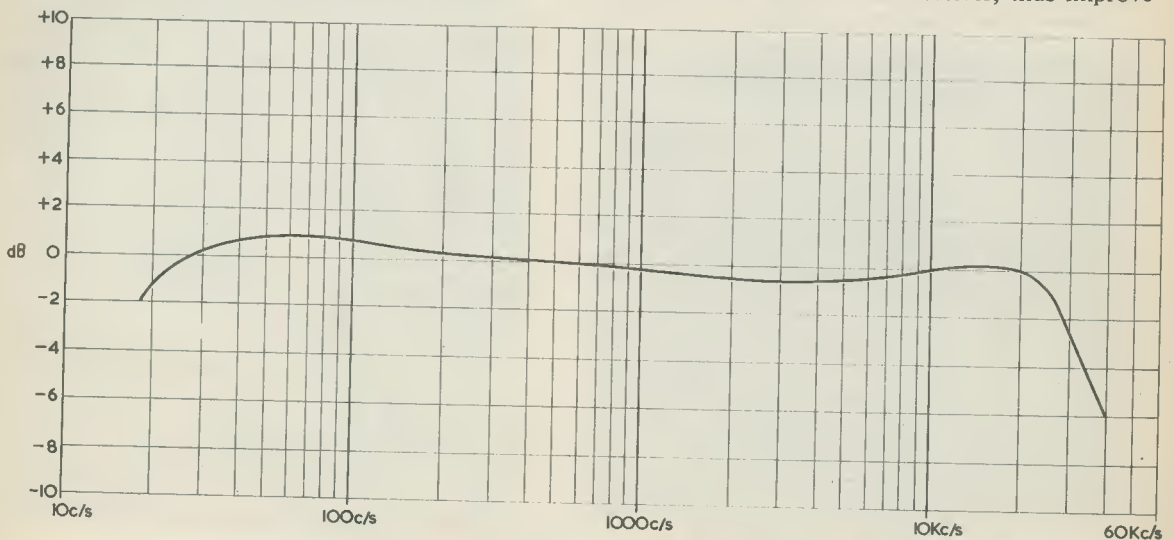

Fig. 8. A typical overall compensated response curve. This is within 2dB from 20 c/s to 25 kc/s

the signal noise ratio.

The pre-amplifier circuit is given in Fig. 6. The signal is amplified by TR₁, fed to the emitter follower TR₂, and thence into the compensation network composed of R₈, R₉, C₇ and C₅. Bass boost is controlled by VR₃ and treble boost by VR₂. The curve given in Fig. 7 illustrates the type of overall response which can be obtained with suitable low settings of VR₂ and VR₃. The high frequency response can be extended well into the 50 kc/s region for pulse work by substituting a 0.02 μ F capacitor for C₁ in Fig. 2, but this will adversely affect the overall linearity.

The a.c. bias oscillator was built around a transistor radio i.f. transformer, padded by C₁₀ to lower its resonant frequency to 45 kc/s. A respectable-looking 45 kc/s sine wave from the oscillator is mixed with the signal at the input to the power amplifier via pre-set capacitor VC₁, this control determining the bias level. Inevitably, some inter-modulation distortion must result from the mixing of bias and signal, but the effect is insignificant, audibly, for most purposes. Nevertheless, when desired, the oscillator may be switched off by means of S₂. It is interesting to note the very marked increase in noise level when bias is inoperative.

The pre-amplifier unit should be completely enclosed in a metal box to prevent regenerative feedback and stray radiation from the bias oscillator. The prototype pre-amplifier was encased in a seamless baking tin with a steel front panel, with coaxial input and output connections.

The circuit of Fig. 6 provides enough gain to work directly into the input of a main amplifier in a normal Hi-Fi system. Alternatively, it can feed into the Radio/Tape input if low gain settings

are used. All the transistors used had a d.c. current gain of around 100. Employing input transformers as applicable, both moving-coil microphones and low-output dynamic pick-ups have been used successfully with the pre-amplifier when coupled to either a Quad or a Williamson amplifier. Tape or radio inputs to the pre-amplifier may also be used.

The ACY28 transistors specified for Fig. 6 may not be a familiar type to the readers. The ACY28 is a general purpose audio transistor with a cut-off frequency of 1.2 Mc/s, a power rating of 200mW in free air, and an h_{fe} of 45 to 150. It can be obtained from either S.T.C. Electronic Services, Edinburgh Way, Harlow, Essex, or Henry's Radio Ltd., 303 Edgware Road, London, W.2. ACY28 transistors are also used in the receiver section.

Complete Installation

The block diagram of Fig. 7 shows the complete Photophone installation. In this diagram, the pre-amplifier of Fig. 6 precedes the transmitter power amplifier, this coupling into the tube power supply and, thence, to the transmitting fluorescent tube. At the receiving end, the modulated light is picked up by a photocell, the resultant signal being passed to a pre-amplifier, a main amplifier, and a speaker or headphones. An overall compensated response curve is given in Fig. 8.

Next Month

The concluding article, to be published next month, gives further details of the transmitter, together with a description of the equipment at the receiving end.

(To be concluded)

Radar Success Story

Marconi Marine's fully transistorised "Raymarc" radar is the choice of three out of four trawler owners for their vessels in Aberdeen's near water trawling fleet, in addition, a further 27 sets are in operation and 14 on order for various other classes of trawler operating from ports on the North-East coast of Scotland, where a reliable radar is a necessity owing to changeable weather conditions and the rugged coastline encountered.

The "Raymarc" has a 12in p.p.i. display unit incorporating seven closely spaced ranges from 20 yards to 48 miles and may be mounted on a bulkhead, table or deckhead, or on a pedestal with tilt and rotation facilities. Nominal power consumption is 500 watts from the normal shipboard supply.

The success of this radar does not, however, end with the trawler, as over 175 home trade and deep sea shipowners in this country alone, with vessels ranging from the smallest coaster to Cunard Line's "Queens", have specified the "Raymarc" as their main or secondary display.

Export orders, which exceed those at home, have been received from maritime countries throughout the world, Canada and Spain figuring prominently in these markets.

This vote of confidence in the "Raymarc" from the shipowner has enabled Marconi Marine to sell or hire out on rental/maintenance terms an average of one set per day for every day since its introduction two and a half years ago, surely a most impressive testimony to the reliability and performance of the "Raymarc".

In Your Workshop



The new year may be full of promise, but it finds Smithy the Serviceman, together with his able assistant Dick, kicking their heels in a Workshop which is bereft of work. However, they don't waste their time, and they take advantage of the situation to discuss the latest hints received from readers.

"A⁻¹⁰".
Smithy, seated at his bench peered down at the sheet of paper in front of him.

"Nothing doing," he replied.

The Serviceman concentrated for a moment.

"It's my turn now," he called out over his shoulder. "B-3."

There was a snort of irritation from Dick's bench.

"Darn it," he growled bad-temperedly, "You've sunk my fourth sub!"

"Good show," remarked Smithy, pleased. "I've been searching for that one."

"Dick swung back into the attack.

"D-7."

"Nothing there," replied Smithy equably. "E-15."

"Stone me," said Dick despairingly, "Now you've gone and hit my last destroyer."

Dick gazed at his own sheet of paper and his brow furrowed with an agony of intense concentration.

"F-3."

"There's nothing there, either," returned Smithy.

"Are you sure?"

The question carried a discernable note of suspicion.

"Of course I'm sure," replied Smithy, affronted at the implied accusation.

"Do you know what I think?" accused Dick. "I think you're moving them around after I've called out the numbers."

"Nonsense," returned Smithy briskly. "E-16!"

There was a clatter as Dick threw his pencil down on his bench.

"That's it then," he said disgustedly. "Down goes my last destroyer."

Readers' Hints

Dick got up, walked over to Smithy's side and gazed distrustfully at the sheet of paper on Smithy's bench.

"Well, it *looks* all right," he conceded reluctantly. "But I'm darned if I can see how you do it. We've been playing Battleships for the last hour and you've sunk my entire fleet at least six times, whilst all I've been able to do is to hit the odd submarine or get an occasional glancing blow on a cruiser. There's something wrong *somewhere*."

"Perhaps it's the New Year's Eve celebrations," offered Smithy helpfully. "They must have blunted your normally high level of discernment."

"Do you think so?"

"I'm certain of it," continued Smithy gravely, "I know that New Year's Eve was on a Saturday this year, and that you had all yesterday to get over it. But, even so, there may still be some lingering effects this Monday morning which prevent you exhibiting your usual keen-wittedness."

"Well, I'm dashed! Go on, Smithy."

"There's nothing much more to add," said Smithy. "Anyway, it's probably a good thing you're not up to your usual mark today, as there's nothing to do anyway."

Dick glanced discontentedly at the empty "For Repair" racks.

"It's always the same at this time of the year," he grumbled. "We clear out all the sets just before Christmas, and then we've got nothing to do at the start of January but sit around twiddling our thumbs."

He brightened as a thought suddenly occurred to him.

"Tell you what, Smithy," he said excitedly. "If we've got no sets to service, how about having a session on hints sent in by readers?"

"Now that," said Smithy approvingly, "really is a good idea. We'll get started on them straight-away."

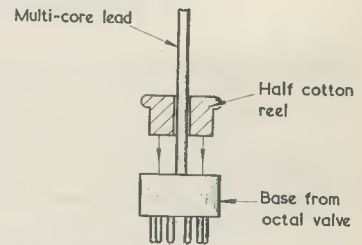

Fig. 1. A low-cost octal plug. The half cotton reel (shown in cross-section) is inserted into the octal valve base and glued in position

Whilst Dick carried his stool over to Smithy's bench and settled himself comfortably, the Serviceman opened a drawer and extracted a sheaf of letters.

"Now let's see what we've got here," he remarked pensively, as he examined the letters. "Ah, here's a good one to start off with. This hint is very simple, but it's a neat little dodge which will be particularly useful for the youngster whose pocket isn't too deep. It's a simple way of making up low-cost octal plugs."

"Oh yes?" said Dick. "That sounds interesting."

"It's quite a knobby idea", replied Smithy, showing Dick a sketch attached to the letter he was holding (Fig. 1). "What you first do is remove the base from an old octal valve and clean it up. You'll be using some sort of multi-core flex to connect to the plug, and so you next solder its leads to the appropriate octal pins. The plug is then completed by cutting a cotton reel in half, passing the multi-core flex through its centre hole and gluing it into position in the octal base. Whereupon—hey presto—you've got a neat octal plug at no greater cost than a raid on the family sewing basket!"

"That's the sort of dodge," remarked Dick, "which I could have used in my younger days when I really *was* broke. Not just stony, as I am today!"

At the sound of a familiar recital, Smithy's eyes turned wearily to the ceiling.

"You're not stony, you're just tight, mate," he commented flatly. "How you can sleep on that mattress of yours with all the notes you've got stuffed in it baffles me. The crackling when you turn over must keep you awake half the night. Anyway, let's get down to the next hint. Ah, here we are!"

Smithy extracted another letter from the sheaf.

"This idea," he continued, "has to do with obtaining a neat speaker grille appearance with a home-made radio or amplifier cabinet. I should imagine it's pretty safe to say that quite a few home-constructors knock up the cabinet as something of an afterthought after they've built the chassis to go into it, and that they don't always apply too much time to cutting out a really neat and clean aperture for the speaker. In the approach which is suggested here, you initially drill as many large holes as is possible in the cabinet surface behind which the speaker cone will appear. This is all the wood-working required. You then cut out a piece of stiff card-

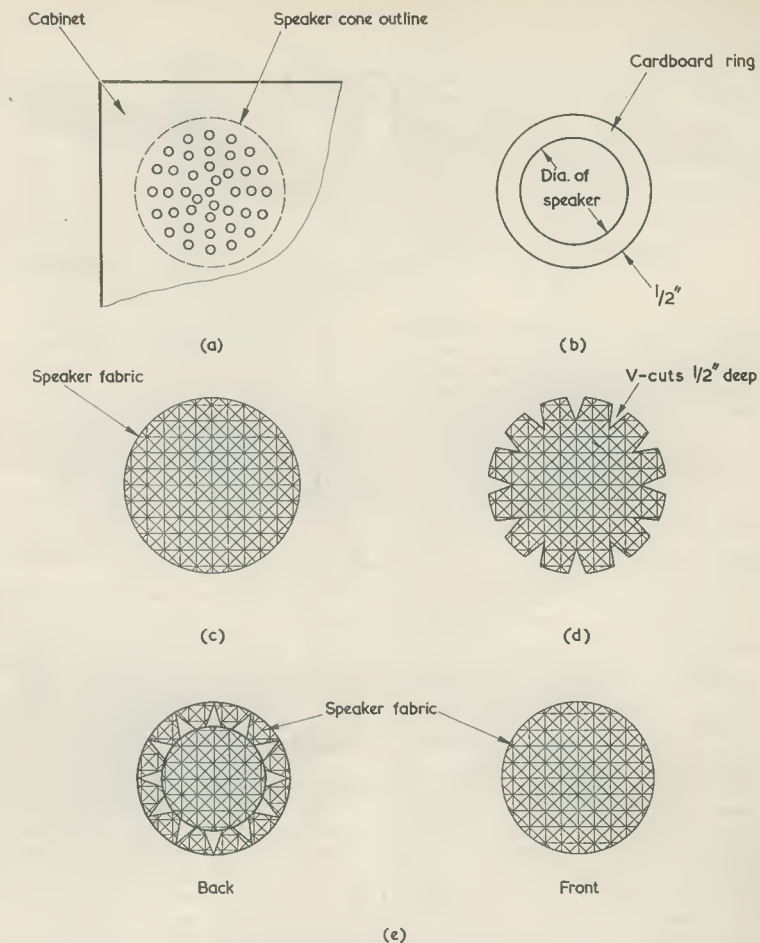

Fig. 2. Successive steps in making a speaker grille which does not require skill in woodworking. First (a) drill a large number of large holes in the cabinet at the speaker position. Then cut out a cardboard ring (b), and a circle of fabric (c) with a diameter 1 in greater than the outside diameter of the ring. Make V-cuts (d), glue the fabric to the ring (e) and glue the assembly to the cabinet in front of the holes of (a)

board in the shape of a ring. There are some sketches with the letter which illustrate this."

Smithy put the sketches in front of Dick. (Fig. 2).

"You next," resumed Smithy, "cut out a circle of speaker fabric with a diameter about an inch greater than the outside diameter of the cardboard ring, and cut a series of fairly closely spaced V's all round the edge to a depth of half an inch. You glue the fabric to the ring, turning over the outside pieces and gluing these down to the back of the cardboard. And, when all this has set, you finally glue the whole assembly to

the front of the cabinet. The cardboard ring is only required to impart the correct shape to the fabric until the final gluing to the cabinet front has been carried out. If you use thin cardboard and a fairly thin fabric you'll get an extremely neat and modern looking appearance. Also, apart from the original speaker holes in the cabinet front, which aren't seen anyway, the only bit of precision work which has to be done can be carried out with the aid of a pair of scissors."

Warm-Up Indicator

"The old family sewing basket," commented Dick, "is taking a bit of

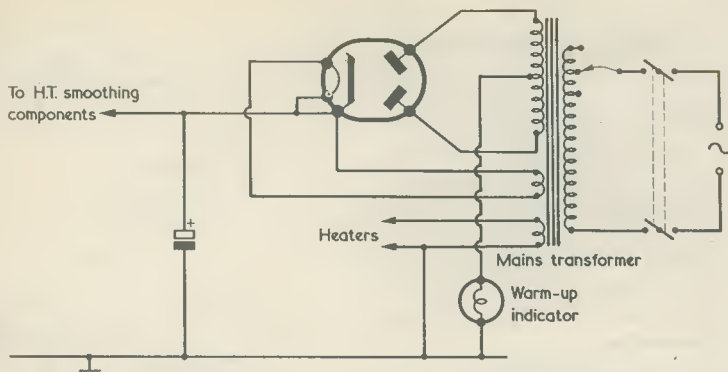

Fig. 3. How a warm-up indicator may be added to a valve a.f. amplifier. The indicator consists of a pilot lamp inserted in series with the h.t. centre-tap connection of the amplifier mains transformer

a bashing this month."

But Smyth was in the process of extracting another letter from the pile on his bench, and he ignored his assistant's remark.

"Here's a neat scheme," he remarked, "for letting you know when a valve a.f. amplifier has warmed up. Normally, the amplifier will be used for gramophone record reproduction and I should guess that even the best of us feel tempted sometimes to run a thumb over the pick-up stylus to see whether it has warmed up after switching on. A practice, I need hardly add, that is highly reprehensible. The present idea assumes that the amplifier will be in the high quality or hi-fi class, whereupon it will have a double-wound mains transformer. The hint consists of inserting a small pilot lamp between the centre-tap of the mains transformer h.t. secondary and chassis. (Fig. 3). This bulb is mounted at the front panel, and it only glows at full brilliance when the full h.t. current is flowing in the amplifier."

"That's a good idea," said Dick approvingly. "What rating should the bulb have?"

"It depends," replied Smyth, "on the h.t. current drawn by the amplifier and the ripple current in the rectifier reservoir circuit. I would say that, rough check, the effective bulb current will be about 40 to 50% higher than the h.t. current drawn by the amplifier, but this is only a very broad approximation. An easy approach consists, of course, of trying bulbs of different current ratings until you find the rating which offers best results. You could start off with a 6.3 volt 0.3 amp bulb, which should not

normally be overrun when the h.t. current is less than 200mA."

"The bulb," interjected Dick, "will also act as an h.t. fuse, won't it?"

"Oh definitely," agreed Smyth. "If a short-circuit occurs which would result in a heavy flow of h.t. current, the bulb will then burn out. Now, let's have a look at some more hints."

Once again, Smyth looked through the sheaf of letters.

"There are two hints here," he remarked, "both in the one letter. They're very simple and are concerned with the fitting of parts in awkward places. As you know, it's sometimes quite difficult to place washers or spacers on to their appropriate bolts when these are in awkward positions. The first thing you do, with the present scheme, is to turn the chassis over so that the end of the bolt projects vertically. You next slip the washers, spacers, or what-not, on to the shaft of a small screwdriver held vertically, the parts being retained with one finger. Then, by placing the end of the screwdriver against the end of the bolt, the washers may be quickly guided on by releasing the hold on them. Even though the bolt itself may be inaccessible, all the washers will shoot onto it in a most satisfying manner, and with none lost in the bottom of the chassis, as usually occurs at least once whilst trying to do the job with tweezers."

"You can certainly say that again," chuckled Dick. "I should hate to think how many times I've had to shake out dropped washers!"

"I've dropped quite a few myself," admitted Smyth. "The second hint in this letter covers rather the same

sort of subject, but in this case it's the application of a nut to a projecting bolt which is similarly in an awkward position. It's not always too easy to get the nut on and started whilst using tweezers or taper-nosed pliers. In radio work a very commonly encountered bolt size is 4BA, and it happens that many of the small electrician's screwdrivers with transparent plastic handles have a blade which will just enter a 4BA nut. If a screwdriver of this type is lightly pressed into one end of a 4BA nut, the nut will be held sufficiently securely for it to be gently transferred to the end of the bolt. By carefully turning the screwdriver the nut may be started onto the bolt thread, and you can then remove the screwdriver and finish the job with a box spanner or ordinary spanner according to the position of the bolt."

"I should imagine," said Dick, thoughtfully, "that this approach would be best with the thicker type of 4BA nut."

"That's right," agreed Smyth absently, as he once more looked through the letters. "It would be desirable to use a full-nut in this instance."

"A what?"

"A full-nut," replied Smyth, looking up at his assistant. "Don't you know what a full-nut is?"

"A nut is a nut," declared Dick firmly. "Where do you get this full-nut business from?"

"Hasn't it been your experience," asked Smyth, "that the ordinary BA nuts you encounter in your work tend to come in two thicknesses?"

"Now you come to mention it," responded Dick, "I suppose they do. Nearly all the ordinary 6BA, 4BA and 2BA nuts I collect in my junk box seem to be either thick nuts or thin nuts."

"There you are, then," said Smyth triumphantly. "The thick nuts are known officially as full-nuts and the thin nuts are known officially as half-nuts. You'll encounter nuts having thicknesses between the full-nuts and the half-nuts, but the vast majority of ordinary nuts used in radio work fall directly into one or other of those two categories."

"Full-nuts and half-nuts, eh?" mused Dick. "Well, that's something I didn't know before. Blimey, Smyth, you're quite a dab hand at passing on those odd little bits of information!"

"It's all part of the service," replied Smyth. "Anyway, whilst we're on the subject of hardware, here's another hint which comes into this category. This hint is concerned with small twist drills.

A snag with the really small drills is that you sometimes need a magnifying glass to read their sizes, and quite a lot of time can be wasted in hunting around for the right one. The present hint suggests the fitting of bands of coloured p.v.c. over each drill, the colours corresponding to the numbers in the resistor colour code. Thus, reading from the point, a No. 43 drill can be identified by a yellow band followed by an orange band, and a No. 56 drill by a green band followed by a blue band. This idea saves a considerable amount of time since any drill which is required can be identified immediately. The bands are short sections of p.v.c. sleeving stripped from p.v.c. covered wire of the appropriate size and colour. These are warmed, if necessary, then slipped over the point of the drill and pushed up until they finally lie just above the end of the flutes. There's a sample attached to the latter."

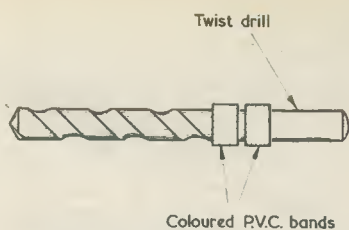

Fig. 4. Small twist drills may be identified by fitting coloured p.v.c. bands to them. The colours correspond to the numbers in the resistor colour code

Smithy passed the sample drill (Fig. 4) over to Dick, who examined it closely.

"This p.v.c. band coding," continued Smithy, as he perused the letter, "can also be used for millimetre size drills. Thus, a 1.5mm

drill may be coded brown and green. Small fractional drills aren't so easy, but one way is to use the decimal equivalent, whereupon a $\frac{1}{8}$ inch drill can be coded 0625, the four colours being readily distinguished. Or you could code it 625, the first zero being understood. The p.v.c. bands stand up to considerable abuse, and can easily be replaced if a drill happens to go into a hole right up to the shank."

Editor's Note.

The hints described in this episode of 'In Your Workshop' were submitted, in the order in which they appear, by .T Nott, A. S. Patterson, M. Alkalay, and M. Hill.

Hints received from readers will be continued in 'In Your Workshop' next month.

Telephone Bell Repeater
(Continued from page 351)

Eddystone diecast box of dimensions $4\frac{1}{8} \times 3\frac{1}{8} \times 2\frac{1}{8}$ in, this also containing the battery and the rocking armature receivers. The simple layout required can be easily followed from the photograph. No trouble should be experienced in fitting the parts together, and drilling and assembly drawings have not been included because different types of output transducers may be used by readers. Before obtaining the box, the constructor should ensure that the particular transducer employed, together with any matching transformer that may be required, can be fitted into it.

Table

Optimum Output Transformer Ratios For Moving-coil Speakers

Speaker Impedance	Ratio
3Ω	7:1
15Ω	3.2:1
35Ω	2.1:1
50Ω	1.7:1
75Ω	1.4:1

Setting Up

To set up the unit, the relay coil is placed beneath the telephone in the centre of the base. In the author's case, a telephone seat and table had previously been made, and the telephone stands above two shelves which hold the directories. The relay coil is mounted directly beneath the telephone on the upper side of the shelf.

The unit is placed in the room where the repeater is required and the screened cable connected to the coil. A friend is then asked to ring the constructor's

Breaks	
6	F
6	R
7	F
8	L
9	N
10	F
10	P

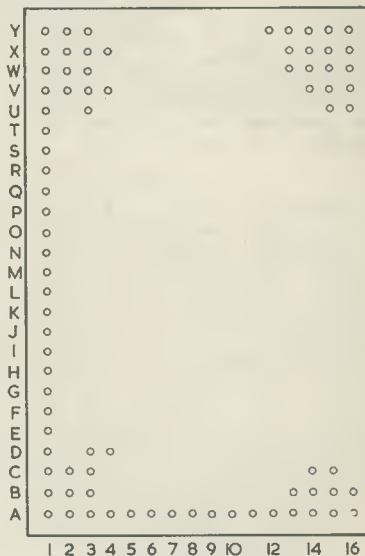

Viewed from component side

Fig. 2. The Veroboard coding, viewed from the component side of the board. There are 16 copper strips, each with 25 holes. Breaks in the strips are made as indicated in the inset Table

number from another telephone.

While the bell is ringing, the relay coil is moved about until the best warbling tone is heard at the unit end by a helper.

Conclusion

The unit has been found to be of great value in the writer's house and an extension is next to be fitted to enable the telephone to be heard whilst out in the garden.



RADIO TOPICS . . .

by Recorder

AND A HAPPY NEW YEAR TO YOU all!

At this time of the year it is the custom to prophesy what is in store for us over the following 12 months. I see no reason why I shouldn't push my way into this particular act and so, without further delay, Old Moore Recorder now gazes into his crystal ball and presents his forecast for 1967.

Predictions for 1967

January. This first month of 1967 shows promise of exciting developments in the forthcoming twelve months. High fidelity circles hear first hints of a revolutionary sound reproducing device which functions from completely new principles. An unexpected announcement concerns the 1967 Radio Show. This will be held for 10 days in early September at Earls Court, and exhibitors will include all British radio and TV manufacturers. Also, the B.B.C. and I.T.V. will combine forces to present a spectacular stage performance every evening during the Show.

February. Another month of fateful pronouncements. TV manufacturers state that, whilst the replacement market for standard television receivers proceeds at low level, the "third receiver" market shows every sign of promise. England and France launch a combined communications satellite. Leading audio circles learn, by way of a press leak, that the new hi-fi reproducer is to be described as the "Capacitance Headphone". I.T.V. spokesman defends colour on 405 lines.

March. Plans for the 1967 Radio Show become even more expansive, and it is announced that piano and

electronic organ manufacturers will also be present. Details of the new Capacitance Headphone, to be demonstrated for the first time at the Audio Fair in April, are released. This sensational new break-through consists fundamentally of two metal plates in insulating housings which are placed over the ears. An a.f. signal at exceptionally high voltage level is then fed to the plates, whereupon the ear-drums of the listener suffer electrostatic attraction and repulsion in sympathy. It is claimed that this technique removes, at one single step, the disadvantages of a normal reproducer in which the a.f. signals have first to be translated to mechanical energy which, in turn, has to be coupled to the air. B.B.C. spokesman defends colour on 625 lines.

April. Angry scenes take place at Audio Fair as violent sparks pass from visitors leaving the Capacitance Headphone demonstration room to queues awaiting entry. Emergency earthing spikes are hastily erected inside the demonstration room to enable those who have used the Capacitance Headphone to subsequently discharge themselves. The Anglo-French communications satellite narrowly misses the Moon and proceeds towards Mars. I.T.V. spokesman wrathfully refutes B.B.C. defence of 625 line colour.

May. B.B.C. spokesman clashes with I.T.V. spokesman over Radio Show stage presentation. It is announced that space will be made available for manufacturers of conventional musical instruments. Also announced is the programme for a C.C.I.R. meeting at Stockholm in June. Subsequent to the international acceptance of the term

Hertz (Hz) for cycles per second (c/s), this C.C.I.R. meeting will examine the names employed for other electrical quantities.

June. Anglo-French communications satellite reported to be changing course in the vicinity of Pluto. C.C.I.R. meeting at Stockholm states that, following current practice in Outer Mongolia, the new International Unit for electric current will henceforth be the Coulomb Per Second instead of the Ampère. The abbreviation for this new unit is c/s. I.T.V. withdraws from Radio Show stage presentation

July. Three leading manufacturers of TV, radio and sound equipment withdraw from Radio Show and announce separate exhibitions at the Festival Hall, the Hilton Hotel and the New Horticultural Hall respectively. Anglo-French communications satellite passes out of tracking range. Manufacturers of Capacitance Headphone state that static charge difficulties can be completely overcome by reliably earthing the person using the headphone and, through audio press, ask hi-fi enthusiasts for postcards suggesting suitable methods of applying the requisite earth connection.

August. Offices of Capacitance Headphone manufacturers deluged with postcards from hi-fi enthusiasts. Remaining manufacturers of radio and TV equipment withdraw from Radio Show and announce separate individual exhibitions. B.B.C. states that their stage presentation will be pruned somewhat, and will consist of a continuous programme of gramophone records played over a studio monitor on the First Floor at Earls Court. Last-minute news release announces that furniture manufacturers will be allowed to exhibit at the Show.

September. Opening of Earls Court Radio Show is delayed for 9 days by unofficial strike of stand erectors, with electricians coming out in sympathy. There are wild scenes during a demonstration by members of the Musicians' Union, who picket musical instrument stands and play "Colonel Bogey" in protest against B.B.C.'s continuous programme of records. Still no news of Anglo-French communications satellite.

October. London TV service engineers baffled by "30-second ghosting" on Channel 33. Furniture manufacturers, reporting record business during single open day of

Radio Show, say that visitors apparently noticed nothing different from usual.

November. Jodrell Bank solves mystery of "30-second ghosting" in London area; reports that ghost signal originates from Anglo-French communications satellite which is now once more within tracking range, and whose repeater circuits have started working on television frequencies. Surprise announcement of *second* Radio Show at Earls Court in December, at which all radio and TV manufacturers will be present. Also, B.B.C. and I.T.V. sink differences to put on the spectacular stage presentation originally planned. During November the "30 second ghosting" delay on Channel 33 reduces progressively until, at the end of the month, the delay before the "ghost" image appears is 5 seconds only.

December. Sensationally successful opening of the *second* Radio Show, with all manufacturers, including even those of the Capacitance Headphone, fully represented. Teeming crowds of visitors queue for entrance. On the first afternoon of the Show the returning Anglo-French communications satellite scores direct hit on Earls Court.

Integrated Circuits

Leaving fantasy for a moment and turning to fact, the more recent news concerning integrated circuits makes fascinating reading. Signetics Corporation of California now consider, for instance, that 70 components per single integrated chip represents commonplace practice and they look forward to something like 2,000 components per chip by 1970. Microminiaturisation indeed!

Integrated circuits are also now available for the home-constructor at quite low prices. Available from L.S.T. Components of Essex are Fairchild integrated circuits type UL900, UL914 and UL923, these being listed (at the time of writing) at 32s., 32s., and 57s. each respectively. These three integrated circuits are housed in epoxy mouldings having the same size as a transistor TO-5 can.

The UL900 is described as a buffer, and its internal circuitry includes three n.p.n. transistors and associated coupling resistors. It can be used for inverting and amplifying input pulses. Type UL914 comprises four n.p.n. transistors in two separate gate circuits. Basically, each gate consists of two transistors working

into a common collector load. Inputs go to the two bases in each gate and outputs are taken from the common collector connection. With positive pulse inputs each pair of transistors acts as a NOR gate since a negative output is given if either one or both bases go positive. If negative pulse inputs are used the circuit becomes a NAND gate since a positive output will only be given if both inputs are negative. The UL923 is a flip-flop which, due to the design approach resulting from integrated circuit construction, has effectively no less than fifteen transistors.

These three integrated circuits may be employed in some eighteen different circuits, many of which are for logic applications. The circuits include a Schmitt trigger, a frequency-to-voltage converter (which can be incorporated in a tachometer or frequency meter) and a divide-by-two circuit. Also feasible are linear amplifiers working from audio frequencies up to 20 Mc/s or more.

Further details on these integrated circuits and the circuits in which they may be employed can be obtained from L.S.T. Components, 23 New Road, Brentwood, Essex.

Soldering Aids

I suppose that, like many constructors, I have fallen into the habit of using odd lengths of solder when carrying out wiring-up jobs. I initially remove about a foot of solder from the reel and carry on with this until I've got about 2 inches or so of solder left. This results in my collecting a large quantity of short lengths of solder which can't be used without burning my fingers. Also, the irritating occasions arise when I find that a length of what appears to be solder inexplicably refuses to melt, and I discover that I've picked up a length of tinned copper wire by mistake!

I have now overcome these difficulties by using the two solder dispensers which were introduced recently by Multicore Solders Ltd. Of these, the Size 5 dispenser, having a diameter of 1in and a length of 4in, contains 18 s.w.g. Multicore Savbit solder, which is a very convenient size for normal radio work. The end of the dispenser is cone-shaped with a hole at the apex through which the solder appears. You just pull out as much solder as you need and take the dispenser, with the solder protruding, up to the work. For fine work, such as occurs, for example, with transistor connections on crowded

printed circuit boards, there is the Size 15 dispenser. This is a longer, thinner job, having a length of 5in and a diameter of $\frac{1}{8}$ in, and it contains 21ft of 22 s.w.g. Multicore Ersin solder.

Readers who have used the well-known Model 3 Bib Wire Stripper (another Multicore product) will be interested to hear of the *de luxe* version which is known as the Model 8. This works in the same way as the Model 3 but it can be very conveniently preset to strip different wire gauges. When the arms of the stripper close, a pin on one arm locates in one of a number of grooves in a wheel on the other arm. These grooves have varying depths, with the result that the wheel can be rotated so that a groove corresponding to the wire diameter may be selected. Thus, it is possible to strip the insulation from all normally encountered wire gauges without fear of nicking the conductor.

All these wiring aids are available through the normal retail channels as, also, is a Multicore leaflet giving "Hints On Soldering" which offers good advice to the newcomer.

Put the Knobs Back

And, finally, just a little servicing tip which will be of help mainly to the beginner.

When a fairly large radio chassis or a TV chassis has been removed from its cabinet, it is a false economy in time not to refit the knobs before you commence fault-finding. There are three main reasons for this. Of these, two are obvious enough, but the third may not be so self-evident.

1. If the chassis is a mains type with a live chassis and metal spindles, there is less risk of shock with the knobs fitted than if the control spindles are handled directly.

2. It is far easier to adjust the controls with the knobs fitted.

3. Crackles may occasionally be heard if a metal spindle is rotated directly by hand. The most usual case is given with radio tuning spindles coupling to cord reduction drives and is due to a "crackly" connection between the spindle and its bush. The intermittent connection between the chassis and the effective earth offered by the human body then causes the crackles as the spindle is rotated. The unsuspecting may be led into looking for a "fault" whereas, in fact, there just wouldn't be any crackling if the spindle were operated by way of its knob in the normal manner.

And that's all for now. See you next month!

**Essential
for the
Short Wave
Enthusiast**

THE RADIO AMATEUR OPERATOR'S HANDBOOK

NOW IN ITS TENTH EDITION

- ★ AMATEUR PREFIXES
 - ★ AMATEUR CODES
 - ★ LOCAL TIME CONVERSIONS
 - ★ OPERATING TECHNIQUE
 - ★ FREQUENCY/WAVELENGTH
CONVERSION TABLES
 - ★ POST OFFICE REGULATIONS
- Many other essential items
- 64 PAGES Only 5/-**



**MAKE SURE
OF YOUR
COPY NOW!**

Post this coupon,
together with
P.O. for 5/5 (to
include postage) to
Data Publications
Ltd., 57 Maida Vale,
London W 9

Please send me the 10th edition of "THE RADIO AMATEUR OPERATOR'S HANDBOOK", Data Book No. 6.
I enclose cheque/crossed postal order for

NAME

ADDRESS

.....

.....

BLOCK LETTERS PLEASE

NEW STYLE SELF-BINDER

for "The Radio Constructor"

The "CORDEX" Patent Self-Binding Case will keep your issues in mint condition. Copies can be inserted or removed with the greatest of ease.

Specially constructed Binding Cords are made from Super Linen of great strength, very hard twisted and twice doubled. They are attached to strong RUSTLESS Springs under tension, and the method adopted ensures PERMANENT RESILIENCE of the Cords. Any slack that may develop is immediately compensated for, and the Cords will always remain taut and strong. It is impossible to overstretch the springs, as a safety check-device is fitted to each.

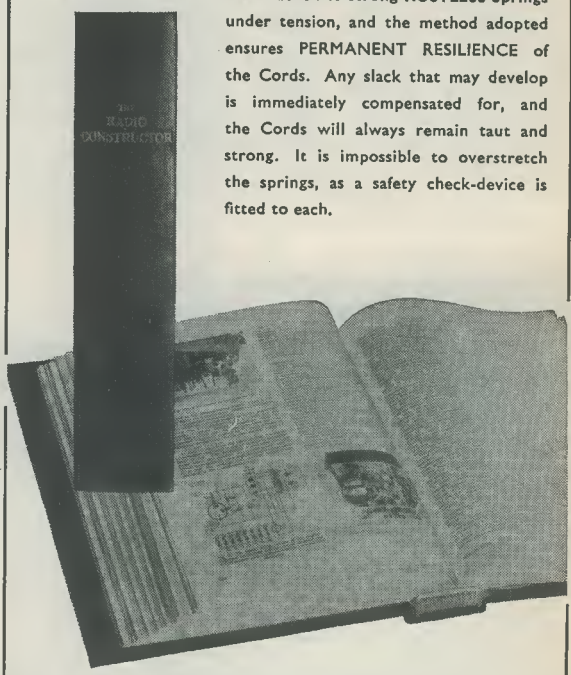

PRICE 15/- Post Free

Available only from:—

Data Publications Ltd.
57 Maida Vale London W9

PLAIN-BACKED NEW STYLE SELF-BINDERS

for your other magazines

(max. format $7\frac{1}{2}'' \times 9\frac{1}{2}''$)

The "CORDEX" Patent Self-Binding Case will keep your copies in mint condition. Issues can be inserted or removed with the greatest of ease. Rich maroon finish. Specially constructed Binding Cords are made from Super Linen of great strength, very hard twisted and twice doubled. They are attached to strong RUSTLESS Springs under tension, and the method adopted ensures PERMANENT RESILIENCE of the Cords. Any slack that may develop is immediately compensated for, and the Cords will always remain taut and strong. It is impossible to overstretch the springs, as a safety check-device is fitted to each.

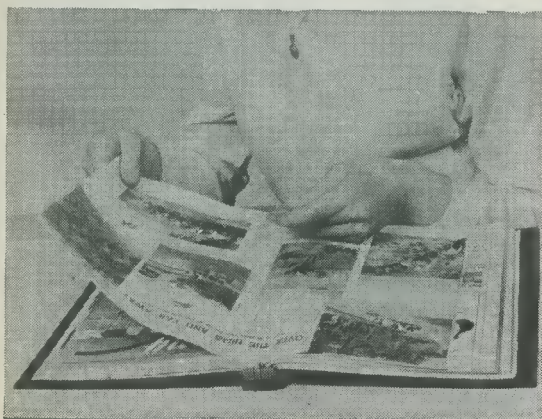

PRICE **14'6** Post Free

Available only from:—

Data Publications Ltd.
57 Maida Vale London W9

"EXPERIMENTAL" PRINTED CIRCUIT KIT

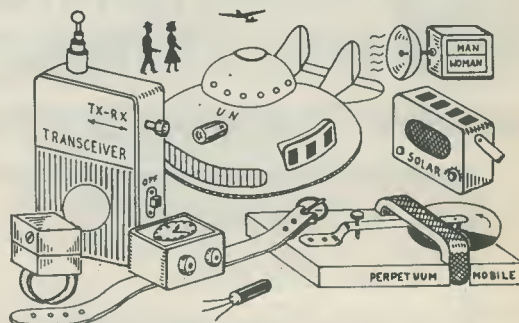

(1) 2 Copper Laminate Boards $4\frac{1}{2}'' \times 2\frac{1}{2}''$. (2) 1 Board for Matchbox Radio. (3) 1 Board for Wrist Watch Radio. (4) Resist. (5) Etchant. (5) Resist Solvent. (6) Cleanser/Degreaser. (7) 16 page booklet. "PRINTED CIRCUITS FOR AMATEURS" containing full etching instructions. Also free with every kit (8) 30 SUGGESTED PROJECTS which you can build on a P.C. chassis. Triplex-reflex with self-adjusting regeneration. 2 Intercoms. Wrist-Watch Radio $1.15'' \times .80''$. Amplifiers. Photoelectric Alarms. Light Controlled Robot. Human Body Radiation Detector. "Perpetual Motion" Machine. Transistor Tester and many more. Price 8/6 Post and pac. 1/6. **YORK ELECTRICS, 181a, York Rd., London S.W.11.** Send S.A.E. for details.

NEW ELECTRONICS CATALOGUE

The convenient way to shop for all your electronic needs. Everything from single components to complete Hi-fi outfits, all at highly competitive prices.

Send P.O. for 1/6 to:

Dept. RC/3

dca ELECTRONICS LIMITED
28 UXBRIDGE ROAD, EALING W.5

BUILD YOUR CIRCUITS ON VEROBOARD

—the Universal Wiring Board—
obtainable from your local retailer

Retail enquiries to:—

NORMAN ROSE (ELECTRICAL) LTD
8 St. Chad's Place, Grays inn Road, London, W.C.1

Technical enquiries to:—

VERO ELECTRONICS LTD
Chandler's Ford, Hampshire

SMALL ADVERTISEMENTS

Rate: 9d. per word.

Minimum charge 12/-.

Box No. 2/- extra.

Advertisements must be prepaid and all copy must be received by the 4th of the month for insertion in the following month's issue. The Publishers cannot be held liable in any way for printing errors or omissions, nor can they accept responsibility for the *bona fides* of advertisers. (Replies to Box numbers should be addressed to: Box No.—, *The Radio Constructor*, 57 Maida Vale, London, W.9.)

SERVICE SHEETS, 1925-1965. From 1s. Catalogue 6,000 models, 2s. 6d. S.A.E. enquiries.—Hamilton Radio, 13 Western Road, St. Leonards, Sussex.

GOVERNMENT SURPLUS electrical and radio equipment. Our new catalogue No. 16 ready now, 2s. 6d. post free, cost refunded on purchase of goods over £2.—Arthur Sallis Radio Control Ltd., 93 North Road, Brighton, Sussex.

RECITALS OF RECORDED MUSIC. The second Saturday evening of each winter month. Next recital: 10th December, 1966, 8 p.m. Woodford Green United Free Church, Woodford Green, Essex. Bus routes 20, 20A, 38A and 179—alight at "The Castle" stop.

TECHNICAL DRAWINGS, Artwork, etc. Electronic and Radio Circuits a speciality. Moderate charges.—B. P. Meaney, 43 Forest Road, Worthing, Sussex.

ARE YOU A MOTORING ENTHUSIAST? The Seven Fifty Motor Club caters for all types of motor sport—racing, rallies, hill climbs, etc. Monthly Bulletin free to members. For full details write to: The General Secretary, Colin Peck, "Dancer's End", St. Winifred's Road, Biggin Hill, Kent.

POSTAL ADVERTISING? This is the Holborn Service. Mailing lists, addressing, enclosing, wrapping, facsimile letters, automatic typing, copy service, campaign planning, design and artwork, printing and stationery. Please ask for price list.—The Holborn Direct Mail Company, 2 Mount Pleasant, London, W.C.1. Telephone: TERminus 0588.

"MEDIUM WAVE NEWS". Monthly during DX season—Details from: B. J. C. Brown, 60 White Street, Derby.

JOIN THE INTERNATIONAL S.W. LEAGUE. Free Services to members including Q.S.L. Bureau. Amateur and Broadcast Translation. Technical and Identification Dept.—both Broadcast and Fixed Stations, DX Certificates, contests and activities for the SWL and transmitting members. Monthly magazine, *Monitor*, containing articles of general interest to Broadcast and Amateur SWLs, Transmitter Section and League affairs, etc. League supplies such as badges, headed notepaper and envelopes. QSL cards, etc., are available at reasonable cost. Send for League particulars. Membership including monthly magazine, etc., 35s. per annum.—Secretary, ISWL, 60 White Street, Derby.

continued on page 383

BENTLEY ACOUSTIC CORPORATION LTD.

38 Chalcot Road, Chalk Farm, LONDON, N.W.1. PR11mrose 9090

47 Norfolk Road, LITTLEHAMPTON, Sussex. Littlehampton 2043

Please forward all mail orders to Littlehampton

IR5	4/-	I7Y4	8/-	I5763	7/6	ECL86	8/-	IGZ34	10/-	IPY801	6/3
IS5	3/3	9D7	7/6	AZ31	7/9	EF36	3/6	GZ37	14/6	U25	11/-
IT4	2/6	10C1	12/6	DAF96	6/6	EF37A	7/-	HABC80	9/3	U26	8/6
3Q4	5/3	10C2	12/-	DF96	6/6	EF39	5/-	KT66	12/3	U191	10/6
3S4	4/3	10F1	9/9	DK92	8/-	EF41	9/-	PABC80	7/6	U301	12/6
3V4	5/-	10F18	7/9	DK96	7/6	EF80	4/3	PC86	8/6	U329	9/-
5Y3GT	4/9	10LD11	9/6	DL96	6/9	EF85	4/6	PC88	8/6	U404	6/-
5Z4	7/6	10P13	12/-	DM70	5/-	EF86	6/6	PC95	6/9	UB01	18/-
6AQ5	4/9	10P14	13/-	DY87	6/9	EF89	4/6	PC97	5/9	UABC80	5/-
6AT6	4/-	12AT6	4/6	E88CC	12/-	EF91	3/-	PC900	9/6	UAF42	7/9
6AU6	5/9	12AU6	5/9	EABC80	5/9	EF92	2/6	PCC84	5/6	UBC41	6/6
6AV6	5/6	12AV6	5/3	EB91	2/3	EF98	10/-	PCC85	6/9	UBC81	6/6
6BA6	4/6	12BA6	5/3	EB91	2/3	EF98	9/9	PCC88	10/6	UBF80	5/6
6BE6	4/3	12BE6	4/9	EB41	6/6	EF183	6/9	PCC89	10/6	UBF89	5/9
6BH6	5/3	12BH7	6/-	EB81	6/3	EF184	6/6	PCC189	8/9	UBL21	10/9
6B16	5/6	19AQ5	7/3	EBF80	5/9	EH90	9/6	PCF80	6/6	UC92	6/3
6BQ7A	7/6	20D1	10/-	EBF83	7/3	EL33	6/6	PCF82	6/-	UCC84	8/3
6BR7	8/3	20F2	11/6	EBF89	5/9	EL41	7/6	PCF84	8/6	UCC85	6/6
6BW6	7/6	20L1	14/-	EBL21	10/3	EL42	7/9	PCF86	6/-	UCF80	8/3
6CD6G	22/-	20P3	16/-	EC92	6/6	EL84	4/6	PCF801	9/6	UCH21	8/-
6CH6	6/-	20P4	16/-	ECC40	10/-	EL85	7/6	PCF802	10/-	UCH22	8/-
6F1	9/6	20P5	16/-	ECC81	3/6	EL86	7/3	PCL82	6/6	UCH81	6/-
6F23	9/-	30C15	10/6	ECC82	4/6	EL95	5/-	PCL83	9/9	UCL82	7/3
6F24	10/-	30C17	11/6	ECC83	4/6	ELL80	14/-	PCL84	7/6	UCL83	9/3
6F25	10/-	30C18	7/6	ECC84	5/6	EM71	14/-	PCL85	8/6	UF41	7/9
6F28	9/6	30F5	13/-	ECC85	5/3	EM80	6/3	PCL86	8/6	UF42	4/9
6J5G	3/9	30FL1	12/-	ECC88	8/9	EM81	7/-	PFL200	14/6	UF80	6/3
6J7G	4/6	30FL12	13/-	ECC189	9/-	EM84	5/9	PL36	9/-	UF85	6/9
6K7G	1/3	30FL14	10/9	ECC80	7/3	EM85	12/-	PL81	7/9	UF86	9/-
6K8C	3/3	30L15	12/6	ECCF82	6/3	EM87	6/6	PL82	5/3	UF89	5/6
6L6T	10/3	30L17	11/6	ECCF86	10/-	EY51	5/6	PL83	6/-	UL41	8/9
6L18	10/3	30P12	10/-	ECC21	10/-	EY81	7/3	PL84	6/3	UL84	5/6
6LD20	6/6	30P19	10/-	ECH35	6/-	EY83	3/9	PL500	14/6	UN80	8/3
6Q7G	5/6	30PL1	13/6	ECH42	8/-	EY84	9/6	PY33	8/9	UY21	9/-
6S17	4/9	30PL13	13/6	ECH81	5/6	EY86	5/9	PY80	4/9	UY41	5/9
6SN7	4/6	30PL14	13/6	ECH83	7/6	EY88	8/9	PY81	5/-	UY85	4/9
6V6G	3/9	30PL15	13/6	ECH84	9/-	EZ40	5/6	PY82	4/9	VP4B	12/-
6X4	5/3	35W4	4/6	ECL80	6/-	EZ41	6/3	PY83	5/6	X41	10/-
6X5	5/3	85A2	6/6	ECL82	6/6	EZ80	3/9	PY80	7/3	X78	26/2
6J30L2	8/9	807	11/9	ECL83	10/-	EZ81	4/3	PY800	5/9	X79	40/9

Terms of business: Cash with order only. No C.O.D. Post/packing 6d. per item. Orders over £5 post free. All orders despatched same day as received. Complete catalogue including transistor section and components with terms of business 6d. Any parcel insured against damage in transit for 6d. extra. We are open for personal shoppers 9 a.m.—5 p.m. Saturdays 9 a.m.—1 p.m.

JACKSON

the big name in **PRECISION** components

Precision built radio components are an important contribution to the radio and communications industry. Be sure of the best and buy Jackson Precision Built Components.

"00" Twin Condenser

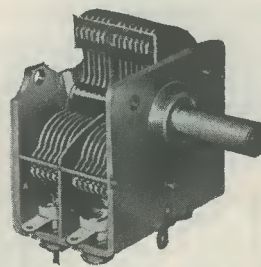

Designed for use in miniature transistor receivers. The front (aerial) section is 208pF to provide coverage for medium waves, and the rear section is 176pF, which may be padded to match the oscillator—very robust yet lightweight. Front area 1 3/4 in. x 1 1/2 in. x 1 in. deep.

In the "ten five" receiver used 3 gang type F price 21/3. 2 air tune 7/9 each caliband drive at 28/-.

JACKSON BROS. (LONDON) LTD.

(DEPT. R.C.), KINGSWAY-WADDON, CROYDON, CR9 4 DG
Phone: Croydon 2754-5 (01-688). Grams: Walfilco, Croydon



Happy Families

These are the times when Simon and Clare know that it has all been worthwhile. But they know too that such moments of happiness are only complete when there is also a feeling of security for the future. And Simon's "Family Unit" Policy with the "Yorkshire" guarantees them *all* a future - if the worst should happen.

Happiness in *your* family too—but for how long? If you or *your wife* should die, how would the rest of the family fare? A Yorkshire "Family Unit" policy provides for both these eventualities in a comprehensive way at a sensible premium. Just ask for a leaflet at your local "Yorkshire" branch and then see the manager. He'll be glad to tell you why ...

it's **YORKSHIRE** for **INSURANCE**

THE YORKSHIRE INSURANCE COMPANY LIMITED

Chief Offices: Rougier Street, YORK
and Becket House, 36-37 Old Jewry, LONDON, E.C.2.

Branches and Agencies throughout the world

Please send me details of the Family Unit Policy, without obligation.

Name.....

Address.....

J.B.

SMALL ADVERTISEMENTS

continued from page 381

LOCAL HISTORY. "A Hundred Years In A Country Chapel". An aspect of life in an Essex village. 64 pages. 7s. post free from:—J. K. Sigournay, B.Sc., 51 Hanging Hill Lane, Brentwood, Essex.

FOR SALE. Oscilloscopes—Galvanometers—Evershed & Vignolles Meggers—Relays—Uniselector Switches—Solenoids. Also other items and components. Free list. Stamp please.—R. & E. Mart, Box 9 G.P.O., Tunbridge Wells, Kent.

A BARGAIN bumper parcel of components, resistors, condensers, smoothing-condensers, connecting and screened wire, sleeving, etc. Send 10s. P.O. to—WAVE-MECHS, 771a High Road, London N.17.

WANTED. Back issues of "The Radio Constructor" November 1963 to July 1964 inclusive, to complete volume. Reasonable price paid and postage. Details to:—Box No. F278.

BY100 AND 25 OHM RESISTOR 4/9d! 25, 50, 100 ohm resistors, 10 watt, 1/- each. Tubes, valves, transistors, huge stocks. Lists.—Bearman, 6 Potters Road, New Barnet, Herts. Telephone: BAR 1934.

WANTED. Generating set, petrol or diesel, or alternator only, also coil winding machine wanted. Anything considered.—Box No. F281.

A GUIDE TO SURPLUS COMMUNICATION RECEIVERS

A detailed guide to thirty-one receivers, including the HRO, AR88, CR100, R107, R1155, PCR, 52 set, etc

7/6, P. & P. 1/-

Mail order only to:

ADKINS, Dept. RC, 72 Courtenay Ave., Harrow, Middlesex

MORSE MADE EASY !!

The famous RHYTHM RECORDED COURSE cuts the practice time down to an absolute minimum.

One student, aged 20, took only 13 DAYS, and another, aged 69, took under a week to read 18 wpm. If you wish to read Morse easily and naturally please enclose 8d. in stamps or two international reply coupons for full explanatory booklet to: G3HSC/D 45 GREEN LANE · PURLEY · SURREY. UPLands 2896

HAMMERITE HAMMER PATTERN BRUSH PAINT FOR PANELS, METALWORK, ETC.

3/6 TIN ● JUST BRUSH ON ● WITHSTANDS 150°C, OIL, WATER ETC.

COLORS: blue, silver, black, or bronze.
2½oz tins, 3/6. ½ pint, 7/6. 1 pint, 15/-. ½ gallon, 35/-* 1 gallon 58/-.*
Carr. up to 5/-, 9d., up to 10/-, 1/9, over 10/-, 3/-.*Sent by road.

From component shops or direct from the manufacturer:
FINNIGAN SPECIALITY PAINTS (RC) Mickley Square, Stocksfield, Northumberland. Telephone: Stocksfield 2280

TREMENDOUS VALUE—Bulk Component Offers

- ★ ASSORTED RESISTORS—Hi-Stab. 300 off (5% 1/10 to 1/2 Watt) 15s.
- ★ ASSORTED CAPACITORS—New Miniature Electrolytic, Polyester, Paper etc. 100 off.....9s. 6d.
- ★ TRANSISTORS—OC44, 45, 70, 72, 81 & 81D Equivalents 3s.
(P & P 1s. 6d. per order, C.W.O.)

Elmbridge Instruments Ltd. Island Farm Avenue West Molesey Surrey

RADIO CONTROL FOR MODELS



RADIO CONTROL FOR MODELS

SHIPS, BOATS and AIRCRAFT

By F. C. JUDD

With sections on servo-mechanisms by

RAYMOND F. STOCK

More than 200 illustrations—circuits, working diagrams, photographs & tables. Each page is packed with information.

192 Pages

15s.

Postage 9d.

This book is basically an amalgamation of "Radio Control for Model Ships, Boats and Aircraft" and "Radio Control Mechanisms". Additional material has been added on Multi-Channel Operation; Transistorised Radio Control Receivers—Simple and Three-Channel; A Compact Efficiency Aerial; Deac Battery Information; Licence Conditions, etc.

To Data Publication Ltd., 57 Maida Vale, London, W.9

Please supply.....copy(ies) of your publication "RADIO CONTROL FOR MODELS" DATA BOOK No. 16.

I enclose cheque/crossed postal order for.....

NAME.....

ADDRESS.....

BLOCK LETTERS PLEASE

CHASSIS and CASES by



287/9 Edgware Road
London W2

TELEPHONE
PADDINGTON 5891/7595

BLANK CHASSIS—Same Day Service

Of over 20 different forms made up to YOUR SIZE.
(Maximum length 35", depth 4".)

SEND FOR ILLUSTRATED LEAFLETS or order straight away, working out total area of material required (including waste) and referring to table below which is for four-sided chassis in 16 s.w.g. aluminium.

48 sq. in.	4/6	176 sq. in.	9/10	304 sq. in.	15/2
80 sq. in.	5/10	208 sq. in.	11/2	336 sq. in.	16/6
112 sq. in.	7/2	240 sq. in.	12/6	368 sq. in.	17/10
144 sq. in.	8/6	272 sq. in.	13/10	and pro rata	
	P. & P. 3/-		P. & P. 3/6		P. & P. 4/-

Discounts for quantities. More than 20 different sizes kept in stock for callers.

FLANGES (1" or 1 1/2"), 6d. per bend.
STRENGTHENED CORNERS, 1/- each corner.
PANELS
Any size up to 3ft at 6/- sq. ft. 16 s.w.g. (18 s.w.g. 5/3).
Plus postage and packing

CASES

ALUMINIUM, SILVER HAMMERED FINISH

Type	Size	Price	Type	Size	Price
U	4 x 4 x 4"	10/-	Y	8 x 6 x 6"	26/6
U	5 1/2 x 4 1/2 x 4 1/2"	15/6	Y	12 x 7 x 7"	41/-
U	8 x 6 x 6"	21/-	Y	13 x 7 x 9"	46/-
U	15 x 9 x 9"	44/6	Y	15 x 9 x 7"	48/-
W	8 x 6 x 6"	21/-	Z	17 x 10 x 9"	66/-
W	12 x 7 x 7"	34/-	Z	19 x 10 x 8 1/2"	71/-
W	15 x 9 x 8"	44/-		* Height	

Type Z has removable back and front panels.
Type Y all-screwed construction.

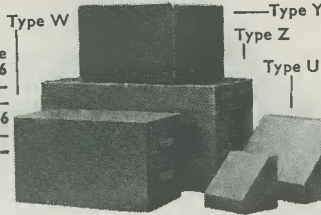

NYLON P.T.F.E.

ROD BAR SHEET TUBE STRIP WIRE

No quantity too small List on application
BRASS COPPER BRONZE ALUMINIUM LIGHT ALLOYS
STAINLESS STEEL

H. ROLLET & CO LTD

HOWIE STREET, LONDON, S.W.11 BATtERSEA 7872
Also at Liverpool, Birmingham, Manchester, Leeds, Glasgow

Hundreds of transistors, diodes, UJT's, FET's, SCR's and other semiconductor devices, are available from:

M. R. CLIFFORD & COMPANY (C5C)

209A, MONUMENT ROAD, EDGBASTON, BIRMINGHAM, 16.

Send 6d. stamps for competitive quotations, or send 1/3d. P.O. for current price list of over 1,000 transistors, OR send 2/- P.O. and receive in addition semiconductor data summaries covering approx. 200 common transistor types.

TYPICAL PRICES: 2N 697, 12/3; 2N 706, 6/-; 2G 302, 5/8; NKT 271, 3/8; BC 108, 7/6; 2N 2926 (orange), 4/3. Etc.

FIELD-EFFECT TRANSISTORS. C 86, 37/6; C 94 & C 95, 75/- ea. EX-STOCK.

TANTALUM CAPACITORS. A range of 40 values including the following: 0.1uF/35v; 0.5uF/35v; 1uF/35v; 4uF/35v; 2uF/25v; 20uF/6v; 30uF/3v; 50uF/3v; 10uF/3v; 15uF/10v; 5uF/20v; 5uF/25v; 5uF/3v; etc. Average size: 0.34in. x 0.24in. dia. All types at 6/- each

CARBON FILM RESISTORS. 1/2 Watt. 5% Tolerance. Size: 10mm x 4mm dia.

Values from 10 ohms to 10 Megohms, at 5d. each.

ELECTROLYTIC CAPACITORS. Comprehensive range available.

Miniature size—Priced from 1/6 to 2/- each.

TEST EQUIPMENT. Specific items quoted for on request.

e.g. NOMBREX Model 27 Signal Generator £10. 16. 9.

MAIL ORDER ONLY PLEASE TERMS: C.W.O.

Please add 1/- P. & P. on all orders of £2 or less.

the unique **PANL** black crackle paint

4/-d. per 1/8 pt. Can

(We regret we can only supply on cash with order basis)

BRUCE MILLER LTD.,

219 Coastal Chambers,
Buckingham Palace Road, S.W.1.

Radio Control

Illustrated Lists of
Radio Kits 1/-

Illustrated Lists of
Boat and Aircraft Kits 2/-

Components available for
most published designs

TELERADIO COMPANY
325/7 Fore Street, London, N.9

SINGLE
Channel
Transmitter
2005M
£10.19.6d.
or as a kit



YUKAN SO PROFESSIONAL THE YUKAN SELF-SPRAY

Get these AIR DRYING GREY **HAMMER** or **BLACK WRINKLE (CRACKLE)** Finishes

Yukan Aerosol spraykit contains 16 ozs. fine quality durable easy instant spray. No stove baking required. Hammers available in grey, blue, gold, bronze. Modern Eggshell Black Wrinkle (Crackle) all at 14/11 at our counter or 15/11, carriage paid, per push-button self-spray can. Also Durable, heat and water resistant Black Matt finish (12 ozs. self-spray cans only) 13/11 carriage paid.

SPECIAL OFFER: I can plus optional transferable snap-on trigger handle (value 5/-) for 18/11, carriage paid. Choice of 13 selfspray plain colours and primer (Motor car quality) also available.

Please enclose cheque or P.O. for total amount to: YUKAN, Dept. RC/1 307a Edgware Rd., London W.2.1
Open all day Saturday. Closed Thursday afternoons.



THE RADIO CONSTRUCTOR ANNUAL SUBSCRIPTIONS to this magazine may be obtained direct from the publishers ONLY 36/- per year, post free

Please send remittance with name and address and commencing issue required to:

DATA PUBLICATIONS LTD 57 MAIDA VALE LONDON W9

Please mention THE RADIO CONSTRUCTOR when writing to advertisers

CHASSIS and CASES by



287/9 Edgware Road
London W2
TELEPHONE
PADDington 5891/7595

BLANK CHASSIS—Same Day Service

Of over 20 different forms made up to YOUR SIZE.
(Maximum length 35", depth 4").

SEND FOR ILLUSTRATED LEAFLETS or order straight away, working out total area of material required (including waste) and referring to table below which is for four-sided chassis in 16 s.w.g. aluminium.

48 sq. in.	4/6	176 sq. in.	9/10	304 sq. in.	15/2
80 sq. in.	5/10	208 sq. in.	11/2	336 sq. in.	16/6
112 sq. in.	7/2	240 sq. in.	12/6	368 sq. in.	17/10
144 sq. in.	8/6	272 sq. in.	13/10	and pro rata	
	P. & P. 3/-		P. & P. 3/6		P. & P. 4/-

Discounts for quantities. More than 20 different sizes kept in stock for callers.

FLANGES (1/2" or 3/4"), 6d. per bend.
STRENGTHENED CORNERS, 1/- each corner.
PANELS

Any size up to 3ft at 6/- sq. ft. 16 s.w.g. (18 s.w.g. 5/3).
Plus postage and packing

CASES

ALUMINIUM, SILVER HAMMERED FINISH					
Type	Size	Price	Type	Size	Price
U	4 x 4 x 4"	10/-	Y	8 x 6 x 6"	26/6
U	5 1/2 x 4 1/2 x 4 1/2"	15/6	Y	12 x 7 x 7"	41/-
U	8 x 6 x 6"	21/-	Y	13 x 7 x 9"	46/-
U	15 x 9 x 9"	44/6	Y	15 x 9 x 7"	48/6
W	8 x 6 x 6"	21/-	Z	17 x 10 x 9"	66/-
W	12 x 7 x 7"	34/-	Z	19 x 10 x 8 1/2"	71/-
W	15 x 9 x 8"	44/-		* Height	

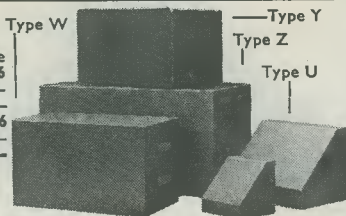

Type Z has removable back and front panels.
Type Y all-screwed construction.

NYLON P.T.F.E.

ROD BAR SHEET TUBE STRIP WIRE
No quantity too small List on application
BRASS COPPER BRONZE ALUMINIUM LIGHT ALLOYS
STAINLESS STEEL

H. ROLLET & CO LTD

HOWIE STREET, LONDON, S.W.11 BATersea 7872
Also at Liverpool, Birmingham, Manchester, Leeds, Glasgow

the unique **PAN L** black crackle paint

4/-d. per 1/8 pt. Can
(We regret we can only supply on cash with order basis)

BRUCE MILLER LTD.,

219 Coastal Chambers,
Buckingham Palace Road, S.W.1.

Hundreds of transistors, diodes, UJT's, FET's, SCR's and other semiconductor devices, are available from:

M. R. CLIFFORD & COMPANY (CSC)

209A, MONUMENT ROAD, EDGBASTON, BIRMINGHAM, 16.

Send 6d. stamps for competitive quotations, or send 1/3d. P.O. for current price list of over 1,000 transistors, OR send 2/- P.O. and receive in addition semiconductor data summaries covering approx. 200 common transistor types

TYPICAL PRICES: 2N 697, 12/3; 2N 706, 6/-; 2G 302, 5/8; NKT 271, 3/8; BC 108, 7/6; 2N 2926 (orange), 4/3. Etc.

FIELD-EFFECT TRANSISTORS. C 86, 37/6; C 94 & C 95, 75/- ea. EX-STOCK.

TANTALUM CAPACITORS. A range of 40 values including the following: 0.1uF/35v; 0.5uF/35v; 1uF/35v; 4uF/35v; 2uF/25v; 20uF/6v; 30uF/3v; 50uF/3v; 10uF/3v; 15uF/10v; 5uF/20v; 5uF/25v; 5uF/3v; etc. Average size: 0.34in. x 0.24in. dia. All types at 6/- each CARBON FILM RESISTORS. 1/2 Watt. 5% Tolerance. Size: 10mm x 4mm dia.

Values from 10 ohms to 10 Megohms. at 5d. each.

ELECTROLYTIC CAPACITORS. Comprehensive range available.

Miniature size—Priced from 1/8 to 2/- each.

TEST EQUIPMENT. Specific items quoted for on request.

e.g. NOMBREX Model 27 Signal Generator £10. 16. 9.

MAIL ORDER ONLY PLEASE TERMS: C.W.O.

Please add 1/- P. & P. on all orders of £2 or less.

Radio Control

Illustrated Lists of
Radio Kits 1/-

Illustrated Lists of
Boat and Aircraft Kits 2/-

Components available for
most published designs

TELERADIO COMPANY
325/7 Fore Street, London, N.9

SINGLE
Channel
Transmitter
200SM
£10.19.6d.
or as a kit



YUKAN SO PROFESSIONAL THE YUKAN SELF-SPRAY AEROSOL WAY — Get these AIR DRYING GREY HAMMER or BLACK WRINKLE (CRACKLE) Finishes

Yukan Aerosol spraykit contains 16 ozs. fine quality durable easy instant spray. No stove baking required. Hammers available in grey, blue, gold, bronze. Modern Eggshell Black Wrinkle (Crackle) all at 14/11 at our counter or 15/11, carriage paid, per push-button self-spray can. Also Durable, heat and water resistant Black Matt finish (12 ozs. self-spray cans only) 13/11 carriage paid.

Other Yukan Air Drying Aerosols include:
Zinc Chromate Primer.
Clear Lacquer.
Anti-Tarnish Gold and Metallic Finishes.

SPECIAL OFFER: 1 can plus optional transferable snap-on trigger handle (value 5/-) for 18/11, carriage paid. Choice of 13 self-spray plain colours and primer (Motor car quality) also available.

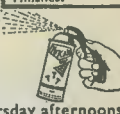

Please enclose cheque or P.O. for total amount to:
YUKAN, Dept. RC/1 307a Edgware Rd., London W.2.
Open all day Saturday. Closed Thursday afternoons.

THE RADIO CONSTRUCTOR ANNUAL SUBSCRIPTIONS to this magazine may be obtained direct from the publishers ONLY 36/- per year, post free

Please send remittance with name and address and commencing issue required to:

DATA PUBLICATIONS LTD 57 MAIDA VALE LONDON W9

Please mention THE RADIO CONSTRUCTOR when writing to advertisers

DATA BOOKS SERIES

NOW AVAILABLE — NEW REVISED AND ENLARGED EDITION

DB5 TV Fault Finding

124 pages. Price 8/6, postage 6d.

Profusely illustrated with photographs taken from a television screen depicting the faults under discussion and containing a wealth of technical information, with circuits, enabling those faults to be eradicated.

Now includes B.B.C.II as well as B.B.C.I and I.T.A.

“... A book that should be in every television dealer's service workshop, and in every home-constructor's, for that matter.”—*Journal of the Television Society*.

DB6 The Radio Amateur Operator's Handbook

64 pages. Price 5/-, postage 5d.

Contains Amateur Prefixes, Radio Zone Boundaries, Amateur Band Frequency Allocations, Call Areas, Charts and Maps, Areas, Codes, Mileage Tables, Prefixes/Directional Bearings, Post Office Regulations, and much other useful operating data. For the beginner there are notes on how to use the mass of information given to obtain the greatest satisfaction from the hobby.

“... For concise knowledge in this field a few shillings well worth spending.”—*Electronics* (Australia).

DB14 Short Wave Receivers for the Beginner

72 pages. Price 6/-, postage 6d.

Contains a selection of both battery and mains operated short wave receivers, circuits, point-to-point wiring diagrams and many illustrations. Introductory chapter gives much information on the Short Wave Spectrum, Clubs, QSL'ing, Aerials, Amateur and Broadcast Band Listening, Frequencies, etc. This book has been specially prepared for the beginner interested in short wave receiver construction and operation.

DB15 Twenty Suggested Circuits

48 pages. Price 3/6, postage 5d.

By G. A. French. Covers subjects ranging from electronic laboratory equipment to the simplest of periodic switches. Includes: simple and inexpensive two-valve capacity bridge, short wave regeneration preselector, one-valve speech operated switching circuit, transformer ratio analyser, series noise limiter, receiver remote mains on-off control, and many other circuits.

DB16 Radio Control for Models

192 pages. Price 15/-, postage 9d.

By F. C. Judd. Contains both theory and practical designs of simple and advanced transmitters and receivers; basic concepts, aerials, uses of radio components, transistorised receivers, multi-channel operation, etc. Sections on servo-mechanisms by Raymond F. Stock. More than 200 illustrations. Circuits, photographs, tables and working diagrams.

DB17 Understanding Television

512 pages. Price 37/6, postage 3/-

By J. R. Davies. This book, which deals with the principles of 625 line reception as fully as 405 line reception, fully explains: the nature of the television signal; the cathode ray tube; receiver tuner units; receiver i.f. amplifiers; a.f. and video amplifiers; vertical and horizontal timebases; deflector coil assemblies; synchronising; automatic gain and contrast control; power supplies and receiver aerials. Also includes a comprehensive introduction to colour television.

“... one of the best books that aims to explain television in simple language. . . .” R.S.G.B. Bulletin.

I enclose Postal Order/Cheque for.....in payment for.....

NAME

ADDRESS

(Please use Block Capitals for both name and address)

Postal Orders should be crossed and made payable to Data Publications Ltd.

Overseas customers please pay by International Money Order

All publications are obtainable from your local bookseller

Data Publications Ltd., 57 Maida Vale, London W.9



MAYFAIR PORTABLE ELECTRONIC ORGAN

Build the World's first All-Transistor Portable Electronic Organ Kit

- Plug-in printed circuits ● 170 transistors and devices ● 10 selected tone colours ● Fully sprung keyboard ● Vibrato ● 6 Octaves of generators ● Simple locked-in tuning ● 110/250 volt mains unit ● Cabinet size 30 1/2" x 15 1/2" x 9" ● Weight 35 lb. Cabinet with detachable legs, music stand and foot swell pedal ● Fully detailed building manual with photos, drawings and full circuits.



COMPLETE RANGE OF ELECTRONIC ORGAN COMPONENTS IN STOCK

CALL IN FOR DEMONSTRATION

★ **COMPLETE KIT with Cabinet and Handbook** **99 GNS.**

(Carriage and Packing 30/- extra)

★ **Detailed leaflet on request**

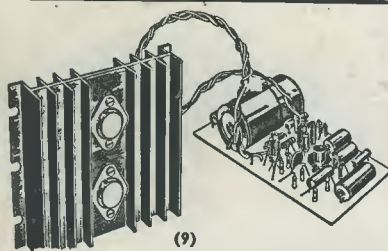

10 & 20 W Mono & Stereo Transistor Amplifiers

(9) **POWER AMPLIFIERS.** 10 watts RMS output, 100mV input. 30 c/s to 20kc/s \pm 1dB. 6-Transistor Push-pull. Panel size 4" x 2 1/2" x 1". H/S 4" x 4".

TPA10/3 3-5 Ω spkr. £4.10.0, p.p. 2/6

TPA10/15 12-16 Ω spkr., £5.5.0, p.p. 2/6

(Mains unit for 1 or 2 amplifiers, 59/6, p.p. 2/6)

The finest High Fidelity at Unbeatable Prices

(10) **PREAMPLIFIERS.** 8 input selector. Treble, bass, volume, filter controls. 1 1/2mV to 300mV inputs. Battery operated or from Mains Unit. Output up to 150mV RMS.

MP2 9 1/2" x 2 1/2" x 2". £5.10.0, p.p. 2/6 (grey and gold front panel 8/6)

SP4 Mono/Stereo, 9" x 3 1/2" x 1 1/2". £10.19.6, p.p. 3/6 (front panel plate 12/6).

ALL UNITS BUILT AND TESTED

(1) **REGENT-6 MW/LW Pocket Radio to Build**
6-Transistor superhet. Geared tuning. Push-pull speaker output. Moulded cabinet 5 x 3 x 1 1/2 in. Phone socket. **69/6**

TOTAL COST TO BUILD P.P. 2/-
Full tuning on both bands

TUNNEL DIODES

1mA 22/6; 5mA 15/-; 15mA 12/6. Brand new at fraction of normal price. Free Specs. supplied.

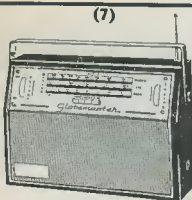

(7)

(2) MW/LW QUALITY TRANSISTOR RADIO TUNER

Fully tunable superhet with excellent sensitivity and selectivity. Output up to 1/2 volt peak. Complete with front panel, etc. 9 volt operated. For use with any amplifier or tape recorder. **TOTAL COST £3.19.6** P.P. 2/6 **TO BUILD**

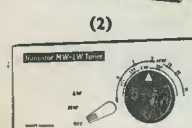

(2)

(4) BUILD A QUALITY 2 OR 4 TRACK TAPE RECORDER

3-speed version using new '363' decks

● **TWO-TRACK.** Deck £10.10.0. Martin Amplifier £14.19.6. Cabinet and speaker 7 gns. Complete kits with FREE 7in. 1200ft. tape, spare spool. P.P. Today's Value £45 **27 gns.** 15/-

● **FOUR-TRACK.** Deck £13.10.0. Martin Amplifier £15.19.6. Cabinet and speaker 7 gns. Complete kits with FREE 7in. 1200ft. tape, spare spool. P.P. Today's Value £50. **30 gns.** 15/-

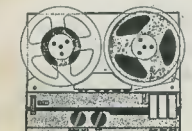

(4)

(6) GARRARD DECKS—BRAND NEW FULLY GUARANTEED

1000 mono	£5 19 6	SP25 stereo	£11 10 0	401 less cart./arm	£27 10 0
1000 stereo	£6 6 0	SP25 Deram	£14 10 0	AT6 mono	£8 19 6
2000 mono	£6 9 6	AT60 less cart.	£11 10 0	AT6 stereo	£9 10 0
2000 stereo	£6 16 6	AT60 mono	£11 19 6	AT6 Deram	£11 19 6
3000 1m stereo	£7 10 0	AT60 stereo	£12 10 0	Decadec Mk. II	£17 17 0
SP25 less cart.	£10 10 0	AT60 Deram	£15 10 0	A70 less cart.	£17 17 0
SP25 mono	£10 19 6	LAB80 less cart.	£27 0 0	(P. & P 5/- any type)	

All other makes of decks and cartridge in stock

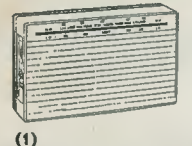

(1)

(7) GLOBEMASTER MW/LW/SW PORTABLE RADIO TO BUILD

Full 3-waveband tuning. Pushbutton wavechange. 6-transistor. Superhet printed circuit. Blackchromed cabinet 11 x 7 1/4 x 3 1/2 in. (SW 17-50m). Ear/Record sockets. 1 watt Push/Pull output. **TOTAL COST £7.19.6** P.P. 3/6 **TO BUILD**

STABILISED POWER SUPPLY

Two outputs. 3.6 volts and 9.6 volt up to 250mA each. Transistorised and Tuner stabilised. 110 to 250 volt mains input. In case with leads. Price 67/6, p.p. 2/6.

SCR's (Thyristors)

50 PIV 7/6. 100 PIV 7/6. 200 PIV 12/6. 300 PIV 15/-. 400 PIV 280V Rms) 17/6. 100 PIV, 3 Amp Stud Type 9/6. 400 PIV, 7 Amp (280V Rms) Stud Type 25/-.

25 watt transistor amplifier £7.19.6, p.p. 3/- (mains unit, 79/6, p.p. 3/-)

(3) 5 WATT AMPLIFIER

6-Transistor Push-pull, 3 ohms. 6mV into 1K. 12/18V supply, 2 1/2" x 2 x 1 1/2 in. **BUILT AND TESTED 69/6** P.P. 2/- (optional mains units 54/-) 2/- 1 1/2 watt version 59/6.

Matching Preamplifier, 6 inputs, treble/bass/selector/volume controls. 6-10mV output. 9-18V supply. 79/6, p.p. 2/-.
For use with only Transistor Amplifier

(5) VHF FM TUNER TO BUILD

87/105 Mc/s Transistor Superhet. Geared tuning. Terrific quality and sensitivity. For valve or transistor amplifiers. 4 x 3 1/2 x 2 1/2 in. Complete with dial plate. (FM Decoder Kit £5.19.6, p.p. 2/-).

TOTAL COST £6.19.6 P.P. 2/6 **TO BUILD** (Cabinet Assembly 20/- extra)

(11) GARRARD BATTERY 2-SPEED TAPE DECK

Brand New with R/P head, erase/osc. head, tape cassette. Specifications and osc. circuits. 2 speed 2-track 9 volt operated. List Price 13 gns.

PRICE £8.19.6 P.P. 3/6

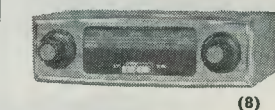

(8)



(5)



(6)



(3)

LATEST CATALOGUE

Have you a copy? Fully detailed and illustrated. 150 pages of components, equipment, etc. Over 5,000 stock items. PRICE 6/-, post paid. Free discount vouchers with every catalogue.

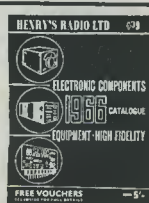

(8) TOURMASTER CAR RADIO

7-Transistor MW/LW Car Radio. 12 volt operated. 3 watt output. Pushbutton wave-change. RF stage. Supplied built, boxed, ready to use with Speaker and Baffle. Car fixing kit and manufacturers' current guarantee. Special Bargain Offer. Buy Now! List Price 13 gns. **£9.9.0** P.P. 3/6 **PRICE**

MARRIOT TAPE HEADS

1/2 Track R/RP/3 Med. z, 7/6. R/RP/1 High z, 8/-. R/RP/1 High z, + R/E/1 erase on block, 19/6. 1/2 Track L/RPS/12 High z, 15/-. L/RPS/7 Med. z, 19/6. 5/ES/19 erase, 12/6. Also HR-RP single track Rec/Play Med. z, 6/6.

HEAVY'S RADIO LTD.

303 Edgware Road, London, W.2 PADDINGTON 1008/9 (STD 01-723-1008) Open Mon. to Sat. 9-6. Thurs. 1 p.m.

FM STEREO DECODER
7-Transistor Printed Circuit Design with Stereo Indicator. For use with any valve or transistor FM. Uses pot cores to Mullard design and ger. and silicon transistors. Complete **£5.19.6** P.P. 2/- Kit Price

NEW 24 PAGE TRANSISTOR CATALOGUE 1/-

We can supply from stock most of the components specified on circuits in this magazine. Send for quotation.