

Melle

Vol 19 No 10

MAY 1966

2/3

DATA PUBLICATIONS

THE Radio Constructor

RADIO · TELEVISION
ELECTRONICS · AUDIO

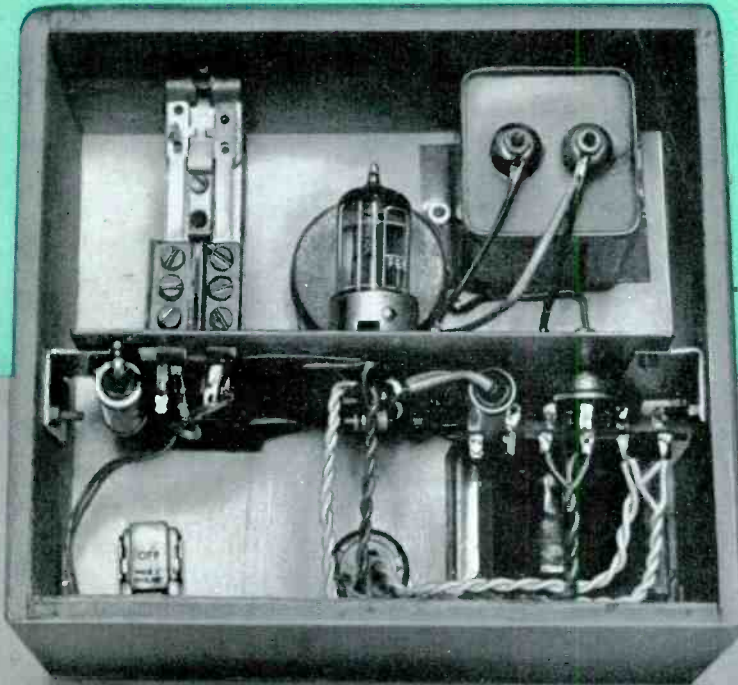

Inexpensive Photographic Timer

Transistorised
Signal Injector



Tape Recorder
Auto-Stop



Simple Stabilised
Power Supply



Archaeological Ground
Resistance Meter

Scottish Insurance Corporation Ltd

38 EASTCHEAP · LONDON · EC3



TELEVISION SETS, RECEIVERS AND TRANSMITTERS

Television Sets, Receivers and Short Wave Transmitters are expensive to acquire and you no doubt highly prize your installation. Apart from the value of your Set, you might be held responsible should injury be caused by a fault in the Set, or injury or damage by your Aerial collapsing.

A "Scottish" special policy for Television Sets, Receivers and Short Wave Transmitters provides the following cover:

- (a) Loss or damage to installation (including in the case of Television Sets the Cathode Ray Tube) by Fire, Explosion, Lightning, Theft or Accidental External Means at any private dwelling-house.
- (b) (i) Legal Liability for bodily injury to Third Parties or damage to their property arising out of the breakage or collapse of the Aerial Fittings or Mast, or through any defect in the Set. Indemnity £10,000 any one accident.
- (ii) Damage to your property or that of your landlord arising out of the breakage or collapse of the Aerial Fittings or Mast, but not exceeding £500.

The cost of Cover (a) is 5/- a year for Sets worth £50 or less, and for Sets valued at more than £50 the cost is in proportion. Cover (b) (i) and (ii) costs only 2/6 a year if taken with Cover (a), or 5/- if taken alone.

Why not BE PRUDENT AND INSURE your installation—it is well worth while AT THE VERY LOW COST INVOLVED. If you write to the Corporation's Office a proposal will be submitted for completion.

Write for full details, quoting reference 5304, to:—

THE MANAGER
SCOTTISH INSURANCE CORPORATION LTD.,
38 EASTCHEAP, LONDON E.C.3

Sinclair Z.12 COMBINED AMPLIFIER & PRE-AMP

For size alone, the Z.12 marks an important advance in quality design, for its amazing compactness opens up exciting new vistas in amplifier housing and application. Combined with this are the fantastic power and superb quality of the Z.12 which can provide an effortless output of 12 watts R.M.S. continuous sine wave from its unique eight transistor circuit. Basically intended as the heart of any good mono or stereo hi-fi system, the size and efficiency of this Sinclair unit make it equally useful for a car radio (with the Micro-6 for example), a high quality radio with the Micro FM, in a guitar, P.A. or intercom system, etc. Other applications are certain to suggest themselves to constructors. The manual included with the Z.12 details many mono and stereo tone and volume control circuits by which inputs can be matched (and switched in) to the pre-amp. The size, performance and price of the Z.12 all favour the constructor seeking the finest in transistorised audio reproduction—it is in fact today's finest buy in top grade high fidelity.

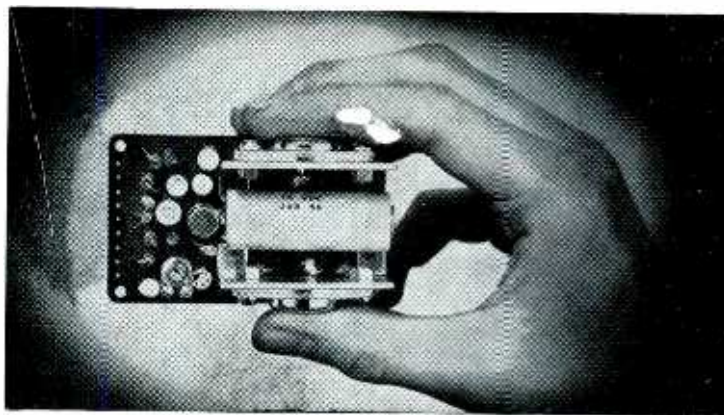

12 WATTS R.M.S. OUTPUT CONTINUOUS SINE WAVE (24 W. PEAK)
15 WATTS R.M.S. MUSIC POWER (30 WATTS PEAK)

- 8 special HF transistors.
- Ultra-linear class B output and generous neg. feed back.
- Response—15 to 50,000 c/s ± 1 dB.
- Output suitable for 3, 7.5 and 15 ohm loads. Two 3 ohm speakers may be used in parallel.
- Input—2mV into 2K ohms.
- Signal to noise ratio—better than 60dB.

Ready built, tested and guaranteed with Z.12 manual

89/6

USE IT FOR HI-FI, RADIO, GUITAR, INTERCOM, P.A. etc.

AN ENTIRELY NEW POWER UNIT

Sinclair PZ.3 uses new transistorised circuitry to provide phenomenally good smoothing for power requirements of Z.12. Two can be driven by PZ.3 For A.C. mains 200/240V.—20V. d.c. out. Ready built.

79/6

SINCLAIR MICRO-6

The smallest set in the world



For power, selectivity and quality, this amazing six stage M.W. receiver is unequalled. 2 stages R.F. amplification, double diode detector, 3 stage A.F. amplifier, A.G.C. etc. Complete with self-contained aerial in white, gold and black case, size 1 1/2" x 1 3/10" x 1/2". Plays anywhere. Very easy to build. Complete kit of parts with ear-piece and instructions.

59/6

MALLORY MERCURY CELL 2M.312 (2 required) each 1s. 11d.

Sinclair MICRO FM

COMBINED POCKET SIZE FM TUNER/RECEIVER

For less outlay, you can enjoy building the most advanced F.M. set in the world when you buy the Sinclair Micro F.M. It needs no aligning. A.F.C. makes tuning easy, and thanks to the two audio outputs, you can use the Micro F.M. both as a TUNER and as an independent pocket portable. This wonderful set is as outstanding in appearance as performance and it will operate in all but the worst F.M. reception areas.

TECHNICAL DESCRIPTION

Measures less than 3in. high x 1 1/2in. wide with a depth of 2in. The set's R.F. amplifier is followed by a self-oscillating mixer and 3 stages of I.F. amplification to dispense with I.F. transformer and all problems of alignment. A pulse-counting detector ensures improved linearity and therefore better audio quality at the output stages. After equalisation the signal is channelled to one output for feeding to amplifier or recorder and to another in which the receiver's own audio amplifying stage enables the Micro FM to be used as an independent self-contained pocket portable. A.F.C. is used to lock the programme tuned in; the telescopic aerial included with the kit will be found sufficient for all but the worst signal areas.

- ★ Supply voltage—9v from self contained standard battery.
- ★ Consumption—5mA
- ★ Sensitivity—Typical—3mV
- ★ Signal to Noise Ratio—30dB at 30mV
- ★ Audio frequency response—10-20,000 c/s. ★ A.F.C.
- ★ Inserting plug of ear-piece or tuner lead switches set ON.

Complete kit inc. transistors, aerial, case, earpiece and instructions.

SEVEN TRANSISTOR SUPERHET FM WITH 2 OUTPUTS



£5.19.6

FULL SERVICE FACILITIES AVAILABLE TO SINCLAIR CUSTOMERS

GUARANTEE If you are not completely satisfied when you receive your purchase from us, your money will be refunded at once in full and without question.

SINCLAIR RADIONICS LTD., 22 NEWMARKET ROAD, CAMBRIDGE

Please send

NAME

ADDRESS

for which I enclose cash/cheque/money order value £.....s.....d.

RC5

Sinclair

SINCLAIR RADIONICS LTD
22 NEWMARKET ROAD, CAMBRIDGE
Telephone 52731

HI-FI AMPLIFIERS ~~~~~ TUNERS ~~~~~ RECORD PLAYERS

20+20
STEREO
AMP.
AA-22U



GARRARD
PLAYER
AT-60



TRANSISTOR MIXER. Model TM-1. A must for the tape enthusiast. Four channels. Battery operated. Similar styling to Model AA-22U Amplifier. With cabinet. Kit £11.16.6 Assembled £16.17.6

20+20W TRANSISTOR STEREO AMPLIFIER. Model AA-22U. Outstanding performance and appearance. Kit £39.10.0 (less cabinet). Attractive walnut veneered cabinet £2.5.0 extra. Assembled £68.16.0

GARRARD AUTO/RECORD PLAYER. Model AT-60. less cartridge £13.1.7 With Decca Deram pick-up £17.16.1 incl. P.T. Many other Garrard models available, ask for Lists.

HI-FI MONO AMPLIFIER. Model MA-5. A general purpose 5W Amplifier, with inputs for Gram., Radio. Attractive modern styling. Kit £10.19.6 Assembled £15.10.0

10W
POWER
AMP.
MA-12



3+3W
STEREO
AMP.
S-33H



10W POWER AMPLIFIER. Model MA-12. 10W output, wide freq. range, low distortion. For use with control unit. Kit £11.18.0 Assembled £15.18.0

3 + 3W STEREO AMPLIFIER. Model S-33. An easy-to-build, low cost unit. 2 inputs per channel. Kit £13.7.6 Assembled £18.12.0

DE LUXE STEREO AMPLIFIER. Model S-33H. De luxe version of the S-33 with two-tone grey perspex panel, and higher sensitivity necessary to accept the Decca Deram pick-up. Kit £15.17.6 Assembled £21.7.6

HI-FI STEREO AMPLIFIER. Model S-99. 9 + 9W output. Ganged controls. Stereo/Mono gram., radio and tape inputs. Push-button selection. Printed circuit construction. Kit £28.9.6 Assembled £38.9.6

POWER SUPPLY UNIT. Model MGP-1. Input 100/120V, 200/250V, 40-60 c/s. Output 6.3V, 2.5A A.C. 200, 250, 270V, 120mA max. D.C. Kit £5.2.6 Assembled £6.12.6



The World Leader in Quality Kits

Easy-to-follow instruction manuals show you how to build the models

FOR THE INSTRUMENTALIST



PA-2

TRANSISTOR PA/GUITAR AMPLIFIER, PA-2. 20 Watt amplifier. Two heavy duty speakers. Four inputs. Two channels. Variable tremolo. Speed and depth controls. Weight 51lb. 18" high x 29" wide x 10" deep. Kit £44.19.0 Assembled £59.10.0

VALVE PA/GUITAR AMPLIFIER, PA-1. 50 Watt amplifier. Kit £54.15.0 Assembled £74.0.0 Castors or legs available as extras.

TRANSISTOR RECEIVERS



UXR-2

"OXFORD" LUXURY PORTABLE. Model UXR-2. Specially designed for use as a domestic, car or personal portable receiver. Many features, including solid leather case. Kit £14.18.0 incl. P.T.



UXR-1

TRANSISTOR PORTABLE. Model UXR-1. Pre-aligned I.F. transformers, printed circuit. Covers L.W. and M.W. Has 7" x 4" loud-speaker. Real hide case. Kit £12.11.0 incl. P.T.



UJR-1

JUNIOR EXPERIMENTAL WORKSHOP. Model EW-1. More than a toy! Will make over 20 exciting electronic devices, incl: Radios, Burglar Alarms, etc. 72 page Manual. The ideal present! Kit £7.13.6 incl. P.T.

JUNIOR TRANSISTOR RADIO. Model UJR-1. Single transistor set. Excellent introduction to radio. Kit £2.7.6 incl. P.T.

WELCOME TO OUR LONDON HEATHKIT CENTRE
233 Tottenham Court Road

We open MONDAY-SATURDAY 9 a.m.-5.30 p.m.
THURSDAY ... 11 a.m.-2.30 p.m.
Telephone No: MUSEum 7349

WHEN YOU ARE IN TOWN, WE HOPE YOU WILL VISIT US THERE

INSTRUMENTS

[NEW] 3" LOW-PRICED SERVICE OSCILLOSCOPE. Model OS-2. Compact size 5" x 7 1/4" x 12" deep. Wt. only 9 1/2 lb. "Y" bandwidth 2 c/s-3 Mc/s ± 3dB. Sensitivity 100mV/cm. T/B 20 c/s-200 kc/s in four ranges, fitted mu-metal CRT Shield. Modern functional styling. Kit £22.18.0 Assembled £30.8.0

5" GEN-PURPOSE OSCILLOSCOPE. Model 10-12U. An outstanding model with professional specification and styling. "Y" bandwidth 3 c/s-4.5 Mc/s ± 3dB. T/B 10 c/s-500 kc/s. Kit £35.17.6 Assembled £45.15.0

DE LUXE LARGE-SCALE VALVE VOLTMETER. Model IM-13U. Circuit and specification based on the well-known model V-7A but with many worth-while refinements. 6" Ernest Turner meter. Unique gimbal bracket allows operation of instrument in many positions. Modern styling. Kit £18.18.0 Assembled £26.18.0

AUDIO SIGNAL GENERATOR. Model AG-9U. 10 c/s to 100 kc/s, switch selected. Distortion less than 0.1%, 10V sine wave output metered in volts and dB's. Kit £22.10.0 Assembled £30.10.0

VALVE VOLTMETER. Model V-7A. 7 voltage ranges d.c. volts to 1,500. A.c. to 1,500 r.m.s. and 4,000 peak to peak. Resistance 0.1Ω to 1,000MΩ with internal battery. D.c. input resistance 11MΩ. dB measurement, has centre-zero scale. Complete with test prods, leads and standardising battery. Kit £13.18.6 Assembled £19.18.6

MULTIMETER. Model MM-1U. Ranges 0-1.5V to 1,500V a.c. and d.c.; 150μA to 15A d.c.; 0.2Ω to 20MΩ. 4 1/2" 50μA meter. Kit £12.18.0 Assembled £18.11.6

R.F. SIGNAL GENERATOR. Model RF-1U. Up to 100 Mc/s fundamental and 200 Mc/s on harmonics. Up to 100mV output. Kit £13.8.0 Assembled £19.18.0

SINE/SQUARE GENERATOR. Model IG-82U. Freq. range 20 c/s-1 Mc/s in 5 bands less than 0.5% sine wave dist. less than 0.15μ sec. sq. wave rise time. Kit £24.10.0 Assembled £36.10.0

TRANSISTOR POWER SUPPLY. Model IP-20U. Up to 50V, 1.5A output. Ideal for Laboratory use. Compact size. Kit £35.18.0 Assembled £47.18.0

Prices and specifications subject to change without notice



OS-2



IM-13U



V-7A



RF-1U



IG-82U

TAPE AMPLIFIERS ~~~~~ TAPE DECKS ~~~~~ CONTROL UNITS



**FM
TUNER
FM-4U**



**MAGNAVOX
DECK**



**TRUVOX
DECK**



**AM/FM
TUNER**

HI-FI FM TUNER. Model FM-4U. Available in two units. R.F. tuning unit (£2.15.0 incl. P.T.) with I.F. output of 10.7 Mc/s, and I.F. amplifier unit, with power supply and valves (£13.13.0). May be used free standing or in a cabinet. **Total Kit £16.8.0**

MAGNAVOX "363" TAPE DECK. The finest buy in its price range. Operating speeds: 1½", 3¼" and 7¼" p.s. Two tracks, "wow" and "flutter" not greater than 0.15% at 7¼" p.s. **£13.10.0**
MAGNAVOX deck with TA-IM Kit £31.5.6

HI-FI AM/FM TUNER. Model AFM-1. Available in two units which, for your convenience, are sold separately. Tuning heart (AFM-T1—£4.13.6 incl. P.T.) and I.F. amplifier (AFM-A1—£22.11.6). Printed circuit board, 8 valves. Covers L.W., M.W., S.W., and F.M. Built-in power supply. **Total Kit £27.5.0**

TRUVOX D-93 TAPE DECKS. High quality stereo/mono tape decks. **D93/2, ½ track, £36.15.0** **D93/4, ¼ track, £36.15.0**

TAPE RECORDING/PLAYBACK AMPLIFIER. Thermometer type recording indicators, press-button speed compensation and input selection. Mono Model TA-1M. **Kit £19.18.0 Assembled £28.18.0**
Stereo Model TA-1S. **Kit £25.10.0 Assembled £35.18.0**

MONO CONTROL UNIT. Model UMC-1. Designed to work with the MA-12 or similar amplifier requiring 0.25V or less for full output. 5 inputs. Baxandall type controls. **Kit £8.12.6 Assembled £13.12.6**

STEREO CONTROL UNIT. Model USC-1. Push-button selection, accurately matched ganged controls to ±1dB. Rumble and variable low-pass filters. Printed circuit boards. **Kit £19.10.0 Assembled £26.10.0**

First in dependability - first in performance

Convenient credit terms available in U.K. over £10



SSU-1

SPEAKER SYSTEMS

HI-FI SPEAKER SYSTEM. Model SSU-1. Ducted-port bass reflex cabinet "in the white". Two speakers. Vertical or horizontal models with legs, Kit **£12.12.0**, without legs, Kit **£11.17.6** incl. P.T.

THE BERKELEY Slim-line SPEAKER SYSTEM, fully finished walnut veneered cabinet for faster construction. Special 12" bass unit and 4" mid/high frequency unit. Range 30-17,000 c/s. Size 26" x 17" x only 7¼" deep. Modern attractive styling. Excellent value.

Kit £18.10.0 Assembled £23.0.0

COTSWOLD SPEAKER SYSTEMS. Outstanding performance for price.

MFS: Size 36" x 16½" x 14" deep.

Kit £25.12.0 Assembled £33.17.0

STANDARD: Size 26" x 23" x 14½" deep.

Kit £25.12.0 Assembled £33.17.0



Berkeley

HI-FI CABINETS

A wide range available including:

GLOUCESTER. Kit **£18.10.0** incl. P.T.

MALVERN. Kit **£18.1.0** incl. P.T.

CHEPSTOW. Kit **£11.12.6** incl. P.T.

We can also make available the well-known RECORD HOUSING range of fully finished cabinets.



Malvern

SEND FOR THE LATEST FREE CATALOGUE

INSTRUMENT AND AMATEUR RADIO BROCHURES
AVAILABLE ON REQUEST

Prices quoted are Mail Order prices.

DAYSTROM LTD DEPT. RC.5
GLOUCESTER

"AMATEUR" EQUIPMENT

THE "MOHICAN" GENERAL COVERAGE RECEIVER. Model GC-1U. With 4 piezo-electric transmitters, variable tuned B.F.O. and Zener diode stabiliser, this is an excellent fully transistorised general purpose receiver for Amateur and Short wave listeners. Printed circuits, telescopic aerial, tuning meter and large slide-rule dial. **Kit £37.17.6 Assembled £45.17.6**

AMATEUR BANDS RECEIVER. Model RA-1. To cover all the Amateur Bands from 160-10 metres. Many special features, including: half-lattice crystal filter; 8 valves; signal strength "S" meter; tuned R.F. Amp. stage. **Kit £39.6.6 Assembled £52.10.0**

160-10M TRANSMITTER. Model DX-100U. Careful design has achieved high performance and stability. Completely self-contained. **Kit £79.10.0 Assembled £104.15.0**

COMMUNICATIONS TYPE RECEIVER. Model RG-1. A high performance, low cost receiver for the discriminating listener. Frequency coverage: 600 kc/s-1.5 Mc/s and 1.7 Mc/s-32 Mc/s. **Kit £39.16.0 Assembled £53.0.0**

REFLECTED POWER METER and SWR BRIDGE. Model HM-11U. Indicates reliably, but inexpensively, whether the RF power output of your TX is being transferred efficiently to radiating antenna. **Kit £8.5.0 Assembled £10.10.0**



GC-1U



RG-1



HM-11U

OUTSTANDING "AMATEUR" EQUIPMENT

A wide range of American Amateur SSB equipment is now available in the U.K. Why not send for full details of range, for example:

FILTER TYPE SSB TRANSCEIVERS.
Models for 80, 40 or 20 metre bands.
Model HW-12 (80M) £66.0.0 each kit.
Model HW-22 (40M) price inc. duty, etc.
Model HW-32 (20M)



**80M Transceiver
HW-12**

Without obligation please send me
FREE BRITISH HEATHKIT CATALOGUE.....

(Tick here)

FULL DETAILS OF MODEL(S).....
(Please write in BLOCK CAPITALS)

NAME

ADDRESS

DEPT. RC.5

IMPROVED STANDARDS of Accuracy and Reliability!

Modern styling in light grey with legible black engraving.

Constructed to withstand adverse climatic conditions.

Ever ready case including leads, prods and clips.

Improved internal assemblies.

Re-styled scale plate for easy rapid reading. 2 basic scales each 2.5 inches in length.

New standards of accuracy using an individually calibrated scale plate: d.c. ranges 2.25% of full scale deflection, a.c. ranges 2.75% of full scale deflection.

Available accessories include a 2,500V d.c. multiplier and 5, 10 and 25A shunts for d.c. current measurement.



The Mk. 4 MULTIMINOR, the latest version of this famous Avo instrument, supersedes all previous models. It is styled on modern lines, with new high standards of accuracy, improved internal assemblies, and incorporating panclimatic properties.

The instrument is supplied in an attractive black carrying case, which also houses a pair of leads with interchangeable prods and clips, and an instruction booklet. It is packed in an attractive display carton. Robust real leather cases are available, if required, in two sizes, one to take the instrument with leads, clips and prods, and the other to house these and also a high voltage multiplier and a d.c. shunt.

D.C. Current: 100μA f.s.d. — 1A f.s.d. in 5 ranges.
 A.C. Voltage: 10V f.s.d. — 1,000 f.s.d. in 5 ranges.
 D.C. Voltage: 2.5V f.s.d. — 1,000 f.s.d. in 6 ranges.
 D.C. Millivolt range: 0 — 100mV f.s.d.
 RESISTANCE: 0-2MΩ in 2 ranges, using 1.5V cell.
 SENSITIVITY: 10,000 Ω/V on d.c. Voltage ranges.
 1,000 Ω/V on a.c. Voltage ranges.

See the latest AVO
 Electrical Testing Instruments
 on STAND G60
 I.E.A. Exhibition, Olympia



MULTIMINOR Mk 4

Write for
 leaflet

AVO LTD

ARCHCLIFFE ROAD, DOVER, KENT Telephone: Dover 2626



MM/17

NEW BRITISH RECORDING TAPE

Famous Mfr.	Bulk Purchase	Genuine recommended Tape Bargain.
Unconditional Guarantee. Fitted Leader and Stop Foils (except 3").		
St'd. (PVC base)	L.P. (PVC base)	D.P. (Milar base) Triple Play
3" 150ft. ... 3/9	225ft. ... 4/9	300ft. ... 6/6
5" 600ft. ... 11/6	900ft. ... 15/-	1,200ft. ... 23/6
5 1/2" 850ft. ... 14/6	1,200ft. ... 17/6	1,800ft. ... 29/6
7" 1,300ft. ... 17/6	1,800ft. ... 22/6	2,400ft. ... 37/6

Post and Packing—3" Reels 6d. Each additional Reel 3d. 4" to 7" Reels 1/-, Each additional Reel 6d. All tape accessories stocked.
EMPTY TAPE REELS (Plastic): 3" 1/3, 5" 2/-, 5 1/2" 2/-, 7" 2/3.
PLASTIC REEL CONTAINERS (Cassettes): 5" 1/9, 5 1/2" 2/-, 7" 2/3.

TRANSISTOR COMPONENTS

Midget I.F.'s—465 kc/s 1/8" diam., first, second or third, each 5/6
 Osc. coil M. & L.W. 3/4" diam. 5/-
 Midget Driver Trans. 9/-
 Ditto O/Put Push-pull 3 ohms 6/-
 Elect. Condensers—Midget Type 15V 1mfd-50mfd, ea. 1/9. 100mfd, 2/-, 15 choke, 2/6.
 Ferrite Aerial—M. & L. W. with car aerial coupling coil, 9/3.
 Condensers—150V wkg. .01mfd. to .04mfd., 9d. .05mfd., 1mfd., 1/-, .25mfd., 1/3, .5mfd., 1/6, etc.
 Tuning Condensers, J.B. "OO" 208+176pF, 8/6. Ditto with trimmers, 9/6, 365pF single, 7/6. Sub-min. 2" DILEPHIN 100pF, 300pF, 500pF, 7/-
 Midget Vol. Control with edge control knob, 5kΩ with switch, 4/9, ditto less switch, 3/9.

TUB-ELECTROLYTICS-CAN
 25/25V, 50/12V, 1/9, 8+8/450V, 4/6;
 50/50V, 100/125V, 2/-, 32+32/275V,
 4/6; 8/450V, 4/350V, 2/3; 50/50/350V,
 6/6; 16+16/450V, 5/6; 100/250/275V,
 12/6; 32+32/450V, 6/6; 100+250/275V,
 12/6.

ENAMELLED COPPER WIRE
 —1lb. reels 14g-20g, 3/-, 22g-28g,
 3/6; 30g-34g, 4/3; 36g-38g, 4/9;
 39g-40g, 5/-, etc.
TINNED COPPER WIRE.
 16-22g, 4/- 1/6.
**ERSIN MULTICORE SOL-
 DER,** 60/40, 4d. per yard, Cartons
 6d., 1/-, 2/6, etc.

TYGAN FRET (Contem. pat.), 12 x 12", 2/-; 12 x 18", 3/-; 12 x 24", 4/-, etc.
EXPANDED ANODISED METAL
 —Attractive gilt finish 1/8" x 1/8" diamond mesh 4/6 sq. ft. Multiples of 6" cut. Max. size 4' x 3', 47/6 plus carr.
BONDACOUST Speaker Cabinet
 Acoustic Wadding (1" thick approx) 18" wide, any length cut. 6/- yd.
Volume Controls—5K-2 Meg-ohms, 3" Spindles Morganite Midget Type, 1 1/2" diam. Guar. 1 year. LOG or LIN ratios less Sw., 3/6. DP. Sw. 5/-. Twin Stereo less Sw., 7/6. D.P. Sw., 9/6 (100 k to 2 Meg. only).
 1/2 Meg. VOL Controls D.P. Sw. 1/2" flatted spindle Famous Mfrs. 4 for 10/- post free.

Condensers—Silver Mica. All values 2pF to 1,000pF, 6d. each. Ditto Ceramics, 9d. Tub. 450V T.C.C. etc. 0.001 mfd to 0.01 and 0.1/ 350V, 9d. 0.0-0.1/500V, 1/-, 0.25 Hunt, 1/6. 0.25 T.C.C., 1/9, etc., etc.
Close Tol. S/Micas—10% 5pF-500pF, 8d. 600-5,000pF, 1/-, 1% 1/9 1/2W, 1/6, etc., etc.



Send for detailed bargain lists, 3d. stamp. We manufacture all types Radio Mains Transf. Chokes. Quality O/P Trans., etc. Enquiries invited for Specials, Prototypes for small production runs. Quotation by return.
RADIO COMPONENT SPECIALISTS
 70 Brigstock Road, Thornton Heath, Surrey
 THO 2188. Hours: 9 a.m.-6 p.m., 1 p.m. Wed. Terms C.W.O. or C.O.D. Post and Packing up to 1/6, 1/-, 1/6. 1/9, 3/6, 3/-, 5/6, 3/9, 8/6, 4/6.

6 VALVE AM/FM TUNER UNIT



Med. and VHF 190m-550m, 86 Mc/s-103 Mc/s, 6 valves and metal rectifier. Self-contained power-unit, A.C. 200/250V operation. Magic-eye indicator, 3 push-button controls, on/off, Med., VHF. Diode and high output Sockets with gain control. Illuminated 2-colour perspex dial 1 1/2" x 4", chassis size 1 1/2" x 4" x 5 1/2". A coloured Fidelity Unit for use with Mullard "3-3" or "5-10" Amplifiers.
BARGAIN PRICE. Complete kit of parts, inc. Power Pack (as illustrated) Price £10.19.6, Carr. 7/6. Ditto, less Power Pack, £9.19.6, carr. 7/6. Circuit and constr's details, 4/6, free with kit.

MULLARD "3-3" & "5-10" HI-FI AMPLIFIERS

3 OHM & 15 OHM OUTPUT
 "3-3" Amp. 3-valve, 3 watt Hi-Fi quality at reasonable cost. Bass Boost and Treble controls, quality sectional output transformer, 40 c/s-25 kc/s ± 1dB, 100mV for 3V, less than 1% distortion. Bronze escutcheon panel. Complete Kit only 7 gns. Carr. 5/-. Wired and tested £8.10.0.
MULLARD "5-10" AMPLIFIER—5 valves 10W, 3 and 15 ohms output. Mullard's famous circuit with heavy duty ultra-linear quality output tfr. Basic amplifier kit price £9.19.6. Carr. 7/6. Ready built 1 1/2 gns.
2-VALVE PRE-AMP. UNIT
 Based on Mullard's famous 2-valve (2 x EF86) circuit with full equalisation with volume, bass, treble, and 5-position selector switch. Size 9" x 6" x 2 1/2". Ready built, wired and tested, £7.19.6. Carr. 3/6.

ALUMIN. CHASSIS. 18 g. Plain Undrilled folded 4 sides, 2in. deep, 6in. x 4in., 4/6; 8in. x 6in., 5/9; 10in. x 7in., 6/9; 12in. x 6in., 7/6; 12in. x 8in., 8/6, etc.
ALUMIN. SHEET. 18g. 6in. x 6in. 1/-; 6in. x 9in., 1/6; 6in. x 12in. 2/-; 12in. x 12in., 4/6 ea.

Jack Plugs. Standard 2 1/2" Igranite Type, 2/6. Screened Ditto, 3/3. Miniature scr. 1 1/2", 2/3. Sub-min., 1/3.
Jack Sockets. Open Igranite Moulded Type, 3/6. Closed Ditto, 4/-. Mixture Closed Type, 1/6. Sub-min. (deaf aid) ditto, 1/6. Stereo Jack Sockets, 3/6. Stereo Jack Plugs, 3/6.
Phono Plugs, 9d. Phono Sockets (open), 9d. Ditto (closed), 1/-. Twin Phono Sockets (open), 1/3.

GREAT REPAIR AID

helps you earn more



2 Volumes of vital time-saving data for nearly 900 Popular Models

Now you can have at your fingertips Circuits and Data for repairing all the popular TV's, Radios, 'Grams, Record players and Tape recorders—right back to 1964. A guaranteed money-spinner . . . saves your time, increases your earning-power!

Compiled by a team of research engineers Newnes RADIO & TV SERVICING not only gives repair information for nearly 60 principal makes but also includes section of latest developments in the industry. Thousands upon thousands of copies of previous editions sold—it's the most sought-after publication in the trade. Seize this opportunity to see it on free trial while sets are available. Send Now!

**TELEVISION • RADIO • RECORD REPRODUCERS
RADIOGRAMS • CAR RADIOS • TAPE RECORDERS**

All these makes covered—Alba, Baird, Bush, Carousel, Cossor, Dansette, Decca, Defiant, Dynaport, Dynatron, E.A.R., E.M.I., Ekco, Elizabethan, Ever Ready, Ferguson, Ferranti, Fidelity, G.E.C., Grundig, H.M.V., Hitachi, Invicta, Kolster-Brandes, McMichael, Magnavox, Marconiphone, Masteradio, Motorola, Murphy, National, Newmatic, Pam, Perdio, Peto-Scott, Philips, Playcraft, Portadyne, Pye, Radiomobile, Regentone, Revelation, R.G.D., Roberts' Radio, S.T.C., Sanyo, Sharp, Sinclair, Smiths' Radiomobile, Sobell, Sound, Standard, Stella, Stereosound, Teletron, Thorn, Trans Arena, Ultra, Zenith.

**OVER 1,000 PAGES • NEARLY 1,400 CIRCUITS
COMPONENT LAYOUT DIAGRAMS AND DRAWINGS**

USE IT FOR A WEEK FREE

BUCKINGHAM PRESS LTD., 15-17 LONG ACRE, LONDON, WC2

If under 21 your father must fill up this coupon.

Please send RADIO & TV SERVICING (2 Volumes, 1964-66 Models) without obligation to buy. If you accept this application I will post 15/- deposit 8 days after receipt of books, then 15/- monthly for 10 months, paying £8 5s. in all—or return the books. Cash in 8 days £8 5s.
Free trial applies G.B. For Eire & N. Ireland send cash price (refundable if title returned in 8 days).

Full Name
(BLOCK LETTERS) (Mr., Mrs., Miss)

Address

Occupation

Signature 100/2247

Tick ✓ where applicable

The address on left is—

My Property	<input type="checkbox"/>
Rented unfurnished	<input type="checkbox"/>
Parents' Home	<input type="checkbox"/>
Furnished Accom.	<input type="checkbox"/>
Temporary Address	<input type="checkbox"/>

NEWNES Radio & TV Servicing

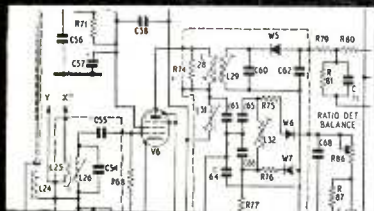

CIRCUITS • DATA

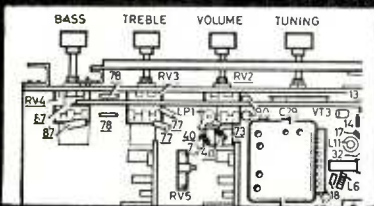

REPAIR HINTS

Any holes in your knowledge of TRANSISTORS?

Whatever your interest in transistor circuitry, you will find the Mullard "Reference Manual of Transistor Circuits" and "Transistor Radios—Circuitry and Servicing", valuable sources of reference.

The former describes more than sixty circuits for both domestic and industrial applications.

The latter is an introduction to the subject and describes the basic properties of semiconductors, their function, elementary circuitry and servicing.

REFERENCE
MANUAL OF
TRANSISTOR
CIRCUITS
U.K. PRICE
12/6
Post extra 1/-

TRANSISTOR
RADIOS
Circuitry and
Servicing
U.K. PRICE
5/-
Post extra 6d.



Get your copies from your radio dealer, or send remittance with order to:

MULLARD LTD · MULLARD HOUSE · TORRINGTON PLACE · LONDON WC1

JACKSON

the big name in PRECISION components

MINIATURE AIR TRIMMER

Jackson type C16 is a robust air di-electric trimmer of very small size. Suitable for use in high grade equipment. The standard component is designed for mounting on its base by two 10 BA (.07") clearance holes; two other forms provide for printed-circuit mounting, 9/6.



Actual Size

- ★ Capacitance: 2.7–7.5 pF., 3–8 pF., 3–11.5 pF.
- ★ Air gap 0.0075 in.
- ★ Length back to front 0.4 in. to 0.58 in.
- ★ End area 0.375 in. square
- ★ Silver-plated brass vanes
- ★ Siliconged ceramic insulation
- ★ Beryllium copper rotor spring
- ★ Temperature coefficient + 50 p.p.m. per deg. C.

Made in England

Write for literature
JACKSON BROS. (LONDON), LTD.
(Dept. R.C.) KINGSWAY-WADDON, CROYDON,
SURREY

Phone: Croydon 2754-5 Grams: Walfilco, Souphone, London

THE WORD **MAXI-Q** IS THE REGISTERED
TRADE MARK
OF DENCO (CLACTON) LIMITED
IT IS ALSO A GUARANTEE OF
WORKMANSHIP AND
TECHNICAL PERFORMANCE

OUR RANGE OF PRODUCTS IS SO GREAT THAT WE NOW HAVE TO REQUEST THE AMOUNT OF 2s. 0d. FOR OUR GENERAL CATALOGUE AND TO SAVE YOU POSTAL ORDER POUNDAGE CHARGE WE REQUEST SEND 2s. 0d. IN STAMPS.

IN RESPONSE TO CONTINUOUS DEMAND we have commenced production of Self-Contained Multiplex Decoder Unit, aligned ready for immediate use, that will convert your two receivers—tuner and two amplifiers—tuner and stereo amplifier or stereo receiver without Multiplex provision to a complete B.B.C. Stereo Broadcast Reception Unit. Price £8.0.0, post paid. Technical Publication MD1, 4s. 0d., post paid.

IFT.11/465 kc/s centre tapped transformer for use in crystal filter circuits, $1\frac{1}{8}$ " x $\frac{1}{8}$ " square. 10s. 6d. plus 8d. post.

IFT.18/465 kc/s and 1.6 Mc/s Double Tuned transistor transformer $1\frac{1}{2}$ " x $\frac{1}{2}$ " square. 10s. 6d., plus 8d. post.

Please send S.A.E. with all enquiries. General Catalogue 2s. 0d.

DENCO (CLACTON) LTD.

(DEPT. R.C.)

357/9 OLD ROAD, CLACTON-ON-SEA, ESSEX

UNIQUE OPPORTUNITY

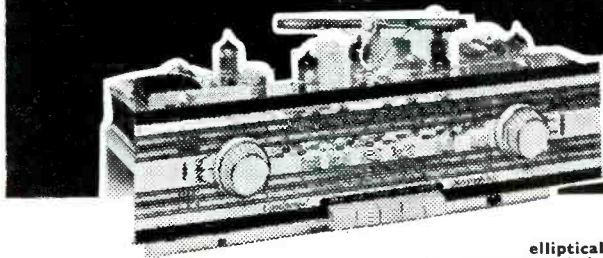

TO PURCHASE STEREOPHONIC RADIOGRAM CHASSIS

Magnificent Stereophonic Radiogram Chassis complete with two 10" elliptical loudspeakers, plus a Mono/Stereo 4-speed automatic record changer.

Only £29.19.6

- ★ Easily fitted
- ★ No soldering or Technical knowledge necessary
- ★ Fits almost any cabinet with minimum trouble
- ★ Modernises your old radiogram
- ★ Built-in ferrite rod aerial
- ★ Piano key switching
- ★ Luxembourg and Caroline received at full strength
- ★ Listen to U.S.A., Russia, Africa, Canada and even Australia
- ★ Unique Lewis Radio 365 day guarantee, even on all the valves
- ★ All British make

SPECIAL terms available of £7.10.0 deposit followed by 18 monthly payments of £1.9.1 (total H.P. £33.13.6) + postage and packing 15/- extra.

INDIVIDUAL CABINETS SUPPLIED ON REQUEST

Send your cheque or P.O. today for £8.5.0 while stocks last to Dept. RC. 56

LEWIS radio

LEWIS RADIO, 100, CHASE SIDE, SOUTHGATE
LONDON, N. 14. Telephone: PAL 3733/9666

AMATEUR RADIO
CHAS. H. YOUNG LTD.

MIDLAND AGENTS FOR

- ★ EDDYSTONE RECEIVERS & COMPONENTS
- ★ NATIONAL RECEIVERS & TRANSCEIVERS
- ★ GREEN & DAVIS EQUIPMENT
- ★ KW EQUIPMENT
- ★ MOSLEY AERIALS
- ★ WITHERS
- H.P. FACILITIES AVAILABLE
- PART EXCHANGES

AERIAL EQUIPMENT

TWIN FEEDER. 300 ohm twin ribbon feeder similar K25, 6d. per yard. 75 ohm twin feeder, 6d. per yard. Post on above feeders and cable, 2/- any length.

COPPER WIRE, 14G, H/D, 140ft, 25/-; 70ft, 13/- . Post and packing 3/3. Other lengths pro rata.

FEEDER SPREADERS. 6" Ceramic type F.S., 10d. each. Postage 2/6 up to 12.

CERAMIC CENTRE PIECE for dipoles, Type AT, 1/6 each. P. & P. 1/-.

2 METRE BEAM, 5 ELEMENT W.S. YAGI. Complete in box with 1" to 2 1/2" masthead bracket. Price 49/- . P. & P. 4/-.

SUPER AERAXIAL, 70/80 ohm coax, 300 watt very low loss, 1/11 per yard. 50 ohm 300 watt, 2/- per yard. P. & P. 2/6.

TOUGH POLYTHENE LINE, type MLI (100lb), 2d. per yd. or 12/6 per 100 yds. Type ML2 (220lb), 4d. per yd. or 25/- per 100 yds., ML4 (400lb), 6d. per yd. Ideal for Guys, L.W. Supports, Halyards, etc. Postage 1/6 on all line.

ABSORPTION WAVEMETERS. 3.00 to 35.00 Mc/s in 3 Switched Bands. 3.5, 7, 14, 21 and 28 Mc/s. Ham Bands marked on scale. Complete with indicator bulb. A MUST for any Ham Shack. ONLY 25/- EACH. Post free.

BANDCHECKER MONITOR, 3.00-35.00 Mc/s in 3 switched Bands. 0-1mA Indicator. Monitor Socket. Very sensitive, £3.13.6. P. & P. 3/6.

VARIABLE CONDENSERS. All brass with ceramic end plates and ball race bearings. 50pF, 5/9; 100, 6/6; 160, 7/6; 240, 8/6; and 300pF, 10/6. Extension for ganging. P. & P. 2/-.

RACK MOUNTING PANELS: 19" x 5 1/2", 7", 8 1/2", or 10 1/2", black crackle finish, 5/9, 6/6, 7/6, 9/- respectively. P. & P. 3/-.

30 WATT MOD. TRANS. 2 x 807 mod. to 807 R.F. Few only, 18/6 each. P. & P. 3/6.

K.W. FROM STOCK

VESPA, £110	PSU. £25
2000, £173	PSU. £32
2000A, £195	PSU. £40

TERMS AND EXCHANGES

CHAS. H. YOUNG LTD

170-172 Corporation St., Birmingham 4

Please print your address. No C.O.D. under £1. 'phone CEN 1635

IF YOU ARE LOOKING for the UNUSUAL

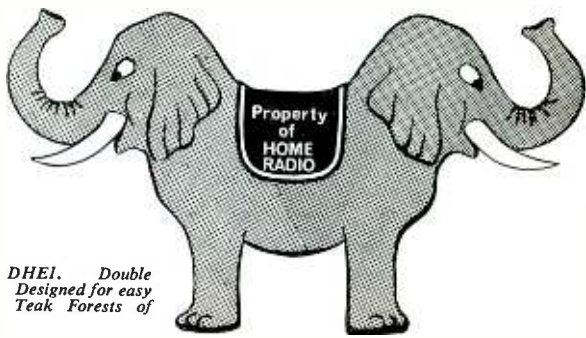

Catalogue No. DHEI. Double Headed Elephant. Designed for easy reversing in the Teak Forests of Mandripore.

... you may find it in our Catalogue. The number of times we hear a customer say "I have been searching everywhere for one of these" leads us to believe that many items which to us are quite standard, may be unusual to many of our customers. May we pin-point a few ...

THERMISTORS

	R53	£1.1.0
Also stocked:	A15	12/6
	A25	12/6
	A54	12/6
	A55	12/6
	R24	£1.1.0

HIGH VOLTAGE RECTIFIERS

	K3/40	9/-
Also stocked:	K3/15	6/-
	K3/50	12/4
	K3/100	£1.0.3
	K3/160	£1.5.6

S.T.C. F.M. CRYSTALS £3.15.0

GANGED STEREO POTS

	10K Log plus 10K A/Log	10/-
	10K plus 10K Log D.P. switch	12/3
Also stocked:	Log or Linear 10K, 25K, 50K, 100K, 250K, 500K, 1M, 2M	10/-
	Log/A Log, 500K, 1M, 2M	10/-
	Log with D.P. switch 500K, 1M	12/3

P.S. We hasten to add that the last two-headed elephant has been sold* but we still have left some excellent catalogues consisting of 210 pages, plus a 21-page supplement, 5800 items (over 900 illustrated). Don't hesitate, send off the coupon and 9/- P.O. or cheque today. Every catalogue contains 5 coupons, each worth a 1/- if used as directed.

*To a politician who wasn't sure which way to go.

RESISTORS

1% 1/2 watt ... 2/-
Most values between 22 Ohms and 10 Meg.

VALVES

TT21 ... £2.8.6

We stock a very comprehensive range of valves, but the following may be considered unusual:—

EN91	18/-	VR105/30	18/6	85A1	£2.11.6
ORP90	£1.6.0	VR150/30	18/6	85A2	15/-
150B2	15/4	6146	£2.0.0	2803U	18/6
150C4	15/9	QVO6/20	£2.8.0	OA2	15/-
5763	£1.0.0			OB2	16/-

TRANSISTORS AND DIODES

AF186	£1.7.6	GET103	7/-	OC76	7/-
AC107	14/6	GET106	17/-	OC77	12/-
BYZ13	11/6	GET111	12/-	OC83	6/-
ASY28	8/6	GET115	9/6	OC84	8/-
GEX66	15/-	(also matched pairs of GET115)		SVC1	18/-
OA5	6/-	GET116	17/-	OAZ222	£1.0.6
OA10	8/-			OAZ223	17/6
OA85	3/-			OAZ224	14/-

Well there they are, but if on the other hand you require all the usual items, Resistors, Condensers, Coils, Transformers, etc., they are all in the Catalogue too, clearly indexed and priced.

Please write your Name and Address in block capitals

Name

Address

.....

.....

.....

Home Radio Ltd., Dept. RC, 187 London Road, Mitcham, Surrey

THE Radio Constructor



Incorporating THE RADIO AMATEUR

MAY 1966

Vol. 19, No. 10
Published Monthly
(1st of month)

*Editorial and
Advertising Offices*
57 MAIDA VALE LONDON W9

Telephone
CUNningham 6141

Telegrams
Databux, London

First Published
1947

Transistorised Signal Injector, <i>by M. C. Harvey</i>	602
Can Anyone Help?	604
Club Events	604
Improved Power Supply with Excess Current Protection (Suggested Circuit No. 186), <i>by G. A. French</i>	605
Making Glass Conduct	607
Illumination Control using Silicon Controlled Rectifiers, <i>by J. B. Dance, M.Sc.</i>	608
Tape Recorder Auto-Stop, <i>by A. Oliver</i>	610
News and Comment	612
The Esso Fuel Cell and Radio Kit	614
Understanding Radio, <i>by W. G. Morley</i> (The Functioning of Valve Oscillators)	616
Using N.P.N. Transistors in Class A Amplifiers, <i>by Sir Douglas Hall, K.C.M.G., M.A.(Oxon)</i>	621
Getting Tape Recording Straight, <i>by D. M. Yearsley</i>	624
Inexpensive Photographic Timer, <i>by H. T. Kitchen</i> (Cover Feature)	628
Simple Stabilised Power Supply, <i>by J. T. Tiernan</i>	631
Simple Calibration Aid, <i>by G. Henshaw</i>	633
In Your Workshop	634
Transistorised A.C. Millivoltmeter, Part 2, <i>by H. Smith and D. L. Woolley, B.Sc.</i>	639
Ground Resistance Meter for the Archaeologist, <i>by S. G. Bullas</i>	645
Radio Topics, <i>by Recorder</i>	648

© Data Publications Ltd., 1966. Contents may only be reproduced after obtaining prior permission from the Editor. Short abstracts or references are allowable provided acknowledgement of source is given.

Annual Subscription 33s. (U.S.A. and Canada \$5) including postage. Remittances should be made payable to "Data Publications Ltd". Overseas readers please pay by cheque or International Money Order.

Published in Great Britain by the Proprietors and Publishers Data Publications Ltd. 57 Maida Vale London W9
Printed by A. Quick & Co. (Printers) Ltd. Clacton-on-Sea England

TRANSISTORISED SIGNAL INJECTOR

By M. C. Harvey

A simple constructional project having particular appeal for the beginner

MOST RADIO CONSTRUCTORS HAVE their own signal generators, these being either commercially purchased or home-built and, in both cases, accurate enough for the alignment of sound radio receivers. However, the writer feels that it is also necessary to have a small self-contained transistorised signal injector, this being inexpensive

to build and very useful for radio servicing. The normal service job should not require a calibrated signal generator to find the section of any sound receiver which is at fault.

The simplicity of the present circuit is due to the fact that no switching is required to control the output frequency. The waveform produced is rich in harmonics, and this enables it to be used for testing any stage between the aerial and the output stages of the receiver.

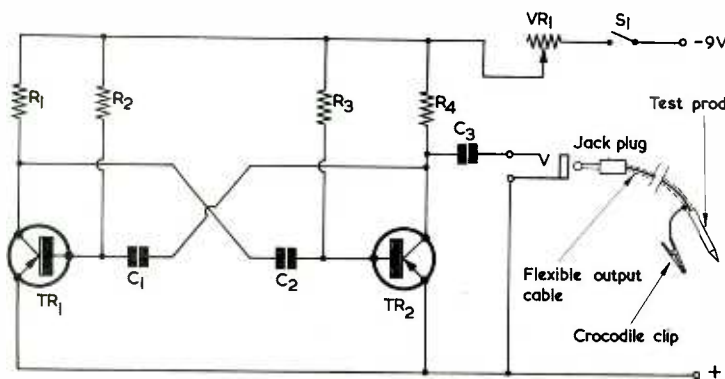

Fig. 1. The circuit of the signal injector. S_1 is ganged with VR_1

The Circuit

The circuit of the signal injector is shown in Fig. 1. It was decided to use an astable multivibrator circuit, which is a free-running relaxation oscillator. Such a circuit has two unstable states and automatically switches from one to other continuously without any external triggering. The supply voltage is 9 volts using a PP3 battery, and the current consumption is about 4mA only at full output.

The transistors used in the circuit are two OC71's, but almost any pair of a.f. transistors will work just as well.

The frequency-determining components in the circuit are C_1 , C_2 ,

Components List

Resistors

(All fixed values $\frac{1}{8}$ watt 20%)

R_1 1.2k Ω

R_2 22k Ω

R_3 22k Ω

R_4 1.2k Ω

VR_1 10k Ω potentiometer, edge operated, ganged with S_1 . (See text)

Capacitors

(Note: All capacitors may be miniature types, but C_3 must be 350V wkg.)

C_1 0.1 μ F

C_2 0.1 μ F

C_3 0.005 μ F

Transistors

TR_1 OC71

TR_2 OC71

Miscellaneous

2 x 8 way tagboard, 4 x 2.5in (See Fig. 3)

Miniature jack socket and plug
9-volt PP3 battery and connecting clips

Crocodile clip

Test prod

Screened output cable

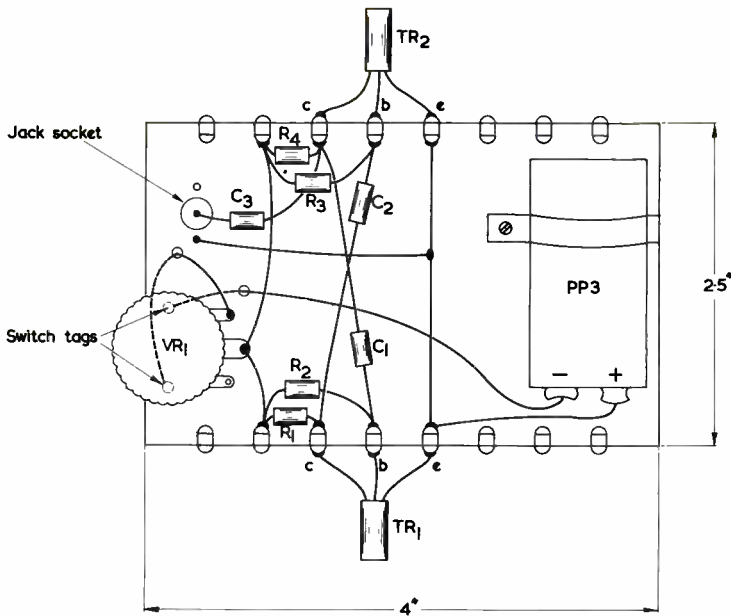

Fig. 2. Component layout and wiring

R_2 and R_3 , and these cause the output square wave to have a basic frequency at a.f.¹

Construction and Testing

The wiring and general layout of the circuit is fairly simple, as shown in Fig. 2. Drilling dimensions for the tagboard are given in Fig. 3. In this diagram, holes A are for two screws securing the tagboard to the rear of the case, whilst holes B accept two screws holding together the front and rear sections of the case. Hole C is for the battery securing bolt and hole D for the output jack socket. Holes E are for the wires to the on/off switch tags. The on/off switch is integral with the output control VR_1 , and this component is mounted by passing the switch tags through two further holes drilled in the tagboard, the tags then being twisted to prevent the switch coming away from the board. The connections to the switch are made on the reverse (non-tag) side of the board, and the two wires brought through the E holes close to the control. It is possible that constructors may not be able to obtain a combined potentiometer and switch with the same tag positions as were given on

¹ This will be of the order of 330 c/s. —EDITOR.

the writer's component but it should not prove difficult, in such a case, to devise an alternative means of mounting the component to the tagboard. The control should be wired so that maximum potentiometer resistance is inserted into circuit when the control is switched off.²

The battery is secured by a metal strip which is bolted to the tagboard. When wiring is completed the transistors are bent over towards the centre of the board, so as to make the unit as compact as possible. Care should be taken when soldering the transistors to the tags because they can be easily damaged. The lead-out wires should not be less than $\frac{1}{8}$ in long and a heat shunt must always be used during soldering.

The output from the signal injector is taken by way of a miniature jack socket and plug. The jack socket projects from the reverse side of the board. Screened cable is connected

² A potentiometer with a linear track would probably be preferable here, but adequate results should be given by the more readily obtainable (in edge-operated controls) log or semi-log tracks.—EDITOR.

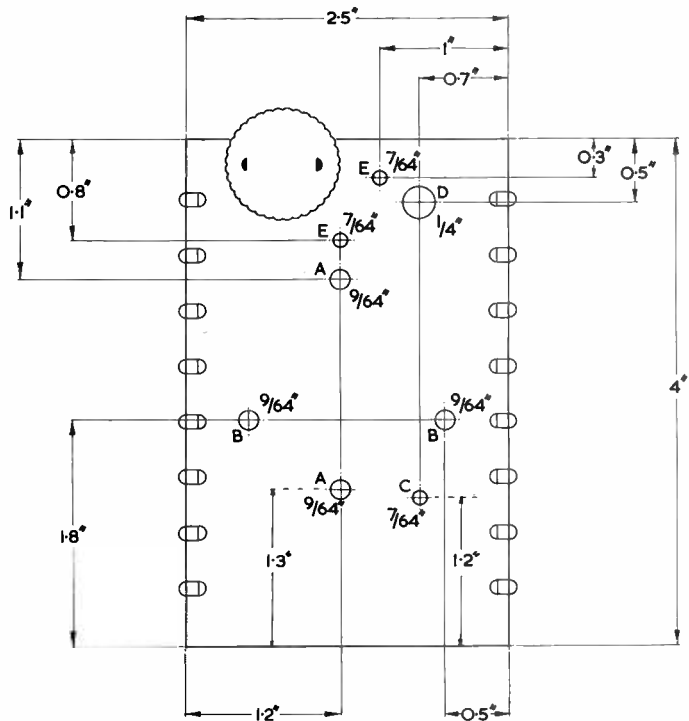

Fig. 3. The dimensions of the tagboard. The functions provided by the various holes are described in the text

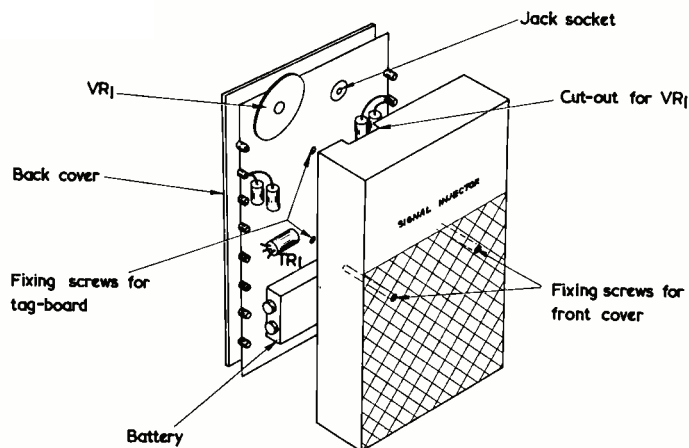

Fig. 4. Mounting the signal injector in a home-built case. This fits snugly around the tagboard, and the front cover has an internal depth of 1in

to the jack plug with the screening terminated by a crocodile clip and the inner cable terminated by a test probe.

A plastic case was used to house the writer's signal injector, although a small home-built wooden case would do just as well. The case may be made in two parts, these being bolted together with the tagboard fixed to the rear section. See Fig. 4.

The operation of the signal injector is quite straightforward. The crocodile clip on the output lead is connected to the chassis of the receiver being tested, whilst the probe is applied to the valve grid or transistor base, as applicable, of any selected stage in the receiver. The output control of the signal injector is then advanced whereupon, if all stages following the point of application are satisfactory, an audible tone should be heard from the speaker.

CAN ANYONE HELP?

Requests for information are inserted in this feature free of charge, subject to space being available. Users of this service undertake to acknowledge all letters, etc., received and to reimburse all reasonable expenses incurred by correspondents. Circuits, manuals, service sheets, etc., lent by readers must be returned in good condition within a reasonable period of time

Reflectograph Tape Recorder.—P. Proto, Sunningdale, 13 Cefn Coed Road, Cardiff—service diagram for model RR 102/104/57, purchase or loan.

* * *

Signal Generator Type 106.—J. Ganci, 110a Gafa Street, Mosta, Malta—instruction manual, circuit, or any other information.

* * *

Electronic Flashgun.—A. Manville, 30 Kew Gardens, Whitley Bay, Northumberland—circuit for such a unit.

R220 Receiver.—D. L. Richardson, 40 Myers Road East, Crosby, Liverpool 23—conversion details from crystal control to tuneable.

* * *

Ekco 368P TV.—B. J. O'Neill, 4 Greenview Place Antrim, Co. Antrim, N. Ireland—circuit or manual.

* * *

Oscilloscope TS-34.—R. Duncan, 17 East Lodge, Catisfield, Fareham, Hants—circuit diagram of this ex-U.S. Navy portable single beam instrument; thought to be equivalent to 110SB/46.

Club Events

Ipswich Radio Club

Hon. Sec.: J. Rhind, 67 Rosecroft Road, Ipswich, Suffolk.
Regular monthly meetings are held on the last Wednesday of each month at Gippeswyk Hall, Ipswich, at 7.30 p.m. A full programme is planned for the year and all are welcome to attend meetings.

Mid-Warwickshire Amateur Radio Society

Hon. Sec.: K. J. Young, 180 Northumberland Court, Leamington Spa, Works.

May 2nd—Single Sideband Telephony, L. White, G3LIW

May 16th—Safety in the Shack, N. Read, BRS1894

"Northern Heights" Amateur Radio Society

Hon. Sec.: A. Robinson, G3MDW, Candy Cabin, Ogden, Halifax, Yorks.

May 11th—Sale of Surplus Equipment

May 25th—Going Mobile, H. Brook, G3GJV

Basildon and District Amateur Radio Society

Hon. Sec.: J. Barker, G3IJB, Milestone Cottage, London Road, Wickford, Essex.

May 3rd—Social

May 19th—NFD Discussion—Mayflower Restaurant (adjacent to the Van Gogh, Paycocke Road, Basildon)

Melton Mowbray Amateur Radio Society

Hon. Sec.: D. W. Lilley, G3FDF, 23 Melton Road, Ashfordby Hill, Melton Mowbray, Leics.

May 19th—Electron Tubes—tape recorded lecture illustrated with slides, 7.30 p.m.

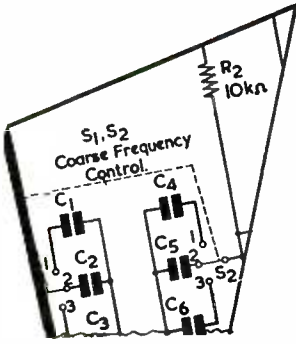

Improved Power Supply With Excess Current Protection

SUGGESTED CIRCUIT No. 186

By G. A. FRENCH

IN SUGGESTED CIRCUIT NO. 185, published in last month's issue, the writer described a power supply circuit for experimental work with transistors. This offered a continuously variable output voltage ranging from slightly in excess of zero up to about 12 volts, and it had the special feature that it was impossible to draw more than a specified maximum current from it. If the specified maximum current was drawn the output dropped instantaneously to zero volts.

The basis of the circuit rested on the fact that a rectified voltage considerably higher than 12 volts was initially produced, this being fed to the output terminals via a series limiting resistor having a value which caused the specified maximum current to flow when the output terminals were short-circuited. Thus, it was impossible for a greater current to be drawn from the unit. Connected across the output terminals was a voltage stabilising device which maintained the output voltage at a reasonably fixed level for all currents below the specified maximum. The stabilising device consisted of a power transistor type OC26 connected as an emitter follower with its base coupled to a continuously variable reference voltage.

Whilst the circuit described last month represented a perfectly useful and reliable item of bench equipment, the voltage regulation of the output was a little poor. Since the article went to press the author has carried out further work on the power supply to improve this feature, and now presents a new circuit which incorporates all the advantages of the previous one and which has, in addition, considerably better regulation. Readers who

have built units employing the previous circuit will find that only slight changes are required to obtain the enhanced performance.

The Circuit

The circuit of the improved power supply is shown in Fig. 1. This is the same as the circuit given in Fig. 2 of last month's article with the exception that a second transistor, TR₂, has been introduced. In the previous circuit the slider of R₂ connected direct to the base of TR₁, as shown in Fig. 2.

It will be helpful here to give a brief description of the operation of the previous circuit, and this may be followed by assuming that

the circuit illustrated in Fig. 2 replaces that shown around TR₂ in Fig. 1. A stabilised voltage appears across zener diode D₃ and, in consequence, across R₂. Potentiometer R₂ is the output voltage control and the reference voltage tapped off by its slider is passed (in the previous circuit) to the base of TR₁. TR₁ functions as an emitter follower, the voltage on its emitter being slightly positive of that applied to its base. As a result, a voltage slightly higher than that at the slider of R₂ is given at the positive output terminal. Current selector switch S₂ selects R₄ on its own, R₄ in series with R₅, or R₄, R₅ and R₆ in series,

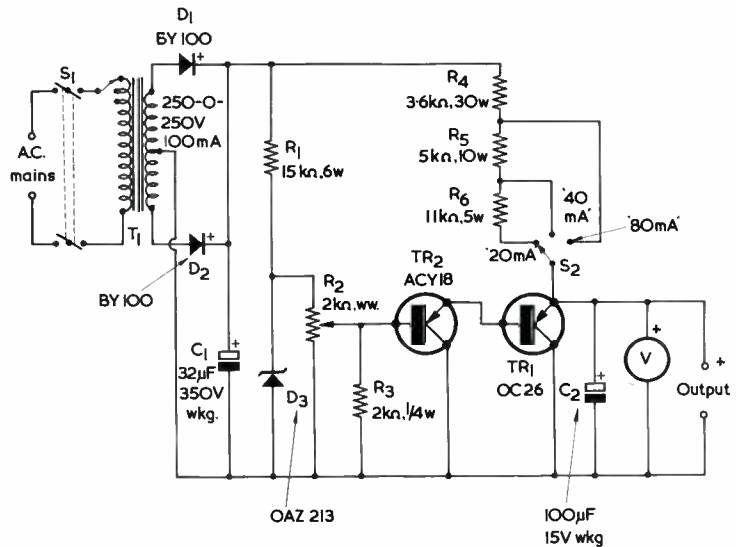

Fig. 1. The circuit of the new, improved, power supply. This is the same as Fig. 2 in last month's Suggested Circuit article, with the exception that TR₂ is interposed between the slider of R₂ and TR₁. The additional current gain offered by TR₂ provides a considerable improvement in output regulation

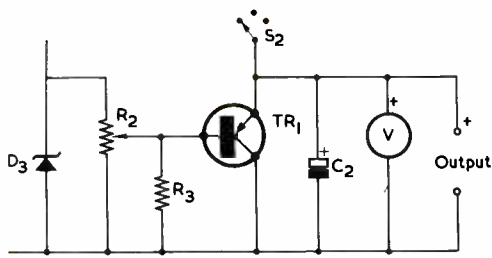

Fig. 2. In the previous circuit, the slider of R_2 coupled directly to the base of TR_1

these resistors having values which ensure that currents in excess of 80mA, 40mA and 20mA respectively cannot flow in the output circuit.

The output voltage is measured by the optional voltmeter shown in the diagrams. The resistor R_3 is a "safety resistor" which ensures (again, in the previous circuit) that adequate base current flows in TR_1 if the slider of potentiometer R_2 momentarily loses contact with its track. Without R_3 in circuit the base of TR_1 would then become open-circuit, an excessively large voltage would appear across its collector and emitter and, in company with any components connected to the output terminals, it would very probably suffer damage. A number of further points apply to the previous circuit arrangement, and these were all dealt with fully in last month's issue.

Turning, now, to the present, improved circuit, operation follows the same lines, except that TR_2 is interposed between R_2 and TR_1 . TR_2 is also an emitter follower, the voltage on its emitter being passed to the base of TR_1 . What occurs now is that the voltage on the emitter of TR_2 is slightly positive of that tapped off by the slider of R_2 . This voltage is passed to the base of TR_1 , whose emitter is, in its turn, slightly positive of the voltage on TR_1 base. Thus, the positive output terminal is positive of the voltage tapped off by the slider of R_2 by the small voltage appearing across the base-emitter junctions of TR_2 and TR_1 . It follows that the output voltage may be varied by adjusting R_2 .

Previously, base current in TR_1 flowed through the voltage control potentiometer circuit, whereupon excessive resistance here was reflected by a correspondingly high regulation resistance in the output. With the improved circuit of Fig. 1, however, nearly all the base current for TR_1

flows through the collector-emitter circuit of TR_2 . Due to the current amplification offered by TR_2 , a much smaller base current flows through the voltage control potentiometer. In consequence, resistance in the potentiometer circuit has much less effect on output voltage regulation, and the latter is very considerably improved. As may be gathered, all that is needed to modify last month's Fig. 2 is to add TR_2 between the slider of R_2 and the base of TR_1 . All other components remain unaltered. It will be noted that R_3 , the "safety resistor", now connects to the base of TR_2 , where it carries out the same function as before. If, with the present circuit, there are momentary disconnections between the slider of R_2 and its track, R_3 holds the base of TR_2 close to chassis potential and TR_2 , in its turn, holds the base of TR_1 close to chassis potential.

Transistor TR_1 can be any small p.n.p. transistor having a maximum collector-emitter voltage rating greater than 15 volts or so. The improvement in output regulation is roughly in proportion to the gain of TR_2 , and it is desirable to choose a high gain transistor here. Apart from these points, the transistor type needed in the TR_2 position is not at all critical, and the writer checked the improved circuit with an ACY18 which happened to be at hand, and which functioned quite satisfactorily.

Increased Output Current

The fact that resistance in the voltage control potentiometer circuit now has much less effect on output regulation means that it is possible to reduce current in the zener diode and potentiometer, and allow more current to become available for the output. The circuit of Fig. 1 enables output currents up to some 80mA to be obtained from a mains transformer with a 100mA h.t. secondary. By changing the associated component values to those shown in Fig. 3, it becomes possible to draw output currents up to some 90mA from a 100mA h.t. secondary. R_1 and R_2 in Fig. 3 are both increased in value, resulting in a standing current through R_1 of around 8mA. R_3 is also increased in value, but it still functions adequately as a "safety resistor" due to the current gain afforded by TR_2 .

Since the maximum output current is now 90mA, the value of limiter resistor R_4 is reduced from 3.6

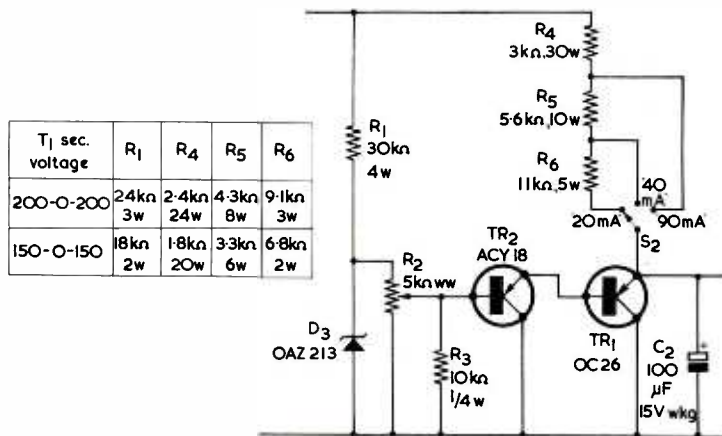

Fig. 3. The current gain afforded by TR_2 in the new circuit arrangement enables voltage control potentiometer current to be reduced, whereupon increased current is available for the output. The component values shown here allow a maximum output current of 90mA to be obtained from a 100mA h.t. secondary

to $3k\Omega$ and the high-current setting of S_2 becomes "90mA" instead of "80mA". As was explained last month, the remaining settings of S_2 may vary from those illustrated here, the constructor selecting series resistor values to suit. As was also explained in the previous article, the circuit will function with mains transformers offering secondary voltages of 200-0-200 and 150-0-150 at 100mA, and suggested values for R_1 , R_4 , R_5 and R_6 with such secondaries are given in the table in Fig. 3. All values specified in Fig. 3 for R_4 , R_5 and R_6 may require slight adjustment to suit differing mains transformer characteristics, although the changes involved should only be small.

Fig. 4 shows regulation curves obtained with the author's prototype circuit, using the component values shown in Fig. 3 and with S_2 set to "90mA". For 3 volts and above, all curves show negligible fall in voltage up to 85mA, after which they change over fairly rapidly to the steep slope given by the limiting resistance, falling rapidly to zero volts at 92mA. The available collector-emitter operating voltage for TR_1 and TR_2 becomes rather low for voltages under 3 and the transistors have less control at these

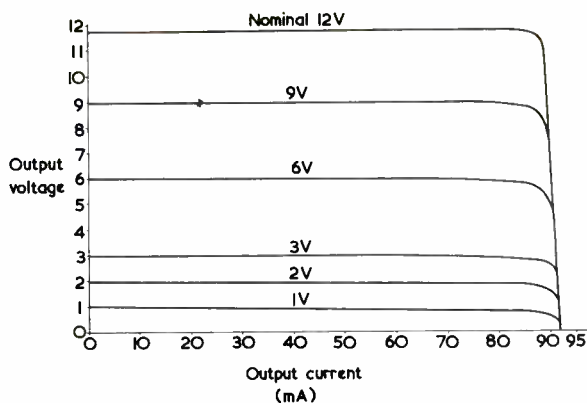

Fig. 4. Regulation curves obtained from the prototype using the component values shown in Fig. 3. The curves for 3 volts and above show negligible drop in output voltage for currents up to 85mA.

voltages. The 2 volt curve drops to 1.8 volts at 80mA and the 1 volt curve to slightly less than 0.8 volt at the same current. However, the 2 volt and 1 volt curves still exhibit a relatively flat characteristic after 80mA until they change over to the steep slope given by limiting resistance.

The top curve starts at 11.7 volts, and is designated "Nominal 12V". This curve corresponded

to the case where, in the prototype, the slider of R_2 was at the top of its track. The OAZ213 has a rather wide spread of zener voltage, this being from 9.4 to 15 volts at 1mA, and the particular zener diode employed by the author stabilised at a voltage slightly less than 11.7. Constructors wishing to obtain an output voltage higher than 12 may have to select a suitable diode for the D_3 position.

MAKING GLASS CONDUCT

Details of an experiment which shows that things aren't always what they seem to be!

GLASS IS NORMALLY AN EXCELLENT INSULATOR and the writer was therefore very surprised to learn that it is quite easy to make a current of several amps pass through a quarter inch diameter rod of ordinary "soft" soda glass.

Two coils of copper wire (of a few turns each) are placed on the glass rod about two inches apart and are used as the electrodes. The wires are connected to a power supply of about 250 volts

(a.c. or d.c.) which can supply a few amps via a current limiting resistor such as an electric fire. A 0-5 amp meter may be included in the circuit if desired.

No detectable current will pass at first. If, however, the section of the glass rod between the electrodes is heated to a dull red heat with a bunsen burner flame a current will flow. The bunsen burner can be taken away when the current reaches about one amp, since enough heat will be given out by the flow of current through the rod to raise the temperature further. The glass rod will melt and break the circuit when the current reaches a value of about three amps. A suitable material should be placed under the apparatus to catch the molten glass.

It seems probable that the electrons in the valency band of the glass gain enough energy at dull red heat to enable appreciable numbers of them to jump out of the valency band into the conduction band where they can carry the current. Although the current first becomes appreciable at about the temperature at which the glass commences to soften, it seems unlikely that the action is an electrolytic one, since no chemical action has been observed at the electrodes.

Illumination Control using Silicon Controlled Rectifiers

By J. B. Dance, M.Sc.

PERHAPS THE ONLY DISADVANTAGE OF ELECTRIC lighting when compared with the gas lighting of the past is that it is not easy to alter the brilliance of an electric lamp which derives its power from the mains. The provision of lamp dimming circuits is convenient for the home, and is essential for stage lighting, and similar applications.

In many dimming systems a variable resistor is placed in series with the lamp, but if the power level is high the resistor must be large in size and it develops much heat. In addition, quite a large fraction of the power input is wasted when the lamp is not operating at full brilliance. Another method of controlling the power dissipation in a lamp involves the use of a continuously variable transformer (such as a "Variac"), but transformers of this type are heavy, bulky, and relatively expensive items. These difficulties can, to a large extent, be eliminated by the use of silicon controlled rectifier dimming circuits.

The Silicon Controlled Rectifier

The silicon controlled rectifier is a p.n.p.n. device; it is also known as a thyristor. The anode is the outer p layer and the cathode the outer n layer. (See Fig. 1.) A third electrode known as the gate is connected to the inner p layer and is used as a triggering electrode.

The silicon controlled rectifier always exhibits a very high reverse resistance, but the forward resistance is either very high or very low. When a small forward voltage is applied between the anode and cathode (with the gate electrode unconnected), the resistance is very large. This is to be expected, since the central junction is reverse biased, although the two outer junctions are forward biased. As the applied forward voltage is increased, a point is

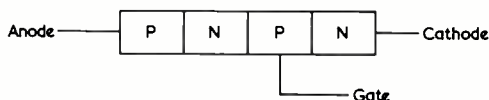

Fig. 1. The silicon controlled rectifier

reached at which the reverse biased central junction breaks down and quite suddenly the forward resistance of the device becomes very small. The voltage which must be applied to cause the device to switch to its highly conducting state is known as the "breakover voltage". A resistor must always be employed in series with the device; when the latter switches to its low resistance state, the voltage across it therefore falls. The silicon controlled rectifier will remain in its low resistance state until the current passing is reduced below a value known as the "holding current".

In many circuits the silicon controlled rectifier is used with an applied forward voltage which is less than the breakover voltage. The device is switched to the conducting state by feeding a current pulse into the gating electrode. If the power supply is alternating or if a rectified but unsmoothed power supply voltage is used, the device returns to its high resistance state when the potential across it momentarily falls to zero.

Circuit Operation

A lamp dimming circuit designed by Standard Telephones & Cables is shown in Fig. 2. The components L_1 and C_2 are included only for the purpose of suppressing radio interference. The rapid switching of the silicon controlled rectifier generates sharp current peaks which would cause interference if they were not eliminated by the low pass filter L_1C_2 .

If the silicon controlled rectifier is in the low resistance state, the point B is effectively connected directly to the point D. The bridge rectifier is connected in series with the lamp across the mains. If the point B is effectively connected to the point D via the silicon controlled rectifier, a current will pass through the lamp to the bridge and the rectified current will pass through the silicon controlled rectifier. The path of this current is shown by the thick lines of Fig. 2. When, however, the silicon controlled rectifier is in its high resistance state, the load on the bridge circuit is very small and little current will flow through the lamp to the bridge.

The average power dissipated in the lamp (and hence its brilliance) can be controlled by varying the ratio of the time during which the silicon controlled rectifier is conducting to the time during which it is in its high resistance state. If the silicon controlled rectifier is switched on and off many times per second, the brilliance of the lamp may be altered by changing the ratio of on/off time. In the circuit of Fig. 2, the lamp is switched on and off once per half-cycle of the mains frequency.

The p.n.p. transistor TR_1 and the n.p.n. transistor TR_2 are connected together in a feedback circuit so that they effectively behave as a single p.n.p.n. device. If the emitter of TR_1 is made very slightly positive with respect to the base, the two transistors switch to the conducting state in the same way as occurs with a silicon controlled rectifier.

During any half-cycle of the mains supply voltage, the capacitor C_1 charges through R_1 , R_2

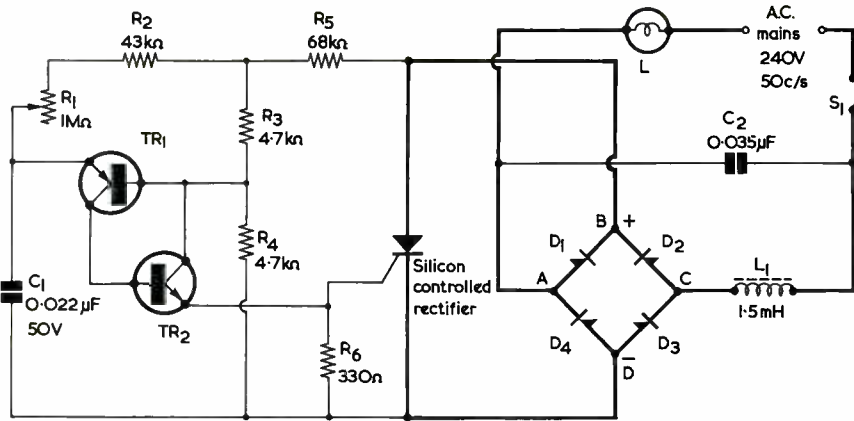

Fig. 2. Lamp dimming circuit using a silicon controlled rectifier

Components List (Fig. 2)

Resistors

- R₁ 1M Ω variable
- R₂ 43k Ω $\frac{1}{8}$ watt, 5%
- R₃ 4.7k Ω $\frac{1}{8}$ watt, 5%
- R₄ 4.7k Ω $\frac{1}{8}$ watt, 5%
- R₅ 68k Ω 2 watt, 10%
- R₆ 330 Ω $\frac{1}{8}$ watt, 10%

Semiconductors

- TR₁ 2S302 (Texas Instruments) or OC200 (Mullard)
- TR₂ BSY95A (S.T.C.)
- SCR CRS3/40AF (S.T.C.)
- D_{1,2,3,4} RAS310AF (S.T.C.)

Switch

- S₁ On-off switch (may be ganged with R₁)

Lamp

- Controlled lamp (see text)

Capacitors

- C₁ 0.022 μ F, 50V wkg.
- C₂ 0.035 μ F, 350V wkg.

Inductor

- L₁ 1.5mH

and R₅. When the voltage across C₁ is great enough, TR₁ and TR₂ are switched to the conducting state and C₁ is thus discharged through the resistor R₆. The pulse which is thereby developed across R₆ is used to switch the silicon controlled rectifier to the conducting state.

The smaller the value of R₁, the shorter the time required from the beginning of any half cycle of the mains frequency for the capacitor C₁ to charge to the voltage at which the transistor circuit conducts. Hence the silicon controlled rectifier is switched to the conducting state earlier in each half cycle if the value of R₁ is small; under these conditions more power will be dissipated in the lamp.

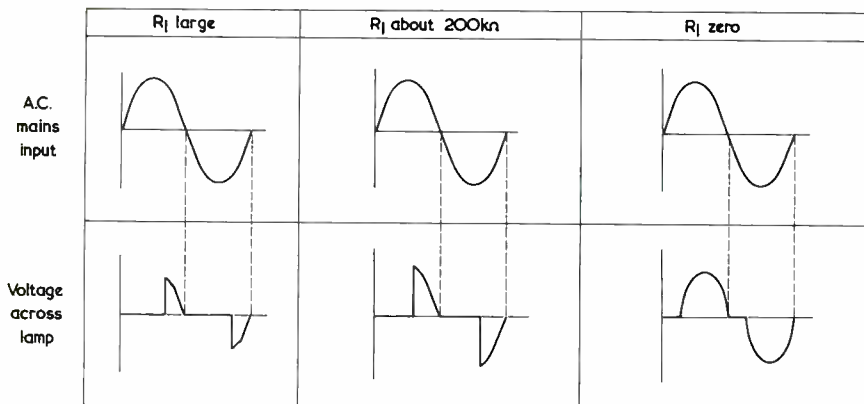

Fig. 3. Waveforms showing the input voltage (above) and the voltage across the lamp (below) for varying values of R₁ in Fig. 2. Decreasing R₁ causes the silicon controlled rectifier to become conductive at an earlier part of the half-cycle

Advantages

The advantages of this type of circuit are the high efficiency, absence of flicker and the fact that if a component should fail, the only effect will be a loss of control.* The power dissipated in the lamp may be varied over a range of about 60:1. When the value of R_1 is small, the power dissipated in the lamp is virtually as great as if it were connected directly across the mains, since the voltage loss is only about 2 volts. At the maximum value of R_1 the lamp is extinguished.

Loading

The silicon controlled rectifier should be mounted on a small aluminium or copper heat sink of dimensions about 2 x 2 x $\frac{1}{8}$ in. The maximum power which may be dissipated in the load is then

* Some silicon controlled rectifier dimming circuits employ the SCR directly in series with the lamp. Under these conditions, SCR control occurs on alternate half-cycles only, and may result in an obvious flickering effect. The use of the bridge rectifier in Fig. 2 ensures that SCR control takes place on all half-cycles and prevents the flicker.—EDITOR.

600 watts at an ambient temperature of 25°C. or 300 watts at an ambient temperature of 80°C. These ratings cannot be increased by using a larger heat sink, since the current is limited by the bridge rectifier diodes. Any type of non-reactive load may be used; for example, the heat output of a soldering iron or of a domestic smoothing iron rated at less than 600 watts may be controlled with this circuit.

Low voltage silicon controlled rectifiers are much cheaper than the type specified for an input of 240 volts a.c. These low voltage types are quite suitable for power control in low voltage circuits.

Acknowledgement

The circuit described in this article has been designed by Standard Telephones & Cables Ltd., Semiconductor Division (Rectifying), and the writer is indebted to this company for providing the requisite information.

Editor's Note

Most of the S.T.C. components referred to in this article may be purchased from: Electronic Services—STC, Edinburgh Way, Harlow, Essex.



Tape Recorder Auto-stop

By A. OLIVER

How to provide automatic switch-off at the end of a tape

AFTER BUILDING AN ECONOMY TAPE RECORDER, using a B.S.R. TD2 deck, for the younger children of the family, the fitting of an auto-stop switch became a "must".

The idea of employing a valve to operate a relay had to be ruled out, because the power pack was fully loaded already. Experiments with the circuit given in Fig. 1 were tried, and these proved entirely successful.

Relay Circuit

A small P.O. relay with a 20Ω coil was used, this having two sets of normally open contacts. It energised with about 1 volt across the coil. The relay contacts were wired in parallel with a microswitch, the latter acting as a start button for the recorder. An a.c. supply was obtained from the centre-tapped 6.3 volt heater winding

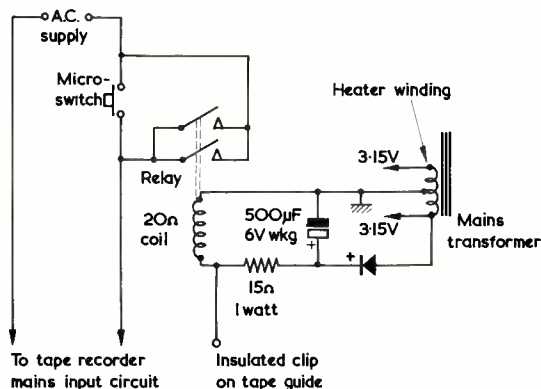

Fig. 1. The circuit of the tape recorder auto-stop

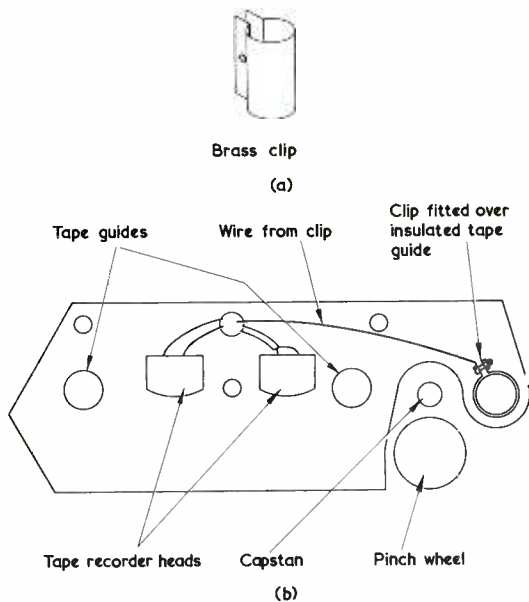

Fig. 2. The operating contact consists of a brass clip (a) fitted over the final guide, as in (b). The guide is insulated by two layers of tape before the clip is fitted

on the mains transformer. The rectifier shown in the diagram can be any low voltage component with a maximum current rating in excess of 300mA.

The final guide on the tape deck was used for the auto-stop operating contact. This was first insulated with two layers of Sellotape, after which a brass clip was fitted over it as shown. See Figs. 2 (a) and (b). The brass clip must be flat, and offer a smooth polished surface to the tape.

The microswitch which functions as start button is fitted with a button in the shape of a "top hat", as illustrated in Fig. 3.

The operation of the circuit is quite simple. To start the recorder the microswitch is closed, applying the a.c. mains to the input circuit of the recorder. This causes an energising voltage to be

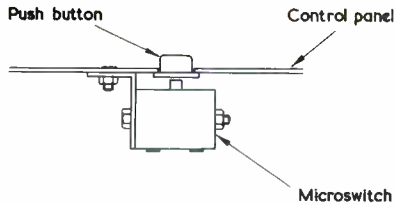

Fig. 3. How the microswitch, which operates as start button, is mounted

applied to the relay, whose contacts close and short-circuit the microswitch. The latter may then be released, as the mains input circuit is now completed by the relay contacts.

When the metal foil at the end of the tape runs through the guides, the insulated brass clip on the final guide is connected to chassis through the other guides. This short-circuits the relay coil. The relay then de-energises, and the mains supply is broken until the start button is pressed again.

The auto-stop was found to work at "record" and "replay" speeds, but not on fast rewind speeds.

Tape Start

It will be seen that the metal foil at the beginning of the tape will also operate the circuit. This could be avoided by holding the start button down until the foil runs through, although there may then be an objectionable noise from the loudspeaker due to the metal foil carrying current as it passes the heads. A remedy is to reduce the effective length of metal foil at the beginning to 1½ in, this being done by splicing or by sticking splicing tape over part of the foil.

In the author's tape recorder the relay, with rectifier and electrolytic capacitor fitted to it, was mounted on the underside of the tape deck.

If desired, the start button could be replaced by a 2-way switch, giving "bypass" as well as "auto-stop". However, this was not done in the author's case, as the primary requirement was to switch the recorder off after being switched on by children, who have a tendency to disappear after a few minutes of listening.

NEXT MONTH IN

THE Radio Constructor

Simple Record Player Amplifier

Transistor Curve Tracer

Tape Accessories without Batteries

NEWS . . . AND



HEAVY DUTY DRILLS WITH STEPLESS SPEED CONTROL

When the principle of stepless speed control by means of the modern semiconductor technique was first introduced in a Skil hobby drill, it was also requested by users of professional tools. Therefore, Skil developed a complete line of heavy duty drills with the Vari-Tour-System, built for continuous professional use. These new tools feature double insulation for extra safety and in addition they are radio suppressed.

Skil's Vari-Tour-System means that every speed range between zero and the tool's maximum r.p.m. is available to the operator. This has been achieved by using a silicon controlled rectifier in the switch circuit. The "electronic brain" works by first changing a.c. to d.c. current and then regulating the duration of the current flow to the motor. By varying finger pressure on the trigger, the operator commands the electronic brain and the tool will run faster or slower.

The widest range of materials can now be drilled, including wood, metal, plastic, composition, stone, by simply changing the r.p.m. to the job requirements.



NEW TELEMIKE

We are pleased to give details of a new product which will be available very shortly—the Amplivox "Telemike".

This is a new hand microphone which will also operate as a two-way unit, i.e. transmit and receive on a single transducer. The colour scheme is an attractive two-tone grey and the case has been carefully tailored to fit snugly in the palm of the hand with the switch button fully accessible for convenient right or left-hand operation.

We are certain that this new microphone will find many applications e.g. for mobile radios and public address systems.

UNITED KINGDOM EURO-OSCAR FUND

The Council of the Radio Society of Great Britain has decided to initiate a United Kingdom Euro-Oscar Fund directed towards collecting donations from United Kingdom amateurs to support the building of two Oscar type satellites by DJ4ZC under the sponsorship of I.A.R.U. Region I. The society has contributed £25 to start the fund.

The European Oscar project began in September 1963 at a meeting of the International Amateur Radio Club in Geneva when the Oscar project leaders offered to arrange for the launch by a U.S. rocket of a satellite constructed by European amateurs. The project was adopted by the International Amateur Radio Union, Region I and the Chairman of the VHF Working Group, Karl Lickfeld, DL3FM, was charged with the responsibility for it. The R.S.G.B. has been closely connected with the project, firstly as it was John Clarricoats, G6CL, then General Secretary of the R.S.G.B., who suggested that Region I I.A.R.U. should be responsible and, secondly because the Society's VHF Manager was appointed to a small steering Committee.

However, for various reasons, progress was almost non-existent for some two years. In the meantime a very talented young German amateur, Karl Meizner, DJ4ZC, had developed and, in 1965, had successfully flown, under Deutsche Amateur Radio Club sponsorship, several 144 Mc/s balloon-borne translators technically similar to the Oscar III satellite which have become known as ARTOB. At a meeting of the I.A.R.C. at Geneva in 1965 D.A.R.C. representatives showed an ARTOB translator, gave details of the results achieved and played tape recordings of actual signals translated by ARTOB. Fortunately the originators of the Oscar project, Bill Eitel, W6UF, and Bill Orr, W6SAI, were present and were very impressed with the achievements of DJ4ZC, to such an extent, that they offered to arrange the launch of a DJ4ZC translator re-engineered to withstand the hazards of launch and the space environment.

Thus the current I.A.R.U. Region I Euro-Oscar project began. DL1XJ, who was in Geneva, took the initiative with the Executive Committee

THE RADIO CONSTRUCTOR

COMMENT

RADIO AIDS FOR 'SIR WINSTON CHURCHILL'

Boys going to sea in the Sail Training Association's 300-ton top-sail schooner, *Sir Winston Churchill*, which has just completed her maiden voyage, will have the use of Marconi Marine radar, echo-sounding, and communications equipment donated to the Association by the English Electric Company and the Marconi Company, through the medium of the Marconi International Marine Co., Ltd., which is also making its contribution to the joint gift.

Marconi Marine's latest transistorised "Raymarc" radar, provides the vessel with radar coverage of distances from a maximum of 48 miles down to less than twenty yards.

Intermediate and high frequency radiotelephone communication requirements for the *Sir Winston Churchill* will be met by a Marconi Marine "Kestrel II" transmitter/receiver. The "Kestrel II" will be provided with a radio goniometer to enable the navigator to take radio bearings. It will be recalled that a "Kestrel" transmitter/receiver was used with great success aboard *Tawau*, the Sail Training Association's entry in the 1964 Tall Ships Race. In the early stages of the race radiotelephone calls to parents and the press were its most popular functions, but on the second leg it was used primarily for reporting progress.

A "Graphette" recording echosounder will provide a permanent graphic record of the contours of the seabed.

Sailing vessels are not always the best of radar "targets" and a radar reflector provided will increase the *Sir Winston Churchill's* reflection potential, and thus provide a good target to ensure observation by other vessels fitted with radar.

The equipment has been installed aboard the schooner by technicians from Marconi Marine's Hull depot.

continued from page 612

of Region I I.A.R.U. and the project was discussed by the VHF Managers at a meeting held in Brussels in November 1965. At that meeting, four National Societies offered financial support for the project, from Germany, Switzerland, Holland and Great Britain.



FISHING MADE EASY

A 70-foot trawler, the *Ken Pat*, manned by Captain Virgil Styron and a crew of three, sets out at night under a cloud of gulls for an eighteen-hour fishing trip in the Atlantic Ocean off the coast of North Carolina. Locating the fish was once a guessing game, but today the Captain can spot their presence with the help of a fish scope (below), a television-like screen that transmits a green picture of the water underneath the boat. Fish down to 50 feet below the surface can be recorded on the scope by a series of dark horizontal lines.

Captain Styron's usual catch is mullet, flounder, ocean trout and perch. When the trawler reaches its fishing ground around midnight, its speed is reduced and the men throw out a 105-foot-long net. First towed along the ocean bottom 30 to 40 feet down in this area, the net may be raised according to what the Captain sees on the fish scope. It is left in the sea for ten minutes to an hour or more, until its pull indicates that a catch has been made. With heads of fish protruding through the mesh the bulging net is hoisted aboard dripping water and sea weed.

Cowshed TV

A farmer near Darlington has installed closed-circuit television to save himself fruitless journeys during the night when cows are calving.

Three spotlights and a camera in the cowshed are connected to a TV receiver in the farmer's bedroom to provide early warning of the latest farmyard "happy event".



The Esso Fuel Cell and Radio Kit



A receiver made up from components in the Esso Kit

FUEL CELLS, WHICH PRODUCE electricity when a fuel such as methanol is oxidised at one electrode and oxygen from the air is reduced at the other electrode, can be readily built; but they are not, at their present level of development, competitive with established methods of producing electricity. Nevertheless, there seems little reason to doubt that, with time, the fuel cell will become economically comparable with existing sources of electricity and that it may, eventually, supplant them. The potential advantage of the fuel cell is that it is theoretically capable of producing electricity from the sources of energy available on the Earth with far greater overall efficiency than any other method at present known.

In consequence, much interest centres on the fuel cell and its possibilities. The Esso Group has carried out research on fuel cell problems and their engineers have built a fuel cell using air, methanol and platinum which provides some 100 watts of electricity. Mindful of the needs of the student in this new technology, the Educational Services Group of Esso Petroleum Company has also been active, and has made available at low cost a simple fuel cell design which can be easily assembled and made to work in school laboratories and similar locations. The output of this simple fuel cell is low but,

to provide a striking demonstration that it can nevertheless do useful work, Esso has used the imaginative approach of coupling it to a small medium and long wave transistor radio.

The complete Esso Fuel Cell and Transistor Radio Kit is available for £1, and it contains all the parts needed for the radio and (apart from locally available items such as a beaker, glass rod, and simple chemicals) all the parts needed for

the fuel cell. The Esso kit forms the subject of this review and details of the items it comprises are given in the accompanying list.

Included in the kit is an 18 page instruction book. This commences with a short article giving the general background of fuel cell operation, after which a second section describes the assembly of the fuel cell. A third, final, section covers the construction of the radio.

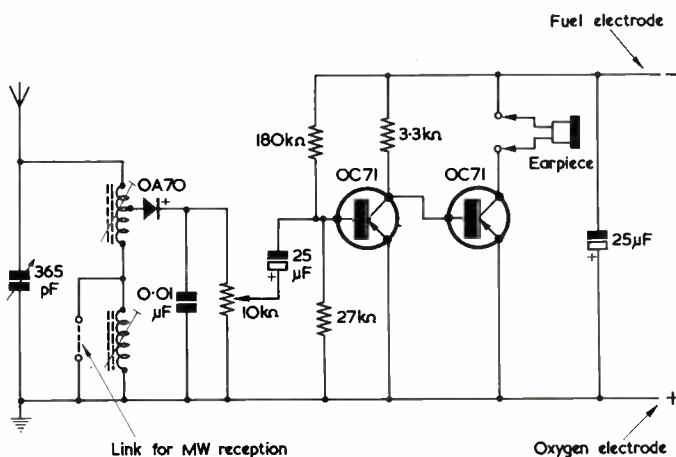

The circuit of the transistor radio, for which components are supplied in the Esso Kit

The Fuel Cell

The electrodes of the fuel cell consist of two strips of nickel gauze measuring 2 x 5in. After cleaning, these are initially immersed in solutions of catalysing agents. One electrode is immersed in a solution of silver nitrate to provide a coating of silver, and this then becomes the "oxygen electrode". The other electrode is immersed in a solution of chloroplatinic acid to give a coating of platinum black, and this becomes the "fuel electrode". Both electrodes are then stored in water until required.

To form the fuel cell, a Pyrex beaker is half-filled with a solution of potassium hydroxide. The two electrodes are placed in the solution, being clipped to the side of the beaker by means of the crocodile clips provided with the kit. A glass rod is placed between the two electrodes to prevent their short-circuiting, and the fuel, methyl alcohol, is added to the potassium hydroxide solution. Also introduced is a length of rubber or plastic tubing behind the oxygen electrode. A supply of oxygen is brought into the cell by blowing gently down this tubing.

The oxygen in the air bubbles is absorbed on to the oxygen electrode causing the formation of negatively charged hydroxyl ions, and a corresponding deficiency of electrons in the oxygen electrode. The negatively charged hydroxyl ions react with the methyl alcohol at the fuel electrode to produce formic acid, water and a surplus of electrons. If the fuel electrode is connected via an external circuit to the oxygen electrode, electrons flow through this circuit from the fuel electrode (with its surplus of electrons) to the oxygen electrode (with its deficiency of electrons).

The output of the cell, with air bubbling over the oxygen electrode, can approach 0.01 watt, and this could increase by several times if pure oxygen were used instead. The voltage supplied to the transistor radio is of the order of 0.6 at 2.5mA. However, the transistor radio will still function from the cell if the air bubbling is discontinued, since sufficient oxygen will have been absorbed to produce the small power required.

An important point is that all the chemicals involved in the assembly of the fuel cell are poisonous, and that some are potentially dangerous for other reasons. For instance, the silver nitrate and

potassium hydroxide are corrosive, and can cause severe burns upon contact with the eyes or the skin. These facts are emphasised in the kit instructions, which must be carefully read before attempting any practical work. Because of these potential dangers the fuel cell should *only* be assembled under laboratory conditions with immediate access to running water, such as would be provided in a school laboratory.

One of the accompanying photographs shows a boy at King's College School, Wimbledon, blowing into the cell solution.

The Radio

The transistor radio employs two OC71's in a simple and reliable circuit which is shown in the accompanying diagram. There is no regeneration, but the aerial coil is a high-Q component and good reception of local medium and long wave stations should be possible in any locality. The 25ft length of red p.v.c. wire provided with the kit functions as an aerial, the black p.v.c. wire being used for making an earth connection. We found that the radio gave good results using less than the 25ft of aerial wire provided and that, for instance, Radio Luxembourg could be received in the evening at good entertainment value. Although not mentioned in the instructions, selectivity could be improved, if necessary, by inserting a capacitor of some 50pF in series with the aerial connection or (for medium wave reception) connecting the aerial to the diode tap. However, these are minor points and the receiver, as it stands, should provide, at least, good local station reception.

Full instructions for assembly are given, and a member of our staff, working leisurely, had the set fully completed and working in 40 minutes. All components fitted into their positions without any trouble.

Conclusion

To sum up, we would say that the Esso Fuel Cell and Transistor Radio Kit offers excellent value and that it provides a very convincing demonstration of simple fuel cell operation. It may be obtained by sending a crossed postal order for £1 to: Educational Services, Esso Petroleum Company Limited, Victoria Street, London, S.W.1. We understand that there is a heavy demand for the kit and that an early application is advised.



A pupil at King's College School, Wimbledon, provides the necessary oxygen for fuel cell operation by blowing gently into a tube near the oxygen electrode (An Esso photograph)

Components Supplied with the Esso Fuel Cell and Radio Kit

- 1 Instruction book
- 1 Printed circuit board
- 1 Medium and long wave coil type ES/1 (Denco)
- 1 365pF air-spaced tuning capacitor
- 2 25 μ F capacitors
- 1 0.01 μ F capacitor
- 1 10k Ω pre-set potentiometer
- 1 3.3k Ω $\frac{1}{2}$ watt resistor
- 1 27k Ω $\frac{1}{2}$ watt resistor
- 1 180k Ω $\frac{1}{2}$ watt resistor
- 1 OA70 (Mullard)
- 2 OC71's (Mullard)
- 1 control knob
- 1 miniature jack socket
- 1 magnetic earpiece (Acos)
- 2 Crocodile clips
- 25ft red p.v.c. wire
- 25ft black p.v.c. wire
- 18in Ersin Multicore solder
- Sundry bolts, washers, nuts, sleeving and wire
- 2 pieces nickel gauze
- 1 phial chloroplatinic acid

The following are required, but are not supplied in the Kit

- 1 Pyrex beaker
- Potassium hydroxide
- Methyl alcohol
- Silver nitrate
- Distilled water
- 1 Glass rod
- Rubber or plastic tubing.

READERS MAY RECALL THAT IN LAST MONTH'S article in this series we dealt with Miller Effect in the triode, after which we introduced the triode oscillator. We saw that a parallel tuned circuit can produce a damped oscillation at its natural resonant frequency due to the continual interchange of energy from the capacitor to the inductor and back again, the oscillation being damped because of the losses in the tuned circuit. It follows from this that a sustained oscillation can be achieved if energy is supplied to the tuned circuit from an external source, and we next examined a simple oscillator circuit in which the required energy was provided by a triode valve.

bias circuit (when the grid signal has a high amplitude), both of which were discussed in the October 1965 issue. However, with the oscillator it is a common practice to make the alternating voltage applied to the grid considerably higher than occurs with either the grid leak detector or the grid current bias circuit, with the result that the voltage at the grid relative to cathode takes up a form similar to that shown in Fig. 342 (b). In Fig. 342 (b) we have the familiar situation in which the positive tips of the grid waveform are slightly positive of cathode potential, the remainder of the waveform then being negative of the cathode; but in this instance the average voltage of the waveform

understanding

The Functioning of Valve Oscillators

By W. G. Morley

Basic Oscillator Circuit

The oscillator circuit described last month is reproduced here, for reference, as Fig. 342 (a). It is usually necessary to have a control of oscillator frequency, and this can be conveniently provided by making the capacitor in the tuned circuit a variable component, as is done in Fig. 342 (a). As was explained in the previous article, the voltage at oscillatory frequency which is applied to the triode grid results in an amplified voltage at the anode which is 180° out of phase with that at the grid. At the same time, the two coils are coupled together and connected in such a manner that the signal fed back to the grid is reversed by a further 180°, whereupon it becomes in phase with the original oscillatory voltage. The positive feedback thereby achieved enables the tuned circuit to maintain a continual oscillation.

As was also mentioned last month, the bias for the triode is obtained by means of a grid leak and capacitor. This bias is formed in the same manner as occurs with a grid leak detector or a grid current

radio



is markedly more negative than the cut-off voltage (at which the valve ceases to draw anode current). It follows that the valve is completely cut off for a large proportion of each cycle, and with normal oscillator design this is, indeed, the case. What happens is that the valve draws anode current only during the periods when the grid is positive of the cut-off voltage, these short periods of anode current being sufficient to enable the tuned circuit to maintain a sustained oscillation. To employ a mechanical analogy, we can say that the "kicks" of anode current are sufficient to maintain oscillation in the tuned circuit in much the same way that the "kicks" applied to the pendulum of a clock by way of the escapement are sufficient to keep this similarly in an oscillating condition. Another mechanical analogy, mentioned last month, refers to a weight on the end of a vertically suspended spring. Such

a weight can be made to oscillate up and down at the natural resonant frequency of the system by imparting a "kick" to it, in the required direction, once each cycle. This is equivalent to the short appearance of anode current, once each cycle, which occurs with a valve oscillator using a grid leak and capacitor.

It should be added that it is by no means necessary to employ grid leak bias for a valve oscillator, and that any other method of biasing is capable of enabling the tuned circuit to produce a sustained oscillation. Other bias arrangements present difficulties, however. If, for instance, a fixed grid bias voltage is applied to the valve, this must not be negative of the cut-off voltage because oscillations will not commence when the supplies to the valve are switched on. The valve will merely remain in the cut-off state, will draw no anode current, and will not oscillate. If, alternatively, a fixed grid bias which is positive of cut-off voltage is applied, the feedback circuit has to be designed with considerable care to ensure that the amplitude of the voltage fed to the grid is not so large that its positive peaks cause appreciable grid current to flow. Even when correctly designed, such a circuit will still not be so *efficient*, in terms of h.t. current consumption, as the oscillator employing grid leak bias. With the latter, the average h.t. current is relatively low because it flows only during a short period in each cycle. A further point is that alternative bias arrangements may be more complicated than the grid leak bias circuit, which merely requires a single capacitor and a single resistor.

Summing up, the grid leak bias circuit enables the oscillator to operate efficiently and to be self-starting, and it only requires two simple components. Because of these advantages, grid leak bias is employed, in practice, in most oscillator circuits likely to be encountered.

In Fig. 342 (a) the grid leak is shown returned to cathode, but it may also be connected in parallel with the grid capacitor, as illustrated in Fig. 342 (c). This results in no significant change in circuit operation, as we saw when considering the same circuit configurations for the grid leak detector in the October 1965 issue. It is necessary, in the circuit of Fig. 342 (c) (and in alternative oscillator types using grid leak bias with the grid leak connected across the grid capacitor) for the coil in the grid circuit to be returned to the valve cathode, as shown.

The anode and grid currents of the valve in the circuits of Figs. 342 (a) and (c) alter markedly if either circuit is changed from the oscillating to the non-oscillating condition, or vice versa. Fig. 343 shows a milliammeter connected in series with the coupling coil in the anode circuit of the valve, a high-value bypass capacitor being connected between the negative terminal of the meter and the h.t. negative line to ensure that the supply applied to the oscillator circuit proper still has a low internal impedance. When the valve is oscillating, anode current flows only for a short period during each cycle and the average current, as indicated by the meter, is low. If the oscillations are made to stop,

say by short-circuiting one of the coils, the negative grid voltage due to grid leak bias disappears and the valve will have only the very low bias given by "contact potential". Anode current will, in consequence, increase dramatically.

Fig. 343 also shows a milliammeter connected between the lower end of the grid leak and the h.t. negative line. It will be helpful, initially, to look

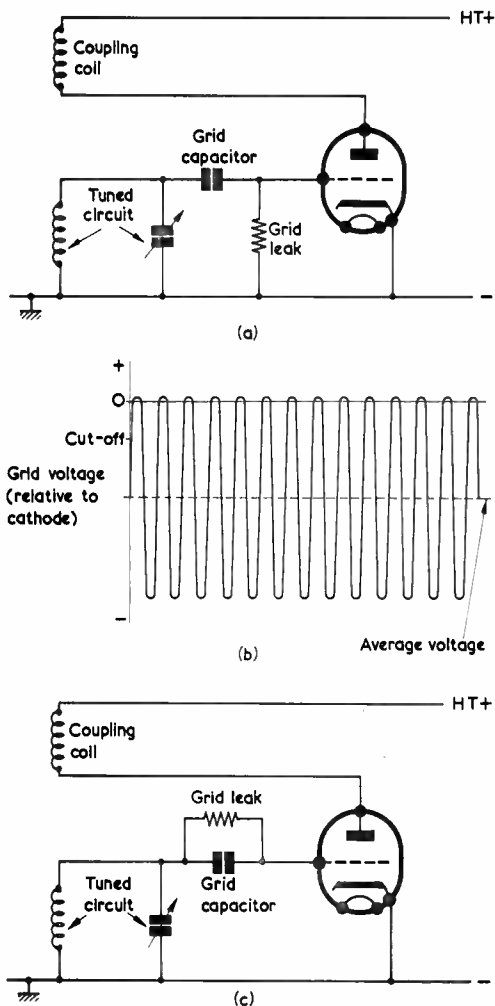

Fig. 342 (a). The series-fed tuned grid oscillator. A variable capacitor is shown in the tuned circuit to provide a control over oscillator frequency. Changes in oscillator frequency could also be given by having this capacitor fixed and by varying the inductance of the tuned coil. The two coils are coupled inductively (b). The waveform at the grid of the triode oscillator of (a). With normal oscillator design the average voltage at the grid is markedly more negative than the cut-off point for the valve, with the result that the valve passes anode current during part of the cycle only (c). There is no significant change in circuit operation if the grid leak of (a) is connected across the grid capacitor instead of between grid and cathode

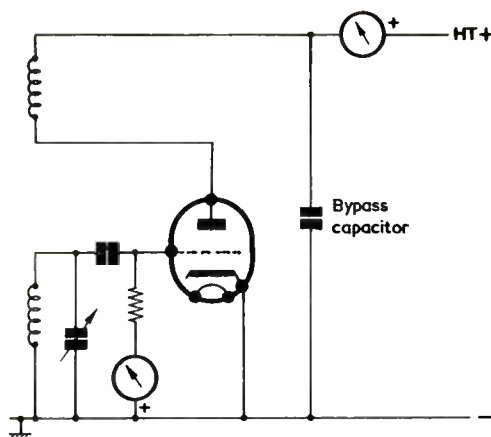

Fig. 343. Inserting milliammeters in series with the h.t. supply and the grid leak of the oscillator of Fig. 342 (a). The bypass capacitor has a low reactance at oscillator frequency

upon the milliammeter and grid leak as a voltmeter in which the grid leak is the series resistor. When the valve is oscillating, the grid leak bias causes the average voltage on the grid to be negative of the cathode, and this voltage may be measured by the milliammeter-and-grid-leak-voltmeter to give a corresponding reading in the meter. This reading then indicates the average negative voltage on the grid.¹ Should oscillations be made to stop, the voltage at the grid will drop to the very low voltage due to "contact potential" and the meter reading will decrease accordingly. We have used a voltmeter concept to explain the meter deflection when the valve is oscillating, but it is more usual to state that the meter at the lower end of the grid leak measures *grid current*. What the meter actually reads, speaking in terms of current, is the average discharge current

¹ If, to take a numerical example, the meter reading were 0.2mA and the grid leak had a value of 100kΩ, the average negative voltage on the grid would be 20 volts.

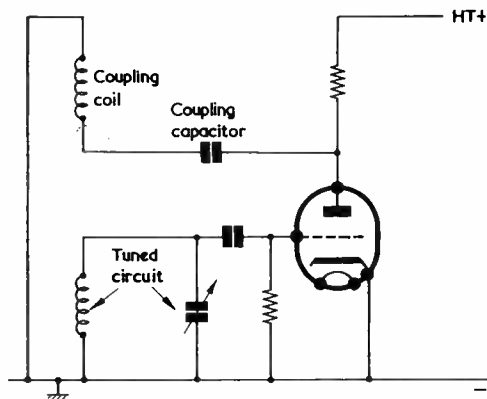

Fig. 344. A shunt-fed tuned grid oscillator. The coupling capacitor has a low reactance at oscillator frequency

of the grid capacitor into the grid leak, this being equal to the average grid current which causes the capacitor to acquire its charge in the first place, and which flows during the positive leaks of the voltage applied to the grid.

It is sometimes necessary to ascertain whether an oscillator is, in fact, oscillating. In the absence of other means of test, a useful check for oscillation can be provided by inserting a current reading meter in series with either the grid leak or the anode supply. The existence of a grid current is usually sufficient to indicate that oscillations are taking place, and this fact can be confirmed by short-circuiting a coil in the oscillator circuit, whereupon the grid current reading should drop dramatically. Similarly, anode current should rise dramatically when a coil is short-circuited. These points apply to any type of valve oscillator employing grid leak bias in which, as is normally the case, a high average negative grid voltage is formed during oscillation.

The Tuned Grid Oscillator

The circuit shown in Fig. 342 (a) represents only one of a number of basic oscillator configurations, and it was chosen to introduce the subject of oscillators because its mode of operation is readily understandable. It is known as a *tuned grid oscillator*. The signal at oscillator frequency generated by the circuit is frequently applied to another, separate, circuit and, where power requirements are small, the output from the oscillator can be obtained by direct connection to the grid. A d.c. blocking capacitor may be interposed, if necessary.² Where an output of appreciable power is required, as could occur in a transmitter, coupling may be made direct (via a d.c. blocking capacitor, if necessary) to the anode, or via a third coil coupled inductively to the two coils in the circuit.

An alternative tuned grid oscillator circuit is shown in Fig. 344. In this diagram the h.t. supply is not applied to the anode via the coupling coil but via a resistor which offers a high impedance at the frequency of oscillation. The anode is coupled to the coupling coil via a capacitor offering a low reactance at the frequency of oscillation. Oscillation takes place in the same way as for Fig. 342 (a). The circuit of Fig. 342 (a) is described as a *series-fed* tuned grid oscillator whilst the circuit of Fig. 344 is described as a *shunt-fed* tuned grid oscillator. The two types can be readily distinguished. In the series-fed circuit the coil is in series with the h.t. supply to the anode. In the shunt-fed circuit no h.t. current flows through the anode coil; it flows, instead, through a separate anode load. The anode load in Fig. 344 is a resistor, but it could also be a choke offering a high impedance at the oscillator frequency. The same applies to other shunt-fed oscillator types.

Stray capacitances appear across the anode

² The term "d.c. blocking capacitor" merely infers that the capacitor in question offers a low reactance to the frequency it is intended to pass whilst, at the same time, preventing the passage of direct current. The "coupling capacitor" in Fig. 344 may also be described as a "d.c. blocking capacitor".

coupling coil, causing it to have a resonant frequency in conjunction with these capacitances. It is good practice to give the anode coil fewer turns than the grid coil to ensure that this resonant frequency is well above the range of frequencies over which the grid tuned circuit can tune. Should the resonant frequency of the anode coil be close to that of the grid tuned circuit, oscillator operation may become erratic and the grid tuned circuit may not have complete control over the frequency of oscillation.

The Tuned Anode Oscillator

Fig. 345 (a) shows a *tuned anode oscillator*. This is very similar to the tuned grid oscillator except that the tuned circuit which controls oscillator frequency is now in the anode circuit of the valve. With this oscillator, the coupling coil is in the grid circuit, and this coil should have fewer turns than the anode coil to ensure that its resonant frequency (with stray capacitances) is well above the range of frequencies covered by the anode tuned circuit. The version shown in Fig. 345 (a) is series-fed, the shunt-fed alternative being illustrated in Fig. 345 (b). Apart from other considerations, the shunt-fed circuit of Fig. 345 (b) has an incidental practical advantage. If it is desired to have the anode coil tuned over a wide range of frequencies by means of a variable capacitor of conventional construction, as could occur in a receiver, the frame of such a capacitor (which is common to its moving vanes) can be mounted directly to the chassis instead of being insulated from it, as would be required by the circuit of Fig. 345 (a).

An output may be obtained from the tuned anode oscillator in the same way as for the tuned grid oscillator.

The Hartley Oscillator

A series-fed *Hartley oscillator* is illustrated in Fig. 346 (a). This oscillator employs a single tuned coil without coupling coils, an h.t. positive tap being made near its centre. The phase requirements for the maintenance of oscillation are satisfied since, at the resonant frequency, the voltage at one end of the coil is 180° out of phase with that at the other. Thus, the voltage fed back from the anode to the grid has the correct phase to maintain oscillation. As with the two preceding oscillators, grid leak bias is employed.

A shunt-fed version of the Hartley oscillator is shown in Fig. 346 (b).

Outputs from the oscillators of Figs. 346 (a) and (b) may be obtained by the same types of coupling as are used for the tuned grid oscillator. A practical disadvantage with both circuits is that neither plate of the tuning capacitor is at chassis potential and a conventional tuning capacitor giving a wide tuning range could not therefore be mounted directly on the chassis. On the other hand, a wide tuning range could be conveniently obtained with a fixed capacitor and the application of permeability tuning to the coil.³

The tap in the tuned coil in Fig. 346 (a) is at chassis potential so far as oscillator frequency is concerned, because it is assumed that the h.t. supply has negligible impedance at that frequency. In Fig. 346 (b) there is an actual chassis connection. The position of the tap, along the coil, controls the amplitude of the signal applied to the grid. If the tap is moved towards the anode end of the coil, the signal fed to the grid increases in amplitude. Too high a grid voltage is not normally desirable,

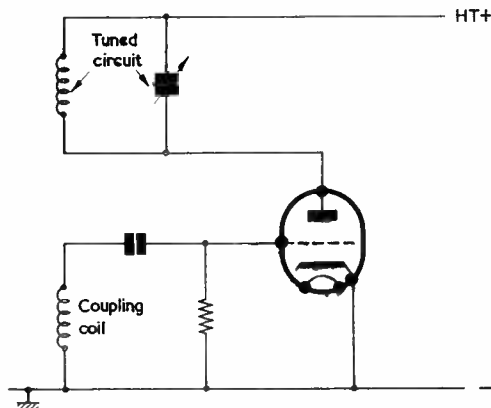

(a)

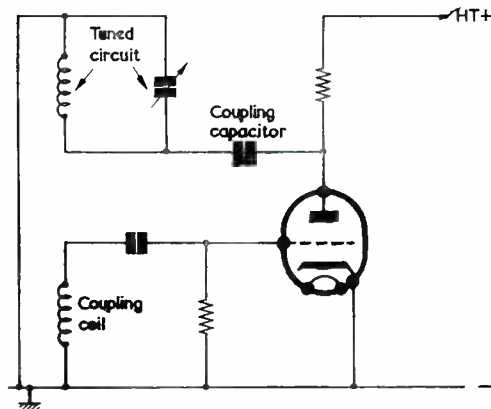

(b)

Fig. 345 (a). The series-fed tuned anode oscillator. The coils are coupled together inductively
(b). The shunt-fed version of the tuned anode oscillator

however, and it is usual to have the tap approximately one third of the coil away from the grid end.

A third Hartley oscillator circuit is shown in Fig. 346 (c). This may, at first sight, appear considerably different from the two versions we have just examined, but the only change is that the effective chassis connection has been moved from the tap to one end of the coil. If we compare Fig. 346 (c) with Fig. 346 (b) we will see that, as occurred previously, the grid couples to one end of the coil. Similarly, there is the same direct connec-

³ See "Understanding Radio" in the April 1963 issue.

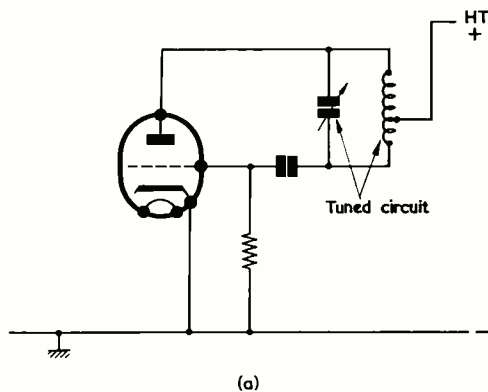

(a)

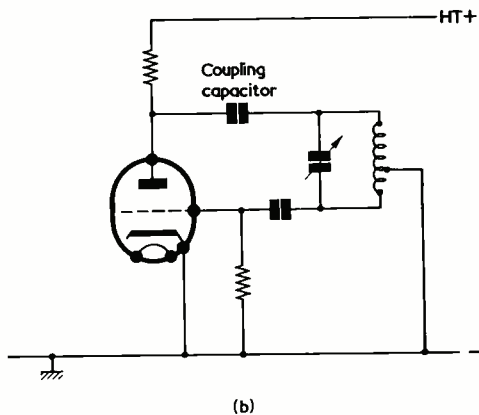

(b)

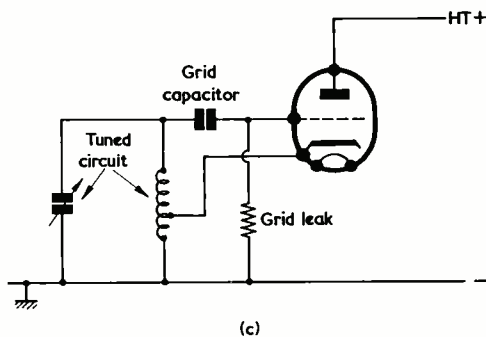

(c)

Fig. 346 (a). The series-fed Hartley oscillator
 (b). A shunt-fed Hartley oscillator
 (c). By moving the chassis connection from the tap to one end of the coil, the circuit of (b) takes up the form shown here.

tion between the cathode and the tap in the coil. Finally, whereas the anode previously connected to the remaining end of the coil via a coupling capacitor, it now couples to that end via the negligible impedance of the h.t. supply.

It will be seen that, in this circuit, the cathode of the valve is not at chassis potential, but carries a voltage at oscillator frequency. This method of operation is satisfactory with an indirectly heated valve because the cathode is insulated from the heater, which is normally at chassis potential. Unlike the two previous Hartley circuits, one plate of the tuning capacitor is at chassis potential, with the result that, if it is intended to use a conventional tuning capacitor, this may be mounted directly to the chassis. Outputs at oscillator frequency may

be taken from grid or cathode, or from a coupling winding. The cathode tap into the coil will, normally, be about a third of the way from the chassis end.

The oscillator circuit of Fig. 346 (c) is frequently employed in what are described as "electron-coupled oscillators" and it is sometimes, incorrectly, described as such. Electron-coupled oscillators employ valves having more electrodes than has a triode, these enabling a screening action to take place, in a single electron stream, between the oscillator circuit proper and the output electrode. The screening action ensures that changes in the output circuit have little effect on oscillator frequency or functioning. We shall be referring to electron-coupled oscillators when we deal with valves having more electrodes than the triode, and the point is raised here merely to present correct terminology. The circuit of Fig. 346 (c) is not an electron-coupled oscillator. It is a Hartley oscillator which may be incorporated in an electron-coupled oscillator.

Next Month

In next month's issue, we shall continue to examine valve oscillators.

Mauritius Sugar Growers Use British Mobile Radiotelephones

Mauritius sugar growers have recently given the island's vital sugar industry a valuable efficiency boost by installing mobile radio communications. The British-made scheme, produced by Pye Telecommunications of Cambridge, will improve standards of security and streamline the handling and transport of sugar cane, both on the estate and on the journey to the sugar factory. It puts supervisory staff, in the fields and on the roads, in constant touch with the estate headquarters. Each estate owner of the Mauritius Sugar Producers Association has his own operating frequency so that there is no interference between one estate and another. There is, however, a common emergency frequency to which all estates can switch when necessary.

Now that Mauritius no longer has a railway system, all transportation of sugar cane is by road and is in the hands of the growers themselves. Efficient supervision of the constant stream of vehicles is therefore of prime importance to the smooth running of the industry. Two-way radio communication helps considerably.

The sugar growers have followed in the footsteps of the Mauritius police, fire and central electricity services who have also installed Pye mobile radio in recent years. The local Pye distributors, Forges Tardieu Ltd. in Port Louis, now have technical personnel under training at Cambridge in the servicing and maintenance of the equipment.

ALTHOUGH THE N.P.N. TYPE OF transistor has been in common use in the United States for some time, it has only recently become easily available in the United Kingdom. Mullard now supply their AC127 which is the n.p.n. complement to the OC81, and is often sold with that transistor, in a matched pair, for use in single ended transformerless Class B output stages. But the n.p.n. transistor can also be used in straight Class A amplifiers, in conjunction with the p.n.p. variety, in a manner which makes for efficiency and economy in components. The resultant circuits are useful as aids to studying design problems in biasing and stabilising arrangements.

The D.R.4. Receiver

Some readers will have read an article recently published in this magazine in which the author described a receiver making use of two p.n.p. and two n.p.n. transistors.¹ In that circuit the combination was used at radio frequency as well as in the audio stages. This article is concerned with making use of the AC127, or an equivalent n.p.n. transistor, in the audio section of a receiver or amplifier.

Fig. 1 shows the basic circuit of the last two stages of the "Spontaflex" D.R.4 receiver just referred to. It will be seen that by using an n.p.n. transistor feeding into a p.n.p. output transistor, and a coupling transformer with a suitable direct current resistance for its secondary winding, great simplicity is achieved with the sensitivity which goes with transformer coupling. Stability is assured by the 100Ω resistor which is common to the emitter of the AC127 and the collector of the GET103 (which could also, of course, be an OC72, OC81 or other approximate equivalent). A disadvantage of this particular arrangement is that the secondary of T₁ must have a resistance of an unusually high value, which limits choice for this component.

This difficulty can be overcome by making use of a decoupling resistor to drop the necessary voltage for base bias, thus making the resistance of the transformer winding unimportant, within limits, and this arrangement is shown in Fig. 2. In the earlier circuit it was necessary for the sequence to be from n.p.n. to p.n.p. in the interests

Using N.P.N Transistors in Class A Amplifiers

By SIR DOUGLAS HALL, K.C.M.G., M.A. (Oxon).

of coupling from a previous stage, but here the position is reversed, and a p.n.p. transistor is used to drive the AC127 as a small power transistor, or as a power driver for a large power transistor (which is not shown in the diagram). By using the transistors this way round it is possible to use the resistor which is common to the emitter of the GET103 and the collector of the AC127 as a source of very stable bias for the base of a preceding p.n.p. stage. This preceding stage will be referred to as TR₁, the GET103 as TR₂ and the AC127 as TR₃.

It will be seen that there is now a resistor in the emitter lead of the output transistor. This was not required in Fig. 1 owing to the accurate resistance offered by the secondary of T₁. In Fig. 2 the emitter resistor allows latitude in the choice of a component for T₁ and provides a further degree of stability over and above that provided by R₄. Indeed, the stability is such that base bias may be taken from R₄ for a previous stage in a state of critical reaction, without that stage being part of a directly coupled loop so far as direct current is concerned. It will be found that the voltage drop across R₄ remains rock steady. R₁ is necessary to prevent negative feedback of the signal notwithstanding the large

capacitors used. Its value is sufficient to prevent feedback without being so large as to cause unnecessary delay in the voltages settling down after switching on.

Most of the components in Fig. 2 have values specified. But R₄ must be chosen to develop the voltage across it which is required by the base of TR₁, and R₃ must likewise be tailored to fit.

If it is decided that the current passed through R₄ should be 10mA (which will correspond to a collector current of, say, 9mA in TR₃ and an emitter current in TR₂ of 1mA—the base current for the preceding stage can be ignored at this stage) we can see, from Ohm's law, that the voltage developed across R₄ will be $\frac{1}{100}$ of the resistance of R₄ in ohms. This makes calculation easy. A consideration of the processes involved is simplified by studying an actual circuit involving TR₁ in a previous stage, and such a circuit is shown in Fig. 3. TR₁ will be recognised as a "Spontaflex" amplifier² using a MAT101 transistor which, for most efficient working with transformer coupling, where saturation can be a problem, will require a collector current of the order of 100μA. This will

² See Sir Douglas Hall's article in the June 1964 issue, and the subsequent note on page 56 of the August 1964 issue.—Editor.

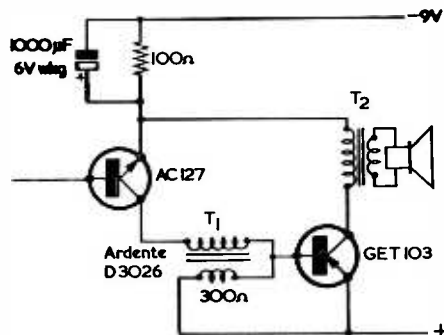

Fig. 1. The a.f. and output stages of the "Spontaflex" D.R.4 receiver described in a previous article

¹ Sir Douglas Hall, "The 'Spontaflex' D.R.4 Transistor Portable", *The Radio Constructor*, March 1966.

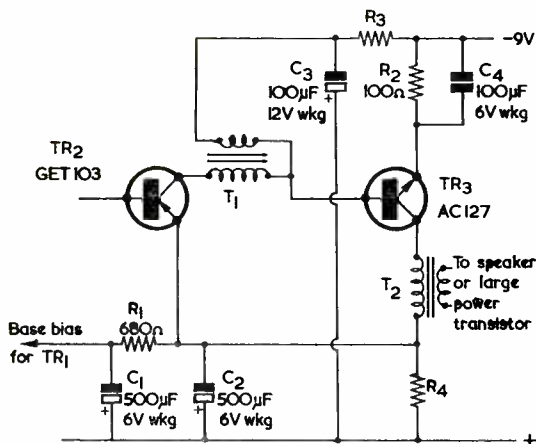

Fig. 2. An alternative approach, in which an n.p.n. transistor follows a p.n.p. type

take place with a base bias of from 0.25 to 0.3 volts between base and positive line for a typical transistor.

Finding Component Values

Components already valued in Fig. 2 are shown by number only in Fig. 3, and values must be found for R_3 , R_4 and R_6 . From what has been said, it will be clear that R_4 should be from 25 to 30 Ω . A standard 27 Ω resistor will suit. It is now necessary to ensure that 10mA will pass through R_4 . Most of this will be TR_3 's collector current and this is determined by the base bias applied to that transistor which is, in turn, settled by the current passing through TR_2 , TR_1 , and the potential divider R_5R_6 , all of which will cause the necessary voltage drop across R_3 . We have already said that collector current of TR_1 should be about 100 μ A, and that 1mA is a suitable collector current to specify for TR_2 . The potential divider will pass about 180 μ A and in addition there will be TR_3 's base current which, for a collector current of 9mA and an estimated current gain of 50 can be taken as a further 180 μ A. Base current for TR_2 and TR_1 add up to a little over 20 μ A. In round figures we can expect some 1.5mA to pass through R_3 .

We can expect that the base of TR_3 should need to be about 0.3V positive as regards its emitter. We know that the emitter current (collector current plus base current) of TR_3 will be about 9.2mA, causing a voltage drop through R_2 of 0.92V, so that we need R_3 plus the resistance of the secondary of T_1 (which is 70 Ω in the case of an LT44 transformer) to drop

1.22V. We now have an equation from Ohm's law, $\frac{1.5}{1000} = \frac{1.22}{R_3 + 70}$, or $R_3 = 740\Omega$ app. As the voltage of the battery will only remain at 9 for a short time we can choose the next size larger in 10% preferred values and settle on 820 Ω for R_3 .

Finally it is necessary to ensure that 1mA is passed through TR_2 . If we settle on 47k Ω for R_5 it remains to find a suitable value for R_6 to provide the correct bias for TR_2 .

The emitter of TR_2 is 0.27V

negative of the positive line. For 1mA to pass through TR_2 we can assume that the base will need to be about 0.15V negative of the emitter, or 0.42V negative of the positive line. With a collector current of 1mA we can also assume a base current of about 20 μ A. From Ohm's law this represents an internal resistance from base to emitter in TR_2 of 21k Ω . This is in parallel with R_6 which, as part of the potential divider, is passing 180 μ A. We can call the resultant of these two resistances in parallel R_x , through which a total of 200 μ A is passing. Again, from Ohm's law, $R_x = \frac{0.42 \times 1000}{0.2}$

$= 2.1k\Omega$. We also know from the rule governing resistances in parallel, that $\frac{1}{R_x} = \frac{1}{R_6} + \frac{1}{21k\Omega}$ or, putting it another way $\frac{1}{R_6} = \frac{1}{2.1k\Omega} - \frac{1}{21k\Omega}$

From this, the value of R_6 should be 2.33k Ω . Using 10% preferred values, two resistors of 1.2k Ω in series will be suitable.

Remaining Components

As regards the rest of the circuit in Fig. 3 the values for components associated with TR_1 are as specified in the original circuit described in the June 1964 issue. A single frame or rod aerial is shown for convenience but dual range can, of course, be provided. Any of

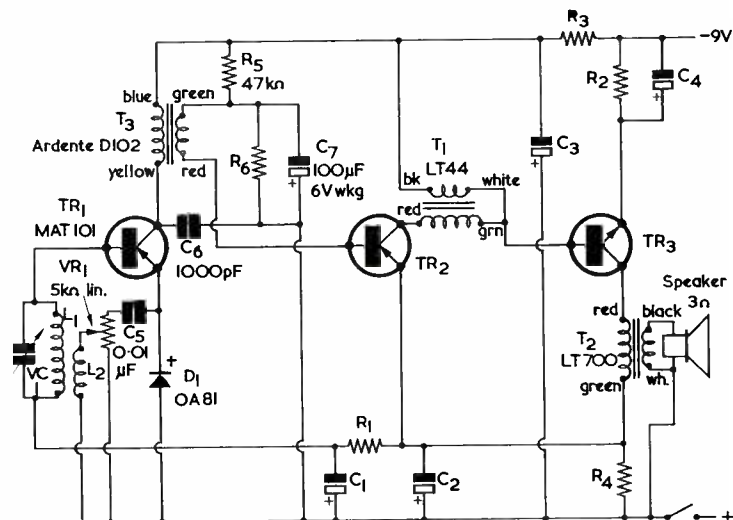

Fig. 3. A practical application of Fig. 2, in which the a.f. stages follow a "Spontaflex" detector and amplifier, thereby forming a complete receiver. The values of R_3 , R_4 and R_6 are calculated in the text, resulting in R_3 , 820 Ω , $R_4 = 27\Omega$ and $R_6 = 2.4k\Omega$. Other numbered components without values alongside have the same values as the similarly numbered components in Fig. 2. VR_1 functions both as a reaction and as a volume control

the arrangements for L_1 , L_2 which have previously been described may be used.³ In the prototype of the present circuit a compromise between the sensitivity given by a fair sized frame, and the convenience of a small ferrite rod, was reached by strapping five ferrite slabs together with Sellotape, each measuring $5 \times \frac{3}{4} \times \frac{1}{8}$ in, thereby making an aerial $5\frac{1}{2}$ in long by $\frac{3}{8}$ in by $\frac{1}{8}$ in. On this assembly, about 35 turns of 32 s.w.g. wire will be suitable for L_1 , and 6 turns for L_2 , to cover the medium waveband. For the long wave band L_1 may have about 150 turns and L_2 20 turns. If this, or any other form of ferrite rod aerial is used, VC_1 need not be larger than 250pF. If a frame is used a 500pF tuner will be needed to cover the necessary range.

T_3 , in the prototype, is an Ardenne DI02, and the connections shown in Fig. 3 will prove correct. An alternative is the Repanco TT53. With this transformer the correct phasing to avoid instability will have to be found by reversing the connections to one of the windings if necessary. T_1 and T_2 are LT44 and LT700 transformers respectively, and should be wired as shown.⁴ They are cheap, efficient, and easily obtainable. The centre tap leads are not used in either case and should be insulated or cut short. If instability is present the aerial rod should be turned through 180° .

The author is at present using a small portable receiver made to the circuit in Fig. 3, and he finds it sensitive and capable of giving alternative programmes at good volume and quality. Although it was originally built to test the various combinations possible between p.n.p. and n.p.n. transistors it seems likely to accompany him on his holidays as a thoroughly practical little receiver.

D.C. Feedback

So far we have considered the problems involved in working out biasing arrangements. An alternative circuit, shown in Fig. 4, is useful for a study of negative feedback of direct current in a multi-stage direct coupled circuit.

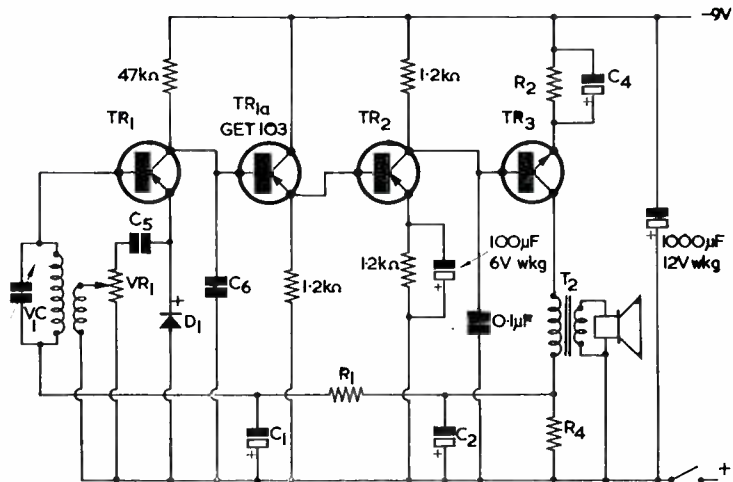

Fig. 4. A direct coupled version of Fig. 3, in which a d.c. negative feedback loop covers the complete circuit. Numbered components have the same values as the similarly numbered components in Figs. 2 and 3

TR_1 is a "Spontaflex" amplifier, resistance coupled to $TR_{1(a)}$ which is a common collector amplifier. Bias for the base of TR_1 is taken from R_4 , in the collector circuit of TR_3 , but in this circuit the direct current loop is continuous throughout, from final output to original input. In fact, the circuit may be unique in that there are six stages, all of which, including the detector, are direct coupled. The result is surprisingly good quality within the limitations of a rather small output which is, nevertheless, ample for normal use when a sensitive speaker is used. Components which are numbered but have no values shown can be taken as having the same values as the similarly numbered components in Figs. 2 and 3. As in the case of TR_2 , $TR_{1(a)}$ may be a GET103 or a roughly equivalent p.n.p. transistor. It will be seen that normal decoupling is not provided, its place being taken by a large-value electrolytic capacitor across the battery.

In order to study the negative feedback arrangement for direct current, let us suppose that TR_3 tends to heat up and therefore pass more current. The voltage drop across R_4 will increase so that the base of TR_1 will become more negative, and TR_1 will pass more current. This will increase the voltage drop through the 47kΩ resistor and, as a result, the base of $TR_{1(a)}$ will become more positive and $TR_{1(a)}$ will draw less current. Consequently, the voltage drop across the resistor in the emitter

circuit of $TR_{1(a)}$ will decrease, the base of TR_2 will become more positive, and TR_2 will draw less current. This will cause a drop in voltage across the resistor in the collector circuit of TR_2 and the base of TR_3 will become more negative. As TR_3 is an n.p.n. transistor, the result will be that current passing through it will drop. In other words, any tendency for TR_3 to draw more current will be accompanied by a corresponding tendency for it to draw less current, and proper negative feedback has been achieved. As the feedback takes place throughout the entire circuit it is extremely effective, and complete stability results with the aid of very few components.

In all circuits involving feedback, whether of direct current, as in this case, or of alternating current, it is important to trace the current through for correct phase. The more stages that are involved, the easier it is to make a mistake which, if not spotted, can cause at the best, hopeless instability, or at the worst, thermal runaway and the destruction of transistors.

Regular readers will notice that the first 3 stages of the circuit in Fig. 3 are nearly identical to the original 3 transistor "Spontaflex" circuit published in the June 1964 issue, except that TR_2 becomes a small signal amplifier feeding into an n.p.n. output stage. Conversion of the original receiver is an easy matter, bearing in mind the possible need to orientate T_2 carefully, or to turn the aerial

³ Articles by Sir Douglas Hall describing designs incorporating the "Spontaflex" system appeared in the following issues: "6-Stage 3-Transistor Short Wave Reflex Receiver", August 1964; "The 'Single Span' Mains Driven Receiver", October 1964; "Economic Hybrid Amplifier and Portable Receiver Circuits", December 1964; "Transistor Circuit for Medium and Long Waves", May 1965; and "The 'Spontaflex' D.R.4 Transistor Portable", March 1966.—Editor.

⁴ The LT44 and LT700 transformers are available from Henry's Radio, Ltd.—Editor.

rod or frame aerial through 180°, if instability takes place on the long waveband.

Given the same aerial arrangements, similar sensitivity may be expected from the circuits of Figs. 3 and 4. The extra sensitivity provided by the fourth transistor in Fig. 4 is roughly cancelled out

by the loss of the two transformers. Neither circuit, of course, can compete with the "Spontaflex" D.R.4 with its second, tuned r.f. stage. But each has the advantage of the simplicity which goes with a single tuned circuit. The circuit in Fig. 4 will take more current than that in Fig. 3, but will give a larger undistorted output. At

the same time, the cost of building the circuit of Fig. 4 is less than in the case of Fig. 3. Quality with the Fig. 3 circuit is good. With the Fig. 4 circuit it is particularly good, though for a few seconds after switching on there may be considerable noise in the form of a hiss, until the voltages have settled down.

Getting Tape Recording Straight

By D. M. YEARSLEY

Is your tape recorder silently rusting away in the loft now that the first flush of enthusiasm in owning it has passed? Such is certainly not the case with our contributor, who has particularly forthright views on this particular subject and who takes the opportunity to air them forcefully in this article!

BUT WHAT IS THE *use* OF A TAPE RECORDER, once the novelty is over? . . ."

At the outset, let it be made plain. This article is *not* going to describe studios and microphones, nor is it concerned with esoteric gimmicks and lore on splicing and cutting.

Let it be said straight away that, save for folk who wish to carry out dictation or would-be musicians who desire a check on prowess, it is assumed that any microphone supplied with a tape recorder will spend most of its existence gathering dust.

This is going to be a most unusual article in that it assumes that tape recorders are (a) musical instruments and (b) are primarily intended to give pleasure and entertainment.

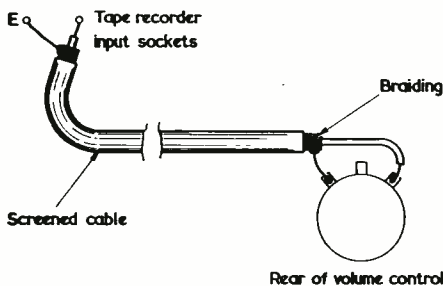

Fig. 1. The simplest method of coupling to the radio receiver. This method may be used when the earthy end of the volume control connects direct to the receiver chassis, and where the volume control does not also function as the a.m. diode load. Do not disturb existing wiring. If the tape recorder input is offered by a jack socket, connect the centre of the screened cable to the jack tip, and the braiding to its sleeve. The text discusses the types of receiver in which the connections shown here and in Fig. 2 are permissible, and must be consulted before they are carried out

The author has owned various tape recorders ever since 1951. His first one was truly a home-made recorder, being made from Meccano and brass pulleys!

Pride of Place

After all these years, the tape recorder still has pride of place among all apparatus and is the most used device. In fact, the author's recorder is actually running as these words are being typed! Because the great thing about a tape recorder is that it is able to "bottle" radio programmes transmitted at inconvenient times—say when TV is on or when one is otherwise busy—and these can then be reproduced later at a more suitable occasion. Some 90% of all the material recorded by the author has not been heard until the moment of playback. It has all been taken from the radio. Why then do so few people use recorders in this fashion? The answer is all too simple. Nobody bothers to explain the correct method of getting good recordings! It is, indeed, astonishing the number of people who try to make tape recordings by holding a mike in front of a loudspeaker! Such an effort is doomed to failure, alas, because (a) the "tone" is horrible and (b) so much noise is kicked up that nobody wants to hear it again anyway.

If you have a mains operated valve radio with an isolating mains transformer you can couple the recorder input to this directly. But *never*, on any account, connect directly to a radio having a chassis connected to one side of the mains, as the tape recorder metalwork may then become live.¹ Assuming you have a suitable radio, how do you connect the recorder to it?

The radio may, for instance, have a pair of sockets on the back. Have you traced where they

¹ See "Radio Topics" in the May 1965 issue for information on coupling a tape recorder to a mains radio having a live chassis. —EDITOR.

go? It is virtually certain that they go direct to the speaker speech coil, which is just about the worst place they could go! This is because (a) hum level will be high, (b) the built-in "top cut" (given by the capacitor across the output transformer primary) will upset the top response, and (c) it is impossible to record "silently", i.e. with the speaker turned off. Therefore, the first and most important step towards good results is a rewire of the sockets to a more suitable portion of the radio's circuitry.

There is one point that fills the bill here—a direct connection to the outer tags of the volume control. All that is needed is half a yard of screened or TV coax, and the job rarely takes more than a few minutes to do. The usual method is shown in Fig. 1. But, in some sets this simple method can't be used because the earthy tag of the volume control is slightly positive of the chassis, so such a connection could upset operating conditions. Another possibility is that, with a small proportion of receivers, the volume control track may also be the a.m. diode load, whereupon a direct voltage may appear across it when a station is tuned in. Fig. 2 shows an alternative method which can be employed in both these instances without disturbing detector potentials. Incidentally, both these methods of connection can be used with transistor radios also. In many receivers the volume control is combined with the mains switch. On no account make a connection unless the wiring is fully understood. Far better get a serviceman to do it for you. Also, and to repeat what was said earlier, **under no circumstances may these connections be made to the type of receiver known as "AC/DC", since so doing may cause the metal parts of the tape deck to be at full mains voltage. Always make certain that the receiver chassis is fully isolated from the mains by a double-wound mains transformer.**

Some readers will be wondering if there is a hidden snag with this simple method of coupling. With v.h.f. receivers there is none. Nor is there if it is intended to use a transistor a.m. radio with a valve recorder. But when a valve a.m. radio is used for recording, a theoretical difficulty arises, due to the nature of the input circuit of the recorder. Fig. 3 shows a typical "Radio Input" circuit in a well-known kit recorder. It will be seen that the impedance to d.c. is of the order of $1.1\text{M}\Omega$, but the a.c. impedance is much lower because of the preceding anode load resistor. It is not intended to pursue the matter here, since it has already been adequately covered in this magazine in "Understanding Radio".² Suffice it to say that the snag may sometimes give rise to distortion on heavily modulated bursts of music. It is recommended that the circuit of Fig. 1 or Fig. 2 be tried in the first instance. If there is noticeable distortion, then the small device shown in Fig. 4 should be inserted at

² The problem here is due to a.c. shunting of the diode load in the receiver, a subject which was covered in "Understanding Radio" in the June 1965 issue. Distortion on high level modulation can result because of additional a.c. shunting given by the tape recorder input circuit connected across the receiver volume control. The approach described in the text offers a good practical solution for the cases where this effect may be troublesome.—EDITOR.

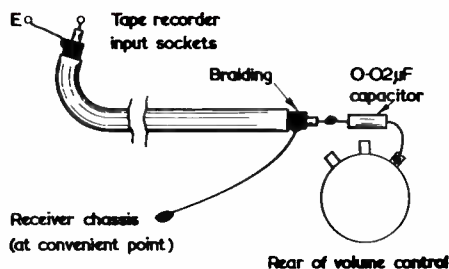

Fig. 2. When in doubt, include an a.f. coupling capacitor as illustrated here. This covers the instances where the earthy end of the volume control is not at chassis potential or where it functions also as a.m. diode load

the recorder end of the screened feeder cable. It can, of course, be built into the recorder as a permanent fixture, if desired. It will slightly reduce recording level, but there should still be ample to load up the amplifier.

The Recorder

We now come to the tape recorder itself. Some indication of suitability for the job may not come amiss. Each distinct type of programme has a certain minimum requirement of performance in your recorder. Let us take each type in turn.

First, speech. For this a very simple and cheap recorder is quite satisfactory. Slow speeds and uneven tape motion are no great disadvantage. But as soon as you need music of even the simplest melodious kind "wow" and "flutter" become important. Of these, more will be said later. Melodious music is usually referred to as "background music", and does not need a particularly wide frequency range. In fact it is nearly always noted that such music is played with a severe "top cut". So a speed of $1\frac{1}{2}$ in/sec is quite satisfactory.

For "pop" music, remarkably enough, a much wider response is needed! Which is strange when you consider how teenagers dote on squeaky

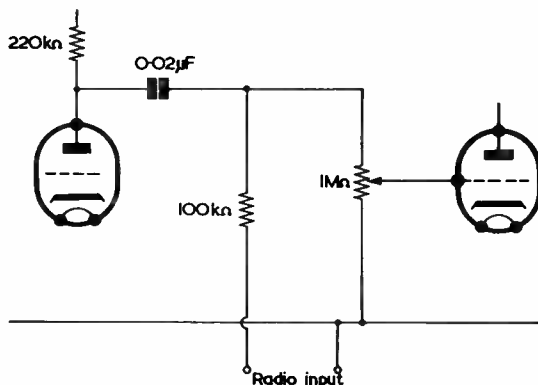

Fig. 3. Typical radio input circuit in a tape recorder. This appears between two of the amplifying valves

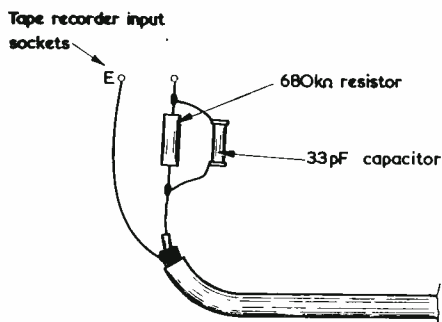

Fig. 4. Occasionally, a.c. shunting due to the recorder input circuit may prove troublesome, whereupon the additional components shown here should be added

“transistors” (sic)! But we are here concerned only with *correct* reproduction. The minimum speed thus becomes $3\frac{1}{2}$ in/sec.

The next step is that of classical music. Here the requirements depend really on the quality of loudspeaker to be used, and the degree of fidelity desired by the user; whether it is desired to hear every instrument in the orchestra—or just get a pleasant sound. For most folk, $3\frac{1}{2}$ in/sec will suffice, and can be quite satisfactory. But for hi-fi fans a speed of $7\frac{1}{2}$ in/sec is advisable, to achieve the maximum clarity. Some authorities recommend 15 in/sec, but this seems a little extreme under home conditions.

Mechanical Details

Some thought should be given to the mechanical details of the actual tape deck. Whether the recorder is complete or assembled from a kit, it stands or falls by the efficiency of the mechanical operations. Such things as jamming controls can be a constant source of annoyance. Curiously enough, the device that causes the most trouble and annoyance is a gadget specifically designed to be an annoyance! This is the “Safety Interlock”, which is to prevent accidental erasure. But what actually happens is that, sooner or later, it causes you to run the thing for a couple of hours under the blissful impression that you are making a recording—only to find that you haven’t! No matter how long the deck is owned, the device is always liable to be forgotten, because the actual moment of starting a recording always tends to be sudden, and it slips the memory. It is very common therefore to find that finally the Interlock gets removed or gimmicked in some way!

Reel Sizes

If the reader is new to tape techniques, some advice about reel sizes may not come amiss. In general, it is always best to obtain 7 in reels. These give plenty of leeway for future needs. A reel of 7 in DP (double play) tape at $3\frac{1}{2}$ in/sec will run for over two hours without handling. Here some mention should be made of the two types of tape heads available. Usually a choice is given between

2-track and 4-track varieties. Normally, with modern heads, there is little or no difference in tonal quality and noise level between the two types.

Since 4-track heads enable twice as much recording to be made, they offer an obvious economic advantage. A 7 in DP reel with 4 tracks at $3\frac{1}{2}$ in/sec will take over 8 hours of material.

Preparing to Make a Recording from the Radio

We shall now assume that there is a radio with a pair of sockets wired as in Figs. 1 or 2, and a tape recorder. To obtain the fullest use, the recorder *must* be permanently wired up to the radio and the a.c. mains.

It is advised that a playing desk be constructed, perhaps combined with a gram turntable, which is a very useful and economical arrangement, since the tape amplifier can double as a gram amplifier. Should the connecting wires be rather long, use TV coaxial cable for the audio wiring, as this has a self-capacitance only a third or quarter of that of the same length of the usual audio “screened single” wire, and is just as hum-free for this purpose. Ensure which of the two radio sockets is the “earthy” one, making a positive identification by means of a small blob of paint or cellulose.

Plug in, get set, and start. “Adjust the Record Indicator to the Manufacturer’s Instructions”. What are these instructions? Are they obvious? If so, why does one hear so many over and under-loaded tapes? It is at this point that you will reap the full benefit of the correct wiring of the radio, because once you have found the optimum setting of the “Record” knob (or Record/Play knob) the *same* setting can *always* be used. This is regardless of what the “little light” is doing. It is therefore worthwhile making a series of test recordings at gradually increasing levels. Use your mike to identify each knob setting without having to shut off.

Wow and Flutter

This article would fail in its purpose were the problem of “wow and flutter” ignored. This is a blanket phrase to describe unwanted variations of tape speed. In general, and as normally used, “wow” refers to cyclical variations of the capstan flywheel. “Flutter”, on the other hand, refers to skidding (frictional) effects tending to make the tape move jerkily. Note that these are the usual meanings. Other effects due to the reeling devices, such as tape fouling as the reels wind, or tape tension, are usually ignored in domestic recorders. This is not to say they aren’t important, but the point should be kept in mind when comparing different makes.

Triple motor decks suffer from a defect of this nature quite commonly. At the end of the reel, where the diameter gets small, tape pull-back tension may get so great as to appreciably slow down the tape, giving rise to a rather horrible noise. The author has found that a $1k\Omega$ 5 watt resistor in series with the pull-back motor will sometimes cure this defect. The one difficulty is in wiring it in such

a manner as not to interfere with fast rewind. Unfortunately, decks vary so much that it is impractical to give a circuit diagram which is in any way typical. If all else fails, a toggle switch could be used to short-circuit the resistor since it is only needed for the last ten minutes of the reel. (Or when playing 3in reels—in this case $2k\Omega$ may be required.) The more technical types may prefer to use a $2k\Omega$ variable resistor for this job, to provide a better control.

“Wow” is rather more of a problem, since the only remedy worth doing involves taking the flywheel out of the deck. The modification consists of filling the recess in the wheel with solder. Some flywheels will take 1lb of plumber’s solder. The difference this makes is astounding if you appreciate piano music. Do not worry about balancing the result—provided the solder is poured evenly, it is unlikely to cause trouble.³

But Why Two?

Are two decks better than one? The answer is

³ Since the modifications described in this section will alter the original design specification for the recorder they may also introduce unexpected troubles. We present these modifications, without guarantee of successful results, as fields of experiment for the more knowledgeable and experienced enthusiast.—EDITOR.

yes—if you want to take this recording lark seriously! A “second string” tape recorder has its uses and, what is more, it need not be a particularly expensive one, since all it need do is to play back well.

Suppose, for example, that you require to choose a tape for a party, only to find that it has some undesirable matter on it such as a news bulletin. What to do? Well, you can erase it, and leave a nasty gap; but the problem is solved if you can re-record a short insert. Or, perhaps right in the middle of a reel is a tune you have been trying to get for years—the answer here being to re-record it on another reel. Again, at the aforesaid party, you notice that a programme is on that you want to hear—just record it on your second deck without inflicting it on your guests, and still keep the music going!

Conclusion

It is, perhaps, curious that someone should actually suggest that a tape recorder is not merely a nine-days’ wonder or a child’s plaything and that it is, instead, a simple-to-use and constant source of high class and good quality entertainment. But why not? After all, that is what it is *for*!

Publication Received . . .

UNDERSTANDING ELECTRONIC CIRCUITS. By Farl J. Waters. 164 pages, $5\frac{1}{2} \times 8\frac{1}{2}$ ins. Published by W. Foulsham & Co. Ltd. Price 24s.

This book is in the Foulsham-Sams Technical Book series, and has an American text with an introductory chapter for English readers. *Understanding Electronic Circuits* is aimed at the reader who is unhappy at the sight of a complex circuit diagram, and the author explains that the complex diagram is really made up of many individual blocks, each of which is a functional circuit on its own. Individual circuits and their operation are then discussed. Most of the circuits covered are those which are likely to appear in radio receivers or simple transmitters. An explanation of each is given and the approach is non-mathematical. The chapters are terminated by review questions, for which answers are given at the end of the book.

Also in the Foulsham-Sams Technical Book series, and published by W. Foulsham & Co. Ltd., are the titles which follow. Each has the $5\frac{1}{2} \times 8\frac{1}{2}$ in format and comprises an American text with an introductory chapter for English readers.

Amplifiers for Transistor Voltmeters

Owing to a printer’s error, Fig. 5 was reproduced in the April issue incorrectly. The correct circuit, a four-transistor amplifier, is shown alongside, values being discussed in the text. In the same article, on page 583, at top of column 3, the word “decreasing” should read “increasing”.

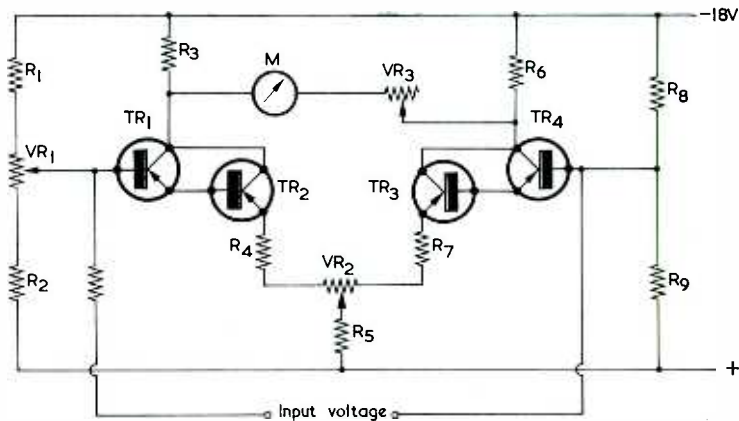

M183



Cover Feature

Inexpensive Photographic Timer

By H. T. KITCHEN

ALTHOUGH INTEREST IN COLOUR photography with the accent on automation, or the "don't do it yourself" hobby, is increasing very rapidly indeed, there are many people who still like to use black and white film and process it themselves, deriving great satisfaction from so doing. There are others again who derive much pleasure from enlarging, and who consider an evening well spent if the result is one or two really good enlarged prints. Although there is at the moment no substitute for experience, personal judgement and preference, automation can be of considerable help and benefit here by controlling the timing of the enlarging period. Once the test strip has been made, or the exposure

arrived at by other esoteric means, all that is subsequently necessary is a flick of a switch and the job is done, leaving the enthusiast time to paddle happily in his dishes of fixer and developer.

Automatic timing of enlargement exposure is the nearest thing to a factory production line when many prints from a single negative are required. It is, also, a great relief to know that the enlarger will be automatically switched off at the end of a preset period, for one can potter about the darkroom knowing that there is no danger of paper wastage through over-exposure.

Timing Periods

Fairly extensive darkroom experience had shown the author

that the majority of enlarging periods lay between 5 and 100 seconds, although longer times have occasionally been necessary. The author prefers an enlarging time in the region of 20 seconds, since this allows some local control to be exercised without being unduly long, so 5 seconds for the shortest period was considered quite adequate. On the rare occasions when longer times are required the enlarger is run through a second cycle after having allowed sufficient time for the timing capacitor in the timer to recharge.

The design for a suitable timer was soon arrived at and Fig. 1 shows the result, which has proved over a very long period to be completely reliable. A similar timer was built for a friend using, instead of a variable resistor for VR_2 , a 6-way switch which selected 6 preset times. However, this had the disadvantage of requiring odd resistor values which necessitated several series-parallel combinations. It is certainly easier to use a variable resistor as in the present design.

Fig. 1 will now be examined in detail so that some of the more important aspects can be discussed. One of these is the dial light, which must be red, as other colours will almost certainly fog the paper. One aspect of the circuit, which may perhaps occasion some surprise, is the lack of the normal rectifier and smoothing components. The answer is that the two sections of the valve are self-rectifying.

C_1 and R_2 form the timing components and these must be of good quality if the timer is to be reliable; R_2 should be a high stability component and C_1 a paper capacitor. VR_2 determines the extent to which C_1 is charged, which in turn determines the timing period. VR_1 is used to set the shortest time obtainable by VR_2 and this, in the prototype, ranged from 2 to 20 seconds. The relay should be a Post Office type 3000 or similar with a coil resistance of $5k\Omega$ or more, and capable of operating at about 5mA. It should have two sets of contacts. One set, light duty, is used to hold the relay closed and is designated RLA_1 in Fig. 1. The other set, RLA_2 , is for heavy duty switching, and should be rated at some 2A. This is used to switch the enlarger lamp, R_7 and C_4 serving to suppress the arcing caused by the lamp being switched. C_3 across the relay coil prevents the relay contacts chattering due to the otherwise unsmoothed d.c. passing through the coil. Its value is not critical and the $2\mu F$ capacitor used

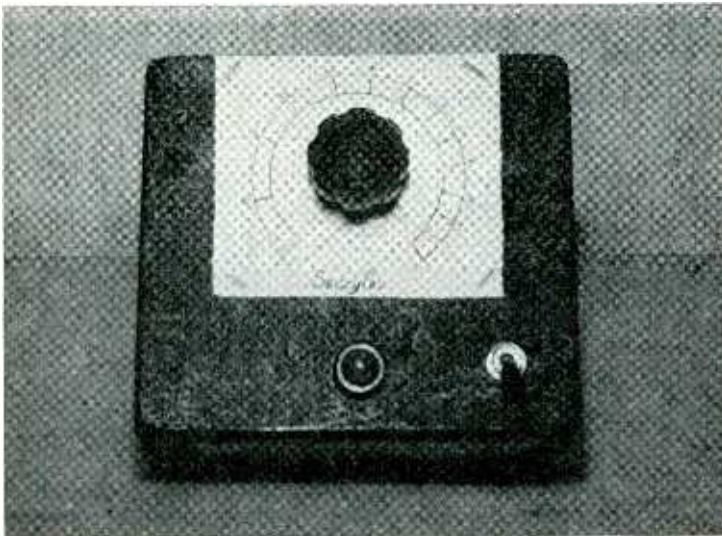

Front panel view of the completed timer.

Components List

Resistors

(All fixed values 10%)

R ₁	27kΩ ½ watt
R ₂	7.5MΩ Hi-Stab
R ₃	100kΩ ½ watt
R ₄	22kΩ 3 watts
R ₅	15kΩ 1 watt (see text)
R ₆	1MΩ ½ watt
R ₇	220Ω ½ watt
VR ₁	10kΩ 1in. wirewound
VR ₂	25kΩ 1in. wirewound

Relay

5kΩ coil, light and heavy duty contacts, both normally open

Dial Lamp

Bulgian type D109 with red bezel and 8V bulb (or 6.3V bulb with series resistor)

Capacitors

C ₁	4μF, paper, 300V wkg
C ₂	0.1μF, paper, 350V wkg
C ₃	2μF, paper, 100V wkg
C ₄	0.1μF, paper, 350V a.c. wkg

Transformer

Mains transformer, secondaries 200V at 25mA, 6.3V at 0.6A

Valve

V₁ 12AU7

Switch

S₁ s.p.s.t. toggle, biased normally open

Valveholder

B9A, ceramic or p.t.f.e.

Knob

With pointer (for VR₂)

represented a compromise between capacitance and physical size. The writer feels that electrolytic capacitors are best avoided in this circuit position.

Circuit Operation

The action of the circuit is fairly simple although the use of an alternating supply voltage makes an explanation somewhat complicated. When the timer is "off" as occurs when S₁ and the relay contacts are open, the cathode of V_{1(a)} is connected to the upper supply line via R₄. For half-cycles when the lower supply line is positive, the cathode and grid of V_{1(a)} form a diode, causing C₁ to charge up to a potential determined by the setting of VR₂, the right hand plate of C₁ being negative. At the same time, the cathode of V_{1(b)} is returned

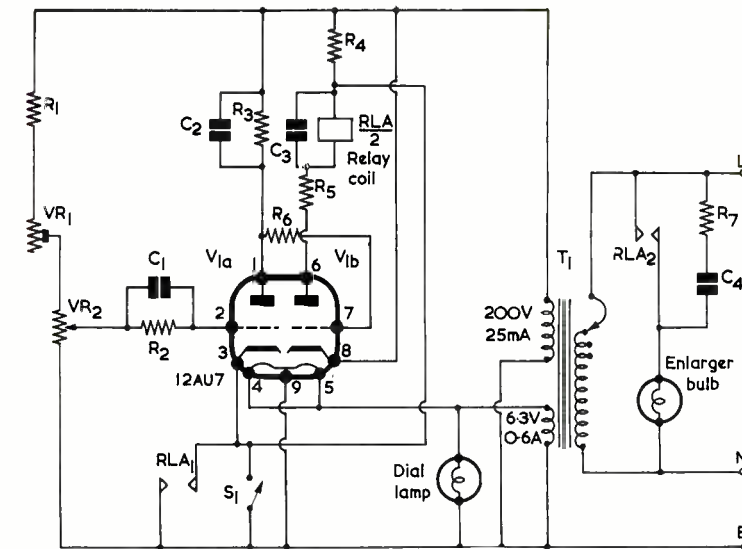

Fig. 1. The circuit of the timer

to the same supply line as its anode, and so the relay is inoperative.

When S₁ is closed, the upper terminal of the relay coil is brought down to the lower supply line so that, given the requisite grid-cathode potential in V_{1(b)}, this valve is capable of passing a current and energising the relay on half-cycles when the lower supply line is positive. (As we shall see very shortly, the grid and cathode of V_{1(b)} are at virtually the same potential, whereupon the relay does energise when S₁ is closed).

The closing of S₁ also brings the cathode of V_{1(a)} to the same potential as the lower supply rail with the result that, on half-cycles when the upper supply line is positive, this valve could, given the requisite grid-cathode potential, also pass a current. But the grid of V_{1(a)} is held negative of cathode by the charge previously acquired by C₁, and so V_{1(a)} does not at this stage conduct.

When S₁ was closed, no voltage was present across C₂ and R₃, and the absence of anode current in V_{1(a)} ensures that this condition is maintained. The consequence is that the potential at the left hand terminal of R₆ is the same as that at V_{1(b)} cathode, allowing V_{1(b)} to conduct on cycles when the lower supply line is positive, and the relay to energise. Contacts RLA₁ close, and S₁ may now be opened without affecting circuit operation any further. Contacts RLA₂ also

close, switching on the enlarger bulb.

After a period of time depending on the setting of VR₂, C₁ discharges sufficiently to enable V_{1(a)} to pass a continually increasing current on half-cycles when the upper supply line is positive. Anode current flows through R₃, and C₂ becomes charged to a continuously increasing voltage, its lower plate being negative. C₂ retains much of its charge during the half-cycles when the lower supply line is positive, causing the grid of V_{1(b)} to go continually more negative of its cathode. The grid of V_{1(b)} soon goes sufficiently negative for the relay to de-energise, whereupon contacts RLA₁ and RLA₂ open and the timing period is at an end. The circuit has then reverted to its previous condition, and C₁ once more commences to charge via R₄ and the cathode-grid diode of V_{1(a)}.

The timing operation may be restarted by closing S₁ once more, but it is necessary to wait a little while to allow C₁ to become fully charged again as, otherwise, the next timing period will be shorter than would be indicated by the setting of VR₂. With the prototype it was found that, for consistent results, at least 10 seconds should be allowed between the end of one timing operation and the commencement of the next. For very consistent results, 15 seconds is recommended. Reducing the charging period between operations to

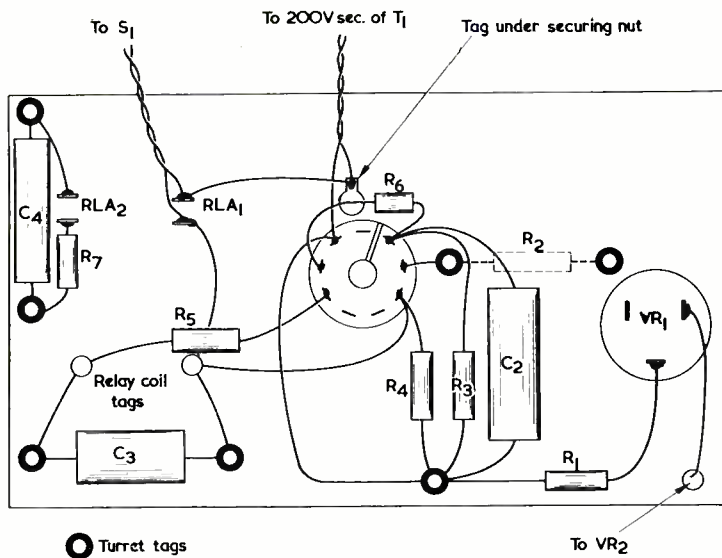

Fig. 2. Wiring underneath the chassis. The prototype employed turret tags, but normal solder tags secured by nuts and bolts could also be used. Not shown here is the heater wiring to the valveholder, or the lead connecting to the lower end of VR₂.

5 seconds lowered a 30 second timing period to 27 seconds, and a 100 second timing period to 91 seconds. The slight wait between timing periods is, of course, no disadvantage for production enlargement work, as other operations have to be carried out between exposures.

If the valve is to have a long and reliable life the current passing through it must be kept to a minimum consistent with accurate operation. The current passing through V_{1(a)} is limited by R₃, so that the current passing through V_{1(b)} is the deciding factor. R₅ was included in series with the relay to limit anode current to the minimum consistent with

reliable operation and will have to be found experimentally, though 15kΩ proved to be just right in the prototype. When the longest timing period is being used the voltage across C₁ rises to quite a high value so it is desirable for this capacitor to have an adequate working voltage.*

Due to the very high resistance required for R₂, leakage across the tags of the valveholder can be a problem, and the use of a ceramic or p.t.f.e. component is desirable. For timing to be repeated consistently and accurately, VR₂ must have as large a diameter as possible. Since the relay contact RLA₁ holds the relay closed once the timing period has been initiated, S₁ must be spring loaded or biased so that it is normally off.

Construction

Most of the components are

* It should be noted that the negative voltages applied to the grid of V_{1(a)}, particularly when the slider of VR₂ is at the bottom end of its track, exceed the maximum figure of -150 volts quoted by Thorn-A.E.I. for the 12AU7. In practice, no trouble was experienced with the prototype on this score, nor did it occur with a basically similar circuit described in our May 1962 issue (Suggested Circuit No.138—Low Cost Electronic Timer) which was checked with 12AU7 and 12AT7 valves. Nevertheless, the fact should be brought to the attention of readers, with the additional point that, as the valve specified is operated out of limits in this one respect there is a risk of damage to it, and that this risk should be accepted by the constructor.—Editor.

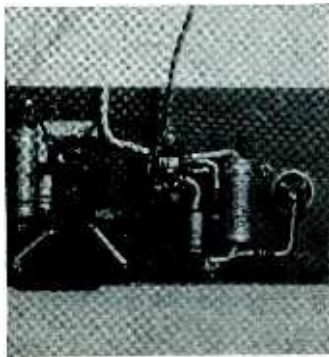

Below-chassis view, compare with Fig. 2.

mounted on a piece of $\frac{1}{16}$ in Paxolin measuring 6 x 3 $\frac{1}{2}$ in, turret tags being used to attach some of the components, as shown in Figs. 2 and 3. Turret tags are much favoured by the author since they are not only neat but allow components to be easily changed as and when necessary. Ordinary solder tags secured by nuts and bolts could also, of course, be used. The fact that the circuit is in no way critical of layout was proved during development when it was assembled as a breadboard "lash-up" with wires going everywhere—and still worked.

A wooden box 6 $\frac{1}{2}$ x 5 $\frac{1}{2}$ x 3 $\frac{1}{2}$ in houses the unit and should either have an open back or else be provided with adequate ventilation holes.

It was mentioned earlier that the dial light must be red or the paper will be fogged. It is also advisable to either run the bulb in series with a resistor or else use an 8 volt bulb so that the light emitted is less than normal. A minor item perhaps, but when all the minor items are added up they can make or mar an enlargement, so it is best to err on the safe side.

The unit should be constructed with a 15kΩ resistor in the R₅ position, as specified, bearing in mind that this resistor may have to be changed during the setting up and adjustment procedure.

Testing and Adjustments

When the timer has been completed and the wiring checked it can be connected to the mains and tried out. VR₁ should be at maximum resistance, and VR₂ set up for minimum time; that is, with its slider at the VR₁ end of the track. S₁ is then closed and immediately released. If the relay energises and holds in for several seconds all is well, and the timer can be calibrated after some 15 to 20 minutes have been allowed for warming up. If the relay tries to close but cannot do so, the value of R₅ will have to be reduced until the relay does close and continues to close in a definite and consistent fashion. VR₂ should then be turned to maximum (by setting the slider to the end of the slider which is remote from VR₁) and, after several seconds, S₁ closed. The relay should now pull in and remain energised for approximately 100 seconds, the actual time depending upon the exact values of C₁ and R₂. VR₂ is then turned to minimum time and VR₁ is adjusted until the desired minimum time is obtained when S₁ is closed; with the prototype this was 5 seconds. The timer

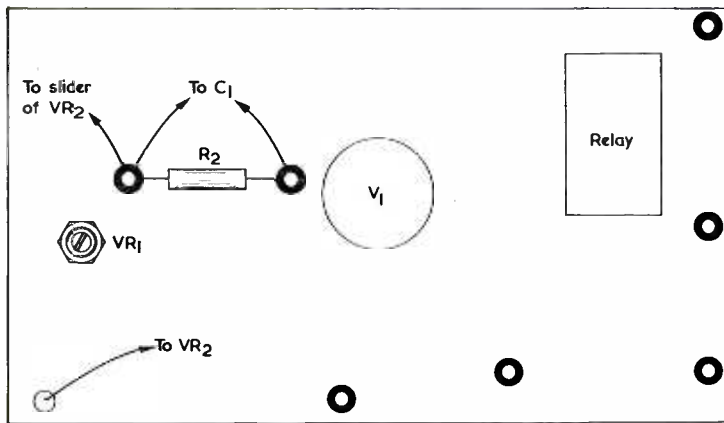

Fig. 3. Components and wiring above the chassis

can now be calibrated, this process being much facilitated if a stop-watch or clock with a large seconds hand is available. All that is necessary is to rotate VR₂ towards maximum time, marking off each selected time as it is reached, until the maximum of 100 seconds is obtained. To facilitate darkroom work the dial itself should be as large as possible, so that the calibrations are more easily seen.

The maximum time obtained depends upon the values of C₁ and R₂. In the prototype, 100 seconds was obtained with C₁ at 4μF and R₂ at 7.5MΩ, and it seems feasible that longer timing periods may be obtained by increasing either C₁ or R₂, or both. This is a point which has not been tried by the author but is offered as a useful possibility to the experimentally minded reader.

SIMPLE STABILISED POWER SUPPLY

By J. T. TIERNAN

This ingenious design requires few components, and it offers automatic short-circuit protection

ALTHOUGH VARIOUS DESIGNS FOR LOW VOLTAGE power supplies have appeared in this and other journals, it is intended to present here a design which may be unfamiliar to many readers. It employs an n.p.n. and a p.n.p. transistor in a complementary arrangement, and one of its most attractive features is that of short-circuit protection without the use of any extra components.

The circuit of the stabilised power supply. Whilst employing very few components, this offers automatic short-circuit protection

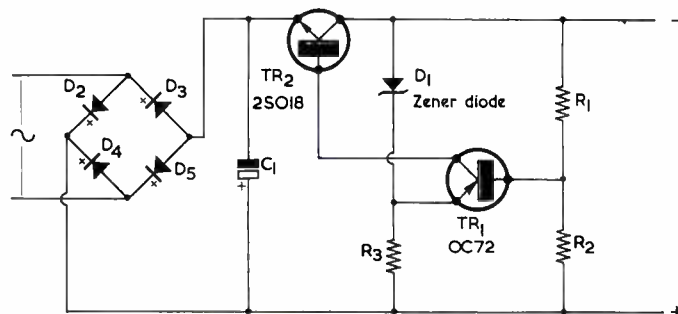

Indeed, the stabilising section proper employs only two transistors, one zener diode and three resistors; an economy which would be difficult to realise in even a simple shunt stabiliser. Typical component values are given for a low power supply, but the main purpose of this article is to present the general circuit as a basis for experiment.

Circuit Operation

Referring to the accompanying circuit diagram, it may be seen that TR₁, a general purpose p.n.p. transistor, acts as a comparator and driver, while TR₂, an n.p.n. silicon type, is the series control element. Any error voltage, due to change in output voltage, is fed to the emitter of TR₁ via zener diode D₁, and the initial d.c. conditions are set by the potential divider R₁ and R₂.

The circuit functions under load conditions in the following manner.

Assume the negative output line goes slightly less negative due to load current flowing. A positive increase of the same value appears at the emitter TR₁ and, since this is equivalent to negative at the base, TR₁ conducts more heavily and causes a positive increment at TR₂ base. TR₂, being n.p.n., thus conducts more heavily to meet the requirements of the load, and the negative output line

tends to return to its original value. A similar compensating action, in reverse of course, takes place when the output voltage tends to increase.

It may be noticed that the base of TR₁ also senses any change in the output voltage in such a way as to counteract the effect just described. However, due to attenuation by R₁ and R₂, this change at the base will be less than that at the emitter, and the overall effect will result from the larger change at the emitter.

Let us next consider the conditions when a short-circuit is placed across the output terminals. With a short-circuit across the output there will be no voltage between the output lines, whereupon the base and emitter of TR₁ will be at the same potential, and TR₁ will, in consequence, be cut off. Under these conditions the base of TR₂ is effectively open-circuit and the output current is limited to that which results from leakage current in TR₁. The leakage current of TR₂ is so small as to be disregarded, and if a p.n.p. silicon type is used for TR₁, then the output current under short-circuit load conditions will be practically zero.

Current limiting for any particular value of load may be accomplished by inserting a resistor of appropriate value in series with the emitter of TR₂. This will result in slight degradation of the regulation performance, but it will still be superior to the equivalent shunt stabiliser due to there being appreciable gain within the control feedback loop.

It is important to notice that without a series limiting resistor the regulator functions quite normally unless grossly overloaded, and does not afford protection unless the load resistor approaches zero. The usual precautions regarding collector dissipation in TR₂ must therefore be observed.

Output Voltage

The circuit as presented is not without its disadvantages. In particular it is not well suited for supplying an output voltage which is variable over a wide range, and the minimum output for good regulation would be approximately ($V_z + 1.0$) volts, where V_z is the zener voltage of D₁. The use of a zener diode with low breakdown voltage will obviously allow a lower output voltage to be obtained, but this will be at the expense of reduced collector-emitter voltage for TR₁, and regulation may suffer in consequence.

The output voltage may be calculated from the following equation:—

$$V_o = V_z \left(1 + \frac{R_2}{R_1} \right)$$

and should be within 1 volt of the calculated value.

Typical component values are given for the circuit. The a.c. input from the transformer used is 12 volts and the output is 10 volts d.c. The maximum output current is about 180mA. Output impedance up to 150mA is less than 1Ω and, though no precise measurements were taken, ripple on the output, with C₁=250μF and an output current of 150mA, is not expected to exceed 50 millivolts peak-to-peak.

With a short-circuit across the output terminals, and a high leakage OC72 used for TR₁, the output current is less than 20mA. With a low leakage OC71 used for TR₁, the output current was less than 10mA. The 2S018 was replaced with a high power 2S012A with no effect on performance. For the present application the 2S018 should be mounted on a small heat sink, a piece of 1/8 in aluminium of 3 square inches area being adequate.

Using the parts specified the unit can hardly be considered expensive, and the cost of basic components, including transformer and four diodes for a bridge rectifier, could be quite low.

Any low leakage p.n.p. transistor is suitable for TR₁, provided the maximum collector-emitter voltage quoted by the manufacturer is not exceeded. If a silicon p.n.p. type is used, the OC200 and 2S301 are available cheaply. Suitable alternatives for TR₂ include 2S019 or 2S017.

Higher Voltages and Currents

The circuit is, of course, quite suitable for higher voltage and current outputs provided components of adequate power rating are used, and it may then be necessary to replace TR₂ with two or more transistors in the high gain Darlington configuration. However, in this case thorough testing would be required before the circuit could be assumed safe so far as short-circuit loads are concerned. The internal impedance of a higher power supply will be lower, and though a short-circuit load may cause cut off, the initial current transient may be of sufficient magnitude and duration to damage or destroy TR₂.

Summarising, the advantages of the circuit, as so far described, are as follows:—(1) Inherent short-circuit protection, (2) good regulation and (3) economy of components.

A further advantage, which has not yet been mentioned, is that there are no passive components between the stabilised and unstabilised sections of the supply. Ripple transmission is, therefore, reduced.

The only real disadvantage lies in the fact that the circuit is best suited for supplying a fixed output voltage, and the minimum output voltage for good regulation is probably around 6 volts.

Finally, no claims for originality are made, but it is hoped that this article may bring some recognition of a very useful, and simple, power supply arrangement.

Editor's Note

The 2S018 is an n.p.n. silicon transistor having a maximum dissipation of 4 watts at 25°C and 1 watt at 150°C, together with a maximum collector voltage of 100 at 25°C. The 2S017 is virtually identical except that maximum collector voltage is 60. The 2S019 is also rated at 4 watts and 60 watts. The 2S012A is a larger transistor rated at 37.5 watts total dissipation at 25°C and 15 watts at 100°C, with a maximum collector voltage of 60. Design centre H_{fe} figures are:—2S017 and 2S018, 20; 2S019, 60; 2S012A, 30. These are all silicon n.p.n. transistors and are available through stockists such as Henry's Radio, Ltd.

Components List

Resistors

(All $\frac{1}{4}$ watt 10%)

R₁ 3.9k Ω
R₂ 820 Ω
R₃ 220 Ω

Capacitor

C₁ 250 μ F, electrolytic, 12V wkg

Semiconductors

TR₁ OC72
TR₂ 2S018
D₁ KS40A or OAZ206 (8.2 volt zener diode)
D₂-D₅ DD000 (Henry's Radio Ltd) or equivalent silicon rectifiers

SIMPLE CALIBRATION AID

By G. HENSHAW

This transistorised unit operates from a 1.5 volt cell and can couple into medium wave receivers by way of its own ferrite-cored coil

THE BEGINNER OFTEN HAS DIFFICULTY IN CALIBRATING home-made receivers, particularly if the coils are home-wound. Commercial signal generators are expensive, and often beyond the pocket of the average constructor.

The calibration aid described here covers the medium wave band. It is easy to construct, and the components are inexpensive and readily available. Apart from enabling the range of a newly constructed receiver to be quickly found, it can also be of assistance in servicing work.

The Circuit

The circuit of the calibration aid appears in the accompanying diagram, and it comprises an r.f. transistor connected in the grounded base mode with feedback applied, via C₁, from collector to emitter. The frequency of oscillation is controlled by the tuned circuit C₃ L₁.

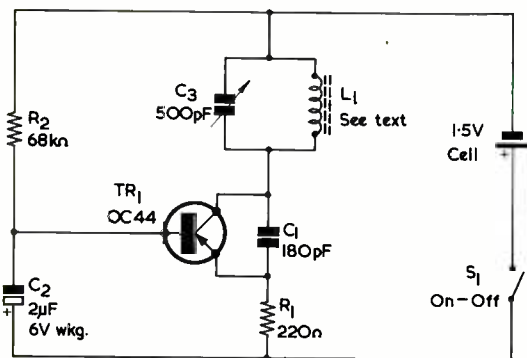

L₁ consists of 30 turns of 32 s.w.g. enamelled wire close-wound on a $\frac{3}{8}$ in diameter ferrite rod having a length of 1 $\frac{1}{2}$ in. The turns are held in place by p.v.c. insulating tape. This coil covers the medium waveband in conjunction with C₃. The latter should be an air-spaced component if maximum range is to be achieved.

The tuning capacitor may be fitted with a scale which can be marked up in terms of wavelength or frequency.

Calibration and Use

Since coil L₁ is wound on a ferrite rod it may be coupled inductively into any receiver having a ferrite rod aerial or unscreened aerial coils. It may also be coupled into a receiver with screened aerial coils by holding it close to the aerial wire.

To calibrate the unit, switch on a medium wave receiver and tune it to a station of known wavelength. Place the calibration aid about 2ft away and adjust C₃ until a heterodyne is heard. Tune to the centre of the heterodyne, whereupon the aid is oscillating at the same frequency as the received signal. Mark the calibration aid scale accordingly, repeat with several other received stations of known wavelength, then complete the scale. (If two heterodynes are given over the range of C₃, guard against using harmonics by choosing the one which corresponds to less capacitance in this capacitor. —EDITOR.)

The reverse process is then applied to an uncalibrated receiver. This is tuned to a station and the calibration aid adjusted to give a heterodyne as before, whereupon the wavelength may be read from its scale.

An alternative scheme, which also simplifies construction, consists of dispensing with the scale for C₃. When a receiver requires calibration, the aid is adjusted to provide a heterodyne with a working receiver on a known station. Without altering the setting of C₃, the aid is next transferred to the receiver to be calibrated, the latter is tuned for the heterodyne, and then calibrated for the station. This procedure may be repeated for other stations until calibration is complete.

Construction of the aid should not raise any problems, as layout is not of importance. The author's version was housed in a wooden chess-box, C₃ and S₁ being mounted on one side.

In Your Workshop

In this month's episode *Smithy the Serviceman*, aided as always by his able assistant, *Dick*, turns his attention to the a.g.c. and detector circuits of transistor radios. In the process he shows *Dick* a simple scheme for locating the faulty section of a receiver which suffers from poor sensitivity

"WHEN these little transistor radios come in," pronounced *Smithy* firmly, "the first thing you should do is to check the battery voltage."

It was obvious that *Smithy* had assumed one of his more dictatorial moods.

"You always say check the battery," protested *Dick*, "and I always *do* check the battery. With the set I've got here the battery's reading a good healthy 9 volts."

"Good," commented *Smithy* briskly. "You also want to check the battery after the set's been on for a while."

"I maintain," replied *Dick*, manifestly irritated at *Smithy's* undeviating concentration on the subject, "a constant watch on battery voltage."

"Excellent," said *Smithy*. "What you have to remember is that a worn-out battery can check good at first, but that it may sag a bit after the set has been switched on for half-an-hour or so."

Weak Reception

Smithy fell silent for a moment.

"If the battery is O.K.," he resumed, "and you haven't any other *immediate* ideas concerning the fault, the next thing with these transistor radios is to make a quick visual check for *obvious* snags. Don't forget that some set-owners are pretty ham-fisted and that the works of the radio are wide open to them whenever they take the back off to replace the battery. The ferrite aerial is particularly vulnerable. Very often, the lead-outs from the ferrite aerial coils to the printed circuit board consist of the winding wire itself. This is thin and can easily be broken if the person changing the battery is careless."

"I've checked the ferrite aerial connections, too," said *Dick*, with increasing exasperation, "and there's nothing wrong there, either."

"Good," continued *Smithy* inexorably. "I don't need to remind you that a broken ferrite aerial lead-out connection can give quite misleading symptoms. If, for instance, the break causes the r.f. circuit to the base of the mixer-oscillator transistor to become open-circuit, the set may even go into oscillation at i.f. frequency. This is because the base isn't held down by what, at the intermediate frequency, is a fairly low impedance."

"In this little radio," said *Dick* through gritted teeth, "there are no obvious visual snags at all."

"What's wrong with it, then?"

"It just," said *Dick*, "gives weak reception, I can pull in the local stations on medium and long waves, but they won't come up at full loudspeaker strength. At the same time there's no distortion of the signal. I've now got stumped on it, and that's why I called you over. With the result," concluded *Dick* bitterly, "that you immediately broke forth into a discourse on basic servicing, and nattered on about stuff I learnt years ago."

"All right, then," replied *Smithy*, nettled. "If you're so blinking clever, what *have* you checked up to now?"

"Well," said *Dick*, his irritation vanishing, now that he held the stage. "I did the obvious bits you've just been going on about. There was no joy there, and so I next got the printed board out of the box and did a few voltage tests, checking against the figures given with the circuit in the service manual. (Fig. 1). The first thing I wanted to ensure was that the correct supply voltage was getting to the various parts of the circuit. This set follows the usual practice of running the output stage and driver collector from the full 9 volts, after which there is a decoupling resistor for the r.f. and i.f. stages. So I checked the supply voltage on either side of the decoupling resistor. Does that seem reasonable?"

"I'm still recovering," announced *Smithy*, "from the news that you got the service manual out! But, still, all you've said up to now is quite reasonable. What did your checks tell you?"

"They told me," replied *Dick*, "that the supply line voltage to the output stage and driver collector was 9 volts. And that the supply line voltage to the remainder of the set was just below 8 volts."

"That sounds pretty fair," commented *Smithy*. "What happened next?"

"I next tested emitter voltages,"



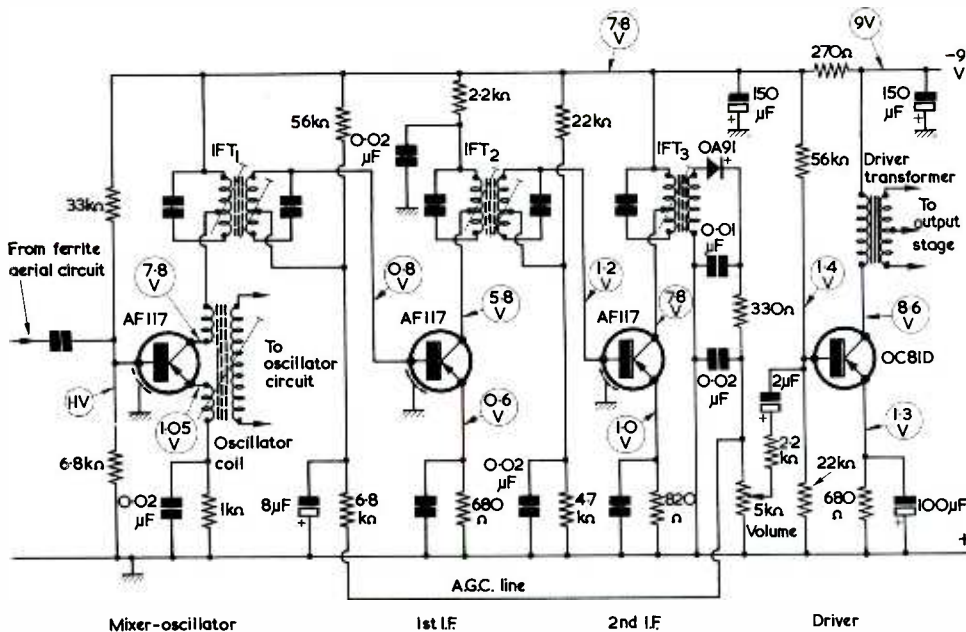

Fig. 1. A simplified circuit, with representative component values, showing typical voltage readings in the mixer-oscillator, i.f. and driver stages of a small 9-volt transistor radio. All voltages are with respect to the positive supply line. In some receivers, the a.g.c. line may connect directly to the positive side of the diode detector, instead of after the i.f. filter resistor, as is shown here. For reasons of simplicity, the output stage is not included

said Dick, "with the positive lead of the testmeter connected to the positive terminal of the battery."

Smithy frowned.

"I don't think I'd have started checking emitter voltages at that stage, myself," he commented. "Incidentally, why did you connect the testmeter to the battery terminal?"

"It's a habit I've got into," explained Dick. "The idea was to check the voltage between the emitters and the positive supply line, whereupon I could have connected the meter lead to any bit of metalwork which was at chassis potential. In some of these sets, though, the chassis is connected to the negative side of the battery instead of to the positive side. So I nowadays connect to the positive battery terminal itself, just to make sure."

"Dear me," remarked Smithy. "Do you know, Dick, there are times when I begin to think that you're really cut out for this servicing business."

Dick considered this statement dubiously, then dismissed it from his mind.

"I next," he announced, "stabbed away at the emitters of the transistors. If I got a low voltage at any emitter, it would indicate that the

transistor concerned wasn't passing enough current."

"Did you do this," asked Smithy, "with the set tuned in to a station?"

"I don't think so," replied Dick, puzzled. "No, now I come to think of it, the set was definitely off a station. But why do you ask?"

"I'll tell you later on," said Smithy. "As I said just now, I'm not at all certain that you should have started checking emitter voltages at this stage. Anyway, go on with the story."

"All the emitters," resumed Dick, a little uncertainly, "showed voltages which were pretty close to the ones given in the service manual."

"Fair enough," said Smithy, "and I'll forget about the order of testing for the moment. If, incidentally, you're doing a rough check on transistor voltages and you haven't got the service manual available, it's usually pretty safe to assume that the emitters of the mixer-oscillator and i.f. transistors of a 9-volt set should be between 0.4 and 1.3 volts when you're not tuned to a station. Usually, the emitter of the first i.f. transistor has a lower voltage than the others. If any emitter voltage is lower than 0.4 volts you should suspect insufficient base bias current, and if it's higher than 1.3 volts you should suspect

too high a base bias current."

"What about the transistor itself?"

"That becomes suspect, too," replied Smithy. "Although I'd look around at a few other components first before I started on the transistor. I must emphasize that, so far as voltages are concerned, I'm only speaking of rough checks for transistor operation. You may occasionally encounter a receiver in which an i.f. or mixer-oscillator transistor is intended to operate outside the emitter voltage figures I've just mentioned. And look out for n.p.n. r.f. and i.f. transistors, particularly in imported sets. In the a.f. stages it's impossible to lay down any hard and fast rules as to the voltages to be expected on the transistors, because there is a wide variance in the circuits employed. But you can find out whether an a.f. transistor is at least, passing a current by seeing that a voltage is dropped across its emitter resistor. Whilst we're on this particular subject, another point is that you should get a slightly higher voltage on the base than is given at the emitter, the base being some 0.05 to 0.3 volts higher. But you need a voltmeter of at least 20,000 ohms per volt to check this point reliably if one of its leads is coupled to the positive supply line, since a

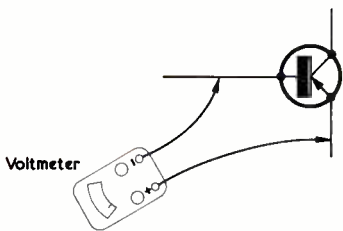

Fig. 2. The low voltage between base and emitter of an operating transistor may be conveniently checked by connecting the test-meter across these electrodes. With a p.n.p. transistor, the base should be negative of the emitter

low resistance voltmeter may draw too much current when it connects to the base. If in doubt, connect the meter directly between base and emitter. (Fig. 2). With a p.n.p. transistor the base should be negative of the emitter."

A Process of Elimination

"In this set," said Dick, "I've carried out emitter and base voltage checks on all the transistors, including those in the output stage. And I've checked the collector voltages as well. The trouble is that everything's just as the service manual says it should be. What's puzzling me even more is that you now say I shouldn't have checked the transistor voltages anyway!"

"I suppose," mused Smythly thoughtfully, "that I can't really blame you for wasting your time with all those voltage readings."

"Blame me?" queried Dick incredulously. "Dash it all, Smythly, everything I've done up to now has been strictly according to the book."

"Not according to *my* book it hasn't," retorted the Serviceman. "You've forgotten the first rule of servicing. Whenever possible, you should always try to isolate the location of a fault by a process of elimination."

"That's just what I have been doing," replied Dick indignantly. "I've been trying to isolate the transistor stage which has been causing the trouble."

"What you did wrong," pronounced Smythly, "was to check transistor voltages too soon. You missed out an important step."

"Did I? How?"

"You should first have established," said Smythly, "whether the weak reproduction of signals was due to a fault in the a.f. stages after the detector or whether it was

due to a fault in the mixer and i.f. stages up to and including the detector. The time to start measuring transistor voltages was *after* you'd taken that step."

"As a matter of fact," said Dick, "I did think of using that approach. I could, for instance, have checked out the a.f. stages by applying the a.f. signal genny to the volume control. Since, however, I don't know what the a.f. level at this point should be to give full output from the speaker, I can't see that it would have been of much assistance to me."

"I wasn't thinking of using a signal genny," replied Smythly. "It's possible to check which section of the receiver is responsible with nothing more complicated than received stations and a testmeter. Indeed, you should get a good idea of which section the fault is in by merely listening to the set. If you get a lot of stations, all at weak loudspeaker level, then the fault is almost certainly in the a.f. stages. And if you can only get a few stations, with one or two considerably louder than the others, then the fault is probably in the stages before the detector."

"I should imagine," suggested Dick, "that a listening test like that would be best carried out in the evening and at night-time, when there are plenty of stations coming in on medium and long waves. I can't see it being exceptionally helpful during the day, when you can only get a few local stations."

"Perhaps you've got a point there," admitted Smythly. "Anyway,

let's have a listen to *this* particular set!"

Smythly turned his attention to the printed circuit board which Dick had removed from its mounting in the receiver cabinet. He switched on and adjusted the tuning capacitor. As Dick had stated, a few local stations only could be received, and these were reproduced at considerably reduced volume.

"They seem to be coming in," remarked Smythly, "at fairly similar volume levels. Which means that the a.g.c. is probably working O.K. and that enough i.f. signal is being passed to the detector to *enable* the a.g.c. to work. I would suggest that the snag is in the a.f. stages. Anyway, we can soon confirm that. Or, rather, you can."

Smythly tuned the receiver off the last station he had selected and switched off. He then stood to one side and motioned Dick to seat himself in front of the receiver.

"Right," commanded Smythly, the anticipatory gleam of the warrior about to go into battle entering his eye. "We're in business! Switch your testmeter to a low volts range and connect its negative lead to the positive terminal of the battery."

"Is that right?" queried Dick, as he picked up the meter leads. "Meter *negative* to the battery?"

"Of course it's right," said Smythly, shortly. "If you're puzzled, the battery is that rectangular-shaped object with 'Every Ready' printed on it."

"I know what a battery is," snorted Dick indignantly. "But

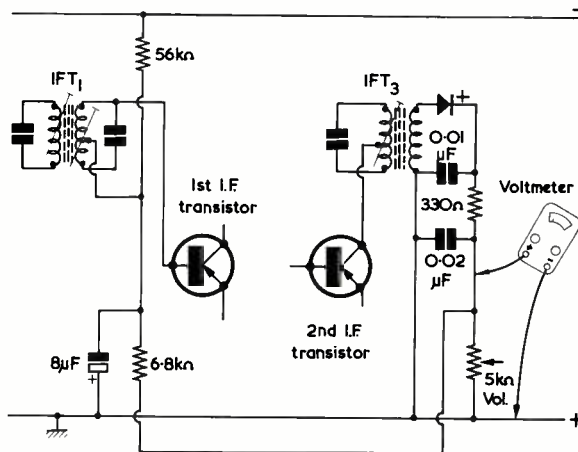

Fig. 3. A detail of Fig. 1, illustrating that the upper end of the volume control track goes positive on reception of a signal. This positive voltage, which may be readily measured by a testmeter, is applied to the base of the first i.f. transistor as a.g.c.

you're putting the meter negative..."

"And," Smithy interrupted him briskly, "clip the positive testmeter lead to the hot end of the volume control track. The volume control," he added helpfully, "is that round component with the three tags poking out of its side."

Smithy's fuming assistant clipped the positive testmeter lead to the appropriate tag. (Fig. 3).

"And now," continued Smithy, "switch on. To operate the switch..."

"I know," snarled Dick, "how to operate the switch. There you are, I've switched it on now."

Dick glanced down at the meter.

"All this is a lot of flipping help, I must say," he added contemptuously. "All that's happening is that the meter needle has gone backwards!"

"These," remarked Smithy cheerfully, "are early days yet. Tune in a station."

Rebelliously, Dick adjusted the tuning capacitor, and the sound of a transmission became weakly audible in the Workshop. Dick looked down at the meter and started.

"Blimey," he gasped. "It's reading half a volt now. And in the right direction, too!"

"That," remarked Smithy, pleased, "is what it's supposed to read. If you adjust the tuning capacitor, you'll find that the meter acts like a tuning indicator."

Dick did as he was bid.

"Well, I'm darned," he remarked incredulously. "The reading goes up as you come more and more on tune. This is a turn-up for the book, I must say!"

"I wouldn't know about that," replied Smithy. "But I do know that what you're doing now represents the test you should have made before you started digging away at those transistor voltages. This test proves conclusively that the a.f. stages are at fault."

"How's that?"

"Because that volume control is the diode detector load," explained Smithy. "We're getting half a volt across it, which means that we're getting half a volt of detected carrier from the diode for feeding back to the base of the first i.f. transistor as automatic gain control. Now, if the a.f. stages were working O.K., they would be capable of reproducing at full loudspeaker strength any signal which resulted in the generation of an appreciable a.g.c. voltage. Since we're getting a very appreciable a.g.c. voltage, it follows that it is the a.f. stages which are causing the weak reproduction."

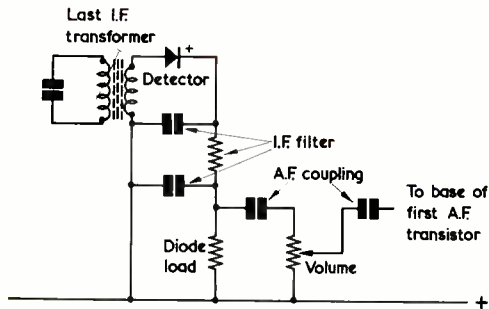

Fig. 4. In some receivers the diode load is a fixed resistor coupled to the volume control by a capacitor. In this instance the presence of a.g.c. voltage may be detected by connecting the testmeter across this fixed load resistor

Faulty A.F. Stages

"Blow me," remarked Dick elegantly. "This is a test I've never even heard of before. I must admit that it's a jolly good approach, though. All you've got to do to check the circuits before the detector is to clip a meter between the positive supply line and the hot end of the volume control."

"That's right," agreed Smithy. "And the volume control tags can, of course, be located very easily. I should mention that in some sets the volume control doesn't constitute the diode load, a fixed resistor which couples to the volume control via a capacitor being used instead. (Fig. 4). You would then have to clip to the fixed resistor. But in most sets it's the volume control that's the load. As you've just seen, the hot end of the volume control track goes slightly negative in the absence of signal. This is due to the current drawn through it by the base bias components for the first i.f. transistor. But when a signal comes along, the hot end of the volume control track goes positive, because of the way the diode detector is connected. And that explains the polarity required in the testmeter leads."

"So it does," said Dick, frowning. "Let's think, now! Why does the voltage at the hot end of the volume control go positive when a signal is tuned in? Ah, I see it all now! It's got to go positive because it's applied as a.g.c. bias to the base of a p.n.p. transistor."

"You've got it," chuckled Smithy. "Well, now, the next job is to locate the snag in the a.f. stages. If you'd carried out the diode load test at its proper station in the scheme of things, you would now be settling down to checking transistor voltages in the a.f. section.

It so happens that you've done these already and found them to be O.K., so we must next scratch our heads and look elsewhere for the snag."

"Could it be due to a fault in the driver transformer? Or in the output stage?"

"Doubtful," replied Smithy judiciously. "You see, all that's wrong is weak volume without distortion. We know that the output transistors are passing the requisite emitter current, and there's no trace of excessive crossover distortion or any distortion which would indicate excessive unbalance in them. All these factors point to the output stage being O.K. Or good enough, at any rate, for us to disregard it for the moment. The fact that the quality of reproduction is quite reasonable makes me feel that things like transformers and coupling capacitors are all right, too. You'd expect the frequency response to be obviously upset if any of these started playing up."

"What about the electrolytic," asked Dick suddenly, "which bypasses the emitter of the driver transistor? (Fig. 5). Could that have gone open-circuit?"

"It could," agreed Smithy. "If it was open-circuit you'd get degeneration and loss of volume. I see it's got a value of 100 μ F, so you'll need to bridge it with another capacitor of pretty high value to make a definite test. It will be O.K. to just connect the second capacitor across the first whilst the set is switched on in this particular instance because, apart from anything else, the base of the driver transistor is isolated from the electrolytic coupling it to the external circuit by a 2.2k Ω resistor. This 2.2k Ω resistor will ensure that any surges which take place when

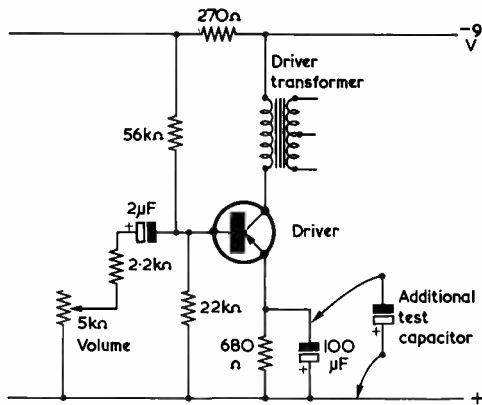

Fig. 5. Temporarily connecting an additional capacitor across the emitter bypass capacitor for the driver transistor. For the purpose of the test, the additional capacitor could have any value between 20 and 100 μ F

you add the second capacitor will lie within safe bounds."

Whilst Smithy was speaking, Dick had found another electrolytic capacitor. He bridged it across the capacitor in the receiver, but there was no improvement in volume level.

"Well, that clears that," said Smithy. "Now, let's see what else might be causing the snag. Why, dash it all, what about that 2.2k Ω resistor itself? That would definitely cause the trouble if it went high in value, because it's in series with the a.f. input to the driver transistor."

"Should I disconnect one end of it," asked Dick, "before I connect the meter across it?"

"With a bit of luck," replied Smithy, "that probably won't be necessary. The resistance reading you'll get will be lower than the true value of the resistor because of the external circuit that's connected across it, but the meter reading should still offer a useful guide. That 2 μ F coupling electrolytic is immediately in series, so the error shouldn't be very great."

"If that electrolytic's in circuit," persisted Dick, "won't it exhibit a low resistance when the testmeter leads are connected one way round?"

"Not very low," replied Smithy. "Electrolytics normally exhibit a lowish leakage current regardless of which way round you connect the ohmmeter leads. I should select a resistance range on the meter of the order of 10 to 100k Ω or so."

"Your wish," said Dick, as he applied his test prods across the resistor in question, "is my command. Blimey, we're in luck. This is the fault all right!"

"What's the meter say?"

"It's reading," replied Dick happily, "no less than 25k Ω !"

"Good show," said Smithy. "Whatever the actual value of that resistor may be, it's a jolly sight higher than the 2.2k Ω that's marked on it!"

A.C./D.C. Load Ratio

Dick busied himself with the side-cutters and the soldering iron whilst Smithy looked on. Very soon, a fresh 2.2k Ω resistor found a new home on the printed circuit board. Dick switched on again and adjusted the tuning capacitor. This time, the volume afforded by the receiver was all that it should be.

"And that," remarked Smithy with great satisfaction, "is that. Another little job cleared up!"

"It's nice to see them out of the way," agreed Dick, "and thanks for the assistance, too. Do you know, Smithy, I'm still rather taken with that dodge of yours for finding whether the fault is before the detector or after it."

"It's simple enough really," replied Smithy. "If you've got a weak transistor set and you can't make up your mind whether the loss is in the r.f. and i.f. stages, or in the a.f. stages, all you do is pop a voltmeter across the diode load, which is usually the volume control. If you get a reading when you tune in a station then it's obvious that the signal across the diode load is sufficiently high to cause an a.g.c. voltage to be formed, whereupon the cause of weak reproduction *must* lie in the a.f. stages. Usually, the a.g.c. voltages across the diode load are quite high, and

they may go up to a volt or so with strong signals. If you don't get an a.g.c. voltage with *any* station, then the cause of weak reception must be in the circuits before the detector, or in the detector circuit itself. Incidentally, I said that you shouldn't check transistor voltages in the i.f. stages with a signal tuned in. The reason for this is that you may get false readings from the first i.f. transistor, which is normally the one to which the a.g.c. is applied. If a high a.g.c. voltage is formed, the base and emitter voltages of this transistor will be much lower than the service manual states, and this could cause you to follow a wrong lead."

"There's one little thing," offered Dick, "which has started to puzzle me."

"What's that?"

"That 2.2k Ω resistor we replaced," said Dick. "What's it included in the circuit for, anyway?"

"You'll find that series resistor in most transistor radios," said Smithy, "and it represents rather a tricky little design feature. If you dig into your a.m. detector theory you may remember that a diode detector has two loads, these being a d.c. load and an a.c. load. The d.c. load is represented in our present circuit by the volume control track, plus the 330 Ω i.f. filter resistor immediately following the diode. The a.c. load includes these two resistors as well, but with the input impedance of the transistor a.f. amplifier connected across the lower part of the volume control."

"Why's that?"

"Because," explained Smithy, "the 2 μ F electrolytic connected to the volume control slider has negligible impedance at a.f. To prevent excessive distortion it's desirable to ensure that the a.c. load isn't a great deal lower in value than the d.c. load, and this can be achieved by giving the input impedance of the transistor a.f. amplifier a high value. This input impedance can be made fairly high by juggling around with negative feedback but, even so, it may still not be high enough to enable a satisfactory ratio between the a.c. and d.c. loads to be given. So a series resistor is added to increase the impedance seen by the slider of the volume control. With the series resistor in circuit, the ratio between the a.c. and d.c. loads then reaches an acceptable figure."

Continuous Performance

"But the series resistor," protested Dick, "causes a loss of a.f. again."

"I know it does," replied Smithy. "It's one of those little things that set designers have to put up with. In practice the loss with a 2.2kΩ resistor would be, very roughly speaking, round about 6dB, which isn't too catastrophic. Anyway, I'm going back to my own bench now, so you can finish off that little set all by yourself."

"A loss of 6dB, eh," said Dick thoughtfully. "That's a loss of one half, isn't it?"

"In terms of voltage or current," replied Smithy, moving away determinedly, "6dB means a ratio of 2:1 or 1:2 according to whether it's a loss or a gain."

Smithy stopped, as a thought suddenly occurred to him.

"And there's another thing, too."

"What's that?"

"Give that battery a check before you let the set go," pronounced Smithy firmly. "With these transistor radios you should always check the battery voltage after the set's been on for some time."

Which is, it would seem, just about where we came in.

TRANSISTORISED A.C. MILLIVOLTMETER *Part 2*

by *H. Smith and D. L. Woolley, B.Sc.*

This concluding article completes the constructional details of an easily-built a.c. millivoltmeter having a range from 10mV to 100V full-scale deflection. Response is flat up to 200 kc/s on the volt ranges, and up to 400 kc/s on the millivolt ranges. The meter is unaffected by external fields and has a very high input impedance.

Cabinet Construction

SINCE, PROVIDED IT IS LARGE enough, cabinet size is not at all critical, the constructor may wish to purchase a suitable metal cabinet and cut out the appropriate holes for the meter and controls. For the prototype, aluminium panels were cut and bent to exact size by H. L. Smith & Co. Ltd., 287/289 Edgware Road, London, W.2.

Although it would be possible to mount the millivoltmeter components into a wooden cabinet with a metal front panel, such a cabinet would not screen the amplifier and pre-amplifier from external electrostatic fields which could easily cause false readings on the lower millivolt ranges. For example, the radio signal from a powerful medium-wave broadcast station situated only 2 miles from the authors' homes produced a small deflection on the millivolt ranges before the instrument had been housed in its cabinet. However, aluminium foil could be used to line a wooden

cabinet in order to act as a screen, but the foil must be electrically continuous and connected to the battery positive line in order to be effective.

As was just mentioned, the prototype metal cabinet was built up from panels of aluminium. These were held together by angle-section brass. Full details of the panel sizes are given in Figs. 6, 7 and 8. Aluminium is costly compared with steel, but it is very much easier to work, especially when large holes have to be cut out of the metal.

For those who decide to make a copy of the original cabinet, the metal-work must be carried out carefully as the panels of the cabinet will not fit together if even one panel is badly out of size or shape. If at all possible, it is a good idea to cut the panels to size using a metal guillotine, for in this way there is little or no sawing and filing to be done.

In Fig. 8 one of the panels is shown bent twice in order to form the two sides and the top

of the cabinet. It is quite possible to use three separate panels and join them together at the corners with more angle brass, and for those constructors who find the bending of metals difficult, this latter method is to be preferred. The positions of the holes to be drilled and tapped must be marked carefully and accurately. All the holes in the aluminium designated to take 6BA bolts should be drilled using a $\frac{1}{8}$ in or a No. 31 twist drill. The size of hole produced gives a little clearance for the bolt and makes the final alignment of the panels more easy. In order to produce 6BA threads in the brass angle, a tapping hole must be drilled using a No. 43 twist drill. A 6BA taper tap is used to produce the actual thread, no lubricant being necessary.

The base, sides and top should be fixed together first of all, followed by the front and back panels. At this stage the cabinet should feel firm and strong. Now, the front may be drilled

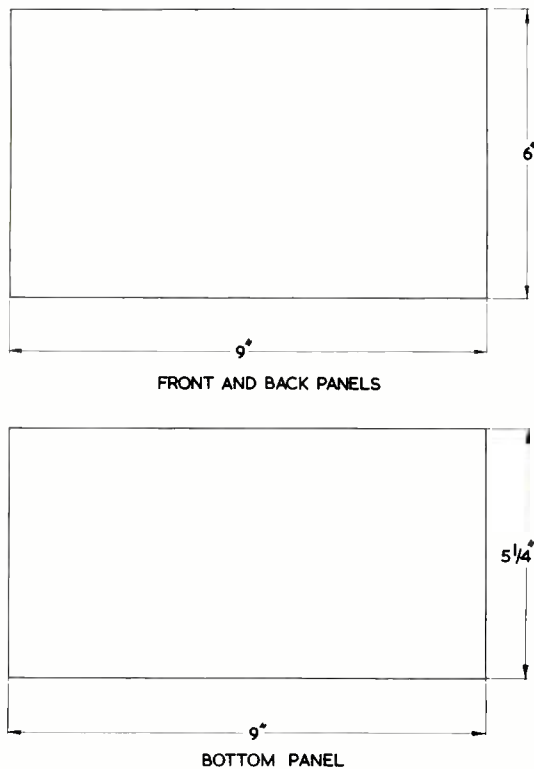

Fig. 6. Outside dimensions of the front, back and bottom panels. A suitable material is 16 s.w.g. aluminium

and cut, according to Fig. 9, to take the meter, switches and terminals, and the other panels drilled to take the mounting bolts for the printed board, choke, variable capacitor and battery clip.

As may be seen from the photographs, C_1 is mounted, on a small bracket, adjacent to the range switch. This bracket may be made up from oddments of aluminium, and its dimensions are not critical. It is necessary to provide a suitably positioned hole in the side of the cabinet near C_1 to enable a screwdriver or similar tool to pass through for adjustments to this component. The hole should be fitted with an insulating bush or grommet.

To give the cabinet a really good finish, it may be polished with fine steel wool and soap, washed, dried and painted. Each panel should be painted separately on the outside and edges

only, leaving the inner faces unpainted. Both black crackle and grey hammer-finish paints produce an excellent finish and are recommended. If the front

panel is finished in white cellulose paint and black knobs are used for the controls, the overall appearance of the millivoltmeter will be pleasing to the eye.

Should it be decided to fit rubber feet and a handle to the cabinet, it is necessary to drill holes for these before painting. Finally, if the bolts are to be screwed into position without harming the paint, washers should be placed under the bolt heads.

Final Assembly

The front panel components should be fitted into place first of all, care being taken not to scratch the painted outer face of the panel. In Fig. 10 the relative position of each component is shown. The relative positions of the components may also be judged from the photographs.

One of the most important components is the range switch, S_1 . This should have ceramic insulation and widely spaced contacts. A miniature, Paxolin insulated switch will cause trouble, as very high value resistors are used on the voltage ranges and the signal will tend to flow through the switch insulation. The overall effect of this is an increase in the high frequency response of the millivoltmeter, as stray capacitances between the contacts and poor insulation

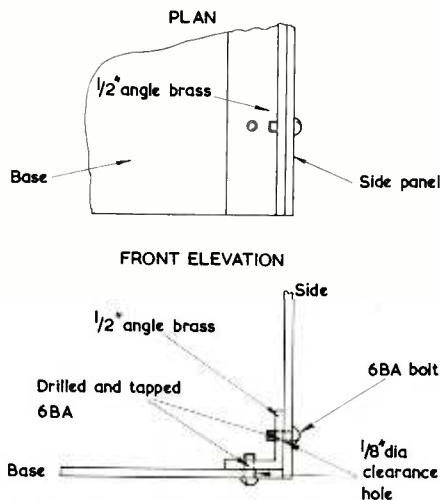

Fig. 7. Detail of cabinet construction, illustrating the manner in which the side and bottom panels are secured to $\frac{1}{2}$ in angle brass

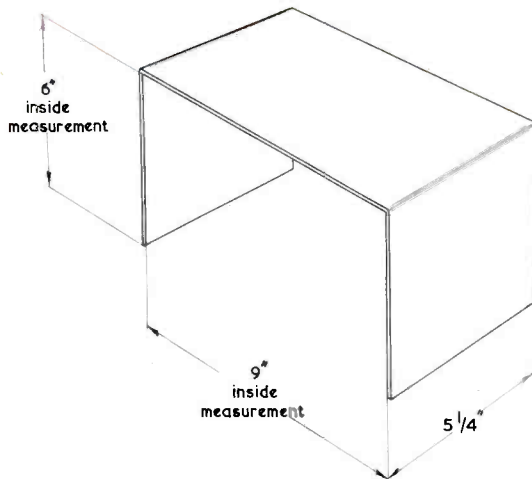

Fig. 8. The top and sides of the cabinet. A suitable material is, once again, 16 s.w.g. aluminium

both by-pass the range resistors as frequency increases.

The meter used in the instrument should be of good quality, with as long a scale as possible. For best results the f.s.d. should be of the order of $500\mu\text{A}$ although, as was mentioned in Part 1, considerable variation in f.s.d. is possible. Ideally, the meter scale should have three ranges, namely 0 to 3.16 volts, 0 to 10 volts, and -6 to -10dB . The actual meter used in the millivoltmeter had these ranges and was a Sifam type M42, the front panel of which is shown in the cover illustration in last month's issue.*

However, much useful work can be done with a meter having only one linear calibration. In fact, any linear calibration already on the meter may prove useful. For example, with a meter scaled 0 to 1 unit (the actual unit being immaterial), it would be possible to have switched full scale deflections of 10, 100 and 1000mV also 10 and 100V. The scale reading is adjusted mentally to suit the actual range in use.

Having chosen a meter, the constructor must decide upon ranges to suit his needs. As VR_1 has a wide range of calibration control, there should

be no need to alter the range resistors R_8 to R_{16} . Of course, if no 300mV range is contemplated, R_{13} will not be necessary, and so on. Some further points concerning the range resistors are given later in this article under "Testing and Calibration."

Input terminals have been chosen instead of a coaxial socket, as the use of the latter implies the use of coaxial cable which, because of its self-capacitance, tends to bypass high-frequency signals and so cause error. The calibration control VR_1 must be wired up carefully.

making sure that, as its spindle is rotated clockwise viewed from the front panel, the resistance between the base of TR_3 and the positive battery line is reduced.

Each lead from the printed board should be cut to size before soldering and placed in position as indicated in Fig. 10. It should be remembered that, as the cabinet is of unit construction, there is no need to fix any panel in place until required. Because of this, there should be no need to solder in awkward corners. Battery leads should be of flexible wire, twisted together and cut to a length that will allow removal of the battery without disconnection. The connections to C_1 should be well spaced from each other.

Testing and Calibration

When the components have been mounted and all the soldered connections checked, the battery may be connected into the circuit, the calibration control rotated fully anti-clockwise, and the instrument switched on. The meter pointer should give a slight kick and then settle down to zero on the scale. As the range switch is rotated, there may be slight disturbances of the pointer, but in all cases the meter should read zero. A milliammeter connected in one of the battery leads should

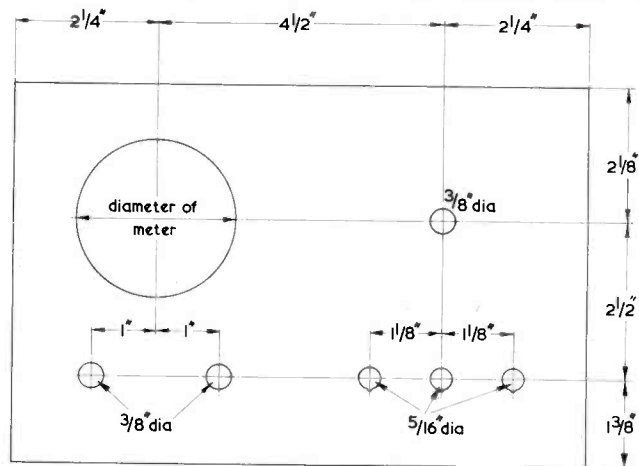

Fig. 9. The layout of the front panel. The three $\frac{5}{16}$ in holes are intended for insulated terminals of the type employed in the prototype. Other insulated terminals may require holes of different diameter

* Sifam instruments are manufactured by Sifam Electrical Instrument Co. Ltd., Woodland Road, Torquay, Devon.—Editor.

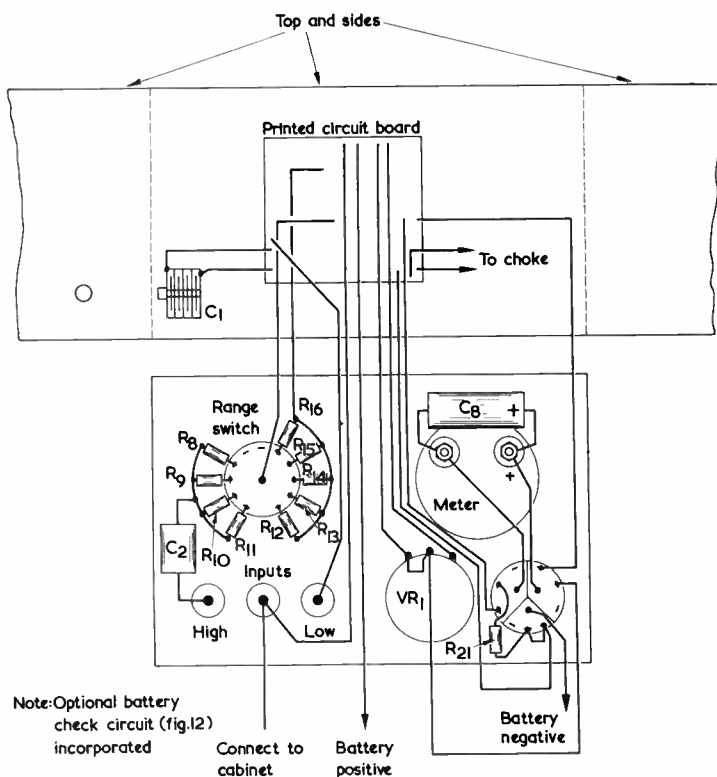

Fig. 10. Layout and wiring of the internal components. This diagram should be followed in conjunction with Fig. 4, published last month, which showed component layout on the printed board. It is important to ensure that the slider of VR₁ and the adjacent tag to which it is joined are connected to the lead from the board which is at chassis potential. The wiring to the 3-way switch assumes that the battery check circuit of Fig. 12 is incorporated

register a current flow of between 10 and 12mA. If readings well outside these figures occur, the instrument should be switched off and the circuit checked again.

The millivoltmeter now needs to be calibrated. Constructors who own or have access to an audio frequency signal generator with a calibrated output will

be able to calibrate the millivoltmeter easily, but if no generator is available, the circuit shown in Fig. 11 can be used to supply a calibrating signal. The procedure is as follows:—

1. Switch on the millivoltmeter and turn the range switch to the 1V position.
2. Apply the calibrating signal,

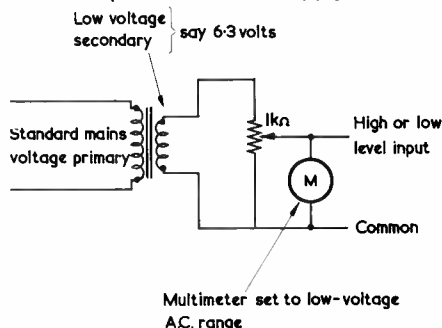

Fig. 11. A simple means of obtaining a calibrating voltage

which should have an r.m.s. value of 1V, to the low level input terminals. A suitable frequency to use would be 1000 c/s or, of necessity, 50 c/s if the circuit shown in Fig. 11 is used.

3. Adjust the calibration control VR₁ until the meter pointer indicates 1V. (VR₁ should not be near full clockwise rotation. If it is, it will be necessary to alter the value of the range resistors in a manner described later).
4. Apply the signal, still at 1V, to the high range input terminals and switch to the 3V or 10V range, depending on the ranges available. The pointer should now indicate 1V without there being any need to adjust VR₁.

If all is well and the range resistors are of good quality, then all the other ranges will be automatically calibrated. Of course, there will be small errors in the calibration. A high accuracy can be achieved by selecting each range resistor individually and comparing the ranges one with the other until satisfactory agreement is reached. For very accurate work, each range may be individually calibrated using VR₁ just before use, but a signal generator is necessary in order to make this possible.

It will have been noted that the range resistors, as specified in the Components List published last month, are given the rather wide tolerance of 5%. The reason for this is that the values of these resistors should, ideally, be in the ratio of 1 to $\sqrt{10}$, that is, 1 to 3.162. In practice the values used for the higher ranges are not exactly in this ratio.

As an example:—68 kΩ to 220 kΩ is a ratio of 1 to 3.235, 220 kΩ to 680 kΩ is a ratio of 1 to 3.091.

These ratios of 3.235 and 3.091 represent a deviation from 3.162 of approximately 2.3%. Therefore, careful selection of 5% resistors will very likely result in the correct ratio of 3.162 whereas close tolerance resistors (say 1%) can never give this ratio. For the low millivolt ranges, this ratio does not apply

and, for a high level of accuracy, the correct value for a range resistor may be found by selection, using the quoted value as a good guide.

It may happen that VR_1 has insufficient range to ensure calibration. As a simple remedy the following component changes should be made:—

1. If VR_1 has to be rotated fully clockwise in attempts to calibrate the millivoltmeter, reduce all the range resistors by a factor of 2; i.e. halve their values.
2. If VR_1 has to be rotated fully anti-clockwise, increase each range resistor by a factor of 2; i.e. double their values.

As VR_1 is also the negative feedback control and so has a considerable effect on the overall frequency response of the millivoltmeter, it is a good idea to try to achieve calibration with VR_1 rotated as far anti-clockwise as possible, this being the condition for maximum negative feedback.

On the millivolt ranges, variable capacitor C_1 is designed to bypass R_1 to an increasing extent as the signal frequency rises, and so maintain, as far as possible, the high frequency response of the instrument. In order to adjust C_1 correctly an audio frequency signal generator is essential. First of all, the 1V range should be calibrated at 1,000 c/s and then the input frequency increased to 20 kc/s. If the scale reading is now found to be slightly less than 1V, C_1 should be adjusted with a small insulated screw-driver or trimming tool until the meter pointer indicates 1V. A further increase in frequency should now be made, up to 100 kc/s, and slight adjustments made to C_1 if necessary. In general, if C_1 is set correctly at 20 kc/s then the response of the millivoltmeter will be nearly linear up to 10 times this frequency.

The introduction of C_1 as a bypass to R_1 does, however, produce a change in the input impedance of the millivoltmeter with change in frequency. This change is not a large one and

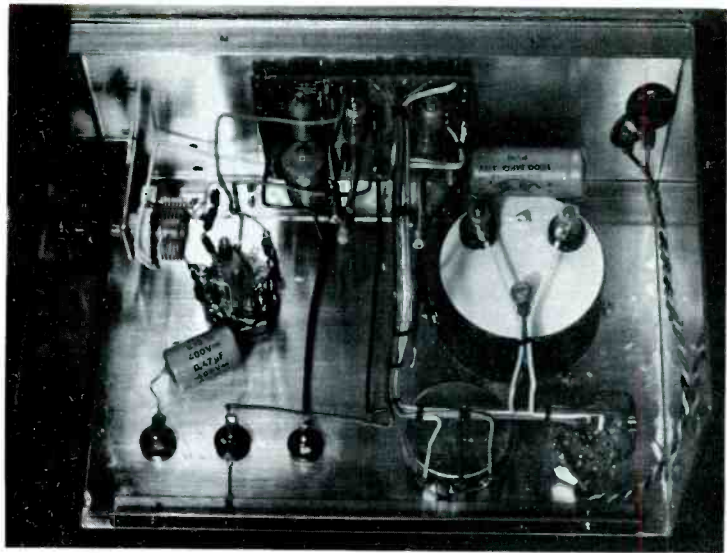

Layout inside the cabinet. The printed circuit board is fitted at the top of the cabinet

is unlikely to cause false readings during normal applications of the instrument.

Battery Check Circuit

As an optional refinement, a battery voltage check circuit may be included in the instrument, following the circuit diagram shown in Fig. 12. R_{21} should be of such value that the full scale deflection of the meter is 10 volts. For example, if a $500\mu A$ meter with an internal resistance of 200Ω is used, R_{21} should be $19.8\text{ k}\Omega$, the formula being:—

$$R_{21} = \frac{\text{F.S.D. required in volts}}{\text{F.S.D. of meter in amps}}$$

$$= \frac{10}{500 \times 10^{-6}} - 200\Omega$$

$$= 20,000 - 200\Omega$$

$$= 19.8\text{ k}\Omega.$$

In this case a $20\text{ k}\Omega$ resistor would be adequate and would introduce negligible error into the voltage-check readings.

With the battery check circuit,

Detail of the range switching components and C_1 . This capacitor is mounted on a small bracket secured to the cabinet top panel

S_3 of Fig. 12 replaces S_2 of Fig. 2 (published last month), and a 3-pole 3-way switch is suitable. When the 9V battery is new, a voltage-check reading should give around 9V to 9.5V. The millivoltmeter will function satisfactorily down to 6V, but calibration is not maintained accurately if the battery is in poor condition. A zener diode stabilisation circuit could be built into the millivoltmeter and so make calibration independent of battery voltage. However, calibration varies only a little with battery voltage and it is always advisable,

Internal Resistance

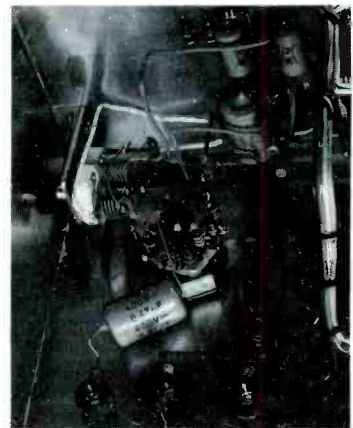

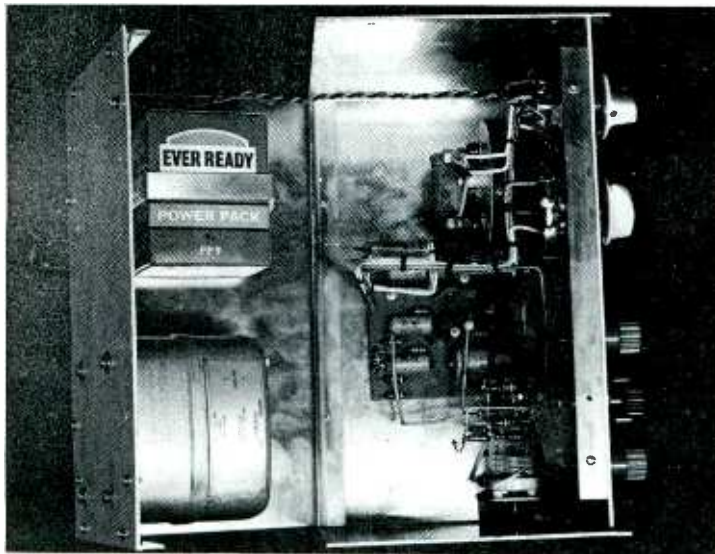

An internal view, showing the general assembly. The choke appears alongside the battery and is mounted on the bottom panel of the cabinet

in any case, to check calibration if any accurate work is intended.

Oscilloscope Monitor

If a capacitor of value $8\mu\text{F}$ (15V wkg.) is connected from the collector of TR_4 to the live contact of a jack socket mounted on the metal case of the instrument, then it will be possible to monitor the signal applied to the millivoltmeter on an oscilloscope connected to the jack socket. The maximum output signal available is 10 volts r.m.s.

This means that a 10mV signal can be amplified within the millivoltmeter to about 10V before being fed to the oscilloscope. If any other instrument is connected via the jack socket to the millivoltmeter, it must present a negligible load to the collector of TR_4 , otherwise calibration will be upset. Most oscilloscopes, when connected to the millivoltmeter, have no effect at all on calibration.

Applications

The millivoltmeter is capable of reading, with accuracy, the r.m.s. value of any alternating voltage applied to the input terminals, between 1mV and 100V. Provided that each range is specially calibrated immediately before use, if at all possible with

a signal having the same waveform as that to be measured, then the overall error in any reading will be less than 1%. However, larger errors may occur if a very distorted and irregular signal is measured, and calibration has been carried out with a pure sine wave signal.

Applications include:—

1. Measuring the frequency response of a complete amplifier in conjunction with an audio frequency oscillator.

2. Analysis of capacitor-resistor and capacitor-inductor tone-control and frequency correction circuits.
3. Measuring the bias voltage applied to a tape recording head. The instrument may also be used as an accurate record-level indicator.
4. Possible intermediate frequency circuit alignment (and certainly at low frequencies such as 85 kc/s).
5. Measurement of voltage output from stereophonic pick-up, microphone and radio tuner.

A decibel scale is not essential as voltage readings may easily be converted into voltage ratios, but such a scale is often a great convenience. The two accompanying Tables enable a conversion to be made from voltage ratios to decibels. Much useful work can be carried out with a single voltage scale from 0 to 1 volt, but the range 0 to 10dB is poorly covered and a 0 to 3 volt scale is required in order to give adequate coverage. 0dB. is taken as 1 volt and values are correct to the nearest 0.5dB.

As a change of 10dB is equivalent to a voltage ratio of $\sqrt{10}$ to 1, i.e. 3.2 to 1 approximately, then the value 3.2 has been used in the Tables. However, if 3 is substituted for 3.2 there will be only a small error.

TABLE I. Decibel Equivalents of Voltage Ratios (10mV to 100V)

SCALE	0	0.1	0.2	0.32	0.4	0.5	0.6	0.7	0.8	0.9	1.0
RANGE											
10mV	-60	-54	-50	-48	-46	-44.5	-43	-42	-41	-40	
100mV	-40	-34	-30	-28	-26	-24.5	-23	-22	-21	-20	
1V	-20	-14	-10	-8	-6	-4.5	-3	-2	-1	0	
10V	0	6	10	12	14	15.5	17	18	19	20	
100V	20	26	30	32	34	35.5	37	38	39	40	

TABLE II. Decibel Equivalents of Voltage Ratios (30mV to 30V)

SCALE	0	0.5	1	1.2	1.4	1.6	1.8	2	2.5	3.2
RANGE										
30mV	-46	-40	-38.5	-37	-36	-35	-34	-32	-30	
300mV	-26	-20	-18.5	-17	-16	-15	-14	-12	-10	
3V	-6	0	1.5	3	4	5	6	8	10	
30V	14	20	21.5	23	24	25	26	28	30	

As an example of use if, on the 100mV range, the scale reading is 40mV this, from Table 1, is equivalent to -28dB below 1V.

Overload Conditions

The moving-coil meter, M_1 , is fully protected by the transistor circuit under accidental overload conditions in that it is impossible to burn out the meter. Tests have shown that if a 10V signal (a.c.) is applied to the 10mV range, then the meter pointer is forced up against the stop near to the f.s.d. position. Fortunately, the action is a gentle one as C_3 absorbs sudden current surges and the maximum meter current is still less than 3mA.

A 240V signal applied to the 30V range did no apparent damage to any component. However, overload conditions should be avoided. To be safe, the total alternating voltage applied to the meter should not exceed 300V r.m.s. Under normal circumstances, the voltage applied to the meter is really the sum of the d.c. voltage component of the signal and the peak value of the a.c. component. The overall value should not exceed 400V.

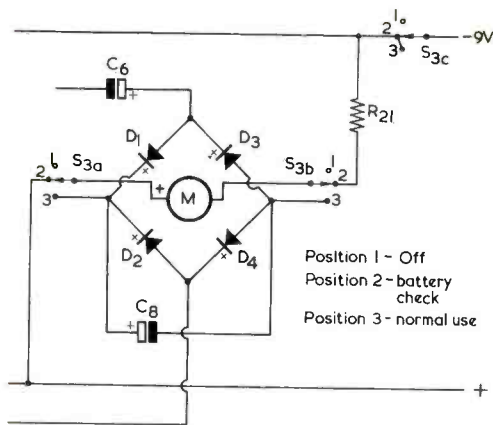

Fig. 12. A circuit which enables battery voltage to be checked. With this arrangement, S_3 takes the place of on-off switch S_2

For example, it would be safe to attempt the measurement of a ripple (or hum) voltage of perhaps 10V r.m.s., superimposed on a d.c. voltage of 400, but a similar measurement involving a 100V ripple component may damage C_2 or C_3 , even if the correct range resistor is used.

Conclusion

The millivoltmeter circuit has been designed using a minimum

number of components and, although it does its job well, there is still room for development. Individual constructors may wish to increase the number of ranges, or stabilise the circuit.

This millivoltmeter can be constructed with new parts for a total cost of less than £8. If care is taken during construction it will be very reliable and, although it has its limitations, it will be found indispensable for all audio measurements.

GROUND RESISTANCE METER FOR THE ARCHAEOLOGIST

By S. G. BULLAS



A simple experimental device which provides comparative measurements of earth resistance at different depths.

THE AUTHOR, WHO IS A KEEN AMATEUR archaeologist, wished to find some method by means of which subterranean roads or large areas of buried material could be detected without having to dig, with possibly negative

results. Manufactured instruments were considered at first, but it was found that even a small instrument would cost in the region of £50 or more.

The unit described here was, in consequence, made up. The total cost to the author, who already

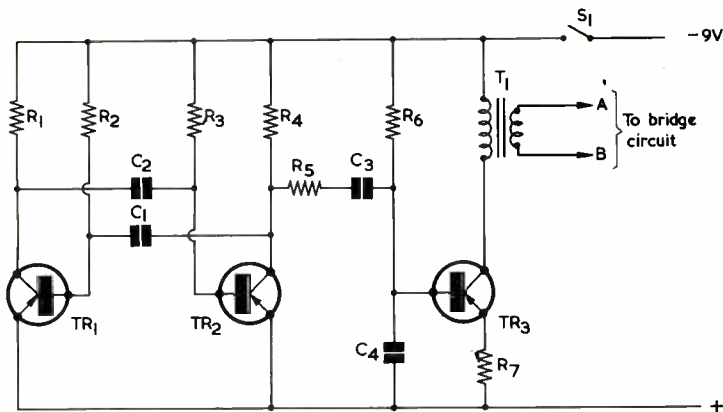
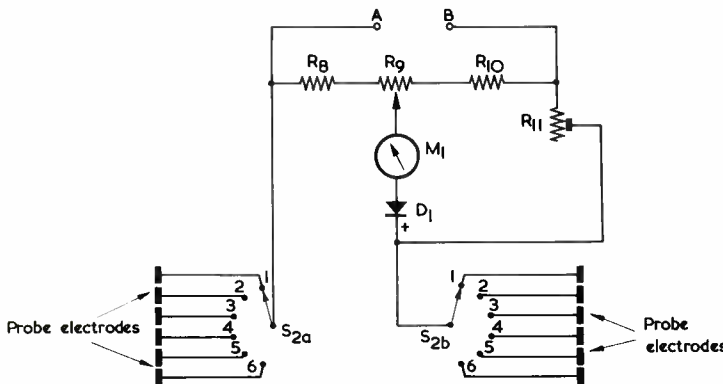

Fig. 1(a). The circuit of the multivibrator and buffer amplifier
(b). The a.c. output of the multivibrator section energises the bridge circuit shown here. Switches $S_{2(a)}$ and $S_{2(b)}$ select probe electrodes of different depths

(a)



S_{2a}, S_{2b} , -yanged

(b)

had some of the components on hand, was about 45s. The most important item was a $50\mu\text{A}$ meter, this being obtained for 35s.

Circuit Details

The resistance meter consists essentially of an a.c. operated bridge, the resistance to be measured being that of the earth between two probes driven into the soil a distance apart from each other. Each probe has six conducting surfaces separated by insulating material with the result that, by a simple switching circuit, it is possible to measure earth resistance between any two conducting surfaces of similar depth. Readings are comparative, but differences in resistance at varying depths can offer a positive indication of change of material between the probes.

It is necessary to use a.c. for resistance measurements of this nature, and with the author's meter this is obtained from the transistor multivibrator whose circuit is shown in Fig.1(a). The multivibrator proper is given by TR_1 and TR_2 , transistor TR_3 functioning as a buffer amplifier. The output of TR_3 feeds into transformer T_1 which, in the author's version,

Components List

Resistors

(All fixed values $\frac{1}{4}$ watt 10%)

R_1	4.7k Ω
R_2	100k Ω
R_3	100k Ω
R_4	4.7k Ω
R_5	10k Ω
R_6	100k Ω
R_7	47 Ω
R_8	47 Ω
R_9	100 Ω potentiometer
R_{10}	47 Ω
R_{11}	500 Ω potentiometer

Capacitors

C_1	0.005 μF
C_2	0.005 μF
C_3	0.1 μF
C_4	1,000pF

Semiconductors

TR_1, TR_2 OC42, OC71, Red Spot, etc.
 TR_3 OC81
 D_1 OA81 or similar

Transformer

T_1 Interval transformer, 1 : 3 (see text)

Switches

S_1 s.p.s.t. on-off
 $S_{2(a)} (b)$ 2-pole 6-way

Meter

M_1 Moving-coil meter 0-50 μA

Miscellaneous

9-volt battery
Material for probes, etc.

was a 1 : 3 interval transformer connected as a step-down component. A 9-volt battery powers the three transistors.

The alternating voltage from T_1 is passed to the bridge circuit shown in Fig.1(b). In this diagram, R_8 and R_{10} form two of the bridge arms in conjunction with R_9 , whilst the other two arms are

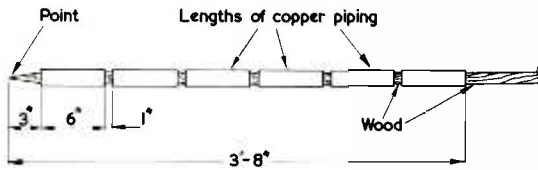

Fig. 2. The construction of the probe. Each piece of copper piping is 6in long, and the spacing between adjacent pieces of piping is 1in

provided by R_{11} and the earth resistance switched into circuit by $S_{2(a)}$ and $S_{2(b)}$. S_2 is a 2-pole 6-way switch and it selects probe conductors at equal depths in the earth. Balance is obtained by adjusting R_9 , the null point corresponding to minimum reading in the microammeter.

The circuit of Fig.1(a) must be screened from that of Fig.1(b) in order to prevent the higher frequency components generated by the multi-vibrator entering the bridge circuit and affecting null indications. There is no necessity, however, to use screened cable between transformer T_1 and the input points, A and B, of the bridge.

The Probes

Each of the two probes is constructed as shown in Fig. 2. On a length of wood of circular cross-section and diameter $\frac{3}{8}$ in are fitted six 6in lengths of thin-wall copper piping having an internal diameter of $\frac{1}{4}$ in. These are positioned with 1in of wood "insulation" between them as shown, and are firmly glued and bolted in place. A 3in length of wood protrudes below the bottom piece of piping, this being sharpened to a point to facilitate driving the probe into the soil.

Six insulated lead-off wires are soldered to the lengths of piping and brought up the side of the probe, being secured in position with Sellotape. These wires then terminate, after a suitable free length, at the appropriate contacts of $S_{2(a)}$ or $S_{2(b)}$ as applicable.

The length taken up on each probe by the six pieces of copper piping, the spacing, and the 3in point at the bottom, is 3ft 8in. A convenient amount of wood may appear above the top length of piping to enable the probe to be easily inserted or withdrawn from the soil.

The probes are inserted to a depth which causes the upper end of the top piece of piping to be level

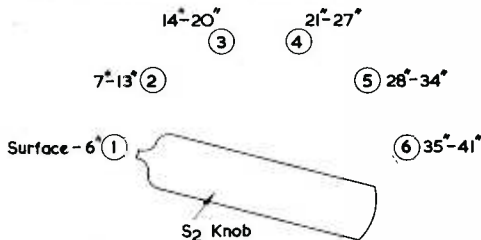

Fig. 3. The depths corresponding to the different positions of S_2 may be marked on the front panel of the meter as illustrated here

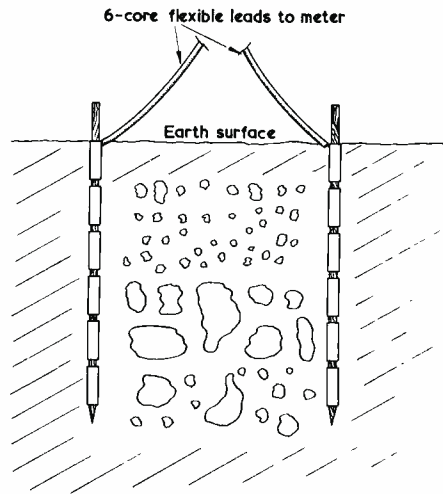

Fig. 4. A possible subterranean configuration which may be detected by the meter and its probes

with the surface of the soil. The resistance readings obtained for different settings of S_2 then correspond to the depths shown in Fig. 3.

In the writer's instance, the probes are inserted in the earth about 8 feet from each other, although such a spacing may not always, of course, be practical or even possible. This spacing has been found to give good results with work on the Roman period, in which the writer is most interested. Other spacings can be used according to the particular work being undertaken.

As an example of the materials which may be investigated by the meter and the two probes, Fig. 4 shows a situation which could result from a possible Roman Road. The "Surface-6in" setting of S_2 will give a reading corresponding to ordinary earth. As S_2 is rotated to select greater depths, the earth resistance will change due, firstly, to the small stones between the probes and, lower down, to the large stones.

Further Points

As was mentioned earlier, the readings given by the meter are comparative only, although, after a little experience, they are quite capable of offering results which can be readily interpreted. In the writer's unit, R_9 is calibrated arbitrarily in $\frac{1}{2}$ divisions from 1 to 10, giving 20 scale markings in all. The pre-set resistor, R_{11} , is adjusted to take up variations between different types of soil and to enable readings to be obtained within the range of R_9 for all settings of S_2 . R_{11} can be useful, for instance, in taking up the difference between soil on a wet day as compared with the same soil on a dry day. If a more sophisticated instrument is required, the circuit could be designed to enable R_9 to be calibrated directly in units, say ohms, but the author has found that the comparative readings which are obtained with the present simple circuit are adequate for his requirements.

The prototype has been used in conjunction with the "Experimental Metal Locator" described

by C. Morgan in *The Radio Constructor* for January 1965, resulting in a quite versatile set of equipment.

RADIO TOPICS . . .

by Recorder

JUST WHEN EVERYTHING IS GOING fairly quietly in the world of electronics, something new and exciting crops up. This time it's integrated circuits.

Readers will remember that we published an article* on this subject in the March issue. This article provides a very good working background on the different types of integrated circuit which are at present available, together with the manner in which they are manufactured and may be used.

Big Business

Integrated circuits are by no means a technical toy, and they represent very big business to the manufacturers concerned. The most obvious applications for integrated circuits lie in digital computers, where wide tolerances in "component" values within the integrated circuit are acceptable for applications where devices are either "on" or "off". Integrated linear amplifiers are also available, and can be used for alternative applications. Such amplifiers are already appearing in the domestic equipment field, and it is reported that Radio Corporation of America are to employ integrated a.f. amplifiers in their 1966 range of colour TV receivers.

The economic importance of integrated circuits is becoming readily apparent, as may be judged from recent City pages in our daily newspapers. Newspaper City writers may get a little hazy over the difference between n and p semiconductor materials, but they're right on the ball when it comes to sniffing out potential profits!

What is, perhaps, the most fascinating thing about integrated circuits—and I'm mainly concerned for the moment with the monolithic type here—is that they represent a very logical *development*. The real break-through which started off all semiconductor devices other than the diode was the transistor, which demonstrated that practicable ampli-

fication did not require the cumbersome paraphernalia of electron streams being modulated in evacuated containers. Amplification could occur, instead, in a tiny sandwich of suitably treated semiconductor materials. The monolithic integrated circuit represents a development, albeit an extremely sophisticated development, from that sandwich of semiconductor materials.

It must not be forgotten, however, that thin film circuits, currently "passive" (in that they contain no amplifying elements) also fall within the integrated circuit category, and that they do not represent so obvious an outcome from basic semiconductor principles. But I would hazard a guess that the applications for thin film circuits would be considerably more limited than they are at present were it not for the fact that their main use is in combination with "active" semiconductor devices.

Integrated circuits may seem, at the time being, to be rather over the head of the average amateur and experimenter. Nevertheless, Motorola, in America, are already making some of their range of integrated circuits available to the amateur. It must also be noted that the only way to manufacture integrated circuits profitably is to have very long production runs, whereupon the inevitable over-production which is bound to occur from time to time may well be channelled into amateur retail avenues.

We have graduated from the valve to the transistor; and the transistor has brought along with it the integrated circuit. These are early days yet so far as the last of these three is concerned, but there seems little doubt that the integrated circuit will make a very noticeable dent in the present order of things. To get our current situation into perspective I've just looked back at our Radio Show Report for 1956. There were, then, only a few commercially-made receivers using transistors throughout in the Show at all. It is worth mentioning that at the previous

Show, for 1955, what was probably the only transistor radio of any sort was our own *Radio Constructor* "Transistorette," a home-constructor design displayed on the stand of Standard Telephones and Cables, Ltd., whose semiconductors were employed in the set.

So far as commercial radio receiver manufacture in the U.K. is concerned, therefore, it has only needed some ten years for the transistor to almost completely oust the valve. A spectacular advance, indeed. Perhaps the advance of the integrated circuit over the next ten years may be equally spectacular.

Electric Jigsaw

The accompanying illustration shows a new electric jigsaw, Model 514H, which has been added to the "Skil" line of portable power tools. The saw is available from Skil (Great Britain) Ltd., 59 High Street, Hounslow, Middlesex.

A special feature of the 514H jigsaw is its orbital blade action. The saw makes 4,000 strokes per minute and may be used for cutting intricate patterns and curved lines, or for ripping and cross-cutting, in wood, metal, composition materials and plastics. It starts its own hole when making pocket cuts. The orbital blade action causes the blade to move into the work on the upstroke and to back away from the material on the downstroke, so that unnecessary friction is eliminated. In consequence, cutting may proceed at high speed, the blade stays sharp for an extra long time and saw chips are cleared immediately.

The jigsaw is light and compact and can be guided easily and accurately with one hand. The sawdust is automatically blown off the line of cut, this enabling the operator to have a clear view of the work all the time.

Other features include double insulation, extra burnout protection for the motor and a built-in radio suppressor. The standard equipment includes 3 assorted sawblades. To introduce the tool, it is being offered in an attractive display carton with 15 assorted blades.

Another Passing Thought

My little joke in the February issue when I said that a 10% cut in the electricity supply could result in a 100% saving in power,

* J. Baguley, G.I.Mech.E., G.I.E.R.E., "Integrated Circuits", *The Radio Constructor*, March, 1966.

whereupon no generators were needed, has resulted in a number of letters reaching me, and I offer my thanks to all their writers. Several readers protested (and they passed on calculations to prove the point) that what I said could not possibly be true. And I must confess that I agree with them.

A reader in Sussex takes the gag a little further by stating that a voltage reduction of 20% would result in a saving in power of 400%, with the consumer putting back into the mains three times as much power as he is taking. The watt-hour meter cannot discriminate in which direction the current is flowing, which explains the high electricity bills he receives for the power cut season of the year!

The Sussex reader then carries on to an interesting little tale concerning another aspect of power cuts. I quote from his letter:

"Over Christmas our mains voltage was down to nearly 200V for days on end instead of being 240V nominal. I complained, and two chaps came along armed with a massive voltmeter. At the time I'd got my Taylor 127A on as a permanent check. This showed 202V, but their meter said 215V, so they told me my meter was up the creek. At this, I trotted out my Heathkit V7A valve-voltmeter, and when that had warmed up it said 203V, so I suggested they went and got their meter re-calibrated. However, they went away and found a fuse gone in one phase (mine) on the ring-feeder, and when this was replaced the mains volts shot up to 240V. They came back to the house to see if all was well, so I said now put your meter on and see what it shows. They did—and it showed 253V!"

The reader then makes the point that perhaps a little doctoring was done to that meter to hoodwink anyone who complained that their mains voltage was low. Could this be true?

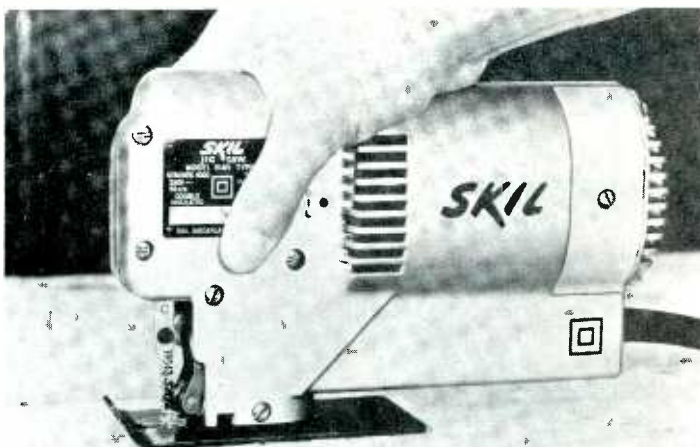

The "Skil" electric jigsaw, Model 514H. This can start its own holes for pocket cuts, and it has an orbital blade action which results in the blade moving into the work on upstrokes only

Voltage Readings

Talking about voltage readings, let me finish off by passing on a little dodge, which is strictly for the beginner.

It is often necessary to use a multimeter to take voltage readings at points having high source resistances. Typical examples are valve anodes and screen-grids fed by way of resistors having very high values. However, if the voltmeter resistance is comparable with the feed resistance, it will draw too much current and give false readings. I encountered the meter resistance problem myself only the other day, when I was trying out an experimental single transistor circuit which was designed to run, via a 240k Ω dropping resistor, from a 250V h.t. supply line. I only had a 20,000 Ω per volt meter on hand, and I wanted to get a reasonably accurate idea of the voltage across the transistor. But I didn't want to draw too much current through the 240k Ω resistor with the meter, and thereby obtain a falsely low reading.

In cases like this, where the multimeter offers too low a resistance at the range one would normally select, simply switch it to a higher f.s.d. With the transistor instance I mentioned just now my meter offered 200k Ω on the 10V range, which was, I felt, too low when compared with that series 240k Ω resistor. But on the 100V range my meter offered the much more satisfactory resistance of 2M Ω and, when switched to that range, it told me, with reasonable reliability, that the voltage across the transistor was of the order of 6.

Taking readings in this manner necessitates setting the meter zero-adjust accurately and taking care to avoid parallax error. A well laid-out meter scale can be read to about one-fiftieth of f.s.d. and, whilst this method of working introduces errors in reading due to the small meter deflection obtained, these errors are not so bad as those given when too low a meter resistance seriously affects circuit operation.

EMI Reconnaissance Systems for Phantom

One of the most important electronic contracts placed by the British Government for equipment to be fitted in the Phantom aircraft, which are to be bought from America for service in the R.A.F. was announced today.

It has been awarded to EMI Electronics Ltd. and is for the systems management and development of a complete reconnaissance system to be fitted in a pod below the aircraft. The contract is of considerable magnitude.

The Defence White Paper emphasised the overwhelming importance of reconnaissance, and this contract will give the Phantom the most modern reconnaissance system in the world. This system can also be easily adapted to fit other types of aircraft.

The equipment will include a Sideways Looking Radar, which makes a complete radar map of the ground on both high and low levels; Line Scan, which produces accurate low level photo-type pictures; and a complete photographic reconnaissance fit for high, low and oblique photography by day or night.

EMI Electronics has for some time now supplied most of the electronic reconnaissance equipment used by the R.A.F. including the equipment in the V-Bombers and the air-to-sea search radar in the maritime Shackleton and its Comet successor. They were also to have provided the TSR2 with both Sideways Looking navigation and reconnaissance radar and Optical Line Scan.

20 SUGGESTED CIRCUITS

by G. A. FRENCH

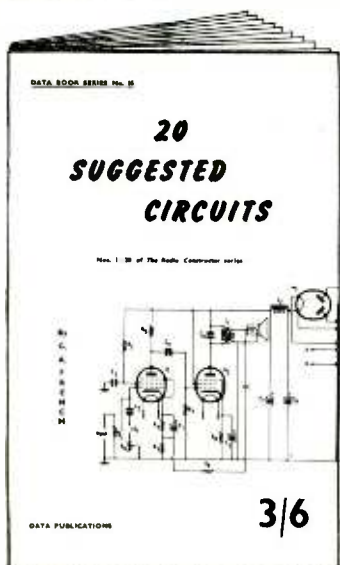

48 Pages DATA BOOK SERIES No. 15
 PRICE 3/6d. Postage 5d.

This book contains the first 20 circuits to be published in the very popular series of the same name appearing in *The Radio Constructor*.

The Contents include: simple and inexpensive two-valve capacity bridge, short wave regeneration preselector, one-valve speech operated switching circuit, transformer ratio analyser, series noise limiter, receiver remote mains on-off control, and many others; covering subjects ranging from electronic laboratory equipment to a simple 2-Stage Gram Amplifier.

TO DATA PUBLICATIONS LTD 57 Maida Vale London W9
 Please supply.....copy(ies) of "20 Suggested Circuits",
 Data Book No. 15. I enclose cheque/crossed postal order
 for.....

NAME

ADDRESS

SMALL ADVERTISEMENTS

Use this form for your small advertisement

To: The Advertisement Manager, Data Publications Ltd., 57 Maida Vale, London, W.9
 Please insert the following advertisement in the issue of **THE RADIO CONSTRUCTOR**

16 words at 9d.
 = 12/-

**ALL WORDING
 IN
 BLOCK LETTERS
 PLEASE**

I enclose remittance of being payment at 9d. a word. **MINIMUM 12/-.**
 Box Number, if required, 2/- extra.

NAME

ADDRESS

Copy to be received four weeks prior to publication. Published on the 1st of every month

SMALL ADVERTISEMENTS

Rate: 9d. per word. Minimum charge 12/-.
Box No. 2/- extra.

Advertisements must be prepaid and all copy must be received by the 4th of the month for insertion in the following month's issue. The Publishers cannot be held liable in any way for printing errors or omissions, nor can they accept responsibility for the bona fides of advertisers. (Replies to Box numbers should be addressed to: Box No.—, The Radio Constructor, 57 Maida Vale, London, W.9.)

SERVICE SHEETS, 1925-1965. From 1s. Catalogue 6,000 models, 1s. 6d. S.A.E. enquiries.—Hamilton Radio, 13 Western Road, St. Leonards, Sussex.

GOVERNMENT SURPLUS electrical and radio equipment. Our new catalogue No. 16 ready now, 2s. 6d. post free, cost refunded on purchase of goods over £2.—Arthur Sallis Radio Control Ltd., 93 North Road, Brighton, Sussex.

FOR SALE. Oscilloscopes—Galvanometers—Evershed & Vignolles Meggers. Also other items and components. Free list. Stamp please.—R. & E. Mart, Box 9 G.P.O., Tunbridge Wells, Kent.

CONVERT ANY TV SET INTO AN OSCILLOSCOPE. Instructions and diagrams, 12s. 6d.—Redmond, 42 Dean Close, Portslade, Sussex.

40 SEMICONDUCTORS commonly used in radio and electronic circuits, consisting of 20 transistors OC42-45-71-81 etc., 10 silicon rectifiers 50-800 p.i.v. 200-800mA. Incl. BY100's plus 10 diodes OA70-79-81 zener and gold bonded. All brand new. Valued over £5. For only 40s. plus post and packing 1s. To:—BI-PAK SEMICONDUCTORS, 8 RADNOR HOUSE, 93/97 REGENT STREET, LONDON W.1.

TRANSISTORS—Good quality, close equivs. OC72, 2s., OC71, 1s. 9d., OC44, 2s., OC170, 2s. 6d., OA70, 8d. P. & P. 9d.—A. P. Wise, 19 Harbeck Road, Bournemouth, Hants.

ANY PRINTED CIRCUIT BOARD SUPPLIED against your full size drawing. 6d. sq. in. plus 2s. 6d. processing. Post free. Prices include drilling.—Temple, 12 Beech House Road, Croydon, Surrey.

WANTED. Information on meteorological FAX radio reception systems, brochures, circuits, surplus equipment, etc.—Box No. F250.

WANTED. To purchase secondhand classical L.P. records in good condition. Reasonable.—Box No. F251.

FOR SALE. RTTY converter, Type A.P. 66286, £5 plus carriage.—Box No. F254.

EXPERIMENTER'S TRANSISTORS. All oscillate 2.5Mc/s, 3s. 6d. doz. plus s.a.e.—Leeming, 185 Brandy House Brow, Blackburn, Lancs.

EXCITING HOLIDAYS with Adventure, Variety and Fun. Sailing, Snorkelling, Pony Trekking, Canoeing, Caving. Please write for our attractive brochure.—P.G.L. Holidays, Department 82, Commerce Lane, Letchworth, Herts.

COMPLETE CLEARANCE. Components, etc. Too numerous to advertise. Inexpensive. S.A.E. list.—2 Fitzgerald Avenue, Seaford, Sussex. Telephone: 4961.

SILICON SEMICONDUCTORS. 2N2926 Planar n.p.n. 18V 200mW HFE 55-180 4s. each; 150-470 5s. each. 2N2646 UJT suitable for rev. counters, timers, etc. 15s. each. SCR 300V 7.4 amps 40s. each. S.A.E. for full list.—Box No. F258.

continued on page 653

BENTLEY ACOUSTIC CORPORATION LTD.

38 Chalcot Road, Chalk Farm, LONDON, N.W.1. 47 Norfolk Road, LITTLEHAMPTON, Sussex. Littlehampton 2043

Please forward all mail orders to Littlehampton

0A2	5/9	6/30L2	8/9	AZ31	9/6	EF36	3/6	GZ34	10/-	IPY800	5/9
0B2	6/-	9D7	7/6	DAF96	6/-	EF37A	7/-	GZ37	14/6	IPY801	7/6
1L4	2/3	10C1	9/9	DF96	6/-	EF39	5/-	HABC80	9/3	U25	8/6
1R5	4/-	10C2	12/-	DK92	8/-	EF41	6/6	KT66	12/3	U26	7/6
1S5	3/3	10F1	10/-	DK96	6/6	EF80	4/3	PABC80	6/9	U191	9/6
1T4	2/3	10F18	9/9	DL96	6/6	EF85	4/6	PC86	9/9	U301	11/-
2D21	5/6	10LD11	9/6	DM70	5/-	EF86	6/6	PC88	9/-	U329	9/-
3D6	3/9	10P13	12/-	DY87	7/6	EF89	4/3	PC95	6/9	U404	6/-
3Q4	5/3	10P14	11/6	EB8CC	13/6	EF91	3/-	PC97	6/9	U801	15/-
3S4	4/9	12AT6	4/6	EABC80	5/9	EF92	2/6	PC900	9/6	UABC80	5/6
3V4	5/-	12AU6	5/9	EAF42	7/9	EF97	10/-	PC884	5/6	UAF42	7/-
5Y3GT	4/9	12AV6	5/9	EB91	2/3	EF98	9/9	PC885	6/9	UBC41	6/3
6A76	7/6	12BA6	5/3	EB41	6/6	EF183	7/3	PC888	10/6	UBC81	6/3
6AQ5	5/9	12BE6	4/9	EB8C1	6/3	EF184	6/6	PC889	11/6	UBF80	5/6
6AT6	3/6	12BH7	6/-	EB80	5/9	EH90	9/6	PCC189	8/9	UBF89	6/3
6AU6	5/5	19AQ5	7/3	EBF83	7/3	EL33	6/6	PCF80	6/6	UBL21	10/9
6AV6	5/6	20D17	11/9	EBF89	5/9	EL36	8/9	PCF82	6/-	UC92	6/3
6BA6	4/6	20F2	11/6	EBL21	10/3	EL41	15/6	PCF84	8/6	UCC84	8/-
6BE6	4/3	20L1	14/-	EC92	6/6	EL42	7/9	PCF87	8/6	UCL83	9/-
6BH6	5/3	20P3	12/-	ECC40	10/-	EL84	4/6	PCF801	9/9	UCF80	8/3
6BJ6	5/6	20P4	13/-	ECC81	3/6	EL85	7/6	PCF802	10/-	UCH21	8/-
6BQ7A	7/6	20P5	11/6	ECC82	4/6	EL86	7/3	PCL82	6/6	UCH42	8/-
6BR7	8/3	30C15	10/-	ECC83	4/6	EL95	5/-	PCL83	9/6	UCH81	6/6
6BV6	7/6	30P17	11/9	ECC84	5/6	EL80	13/6	PCL84	7/6	UCL82	7/3
6CD6G	18/-	30C18	8/-	ECC85	5/6	EL81	15/6	PCL85	8/6	UCL83	9/-
6CH6	6/6	30F5	7/3	ECC88	8/9	EM80	6/3	PCL86	8/9	UF41	6/9
6F1	9/6	30FL1	9/3	ECC189	11/6	EM81	7/-	PEN45	7/-	UF42	4/9
6J5G	3/9	30FL14	11/-	ECF80	7/3	EM84	6/-	PL36	9/-	UF80	6/3
6J7G	4/6	30L15	10/3	ECF82	6/3	EM85	8/9	PL38	16/-	UF85	6/9
6K7G	1/3	30L17	11/6	ECF86	10/-	EM87	7/6	PL81	6/9	UF86	9/-
6K8G	3/3	30P12	7/6	ECY21	10/-	EY51	5/6	PL82	5/3	UF89	5/6
6L6GT	7/3	30P19	12/-	ECH35	6/-	EY81	7/3	PL85	6/-	UL41	7/-
6L18	10/-	30PL1	9/6	ECH42	8/-	EY83	9/3	PL84	6/3	UL84	5/6
6LD20	6/6	30PL13	10/6	ECH81	5/9	EY84	9/6	PM84	9/3	UM80	8/3
6O7GT	7/9	30PL14	11/3	ECH83	6/6	EY86	5/6	PY33	8/9	UY21	9/-
6S17	4/9	30PL15	9/6	ECH84	9/6	EY88	8/9	PY80	4/9	UY41	5/-
6SN7	4/6	35Y4	4/6	ECL80	5/9	EZ40	5/6	PY81	5/-	UY85	4/9
6V6G	3/6	85A2	6/6	ECL82	6/6	EY41	6/3	PY82	4/9	VP4B	12/-
6X4	3/9	80C7	11/9	ECL83	10/-	EZ80	3/9	PY83	5/6	X4	10/-
6X5	5/3	5763	7/6	ECL86	8/-	EZ81	4/3	PY88	7/3	X7B	26/2

Terms of business: Cash with order only. No C.O.D. Post/packing 6d. per item. Orders over £5 post free. All orders despatched same day. Complete catalogue including transistor section and components with terms of business 6d. Any parcel insured against damage in transit for 6d. extra. We are open for personal shoppers 9 a.m.-5 p.m. Saturdays 9 a.m.-1 p.m.



MAKE 5 DIFFERENT RADIOS FOR 35/-

Amazing Radio Construction Set! Become a radio expert for 35/-. A complete Home Radio Course. No experience needed. Parts include instructions for each design, Step-by-Step plan, all Transistors, loud-speaker, personal phone, knobs, screws, etc., all you need. Box size 14" x 10" x 2" (parts available separate). Originally £6. NOW 35/- plus 3/6 p. & p.

NEW RADIO ONLY 19/6



New RADIO Anyone CAN BUILD in 2-3 hours! Only 19/6. EVEN THE OLDER CHILDREN BUILD THEM! No soldering.

Only 16 connections! Then hear it reach out bringing in station after station.

ASTONISHING CIGARETTE RADIO



Yes a perfectly ordinary packet ONLY 18/6 of cigarettes!—but it fetches in station after station, loud and clear! Holds 10 Cigarettes—yet cleverly conceals highly sensitive, fully transistorised circuit (incl. tiny battery). Even a young boy can assemble it in under 2 hours. No soldering. No experience necessary. Only 16 connections. From our bulging testimonial file Mr. D. B. of Huddersfield writes: "... I have fitted the parts in and it is working wonderfully. ... ALL PARTS including Semi-conductors, A.B.C. Plans, etc. ONLY 18/6 plus 2/6 post, etc.

CONCORD ELECTRONICS LTD (Mail Order Only) (Dept. R.C.13) 77 NEW BOND STREET W.1



ESTABLISHED

1865

Savings in this old established Building Society combine sound investment with an attractive return

THE DUCHESS OF KENT PERMANENT BUILDING SOCIETY

Member of the Building Societies Association

Shares are in units of £25 each (maximum investment £5,000) . . . BUT, for the smaller saver, Subscription Share accounts may be opened with any sum from 1/- upwards. Interest is payable half-yearly on Fully Paid Shares—credited annually on Subscription Shares—all interest accrues monthly

Withdrawals at short notice

INTEREST IS AT 4% PER ANNUM

(There is NO DEDUCTION FOR INCOME TAX, as this is paid by the Society)

For further information apply to

**DUCHESS OF KENT
PERMANENT BUILDING SOCIETY
289/293 Regent Street London W1
Telephone MUSEum 4876-9**

Please send to me, without obligation, free brochure and a copy of the audited statement of accounts. (I understand that I shall not be troubled with calls by representatives)

Name

(If lady, please state Mrs. or Miss)

Address

.....R.C.
(Please use Block Capitals for both name and address)

SPECIAL OFFER

1 Watt S.T.C. 300 Mc/s N.P.N. Silicon Planer 100% Transistors, £1 for 6.

3/- each OC44, OC45, OC70, OC71, OC81, OC81D, OC200, GET16, GET20.

4/- each AF114, AF115, AF116, AF117, OC170, OC171.

5/- each OC139, OC140, GET7, GET8, GET9, XC141, BY100, OA211.

SUN SOLAR CELL KIT

4 Sun Solar Cells plus 24-page Booklet on Experiments, 11/- set.

G.P.O. DIAL TELEPHONES

20/- each 35/- pair

Send 6d. for Full Lists including S.C.R. Zeners, etc.

CURSONS

78 BROAD STREET, CANTERBURY, KENT

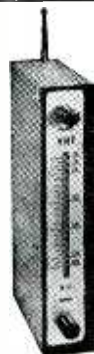

TELECOM MK. II

Pocket size V.H.F. 118-136 Mc/s

AIRCRAFT-BAND TRANSISTOR RECEIVER

complete with telescopic aerial,
loudspeaker and battery

£26 . 0 . 0

carr. paid in U.K.

BRITEC LIMITED

17 Charing Cross Road, London, W.C.2
Whitehall 3070

NEW EDITION

★ Instructions to ★ RADIO CONSTRUCTORS

R. H. Warring. This popular book has now been brought right up to date with full details of all the latest components and techniques, including a chapter on sub-miniature receivers.

Illustrated 15/-



MUSEUM PRESS



39 Parker Street, London WC2

SMALL ADVERTISEMENTS *continued from page 651*

FOR SALE. Heathkit Balun Coil Unit, B-1U. £4.—Box No. F259.

BOOKS TO CLEAR. "Transistors work like this" (Larsen) 5s. "Electronic Music & Musique Concrete" (Judd) 7s. 6d. "The Technical Writer" (Godfrey & Parr) 17s. 6d. "Man in Space" (Haber) 10s. "Realities of Space Travel" (Carter) 10s. "The Story of Astronomy" (Draper and Lockwood) 5s. "Santos-Dumont" (Peter Wykeham) 17s. 6d. "Teach Yourself Russian" 5s. "The Manual of Rugby Union Football" 5s. "How to develop a Super-Power Memory" (Harry Lorayne) 10s. "The Principles of Modern Book-Keeping" (Hamilton) 5s.—Box No. F260.

FOR SALE. 2.5 watt push-pull audio amplifier 38s. Also mains p.u. for transistor radio 12s.—Box No. F261.

RESERVE CAPACITY AVAILABLE mechanical, electro-mechanical assembly, electronic assembly and wiring. Lead time six weeks. Top quality assurance and supporting technical service. Based North Wales.—Box No. F262.

RADIO CONSTRUCTOR AC MILLIVOLTMETER. Printed circuit panel supplied drilled 10/- each. Or complete with all components ready to assemble as specified in the April issue, including transistors, 65/- . Terms C.W.O. Wasco Electronics, 40 Hill Street, Camforth, Lancs.

CONSTRUCTOR SELLING UP. Valves, meters, transformers, components, twin-gangs, relays, many misc. items. All cheap. Callers evenings. S.A.E. for list. Gott, 25 Cherry Nook Road, Deighton, Huddersfield, Yorks.

TECHNICAL DRAWINGS, Artwork, etc. Electronic and Radio Circuits a speciality. Moderate charges.—B. P. Meaney, 43 Forest Road, Worthing, Sussex.

ARE YOU A MOTORING ENTHUSIAST? The Seven Fifty Motor Club caters for all types of motor sport—racing, rallies, hill climbs, etc. Monthly Bulletin free to members. For full details write to: The General Secretary, Colin Peck, "Dancer's End", St. Winifred's Road, Biggin Hill, Kent.

POSTAL ADVERTISING? This is the Holborn Service. Mailing lists, addressing, enclosing, wrapping, facsimile letters, automatic typing, copy service, campaign planning, design and artwork, printing and stationery. Please ask for price list.—The Holborn Direct Mail Company, 2 Mount Pleasant, London, W.C.1. Telephone: TERminus 0588.

"MEDIUM WAVE NEWS" Monthly during DX season—Details from: B. J. C. Brown, 60 White Street, Derby.

continued on page 655

NEW TRANSISTOR CATALOGUE

Please send two shillings for catalogue

marlison "Dual-tone" 49/- test oscillators

Printed circuit construction. 9v batt. conns for PP3. Output: 100mV. 10K ohms, co-ax socket (1Kc. & 2.5Kc standard) mixed, but separately switched. Suitable for testing 55B transmitters. Easily mounted or built into other equipment. 3½" X 1½"

JOHN WILLIAMS ELECTRONICS LIMITED
176 HAGLEY ROAD, HALESOWEN, BIRMINGHAM

How would you like to be an officer in the Royal Navy?

and then train to be a fully qualified Electronic Engineer?

Impossible?

Very possible!

Not many people know this: but it's possible to train to be a graduate member of the Institution of Electronic and Radio Engineers while you're an officer in the Royal Navy.

As an electrical officer, you are given a training that lasts 4 years and which costs literally thousands.

You then get the technical and administrative experience to qualify you for the standing of chartered engineer. Which is getting the best of both worlds: a commission and an excellent civilian qualification.

What of the future? The Defence Review has re-affirmed the world-wide role of the Royal Navy. The vital protection of our shipping remains its constant task. The most modern technologies of nuclear propulsion, guided missiles and electronics are developing, and Polaris will take over the deterrent role by the 1970s. Here's a career that offers you responsibility, rich opportunities—and real reward.

Entry - Qualifications: G.C.E. 'O' level in English, with (i) suitable O.N.C., or (ii) three further G.C.E. passes including 2 at 'A' level. (One 'A' level should be in an appropriate maths or physics subject.) Scottish or Northern Ireland certificates equivalent to the above. **Age Limits:** 17½-25. **Training Course:** 4 years. **Service Period:** 16 years (pensionable) with every opportunity to put in for a permanent commission.

For full details complete and send the coupon below. You should apply before the end of July.

	Captain J. H. F. Eberle R.N., Officer Entry Section (836 UI), Old Admiralty Building, London, S.W.1.
Please send me full details about the opportunities of training for a commission in the Electrical Branch.	
NAME _____	
ADDRESS _____	
Date of birth _____	

THE MODERN BOOK CO

The Radio Amateur's Handbook. 1966. A.R.R.L. 40s. Postage 2s. 6d.

TV Diagnosis and Repair. By PF Reporter Ed. Staff. 13s. 6d. Postage 1s.

ABC's of Silicon Controlled Rectifiers. By A. Lytel. 16s. Postage 1s.

Circuits for Audio and Tape Recording. By F. C. Judd. 7s. 6d. Postage 9d.

Instructions in Electronics. By C. N. G. Matthews. 15s. Postage 1s.

Know Your Signal Generators. By R. G. Middleton. 20s. Postage 1s.

Advanced Radio Control. By E. L. Safford. 25s. Postage 1s.

Radio and Television Test Instruments. By G. J. King. 25s. Postage 1s. 6d.

Transistors for Technical Colleges. By L. Barnes. 25s. Postage 1s.

Transistor Substitution Handbook. Pub. Foulsham-Sams. 12s. 6d. Postage 1s.

Servicing Electronic Organs. By C. R. Pittman and E. J. Oliver. 30s. Postage 1s.

Transistor Radio Servicing Made Easy. By W. Lemons. 20s. Postage 1s.

Semiconductor Devices. By J. J. Brophy. 18s. Postage 1s.

1966 World Radio TV Handbook. 20th ed. 28s. Postage 1s.

RSGB Amateur Radio Call Book. 1966. 6s. Postage 9d.

The Radio Amateurs' Examination Manual. R.S.G.B. 5s. Postage 9d.

Complete Catalogue 1s.

We have the Finest Selection of English and American Radio Books in the Country

19-21 PRAED STREET (Dept RC) LONDON W2

Telephone PADDington 4185

FREE inside every copy!

24-PAGE POCKET GUIDE TO TRANSISTOR CIRCUITS

All the data you need at-a-glance! Deals with transistor circuit techniques and covers r.f., i.f. and a.f. amplifiers plus many other modern circuit arrangements

ALSO IN THIS ISSUE: HOW TO BUILD A SUB-MINIATURE 300mw AMPLIFIER

"IMPERIAL" 3-BAND TRANSMITTER
TRANSISTOR SET BOOSTER

JUNE ISSUE
OUT MAY 5
2/6

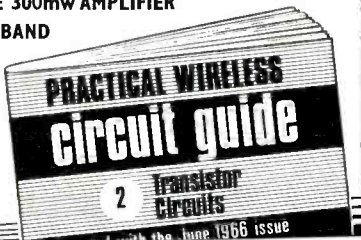

PRACTICAL WIRELESS

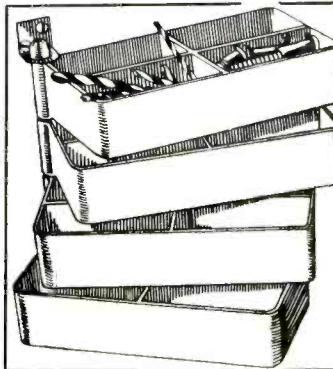

SWIVEL STORAGE RACKS

Ideal for Nuts and Bolts, Resistors, etc. Unbreakable Plastic Trays 5 1/4" x 3" x 1 1/4" with Two Divisions with Brackets for fixing to wall.

4 trays 6/-

6 trays 9/-

8 trays 12/-

P. & P. 1/4 any size.

JIGTOOLS

PENTYRCH, CARDIFF

SPACEMOBILE

A travelling exhibition with Lecture/Demonstrators will be touring Schools, Colleges, Universities, etc:

Details available upon request.

6th EUROPEAN SPACE SYMPOSIUM

Brighton, 23-25 May, 1966

Further information on the above, education publications and other details can be obtained from:-

L. J. Carter, F.B.I.S.,

BRITISH INTERPLANETARY SOCIETY
12 Bessborough Gardens, London, S.W.1

SMALL ADVERTISEMENTS

continued from page 653

JOIN THE INTERNATIONAL S.W. LEAGUE. Free Services to members including Q.S.L. Bureau. Amateur and Broadcast Translation. Technical and Identification Dept.—both Broadcast and Fixed Stations, DX Certificates, contests and activities for the SWL and transmitting members. Monthly magazine, *Monitor*, containing articles of general interest to Broadcast and Amateur SWLs, Transmitter Section and League affairs, etc. League supplies such as badges, headed notepaper and envelopes. QSL cards, etc., are available at reasonable cost. Send for League particulars. Membership including monthly magazine, etc., 35s. per annum.—Secretary, ISWL, 60 White Street, Derby.

EDUCATIONAL

TV AND RADIO. A.M.I.E.R.E., City & Guilds, R.T.E.B. Cert., etc., on "Satisfaction or Refund of Fee" terms. Thousands of passes. For details of Exams. and home training courses (including practical apparatus) in all branches of radio, TV and electronics, write for 156 page Handbook—FREE.—B.I.E.T. (Dept. 141K), 29 Wright's Lane, London, W.8.

MORSE MADE EASY FOR THE S.W.L.

Don't miss the thrill of receiving rare D.X. because you think learning Morse is difficult. You can master the code at 18/20 w.p.m. in about 3 weeks with only 20 minutes practice daily.

Send 8d. in stamps for full details to:
G3CHS/D, 45 Green Lane, Purley, Surrey.

HAMMERITE

HAMMER PATTERN BRUSH PAINT

The pattern is in the tin. All you do is brush it on.

COLOURS: blue, silver, black, or bronze.

2½oz tins 3/6, 1 pint, 7/6, 1 pint, 15/—, ½ gallon, 35/—* 1 gallon 58/—,*

Carr. up to 5/— 9d., up to 10/—, 1/9, over 10/—, 2/9. * Sent by road.

From component shops or direct from the manufacturer:

FINNIGAN SPECIALITY PAINTS (RC), Mickley Square, Stocksfield, Northumberland. Telephone: Stocksfield 2280

TV SETS from **10/-**
NOT WORKING
CALLERS ONLY

20 PALMERSTONE ROAD · EARLEY · READING · BERKS

SITUATIONS VACANT

KEEN AMATEUR CONSTRUCTOR

Excellent opportunity to join a small team engaged in the manufacture and modification of specialised television test equipment. Varied and interesting work. Applicants are required to be adaptable and capable of good workmanship. 37½ hour week, staff position and superannuation scheme. Apply in writing to:—

Production Supervisor,
Test Engineering, Radio Rentals,
Works Centre, 14 Beresford Avenue,
Wembley, Middlesex.
Or telephone Wembley 7871 Ext.11.

SITUATIONS VACANT



TELECOMMUNICATIONS

Vacancies exist for Young Men keen to make Electronics their career who have not necessarily acquired great practical or theoretical knowledge, but who have suitable interest and who have possibly already constructed some equipment themselves. Training will be provided and applicants will be encouraged to take technical studies to further their careers.

Applications to Personnel Manager,
Cambridge Works Ltd.,
Haig Road, Cambridge.
Telephone: Cambridge 51351.

Eastern Electricity

CHILTERN SUB-AREA

MEASUREMENTS AND COMMUNICATIONS SECTION

A vacancy exists in the Measurements and Communications Section of the Sub-Area Engineer's Department for a craftsman who has a sound knowledge of basic Electronics and preferably experience in V.H.F./U.H.F. radio-telephone installation and maintenance. The successful applicant will be based at Leighton Buzzard, Bedfordshire.

Salary is in accordance with the National Joint Industrial Council Agreement, Group 'G', and a stagger pattern of working is in operation for which an additional payment will be made.

Basic rate of pay—£16 11s 9d. per week including incidental overtime allowance.

Plus 10s 6d per week productivity bonus.

Plus £1 10s 0d per week stagger payment.

Total pay £18 12s 3d

Also an additional 7/8d. per week will be paid after two years service and a further 7/8d. per week after three years service.

Applications should be made, in writing, stating age, experience and present position to the Manager, Chilterns Sub-Area, Eastern Electricity, Prebend Street, Bedford, as soon as possible.

CHASSIS and CASES by



287/9 Edgware Road
London W2
TELEPHONE
PADdington 5891/7595

BLANK CHASSIS—Same Day Service

Of over 20 different forms made up to YOUR SIZE.
(Maximum length 35", depth 4")

SEND FOR ILLUSTRATED LEAFLETS

or order straight away, working out total area of material required and referring to table below which is for four-sided chassis in 16 s.w.g. aluminium.

48 sq. in.	4/3	176 sq. in.	9/-	304 sq. in.	13/6
80 sq. in.	5/6	208 sq. in.	10/-	336 sq. in.	14/9
112 sq. in.	6/6	240 sq. in.	11/3	368 sq. in.	15/9
144 sq. in.	7/9	272 sq. in.	12/6	and pro rata	
	P. & P. 3/-		P. & P. 3/6		P. & P. 4/-

Discounts for quantities. More than 20 different sizes kept in stock for callers.

FLANGES (1/2" or 3/4"), 6d. per bend.
STRENGTHENED CORNERS, 1/- each corner.

PANELS

Any size up to 3ft at 5/3 sq. ft. 16 s.w.g. (18 s.w.g. 4/6).
Plus postage and packing

CASES

ALUMINIUM, SILVER HAMMERED FINISH

Type	Size	Price	Type	Size	Price
U	4 x 4 x 4"	10/-	Y	8 x 6 x 6"	26/6
U	5 1/2 x 4 1/2 x 4 1/2"	15/-	Y	12 x 7 x 7"	41/-
U	8 x 6 x 6"	21/-	Y	13 x 7 x 9"	46/-
U	15 x 9 x 9"	44/6	Y	15 x 9 x 7"	48/6
W	8 x 6 x 6"	21/-	Z	17 x 10 x 9"	48/6
W	12 x 7 x 7"	34/-	Z	19 x 10 x 8 1/2"	71/-
W	15 x 9 x 8"	44/-		* Height	

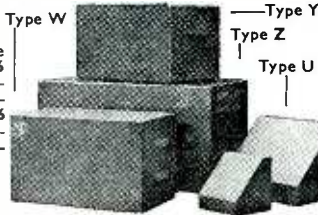

Type Z has removable back and front panels.
Type Y all-screwed construction.

NYLON P.T.F.E.

ROD BAR SHEET TUBE STRIP WIRE
No quantity too small List on application
BRASS COPPER BRONZE ALUMINIUM LIGHT ALLOYS
STAINLESS STEEL

H. ROLLET & CO LTD

HOWIE STREET, LONDON, S.W.11 BATtersea 7872
Also at Liverpool, Birmingham, Manchester, Leeds, Glasgow

SEMICON-INF SERVICE

(500/9A)
Suppliers of all types of INDUSTRIAL & ENTERTAINMENT semi-conductor devices. AMERICAN & CONTINENTAL items are our speciality. Send 1/3d. P.O. for Price List of over 1,000 transistor types. (Available late April.)

POWER Transistors for Audio Amplification & Switching.

TYPE	V _{CB}		I _C		P _D		h _{FE}		I _{CBO}		CASE	PRICE
	max.	typ.	max.	typ.	max.	typ.	max.	typ.	max.	typ.		
ADY 26	-80		30A		75W		80		4.0mA		TO-36	£3 10 6
ADZ 11	-50		20A		45W		80		4.0mA		TO-36	£2 3 6
2N 277	-40		15A		150W		55		2.0mA		TO-36	£1 16 9
2N 301	-40		10A		30W		90		5.0mA		TO-3	£- 19 0
2N 307	-35		1A		100W	> 20			15mA		TO-3	£- 17 3
2N 554	-15		3A		65W	35dB			7.0mA		TO-3	£- 7 9
2N 555	-30		3A		65W	35dB			7.0mA		TO-3	£- 9 6

Power Transistor Sockets. TO-3 style. 1/11 each.

Please add 1/- P. & P. on all orders of £2 or less.

TERMS: C.W.O.

MAIL ORDER ONLY PLEASE.

M. R. CLIFFORD & CO. (R)

66 OLD OSCOTT LANE, BIRMINGHAM, 22A

the unique **PANL** black crackle paint

4/-d. per 1/8 pt. Can

(We regret we can only supply on cash with order basis)

BRUCE MILLER LTD.,

219 Coastal Chambers,
Buckingham Palace Road, S.W.1.

YOUR CAREER IN RADIO?

Big opportunities and big money await the qualified man in every field of Electronics today—both in the U.K. and throughout the world. We offer the finest home study training for all subjects in radio, television, etc., especially for the CITY & GUILDS EXAMS. (Technicians' Certificates); the Grad. Brit. I.R.E. Exam.; the RADIO AMATEUR'S LICENCE; P.M.G. Certificates; the R.T.E.B. Servicing Certificates; etc. Also courses in Television; Transistors; Radar; Computers; Servomechanisms; Mathematics and Practical Transistor Radio course with equipment. We have OVER 20 YEARS' experience in teaching radio subjects and an unbroken record of exam. successes. We are the only privately run British home study Institute specialising in electronic subjects only. Full details will be gladly sent without any obligation.

SEND FOR FREE BROCHURE TO:

BRITISH NATIONAL RADIO SCHOOL
DEPT 4, RADIO HOUSE · READING · BERKSHIRE

YUKAN SELF-SPRAY

SO PROFESSIONAL
THE YUKAN
AEROSOL WAY!

GET THIS AIR DRYING HAMMER FINISH

NOW!

YUKAN Aerosol spraykit contains 16 ozs. fine quality, durable, easy instant spray. No stove baking required. Available in Grey, Blue, Gold, Bronze at 14/11 at our counter or 15/11, carriage paid, per pushbutton self-spray can. SPECIAL OFFER: 1 can plus optional transferable snap-on trigger handle (value 5/-) for 18/11 carr. paid.



Choice of 13 self-spray plain colours and primer (motor car quality) also available.

Please enclose cheque or P.O. for total amount to:

YUKAN · DEPT RC/5 · 307a EDGWARE ROAD · LONDON · W.2

THE RADIO CONSTRUCTOR — BOUND VOLUMES

NOW AVAILABLE

Volume 18, August 1964 to July 1965. Price £1 10s. 0d. Postage 3s. 6d.

Where all issues are returned: Price £1. Postage 3s. 6d.

We regret earlier volumes now sold out.

Send for list containing details of our other publications

DATA PUBLICATIONS LTD 57 MAIDA VALE LONDON W9

Please mention **THE RADIO CONSTRUCTOR** when writing to advertisers

BOOK LIST

DATA BOOKS SERIES

DB5 TV Fault Finding

96 pages. Price 6/-, postage 6d.

Profusely illustrated with photographs taken from a television screen depicting the faults under discussion and containing a wealth of technical information, with circuits, enabling those faults to be eradicated. Covers both B.B.C. and I.T.A.

"... A book that should be in every television dealer's service workshop, and in every home-constructor's, for that matter."—*Journal of the Television Society*.

DB6 The Radio Amateur Operator's Handbook

64 pages. Price 5/-, postage 5d.

Contains Amateur Prefixes, Radio Zone Boundaries, Amateur Band Frequency Allocations, Call Areas, Charts and Maps, Areas, Codes, Mileage Tables, Prefixes/Directional Bearings, Post Office Regulations, and much other useful operating data. For the beginner there are notes on how to use the mass of information given to obtain the greatest satisfaction from the hobby.

"... For concise knowledge in this field a few shillings well worth spending."—*Electronics* (Australia).

DB14 Short Wave Receivers for the Beginner

72 pages. Price 6/-, postage 6d.

Contains a selection of both battery and mains operated short wave receivers, circuits, point-to-point wiring diagrams and many illustrations. Introductory chapter gives much information on the Short Wave Spectrum, Clubs, QSL'ing, Aerials, Amateur and Broadcast Band Listening, Frequencies, etc.

This book has been specially prepared for the beginner interested in short wave receiver construction and operation.

DB15 Twenty Suggested Circuits

48 pages. Price 3/6, postage 5d.

By G. A. French. Covers subjects ranging from electronic laboratory equipment to the simplest of periodic switches. Includes: simple and inexpensive two-valve capacity bridge, short wave regeneration preselector, one-valve speech operated switching circuit, transformer ratio analyser, series noise limiter, receiver remote mains on-off control, and many other circuits.

DB16 Radio Control for Models

192 pages. Price 15/-, postage 9d.

By F. C. Judd. Contains both theory and practical designs of simple and advanced transmitters and receivers; basic concepts, aerials, uses of radio components, transistorised receivers, multi-channel operation, etc. Sections on servo-mechanisms by Raymond F. Stock.

More than 200 illustrations. Circuits, photographs, tables and working diagrams.

DB17 Understanding Television

512 pages. Price 37/6, postage 2/6

By J. R. Davies. This book, which deals with the principles of 625 line reception as fully as 405 line reception, fully explains: the nature of the television signal; the cathode ray tube; receiver tuner units; receiver i.f. amplifiers; a.f. and video amplifiers; vertical and horizontal timebases; deflector coil assemblies; synchronising; automatic gain and contrast control; power supplies and receiver aerials. Also includes a comprehensive introduction to colour television.

"... one of the best books that aims to explain television in simple language ...". R.S.G.B. Bulletin.

I enclose Postal Order/Cheque for

NAME

ADDRESS

(Please use Block Capitals for both name and address)

Postal Orders should be crossed and made payable to Data Publications Ltd.

Overseas customers please pay by International Money Order

All publications are obtainable from your local bookseller

Data Publications Ltd., 57 Maida Vale, London W.9

1966 150 BIG PAGE
CATALOGUE
 5,000 stocked items. Fully PRICE
 detailed and illustrated. 6/-
 FREE vouchers give 2/- in (post paid)
 the £ discount.

PROVED & TESTED DESIGNS
FULL AFTER SALES SERVICE AND GUARANTEE
 Largest range available of components and accessories
 Let us quote for your circuit
DETAILED LEAFLETS FREE ON REQUEST

FREE New 16 page
 catalogue 500 transistors,
 rectifiers, scr's, light devices,
 heat sinks, 1,000 crystals,
 800 valves, etc. Ask for your
 FREE copy NOW

MW/LW POCKET SUPERHET



RADIO
 TOTAL COST
 TO BUILD
85/- P.P. 2/-
 (Battery 2/6
 Phone 5/-)

- ★ 6-Transistor design. Push-pull output.
- ★ 2 1/2" Cleartone speaker. Printed circuit.
- ★ Attractive moulded cabinet.
- ★ Slow motion tuning.
- ★ Full medium and long waves.
- ★ Size: 5" x 3" x 1 1/4".

● **AMAZING SENSITIVITY AND SELECTIVITY** ●

- ★ 6-Transistor push-pull design.
- ★ Uses factory built panels.
- ★ Permeability geared tuning.
- ★ Full med./long wave tuning with push-button wave change.
- ★ Double tuned IFT's.
- ★ Chromed front panel plate.
- ★ Size: 7" x 4" x 2". Fits any car.
- ★ Pre-built units sold separately.

TOTAL
 COST TO
 BUILD
£8.19.6
 P.P. 3/6



(7" x 4" speaker with car fixing kit and baffle board 20/- extra.)

TWO WAVEBAND ALL-TRANSISTOR CAR RADIO TO ASSEMBLE
 ● **HIGH PERFORMANCE SUPERHET** ●

2- AND 4-TRACK TAPE RECORDERS TO ASSEMBLE

Pre-built
 Equipment—6
 Valves—Collaro
 Studio Decks—
 Portable Cabinets
 with Speakers.
 Complete record
 and playback.



★ 2 track deck
 10 gns. P.P. 5/- Amplifier
 11 gns. Cabinet with speaker 5 gns.

OR SPECIAL PRICE £26 P.P. **TWO TRACK**
 8/6

★ 4-track deck £13.10.0. P.P. 5/- Amplifier
 12 gns. Cabinet with speaker 5 gns.
OR SPECIAL PRICE £30 P.P. **FOUR TRACK**
 (Now with new '363' decks) 8/6

10W & 20W HI-FI AMPLIFIERS

Prebuilt and
 tested units.
 Low distortion,
 low
 noise



UNITS 1 & 2

★ **POWER AMPLIFIERS.** 10
 watts R.M.S. music power. 20
 watts peak. 6-Transistor design.
 Panel size 4" x 2 1/2" x 1 1/4". Response
 40 c/s to 20 kc/s. 100mV into
 33kΩ input.

UNIT 1. For 12/15 ohm
 speakers. 40 volt supply.

PRICE
BUILT £5.19.6 P.P. 2/6

UNIT 2. For 3 to 5 ohm
 speakers. 24/28 volt supply.

PRICE
BUILT £5.10.0 P.P. 2/6

★ **MAINS UNITS.** 59/6. To power
 one amplifier or 69/6 to power two
 amplifiers. (State 24 or 40 volt version.)

PREAMPLIFIERS. Mono and stereo
 versions, 8 inputs, 1 1/2 to 300mV at 1k
 to 500k. Response 30 c/s to 20 kc/s.
 Complete range of controls. Mains
 unit or battery operated. For pick-
 ups, tuners, tape, microphones, etc.

UNIT 3. Mono full-function pre-
 amplifier. Size 9 1/2" x 2 1/2" x 2".

PRICE
BUILT £5.10.0 P.P. 2/-

(Brown/Gold front panel plate 8/6)

UNIT 4. Simplified version of Unit 3.
 Price 65/- P.P. 1/6. Panel plate 6/6.

UNIT 5. Stereo preamplifier for
 use with two units 1 or 2. Size
 9" x 3 1/2" x 1 1/4".

PRICE
BUILT £10.19.6 P.P. 3/6

(Front panel plate 12/6)

**THE FINEST QUALITY HI-FI
 AT UNBEATABLE PRICES**



TRANSISTOR PORTABLE TEST EQUIPMENT

All units size 6 1/2" x 4 1/2" x 2 1/2".
 ★ RF generator,
 150 kc/s to 350
 Mc/s in 8 ranges.
 RF, Mod. RF,
 AF outputs.

PRICE **£9.10.0** P.P. 2/6

★ Resistance/capacitance bridge. £8.5.0. P.P. 2/6.

★ Audio generator 10 c/s-100 kc/s. 4 ranges. £16.15.0. P.P. 2/6.

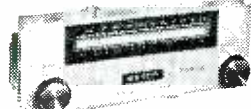

VHF/FM TUNER TO ASSEMBLE

★ Two pre-built plus metal work and front panel.

Total Cost
£12.17.6
 P.P. 2/6.

- ★ Size: 9 1/2" x 3 1/2" x 4".
- ★ 88 to 108 Mc/s tuning.
- ★ 100mV to 100kΩ output
- ★ 6-Transistor printed cct. superhet design.

NEW SW/MW/LW PUSH-BUTTON PORTABLE TO BUILD. 3 wavebands

TOTAL
 COST
£8.19.6
 P.P. 3/6

The only fully Tunable 3-waveband radio for home construction.



- ★ Push-button coil pack.
- ★ 1 watt push-pull output.
- ★ Ferrite aerial/Telex. aerial/special car coils.
- ★ Printed circuit 6-transistor design.
- ★ SW 17/50m. LW 1100/1900m. MW 195/550m.
- ★ Car aerial and tape sockets.
- ★ Attractive sturdy cabinet with handle. Size 11" x 7 1/2" x 3 1/4". Black fabric with chrome fittings.

LET US QUOTE PARTS FOR YOUR CIRCUIT,
 SEND LIST FOR QUICK REPLY

TRANSISTOR TRANSMITTER/RECEIVERS



★ 1/2 mile range,
 price per pair
£7.19.6

★ 5 mile range,
 price per pair
£22.10.0

4-CHANNEL MICROPHONE MIXER



Transistorised, 4 in-
 puts up to 100kΩ.
 Full mixing. 49/6
Stereo 72/6

SINCLAIR FM RADIO POCKET

VHF Kit **£5.19.6**

X20 AMPLIFIER Kit **£7.19.6**

Z12 AMPLIFIER **89/6**

MICRO-6 MW RADIO **59/6**

5 WATT AND 1 1/2 WATT PACKAGED AMPLIFIERS

- ★ 6-Transistor push-pull printed circuit designs.
 - ★ Size only 2 1/2" x 2" x 1 1/2".
 - ★ 5 watt 18 volt. 1 1/2 watt 12 volt.
 - ★ For 3 to 5 ohm speakers.
 - ★ 7mV into 1kΩ 30 c/s to 16 kc/s.
- PRICES BUILT
1 1/2w 65/- P.P. 1/6 **5w 79/6** P.P. 1/6



● **Mono PREAMPLIFIER**

Full range of controls, inputs for mic, p.-u., tuner, etc. Output 6-10mV. Suitable for any sensitive transistor amplifiers as above. 7 1/2/12/18V operated. Price built/tested incl. panel **79/6**. P.P. 2/6.

HI-FI ALL MAKES AVAILABLE—New Hi-Fi Demonstration Room now open

VHF/FM TRANSISTOR TUNER TO BUILD

TOTAL
 COST
£6.19.6

P.P. 2/6 (complete with frontplate) (Goldsprayed cabinet 20/- extra).



- ★ 5-Transistor 4 diodes.
- ★ Printed circuit superhet.
- ★ Geared tuning 87 to 105 Mc/s FM.
- ★ RF stage and double tuned IFT's.
- ★ Output up to 1 volt peak up to 100kΩ.
- ★ 9 volt 9mA supply.
- ★ Size in cabinet 4" x 3 1/4" x 2 1/4".
- ★ All parts sold separately.

HENRY'S RADIO LTD.
 303 EDGWARE ROAD, LONDON, W2
 PADDINGTON 1008/9

Open Mon. to Sat. 9-6. Thurs. 1 p.m.
 Open all day Saturday