

THE Radio Constructor

2/3

MARCH 1966

RADIO · TELEVISION
ELECTRONICS · AUDIO

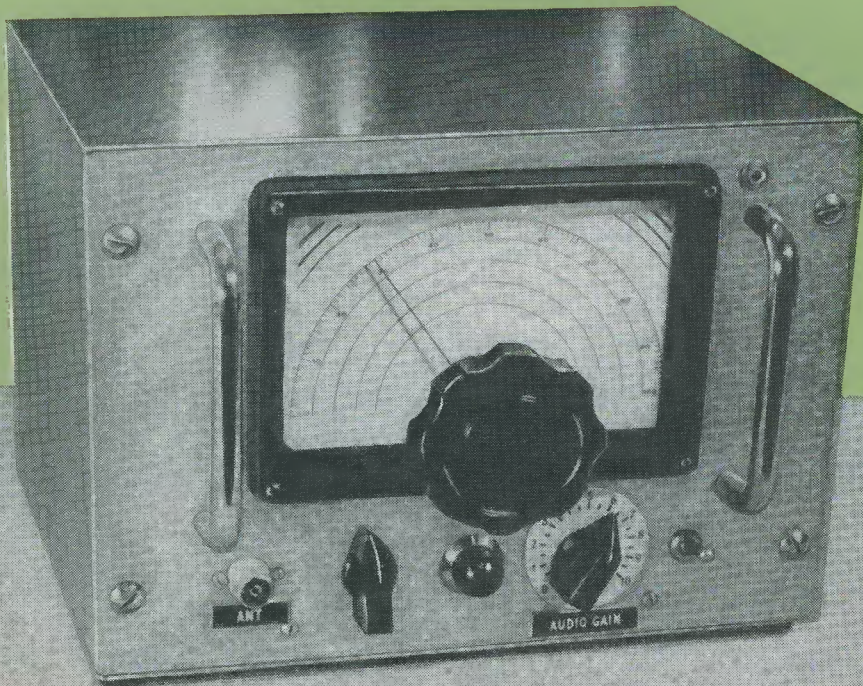

Dual-
Conversion
Superhet
for 2
Metres

Integrated
Circuits



Plug-in
Speech Clipper



Dual-Purpose
Power Supply



Circuits for
S.C.R.'s



Eddystone

TWO FINE RECEIVERS

840c

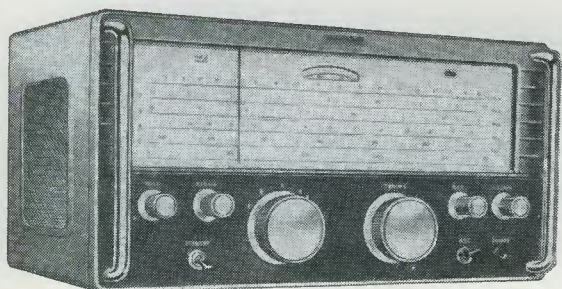

The Eddystone '840c' is an inexpensive, soundly engineered communications receiver giving full coverage from 480 kc/s to 30 Mc/s. It possesses a good performance and is built to give years of reliable service. The precision slow motion drive—an outstanding feature of all Eddystone receivers—renders tuning easy right up to the highest frequency, and the long horizontal scales aid frequency resolution. Modern styling and a pleasing two-tone grey finish lead to a most attractive receiver.

List price **£66 0s. 0d**

940

The Eddystone '940' is a larger and more elaborate communications receiver, with a correspondingly better performance. It has two fully tuned radio frequency stages and two intermediate frequency stages; variable selectivity with a crystal filter; built-in carrier level meter and push-pull output stage. Sensitivity is very high and outstanding results can be expected. Workmanship, construction, and finish are all to the usual high Eddystone standards. Styling is modern with two-tone grey finish.

List price **£133 0s. 0d**

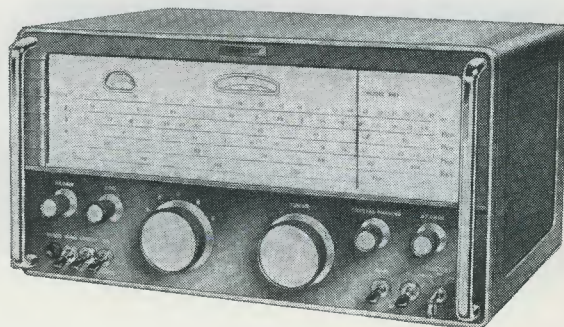

**There's an Eddystone communications receiver
for any frequency between 10kc/s and 1,000 Mc/s**

Eddystone Radio Limited

Eddystone Works, Alvechurch Road, Birmingham 31
Telephone: Priory 2231 Cables: Eddystone Birmingham Telex: 33708

LTD/ED7

6 VALVE AM/FM TUNER UNIT

Med. and VHF 190m-550m, 8.6 Mc/s-103 Mc/s, 6 valves and metal rectifier. Self-contained power unit, A.C. 200/250V operation. Magic-eye indicator, 3 push-button controls, on/off, Med., VHF. Diodes and high output sockets with gain control. Illuminated 2-colour perspex dial 1 1/2" x 4", chassis size 1 1/2" x 4" x 5 3/4". A recommended Fidelity Unit for use with Mullard "3-3" or "5-10" Amplifiers.

Bargain Price: Complete kit of parts, inc. Power Pack, £10.19.6, carriage and insurance, as illustrated. Ditto less Power Pack, £9.19.6. Carr. 7/6. Circuit and constr's details, 4/6 Free with kit.



7 VALVE AM/FM RADIOGRAM CHASSIS

New 1965 Model Now Available.

Three Waveband & Switched Gram positions. Med. 190-550m, 8.6 Mc/s-103 Mc/s. VHF/FM 88-95 Mc/s. Phillips Continental Tuning insert with permeability tuning on FM and combined AM/FM IF transformers. 460 kc/s and 10.7 Mc/s. Dust core tuning all coils. Latest circuitry including AVC & Neg. Feed back. 3 watt output. Sensitivity and reproduction of a very high standard. Chassis size: 1 1/2" x 4 1/2" x 3 1/2". Vert. pointer for station names. Gold on brown bakelite ground. A.C. 200/250V operation. Magic-eye tuning. Circuit diag. now available.

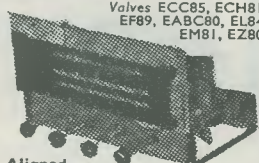

Valves ECC85, ECH81, EF89, EABC80, EL84, EM81, EZ80
Aligned and tested ready for use. Carr. & ins. 7/6. **£13.19.6**

Comp. with Tape, O/P socket, ext. spkr. & P/U sockets and indoor F.M. aerial, and 4 knob-walnut or ivory to choice. 3 P.M. Speaker only required. Recommended Quality Spea kers 10" Elac, 27/6. 13 1/2" x 8" E.M.I. Fidelity, 37/6. 12" R.A. with conc. Tweeter, 412/6. Carr. 2/6.

Jack Plugs. Standard 2 1/2" Igranite (ditto) 1/6. Stereo Jack Sockets, 3/6. Miniature scr. 1 1/2", 2/3. Sul-min. 1/3. Jack Sockets. Open Igranite Mounted Type, 3/6. Closed Ditto, 4/-. Miniature Closed Type, 1/6. Sub-min. (deaf

NEW BRITISH RECORDING TAPE

Famous Mfr. Bulk Purchase—Genuine recommended Tape Bargain. Unconditional Guarantee. Fitted Leader and Stop Foils (except 3").

Se'd. (PVC base)	L.P. (PVC base)	D.P. (Milar base)	Triple Play
3" 150ft. ... 3/9	225ft. ... 4/9	300ft. ... 6/6	3" 450ft. ... 12/6
5" 600ft. ... 11/6	900ft. ... 15/-	1,200ft. ... 23/6	4" 900ft. ... 25/-
5 1/2" 850ft. ... 14/6	1,200ft. ... 17/6	1,800ft. ... 29/6	
7" 1,300ft. ... 17/6	1,800ft. ... 22/6	2,400ft. ... 37/6	

Post and Packing—3" Reels 1/6. Each additional Reel 3d. 4" to 7" Reels 1/-. Each additional Reel 6d. A full tape accessories stocked.

EMPTY TAPE REELS (Plastic): 3" 1/3, 5 1/2", 5 3/4" 2/-. 7" 2/3.

PLASTIC REEL CONTAINERS (Cassettes): 5" 1/9, 5 3/4" 2/-. 7" 2/3.

New Boxed	VALVES	Reduced Bargain Prices	Electrolytics All Types New Stock						
IT4	3/6	EF80	7/6	P CFB0	8/-	25/25V	1/9	8+8/450V	4/6
IR5	6/-	EF86	8/6	P CLB3	10/6	50/12V	1/9	16+16/450V	5/6
IS5	6/-	EL33	12/6	P CLB4	10/6	50/50V	2/-	32+32/275V	5/6
IS4	7/-	EL34	12/6	P CLB5	11/6	100/25V	2/-	50+50/350V	5/6
IS4	7/-	EL35	12/6	P CLB6	10/6	8/450V	2/3	60+250/275V	5/6
ECC81	7/-	EY51	9/-	PLB1	9/6	4/350V	2/3	100+300/275V	12/6
ECC82	7/-	EY86	9/-	PLB3	8/-	16+16/450V	5/6		
ECC83	7/-	EZ80	7/-	P Y33	10/6	32+32/450V	6/6	2000+4000/6V	
ECL80	9/-	EZ81	7/-	P Y82	7/-	1000/25V	3/9		3/6
ECL82	10/6	GZ32	9/6	U25	10/6	Ersin Multicore	Solder 60/40, 4d.		
ECL86	10/6	PCC84	8/6	UL14	9/-				

DE LUXE R/PLAYER KIT

Incorporating 4 Speed Garrard Auto-Slim unit and Mullard latest 3 watt printed circuit amplifier (ECL 86 and EZ 80). Open brass and treble controls, with 8" x 5" 10,000 line speaker. Superb quality reproduction.

Contemporary styled two-tone cabinet, charcoal grey and off-white with matching blue relief. Size: 17 1/2" x 16" x 8".

COMPLETE KIT £13.19.6 Carr. & ins. 12/6

Ready wired, 3/0/- extra. Illuminated Perspex escutcheon, 7/6 extra. 4 Contemp' legs 6" 10/6, 9" 11/6, 12" 12/6, ex. Catalogue & construction details 2/6 (free with kit).

STANDARD RECORD PLAYER KIT

Using BSR UA14 Unit, complete kit £11.10.0, carr. 7/6. Ready wired Amplifier, 7" x 4" quality Speaker and O/P trans., £3.19.6, carr. 2/6. BSR UA14 Unit, £6.10.0, carr. & ins. 5/-. Rexine covered cabinet in two-tone maroon and cream, size 15 1/2" x 14 1/2" x 8 1/2" with all accessories plus uncut record player mounting board 14" x 13", 59/6, carr. & ins. 5/-.

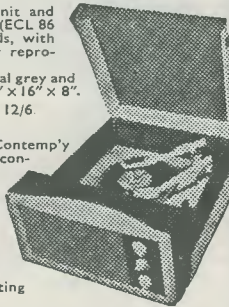

Condensers—S/Mica all values: 2pF to 1,000pF 6d. Ditto Ceramic 9c/s. each. .005, .01 and .1, etc., 1/-. Paper Tubular 450V .001 mfd. to .01 mfd and 1/1350V 9d., .02-1 mfd 1/-, .25 mfd 1/6, 5 mfd 1/9.

Speakers P.M.—2" Plessey 75 ohms, 15/6. 2 1/2" Continental 8 ohms, 13/6. 7" x 4" Plessey 35 ohms, 23/6. Ear Plug Phones—Min. Continental type, 3ft. lead, jack plug and socket. High Imp. 8/-, Low Imp. 7/6. High sensitivity M/coil 8-10 ohms, 12/6.

ANOTHER TAPE RECORDER BARGAIN

New re-designed contemporary Cabinet. Famous Mfrs. end of production Surplus Offer

A 24 gns. Tape Recorder offered at the fabulous bargain price of only 15 gns. + 10/- Carr. Supplied in 3 Units already wired and tested—only simple inter-Unit connections necessary. A modern Circuit for quality recording from Mike, Gram or Radio, incorporating the latest BSR Twin Track Monardeck Type TD2. Housed in attractive two-tone Cabinet of contemporary design, size 14" x 13 1/2" x 7 1/2" complete with Tape and Mike storage pockets. Valve line up—EF86, ECL82, EM84, EZ80 and Silicon Diode.

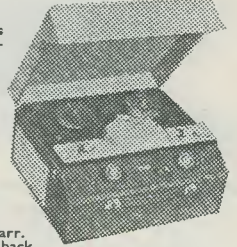

Complete Kit comprising items below.

BARGAIN PRICE 15 gns. + 10/- carr.

Cabinet and 7" x 4" Speaker, £3.5.0 + 5/- Carr. Wired Amplifier complete with Record/Playback Switching, 4 Valves, front Panel, Knobs, etc., £5.19.6 + 3/6 Carr. BSR Monardeck Type TD2, £7.7.0 + 4/6 Carr. Accessories—Mike, Tape, empty Reel, screened Lead & Plugs, Instructions, etc., £11.0.0 + 2/- Carr.

Volume Controls—SK-2 Meg-ohms, 3" Spindles Morganite Midget Type, 1 1/2" diam. Usual 1 year. LOG or LIN ratios less Sw. 3/- DP. Sw. 4/6. Twin Stereo less Sw. 7/6. DP. Sw. 9/6 (100 k. to 2 Meg. only). 1/2" Meg. VOL Controls D.P. Mfrs. 1/2" flatted spindle, Famous Mfrs. 4 for 10/- post free.

COAX 80 OHM CABLE

High grade low loss Cellular air spaced Polythene—1" diameter. Stranded cond. Famous mfrs. Now only 6d. per yard.

Bargain Prices—Special lengths:
20 yds. 9/-, P. & P. 1/6.
40 yds. 17/6, P. & P. 2/-.
60 yds. 25/-, P. & P. 3/-.
Coax Plug 1/-. Sockets 1/-.
Couplers 1/3. Outlet Boxes 4/6.

Close Tol. S/Micas—10% 5pF-500pF 8d. 600-5,000pF 1/-, 1% 2pF-100pF 9d. 100pF-500pF 11d. 575pF-5,000pF 1/6. Resistors—Full Range 10 ohms-10 megohms 20% 1/2 and 1/4 W 3d., ditto 10% 4d. 1/2 W 5d. (Midget type modern rating) 1W 6d., 2W 9d. Hi-Stab 5% 1/2 W 100 ohms 1 megohm 6d. Other values 9d. 1% 1/4 W 1/6. W/W Resistors 25 ohms to 10K 5W 1/3, 10W 1/6, 15W 2/-. Pre-set T/V Pots, W/W 25 ohms-50K 3/-. 50K-2 Meg. (Carbon) 3/-. Speaker Fret—Expanded gilt anodised metal 1/2" x 1/2" diamond mesh, 4/6 sq. ft., multiples of 6" cut. Max. size, 4ft. x 3ft. 47/6. Carr. extra. Ditto, finer mesh, 4/6 sq. ft. Multiples 1/2 only, max size 3ft x 2ft. 27/6. Plus Carr.

TYGAN FRET (contemp. pat.) 12" x 12" 2/-, 12" x 18" 3/-, 12" x 24" 4/-, 18" x 18" 4/6, etc.

BONDACOUST Speaker Cabinet Acoustic Wadding, superior grade, 1 ft. thick, 18" wide, any length cut 2/3 per ft. 6/- per yd.

ENAMELLED COPPER WIRE—1 lb reels, 14g-20g, 3/-; 22g-28g, 3/6; 36g-38g, 4/9; 39-40g, 5/-, etc.

TINNED COPPER WIRE—14-22g. 4/- 1 lb.

PVC CONNECTING WIRE—10 colours (for chassis wiring, etc.)—Single or stranded conductor, per yd., 2d. Sleeving, 1mm. and 2mm., 2d. yd., etc.

KNOBS—Modern Continental types: Brown or ivory with Gold Centre, 1" dia., 9d. each; 1 1/2", 1/3 each; Conc. knobs with gold centre 1 1/2" dia., 2/9 per pair. Matching ditto, 2/6 each. **LARGE SELECTION AVAILABLE.**

TRANSISTOR COMPONENTS

Midget I.F.'s—465 kc/s 1/4" diam., first, second or third 5/6
Osc. coil M. & L.W. 1/4" diam. 3/0
Midget Driver Trans. 9/1
Ditto O/Put Push-pull 3 ohms 6/0

Elect. Components—Midget Type 15V 1mf-50mf, ea. 1/9, 100mf, 2/-, Ferrite Aerial—M. & L.W. with car aerial coupling coil, 9/3.

Condensers—150V. wkg. .01 mfd. to .04 mfd., 9d. .05 mfd., .1 mfd., 1/-, .25 mfd., 1/3. .5 mfd., 1/6, etc.

Tuning Condensers. J.B. "00" 208 + 176pF, 8/6. Ditto with trimmers, 9/6. 365pF single, 7/6. Sub-min. 2" DILEMIN 100pF, 300pF, 500pF, 7/-.

Midget Vol. Control with edge control knob, 5kΩ with switch, 4/9, ditto less switch, 3/9.

JASON FM TUNER UNITS

Designer-approved kit of parts:

FMT1, 5 gns. 4 valves, 20/-

FMT2, £7.10.0. 5 valves, 35/-

JTV MERCURY 10 gns.

3 valves, 22/6.

JTV2 £13.19.6. 4 valves, 28/6.

NEW JASON FM HANDBOOK, 2/6. Prompt Alignment Service 7/6. P. & P. 2/6.

MULLARD "3-3" & "5-10" HI-FI AMPLIFIERS

3 OHM & 15 OHM OUTPUT

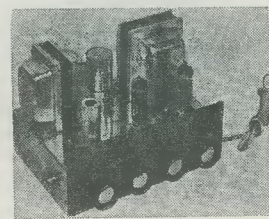

"3-3" Amp. 3-valve, 3 watt, Hi-Fi quality at reasonable cost. Bass Boost and Treble controls, quality sectional output transformer, 40 c/s-25 kc/s ± 1dB, 100mV for 3V, less than 1% distortion. Bronze escutcheon panel.

Complete Kit only 7 gns. Carr. 5/-, Wired and tested £8.10.0

MULLARD "5-10" AMPLIFIER—5 valves 10W, 3 and 15 ohms output.

Mullard's famous circuit with heavy duty ultra-linear quality output transformer. Basic amplifier kit price £9.19.6. Carr. 7/6. Ready built 11 1/2 gns.

2-VALVE PRE-AMP. UNIT

Based on Mullard's famous 2-valve (2 x EF86) circuit with full equalisation with volume, bass, treble, and 5-position selector switch. Size 9" x 6" x 2 1/2". Ready built, wired and tested, £7.19.6. Carr. 3/6.

Send for detailed bargain lists, 3d. stamp. We manufacture all types Radio Mains Transf. Chokes, Quality O/P Trans., etc. Enquiries invited for Specials, Prototypes for small production runs. Quotation by return.

RADIO COMPONENT SPECIALISTS

70 Brigstock Road, Thornton Heath, Surrey THO 2188. Hours: 9 a.m.-6 m., 1 p.m. Wed. Terms C.W.O. or C.O.D. Post and Packing up to 1/6 1/-, 1 lb. 1/9, 3 lb. 3/-, 5 lb. 3/9, 8 lb. 4/6.



Est. 1946

HI-FI AMPLIFIERS ~~~~~ TUNERS ~~~~~ RECORD PLAYERS

20+20
STEREO
AMP.
AA-22U

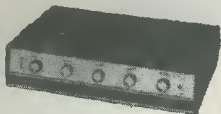

GARRARD
PLAYER
AT-60



10W
POWER
AMP.
MA-12



3+3W
STEREO
AMP.
S-33H

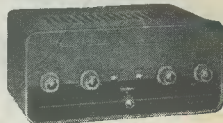

TRANSISTOR MIXER. Model TM-1. A must for the tape enthusiast. Four channels. Battery operated. Similar styling to Model AA-22U Amplifier. Kit **£11.16.6** Assembled **£16.17.6**

20+20W TRANSISTOR STEREO AMPLIFIER. Model AA-22U. Outstanding performance and appearance. Kit **£39.10.0** (less cabinet). Attractive walnut veneered cabinet £2.5.0 extra.

GARRARD AUTO/RECORD PLAYER. Model AT-60. less cartridge **£13.1.7** With Decca Deram pick-up **£17.16.1** incl. P.T. Many other Garrard models available, ask for Lists.

HI-FI MONO AMPLIFIER. Model MA-5. A general purpose 5W Amplifier, with inputs for Gram., Radio. Presentation similar to S-33. Kit **£10.19.6** Assembled **£15.10.0**

HI-FI MONO AMPLIFIER. Model MA-12. 10W output, wide freq. range low distortion. Kit **£11.18.0** Assembled **£15.18.0**

3 + 3W STEREO AMPLIFIER. Model S-33. An easy-to-build, low cost unit 2 inputs per channel. Kit **£13.7.6** Assembled **£18.18.0**

DE LUXE STEREO AMPLIFIER. Model S-33H. De luxe version of the S-33 with two-tone grey perspex panel, and higher sensitivity necessary to accept the Decca Deram pick-up. Kit **£15.17.6** Assembled **£21.7.6**

HI-FI STEREO AMPLIFIER. Model S-99. 9 + 9W output. Range controls. Stereo/Mono gram., radio and tape inputs. Push-button selection. Printed circuit construction. Kit **£28.9.6** Assembled **£38.9.6**

POWER SUPPLY UNIT. Model MGP-1. Input 100/120V, 200/250V 40-60 c/s. Output 6.3V, 2.5A A.C. 200, 250, 270V, 120mA max. D.C. Kit **£5.2.6** Assembled **£6.12.6**



Make the most of your leisure time...

FOR THE INSTRUMENTALIST

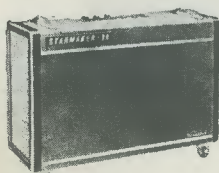

PA-2

NEW! STARMAKER-33

TRANSISTOR PA/GUITAR AMPLIFIER, PA-2. 20 Watt amplifier. Two heavy duty speakers. Four inputs. Two channels. Variable tremolo. Speed and depth controls. Weight 51lb.

18" high x 29" wide x 10" deep.

Kit **£44.19.0** Assembled **£59.10.0**
Castors or legs available as extras.

INSTRUMENTS

NEW! 3rd LOW-PRICED SERVICE OSCILLOSCOPE. Model OS-2. Compact size 5" x 7 1/4" x 12" deep. Wt. only 9 1/2lb. "Y" bandwidth 2 c/s-3 Mc/s ± 3dB. Sensitivity 100mV/cm. T/B 20 c/s-200 kc/s in four ranges, fitted mu-metal CRT Shield. Modern functional styling.

Kit **£22.18.0** Assembled **£30.8.0**

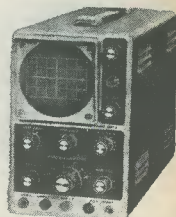

OS-2

5th GEN-PURPOSE OSCILLOSCOPE. Model 10-12U. An outstanding model with professional specification and styling. "Y" bandwidth 3 c/s-4.5 Mc/s ± 3dB. T/B 10 c/s-500 kc/s.

Kit **£35.17.6** Assembled **£45.15.0**

DE LUXE LARGE-SCALE VALVE VOLTMETER. Model IM-13U. Circuit and specification based on the well-known model V-7A but with many worth-while refinements. 6" Ernest Turner meter. Unique gimbal bracket allows operation of instrument in many positions. Modern styling. Kit **£18.18.0** Assembled **£26.18.0**

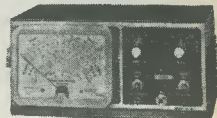

IM-13U

AUDIO SIGNAL GENERATOR. Model AG-9U. 10 c/s to 100 kc/s, switch selected. Distortion less than 0.1%, 10V sine wave output metered in volts and dB's.

Kit **£22.10.0** Assembled **£30.10.0**

VALVE VOLTMETER. Model V-7A. 7 voltage ranges d.c. volts to 1,500. A.c. to 1,500 r.m.s. and 4,000 peak to peak. Resistance 0.1Ω to 1,000MΩ with internal battery. D.c. input resistance 11MΩ. dB measurement, has centre-zero scale. Complete with test prods, leads and standardising battery.

Kit **£13.18.6** Assembled **£19.18.6**



V-7A

MULTIMETER. Model MM-1U. Ranges 0-1.5V to 1,500V a.c. and d.c.; 150μA to 15A d.c.; 0.2Ω to 20MΩ. 4 1/4" 50μA meter.

Kit **£12.18.0** Assembled **£18.11.6**



MM-1U

R.F. SIGNAL GENERATOR. Model RF-1U. Up to 100 Mc/s fundamental and 200 Mc/s on harmonics. Up to 100mV output.

Kit **£13.8.0** Assembled **£19.18.0**

NEW! SINE/SQ GENERATOR. Model IG-82U. Freq. range 20 c/s-1 Mc/s in 5 bands less than 0.5% sine wave dist. less than 0.15μ sec. sq. wave rise time.

Kit **£24.10.0** Assembled **£36.10.0**

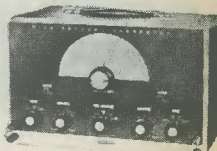

IG-82U

TRANSISTOR POWER SUPPLY. Model IP-20U. Up to 50V, 1.5A output. Ideal for Laboratory use. Compact size.

Kit **£35.18.0** Assembled **£47.18.0**

Prices and specifications subject to change without notice

TRANSISTOR RECEIVERS



UXR-2

"OXFORD" LUXURY PORTABLE. Model UXR-2. Specially designed for use as a domestic, car or personal portable receiver. Many features, including solid leather case. Kit **£14.18.0** incl. P.T.



UJR-1

TRANSISTOR PORTABLE. Model UXR-1. Pre-aligned I.F. transformers, printed circuit. Covers L.W. and M.W. Has 7" x 4" loud-speaker. Real hide case. Kit **£12.11.0** incl. P.T.



UJR-1

JUNIOR EXPERIMENTAL WORKSHOP. Model EW-1. More than a toy! Will make over 20 exciting electronic devices, incl: Radios, Burglar Alarms, etc. 72 page Manual. The ideal present! Kit **£7.13.6** incl. P.T.

JUNIOR TRANSISTOR RADIO. Model UJR-1. Single transistor set. Excellent introduction to radio. Kit **£2.7.6** incl. P.T.

WELCOME TO OUR LONDON HEATHKIT CENTRE

In response to the request of many customers, we have opened a showroom and retail stores at:

233 Tottenham Court Road

WHEN YOU ARE IN TOWN, WE HOPE YOU WILL VISIT US THERE

TAPE AMPLIFIERS ~~~~~ TAPE DECKS ~~~~~ CONTROL UNITS

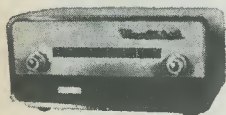

**FM
TUNER
FM-4U**



**MAGNAVOX
DECK**



**TRUVOX
DECK**



**AM/FM
TUNER**

HI-FI FM TUNER. Model FM-4U. Also available in two units. R.F. tuning unit (£2.15.0 incl. P.T.) with I.F. output of 10.7 Mc/s, and I.F. amplifier unit, with power supply and valves (£13.13.0).

Total Kit **£16.8.0**

MAGNAVOX "363" TAPE DECK. The finest buy in its price range. Operating speeds: 1½", 3¼" and 7½" p.s. Two tracks, "wow" and "flutter" not greater than 0.15% at 7½" p.s. **£13.10.0**

HI-FI AM/FM TUNER. Model AFM-1. Available in two units which, for your convenience, are sold separately. Tuning heart (AFM-T1—£4.13.6 incl. P.T.) and I.F. amplifier (AFM-A1—£22.11.6). Printed circuit board, 8 valves. Covers L.W., M.W., S.W., and F.M. Built-in power supply. Total Kit **£27.5.0**

TRUVOX D-93 TAPE DECKS. High quality stereo/mono tape decks. D93/2, ¼ track, **£36.15.0** D93/4, ¼ track, **£36.15.0**

TAPE RECORDING/PLAYBACK AMPLIFIER. Thermometer type recording indicators, press-button speed compensation and input selection. Mono Model TA-1M. Kit **£19.18.0** Assembled **£28.18.0**
Stereo Model TA-1S. Kit **£25.10.0** Assembled **£35.18.0**

MONO CONTROL UNIT. Model UMC-1. Designed to work with the MA-12 or similar amplifier requiring 0.25V or less for full output. 5 inputs. Baxandall type controls. Kit **£8.12.6** Assembled **£13.12.6**

STEREO CONTROL UNIT. Model USC-1. Push-button selection, accurately matched ganged controls to ±1dB. Rumble and variable low-pass filters. Printed circuit boards. Kit **£19.10.0** Assembled **£26.10.0**

Enjoy yourself building a Heathkit model



SSU-1

SPEAKER SYSTEMS

HI-FI SPEAKER SYSTEM. Model SSU-1. Ducted-port bass reflex cabinet "in the white". Two speakers. Vertical or horizontal models with legs, Kit **£12.12.0**, without legs, Kit **£11.17.6** incl. P.T.

NEW! BERKELEY Slim-line SPEAKER SYSTEM, fully finished walnut veneered cabinet for faster construction. Special 12" bass unit and 4" mid/high frequency unit. Range 30-17,000 c/s. Size 26" x 17" x only 7½" deep. Modern attractive styling. Excellent value.

Kit **£18.10.0** Assembled **£23.0.0**

COTSWOLD SPEAKER SYSTEMS. Outstanding performance for price.

MFS: Size 36" x 16½" x 14" deep.

Kit **£25.12.0** Assembled **£33.17.0**

STANDARD: Size 26" x 23" x 14½" deep.

Kit **£25.12.0** Assembled **£33.17.0**

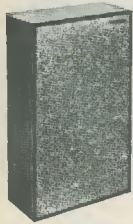

Berkeley

HI-FI CABINETS

A wide range available including:

PLAYBOX Table Player. Available in walnut, mahogany or teak finish.

Assembled **£10.10.0**

GLOUCESTER. Kit **£18.10.0** incl. P.T.

MALVERN. Kit **£18.1.0** incl. P.T.

CHEPSTOW. Kit **£11.12.6** incl. P.T.

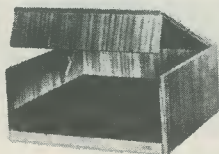

**PLAYBOX
finished Cabinet**

MANY OTHER BRITISH MODELS

Send for free Catalogue

Deferred terms available in U.K. over £10.
Prices quoted are Mail Order prices.

DAYSTROM LTD DEPT. RC.3
GLOUCESTER

"AMATEUR" EQUIPMENT

THE "MOHICAN" GENERAL COVERAGE RECEIVER. Model GC-1U. With 4 piezo-electric transmitters, variable tuned B.F.O. and Zener diode stabiliser, this is an excellent fully transistorised general purpose receiver for Amateur and Short wave listeners. Printed circuits, telescopic aerial, tuning meter and large slide-rule dial. Kit **£37.17.6** Assembled **£45.17.6**

AMATEUR BANDS RECEIVER. Model RA-1. To cover all the Amateur Bands from 160-10 metres. Many special features, including: half-lattice crystal filter; 8 valves; signal strength "S" meter; tuned R.F. Amp. stage. Kit **£39.6.6** Assembled **£52.10.0**

160-10M TRANSMITTER. Model DX-100U. Careful design has achieved high performance and stability. Completely self-contained. Kit **£79.10.0** Assembled **£104.15.0**

COMMUNICATIONS TYPE RECEIVER. Model RG-1. A high performance, low cost receiver for the discriminating listener. Frequency coverage: 600 kc/s-1.5 Mc/s and 1.7 Mc/s-32 Mc/s. Kit **£39.16.0** Assembled **£53.0.0**

REFLECTED POWER METER and SWR BRIDGE. Model HM-11U. Indicates reliably, but inexpensively, whether the RF power output of your TX is being transferred efficiently to radiating antenna. Kit **£8.5.0** Assembled **£10.10.0**

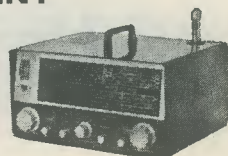

GC-1U



RG-1



HM-11U

AMERICAN HEATHKIT "AMATEUR" EQUIPMENT

A wide range of American Amateur SSB equipment is now available in the U.K. Why not send for full details of range, for example:

80-10M RECEIVER. Model SB-300E. Of advanced design employing up-to-date construction techniques, its specification ensures unparalleled performance. Kit **£139.0.0** (less speaker) price incl. carriage, duty, etc.

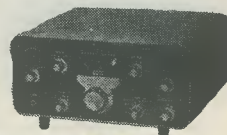

SB-300E

Without obligation please send me **FREE BRITISH HEATHKIT CATALOGUE** (Tick here)

FULL DETAILS OF MODEL(S)

(Please write in BLOCK CAPITALS)

NAME

ADDRESS

DEPT. RC.3

Scottish Insurance Corporation Ltd

38 EASTCHEAP · LONDON · EC3



TELEVISION SETS, RECEIVERS AND TRANSMITTERS

Television Sets, Receivers and Short Wave Transmitters are expensive to acquire and you no doubt highly prize your installation. Apart from the value of your Set, you might be held responsible should injury be caused by a fault in the Set, or injury or damage by your Aerial collapsing.

A "Scottish" special policy for Television Sets, Receivers and Short Wave Transmitters provides the following cover:

- (a) Loss or damage to installation (including in the case of Television Sets the Cathode Ray Tube) by Fire, Explosion, Lightning, Theft or Accidental External Means at any private dwelling-house.
- (b) (i) Legal Liability for bodily injury to Third Parties or damage to their property arising out of the breakage or collapse of the Aerial Fittings or Mast, or through any defect in the Set. Indemnity £10,000 any one accident.
- (ii) Damage to your property or that of your landlord arising out of the breakage or collapse of the Aerial Fittings or Mast, but not exceeding £500.

The cost of Cover (a) is 5/- a year for Sets worth £50 or less, and for Sets valued at more than £50 the cost is in proportion. Cover (b) (i) and (ii) costs only 2/6 a year if taken with Cover (a), or 5/- if taken alone.

Why not BE PRUDENT AND INSURE your installation—it is well worth while AT THE VERY LOW COST INVOLVED. If you write to the Corporation's Office a proposal will be submitted for completion.

Write for full details, quoting reference 5304, to:—

THE MANAGER
SCOTTISH INSURANCE CORPORATION LTD.,
38 EASTCHEAP, LONDON E.C.3

SPECIAL FROM SINCLAIR

SINCLAIR MICRO FM COMBINED POCKET-SIZE FM TUNER RECEIVER



THE ONLY DESIGN OF ITS KIND IN THE WORLD

For far less money and trouble you can enjoy building and using the most advanced FM design in the world when you buy the Sinclair Micro FM. This fully fledged 7 transistor, 2 diode FM superhet has original features that ensure superb audio quality and great sensitivity together with utmost ease of assembly. There are two separate output sockets—an exclusive Sinclair feature which enables you to use your Micro FM as a tuner and an independent pocket size portable receiver whenever you wish. This wonderful set is as outstanding in appearance as in performance. Many other excellent features are included in the Micro-FM to make building an FM set easy for any constructor. Best of all, it brings first-class performance with a saving of pounds.

- ★ Size: $2\frac{1}{2}'' \times 1\frac{1}{2}'' \times \frac{3}{8}''$
- ★ Powerful A.F.C.
- ★ Pulse counting discriminator
- ★ Low I.F. eliminates alignment problems
- ★ Tunes from 88 to 108 Mc/s
- ★ Audio response: 10 to 20,000 c/s ± 1 dB
- ★ Signal to Noise Ratio: 30dB at 30 microvolts
- ★ Operates from standard 9V battery, self-contained
- ★ Plastic case with brushed and polished aluminium front and spun aluminium tuning dial

Complete kit inc. telescopic aerial, case, earpiece, and instructions **£5.19.6**

SAVE 19/- By buying Micro FM with Z.12 Amplifier. Usual price £10.9.0. Makes an ideal combination. Send for PACK "A" **£9.10.0**

A KIT EVERY CONSTRUCTOR WILL BE PROUD TO BUILD

SINCLAIR MICRO-6

The world's smallest radio

The power, selectivity and quality of the Micro-6 are remarkable by any standards, and building is simplicity itself. Tunes over the medium waveband with bandspread for Luxembourg, etc. This 6-stage marvel is absolutely complete with batteries and ferrite rod aerial in its attractive white, gold and black case, size $1\frac{4}{5}'' \times 1\frac{3}{10}'' \times \frac{1}{2}''$. It virtually plays anywhere.



Complete with transistors, case, earpiece and instructions.

59/6

MALLORY CELL TYPE ZM.312 (2 required) 1/11 each.

SAVE 9/- By buying your Micro-6 together with a Z.12 Amplifier. Usual price £7.9.0. Send for PACK "B" **£7.0.0**

SINCLAIR Z.12 COMBINED 12 WATT AMPLIFIER AND PRE-AMP

The ultimate in power, quality and size

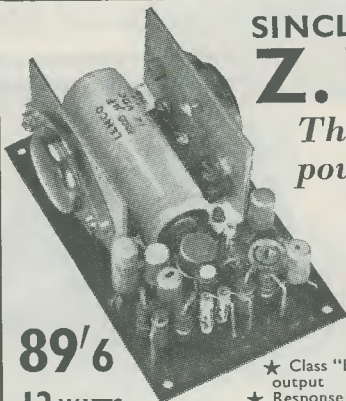

Never has such power and quality been obtained from so compact an amplifier. Uses 8 special H.F. transistors. May be operated at any voltage from 6-20V d.c. and the output fed directly into any load from 1.5 to 15Ω. Supplied ready built, tested and guaranteed together with manual showing all types of suitable tone and volume control circuits.

89/6

12 WATTS R.M.S. (24W PEAK)

$3'' \times 1\frac{1}{2}'' \times 1\frac{1}{3}''$

IDEAL FOR 12V OPERATION

- ★ Class "B" ultra-linear output
- ★ Response 15-50,000 c/s ± 1 dB
- ★ Output 12W r.m.s. continuous sine wave (24W peak), 15W r.m.s. music power (30W peak)
- ★ Output impedance—suitable for 3, 7.5 or 15Ω.

- Two 3Ω speakers may be used in parallel
- ★ Input—2mV into 2kΩ
- ★ Signal to noise ratio—better than 60dB
- ★ Quiescent current consumption—15mA
- ★ Power requirements—from 6 to 20V d.c.
- ★ POWER PACK PX-1—£2.14

SAVE 11/- By buying two Z.12 amplifiers together (for stereo, etc.). Usual price £8.19.0. Send for PACK "C" **£8.8.0** Power Pack PX-1—£2.14.0

FULL SERVICE FACILITIES AVAILABLE TO SINCLAIR CUSTOMERS

GUARANTEE If you are not completely satisfied when you receive your purchase from us, your money will be refunded at once in full and without question.

SINCLAIR RADIONICS LTD., 22 NEWMARKET ROAD, CAMBRIDGE

Please send

NAME _____
ADDRESS _____

for which I enclose cash/cheque/money order value £.....s.....d.

RC3

Sinclair
Now at new and larger premises
SINCLAIR RADIONICS LTD
22 NEWMARKET ROAD, CAMBRIDGE
Telephone 52731

FREE TO AMBITIOUS ENGINEERS

— THE LATEST EDITION OF ENGINEERING OPPORTUNITIES

Have you sent for your copy?

ENGINEERING OPPORTUNITIES is a highly informative 156-page guide to the best paid engineering posts. It tells you how you can quickly prepare at home for a recognised engineering qualification and outlines a wonderful range of modern Home Study Courses in all branches of Engineering. This unique book also gives full details of the Practical Radio & Electronics Courses, administered by our Specialist Electronics Training Division—the B.I.E.T. School of Electronics, explains the benefits of our Employment Dept. and shows you how to qualify for five years' promotion in one year.

SATISFACTION OR REFUND OF FEE

Whatever your age or experience, you cannot afford to miss reading this famous book. If you are earning less than £30 a week, send for your copy of "ENGINEERING OPPORTUNITIES" today—FREE.

BRITISH INSTITUTE OF ENGINEERING TECHNOLOGY
(Dept. 752B), 29 Wright's Lane, London, W.8

THE B.I.E.T. IS THE LEADING INSTITUTE OF ITS KIND IN THE WORLD

WHICH IS YOUR PET SUBJECT?

Mechanical Eng.,
Electrical Eng.,
Civil Engineering,
Radio Engineering,
Automobile Eng.,
Aeronautical Eng.,
Production Eng.,
Building, Plastics,
Draughtsmanship,
Television, etc.

GET SOME LETTERS AFTER YOUR NAME!

A.M.I.Mech.E.
A.M.I.C.E.
A.M.I.Prod.E.
A.M.I.M.I.
A.I.O.B.
B.Sc.
A.M.I.E.R.E.
City & Guilds
Gen. Cert. of Ed.
Etc., etc.

PRACTICAL EQUIPMENT

Basic Practical and Theoretical Courses for beginners in Radio, T.V., Electronics, Etc., A.M.I.E.R.E., City & Guilds

Radio Amateurs' Exam.
R.T.E.B. Certificate
P.M.G. Certificate
Practical Radio
Radio & Television Servicing
Practical Electronics
Electronics Engineering
Automation

INCLUDING TOOLS!

The specialist Electronics Division of B.I.E.T. NOW offers you a real laboratory training at home with practical equipment. Ask for details.

B.I.E.T. SCHOOL OF ELECTRONICS



POST COUPON NOW!

Please send me your FREE 156-page "ENGINEERING OPPORTUNITIES" (Write if you prefer not to cut page)

NAME

ADDRESS

SUBJECT OR EXAM THAT INTERESTS ME 752B

IMPROVED STANDARDS of Accuracy and Reliability!

Modern styling in light grey with legible black engraving.

Constructed to withstand adverse climatic conditions.

Ever ready case including leads, prods and clips. Improved internal assemblies.

Re-styled scale plate for easy rapid reading. 2 basic scales each 2.5 inches in length.

New standards of accuracy using an individually calibrated scale plate: d.c. ranges 2.25% of full scale deflection. a.c. ranges 2.75% of full scale deflection.

Available accessories include a 2,500V d.c. multiplier and 5, 10 and 25A shunts for d.c. current measurement.

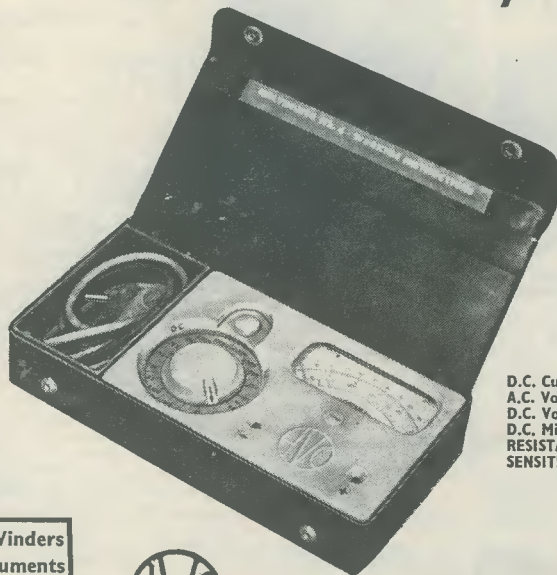

The Mk. 4 MULTIMINOR, the latest version of this famous Avo instrument, supersedes all previous models. It is styled on modern lines, with new high standards of accuracy, improved internal assemblies, and incorporating panclimatic properties.

The instrument is supplied in an attractive black carrying case, which also houses a pair of leads with interchangeable prods and clips, and an instruction booklet. It is packed in an attractive display carton. Robust real leather cases are available, if required, in two sizes, one to take the instrument with leads, clips and prods, and the other to house these and also a high voltage multiplier and a d.c. shunt.

D.C. Current: 100µA f.s.d. — 1A f.s.d. in 5 ranges.
A.C. Voltage: 10V f.s.d. — 1,000 f.s.d. in 5 ranges.
D.C. Voltage: 2.5V f.s.d. — 1,000 f.s.d. in 6 ranges.
D.C. Millivolt range: 0 — 100mV f.s.d.
RESISTANCE: 0–2MΩ in 2 ranges, using 1.5V cell.
SENSITIVITY: 10,000 Ω/V on d.c. Voltage ranges.
1,000 Ω/V on a.c. Voltage ranges.

See the latest AVO Coil Winders & Electrical Testing Instruments on STAND HH4 A.S.E.E. Exhibition, Earls Court



MULTIMINOR Mk 4

Write for leaflet

AVO LTD

AVOCET HOUSE, 92-96 VAUXHALL BRIDGE ROAD, LONDON, SW1

Telephone: VICTORIA 3404



MM/17

JACKSON



the big name in **PRECISION** components

Precision built radio components are an important contribution to the radio and communications industry.

SL 16 DRIVE

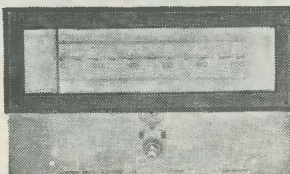

A general purpose slide rule Drive for F.M./V.H.F. Units, short-wave converters, etc. Printed in two colours on aluminium, with a 0-100 scale and provision is made for individual calibrations. Complete with bronze escutcheon and glass. 15/-.

It's reliable if it's made by JACKSON!

MADE IN ENGLAND

JACKSON BROS. (LONDON) LTD.

Dept. R.C., Kingsway-Waddon, Croydon, Surrey

Telephone Croydon 2754-5

Telegrams Walfilco, Souphone, London

Any holes in your knowledge of TRANSISTORS?

Whatever your interest in transistor circuitry, you will find the Mullard "Reference Manual of Transistor Circuits" and "Transistor Radios—Circuitry and Servicing", valuable sources of reference.

The former describes more than sixty circuits for both domestic and industrial applications.

The latter is an introduction to the subject and describes the basic properties of semiconductors, their function, elementary circuitry and servicing.

REFERENCE
MANUAL OF
TRANSISTOR
CIRCUITS
U.K. PRICE
12/6
Post extra 1/-

TRANSISTOR
RADIOS
Circuitry and
Servicing
U.K. PRICE
5/-
Post extra 6d.



Get your copies from your radio dealer, or send remittance with order to:

MULLARD LTD · MULLARD HOUSE · TORRINGTON PLACE · LONDON WC1



FIRST QUALITY PVC TAPE

5½" Std. 850ft	9/-	5" L.P. 850ft	10/6
7" Std. 1200ft	11/6	3" T.P. 600ft	10/6
3" L.P. 240ft	4/-	5" T.P. 1800ft	25/6
5½" L.P. 1200ft	11/6	5½" T.P. 2400ft	32/6
7" L.P. 1800ft	18/6	7" T.P. 3600ft	42/6

P. & P. on each 1/6, 4 or more post free.

G.E.C. FLAT HEATER ELEMENT 500W

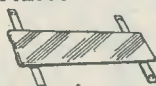

Can be used for wash boilers, washing machines, etc. Five or six elements can be used in parallel to give 2500/3000W. Size 5½" x 1½", copper enclosed. 2/6 each, P. & P. 1/-, 4 or more post paid.

3 to 4 WATT AMPLIFIER KIT

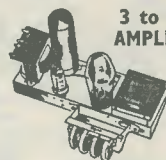

comprising chassis 8½" x 2½" x 1". Double wound mains transformer, output transformer, volume and tone controls, resistors, condensers, etc. 6V6, ECC81 and metal rectifier. Circuit 1/6, free with kit. 29/6, plus 4/6 P. & P.

8-watt 5-valve PUSH-PULL AMPLIFIER & METAL RECTIFIER

Size: 9" x 6" x 1½" A.C. Mains 200-250V 5 valves. For use with Std. or L.P. records, musical instruments, all makes of pick-ups and mikes. Output 8 watts at 5 per cent total distortion. Separate bass and treble lift controls. Two inputs, with controls, for gram, and mike. Output Transformer tapped for 3 and 15 ohms speech coils. Built and tested. £3.19 6. P. & P. 8/-.

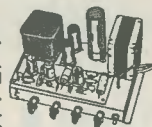

MUSETTE 6-Transistor Superhet Portable Radio

★ 2½" Speaker. ★ Output 200mw. ★ Plastic Cabinet in red, size 4½" x 3" x 1½", and gold speaker louvre. ★ Horizontal Tuning Scale. ★ Internal Aerial. ★ IF 460 Kc/s. ★ All components and Tuning Assembly mounted on printed board. ★ Operated from PP3 Battery. ★ Full instructions and point-to-point wiring diagram. ★ Printed Circuit. ★ Medium and long waves.

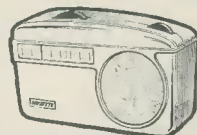

Price 39/6d P. & P. 3/6 inc. carrying strap. Circuit Diagram 2/6—free with parts.

TRANSISTORISED SIGNAL GENERATOR

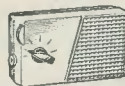

Size 5½" x 3½" x 1½". For IF and RF alignment and AF output, 700 c/s frequency coverage 460 Kc/s to 2 Mc/s in switched frequencies. Ideal for alignment to our Elegant Seven and Musette. Built and tested. 39/6. P. & P. 3/6.

POWER SUPPLY KIT to purchasers of Elegant Seven parts, incorporating mains transformer, etc. A.C. mains 200-250V. Output 9V 50mA. 7/6d. extra.

'ELEGANT SEVEN' Mk. II

Combined Portable and Car Radio
The Radio with the "Star" Features

- ★ 7-transistor superhet. Output 350mW.
- ★ Wooden cabinet, fitted handle with silver coloured fittings. Size 12½" x 8½" x 3½".
- ★ Horizontal tuning scale, size 11½" x 2½" in silver and black lettering.
- ★ All stations clearly marked.
- ★ Ferrite-rod internal aerial.
- ★ I.F. Neutralisation on each stage. 460 kc/s.
- ★ D.C. coupled output stage with separate A.C. negative feed back.
- ★ All components, ferrite rod and tuning assembly mounted on printed board. ★ Operated from PP9 battery. ★ Full comprehensive instructions and point-to-point wiring diagrams. ★ Printed circuit board, back printed with all component values. ★ Fully tunable over medium and long waveband. ★ Car aerial socket.
- ★ Full after-sale service. 4" SPEAKER.

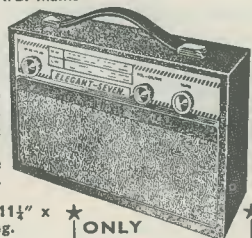

ONLY
£4.4.0
Plus 6/6 Post & Packing

Parts list and circuit diagram 2/6, FREE with parts.

Shop Hours 9 a.m.—6 p.m. Early Closing Wednesday
Goods not despatched outside U.K. Terms C.W.O.
All enquiries Stamped Addressed Envelope.

RADIO & TV COMPONENTS (ACTON) LTD.
21F High St., Acton, London, W.3



WHAT'S THE CONNECTION

between Stonehenge and the Home Radio Catalogue?

The connection is not so remote as may first appear. Professor Hawkins of Harvard University had never actually seen Stonehenge but he collected all available data about it and fed it into a modern computer. The answer came back very clearly that Stonehenge itself was a computer, computing the position of sunrise on midsummer and midwinter day and the positions of the moon—including total eclipses. Now computers, ancient and modern, are designed to save man time. *So is the Home Radio Components Catalogue*—hence the connection! Take the index for example. A good index is vital to a catalogue. To be of maximum use, everything must be cross-referenced. If you were after Iron Dust Slugs you might look under Iron, or Dust, or Slugs—or even Cores. In our catalogue index, whichever you plumped for, you would find it! Take another example. We list several makes of electrolytic and paper condensers, but we know that many of our customers simply want a capacitor of a particular capacity and voltage. At the beginning of each condenser section therefore, we give a list of all the condensers we stock in their order of capacity and voltage.

These are just two examples of the trouble we have gone to to make our catalogue as computer like as possible in its time-saving (and temper-saving) efficiency. Judge for yourself—just send off the coupon with your cheque or P.O. for 9/- (7/6 plus 1/6 p & p.) and you will receive this superbly produced 210-page catalogue, plus a 21-page price supplement, plus a semi-conductor list and a special bargain list. Remember every catalogue contains 5 coupons, each worth 1/- when used as directed.

Please write your Name and Address in block capitals

Name

Address

Home Radio Ltd., Dept. RC, 187 London Rd., Mitcham, Surrey

THE Radio Constructor



Incorporating THE RADIO AMATEUR

MARCH 1966

Vol. 19, No. 8
Published Monthly
(1st of month)

*Editorial and
Advertising Offices*
57 MAIDA VALE LONDON W9

Telephone
CUNningham 6141

Telegrams
Databux, London

First Published
1947

Integrated Circuits, <i>by J. Baguley, G.I.Mech.E., G.I.E.R.E.</i>	474
9-Volt Battery Eliminator for Transistor Radios (Suggested Circuit No. 184), <i>by G. A. French</i>	481
Photo-Electric Transistors, <i>by J. F. Phillips</i>	484
Plug-in Speech Clipper, <i>by Frederick Sayers</i>	485
Further Notes on the Phototransistor Sports Timer, <i>by John G. Dew, B.Sc.</i>	488
Circuits for S.C.R.s, <i>by H. N. Rutt</i>	490
The "Spontaflex" D.R.4 Transistor Portable, <i>by Sir Douglas Hall, K.C.M.G., M.A.(Oxon)</i>	493
Recent Publications	497
News and Comment	498
In Your Workshop	500
Hot Carrier Diodes, <i>by J. B. Dance, M.Sc.</i>	507
Dual-Conversion Superhet for 2 Metres, <i>by D. J. Bunn, G3OEQ</i> (Cover Feature)	508
Diacs and Triacs	516
Radio Topics, <i>by Recorder</i>	517
Dual-Purpose Power Supply, <i>by M. L. Martin</i>	518
Can Anyone Help?	521
Club Events	521

© Data Publications Ltd., 1966. Contents may only be reproduced after obtaining prior permission from the Editor. Short abstracts or references are allowable provided acknowledgement of source is given.

Annual Subscription 33s. (U.S.A. and Canada \$5) including postage. Remittances should be made payable to "Data Publications Ltd". Overseas readers please pay by cheque or International Money Order.

Published in Great Britain by the Proprietors and Publishers Data Publications Ltd. 57 Maida Vale London W9
Printed by A. Quick & Co. (Printers) Ltd. Clacton-on-Sea England

INTEGRATED CIRCUITS

By J. BAGULEY, G.I.Mech.E., G.I.E.R.E.

Although they have not yet made any significant inroads into the sphere of domestic and entertainment electronics, integrated circuits are proving to be of considerable importance in computers and logic engineering. A basic integrated circuit can be formed on a single tiny chip of semiconductor material, and our contributor gives a fascinating insight into the processes which are involved. He also discusses the many applications for which these circuits may be used, both at the present time and in the future

INTEGRATED CIRCUITS ARE PROVIDING WHAT IS probably the greatest impact on the electronics industry since the arrival of the transistor in 1948. The impetus behind their rapid development, all of which has taken place since 1960, has mainly been provided by the requirements of the American Space and Aviation Programme for greater reliability and space and weight saving. The full impact of integrated circuits has yet to be felt, however, because they are only just becoming competitive in price and because, due to certain technical limitations, their main application so far has been in digital circuits.

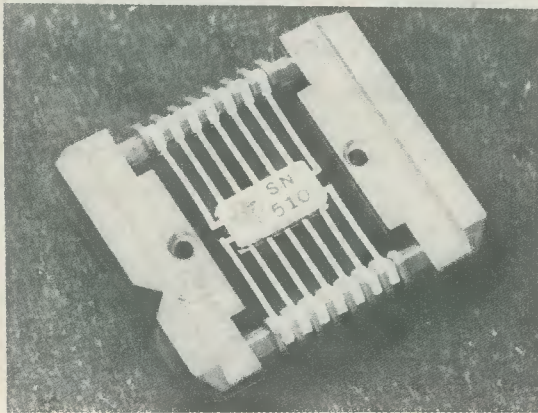

A Texas Instruments flat package. The integrated circuit proper is in the central rectangle, this being removed from the container (or "Mechpack") which surrounds it by cropping the conductors about $\frac{1}{8}$ in. from its long edges. The Mechpack is merely convenient for testing and breadboard working. The length of the central rectangle is $\frac{1}{2}$ in. (Courtesy Texas Instruments Ltd.)

What is an Integrated Circuit?

The integrated circuit is a module containing one or more complete circuit functions (e.g. gate, amplifier, etc.) and in which no discrete components are used as such. It is usually much smaller than the equivalent circuit would be with conventional components; and it is immediately ready for use, needing only power supplies and input and output to be connected to it. It is constructed using semiconductor and/or thin film techniques and is contained either in a modified version of the well-known TO5 can or in a flat package. A typical example of the latter is illustrated here.

The integrated circuit continues the philosophy of the more familiar digital circuit block, which is made up using encapsulated conventional components. However, circuit blocks typically contain two gates of a bistable within a volume of a half to one cubic inch, while some integrated circuits, using the illustrated package, contain four gates or two bistables within one-thousandth of a cubic inch!

The Implications of Integrated Circuits

So far, integrated circuits have mainly affected the military and digital fields. This is due to technical limitations (as already mentioned) and to tooling and development costs, the latter needing the justification of large quantities of identical circuits. Hence, the implications in these fields will be discussed first. They are mainly fourfold.

1. *Volume.*—A typical digital computer without its peripheral equipment would fill a large room if made using valves. With transistors mounted on orthodox printed circuits it would occupy a couple of 6ft racks, whilst with block modules it would occupy a 4ft rack. With integrated circuits it could be expected to occupy a mere $\frac{1}{4}$ to 1 cubic ft, and this would include power supplies!

2. *Cost*.—At present, circuit function for circuit integrated circuits are competitive with circuit blocks when “reduced temperature ranges” (0 to 75°C.) are used. (Full temperature range is typically -55°C. to 125°C. and twice as expensive.) When used and produced in greater numbers their eventual price will be a fraction of that of circuit blocks. The spot welding equipment necessary to weld the flat packages into position is expensive; nevertheless, with printed circuits the only wiring which needs to be done is from board to board externally. Thus, with sufficient quantities there will be further great savings in cost. On the development side there will be considerable savings in circuit design due to eliminating the duplication of similar designs.

3. *Reliability*.—In a large system using valves, mean time between failure could well be so low that the system would be virtually inoperable. This problem has even become serious with transistors in today’s large systems, since so much relies also on the many interconnecting links. Duplication of circuitry to allow for failure is a recent solution which lends itself very well to integrated circuits, with which vital extra circuits can in many cases take up no extra space. Also, by having less external connections (e.g. between components) the integrated circuit is inherently more reliable.

4. *The Role of the Circuit Designer*.—Where integrated circuits of standard form are used the customer’s circuit designer has no place. Instead, system and logic design engineers are required to interconnect the circuits correctly. This is not as serious as it may at first seem since the circuit designer is still necessary if special circuits (integrated or otherwise) are involved, and the situation is little different to that already experienced in using circuit blocks.

Other Fields

In other fields, where either less identical elements are required or where integrated circuits may be less suitable (or not yet possible) the implications are not as clear-cut. Nevertheless, even in the commercial radio field, to take an example, it should be possible to eventually standardise on, say, an integrated circuit i.f. amplifier, since potential quantity requirements would certainly be sufficient. The attendant advantages of cost, size and weight reduction allied to reliability would then automatically follow. It seems that it will not be long before many of the more “difficult” circuits are built in integrated form commercially, typical instances being power supplies, power amplifiers, filters, v.h.f. circuits, television timebases, and so on. Therefore it seems that the integrated circuit will eventually offer its many advantages in a wide range of fields.

Types and Methods of Manufacture

The types of integrated circuit manufacturing methods are best shown by the “family tree” of Fig. 1, and these will now be described.

1. *Monolithic Integrated Circuits*.—This method

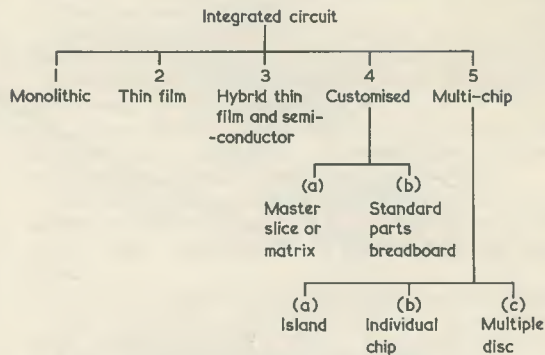

Fig. 1. The integrated circuit “family tree”

of manufacture is a natural extension of the techniques used in the making of silicon planar and epitaxial transistors. A description of a typical process follows and is illustrated in Fig. 2. Note that while, in practical circuits, a single dice contains many elements, the diagrams will only give a sectional view of two (transistor and resistor) for descriptive purposes.

Fig. 2 (a) shows an epitaxial wafer. P type silicon substrate is formed as a cylindrical ingot using a refined silicon crystal. This ingot is sliced into wafers which are polished by lapping and further reduced in thickness by chemical etching. A layer of n type silicon is epitaxially grown on the substrate wafer and provides a p.n junction, becoming a single crystal extension of the substrate wafer. The surface is finally protected by oxidation, this giving a silicon dioxide (glass) layer.

The next process consists of isolation masking and the first diffusion, this creating isolated n regions. “Windows” are selectively photo-etched through the oxide layer to prepare for isolation diffusion. P type impurity is diffused through the exposed areas, providing isolated n type areas by changing through to the p type substrate. These isolated “islands” of n type material make possible the isolated deposition of multiple elements in the same chip and, typically, form the collectors of transistors. Finally, a new oxide layer is formed to cover the exposed areas, giving the result shown in Fig. 2 (b).

A second diffusion follows, this creating transistor bases, diffused resistors and diode anodes. Further “windows” are etched through the two oxide layers at suitable locations. A short p type diffusion forms in these areas, after which another oxide layer is provided. See Fig. 2 (c).

A third diffusion enables transistor emitters and diode cathodes to be formed. Again, suitably positioned “windows” are etched. In the case of resistors, no further change is required, and these areas remain covered by the oxide layers. An n type diffusion forms transistor emitters or diode cathodes, etc., and the final oxide layer is then added, as shown in Fig. 2 (d).

The various circuit elements are now connected to form the required circuit configuration, as

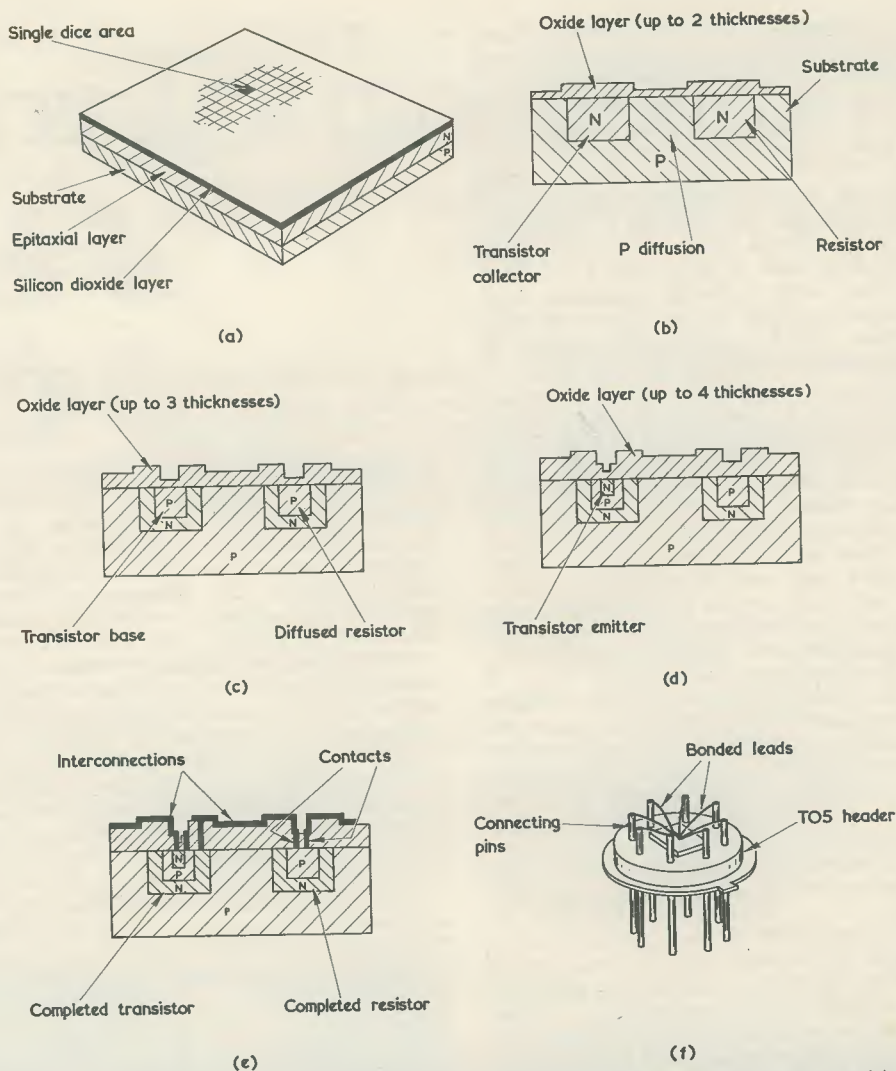

Fig. 2. The monolithic integrated circuit process. The basic epitaxial wafer, comprising substrate (p), epitaxial layer (n) and silicon dioxide protective layer, is shown in (a). The condition of a single dice after the first diffusion with p type impurity and the application of a new oxide layer is illustrated in (b). The points where the original oxide layer was etched away is evident from the fact that these now have only one thickness of oxide at this stage. In (c) a second short diffusion, of p material, creates transistor bases, diffused resistors and diode anodes. A third diffusion (d) of n type material forms transistor emitters and diode cathodes, whilst (e) illustrates conditions after contacts and interconnections have been made. In (f) a single chip is mounted on a TO5 header

illustrated in Fig. 2 (e). To do this, holes are etched in the oxide layers using one mask, and the contacts and interconnections are deposited as a thin layer of aluminium or gold using another. Some manufacturers prefer to metallise the whole surface and etch away the unwanted areas, leaving the required interconnections. Thin film components can also be deposited above the oxide layers at this stage if a hybrid circuit is to be made.

The next process consists of wafer scribing and dicing. The wafers are scribed by diamond cutters and chipped into individual circuit chips by the

application of carefully controlled mechanical pressure. After testing in the complete wafer form and chipping, they are ready for mounting into their individual TO5 cans or flat packages.

Each chip is mounted on a ceramic wafer, for attaching to either a TO5 header or a flat package, with a high temperature eutectic solder. Short gold wires are bonded to the input, output and power supply pads by thermocompression bonding, and are then spot welded to the interconnecting pins. An example is shown in Fig. 2 (f), in which a TO5 header is used.

The final process is hermetic sealing. The element is tested and dried, and its can or flat package cover welded in position. All this takes place within an evacuated chamber.

Transistors, diodes, resistors and capacitors (inductors experimentally) are produced in the manner just described as part of the integrated circuit.

The transistors are isolated at their collectors by the back-biased substrate junction. (Diodes are similarly isolated.) This "isolation diode" adds shunt capacitance and a reverse leakage current which, associated with other parasitic effects, leads to a performance which is slightly inferior to that achievable by equivalent conventional semiconductor components.

Resistors, whether produced by substrate resistance or by a back-biased diffused junction, are subject to large tolerances and temperature coefficients. In many applications this does not matter, since the ratios of the resistors produced can be held to quite close tolerances. Until recently, capacitors have been avoided where possible since they are normally produced by a back-biased junction. Consequently, for values above a few picafarads large junctions are required, and these result in heavy leakage currents. They are also subject to large tolerances and vary considerably with temperature and the voltage across the junction.

It can be seen that digital circuits, with their ability to function with wide component tolerances and parasitics, are naturally first to find extensive application for integrated circuits. The difficulty of producing suitable inductors and large capacitor values has explained a lack of r.f. and low frequency circuits. But the technical difficulties involved are rapidly being overcome. Active filters and i.f. amplifiers are being made with the aid of negative impedance converters and reflected capacitance. Direct coupled video amplifiers with a flat response from d.c. to 40 Mc/s and 40dB gain are being marketed. Again, field effect transistors are integrated for very high input impedance. Power drive capability has increased to 0.5 amp, and 3 c/s oscillators have been produced using the temperature flow time constant of a metal bar. For the future, therefore, it seems that there will be few technical difficulties which will not be overcome.

Yield is currently low at the wafer stage due to flaws but most testing, which represents the costliest part of manufacturing, takes place afterwards, when the yield approaches 90%.

2. Thin Film Integrated Circuits.—Active thin film elements are being pursued experimentally but are not, as yet, available commercially. Resistors, capacitors and inductors can be readily made.

Resistors are normally made by hydrolysis of a tin oxide film or by depositing an indium oxide, metal or alloy film. They can be produced to close tolerances and have a low temperature coefficient.

Capacitors are either sandwiches of deposited metal, silicon monoxide and metal; sputtered metal anodised to provide a dielectric followed by another

sputtered layer; or deposited oxide and a metal film on a semiconductor.

Inductors are made by depositing nickel iron or ferrite films, or by using a ferrite substrate as a core.

Conductors are made by vacuum evaporation, sputtering, pyrolysis or plating.*

Component isolation is by oxidation produced by anodising, pyrolytic decomposition, vacuum evaporation, plasma deposition or spraying.

The elements are more useful than the passive elements created as part of a monolithic integrated circuit, since they are more predictable and more stable.

3. Hybrid Thin Film and Semiconductor Circuits.

—Full integrated monolithic circuits have advantages, particularly of volume, but they also have disadvantages as outlined previously. Hence, it seems reasonable that thin film circuits with their superior passive components can be combined with semiconductor chips to form hybrid integrated circuits.

This approach can be used for the multi-chip and customised circuits which are described later, or thin film elements can be deposited on the final oxide layer of a monolithic integrated circuit as already discussed.

4. Customised Circuits.—The design and development of integrated circuits is expensive. A user is therefore basically faced either with this expense or with the limitation of the standard integrated circuit ranges. There are two basic customised approaches which bypass this expense and, also, the objection that a user is not able to design from scratch a circuit suitable for later production in integrated form.

Customised circuits may employ the master slice or matrix scheme. This consists of a standard integrated circuit containing a variety of circuit elements, and it is capable of a number of circuit functions simply by depositing different inter-connection patterns. It is sufficiently versatile for the customer to supply his own inter-connections. Later the circuit can be made as a production integrated circuit with additional elements if desired.

Alternatively, a standard part approach may be adopted. Standard integratable elements or sets of elements are packaged in TO5 cans for external connection by the user. They are later built in integrated form. The user must know how many elements can be integrated into the final package, must take account of the additional parasitic elements when integrated and must also ensure that the isolation diodes in the breadboard connection of standard parts are reverse-biased.

5. Multi-Chip Circuits.—All the integrated circuits so far described are intended for eventual (if not initial) production as fully integrated circuits. However, for some applications the numbers required are small, this necessitating a more versatile

* Pyrolysis is the thermal decomposition of a volatile compound into volatile and non-volatile byproducts and is usually carried out in an inert gas. It is particularly suitable where the whole surface has to be coated.

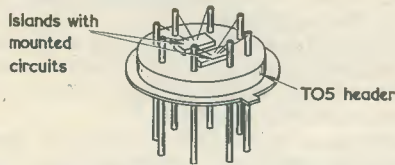

Fig. 3. The "island" approach to multi-chip circuit assembly

approach which must also take advantage of the benefits of integrated circuits. There is the further fact that the hybrid use of semiconductor and thin film circuits can represent an advantage. Multi-chip circuits are produced for these purposes.

The multi-chip circuit is made on more than one chip, semiconductors and passive elements tending to be grouped. The chips are then mounted separately, usually on a TO5 or similar header and are interconnected within it. They can be readily applied to linear circuits, are less economical in space than the fully integrated circuits, and enable "special" circuits in final form to be produced rapidly and cheaply. There are three main approaches to this method.

The first of these is the "island" approach. Metallised islands are formed on a TO5 header and a variety of chips are attached. The islands, and hence the chip substrates, are isolated from the header but are connected to a header pin. Circuit changes are easily and cheaply made because no expensive tooling is involved; but the approach is wasteful in space and different types of semiconductor component are not usually able to be mounted on the same island. A 2-island example is shown in Fig. 3.

The second multi-chip approach involves the use of individual chips. It is similar to the island approach but the individual chips are mounted directly to the header insulating material which is usually ceramic. Bonded metallised conducting leads are used. Space is utilised less wastefully than with the island approach but versatility is similar.

Thirdly, there is the multiple disc approach. Several ceramic discs, each with several chips bonded to it, are stacked over the header pins, using holes in the disc peripheries. Lead connections are made either by bonding or by deposited conductors. The component density is greater than with the other two approaches but circuit changes are

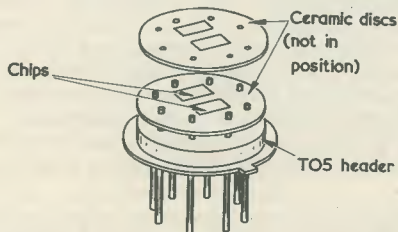

Fig. 4. An example of the multiple disc approach

expensive if masks are required for conductor deposition. An example of the multiple disc approach is shown in Fig. 4.

Packages and Integrated Circuit Mounting

The normal packages into which integrated circuits are mounted are the TO5 can illustrated in Fig. 5 with additional leads, or the flat package. An example of the flat package is shown in Fig. 6 and the first illustration.

The TO5 can is more wasteful in space than the various flat packages but it is cheap, readily available and lends itself to mounting on a printed circuit with orthodox components. Similar lead bonding and encapsulation problems exist for both packaging methods. These include the "purple plague", which is the formation of a brittle gold and aluminium compound at the junction of lead-in wires and chip connection areas. However, we will not discuss these problems further but will consider the mounting of flat packages.

For breadboarding of flat packages, several ingenious arrangements are available. These are, typically, printed circuit boards to which external solder connections are made and on which the element is held in place by chips, pressure pads, or soldering. A 0.050in pitch Veroboard has recently become available and may also be used. A particularly neat solution is the Texas Instruments "Mechpack" shown in the leading photograph, in which the element is supplied and later removed for use by a cropping tool; solder connections can be made to the pack. Texas Instruments also market a complete breadboarding "patch panel" with self contained power supplies, test oscillator, and plug-in printed circuit cards onto which the elements are soldered. The purpose of all these aids is to enable a system design to be tried out before committing it to expensive printed circuit masters.

Once the system design is finalised, printed circuits are produced. However, there are several differences between using integrated circuits and normal components. The elements are spot welded to the printed circuits by a special machine, an example of which is shown in the second illustration.

To withstand the rigours of spot welding, the board material is usually fibreglass with conductors of aluminium, mild steel and nickel plating or

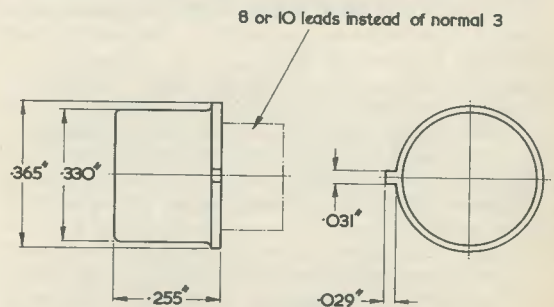

Fig. 5. The dimensions of the TO5 can

nickel plated copper. These metals ensure a good bond between board and track, and between track and element. The boards are normally double-sided or even multi-layer with interconnection by tape "feed throughs" spot welded to the tracks.

A slightly different philosophy is required when laying out printed circuits for integrated circuits due to the different method of mounting, the narrower conductors, increased connection intricacy and the ability to pass the track under the elements between connections. A typical printed circuit is shown in the third illustration.

For connection to the printed circuit, edge connectors with 0.050in pitch are available but direct connections of various types can also be made where it is required to take full advantage of the increased reliability of integrated circuits.

Integrated Circuits Available

From the many integrated circuits currently available, a typical example is provided by the

Texas Instruments 53 Series Logic Circuits. This series is of American origin and is also available in a cheaper, reduced temperature, form as the 108 series. Each package contains between 50 and 85 circuit elements according to the particular type. The thirteen types in the range include packages functioning as single-phase flip-flops, dual flip-flops, 5-input expandable NAND/NOR gates, quadruple inverter/drivers and monostable multivibrators.

A further series, manufactured by Ferranti, are of British origin. These fit into a can slightly shorter than the TO5, and include twin NOR gates, transient memory-NOR circuits, multiple p.n.p. emitter followers and twin power drivers.

Also of British origin is the Mullard OMY series, these similarly fitting into a can slightly shorter than the TO5. The series includes NAND/NOR gates and bistable circuits.

Fairchild integrated circuits are available either in TO5 or flat packages and one particularly interesting item in the range is the wideband d.c.

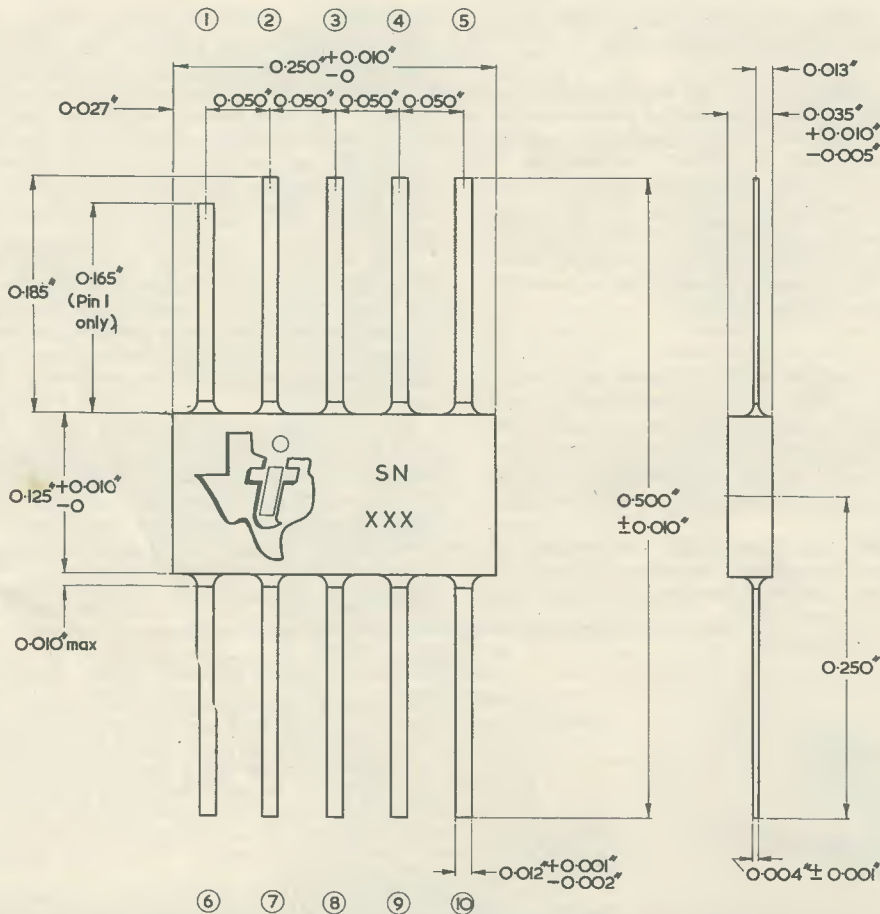
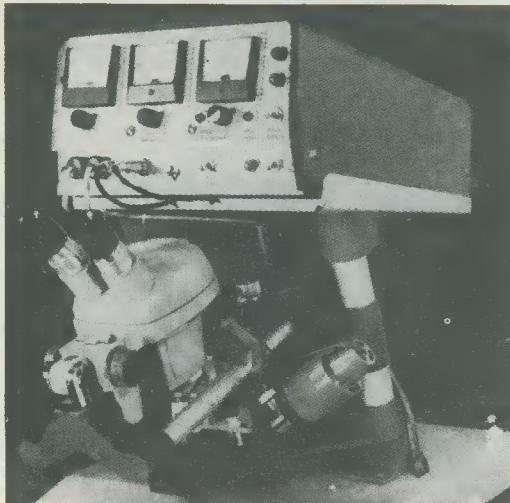

Fig. 6. An outline drawing of the Texas Instruments flat package (or "semiconductor network welded package"). All dimensions are in inches with a tolerance of ± 0.005 in. unless otherwise noted. The top and bottom of the package are conductive. The circuit within the package is electrically isolated from the case. (Courtesy Texas Instruments Ltd.)



The Texas Instruments spot welding machine.
(Courtesy Texas Instruments Ltd.)

amplifier type μ A-702. This is constructed on a single silicon chip using an epitaxial process and is useful up to 10 Mc/s. A typical open-loop voltage gain of 2,600 is quoted.

Another integrated circuit amplifier, manufactured by Texas Instruments, is the type SN5510 video differential amplifier which has a flat frequency response from d.c. to 40 Mc/s and a single ended gain of 40dB. This remarkable amplifier is provided in a standard $\frac{1}{2}$ x $\frac{1}{8}$ in flat package.

The Future

Special user circuits can be catered for, as has been described. Also, more difficult circuits will become available as technical problems are overcome; indeed it appears that the eventual limitations will be few. Great savings of design and manufacturing effort, also of space and power consumption, will result.

Regarding cost, at present the "industrial" or "reduced temperature range" versions of the logic elements are now being sold for £3 to £4 each. This

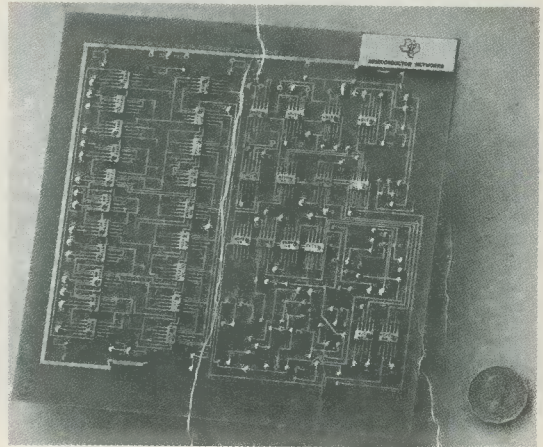

A printed circuit assembly using flat packages.
(Courtesy Texas Instruments Ltd.)

is already competitive, circuit function for circuit function, with logic blocks. Assuming that, with the economies of scale, the same history takes place as took place with the various types of transistor, it seems that the present contents of an integrated circuit will in future occupy less space and will eventually be available for around 15 shillings. This will virtually eliminate logic block competition. The same story will apply to linear and other circuits.

The welding machines are expensive (around £1,500) but this will not bother manufacturers who use large numbers of integrated circuits; while for prototype quantities some integrated circuit manufacturers will undertake element welding for one shilling each, and feed-through welding for sixpence each.

Summarising, the integrated circuit has arrived in industry even though we in this country are as yet a little slow to adapt it wholeheartedly. The circuits which can be made in integrated form are increasing rapidly and we may well become a professional collection of system engineers.

At present the technique is too expensive for the amateur to contemplate—so far!

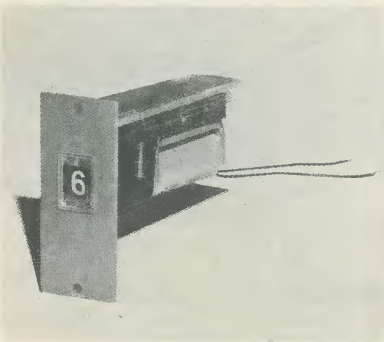

ELMA COUNTER TYPE B.O.

RADIATRON announce a new addition to their range of ELMA single decade counters—the B.O. This represents a major break-through in terms of simplicity and low cost in the field of single decade impulse counters.

The B.O. has a standard modular front panel measuring 23 x 56mm, with a displayed figure height of 7mm. It is capable of counting at speeds up to 25 impulses per second and has electrical zero reset. It is also equipped with a transfer contact which enables the use of several counters in cascade to form a multi-digit counter. Normal life expectancy is in excess of forty million impulses.

Priced at only £2 16s. 10d., the B.O. is ideally suited for low cost counting applications and has the advantage of being easily interchanged and having an easily read display. It can be supplied for either forward or backward counting.

Further information is available from: **RADIATRON, 7 Sheen Park, Richmond, Surrey.** Telephone: RIC 3285 and RIC 9352.

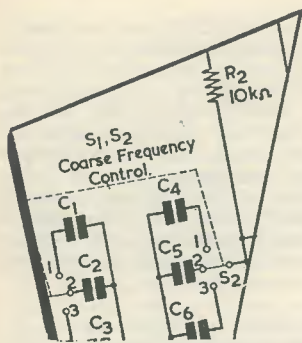

9-Volt Battery Eliminator for Transistor Radios

SUGGESTED CIRCUIT No. 184

By G. A. FRENCH

TRANSISTOR RADIOS ARE PLAYED for considerable periods of time in some households, with the result that battery replacements tend to become expensive. It follows from this that a saving in running costs would be achieved if the battery fitted to a transistor radio could be replaced, even if only for part of the time the set is in use, by a mains power supply. It was with this end in view that the author set out to produce the battery eliminator which forms the subject of this month's "Suggested Circuit" article.

The writer decided to work to a design which would meet the following five requirements.

1. The power unit must provide complete and reliable isolation from the mains supply.
2. The unit should offer a supply having a nominal voltage of 9 with sufficiently good regulation to meet the needs of a conventional medium and long wave transistor superhet having the normal Class-B output stage. It has to be remembered, here, that the Class-B output circuit fitted to receivers of the type in question raises particular problems so far as regulation is concerned, since receiver current consumption increases by a considerable amount at high audio output levels.
3. When powered from the unit, the receiver should have negligible hum in its output.
4. Components which are readily available to the home-constructor should be used.
5. The power unit should be as small as possible. Ideally, it should be possible for the power unit to be fitted inside the receiver cabinet in place of the battery, whereupon the

set would become a completely self-contained mains-operated receiver.

As it turned out, this last requirement was the controlling factor for the whole design, and it was found possible, by employing a bell transformer available from the chain stores, to make up a unit which could be completely enclosed in a case having the same dimensions as a PP9 battery. In this form the whole unit could then be fitted in the cabinet of any receiver which normally employed a PP9 battery.

Initial Design Steps

The bell transformer used for the prototype has the appearance and dimensions given in Fig. 1 and is available at low cost from the electrical counters at Woolworth's Stores. One version purchased by the writer was a "no-name" component; apart from legends identifying the input and output terminals, its only other markings were the words "Bell Transformer—Made in England". Another version, purchased later, was identical in size, appearance and performance, and it had, in addition, the "WG" trade-mark of Ward & Goldstone Ltd. The bell transformer has a brown Bakelite housing and, as may be seen from Fig. 1, quite small dimensions. For standard mains inputs it offers an output of 8 volts with a tapping at 5 volts.

From the points of view of size, cost, availability and isolation from the mains, this transformer is an excellent choice for the design under consideration. A slight disadvantage is that the secondary voltage of 8, when applied to a standard rectifier and smoothing circuit, is not sufficiently high to allow voltage stabilising to be

employed. Nevertheless, it was found that the voltage regulation offered, although worse than that given by a 9-volt battery, was still more than adequate for the types of transistor radio with which the unit was intended to be used.

In initial tests the secondary of the bell transformer was coupled to a silicon diode rectifier, the output of which connected to a reservoir capacitor and thence, via a smoothing resistor, to a standard transistor radio. Most of the internal resistance in the power unit circuit was due to the smoothing resistor and this had to be given a small value which was still, nevertheless, sufficiently high to ensure that hum level in the receiver was negligible. The small value smoothing resistor entailed, in its turn, a large value of reservoir capacitance, whereupon the questions of size and component availability once more arose. These were solved by choosing a component

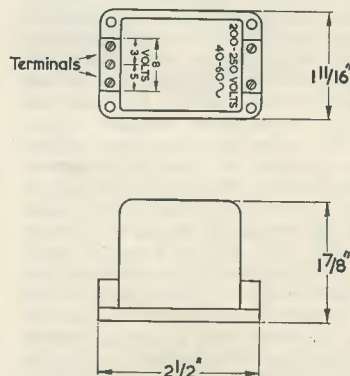

Fig. 1. The dimensions and appearance of the bell transformer employed in the battery eliminator unit

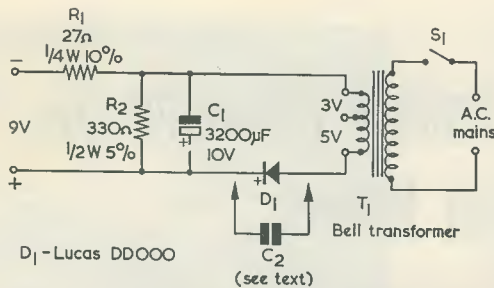

Fig. 2. The circuit of the unit. C_2 is an anti-mains-modulation capacitor, and it may be necessary to connect it across the silicon rectifier

from the Mullard range of electrolytic capacitors. The capacitor selected is sold by home-constructor suppliers and its small dimensions readily enable the complete unit to be constructed inside a case having the same size as a PP9 battery. Also checked during initial trials was the use of a bridge rectifier as opposed to a half-wave rectifier. It was found that a half-wave rectifier gave a regulation which was only slightly inferior to that given by a bridge rectifier and it was decided, in consequence, to incorporate a half-wave rectifier in the design.

A final step was the provision of a shunt resistor across the reservoir capacitor to limit the voltage which appeared across it under no-load conditions. This resistor also gave a small but significant improvement in regulation.

The Circuit

After these initial steps had been taken the final circuit was evolved, and this appears in Fig. 2. In this diagram the a.c. mains is fed via switch S_1 to the primary of the bell transformer, which is identified as T_1 . The 8 volt secondary of T_1 is applied to the half-wave rectifier given by D_1 , the rectified output then appearing across electrolytic capacitor C_1 . Resistor R_2 is the shunt resistor across C_1 , and R_1 is the smoothing resistor. There is no smoothing capacitor because the function of this component is carried out by the high-value capacitor which will normally be found already connected across the battery supply lines in the receiver itself. Such capacitors have values in the range of 75 to 350 μ F and should be adequate to provide final smoothing. Capacitor C_2 is an anti-mains-modulation component and the manner in which it is connected is discussed later.

Capacitor C_1 is the Mullard electrolytic component just mentioned, and it appears in the Mullard

C431 series of fixed capacitors. Its type number commences with the group "C431B" followed by another letter (which may vary), an oblique stroke, and the final group "D3200"; and it is referred to as a 3,200 μ F capacitor with a voltage of 10. This component is available both from Henry's Radio, Ltd., and from Home Radio (Mitcham) Ltd. It is important to note that, whilst the capacitor is capable of working continuously at 10 volts, this voltage should not be exceeded for continuous operation. Thus, with this capacitor, what may be described as the "working voltage" is also the maximum voltage which should appear across it. The dimensions of the capacitor can (excluding lugs) are 49mm in length and 25mm in diameter. These figures correspond to 1.93 and 0.98 in respectively. Care should be taken to ensure that the capacitor is connected in circuit with correct polarity.

The shunt resistor, R_2 , prevents the voltage across C_1 from rising above 10 under no-load conditions, and it also provides an improvement in regulation. The current drawn by R_2 is of the order of 30mA and a $\frac{1}{2}$ watt component is quite adequate here.

Diode D_1 is a Lucas silicon

rectifier type DD000, and is available from Henry's Radio Ltd. This diode has a maximum forward current of 500mA and a maximum peak inverse voltage of 50, so it is run well within limits in the present circuit. It is a small wire-ended component with a body diameter of about $\frac{3}{16}$ in and a body length of about $\frac{1}{4}$ in. The positive lead-out is coded red, and it must, of course, be wired into circuit with correct polarity.

Assembling The Components

As is intended, all the components in the circuit of Fig. 2 may be assembled in a case having the same size as a PP9 battery, the nominal dimensions for which are $2\frac{3}{16}$ x $2\frac{1}{16}$ x $3\frac{3}{16}$ in. There are only two bulky components, T_1 and C_1 , and Fig. 3 shows these contained within dashed frames corresponding to the outlines of a PP9 battery. As may be seen, more than adequate space is available for the diode and other components. A suitable construction would be given by fitting T_1 at the base of the case, as in Fig. 3, and fitting a Paxolin panel immediately above it with the aid of two long 6BA bolts passing through the transformer mounting holes. The remaining components may then be fitted to lugs mounted on the Paxolin panel.

The complete unit could be housed in a case made of insulating material, and a neat finish would be given by fitting this with two PP9 terminals as taken from a discarded battery. The receiver battery terminations could then be clipped to these whenever the mains unit was in use.

The existing receiver on-off switch may not be rated at mains voltages so no attempt should be made to rewire it so that it switches the mains supply to T_1 . The mains switch, S_1 in Fig. 2, should be a separate component and it could be conveni-

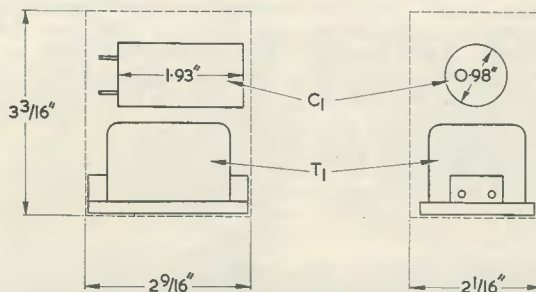

Fig. 3. The two bulky components in the unit are the bell transformer, T_1 , and the reservoir capacitor, C_1 . These are shown here enclosed in dashed outlines which correspond to the nominal dimensions of a PP9 battery. As may be seen, there is plenty of space for the other components in the circuit

ently inserted as a small series switch in the mains lead itself.

Results with the Prototype

After initial work has been completed, the finalised unit was checked with a conventional 6-transistor medium and long wave superhet having a ferrite rod aerial and an output stage which employed two OC81's in a normal Class-B circuit. The capacitor already fitted across the battery supply lines in this receiver had a value of $100\mu\text{F}$. There was no audible evidence of hum when the power supply unit was connected in place of a battery. The voltage across the output terminals of the power unit remained steadily at 9 for low output levels from the receiver. When the receiver volume was turned to a level slightly higher than that needed for normal domestic listening, the power unit output dropped to approximately 8.5 volts at the louder programme passages. The receiver volume was next turned to full, causing the output stage to be obviously overloaded. Sustained loud notes of music then caused the power unit output to drop, at worst, to some 7.8 volts. No perceptible difference in performance between operation with a battery and with the power unit could be observed.

Results with other, similar, receivers should be of the same order. There is a slight possibility that a low hum level may be detectable with sets having a better low frequency response than is offered by most receivers in this class, and such hum may only be cleared by adding a further smoothing capacitor after R_1 . A few of the smaller transistor radios are not fitted with a capacitor across the battery supply leads, whereupon such a component will have to be added. A suitable value would be of the order of $100\mu\text{F}$. A point to watch for is that the receiver oscillator does not cease functioning at battery voltages below

about 7.6 or so, although this, in practice, really suggests a fault condition. The fact that the regulation of the power supply unit is not as good as is given by a battery may preclude its use with transistor radios having short wave or f.m. bands, as there is a risk of noticeable oscillator detuning when high-level audio signals are reproduced by the speaker.

As was mentioned in the introductory paragraphs, most of the internal resistance in the power supply unit is due to the smoothing resistor R_1 . Regulation may be improved by reducing the value of this resistor, but if this process is carried too far it will very probably be necessary to add a second large-value capacitor across the output terminals to provide additional smoothing. The present design was intended only for use with the normal category of medium and long wave transistor superhet, and the regulation it provides should be adequate for this purpose without the necessity of introducing extra components.

Modulation hum, discernable when a station is tuned in, may be encountered with some receivers. If this occurs, it should be possible to clear it by connecting a capacitor of around $0.01\mu\text{F}$ across D_1 . This is the function intended for C_2 in Fig. 2. If no modulation hum occurs, C_2 is not needed. It should be pointed out that modulation hum only appears when a carrier is being received, and that it should not be confused with the continual hum which results from insufficient smoothing. In some cases, modulation hum may be cleared by merely reversing the mains input connections.

Curves showing rectified voltage against load current for the half-wave circuit of Fig. 2 are given in Fig. 4, these being taken for a mains input of 240 volts. The upper curve shows the voltage across C_1 , and the lower curve the output voltage after R_1 , for load currents up to 60mA. The effect of R_1 in reducing regulation is plainly evident. It should be added that the curves were drawn under static conditions. The heavier currents drawn by a Class-B output stage in a transistor radio due to high audio outputs are of a short-term nature only, and the presence of high-value capacitors across the supply lines tends to prevent drops in supply voltage which are as high as is indicated by Fig. 4.

Also shown in Fig. 4 are regulation curves given with a bridge rectifier circuit. These are included to demonstrate the fact that regulation is only slightly inferior with the half-wave circuit, whereupon the writer felt that expenditure on the three extra silicon diodes required for a bridge circuit was not justified for the simple applications envisaged.

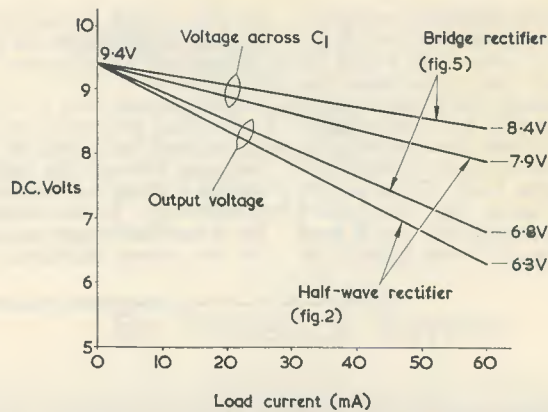

Fig. 4. Curves showing voltage regulation for currents up to 60mA under static conditions. Most of the internal resistance of the unit is due to R_1 and, as is discussed in the text, this can be reduced in value if improved regulation is required

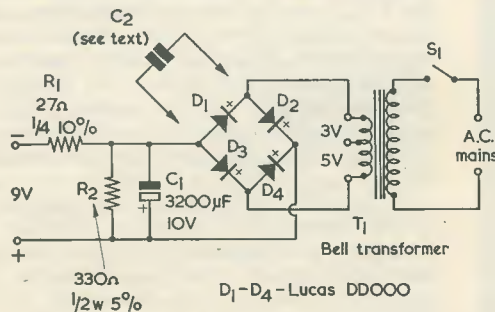

Fig. 5. An alternative circuit employing a bridge rectifier

If, nevertheless, constructors wish to employ a bridge rectifier, the appropriate circuit is shown in Fig. 5. It will be seen that, apart from the rectifier section, this is the same as Fig. 2. Listening tests showed that R_1 required about the same value as in the half-wave circuit to keep hum at a negligible level. Capacitor C_2 is, once more, an anti-mains-modulation component, and it may have a value of around $0.01\mu\text{F}$. It

is only needed if modulation hum occurs, and it should be connected across each diode in turn until the hum clears.

If the power unit is to be fitted inside the cabinet of a transistor radio there is a risk of inductive coupling between the mains transformer and any a.f. transformers in the receiver. In the writer's set-up the mains transformer was held close to the driver transformer in the

receiver, but no induced hum could be heard. It seems unlikely that much trouble will be experienced, in practice, on this score.

Finally, the power supply unit was given a "soak test" by running it continuously for eight hours with a load across its output terminals which consumed a steady 50mA. At the end of this period it was found that all components were cool and that performance was unaltered

Photo-Electric Transistors

J. F. PHILLIPS

Although the effect discussed in this short article is not new to the pages of The Radio Constructor (it was described by R. C. Crafer in "Photo-Sensitive Relays" in the April 1963 issue) we feel that a further reference to it would not be out of place. The older type of OC71 mentioned in the article, which is capable of being converted to a phototransistor by scraping away its paint coating, may be difficult to obtain at present, but there should be many in constructors' spares boxes. The OCP71, which is intended to function as a phototransistor, will offer similar results without any modification

WHILST EXPERIMENTING WITH SOME OLD OC71's recently, an interesting phenomenon was discovered. Older OC71's, as many constructors know, are contained in a glass capsule coated with a light-protective black paint, with the electrodes surrounded by a translucent grease (later OC71's have an opaque white grease and are less suitable for the experiment). Without its light-protective covering, the semiconductor's intrinsic conduction alters with changes in the incident light, i.e. its resistance decreases as the light intensity increases, and this fact is usually borne in mind in the design of many phototransistor light switches.

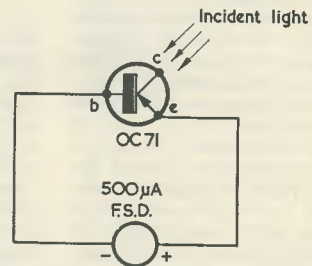

Obtaining a current from a "scraped" OC71, due to incident light. No external e.m.f. is applied

However, the unit to be described does not use any external source of e.m.f. at all. A "scraped" OC71 is connected across a $500\mu\text{A}$ moving coil meter as shown in the diagram. Incident light on the junction between the emitter and base of the transistor produces a deflection in the meter.

The device is also very sensitive to infra-red light, and will even show a reading off a hot electric iron if placed near enough. When placed near the element of an electric fire, there is a deflection of $500\mu\text{A}$, but this soon drops as the transistor heats up.

When light is incident on the emitter-base boundary, photo-electrons are emitted, a conversion from light energy into electrical energy is achieved, and a current flows in any external circuit which is connected. This effect is also observed if, instead of the emitter, the collector is connected to the positive terminal of the meter. But the effect occurs to a lesser extent, due to the higher internal resistance when the transistor is connected in this way.

It has also been found that the metal casing of the newer OC71's can be carefully removed, revealing the transistor junction covered by a translucent grease which is suitable for the experiment. An OCP71 will also work, but is more expensive than the "scraped" or "de-metallised" OC71's.

PLUG-IN SPEECH CLIPPER

By Frederick Sayers

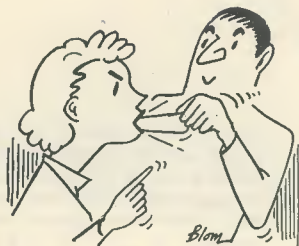

Our contributor describes a simple speech clipper for the amateur transmitter. The prototype was primarily intended to be added to a modulator which employed a 6J5 driving two 6L6's, but it can be used equally well with different valves and in alternative positions. Most of the components are non-critical and many may already be available in the spares box

IT WAS DECIDED TO TRY USING A SPEECH CLIPPER with a large transmitter, both to prevent careless overmodulation and to allow a higher audio level. To avoid any permanent changes in the modulator, the plug-in unit described here was made up. It can be brought into circuit by simply removing a valve in the modulator, and inserting an octal plug in the valveholder thus left vacant. The removed valve is placed in the clipper unit.

This method is particularly easy with a modulator using an octal triode, as the scrap box should furnish an old valve base with pins, which can be readily brought into use as an octal plug. Miniature 7-pin and 9-pin plugs to fit B7G and B9A holders can be purchased as, of course, can octal plugs, if necessary.

The circuit is shown in Fig. 1. The audio signal which would normally reach V_2 control grid is taken through C_1 to the first cathode of the 6H6, V_1 . VR_1 adjusts the level at which positive and negative peak clipping takes place, and the clipped signal passes through C_3 to V_2 . From V_2 anode the signal returns to the modulator via pin 3 of the plug.

In Fig. 1, the heaters are fed by twin flex from pins 2 and 7 of the plug. In many modulator circuits pin 2, or pin 7, will be returned to the chassis. But if the heater circuit is as shown, it is not necessary to examine the modulator to find which pin should be taken to the chassis. Also, the circuit is suitable if there is a centre-tapped heater supply. V_2 operates with its original anode and cathode circuits.

If a miniature valve is to be removed from the modulator, it will be used as V_2 , so a miniature valveholder becomes necessary here. It may then be preferred to use a B7G 6AL5 for V_1 , instead of the octal 6H6.

A return connection between clipper chassis and modulator chassis is required, and this should be made by means of a short length of wire. An h.t. positive connection is also necessary, so a flexible lead with a clip is taken from R_3 . This goes to any convenient point on the modulator or power pack where about 200 to 350 volts is available.¹

R_1 and R_4 should be reasonably well balanced in value. Two 220k Ω resistors are equally satisfactory, and may be used instead of the 270k Ω

¹ The h.t. voltage chosen will affect the range of voltages selected by VR_1 . If desired, R_3 could be adjusted in value to ensure that the control offered by VR_1 does not have excessive cramping.—EDITOR.

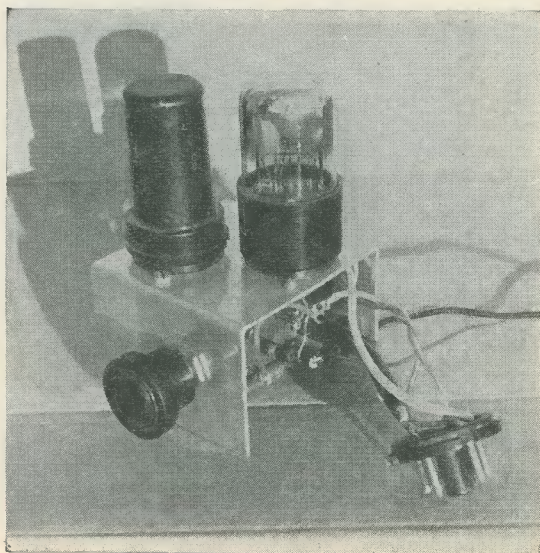

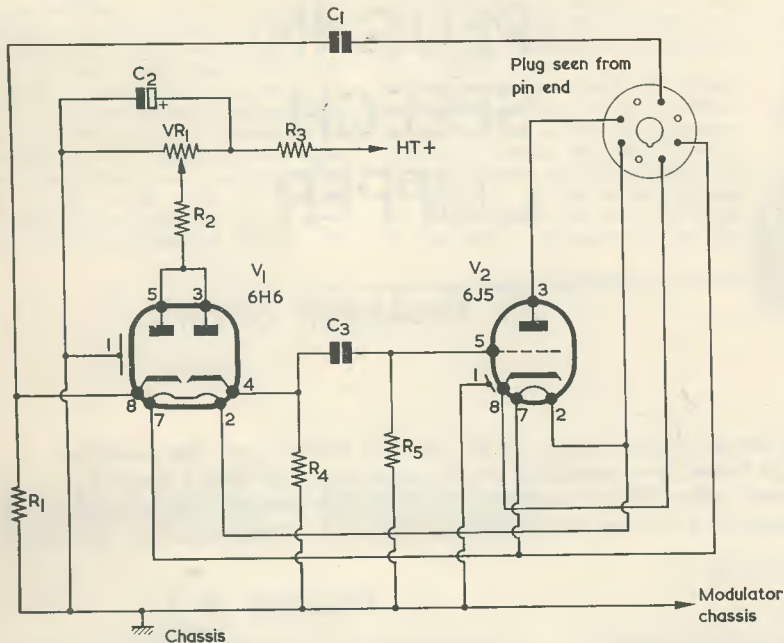

Fig. 1. The circuit of the plug-in speech clipper. A 6J5 is shown in the V_2 position but, as is explained in the text, any other valve may appear here. Similarly, V_1 could be a 6AL5

components specified. C_2 may have any value from $2\mu\text{F}$, according to components at hand.

Constructional Work

A small chassis $2\frac{1}{2} \times 2\frac{1}{2} \times 1\frac{3}{4}$ in was made by bending down runners on a piece of aluminium measuring $2\frac{1}{2} \times 6$ in as shown in Fig. 2. This chassis could be placed on the modulator chassis, near the valveholder from which the valve was removed. The grid circuit to V_1 is screened, the braiding being connected to chassis. Since it is intended that the

anode circuit will be handling the audio signal at a relatively high level, it should not normally be necessary to screen the lead from V_2 anode to pin 3 of the octal plug. Nevertheless, this lead may be screened if it is felt that instability or hum might result, the braiding being similarly earthed at the clipper chassis. A single insulated tag anchors R_3 and the h.t. positive lead.

If the layout of other items permits, it may be preferred to attach the clipper chassis to the octal plug by means of a bracket, strip, or threaded rod. The clipper will then form a rigid plug-in unit. An alternative is to bolt the clipper chassis to the modulator chassis, with brackets. If the transmitter is not likely to be moved, the clipper can simply stand on the modulator chassis. It must be possible to reach the control knob of VR_1 for initial adjustment.

Circuit Position

The clipper is best inserted at a circuit position where the audio signal has already received fair amplification. V_2 should generally be the stage immediately preceding the driver, or it may be the driver itself.

The unit described here has been used successfully with two modulators. The smaller of these had a double-triode as voltage amplifier, followed by a small power pentode (triode connected) as driver, this working into a pair of 807's. Here, the clipper was so inserted that the 6H6 came between the final stage of the double-triode and the driver. In the larger amplifier, a double-triode pre-amplifier was followed by a 6J5, which drove two 6L6's (triode connected), which in turn drove a pair of DA41's. Here, the clipper plug was inserted in the 6J5 holder.

Components List

Resistors

(All fixed values 10% $\frac{1}{4}$ watt unless otherwise stated)

- R_1 270k Ω 5%
- R_2 470k Ω
- R_3 220k Ω $\frac{1}{2}$ watt (see text)
- R_4 270k Ω 5%
- R_5 470k Ω
- VR_1 50k Ω potentiometer, linear track

Capacitors

- C_1 0.01 μF paper
- C_2 2 μF or more, electrolytic, 150V wkg.
- C_3 0.01 μF paper

Valves

- V_1 6H6 (see text)
- V_2 6J5 (see text)

Miscellaneous

- Valveholders
- Octal plug (or as applicable)
- Knob
- Chassis, etc.

Fig. 2. Under-chassis view, showing the layout and wiring of the clipper unit. Chassis depth is $1\frac{1}{2}$ in

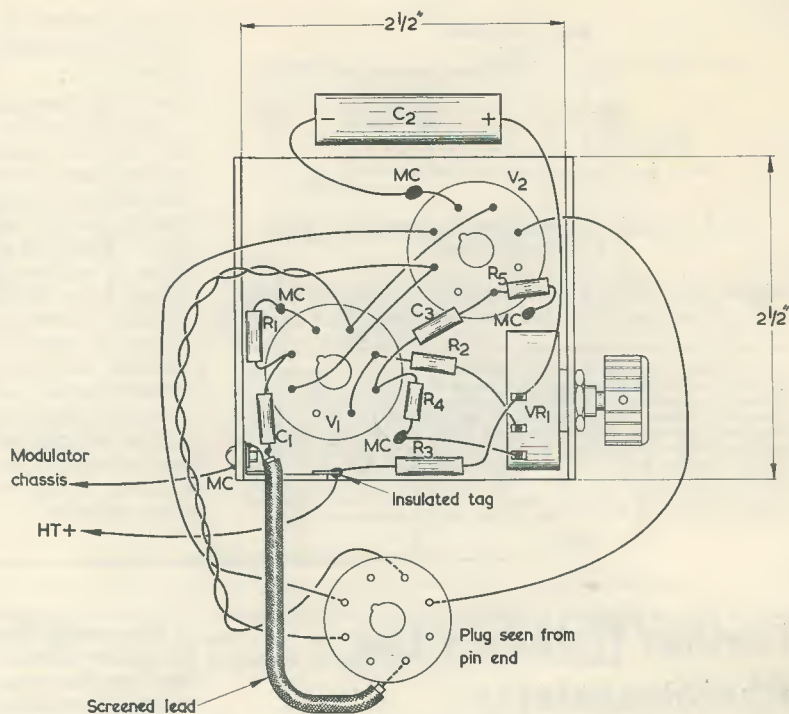

It is normally best to place the clipper as near to the output stage as possible. Clipping is then taking place at a fairly high level.

Method of Use

With VR_1 turned to apply maximum voltage to the 6H6 anodes, no clipping takes place. There is a slight loss of gain, so the modulator gain control may need advancing. When VR_1 is rotated, peaks on the audio signals are progressively clipped, or prevented from exceeding the pre-set level.

With normal speech, occasional peaks are much higher than the general level. By clipping these peaks, the general audio level can be raised, without overmodulation on peaks. It is usually considered feasible to increase the general audio level by two to four times, without any important loss in speech quality (for communication purposes).

The second purpose of the clipper is to prevent overmodulation, due to raising the voice, or moving close to the microphone. The clipper is thus a "safety device" against overmodulation.

Setting Up Clipping Level

If an oscilloscope is available, this offers an ideal method of setting up VR_1 . Load the transmitter to its normal input, and adjust the oscilloscope gain and trace speed to obtain a clear display. Audio input to the modulator can be obtained from an audio oscillator, if available. VR_1 is then slowly turned back until modulation peaks are *just* seen to flatten when overmodulation is attempted. With this setting, increasing the audio input will cause

more and more flattening of peaks, but not overmodulation.

If no oscilloscope is available it is convenient to feed the transmitter into an artificial aerial load and by listening to the signal on the station receiver, check for sideband splatter caused by overmodulation. Adjust VR_1 until this splatter just ceases. It may also be helpful to obtain a few reports from other stations.

Subsequent Filter

Clippers of this type are usually followed by a low-pass audio filter, to remove high frequency peaks which may arise from the clipped audio signal. The extent to which this effect is troublesome depends to some extent on the response in the section of the modulator following the clipper.²

With the larger modulator described, no trouble from this cause could be discovered at all, checking with both the oscilloscope and the receiver. This modulator was a high quality type, with high frequency response deliberately curtailed to suit voice transmission.

With the small 60-watt modulator using 807's, the simple filter in Fig. 3 was added after the

² It will also depend, of course, on the degree of clipping. If heavy clipping is intended, difficulties with the high audio frequencies which result from squaring the applied a.f. may well necessitate the use of a fairly comprehensive low-pass filter after the clipping circuit. If the unit is used for light clipping and/or the prevention of overmodulation the filter may be dispensed with, or it could be made up in quite simple form.—EDITOR.

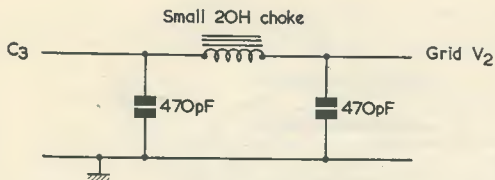

Fig. 3. A simple low-pass filter for insertion between C_3 and the grid of V_2

clipper.³ Trouble is not very likely unless the audio gain of the modulator is so much increased that a

³ This filter requires a small 20H choke and constructors will obviously not wish to use a bulky choke of the smoothing type if this can be avoided, or if they cannot obtain a suitable component through retailers. As a suggestion, the primary of the Ardente transistor interstage transformer type D239 has an inductance of 20H, and this winding could be used as the choke in the circuit of Fig. 3. Another small component is the Repanco choke type AF1. This has an inductance of 10H (at zero current) and would necessitate an increase in the values of the two filter capacitors if identical results to that given by the Fig. 3 circuit were required.—EDITOR.

Further Notes on the Phototransistor Sports Timer

By John G. Dew, B.Sc.

Editor's Note

The article "Phototransistor Sports Timer" which appeared in our August 1965 issue, was well received by readers. One correspondent, Mr. W. A. Smith, who is an official R.A.C. timekeeper, pointed out that difficulties are liable to result from multiple pulses caused when some vehicles pass the monitoring stations, and that it may in some cases be physically difficult to reset the timer if the photo-head is not sufficiently near the timekeeper.

Both these points are taken up by the author of the article, who describes here an alternative flip-flop circuit which may be used, if desired, to provide the additional facilities required. Also discussed are several final points concerning accuracy of timing.

SINCE THE ARTICLE "PHOTOTRANSISTOR SPORTS Timer" was published, a letter has been received from an official R.A.C. timekeeper, Mr. W. A. Smith.

Mr. Smith points out that, in his experience of light operated timers, it is difficult to place the light beam and photo-head in such a way as to reliably produce a single pulse for all cars which pass. The usual difficulty appears to be multiple interruptions of the beam due to reflections and to protrusions such as over-riders.

large amount of clipping is taking place. This could in any case degrade speech quality badly.

Use With Receiver

The clipper can be employed in exactly the same way with a receiver, whereupon it can prevent sudden bursts of volume in headphones or speaker. The 6H6 can then usually precede the output valve, in which case V_2 becomes the original output valve itself. A tetrode or pentode will normally be present here. If so, the screen grid supply must of course be run from the plug to the new V_2 valveholder.

When the clipper is used with a receiver, VR_1 should be within easy reach. It can be set to the required maximum volume level. Turning up the receiver audio volume control much beyond this level will then cause quality to degenerate. The clipper will prevent static interference exceeding the general audio level, as well as avoiding sudden blasting of the ears from powerful stations when using phones.

The remedy suggested by Mr. Smith is to "steer" the pulses from the phototransistor so that, once the timer has been started, subsequent interruptions of the beam have no effect. The modified circuit of the flip-flop which carries out this "memory" function is shown in the accompanying diagram.

"Steering" Circuit

When the timekeeper is about to start, the timekeeper switches S_1 to the "Start" position. As the car breaks the light beam a positive-going pulse from the Schmitt trigger stage is applied, via diode D_1 , to the base of transistor TR_1 , and the electromagnetic counter begins to operate. Any further interruptions of the beam can then have no effect on TR_1 , which is now non-conducting.

After the car is well under way, S_1 is returned to the "Finish" position. The first break in the beam will then switch off TR_2 and will stop the timer indefinitely.

A third position of switch S_1 prevents any pulses being applied to the flip-flop, so rendering the timer immune to random signals such as reflections.

Another point mentioned by Mr. Smith is the desirability of including a manual reset facility. Of course, one may simply wave a hand over the photo-head, but this becomes inconvenient if the timekeeper and his equipment are some distance from the phototransistor.

A reset pulse may be applied to the flip-flop by means of a diode "steering" system identical to that used in the original circuit. Normally, the input capacitors, C_2 and C_3 , are charged to around 6 volts by connection to the negative supply via the 100k Ω resistor, R_{12} . When the Reset button is pressed the junction of the capacitors is connected to the positive line; this produces a positive-going pulse which is "steered" by D_3 or D_4 to whichever transistor is conducting. By this means the counter

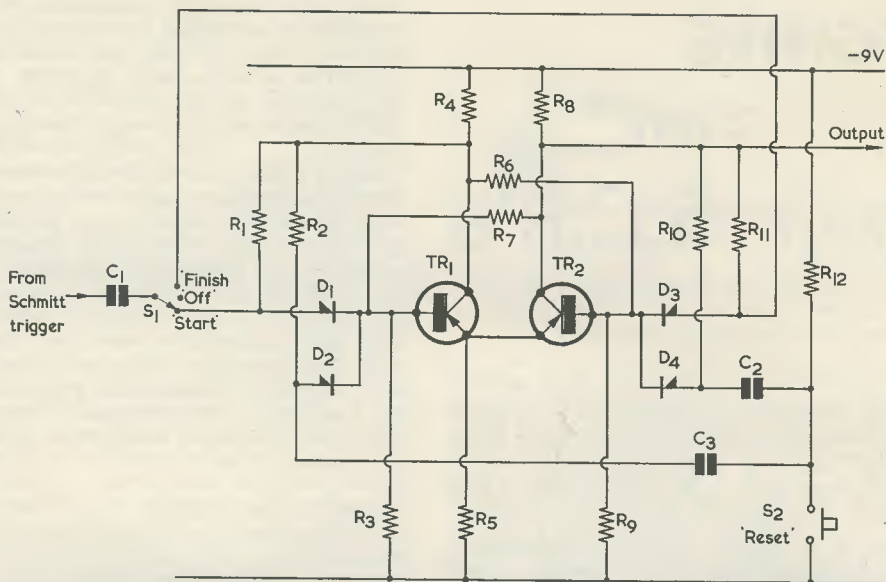

An alternative flip-flop with "steering" facilities. This follows the collector of TR₃ in Fig. 2 published on page 45 of the issue for August 1965. The output of the present flip-flop is the same as that given at the collector of TR₅ in the previous circuit. It should be noted that component numbering is not as used previously

can be switched on or off at will, and in fact the reset facility provides a test of operation.

Timing Accuracy

Finally, some comments on timing accuracy of the instrument are made. Mr. Smith has calibrated his timer against a crystal controlled unit and has found the stability to be excellent. However, it is stressed that this performance can only be achieved by the use of good quality capacitors in the multivibrator. To this end it would be advantageous to use capacitors with a high working voltage rating which, although physically larger, will have better stability than lower voltage types.

The temperature coefficient of the capacitors will also affect the timing accuracy. Metallised paper capacitors have a temperature coefficient of about 100 parts per million per degree Centigrade. Hence an ambient temperature variation of about 17°C, or 30°F, would cause a maximum error of $\pm \frac{1}{2}$ second in 5 minutes. If this is not considered negligible, it is worth noting that polyester capacitors have a temperature coefficient of *minus* 100 p.p.m. If one capacitor in the multivibrator were a metallised paper type and one a polyester type the resulting temperature effect should be insignificant.

Components List

Resistors

(All $\frac{1}{4}$ watt 10%)

R _{1,2}	33kΩ
R ₃	10kΩ
R ₄	1kΩ
R ₅	470Ω
R _{6,7}	2.7kΩ
R ₈	1kΩ
R ₉	10kΩ
R _{10,11}	33kΩ
R ₁₂	100kΩ

Capacitors

C _{1,2,3}	0.05μF
--------------------	--------

Transistors

TR _{1,2}	OC71, etc.
-------------------	------------

Diodes

D _{1,2,3,4}	OA81, etc.
----------------------	------------

Switches

S ₁	Single-pole three-way
S ₂	Push-button

UNDERSTANDING RADIO

We regret that, due to pressure on space, this feature has been held over until next month.

Circuits

By for H. N. RUTT S.C.R.'s

The silicon controlled rectifier, which is now becoming available at relatively low cost, offers a number of interesting applications to the more experienced constructor and experimenter. This article gives a brief description of s.c.r. operation, then carries on to discuss light and temperature operated switches, together with a holding circuit for the s.c.r. when it controls an alternating current

THE SILICON CONTROLLED RECTIFIER (S.C.R.) IS one of a group of semiconductor devices having a p.n.p.n. structure. Its properties are probably well known to most constructors, but a summary of them is given to help those who may not be familiar with this device. The most common application of the s.c.r. is in power control, and indeed this seems to be the only application for which it is considered, but it is the purpose of this article to show that the s.c.r. can form the heart of various novel circuits, particularly when it is desired to keep these purely electronic. Although s.c.r.'s have yet to become available on the surplus market, they are readily available at a quite moderate price, direct from the manufacturers.

S.C.R. Operation

Referring to Fig. 1, if the gate is left open-circuit, then the device will present a high resistance between the anode and the cathode, regardless of the polarity, until the breakdown voltage is reached. The forward resistance (anode positive of cathode) and reverse resistance (anode negative of cathode) are usually (though not always) the same. If the anode is made positive of the cathode, and a trigger pulse of sufficient size is applied to the gate, driving the gate positive of the cathode, then the anode-to-cathode resistance drops rapidly to a very low value, and will remain low as long as sufficient forward current flows in the anode-to-cathode

circuit. When this current drops below a critical value (the "holding" current) the device springs back to its "off" state. The removal of the trigger supply to the gate does not switch the device off unless the anode-cathode supply is a.c., in which case the s.c.r. will be turned off by the first half-cycle which reverse-biases it after the trigger pulse has finished.

S.C.R.'s are normally made with very high anode-to-cathode current ratings (100 amps is common), and so the s.c.r. can be used as a purely electronic relay. The main advantages of the s.c.r. over the conventional relay are that it is very much faster, has no contacts to wear out through arcing, and will operate under conditions of vibration and mechanical shock which would make a relay quite useless. Its main disadvantages are that, like most semiconductors, it is easily damaged by momentary high transient reverse voltages, and that it must be derated for high temperature operation.

Light Sensitive Switches

Circuits for three light sensitive switches are shown in Figs. 2, 3 and 4, all using the s.c.r. as a "relay". The simplest possible type is shown in Fig. 2. In this circuit the s.c.r. will remain "off" until enough light is falling on the ORP12 for it to conduct sufficiently to fire the s.c.r. Because of the wide variations in the trigger current required to fire any given s.c.r. of a particular type it is possible that the circuit of Fig. 2 would not work with some s.c.r.'s, even of the stated type, although it should work satisfactorily with a "typical" device. R_1 limits the dissipation that can occur in the ORP12, and VR_1 acts as sensitivity control. The C20B s.c.r. specified will withstand a continuous gate dissipation of 0.5 watts. As with most s.c.r.'s, the maximum gate reverse voltage (gate negative of cathode) is very low, at only 5 volts, and one must always remember this when designing firing circuits.

Unfortunately, the simple circuit of Fig. 2 is rather insensitive, even with a good s.c.r., but that of Fig. 3 has sufficient sensitivity for most applications. In this case the current supplied by the ORP12 is amplified by the OC72, thus making the s.c.r. fire at a very much lower light level. The circuit could probably be made even more sensitive by replacing the OC72 with a higher gain transistor, or possibly with a Darlington pair,¹ although if

¹ Two directly coupled transistors, the first acting as an emitter-follower.—EDITOR.

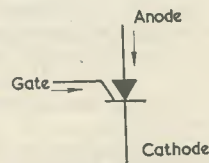

Fig. 1. The usual symbol for an s.c.r.

this were done silicon transistors would probably have to be used to prevent leakage currents firing the s.c.r. Because of the variable gate characteristics of s.c.r.'s the optimum value of VR_1 may vary. The value shown is suitable for an average unit, but it might need to be reduced to about $10k\Omega$ for a particularly insensitive s.c.r.

A circuit which will fire the s.c.r. when the light level falls below a preset value is shown in Fig. 4. While the ORP12 is conducting the OC72 does not receive enough bias to fire the s.c.r., but as soon as the amount of light falling on the ORP12 falls, its resistance rises, increasing the base bias of the OC72 and so firing the s.c.r. By adjusting VR_1 so that the s.c.r. is just not fired by the normal light level the circuit can be made to operate when the slightest shadow falls on the ORP12. The values of R_1 and VR_1 might need adjusting if the circuit were used in particularly high or low ambient light levels, and the optimum value will depend on the s.c.r. Again, a higher gain transistor would increase the sensitivity of the device. The reactions of the ORP12 are rather slow, and to make the circuit sensitive to rapid light changes it would be desirable to use a faster-acting photo sensitive device.

The circuit of Fig. 4, set up so as not to be too sensitive, could be used to switch on lights (e.g. car lights) at dusk. It has the great advantage that it uses no relay, for relays tend to be upset by the vibration in a car. The s.c.r. would have to be mounted away from the engine, on a suitable heat sink. An 8in square piece of 10 s.w.g. aluminium, painted matt black, with the s.c.r. mounted at the centre, will enable devices in the C20 range (such as the C20B specified) to be run at their maximum ratings at normal temperatures. If the car body were used as a heat sink it must be remembered that this is normally connected to one side of the car battery.

If any of these circuits were to be used to operate a bell or buzzer one would have to check that high voltage transients were not produced, for devices such as bells, which rapidly make and break an inductive circuit, are very liable to produce damaging transients. If it is found that the device in question does produce such transients they can frequently be suppressed by simple RC filters, but if such simple measures fail to reduce the transients to a safe level special semiconductor devices, known as Thyrector Diodes, are available from A.E.I. Ltd., and these devices are especially designed for this job. They are quite cheap and may save an expensive s.c.r. from destruction.² The easiest way of detecting these transients is by observing the waveform across a device suspected of producing them, preferably with a wide band oscilloscope.

² Thyrector Diodes, manufactured by the American General Electric Company, are transient voltage suppressors using a selenium semiconductor. The reverse characteristic of these devices has a very sharp breakdown point and results in a performance similar to zener diodes. This, coupled with the surge handling capabilities of selenium, makes Thyrector Diodes particularly suitable for transient voltage suppression applications. Further details are available from A.E.I. Valve and Semiconductor Sales Dept., Associated Electrical Industries Ltd., Carholme Road, Lincoln.—EDITOR.

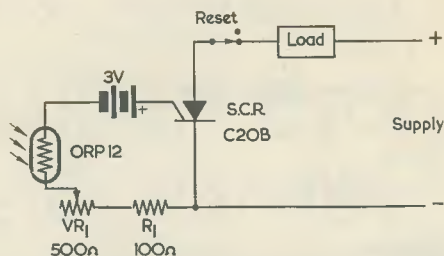

Fig. 2. A simple light-sensitive switch. This requires an s.c.r. having a low gate trigger current, and some C20B's may not function in the circuit

Failing this, connecting a neon bulb across the suspect device will often show their presence, for if the transients are of sufficient size to be damaging, they will normally also be of sufficient size to make the neon glow, at least feebly.

In the circuits just described the limiting values of the supply voltage are the forward breakover voltage (200 volts in the case of the C20B) and, at the lower end, the voltage required to overcome depletion region effects. This is, typically, 0.6 volts. Experiments have shown that satisfactory results are given by a 1.5 volt supply (as long as one remembers that the s.c.r. will drop about 0.6 volts). The load current which will flow after firing has only a very small effect on the gate sensitivity of the s.c.r., this point having been checked over the load current range of 50mA to 1 amp.

Temperature Sensing Device

An interesting variant of the circuits shown in Figs. 2, 3 and 4 is to replace the ORP12 by a suitable thermistor. In this case the s.c.r. in Figs. 2 and 3 will fire when the temperature rises above a preset level, whilst that in Fig. 4 will fire when the temperature falls below the preset level. Both have obvious uses—the first two as fire alarms and the third to turn on heating equipment. In these applications the extra reliability of the s.c.r. would be an advantage. The C20B shown in these circuits has a peak reverse voltage of 200 and is *not* suitable for switching mains voltages, but it could be replaced by the C20D (p.i.v.=400V)

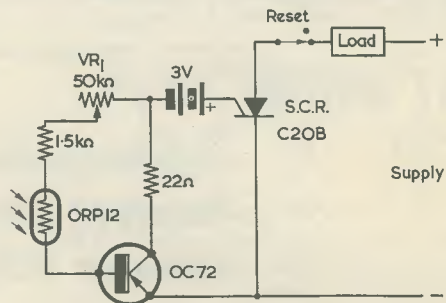

Fig. 3. A light-sensitive switch offering much higher sensitivity than that of Fig. 2

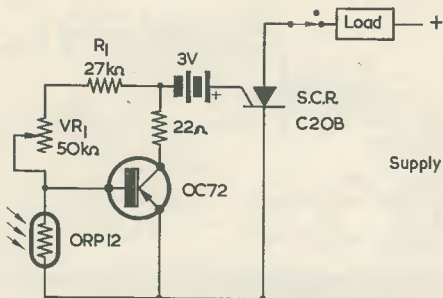

Fig. 4. A light-sensitive switch which operates when light falls below a preset level

for switching mains into a purely resistive load. Even in this case, however, it would be wise to include transient suppression networks, as the safety margin is rather narrow.

It must be remembered that, if a single s.c.r. is used to switch alternating current, the load supplies through it will only receive half its normal power, as the s.c.r. continues to block in the reverse direction. It should be possible, however, to devise a circuit using two s.c.r.'s, connected so that while one is reverse-biased the other is forward-biased. Such a circuit would have to be designed in such a way that it ensured that both s.c.r.'s fired simultaneously—simply connecting them both to the same triggering voltage would not be enough to ensure this because of the variable gate characteristics. Another point to remember is that if the anode-to-cathode circuit is supplied with a.c., or with any other waveform containing a portion such that no forward current flows through the s.c.r., the s.c.r. will, as explained earlier, switch "off" when the triggering voltage is removed. In many cases, such as the control of heaters and lights, this would be an advantage, but if it were desired to lock the s.c.r. on, the circuit of Fig. 5 should work satisfactorily.

When the s.c.r. of Fig. 5 fires it will supply half-wave rectified a.c. to the load and to T_1 . The output from T_1 is rectified by D_1 , a charge builds up on C_1 , and this will hold the s.c.r. on when the normal triggering circuit ceases to supply power to the gate. Diodes D_2 and D_3 are required to prevent the firing and holding circuits from affecting one another. The actual components used will

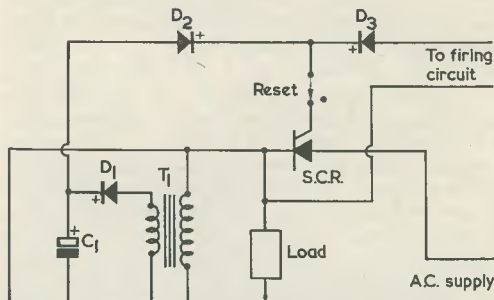

Fig. 5. A holding circuit for an s.c.r. controlling an alternating current

depend on the load, the s.c.r., and the supply voltage in any given circuit, but T_1 will have to have a secondary voltage at least twice that which would be needed to hold the s.c.r. on if the transformer were receiving normal a.c.³

Availability

S.C.R.'s suitable for most applications are available from A.E.I. Valve and Semiconductor Sales Dept., Associated Electrical Industries Ltd., Carholme Road, Lincoln, and for general experimentation the C20 range of s.c.r.'s is admirably suited. These s.c.r.'s are manufactured by the American General Electric Company, and are marketed by A.E.I. Ltd.

The C20 series has an r.m.s. forward current rating of 7.4 amps, which should be ample for most circuits. Units with higher current ratings are also available. Unfortunately, the high p.i.v. types tend to be a little expensive, but up to 200 volts p.i.v. the price is not excessive.

Many variants of the circuits shown are possible, taking advantage of the various properties of the s.c.r. A property not so far referred to is the fast turn-on of the s.c.r., and this can be an advantage in short period delay circuits, or in safety cut-outs, where speed may be all important. The four circuits given serve to illustrate some of the more unusual uses to which s.c.r.'s can be put, and the basic considerations in the design of these circuits.

³ Gate trigger currents for s.c.r.'s in the C20 series have a spread from less than 4 to some 25mA at 25° C. It should be possible, in consequence, to use germanium diodes of the OA81 class in the D_1 , D_2 and D_3 positions for most applications.—EDITOR.

NEXT MONTH

- ★ **Transistorised A.C. Millivoltmeter**
- ★ **Receiver Circuit for Caravans**
- ★ **Home or Office Intercom System**

From your Newsagent 2s 3d

SOME TIME AGO THE AUTHOR introduced a reflex circuit which he has called the "Spontaflex",* and since then a number of circuits have been published which have incorporated this very sensitive arrangement. The circuit now described as the "Spontaflex double reflex four transistor" (Spontaflex D.R.4) employs a second, tuned, high frequency amplifier, the second a.f. stage being reflexed in addition to the reflex effect within the "Spontaflex" amplifier. The circuit thus employs a total of seven stages; two at radio frequency, a detector, and four at audio frequency. The sensitivity is such that in South Devon the West Home service on both wavelengths, the Home service from London, the Wales Home Service, the Light programme, the Third programme on both wavelengths and five Continental stations, can all be received at good volume at noon, together with a number of other stations at somewhat reduced strength. After dark, all Home services (including Scotland!) as well as very many Continental stations are regularly available at good volume. Indeed, switching is

* See Sir Douglas Hall's article in the June 1964 issue, and the subsequent note on page 56 of the August 1964 issue.—EDITOR.

The "Spontaflex" D.R.4 Transistor Portable

By Sir DOUGLAS HALL
K.C.M.G., M.A.(Oxon)

A comprehensive medium wave receiver design which employs either three or four transistors according to the sensitivity desired. When four transistors are switched in, the receiver has, effectively, no less than seven stages!

incorporated to cut out one a.f. stage and reduce the working transistors to three when necessary. It will probably be found that most listening is done with only three transistors in circuit and some constructors may wish to build a version using three transistors only, as will be described later.

The Complete Circuit

The receiver circuit is shown in Fig. 1. The signal is picked up by the frame aerial, L₁. This is tuned by

VC₁ which is one section of a 500pF twin gang capacitor. The signal is fed via C₁, a small value capacitor, to the emitter of TR₁. The effect of C₁ and the choke, L₄, is to tap the emitter well down the tuned circuit at a point suitable for a common base amplifier. L₂, tuned by VC₂, is the collector load for TR₁. This transistor has a very high output impedance so that the whole of the tuned circuit is included as the load. Trimmers are shown across VC₁ and VC₂ and these will be referred to

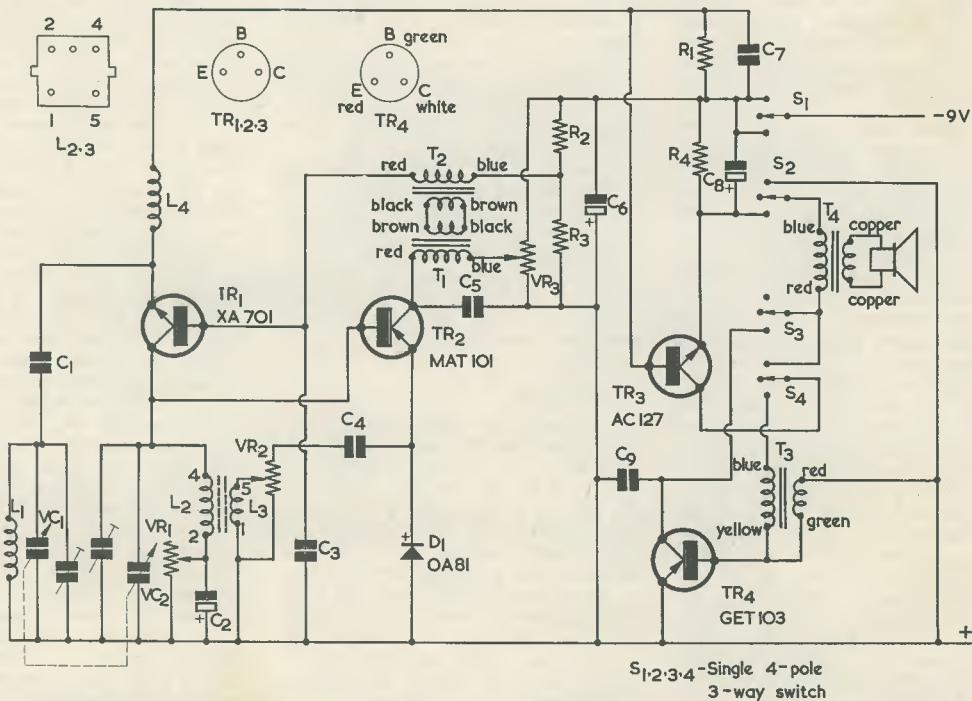

Fig. 1. The complete circuit of the receiver. In the upper position of S_{1,2,3,4} the receiver employs a 3-transistor circuit and, in the lower position, a 4-transistor circuit. The receiver is switched off in the central position

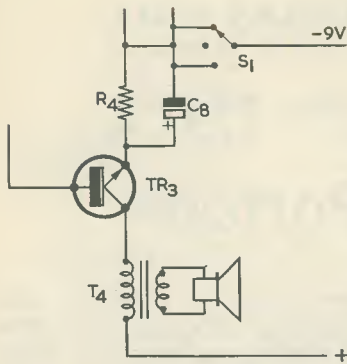

Fig. 2. The circuit conditions given when $S_{1,2,3,4}$ is in the upper position

later. The amplified signal is now applied to the base of TR_2 which, as a Spontaflex amplifier, performs as a common collector amplifier at radio frequencies. Consequently, it has a very high input impedance. It is an efficient arrangement to have a common base amplifier feeding directly to a common collector amplifier.

Demodulation takes place in the emitter circuit of TR_2 which then amplifies audio frequencies by the common base mode, D_1 being the input load. It is now necessary for the signal to be passed back to TR_1 for further amplification. But any signal appearing at the collector of TR_2 will be in phase with any signal at the base of TR_1 . Because of this, and because there will always be some a.f. at the base, even though it is theoretically at earth potential, it would be found that direct coupling between these two points would bring about instability. It is necessary, therefore, to reverse the phase at the collector of TR_2 before it passes back to the base of TR_1 . It is also necessary to ensure that both the output circuit of TR_2 and the input circuit of TR_1 have a high impedance to match the characteristics of these two transistors operating, at audio frequencies, as common base and common collector amplifiers respectively. The arrangement adopted to bring about these requirements is to use two high-ratio transformers with large inductance primaries, the secondaries being connected together out of phase. This produces, in effect, a large inductance choke with its winding divided into two parts. The circuit has the advantage over a straight centre-tapped arrangement of facilitating biasing.

The signal at the collector of TR_2 , therefore, has had its phase reversed

and has then passed to the base of TR_1 which, being now a common collector amplifier, produces its output at its emitter across R_1 . C_7 offers a bypass for unwanted radio frequency currents. L_4 has little effect at audio frequencies.

The signal across R_1 is applied to the base of TR_3 which is a common emitter amplifier. If the switch $S_{1,2,3,4}$ is in the upper position the output transformer will appear between the collector of TR_3 and the positive line. TR_3 is, of course, an n.p.n. transistor. TR_3 then functions as a large signal output transistor, and TR_4 is out of use. If, however, the switch is in the lower position, the collector of TR_3 has the two windings of T_3 , which is connected as an auto-transformer, as its load, and the signal is applied to TR_4 as a common emitter output transistor. It is important that the specified transformer be used for T_3 as the d.c. resistance of its secondary, 300Ω , determines the base bias for TR_4 . Stabilisation at d.c. for TR_3 and TR_4 is brought about by the emitter bias resistor for TR_3 (R_4) being in series with the primary of the output transformer. Thus, if TR_4 tends to take more current, the voltage drop across R_4 increases and TR_3 draws less current. As a result, the voltage drop across the secondary of T_3 is reduced and the current through TR_4 drops. This arrangement, and the choice of a transformer with a secondary of correct d.c. resistance result in a considerable saving of components, whilst providing the extra efficiency of transformer coupling.

Because of the switches it may be a little difficult to follow the circuit arrangements for TR_3 and TR_4 in Fig. 1. Fig. 2 shows the effective circuit when the switch is in the 3-transistor position, and Fig. 3 shows what occurs when the full circuit is in use with the receiver switched for four transistors.

D.C. Supply

As regards the supply of d.c. for the two earlier transistors, it will be seen that TR_1 is fully stabilised by means of R_1 , R_2 and R_3 . Base bias for TR_2 is settled, once and for all, by adjustment of VR_1 which is in the collector circuit of TR_1 . It is obvious that it is necessary for TR_1 to be an n.p.n. transistor. In fact, the comparative simplicity of this 7-stage circuit is to a considerable extent, the result of the proper combination of p.n.p. and n.p.n. transistors.

Reaction is preset by adjustment of VR_1 and VR_2 . VR_3 , which is the

volume control, provides also a vernier control of reaction towards the "full on" end of its movement, while at the same time acting as a true volume control at lower settings by cutting down the d.c. supply to TR_2 . The method of adjusting VR_1 and VR_2 will be described later.

Reaction is very effective with this circuit as it not only increases signal amplitude and tuned circuit selectivity at the base of TR_2 , but also increases the amplification and selectivity offered by TR_1 by increasing the output load for that transistor. As TR_1 is a common base amplifier there will be no trouble with coupling between the two sets of tuned circuits through this transistor. It is necessary, nevertheless, to ensure that stray capacitances in the wiring are reduced to a minimum. Indeed, with seven stages there is always a risk of instability, and a layout and wiring plan is therefore provided in Fig. 4. If this is followed, there should be no trouble.

Construction

A wooden baseboard, which is also the back of the front panel, is required. It should be 11in square by $\frac{1}{4}$ or $\frac{3}{8}$ in thick. All components, including the 6in loudspeaker, are mounted on this as shown in Fig. 4. It is suggested that VR_2 be mounted on a small bracket which is held to the board by one of the screws fixing the loudspeaker in position. VR_1 may be a small preset potentiometer of the type which can be held in place by the wiring, provided fairly thick wire is used for the purpose. C_8 , R_1 and C_7 are shown slightly out of position for clarity. They will have to be moved upwards a little to allow the vanes of the tuning capacitor to open. Also, for clarity, the four transistors are not shown. But the tags to which their electrodes should be soldered are marked.

The two transformers T_1 and T_2 are fixed in position by soldering their wire leads to insulated solder tags mounted on the baseboard. Great care must be taken in handling the leads of these transformers, particularly the primary leads, as if these are twisted or roughly handled it is probable that the internal connections to the very fine wire of the windings will be broken. Once the leads are soldered to the tags and are thus held firm, all will be well.

The output transformer, T_4 , is mounted by one of its feet only, this having been bent through 90° . This method of mounting causes the transformer to stand on one end and keeps its axis at right angles to the

axis of the frame aerial. The centre tap leads of T_3 and T_4 are not required and may be cut short. They must not be allowed to short-circuit against other components or wiring.

It is assumed that trimmers will be fitted to the tuning capacitor used and they are not, in consequence, shown in Fig. 4. If separate trimmers are used they should have values of about 30 to 50pF and must, of course, be wired across the two sections of the tuning capacitor.

The frame aerial is made with two pieces of $\frac{3}{8}$ in plywood and two pieces of hardboard, or thin plywood, cut as shown in Fig. 5. Five shallow cuts are made in the ends of two 10 $\frac{1}{2}$ in pieces, as shown, these then being pinned to two 10in sides with a small overlap so that the turns of the winding are held in position by the slots. Fifteen turns of 32 s.w.g. enamelled wire are used, three turns in each slot. The slots are spaced at $\frac{1}{4}$ in intervals. The frame is fitted to the baseboard, after all components have been mounted and wiring is complete, by means of small wood screws. It is fitted so that the windings are remote from the baseboard. The direction of the winding is unimportant.

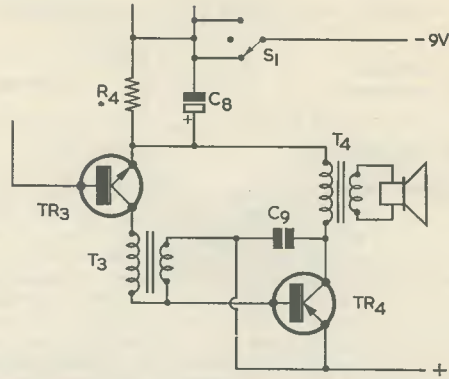

Fig. 3. Putting $S_{1,2,3,4}$ to the lower position brings TR_4 into the circuit

Setting Up

Once assembly and wiring has been completed and checked, it is necessary to trim and adjust. This will prove quite simple if the instructions are followed and does not need the use of a signal generator. In fact the prototype was set up the morning after the author had had his workshop burgled and his signal generator stolen!

Set VR_2 about three-quarters advanced, in a clockwise direction,

and VR_1 so that the slider is about two-thirds of the way away from the "live" end (i.e. the end with the connection) of the track. Open both trimmers fully. Turn VR_3 full on. Connect up a PP9 battery and switch on to the 3-transistor position. This will be anti-clockwise, looking at the switch knob. Turn the tuning capacitor until the local station is heard. If it is very loud, find a weaker signal. If whistles show that the receiver is oscillating turn VR_2

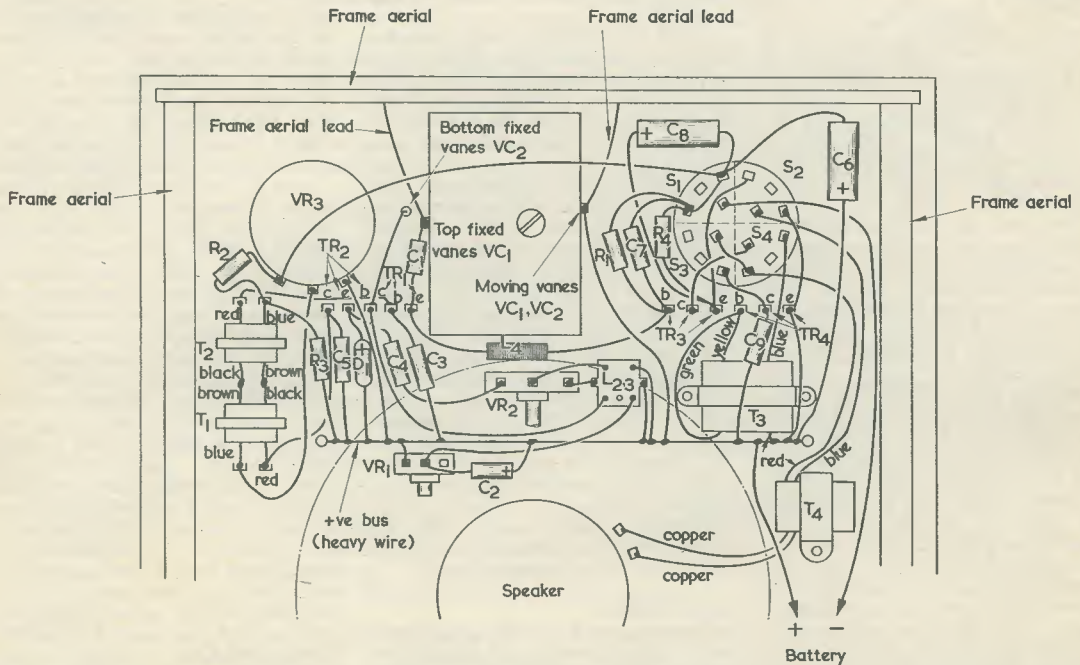

Fig. 4. The layout and wiring of the receiver. The dashed lines across $S_{1,2,3,4}$ divide this switch into its four sections. Constructors should ascertain the outside contacts which correspond to each of the four central contacts before wiring, as the relative positioning in some switches may differ from that shown here

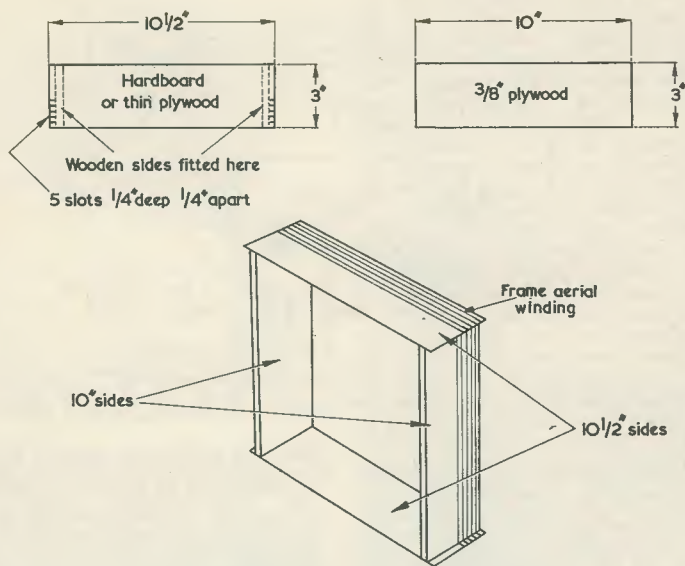

Fig. 5. Details of the frame aerial assembly

in an anti-clockwise direction until oscillation stops. If oscillation cannot be produced with VR₂ fully clockwise, adjust VR₁ until it can. VR₁ may need turning in either direction.

Using a trimming tool, or sharpened match stick (but *not* a metal screwdriver) adjust the core of L_{2,3} for loudest signal, rocking the tuning capacitor at the same time since this will need readjustment as the core is turned. If oscillation starts again as the signal is brought up in strength, back down VR₂ (anti-clockwise). When the station has been brought to its maximum volume turn the tuning capacitor until a station is found with most of the vanes enmeshed. Repeat the process of adjusting the core of L_{1,3} while rocking the tuning capacitor until this longer wavelength station is at its loudest.

Now find a station with the vanes of the tuning capacitor nearly open. Leave the core of L_{2,3} alone, and adjust the trimmer across the section of the tuning capacitor connected to the frame aerial. This should have little effect on the setting of the tuning capacitor and should either increase or decrease the volume. If volume is increased as the trimmer is screwed down, adjust for maximum strength. If volume is decreased, open the frame aerial, trimmer, and adjust the other trimmer. This time it will be necessary to rock the tuning capacitor, as was done when adjusting the core of L_{2,3}. Having obtained maximum strength, return

to the station at the long wavelength end of the scale and repeat the process of adjusting the core of L_{2,3}. Then readjust the trimmer on the short wavelength station. The receiver may then be regarded as aligned.

Final adjustments should now be made to VR₁ and VR₂. The object here is to find a setting of VR₁ which just causes the receiver to oscillate at the long wavelength end of the scale with VR₃ turned full on and VR₂ turned back in an anti-clockwise direction till oscillation is just taking place. This adjustment should be made at a point on the tuning scale where no signal is being received, which probably means during the hours of daylight! The right setting will result in maximum high frequency amplification by TR₂, and maximum a.g.c. effect (which is limited but useful) when using three transistors only. The current passed by TR₂ at the correct setting will probably be from 150 to 200 μA with no signal, rising by some 30% with a strong signal. This assumes that VR₃ will be near maximum position, as will be probable when listening to a fading station on three transistors only.

A.G.C. Effect

Readers may be puzzled as to how a.g.c. works with a Spontaflex circuit, since it would seem that an increase in current through D₁ must increase the collector current of TR₂ and hence the amplification offered. This is true, and if VR₁ is adjusted

so that the standing current through TR₂ is too small, a.g.c. will be in reverse and reaction will be accompanied by backlash. But as the standing current passed by TR₂ is increased a further effect exerts its influence. The impedance of D₁ becomes reduced, and as it is the output load of a common collector amplifier, the input impedance of that amplifier is also reduced and the tuned circuit at its base is damped. An additional, smaller, effect is due to D₁ being in parallel with L₃ so that reaction is reduced as that inductor becomes damped by the lowering impedance of D₁.

There is a critical current value for TR₂, which varies slightly with the setting of the tuning capacitor, at which the two effects increased amplification and increased damping equalise. At this setting, which will have been found by adjustment of VR₁ as described, any increase or decrease in current through TR₂ will cause a drop in amplification. If, as has been done, this setting is chosen for the long wavelength end of the scale, it will be found that at all lower wavelength settings of the tuning capacitor the damping effect will predominate. A reduction of current through TR₂ will then increase amplification whilst an increase in current will produce a rapid falling off in signal strength. As the setting was done at a point where no station was being received there are no circumstances in which the current can become less (short of a failing battery). Current will always increase on receipt of a signal and the a.g.c. effect will take place.

A.G.C. is most effective when plenty of reaction is being used and, because of this, constructors will probably find that they get best results after dark, with only three transistors in use. In fact, some constructors may wish to start off with three transistors only, in which case they can postpone purchase of TR₄, T₃ and C₉, and wire the remaining part of the receiver to the layout shown in Fig. 4. S_{1,2,3,4} can, of course, be replaced with a simple on-off switch. It will be an easy matter to add the fourth transistor at a later date if this is felt necessary, as would occur in daylight when fading is less of a problem and when stations are weaker and selectivity is less important. The use of the fourth transistor would then allow very good daylight reception from distant stations without pushing reaction anywhere near its limit. But with most stations, after dark, amplification is so great that the full selectivity and a.g.c. effect, obtainable with reaction well advanced, cannot be

made without overloading the receiver. The radio frequency amplification, even without reaction, is such that it is necessary, at the author's home, to turn the receiver out of line with the local station, to avoid overloading TR₂.

Components List

Resistors

(All fixed resistors $\frac{1}{4}$ watt 10%)

- R₁ 1k Ω
- R₂ 2.2k Ω
- R₃ 8.2k Ω
- R₄ 100 Ω
- VR₁ 500 Ω potentiometer, linear track, preset
- VR₂ 5k Ω potentiometer, linear track
- VR₃ 25k Ω potentiometer, wire-wound

Capacitors

- C₁ 22pF, silver-mica or ceramic
- C₂ 100 μ F, electrolytic, 6V wkg.
- C₃ 0.01 μ F, paper
- C₄ 0.01 μ F, paper
- C₅ 1,000pF, ceramic or paper
- C₆ 1,000 μ F, electrolytic, 12V wkg.
- C₇ 0.1 μ F, paper
- C₈ 1,000 μ F, electrolytic, 6V wkg.
- C₉ 0.1 μ F, paper
- VC_{1,2} 500 + 500pF, twin gang, with trimmers

Inductors

- L₁ Frame aerial (see text)
- L_{2,3} Aerial coil type XMA16 (Repanco)
- L₄ 5mH choke type CH2 (Repanco)

Transformers

- T₁ Transformer type TT53 (Repanco)
- T₂ Transformer type TT53 (Repanco)
- T₃ Transformer type D3026 (Ardente)
- T₄ Transformer type TT5 (Repanco)

Semiconductors

- TR₁ XA701 (Ediswan)
- TR₂ MAT101 (Sinclair)
- TR₃ AC127 (Mullard)
- TR₄ GET103 (G.E.C.-Mullard)
- D₁ OA81 (Mullard)

Switch

- S_{1,2,3,4} 4-pole 3-way miniature rotary

Speaker

- 3 Ω , 3in loudspeaker

Battery

- 9-volt battery, PP9 or similar

RECENT PUBLICATIONS . . .

FAULT LOCATION EXERCISES IN RADIO AND TELEVISION SERVICING. Volume I. By K. J. Bohlman. 79 pages, 5 $\frac{1}{2}$ x 8 $\frac{1}{2}$ in. Published by Norman Price (Publishers) Ltd. Price 7s. 6d.

K. J. Bohlman is Lecturer in Radio and Television Servicing at Lincoln Technical College and his book, the first of three volumes, is intended mainly for student service engineers who are preparing for City & Guilds and R.T.E.B. certificates in Radio and Television Servicing. The present volume is intended for use by first and second year students. The book has a wider appeal, also, for radio amateurs, experimenters and home-constructors.

The book is divided into three sections, the first of which deals with components, the second with simple circuits, and the third with audio amplifier faults. Each section consists of a series of questions, these being followed by their answers. The questions are searching and thought-provoking, and the answers give full information with conciseness and accuracy. Emphasis is continually laid on practical aspects of servicing.

This book will be of considerable use to the student for whom it has been written, not only because it enables much useful information to be pleasurably absorbed but also because it makes the reader "examination-minded".

RADIO AND TELEVISION SERVICING, ELECTRONICS SERVICING—SPECIMEN ANSWERS TO INTERMEDIATE PAPERS 1961/64. By F. O. M. Bennewitz, Grad.I.E.R.E., A.M.Inst.E. 94 pages, 5 $\frac{1}{2}$ x 8 $\frac{1}{2}$ in. Published by Norman Price (Publishers) Ltd. Price 8s. 6d.

Another book for the servicing student, this gives specimen answers to four years of questions (first and second written papers) set by the City & Guilds of London Institute and the Radio Trades Examination Board. It should be mentioned that the first written paper is common to both courses.

Specimen answers to previous examinations are always of great help to the student because, apart from the technical subjects covered, they give him an idea of what is expected of him within the confines of the examination itself. The author of this book is lecturer in Radio and Television at Bradford Technical College, and the answers he sets out take into account the fact that limited time is available during the examinations concerned. The author has, also, restricted the answers to what would be expected from a good student.

This is a book which will be of great help to the student, for whom it can be fully recommended.

101 WAYS TO USE YOUR AUDIO TEST EQUIPMENT. By Robert G. Middleton. 140 pages, 5 $\frac{1}{2}$ x 8 $\frac{1}{2}$ in. Published by W. Foulsham & Co. Ltd. Price 18s.

This title is in the Foulsham-Sams Technical Books series and has an American text with an introductory chapter for English readers. It gives details of 101 tests which can be carried out with audio equipment.

The first nine tests consist of checks of measuring equipment, after which there are descriptions of 54 tests on audio amplifiers, 24 tests on components and 14 system checks. The descriptions of most of the tests take up slightly longer than one page, and the text for each test appears under the sub-headings *Equipment, Connections Required, Procedure and Evaluation of Results*. Frequently, one or more *Notes* follow this standardised layout to give further information.

Included, typically, among the tests are the checking of an amplifier for crossover and notch distortion, the checking for cross-talk in a stereophonic amplifier and the measurement of phase shift around a feedback loop. The approach is entirely practical and there are many well-drawn diagrams and clear photographs of oscilloscope traces.

FUNDAMENTALS OF MODERN SEMICONDUCTORS. By Barron Kemp and R. H. McDonald. 166 pages, 5 $\frac{1}{2}$ x 8 $\frac{1}{2}$ in. Published by W. Foulsham & Co. Ltd. Price 24s.

This book, which also appears in the Foulsham-Sams Technical Books series, examines modern semiconductor devices with a minimum of mathematics and formulae, each semiconductor type being described from the point of view of operation and application.

Longer Guarantee on TV Tubes

The guarantee period on Mullard television picture tubes has been doubled from twelve months to two years. Furthermore, guarantee procedures have been simplified for both customer and dealer.

These new measures by Britain's largest tube maker stress the continuing rise in the reliability of the company's tubes. Of all Mullard tubes sold through retailers during the past twelve months less than one half of one per cent were returned for replacement under guarantee.

The two-year guarantee applies to all tubes sold in the United Kingdom and the Republic of Ireland. It took effect on 1st January 1966, but has been made retrospective so that the owners of tubes registered at any time during 1965 will also benefit.

It covers Mullard black and white tubes of all sizes and types, including the recently introduced "Panorama" types which improve picture quality by eliminating the need for a protective shield in front of the tube.

For Mullard colour tubes—now being supplied in pilot quantities—guarantee terms are being worked out so that when the production of colour receivers begins on a commercial scale the tubes will carry a comprehensive assurance to the viewer of the reliability and life.

Most of the 14 million sets in Britain are fitted with Mullard tubes. With its own glass-making factory, the company's plant at Simonstone, Lancashire, is Europe's biggest and most highly-automated tube producer.

Guarantee Procedure Simplified

Mullard have also announced that customers will no longer have to register their tube guarantee. The existing multi-part guarantee card of the kind now in common use is to be scrapped—and with it the attendant clerical work by both customer and dealer. In its place will come a simple, one-part card that does not have to be returned to Mullard for registration. Instead, the customer will retain the card, handing it to the dealer if the tube should require replacement under guarantee.

Two-year cards in the new style are now ready. Meanwhile existing cards will be honoured for the longer period.

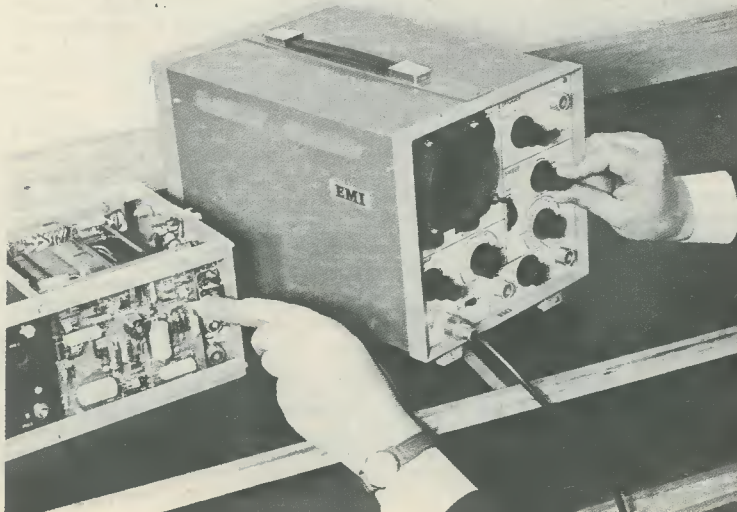

British Amateur Tape Recording Contest

It is anticipated that the British Amateur Tape Recording Contest for 1966 will be the biggest competition for amateur tape enthusiasts yet organised in Britain.

A committee under the chairmanship of Cyril Rex Hassan, Director of the International Audio Festival, has been formed to organise the 1966 contest, the headquarters for which will again be the offices of *Tape Recording Magazine*.

Sponsors of the contest are nine of the big names in amateur tape recording in this country—Agfa, BASF, Emitape, Grundig, Ilford, Kodak, Mastertape, Philips and Scotch.

Making a tape for the British Tape Recording Contest can provide an enormous amount of fun and also give the opportunity to win an exciting prize.

To encourage even those who only obtained their tape recorders at Christmas there is a novice class, suggested subjects being children, transport, holidays, birds and animals, music and other sounds.

Advanced amateurs can submit their own newsreels, dramatic, musical and technical experimental tapes. There is also a special class for group entries from schools and clubs.

The best entry will be named the "Tape of the Year" and will win £100, a silver trophy, and a trip to London. On occasions the winning entry has been broadcast by the B.B.C.

Contest enquiries should be addressed to the contest committee at 7 Tudor Street, London, E.C.4.

EMI Oscilloscope 101

From EMI's design laboratories comes a new 3in general purpose oscilloscope with a remarkable combination of practical features.

The 101, which costs £170, is a portable 3in general purpose oscilloscope. Designed following extensive user research, this ruggedly-constructed instrument weighs only 17lb, requires a power consumption of only 20W and can be mains or

COMMENT

battery operated. It has 18 calibrated sweep speeds, a bandwidth of 15 Mc/s and a built-in voltage calibrator.

The new oscilloscope has an almost unlimited variety of applications in industry, education and research.

An attractive and informative brochure describing the 101 may be obtained from the Publicity Department, EMI Electronics Ltd., Hayes, Middlesex.

Shot in the Arm for Exports

An exhibition which will draw to London many thousands of specialist engineers from all over the world is going to give a valuable shot in the arm to one of Britain's major export industries—electronics.

The International Instruments, Electronics and Automation Exhibition at Olympia, from 23rd to 28th May, makes London the world's electronic centre. By international agreement, the 1966 IEA is classified as the major technological exhibition of its kind.

It is expected by the organisers, Industrial Exhibitions Ltd., that at least 10,000 overseas visitors will be at the show, the majority of them in the "buyer" class, representing government departments, the armed forces, industry and universities.

The 1966 IEA is the most comprehensive exhibition of its kind ever staged. More than 850 firms will display new equipment worth at least £30 million Sterling.

A third of the exhibitors will be from overseas. The United States Government will occupy the biggest stand of the 11-acre exhibition. France and Czechoslovakia will also present national exhibits and there will be at least 240 individual overseas firms representing another dozen countries.

The International IEA is sponsored by the British Electrical and Allied Manufacturers' Association, the Radio and Electronic Component Manufacturers' Federation, the Electronic Engineering Association, and the Scientific Instrument Manufacturers' Association of Great Britain. The Organisers are Industrial Exhibitions Limited.

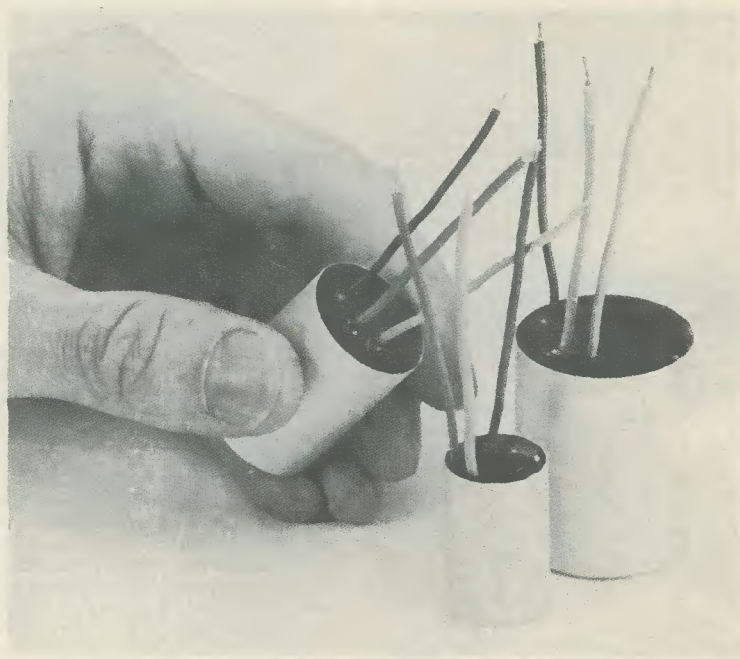

Three of the new Kynmore range of miniature charger modules for nickel-cadmium rechargeable batteries

New Miniature Charger Modules

Transistor radios, pocket flashlights, hearing aids and paging systems are all small items of portable consumer equipment depending on battery operation, and increasingly on nickel-cadmium rechargeable batteries. A new range of miniature charger modules no larger than the batteries themselves is available from Kynmore Engineering Co. Ltd., 19 Buckingham Street, London, W.C.2. Based on an earlier module developed for one particular manufacturer, they are now generally available from Kynmore for the first time. As they may be permanently connected across their batteries and then built into equipment, they provide the possibility of instant recharging simply by plugging into the mains. Another possible use is in complete battery chargers, in which the miniature modules may be incorporated.

Each module consists of a tubular aluminium can containing a capacitor, resistors and a semiconductor-type rectifying arrangement encapsulated in Araldite, from which the 2½in colour-coded leads protrude. The three connecting leads are identically coded: grey and red are a.c. live battery positive respectively, while blue is common. Four wire types are also available. Six different sizes are available in the standard range, with capacities ranging from 2 to 45 milliamps. Corresponding dimensions range from 0.8in long by 0.6in diameter to 1.7in long by 1.25in diameter. The charging rate remains substantially constant irrespective of the state of charge of the accumulators, which makes the modules suitable for charging even completely exhausted cells. All units are suitable for continuous operation and are available at short notice for evaluation.

In Your Workshop



This month Smithy the Serviceman, aided as always by his able assistant Dick, eschews the pleasures of TV servicing and turns his attention to an out-of-the-way fault on a stereo radiogram. In the process he is also able to explain to Dick the workings of an ingenious commercial design which allows two output valves to be single ended on stereo and to work in push-pull for radio reproduction

"A H," SAID DICK ADMIRINGLY, "now that's what I call a cabinet."

Smithy's assistant gazed appreciatively at the large and impressive a.m.-f.m. stereo radiogram which took pride of place in the centre of the Workshop.

"That," he continued, "is the sort of cabinet that really brings *distinction* to a home. You can keep your old plastic boxes. There's nothing better for bringing back the atmosphere of gracious living our forebears knew than some good solid timber with a shiny polyester finish, mate!"

"All right, Chippendale," grunted Smithy irritably. "Let's forget the carpentry for the moment and start thinking about the electronics."

"Righty-ho," said Dick equably. "Shall we have a go at fixing this one together?"

"I wouldn't mind," replied Smithy negligently. "There isn't a great deal to do this morning, and a break from TV sets would make a very nice change."

He bent over and examined a small label attached to the back of the instrument.

"I see," he added, "that this label says 'customer complains of poor results on radio'. Well, we'll see about that!"

Low Radio Output

Pleased at the thought that Smithy would be at his side to offer assistance, Dick picked up the radiogram mains lead and inserted its plug in the appropriate socket at the rear of his bench. He switched on.

The dial lamps lit up. Encouraged, Dick selected medium waves and waited for audible results. After a short period, the tuning indicator commenced to glow and a faint background hiss became audible.

Dick swung the tuning knob and located the local station. Reproduction seemed to be reasonably good. Dick swept the tuning knob over the medium waveband, to find that sensitivity and selectivity were perfectly adequate. He next turned to the long waveband, to encounter similar results. Finally, he switched to the v.h.f. band. Once again, the radiogram appeared to be giving a reasonably good performance as Dick successively tuned in the three local stations.

"It doesn't," Dick remarked, "appear to be *terribly* bad on the radio side."

Smithy frowned, as he listened to the output of the radiogram.

"The r.f. performance, at any rate, is O.K.," he commented eventually, "and there's plenty of shadow angle change in the tuning indicator as you tune in each station, which means that there's a correspondingly healthy amount of a.g.c. voltage being formed."

The Serviceman frowned.

"What I'm trying to do, though," he continued, a little uncertainly, "is to judge the a.f. performance. The customer says that results are poor on radio, and I'm wondering whether he means that it's the *audio* performance which isn't too hot. So far as I can tell up to now, this radiogram doesn't seem to be giving quite the power and quality I associate with models of this type. Turn the wick up a bit."

Obligingly, Dick did as he was bid. Smithy listened intently, then walked to the front of the radiogram. He bent down at each loudspeaker.

"Well," he remarked, straightening up and turning back the volume level, "at least there's an equal amount of sound coming out of both the speakers."

"Is that important?"

"It might be," replied Smithy cautiously. "To tell you the honest truth, I'm still not entirely certain of my diagnosis at the moment. I've been doing so many TV's recently that I've forgotten what quality reproduction really sounds like!"

"Oh, come off it," snorted Dick scornfully. "It's just a radiogram, isn't it? And we've had quite a few of them in here before now. Although I must admit that most of the really big ones have been mono jobs and not stereo."

"You shouldn't," reproved Smithy, "think of stereo radiograms in the same terms as single-channel mono radiograms. There are a number of important differences. One of the basic differences, for instance, is the obvious fact that a stereo radiogram has a loudspeaker at each end of the

cabinet so that, if you play stereo records on it, the left hand speaker carries the left hand stereo channel and the right hand speaker carries the right hand stereo channel. When, however, you switch to a mono signal, as you get from the radio circuits, both speakers handle the single signal in phase. If you visualise the inside of a stereo radiogram in the form of individual sections (Fig. 1) you will find that you have one section for the left hand channel a.f. amplifier and one section for the right hand channel a.f. amplifier, these feeding the left and right hand speakers respectively. When the pick-up plays stereo records its left hand output goes to the left hand amplifier and its right hand output goes to the right hand amplifier, giving you the set-up required for stereo reproduction. It would be silly to have two amplifiers and only use one for mono so, when you want to reproduce the mono radio signal, you connect the inputs of the two amplifiers in parallel and apply the mono signal to this combined input. The mono signal then goes through each amplifier in phase and pops out of each speaker similarly in phase."

Smithy paused.
 "Anyway," he resumed, "it's no good my chuntering on like this when we have a fault to clear, so let's see what things sound like with a stereo disc."

Still wearing his preoccupied frown, Smithy walked to the stores cupboard and produced a 12in l.p. sleeve. He gravely extracted a record from this sleeve and handed it to Dick.

"It's not," asked Dick anxiously, "that old fire-engine one again, is it?"

"No," replied Smithy soothingly, "just a straightforward orchestral stereo disc."

Dick placed the record on the changer of the instrument, selected "gram" and started the motor. The record fell to the turntable, and the pick-up rose from its rest.

"The changer," announced Dick cheerfully, "seems to be working O.K."

"So it is," said Smithy absently, as the sound of music from the record filled the Workshop. Smithy experimented with the volume control.

"Now this," he said suddenly, "is how this radiogram *should* sound like! There's plenty of power in hand and there's really good quality!"

He switched to v.h.f., listened carefully to the sound from the local f.m. station, then switched back to

"gram" again. Finally, he turned the volume down.

"It's quite definite," he remarked, satisfied. "There's a definite difference in the available power between the output on 'radio' and the output on 'gram'. The trouble with listening tests is that they're so subjective, but I'm certain of my facts now. Whatever the snag is, it's appearing in the a.f. circuits and it's evident on radio and *not* on gram."

Now that his doubts were banished, Smithy at once assumed the mantle of the man of action.

"Right," he announced, briskly. "I'm now going to get the service manual out. Whilst I'm doing that you might as well be getting the back off that cabinet."

Decisively, Smithy marched to the cupboard in which the manuals were filed, whilst Dick busied himself behind the radiogram. Smithy returned with the required manual and opened it out at its circuit diagram.

"Aha!" he remarked after a moment. "I think I've already got an idea about what's happening here."

He selected the v.h.f. signal on the radiogram once more, and turned the volume up.

"Have you got the back off?"
 "All the works," responded Dick cheerfully, as he rose to his feet, "are now fully exposed to the public gaze."

"Good," said Smithy. "Well, we'll try pulling out one of the output valves whilst the radiogram's reproducing a radio signal. There's no need to turn the set off whilst you do it."

Smithy peered inside the cabinet.
 "Pull out that one," he remarked, pointing to a valve with his finger. "It may be hot, mind."

Picking up a rag, Dick removed the valve from the chassis. There was no noticeable change in the output of the radiogram.

"Aha!" repeated Smithy, obviously pleased. "Pop it back in again."

Dick replaced the valve, and the Serviceman waited a few seconds for it to return to working temperature.

"Now," he said, indicating a second valve in the chassis, "try that one."

Dick removed the second valve, whereupon the radiogram became almost completely silent. Only a very faint version of the signal was audible. A glint of triumph gleamed in Smithy's eye. He went to the front of the cabinet and selected "gram". The sound of the stereo disc, still rotating on the turntable, became evident, but it was not the same as before. Smithy stooped in front of the speakers.

"Excellent, excellent," he enthused. Dick's voice rose up from the back of the cabinet.

"What's excellent?"
 "There's no sound from the right hand speaker," replied Smithy exultantly, "and the left hand speaker is reproducing the left hand channel of the record at full whack. Bung that valve back in, let it warm up, then whip the first one out again."

Muffled sounds from the interior of the cabinet indicated that Dick was carrying out the Serviceman's wishes. After some moments the right hand speaker came slowly to life. Suddenly, the left hand speaker became silent. The right hand speaker now produced, on its own and at full strength, the right hand channel of the stereo record.

"Is that the other valve out?" asked Smithy.

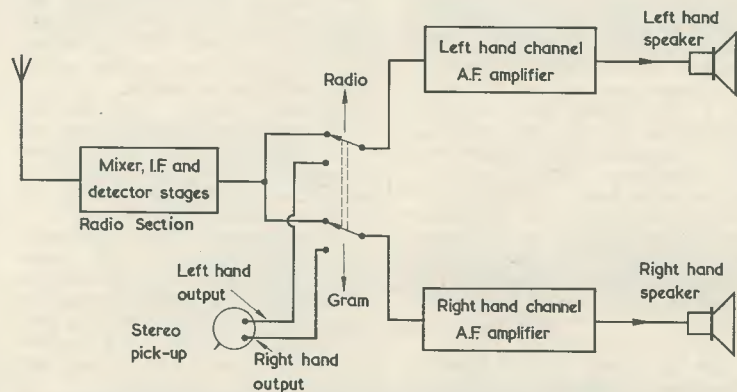

Fig. 1. The basic arrangements for a stereo radiogram. As is explained later by Smithy, some stereo radiograms have an alternative a.f. amplifier input connection for mono records

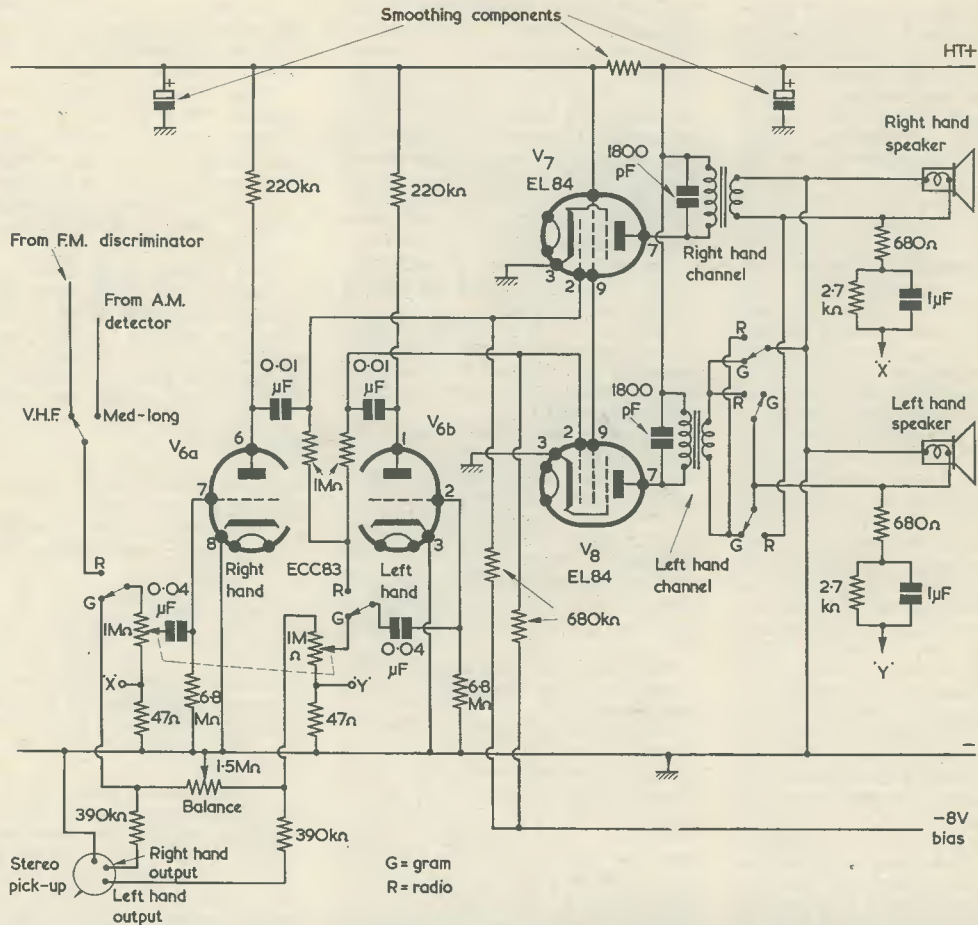

Fig. 2. The a.f. amplifier circuit (slightly simplified) in the stereo radiogram serviced by Dick and Smithy. The gram/radio switches shown in this circuit are part of the main wavechange switching, as also is the v.h.f./med.-long switch at the left. Valves V_1 to V_5 are employed in the preceding radio section of the radiogram. (The circuit technique shown here is employed in stereo radiograms manufactured by the Thorn group of companies)

"It is," said Dick, "and it's bleeding hot, too."

"Now, there's no call for that sort of talk," replied Smithy severely. "I've always endeavoured to maintain a high moral tone in this establishment and I'm not going to have it dragged down to the level of B.B.C. Television. Anyway, you can pop that valve back in again."

Shortly afterwards, the left hand speaker reproduced, in company with the right hand speaker, the output from the stereo record. A dishevelled Dick rose from the depths.

"Any more valves to try?"

"Not for now," replied Smithy. "The next job is to get the chassis out."

Circuit Operation

It was obvious that Smithy was intensely pleased with himself, and

he watched the activities of his assistant with an air of immense self-satisfaction. It was not long before Dick laid the chassis of the radiogram down on his bench.

"If we're lucky," said Smithy, "we'll probably be able to find out what's wrong with just a few simple ohmmeter checks. So I shouldn't bother to couple the chassis up to the speakers or the pick-up."

"I," announced Dick, aggrievedly, "am now completely in the dark. If you could give me a glimmering of understanding about what you've been up to, I might be able to find out what's going on. All I've done up to now has been to pull out valves."

"Fair enough," said Smithy. "If that's how you feel, it looks as though I'd better give you some gen on this particular radiogram. Now,

as I said a few minutes ago, stereo radiograms contain two separate a.f. amplifiers, one of these being for the left hand channel and the other for the right hand channel. Since the radiogram we have here is a valve job, we'll now carry on in terms of valve radiograms only. In some valve stereo radiograms you'll find that each of the separate amplifiers has a push-pull output stage. In other models, the separate amplifiers have single-ended output stages employing a single output valve each. There are, however, a number of stereo radiograms which use quite a different technique, and the one we're working on here is one of them. In these radiograms the two amplifiers have single-ended output stages on stereo, but the two output stages are combined together to form a single push-pull output stage

when you reproduce the mono signal given on radio.

"And now," concluded Smithy, "having played the prologue, I'll get down to the plot."

Smithy laid the service manual, open at the circuit of the radiogram, on the top of its cabinet.

"Here," he said indicating a section of the circuit with his finger, is the a.f. amplifier circuit of our radiogram (Fig. 2), and we'll first examine it when it's switched to 'gram', in which condition it's capable of handling stereo signals. We'll commence at the stereo pick-up. As you'd expect, this offers two outputs, one being the right hand output and the other the left hand output."

"What," asked Dick, "is the 1.5M Ω pot connected across the pick-up outputs for?"

"That's the balance control," replied Smithy. "Each channel should offer the same amount of loudspeaker output for the same amount of modulation in the record groove. In the present circuit, the balance control varies the pick-up output level which is fed to each amplifier channel, whereupon it can be adjusted to take up variations in amplifier gain and in the pick-up itself. You'll notice that there are two 390k Ω resistors in series with the pick-up outputs, and each of these forms a potentiometer with the section of the 1.5M Ω pot track they connect to. If you move the 1.5M Ω pot slider towards the 390k Ω resistor coming from the right hand output of the pick-up you obviously reduce the amount of right hand signal passed to the right hand amplifier and increase the amount of left hand signal. And vice versa. All right?"

"Yes," replied Dick. "I'm with you on that."

"Good," said Smithy. "Let's next trace the route of the right hand output from the pick-up. After the balance control, this passes through a section of the gram-radio switch to a 1M Ω volume control, after which it carries on through a 0.04 μ F capacitor to one half of an ECC83 which, in this diagram, is designated V_{6(a)}. O.K.?"

"Sure," said Dick happily. "This is the sort of nice simple circuit that I feel really at home with."

"Fine," replied Smithy. "Let's next trace the left hand output from the pick-up. After the balance control, this goes direct to a second 1M Ω volume control which is ganged to the first, and then, via another section of the overall gram-radio switch, and another 0.04 μ F capacitor, to the grid of the remaining

half of the ECC83. The latter is shown here as V_{6(b)}."

Smithy paused for a moment.

"We have found," he continued, "that with all the switch sections we've considered set to 'gram', both outputs from the pick-up pass through identical circuits on their way to the grids of V_{6(a)} and V_{6(b)}. A minor point to notice is that these triodes have their cathodes connected direct to chassis, and that they both have high value 6.8M Ω grid leaks which provide grid current bias."

"Everything up to now," commented Dick, "seems to be all tidy and symmetrical."

"It is," agreed Smithy, "and it stays that way right up to the speakers. The anodes of V_{6(a)} and V_{6(b)} both have 220k Ω loads, and they couple, via 0.01 μ F capacitors, to the grids of the two EL84 output valves. These are shown in the circuit as V₇ and V₈. There are 680k Ω grid leaks connected to the grids of the output valves, and these are returned to an auto-bias point, obtained from the power supply section, which gives 8 volts negative. So the cathodes of the output valves also go straight to chassis."

"What about those two 1M Ω resistors from the EL84 grids going down to the section of the gram-radio switch which controls the left hand pick-up output?"

"Don't worry about them," said Smithy. "When that section of the gram-radio switch is in the 'gram' position, those resistors have no effect on circuit operation. Now, where was I?"

"At the output grids."

"Oh yes," said Smithy, "so I was! Well, the situation now existing is that we are applying right and left hand signals, which have each passed through a similar amplifying stage, to the grids of V₇ and V₈. V₇ and V₈ amplify in normal manner and pass their anode signals to the primaries of the two output

transformers. To get true stereo output, these signals must then be fed to the two speakers in phase."

"The secondary of the output transformer in the right hand channel," commented Dick, "goes straight to its speaker. But the secondary of the transformer in the left hand channel goes into a whole network of switch sections."

"True enough," agreed Smithy. "But if you follow the circuit through those switch sections—which are all part of the overall gram-radio switching arrangements, by the way—you'll find that, when they're in the 'gram' position, the connection from the left hand channel output transformer secondary to the left hand channel speaker is identical to that in the right hand channel circuit. (Fig. 3.) Trace the left hand channel circuit through, and you'll soon see that this is the case."

Dick picked up a small screwdriver and passed it over the lines in the switching circuit.

"You're not wrong, you know, Smithy," he conceded. "You're dead right!"

"Of course I'm right," replied Smithy, affronted. "I don't lightly make statements such as that."

"I'm certain you don't," said Dick, soothingly. "But why is it necessary to have the switching circuit in the first place?"

"It's all part," replied Smithy, "of the overall stereo-mono amplifier switching arrangements, which I'll be explaining very shortly. In the meantime, can you briefly sum up the situation which exists when all the switch sections we've dealt with are set to 'gram'?"

"Certainly," said Dick obligingly. "What happens is that the right and left hand outputs of the stereo pick-up pass through a pair of ganged volume controls to the grids of V_{6(a)} and V_{6(b)}. The anodes of these valves couple to the two output

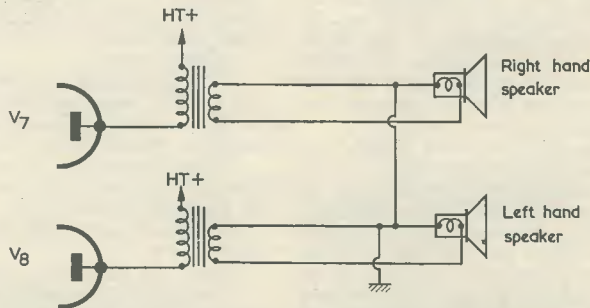

Fig. 3. When the switches in the secondary circuit of the left hand channel output transformer are in the "gram" position both speakers are connected in the same phase

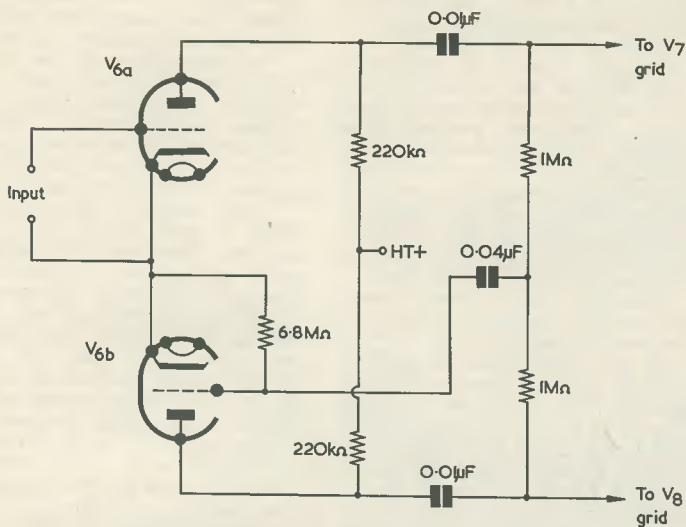

Fig. 4. When the amplifier is switched to "radio", $V_{6(a)}$ and $V_{6(b)}$ form a floating paraphase inverter, as shown here

valves, and these then work into the right and left hand speakers, in phase, by way of identical output transformer circuits."

"In other words," stated Smithy, "you've got exactly the set-up you require for stereo reproduction. What sort of output circuit do V_7 and V_8 appear in?"

"They're in single-ended output circuits," replied Dick promptly. "Each valve has its own output transformer and the only things they share in common are the 8 volt negative grid bias supply and the h.t. supply."

Operation on "Radio"

"Excellent," said Smithy. "Well, that's got the stereo side all buttoned up. What we're now going to do is to put all those switch sections you've been worrying about in the 'radio' position. In practice, this will be done by selecting either 'u.h.f.', 'medium' or 'long' on the main wavechange switch. The whole circuit will then become converted to a mono amplifier, with the two output valves working together in a push-pull configuration."

"Blimey," remarked Dick, impressed. "This I must see!"

"We'll start off," said Smithy, "at the input end again. If we commence with the gram-radio switch section at the left of the diagram, we'll see that this disconnects the grid circuit of $V_{6(a)}$ from the right hand channel output of the pick-up and connects it to the output of the radio section of the radiogram. It is preceded by another switch which selects the

output of the a.m. detector or f.m. discriminator, according to whether the receiver is switched to medium or long waves or for v.h.f. reception. This last switch is also part and parcel of the overall wavechange switching circuits, and it need concern us no further. What we now have is a detected radio signal passing to the left hand volume control and, thence, to the grid of $V_{6(a)}$. Whereupon $V_{6(a)}$ amplifies the signal in normal fashion."

"What about $V_{6(b)}$?"

"Things are now very different so far as $V_{6(b)}$ is concerned," replied Smithy. "This is because the section of the gram-radio switch in its grid circuit now disconnects the grid from the $1M\Omega$ volume control which followed the left hand channel output of the pick-up. The grid of $V_{6(b)}$ is coupled, instead, to the junction of the two $1M\Omega$ resistors immediately following $V_{6(a)}$ and $V_{6(b)}$. The result is that $V_{6(a)}$ and $V_{6(b)}$ enter a floating paraphase phase inverter circuit."

"Come again?"

"A floating paraphase phase inverter circuit," repeated Smithy.

"I thought," commented Dick uneasily, "that's what you said."

"Now the outputs of this inverter circuit," continued Smithy, "couple to the grids of V_7 and V_8 ."

"I have," said Dick flatly, "no doubt of it."

There was silence for a moment.

"You seem," remarked Smithy at length, "to be deeply troubled about something."

"I should jolly well think I am," snorted Dick indignantly. "I'm

still stuck with the floating paraphase whatsit!"

"It's just," replied Smithy, "a common-or-garden phase inverter."

"Not to me it isn't," said Dick shortly. "I don't even know what it's supposed to do!"

"Oh, all right, then," grunted Smithy. "It looks as though we'll have to spend a little time on this bit of the circuit before we press on. The best thing for me to do will be to draw it out in simpler form and without the switching."

Taking out a pencil, Smithy lightly sketched out a circuit diagram at the edge of the service manual sheet. (Fig. 4.)

"Here we are," he said, "and you'll soon find that it's all very easy and straightforward. The purpose of the circuit is, quite simply, to supply equal out-of-phase a.f. voltages to the grids of a following push-pull stage."

"Oh," exclaimed Dick, as light broke in, "it's a phase-splitter."

"Not exactly," replied Smithy.

"A phase-splitter is normally given by a voltage amplifier valve with equal values of resistance in its anode and cathode circuits, the out-of-phase signals for the push-pull stage which follows being taken from the anode and cathode. The present circuit does the same thing, but its correct name is a phase inverter. Anyway, don't let's get too pedantic about words and let's start thinking about how the circuit works instead."

Smithy tapped the circuit he had sketched out with his pencil.

"I've retained the same valve numbers in this circuit," he continued, "and so the input signal goes, as in the service manual diagram, to the grid of $V_{6(a)}$. The $0.04\mu F$ capacitor in the grid circuit of $V_{6(b)}$ has negligible reactance at a.f., so that we can say that the signal at the anode of $V_{6(a)}$ is applied to the a.f. potentiometer given by the upper $1M\Omega$ resistor and the $6.8M\Omega$ grid leak for $V_{6(b)}$, the signal at the junction of these two resistors being applied to $V_{6(b)}$ grid. But $V_{6(b)}$ amplifies this signal and causes another signal, of opposite phase to that at $V_{6(a)}$ anode, to be applied to the lower $1M\Omega$ resistor. The result is that the signal level applied to the grid of $V_{6(b)}$ becomes much smaller than would occur if the lower $1M\Omega$ resistor were not in circuit. The circuit is self-balancing and, if the values are right, results the appearance of what are virtually equal out-of-phase voltages at the anodes of $V_{6(a)}$ and $V_{6(b)}$. To obtain good balance it is desirable for $V_{6(b)}$ to have a high

gain figure, and this is achieved in the present circuit because $V_{6(b)}$ is one-half of an ECC83, which is a high gain double-triode. I should add, incidentally, that the circuit gets the name 'floating' because the voltage applied to the grid of $V_{6(b)}$ isn't tied to any fixed circuit point."

"I can understand the circuit now," said Dick. "It's not too difficult to follow, either. Turning back to the service manual circuit, I see that the out-of-phase voltages are then fed to the grids of the output valves."

"That's right," confirmed Smithy. "These signals are passed to V_7 and V_8 , which now form a push-pull output stage."

"But," objected Dick, "there are two output transformers. A push-pull output stage should only have one output transformer."

"True enough," agreed Smithy. "What we're looking at here is a rather unconventional form of push-pull output stage; but it's push-pull, nevertheless. You can see how it works when you put the three switch sections in the secondary circuit of the left hand channel output transformer into the 'radio' position. If you do this, you'll find that the connection to the left hand channel speaker is reversed in phase. You'll also find that the secondary of the left hand channel transformer is connected, with reversed phase, in parallel with the secondary of the right hand channel output transformer." (Fig. 5.)

"So it is," exclaimed Dick excitedly, as he traced out the switch circuit. "This is all beginning to sort itself out now! You start off with a single-phase signal going into the grid of $V_{6(a)}$ which, by means of the switch section in the grid of $V_{6(b)}$, is now part of a floating paratwiddle thingummybob."

Immersed in his explanation, Dick failed to see the anguish which momentarily passed over the Serviceman's face.

"The outputs at the anodes of $V_{6(a)}$ and $V_{6(b)}$," Dick raved on, "are in anti-phase and have equal amplitude, and they are passed to the grids of V_7 and V_8 . These form a push-pull amplifier stage, but in this case there are two separate output transformers. The secondaries of these two transformers are connected together in parallel in such a manner that both signals come into phase again."

"That's right," confirmed Smithy. "The two speakers are in phase, too, so all requirements for correct mono reproduction are met."

"I wonder," mused Dick, "whether there is any difference in using two

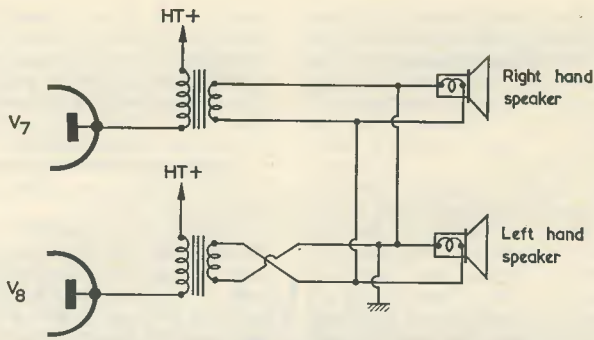

Fig. 5. Switching to "gram" causes the output transformer secondary circuits to take up the phase relationship illustrated here. Also, the two speakers are connected in parallel

output transformers instead of a single one."

"There are bound to be differences," commented Smithy. "The two primaries aren't, for instance, coupled together as tightly as they would be in a single push-pull output transformer, although there's still quite a tight degree of coupling between them due to the secondaries being connected in parallel. In a single transformer, the magnetic fields due to the d.c. components of the anode current of each valve cancel out, and you don't get that effect here. But you do get the same cancellation effect with even harmonics. Incidentally, the switching circuit in the secondary of the left hand channel output transformer may have looked a little complicated at first, but you can see now that it has to carry out two functions. It has, firstly, to reverse the phase of the secondary connections and, secondly, to connect the two secondaries together for mono reproduction. All in all, the complete circuit is a most ingenious arrangement and, with its two output valves, offers very good results for both stereo and mono."

"It certainly is neat," agreed Dick. "Incidentally, do I spot a little

negative feedback from those output transformer secondaries?"

"You do," confirmed Smithy. "There are feedback components from each output transformer secondary to the bottom end of the volume control on either side. On 'gram' both feedback loops are in operation but, on 'radio', only the one from the right hand channel output transformer is in circuit."

"What," asked Dick, "about the 8 volts bias for the grids of V_7 and V_8 ?"

"That's taken from the h.t. rectifier circuit," replied Smithy, indicating the appropriate section in the circuit diagram. (Fig. 6.) "The radiogram uses a bridge h.t. rectifier and a 100Ω resistor is inserted between the negative end of the reservoir capacitor and chassis. The voltage dropped across this is 8 volts and it is applied, via a smoothing circuit to remove the ripple, to the grid leaks of the output valves."

Fault Finding

"I've just remembered something," exclaimed Dick.

"What's that?"

"We've still," said Dick, "got a fault to clear!"

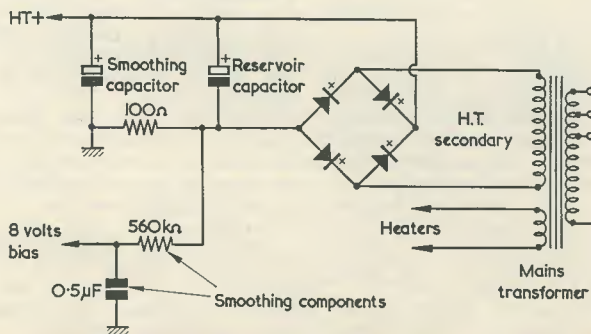

Fig. 6. The manner in which the 8 volts bias for the two EL84's is obtained

"Oh, *that*," said Smithy. "Unless we're unlucky and have switch or wiring trouble, I should imagine that there are only three components which could be causing the trouble."

"Only three?" queried Dick incredulously. "That's rather a hasty opinion, isn't it?"

"Not really," replied Smithy. "But, then, I haven't told you about those valves you pulled out for me. The first one you removed was V₆. We were on 'radio' then, and you may recall that there was no difference in output level. You next put V₈ back and took out V₇, and this silenced the radio output almost completely. We then changed over to 'gram', whereupon we found that the left hand channel was working at full strength. You then replaced V₇, whereupon the right hand channel came up at full strength, and removed V₈, which killed the left hand channel. It is obvious from these rough tests that, when the amplifier is switched for stereo operation, the left and right hand channels from the pick-up are finding their way through to the left and right hand channel speakers without any trouble at all. It follows also that there's nothing seriously wrong with valves V_{6(a)}, V_{6(b)}, V₇ and V₈. When we were on 'radio' and switched for mono reproduction, though, it was quite a different story. When you pulled out V₈, the radiogram output remained unchanged. But when you pulled out V₇ the output disappeared almost completely."

"I think I see what you're getting at," said Dick thoughtfully. "On 'gram' both V₇ and V₈ are pushing out an output, because removing either of them kills the channel they're amplifying. On 'radio', though, almost all the output is coming from V₇, with V₈ contributing hardly anything at all. Wait a minute, though!"

"Yes?"

"If," said Dick, "only V₇ is amplifying on 'radio', why did the sound come out of both speakers? It should have come out of the right hand speaker only."

"No it shouldn't," replied Smithy. "Don't forget that, on 'radio', the two speakers are in parallel. What happened was that V₇ was pumping its output into two speakers connected in parallel. Which means that, not only was it working on its own, but it was also working into half its optimum load impedance. And that explains the poor results on 'radio'."

"The output didn't," said Dick, "sound all that *terrible* to me."

"It didn't sound right, either," commented Smithy. "Don't forget that an EL84 is a pretty powerful

bottle, and it can knock out in excess of 5 watts all on its own. So, even on its own, it is capable of putting up a creditable performance in a push-pull circuit despite the fact that its partner is contributing nothing to the proceedings."

"What about those three components which you think may be causing the fault?"

"Well," replied Smithy, "these are the result of a bit of mental detective work on my part. The first thing we have to consider is that V_{6(b)} and V₈ work O.K. on 'gram'. So, if there are no switch or connection troubles, we have first to look for the components which provide a feed to V_{6(b)} when 'radio' is selected. The most probable culprit is the 1M Ω resistor following the anode of V_{6(a)}. This could have gone high or, more probably, open-circuit. The next one is the 1M Ω resistor following the anode of V_{6(b)}. This would be less likely to bring the fault on, because it would have to go *down* in value, and to a pretty low figure at that. And, finally, there's the 0.04 μ F capacitor connecting to the grid of V_{6(b)}. This could have gone short-circuit or low resistance."

"But," protested Dick, "that capacitor is in circuit on 'gram' as well."

"I know it is," agreed Smithy. "And that's one reason why it's the third on my list of possibly faulty components. I don't think it's causing the present trouble because, if it *had* gone short-circuit, it would have upset the grid current biasing for V_{6(b)}, and there might have been some distortion in the left hand channel on 'gram'."

Dick scratched his head.

"Wouldn't it," he asked, "have merely caused the same sort of distortion on 'radio'?"

"No," replied Smithy. "On 'radio' it would have allowed some of the 8 volts negative bias in the output grid circuit to be passed to the grid of V_{6(b)}. An ECC83 triode has a short grid base, and this amount of bias could, conceivably, have cut it off. I know it's rather a long shot but, if the 1M Ω resistors are O.K., we should definitely check that capacitor."

However, Dick was already in process of locating the 1M Ω resistors in question. Switching the chassis to 'gram' to isolate their junction, he excitedly applied the test prods of his meter.

"Smithy," he called out happily. "You're a genius! It's the first component you named, the 1M Ω resistor following the anode of V_{6(a)}. It's gone sky-high!"

"Good show," said Smithy. "I

should check the other one for good measure while you're at it, as they'll both be out of the same batch at the factory. Then pop in a new resistor and we'll see how things turn out."

Replacement

As Dick occupied himself with the replacement of the resistor, a thought occurred to him.

"We've just," he remarked, "played a stereo record on that radiogram. What happens when we play a mono record?"

"The mono record," replied Smithy, "is reproduced in phase by both channels at the same strength. In theory, if a stereo pick-up plays a mono record it gives equal in-phase outputs on each channel, whereupon these can be amplified and reproduced at equal strength, and in phase, by the two stereo speakers. In practice there tend to be complications, but you can rest assured that, in stereo radiograms of the type we have here, the pick-up cartridge will be intended to offer this class of service. In some stereo radiograms there are two 'gram' settings of the overall wavechange switch, one being designated 'stereo' and the other 'mono'. On 'stereo' the two outputs of the pick-up go through the two channel amplifiers in normal way. On 'mono', though, the two pick-up outputs are connected in parallel before being applied to the two amplifiers. In this instance, compatibility from stereo to mono is given when the pick-up outputs are paralleled."

"I see," said Dick. "Well, I've got the new resistor in now. Shall we try it out?"

"Definitely," said Smithy. "Just pop the chassis temporarily into the cabinet and we'll see how it goes."

And, this time, the radiogram produced its full output both on 'gram' and on 'radio'. Smithy checked that he had finally cleared the fault by having Dick first remove one of the output valves and then the other whilst reproducing a radio signal. In either case there was a noticeable loss in power and an increase in distortion as the valve was removed.

"That's it, then," said Smithy, pleased. "Job complete! And a very interesting one it's proved to be, too."

"I'll say," agreed Dick. "I must admit that I'm impressed with the improvement in output given on 'radio' when both the EL84's are in operation. Smashing, it sounds!"

"It does sound impressive," agreed Smithy.

He sighed.

"I suppose my next job," he continued, "will be something like a little transistor set having a 2 inch speaker driven by a couple of OC72's in Class-B. Still, it's a living!"

Editor's Note

The a.f. amplifying system shown in basic form in Fig. 2, in which the two output valves are in push-pull

for radio reproduction and are in single-ended circuits for gram reproduction, is employed in stereo radiograms manufactured by the Thorn group of companies.

HOT CARRIER DIODES

By J. B. DANCE, M.Sc.

THE SPEED OF OPERATION OF ORDINARY P-N junction diodes is limited by the storage of minority carriers in the semiconductor material. This limitation can be virtually eliminated by the use of the recently introduced "hot carrier diodes" which are manufactured by Hewlett-Packard Ltd. These diodes consist essentially of a metal whisker in contact with a piece of semiconductor material, the construction being rather like that of a point contact diode.

Nomenclature

Hot carrier diodes derive their name from the majority carriers which are injected into the metal whisker from the semiconductor material. These majority carriers move at a much greater speed than their "thermal velocity" (which is the velocity with which they would move through matter at room temperature after colliding many times with the electrons in it). A typical electron in matter would move with the high velocity of the majority carriers only if the matter were very hot. Thus the carriers which enable the diodes to operate may be called "hot carriers" to indicate that they have a very high velocity.

Types

There are two main types of hot carrier diodes. If a piece of n type silicon is placed in contact with a metallic whisker, hot electrons will be injected into the metal. If p type silicon is used, however, a hot hole diode will be formed, the hot holes passing from the p type material into the metal whisker. It appears that hot hole diodes will not be widely used, since the hot electron diodes have a better high frequency performance, owing to the fact that the mobility of electrons in a semiconductor material is greater than that of holes.

Hot carrier diodes with various heights of potential barrier are available. For example, the 2101 diode has a forward characteristic resembling that of a conventional germanium diode, whilst that of the 2001 diode is more like that of a conventional silicon junction diode. In each case the reverse

characteristic is similar to that of a conventional silicon diode. The 2101 diodes are especially suitable for use as detectors or mixers at very high frequencies.

Charge Storage

In the case of a normal junction diode, electrons diffuse from the n type material into the p type material under conditions of forward bias. The number of electrons present in the p type material at any instant is limited by the rate of recombination of the electrons with holes. Thus when the forward bias on a normal junction is reversed, some of the stored electrons in the p type material flow back into the n type material. This reverse current increases the reverse recovery time of the device.

If, however, a forward bias is applied to a hot carrier diode, hot electrons from the n type material spill over the potential barrier and pass into the metal whisker, losing their energy to the metal atoms. If the diode is suddenly reversed biased, the electrons which have passed through the barrier into the metal during the period of forward biasing do not have enough energy to return across the barrier. Thus the frequency response is not limited by stored charge in the form of minority carriers.

Hole storage as well as electron storage can occur in semiconductor materials.

Applications

The hot carrier diode has a much greater contact area than the point contact diode and can therefore handle greater power, but the capacitance is greater.

Hot carrier diodes find application in high frequency circuits and in pulse circuits where an extremely minute response time is required. They are used for detection and mixing at microwave frequencies and in pulse circuits for very high speed gating and voltage clamping.

Further information on hot carrier diodes is given in the article "Hot Carrier Diodes. Their Design and Applications" by the applications group of Hewlett-Packard Ltd., which was published in *Electronic Components*, Vol. 6, No. 6, page 527 (June 1965).



Cover Feature

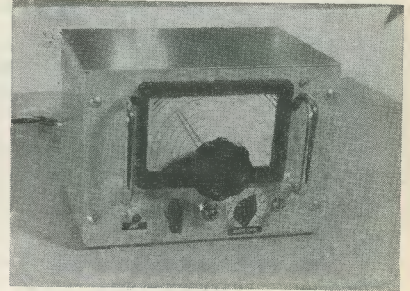

DUAL-CONVERSION SUPERHET FOR 2 METRES

By D. J. BUNN, G3OEQ

A compact self-contained receiver which features a comprehensive circuit design and a very high level of performance

WHILST IT IS, PERHAPS, RATHER MORE THE custom to use a converter for the reception of 2-metre signals, there are those who do not want the main station receiver tied into another unit just for the reception of one band of frequencies or who do not, similarly, wish to have to change over connections when bringing the converter into use or when reverting to the main receiver. A separate and completely self-contained 2-metre receiver has, in consequence, a considerable appeal when compared with a converter. Such a receiver also solves the problems of constructors who may not have a short wave receiver which is suitable for use with the more conventional 2-metre converter.

The receiver described in this article is comparatively simple to build, and it gives good results. With it one can listen to the transmissions of local amateurs as well as, when conditions are good, transmissions from European amateurs. The receiver is capable of driving a loudspeaker and, as may be seen from the accompanying photographs, has a neat and attractive appearance.

Circuit Design

The block diagram of Fig. 1 demonstrates the basic manner in which the receiver operates. The aerial input signal is applied to a cascode r.f. amplifier type E88CC which provides broad-band amplification over the 2-metre range from 144 to 146 Mc/s. The output of this r.f. amplifier is then fed, in company with a crystal controlled signal having a frequency (in the prototype) of 130.2 Mc/s, to an ECC85 first mixer. An i.f. output in the range 13.8 to 15.8 Mc/s appears at the anode of the ECC85, this being applied to a second mixer and

v.f.o. stage employing an ECH81. The oscillator section of the ECH81 is tunable over a range 460 kc/s higher than the 13.8 to 15.8 Mc/s offered by the ECC85, whereupon a second i.f. of 460 kc/s becomes available for application to a conventional 460 kc/s i.f. amplifier. This 460 kc/s i.f. amplifier employs an EF183.

The output of the 460 kc/s i.f. amplifier is passed to the noise limiter and detector circuits, after which the detected signal is fed to the a.f. amplifier, output valve and loudspeaker. A.G.C. is derived from the detector stage, and this is fed back to the ECH81 and EF183 stages.

The power supply section incorporates a double-wound mains transformer, h.t. being given by two BY100 silicon rectifiers in a full-wave circuit. A stabilised supply at 150 volts is provided for the oscillator section of the ECH81.

Fig. 2 shows the crystal oscillator chain. The prototype receiver employed a 10.85 Mc/s crystal, its frequency being multiplied to 32.55 Mc/s by an EF91 oscillator-multiplier, and then to 65.1 Mc/s and 130.2 Mc/s by the two triodes of an ECC81. The 130.2 Mc/s signal is applied to the first mixer.

R.F. Stages

The full circuit diagram of the r.f. amplifier, first mixer, crystal oscillator and multiplier stages is

HEADING ILLUSTRATION

The neat professional finish of the completed receiver. Below the tuning dial, from left to right, are the aerial input socket, the four-way function switch S₁, the panel lamp, the audio gain control R₂₇ and the on-off switch S₂. The socket immediately above the right hand handle is the loudspeaker jack

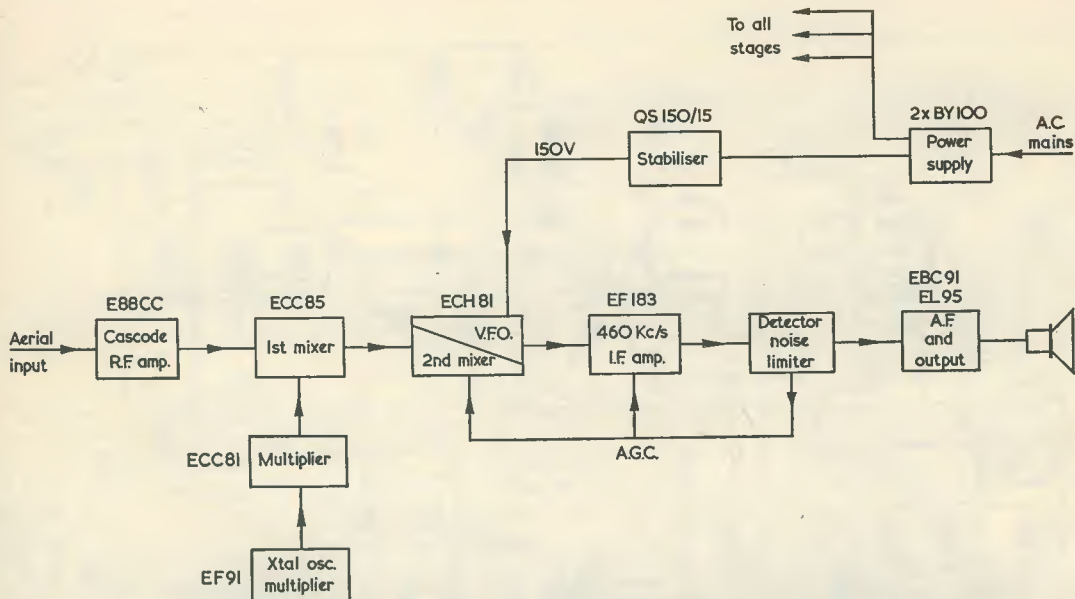

Fig. 1. Block diagram showing receiver functions. The aerial input signal range of 144 to 146 Mc/s is converted to approximately 14 to 16 Mc/s (depending on crystal oscillator frequency) in the first mixer, and then to 460 kc/s at the second, tunable, mixer

given in Fig. 3. In this diagram L_1 and L_2 form an r.f. input transformer tuned to the centre of the 2-metre band. V_1 is a double-triode cascode r.f. amplifier, with L_3 functioning as peaking coil. It will be noted that the two halves of V_1 are screened from each other, coil L_3 passing through the screen. Details of coils L_1 , L_2 and L_3 , together with information on the other coils in the receiver, are given in the accompanying Table.

Coils L_4 and L_5 , tuned by C_3 and C_5 respectively, couple the anode of $V_1(b)$ to the grid of the additive mixer V_2 . V_2 is one triode of an ECC85. The other triode (not shown in the diagram) is unused, and its anode, grid and cathode are all connected to chassis.

V_3 is the crystal oscillator. This operates in a modified Colpitts circuit, and the third harmonic, tuned by L_8 and stray capacitances, is taken off at the anode. $V_4(a)$ follows, functioning as a doubler with L_9 and C_{17} in its anode circuit tuned to six times the original crystal frequency, and is succeeded by the second doubler, $V_4(b)$. L_{10} and C_{20} , in the anode circuit of $V_4(b)$, are tuned to twelve times the original crystal frequency, and this final frequency is applied to mixer V_2 via C_{19} .

Appearing at the anode of V_2 is the band of difference frequencies 13.8 to 15.8 Mc/s. L_6 in conjunction with C_9 is broadly resonant at this band, and coupling coil L_7 provides a low impedance link coupling to the primary, L_{11} , of a standard r.f. coil.

This r.f. coil is L_{11} , L_{12} , and it appears in Fig. 4, which diagram also shows the remainder of the receiver circuit with the exception of the power supply section. L_{11} , L_{12} couples to the signal grid of the second mixer V_5 , the corresponding oscillator

coil being L_{13} and L_{14} . The two coils are tuned by the two-gang capacitor C_{22} , C_{29} , this being the main tuning control for the receiver. The circuit around V_5 may be considered as a standard frequency-changer stage whose function is to tune over the 13.8 to 15.8 Mc/s band of frequencies which appears at the anode of V_2 .

I.F. and Detector Stages

The i.f. amplifier which follows V_5 conforms with conventional practice, and IFT_1 and IFT_2 are standard i.f. transformers tuned to 460 kc/s. V_6 is a frame-grid pentode having a high mutual conductance, and it provides a large degree of gain.

The signal detector is provided by the diode of V_7 whose anode connects to pin 5, and the detector circuit incorporates a noise limiter. On reception of a signal, the relatively large-value capacitor C_{41} becomes charged such that a negative voltage proportional to carrier level appears on its non-earthly plate. This voltage is more negative than the detected a.f. voltage appearing after i.f. filter C_{38} , R_{24} and C_{39} , with the result that diode D_1 is always forward-biased and allows the detected a.f. signal to be passed, via C_{42} , to volume control R_{27} . In the presence of impulsive interference, however, the detected pulse peaks carry the "anode" of D_1

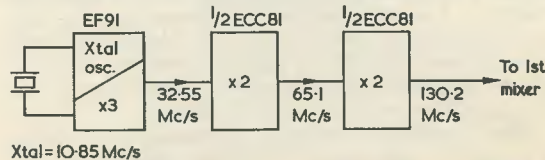

Fig. 2. The crystal oscillator and multiplier chain

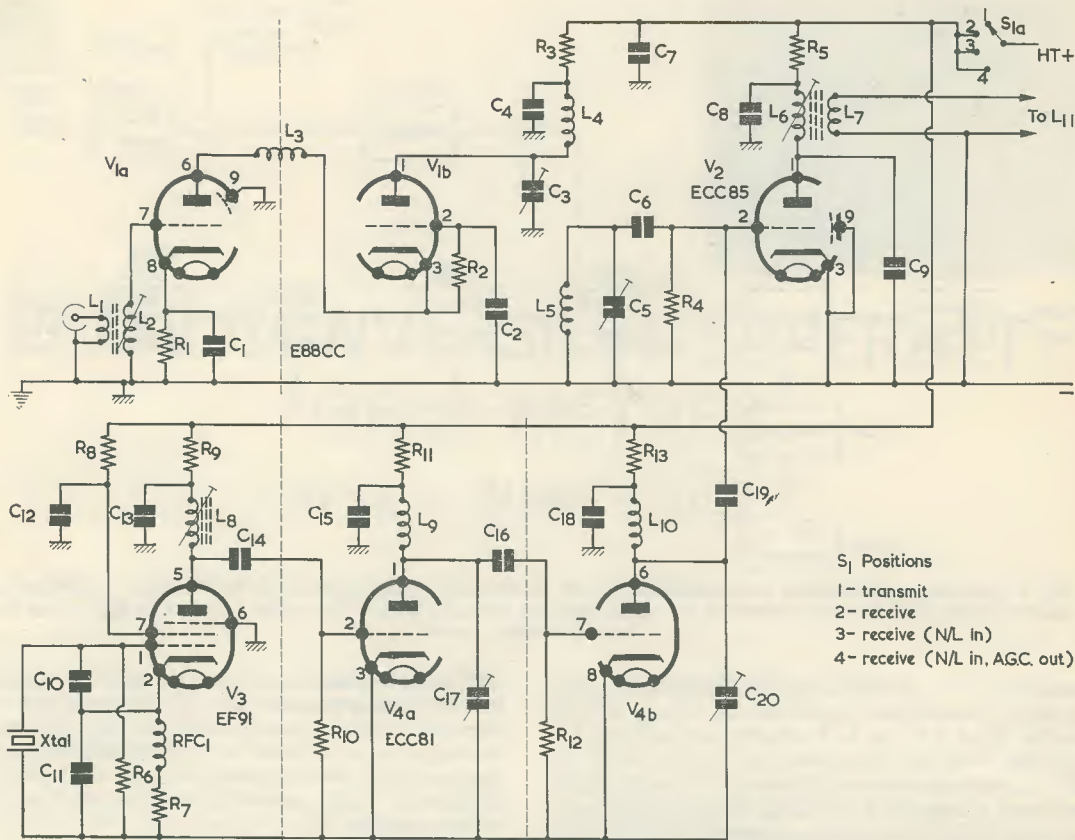

Fig. 3. Circuit of the aerial amplifier, first mixer and oscillator chain. Only one half of V_2 is used, the anode, grid and cathode of the other half (not shown) being earthed to chassis. The earthed pins are 6, 7 and 8

negative of the voltage on the non-earthly plate of C_{41} , with the result that D_1 becomes non-conductive and the peaks are not passed to the subsequent volume control. The negative voltage on the non-earthly plate of C_{41} does not increase to any significant extent during impulsive interference because of the relatively long time constant given by its high value in conjunction with R_{25} .

When the noise limiter circuit is not required, it may be rendered inoperative by $S_{1(b)}$ which, on position 2, short-circuits diode D_1 .

The a.g.c. diode in V_7 is that whose anode connects to pin 6 and, with C_{40} and R_{32} , it forms a shunt detector circuit. A delay is provided by the cathode bias voltage appearing across R_{29} , with the result that no a.g.c. appears until the peak value of the i.f. signal from V_6 anode exceeds this bias voltage. A.G.C. is applied, via filters R_{33} , C_{43} , R_{23} and C_{25} , to the grid circuits of V_6 and V_5 . No a.g.c. is fed back to the valves before V_5 . A.G.C. can be switched out by $S_{1(c)}$ which, on position 4, short-circuits the a.g.c. line to chassis.

The a.f. voltage appearing at volume control R_{27} is applied to the grid of V_7 triode, which operates as a voltage amplifier with its anode circuit decoupled

by R_{31} and C_{45} . The anode of V_7 couples to the output valve V_8 via C_{46} , and the anode of V_8 connects, in turn, to the primary of output transformer T_1 . The secondary of T_1 connects to the output jack, into which is plugged an external 3Ω loudspeaker.

Reference has already been made to switches $S_{1(b)}$ and $S_{1(c)}$. These are part of the rotary three-pole four-way function switch $S_{1(a)}$ (b) (c), the $S_{1(a)}$ section of which appears in Fig. 3. In position 1, "Transmit", S_1 breaks the h.t. supply to V_1 , V_2 , V_3 and V_4 , this making the receiver inoperative whilst transmission is in progress. In position 2, "Receive", h.t. is restored to V_1 , V_2 , V_3 and V_4 , whilst section $S_{1(b)}$ short-circuits the noise limiter diode D_1 . In position 3, "Receive (N/L in)", the short-circuit is taken off D_1 and the noise limiter circuit functions normally. In position 4, "Receive (N/L in, A.G.C. out)", the noise limiter circuit still functions, whilst $S_{1(c)}$ short-circuits the a.g.c. line to chassis.

Some constructors may prefer to have these functions carried out by individual switches. In this case, three s.p.s.t. toggle switches may be used. One of these can replace $S_{1(a)}$ and function as a

- S_1 Positions
 1 - transmit
 2 - receive
 3 - receive (N/L in)
 4 - receive (N/L in, AGC. out)

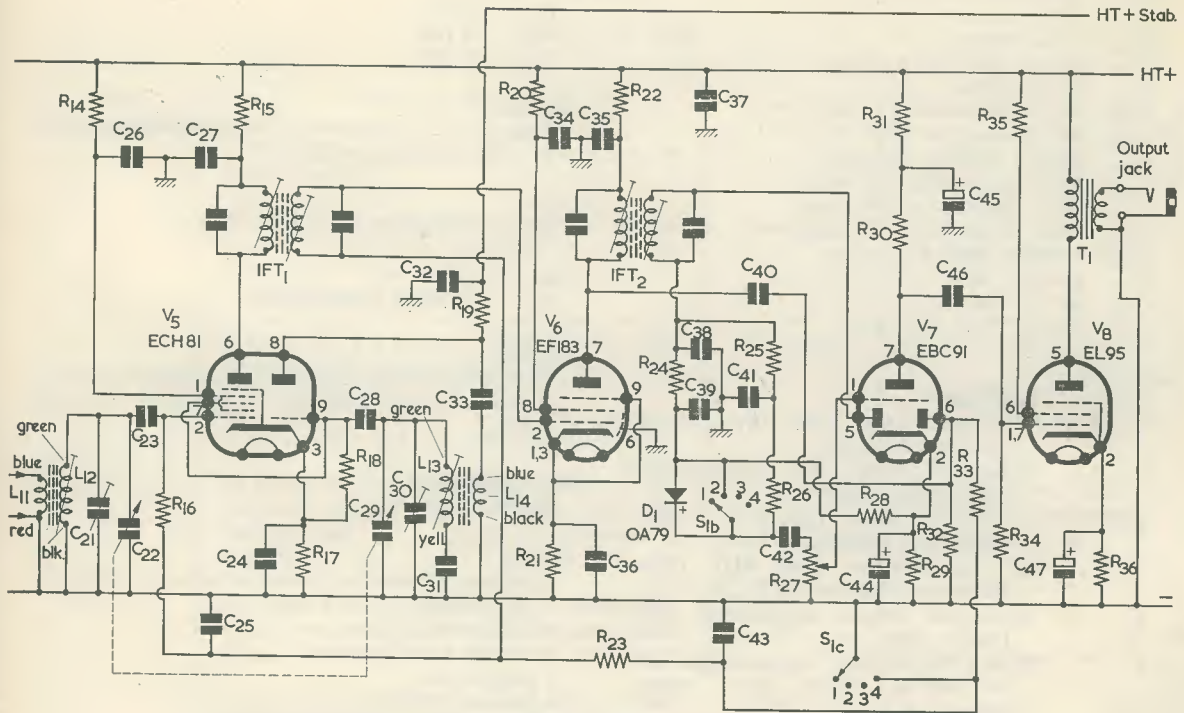

Fig. 4. The second mixer, 460 kc/s i.f. amplifier, noise limiter, detector and a.f. stages of the receiver

Components List

Resistors

(All fixed values 20% 1/4 watt unless otherwise stated)

R ₁	68Ω	R ₂₇	1MΩ pot log track
R ₂	220kΩ	R ₂₈	470kΩ
R ₃	4.7kΩ 1 watt	R ₂₉	2.2kΩ
R ₄	1MΩ	R ₃₀	100kΩ
R ₅	2.2kΩ	R ₃₁	10kΩ
R ₆	47kΩ	R ₃₂	470kΩ
R ₇	220Ω	R ₃₃	470kΩ
R ₈	10kΩ	R ₃₄	470kΩ
R ₉	2.2kΩ	R ₃₅	1kΩ
R ₁₀	100kΩ	R ₃₆	330Ω 1/2 watt
R ₁₁	2.2kΩ	R ₃₇	6.8kΩ 1 watt
R ₁₂	100kΩ	R ₃₈	220kΩ
R ₁₃	2.2kΩ	R ₃₉	1kΩ 5 watts wirewound
R ₁₄	33kΩ		
R ₁₅	4.7kΩ		
R ₁₆	1MΩ		
R ₁₇	150Ω		
R ₁₈	47kΩ		
R ₁₉	4.7kΩ 2 watts		
R ₂₀	33kΩ		
R ₂₁	150Ω		
R ₂₂	2.2kΩ		
R ₂₃	1MΩ		
R ₂₄	100kΩ		
R ₂₅	1MΩ		
R ₂₆	470kΩ		

Capacitors

C ₁	1,000pF ceramic
C ₂	1,000pF feed-through
C ₃	2-8pF trimmer, Philips concentric
C ₄	1,000pF ceramic
C ₅	2-8pF trimmer, Philips concentric
C ₆	47pF ceramic
C ₇	1,000pF ceramic
C ₈	5,000pF ceramic
C ₉	22pF ceramic
C ₁₀	15pF ceramic
C ₁₁	47pF ceramic

C ₁₂	1,000pF ceramic
C ₁₃	1,000pF ceramic
C ₁₄	22pF ceramic
C ₁₅	1,000pF ceramic
C ₁₆	22pF ceramic
C ₁₇	3-30pF trimmer, Philips concentric
C ₁₈	1,000pF ceramic
C ₁₉	2.2pF ceramic
C ₂₀	2-8pF trimmer, Philips concentric
C ₂₁	Part of L ₁₁ , L ₁₂ assembly
C ₂₂	75pF variable, part of 2-gang
C ₂₃	100pF silver-mica 5%
C ₂₄	0.047μF Mullard polyester
C ₂₅	0.047μF Mullard polyester
C ₂₆	0.047μF Mullard polyester
C ₂₇	0.047μF Mullard polyester
C ₂₈	100pF silver-mica 5%
C ₂₉	75pF variable, part of 2-gang
C ₃₀	Part of L ₁₃ , L ₁₄ assembly
C ₃₁	100pF silver-mica 2%
C ₃₂	0.047μF Mullard polyester
C ₃₃	100pF silver-mica 10%
C ₃₄	0.047μF Mullard polyester
C ₃₅	0.047μF Mullard polyester
C ₃₆	0.047μF Mullard polyester
C ₃₇	5,000pF ceramic
C ₃₈	100pF silver-mica

- C₃₉ 100pF silver-mica
- C₄₀ 22pF ceramic
- C₄₁ 0.1μF paper
- C₄₂ 0.01μF Mullard polyester
- C₄₃ 0.1μF paper
- C₄₄ 25μF electrolytic 6V wkg.
- C₄₅ 8μF electrolytic 350V wkg.
- C₄₆ 0.01μF Mullard polyester
- C₄₇ 50μF electrolytic 25V wkg.
- C₄₈ 32μF electrolytic 350V wkg.
- C₄₉ 32μF electrolytic 350V wkg.
- C₅₀ 1,800pF 400V A.C. wkg.
- C₅₁ 1,800pF 400V A.C. wkg.
- C₅₂ 0.05μF 300V A.C. wkg.
- C₅₃ 0.05μF 300V A.C. wkg.

Inductors

- L₁-L₁₀ See Table
- L₁₁, L₁₂ "Stabcoil" type RF4 (Electroniques (Felixstowe) Ltd.)
- L₁₃, L₁₄ "Stabcoil" type OS4 (Electroniques (Felixstowe) Ltd.)
- RFC₁ 2.5mH r.f. choke type RFC1 (Electroniques (Felixstowe) Ltd.)
- I.F.T._{1,2} I.F. Transformer type MIF (Electroniques (Felixstowe) Ltd.)
- T₁ Miniature output transformer, 50:1 (8kΩ : 3Ω)
- T₂ Mains transformer. Secondaries 250-0-250V at 80mA; 6.3V, centre-tapped, at 3A

Valves

- V₁ E88CC
- V₂ ECC85
- V₃ EF91
- V₄ ECC81
- V₅ ECH81
- V₆ EF183
- V₇ EBC91
- V₈ EL95
- V₉ QS150/15

"Receive/Transmit" switch. The second may replace S_{1(b)} and operate as a "Noise Limiter In/Out" switch, whilst the third may be connected across C₄₃ and provide an "A.G.C. In/Out" control.

If, alternatively, the rotary switch is employed, some constructors may require that its functions appear in a different order from that given here. Such changes can, of course, be readily carried out by appropriately modifying the connections to the fixed contacts.

Power Supply Section

The circuit of the power supply section is given in Fig. 5 and it will be seen that this is quite conventional. A full-wave rectifier circuit is employed using two silicon rectifiers type BY100, these being bridged by 1,800pF capacitors to bypass the peaks of any "spikey" waveforms appearing on the mains supply. Smoothing is given by C₄₉, R₃₉ and C₄₈ and this, together with the extra smoothing offered by C₄₅ of Fig. 4, ensures that the audio

Diodes

- D₁ OA79
- D₂ BY100
- D₃ BY100

Switches

- S_{1(a)} (b) (c) 3-pole, 4-way rotary switch (see text)
- S₂ d.p.s.t. toggle switch

Bulb

- B₁ m.e.s. pilot lamp, 6.3V 0.3A

Fuse

- F₁ Cartridge fuse, 100mA

Crystal

- 10.85 Mc/s crystal (see text). Cathodeon Type 2L with $\frac{1}{2}$ in pin spacing. (Cathodeon Crystals Ltd.)

Loudspeaker

- 3Ω loudspeaker

Sockets

- 5 B9A valveholders (2 low-loss with centre spigots (Radiospares), for V₁ and V₂)
- 4 B7G valveholders
- 1 coaxial aerial socket
- 1 output jack
- 1 holder for fuse
- 1 socket assembly for pilot lamp
- 1 holder for crystal

Miscellaneous

- 1 Dial and Drive type 598 (Eddystone)
- 6 Nylon lead-throughs (Electroniques (Felixstowe) Ltd.)
- 2 Pointer knobs
- 1 Flexible $\frac{1}{4}$ in spindle coupler
- Chassis 8 x 6in (see text)
- Cabinet, with panel, 10 x 7 x 7in (see text)

output of the receiver is adequately free from hum. A stabilised supply at 150 volts is provided by V₉, the stabilised voltage being fed to the oscillator section of V₅, in Fig. 4, by way of C₃₂ and R₁₉. The valve employed for V₉ in the prototype has a maximum burning current of 15mA and any alternative 150 volt stabiliser with a similar or greater maximum current could be employed in its place. The valve specified also has a priming electrode (connected to pin 4). Alternative stabilisers may not have this electrode, whereupon R₃₈ would not then be required.

The 6.3 volt heater supply is obtained from a centre-tapped winding on mains transformer T₂. The wiring to the valve heaters in the receiver chassis should consist of tightly twisted wire.

Anti-mains-modulation capacitors, C₅₂ and C₅₃, are also fitted. These have fairly high capacitances and may cause an appreciable a.c. voltage to appear on the chassis unless the latter is earthed. As it is desirable to prevent the risk of even mild shock

TABLE
Details of Coils

Coil	Details of Winding	Screening	Mounting Position
L ₁ ..	1 turn 22 s.w.g., p.v.c. wire, interwound at earthy end of L ₂	Unscreened	Below chassis adjacent to aerial input socket
L ₂ ..	3 turns 18 s.w.g. tinned copper wire on $\frac{1}{4}$ in diameter (approx.). Aladdin former 1in long. Slug tuned with dust core type A. Winding length $\frac{1}{4}$ in.		
L ₃ ..	5 turns 22 s.w.g. enamelled copper wire, close-wound, $\frac{1}{4}$ in internal diameter, self-supporting.	Unscreened	Below chassis, between pins 6 and 3 of V ₁ , passes through screen.
L ₄ ..	3 turns 22 s.w.g. p.v.c. wire, wound over L ₅ .	Unscreened	Below chassis, axis horizontal, between V ₁ and V ₂ .
L ₅ ..	2 $\frac{1}{2}$ turns 18 s.w.g. tinned copper wire on $\frac{3}{8}$ in diameter former, spaced wire diameter. Earthy ends of L ₄ and L ₅ at same end of assembly.		
L ₆ ..	15 turns 26 s.w.g. enamelled copper wire, close-wound on $\frac{1}{4}$ in. Aladdin former 1 $\frac{1}{4}$ in long. Slug tuned with dust core type A.	In can	Above chassis alongside V ₂ .
L ₇ ..	2 turns 22 s.w.g. p.v.c. wire, wound over L ₆ at h.t. positive end.		
L ₈ ..	10 turns 28 s.w.g. enamelled wire, close-wound on $\frac{1}{4}$ in. Aladdin former 1 $\frac{1}{4}$ in long. Slug tuned with dust core type A.	In can	Above chassis, in chassis corner alongside crystal and V ₃ .
L ₉ ..	6 turns 18 s.w.g. tinned copper wire, $\frac{3}{8}$ in internal diameter, spaced wire diameter self-supporting.	Unscreened	Below chassis, axis horizontal, close to V ₄ .
L ₁₀ ..	3 turns 18 s.w.g. tinned copper wire. $\frac{3}{8}$ in internal diameter, spaced wire diameter, self-supporting.	Unscreened	Below chassis, axis horizontal and at right angles to L ₉ , between V ₄ and V ₂ .
L ₁₁ , L ₁₂	See Components List	In can	Above chassis, adjacent to V ₅ and C ₂₂ .
L ₁₃ , L ₁₄	See Components List.	In can	Below chassis, adjacent to V ₅ .
IFT ₁ ..	See Components List.	In can	Above chassis, on crystal side of V ₆ .
IFT ₂ ..	See Components List.	In can	Above chassis, between V ₆ and V ₇ .

(particularly when working on aerial equipment connected to the receiver) *it is important to ensure that the receiver chassis is connected to a reliable earth.* The presence of an earth connection is indicated, below the aerial input socket, in Fig. 3.

Further Points

A few further points concerning the circuit need to be mentioned before proceeding to constructional details.

As has already been stated, details of the coils

must, of course, be kept as short as possible, and valveholder orientation should be planned with this end in view. Particular attention should be paid to ensuring a short connection to C_2 . All air-cored coils and all trimmers must be mounted as near as possible to the appropriate valveholders allowing accessibility for adjustments at a later date. The link connection from L_7 to L_{11} is made via a short length of coaxial cable taken out through the side screen, and with the outer braiding earthed to chassis at both ends.

The major trouble to guard against is break-through in the 13.8 to 15.8 Mc/s band of frequencies, so plenty of screening is advisable. At first, the author found that even the short coaxial lead from L_7 to L_{11} gave trouble on this score, and the only solution to the problem with this, and any similar u.h.f. receiver, is to pay full attention to the provision of adequate screening. It has to be added that the use of a metal cabinet completely enclosing the receiver assists in preventing break-through at the first i.f., but it is still good practice to ensure that the break-through is not evident without such a cabinet. A baseplate (of 18 s.w.g. aluminium or similar) should also be fitted.

The rest of the receiver follows normal superhet construction practice. The stages which require most careful attention are those around V_5 and V_6 , as bad layout here can cause trouble.

Coil L_{11} , L_{12} is mounted above the chassis, a $\frac{3}{8}$ in hole being cut in the chassis for adjustment of C_{21} (which is part of the coil assembly). Oscillator coil L_{13} , L_{14} is mounted, complete with can, below the chassis, its position being evident from Fig. 6 (a) and the under-chassis photograph. Both L_{11} , L_{12} and L_{13} , L_{14} should be as close as possible to the two-gang capacitor C_{22} , C_{29} , and to the valveholder of V_5 . The two-gang capacitor should be rubber mounted (i.e. fitted to the chassis on soft rubber grommets) to reduce the risk of microphonic effects.

The i.f. transformers need to be mounted close to the valveholder of the high-gm i.f. amplifier V_6 , with short leads to grid and anode. Short connections are also required for the screen-grid bypass capacitor, C_{34} . Provided these points are observed, and the values specified in the Components List are

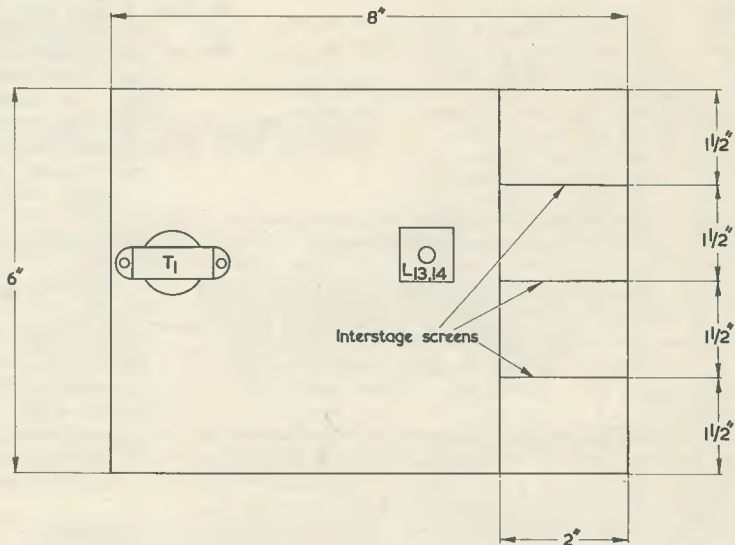

(a)

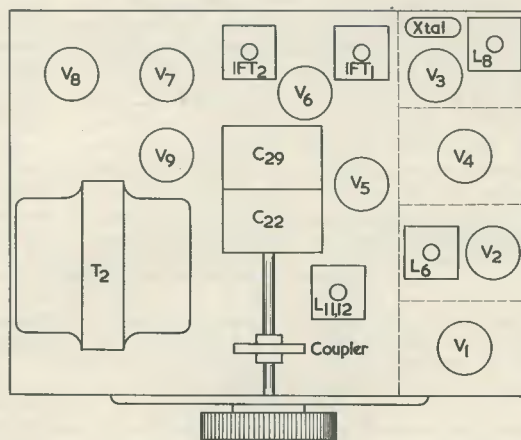

(b)

Fig. 6 (a). Underchassis screening layout. Also shown are the positions of T_1 and L_{13} , L_{14} . The depth of the chassis is $2\frac{1}{2}$ in

employed, there should be no risk of instability in the V_6 stage and the correct amount of i.f. gain should be achieved.

The remaining stages, detector, noise limiter, a.g.c., and a.f. amplifier, are conventional, and no problems should be encountered here. The same applies to the power supply section.

Alignment

The test instruments required for alignment are a modulated signal generator and a grid dip oscillator. When construction is completed and initial tests have been made, alignment may commence. A.G.C. is, of course, switched out during this process.

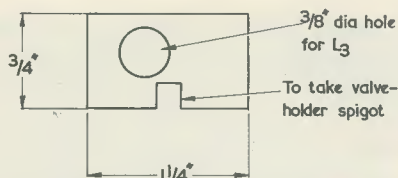

Fig. 7. The screen which is fitted to V_1 valveholder to isolate the two sections of this valve

First, feed in a 460 kc/s signal at the control grid of V_6 and adjust IFT_2 cores for maximum output. Transfer the signal generator to the signal grid of V_5 and adjust IFT_1 cores. Repeat adjustments on IFT_2 and IFT_1 until no further improvement results.

The next part of the alignment is carried out at the first i.f., and it is assumed that this covers the 13.8 to 15.8 Mc/s range given by a 10.85 Mc/s crystal. If, due to a different crystal frequency, the first i.f. range is slightly different from these figures, the alignment frequencies should be modified accordingly.

Inject a 13.8 Mc/s signal (lowest frequency of first i.f. range) into the signal grid of V_5 , set the two-gang capacitor to maximum capacitance, and adjust L_{13} core for maximum output. Change input frequency to 15.8 Mc/s (highest frequency of first i.f. range), set the two-gang capacitor for minimum capacitance, and adjust C_{30} for maximum output. Repeat these two processes until no further improvement if given.

Transfer the signal generator output to L_{11} , select 13.8 Mc/s (lowest frequency of first i.f. range), set

the two-gang capacitor for maximum capacitance, and adjust L_{12} core for maximum output. Change input frequency to 15.8 Mc/s (highest frequency of first i.f. range), set the two-gang capacitor to minimum capacitance, and adjust C_{21} for maximum output. Repeat these two processes until no further improvement results.

Apply 14.8 Mc/s (centre frequency of first i.f. range) to the grid of V_2 , tune in this signal on the two-gang capacitor, and adjust L_6 core for maximum output.

Check coils L_8 , L_9 and L_{10} with the grid dip oscillator for correct frequencies with trimmers, where applicable, at mid-setting. Next, tune all these coils for maximum noise output.

At this stage local 2-metre signals should be heard when an aerial is connected. Tune to approximately mid-band (145 Mc/s) and adjust C_3 , C_5 and L_2 core for maximum signal.

The receiver is now ready for use.

Conclusion

Although, possibly, this receiver is of simple design, its performance has proved to be very good, resulting in satisfaction by all users. Aerials employed have been a quarter wavelength of wire, and a six-over-six beam. The writer hopes, in consequence, that all would-be builders will avail themselves of the same pleasing results and will construct and own a complete 2-metre receiver.

No b.f.o. has been incorporated in the present design. However, the writer is working on a suitable unit for addition to the receiver and hopes to contribute an article describing its construction at a later date.

DIACS AND TRIACS

THE NORMAL SILICON CONTROLLED RECTIFIER CAN conduct only in one direction; its principles of operation have been discussed in previous issues of *The Radio Constructor*. The "triac" is a fairly new device which is rather similar to the silicon controlled rectifier but which can conduct in either direction. Its name is derived from the fact that it has three electrodes and that it can control a.c. power ("tri-AC").

The triac will withstand voltage transients much more readily than a silicon controlled rectifier and does not therefore require the use of additional components to protect it. Although silicon controlled rectifiers can perform the same functions as triacs, two of the controlled rectifiers must be connected "back to back" (that is, in parallel, with the anode of the one connected to the cathode of the other) if the combined device is to be bi-directional. It is claimed that the use of triacs for a.c. power control enables the number of com-

ponents required to be reduced by a factor of about three.

The "diac" is an asymmetrical silicon diode which has been especially developed for the triggering of triacs. Alternatively a triac may be triggered by neons, unijunction transistors, etc. Either a positive or a negative gating current may be used for triggering the devices.

Triacs are available which will handle 6 or 10 amps, the minimum breakover voltage being 400 in either direction. Both stud mounting and press fit versions are available.

The triac can be used in lamp dimming circuits or in almost any other circuit in which a moderate amount of a.c. power is to be controlled; for example, in a heating and air conditioning system. When compared with thyratrons, relays, magnetic amplifiers, etc., triacs offer circuit simplicity, longer life and greater reliability. In addition the size, weight and cost are reduced.

Further details of the devices may be obtained from the manufacturers, Messrs. International General Electric Co. of Lincoln House, 296-302 High Holborn, London, W.C.1.

RADIO TOPICS . . .

by Recorder

SERVICING STORIES TEND TO FALL into the same category as fishing stories, in so far that the person obtaining greatest satisfaction from the tale is the teller himself. Nevertheless, I feel I am justified in starting off this month with the tale of a simple servicing job I carried out recently, because it enabled me to stumble on two very useful little dodges which could have a general application. And I hope that the more sophisticated reader will bear with me if I explain some basic technical features for the benefit of newcomers to the servicing field.

A Little Servicing Job

The service job in question was a diminutive transistor radio of the imported variety which was not performing as well as it should. It was a superhet covering medium waves only and the first snag I encountered (as if you hadn't guessed already!) was that the 9-volt battery was delivering a reluctant 6 volts, and even less on the louder passages.

After popping in a new battery the set became quite lively, with Luxembourg pounding away at full blast near the high frequency end of the band. As I rotated the dial towards the low frequency end, however, I found that sensitivity decreased markedly, and it seemed fairly evident that the aerial and oscillator tuned circuits were not tracking at all well. Since the appropriate stations were coming in at roughly the correct points on the dial, as indicated by a few hopeful numbers that appeared at intervals behind a little window as the tuning knob was rotated (and which represented kc/s divided by 100), it seemed pretty safe to assume that the oscillator tuned circuit was working over its correct frequency range. Whereupon it didn't need an inspired guess to reason out that the next thing to do was to give the aerial coil an exploratory shove along the ferrite aerial rod.

All this is of course, perfectly straightforward. So far as superhet tracking is concerned, one trims at the high frequency end of the band by adjusting parallel trimming capa-

citance, and one pads at the low frequency end of the band by adjusting tuned circuit inductance. The fact that stations were being received at approximately the correct dial settings argued that the oscillator tuned circuit was both trimmed and padded with reasonable accuracy. The obvious thing to check was the aerial coil padding, which meant ensuring that the aerial coil was in the correct position along its ferrite rod.

The ferrite rod, mounted at one end of the crowded little printed circuit board wasn't even 2 inches long, and it was supported by a bracket at the centre and another at one end. The aerial coil was on the other side of the centre bracket and, with a station at the low frequency end of the medium waveband tuned in, I moved it towards the centre. Volume increased very noticeably, and it continued to increase as I pushed the coil towards the centre. The sensitivity reached its maximum when the coil former was in contact with the centre bracket and could be moved no further. A quick check over the dial revealed that sensitivity over the low frequency end of the band was now satisfactory, but I wasn't too happy at leaving things in this state. There was the nagging thought that, to obtain *really* maximum results, that aerial coil might need just a bit more inductance. Had I been able to take the coil *through* a peak I would have been completely satisfied.

It was at this moment that I remembered the "tuning wands" which were so popular some years ago. These had an iron-dust slug at one end of an insulated rod and an aluminium or brass slug at the other end. If the iron-dust end was inserted into a coil it increased inductance, and if the aluminium or brass slug was inserted it decreased inductance. I decided to see whether the same idea could be used in the present instance, and so I took a 6 inch ferrite rod from the spares box. I next tuned the receiver once more to a station at the low frequency end of the band and brought the 6 inch rod close to the rod in the receiver. At a spacing of about half an inch volume commenced to drop,

decreasing rapidly as the 6 inch rod was brought closer still. I next moved the aerial coil away from the centre bracket, where I knew it could not have sufficient inductance. This time, the volume level went through a definite *peak* as the 6 inch rod approached the rod in the receiver. It was obvious now that the aerial coil was at optimum inductance when it was pushed against the centre bracket so, with my little doubt set to rest, I returned it to that position, slightly retrimmed at the high frequency end and considered the job done.

Servicing Aids

Intrigued by my experience with the little radio, I investigated the serious use of a ferrite rod as a servicing aid for transistor radios. Normally, one checks whether a ferrite rod aerial coil has correct inductance by moving it experimentally along its rod. Quite often, however, such an adjustment is not too easy to carry out, as the coil may be too tight on the rod, the rod mounting may be fragile, there may, as occurred with me, be insufficient range of adjustment, and so on. In circumstances like these, it can be very helpful to be able to ascertain if the coil is in its correct position without having to actually move it. I should add that one theoretical method of determining whether the aerial coil has correct inductance is given by experimentally adjusting the aerial trimmer; if this peaks at the same setting as for the high frequency end of the band then it is obvious that the aerial coil has correct inductance. In practice, though, the aerial trimmers in transistor radios normally have a small capacitance range, and tuning is too flat at the low frequency end of the band for the trimmer to give any discernable effect.

As I discovered with my subsequent checks on a number of receivers the bringing of a second ferrite rod close to the aerial coil being investigated has, on the other hand, a very considerable effect. If the ferrite aerial coil in the receiver has too low an inductance, this is definitely demonstrated as the second rod is brought close to it, the second rod beginning to make its presence felt when it is about an inch away from the rod in the receiver. It is essential that the second rod be parallel with the rod in the receiver, and it should be centralised on the coil being investigated.

The second ferrite rod offers a most effective check for too little inductance in the aerial coil, but it doesn't tell you whether there is too

much inductance in the coil. Such a check is also desirable.

Falling back on tuning wand principles I next tried the effect of bringing up a brass rod to a ferrite rod aerial coil which I had purposely set too high an inductance. The effect was by no means as dramatic as with the second ferrite rod, and I found that slightly better results were given by bringing a non-ferrous metal plate up to the coil being investigated. If the coil had a little too much inductance, then the signal went through a peak as the plate approached the coil. But the losses introduced by the plate were high, and the effect was not sufficiently obvious to be of great help in normal servicing work.

Discarding the metal plate idea, I became visited with inspiration for the second time. Instead of using a metal plate, I tried the effect of applying a powerful permanent magnet to the receiver ferrite rod.

Results were nearly as good as with the second ferrite rod. If one pole of a permanent magnet is brought near the end of the receiver ferrite rod, the latter suffers a loss in incremental permeability and the inductance of the aerial coil drops. If the aerial coil has too much inductance a very noticeable peak can then be observed as the magnet approaches the end of the rod. It is important to bring the magnet up to the rod end which is nearer the coil being investigated. So far as I could ascertain, there was no difference in ferrite rod performance after its temporary magnetisation.

Two for the Toolbox

Summing up, therefore, it becomes possible to check the inductance of a ferrite aerial coil without moving it, in the following manner. First, tune in a weak signal at the low

frequency end of the band concerned. Next, bring up a second ferrite rod to that in the receiver. If signal strength increases the receiver aerial coil requires more inductance. If signal strength decreases the receiver aerial coil either has correct, or too much inductance. Next, bring up one pole of a strong permanent magnet to the appropriate end of the receiver aerial rod. If signal strength increases the aerial coil has too much inductance. If it decreases the coil has correct inductance.

This sort of check, incidentally, is well worth while with the smaller transistor radios. The tiny ferrite rods used in these sets require very critical aerial coil tuning if maximum sensitivity is to be assured.

However, don't take my word for the effects I've just described; try them out for yourself. You may well end up by adding two extras to your servicing kit: a ferrite rod and a permanent magnet!

DUAL-PURPOSE POWER SUPPLY

By M. L. MARTIN

Ideal for experimental work with both valve and transistor circuits, this power pack offers 250 volts h.t. at 100mA, together with a low voltage which is variable in small steps from 3 to 30 volts

THIS UNIT WAS DESIGNED TO supply both valve and transistor circuits, and it offers a positive high tension output, a negative low voltage output and 6.3 volts a.c. for heaters. By using a mains transformer with a tapped secondary for the low voltage supply it is possible to obtain a wide range of output voltages from this section.

A built-in meter is provided, and this can be switched to read h.t. current, low voltage supply current and low voltage potential.

The Circuit

The circuit of the unit appears in Fig. 1.

In the h.t. section, mains is applied to the primary of T_1 via switch S_4 ,

whereupon D_5 and D_6 function as a full-wave rectifier working into the reservoir and smoothing circuit given by C_3 , R_6 and C_2 . The rectified and smoothed h.t. voltage is then fed to the h.t. positive output terminal via the 100mA fuse F_1 , and the meter shunt R_1 . R_5 acts as a bleeder resistor, and discharges the electrolytic capacitors when the h.t. section is switched off.

Diodes D_5 and D_6 are type BY100, with a maximum peak inverse voltage of 800 volts. It is desirable to ensure that voltages in excess of 250 r.m.s. are not applied to these diodes and the transformer employed in the T_1 position should not, in consequence, have a secondary voltage higher than the 250-250 volt

figure specified. Also, the primary mains tapping should correspond to the nominal voltage of the supply mains with which the unit is to be employed.

The mains transformer also has a 6.3 volt 2.5 amp heater secondary. This connects direct to the 6.3 volt output terminals and can be used to power the heaters of external valve equipment.

As may be gathered, the choice of transformer for T_1 is not exceptionally critical. The main requirement is an h.t. secondary capable of offering 100mA at a potential which does not exceed 250-250 volts, and a heater secondary providing 6.3 volts at a current which is adequate for all projects envisaged.

The low voltage section is switched on by S_5 , which applies the mains supply to the primary of transformer T_2 . The transformer specified here has a 2 amp secondary with connections at 0, 12, 15, 20, 24 and 30 volts. These voltages are applied, via selector switches S_2 and S_3 , to the bridge rectifier given by diodes D_1 , D_2 , D_3 and D_4 , a rectified output appearing across capacitor C_1 . The positive low voltage output is made common with the h.t. negative output (and the power supply

Components List

Resistors

- R₁ 100mA shunt*
- R₂ Series voltmeter resistor*
- R₃ 100mA shunt*
- R₄ 2kΩ 1 watt 20%
- R₅ 100kΩ 1 watt 20%
- R₆ 200Ω 4 watts 20%
- R₇ To suit NE₁*
- R₈ To suit NE₂*

Capacitors

- C₁ 1,000μF, electrolytic, 30V wkg.
- C₂ 16μF, electrolytic, 350V wkg.
- C₃ 16μF, electrolytic, 350V wkg.

Transformers

- T₁ Mains transformer. Secondary voltages: 250-0-250 at 100mA; 6.3V at 2.5A (see text)
- T₂ Mains transformer. 2A secondary tapped at 12, 15, 20, 24 and 30V. Type MT/3AT (Douglas).

Rectifiers

- D₁, D₂, D₃, D₄ BY114
- D₅, D₆ BY100

Switches

- S_{1(a), (b)} 2 pole, 4 way (see text)
- S₂ 1 pole, 6 way
- S₃ 1 pole, 6 way
- S₄ s.p.s.t. toggle
- S₅ s.p.s.t. toggle

Meter

- M₁ Moving coil meter, 1mA f.s.d.

Neons

- NE₁, NE₂ Neons, with panel mounting holders

Fuses

- F₁ F₂ 100mA fuses, with panel mounting holders

* See text.

chassis), and the negative output is applied to the appropriate output terminal. Fuse F₂ and meter shunt R₃ are inserted in the negative low voltage output line.

The alternating voltage applied to diodes D₁-D₄ may be varied by adjusting switches S₂ and S₃. Each switch position is marked with the transformer secondary voltage to which it corresponds, whereupon the alternating voltage fed to these diodes becomes equal to the difference between switch indications. Thus, if S₂ is set to "20" and S₃ to "12", an alternating voltage of 8 is

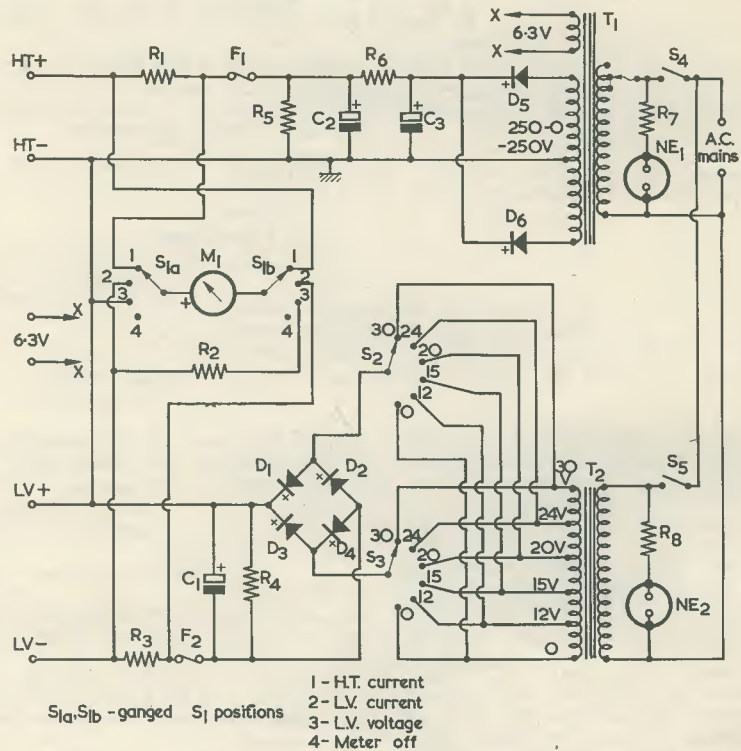

Fig. 1. The circuit of the power supply unit

passed to the bridge rectifier. By suitable combinations of the switches it is possible to obtain alternating voltages of 3, 4, 5, 6, 8, 9, 10, 12, 15, 18, 20, 24 and 30. Corresponding rectified voltages then appear at the low voltage output terminals.

It would have been possible to obtain the voltages selected by S₂ and S₃ in a single switch having 13 positions (or, more conveniently if using normally available switches, 12 positions with one voltage sacrificed), but it was felt that the advantage of ease of operation was outbalanced by the complex wiring involved.

Since the low voltage supply was only intended for transistor circuits, it was felt that a maximum current of 100mA would be quite adequate. In consequence, fuse F₂ is rated at 100mA, and meter shunt R₃ has a value which causes f.s.d. to be given at this current. Both the transformer and rectifier diodes are capable of passing higher currents than this (up to 550mA—the maximum forward current for diodes D₁-D₄), and if higher currents are required the values of F₂ and R₃ may be changed accordingly. However, a maximum current of 100mA should be more

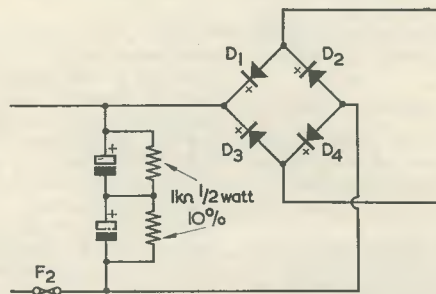

Fig. 2. Using two capacitors of lower working voltage, with bridging resistors, instead of C₁

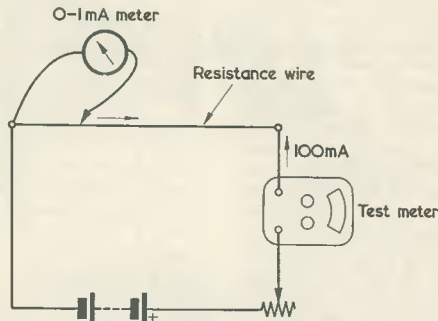

Fig. 3. Finding the length of resistance wire needed for shunts R_1 and R_3

than adequate for most transistor work. It should be remembered, if higher currents are envisaged, that 15mA at 30 volts flows in R_4 .

Since, without any loading, the voltage across C_1 would fall only slowly when a lower alternating voltage is selected by S_2 and S_3 , it is necessary to add a bleeder resistor across this capacitor. This function is carried out by R_4 .

Neons NE_1 and NE_2 indicate when the h.t. and low voltage supplies are switched on. It is, of course, possible to have both supplies running at the same time. These neons are intended to be mounted on the front panel. Any suitable type of neon may be employed, and R_7 and R_8 are given values which are suitable for operation at 250 volts a.c.

Capacitor C_1 has a working voltage of 30, and it may be difficult, in practice, to obtain a capacitor with this working voltage. In such an instance, two 2,000 μ F capacitors of lower working voltage may be connected in series, as in Fig. 2, in place of C_1 . These capacitors are bridged by 1k Ω resistors to ensure equal voltage distribution. The total working voltage then becomes the sum of the individual working voltages, and the total capacitance half that of either capacitor. Also, the two 1k Ω resistors take the place of R_4 of Fig. 1, which is not then required.

Meter Switching

The meter is a 0-1mA moving-coil movement which was obtained from surplus sources. It is connected into circuit by the 2-pole 4-way switch $S_1(a)$, $S_1(b)$.

When S_1 is set to position 1, the positive terminal of the meter is connected to the right hand side of R_1 , and the negative terminal to the left hand side of R_1 . H.T. current then causes the meter to read in the

correct direction, and the value of R_1 is such that the meter reads 100mA f.s.d.

In position 2 of S_1 , the positive

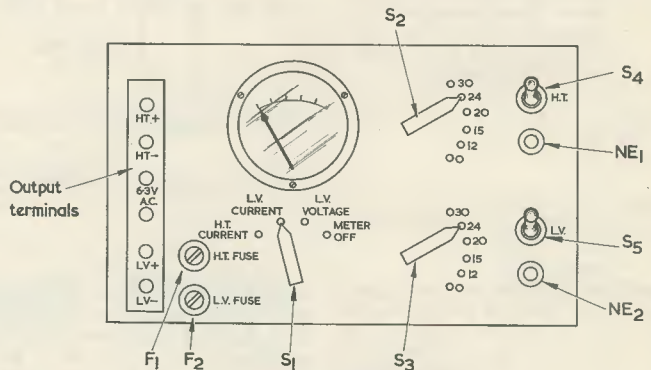

Fig. 4. A suitable front panel layout

terminal of the meter connects to the left hand side of R_3 , and the negative terminal to the right hand side of R_3 . Current in the low voltage circuit then, once more, causes the meter to read in the correct direction. The value of R_3 is such that the meter reads 100mA f.s.d. (or a higher current, as was discussed above).

Setting S_1 to position 3 causes the positive terminal of the meter to connect to the positive low voltage output terminal and the negative terminal of the meter to connect, via R_2 , to the negative low voltage output terminal. The meter then functions as a voltmeter, indicating the output voltage resulting from adjustments in S_2 and S_3 . The value chosen for R_2 depends upon the meter f.s.d. reading required by the constructor. If an f.s.d. of 50 volts is required, R_2 needs to be 50k Ω $\frac{1}{4}$ watt. Lower f.s.d. readings require correspondingly lower values in R_2 .

The values of the meter shunts, R_1 and R_3 , are governed by the internal resistance of the meter. A simple method of making up the shunts consists of obtaining a length of resistance wire and passing 100mA through it, as shown in Fig. 3. The 0-1mA meter is then connected between one end of the resistance wire and a slider which can travel along it. Starting at the same end as that at which the meter connection is made, the slider is moved along the resistance wire until f.s.d. is indicated, whereupon the requisite amount of resistance wire for a 100mA shunt has been tapped off. If, as mentioned earlier R_3 is intended to act as a shunt for currents higher than 100mA then the requisite current should be passed through the resistance wire when making up this shunt.

An important point concerning

the meter circuit is that it is essential to employ a good quality switch for S_1 , each contact of which *must* break reliably before the next contact in either section is selected. For this reason, switches of the "miniature wavechange" type should be avoided. If contact action is unreliable in this respect, it is possible for high voltages to be applied to the meter, causing it to become damaged or to burn out. For the same reason, especial care is needed to ensure that the wiring to S_1 is correctly carried out.

Construction

The layout of the unit is not critical, and any reasonable method of assembly may be employed.

A suitable panel layout is shown in Fig. 4, and it will be seen that this enables all switches to be easily accessible, with the meter in a position where it can readily be observed.

CAN ANYONE HELP?

Requests for information are inserted in this feature free of charge, subject to space being available. Users of this service undertake to acknowledge all letters, etc., received and to reimburse all reasonable expenses incurred by correspondents. Circuits, manuals, service sheets, etc., lent by readers must be returned in good condition within a reasonable period of time

R1/ARR1 Receiver (No. CW18784).—W. J. Donnelly, 5 Campbell Road, Bedford—circuit and/or pin connector information.

* * *

Shorrock Clubman Aircraft Band Rx.—J. McCabe, 29 Sylvia Court, Wembley, Middx.—circuit or any other information.

* * *

R220 Receiver.—R. Scrimgeour, 19 Wellington Street, Dundee, Angus—conversion details, from crystal controlled to tunable.

* * *

Brenell Tape Recorder Mk. II.—M. C. Quance, 76 Shrewsbury Road, Whitleigh, Plymouth, Devon—purchase or borrow circuit diagram or service manual.

* * *

Indicator Unit 198.—R. L. Jenkins, 42 Warwick Road, Birmingham, 32—circuit diagram or manual or any information.

P58 Receiver.—H. W. Elliott, 1 Church Lane, Bearsted, Maidstone, Kent—circuit or manual of this ex-Admiralty receiver.

* * *

Radio Manual.—D. J. Thomas, 5 Western Road, Runcorn, Cheshire—requires an out-of-print publication, *Listener's Guide 1957 Edition*, by B. Babani.

* * *

Wireless Set No. 18 Mk. III.—E. Ede, 27 Third Avenue, Denvilles, Havant, Hants.—circuit or any information.

* * *

Mayfair FT-303 Battery Tape Recorder.—R. E. Fields, 49 Torkington Road, Gatley, Cheshire—circuit or service manual. Also 1st edition of the *Mullard Maintenance Manual*.

Club Events

Basildon and District Amateur Radio Society

Hon. Sec.: J. Barker, G3JB, Milestone Cottage, London Road, Wickford, Essex.

April 5th—Social.

April 20th—Lecture—SSB Working—at the Mayflower Restaurant (adjacent to Van Gogh, Paycocke Road, Basildon).

Northern Heights Amateur Radio Society

Hon. Sec.: A. Robinson, G3MDW, Candy Cabin, Ogden, Halifax.

April 13th—Annual General Meeting.

April 27th—Design and Construction of small mains Power Transformers, by K. Walton, G3IKS, M.A.S.E.E.

Melton Mowbray Amateur Radio Society

Hon. Sec.: D. W. Lilley, G3FDF, 23 Melton Road, Asfordby Hill, Melton Mowbray, Leics.

April 21st—Micro-wave Radio Relay Systems, by J. L. Bowley, G3FXP.

All meetings are held in the St. John Ambulance Brigade Hall, Asfordby Hill, Melton Mowbray, and commence at 19.30 hrs. Top Band Net on 1910 kc/s at 20.00 hrs. Wednesdays and 11.15 hrs. Sundays. Slow Morse transmissions on 1825 kc/s at 19.00 hrs. on Mondays, Tuesdays, Thursdays and Fridays.

FOR YOUR DIARY

Derby and District Amateur Radio Society

Hon. Sec.: F. C. Ward, G2CVV, 5 Uplands Avenue, Littleover, Derby.

May 8th—144 Mc/s Portable Contest.

June 4th/5th—National Field Day.

July 3rd—144 Mc/s Portable Contest.

August 14th—Ninth Annual Mobile Rally.

September 3rd/4th—VHF National Field Day.

Harlow and District Amateur Radio Society

Hon. Sec.: G. O'Donald, G3TLJ, "Great East", Harlow Road, Roydon, Harlow, Essex.

25th September—1966 Annual Mobile Rally.

SMALL ADVERTISEMENTS

Use this form for your small advertisement

To: The Advertisement Manager, Data Publications Ltd., 57 Maida Vale, London, W.9
Please insert the following advertisement in the issue of THE RADIO CONSTRUCTOR

16 words at 9d.
= 12/-

ALL WORDING
IN
BLOCK LETTERS
PLEASE

I enclose remittance of being payment at 9d. a word. MINIMUM 12/-.
Box Number, if required, 2/- extra.

NAME.....

ADDRESS

Copy to be received four weeks prior to publication. Published on the 1st of every month



MIDLAND AGENTS FOR

- * EDDYSTONE RECEIVERS & COMPONENTS
- * NATIONAL RECEIVERS & TRANSCEIVERS
- * GREEN & DAVIS EQUIPMENT
- * KW EQUIPMENT
- * MOSLEY AERIALS
- * WITHERS

- H.P. FACILITIES AVAILABLE
- PART EXCHANGES

AERIAL EQUIPMENT

TWIN FEEDER. 300 ohm twin ribbon feeder similar K25, 6d. per yard. 75 ohm twin feeder, 6d. per yard. Post on above feeders and cable, 2/- any length.

COPPER WIRE, 14G, H/D, 140ft, 25/-; 70ft, 13/-. Post and packing 3/3. Other lengths pro rata.

FEEDER SPREADERS. 6" Ceramic type F.S., 10d. each. Postage 2/6 up to 12.

CERAMIC CENTRE PIECE for dipoles, Type AT, 1/6 each. P. & P. 1/-.

2 METRE BEAM, 5 ELEMENT W.S. YAGI. Complete in box with 1" to 2 1/2" masthead bracket. Price 49/- P. & P. 4/-.

SUPER AERIAL, 70/80 ohm coax, 300 watt very low loss, 1/11 per yard. 50 ohm 300 watt, 2/- per yard. P. & P. 2/6.

TOUGH POLYTHENE LINE, type MLI (100lb), 2d. per yd. or 12/6 per 100 yds. Type ML2 (220lb), 4d. per yd. or 25/- per 100 yds., ML4 (400lb), 6d. per yd. Ideal for Guys, L.W. Supports, Halyards, etc. Postage 1/6 on all line.

ABSORPTION WAVEMETERS. 3.00 to 35.00 Mc/s in 3 Switched Bands. 3.5, 7, 14, 21 and 28 Mc/s. Ham Bands marked on scale. Complete with indicator bulb. A MUST for any Ham Shack. ONLY 25/- EACH. Post free.

BANDCHECKER MONITOR, 3.00-35.00 Mc/s in 3 switched Bands. 0-1mA Indicator. Monitor Socket. Very sensitive, £3.13.6. P. & P. 3/6.

VARIABLE CONDENSERS. All brass with ceramic end plates and ball race bearings. 50pF, 5/9; 100, 6/6; 160, 7/6; 240, 8/6; and 300pF, 10/6. Extension for ganging. P. & P. 2/-.

RACK MOUNTING PANELS: 19" x 5 1/2", 7", 8 1/2", or 10 1/2", black crackle finish, 5/9, 6/6, 7/6, 9/- respectively. P. & P. 3/-.

30 WATT MOD. TRANS. 2 x 807 mod. to 807 R.F. Few only, 18/6 each. P. & P. 3/6.

K.W. FROM STOCK

VESPA, £110	PSU. £25
2000, £173	PSU. £32
2000A, £195	PSU. £40

TERMS AND EXCHANGES

CHAS. H. YOUNG LTD

170-172 Corporation St., Birmingham 4

Please print your address. No C.O.D. under £1. 'phone CEN 1635

SMALL ADVERTISEMENTS

Rate: 9d. per word. Minimum charge 12/-.
Box No. 2/- extra.

Advertisements must be prepaid and all copy must be received by the 4th of the month for insertion in the following month's issue. The Publishers cannot be held liable in any way for printing errors or omissions, nor can they accept responsibility for the bona fides of advertisers. (Replies to Box numbers should be addressed to: Box No.—, The Radio Constructor, 57 Maida Vale, London, W.9.)

SERVICE SHEETS, 1925-1965. From 1s. Catalogue 6,000 models, 1s. 6d. S.A.E. enquiries.—Hamilton Radio, 13 Western Road, St. Leonards, Sussex.

HAMMERITE hammer pattern brush paint, for panels and boxes, gives a perfect pattern in only 10 sec. Just brush it on!

Colours: Blue, silver or metallic black.
2½ oz. tins 3s. 6d. ½ gallon 35s.*
½ pint 7s. 6d. 1 gallon 58s.*
1 pint 15s. (* sent by road).

Carriage: Orders up to 5s., 9d.; up to 10s., 1s. 9d.; over 10s., 2s. 9d.

Return of post service Monday to Friday.

From your component shop, or direct from the manufacturer: **FINNIGAN SPECIALITY PAINTS, (RC)**, Mickley Square, Stocksfield, Northumberland. Telephone: Stocksfield 2280.

GOVERNMENT SURPLUS electrical and radio equipment. Our new catalogue No. 16 ready now, 2s. 6d. post free, cost refunded on purchase of goods over £2.—Arthur Sallis Radio Control Ltd., 93 North Road, Brighton, Sussex.

FOR SALE. Oscilloscopes—Galvanometers—Evershed & Vignolles Meggers. Also other items and components. Free list. Stamp please.—R. & E. Mart, Box 9 G.P.O., Tunbridge Wells, Kent.

FIVE-TON FACTORY CLEARANCE. Radio, TV, Electrical components in mixed parcels. Example: 22lb. mixed parcel £1 p.p. 7/6d. Speakers, grilles, valves, bases, i.f.'s, covers, condensers, etc. Hundred other items. S.A.E. list and postal orders to: P. Newton, 16 Shalcross Crescent, Hatfield, Herts.

NEW TRANSISTOR BARGAINS. XA702 (2N2190 n.p.n.) 4s., XB104 (OC70) 1s., OC76 2s., GET105 with heat sink 4s. 6d., OC170 3s. 9d., MAT393 3s. Power Transistors OC29 12s., OC30 7s. Diodes GJ5D 2s., CG6E, GEX45/1, CG63H all 1s. 3d. Post free over 5s. order or add 6d. Many other bargains in our stocklist, send 6d. stamp. Still available, our famous 25 transistors for 10s. offer and 125 diodes (not tested) for 12s.—L.S.T. COMPONENTS, 23 New Road, Brentwood, Essex.

RELAY BARGAINS. Hi-speed plug-in relays, two-independent coils, no contact bounce, 10s. 6d. incl. base. Plus 1s. 6d. postage.—A. Knox, 101 Dalkeith Road, Edinburgh.

WANTED. Information on meteorological FAX radio reception systems, brochures, circuits, surplus equipment, etc.—Box No. F250.

continued on page 525

BENTLEY ACOUSTIC CORPORATION LTD.

38 Chalcot Road, Chalk Farm,
LONDON, N.W.1.
PRImrose 9090

47 Norfolk Road,
LITTLEHAMPTON, Sussex.
Littlehampton 2043

Please forward all mail orders to Littlehampton

0A2	5/91630L2	8/91AZ31	9/6EF36	3/6GZ33	14/6PY800	5/9
0B2	6/-10C1	9/9DAF96	6/-EF37A	7/-GZ34	10/-PY801	7/6
1L4	2/310C2	12/-DF96	6/-EF39	5/-GZ37	14/6U25	8/6
1R5	4/-10F1	10/-DK92	8/-EF41	6/6HABC80	9/3U26	7/6
1S5	3/310F18	9/9DK96	6/6EF80	4/3KT66	12/3U191	9/6
1T4	2/310LD11	9/6DL96	6/6EF85	4/6PABC80	6/9U301	11/-
2D21	5/610P13	12/-DM70	5/-EF86	6/6PC86	9/9U329	9/-
3D6	3/910P14	11/6DY87	7/6EF89	4/3PC88	9/-U404	6/-
3Q4	5/312AH8	10/9E88CC	13/6EF91	3/-PC95	6/9U801	15/-
3S4	4/912AT6	4/6EABC80	5/9EF92	2/6PC97	6/9UABC80	5/6
3V4	5/-12AU6	5/9EAF42	7/9EF97	10/-PCC84	5/6UAF42	7/-
5Y3GT	4/912AV6	5/9EB91	2/3EF98	9/9PCC85	6/9UBC41	6/3
5Z4	7/612BA6	5/3EBC41	6/6EF183	7/3PCC88	10/6UBC81	6/3
6A05	5/912BE6	4/9EBC81	6/3EF184	6/6PCC89	11/6UBF80	5/6
6AT6	3/612BH7	6/-EBF80	5/9EH90	9/6PCC189	9/6UBF89	6/3
6AU6	5/919AQ5	7/3EBF83	7/3EL33	6/6PCF80	6/6UBL21	10/9
6AV6	5/620D1	10/-EBF89	5/9EL36	8/9PCF82	6/-UC92	6/3
6BA6	4/620F2	11/6ELB21	10/3EL41	7/-PCF84	8/6UCC84	8/-
6BE6	4/320L1	14/-EC92	6/6EL42	7/9PCF86	8/3UCC85	6/6
6BH6	5/320P1	12/6ECC40	10/-EL8	4/6PCF801	9/9UCPC80	8/3
6BJ6	5/620P3	12/-ECC81	3/6EL85	7/6PCF802	10/-UCH21	8/-
6BQ7A	7/620P4	13/-ECC82	4/6EL86	7/3PCL82	6/6UCH22	8/-
6BR7	8/320P5	11/6ECC83	4/6EL95	5/-PCL83	9/6UCH81	6/6
6BY6	7/630C15	10/-ECC84	5/6ELL80	13/6PCL84	7/6UCH82	7/3
6CD6G	18/-30C17	11/9ECC85	5/9EM71	15/6PCL85	8/6UCH83	9/-
6CH6	6/630C18	9/3ECC88	8/9EM80	6/3PCL86	8/9UF41	6/9
6FI	9/630F5	7/3ECC189	11/6EM81	7/-PEN45	7/-UF42	4/9
6J5G	3/930FL1	9/3ECF80	7/3EM84	6/-PL36	9/-UF80	6/3
6J7G	4/630L15	10/3ECF82	6/3EM85	8/9PL38	16/-UF85	6/9
6K7G	1/330L17	11/6ECF86	10/-EM87	7/6PL81	6/9UF86	9/6
6K9G	3/330P12	7/6ECH121	10/-EY51	5/6PL82	5/3UF89	5/6
6L6GT	7/330P19	12/-ECH35	6/6EY81	7/3PL83	6/-UL41	7/-
6L18	10/-30PL1	9/6ECH42	8/-EY83	9/3PL84	6/3UL84	5/6
6LD20	6/630PL13	10/6ECH81	5/9EY84	9/6PM84	9/3UM80	8/3
6Q7GT	7/930PL14	11/3ECH83	6/6EY86	5/6PY33	8/9UY21	9/-
6SL7	4/930PL15	9/6ECH84	9/6EY88	8/9PY80	4/9UY41	5/6
6SN7	4/63SW4	4/6ECL80	5/9EZ40	5/6PY81	5/-UY85	4/9
6V6G	3/68SA2	6/6ECL82	6/6EZ41	6/3PY82	4/9V48	12/-
6X4	3/9807	11/9ECL83	10/-EZ80	3/9PY83	5/6X41	10/-
6X5	5/35763	7/6ECL86	8/-EZ81	4/3PY88	7/3X78	26/2

Terms of business: Cash with order only. No C.O.D. Post/packing 6d. per item. Orders over £5 post free. All orders despatched same day. Complete catalogue including transistor section and components with terms of business 6d. Any parcel insured against damage in transit for 6d. extra. We are open for personal shoppers 9 a.m.-5 p.m. Saturdays 9 a.m.-1 p.m.

SPECIAL OFFER

1 Watt S.T.C. 300 Mc/s N.P.N. Silicon Planar 100% Transistors, £1 for 6.

3/- each OC44, OC45, OC70, OC71, OC81, OC81D, OC200, GET16, GET20.

4/- each AF114, AF115, AF116, AF117, OC170, OC171.

5/- each OC139, OC140, GET7, GET8, GET9, XC141, BY100, OA211.

SUN SOLAR CELL KIT

4 Sun Solar Cells plus 24-page Booklet on Experiments, 11/- set.

G.P.O. DIAL TELEPHONES

20/- each 35/- pair

Send 6d. for Full Lists including S.C.R. Zeners, etc.

CURSONS

78 BROAD STREET, CANTERBURY, KENT

THE MODERN BOOK CO

1966 World Radio TV Handbook. 20th ed. 28s. Postage 1s.

Transistor Pocket Book. By R. G. Hibberd. 25s. Postage 1s.

Servicing AGC Circuits. By H. E. Thomas. 28s. Postage 1s.

The A.R.R.L. Antenna Book. 18s. Postage 1s. 6d.

Single Sideband for the Radio Amateur. By A. R. R. L. 22s. Postage 1s. 6d.

Handbook of Electronic Circuits. By R. Feimberg. 50s. Postage 1s. 6d.

Basic Electricity/Electronics Laboratory Workbook. By Training and Retraining Inc. 35s. Postage 2s.

A Beginner's Guide to Television. Pub. Newnes. 8s. 6d. Postage 9d.

Transistor Radios Circuitry and Servicing. Mullard. 5s. Postage 6d.

Getting Started with Transistors. By L. E. Garner, Jnr. 28s. Postage 1s.

An Electronic Organ for the Home Constructor. By A. Douglas. 20s. Postage 1s.

Troubleshooting with the Oscilloscope. By R. G. Middleton. 20s. Postage 1s.

Electronic Organ Handbook. By H. E. Anderson. 35s. Postage 1s.

Radio and Line Transmission. By G. L. Danielson and R. S. Walker. Vol. 1. 21s. Vol. 2. 22s. 6d. Postage 1s. each.

Transistor Transmitters for the Amateur. By D. L. Stoner. 21s. Postage 1s.

101 Ways to use your Ham Test Equipment. By R. G. Middleton 21s. Postage 1s.

Hi Fi Stereo Handbook. By W. F. Boyce. 32s. Postage 1s.

Motorola Semiconductor Circuits Manual. 16s. Postage 1s.

Complete Catalogue 1s.

We have the Finest Selection of English and American Radio Books in the Country

19-21 PRAED STREET (Dept RC) LONDON W2

Telephone PADdington 4185

THE WORD

MAXI-Q

IS THE REGISTERED
TRADE MARK

OF DENCO (CLACTON) LIMITED

IT IS ALSO A GUARANTEE OF
WORKMANSHIP AND
TECHNICAL PERFORMANCE

OUR RANGE OF PRODUCTS IS SO GREAT THAT WE NOW HAVE TO REQUEST THE AMOUNT OF 2s. 0d. FOR OUR GENERAL CATALOGUE AND TO SAVE YOU POSTAL ORDER POUNDAGE CHARGE WE REQUEST SEND 2s. 0d. IN STAMPS.

IN RESPONSE TO CONTINUOUS DEMAND we have commenced production of Self-Contained Multiplex Decoder Unit, aligned ready for immediate use, that will convert your two receivers—tuner and two amplifiers—tuner and stereo amplifier or stereo receiver without Multiplex provision to a complete B.B.C. Stereo Broadcast Reception Unit. Price £8.0.0, post paid. Technical Publication MDI, 4s. 0d., post paid.

I.F.T.11/465 kc/s centre tapped transformer for use in crystal filter circuits, $1\frac{3}{8}'' \times \frac{11}{16}''$ square. 10s. 6d. plus 8d. post.

I.F.T.18/465 kc/s and 1.6 Mc/s Double Tuned transistor transformer $1\frac{1}{2}'' \times \frac{1}{2}''$ square. 10s. 6d., plus 8d. post.

Please send S.A.E. with all enquiries. General Catalogue 2s. 0d.

DENCO (CLACTON) LTD.

(DEPT. R.C.)

357/9 OLD ROAD, CLACTON-ON-SEA, ESSEX

SMALL ADVERTISEMENTS

Rate: 9d. per word. Minimum charge 12/-.
Box No. 2/- extra.

Advertisements must be prepaid and all copy must be received by the 4th of the month for insertion in the following month's issue. The Publishers cannot be held liable in any way for printing errors or omissions, nor can they accept responsibility for the *bona fides* of advertisers. (Replies to Box numbers should be addressed to: Box No.—, *The Radio Constructor*, 57 Maida Vale, London, W.9.)

continued from page 523

WANTED. To purchase secondhand classical L.P. records in good condition. Reasonable.—Box No. F251.

WANTED. Plug-in coils for the wartime H.R.O. receiver.—R. & E. Mart, Box 9, G.P.O., Tunbridge Wells, Kent.

FOR SALE. Jasonkit W11 wobulator, wired, unused. £12.—36 Franklin Road, Gillingham, Kent. (Saturdays.)

CONVERT ANY TV SET INTO AN OSCILLOSCOPE. Instructions and diagrams, 12s. 6d.—Redmond, 42 Dean Close, Portslade, Sussex.

FOR SALE. RTTY converter, Type A.P. 66286, £5 plus carriage.—Box No. F254.

FOR SALE. A number of early radio textbooks. Would suit technical college or school reference library. S.A.E. for details.—Box No. F255.

FOR SALE. Electrical, radio, TV, electronic, engineering, contracting, manufacturing, sales, M.O.S., business. Premises 7,000 sq. ft. Site 15,000 sq. ft. High Street. Spacious living accommodation, grounds, 5 bedrooms. Frontage 168 ft. Possession on completion. Would consider working partner. South Lincolnshire.—Box. No. F256.

WANTED. Copy of Harmsworth's *Wireless Encyclopedia* (published approximately 1925).—Box No. F257.

COMPLETE CLEARANCE. Components, etc. Too numerous to advertise. Inexpensive. S.A.E. list.—2 Fitzgerald Avenue, Seaford, Sussex. Telephone: 4961.

FOR SALE. Embossed plastic panel signs. 1½d. per word, 6d. P. & P. Send for words you require with P.O.—T. Howard, 22 The Pits, Isleham, Ely, Cambs.

"MEDIUM WAVE NEWS" Monthly during DX season—Details from: B. J. C. Brown, 60 White Street, Derby.

TECHNICAL DRAWINGS, Artwork, etc. Electronic and Radio Circuits a speciality. Moderate charges.—B. P. Meaney, 43 Forest Road, Worthing, Sussex.

ARE YOU A MOTORING ENTHUSIAST? The Seven Fifty Motor Club caters for all types of motor sport—racing, rallies, hill climbs, etc. Monthly Bulletin free to members. For full details write to: The General Secretary, Colin Peck, "Dancer's End", St. Winifred's Road, Biggin Hill, Kent.

continued on page 527

BUILD THIS REFLEX 2 TRANSISTOR RECEIVER

SHOWN ACTUAL SIZE

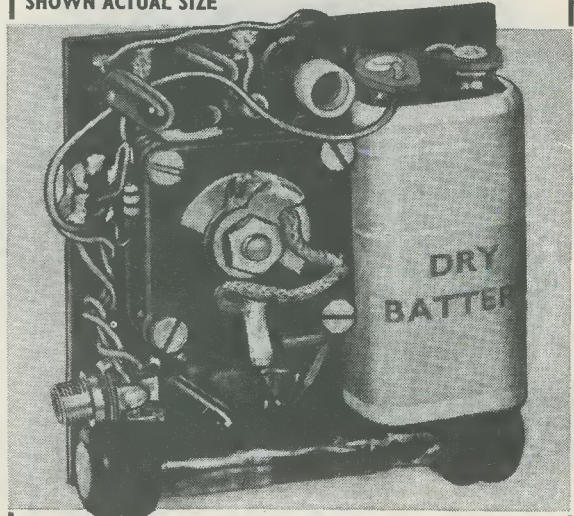

You'll enjoy constructing this easily assembled 2-transistor, 4-stage pocket radio. **SPECIAL FEATURES:** twin-gang tuning for added selectivity and sensitivity—output suitable for crystal earpiece—eyeletted circuit board for easy construction—plastic case and dial available. Simple, step-by-step assembly instructions in *Practical Wireless*.

**PLUS PRIVILEGE PRICE BOOK OFFER
RADIO & TELEVISION REFERENCE DATA**
for only 5/- (value 10/6)

PRACTICAL WIRELESS

APRIL ISSUE OUT MARCH 3rd—2/-
Make sure of your copy!

The Radio Amateur Operator's Handbook

LATEST EDITION

TIME CONVERSION
GREENLAND?

BEARING KR6?

64
pages



5/-

BY POST 5/5d.

LONDON TO VALPARAISO?

PREFIX MADAGASCAR?

The Answers to these and many other questions will be found in the latest, ninth edition, of the THE RADIO AMATEUR OPERATOR'S HANDBOOK

In the ninth edition of this well established handbook, several new features have been included in addition to the complete revision of the Amateur Prefix lists—these containing the latest issued information.

Essential to both the Transmitter and the Listener, it is full of such information as Radio Zone Boundaries—1/40, Call Areas, Amateur Band Frequency Allocations, Local Time Conversions, Mileage Table, Amateur Codes and Abbreviations, the Amateur Licence, International Morse Code, QSL Bureaux of the World, Standard Frequency Transmissions, Operating Technique, Charts on which countries, states, zones and counties worked or heard can be recorded, Prefix/Directional Bearing List, 2 Metre and 70 cm. Band Plan with map, Frequency/Wavelength Conversion Chart, Amateur Radio News Broadcasts, National Societies with addresses and Call Area Maps of Australia, U.S.S.R., South America, Canada, U.S.A. and Weather Forecast Areas, Post Office Regulations, etc.

To Data Publications Ltd., 57 Maida Vale, London, W.9

Please supply.....copy(ies) of your latest publication "THE RADIO AMATEUR OPERATOR'S HANDBOOK" DATA BOOK No. 6. I enclose cheque/crossed postal order for

NAME.....

ADDRESS

BLOCK LETTERS PLEASE

SMALL ADVERTISEMENTS

Rate: 9d. per word. Minimum charge 12/-.
Box No. 2/- extra.

Advertisements must be prepaid and all copy must be received by the 4th of the month for insertion in the following month's issue. The Publishers cannot be held liable in any way for printing errors or omissions, nor can they accept responsibility for the *bona fides* of advertisers. (Replies to Box numbers should be addressed to: Box No.—, *The Radio Constructor*, 57 Maida Vale, London, W.9.)

continued from page 525

JOIN THE INTERNATIONAL S.W. LEAGUE. Free Services to members including Q.S.L. Bureau. Amateur and Broadcast Translation. Technical and Identification Dept.—both Broadcast and Fixed Stations, DX Certificates, contests and activities for the SWL and transmitting members. Monthly magazine, *Monitor*, containing articles of general interest to Broadcast and Amateur SWLs, Transmitter Section and League affairs, etc. League supplies such as badges, headed notepaper and envelopes. QSL cards, etc., are available at reasonable cost. Send for League particulars. Membership including monthly magazine, etc., 35s. per annum.—Secretary, ISWL, 60 White Street, Derby.

POSTAL ADVERTISING? This is the Holborn Service. Mailing lists, addressing, enclosing, wrapping, facsimile letters, automatic typing, copy service, campaign planning, design and artwork, printing and stationery. Please ask for price list.—The Holborn Direct Mail Company, 2 Mount Pleasant, London, W.C.1. Telephone: TERminus 0588.

RECITALS OF RECORDED MUSIC. The second Saturday evening of each winter month. Next recital: Saturday, 12th March, 1966, 8 p.m. at Woodford Green United Free Church, Woodford Green, Essex. Bus routes—20, 20a, 38a and 179.

EDUCATIONAL

TV AND RADIO. A.M.I.E.R.E., City & Guilds, R.T.E.B. Cert., etc., on "Satisfaction or Refund of Fee" terms. Thousands of passes. For details of Exams. and home training courses (including practical apparatus) in all branches of radio, TV and electronics, write for 156 page Handbook—FREE.—B.I.E.T. (Dept. 141K), 29 Wright's Lane, London, W.8.

MORSE MADE !!

The famous RHYTHM RECORDED COURSE cuts practice time down to an absolute minimum!
One student, aged 20, took only 13 DAYS and another, aged 71, took 6 WEEKS to obtain a G.P.O. pass certificate. If you wish to read Morse easily and naturally, please enclose 8d. in stamps for full explanatory booklet to:—
G3CHS/D, 45 Green Lane, Purley, Surrey.

AERIAL MATCHING TUNING UNITS

These well-made tuning units, made for the American 19Tx—Rx are housed in a metal case, green or brown, using a large precision calibrated scale, are an essential piece of equipment for the serious Tx or Rx operator. This unit will match an untuned wire or whip aerial to almost any short wave receiver or transmitter, exceptionally good for mobile Top Band use. This American version being well noted as far superior to any other. GUARANTEED BRAND NEW, only 20/-, post 7/6. Instructions supplied.

JOHN'S RADIO
OLD CO-OP., WHITEHALL RD., DRIFLINGTON, BRADFORD

SITUATIONS VACANT

ELECTRONIC TECHNICIAN

Do you enjoy playing around with electronic gadgets? Here is a chance to make a career of your hobby. We offer you interesting and varied work in the field of electronic instrumentation. This small but expanding department is concerned with the design and application of electronic circuits required for the testing of diesel engines and their fuel injection systems.

Staff conditions are good and include sickness and Contributory Pension and Life Assurance schemes, restaurant facilities, etc.

In the first instance, applicants should write in confidence, giving only brief personal details to:—

The Personnel Manager,
SIMMS MOTOR UNITS LTD.,
Oak Lane,
East Finchley, N.2.
FIN 2692.



MAKE 5 DIFFERENT RADIOS FOR 35/-

Amazing Radio Construction Set! Become a radio expert for 35/-. A complete Home Radio Course. No experience needed. Parts include instructions for each design, Step-by-Step plan, all Transistors, loud-speaker, personal phone, knobs, screws, etc., all you need. Box size 14" x 10" x 2" (parts available separate). Originally £6. NOW 35/- plus 3/6 p. & p.

NEW RADIO ONLY 19/6



Only 16 connections! Then hear it reach out bringing in station after station.

4 1/2" x 2 1/2" x 1 1/2". Many Testimonials:

M.H. of Bradford, writes: "... I have just completed one of your sets successfully, it is the first time I have ever tackled anything like a radio and I must state here and now, I am amazed how easy it is to a layman like me. Your instructions and plan have obviously been very carefully thought out so that even the most dim can follow them. . . ." 19/6 plus 2/6 post, etc.

New RADIO Any-one CAN BUILD in 2-3 hours! Only 19/6. EVEN THE OLDER CHILDREN BUILD THEM! No soldering.

ASTONISHING CIGARETTE RADIO

Yes a perfectly ordinary packet ONLY of cigarettes!—but it fetches in station after station, loud and clear! Holds 10 Cigarettes—yet cleverly conceals highly sensitive, fully transistorised circuit (incl. tiny battery). Even a young boy can assemble it in under 2 hours. No soldering. No experience necessary. Only 16 connections. From our bulging testimonial file Mr. D. B. of Huddersfield writes: "... I have fitted the parts in and it is working wonderfully. . . ." ALL PARTS including Semi-conductors, A.B.C. Plans, etc. ONLY 18/6 plus 2/6 post, etc.



CONCORD ELECTRONICS LTD (Mail Order Only)
(Dept. R.C.11.) · 77 NEW BOND STREET · W.1

CHASSIS and CASES by



287/9 Edgware Road
London W2

TELEPHONE
PADDINGTON 5891/7595

CASES

ALUMINIUM, SILVER HAMMERED FINISH

Type	Size	Price	Type	Size	Price
U	4 x 4 x 4"	10/-	Y	8 x 6 x 6"	26/6
U	5 1/2 x 4 1/2 x 4 1/2"	15/-	Y	12 x 7 x 7"	41/-
U	8 x 6 x 6"	21/-	Y	13 x 7 x 9"	46/-
U	15 x 9 x 9"	44/6	Y	15 x 9 x 7"	48/6
W	8 x 6 x 6"	21/-	Z	17 x 10 x 9"	66/-
W	12 x 7 x 7"	34/-	Z	19 x 10 x 8 1/2"	71/-
W	15 x 9 x 8"	44/-		* Height	

Type W

Type Y

Type Z

Type U

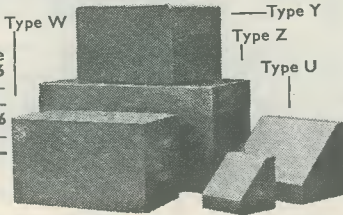

Type Z has removable back and front panels.
Type Y all-screwed construction.

BLANK CHASSIS—Same Day Service

Of over 20 different forms made up to YOUR SIZE.
(Maximum length 35", depth 4".)

SEND FOR ILLUSTRATED LEAFLETS

or order straight away, working out total area of material required and referring to table below which is for four-sided chassis in 16 s.w.g. aluminium.

48 sq. in.	4/3	176 sq. in.	9/-	304 sq. in.	13/6
80 sq. in.	5/6	208 sq. in.	10/-	336 sq. in.	14/9
112 sq. in.	6/6	240 sq. in.	11/3	368 sq. in.	15/9
144 sq. in.	7/9	272 sq. in.	12/6		and pro rata
	P. & P. 3/-		P. & P. 3/6		P. & P. 4/-

Discounts for quantities. More than 20 different sizes kept in stock for callers.

FLANGES (1/2" or 3/8"), 6d. per bend.
STRENGTHENED CORNERS, 1/- each corner.
PANELS

Any size up to 3ft at 5/3 sq. ft. 16 s.w.g. (18 s.w.g. 4/6).
Plus postage and packing

NYLON P.T.F.E.

ROD BAR SHEET TUBE STRIP WIRE

No quantity too small List on application

BRASS COPPER BRONZE ALUMINIUM LIGHT ALLOYS
STAINLESS STEEL

H. ROLLET & CO LTD

HOWIE STREET, LONDON, S.W.11 BATtERSEA 7872
Also at Liverpool, Birmingham, Manchester, Leeds, Glasgow.

(500/9)

SEMICON-INF SERVICE

Suppliers of all types of INDUSTRIAL & ENTERTAINMENT semiconductor devices. AMERICAN & CONTINENTAL items are our speciality. Send 9d. in stamps for a copy of our current Stock/Price list of over 650 types.

POWER Transistors for Audio Amplification & Switching.

TYPE	V _{CB}	I _C	P _D	h _{FE}	I _{CBO}	CASE	PRICE
ADY 26	-80	30A	75W	80	4.0mA	TO-36	£3 10 6
ADZ 11	-50	20A	45W	80		TO-36	£2 3 6
2N 277	-40	15A	150W	55	2.0mA	TO-36	£1 16 9
2N 301	-40	10A	30W	90	5.0mA	TO-3	£- 19 0
2N 307	-35	1A	100W	> 20	15mA	TO-3	£- 17 3
2N 554	-15	3A	65W	35dB	7.0mA	TO-3	£- 7 9
2N 555	-30	3A	65W	35dB	7.0mA	TO-3	£- 9 6

Power Transistor Sockets. TO-3 style. 1/11 each.

Please add 9d. P. & P. on all orders of £2 or less.

TERMS: C.W.O.

MAIL ORDER ONLY PLEASE.

M. R. CLIFFORD & CO. (R)

66 OLD OSCOTT LANE, BIRMINGHAM, 22A

the unique **PANL** black crackle paint

4/-d. per 1/8 pt. Can

(We regret we can only supply on cash with order basis)

BRUCE MILLER LTD.,

249 Coastal Chambers,
Buckingham Palace Road, S.W.1.

YOUR CAREER IN RADIO ?

Big opportunities and big money await the qualified man in every field of Electronics today—both in the U.K. and throughout the world. We offer the finest home study training for all subjects in radio, television, etc., especially for the CITY & GUILDS EXAMS. (Technicians' Certificates); the Grad. Brit. I.R.E. Exam.; the RADIO AMATEUR'S LICENCE; P.M.G. Certificates; the R.T.E.B. Servicing Certificates; etc. Also courses in Television; Transistors; Radar; Computers; Servo-mechanisms; Mathematics and Practical Transistor Radio course with equipment. We have OVER 20 YEARS' experience in teaching radio subjects and an unbroken record of exam. successes. We are the only privately run British home study Institute specialising in electronic subjects only. Fullest details will be gladly sent without any obligation.

SEND FOR FREE BROCHURE TO:

BRITISH NATIONAL RADIO SCHOOL
DEPT 4, RADIO HOUSE · READING · BERKSHIRE

YUKAN SELF-SPRAY

SO PROFESSIONAL
... THE YUKAN
AEROSOL WAY!

GET THIS AIR DRYING HAMMER FINISH

NOW!

YUKAN Aerosol spraykit contains 16 ozs. fine quality, durable, easy instant spray. No stove baking required. Available in Grey, Blue, Gold, Bronze at 14/11 at our counter or 15/11, carriage paid, per pushbutton self-spray can. SPECIAL OFFER: 1 can plus optional transferable snap-on trigger handle (value 5/-) for 18/11 carr. paid.



Choice of 13 self-spray plain colours and primer (motor car quality) also available.

Please enclose cheque or P.O. for total amount to:

YUKAN · DEPT RC/3 · 307a EDGWARE ROAD · LONDON · W.2

Open all day Saturday

Close Thurs. afternoons

THE RADIO CONSTRUCTOR — BOUND VOLUMES

NOW AVAILABLE

Volume 18, August 1964 to July 1965. Price £1 10s. 0d. Postage 3s. 6d.

Where all issues are returned: Price £1. Postage 3s. 6d.

We regret earlier volumes now sold out.

Send for list containing details of our other publications

DATA PUBLICATIONS LTD 57 MAIDA VALE LONDON W9

Please mention **THE RADIO CONSTRUCTOR** when writing to advertisers

BOOK LIST

DATA BOOKS SERIES

DB5 TV Fault Finding

96 pages. Price 6/-, postage 6d.

Profusely illustrated with photographs taken from a television screen depicting the faults under discussion and containing a wealth of technical information, with circuits, enabling those faults to be eradicated. Covers both B.B.C. and I.T.A.

"... A book that should be in every television dealer's service workshop, and in every home-constructor's, for that matter."—*Journal of the Television Society*.

DB6 The Radio Amateur Operator's Handbook

64 pages. Price 5/-, postage 5d.

Contains Amateur Prefixes, Radio Zone Boundaries, Amateur Band Frequency Allocations, Call Areas, Charts and Maps, Areas, Codes, Mileage Tables, Prefixes/Directional Bearings, Post Office Regulations, and much other useful operating data. For the beginner there are notes on how to use the mass of information given to obtain the greatest satisfaction from the hobby.

"... For concise knowledge in this field a few shillings well worth spending."—*Electronics* (Australia).

DB14 Short Wave Receivers for the Beginner

72 pages. Price 6/-, postage 6d.

Contains a selection of both battery and mains operated short wave receivers, circuits, point-to-point wiring diagrams and many illustrations. Introductory chapter gives much information on the Short Wave Spectrum, Clubs, QSL'ing, Aerials, Amateur and Broadcast Band Listening, Frequencies, etc.

This book has been specially prepared for the beginner interested in short wave receiver construction and operation.

DB15 Twenty Suggested Circuits

48 pages. Price 3/6, postage 5d.

By G. A. French. Covers subjects ranging from electronic laboratory equipment to the simplest of periodic switches. Includes: simple and inexpensive two-valve capacity bridge, short wave regeneration preselector, one-valve speech operated switching circuit, transformer ratio analyser, series noise limiter, receiver remote mains on-off control, and many other circuits.

DB16 Radio Control for Models

192 pages. Price 15/-, postage 9d.

By F. C. Judd. Contains both theory and practical designs of simple and advanced transmitters and receivers; basic concepts, aerials, uses of radio components, transistorised receivers, multi-channel operation, etc. Sections on servo-mechanisms by Raymond F. Stock.

More than 200 illustrations. Circuits, photographs, tables and working diagrams.

DB17 Understanding Television

512 pages. Price 37/6, postage 2/6

By J. R. Davies. This book, which deals with the principles of 625 line reception as fully as 405 line reception, fully explains: the nature of the television signal; the cathode ray tube; receiver tuner units; receiver i.f. amplifiers; a.f. and video amplifiers; vertical and horizontal timebases; deflector coil assemblies; synchronising; automatic gain and contrast control; power supplies and receiver aerials. Also includes a comprehensive introduction to colour television.

"... one of the best books that aims to explain television in simple language...". R.S.G.B. Bulletin.

I enclose Postal Order/Cheque for

NAME

ADDRESS

(Please use Block Capitals for both name and address)

Postal Orders should be crossed and made payable to Data Publications Ltd.

Overseas customers please pay by International Money Order

All publications are obtainable from your local bookseller

Data Publications Ltd., 57 Maida Vale, London W.9

1966 150 BIG PAGE
CATALOGUE

5,000 stocked items. Fully detailed and illustrated. FREE vouchers give 2/- in (post paid) the £ discount.

PRICE 6/-

PROVED & TESTED DESIGNS

FULL AFTER SALES SERVICE AND GUARANTEE

★ **CALL IN FOR DEMONSTRATIONS** ★

DETAILED LEAFLETS FREE ON REQUEST

FREE New 16 page catalogue 500 transistors, rectifiers, scr's, light devices, heat sinks, 1,000 crystals, 800 valves, etc. Ask for your FREE copy NOW

MW/LW POCKET SUPERHET RADIO

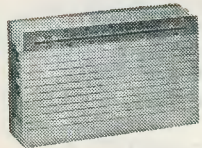

TOTAL COST TO BUILD **85/-** P.P. 2/-
(Battery 2/6 Phone 5/-)

★ All parts sold separately.

- ★ 6-Transistor design. Push-pull output.
- ★ 2 1/2" Cleartone speaker. Printed circuit.
- ★ Attractive moulded cabinet.
- ★ Slow motion tuning.
- ★ Full medium and long waves.
- ★ Size: 5" x 3" x 1 1/2".

● **AMAZING SENSITIVITY AND SELECTIVITY** ●

- ★ 6-Transistor push-pull design.
- ★ Uses factory built panels.
- ★ Permeability geared tuning.
- ★ Full med./long wave tuning with push-button wave change.
- ★ Double tuned IFT'S.
- ★ Chromed front panel plate.
- ★ Size: 7" x 4" x 2". Fits any car.
- ★ Pre-built units sold separately.

TOTAL COST TO BUILD **£8.19.6** P.P. 3/6

(7" x 4" speaker with car fixing kit and baffle board 20/- extra.)

TWO WAVEBAND ALL-TRANSISTOR CAR RADIO TO ASSEMBLE
● **HIGH PERFORMANCE SUPERHET** ●



2- AND 4-TRACK TAPE RECORDERS TO ASSEMBLE

Pre-built Equipment—6 Valves—Collaro Studio Decks—Portable Cabinets with Speakers. Complete record and playback.



★ 2 track deck 10 gns. P.P. 5/- Amplifier 11 gns. Cabinet with speaker 5 gns.

OR SPECIAL PRICE **£26** P.P. **TWO TRACK** 8/6

★ 4-track deck £13.10.0. P.P. 5/- Amplifier 12 gns. Cabinet with speaker 5 gns.

OR SPECIAL PRICE **£30** P.P. **FOUR TRACK** 8/6
(Now with new '363' decks)

10W & 20W HI-FI AMPLIFIERS

Prebuilt and tested units. Low distortion, low noise

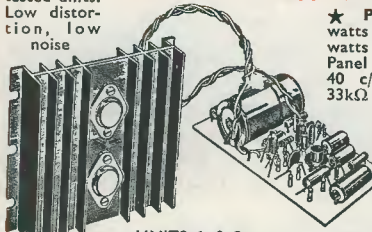

UNITS 1 & 2

★ **POWER AMPLIFIERS.** 10 watts R.M.S. music power. 20 watts peak. 6-Transistor design. Panel size 4" x 2 1/2" x 3". Response 40 c/s to 20 kc/s. 100mV into 33kΩ input.

UNIT 1. For 12/15 ohm speakers. 40 volt supply.

PRICE BUILT **£5.19.6** P.P. 2/6

UNIT 2. For 3 to 5 ohm speakers. 24/28 volt supply.

PRICE BUILT **£5.10.0** P.P. 2/6

★ **MAINS UNITS.** 59/6. To power one amplifier or 69/6 to power two amplifiers. (State 24 or 40 volt version.)

PREAMPLIFIERS. Mono and stereo versions, 8 inputs, 1 1/2 to 300mV at 1k to 500k. Response 30 c/s to 20 kc/s. Complete range of controls. Mains unit or battery operated. For pickups, tuners, tape, microphones, etc.

UNIT 3. Mono full-function pre-amplifier. Size 9 1/2" x 2 1/2" x 2".

PRICE BUILT **£5.10.0** P.P. 2/-

(Brown/Gold front panel plate 8/6)

UNIT 4. Simplified version of Unit 3. Price 65/- P.P. 1/6. Panel plate 6/6.

UNIT 5. Stereo preamplifier for use with two units 1 or 2. Size 9" x 3 1/2" x 1 1/2".

PRICE BUILT **£10.19.6** P.P. 3/6

(Front panel plate 12/6)



UNIT 5

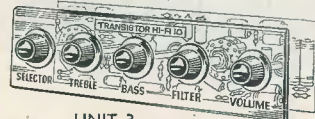

UNIT 3

THE FINEST QUALITY HI-FI AT UNBEATABLE PRICES

TRANSISTOR TRANSMITTER/RECEIVERS



★ 1/2 mile range, price per pair **£7.19.6**

★ 5 mile range, price per pair **£22.10.0**

4-CHANNEL MICROPHONE MIXER



Transistorised, 4 inputs up to 100kΩ. Full mixing. 49/6
Stereo 72/6

SINCLAIR DESIGNS

- ★ Micro-6 MW radio 59/6
- ★ TR750 "Add-on" power amp. 39/6
- ★ Micro injector 27/6
- ★ Micro amp. 28/6
- ★ X10 Amp. kit **£5.19.6**

NEW FM RADIO

- ★ **POCKET VHF KIT £5.19.6**
- ★ **X20 AMPLIFIER Kit £7.19.6**
- ★ **Built £9.19.6**
- ★ **Mains unit 99/6**
- ★ **Z12 AMPLIFIER 89/6**

5 WATT AND 1 1/2 WATT PACKAGED AMPLIFIERS

- ★ 6-Transistor push-pull printed circuit designs.
- ★ Size only 2 3/4" x 2" x 1 1/2".
- ★ 5 watt 18 volt, 1 1/2 watt 12 volt.
- ★ For 3 to 5 ohm speakers.
- ★ 7mV into 1kΩ 30 c/s to 16 kc/s.



PRICES BUILT **1 1/2w 65/-P.P. 1/6** **5w 79/6 P.P. 1/6**

● **Mono PREAMPLIFIER**

Full range of controls, inputs for mics, p.-u., tuner, etc. Output 6-10mV. Suitable for any sensitive transistor amplifiers as above. 7 1/2/12/18V operated. Price built/tested incl. panel 79/6. P.P. 2/6.

HI-FI ALL MAKES AVAILABLE—New Hi-Fi Demonstration Room Opening Shortly

TRANSISTOR PORTABLE TEST EQUIPMENT

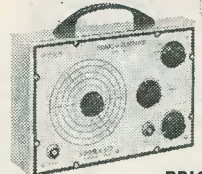

All units size 6 1/2" x 4 1/2" x 2 1/2".

★ RF generator, 150 kc/s to 350 Mc/s in 8 ranges. RF, Mod. RF, AF outputs.

PRICE **£9.10.0** P.P. 2/6

- ★ Resistance/capacitance bridge. **£8.5.0** P.P. 2/6.
- ★ Audio generator 10 c/s-100 kc/s. 4 ranges. **£16.15.0**. P.P. 2/6.

VHF/FM TUNER TO ASSEMBLE



★ Two pre-built plus metal work and front panel. Total Cost **£12.17.6** P.P. 2/6.

- ★ Size: 9 1/2" x 3 1/2" x 4".
- ★ 88 to 108 Mc/s tuning. **£12.17.6** P.P. 2/6.
- ★ 100mV to 100kΩ output
- ★ 6-Transistor printed cct. superhet design.

NEW SW/MW/LW PUSH-BUTTON PORTABLE TO BUILD. 3 wavebands

TOTAL COST **£8.19.6** P.P. 3/6

The only fully Tunable 3-waveband radio for home construction.



- ★ Push-button coil pack.
- ★ 1 watt push-pull output.
- ★ Ferrite aerial/Telex. aerial/special car coils.
- ★ Printed circuit 6-transistor design.
- ★ SW 17/50m. LW 1100/1900m. MW 195/550m.
- ★ Car aerial and tape sockets.
- ★ Attractive sturdy cabinet with handle. Size 11" x 7 1/2" x 3 1/2". Black fabric with chrome fittings.

LET US QUOTE PARTS FOR YOUR CIRCUIT, SEND LIST FOR QUICK REPLY

VHF/FM TRANSISTOR TUNER TO BUILD

TOTAL COST **£6.19.6**

P.P. 2/6 (complete with frontplate) (Goldsprayed cabinet 20/- extra).

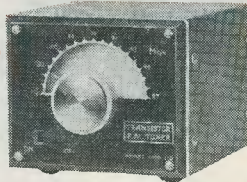

- ★ 5-Transistor 4 diodes.
- ★ Printed circuit superhet.
- ★ Geared tuning 87 to 105 Mc/s FM.
- ★ RF stage and double tuned IFT'S.
- ★ Output up to 1 volt peak up to 100kΩ.
- ★ 9 volt 9mA supply.
- ★ Size in cabinet 4" x 3 1/2" x 2 1/2".
- ★ All parts sold separately.

HENRY'S RADIO LTD.

303 EDGWARE ROAD, LONDON, W2

PADddington 1008/9

Open Mon. to Sat. 9-6. Thurs. 1 p.m. Open all day Saturday