

155P

THE Radio Constructor

RADIO
TELEVISION
AUDIO
ELECTRONICS

VOLUME 19 NUMBER 3
A DATA PUBLICATION
TWO SHILLINGS & THREEPENCE

October 1965

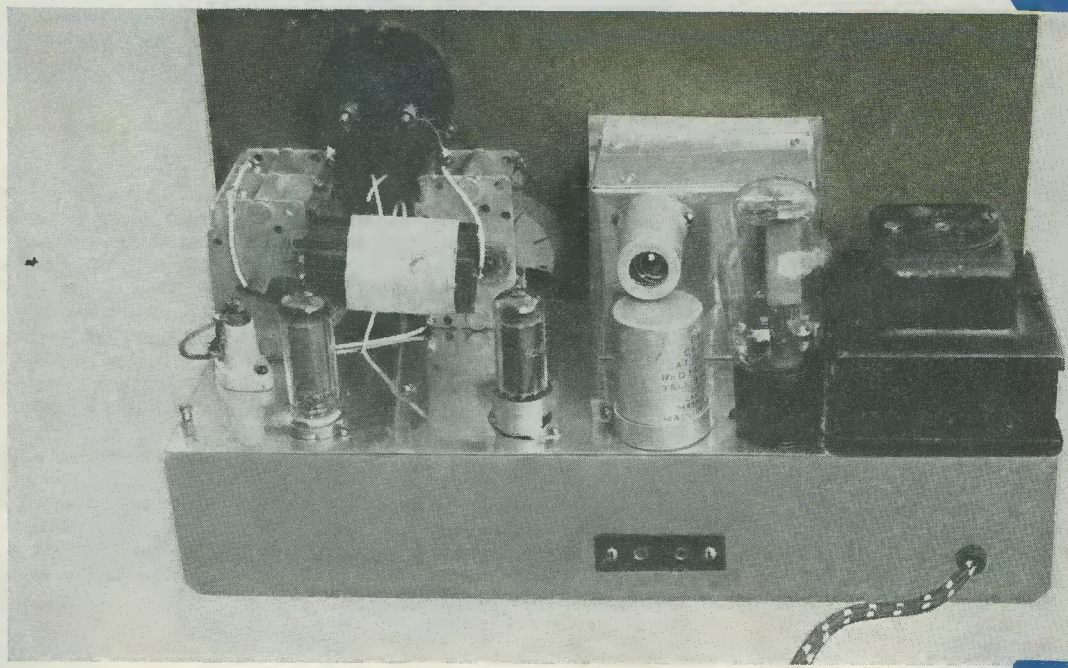

VFO Top Band Phone Transmitter

Sine/Square Wave
Converter



Infra-Red Ray
Alarm System



HFE Tester for
Power Transistors



Quality
Multimeter



Eddystone

HIGH STABILITY
AMATEUR BANDS
COMMUNICATIONS RECEIVER

EA 12
£185

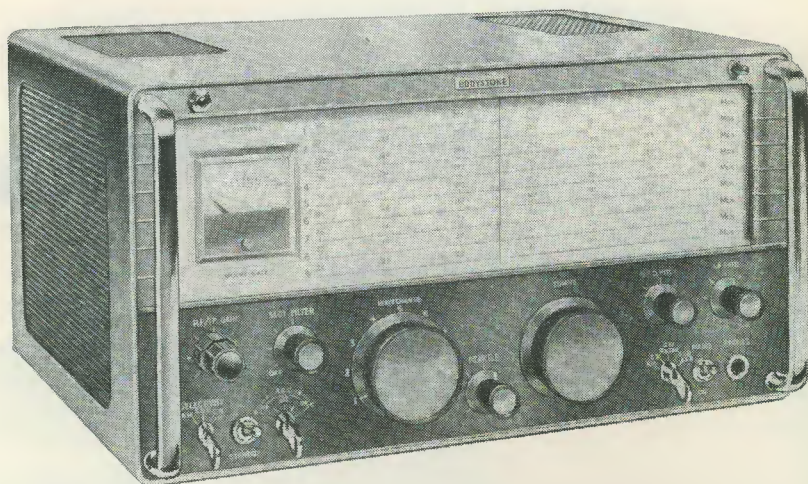

The Eddystone "EA12" receiver is specially designed and built to give the extremely high performance, allied with ease of control, necessary for communications on the amateur bands under present-day conditions. With the many refinements included, this model will produce first-class results with all modes of signal.

The first oscillator is crystal controlled. The oscillator which is tuned simultaneously with the first intermediate frequency section has very high stability, as is so essential with reception of s.s.b. and c.w. signals. The correct degrees of selectivity for optimum performance are obtained in the second intermediate frequency (100 kc/s) stages.

A more than adequate degree of bandspread is provided by the superb slow-motion drive (140/1 reduction ratio) in conjunction with the wide linear scales, each of which covers 600 kc/s. A crystal calibrator and cursor adjuster permit accurate frequency resolution.

Other features to note—full coverage on six amateur bands; switched sideband selection; fine tuning control (s.s.b.); crystal filter; deep slot filter; noise limiter effective all modes; large "S" meter; two AGC time-constants; independent gain controls; stand-by sensitivity control; bright scale illumination; robust construction; modern styling and fine finish.

Comprehensive information obtainable from any Eddystone Distributor or from the Manufacturers

Eddystone Radio Limited

Eddystone Works, Alvechurch Road, Birmingham 31

Telephone Priory 2231 Cables Eddystone Birmingham Telex 33708

EXCEL in

RADIO AND ELECTRONICS

AS A CAREER OR AS A FASCINATING HOBBY...

THERE IS AN ICS COURSE FOR YOU!

By taking an ICS specialised home study course you gain a sound theoretical and practical knowledge of valve and transistor circuits and servicing work while building your own 5-valve receiver, transistor portable (or a.f. amplifier), signal generator and multi-test meter. *All under expert tuition!*

ICS Construction Courses have been specially written and designed by experienced radio engineers to enable YOU to learn easily and quickly, in your own home, in your own time.

ICS training will take you from basic principles to advanced applications of various circuits, all made up from the kits supplied.

With the ICS Complete Radio and Electronics Construction Course you get SIX kits, including testing instruments, tools and first class components. And, what is most important, a personal library of Instruction Manuals.

If you are making a career in the Radio Industry, you will be interested in the wide range of examination and specialist diploma courses offered by ICS. These include:

Radio and Television Engineering, Industrial Television, Radio and Television Servicing, Colour Television, Electronic Technicians, Servomechanisms, Radio-Electronic Telemetry, Instrumentation, Principles of Automation, Calculus for Electronics, Digital and Analogue Computers.

Specialised coaching for Grad.I.E.R.E., C.&G. Telecommunication Technician's Cert. Radio & TV Servicing Cert.(R.T.E.B.), P.M.G. Certs. and Radio Amateur's Exam.

Examination students coached until successful

PRACTICAL INSTRUCTION!

1

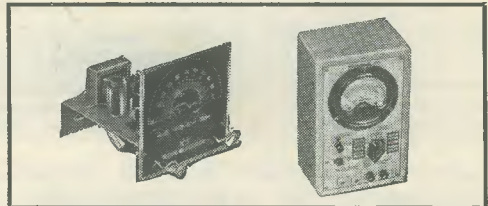

Assembly and use of signal generator and multi-test meter (especially valuable in servicing work).

2

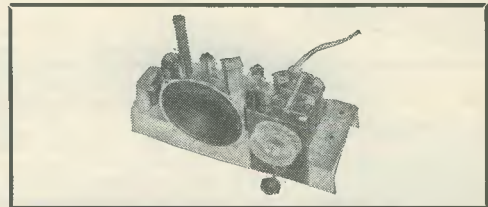

Construction of 5-valve 2-waveband AC/DC super-heterodyne receiver, and a number of instructional experiments, using testing instruments.

3

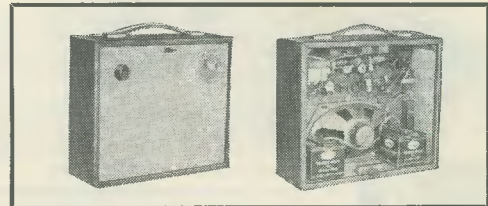

Construction of 6-transistor (with semiconductor diode) 2-waveband portable, and a number of instructional experiments, including a.f. amplifier with microphone pre-amplifier.

For full details
of ICS Radio and
Electronics Courses
post coupon
TODAY

ICS (DEPT. 248) INTERTEXT HOUSE
PARKGATE ROAD, LONDON, S.W.11

NAME

AGE

ADDRESS

10.65

INTERNATIONAL CORRESPONDENCE SCHOOLS

Member of the Association of British Correspondence Colleges



Choose Heathkit models for value and performance
Easy-to-follow instruction manuals tell you how to build any model

HI-FI AMPLIFIERS ~~~~~ TUNERS ~~~~~ RECORD PLAYERS

STEREO AMP. AA-22U

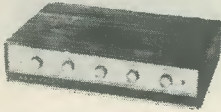

PLAYER AT-60



TRANSISTOR MIXER. Model TM-1. A must for the tape enthusiast. Four channels. Battery operated.
Kit £11.16.6 Assembled £16.17.6

20+20W TRANSISTOR STEREO AMPLIFIER. Model AA-22U. Outstanding performance. Handsome, walnut-veneered cabinet.
Kit £43.18.0 Assembled £68.16.0

GARRARD AUTO/RECORD PLAYER. Model AT-60. less cartridge £13.1.7 With Decca Deram pick-up £16.15.1 incl. P.T.

HI-FI MONO AMPLIFIER. Model MA-5. A general purpose 5W Amplifier, with inputs for Gram., Radio. Presentation similar to S-33.
Kit £10.19.6 Assembled £15.10.0
Many other Garrard models available.

PA AMPLIFIER, Model PA-1. 50W amplifier. The ideal, compact unit. Two heavy duty speakers. Variable tremolo.
Legs optional extra 17/6 Kit £54.15.0 Assembled £74.0.0

NEW MODEL !

TRANSISTOR PA/GUITAR AMPLIFIER, PA-2. 20 Watt amplifier, Two heavy duty speakers. Four inputs on two channels. Variable tremolo. Speed and depth controls. Elegant compact cabinet, weight 51lb. 18" high x 29" wide x 10" deep.
Kit £44.19.0 Assembled £59.10.0
Castors or legs available as extras.

TRANSISTOR RECEIVERS

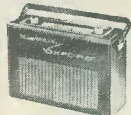

UXR-2



UXR-1



UJR-1

"OXFORD" LUXURY PORTABLE. Model UXR-2. Specially designed for use as a domestic, car or personal portable receiver. Many features, including solid leather case. Kit £14.18.0 incl. P.T.

TRANSISTOR PORTABLE. Model UXR-1. Pre-aligned I.F. transformers, printed circuit. Covers L.W. and M.W. Has 7" x 4" loudspeaker. Real hide case.
Kit £12.11.0 incl. P.T.

JUNIOR EXPERIMENTAL WORKSHOP. Model EW-1. More than a toy! Will make over 20 exciting electronic devices, incl: Radios, Burglar Alarms, etc. 72 page Manual. The ideal present! Kit £7.13.6 incl. P.T.

JUNIOR TRANSISTOR RADIO. Model UJR-1. Single transistor set. Excellent introduction to radio. Kit £2.7.6 incl. P.T.

We shall be exhibiting at the
INTERNATIONAL
RADIO COMMUNICATION EXHIBITION
Seymour Hall, London,
27-30 October 1965, Stands 22, 23

POWER AMP. MA-12

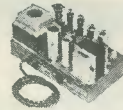

STEREO AMP. S-99

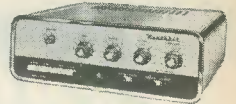

HI-FI MONO AMPLIFIER. Model MA-12. 10W output, wide freq. range low distortion.
Kit £11.18.0 Assembled £15.18.0

DE LUXE STEREO AMPLIFIER. Model S-33H. De luxe version of the S-33 with two-tone grey perspex panel, and higher sensitivity necessary to accept the Decca Deram pick-up.
Kit £15.17.6 Assembled £21.7.6

HI-FI STEREO AMPLIFIER. Model S-99. 9 + 9W output. Ganged controls. Stereo/Mono gram., radio and tape inputs. Push-button selection. Printed circuit construction.
Kit £28.9.6 Assembled £38.9.6

POWER SUPPLY UNIT. Model MGP-1. Input 100/120V, 200/250V 40-60 c/s. Output 6.3V, 2.5A A.C. 200, 250, 270V, 120mA max. D.C.
Kit £5.2.6 Assembled £6.12.6

HI-FI CABINETS. A wide range available, prices from £8.8.0 to £46.4.0 incl. P.T. Assembled or in kit form.

INSTRUMENTS

DE LUXE LARGE-SCALE VALVE VOLTMETER: Model IM-13U. Circuit and specification based on the well-known model V-7A but with many worth-while refinements. 6" Ernest Turner meter. Unique gimbal bracket allows operation of instrument in many positions. Modern styling.
Kit £18.18.0 Assembled £26.18.0

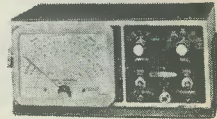

IM-13U

AUDIO SIGNAL GENERATOR. Model AG-9U. 10 c/s to 100 kc/s, switch selected. Distortion less than 0.1%, 10V sine wave output metered in volts and dB's.
Kit £22.10.0 Assembled £30.10.0



V-7A

VALVE VOLTMETER. Model V-7A. 7 voltage ranges d.c. volts to 1,500. A.c. to 1,500 r.m.s. and 4,000 peak to peak. Resistance 0.1Ω to 1,000MΩ with internal battery. D.c. input resistance 11MΩ. dB measurement, has centre-zero scale. Complete with test prods, leads and standardising battery.
Kit £13.18.6 Assembled £19.18.6



RF-1U

MULTIMETER. Model MM-1U. Ranges 0-1.5V to 1,500V a.c. and d.c.; 150μA to 15A d.c.; 0.2Ω to 20MΩ. 4½" 50μA meter. Kit £12.18.0 Assembled £18.11.6

R.F. SIGNAL GENERATOR. Model RF-1U. Up to 100 Mc/s fundamental and 200 Mc/s on harmonics. Up to 100mV output.
Kit £13.8.0 Assembled £19.18.0

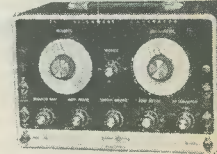

HFW-1

T.V. ALIGNMENT GENERATOR. Model HFW-1. Offers max performance at lowest cost. Covers 3.6 to 220 Mc/s fundamentals. Electronic sweep oscillators. Built in marker generators (5 Mc/s crystal).
£37.18.0 Kit
£47.10.0 Assembled

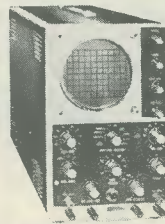

IO-12U

5" GENERAL-PURPOSE LABORATORY OSCILLOSCOPE. Model IO-12U. This outstanding oscilloscope, with its professional specification and styling fulfils most laboratory and service requirements. Vertical frequency response 3 c/s to over 4.5 Mc/s, sensitivity 10mV r.m.s. per cm. at 1 kc/s. T/B covers 10 c/s to 500 kc/s. Kit £35.17.6 Assembled £45.15.6

2½" PORTABLE SERVICE SCOPE. Model OS-1. This is a light, compact oscilloscope, ideal for servicing, etc. Dimensions 5" x 8" x 14½" long. Wt. 10½lb. Fitted with metal CRT shield. Kit £22.18.0 Assembled £30.8.0

ELECTRONIC SWITCH. Model S-3U. Converts a single beam scope to double beam operation at low cost.
Kit £12.18.0
Assembled £18.10.0

TRANSISTOR POWER SUPPLY. Model IP-20U. Up to 50V, 1.5A output. Ideal for Laboratory use.
Kit £35.8.0
Assembled £47.8.0

Enjoy Yourself and Save Money with these Kits

No previous experience required to build any Heathkit model



TAPE AMPLIFIERS ~~~~~ TAPE DECKS ~~~~~ CONTROL UNITS

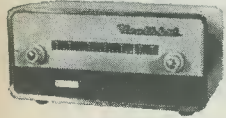

FM
TUNER
FM-4U

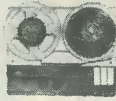

MAGNAVOX
NEW
TAPE
DECK

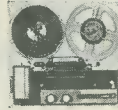

TRUVOX
TAPE
DECK



AM/FM
TUNER

HI-FI FM TUNER. Model FM-4U. Also available in two units. R.F. tuning unit (£2.15.0 incl. P.T.) with I.F. output of 10.7 Mc/s, and I.F. amplifier unit, with power supply and valves (£13.13.0).

Total Kit **£16.8.0**

MAGNAVOX NEW TAPE DECK. The finest buy in its price range. Operating speeds: 1½", 3½" and 7½" p.s. Two tracks, "wow" and "flutter" not greater than 0.15% at 7½" p.s. **£14.19.6**

HI-FI AM/FM TUNER: Model AFM-1. Available in two units which, for your convenience, are sold separately. Tuning heart (AFM-T1—£4.13.6 incl. P.T.) and L.F. amplifier (AFM-A1—£22.11.6). Printed circuit board, 8 valves. Covers L.W., M.W., S.W., and F.M. Built-in power supply. Total Kit **£27.5.0**

TRUVOX D-93 TAPE DECKS. High quality stereo/mono tape decks. D93/2, ¼ track, **£36.15.0** D93/4, ¼ track, **£36.15.0**

TAPE RECORDING/PLAYBACK AMPLIFIER. Thermometer type recording indicators, press-button speed compensation and input selection.

Mono Model TA-1M. Kit **£19.18.0** Assembled **£28.18.0**
Stereo Model TA-1S. Kit **£25.10.0** Assembled **£35.18.0**

MONO CONTROL UNIT. Model UMC-1. Designed to work with the MA-12 or similar amplifier requiring 0.25V or less for full output. 5 inputs. Baxandall type controls. Kit **£8.12.6** Assembled **£13.12.6**

STEREO CONTROL UNIT. Model USC-1. Push-button selection, accurately matched ganged controls to ±1dB. Rumble and variable low-pass filters. Printed circuit boards. Kit **£19.10.0** Assembled **£26.10.0**

SPEAKER SYSTEMS

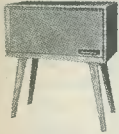

SSU-1

HI-FI SPEAKER SYSTEM. Model SSU-1. Ducted-port bass reflex cabinet "in the white". Two speakers. Vertical or horizontal models with legs, Kit **£12.12.0**, without legs, Kit **£11.17.6** incl. P.T.



MFS

COTSWOLD "MFS" SYSTEM. Designed to give best possible results where floor space is at a premium. This minimum floor space model is based on standard Cotswold. Size: 36" high x 16½" wide x 14½" deep.

Kit **£25.12.0** Assembled **£33.17.0**

THE "COTSWOLD". This is an acoustically designed enclosure 26" x 23" x 15½" housing a 12" bass speaker with 2" speech coil, elliptical middle speaker together with a pressure unit to cover the full frequency range of 30-20,000 c/s. Capable of doing justice to the finest programme source, its polar distribution makes it ideal for really Hi-Fi Stereo.

Kit **£25.12.0** Assembled **£33.17.0**

"AMATEUR" EQUIPMENT

AMATEUR BANDS RECEIVER. Model RA-1. To cover all the Amateur Bands from 160-10 metres. Many special features, including: half-lattice crystal filter; 8 valves; signal strength "S" meter; tuned R.F. Amp. stage.

Kit **£39.6.6** Assembled **£52.10.0**

THE "MOHICAN" GENERAL COVERAGE RECEIVER. Model GC-1U. With 4 piezo-electric transfilters, variable tuned B.F.O. and Zener diode stabiliser, this is an excellent fully transistorised general purpose receiver for Amateur and Short wave listeners. Printed circuits, telescopic aerial, tuning meter and large slide-rule dial.

Kit **£37.17.6** Assembled **£45.17.6**

160-10M TRANSMITTER. Model DX-100U. Careful design has achieved high performance and stability. Completely self-contained.

Kit **£79.10.0** Assembled **£104.15.0**

COMMUNICATIONS TYPE RECEIVER. Model RG-1. A high performance, low cost receiver for the discriminating listener. Frequency coverage: 600 kc/s-1.5 Mc/s and 1.7 Mc/s-32 Mc/s.

Kit **£39.16.0** Assembled **£53.0.0**

REFLECTED POWER METER and SWR BRIDGE. Model HM-11U. Indicates reliably, but inexpensively, whether the RF power output of your TX is being transferred efficiently to radiating antenna.

Kit **£8.5.0** Assembled **£10.10.0**

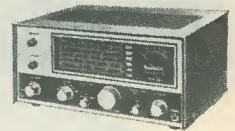

RA-1

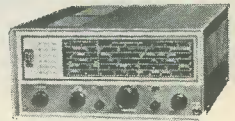

RG-1



HM-11U

NEW MODELS



IM-30U

TRANSISTOR TESTER IM-30U

Provides complete d.c. analysis of PNP and NPN transistors and diodes. Kit **£24.18.0** Assembled **£35.10.0**

HARMONIC DIST. METER IM-12U

Freq. coverage 20-20,000 c/s. Dist. ranges 1, 3, 10, 30, 100% f.s.d. VM ranges 0, 1, 3, 10, 30 volts f.s.d. Input Resistance 300kΩ. Kit **£24.15.0** Assembled **£34.0.0**

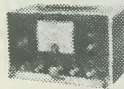

IM-12U

AMERICAN HEATHKIT "AMATEUR" EQUIPMENT

A wide range of American Amateur SSB equipment is now available in the U.K. Why not send for full details of range, for example:

80-10M RECEIVER. Model SB-300E.

Of advanced design employing up-to-date construction techniques, its specification ensures unparalleled performance.

Kit **£133.14.0** (less speaker) + import levy



SB-300E

MANY OTHER BRITISH MODELS

Send for free Catalogue

Deferred terms available in U.K. over £10.
Extended terms over £75. Send for details.

DAYSTROM LTD

DEPT. RC.10
GLOUCESTER

Without obligation please send me

FREE BRITISH HEATHKIT CATALOGUE

FULL DETAILS OF MODEL(S)

(Please write in BLOCK CAPITALS)

NAME

ADDRESS

(Tick here)

DEPT. RC.10

AN ALL-BRITISH PRODUCT

Sinclair's greatest achievement yet!

THE WORLD'S FIRST POCKET-SIZE COMBINED F.M. TUNER AND RECEIVER

SINCLAIR MICRO FM

7 TRANSISTORS • 2 DIODES • AFC • 2 OUTPUTS



SIZE
2 1/16" x 1 5/8" x 3/4"

Sinclair's latest design, the SINCLAIR MICRO FM is a high quality FM tuner designed to be used with hi-fi amplifier or tape recorder. It can also be used independently as a self-contained pocket F.M. receiver for personal listening anywhere. This exciting Sinclair triumph, barely half the size of a packet of 20 cigarettes, is a fully fledged 7 transistor-2 diode superhet circuit incorporating many unique and original design features to achieve fantastically good standards of performance. Pulse counting detection ensures better linearity than conventional detection methods, and therefore better audio quality. Powerful A.F.C. together with unusually good sensitivity make tuning easy, and the set's own telescopic aerial suffices almost everywhere. The two-output arrangement allows the unit to be used both as a tuner and as a self-contained receiver. In styling, this is the most elegant, most professional looking design in miniaturised equipment ever made available to constructors, and is one you will be justifiably proud to possess. **YET WITH ALL THESE WONDERFUL FEATURES, THE SINCLAIR MICRO F.M. COSTS POUNDS LESS AND OFFERS ADVANTAGES NOT FOUND IN ANY OTHER F.M. TUNER.**

Advance design features ensure superb performance

- Pulse counting detector
- A.F.C.
- Unique circuitry
- Professionally styled case
- High sensitivity
- Tunes from 88-108 Mc/s
- Requires no alignment
- A SINCLAIR GUARANTEED DESIGN

USE IT AS A TUNER AND A POCKET F.M. RADIO

★ TECHNICAL DESCRIPTION

Seven transistor, two diode F.M. superhet for use both as a tuner and a self-contained pocket portable receiver. The screw-on telescopic aerial is coupled to an R.F. amplifier followed by a self-oscillating mixer. Use of a low I.F. dispenses with the need for bulky I.F. transformers and alignment. A three stage I.F. amplifier amplifies and limits the signal to produce a square wave of constant voltage which is fed into the pulse counting discriminator. This converts the square wave formation into uniform pulses, the average output from which is directly proportional to the signal frequency, so that the original modulation is reproduced exactly. After equalisation for pre-emphasis, the signal is fed to the audio output socket for use with an amplifier or recorder and also to the receiver's own audio amplifying stage which enables the Micro FM to be used also as an independent self-contained receiver. A.F.C. makes tuning simple as each station is automatically "locked" as the dial is turned. THE SINCLAIR MICRO FM is completely self-contained

within a neat black plastic case faced by an elegantly designed front panel of brushed and polished solid aluminium with spun aluminium tuning dial to match. The tuning scale is marked in Mc/s.

- SUPPLY VOLTAGE—9V from self-contained standard battery
- CONSUMPTION—5mA
- SENSITIVITY—Typically 3 microvolts
- AUDIO OUTPUT—300MV approx. from 25K ohms
- HIGH LEVEL AUDIO OUTPUT—9V peak
- TUNING RANGE—87.5 to 108 Mc/s.
- SIGNAL TO NOISE RATIO—30dB at 30 microvolts
- AUDIO FREQUENCY RESPONSE—10 to 20,200 c/s ± 1dB

THE COMPLETE KIT OF PARTS for building the SINCLAIR MICRO FM including extending aerial, 7 transistors, case, tuning dial, aluminium front panel, lightweight earpiece, plugs and sockets and instructions cost only

£5.19.6

FULL SERVICE FACILITIES ALWAYS AVAILABLE TO SINCLAIR CUSTOMERS

SINCLAIR

SINCLAIR RADIONICS LTD.,
COMBERTON, CAMBRIDGE Telephone: COMBERTON 682

DESIGNED FOR POWER & QUALITY

SINCLAIR X-20

INTEGRATED 20 WATT P.W.M. AMPLIFIER AND PRE-AMP.

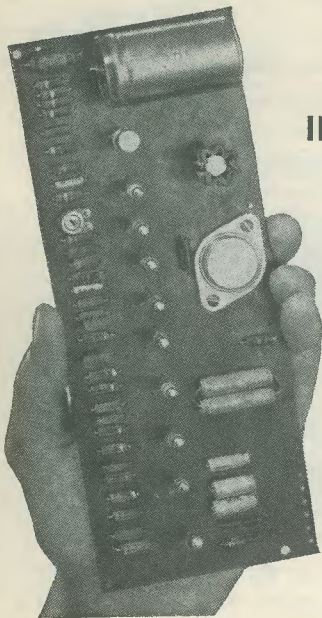

By the use of Pulse Width Modulation in circuitry developed exclusively by Sinclair Radionics, the unique X-20 achieves standards never before reached by any audio amplifier in the world. From the input through to the power output stage, this amazing amplifier gives quality and power far ahead of anything in its class to make it the most original and interesting design for years. You use your X-20 like any conventional quality amplifier. It has

brilliant transient response and a flat frequency response from 20 to 20,000 c/s well as a reserve of power to give you all you will ever want in real high fidelity reproduction, yet with all these features this remarkable amplifier, which is complete with integrated pre-amp occupies far less space, costs less and behaves perfectly. It brings a refreshingly new approach to audio that is setting the standard for the whole industry. You can build the X-20 in a single evening!

MEASURES 8 $\frac{1}{4}$ " x 3 $\frac{1}{4}$ " x 1" — DELIVERS 20 WATTS R.M.S.

Only the Sinclair X-20 has all these features!

- ★ 12 Transistors including silicone epitaxial planars in output stage.
- ★ Constant square wave amplitude
- ★ 95% conversion efficiency factor at output
- ★ Frequency response—20 to 20,000 c/s 1dB
- ★ Total harmonic distortion—0.1% at 10 watts R.M.S.
- ★ Input sensitivity—1mV into 5k Ω
- ★ Signal to noise ratio—better than 70dB
- ★ Output into 7.5 ohms—20 watts R.M.S. music power 15 watts R.M.S. continuous
- ★ Output into 15 ohms—15 watts R.M.S. music value 10 watts R.M.S. continuous
- ★ Also makes an ideal guitar of P.A. amplifier
- ★ Built-in low-pass filter ensures wide tolerance-to-load at output
- ★ Power requirements—36V d.c. at 700mA
- ★ Add tone and volume control systems to choice, mono or stereo, as described in the X-20 manual

X-20 MANUAL

Details in full tone and volume control systems to suit the equipment you use with your X-20. Includes stereo, stereo balance and input switching. FREE with all X-20 amplifiers. Available separately 2/- post free.

Complete kit of parts including X-20 Manual and instructions.

£7.19.6

Ready built and tested

£9.19.6

X-20 power supply unit to drive up to two X-20s.

£4.19.6

Everybody's building the smallest set in the world! — It's fantastic!

- SIZE 1 $\frac{4}{5}$ " x 1 $\frac{3}{10}$ " x 1 $\frac{1}{2}$ "
- WEIGHT UNDER 1 OZ
- AMAZING POWER AND SELECTIVITY
- GETS LUXEMBOURG LIKE A LOCAL STATION
- BUILT IN AN EVENING

SINCLAIR MICRO-6

No transistor set has ever yet compared with the six-stage Micro-6 for size, power, performance and design. No set has ever given such pleasure and satisfaction both in building and using it. Everything except the lightweight earpiece is contained within the tiny, elegant white, gold and black case. Important features include bandspread at the higher frequency end of the tuning for easy reception of Luxembourg, powerful A.G.C. to counteract fading of distant stations, and vernier type tuning. Quality is outstandingly good. Many thousands of Micro-6 receivers have been built all over the world, and it cannot be too highly recommended as an intriguing design to build and a most practical radio to use. When you have built it you will want your Micro-6 with you always—and it plays everywhere!



It's easy for anyone to build the Micro-6 and have it working in an evening. All parts including the special Metal Alloy Transistors, case, dial, lightweight earpiece, all parts and easy to follow instructions come to

59/6 COMPLETE

MALLORY MERCURY CELL ZM312 (2 required) each 1/11 (Pack of 6—10/6)

GUARANTEE

Should you not be completely satisfied with your purchase when you receive it from us, your money will be refunded in full and at once without question.

GUARANTEE ORDER FORM

To: SINCLAIR RADIONICS LTD., COMBERTON, CAMBRIDGE

Please send me under guarantee

for which I enclose Cash/Cheque/Money Order value £.....s.....d.

NAME

ADDRESS

If you do not wish to cut page, please mention R.C.10 when writing your order.

Scottish Insurance Corporation Ltd

38 EASTCHEAP · LONDON · EC3



TELEVISION SETS, RECEIVERS AND TRANSMITTERS

Television Sets, Receivers and Short Wave Transmitters are expensive to acquire and you no doubt highly prize your installation. Apart from the value of your Set, you might be held responsible should injury be caused by a fault in the Set, or injury or damage by your Aerial collapsing.

A "Scottish" special policy for Television Sets, Receivers and Short Wave Transmitters provides the following cover:

- (a) Loss or damage to installation (including in the case of Television Sets the Cathode Ray Tube) by Fire, Explosion, Lightning, Theft or Accidental External Means at any private dwelling-house.
- (b) (i) Legal Liability for bodily injury to Third Parties or damage to their property arising out of the breakage or collapse of the Aerial Fittings or Mast, or through any defect in the Set. Indemnity £10,000 any one accident.
- (ii) Damage to your property or that of your landlord arising out of the breakage or collapse of the Aerial Fittings or Mast, but not exceeding £500.

The cost of Cover (a) is 5/- a year for Sets worth £50 or less, and for Sets valued at more than £50 the cost is in proportion. Cover (b) (i) and (ii) costs only 2/6 a year if taken with Cover (a), or 5/- if taken alone.

Why not BE PRUDENT AND INSURE your installation—it is well worth while AT THE VERY LOW COST INVOLVED. If you write to the Corporation's Office a proposal will be submitted for completion.

Write for full details, quoting reference J/B, to:—

THE MANAGER
SCOTTISH INSURANCE CORPORATION LTD.,
38 EASTCHEAP, LONDON E.C.3

J/B

6 VALVE AM/FM TUNER UNIT

Med. and VHF 190m-550m, 86 Mc/s-103 Mc/s, 6 valves and metal rectifier. Self-contained power unit, A.C. 200/250V operation. Magic-eye indicator, 3 push-button controls, on/off, Med., VHF. Diodes and high output sockets with gain control. Illuminated 2-colour perspex dial 1 1/2" x 4", chassis size 1 1/2" x 4" x 5 1/2". A recommended Fidelity Unit for use with Mullard "3-3" or "5-10" Amplifiers. Available only at present as built-up units, aligned and tested ready for use.

Bargain Price £12.10.0. Carr. & Ins. 7/6. This popular unit will be available in kit form within the next few weeks. Circuit and constr's details, 4/6. Free with kit.

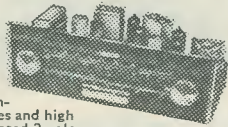

7 VALVE AM/FM RADIOGRAM CHASSIS

New 1965 Model Now Available.

Three Waveband & Switched Gram positions. Med. 200-550m. Long, 1,000-2,000m. VHF/FM 88-95 Mc/s. Phillips Continental Tuning insert with permeability tuning on FM & combined AM/FM IF transformers. 450 kc/s and 10.7 Mc/s. Dust core tuning all coils. Latest circuitry including AVC & Neg. Feedback, 3 watt output. Sensitivity and reproduction of a very high standard. Chassis size 3 1/2" x 6 1/2". Height 7 1/2". Edge illuminated glass dial 1 1/2" x 3 1/2". Vert. pointer Hertz station names. Gold on brown background. A.C. 200/250V operation. Magic-eye tuning. Circuit diag. now available.

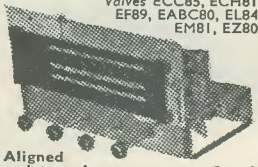

Aligned and tested ready for use. **£13.19.6** Carr. & Ins. 7/6.

Comp. with Tape, O/P socket, ext. spkr & P/U sockets and indoor F.M. aerial, and 4 knobs—walnut or ivory to choice. 3 P.U.M. Speaker only required. Recommended Quality Speakers 10" Rola, 27/6. 13 1/2" x 8" E.M.I. Fidelity, 37/6. 12" R.A. with conc. Tweeter, 42/6. Carr. 2/6.

Jack Plugs. Standard 2 1/2" Irganic Type, 2/6. Screened Ditto, 3/3. Miniature scr. 1 1/2", 2/3. Sub-min. 1/3. **Jack Sockets.** Open Irganic Moulded Type, 3/6. Closed Ditto, 4/-. Miniature Closed Type, 1/6. Sub-min. (deaf aid) ditto, 1/6. Stereo Jack Sockets, 3/6. Stereo Jack Plugs, 3/6. **Phono Sockets.** 9d. Phono Sockets (open), 9d. Ditto (closed), 1/-. Twin Phono Sockets (open), 1/3. **Grundig Continental.** 3 p. or 5 p. plug, 3/6. Sockets, 1/6. **Soldering Irons.** Mains 200/220V or 230/250V. Solon 25W Inst., 24/6. Spare Elements, 5/6. Bits, 1/3. 65W, 29/6, etc. **Alumin. Chassis.** 18g. Plain Undrilled, folded 4 sides, 2" deep, 6" x 4", 4/6, 8" x 6", 5/9, 10" x 7", 6/9, 12" x 6", 7/6, 12" x 8", 8/-. **Alumin. Sheet.** 18g. 6" x 6", 1/-. 6" x 9", 1/6, 6" x 12", 2/-. 12" x 12", 4/6, etc.

L.P. RECORDING TAPE BARGAIN OFFER!

By leading British manufacturers—**PROFESSIONAL GRADE—DOUBLE-SIDED** (each side coated) 5 1/2" reels only

Special Price Offer 1,450 feet (2 reels) **20/-** post free

Ideal for the experimenter who wants to record both sides, and a good L.P. Tape for the enthusiast who wishes to record single side only.

New Boxed	VALVES	Reduced Bargain Prices	Electrolytics All Types	New Stock					
174	3/6	EF80	7/6	PCF80	8/-	25/25V	1/9	8+8/450V	4/6
1R5	6/-	EF86	8/6	PCCL83	10/6	50/12V	1/9	16+16/450V	5/6
155	6/-	EL33	12/6	PCCL84	10/-	50/50V	2/-	32+32/275V	4/6
354	7/-	EL34	12/6	PCCL85	11/6	100/25V	2/-	50+50/350V	6/6
3V4	7/-	EL87	7/6	PL36	10/6	8/450V	2/3	60+250/275V	12/6
ECC81	7/-	EY51	9/-	PL81	9/6	4/350V	2/3	100+300/275V	12/6
ECC82	7/-	EY86	9/-	PL83	8/-	16+16/450V	5/6	2000+4000/6V	12/6
ECC83	7/-	EZ80	7/-	PY33	10/6	32+32/450V	6/6	1000/25V	3/9
ECL80	9/-	EZ81	7/-	PY82	7/-	1000/25V	3/9	Erskin Multicore	Solder 60/40, 4d.
ECL82	10/-	GZ32	9/6	U25	10/6				per yard. Cartons 2/6, etc.
ECL86	10/6	PC84	8/-	UL84	9/-				

DE LUXE R/PLAYER KIT

Incorporating 4 Speed Garrard Auto-Slim unit and Mullard latest 3 watt printed circuit amplifier (ECL 86 and EZ 80), volume, bass and treble controls, with 8" x 5" 10,000 line speaker. Superb quality reproduction.

Contemporary styled two-tone cabinet, charcoal grey and off-white with matching blue relief. Size: 17 1/2" x 16" x 8".

COMPLETE KIT £13.19.6 Carr. & ins. 12/6. Illuminated Perspex escutcheon, 7/6 extra. Ready wired 30/- ex., 4 Contemp'y legs 6" 10/6, 9" 11/6, 12" 12/6, ex. Catalogue & construction details 2/6 (free with kit)

STANDARD RECORD PLAYER KIT

Using BSR UA14 Unit, complete kit £11.10.0, carr. 7/6. Ready wired Amplifier, 7" x 4" quality Speaker and O/P trans., £3.19.6, carr. 2/6. BSR UA14 Unit, £6.10.0, carr. & ins. 5/-. Rexine covered cabinet in two-tone maroon and cream, size 15 1/2" x 14 1/2" x 8 1/2" with all accessories plus uncvt record player mounting board 14" x 13", 59/6, carr. & ins. 5/-.

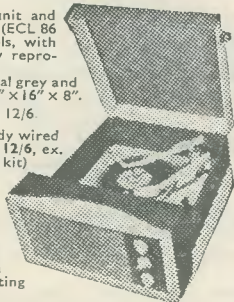

Condensers—S/Mica all values 2pF to 1,000pF 6d. Ditto Ceramic 9d. each, .005, .01 and 1, etc., 1/-. Paper Tubular 450V .001 mfd. to .01 mfd and 1/350V 9d., .02-1 mfd 1/-, .25 mfd 1/6, .5 mfd 1/9. **Speakers** P.M.—2" Plessey 75 ohms, 15/6. 2 1/2" Continental 8 ohms, 13/6. 7" x 4" Plessey 35 ohm, 23/6. **Ear Plug Phones**—Min. Continental type, 3ft. lead, jack plug and socket. High Imp. 8/-, Low Imp., 7/6. High sensitivity M/coil 8-10 ohms, 12/6.

26 1/2 gns TAPE RECORDER for ONLY £19.10.0

Bargain of the Year Offer—Cancelled Export Contractor

Famous manufacturer's brand new unused and factory tested 2-speed, 3 1/2 and 7 1/2 i.p.s., twin track tape recorders. 3 Watt output. Tape position Rev-counter, fast forward and rewind, takes 7" reels, mike and gram input. Straight through amplifier facilities. Output sockets for ext. speaker, monitor or external amplifier. Super-impose switching, magic eye recording level and mains neon indicators. Volume and tone controls, 7" x 4" speaker. Attractively styled cabinet, with detachable lid, mike and reel storage facilities, AC 200/250 volts operation. Complete with crystal mike, tape, spare reel and screen lead, etc.

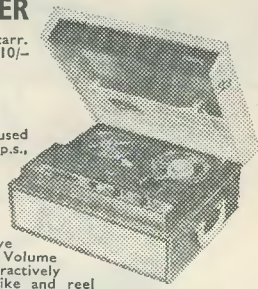

Volume Controls—5K-2 Meg-ohms, 3" Spindles Morganite Midget Type. 1 1/2" diam. Guar. 1 year. LOG or LIN ratios less Sw. 3/-. D.P. Sw. 4/6. Twin Stereo less Sw. 7/6. D.P. Sw. 9/6 (100 k. to 2 Meg. only). 1/2 Meg. VOL Controls D.P. Sw. 1/2" flatted spindle. Famous Mfrs. 4 for 10/- post free.

COAX 80 OHM CABLE High grade low loss Cellular air spaced Polythene—1/2" diameter. Stranded cond. Famous mfrs. Now only 6d. per yard. **Bargain Prices**—Special lengths: 20 yds. 9/-, P. & P. 1/6. 40 yds. 17/6. P. & P. 2/-. 60 yds. 25/-, P. & P. 3/-. Coax Plugs 1/-. Sockets 1/6. Couplers 1/3. Outlet Boxes 4/6.

Close Tol. S/Micas—10% 5pF-500pF 8d. 600-5,000pF 1/-. 1% 2pF-100pF 9d. 100pF-500pF 11d. 575pF-5,000pF 1/6. **Resistors**—Full Range 10 ohms-10 megohms 20% 1/2 and 1/3W 3d., ditto 10% 4d., 1/2W 5d. (Midget type modern rating) 1W 6d., 2W 9d., Hi-Stab 5% 1/2W 10d. 10 ohms 1 megohm 6d. Other values 9d. 1/2W 1/6. **W/W Resistors** 25 ohms to 10K 5W 1/3, 10W 1/6, 15W 2/- **Pre-set T/V Pots.** W/W 25 ohms-50K 3/-, 50K-2 Meg. (Carbon) 3/-. **Speaker Fret**—Expanded gilt anodised metal 1/2" x 1/2" diamond mesh, 4/6 sq. ft., multiples of 6" cut. Max. size, 4ft. x 3ft. 47/6. Carr. extra. Ditto, finer mesh, 4/6 sq. ft. Multiples 12"-only, max size 3ft x 2ft. 27/6. Plus Carr. **TYPAN FRET** (contemp. pat.) 12" x 12" 2/-, 12" x 18" 3/-. 12" x 24" 4/-, 18" x 18" 4/6, etc. **BONDACOUST** Speaker Cabinet Acoustic Wadding, superior grade, 1" thick, 18" wide, any length cut 2/3 per ft, 6/- per yd.

ENAMELLED COPPER WIRE—1 1/2 lbs reels, 14g-20g, 3/-; 22g-28g, 3/6; 36g-38g, 4/9; 39-40g, 5/-, etc.

TINNED COPPER WIRE—14-22g, 3/- 1 lb.

PVC CONNECTING WIRE—10 colours (for chassis wiring, etc.)—Single or stranded conductor, per yd., 2d. Sleeving, 1mm, and 2mm., 2d. yd., etc.

KNOBS—Modern Continental types: Brown or Ivory with Gold Centre, 1" dia., 9d. each; 1 1/2", 1/3 each; Conc. knobs with gold centre 1 1/2" dia., 2/9 per pair. Matching ditto, 2/6 each. **LARGE SELECTION AVAILABLE.**

TRANSISTOR COMPONENTS

Midget I.F.'s—465 kc/s 1/2" diam., first, second or third 5/6 Osc. coil M. & L.V. 1/2" diam. 5/0 Midget Driver Trans. 9/- 6/0 Ditto O/P Push-pull 3 ohms 6/0 **Elect. Condensers**—Midget Type 15V 1mfd-50mfd, ea. 1/9. 100mfd. 2/- **Ferrite Aerial**—M. & L. W. with car aerial coupling coil, 9/3. **Condensers**—150V. wkg. .01 mfd. to .04 mfd., 9d. .05 mfd., 1 mfd., 1/-, .25 mfd., 1/3. .5 mfd., 1/6, etc. **Tuning Condensers.** 1.8. "00" 208 + 176pF, 8/6. Ditto with trimmers, 9/6. 365pF single, 7/6. Sub-min. 1/2" DILEMIN 100pF, 300pF, 500pF, 7/-, Midget Vol. Control with edge control knob, 5kΩ with switch, 4/9, ditto less switch, 3/9.

JASON FM TUNER UNITS

Designer-approved kit of parts: **FMT1**, 5 gns. 4 valves, 20/-, **FMT2**, £7.10.0. 5 valves, 35/-, **JTV MERCURY** 10 gns. 3 valves, 22/6. **JTV2** £13.19.6. 4 valves, 28/6. **NEW JASON FM HAND-BOOK**, 2/6. Alignment Service 7/6. P. & P. 2/6.

MULLARD "3-3" & "5-10" HI-FI AMPLIFIERS

3 OHM & 15 OHM OUTPUT

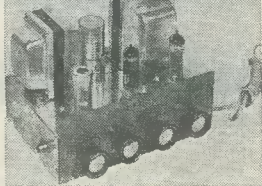

"3-3" Amp. 3-valve, 3 watt, Hi-Fi quality at reasonable cost. Bass Boost and Treble controls, quality sectional output transformer, 40 c/s=25 kc/s ± 1dB, 100mV for 3V, less than 1% distortion. Brnve escutcheon panel.

Complete kit only £6.19.6. Carr. 5/-. **Wired and tested £8.10.0.**

MULLARD "5-10" AMPLIFIER—5 valves 10W, 3 and 15 ohms output.

Mullard's famous circuit with heavy duty ultra-linear quality output tfr. **Basic amplifier kit price £9.19.6.** Carr. 7/6. **Ready built 11 1/2 gns.**

2-VALVE PRE-AMP UNIT

Based on Mullard's famous 2-valve (2 x EF86) circuit with full equalisation with volume, bass, treble, and 5-position selector switch. Size 9" x 6" x 2 1/2". **Ready built, wired and tested, £7.19.6.** Carr. 3/6.



Send for detailed bargain lists, 3d. stamp. We manufacture all types Radio Mains Transf. Chokes, Quality O/P Trans., etc. Enquiries invited for Specials, Prototypes for small production runs. Quotation by return. **RADIO COMPONENT SPECIALISTS** 70 Brigstock Road, Thornton Heath, Surrey TW20 1BB. Hours: 9 a.m.-6 p.m., 1 p.m. Wed. Terms C.W.O. or C.O.D. Post and Packing up to 1 lb. 1/-, 1 lb. 1/9, 3 lb. 3/-, 5 lb. 3/9, 8 lb. 4/6.

Est. 1946



YOU'VE GOT TO GET "WIV IT" SIR!

(Office Junior slangs Boss's advertising)

Boss But I don't *want* to get "wiv it"! I'm not a Beatle or a Stone, or anything, and I'm sure I'm much better off without it!

Office Junior Well I should fink all 'em customers are chuffed, readin' about your dozey old catalogue.

B. All right . . . what would *you* tell them?

O.J. Tell 'em it's in the Top Ten!

B. Top Ten be blowed . . . it's in the Top One! !

O.J. (Commencing to wiggle hips and wave arms) Right, then tell 'em it really swings.

B. You wouldn't like me to set it to music I suppose?

O.J. Not — likely, 'cos I should get all the — checking to do.

B. Go on then.

O.J. Tell 'em it's gorgeous, 'andsome, smart. Tell 'em it's fab! Tell 'em they 'aven't lived until they've read it!

B. Have it your own way, but I still say they would rather know that the pages are 9½" x 7¼"; that there are 210 of them, *plus* a 21-page Supplement; that we list about 5,800 items of which 900 are illustrated; that with each catalogue

we send a special Semi Conductor Centre brochure listing the latest electronic items from America; that we also send under separate cover our latest Bargain List; finally that the price is 7/6 plus 1/6 postage and packing, and that the catalogue contains 5 coupons each worth 1/- when used as directed.

O.J. You're a Square!

B. O.K. Roundy!

O.J. *departs singing "Can't buy me love".*

B. Now where was I? Oh yes.

Dear Customer . . .

Get "wiv it" . . . fill in the Coupon right away and send it with your cheque or P.O. for 9/- to

HOME RADIO LTD.,
Dept. RC, 187 London Road,
Mitcham, Surrey

Please write your Name and Address in block capitals

Name

Address

Home Radio Ltd., Dept. RC, 187 London Rd., Mitcham, Surrey

THE Radio Constructor



Incorporating THE RADIO AMATEUR

OCTOBER 1965

Vol. 19, No. 3
Published Monthly
(1st of month)

*Editorial and
Advertising Offices*
57 MAIDA VALE LONDON W9

Telephone
CUNningham 6141

Telegrams
Databux, London

First Published
1947

Sine Wave-Square Wave Converter, <i>by P. Cairns, A.M.I.P.R.E., G3ISP</i>	154
Can Anyone Help?	160
Zener Diode Speech Clipping Circuits (Suggested Circuit No. 179), <i>by G. A. French</i>	161
Club Events	163
A Quality Multimeter, Part 2, <i>by W. Kemp</i>	164
News and Comment	172
Infra-Red Ray Alarm System, <i>by E. V. King</i>	173
In Your Workshop	176
The Story of the Valve, Part 2, <i>by C. H. Gardner</i>	183
VFO Top Band Phone Transmitter, <i>by Frederick Sayers</i> (Cover Feature)	185
An HFE Tester for Power Transistors, <i>by A. Thomas</i>	192
Understanding Radio, <i>by W. G. Morley</i> (Current Bias and the Grid Leak Detector)	195
Radio Topics, <i>by Recorder</i>	200

© Data Publications Ltd., 1965. Contents may only be reproduced after obtaining prior permission from the Editor. Short abstracts or references are allowable provided acknowledgement of source is given.

Annual Subscription 33s. (U.S.A. and Canada \$5) including postage. Remittances should be made payable to "Data Publications Ltd". Overseas readers please pay by cheque or International Money Order.

Published in Great Britain by the Proprietors and Publishers Data Publications Ltd. 57 Maida Vale London W9
Printed by A. Quick & Co. (Printers) Ltd. Oxford Road Clacton-on-Sea England

SINE WAVE-SQUARE WAVE CONVERTER

By P. CAIRNS, A.M.I.P.R.E., G3ISP

THE UNIT TO BE DESCRIBED PROVIDES A SIMPLE, compact, and relatively cheap method of converting any sine wave voltage between wide amplitude and frequency limits into a square waveform having an extremely fast rise time and variable amplitude output. This useful piece of apparatus may be made as a separate unit or built into an existing sine wave audio signal generator, both methods of construction being described. The unit uses six transistors, and all the components are easily obtainable, no close tolerance or special types being required.

To anyone engaged in serious amplifier work, whether audio or wide band, this device should prove most useful as the extremely square waveform obtained, together with the very fast rise time, quickly shows up any design faults such as incorrect or badly adjusted h.f. or l.f. compensation, etc. The writer has found it indispensable in checking and correctly setting up the amplifiers and attenuators of oscilloscope circuits, particularly the compensation networks in d.c. coupled wide band amplifiers. On the other hand it has also been employed to show that certain "hi-fi" amplifiers were not quite so good as was at first imagined. Some of the uses to which the unit may be put will be discussed later.

Specification

The specification of the converter, the circuit of which is shown in Fig. 1, may be summarised as follows:

Input: any sine wave or near sine wave voltage between 0.5 and 50 volts r.m.s. at any frequency between 20 c/s and 75 kc/s.

Output: square wave with mark-space ratio of 1:1, amplitude variable between 0 and 12 volts peak-to-peak and rise time less than $0.5\mu\text{S}$. These output figures hold good for all frequencies between 20 c/s and 75 kc/s.

Current consumption from the 12 volt supply is 14mA.

Though an upper frequency limit of 75 kc/s is quoted, the actual upper limit is somewhat dependent upon the frequency-gain characteristics of the front-end transistors. By using transistors with a better frequency-gain characteristic, the writer has had the unit working satisfactorily up to 110 kc/s. If an upper frequency limit of 20-25 kc/s would be satisfactory, the three front-end transistors TR₁, TR₂, TR₃ (OC202, OC200, OC200) can be replaced by three OC71 type transistors without any other circuit changes being necessary. As OC71's are much cheaper, this reduces the cost of the converter although, as just stated, it also reduces the maximum

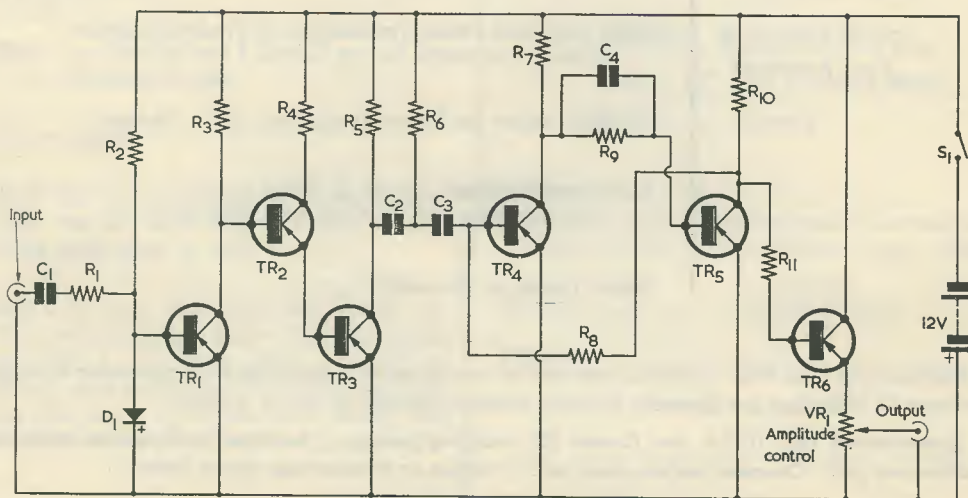

Fig. 1. The circuit of the converter

frequency limit to about 20 to 25 kc/s. If it is intended to work only on audio equipment, such a range should be quite satisfactory.

Operation

The action of the converter is relatively straightforward. Referring to Fig. 1, the circuit may be regarded as being composed of four sections: D_1 , TR_1 , TR_2 and TR_3 , squarer and amplifier; C_2 and R_6 , differentiating and trigger circuit; TR_4 and TR_5 , bi-stable multivibrator circuit; and TR_6 , emitter follower output.

The sine wave input is applied to the base of TR_1 via the limiting resistor R_1 , the positive and negative peaks being clipped off this waveform by diode D_1 and the base-emitter diode of TR_1 . The base of TR_1 is biased by means of R_2 to ensure that this clipping action is symmetrical, so that a 1:1 mark-space ratio is obtained. The capacitor C_1 provides d.c. isolation between the sine wave source and TR_1 . An amplified version of this clipped waveform is developed across the load resistor R_3 , this being applied to the cascaded amplifier pair TR_2 and TR_3 . The advantage of using a pair of transistors in this type of cascade connection is that an extremely high overall gain is achieved, the signal swing developed across the output load resistor R_5 being between the fully cut off and fully bottomed positions, i.e. a signal swing of almost the full 12 volts. This circuit is for all practical purposes independent of transistor gain characteristics and transistor tolerance spreads.

Components List (Fig. 1)

Resistors

(All fixed resistors 10% $\frac{1}{2}$ watt)

R_1	10k Ω
R_2	1M Ω
R_3	220k Ω
R_4	3.3k Ω
R_5	2.2k Ω
R_6	100k Ω
R_7	2.2k Ω
$R_{8,9}$	33k Ω
R_{10}	2.2k Ω
R_{11}	1k Ω
VR_1	1k Ω potentiometer, linear

Capacitors

C_1	0.1 μ F paper, 150V wkg.
C_2	0.002 μ F paper, 150V wkg.
C_3	0.1 μ F paper, 150V wkg.
C_4	0.002 μ F paper, 150V wkg.

Transistors

TR_1	OC202 or OC71 (see text)
$TR_{2,3}$	OC200 or OC71 (see text)
$TR_{4,5}$	OC44
TR_6	OC200

Diode

D_1	OA81
-------	------

Miscellaneous

- 1 toggle switch (s.p.s.t.)
- 2 coaxial sockets
- 2 O-Z sockets and plugs (Belling-Lee)
- 1 pointer knob

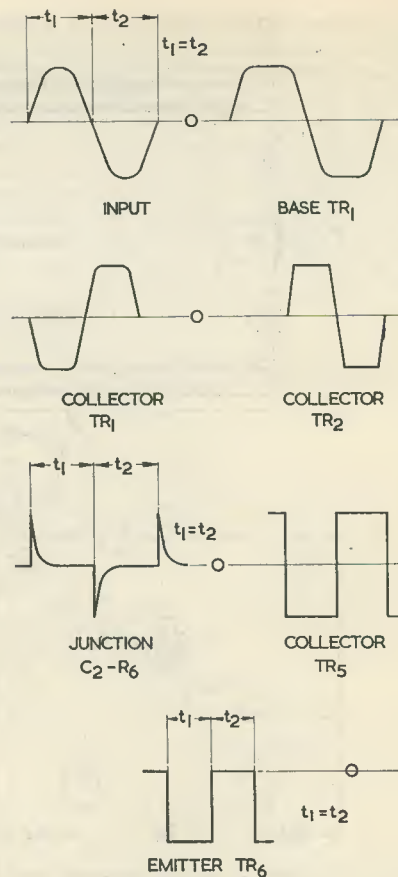

Fig. 2. The waveforms appearing at the various stages in the converter

R_4 is a limiting resistor to prevent the possibility of damage to TR_2 and, as far as circuit function is concerned, can be ignored. The output from TR_3 is, therefore, a 12 volt peak-to-peak square wave having quite a sharp rise time.

It may be mentioned at this point that only the first stage is in any way critical, though even here a fair degree of tolerance is permissible. This is because the correct bias setting on this stage does ensure an exact 1:1 mark-space ratio. Should the base of TR_1 be over or under biased, non-symmetrical clipping takes place, resulting in a non-symmetrical output. If an oscilloscope is available, the mark-space ratio can be checked and R_2 adjusted if necessary. However, no adjustment should be required if TR_1 has average gain characteristics. For most practical purposes an exact 1:1 mark space ratio is not in any case entirely necessary, so that no setting up procedure should generally be necessary. Typical waveforms throughout the circuit are shown in Fig. 2.

The output at the collector of TR_3 is applied to the differentiating network C_2 , R_6 . This changes the positive and negative-going edges of the square

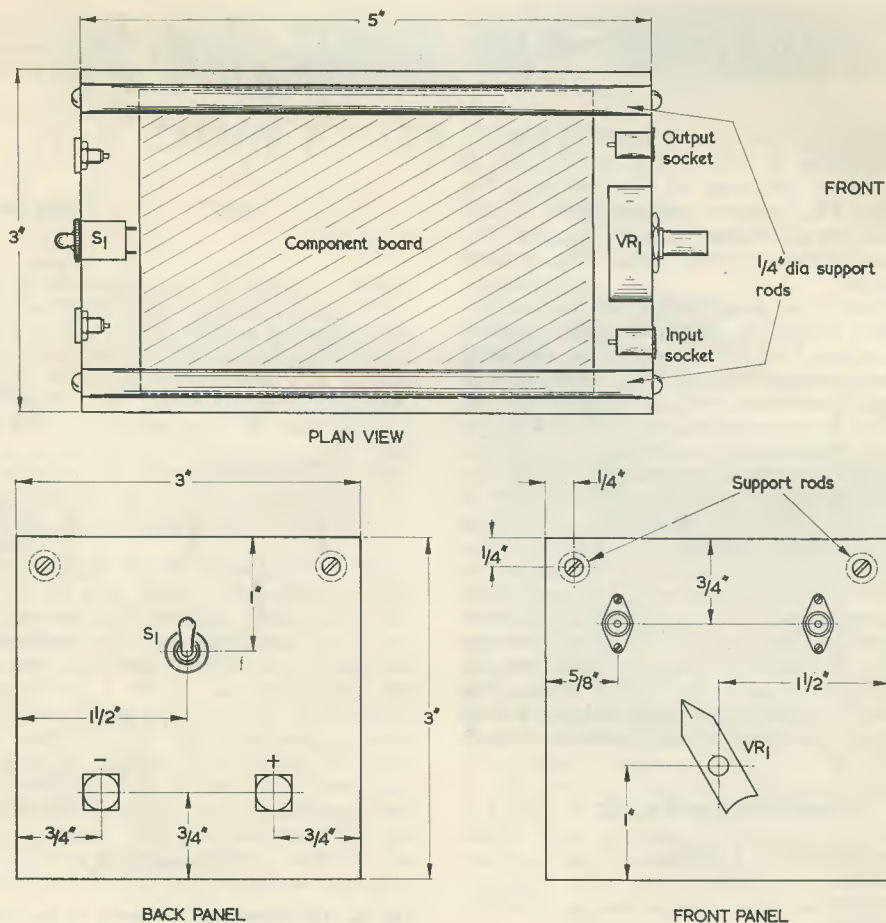

Fig. 3. The mechanical construction of the chassis

wave into a series of sharp positive and negative-going spikes. The time constant of this circuit was carefully chosen to ensure that with low frequencies the spike was not so sharp that it failed to trigger the following circuit and that, with high frequencies, the spike was not so slow that the trigger point was uncertain, thus resulting in an erratic output. A compromise between these two extremes was therefore chosen.

The output spike from the differentiating circuit is applied to the base of TR₄ in the bi-stable circuit. The coupling capacitor C₃ provides d.c. isolation between the two circuits and has negligible effect on the differentiated waveform, its reactance being very much larger than the reactance of C₂.

TR₄ and TR₅ comprise the bi-stable multivibrator circuit, i.e. a circuit which has two stable conditions. If TR₅ is cut off TR₄ will be bottomed. Under these conditions a positive-going spike applied to TR₄ base will switch the circuit to its other stable condition, with TR₅ on and TR₄ off. The application of a negative-going spike to TR₄ base will then cause the circuit to revert to its

original condition, with TR₄ on and TR₅ off. These transistors are, therefore, alternately driven between fully cut off and fully bottomed at a rate dependent upon the time duration between the alternate positive and negative-going spikes from C₃. When the spikes are originally derived from a sine wave, as in this instance, it follows that the bi-stable circuit will be switched between its on and off positions at the same frequency as the sine wave. Also, if the spikes derived from this sine wave are of 1:1 mark-space ratio, the bi-stable circuit (assuming that it has symmetrical components, as shown) will similarly have a 1:1 mark-space ratio. Thus, the output obtainable at either TR₄ or TR₅ collector is a square wave. Also, since the bi-stable circuit is d.c. coupled by means of R₈ and R₉, the rise time of this square wave will be extremely fast, since it approaches the switching time of the transistors themselves. Compensating capacitors C₄ and C₅ help to speed up this switching time. As TR₄ and TR₅ are switched or driven between their extreme conditions, they may simply be regarded as switches with a very rapid change-over mechanism, and not as amplifiers

in the normal acceptance of the word.

The principal advantage of this circuit is that the output is completely independent of the input, and the rise time and amplitude of the output waveform will remain constant regardless of the input amplitude or frequency within the very wide limits quoted. Another advantage of the circuit is that it is independent of changes or spread in transistor characteristics, as the transistors are not used as conventional amplifiers but as switches.

The final section of the circuit, TR₆, is an emitter follower d.c. coupled to the bi-stable output via the limiting resistor R₁₁. A variable resistor VR₁, in

the emitter circuit of this stage, allows the output amplitude to be varied between zero and almost 12 volts. The advantage of the emitter follower circuit is twofold: it gives isolation between the bi-stable circuit and the output, the loading effect being negligible, and a low impedance output is obtained. In consequence, the output can be loaded to quite a considerable extent before any noticeable damping effects occur. The output impedance of this circuit is in the order of 75Ω, thus matching standard coaxial cable. By using d.c. coupling in the final stage the rise time and squareness of the waveform is maintained.

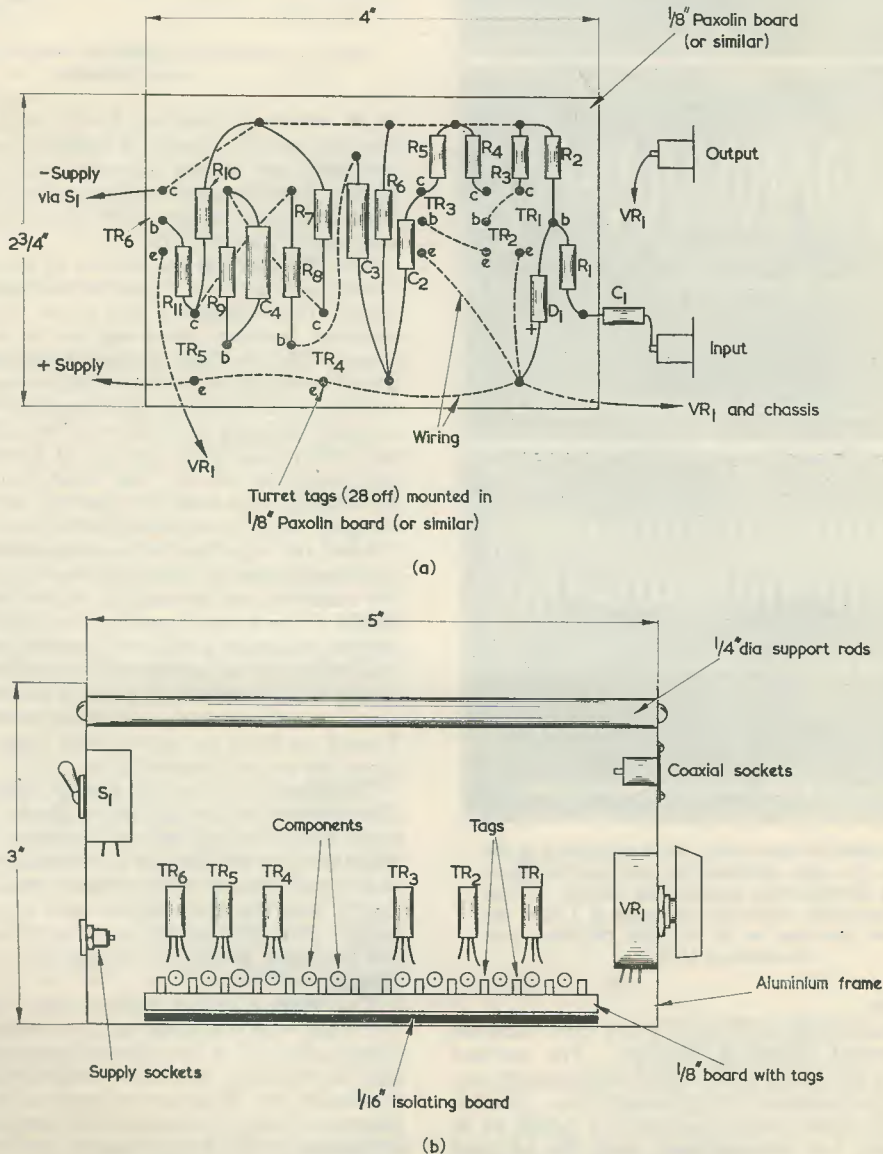
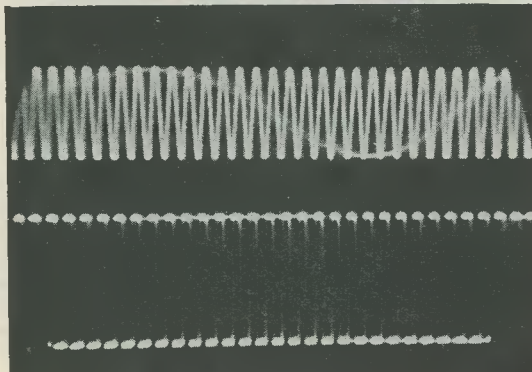
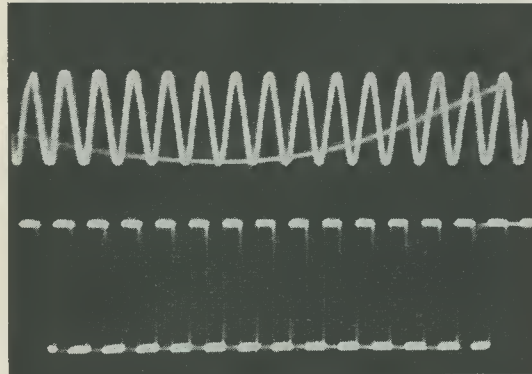
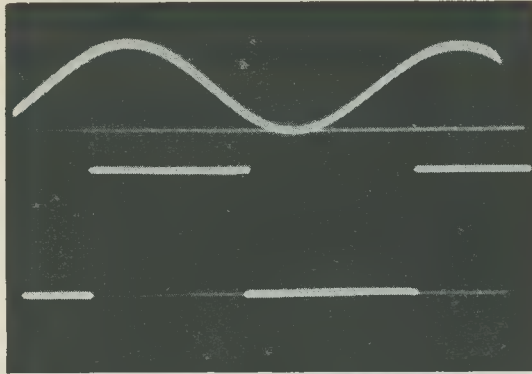

Fig. 4 (a). The layout of components on the Paxolin board
 (b). Side view, showing the assembly with the transistors wired into position



Actual waveforms illustrating the performance of the converter. In each instance the sine wave is shown above the corresponding square wave output. The top pair of waveforms illustrates operation at 1 kc/s, the centre pair operation at 10 kc/s and the lower pair operation at 25 kc/s

Construction

The construction of the unit offers no difficulties and no special layout is required. The method followed by the writer is described here, though any other forms of construction which are more suitable to the needs of the individual user or which fit in with existing test arrangements may be adopted instead. It should be mentioned, however, that one of the benefits of the unit is that it can be constructed

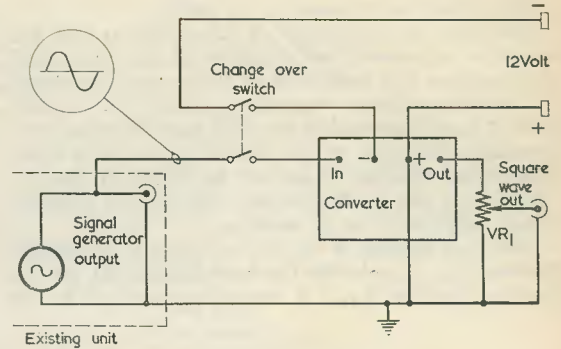

Fig. 5. Installing the converter into an existing sine wave generator

in an extremely compact form. Any type of construction which occupies a large amount of space is obviously not taking full advantage of this point. In the writer's unit coaxial sockets are used for both input and output. The 12 volt battery supply was external to the unit.

The construction and layout of the converter are shown in Figs. 3 and 4 together with relevant dimensions. The transistors and other components are mounted between turret tags set in a Paxolin base board. This is fixed to the aluminium chassis or frame by means of impact adhesive, a thin wafer of similar insulating material being fixed with the same adhesive between the bottom of the base board and the aluminium. This method of assembly obviates the possibility of the tags short-circuiting on the aluminium. As is shown in Fig. 4, an extremely compact form of construction is achieved.

After the tags have been mounted on the board, the interconnecting wires are first connected in, next the resistors and capacitors, and finally the transistors. These are mounted by their leads in an upright position, a piece of sleeving over the leads preventing any accidental short-circuits. When soldering the transistors in place it is advisable to use a heat sink, particularly with the OC44's and OC71's, if used, as these are germanium types. The silicon types are not so susceptible to heat.

The frame, or chassis, is simply a piece of 18 s.w.g. aluminium bent into the shape shown, the necessary holes being drilled before bending. Two rods of metal or fibre are used as strengtheners between the two upper corners of the chassis, these being cut to length and the ends drilled and tapped 6BA for fixing. Finally a small wood or aluminium cover can be made if desired, though this is a matter of choice.

The method of construction just described is for use when the converter is to be employed as an individual unit. It can, alternatively, be easily fitted into an existing sine wave audio generator, thus converting the latter into a sine wave-square wave generator. Here the circuit is wired up on the board as shown in Fig. 4 but, instead of fitting it into an aluminium frame, it is fitted into any convenient space inside the sine wave generator. As the unit

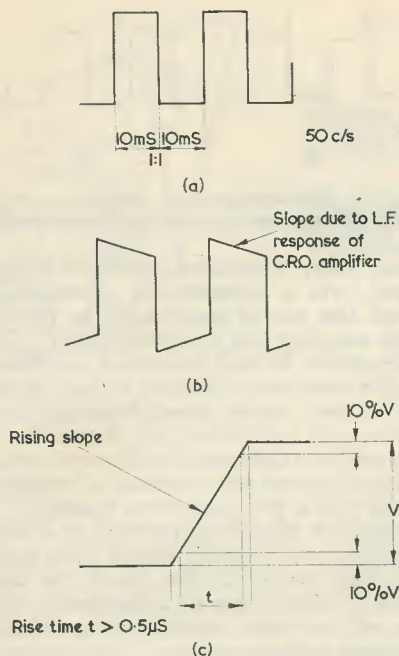

Fig. 6. Testing the converter with a 50 c/s input. The square wave which should be displayed by a d.c. coupled oscilloscope amplifier is shown in (a), whilst (b) illustrates a typical response if the amplifier is a.c. coupled. The rise time of the waveform may be checked as shown in (c)

in this form only occupies a space of $4 \times 2\frac{3}{4} \times 1\frac{1}{2}$ in no difficulty should be found fitting it in. The unit is then connected up as illustrated in Fig. 5, extra holes having to be drilled for one output coaxial socket, two Belling-Lee O-Z sockets (for the 12 volt supply), potentiometer VR₁, and a d.p.s.t. toggle switch. These holes can be drilled in the front panel or, if insufficient panel space is available, the O-Z sockets can be mounted with the toggle switch at the rear of the generator.

Checking

Before connecting any supplies to the converter the wiring should be carefully checked, paying particular attention to see that the diode and transistors are connected correctly. To check the waveform for rise time and mark-space ratio an oscilloscope is required.

To test the converter, connect a sine wave supply to the input (a 6.3 volt 50c/s heater supply being quite adequate), set VR₁ to its maximum output position, and switch on the 12 volt d.c. supply. The output is taken to the Y1 input on the oscilloscope, which should be set to a sensitivity of about 3 volts/cm with a sweep speed of about 10mS/cm. If the c.r.o. has a d.c. coupled amplifier the waveform should appear as in Fig. 6 (a). An a.c. coupled c.r.o. amplifier will give a waveform like that shown in Fig. 6 (b), the slope being due to the l.f. response of the amplifier. The mark-space ratio should be

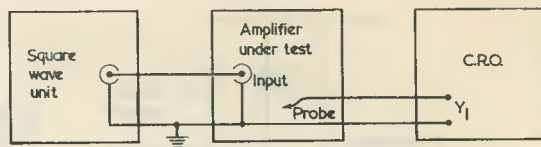

Fig. 7. Checking the response of an amplifier

1:1 and, as previously stated, a slight adjustment in the value of R₂ will correct any error here though this should not generally be necessary. If it is required to check the rise time a sweep speed of at least 2μS/cm is required, rise time being measured as shown in Fig. 6 (c). Lastly, check the amplitude of the square wave and ensure that it falls linearly as VR₁ is reduced from maximum to minimum.

Practical Applications

Finally, a few points will be mentioned on some practical applications of the converter. The first and obvious use to which the unit can be put is in the testing of high quality a.f. amplifiers. The test circuit can be set up as shown in Fig. 7, 1 kc/s being the usual standard frequency used. Fig. 8 shows some of the common waveforms likely to be met, as compared with the ideal waveshape. VR₁ should be adjusted so as to avoid overloading the amplifier under test and the waveforms checked through the amplifier a stage at a time. Faulty compensation networks will be immediately apparent and adjustments can be made to obtain optimum square wave response. The frequency of the test supply can then be reduced to a low value, say 30 c/s, and then up to say 5 or 10 kc/s, the output

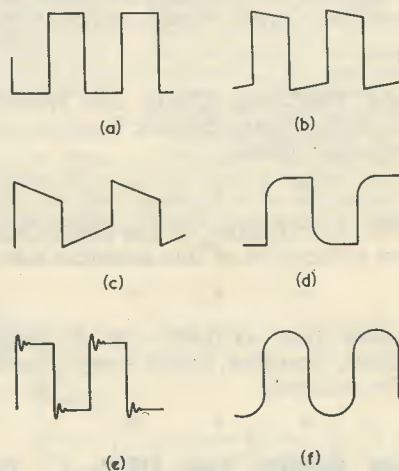

Fig. 8 (a). An ideal output waveform from the amplifier under test
 (b). A good practical response
 (c). A response indicating poor low frequency response
 (d). The result of poor high frequency response
 (e). High frequency peaking resulting in parasitic oscillation
 (f). The effect given by inductive bass boost with high frequency fall-off

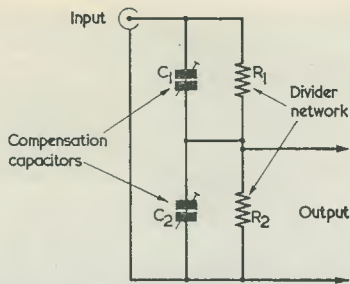

Fig. 9. One section of a typical simple c.r.o. attenuator

waveshapes being checked at each frequency. This is an excellent method of checking the effectiveness (or lack of effectiveness) of bass and treble tone circuits. It will be found with experience that amplifiers which had previously been known to have quite a good response to a sine wave signal have a completely different response to a square wave. In the opinion of the writer this is the only method of finding the true response characteristic of a quality amplifier and for the correct assessment of the efficiency of compensation and tone control networks.

The testing of wide band oscilloscope amplifiers is carried out in a similar manner except that the

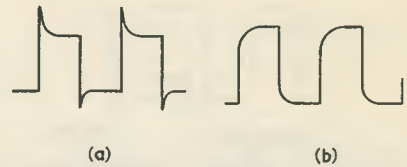

Fig. 10 (a). Over-compensation can result in overshoot (b). The opposite effect resulting in undershoot

frequency range is extended. As most amplifiers of this type have a compensated attenuator at the front end this can in many cases be disconnected from the amplifier and set up separately. The trimming capacitors on the attenuator (see Fig. 9) are set to give minimum overshoot without undershoot at the highest square wave frequency available. Overshoot and undershoot are shown in Fig. 10. For the correct alignment of wide band oscilloscope amplifiers a square wave source of relatively high frequency with a fast rise time is essential.

The above is but a brief mention of a few of the basic uses to which a good square wave source can be put, and the writer has found the converter described in this article of considerable help in a number of practical applications, particularly in experimental pulse circuits.

CAN ANYONE HELP?

Requests for information are inserted in this feature free of charge, subject to space being available. Users of this service undertake to acknowledge all letters, etc., received and to reimburse all reasonable expenses incurred by correspondents. Circuits, manuals, service sheets, etc., lent by readers must be returned in good condition within a reasonable period of time

Ace Model TR62.—A. Currie, c/o Hunter, 3c Sunnyside, Saint Nintang, Stirling, Scotland—circuit of this transistor radio.

* * *

CRT 3FP7.—B. P. Bradley, 63 The Lowe, Chigwell, Essex—pin connections of this American tube.

* * *

62H Receiver Unit AP61357.—W. E. Newman, 108 The Drive, Hounslow, Middx.—any information (all will be returned).

* * *

Peto Scott Receiver Type HE72.—C. Taylor, 73 Wellington Street, Matlock, Derbyshire—service sheet or manual on loan.

* * *

Control Unit 704, Indicator Type 230.—A. A. Stuttard, "Burwood", Lostock, Bolton, Lancs.—any information and circuits. The latter unit contains Wavemeter W1646.

Oscilloscope No. 11.—R. Yates, 36 Milkingstie Lane, Lancaster—circuit and any information for extending the timebase of this unit (AA Predictor Mk. I OS 18799A).

* * *

Hallicrafter 5-10 Receiver.—Simmons, 19 Gt. Bounds Drive, Southborough, Tunbridge Wells, Kent—circuit, loan or purchase.

* * *

R220 Receiver Mk. II.—J. Anderson, 6 Arley Close, Macclesfield, Cheshire—circuit, technical manual or details of conversion for variable tuning. Material on loan will be photo-copied and returned.

* * *

Transmitter Type LMR61.—P. Debono, Mt. Sinai House, New Str., St. Catherine Str., Zejtun, Malta G.C.—any information on this and the following units, receiver type IMR60M; transmitter type T10A; transmitter type LMR83, D.F. type LMR72 and units type AL/27; E7AA; AKU; R19 I/P27A/S B85/1.

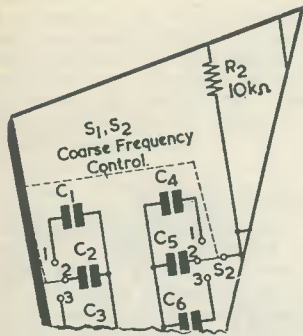

SUGGESTED CIRCUIT No. 179

Zener Diode Speech Clipping Circuits

By G. A. FRENCH

A TECHNIQUE COMMONLY employed to improve the efficiency of amateur phone transmitters is provided by speech clipping. A speech clipping circuit is included in the modulation amplifier, and it clips the speech signals at a level which corresponds to 100% modulation. If the circuit is correctly set up, it then becomes impossible to overmodulate the transmitter regardless of the sound intensity at the microphone input.

A second, and more useful, advantage conferred by speech clipping is that it allows a higher average level of a.f. power to modulate the transmitter, with a consequent increase in sideband power. Quite high levels of clipping, up to some 20dB, are feasible before loss of intelligibility becomes significant. As is to be expected, the distortion resulting from such heavy clipping impairs the naturalness of the speech. Lower levels of clipping cause less distortion, and still enable a worthwhile increase in sideband power to be achieved.

Since the audio signals clipped take up what is very nearly a square wave form, the process results in the production of a large number of high frequency harmonics, and these have to be suppressed before modulation takes place. Such suppression may be achieved by a low pass filter following the clipping circuit, this allowing a band of frequencies up to about 3 kc/s only to be passed on to subsequent stages.

Symmetrical Clipping

There are several ways in which speech clipping can be achieved, and a particularly popular method amongst amateur transmitter enthusiasts makes use of a symmetrical clipping technique. The symmetrical clipper limits both positive and negative excursions of the a.f. signal

(as opposed to the asymmetrical clipper, which clips only on peaks of one polarity), and it is interposed between two stages in the modulation amplifier. Symmetrical clipping is provided, typically, by two diodes, each having a fixed voltage delay. In a series clipping circuit the diodes become non-conductive for signal voltages above the delay voltage, whilst in a shunt clipping circuit the diodes become conductive when the signal voltage reaches the delay voltage. Clipping level in circuits of this nature is usually of the order of 3 to 5 volts peak-to-peak.

These clipping circuits are quite simple, but they can be made simpler still by taking advantage of the characteristics of the zener diode. Two suggested methods in which a zener diode may be employed for symmetrical shunt clipping will now be discussed, and they form the basis of this article.

Fig. 1 shows a clipping circuit comprising two zener diodes, these appearing between two stages of a modulation a.f. amplifier. In the absence of signal the voltage across

the diodes with respect to chassis is zero, due to the presence of potentiometer R_2 .

Let us now see what happens during a half-cycle of signal voltage which causes the anode of V_1 to go positive. This positive anode excursion then appears (slightly reduced in amplitude because of the potential divider R_1R_2) across the diodes. However, the diodes have no effect on circuit operation until the positive voltage of the "cathode" of D_1 reaches the zener voltage for this diode. D_1 then assumes the low slope resistance characteristic of a zener diode, whilst D_2 conducts in the same way as does an ordinary diode. The combination of D_1 functioning as a zener diode and D_2 as an ordinary diode limits any further positive excursion on the "cathode" of D_1 . Increased positive excursions at the anode of V_1 merely become dropped across R_1 .

Negative excursions on the anode of V_1 have the same effect, except that limiting occurs when the zener voltage of D_2 is reached. D_2 then functions as a zener diode whilst D_1

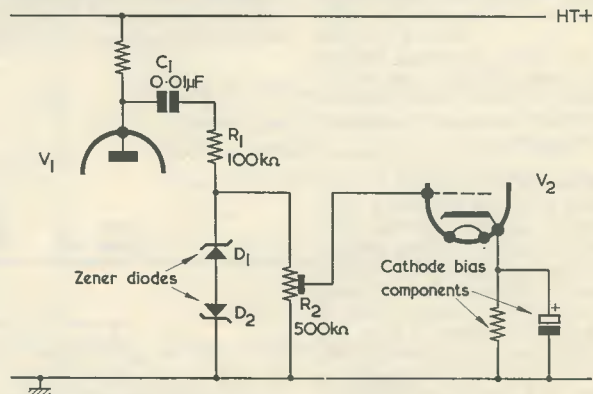

Fig. 1. A speech clipping circuit employing two zener diodes

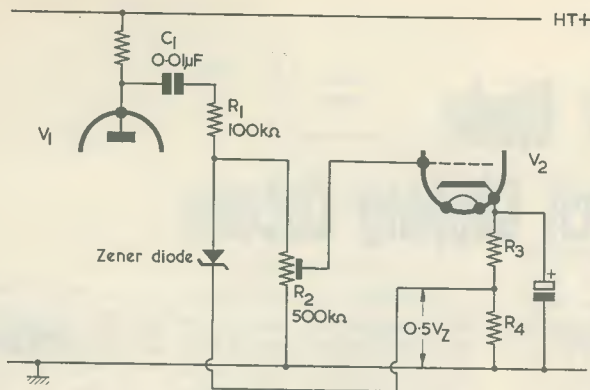

Fig. 2. A single diode clipping circuit

functions as an ordinary diode.

Summing up, it may be seen that the a.f. signal is limited in the positive direction by the zener voltage of D_1 and in the negative direction by the zener voltage of D_2 . If both diodes have the same zener voltage, symmetrical clipping takes place.

An interesting point is that there is no necessity for a d.c. blocking capacitor between the diodes and R_2 , because the grid input signal at the upper end of R_2 swings positive and negative of chassis in just the same way as would occur if the diodes were not in circuit.

In the explanation just given it was stated that the diodes conducted as soon as the zener voltage of one diode was reached, the other then functioning as an ordinary diode. This does not give a complete picture of circuit operation, however, because the assumption is made that the second diode commences to conduct at virtually zero forward voltage. In practice, silicon diodes of the type employed for zener operation normally become conductive at forward voltages of the order of 0.6. So, the limiting voltage across the diodes is given by the zener voltage of the one which functions as a zener diode plus the forward voltage required for conduction in the other.

Limiting Levels

Limiting levels at around 9 volts peak-to-peak can be achieved with the circuit of Fig. 1 using readily available zener diodes. The OAZ200, for instance, offers a typical zener voltage of 3.9 at 0.1mA, with a tolerance ranging from 3.6 to 4.2 volts at this current. If the 0.6 volts required for forward conduction is added, two OAZ200's would clip for either polarity at, typically, some

4.5 volts. A swing of 4.5 volts positive and negative of chassis will, normally, be too large for the valve employed in the V_2 position, and it is reduced by the pre-set potentiometer R_2 . This potentiometer may then be the control which sets clipping level to correspond with 100% modulation.

If, assuming OAZ200's are used, one of the two diodes is on bottom tolerance, with a zener voltage of 3.6, and the other is on top tolerance, at 4.2 zener volts, excursions in one direction will be clipped at about 4.2 volts ($3.6 + 0.6$) and in the other direction at about 4.8 volts ($4.2 + 0.6$). The resultant lack of symmetry, which corresponds to the worst combination of OAZ200's, should not have any serious consequences in practice.

The "hardness" of clipping (i.e. the speed of transition in the diodes from the non-conductive condition to the low resistance condition as voltage increases) which is given by the circuit of Fig. 1 will be about half that given by a normal shunt clipping circuit using semiconductor diodes, and should be adequate for all normal purposes. The "hardness"

of clipping can be increased, if desired, by reducing the value of R_1 so that the forward-plus-zener current in the diodes is increased when clipping occurs and, if necessary, arranging the V_1 stage so that the necessary increased signal current is provided.

Single Diode Circuit

A circuit employing a single zener diode is shown in Fig. 2. In this diagram the "cathode" of the zener diode is returned to a point in the cathode bias resistor circuit of V_2 which offers half the zener voltage above chassis. The resistors employed in the cathode circuit of V_2 will have low values compared with R_1 , and the voltage provided at the junction of R_3 and R_4 can be considered, for the purposes of the circuit, as being fixed.

In the absence of signal from V_1 , the upper electrode of the zener diode is held negative of the "cathode" by R_2 , R_3 and R_4 . Since the voltage across the diode is half the zener voltage it does not then conduct in either mode.

Let us now apply a signal; and we shall assume for the moment that the diode conducts as an ordinary diode at zero forward voltage. When the signal voltage on the upper electrode of the diode goes positive of chassis by half the zener voltage, the diode commences to conduct as an ordinary diode. This is because its "cathode" is similarly positive of chassis by the same potential. When the signal applied to the diode goes negative of chassis by half the zener voltage, the diode commences to conduct as a zener diode. This is because its "cathode" is half the zener voltage positive of chassis, whereupon the whole zener voltage becomes applied across the diode. Thus, the signal is clipped, in either direction, by half the zener voltage, and the peak-to-peak amplitude is the zener voltage itself.

We have, however, ignored the

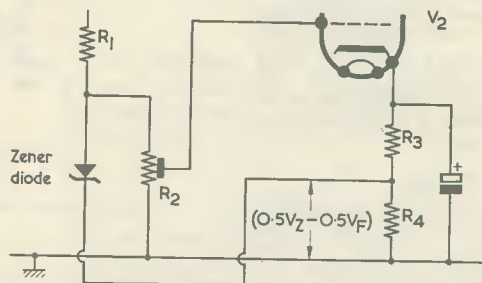

Fig. 3. To obtain symmetrical clipping, the forward voltage needed for conduction in the diode has to be taken into account, whereupon the voltage at the junction of R_3 and R_4 should be that shown here

forward voltage needed to cause the diode to conduct. When this forward voltage is taken into consideration we then find that the peak-to-peak clipped amplitude increases to the zener voltage *plus* the forward voltage. Also, to achieve symmetrical clipping the voltage at the junction of R_3 and R_4 has to be changed so that it becomes half the zener voltage less half the forward voltage. This is shown in Fig. 3 as $0.5V_Z - 0.5V_F$, where V_Z is the zener voltage and V_F is the forward voltage. On positive signal excursions, the zener diode of Fig. 3 will conduct at $(0.5V_Z - 0.5V_F) + V_F = 0.5(V_Z + V_F)$. On negative signal excursions the zener diode will conduct at $(0.5V_Z - 0.5V_F) - V_Z = -0.5(V_Z + V_F)$. Thus, symmetry is achieved.

The single diode circuit enables a low peak-to-peak clipped amplitude to be obtained. With the OAZ200, for instance, the peak-to-peak amplitude can be of the order of 4.5 volts. If desired, and if a suitable valve is employed in the V_2 position, this signal could be fed direct to the grid of V_2 , as in Fig. 4, whereupon the clipper level control can be placed at a later point in the amplifier chain.

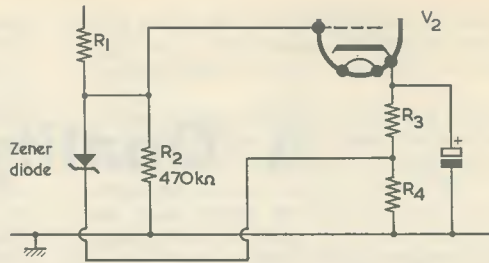

Fig. 4. With the single diode circuit, R_2 may be replaced by a fixed grid leak

To find the values needed in R_3 and R_4 to give $0.5V_Z - 0.5V_F$ at their junction, it will be necessary to find V_Z and V_F at a current of around 0.1mA for the particular zener diode employed. However, little serious error should be introduced with, say, a 5% zener diode if it is assumed that V_Z is the typical zener voltage at about 0.1mA quoted in the manufacturer's literature, and V_F is 0.6 volts. An alternative approach would consist of temporarily fitting a potentiometer in the R_3R_4 position, connecting its slider to the diode and adjusting this until symmetrical clipping is given, as shown by an oscilloscope. The potentiometer could then be replaced

by fixed resistors of the appropriate value.

It is, of course, necessary for the cathode voltage of V_2 to be greater than $0.5V_Z - 0.5V_F$, but this requirement may be readily met when low voltage zener diodes such as the OAZ200 are used.

The "hardness" of clipping offered by the single diode circuit will be of the same order as a normal shunt circuit using semiconductor diodes. As with the circuit of Fig. 1, the "hardness" of clipping may be increased by reducing the value of R_1 and, if necessary, arranging the V_1 stage to offer the increased signal current required.

Club Events

Northern Heights Amateur Radio Society

Hon. Sec. A. Robinson, G3MDW, Candy Cabin, Ogden, Halifax.

October 13th—Setting up Scout Jamboree Station.

October 16th—Scout Jamboree on the air (also 17th).

October 27th—Visit to Baird Television Works, Bradford.

October 30th—Visit to the International Radio Communications Exhibition, (London).

Derby and District Amateur Radio Society

Hon. Sec. F. C. Ward, 5 Uplands Avenue, Littleover, Derby.

October 3rd—Contest for President's D.F. Trophy.

October 10th—Amateur Radio Convention at Belle Vue, Manchester.

October 16th—Jamboree on the air (also 17th).

October 27th—International Radio Communications Exhibition, (London).

The Slade Radio Society

Hon. Sec. D. Wilson, 177 Dower Road, Sutton Coldfield.

October 2nd—Television Spectacular '65.

October 9th—Double Midnight D.F. Test.

October 23rd—Annual Dinner, Market Hotel.

Electronic Counting with Dekatrons

We regret that Part 2 of this series has been held over until the next issue.

A Quality Multimeter

By W. KEMP

Part Two

In this concluding article our contributor discusses overload protection devices, then carries on to the complete circuit of the 30-range testmeter

Overload Protection

SOME KIND OF AUTOMATIC OVERLOAD PROTECTION is almost essential on any general purpose meter, as the inadvertent use of the instrument on too low a range can result in severe damage to the basic movement. While it is true that most meters can withstand a considerable overload (as much as 100 times f.s.d. with some of the better quality types), there is no doubt that, even if the overload may cause no great harm, it most certainly won't do the meter any good!

Several methods of obtaining overload protection are available, each with its own particular advantages and applications. A few of these will now be described.

Germanium Diode Protection

Fig. 11 shows a simple overload protection device that has applications in a number of special circuits where linearity of meter readings is not essential. As can be seen, the circuit consists simply of the meter and a resistor, R_1 , in series, with a germanium diode wired across the combination in the forward direction. The diode is a non-linear device, the forward resistance of which varies with applied voltage. At very low voltages, in the order of millivolts the forward resistance may be some hundreds of kilohms; at higher voltages, of perhaps half a volt, the forward resistance may fall to several hundred ohms or so. By wiring the diode into the circuit as shown it is made to act as a variable shunt across the meter, so that whilst an input current of

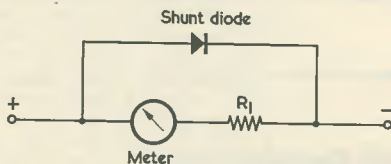

Fig. 11. Using a semiconductor diode to provide overload protection

perhaps $5\mu\text{A}$ may cause the meter pointer to move to one-tenth of f.s.d., a current of 1mA , or 200 times $5\mu\text{A}$ may be needed to read f.s.d. These figures relate to a $50\mu\text{A}$ movement.

Such a circuit gives a roughly log scale reading and the precise working points of the diode, and thus the total input current for f.s.d. can be varied by choosing different values of R_1 . A circuit of this type is of particular use as an indicator in bridges.

Silicon Diode

If the germanium diode of the above circuit is replaced by a silicon diode, a completely different meter scale characteristic is obtained, although the principle of operation is exactly the same as already outlined.

In the case of the silicon diode the forward resistance is still quite high at very low voltage levels, but it is found that as the voltage is increased, perhaps to the order of well over 200 millivolts in some cases, very little decrease in forward resistance takes place. Then, quite sharply, at perhaps half a volt input, the forward resistance begins to fall. If a silicon diode characteristics graph is studied, it will be observed that a sharp knee occurs at this point on the current/voltage curve.

If the silicon diode is used in the circuit of Fig. 11, it will be found that, when a suitable value of R_1 is chosen such that the "knee" occurs at three or four times the f.s.d. voltage, then almost no shunting at all will take place over the working range of the meter and the scale will be reasonably linear. On the other hand, when an overload input current of, for example, one hundred times f.s.d. is applied to the circuit, the meter current will be only five or six times that of f.s.d., and no damage will occur.

Such a circuit has applications in low-cost general purpose multimeters.

Protection By Time Constant

Whenever an overload current is applied to a meter the operator has an indication of the fact by

the way in which the needle flashes across the meter dial at high speed. Unfortunately, the speed of movement in such cases is so high that the operator has no time in which to take advantage of the warning. If, however, a large capacitor is wired in parallel with the meter a time constant is obtained, determined by the value of the meter resistance and the capacitor. The time constant in seconds is given approximately by the formula $T=RC$, so that when a meter with an internal resistance of $1,000\Omega$ is wired in parallel with a capacitor of $1,000\mu F$ a time constant of about 1 second is obtained. If sufficient voltage is now applied to the input of the circuit to give an f.s.d. reading, it will be found that the actual meter current will slowly rise from zero until some time after 1 second, the f.s.d. reading is obtained. Should an overload of ten times f.s.d. be applied instead, however, f.s.d. will be reached in one tenth of the time. Although this is a fairly short time it is still sufficient for the operator to react, and to disconnect the input and prevent damage to the meter. While it is not possible to make wonderful claims for so simple a device, it does at least give *some* degree of protection against damage, and that is far better than none at all.

It should be noted that the above system is best suited for a d.c. instrument. On a.c. the capacitor may act as a shunt, the value of which varies with frequency.*

Alternative Overload Protection Devices

All of the circuits mentioned so far have distinct disadvantages when applied to *accurate* multimeters and are far from foolproof. This latter point is due to the fact that none of the devices are positive in action. For full protection a device that gives a very positive action is essential. When the f.s.d. current of the meter is exceeded the device should cause the input to be automatically removed completely from the circuit until a "re-set" order is given by the operator. A number of systems may be used to meet the above requirement but only a few of them will be discussed here, and all of these, except that used on the instrument to be described, mentioned briefly only.

The systems may be operated by either current values, voltage values, or both. In the former case, a sensitive moving coil relay may be wired in series with the meter circuit so that, when an overload current flows, the relay operates and cut the input to the meter. The relay must be self-latching, and this can be arranged by causing the moving coil relay to feed a second, battery-operated relay. The moving coil relay need not be as sensitive as the basic meter, and may operate at, say, ten times f.s.d. current, but the meter manufacturer's literature should be consulted first before settling on this figure.

Voltage operated safety circuits may use the voltage developed across a series resistor or the meter itself to feed a transistor-operated relay. In

such a case the transistor circuit should have a fairly high input impedance, otherwise non-linearity in readings may be obtained due to varying shunt effects.

The system employed with the meter that forms the basis of this article uses the basic meter movement itself to act as the overload device, and takes advantage of the fact that, when the f.s.d. value of the basic meter is exceeded, the pointer presses against the end stop. This end stop is flexible and moves back under the pressure of the pointer. Behind the stop is a fixed arm or contact, and when sufficient pressure is exerted on the stop it bends back and presses against the fixed arm, causing a

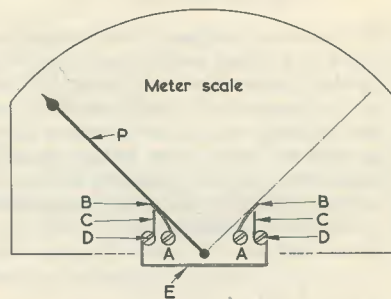

Code: B - Light spring end stop
A - Screw securing 'B' to meter scale
C - Light spring 'contact'
D - Screw securing 'C' to scale
E - Shorting link between 'C' and 'C'
P - Meter pointer

(a)

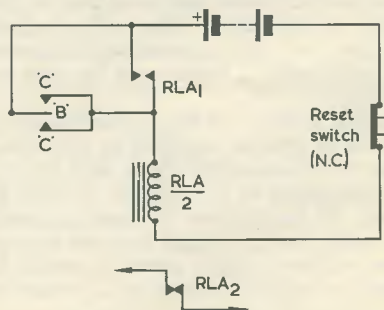

(b)

Fig. 12 (a). Details of overload contacts. It should be noted that parts "B" will probably be in contact with the meter scale and body; if so, "C" and "E" must be insulated from same. Parts "B" and "C" are made from light spring wire, the contact gap between them being adjusted so that contact is made at between 1.5 and 2 times f.s.d. current. Normally, parts "B" will be connected together via the meter scale or body

(b). The overload relay circuit. Contacts RLA2 are in series with the positive multimeter terminal. The relay should be as sensitive as possible consistent with being able to handle currents up to 10 amps via its RLA2 contacts

* If the capacitor were to immediately follow the meter rectifier it could also act as a reservoir.—EDITOR.

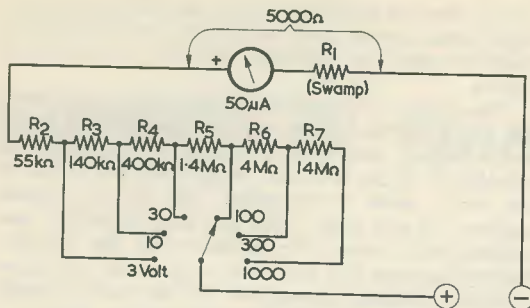

Fig. 13. The "D.C. Volts" section, shown switched to the 100 volt range

short-circuit between the two. The assembly thus acts as a make and break switch, operated when an overload current flows. The two "contacts" of this "switch" are connected in series with a battery operated self-latching relay, the contacts of which are in series with the multimeter input. A sketch of the mechanical arrangement is shown in Fig. 12 (a), which is self-explanatory (in conjunction with its caption) so far as constructional details are concerned. The electrical circuit diagram of the complete automatic overload protection circuit is shown in Fig. 12 (b).

General Notes on Moving Coil Meters

Articles sometimes appear in the pages of the amateur radio magazines in which the contributors tend to become rather carried away with their own enthusiasm and as a result have made rather wild claims for the equipment they describe. This is particularly so in the case of multimeter articles and is due to the fact that certain simple, elementary facts of life are overlooked. The author is thinking, in particular, of the relationship between the accuracy with which a meter may be read and its physical size.

When using a meter, it is very unlikely that the operator will be able to "read" it to an accuracy of better than 10 thousandths of an inch (0.01 inch), due to the thickness of the pointer, parallax errors, and so on. In most cases, in fact, two different operators may "see" readings that are as much as 0.02 inches different under normal conditions, i.e. when only "normal" care is taken in obtaining the

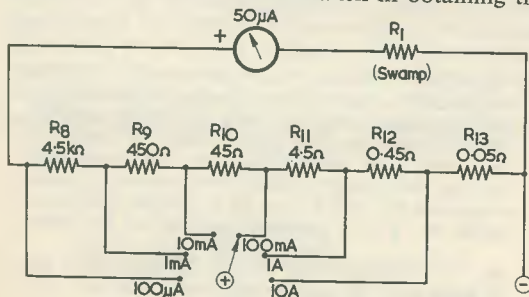

Fig. 14. The "D.C. Current" section, switched to the 100mA range

reading. If a 2 inch diameter meter is used, therefore, and the reading is taken at f.s.d., an "error" of as much as 1% may be incurred. If the reading is taken at half f.s.d., the error will be 2%, and will become progressively higher as the pointer becomes removed from f.s.d. If, however, a 6 inch meter is used under these conditions, the errors would be only 0.3% and 0.6% respectively. It can be seen, then, that for accurate readings a large diameter meter is essential, and should preferably have a mirror scale.

If the reader has a steady hand and a great deal of patience, he will find it possible to convert a small diameter meter to a larger diameter one, such as, for example, from 2½ to 4 inches. *It must be emphasised that the conversion process should only be attempted by those who have the requisite skill and are competent to carry it out, as it is easily possible to ruin a good instrument if great care is not taken.* The conversion may be made in the following manner, the work being carried out in a clean dust-free room.

Remove the meter from its case, and carefully remove the scale. Make up a new scale of the required size from thin aluminium, suitably marked, and secure this in place of the old one. The old meter case will now have to be either considerably modified or a new one made up, preferably from glass fibre, to take the enlarged meter assembly.

When the above has been completed and care taken to ensure that a good fit is obtained, the movement has to be modified. Lengthen the pointer, using either fine aluminium wire or special pointer wire (obtainable from instrument dealers), securing the extension to the old pointer with a touch of varnish. Next, and this is the most difficult part of the whole procedure, the pointer assembly must be re-balanced. It will be found that the pointer assembly has the form of a cross, the three short arms being nearest to the pivot. Balancing is carried out by adding, by trial and error, suitable weights to these cross pieces. The weights may consist simply of dabs of varnish, or wire secured with varnish. When correctly balanced, the pointer will remain in the same relative position regardless of the position of the movement, vertical or horizontal.

Finally, when all this work has been carried out, the f.s.d. current should be checked against a standard meter. If any error has appeared the magnetic shunt, a small piece of metal screwed to one of the poles of the moving coil magnet and fitted on all moving coil instruments, should be adjusted until the correct reading is obtained.

It must be stressed again that this procedure must *not* be tackled by the ham-fisted or impatient types, and in any case, the system should be tried first on a "not-very-expensive" meter, before proceeding to the better type; a basic mistake will then be less expensive. (The author damaged three meters before he finally got the hang of things!)

The 30-Range Multimeter

Having dealt with the basic design principles

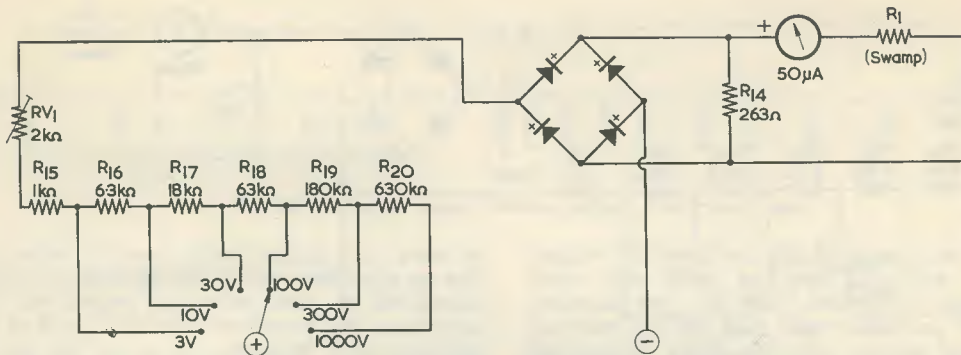

Fig. 15. The "A.C. Volts" section, switched to the 100 volts range

involved, the practical multimeter which forms the subject of this series can now be considered in detail. The instrument to be described is very comprehensive, having the following ranges:

D.C. Volts: (f.s.d. readings), 3, 10, 30, 100, 300 and 1,000 volts.

A.C. Volts: 3, 10, 30, 100, 300 and 1,000 volts r.m.s. (Sine).

D.C. Current: 100µA, 1, 10, 100mA, 1 and 10 Amp.

A.C. Current: 10, 100 and 300mA, 1, 3 and 10 Amp, r.m.s. (Sine).

Ohms: Basic range with centre scale of 1,000Ω, giving a reasonable indication from 100Ω to 10,000Ω. (Full coverage of basic range is 0 to 100,000Ω, but ends of scale are cramped.) Multipliers of times 0.1, 1, 10 and 100. Full coverage is 1Ω to 10MΩ.

In addition to the above, two more ranges, giving 50µA or 250mV d.c. are available, making up the total to 30 ranges.

When designing a multimeter, the procedure is to deal with the individual range sections first; i.e., d.c. volts, a.c. volts, etc., and when all the values have been worked out, design the required switching arrangements to suit. To help the reader to follow the principles, the full circuits of the *individual* range sections are given, as well as the circuit of the complete instrument. The individual circuits will now be introduced.

D.C. Volts Ranges

The circuit used for the direct voltage ranges is shown in Fig. 13. The first point to note is that a swamp resistor, R_1 , has been incorporated. The value of this should be chosen so that the *total* series resistance of R_1 and the meter is 5,000Ω. The swamp has been included so that *any* 50µA meter movement may be used in the multimeter, without fear of errors creeping into the readings of the finished job. The swamp is in circuit with all the remaining ranges.

		S ₁ SWITCH POSITION					
		1 DC Volts	2 DC Current	3 AC Volts	4 AC Current	5 Ohms	6 DC Current or Volts
S ₂ SWITCH POSITION	1	3V	100µA	3V	10mA	÷10	50µA 250mV
	2	10V	1mA	10V	100mA	×1	50µA 250mV
	3	30V	10mA	30V	300mA	×10	50µA 250mV
	4	100V	100mA	100V	1A	×100	50µA 250mV
	5	300V	1A	300V	3A	—	50µA 250mV
	6	1,000V	10A	1,000V	10A	—	50µA 250mV

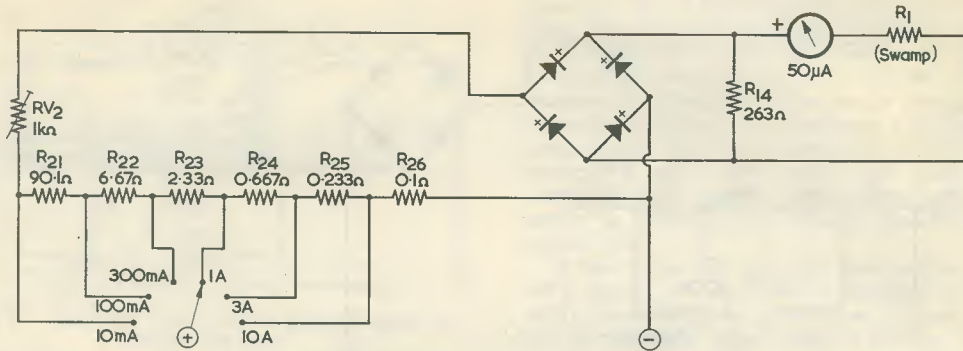

Fig. 16. The "A.C. Current" section, shown switched to the 1 amp range

A "ladder type" multiplier system has been used, although this is not essential to general design. The multiplier values used are non-standard, but there is no way round this snag even if the ladder system is not used. When designing the instrument it was decided that ranges of 30, 300, etc., were far more useful than ones of 25, 250, etc., although the latter would have enabled more readily obtainable resistors to be used. More will be said on this matter under "Constructional Notes".

D.C. Current Ranges

See Fig. 14 for the direct current section. The design of this circuit was dealt with in full in Part 1 and no further comments are required at the moment.

A.C. Voltage Ranges

The a.c. voltage ranges are shown in Fig. 15. The meter is shunted to read 1mA f.s.d. by R₁₄. A ladder type chain is again used, the 3 volt range being made up of RV₁ and R₁₅ in series. See under "Constructional Notes".

A.C. Current Ranges

Fig. 16 shows the a.c. current ranges. The design procedure has been dealt with in full in Part 1 and no further notes are needed here.

Resistance Ranges

The resistance range section is shown in Fig. 17. The circuit used is that given in Fig. 10 (c) of Part 1 of this series. The extra complication is due to the fact that it was considered desirable to have only one "set zero" control, rather than the three or four that might otherwise be required. Roughly speaking, the basic meter has been shunted by R₂₇ and RV₃ so that it reads 67µA, variable to about -10% to +20%, thus allowing for changes in battery voltage.

To operate, the circuit is required to pass an f.s.d. current that is dictated by the range in use, i.e. by the battery voltage and series resistance. The current (f.s.d.) required by the individual ranges of this particular meter are: times 0.1 = 15mA, times 1 = 1.5mA, times 10 = 1.35mA and times 100 = 135µA. It was decided, in view of the need for only one "set zero" control, to make the variable shunt meter as it now is, into a multi-range current meter to meet the above requirements. This is accomplished by resistors R₂₈ to R₃₁ inclusive.

When explaining the principles of operation of the circuit in Part 1 of this series, it was mentioned that the series resistor should be made the same value as the required centre scale reading. When working out the value of this series resistor the resistance of the basic meter has also to be taken

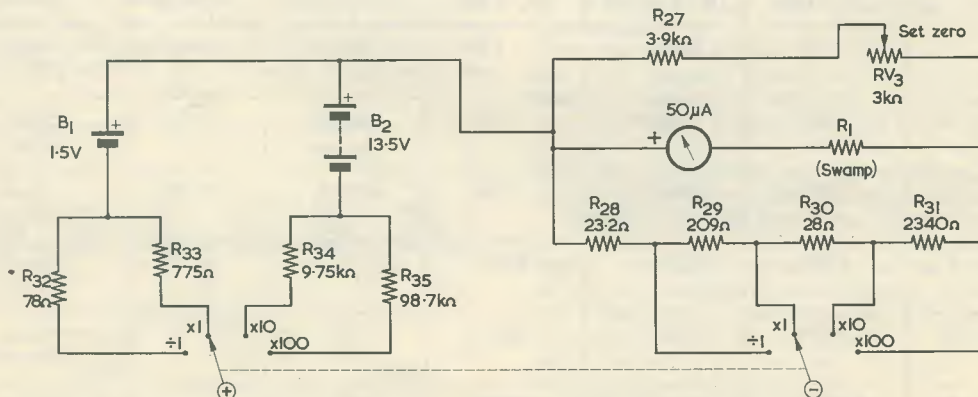

Fig. 17. The resistance measuring section, switched to "X1". The two switch poles are ganged together

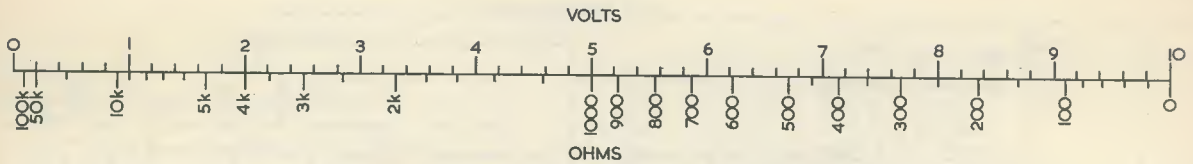

Fig. 18. Resistance range calibration against a linear volts scale

into account in some cases, and it may even be necessary to allow for the battery resistance as well if very low ranges are to be used. In the design shown in Fig. 17 the input resistance of the universal shunt has also had to be considered when choosing the values of resistors R_{32} to R_{35} . Even so, on the lowest range (times 0.1) it has not been possible to allow fully for varying resistance of the 1.5 volt battery, and errors of as much as 3% may creep into the readings with a battery that is not in very good condition.

Shown in Fig. 18 is a typical calibrated ohms scale for use on the finished meter, although it would be preferable to calibrate the individual meter against a standard.

The one calibrated scale will serve for all four ranges.

50 μ A and 250mV Ranges

These two ranges are made available by connecting the input directly across the meter and swamp resistor terminals.

Constructional Notes

Although only 35 fixed-value resistors (a low figure considering the number of ranges provided) are shown in the complete circuit diagram, the practical instrument will contain considerably more than this figure, as many of the resistance values will have to be made up by connecting two or more resistors in a series or parallel combination.

All of the resistive values shown have been chosen to give an accuracy of better than 0.5%. If, however, this degree of accuracy is not needed, then the values may be altered slightly to allow more readily obtainable components to be used. If, for example, the awkward value of 98.7k Ω shown for R_{35} were changed for 100k Ω , the latter component would only give an error of 1.3% in readings. Similarly, if R_4 and R_6 were changed to 390k Ω and 3.9M Ω respectively, errors of only about 1.6% would be expected, and so on.

The circuit of the complete instrument (less the overload circuit) is shown in Fig. 19. Two six-pole six-way switches are required.

For the meter rectifier, either one of the special 1mA instrument types or four germanium diodes may be used.

The first step in construction is to decide on the practical layout to be used, checking that sufficient space is provided for all of the components and bearing in mind that some of the individual resistive values will have to be made up by a combination of two or more resistors. Once the layout has been

decided the meter box should be made up, preferably from glass fibre, and the holes for the meter, switches, etc., cut out. Bushes or bolts may be moulded into the glass fibre so that tag boards may be secured inside the box without spoiling the external appearance of the finished instrument. The following notes on the wiring procedure should be observed.

(1) Determine the required value for R_1 and solder into place. The correct value for this resistor is 5,000 Ω minus the meter internal resistance, r , the latter being determined by the method described in Part 1. A standard meter will have to be used for setting up certain of the multimeter ranges and, as a check that the correct value of R_1 has been used, it should be verified that with 250mV connected between the positive terminal and the end of R_1 , the 50 μ A meter reads f.s.d.

The use of a standard meter will in some cases be available at the reader's place of work or, failing this, the local technical college may make their instrument available, under supervision. Other possibilities may also occur to the reader's mind.

(2) Before proceeding with the main meter ranges, the overload safety circuit should be wired in place, using the diagram of Fig. 12. The operation of the circuit should be checked, ensuring that the trip and re-set systems work correctly.

(3) When wiring the d.c. voltage range multipliers, it will be necessary to check the calibration of the meter after each resistor is soldered in place, as a fault in one stage will affect the readings of all following stages.

(4) The next stage in construction is the wiring up of the d.c. current ranges. Here the three lowest value resistors will have to be made up from resistance wire, and approximate lengths and s.w.g. figures are included in the Components List. The exact length of resistance wire will have to be determined finally by trial and error, and the following system of construction should be followed.

First, make up a suitable tag board to hold all the resistors required, and then wire the resistors temporarily in place, making sure that R_8 is exactly 4.5k Ω and that the total resistance of the chain is 5k Ω within 1%. It should be noted that, at this stage, the exact value of R_{11} , R_{12} and R_{13} is not of great importance, as if, for example, R_{11} is out of tolerance by as much as 100% a total error on the 100 μ A range of only 0.1% will result. It is the value of R_8 and the sum of the rest of the chain that counts at this stage.

Next, the calibration of the 100 μ A range must be checked against the standard. If any error occurs

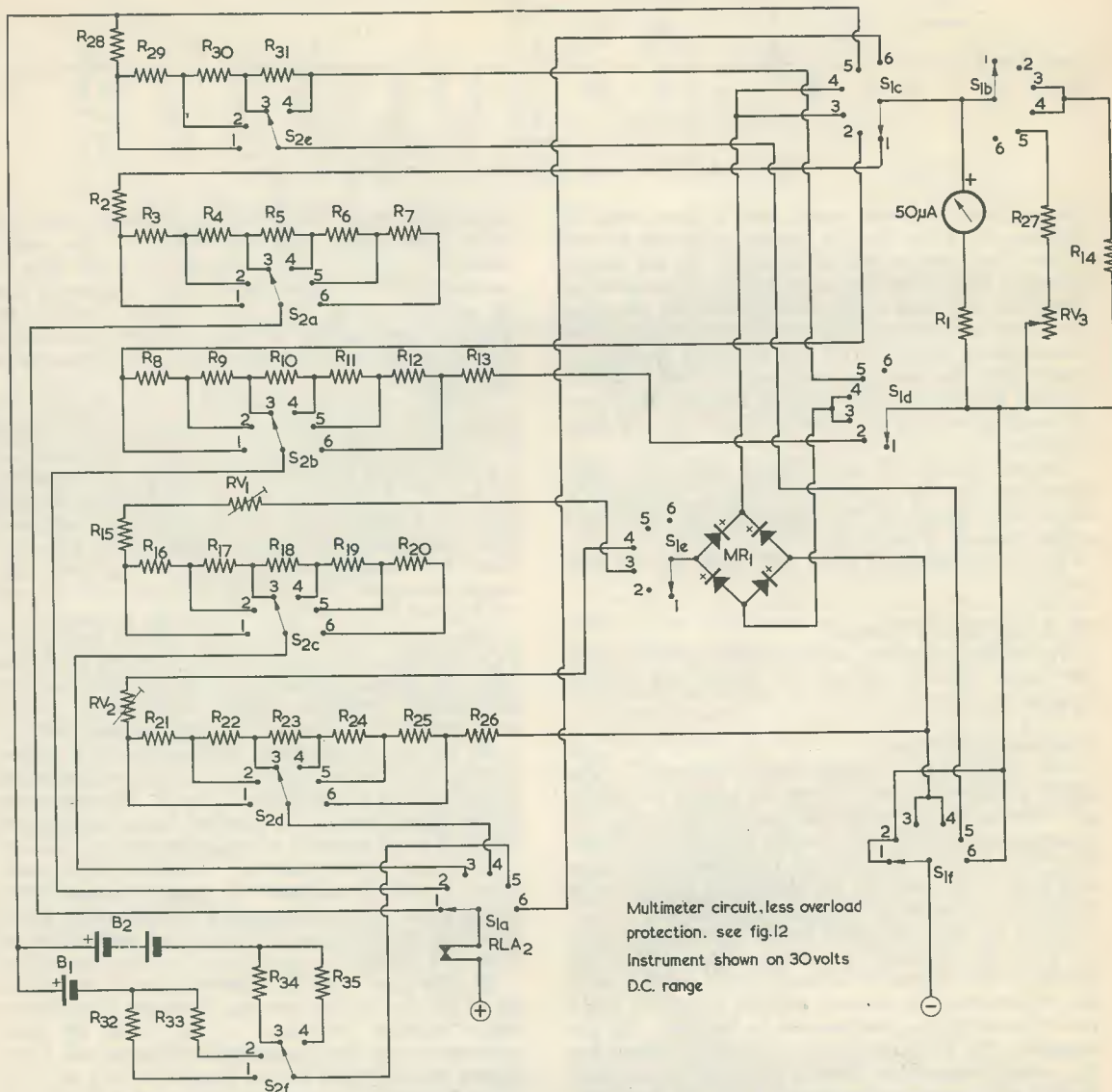

Multimeter circuit, less overload protection. see fig.12
Instrument shown on 30volts D.C. range

Fig. 19. The circuit of the complete 30-range instrument. This includes contacts RLA2 of Fig. 12 (b), but the remainder of the overload circuit is not shown here

it can only be because one of the above points has not been observed or because a dry joint has been made. When the correct calibration has been observed, resistor R_8 should be soldered permanently in place and the calibration again checked.

Now check the calibration of the 1mA range, ensuring that R_9 is 450Ω and that the sum of R_{10} , R_{11} , R_{12} and R_{13} is 50Ω . When satisfied, again solder the relevant resistor (R_9) permanently in place. Use a similar procedure for the 10mA range.

On the remaining three ranges, the values of the home-made resistors will have to be adjusted on test to bring the calibration within the desired degree

of accuracy; i.e. if the meter reads low, the resistance will have to be increased, and vice versa. To increase the resistance of the wire, the length can be either increased or the diameter reduced by filing. To reduce the resistance, either reduce the length or apply solder to a suitable length of the wire.

After the correct value of each resistor has been obtained, the accuracy of the preceding range should be checked, and if an error of greater than about 10% is found, check the stage before that as well and correct the errors. It should be noticed that an error of a given magnitude in one stage

Components List (Fig. 19)

Resistors

(All resistors listed hereunder should be high stability types with a tolerance of 1% or better—see text)

R ₁	5k Ω meter resistance (see text)
R ₂	55k Ω
R ₃	140k Ω
R ₄	400k Ω
R ₅	1.4M Ω
R ₆	4M Ω
R ₇	14M Ω
R ₈	4.5k Ω
R ₉	450 Ω
R ₁₀	45 Ω
R ₁₄	263 Ω
R ₁₅	1k Ω
R ₁₆	6,300 Ω
R ₁₇	18k Ω
R ₁₈	63k Ω
R ₁₉	180k Ω
R ₂₀	630k Ω
R ₂₁	90.1 Ω
R ₂₇	3.9k Ω
R ₂₈	23.2 Ω
R ₂₉	209 Ω
R ₃₀	28 Ω
R ₃₁	2,340 Ω
R ₃₂	78 Ω
R ₃₃	775 Ω
R ₃₄	9,750 Ω
R ₃₅	98.7k Ω

Resistors (Wirewound)

(See text concerning construction of the resistors listed hereunder)

R ₁₁	4.5 Ω (32in 30 s.w.g. Eureka)
R ₁₂	0.45 Ω (9in 24 s.w.g. Eureka)

shows up as an error reduced by powers of ten in all preceding stages. To take an example, if, when setting up R₁₁ it is necessary to change the resistance value by 10% in order to set the calibration, an error of only 1% will occur in the preceding (10mA) stage, of 0.1% in the 1mA stage and 0.01% in the 100 μ A stage.

(5) Wire R₁₄ into circuit and check that, with the switching set to the appropriate positions, the meter is shunted to read 1mA f.s.d. Next, connect the bridge rectifier and ensure that it is functioning correctly.

(6) The alternating voltage multipliers are now wired up. First, wire in RV₁ and R₁₅ and adjust RV₁ to give 3 volts f.s.d., from a sine wave (the mains, fed through a suitable transformer), checking against the standard meter. Lock RV₁ in position. Wire in the multipliers for the remaining ranges, proceeding as described in (3) above.

(7) The alternating current ranges come next. Wire the pre-set resistor, RV₂, in circuit with one end to the bridge rectifier input as indicated in the circuit diagram and then, with a low level alternating

R ₁₃	0.05 Ω (24in 12 s.w.g. Eureka)
R ₂₂	6.67 Ω (49in 30 s.w.g. Eureka)
R ₂₃	2.33 Ω (34in 26 s.w.g. Eureka)
R ₂₄	0.667 Ω (13.5in 24 s.w.g. Eureka)
R ₂₅	0.233 Ω (24in 18 s.w.g. Eureka)
R ₂₆	0.1 Ω (47in 12 s.w.g. Eureka)

Variable Resistors

RV ₁	2,000 Ω pre-set, 1in, wirewound
RV ₂	1,000 Ω pre-set, 1in, wirewound
RV ₃	3,000 Ω , 1in, carbon

Switches

S _{1,2}	6-pole, 6-way
------------------	---------------

Rectifier

MR ₁	1mA instrument type, or four germanium diodes wired as a bridge
-----------------	---

Meter

Moving coil, 50 μ A f.s.d., any internal resistance

Batteries

B ₁	1.5 volt cell
B ₂	13.5 volt battery (three 4.5 volt batteries in series)

Overload Components (see Fig. 12 (b))

Relay RLA/2
Battery
Reset switch

Miscellaneous

2 terminals
Case
Wire, etc.

voltage connected between the free end of RV₂ and the other input of the rectifier, adjust RV₂ to give 1 volt f.s.d., checking against the standard. Lock RV₂.

Make up the universal shunt, as shown in the circuit diagram and consisting of R₂₁ to R₂₆ inclusive, using the method described in (4) above.

(8) Wire R₂₇ and the "set zero" control, RV₃, into circuit as shown and check that, with the switching set to the required positions, the meter reads approximately 67 μ A, variable by about -10% to +20%. Now wire up the resistance-measuring circuit, and then check that this functions correctly. If it is found to be impossible to set zero on any of the ranges, the action of the universal shunt section, consisting of R₂₈ to R₃₁ inclusive, should be checked as for a multi-range direct current meter, using the figures given in the "Resistance Ranges" section.

When the wiring of the resistance ranges has been completed and it has been checked that the "set zero" control works correctly, check that the centre

(continued on page 194)

NEWS AND COMMENT . . .

T.E.P.

T.E.P. stands for Transequatorial Propagation. It is a transmission mode of high frequency radio signals over long distances, which has been discovered mainly through the activities of radio amateurs. The upper layers of the ionosphere tend to be more dense over the equator than over the Polar regions, so that stations situated such that their path of communication passes across the equator are often able to communicate on frequencies far higher than one would expect. Regular recording of signals from amateur operated beacon transmitters, working in the range 29 to 50 Mc/s, over the past few years, has thrown much light on this phenomenon. Readers who would like to know more about this matter should read the article "Transequatorial Radio Propagation during the Years of the Quiet Sun", by R. C. Cracknell, ZE2JV; and R. A. Whiting, ZC4WR, in the June 1965 R.S.G.B. *Bulletin*. We liked very much the final paragraph of this article which reads:

"T.E.P. has been mainly an amateur discovery, and the team work which has gone into its development is of the type that should in some measure justify the continued allocation of frequencies for amateur use, and has been, to quote Ed Tilton, V.H.F. Editor of *QST*, 'One of the finest examples of Amateur Radio's potential for worthwhile contributions to wave-propagation knowledge'."

Car Radio New Use

A car radio that sounds a reminder if a driver forgets to turn off his headlights has been introduced in the United States. It works if the lights are left on after the ignition has been turned off, and gives its signal even if the radio is not turned on.

The warning unit has been produced by the Motrolo Corporation.

Ghana TV

The Ghana television service, the most modern and comprehensive television broadcasting system in the African continent, was officially declared open by President Kwame Nkrumah on July 31st, 1965.

Designed, built and installed by The Marconi Company, in col-

laboration with the Ghana Broadcasting Corporation, the new service has three television transmitting stations at Accra, Kumasi and Sekondi-Takoradi. These stations cover approximately one quarter of the country including the Atlantic seaboard, the most heavily populated part of Ghana. Each of the three stations is served by a central studio complex in Accra, the capital.

The whole of the new television broadcasting service was a "turnkey" project and was handed over as a fully operational concern. Engineers and technicians from the Ghana Broadcasting Corporation have received extensive training in the techniques of television broadcasting at the Company's headquarters in Chelmsford and have now taken over the running of the new service.

The order, which was the largest single broadcasting contract ever awarded to the Company, also included major extensions to the existing sound broadcasting service. These have considerably improved the coverage of the Ghana Home Service and also of the external broadcasting services.

This order is another step in the close association of The Marconi Company with the development of broadcasting in Ghana. The Company built the first station there in 1935 and have since been responsible for a number of other

projects, including the ultra-modern external broadcasting station at Tema, opened by President Nkrumah in 1961.

TV by Gramophone

A gramophone record that plays television still pictures has been developed in the United States. Along with the pictures, sound comes from the same long-playing disc. The system has been named Phonovid.

Both sound and pictures are represented in the grooves of the record, and both are picked up by the gramophone needle. Up to 400 pictures and 40 minutes of voice and music can be recorded on the two sides of a 12-in recording that turns at $33\frac{1}{3}$ revolutions per minute.

The recording is played on an ordinary turntable. Any part of the recording can be held, skipped or repeated by manually lifting the tone arm.

Standard sound and television equipment can be used. But a specially developed scan converter, must be used to link the conventional record player and television set.

Information from the record is stored in the scan converter's special electronic storage tubes. Every six seconds, a complete picture is built up in the tubes and flashed on the screen. While this picture is displayed, the next picture is being formed in the tube from information supplied from the grooves in the recording.

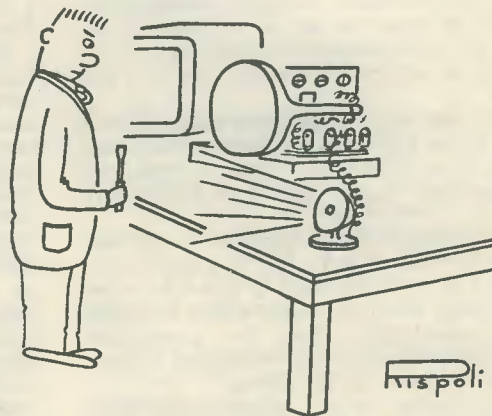

"Do not adjust your set, the breakdown is only temporary!"

Infra-Red Ray Alarm System

By E. V. KING

THE DEVICE DESCRIBED IN THIS ARTICLE WILL give faultless warning of any object passing a narrow invisible beam and will function equally well as a Burglar Alarm, Fog Alarm, Smoke Alarm or Customer Alarm. A phototransistor with a d.c. amplifier transistor is used to operate a relay circuit and an electric, battery operated, bell. Light incident on the transistor prevents the bell working, darkness causes it to ring.

No great knowledge of electronics is required and successful operation is sure from the start. There are three versions of the alarm, these differing only in the relay circuits required.

The Circuits

The simplest of the three circuits is illustrated in Fig. 1. In this diagram an OCP71, TR₁, is illuminated by an infra-red beam, whereupon it conducts. This causes a relatively heavy current to flow through R₂, and allows only a small amount of base current to pass to TR₂. TR₂ collector current is, therefore, also small, and the relay remains de-energised. If the infra-red beam is interrupted, the current drawn by TR₁ reduces considerably, allowing a greater bias current to flow through R₂ to TR₂. The consequently increased collector current in TR₂ flows through the relay, which then energises. The 150Ω resistor, R₁, limits transistor current.¹

¹ R₁ was fitted in the author's prototype, but it could in practice be omitted, if desired, without upsetting circuit operation unduly. —EDITOR.

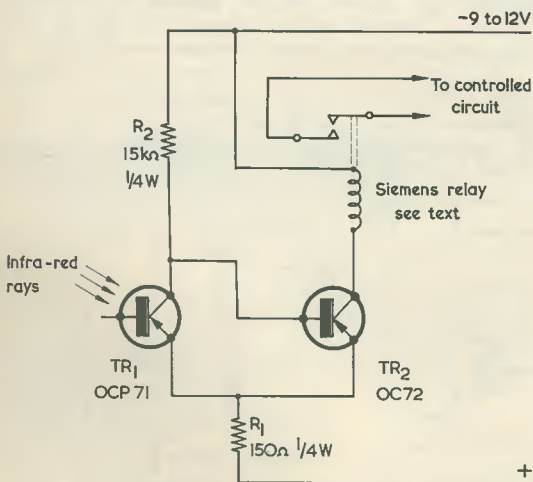

Fig. 1. The simplest version of the alarm

The relay employed is a Siemens 1000+1000Ω high speed type, with the two coils in series. Its contacts are not heavy enough to switch such loads as an electric bell more than about 50 times without cleaning. Whilst it could, therefore, be employed to control a bell for occasional use, more frequent usage requires that a second relay be incorporated in the circuit. The circuit of Fig. 1 will, of course, switch low currents other than that needed for a bell.

The second relay may be a P.O. type 3000 unit with a 200Ω coil, and it is connected into circuit as shown in Fig. 2. When the Siemens relay contacts close, the P.O. relay is energised. Its contacts then close and cause the bell to ring. It is assumed, in Fig. 2, that the 9-12 volt supply will also be applied to the bell. If the bell is designed to run from a lower voltage it may be necessary to insert a resistor in series for correct operation. A suitable resistor, as employed by the writer, is a 12 volt 3 watt lamp.

The third circuit is shown in Fig. 3. This is a development from Fig. 2 and includes a lock-in facility. When the P.O. relay energises, a second set of contacts short-circuit the Siemens relay contacts, causing the P.O. relay to remain permanently energised until the supply is disconnected.

It should be noted that this circuit is of the "fail-safe" type in so far that the alarm is always given if the lamp illuminating the OCP71 fails.

Components

For the prototype, the author obtained the Siemens relay from Service Trading Co., 47-49

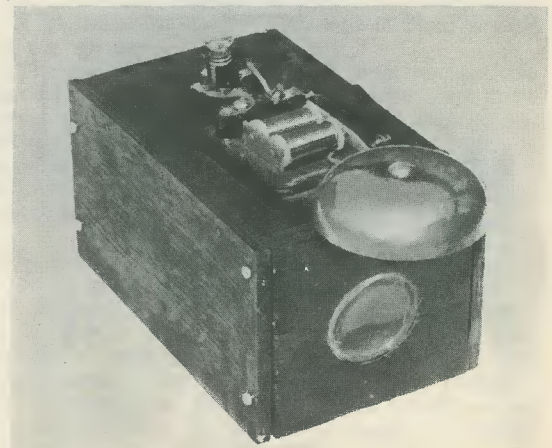

The cabinet housing the transistors and the relays

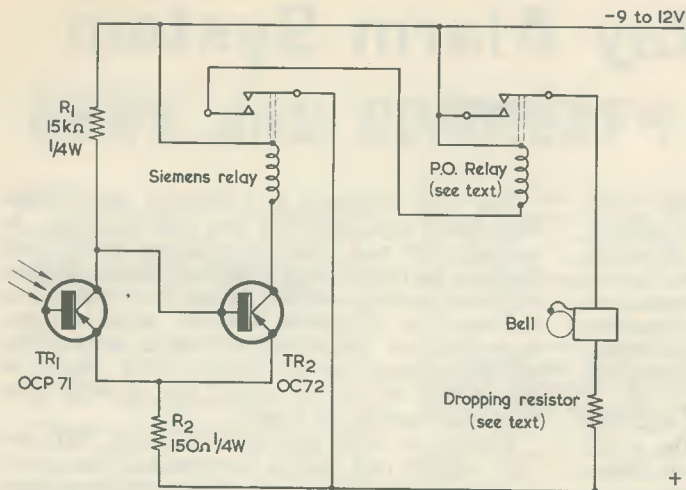

Fig. 2. Adding a second relay to allow higher currents to be switched. The resistor in series with the bell is discussed in the text

High Street, Kingston-on-Thames, Surrey. The P.O. relay was obtained from Messrs. Arthur Sallis, 93 North Road, Brighton, Sussex.

TR₁ is an OCP71, but one of the early OC71's with transparent glass cover and transparent internal grease could also be used with the outside paint scraped away. Currently available OC71's are metal cased and cannot be modified in this way. TR₂ is an OC72, and the supply may be provided by a transistor battery or batteries.

It is also necessary to provide the infra-red illumination for the phototransistor and one of the components required here is a focusing torch. An inexpensive focusing torch is available from Messrs. Boots the Chemist. The infra-red filter may be obtained from photographic stores, and it should be capable of being fitted to the torch.²

² The writer states that he has found that a plastic bathroom tile, known as "Polytile S & S", makes an excellent infra-red filter.
—EDITOR.

A further requirement is a focusing lens for the OCP71, and this should be 1½ to 2in in diameter, convex, and with a focal length of 3 to 4in. Lens No. 24 in the catalogue of Messrs. H. W. English, Rayleigh Road, Brentwood, Essex, will suit.

Finally required are a small carpenter's G-clamp, and an adjustable ball joint. The latter may be a photographic ball joint or that employed with a cycle handlebar mirror.

Making The Cabinet

A cabinet for the transistors and relays is required, and this may take up the form in the illustration (on which the bell and a lamp are also mounted). The convex lens is fitted to the circular aperture at the front. The dimensions of the author's unit were 6in long, 3in wide and 3in high. The lens hole is cut exactly to size and the lens glued within using Durofix. A small side aperture is provided as shown in the second photograph.

Fig. 3. Incorporating the lock-on facility. Once the P.O. relay has energised it remains in this condition, thereby sounding the bell continuously even if the infra-red ray has been broken momentarily only

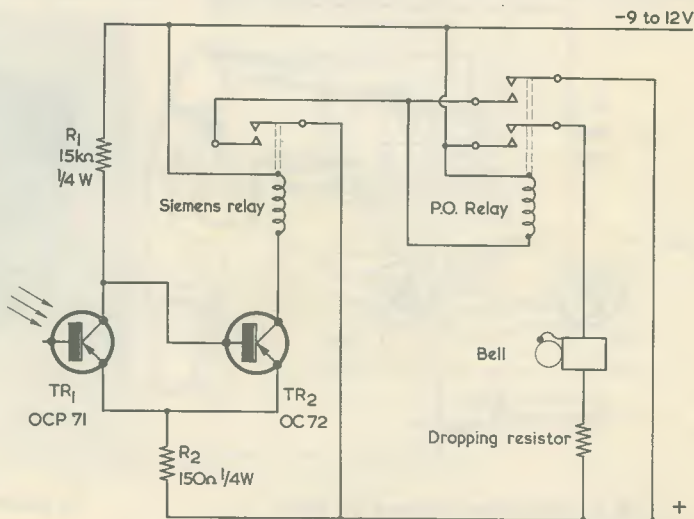

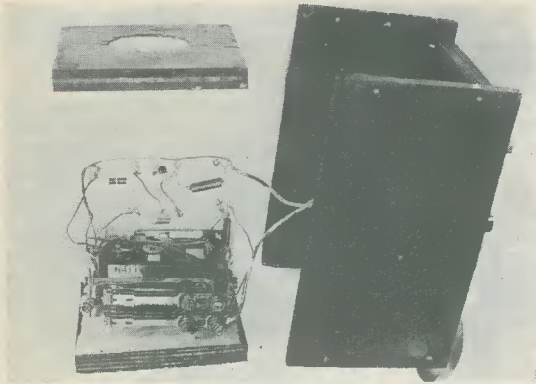

The components inside the cabinet

This can be opened to enable the position of the phototransistor to be adjusted. The inside of the cabinet should be painted with Berlin Black. The battery is not fitted inside the cabinet in the author's version.

Preliminary Test

Plug in a battery of 9 to 12 volts, being careful to have the polarity correct. In the dark the relay (or relays, if Fig. 2 or Fig. 3 are used) should pull in, and if a match is struck nearby it should release automatically until darkness returns. If the lens is used to focus the filament of a lamp bulb on to the transistor the relay should again fall out. Now connect the bell so that it rings when the match test is applied. Light mutes the bell, darkness causes it to ring.

Next, shine a torch into the lens and adjust the position of the phototransistor to coincide with the image of the filament and then by trial and error find the most sensitive part of the transistor (usually the filament should be on the collector/base junction if this can be distinguished). When an OCP71 is used, follow the maker's instructions regarding positioning relative to the light source. Any future adjustment, which should normally be unnecessary, will have to be made via the side window of the cover.

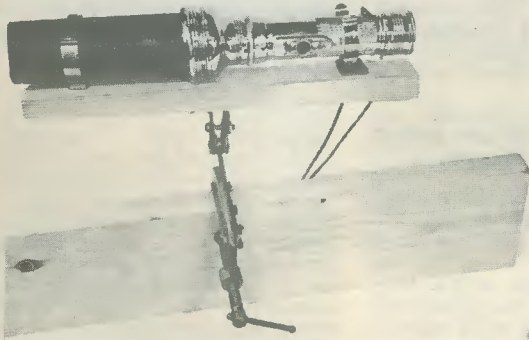

The infra-red light source and the manner in which it is mounted

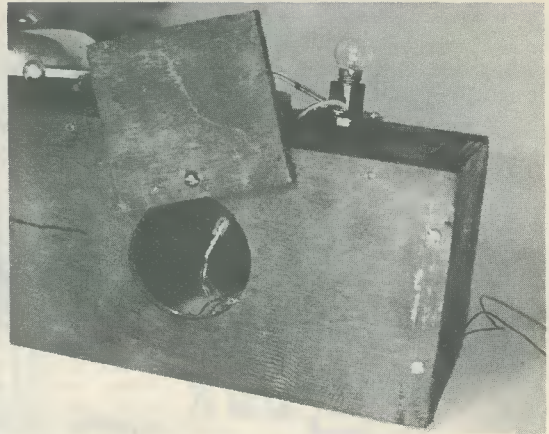

A side aperture is provided for final adjustment of the OCP71

The Light Source

This is best hidden under stairs, etc., and it is made in such a way that the fixing is virtually universal. The focusing torch is fitted with a dummy battery made from a piece of broom stick or dowel on which are fixed dummy brass screw contacts at top and bottom. Wires to these pass through grommets fitted into the side of the torch. A tube of metal or card is painted with Berlin Black and fixed over the glass of the torch by soldering or making a flange.

It is easier to use the torch if it is fitted with Terry clips on a piece of wood as shown in the appropriate illustration, this in turn being held in a ball joint attached to a carpenter's clamp. The leads are taken to a 12 volt heater transformer and a small wattage 12 volt lamp fitted in the torch. If desired the voltage may later be reduced to 8 watts or so to prolong bulb life.

The whole apparatus is now tested with a white light source (i.e. no filter) the torch being directed at the lens in front of the OCP71. A piece of infra red filter material is then cut to the same size as the glass of the torch and is fitted in lieu of the glass.

The transistor will now be almost as sensitive to the invisible rays, but since these cannot be seen, initial adjustment is tricky. If the bell is allowed to ring it will cease when the beam is correctly aiming at the lens. If the circuit of Fig. 3 is used, it will be helpful to disconnect the locking contacts of the P.O. relay during this operation.

How to fix up the alarm

When made and tested the alarm is placed in any position away from heat. For burglar use it should be hidden, say under the stairs with only the "infra-red ray hole" visible and the bell (and/or lamp) wired to any point in the house.

The battery should be in good condition as, if it is run down, the unit will tend to go in and out of operation continuously.

When setting up the locking burglar alarm

the light must be put on first or the unit will, of course, automatically sound the alarm. The author has left out a switch and other testing devices to make the unit as simple as possible.

It should be added that the prototype has been continuously tested for six months and is functioning well.

IN YOUR WORKSHOP

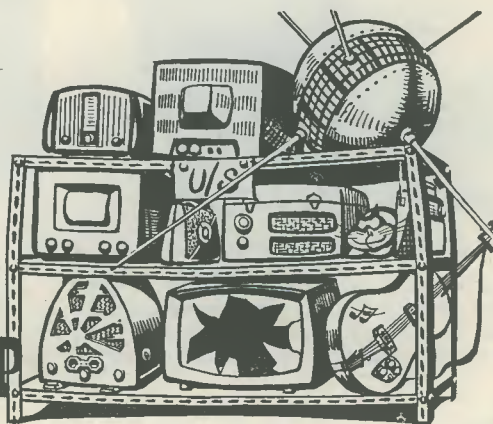

This month *Smithy the Serviceman*, aided as always by his able assistant *Dick*, discusses some of the finer points of design in transistor mixer-oscillator circuits, and deals in particular with typical examples of the *Luxembourg* tuning circuits fitted in commercial receivers.

RPAIR that?"
Dick pointed a scornful finger at the battered little transistor radio which lay on his bench.

"Yes, of course," said *Smithy*, puzzled at *Dick's* reaction. "Why on earth shouldn't we?"

"Look at the state it's in," protested *Dick*. "It's wrecked before we even get it out of the case."

Smithy picked up the little radio and examined it carefully.

"It is," he remarked eventually, "rather battered, I must say. Hello, what's this? Someone's scratched something on the case."

The *Serviceman* peered at the plastic back of the receiver.

"Jagger for President," he read out haltingly. "Dear me, what a way to treat a radio. Hello, there's something on the side, too. 'Good old Baillie Vass.'"

No Output

"That's what I mean," said *Dick*. "That set's been so bashed around and badly treated that it isn't even worth the trouble of fixing it."

"Oh, I don't know," replied *Smithy*. "We've got an hour to kill before packing-up time, and we've cleared out all the other sets in the Workshop."

"All right, then," said *Dick* resignedly, as he picked up a screw-driver. "But we were meant to do better jobs than this, you know!"

As *Dick* unscrewed the bolt holding the rear of the case, *Smithy* walked to his bench and returned with his stool.

"There we are," he said, as he settled himself comfortably alongside his assistant. "It isn't too bad inside after all, is it?"

"I suppose not," agreed *Dick* grudgingly, as he examined the components which were packed on to the Lilliputian printed board. "Perhaps it's worth having a go at it, after all."

Experimentally, he applied his thumb to the rim of the volume control. There was a click as the on-off switch operated. *Dick* turned the control to full, but no sound came from the receiver.

"I should check the battery," advised *Smithy*, "it's amazing how many faulty transistor sets there are which suffer from nothing else but a run-down battery!"

Obediently, *Dick* adjusted the switch of his testmeter and applied the test prods to the terminals of the battery.

"It's reading," he announced, "about 8.8 volts. No it isn't, it's gone down to 8.4 volts. Wait a minute, though, it's back at 8.8 volts. Now it's back to 8.4 volts again! Blimey, it's wandering around from 8.4 up to 8.8 all the time now!"

Dick stared unbelievably at the battery.

"I've heard about intermittents," he said incredulously, "but this is ridiculous. Who ever made a battery which gives a variable voltage output?"

Wearily, *Smithy* reached over and turned the tuning dial of the receiver.

"Try it now," he commanded.

Once more *Dick* applied his test prods.

"Well, I'm dashed," he said, staring at his meter. "It's dead steady at 8.8 volts now."

"Fair enough," commented *Smithy*. "We won't have far to look for this particular snag."

"Hey?"

"The trouble is obvious," continued *Smithy*. "It's almost 100% certain that this set was tuned to a station when you first applied the test prods, and that the output transistors were running on a good strong signal in consequence."

"Oh, I see what you mean," exclaimed *Dick*, as light broke in. "The varying battery voltage would be the result of the heavy current drawn by the output transistors, and this current would alter according to the sound being broadcast."

"That's right," agreed *Smithy*, "and this point is confirmed by the fact that, after I'd moved the tuning capacitor off the station, the battery voltage remained steady. With the set off tune, the output transistors weren't handling any heavy signal."

"If that's the case," said *Dick*

promptly, "the speaker's gone open-circuit."

Smithy sighed. "I do wish," he complained, "that you wouldn't keep jumping to these illogical conclusions of yours."

"What's so illogical about that?" queried Dick indignantly. "If the output transistors are handling a large signal and there's no noise coming out of the speaker, something must be wrong in the speaker circuit. What could be more logical than the speaker itself?"

"Plenty of things," replied Smithy patiently. "The flexible connections between the printed circuit board and the speaker for one, and the earphone socket for another. It's very common practice to put the earphone socket in the speaker circuit and give it a contact which breaks the connection to the speaker when the earphone is plugged in. (Fig. 1.) Incidentally, I've often thought that the people who use an earphone with the full whack of the output going into it must have rubber eardrums, but that's another story!"

Whilst Smithy was speaking, Dick had already switched off the receiver and was now examining the socket in question. Picking up a pair of taper-nosed pliers he carefully applied them to the socket and twisted them slightly.

"That should fix it," he remarked cheerfully. "The connection those contacts made looked a bit dicey, so I've just given the fixed one a wee bend in the right direction."

Dick switched on the receiver once more, whereupon a comforting hiss was immediately audible from the speaker. He swung the tuning dial, to find that both sensitivity and reproduction were satisfactory.

Light Programme Switching

"That's got this one fixed then," he remarked exultantly. "Last job of the day done. Good show!"

"Does it work on both wavebands?"

"Oh yes," replied Dick. "It's one of those sets with contacts on the tuning capacitor which switch over to the long waves around 1500 metres for the Light Programme. And the Light Programme's coming in fine."

"Fair enough," said Smithy. "Seeing that you've been playing around with the earphone socket you'd better test it with an earphone as well, before you finally let the set go."

Dick rummaged around on his bench and unearthed a small earphone with a flexible cord. He plugged this into the receiver,

whereupon the speaker became silent and the little earphone rattled away as it reproduced the signal received by the set. Dick unplugged the phone, and the receiver's speaker once more became operative. He switched off the set and pushed it to one side.

"And that," he remarked, "is that. I wish they were all as easy."

A thought struck him.

"By the way, Smithy," he asked, "how do those long wave switching circuits work? The ones with the contacts on the tuning capacitor."

"Oh, those," said Smithy. "Well, all that happens normally is that the contacts just connect extra capacitance across the oscillator tuned circuit and the aerial tuned circuit. If you look at the back of the tuning capacitor you'll see that there are two fixed contacts mounted on it. These connect to a third moving contact when the tuning capacitor is tuned past the low frequency end of the medium wave band, and they cause long waves to be selected. The moving contact is earthed, and so the fixed contacts can then add extra fixed capacitors across the aerial and oscillator tuned circuits." (Fig. 2.)

"No trimmers?"

"Not normally," replied Smithy. "The tuning capacitor still offers a change of capacitance when the contacts are made, and so its oscillator section can enable you to tune in the Light Programme accurately. The extra aerial tuned circuit capacitance is pretty large and so you get a low L/C ratio, giving this part of the circuit a broad response. Because of this, it's hardly worthwhile using a long wave aerial trimmer."

"Won't the additional capacitance cause the oscillator tuned circuit to have a low L/C ratio as well?"

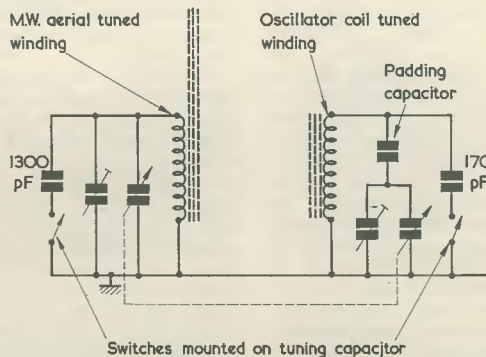

Fig. 2. A simple wave-change switching circuit, as is used when the wave-change contacts are closed by turning the tuning capacitor. The values shown for the two fixed capacitors switched into circuit on long waves are representative of commercial practice

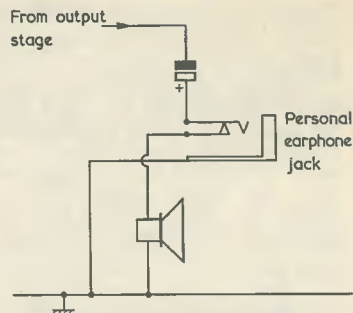

Fig. 1. A typical earphone jack circuit in a transistor receiver. Inserting the earphone jack plug breaks the circuit to the loudspeaker

"Not really," explained Smithy. "The extra capacitance connected across the oscillator tuned circuit is around 170pF only. The extra capacitance across the aerial tuned circuit is normally about 1,300pF."

Dick listened to this information with obvious scepticism.

"That doesn't make sense," he declared. "You're switching both circuits from medium waves to long waves, and yet one of the additional capacitors is nearly ten times as big as the other."

"Who," asked Smithy, "said anything about switching the oscillator tuned circuit to long waves?"

"You must do," stated Dick. "If it isn't switched to long waves, how the heck do you pick up the Light Programme?"

"One of these days," sighed Smithy, "I'll let you into the secret of how a superhet works. In the meantime, please take my word for it that the oscillator frequency is removed from the signal frequency by the intermediate frequency. In most receivers, including broadcast

band receivers, it runs above the signal frequency. O.K.?"

"I'm prepared," said Dick reluctantly, "to accept that."

"Having established these basic facts," Smithy went on, "let's now see how things in our medium-long wave switching circuit work out in terms of frequency. To start off with, the tuning capacitor switch comes into action at the low frequency end of the medium waveband,

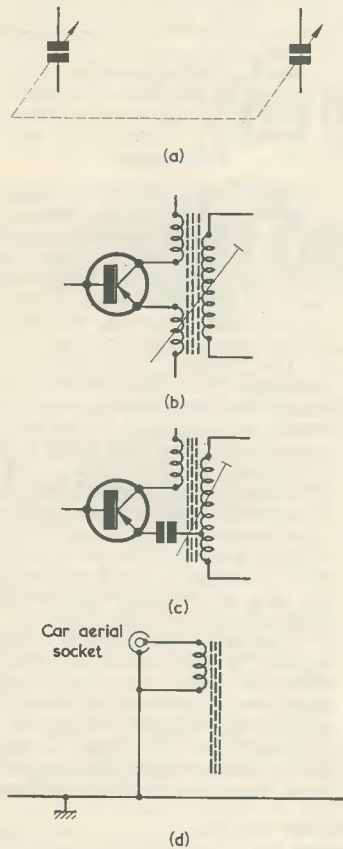

Fig. 3. When tracing out complicated transistor receiver wave-change switching circuit diagrams, it is helpful to locate the more obvious "landmarks" first. These are (a) the two sections of the tuning capacitor, identifiable by the dashed line that joins them; and the readily recognisable pattern (b) of the mixer-oscillator transistor and its oscillator coil, with the occasionally-met variant shown in (c). Ferrite rod winding arrangements tend to vary from set to set but the car aerial coupling circuit is almost always that shown in (d)

where the signal frequency is round about 600 kc/s. Right?"

"That seems," said Dick, "to be reasonable enough."

"Good. Now, the oscillator frequency is higher than this by the intermediate frequency. If we say that the i.f. of the receiver is 450 kc/s, then the oscillator frequency will be 600 plus 450 kc/s. Which, to my way of reckoning, comes out at 1,050 kc/s. Agreed?"

"I would," said Dick condescendingly, "accept that figure."

Smithy gritted his teeth. Life can be difficult for those who have knowledge to impart.

"Right," he said shortly. "So now let's add the extra capacitance needed to tune in the Light Programme on long waves, and see how the two frequencies come out. The Light Programme is on 1,500 metres, or 200 kc/s, and so this is our new signal frequency. The new oscillator frequency is 200 plus 450 kc/s, or 650 kc/s. In consequence, switching to the Light Programme results in the signal frequency dropping to a third of its previous value. But the oscillator frequency only drops from 1,050 to 650 kc/s, which isn't even half. Apart from anything else, therefore, you *have* to add a larger capacitor across the aerial tuned circuit than is needed across the oscillator circuit."

"Well, blow me," said Dick. "It's obvious when you look at it from the frequency point of view."

"Of course it is," replied Smithy. "I should add, by the way, that these added capacitance values are chosen to give best results in the aerial tuned circuit at 200 kc/s and a small range on either side only."

Wave-change Circuits

"Wouldn't it be better," queried Dick, "to switch in a long wave coil on the ferrite rod aerial than to add a large capacitor across the medium wave coil?"

"Probably," replied Smithy, "but the circuit complications might not be acceptable in a very small low-cost receiver, and it would be difficult to switch in an extra coil with the two contacts that are given by the tuning capacitor switch. If the set has a separate wave-change switch this can provide one or two more switching poles, and the switching circuit will then almost always bring in a long wave coil on the ferrite rod. This occurs even if the receiver is of the type which offers a limited long wave range on either side of the Light Programme."

"Talking about wave-change switches," volunteered Dick, "re-

minds me that some of these transistor wave-change switching circuits aren't half complicated."

"How d'you mean?"

"Well," said Dick, "you open up the service sheet to look at the circuit, and you find a whole jungle of switches and components around the oscillator-mixer transistor. Dead complicated, some of them are."

"Don't tell me," said Smithy, surprised, "that you've actually started *looking* at service sheets."

"Of course I look at them," replied Dick, indignantly. "Mind you, I don't believe in getting out the service sheet as soon as I get a set on the bench. I like to have a little prod around first."

"So," remarked Smithy, "I have noticed. I'd hate to have to add up the hours you've spent in prodding around when the service sheets are available to give you all the gen you want."

"What I was saying," said Dick, ignoring Smithy's criticism, "is that some of these transistor wave-change switching circuits are jolly complicated."

"A few of them *do* tend to give that impression," conceded Smithy. "The trouble is that a lot of transistor receivers use push button wave-change switches in which the depressed button springs out when a new one is pressed, and the circuit diagrams become a wee bit harder to follow than in the cases where normal switches and normal switch symbols are used. If you've got a *really* complicated wave-change circuit, it's a good plan to find your landmarks first."

"How d'you mean?"

"You want to find," explained Smithy, "the easily recognisable components. The first of these are the two sections of the tuning capacitor, and these can be very quickly identified by the dashed line which joins them to indicate that they are ganged. (Fig. 3 (a).) The next component is the oscillator coil, and this almost always sits in a very distinctive arrangement with two coupling coils connected to the emitter and collector of the oscillator-mixer transistor, and with a separate tuned winding. (Fig. 3 (b).) Sometimes the emitter couples into the tuned winding itself (Fig. 3 (c)) but you still get the familiar and easily recognisable basic pattern. Another landmark is the ferrite rod aerial but here, unfortunately, things aren't quite so straightforward, because ferrite rod winding combinations can vary quite a lot from set to set. One consistent bit is that, if there's a car aerial socket, this almost always goes to its own separate winding. (Fig. 3

(d.) If, with an unfamiliar and complicated mixer-oscillator circuit, you first identify and place the components I've just mentioned, you can save yourself quite a bit of time. This is particularly true if the wave-change switching circuit has lots of trimmers and fixed capacitors in it."

"Some wave-change circuits," said Dick, "bring in resistors as well. The wave-change switch connects a resistor across the oscillator tuned winding on medium waves."

"That's quite a common practice," agreed Smithy. "These resistors usually range from around 50kΩ up to 250kΩ, and they damp the oscillator coil down a bit on medium waves, where there is less tuning capacitance than on long waves. The result is that oscillation amplitude is at more nearly the same level on the two wavebands than would occur if the resistor weren't fitted."

Smithy stopped and looked at his watch.

"Dash it all," he said, "there's still half an hour to go yet. I want to get away dead on packing-up time tonight, too, because I've got a bit of a night on at the club."

"So," said Dick, "have I."

"At the club? You aren't even a member."

"Of course I'm not," replied Dick. "I'm going down to Joe's Caff."

Smithy's eyebrows shot up.

"Joe's Caff?" he repeated in surprise. "I thought you'd given that place up ages ago."

"We keep on keeping away," explained Dick. "But, somehow or other, everyone seems to drift back again after a while."

"Isn't Joe the bloke who's always changing the place around and giving it different names?"

"That's right," said Dick. "He used to follow all the raves, like the Merseyside bit and being satirical and all that, but there just aren't any decent raves going these days. So he's now called his place 'The Mandarin's Nosh' and changed it to a Chinese restaurant."

"Sounds charming," commented Smithy. "And does he dish up the real Chinese food?"

A look of uncertainty crept over Dick's face.

"Well, he keeps on saying it is," he replied hesitantly, "but we're all beginning to get extremely suspicious. If we say anything, though, he just says that it's exactly the same food as the Chinese eat out in Hong Kong. Since none of us have got a clue as to what the Chinese do eat out in Hong Kong we just have to take his word for it."

"I think I can understand the problem," said Smithy sympathetic-

ally. "You've got a nasty feeling that he's diddling you in some way, but you just can't put your finger on it."

"That's exactly it," said Dick, pleased at Smithy's understanding of the situation. "I couldn't have put it better myself."

"What," asked Smithy, "are some of the meals he serves?"

"Well," said Dick, a little doubtfully, "to start off with, there's *Phoo Sten Lung*."

"And what's that consist of?"

"Egg and chips."

Smithy swallowed.

"Any more?" he asked.

"Oh yes," replied Dick. "There's *Sung Tan Choy*."

"And what's that?"

"Sausage and chips."

"Any others?"

"There's *Chow Pung Choo*."

"What's that?"

"Beans and chips."

"What," asked Smithy gently, "is your favourite one?"

"Ah," said Dick enthusiastically, momentarily forgetting his suspicions of unscrupulous trading on the part of Joe, "that's the old *Clong Chan Phooey*."

"Ye gods," breathed Smithy, "and what does that comprise?"

"Pie and chips," replied Dick appreciatively. "And if you want a real super version of it, you can't beat the *Clong Chan Phooey Chop-Chop!*"

"But," protested Smithy, "that's the same as the last one with *Chop-Chop* added."

"Exactly," said Dick. "It's meat pie and chips with two splodges of chop sauce on the side of the plate!"

"Well," commented Smithy, "you certainly seem to be enjoying your Chinese food at any rate."

"I suppose I'll get used to it in time," replied Dick. "But it's very difficult at first."

"How's that?"

"Have you," asked Dick, "ever tried eating meat pie and chips with chop-sticks? How those Chinese out in Hong Kong manage it baffles me completely."

He stared moodily at the wall behind his bench.

"I suppose," he added gloomily, "it's what you're brought up to, and that's all there is to it."

"Lux" Tuning

Smithy decided that a change of topic might well be profitable.

"Is there anything else," he enquired, "that you want to know concerning transistor tuning circuits before we pack up?"

"Oh yes," said Dick, wrenching

his mind away from the inscrutable customs of the Orient when dealing with pie and chips. "What about these medium wave bandsread tuning circuits that are fitted to so many sets these days?"

"You mean," queried Smithy, "the Luxembourg tuning circuits?"

"That's right."

"Well, most of these," said Smithy, "are intended to give easier tuning around the high frequency end of the medium waveband. This end tends to get a little cramped with the tuning circuits you get in these little transistor sets, and the lack of a high ratio tuning drive makes the selection of stations even more difficult. Also, the two major pop stations, Luxembourg and Caroline, appear at the high frequency end. These are liable to fade a bit, which further increases the difficulty of tuning. All these points make bandsread tuning over the high frequency end of the medium waveband an attractive proposition, and a common approach consists of having the bandsread range cover about 185 to 215 metres."

"Radio Luxembourg," remarked Dick, "comes up on 208 metres. What's the wavelength of Radio Caroline?"

"The last I heard," said Smithy, "was that, of the two Radio Caroline ships, Caroline North comes up on 199 metres and Caroline South on 201 metres. This assumes that nobody's thrown any grappling irons on to them yet. So, both the Caroline stations come within the bandsread range I've just mentioned."

"What about the other pirate stations?"

"Well," said Smithy, "Radio King is on 236 or 238 metres, Radio London is on 266, Invicta is on 306 and Radio City is on 299 metres. I'm again assuming that no boarding parties have been in operation, or that conditions haven't caused them to shift frequency. All these fall outside the normal bandsread range, although they do, of course, appear at points on the ordinary medium wave range where tuning is easier. I should add, by the way, that the nominal function of the bandsread circuits we're talking about now is to ease the tuning in of Radio Luxembourg only, and they are usually referred to as the 'Lux' or 'Luxembourg' circuits. These bandsread circuits inevitably make the high frequency end of the 'Lux' range the same as on the standard medium wave range, and so Radio Caroline, at least, manages to come up on bandsread as well."

"How is the bandsreading done?"

"The simplest arrangement," said Smithy, "consists of inserting capacitance in series with the tuning capacitor sections. You'll encounter this on quite a few receivers."

Smithy drew out a pen and

sketched a circuit on Dick's notepad. (Fig. 4 (a).)

"This," he remarked, "is a rather simplified circuit because I've omitted the switching for long waves. All that happens is that, when you

select 'Lux', you insert a fixed capacitor in series with the oscillator tuning capacitor and its padding capacitor, and a trimmer in series with the aerial tuning capacitor. The fixed capacitor normally has a value around 22pF, and the trimmer a range of about 5 to 50pF."

"Why not have fixed capacitors in both positions?"

"Because," replied Smithy, "the ferrite rod medium wave coil peaks pretty sharply at the high frequency end of the band and it is better to use a trimmer which can take up small variations in circuit and stray capacitances than to rely on the results given by two close-tolerance fixed capacitors. Another point is that, in the oscillator circuit, the most critical variable component, so far as the bandspread range is concerned, is the trimmer across the oscillator tuned circuit. This will have a considerable effect on the position of stations on the dial when you're switched to 'Lux'. The usual approach, when aligning a set of this nature, is to get the oscillator trimmer adjusted correctly with the 'Lux' band selected, because this is where the high frequency end of the medium waveband is opened out and where errors in dial calibration become most noticeable. The next step is to adjust the medium wave aerial trimmer when switched to medium waves. The final operation then consists of selecting 'Lux' again, tuning in Luxembourg or the output of a signal generator set to 208 metres, and peaking up the series aerial trimmer which is brought into circuit on the 'Lux' range. Do all these operations and the set works perfectly well on medium waves, and it's spot-on for Radio Luxembourg."

"I can see now," said Dick, "what you meant when you said that the 'Lux' range must inevitably start at the top end of the medium wave range. Since you're inserting series capacitance into the two tuned circuits, you're only reducing the maximum tuning capacitance. The minimum tuning capacitance is pretty well the same as before."

"Actually," Smithy pointed out, "it's a tiny bit reduced on 'Lux', because the tuning capacitor will still have a small capacitance even when its vanes are fully open. So the extra series capacitance introduced on 'Lux' enables a slightly higher resonant frequency to be given. The high frequency end of the 'Lux' band then becomes a metre or two less than the high frequency end of the medium waveband. However, that's only a minor point."

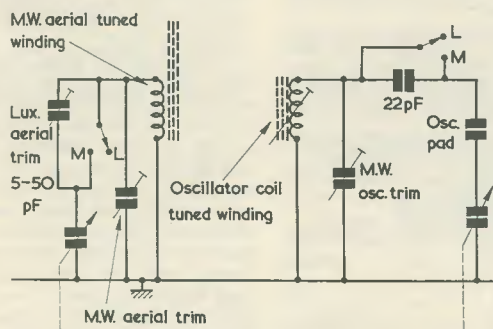

Switches ganged M - medium waves L - Luxembourg

(a)

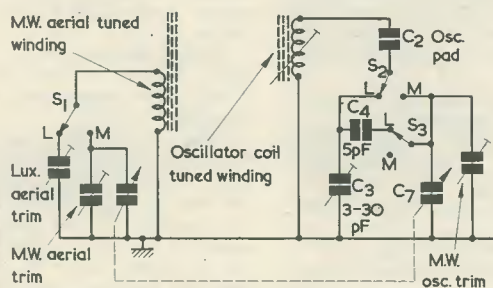

S₁, S₂, S₃ - ganged M - medium waves L - Luxembourg

(b)

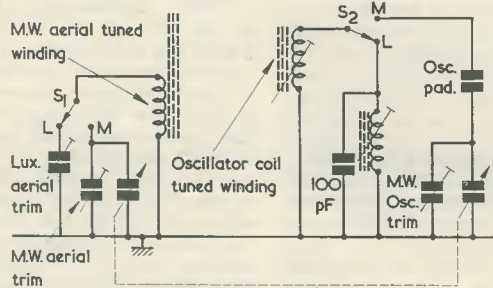

S₁, S₂ - ganged M - medium waves L - Luxembourg

(c)

Fig. 4 (a). A typical method of obtaining bandspread tuning over about 185 to 215 metres. In this diagram, and in (b), component values shown are representative of normal practice

(b). Another method of bandspreading. In this case reception is centred on Radio Luxembourg only, with a small amount of coverage on either side

(c). A circuit which provides pre-set tuning of Radio Luxembourg. The main tuning capacitor has no control when Luxembourg is selected

"Are there any other methods of getting 'Lux' bandspreading?"

"Oh yes," said Smythy. "Another approach, which you'll bump into with some receivers, is a variation on the one I've just mentioned. In this case, however, the tuning is intended to cover only a small range on either side of Radio Luxembourg."

Once more Smythy scribbled out a circuit on Dick's notepad. (Fig. 4 (b).)

"Here," said Smythy, "is the basic idea. Let's tackle the oscillator switching circuit first. Once again, I've omitted any other wave-change switching which may be present, and am only concentrating on the medium wave—'Lux' switching. When the two switches S_2 and S_3 are in the 'position I've marked 'M', medium waves is selected. The tuning capacitor and its parallel trimmer are then applied, in series with the padding capacitor, C_2 , to the tuned winding of the oscillator coil. The result is that the medium waveband is tuned in normal manner. The padding capacitor, incidentally, will have a value of the order of 250pF or so. When you switch S_2 and S_3 to position 'L' you enter 'Lux'-land. What happens now is that trimmer C_3 connects, via the padder, C_2 , across the tuned coil. At the same time the tuning capacitor is connected across C_3 via the low-value capacitor, C_4 . The result is that trimmer C_3 has the major control over oscillator tuning, and is trimmed, in its turn, by the receiver tuning capacitor. You usually align a circuit of this type by first of all doing all the trimming and padding needed for medium and long waves. You then switch to 'Lux', set the main tuning capacitor to a point on the scale as specified by the makers of the set, and adjust C_3 to bring in Radio Luxembourg, or a signal generator output of the same frequency. The situation then is that C_3 has selected the correct oscillator frequency, whilst the main tuning capacitor allows a small bit of fine tuning on either side."

"What about the aerial circuit?"

"That," replied Smythy, "is a piece of cake. Since you're only interested in picking up Luxembourg on the 'Lux' range, all you do is to switch in a trimmer across the ferrite rod medium wave coil in place of the normal tuning capacitor. In my circuit, this little job is done by S_1 . After you've got the oscillator section right, you merely peak up the aerial trimmer, which I've shown as C_1 , so that it offers maximum reception of the Radio Luxembourg signal."

Pre-Set Tuning

Smythy paused for a moment, as a thought suddenly struck him.

"What's up?" asked Dick.

"It's something that's been niggling away at the back of my mind," said Smythy, "ever since we did that little transistor set on your bench."

"We fixed it O.K., didn't we?"

"Oh yes," replied Smythy. "That's all right. It's just that I'm trying to place this Baille Vass character. The name seems familiar, but I can't remember where I've seen it."

"In a newspaper?"

"No," said Smythy, frowning thoughtfully.

"A magazine, then?"

"That's probably it," replied Smythy, his face clearing. "The only time I get to look at magazines these days is down at the club, so I must have seen that name in one of the mags they leave out for members."

"That club of yours seems to be well organised."

"We pride ourselves," said Smythy proudly, "on catering for most tastes."

"That's what my uncle says."

Smythy sighed. One of the major complaints he held against the Fates, was that, out of Dick's multitudinous array of aunts and uncles, one of the uncles was the Steward at his club. He always felt that his actions at the club were like those of a servo motor, the inhibiting feedback path being the verbal link from Dick's uncle to Dick.

"Let's," he said hastily, "get back to those Luxembourg tuning circuits."

"Righty-ho," said Dick obligingly.

"What's the next one?"

"This one is a pre-set tuning circuit," replied Smythy, once more scribbling on Dick's note pad. "And in this case it's *really* pre-set. When you press the 'Lux' button in receivers employing this circuit, you get Luxembourg spot on the nose, and the receiver tuning capacitor has no control over tuning at all."

"That's a funny looking arrangement," said Dick critically, as he gazed at the circuit Smythy was sketching out. "This time you switch in a coil as well as a capacitor."

"That's right," agreed Smythy, putting the final touches to the circuit. (Fig. 4 (c).) "Now this shows, once more, the basic idea, and let's start off again with the oscillator section. When switch S_2 is set to 'M' you get medium wave tuning in the normal manner by way of the receiver tuning capacitor, a padding capacitor and a trimmer.

So there's no need to bother any more about that section of the circuit, as it's perfectly normal and straightforward. Now, when we set S_2 to 'L' we completely disconnect the tuning capacitor and its associated components, and we connect a second coil with an adjustable dust core straight across the tuned winding of the oscillator coil. The second coil has a fixed capacitor of about 100pF across it, whereupon we have a parallel combination of this capacitor, the new coil and the oscillator tuned winding."

"Blimey," said Dick, "this lot baffles me!"

"It's dead simple," replied Smythy. "What happens is that the two coils in parallel provide an inductance which is lower than either of them possess on their own. This inductance is then tuned by the 100pF parallel capacitor so that it resonates at the oscillator frequency needed to bring in Radio Luxembourg."

"I still," said Dick, "don't get it! Why introduce the complication of an extra coil?"

"Because," explained Smythy, "if you want an adjustable tuned circuit to stay exactly on frequency over a long period of time without using expensive components, the best course consists of making the frequency adjustment by means of an iron dust core in a coil rather than by means of a trimmer. I don't suppose you'll remember the old press-button medium and long wave sets which were on the market many years ago, and in which you selected your station by pressing a button. In the oscillator section of these sets, the buttons switched in different iron-cored inductors to vary the oscillator frequency, whereas they switched in different trimming capacitors in the aerial circuit. Trimming capacitors had a long-period stability which was good enough for the aerial circuits, but which was certainly not good enough for the oscillator circuits. The latter used inductors with adjustable iron dust cores, because these cores would stay reliably in position over very long periods of time. I should add, for the sake of completeness, that you would sometimes find the oscillator frequency controlled by trimming capacitors as well, but this was only on the button circuits which selected stations at the low frequency end of the band concerned. At the low frequency end, shifts in oscillator tuning capacitance had less detuning effect, and the trimmers could be low-capacitance components shunted by high value fixed capacitors of high stability."

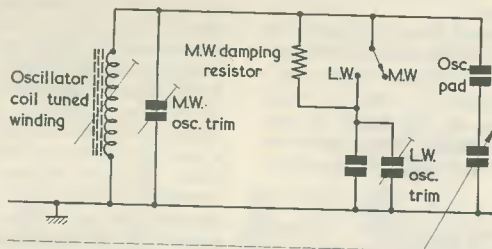

Fig. 5. A method of obtaining oscillator coil damping on medium waves without extra switch contacts. The damping resistor will usually be of the order of 50 to 100k Ω according to receiver design. The fixed capacitor in parallel with the long wave oscillator trimmer will have a value around 200 to 250pF

"Is that," asked Dick, "why the 'Lux' circuit we're looking at now has the 100pF capacitor across the tuned circuit?"

"To a limited extent, yes," said Smithy. "Using the additional coil to tune in Radio Luxembourg confers two advantages. First of all, it enables the pre-set tuning to be carried out by an adjustable iron dust core, with its attendant long-term stability. And secondly, because it reduces the overall oscillator tuning inductance, it enables you to put a reasonably large fixed capacitor across it to swamp out the small self-capacitances which exist in the circuit. These self-capacitances can shift with time, but they don't cause any serious detuning because they are swamped out by the 100pF capacitor."

An Additional Point

"That's neat," said Dick, approvingly. "A most knobby arrangement!"

"It's a very good idea," agreed Smithy. "In the previous circuit we looked at, Luxembourg tuning was achieved with a trimming capacitor, but it was still possible to do some fine tuning with the main tuning capacitor in the receiver. The latter enabled you to get exactly on correct frequency, even if the trimmer circuit drifted a wee bit with time. The present idea has a very high long term stability which means that there's no need to bring in the tuning capacitor at all. Incidentally, when you're setting up circuits of this nature it's always very advisable to do the final trimming on Radio Luxembourg itself. If you finally set up the circuit against a signal generator, you may find that calibration error in the generator causes the adjustment to be a wee bit off the actual station itself."

"What," asked Dick, "about the aerial circuit?"

"It's the same as with the previous arrangement," replied Smithy. "When you go on to 'Lux' you simply disconnect the tuning capacitor and connect a trimmer across the medium wave ferrite rod tuned coil. There may be a small fixed capacitor across this trimmer to give increased long term stability. The trimmer is, of course, adjusted for optimum strength of Radio Luxembourg."

"I see," said Dick. "Incidentally, is it packing up time now?"

"Just on it," replied Smithy, gravely consulting his watch.

"Fine," said Dick, rising from his stool. "Then I'm off!"

"Hang on a jiff," said Smithy, "there's a final point I want to clear up."

"But I'll be late," protested Dick, "for our get-together down at Joe's."

"This," said Smithy soothingly, "won't take a moment. You remember I said earlier on that, in some receivers, a fairly high value resistor was switched across the oscillator tuned coil on medium waves to damp it down a bit."

"Yes," said Dick impatiently.

"Well," continued Smithy, "on some sets you'll find a little circuit dodge which combines this resistor with the long wave switching."

Smithy sketched out a further circuit on Dick's pad (Fig. 5), whilst his assistant looked on restlessly.

"This," went on Smithy, "is a very neat circuit and it saves switching contacts. When the switch is set to long waves, the resistor is shorted out, and you have the additional capacitance across the oscillator tuned coil which is needed to cause it to work on long waves. This switching circuit doesn't, by the way, apply only to sets with limited long wave coverage around the Light Programme. It can also be found in sets which have full long wave coverage."

"What happens," interjected Dick hurriedly, "if you switch over to medium waves?"

"When," said Smithy, "you go over to medium waves, you take the short off the resistor. The parallel capacitance switched in on long waves will have a value of the order of 250pF or so and its reactance, at medium wave oscillator frequencies, is then in the region of hundreds of ohms only. This is very much lower than the value of the damping resistor, with the result that the two, in series, apply an impedance across the oscillator tuned coil which is almost entirely resistive. The result is that you get the required damping on medium waves, as would be given by a resistor on its own, without any further switching than is needed, in the first place, to select medium and long waves."

Final Words

"That's a good idea," commented Dick, forgetting his hurry for the moment. "You know, Smithy, there aren't half some crafty schemes stowed away in these little transistor sets."

"There are indeed," agreed Smithy, getting up, "and all we've covered during this little session have been a few facets of the mixer-oscillator stage in the simpler type of receiver. We haven't looked at all at what happens, for instance, with transistor sets which cover the short wavebands or, even more interesting, transistor sets which cover v.h.f./f.m. in addition to the a.m. broadcast bands."

Dick suddenly remembered that valuable time was passing by.

"Take it easy," he chuckled, as he hastily got ready to leave, "you're beginning to get all complicated now!"

"Not at all," replied Smithy, turning off the Workshop switches and holding the door open for his assistant. "All these sets are dead easy when you start examining them in detail. It's only when you try to tackle a complex circuit all at once, instead of in little bits, that you're liable to start getting confused."

With which words, Smithy passed through the door, closed and locked it and fell in step beside his assistant. And the Workshop fell into silence as the two departed, one to sample the reckless joys of his club under the eagle eye of the other's uncle, and the second to embark on the even headier delights of exotic Eastern dishes as concocted by the proprietor of Britain's most reactionary Chinese Restaurant.

The Story of the Valve

Part 2

C. H. Gardner

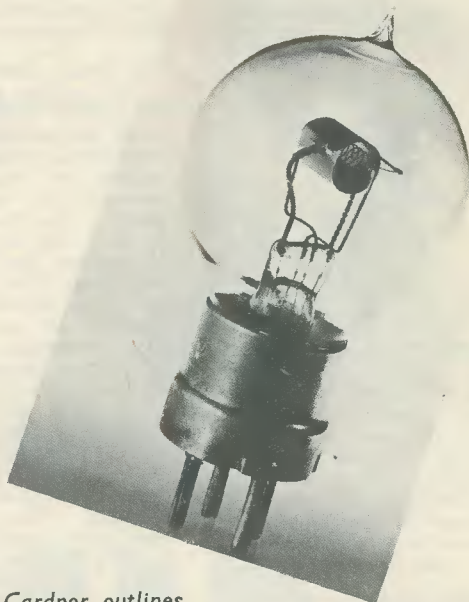

In this second article of his 4-part series, C. H. Gardner outlines the development of the valve from the early battery triode to the all-mains indirectly heated valve

FROM THE EARLY 1920's ONWARDS, valve development may, as we saw last month, be considered as progressing along three distinct but complementary lines. Valves had to have improved performance, intensive engineering research was needed for high quantity production, and valves had to be made more reliable and have longer life.

The valve manufacturer thus found it necessary to establish a number of ancillary departments which included laboratories to meet these research requirements. Further departments were devoted to experimental work connected with valve application and laboratories dealing with the control of quality.

Receiver Conditions

The valve manufacturer had to endeavour to visualise the changes in design which would be necessary to deal with the conditions under which receivers might have to operate several years ahead. Some considerable foresight was necessary here, as a lengthy period between drawing board and production was unavoidable. Normally, a few sample prototypes would be made and

tried out in the applications laboratory. If results showed promise a trial run of a few hundred would be made to establish that the type could be manufactured in quantity within the required tolerances, and at a cost which would allow of its adoption within the "standard" range. Samples would be provided for equipment manufacturers and these would be accompanied by very full reports from the applications laboratory regarding suitable associated circuitry and component design. Modification of the original design might be called for at any stage of the proceedings, whereupon a further journey through the various steps would be needed before quantity production could proceed.

Even apparently minor modifications to a valve are not such a simple matter as may appear at first sight. The valve is a complex device dependent for its successful operation on a number of factors including mechanical construction, electronics and chemistry. A minor change in any single factor may produce unexpected difficulties in one or more of the others. For instance, a change in the metal

from which the grid is made could well change the contact potential between cathode and grid, with a consequent alteration in the valve's characteristics.

Although quite astonishing performances were being obtained in the early 1920's by the use of simple triode valves as radio frequency amplifiers their limitations were already being recognised. At that time it was quite common to find a combination of five triodes in a broadcast receiver, the first two operating as r.f. amplifiers, the third as a detector and the final two as audio frequency amplifiers. In many cases the r.f. valves were coupled by tuned (but not ganged) circuits, stability being obtained at the expense of some loss of amplification. There were also a number of "suitcase" portable receivers with frame aerials in the lid of the case, and in which all five valves were resistance-capacitance coupled, their functions being determined by suitably chosen values of components and the bias applied to the valve grids. One was inclined to a suspicion that, as the batteries ran down, the valves did not always continue to function in the intended manner and, instead of having a 2 r.f., detector and 2 a.f. receiver, one had a detector and 4 a.f. set.

A major factor influenced the design of receivers of that period and, in fact, continued so to do for some years following. The public were inclined to judge a

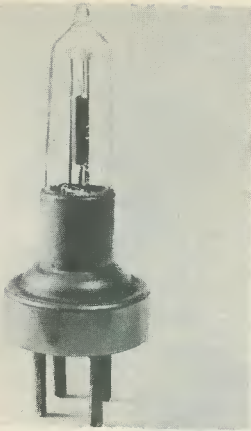

A Mullard "Weco" valve, produced around 1925. Its filament consumed 0.25 amp at 1 volt, and was normally powered by a single dry cell via a rheostat. The rheostat was adjusted to allow for voltage change as the battery ran down (courtesy Mullard Ltd.)

receiver not upon its quality of reproduction but by the number of stations that it could receive. A further factor in both receiver and valve design was the fact that the filament supply had to be obtained from a heavy accumulator, which had to be carried to the local garage or radio dealer for recharging at all too frequent intervals.

In order to reduce filament consumption, investigation of cathode materials offering adequate emission at lower temperatures was undertaken, and this resulted in the production of what came to be known as "dull emitter" valves. The filaments of these valves operated at dull red heat instead of with the lamp-like bright glow to which we had been previously accustomed. Dull emitter valves made their debut in the 1924-1926 period, and their ratings varied considerably. One type had a rating of 3 volts at 0.06 amps, thus making it a suitable type for dry battery operation, whilst others were rated at 2 volts and a higher current.

At the same time triode valves of reduced size appeared on the market, these having the curious rating of a quarter of an amp at 1 volt. This meant that a five valve receiver would consume $1\frac{1}{4}$ amps at 1 volt, a fact which would not indicate a prolonged life for a dry cell. One of these valves, the "Weco", is shown in the accompanying illustration.

The story of the continual search for cathode materials which could provide both efficiency and long life is one which will be dealt with more fully next month.

The Screen Grid Valve

The inability of the triode valve to provide high amplification of radio frequencies was due to the capacitance between grid and anode causing an undesirable coupling between the input and output circuits. The first tetrode appeared in 1924, the extra grid operating as a screen, but it was appreciably later than 1924 before the screen grid valve began to appear in any quantity in broadcast receivers. It is interesting to note that two well-known home-constructor kits made available by valve manufacturers in 1928, the Mullard "Master Three" and the Cossor "Melody Maker", specified battery triodes.

With the appearance of the loud-speaker the "power" valve became available. These "power" valves were low impedance triodes with longer grid bases and a rather more heavy anode consumption than other valves. A typical 2 volt power valve would have an anode impedance of 2000Ω , an amplification factor in the region of 7 or 8, and would consume about 10 to 15mA at 100 or 150 volts. Being rather expensive so far as h.t. battery replacement was concerned, they became more popular when the so-called "battery eliminator" appeared on the scene, as this allowed the h.t. supply to be obtained from the electric light mains.

A competitor to the "power" valve arrived in the form of the pentode, this having an extra grid, connected to cathode, between the screening grid and the anode. The extra grid overcame an undesirable feature of the screen

grid valve by suppressing secondary emission from the anode.

Pentode valves were designed in two types, one for r.f. amplification and the other for use as an output valve. The output pentodes had a much shorter grid base than the triode output valves but gave a much higher degree of amplification. The "quality" enthusiast of that time was apt to suggest that "quality" could be obtained only by the use of triodes in the output stage, a fact which may come as rather a shock to the user of modern hi-fi equipment. But then there were also those who maintained that real "quality" could be obtained only from a crystal detector and a pair of headphones and, at a later period, those who affirmed that only a battery set could provide good reception, mains-driven sets being useless for high "quality"!

The "All-Mains" Valve

Mention must next be made of the indirectly heated "all-mains" valves which made their appearance in the 1928-1930 period. In the early versions of these valves the heater was a spiral of wire inserted in an insulating tube which, in turn, was inserted in a nickel cathode tube sprayed with an emissive powder. They were made to operate at 4 volts, 1 amp, the heater supply being taken from a suitable winding on the mains transformer which also provided the necessary h.t. supply. The rigid cathode made it possible to reduce the clearance between cathode and grid, and thus materially improve the performance of the valve. As the h.t. supply was also taken from the mains, higher anode currents and voltages could be used. This, in turn, required re-consideration of cathode efficiency in order to obtain the requisite



These vans, and particularly that with its bodywork in the shape of a valve of the period, were a familiar sight on the comparatively peaceful roads of 1924 (courtesy of Mullard Ltd.)

emission without unduly high heater wattage.

Thus, a whole new series of problems arose, a great many of which were concerned with the design of the heater and cathode

assembly. The use of indirectly heated valves provided opportunity for numerous developments in circuit design and many such developments, in turn, made more stringent demands on the valves. This is

a "battle" which has carried on for more than 30 years and which still continues. Some of the major difficulties encountered in this battle of progress will be the subject of the next article.

(to be continued)

Cover Feature



This article describes a simple design for the 160 metre band which combines efficient operation with low cost. Many of the components are non-critical and may already be on hand, and the author fully discusses suitable types and alternatives. For this reason, such components are not specified by make and type number in the Components List. The design includes a modulation amplifier suitable for use with a carbon microphone or, by employing an external pre-amplifier, a crystal microphone. A further alternative is a separate modulation amplifier, for which details will appear in next month's issue

Readers are reminded that this transmitter must not, of course, be operated without the requisite Post Office licence

THIS TRANSMITTER SHOULD SUIT THE NEWCOMER who wishes to get started without too much outlay, or the old timer who is looking for a simple Top Band phone rig. It is constructed almost wholly from receiver type components, is very free from snags, and is easy to operate.

The circuit is shown in Fig. 1. In this diagram, one section of the 12AT7 twin triode, V_1 , is used as a Clapp oscillator, and is tuned by VC_1 . This gives complete v.f.o. coverage from 1.8-2 Mc/s. The second half of the 12AT7 is a buffer-amplifier, and serves to help isolate the v.f.o. L_2 is broadly tuned to about 1.9 Mc/s, and needs no further adjustment. The complete v.f.o. and buffer stages occupy a small screened box, with the valve projecting horizontally from the back in order to remove the main source of heat from L_1 and associated components. The 12AT7 will provide about 2mA grid drive for the power amplifier.

The p.a. is a 6BW6 (V_2) which is suitable for r.f. applications up to about 150 Mc/s. If a 5763 is to hand, this may be fitted instead, holder wiring being changed to suit. Bias is developed across R_5 . If an initial test shows that sufficient grid drive is available, the choke RFC_2 may be omitted. This depends to some extent on valve performance and h.t. voltage.

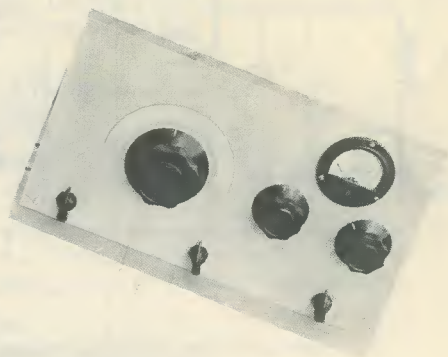

VFO Top Band Phone Transmitter

FREDERICK SAYERS

Anode current is shown by the 100mA meter and, with 250V reaching the p.a., 40mA corresponds to the maximum permitted input of 10 watts. L_3 , in conjunction with VC_2 and the 2-gang capacitor VC_3 , forms the customary pi-output circuit, which will load directly into many aerials. For Top Band, an end-fed wire is often used.

The modulator is extremely simple, and was adopted after some experiments with other circuits. The 6CH6, V_3 , has very high gain, and was found to give adequate results on its own. The bias developed across R_6 is about 4.5V, and this was suitable for the carbon mike employed, and should suit most carbon microphone inserts. T_1 is a 50:1 or similar carbon microphone transformer.

It will be clear that the r.f. section can be used with a more elaborate modulator, if wanted. Notes on the use of a crystal microphone are given later, and a push-pull modulator will be described in next month's issue.

Choke modulation is used, the inductor LFC_1 being a mains pentode type output transformer, with the speaker secondary unused. With this type of circuit, overmodulation which would break the carrier is impossible, and this was felt to be an advantage. Reports on speech quality and modulation depth are good. If an attempt is made to use

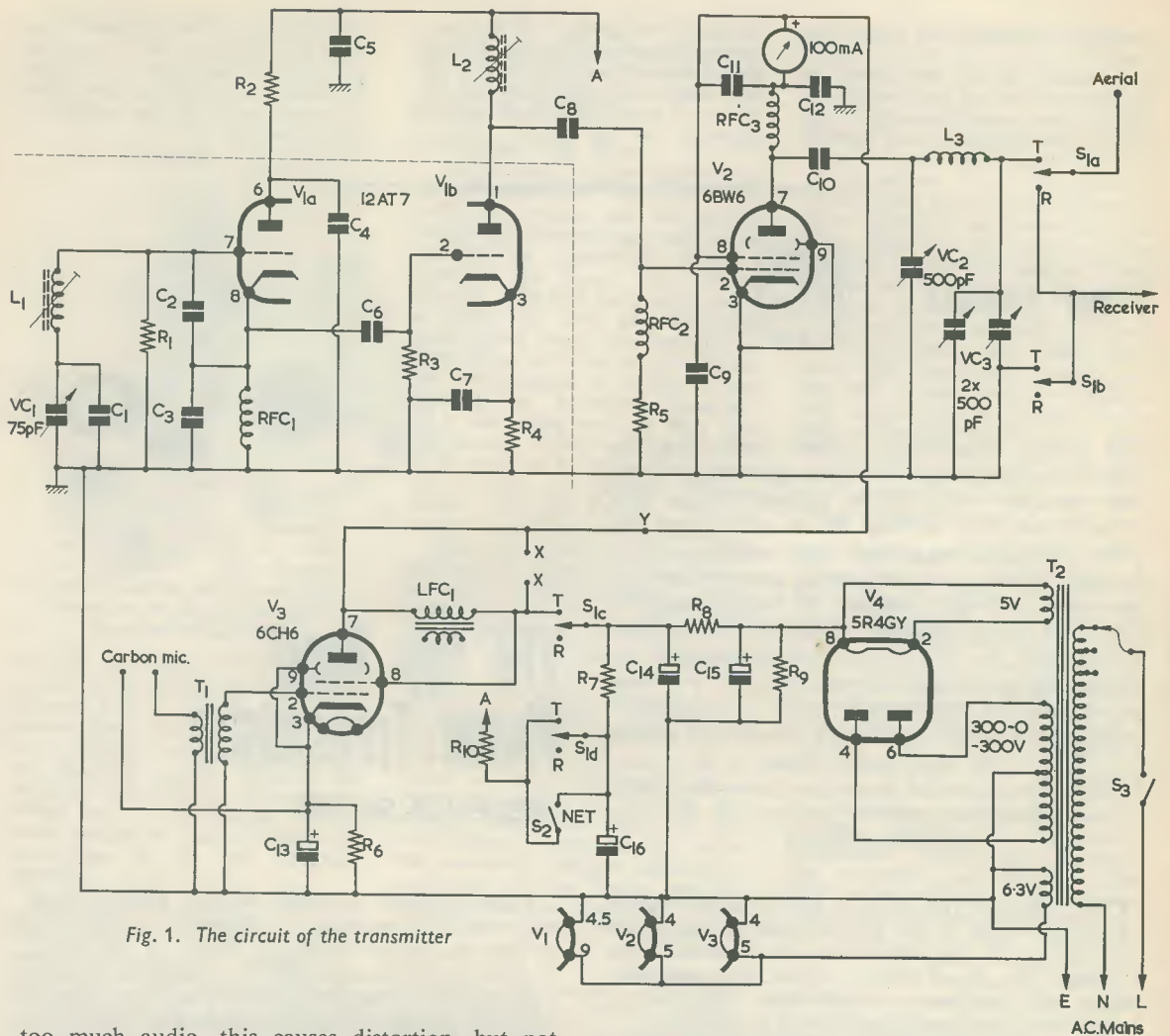

Fig. 1. The circuit of the transmitter

too much audio, this causes distortion, but not overmodulation which would break the carrier.

Transmit/Receive switching is included, and is provided by the 4-pole 2-way switch, S_1 . Section $S_{1(a)}$ transfers the aerial from the transmitter pi tank to the receiver aerial socket. Section $S_{1(b)}$ short-circuits the receiver aerial circuit to chassis in the Transmit position, to avoid overloading the receiver. H.T. is applied to the v.f.o., modulator and p.a. by switch sections $S_{1(c)}$ and $S_{1(d)}$. The "Net" switch, S_2 , applies h.t. to the v.f.o. only, so that the transmitter can be adjusted to the receiver frequency, or netted on an incoming signal. Resistor R_{10} is included to obviate the slight sparking at the switch which would otherwise occur when applying h.t. to C_6 .

Power Supply

The h.t. secondary of the mains transformer, T_2 , is best rated at 100mA to avoid undue drop in voltage. An h.t. secondary giving 250V, 275V

or 300V may be used. There is some loss of voltage in the rectifier, in R_8 , and in LFC_1 , causing a reduction in p.a. anode voltage. The d.c. resistance of the speaker transformer primary, LFC_1 , was 300Ω , dropping over 25V when passing the anode current of the 6CH6 and the anode and screen currents of the 6BW6. In tests with a 250-0-250V transformer, the p.a. received 200V, corresponding to an input of 8W at 40mA. Loading to 50mA at 200V, for 10W input, gave virtually no increase in r.f. output. Good results were obtained with the 8W input. Nevertheless, it is better to have a more adequate voltage available, so a 300-0-300V transformer is preferred. Should a better component, with less d.c. resistance, be to hand for LFC_1 , this will avoid some of the drop in voltage. R_8 can also be replaced by a smoothing choke of lower d.c. resistance, if available, and this will allow a little more voltage on the p.a. So if a 250V 100mA mains transformer is to hand, it

Components List

Resistors

(All fixed values $\frac{1}{2}$ watt 10% unless otherwise stated)

R ₁	56k Ω
R ₂	3.3k Ω
R ₃	100k Ω
R ₄	100 Ω
R ₅	20k Ω
R ₆	100 Ω
R ₇	5.6k Ω 1 watt
R ₈	100 Ω 2 watts
R ₉	100k Ω 1 watt
R ₁₀	27 Ω

Capacitors

C ₁	40pF 2% silver mica
C ₂	1,000pF 2% silver mica
C ₃	1,00pF 2% silver mica
C ₄	0.05 μ F ceramic
C ₅	0.01 μ F ceramic
C ₆	200pF silver mica
C ₇	0.01 μ F ceramic
C ₈	200pF silver mica
C ₉	2,000pF ceramic
C ₁₀	5,000pF 1kV wkg. mica
C ₁₁	0.01 μ F ceramic
C ₁₂	5,000pF ceramic
C ₁₃	50 μ F 12V wkg. electrolytic
C ₁₄	16 μ F 450V wkg. electrolytic
C ₁₅	8 μ F 450V wkg. electrolytic
C ₁₆	32 μ F 450V wkg. electrolytic
VC ₁	75pF variable
VC ₂	500pF variable
VC ₃	500+500pF variable, two-gang

may be pressed into service.

The heaters of V₁, V₂ and V₃ require 1.5A, and this is easily within the capacity of most transformers. The 5R4GY rectifier needs a 5V 2A supply. Numerous other rectifiers are satisfactory, if able to supply 100mA.

Chassis And Panel

The layout of components and dimensions are not likely to be too important, but a chassis about 13 $\frac{1}{2}$ x 5 $\frac{1}{2}$ in, and 2 $\frac{1}{2}$ or 3in deep will allow everything to be accommodated without cramping. The positions of most of the major components can be seen from Fig. 2. The panel is 13 x 8in and can be cut from hardboard or aluminium. If hardboard is employed, a piece of aluminium about 4 x 3 $\frac{1}{2}$ in must be fitted between the v.f.o. box and the panel. There is 2in clearance below V₁ for C₁₄ and C₁₅, and a taller capacitor could be used if placed to one side of this valve's screening can, which projects horizontally from the rear of the v.f.o. box.

VC₂ is a non-miniature 500pF air-spaced tuning capacitor as used in receivers. Miniature capacitors with very closely spaced plates should not be used as they are likely to spark over. A maximum capacitance of 300pF is actually sufficient. VC₃

Inductors

L ₁ , L ₂ , L ₃	See text
RFC _{1,2}	2.5mH chokes
RCF ₃	2.5mH choke (60mA)
LFC ₁	mains pentode speaker transformer primary
T ₁	50:1 (or similar) carbon mic. transformer
T ₂	Mains transformer; secondaries: 300-0-300V 100mA, 6.3V 1.5A (minimum), 5V 2A (minimum). See text

Valves

V ₁	12AT7
V ₂	6BW6
V ₃	6CH6
V ₄	5R4GY

Switches

S ₁	4-pole 2-way rotary (Transmit-Receive)
S ₂	s.p.s.t. rotary or toggle (Net)
S ₃	s.p.s.t. rotary or toggle (Mains on-off)

Valveholders

1	B9A holder with skirt and 2in screen
2	B9A holders, skirts optional
1	octal holder

Meter

1 moving-coil meter, 100mA

Miscellaneous

8 x 3in "Universal Chassis" runner (Home Radio (Mitcham) Ltd.)
 Aluminium sheet for chassis
 Aluminium sheet or hardboard for panel
 Stand-off insulator
 Knobs, as required, including large knob or dial for v.f.o.

is 1000pF in all, this being obtained by wiring both sections of a 500pF 2-gang tuning capacitor in parallel. A 3-gang capacitor is equally satisfactory, and may in some cases be an advantage. These capacitors are bolted to the panel, and grounded to the chassis by short leads to soldering tags.

A meter reading 100mA full-scale is convenient, but a more sensitive meter can easily be shunted, if to hand. Leads from the meter pass through the chassis to RFC₃ and LFC₁. It is not necessary to read grid current, once this has been checked when first testing the transmitter.

The tank coil L₃ was wound on a ribbed former, and fixed to VC₃ by a bracket. See Fig. 2. It is 1 $\frac{1}{2}$ in in diameter, and has 55 turns of 24 s.w.g. wire. A 1 $\frac{1}{4}$ in diameter smooth former would be perfectly satisfactory, also with 55 turns. If a somewhat similar coil is to hand, it will probably prove suitable.

V.F.O. Box

The v.f.o. box is 2 $\frac{1}{4}$ x 3 $\frac{1}{2}$ x 3in high. It is very easily made by purchasing a "Universal Chassis"

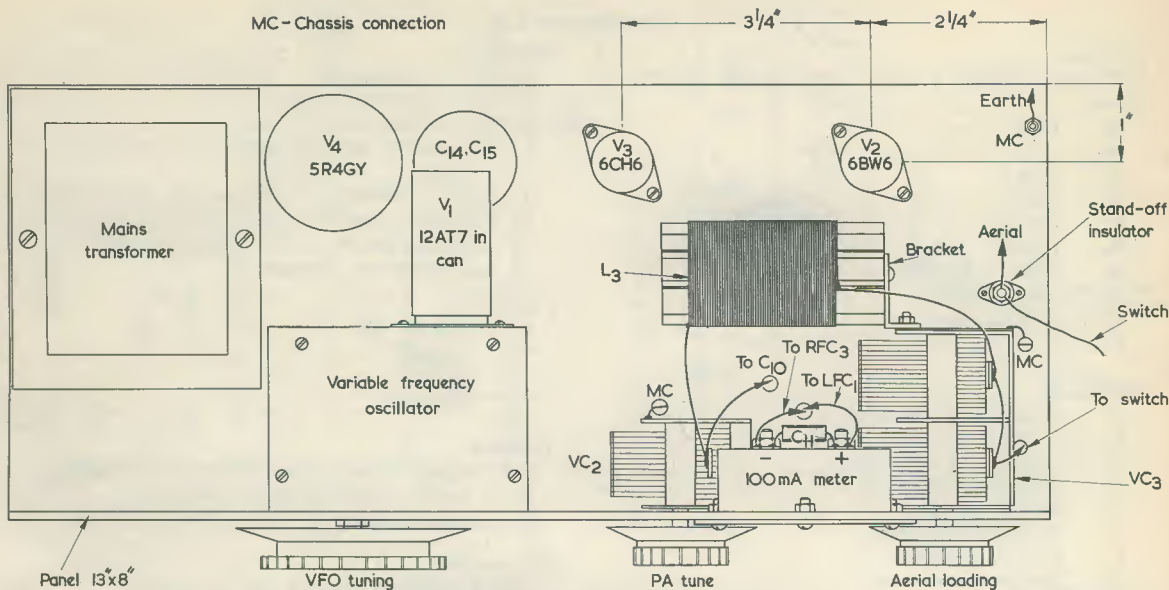

Fig. 2. Component layout above the chassis

runner 8in x 3in (Home Radio, Mitcham) and cutting two 90° sections from the flanges, 2½in from each end. Two right-angle bends can then be made, to obtain the two sides and rear of the box. After wiring, the box is bolted to the chassis and panel, and closed on top by a piece of aluminium, 2¼ x 3½in, held in place with four self-tapping screws. This forms a rigid assembly. If the panel is not metal, do not forget the screen between panel and box, as mentioned.

The v.f.o. box is not attached to the panel and chassis until the 12AT7 valveholder has been wired. Colour coded leads pass down through a ½in hole in the chassis, and are taken to the appropriate points under the chassis when the box is finally bolted in position. One lead is from tag 6 (V_{1(a)} anode) and another from tag 1 (V_{1(b)} anode).

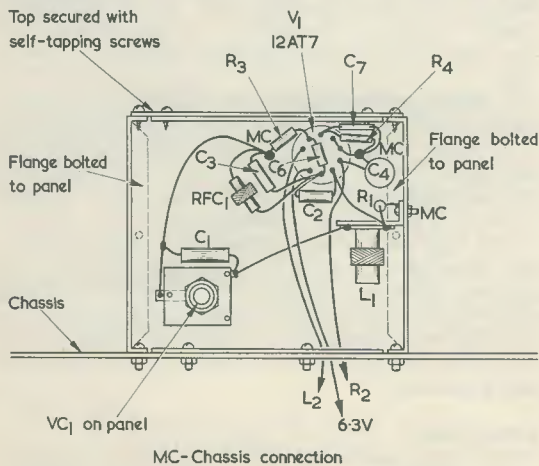

Fig. 3. Layout of components in the b.f.o. box

The final lead is from tag 9 (heater). The dotted line in Fig. 1 shows which components are in the v.f.o. box.

Fig. 3 illustrates the v.f.o. wiring. Connections are short, as movement or vibration will tend to cause shifts in frequency. Various chokes were tried for RFC₁, and a miniature transistor type choke (2.5mH) was finally adopted. The usual type of 2.5mH short wave choke having 4 or 5 sections is equally satisfactory. A small "all-wave" r.f. choke was also found suitable. The choke must be effective at 1.8–2 Mc/s, and without resonances in this band. This is not a very difficult requirement to meet.

Various coils were tried for L₁, and eventually a surplus medium wave coil, with some turns removed, was chosen. No pre-set capacitor is needed in the v.f.o. Final calibration is only made when the transmitter is finished, and has been left running for at least fifteen minutes.

V.F.O. Calibration

V.F.O. calibration can be done with the aid of a receiver and 100 kc/s crystal marker. The v.f.o. signal is coupled into the receiver by placing the receiver aerial lead near C₈. With VC₁ closed, the signal will probably be heard fairly near the bottom of the medium wave band, if a medium wave coil has been connected. The slug of L₁ should be adjusted to a mid-way position, so that subsequent fine changes to inductance can be made. Turns are then removed from L₁ until the v.f.o. signal is heard near 1.8 Mc/s. The coil can then be properly wired, and the v.f.o. box cover may be screwed on.

The receiver is then tuned to the 100 kc/s crystal harmonic which corresponds to 1.8 Mc/s, and the core of L₁ is rotated until the v.f.o. signal gives zero beat with the harmonic, with VC₁ nearly

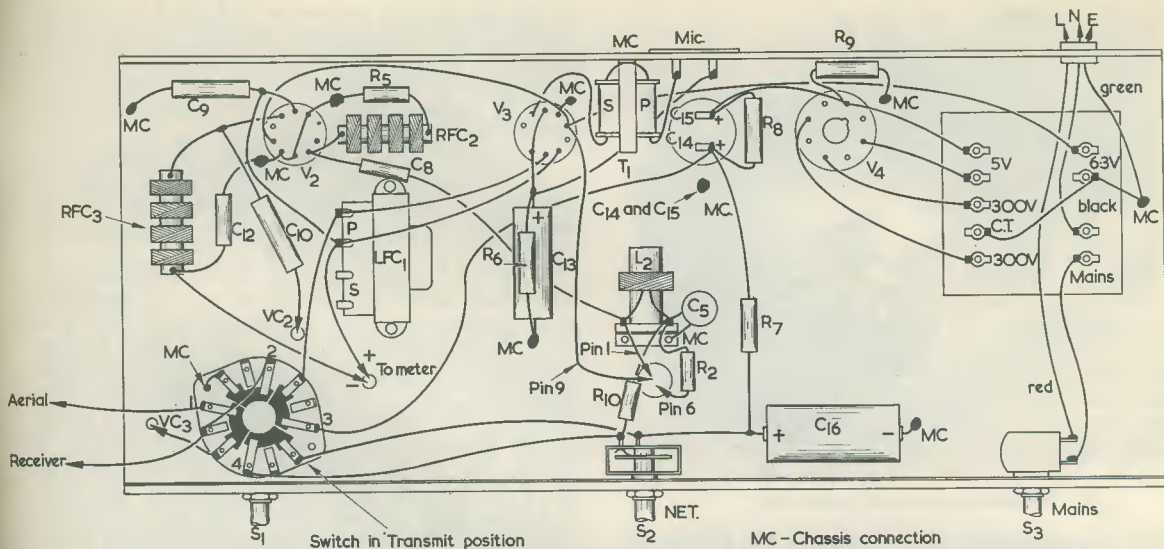

Fig. 4. Components and wiring below the chassis. The tag layout for the two transformers and LFC₁ apply to the components employed in the prototype; other components may have differing layouts or lead-out wires

closed.* The v.f.o. dial or scale is then marked for 1.8 Mc/s. The receiver is next tuned to 1.9 Mc/s by reference to the 100 kc/s crystal, and the v.f.o. tuned again to zero beat, and calibrated for 1.9 Mc/s. This is repeated for 2 Mc/s. Not quite the full 180-degree rotation of VC₁ will be employed.

For the 0.05 Mc/s marks, tune the receiver to the crystal harmonic which falls on 3.7 Mc/s, and adjust the v.f.o. to 1.85 Mc/s, so that its second harmonic is at zero beat with the crystal. Mark the scale, and repeat for 1.95 Mc/s. The 0.01 Mc/s marks between 1.8 Mc/s and 1.85 Mc/s can be estimated with sufficient accuracy, as can those up to 2 Mc/s.

If a friend has a calibrated v.f.o., this may be used to calibrate the Top Band transmitter v.f.o., by comparing signals with a receiver. An accurate heterodyne frequency meter, or similar apparatus will also be satisfactory.

For a home-wound v.f.o. coil, 95 turns of 34 s.w.g. enamelled wire, side by side on a ½ in diameter cored former, can be used. Turns must be sealed to prevent movement.

A large knob was found satisfactory for VC₁, but a small reduction drive could be added. This capacitor should be free from wobble, and of good construction.

Under the Chassis

Fig. 4 shows the under-chassis wiring. Heater and h.t. circuits are run close to the chassis. For the "Net" and mains circuits, on/off toggle switches are equally satisfactory instead of the rotary types shown.

Leads to C₈ and RFC₂ are clear of the chassis, and well removed from C₁₀. With the layout

shown, the p.a. is perfectly stable. Wiring should be reasonably short and direct.

When the 6BW6 holder has been wired, a check can be made for grid current, if wished. Alternatively, this test can be left until all construction is finished. The valve should be in place, but no anode or screen-grid voltage should be present. This will occur if the Transmit/Receive switch is left at "Receive" and the "Net" switch is closed. A meter is then inserted between R₅ and the chassis. In the prototype, L₂ was a medium wave coil, broadly resonant with stray capacitance to about 1.9 Mc/s. It is only necessary to set the v.f.o. to about 1.9 Mc/s, and rotate the core of L₂ until a slight rise in grid current shows resonance. It was found that grid current remained at about

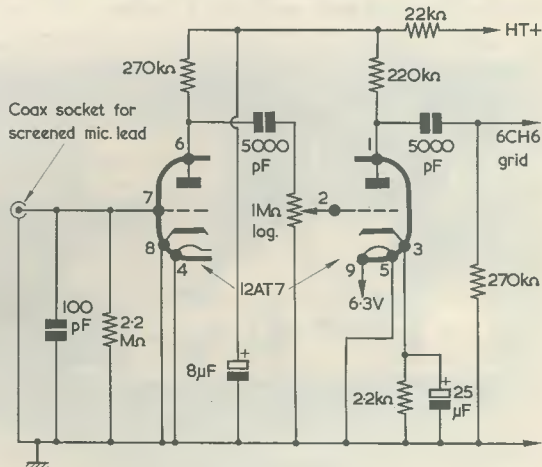
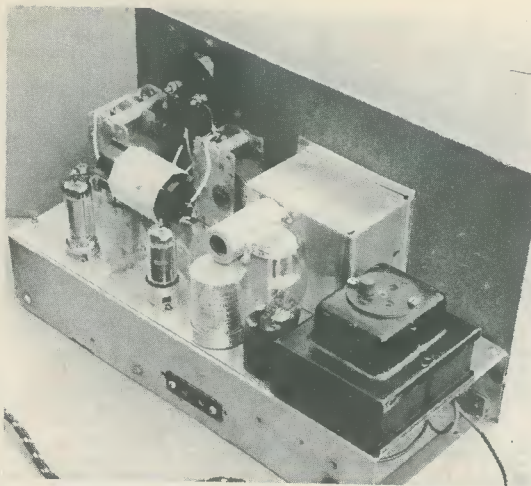

Fig. 5. A suitable pre-amplifier for a crystal microphone

* This adjustment may be made via the ½ in hole through which the wires to the v.f.o. pass. Alternatively, a small hole may be provided for this purpose in the cover plate.—EDITOR.



Above chassis view of transmitter

2mA throughout the whole range of the v.f.o.

If grid current is too high (say over $2\frac{1}{2}$ –3mA) the resistors at R_2 and R_7 can be increased in value. Should there be plenty of grid current, RFC_2 may be omitted, with no loss of efficiency. If grid current is too low (say under $1\frac{3}{4}$ mA) there may be insufficient h.t. applied to the v.f.o. or buffer, or L_2 may not have been tuned to the band. Small changes in grid current do not produce any significant change in r.f. output, provided the grid current is around the 2mA mark. This represents 40V bias developed across R_5 .

Once grid current has been checked, R_5 can be connected to the chassis, and the meter removed. When operating, it is only necessary to monitor anode current, with the panel 100mA meter.

Modulator

This is of the simplest possible type, with d.c. for the carbon microphone developed across R_6 , thereby avoiding any need for a battery. If it is

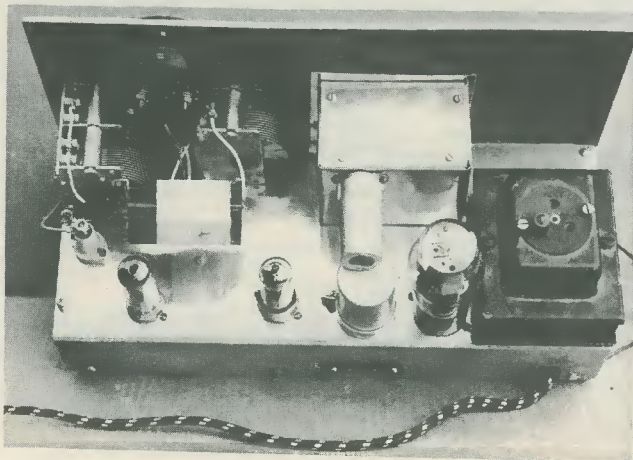

Illustration showing coil and variable capacitors

wished to cut top somewhat, a $0.05\mu F$ or $0.01\mu F$ capacitor may be connected from the 6CH6 anode to chassis. This depends to some extent on the user's voice, and the microphone. The telephone insert type of carbon microphone can provide quite acceptable speech quality.

If a crystal mike is preferred, it will be necessary to provide two stages of amplification between this and the 6CH6. While experimenting with an inexpensive crystal microphone, the circuit in Fig. 5 was found satisfactory.

It will be realised that any audio amplifier able to provide some 5 watts or so can be employed as a modulator. The modulator can then run from its own power supply. The speaker output transformer of the audio amplifier must be disconnected, and a modulation transformer substituted. The secondary of the modulation transformer is connected to the points X-X in Fig. 1, and T_1 , V_3 , LFC_1 , and the bias components C_{13} and R_6 taken out of circuit. If the p.a. is loaded to a total input (anode and screen grid) of about 45mA, at 250V, its modulating impedance is about $5,500\Omega$. A 1:1 ratio transformer will this do when using an audio amplifier with output valves having an optimum load of about 5,000 to 6,000 Ω or so. A small 5-watt push-pull amplifier is ideal.

When ample h.t. voltage is available, and a single valve is used as a choke coupled modulator, as in Fig. 1, modulation depth can be increased by introducing a resistor at point Y of Fig. 1. A $2\mu F$ capacitor is connected across the resistor. This resistor can normally be between 1k Ω and 2k Ω in value.

Aerial and Loading

A Top Band dipole would be about 246ft long, and is seldom possible. So shorter, end-fed aerials are generally employed. These may often be operated successfully directly from the transmitter, an approach which has the merit of simplicity. In general, the longer the aerial, the better will results be. Aerials actually employed by the writer

include 45ft sloping from the operating room to a pole on a chimney; 100ft and 120ft wires in the usual inverted L; and 185ft with a 45ft down-lead. All these gave good results. Signal strength is improved when the wire is reasonably long and well clear of ground, walls, etc.

An earth connection should be taken to the transmitter chassis. With relatively short end-fed aerials, the efficiency of the earth has quite a large effect on the strength of the radiated signal.

When the transmitter is to be put on the air, a clear channel should be sought with the receiver. The "Net" switch is then closed, and the v.f.o. tuned to the receiver frequency. There will normally be enough stray coupling to the receiver aerial circuit for this to be done easily. The "Net" switch is then returned to its "Off" position, and is not required for normal transmitting and receiving.

VC_3 should be closed, and the equipment

switched to "Transmit". VC₂ is then rotated to find the dip in anode current, as shown by the meter. The dip may be far too low, representing insufficient input to the p.a., so VC₃ is opened, VC₂ being re-adjusted as necessary. This is continued until the p.a. draws the required anode current. VC₂ is always tuned for *minimum* anode current.

An initial test can be made by loading the transmitter into a 15W domestic lamp (200/250V) which should light with fair brilliance. If the signal is monitored with a receiver having a loudspeaker avoid feedback to the microphone, or howling will arise.

Very short aerials will not present an impedance which will load the transmitter. This problem is best overcome by using one of the usual methods, such as placing a loading coil in series with the aerial, or building a 160 metre tuner, and tuning the aerial against ground. The loading coil is particularly simple to use. It may be 2 to 4in in diameter, and should be wound with 16 s.w.g. or other stout wire, to avoid unnecessary losses.

If an 80 metre dipole, or other co-axial or twin-feeder dipole for a high frequency band is available, this will often work quite well as a Top Band aerial. The two conductors are joined, and the whole worked against ground, as for the end-fed wire. It is also quite easy to try vertical wires, whips, and other aerials electrically resembling those used for mobile work. In some cases where it is wished to work into a low impedance with a minimum of trouble, it may be worth adding extra capacitors in parallel with VC₃, or modifying the turns on L₃.

It is worth remembering that quite considerable distances are covered by Top Band mobile transmitters, where the type of aerial is severely restricted. An equivalent, or much better, aerial should generally be possible at any fixed location.

Next Month

In next month's issue, a push-pull modulator suitable for use with this transmitter will be described.

New Edge Contact-Cooled Selenium Rectifiers

A number of new edge contact-cooled selenium rectifiers are now available from Westinghouse Brake and Signal Co. Ltd. They utilise high current density elements which allow improved current ratings. All of these units are fully encapsulated and are ideally suited for electronic or other equipment subject to damp or humid conditions.

Single-phase bridge, centre-tap, voltage-doubler and half-wave units are available. In full-wave circuits maximum current ratings are 180mA and 250mA and in half-wave and voltage-doubler circuits the ratings are 90mA and 125mA.

The following are representative of the range available: Type EC401, rated at 250 volts 180mA output in single-phase bridge circuit; case size $2\frac{5}{16} \times \frac{1}{2} \times \frac{5}{8}$ in. Type EC403 rated at 250 volts 250mA output in single-phase bridge; case size $2\frac{5}{8} \times \frac{3}{8} \times \frac{3}{4}$ in. Type EC402 rated at 250 volts 90mA in half-wave; case size $1\frac{3}{4} \times \frac{1}{2} \times \frac{5}{8}$ in.

IN

THE Radio Constructor

NEXT MONTH

Electronic Car Ignition Analyser

This article will prove of interest to every car-owning reader and the completed instrument—full details of which are given—will enable motoring enthusiasts to obtain the optimum performance from their ignition system.

Simplicity and Sensitivity with 3 Transistors

An ingenious reflex design which provides loud-speaker reception on medium and long waves with the use of 3 transistors only.

Top Band Push-Pull Modulator

Design for a separate modulation amplifier for use with the VFO Top Band Phone Transmitter featured on page 185 of this issue.

November issue out November 1st. From your local Newsagent (2/3).

For an Annual Subscription (33/- p.a.) complete and send in the coupon below or, if you do not wish to cut your copy, supply the required information by letter.

To Data Publications Ltd.,
57 Maida Vale, London, W.9.

I enclose remittance of 33/- for Annual Subscription to *The Radio Constructor* commencing with the..... issue.

Name.....

Address.....
(Block Capitals)

An HFE Tester for Power Transistors

By A. THOMAS

THIS PIECE OF TEST EQUIPMENT ENABLES H_{FE} measurements to be carried out on power transistors at high currents.¹ The parameter H_{FE} is the common emitter large signal current gain of the device, $H_{FE} = \frac{I_c}{I_b}$.

The normal method of making a H_{FE} measurement is to measure the current required in the base for a given collector current, then $H_{FE} = \frac{I_c}{I_b}$. To be able to carry out d.c. tests with this method, the transistor under test would have to dissipate a lot of power and, due to heating, would need to be mounted on a heat sink. This is not a convenient method just to test the transistor. When this method is used, therefore, it is carried out with pulses of short duration such that the mean power is low.

The test circuit to be described here uses a modified form of pulse test such that the base is fed with constant current pulses 200 microseconds wide at a repetition rate of 45 pulses per second. The collector current is then measured and displayed on a meter calibrated in units of H_{FE}. This method requires less circuitry than the pulse method described earlier. The mean current under these conditions is:

$$\begin{aligned} \frac{\text{Pulse width}}{\text{Repetition time}} \times I_{\text{peak}} &= \\ \frac{200 \times 10^6}{22 \times 10^3} \times I_{\text{peak}} &= \\ &= 0.9\% I_{\text{peak}} \end{aligned}$$

Circuit Description

In Fig. 1, transistors TR₁ and TR₂ form a free running multivibrator giving a square wave output at 45 c/s. The frequency determining components are R₃, C₁, and R₄, C₂, and the frequency is given

¹ For the record, H_{FE} is elsewhere defined as "static forward current gain in common emitter connection."—EDITOR.

by: $R_3, C_1 = 0.7t$, where t is one complete cycle time.

That is, $t = \frac{1}{f} = \frac{1}{45} = 0.022$, where f is in c/s, t is in seconds, R is in MΩ, and C is in μF.

The output from the multivibrator is a negative-going square wave, this being fed into the base of an inverter stage TR₃. The output from TR₃ is differentiated by C₄ and R₈, and the resultant positive and negative-going spikes are fed to a diode D₁, whence the negative-going spike is passed to a monostable trigger given by TR₄ and TR₅. The positive-going spike is stopped by the diode.

The monostable trigger is normally in the state where TR₄ is cut off and TR₅ is conducting. The negative-going spike at the base of TR₄ causes TR₄ to start to conduct. Due to the collector voltage of TR₄ falling towards earth, the base of TR₅ follows via capacitor C₅ and TR₅ starts to cut off. Due to TR₅ collector rising towards negative, TR₄ is driven harder on via the 8.2kΩ collector-to-base resistor, R₁₂. The 220Ω emitter resistor, R₁₃, assists in this positive feedback. The circuit will stay in the state of TR₄ conducting and TR₅ cut off until C₅ capacitor charges to negative via R₁₄. When the base of TR₅ reaches a certain voltage, TR₅ will start to conduct and the circuit will rapidly switch to its normal state.

The output from the monostable trigger will be a negative-going pulse at TR₅ collector. The width of the pulse depends on the values of C₅ and R₁₄ and is determined from the following: pulse width $t = 0.7 C_5 R_{14}$, where t is in seconds, C is in μF and R is in MΩ. The 200μs square pulse at 45 pulses per second is fed from the monostable trigger via the 1μF capacitor C₆ to the emitter follower stage, TR₆. The pulse amplitude at the emitter of TR₆ is 5V, this is fed via the 100Ω resistor, R₁₇, to the base of the transistor under test. The input resistance of the transistor under test is low compared with the 100Ω resistor, therefore virtually a constant current (50mA) flows, independent of the transistor under test.²

The transistor under test has, as a collector load, the 2Ω resistor R₁₈. This enables currents up to approximately 5 amps to flow, and the collector voltage drops according to $E = IR$, where R is 2 and I is the collector current. Therefore it can be seen that the collector current is directly proportional to the pulse of voltage appearing at the collector.

The voltage pulse at the collector is fed via the 10μF capacitor C₇ to a peak-reading voltmeter, where the 1μF capacitor, C₈, charges via the diode to the peak of the voltage pulse. This is displayed

² In practice there will be a small V_{be} in the transistor under test, and this may reduce the accuracy of the H_{FE} readings obtained. (The pulse amplitude at the output from the TR₄, TR₅ circuit will be reasonably accurate due to this circuit being switched between the hard on and off conditions.) If it is considered desirable to overcome the effect of V_{be} in the transistor under test R₁₇ could be made variable, consisting of an 82Ω and 20Ω potentiometer in series. The potentiometer could then be calibrated in terms of V_{be} in the transistor under test. An alternative approach would consist of giving R₁₇ a value such that a transistor with a V_{be} of 300mV gives a correct result. A lower V_{be} will then give a high H_{FE} reading, and a higher V_{be} will give a low reading. The maximum error should not exceed 5%. In this case R₁₇ may have a value of $\frac{5-0.3}{0.05} = 94\Omega$.

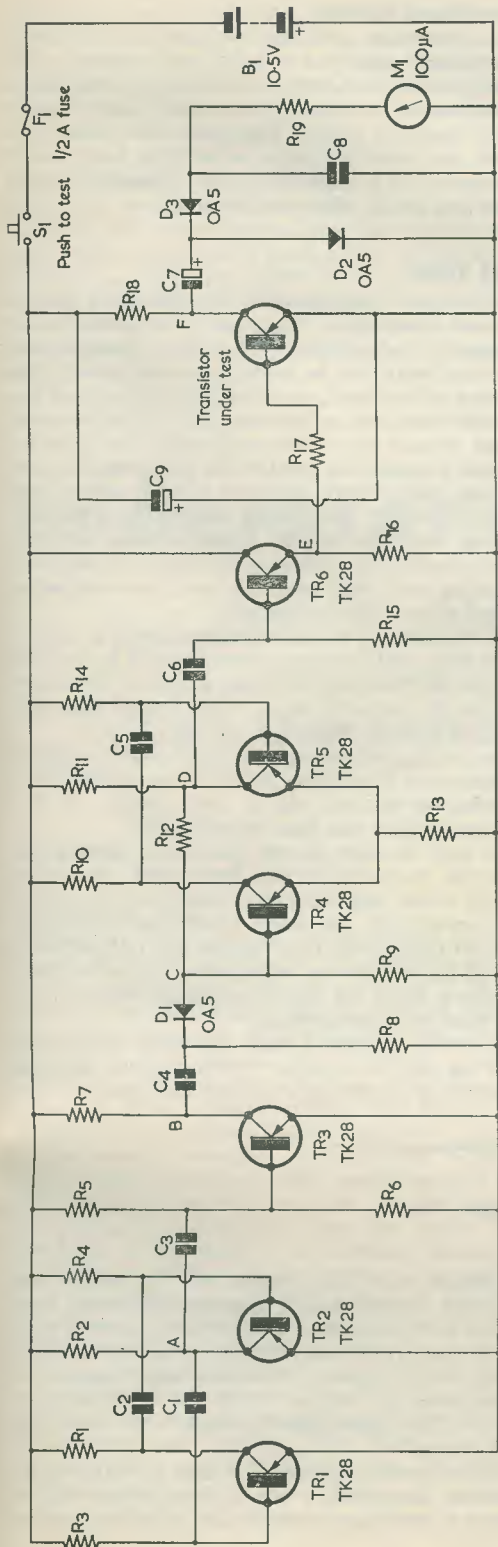

Fig. 1. The circuit of the transistor tester

Components List

Resistors

(All resistors $\frac{1}{4}$ watt 5% unless otherwise stated)

R _{1,2}	8.2k Ω	R _{10,11}	680 Ω
R _{3,4}	33k Ω	R ₁₂	8.2k Ω
R ₅	1M Ω	R ₁₃	220 Ω
R ₆	100k Ω	R ₁₄	15k Ω
R ₇	10k Ω	R ₁₅	8.2k Ω
R ₈	100k Ω	R ₁₆	1k Ω
R ₉	8.2k Ω		
R ₁₇	100 Ω (see text)		
R ₁₈	2 Ω wirewound 1 watt minimum		
R ₁₉	100k Ω $\frac{1}{2}$ watt 1%		

Capacitors

C _{1,2}	0.47 μ F paper
C _{3,4}	0.1 μ F paper
C ₅	0.02 μ F paper
C ₆	1 μ F paper
C ₇	10 μ F electrolytic 12V wkg.
C ₈	1 μ F paper
C ₉	2,000 μ F electrolytic 12V wkg.

Semiconductors
 TR₁ to TR₆, TK28 (Standard Telephones & Cables)
 D_{1,2,3} OA5

Switch
 S₁ s. p. s. t., push-to-make

Fuse
 F₁ $\frac{1}{2}$ amp fuse

Meter
 M₁ 0-100 μ A, moving-coil meter

Battery
 B₁ 10.5 volt battery (may be given by two 4.5 volt batteries and one 1.5 volt cell)

on a 100 μ A, 10 volts full scale meter, the scale being calibrated 0-100 in units of H_{FE}.

Transistor TR₆ should be of a type with a low collector to emitter leakage current I_{CEO}, otherwise it may dissipate an excess of power if the test button is operated, with a transistor in the test socket, too long. The TK28 has been specified in this instance for all positions, but almost any transistor will carry out the necessary functions if reference is made to the requirements for TR₆.

Power Supply

The power supply may be mains driven, but it was found more convenient to use batteries contained in the cabinet of the tester. The normal drain from the 10.5 volt batteries, with the test button

operated, is 0.017 amp, and C_9 the 2,000 μ F capacitor, supplies the high current pulses for 200 μ s. The capacitor C_9 should be connected as shown in the circuit diagram, that is, directly across R_{18} and the emitter connection of the transistor under test. The end of life of the batteries occurs when the terminal voltage is down to 9 volts with a load of 0.017 amps. The tester may be used after this point has been reached, but the accuracy is impaired. The battery voltage may be monitored by taking a connection from the junction of R_{19} and D_3 , via a switch, to the negative terminal of the battery. The meter will then read just over full scale, for a battery voltage of 10.5, when the switch is operated.

Waveforms are shown at points throughout the tester in Fig. 2, and the letters in Fig. 2 refer to the points marked on the circuit diagram.

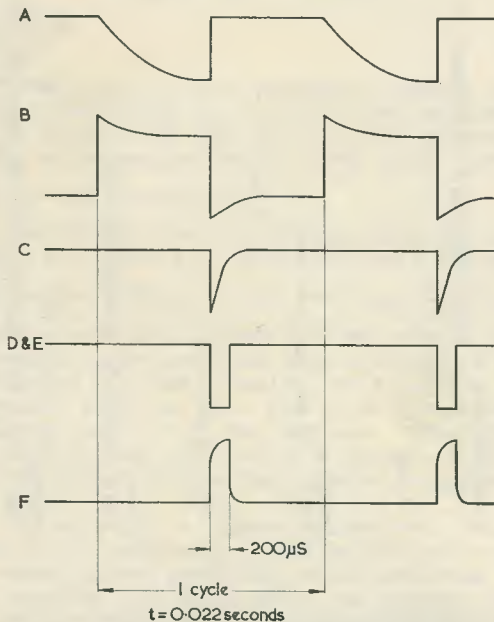

Fig. 2. The waveforms appearing at the points identified by letters A to F in Fig. 1

Constructional Details

The circuit was constructed on an 8 x 4.8in piece of Veroboard with 0.2 x 0.1in hole matrix. The Veroboard was then mounted behind a panel which had the meter, transistor holder and push button switch, mounted on it. The panel was fixed to a pressed steel cabinet with a sloping front. The batteries and C_9 capacitor were mounted in the cabinet and leads taken to the panel.

Use of Tester

The tester is indispensable for the quick testing of power transistors. If a test is required on a transistor already mounted in a piece of apparatus, then three leads may be taken from the tester to the transistor to be tested, ensuring beforehand that any transistor electrode is disconnected if it embarrasses the test in any way. Normally only the collector and base connections need to be disconnected, and in some cases where there is a high value base resistor (greater than 20 Ω) only the collector. Carrying out tests in this manner does not give accurate results, but it does check that the transistor is working and may even be used for comparing matched pairs whilst in circuit.

If it is necessary to test transistors with a H_{FE} of greater than 100 then the circuit would have to be modified by reducing the base drive to 25mA (by doubling the value of R_{17}). This would then give a meter scale of 0-200.

If no reading is shown on the meter and it is known that the tester is working, then the transistor under test must be open-circuit or short-circuit. If it is short-circuit then the fuse should blow.

Low and medium power transistors should not, in general, be tested on this instrument. Nevertheless, the writer has checked a large number of low power transistors, the meter giving results between 5 and 10 (H_{FE}). As H_{FE} figures are not generally required for low power transistors, the only reason for testing them on this instrument would be to check that they are working.

The circuit described here has been constructed and in use for two months. No faults have occurred and accurate results have always been given.

A QUALITY MULTIMETER *(continued from page 171)*

scale resistance reading of each range is as it should be. (Again see "Resistance Ranges" section.) Any error here will be due to an incorrect value of one of the resistors R_{32} to R_{35} , depending on the range in use.

(8) Finally, when all of the wiring and setting up has been completed, again check that the calibration of all ranges is correct, and then proceed to mark the full ranges on the scale. Common, linear scales will suffice for the d.c. volts and current ranges, and also for all but the lowest alternating volts range.

A common, non-linear scale will be needed for alternating current, and a separate non-linear scale for the 3 volt a.c. range. A common scale will serve for all four resistance ranges, which should be checked either against close-tolerance resistors of known value or marked from the scale given in Fig. 18. The 50 μ A/250mV ranges will need individual scales.

If only a small scale meter is used to make up the multimeter described, it will be found convenient to make up a conversion chart for the individual ranges.

IN LAST MONTH'S ISSUE WE CONTINUED OUR examination of the triode by describing how it may be coupled to a loudspeaker by way of a step-down transformer of suitable ratio and primary current rating. We also discussed the few advantages and many disadvantages given by employing a transformer to provide coupling between two a.f. amplifier triodes. We next examined the important point that the alternating voltage at the anode of a triode is 180° out of phase with that applied to the grid, and we finished by seeing how the triode may be used as a cathode follower, as a phase splitter and as a grounded grid amplifier. We shall now turn our attention to several more basic attributes of the triode, including the grid current bias circuit and the grid leak detector.

In a triode the grid and cathode form an effective diode, with the grid functioning as the anode. Because of this, the grid may assume a contact potential in just the same way as does the anode of a diode. The presence of this contact potential may be similarly checked with the aid of a high resistance voltmeter. The contact potential makes it possible to operate some triodes intended for a.f. voltage amplification in the circuit shown in Fig. 316.

At first sight it would appear that the triode in Fig. 316 is operated at zero bias, but it is, in practice, biased by the contact potential on its grid. To ensure that the contact potential remains sufficiently high it is necessary to give the grid resistor a large

understanding

CURRENT BIAS AND THE GRID LEAK DETECTOR

By W. G. Morley

Grid Current Bias

When, in earlier articles, we dealt with the diode we saw that this exhibits a phenomenon which is usually referred to as "contact potential".¹ As was explained in the previous article, contact potential in a diode results in the same effect as would be given by a small internal e.m.f. having a polarity such that anode current still flows when the anode voltage is zero. Anode current only falls to zero when the anode is made slightly negative to counteract the contact potential. The fact that a negative anode voltage results in zero anode current infers that the anode voltage has then become equal to the contact potential and that the anode would therefore, in the absence of external connections, exhibit a potential which is negative of the cathode. This assumption is, in fact, true and it may be demonstrated quite readily in practice by connecting a high resistance voltmeter across the anode and cathode of an indirectly heated diode whose cathode is at emitting temperature. The voltmeter will show that the anode is negative of the cathode, the actual voltage indicated ranging from some 0.1 to 0.6 volts according to the diode type and the resistance of the voltmeter.

¹ See "Understanding Radio", in the July 1965 issue, page 833.

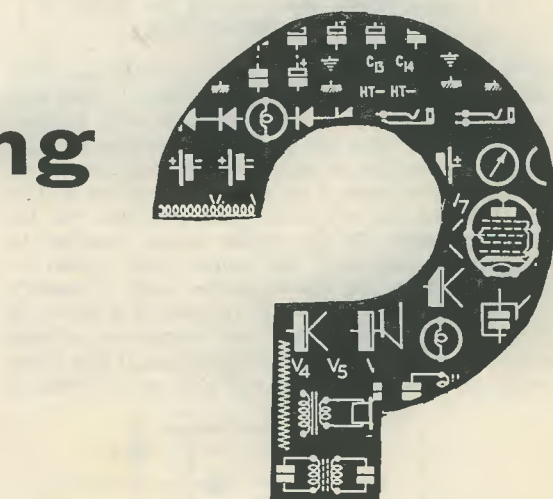

radio

value, a typical figure being 10MΩ as opposed to the 250kΩ to 1MΩ which is normal with triodes using the bias circuits we have previously considered.

The triode of Fig. 316 remains biased by the contact potential for small signal inputs. Since the contact potential causes the grid to be negative of cathode a small current flows through the grid resistor. This is very low in value, being much less than 1μA.²

The current in the grid resistor is modified by the input a.f. voltage, and if the latter is made sufficiently high in amplitude the positive peaks of the signal may cause *positive grid current* to flow, whereupon the grid acts in the same manner as the anode of a rectifier diode. A different method of biasing now takes over and this may be understood by reference to Fig. 317 (a), in which we have an alternating voltage generator, a capacitor and a diode. It will

² Footnote 2, in "Understanding Radio" in the August 1965 issue, referred briefly to the small currents which could flow in the grid circuit even when the grid is negative of cathode. Such currents are due to the effect we are now discussing.

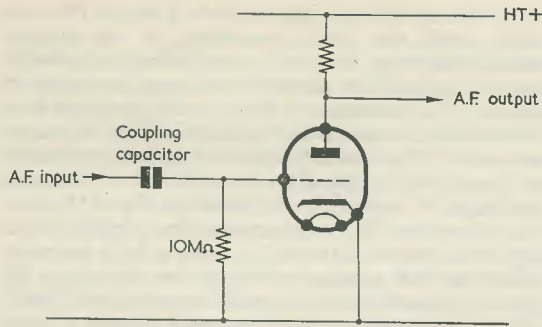

Fig. 316. A triode a.f. amplifier with grid current bias. The value of $10M\Omega$ shown for the grid resistor is typical in this type of circuit

at once be seen that Fig. 317 (a) resembles the half-wave rectifier circuits we have previously examined, and that the capacitor will become charged to the peak value of the alternating voltage. Due to the manner in which the diode is connected, the right hand plate of the charged capacitor will be negative and the left hand plate positive. So far as the voltage on the diode anode, relative to cathode, is concerned, the same result would be given by replacing the capacitor with a battery having the same polarity and voltage, as is shown in Fig. 317 (b). The battery and alternating voltage generator are in series and the voltage at the diode anode relative to cathode will still be the same if

we take the further step of transposing the battery and generator, as in Fig. 317 (c).

If we finally replace the diode by the grid and cathode of a triode, as we do in Fig. 317 (d), we may see that, due to the charging of the capacitor, we have obtained the same effect as would be given by inserting a grid bias battery in series with the generator in the normal manner! There is, however, the important difference that the voltage of the "battery" in Fig. 317 (d) is the same as the peak value of the applied alternating voltage, with the consequence that the bias voltage increases when the input alternating voltage increases.

Another way of looking at the circuit of Fig. 316 is to say that the grid-cathode diode conducts on positive half-cycles of the applied alternating voltage, causing the capacitor to charge to peak potential. The average value of the applied alternating voltage then goes sufficiently negative of the diode cathode to ensure that only the positive peaks are at cathode potential, the remainder of the waveform being negative of cathode.

Fig. 316 differs from the diode circuits of Fig. 317 by having a resistor between the grid and cathode. This resistor allows the capacitor to discharge (via the source of alternating voltage) when the amplitude of the alternating voltage decreases. The rate of discharge may, in practical circuits, be quite slow. In a typical a.f. amplifier circuit the capacitor could be a coupling component having a value of $0.01\mu F$, whilst the grid resistor would be of the order of $10M\Omega$. Ignoring any internal resistance in the

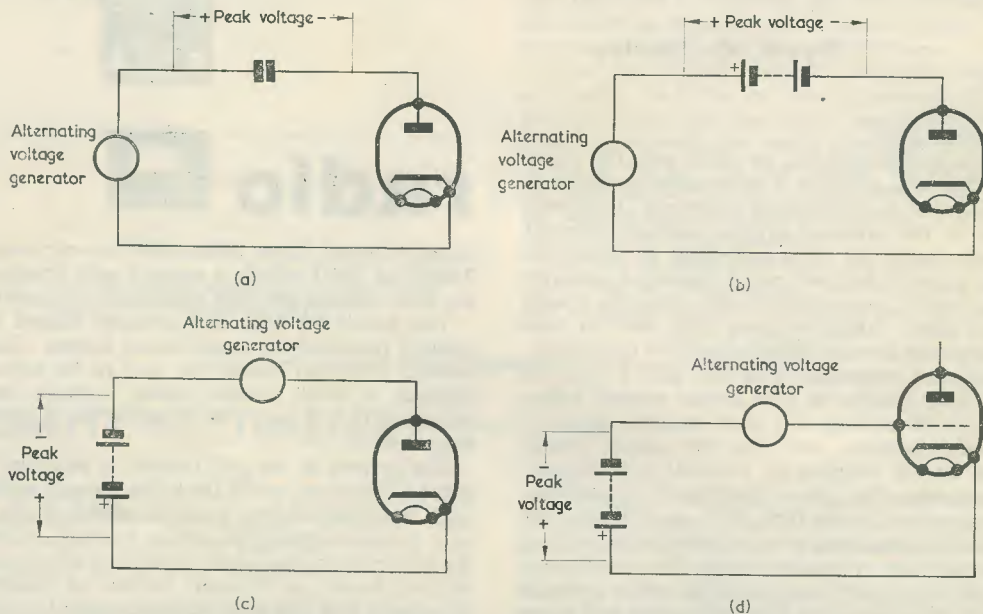

Fig. 317 (a). For input signals of sufficient amplitude to overcome contact potential the coupling capacitor of Fig. 316 appears, effectively, in this circuit, whereupon it charges up to peak potential
 (b). The charged capacitor could be replaced by a battery of the same polarity and voltage
 (c). The voltage on the anode of the diode, relative to cathode, remains unaltered if the generator and battery of (b) are transposed
 (d). Replacing the diode by the grid and cathode of a triode results in the conventional grid bias battery circuit

source of alternating voltage, these figures give a time constant which is as long as 0.1 second.

We may now sum up the biasing action of the circuit of Fig. 316. For low input voltages, the triode is biased by contact potential. As input voltage increases, the rectifying action of Fig. 317 (a) takes over, whereupon bias varies according to the amplitude of the input signal. Small changes in bias voltage do not have any serious effect on the amplification provided by the valve, and so this method of working gives quite acceptable results provided the input signal amplitude is not excessive. The method of bias under discussion is described as *grid current bias*, or *grid leak bias*. A grid leak, it may be added, is a grid resistor which, by allowing a current to "leak" through it, enables a grid bias voltage to be provided.

Grid current bias should only be used with valves when the maker's technical literature sanctions this method of operation, and it is usually preferable to keep input voltage amplitude below about 1 volt peak to avoid excessive distortion.

A.M. Detector Amplifier

In two preceding articles in this series³ we examined typical amplitude modulation detector circuits employing diodes. We shall next turn our attention to the manner in which an a.f. voltage amplifier valve may be coupled to the output of such detectors.

Fig. 318 (a) illustrates a diode detector circuit which was described in one of the previous articles, and which would be capable of operating on the medium or long wave bands.⁴ Its functioning may be briefly summed up in the following manner. Resistor R_1 is the diode load, whilst R_2 and C_2 form a low pass filter to attenuate the radio frequencies present in the detected output from the diode. Looking upon the diode as though it were a half-wave rectifier, C_1 functions in the same way as a reservoir capacitor, the average a.f. voltage across this component being nearly equal to the peak value of the applied r.f. signal. Capacitor C_3 has a low reactance at audio frequencies, and its function is to prevent the direct voltage which appears across the diode load from appearing in the output. At the same time, resistor R_3 ensures that the average voltage on the right-hand plate of C_3 is at chassis potential, so that the a.f. signal appearing on that plate swings positive and negative of chassis by equal amounts.

A triode amplifier valve may be added as shown in Fig. 318 (b). In this diagram R_3 now serves also as grid resistor for the triode, and the valve is biased by a conventional cathode bias circuit. An amplified version of the detected signal appears at the anode of the triode.

An alternative method of biasing the triode is shown in Fig. 318 (c). In this instance a bias battery (or other source of bias voltage) is interposed between R_3 and chassis. R_3 serves once more as

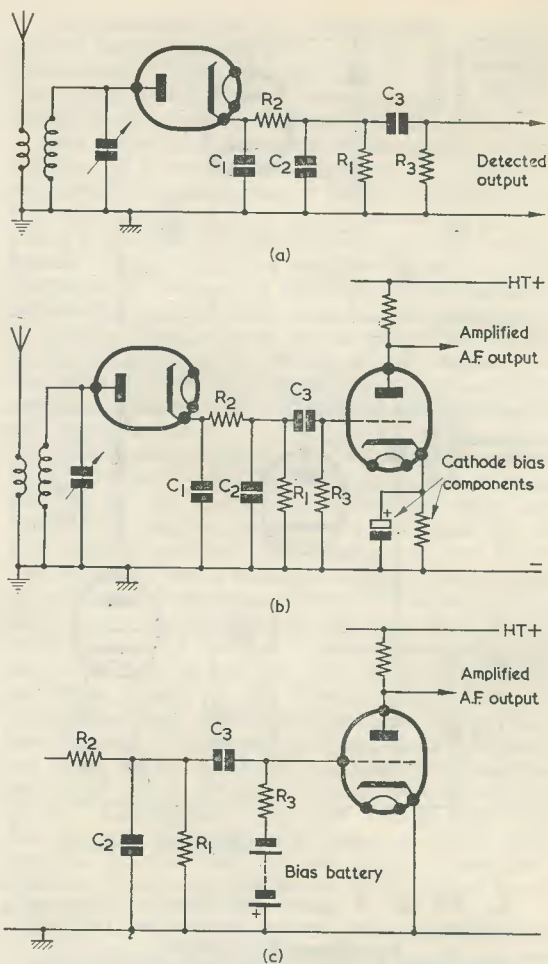

Fig. 318 (a). A diode detector circuit, suitable for reception of medium and long wave signals
 (b). An a.f. voltage amplifier valve may be added as shown here
 (c). An alternative method of biasing the voltage amplifier

grid resistor and it ensures that the signal on the right-hand plate of C_2 swings positive and negative of the bias voltage.

A variation on the diode circuit of Fig. 318 (a) is that shown in Fig. 319 (a).⁵ This is typical of the detector circuit appearing after the last intermediate frequency transformer in a superhet, and a triode amplifier may be coupled up to it in the manner shown in Fig. 319 (b). As will be seen R_3 is, once again, the grid resistor for the triode. The alternative bias arrangement shown in Fig. 318 (c) may similarly be used.

The triode could also employ grid current bias, as in Fig. 316 of the present article. In this instance the circuit would be the same as Figs. 318 (b) and 319 (b), but with the cathode bias components

³ In the May and June, 1965, issues.

⁴ This circuit appeared, as Fig. 283 (c), on page 744 of the June 1965 issue.

⁵ This circuit appeared, as Fig. 285 (a), on page 745 of the June 1965 issue.

as a diode, whereupon these two electrodes offer a low impedance for voltages causing the grid to go positive of the cathode. Thus, positive r.f. peaks go only slightly positive of the cathode and the grid capacitor becomes charged in consequence. Between each positive peak the grid capacitor discharges into the grid resistor, with the result that the succeeding positive peak similarly encounters the low impedance offered by the grid and cathode. The modulated r.f. waveform then takes up the distorted shape shown in the diagram.

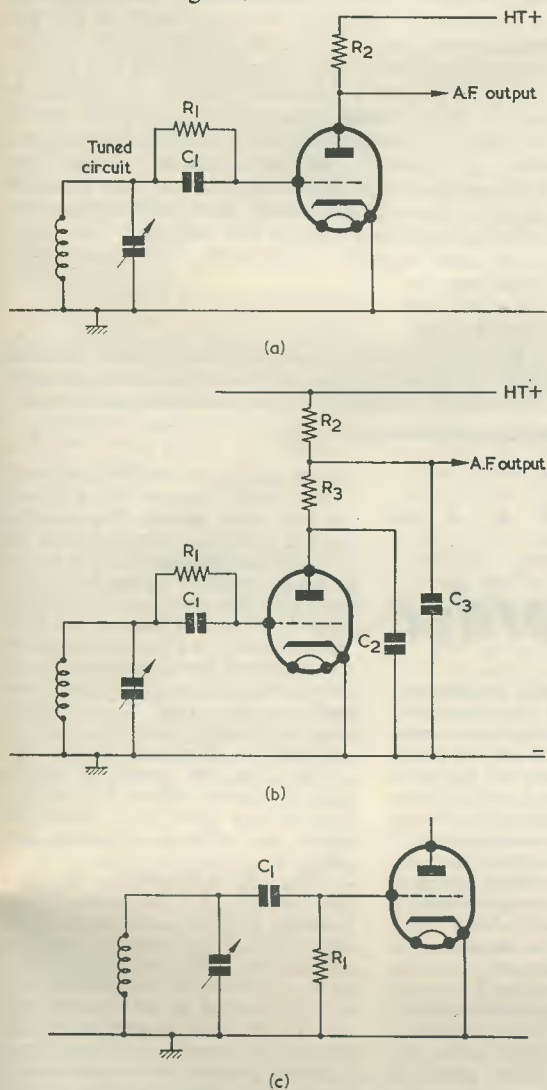

Fig. 320 (a). The basic grid leak detector (b). The triode amplifies radio frequencies as well as the detected audio frequencies, and a low pass filter in the anode circuit prevents the radio frequencies being passed to subsequent stages. In this circuit R_3 could have a value around $10k\Omega$, and C_2 and C_3 200pF each (c). Frequently, the grid resistor, R_1 , is connected between grid and chassis, instead of across C_1

This waveform has an average value, shown in dashed line, which varies in sympathy with the a.f. modulation of the r.f. signal. Detection has therefore taken place, and the detected signal can be amplified, as an audio frequency, by the triode.⁶

Also present at the grid is an average direct voltage. If a current reading meter is inserted in series with the anode load of the grid leak detector, this will indicate a drop in anode current when a signal is tuned in, because the average direct voltage has the effect of applying negative bias to the grid. (In practice, however, a relatively strong signal is required for a noticeable drop in anode current to be given. Signals given by an aerial and tuned circuit without any amplification will normally be too weak to cause any significant change in meter reading, although they will still be detected by the grid leak detector.)

A disadvantage with the grid leak detector is that it can be overloaded by high amplitude signals. Because of the diode action between grid and cathode the positive peaks of the r.f. signal are all held slightly positive of cathode, with the result that, when r.f. signal strength increases, the average a.f. voltage goes more negative of the cathode. Too high an r.f. signal amplitude will cause part, or all, of the average a.f. voltage to approach or go beyond the valve's cut-off voltage, with the result that the amplified signal at the triode anode becomes distorted. Thus, the amplitude at which the grid leak detector commences to overload is governed, not by the ability of the grid and cathode to function as a diode, but by the ability of the triode to function as an a.f. amplifier. The fact that a grid leak detector can be overloaded makes it useful as a detector of low level signals only. There are, however, many applications in which it can be so employed.

⁶ The amplitude of the average a.f. voltage in Fig. 321 is the same as that for a diode detector shown in Fig. 281 on page 683 of the May 1965 issue, even though the presentation is "upside-down" as compared with the previous diagram. In both instances, a.f. amplitude is that between r.f. peaks and the average value of the modulated waveform.

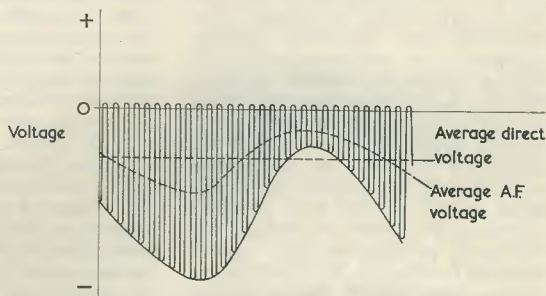

Fig. 321. The waveform at the grid of the grid leak detector, relative to cathode. (The waveform is shown in slightly idealised form, since it depicts all positive peaks as terminating at the same level above cathode potential. In practice the positive peaks for the high amplitude section will rise a little higher above cathode potential than the positive peaks of the low amplitude section)

The main advantage conferred by the grid leak detector is that it combines two valves in one. Another advantage, which we shall examine in a later article, is that it lends itself particularly well to circuits in which feedback from the anode to the grid is provided. Such feedback can increase sensitivity to an extremely high level.

The grid leak detector we have discussed here employs a triode. Valves with more complicated electrode structures may be put into service as grid leak detectors just as readily, the main proviso being that they are capable of operating as a.f. voltage amplifiers.

The grid leak detector has been in use for many years and has acquired several other names which will also be encountered in radio work. The most commonly encountered alternatives are *leaky-grid detector*, *cumulative grid detector* or, simply, *grid detector*.

The similarity between the grid leak detector circuit and the grid current bias circuit of Fig. 316 may be a little confusing to the beginner, because the two circuits appear to do different things. This is not entirely true, however. With the current bias circuit, the function of the grid capacitor and resistor is to cause the grid to be negatively biased (for input signals overcoming the contact potential). It may be said that the same is true for the grid leak

detector circuit except that, in this case, the grid is caused to go more negative or less negative (according to the instantaneous amplitude of the modulated r.f. signal) at an *audio frequency*, whereupon the detected audio frequency becomes available at the anode. At the same time, the grid leak circuit resembles the grid current bias circuit in that the average direct voltage on the grid increases with input signal strength, resulting in the drop of anode current as measured by a meter (which does not respond to r.f. or a.f.) noted earlier. A further point is that contact potential is not so high in the grid leak detector as in the current bias circuit because the grid resistor of the former normally has a lower value. To give a complete picture, it should be added, nevertheless, that contact potential is still of some importance with the grid leak detector, and that it prevents the grid-cathode diode from functioning as an "ideal" rectifier on very low-level signals. Such signals are still detected, but they may suffer some distortion in the process. The same point also applies, incidentally, to valve diode detectors.

Next Month

In next month's issue we shall discuss another type of detector, the infinite impedance detector, after which we shall carry on to triode characteristics.

RADIO TOPICS . . .

by Recorder

ONE GREAT ADVANTAGE ABOUT being in the Services during and shortly after the last war was that you met so many amiable nuts. I was reminded of this the other day when a friend, who maintains the electronic control equipment at an aluminium processing plant, described a little bitterly his experiences on being shifted to a section he had never worked in before. The burden of his complaint was that the chaps who were already there knew the equipment inside-out, but they wouldn't pass on any information to him.

It was at this moment that I recalled the Signals Warrant Officer at one large R.A.F. station in the later 1940s. The telephone wiring around this station was a haphazard tangle of pre-war and hurried wartime installations, with junction box outlets popping up all round the perimeter track and in many other widely dispersed places. The wiring was, of course, used for d.f. homer stations, remote control of v.h.f.

transmitters and similar purposes, in addition to its more mundane function of providing telephone links. There was only one set of plans covering all the wiring on the unit, and a normal person would have thought that the obvious thing to do was to get a few copies run off at the earliest opportunity. But this Signals Warrant Officer thought otherwise, and he *carried* this single set of plans around with him wherever he went. On the occasions when it was necessary to take advantage of the existing wiring to run some new equipment he had, then, always to be called in, because he was the only person with the essential (and jealously guarded) information.

Hugging Information

I wonder why it is that people delight in hugging to themselves information which should be generally known. Most of us have had the same experience, on starting at a new place of work, as did my friend

on the electronic control equipment. I've certainly bumped into it myself. At one place, indeed, I've even had to ask a second person where the lavatory was because the first person I asked couldn't bring himself to part with this precious bit of intelligence! A typical instance of what you encounter at a new establishment can consist of spending several hours' work with, say, a signal generator, only to find that the particular generator you've chosen is 5% off calibration. Everyone around you knows that the generator you've picked to work with is 5% out, but they've been quite happy to let you press on without warning you about it.

After you've found your feet at a place of work it is, of course, always possible to have a chuckle at the initial lack of co-operation you first encountered. But it still seems to me to be a pity that the new initiate has, so often, to put up with people who are not prepared to pass on a little advice on locally known things. I should imagine that quite a lot of man-hours must be lost in this country, to say nothing of the frustration which is engendered, due to the reluctance of some people to enlighten the ignorant newcomer.

I think I've applied that last adjective to the wrong noun. In cases like this, it isn't the newcomer who's ignorant.

Buried H.T.

Talk of those Service days reminds me, also, of a time during the war when a crowd of R.A.F. wireless mechanics, in company with myself, spent a period in tented accommodation alongside the happily-named Sweet Water Canal in Egypt. These characters managed to scrounge enough parts to knock up a radio, but the only sources of supply they could lay their hands on were a 6 volt accumulator for the heaters and a small 6 to 200 volt motor-generator for h.t. There was, of course, no such thing as a mains supply available.

The only snag with the motor-generator was that it created a considerable amount of r.f. interference, but this was cured by the very simple process of burying it in the sand about thirty feet away from the tent with the connecting wires similarly buried.

Which meant that the inhabitants of the tent could lean back and enjoy the delights of radio reception without interference. But it was very disturbing for the wanderers over the desert who happened to walk near the hidden generator, as it busily whirred away under the sands of ancient Egypt.

Smithy Rides Again

But that's enough about the past. Let's move forward now to December of last year, in which issue of *The Radio Constructor* Smithy the Serviceman made one of those little telling points of his.

Talking about transistorised u.h.f. TV tuners, Smithy stated that the base voltage pre-set potentiometers fitted to these would be disappearing in the future as manufacturers gained more experience, and would be replaced by ordinary fixed resistors. And I now see that this is exactly what's happening. The new Thorn 950 television chassis has a transistorised u.h.f. tuner, and its base voltage potentiometers have been replaced by fixed resistor circuits.

Dead with it and switched-on is our Smithy.

The First Transistor

How did you get on with the "20 Semiconductor Questions" we published in the July issue? Most people seem to have got through the quiz fairly easily. However, Question No. 4 has raised a point which deserves a little further consideration.

Question No. 4 asked which was the first type of transistor to be invented, and our answer was that

it was the point contact type. Whereupon, two of our readers wrote in to say that this was not so, since the first transistor to be invented was the *junction* type. Not only was this the case but, also, the junction transistor in question was patented in Canada in 1925 and in the United States in 1930!

Our readers stated that their source of information was an article, "The Twenty Lost Years of Solid-State Physics" by Theodore L. Thomas, which appeared in *Analog Science Fact-Science Fiction* magazine for March 1965. (*Analog*, I should add, is published in America but may be obtained in Britain through any newsagent.) Naturally, we examined the details referred to by our readers.

In his *Analog* article, Theodore L. Thomas gives some intriguing details of the early invention, this being for an amplifying device which could nowadays be described as a transistor. The inventor was Dr. Julius Edgar Lilienfeld, previously a professor at the University of Leipzig in Poland. The patents covering his amplifying device were filed in Canada on 22nd October, 1925, and, in the U.S., on 28th January, 1930. Patents for later developments were filed, in the U.S., on 13th September, 1932, and 7th March, 1933. The March issue of *Analog* also gives a facsimile reproduction of the 1930 patent application, this being No. 1,745,175 at the United States Patent Office.

The amplifying device described in the patent application comprises materials deposited on a small rectangular base of insulating material, such as glass. The glass is cracked across its width at approximately the centre, the two pieces being joined together again with a piece of 0.0001 in aluminium foil sandwiched in between, the upper end of the foil being flush with the upper surface of the glass. Deposited on the upper glass surface, on either side of the aluminium foil, are two thin layers of conductive material such as copper. The inside edges of these layers closely approach the aluminium foil. Finally deposited over the metal, glass and aluminium is a thin film of a compound of copper and sulphur, which Mr. Thomas identifies, in his article, as cuprous sulphide.

Thus, starting from one end of the glass base, we have a layer of deposited metal, such as copper. This terminates just before the flush edge of the aluminium foil interposed in the crack in the glass. Just after the aluminium foil the second layer

of conductive material starts, this continuing to the other end of the glass base. And, over the lot, is deposited the thin film of the compound of copper and sulphur.

In the patent application, this device is shown connected up in exactly the same way as an earthed emitter n.p.n. transistor. Using present-day terms, one of the layers of conductive material could be referred to as the emitter, the other as the collector, and the aluminium foil, which appears in between, as the base. The input signal is applied to this "base" via a source of positive bias, and the amplified output signal is taken from the "collector" via a transformer primary coupled to a higher positive potential.

Full acknowledgements are due to Theodore L. Thomas and *Analog* magazine for unearthing and publishing these fascinating facts. There seems little doubt that this early device provided amplification, whereupon it would seem that it must surely be the world's first transistor.

Our thanks, also, to the readers who brought this interesting information to our attention.

Best Buy

Just to demonstrate one of the little social pitfalls that wait, these days, for the unwary, let me finish by recounting a cautionary tale which has to do with that excellent journal *Which?* and domestic electric equipment.

Our household recently required a new vacuum cleaner and, being pushed for time, I made no investigation of different makes and models but simply went straight out and bought the cleaner recommended in *Which?* as Best Buy. And a very good purchase it has turned out to be, too.

Mentioning the episode to a friend I said that the *Which?* report had not been entirely complimentary with one particular model, which I shall refer to here by the fictitious name of Alpha "Super Sucker". I noticed that the conversation palled somewhat after this point, and it wasn't until later that I discovered that my friend had just bought an Alpha "Super Sucker".

Failing to profit from this experience, I described this last discourse to another friend, referring with some amusement to the palling of the conversation after I'd got to the Alpha "Super Sucker" bit. Whereupon, *this* conversation palled.

My second friend had just bought an Alpha "Super Sucker", too.

LEARN ELECTRONICS AS YOU BUILD 25 CIRCUITS . . . EXPERIMENTS . . . TEST GEAR . . .

including

● CATHODE RAY OSCILLOSCOPE

- VALVE EXPERIMENTS
- SQUARE WAVE GENERATOR
- SIGNAL TRACER
- BASIC AMPLIFIER
- SIMPLE TRANSMITTER
- BASIC COMPUTER CIRCUIT
- BASIC RECTIFIER
- TRANSISTOR EXPERIMENTS
- BASIC RADIO RECEIVER
- PHOTO ELECTRIC CIRCUIT
- BASIC OSCILLATOR
- MORSE CODE OSCILLATOR
- TIME DELAY CIRCUIT
- ELECTRONIC SWITCH
- ETC. ETC.

This complete practical course will teach you all the basic facts of electronics by making experiments and building apparatus. You learn how to recognise and handle all types of components—their symbols and how to read a circuit diagram. You see how circuits are built and how they work **BY USING THE OSCILLOSCOPE PROVIDED**. Applications of all the main electronic circuits are

demonstrated—radio reception and transmission; photo-electrics; computer basics; timers; control circuits; etc.; including servicing techniques. **NO MATHS USED OR NEEDED. NO THEORY NEEDED. NO PREVIOUS KNOWLEDGE OR EXPERIENCE NEEDED.** Tutor service available. No extras needed—tools provided. Send now, for *Free Details* without obligation, to address below

To **RADIOSTRUCTOR**, Dept. K3, READING, BERKS. Please send free details of your electronics kit set to:

POST NOW 

NAME

ADDRESS

SMALL ADVERTISEMENTS

Use this form for your small advertisement

To: **The Advertisement Manager, Data Publications Ltd., 57 Maida Vale, London, W.9**
 Please insert the following advertisement in the issue of **THE RADIO CONSTRUCTOR**

16 words at 9d.
= 12/-

**ALL WORDING
IN
BLOCK LETTERS
PLEASE**

I enclose remittance of being payment at 9d. a word. **MINIMUM 12/-**.
 Box Number, if required, 2/- extra.

NAME

ADDRESS

Copy to be received four weeks prior to publication. Published on the 1st of every month

SMALL ADVERTISEMENTS

Rate: 9d. per word.

Minimum charge 12/-.

Box No. 2/- extra.

Advertisements must be prepaid and all copy must be received by the 4th of the month for insertion in the following month's issue. The Publishers cannot be held liable in any way for printing errors or omissions, nor can they accept responsibility for the *bona fides* of advertisers. (Replies to Box numbers should be addressed to: Box No. —, *The Radio Constructor*, 57 Maida Vale, London, W.9.)

THE INCORPORATED PRACTITIONERS IN RADIO AND ELECTRONICS (I.P.R.E.) LTD. Membership conditions booklet 1s. Sample copy of I.P.R.E. Official Journal 2s. post free.—Secretary, Dept. D, 32 Kidmore Road, Caversham, Reading, Berkshire.

SERVICE SHEETS, 1925-1965. From 1s. Catalogue 6,000 models, 1s. 6d. S.A.E. enquiries.—Hamilton Radio, 13 Western Road, St. Leonards, Sussex.

HAMMER FINISH PAINT. The modern finish for electronics. Can be BRUSHED or sprayed. Blue or Silver. 2½ oz tins 3s. 6d., post 8d., ½ pint 7s. 6d., post 1s. 9d., 1 pint 15s., post 2s. 9d. Orders over 30s. post free. Retailers supplied. Write for details. Amazing results! Return of post service.—Finnigan Speciality Paints (RC), Mickley Square, Stocksfield, Northumberland.

GOVERNMENT SURPLUS electrical and radio equipment. Our new catalogue No. 16 ready now, 2s. 6d. post free, cost refunded on purchase of goods over £2.—Arthur Sallis Radio Control Ltd., 93 North Road, Brighton, Sussex.

CHASSIS ARE OLD HAT! Get with it. Radiomatics printed circuit kits. D.I.Y. Complete with all chemicals to etch and process many printed circuits. With approx. 50 square inches of p.c. board and comprehensive instruction book. 8s. 6d. plus 2s. 6d. post.—From: Radiomatics, 140 Oak Street, Norwich, Norfolk.

FOR SALE. Oscilloscopes—Galvanometers—Evershed & Vignolles Meggers. Also other items and components. Free list. Stamp please.—R. & E. Mart, Box 9 G.P.O., Tunbridge Wells, Kent.

VALVES REACTIVATED to as new condition. Receiving 3s. each, transmitting 4s. Post 6d. per valve. Restore performance of your equipment at minimum cost. Send stamp for leaflet.—G. Elliott, 3 Sandgate Avenue, Tilehurst, Reading, Berks.

CONVERT ANY TV SET INTO AN OSCILLOSCOPE. Instructions and diagrams, 12s. 6d.—Redmond, 42 Dean Close, Portslade, Sussex.

FOR SALE. Heathkit Balun coil unit Model B-1U, £3. Postage extra.—Box No. F236.

continued on page 205

FREE

 inside every copy!

24-PAGE

PRACTICAL WIRELESS

POCKET GUIDE

Packed with essential at-a-glance data that you'll refer to again and again, including:—

- **BASIC RADIO DATA AND FORMULAE**
- **OHMS LAW CALCULATIONS**
- **TRANSISTOR BASE CONNECTIONS**
- **WORKSHOP DATA & TABLES**

ALSO IN THE NOVEMBER ISSUE:

Building a Miniature Oscilloscope—Bandswitching the "Ten-Five"—Self-Regulating Transistor Circuits—Reducing TV Interference

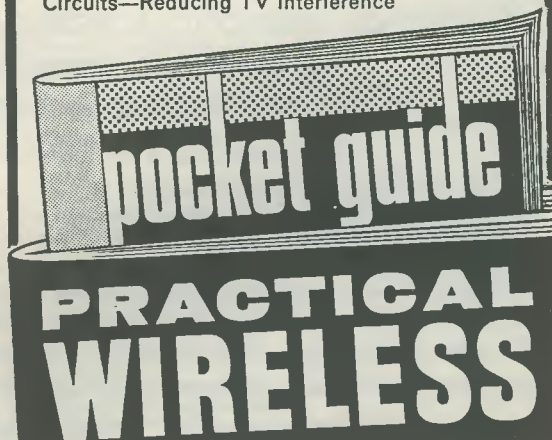

NOVEMBER 2/- on sale Oct. 7th

BIG DEMAND!

MAKE SURE OF YOUR COPY!

THE MODERN BOOK CO

The Radio Amateur's V.H.F. Manual. By A.R.R.L. 18s. Postage 1s. 6d.

Basic Theory and Application of Transistors. U.S. ARMY. 10s. Postage 1s.

An Electronic Organ for the Home Constructor. By A. Douglas. 20s. Postage 1s.

The Amateur Radio Handbook. An R.S.G.B. Pub. 34s. Postage 2s. 6d.

A Beginner's Guide to Radio. Pub.: Newnes. 8s. 6d. Postage 9d.

Radio Control for Models. By F. C. Judd. 15s. Postage 1s.

Transistor Substitution Handbook. 12s. 6d. Postage 1s.

Tube Substitution Handbook. Pub.: Foulsham-Sams. 12s. 6d. Postage 1s.

Transistor Radios Circuitry and Servicing. By Mullard. 5s. Postage 6d.

How To Listen To The World, 1965-66. 20s. Postage 1s.

Advanced Radio Control. By E. L. Safford. 25s. Postage 1s.

Transistor Electronic Organs for the Amateur. By A. Douglas and S. Astley. 18s. Postage 1s.

Guide to Broadcasting Stations. Compiled by "W.W." 5s. Postage 6d.

Radio and Television Test Instruments. By G. J. King. 25s. Postage 1s. 6d.

Television Servicing Handbook. By G. J. King. 35s. Postage 1s. 6d.

ABC's of Hi-Fi and Stereo. By H. Fantel. 16s. Postage 1s.

Amateur Radio Mobile Handbook. By C. Caringella. 24s. Postage 1s.

Organ Builders Manual, 6th Ed. Pub.: Artisan Organs. 35s. Postage 2s.

Complete Catalogue 1s.

We have the Finest Selection of English and American Radio Books in the Country

19-21 PRAED STREET (Dept RC) LONDON W2

Telephone PADDington 4185

THE WORD

MAXI-Q

IS THE REGISTERED
TRADE MARK

OF DENCO (CLACTON) LIMITED
IT IS ALSO A GUARANTEE OF
WORKMANSHIP AND
TECHNICAL PERFORMANCE

OUR RANGE OF PRODUCTS IS SO GREAT THAT WE NOW HAVE TO REQUEST THE AMOUNT OF 2s. 0d. FOR OUR GENERAL CATALOGUE AND TO SAVE YOU POSTAL ORDER POUNDAGE CHARGE WE REQUEST SEND 2s. 0d. IN STAMPS.

IN RESPONSE TO CONTINUOUS DEMAND we have commenced production of Self-Contained Multiplex Decoder Unit, aligned ready for immediate use, that will convert your two receivers—tuner and two amplifiers—tuner and stereo amplifier or stereo receiver without Multiplex provision to a complete B.B.C. Stereo Broadcast Reception Unit. Price £8.0.0, post paid. Technical Publication MDI, 4s. 0d., post paid.

IFT.11/465 kc/s centre tapped transformer for use in crystal filter circuits, $1\frac{1}{8}'' \times \frac{11}{16}''$ square. 10s. 6d. plus 8d. post.

IFT.18/465 kc/s and 1.6 Mc/s Double Tuned transistor transformer $1\frac{1}{2}'' \times \frac{1}{2}''$ square. 10s. 6d., plus 8d. post.

Please send S.A.E. with all enquiries. General Catalogue 2s. 0d.

DENCO (CLACTON) LTD.

(DEPT. R.C.)

357/9 OLD ROAD, CLACTON-ON-SEA, ESSEX

SMALL ADVERTISEMENTS

continued from page 203

TREASURE HUNT! Help me to find certain types of relays and contacts, to earn some cash. Send s.a.e. for details. New "Red Spot" and "White Spot" transistors 28s. per 100 (minimum quantity either type).—G3LMR, 112 Groby Road, Glenfield, Leicester.

FOR SALE. Heathkit valve millivoltmeter, model AV-3U. Unused. £15.—Box No. F240.

FOR SALE—VALVES. DL92, EB91, EF92, IT4 at 1s. 6d. ECC82, EL91 at 3s. CV1075, U14, VR91, VT136, 955, 6AT6 at 5s. EF40, 801, 830B, T20 at 7s. 6d.—Box No. F241.

FOR SALE. R.C.A. AR88D and speaker, instruction manual, circuit diagram, £35.—Thorner, 63 High View Road, London, W.13.

WANTED. December 1963 copy of *The Radio Constructor*. Cover price and postage paid.—Box No. F245.

STEREO RECORDS FOR SALE. *Marches from Operas*, AF.FCS 50008; *Stainer's Crucifixion*, HMV ASD 454; *Bob Sharples and His Music*, Decca SKL 4110; *Tchaikovsky in Phase Four*, Decca PFS 4044. All unblemished at 15s. each.—Box No. F246.

WANTED. Line output transformer for Philips projection TV model No. 600A.—Box F247.

YOUR KITS EXPERTLY BUILT. Mains, battery radios of every description. S.A.E. enquiries.—W. Thomas, 106 Wynnville, Ruabon, Nr. Wrexham, Denbighshire.

TECHNICAL DRAWINGS, Artwork, etc. Electronic and Radio Circuits a speciality. Modest charges.—B. P. Meaney, 43 Forest Road, Worthing, Sussex.

INTERESTED IN AMATEUR RADIO TELEPRINTING? Then join the British Amateur Radio Teleprinter Group. Details from Hon. Sec., G3LLV, 15 Havelock Square, Broomhill, Sheffield 10.

"MEDIUM WAVE NEWS" Monthly during DX season—Details from: B. J. C. Brown, 60 White Street, Derby.

ARE YOU A MOTORING ENTHUSIAST? The Seven Fifty Motor Club caters for all types of motor sport—racing, rallies, hill climbs, etc. Monthly Bulletin free to members. For full details write to: The General Secretary, Colin Peck, "Dancer's End", St. Winifred's Road, Biggin Hill, Kent.

JOIN THE INTERNATIONAL S.W. LEAGUE. Free Services to members including Q.S.L. Bureau. Amateur and Broadcast Translation. Technical and Identification Dept.—both Broadcast and Fixed Stations, DX Certificates, contests and activities for the SWL and transmitting members. Monthly magazine, *Monitor*, containing articles of general interest to Broadcast and Amateur SWLs, Transmitter Section and League affairs, etc. League supplies such as badges, headed notepaper and envelopes. QSL cards, etc., are available at reasonable cost. Send for League particulars. Membership including monthly magazine, etc., 35s. per annum.—Secretary, ISWL, 12 Gladwell Road, London, N.8.

continued on page 207



FIRST QUALITY PVC TAPE

5 1/2" Std. 850ft	9/-	5" L.P. 850ft	10/6
7" Std. 1200ft	11/6	3" T.P. 600ft	8/-
3" L.P. 240ft	4/-	5" T.P. 1800ft	20/6
5 1/2" L.P. 1200ft	11/6	5 1/2" T.P. 2400ft	27/6
7" L.P. 1800ft	18/6	7" T.P. 3600ft	37/6

P. & P. on each 1/6, 4 or more post free.

Complete with McLaren Variable Thermostat 90° to 180°F. 20 amp. A.C. and GEC double pole 20 amp. mains switch. 18", 30" and 36". State length required. £2.0.0, plus 5/- P. & P.

3kW IMMERSION HEATER

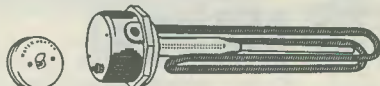

"PREMIER" KETTLE ELEMENT

1000W, 8/6 plus 3/- P. & P. Retaining nut and flange 2/6, switch plug to suit 2/6.

A.C. MAINS MOTOR



Can be used for a variety of purposes, silent running, satisfactory in every way. 230/250V A.C. 9/6. P. & P. 3/-.

3 to 4 WATT AMPLIFIER KIT

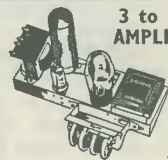

comprising chassis 8 1/2" x 2 1/2" x 1". Double wound mains transformer, output transformer, volume and tone controls, resistors, condensers, etc. 6V6, ECC81 and metal rectifier. Circuit 1/6 free with kit. 29/6, plus 4/6 P. & P.

40W FLUORESCENT LIGHT KIT



incorporating GEC Choke size 8 1/2" x 1 1/2" x 1 1/2", 2 bi-pin holders, starter and starter holder, 11/6. P. & P. 4/6.

Similar to above: 80W Fluorescent Light Kit incorporating GEC choke size 11 1/2" x 1 1/2" x 1 1/2", 2 bi-pin holders, starter and starter holder, 17/6. P. & P. 5/6.

8-watt 5-valve PUSH-PULL AMPLIFIER & METAL RECTIFIER

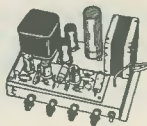

Size: 9" x 6" x 1 1/2" A.C. Mains 200-250V 5 valves. For use with Std. or L.P. records, musical instruments, all makes of pick-ups and mikes. Output 8 watts at 5 per cent total distortion. Separate bass and treble lift controls. Two inputs, with controls, for gram. and mike. Output Transformer tapped for 3 and 15 ohms speech coils. Built and tested. £3.19 6. P. & P. 8/-.

SPECIAL OFFER: POWER SUPPLY KIT to purchasers of *Elegant Seven* parts, incorporating mains transformer, etc. A.C. mains 200-250V. Output 9V 100mA. 7/6.

'ELEGANT SEVEN' Mk. II

Combined Portable and Car Radio The Radio with the "Star" Features

- ★ 7-transistor superhet. Output 350mW.
- ★ Grey wooden cabinet, fitted handle with silver coloured fittings. Size 12 1/2" x 8 1/2" x 3 1/2"
- ★ Horizontal tuning scale, size 11 1/4" x 2 3/4" in silver and black lettering.
- ★ All stations clearly marked.
- ★ Ferrite-rod internal aerial.
- ★ I.F. Neutralisation on each stage. 460 kc/s.
- ★ D.C. coupled output stage with separate A.C. negative feed back.
- ★ All components, ferrite rod and tuning assembly mounted on printed board. ★ Operated from PP9 battery. ★ Full comprehensive instructions and point-to-point wiring diagrams. ★ Printed circuit board, back printed with all component values. ★ Fully tunable over medium and long waveband. ★ Car aerial socket.
- ★ Full after-sale service. 4" SPEAKER.

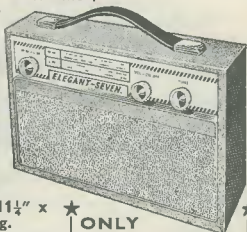

★ ONLY
£4.4.0
★ Plus 6/6 Post & Packing

Parts list and circuit diagram 2/6, FREE with parts. Shop Hours 9 a.m.-6 p.m. Early Closing Wednesday Goods not despatched outside U.K. All enquiries S.A.E. Terms C.W.O.

RADIO & TV COMPONENTS (ACTON) LTD.

21F High St., Acton, London, W.3

Mullard MAINTENANCE MANUAL

Service Engineers will find the latest edition of the MULLARD MAINTENANCE MANUAL an essential source of information on all current replacement valves, semiconductors and cathode ray tubes.

It includes comprehensive data on over 200 types. The equivalents list provides cross references to over 500 types.

Supplementary data sheets, on new types are issued periodically and are included in the initial price of 16/-.

Applications for this service should be made direct to:

MULLARD LIMITED,
MULLARD HOUSE,
TORRINGTON PLACE,
LONDON W.C.1.

TESTED TRANSISTORS

1/- each Red or White Spots. 10/- per doz.

2/- each XA101, XA102, XA111, XA112, XB103, NKT122, 2E1, OA70, OA90, OC430.

3/- each OC44, OC45, OC70, OC71, OC81, OC81D, OC82, OC82D, OC169, OC200.

4/- each AF114, AF115, AF116, AF117, XA103, XB102, XC121, XU611, OC170, OC171.

5/- each OC72, OC139, OC204, ORP60, XC141, BY100. ACY22, GET8, AFZ11, AFZ12.

10/- each OC22, OC26, OC28, OC35, ORP12, AFY19, GET571, BFY17, BSY26, BSY29.

ZENER DIODES 4.7 volt to 30 volt $\frac{1}{4}$ watt, 3/6 each, 1.5 watt, 5/- each, 7 watt, 6/- each.

Plus lots not listed—i.e. S.C.R.'s, V.H.F. and N.P.N.'s.

Send 6d. stamp for Full Lists and Equivalent Chart.

B. W. CURSONS

78 BROAD STREET, CANTERBURY, KENT

The Radio Amateur Operator's Handbook

64 PAGES

DATA BOOK
SERIES No. 6

PRICE 5/-

POSTAGE 5d.

In the ninth edition of this well established handbook, several new features have been included in addition to the complete revision of the Amateur Prefix lists—these containing the latest issued information.

Essential to both the Transmitter and the Listener, it is full of such information as Radio Zone Boundaries—1/40, Call Areas, Amateur Band Frequency Allocations, Local Time Conversions, Mileage Table, Amateur Codes and Abbreviations, the Amateur Licence, International Morse Code, QSL Bureaux of the World, Standard Frequency Transmissions, Operating Technique, Charts on which countries, states, zones and counties worked or heard can be recorded, Prefix/Directional Bearing List, 2 Metre and 70 cm. Band Plan with map, Frequency/Wavelength Conversion Chart, Amateur Radio News Broadcasts, National Societies with addresses and Call Area Maps of Australia, U.S.S.R., South America, Canada, U.S.A. and Weather Forecast Areas, Post Office Regulations, etc.

To Data Publications Ltd., 57 Maida Vale, London, W.9

Please supply.....copy(ies) of your latest publication "THE RADIO AMATEUR OPERATOR'S HANDBOOK" DATA BOOK No. 6 at 5s. 0d. each, postage 5d.

NAME

ADDRESS

BLOCK LETTERS PLEASE

SMALL ADVERTISEMENTS

continued from page 205

POSTAL ADVERTISING? This is the Holborn service. Mailing lists, addressing, enclosing, wrapping, facsimile letters, automatic typing, copy service, campaign planning, design and artwork, printing and stationery. Please ask for price list.—The Holborn Direct Mail Company, Telephone: TERminus 0588.

EDUCATIONAL

TV AND RADIO. A.M.I.E.R.E., City & Guilds, R.T.E.B. Cert., etc., on "Satisfaction or Refund of Fee" terms. Thousands of passes. For details of Exams. and home training courses (including practical apparatus) in all branches of radio, TV and electronics, write for 156 page Handbook—FREE.—B.I.E.T. (Dept. 303), 29 Wright's Lane, London, W.8.

SITUATION VACANT

A FULL TIME TECHNICAL EXPERIENCED SALESMAN required for retail sales.—Write giving full details of age, previous experience and salary to: The Manager, Henry's Radio Ltd., 303 Edgware Road, London, W.2.

SITUATION WANTED

RADIO REPAIRMAN. Age 21. Radio work and salesmanship. Speaks French. Good experience. Wants job in Great Britain. Write to—Lo Quun Chong, Ritz Bar, Curepipe, Mauritius.

YOUR CAREER IN RADIO?

Big opportunities and big money await the qualified man in every field of Electronics today—both in the U.K. and throughout the world. We offer the finest home study training for all subjects in radio, television, etc., especially for the **CITY & GUILDS EXAMS**, (Technicians' Certificates); the Grad. Brit. I.R.E. Exam.; the **RADIO AMATEUR'S LICENCE**; P.M.G. Certificates; the R.T.E.B. Servicing Certificates; etc. Also courses in Television; Transistors; Radar; Computers; Servomechanisms; Mathematics and Practical Transistor Radio course with equipment. We have **OVER 20 YEARS'** experience in teaching radio subjects and an unbroken record of exam. successes. We are the only privately run British home study Institute specialising in electronic subjects only. Full details will be gladly sent without any obligation.

SEND FOR FREE BROCHURE TO:

BRITISH NATIONAL RADIO SCHOOL
DEPT 4, RADIO HOUSE · READING · BERKSHIRE



ESTABLISHED

1865

Savings in this old established Building Society combine sound investment with an attractive return

THE DUCHESS OF KENT PERMANENT BUILDING SOCIETY

Member of the Building Societies Association

Shares are in units of £25 each (maximum investment £5,000) . . . **BUT, for the smaller saver**, Subscription Share accounts may be opened with any sum from 1/- upwards. Interest is payable half-yearly on Fully Paid Shares—credited annually on Subscription Shares—all interest accrues monthly

Withdrawals at short notice

INTEREST IS AT 4% PER ANNUM

(There is NO DEDUCTION FOR INCOME TAX, as this is paid by the Society)

For further information apply to

**DUCHESS OF KENT
PERMANENT BUILDING SOCIETY**

103 Cannon Street London EC4

Telephone MANsion House 8011

Please send to me, without obligation, free brochure and a copy of the audited statement of accounts. (I understand that I shall not be troubled with calls by representatives)

Name

(If lady, please state Mrs. or Miss)

Address

.....R.C.

(Please use Block Capitals for both name and address)

CHASSIS and CASES by



287/9 Edgware Road
London W2

TELEPHONE
PAddington 5891/7595

BLANK CHASSIS—Same Day Service

Of over 20 different forms made up to YOUR SIZE.
(Maximum length 35", depth 4".)

SEND FOR ILLUSTRATED LEAFLETS

or order straight away, working out total area of material required and referring to table below which is for four-sided chassis in 16 s.w.g. aluminium.

48 sq. in.	4/3	176 sq. in.	9/-	304 sq. in.	13/6
80 sq. in.	5/6	208 sq. in.	10/-	336 sq. in.	14/9
112 sq. in.	6/6	240 sq. in.	11/3	368 sq. in.	15/9
144 sq. in.	7/9	272 sq. in.	12/6	and pro rata	
	P. & P. 3/-		P. & P. 3/6		P. & P. 4/-

Discounts for quantities. More than 20 different sizes kept in stock for callers.

FLANGES (1/2" or 3/8"), 6d. per bend.
STRENGTHENED CORNERS, 1/- each corner.
PANELS

Any size up to 3ft at 5/3 sq. ft. 16 s.w.g. (18 s.w.g. 4/6).
Plus postage and packing

CASES

ALUMINIUM, SILVER HAMMERED FINISH

Type	Size	Price	Type	Size	Price
U	4 x 4 x 4**	10/-	Y	8 x 6 x 6"	26/6
U	5 1/2 x 4 1/2 x 4 1/2"	15/-	Y	12 x 7 x 7"	41/-
U	8 x 6 x 6"	21/-	Y	13 x 7 x 9"	46/-
U	15 x 9 x 9"	44/6	Y	15 x 9 x 7"	48/6
W	8 x 6 x 6"	21/-	Z	17 x 10 x 9"	66/-
W	12 x 7 x 7"	34/-	Z	19 x 10 x 8 1/2"	71/-
W	15 x 9 x 8"	44/-		* Height	

Type Z has removable back and front panels.
Type Y all-screwed construction.

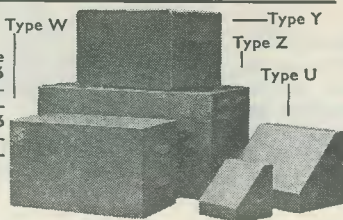

BRASS · COPPER · LIGHT ALLOYS · ALUMINIUM BRONZE · STAINLESS STEEL

ROD, BAR, SHEET, TUBE, STRIP, WIRE. 3,000 STANDARD STOCK SIZES
No Quantity too small List on application

H. ROLLET & CO LTD
HOWIE ST. LONDON SW11 BATTERSEA 7872
Also at Liverpool, Birmingham, Manchester, Leeds, Glasgow

the unique **PANL** black crackle paint

4/-d. per 1/8 pt. Can
(We regret we can only supply on cash with order basis)

BRUCE MILLER LTD.,
219 Coastal Chambers,
Buckingham Palace Road, S.W.1.

V.H.F. RECEIVER: Pye PTC114, 65-100 Mc/s, 12 volts D.C. supply.
This is an 11 Valve Double Superhet Receiver, operating on one fixed frequency between 65-100 Mc/s, crystal controlled, speaker output using midjet valves throughout. Supplied in first-class condition with tuning data, circuit diagram, and complete crystal formula. Ideal for the 4 meter band (70.2 Mc/s) offered at only 70/-, post 5/-.

Aerial Matching Tuning Units. These well made tuning units, made for the American 19 Tx-Rx, are housed in a metal case, colour green or brown, using a large precision calibrated scale, are an essential piece of equipment for the serious Tx or Rx operator. This unit will match an untuned wire or Whip Aerial to almost any Short Wave Receiver or Transmitter, exceptionally good for Mobile Top Band use. This American version being well noted as far superior to any other. **GUARANTEED BRAND NEW, only 20/-, Post 7/6.** Instructions supplied. **Guaranteed Brand New in original carton, CANADIAN MARCONI 52 RECEIVERS.** Few only at £9.10.0. Carr. 20/-. Mains Power Unit, £2.10.0. Supplied with Outer Case, Handbook and Circuit. Set has Crystal Calibrator, Speaker, etc. Range 1.75-16 Mc/s.

JOHN'S RADIO (Dept. D.),
OLD CO-OP., WHITEHALL ROAD,
DRIGLINGTON, BRADFORD, YORKS.

YUKAN SELF-SPRAY

Get this Air-drying Grey
HAMMER FINISH
NOW —

IT'S SUPERB THE PUSHBUTTON WAY !

YUKAN Aerosol spraykit contains 16 ozs. fine quality durable easy instant spray. No stove baking required. Available in Grey Hammer at 14/11 at our counter or 15/11, carr. paid, per pushbutton self-spray can. **SPECIAL OFFER:** I can plus optional transferable snap-on trigger handle (value 5/-) for 18/11. Please enclose cheque or P.O. for total amount to:



YUKAN

Dept. RC/10 307a EDGWARE ROAD LONDON W.2
(Closed Thursday afternoons, open all day Saturdays)

Choice of 13 self-spray plain colours and primer (motor car quality) also available

(500/4) SEMICON-INF SERVICE

Suppliers of all INDUSTRIAL and ENTERTAINMENT types of semi-conductor devices. AMERICAN and Continental devices are our speciality. Send 9d. in stamps for price lists of over 650 types.

TRANSISTORS.—Comprehensive range available ex-stock: AC127, 9/6; 2G381, 4/-; 2N301, 19/-; 2N1302/3, 5/8; OC45M, 5/-; 2G415, 7/-; 2N404, 4/8; 2N1304/5, 6/9; OC71, 4/-; 2G416, 6/6; 2N699, 23/2; 2N1306/7, 8/8; 2G302, 5/8; 2N174, 42/-; 2N706, 13/6; 2N2613, 6/5. Also UJT'S: 2N1671 at 42/-; 2N2646 at 16/5; 7072 at 15/2 each. SCR'S: (ALL in TO-5 case) 1.6A/25V at 21/-; 1.6A/50V at 23/-; 1.6A/200V at 33/-; Other SCR'S up to 25A/400V, £7.6.3. Varicap Diodes: BA110 at 6/3 each (8-12pF at 30 Mc/s, V_R 2V).

Please add 9d. P. & P. on all orders of less than £2.
MAIL ORDER ONLY PLEASE. TERMS: C.W.O.

M. R. CLIFFORD & CO. (R)
66 Old Oscott Lane, Birmingham, 22A

THE RADIO CONSTRUCTOR — BOUND VOLUMES

NOW AVAILABLE

Volume 18, August 1964 to July 1965. Price £1 10s. 0d. Postage 3s. 6d.

Where all issues are returned: Price £1. Postage 3s. 6d.

We regret earlier volumes now sold out.

Send for our latest brochure containing details of our other publications

DATA PUBLICATIONS LTD 57 MAIDA VALE LONDON W9

FULLY DETAILED AND ILLUSTRATED CATALOGUE

Now 96 big pages. The largest range available in the country. All types of components and equipment at competitive prices.

PRICE 2/6 (post paid)

PROVED & TESTED DESIGNS

FULL AFTER SALES SERVICE AND GUARANTEE

★ CALL IN FOR DEMONSTRATIONS ★

DETAILED LEAFLETS FREE ON REQUEST



MW/LW POCKET SUPERHET RADIO

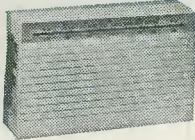

TOTAL COST TO BUILD **85/-** P.P. 2/-

(Battery 2/6 Phone 5/-)

★ All parts sold separately.

- ★ 6-Transistor design. Push-pull output.
- ★ 2 1/2" Clearitone speaker. Printed circuit.
- ★ Attractive moulded cabinet.
- ★ Slow motion tuning.
- ★ Full medium and long waves.
- ★ Size: 5" x 3" x 1 1/4".

● AMAZING SENSITIVITY AND SELECTIVITY ●

- ★ 6-Transistor push-pull design.
- ★ Uses factory built panels.
- ★ Permeability geared tuning.
- ★ Full med./long wave tuning with push-button wave change.
- ★ Double tuned IFT's.
- ★ Chromed front panel plate.
- ★ Size: 7" x 4" x 2". Fits any car.
- ★ Pre-built units sold separately.

TOTAL COST TO BUILD

£8.19.6 P.P. 3/6

(7" x 4" speaker with car fixing kit and baffle board 20/- extra.)

TWO WAVEBAND ALL-TRANSISTOR CAR RADIO TO ASSEMBLE

● HIGH PERFORMANCE SUPERHET ●



2- AND 4-TRACK TAPE RECORDERS TO ASSEMBLE

Pre-built Equipment—6 Valves—Collaro Studio Decks—Portable Cabinets with Speakers. Complete record and playback.

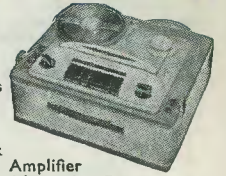

★ 2-track deck 10 gns. P.P. 5/- Amplifier 11 gns. Cabinet with speaker 5 gns.

OR SPECIAL PRICE **£26** P.P. 8/6 **TWO TRACK Amplifier**

★ 4-track deck **£13.19.6** P.P. 5/- Amplifier 12 gns. Cabinet with speaker 5 gns.

OR SPECIAL PRICE **£30** P.P. 8/6 **FOUR TRACK**

Prebuilt and tested units. Low distortion, low noise.

10W & 20W HI-FI AMPLIFIERS

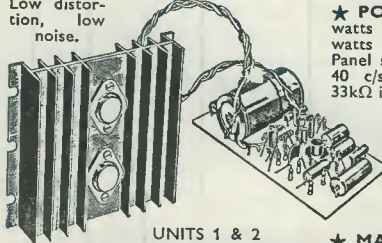

UNITS 1 & 2

★ POWER AMPLIFIERS. 10 watts R.M.S. music power. 20 watts peak. 6-Transistor design. Panel size 4" x 2 1/2" x 3 1/2". Response 40 c/s to 20 kc/s. 100mV into 33kΩ input.

UNIT 1. For 12/15 ohm speakers. 40 volt supply.

PRICE BUILT **£5.19.6** P.P. 2/6

UNIT 2. For 3 to 5 ohm speakers. 24/28 volt supply.

PRICE BUILT **£5.10.0** P.P. 2/6

★ MAINS UNITS. 59/6. To power one amplifier or 69/6 to power two amplifiers. (State 24 or 40 volt version.)

★ PREAMPLIFIERS. Mono and stereo versions, 8 inputs, 1 1/2 to 300mV at 1k to 500k. Response 30 c/s to 20 kc/s. Complete range of controls. Mains unit or battery operated. For pickups, tuners, tape, microphones, etc.

UNIT 3. Mono full-function pre-amplifier. Size 9 1/2" x 2 1/2" x 2".

PRICE BUILT **£5.10.0** P.P. 2/-

(Brown/Gold front panel plate 8/6)

UNIT 4. Simplified version of Unit 3.

Price 65/- P.P. 1/6. Panel plate 6/6.

UNIT 5. Stereo preamplifier for use with two units 1 or 2. Size 9" x 3 1/2" x 1 3/8".

PRICE BUILT **£10.19.6** P.P. 3/6

(Front panel plate 12/6)



UNIT 5

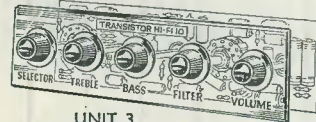

UNIT 3 THE FINEST QUALITY HI-FI AT UNBEATABLE PRICES

We stock:

- TRANSISTORS
- RECTIFIERS
- VALVES
- CRYSTALS
- MICROPHONES
- TEST GEAR
- TAPE DECKS
- SPEAKERS
- MULTI-METERS
- RADIO
- CONTROL
- AMPLIFIERS
- RECORDERS
- TUNERS
- RECORD DECKS
- TWEETERS
- RECEIVERS
- GENERATORS
- COMPONENTS
- AND
- ACCESSORIES
- SEE LATEST CATALOGUE

SINCLAIR DESIGNS

- ★ Micro-6 MW radio 59/6
- ★ TR750 "Addon" power amp. 39/6
- ★ Micro injector 27/6
- ★ Micro amp. 28/6
- ★ X10 Amp. kit £5.19.6

BUILT **£6.19.6**

NEW FM RADIO POCKET VHF KIT £5-19-6

- X20 AMPLIFIER Kit £7-19-6
- Built £9-19-6
- Mains unit 99/6

5 WATT AND 1 1/2 WATT PACKAGED AMPLIFIERS

- ★ 6-Transistor push-pull printed circuit designs
- ★ Size only 2 1/2" x 2" x 1 1/2"
- ★ 5 watt 18 volt, 1 1/2 watt 12 volt
- ★ For 3 to 5 ohm speakers
- ★ 7mV into 1kΩ
- ★ 30 c/s to 16 kc/s

PRICES BUILT

1 1/2w **65/-** P.P. 1/6 5w **79/6** P.P. 1/6

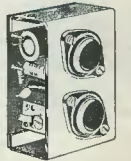

4-CHANNEL MICROPHONE MIXER

Transistorised, 4 inputs up to 100 kΩ. Full mixing. PRICE **49/6** P.P. 1/6



Let us quote for parts for your circuit. Send a list for quick reply. Quality components at realistic prices.

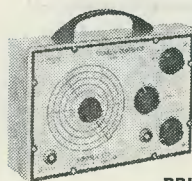

TRANSISTOR PORTABLE TEST EQUIPMENT

All units size 6 3/8" x 4 3/8" x 2 3/8".

★ RF generator, 150 kc/s to 350 mc/s in 8 ranges. RF, Mod. RF, AF outputs.

PRICE **£9.10.0** P.P. 2/6

★ Resistance/capacitance bridge. **£8.5.0.**

★ Audio generator 10 c/s-100 kc/s. 4 ranges. **£16.15.0.** P.P. 2/6.



VHF/FM TUNER TO ASSEMBLE

★ Two pre-built plus metal work and front panel.

Total Cost **£12.17.6**

P.P. 2/6

- ★ Size: 9 1/2" x 3 1/2" x 4"
- ★ 88 to 108 mc/s tuning.
- ★ 100mV to 100kΩ output
- ★ 6-Transistor printed cct. superhet design

NEW SW/MW/LW PUSH-BUTTON PORTABLE TO BUILD. 3 wavebands

TOTAL COST

£8.19.6 P.P. 3/6

The only fully Tunable 3-waveband radio for home construction.

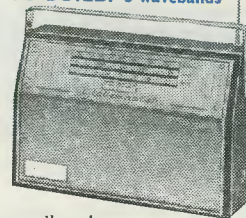

- ★ Push-button coil pack.
- ★ 1 watt push-pull output
- ★ Ferrite aerial/Telex. aerial/special car coils
- ★ Printed circuit 6-transistor design
- ★ SW 17/50m. LW 1100/1900m. MW 195/550m.
- ★ Car aerial and tape sockets
- ★ Attractive sturdy cabinet with handle. Size 11" x 7 1/2" x 3 1/4". Black fabric with chrome fittings.

SENSITIVE SUPERHET RADIO TO BUILD

● CONVAIR 2-BAND as previously advertised still available **£7.19.6**, pp. 3/6.

VHF/FM TRANSISTOR TUNER TO BUILD

TOTAL COST

£6.19.6

P.P. 2/6 (complete with frontplate)

(Gold sprayed cabinet 20/- extra).

- ★ 5-Transistor 4 diodes.
- ★ Printed circuit superhet.
- ★ Geared tuning 87 to 105 Mc/s FM
- ★ RF stage and double tuned IFT's.
- ★ Output up to 1 volt peak up to 100kΩ.
- ★ 9 volt 9mA supply.
- ★ Size in cabinet 4" x 3 1/2" x 2 1/4".
- ★ All parts sold separately.

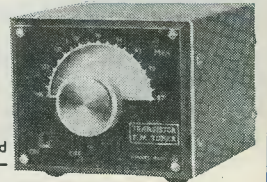

HENRY'S RADIO LTD.

303 EDGWARE ROAD, LONDON, W2

PADDINGTON 1008/9

Open Mon. to Sat. 9-6. Thurs. 1 p.m.

Open all day Saturday