

155P

# THE Radio Constructor

RADIO  
TELEVISION  
AUDIO  
ELECTRONICS

VOLUME 18                      NUMBER 2  
A DATA PUBLICATION  
TWO SHILLINGS & THREEPENCE

September 1964

simple  
wavemeter  
for  
model  
control

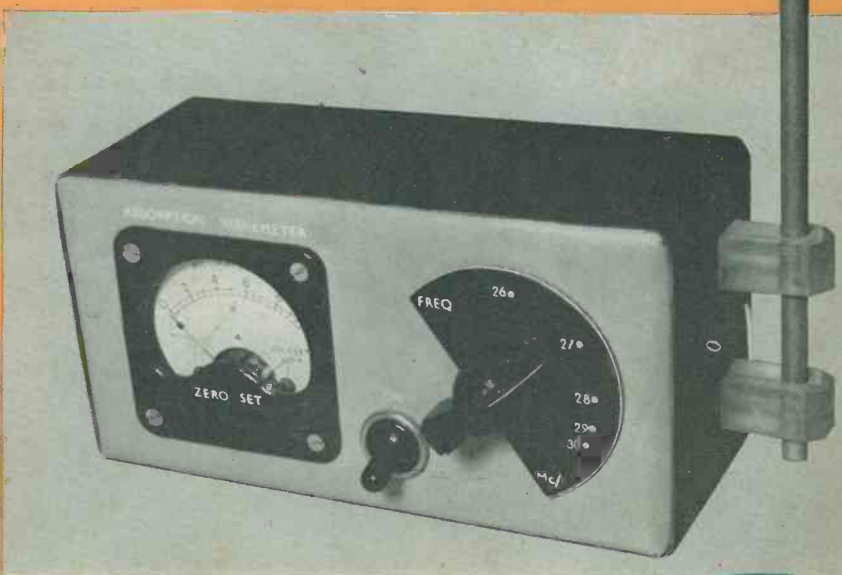

B.B.C.-2 UHF  
Amplifier



Modulated-Light  
Transmitter/Receiver



Timebase Expansion  
Generator



Fundamentals of  
Single-Sideband

# COMPREHENSIVE TECHNICAL HANDBOOK SERVICE

For complete data on Mullard Valves  
Tubes, Semiconductors and Components

The Mullard Technical Handbook is a loose-leaf publication, issued on a subscription basis and containing data sheets on Mullard valves, tubes, semi-conductor devices and components in current production. From one to twenty pages are devoted to each valve, tube or semiconductor type; data including the standard ratings and performance figures for various applications. Subscribers automatically receive revised sheets and supplementary data on new types, as they are introduced.

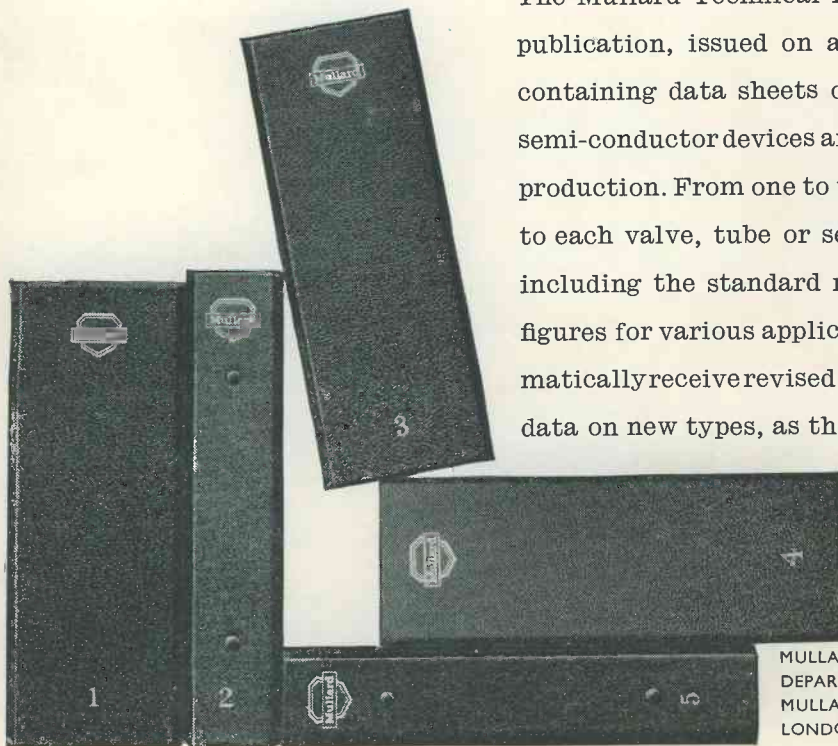

*Please write for details to:*

## **Mullard**

MULLARD LIMITED  
DEPARTMENT C  
MULLARD HOUSE, TORRINGTON PLACE  
LONDON, W.C.1  
MVM 1913

# EXCEL in

# RADIO AND ELECTRONICS

AS A CAREER OR AS A FASCINATING HOBBY...

THERE IS AN ICS COURSE FOR YOU!

By taking an ICS specialised home study course you gain a sound theoretical and practical knowledge of valve and transistor circuits and servicing work while building your own 5-valve receiver, transistor portable (or a.f. amplifier), signal generator and multi-test meter. *All under expert tuition!*

ICS Construction Courses have been specially written and designed by experienced radio engineers to enable YOU to learn easily and quickly, in your own home, in your own time.

ICS training will take you from basic principles to advanced applications of various circuits, all made up from the kits supplied.

With the ICS Complete Radio and Electronics Construction Course you get SIX kits, including testing instruments, tools and first class components. And, what is most important, a personal library of Instruction Manuals.

If you are making a career in the Radio Industry, you will be interested in the wide range of examination and specialist diploma courses offered by ICS. These include:

Radio and Television Engineering, Industrial Television, Radio and Television Servicing, Colour Television, Electronic Technicians, Servomechanisms, Radio-Electronic Telemetry, Instrumentation, Principles of Automation, Calculus for Electronics, Digital and Analogue Computers.

Specialised coaching for Grad.I.E.R.E., C.&G. Telecommunication Technician's Cert. Radio & TV Servicing Cert.(R.T.E.B.), P.M.G. Certs. and Radio Amateur's Exam.

Examination students coached until successful.

PRACTICAL INSTRUCTION!

1

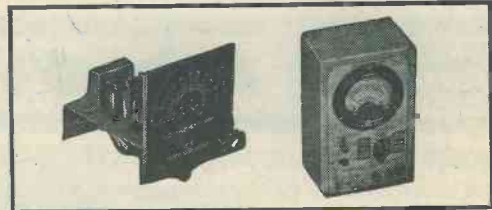

Assembly and use of signal generator and multi-test meter (especially valuable in servicing work).

2

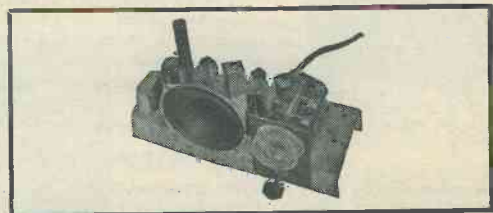

Construction of 5-valve 2-waveband AC/DC superheterodyne receiver, and a number of instructional experiments, using testing instruments.

3

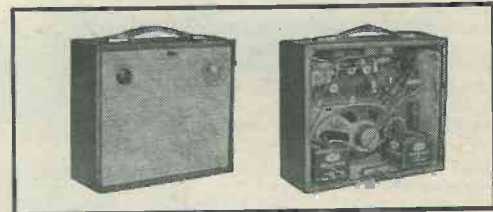

Construction of 6-transistor (with semiconductor diode) 2-waveband portable, and a number of instructional experiments, including a.f. amplifier with microphone pre-amplifier.

For full details  
of ICS Radio and  
Electronics Courses  
post coupon  
TODAY

ICS (DEPT. 248) INTERTEXT HOUSE  
PARKGATE ROAD, LONDON, S.W.11

NAME \_\_\_\_\_

AGE \_\_\_\_\_

ADDRESS \_\_\_\_\_

\_\_\_\_\_

\_\_\_\_\_

9.64

## INTERNATIONAL CORRESPONDENCE SCHOOLS

Member of the Association of British Correspondence Colleges

# HI-FI AMPLIFIERS TUNERS RECORD PLAYERS

S-33



S-99



AT-6



MA-12



**HI-FI 6W STEREO AMPLIFIER.** Model S-33. 3 watts per channel 0.3% distortion at 2.5W/chnl., 20dB N.F.B. Inputs for Radio (or Tape) and Gram, Stereo or Monaural, ganged controls. Kit **£13.7.6** Assembled **£18.10.0**

**DE LUXE STEREO AMPLIFIER.** Model S-33H. De luxe version of the S-33 with two-tone grey perspex panel, and higher sensitivity necessary to accept the Decca Deram pick-up. Kit **£15.17.6** Assembled **£21.7.6**

**HI-FI STEREO AMPLIFIER.** Model S-99. 18W output. Ganged controls. Stereo/Mono gram., radio and tape inputs. Push-button selection. Printed circuit construction. Kit **£27.19.6** Assembled **£37.19.6**

**POWER SUPPLY UNIT.** Model MGP-1. Input 100/120V, 200/250V. 40-60 c/s. Output 6.3V, 2.5A A.C. 200, 250, 270V, 120mA max. D.C. Kit **£5.2.6** Assembled **£6.12.6**

A wide range of American equipment available under direct mail order scheme. Full details and catalogue 1/- post paid.

**GOLDRING LENCO TRANSCRIPTION PLAYER.** Model GL-58. With G-60 pick-up arm and Ronette 105 cartridge. **£20.1.3**

**GARRARD AUTO/RECORD PLAYER.** Model AT-6. With R 105 cartridge. **£13.12.1** With Decca Deram pick-up **£14.6.1**

**SUGDEN MOTOR UNIT "CONNOISSEUR CRAFTSMAN".** Heavy duty motor operating at 33½ and 45 r.p.m. Very heavy 12" turntable. Virtually no rumble. **£17.2.11**

**HI-FI MONO AMPLIFIER.** Model MA-5. A general purpose 5W Amplifier, with inputs for Gram., Radio. Presentation similar to S-33. Kit **£10.19.6** Assembled **£15.10.0**

**HI-FI MONO AMPLIFIER.** Model MA-12. 12W output, wide freq. range, low distortion. Kit **£11.18.0** Assembled **£15.18.0**



## Enjoy Yourself and Save Money

### FOR THE INSTRUMENTALIST



PA-1

**PA AMPLIFIER PA-1.** The ideal compact unit for VOCALISTS, INSTRUMENTALISTS, RECORDS, with 50 Watt output, 2 Heavy Duty Speakers. Variable TREMOLO. Elegant modern cabinet. Kit **£54.15.0** Assembled **£74.0.0**

Legs optional extra 17/6 set of 4

**POWER AMPLIFIER MA-50** 50W output. Kit **£19.18.0** Assembled **£27.18.0**

### ELECTRONIC ORGAN

(fully transistorised). Ideal for Soloists, Home use, Groups. FULL 20 WATTS VOLUME. **£187.10.0** Matching bench **£14.10.0** extra.

### TRANSISTOR RADIOS

**"OXFORD" LUXURY PORTABLE.** Model UXR-2. Specially designed for use as a domestic, car or personal portable receiver. Many features, including solid leather case. Kit **£14.18.0**



UXR-2

**TRANSISTOR PORTABLE.** Model UXR-1. Pre-aligned I.F. transformers, printed circuit. Covers L.W. and M.W. Has 7" x 4" loudspeaker. Real hide case. Kit **£12.11.0**



UXR-1

**TRANSISTOR PORTABLE RECEIVER.** Model RSW-1. In a handsome leather case, it has retractable whip aerial and socket for car radio use. Covers Med., Trawler and two S wave bands. Kit **£19.17.6**

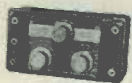

UJR-1

**JUNIOR TRANSISTOR RADIO.** Model UJR-1. Single transistor set. Excellent introduction to radio. Kit **£2.7.6**

### Money-back Guarantee

Daystrom Limited unconditionally guarantees that each Heathkit product assembled in accordance with our easy-to-understand instruction manual must meet our published specifications for performance or the purchase price will be cheerfully refunded.

### TEST INSTRUMENTS

**T.V. ALIGNMENT GENERATOR.** Model HFV-1. Offers max performance at lowest cost. Covers 3.6 to 220 Mc/s fundamentals. Electronic sweep oscillators. Built in marker generators (5 Mc/s crystal) **£30.15.0** Kit **£44.10.0** Assembled

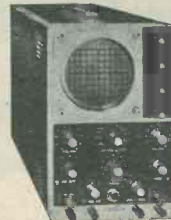

IO-12U



S-3U

**DE LUXE LARGE-SCALE VALVE VOLTMETER.** Model IM-13U. Circuit and specification based on the well known model V-7A but with many worth-while refinements. 6" Ernest Turner meter. Unique gimbal bracket allows operation of instrument in many positions. Modern styling. Kit **£18.18.0** Assembled **£26.18.0**



HFV-1

**5" GENERAL-PURPOSE LABORATORY OSCILLOSCOPE.** Model IO-12U. This outstanding oscilloscope, with its professional specification and styling, fulfills most laboratory and service requirements. Vertical frequency response 3 c/s to over 4.5Mc/s, sensitivity 10mV r.m.s. per cm. at 1 kc/s. T/B covers 10 c/s-500 kc/s. Kit **£32.12.6** Assembled **£41.10.0**

**24" PORTABLE SERVICE SCOPE.** Model OS-1. This is a light, compact oscilloscope, ideal for servicing, etc. Dimensions 5"x8"x14 1/4" long. Wt. 10½lb. Kit **£21.18.0** Assembled **£29.8.0**

**ELECTRONIC SWITCH.** Model S-3U (Oscilloscope Trace Doubler). Enables a single beam oscilloscope to give simultaneous traces of two separate and independent signals. Switching rates approx. 150, 500, 1,500, 5,000 and 15,000 c/s. Sig. freq. response 0-100 kc/s. ±1dB. Separate gain controls and sync. output. Sig. input range 0.1-1.8V r.m.s. Kit **£12.18.0** Assembled **£18.10.0**



IM-13U

**AUDIO SIGNAL GENERATOR.** Model AG-9U. 10 c/s to 100 kc/s, switch selected. Distortion less than 0.1%. 10V sine wave output metered in volts and dB's. Kit **£22.10.0** Assembled **£30.10.0**

**VALVE VOLTMETER.** Model V-7A. 7 voltage ranges d.c. volts to 1,500. A.c. to 1,500 r.m.s. and 4,000 peak to peak. Resistance 0.1Ω to 1,000MΩ with internal battery. D.c. input impedance 11MΩ. dB measurement, has centre-zero scale. Complete with test prods, lead and standardising battery. Kit **£13.18.6** Assembled **£19.18.6**



V-7A

**MULTIMETER.** Model MM-1U. Ranges 0-1.5V to 1,500V a.c. and d.c.; 150µA to 15A d.c.; 0.2Ω to 20MΩ. 44" 50µA meter. Kit **£12.18.0** Assembled **£18.11.6**

**R.F. SIGNAL GENERATOR.** Model RF-1U. Up to 100 Mc/s fundamental and 200 Mc/s on harmonics. Up to 100 mV output. Kit **£13.8.0** Assembled **£19.18.0**



RF-1U

A WIDE RANGE OF BOOKS ON ELECTRONICS AND RADIO AVAILABLE. SEND FOR LISTS OF PRICES

## TAPE DECKS      CONTROL UNITS      TAPE AMPLIFIERS



**COLLARO**

**COLLARO "STUDIO" TAPE DECK.** The finest buy in its price range. Operating speeds: 1 $\frac{1}{2}$ ", 3 $\frac{1}{2}$ " and 7 $\frac{1}{2}$ " p.s. Two tracks, "wow" and "flutter" not greater than 0.15% at 7 $\frac{1}{2}$ " p.s. **£17.10.0**



**D-93**

**TRUVOX D93 TAPE DECKS.** High quality stereo/mono tape decks.

D93/2,  $\frac{1}{2}$  track, **£36.15.0**    D93/4,  $\frac{1}{4}$  track, **£36.15.0**

**HI-FI AM/FM TUNER. Model AFM-1.** Available in two units which, for your convenience, are sold separately. Tuning heart (AFM-T1—£4.13.6 incl. P.T.) and I.F. amplifier (AFM-A1—£21.16.6). Printed circuit board, 8 valves. Covers L.W., M.W., S.W., and F.M. Built-in power supply. **Total Kit £26.10.0**



**FM-4U**

**HI-FI FM TUNER. Model FM-4U.** Also available in two units. R.F. tuning unit (£2.15.0 incl. P.T.) with I.F. output of 10.7 Mc/s, and amplifier unit, with power supply and valves (£13.3.0). **Total Kit £15.18.0**



**AM/FM**

**TAPE RECORDING/PLAYBACK AMPLIFIER.** Thermometer type recording indicators, press-button speed compensation and input selection. Mono Model TA-1M, Kit **£19.18.0** Assembled **£28.18.0**  
Stereo Model TA-1S, Kit **£25.10.0** Assembled **£35.18.0**

**MONO CONTROL UNIT. Model UMC-1.** Designed to work with the MA-12 or similar amplifier requiring 0.25V or less for full output. 5 inputs. Baxandall type controls. **Kit £8.12.6** Assembled **£13.12.6**

**STEREO CONTROL UNIT. Model USC-1.** Push-button selection, accurately matched ganged controls to  $\pm 1$ dB. Rumble and variable low-pass filters. Printed circuit boards. **Kit £19.10.0** Assembled **£26.10.0**

# Building these Heathkit models



### AMATEUR EQUIPMENT



**SB-10U**

**SINGLE SIDEBAND ADAPTOR. Model SB-10U.** May be used with most A.M. transmitters. Less than 3W R.F. input power required for 10W output. Operation on 80, 40, 20, 15 and 10m bands on U.S.B., L.S.B. or D.S.B. **Kit £39.5.0** Assembled **£54.8.0**

**VARIABLE FREQUENCY OSCILLATOR. Model VF-1U.** Calibrated, 160-10 m. Fundamentals on 160 and 40m. Ideal for our DX-40U and similar transmitters. **Kit £10.17.6** Assembled **£15.19.6**

**COMMUNICATIONS TYPE RECEIVER. Model RG-1.** A high performance, low cost receiver for the discriminating listener. Frequency coverage: 600 kc/s-1.5 Mc/s and 1.7 Mc/s-32 Mc/s.

**Kit £39.16.0** Assembled **£53.0.0**

**AMATEUR TRANSMITTER. Model DX-40U.** Covers all amateur bands from 80 to 10 metres; crystal controlled. Power input 75W C.W., 60W peak controlled carrier phone. Output 40W to aerial. Provision for V.F.O. Filters minimise TV interference.

**Kit £33.19.0** Assembled **£45.8.0**

**AMATEUR BANDS RECEIVER. Model RA-1.** To cover all the Amateur Bands from 160-10 metres. Many special features, including: half-lattice crystal filter; 8 valves; signal strength "S" meter; tuned R.F. Amp. stage.

**Kit £39.6.6** Assembled **£52.10.0**

**THE "MOHICAN" GENERAL COVERAGE RECEIVER. Model GC-1U.** With 4 piezo-electric transmitters, variable tuned B.F.O. and Zener diode stabiliser, this is an excellent fully transistorised general purpose receiver for Amateur and Short wave listeners. Printed circuits, telescopic aerials, tuning meter and large slide-rule dial.

**Kit £37.17.6** Assembled **£45.17.6**

**AMATEUR TRANSMITTER. Model DX-100U.** The world's most popular, compact and completely self-contained Amateur Transmitter. Covers all amateur bands: 160-10 m. 150W d.c. input. Careful design has achieved the stability and high performance for which the DX-100U is noted.

**Kit £79.10.0** Assembled **£104.15.0**

A wide range of American amateur equipment.



**RG-1**



**RA-1**

**All models also available assembled**

**Deferred Terms available UK**

**on all purchases over £10. Send for lists**

**DAYSTROM LTD    DEPT. RC.9    GLOUCESTER**

SEPTEMBER 1964

### SPEAKER SYSTEMS



**SSU-1**

**HI-FI SPEAKER SYSTEM. Model SSU-1.** Ducted-port bass reflex cabinet "in the white". Two speakers. Vertical or horizontal models with legs, Kit **£11.12.0**, without legs, Kit **£10.17.6**.

**THE "COTSWOLD".** This is an acoustically designed enclosure 26" x 23" x 15 $\frac{1}{2}$ " housing a 12" bass speaker with 2" speech coil, elliptical middle speaker together with a pressure unit to cover the full frequency range of 32-20,000 c/s. Capable of doing justice to the finest programme source, its polar distribution makes it ideal for really Hi-Fi Stereo.

**Kit £23.4.0** Assembled **£30.15.0**



**MFS**

**COTSWOLD "MFS" SYSTEM.** Specially developed to give best possible results in small rooms. This minimum floor space model is based on standard Cotswold. Size: 36" high x 16 $\frac{1}{2}$ " wide x 14 $\frac{1}{2}$ " deep.

**Kit £23.4.0** Assembled **£30.15.0**

### HI-FI EQUIPMENT CABINETS



**"GLOUCESTER"**

A wide range of equipment cabinets are available to meet the differing needs of enthusiasts. Designed for max. operating convenience or for where room space is an overriding consideration, this range includes kits, ready assembled cabinets or fully finished cabinets, and has at least one model to suit your requirements. Send for full details. Prices from **£7.7.0** to **£37.16.0**

### SEND FOR FREE BRITISH HEATHKIT CATALOGUE

American catalogue also available 1/- post paid

Without obligation please send me **FREE BRITISH HEATHKIT CATALOGUE** (Tick here)

**FULL DETAILS OF MODEL(S)** \_\_\_\_\_

(Please write in BLOCK CAPITALS)

**NAME** \_\_\_\_\_

**ADDRESS** \_\_\_\_\_

**DEPT. RC.9**

# LASKY'S RADIO

## FOR THE FINEST RANGE OF TRANSISTOR RECEIVERS

We consider our construction parcels to be the finest value on the home constructor market. If on receipt you feel not competent to build the set, you may return it as received within 7 days, when the sum paid will be refunded, less postage.

### THE SKYROVER AND THE SKYROVER DE LUXE



#### THE SKYROVER

Controls: Waveband Selector, Volume Control with On/Off Switch, Tuning Control. In plastic cabinet, size 10" x 6 1/2" x 3 1/2", with metal trim and carrying handle.

Can now be built for

**£8.19.6**

P. and P. 5/- extra

★ **LONG WAVEBAND COVERAGE IS NOW AVAILABLE FOR THESE WELL-KNOWN SETS**

A simple additional circuit provides coverage of the 1100/1950 M. band (including 1500 M. Light programme). This is in addition to all existing Medium and Short wavebands. All necessary components with construction data.

Only 10/- extra Post Free

This conversion is suitable for both models that have already been constructed.

**GENERAL SPECIFICATION.** 7 transistor plus 2 diode superhet, 6 waveband portable receiver. Operating from four 1.5V torch batteries. The SKYROVER and SKYROVER DE LUXE cover the full medium waveband and short waveband 31-94 M, and also 4 separate switched band-spread ranges, 13 M, 16 M, 19 M and 25 M, with band-spread tuning for accurate station selection. The coil pack and tuning heart is completely factory assembled, wired and tested. The remaining assembly can be completed in under three hours from our easy to follow, stage by stage instructions.

**SPECIFICATION:** Superhet, 470 kc/s. All Mullard transistors and diodes. Uses 4 U2 batteries. 5" Ceramic Magnet P.M. Speaker. Easy to read Dial Scale. Band-spread Tuning. 500mW Output. Telescopic Aerial and Ferrite Rod Aerial.

**WAVEBAND COVERAGE:** 180-576 M, 31-94 M, and band-spread on 13, 16, 19 and 25 metre bands.

All components available separately. Four U2 batteries 3/4 extra. Data for each receiver, 2/6 extra, refunded if you purchase the parcel.

### THE SKYROVER DE LUXE

Tone Control circuit is incorporated, with separate Tone Control in addition to Volume Control, Tuning Control and Waveband Selector. In a wood cabinet, size 11 1/2" x 6 1/2" x 3", covered with a washable material, with plastic trim and carrying handle. Also car aerial socket fitted.

Can now be built for

**£10.19.6**

H.P. Terms:—25/- deposit and 11 months at 20/-

P. and P. 5/- extra



### REALISTIC SEVEN

★ 7-transistor Superhet. ★ 350 milliwatt output into 4" high flux speaker. ★ All components mounted on a single printed circuit board, size 5 1/2" x 5 1/2" in one complete assembly.

★ Plastic cabinet with carrying handle, size 7" x 10" x 3 1/2", available in Blue/Grey or all Grey. ★ Easy to read Dial. ★ External socket for car aerial. ★ 470 kc/s frequency. ★ Ferrite rod internal aerial. Operates from PP9 or similar battery. ★ Full comprehensive data supplied with each receiver. ★ All coils and I.F.s, etc., fully wound ready for immediate assembly.

An Outstanding Receiver. **LASKY'S PRICE** for the complete parcel including Transistors, Speaker, etc., and Full Construction Data. Can be built for: **£5.19.6**

P. and P. 4/6

PP9 Battery, 3/9. Data and instructions separately, 2/6. Refunded if you purchase the parcel.

### REALISTIC 'Seven' De Luxe

With the same specification as standard model —PLUS a superior wood cabinet in contemporary styling. ALSO a full vision circular dial

FOR ONLY **£1 EXTRA**  
P. & P. as std. model

#### NEW SUPER MINIATURE POCKET RADIOS

##### THE SINCLAIR SLIMLINE

The new 2-transistor pocket radio, size only 2 3/4" x 1 5/8" x 1 5/8". Micro alloy transistors and printed circuit. Easy to assemble.

CAN BE BUILT FOR **49/6**

All components available separately.

##### THE SINCLAIR MICRO-6

Self-contained pocket radio size only 1 4/5" x 1 3/10" x 1 1/2". CAN BE BUILT FOR **59/6**

Mercury cell 1/11 extra.

### READY BUILT BARGAIN

**6-TRANSISTOR POCKET RADIO** Fully built. 4" x 2 1/2" x 1", with 2 1/2" speaker. Uses single PP3-type battery. Supplied complete with personal earpiece and leather case. Tunable over full Medium waveband.

**LASKY'S PRICE 69/6**

complete with all accessories. Post Free.

#### TRANSFILTERS BY BRUSH CRYSTAL CO.

TO-01B 465 kc/s ± 2 kc/s  
TO-01D 470 kc/s ± 2 kc/s  
TO-02B 465 kc/s ± 1 kc/s  
TO-02D 470 kc/s ± 1 kc/s  
TF-01B 465 kc/s ± 2 kc/s  
TF-01D 470 kc/s ± 2 kc/s

**6/6** each  
P. & P. 6d.

#### GUITAR PICK-UP

Crystal—high imp. Size only 1 1/2" x 3/4" x 1/4". Clips to fingerboard—no screws. Complete with cable.

**LASKY'S PRICE 15/11** P. & P. 1/-

#### TAPE POSITION INDICATOR

Open type—as used by most makers. With re-set knob:  
3 DIGIT 7/6; 4 DIGIT 10/6. P. & P. 9d. on each.

### IT'S FABULOUS! THE TRANSISTOGRAM

A portable battery operated fully transistorised Record Player—for the music of your choice—any time, any place! Made by famous British manufacturer fully guaranteed. Size only 6 1/2" x 12" x 10 1/2". Weight 10lb. Operates on 6 U2 torch batteries. 4 speeds—16 2/3, 33 1/3, 45 and 78 r.p.m. Goldring Synet record player unit with lightweight pick-up fitted with CFI-60 turn over ceramic cartridge. Output 500mW to 5" ceramic magnet loud-speaker fitted into lid for maximum sound distribution. Cabinet constructed of wood, covered in two-tone (pale blue/grey) leather cloth. Fitted carrying handle and strong lid catches. High quality amplifier with tone and vol. controls gives excellent reproduction at all speeds. Plays 7", 10" and 12" records. Today's value 12 Gns.

**LASKY'S PRICE £6.19.6** Carr. & Ins. 7/6

New, boxed and guaranteed—Exc. batts.

#### TAPE DECK MOTORS



Motors for the Collaro Studio Deck—new and unused. 200-150V A.C. Take-up and rewind. Listed at £2 5s. each. **LASKY'S PRICE 14/11** each. P. & P. 2/6.

State motor required when ordering.

High quality tape deck capstan motor made by E.M.J. Holland. Bi-directional. Size: 4" dia., x 2" high. 1" x 1/2" spindle. **LASKY'S PRICE 19/11**. P. & P. 3/6.

#### RECORDING TAPE SPLICER

By famous manufacturer—all metal construction. Listed at 16/6 **LASKY'S PRICE 14/6** Post Free

#### LAFAYETTE TAPE

Famous American Brand—Fully Guaranteed at record low prices. In sealed cartons.

5in double play, 1,200ft. Mylar base ...	15/-
5in long play, 900ft. Acetate base ...	10/-
5in standard play, 600ft. PVC base ...	8/6
5 1/2in long play, 1,200ft. Mylar base ...	15/-
5 1/2in double play, 1,800ft. Mylar base ...	22/6
5 1/2in long play, 1,200ft. Acetate base ...	12/6
5 1/2in standard play, 850ft. PVC base ...	11/6
7in standard play, 2,000ft. Mylar base ...	12/6
7in long play, 1,800ft. Mylar base ...	19/6
7in double play, 2,400ft. Mylar base ...	25/-
7in long play, 1,800ft. Acetate base ...	15/6
3in message tape, 150ft ...	3/6
3in message tape, 225ft ...	4/6
3in message tape, 300ft ...	7/6
3in triple play, 450ft. Mylar base ...	12/6
4in triple play, 900ft. Mylar base ...	22/6
5in triple play, 1,800ft. Mylar base ...	42/6
5 1/2in triple play, 2,400ft. Mylar base ...	55/-
7in triple play, 3,600ft. Mylar base ...	75/-

P. & P. 1/- extra per reel; 4 reels and over Post Free.

#### HI-FI TAPE RECORDER HEADS

High Impedance Record Play. Low impedance erase. Upper or lower track.

**LASKY'S PRICE 29/6** Post free per pair. State track required when ordering.

MARRIOTT "X" Type ± track heads. Record/Play and Erase.

**LASKY'S PRICE 4 GNS. PAIR**  
± Track heads Record/Play and Erase 59/6 pair.

#### TRANSISTORS

All New and Guaranteed  
GET.51, GET.55, GET.56—2/6; 837A, 874P—3/6; OC.45, OC.71, OC.81D—4/6; OC.44, OC.70, OC.76, OC.81 (matched pair 10/6); 515; AF.117, OC.75, OC.171, OC.200—6/6; OC.42, OC.43, OC.73, OC.82D—7/6; OCP.71—9/6; OC.28, OC.201, OC.204—15/-; OC.205, OC.206—19/6; OC.28—24/6.

33 TOTTENHAM COURT ROAD · W1

2 mins. Oxford St. Nearest Station: Goodge St. MUSEUM 2405

Tottenham Ct. Rd. & Edgware Rd. addresses open all day Sat. Close 1 Thur.

207 EDGWARE ROAD · W2

Few yards from Praed St. PADDINGTON 3271/2

Please address all Mail Orders to Dept. W at above Edgware Road address

152/3 FLEET STREET · EC4

(ELECTRONICS Fleet St. Ltd) FLEET 2833. Open all day Thurs. Closed 1 p.m. Sat.

Dept. W at above Edgware Road address



**that is, if you can see it from there . . . !**

*What is it?* It's a radio—a real honest to goodness station-getting six stage British set so small that not even the Japanese, Americans or Germans have got anywhere near it. A gimmick did you say? Indeed not! If you're technical, you'll see on the pages which follow how this cute little Micro-6 works. All I can tell you is that it's loud, it's clear and there seems no end to the stations you can tune in. You have to build it yourself of course, but they say that's half the fun. This one was given to me . . . makes a lovely present for someone, doesn't it?

**It's the SINCLAIR MICRO-6**  
**—the smallest set on earth!**

**A BRITISH  
 PRODUCT**



**ACTUAL  
 SIZE**



All parts including case, earpiece, transistors and 8 p. instructions manual come to:

**59'6**

- **SIZE** 1<sup>4</sup>/<sub>5</sub>" x 1<sup>3</sup>/<sub>10</sub>" x 1<sup>1</sup>/<sub>2</sub>"
- **WEIGHS LESS THAN 1 oz.**  
INCLUDING SELF-CONTAINED AERIAL & BATTERIES
- **YOU CAN BUILD IT IN AN EVENING**

Technical details and more Sinclair designs on next pages

**SINCLAIR RADIONICS LTD., COMBERTON, CAMBRIDGE**

Telephone:  
 Comberton 682

# THE WORLD'S SMALLEST RADIO

## 6 STAGES FROM ONLY 3 TRANSISTORS

IN A CIRCUIT THAT ONLY UNIQUE M.A.T.s AND APPLIED RESEARCH MAKE POSSIBLE

**MICRO-6  
CIRCUIT AND  
BLOCK  
DIAGRAMS**

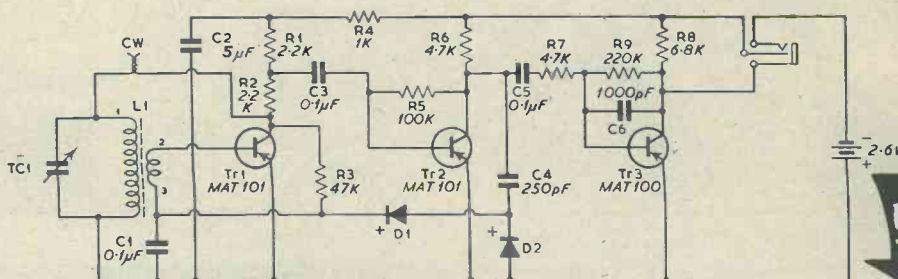

### THE MOST ADVANCED RADIO CIRCUIT EVER MADE AVAILABLE TO CONSTRUCTORS

The Micro-6 uses three Micro-Alloy Transistors (MATs) in a unique double reflex circuit. The signal selected by L1 and TC1 is amplified at R.F. by Tr1 and Tr2. The output from Tr2 is rectified by the detector stage D1 and D2, and the resultant A.F. signal passed back to Tr1. Tr1 and Tr2 then amplify the signal again—this time at A.F. Thus both Tr1 and Tr2 have been used twice and give a gain normally only obtainable with four transistors. The output from Tr2 drives Tr3, the

output stage, which feeds into the featherweight ear piece (or the TR750 power amplifier). Tuning is over the medium waveband with bandspread for easy reception of Luxemburg and A.G.C. eliminates fading. It is important to realise that the Micro-Alloy Transistors which the Micro-6 uses not only give extremely high gains and low noise levels, but they consume only a fraction of a mA from the two minute batteries used to power the set. Battery working life is over 70 hours!

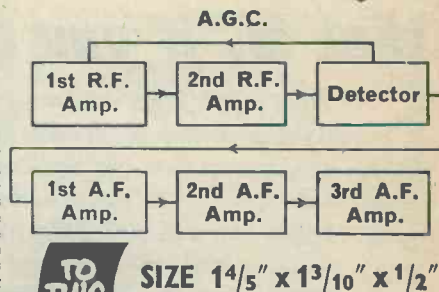

SIZE 1 4/5" x 1 3/10" x 1/2"

## YOU CAN BUILD THIS SET IN AN EVENING!

### No Special Tools or Skills Required

The Micro-6 is simplicity itself to build when you follow the meticulously detailed instructions. No special tools are required to build the set. All parts including transistors, diodes, elegant white and gold case, lightweight earpiece and 8-page manual come to

# 59/6

"Transista" strap for wearing your Micro-6 on the wrist. Black or grey nylon.

7/6

MALLORY MERCURY CELL — Type ZM312 (2 required) each 1/11  
Pack of 6 10/6

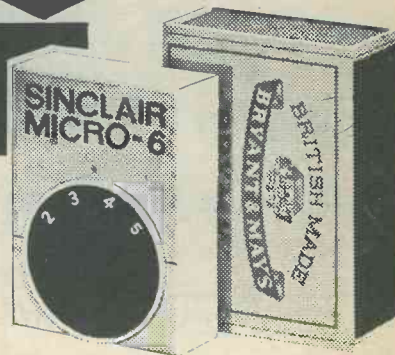

# SINCLAIR MICRO-6

USE THIS ORDER FORM

SINCLAIR RADIONICS LTD., COMBERTON, CAMBRIDGE Telephone COMBERTON 682



# ..... AND IT'S BRITISH !

## The MICRO-6 uses the smallest components ever

We show here some of the components (except case, dial and earpiece) required for building the Micro-6, drawn to actual size. They include the smallest ever to be made available to domestic set constructors, being of the kind used in space and computer electronics, so they have to be reliable. The tuning system has ingenious vernier control for easy station separation. 8-page fully illustrated instructions manual and all parts including case, vernier dial and earpiece come to

**59/6**

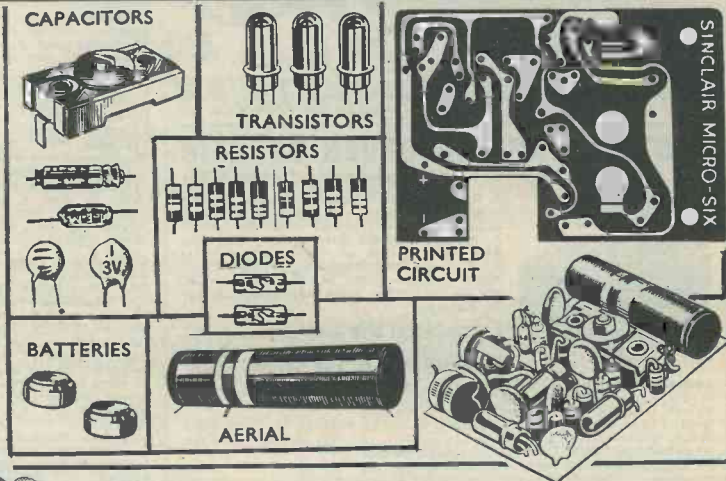

## SINCLAIR TR750

**POWER AMPLIFIER**  
perfect for use with the Micro-6 and 'Slimline'

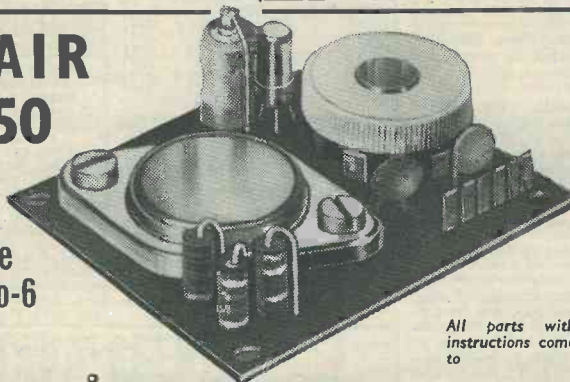

*Hundreds already in use*

Measuring only 2" x 2" and having its own built-in volume control and on-off switch, the TR750 has a full 750 milliwatt transformerless output for 10mV into 10kΩ. Frequency response is from 30 to 20,000 c/s within ±1dB. This amplifier makes a powerful car, domestic or portable radio used with the Micro-6 or Slimline receivers, or a hi-fi record reproducer used singly or paired for stereo. There are many other uses for the TR750 which is available for building or ready built.

All parts with instructions come to **39/6**

Ready built and tested **45/-**

### SINCLAIR MICRO-INJECTOR

Using two MATs it generates and injects a test signal into any part of equipment at any frequency from 1 kc/s to 30 Mc/s to locate faults rapidly. 1½" x 1½" x ½", excluding probe.

All parts with instructions come to **27/6**  
Ready built and tested **32/6**

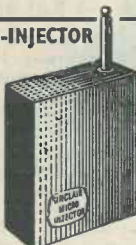

### BUILD AN F.M. TRANSMITTER WITH THE SINCLAIR MICRO-AMPLIFIER



Smaller than a 3d. piece. Frequency response 30 to 50,000 c/s ±1dB, power gain 60dB (1,000,000 times)—can also be used for a broadband R.F. amplifier, or a sub-miniature hi-fi amplifier with an output suited to any earpiece or even loudspeaker. With MATs instructions and all parts. **28/6**

### SINCLAIR 'SLIMLINE' EXTRA EASY TO BUILD

Has self-contained ferrite rod aerial and takes standard PP5 battery, yet measures only 2½" x 1½" x ¾". Tunes over the medium waveband. Great power and quality. Building is particularly easy.

All parts, including royal blue and gold case, earpiece, and instructions come to **49/6**



### UNIQUE SINCLAIR GUARANTEE

If you are not completely satisfied with your purchase immediately on arrival (we are confident you will be delighted) your full purchase price will be refunded instantly without question if you return the goods as received.

**FULL SERVICE FACILITIES ALWAYS AVAILABLE TO ALL SINCLAIR CUSTOMERS**

If you do not wish to cut this page, please mention RC9 when ordering.

**TO SINCLAIR RADIONICS LTD., COMBERTON, CAMBRIDGE. Comberton 682**

Please send items detailed below

£ s d |

NAME .....

ADDRESS .....

TOTAL £

For which I enclose cash/cheque/money order

RC.9

## 7 VALVE AM/FM RADIOGRAM CHASSIS

Three Waveband & Switched Gram positions. Med. 200-550m. Long 1,000-2,000m. VHF/FM 88-95 Mc/s. Phillips Continental Tuning insert with permeability tuning on FM & combined AM/FM F transformers. 460 kc/s and 10.7 Mc/s. Dust core tuning all coils. Latest circuitry including AVC & Neg. Feedback. 3 watt output. Sensitivity and reproduction of a very high standard. Chassis size 13 1/2" x 6 1/2". Height 7 1/2". Edge illuminated glass dial 1 1/2" x 3 1/2". Vert. pointer Horiz. station names. Gold on brown background. A.C. 200/250V operation. Magic-eye tuning. Circuit diag. now available.

Comp. with 4 knobs—walnut or ivory to choice. Indoor FM aerial 3/6 ex. 3 Ω P.M. Speaker only required. Recommended Quality Speakers 10" Elac H/D, 30/-, 13 1/2" x 8" E.M.I. Fidelity, 37/6 12" R.A. with conc. Tweeter, 42/6 Carr. 2/6.

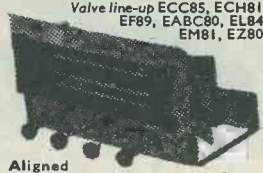

Valve line-up ECC85, ECH81 EF89, EABC80, EL84 EM81, EZ80

Aligned and tested ready for use. £13.10.0 Carr. & Ins. 7/6

Volume Controls—SK-2 Megohms, 3" Spindles Morganite Midget Type. 1 1/2" diam. Guar. 1 year. LOG or LIN ratios less Sw. 3/-. DP. Sw. 4/6. Twin Stereo less Sw. 6/6. D.P. Sw. 9/6 (100 k. to 2 Meg. only). Meg. VOL Controls D.P. Sw. 1/1" flattened spindle. Famous Mfrs. 4 for 10/- post free.

### COAX 80 OHM CABLE

High grade low loss Cellular air spaced Polythene 1/4" diameter. Stranded cond. Famous mfrs. Now only 6d. per yard.

Bargain Prices—Special lengths: 20 yds. 9/-. P & P. 1/6. 40 yds. 17/6. P & P. 2/-. 60 yds. 25/-. P & P. 3/-. Coax Plugs 1/-. Sockets 1/-. Couplers 1/3. Outlet Boxes 4/6.

BONDACOUST Speaker Cab. Acoustic Wadding, superior grade, 1" thick, 12" wide, any length cut 1/6 per 5, 4/- per yd. ENAMELLED COPPER WIRE—Hb reels, 14g-20g, 2/6; 22g-28g, 3/-; 36g-38g, 4/3; 39g-40g, 4/6, etc. TINNED COPPER WIRE—14-22g, 2/6 ± lb.

PVC CONNECTING WIRE—10 colours (for chassis wiring, etc.)—Single or stranded conductor, per yd., 2d. Sizing, 1mm. and 2mm., 2d. yd., etc. KNOBS—Modern Continental types: Brown or Ivory with Gold Ring, 1" dia., 9d. each; 1 1/2", 1/- each; Brown or Ivory with Gold Centre, 1" dia., 10d. each; 1 1/2", 1/3 each. LARGE SELECTION AVAILABLE.

### TRANSISTOR COMPONENTS

Midget I.F.'s—465 kc/s 1/4" diam. 5/6 Osc. Coil—1/4" diam. M/VV. 5/3 Osc. coil M. & L.W. 5/9 Midget Driver Trans. 3.5:1 6/9 Ditto O/Put Push-pull 3 ohms 6/9

Elect. Condensers—Midget Type 15V 1mfd-50mfd, 1/9. 100mfd, 2/-. Ferrite Aerial—M. & L.W. with car aerial coupling coil, 9/3. Condensers—150V. wkg. .01 mfd. to .04 mfd., 9d. .05 mfd., 1 mfd., 1/-. .25 mfd., 1/3. .5 mfd., 1/6, etc.

Tuning Condensers. J.B. 100" 208 + 175pF, 9/6. Ditto with trimmers, 9/6. 365pF single, 7/6. Sub-min. 3" DILEMIN 100pF, 300pF, 500pF, 7/-. Midget Vol. Control with edge control knob, 5kΩ with switch, 4/9, ditto less switch, 3/9.

Speakers P.M.—2" Plessey 75 ohms, 15/6. 2 1/2" Continental 8 ohms, 13/6. 7" x 4" Plessey 35 ohm, 23/6. Ear Plug Phones—Min. Continental type, 3ft. lead, jack plug and socket. High Imp. 8/-. Low Imp., 7/6. High sensitivity M/coil 8-10 ohms, 12/6.

Brand New Mfrs. surplus list grade. 1 OC44 & 2 OC45, 15/6. 1 OC81D & 2 OC81, 15/-. All above and OC81, 32/6, post free.

### TRANSISTOR BARGAINS

Brand New—BVA 1st Grade

OC44	8/6	OC70	5/6
OC45	8/-	OC71	6/-
OC81D	7/6	GEX34	2/9
2/OC81	13/6	OA70	2/9
2/ET114	6/6	OA81	2/9
OC72	7/6	GEX13	2/9
AF17	9/6		

Speakers P.M.—3 ohms 2 1/2" E.M.I. 15/6. Goodmans 3 1/2" 16/6. 5" Rola 15/6. 6" Elac 16/6. 7" x 4" Goodmans 15/6. 8" Rola 19/6. 9" R. x A. 25/-. 9" x 6" Goodmans 22/6. E.M.I. Tweeter 22/6.

Speaker Fret—Expanded gilt anodized metal 1/4" x 1/4" diamond mesh, 4/6 sq. ft., multiples of 6" cut. Max. size, 4ft. x 3ft. 47/6. Carr. extra.

TYGAN FRET (contemp. pat.) 12" x 12" 2/-. 12" x 18" 3/-. 12" x 24" 4/-. 18" x 18" 4/6, etc.

### JASON FM TUNER UNITS

Designer-approved kit of parts: FMT1, 5 gns. 4 valves, 20/-; FMT2, 4 1/2 gns. 5 valves, 35/-; JTW MERCURY 10 gns. 3 valves, 22/6. JTV2 £13.19.6. 4 valves, 28/6. NEW JASON FM HANDBOOK, 2/6. 48 hr. Alignment Service 7/6. P. & P. 2/6.

TRIMMERS, Ceramic (Compression Type)—30pF, 50pF, 70pF, 9d.; 100pF, 150pF, 1/3; 250pF, 1/6; 600pF, 1/9. Philips Concentric Type—2-10pF, 1/9; 3-30pF, 1/-. METAL RECTIFIERS—STC Types—RM1, 4/9; RM2, 6/3; RM3, 7/6; RM4, 16/-. RMS, 21/-; RM4B, 17/6.

## ANOTHER TAPE RECORDER BARGAIN

Manufacturers' end of production Surplus Offer



A 24 gns. Tape Recorder offered at the bargain price of only 15 gns. plus 10/- carr. Supplied in 3 Units already wired and tested. A Modern Circuit for quality recording from Mike Gram or Radio, using latest B.S.R. Twin Track Monardeck Type TD2. Valve line-up—EF86, ECL82, EM84, EZ80 and Silicon Diode. Send for detailed list—3d. stamp.

Completed Kit comprising items below

BARGAIN PRICE 15 Gns. + 10/- Carr.

2-tone Cabinet and 8" x 5" Speaker. Size 14" x 10 1/2" x 7 1/2" ... £3 10 0 + 5/- Carr.

Wired Amplifier complete with 4 Valves, front Panel, Knobs, etc. ... £5 12 6 + 3/6 Carr.

B.S.R. Monardeck Type TD2 ... £7 7 0 + 4/6 Carr.

Accessories: Mike, Tape, empty Reel, screened Lead and Plugs, Instructions, etc. ... £1 0 0 + 2/- Carr.

Jack Plugs. Standard 2 1/2" Igranite Type, 2/6. Screened Ditto, 3/3. Miniature scr. 1 1/2", 2/3. Sub-min. 1/3. Jack Sockets. Open Igranite Moulded Type, 3/6. Closed Ditto, 4/-. Miniature Closed Type, 1/6. Sub-min. (deaf aid) ditto, 1/6. Stereo Jack Sockets, 3/6. Stereo Jack Plugs, 3/6. Phono Plugs, 9d. Phono Sockets (open), 9d. Ditto (closed), 1/-. Twin Phono Sockets (open), 1/3. Grundig Continental. 3 p. or 5 p. plug, 3/6. Sockets, 1/6.

Soldering Irons. Mains 200/220V or 230/250V. Solon 25 watt Int. 22/6. Spare Elements, 4/6. Bits, 1/- 65 watt, 27/6 etc.

Alumin. Chassis. 18g. Plain Undrilled, folded 4 sides, 2" deep, 6" x 4", 4/6. 8" x 6", 5/9. 10" x 7", 6/9. 12" x 6", 7/6. 12" x 8", 8/- each. Alumin. Sheet. 18g. 6" x 6", 1/- 6" x 9", 1/6. 6" x 12", 2/-. 12" x 12", 4/6 etc.

## RECORDING TAPE

Famous American Columbia (CBS) Premier quality tape at NEW REDUCED PRICES. A genuine recommended Quality Tape—TRY IT Brand new, boxed and fully guaranteed. Fitted with leader and stop foils.

Standard	Double Play	Long Play			
5' 600"	13/-	1,200"	31/6	900"	17/6
5 3/4' 900"	10/-	1,800"	37/6	1,200"	19/6
7 1/2' 1,200"	21/-	2,400"	47/6	1,800"	28/6

Post & Package per reel, 1/- plus 6d. each for additional reels.

SPECIAL OFFER. 3" L.P. tape size 150', 3/9; 3" L.P. 225', 4/9; 3" D.P. 300', 6/6. P. & P. per reel 6d.

TAPE REELS. Mfrs. surplus 7", 2/3; 5 1/2", 2/-; 5", 2/-; 3", 1/3; Plastic spool containers, 5", 1/9; 5 1/2", 2/-; 7", 2/3.

New Boxed	VALVES	Reduced Bargain Prices	Electrolytics All Types New Stock	TUBULAR	CAN TYPES		
IT4	3/6	ECC83 7/-	PCC84 8/-	25/25V	1/9	8+8/450V	4/6
IR5	6/6	ECL82 10/-	PCF80 8/-	50/12V	1/9	16+16/450V	5/6
IS5	6/-	ECL80 9/-	PCL83 10/6	50/50V	2/-	32+32/275V	4/6
354	7/-	EF80 7/6	PCL84 10/6	100/25V	2/-	50+50/350V	6/6
3V4	7/-	EF86 8/6	PL81 9/6	8/450V	2/3	60+250/275V	12/6
DAF96	8/-	EL84 7/-	PL82 9/6	4/350V	2/3	100+300/275V	12/6
DF96	8/-	EY81 9/-	PL83 8/-	16+16/450V	5/6	2000+4000/6V	3/6
DK96	8/-	EY86 9/-	PY32 10/6	32+32/450V	6/6		
DL96	8/-	EZ81 7/-	PY81 8/-	1000/25V	3/9		
ECC81	7/-	GZ32 9/6	PY82 7/-	Erwin Multicore Solder 60/40, 4d. per yard. Cartons 2/6, etc.			
ECC82	7/-	EM84 8/6	U25 10/6				

## DE LUXE R/PLAYER KIT

Incorporating 4 Speed Garrard Auto-Slim unit and Mullard latest 3 watt amplifier (ECL 86 and EZ 80), volume, bass and treble controls, with 8" x 5" 10,000 line speaker.

Contemporary styled two-tone cabinet, charcoal grey and off-white with matching blue relief. Size: 17 1/2" x 16" x 8".

COMPLETE KIT £13.19.6 Carr. & ins. 10/-.

Catalogue & construction details 2/6 (free with kit)

### STANDARD RECORD PLAYER KIT

Using BSR UA14 Unit, complete kit £11.10.0, carr. 7/6. Ready wired Amplifier, 7" x 4" quality Speaker and O/P trans., £3.19.6, carr. 2/6. BSR UA14 Unit, £6.10.0, carr. 8/6, ins. 5/-. Resine covered cabinet in two-tone maroon and cream, size 15 1/2" x 14 1/2" x 8 1/2" with all accessories plus uncut record player mounting board 14" x 13", 59/6, carr. & ins. 5/-.

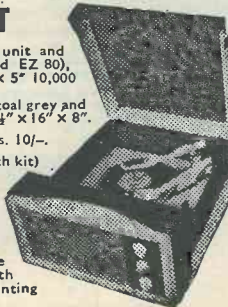

## MULLARD "3-3" HI-FI AMPLIFIER

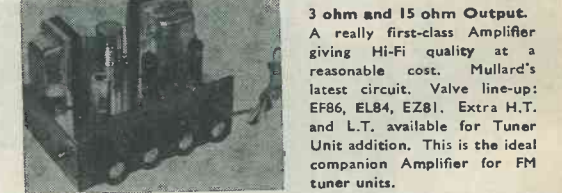

3 ohm and 15 ohm Output. A really first-class Amplifier giving Hi-Fi quality at a reasonable cost. Mullard's latest circuit. Valve line-up: EF86, EL84, EZ81. Extra H.T. and L.T. available for Tuner Unit addition. This is the ideal companion Amplifier for FM tuner units.

TECHNICAL SPECIFICATION—Freq. Response: ± 1dB. 40 c/s-25 kc/s Tone controls, max. treble cut 12dB at 10 kc/s. Max. Bass Boost 14dB at 80 c/s sensitivity: 100MV for 3W output. Output Power (at 400 c/s): 3W at 1% total harmonic distortion. Hum and Noise Level: At least 70dB below 3W.

COMPLETE KIT (incl. valves, all components, wiring diagram and special quality sectional Output Trans.) BARGAIN PRICE £6.19.6 carr. 4/6. Complete wired and tested, 8 gns. Wired power O/P socket and additional smoothing for Tuner Unit, 10/6 extra.

Bronze Escutcheon Panel, Printed Vol., Treble, Bass, On-Off, supplied with each kit. Recommended Speakers—R. Allen 12" with tweeter 42/6. WGH10—12 1/2" 42/6. Goodmans Axiote £5.5.0. Axiom 10 £6.5.0. Audiom 51 £8.10.0. 10/6 extra.

Send for detailed bargain lists, 3d. stamp. We manufacture all types Radio Mains Transf. Chokes, Quality O/P Trans., etc. Enquiries invited for Specials, Prototypes for small production runs. Quotation by return.

RADIO COMPONENT SPECIALISTS  
70 Brigatoc Rd., Thornton Heath, Surrey  
TD1 2BB Hours: 9 a.m.-6 p.m., 1 p.m. Wednes. Terms C.W.O. or C.O.D. Post and Packing up to 1/2 lb. 9d., 1 lb. 1/3, 3lb. 2/3, 5 lb. 2/9, 8 lb. 3/6.



Est. 1946

LATEST HIGH QUALITY COMPONENTS FROM THE MAXI-Q RANGE . . .

TESTED AND TRIED OVER 5 FREQUENCY RANGES

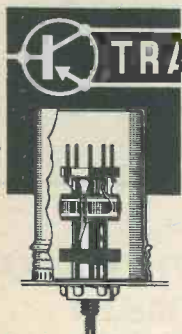

## TRANSISTOR TUNING COILS

Coils for transistor superhets or converters, with or without an R.F. stage and using 465 kc/s or 1.6 Mc/s I.F.

- ★ Noval B9A Based for Plug-in application—Screw threaded for Chassis application.
- ★ Formers moulded in low-loss polystyrene for best results.
- ★ Each coil is packed in an aluminium container which may be used as a screening can.
- ★ Brass threaded adjustable iron-dust cores.

The following colour code identifies the coils:

BLUE—Aerial coil with base input winding.

YELLOW—Interstage R.F. coil with couplings.

RED—Oscillator coil for 465 kc/s I.F.

WHITE—Oscillator coil for 1.6 Mc/s I.F.

PRICE 4/9 each.

Coverages: Range 1T—15/4 Mc/s; 2T—515/1.545 Mc/s; 3T—1.67/5.3 Mc/s; 4T—5/15 Mc/s; 5T—10.5/31.5 Mc/s. Full technical details now included in Technical Bulletin DTB.4—1/6d.

IFT.13 Miniature 465 kc/s I.F. Transformer .. 7/6d. each

GENERAL CATALOGUE covering full range of components send 1/6d. in stamps.

IFT.14 Miniature 465 kc/s Last I.F. Transformer .. 7/6d. each

PLEASE SEND S.A.E. WITH ALL OTHER ENQUIRIES.

IFT.16 Miniature 1.6 Mc/s I.F. Transformer .. 6/6d. each

IFT.17 Miniature 1.6 Mc/s Last I.F. Transformer .. 6/6d. each

DENCO (GLACTON) LTD (DEPT. R.C.) 357/9 Old Road Clacton-on-Sea Essex

AMATEUR RADIO  
CHAS. H. YOUNG LTD.

MIDLAND AGENTS  
FOR

- ★ EDDYSTONE RECEIVERS & COMPONENTS
- ★ NATIONAL RECEIVERS & TRANSCEIVERS
- ★ GREEN & DAVIS CONVERTERS
- ★ KW EQUIPMENT
- ★ MOSLEY AERIALS

- H.P. FACILITIES AVAILABLE
- PART EXCHANGES

### AERIAL EQUIPMENT

**TWIN FEEDER.** 300 ohm twin ribbon feeder similar K25, 6d. per yard. K35B Telecon (round), 1/6 per yard. 75 ohm twin feeder, 6d. per yard. Post on above feeders and cable, 1/6 any length.

**COPPER WIRE, 14G, H/D, 140ft, 17/-; 70ft, 8/6.** Post and packing 2/6. Other lengths pro rata.

**FEEDER SPREADERS.** 6" Ceramic type F.S., 10d. each. Postage 1/6 up to 12.

**CERAMIC CENTRE PIECE** for dipoles, Type AT, 1/6 each. P. & P. 1/-.

**2 METRE BEAM, 5 ELEMENT W.S. YAGI.** Complete in box with 1" to 2 1/2" masthead bracket. Price 49/- . P. & P. 3/6.

**SUPER AERAXIAL, 70/80 ohm coax, 300 watt very low loss, 1/8 per yard.** P. & P. 2/-.

**TOUGH POLYTHENE LINE,** type MLI (100lb), 2d. per yd. or 12/6 per 100 yds. Type ML2 (220lb), 4d. per yd. or 25/- per 100 yds., ML4 (400lb), 6d. per yd., post free. Ideal for Guys, L.W. Supports, Halyards, etc.

**ABSORPTION WAVEMETERS.** 3.00 to 35.00 Mc/s in 3 Switched Bands. 3.5, 7, 14, 21 and 28 Mc/s. Ham Bands marked on scale. Complete with indicator bulb. A MUST for any Ham Shack. ONLY 12/6 EACH. Post free.

**BANDCHECKER MONITOR,** 3.00-35.00 Mc/s in 3 switched Bands. 0-1mA Indicator. Monitor Socket. Very sensitive, £3.13.6. P. & P. 2/6.

**VARIABLE CONDENSERS.** All brass with ceramic end plates and ball race bearings. 50pF, 5/9; 100, 6/6; 160, 7/6; 240, 8/6; and 300pF, 9/6. Extension for ganging. P. & P. 1/-.

**RACK MOUNTING PANELS:** 19" x 5 1/2", 7", 8 1/2", or 10 1/2", black crackle finish, 5/9, 6/6, 7/6, 9/- respectively. P. & P. 2/-.

**GELOSO VFO UNITS.** 4/102 with new dial and escutcheon. Outputs on 80, 40, 20, 15 and 10. For 2-807 or 6146 Tubes. Only £8.15.3, valves to suit, 24/- . ALL POST FREE.

**SHADED POLE MOTORS, 230V or 110V operation, ideal for fans, blowers or models.** Single Unit 12/6, plus 2/- P. & P., or Pair £1, plus 2/6 P. & P.

**PARMEKO TRANS.** 200/200 40mA, 6.3V, 3A. New, not ex-W.D. Only 12/6. P. & P. 2/6.

CHAS. H. YOUNG LTD

170-172 Corporation St., Birmingham 4

Please print your address. No C.O.D. under £1. 'phone CEN 1635

# HOME RADIO of MITCHAM

DEPT. RC, 187 London Road, Mitcham, Surrey. MIT 3282

Shop hours: 9-5.30; Fri. 9-6.30. Closed all Wed.

## TRANSFILTERS

Transfilters are ceramic filters which take the place of tuned i.f. transformers in transistor superhets. As they operate at the first overtone of their fundamental frequency it is advisable to precede them with one conventional tuned circuit. Three types are available: TO-01 Resonant tuned, TO-02 Anti-resonant tuned, and TF-01 which is a two-connection type that replaces the emitter by-pass capacitor and gives increased selectivity. Further details are available in "Transistor Circuits for the Constructor" No. 4, price 3/6, postage 1/6.

The following transfilters are in stock:

TO-01 A	455KC	7/6
TO-01 B	465KC	7/6
TO-01 D	470KC	7/6
TO-02 A	455KC	7/6
TO-02 B	465KC	7/6
TO-02 D	470KC	7/6
TF-01 A	455KC	6/-
TF-01 B	465KC	6/-
TF-01 D	470KC	6/-

**WE STOCK THE FULL RANGE OF THE NEW MULLARD POLYESTER CAPACITORS.**

*We also stock the*

## JORDON-WATTS MODULAR HIGH FIDELITY LOUDSPEAKERS

Loudspeaker driving unit  
12 watts Hms.  
**£10.10.0**

"MINI 12" Slender Infinite Baffle.  
12 watts  
**£16.12.6**

Model A12 Full Range Reflex Enclosure. 12 watts .....**£22.0.0**  
A25. 25 watts .....**£36.15.0**  
B50. 50 watts .....**£64.6.3**

## CEIBALINE

A sound-absorbing material made by Kapok Ltd. This is the perfect material for lagging the inside surfaces of high fidelity loudspeaker enclosures to improve quality of sound reproduction. It is rot proof, fire resistant and will not support moths or other insects. It is easily cut to size with scissors and has a special self-adhesive backing for instant fixing. It is made only in a width of 2ft 9in and costs 2/6 per square foot. Set out below is a table of prices.

33" x 4" ... ..	2/6	33" x 40" ... ..	22/6
33" x 9" ... ..	5/-	33" x 45" ... ..	25/-
33" x 13" ... ..	7/6	33" x 49" ... ..	27/6
33" x 18" ... ..	10/-	33" x 53" ... ..	30/-
33" x 22" ... ..	12/6	33" x 57" ... ..	32/6
33" x 26" ... ..	15/-	33" x 62" ... ..	35/-
33" x 31" ... ..	17/6	33" x 66" ... ..	37/6
33" x 36" ... ..	20/-		

# HOME RADIO CATALOGUE

*New Edition! New Policy!*

With the arrival of the 10th Edition of the famous Home Radio Catalogue we announce a fresh policy. The new price of 5/- will just cover the cost of the paper and printing, but on the first page of the catalogue you will find 5 coupons, each worth 1/- if used as directed. Briefly the system will operate thus: for each complete £1 of your order you enclose one of the coupons and deduct 1/- from the money you send. There is no time limit so if you purchase £5 worth of components from us—even though spread over several years—your catalogue will have cost you nothing!

We need only add that our new Catalogue is bigger and better than ever . . . so fill in the Coupon, enclose 6/- (5/- plus 1/- postage), and pop it in a letter box right away!

Please write your Name and Address in block capitals

Name \_\_\_\_\_

Address \_\_\_\_\_

Home Radio Ltd. Dept. R.C., 187 London Road, Mitcham

# THE Radio Constructor



Incorporating THE RADIO AMATEUR

## SEPTEMBER 1964

Vol. 18, No. 2  
Published Monthly  
(1st of month)

*Editorial and  
Advertising Offices*  
57 MAIDA VALE LONDON W9

*Telephone*  
CUNningham 6141

*Telegrams*  
Databux, London

First Published  
1947

Combined AF Signal Generator and Tracer, <i>by Peter F. Bretherwick</i>	84
Suggested Circuits No. 166: Geometric Progression Resistance Box, <i>by G. A. French</i>	88
News and Comment	91
Fundamentals of Single-Sideband, <i>by R. Youngs</i>	92
Can Anyone Help?	96
Understanding Radio, Part 36, <i>by W. G. Morley</i>	97
Modulated-Light Transmitter and Receiver, <i>by M. J. Banthorpe</i>	101
Trade Review—A Versatile Matrix Board	102
Timebase Expansion Generator, <i>by J. R. Knight</i>	103
In Your Workshop	107
Quicker and Cheaper Method of Etching Printed Circuits, <i>by C. D. Auger</i>	112
Simple Wavemeter for Model Control, <i>by M. Whitford-Walders</i>	114
Using Transistors in Pulse Circuits, <i>by M. F. Audus</i>	116
BBC2 UHF Amplifier, <i>by John D. Benson</i>	121
Experiences of an Early Amateur, Part 2, <i>by C. H. Gardner</i>	123
The New Dual-Standard TV Sets, Part 5, <i>by Gordon J. King, Assoc. Brit. I.R.E., M.T.S., M.I.P.R.E.</i>	127
Operation and Use of Thermal Delay Switches, <i>by E. Lawrence</i>	131
Radio Topics, <i>by Recorder</i>	133

© Data Publications Ltd., 1964. Contents may only be reproduced after obtaining prior permission from the Editor. Short abstracts or references are allowable provided acknowledgement of source is given.

Annual Subscription 33s. (U.S.A. and Canada \$5) including postage. Remittances should be made payable to "Data Publications Ltd". Overseas readers please pay by cheque or International Money Order.

# Combined A.F. Signal Generator and Tracer

By Peter F. Bretherwick

THE UNIT DESCRIBED IN THIS ARTICLE WAS designed primarily to facilitate the testing and servicing of audio frequency amplifiers and, secondly, to allow sine waves of various frequencies to be presented on an oscilloscope, with the advantage that the note being observed on the screen may be heard.

It was built to have a good outward appearance whilst maintaining a comparatively low cost. It had, however, to be robust in construction and simple in use. It was decided, therefore, to purchase a strong metal case and to make the circuit simple, using a minimum of cheap readily-obtainable components.

## The Circuit

The circuit was designed around two very common miniature B9A base valves, which may usually be obtained from a discarded television set. (See Fig. 1.)

The EF80 is a high slope radio frequency pentode which is used in a conventional phase shift oscillator circuit. The potentiometer VR<sub>1</sub> and the switch S<sub>1</sub> provide a variation in frequency between approximately 128 and 512 c/s, roughly corresponding to one octave either side of Middle C.\*

The ECL80 is a combined triode-pentode functioning as a normal resistance-capacitance coupled two-stage amplifier, driving a 7 x 4in elliptical speaker.

Power is provided by a double-wound miniature mains transformer and contact-cooled rectifier. The transformer provides 6.3V at 1.5A and 250V at 50mA. A double-wound mains transformer must be used in this circuit as, quite apart from safety reasons, the unit will be used for testing various

\* It will be noted that V<sub>1</sub> has a screen-grid resistor of 1kΩ and an anode load of 10kΩ. It was found, with the prototype, that the value of the screen-grid resistor, between zero and 0.5MΩ, had little effect on performance. A value of 10kΩ as anode load was found to give best results.—EDITOR.

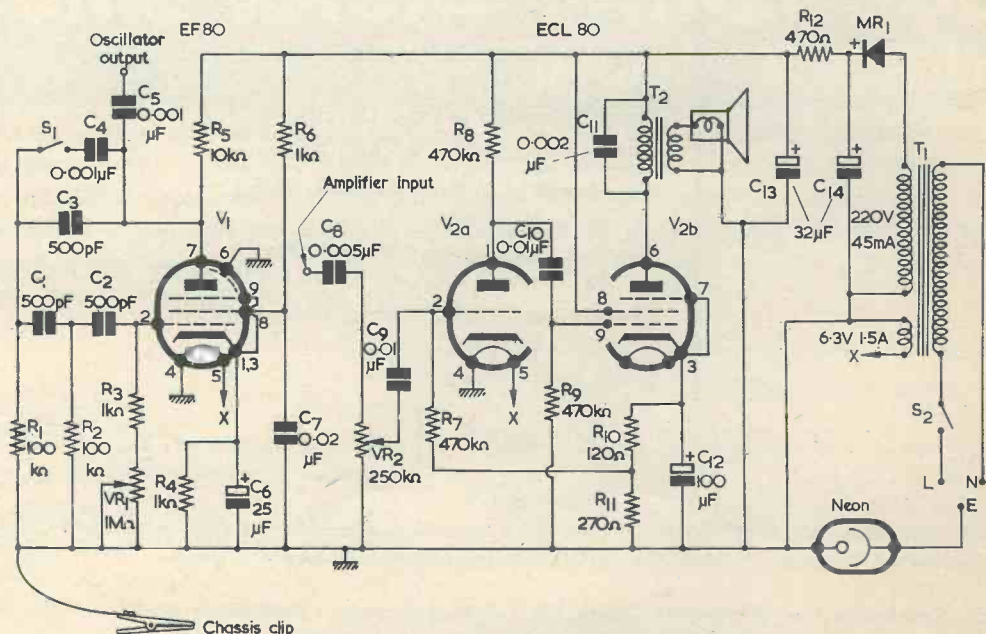
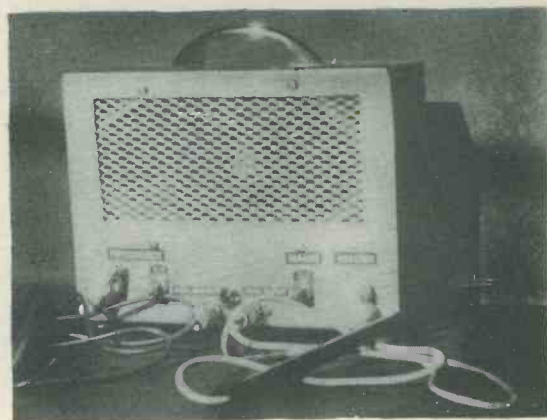

Fig. 1. The circuit of the complete signal generator and tracer

pieces of equipment whose chassis may be earthed or may, as in the case of a.c./d.c. equipment, even be live. To guard against the latter instance a neon indicator light is fitted between the chassis of the instrument and earth. If it lights up, the chassis of the equipment under test is live, and the associated plug must be reversed.

### Construction

The first task is to drill the metal case and cut the speaker aperture. The dimensions for this are shown in Fig. 2. The  $6\frac{1}{2} \times 3$  in aperture for the speaker may be cut by a sharp hacksaw blade after drilling  $\frac{1}{4}$  in diameter holes at the corners to accommodate the blade. The chassis should then be made, this being in the form of a shelf bent to fit the case and made from a piece of 18 s.w.g. bright mild steel measuring  $3 \times 10$  in. The chassis should be drilled and bent as shown in Fig. 3. The fixing holes that secure the chassis to the case are best drilled when the chassis is in position; this ensures that the holes are coincident.



Fitting the major components is the next task, these consisting of the mains transformer, metal rectifier, valveholders and tagstrips. They should

### Components List

#### Resistors

(All fixed resistors  $\frac{1}{4}$ W 20% unless otherwise specified)

R <sub>1</sub>	100k $\Omega$
R <sub>2</sub>	100k $\Omega$
R <sub>3</sub>	1k $\Omega$
R <sub>4</sub>	1k $\Omega$
R <sub>5</sub>	10k $\Omega$ $\frac{1}{2}$ W
R <sub>6</sub>	1k $\Omega$
R <sub>7</sub>	470k $\Omega$
R <sub>8</sub>	470k $\Omega$
R <sub>9</sub>	470k $\Omega$
R <sub>10</sub>	120 $\Omega$
R <sub>11</sub>	270 $\Omega$ $\frac{1}{2}$ W
R <sub>12</sub>	470 $\Omega$ 1W
VR <sub>1</sub>	1M $\Omega$ Lin.
VR <sub>2</sub>	250k $\Omega$ Log.

#### Capacitors

C <sub>1</sub>	500pF 350V wkg.
C <sub>2</sub>	500pF 350V wkg.
C <sub>3</sub>	500pF 350V wkg.
C <sub>4</sub>	0.001 $\mu$ F 350V wkg.
C <sub>5</sub>	0.001 $\mu$ F 350V wkg.
C <sub>6</sub>	25 $\mu$ F 12V wkg.
C <sub>7</sub>	0.02 $\mu$ F 350V wkg.
C <sub>8</sub>	0.005 $\mu$ F 350V wkg.
C <sub>9</sub>	0.01 $\mu$ F 350V wkg.
C <sub>10</sub>	0.01 $\mu$ F 350V wkg.
C <sub>11</sub>	0.002 $\mu$ F 350V wkg.
C <sub>12</sub>	100 $\mu$ F 12V wkg.
C <sub>13</sub>	{ 32+32 $\mu$ F 275V wkg.
C <sub>14</sub>	

#### Transformers

T <sub>1</sub>	Mains transformer: top shrouded drop-through. Sec: 220V 45mA 6.3V 1.5A (G. W. Smith & Co., 3-34 Lisle Street, London, W.C.2)
----------------	--

T<sub>2</sub> Standard pentode output transformer, 60:1

#### Valves

V <sub>1</sub>	EF80
V <sub>2</sub>	ECL80

#### Switches

S<sub>1</sub> S<sub>2</sub> s.p.s.t. panel-mounting toggle switches

#### Rectifier

MR<sub>1</sub> Contact cooled, 250V 50mA

#### Neon

Mains or "button" type, with series resistor

#### Speaker

7 x 4in elliptical, 3 $\Omega$  impedance

#### Plugs, Sockets

2 Coaxial plugs  
2 Coaxial sockets. (Belling-Lee type L604/S or equivalent)  
2 B9A valveholders, with skirts

#### Case, Chassis

Case: 8 x 6 x 3in, stoved finish, pressed-steel box (Tele-Radio (1943) Ltd., 189 Edgware Road, London, W.2)  
Chassis: 10 x 3in, 18 s.w.g. bright mild steel

#### Miscellaneous

1ft  $\frac{1}{8}$ in diameter copper rod  
1ft  $\frac{3}{16}$ in inside diameter aluminium tube  
1 7-way tagstrip (3 earth tags)  
1 5-way tagstrip (centre tag earth)  
2  $\frac{3}{16}$ in rubber or p.v.c. grommets  
Expanded metal speaker grille.

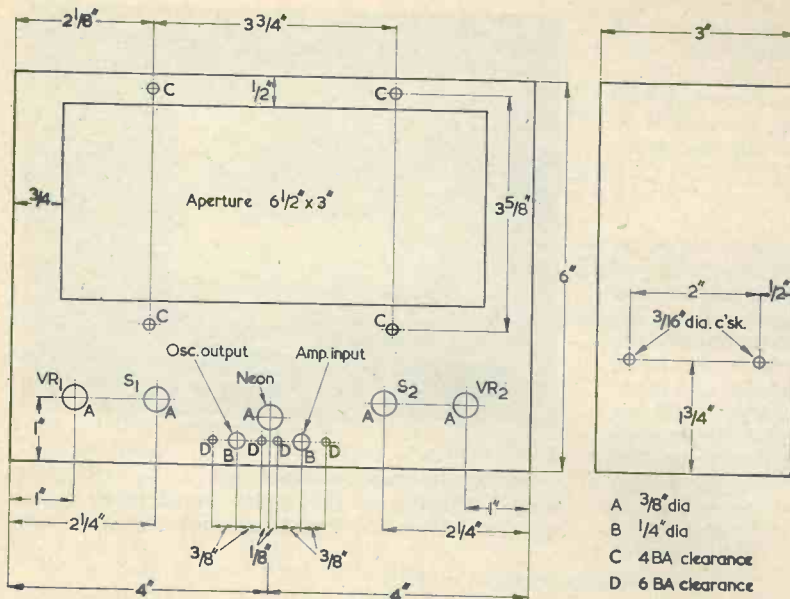

Fig. 2. Drilling details for the cabinet. The "C" holes for the speaker may vary in position for different models. A  $\frac{1}{8}$  in hole (not shown here) is required at the rear of the right side for the mains lead

- A  $\frac{3}{8}$ " dia
- B  $\frac{1}{4}$ " dia
- C 4BA clearance
- D 6 BA clearance

be securely bolted into position and the remainder of the components soldered in, taking care that enough room is left for the controls on the front panel and that the resistance-capacitance network for the phase shift oscillator is kept reasonably clear of the amplifying section. Layout is not critical but should be compact, using small components. (See Fig. 4.)

The chassis should be bolted into the case by means of  $\frac{1}{2}$  in No. 6 countersunk self-tapping screws and the controls on the front panel fitted. Only the speaker, speaker fret and output transformer now remain and these are fastened with 4BA nuts and bolts, using a slightly longer bolt on the top right-hand corner for the output transformer. This last component is secured by one lug only. Connections should finally be made to the speaker, output transformer and capacitor C<sub>11</sub>, whereupon the valves may be inserted and the unit tested.

### Test

If the output from the oscillator is connected to the input of the amplifier, i.e. the two coaxial sockets on the front panel coupled together, a plain note or whistle should be heard from the speaker. The note should change frequency and finally stop as VR<sub>1</sub> is turned fully clockwise or anti-clockwise.

### The Test Prods

The test prods are made up as shown in Fig. 5. A piece of  $\frac{1}{8}$  in diameter copper rod 5  $\frac{1}{2}$  in long is sharpened at one end and a flat filed on the other. The inner core of a screened cable is then soldered to the flat and a piece of tightly fitting sleeving passed over the rod, leaving only the point protruding. Heating the rod slightly should assist this procedure. A piece of  $\frac{3}{8}$  in inside diameter aluminium tube is then passed over the top of this, again leaving the point protruding, and is flattened,

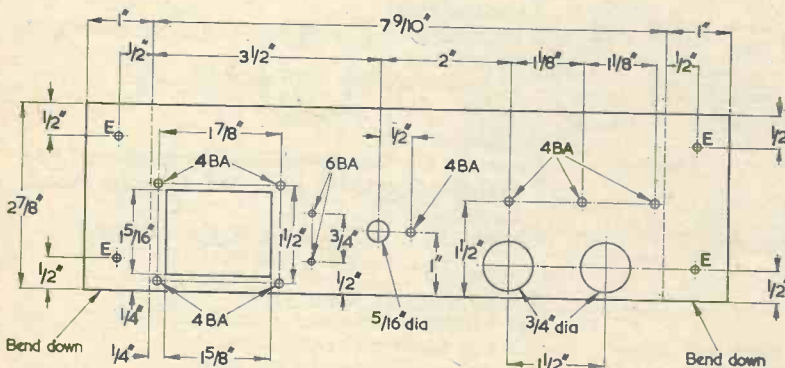

E  $\text{O} \cdot 104$ " dia. (No. 37 drill)

Fig. 3. Top view of the chassis, showing dimensions. The positioning of the holes for the mains transformer, rectifier and 7-way tagstrip corresponds to the components employed by the writer



Fig. 4. Under-chassis layout of the principal contents

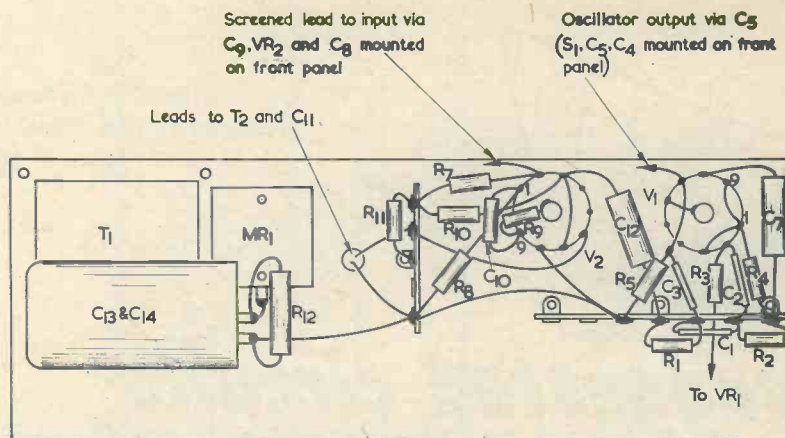

at the end in order to grip the screening of the lead. Finally, a piece of flexible rubber hose, of the type used for gas fittings, is passed over the whole assembly. Two such prods should be made up with about 3ft of screened lead and a coaxial plug on each at the end remote from the test prod. In this way two robust test prods are made which are completely screened.

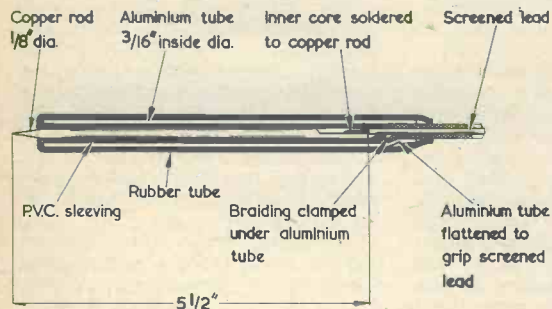

Fig. 5. The construction of the screened test prods

### Method of Use

The chassis clip should first be connected to the chassis of the apparatus under test. As has been already explained, if the neon indicator glows the plug of the apparatus under test should be reversed. The apparatus may now be tested in two different ways.

(1) A signal that is already present may be traced, using the amplifying section of the unit. This is done by connecting the appropriate prod to the grid of the first valve and then to the anode, proceeding from there to the grid of the second valve and so on. A cessation of signal from the speaker of the unit indicates that the fault lies in the preceding section of the amplifying chain. This method is useful for tape recorder and record player amplifiers, and for the a.f. sections of radio and television sets.

(2) The second method involves the use of the oscillator section of the unit, working backwards through the circuit under test from the output transformer, and using the prod connected to the left-hand socket of the unit.

Both methods may, of course, be used simultaneously.

## New Grant for Semiconductor Research

A three-year research project to seek experimental confirmation of recent theory on electrical conduction in certain materials on the borderline between insulators and semiconductors is to be carried out by the Electrical Research Association with the support of a DSIR "earmarked" grant of up to £17,400. The balance of the £20,400 total cost estimated for the project will be provided from the Research Association's funds.

There is a wide range of non-metallic substances, inorganic and organic, which are good insulators at low temperatures but exhibit a gradual transition to semiconducting properties as the temperature is raised. For such substances neither the theory nor the necessary techniques of investigation are at present well established. The work proposed in the present project will start from the basis of theoretical work done at Liverpool University which has yet to be confirmed experimentally.

The importance of better knowledge in this field falls under two headings. Firstly there is the potential value of knowledge on controlled semiconducting devices operable at high temperatures, and although the work to be done is of a speculative nature it might lead to advances in transistors, capacitors and high-temperature thermocouples. Secondly there is the demand for new materials giving good electrical insulation at high temperatures in, for instance, the atomic energy industry.

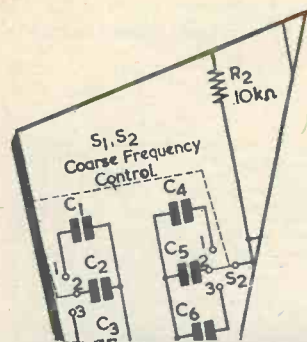

## suggested circuits

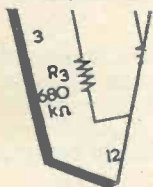

The circuits presented in this series have been designed by G. A. French, specially for the enthusiast who needs only the circuit and essential data

### No. 166 Geometric Progression Resistance Box

IT OCCASIONALLY HAPPENS, DURING experimental work, that it is necessary to provide adjustable values of fixed resistance within close tolerance. These values of resistance may be employed for balancing a bridge, for checking the operation of a circuit, or for setting up networks in which a resistive section must have a value which is known to a high degree of accuracy.

#### The Decade Box

One method of providing known values of fixed resistance is given by the decade box. A typical decade resistance box circuit is illustrated in Fig. 1. In this diagram, four banks of resistors offer varying resistance values from zero to 9,999Ω, changes in resistance being obtainable in steps of 1Ω. Setting up the decade box is a very simple process, since all that needs to be done is to adjust the switches to the value of resistance required. Thus, to select 7,560Ω, S<sub>1</sub> is set to position 7, S<sub>2</sub> is set to position 5, S<sub>3</sub> is set to position 6 and S<sub>4</sub> is set to position 0. The total amount of resistance switched in is then 7,000+500+60=7,560Ω. To select, say, 427Ω, S<sub>1</sub> is set to position 0, S<sub>2</sub> to position 4, S<sub>3</sub> to position 2 and S<sub>4</sub> to position 7.

A disadvantage with the decade box is that it requires a relatively large number of fixed resistors. These resistors need to be close tolerance types and to have a high degree of stability, whereupon the construction of a decade box can incur a somewhat heavy outlay. The

decade box of Fig. 1, for example, has an upper limit of 9,999Ω only, yet it requires no less than 36 resistors.

By employing an alternative circuit, which incorporates a somewhat less convenient method of switching, it is possible to obtain a resistance box which requires considerably fewer fixed resistors. With the alternative circuit it is possible, for instance, to obtain a range from zero to 12.8kΩ in 1Ω steps (a higher range than is given by Fig. 1) with the use of only 14 resistors. In this instance, the alternative circuit would need 14 s.p.s.t. switches, as against the four 10-way switches required in Fig. 1. However, the 14 s.p.s.t. switches would only be required to short-circuit individual resistors, and it may be found possible to employ relatively cheap and simple short-circuiting arrangements to carry out this function. The switches used in the Fig. 1 circuit have, on the other hand, to be robust rotary types.

#### The Alternative Circuit

A comprehensive version of the alternative circuit is shown in Fig. 2, and it forms the basis of this month's article. The circuit is that of a resistor substitution box which employs 25 resistors, and which offers resistance values ranging from zero to greater than 16MΩ. The circuit of Fig. 2 may be more elaborate than is required by some experimenters, but it is a very simple matter to use sections of it only, or to adapt the principle involved to provide different

ranges to those specified.

The reason why only a small quantity of resistors is needed for the circuit of Fig. 2 is that the resistance values switched in or out ascend in geometric progression. The first resistor has a value of 1Ω, the second one of 2Ω, the third resistor a value of 4Ω, the fourth one of 8Ω, and so on. It is this choice of values which allows the economy in resistors to be achieved.

To start off, let us assume that we require a resistance of zero ohms across the terminals of the box shown in Fig. 2. This resistance is given when all switches are closed. To obtain 1Ω, we open S<sub>1</sub>. To obtain 2Ω we close S<sub>1</sub> and open S<sub>2</sub>. For 3Ω we open both S<sub>1</sub> and S<sub>2</sub>. For 4Ω we close S<sub>1</sub> and S<sub>2</sub> and open S<sub>3</sub>. Further values up to and including 7Ω may then be obtained by keeping S<sub>3</sub> open and adjusting S<sub>1</sub> and S<sub>2</sub> for 1, 2 or 3Ω, as required.

A resistance of 8Ω is provided by closing S<sub>1</sub>, S<sub>2</sub> and S<sub>3</sub>, and opening S<sub>4</sub>. Values of resistance up to and including 15Ω are then provided by keeping S<sub>4</sub> open and adjusting S<sub>1</sub>, S<sub>2</sub> and S<sub>3</sub> to give the required additional values of resistance from 1 to 7Ω. Closing S<sub>1</sub> to S<sub>4</sub> and opening S<sub>5</sub> gives 16Ω. Values up to 31Ω are then provided by adjustment of S<sub>1</sub> to S<sub>4</sub>, these giving additional resistances from 1 to 15Ω.

Continuing along the chain, it may be seen that to obtain 32Ω we close S<sub>1</sub> to S<sub>5</sub> and open S<sub>6</sub> on its own. Additional series resistances up to 31Ω are then available from S<sub>1</sub> to S<sub>5</sub>,

bringing the range up to 63Ω. A similar process, with  $S_7$  open, extends the range up to 127Ω.

Switches  $S_1$  to  $S_7$  provide, therefore, a range of resistance from zero to 127Ω which is variable in 1Ω steps. To obtain any value within this range, it is merely necessary to open the switches such that the resistance values inserted into the circuit add up to the figure desired. The process of selecting the switches may be carried out by working from "right to left". To take an example, let us assume that we require a resistance of 45Ω. 64Ω is obviously too large, and so we keep  $S_7$  closed. 32Ω is smaller than 45Ω, and so we open  $S_6$ , whereupon we require a further 13Ω to reach the desired figure of 45Ω. This is smaller than 16Ω and so we keep  $S_5$  closed. However, 13Ω is larger than 8Ω and so we open  $S_4$ , leaving a further 5Ω to be provided. This is given by opening  $S_3$  and  $S_1$ . Other values up to 127Ω may be selected by a similar process.

#### Breaking the Progression

Although switches  $S_1$  to  $S_7$  offer a range from zero to 127Ω, it is undesirable to extend the geometric progression beyond  $S_7$ , because the arithmetic needed to sum up the values becomes unwieldy. In consequence, a new progression is introduced by switches  $S_8$  to  $S_{14}$ , this starting at 100Ω and offering increases in resistance, varying in 100Ω steps, from zero to 12.7kΩ. Since  $S_1$  to  $S_7$  offer resistances ranging up to 127Ω, there is an overlap between 100 to 127Ω in the values which may be selected by  $S_1$

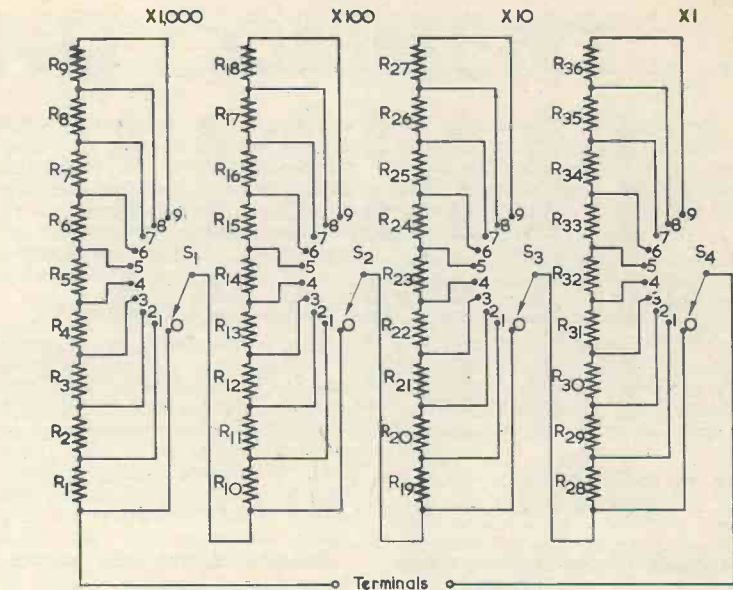

$R_1$ - $R_9$  1,000Ω     $R_{19}$ - $R_{27}$  10Ω  
 $R_{10}$ - $R_{18}$  100Ω     $R_{28}$ - $R_{36}$  1Ω

Fig. 1. A decade box offering varying values of resistance between zero and 9,999Ω

to  $S_8$  and by  $S_1$  to  $S_7$ . In consequence it is preferable to look upon  $S_1$  to  $S_7$  as providing a range up to 99Ω only, values of resistance above 100Ω being introduced by opening  $S_8$ .

The resistances brought into circuit by  $S_8$  to  $S_{14}$  increase in the same geometric progression as do

those offered by  $S_1$  to  $S_7$ , and they may be adjusted in a similar manner to provide resistance increases in steps of 100Ω. It is, once again, desirable to break the progression at  $S_{14}$  in order to prevent cumbersome calculations. The result is that  $S_8$  to  $S_{14}$  may be considered as providing resistance, in 100Ω steps, up to 9.9kΩ only. Additional values of resistance which appear between the 100Ω steps are provided by  $S_1$  to  $S_7$ . Thus, 1.65kΩ is selected by opening  $S_{12}$ ,  $S_6$ ,  $S_5$  and  $S_2$ .

After  $S_{14}$  the progression starts again at 10kΩ, with  $S_{15}$  to  $S_{21}$ . This group of switches offers increases of resistance, in 10kΩ steps, from zero to 1,270kΩ. Again, however, the progression is broken after  $S_{21}$ , whereupon switches  $S_{15}$  to  $S_{21}$  may be considered as taking the range (working to 3 significant figures) up to 999kΩ only.

The final group of switches,  $S_{22}$  to  $S_{25}$ , incorporates a new progression starting at 1MΩ and offering increases of resistance, in 1MΩ steps, up to 15MΩ. Working from the assumptions made concerning the ranges offered by the previous groups of switches, the maximum theoretical resistance offered by the box then becomes 1Ω short of 16MΩ. However, due to

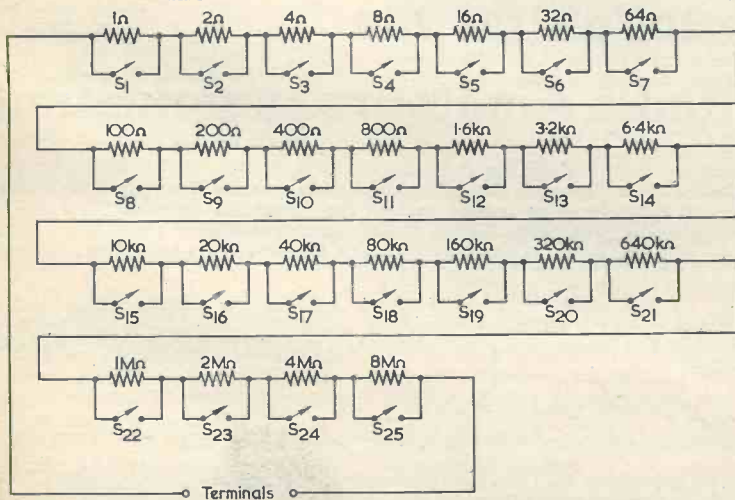

Fig. 2. A resistance box employing a geometric progression in resistor values and giving a range of resistance from zero to greater than 16MΩ

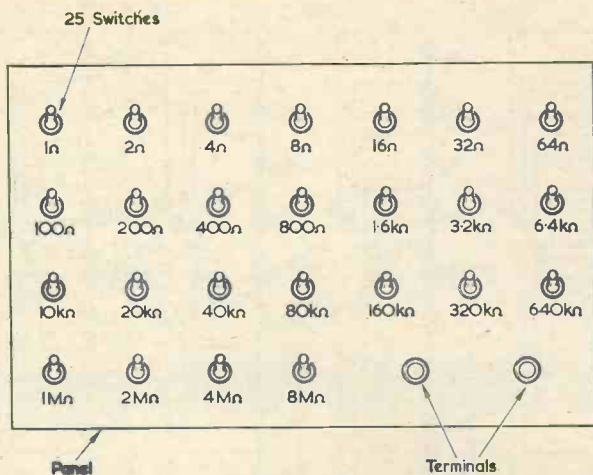

Fig. 3. A suitable panel layout for the switches shown in Fig. 2

the ignored overlaps between ranges it is actually possible to obtain resistances well in excess of  $16M\Omega$ , although the process of their selection may incur more complex additions.

#### Practical Points

In practice, there will be no point in attempting to switch in resistance values having an accuracy greater than that dictated by the tolerance of the resistors employed in the box. If, for instance, 1% resistors are used, the tolerance of the resistance value finally selected will similarly have a tolerance of 1%.

Because of the tolerance question, the number of significant figures in the resistance value to be selected has to be restricted. When 1% resistors are employed there is no point in attempting to switch in values having more than 3 significant figures. Thus, it would be reasonable to switch in a value of, say,  $2.67M\Omega$  (which is given by opening  $S_{23}$ ,  $S_{21}$ ,  $S_{16}$  and  $S_{15}$ ) whereupon the resistance offered should be  $2.67M\Omega \pm 1\%$  (i.e. between  $2.64$  and  $2.70M\Omega$ ). At the same time it would be unreasonable to switch in a value of, say,  $2.678M\Omega$ , because the final

digit would be "swamped" by the tolerance. This restriction in the number of significant figures in the value selected applies also, of course, to the decade box of Fig. 1.

As was mentioned earlier, it is possible that the circuit of Fig. 2 may be more elaborate than is required by individual experimenters. For some classes of electronic work it could be considered, for instance, that a range of resistance from zero to  $128k\Omega$ , in steps of  $10\Omega$ , would be quite adequate. Such a range can be provided by  $S_1$  to  $S_{14}$  inclusive, the values of the resistors connected across the switches being multiplied by 10. Another useful range for electronic work would be given by a range from zero to  $12.7k\Omega$  in steps of  $100\Omega$ . This range is provided by  $S_8$  to  $S_{14}$  inclusive, using the resistor values shown in the diagram. As may be gathered, the basic arrangement employing the geometric progression technique offers a wide range of variations. It should be added, nevertheless, that the complete circuit of Fig. 2 offers a range of resistance values which should satisfy almost all requirements in general electronic work.

A suitable method of assembly for the resistance box would consist of mounting the switches on a panel so that they take up the same layout as occurs in Fig. 2. (See Fig. 3.) Each switch is marked with the resistance value which it brings into circuit. The resistors themselves would, of course, be mounted behind the panel.

## Courses of Instruction for the City and Guilds Radio Amateurs Examination

### Birmingham

Classes will be held at the Lea Mason Centre of the Central Evening Institute, Bell Barn Road, Birmingham 15. Enrolment week commences on Monday 7th September. Classes commence on 14th September.

Classes will also be held on basic radio theory in preparation for the R.A.E. course 1965/66.

Further particulars may be obtained from M. A. Brett, G3HBE, 55 Chestnut Drive, Birmingham, 24.

### Ilford, Essex

A course for the R.A.E. will be held at the Ilford Literary Institute, High School, Cranbrook Road, Ilford, commencing 23rd September. Enrolment 7th-10th September, 7-8.30 p.m. Apply (in first instance) to W. G. Hall, G8JM, 48 Hawkdene, North Chingford, London, E.4. (please enclose s.a.e.)

### Finchley, London, N.12

An R.A.E. course will be held at the Northside School, Percy Road, Finchley, N.12 on Wednesday evenings from 7.30 till 9.30 p.m.

Enrolment evenings are from Monday 14th September till Thursday 17th September inclusive, 6.30 to 9.30 p.m. First term begins on 21st September. Fees are 30/- per session. Arrangements will be made for coaching in Morse to be given later in the session or early in the following session. Examinations will be held at the Southgate Technical College in May 1965.

# NEWS AND COMMENT . .

**R**ECENTLY THE ROYAL SCHOOL OF Military Engineering held a series of demonstrations in North Kent where the complete control and co-ordination of bridging operations, vehicle movement, etc., was carried out by the use of the Spemby Inductive Loop system of communications. The Spemby Loop has been developed to a very high standard of communication and this recent demonstration proved the effectiveness of the Loop system for prompting, cueing and team control throughout operations of this nature.

By establishing a low level alternating magnetic field in the required area of communication, personnel moving within this area and equipped with suitable receivers pick up the speech signals by means of an earphone coupled to the receiver.

This magnetic field is created by signal currents from a microphone transmitter-amplifier assembly, flowing in a loop cable surrounding the area of reception.

At the Gordon Barracks, during the R.S.M.E. demonstration, officers in charge of Army, R.A.F., and R.N. Bomb Disposal squads together with the American E.O.D. party were equipped with receivers, and cueing instructions were passed by means of the Spemby equipment. The Chief Control Officer co-ordinated all vehicle and personnel movements including platoon commanders, armoured cars, etc., and reconnaissance, monitoring, demolition and detonation were similarly achieved.

At Upnor on the River Medway, a Spemby Loop was used to control bridging operations and a particularly interesting feature was the control of submerged frogmen.

Spemby Inductive Loop communication equipment has been used in the Arts, Sciences and the Services, wherever immediate team control is required.

## R.E.C.M.F. Exhibition in Stockholm

More than 50 British firms will be taking part in the British Electronic Component and Instrument Exhibition to be held in Stockholm from 13th to 16th October, 1964.

Promoted by the Radio and Electronic Component Manufacturers Federation, this exhibition is the latest in the series regularly held in Stockholm over the last fifteen years and is by far the largest in

firms represented and space occupied. It will be opened by His Excellency The British Ambassador who will also be a guest of honour at the special opening luncheon to be attended by representatives of Swedish government, professional, industrial and academic circles.

Although 90% of the available space in the exhibition is now occupied, enquiries from potential exhibitors are still being received by Industrial Exhibitions Ltd., and the number of exhibitors, both members and non-members of the R.E.C.M.F. may still substantially increase. Visitor interest in Sweden and Scandinavia in general is also high and the exhibition, even in a year with many other electronic events, seems set to be a major occasion.

## Amateurs' Moon Bounce

Two British amateur radio operators, Mr. Peter Blair of Galleywood, Essex, and Mr. Bertram "Bill" Sykes of Northampton, succeeded in making two-way radio contact last month with the 1,000ft radio telescope at Arecibo, Puerto Rico, by beaming signals off the moon.

The exchange originated in Puerto Rico, where a radio amateur (KP4BPZ) using the Arecibo telescope sent signals to the moon, which were picked up by the two radio amateurs in this country. They in turn sent out signals which were picked up by the giant dish in Puerto Rico. Several exchanges between the amateurs were made.

The Arecibo telescope became operational last November and is the largest instrument of its kind in the world.

Built at a cost of \$8,000,000, it rests in a natural bowl formed by several mountain peaks and can also be used as a radar unit.

Mr. Blair used a 15ft dish of zinc wire mesh carried on concentric circles of galvanized wire. He also heard signals on 144 Mc/s (2 metres) and took tape recordings of his contacts.

Mr. Sykes (G2HCG) worked on the 144 megacycle waveband, with a J-Beam aerial. He also took tape recordings of the contact. A radio message from Puerto Rico confirmed Mr. Sykes's contact.

## 1964 R.S.G.B. Exhibition

Mr. E. D. Whitehead, M.B.E., B.Sc., M.I.E.E., Director of Electri-

cal Inspection at the Ministry of Aviation, will open this Exhibition, which will again be held at Seymour Hall, Seymour Place, Marble Arch, London, from the 28th to the 31st October.

Space has been taken for a special Stage Presentation of Radio in Ships. The Radio Society will also be transmitting and receiving every day with the call signs GB3RS and GB2VHF on 70 cms. and 2 and 4 metre bands as well as on their other wavelengths, and can talk in mobile licensed vehicles from all parts of Britain.

Home constructors can win outright the 1964 Silver Plaque for the most outstanding home-built piece of equipment and further prizes will also be presented for equipment made outside the London area, and members not connected with the radio industry.

Manufacturers new products will include a new range of communication overseas receivers to this country, together with the new British types and new transceivers for both fixed and mobile working. New types of test equipment, amplifiers, and transistor equipment of many types and makes.

The show will open daily from 10 a.m. to 9 p.m. and the admission fee will be 3s.

## You Never Know

Reporters met an African chief at the airport.

"Good morning, sir," said one of them. "Have you had a smooth and pleasant flight?"

The chieftain emitted a series of prolonged hisses, honks, toots and squeals, and then in a most perfect Oxford accent said: "Excellent, thank you."

"And how long do you intend staying over here, sir?" enquired another reporter.

The dusky potentate let drive with the same stream of odd noises, adding, in an equally impeccable accent, "Approximately a month, I should say."

"Do allow me to congratulate you, sir, on your English," rejoined the reporter. "Might I enquire where you learnt it?"

There followed another emission of the same peculiar noises. "Short wave radio," added the chief.

From *Humour Variety*

# Fundamentals of Single-Sideband

By R. Youngs

**S**.S.B. (SINGLE-SIDEBAND) IS ONE OF THE MOST efficient means of conveying telephony through the ether. It has recently become very popular with amateurs, but there still remain many who consider it taboo. The main grouse against s.s.b. seems to be the apparent difficulty of demodulating. For those who have found demodulation difficult a basic explanation of s.s.b. follows, whereby it is hoped that it will no longer remain a profound mystery.

## Amplitude Modulation

S.S.B. is a specialised form of a.m. (amplitude modulation). Let us, therefore, first take a look at a.m. to see what relevant disadvantages have caused it to become less popular among the more discerning amateurs than s.s.b.

Fig. 1 is a graphical representation of an a.m. signal. The carrier remains constant in frequency and amplitude; it conveys no intelligence but merely serves as a foundation against which the sidebands are demodulated. The sidebands are the intelligence-conveying components. These are continuously changing in sympathy with voice intensities but may not exceed an amplitude greater than 50% of the carrier if overmodulation is to be avoided. The total bandwidth of an a.m. signal, for telephony purposes, is about 6 kc/s, or 3 kc/s each sideband. Therefore, when using a receiver with an i.f. bandwidth of 6 kc/s both sidebands add up in phase to contribute to the receiver output. However, under the crowded conditions of the short wave bands these days, 3 kc/s is generally accepted as a receiver bandwidth capable of providing reasonable separation between stations without impairing the quality of

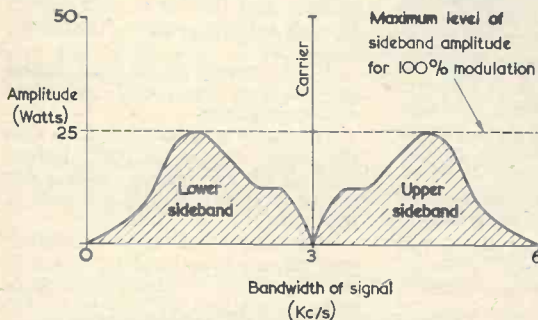

Fig. 1. Section across an amplitude modulated signal. The figures on the amplitude axis are representative of typical transmitter output

transmissions. When using a receiver with a bandwidth of 3 kc/s only one sideband can contribute to the receiver output, with the result that 50% of sideband energy is not received and a considerable loss in transmitter-to-receiver efficiency is experienced.

## Disadvantages of A.M.

One of the foremost disadvantages of a.m. is the fact that it is an uneconomical method of transmission, a fact that can best be realised by referring to some numerical examples applied to Fig. 1.

As has already been mentioned, the intelligence-conveying components of the signal are the sidebands. In Fig. 1, and assuming a carrier power of 50 watts, these represent a total power of 25 watts. When received on a selective receiver with a bandwidth of 3 kc/s, only one sideband, representing 12.5 watts, contributes to the receiver's output. So, for the cost of obtaining, running, and maintaining an a.m. transmitter, it seems a very poor return indeed that for the generation of 75 watts, sidebands plus carrier, only 12.5 watts contributes to the receiver output.

Another, and infuriating, disadvantage of a.m. is the considerable amount of heterodyne interference it causes in the short wave bands. This type of interference reveals itself as a penetrating squeal on the transmission to which one is tuned. It is caused by adjacent carriers beating together and, owing to the ever-increasing numbers of a.m. transmitters appearing within our narrow amateur bands, is becoming extremely severe.

Phase distortion can be very troublesome. This occurs when a portion of the transmitted signal appears at the receiver out of phase with the rest of the signal and, as a result, severe distortion of the receiver's output is experienced. Phase distortion is due entirely to adverse propagation effects, and appears on an a.m. signal at intervals similar to that of fading.

## Single Sideband

Having discussed some of the fundamental aspects of a.m., we are now in a position to discover how s.s.b. is developed from it.

Looking at Fig. 1 again it will be noted that three components form the a.m. signal, namely the lower sideband, the carrier, and the upper sideband. The carrier is a constant frequency/amplitude oscillation at r.f. which conveys no intelligence so, if it were suppressed to an insignificant amplitude and the full

Fig. 2. Block diagram of a simple s.s.b. transmitter

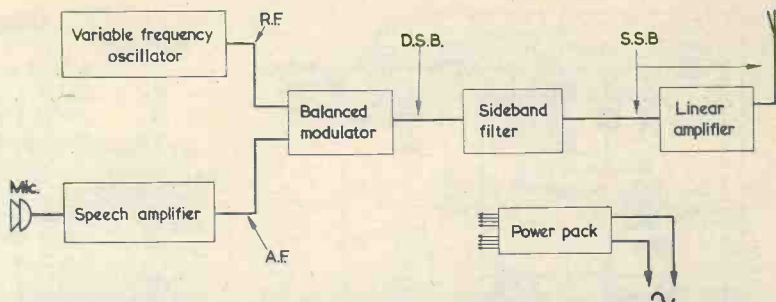

capacity of the transmitter used to radiate sideband energy, 100% of the transmitter output could then convey intelligence to the listener. We can achieve still greater efficiency by eliminating one of the sidebands. Having done this the full capacity of the transmitter may then radiate a single-sideband signal over a bandwidth of only 3 kc/s. This enables a selective receiver with a bandwidth of 3 kc/s to be used, and 100% of the power radiated by the transmitter contributes to receiver output.

By dispensing with portions of the original signal, receivers and transmitters have taken on an entirely new shape, the form of which will now be discussed. Particular emphasis will be placed on demodulation techniques, where a certain amount of difficulty persists.

### S.S.B. Transmitters

There are several methods of generating an s.s.b. signal, but usually they all stem from the simple block diagram shown in Fig. 2.

The speech amplifier is normally a small pentode such as an EF86. This gives only a small output but it nevertheless supplies the total modulating voltage required. Compare this with the 75 to 100 watts of audio required to modulate an a.m. transmitter running at maximum input.

The r.f. oscillator is the frequency determining portion of the transmitter, and it gives outputs in the amateur bands.

The outputs of the speech amplifier and r.f. oscillator are fed into the balanced modulator. This circuit may incorporate a double-triode valve which is arranged to phase out the carrier. The two triode sections of this valve must have identical characteristics in order that reasonable carrier suppression is obtained. Ideally this circuit should completely phase out the carrier, but it is almost impossible to achieve such aims with just the balanced modulator. For greater carrier suppression an additional circuit, to provide extra balancing, is usually incorporated, and this gives around 60dB suppression, above which any advantage would be negligible.<sup>1</sup> The output of the balanced

modulator appears as d.s.b. (double-sideband). This is similar in form to Fig. 1 but minus the carrier. The d.s.b. signal is then converted to s.s.b. by a circuit that may either filter, or phase out, one of the sidebands. Complete suppression of one of the sidebands is also virtually impossible, and about 40dB is considered adequate for amateur use. At this point we have arrived at an s.s.b. signal, but it is not much use for communication purposes yet since it is not of sufficient amplitude. A linear r.f. amplifier is used to boost the s.s.b. signal up to full output power. This amplifier, as its name implies, should be capable of producing a magnified and virtually undistorted replica of its input.

### Receiving S.S.B.

The normal short wave receiver, when tuned to an s.s.b. transmission, reproduces at its output a completely unreadable sound not unlike the proverbial "Donald Duck" talk. This is because the a.m. detector stage of a receiver depends on a resting carrier for successful demodulation, and not until the missing carrier has been reinserted can the signal be rendered intelligible. There are two well known methods of reinserting the carrier, both of which will be described. Although one sideband is not transmitted this causes no reception difficulties, as very often a.m. receivers have a selectivity factor of 3 kc/s, sufficient only for one sideband and the carrier to be accommodated within their passbands.

### Improving Selectivity

As the total bandwidth of an s.s.b. signal for voice communication is 3 kc/s, the receiver selectivity need not be greater than this figure for optimum signal reception. If the receiver has a bandwidth greater than this a certain amount of overlapping may be experienced, both in the s.s.b. and a.m. portions of the short wave bands. A very efficient and cheap way of improving the selectivity of a superhet receiver is to incorporate a Q-multiplier. Fig 3 shows the circuit of such a unit. Its output is taken to the first i.f. transformer primary by way of screened cable. The inner conductor of this cable connects to the anode end of the primary winding of the i.f. transformer, and the outer braiding to receiver chassis. It may be found necessary to re-align the core of the i.f. transformer after the Q-multiplier has been connected, to counteract any

<sup>1</sup> A balanced modulator employing two triodes (or other types of amplifying valve) normally functions by applying the r.f. input to the grids in phase, the anodes feeding into the ends of a coil whose centre-tap is at chassis potential. For a high level of carrier suppression, the two halves of the circuit have to be carefully balanced to ensure almost complete phasing out in the common anode coil. Other methods of carrier suppression are provided by bridge circuits employing diodes, or by circuits using the specially developed R.C.A. valve type 7360.—EDITOR.

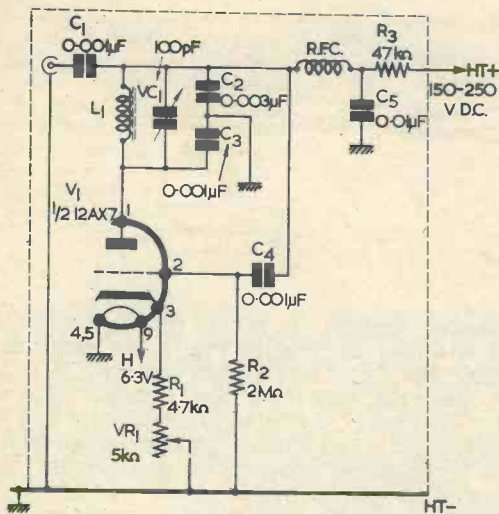

Fig. 3. A Q-multiplier

additional inductance offered by it.<sup>2</sup> The basic function of the Q-multiplier is to boost the Q of the i.f. amplifier, so that a general increase in selectivity takes place, and to allow the bandwidth of the receiver to be continuously adjustable from the original 6 to 10 kc/s down to about 500 c/s.

The operation of the Q-multiplier is quite simple. VC<sub>1</sub> is rotated until the signal begins to peak and VR<sub>1</sub> is then used to vary the i.f. bandwidth. If VR<sub>1</sub> is advanced too far oscillation will occur. The correct settings of the Q-multiplier are reasonably critical and, as a general rule, it should be adjusted for maximum readability on telephony. The Q-multiplier may either be built into the receiver or incorporated as an outboard accessory. In both cases, careful attention should be paid to ensure that the unit is adequately screened to prevent any troublesome stray couplings. The values of the components specified are suitable for a first i.f. of 460 to 470 kc/s. For a first i.f. of 1.6 Mc/s, L<sub>1</sub> should be replaced by a similar coil, but of 50 to 100µH inductance, and C<sub>2</sub> and C<sub>3</sub> substituted for 750pF and 250pF silver-mica capacitors respectively. Suitable inductors may be obtained from Electroniques (Felixstowe) Ltd.<sup>3</sup>

### S.S.B. Demodulation

Having attended to the selectivity of the receiver, we may now consider the problems relating to the detector stage.

As no carrier is radiated by the transmitter we must provide one within the receiver. This is accomplished by the addition of an oscillator which has to be continuously tunable through the i.f. passband. This oscillator is normally called the b.f.o. (beat frequency oscillator), or c.i.o. (carrier insertion oscillator). However, we will refer to it

<sup>2</sup> Re-alignment will also be necessitated by the additional capacitance introduced by the screened cable.—EDITOR.

<sup>3</sup> Electroniques (Felixstowe) Ltd., Radio Works, Bridge Road, Felixstowe, Suffolk.

### Components List (Fig. 3)

#### Resistors

- R<sub>1</sub> 4.7kΩ ½ watt
- R<sub>2</sub> 2MΩ ½ watt
- R<sub>3</sub> 47kΩ ½ watt
- VR<sub>1</sub> 5kΩ linear pot.

#### Capacitors

- C<sub>1</sub> 0.001µF ceramic
- C<sub>2</sub> 0.003 µF silver mica 2%
- C<sub>3</sub> 0.001µF silver mica 2%
- C<sub>4</sub> 0.001µF ceramic
- C<sub>5</sub> 0.01µF ceramic
- VC<sub>1</sub> 100pF variable air-spaced

#### Inductors

- L<sub>1</sub> 150µH High-Q ferrite potted (Electroniques (Felixstowe) Ltd.)
- RFC 2.5mH

#### Valve

- V<sub>1</sub> ½ 12AX7

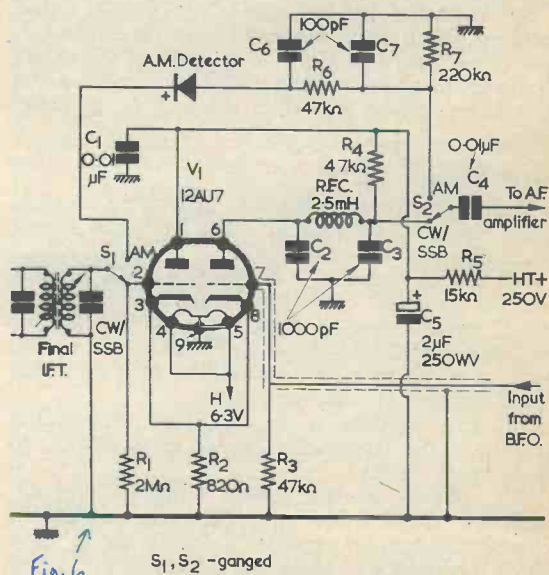

Fig. 4. A beat frequency oscillator suitable for s.s.b. reception

here as the b.f.o. since this is the more common title.<sup>4</sup>

The output of the b.f.o. is taken to the a.m. detector via a small value capacitor. An s.s.b. signal is tuned in, for maximum volume, and the b.f.o. is then adjusted through the i.f. passband until

<sup>4</sup> In a receiver which is not designed for s.s.b. reception it is possible to obtain somewhat poor s.s.b. demodulation by employing the b.f.o. which is fitted for the reception of c.w. signals. S.S.B. demodulation then takes place in the diode detector, but the system suffers from the main disadvantage that b.f.o. amplitude at the detector is small, relative to sideband amplitude. Much better results are given if a higher level b.f.o. signal is fed to a detector (such as a product detector) which is specifically intended for s.s.b. demodulation.—EDITOR.



### Components List (Fig. 5)

R <sub>1</sub>	5kΩ 5 watts
C <sub>1</sub>	0.01μF ceramic
V <sub>1</sub>	VR150/30

the signal becomes intelligible. The correct frequency of the b.f.o. will normally be  $\pm 2$  kc/s of the nominal i.f. frequency, depending on whether the upper or lower sideband is being radiated by the transmitter. A large proportion of short wave listeners use this inferior method of reinserting the carrier, and are in the main disappointed by the results obtained, mainly because their b.f.o.'s are not usually stable enough and, secondly, because the degree of reinsertion by the b.f.o. is, nine times out of ten, not flexible. To overcome some of these carrier insertion difficulties, the product detector was developed. This is a mixer-type demodulator allowing the reception of s.s.b. to be less critical than with the previous method, and it also produces a minimum of distortion of the audio output. The b.f.o. frequency stability is of course still critical but, providing care is taken with its layout and construction, no difficulties should arise as the operative frequency is quite low.

### Components List (Fig. 4)

#### Resistors

R <sub>1</sub>	Part of coil unit
R <sub>2</sub>	10kΩ $\frac{1}{2}$ watt

#### Capacitors

C <sub>1</sub> , C <sub>2</sub> , C <sub>3</sub>	Part of coil unit
C <sub>4</sub>	100pF ceramic
VC <sub>1</sub>	50pF variable air-spaced

#### Inductor

L <sub>1</sub>	Part of coil unit Type HSO 460 (Electroniques (Felixstowe) Ltd.)
----------------	--

#### Valve

V <sub>1</sub>	6C4
----------------	-----

### The B.F.O.

Fig. 4 shows the circuit of a simple beat frequency oscillator. A suitable coil unit, type HSO 460, may be obtained from Electroniques (Felixstowe) Ltd. This unit incorporates all the components contained within the dotted lines except V<sub>1</sub>, VC<sub>1</sub> and C<sub>4</sub>, and

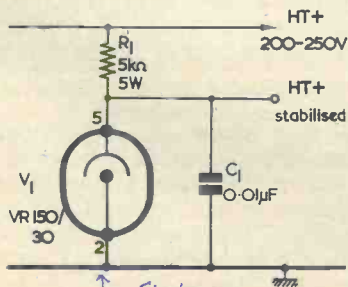

Fig. 5. A product detector

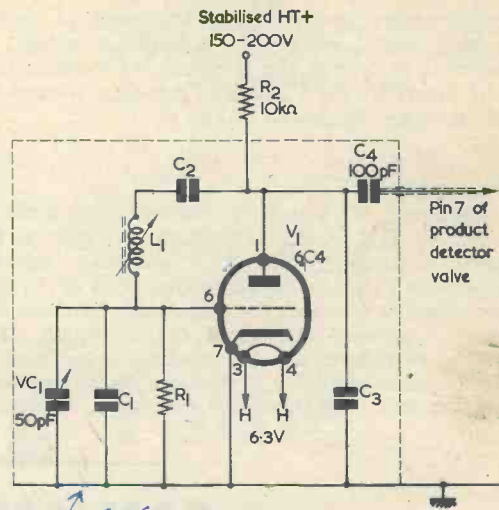

Fig. 4. A simple method of obtaining a source of stabilised h.t.

### Components List (Fig. 6)

#### Resistors (all $\frac{1}{2}$ watt types)

R <sub>1</sub>	2MΩ 10%
R <sub>2</sub>	820Ω 10%
R <sub>3</sub>	47kΩ 10%
R <sub>4</sub>	47kΩ 10%
R <sub>5</sub>	15kΩ
R <sub>6</sub>	47kΩ
R <sub>7</sub>	220kΩ

#### Capacitors

C <sub>1</sub>	0.01μF ceramic
C <sub>2</sub>	1,000pF ceramic
C <sub>3</sub>	1,000pF ceramic
C <sub>4</sub>	0.01μF paper
C <sub>5</sub>	32μF 250V wkg electrolytic
C <sub>6</sub>	100pF ceramic
C <sub>7</sub>	100pF ceramic

#### Inductor

RFC	2.5mH
-----	-------

#### Valve

V <sub>1</sub>	12AU7
----------------	-------

#### Switch

	2-pole 2-way switch
--	---------------------

will operate within the range 410–515 kc/s. For other intermediate frequencies alternative units are available. C<sub>4</sub> is a 100pF capacitor and must be connected as close as possible to pin 1 on V<sub>1</sub>. This unit must be completely screened, including V<sub>1</sub>, and situated as close as possible to the product detector. Not only is it necessary for the b.f.o. to be very stable in frequency—just as much depends on the stability of the receiver's local oscillator. An additional precaution to ensure optimum stability is attained, after all other factors have been taken into

consideration, by providing a stabilised h.t. supply to both these oscillators. A suitable method of obtaining this, from the receiver's h.t. positive line, is by incorporating a gas-filled regulator tube in the configuration illustrated in Fig. 5.

### Product Detector

The circuit of a suitable product detector is shown in Fig. 6. This works on the same principle as the receiver's frequency changer. The b.f.o. and i.f. signals are fed into the respective grids of  $V_1$  and the difference between the frequencies of these two signals represents the audio output which, after filtering to remove any r.f. content, is fed straight into the audio amplifier. Fig. 6 also shows a suitable a.m. detector, together with a.m./s.s.b. switching.

The layout of this unit is not critical; but it is advisable to keep the wiring symmetrical, similar to the circuit diagram, and screened from the a.f. amplifier.

The operation of the product detector is quite straightforward. An s.s.b. signal is tuned in for maximum volume. The b.f.o. is tuned through the i.f. passband until the signal becomes readable. Should the audio output sound distorted on a very strong signal, the r.f. gain controls should be reduced. It will be found that, when using a product detector, the audio output will be much clearer and the b.f.o. input less critical, than with the comparatively primitive method of injecting the b.f.o. signal into the a.m. detector. Also, it must be noted that the product detector is only suitable for demodulating c.w. and s.s.b.

## CAN ANYONE HELP?

*Requests for information are inserted in this feature free of charge, subject to space being available. Users of this service undertake to acknowledge all letters, etc., received and to reimburse all reasonable expenses incurred by correspondents. Circuits, manuals, service sheets, etc., lent by readers must be returned in good condition within a reasonable period of time.*

**R1132A Receiver.**—F. H. Ladd, 4 Wellington Close, Melbourne Park, Chelmsford, Essex, requires the loan or purchase of the handbook, circuit, or any other available information.

\* \* \*

**Bendix RA10DB Receiver.**—C. F. Scammell, 79 Stonehill Road, Leigh-on-Sea, Essex, wants the loan of a circuit for this receiver.

\* \* \*

**Control, Radar Set 435-20-3001A.**—J. Coward, 61 Woodcrest Road, Purley, Surrey, wishes to obtain any information on both this and the Indicator 435-70-2001 by Hughes Aircraft Co.

\* \* \*

**Ecko Car Radio Model CR61.**—C. Pearson, 15 Tyrone Street, South Yarra, Melbourne, Victoria, Australia, would like to obtain the circuit or any other information.

\* \* \*

**R107 Receiver.**—J. Sartorius, 88 Urmsom Road, Wallasey, Cheshire, wishes to obtain the manual, borrow or purchase.

\* \* \*

**BC624A Receiver.**—F. H. Sweetland, 3d Gillam Road, Northbourne, Bournemouth, Hants, would appreciate loan of the manual.

\* \* \*

**Stella TV ST1023U.**—J. F. Warburton, 40 Hall Green, Malvern, Worcs, wishes to purchase, or obtain on loan, the service manual or circuit diagram.

\* \* \*

**National HRO Receiver.**—L. J. Carpenter, 22

Regency Road, Malvern Link, Worcestershire, would like to obtain information on fitting electrical bandspread to 7 to 14.4 and 1.7 to 4 Mc/s general coverage coils.

\* \* \*

**GB Film Projector Model L516.**—E. Brayshaw, 351 Halifax Road, Cross Roads, Keighley, Yorks, requires to purchase the service manual and circuit diagram of the sound system.

\* \* \*

**Cossor Oscillograph Model No. 339A.**—P. C. Hunt, The Vicarage, Colston Bassett, Notts, would be pleased to receive the circuit, or any other information, either on loan or purchase.

\* \* \*

**McMichael Model 135 Receiver.**—B. Lloyd, 19 Melbourne Road, Llanishen, Cardiff, would like to receive the circuit diagram.

\* \* \*

**HMV AM/FM Receiver Model 1128.**—A. K. Clarke, 64 Goldcroft Road, Weymouth, Dorset, wishes to obtain loan or purchase of service manual or circuit diagram.

\* \* \*

**Induction Disc Motor.**—R. Woolnough, 72 The Commons, Welwyn Garden City, Herts, wishes to contact anyone possessing a gram using this type of motor.

\* \* \*

**Oscilloscope Timebase Circuit.**—R. Goryton, 23 Thornton Hill, Exeter, Devon, requires a circuit capable of sweep speeds of 2–10 secs/cm.



The thirty-sixth in a series of articles which, starting from first principles, discusses the basic theory and practice of radio

part 36

# understanding radio



By W. G. MORLEY

**I**N LAST MONTH'S ARTICLE IN THIS SERIES WE continued our discussion of the moving-coil loudspeaker, commencing by examining the means employed for high frequency diffusion. We then carried on to loudspeaker impedance and resonance, showing how the impedance consists of a combination of coil resistance, inductive reactance and motional impedance. The overall speech coil impedance rises to a maximum at the resonant frequency of the loudspeaker because of the high motional impedance at this frequency. It also tends to rise again, as frequency increases above about 800 c/s, because of increasing inductive reactance. We shall now continue to discuss the questions of resonance and impedance.

## Loudspeaker Resonance And Impedance

Our examination of loudspeaker resonance has shown that speech coil impedance rises to a high level at the resonant frequency of the loudspeaker. It has also shown us that a simple method of finding the resonant frequency, and of obtaining an estimate of cone movement at this frequency, consists of measuring the speech coil impedance over the audio frequency range. It is convenient to be able to check conditions at resonance by measuring impedance, as impedance measurement may be achieved by the relatively simple process of checking the signal voltage applied to the speech coil and the current which flows through it.

The impedance curve of a loudspeaker at frequencies close to resonance becomes altered when we mount the loudspeaker in an enclosure which modifies its functioning at such frequencies. We have already seen this effect in Fig. 224<sup>1</sup> where a loudspeaker was fitted in a reflex enclosure. The pronounced single resonant peak of the loudspeaker response then became altered to two, or more,

smaller peaks. This effect was clearly shown by the impedance/frequency curve for the loudspeaker.

In order that a loudspeaker may be matched to an a.f. amplifier (which provides the audio frequency signals for the speech coil) it is necessary to specify a figure for loudspeaker impedance. However, this requirement conflicts with the fact that the impedance of a loudspeaker is by no means a constant quantity, and that it varies considerably over the range of audio frequencies. This variation is accepted, it being usual practice to quote the impedance which is given at 400 c/s, and to work to this figure for matching purposes. If we refer to the impedance/frequency curve of Fig. 232<sup>2</sup>, we can see that the 400 c/s point appears in the relatively flat trough between the resonant frequency peak and the frequency at which inductive reactance commences to become significant.

Typical loudspeaker nominal impedances which are likely to be encountered in practice are 3Ω, 8Ω and 15Ω. Loudspeakers with nominal impedances of 3Ω are encountered very frequently in radio and television receivers, and in tape recorders and record players. All three impedances may be encountered in loudspeakers intended for high fidelity reproduction. With transistor receivers and transistor a.f. amplifiers it is common practice to employ loudspeakers having much higher nominal impedances, typical figures lying between 25Ω and 75Ω.

The curve shown in Fig. 232 showed an extremely high peak at the resonant frequency of 40 c/s, and it may be thought that the loudspeaker would give a very loud sound at this frequency, thereby providing an obviously unbalanced version of the a.f. signal applied to it. In practice, however, the increase in sound output at the resonant frequency may be much smaller than the curve would lead one to believe.

<sup>1</sup> Published in "Understanding Radio" part 34, July 1964 issue.

<sup>2</sup> Published last month.



Frequency (c/s)

(a)

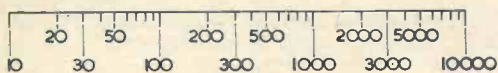

Frequency (c/s)

(b)

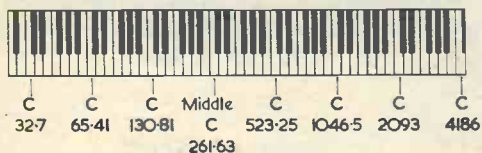

Frequency (c/s)

(c)

**Fig. 233 (a).** A linear scale covering the frequencies from zero to 10,000 c/s

**(b).** A logarithmic scale covering the range of 10 to 10,000 c/s. If this is compared with (a), it will be seen that it allows the details in a loudspeaker response curve around resonance to be more conveniently presented

**(c).** The piano keyboard. Although the ear ascribes equal spacing between the notes, their frequencies increase in logarithmic manner

Let us assume that an a.f. amplifier having a well regulated output voltage at all frequencies is connected to the loudspeaker.<sup>3</sup> At frequencies in the trough of the response curve the impedance of the loudspeaker is low, and a relatively high current flows in the speech coil. The speech coil is then actuated by this high current. At the resonant frequency the impedance of the loudspeaker is very much higher and a considerably smaller current flows in the speech coil. Thus, although the loudspeaker is most efficient (in converting electrical power to sound power) at the resonant frequency, there is a counteracting reduction in speech coil current at this frequency. These two effects do not entirely cancel each other out, but they may typically (and assuming high fidelity equipment) result in an increase in sound output power at resonance which is of the order of 30% only. This situation will worsen if an amplifier with poorer output voltage regulation is employed, because the ratio between the voltage across the speech coil at resonance and that across the speech coil at frequencies in the trough of the curve becomes increased. When a well regulated output is used, the voltage applied to the speech coil is nearly the same both at the resonant frequency and at

<sup>3</sup> The term "well regulated" means that output voltage drops only slightly when output current increases.

frequencies in the trough of the response curve. With a poorly regulated output, the lower current at resonance results in a considerably higher voltage across the speech coil at this frequency than occurs at trough frequencies. There is, therefore, a proportionate increase in the power consumed by the speaker at resonance as compared with that at frequencies in the trough. A corresponding increase in sound output at the resonant frequency then becomes evident.

The loudspeaker we have employed as a basis for our discussion on impedance has a resonant frequency at 40 c/s. This is representative of what is offered by large loudspeakers intended for high fidelity reproduction, and the loudspeaker would probably give an adequate performance on its own when connected to a high fidelity amplifier. It would also be a very satisfactory woofer for a woofer and tweeter combination.

All mechanical objects capable of vibration tend to exhibit a natural resonant frequency, and this fact applies to the cone and speech coil assembly of a moving-coil loudspeaker. In the instance we have discussed, the loudspeaker will have been purposely designed to have a natural resonant frequency at 40 c/s. Apart from the necessity for a large cone, adequate reproduction of the very low audio frequencies requires relatively large movements in the speech coil. The existence of a resonance at 40 c/s assists in providing these large speech coil movements. Careful design of the associated equipment (amplifier and enclosure) is still needed, however, if sound output at the resonant frequency is not to be over-accentuated. Because of its single resonant peak the loudspeaker we have been discussing might, perhaps, offer rather disappointing results when mounted on a flat baffle, whereas it could give an excellent performance when its response curve is modified by fitting it in a well-designed reflex enclosure.

Loudspeakers designed for normal radio and television receivers and the like are not intended to give by any means the same standard of reproduction, and they are smaller and cheaper than the type we have just examined. These loudspeakers still exhibit resonant frequencies and, partly because of the use of smaller cones, these may extend well into the audio frequency range. Resonant frequencies above 150 c/s tend to increase the apparent sensitivity of the loudspeaker. With some inexpensive loudspeakers, the cone and speech coil assembly may be designed such that peaks in the response appear, also, above 1,000 c/s, whereupon there is an increase in apparent sensitivity at the higher frequencies. These techniques are not, of course, compatible with high fidelity reproduction, but they enable a generally acceptable quality of reproduction to be achieved in low cost equipment.

#### Logarithmic Frequency Scale

In loudspeaker response curves, the horizontal frequency axis is always graduated with a logarithmic scale instead of a linear scale. In the latter

instance, the graduations would be evenly spaced, as occurs in Fig. 233 (a). With the logarithmic scale, as shown in Fig. 233 (b), there is not an even scale, and the same spacing occurs between the 10 c/s and 100 c/s points as occurs between the 100 c/s and 1,000 c/s points.

Also, the same spacing exists between numbers having the same ratios. Thus, the spacing between 100 and 300 is the same as that between 300 and 900. There is, similarly, the same spacing between 50 and 100 as there is between 100 and 200, 200 and 400, 400 and 800, and so on. This logarithmic spacing is, incidentally, the same as that employed for the scales of a slide rule.

It will be interesting to digress for a moment to see what particular advantages accrue from the use of a logarithmic scale with loudspeaker response curves.

Apart from any other factor, logarithmic graph scales can be of considerable use when the associated co-ordinates cover a wide range. A typical audio frequency response curve may extend from 10 c/s to 10 kc/s, whereupon the highest figure is no less than 1,000 times the lower figure. Where there is a great deal of detail in the lower frequency part of the curve, as occurs around the resonant frequency of a loudspeaker, this is automatically "opened out" by the use of the logarithmic scale.

In the present instance there is another advantage to using logarithmic graduations for the frequency scale. Fig. 233 (c) shows the piano keyboard and it will be noted that the frequency of each C is twice that of the C an octave below. However, so far as our perception of frequency is concerned, there are twelve semitones difference between any two neighbouring C's. Our perception tells us, therefore, that all the C's are equally spaced along the keyboard, even though we know that their frequencies become doubled as we go up from one octave to the next. When the frequencies corresponding to the C's are examined, we find we have the same type of spacing as occurs along the logarithmic scale of Fig. 233 (b).

The logarithmic scale employed for depicting frequency for a loudspeaker response curve has, therefore, the further advantage that it presents audio frequencies in the same manner as such frequencies are perceived by the ear. We may, in consequence, obtain from the response curve an accurate idea of how the loudspeaker will sound.

### Restoring Force

When a current flows in the speech coil of a loudspeaker, the coil is displaced from its position at rest. The force displacing the speech coil acts against the *restoring force*, which is provided almost entirely by the speech coil centring device. (The surround of the cone may provide a small proportion of this restoring force also, particularly when there are large movements of the cone.) The amount of speech coil displacement depends, therefore, on the current flowing through the coil and the

magnitude of the restoring force.

If the loudspeaker is to reproduce a true copy of the electrical signal applied to it, speech coil displacement should be equal to the amplitude of the signal at any instant. This necessitates the provision of a *linear* restoring force; i.e. the centring device should provide a restoring force which varies in direct proportion to speech coil displacement. Whilst it is a relatively simple matter to design a centring device which offers a linear restoring force for small movements of the speech coil, it is much more difficult to design for linear restoring force when there are large movements of the coil. The mechanics of the loudspeaker assembly dictate that the restoring force must inevitably become non-linear at some displacement of the speech coil.

A loudspeaker intended for high fidelity reproduction should have a reasonably linear restoring force (over the audio frequency range) for all speech coil displacements the loudspeaker is designed to handle. This design criterion can

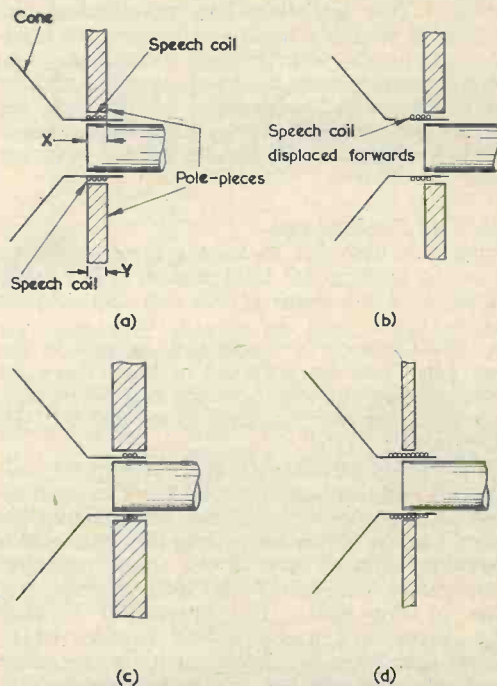

Fig. 234 (a). In this diagram the length of the speech coil (dimension "X") is approximately equal to the depth of the magnet gap (dimension "Y")  
 (b). The result of the equal dimensions in (a) is that part of the winding leaves the gap whenever the speech coil is displaced, whereupon speech coil displacement is not proportional to current  
 (c). Linear speech coil displacement may be achieved by shortening the coil and increasing the depth of the gap  
 (d). An alternative approach consists of lengthening the coil and decreasing the depth of the gap. In this case, the number of coil turns in the gap remains constant

then be satisfied in subsequent use by specifying a maximum power figure for the loudspeaker. If the signal from the associated a.f. amplifier exceeds this figure, speech coil displacement becomes too high and the restoring force becomes markedly non-linear. The loudspeaker then produces a seriously distorted copy of the electrical signal applied to it. If the power figure is grossly exceeded, the loudspeaker will, of course, suffer damage.

With cheaper loudspeakers, as are fitted to radio and television receivers, the linearity of the restoring force is not expected to meet the standards required for high fidelity reproduction. Nevertheless, the restoring force should be reasonably linear for small displacements of the speech coil. Sometimes the restoring force components may be purposely designed to give non-linearity, with the result that restoring force increases by disproportionately large amounts with increases in speech coil displacement. Relatively high power signals may in consequence be fed to the loudspeaker before the latter suffers damage, but they are reproduced with considerable distortion. This technique has, nevertheless, the advantage of enabling small and inexpensive loudspeakers to handle large powers without damage, and the distortion only becomes excessive at high signal levels. With loudspeakers of this type, the maximum power specified may refer to the maximum the loudspeaker can handle without suffering damage.

#### Speech Coil Displacement

Whilst it is desirable to have a linear restoring force in the moving-coil loudspeaker, it is equally desirable to have a linear speech coil displacement force.

Fig. 234 (a) show a speech coil at rest in the magnet gap. For the purposes of illustration, we will assume that the length of the coil (dimension "X") is approximately the same as the depth of the gap (dimension "Y").

In Fig. 234 (b) we pass a current through the coil, causing it to be displaced forward from its position of rest. It will be obvious that, whereas in Fig. 234 (a) all of the coil is in the magnetic field which appears immediately between the centre pole and the pole-pieces, in Fig. 234 (b) only half the coil appears in this field. The interaction between electric current and magnetic field strength which provides speech coil displacement is therefore reduced, and the coil has not undergone the full displacement from its position of rest which we require of it. With the coil length and gap depth dimensions shown in Figs. 234 (a) and (b), increasing

coil currents do not result in proportionate displacements of the coil, because the interaction between coil current and magnetic field reduces as the coil moves away from its position of rest. Speech coil displacement becomes, therefore, non-linear.

One method of overcoming this undesirable state of affairs consists of decreasing the length of the coil and increasing the depth of the gap, as shown in Fig. 234 (c). Provided that no part of the coil passes beyond the edges of the pole-pieces when a signal is applied, the coil will always be in a uniform magnetic field, and its displacement will be proportional to coil current. The speech coil displacement then becomes linear.<sup>4</sup>

Another approach towards obtaining linear speech coil displacement is shown in Fig. 234 (d). In this case the coil length is made considerably greater than the gap depth. Provided that, when a signal is applied, the ends of the coil do not pass inside the edges of the pole-pieces, a constant number of coil turns then appear in the magnetic field.

Both the approaches shown in Figs. 234 (c) and (d) are employed in practical loudspeakers to ensure linear speech coil displacement. The method shown in Fig. 234 (d) is particularly common with cheaper loudspeakers, since the provision of a long coil is a relatively inexpensive process. It suffers from the disadvantage that efficiency is lost since some of the turns in the coil do not offer any useful contribution towards coil displacement. There is also the fact that the speech coil assembly is heavier than occurs in Fig. 234 (c), whereupon the resultant mechanical inertia may reduce high frequency response.

The technique of Fig. 234 (c) is more efficient and it employs a light speech coil assembly. However, the wide gap depth necessitates a stronger magnetising force to maintain the required flux density in the gap. Larger pole-pieces are also needed; these tend to be expensive in themselves and they require to be machined over a larger area at the gap face.

#### Next Month

In next month's issue we shall conclude on the subject of moving-coil loudspeakers by dealing with magnet types and strengths. If space permits, we shall then carry on to a brief examination of other types of loudspeakers.

<sup>4</sup> To be precise, no part of the speech coil of Fig. 234 (c) should too closely approach the edges of the pole-pieces if accurately linear displacement is required. This is because the field at the pole-piece edges tends to spread outwards, and is slightly weaker than at the central section of the gap.

### Royal College of Science and Technology, Glasgow, Places Solartron's Fourth Large Computer Order for 1964

A large general purpose Analogue Computer, Type 247, costing approximately £19,000, has been ordered by the Royal College of Science and Technology, Glasgow, from the Solartron Electronic Group Ltd., Farnborough, Hampshire.

This is the fourth large 247 Computer to be ordered this year. The other three are already installed at the University of Sheffield, College of Science and Technology, Manchester, and Battersea College of Advanced Technology.

The Glasgow computer will be installed in the Electrical Engineering Department and will be used for the investigation of Automatic Control Systems and General Research.

# Modulated-Light Transmitter and Receiver

By M. J. Banthorpe

Another successful modulated-light system

**T**HIS ARTICLE GIVES DETAILS OF A modulated-light transmitter and receiver which was constructed by the author for experimental purposes. The general principle of operation is shown, in block diagram form, in Fig. 1.

## The Transmitter

A 3 to 5 watt amplifier, or the output stage of a domestic valve radio (with the input fed to the gram sockets), is used to amplify the signal from a crystal microphone.\* The speaker is disconnected from the secondary of the output transformer and, in its place, is connected a battery and a 2.5 volt flashlamp bulb mounted in a reflector. (See Fig. 2.) A car headlamp reflector is suitable for this purpose. Care should be taken not to use the amplifier without

\* It may be necessary to use a single valve pre-amplifier to obtain sufficient gain, if the a.f. section of a radio receiver is employed. Although this is not, of course, a high fidelity application, the crystal microphone should still work into a fairly high input resistance for best results. Quality could be judged with the loudspeaker before coupling up the lamp and 1.5 volt cell.—**ERROR**.

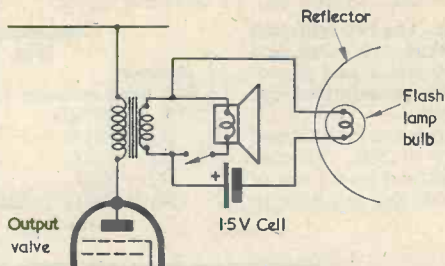

Fig. 2. Coupling the transmitting lamp to the output stage of the microphone amplifier

either the speaker or bulb connected, as this may cause excessive voltages to appear across the primary of the output transformer.

## The Receiver

An OCP71 phototransistor was chosen as the photo-sensitive element because of its high sensitivity, rapid response and general availability. The circuit of the receiver is shown in Fig. 3.

The OCP71 phototransistor is mounted in a reflector similar to that used at the transmitter. The circuit consists of the phototransistor stage followed by a conventional 3-transistor 250mW amplifier. If desired, a 250Ω earpiece may be substituted for the primary winding of the driver transformer, T<sub>1</sub>, and the push-pull output stage omitted.

## Operation

The signal voltage in the secondary winding of the output transformer at the transmitter causes the light output of the bulb to fluctuate accordingly. The light fluctuations are sensed by the phototransistor and converted back to sound signals. Since the filament of the bulb does not cool down instantaneously when it is not receiving current, signals above 2 to 3 kc/s cannot be transmitted. Some bulbs work better in this respect than others and it is best to experiment with several types to find that which is most satisfactory. The quality of reproduction, although poor, permits the transmission of

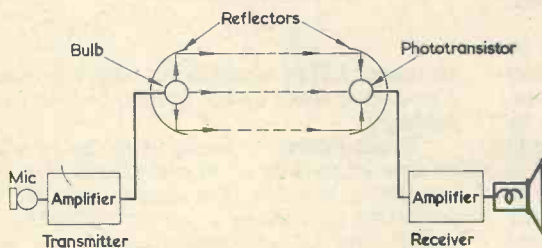

Fig. 1. The essentials of a light-modulated communication system

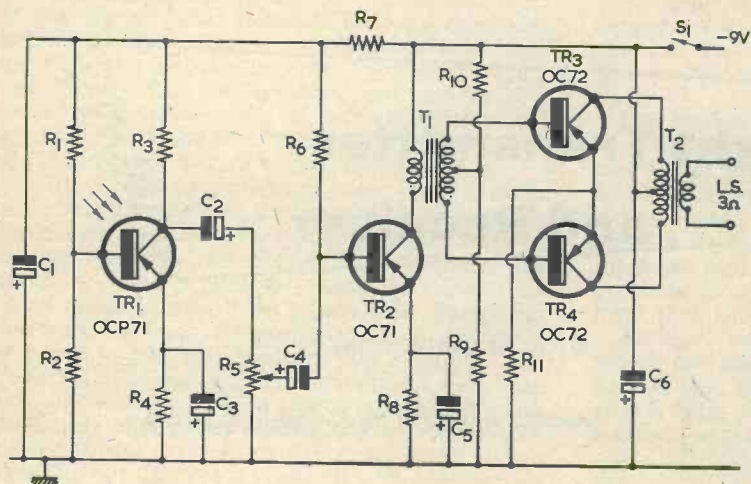

Fig. 3. The circuit of the receiver

- R<sub>6</sub> 33kΩ
- R<sub>7</sub> 470Ω
- R<sub>8</sub> 1kΩ
- R<sub>9</sub> 220Ω
- R<sub>10</sub> 5.6kΩ
- R<sub>11</sub> 4.7Ω

**Capacitors**

- C<sub>1</sub> 100μF electrolytic 12V wkg.
- C<sub>2</sub> 2μF electrolytic 12V wkg.
- C<sub>3</sub> 8μF electrolytic 6V wkg.
- C<sub>4</sub> 4μF electrolytic 6V wkg.
- C<sub>5</sub> 50μF electrolytic 6V wkg.
- C<sub>6</sub> 100μF electrolytic 12V wkg.

**Transformers**

- T<sub>1</sub> Driver transformer type D.3034 (Ardente)
- T<sub>2</sub> Output transformer type D.3035 (Ardente)

**Transistors**

- TR<sub>1</sub> OCP71
- TR<sub>2</sub> OC71
- TR<sub>3, 4</sub> OC72 (matched pair)

**Switch**

- S<sub>1</sub> s.p.s.t., on-off

**Loudspeaker**

- 3Ω impedance

**Battery**

- 9 volt battery

intelligible speech. The two reflectors must be in line with each other, and the positions of the bulb and photo-transistor should be adjusted for maximum response.

Intelligible speech can be obtained at a range of 15 to 20ft. Greater ranges can be obtained by the use of higher output from the amplifier to the bulb.

**Components List**  
(Fig. 3)

**Resistors**

(All fixed resistors ¼ watt 10%)

- R<sub>1</sub> 180kΩ
- R<sub>2</sub> 10kΩ
- R<sub>3</sub> 10kΩ
- R<sub>4</sub> 1kΩ
- R<sub>5</sub> 50kΩ potentiometer, log track

**TRADE REVIEW . . .**

**“Eyelet-Board” A Versatile Matrix Board**

A VERSATILE NEW PRODUCT, “EYELET-BOARD”, IS now available to home-constructors, laboratories, colleges and schools. This comprises a laminated insulating board perforated with 200 holes, into which tinned brass eyelets may be inserted at any position. The board is available in 4½ x 2½in only, and the 200 holes appear in a rectangular pattern of 10 x 20. Spacing between holes is 0.2in. An idea of the hole layout may be obtained from the accompanying illustration of one end of a board.

After insertion, the eyelets are held in place by the application of a centre-punch, whereupon they provide junctions for connections between components and wiring, etc. The samples checked by ourselves tinned instantly as soon as a soldering iron was applied. Since the eyelets may be inserted in any position, a practical layout can approximate to the theoretical circuit. Alternatively, any other component layout capable of being accommodated on the board can be used. A feature of the product is that the use of eyelets makes it easier to unsolder components. There is, of course, no risk of damage



to copper foil as would occur with a printed circuit. Component leads do not have to be bent over before soldering.

“Eyelet-Board” is available in the 4½ x 2½in size, as also are packets of 40 eyelets and 4½ x 2½in plain insulating boards. The latter may be used for insulating or backing a perforated board. Further details and samples are available (on receipt of stamped addressed envelope) from R. and E. Lamb, Electronic Assemblies, 17 Queens Road, Leytonstone, London, E.11.



# Timebase

# EXPANSION

## Generator

By J. R. Knight

An ingenious design which enables part of an oscilloscope trace to be expanded at will

THE INSTRUMENT TO BE DESCRIBED WAS DEVELOPED to enable the author to carry out detailed examination of narrow pulses at low repetition frequencies in connection with control circuit transients, and without serious modification to the oscilloscope used. Timebase amplification was ruled out because it did not permit the whole waveform of one cycle to be viewed at once. For a similar reason, running a timebase at a multiple of the input frequency was also rejected. This left only the "strobe timebase" method, whereby the spot on the screen is speeded up for a portion of the trace. Fig. 1 illustrates the effect of expanding part of a series of sine waves. Fig. 2 (b) shows how a strobe timebase can achieve this: the strobe timebase is an auxiliary timebase which delivers one cycle at a predetermined point on the main timebase waveform, during each sweep of the scan. Note, however, that part of the trace is "lost" during the strobe flyback; the effect is to fold it back under the portion of the picture which has been expanded, and this may cause confusion.

### Ideal Timebase Expansion

The ideal timebase expansion waveform is shown in Fig. 2 (c) and this is obtained with the author's

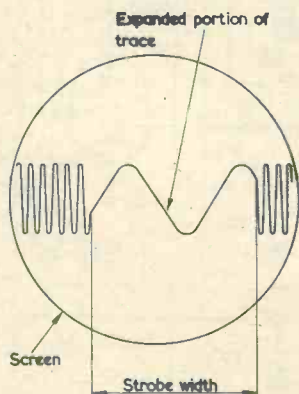
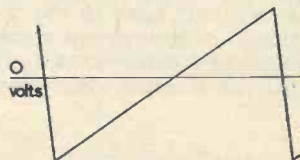

Fig. 1. Illustrating a portion of a sine wave display expanded by a strobe timebase under ideal conditions

design. It is possible to modify a Miller timebase so that the run down rate can be altered at different parts of the sweep; but this idea was discarded since, although the author's oscilloscope employs a Miller timebase, a major circuit modification is required. Fig. 3 shows, in block form, the final circuit adopted by the author. Note that the only



Timebase sawtooth voltage waveform

(a)

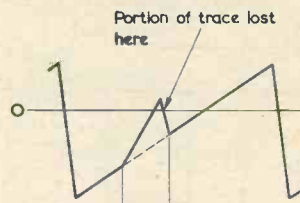

Expanded portion

Strobed timebase

(b)

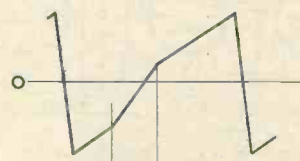

Expanded portion

Ideal timebase expansion

(c)

Fig. 2. The effect on the timebase sawtooth waveform of expansion under two different conditions

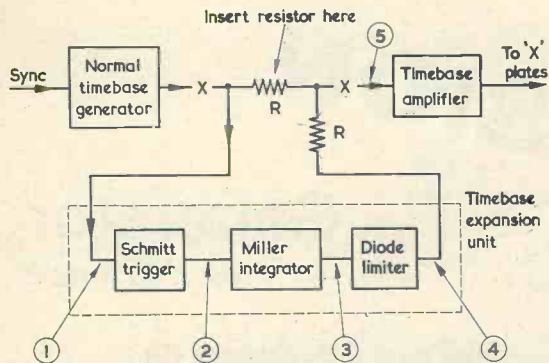

Fig. 3. Block diagram illustrating the modification to the existing circuit of the oscilloscope

alteration to the oscilloscope circuit is the inclusion of a resistor in the timebase feed. Fig. 4 shows the waveforms at the numbered points indicated in Fig. 3. The actual circuit is shown in Fig. 5.

### Schmitt Trigger

The timebase sawtooth input in Fig. 5 is used to operate the Schmitt trigger circuit comprising  $V_1$  and  $V_2$ . When the grid potential of  $V_1$  rises above cut-off potential, at a point determined by the

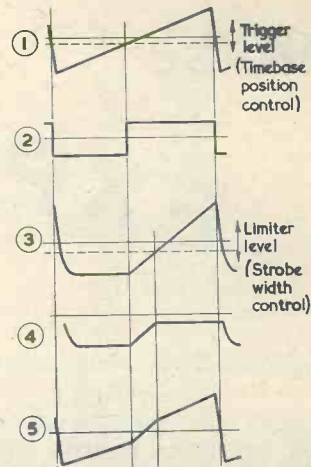

Fig. 4. The waveforms obtained at the numbered points indicated in Fig. 3

trigger level setting of the Pulse Position control, a cumulative action is set up which results in a square wave output at the anode of  $V_2$ . The square wave is terminated when the timebase voltage falls below the trigger level during flyback. This pulse drives  $V_3(a)$  and causes it to conduct.

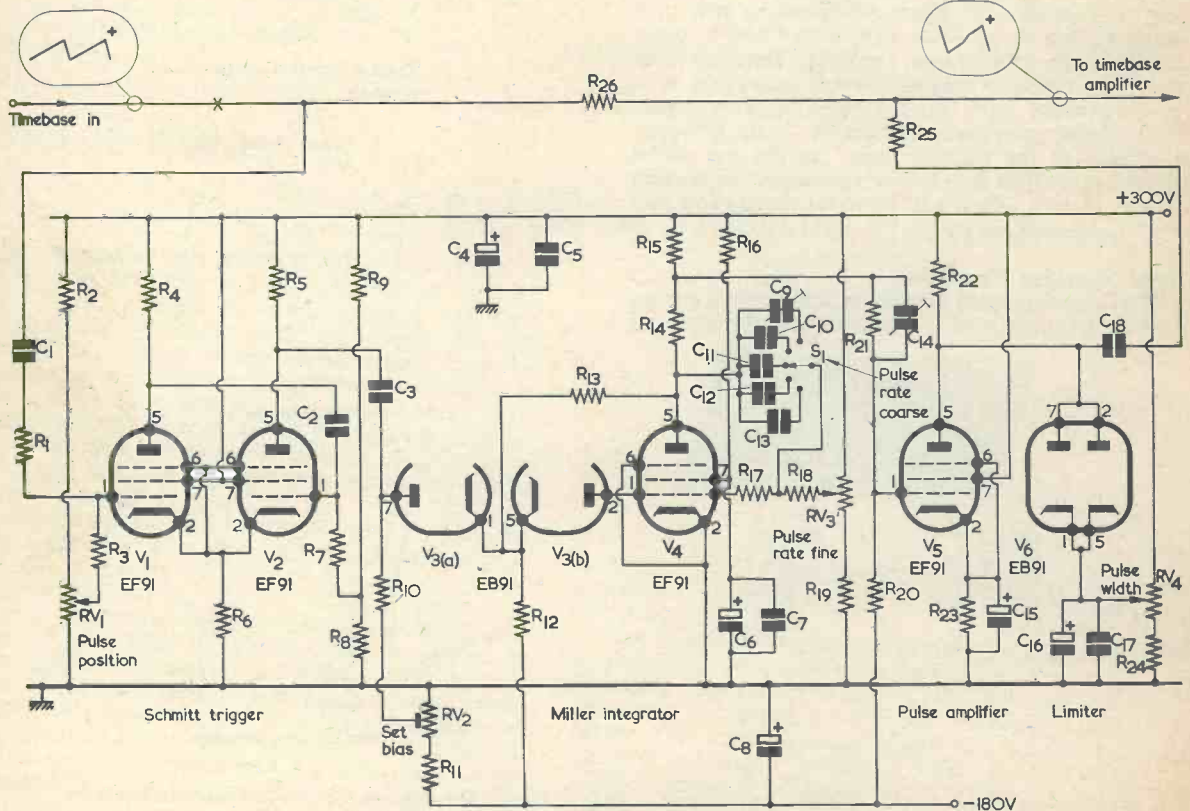

Fig. 5. The complete circuit diagram of the timebase expansion generator

### Miller Integrator

The pulse from V<sub>2</sub> anode would normally be used to lift a cut-off bias on the suppressor of the Miller valve V<sub>4</sub>. However, this causes an initial step in the output sawtooth, which is undesirable in the present application; instead, a bias is provided via V<sub>3(b)</sub> and R<sub>12</sub> which cuts off the Miller valve, and this is lifted by the incoming pulse, via V<sub>3(a)</sub>. The step is thus eliminated.

The Miller valve next runs down at a rate determined by the setting of the Pulse Rate controls, and a negative-going sawtooth is taken from the junction of R<sub>14</sub> and R<sub>15</sub> and passed to V<sub>5</sub>. The end of the run down is caused either by V<sub>4</sub> bottoming or the termination of the gating square wave, whichever occurs first; the flyback then takes place on the termination of the gating pulse.

### Pulse Amplifier

The pulse amplifier, V<sub>5</sub>, serves merely to invert the sawtooth from V<sub>4</sub>. C<sub>14</sub> is set to give the best possible sawtooth across R<sub>22</sub>. V<sub>6</sub> clamps the sawtooth as soon as it exceeds the potential set by RV<sub>4</sub>, the Pulse Width control. The flat-topped sawtooth then passes via C<sub>18</sub> to the junction of R<sub>25</sub>

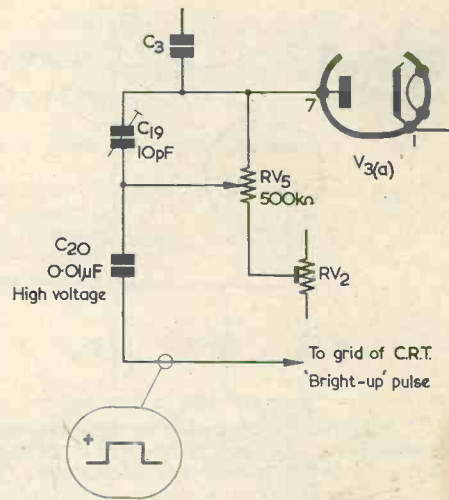

Fig. 6. A modification which allows the application of a bright-up pulse. In this diagram, RV<sub>5</sub> replaces R<sub>10</sub>, whilst C<sub>19</sub> and C<sub>20</sub> are additional components

### Components List (Fig. 5)

#### Resistors

(All fixed values  $\frac{1}{4}$  watt 10% unless otherwise stated)

R <sub>1</sub>	100k $\Omega$
R <sub>2</sub>	100k $\Omega$ $\frac{1}{4}$ watt
R <sub>3</sub>	100k $\Omega$
R <sub>4</sub>	18k $\Omega$ 1 watt
R <sub>5</sub>	18k $\Omega$ 1 watt
R <sub>6</sub>	15k $\Omega$ 1 watt
R <sub>7</sub>	100k $\Omega$
R <sub>8</sub>	150k $\Omega$ $\frac{1}{4}$ watt
R <sub>9</sub>	100k $\Omega$ $\frac{1}{4}$ watt
R <sub>10</sub>	470k $\Omega$
R <sub>11</sub>	330k $\Omega$
R <sub>12</sub>	150k $\Omega$ $\frac{1}{4}$ watt
R <sub>13</sub>	220k $\Omega$ $\frac{1}{4}$ watt
R <sub>14</sub>	33k $\Omega$ $\frac{1}{4}$ watt
R <sub>15</sub>	68k $\Omega$ $\frac{1}{4}$ watt
R <sub>16</sub>	47k $\Omega$ $\frac{1}{4}$ watt
R <sub>17</sub>	330k $\Omega$
R <sub>18</sub>	1.5M $\Omega$ 5%
R <sub>19</sub>	100k $\Omega$
R <sub>20</sub>	120k $\Omega$
R <sub>21</sub>	100k $\Omega$
R <sub>22</sub>	10k $\Omega$ 1 watt
R <sub>23</sub>	10k $\Omega$ 1 watt
R <sub>24</sub>	100k $\Omega$
R <sub>25</sub>	100k $\Omega$
R <sub>26</sub>	100k $\Omega$
RV <sub>1</sub>	250k $\Omega$ lin track
RV <sub>2</sub>	100k $\Omega$ preset lin track
RV <sub>3</sub>	2M $\Omega$ lin track
RV <sub>4</sub>	250k $\Omega$ lin track

#### Capacitors

(All 350V wkg. unless otherwise stated)

C <sub>1</sub>	0.25 $\mu$ F
C <sub>2</sub>	0.05 $\mu$ F
C <sub>3</sub>	0.1 $\mu$ F
C <sub>4</sub>	16 $\mu$ F electrolytic
C <sub>5</sub>	0.01 $\mu$ F
C <sub>6</sub>	8 $\mu$ F electrolytic
C <sub>7</sub>	0.01 $\mu$ F
C <sub>8</sub>	8 $\mu$ F electrolytic 250V wkg.
C <sub>9</sub>	40pF trimmer (see text)
C <sub>10</sub>	50pF
C <sub>11</sub>	200pF
C <sub>12</sub>	1,000pF
C <sub>13</sub>	0.01 $\mu$ F
C <sub>14</sub>	10pF trimmer (see text)
C <sub>15</sub>	20 $\mu$ F electrolytic 200V wkg.
C <sub>16</sub>	16 $\mu$ F electrolytic
C <sub>17</sub>	0.01 $\mu$ F
C <sub>18</sub>	0.25 $\mu$ F

#### Valves

V <sub>1</sub>	EF91 Mullard, 6AM6, Z77
V <sub>2</sub>	EF91 Mullard, 6AM6, Z77
V <sub>3</sub>	EB91 Mullard, 6AL5, 6D2
V <sub>4</sub>	EF91 Mullard, 6AM6, Z77
V <sub>5</sub>	EF91 Mullard, 6AM6, Z77
V <sub>6</sub>	EB91 Mullard, 6AL5, 6D2

(Note: V<sub>1</sub>, V<sub>2</sub>, V<sub>4</sub>, V<sub>5</sub> may be Z66 or SP61. V<sub>3</sub>, V<sub>6</sub> may be 6H6. V<sub>3(a)</sub>, (b) may be EA50.)

#### Switch

S <sub>1</sub>	Single pole, 5-way, ceramic
----------------	-----------------------------

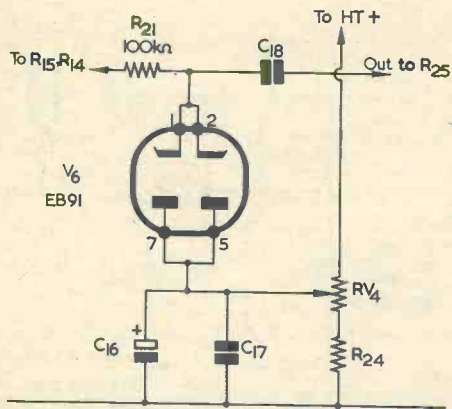

Fig. 7. Modification for use when the timebase input is negative-going. Operation is described in the text. (C<sub>14</sub> across R<sub>21</sub>, may be added if necessary)

and R<sub>26</sub>, where it is additively combined with the main timebase input to give the required waveform.

#### Bright-up Pulse

Where very rapid strobing is used, a "bright-up" pulse may be fed to the grid of the c.r.t. to maintain the brightness during the expanded portion of the trace. The arrangement is shown in Fig. 6, in which diagram C<sub>19</sub> and RV<sub>5</sub> are set for best results. This bright-up pulse may be used to emphasise the expanded portion of the trace for demonstration purposes. An alternative bright-up pulse could be taken from the anodes of V<sub>6</sub> via a differentiating circuit, but this has not been tried by the author.

#### Modification for Negative Timebase

Many timebase circuits give a negative-going output sawtooth; in this case the gating waveform is taken from V<sub>1</sub> anode via C<sub>3</sub>, instead of as shown. In addition, the pulse inverter V<sub>5</sub> is omitted, and the connection to V<sub>6</sub> is taken via R<sub>21</sub> and C<sub>14</sub> direct; R<sub>20</sub> is omitted. Finally, the diode V<sub>6</sub> must be reversed, as the sawtooth is now of opposite polarity; and the circuit becomes that of Fig. 7. These changes are necessary because the strobe output must be of the same polarity as the main timebase input.

#### Construction and Setting-Up

No constructional details are given as these are left to the constructor; however, wiring should be short and direct for all stages, with the minimum possible stray capacitances. Screened cable should not be used. It is recommended that the timebase switch, S<sub>1</sub>, be of the ceramic type. The author's unit was built on Paxolin and fitted in a plain steel case.

RV<sub>2</sub> should be set so that V<sub>3(a)</sub> is reverse biased by about 5 to 10 volts. V<sub>3(b)</sub> should be forward biased; if this is not the case reduce R<sub>12</sub> slightly, then set RV<sub>2</sub>. The highest range of the Miller integrator, V<sub>4</sub>, is set by adjustment of C<sub>9</sub> to give the desired range. C<sub>14</sub> is set to give a good sawtooth

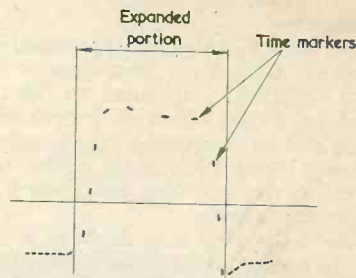

Fig. 8. The appearance of a typical trace when a calibrating waveform is applied to the grid of the oscilloscope tube

across R<sub>22</sub>. The power supply requirements are 300 volts at 50mA for h.t. and 6.3V at 1.8A for heaters when the valves specified are employed. (An increased heater current is needed if Z66 or SP61 valves are employed. The Z66 requires 0.63A at 6.3V and the SP61 requires 0.6mA.)

The 180 volts negative bias line should be stabilised. The author took this supply from a line already present for biasing the d.c. Y amplifier in the oscilloscope, but a simple supply may be furnished by a metal rectifier with good smoothing. Slight alteration of R<sub>12</sub> and R<sub>20</sub> would probably permit the use of a 150 volts negative bias line stabilised by a VR150/30 gas tube.

In operation, the Miller integrator is set to about the same sweep speed as the main timebase; the Pulse Position control is set until the beginning of the expanded portion is in the correct position on the trace, then the Pulse Width control is set for the correct width of the expanded portion. The degree of expansion is next adjusted by altering the run down of the Miller integrator; this may be switched up to the next range if required. The final result, with a little practice, enables the whole of the trace to be seen at once on the screen, and any part of it may be expanded as required. A little experiment with the X shift and X gain controls will also help.

#### Timebase Ranges

The timebase ranges are shown in the accompanying Table.

TABLE  
Timebase Ranges

Range Capacitor (C <sub>9</sub> to C <sub>13</sub> )	Frequency Range	Sweep Time Range
0.01μF	10-100 c/s	100-10mS
1000pF	100-1,000 c/s	10-1mS
200pF	1-10 kc/s	1-0.1mS
50pF	10-100 kc/s	100-10μS
40pF preset	100-500 kc/s	10-2μS

For most purposes, the expansion frequency should be about 10 times the frequency of the main

timebase, i.e. one range higher. For very narrow pulses, expansion frequency may have to be increased to 100 times the main timebase frequency, or even more. The exact position and width of the expanded portion may readily be determined by increasing the bright-up control setting until part of the trace is significantly brighter than the remainder. Turning down the normal brilliance will also help here.

If desired, the width of the pulse may be found by

using a calibrating waveform applied to the grid of the oscilloscope tube, to cause the usual dots to appear. If the number of the dots is  $N$  say, and the calibration frequency is  $F$ , then the length of the

pulse  $T$  (secs.) is given by  $T = \frac{N}{F}$ . Again, some

adjustment of bright-up and brilliance is necessary. The appearance of a trace with a typical pulse is given in Fig. 8, where  $N$  is clearly 10.



This month Smithy the Serviceman, aided as always by his able assistant Dick, embarks on an explanation of the manner in which carbon composition resistors are rated for power dissipation

**O**VER MY BENCH?" SAID SMITHY, horrified. "Never!"

"Well, can I put it over my own bench?"

"Of course you can't. There's too much test gear lying around."

"How about," suggested Dick hopefully, "sticking it up at the racks?"

"Dash it all," snorted the Serviceman, "have a bit of sense! There are sets on the racks which are either in for repair or have already been repaired."

"We could always move them down to the bottom shelves."

"Not a chance," replied Smithy. "The sets stay where they are."

"Then where," wailed Dick, "can I put it?"

Smithy gazed stonily at his assistant and declined to reply.

#### Resistor Dissipation

The pair had arrived at an obvious

impasse. With the usual mug of tea at his side, Smithy the Serviceman munched stolidly at the pilchard sandwiches which constituted his midday repast. His assistant, on the other hand, was too preoccupied with his immediate problems to be interested in lunch.

"Don't be like that, Smithy," wheedled Dick. "I've just got to get a bit of practice in some time today."

"Is it my fault," queried Smithy, "that you've gone and joined the local darts team?"

"I'm only the caller," confessed Dick, "but I may still be required to throw a dart tonight if one of the team doesn't turn up."

"Well, you aren't going to practice here," pronounced Smithy, "and you are definitely not going to hang up that dart board of yours anywhere in *this* Workshop."

Dick carefully examined the Ser-

viceman's expression, and he realised that Smithy's mind was made up. Their lunch hour break had only just commenced, and Dick decided that it might be better to leave the matter for the time being.

"As you like, then," he said grumpily. "I'll have to leave my practice till later on."

Smithy turned a suspicious eye on his assistant, who had now started to unwrap his own lunch. Dick produced a number of rolls which looked deliciously crisp, half of these having what was obviously a very palatable ham and lettuce filling and the remainder a mouth-watering filling of tongue. These were accompanied by two large and luxuriantly ripe tomatoes, and an apple with a beautifully rosy red skin. Smithy turned with some distaste to his own soggy sandwiches, from which emanated an aroma reminiscent of "Puss-Puss," the Wonder Cat Food. A

minor irritation of Smithy's life was that in the matter of lunch-time diet his assistant never ceased to be other than one-up. The Serviceman decided to introduce a new topic of conversation.

"I was talking, the other day," he remarked carelessly, "to a chap who's in the kit business."

"How d'you mean?" asked Dick, taking a bite from one of his tomatoes.

"He sells kits for radio sets through the post," Smithy explained, "and one of his troubles has to do with fixed resistors."

"With fixed resistors?" queried Dick. "There shouldn't be much trouble there, surely."

"Apparently there is," replied Smithy. "If he sends his customers resistors with a 10% tolerance where the components list for the kit quotes 20%, one or two are liable to write back and say they want the 20% types which are specified!"

"I don't get that," commented Dick. "A 10% resistor is obviously better than a 20% resistor."

"Of course it is," said Smithy. "But this fact may not be so obvious to a beginner. After all, everyone has to start from scratch at some time, and it seems reasonable to expect that a beginner wants exactly the right components for the set he's going to make before he starts putting it together."

"I heard something like that the other day, myself," proffered Dick. "It seems that a rumour which crops up occasionally amongst groups of beginners is that it's undesirable to use a carbon composition resistor at less than its full wattage rating. That is to say, if you use a 1 watt resistor in a circuit application where it only dissipates  $\frac{1}{2}$  watt, the resistor gradually deteriorates."

"That's a new one on me," confessed Smithy. "It isn't true, of course. Provided the wattage rating of a fixed carbon resistor is not exceeded it can be used at any level of power dissipation you like. In some applications, such as are given by valve grid leaks or damping resistors across receiver i.f. or r.f. coils, the power dissipation due to the circuit is almost negligible. And yet, as we all know,  $\frac{1}{2}$  or  $\frac{1}{4}$  watt carbon resistors are used in such applications without suffering any deterioration whatsoever. There are, of course, some common-sense rules to apply here. A high wattage resistor is obviously more bulky than a low wattage type, and it mightn't be possible to squeeze it into a miniaturised layout or into a coil can or something like that. Also, because of its larger size, a

high wattage resistor will offer a higher stray capacitance to chassis and neighbouring components than will a low wattage type. Again, in circuits operating at high radio frequencies of the order of 40 Mc/s and up, it may be undesirable to use a resistor whose wattage rating is very much larger than is actually needed, because of the increased length of circuit path it may introduce into an r.f. circuit. However, these points are all concerned with the physical size of the resistor, and have nothing to do with its electrical qualities."

"All that's simple enough," commented Dick, as he thoughtfully attacked his second tongue roll. "However, there is one aspect of carbon resistor wattage ratings which has been puzzling me a bit lately."

#### Resistor Replacements

"Oh yes," said Smithy, "and what's that?"

"If I replace a burnt-out fixed resistor in, say, a TV receiver," replied Dick, "I normally look at the service manual to check on its value, tolerance and wattage. I often find that the burnt-out resistor looks to me like a  $\frac{1}{2}$  watt component, and yet the manual says it's only a  $\frac{1}{4}$  watt type. What I've done in cases like this is to fit a replacement resistor of the same size as the burnt-out one, even though it does seem to have twice the wattage rating that is needed."

"You've raised an important point here," said Smithy, "and it's one which causes quite a little confusion now and again, particularly with home-constructors. The question of wattage rating for fixed carbon composition resistors is, in fact, a wee bit complicated; and it is necessary to get the full information on such components from the resistor manufacturer if you want the whole story. To start off with, why do resistors have wattage ratings in the first place?"

"That's obvious," said Dick. "It's to tell us the maximum electrical power the resistor is capable of dissipating."

"Fair enough," said Smithy, "and what does the electrical power do to the resistor?"

"It makes it get hotter, of course."

"Exactly," commented Smithy. "We next have to remember that the resistor must get rid of some of this heat. If it doesn't its temperature will continue to rise until it eventually burns out. How does it get rid of the heat?"

Dick screwed up his eyes in thought.

"I should imagine," he said, after a moment, "that it loses part of the

heat by radiation from its surface. Some more of it will be lost by convection. That is to say, the resistor will warm the air around it, whereupon the warmed air will rise to be replaced by cooler air from below. Finally, it may lose a bit by conduction through its lead-out wires."

"Dear me," said Smithy, impressed. "You are with it today! What you've said is perfectly correct, and it is pretty safe to say that the two methods of losing heat which count most in practice are radiation and convection. It follows from this that if you want to manufacture a resistor with a high wattage rating you have to give it a large surface area."

"That brings us," commented Dick, "back to exactly the same point where we started! We know that a high wattage resistor has a larger surface area than a low wattage resistor because it's a larger component, anyway. So what have we learned?"

"If you weren't so impatient," replied Smithy, nettled, "you might realise that we're getting very close to the reason why the resistors in those TV sets of yours had ratings in the manual which were half the ones you expected. As we've just discussed, if a resistor isn't to cook itself up to destruction, it has to lose part of its heat by radiation and by convection in the air around it. Whereupon it becomes patently obvious that if the ambient temperature of the air around it is high, the resistor cannot lose as much heat as when the ambient temperature is low."

"Hey?"

"The resistor," continued Smithy, "has to come to a condition of thermal equilibrium with its surroundings. In other words, when the associated equipment has been switched on for some time, the temperature of the resistor has to stabilise at a figure which is not so high as to allow it to become damaged."

"All that," said Dick, "sounds rather complicated. I never even think of ambient temperature when I select a resistor."

"Perhaps not," replied Smithy, "but it's still worthwhile bearing in mind. What you have to remember is that the permissible power dissipation in a resistor decreases as the ambient temperature increases."

"That's still complicated!"

"It isn't in practice," persisted Smithy. "Most of the fixed carbon composition resistors you encounter in this country have two quoted wattage ratings. One of these is for an ambient temperature of 40°C, whilst the other is for an ambient

temperature of 70°C. You will almost always find that the quoted wattage rating at 70°C is exactly half that at 40°C."

The expression on Dick's face indicated that light was beginning to dawn.

"That explains," he said excitedly, "why the resistors in those TV sets were specified, in the manual, at half the wattage I'd expected. I was thinking in terms of a 40°C wattage rating, whilst the manufacturer was working at the 70°C rating."

"You've got it," confirmed Smithy. "It's usual for TV manufacturers to work with the 70°C figure. This is particularly true with respect to TV receivers because a lot of heat is dissipated inside their cabinets, and an ambient temperature of 70°C is not at all out of the way. You get pretty high temperatures inside valve radio cabinets, too, and this often makes it worthwhile working to the 70°C figure for resistor wattage ratings also. On the other hand, it would be safe enough to use the 40°C rating on transistor radios and the like, because the ambient temperature here will be pretty well the same as the ambient temperature of the air outside the cabinet. So far as I know, many of the fixed composition resistors sold on the home-constructor market are quoted at the wattage figure for 40°C. This is perfectly O.K. for most home-constructor applications because such resistors will not normally be mounted in locations where there are high ambient temperatures. In any case, the experienced home-designer does not normally choose composition resistors so that they continually dissipate at their full quoted wattage rating. He usually prefers, instead, to use a resistor which is a size larger. This approach gives a degree of safety in hand, and allows for increased ambient temperatures."

#### Derating Curves

Smithy devoured the last of his odoriferous sandwiches and took a large draught of tea from the mug at his side.

"That's better," he remarked. "Incidentally, I've got a question about you that's been puzzling me for the last ten minutes."

"About me?"

"About you," confirmed Smithy gravely. "What did you mean when you said just now that you were the caller for your darts team?"

"I shout out the scores," replied Dick, "whereupon the marker puts them upon the board."

"Is that all?" queried Smithy incredulously. "Just call out the

scores? It doesn't sound a very difficult job to me."

"You've never been to any of our matches," said Dick bitterly. "You've only got to make one error and you're suspect for the rest of the evening."

"I suppose," said Smithy, "that each player throws three darts when his turn comes round."

"Of course."

"Well, there you are, then," said Smithy triumphantly, "all you've got to do is to add up three numbers and call out the answer."

"All right, then," said Dick sarcastically, "If you're so clever what's double 17, treble 9 and 6?"

"67," replied Smithy promptly.

"Then what," continued Dick, "is treble 18, double 19, and treble 12?"

"128," said Smithy, equally promptly.

"I should have guessed," said Dick in disgust, "that you'd get the answers straight off. It takes me ages, and even then there are arguments!"

"I must say," commented Smithy, "that if your team gets scores as high as those you've just mentioned, they must be very good. I suppose it's to be expected though; some men devote all their spare time to darts."

A look of discomfiture crept over Dick's face.

"Actually," he confessed in an embarrassed tone, "there aren't any men in the team. Except me, of course."

Smithy raised an enquiring eyebrow.

"What it is," continued Dick haltingly, "is that I'm the caller for our local Ladies' Dart Team!"

The Serviceman gave forth a delighted guffaw at this information.

"How on earth," he exulted, "did you get lumbered with a job like that?"

"It's this girl I know," replied Dick simply. "She talked me into it."

Smithy pondered for a moment.

"Perhaps it's not so bad an idea at that," he conceded. "Going out with a darts team is a very good way of making reliable dates."

"They're reliable all right," said Dick morosely. "Her mother's the captain of the team!"

"You certainly live an involved life," chuckled Smithy. "Anyway, now that you've explained your function with the darts team, let's get back to these resistor wattage ratings."

"It's because of the darts team," put in Dick, "that I want to get in a bit of practice on the board. Can't

I just hang it up for half an hour or so before we start work again?"

"Let's get back," repeated Smithy firmly, "to resistor wattage ratings."

The Serviceman took a sip from his mug.

"I said just now," he remarked, "that fixed carbon composition resistors are usually quoted for wattage rating at 40°C and 70°C. However, this doesn't give the full picture, because the permissible wattage rating of a resistor of this type is subject to a derating curve."

"To a what?" asked Dick, forgetting his social obligations for the moment.

"To a derating curve," repeated Smithy. "That is, a graph which shows how the wattage figure should be derated, or reduced, at ambient temperatures above 40°C. A typical derating curve for a carbon composition resistor specified as 1 watt at 40°C may consist of a straight line. This would start at 1 watt for 40°C and drop down to zero watts at a temperature just below 110°C (Fig. 1 (a)). The curve means that at the final temperature the resistor is as hot as it can be without suffering damage, and that it is incapable of dissipating any electrical power in the form of further heat. At 70°C the curve is slightly higher than  $\frac{1}{2}$  watt, which accounts for the fact that the wattage rating at this temperature is half of that at 40°C. If you look at the derating curve for a similar type of resistor whose 40°C rating is  $\frac{1}{2}$  watt, you get the same sort of thing. (Fig. 1 (b).) In this instance, the curve shows a rating slightly in excess of  $\frac{1}{4}$  watt at 70°C."

"Do all carbon resistors," asked Dick, "have the same sort of derating curve?"

"They will all," replied Smithy, "be very similar, insofar that permissible wattage rating drops when ambient temperature rises. High stability resistors are treated in a slightly different manner to composition resistors, and it's usual to start the curve for a high stability resistor at 70°C. (Fig. 2 (a).) A wattage rating is given for 70°C, and it is assumed that this figure applies for all ambient temperatures below this figure. Above 70°C you then get a derating which extends to zero at the maximum temperature for the type of resistor being considered. In practice, it is possible that, at ambient temperatures below 70°C, the resistor could dissipate at a rating higher than the figure specified for that temperature (Fig. 2 (b)) but it would, in practice, be rather unwise to exceed the quoted rating."

"I seem to remember," said Dick, "hearing something about the 'load-

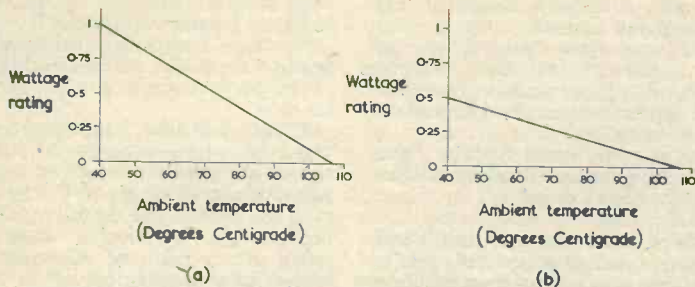

Fig. 1 (a). A typical derating curve for a carbon composition resistor rated at 1 watt at an ambient temperature of 40°C. At 70°C the rating is slightly higher than  $\frac{1}{2}$  watt  
 (b). The derating curve for a similar resistor with a  $\frac{1}{2}$  watt rating at 40°C. At 70°C the rating is slightly in excess of  $\frac{1}{4}$  watt

ing' of a composition resistor."

"You occasionally bump into that term," confirmed Smithy. "You may, for instance, encounter a carbon composition resistor which is described as being a  $\frac{1}{4}$  watt type with a 'loading' of  $\frac{1}{2}$  watt. I would assume that such a resistor would be able to dissipate  $\frac{1}{2}$  watt at low ambient temperatures only. If it had to work at high ambient temperatures it would be safer to assume that its top figure was  $\frac{1}{4}$  watt only. In other words, it would be subject to the same derating curve as occurs with the other composition resistors we've just discussed. I should add, though, that most British manufacturers stick to the 40°C and 70°C figures for composition resistors, the wattage figure at 70°C being half that at 40°C."

"This all seems fair enough," commented Dick. "I suppose I must ask the obvious question next."

"What's that?"

"What happens if you exceed the wattage rating?"

"A good point," chuckled Smithy. "If you exceed the wattage rating specified by the resistor manufacturer for the particular ambient temperature in which it works, then you are asking more of the resistor than the manufacturer has put into it. It is very liable to suffer damage, and it will all be your fault! Don't forget, incidentally, that the heat dissipated by the resistor may, itself, cause a significant rise in the ambient temperature."

"That's a good point, too," said Dick. "Is there anything else concerning the wattage ratings of carbon composition resistors?"

"At the level at which we are discussing these ratings," replied Smithy, "there is only one further point I can think of. And that is, don't be misled by the size of composition resistors when they have ceramic sleeves fitted to them."

"I'm a bit out of my depth here," confessed Dick. "A little more explanation please!"

"Most of the composition resistors

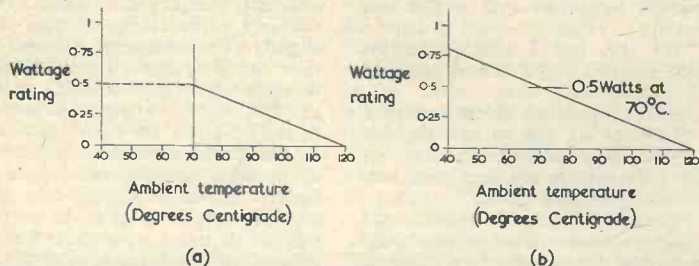

Fig. 2 (a). Typical derating conditions for a  $\frac{1}{2}$  watt high stability resistor. The wattage ratings of high stability resistors are usually quoted for an ambient temperature of 70°C, with the result that the derating curve applies above this figure only. It is assumed that the wattage rating at 70°C holds true for lower temperatures also, whereupon the derating curve may appear as a horizontal line between 40°C and 70°C, as shown here in broken line  
 (b). By continuing the derating curve back to 40°C, the wattage rating increases above that which is applicable at 70°C. A curve such as this is provided for some high stability resistors

we work with," enlarged Smithy, "consist either of a rod of the composition material covered with a thin coating of enamel (Fig. 3 (a)), or they consist of the rod inserted into a protective ceramic sleeve or tube (Fig. 3 (b)). The ceramic sleeve offers no significant change in heat dissipation. So, if the composition rod has approximately the same dimensions in both instances, the wattage ratings will almost certainly be the same for both types of resistor, even though the one with the ceramic sleeve is quite a lot larger in overall physical size. This difference in size is especially noticeable for ratings below 1 watt or so."

#### Wirewound Resistors

Smithy paused and drained his mug of tea. He was relieved to see that Dick had consumed his delectable lunch, and he held up his mug without comment. With a reaction ingrained by long custom, Dick rose and took the mug over to the Workshop sink for replenishment.

"You know, Smithy," he said persuasively over his shoulder, "there's still some twenty minutes left before we start work."

"Well?"

"I could," persisted Dick, "get in that much practice on the dart board before we start work again."

"Can't you ever," asked Smithy wrathfully, "take no for an answer? I hope, incidentally, that this business of pestering me about your dart board isn't going to become a habit with you."

"I was rather thinking," remarked Dick off-handedly, "of doing a bit every lunch hour."

A sudden vision rose in Smithy's mind, and he saw an endless succession of lunch breaks devoted entirely to darts practice on the part of his assistant. It was evident that something would have to be done.

"I'll tell you what," he announced after a moment, "I used to throw quite a good dart in the old days, and I'll give you a game now. But only on one condition."

"Will you?" said Dick, delighted. "What's the condition?"

"If you lose," said Smithy, "there will be an end to this darts business, and you'll take that datted board of yours away and never bring it back again."

"And if I win?"

"If you win," said Smithy, "you can have as much further practice as you like."

"Done!" said Dick enthusiastically.

"What's more," continued Smithy, "I'll let you double every score you get."



"You'll what?"

"Let you doubt," repeated Smythy, "every score you get. If, for instance, you get 15 with any dart you throw you can count it as 30. O.K.?"

"Blimey," said Dick, "I'll say!"

"Right," said Smythy. "Well, I'm not going to start yet, because I haven't quite finished my tea."

"There's no rush," said Dick hastily. "Take as much time as you like."

"Right," said Smythy. "In that case I might as well give you a final bit of gen on this wattage rating business."

"I thought you'd finished."

"Only," replied Smythy, "so far as carbon resistors are concerned. There are a few points to make about wirewound resistors."

"Do they have derating curves as well?"

"Not so far as components intended for radio and TV work are concerned," replied Smythy. "These are normally given a nominal wattage rating which, in most cases, you can assume to apply to an ambient temperature of 70°C. Since wirewound resistors are usually capable of operating at considerably higher temperatures than composition types, the effect of ambient temperature on wattage rating is somewhat less important."

"I see," said Dick, musingly. "Incidentally, I've always looked upon wirewound resistors as being extremely reliable and robust components. And yet I got one out of the spares cupboard the other day, and it was completely open-circuit!"

"That's interesting," replied Smythy. "I've bumped into that trouble once or twice myself, over the years. Did it have a vitreous covering or a cement-like covering?"

"A cement-like covering," replied Dick, "with green colouring on the outside."

"I see," said Smythy. "There is a reason for that open-circuit which was passed on to me some years ago by a component manufacturer. Some of these cement-like coverings never become completely 'cured' at the resistor factory, and they need a few hours of heat dissipation from the resistance wire itself before they become finally set. The result is that there may be a small amount of free chemicals in the covering which can attack the resistance wire itself and cause it to go open-circuit. I must hasten to add that this effect would only occur with high-value resistors of this type, since these are wound with very thin resistance wire. Even then, only an extremely small proportion of the resistors may be affected in this way, if they are

affected at all. It's a rare occurrence, and it usually takes a year or so to take place."

"I'm with it," said Dick. "It seems that, if you've had a brand-new wirewound resistor of this type lying around in stock for a few years it's worthwhile giving it a quick check with the ohmmeter before wiring it into circuit."

"That's right," said Smythy. "I must reiterate the fact that the chances of the resistor going open-circuit whilst in stock are extremely low, indeed. Nevertheless, the effect can take place, and I've encountered it myself on one or two occasions in the past. And that, I think, just about exhausts this particular subject."

### Double Score

No sooner were the words out of Smythy's mouth than Dick had

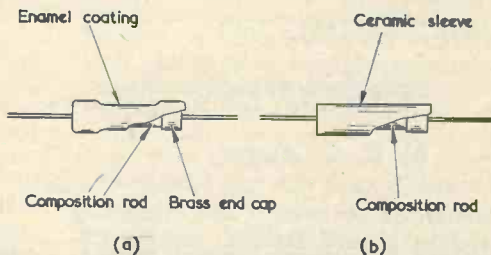

Fig. 3. A carbon composition resistor with (a) an enamel coating and (b) a protective ceramic sleeve. Brass end-cap connections are assumed. If both types of resistor have composition rods of the same dimensions their wattage ratings will normally be equal, despite the fact that the ceramic version has a greater overall size

scrambled to his feet and was already carrying his dart board over to the wall above the Workshop sink. He found a convenient nail and hung it up. Three darts appeared miraculously in his hand.

"You can start," said Smythy generously, rising slowly from his seat.

"Okey-doke," replied Dick excitedly. "We'll play for 301, and we have to start and end with a double. Fair enough?"

Smythy nodded his assent gravely.

Dick's first dart lodged centrally in the double 20 position, his second at treble 20, and his third at 1.

"Very good," commented Smythy. "You're away with your first dart, and you've scored 101. Which, as I'm allowing you to double your score, makes 202."

"Whizzo," said Dick exultantly. "This is a piece of cake. 202 from 301 gives me 99. Your turn, Smythy!"

Smythy carefully squared himself

up to the board, weighed the darts in his hand and finally assumed a stylish posture reminiscent of a javelin-thrower. His first dart went neatly into the spout of the Workshop kettle, whilst the second ricocheted from a point on the wall several feet away from the board, missing Dick by inches on its return journey. His third dart did not even reach the vicinity of the board at all. It traversed a small weak trajectory in the air, falling to the floor several feet in front of Smythy's shoes.

"What happened then?" queried Dick.

"I don't know," confessed Smythy, looking a little puzzled. "I seemed to lose control half-way through."

"Well, it makes things very much easier for me," said Dick confidently. "I'm going to whitewash you in this game!"

Dick collected the three darts from

their scattered lodging places, and concentrated on the board. His first dart scored double 19.

"How about that?" he boasted. "That's another 38."

"Don't forget to double it," Smythy reminded him. "Twice 38 is 76. So you've got 23 left."

Dick's next dart scored 9.

"That," pronounced Smythy, "is 18 after it's been doubled. So you've got 5 left."

Confidently, Dick drew back his arm with the third dart. Just as he was about to throw it his face assumed a puzzled expression.

"I don't quite know how I'm going to get that 5," he said doubtfully. "If I score 2 that will be doubled, leaving me only 1. And if I score 1, that will be doubled to 2, giving me 3 to get. But even then I can't end on a double."

"Why," asked Smythy helpfully, "don't you bust your score and go back to 99?"

Dick's expression lightened at the

suggestion, but the change was momentary only.

"Even then," he said undecidedly, "I'm still in trouble. Whatever score I get is doubled, and so I'm always left with an odd number."

At long length realisation struck home, and Dick turned a furious eye on the Serviceman.

"You rotten old cheat," he exclaimed indignantly. "This business of doubling my score means that I just can't end on a double at all!"

"You," grinned Smithy, "accepted the terms."

"I can't," wailed Dick, "possibly win."

"That's right."

"I give in," announced Dick. "I'll take the dart board down right away."

And that was the end of the Episode of the Dart Board.

But not quite the end. Whilst congratulating himself on having secured uninterrupted lunch breaks

for the future, Smithy could not help but feel disturbed at the sad deterioration, over the years, of his own cunning with the dart. The thought struck him that a little practice might not be a bad idea so far as he, himself, was concerned. His eye wandered musingly around the Workshop, looking for a space where a practice dart board could hang with minimum damage.

On the inside of the door would be a good place. . . .

## QUICKER and CHEAPER METHOD of ETCHING PRINTED CIRCUITS

by C. D. Auger

*This article describes an unusual and interesting method of etching printed circuits. An electrochemical action is employed and all the materials required are readily available*

THE PROCEDURE FOR ETCHING PRINTED CIRCUITS described in this article represents the result of a number of experiments aimed at a method of removing waste copper without the use of corrosive liquids, and at a higher speed than is usually obtained. Both these requirements seem to have been fulfilled by the method devised.

Previous experiments had involved the use of solutions other than that employed in the present process; but these were all found to be unsatisfactory because of one of a number of reasons, including the facts that they were corrosive, produced obnoxious fumes or could not be used twice.

A solution of ammonium sulphate is used for the present process. It is possible for a solution of copper sulphate to be employed also, but ammonium sulphate is cheaper than copper sulphate, and so the use of the latter is hardly worth while. In addition, if copper sulphate is employed, a small amount of sulphuric acid may be formed. When a current is passed through the ammonium sulphate solution, some of the waste copper becomes cupra-ammonium sulphate and some copper sulphate. The left-over ammonia combines with the water to form ammonium hydroxide. This neutralises any acid formed, and produces ammonium sulphate and water. Thus, the process goes on indefinitely.

### The Etching Process

The following apparatus is required for the etching process:

A flat glass or plastic dish to suit the size of the printed circuit.

Copper-clad laminate.

A 12 to 25 volt d.c. supply capable of offering at least 2 amps.

An ammeter with an f.s.d. of 10 amps (optional).

Ammonium sulphate.

Model aircraft cellulose dope.

A fine paint brush.

Acetone.

Dura-Glit 'Magic' Wadding.

A piece of copper-clad laminate is cut to the shape needed, a fretsaw being very useful here if the piece is large. The copper surface is then thoroughly cleaned with the Dura-Glit wadding. After this the copper should be touched as little as possible with the fingers, so as to avoid putting grease on it. Any holes which have to be made in the board should be marked with a punch at this stage.

The circuit is next carefully painted on to the copper, using the cellulose dope. It is advisable to make the "lines" of the circuit slightly wider than

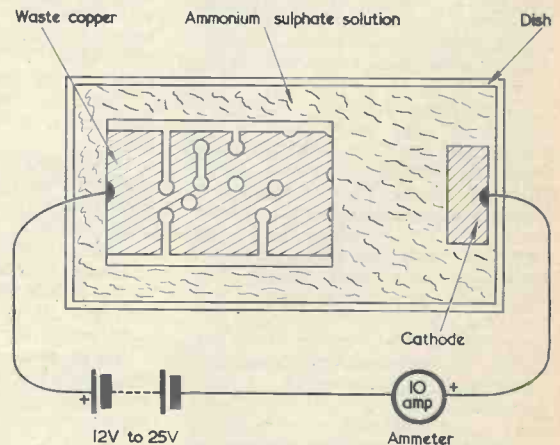

Fig. 1. Etching a printed circuit board by the process described in this article. The ammeter inserted in the negative supply lead is optional

is actually needed, since it often happens that some parts are not fully covered by the dope and become etched away with the rest of the uncovered copper. The dope is left to dry for about 30 to 45 minutes.

The flat dish is then three-quarters filled with a fairly strong solution of ammonium sulphate (the actual strength of the solution can be altered to suit the current available). A small piece of copper-clad laminate, say  $\frac{1}{2} \times 2$  in, is soldered to a length of wire and is placed in the solution at one end of the dish, as illustrated in Fig. 1. This acts as a cathode, and is connected to the negative terminal of the d.c. supply. If available, the ammeter may be inserted in this lead to measure the current flow.

A second length of wire is soldered to the waste copper at one end of the printed circuit board, and this is connected to the positive side of the d.c. supply. The printed circuit board is then placed in the solution as shown in the diagram. Either the whole board may be placed in at once or, if this causes too much current to flow, it can be lowered slowly into the solution, starting at the end furthest away from the connection to the positive terminal of the d.c. supply.

After all the waste copper has been removed, the printed circuit board is taken out of the solution, washed, and dried with a rag. The dope may then be removed by rubbing with a piece of cloth dipped in acetone. If any of the copper in the circuit proper has been removed by the etching solution, its loss can usually be made good by the use of a soldering iron and a piece of wire.

As there are a number of variables in the procedure, the author suggests that newcomers to the process experiment with odd pieces of printed circuit board and different solution strengths before carrying on to make an actual circuit.

#### Positioning in the Dish

An important point, which may not be immediately obvious from the description just given, is that it is necessary to ensure that the positive

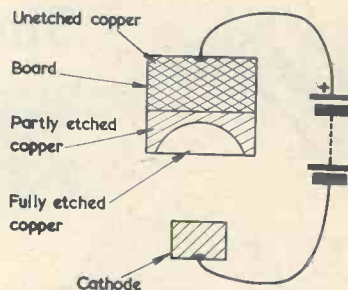

Fig. 2. The process causes the area of etched copy to continually extend away from the side nearest the cathode

connection to the waste copper is at the end of the printed circuit board furthest away from the cathode.

The solution in the dish will offer a constant resistance per unit volume, whereupon the resistance between the cathode and points on the board close to it will be lower than the resistance between the cathode and points further away. It follows that the parts of the waste copper which are nearer the cathode will have a greater current passing through them than the parts which are further away. In consequence they will become etched earlier.

Fig. 2 shows a board after a short period of etching and it will be seen that the area of etched copper travels progressively back towards the positive connection. Were this not to happen, it would be possible for areas some distance away from the positive connection to become isolated if the intervening copper were etched away first.

If it appears that any portion of the waste copper is liable to be left unetched due to becoming isolated in this manner, the position of the cathode can be altered so as to accommodate this new state of affairs.

**I E E**

## Provides New Service for Engineers

The first issue of the new I.E.E. monthly broadsheet *Current Papers* is now available.

As already announced, the new publication will consist each month of a list of about 700 titles (with authors and references) of papers covering the field of electrical and electronics engineering that will have been selected mainly from about 150 of the current and more important British and foreign periodicals. Foreign titles are translated into English and an indication given of the language in which the original is written.

*Current Papers* has been introduced to help the electrical and electronics engineer to learn at a glance what recent papers relevant to his subject are available. Unlike the associated publication *Science Abstracts*, which is a permanent work of reference, *Current Papers* is ephemeral; its importance is its cheapness and speed of production. Generally it will list titles of articles from periodicals received in the office in the month ending about two weeks before its publication.

The annual subscription rate is £1 per annum.

Cover Feature

# Simple

# WAVEMETER

## for Model Control

M. Whitford-Walders

AS ENTHUSIASTS IN THE HOBBY OF RADIO CONTROL of models will already be aware, the permitted frequency bands allowed under the provisions of the Wireless Telegraphy Act of 1949 are 26.96 to 27.28 Mc/s and 458.5 to 459.5 Mc/s. The transmitting equipment must not be operated without a licence, and the licensee must provide equipment for frequency measurement capable of verifying that transmissions are within the authorised bands.<sup>1</sup> The simple wavemeter described in this article provides frequency measurement at frequencies around 27 Mc/s.

### The Wavemeter

Basically, the wavemeter (whose circuit is shown in Fig. 1) is merely a crystal set, close-tuned to 27 Mc/s, with a single transistor amplifier stage following the detector. The minute currents from the detector are amplified by the transistor and are monitored by the 1mA moving coil meter. This latter may, if preferred, be replaced by some audio means of indication, such as a pair of headphones. The emitter-follower amplifier is powered by a flat 4.5 volt pocket lamp battery and is operated by  $S_1$ . When radio energy at the right frequency is fed to the aerial coil, the emitter current, and hence the meter deflection, peaks quite sharply.

<sup>1</sup> The licence fee is £1, payable in advance, for a period of five years. Details of licence provisions, and application forms, are available from the G.P.O., Radio Services Department, Headquarters Building, St. Martin's-Le-Grand, London, E.C.1.

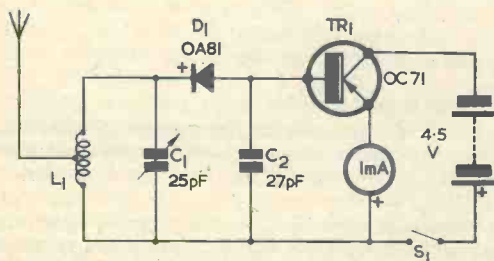

Fig. 1. The circuit of the wavemeter. The components employed are discussed in the text

The response curve given by the prototype when set to 27 Mc/s is shown in Fig. 2. As may be seen, a satisfactory sharp response occurs at resonance.

In Fig. 1,  $C_2$  is a fixed 27pF capacitor, and can be either a ceramic or silver-mica component.  $C_1$  is a 25pF variable capacitor, and may consist of any suitable miniature type with bush mounting. A Jackson Bros. type C.804 would represent a satisfactory choice here. The capacitance should be specified if this component is ordered.

The coil  $L_1$  consists of 8 turns of 18 s.w.g. enamelled copper wire, centre-tapped. The internal diameter is  $\frac{7}{8}$  in, and the turns are spaced so that coil length is 1 in.

The 1mA meter is an ex-Government item (ref. no. 10A/1347). Its appearance and dimensions may be adjudged from Fig. 3 and the photograph.

With the component values specified, peaking of the meter reading can be arranged to occur at any frequency between about 25 to 30 Mc/s by setting  $C_1$  accordingly. To tune the transmitter,  $C_1$  is set to the required frequency and the transmitter frequency adjusted until the wavemeter peaks. Not only will this instrument calibrate transmitters, it can be usefully employed also in comparing different strengths at various points in the control area.

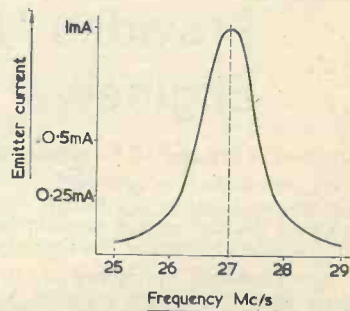

Fig. 2. The response curve given by the prototype when set to 27 Mc/s

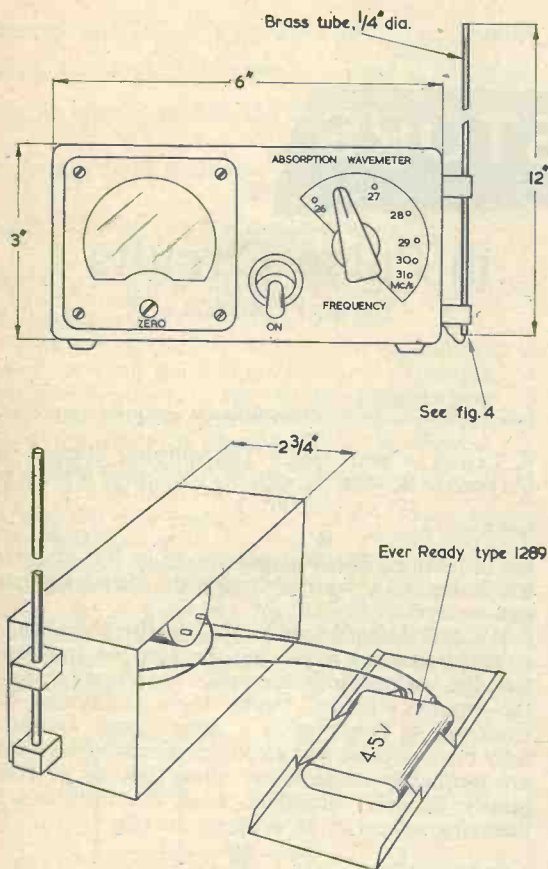

Fig. 3. The appearance of the author's unit. This diagram also shows a detail of the lid and battery fitting. The lid is a press fit. Two flanges are cut and bent over to secure the battery

### Construction

The case, which is of 18 s.w.g. aluminium alloy, is made to the dimensions shown in Fig. 3. The holes for the meter, switch and variable capacitor are then drilled, and these components mounted. The remaining components are subsequently wired straight into the case using the minimum of leads. The resulting assembly is not particularly neat, but it serves its purpose in keeping stray capacitances to a minimum. The lead from the centre-tap of the aerial coil passes out from the case just below the bottom aerial stand-off insulator, and joins to the aerial as shown in Fig. 4. The aerial is of aluminium or brass in the form of a tube 12in long by  $\frac{1}{4}$ in diameter.

Finally, the case is finished to personal taste with either paint or "Fablon" and, as indicated in the photograph, Data Publications "Panel Signs" may be put to good use in producing a professional finish. The scale is attached to the instrument front solely by the large, flat nut that

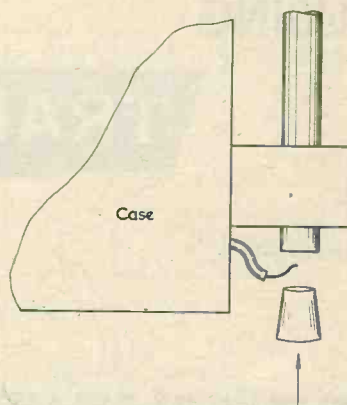

Fig. 4. How the input lead is connected to the aerial. The bared end of the wire is wedged into the base of the metal tube with a hardwood bung

holds  $C_1$  in place and it is also marked, after calibration, with "Panel-signs".

### Calibration

To calibrate the instrument, a signal generator is required. The output from this is loosely coupled to the aerial of the wavemeter and the frequency is set to 27 Mc/s.<sup>2</sup>  $C_1$  is then set at half-mesh and  $S_1$  closed. A peak should be imminent. If not, the aerial coil is gently opened out or closed up, a little at a time, until a definite maximum is shown on the meter. It must be stressed that, after each adjustment, the hands must be kept clear of the circuit, as a false reading will otherwise result.

Having set the 27 Mc/s point approximately in the centre of the scale, the case is shut and  $C_1$  adjusted for a peak. When this has been obtained, the knob itself is loosened and moved to the mid-point of the scale, taking great care not to rotate the capacitor spindle. Finally, the signal generator frequency is changed and the positions of other adjacent frequencies are inserted on either side of the 27 Mc/s mark.

Once the meter has been calibrated, the internal components should never be touched and care should be taken, when carrying out the infrequent task of replacing the battery, to see that this does not happen.

<sup>2</sup> To prevent detuning of the wavemeter resonant circuit and consequent false calibration, there should be very loose coupling between the signal generator and the wavemeter tuned circuit whilst final calibrations are being made. A suitable approach would consist of connecting the earthy side of the signal generator output to the metal case of the wavemeter, and the "live" side of the signal generator output to a metal rod (or wire) about 12in long. If sufficient output is available from the signal generator it should be possible to obtain a noticeable deflection in the meter of the wavemeter when this rod is held some distance away from the wavemeter aerial. The signal generator calibration accuracy must, of course, be accurate.—EDITOR.

# USING

# TRANSISTORS

## in Pulse Circuits

By M. F. Audus

**D**URING THE LAST FEW YEARS A CONTINUALLY increasing number of "electronic", as opposed to "radio", circuits have been published. While many readers know how to design their own radio circuits, it is probable that relatively few readers are as clear about electronic circuits.

This article describes some of the basic pulse and switching devices from which electronic circuits are built. In this field the transistor really comes into its own, and is in fact the most efficient form of electronic switch yet devised. From the experimenter's point of view it has many advantages. It is easily powered by a small battery and heater circuits and screen grid supplies are not required, thus simplifying circuitry and keeping costs down. This article deals exclusively with transistor circuits.

### The Transistor as a Switch

The basic switching circuit for a p.n.p. transistor is shown in Fig. 1. The load may consist of a relay

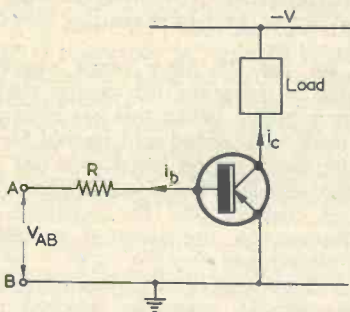

coil, a meter, or perhaps an indicator lamp, in fact any electrical device which may be operated simply by passing a current through it. The current which flows through the transistor from emitter to collector is determined by the voltage applied between the terminals A B, and the value of the resistor R. Current can only flow through the transistor if A is negative with respect to B. If A is positive with respect to B no current flows and the transistor is switched off. No current then flows through the load. If A is negative the current flowing through the transistor depends on the current drawn from the base. The base current is given approximately by

$$i_b = \frac{V_{AB} - 300\text{mV}}{R} \quad (\text{The } 300\text{mV} \text{ may be neglected if } V_{AB} \text{ is several volts.})$$

$$i_c = \alpha' i_b = \alpha' \frac{(V_{AB} - 300\text{mV})}{R} \quad \text{where } \alpha' \text{ is the gain of the transistor.}$$

This is, typically, 35 to 70. Thus, by increasing  $V_{AB}$  we may make the transistor pass more current.

We can in fact increase  $V_{AB}$  to the point where so much current is passing through the transistor that the voltage drop across the load nearly equals the supply voltage. Under these conditions the transistor is behaving as a short circuit and it is fully on. In pulse and electronic circuits transistors are frequently made to be either fully on or completely cut off; in which case the transistor is behaving almost as an ordinary switch.

### A Practical Example

To clarify matters we will consider a practical case to show the experimenter how to design circuits to his own particular needs.

Suppose we require to operate a relay from a signal which is too small to operate the relay directly. If the relay is a 12 volt component having a coil resistance of  $600\Omega$  we could use the circuit of Fig. 2. When the transistor is turned fully on,

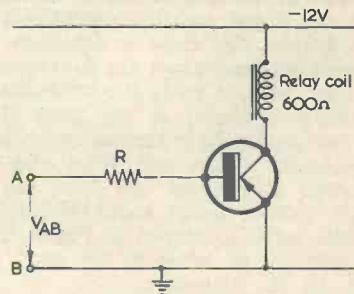

nearly all the 12 volts of the supply drops across the relay coil and the relay operates. Now suppose the signal is 1 volt; what value do we give to R? We know that when the transistor is on the current

through the relay is, by Ohms Law,  $\frac{12V}{600\Omega} = 20\text{mA}$ .

Hence we require the collector current to be 20mA.

But we also know that the base current is  $i_b = \frac{i_c}{\alpha'}$ .

Suppose  $\alpha'$  is 50, then  $i_b = \frac{20\text{mA}}{50} = 0.4\text{mA}$ . We now

apply Ohms Law to R which gives  $i_b = \frac{V_{AB} - 300\text{mV}}{R}$

or  $R = \frac{V_{AB} - 300\text{mV}}{i_b} = \frac{0.7V}{0.4\text{mA}} = 17.5\text{k}\Omega$ . In practice

R could be 15k $\Omega$ .<sup>1</sup>

This sort of calculation gives the experimenter a good idea of the required value. However, as mentioned earlier,  $\alpha'$  may be anything between 35 and 70 so either a little experimenting is called for or, alternatively, if the calculation is repeated for the lowest gain transistor, a value of R is arrived at which will work for any transistor.

### The Multivibrator

The multivibrator is one of an important family of pulse circuits. Before studying the action of this circuit it is necessary to examine further the behaviour of a capacitor. In radio work the idea of a capacitor having a certain reactance at a certain frequency will be familiar to readers.

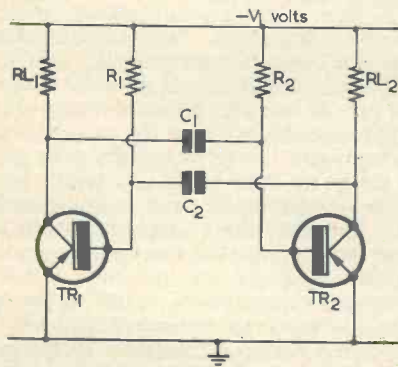

However, the term "frequency" is not quite so important in pulse work and, as sine waves are rarely used, the notion of capacitor reactance is not very useful.

Consider the simple circuit of Fig. 5 with the switch opened and the capacitor initially uncharged. When the switch is closed the capacitor charges up to the battery voltage E, but the important point is that this does not happen immediately. In fact it takes approximately 5CR seconds to charge up where C is in Farads and R in ohms.<sup>2</sup> The voltage across the capacitor is plotted against time in Fig. 6. Thus, at the moment we close the switch

<sup>1</sup> Although not relevant to the author's subject matter here, it should be noted in passing that it is normally desirable to connect a diode across the relay coil of Fig. 2 such that its cathode is towards the p.n.p. transistor collector. If the transistor is suddenly turned off, the diode then short-circuits the back e.m.f. in the relay coil and prevents the appearance of an excessive voltage on the collector.—EDITOR.

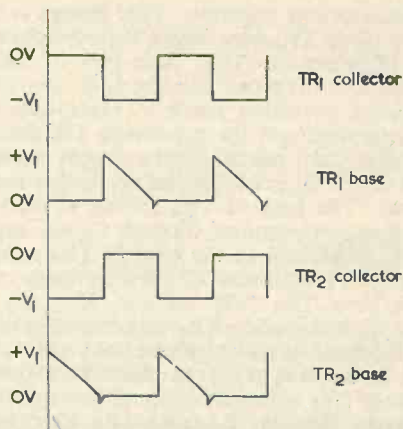

the voltage at A jumps up suddenly to E volts (since there is no voltage across the capacitor at that instant) and subsequently dies away to zero as the capacitor charges up. After 5CR seconds the capacitor is fully charged, the point A is at zero volts, and no more current flows.

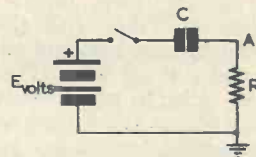

We return now to Fig. 3 and the action of the multivibrator. When the supply is first switched on since both bases are joined to a negative source of voltage, the current in both transistors will rise. Due to slight discrepancies in component values, etc., the current will increase faster in one (say TR<sub>1</sub>)

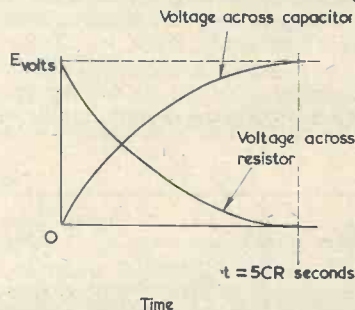

than the other. As the current in TR<sub>1</sub> rises the voltage across the load R<sub>L1</sub> rises also and, because the capacitor C<sub>1</sub> takes time to charge, the positive-going voltage at TR<sub>1</sub> collector appears also at TR<sub>2</sub> base. The same thing happens at TR<sub>1</sub> base, of course, but we assumed a faster rise of current in TR<sub>1</sub>, so the positive-going voltage at TR<sub>2</sub> base is larger. This voltage reduces the current in TR<sub>2</sub> and

<sup>2</sup> Actually the capacitor never becomes fully charged, although the difference between the voltage across the plates and the supply voltage becomes negligibly small after a period. That period could be assumed to be 5CR seconds for approximate work.—EDITOR.

its collector swings negative. This change is transmitted by  $C_2$  to  $TR_1$  base where it further increases the rise of current in  $TR_1$ . This type of action is very common in pulse circuits and is called a "regenerative switching action". Once initiated it is self-sustaining, and the current in  $TR_1$  increases very rapidly until nearly all the supply voltage is dropped across  $R_{L1}$ , whereupon no further increase can occur. The base of  $TR_2$  started at zero volts and the charge transmitted through  $C_1$  was approximately  $V_1$  volts, and so the base of  $TR_2$  reaches a voltage of  $+V_L$  volts and  $TR_2$  is completely cut off. We now have  $TR_1$  fully on and  $TR_2$  off. The capacitor  $C_1$  is joined to  $TR_1$  collector at zero volts and  $R_2$  is joined to the supply at  $-V_1$  volts. Their junction is at  $+V_1$  volts so there is a potential difference of  $2V_1$  volts across  $R_2$ . The capacitor  $C_1$  thus charges through  $R_2$ , and  $TR_2$  base falls in potential towards  $-V_1$  volts. However, when  $TR_2$  base has fallen in potential from  $+V_1$  to zero, transistor  $TR_2$  begins to conduct once more. The collector of  $TR_2$  then swings positive and this change is transmitted via  $C_2$  to  $TR_1$  base where it acts to reduce  $TR_1$  collector current. The collector of  $TR_1$  thus swings negative and this change, transmitted via  $C_1$  to  $TR_2$  base, further increases the collector current in  $TR_2$ . This then is another regenerative switching action, and it rapidly brings  $TR_2$  fully on and cuts off  $TR_1$ . Finally,  $TR_1$  base falls from  $+V_1$  volts to zero, whereupon a third switching action occurs and the cycle is complete.

The only remaining feature not yet explained is the horizontal part of the base waveform at zero volts while the transistor is on. (See Fig. 4.) At first sight one might expect a large negative-going spike here, this being generated by the other transistor as it switches off. But the base emitter junction of the conducting transistor behaves as a very low resistance, causing the capacitor to be very rapidly discharged, and in practise only a very small spike is produced.

#### Another Example

To clarify the foregoing description we will design

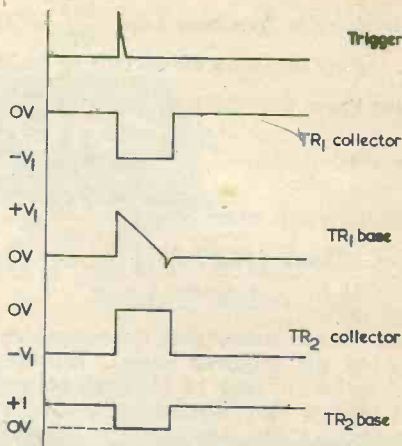
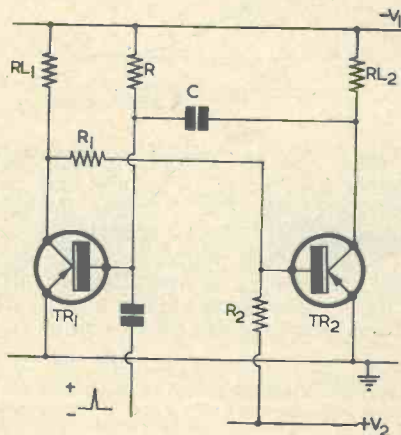

a multi-vibrator. Suppose we decide to use a 6 volt supply and suppose the transistors are to draw 3mA of collector current while they are conducting. In the conducting state nearly all of the supply voltage falls across  $R_L$  and so, by Ohms Law,  $R_{L1}=R_{L2}=\frac{6 \text{ volts}}{3 \text{ mA}}$

$=2\text{k}\Omega$  (in practice  $2.2\text{k}\Omega$  will do).

In order that 3 mA of collector current shall flow we require a base current of  $\frac{3 \text{ mA}}{\alpha'}$  where  $\alpha'$  is

the gain of the transistor. Now the manufacturer cannot at the moment control the gain of his transistors very accurately and most manufacturers quote the gain as being in a certain range—35 to 70 for example. So we work on the assumption that our transistors are two of the worst with gains of 35. For safety we even lower this a little and call it 30. This approach may seem to be unjustifiably pessimistic but there are two good reasons for it. Firstly, we can be sure our circuit will work with any transistor, and selecting transistors is not only tedious but can be expensive; secondly, the way in which the manufacturer measures the gain of a transistor is not always appropriate to the present sort of use, and it usually turns out that a transistor in a pulse circuit behaves as if it had a somewhat lower gain than its quoted figure. Returning now to the design, the voltage across  $R_1$  while  $TR_1$  is conducting is nearly 6 volts and we require a current

of  $\frac{3 \text{ mA}}{30}=0.1 \text{ mA}$  so, again by Ohms Law,  $R_1=\frac{6 \text{ volts}}{0.1 \text{ mA}}=60 \text{ k}\Omega$  (56k $\Omega$  in practice). Notice that  $R_1=\alpha' R_{L1}$  as use of this fact speeds up practical calculations.

The value of  $C_2$  is now chosen to give the required width to the pulses. Independent of the supply voltage it takes approximately  $0.7 C_2 R_1$  secs (C in farads, R in ohms) for the base voltage to fall from its maximum positive value to zero. The "half period" of the multivibrator is thus  $0.7 C_2 R_1$  secs. Suppose we require a half period of 500 microseconds. Then  $500 \mu\text{s}=0.7 C_2 R_1$ . But  $R_1$  is 56k $\Omega$ .



$$\text{Hence } C_2 = \frac{500 \times 10^{-6}}{0.7 \times 56 \times 10^3} = 12.8 \times 10^{-9} \text{F} = 0.0128 \mu\text{F}.$$

Usually a capacitor of  $0.01 \mu\text{F}$  would be near enough. Alternatively two capacitors of  $0.01 \mu\text{F}$  and  $0.003 \mu\text{F}$  in parallel could be used.

If the multivibrator is to provide square waves the half periods are equal and  $R_1 = R_2$  and  $C_1 = C_2$ , so our design is complete.

The steps are summarised as follows:

- (1)  $R_{L1} = \frac{\text{Supply Voltage}}{\text{Required Collector Current}}$
- (2)  $R_1 = 30 \times R_{L1}$
- (3)  $C_2 = \frac{\text{Required half period}}{0.7 \times R_1}$

The repetition frequency is

$$\left( \frac{1}{\text{The sum of the half periods}} \right),$$

in this case  $\frac{1}{500 \mu\text{s} + 500 \mu\text{s}} = 1 \text{ kc/s.}$

### The Flip-Flop

The second circuit in the multivibrator family is the flip-flop. This circuit produces a single output pulse in response to a triggering pulse. The circuit is shown in Fig. 7 and the waveforms in Fig. 8. The base of  $TR_1$  is joined to the negative supply via  $R$  and so  $TR_1$  is on. Consequently its collector voltage is about zero. The resistors  $R_1$  and  $R_2$  form a potential divider between zero and  $+V_2$  volts (which is derived from a second battery). The ratio of  $R_1$  and  $R_2$  is such that the base of  $TR_2$  is positive by a volt or two. In consequence  $TR_2$  is off and its collector is at  $-V_1$  volts.

Now suppose a short positive-going pulse is applied to the base of  $TR_1$ . This reduces the collector current and the collector goes negative. When the collector has gone sufficiently negative for the base of  $TR_2$  to fall to zero volts  $TR_2$  starts to conduct, bringing its collector positive from  $-V_1$  volts. This positive-going step is transmitted via  $C$  to the base of  $TR_1$  where it aids the original change. Thus a regenerative switching action takes place and  $TR_1$  is rapidly switched off and  $TR_2$  switched on. The capacitor  $C$  now charges until the base of  $TR_1$

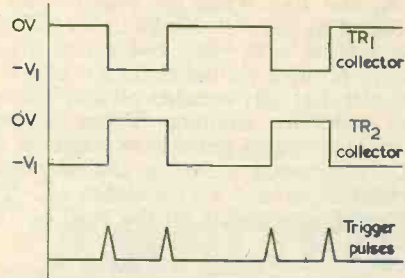
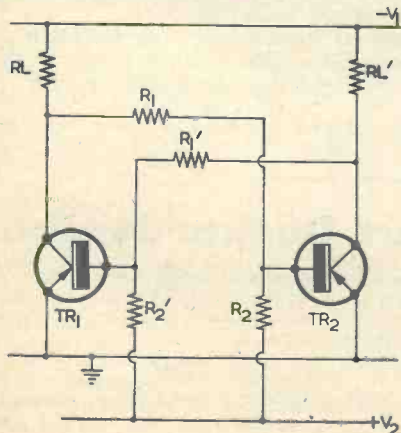

has fallen to zero, when  $TR_1$  again starts to conduct. Another regenerative switching action occurs,  $TR_1$  becomes switched on, and  $TR_2$  is switched off once more. The voltage on the base of  $TR_2$  is, however, fixed by two resistors  $R_1$  and  $R_2$  which cannot charge up like the capacitor, so the situation now reached is quite stable. Nothing more occurs until another trigger pulse arrives.

We will now design a flip-flop. Suppose we have two batteries of 6 volts available so that  $V_1 = V_2 = 6$  volts. Suppose we require the transistors to draw 5mA in the conducting state then immediately by

Ohms Law we have  $R_{L1} = R_{L2} = \frac{6 \text{ volts}}{5 \text{ mA}} = 1.2 \text{ k}\Omega.$

With  $TR_1$  on, the base of  $TR_2$  has to be positive by a small amount. Let us say 1 volt. We need not have a very large current flowing through  $R_1$  and  $R_2$ , and 0.5mA would be adequate.

$$\text{Thus } R_1 + R_2 = \frac{V_2}{0.5 \text{ mA}} = \frac{6 \text{ volts}}{0.5 \text{ mA}} = 12 \text{ k}\Omega$$

$$\text{The ratio of } R_1/R_2 = \frac{1}{V_2 - 1} = \frac{1}{6 - 1} = \frac{1}{5}.$$

Hence  $R_1 = 2 \text{ k}\Omega$  and  $R_2 = 10 \text{ k}\Omega$  (2.2k $\Omega$  and 10k $\Omega$  in practice). The value of  $R$  is determined in exactly the same way as for a multivibrator from the equation  $\alpha' R_{L1} = R$ . Call  $\alpha' = 30$  then  $R = 30 \times 1.2 \text{ k}\Omega = 36 \text{ k}\Omega$  (or 33k $\Omega$  in practice). The value of  $C$  is fixed by the required duration of the output pulse. Suppose this to be  $500 \mu\text{s}$ . Then, as for a

$$\text{multivibrator, } 500 \mu\text{s} = 0.7CR, \text{ and } C = \frac{500 \mu\text{s}}{0.7 \times 33 \text{ k}\Omega} = 0.0216 \mu\text{F}.$$

### The Bistable Circuit

This is the last of the multivibrator family and is the basis of many counting circuits. The circuit, shown in Fig. 9, has two stable conditions and can remain permanently in either. On receiving a trigger pulse it changes over to the other condition and, on receiving a second trigger pulse, it changes back to the original condition. The two conditions are either  $TR_1$  on and  $TR_2$  off or vice versa. Suppose  $TR_1$  is on. Then its collector is at zero volts and the ratio of  $R_1$  and  $R_2$  is such that the base of  $TR_2$  is a volt or two positive. Thus  $TR_2$  is off.

Now suppose a positive-going pulse is applied to the base of  $TR_1$ . The collector current of  $TR_1$  is reduced and the collector falls negatively. This change is transmitted to the base of  $TR_2$  via the

chain  $R_1$  and  $R_2$ . When the base of  $TR_2$  reaches zero volts,  $TR_2$  starts to conduct. Its collector rises positively from  $-V_1$  volts and drives the base of  $TR_1$  more positive via the chain  $R_1'$  and  $R_2'$ . The net result is that  $TR_1$  switches off and  $TR_2$  switches on. In order for anything further to happen a positive-going trigger pulse is required on the base of  $TR_2$ , whereupon a similar change occurs, and  $TR_1$  switches on and  $TR_2$  switches off. The next trigger pulse is required on the base of  $TR_1$ , and so on.

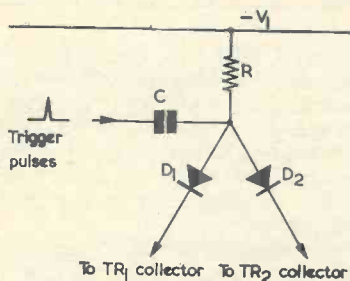

So we need a steering system to put the trigger pulses on the base of the conducting transistor. A suitable circuit is shown in Fig. 11. Suppose  $TR_1$  is on, then its collector voltage is zero and diode  $D_1$  is reverse-biased by about  $-V_1$  volts. The collector of  $TR_2$  is at some voltage intermediate between zero and  $-V_1$  volts since it is connected between the junction of  $R_{L1}$  and  $R_1'$ , and the lower end of  $R_1'$  is at zero since  $TR_1$  is on. Usually, the collector voltage of  $TR_2$  is nearer  $-V_1$  volts than zero, so  $D_2$  is reverse-biased by somewhat less than half of  $-V_1$  volts. Suppose now a positive pulse of about half  $V_1$  is applied. This does not overcome the reverse bias on  $D_1$  but it will overcome the reverse bias on  $D_2$ , with the result that the pulse sends the collector of  $TR_2$ , and hence the base of  $TR_1$ , positive and triggers the circuit. Thus, the steering system always directs the trigger pulses correctly to the base of the conducting transistor.

It will be noted from the waveforms of Fig. 10 that the circuit returns to its original condition after two trigger pulses. It thus produces one "output pulse" for every two input pulses. The "width" of the output pulse depends on the interval between two trigger pulses and this of course may vary. For this reason the circuit is best regarded as "dividing by two". In counting circuits several bistable circuits would be connected in cascade so

that the second circuit produced one output pulse for every four pulses triggering the first circuit and so on. A low consumption bulb may be connected in series with  $R_{L1}$  in each circuit to indicate in which condition the circuit is operating. In this way the state of each bistable circuit in a chain may be ascertained and, hence, the total number of trigger pulses easily worked out.

We will now design a bistable circuit. Suppose we have two 6 volt batteries as before and that the transistors are to take 5mA.

$$\text{Then } R_L = R_L' = \frac{V_1}{5\text{mA}} = \frac{6 \text{ volts}}{5\text{mA}} = 1.2\text{k}\Omega.$$

Suppose the non-conducting transistor has its base at +1 volt.

$$\text{Then } \frac{R_1}{R_2} = \frac{R_1'}{R_2'} = \frac{1}{V_2 - 1} = \frac{1}{6 - 1} = \frac{1}{5}$$

Also, if  $R_1$  and  $R_2$  draw 0.5mA

$$R_1 + R_2 = \frac{V_2 \text{ volts}}{0.5\text{mA}} = \frac{6 \text{ volts}}{0.5\text{mA}} = 12\text{k}\Omega$$

Hence  $R_1 = 2\text{k}\Omega$ ,  $R_2 = 10\text{k}\Omega$ . (Also  $R_1' = 2\text{k}\Omega$ ,  $R_2' = 10\text{k}\Omega$ ).

It is usually reasonable to make the current through  $R_1$  and  $R_2$   $\frac{1}{10}$  that through the transistors. Increasing the chain current merely wastes battery current whereas, if it is too small,  $R_1$  turns out to be a large resistor which may prevent the transistors from turning on fully.

#### Conclusion

This article has described how to set about designing some of the more common pulse circuits and it is hoped that it will help readers in their own experiments. A few practical tips are now offered.

If the experimenter has even a simple oscilloscope at his disposal, this will obviously help greatly in experiments of this kind and to an understanding of the action of these circuits. Several oscilloscopes have been described in *The Radio Constructor*.

Nothing has been said so far about the choice of transistors. Clearly the transistor must be capable of carrying the required current and withstanding the required collector voltage. Additionally it should be capable of dissipating  $\frac{1}{4} V_1 I_c$  watts where  $V_1$  is the collector supply voltage and  $I_c$  is the collector current while fully on.

The cut-off frequency of the transistor is also important. If the pulse width is T seconds then the cut-off frequency in grounded emitter should preferably exceed  $\frac{10}{T}$  c/s.

## Cossor Meteorological Radars Go Into Service

The Radar Division of Cossor Electronics announce that deliveries have commenced of the CR353 Meteorological Radars for further installations in the United Kingdom, and new installations in Malta, Cyprus, North Africa and other locations.

The equipments are ordered by the Meteorological Office of the Air Ministry.

In addition eight equipments have been delivered to New Zealand and will shortly be installed in Fiji, Funafuti, Raratongo and New Zealand.

The CR353 can, by the use of various optional units, be employed as a windfinder or for weather surveillance, and it is stated that the design of the advanced tracking and display facilities reduces personnel requirements to a minimum.

# B.B.C. 2

# UHF

# AMPLIFIER

JOHN D. BENSON

WITH THE OPENING OF THE B.B.C.'S SECOND channel there will be many viewers who will be unable to receive satisfactory reception, even when using elaborate aerial arrays.

The simple pre-amplifier described in this article can overcome this inadequacy, and where only a ghost picture is being received should give enough boost to enable first-class viewing to be enjoyed.

## U.H.F. Transistors

The design is made possible by the use of one of the new u.h.f. transistors which are now available. The construction is simple and well within the average constructor's range, provided certain precautions are strictly adhered to. The first important point is that all connections to the transistor must be kept to minimum length. This leads to the second point of major importance—a heat shunt *must* be used when making these joints, to prevent permanent damage to the transistor. Components should be carefully selected and only the best used. There is no wiring, as the coil is self-supporting, and the components are held rigid by reason of the short connections. The chassis is copper, which facilitates soldering, and its dimensions are such that it can be held to the two PP9 batteries which power the amplifier by means of a strong elastic band. Some constructors may prefer to build a container for the complete amplifier and batteries.

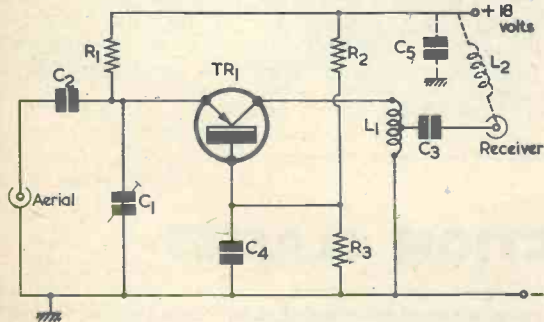

Fig. 1. The circuit of the u.h.f. amplifier.  $L_2$  and  $C_5$  are required only when the amplifier is fitted at the mast-head

The best results are obtained if the amplifier is fitted at the mast-head. If this is carried out, the amplifier will have to be fitted in a waterproof box, the inlet and outlet cables being taken through grommets. The power supply is fed through the feeder cable, and the method used for doing this is shown in the circuit diagram.

The amplifier is wide band and will cover the

## Components List

### Resistors

All resistors  $\frac{1}{4}$  watt 10%

$R_1$  2.2k $\Omega$

$R_2$  5.6k $\Omega$

$R_3$  12k $\Omega$

### Capacitors

$C_1$  2-8pF, air-spaced, Mullard concentric

$C_2$  4.7pF ceramic

$C_3$  5.6pF ceramic

$C_4$  470pF ceramic

\* $C_5$  70pF ceramic

\* $C_6$  70pF ceramic

### Inductors

$L_1$  4 turns, tapped at  $1\frac{1}{4}$  turns from earthy end, of 16 s.w.g. tinned copper. Outside diameter  $\frac{1}{4}$ in, spread to  $\frac{1}{2}$ in in overall

\* $L_2$  20 turns of 36 s.w.g. silk or enamelled copper, close-wound on  $\frac{1}{8}$ in former. Turns doped after winding

\* $L_3$  As  $L_2$

### Transistor

$TR_1$  AF139 (Siemens) or T2028 (Philco)

### Batteries

Two 9-volt batteries. (EverReady type PP9)

### Miscellaneous

2 coaxial sockets and plugs

Single-way tagstrip

1 tool-clip (or screen)

Chassis, Paxolin, etc.

\* These components are needed only when the amplifier is used at the mast-head.

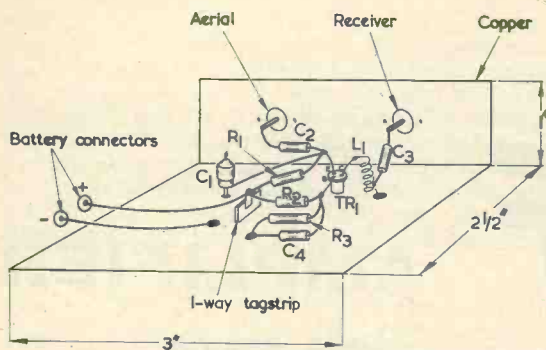

Fig. 2. The layout of the amplifier. For clarity, components are shown with greater spacing than is required and they should, in practice, be mounted closer together. The transistor body may be held by a tool-clip, but it is preferable to use the screen shown in Fig. 4

four London channels in Band IV. Tuning needs a little patience if best results are to be obtained. First tune C1 for maximum results and then carefully expand or compress the coil, noting any increase or decrease in the signal. The coil should be adjusted to give highest gain consistent with good definition. These adjustments are best carried out during Test Card periods.

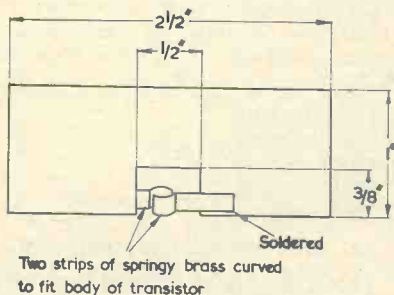

Fig. 4. A combined screen and heat sink for the transistor. The screen is mounted vertically, and it separates the collector circuit from the base and emitter circuits

The amplifier is capable of giving 10-14dB gain, with a current consumption of 3mA. An outstanding feature of the u.h.f. transistor is its

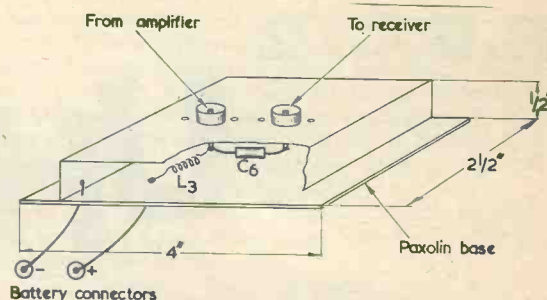

Fig. 3. When the amplifier is employed at the mast-head, power is fed to it via the coaxial down-lead. The socket panel shown here may then be positioned near the receiver

low noise factor. It is much lower than that of an equivalent u.h.f. valve.

If the amplifier is constructed as a mast-head fitting, input and output coaxial sockets can be made up as a panel to fit on top of the batteries, using snap connectors to facilitate easy removal when exhausted. See Fig. 3. An added refinement would be an on/off switch, which would obviate the removal of the power supply plug each time the amplifier is used, and would also eliminate any chance of the cables being transposed.

#### Further Points

When the pre-amplifier is used as a mast-head fitting it must be remembered that it will be subjected to large changes in ambient temperature. With this in mind, the container should be made of heat-resisting material, such as Paxolin, plastic or wood (weather proofed). These precautions are very necessary if the life of the transistor is to be protected.

The transistor may be held in position on the chassis by means of a tool-clip. It has been found, however, that an improvement is given by fitting it to a screen instead, this separating the collector circuit from the emitter and base circuits. Details of the screen are given in Fig. 4.

Supplies of the particular transistor required are, at the time of writing, available from Carlow Radio Ltd., 11 West Arcade, Bedford, Beds. It is possible that the transistors may also be available from other stockists when this article appears in print.

## MORSE INSTRUCTION CLASSES

There is a possibility of such classes (Radio Amateurs) being arranged for evening attendances, by the following departments. If interested readers would forward their names and addresses to either or both of these departments as soon as possible, further arrangements can be made.

W. J. Potter, (Principal), Oldbury College of Further Education, Wolverhampton New Road, Causeway Green, Worcs., or W. L. Woodcraft, (Organiser), Education Offices, Highfields, West Bromwich, Staffs.

## Experiences of an



## Early Amateur

### The Second of a Five-part Series

**A**LTHOUGH THESE ARTICLES ARE INTENDED TO describe the experiences of one particular amateur rather than to provide a historical record of the movement in its early days, the period immediately before the First World War cannot be passed over without referring to the formation of the Wireless Society of London in 1913. This was a natural outcome brought about by the mutual interests of those concerned with the construction and operation of wireless equipment as a hobby. The desire to discuss their work and the merits of various circuits and items of equipment had resulted in the formation of clubs and societies in the provinces as well as in London, but it was perhaps natural that more official status should be given to the one which was in a position to collaborate with the Post Office in matters of general interest to the amateur. The formation of the Wireless Society of London (later, in 1922, to become the Radio Society of Great Britain) was a vital step in the protection and furtherance of the interest of the amateur radio enthusiast.

But, in the particular area in which I lived at that time, no club or society had been formed. Nevertheless we enthusiasts regularly visited each other's houses and, as newcomers to our hobby, became known, they were soon added to our visiting list. This had a rather unfortunate result for one gentleman, but more of that later.

#### Outbreak of War

The probability of an early outbreak of war became manifest when I heard signals recalling large numbers of German passenger and cargo ships back to port. At that time I possessed a book of call signs which included a large portion of those ships in which wireless had been installed. The fact

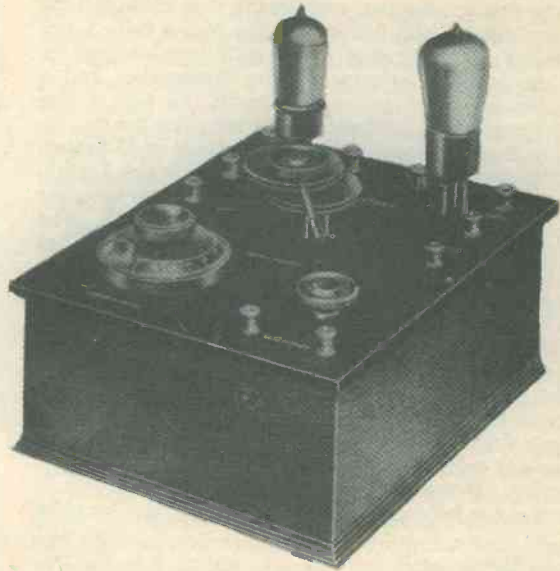

that this directory could be purchased for 15 shillings and was only about 3in thick with not very large pages, and that it was alleged to contain the call signs of all land and ship stations throughout the world, provides an indication of the extent of the use of wireless at that time.

Very shortly before war was actually declared we were informed by the Post Office that our receivers must be closed down and that in due course our apparatus would be collected by their officials and stored by them until the termination of hostilities. In view of the rather simple nature of our equipment this struck me as being rather naive on the part of the Post Office and I often wondered just how much equipment was actually handed over. I myself kept a "spare" crystal detector and a pair of headphones, having a thought that I could still have fun with a buzzer and room-to-room transmission. Much to my surprise, on making an earth connection to a water pipe and without the use of any form of tuner, I found myself able to receive quite audible signals from the transmitter at Cleethorpes, nearly 100 miles away. Pondering on the effectiveness or otherwise of the Post Office security methods I recalled that a few weeks earlier I had been taken by a friend to visit a German gentleman to view his receiver. This comprised some highly professional-looking equipment contained in a glass-fronted cabinet. He seemed to be in no great hurry to allow us to view the equipment too closely, but explained that he had bought all the parts ready-made as he had no skill as a constructor. I enquired of the Post Office authorities as to whether they had called

#### HEADING ILLUSTRATION

A "box unit" assembly of the 1920s, incorporating in this instance both tuning and reaction circuits

upon this gentleman, and learnt that they had no knowledge of him but would pay him a call. Later I heard that they had found additional apparatus in the form of a very effective transmitter and a hidden aerial. I gathered that he, as well as his equipment, was interned for the next few years.

Having now reached the ripe old age of 18 I came to the conclusion that the only way in which I could legitimately continue my hobby would be to enlist in the signals section of the Royal Engineers. The Royal Engineers of those days used vast quantities of horses as well as a few bits of wireless equipment. In accordance with army practice I was enlisted as an "Instrument Mender", my actual duties consisting of cleaning out stables. When an opportunity arose to transfer to an O.T.C. unit, I felt the time was ripe for a move. Although, by the time the war was over I had held commissions in the Army, the Navy and the Air Force, I never handled or even saw any wireless equipment during my four years' service. However I did, on one leave, manage to pursue my hobby for a brief hour or two. An elder

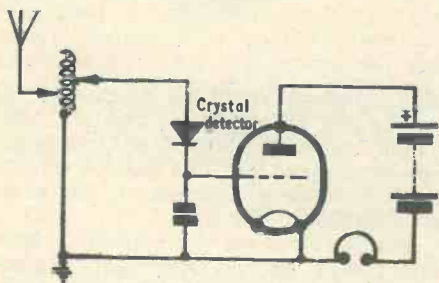

Fig. 1. The circuit of an early valve receiver. Note the absence of a bias supply, or of any attempt to employ the valve as a detector

friend who owned a small engineering works, and who was a keen amateur wireless enthusiast, suggested that it would be nice to hear some signals again, and this brought me to mention the crystal detector and headphones which were still in my possession. He suggested that I should wind myself a tuning inductance and that he would meet me with his car after dark, whereupon he would find the necessary aerial. In due course we took the equipment to his office which, with blinds drawn, provided a suitable "shack". I still wondered where the aerial was going to be found but, armed with a hammer and chisel, we walked to the works chimney, the foot of which was conveniently near his office. A cut through the lightning conductor soon provided a most effective aerial, but I have often wondered how this was explained to his maintenance staff. Or did he risk a permanent small spark gap? We were dyed-in-the-wool enthusiasts in those days.

#### Wonders of the Valve

When the war was over, I was naturally anxious to get busy with my hobby again. In the meantime some vital changes had taken place and we began to hear of the wonders of the valve. It was not easy

to see how one could become the owner of one of these highly desirable pieces of equipment, but by rummaging around I found, in a war disposals dump, a small wooden box alleged to contain a valve, and this I was able to obtain for a few shillings. The box contained a round glass bulb with some wires leading from it. In the lid was a note stating that, in order to put the valve into operation, it was necessary to warm it with a match. Connecting it in a tuning circuit in what seemed to be the only possible way many boxes of Swan Vestas were used and much damage to finger ends was suffered before at last a slight hiss was heard in the headphones. Unfortunately for the match industry, but fortunately for my finger ends, I eventually dropped the valve on a stone floor, providing what was perhaps a fitting end to the experiments. If any reader has had experience in the use of this valve in the Service I am sure that we would all be delighted to know just how it really worked. So far as I am concerned it still remains a mystery.

It was not too long before the odd triode valve could be obtained, the price being something in the neighbourhood of a couple of pounds a time. The reader may reflect that this is the equivalent of 5 or 6 pounds today and that therefore an accidental burn out or filament breakage was a major tragedy. The main sources of supply seemed to be in Holland or France, the French valve having the reputation of being the "harder".

During this immediate post-war period the amateur was faced with many difficulties. The war had resulted in considerable technical progress, but information about this was hard to come by. The manufacture of equipment for amateur use had not re-commenced and war disposals apparatus was not normally available through channels to which the amateur had access. Progress in these directions became fairly rapid from 1920 onwards, but in the 1918-19 period the going was hard. The circuit shown in Fig. 1, which represents my first attempt to use a valve, will well illustrate the point. Even the high tension battery presented difficulties and this had to be built up with quantities of flashlamp batteries connected in series. Luckily the valves would not stand much over 60 volts h.t. The lack of any form of bias supply will be noticed.

The present-day constructor with even the most elementary knowledge may find it difficult to understand the absence of bias, the failure to use the valve as a detector-amplifier with reaction and the lack of an intervalve transformer, but of these things we amateurs knew nothing, neither did our technical knowledge lead us to try out such refinements. It is quite astonishing to think how long it was before the high tension battery was replaced by a supply from the mains and to realise that the early attempts to do away with this battery was by means of a rotary converter to work from an accumulator. Yet the principles of rectification, smoothing and voltage dropping had been quite well-known to electrical engineers for some considerable time.

## Technical Information

Today, manufacturers consider research laboratories manned by highly trained personnel to be a vital part of their business, and technical developments and discoveries are the subject of papers which are read to interested societies. All this information is quickly spread through the technical and often not-so-technical press, and is readily available to anyone who cares to take the trouble to do a little reading. But, in the period of which I am writing, it was far from easy for the ordinary amateur to find access to the information for which he was thirsting, and much experimental work and probing around in the dark was necessary to enable him to make any sort of progress.

The appearance on the market of a few ex-Government intervalve transformers, quickly followed by the publication of details of the valve used as a detector-amplifier with reaction, soon altered the whole picture of amateur reception. The "loose coupler" (shown in Fig. 2 of last month's article) provided an easy way of getting a valve circuit into operation. So little was known about intervalve transformers at that time that I was given a fee of ten guineas for advice to a board meeting of a city company for confirming that such transformers with valves could be used to amplify sounds. I also (without fee) had a discussion about this with the late Grindell Matthews who was experimenting with the possibility of "talking pictures".

The old form of tuning inductance was now rapidly being replaced by plug-in coils of various types, these enabling a greater range of frequencies to be covered more efficiently. The coils manufactured by the Igranic Company became very popular. These were wound in honeycomb manner and, since they plugged into holders whereby two or three coils could easily be adjusted in position to offer varying couplings, they provided an easy method of forming different tuning circuits. Other types were wound on ebonite formers as simple layer windings, one coil being allowed to swivel over the other to provide the variation in coupling. These types were normally provided with valve pins so that they could be plugged into a four-pin valve socket. A range of coils usually gave coverage from 180 to 10,000 metres. The longer wavelength was used for commercial transatlantic transmissions, whilst the shorter one was viewed much in the light that we view centimetre wavelengths today: something which is possible but not too easy.

Much of the receiving gear constructed by amateurs was assembled by screwing components down to a wooden base but, in the interests of neatness of appearance and space saving, the vogue of assembly on an ebonite panel soon came into being. In this case the major components which might necessitate adjustment were mounted on the top of the panel. The wiring and remainder of the components appeared on the underside. The panel was then mounted on a polished wooden box, providing a highly professional appearance. The high polish obtained by some manufacturers on their ebonite panels was a great source of envy to

the amateur and in connection with this I had an experience which caused me some little trouble. A series of units I had constructed failed to operate at all, although the ebonite gleamed with a magnificent shine. It was only after a somewhat prolonged investigation that I found that the surface of the ebonite was highly conductive to a deposit left on the surface by the final processing, which included pressing between tinfoil sheets.

The use of reaction not only allowed for the reception of c.w. signals but also provided a means of constructing a simple transmitter, the power of which was limited by the capabilities of an ordinary triode receiving valve supplied from dry batteries.

About this time a minor national emergency took place as the result of a labour dispute, and a notice appeared in the national press asking radio amateurs to get into touch with their nearest Army Command. This I promptly did by making an 80 mile journey on my motor cycle, but I was rewarded at the end by being presented with half a dozen valves and given instructions to assemble a suitable transmitter and receiver and establish radio contact with them as soon as possible. Luckily the emergency ceased before the equipment was completed, and I have serious doubts as to whether it could have played much of a vital part in communications.

## Radio Telephony

At that period I was living in the Peak District of Derbyshire, but business took me to London to live, and this move opened up a series of interesting experiences the like of which could not possibly be presented to the radio constructor of today. The thrill and excitement of receiving one's first radio telephony signal has been described by more able pens than my own. No amateur who heard the transmissions from 2 Emma Toc will ever forget these, or the reception of "Land of Hope and Glory" sung by Dame Melba from that station in its early experimental stages.

The ability to receive speech and music, together with the increase of signal strength available from valves, resulted in a need for something better than headphones in a pudding basin to act as a loud-speaker. One large concern, who had already been making loudspeakers for use on naval vessels, was soon joined by another in manufacturing speakers more suitable for the home. The earliest models were little more than an enlarged telephone earpiece surmounted by a more-or-less ornamental horn. Their performance was measured more by their ability to provide loudness rather than by the quality of the sound.

An amusing example of this occurred when one of the two loudspeaker manufacturers arriving at my "den" one evening with a prototype model. He also brought with him a sample of his competitor's effort. After explaining that there was no suitable wireless receiver at the factory he suggested that we should make a comparative test of the two speakers. This we did by opening the window and walking down the garden in order to see which speaker could be heard from the greater distance. It is only fair

to state that this manufacturer, having satisfied himself regarding the sensitivity of the speaker, then concentrated on the quality of reproduction. He was quite a fan on this latter point as he also manufactured quality gramophones which he insisted on testing personally between 2 a.m. and 4 a.m. This was the only time, he said, in which it was possible to obtain a soundless background for his tests.

The history of the development of the loudspeaker and the search for "true bass" makes fascinating reading, and I well remember (although this really belongs to a later period) paying some £20 for a balanced armature loudspeaker with a cone six feet in diameter. For the period, its reproduction was outstanding, but it had the disadvantage of necessitating everyone ducking their heads as they passed underneath, as it was hung in "free air".

### On the Air

Having passed my twelve words per minute Morse test at the G.P.O. I became the possessor of the call sign 2WQ, and installed some primitive transmitting equipment in my den. The transmitter consisted of a single valve, the grid of which was directly modulated from the microphone. This put the microphone at h.t. potential, which caused no trouble until I fitted a metal trumpet to it. The h.t. supply consisted of some 150 "inert" cells in series\* and, when a friend to whom I was transmitting asked me to speak a little closer to the microphone, I absent-mindedly inserted my nose in the trumpet. This resulted in my being knocked flat on my back with the complete transmitter and some 150 "inert" cells on top of me.

This transmitter served one quite useful purpose during its existence. The first radio exhibition to be held in London took place at the Central Hall, Westminster, in September 1922. Although considerable equipment was on show it could not be demonstrated satisfactorily owing to the absence of suitable transmissions. Thus it came about that I received an urgent telephone call from the organisers asking me if I could transmit some gramophone records to them. I cannot believe that the resultant reception offered much encouragement to potential listeners, but a request for further transmissions did at any rate indicate that some sort of noise had been received!

The year 1922 saw a rapid expansion of amateur wireless. The ability to hear speech and music as

\* "Inert" cells were dry batteries of the Léclanché type, which could be brought into use by pouring water into each cell. Before the application of the water, "inert" cells could be stored for relatively long periods without serious deterioration.—EDITOR.

well as morse, and the feeling that official broadcasting was well on the way, provided a new category of amateurs with not a great deal of technical knowledge but who were keen on "constructing" their own equipment. This resulted in manufacturers producing what came to be known as "units". These generally consisted of polished wooden boxes with top ebonite panels. Each "unit" comprised a single stage of a receiver and was provided with suitably marked terminals. The "constructor" only then required a few pieces of flex to complete the receiver, to which additional stages could be added at any future time. A three-valve receiver with batteries was inclined to occupy the whole of a good-sized table top or, even, the top of a grand piano as I found on paying one visit to a friend. As these receivers normally employed a first stage consisting of a tuner with reaction feeding back into the aerial coil, and as their sensitivity depended largely on working the equipment just off the point of self-oscillation, reception was apt to be punctuated with numerous howls and whistles.

### Radio on a Racing Car

It was towards the end of 1922 that a friend approached me in my den and told me that the then famous racing motorist Mr. S. F. Edge was, on the next morning, about to start an attempt to break the world's speed record for the double twelve hours. This was to take place on the now defunct Brooklands track at Weybridge. Mr. Edge had asked him if it would be possible to pass wireless messages from the racing car to his repair and refuelling depot on the side of the track. My friend, not being a technician, had told him that this was possible and that I would undertake to arrange it for him.

The temptation to have a crack at this challenge was too strong for me to resist, although the problems seemed unsurmountable. The use of valves for the transmitter was definitely out, as no valves then in existence would withstand the battering of being bounced about in a car travelling at speed on that track. Also, the provision of the necessary h.t. supply in the space available was out of the question. The aerial presented a further problem, as no suitable erection could be made on the car. Just to make the whole thing still more difficult I found, on enquiry, that it would be necessary to install the transmitter in less than two minutes during one of the refuelling stops, and that the whole equipment must be ready for installation by the time of the first refuelling stop at ten o'clock the next morning. How this was done, and a description of the trials and tribulations resulting, must wait until next month's instalment.

*(To be continued)*

## BRITISH POLARIS CONTRACT FOR EMI

EMI Electronics Ltd., in conjunction with its associated company in America, the Hughes Aircraft Company, has been selected as the main contractor for simulators at the Royal Navy Polaris School now under construction at Faslane in Scotland. This school will provide full synthetic training for the R.N. personnel, using a weapon control simulator manufactured by the Hughes Aircraft Company. EMI engineers will assist in the installation, testing and tuning of this device and will also train naval personnel in its use.



# THE NEW DUAL-STANDARD TV SETS

By Gordon J. King, Assoc. Brit. I.R.E., M.T.S., M.I.P.R.E.

PART 5

*This article, the fifth in our series on 405-625 line receivers, discusses video detector and video amplifier switching circuits and describes how a.g.c. blocking is avoided on 625 lines*

LAST MONTH WE SAW HOW THE DUAL-STANDARD i.f. channel response is tailored by switched filters to suit the two signal characteristics. It was seen that the channel is designed essentially to provide the requisite 625 response and that this is narrowed and shaped by filters to suit the 405 response when the standard-change switch is set to 405 lines.

It was also shown that the "phasing" of the vision detector needs to be adjusted over the two standards to suit both the positive vision modulation of the 405 system and the negative modulation of the 625 system.

## Diode Clamp

Fig. 13 (published last month) shows a triode section ( $V_{8(b)}$ ) connected as a diode (i.e., anode and grid strapped). The "diode" anode is connected to the vision a.g.c. line and in the "405" position the cathode is connected, via SW2-7, to chassis. Under this condition the diode serves as a conventional "clamp". It may be recalled that all 405-line-only sets feature such a diode (often a semiconductor diode) in this position permanently, and that its purpose is to prevent the a.g.c. line from rising positively under conditions of zero signal.

Fig. 16 shows basically how the a.g.c. bias is derived from the sync separator-control grid of many single-standard models. Here, the sync separator valve is given a short grid base by the high value anode load and by the screen-grid potential divider. To the control grid of the sync separator is applied the video signal from the output of the video amplifier valve.

Grid current flows on the positive-going sync pulses (the vision signal being negative-going at the output of the video amplifier since it is applied to the picture tube *cathode*) and charges  $C_1$ .  $C_1$  discharges through  $R_1$  during the picture period, thereby making the control grid negative with respect to chassis (i.e., relative to the cathode of the sync separator valve which is strapped to chassis). The valve thus becomes cut-off so far as picture signal is concerned and anode current flows only during the sync pulses. These pulses are therefore developed across the anode load and are fed to the appropriate timebase generators, through filters, in the normal manner.

The charge held by  $C_1$  is governed by the time-constant  $C_1 R_1$ , and by the strength of the video signal applied to the control grid. The stronger this signal, the greater the negative bias developed at the control grid. This bias is fed back to the controlled r.f. and i.f. valves to give automatic control of gain.

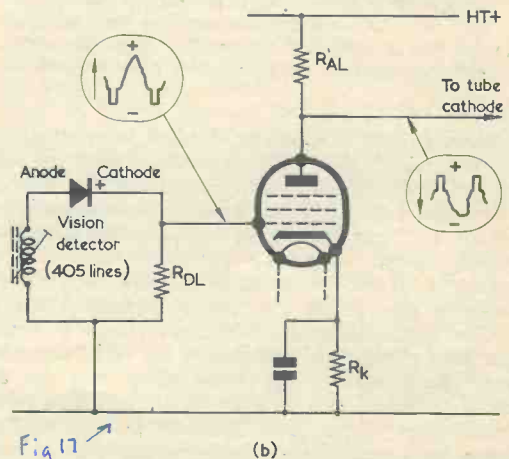
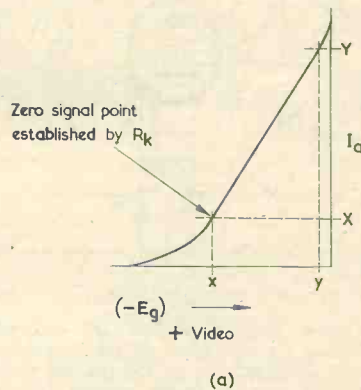

Fig 17

Fig. 16. This circuit shows the basic mean level a.g.c. system in the vision channel, the manual contrast control circuit and the clamp diode. The resistor in series with the slider of  $R_2$  will normally have a value around  $2M\Omega$ .

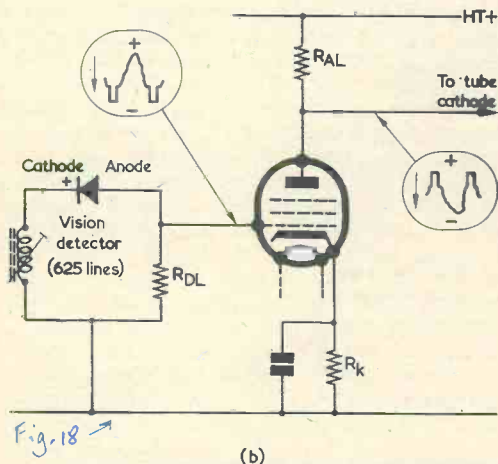
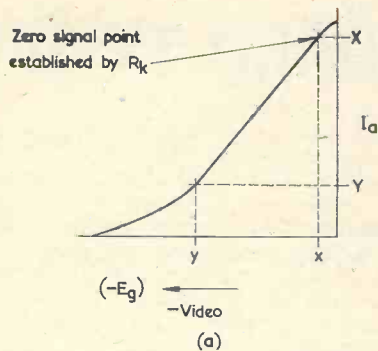

Fig. 17. Vision detector polarity (b) and video amplifier biasing for 405 lines. At (a) is shown the standing bias, as established by the cathode resistor  $R_k$ . This gives rise to anode current  $X$ . The positive-going video drive ( $x$  to  $y$ ) from the detector load  $R_{DL}$ , counters the standing bias and causes a rise in  $I_a$  to point  $Y$  at peak white. Across the anode load  $R_{AL}$  appears a negative-going picture signal, as shown

Manual gain or contrast control is provided by potentiometer  $R_2$ . Turning the slider of this control towards h.t. positive counteracts a proportion of the a.g.c.-derived negative bias and therefore reduces the negative voltage passed to the controlled valves. Here, then, is where the clamp diode comes in. If the line tends to go positive the diode conducts and keeps the line at chassis potential.

This a.g.c. clamping technique is used in single- and dual-standard models alike for 405-line reception, the process of deriving a.g.c. bias for the vision channel from the sync separator being called "mean-level" a.g.c. For domestic TV applications mean level a.g.c. is perfectly sound but it does tend to destroy the "black level" of the vision signal. As the picture rises towards peak white, so the a.g.c. bias increases negatively, an effect which pulls back the video gain of the receiver. For optimum studio demands, gated a.g.c. systems

are employed. These are also employed in some domestic receivers.

In last month's Fig. 13, then, the diode-connected  $V_{8(b)}$  performs as the clamp on 405 lines. If this circuit is now referred to, it will be seen that on 625 lines the diode cathode is switched from the chassis to the "anode" side of the vision detector and its load  $R_{40}$ .

This switching action is included to prevent the a.g.c. system from "blocking" on the 625-line signal (a process which we shall understand a little better towards the end of this article). What happens is that the negative potential at the "anode" side of the detector load is fed through the diode,  $V_{8(b)}$ , to the a.g.c. line, so that the a.g.c. line is supplemented by a little negative voltage derived direct from the vision signal. Thus, in the event of the normal a.g.c. system blocking, the set is at least brought back to gain equilibrium by the negative voltage from the detector.

Without this artifice, blocking of the nature under consideration could neutralise the sync separator-derived a.g.c. voltage and lock the a.g.c. line to chassis (or some predetermined negative value via the clamp diode) and thus "kill" completely the normal operation of the contrast control.

#### Video Conditions

When the vision detector diode is connected to accommodate the positive modulation of the 405 standard (Fig. 17), the signal voltage across the load rises positively with increase in white information. At zero signal the voltage across

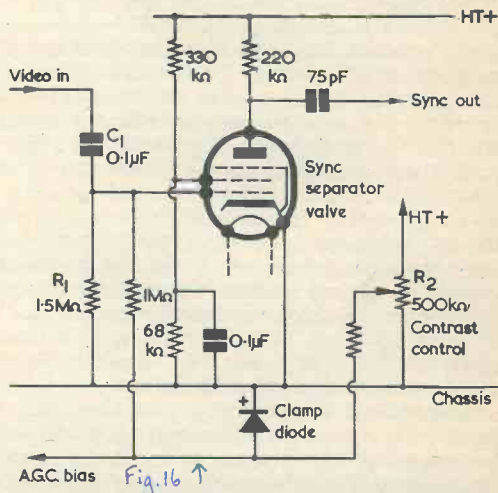

Fig. 18. Vision detector polarity (b) and video amplifier biasing for 625 lines. At (a) is shown the standing bias, as established by the cathode resistor  $R_k$ . This gives rise to anode current  $X$ , while the signal at the tips of the sync pulses pulls the anode current down to  $Y$ . As the picture signal rises towards white the voltage developed across the detector load  $R_{DL}$  goes less negative (that is, from  $y$  to  $x$ ), and the anode current operates between points  $Y$  and  $X$ . This also gives a negative-going picture signal at the video amplifier anode, as shown

the load is, of course, zero while at black level the signal is about 30% of that at peak white.

The picture tube cathode needs a negative-going picture signal, which means that the video amplifier stage is called upon to reverse the signal polarity. This is a normal process for any common-cathode valve amplifier.

The video amplifier valve is required to be biased so that at zero signal there is only a small "standing" anode current, this increasing as the signal rises positively with white picture. The increase in anode current causes a fall in anode voltage (due to the increasing volts drop across the anode load) and this, of course, gives us our negative-going picture signal for the tube cathode. These factors are illustrated in Fig. 17.

It will be seen that the zero-signal operating point of the video amplifier valve on the transfer characteristic falls just above the initial major curvature. Thus, the video signal operates over the most linear part of the curve. The video amplifier valve is biased by a cathode resistor in most circuits to a condition somewhat below that for Class A working.

While conditions for the 405-line standard are relatively easy to understand, confusion sometimes arises when a comparison is attempted with the 625-line standard. There is really no need for this, and Fig. 18 shows why.

Here is shown the basic vision detector circuit wired for negative modulation. As with the 405 system, there is no voltage across the load when the signal is zero. The signal rises to maximum on the tips of the sync pulses, and the voltage across the detector load then assumes a maximum negative value. From this maximum, towards white the negative voltage across the load decreases. This is the same, relatively, as the voltage rising positively across the load towards white!

This time, however, the video amplifier needs to be biased so that at zero signal the anode current is at a maximum. When signal is applied, the valve grid goes negative due to the negative voltage across the detector load, and as the signal rises towards white so the negative voltage on the grid reduces.

At the video amplifier valve anode, the conditions appear to be identical on both standards. On 405 lines increasing white results in increasing anode current and reducing anode voltage (giving a negative output signal), while exactly the same happens on 625 lines, since increasing white on that

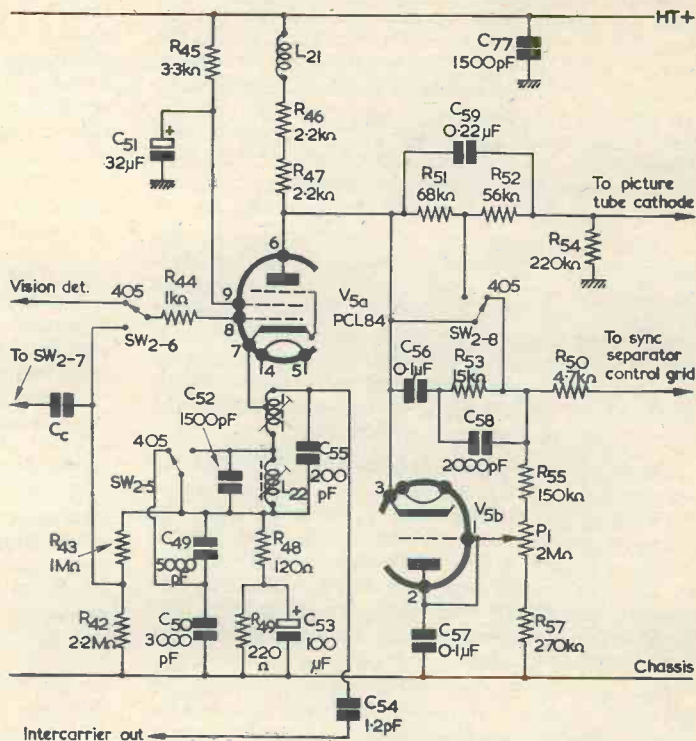

Fig. 19. The video amplifier and vision interference limiter circuit of a dual standard set. The former is dealt with in the text and the latter will be considered next month

standard reduces the negative voltage on the video amplifier valve grid.

#### Bias Requirements

Fig. 18 shows that the standing video amplifier valve bias for 625-line working needs to be much smaller than that for 405-line working, for in the former case a high anode current is required under conditions of zero signal, while in the latter case a relatively low current is called for.

The above reasoning is based on the assumption that direct coupling is adopted between the vision detector and the control grid of the video amplifier valve. D.C. coupling is always used in 405-line-only sets and often in dual standard models. However, in some versions the d.c. coupling between the detector and the video amplifier is purposely broken on the "625-line" position of the standard-change switch, though retained on 405 lines.

This then means that the signal handled by the video amplifier valve is the same for both standards and a common bias circuit to give approximately class A conditions can be utilised.

The idea is adopted in the circuit shown in Fig. 19.

Here the signal from the 625-line detector (as fed from SW<sub>2-7</sub>—see last month's Fig. 13) is fed to the control grid of the video amplifier valve (V<sub>5(a)</sub>) through C<sub>(c)</sub> (which destroys the d.c. coupling) and the detector selector switch section SW<sub>2-6</sub>. In the "405" position, however, the 405-line detector load is connected direct to the control grid of the video valve through SW<sub>2-6</sub>. Thus, we have direct coupling on 405 lines and a.c. coupling on 625 lines.

There is, nevertheless, a small change in the biasing conditions over the two standards, for while on 405 lines the detector load is connected direct to chassis (via SW<sub>2-7</sub>—Fig. 13) on 625 lines the control grid circuit of the video amplifier is returned to the junction of a potential divider formed by R<sub>42</sub> and R<sub>43</sub> across the cathode resistors. A slightly smaller bias is thus given to the amplifier on 625 lines compared with that on 405 lines.

On 405 lines the valve is biased by the volts drop across R<sub>48</sub> and R<sub>49</sub> in series, but on 625 lines a portion of this voltage only is extracted from the potential divider, as explained above. The cathode biasing network is formed by two cathode resistors so that the correct degree of compensation can be applied, and this is done by C<sub>49</sub> and C<sub>50</sub>. C<sub>53</sub> is of large value and gives virtually no video compensation of the response.

L<sub>22</sub> tuned by C<sub>55</sub> and C<sub>52</sub> serves on 405 lines as a 3.5 Mc/s rejector to prevent the beat between the sound and vision carriers showing up on the picture as a dot pattern. The 3.5 Mc/s signal is, in fact, deleted from the tube circuits by this rejector.

In the "625" position, SW<sub>2-5</sub> changes over and

short-circuits C<sub>52</sub> and a section of L<sub>22</sub> and thus steps up the rejector frequency to 6 Mc/s, this being the difference between the 625-line sound and vision carriers. Note, however, that this "difference" signal forms the intercarrier signal on 625 lines, and this in some sets is encouraged to pass through the video amplifier, as we shall see in a later article. In the circuit under discussion, the 6 Mc/s intercarrier signal as developed across the rejector is fed out to the intercarrier sound channel through C<sub>54</sub>.

#### Sync Out

No systems switching is required in the sync separator circuits, since, due to the vision detector switching discussed in the foregoing paragraphs, the sync separator operates in the conventional manner with signals from the video amplifier anode which have the same polarity on both standards.

With mean level a.g.c., blocking can occur, particularly with the negative modulation of the 625-line signal. In effect, the a.g.c. system becomes overloaded. What happens is that the sudden application of a strong signal can cause the sync pulses to be severely attenuated or cut off completely at the grid of the video amplifier. The sync separator then fails to produce its normal negative voltage, the gain of the vision channel tends to rise and the effect is aggravated. Here, then, is the reason for the use of the "anti-blocking diode" between the 625-line detector load and the a.g.c. line, as the supplementary negative potential from the detector holds the line negative and suppresses the blocking tendency.

*(To be continued)*

## Courses of Instruction for the City and Guilds Radio Amateurs Examination

### East Ham, London, E.6.

A course will be held at the East Ham Technical College, High Street South and candidates should enrol on the 14th, 15th or 16th September from 7 till 9 p.m.

The course will commence with morse classes on Monday 21st September and theory on Wednesday 23rd, 7 p.m. till 9 p.m.

Fees for the complete course will be 51/- or 31/- (either part) for students over 21 and 41/- or 26/- for those under 21.

### Wembley, Middx.

Classes will be held at the Wembley Evening Institute, Copland School, Wembley High Road, where enrolment will take place on Monday 14th to Thursday 17th inclusive between 7.15 and 9.15 p.m.

The classes, which are held on Monday evenings, 7-10 p.m., begin the following week, Monday 21st September. Morse is from 7-8 p.m. and theory from 8-10 p.m. The session runs for 30 weeks, ending just before Whitsun 1965 and the fee is 30/-.

### Brentford, Middx.

Classes will be held at the Brentford Evening Institute, Clifden Road, Brentford. Applications for enrolment can be received now by post to the Head of the Evening Institutes, Education Offices, Town Hall, London, W.4., or by personal application to the Institute during enrolment week 14th to 17th September. Classes commence on 21st September.

Monday evenings—Radio Amateurs' Course for the City and Guilds Certificate; Thursday evenings—Morse code for Post Office Certificate (12 words per minute) and Friday evenings—Mathematics of Radio (course specially designed for those who are weak mathematically).

All examinations are taken at the Institute. The fees are 30/- for one course and 7/6 for each additional course. The mathematics course will commence on 20th October when the fee will be 20/- or 5/- as an additional course.

Additionally, other courses on radio and TV servicing are held on Tuesday and Thursday evenings and tape recording on Wednesday evenings. Full details of these may be obtained from the Head of the Evening Institutes.

# OPERATION AND USE OF THERMAL DELAY SWITCHES

By E. Lawrence

**W**HILST THE AVERAGE EXPERIMENTER IS UNLIKELY to find much use for the thermal delay switches available on the surplus market, the amateur who is preparing to construct a transmitter power unit incorporating mercury vapour rectifiers will find it imperative to employ these devices. They will then be used to provide a safeguard against applying high voltage to the anodes of the rectifiers before their cathodes have attained correct working temperature. Manually operated switches can be used for this purpose, but there will almost inevitably be an occasion when the correct operating sequence is not carried out, to the detriment of the valves.

## Types Available

Two patterns of thermal delay switch are available in the surplus market, as shown in the photograph. The left hand example is an open type, in which the working parts have no protection from dust and mechanical damage but are accessible for adjustment; whilst the right hand switch has all the essential parts enclosed in an evacuated glass envelope with the connections brought out to a plug-in base similar to that of a valve.

The principle of operation depends upon the simple fact that a metal expands when it is heated. If identical lengths of different metals are each raised in temperature by an equal amount, for simplicity say  $1^{\circ}\text{C}$ , and are then measured, it

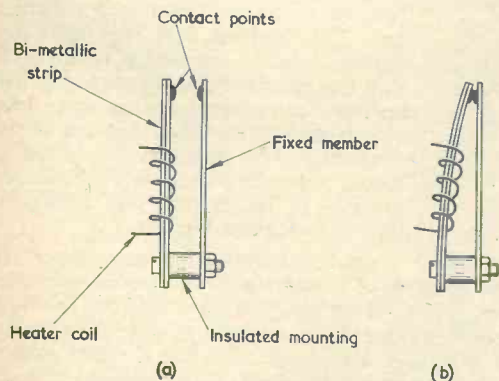

Fig. 1 (a). The thermal switch at rest  
(b). When the bi-metallic strip is heated, it bends and causes the two contact points to come together

**TABLE**  
Some coefficients of linear expansion with heat.  
(The figures show the fraction of increase in length per  $^{\circ}\text{C}$ .)

Aluminium .. .. .	0.000025
Brass .. .. .	0.0000189
Copper .. .. .	0.0000168
Iron .. .. .	0.000012
Platinum .. .. .	0.0000089
Invar .. .. .	0.0000009

will be found that each has increased in length by a small amount which is characteristic of the particular metal. The coefficients of linear expansion for several common metals are listed in the Table.

The degree of expansion in a short length for a small increase in temperature is, of course, minute,

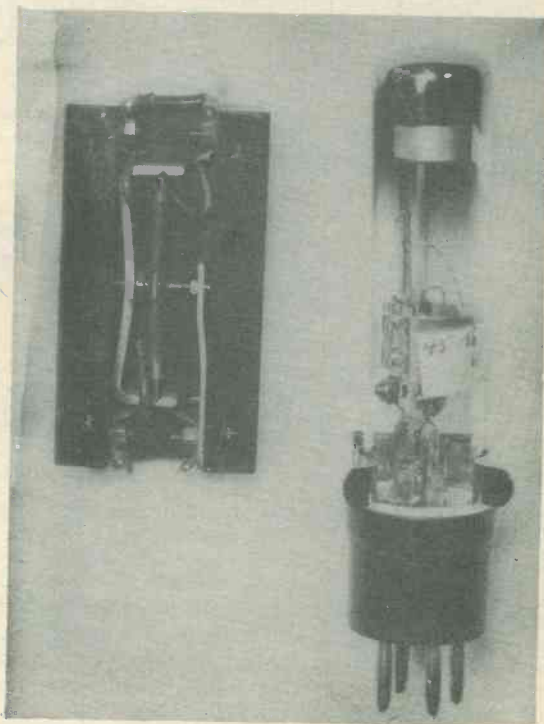

Two thermal delay switches of the type encountered on the surplus market

but in a large structure, such as a bridge under normal day-to-day temperature variations, it becomes very significant and due allowance must be made to avoid distortion which may lead to damage.

If two dissimilar metal strips are closely bonded together and heated, the greater expansion of one relative to the other will cause the combination to bend. This can be proved quite easily by means of a simple experiment. Take a strip of tin-plate and another of copper, both being about half an inch wide, six inches long, and having similar thicknesses, then bolt them together at intervals along their length. Check that they are straight by viewing them edge on against a ruler, and apply heat from a gas flame. After a minute or two a further check with the ruler will show that the combination has bent by as much as three-quarters of an inch. On being allowed to cool, the strips will reassume their straightness. The strip on the outer side of the curve is that which has expanded most.

### Electrical Application

In Fig. 1 (a) a bi-metallic strip formed by bonding two dissimilar metal strips together is provided at one end with a suitable electrical contact point, and is anchored in close proximity to a second fixed and unheated member which also carries a contact. When the bi-metallic strip is heated it will gradually bend until, after an interval of some 30 seconds or so, its contact point meets that on the fixed arm to complete an external circuit. Fig. 1 (a) illustrates the switch at rest whilst Fig. 1 (b) shows it at the end of the "make" cycle of operation. The position of the heater coil is also shown.

It will be obvious that, if the current in the heater coil is maintained, the continual deformation of the bi-metallic strip will cause the external circuit to remain closed until it is desired to switch off, whereupon it would be sufficient to cut off the heater current and allow the strip to cool down. This procedure is undesirable in practice, however, due to the delay thereby introduced into the switching-off cycle. Also, extended heating may shorten the life of the component.

To avoid this situation it is normal to use the thermal delay switch to initiate action in a separate relay (which can conveniently be one of the Post Office types), and this deals with the main circuit which it is intended to control. By means of suitable additional contacts, the relay can also disconnect the thermal switch heater supply at the appropriate time, and allow this to cool ready for the next cycle of operation. The relay can, further, hold itself in the "on" condition after the bi-metallic strip contacts open.

It is preferable that the supply for both the rectifier heaters and the delay circuit should have a common mains origin so that action is initiated simultaneously in both when first switching on. This ensures that the full delay period is taken advantage of in order that the rectifier heaters can reach their correct temperature before the delay switch makes the high tension circuit available. The common mains circuit would normally be that which feeds the primary of the transformer associated with the rectifier heaters.

An additional advantage, from the point of view of protection of the power amplifier valve, is given if the bias voltage is also derived from the common mains source, and is arranged to energise the relay associated with the thermal switch. Absence of bias voltage will then prevent the high-tension circuit from being activated and, if it subsequently fails, the high-tension supply will be immediately disconnected by the consequently de-

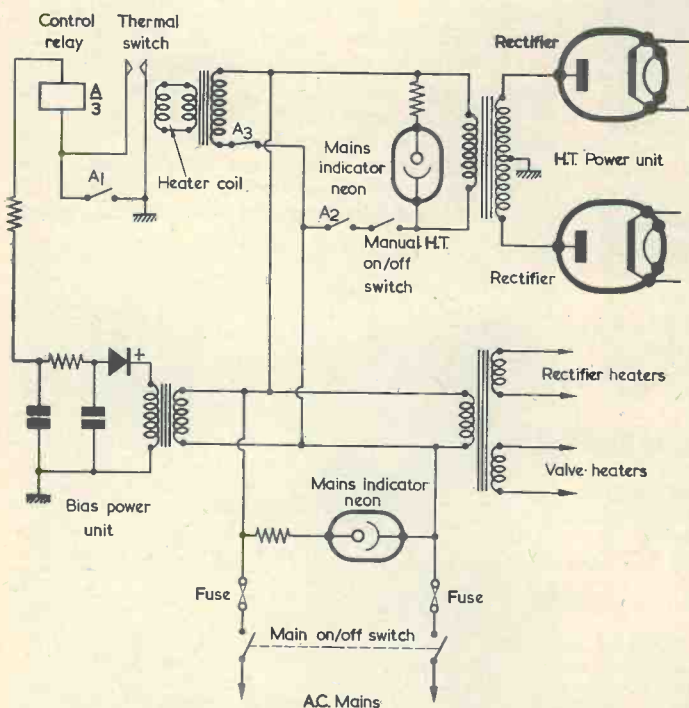

Fig. 2. A thermal delay switch circuit suitable for use with a transmitter

The switches available from Government surplus sources were originally produced with little regard to cost and were required to give long service with stable characteristics, and the metals employed normally include one of the low temperature coefficient alloys such as Invar, in association with, perhaps, brass. Less expensive switches would, however, replace the special material with a more common type such as iron.

energised control relay. The bias circuit should have the minimum value of capacitance commensurate with adequate smoothing, and the relay coil resistance should be chosen so that the current it draws is sufficient to ensure rapid release of the relay should the bias voltage fail. This additional current drain on the bias supply can contribute a stabilising influence, particularly when the load is in the form of widely varying grid current.

#### A Typical Protection Circuit

A typical protection circuit employing a thermal delay switch is shown in Fig. 2. The operating sequence starts with the closing of the main on/off switch. This applies the mains voltage to the transformers which supply current to the thermal delay heater winding, the bias power unit, and the valve heaters, including those of the rectifiers. The bi-metallic strip gradually warms up and bends, whereupon, after the prescribed period of time has elapsed, its contacts close and complete the circuit through relay  $\frac{A}{3}$ . With this relay energised, contacts A3 open, thus disconnecting the thermal switch heater circuit and allowing the bi-metallic strip to return to normal. Contacts A1 close and hold the relay "on" after the delay switch contacts have opened, whilst contacts A2, which are in series with the manual h.t. on/off switch and the primary

of the high-tension transformer, close. High voltage can now be applied to the rectifier anodes with confidence by means of the manual switch.

When the main switch is thrown off the bias supply decays and releases relay  $\frac{A}{3}$  which, in turn, resets the whole circuit ready for the next delayed switching cycle.

The circuit of Fig. 2 shows the salient features of a typical transmitter power unit incorporating a thermal delay device, but variations can be introduced to suit available components or preferred schemes. It would be possible, for instance, to derive the delay switch heater current from the 6.3 volt valve heater line by way of a resistor. It would also be possible to modify the delay time within small limits by variation of this series resistance. Again, the control relay could be energised from a normal 250V h.t. supply or, with appropriate coil resistance, from a low voltage transformer winding via a solid state rectifier.

#### EDITOR'S NOTE

Before putting a thermal delay circuit into operation, the manufacturers' literature concerning minimum cathode heating time for the rectifiers employed should be carefully checked. The circuit should then be tested several times without h.t. to ensure that it offers adequate delay in practice. As is stated by the writer, adjustments in the delay time may be obtained by varying the current in the thermal switch heater coil. In Fig. 2, contacts A3 of the relay could, if desired, appear between the heater coil and the secondary of the associated transformer.

## RADIO TOPICS . . . by Recorder

**I**T IS SURPRISING HOW OFTEN THE wheel turns full circle. When radio broadcasting first commenced, home-constructors used to mount their components on sheets of ebonite. After this, home-built receivers graduated to wooden chassis and then to metal chassis. But we are now coming back to mounting our components on sheets of insulating material all over again. Only, this time, the material is Paxolin.

#### Wooden Chassis

One of the most interesting steps in the development of chassis for home-built receivers occurred in the years just before the war, when it was the custom for home-constructors to use chassis made of wood. For some reason there was no great keenness in those days to employ metal chassis, and most receivers were built up on pieces of plywood. If, in order to obtain screening and earth returns, the equivalent of a

metal chassis was required, it was common practice to screw a layer of copper foil to one surface of the wood. I remember an old two valve short wave radio I knocked up in those days. The components were secured with wood screws to a wooden baseboard about 1in thick, and the panel consisted of a piece of plywood to suit. Both the top surface of the baseboard and the back surface of the panel were lined with copper foil. For those who didn't want to use the copper foil idea it was possible to obtain plywood which was treated on one side with a metallic conductive surface. This plywood could be cut to size as required, and the metallic surface made quite an efficient screen. The home-constructor was warned not to attempt to pass mains valve heater currents through it!

Nowadays, the advent of miniaturised transistor receivers has caused us to revert to light assemblies

mounted on Paxolin. Commercial receiver production employs the printed circuit technique, of course, but this is not always attractive to the home-constructor who only wants to make "1-off" of a receiver. In the amateur context printed circuits come into their own, nevertheless, with the kit receivers offered by component houses, because a large volume of sales renders the use of such circuits an economic project.

The home-constructor who designs and builds his own receivers is, therefore, very likely to mount the components on a sheet of Paxolin. There are several possible approaches here. One consists of drilling holes in the Paxolin where wire and lead-out anchoring is required, eyelets being inserted into these holes. The wires and lead-outs may then be soldered directly to the eyelets. It is even possible to dispense with the eyelets, the wiring being supported here and there by judiciously positioned solder

tags bolted to the board. Despite the fact that some of the joints are then of the "mid-air" variety an assembly of this nature can be perfectly rigid, the majority of the joints being made to thick tinned copper wires secured to the solder tags.

Two recent developments offer considerable help in this method of construction. One of these is Veroboard (manufactured by Vero Electronics, South Mill Road, Southampton). For those who haven't yet encountered Veroboard, it should be explained that this consists of an insulating sheet having parallel copper foil strips on one surface. A series of holes are pierced along each of these strips at regular intervals, these holes forming a square or rectangular pattern. Component lead-outs are then passed through these holes as desired, and soldered to the copper strips. Hole spacing may be 0.2 x 0.2in, 0.2 x 0.1in or 0.1 x 0.1in. The 0.2 x 0.2in spacing is that which is, perhaps, most convenient for home-constructor use, and we featured a receiver employing this type of Veroboard in the January issue for this year.<sup>1</sup> We have, also, some designs for the future which will similarly use this material. The copper foil strips can be interrupted at any point along their length quite easily. Personally, I find Veroboard extremely useful for small or miniaturised equipment, and I should add that this material is nowadays available from most of the component stockists.

A newer material is Eyelet-Board, this consisting of a sheet of insulating material pierced with holes at 0.2in spacing to form a square pattern. In this instance anchor points are provided by inserting eyelets, where required, into any of the holes. The eyelets, supplied separately in packets, are secured in place by a tap with a centre-punch, and the great advantage of the Eyelet-Board idea is its versatility. The eyelets can be positioned at any desired points. The boards are available in 4½ x 2½in, together with packets of 40 eyelets. The Eyelet-Board is reviewed in this issue and so I shall not pass on any further points here. However, readers who are interested may obtain details and samples by dropping a line (with s.a.e.) to R. and E. Lamb, Electronic Assemblies, 17 Queens Road, Leytonstone, London, E.11.

Turning to my opening remark, the thought passed momentarily through my mind that, in the old

days of ebonite panels, nobody ever considered fitting these with copper strips or eyelets. The thought was soon dismissed, though. Nobody ever considered soldering any connections in those old receivers, either! I should hasten to add, for the benefit of readers who have not encountered any of this earlier equipment, that their components carried bright nickel-plated screw terminals under which all connecting wires were secured.

#### Silver Lining

Things are quite often not as bad as they appear at first sight. This little truism holds good even in radio, as the following episode demonstrates.

I was recently offered a second-hand medium and long wave transistor for what was little more than the proverbial song. The cabinet was in quite good condition and, since it would provide a nice little surprise for a junior member of my family, I decided to take advantage of the offer. The only snag was that, whilst the set worked excellently on long waves, medium wave reception was very poor. A glance inside the cabinet showed straightaway, however, that the ferrite aerial rod had broken, a short section with the medium wave coil still on it lying disconsolately amongst the works. The fault looked obvious enough, and so I bought the set and carried it off home for later examination and repair.

On checking the receiver, I inspected the broken ferrite rod more carefully. This had, in its unbroken state, a length of about 8½in. A 3in section, complete with medium wave coil, had broken away, the remainder of the rod being firmly anchored by its mounting. I held the medium wave section of the rod up against the remainder so that the broken surfaces were in contact, and switched the set on. But medium wave reception was still very poor and it was evident that there was another fault. A little further examination soon revealed that the broken section had been rattling around inside the cabinet and that the two end turns of the medium wave coil were frayed at one point and had become open-circuit. My heart sank a little when, on examining the severed ends, I found that the coil was wound with litz wire.

So there I was, complete with one bargain set, a broken ferrite rod and two breaks to repair in a litz-wound coil. I would need to obtain a new ferrite rod, and I would have to tackle all those strands in the litz coil wire.

It was at that precise instant that my memory, which had been of no help whatsoever until then, came into action and opened up a few of the doors I keep in the dusty recesses between the ears. The first memory was that, a year or so ago, a short article in *Mullard Outlook* had stated, contrary to my previous belief, that it is O.K. to repair broken Ferroxcube aerial rods by sticking the two ends together again. I quickly found the issue concerned and confirmed this.<sup>2</sup> The two ends should be in proper alignment with each other when brought together, and most of the commercially available adhesives can be used for the job. Important points are that none of the rod material on the mating surfaces should be removed by the use of abrasive materials, etc., and that no adhesive requiring heat may be employed. The latter would impair the magnetic qualities of the rod.

So, instead of having to order a new rod I would, with luck, be able to stick the existing one together again.

At this stage my memory once more swung into action, this time in connection with the litz wire. I suddenly remembered that, in these days of self-soldering enamel, hardly any commercial receiver manufacturer was going to lumber himself with litz wire having ordinary enamel insulation on the strands. To check this I raised one of the severed coil wire ends away from the former, and applied the soldering iron together with a little cored solder. I took the iron away, to find that all the strands of the litz wire were now beautifully tinned and soldered together.

After all this initial brain-work the actual repair took hardly any time at all. I first tinned the remaining broken litz wire ends of the coil and bridged them over with the aid of short lengths of tinned copper wire. I next applied, as per the instructions on the tube, a spot of my favourite "stickite"—Bostik No. 1 Clear Adhesive—and stuck the ferrite rod together, keeping the medium wave section temporarily in place by wedging an empty cigarette packet between its end and the inside surface of the cabinet. The packet would, of course, be removed when the adhesive had finally set.

After that, it was merely a question of switching on and trying out the medium wave band. This was now

<sup>1</sup> D. B. Pitt, "The 'Veronica' 2-Transistor Receiver", *The Radio Constructor*, January, 1964.

<sup>2</sup> Unfortunately, I can't quote the issue of *Mullard Outlook* as the "Service Department" section, in which the piece appeared, does not carry a date.



entirely satisfactory. The final job was to tune in a weak station at the low frequency end of the band and see if the medium wave coil needed to be shifted along the repaired rod for optimum reception. To my surprise I found that hardly any adjustment to the coil was needed.

I only wish that all radio repairs were as simple as that particular one turned out to be!

#### Caroline in Ayrshire

It looks as though the reflex circuit introduced by Sir Douglas Hall in his article in our June issue is going to prove a real winner. You may recall that the basis of the circuit is a micro-alloy transistor which functions, at r.f., as a common collector amplifier, then, at a.f., as a

common base amplifier.

One of our readers, who lives in Ayrshire, has written in to say how pleased he is with the circuit. Although Ayrshire is noted for poor reception he is obtaining, with the four-transistor version of the circuit, Radio Caroline at ample loud-speaker strength. There is no fading and tone is very good.

It's pleasant to see an ingenious development of this nature giving such obviously good results.

#### Two Equals One

I was talking to some young radio enthusiasts recently, and the conversation turned to simple algebraic calculations. As a gag I showed them a "proof" that 2 equals 1. This "proof" is rather an oldie, but no-

body in the company had heard of it before. So, for the benefit of others who, similarly, may not have encountered this little bit of juggling with the rules of algebra, I pass it on here.

You start off by assuming that  $x$  equals  $y$ . The "proof" then carries on in the following manner:

$$\begin{aligned} x &= y \\ \therefore x^2 &= xy \\ \therefore x^2 - y^2 &= xy - y^2 \\ \therefore (x+y)(x-y) &= y(x-y) \\ \therefore x+y &= y \\ \therefore 2x &= x \\ \therefore 2 &= 1 \end{aligned}$$

Simple, isn't it?

Most of you will probably have spotted the error. If you haven't I'll tell you what it is next month!

## NEW ELECTRONIC TECHNIQUE CHECKS

### PROPELLER BLADES' PITCH

Variable-pitch ejectable propellers, which provide a stand-by electrical or hydraulic power supply in an emergency on VC10 and Trident aircraft, are being tested at Dowty Rotor Ltd's Gloucester plant by an ingenious technique using a stroboscope in conjunction with a closed-circuit television system, both supplied by EMI Electronics Ltd.

Checking the pitch of these propeller blades—the angle at which they meet the air—at speeds from 6,000 to 9,000 r.p.m. is undertaken in strengthened, soundproofed test-cells. Previously it was necessary for an engineer to remain in the test-cell to gauge the pitch of each blade by eye. This was a dangerous, uncomfortable procedure, and was only accurate to  $\pm 3^\circ$ .

Using the new technique, a stroboscope "freezes" the propeller as it rotates on the test rig at a known speed. The light from the stroboscope is reflected along the line of sight of the camera by a polished stainless steel sheet with a central hole through which the camera looks.

A type 8 camera views the blade in its plane of rotation and a picture of the blade root is clearly seen on the television receiver outside the test cell.

The blade root has a scale marked on it which lines up with a fixed pointer on the hub and from this arrangement the blade angle can be assessed within an accuracy of  $\pm 1^\circ$ . In this way engineers can check whether, under flight conditions, the blade will rotate at the correct speed.

When it is lowered from an aircraft's fuselage during an electrical power failure, the propeller's rotational speed rapidly builds up to 8,000 r.p.m. by a windmilling action as the aircraft moves through the air. If accurately pitched, the propeller then "bites" enough air to maintain this rotational speed of 8,000 r.p.m., irrespectively of whatever load is being taken from the alternator or hydraulic pump. This provides a constant electrical or hydraulic power supply to the aircraft for the duration of the emergency.

**Queries.** We regret that we are unable to answer queries other than those arising from articles appearing in this magazine nor can we advise on modifications to equipment described. Queries should be submitted in writing.

**Correspondence** should be addressed to the Editor, Advertising Manager or the Publishers, as appropriate.

**Opinions** expressed by contributors are not necessarily those of the Editor or proprietors.

Contributions on constructional matters are invited, especially when they describe the building of particular items of equipment. Articles should be written on one side of the sheet only and should preferably be typewritten, diagrams being on separate sheets. Whether handwritten or typewritten, lines should be double-spaced. Diagrams need not be large or perfectly drawn, as our draughtsmen will re-draw in most cases, but all relevant information should be included. Photographs should be clear and accompanied by negatives. Details of topical ideas and techniques are also welcomed and, if the contributor so wishes, will be re-written by our staff into article form. All contributions must be accompanied by a stamped addressed envelope for reply or return, and should bear the sender's name and address. Payment is made for all material published.

**Production.**—Letterpress/contact litho.

Published in Great Britain by the Proprietors and Publishers Data Publications Ltd. 57 Maida Vale London W9

Printed by A. Quick & Co. (Printers) Ltd. Oxford Road Clacton-on-Sea England

Obtainable abroad through the following Collets Subscription Service Continental Publishers & Distributors Ltd William Dawson & Sons Ltd. Australia and New Zealand Gordon & Gotch Ltd. Electronics Publications (Australia) South Africa Central News Agency Holland "Radio Electronica"

**FREE** THIS BOOK WILL INTEREST YOU!

LEARNING the PRACTICAL WAY

**FOR**

- ... Your Career
- ... Your Own Business
- ... An Absorbing Hobby

**Radiostructor**  
EQUIPMENT-COURSES

## A NEW-PRACTICAL WAY of UNDERSTANDING

### RADIO • TELEVISION • ELECTRONICS

Including: Transistors; VHF/FM; Hi-Fi Equipment; Computers; Servo-Mechs. Test Instruments; Photo-electrics; Nucleonics; etc.

Radiostructor—an organisation specialising in electronic training systems—offers a new self-instructional method using specially designed equipment on a “do-it-yourself” basis. You learn by building actual equipment with the big kits of components which we send you. You advance by simple steps, performing a whole series of interesting and instructive experiments—with no complicated mathematics! Instructional manuals employ the latest techniques for showing the full story of electronics in a practical and interesting way—in fact, you really have fun whilst learning!

# RADIOSTRUCTOR

LEADS THE WORLD  
IN ELECTRONICS TRAINING

## POST NOW

To RADIOSTRUCTOR (Dept. G149), READING, BERKS.  
Please send brochure, without obligation, to:

\*Name .....

\*Address .....

(We do not employ representatives) 9/64  
\*Block Caps Please

## TV FAULT FINDING

Data Book Series No. 5

Contains information and fault finding details of both the B.B.C. and I.T.A. transmissions. Lavishly illustrated by photographs taken from the screen of a television set exhibiting the faults under discussion. A comprehensive fault finding guide is included, and this is cross referenced to the book itself.

**104** pages, high quality paper with laminated plastic board cover

**Over 100** Illustrations and Diagrams

**Price 6/-**

Postage 6d.

“... A book that should be in every television dealer's service workshop, and in every home-constructor's, for that matter.”—*Journal of the Television Society*

“... The book will undoubtedly be of value to TV service engineers, particularly those who are not fully experienced in translating the appearance of faulty pictures into the necessary adjustments or receiver fault location.”—*Wireless and Electrical Trader*.

### TO DATA PUBLICATIONS LTD 57 Maida Vale London W9

Please supply.....copy(ies) of “TV Fault Finding”, Data Book No. 5. Price 6/-. Postage 6d.

NAME.....

ADDRESS.....

# THE NEW RADIO AND TELEVISION

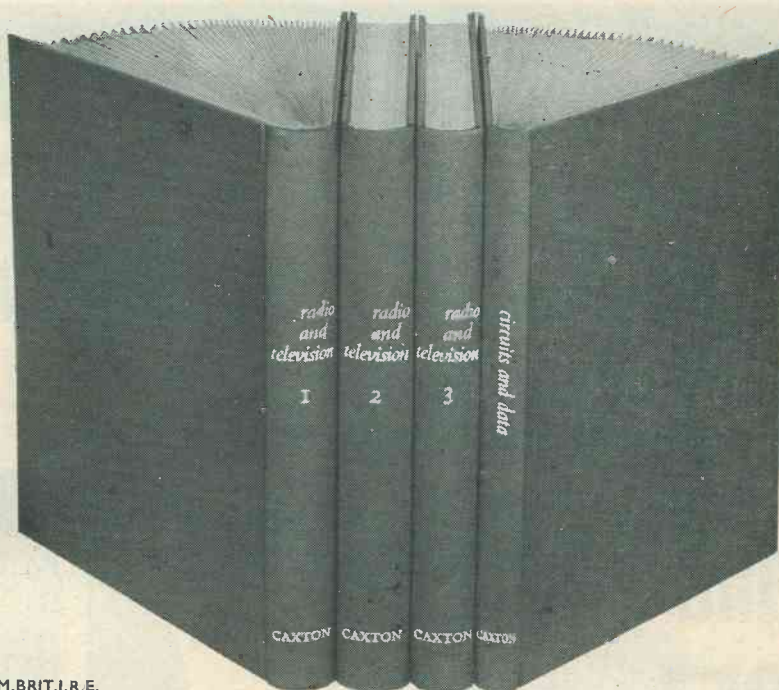

by C. A. QUARRINGTON, A.M.BRIT.I.R.E.

**RADIO AND TELEVISION** is the most up-to-date work which deals with the principles, design considerations, applications, component parts, maintenance, adjustment and repair of radio and television. Essential for every radio and television engineer and enthusiast, these four magnificent volumes have been designed to meet the needs of all connected with this branch of engineering. By mastering everything in this work and using it for reference, you can join the ranks of men who are sought after because they know the trade from A to Z.

**FREE INFORMATION BUREAU.** To every purchaser we offer a free postal information service to keep him in touch with what is happening today, what happened yesterday, and even what may happen tomorrow.

## SOME OF THE CONTENTS

Waves in free space - Inductance - Capacitance - The tuned circuit - Detection - R.F. pentode - R.F. amplifier - The superheterodyne - Frequency changing stage - A.G.C. and tuning indicators - R.F. coils, screens and switches - Output stage - Press-button tuning - Combined A.M. and F.M. receivers - Transistors and diodes - Power supply and decoupling - High fidelity and stereo reproduction - Microphones and pre-amplification - Tape recording - Car radio - Low-power transmission - Video signal - Waveform generator - Synchronising circuits - Automatic gain control - Vision detection and amplification - Interference limiters - Colour television - Aerials - Fault diagnosis - Workshop equipment - Voltage and current testing - Testing basic components - Instability and motor-boating - Mains hum and background noise - Tracing distortion - Radio receiver alignment - Blank screen - Poor interlacing, television - Pattern on screen - Television receiver alignment - Projection television.

## SEND NOW FOR FULL INFORMATION

To THE CAXTON PUBLISHING CO. LTD.,  
Dept. 73/27, Gatehouse Industrial Estate, Aylesbury, Bucks

Please send me full information about "Radio and Television"

NAME .....  
(BLOCK LETTERS PLEASE)

ADDRESS .....

RT 73/27

# Free!

Inside every copy of  
**PRACTICAL  
WIRELESS**

## Complete TRIMMER and ALIGNMENT

### SET \* 6 TOOLS plus EXTENSION HANDLES and HANDY STAND

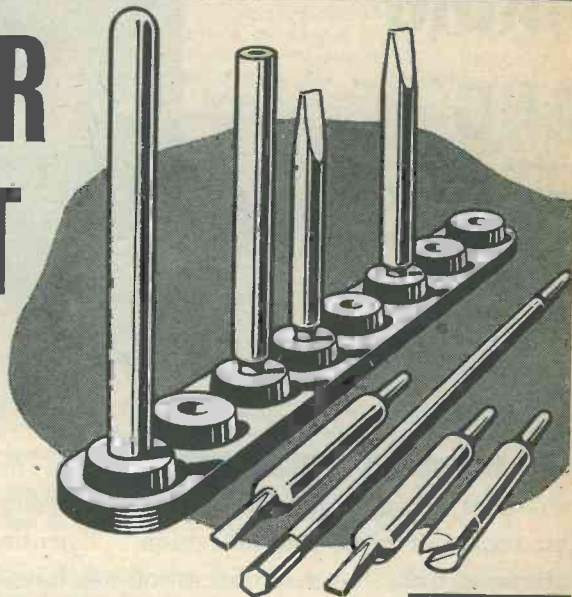

Specially designed to adjust all standard coil cores and trimmers . . . made in A.B. Styrene, tough, durable, and of course non-conductive. Make sure of yours now — FREE inside the October Practical Wireless

#### ALSO IN THE OCTOBER ISSUE

How to construct:—

- A 10 Transistor Double-conversion Communications Receiver.
- A Simple Transistor Tester.
- An Experimental Unit for Chromosonic Display.

ON  
SALE  
SEPT  
4

# PRACTICAL WIRELESS

OCTOBER ISSUE 2/- ORDER NOW



Order yours today  
**Air-O-Ear**

4-Band  
home or office  
aircraft receiver

No other radio,  
regardless of  
price, can bring  
you all these  
communications

**VHF** (108-130 Mc/s)

**BAND 1** Aircraft, right in your own home or office. Tune in airline jets, business and private planes (even your own), and towers. Hear what pilots say when weather is bad, in fog, snow or icing conditions. Sharpen your VHF radio procedure by listening to experts. Learn what goes on during an emergency.

**LOW FREQUENCY**

(200-400 kc/s)

**BAND 2** Monitor continuous aviation weather reports for 200 miles around. 24 hour weather information winds aloft, cloud conditions, forecasts. Air-O-Ear is a real necessity for every pilot and boat owner.

**M.F. & SHORT WAVE**

(1500-5000 kc/s)

**BAND 3** Police broadcasts, marine radio-telephone, ship to shore or ship, Coast Guard, hams, government services, foreign broadcasts.

**BROADCAST** (500-1600 kc/s)

**BAND 4** Music and news. Your favourite radio programmes. Powerful circuit delivers full, rich sound. Enjoyment for entire family.

**SPECIAL CLEARANCE  
OFFER—**

**4-BAND RECEIVER**

NORMALLY RETAILS AT £45  
SPECIAL OFFER BY MAIL £25 COMPLETE

**FEATURES:** 4-band receiver plugs in anywhere. Has built-in antennas, 7 tubes plus rectifier, heavy duty 6" speaker, pilot lighting, precision slide rule tuning. Headset jack with automatic speaker cut-out permits you to listen without disturbing others. Tuner output jack can furnish signal to your hi-fi amplifier. Exclusive *Squelch Control* eliminates noise and interference on VHF band. Complete instruction manual.

6" x 12" x 6" Weighs 7 lb.

Shipped in rugged, shockproof carton, hermetically sealed.

Leading companies using Air-O-Ear  
American Airlines, KLM Royal Dutch Airlines, Standard Oil, Pan American, T.W.A., Champion Spark Plugs, Flying Tigers. Also Federal

Aviation Agency, Atomic Energy Commission, U.S. Weather Bureau.

Over 20,000 satisfied users:

"... very impressed with performance. . . ." Federal Aviation Agency.

"... excellent . . . I certainly would recommend the Air-O-Ear 4-Band VHF receiver to other aviation enthusiasts. . . ." Kay Buckley, Franklin Park, Illinois.

"... our set is operated 24 hours a day and gives us very satisfactory service. . . ." Alamo Airways, Las Vegas, Nevada.

"... send us 10 more Air-O-Ear receivers. . . ." KLM Airlines.

"... use it for weather, general enjoyment, and to learn the language used in aviation. . . ." E. Brown, Portsmouth, Ohio.

"... I would like to order one of the 4-band Air-O-Ear receivers. I have learned that a friend of mine has one and is very pleased with it." Sen. Barry Goldwater, Washington, D.C.

**10 DAY MONEY-BACK RETURN PRIVILEGE**

Unconditional, with no explanation asked. Nova-Tech is a million dollar company, D & B listed, member of California Chamber of Commerce. All shipments insured, unconditionally guaranteed.

**nova-tech** INC.

72 Wardour Street, London, W.1

**Order your Air-O-Ear today—**

**Nova-Tech Inc., 72 Wardour Street, London, W.1**

Please send Air-O-Ear 4-band Aircraft Receiver at £25, with 10-day return privilege.

I enclose payment in full     Send C.O.D.

Name .....

Address .....

R.C.

## SMALL ADVERTISEMENTS

continued from page 139

**HIGH QUALITY "BRAND FIVE" RECORDING TAPE** at reduced prices. Acetate. 5in, 900ft, 13s.; 5½in, 1,200ft, 16s. 6d.; 7in, 1,800ft, 24s. 6d.; Mylar 5in, 1,200ft, 26s. All new. Money back guarantee. All enquiries S.A.E.—Spectron, 6 Bingham Road, Radcliffe-on-Trent, Nottingham.

**TRANSISTORISED CCTV CAMERAS**, all essential components, focus units, inductors, etc., at competitive prices. Details S.A.E.—Worland Electronic, 16 Woollett Street, London, E.14. Telephone: East 4837.

**NEW VALVES.** 12 months guarantee! Free lists. ECC82/3, 6s. 6d.; BY100, 7s. Also tubes, transistors, etc.—Bearman, Leicester Road, New Barnet, Herts. Telephone: BARnet 1934.

**COLLECTOR** interested in purchasing really early wireless valves—First World War or earlier. Has for disposal numerous mid-1920s types. Also for sale several early crystal detectors.—Enquiries to Box No. F205.

**FOR SALE.** Quantity of new accumulators. Willard Radio-20-2, 2 volt. Size: 5in high x 3½in x 2½in., 5s. each plus carriage.—Box No. F207.

**VALVES TO CLEAR.** All at 5s. each, post paid. 83, 5Y3, 6AG5, 6AT6, 6B8, 6BR7, 6SA7, 6SK7, 12AT7, 6J6, DAF91, DL92, DK91, ECC82, EF40, EF91, EL41, EL91, IT4, IS5, VR150, VT136, T20.—Box No. F208.

**FOR SALE.** Eddystone 940 receiver, as new. January 1946. Hardly used. £75.—F. Barker, 5 High Street, Swanscombe, Kent.

**WANTED.** Following back numbers of *Electronic Engineering*: March and July 1945, October 1946, November 1950, February 1951, March 1952, October 1955, all 1959, all 1960, most 1961.—Replies to J. Wilson, 78 Malone Avenue, Belfast 9.

**FOR SALE.** Heathkit valve voltmeter model AV-3U. Unused. £15 o.n.o.—Box No. F212.

**WANTED.** Marine sextant. Cash or exchange radio gear. Micrometer type preferred.—Box No. F214.

**OFFERS** for Philips 3-speed playing deck with auto change and 5 watt amplifier.—Box No. F216.

**TELEVISION AMATEURS.** Continental 625 line television for sale. Tuned Sweden. Circuit diagram.—Write to D. Weston, 121A Brighton Road, Coulsdon, Surrey.

**FOR SALE.** Professionally built Heathkit OS-1 oscilloscope and AO-1U audio generator. Also Nombrex transistorised signal generator and power supply unit. Best offer secures.—Douglass, 19 Byron Drive, Clifton, York.

continued on page 143

# JACKSON

the big name in **PRECISION** components

Precision built radio components are an important contribution to the radio and communications industry.

## SL 16 DRIVE

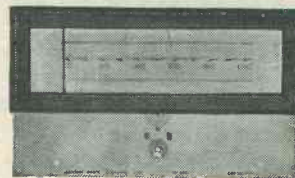

A general purpose slide rule Drive for F.M./V.H.F. Units, short-wave converters, etc. Printed in two colours on aluminium, with a 0-100 scale and provision is made for individual calibrations. Complete with bronze escutcheon and glass.

*It's reliable if it's made by JACKSON!*

## JACKSON BROS. (LONDON) LTD.

Dept. R.S., Kingsway-Waddon, Croydon, Surrey  
Telephone Croydon 2754-5  
Telegrams Walfilco, Souphone, London

## RETURN-OF-POST

ON CASH OR C.O.D. ORDERS

LATEST TEST METERS	Cash Price		Hire Purchase	
	Deposit	Mthly Pmts.	Deposit	Mthly Pmts.
AVO Model 8, Mark III ...	£24. 0.0	£4.16.0	12 of	£1.15. 2
AVO Model 7, Mark II ...	£21. 0.0	£4. 4.0	12 of	£1.10.10
AVO Multiminor Mark IV ...	£9.10.0	£1.18.0	12 of	14/4
T.M.K. TP10 ...	£3.19.6	£1. 3.6	3 of	£1. 2. 0
T.M.K. TP55 ...	£5.19.6	£1.15.6	3 of	£1.11. 4
T.M.K. Model 500 ...	£8.19.6	£1.15.6	12 of	13/8
TAYLOR Model 127A ...	£10.10.0	£2. 2.0	12 of	15/8

Full details of any of the above supplied free on request. The AVO Models 7 and 8 are both latest models from current production—not to be confused with Government surplus.

### GRAMOPHONE EQUIPMENT

ALL LATEST MODELS ALL POST FREE	Cash Price		Hire Purchase	
RECORD CHANGERS	Deposit	Mthly Pmts.	Deposit	Mthly Pmts.
GARRARD AUTOSLIM (Mono PU) ...	£6.17.6	£1.12.6	6 of	£1. 0. 0
GARRARD AUTOSLIM De-luxe AT6 (Mono PU) ...	£11. 9.0	£2. 6.0	12 of	16/11
GARRARD AUTOSLIM AT6 (Stereo/Mono PU) ...	£12. 5.4	£2. 9.4	12 of	18/-
B.S.R. UA14 (TC8 Mono PU) ...	£6.15.0	£1.10.0	6 of	£1. 0. 0
B.S.R. UA14 Monarch (TC8 Stereo/LP/78) ...	£7.15.0	£1.18.0	6 of	£1. 2. 0
B.S.R. UA15 (TC8 Mono PU) ...	£7.15.0	£1.18.0	6 of	£1. 2. 0
B.S.R. UA15 (TC8 Stereo/LP/78) ...	£8.15.0	£2. 6.0	6 of	£1. 4. 0

Many of the above can be supplied for stereo working. See our Gramophone Equipment List for details.

### AMPLIFIER KITS

We have full stocks of all components for the Mullard 510, Mullard 3-3, Mullard 2 and 3 Valve Pre-Amp, Mullard Stereo, Mullard Mixer. Fully detailed list on any of these sent upon request. Instruction Manual: All Mullard Audio Circuits in "Circuits for Audio Amplifiers", 9/5. Post Free.

### ILLUSTRATED LISTS

Illustrated lists are available on LOUDSPEAKERS, TAPE DECKS, TEST GEAR, GRAMOPHONE EQUIPMENT, AMPLIFIERS. Any will be sent free upon request.

## WATTS RADIO (MAIL ORDER) LTD

54 CHURCH STREET WEYBRIDGE SURREY

Telephone Weybridge 47556  
Please note: Postal business only from this address  
Callers welcome by appointment

## THE MODERN BOOK CO

**An Electronic Organ for the Home Constructor.** By A. Douglas. 20s. Postage 1s.

**Wireless for Beginners.** By G. L. Boltz. Revised T. Roddam. 18s. Postage 9d.

**Television Servicing Handbook.** By H. J. King. 35s. Postage 1s. 6d.

**Instant Maths.** By A. Cutler. 10s. 6d. Postage 1s.

**Know Your Oscilloscope.** By P. C. Smith. 20s. Postage 1s.

**Radio Control for Models.** By F. C. Judd. 15s. Postage 9d.

**Understanding Amateur Radio.** An A.R.R.L. publication. 18s. Postage 1s. 3d.

**Radio Valve Data, 7th Ed.** Compiled by "WW". 7s. 6d. Postage 10d.

**Guide to Broadcasting Stations.** By "WW". 5s. Postage 6d.

**Handbook of Test Gear for Amateurs.** By *Practical Wireless*. 3s. 6d. Postage 6d.

**TV Fault Finding.** A Data Publication. 5s. Postage 6d.

**The Radio Amateur's Handbook, 1964 Ed.** By A.R.R.L. 36s. Postage 2s. 3d.

**Fun With Transistors.** By G. Davey. Ed. J. Cox. 12s. 6d. Postage 1s.

**Radio Servicing Problems.** By W. A. L. Smith. 5s. Postage 6d.

**Basic Industrial Electronics.** By A. Haas. 35s. Postage 1s.

**A Beginner's Guide to Radio.** By F. J. Camm. 8s. 6d. Postage 6d.

Complete Catalogue 1s.

We have the Finest Selection of British and American Radio Books in the Country

**19-21 PRAED STREET (Dept RC) LONDON W2**

Telephone PADdington 4185

# A NEW WAY TO BUILD HI-FI

## STAGE BY STAGE



**MARTIN AUDIOKITS** comprise a cleverly designed series of fully transistorised units from which you can start a basic combination of your own choice and add to it stage by stage. Standardised connections makes assembly of these prefabricated, tested and guaranteed units fascinatingly easy. So far, there are 10 to choose from, and attractive escutcheon plates are available to suit the assembly selected.

### FROM A PRE-AMP TO A 20 WATT HI-FI STEREO ASSEMBLY

**MARTIN AUDIOKITS** include single pre-amp stage, tone control stage, 5-stage selector unit, unique 3 channel mixer unit, 3 and 15 ohm power amplifiers, mains supply units, etc. Mono can be easily converted to stereo, or stereo units bought complete. **QUALITY IS SUPERB—AND SAVING IN CASH TERRIFIC.**

***Make it  
Martin!***

**MARTIN AUDIOKITS** for hi-fi systems. Martin Recordakits for tape enthusiasts. From good stockists everywhere. Leaflets free on request.

**MARTIN**  
Audiokits

**MARTIN ELECTRONICS LTD**  
154-155 HIGH STREET, BRENTFORD, MIDDLESEX

Telephone :  
ISLeworth 1161/2

**MARTIN ELECTRONICS, 154/5 HIGH STREET, BRENTFORD, MIDDLESEX**  
Latest leaflet of complete AUDIOKIT programme please

NAME \_\_\_\_\_  
ADDRESS \_\_\_\_\_  
BLOCK LETTERS \_\_\_\_\_ RC-9



## SMALL ADVERTISEMENTS

continued from page 141

**FOR SALE.** Televet 877: Pattern generator, c.r.o., VTVM, signal generator 10/70 Mc/s, 170/230 Mc/s, crystal marker, £38. Jason W11 wobblator 0-2 Mc/s, 0-40 Mc/s, 40-80 Mc/s, £10. Heathkit V-7A VTVM, £10. Taylor 240A pattern generator 40/70 Mc/s, £9. Contessa Transistor, £6. Details and offers, S.A.E.—Box No. F217.

**FOR SALE.** Collaro studio tape deck and transcriber turntable. Mullard designed tape pre-amp, stereo pre-amp, "5-10" amplifier. N.E.A.T. arm, Stentorian tweeter and cross over. Excellent condition, less than half original cost.—Box No. F218.

**INTERESTED IN AMATEUR RADIO TELEPRINTING?** Then join the British Amateur Radio Teleprinter Group. Details from Hon. Sec., G2UK, East Keal, Romany Road, Oulton Broad, Suffolk.

**JOIN THE INTERNATIONAL S.W. LEAGUE.** Free Services to members including Q.S.L. Bureau. Amateur and Broadcast Translation. Technical and Identification Dept.—both Broadcast and Fixed Stations, DX Certificates, contests and activities for the SWL and transmitting members. Monthly magazine, *Monitor*, containing articles of general interest to Broadcast and Amateur SWLs, Transmitter Section and League affairs, etc. League supplies such as badges, headed notepaper and envelopes. QSL cards, etc., are available at reasonable cost. Send for League particulars. Membership including monthly magazine, etc., 21s. per annum.—Secretary, ISWL, 12 Gladwell Road, London, N.8.

**THE INTERNATIONAL HAM HOP CLUB** is a non-profit-making organisation open to RADIO AMATEURS AND SHORT WAVE LISTENERS. OBJECT: to improve international relationships through an organised system of hospitality. MEMBERS offer overnight hospitality to visiting members, subscription 10s. per annum. ASSOCIATE MEMBERS invite radio amateurs to visit their stations. Associate membership 5s. per annum. FAMILY EXCHANGE holidays arranged, also FRIENDSHIP LINKS between radio clubs. The Club's official journal is free to both Full and Associate Members.—Hon. Gen. Secretary: G. A. Partridge, G3CED, 17 Ethel Road, Broadstairs, Kent.

### SITUATION VACANT

**Experienced Wired Vision Equipment Engineer,** must be fully conversant with all aspects of Relay Network. Apply in strictest confidence to:—

Engineer in Charge,  
Rank Relay Services,  
430 High Road, Chiswick, W.4

### NYLON P.T.F.E.

ROD BAR SHEET TUBE STRIP WIRE  
*No quantity too small* *List on application*  
BRASS COPPER BRONZE ALUMINIUM LIGHT ALLOYS  
STAINLESS STEEL

### H. ROLLET & CO LTD

HOWIE STREET, LONDON, S.W.11 BATtersea 7872  
Also at Liverpool, Birmingham, Manchester, Leeds, Glasgow

TO DESIGNERS & CHIEF ENGINEERS

# OSMOR

SPECIALISES IN WINDING MINIATURE COILS AND TRANSFORMERS OF INTEREST TO BULK MANUFACTURERS IN THE INDUSTRIAL FIELD.

MANUFACTURERS USING UP TO 50 S.W.G. WOULD FIND OUR SERVICE ECONOMICAL AND RELIABLE. ENQUIRIES APPRECIATED.

## LARGE CAPACITY AVAILABLE

PLEASE TELEPHONE CRO 5148  
FOR SWIFT ACTION

## OSMOR RADIO PRODUCTS

540 PURLEY WAY (PARKING FACILITIES)  
CROYDON  
CRO 5148/9

## TESTED TRANSISTORS

- |           |   |
|-----------|---|
| 1/- each  | Red or White Spots. OA81, OA202.                        |
| 2/- each  | XA101, XA102, XA111, XA112, XB103, NKT122, OA90, OC430. |
| 3/- each  | OC44, OC45, OC81, OC81D, OC200, GET16.                  |
| 4/- each  | AF114, AF115, AF117, OC170, OC171 SX658, XV611.         |
| 5/- each  | OC72, OC139 OC140, OC204, GET8, ORP60, BY100.           |
| 10/- each | OC35, OC26, OC28, AFY19, 2S013, ORP12, GET571.          |

ZENER DIODES 4.7 volt to 33 volt  $\frac{1}{4}$  watt,  $\frac{3}{6}$  each, 1.5 watt, 5/- each, 7 watt, 6/- each.

Send 3d. stamp for Full Price List, and Free Equivalent Chart

## B. W. CURSONS

78 BROAD STREET, CANTERBURY, KENT

## CHASSIS and CASES by



287/9 Edgware Road  
London W2  
TELEPHONE  
PADdington 5891/7595

**BLANK CHASSIS—Same Day Service**  
Of over 20 different forms made up to YOUR SIZE.  
Order EXACT SIZE you require to nearest 1/16th.  
(Maximum length 35", depth 4".)  
Specials dealt with promptly.

**SEND FOR ILLUSTRATED LEAFLETS**  
or order straight away, working out total area of material required and referring to table below which is for four-sided chassis in 18 s.w.g. (for 16 s.w.g. add 1/6th).

48 sq. in.	4/-	176 sq. in.	8/-	304 sq. in.	12/-
80 sq. in.	5/-	208 sq. in.	9/-	336 sq. in.	13/-
112 sq. in.	6/-	240 sq. in.	10/-	368 sq. in.	14/-
144 sq. in.	7/-	272 sq. in.	11/-	and pro rata	
		P. & P. 2/6	P. & P. 2/9	P. & P. 3/-	

Discounts for quantities. Finishes arranged for quantities of 25 or over.  
**FLANGES** (1/2" or 3/4"), 6d. per bend.  
**STRENGTHENED CORNERS**, 1/- each corner.  
**PANELS**  
Any size up to 3ft at 4/6 sq. ft. 18 s.w.g. (16 s.w.g. 5/3).  
Plus postage and packing (orders over £2 Post Free).

### CASES

ALUMINIUM, SILVER HAMMERED FINISH		Type W		Type Y	
Type	Size	Price	Type	Size	Price
U	4 x 4 x 4"	9/6	Y	8 x 6 x 6"	25/-
U	5 1/4 x 4 1/4 x 4 1/4"	14/6	Y	12 x 7 x 7"	39/-
U	8 x 6 x 6"	20/-	Y	13 x 7 x 9"	44/-
U	15 x 9 x 9"	42/6	Y	15 x 9 x 7"	46/-
W	8 x 6 x 6"	19/6	Z	17 x 10 x 9"	63/-
W	12 x 7 x 7"	32/6	Z	19 x 10 x 8 1/2"	67/6
W	15 x 9 x 8"	42/-			

\* Height

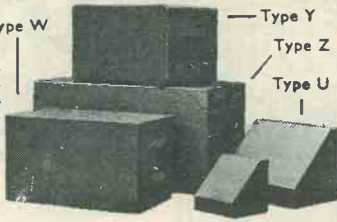

Type Z has removable back and front panels.  
Type Y all-screwed construction.

## For Discerning Enthusiasts Quality Transistors and Components

MULLARD Industrial Grade Transistors, Miniature Electrolytics and MILLIFARAD Capacitors: 2,500µF 64V, 18/9. 3,200µF 10V and 1,250µF 25V, 8/6 each. Printed circuit board for "Pi-mode" 10W Amplifier, 12/6. Transistors for special purposes, e.g. 2G414 VHF amp. useful to 120 Mc/s, 20V 100mW, 7/3. GMO 290 1,000 Mc/s U.H.F. amp. (B.B.C. 2), 31/6. 2N3053 60V 5W  $f_T=100$  Mc/s Silicon planar, 15/- . Tunnel Diodes, e.g. TD-1, 1mA Ipk, 2,300 Mc/s, 50/3. TD-5 22mA Ipk, 1,600 Mc/s, 25/- .

PROMPT SERVICE. C.W.O. PLEASE. POSTAGE 6d.  
PLEASE SEND 1/- (STAMPS) FOR NEW REFERENCE CATALOGUE

**J. WILLIAMS & CO. (C)**, 208 HAGLEY ROAD  
BIRMINGHAM 16

## Hammer Finish Paint

The modern finish for all electronic equipment. (Not crackle finish.) Just brush it on, no stoving. The effect appears at once and dries in 20 minutes. As supplied to laboratories and manufacturers throughout the country. Looks fabulous on chassis, etc. In blue or pewter (other colours discontinued). 2 1/2 oz. tins 3/6, 1/2 pint 7/6, 1 pint 15/-. From radio & model shops or post free from us. Trade supplied.

**FINNIGAN SPECIALITY PAINTS (RC)**  
Mickley Square · Stocksfield · Northumberland

## P A N L BLACK CRACKLE PAINT

Give your metalwork a really professional finish.  
Easily applied by brush. Air drying.

Available by post from

**THE BRUCE MILLER CO. LTD**  
249 COASTAL CHAMBERS  
BUCKINGHAM PALACE ROAD SW1

4/- per 1/2 pint can which includes application instructions, postage and packing

## YOUR CAREER IN RADIO ?

Big opportunities and big money await the qualified man in every field of Electronics today—both in the U.K. and throughout the world. We offer the finest home study training for all subjects in radio, television, etc., especially for the **CITY & GUILDS EXAMS**. (Technicians' Certificates); the Grad. Brit. I.R.E. Exam.; the **RADIO AMATEUR'S LICENCE**; P.M.G. Certificates; the R.T.E.B. Servicing Certificates; etc. Also courses in Television; Transistors; Radar; Computers; Servo-mechanisms; Mathematics and Practical Transistor Radio course with equipment. We have **OVER 20 YEARS'** experience in teaching radio subjects and an unbroken record of exam. successes. We are the only privately run British home study Institute specialising in electronic subjects only. Full details will be gladly sent without any obligation.

SEND FOR FREE BROCHURE TO:

**BRITISH NATIONAL RADIO SCHOOL**  
DEPT 4, RADIO HOUSE · READING · BERKSHIRE

## THE RADIO CONSTRUCTOR—BOUND VOLUMES

Now available

Volume 17, August 1963 to July 1964 Price £1 10s 0d Postage 3s 0d

Where all issues are returned: Price £1 Postage 3s 0d

Limited number also available of:—

Volume 13, August 1959 to July 1960 Price £1 5s 0d Postage 2s 6d

Volume 16, August 1962 to July 1963 Price £1 10s 0d Postage 3s 0d

Where all issues are returned: Price £1 Postage 3s 0d

We regret Volumes 14 and 15 are now sold out

Send for latest brochure containing details of our other publications

**DATA PUBLICATIONS LTD 57 MAIDA VALE LONDON W9**

### MULTI-METERS



Multi-range test meters featuring easy to read scales and provided with full operating instructions, lead and batteries. Suitable for amateurs, designers, repair shops, all domestic uses. Full details and specifications in our catalogue.

- ★ PT34, 1kΩ/V ... .. £1.19.6
- ★ M1, 2kΩ/V ... .. £2. 9.6
- ★ THL33, 2kΩ/V (illus) ... £3.15.0
- ★ EP10K, 10kΩ/V\* ... .. £4. 9.6
- ★ ITI-2, 20kΩ/V ... .. £5. 5.0
- ★ TP55, 20kΩ/V\* ... .. £5.19.6
- ★ EP30K, 30kΩ/V\* ... .. £6.19.6
- ★ 500, 30kΩ/V\* ... .. £8.19.6
- ★ EP50K, 50kΩ/V\* ... .. £9.19.6
- ★ EP100K, 100kΩ/V ... .. £9.19.6

(\*Leather Cases Available)

### BUILD A QUALITY TAPE RECORDER



★ Pre-Built Equipment—6 Valves—Collaro Studio Decks—Portable Cabinets with Speakers.

### TWO TRACK Total Cost £26

P.P. 8/6  
OR Deck 10 gns. P.P. 5/-; Amplifier 11 gns. P.P. 3/6. Cabinet with Speaker 5 gns. P.P. 3/6.

### FOUR TRACK Total Cost £30

P.P. 8/6  
OR Deck £13.19.6. P.P. 5/-; Amplifier 12 gns. P.P. 5/6. And Cabinet with Speaker 5 gns. P.P. 3/6.  
All complete in every detail. Illustrated leaflets on request. Ideal for portable or domestic equipment.

### GARRARD 2-TRACK BATTERY TAPE DECK

9V operated, 2 track, 2 speed. Brand new, fitted heads, etc. Supplied complete with cassette. Brand New.  
£11.15.0 P.P. 3/6

### FM VHF TUNING HEART

Printed circuit construction, fully tunable 85 to 105 Mc/s. Completely screened. Requires UCC85 (8/6), R.F. stage and osc./mixer stage. With circuit.  
Brand new in maker's cartons 15/- . P.P. 1/-

### TRANSISTOR SUPERHET TUNER



9V medium wave 3-transistor and diode superhet radio tuner. Ideal for all amplifiers  
Price with circuit 67/6. P.P. 1/6.  
Also mW/sW 4-transistor £7.9.6.

## TRANSISTORS, CRYSTALS, VALVES AND COMPONENTS

### THE LARGEST RANGE OF THE ABOVE ITEMS IN THE COUNTRY

We stock far too many types to list here. See our Catalogue for full selection

LET US QUOTE FOR PARTS FOR YOU RETURN OF POST SERVICE

### A SELECTION FROM OUR STOCKS

- See Catalogue for full details
- Sinclair Micro-6 (to build) ... .. 59/6
  - Sinclair TR750 Amplifier (to build) ... 39/6
  - Sinclair Micro Injector (to build) ... 27/6
  - Tape Jack Tuner (Full Med. Wave) ... 29/6
  - 10-Watt Horn Tweeter ... .. 29/6
  - 20-Watt Super Tweeter ... .. 69/6
  - Two-channel Mixer for Mics/Pu's ... 15/-
  - 1 to 200 Mc/s Field/str. Meter ... 59/6
  - 5-hole Chassis Punch Kit ... .. 49/6
  - Headphones 2kΩ 12/6; 4kΩ ... .. 14/6
  - Stereo Stethoscope Headset, 8+8 arm 25/-
  - Resistor Substitution Box ... .. 32/6
  - Crystal Mono Stethoscope Headset ... 10/6
  - Magnetic Mono Stethoscope Headset... 12/6
  - Transistor Signal Injector ... .. 39/6
  - Fully Disappearing Car Aerial ... .. 35/-
  - Test Lead Kit with Pouch ... .. 8/6
  - Capacitor Substitution Box ... .. 25/-
  - De Luxe Stereo Headsets with junction box ... .. £6
  - PP3 9V Batt. Eliminator ... .. 18/6
  - Transistor Telephone Amplifier ... 65/-
  - 8+8Ω Stereo Headphones ... .. 62/6
  - Crystal Lapel Microphone ... .. 12/6
  - 2kΩ Magnetic Lapel Microphone ... 8/6
  - Crystal Contact Microphone ... .. 12/6
  - 2kΩ 1/2 track Tape Head ... .. 15/-
  - 2kΩ 1" diam. Mag. Mic. Insert... .. 15/-
  - MCI Crystal Mic. Insert ... .. 5/-
  - Earphones, Crystal or Magnetic Complete with Jack and Socket. ... 5/-
  - Telephone Recording Attachment ... 12/6
  - 50-0-50μA Edgewise Meter ... .. 25/-
  - 6/12V Min. Stereo Receiver ... .. 12/6
  - Transistor Coil Set With Tuner, Ferrite Aerial and Circuit ... .. 20/-
  - Complete Test Lead Kit ... .. 8/6
  - 30W Pocket Mains Solder Iron ... 14/6
  - 8" Hi-Fi 15/16 ohm Speaker ... .. 79/6
  - 100 kc/s Quartz Crystal ... .. 15/-
  - Twin Crystal 1 Mc/s and 100 kc/s ... 22/6

### RECORD/REPLAY/ERASE TAPE HEADS

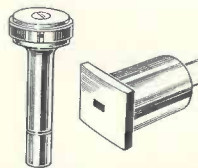

Marriot Type R/RP/3 1/2 track record-replay head and Mullard type TS erase head with mounting post. Ideal for transistor circuits. Bargain Offer 15/- Pair. P.P. 1/-  
★ 700Ω IMPEDANCE ★

### CRYSTAL MICROPHONES



(See Catalogue for details and for Dynamic Mics)

- Acos 39-1 Stick Microphone ... 32/6
- Acos 40 Desk Microphone ... 15/-
- Acos 45 Hand Microphone ... 19/6
- Lapel/Hand Microphone ... 12/6
- Acos Stick Microphone ... 15/-
- 100C Stick with Stand ... 39/6
- BM3 Stick with Stand ... 49/6
- Lapel/Hand Magnetic ... 8/6
- MM71 2k Mag. Mic ... 12/6

### NOMBREX TEST EQUIPMENT

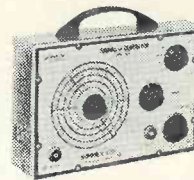

LEAFLETS ON REQUEST

FULLY GUARANTEED

All transistor portable units supplied with full instructions.

- ★ 150 kc/s to 350 Mc/s generator. RF Mod., AF, 8 ranges. Leads, batt., instructions, £9.10.0.
- ★ Resistance/Capacitance Bridge, £8.5.0.
- ★ Transistorised Power Supply, £6.10.0.
- ★ Audio Generator, £16.15.0.
- ★ Inductance Bridge, £18.

### 4-CHANNEL TRANSISTOR MIXER

4-inputs, suitable for Mics, Pick-Ups, Tuners, etc. Built-in Battery. 55/- . P.P. 1/6

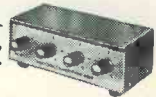

### TRANSISTOR PORTABLE WALKIE-TALKIES

9-Transistor Portable Trans-receivers. Supplied complete with leather cases, batteries, aerials, etc., in presentation case. Range up to 5 miles in favourable conditions. Sizes 6 1/2" x 3" x 1 1/4". Superhet crystal controlled on transmit and receive.  
Price £25 Per Pair. P.P. 3/6

### POCKET RADIOS



All complete with battery, earphone, carry case and fully guaranteed. 6 and 7 transistor superhet designs.

- ★ 6-Transistor Med. Wave, 69/6. P.P. 2/-
- ★ 7-Transistor Med. Wave, 79/6. P.P. 2/-
- ★ 6-Transistor Med./Long Wave, 5 gns. P.P. 2/6
- ★ 7-Transistor MW/LW/SW, 13 gns. P.P. 3/6

### MAINS AND BATTERY RECORD DECKS

ALL COMPLETE WITH ARM and CARTRIDGE

- ★ BSR UA14 4-speed ... .. £5.19.6
- ★ BSR UA15 4-speed ... .. £6.19.6
- ★ Garrard Autoslim 4-speed ... .. £6.10.0
- ★ Unpluggable Head Version ... .. £6.19.6
- ★ Stereo Version ... .. £7.19.6
- ★ SRP10 4-speed or BSRGUT... .. £5. 0.0
- ★ Garrard AT6 with Stereo Cartridge, 4-speed ... .. £10.19.6
- ★ AT6 with Mono Head ... .. £10.10.0
- ★ P. & P. 3/6 any type above
- ★ AT6 with EV26 or Sonotone ... £11.19.6
- ★ 9V Star, 45 r.p.m. ... .. £11.19.6
- ★ 45 and 33 r.p.m. Star, 9V ... .. £4.12.6
- ★ 45 r.p.m. Garrard 6V ... .. £11.15.0
- ★ 4-speed B.S.R., 9V or S.R.P.10 9V ... .. £5. 5.0
- ★ P. & P. 2/6 any of above

## HENRY'S RADIO LTD

303 EDGWARE ROAD LONDON W2

PADddington 1008/9

Open Monday to Sat. 9-6. Thurs. 1 o'clock

PLEASE TURN TO BACK PAGE

# Components and Equipment Specialists for more than 20 years

## Transistor High Fidelity Equipment FOR MAINS OR BATTERY OPERATION

### ● MONO FULL FUNCTION PRE-AMPLIFIER/CONTROL UNIT

PRICE **£5.10.0** P.P. 2/-  
OR KIT 99/9 P.P. 2/-

★ Dark brown and gold front panel plate 8/6

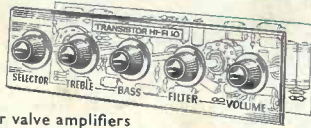

For use with transistor power amplifiers as below or valve amplifiers—hum free—high sensitivity—8 inputs between 1.5mV and 300mV, with full equalisation. For all pick-ups—microphones, tuners—tape replay. Separate treble and bass with cut and boost—4 position low pass filter. Volume, 40 c/s and 20 kc/s, etc. Output 250mV. Overall size 9" x 2½" x 2". Battery operated (2½mA) or from power supply. Signal to noise ratio 70dB at 10 watts with power amplifier. Supplied built and ready to use.

### ● INTEGRATED STEREO PRE-AMPLIFIER



For use with Valve or Transistor Equipment

Two channel version of above with addition of balance and mono/stereo controls. Overall size 9" x 3½" x 1½" deep. Designed to feed two 10 watt power amplifiers as below. Supplied built and ready to use. 5mA current. Battery operated (5mA) or from mains unit.

PRICE **£10.19.6** P.P. 3/6 ★ Dark brown and gold front panel plate 12/6

### ● MULTI-INPUT PRE-AMPLIFIER

For use with the transistor power amplifier or as a general purpose pre-amplifier. A simplified version of the full function pre-amp. 8 inputs from 1.5mV to 300mV. Input selector, tone and volume controls. Size 5" x 2½" x 2". Ideal for public address systems, for microphones and pick-ups.

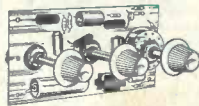

PRICE **65/-** P.P. 1/6 ★ Dark brown and gold front panel plate, 6/6

### ● 10 WATT POWER AMPLIFIERS

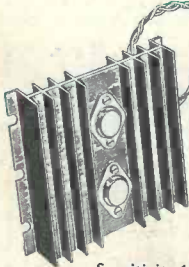

★ 15Ω 10 watt 40V supply. **£5.19.6** P.P. 2/6

OR KIT **£5.10.0** P.P. 2/6

★ 3Ω 10 watt 24V supply. **£5.10.0** P.P. 2/6

Direct coupled transformerless design. Sensitivity 100mV from 10kΩ or less source for 10 watts output. Response ±1dB 40 c/s to 10 c/s. 0.25% total distortion at 10 watts. Push-pull class B output. 60dB feedback. Two versions available for 3Ω to 4Ω and 15Ω to 16Ω output. Battery or mains supply operation. For use with mono or stereo preamplifiers as above. Supplied built and ready to use. The 24V version is suitable for 12V operation with an output of 3/4 watts. Also 4½/8 or 15 ohm speakers.

### ● MAINS POWER PACKS (Optional extra)

PS245. Single amplifier, 24V - 59/6 PS24. Two amplifiers, 24V - 69/6  
PS402. Single amplifier, 40V - 59/6 PS40. Two amplifiers, 40V - 69/6

DETAILS WITH CIRCUITS OF ABOVE UNITS ON REQUEST (TRADE SUPPLIED)

PLEASE TURN PAGE

We can supply from stock most of the components and items specified on circuits published in this and other magazines and radio books. Let us quote for your circuit.

## HENRY'S RADIO LTD

303 EDGWARE ROAD LONDON W2  
PADdington 1008/9  
Open Monday to Sat. 9-6. Thurs. 1 o'clock

## CONVAIR PUSH-BUTTON PORTABLE/CAR RADIO



- ★ New printed circuit 6-transistor superhet design. Over 700mW push-pull output.
- ★ Push-button selection of MW and LW with full tuning on both wavebands.
- ★ A new design with amazing performance at a realistic price.
- ★ New attractively designed portable cabinet with horizontal tuning and all stations marked. Size: 10" x 7" x 3½"

Total Cost of **£7.19.6** P.P. 3/6 (Batteries 6/- extra)  
ALL PARTS SOLD SEPARATELY

FOLLOWING A LINE OF QUALITY AND VALUE IN PORTABLES

### ● VHF FM TRANSISTOR TUNER

- ★ Mullard 5-Transistor.
- ★ 4 Diodes.
- ★ Full coverage 87 to 105 Mc/s.
- ★ AFC and AVC.
- ★ Over 1V output.

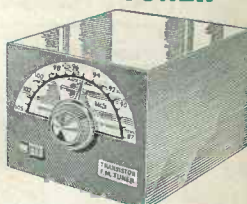

Printed circuit superhet design of high sensitivity and quality. Output for valve or transistor amplifiers. Size 3½" x 2½" x 3". Simplified building instructions. Operates from 9V 9-10mA. All parts sold separately. Complete with dark brown and gold panel plate.

TOTAL **£7.19.6** P.P. 2/6  
COST (Cabinet assembly 20/- extra)

Detailed Circuit Book on Request

### Minigram Transistor Portable Record Player



★ Made by well known British manufacturer. Features ready built 4 transistor printed circuit, 1 watt amplifier, elliptical speaker and volume control. Low current Starr constant speed 45 r.p.m. turntable with crystal pick-up. Strong moulded two-colour cabinet with handle. Plays anywhere on long life 9 volt battery. Requires less than half an hour's work to connect up using ready built units and easy instructions.

TOTAL **79/6** P.P. 5/- (Battery 3/9)

Or Amplifier with volume control and 5" x 3" Speaker, 4-Transistor, 35/-, P.P. 2/-  
9V Starr Player with Pick-up 39/6, P.P. 2/6  
And Two-Tone Case 5/-, P.P. 2/-

### ½ WATT 4-TRANSISTOR AMPLIFIER

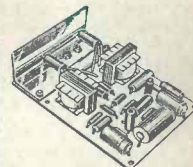

1½ watt peak output. Built **49/6** P.P. 1/6

±3dB 70 c/s to 12 kc/s. Output to 3 ohm speaker 9V operated. Or Kit **39/6** P.P. 1/6

Details on request.

### 7-TRANSISTOR RECORD PLAYER PORTABLE AMPLIFIER

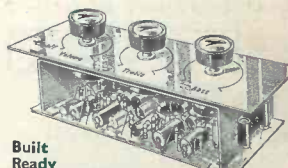

Built Ready To Use **£5.19.6** P.P. 2/-

★ New Improved High Gain Version ★

### LATEST CATALOGUE

86 PAGES, 10" x 7½"  
Up to date with new items and many price reductions.  
Fully detailed and illustrated.  
Price 2/6 post paid.