

THE **Radio Constructor**

**RADIO
TELEVISION
AUDIO
ELECTRONICS**

VOLUME 16 NUMBER 6

A DATA PUBLICATION

PRICE TWO SHILLINGS

January 1963

**INEXPENSIVE
S.W.
PRE-SELECTOR**

Also featured

Comprehensive Valve Tester



Mains Portable Superhet



Detector for Nuclear and
Rocket Firings

etc., etc., etc.

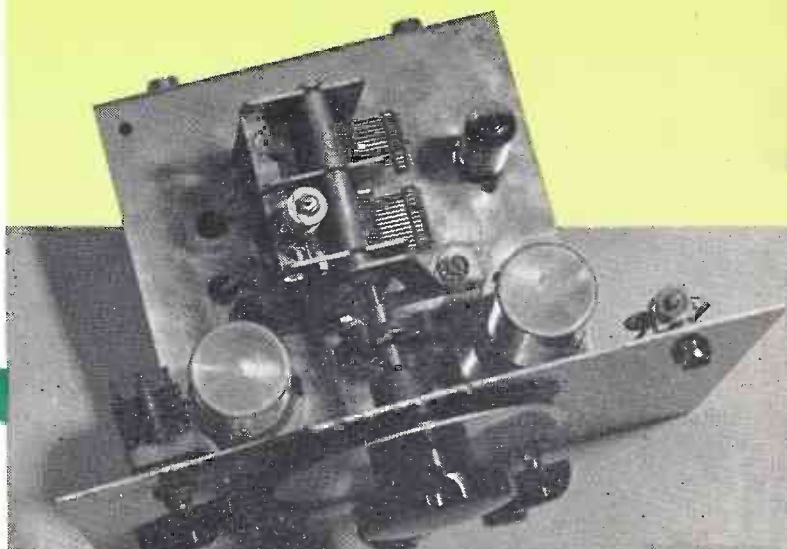

THE MODERN BOOK CO

Radio Control for Models (New Ed.).
By F. C. Judd. 15s. Postage 9d.

Radio Data Reference Book. An
R.S.G.B. Publication. 12s. 6d. Postage 1s.

Transistor Radios: Circuitry and Servicing. Mullard. 5s. Postage 6d.

Principles of Colour Television. By
G. N. Patchett. 16s. Postage 6d.

Basic Electronic Circuits (Common Core). Part 1. 18s. Postage 1s.

Service Valve Equivalents. An R.S.G.B.
Publication: 5th Edition. 3s. Postage 6d.

Radio Valve Data, 7th Ed. Compiled
by "W.W." 6s. Postage 10d.

Introducing Hi-Fi. By A. H. Rasheed.
6s. Postage 6d.

Radio Astronomy for Amateurs. By
F. W. Hyde. 25s. Postage 1s.

Servicing Transistor Radios and Printed Circuits. By L. Lane. 42s.
Postage 1s. 3d.

1963 Yearbook of Astronomy. By
J. G. Porter. 15s. Postage 1s.

Circuits for Audio Amplifiers. By
Mullard. 8s. 6d. Postage 1s.

Pin-Point TV Troubles in Ten Minutes.
A Coyne Publication. 31s. 6d. Postage 1s.

Amateur Radio Call Book. An R.S.G.B.
Publication. 1963. 4s. 6d. Postage 6d.

Collecting Gramophone Records. By
E. T. Bryant. 12s. 6d. Postage 6d.

Hi-Fi for Beginners. By J. Bowick.
7s. 6d. Postage 6d.

We have the Finest Selection of British and American Radio Books in the Country
Complete catalogue 1s.

19-21 PRAED STREET (Dept RC) LONDON W2

Telephone PADdington 4185



SCOTTISH INSURANCE CORPORATION LIMITED

38 EASTCHEAP • LONDON • EC3

TELEVISION SETS, RECEIVERS AND TRANSMITTERS

Television Sets, Receivers and Short Wave Transmitters are expensive to acquire and you no doubt highly prize your installation. Apart from the value of your Set, you might be held responsible should injury be caused by a fault in the Set, or injury or damage by your Aerial collapsing.

A "Scottish" special policy for Television Sets, Receivers and Short Wave Transmitters provides the following cover:

- (a) Loss or damage to installation (including in the case of Television Sets the Cathode Ray Tube) by Fire, Explosion, Lightning, Theft or Accidental External Means at any private dwelling-house.
- (b) (i) Legal Liability for bodily injury to Third Parties or damage to their property arising out of the breakage or collapse of the Aerial Fittings or Mast, or through any defect in the Set. Indemnity £10,000 any one accident.
- (ii) Damage to your property or that of your landlord arising out of the breakage or collapse of the Aerial Fittings or Mast, but not exceeding £500.

The cost of Cover (a) is 5/- a year for Sets worth £50 or less, and for Sets valued at more than £50 the cost is in proportion. Cover (b) and (ii) costs only 2/6 a year if taken with Cover (a) or 5/- if taken alone.

Why not BE PRUDENT AND INSURE your installation—it is well worth while AT THE VERY LOW COST INVOLVED. If you will complete and return this form to the Corporation's Office at the above address, a proposal will be submitted for completion.

NAME (Block Letters).....
If Lady, state Mrs. or Miss
ADDRESS (Block Letters).....

J/B

PCR COMMUNICATION RECEIVERS

Manufactured by **Pye and Philips**. One of the Army's most versatile and sensitive sets. RF stage and 2 of IF, using 6 British I.O. type valves Large 180 degrees. Illuminated and Calibrated Dial. Flywheel tuning with locking device. Aerial trimmer. Tone and volume controls. Band switch from panel jacks for speaker or phones. In black metal case, size 17" L x 8" H x 10" D. Model PCR covers 6-18 Mc/s, 200-550 metres and 850-2,000 metres and has internal 5" speaker. **£6.19.6**. Model PCR2 has similar L & M waveband coverage. Short wave 6-22 Mc/s, but no speaker. Used but excellent condition, **£5.19.6**. Model PCR3. As PCR2 but has 2 Short Wave Bands, 2.0-7.0 Mc/s and 7.0-23.0 Mc/s, and Medium Wave Band 190-550 metres. **ONLY £8.8.0**. Every receiver aerial tested before despatch. Add 10/6 carr. all models. Designed to operate from bulky EXTERNAL power supply, but any set can be fitted with **BRAND NEW COMPONENTS INTERNAL PACK** for 200/250V a.c. at extra cost of **£2**.

S.A.E. FOR ILLUSTRATED LEAFLET

TEST METERS FOR EVERY PURPOSE & POCKET



2,000 O.P.V. MODEL TP-10. Reads A.C. and D.C. volts up to 1,000; D.C. Current to 500mA; resistance to 1 Meg; Capacitance to 1µF; Decibels from -20 to +36; Output jack for Audio Measurements. Size 3½" x 5" x 1¼". **£3.19.6**



20,000 O.P.V. MODEL TP-5S. Reads Voltage up to 1,000; D.C. at 20,000 ohms per volt and A.C. at 10,000 o.p.v.; D.C. Current to 500mA; Resistance to 10 Meg.; Capacitance to 0.1µF; Decibels from -20 to +36. Size 3½" x 5¼" x 1¼". **£5.19.6**

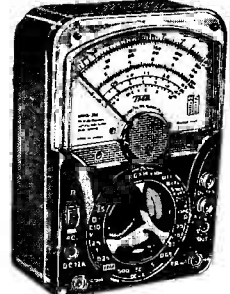

30,000 O.P.V. MODEL 500 Volts to 1,000; D.C. at 30,000 o.p.v. A.C. at 20,000; 12 Amps D.C. Current; 60 Meg. Resistance; -20 to +56 Decibels; Internal buzzer short circuit warning. Size 3½" x 6¼" x 2¼". **£8.19.6**

All new stock, with leads, prods & internal batteries. 6 mths. guar. backed by full service facilities. Details S.A.E.

FOR CALLERS ONLY

10 Valve Canadian Receiver No. 52. Covers 1.75-16 Mc/s (19-170 metres) in 3 bands. Built-in 3-valve crystal calibrator and internal speaker. Circuit and instructions supplied. Store soiled and untested, and accordingly will only be sold to callers. **ONLY 50/-**.

HRO Senior Table Model Receivers. Complete with 9 coil sets covering 50 kc/s to 30 Mc/s. Used, very good condition, aerial tested. **ONLY £17.10.0** (carriage, etc., 30/-). A few late **Model 5T** with I.O. valves, **£22.10.0** plus carr.

R107 RECEIVER RF UNIT. Brand New Tuning Sections of the famous R107 Receiver. A 3 stage unit, complete with 4 gang condenser and dial calibrated 1.2-17.5 Mc/s in 3 bands, Coil Pack and Wave change switch, Aerial Trimmer. Less valves. Ideal front end for constructing a superhet receiver. Complete R107 circuit supplied. **BRAND NEW IN MAKER'S CARTONS.** **ONLY 35/-** (carriage 5/-).

DOUBLE BEAM OSCILLOSCOPE TUBES TYPE CV1596. Equivalent to COSSOR O9D as used in Oscilloscopes by Cossor (339 series) and Hartley & Erskine (13 series). Listed **£12**. **BRAND NEW IN MAKER'S CRATES.** **ONLY 25/-** (carriage 5/-).

LAVOIE UHF WAVEMETER MODEL 105. Coverage 375/725 Mc/s. Complete with correct Calibration Chart. First-class condition. Battery operated and portable, size 11" x 8" x 7¼". **ONLY £3.19.6** (carriage 7/6).

AVOMETERS MODEL 7. Reconditioned and in perfect order, with leads, internal batteries, and instructions. **ONLY £11.0.0** (Regd. post 5/-).

AVOMETER MODEL 7 LEATHER CASES, fitted with carrying handle and long strap. **BRAND NEW.** **ONLY 32/6** (post 2/6).

COMBINED VIBRATOR/MAINS UNIT. The Power Pack section of the Army R.107 Receiver. Has Vibrator for 12 volts DC operation, and Mains Transformer for 100/250 volts AC. Output 12.6 volts 3 Amps LT, and 250 volts 100mA HT. Complete with Vibrator, 6X5G Rectifier, and connecting data. Ideal for driving TCS or Type 52 Receivers, etc., or Mobile Equipment. **BRAND NEW IN MAKER'S CARTONS.** **ONLY 45/-** (carr. 5/6).

THE "GOOD COMPANION" Mk. II
Using transfilters, the latest manufacturing technique to save alignment difficulty.

As described in "THE RADIO CONSTRUCTOR", August issue
THE FINEST COMBINED PORTABLE AND CAR RADIO
YET DESIGNED FOR THE HOME CONSTRUCTOR

★ 750mW output.

★ 6 transistors and 1 diode.

★ Full Medium and Long Wave coverage.

★ Quality speaker.

★ Brilliantly styled 2-tone cabinet, size 11" x 8" x 3".

★ Very fine tuning with calibrated dial.

★ Latest printed circuit. ★ Internal high gain aerial with car aerial socket. Easy to follow construction data (available separately 3/6).

All parts sold separately and full illustrated details will be sent on request.

Total Cost **£9.19.6**

With alternative luxury cabinet using 7" x 4" speaker, **£10.19.6**. Either type, plus 5/- post and ins. (Battery 3/6 extra.)

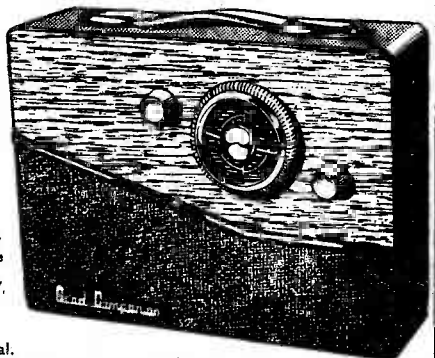

"P.W." 6 TRANSISTOR PERSONAL RECEIVER

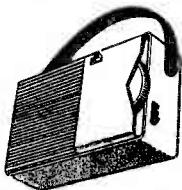

BATTERY AND CABINET NOW

Designed by the technical staff of **Practical Wireless**: easy to build, using printed circuit and 1st grade Matched Transistors and Diode. Full Medium and Long Wave coverage to internal speakers. All parts sold separately (new components only) enabling you to buy as required, and full detailed price list will be sent on request. Constructional details 1/6. Newly designed OSMOR Cabinet and reduced price. **TOTAL COST INCLUDING £7.19.6.** S.A.E. for 7 transistor version.

"POCKET 4" TRANSISTOR RECEIVER

Uses miniature speaker, proper tuning condenser, and volume control. Built-in aerial makes unit efficient and portable. Ideal for the beginner. Full medium wave coverage. All components and case for only **42/6** (p. & p. 2/6). Ten-page constructional book free with parts or separately 1/6. S.A.E. for parts price list.

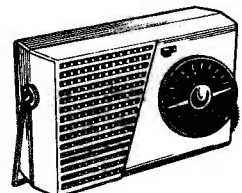

HARRIS ELECTRONICS (LONDON) LTD

(DEPT. M)
138 GRAY'S INN ROAD LONDON WC1

Telephone **TERminus 7937**

Please include carriage costs on ALL items.
(Open until 1 p.m. Saturdays.) We are 2 mins. from High Holborn (Chancery Lane Station) and 5 mins. by bus from King's Cross.

Build the Sinclair MICRO-AMPLIFIER

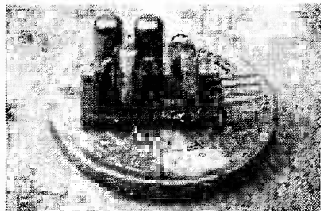

ACTUAL SIZE
ONLY $\frac{1}{4}$ " \times $\frac{3}{8}$ " \times $\frac{1}{2}$ "

This microscopic amplifier, the smallest of its type in the world, out-performs amplifiers 20 times as large.

Power Gain—60dB (1,000,000 times).

Frequency Response—30 c/s to 50 kc/s \pm 1dB.

Output Power—sufficient for any earpiece or small loudspeaker.

Simple to build using ordinary tools.

Uses brand new micro-miniature components and **micro-alloy transistors**.

Very low noise level. May be used as tape recorder pre-amplifier.

Free applications data supplied with every kit showing how to use the micro-amp in **micro-radios** and **transmitters**, and with high and low impedance pick-ups, microphones and stereo headphones.

28/6 plus 1/6 postage and packing

Trade enquiries invited.

MICRO-ALLOY TRANSISTORS

MAT 100 7/9

MAT 101 8/6

MAT 120 7/9

MAT 121 8/6

★ Extremely high gains even at very low and high power levels.

TYPICAL BETAS OF 150

★ Cut-off frequencies of 120 Mc/s. Ideal for V.H.F.

★ Gold-plated for easy soldering and protection.

★ Very small size for compact circuits. Low noise levels.

★ Far and away the best for all A.F., R.F. and V.H.F. applications.

SEND FOR COMPLETE BOOK ON MICRO-ALLOY TRANSISTORS

22 TESTED CIRCUITS
USING MICRO-ALLOY TRANSISTORS

Only 5/9 including postage

This book includes new circuits for amplifiers, transmitters, micro-radios, F.M. tuners, pre-amplifiers, etc.



TRADE ENQUIRIES INVITED



INCREASE YOUR KNOWLEDGE



RADIO TELEVISION ELECTRONIC ENGINEERING

MEMBER OF THE ASSOCIATION OF BRITISH
CORRESPONDENCE COLLEGES

CHOOSE THE RIGHT COURSE FROM:

RADIO AND TELEVISION ENGINEERING, INDUSTRIAL TELEVISION, RADIO AND TELEVISION SERVICING, RADIO SERVICE AND SALES, VHF/FM ENGINEERING, ELECTRONICS, COMPUTERS AND PROGRAMMING, ELECTRONIC TECHNICIANS, SERVOMECHANISMS, TELEMETRY, COLOUR TV, INSTRUMENTATION, AND PRINCIPLES OF AUTOMATION.

ALSO EXAMINATION COURSES FOR:

A.M.Brit.I.R.E.; City and Guilds Telecom. Technicians, C. & G. Radio and T.V. Servicing (R.T.E.B.), and P.M.G.'s Certificates. C. & G. Radio Amateurs' Certificates.

LEARN AS YOU BUILD

Practical Radio Courses: Gain a sound knowledge of Radio as you build YOUR OWN 5-valve superhet radio receiver, Signal Generator and High-quality Multitester. At the end of the course you have three pieces of permanent and practical equipment and a fund of personal knowledge and skill. ICS Practical Radio Course opens a new world to the keen Radio amateur.

THERE IS AN ICS COURSE FOR YOU

Whether you need a basic grounding, tuition to complete your technical qualifications, or further specialised knowledge, ICS help you with a course individually adapted to your requirements.

There is a place for you among the fully-trained men. They are the highly paid men—the men of the future. If you want to get to the top, or to succeed in your own business, put your technical training in our experienced hands.

ICS Courses are written in clear, simple and direct language, fully illustrated and specially edited to facilitate individual home study. You will learn in the comfort of your own home—at your own speed. The unique ICS teaching method embodies the teacher in the text; it combines expert practical experience with clearly explained theoretical training. Let ICS help you to develop your ambitions and ensure a successful future. Invest in your own capabilities.

FILL IN AND POST THIS COUPON TODAY

You will receive the FREE ICS Prospectus listing the examinations and ICS technical course in radio, television and electronics, PLUS details of over 150 specialised subjects.

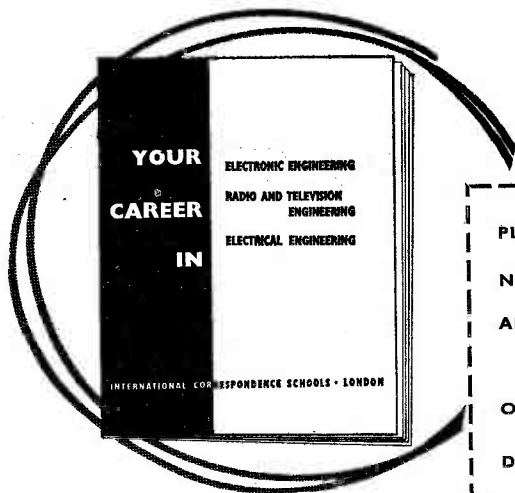

PLEASE SEND FREE BOOK ON _____

NAME _____

ADDRESS _____

OCCUPATION _____

AGE _____

INTERNATIONAL CORRESPONDENCE SCHOOLS
Dept. 248, INTERTEXT HOUSE, PARKGATE ROAD, London SW11

1.63

Page 396

Missing

Building Your Own Equipment!



DX-100U

THE "MOHICAN" GENERAL COVERAGE RECEIVER. Model GC-1U. With 4 piezo-electric tunefilters, variable tuned B.F.O. and Zener diode stabiliser, this is an excellent fully transistorised general purpose receiver for Amateur and Short wave listeners. Printed circuit boards, telescopic whip antenna, tuning meter and large slide-rule dial, 10 transistors. **£39.17.6**

AMATEUR TRANSMITTER. Model DX-100U. The world's most popular, compact and completely self-contained Amateur Transmitter. Covers all amateur bands: 160-10 m. 150W d.c. input. Careful design has achieved the stability and high performance for which the DX-100U is noted and no less than 35 disc ceramic capacitors reduce TVI to a minimum. **£74.19.0**

VARIABLE FREQUENCY OSCILLATOR. Model VF-1U. Calibrated, 160-10 m. Fundamentals on 160 and 40 m. Ideal for our DX-40U and similar transmitters. **£11.17.6**

BALUN COIL UNIT. Model B-1U. Will match unbalanced co-axial lines to balanced lines of either 75 or 300Ω impedance. **£4.15.6**

Q MULTIPLIER KIT. Model QPM-1. May be used with receivers having 450-470 kc/s I.F. provides either additional selectivity or signal rejection. Self-powered. **£7.12.6**



VF-1U

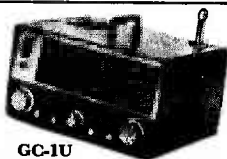

GC-1U

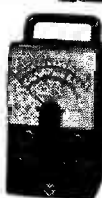

V-7A



MM-1U



RF-1U

VALVE VOLTMETER. Model V-7A. 7 voltage ranges d.c. volts to 1,500. A.C. to 1,500 r.m.s. and 4,000 peak to peak. Resistance 0.1Ω to 1,000MΩ with internal battery. D.C. input impedance 1MΩ. dB measurement, has centre-zero scale. Complete with test prods, lead and standardising battery. **£13.18.6**

MULTIMETER. Model MM-1U. Ranges 0-1.5V to 1,500V A.C. and D.C.; 150μA to 15A D.C.; 0.2Ω to 20MΩ. 4 $\frac{1}{2}$ 50μA meter. **£12.10.0**

R.F. SIGNAL GENERATOR. Model RF-1U. Up to 100 Mc/s fundamental and 200 Mc/s on harmonics and up to 100mV output on all bands. **£12.15.6**

AUDIO WATTMETER. Model AW-1U. Up to 25W continuous, 50W intermittent. **£15.15.0**

AUDIO VALVE MILLIVOLTMETER. Model AV-3U. 1mV-300V A.C. 10 c/s to 400 kc/s. **£14.17.6**

AUDIO SINE-SQUARE WAVE GENERATOR. Model AO-1U. Covers 20 c/s to 150 kc/s and square waves to 50 kc/s in four ranges. Maximum output 10V, distortion less than 1%. **£13.15.0**

Deferred terms available over £10

you can build any of our Heathkit models



USC-1



Truvox D83



FM TUNER



SSU-1

HI-FI FM TUNER. Model FM-4U. Also available in two units. R.F. tuning unit (£3.2.0 incl. P.T.) with I.F. output of 10.7 Mc/s, and amplifier unit, with power supply and valves (£12.6.0). Total **£15.8.0**

TRUVOX D83 & D84 TAPE DECKS. High quality mono/stereo tape decks.

D83, 2 track, for highest fidelity.
D84 (identical presentation), 4-track. **£31.10.0**
£29.8.0

STEREO CONTROL UNIT. Model USC-1. Push-button selection, accurately matched ganged controls to \pm 1dB. Negative feedback, rumble and variable low-pass filters. Printed circuit boards. **£19.10.0**

ELECTRICITY MAINS EXTENSION KIT. Model PUE-1. Completely safe, conforms fully to I.E.E. Regulations, ideal light and power source to out-buildings (or for soil heating). Complete with sockets, cables, switches, lampholder, junction box, etc. **£4.15.6**

MAINS POWER SUPPLY—BATTERY ELIMINATOR KIT. Model UBE-1. Designed to supply 9V or 12V d.c. to transistor receivers. Many other uses. Sizes: 3 $\frac{1}{2}$ " x 2 $\frac{1}{2}$ " x 1 $\frac{1}{2}$ ". **£2.17.6**

TRANSISTOR PORTABLE. Model UXR-1. Pre-aligned I.F. transformers, printed circuit. Covers L.W. and M.W. Has 7" x 4" loudspeaker. Real hide case. **£14.3.0**

TELEPHONE AMPLIFIER. Model TTA-1. Easy-to-assemble. Transistorised, enables hand-free conversation. Ivory toned cabinet. **£7.9.6**



UXR-1



TTA-1

Assembled models also available — prices on request.

HI-FI SPEAKER SYSTEM. Model SSU-1. Ducted-port bass reflex cabinet "in the white". Twin speakers. With legs **£11.19.6**

CAPACITANCE METER. Model CM-1U. Direct-reading 4 $\frac{1}{2}$ " scale. Full-scale ranges 0-100μF, 0-1,000μF, 0-0.01μF and 0-0.1μF. **£15.15.0**

HEATHKIT ELECTRONIC WORKSHOP. Model EW-1. This educational kit will teach and amuse your children. It can make 21 exciting experiments including transistor radios, burglar alarm, radio or TV silencer, intercom, etc. **£7.18.0**

JUNIOR TRANSISTOR RADIO. Model UJR-1. Single transistor set. Excellent introduction to radio. An instructive present. **£2.13.6**

HI-FI STEREO AMPLIFIER. Model S-99. 18W output. Ganged controls. Stereo/mono gram, radio and tape recorder inputs. Push-button selection. Printed circuit construction. **£27.19.6**

THE "COTSWOLD". This is an acoustically designed enclosure 26" x 23" x 15 $\frac{1}{2}$ " housing a 12" bass speaker with 2" speech coil, elliptical middle speaker together with a pressure unit to cover the full frequency range of 32-20,000 c/s. Capable of doing justice to the finest programme source, its polar distribution makes it ideal for really Hi-Fi Stereo. **£23.4.0**

COTSWOLD "MFS" SYSTEM. Specially developed to give best possible results in small rooms. This minimum floor space model is based on standard Cotswold. Size: 36" high x 16 $\frac{1}{2}$ " wide x 14 $\frac{1}{2}$ " deep. Either Model, **£23.4.0**



S-99



THE "COTSWOLD"

Without obligation please send me

FREE BRITISH HEATHKIT CATALOGUE (Tick here)

FULL DETAILS OF MODEL(S)

(Please write in BLOCK CAPITALS)

NAME _____

ADDRESS _____

DAYSTROM LTD DEPT. RC1 GLOUCESTER

Stern's

MULLARD DESIGNS

COMPLETE KIT OF PARTS

Designed by MULLARD—presented by STERNS strictly to specification

MULLARD "5-10" MAIN AMPLIFIER

For use with MULLARD 2-stage pre-amplifier with which an undistorted power output of up to 10 watts is obtained. SPECIFIED COMPONENTS AND MULLARD VALVES including PARMEKO MAINS TRANSFORMER and choice of PARMEKO or PARTRIDGE Output Transformer. COMPLETE KIT £10.00 (Parmeko Output Trans.)



ASSEMBLED AND TESTED £11.10.0
 ABOVE INCORPORATING PARTRIDGE OUTPUT TRANSFORMER £11.6.0 extra.

THE MULLARD 510/RC AMPLIFIER

The popular complete "5-10" incorporating Control Unit providing up to 10 watts. Specified components and new MULLARD VALVES. Includes PARMEKO MAINS TRANSFORMERS and choice of the latest PARMEKO or PARTRIDGE output Transformers.



Price: COMPLETE KIT £11.10.0
 Deposit £2.6.0 and 12 months 17/-
 ASSEMBLED AND TESTED £13.10.6
 Deposit £2.14.0, 12 months at 19/10.
 with PARTRIDGE OUTPUT TRANSFORMER £1.6.0 extra.

THE MULLARD 33/RC

HIGH QUALITY AMPLIFIER DEVELOPED FROM THE VERY POPULAR 3-WATT MULLARD "3-3" DESIGN. KIT OF PARTS £7.10.0

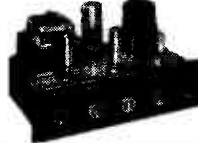

ASSEMBLED AND TESTED £8.19.6
 Complete to the MULLARD specification including PARMEKO OUTPUT TRANSFORMER. Switched inputs for 78 and L.P. records plus a Radio position. Extra power to drive a Radio Tuning Unit is also available.

THE MONO-GRAM

A small Amplifier of genuine high quality performance. Incorporates new MULLARD ECL86 Valve, separate BASS and TREBLE controls and produces up to 3 watts undistorted output.



KIT OF PARTS £4.5.0 ASSEMBLED AND TESTED £4.19.6

Perfectly suited for Portable Installations for which purpose we offer... PORTABLE CASE £3.10.0, the AMPLIFIER (Kit) and 8 x 5 in. SPEAKER (£1). All for £8.5.0. Alternatively with ASSEMBLED AMPLIFIER £9.

The case quoted above will accommodate some 4 speed Single Record Units. A larger model for auto-changer is available for extra 10/-. With this equipment a COMPLETE PORTABLE RECORD PLAYER CAN be built for from £13.10.0.



MULLARD FOUR CHANNEL MIXING UNIT

Self powered Cathode follower output. Incorporates two inputs for CRYSTAL MICROPHONES, one for CRYSTAL PICK-UPS and a fourth for Radio or Tape.



KIT OF PARTS £8.8.0 ASSEMBLED AND TESTED £10.0.0
 Alternative Model I/L provides for one input matched for moving coil or ribbon mike £1.17.5x.

!!! SENSATIONAL BARGAINS !!!
 A BULK PURCHASE ENABLES US TO OFFER THESE TWO GRUNDIG MODELS AT APPROX. HALF PRICE... Each is fully GUARANTEED. THE GRUNDIG "MINIBOY"

The "LITTLE" SET with "BIG" PERFORMANCE

Original Price is £26.5.0
 PRICE ONLY £10.10.0

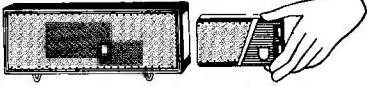

INCLUDING SPEAKER ENCLOSURE

A six Transistor (plus two Diodes) Portable covering the Medium Waveband. Small enough to slip into Handbag or Pocket (4 x 2 1/2 x 1 in.) but when at home "big set" performance is obtained simply by slipping the set into the companion Speaker Enclosure (size 9 1/2 x 3 1/2 x 1 1/2 in.).

GRUNDIG T.M.60 TAPE UNIT

FOR STEREOPHONIC or MONOPHONIC OPERATION. BEAUTIFULLY STYLED WITH FINGER TIP CONTROLS. CONSISTING OF TAPE DECK INCORPORATING HIGH QUALITY PREAMPLIFIER. LIST PRICE IS £94.10.0.

OUR PRICE ONLY £49.10.0
 Deposit £9.18.0, 12 months of £3.15.10.

A completely self-contained self-powered Unit designed to add full TAPE RECORDING facilities to existing sound reproducing equipment. Will operate with the majority of high quality audio installations and ideally suited for our MULLARD AMPLIFIERS. When ordering please state the make and type of Amplifier or Radio-gam to be used with the Unit.



MULLARD'S 2-VALVE PRE-AMPLIFIER TONE CONTROL UNIT

Employing two EF86 valves and designed to operate with the Mullard MAIN AMPLIFIER but also perfectly suitable for other makes.

- ★ Equalisation for the latest R.I.A.A. characteristic.
 - ★ Input for Crystal Pick-ups and variable reluctance magnetic types.
 - ★ Input (a) Direct from High Imp. Tape Head. (b) from a Tape Amplifier or Pre-Amplifier.
 - ★ Sensitive Microphone Channel. ★ Wide range BASS and TREBLE Controls.
- KIT OF PARTS £6.6.0 ASSEMBLED AND TESTED £8.0.0



MULLARD 3 VALVE PRE-AMPLIFIER TONE CONTROL UNIT

Designed mainly for the STERN/MULLARD range of monophonic Power Amplifiers, but also suitable for any Amplifier requiring an input signal up to 250 mV. Five inputs, including one equalised for replay direct from high impedance tape head, and one for low output magnetic pick-up. Output for tape record. Separate Bass and Treble controls. High Pass Filter 20 to 160 c/s. Low pass Filter 5 to 9 Kc/s. Power requirement 250 v. at 6 mA, 6.3 v. at 0.8 amps. Totally enclosed case silver hammered. Size: 1 1/2 x 4 1/2 x 4 1/2 in. Front panel. Polished perspex in choice Black or White.

KIT OF PARTS £10.0.0 ASSEMBLED AND TESTED £13.13.0

COMBINED PRICE REDUCTIONS

- (a) The KIT OF PARTS to build both the "5-10" Main Amplifier and the 2-Stage Pre-Amplifier £15.15.0
 Deposit £3.3.0, and 12 months £17.6.
- (a) The "5-10" and the 2-Stage Pre-Amplifier both Assembled and Tested £18.18.0
 Deposit £3.16.0, and 12 months at £1.8.11. With PARTRIDGE OUTPUT TRANSFORMER £1.6.0 extra.
- (b) The KIT OF PARTS to build the "5-10" Main Amplifier and 3 Valve Pre-Amplifier £19.10.0
 Deposit £3.18.0, 12 months at £1.9.10.
- (b) The "5-10" and 3 Valve Pre-Amplifier both Assembled and Tested £24.10.0
 Deposit £4.18.0, 12 months £1.17.6.

LOUDSPEAKERS

WE STOCK THE COMPLETE RANGE OF HIGH FIDELITY UNITS by ... GOODMANS, WHARFDALE and W. B. STENTORIAN

A few recommended examples:

8 INCH TYPES	
GOODMANS "AXIETTE"	£5.17.7
W.B. HF.816	£6.13.9
WHARFDALE "SUPER 8/RS/DD"	£7. 9.5
10 INCH TYPES	
GOODMANS "AXIOM 10"	£7. 0.0
W.B. Model HF.1016	£7.16.0
WHARFDALE "GOLDEN 10/RS/DD"	£8.15.5
12 INCH TYPES	
GOODMANS "AXIOM 201" 15 watts	£10. 7.0
GOODMANS "AXIOM 301" 20 watts	£14.10.0
W.B. Model HF.1214 15 watts	£10. 5.6
WHARFDALE "W12/RS"	£10.10.0
WHARFDALE "Super 12/RS/DD"	£17.10.0

LEAK AND QUAD AMPLIFIERS

LEAK "TL12 PLUS" POWER AMPLIFIER with the "POINT ONE PLUS" PRE-AMPLIFIER .. 14 watts rated output	£31.10.0
LEAK "TL25 PLUS" with the "POINT ONE PLUS" PRE-AMPLIFIER .. 28 watts rated output	£37.16.0
LEAK "STEREO 20" POWER AMPLIFIER with the "VARIABLE SLOPE STEREO" PRE-AMPLIFIER .. 22 watts (11 watts per channel)	£55.9.0
QUAD II. POWER AMPLIFIER with QUAD II CONTROL UNIT 15 watts output	£42.0.0

RECORD PLAYERS

THE COLLARO "JUNIOR" 4-speed single player with separate crystal pick-up	£3.15.0
GARRARD Model SRP10. Single Record Player fitted with high output crystal pick-up	£6.6.0
THE NEW GARRARD "AUTOSLIM" 4-speed Autochanger with crystal pick-up	£7.19.6
GARRARD "AUTOSLIM DE LUXE" 4-speed Autochanger, incorporates transcription Pick-up Arm	£12.14.6
THE COLLARO "C60" 4-speed autochanger unit with Studio pick-up	£7.19.6
B.S.R. Model UA14, a 4-speed Mixer Autochanger with crystal pick-up	£7.19.6
The new GARRARD Model 4HF High Quality Single Record Player fitted with the latest T.P.A. 12 pick-up arm and G.C.S. crystal Cartridge	£18.19.0
PHILIPS Model AG1016. A 4-speed Player which can be operated both manually and automatically. Suitable for Mono or Stereo operation	£13.13.0
Carriage and insurance on each above, 5/- extra.	

HOME CONSTRUCTORS

A Range of "EASY TO ASSEMBLE" PREFABRICATED CABINETS Designed by the W.B. STENTORIAN "COMPANY" for "Hi-Fi" Loudspeaker systems or to accommodate high quality equipment. FULL RANGE IN STOCK, please enclose S.A.E. for descriptive leaflets.

IF YOU ARE PLANNING TO INSTALL HI-FI

AND UNCERTAIN OF THE TYPE OF EQUIPMENT TO USE—OUR WIDELY EXPERIENCED TECHNICAL STAFF WILL WITH PLEASURE PUT FORWARD RECOMMENDATIONS—STATE TYPE OF INSTALLATION CONTEMPLATED AND APPROX. PRICE LEVEL.

HIRE PURCHASE TERMS are available on all Equipment over £10. FULLY DESCRIPTIVE LEAFLETS are readily available... please enclose S.A.E.

Stern's

SPECIALISTS IN SOUND EQUIPMENT FOR OVER 50 YEARS

TAPE RECORDING EQUIPMENT

STEREO TAPE PRE-AMPLIFIER

Model STP-1. For use with current TRUVOX, BRENNELL or COLLARO "STUDIO" $\frac{1}{2}$ and $\frac{1}{4}$ track Stereo Decks. Incorporates Ferroxcube Oscillator, 4-speed Equalization Signal Level Meter and separate Gain Controls. Includes separate Power Unit.

KIT OF PARTS **£22.00** ASSEMBLED AND TESTED **£28.00**



MULLARD'S TYPE "C" TAPE PRE-AMPLIFIER

Suitable for most $\frac{1}{2}$ -track Mono Tape Decks. Incorporates Ferroxcube Push Pull Oscillator and 3-Speed Treble Inductor. Includes separate Power Unit.

KIT OF PARTS **£14.00** ASSEMBLED AND TESTED **£17.00**



MULLARD'S TAPE AMPLIFIER (Model HF/TR3)

Based on Mullard's Type "A" design and suitable for most $\frac{1}{2}$ track Mono Tape Decks. Incorporates Ferroxcube 3-speed Treble Inductor and Gilson Output Transformer. Includes separate Power Unit.

KIT OF PARTS **£13.13.0** ASSEMBLED AND TESTED **£17.00**



STERN'S "ADD-A-DECK"

A self-contained Unit consisting of Garrard Deck and matched Pre-amplifier on one chassis. Provides full tape recording facilities and replays through Pick-up Sockets of standard Radio receiver or Amplifier.

PRICE: Includes Spool of Tape **£18.18.0**



TAPE DECKS AND COMPLETE RECORDERS

By Collaro, Brenell, Truvox, Wearite, Grundig, Ferragraph, Philips and others... Descriptive leaflets readily available.



THE "TUDOR" AM/FM TUNING UNIT
A SELF-POWERED HIGH FIDELITY TUNER OF OUTSTANDING DESIGN. PROVIDES FULL COVERAGE OF THE VHF/FM TRANSMISSIONS and also the

LONG and MEDIUM WAVEBANDS.

PRICE ONLY **£19.19.0** Deposit £4 and 12 months **£1.10.7**.

Operates perfectly with the STERN-MULLARD AMPLIFIERS and contains matching FRONT PANEL in Black/Gold or White/Black. Also operates equally well with any Amplifier requiring input of 100 to 350 mV/olts.

Mk. II "Fidelity" FM TUNING UNIT

An attractively presented Unit incorporating MULLARD PERMEABILITY TUNING HEART and corresponding Mullard valve line-up. Very suitable to operate with our Mullard Amplifiers.

KIT OF PARTS **£10.10.0**

ASSEMBLED AND TESTED **£14.5.0**

ARMSTRONG RADIOGRAM CHASSIS

We have the full range in stock. **£22.18.0**

Prices Range from **£22.18.0**
Full details are readily available.



THE "TUDOR" STEREO AMPLIFIER

PRICE ONLY **£18.18.0**

Deposit: **£3.16.0**, 12 months **£1.8.11**

A self-contained Amplifier designed to provide high quality stereophonic and monophonic reproduction. Each channel provides a rated output of 6 watts and for monophonic operation approx. 12 watts is produced. Separate BASS and TREBLE CONTROLS.

COMBINED PRICE OFFERS

STP-1 (Kit) and "STUDIO" Deck	£39.0.0
STP-1 (Assembled) "STUDIO" Deck	£45.0.0
STP-1 (Kit) and Brenell Deck	£61.0.0
STP-1 (Assembled) Brenell Deck	£67.0.0
STP-1 (Kit) and Truvox Deck	£48.0.0
STP-1 (Assembled) Truvox Deck	£54.0.0

COMBINED PRICE OFFERS

TYPE "C" (Kit) and "STUDIO" Deck	£26.10.0	Assembled	£29.10.0
TYPE "C" (Kit) and BRENNELL Deck	£43.0.0	Assembled	£46.0.0
TYPE "C" (Kit) and TRUVOX D82 Deck	£39.10.0	Assembled	£43.0.0
TYPE "C" (Assembled) and WEARITE Deck	£60.10.0	Includes Head Lift Transf.	

COMBINED PRICE OFFERS

HF/TR3 (Kit) and "STUDIO" Deck	£26.0.0	Assembled	£29.10.0
HF/TR3 (Kit) and BRENNELL Deck	£42.0.0	Assembled	£45.10.0
HF/TR3 (Assembled) and WEARITE Deck	£60.10.0	Includes Head Lift Transf.	

To build a complete TAPE RECORDER... We offer HF/TR3 AMPLIFIER, STUDIO DECK, PORTABLE CASE... ROLA 10 x 6 SPEAKER... MICROPHONE and 1200 ft. TAPE... ALL FOR **£35.0.0**.

Stereo Amplifiers

MULLARD'S "10+10" STEREO AMPLIFIER

A HIGH FIDELITY DESIGN PROVIDING UP TO 10 WATTS (per channel). SUPERB REPRODUCTION FREQUENCY RESPONSE FLAT TO WITHIN 3dB from 3 c/s to 60 kc/s at 50mV.

TOTAL HARMONIC DISTORTION AT 10 WATTS, 0.1%.

PRICE: (a) ASSEMBLED AMPLIFIER **£21.0.0** (As illustrated).

(b) KIT OF PARTS **£18.10.0**

Built to the highest technical standards and presented strictly to MULLARD'S specification. Two specially designed GILSON OUTPUT TRANSFORMERS with 20% taps are used.

We can also supply the assembled MAIN AMPLIFIER only for operation with our DUAL CHANNEL PRE-AMPLIFIER; this provides for a more versatile installation and is essential if a low output Magnetic Pick-up is to be used. When ordering, specify loudspeaker impedance.

(a) THE ASSEMBLED MAIN AMPLIFIER and ASSEMBLED DUAL CHANNEL PRE-AMP **£30.0.0** Deposit **£6**, 12 months of **£2.4.0**.

(b) KIT OF PARTS for both Units **£26.0.0** Deposit **£5.4.0**, 12 months **£1.19.10**



THE "TWIN THREE" STEREO AMPLIFIER

ASSEMBLED AND TESTED for **£7.15.0** (Carr. & Ins. 7/6 extra)

Based on a recent design by MULLARD LTD. is ideally suited for use in PORTABLE RECORD PLAYERS for which purpose we offer a specially designed case:

It incorporates MULLARD ECL 86 Valves, separate BASS and TREBLE CONTROLS and produces up to 3 watts per channel. Frequency response 40 c/s to 30 Kc/s, size 11 1/2 in. x 3 in. x 5 in. To construct a STEREO PORTABLE RECORD PLAYER we offer :- Assembled AMPLIFIER with two ROLA 8 in. x 5 in. LOUDSPEAKERS and PORTABLE CASE for **£16** (Carr. and Ins. 10/- extra).



MULLARD DUAL CHANNEL PRE-AMPLIFIER

A four Valve design for both STEREOPHONIC and MONOPHONIC operation. Operate equally well with any make of Amplifier requiring input of up to 250 mV.

KIT OF PARTS **£12.10.0** Deposit **£2.10.0**, 12 months **£19.2.**

ASSEMBLED AND TESTED **£15.0.0** Deposit **£3**, 12 months **£1.3.0**.



POSTAL ENQUIRIES and MAIL ORDERS TO...
STERN RADIO LTD.
6-12, TUDOR PLACE, TOTTENHAM COURT RD.
LONDON, W1. TEL. MUSEUM 6128/9

DEMONSTRATION and SHOWROOMS AT...
STERN RADIO LTD.
109, FLEET ST. LONDON, EC4
TEL. FLEET ST. 5812/3
OPEN...9 a.m. to 6 p.m. SAT. close 1 p.m.

PREMIER RADIO
23, TOTTENHAM COURT RD.
LONDON, W1. TEL. MUSEUM 6128/9
OPEN...9 a.m. to 8 p.m. THURS close 1 p.m.

NEW

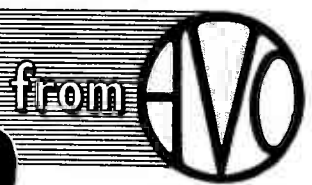

Regd. Trade Mark

Modern styling in light grey with black engraving

Constructed to withstand adverse climatic conditions

Ever ready case, including leads, prods and clips.

Improved internal assemblies

New standard of accuracy, using an individually calibrated scale plate:
d.c. ranges 2.25% of f.s.d.
a.c. ranges 2.75% of f.s.d.

Re-styled scale plate for easy, rapid reading.



AVO are proud to present an entirely new version of the now famous MULTIMINOR, styled on modern lines, with new high standards of accuracy, improved internal assemblies and incorporating panclimatic properties.

The new Mark 4 MULTIMINOR, which supersedes all previous models, is supplied in an attractive black carrying case, which also houses a pair of leads with interchangeable prods and clips. The whole is packed in a strikingly handsome "Astralux" carton. Two kinds of real leather cases are also available if required.

MULTIMINOR Mk 4

Write for full details of this great new pocket-size instrument

D.C. Current: 100 μ A f.s.d.—1A f.s.d. in 5 ranges.
A.C. Voltage: 10V f.s.d.—1,000 f.s.d. in 5 ranges
D.C. Voltage: 2.5V f.s.d.—1,000 f.s.d. in 6 ranges.
D.C. Millivolt range: 0—100mV. f.s.d.

RESISTANCE: 0-2M Ω in 2 ranges, using 1.5V cell.
SENSITIVITY: 10,000 Ω /V on d.c. Voltage ranges.
1,000 Ω /V on a.c. Voltage ranges.

AVO LTD AVOCET HOUSE 92-96 VAUXHALL BRIDGE ROAD LONDON SW1 Telephone: VICTORIA 3404 (12 lines) **M** AGENTS

Premier RADIO

23 Tottenham Court Road London W1 Telephone MUSEum 3451/2 and 309 Edgware Road London W2 Telephone PADdington 6963



THE "MID-FI" A NEW DESIGN 4W AMPLIFIER KIT
MAY BE BUILT FOR 95/- plus 3/- P & P.

A new circuit for the home constructor requiring a good quality med. powered amplifier for reproduction of records or f.m. broadcasts. Technical spec.: sep. bass and treble controls. Valves: EF86, EL84, EZ80. Voltage adjustment for a.c. mains from 200/250V, 3 or 15 Ω imp. Neg. feedback. Size 7" x 5" x 2", overall ht. 5". Silver hammered finished chassis.

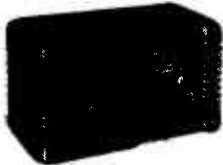

WHY NOT DO IT YOURSELF!

Long & Medium Waveband
T.R.F. Receiver

May be built for **£5. 10. 0** Plus 5/- P. & P.

This receiver uses the very latest circuitry and when constructed is housed in a Bakelite cabinet size 12" x 6 $\frac{1}{2}$ " x 5 $\frac{1}{2}$ ", available in either walnut or ivory. Individual instruction books 1/- each, post free.

WE HAVE BEEN APPOINTED STOCKISTS FOR FULL RANGE OF STERN'S RADIO (Fleet Street)

Famous Mullard Designs such as Type 'C' Tape Pre-amplifier and Erase Unit, including separate Power Supply. Complete Kit of Parts £14. 0. 0 or Completely assembled and tested

£17. 0. 0 Also available Less Power Supply at £11.15.0 and £14.10.0 respectively.

Stern's Model HF/TR3 Mk.2. Tape Amplifier

Complete Kit of Parts £13.14. 0 or Completely assembled and tested

£17. 0. 0

Complete Mullard 5-10 Amplifier with Pre-amplifier on same Chassis

Complete Kit with Parmeko O/P and Mains Transformers £11.10. 0

Completely assembled and tested £13.10. 0

Complete Mullard 3-3 Amplifier

Kit £7.10. 0

Completely assembled and tested

£8.19. 6 P. & P. 6/6

Mullard 10-10 Stereo Power Amplifier based on the famous Mullard 5-10

Complete Kit of Parts £18.10. 0

Completely assembled and tested

£21. 0. 0 (Control Unit on Main Chassis)

Also available with separate dual-channel Pre-amp.

Complete Kit for Power Amp. & Pre-amp

£26. 0. 0

Complete assembled and tested £30. 0. 0

All components used in these Kits are of the highest possible standard and strictly to circuit specifications.

Full descriptive literature available on these products and Circuit Diagrams may be purchased separately.

The "Handyphone" Intercom



Fully Transistorised Battery Operated

89/6 P. & P. 4/-

Including PP3-Battery and 25 yds. lead with plugs.

At last a completely Portable Intercom with 101 uses being ideally suitable for the office or even as a Baby Alarm, since being battery operated, it is completely safe. Two-way calling system and volume on/off switch, the units are housed in attractive plastic cabinets (black/white) with chrome stands. It is extremely economical operating on one 9-volt battery, replacement price being 2/6.



The "Petite" PORTABLE

MAY BE BUILT FOR **£7.0.0** plus 5/- P. & P.

Batteries extra HT 10/- (Type B126) or equiv. LT 1/6 (Type AD35) or equiv.

★ Size only 8" x 8" x 4 $\frac{1}{2}$ "

★ Instruction book 1/6

Battery Eliminator, available in component form price 37/6 plus 2/- P. & P.

JACKSON



the big name in **PRECISION** components

Precision built radio components are an important contribution to the radio and communications industry. Be sure of the best and buy Jackson Precision Built Components

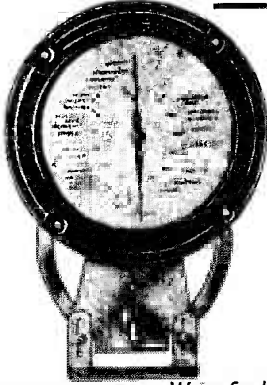

AIRPLANE DRIVE

3 $\frac{3}{8}$ " diameter circular scale printed 2 wavebands and station names. A bronze-finished escutcheon with glass is supplied. Ratio 8-1. Price 13/9.

Write for literature.

JACKSON BROS. (LONDON) LTD.

Dept. R.C., KINGSWAY-WADDON, SURREY

Phone: Croydon 2754-5 Grams: Walfico, Souphone, London

SMITH'S of Edgware Road BLANK CHASSIS

Precision made in our own works from commercial quality half-hard Aluminium. Two, three or four sided.

SAME DAY SERVICE

of over 20 different forms made up to YOUR SIZE. Order EXACT size you require to nearest $\frac{1}{16}$ " (maximum length 35", depth 4").

SPECIALS DEALT WITH PROMPTLY

SEND FOR ILLUSTRATED LEAFLET

Or order straight away, working out total area of material required and referring to table below, which is for four-sided chassis in 18 s.w.g. (for 16 s.w.g. add $\frac{3}{8}$ th)

48 sq. in.	4/-	176 sq. in.	8/-	304 sq. in.	12/-
80 sq. in.	5/-	208 sq. in.	9/-	336 sq. in.	13/-
112 sq. in.	6/-	240 sq. in.	10/-	368 sq. in.	14/-
144 sq. in.	7/-	272 sq. in.	11/-	and pro rata	
	P. & P. 2/6		P. & P. 2/9		P. & P. 3/-

Discount for quantities. Trade enquiries invited. Spray finish arranged for quantities of 25 or over.

FLANGES ($\frac{1}{4}$ ", $\frac{3}{8}$ " or $\frac{1}{2}$ ") 6d. per bend.

STRENGTHENED CORNERS, 1/- each corner.
PANELS. The same material can be supplied for panels, screens, etc. Any size up to 3ft (18 s.w.g.) at 4/6 sq. ft. (16 s.w.g. 5/3). P. & P., up to 72 sq. in. 1/3, 108 sq. in. 2/-, 144 sq. in. 2/6, 432 sq. in. 2/9, 576 sq. in. 3/3.

H. L. SMITH & CO. LTD

287/289 EDGWARE ROAD LONDON W2
Telephone PAD 5891/7595

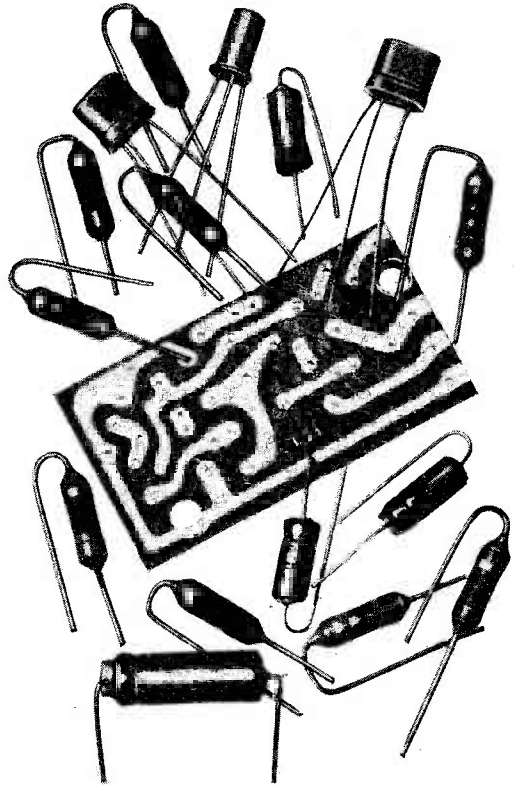

seventeen into one



will go

pre-assembled packaged circuits by Pye Industrial Electronics save space, time, and money

The P.C.1. first of a new range! This transformer-less 125mW-9V audio amplifier circuit provides a pre-assembled block for simplifying the design and assembly of laboratory equipment and intercomm sets etc. The unit uses Newmarket matched npn/npn audio transistors in complementary symmetry circuits to achieve low distortion (typically 2% total) medium high sensitivity (50mV max out of 600 ohms for 50mW out) and low standby battery current (typically 4mA). Measuring only 2" x 1" x $\frac{3}{8}$ " the P.C.1. is guaranteed for one year.

Write for full technical data to:

Pye Industrial Electronics Ltd, Exning Road,
Newmarket. Telephone: Newmarket 3381



LASKY'S RADIO

**LONDON'S LARGEST STOCKS OF
EQUIPMENT AND COMPONENTS**
SPEEDY MAIL ORDER SERVICE

Lasky's for All Types of Pocket and Personal Transistor Radios

COROVER "6"

A 6 transistor plus two diode receiver using the latest circuitry
★ Three Mullard AF117 alloy diffused transistors are used with OA79 and OA91 diodes, followed by OC81D and two OC81s in push-pull ★ I.F. Frequency 470 kc/s.
★ Covers the full medium and long wavebands.

★ Sockets are provided for a personal earpiece or tape recorder, and car radio aerial ★ Large internal ferrite rod aerial gives high sensitivity ★ Operates from four 1.5 volt pen torch batteries.

★ All components mounted on a single printed circuit. Easy to build from simple stage-by-stage instructions.

★ Cabinet size 6½" x 4" x 1½". With carrying handle. All coils and if.s ready wound.



ALL COMPONENTS AVAILABLE SEPARATELY. CAN BE BUILT FOR

£5.19.6

P. & P. 4/- extra. Data and instructions separately 2/6. Refunded if you purchase the parcel.



THE SPRITE

★ A Six-Transistor Superhet Miniature Personal Pocket Radio ★ Fully tuneable over Long and Medium wavebands ★ Uses single PP3 battery
★ Ferrite Rod aerial ★ High sensitivity circuit ★ I.F. Frequency 470 kc/s ★ Transistors used: 3 x Philco 2067's, 2 x Mullard OC81 M, OC81 DM and OA90 diode ★ 3" speaker ★ Printed circuit 2½" x 2" ★ Slow Motion Drive ★ In very attractive plastic case, size 4" x 2½" x ¾".

FOR YOUR CONVENIENCE and in order to ensure perfect results, **The Sprite** is supplied to you with R.F. and I.F. stages. Driver and Output stages, ready built with all components ready mounted on the printed circuit. In order to complete assembly you only have to fit the wave-change switch, tuning condenser and drive, volume control, earphone socket and aerial rod; the remaining components all having been pre-fitted at the factory for you. **The Sprite** is offered as above, pre-assembled, plus cabinet, speaker and all components for final construction at the inclusive price of **89/6**

Postage and Packing 3/6 extra

Data and Instructions separately 2/6. Refunded if parcel is purchased. Real calf leather case, wriststrap, personal earphone and case for earphone 10/- the lot extra. Make no mistake this is SUPERHET receiver of genuine commercial quality. It is not a regenerative circuit.

TELEFUNKEN Stereo High Fidelity Amplifiers

A complete amplifier of unsurpassed quality, with inputs for radio, tape recorder, F.M. tuner or any other hi-fi source, monaural or stereo. Output power 5 watts total (2½ watts each channel). New and unused. Listed at 16 gns.



LASKY'S PRICE **£5.19.6**
Post 7/6.

Further great purchase enables us to offer this Excellent Unit at **£5.19.6**.

Build it yourself REALISTIC "7"

The finest receiver at present available for home construction. Fully tuneable long and medium wavebands. Uses 7 Mullard Transistors: OC44, 2 OC45s, OC71, OC81D and 2 OC81s, plus Crystal Diode OA70.

STAR FEATURES ★ ★ ★ ★ ★

7 Transistor Superhet. 350 milliwatt output into 4" high flux speaker. All components mounted on a single printed circuit board, size 5½" x 5½", in one complete assembly. Plastic cabinet with carrying handle, size 7" x 10" x 3¼", in choice of colours: red/grey, blue/grey, all grey. Easy to read dial. External socket for car aerial. I.F. frequency 470 kc/s. Ferrite Rod internal aerial Operates from PP9 or similar battery. Full comprehensive data supplied with each Receiver. All coils and I.F.s, etc., fully wound ready for immediate assembly.

An Outstanding Receiver. Lasky's price for the complete parcel including Transistors, Cabinet, Speaker, etc., and Full Construction Data. All components available separately. Battery 3/9 (included free with complete parcel). Data and instructions separately, 2/6, refunded if you purchase the parcel.

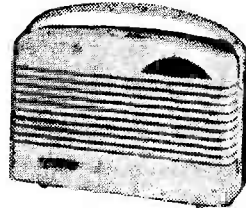

£6.19.6

Post and Packing 4/6.

KAPURA Model U1 Multi-Test Meters

★ Complete with test leads.

★ Brand new, fully guaranteed.

Sensitivity: 1,000 ohms per volt A.C. and D.C.
Ranges: (A.C. and D.C.) 0-15-50-250-500-1,000 v. D.C. current 0-100-500 mA, 0-1 mA (used at 0-10 v. range). Resistance: 1-2,000 ohms (centre 24 ohms). 100-200,000 ohms (centre 2.4k.) Size 5" x 3" x 2¼".

Lasky's Price **39/6**

Carriage and Packing 5/-

Beta Two

A 2-transistor plus 2 diode personal receiver for home construction. Uses printed circuit and ferrite rod aerial. Personal earphone gives clear reception for private listening. Tunes over full medium waveband. Size 5½" x 3½" x 1½" overall. All components available separately.

Can be built for **21/-**

Postage 2/6 extra

including personal earphone, cabinet, etc. Circuit diagram and step-by-step instructions 1/6. (Free with parcel.)

Get this superb 100-page Catalogue

Read all about hi-fi equipment of every kind in our superb Catalogue. Over 100 large pages (11¼" x 8¼"), in photogravure and colour. Price 5/-, plus part post 6d. (returnable in full on making your first hi-fi purchase from the Catalogue). Call or send for it right away!

33 TOTTENHAM COURT ROAD · W1

2 mins. Oxford Street
Nearest Station: Goode Street
MUSEUM 2605

Both addresses open all day Saturday. Close 1 p.m. Thursday.

207 EDGWARE ROAD · W2

Few yards from Praed Street
PADDINGTON 3271/2

Please address all Mail Orders to Dept. W at above Edgware Road address

152/3 FLEET STREET · EC4

FLEET 2833
Open all day Thursday.
Closed 1 p.m. Sat.

RETURN-OF-POST SERVICE

We offer a really efficient Mail Order Service on all items stocked. All cash orders are dealt with on the day of receipt. ★ Hire purchase orders are subject to slight delay but this is kept to the absolute minimum.

● MARTIN STEREO AMPLIFIER KITS

Printed circuit, already wired and tested. Only requires wiring to mains and output transformers. Complete kit with plastic cabinet, escutcheon and full instructions £6.6.0.

● TRANSISTORISE YOUR CRYSTAL SET

We have two new designs for Transistor amplifiers which can be used to greatly improve the signal from any crystal set. RLD4 Kit, one stage, 12/-; RLD5 Kit, two stage, 21/-; both post free. The kits are easy to build and very detailed instructions are supplied. Leaflet available.

● NEW MULLARD CONDENSERS

We now stock the following range of the new Mullard Miniature Foil and Polyester condensers as used in the latest TV and Transistor sets. Fully detailed list available giving full technical information and dimensions
Miniature Foil. 30 volt working for Transistor sets. .01mfd, 7jd; .022mfd, 9d.; .047mfd, 1d.; 1mfd, 11d.

Polyester Tubular Capacitors. Moulded outer case designed to withstand accidental contact with the soldering Iron. Tolerance 10%. 125V range: .01mfd, .022mfd, .047mfd, all 9d. each. .1mfd, 1/2; .22mfd, 1/3; .47mfd, 1/6; 1mfd, 3/-.

400V range: .001mfd, .0022mfd, .0047mfd, .01mfd, .022mfd, all 9d. each. .047mfd, 1/2; .1mfd, 1/3; .22mfd, 1/6; .47mfd, 2/5. Postage extra.

● TAPE RECORDING EQUIPMENT

TAPE DECKS	Cash Price	Deposit	Hire Purchase
ALL CARRIAGE FREE			Mthly/Pmts.
B.S.R. TD2	£8.19.6	£1.16.6	12 of 13/7
Latest COLLARO Studio	£10.19.6	£2.3.6	12 of 16/4

TAPE AMPLIFIERS

We now stock the Martin Recorder Kits. These are partly assembled kits for complete tape recorders. The Amplifier Printed Circuit panels are completely wired, but the assembly of this and external components is left to the constructor. Very complete instructions are supplied. Send for leaflet.

MODEL C for Collaro Studio Deck, £11.11.0.

MODEL B for BRS TD2 Deck, £8.8.0.

CARRYING CASES. Smart carrying cases are available to take the above amplifiers and decks. Fitted with speaker. For Model C Amplifier and Collaro Deck, £5.5.0.

For Model B Amplifier and BSR Deck, £4.4.0.

H.P. Terms available for amplifiers, cases and decks.

TAPE PRE-AMPLIFIERS

MULLARD TAPE C PRE-AMPLIFIER. We stock complete kits and all components. Send for list.

MARTIN. Pre-amp kit for Collaro Studio Deck, £8.8.0.

● "BRAND FIVE" RECORDING TAPE

Long Play: 900' (5"), 18/6; 1,200' (5 1/2"), 23/6; 1,800' (7"), 35/-, post free

● JASON F.M. TUNER KITS

Kits supplied complete with every item needed including instruction manuals. Fully detailed list available. Separate items supplied, ask for price list. H.P. Terms available on any kit.

FMT1, £6.12.6; FMT2 (less power), £7.15.0.

FMT2 (with power), £9.12.6; FMT3 (less power), £9.9.6.

FMT3 (with power), £11.7.6. Mercury 2, £10.14.6. JTV/2, £14.12.6.

● ILLUSTRATED LISTS

Illustrated lists are available on LOUDSPEAKERS, TAPE DECKS, TEST GEAR, GRAMOPHONE EQUIPMENT, AMPLIFIERS. Any will be sent free upon request.

● STEREO COMPONENTS

Morganite ganged potentiometers as specified for the Mullard circuits. ★ Log/Anti-Log, 500k, 1 meg., 2 meg. ★ Log/Log, 50k, 250k, 1 meg., 2 meg. ★ Lin/Lin 250k, 500k, 1 meg. All 10/6 each.

● TRANSISTORS

MULLARD. Reduced prices. Current production types, not rejects. All in makers' boxes. Postage 3d. on each. OC44, 9/3; OC45, 9/-; OC70 and OC71, 6/6; OC72, 8/-; OC72 Matched Pairs, 16/-; OC78, 8/-; OC81, 8/-; OC170, 9/6; OC171, 10/6.

● AMPLIFIER KITS

We have full stocks of all components for the Mullard 510, Mullard 3-3, Mullard 2 and 3 Valve Pre-amp, Mullard Stereo, Mullard Mixer, GEC 912 Plus. Fully detailed list on any of these sent upon request. Instructional Manuals: All Mullard Audio Circuits in "Circuits for Audio Amplifiers", 9/5. GEC912, 4/6. All post free.

● TERMS OF BUSINESS

Cash with order or C.O.D. We charge C.O.D. orders as follows: Up to £3, minimum of 3/2. Over £3 and under £5, 1/6. Over £5 and under £10, 1/8. Over £10, no charge. Postage extra on CASH orders under £3 except where stated. Postage extra on overseas orders irrespective of price.

● GRAMOPHONE EQUIPMENT

ALL LATEST MODELS
ALL POST FREE

Cash Price Deposit Hire Purchase Mthly/Pmts.

RECORD CHANGERS

GARRARD AUTOSLIM ... £7.19.6 £1.12.6 12 of 12/3

GARRARD AUTOSLIM De-luxe (Mono PU) ... £12.14.8 £2.11.8 12 of 18/8

GARRARD AUTOSLIM De-luxe (Stereo/Mono PU) ... £13.12.9 £2.14.9 12 of 20/-

B.S.R. UA14 (TC8 Mono PU) ... £7.17.6 £1.12.6 12 of 12/1

B.S.R. UA14 Monarch (TC8 Stereo/LP/78) ... £8.17.6 £1.16.6 12 of 13/5

SINGLE RECORD PLAYERS

B.S.R. TU12 (TC8 Mono PU) ... £4.5.0 £1. 5.0 3 of £13.4

B.S.R. GU7 (TC8 Mono PU) ... £5.11.6 £1.13.6 3 of £19.4

TRANSCRIPTION UNITS

GARRARD 4HF (GC8 PU) ... £17.19.6 £3.11.6 12 of £1.65

PHILIPS AG1016 ... £13.13.0 £2.15.0 12 of £1.00

Many of the above can be supplied for stereo working. See our Gramophone Equipment List for details.

● LOUDSPEAKERS

GOODMANS: Axiote 8", £5.17.7; Axiom 10", £7.0.0; 12", Axiom 201, £10.7.0; 12", Axiom 301, £14.10.0; 12", Axiom 51 Bass, £8.14.0; 12" Audiom 61 Bass, £13.14.0; Trebax Tweeter, £6.4.0; X05000 Crossover unit, £1.19.0.

WHITELEY: HF1016 10", £7.16.0; HF1012 10", £4.17.6; HF816 8", £6.13.9; T816 8", £6.6.9; T10 Tweeter, £4.8.3; T359 Tweeter, £1.14.0; CX3000 Crossover unit, £11.6.6; CX1500 Crossover unit, £2. H.P. Terms available on all speakers.

Terms available on all speakers.

● P.W. STRAND, MAYFAIR & SAVOY UNITS

We stock parts for the P.W. Strand Amplifier, Mayfair Pre-amplifier and Savoy F.M. Tuner. Detailed price lists are available.

● P.W. MERCURY

P.W. Mercury (Osmor printed circuit version) including Mullard first grade transistors and instruction manual. Complete set of parts, £9.19.6. Instruction manual available separately at 2/6 post free. Separate components supplied. Send for list.

● LATEST TEST METERS

Cash Price Deposit Hire Purchase Mthly/Pmts.

AVO Model 8 Mark II ... £24. 0.0 £4.16.0 12 of £115. 2

AVO Model 8 with leather carrying case ... £27.18.0 £5.12.0 12 of £2. 0.11

AVO Model 7 Mark II ... £21. 0.0 £4. 4.0 12 of £110.10

AVO Multiminor ... £9.10.0 £1.19.0 12 of 14/4

AVO Multiminor with leather carrying case ... £11. 9.0 £2. 5.0 12 of 17/-

TAYLOR MODEL 127A ... £10.10.0 £2. 0.0 12 of 15/8

CABY A-10 ... £4.17.6 £1. 7.6 3 of £1. 6.8

CABY B-20 ... £6.10.0 £2. 0.0 3 of £11. 4.4

CABY M-1 ... £2.14.0

Full details of any of the above supplied free on request
The AVO Models 7 and 8 are both latest models from current production—not to be confused with Government Surplus.

● OUTPUT TRANSFORMERS

GILSON: W0696A, W0696B, 50/6, post 2/6. W0710, 55/6, post 2/6. W0892, 62/3, post free; W0767, 27/-, post 1/6. W01796A, 57/6, post 2/6. W01932, 84/- post free.

PARTRIDGE: P3667, 75/-; P4131, 65/-; P5202, P5203, £5.18.6. All post free.

PARMEKO: P2629, 45/6; P2642, 43/3; P2643, 45/6. All plus post 2/9. P2641, 28/3, post 2/-; P2928, 15/3, post 2/-; P2932, 39/3, post 2/6.

ELSTONE: OT/ML, 45/-, post 2/9; OT/3, 25/-, post 2/6.

● MAINS TRANSFORMERS

GILSON: W0741AB, 63/-, post free; W0839, 48/9, post 2/9; W01328 58/6, post 3/6; W01288, 58/-, post 3/6; W01566, 80/-, post free; W01341 (Choke), 36/-, post and packing 2/-.

PARMEKO: P2631, 33/9, post 2/9; P2630, 52/6, post 3/3; P2644, 73/6, post free; P2930, 39/3, post 3/-; P2931, 54/6, post 3/3.

ELSTONE: MT/MU, 45/-, post 3/3; MT3/M, 35/-, post 3/-; MT/510, 42/-, post 3/3.

WATTS RADIO

(MAIL ORDER) LTD.

54 CHURCH STREET WEYBRIDGE SURREY

Telephone Weybridge 47556

Please note: Postal business only from this address

● HIRE PURCHASE TERMS

are available on any item. Repayments may be spread over 3, 6 or 12 months. Details as follows: Three months; Deposit 6/- in the £. Service charge 5 per cent but minimum charge of 10/-. Six and Twelve months; Deposit 4/- in the £. Service charge 10 per cent, but minimum charge 20/-.

HOME RADIO OF MITCHAM

DEPT. AC, 187 London Road, Mitcham, Surrey. MIT 3282

Shop hours 9.0 a.m. to 6 p.m. (Wed. 1 p.m.)



**STOCKISTS FOR THE
INCOMPARABLE
LEAK HI-FI
EQUIPMENT**

This superb equipment is still the standard by which all other Hi-Fi is judged. Full range of pre-amplifiers, amplifiers, mono and stereo, and tuners normally in stock.

TL12 PLUS, 12 watt mono amplifier	18 gns.	POINT-ONE STEREO pre-amp.	20 gns.
POINT-ONE PLUS pre-amplifier	12 gns.	VARISLOPE STEREO pre-amp.	£25
VARISLOPE III pre-amplifier	15 gns.	TL25 25 watt amplifier	24 gns.
STEREO 20, 20 watt stereo amp.	29 gns.	TL50 50 watt amplifier	32 gns.
TROUGH-LINE FM/VHF tuner	£32.12.6		

TRIPLETONE FM TUNER



A really first-class immaculately engineered FM/VHF tuner designed to bring crystal-clear interference-free reception of all B.B.C. programmes. Coverage 86-104 mc/s. Complete in case for shelf or cabinet mounting. Very sensitive and with inter-station muting to give quiet tuning. Size 11" x 6 1/2" x 3". PRICE without power pack £13.19.6, plus 1/6 post. Self-powered £15.14.6, post 1/6.

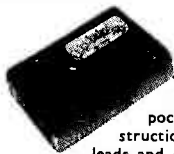

AVO MULTIMINOR

A well designed simple to use rectifier/moving coil test meter of pocket size and sturdy construction, complete with test leads and clips. 19 different ranges covering AC and DC voltages, DC current and resistance up to 2 megohms. Full details on request. PRICE £9.10.0, post 1/6.

GLOBE KING 100/A

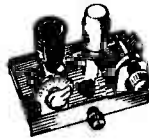

Have fun on short waves touring the world from your own fireside. The Globe King 100/A one valve battery receiver is still accepted as the best in its class. KIT OF PARTS with three plug-in coils £3.19.6, post 1/6. Additional parts for extra stage 21/6.

**WE ARE
MAIN STOCKISTS
FOR THE FAMOUS
HEATHKITS**

*Mullard ECL86 Amplifier
Printed Circuit Boards 12/6*

ACKNOWLEDGED TO BE THE BEST COMPONENT CATALOGUE

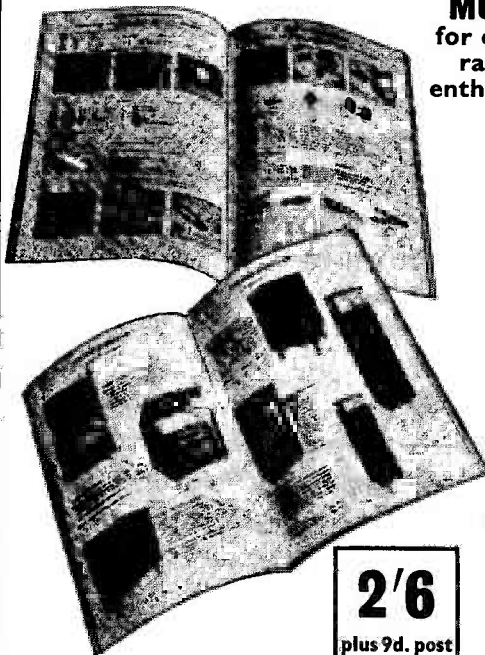

**A
MUST
for every
radio
enthusiast**

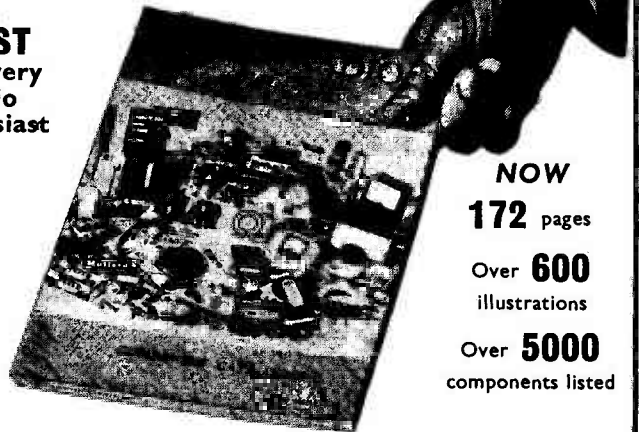

**NOW
172 pages
Over 600
illustrations
Over 5000
components listed**

This is today's most up-to-date and most comprehensive component catalogue for the radio constructor, experimenter, electronic engineer and hi-fi enthusiast.

**2/6
plus 9d. post**

**POST
COUPON
TODAY**
Write
CATALOGUE
on top left of
envelope.
Enclose P.O. 3/3

Name _____
Address _____
Home Radio Ltd., (AC), 187 London Road, Mitcham, Surrey

THE Radio Constructor

Incorporating THE RADIO AMATEUR

JANUARY 1963

Suggested Circuits No. 146: Employing Silicon Rectifiers as Heater Droppers, by G. A. French	406
Featherweight Earphones, by Thomas Kamester	410
Mains Portable Superhet, by V. E. Holley	411
News and Comment	419
Detector for Nuclear and Rocket Firings, by C. Morgan	420
Understanding Radio, Part 17, by W. G. Morley	422
Can Anyone Help?	428
Simple 3-Transistor Receiver, by G. Jeffries	429
In Your Workshop	431
Inexpensive Short Wave Pre-Selector, by James S. Kent	437
Electronics in Third Stage Music, Part 2, by F. C. Judd, A.Inst.E.	442
Radio Astronomy, Part 2: A Radio Astronomy Receiver, by Frank W. Hyde, F.R.S.A., F.R.A.S.	446
Book Reviews	452
Radio Topics	453
Comprehensive Valve Tester, Part 1, by P. Cairns, A.M.I.P.R.E.	455
Trade Review: Handy Tool for Hobby and Household	460
Simple Timer Circuits, by N. W. Bridge	461

© Data Publications Ltd, 1963

CONTENTS may only be reproduced after obtaining prior permission from the Editor. Short abstracts or references are allowable provided acknowledgment of source is given.

CONTRIBUTIONS on constructional matters are invited, especially when they describe the construction of particular items of equipment. Articles should be written on one side of the sheet only and should preferably be typewritten, diagrams being on separate sheets. Whether hand-written or typewritten, lines should be double spaced. Diagrams need not be large or perfectly drawn, as our draughtsmen will redraw in most cases, but all relevant information should be included. Photographs should be clear and accompanied by negatives. Details of topical ideas and techniques are also welcomed and, if the contributor so wishes, will be re-written by our staff into article form. All contributions must be accompanied by a stamped addressed envelope for reply or return, and should bear the sender's name and address. Payment is made for all material published.

OPINIONS expressed by contributors are not necessarily those of the Editor or the proprietors.

TRADE NEWS. Manufacturers, publishers, etc., are invited to submit samples or information of new products for review in this section.

TECHNICAL QUERIES must be submitted in writing. We regret that we are unable to answer queries, other than those arising from articles appearing in this magazine; nor can we advise on modifications to the equipment described in these articles.

CORRESPONDENCE should be addressed to the Editor, Advertising Manager, Subscription Manager or the Publishers, as appropriate.

REMITTANCES should be made payable to "DATA PUBLICATIONS LTD."

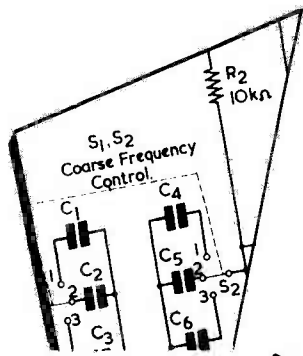

suggested circuits

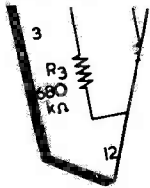

The circuits presented in this series have been designed by G. A. FRENCH, specially for the enthusiast who needs only the circuit and essential data

No. 146 Employing Silicon Rectifiers as Heater Droppers

IN THE DESIGN OF SMALL AND inexpensive valve equipment designed for operation from the mains it is necessary to provide both a high tension supply and a heater supply. The high tension supply can be obtained by normal rectifier techniques, and needs no further comment here. Heater requirements, on the other hand, tend to introduce problems with regard to heat dissipation and the chassis space occupied by the heater supply components.

For many years, heater supplies in equipment of the type under discussion have been achieved by the use of dropper resistors. The heaters are connected in series and are then applied across the mains supply in series with a dropper resistor. This arrangement has the advantage that the heater supply functions with both a.c. and d.c. mains. However, if the dropper has a high voltage across it, excessive power is wasted and a high level of heat is dissipated inside the equipment cabinet. Despite this shortcoming, the use of dropper resistors is still attractive, especially with television receivers wherein the large number of valve heaters connected in series results in only a low voltage appearing across the dropper.

Alternative schemes have been introduced to overcome the heat problem given by the dropper. One solution consists of employing three-way "line cord", in which the third conductor is a resistance element. This third conductor then functions as the dropper resistor, and the heat it dissipates is outside the cabinet.

Also, no space is required on the chassis. Line cords are not, however, generally considered to be entirely safe or reliable, and they are only rarely encountered these days.

Another method of supplying heater power is to employ a series capacitor in place of the dropper resistor. The reactance of the capacitor then causes the desired voltage to appear across the heater chain when an a.c. mains supply is applied. Negligible heat is dissipated by the series capacitor, but it tends to be bulky. Also, there is a considerable risk of its breaking down, with the result that one or more valves in the chain may burn out.

Yet another solution consists of wiring the valve heaters in parallel and employing a heater transformer. Only a small amount of heat is dissipated by the transformer, and it can be made quite small in physical size. Again, an a.c. mains supply is required.

The Silicon Rectifier

The introduction of silicon h.t. rectifiers for television receivers has introduced a further variant into the methods of heater supply which can be employed in small valve equipment operated from a.c. mains. Television silicon rectifiers operate in half-wave circuits at the a.c. mains voltages which are encountered in the U.K., and they can pass high currents. Due to an extremely low forward resistance they dissipate very little heat, and they are small in physical size. A typical example of

such a rectifier is the Mullard BY100 which has a maximum recurrent p.i.v. of 800 volts together with a maximum average forward current rating of 450mA for ambient temperatures above 50° C, and whose body has a diameter of approximately 0.4in at its widest point and a length of approximately 0.7in. (The latest version has a length of approximately 0.4in only.)

If a rectifier of this type is introduced in series with an a.c. supply and a resistive load, the power dissipation in the latter is halved. The load may consist of a number of valve heaters in series with a dropper resistor, whereupon the introduction of the rectifier enables the value of the dropper to be reduced for the same dissipation in the heaters. In consequence, a series combination of dropper and silicon rectifier is more attractive than a dropper on its own because, for equivalent dissipation in the heaters, less dropper resistance is required and less waste heat is dissipated inside the cabinet. Also, the dropper resistor may be made smaller in size, with a consequent saving of chassis space. The additional silicon rectifier takes up little more space than a small carbon resistor, and it dissipates negligible heat. The combination of dropper and silicon rectifier could, in addition, be significantly smaller than a heater transformer. The use of silicon rectifiers for miniature valve equipment intended for operation from a.c. mains supplies is, therefore, well worth investigation.

The writer has on several occasions encountered the mistaken impression that the insertion of a silicon rectifier causes the "available voltage" for the heaters and dropper to be halved. This impression is quite incorrect and, in the present article, the voltages resulting from the introduction of a silicon rectifier into a heater supply circuit are fully discussed. Also described are several experiments which were carried out by the writer to check that a silicon rectifier performs in practice in the manner which would be expected from a theoretical consideration. For these tests, the writer devised a simple and inexpensive instrument for measuring the heating effect of the non-sinusoidal current passed by the rectifier. This low-cost device may be of incidental interest to readers who wish to carry out similar investigations without incurring the expense of the additional measuring equipment which might otherwise be required.

Power Dissipation

To fully appreciate the effect of introducing a silicon rectifier into a valve heater circuit it is necessary, first of all, to examine circuit operation from basic principles. Fig. 1 (a) shows an a.c. generator which provides an r.m.s. potential of E_1 volts, and which is coupled directly to a

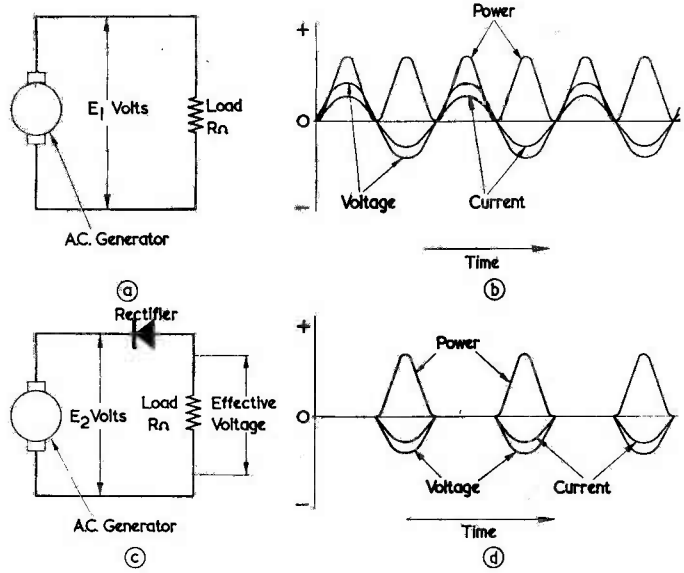

M620

Fig. 1 (a). An a.c. generator connected to a resistive load
 (b). The voltage, current and power waveforms given by (a)
 (c). Inserting a series rectifier
 (d). The rectifier causes power to appear on alternate half-cycles only

resistive load having a value of R ohms. Both current and voltage are in phase and these are shown in Fig. 1 (b). The power dissipated in the load (in the form of heat) is, at any instant, equal to the product of the corresponding instantaneous voltage and instantaneous current. If the curve for power is drawn, it takes up the form illustrated in the diagram. The power is positive, both for positive and negative half-cycles, and is equal to $\frac{E_1^2}{R}$ watts.

In Fig. 1 (c) we insert in series a rectifier having perfect characteristics, with the result that no current flows on alternate half-cycles. The result is shown in Fig. 1 (d). As may be seen, the curve representing power now appears only during alternate half-cycles. The manner in which the rectifier is connected is of no importance; if the rectifier of Fig. 1 (c) were reversed the current would flow during the half-cycles of opposite polarity, but the curve representing power would still appear on alternate half-cycles. In Fig. 1 (c) we require to dissipate the same heat in the load as occurred in Fig. 1 (a), and so we increase the r.m.s. voltage provided by the generator to E_2 volts.

The power appearing in Fig. 1 (d) is obviously half of that which would be given if the rectifier were not in

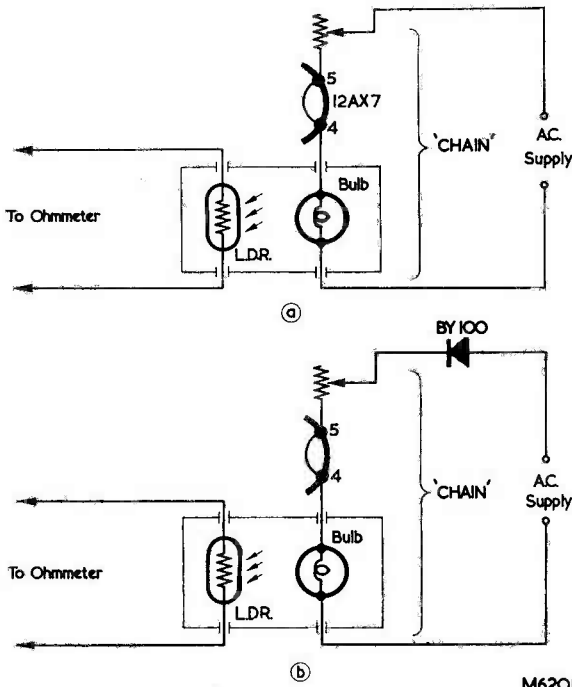

M620b

Fig. 2 (a). The initial experimental circuit
 (b). Adding the silicon rectifier in series with the supply

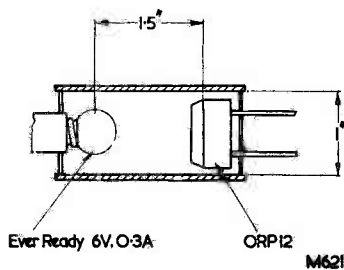

Fig. 3. The bulb-l.d.r. assembly

circuit and the power curve resembled that of Fig. 1 (b). In consequence, the power dissipated in the resistor in the Fig. 1 (c) instance is half of that which would be given without the rectifier, and it is equal to $\frac{1}{2} \times \frac{E_2^2}{R}$

The same heat is dissipated in the load for both the Fig. 1 (a) and Fig. 1 (c) case, with the result that

$$\begin{aligned} \frac{1}{2} \times \frac{E_2^2}{R} &= \frac{E_1^2}{R} \\ \therefore \frac{1}{2} \times E_2^2 &= E_1^2 \\ \therefore E_2^2 &= 2E_1^2 \\ \therefore E_2 &= \sqrt{2}E_1 \\ &= 1.414E_1. \end{aligned}$$

This result tells us that the r.m.s. voltage provided by the generator of Fig. 1 (a) has to be multiplied by 1.414 to give the same heating effect when the series rectifier is introduced. This relationship holds true, regardless of the current drawn by the load.

When calculating heater chain voltages it is a little inconvenient to think in terms of an increase in supply voltage due to the series rectifier. Because of this, it is preferable to state that in Fig. 1 (c) a voltage, which we shall describe here as an "effective" voltage, appears across the load, and that this effective voltage is equal to an r.m.s. voltage providing the same heat dissipation in the load. For E_2 volts across the generator (Fig. 1 (c)) the effective voltage is then equal to E_1 volts (Fig. 1 (a)). Since

$$\begin{aligned} E_2 &= \sqrt{2}E_1 \\ E_1 &= \frac{E_2}{\sqrt{2}} \\ &= 0.707E_2. \end{aligned}$$

Thus, by inserting the series rectifier, an effective voltage appears across the load which is equal to 0.707 times the supply voltage.

This solution may also be arrived at by consulting the literature dealing in detail with half-wave rectifier circuits. The effective voltage given by a perfect half-wave rectifier without reservoir capacitor is 0.5 times peak voltage.* Since peak voltage is 1.414 times r.m.s. voltage, the effective voltage is equal to $0.5 \times 1.414 (=0.707)$ times r.m.s. voltage.

Practical Tests

In order to check that a silicon rectifier would give the anticipated results in practice, several simple experiments were carried out employing a Mullard BY100 rectifier. The theoretical consideration assumes a perfect rectifier and for the present application, the BY100 is not far short of this ideal. Indeed, it exhibits a forward resistance as low as 20Ω at the voltages associated with simple ohmmeter tests.

For the experiments, a measuring instrument was required which would indicate the heating effect of the current flowing through the heater circuit when the rectifier was introduced. A rectifier moving-coil meter cannot be relied on for such measurements because the current is not sinusoidal, and they would best be made with either a thermo-couple instrument or a dynamometer. The writer had neither of these instruments to hand and he employed instead a simple device consisting of a light dependent resistor illuminated by a bulb. The resistance of the l.d.r. was measured for differing direct currents flowing through the bulb, and the results were noted and plotted on a graph. The bulb was inserted into the heater chain, whereupon its illumination would be proportional to the heating effect of the current which flowed through it. This current would then give the

* See, for instance, *Radio Engineering Handbook* (McGraw-Hill), edited by K. Henney, 4th edition, pp. 308-309.

same l.d.r. resistance as a direct current having the same heating effect. As a device which was only required to offer short-term accuracy, this arrangement worked quite satisfactorily. It is described in more detail at the end of this article.

A heater "chain" was made up comprising the bulb just mentioned, the heater of a 12AX7, and a variable resistor. It was assumed that the 12AX7 and bulb in series would drop approximately 16 volts at 150mA, and it was initially intended to connect the chain to the mains in normal manner, as shown in Fig. 2 (a). The mains supply gave a measured voltage of 245, with the result that the variable resistor was required to drop 245 minus 16 (=229) volts at 150mA. The variable resistor was set to 1,530 Ω in consequence, and the mains voltage applied. As was to be expected, an a.c. voltage of 12.6 appeared across the 12AX7 heater (this being measured with a rectifier moving coil meter, which could be considered accurate for sinusoidal a.c.). At the same time, the bulb-l.d.r. assembly indicated a current of 148mA, which was considered sufficiently close to the anticipated current of 150mA to meet all practical requirements.

It was next intended to introduce the BY100 rectifier, as in Fig. 2 (b). This would then result in an effective voltage of $0.707 \times 245 (=173)$ appearing across the chain, whereupon the variable resistor would have to drop 173 minus 16 (=157) volts at 150mA. The resistor was, accordingly, set to 1,050 Ω . When the mains supply was re-applied, the valve heater glowed at normal level, and the bulb-l.d.r. assembly indicated a current of 149mA. It could be stated, in consequence, that the BY100 caused an effective voltage of 0.707 times the applied voltage to appear across the heater chain, as had been anticipated from the theoretical consideration.

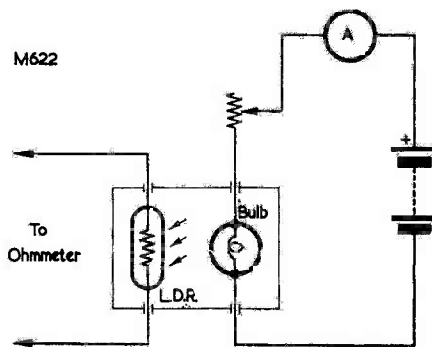

Fig. 4. Calibrating the assembly with direct current

A quick check was then carried out with the rectifier in circuit and the variable resistor reduced to 710Ω. This would correspond to the instance where, incorrectly, it is assumed that the rectifier causes an effective voltage equal to half the applied voltage to appear across the chain. When the mains supply was re-connected the valve heater was visibly over-run, and the bulb-l.d.r. assembly indicated a current around 230mA. Obviously, this method of operation was both incorrect and unsafe.

Calculations

If, in order to reduce heater dropper dissipation, a constructor wishes to employ a silicon rectifier in series with the chain, the requisite procedure is as follows:

1. Determine the mains supply voltage and multiply this by 0.707. This gives the effective voltage appearing after the rectifier.
2. "Add up" the heater voltages for the valves which will appear in the chain, and subtract the total from the effective voltage appearing after the rectifier.
3. The heater dropper resistor must then have a value which causes it to drop the voltage resulting from step 2 at the current drawn by the valves. The power it dissipates will, of course, be the product of this voltage and the current.

As was stated above, it is immaterial which way round the rectifier is connected. Rectifiers equivalent to the BY100 should be capable of operating quite comfortably with heater chains drawing up to 300mA. On no account should a reactive component be connected anywhere in the circuit. If, for instance, a capacitor were connected across the chain it would function as a reservoir and cause an increase in effective voltage. Also, the equipment should not be connected to d.c. mains. In this instance the rectifier could act as a short-circuit and cause the full mains voltage to appear across the chain. The circuit may only be employed with a.c. mains.

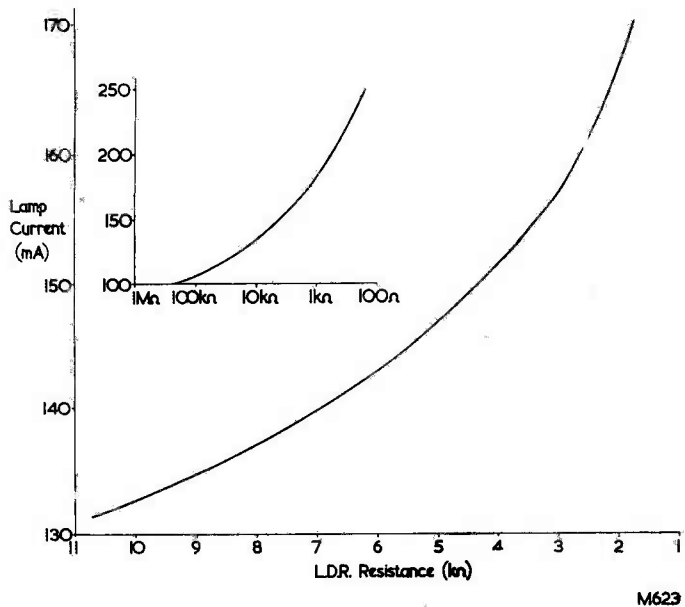

Fig. 5. The current-resistance curves obtained with the writer's assembly

The Bulb-L.D.R. Assembly

The bulb-l.d.r. measuring assembly was made up in the simple manner shown in Fig. 3. In this, the bulb and the l.d.r. were sealed in a light-proof cylinder having an internal diameter of 1in, and the distance between the bulb filament and the front surface of the l.d.r. was 1.5in. It was felt desirable to employ a bulb whose filament exhibited a fair degree of thermal inertia, in order to avoid excessive modulation of its illumination by the alternate half-cycles given when the BY100 was in circuit. An EverReady cycle dynamo bulb rated at 6 volts 0.3 amps was chosen. This type takes an appreciable time to lose its glow when its supply is removed, and a fairly high thermal inertia could then be assumed. The l.d.r. was an ORP12, its resistance being checked by the simple process of connecting an ohmmeter to its terminals.

The bulb-l.d.r. assembly was first connected up in the circuit shown

in Fig. 4, and a graph drawn for bulb current against l.d.r. resistance. The large graph in Fig. 5 shows the results obtained with the writer's assembly over the range 130 to 170mA, whilst the small graph in this diagram shows the curve for 100 to 250mA. It will be noted that, in the large graph, variation in l.d.r. resistance is quite high for small changes in current. When the bulb was connected in the circuits of Figs. 2 (a) and (b), the consequent resistance across the l.d.r. was measured. By using the graph, this resistance then indicated the direct current which would have the same heating effect as that flowing through the bulb.

A device of this nature can, of course, only be expected to have a short-term accuracy. Nevertheless, after the heater chain measurements had been completed, the assembly was re-checked with d.c. at several currents around 150mA; and it was found that no noticeable shift in calibration had taken place.

Three More British TV Cameras For Japan

Nippon Educational Television Co.—a commercial television station in Tokyo—has ordered for its latest studio a further three 4½in image orthicon television cameras from E.M.I. Electronics Ltd. Worth £22,000 the order follows the satisfactory acceptance tests on an E.M.I. 4½in image orthicon channel delivered earlier last year.

Equipment ordered includes a four bay control console with picture and wave form monitors. The cameras will operate on the American F.C.C. 525-line standard.

Featherweight

By THOMAS KAMESTER

EARPHONES

THE STETHOSCOPE-STYLE EARPHONES DESCRIBED IN this article are under one ounce in weight and may be used for all radio purposes in preference to the usual headphones. They are self-clinging, easily slipped on and off, can be worn for long periods without discomfort, and are never in the way of hand or body movements. By instant change of earphone, either a high or low impedance type can be used. If the latter type is connected to a radio, television or tape recorder speaker, the resultant personal listening is pleasurable and can be a real boon for the hard of hearing.*

Construction

Details of the sound box are given in Fig. 1. Part A is made up of four pieces of $\frac{1}{8}$ in Perspex measuring $\frac{3}{4} \times \frac{5}{16}$ in. These are cemented together as shown, the corners then being rounded off. Part B is a sheet of thin celluloid or Perspex $\frac{1}{8}$ in square and is cemented to Part A. Part D is a standard phone earpiece section, the flange with circlip being sawn off. Part C is the same as B but with a central hole to suit D.

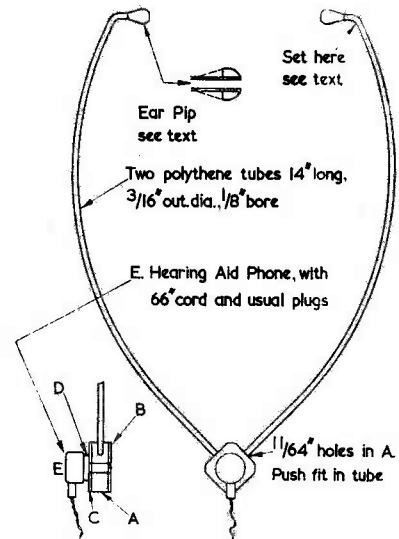
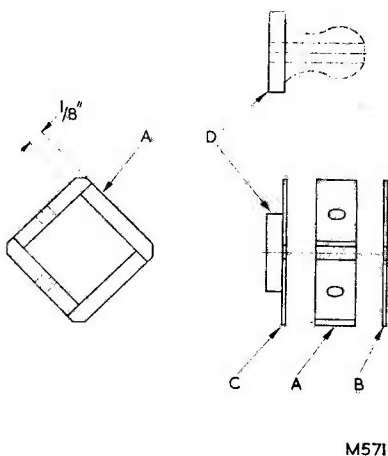

Parts D and C are cemented together, after which C is cemented to A. Corners on B and C are then rounded off.

The final assembly is shown in Fig. 2. The polythene tubing is a standard line available at most component houses. The set at the end of the tubing was produced by carefully holding it over a spirit flame with a short length of pipe-stem cleaner inserted to prevent wall collapse. It is advisable to practice on a spare length of tubing first. The two lengths of tubing are push fit mounted in two holes drilled in Part A of Fig. 1.

The ear-pips were the result of raiding a lady's button-box. Two thin gilt metal spheres about $\frac{7}{16}$ in diameter provided the half-spheres. The tubes were centred in these, and filled with a self-setting plastic resin, fairing this off as illustrated.

A suitable earphone and cord is Type ER100, available from Henry's Radio Ltd., 5 Harrow Road, London, W.2.

* Ensure isolation from the mains supply when running the earphone from live-chassis equipment.—EDITOR.

Mains

Portable Superhet

By V. E. HOLLEY



The receiver described in this article employs a straightforward design and is eminently suitable for construction by the amateur. It should be noted that a non-standard tuning scale and tuning capacitor drive spindle and drum have been employed in the author's prototype, and that these are not specified by make and type number in the Components List. Components of this nature are available from stockists, sometimes as manufacturers surplus, and their choice is left to the individual constructor. They may, alternatively, be made by the constructor himself

THIS IS A COMPACT LIGHTWEIGHT RECEIVER covering the long and medium wave bands. Its sensitivity is such that it will give a good performance in the less favourable reception areas, while superhet selectivity plus the directional properties of the internal aerial make it well able to cope with the congested conditions on the medium wave band both in daylight and in darkness. A 6½in speaker provides a good standard of reproduction.

Aerial Circuit

As shown in Fig. 1, the signal is derived from a ferrite rod aerial, the windings of which are tuned by one section of a two-gang 500pF capacitor and its associated trimmer. Switch S₁ selects the appropriate tuned circuit and connects it to the signal grid of the first valve. This connection is made via the 100pF capacitor C₁, so that a.g.c. voltage can be parallel-fed to the grid and the lower ends of the aerial windings can be returned direct to chassis.

Mixer-Oscillator

This function is performed by a triode-heptode valve, type 12AH8. Minimum bias is provided by the resistor, R₂, this being bypassed in the usual manner. The local oscillator is shunt fed, energy passing back from anode to grid via switch S₃ and the appropriate oscillator coil, the series resistor R₅ limiting the amplitude of oscillation to the optimum value for good conversion conductance on both wave bands. The oscillator circuit is completed with the usual grid leak and capacitor, R₄ and C₆. Signal and oscillator frequencies are combined by the valve and appear at the anode in

amplified form, whereupon the first i.f. transformer selects the difference frequency of 465 kc/s and passes it on for further amplification.

I.F. Stage

Amplification at the intermediate frequency is provided by V₂, this being a high slope, variable-mu valve, type 6BA6. Resistor R₇ provides minimum bias and is bypassed by the capacitor C₁₂. The screen-grid receives its supply through the voltage dropping resistor, R₆. This resistor also supplies the screen-grid of V₁ but, since the two valves work at different frequencies, there is no interaction. The second i.f. transformer is in the anode circuit and passes the amplified signal on to the detector stage. A.G.C. voltage is applied to the grid of V₂ via the secondary winding of the second i.f. transformer.

Detection and A.G.C.

Detection is accomplished by one of the diodes in V₃, a double diode triode, type 6AT6. Resistor R₈ and the potentiometer VR₁ form the load proper, while the two 100pF capacitors bypass to chassis the now unwanted intermediate frequencies. A.G.C. voltage is provided by the second diode which is fed from the primary of I.F.T.₂ through capacitor C₁₃ (the insulation of which, incidentally, should be above suspicion). The signal available at this point is larger than that at the secondary, so that the control voltage is correspondingly greater and more effective. R₁₀ forms the a.g.c. diode load and the filter R₉, C₁₆, removes the audio component before the control voltage is passed to the grids of V₁ and V₂. It will be noticed that as the cathode of V₃ is, for practical purposes, at chassis potential,

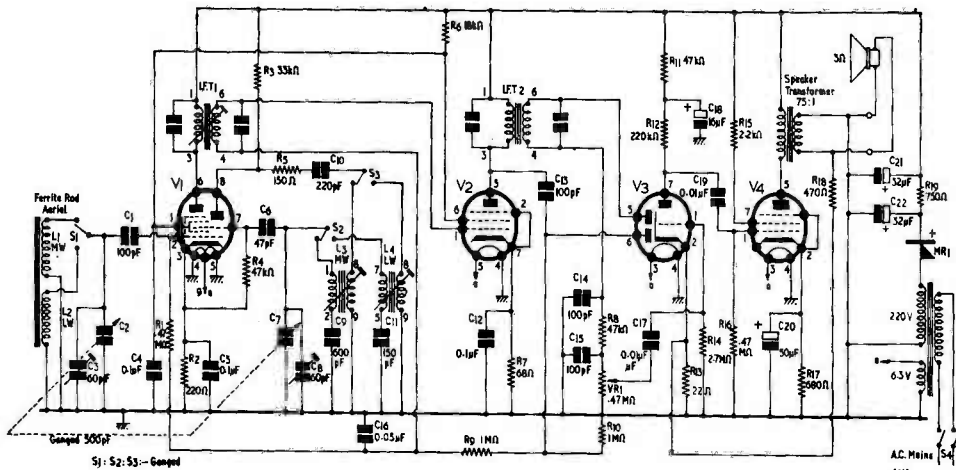

Fig. 1. Circuit of the Mains Portable Superhet

there is virtually no delay voltage in the a.g.c. system. This slightly reduces the sensitivity of the receiver to weak signals but, as a set of this nature would not normally be used for the reception of weak and distant signals, no disadvantage results.¹

A.F. Amplification

The triode section of V_3 is arranged as a resistance coupled amplifier with an anode load of $220k\Omega$, additional smoothing being provided by R_{11} and C_{18} . Bias is arranged by the grid leak method, thus avoiding the need for a bias resistor and electrolytic bypass capacitor. The 22Ω resistor in the cathode circuit is employed solely to provide a point for the injection of negative voltage feedback.

Output Stage

The output stage is the largest consumer of current in any receiver and if the size, weight and cost of the power supply is to be limited, it is necessary to select a valve of modest requirements. The miniature output pentode 6AM5 is very suitable and, in return for an anode current of only 16mA, it provides an output of 1.4 watts which is satisfactory for ordinary domestic listening. The optimum load is $16,000\Omega$ and if, as will usually be the case, a 3Ω speaker is used, the output transformer in the anode circuit must have a ratio of about 75:1. Suitable transformers are readily available under the general description "small pentode". As a rule, the d.c. resistance of the primary windings of such transformers is high enough to produce a noticeable voltage drop at the valve anode, and the $2.2k\Omega$ resistor R_{15} is inserted in the screen-grid supply to ensure that the voltage at this electrode does not exceed that at the anode.

¹ It will be noted that the voltage developed across R_{13} , both d.c. and a.f. via R_{18} , is injected into the signal detector circuit. In practice, this voltage is small and has negligible effect on signal detector operation. No noticeable difference is apparent if VR_1 is returned to the cathode of V_3 instead of to chassis.

The 680Ω resistor R_{17} provides bias, and is bypassed by a $50\mu F$ electrolytic capacitor.

Negative Feedback

A small amount of negative feedback is taken from the output transformer secondary and injected at the cathode of V_3 . This has some effect in improving the overall response of the receiver and removes residual hum; it also makes it possible to dispense with the RC network which would otherwise be required across the output transformer primary to correct the response at the higher frequencies. The amount of feedback can be varied as desired by altering the value of the series resistor R_{18} ; any value between 200 and $1,000\Omega$ may be used.

Power Supply

The use of a double wound mains transformer for the power supply has two substantial advantages. Firstly, it makes the chassis safe to handle at all times and, secondly, it almost completely eliminates mains borne interference which is often troublesome in portable receivers of the a.c./d.c. type. The penalty of increased weight and cost is reduced to a minimum in this receiver by using a miniature transformer. The component specified has a 220V half-wave secondary capable of supplying 45mA and a 6.3V heater winding rated at 2A. A contact cooled metal rectifier is used and smoothing is provided by the two electrolytic capacitors in conjunction with the resistor R_{19} . The mains transformer does not have a tapped primary and if the receiver is to be used on the lower mains voltages (200–220), the smoothing resistor must be replaced by a choke of about 10 henries inductance and a d.c. resistance of 250Ω or so, in order that the h.t. line voltage shall be not less than about 250. Space for this choke is allowed on the chassis.

Components List

Resistors ($\frac{1}{4}$ W 10% tolerance unless otherwise stated)

R ₁	0.47M Ω
R ₂	220 Ω
R ₃	33k Ω 1W
R ₄	47k Ω
R ₅	150 Ω
R ₆	18k Ω 1W
R ₇	68 Ω
R ₈	47k Ω
R ₉	1M Ω
R ₁₀	1M Ω
R ₁₁	47k Ω
R ₁₂	220k Ω
R ₁₃	22 Ω
R ₁₄	2.7M Ω
R ₁₅	2.2k Ω
R ₁₆	0.47M Ω
R ₁₇	680 Ω
R ₁₈	470 Ω (see text)
R ₁₉	750 Ω , 2W (see text)
VR ₁	0.47M Ω log. with two pole on-off switch, S ₄

Capacitors (350V wkg. unless otherwise stated)

C ₁	100pF mica or ceramic
C ₂	} 500pF 2-gang
C ₇	
C ₃	60pF trimmer
C ₄	0.1 μ F paper
C ₅	0.1 μ F paper
C ₆	47pF ceramic
C ₈	60pF trimmer
C ₉	600pF mica, 5% tolerance
C ₁₀	220pF mica or ceramic
C ₁₁	150pF mica, 5% tolerance
C ₁₂	0.1 μ F paper
C ₁₃	100pF mica or ceramic
C ₁₄	100pF mica or ceramic
C ₁₅	100pF mica or ceramic
C ₁₆	0.05 μ F paper
C ₁₇	0.01 μ F paper
C ₁₈	16 μ F electrolytic*
C ₁₉	0.01 μ F paper
C ₂₀	50 μ F electrolytic, 25V working
C ₂₁	32 μ F electrolytic*
C ₂₂	32 μ F electrolytic*

* C₁₈, C₂₁ are combined in a single can with mounting clamp. C₂₂ is wire-ended.

Components

The mains transformer must be a miniature type and it is helpful, though not essential, if the two-gang tuning capacitor is somewhat smaller than standard. Apart from this, standard components are quite satisfactory and the constructor can use whatever may be available. The use of a metal rectifier means that h.t. will appear before the valve cathodes have warmed up, and all the capacitors except those in cathode circuits must therefore be rated for 350V working. The wattage rating for the resistors is given in the components list.

Valves

V ₁	12AH8
V ₂	6BA6
V ₃	6AT6
V ₄	6AM5

Valveholders

1	B9A, with centre spigot
3	B7G, with centre spigot

Transformers

Mains—Secondaries: 220V 45mA, 6.3V 2A (Radio Component Specialists)
Output—"Small pentode", 75:1
I.F.—465 kc/s (Denco type IFT 11/465 are suitable)

Coils

L ₁	} Ferrite rod aerial, type FRA.2 with mounting brackets (Denco)
L ₂	
L ₃	Denco, range 2, red, chassis mounting
L ₄	Denco, range 1, red, chassis mounting

Switch

S ₁ , 2, 3	3-pole, 2-way
S ₄	See VR ₁

Rectifier

Contact cooled, 250V 45mA minimum

Dial Light

6.3V 0.3A

Speaker

6 $\frac{1}{2}$ in, 3 Ω impedance

Miscellaneous

Tuning scale
Tuning drive (drum, drive spindle, cord)

The tuning scale and capacitor are not critical but if the stations are to be received at the points marked on the scale, they must be compatible and the scale must cover the range of the coils as stated by the manufacturer.²

The two 60pF trimmers, C₃ and C₈ serve for both wavebands and should be fitted on top of the tuning capacitor.

Construction

The receiver is constructed upon a chassis of

² See the remarks in the Introduction to this article.—EDITOR.

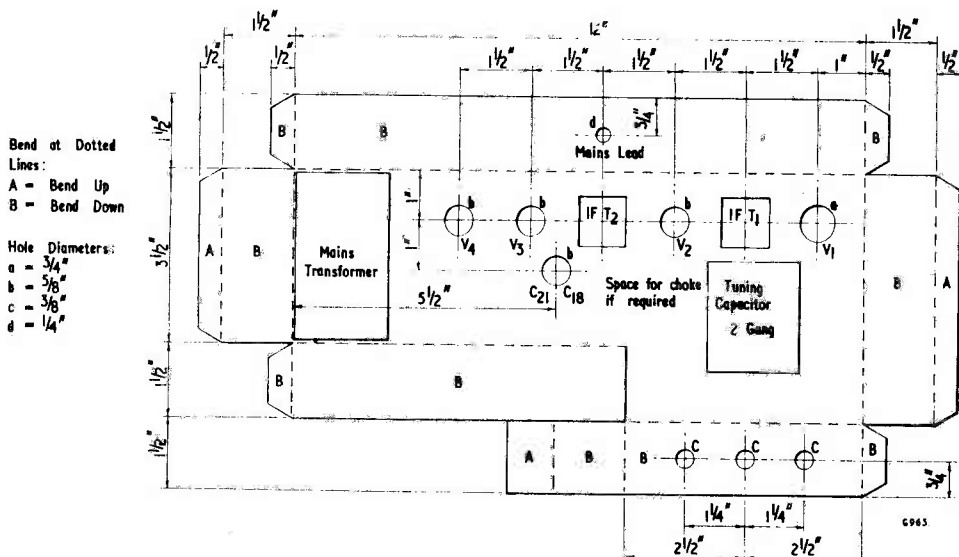
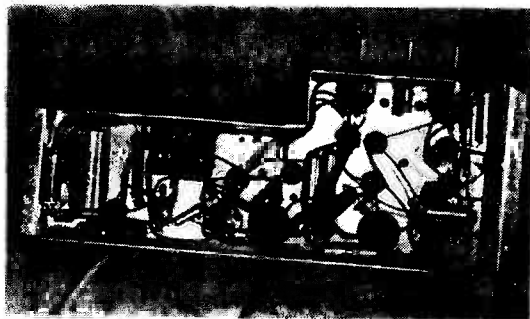

Fig. 2. Plan of chassis showing principal holes. The positions of the remaining holes, for component mounting, grommets, etc., may be judged from Fig. 4. Holes are also required for the tuning drive spindle

18 s.w.g. sheet aluminium, 12 x 5 x 1 1/2 in, as shown in Fig. 2. Over roughly half its length the width of the chassis is reduced to 3 1/2 in so as to provide a space in the cabinet for mounting the 6 1/2 in speaker. This method of construction avoids the need to make an awkwardly shaped cut-out in the deck and front runner of the chassis and, if the bends are made in suitable sequence, fabrication from a single sheet presents no difficulties. A piece of 1/2 in hardboard, 6 x 5 in in which apertures have been cut for the control spindles and the tuning scale, is bolted to the front runner in two places and is supported by a light aluminium bracket in the rear at one end. The board also carries the dial light and the mounting brackets for the ferrite rod aerial. These brackets were thought not sufficiently rigid and the assembly was reinforced in the prototype with a rectangular piece of hardboard secured between them with impact adhesive. The arrangement will be clear from Fig. 3.³

³ The ferrite rod mounting brackets are supplied with the aerial.



Below-chassis view of the receiver

It is convenient to fit the valveholders first, followed by the mains and i.f. transformers and the smoothing and tuning capacitors; then the controls, oscillator coils and ferrite rod aerial. A rough wooden box should then be made in which the chassis can be placed upside down, suspended by the end flanges, whilst the wiring is carried out. Note that holes are required in the chassis for the drive cord to pass up from the tuning spindle to the drive drum and down again.

The specified oscillator coils are a little more than 1 1/2 in high and the spill connections must be bent outwards through 90° before wiring up. Care is necessary in soldering to these spills, as the heat quickly softens the polystyrene formers so that the spills become loose.

The i.f. transformers used in the prototype are conventional litz wound components, and have similar characteristics to those of the Denco type IFT11/465.

Wiring

Fig. 4 shows the connections the the approximate positions of all the components below the chassis. The wiring has been opened out for clarity, with the result that some of the connections seem rather long; in construction they should be kept to minimum length. The gain of V₂ is high and the grid and anode connections, though short, must be screened to ensure stability. For the same reason, the lead from the signal grid (pin 2) of V₁ passes through the chassis immediately it leaves the grid, C₁ being fitted on top of the chassis. Apart from this, the construction and arrangement of the components is not at all critical. Flexible p.v.c. covered wire is recommended for the heaters and 22 s.w.g. tinned copper for the remainder of the

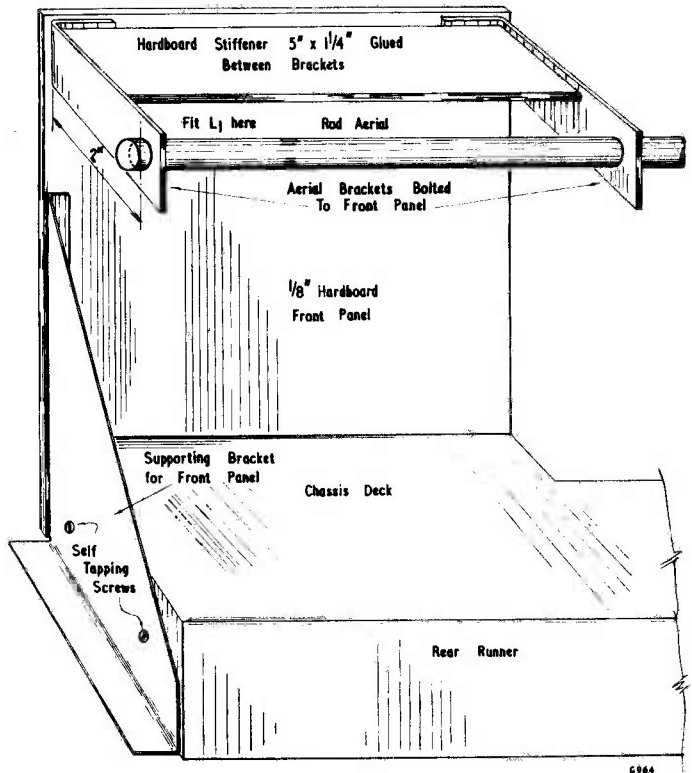

Fig. 3. Details of the aerial mounting

wiring, lengths of more than an inch or so being covered with Systoflex. The connection between the resistor R_{18} and the secondary of the output transformer should not be made till the testing stage is reached.

Testing

When the wiring has been completed and checked with Fig. 4, a meter switched to a high ohms range should be applied between C_{22} and chassis to see there there are no short-circuits in the h.t. wiring. The flow of meter current into the smoothing capacitors will cause the meter to indicate a low resistance at first, increasing slowly to a megohm or so as the capacitors become charged. Power can then be applied and a further check made with the meter that voltage is present at the valve electrodes. The h.t. rail voltage should also be measured; it should be $250 \pm 15V$ and, if not, it must be brought within this range by altering the value of the resistor R_{19} . The exact value required will depend on the output of the transformer-rectifier combination employed and on the mains supply voltage. If a choke has been used instead of R_{19} , it is unlikely that any alteration will be required unless the receiver is to be used on the higher mains voltages, in which case it may be necessary to insert a resistor in series with the choke.

The resistor R_{18} can now be connected to the

output transformer secondary. If instability results, the connections to either the primary or secondary of the transformer should be reversed to make the feedback negative.

I.F. Alignment

Unless pre-tuned i.f. transformers have been used, a signal generator will be required for alignment. Inject at the grid of V_1 a signal of 465 kc/s and adjust the cores of the i.f. transformers for maximum response as indicated by an output meter or a high resistance d.c. voltmeter connected across

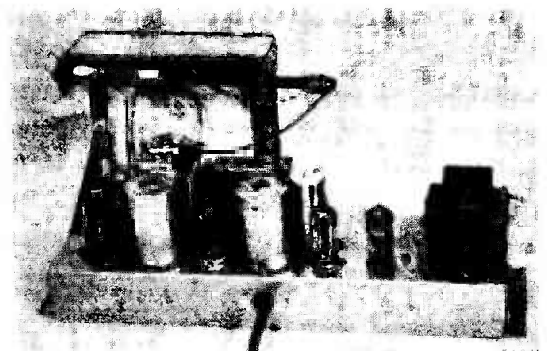

Above-chassis view of the receiver

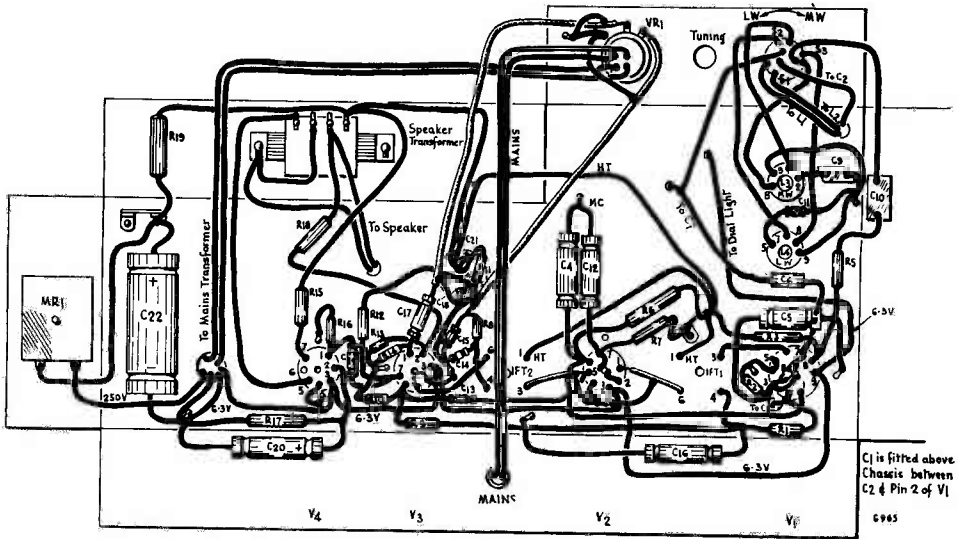

Fig. 4. Under-chassis wiring

VR₁. If neither of these instruments is available, use a modulated signal and adjust for maximum sound output from the loudspeaker. The signal from the generator should be kept to the minimum needed for adequate response and should be reduced as the circuits come into line.

Signal and Oscillator Circuits

As the padder capacitors are of fixed value, alignment of the signal and oscillator circuits is simple and straightforward. Commencing with the medium waveband, set the aerial coil, L₁, half an inch from the end of the ferrite rod and, with the tuning capacitor at minimum value, inject a signal of 1,545 kc/s. A suitable method of injection is to bring the output lead from the generator into close proximity with the aerial but without any connection to it. Tune for maximum response with the trimmers C₃ and C₈. Fully close the tuning capacitor, inject a signal of 515 kc/s and adjust the core of L₃ and the position of L₁ upon the rod for maximum response. Repeat both adjustments two or three times. The coverage is now correct and it remains to track the oscillator near each end of the range.

Inject a signal of 1,450 kc/s and by manipulating the tuning capacitor and the trimmer C₈, find the combination of settings for maximum output; note the scale position carefully (Point A). Returning to the other end of the band, inject a signal at 575 kc/s and again find the optimum combination by manipulating the tuning capacitor and the core of L₃. Note the scale reading (point B). Repeat the adjustments at points A and B till no further improvement can be obtained, finishing off with C₈ at point A. When this position has been reached, the coil L₁ should be secured in position on the ferrite rod with a little beeswax or similar material. Care is necessary during alignment to see that L₁ does not move about and it is a good idea to wedge

it lightly in position with a piece of paper inserted between rod and former.

Turning now to the long wave band, close the tuning capacitor fully, inject a signal of 175 kc/s and adjust the core of L₄ and the position of L₂ upon the ferrite rod for maximum response. Check the adjustments by tuning in the Light Programme on 200 kc/s and finally seal L₂ in position. Do not make any alterations to the trimmers C₃ and C₈.

Alignment Without a Generator

If a generator is not available, pre-tuned i.f. transformers must be used. They will require little attention and the constructor will be able to proceed with alignment of the signal and oscillator circuits as already described, using identifiable programme transmissions instead of generator signals. It will not be possible to check the coverage exactly but it is usually possible to find transmissions at each end of the band from which a reasonable approximation can be made. When the circuits have been satisfactorily aligned, the Light programme on 200 kc/s should be tuned in very accurately and the cores of the i.f. transformers peaked for maximum signal. Only small adjustments will be needed to compensate for differences in circuit stray capacitances.

Whatever the method of alignment, a meter always gives a more accurate indication of peak response that can be obtained by ear and it should therefore be used if available. Also, final adjustments should always be carried out with a low-level signal.

Cabinet

The professional looking cabinet shown in the illustration can be made from $\frac{3}{8}$ in plywood having an oak, walnut, etc., facing. No special skill is required. The sides are each $7\frac{1}{2}$ x $5\frac{1}{2}$ in and must have rebates formed on the unfaced surfaces at top

and bottom, $\frac{1}{4}$ in deep and very slightly more than $\frac{3}{8}$ in wide, into which the top and bottom, each $13\frac{3}{4} \times 5\frac{1}{2}$ in can be fitted. In the absence of more specialised tools, these rebates can be produced very satisfactorily by first making a $\frac{1}{4}$ in deep cut with a tenon saw and then splitting off the unwanted layers of ply with a chisel. Finish off with glass paper. Time and effort spent on really accurate cutting of the four pieces of wood to size and the formation of the rebates is well repaid and saves a lot of hard work with glasspaper later on. A fifth piece of $\frac{3}{8}$ in plywood, approximately $6\frac{1}{2}$ in square and which need not be faced, is required for mounting the speaker, and a circular aperture $5\frac{1}{2}$ in in diameter must be made in the centre of it. If a coping saw is not to hand, this aperture may be cut with a hacksaw blade held in a pad handle after first making a hole about 1 in in diameter on the circumference with a brace and bit. The sawn edge need not be sanded smooth—it is sufficient to remove splinters, etc.

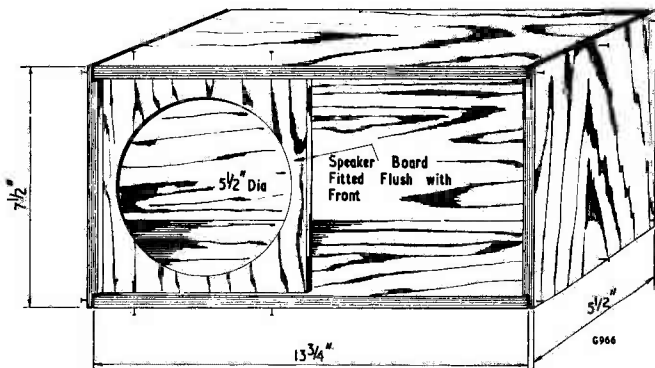
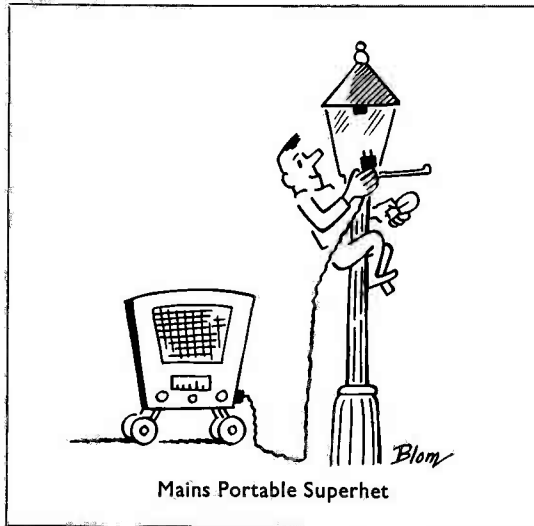

Fig. 5. Construction of the cabinet

Assembly

Now make a trial assembly of the top, bottom and sides as in Fig. 5, using $\frac{3}{4}$ in panel pins driven halfway home at each corner, and trim the speaker mounting board till it is a neat sliding fit into the rectangle thus formed. When a satisfactory fit has been obtained, mark the joints for identification, dismantle, coat the mating surfaces with glue and

reassemble, driving the panel pins right home and punching the heads slightly below the surface. A small wire nail with the point sawn off makes a good punch for this last operation. Rapid and accurate reassembly after the application of glue will be facilitated if the panel pins driven through the sides are placed in position with their points projecting slightly through the wood so that they

Fig. 6. Front of cabinet. Inset—cross section of moulded surround

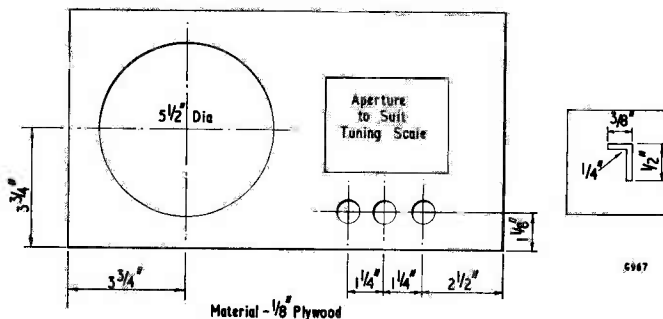

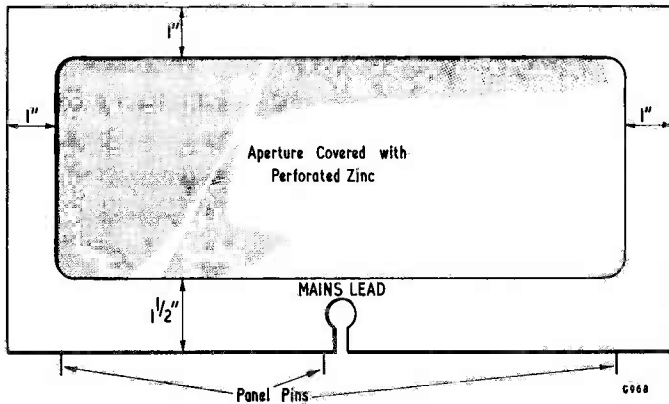

Fig. 7. Back of cabinet

locate easily the holes in the top and bottom into which they were previously driven.

A piece of $\frac{3}{8}$ in ply, 14 x $7\frac{1}{2}$ in in which apertures have been cut as in Fig. 6, must now be fitted, with panel pins and glue, to the front of the cabinet. The size, shape and position of the tuning scale aperture will of course need to be varied to suit the scale and the height of the tuning capacitor spindle above the chassis.

Finishing

The indentations above the heads of the panel pins and any other blemishes should be filled with plastic wood of the colour in which the cabinet is to be finished. When the plastic wood is hard, the top and sides should be given a good rub down with No. 2 glasspaper, removing any old polish, projections at the corners, etc. Finish off with No. 0 paper and make sure that no blemishes or scratches remain. Wood dye of the desired colour can now be applied. Amateur french polish is best for the final finish and is not difficult to apply if the manufacturer's instructions are followed. Alternatively, quite a good result can be obtained by applying clear varnish, particularly if oak faced ply has been used. About three coats will be needed with a light rub down between each.

When this has been done, cover the front completely with Tygan, using an impact adhesive to secure it. It is not necessary to apply adhesive all over the ply but particular attention should be paid to the edges of the apertures. When dry, make two diagonal cuts, corner to corner, through the Tygan over the scale aperture, fold the material back through the aperture and secure it with adhesive to the rear of the ply. The control openings can be treated in the same way, making a number of radial cuts from the centre of each, with a sharp knife. A piece of $\frac{3}{8}$ in clear Perspex can now be fitted into the scale aperture. Cut it a little larger than required and trim it down carefully till it is a tight push fit into the opening. Adhesive can be used to secure it if necessary but if the fit is good it will not be required.

The next operation is to fit with impact adhesive a picture frame moulding around the front. This material is available in a wide variety of shapes and sizes and can be selected according to individual preference; the only functional requirement is that it should be wide enough to cover the edge of the $\frac{3}{8}$ in plywood. A cross section of that used on the prototype is given in Fig. 6. The moulding can be stained and polished or varnished in the same way as the cabinet, although the most attractive appearance is perhaps achieved by having it several shades lighter in colour. Four small rubber buffers should be fitted to the bottom of the cabinet to raise it about $\frac{3}{8}$ in so that the moulding at the bottom will be clear of any surface on which the receiver may stand.

Fitting the Receiver

Cut the control spindles to the required length and place the receiver in position in the cabinet. Drill upwards, through the bottom and through the flanges at the ends of the chassis, holes of $\frac{3}{8}$ in diameter, one at each end. Enlarge and countersink the holes in the wood only. Wood screws of suitable size can now be inserted through the bottom and into the holes in the aluminium, where they will have a self-tapping action and will secure the receiver very firmly.

If use is made of the directional properties of the internal aerial, the back of the cabinet will at times be in view and the treatment here should be such that, at least, it does not offend the eye. A back panel of $\frac{3}{8}$ in plywood trimmed to size and having the centre portion removed as in Fig. 7 is a neat solution, the aperture being covered on the inside with perforated zinc secured with impact adhesive. Insert two or three panel pins into the bottom edge so that they project about $\frac{3}{8}$ in and file the heads to sharp points which can be pressed into the bottom of the cabinet. At the top, the panel can be secured with wood screws into two small fillets glued into the top corners of the cabinet. A little wood dye applied to the back panel and the rear edges of the cabinet will complete a professional looking job.

News and Comment . . .

There were some photographs in *The Times*, recently, showing an application of radio and radar techniques which was new to us. Apparently large areas of vineyards in Georgia U.S.S.R. used to be destroyed by hailstorms. Now this is much rarer because there is an anti-hail service which first tracks clouds by radar, then despatches helicopters carrying rockets to appropriate launching sites, and after launching, the rockets fire lead iodide into the clouds turning hail into rain.

Ceramic Rod Generates Electricity

A simple ceramic rod which spontaneously generates electricity has been developed by engineers at the Martin Marietta Corporation's Nuclear Division near Baltimore, Maryland.

Working under contract with the U.S. Atomic Energy Commission, the Martin researchers have combined two forms of the element strontium into a one-piece thermoelectric generator which serves as its own heat source.

The small strontium titanate rod has radioactive strontium-90 concentrated at one end. This spontaneously produces heat, which is converted to electrical energy through the thermoelectric effect in the strontium titanate.

Power output of the experimental rod is a fraction of a watt.

I.E.E. Membership Reaches 50,000

The Institution of Electrical Engineers started in 1871 with 70 founder members and was then known as the Society of Telegraph Engineers. Its membership grew rapidly and by 1900 there were 3,660 members. At the beginning of the Second World War the figure was approaching 20,000, and in the ensuing 20 years, due mainly to the striking advances in technological developments, the membership more than doubled.

Now the Council of the I.E.E. has admitted their "50,000th member", Mr. William R. Matthews, a student, who was formally congratulated by the President, Mr. C. T. Mellings, at a recent meeting.

Mr. Matthews, 23, comes from Saltash, Cornwall, and is in his final Dip. Tech. year at Northampton College of Advanced Technology in London, where he is taking a "Sandwich" course in telecommunication engineering, concentrating on microwave aerials. He is sponsored by the G.P.O. Engineering Department and hopes eventually to work on satellite communication projects like *Telstar*.

New U.S. Radio Telescope

A gigantic radio telescope with a dish-shaped antenna 300 feet in diameter is collecting data on the moon-ringed planet Jupiter. Built at a cost of \$1 million, the radio telescope has collected more information in one day than smaller instruments do in a month.

It is located at the National Radio Astronomy Observatory of the National Science Foundation at Green Bank, West Virginia.

The new Green Bank instrument—completed in September—is called a "Transit" telescope and the dish moves only in a north-south direction. In operation it is pointed at a specific "radio source" such as Jupiter, and the rotation of the earth carries the source through the telescope's beam. The telescope remains still. During this "transit", generally a matter of a minute or so, radio emissions are automatically recorded on paper charts and the data are punched at high speed on to tapes and fed into a computer for analysis. Astronomers expect to get more precise information on the Van Allen type radiation belts surrounding Jupiter, its magnetic field, and its 12 moons.

Colour Television

The chairman of Electric & Musical Industries Ltd., Sir Joseph Lockwood, had some interesting things to say about colour television in his Annual Review to shareholders. The relevant section was as follows:

"I mentioned last year the problems of colour television and my conviction that more research and experiment are needed before we can finally decide on a method of colour transmission which will give complete satisfaction.

"During the past year these questions have been actively pursued in our Research Laboratories, and the results of our work—together with those reported from other laboratories—have strengthened our convictions on this point. We believe that the N.T.S.C. system now used in the United States needs to be modified in order to further the development of colour cameras and receivers. As a result of our investigations, we have put forward proposals in the scientific Press which we believe would enable improved pictures to be obtained both in colour and compatible monochrome and would hold out the prospect of further development in the future.

The Government White Paper of July 1962, which endorsed the view of the Pilkington Committee that colour television should be introduced at an early date, has brought these technical questions to the fore.

We advocate that these problems should be seriously considered by the broadcasting authorities, that no hasty decisions should be taken, but that adequate funds should be made available for experimental testing of some of the ideas now being put forward. Only in this way can we hope to avoid the very high cost and dislocation which would ensue if we are forced to change the system after a public service is in operation."

Award

At the recent International Radio Communications Exhibition, K.W. Electronics Ltd., with their new K.W.77 triple conversion amateur bands communications receiver, were awarded the silver plaque for the most interesting piece of new commercial equipment for the amateur.

It may be remembered that our report of the exhibition spoke very highly of the above receiver.

International Ham Hop Club

We wish, very briefly, to commend the above organisation to our readers who are radio amateurs.

The club has three categories of membership: Full, subscription 10s. p.a.; Associate, subscription 5s. p.a.; and Honorary. Members receive a quarterly newsletter. Full members must offer overnight hospitality to visiting members twice a year, as a maximum. Associate members are expected to invite radio amateurs to visit their stations.

The aims of the organisation are to provide friendly contacts with others who have a common interest in radio, while travelling on holiday, and to provide an insight into the life of the people in the district being visited in a way not possible to a person staying at a hotel, and at the same time effecting a considerable saving in expenses.

There is a "Code of Ethics": be adaptable; consider other people's time being used on your behalf; be one of the family; show appreciation; use common sense.

If you are one of our many radio amateur readers why not write for further details to the Honorary Secretary, G. Partridge, G3CED, 17 Ethel Road, Broadstairs, Kent.

We only wish that radio amateurs could be referred to by some other appellation than "ham", but "alliteration's artful aid" will, no doubt, ensure that the organisation does not change its title.

By
C. MORGAN

Detector for Nuclear and Rocket Firings

This article, which is aimed strictly at the experimenter only, introduces a fascinating new project. The unit described is a conventional a.f. amplifier coupled to a tuned frame aerial, and its function is purely that of picking up any radiations which may occur at very low frequencies, so that these may be studied by the user

ALTHOUGH RADIO AND TELEVISION HAVE NOT lost their popularity as forms of entertainment, it is usual, in that certain group of people who were vaccinated with electrons instead of the usual phial of liquid, to be continually on the search for experiments with something different. The present trend to higher and higher frequencies seems to be losing its popularity. This is possibly because of the high cost of the very specialised gear involved.

On the other hand, the Very Low Frequency band is not dead; there are quite a number of stations still using these frequencies and one of the most interesting points is that the receiving gear required calls for no special talent or crafty circuitry.

reading the press release announcing the results of a rocket or atomic test.

Also, the next day's weather can be examined electrically. Thunderstorms many miles away can be heard approaching hours before they are in evidence and, if the gear is coupled to a pen recorder, it is a simple matter of examination to determine and identify the various pulses.

Radio waves generated during a missile launching are the result of the violent motion of charged particles in the high velocity exhaust of the rocket motor. There is also a discharge path between the earth and the atmosphere given by the vertical column of intensely ionised gases which is left

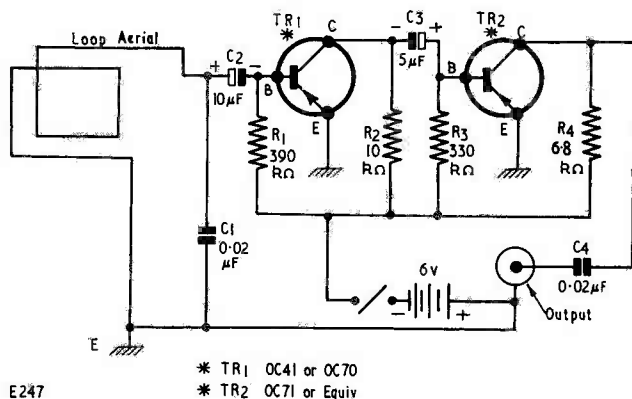
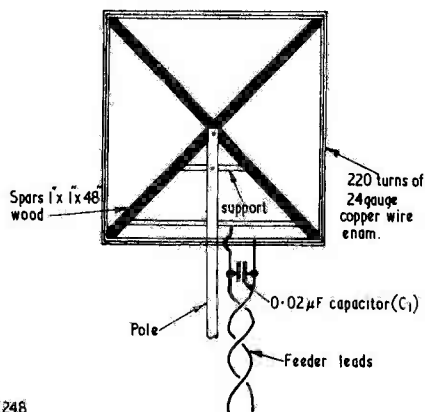

Fig. 1. The circuit of the detector. The output is coupled to an a.f. amplifier

The circuit shown in Fig. 1 requires two transistors, four capacitors, a few resistors, and the ability to differentiate between a thunderstorm, a missile, an atomic explosion, and the upper atmosphere's dawn chorus. This may sound, at first, more than the average radio man can manage but with a little explanation and some very interesting experimenting with an oscilloscope or tape recorder, or even with phones, this confusion can be simply reduced, and the results checked afterwards by

behind the missile as it climbs upwards. This column acts as a very effective aerial at low frequencies. The effect of an atomic explosion, on or above the ground, bears a similar relation to that given by a missile.

It is an established fact that v.l.f. signals can travel great distances without excessive attenuation. With the present circuit, numerous thunderstorms can be heard quite comfortably at a distance of hundreds of miles. These add to the QRM on the



E248

Fig. 2. Construction of the aerial frame and winding

phones but, on the oscilloscope, they can be clearly observed as peaks of rising amplitude according to the distance and energy created. A missile, however, produces a much different shape on the oscilloscope, the apex being sharper and very pronounced. Also, the duration is longer, and there is only one peak to observe.

We are unfortunate in this country in that the first stage power firings from America or Russia cannot be recorded. However, as the rocket ascends and fires second stage, it is at a sufficient height for the vertical column of ionised gas to radiate enough energy to be recorded in the U.K. This also applies to the final stages.

At second stage firings the noise will occur as bursts and not random static. These will be observed on the oscilloscope as vertical traces. On final firing the rising peak of the trace will show up very cleanly, the difference between this and static being very remarked. Once one has been fortunate enough to observe these signals they are readily identifiable when encountered later.

Before using the detector described here in trying to analyse the signals heard and observed, it is best to determine and eliminate mains hum. The detector will readily track mains hum and, as the frequency is easily recognisable, no trouble should be experienced from that direction.

A method of finding the bandpass of the detector consists of using an audio frequency generator coupled into the aerial circuit, together with a suitable oscilloscope on the output end. These will give an indication as to the performance of the circuit.

Construction of the Aerial

The aerial is made in loop form, and is mounted so that it can be rotated by hand. In the writer's shack the aerial is fitted just outside the window, and is rotated by a loop of stout cord wound over a pole upon which the framework is fitted. The

aerial framework consists of two spars, 1 x 1 x 48in, these being crossed at the centre at 90 degrees and lightly bound together to keep them in place while the windings are put on.

On the four ends of the spars are glued four $\frac{1}{4} \times \frac{1}{2} \times 2$ in pieces of timber, one to each end. These take the aerial winding, which consists of 220 turns of 24 s.w.g. enamelled copper wire. However, the gauge is not critical. The ends of the aerial should be terminated on to a connecting block, and across these two ends is soldered a 0.02 μ F capacitor. When completed, the whole of the windings and the frame should be given a coating of shellac varnish. When winding on the aerial turns put the wooden frame in a vice first; this will ensure that if a turn is dropped it will be observed in time. If both the wire and the frame are held in the hand when a turn is dropped off the frame, then many more turns will be dropped before the original is recovered.

The leads from the aerial to the receiver can be of any length, as this is not critical. A point to

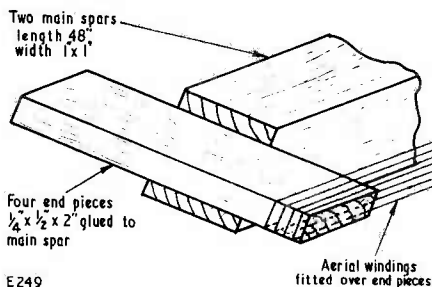

E249

Fig. 3. Showing how the end pieces are fitted to the frame aerial spars

watch is that these leads should not run near mains wiring, since this will result in hum pick-up and add to the QRM. At v.l.f. the feeder length is of no great importance, so the wires can even be fed along the ground.

Circuit Description

The "loop aerial" tunes between 4 and 5 kc/s with the 0.02 μ F capacitor in circuit. The impedance of this tuned circuit is greater than the input impedance of TR₁. This is a deliberate mismatch to load the aerial and thereby broaden its response to cover the portion of the v.l.f. band selected to receive these transmissions. TR₂ is the final amplifier stage. The unit, when completed, is plugged into any high impedance amplifier or recorder. In the prototype the detector was plugged into a recorder which was also connected to an oscilloscope. The results were then recorded on to tape, and later played back, notes being made as to the results obtained.



The seventeenth in a series of articles which, starting from first principles, describes the basic theory and practice of radio

part 17

understanding radio

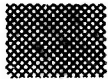

By W. G. MORLEY

IN LAST MONTH'S contribution to this series we examined the effect of connecting an a.c. generator to an inductor, and saw that the current which flowed lagged by 90° on the voltage across the inductor. We then introduced vectors and, with these, investigated the impedance given by a resistor and an inductor connected in series. We shall now carry on to investigate the impedance offered by a resistor and a capacitor in series.

Resistance and Capacitance

In Fig. 99 (a) we have an a.c. generator connected to a capacitor having a value of C farads in series with a resistor of R ohms. A voltage equal to E_C appears across the capacitor and a voltage of E_R across the resistor, and we wish primarily to find the relationship between these two voltages and that provided by the generator.

We undertook a similar project last month with a resistor and an inductor, and the present exercise is carried out in very much the same manner.

Obviously, only one current (I) flows in the circuit, and we may represent this in direction by line OW of Fig. 99 (b). The voltage across the resistor is in phase with the current and so we may draw its vector, OX, in the same direction as OW. Also, we shall give it the length E_R , which is the voltage appearing across the resistor. This voltage is equal to IR.

The voltage across a capacitor lags on the current by 90° and so its vector has to be drawn at 90° to OW. As we saw in Fig. 97 (c),¹ the vector of a lagging quantity is, by convention, shown as being clockwise of the reference vector. In Fig. 99 (b) vector OY is 90° clockwise of OW and therefore meets both the requirements just mentioned. We give it the dimension $E_C (=IX_C)$.

As with the resistor and the inductor, we may now complete the parallelogram about the two voltage vectors, obtaining the resultant vector OZ, whose length is proportional to the voltage appearing across the a.c. generator, and which we designate here as E_{TOTAL} . The length of XZ is equal to OY so, from Pythagoras, we have

$$(E_{TOTAL})^2 = E_R^2 + E_C^2$$

$$\text{therefore } E_{TOTAL} = \sqrt{E_R^2 + E_C^2}$$

We see, also, that the angle of lag is less than 90°. This angle may be found by drawing the vector diagram and measuring it with a protractor, or we may express it as a trigonometrical ratio.²

We next take the step of stating that the combination of resistor and capacitor offers an impedance, Z, and that E_{TOTAL} is equal to ZI. Since I is the same for the resistor, the capacitor, and their series combination, we can divide E_R , E_C and E_{TOTAL} by this common quantity; whereupon the lengths of our three vectors can now be presented as being proportional to R, X_C , and Z respectively, as in Fig. 99 (c). From this diagram we see that³

$$Z = \sqrt{R^2 + X_C^2}$$

The steps involved in arriving at the diagram of Fig. 99 (c) are the same as were needed to arrive at the similar vector diagram given by a resistor and inductor in series, and which we considered last month. The major difference is that, where we previously had the vector for inductive reactance leading by 90° on the reference vector (whereupon it was shown anticlockwise of the reference vector), we now have a vector for capacitive reactance which lags by 90° on the reference vector (whereupon it is shown clockwise of the reference vector).

² Whereupon the tangent of the angle of lag is $\frac{E_C}{E_R}$.

³ We may also see that the tangent of the angle of lag is $\frac{X_C}{R}$.

¹ Published in last month's issue.

Resistance, Inductance and Capacitance

We must next turn our attention to series circuits containing resistance, inductance and capacitance. Such a circuit is illustrated in Fig. 100 (a) wherein an a.c. generator connects to a resistor of R ohms, an inductor of L henrys and a capacitor of C farads, all of which are in series. We assume that potentials of E_R , E_L and E_C volts appear across the resistor, inductor and capacitor respectively.

Once more, we may employ vector diagrams to find the total voltage across the combination. The same current must flow through all three components and so we start off, as before, by drawing reference vector OP to indicate the direction of current. See Fig. 100 (b). Since the voltage across the resistor is in phase with the current which flows through it, we can next add vector OQ , which points in the same direction as OP . We give vector OQ a length which is proportional to $E_R (=IR)$.

The voltage across the inductor leads on the current, so we next draw vector OR to represent this voltage, and we position it 90° anticlockwise of OQ . It has a length proportional to $E_L (=IX_L)$. At the same time the voltage across the capacitor lags on the current, so we draw a third vector, OS , to represent this voltage. It is positioned 90° clockwise of OQ and it has a length proportional to $E_C (=IX_C)$.

Fig. 100 (b) shows us the three vectors representing the voltages across the inductor, the capacitor and the resistor, but it does not immediately present any method of finding the resultant vector. An intermediate step is necessary. For this step we must refer back to last month's article, in which vectors were introduced by employing them as a means for finding the actual ground speed and direction of an aircraft when its air-speed and the direction in which it points are known. If the aircraft, with an air-speed of 100 m.p.h., flies directly into an opposing wind having a speed of 50 m.p.h., the aircraft direction remains unaltered, and its ground speed drops to 50 m.p.h. We deduced from this that, when two vector quantities are opposed to each other in direction, the resultant is equal to their difference, and points in the same direction as the larger vector.

We have exactly this condition in Fig. 100 (b), in which vector OR points in the opposite direction to OS . Also, in this diagram OR happens to be larger than OS . We can in consequence resolve these two opposing vectors into the single vector OT of Fig. 100 (c). OT is equal to OR minus OS and its points in the same direction as did OR .

We are now in a position to find the resultant vector. All we need to do is to complete the parallelogram $OTUQ$ as in Fig. 100 (d), whereupon the diagonal from O to U gives us the dimension of the voltage across the generator (which is designated as E_{TOTAL}).

In Figs. 100 (b), (c) and (d) it is assumed that OR is larger than OS , or that, in other words, the voltage across the inductor is greater than the voltage across the capacitor. However, it is just as possible for the voltage across the capacitor to be larger than that across the inductor, whereupon we

can obtain a vector diagram similar to that shown in Fig. 100 (e). To obtain the resultant vector, we have to subtract vector OR from vector OS (because OS is now the larger) and we obtain the final diagram shown in Fig. 100 (f). In this, vector OT represents OS minus OR , and the resultant vector OU represents the total voltage across the generator.

It will be noted that, in Fig. 100 (d), where the voltage across the inductor is greater than that

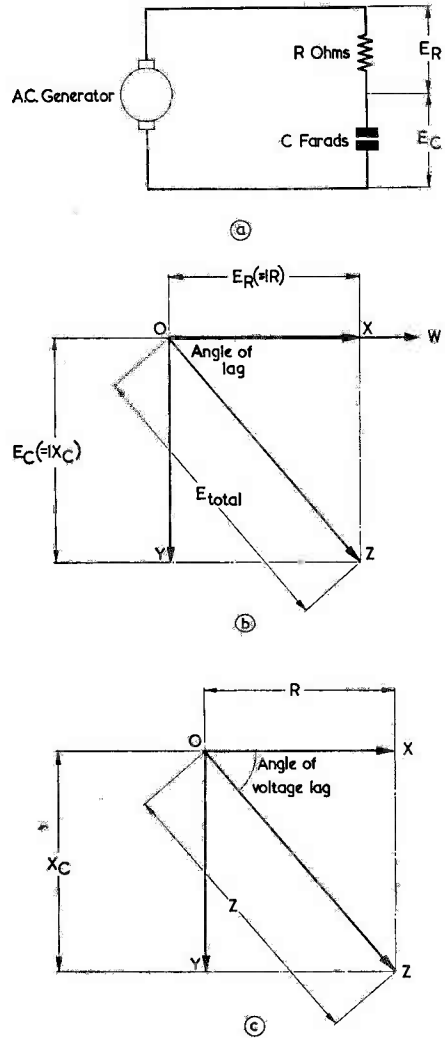

M624

Fig. 99 (a). An a.c. generator connected to a resistor and capacitor in series
 (b). The vector diagram corresponding to the circuit of (a). Vector OZ represents the voltage across the generator
 (c). Since the same current flows through the resistor, the capacitor, and their series combination, the vectors of (b) may be re-dimensioned in terms of resistance, reactance and overall impedance

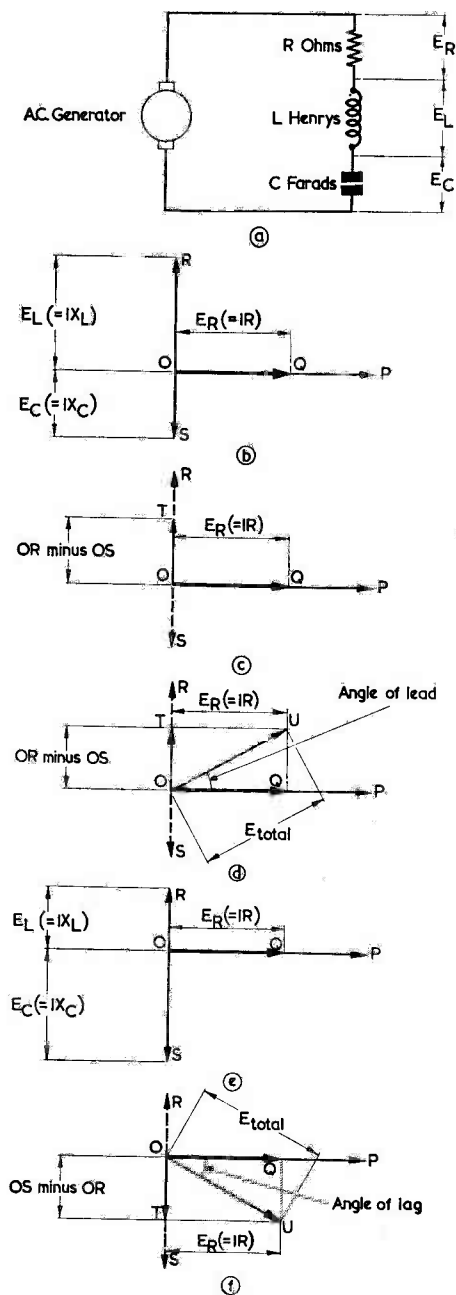

Fig. 100 (a). An a.c. generator connected to a resistor, an inductor, and a capacitor in series
 (b). The voltages in (a) expressed as vectors
 (c). The opposing vectors OR and OS of (b) may be resolved into the single vector OT
 (d). Obtaining the resultant vector from OT and OQ (e). In this instance OS is larger than OR
 (f). Again, OS and OR resolve into the single vector OT, enabling the resultant vector to be found.

across the capacitor, the resultant voltage leads on the current. Indeed, the vector diagram illustrates the point (which is true in practice) that the circuit really behaves as though it contained inductance and resistance only. In Fig. 100 (f), wherein the voltage across the capacitor is greater than that across the inductor, the resultant voltage lags on the current. This time the circuit behaves as though it contained capacitance and resistance only.

With previous vector diagrams for components in series we have shown that, because the same current flows through the circuit, the length of each vector is proportional to the resistance or reactance of the individual components, and that the resultant vector is proportional to their overall impedance. Exactly the same process may be carried out with the diagrams of Figs. 100 (d) and (f) by re-dimensioning them as in Figs. 101 (a) and (b). We see once more, then, that the circuit behaves as if it is composed of inductance and resistance (Fig. 101 (a)) when the inductive reactance is greater than the capacitive reactance, and that it behaves as though it were composed of capacitance and resistance (Fig. 101 (b)) when the capacitive reactance is greater than the inductive reactance. Also, the effective inductive reactance of the Fig. 101 (a) diagram is lower than the inductive reactance possessed by the actual inductor, and the effective capacitive reactance of the Fig. 101 (b) diagram is lower than the capacitive reactance possessed by the actual capacitor.

The Series Resonant Circuit

In the vector diagrams of Figs. 101 (a) and (b) we assumed that either the reactance of the inductor or the reactance of the capacitor in the Fig. 100 (a) circuit was greater than the other, and we drew the vectors which represented these quantities with corresponding lengths. We shall now carry on to the very important instance in which the inductive reactance is *equal* to the capacitive reactance.

This state of affairs is depicted in Fig. 102 (a) in which vector OR represents the resistance of the resistor, OR the reactance of the inductor and OS the reactance of the capacitor. Apart from the fact that OR is equal in length to OS, the diagram of Fig. 102 (a) is the same as Fig. 101 (a) or Fig. 101 (b) without the resultant vectors.

Since vector OR is equal to vector OS and the two vectors point in opposite directions, they *completely cancel each other out*. The resultant vector is that shown in Fig. 102 (b), and it is exactly the same as the original vector which represented resistance. *In other words if, in a circuit containing inductance, capacitance and resistance in series, the inductive reactance is equal to the capacitive reactance, the overall effect is that offered by the resistance on its own.*

A second important point is that, under this condition, the circuit offers least opposition to the flow of electric current. If either inductive reactance or capacitive reactance becomes greater, the vector diagram reverts to that shown in Fig. 101 (a) or in Fig. 101 (b). In both these diagrams the resultant

impedance is obviously greater than the resistance. It is only in Fig. 102 (b) that we obtain minimum opposition to current flow, and in this instance opposition is provided by the resistance only.

Now, we know⁴ that the reactance of an inductor is equal to $2\pi fL$, and that the reactance of a capacitor

is equal to $\frac{1}{2\pi fC}$, where f is frequency in cycles per

second, L is inductance in henrys and C is capacitance in farads. These expressions tell us that the reactance of an inductor increases with frequency increase, and that the reactance of a capacitor decreases with frequency increase. It follows from this that, by varying the frequency of the a.c. generator of Fig. 100 (a), we can cause opposing changes in the inductive and capacitive reactances in the series circuit. If, at a particular frequency, the inductive reactance is greater than the capacitive reactance we can, by reducing the frequency, cause

⁴ From "Understanding Radio" Parts 15 and 16 (November issue and last month's issue).

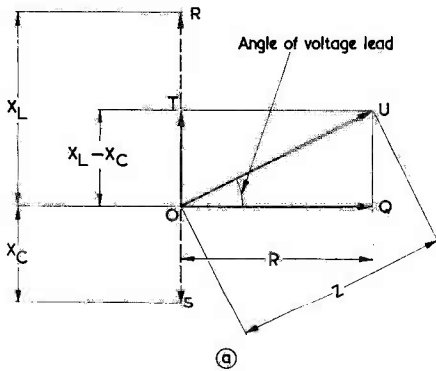

M626

Fig. 101 (a). The vector diagram of Fig. 100 (d) may be re-dimensioned in terms of resistance, reactance and overall impedance, as shown here
(b). A similar re-dimensioning may occur for Fig. 100 (f)

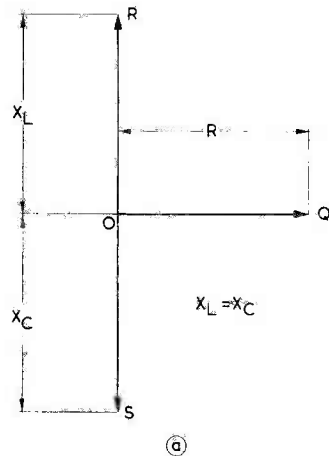

(a)

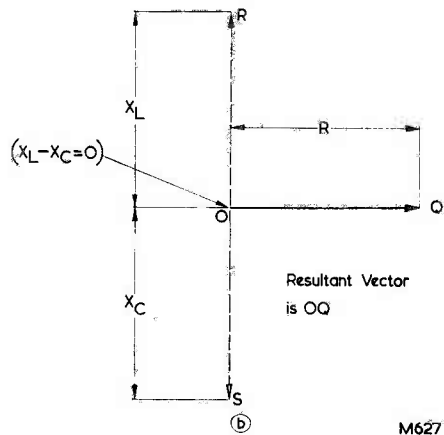

(b)

M627

Fig. 102 (a). The case where inductive reactance is equal to capacitive reactance
(b). The resultant vector for (a) is the same as that for the resistance

both the capacitive reactance to rise and the inductive reactance to fall. In consequence we must eventually arrive at a frequency where the capacitive reactance and the inductive reactance become equal, whereupon the opposition to current flow will be given by resistance only, as in Fig. 102 (b). If we further lower the frequency, the capacitive reactance will become greater than the inductive reactance. Therefore, too high a frequency gives us the effect of Fig. 101 (a) and too low a frequency gives us the effect of Fig. 101 (b). At the one frequency which causes capacitive and inductive reactances to be equal, we get the effect of Fig. 102 (b).

This last frequency is known as the *resonant frequency* of the series circuit, and can be defined as that frequency which causes the circuit to offer minimum opposition to current flow. If we express the resonant frequency as f_r , then $2\pi f_r L$ (the reactance of the inductor) must be equal to $\frac{1}{2\pi f_r C}$ (the

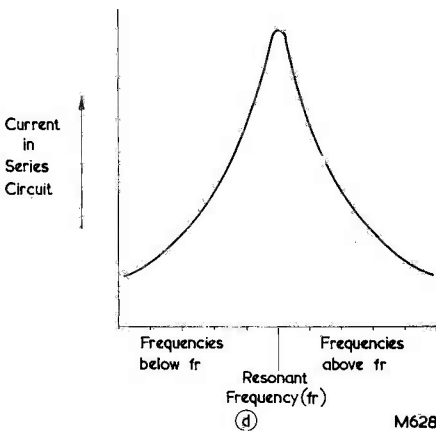
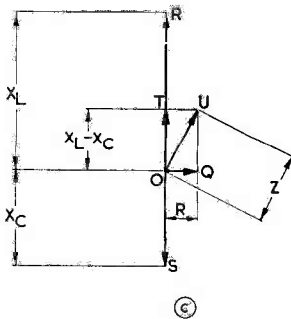
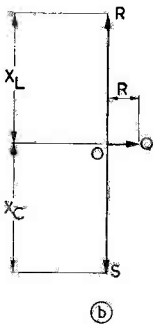
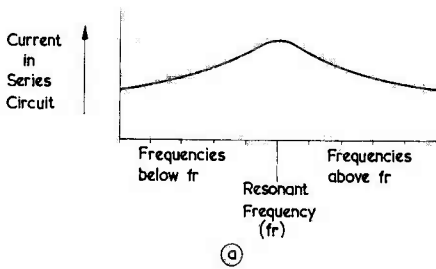

reactance of the capacitor). This relationship enables us to obtain an equation for the resonant frequency in terms of L and C.

$$\text{Since } 2\pi f_r L = \frac{1}{2\pi f_r C}$$

$$\text{Then } f_r^2 = \frac{1}{2\pi L \times 2\pi C}$$

$$= \frac{1}{(2\pi)^2 \times LC}$$

$$\text{Therefore } f_r = \frac{1}{2\pi \sqrt{LC}}$$

This equation gives the resonant frequency of a series resonant circuit, where f_r is the resonant frequency in cycles per second, L is the inductance in henrys, and C is the capacitance in farads.

Response Curves

The series circuit containing inductance, capacitance and resistance offers minimum opposition to current flow at the resonant frequency, as shown at Fig. 102 (b). However, if we compare Fig. 102 (b) with the non-resonant conditions of Fig. 101 (a) or 101 (b), we may see that the resultant impedances in the last two cases are not *very* much greater than the resistance in Fig. 102 (b). Nevertheless, the resonant effect is still quite noticeable, and could be reproduced as shown in the graph of Fig. 103 (a). This graph illustrates the increase in current which flows through the series circuit (assuming constant voltage from the generator) for various frequencies. At resonant frequency the current is, of course, at its greatest.

We have assumed rather a large value of resistance in our vector diagrams up to now, and it would be of interest to see what happens if we reduce this, as we do in Fig. 103 (b). In this diagram, the vectors representing inductive and capacitive reactance are much larger than OQ, which represents the resistance. In Fig. 103 (c) we make the inductive reactance slightly larger than the capacitive reactance, giving us the resultant impedance vector shown. It is at once apparent that the resultant impedance of Fig. 103 (c) is considerably larger than the resistance vector, and that we have achieved this effect purely by reducing the resistance relative to the inductive and capacitive reactances. A similar result to that shown in Fig. 103 (c) would be given if we were to make the capacitive reactance slightly larger than the inductive reactance.

Fig. 103 (a). A typical response curve for a series resonant circuit having a large amount of resistance
 (b). Vector diagram for a series resonant circuit having a low value of resistance
 (c). When a low value of resistance is present, small differences in inductive and capacitive reactances result in impedances which are much larger than the resistance
 (d). A typical response curve for a resonant circuit having a low value of resistance. Frequency units may be assumed as being the same as for (a)

If we draw the frequency-current graph corresponding to the reduced-resistance instance we would now get that shown in Fig. 103 (d). This is much more pronounced in its effect than that of Fig. 103 (a), and we have achieved this result merely by reducing the value of R.

The graphs shown in Figs. 103 (a) and (d) are described as *response curves*, and they illustrate the "response" of the series resonant circuit over a range of frequencies on either side of that at which it is resonant. The terms *broad* and *sharp* are employed in a comparative sense to define the shape of a response curve. The curve of Fig. 103 (d) would be described as being *sharper* than that of Fig. 103 (a).

Magnification Factor—Q

It is normally desirable, in radio work, for series resonant circuits to have sharp response curves. As we have seen, these may be produced by reducing the value of the resistance. In practice, a physical resistor would not be employed at all, whereupon it can be assumed (at this stage) that the resistance in the circuit would be provided by the unavoidable resistance in the wire of the inductor itself. This resistance may be represented as a physical resistor in series with the inductor, whereupon we are back, once more, to the basic circuit of Fig. 100 (a). It will be apparent that, if we are to attain very sharp response curves, we have to design our inductor such that it offers a very low resistance to the circuit.

In Fig. 103 (b) the two vector lines depicting inductive and capacitive reactance are much longer than that depicting resistance. Since the same current flows through the resistance, inductance and capacitance, we may reverse the process we have carried out with previous vector diagrams and re-dimension the vector lines of Fig. 103 (b) in terms of the voltages across the individual components, as we do in Fig. 104. It will be at once apparent that the voltages across the inductor and the capacitor are much greater than that across the resistor. These higher voltages appear in practice at the resonant frequency but, since they are equal in magnitude and are out of phase with each other, they cancel out so far as any effect outside the series combination of components is concerned. The voltage across the resistor is, then, that which appears across the outside terminals of the series combination.

The ratio between the voltage across either the inductor or the capacitor and that applied to the series resonant circuit (which is the same voltage as that across the resistor) is usually known as the *magnification factor* for the circuit. This is numerically equal to $\frac{E_L}{E_R}$ or $\frac{E_C}{E_R}$. It is also equal, as may

be seen by comparing Figs. 104 and 103 (b), to $\frac{X_L}{R}$ or $\frac{X_C}{R}$ and the latter expressions define the

quality factor, or Q, of the resonant circuit. Since the response curves we have already seen (in Figs.

103 (a) and (d)) become sharper when R is reduced in comparison with X_L or X_C , it follows that they will similarly become sharper if Q is increased. Thus, a circuit with high Q provides a sharper response curve than one with a lower Q.

Several paragraphs above, it was stated that it could be assumed at this stage that the resistance in the resonant circuit was almost entirely provided by the unavoidable resistance of the wire in the inductor. In practice, this assumption is only partly accurate and it must be pointed out that practical inductors present effective resistances which *add* to the resistance in the wire with which they are wound. For the time being we shall refer, loosely,

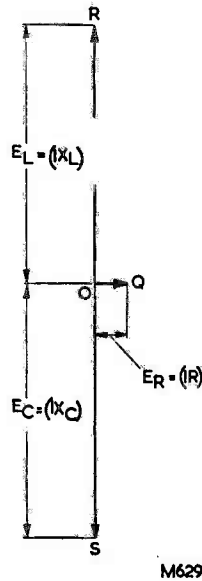

Fig. 104. Re-dimensioning the vector diagram of Fig. 103 (b) in terms of voltage. The voltages across the inductor and the capacitor are much larger than that across the resistor

to these additional effective resistances as "losses", and we shall deal with them in detail later. If the circuit in which an inductor is employed is required to have a high Q, the inductor is designed to have low "losses" as well as low resistance.

The capacitor in a practical resonant circuit at frequencies up to 50 Mc/s or so offers very small resistance or "losses".⁵ In consequence, the Q of the circuit depends almost entirely upon the design of the inductor.⁶

L/C Ratio

We have seen that the response curve of a resonant circuit becomes sharper when R is reduced. If R

⁵ Provided that a capacitor type suitable for the resonant frequency is employed.

⁶ Frequently, an inductor may be described as having a quality factor, or Q. The Q figure given in this case will be very slightly higher than the Q of a resonant circuit in which the inductor is employed. This is because the latter takes into account the small "losses" given by the capacitor.

remains constant, the response curve will similarly become sharper if X_L or X_C is increased. X_L may be increased by increasing the value of the inductance and X_C by decreasing the value of the capacitance. Thus, for a given resonant frequency, and assuming constant resistance, the response curve of a resonant circuit may be made sharper by increasing its inductance and reducing its capacitance. Because of this, the ratio between inductance and capacitance in a resonant circuit can provide a rough indication

of the sharpness of its response curve. In most cases, a circuit having a high L/C ratio can be assumed to have a sharper response curve than a generally similar circuit having a low L/C ratio.

We shall return to the question of L/C ratio in more detail in a later article in this series.

Next Month

In next month's issue, we shall examine the parallel resonant circuit.

CAN ANYONE HELP?

Requests for information are inserted in this feature free of charge, subject to space being available. Users of this service undertake to acknowledge all letters, etc., received and to reimburse all reasonable expenses incurred by correspondents. Circuits, manuals, service sheets, etc., lent by readers must be returned in good condition within a reasonable period of time

VCR514 CRT.—W. J. Niall, 36 Windsor Avenue, Coleraine, Co. Derry, N. Ireland, requires any information on this tube and a suitable circuit for an oscilloscope.

* * *

National HRO Receiver.—W. R. Young, Giggleswick School, Settle, Yorks, would like to obtain a circuit for this receiver.

* * *

MCR1 Receiver.—4260715 J/T Abbott, J.A.T.C.C. (R.A.F. Element), Paya Lebar Airport, Singapore 19, is in need of any information, circuit, etc., and any conversions applicable to this receiver.

* * *

PCR2 Communication Receiver.—A. Thomson, 109 Hyndland Road, Glasgow, W.2, wishes to obtain circuit diagram and any technical information on this receiver—including the addition of a b.f.o. circuit.

* * *

Mixer Unit Type 79.—R. H. Martin, 5 Chapel View, South Croydon, Surrey, would like any information, circuit, etc., on this unit. (Marked Ref. No. 10D/18317.)

* * *

R1155 Receiver.—A. Dixon, 1 Garfit Road, Kirby Muxloe, Leics, requires information on converting the 200–75 kc/s frequency coverage to that of 3 to 1.5 Mc/s.

* * *

Transmitter/Receiver RT-10/APS-3.—R. K. Lloyd, P.O. Box 1164, Lusaka, North Rhodesia, Central Africa, would like to receive any information on this receiver—especially in relation to working instruction and voltages.

* * *

R206 Mk. II Receiver.—D. Smith, 56 Lansdowne Road, Stanmore, Middx, wishes to obtain the service manual or circuit for this receiver.

PCR2 Communication Receiver.—R. I. Kressman, 72 Harford Drive, Watford, Herts, would like to purchase or borrow the manual for this receiver.

* * *

Oscilloscope.—A. W. Wakefield, 33 Waverley Gardens, Stamford, Lincs, would be very pleased to hear from any reader who has constructed or designed a fully transistorised oscilloscope. (So would we.—*Editor.*)

* * *

Oscilloscope No. 11, AA Predictor MkI.—G. Powell, Weald Rise, Litmarsh, Marden, Herefords, wishes to obtain the manual, on loan, for this equipment.

* * *

Ferguson 201 Radio.—G. Pearson, c/o Cook, 16 Seafield Road, Dundee, would like to purchase or hire the service sheet for this receiver. Would also like to contact any radio amateur or enthusiast in the Dundee area and to correspond with constructors in the U.K.

* * *

Sandown D120 Receiver.—J. R. Paterson, 22 Majda Avenue, London, E.4, would like to obtain the circuit of this receiver which was manufactured by Masteradio Ltd.

* * *

Indicator Unit Type 62.—L. Elliott, Strode's School, Egham, Surrey, wishes to obtain some information, circuit diagrams and/or conversion data for this unit.

* * *

Philips Receiver.—J. A. Gearing, The Swallows, Hammond Road, Hatfield Broad Oak, Nr. Bishops Stortford, Herts, has obtained this receiver, type No. L2G77B-01. The design is that of a 4-valve portable (67V h.t. and 1.5V l.t.) the set being numbered BA63510. Can any reader supply a circuit diagram?

Simple 3-TRANSISTOR RECEIVER

by
G. JEFFRIES

THE TRANSISTOR RECEIVER DESCRIBED IN THIS article is easy to construct, is cheap, and gives very acceptable results on the medium wave-band. In Manchester the local B.B.C. Home Service and the medium wave Light Programme are received at good strengths, as also are Luxembourg, A.F.N., many Continental stations, and the amateur

"Top Band". Also received loud and clear are weather broadcasts from Shannon Airport.

The set is completely portable with its own ferrite frame aerial, and it employs three transistors operated from a 9 volt battery. All components may be purchased very easily. The aerial is, however, home-made.

Components List

Resistors. (All $\frac{1}{4}$ watt)

- R₁ 1M Ω
- R₂ 3.9k Ω
- R₃ 3.9k Ω
- R₄ 1k Ω
- R₅ 4.7k Ω
- R₆ 24k Ω
- R₇ 100 Ω
- R₈ 5.6k Ω

Capacitors

- C₁ 500pF variable, solid dielectric
- C₂ 500pF variable, solid dielectric
- C₃ 1,000pF
- C₄ 1,000pF
- C₅ 0.01 μ F
- C₆ 8 μ F, 12 w.v. electrolytic
- C₇ 100 μ F, 12 w.v. electrolytic
- C₈ 100 μ F, 6 w.v. electrolytic
- C₉ 0.1 μ F

Semiconductors

- TR₁ OC44
- TR₂ GET114
- TR₃ GET114
- D₁ OA81
- D₂ OA81

Battery

- 9 volt. (Size to suit available space in cabinet)

Inductors

- L₁ Ferrite frame aerial (see text)
- L₂ R.F. choke, 2.5mH (Elpico)
- T₁ Speaker transformer, 15 : 1 (Repanco type TT5)

Speaker

- 3 Ω , 4in round

Switch

- S₁ On/off, toggle

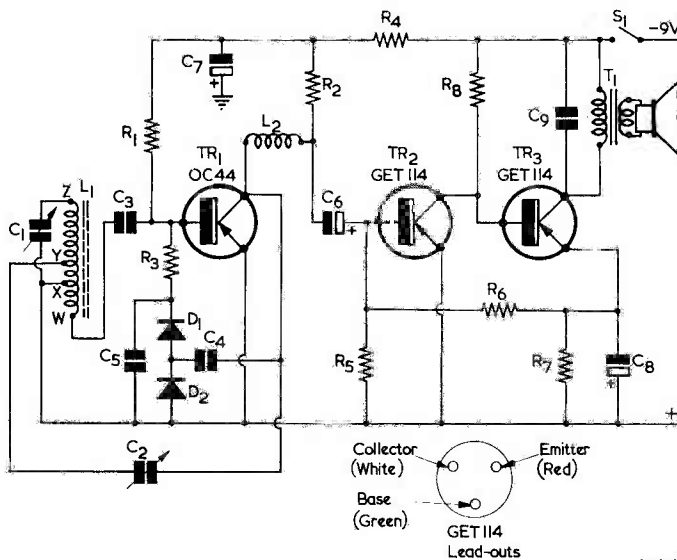

Fig. 1. Circuit of the 3-transistor receiver

M616

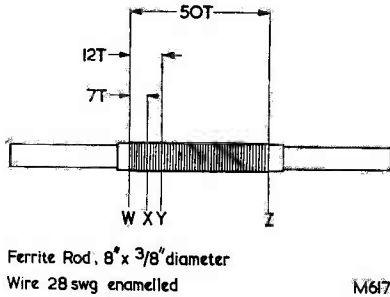

Fig. 2. The ferrite frame aerial

The Circuit

The circuit of the receiver appears in Fig. 1, and in this the r.f. transistor TR_1 functions as a reflexed r.f. and a.f. amplifier with regeneration. The ferrite frame is tuned by C_1 and is coupled via C_3 to the base of TR_1 . The amplified r.f. on the collector of this transistor is fed to the voltage doubling detector provided by D_1 and D_2 , the detected a.f. being returned to the base of TR_1 via R_3 . The output from the detector contains a d.c. component which is proportional to signal strength, and which tends to reduce the base bias. In consequence, the circuit provides a degree of a.g.c., and it prevents oscillation at high signal levels.

A regeneration circuit is obtained by coupling the collector of TR_1 back to the ferrite frame via the variable capacitor C_2 .

The a.f. output from TR_1 is coupled to TR_2 via C_6 . TR_2 and TR_3 are employed in a direct coupled circuit, this allowing an a.f. amplifier of good performance to be built with a minimum of components. A high level of gain is achieved.

The Ferrite Frame

The aerial coil consists of 50 turns of 28 s.w.g. enamelled wire wound on a paper former fitted to a ferrite rod 8in long and 3/8in in diameter. Taps are made at 7 and 12 turns, as shown in Fig. 2.

The Groupboard

All components, with the exception of C_2 , S_1 and

Fig. 3. The components and wiring on the groupboard

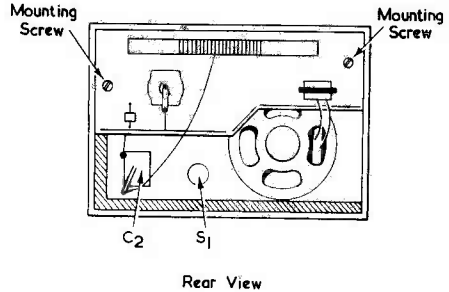
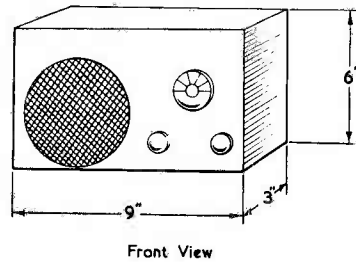
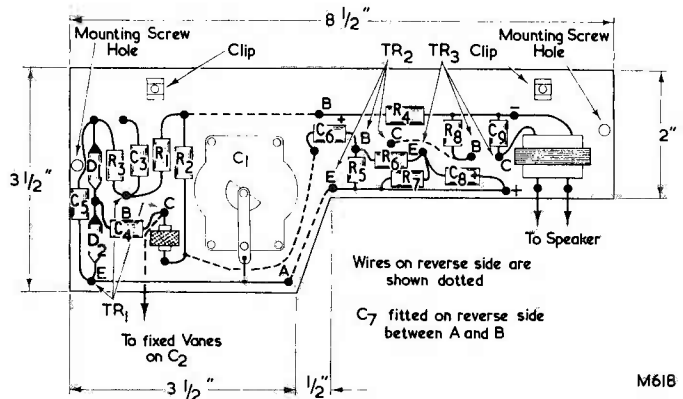

Fig. 4. A suitable cabinet for the receiver

the speaker are fitted to the groupboard shown in Fig. 3. This is 8 1/2in long, 2in wide at one end and 3 1/2in wide at the other, the shape employed permitting a compact assembly in the cabinet. Two Terry clips are provided for securing the ferrite rod.

Interconnections between the groupboard, the ferrite frame, and the remaining components not shown in Fig. 3 are as follows:

- (1) Positive connection (+) to battery positive.
- (2) Negative connection (-) to battery negative.
- (3) Ferrite frame "W" to C_3 .
- (4) Ferrite frame "X" to moving vanes of C_1 .
Ferrite frame "Y" to moving vanes of C_2 .
Ferrite frame "Z" to fixed vanes of C_1 .

The Cabinet

A suitable cabinet is shown in Fig. 4. This has approximate dimensions of 9 x 6 x 3 1/2in, and a 4in

diameter round hole is cut in the left hand side of the front panel to accommodate the speaker. Fitted to the inside of the cabinet are two pieces of $\frac{1}{2} \times 1$ in beading 3 in long. These are glued to the front and side panels at the top, and take the mounting screws for the groupboard.

As will be seen, capacitor C_2 and switch S_1 are fitted to the front panel of the cabinet, being wired into circuit after the groupboard has been fitted.

Since individual speakers may differ in size, and as the material employed for constructing the

cabinet may vary according to the individual constructor's taste, it will be necessary to design the cabinet so that it takes the components employed whilst retaining a symmetrical control layout.

Operation

The receiver should function satisfactorily after it has been completed, and it should be remembered that the ferrite frame has directional properties. The regeneration control also, of course, controls volume.

IN YOUR WORKSHOP



After having exchanged their New Year greetings, Dick and Smithy find themselves, on January the First in the pleasant position of having nothing to do. They don't waste the opportunity, however, and they devote their time to examining the latest batch of hints from readers.

"I MUST SAY," COMMENTED DICK, "that 1963 seems to be quite a good year."

"Dash it all," protested Smithy the Serviceman, "you've only seen nine hours of it up to now!"

Dick settled himself more comfortably on his stool.

"I don't care," he replied. "I saw a wee bit of it last night after midnight and it looked excellent then. Nothing's happened since to make me change my opinion!"

Smithy leaned back against his bench with a relaxed expression on his face.

"I wouldn't disagree," he commented. "I, also, saw the New Year in last night, and I had the distinct impression of an atmosphere of enhanced prosperity. There's also the fact that there will be some quite interesting and exciting things to come during the next twelve months.

We shall, for instance, see the hardening of set-maker's design policies on 405-625 line TV receivers. With a bit of luck, we may even see the start of regular 625 line programmes in the London area before the year is finished."

"I thought they weren't due to start until early 1964," said Dick.

"They aren't," replied Smithy. "But you never know with these things."

Hints From Readers

"There's one thing you'll miss in 1963," said Dick.

"What's that?"

"Your crafty trip up to the Smoke," Dick replied promptly.

"You haven't got the excuse of a Radio Show this year, you know."

Smithy frowned.

"I am quite certain that your overheated imagination," he complained,

"continually imputes the most frightful things to me whenever I leave this neighbourhood. As I've said before, my visits to London during the Radio Show are completely innocent and innocuous, and I devote myself entirely to electronic matters."

"That's what *you* say!"

"In any case," sighed Smithy, wearily giving up the battle, "there may still be a London trade show of some sort instead of the Radio Exhibition."

"And I bet," said Dick triumphantly, "that you'll be off to it as fast as British Railways can carry you. Pick up a few leaflets to say you've been, and the rest of the time down Soho!"

"Another thing that will occur in 1963," said Smithy, changing the subject abruptly, "is an increasing public interest in colour television. Now that we've settled for 625 lines

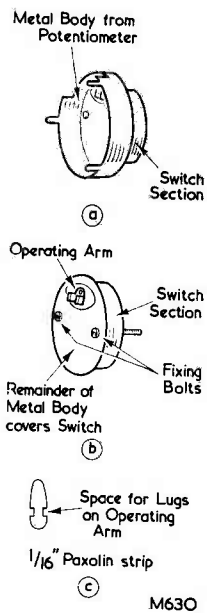

Fig. 1 (a). The metal body and switch section removed from a discarded potentiometer
 (b). The body is cut back to the switch section, as shown here
 (c). A Paxolin strip is fitted to the operating arm lugs, whereupon the assembly provides a useful miniature switch at negligible cost

“Here’s a nice one to start off with. This hint describes a simple method of fabricating miniature on-off switches. Most volume controls, when they are discarded, still have a switch which is perfectly good for further use. What you first do is to remove the metal cover from the control (Fig. 1 (a)), after which you cut away the upstanding metal, leaving the switch section covered on its inside. (Fig. 1 (b).) The metal and the switch moulding are normally held together by rivets or eyelets, and it’s a very simple job to remove these and replace them by nuts and bolts. The bolts can then project out on whichever side of the assembly you please, and the projections can be employed for mounting purposes. The final touch is to add a small Paxolin strip cut to fit into the operating arm lugs of the

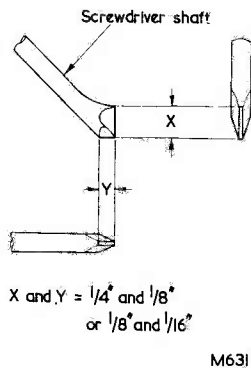

Fig. 2. Two screwdrivers for the price of one. Three views of the modified screwdriver blade are shown here, and it is intended for starting “difficult” screws

“has to do with small screws and bolts which seize up or are difficult to start for any other reason. A useful tool for these can be made from an old screwdriver which should, preferably, be large and have a strong blade. The tip is ground to a V-shape (Fig. 2) to give what are, in effect, two screwdriver blades at an angle to the shaft. According to the size of the bolt head, you apply to its slot either the large or the small section of the modified screwdriver, whereupon the fact that you are working at an angle gives you additional leverage. A screwdriver of this type should be capable of starting the most obstinate of screws and can be especially useful when they are countersunk.”

Smithy paused for a moment. “The third hint from this reader,” he continued, “should be of particular value to the experimenter or constructor who has a large selection of transistors of varying makes and sources. Not all transistors have their lead-out wires appearing in the ‘emitter-base-collector’ order and, in some anonymous surplus types, the identifying spot may even be against the emitter instead of the collector. These variations can be very confusing and may lead to transistors being connected into a circuit incorrectly, whereupon they may still pass a signal at reduced efficiency despite the wrong connection. The cure is to cut the leads of all transistors where confusion may occur, the collector lead being left longest, the emitter shortest, and the base in between. (Fig. 3.) If a screening connection is incorporated this is cut shorter than the emitter. With this scheme it is a very quick process to connect any transistor in stock to a tester, because incorrect

in this country, there’s no technical hold-up on colour development at all.”

Dick groaned.

“There’s always something,” he complained. “Anyway, I suppose I’d better get down to my first job for the New Year.”

“There’s nothing to do,” grinned Smithy. “We’ve cleared out all the sets that are in for repair and, until some more come in, we’ve got nothing to do but just sit down and natter.”

Dick’s expression brightened considerably.

“I knew this was going to be a good year,” he said happily. “If we’ve got some time to spare, how about having a session on readers’ hints? We haven’t had one for quite some time, you know.”

“That’s an excellent idea,” said Smithy, opening a drawer in his bench, and extracting a sheaf of letters. “We’ll start right away.”

Dick waited expectantly as Smithy looked through the letters.

“Ah, here we are,” said Smithy.

switch. (Fig. 1 (c).) These are then squeezed over the strip, whereupon the switch may be turned on and off safely and easily. Incidentally, the metal operating arm is usually insulated from the switch contacts, anyway. A switch of this type taken from a miniature volume control is particularly neat and compact, and it costs nothing.”

“Well, that’s a knobby idea,” said Dick enthusiastically. “It’s just the thing for home-made midget transistor receivers and similar gubbins.”

“As you say,” agreed Smithy, looking through the letters. “I see that I have two further hints from the same reader, as well.”

“Fire away!”

“Well, the next idea,” said Smithy,

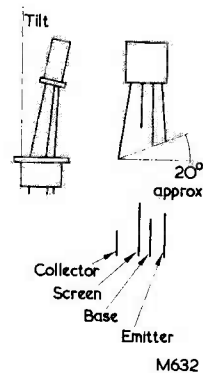
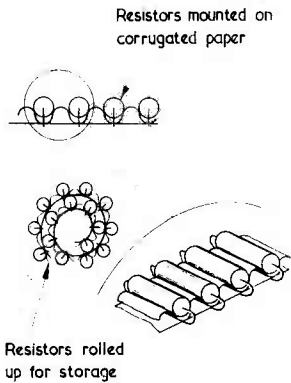

Fig. 3. Identifying transistor lead-outs by cutting them to different lengths



M633

Fig. 4. A simple means of storing resistors and capacitors

insertion will cause the transistor to tilt the wrong way in the holder. Since most transistors have longer leads than are required for soldering permanently into a circuit, the process does not, of course, reduce their final usefulness."

"It's certainly a very neat idea," said Dick. "Especially if you're sorting your way through batches of surplus transistors."

"It is, indeed," agreed Smithy. "Now here's an idea from another reader which is directed towards the perennial problem of storing resistors and capacitors. Instead of having these lie around the junk-box, the scheme is to fasten them, with their own lead-out wires, in the indentations in corrugated paper. (Fig. 4.) The components can then be examined and sorted out very quickly, and the corrugated paper can be rolled up for storage, if desired."

Replacing Valveholder Contacts

Smithy picked up the next letter in his pile.

"Now, here we have two hints in one letter," he announced, "and the first one deals with faulty contacts in valveholders. When you have a valveholder contact which is broken or which has ceased to make proper connection, you are usually faced with the job of removing all the wiring from the valveholder, drilling out its mounting eyelets or rivets, refitting a new one, and then wiring the whole circuit up again. Quite a tedious process. However, there is a certain type of moulded valveholder with which it is possible to avoid all this work. This type has contacts in the shape of a small tuning fork. (Fig. 5 (a).) Each contact is inserted, during manufacture, from the top of

the valveholder, the tag being bent over to retain it in position. (Fig. 5 (b).) If one of these contacts becomes faulty, all you have to do is to unsolder the connections to it, remove any excess solder on the tag and bend the latter straight again. It is then quite easy to work the contact upwards and out of the moulding. There will usually be a spare unused contact of the same type in some other valveholder in the receiver, and this can be removed in similar fashion. It is then inserted in place of the faulty contact, its tag bent over to retain it in position, and finally re-wired up. It is even worth purchasing a spare valveholder of the type under discussion, so that its contacts can be used for repairs of this type."

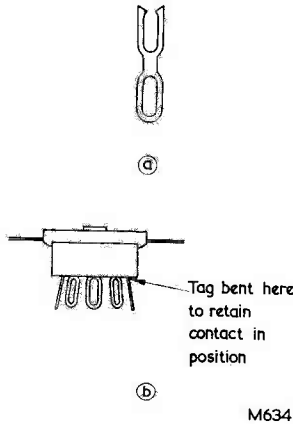

Fig. 5 (a). A type of valveholder contact which is frequently encountered

(b). The contact is fitted through the top of the valveholder moulding, the tag being bent to retain it in position

"Well," said Dick, "that's a servicing short-cut with a vengeance! I must keep my eyes open for moulded valveholders of the type you mention."

"There are plenty of them about," said Smithy. "Now let's get on to the second hint from our contributor. This offers some ideas on the old problem of preventing resistor and capacitor values from being rubbed off or obscured with dirt. All you do is to apply a thin coat of Durofix adhesive over the markings when the component is purchased. This forms a protective transparent varnish and prevents the trouble from occurring. An alternative idea consists of applying a strip of Sellotape over the markings. This has to be passed

right round and stuck on itself to ensure maximum adhesion. If you don't stick the Sellotape on itself it may come off and, in the case of waxed capacitors, take all the lettering with it!"

Dick chuckled.

"That's a point," he said. "We're certainly getting some good ideas this time! Have you got any more hints on transistors?"

"Hang on a moment," replied Smithy. "My throat's getting dry with all this talking! I would suggest that we should shortly indulge in a dish of tea."

"Ding-dong," said Dick enthusiastically. "I'll get ready with the makings straight away. Incidentally, I suppose we could describe this as being rather an auspicious occasion, couldn't we?"

"How so?"

"Well," said Dick, "we're embarking on our first cup of tea for 1963. It is something of an event."

A gleam came into Smithy's eye and he rummaged under his bench.

"It is even more auspicious than you realise," he said. "Just take a look at this!"

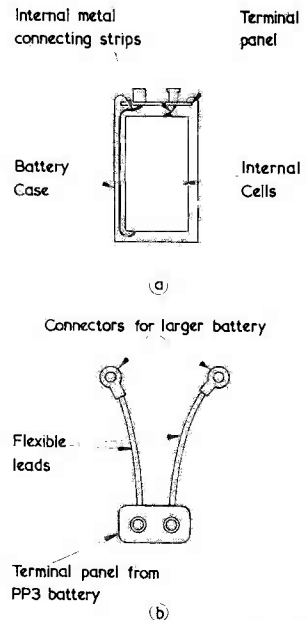

Fig. 6 (a). Cross-section through a PP3 battery, showing the internal connecting strips between the terminals and the cells

(b). A simple adaptor employing a terminal panel taken from a PP3 battery

"Blimey," said Dick, gazing astoundedly at the shining object which Smithy held out. "Don't say that, after all these years, the Workshop is getting a new kettle!"

"It is, indeed," said Smithy. "Furthermore, it's a whistler. I'm fed up with having the kettle boil dry because we're too engrossed to keep an eye on it."

Reverently, Dick picked up the glistening utensil and carried it over to the sink. He filled it carefully at the tap, replaced the whistle and stood it on the begrimed hot-plate which represented the entire culinary apparatus of the Workshop. He stood back and gazed at the kettle in silence.

"It shows up the crocks a bit, doesn't it?" he remarked eventually.

Dick gestured towards the motley array of utensils lined up alongside the sink.

"I'm going to start clearing those up too," said Smithy proudly. "To begin with, I'll be getting another teapot in 1964. After that I'll see about the cups."

"I think we'll need a new pot sooner than that," commented Dick critically. "The spout's broken on the one we've got now and it doesn't pour properly."

"It's probably the cack-handed way you hold it," replied Smithy severely. "In any case, all that spout needs to pour properly is a bit of half-inch Systoflex tubing stuck over the end. I've been keeping my eyes open for some time now in case a junked-up receiver comes in with a length of tubing the right size."

Dick considered Smithy's statement with a noticeable lack of enthusiasm.

"But that's not hygienic," he protested, "the tubing will be all dirty and waxy."

"Only for the first few cups," replied Smithy briskly. "Now, let's get on to those transistor hints you were asking me about."

"Right you are," said Dick, forgetting Smithy's projected scheme for the moment. "I'm all ears."

"Fair enough," commented Smithy. "Now we have, once again, two hints from the same reader. The first offers a scheme for experimenters who have a large number of transistors which are either of the no-name variety or whose coding has rubbed off. The idea consists, quite simply, of mounting a number of transistor holders on a sheet of Paxolin or similar material and of indicating the transistor type against each. This is a far better method than keeping the transistors loose in a box. If you have some 50 or more

transistors of various types in stock, it also saves a lot of time in selection during experiments or construction. Again, it saves you the bitter experience of finding transistors with wires broken off due to careless storage, this being particularly liable to happen with types having short leads. Of course, the number of transistor holders and the size of the board they are fitted to depends entirely upon personal preference. It's a good idea, incidentally, to mount the board in an old cigar box, tobacco tin or any other suitable container. This will give the transistors maximum protection."

"I've got quite a few gash transistors knocking around at home," volunteered Dick. "I think I'll make up a board like that for them. I've had quite a few go u/s recently, just because they've been stored loose."

"It's well worthwhile looking after components of this nature," agreed Smithy. "Anyway, let's see what the second hint is about. Ah, now, this

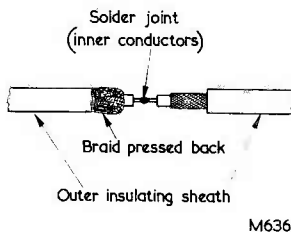

Fig. 7. A preliminary step in joining coaxial or screened cable without breaking the screening

is a neat little idea for transistor receivers which use PP3 batteries or similar types. It consists of an adaptor which enables a larger battery of the same voltage to be temporarily connected to the receiver for reasons of economy or whilst servicing. You first of all take the connectors from an existing PP3 battery by cutting away the case and the internal metal strips. (Fig. 6 (a)), this leaving you with the battery terminal panel. You next cut away the metal strips to a length that enables you to make good solder joints, and solder on two flexible leads terminated in connectors for a larger battery. (Fig. 6 (b).) When you use the adaptor, you merely fit the receiver connectors to the PP3 panel, and fit the larger connectors to an external battery. The receiver then runs from the external battery. Obviously, it is advisable to tape up the PP3 panel so that all metal points other than the connectors are covered in order to avoid the risk of shorts inside the transistor

receiver. This little adaptor can be quite a useful gadget to have around the workshop for both the serviceman and the home-constructor, and it can be used with miniaturised transistor amplifiers, and so on, as well as with receivers."

Connecting Coaxial Cable

"That's another gadget which I think I'll knock up," said Dick, "These little items all help to make servicing easier. Have we got any run-down PP3 batteries, Smithy?"

"Not at the moment," replied the Serviceman absently, as he thumbed through his letters. "The only ones I've got are brand new."

"I can soon run one of those down, then," said Dick enthusiastically. "I've got a bit of 16 gauge copper wire specially designed for the job!"

"You'll do nothing of the sort," returned Smithy sharply. "You can jolly well wait until a worn-out battery turns up! Now, forget about batteries for a moment, because I've got some very useful hints here on coaxial connections."

"Coaxial connections?" said Dick. "That sounds interesting."

"It is," confirmed Smithy. "Actually, there are four hints in this particular letter, three of which deal with the connections. The first idea has to do with soldering coaxial cable to terminal points. When it is necessary to solder the outside braid of coaxial cable to large objects, the high level of heat required for a satisfactory joint can cause the insulation between inner and outer conductors to melt. The solution is to slip a metal spacer in the form of a short tube between the braid and the centre insulation. To get the spacer in it is necessary to compress the braid back a little, thereby increasing its internal diameter. The spacer functions by conducting heat away from the insulation. For jobs where a considerable amount of heat is required for the joint, the exposed end of the spacer can be grasped with pliers, which then provide a heat sink.

"The second idea," continued Smithy, "covers the joining of two lengths of coaxial or screened cable without breaking the screening. The outer insulating sheath on each cable is stripped back for say 2½ in, after which the braid on one piece is compressed back. (Fig. 7.) The inner conductors are then cut about ½ in from the ends of the braid and soldered together. The joint is next covered with p.v.c. tape and the compressed braid drawn over the joint so that it overlaps the braid on

the other side. The overlap is then bound with thin tinned copper wire to ensure a good mechanical joint between the two outer conductors. This completes the job, and our correspondent states that he has used this technique for repairing the output cable on his Marconi signal generator and that it provides perfect screening. Even with 100mV output, no leakage can be detected with a communications receiver. If you wanted to solder the two outer conductors together at the point of overlap, you could use the tubular spacer idea described in the first hint, but the spacer could not, of course, be recovered afterwards."

"Those," commented Dick, "are two very useful ideas. Soldering coaxial and screened cables can be a very fiddling process, sometimes."

"True enough," agreed Smithy. "Now the third hint in this group is concerned with back-to-back coaxial adaptors, of the type which take a plug on either side. Our correspondent states that these don't last long with continued plugging and unplugging because the inner conductors get pushed through the insulation. In consequence, an alternative adaptor has been devised which appears to last indefinitely. This consists of two panel-mounting coaxial sockets secured together by 6BA nuts and bolts, the centre tags being soldered together. (Fig. 8.) The construction offers a very rigid mounting for the centre conductors and the adaptor can be described as a 'heavy-duty' item. There is the disadvantage that there is a loss of screening at the junction, together with a slight blip in the characteristic impedance of the cable, but these will not cause any trouble in normal servicing applications. There is the further fact that coaxial sockets may be obtained at virtually no cost from scrap television receivers and converters, and so the expense involved in making up the adaptor is pretty well negligible."

"Very neat," said Dick, "and nice and simple, too."

"Isn't it?" replied Smithy. "Also, it's surprising how useful these simple ideas can be in practice. Anyway, let me get on now to the fourth hint in this letter. When equipment is being modified, it is very often necessary to enlarge a hole in a chassis, a typical instance being given if a B7G valveholder is to be replaced by an octal type. The usual form of 'hacksaw blade wrapped around a cylinder' chassis-cutter is very useful for this job, but it requires a 1/4 in hole for the shaft of the drill. This can easily be provided by fitting a piece of 1/4 in bushing, from,

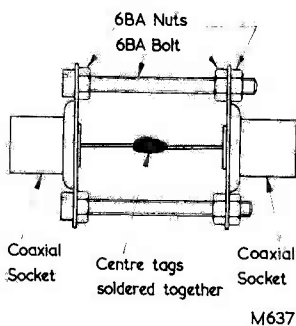

Fig. 8. A robust coaxial adaptor, which can be especially useful in the service workshop

say, a discarded potentiometer, to the original hole with the aid of two large washers. (Fig. 9.) The bushing then provides a suitable hole for the chassis-cutter drill. If the original hole has a diameter around 3/8 in, the bushing could be fitted without washers."

"That's a very useful tip, too," commented Dick. "Have you any more hints, Smithy?"

"There are still quite a few outstanding," replied Smithy. "I've got one here that is rather out-of-the-way, in fact. This hint points out that artery forceps, or Spencer-Wells forceps, are extremely useful as heat shunts for transistors. Old forceps may be available from hospitals or doctors and they clip tightly on to the wire, leaving the operator's hands free for soldering. I've checked up on the question of availability of these forceps and have found that, whilst the possibility of obtaining them from hospitals or doctors may be problematic, they can be bought over the counter at most chemist's shops fairly cheaply. A good pair of forceps, of adequate quality for workshop use, would in fact cost about fifteen shillings to a pound.

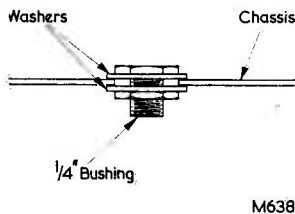

Fig. 9. When enlarging a hole in a chassis, the chassis-cutter usually requires a 1/4 in centre hole. This may be provided by a 1/4 in bushing, as illustrated here

Indeed, I've heard of a service workshop which issues a pair of these forceps to each mechanic. They use the long, 6in, variety and they find them very useful for holding small nuts, bolts, and components in awkward places."

"Well, I don't know," commented Dick. "Service workshops are getting more like operating theatres every day! They'll be bringing the sets in on trolleys soon and we'll be going through the old 'scalpel-scalpel' routine."

"I shouldn't say too much," chuckled Smithy, "or you'll have the doctors taking over your job instead!"

Dick's brow creased in a frown of agonised concentration as a thought suddenly struck him. Smithy, who recognised the signs from long experience, gave vent to an audible sigh.

"Don't say," he groaned, "that you're going to inflict some more of your doggerel on us again."

"Just a moment, Smithy," said Dick excitedly, holding up his hand. "I've nearly got it! It was your comment about doctors taking over servicing jobs that started me off. Here we go—just listen to this!

*"Dr. Kildare prepares for the theatre,
Ben Casey is out with the van.
There's a serious op. in the offing,
A TV that has lost its line scan!*

*"Dr. Finlay sets up all the test gear,
And counts the tools over again.
He checks on the Spencer-Wells
forceps,
Out on loan from Emergency
Ward 10!*

*"Ben Casey returns with the patient,
It's wheeled to Kildare straight
away.
He measures the e.h.t. voltage,
And pronounces that this is O.K.*

*"Gillespie arrives and takes over,
And probes round the l.o.p.t.
He jumps back with a curse as his
fingers
Encounter the boosted h.t.!*

*"There's a lead come adrift from that
trammy;
Gillespie reveals with a croak.
'Fix that and the set will be mended,
'Cause it goes to the deflection
yoke!"*

*"The tag is made sterile by Casey,
Kildare strips the wire to fit,
Finlay holds the Spencer-Wells
forceps,
And Gillespie applies a hot bit!*

*"At long last the repair is completed,
Excess flux is cleaned off with a
swab,
And a bright and immaculate picture
Offers proof of a successful job.*

*"So, once more, our benevolent
healers,
Who seek neither glory nor wealth,
Have reclaimed a TV from its sick-
bed
And it's all on the National
Health!"*

Applying Transfers

Dick swung triumphantly to the end of his offering and waited expectantly for the Serviceman's comments.

"Well," said Smithy critically. "I should imagine that, if you polished up the scansion a bit, you'd stand a good chance of getting that effort accepted for the next edition of *The Golden Treasury*."

Dick looked pleased.

"Oh, I wouldn't know about that," he said, off-handedly, "I mean, some of the geysers in that book have been at it for years, haven't they?"

"I suppose so," replied Smithy hastily. "Anyway, let's return to our hints. I've got a very good one here concerning panel labelling."

"That sounds intriguing," said Dick, forgetting his Muse for the time being. "What's it all about?"

"Our contributor describes," replied Smithy, "how he applied a transfer to the wrong place when he was recently labelling the controls of an oscilloscope he had just built. Also, Finagle's Law being what it is, he didn't have a duplicate in the packet. This experience prompted him to use an alternative method, which gives excellent results. You stick a length of p.v.c. insulating tape on to a smooth piece of aluminium and apply the transfer to

this. Next, apply a thin coat of clear cellulose for protection and, with a sharp knife, trim the tape to give the correct surround to the legend. Peel the tape off the aluminium and apply it to the desired point of the panel. If the tape slips it can be peeled off again and re-applied. Our correspondent encloses some samples using green p.v.c. tape, and they look very good indeed. This is quite an ingenious method of applying Panel-Sign transfers to a panel, and there are the further advantages that the tape can cover countersunk bolt heads or holes drilled in error, and that it can be fitted in awkward positions. It is, of course, also possible to mark the tape with indian ink as well as transfers, before applying the cellulose varnish."

"I see," said Dick, examining the samples. "They certainly look very neat. I would say that you could further the effect by using different colour tape for different legends. Such as, for instance, employing red tape for controls which are in h.t. circuits and so on."

"That's the idea," agreed Smithy. "There are quite a number of possibilities like that."

A Newcomer

Smithy stopped suddenly and cupped his hand to his ear.

"That's a queer noise," he remarked. "Have you got a set on somewhere?"

"We haven't," Dick happily reminded him, "any sets in the place *ro* have on. What's the trouble?"

"There's a peculiar noise," replied Smithy worriedly. "It sounds like quick motor-boating superimposed on a multivib running at a low audio frequency. Dash it all, it's started going up in frequency now. *And* it's getting louder."

Smithy jumped as the new Workshop kettle unexpectedly achieved full pressure and emitted a piercing shriek. Dick walked over and took it from the hot-plate, whereupon the whistle died down to an indignant spluttering.

"Dear, oh dear me," chuckled Smithy in mock self-abasement. "How absent-minded can you get? Do you know, I'd completely forgotten about that kettle! At any rate, let's get cracking on a nice cup of tea."

"Righty-ho Smithy," said Dick, busy at the sink. "It'll be coming up in a minute. Shall we carry on with some more hints afterwards?"

"I'm afraid not," replied Smithy, "because we've now come to the end of our present ration. However, we'll be having another session shortly. In the meantime, let's get down to our first spot of 1963 tea! It isn't often we get the chance to sit around and just take things easy."

Dick brought two cups from the sink and handed one over to Smithy. He sat down and gave a sigh of complete satisfaction.

"It's as I was saying," he remarked contentedly, "just now."

"What is?"

"1963."

"What about 1963?"

"It's something I can feel in my bones," replied Dick, with an air of supreme confidence. "1963 is going to be one of those very good years."

He paused and sipped at his tea.

"You'll see!" he added.

The hints described in this month's episode of "In Your Workshop" were contributed (in the order in which they appear) by T. E. Millsom, G. Brocklehurst, R. Wallace, J. V. Lay, D. Powell, D. A. Griffith, and G. Meachen.

Further hints for this feature are welcomed, and payment is made for all that are published.—Editor.

Improvements at B.B.C.'s Scottish TV Station at Rosemarkie

The B.B.C. has placed a contract with Messrs. A. & H. Chisholm, of Inverness, for the building of an extension at the Rosemarkie television station. The extension will house additional transmitting equipment which, with improvements to be made to the aerial, will provide a considerable increase in the effective power of the transmissions. This has been made possible by the easing of international restrictions agreed at the 1961 European Broadcasting Conference in Stockholm.

These improvements, which are expected to be completed towards the end of 1963, will provide better reception of the Rosemarkie transmissions and will be important in the extension of the B.B.C. Television Service to the Western Highlands and the outlying islands of Scotland by means of low-power relay stations now under construction or being planned. The programmes from Rosemarkie will be picked up at special receiving sites and carried by radio links to the relay stations for re-transmission.

Cover Feature

Inexpensive short wave Pre-Selector

by James S. Kent

WITH THE PRESENT-DAY CROWDED CONDITIONS ON both the amateur and the broadcast short wave bands it soon becomes apparent to the enthusiast that, for the reception of comparatively weak stations, some form of pre-selection is desirable. This is especially so where an old pre-war or a "surplus" receiver is used as the main equipment. Many of these receivers are completely outdated for the crowded conditions now prevailing, some have no r.f. stages at all, others again only possess one such stage, whilst many are fitted with coil packs having a low Q value, old type valves and inefficient (by present-day standards) i.f. transformers. Indeed, most of these receivers are in excess of 25 years of age and they were, in the main, designed some 28 to 30 years ago! It is for this type of equipment—still being used in large numbers and currently offered for sale in the amateur radio press—that the present design is featured here.

The pre-selector itself had to be inexpensive, run from an existing small power pack already supplying power to other small auxiliary units and to work in

conjunction with an old pre-war National receiver having no r.f. stages at all. The receiver itself suffered from insufficient sensitivity, and was subject to i.f. breakthrough and second channel interference. Having no r.f. stage, it was exhibiting a low signal-to-noise ratio.

A pre-selector, as such, is nothing more than a high gain tuned r.f. amplifier and, when interposed between the aerial and the existing receiver input terminal, will select and amplify the small signals received from the aerial and pass them on to the receiver input circuit. In so doing several advantages or improvements are conferred, the first being that the strength of the required signal is very much greater than any interfering (unwanted) signal on the image frequency with the result that image breakthrough, heterodynes and i.f. breakthrough are eliminated. A high signal-to-noise ratio is gained due to the design of the aerial input stage, this causing the reception of weak and previously unheard signals to be a relatively easy matter.

Under-chassis view of the completed pre-selector unit, as described in the text

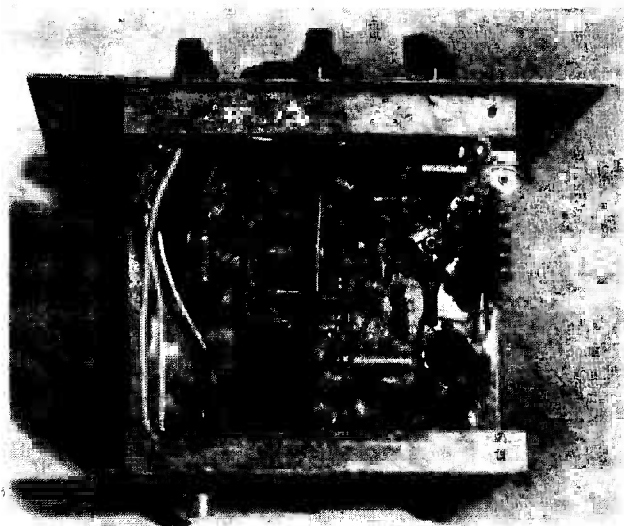

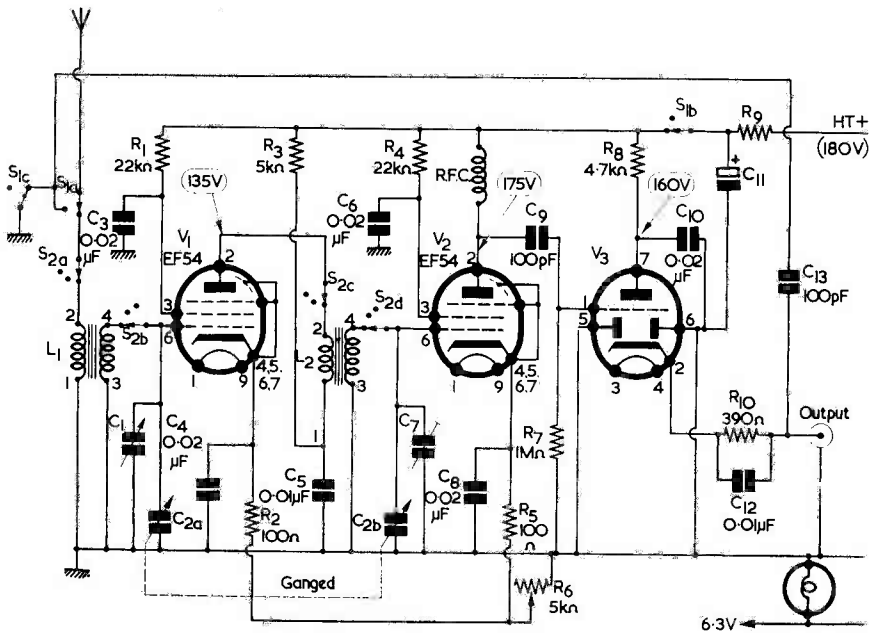

Fig. 1. Circuit of the pre-selector

M609

Components List

Resistors

All $\frac{1}{4}$ watt unless otherwise stated

- R₁ 22k Ω
- R₂ 100 Ω
- R₃ 5k Ω $\frac{1}{2}$ watt
- R₄ 22k Ω
- R₅ 100 Ω
- R₆ 5k Ω pot. wirewound
- R₇ 1M Ω
- R₈ 4.7k Ω
- R₉ 1k Ω 1 watt. (see text)
- R₁₀ 390 Ω

Valves

- V₁ EF54 (VR136 or CV1136). Henry's Radio Ltd.
- V₂ EF54 (VR136 or CV1136). Henry's Radio Ltd.
- V₃ 6AT6 Brimar Henry's Radio Ltd. complete with valveholders

Main Tuning Dial

Eddystone Cat. No. 843 (Home Radio Ltd.)

Coaxial Plugs, Sockets

Belling Lee, type L734/P (Home Radio Ltd.)

Knobs, Flexible Coupler

H. L. Smith & Co Ltd.

Capacitors

- C₁ 100pF (Jackson Bros type C801)
- C₂ 500pF two-gang variable (see text)
- C₃ 0.02 μ F, TCC type CP33N
- C₄ 0.02 μ F, TCC type CP33N
- C₅ 0.01 μ F paper
- C₆ 0.02 μ F, TCC type CP33N
- C₇ 3-30pF Philips concentric trimmer
- C₈ 0.02 μ F, TCC type CP33N
- C₉ 100pF ceramic
- C₁₀ 0.02 μ F, TCC type CP33N
- C₁₁ 8 μ F, 350 w.v. electrolytic (see text)
- C₁₂ 0.01 μ F paper
- C₁₃ 100pF ceramic

Chassis and Panel

See text (Kendall & Mousley Ltd.)

Coils

Osmor type QA1, QA3, QA4, 2 of each (Home Radio Ltd.)

RFC

2.5mH (H. L. Smith & Co Ltd.)

Pilot Light Assembly

Red, complete with bulb (H. L. Smith & Co Ltd.)

The one great disadvantage of a pre-selector is that it must be tuned "in step" with the main receiver but the writer has always considered this to be a small debit among the large credits conferred when using such a unit. In any event, at least when tuning in the normal strong signals always to be heard on the broadcast bands, the design includes a switch which effectively cuts out the pre-selector should this condition be desired.

Circuit

The circuit of the pre-selector is shown in Fig. 1, from which it will be seen that three valves are employed, each being currently available on the "surplus" market and thereby assisting in keeping the cost of the unit low. The EF54 is a high gain r.f. pentode and performs admirably in this configuration whilst the 6AT6, used here as a triode, also performs well as the cathode follower output stage.

The aerial may be switched into the pre-selector circuit by means of $S_{1(a)}$ or alternatively it may be into the receiver input terminals via C_{13} . When $S_{1(a)}$ is set to "Pre-selector", there is a feedback path existing from the output via C_{13} and the stray capacitance in $S_{1(a)}$ right back to the aerial input. $S_{1(c)}$ effectively removes this path by shorting the length of wire from C_{13} down to chassis. This introduces the snag that C_{13} is now across the pre-selector output but this has not been found to cause any significant reduction in gain at the impedances involved. S_2 is a three-way, four-pole Yaxley switch, $S_{2(a)}$ being that portion which selects the primary winding of the aerial coil. Three frequency ranges are covered with the coils specified, QA1, 13 to 35 metres (23 to 8.5 Mc/s approx.); QA3, 35 to 120 metres (8.5 to 2.5 Mc/s approx.) and QA4, 70 to 230 metres (4.3 to 1.3 Mc/s approx.) using a two-gang 500pF variable capacitor. The writer does not consider the use of a pre-selector above 20 Mc/s to be of much use, the answer here being a converter.

The connections for the coils are given in Fig. 2, those shown in Fig. 2 (a) being for the aerial coils, and those in Fig. 2 (b) for the anode-grid circuits of V_1 and V_2 . Only one of each of the coils is shown in the circuit diagram for reasons of clarity.

V_1 operates as a high gain stage, the grid being tuned by $C_{2(a)}$ (ganged with $C_{2(b)}$) and C_1 , the latter being the aerial trimmer control which considerably assists by really peaking the signal exactly into resonance. The aerial trimmer control is mounted on the front panel and it has been included in the design by virtue of the fact that, with the tight coupling employed, it is very difficult to obtain accurate tracking of the two tuned circuits. This control therefore, together with C_7 (3-30pF concentric trimmer) ensures the exact and correct "bringing into line" of both the tuned circuits.

The cathodes of both V_1 and V_2 are terminated in the gain control R_6 , a 5k Ω wirewound potentiometer. Both the bias resistors have a value of 100 Ω and this has been found to produce the best results in practice, the unit going into oscillation at the

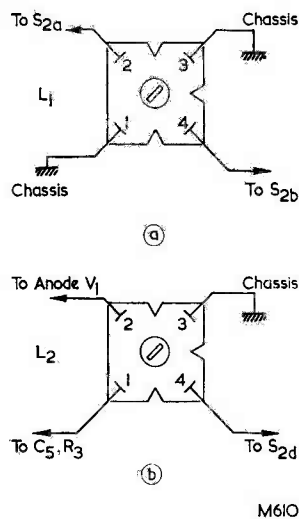

Fig. 2. Coil connection details

extreme end of R_6 track—a feature much favoured by the writer. Should this not be desired then it is an easy matter for the value of R_2 to be raised somewhat—400 Ω to 1k Ω —experimentally.

It should be noted that pins 4, 5, 6 and 7 of both V_1 and V_2 should be connected together externally. In addition to this, and in order to prevent these high gain valves "taking-off", a small metal screen should be soldered across the valveholder in such a manner that it is earthed to the central metal spigot and effectively screens the anode from the grid connections.

The anode supply of V_1 is fed via R_3 and the primary winding of L_2 into the switch $S_{2(c)}$ and from thence to the anode, decoupling to chassis being via C_5 .

The signal induced into the secondary of L_2 is applied to the grid of V_2 via the switch $S_{2(d)}$, being tuned by $C_{2(b)}$ with C_7 in parallel. The anode supply is applied via an r.f. choke, the resultant amplified r.f. signal being passed to V_3 via C_9 .

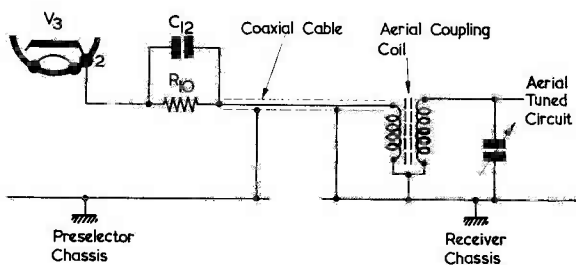

Fig. 3. Method used in coupling the output of the pre-selector into the associated receiver

The cathode follower, V_3 , has the task of providing the maximum transfer of r.f. to the aerial coil of the actual receiver itself and this is achieved by causing the receiver coupling coil to complete the cathode circuit of V_3 . Fig. 3 shows the coupling arrangement, and from this it will be noted that a d.c. path from the aerial and earth terminals of the main receiver is essential, this being nearly always the case with most communication receivers.

In an arrangement such as this, the maximum r.f. current will pass through the coupling winding of the receiver aerial coil and, consequent upon this, the maximum r.f. voltage will appear across the grid winding. With the range of frequencies being dealt with here, capacitor C_{12} is virtually a short circuit. Cathode bias for V_3 is supplied by resistor R_{10} .

When it is required to operate the associated receiver without the pre-selector in circuit, $S_{1(a)}$ disconnects the aerial input to $S_{2(a)}$ and, in addition, breaks the h.t. supply to the unit as a whole by means of $S_{1(b)}$. The power supply to the pre-selector is provided by an existing external power pack which also feeds other ancillary equipment. The resistor R_9 and capacitor C_{11} , shown in Fig. 1, are included in the actual power pack in order to provide the required h.t. potential for the preselector. With the small power requirements of the latter, no trouble was experienced with the switching arrangement of $S_{1(b)}$. Should some readers consider that they require a small power supply specifically for supplying the preselector on its own, then it would be advisable to include a bleeder resistor to offset the sudden termination of h.t. supply. Such a resistor, suitably rated, should be connected from the "free" contact of $S_{1(b)}$ to chassis, the unwanted power being dissipated in the form of heat when the pre-selector is switched off. The capacitor C_{13} effectively isolates the aerial from the cathode of V_3 when the pre-selector is in use.

The output from the pre-selector is via a short length of screened coaxial cable and the use of this type of cable is important if feedback to the aerial input of the pre-selector, with the risk of instability involved, is to be avoided. The actual cable employed was ordinary 75Ω TV coaxial, this being easily obtainable. Provided its length is kept as short as possible, a high standing wave ratio is unlikely at the frequencies dealt with here.

Construction

The above-chassis layout is clearly shown in the illustration on the cover of this issue. V_1 is situated at the left-hand side of the chassis whilst V_2 is at the right-hand side. The cathode follower V_3 is to the rear, behind V_2 . The variable capacitor C_1 (r.f. trimmer) is mounted to the front panel above V_1 whilst the pilot light assembly is situated above V_2 .

Referring again to the heading illustration, the lower panel controls are, from left to right, $S_{1(a),(b),(c)}$ pre-selector on/off; $S_{2(a),(b),(c),(d)}$ wavechange switch and, extreme right, R_6 , the r.f. gain control. Panel-Signs Set No. 1 has been used with the

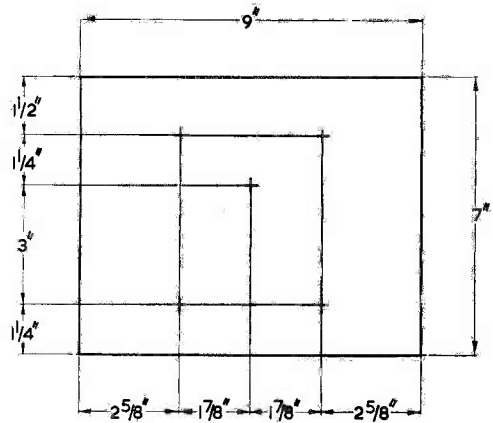

M612

Fig. 4. Panel measurements

foregoing controls, these being admirably suited to the purpose as well as being inexpensive and easy to apply to the panel. The main tuning dial is the Eddystone full vision dial (Cat. No. 843), this being an anodised satin-finished hard aluminium type of 4in diameter with a scale having 100 divisions marked over 180° . The driving head, shown behind the front panel, is a totally enclosed ball-bearing epicyclic type giving a reduction ratio of some 10 to 1.

The dimensions and details of the front panel are given in Fig. 4 from which it will be seen that the overall size is 7 x 9in. All the panel holes except that of the main tuning dial should be

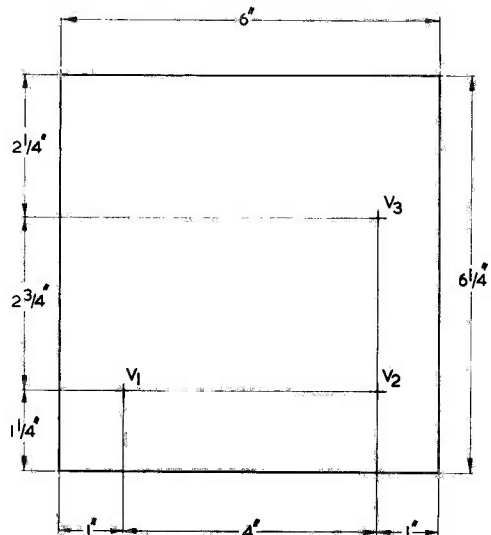

M613

Fig. 5. Chassis measurements

of the normal $\frac{3}{8}$ " in diameter in order to accommodate the switches and potentiometer, etc. The hole for the main tuning control should be of $\frac{1}{8}$ " in diameter to take the hub of the slow motion driving head.

The two-gang variable capacitor is of the type having three mounting lugs already fitted to the capacitor frame but, should some other type be to hand, then adaptations will have to be made in order to line-up the capacitor spindle with that of the slow motion driving head. Coupling between the two spindles is made by means of a flexible coupler. The driving head is fitted to the front panel by means of two 4BA nuts and bolts.

Fig. 5 shows the chassis dimensions and the positions of the three valves. No details have been included for the variable capacitor mounting as this may vary in individual cases. Fig. 6 shows the chassis back-drop details, the aperture to the left being that for the output to the receiver, that to the centre being a grommetted power input hole, and that to the right the aerial input.

From the illustration of the under-chassis view a clear indication of the layout is given. The coils (see Components List) are mounted on a small aluminium screen, those associated with V_1 being to the left and those for V_2 being to the right. Ideally, this screen could be slightly longer than that shown, extending as close to the switch mounted on the front panel as possible. An extended screen is, in fact, employed with the version at present in use, this being the only alteration made to the original pre-amplifier described herewith. It must be remembered, however, that all coils should be mounted at a height from the chassis which is sufficient to allow some adjustment to the cores to be made once the unit is completed. This latter point is particularly important with reference to the coils associated with V_2 , these being mounted on the screen somewhat lower than those for V_1 . The highest frequency coils are mounted nearest to the switch.

Each valveholder should be mounted with an associated earthing tag and in such a manner that the leads to the wavechange switch are kept to a minimum length.

Alignment

The process of alignment is extremely simple and for most constructors a signal generator is not required. The preselector is connected to the receiver with which it is to be used and the gain control R_6 is set to the maximum gain position. The associated receiver should have its a.g.c. line in operation, whereupon the S-meter (or other similar tuning indicator) can be employed to indicate signal level at the receiver input.

Alignment should commence with the lowest frequency band and proceed to the highest frequency band.

As the first tuned circuit is fitted with its own parallel capacitor (C_1) it is only required that the setting of C_7 should be somewhat central for each band. The most selective circuit will be found

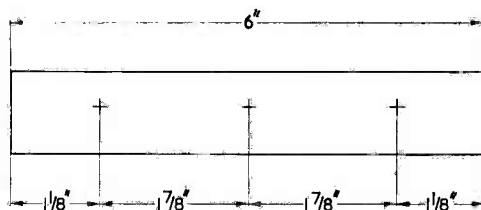

M614

Fig. 6. Chassis back-drop measurements

to be that in the grid of V_2 and the procedure for each coil here consists of setting the cores in order to provide the frequency required at the low frequency end, adjusting the cores of the aerial coils to provide the maximum sensitivity. Following this, it should be ascertained that optimum aerial trimming is obtainable over the range being aligned by variation of C_1 at several points within the frequency range.

Operation

With the receiver set to a particular frequency, say 1850 kc/s, set the wavechange switch to the appropriate range and switch the pre-selector into circuit. With the gain control near maximum and C_1 at the central position, tune the main variable capacitor until a considerable increase in signal strength is achieved. Having brought both the pre-selector and receiver "into line", adjust C_1 for any further improvements in sensitivity. Note that setting the gain control at the maximum gain position will bring the pre-selector into oscillation and "block" the receiver.

For Beginners

This unit is perfectly capable of being built by the beginner who requires a boost between his aerial and receiver. As such, it may, if desired, be constructed in three easy stages, this considerably reducing the risk of wiring errors and allowing the various parts to be purchased as the available cash permits.

The circuit of V_1 should be constructed in the first instance with the following small modifications.

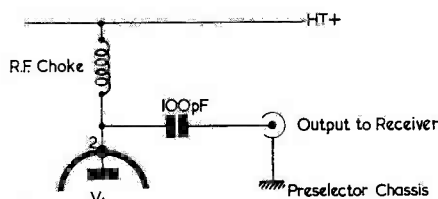

M615

Fig. 7. Modifications to V_1 when used as a single valve unit

The interstage coils will not be required. In the anode circuit of V_1 , from the h.t. line, should be inserted the r.f. choke (this may be later included in the V_2 circuit) and a 100pF capacitor (later to become C_9 in the V_2 circuit). The circuit arrangement is shown in Fig. 7. All other component values and connections with reference to V_1 remain as shown in Fig. 1.

With this stage working correctly that of V_2 may next be added, and this should be constructed exactly as shown in Fig. 1, placing both the r.f. choke and the 100pF capacitor (C_9) into the correct

positions as shown. The output from these two r.f. stages will therefore be via C_9 into the receiver input terminals, R_7 of course (Fig. 1) being a part of the V_3 circuit. With either of the two stages just discussed, $S_{1(a),(b) \text{ and } (c)}$ together with C_{13} , could be included provided C_{13} was connected to the pre-selector output terminal only and not to any other point.

Having aligned both these stages and ensured that they are correctly working, it is a relatively easy matter to add the third and final stage of V_3 .

ELECTRONICS IN THIRD STAGE MUSIC

By F. C. JUDD, A.Inst.E. (PART 2)

In the article published last month the writer discussed the parameters of Electronic Music and the allied Musique Concrete, and outlined very briefly some of the electrical transformations employed by composers in the electronic music studios. This article deals with the technical aspect of electronic music creation and some of the equipment used in the studios

IN EVERY PERIOD OF HISTORY MUSICAL INSTRUMENTS have been built with whatever means were available and it is only natural that "electronics" should now be employed for this purpose. To the electronics and acoustics engineer this opens up a new and fascinating field of activity in which the following applications are involved:

- (a) Electronic imitation of musical instruments.
- (b) Electronic denaturing of everyday sound (Musique Concrète).
- (c) Production by electronic means of musical sounds which cannot be produced mechanically (and/or acoustically).

Most of the original research and experimental work concerned with electronic music was carried out in Germany by K. Stockhausen in the Cologne studios of the N.W.D.R. Eventually a complete electronic music studio was built and this is now the world centre of experimental music.¹

The work of the Cologne studio is devoted primarily to the fields of electronic and concrete music as well as the production of sound effects for radio plays, etc. In this country the B.B.C.

¹ *Technical Facilities of the Electronic Music Studios, Cologne Broadcasting Station (N.W.D.R.). Technical Translation No. TT603. National Research Council of Canada, Ottawa.*

Fig. 3. Schematic for electronic music studio

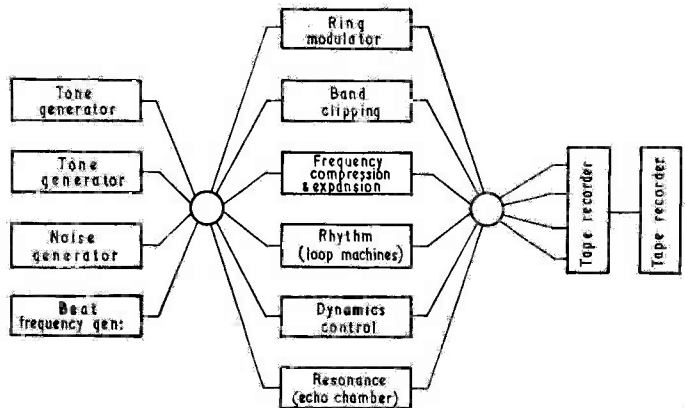

E250

Studie II

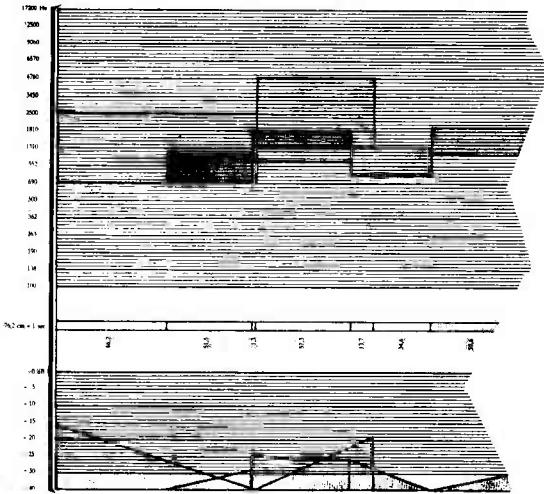

Electronic music score, *Studie II* by K. Stockhausen. (Hz=c/s.) (By kind permission of Universal Edition, London)

has a similar studio known as the Radiophonics Workshop (Fig. 1) which is used for special sound effects and electronic music. In France there is the "R.T.F. Studio for Experimental Music", in Italy the "Milan Studio for Electronic Music", and there are studios in the U.S.A., Japan, Canada and several other European countries.²

Basic Equipment

In order to fulfil the purposes of an electronic music studio the following technical equipment is considered necessary:

- (a) Electronic sound and noise-producing generators which provide the raw material for further processing.
- (b) Electrical "tone shaping" devices such as filters and modulators. The methods employed are taken mainly from communication techniques and provide sound phenomena which cannot be produced by mechanical or acoustical methods.
- (c) Magnetic sound recording apparatus for further processing of the material obtained with (a) and (b) above, and for the assembly of the final composition.

These methods make it possible for the composer to create his works exactly in accordance with his conceptions and have it performed without the help of an orchestra or conductor. The important parts of an electronic music studio are shown in block form in Fig. 3.

Electronic Sound and Noise Producers

In the Cologne studio of N.W.D.R., a device known as the "Electronic Melochord" is frequently

² die Reihe, *Electronic Music No. 1*. Universal Edition, London.

employed, together with pure tone generators and a white noise source. The Melochord is a special keyboard instrument developed from the Trautonium specifically for electro-acoustic purposes.

The tone generators are similar to those used by engineers for the testing of audio equipment, except that they are usually highly stable narrow frequency range generators, several being used to cover the audio spectrum.

For the production of white noise a generator operating on the super-regenerative principle is employed, together with filtering elements for producing bands of noise having a definable frequency (pink noise).³

Shaping Techniques

By multiple mixture of sounds new sound phenomena can be produced which are no longer related with the raw material. For this purpose a "ring modulator" and a "quadripole modulator" are employed. The ring modulator (Fig. 4) is used primarily for frequency transposing, i.e. the displacement of frequency spectra to other frequency ranges, whilst still retaining all the frequency intervals. (This can be done by the production of sum and difference tones.)

The quadripole modulator is a variation of the ring modulator in which four different frequency spectra of the sounds to be mixed can be obtained by switching.⁴

Frequency Band Clipping

If a recorded sound is replayed at a speed other than the original recording speed the reproduction may be so changed, from the subjective point of view, as to become unrecognisable. A curtailment of "time" in this case is acoustically equivalent to an expansion of the frequency band, whilst a lengthening of time constitutes a contraction of the original frequency band. Considerable modification to sounds in this way can be obtained by tape recording techniques and speed variation.

Provision of Rhythm

Rhythm may be easily imposed on electronic

³ *Electronic Music and Musique Concrète*, F. C. Judd, A.I.N.S.T.E. Neville Spearman Ltd., London.

⁴ *Filter Circuits for Electronic Sound Reproduction*, Technical Translation No. TT605. National Research Council of Canada, Ottawa.

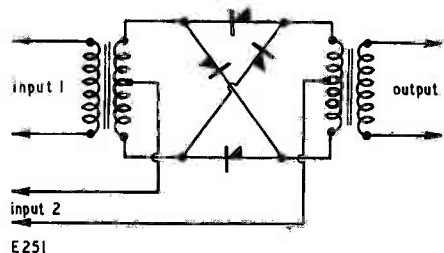

Fig. 4. The basic "ring modulator"



Part of the B.B.C. Radiophonic Workshop.
(Courtesy of the British Broadcasting Corporation)

music structures by means of ring modulators and tape loops. Fig. 5 shows how a sequence of sounds and audio frequency tones are picked up from a scanned tape loop and fed to the input terminals of a modulator. The ring modulator passes sound only when carrier and signal frequency are applied simultaneously.

Sound Recording

There are many other forms of electronic treatment to which original sounds can be subjected, these including, for instance, the production of resonance and echo by tape recording and mechanical echo systems. Shaping of a sound can be accomplished by tape cutting (removal of attack or decay of an original sound). Volume expansion by electronics, or manual control, provides swell effects. Electronic

vibrato is another means used by the composer to introduce unusual effects.^{5,6,7,8.}

The next important asset to the composer is the magnetic tape recorder, for it is with magnetic tape that rapid strides in the creation of electronic music and musique concrète have become possible. All the studios use professional grade tape recording and sound mixing equipment having fixed tape speeds of 30, 15 and $7\frac{1}{2}$ i.p.s. Variable speed and variable speed/constant frequency recorders such

⁵ *Electronic Music*, H. Badings, et al. *Phillips Technical Review* No. 6, 1957-58, Vol. 19.

⁶ *Electronic Music*, Hugh le Caine. *Proc. I.R.E.*, April 1956, p. 457.

⁷ *The Elements of Electronic Music*, F. C. Judd, A.INST.E. *Wireless World*, September 1961.

⁸ *Magnetic Tape Techniques for Electronic Music*. Technical Translation No. TT604. National Council of Research, Canada, Ottawa.

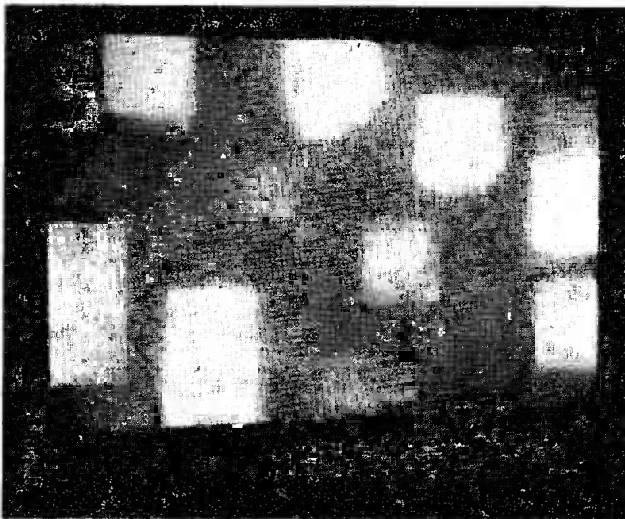

Chromasonics: an audio-visual system for displaying electronic music in co-ordinated blocks of shape and colour. The illustration shows a sound represented by multi-colour illuminated blocks. This special display was designed by F. J. Judd, the author of this article

The "Phonogene". This is a multi-speed, multi-head recording machine which provides a sound with related musical pitch

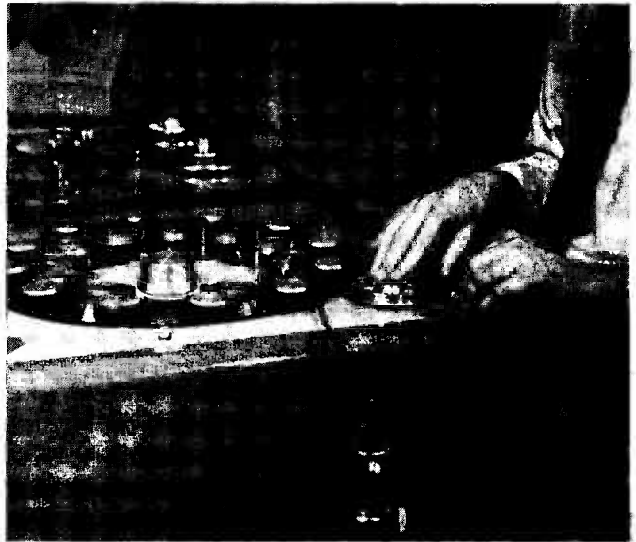

as the Telefonbau und Normalzeit loop recorders are also employed (Springer machine). For pitch constancy very high demands are made on the uniform speed of the studio recorders, which are usually powered from constant frequency mains supplies.

For the production of musical intervals special machines are used which have multiple heads and speed changing facilities. An example is the Phonogene which was developed in the R.T.F. Studio of Musique Concrète.

A favourite means of electronic composition technique consists of successive recordings, each superimposed upon the others. Here the sounds are recorded on endless loops which are fed into the master recording. These recordings are made with the erase head rendered ineffective.

The Master Recording

The final composition is produced by assembling the desired sound tracks in the order required but this frequency means considerable "band cutting" or editing. The success of the tape cutting technique depends largely on the accuracy of

the cutting which, in turn, depends on the length of the tape containing the sound or sounds. It is not unusual to require a sound or part of a sound occupying as little as 1 centimetre of tape. The final composition may consist of hundreds of pieces of tape varying in length from 1 centimetre to several metres. Part of a score for electronic music is shown herewith which indicates not only the frequency blocks and dynamic levels but also the duration of the sounds in terms of "tape length in centimetres".

Visual Aids to Electronic Music

Aside from using these new forms of music for radio, television and film drama, considerable attention has been given to the provision of visual aid to the music itself. Much experimental work has been carried out in the U.S.A. and in this country with cathode ray tube displays, coloured lighting, animated shape and colour drawn on film, and projected coloured shapes on opaque screens. The "Chromasonics" technique, devised by the writer, has aroused considerable interest in Great Britain, and demonstrations have been given in London and many of the provincial towns.⁹

There is still room for experiment with these new forms of music and abstract visual display, for they have considerable potentiality in exhibitions and advertising as well as in more aesthetic use for entertainment.¹⁰

In conclusion the writer would like to mention that technical information concerning the techniques of electronic music is now more readily available. Apart from the books and articles quoted in the references, the series of "technical translations" by the National Research Council of Canada

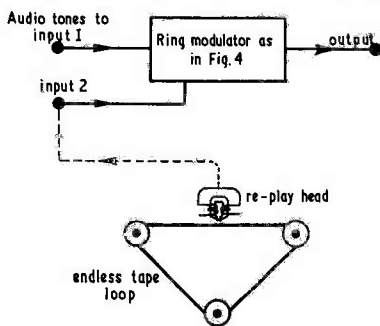

E252

Fig. 5. Imposition of rhythmic structure on sounds by means of a "ring modulator" and tape loop

⁹ "Chromasonics," F. C. Judd, A.I.N.S.T.E. *Amateur Tape Recording Magazine*, Jan.-Feb. 1962.

¹⁰ *Electronic Music Synthesis*, H. F. Olsen, et al. *Journal Acous. Soc. America*, Vol. 32, No. 3, March 1960.

cover the entire field of Electronic Music.¹¹

The R.T.F. Studio of Musique Concrete also publishes considerable information provided by

¹¹ *Technical Translations Nos. TT601 to TT612.* Each of the 12 publications deals with a different aspect of electronic music as in refs. 1, 4, 8.

their music research groups. Recordings of electronic music are as yet not too plentiful, but the recordings given in the references are available in this country.

Recording of Electronic Music (conclusion)

Deutsche Grammophon Gesellschaft. Long play 33 r.p.m. records Nos. LP.16132, LP.16133 and LP.16134. Compositions by K. Stockhausen, H. Eimert, E. Krenek and G. M. Koenig.

A Radio Astronomy Receiver

for the Advanced Constructor

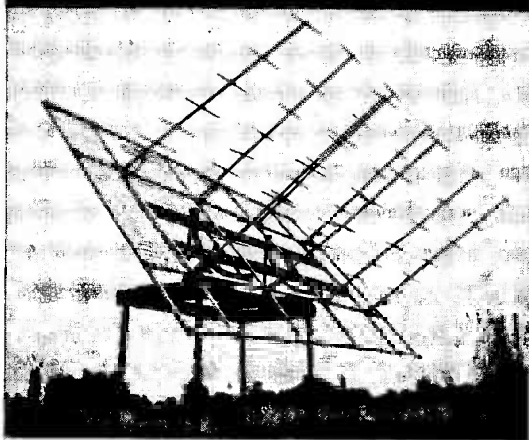

IN PART I OF THIS SERIES THE FRONT END OF THE receiver was discussed, and the arrangement of the radio frequency stages, the mixer, and the intermediate frequency stages as far as the second detector, was described.

This part will be devoted to the description of the measuring and monitoring sections of the receiver, instructions for alignment and, finally, details of the stabilised power supply system.

Measuring and Monitoring Section

The measuring and monitoring section of the receiver consists of two systems for measurement and one for monitoring. The complete layout of the chassis showing the position of the various stages was shown last month.

Referring to the circuit diagram of the measuring and monitoring section, shown in Figure 9, it will be observed that the output from the diode is fed

By Frank W. Hyde F.R.S.A., F.R.A.S.

This is the second of a series of four articles written by the foremost amateur authority on radio astronomy in this country. These articles cover the construction and assembly of a complete radio telescope installation.

via the $0.1\mu\text{F}$ capacitor C_1 to the grid of V_1 (EF86), the signal appearing across the $680\text{k}\Omega$ resistor, R_1 .

The first valve in the chain is a simple audio-frequency amplifier and its anode output is divided into two parts. One part is routed to the measuring system via the $0.05\mu\text{F}$ capacitor C_3 . The measuring system has two resistance-capacitance coupled audio stages of amplification before the signal is applied to the translator diode. These two stages are the two sections of an ECC82, designated $V_{2(a)}$ and $V_{2(b)}$. The output from C_3 appears across the $250\text{k}\Omega$ potentiometer R_5 , the slider of which is connected to the grid of $V_{2(a)}$. The anode of this section is coupled to the grid of $V_{2(b)}$ via the $0.05\mu\text{F}$ capacitor, C_7 , and the grid resistor, R_8 . The output at the anode of this section appears across R_{11} via the capacitor C_9 . The voltage developed across R_{11} is fed to the triode section of an ECF82, shown in the diagram as $V_{3(a)}$ and $V_{3(b)}$. The triode section has its grid and anode strapped together to form a diode, its load being the $680\text{k}\Omega$ resistor R_{12} . It is here that the time constant is introduced and it is given by the capacitors CT and CT_1 , selected by the switch S_1 . The diode feeds the translator amplifier $V_{3(b)}$ and it is from here that the signal is fed to one half of the d.c. amplifier $V_{4(a)}$ and $V_{4(b)}$. The translator amplifier $V_{3(b)}$ has in its cathode circuit an 820Ω resistor R_{13} , and it is across this that the meter is placed in association with the backing-off resistor network made up of R_{15} , a $25\text{k}\Omega$ variable potentiometer, and the $100\text{k}\Omega$ fixed resistor R_{16} . With the switch in the translator position the meter is placed between the tapping point on the $25\text{k}\Omega$ potentiometer and the cathode end of R_{13} . When the switch is moved to the valve voltmeter position the meter is between the two anodes of $V_{4(a)}$ and $V_{4(b)}$; the two halves of the

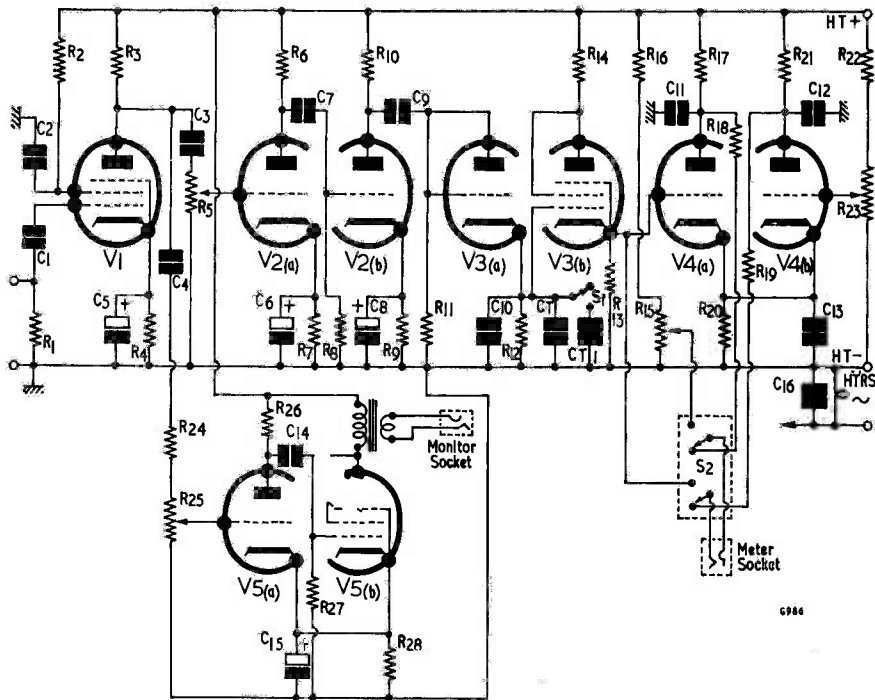

Fig. 9. Circuit of the measuring and monitoring section

Components List (Fig. 9)

Resistors. (See text for note on wattage)

- R₁ 680k Ω
- R₂ 1M Ω
- R₃ 220k Ω
- R₄ 2.2k Ω
- R₅ 250k Ω pot.
- R₆ 220k Ω
- R₇ 3.9k Ω
- R₈ 330k Ω
- R₉ 3.9k Ω
- R₁₀ 220k Ω
- R₁₁ 680k Ω
- R₁₂ 680k Ω
- R₁₃ 820 Ω
- R₁₄ 1k Ω
- R₁₅ 25k Ω wirewound pot.
- R₁₆ 100k Ω
- R₁₇ 22k Ω
- R₁₈ 3.3k Ω
- R₁₉ 3.3k Ω
- R₂₀ 500 Ω
- R₂₁ 22k Ω
- R₂₂ 82k Ω
- R₂₃ 25k Ω wirewound pot.
- R₂₄ 15k Ω
- R₂₅ 250k pot.
- R₂₆ 47k Ω
- R₂₇ 1M Ω
- R₂₈ 150 Ω

Capacitors

- C₁ 0.1 μ F
- C₂ 0.5 μ F
- C₃ 0.05 μ F
- C₄ 0.05 μ F
- C₅ 16 μ F electrolytic 12 w.v.
- C₆ 8 μ F electrolytic 12 w.v.
- C₇ 0.05 μ F
- C₈ 8 μ F electrolytic 12 w.v.
- C₉ 0.5 μ F
- C₁₀ 0.1 μ F
- C₁₁ 0.02 μ F
- C₁₂ 0.02 μ F
- C₁₃ 0.005 μ F
- C₁₄ 0.05 μ F
- C₁₅ 8 μ F electrolytic 25 w.v.
- C₁₆ 0.1 μ F
- C_T 2 μ F paper
- C_{T1} 4 μ F paper

Valves

- V₁ EF86
- V₂ ECC82
- V₃ ECF82
- V₄ ECC82
- V₅ ECL80

Switches

- S₁ s.p.d.t.
- S₂ d.p.d.t.

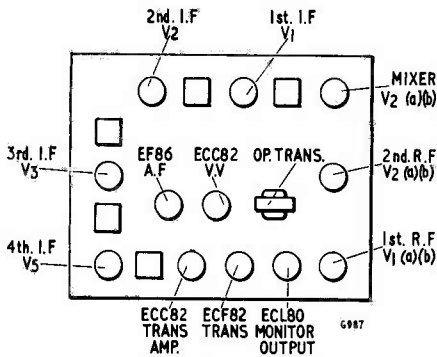

Fig. 10. Layout of main components on the chassis

valves being balanced by the backing-off network consisting of R_{22} and R_{23} . A 0-1mA meter may be employed.

Both the translator and the d.c. amplifier operate on the same principle, that is, one of unbalance. In the case of the translator, the change of d.c. voltage across the cathode resistor unbalances the meter which has already been backed-off, and any variation in voltage at the cathode causes the meter to operate.

In the case of the d.c. amplifier, the meter is balanced between the two anodes by means of the backing-off circuit which controls $V_{4(b)}$, and any alteration in voltage on the grid of $V_{4(a)}$ causes unbalance in the anode circuits. Current flows, therefore, through the meter, which indicates the change of voltage on the grid of $V_{4(a)}$.

When referring to V_1 it was said that the output was divided. One half is applied to the measuring system which has already been described, and the other half is applied to the monitor via the capacitor C_4 and the stopper resistance R_{24} to the potentiometer R_{25} , which is a 250k Ω variable; the slider of this potentiometer applies the voltage to the triode section of the ECF80, $V_{5(a)}$. This triode section is resistance-capacitance coupled to the pentode section, whose output is taken off via the a.f. transformer, the secondary of which is connected

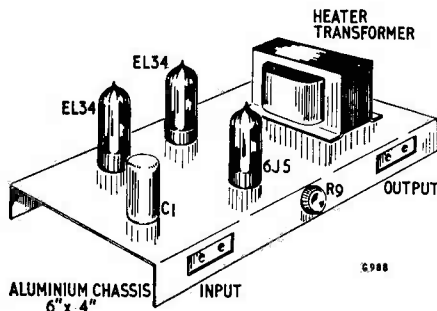

Fig. 11. Suggested layout for the stabiliser unit. This can be fitted into the power unit with some rearrangement of chokes and capacitors

to the output jack for monitoring. Either phones or a speaker may be employed.

The whole of this measuring system is an amplifier of extremely high gain, and some care is needed in setting it up: The components relative to each valve should be restricted to the area of the valveholder as far as is practicable, depending upon their size. The largest of these are, of course, the time constant capacitors associated with the triode section and amplifying section of the ECF82. Fig. 10 shows the layout of the chassis, with the individual stages itemised from the r.f. to the a.f. and measuring sections.

It should be mentioned that, so far as resistors are concerned, these should be of as high a wattage rating as can be accommodated in the space in order to reduce the effects of circuit noise.

Routine Tests

The construction of the receiver having now been described, it is necessary to turn attention to the routine tests. It will be assumed that the normal snags have been removed, that is to say, inadvertent h.t. shorts and wrong connections. Having checked the wiring mechanically and seen that it is correct, h.t. voltages should be checked at the various points given in Table I. The figures given are for guidance only and some latitude is permissible in either direction above or below the values quoted.

The first operation now is to check that the a.f. sections are working and this is best done by feeding in an audio signal via C_1 . After checking that the monitor is operating satisfactorily, this section can be left in operation to monitor all future tests. Set the time constant switch to the short time constant position and turn the selector switch to the valve voltmeter position. Connect the milliammeter to the anodes of the ECC82 via the jack socket. With the sensitivity control measuring system turned completely off, adjust the reading of the meter by means of the d.c. amplifier centring control, R_{23} , so that the meter reads some arbitrary value, say at about one third of the scale. Now with the audio frequency source set to a very low level that can just be heard in the monitor, increase the sensitivity, whereupon this should show an immediate increase in the meter reading from the d.c. amplifier. Switch to the translator cathode, repeating the procedure by testing the pre-set backing-off control, R_{15} , so that the meter again reads some arbitrary value, preferably the same threshold at which the d.c. amplifier was adjusted. That is, the sensitivity should first be turned to zero and the meter adjusted to read at a point about one third of the full scale reading. Then, with the sensitivity control increased and leaving the audio-source level in the same position, note the reading on the meter. This will give the comparative sensitivity of the two systems. The audio source may now be disconnected.

The I.F. Stages

The next procedure is to set up the intermediate frequency amplifier. This can be done in two ways,

Front panel view of the power unit type
234A

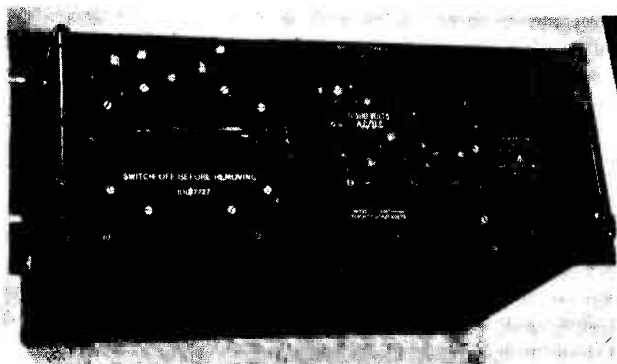

depending upon the equipment available. If a suitable signal generator or source of signal is available this should be used; if not to hand, then, as a preliminary test, the Channel 1 programme of the B.B.C. can be used. This will be sufficiently near the intermediate frequency for a preliminary line-up to be made. It should be mentioned at this point that the noise generator, which will no doubt have already been prepared, cannot be used for preliminary alignment since its frequencies cover such a wide spectrum that it is not tunable, and our receiver must be first brought to the tunable condition before we can do the final setting up with the noise generator.

The signal generator is set to a frequency of 38 Mc/s and should first be applied across the grid of V_4 . The output control of the generator is turned to maximum output with the r.f. carrier modulated by an audio tone between 400 and 1,000 c/s.

Disconnect the meter from the measuring section and use only the monitor, which should be adjusted for maximum sensitivity. Adjust the last i.f. transformer for maximum output, and having done this, make a note of the signal generator frequency at which it is set. This is important for future testing.

The next step is to move one stage towards the

front end of the amplifier and apply the signal to the grid of V_3 , reducing the output from the generator as necessary. Tune this i.f. transformer also to give maximum output and then, having brought this stage to the maximum level possible, re-trim the last stage i.f. transformer and then again the last stage but one. This should ensure that the maximum tuning point for each of these two transformers has been achieved. It is important to ensure that, when adjusting the iron dust core, the tuning goes through the point of maximum signal to a minimum signal on either side. When this process has been completed, connect the generator one stage further forward again and feed the signal into the grid of V_2 , at the same time again reducing the generator output as necessary. Trim the transformer of this stage to maximum, then again check the last stage and work back to the one to which the generator is connected. At this point the gain may be such that there is a tendency for the whole system to become unstable. If this happens, connect the generator to the last stage again and, having already noted the frequency at which this was aligned, slightly detune the generator about 500 kc/s, and readjust the last i.f. transformer to maximum. Do not disturb the other transformers at this stage. Make a note also whether this transformer has been

Above-chassis view of the power unit type
234A

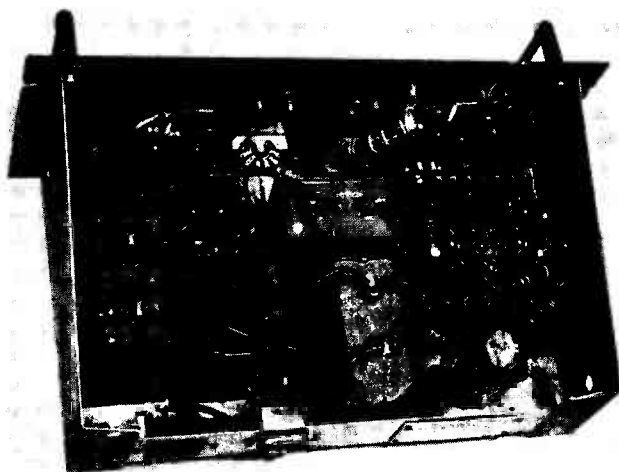

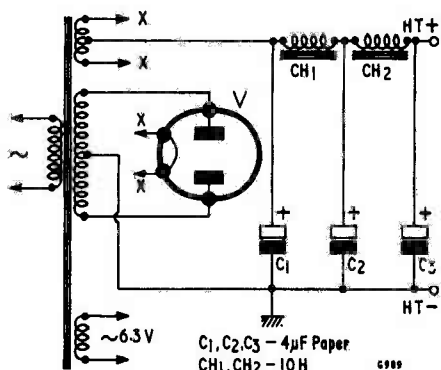

Fig. 12. Basic circuit of the type 234A power unit. For clarity all switches and wiring, etc., have been omitted

detuned to a frequency higher or lower than the original frequency. It is immaterial which is chosen, but it is important that, as the sequences are later carried out, they must be at alternate sides of the centre frequency.

Now that these three stages have been trimmed satisfactorily we can proceed to the first stage, applying the signal to V_1 grid, again with the signal generator output suitably reduced. Should it be impossible to reach maximum tuning position on the first i.f. transformer without instability it will be necessary to go back to the previous stage and perform the same operation as on the last i.f. stage. However, in this case the detuning should be in the opposite direction to that of the last stage; so that if the last transformer had an increase in frequency the present transformer will be tuned to 500 kc/s below the centre frequency.

TABLE I

R.F. Section	I.F. Section	Measuring Section	
Anode	Anode	Anode	Screen
$V_{1(a)}$ 80V	V_1 160V	V_1 175V	140V
$V_{2(a)}$ 100V	V_2 160V	$V_{2(a)}$ 100V	
$V_{2(b)}$ 168V	V_3 180V	$V_{2(b)}$ 100V	
$V_{3(a)}$ 160V	V_4 160V	$V_{3(a)}$	
$V_{3(b)}$ 160V		$V_{3(b)}$ 160V	
		$V_{4(a)}$ 100V	
		$V_{4(b)}$ 100V	
		$V_{5(a)}$ 90V	
		$V_{5(b)}$ 180V	180V

Return again to the first stage of the intermediate amplifier and repeat the testing sequence, again making sure that the slug of the i.f. transformer goes through the optimum tuning point in each case.

The whole system can next be tested by connecting the meter, preferably to the translator section. Feed in the modulated signal and observe the change in meter reading. As the i.f. signal increases, be careful to notice whether there are signs of overloading in any of the intermediate frequency amplifier stages or in the audio frequency stages of the measuring system. Adjust the sensitivity controls in order to make a satisfactory test showing that the i.f. amplifier output, with an increase of signal, does increase in a linear manner to the full extent to the measuring system. Careful attention to this part of the lining-up procedure will save a considerable amount of time when the final testing of the whole system comes into operation. If this part of the work is done correctly it will not be necessary at a later stage to make any adjustments to this section of the receiver at all. As the i.f. amplifier and its audio stages have now become an extremely sensitive receiver, the choice of 38 Mc/s should ensure that it is sufficiently far removed from Channel I of the B.B.C. to avoid breakthrough. Should there be signs of this in spite of the spacing away from the B.B.C. frequency (i.e. some 3-4 Mc/s), it may be necessary to introduce a trap into the first i.f. amplifier stage. This has not been found necessary at the author's observatory, where the B.B.C. signal is of the order of 200µV.

As a final check the signal generator should be connected to the grid of the frequency changer. The generator should be adjusted for maximum output. It may be that the output appears to be slightly reduced when the generator is so connected and that a higher input is required to read the same level at the monitor, but this is not important. Tuning can be effected without disturbing the other parts of the intermediate frequency amplifier.

The testing procedure so far has specified the use of a signal generator but it is possible that a signal generator is not available at the frequency to be used. If this should be the case then a simple oscillator would suffice for the purpose. Alternatively, if the Channel 1 B.B.C. station is available this could be used for preliminary tuning, the final setting being effected by moving the frequency slightly in the last alignment.

The R.F. Stages

The next step is to tune the r.f. section. Set the signal generator to the frequency that has been chosen. A very large input may be necessary at this stage. Tune the oscillator coil so that a signal is audible, and proceed to adjust the dust cores of the aerial and intermediate r.f. sections in turn.

When these have been tuned to maximum it will be necessary to check to see that they have not been tuned to the oscillator frequency. In order to determine this, feed in a fairly large input from the signal generator, then rock the tuning control of

Components List

(Fig. 13)

Resistors

R ₁	100Ω	¼W
R ₂	100Ω	¼W
R ₃	1kΩ	¼W
R ₄	1kΩ	¼W
R ₅	75kΩ	½W
R ₆	100kΩ	½W
R ₇	150Ω	¼W
R ₈	10kΩ	¼W
R ₉	100kΩ	wirewound pot.
R ₁₀	33kΩ	½W

Valves

V ₁	EL34
V ₂	EL34
V ₃	6J5

Capacitor

C ₁	8μF electrolytic 450 w.v.
----------------	---------------------------

Transformer

T ₁	Heater transformer
----------------	--------------------

Neon

N ₁	Stabilising tube type 90C1
----------------	----------------------------

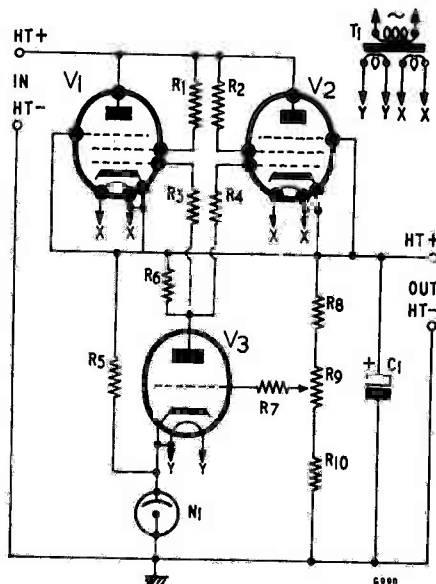

Fig. 13. Circuit of the stabilising unit

the generator until two signals are apparent: one should be slightly greater in output than the other. When this has been discovered set the generator to this point, reduce the input so that the output is just audible, and then retune the r.f. sections again, leaving the oscillator where it is. It is advisable to rock the tuning of the oscillator while doing this to avoid "pulling". If a signal generator is not available then the local I.T.A. television station can be used, providing it lies within the frequency band chosen for the receiver.

Checking Sensitivity

Having now completed the alignment it is time to assess the real sensitivity by the use of the noise generator. Connect the noise generator to the aerial terminal and set it at such a level that there is an audible hiss on the monitor loudspeaker. Set up the translator meter or the pen recorder, as the case may be, and then increase the noise generator output. It will be remembered that this may first show a fall and then rise. Adjust it so that there is a rise and then very carefully readjust all circuits slightly for maximum output, but being very careful not to disturb the bandpass response which has been created in the r.f. section. Again, it should not be necessary to alter the tuning of the i.f. section, the only coil likely to be affected is L₈ in the anode of the frequency changer. The receiver is now ready for use and should be allowed to run on test for some time. The reason for this testing is that there may be components such as resistors which become noisy after a period of running, and it is important to know this before the receiver is applied to the aerial for study of extra terrestrial radiations.

Power Supplies

The next items are the power pack and the stabiliser. These have been designed around one of the standard surplus units which are readily available on the market for quite a nominal sum. The power unit is the type 234A (see illustrations). It requires modification for the purpose of stabilisation, or a separate stabilising unit can be built up. A suggested layout for this is shown in Fig. 11. If the stabilisa-

TABLE II

Coil Winding Details

(See Figs. 2 and 3, December issue. All formers used are standard Aladdin 9mm types fitted with dust cores)

R.F. Unit

L ₁	2 turns, 22 s.w.g., enamelled, close spaced, wound over L ₂
L ₂	4 turns, 22 s.w.g., p.v.c., close spaced
L ₃	4 turns, 18 s.w.g., p.v.c., close spaced, self-supporting (V ₁)
L ₄	4 turns, 22 s.w.g., enamelled, close spaced
L ₅	4 turns, 22 s.w.g., enamelled, close spaced, wound over L ₄
L ₆	4 turns, 22 s.w.g., p.v.c., close spaced, self-supporting (V ₂)
L ₇	4 turns, 22 s.w.g., p.v.c., close spaced
L ₈	7 turns, 22 s.w.g., enamelled, close spaced
L ₉	1½ turns, 14 s.w.g., silver plated copper, spaced dia. of wire (wound on 9mm Aladdin former)

I.F. Unit

L ₁	9 turns, 26 s.w.g., enamelled, tapped at 4 turns from anode, close spaced (V ₄)
L ₂	As for L ₁ (V ₅)
L ₃	As for L ₁ (V ₆)
L ₄	12 turns, 26 s.w.g., enamelled, close spaced (primary V ₇)
L ₅	7 turns, 26 s.w.g., enamelled, close spaced, wound over L ₄ (secondary V ₇)

tion is to be introduced into the power unit as it stands, a certain amount of rearrangement of components in the basic unit will be necessary and this is left to the individual constructor. The basic circuit of the power supply unit is shown in Fig. 12. The stabilising section, which consists of two valves type EL34 and a 6J5 is shown in Fig. 13. This will be described as though it were a separate unit, it can however be incorporated in the main unit.

The transformer T_1 is a heater transformer supplying the heaters of the EL34's and the 6J5. The input to the stabilising unit is to the anodes of the EL34's which are strapped together, and the output is taken from the cathodes across the smoothing capacitor. The control network is given by the 6J5 and the appropriate resistors, the cathode

being stabilised with a 90 volt neon, type 90C1. The 100k Ω potentiometer, R_9 , is for the purpose of setting the balance so that maximum current flow through the EL34's is achieved. Variation of the load will cause changes to the output voltage, this being offset by the control voltage on the grids of the EL34's. This unit will be found to give adequate stabilisation for the purpose required, at the same time leaving sufficient current handling capacity in reserve for any more ancillary apparatus that may be added to the receiver at a later date.

In Table II are details of the r.f. coils and the i.f. transformers. The next article will deal with the aerial and its pre-amplifier.

(To be continued)

BOOK REVIEWS . . .

COMMUNAL AERIALS AND COAXIAL RELAY PRACTICE. By Gordon J. King, Assoc. Brit. I.R.E., Grad. T.P.A. 72 pages, 5½in by 8¾in. Published by Gordon J. King (Enterprises) Limited. Price 8s. 6d.

It is interesting to learn that coaxial relay distribution of television and sound programmes is only some eight years old. Since its inception, coaxial relay networks have spread extensively, and have provided high definition television programmes to subscribers in many "fringe" districts, including areas in Wales and the south of England, and at Bath and Oxford.

Basically, a coaxial relay system comprises a receiving station sited at a favourable position, a "virgin cable" carrying the received signals to a central distribution point, and subsequent cables radiating out to subscribers. However, a large number of technical problems have to be overcome before this simple concept can be made to work in practice, these including the provision of repeaters, frequency-changing equipment (to convert Band III signals to Band I for transmission through the cable), splitter units (where one cable divides into two or more), together with a continual guard against cross-modulation at all points throughout the system. A further complication is the necessity for a g.c. at repeater and distribution stations to overcome varying attenuations in the system. The attenuation over a mile of cable can vary by as much as 20dB between summer and winter due to the differing ambient temperature conditions.

Technical questions are only part of the problems involved in setting up a relay system. After a wiring concession has been granted, cable route planning and wayleaves have to be negotiated and agreed. Also, many G.P.O. requirements, including radiation and attenuation at distribution points, have to be met.

The author, who has been associated with coaxial relays since their introduction in this country, covers all these points with authority and in considerable detail. Apart from its obvious appeal to the reader who is directly involved with coaxial relay systems, this book can be recommended to any radio and television engineer who seeks to increase his knowledge in his chosen field.

RADIO ASTRONOMY FOR AMATEURS. By Frank W. Hyde, F.R.S.A., F.R.A.S. 236 pages, 6in by 7in. Published by Lutterworth Press. Price 25s.

Mr. Hyde's contribution to radio astronomy, as an amateur, has already been made known to a wide audience through his appearances on B.B.C. television in Patrick Moore's programme "The Sky at Night". In this volume he tells us more about this fascinating branch of science and clearly indicates how the amateur can contribute to it. This book deals in a thoroughly practical manner with the receivers, aeriels, recording equipment and accessory electronic units required for amateur radio astronomy observation. So far, little practical information on this subject has been published and this book can be thoroughly recommended to all who would like to take not only a theoretical interest in radio astronomy but would like to try their hand at some practical work as well.

Complete with circuits, component lists, half-tone illustrations and diagrams, etc., we feel that this work will not only be a worthwhile addition to the bookshelf but will also become a reference book on the subject.

R.S.G.B. AMATEUR RADIO CALL BOOK, 1963 Edition. 80 pages, 7¼in by 9¼in. Published by Radio Society of Great Britain. Price 4s. 6d.

This latest edition of the R.S.G.B. *Amateur Radio Call Book* includes all the many changes that have taken place since the last edition (1962) closed for press in September of 1961. During the year more than 560 new calls have been issued, 100 have been re-issued, nearly 300 cancelled and, in addition, more than 900 changes of address have been recorded.

The 1962 edition, as an innovation, listed the call-signs of more than 1,000 Amateur (Sound Mobile) Licence-holders and the new edition records more than 300 amendments to that list.

This current edition also features an up-to-date list of countries and international prefixes completely revised and recording the many changes that have taken place in recent months. The list of Societies and Clubs affiliated to the R.S.G.B., complete with names and addresses brought up to date where necessary, has again been included, this being a most useful feature for those wishing to make contact with such Societies, etc.

This latest edition of the R.S.G.B. *Amateur Call Book* is, we feel, virtually indispensable to both the transmitting amateur and short wave listener.

RADIO topics

By RECORDER

IF, IN THE FUTURE, YOU SHOULD happen to call at the headquarters of Securicor Ltd., you may find yourself confronted with a remote-control doorkeeper. A voice from a loudspeaker will tell you to face the camera installed at the entrance. If your face fits, the door will then be automatically unlocked and opened for you.

This example of closed circuit television is only one of many which takes advantage of the newly announced low-price transistorised video monitors available from Beulah Electronics, 138 Lewisham Way, New Cross, London, S.E.14. These monitors are claimed to be the first of their type in the U.K., and they are available in two models, these being the "Beulah 1400" with a 14in screen, and the "Beulah 850" with an 8½in screen. The price of the "Beulah 1400" is quoted as 75 guineas, and that of the "Beulah 850" as 69 guineas.

Space Saving

Apart from low cost, the outstanding advantages of these new monitors are their small size and low current consumption. The "Beulah 850" is, for instance, only 11½ x 9 x 9in in outside dimensions. All controls are fitted to the front of the monitors, and it is possible to stack six of these on a shelf measuring 9in deep and 28½in wide. Each monitor consumes 30 watts of electricity and, in consequence, dissipates much less heat than the average valve type. The result is that cooling problems are almost non-existent, and there is no necessity to employ internal fans or similar cooling devices. A very useful feature is that the monitor coaxial inputs are arranged for linked loop working. This means

that a large number of monitors can be linked together without any external coupling device being required.

Both the Beulah monitors are designed for 24 hours continuous working, especial attention having been paid to safety margin on all semiconductor devices. Design centre sync level for each monitor is 1.5 volts peak-to-peak, but the vertical and horizontal timebases are still locked solid if this is reduced to as little as 0.75 volts.

The monitors are intended for work with low priced closed circuit cameras, but they can, for a small extra charge, be supplied to operate with standard B.B.C. video signals. Because they are portable, they are ideal for line and point testing purposes.

The accompanying illustration shows two officers of Securicor Ltd. inspecting the model 850 monitor, and the neat and simple layout of the

unit is immediately apparent. The monitor displays, apparently, a picture of someone stealing a telephone.

"Simple Regenerator"

The September 1962 issue of the Soviet publication *Radio* is (a little belatedly) to hand, and it contains an article giving details of a rather unusual and interesting technique for obtaining reaction in valve receivers. The article, "Simple Regenerator" by B. Dobrovski and B. Smurblik, describes a home-constructor receiver covering 520 to 1,600 kc/s (577 to 188 metres) and 7.5 to 12 Mc/s (40 to 25 metres), this employing two triode-pentode valves with Russian type numbers. From the anode voltages and resistor values appearing in the circuit, I would hazard a guess that the triode-pentodes are television tuner types, similar to the ECF80.

The circuit is quite simple, and it



Two officers of Securicor Ltd. inspect the newly released "Beulah 850" transistorised closed circuit television monitor

is only necessary to describe it for one of the two wavebands covered. The aerial is applied to a coupling winding on a conventional r.f. transformer, the secondary winding being tuned by one half of a two-gang capacitor. This tuned winding connects between chassis and the triode grid of one triode-pentode. The triode cathode taps one-tenth of the way up a second tuned winding (screened from the aerial r.f. transformer), whose lower end connects to chassis and which is paralleled by the second half of the two-gang capacitor. The top end of the second tuned circuit couples to the pentode grid of the triode-pentode by way of a conventional grid capacitor and leak. The set-up so far, therefore, is that the triode of the triode-pentode functions as a cathode-follower, and its cathode feeds a second tuned circuit in the grid of the pentode section, which then functions as a leaky-grid detector.

The pentode anode next connects to one end of a regeneration winding fitted to the aerial r.f. transformer, the other end of the regeneration winding connecting to h.t. positive via a $5k\Omega$ resistor. A.F. is taken from the junction of the regeneration winding and the $5k\Omega$ resistor via a $0.01\mu F$ capacitor. This is applied to a volume control and, thence, to the second triode-pentode which functions as a two-stage a.f. amplifier feeding the loudspeaker. There are no r.f. bypass components of any sort after the regeneration winding.

An important point I haven't mentioned yet is that the anode of the triode cathode-follower connects to the slider of a $100k\Omega$ potentiometer between h.t. positive and chassis. It is decoupled by a $0.1\mu F$ capacitor.

All in all, the circuit operates in the following manner. The aerial input is applied to a tuned r.f. transformer and, thence, to a cathode follower. The cathode-follower feeds a second tuned circuit which connects to a leaky-grid pentode detector. Regeneration is then obtained over both the cathode-follower and the pentode by coupling the pentode anode back to the aerial r.f. transformer. The degree of regeneration is adjusted by varying the voltage on the cathode-follower anode by means of the potentiometer across the h.t. supply.

I haven't, of course, tried out the circuit, but it may well offer some advantages over the more usual t.r.f. arrangement having two tuned circuits and a pentode amplifier in between. The first tuned circuit of such a receiver notoriously tunes flatly, owing to the damping given

by the aerial. In the circuit under discussion, however, this tuned circuit is sharpened up because of the regeneration applied to it. An improvement in overall selectivity may, therefore, result. The cathode-follower after the aerial tuned circuit could offer a fringe benefit by reason of its high input impedance, but it is much more probable that its purpose is to provide a coupling with zero gain. Although two tuned circuits appear in the regeneration loop, the gain provided is only that of the pentode on its own plus auto-transformer action in the second tuned circuit. Regeneration should, in consequence, be fairly easy to control.

The absence of r.f. decoupling components after the leaky-grid pentode anode may make the receiver tend towards instability and increase the regeneration effect. At any event, the regeneration coil has only about one-fifth of the turns in the tuned winding to which it couples, and it is spaced away from that tuned winding. The low anode load resistance of $5k\Omega$ is probably necessary because the pentode type employed draws about 20mA anode current (at an anode voltage of 85) when used as a leaky-grid detector, but it may also help to keep down general instability.

How to Fix a Receiver

One of the most delightful servicing stories I have heard for a long time appears in the "From the Serviceman Who Tells" feature in the September 1962 (belated again!) issue of our Australian contemporary *Radio, Television and Hobbies*. The set concerned was a four-plus-one valve receiver of good quality, and its owner quite freely admitted that he'd had a "go at it". The first thing our Australian serviceman noticed was that the cord drive had been "fixed". The owner had pulled the new cord so tight that a die-cast bracket had broken away. Shock No. 2 was that, apart from the rectifier, all the valves in the set were type 6J8! The next thing discovered was that the a.f. coupling capacitor to the output pentode grid had been changed for a 100pF component. After this, there was a little matter of sorting out incorrectly valued replacement screen-grid and anode resistors in the voltage amplifier pentode circuit.

This seemed to account for all the snags which had been introduced to the a.f. stages, and a 455 kc/s signal was next injected into the i.f. amplifier. Whereupon the first i.f. transformer turned out to be a type occasionally employed in Australian

wide band tuners, and which operates at 1,900 kc/s! The final "repair" encountered was that the 100pF coupling capacitor to the a.g.c. diode had been carefully cut out. After this, all that was required was re-alignment of the frequency-changer tuned circuits, which were (of course) much further out of alignment than could be accounted for by ordinary drift.

The imagination baulks at the mental processes which caused the set-owner to subject his receiver to treatment of this nature. Nevertheless, the story is quite true, and it offers an illuminating picture of what can happen when a really inspired meddler gets his hands on electronic gear!

Seed Sorting

Electronic devices appear in all manner of places in this increasingly mechanised day and age, and a news item which has just been passed on by E.M.I. Electronics Ltd. describes one of the more unusual applications. In this, "seeds" (which may be peas, garden beans, coffee beans or any other commodity of similar size) are checked at high speed for flaws or stains.

The seeds are fed from a hopper on to a grooved belt, where they run horizontally at a constant speed in single file. They are then projected from the belt, as a succession of single seeds, into a "scanning chamber". This chamber is fitted with slides of a standard colour which corresponds to the desired colour in the product. The seeds passing through the chamber are scanned by E.M.I. photomultipliers from four sides, this process being possible since, at the moment of scanning, each seed is in mid-air.

If, because of flaws or stains, any seed varies from the standard colour by more than a pre-set amount, the change in illumination of the photomultipliers causes an electro-magnetically controlled air valve to operate immediately below the point of scanning. The reject seed is then deflected to a separate outlet from the chamber. Satisfactory seeds pass through the chamber undeflected.

The seed-sorting machines employing this technique are manufactured by R. W. Gunson (Seeds) Ltd., and they are capable of dealing with very large quantities of the product. A single machine can, in fact, handle 5 cwt. of peas in an hour.

Advance and Nagard

Many readers, and especially those in the professional field, will be familiar with the excellent test

equipment manufactured by Advance Components Ltd. They will also be aware of the high performance oscilloscopes and pulse generators made by Nagard Ltd.

Advance Components Ltd. announce that they have now acquired the share capital of Nagard Ltd. Nagard instruments are, in consequence, added to the Advance Components product range, and

their marketing is handled by the Advance Components Sales Department at Roebuck Road, Hainault, Essex. However, the servicing of Nagard instruments continues to be carried out at the Nagard works at Avenue Road, Belmont, Surrey.

January Again

By the time these notes appear in print we shall be on the point of

entering yet another year. Let me proffer the wish that 1963 will be truly prosperous, and that the twelve months will see all home constructor projects working from the instant they are first switched on, together with brand new manufacturers' surplus retailing at ten shillings the ton!

And, of course, a very Happy New Year to you all.

Comprehensive

PART 1

VALVE TESTER

By P. CAIRNS, A.M.I.P.R.E.

Our contributor describes a relatively inexpensive valve tester which is capable of carrying out the comprehensive checks given by a professional instrument. Constructors should note that two of the mains transformers used in the tester may need to be obtained through surplus channels or home-wound. The article gives winding details for these components.

ONE OF THE MAIN PROBLEMS MET WITH IN THE amateur construction and servicing workshop is the testing of valves. These may have to be taken to the local service store (often at some inconvenience) and left for testing. Even then, the results are not always conclusive.

In the case of the amateur experimenter who requires a complete set of curves for a particular valve, or a matched pair for an audio amplifier, either a special test rig has to be made or the manufacturer's data assumed to be correct. In the case of surplus or ex-W.D. valves, such figures cannot always be believed.

In the following article a comprehensive valve tester is described which can be built at a relatively low cost by the average constructor. This unit has facilities for testing the static characteristics of the vast majority of valves in common use in the radio and electronic fields, and should prove useful to both the amateur and professional engineer, particularly where experimental and servicing work is carried out.

Design

The basic circuit for testing valve characteristics is shown in Fig. 1. With such a circuit the degree of emission may be checked and the valve slope, or gm, found. Also, its amplification factor, μ , and impedance, r_a , can be computed. A complete family of curves may be taken, those consisting of changes in grid voltage (V_g) plotted against changes in anode current (I_a) for various levels in anode voltage (V_a), and changes in V_a plotted against changes in I_a for various levels of V_g .

This means that the static characteristics of the valve under all possible variations in working conditions can be found. In the design of radio and electronic apparatus such information is a necessity. The simple test circuit of Fig. 1 may, therefore, be used to check a suspect valve for emission or for checking the complete characteristics for design purposes. Such a simple rig is, however, of limited use when the large number of different valve types in current use are considered, together with their wide range of heater and electrode voltages and the almost infinite number of base and pin combinations. The unit described was designed to cover all these variables whilst maintaining a relatively straightforward test circuit involving no complex switching arrangements. The unit allows the testing of both single and double

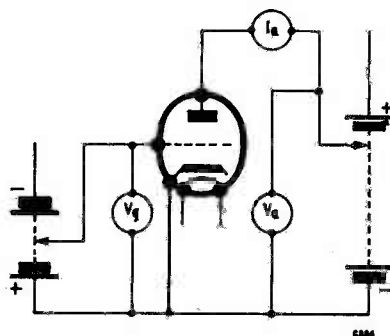

Fig. 1. The basic testing circuit

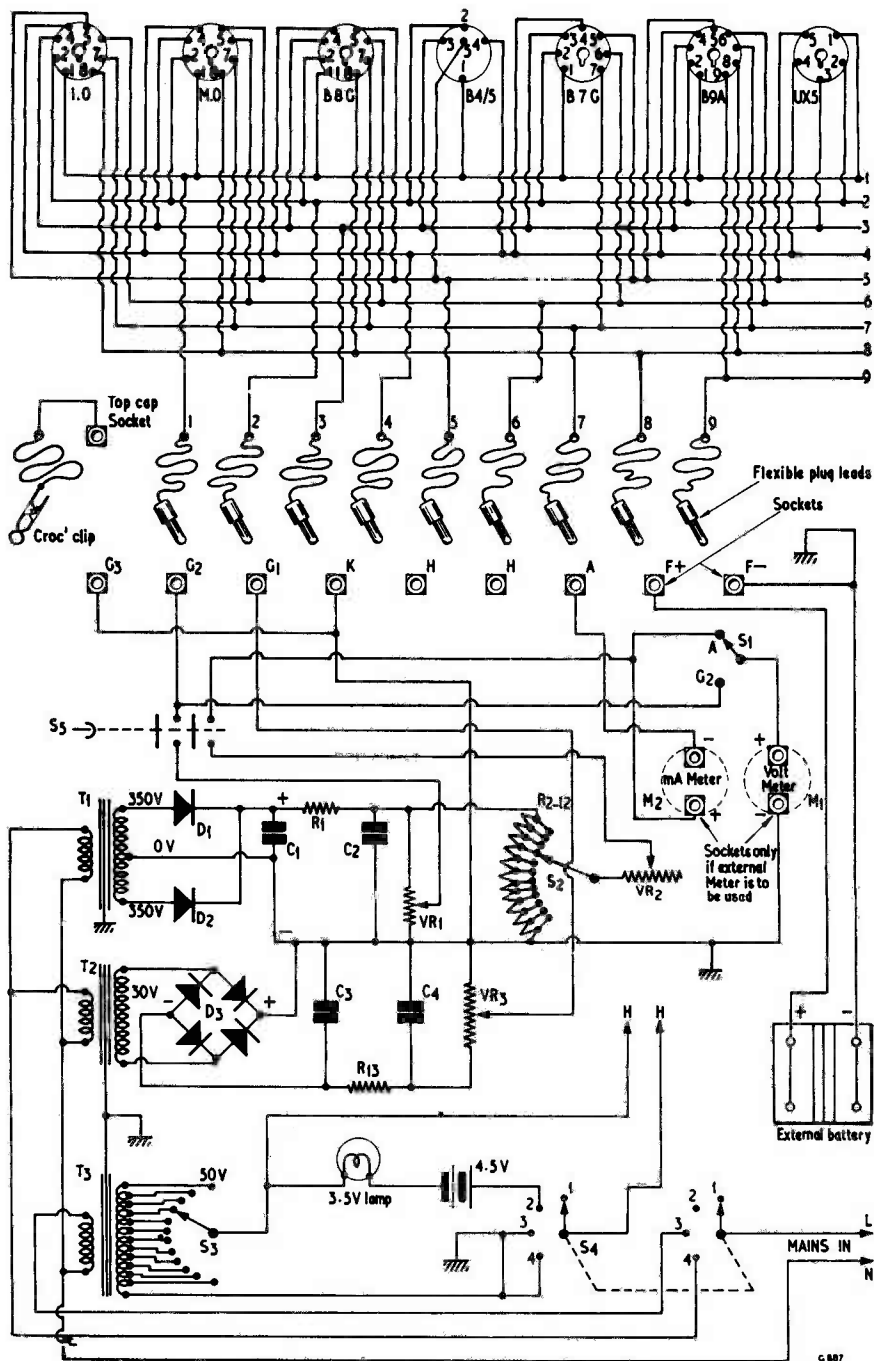

Fig. 2. Circuit of comprehensive valve tester

ended valves of any base type and any combination of pin connections. Though only seven types of valveholder were included in the prototype, further types may be added at any time. Valve base and pin selection are carried out as follows: all similar

valve pin numbers on each valveholder are connected together and brought out through the front panel via a flexible plug lead. Mounted along the top of the panel are a set of sockets to which are wired internally the various electrode supply

Components List (Fig. 2)

Resistors

R ₁	470Ω 1 watt
R ₂ -R ₁₂	4.7kΩ 1 watt
R ₁₃	680Ω 1 watt
VR ₁	50kΩ 3 watt wirewound
VR ₂	3kΩ 3 watt wirewound
VR ₃	3kΩ 3 watt wirewound

Capacitors

C ₁	16μF, 500V electrolytic
C ₂	16μF, 500V electrolytic
C ₃	100μF, 50V electrolytic
C ₄	100μF, 50V electrolytic

Meters

M ₁	0-350 or 0-500V (at least 1,000Ω per V)
M ₂	0-50 or 0-100mA (M ₁ , M ₂ not required if multimeter to be used)

Rectifiers

D ₁	350V selenium 100mA
D ₂	350V selenium 100mA
D ₃	50V selenium 10mA

voltages, each socket being appropriately labelled. By inserting a plug lead in the requisite socket, any particular electrode supply can be applied to any set of similarly numbered valve base pins. There will therefore be nine flexible plug leads, each corresponding to a particular pin number on any base; together with seven sockets corresponding to anode, cathode, heaters, and three grids, the appropriate supply connecting internally to each. By plugging the correct pin numbers into the appropriate sockets, complete flexibility of valve base and pin connections is obtained without resorting to the complex switching devices often met with in commercial valve testers.

Two extra sockets (F+, F-, in Fig. 2) are included for testing battery valves with d.c. filaments. These sockets are brought out to a two-way terminal block on the front panel to allow an external d.c. or battery supply of the appropriate voltage to be applied. These sockets are selected when required by means of the plug leads just described.

With regard to metering either a voltmeter and milliammeter can be built into the unit, thereby making it completely self-contained, or a normal type multimeter can be used externally. In the latter case the appropriate metering points are brought out to sockets on the front panel. The writer adapted this method himself with complete success, as a multimeter was already available.

Transformers

T ₁	Standard mains with 350-350V 100mA secondary
T ₂	30V secondary (see text)
T ₃	Sec. voltages 4, 5, 6.3, 12.6, 15, 20, 26, 31, 35, 39, 45 and 50 (see text)

Switches

S ₁	s.p.d.t. toggle
S ₂	12-pole, 1-way
S ₃	12-pole, 1-way
S ₄	1-pole, 4-way and 1-pole (double wiper) 4-way, 2-bank
S ₅	Spring-loaded 2-pole push button or key switch

Miscellaneous

- 10 sockets, all one colour; plus 2 black and 2 red sockets if internal meters are not used.
- 11 plugs, all one colour; plus 1 black and 1 red plug if internal meters are not used.
- 1 heavy-duty crocodile clip
- 6 pointer knobs
- 1 ea valveholders—B7G, B9A, I.O., M.O., B8G, B4/5, UX5, plus any further types desired
- 1 3.5V lamp with holder
- 1 4.5V dry battery
- 1 2-way terminal block
- 1 external dry battery

In consequence, the expense of an extra two meters was avoided. The meter or meters used should be at least 1,000Ω per volt and the more accurate they are the more accurate will be the test results obtained. The milliammeter reads anode current and the voltmeter can be switched by means of S₁ to read either anode or screen-grid voltage.

The various electrode voltages are supplied from conventional power packs, metal rectifiers being used throughout to avoid any warming up period. The screen-grid voltage for the G₂ socket is continuously variable, through VR₁, between 0 and about +350 volts. The anode voltage is selected between similar limits by S₂ in a series of twelve steps, with VR₂ giving fine voltage control between steps. Control grid voltage (G₁) is continuously variable by means of VR₃ between 0 and about -30 volts. Various values of heater voltage between 4 and 50 are selected by S₃, these being the values or near-values of heater voltage most commonly met with in practice. S₄ is the test selection switch, of which position 1 is "Off", position 2 is "Heater Continuity Test" (lamp and l.t. battery in series with heater), position 3 is "Heater Transformer On", and position 4 is "H.T. and Grid Transformers On." A spring-loaded push button or key switch, S₅, is included in the anode and screen grid lines, this having to be pressed when setting up h.t. voltages or taking

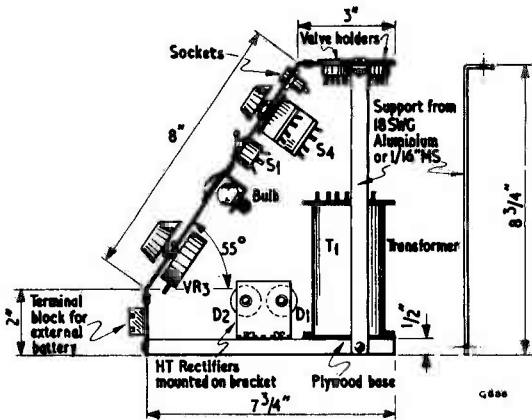

Fig. 3. Side view of the unit

a current reading. The valve under test is therefore conducting only when taking a reading or when setting up. This prevents overloading valves, particularly large output types, or running them at maximum rating for long periods when taking a series of curves at maximum values of anode current.

After a brief study of the circuit in Fig. 2 the working of the unit should be self-explanatory. Full constructional details and examples of typical practical valve tests and results will be described.

It will be seen that no facilities are available for checking internal short-circuits between electrodes. As this would involve some rather complex switching it was not considered worthwhile. In any case such short-circuits generally show up in the form of unaccountable readings or internal sparking when the valve is being tested.

A stabilised h.t. line was also considered, as the regulation of the transformer may not be too good when testing valves with a large I_a value. As, however, the anode and screen grid voltages are set up with S_5 pressed and the valve conducting regulation problems are avoided, and this allows the extra bulk and expense of a stabilising circuit to be dispensed with.

Construction

The layout and construction of the unit is not critical and may be made to suit individual requirements or to fit in with an existing test panel. A suitable form of construction is shown with suggested dimensions and component layout in Figs. 3, 4 and 5. The transformers are mounted at the rear of the 1/2 in thick plywood base, the rectifiers and smoothing circuit being mounted in front of these. The remainder of the components, variable resistors, switches, sockets, valveholders, etc., are mounted on the aluminium front panel which is bent as shown in the sketch. The complete panel should be marked off and drilled before being bent.

Before the panel is screwed to the base all the wiring should be completed, the connections

between the base and front panel components being made flexible and a little longer than necessary to allow the two sections to be "opened" for simplicity of wiring.

The small holes through which the flexible plug leads are brought should be made large enough to allow the leads to slip back into the panel when not in use, leaving only the plug above the front panel. This gives a tidy appearance to the unit. The various controls, sockets, leads, etc., can be mounted and inscribed as shown in Fig. 5. The top cap clip (see Fig. 6) is simply a large, heavy-duty, crocodile clip.

The only further point to mention regarding construction concerns the transformers. The heater transformer will almost certainly have to be wound by hand, full details being given at the end of this article. If, however, any spare mains transformers are to hand, the secondary can be carefully removed leaving only the primary winding. T_3 secondary can then be wound on top of this primary, thus saving the bother of winding a primary with its large number of turns. Due allowance must be made for differing number of turns per volt. The number of turns per volt is generally dependent upon core area, a larger core having less turns per volt.

The h.t. transformer T_1 is a conventional mains transformer with a 350-0-350 100mA secondary. If desired, the heater windings usually fitted on such transformers can be removed, whereupon sufficient space will be left for the 30 volt control grid winding to be included in this transformer, thereby dispensing with T_2 . Again, allowance must be made for turns per volt. As suitable transformers are sometimes available on the surplus market it may not be necessary to wind these. Transformers assembled by the constructor should be evenly wound so as to ensure getting all the turns in the window space available.

Setting Up Tests

When the unit is completed it should first be tested so as to ensure it is working correctly before

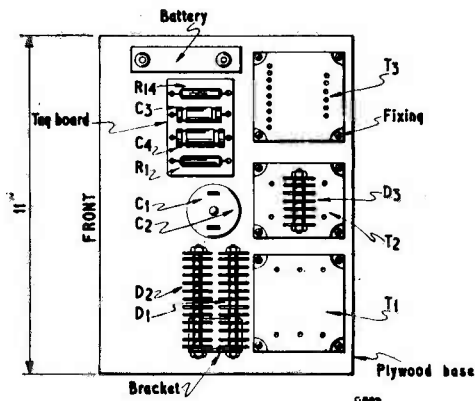

Fig. 4. Plan view of the baseboard without the front panel

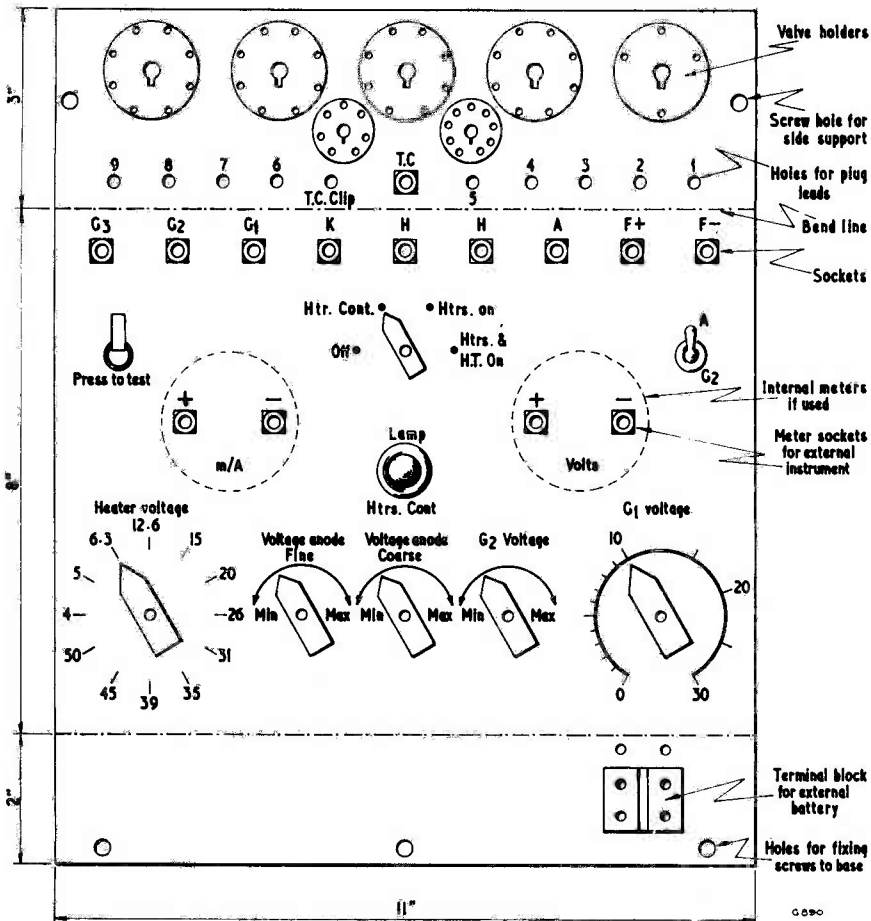

Fig. 5 Front view of panel and markings before bending. Material is 18 s.w.g. aluminium

any valve checks are carried out. The following tests and calibrations should be carried out:

- (1) Check for continuity between each similarly-numbered set of valveholder pins and the appropriate plug to ensure there are no crossed pin connections in the wiring of the valveholders.
- (2) Check all other wiring, particularly in the mains and S_4 circuits.
- (3) Put S_4 into position 2 and connect a 5Ω resistor between sockets H and H. The heater continuity lamp should then light. Remove the resistor.
- (4) With the unit plugged into the mains, switch S_4 to position 3 and connect an a.c. voltmeter between sockets H and H. Rotate S_3 through all 12 positions and check for correct heater voltage at each step. The voltages can be marked on the panel in indian ink or by the use of number transfers. The voltages measured may be slightly high due to the transformer being on open circuit.
- (5) Put S_4 to position 4, S_1 to "G2", VR_1 to

maximum h.t. volts. If an internal meter is fitted it should read about 350 volts when S_5 is pressed. Otherwise connect a suitable d.c. voltmeter between sockets K and G_2 and the shorting link across the milliammeter sockets, a similar voltage should be read when S_5 is pressed. Next rotate VR_1 to the other end of its scale, whereupon the voltage should then be zero. The scale of VR_1 can now be calibrated in terms of minimum and maximum voltage as shown in Fig. 5.

(6) Switch S_1 to "A", S_2 to maximum h.t. An internal meter should read the same as in (5) when S_5 is pressed. Otherwise connect an external meter between the K and A sockets, leave the shorting link across the milliammeter sockets, then check for correct voltage when S_5 is pressed. This same reading should be given when the external meter is plugged into the voltmeter sockets. When S_2 is rotated the voltage should drop approximately 25 volts at each step. VR_2 will have negligible effect as there is no external series load. Calibrate

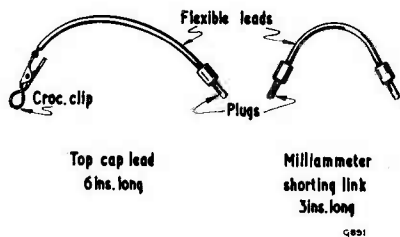

Fig. 6 The top cap lead and milliammeter shorting link

S_2 and VR_2 in terms of minimum and maximum voltage as shown in Fig. 5.

7) With the anode voltage set to about 300 connect a milliammeter in place of the shorting link, (if no internal meter is used). Now connect a $33k\Omega$ resistor between the K and A sockets, being careful

not to touch the wire ends of the resistor. When P_1 is pressed a current of about 9mA should be read. Remove the resistor and external meter.

(8) Connect a suitably scaled d.c. voltmeter between K and G_1 sockets. With VR_3 at the extreme negative end of the potentiometer, the meter should read slightly over 30 volts, dropping to zero when VR_3 is turned in the opposite direction. A scale for VR_3 can now be marked on the front panel calibrating in 1 volt steps from 0 to 10 volts, and in 5 volt steps from 10 to 30 volts. As the G_1 volts are very important a great deal of care must be taken when calibrating this scale to ensure that a high degree of accuracy is achieved.

With the above tests satisfactorily completed, return S_4 to position 1 and all voltage controls to their minimum value. Never begin to test a valve with the h.t. voltage controls set at a high value. Always set the heater and G_1 voltages to the correct value before inserting the valve.

(To be continued)

TRADE REVIEW . . .

Handy Tool for Hobby and Household

A new composite tool, the "8 in 1", consists of an unbreakable imitation amber handle fitted with a chuck which will take a set of implements for seven different applications. These implements are—a hacksaw, a hammer complete with a nail claw, a Philips screwdriver, two normal screwdrivers and an awl. The various screwdrivers and the awl fit within the handle when not required for use.

The whole assembly is shown in the illustration herewith. The price is 10s. and 6d. post free and the tool may be obtained direct from F. W. Lee (Industrial Equipment) Ltd., 23a Bond Street, Ealing, London, W.5.

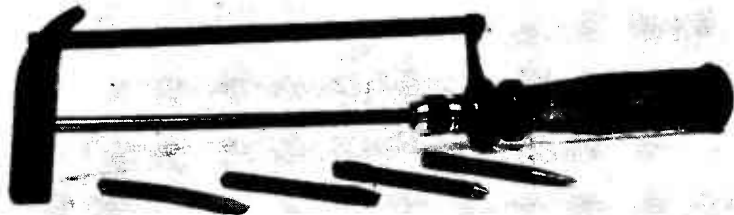

NEXT MONTH . . .

- THE "CRYSTELLA" Crystal-Controlled FM Tuner
- 20-50 METRE Short Wave Mains Two
- "TOP BAND" Converter

SIMPLE TIMER CIRCUITS

By N. W. BRIDGE

Electrolytic capacitors with very high values are now becoming available. Such components can be used to provide relatively long periods in timing circuits with a minimum of components. Our contributor describes simple timer circuits which may be constructed around a single 20,000 μ F capacitor

THERE ARE MANY USES FOR A SIMPLE TIMER WHICH do not warrant the expense of valves or transistors and the circuit to be described can be made about as simple as it is possible to be. There must of course be some form of power supply and control for any type of timer, but apart from these, this circuit in its simplest form has two components only, i.e. a relay and a capacitor. Slugging a relay with a capacitor to make it drop out slowly is a very old and well known method, and the author recently obtained a 20,000 μ F capacitor, 25 w.v., which meant that a high speed relay with its two 1,700 Ω coils in series could be made to drop out after about two minutes. The 20,000 μ F capacitor is a Plessey component type CE.12002/8.

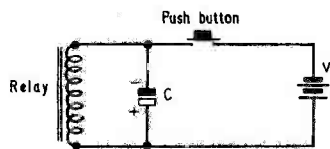

E194

Fig. 1

Fig. 1 shows the circuit, with a push button switch used to charge the capacitor C to the supply voltage V. When the button is pressed, the relay energises and the capacitor charges (after a moment) to the full supply voltage. On releasing the button, the capacitor discharges through the relay according to the curve shown in Fig. 2. After some time, the current falls to the drop out current of the relay, therefore its contacts (not shown in Fig. 1) revert to normal.

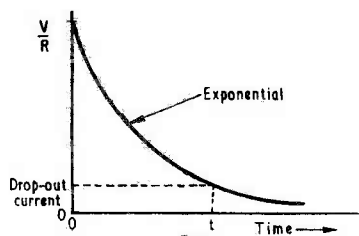

E195

Fig. 2

Practical Circuits

The first circuit used in practice was that of Fig. 3. The relay is a normal P.O. type 3,000 with two 400 Ω coils in series, this energising at any voltage greater than 9 and dropping out at about 3V. The circuit enabled contacts A₁ to remain closed for approximately 25 seconds. On raising the supply voltage to 25, the contacts remained closed for 45 seconds. R₁ is a small value resistor, of a few ohms, to limit the charging current for the capacitor. If this resistor is too large, the push button must be pressed longer to ensure full charging.

In order to obtain longer periods, it was necessary to increase either C or R, and a high speed relay of 1,700 Ω each coil was tried. This gave a period

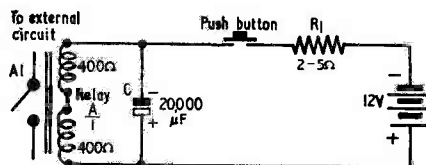

E196

Fig. 3

of some two minutes for an applied voltage of 15 to 25.

It was possible in both cases to get shorter periods by using one relay coil only, or both coils in parallel.

To avoid using a battery, the circuit of Fig. 4 may be employed. This does not even require magnetising current for the transformer when the button is not being pressed. If only a low voltage button is used (such as a bell push) it should be

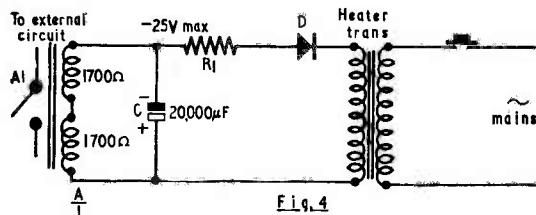

E197

Fig. 4

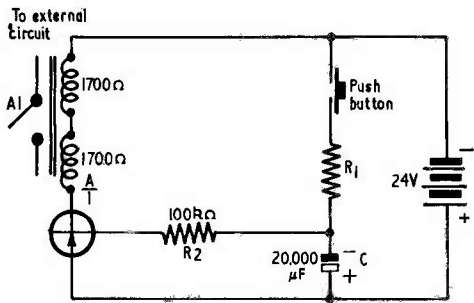

Fig. 5

E198

inserted between the diode and R_1 , but there will then be a small current continuously taken from the mains.

Adding a Transistor

It was found possible to get longer times of switching from the simple capacitor-relay circuits because higher resistance relays needed higher operating voltages, which the capacitor could not stand. Hence a transistor was employed as in the circuit of Fig. 5. The values of C and R_1 are as

before but, when the capacitor has been charged by pressing the push button, it now discharges through R_2 , switching on the transistor. The collector current is about α' times the base current and enough to pull in the relay. The time taken to discharge through the high resistance is much longer than before, and since the relay drop out current remains the same (say 2mA) the base current can fall to some 40 μ A if α' is 50, before the relay drops out. In this way, a time of about 27 minutes was obtained in practice, though α' was only about 20 for the transistor used.

It is normally necessary to connect a diode across a relay winding in a collector circuit to absorb the high voltage developed if the transistor switches off quickly. Here the collector current reduces exceedingly slowly, so the diode is not needed.

A control of the length of the switching period would be given by varying R_2 , subject to the limit of maximum base current, which must not be exceeded.

A somewhat more accurate timing period with these circuits would be given if the push button had a second pole, thus completing the external circuit via the relay contact when the push button was released. Timing would then commence when the push button was released, and the period would not have added to it the probably varying time when the push button is initially pressed.—EDITOR

Royal Navy Survey Ship Discovers New Ocean Depth

★ H.M.S. Cook Records 6,297 Fathoms in Pacific

H.M.S. *Cook*, one of the Royal Navy's survey ships employed on oceanographic surveys in the Pacific, has reported to the Admiralty the discovery of a new greatest depth in the world's oceans.

A corrected sounding of 6,297 fathoms (37,782 feet; 11,560 metres) was recorded by deep echo sounding machine in a position 6 degrees 6 minutes north, 127 degrees 25 minutes east in the Mindanao Trench close to the eastward of the Philippines.

H.M.S. *Cook's* sounding survey has revealed the existence of a narrow trough some 15 miles long, in the north-south direction, and 1½ to 4 miles wide with a depth exceeding 6,000 fathoms (36,000 feet; 10,973 metres). This new sounding is 263 fathoms (1,578 feet; 481 metres) deeper than any previously recorded depth.

This again shifts the location of the greatest known depth in the world's oceans from the Marianas Trench where, in the Challenger Deep, the U.S. Bathyscaphe *Trieste* descended to the sea bed in 5,967 fathoms (35,802 feet; 10,912 metres) in 1960 and where, in 1959, the Russian research ship *Vityaz* reported a depth by echo sounding machine 6,034 fathoms (36,204 feet; 11,035 metres)—until H.M.S. *Cook's* discovery the deepest recorded depth anywhere in the world.

In the Mindanao Trench the greatest depth previously recorded was 5,740 fathoms (34,440 feet; 10,499 metres) obtained by the U.S.S. *Cape Johnson*.

Detailed results of H.M.S. *Cook's* survey of the "Cook Deep" are awaited at the Admiralty, and the ship has now resumed her work in carrying out a survey of the sub-surface counter equatorial current in the Pacific. She was on her way to the Gilbert Islands, obtaining deep water samples for the National Institute of Oceanography in the Mindanao Trench, when the new depth soundings were recorded.

NOW YOU can MASTER ELECTRONICS!

**BRITAIN'S MOST COMPREHENSIVE PRACTICAL
COURSE IN RADIO
ELECTRONICS • TELEVISION!**

**THESE SPECIAL TRAINING
KITS — YOURS TO KEEP**



Multi-Range
TEST METER



CATHODE RAY
OSCILLOSCOPE

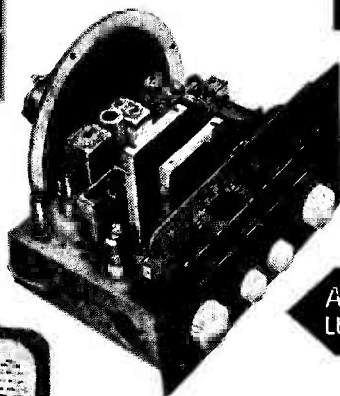

AM and VHF/FM
LUXURY RECEIVER



SIGNAL GENERATOR



Complete set of
Picture Way books and
Experimental Manuals

**LEARN BY BUILDING
NOW for your
CAREER • HOBBY
OWN BUSINESS**

YOU RECEIVE

- Complete kits of equipment as illustrated.
- Complete set of experimental manuals.
- Complete set of "picture-way" theory books.
- Modern test-yourself examination sheets.
- Study programme.
- Unlimited consultation with Tutors.

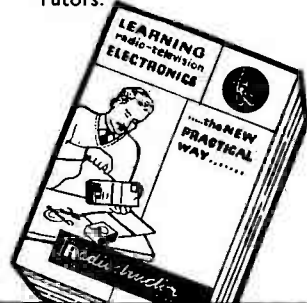

**FREE
BROCHURE**

POST NOW

RADIOSTRUCTOR

TO RADIOSTRUCTOR (DEPT. M.31)
READING, BERKS.

Name

Address

**BLOCK
CAPS
PLEASE**

(We do not employ representatives)

1.63

with a MARTIN RECORDAKIT

YOU CAN BUILD YOUR OWN

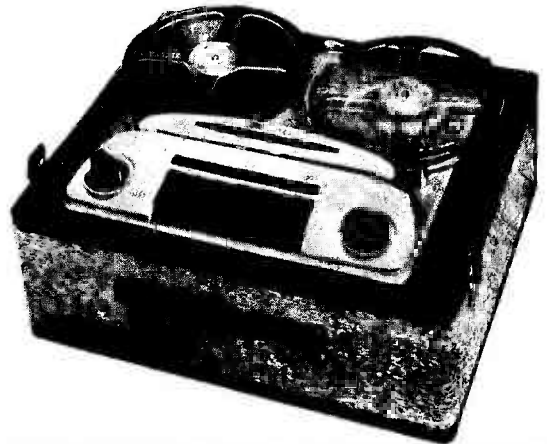

**TAPE RECORDER QUICKLY, EASILY, CHEAPLY
WITH NO PREVIOUS EXPERIENCE**

With a Martin Recordakit everything you need is supplied, ready to assemble—even down to wire cut to length. The easiest and cheapest way to own a Hi-Fi quality Tape Recorder. Fill in the coupon for full details.

Post to: MARTIN ELECTRONICS LTD.
155 HIGH STREET, BRENTFORD, MIDDX.
Please send me free leaflet on Martin Recordakits
NAME
ADDRESS
(In block letters)..... RC 1.63

EVERYTHING FOR THE ENTHUSIAST

GELOSO V.F.O. UNITS. 4/102 with new dial and escutcheon. Outputs on 80, 40, 20, 15 and 10. For 2-807 or 6146 tubes. Only £8.5.0. 3 valves to suit, 24/-. All post free.

ALSO PI TANK COILS for 1 or 2 valve P.A. 24/-. P. & P. 2/-.

MULTI-WAY CABLE. 3-core screened 1/- yd.; 12-core screened 2/- yd. First grade Mike Cable 9d. yd. P. & P. 2/-.

EDDYSTONE VARIABLES. .080 spacing, 3 types 25 x 25pF, 50 x 50pF and 100pF diff. 10/- each. Post free.

TOUGH POLYTHENE LINE. Type ML1 (100 lb) 2d. per yd. or 12/6 per 100 yds. Type ML2 (220 lb) 4d. per yd. or 25/- per 100 yds. Post free.

Absorption Wave-Meters. 3.00 to 35.00 Mc/s in 3 switched bands, 3.5, 7, 14, 21 and 28 Mc/s ham bands marked on scale. Complete with indicator bulb. A MUST for any hamshack. ONLY 22/6 Post free.

RACK MOUNTING PANELS. 9" x 5 1/2", 7", 8 1/2" or 10 1/2" black crackle finish, 5/9, 6/6, 7/6 and 9/- respectively, postage and packing 2/-.

WOULD ALL OUR MANY CUSTOMERS, MAIL ORDER AND CALLERS PLEASE NOTE:

On & After JAN 21st 1963

We are moving to NEW & EXTENSIVE PREMISES AT:

170 - 172 CORPORATION ST. BIRMINGHAM 4

After that date ALL COMMUNICATIONS should be to that Address. TEL. NO. as before: CEN 1635

AERIAL EQUIPMENT

COPPER WIRE. 14g. h.d.: 140' 17/-; 70' 8/6; 7/25 stranded: 140' 10/-; 70' 5/-, plus 2/- P. & P.

RIBBED GLASS INSULATORS. 3" 1/9 each. P. & P. 1/6 up to 12.

TWIN FEEDER. 300 ohm twin ribbon feeder, similar K25, 6d. per yd. K358 Telcon (round) 1/6 per yd. Post on above feeder and cable 1/6 any length.

SUPER AERAXIAL CABLE 1/8 per yd. P. & P. 2/-.

CERAMIC FEEDER SPREADERS. Type F.S. 6" 10d. each. P. & P. 2/- up to 12.

CERAMIC "T" PIECES. Type AT for centre of dipoles, 1/6 each. P. & P. 1/-.

NEW MOSLEY POWER BEAMS. Write for details, 300 watt, 50 ohm COAX, 1/4" dia. very low loss, 1/9 yd. P. & P. 2/-.

SHELL INSULATORS. 2" 9d. each, 8/- doz. P. & P. 2/- up to 12.

CERAMIC COIL FORMERS. 2 1/2" x 1 1/2". IDEAL FOR VFO or P.A. on Mobiles, 1/9 each or 17/6 doz.

BTX. 3 1/2" x 1 1/2" with 32 Grooves for P. Tanks 6/- ea.

TFX. 2 1/2" Dia. 5" WINDING SPACE. Ideal Hi Power Lin. Amps 8/6.

150 OHM GENUINE BEADED COAX. 20yd. lengths. Very low loss. 10/- per coil. Post free.

SPECIAL OFFER

BEL-CLEER HI-FI RECORDING TAPE 5" (600ft) STD. 12/6
7" (1200ft) 18/6. 5" (900ft) L.P. 15/-
7" (1800ft) 25/- P. & P. 1/6.

SHADED POLE MOTORS. 230V or 110V operation. Ideal for fans, blowers or models. One only: 12/6, plus 2/- P. & P. Or pair: £1, plus 2/6 P. & P.

MOSLEY TRI-BAND BEAMS
T33, JR, 3 EL ... £24.15.0
TA32 JR, 2 EL ... £17.10.0
V3 JR, Vertical 3 Band ... £7.10.0
PLACE YOUR ORDER EARLY

CHAS H. YOUNG LTD (Dept. R)

110 DALE END BIRMINGHAM 4
(Tel. all departments) CEN 1635

FREE TO AMBITIOUS ENGINEERS

— THE LATEST EDITION OF ENGINEERING OPPORTUNITIES

Have you sent for your copy?

ENGINEERING OPPORTUNITIES is a highly informative 156-page guide to the best paid engineering posts. It tells you how you can quickly prepare at home for a recognised engineering qualification and outlines a wonderful range of modern Home Study Courses in all branches of Engineering. This unique book also gives full details of the Practical Radio & Electronics Courses, administered by our Specialist Electronics Training Division—the *B.I.E.T. School of Electronics*, explains the benefits of our Employment Dept. and shows you how to qualify for five years promotion in one year.

We definitely Guarantee "NO PASS — NO FEE"

Whatever your age and experience you cannot afford to miss reading this famous book. If you are earning less than £25 a week send for your copy of "ENGINEERING OPPORTUNITIES" today—FREE.

BRITISH INSTITUTE OF ENGINEERING TECHNOLOGY (Incorporating *E.M.I. Institutes*)
(Dept. SE/23), 29 Wright's Lane, London, W.8

THE B.I.E.T. IS THE LEADING ORGANISATION OF ITS KIND IN THE WORLD

WHICH IS YOUR PET SUBJECT ?

Mechanical Eng.,
Electrical Eng.,
Civil Engineering,
Radio Engineering,
Automobile Eng.,
Aeronautical Eng.,
Production Eng.,
Building, Plastics,
Draftsmanship,
Television, etc.

GET SOME LETTERS AFTER YOUR NAME!

A.M.I.Mech.E.
A.M.I.C.E.
A.M.I.Prod.E.
A.M.I.M.I.
L.I.O.B.
A.F.R.Ae.S.
B.Sc.
A.M.Brit.I.R.E.
City & Guilds
Gen. Cert. of Education
Etc., etc.

PRACTICAL EQUIPMENT

Basic Practical and Theoretic Courses for beginners in Radio, T.V., Electronics, Etc., A.M.Brit.I.R.E. City & Guilds Radio Amateurs' Exam. R.T.E.B. Certificate P.M.G. Certificate Practical Radio Radio & Television Servicing Practical Electronics Electronics Engineering Automation

INCLUDING TOOLS!

The specialist Electronics Division of *B.I.E.T. (Incorporating E.M.I. Institutes)* NOW offers you a real laboratory training at home with practical equipment. Ask for details.

B.I.E.T. SCHOOL OF ELECTRONICS



POST COUPON NOW!

Please send me your FREE 156-page "ENGINEERING OPPORTUNITIES" (Write if you prefer not to cut page)

NAME

ADDRESS

SUBJECT OR EXAM THAT INTERESTS ME

THE DUCHESS OF KENT PERMANENT BUILDING SOCIETY

Member of the Building Societies Association



ESTABLISHED

1865

Savings in this old established Building Society combine sound investment with an attractive return

Shares are in units of £25 each (maximum investment £5,000) . . . BUT, for the smaller saver, Subscription Share accounts may be opened with any sum from 1/- upwards. Interest is payable half-yearly on Fully Paid Shares—credited annually on Subscription Shares—all interest accrues monthly

WITHDRAWALS AT SHORT NOTICE

INTEREST IS AT 4% PER ANNUM

(There is NO DEDUCTION FOR INCOME TAX, as this is paid by the Society)

FOR FURTHER INFORMATION APPLY TO

**DUCHESS OF KENT
PERMANENT BUILDING SOCIETY**
103 Cannon Street London EC4

Telephone MANSION HOUSE 8011

Please send to me, without obligation, free brochure and a copy of the audited statement of accounts. (I understand that I shall not be troubled with circulars or calls by representatives)

Name

(If lady, please state Mrs. or Miss)

Address

..... R.C.

(Please use Block Capitals for both name and address)

COLLARO STUDIO TAPE RECORDER KIT

SPECIAL BARGAIN OFFER. Comp. Kit only **£25** Carr. 12/6

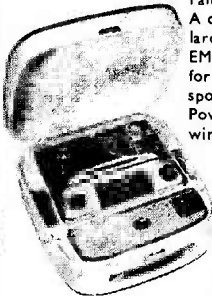

COLLARO TAPE DECK
£12.10.0 Carr. 7/6

Famous mfr's surplus offer—listed 42 gns. A quality Tape Recorder Kit based on Mullard's famous design—EF86, ECC83, EL84, EM81 and Rectifier. Specially designed Kit for Collaro latest Studio Deck, freq. response $\pm 3\text{dB}$, 60 c/s—10 kc/s. Amp. and Power Pack already wired, inter. unit wiring only required. Cabinet size: 18" x 16 $\frac{1}{2}$ " x 6" finished in contemp. 2-tone blue Rexine with gilt Speaker Escutcheon. Magic Eye indicator. Circuit and Tech. H/book, supplied free with kit. Send 3d. stamp now for full details of today's outstanding Tape Recorder Bargain.

CABINET **£3.15.0** P. & P. 6/6
AMPLIFIER KIT **£8.19.6** P. & P. 5/-
SPEAKER 7" x 4" 16/6. P. & P. 2/-
If above items are purchased together **£12.19.6** P. & P. 10/-

New Boxed	VALVES	All Guaranteed	Electrolytics All Types New Stk.	TUBULAR	CAN TYPES
1T4	6/-	ECC83 8/-	PCC84 9/6	25/25V	1/9 8+8/450V 4/6
1R5	7/6	ECL82 10/6	PCF80 9/6	50/12V	1/9 16+16/450V 5/6
1S5	7/6	ECL80 10/6	PCF83 12/6	50/50V	2/- 32+32/275V 4/6
354	7/6	EF80 8/-	PCL84 12/6	100/25V	2/- 50+50/350V 6/6
3V4	7/6	EF86 12/6	PL81 12/6	8/450V	2/3 60+250/ 12/6
DAF96	9/-	EL84 8/6	PL82 9/6	4/350V	2/3 275V 12/6
DF96	9/-	EY51 9/6	PL83 10/6	16+16/450V 5/6	100+200/ 12/6
DK96	9/-	EY86 10/6	PY32 12/6	32+32/450V 6/6	275V 12/6
DL96	9/-	EZ81 7/6	PY81 9/6		
ECC81	8/-	GZ32 12/6	PY82 7/6		
ECC82	8/-	EM84 9/6	UY25 12/6		

RECORDING TAPE—REDUCED BARGAIN PRICES
Famous American Columbia (CBS) Premier Quality Tape at NEW REDUCED PRICES. A genuine recommended Quality Tape—TRY IT! Brand new, boxed and fully guaranteed. Fitted with leader and stop folds.

Standard	Long Play	Double Play
5" 600ft. 13/-	900ft. 17/6	1,200ft. 31/6
5 $\frac{1}{2}$ " 900ft. 16/-	1,200ft. 19/6	1,800ft. 37/6
7" 1,200ft. 21/-	1,800ft. 28/6	2,400ft. 47/6

Post and Packing, per reel, 1/-, plus 6d. each for additional reels.
SPECIAL OFFER—3" mfrs. surplus tape, Std. 150 ft. 3/9, L.P. 22 $\frac{1}{2}$ ft. 4/9, D.P. 300 ft. 6/6. P. & P. per reel 6d. Plastic Tape Reels 3" 1/3, 5" 2/-, 5 $\frac{1}{2}$ " 2/-, 7" 2/3. Plastic Spool Containers 5" 1/6, 5 $\frac{1}{2}$ " 2/-, 7" 2/3

Jack Plugs. Standard 2 $\frac{1}{2}$ " Igranite Type, 2/6. Screened Ditto, 3/3. Miniature 1 $\frac{1}{2}$ ", 2/3. Screened Ditto, 2/6.
Jack Sockets. Open Igranite Moulded Type, 3/3. Closed Ditto, 3/9. Miniature Closed Type, 1/9. Sub-min (deaf aid) ditto, 1/3.
Phono Plugs 1/-. Phono Sockets (open), 1/- Ditto Closed, 1/6. Twin Phono Sockets (open), 1/6.
Soldering Irons. Mains 200/220V or 230/250V. Solon 25 watt Inst., 22/6. Spare Elements, 4/6. Bits, 1/- 65 watt, 27/6 etc.
Alumin. Chassis. 18g. Plain Undrilled, folded 4 sides, 2" deep. 6" x 4", 4/6, 8" x 6", 5/9, 10" x 7", 6/9, 12" x 7", 7/6, 12" x 8", 8/- etc.
Alumin. Sheet. 18g. 6" x 6", 1/- 6" x 9", 1/6, 6" x 12", 2/-, 12" x 12", 4/6 etc.

MULLARD "3—3" HI-FI AMPLIFIER

3 VALVES 3 WATT

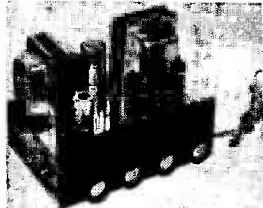

3 ohm and 15 ohm Output
A really first-class Amplifier giving Hi-Fi quality at a reasonable cost. Mullard's latest circuit. Valve line-up: EF86, EL84, EZ81. Extra H.T. and L.T. available for Tuner Unit addition. This is the ideal companion Amplifier for FM tuner units.

TECHNICAL SPECIFICATION—Freq. Response: $\pm 1\text{dB}$. 10 Kc/s. Max. Bass Boost 14 dB. at 80 c/s. sensitivity: 100 MV. for 3W. output. Output Power (at least 70 dB. below 3W).

COMPLETE KIT (incl. valves, all components, wiring diagram and special quality sectional Output Trans.)

ONLY £6/19/6 carr. 4/6d.
400 plate wired and tested 8 gns. Wired power O/P socket and additional smoothing for Tuner Unit, 10/6 extra.

Bronze Escutcheon Panel, Printed Vol., Treble, Bass, On-Off, supplied with each Kit.

Recommended Speakers—WBHF 10 12 £5, Goodmans Axiom 10 £5/15/8, Axiette £6/10, or Axiom 112 £8/10,

Volume Controls—SK-2 Meg-ohms, 3" Spindles Morganite Midget Type. 1 $\frac{1}{4}$ " diam. Guar. 1 year. LOG or LIN ratios less Sw. 3/- DP. Sw. 4/6. Twin Stereo less Sw. 6/6. D.P. Sw. 8/-.

COAX 80 OHM CABLE
High grade low loss Cellular air spaced Polythene— $\frac{1}{4}$ " diameter. Stranded cond. Famous mfrs. Now only 6d. per yard.
Bargain Prices—Special lengths 20 yds. 9/- P. & P. 1/6.
40 yds. 17/6. P. & P. 2/-
60 yds. 25/- P. & P. 3/-
Coax Plugs 1/- Sockets 1/6
Couplers 1/3. Outlet Boxes 4/6.

Close Tol. S/Micas—10% 5pF-500pF 8d. 600-5,000pF 1/- 1 $\frac{1}{2}$ 2pF-100pF 9d. 100pF-500pF 11d 575pF-5,000pF 1/6. **Resistors—Full Range** 10 ohms-10 megohms 20% $\frac{1}{4}$ and $\frac{1}{2}$ W 3d., $\frac{1}{2}$ W 5d. (Midget type modern rating) 1W 6d., 2W 9d., Hi-Stab 10% $\frac{1}{2}$ W 5d., $\frac{1}{2}$ W 7d., 5% $\frac{1}{2}$ W 9d., 1% $\frac{1}{2}$ W 1/6.
W/W Resistors 25 ohms to 10K 5W 1/3, 10W 1/6, 15W 2/- **Pre-set T/V Pots.** W/W 25 ohms—50 K 3/- 50 K-2 Meg. (Carbon) 3/-

JASON FM TUNER UNITS
Designer-approved kits of parts:
FMT1, 5 gns. 4 valves, 20/-
FMT2, £7. 5 valves, 37/6.
JTV MERCURY 10 gns.
JTV2 £13.19.6. 4 valves, 32/6.
NEW JASON FM HANDBOOK, 2/6. 48 hr. Alignment Service 7/6. P. & P. 2/6.

Speakers P.M.—3 ohms 2 $\frac{1}{2}$ " E.M.I. 17/6. Goodmans 3 $\frac{1}{2}$ " 18/6. 5" Rola 17/6. 6" Eiac 18/6. 7" x 4" Goodmans 18/6. 8" Rola 20/- 10" R. x A. 25/- 9" x 6" Goodmans 25/- E.M.I. Tweeter 29/6.
Speaker Fret—Expanded bronze anodised metal $\frac{1}{4}$ " x $\frac{1}{2}$ " diamond mesh, 4/6 sq. ft., multiples of 6" cut. Max. width 4 ft.

TYGAN FRET (contemp. pat.) 12" x 12" 2/-, 12" x 18" 3/-, 12" x 24" 4/-, 18" x 18" 4/6

BARGAINS 4-SPEED PLAYER SINGLE PLAYERS carr. 3/6
Garrard TA Mk. 2 £7.19.6
B.S.R. Latest Model TU12 79/6
E.M.I. Junior '985" 89/6
Auto-Changers carr. 5/-
Garrard RC209 9/6 gns.
Garrard "Auto-Slim" £8.12.6
Collaro C60 £7.15.0
B.S.R. (UA14) £7.10.0

RECORD PLAYER CABINETS

Contemporary style, rexine covered cabinet in mottled red and white polka dot. Size 18 $\frac{1}{2}$ " x 13 $\frac{1}{2}$ " x ht. 8 $\frac{1}{2}$ ", fitted with all accessories including baffle board and anodised metal fret. Space available for all modern amplifiers and auto-changers, etc. Uncut record player mounting board 14" x 13" supplied.
Cabinet Price £3.3.0 Carr. and Ins. 5/-

2-VALVE 2 WATT AMPLIFIER
Twin stage ECL82 with vol. and neg. feedback tone control. A.C. 200/250V with knobs, etc., ready wired to fit above cabinet. £2.17.6. P. & P. 1/6. 6" Speaker and trans. 22/- P.P. 2/-

COMPLETE R/PLAYER KIT. As ill. inc. BSR UA14 Unit £12.19.6. Carr. 7/6.

ENAMELLED COPPER WIRE— $\frac{1}{16}$ reels, 14g-20g, 2/6; 22g-28g, 3/-; 30g-40g, 3/9. Other gauges quoted for.

PVC CONNECTING WIRE—10 colours (for chassis wiring, etc.)—Single or stranded conductor, per yd., 2d. Sleeving 2d. yd.

TRANSISTOR COMPONENTS

Midget I.F.'s—465 Kc/s $\frac{1}{8}$ " diam. 5/6
Osc. Coil— $\frac{1}{8}$ " diam. M/W. 5/3
Osc. coil M. & L.W. 5/9
Midget Driver Trans. 3.5-1 6/9
Ditto O/Put Push-pull 3 ohms 6/9
Elect. Condensers—Midget Type 12V 1mfd-50mfd, ea. 1/9. 100mfd, 2/-
Ferrite Aerial—M. & L.W. with car aerial coupling coil, 9/3.

Condensers—150V. wkg. .01 mfd., to .04 mfd., 9d. .05 mfd., 1 mfd., 1/-, .25 mfd., 1/3. .5 mfd., 1/6, etc.

Tuning Condensers. J.B. "00" 208+176pF, 8/6. Ditto with trimmers, 9/6. 365pF single, 7/6. Sub-min. 2" DILEMNI 100pF, 300pF, 500pF, 7/-.

Midget Vol. Control with edge control knob, 5k Ω with switch, 4/9, ditto less switch, 3/9.

Speakers P.M.—2" Plessey 75 ohms, 15/6. 2 $\frac{1}{2}$ " Continental 8 ohms, 13/6. 7" x 4" Plessey 35 ohm, 23/6.

Ear Plug Phones—Min. Continental type, 3ft. lead, jack plug and socket, High Imp. 8/- Low Imp., 7/6.

TRANSISTOR BARGAINS

Brand New—BVA 1st Grade

OC44	8/6	OC70	5/6
OC45	8/-	OC71	6/-
OC81	7/6	GEX34	2/9
2/OC81	15/6	OA70	2/9
GET114	6/6	OA81	2/9
OC72	7/6		

SPECIAL OFFER
OC44 OC81D 19/6
2/OC45 2/OC81

TRIMMERS, Ceramic (Compression Type)—30pF, 70pF, 9d., 100pF, 150pF, 1/3; 250pF, 1/6; 600pF, 1/4.

PHILIPS, Bee Hive Type (conc. air spaced)—2.8pF, 1/-; 3-30pF, 1/-.

KNOB—Modern Continental types: Brown or Ivory with Gold Ring, 1" dia., 9d. each; 1 $\frac{1}{2}$ ", 1/- each; Brown or Ivory with Gold Centre, 1" dia., 10d. each; 1 $\frac{1}{2}$ ", 1/3 each. **LARGE SELECTION AVAILABLE.**

METAL RECTIFIERS, STC Types—RM1, 4/9; RM2, 5/6; RM3, 7/6; RM4, 16/-; RM5, 21/-; RM4B, 17/6.



Send for detailed bargain lists, 3d. stamp. We manufacture all types Radio Mains Trans. Chokes, Quality O/P Trans., etc. Enquiries invited for Specials, Prototypes for small production runs. Quotation by return

RADIO COMPONENT SPECIALISTS
70 Brigstock Rd., Thornton Heath, Surrey
THO 2188 Hours: 9 a.m.—6 p.m., 1 p.m. Wed. Terms C.W.O. or C.O.D. Post and Packing up to $\frac{1}{2}$ lb 9d., 1 lb., 1/3 3 lb., 2/3 5 lb., 2/9 8 lb., 3/6

SMALL ADVERTISEMENTS

Private: 3d. per word, including address.
Minimum charge 2/6.
Use of Box Number, 2/- extra.

Trade: 9d. per word. Minimum charge 12/-.
Terms: Cash with order.

All copy must be received by the 6th of the month for insertion in the following month's issue. The Publishers cannot be held liable in any way for printing errors or omissions, nor can they accept responsibility for the bona fides of advertisers.

PRIVATE

FOR SALE. Overseas student leaving must sell National HR0 complete with separate power supply, 9 coils 50 kc/s-30 Mc/s, speaker. Detailed circuit and instruction book. Six months' occasional use only. £20.—Call or write to Dr. Ibrahim, 11 Venner Road, Sydenham, London, S.E.26.

FOR SALE. Two Philips rectifiers type ES4000/2, input 400/440V, output 110V, 3 phase, 50 c/s, 2kW, 18.2 amps, continuous rating, £50 each or nearest offer.—South West Metropolitan Hospital Board, Winnall Valley Road, Winchester, Hants.

FOR SALE. Marriot transistor recorder and erase heads. £2 10s. 0d. pair. Two Starkinder battery recorder motors, 15s. each. Home-constructed variable voltage stabilised power supply, 75-300V, 0-100mA output, £10 o.n.o.—14 Charlwood Road, Luton, Beds.

FOR SALE. R1155, wood table cabinet, no d.f. or b.f.o., plastic faced panel £9. G.E.C. Res.-Cap a.c. Bridge £4 15s. 0d. Signal Gen. £4 10s. 0d. TR1196 valves and circuit £1 2s. 0d. Communication receivers: Hallicrafters, 5 valves and circuit 35s.; BC455 6-9 Mc/s, m.w. coil, 6 valves, h.f., two i.f.s., d.d.t., output 35s. Various Mains valves, 9d. to 4s. 50 resistors, 1/2 watt 2/-, Output trans. 3s., 3 ratio 4s., 80mA, c.t. 7s. New mains soldering iron 5s. 6d. Moving coil meters: d.c. testmeter 8s. 6d., 8 range a.c./d.c. volts 12s. 6d., both in cases. Marconi CR100 trimming tools 5s., cost £1. Mains transformers new 350V, 400V, 250mA, 6.3V, 4V and 4V, 8s. 6d., 13, 6.3V, 13, 4V, 5s. 6d. Valve tester trans. tapped 1.4-50V and indicating switch 8s. 6d. SCPI, VCR517C and VCR97 tubes.—Cordingley, 86 Tennant Street, Bradford 5, Yorks.

FOR SALE. M.W. Command Rx. £4. ARR.5. 27-144 Mc/s, AM/FM £20, 440B £2 10s. 0d. AR88 £30. Wanted: RX1475, Valves, QQVO3-10, QQVO3-20, QQVO2-6. Heathkit 'scope or similar.—43 Brompton Road, Northallerton, Yorks.

VALVES TO CLEAR. All at 5s. including postage: 6AG5, 6AG7, 6AT6, 6BA6, 6BW6, 6K7, 6SA7, 6SK7, 12AT7, DL92, ECC82, T20, VR150-30, VT136, 807, 83, CV51. At 2s. 6d. each including postage: 1S5, EL91, EB91, 6B8. Mains transformer, Admiralty pattern 57239, 2.5V 3A (x2), 6.3V 11A, 265V-230V-0-230V-265V at 150mA, 125V-0-125V at 30mA, £2 10s. 0d., post paid.—Box No. F165.

WANTED. Publication covering construction of Williamson amplifier. State price.—Dodd, 266 King's Drive, Eastbourne, Sussex.

continued on page 469

BENTLEY ACOUSTIC CORPORATION LTD

38 CHALCOT ROAD CHALK FARM LONDON NW1
THE VALVE SPECIALISTS Telephone PRIMROSE 9090
ALL GOODS LISTED BELOW IN STOCK

*Indicates valves with new type chemical cathode for extra life & reliability

0A2	17.6	757	9.6	DAF96	7.6	EL360	27	-SP61	3.6	MIDGET	
0B2	17.6	7Y4	7.6	DD41	13.7	EL820	18.2	SU25	27.2	SILICONE	
OZ4GT	5	-8D2	3.6	DF66	15	-EL821	25.11	T41	9	RECTIFIERS	
1A5	6	-9BW6	14	11	DF96	7.6	EL822	19.6	TD4	12.6	
1A7	12	-9D2	4	-DF97	9	EM4	17.9	TP22	15	-	
1C5	12.6	10C2	12.6	DH76	5	EM34	9.6	TY86F	13	Mullard	
1C6	17.6	10C7	8	DH70	7.6	EM13	16	U12	14	BY100	
1HSGT	10.6	10D2	11.8	DK92	10.6	EM80	9	-U16	10	Output 250	
1L4	3	-10F1	25.11	DK96	8.6	EM81	9.6	U18/20	8.6	v. at 1 amp.	
1LD5	5	-10P13	15	-DL66	17.6	EM84	10.6	U19	48.6	No larger	
1LN5	5	-10P14	18.9	DL68	15	-EM85	16.10	U22	8	-than a shirt	
1NSGT	10.6	12A6	5	-DL96	7.6	EN31	53	-U24	29.1	button!	
1R5	6	-12AC6	14.11	DL510	10.6	EY51*	8.6	U25*	17.6	B. - each.	
1S4	9	-12AD6	16	DH70	7.6	EM13	16	U36*	9	-	
1S5	5	-12AE6	13.7	EBOF	30	EY86*	7.6	U1	11.6	TRANSISTORS & DIODES	
1T4	3	-12AH8	12.6	EB3F	30	EZ40	6.6	U33	29.1	-	
1U4	12.6	12AT6	7.6	E180F	34.6	EZ41	7	-U35	29.1	-	
1U5	5.6	12BA6	8	-EABC80	9	-EZ80	6	-U37	32.4	GD3 5.6	
2D21	15	-12BE6	9	-EAC91	4	-EZ81	6	-U45	13.6	GD4 5.6	
2X2	4.6	12BH7	20.9	EAF42	9	-GU50	41.6	U50	5.6	GD5 5.6	
3A4	6	-12CG7	8	-EB42	8.6	GZ32	10	-U52	4.6	GD6 5.6	
3A5	10.6	12K5	17.6	EB91	4	-GZ33	10	-U76	6	GD12 4	
3B7	12.6	12K7GT	5	-EBC33	5	-GZ33	19.5	U107	19.5	GD15 8	
3D6	5	-12K8	14	-EBC41	8	-GZ34	14	-U191	16.2	GD16 4	
3Q4	7.6	12Q7GT	5	-EBC81	8	-HL2	7.6	U201	16.2	GET106 17.6	
3Q5	9.6	12SA7	8.6	EB-80	8	-HN309	29.1	U281	19.5	GET114 6.6	
3S4	6	12SC7	8.6	EB-82	13.7	-VR2	10	-U282	22	GET173 9.5	
3Z4	4	7.6	12SK7	8.6	EB-84	6	HVR82A	6	U36	9	GET178 13.6
5R4GY	17.6	12SQ7	11.6	EBC19	22	KT2	8.2	-U32	14	GETX30 10	
5U4G	4.6	19AQ5	10.6	EC70	12.6	KT33C	8	-U339	16.2	GETX45 6.6	
5V4G	10	-19H1	10	-EC81	27.6	KT36	32.4	U404	6.6	GETX51/1	
5Y3	5.6	20D1	14.11	EC92	13	-KT41	29.1	U801	29.1	15	
5Z3	19.5	20P2*	25.11	EC32	5.6	KT44	12.6	U4020	18.2	GETX64 11.6	
5Z4G	9	20L1*	25.11	ECG3433	11	KT6	12.6	UABC80	9	GETX69 15.6	
6A8	9	-20P1*	25.11	EC35	8.6	KT63	7	-UAF42	9.6	AF102 27.6	
6AG5	5.6	20P3*	22.8	ECC40	17.6	KT66	15	-UB41	12	-AF114 11	
6AK5	8	-20P4*	25.11	EC81	5	-KT88	43.6	UBC41	8.6	AF115 10.6	
6AQ5	7.6	20P5*	22.8	ECC82	5	-KT101	32.4	UBC81	11	-AF116 10	
6AT6	6	-25A6G	10.6	ECC83*	7	-KTW61	6.6	UBF80	9	-AF117 9.6	
6C6	10	-25AGT	11.6	ECC84	9	-KTW62	7.6	UBF89	9.6	ACT100 13.6	
6B8	3	-25Z4G	11.6	ECC85	7.6	KTW63	6.6	UCC85	7	MAT101 8.6	
6BA6	6	-25Z5	10.6	ECC88	18	-MHL4	7.6	UCF80	16.2	MAT120 7.9	
6BE6	6	-275U	25.11	ECCF80*	10.6	MS48	22.8	UCH42	9.6	MAT21 8.6	
6BH6	8	-28D7	7	-ECF82	10.6	MU14	8	-UCH81	9.6	OA5 6	

We have large stocks of obsolete and hard to get valves. Quotation by return of receipt of stamped addressed envelope.

6B16	6	-30C1*	7.6	ECCF86	19.5	N37	25.11	UCLB2	9.6	OA10	8
6BQ7A	15	-30C15	16.2	ECH35	6.6	N78	29.1	UCLB3*	18.9	OA70	3
6BR7*	9	-30F5*	6	-ECH42	9.6	N108	29.1	UF41	9	-OA73	3
6BR8	18.2	30FL1*	9.6	ECH81	7.6	N308	20	UF42	12.6	OA79	3
6BW6*	10.6	30L1*	7.6	ECH83	13.7	N339	15	UF80*	10.6	OA81	3
6BW7*	10.6	30LV*	9	ECH84	9	PC95	4	UF85*	9	OA83	3
6C5	6.6	30P4*	15	-ECLB2	9.6	PCCB8*	7.6	UF86*	13.6	OA86	3
6C9	13.6	30P12	7.6	ECLB3	18.9	PCCB5	9.6	UF89	8	-OA91	3
6CD6G	35	8	30PL1	9.6	ECLB6	16.2	PCCB8	18	-UL41	10.6	OA95 3.6
6CH6	7.6	30PL13	10.6	EF29	22.8	PCCB9*	8.6	UL44	25.11	OA210 9.6	
6D6	6.6	30P15	9	-EF32	14	PCFB5	7.6	UL45	16.2	OA211 9.6	
6E5	12.6	35L6GT	9.6	EF36	4	PCFB8	10	ULB8*	8	OC16W35 13.6	
6F1	25.11	35W4	7.6	EF37A	8	PCFB4	16.2	UUA	17.9	OC19 25	
6F6G	7	-35Z3	18.2	EF39	4.6	PCF86*	9.6	UM34	16.10	OC22 23	
6F13	10	-35Z4GT	6	-EF40	15	-PCLB2*	9.6	UM80	14	OC26 25	
6F23	10.6	35Z5GT	9	-EF41	8	-PCLB3*	9.6	UR1C	18.2	OC35 18	
6F44	9.6	50C5	10	-EF42	10	PCLB4*	7.6	UJ6	19.5	OC36 21.6	
6F33	7.6	50L6GT	10	-EFS0A	7	-PCLB5*	10	-UUB	25.11	OC41 9	
6J5	5	-52KU	14.4	EFS0E	5	-PCLB6	16.2	UJ9	6	OC44 9.3	
6J6	3	-53KU	19.5	EF73	10	PEN25	4.6	UY19	18.2	OC44PM 9.3	
6J7G	4	6	72	EF80*	5	-PEN45	19.6	UY21	16.2	OC45 9	
6K7C	2	-78	6	EF85*	6	-PEN46	4.6	UY41	6.6	OC45PM 9	
6K8G	15	-80	6	EF86*	9	-PL33	18.9	UY85	6	OC63 22.6	
6K25	19.5	83	15	-EF89	9	-PL36*	15	-VMS4B	15	OC66 25	
6L1	22.8	85A2	16	-EF91	3.6	PL38	25.11	VP4	15	OC70 6.6	
6L6G	7.6	90AG	67.6	EF92	4.6	PL81*	10.6	VP4B	22.8	OC71 6.6	
6L7GT	7.6	90AV	67.6	EF97	13	-PL82	7.6	VP13C	7	OC72 8	
6L18	13	-10CG	37.6	EF98	18	-PL83	9	VP23	6.6	OC73 16	
6N7	8	-90CV	37	EF183	18.2	PL84*	12.4	VR105	7	OC75 8	
6P28	25.11	90C1	16	-EF184	9.6	PL80	18.2	VR150	7	OC76 7	
6Q7G	6	-150B2	18	-EK32	8.6	PM84	16.10	W76	5.6	OC77 12	
6R7G	10	-150C2	17.6	EL32	5	-PX4	10.6	W81M	6	OC78 8	
6S17	6	185B7	32.4	EL33	12.6	PY31	16.2	X61	12.6	OC81 8	
6S18	6	807	6	EL34	15	-PY32*	13.6	X65	12.6	OC82 10	
6G4GT	12.6	5763	7.6	EL37	23.11	PY33*	13.6	X66	12.6	OC83 6	
6G5G	7.6	AC6PEN7	6	EL38	25.11	PY80	7.6	X76M	14	OC84 8.6	
6V6G	4.6	AZ31	10	-EL41	9	-PY81	7.6	X78	29.1	OC140 29	
6V6GT	8.6	AZ41	13.7	EL42	10	-PY82	7	X79	45.3	OC170 9.6	
6X4	4	6	36	ELB1	16	PY83	7.6	XDI15	6	OC171 10.6	
6X5	5	-BL63	7.6	ELB3	15	PF88	13	XFG1	18	OC172 10	
630L2	10	-CL33	18.9	EL84*	7.6	PZ30	19.5	XFY34	17.6	PXC101 6.6	
7B7	8.6	CY1	18.2	EL85	13.7	A16	25.11	XFY54	18	PXC101A 6	
7C5	8	-CY31	11	-EL86	16.10	R18	14	-XHI1.51	6.6	6.6	
7C6	8	-D15	10.6	EL91	5	-R19	19.5	Y63	7.6	XA103 15	
7H7	8	-D43	17.9	EL95	10.6	SP41	3	Z66	9.6	XA104 18	

All goods new and first grade only. Please note that we do not sell secondhand goods. Complete list of valves, resistors, condensers, metal rectifiers, loudspeakers, transformers of all types and other components 6d. Terms of business—Cash with order or C.O.D. only. Post 6d. per item. Orders over £3 post free. C.O.D. 2.6 extra. All orders despatched same day. C.O.D. orders by telephone accepted for immediate despatch until 3.30 p.m. Any parcel insured against damage in transit for 6d. extra. We are open for personal shoppers 8.30-5.30. Sacs. 8-1 p.m.

----- Our Latest Publication

RADIO CONTROL FOR MODELS SHIPS, BOATS AND AIRCRAFT

BY F. C. JUDD With sections on servo-mechanisms by RAYMOND F. STOCK



More than 200 illustrations — circuits, working diagrams, photographs & tables. Each page is packed with information

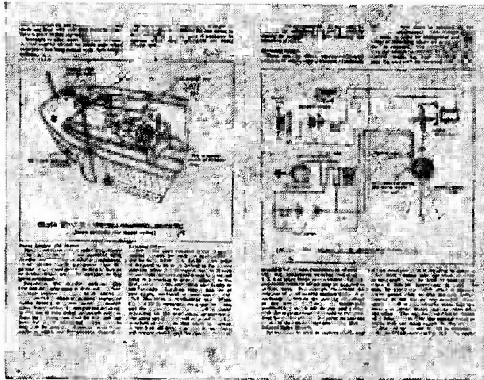

192 Pages

15s.

This book is basically an amalgamation of "Radio Control for Model Ships, Boats and Aircraft" and "Radio Control Mechanisms". Additional material has been added on Multi-Channel Operation; Transistorised Radio Control Receivers—Simple and Three-Channel; A Compact Efficiency Aerial; Deac Battery Information; Licence Conditions, etc.

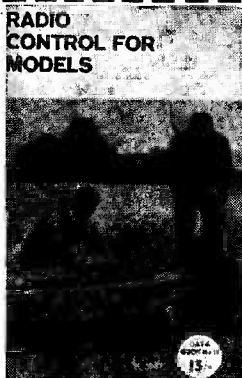

To Data Publications Ltd., 57 Maida Vale, London, W.9

Please supply.....copy (ies) of your latest publication "RADIO CONTROL FOR MODELS" DATA BOOK No. 16 at 15s. each, postage 9d.

NAME

ADDRESS.....

BLOCK LETTERS PLEASE

Page 469

Missing

Page 470

Missing

SMALL ADVERTISEMENTS

continued from page 469.

TRADE—continued

RADIO AMATEUR COURSE. A postal course for those wishing to take the Amateur Examination. A sound basic training in radio communication. Very reasonable terms. Send for brochure.—Premier School of Radio, BCM/Wireless, London, W.C.1.

SERVICE SHEETS (1930–1962) from 1s. Catalogue 6,000 models, 1s. 6d. S.A.E. enquiries.—Hamilton Radio, 13 Western Road, St. Leonards, Sussex.

THE INCORPORATED PRACTITIONERS IN RADIO AND ELECTRONICS (I.P.R.E.) LTD. Membership conditions booklet 1s. Sample copy of I.P.R.E. Official Journal 2s. post free.—Secretary, 20 Fairfield Road, London, N.8.

THE INTERNATIONAL HAM HOP CLUB is a non-profit-making organisation open to RADIO AMATEURS AND SHORT WAVE LISTENERS. OBJECT: To improve international relationships through an organised system of hospitality. MEMBERS offer overnight hospitality to visiting members, subscription 10s. per annum. ASSOCIATE MEMBERS invite radio amateurs to visit their stations. Associate membership 5s. per annum. FAMILY EXCHANGE holidays arranged, also FRIENDSHIP LINKS between radio clubs. The Club's official journal is free to both Full and Associate members.—Hon. Gen. Secretary: G. A. Partridge, G3CED, 17 Ethel Road, Broadstairs, Kent.

SITUATIONS VACANT

RADIO SOCIETY OF GREAT BRITAIN

SECRETARY-ACCOUNTANT

Applications are invited for this newly-created post on the Headquarters staff. Candidates must possess a sound knowledge of office administration and book-keeping. An interest in Amateur Radio would be an advantage.

EDITORIAL STAFF

A keen licensed (or prospective) radio amateur is required to join the editorial staff of the *R.S.G.B. Bulletin*, the Society's monthly journal. Enthusiasm, coupled with a good command of English, is more important than experience.

Write in confidence giving details of career to date and salary required to General Secretary, Radio Society of Great Britain, 28 Little Russell Street, London, W.C.1.

OSMOR

P.W. BEST SETS

P.W. POCKET S'HET

Case $5\frac{1}{2} \times 3\frac{1}{2} \times 2$ 12/6

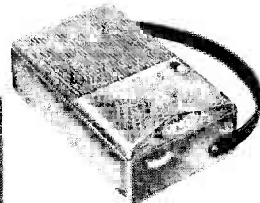
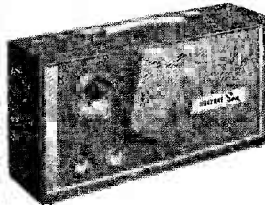

Case $14\frac{1}{2} \times 7\frac{1}{4} \times 3\frac{1}{4}$ 48/-

P.W. MERCURY SIX

3 IFS and Osc. 22/-
Driver and Output 16/3

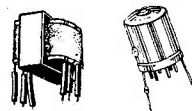

For above and all similar transistor circuits

CONSTRUCTIONAL BOOKLETS 2/6 each

COMPONENT LISTS ON REQUEST

OSMOR LTD 418 BRIGHTON ROAD
S. CROYDON SURREY

Glasgow Electronic Services

21 OLD DUMBARTON ROAD GLASGOW C3

Telephone WEST 2642

First grade, fully guaranteed, commercial components only

HOOK-UP WIRE. Stranded, 7/010 conductors, PVC covered, available 36' reels, 21 colour and/or tracer combinations at 2/3 reel. State colours required. Also available 12 different colours, 1 yard each to bundle, our selection, 2/9 bundle.

MULTI-CORE CABLE. Tinned copper screened, PVC sheathed. Cores individually colour coded, 7/0076 conductors. 4, 8, 12, 20 way at 2/-, 2/8, 3/6, 4/6 yd. respectively.

SIGNAL LAMP HOLDERS. Adjustable bracket panel mounting. MES bulbs, Red, Green, Amber, Clear at 1/10 each.

PANEL LAMP HOLDERS. Totally enclosed, MES Bulbs, Red, Green, Amber, Blue or Clear, 5/6 each. Also available for Lilliput bulbs, 3/6 each.

PANEL NEON INDICATORS. Operates direct from 200/250 mains. Moulded body, Red only, 4/- each.

MIDGET SWITCHES. Single bank wafer type. 1P3W: 2P6W: 4P2W: 1P12W: 3P4W: 4P3W at 4/3 each.

SILICON RECTIFIERS. 125V rms 500 m/a, 8/- 250V rms 500 m/a, 11/9.

WIRE WOUND VOL. CONTROLS. Midget type, rated 1w, linear track. 10Ω, 25Ω, 50Ω, 100Ω, 250Ω, 500Ω, 1kΩ, 2kΩ, 3kΩ, 5kΩ, 10kΩ, 15kΩ, 20kΩ, 25kΩ at 5/4 each.

TANDEM GANGED CONTROLS. Two similar controls mounted on same shaft, log tracks, suitable stereo, instrument work, etc., less switch 250kΩ, 500kΩ, 1MΩ, 2MΩ at 8/- each.

MOVING COIL METERS. Miniature Panel meters. Clear plastic cases, Silver/Black scales. Approx. size $1\frac{1}{4}$ cube. 0-50μa, 39/6: 0-500μa, 32/6: 0-1 m/a, 27/6: 0-5 m/a, 27/6.

Terms of business: Cash with order; C.O.D. 3/- extra; postage extra under £3 total value. General list stamp please.

The thrills of VHF can now be yours for only 39/6d, complete kit! Tunable 150-100 Mc/s, simplified construction, write today for leaflet. Also, if a newcomer to Amateur Radio, ask for free copy of the world famous "Globe-King" kits and receivers, stamp please to cover postage:

Johnsons (Radio) St. Martin's Gate Worcester

G2ACC offers you . . .

- A 56 page illustrated catalogue No. 12 Your buying guide for short wave, broadcast and transmitting components. 9d. post free (refundable on first order). U.K. and H.M. Forces anywhere.

SOUTHERN RADIO AND ELECTRICAL SUPPLIES

SORAD WORKS REDLYNCH SALISBURY WILTS Telephone Downton 207

SUPERHET RADIO CHASSIS

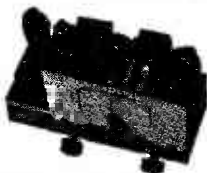

These well-made chassis were made for the Government for Forces entertainment using 6K8, 6K7, 6Q7, 6V6. Choke smoothing slow-motion tuning, printed scale, 200-550 metres. BRAND NEW, only 57/6, post 5/-. Case with 8" speaker to fit, 27/6.

12 VOLT VIBRATOR UNIT to 250 Volts (P.C.R. series) 100mA output, double choke smoothed, bridge rectified, spare vibrator, fusewire, battery clips, indicator bulbs. Brand New in maker's cartons. Only 22/6, carr. 5/6.



J. T. SUPPLY (Dept. Q) 309 Meanwood Rd. Leeds 7

SURPLUS RADIO SUPPLIES

2 LAING'S CORNER MITCHAM SURREY

SEND 2/6 FOR OUR CATALOGUE OF 400 BARGAINS

(2/- REFUNDED ON FIRST ORDER OVER 10/-)

S.A.E. for list of meters

New Boxed Meters by Sangamo Weston

50 microamps full scale deflection. Limited quantity 19/6. P. & P. 2/6

NYLON P.T.F.E.

ROD BAR SHEET TUBE STRIP WIRE

No quantity too small List on application

BRASS COPPER BRONZE ALUMINIUM LIGHT ALLOYS

H. ROLLET & CO LTD

6 CHESHAM PLACE, LONDON, SW1 BELGRAVIA 4300
Also at Liverpool, Birmingham, Manchester, Leeds

Quality Components FOR CONSTRUCTORS

capacitors, resistors, coils, valves, transistors, controls, chassis, transformers, speakers, pick-ups, cartridges, stylis, and all types of components in stock.

PRICE LISTS AVAILABLE ON REQUEST

J. T. FILMER

82 DARTFORD ROAD
DARTFORD KENT
Telephone Dartford 24057

FAULT FINDING IS EASY!

Controlled Electronics Model 644 is a pencil-sized, signal injecting fault locator, which will pin-point in seconds trouble in R.F., I.F. and A.F. stages of radio and some stages of TV receivers. It can save you headaches, time and money. Available from your local dealer, or by mail direct from us at 55/6 plus 2/6 P.P. Battery 1/10 extra. S.A.E. for details.

CONTROLLED ELECTRONICS 62 High St. Croydon Surrey

H.A.C. THE ORIGINAL SUPPLIERS OF SHORT-WAVE KITS

One valve Super Sensitive All-dry Short-wave Receiver, Model "K". Complete kit including valve and chassis, 77/-. (Other S.W. kits from 23/-) Before ordering call and inspect a demonstration receiver, or send stamped envelope for full specification, catalogue and order form.

H.A.C. SHORT-WAVE PRODUCTS (DEPT. R)
44 OLD BOND STREET LONDON W1

SPARES, VALVES, TUBES 1930-1960

Guaranteed perfect, set tested, ex-working equipment

5U4	4/-	7S7	6/-	20P1	4/-	KT81	6/-	PY80	4/-
5R4	6/-	10P13	4/-	20P3	6/-	N37	6/-	PY81	4/-
6AQ5	4/-	10P14	4/-	20P4	12/6	PCC84	4/-	PY82	4/-
6AU6	4/-	12AT7	2/6	185BT	10/-	PCF80	4/-	PZ30	4/-
6BG6	12/6	12AU7	4/-	ECC85	5/-	PCL82	4/-	U191	7/6
6BQ7A	5/-	12AX7	4/-	ECC88	5/-	PCL83	4/-	U403	6/-
6CH6	6/-	12BH7	4/-	ECC80	5/-	PenA4	5/-	U801	15/-
6U4	6/-	12E1	6/-	ECC82	5/-	Pen45	4/-	UCH42	6/-
6SN7	2/6	12SN7	4/-	ECL80	4/-	PL81	4/-	UL41	4/-
6SJ7	4/-	20D1	2/6	EL38	4/-	PL82	4/-	OC44	8/6
7B7	5/-	20F2	4/-	EL81	6/-	PL83	4/-	OC45	7/6
7C5	5/-	20L1	4/-	EL90	6/-	PY31	4/-	OC201	15/-

Most pre-war 4, 5, 7, 9-pin valves 5/- each. P. & P. 6d. per valve VALVE PARCEL. 12 assorted, all different, 8/6. Postage 1/6.

CONSTRUCTOR'S PARCEL. 2 lb mixed resistors, condensers pots, valveholders, electrolytics, etc. 7/6, postage 2/6. Send S.A.E. with enquiries or for list of 1,000 valves

ST. JOHN'S RADIO 3 Jews Row, SW18 Tel. VAN 8822

THE RADIO CONSTRUCTOR BOUND VOLUMES

Volume 12, August '58 to July '59 £1.5.0 postage 2/3
Volume 13, August '59 to July '60 £1.5.0 postage 2/3
Volume 14, August '60 to July '61 £1.5.0 postage 2/3
Volume 15, August '61 to July '62 £1.9.0 postage 2/9

Where all issues of a volume are returned for exchange
Vols. 12-14 12s. 6d. post 2/3
Vol. 15 14s. 6d. post 2/9

Attractively bound in blue cloth, with gold-blocked spine

DATA PUBLICATIONS LTD 57 MAIDA VALE LONDON W9

BRAND NEW TEST METERS - BEST VALUE - FOR ALL PURPOSES

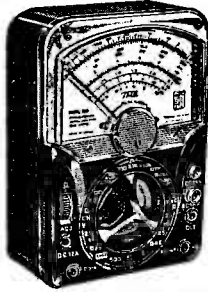

£8.19.6

**30,000 ohms per Volt
Model 500**

8 Ranges D.C. volts to 1 kV.
7 Ranges A.C. volts to 1 kV.
5 Ranges D.C. current to 12 amps.
3 Range resistance to 60 meg.
Short circuit buzz test. Output meter dB, etc., etc. Size 6½" x 4½" x 2¼". With Leads, Batteries and Instructions.

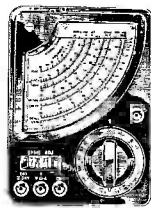

5 GNS.

**20,000 ohms per Volt
Model ITI-2**

6 Ranges D.C. voltage to 2½ kV.
5 Ranges A.C. voltage to 1 kV.
3 Ranges D.C. current to 250mA.
Resistance to 6 meg.
Capacity and dB ranges.
Size 4½" x 3½" x 1½" with leads, batteries and instructions.



75/-

**2,000 ohms per Volt
Model THL33**

0/10/50/250/500/1,000 volts D.C.
0/10/50/250/500/1,000 volts A.C.
0/500µA/10/250mA., D.C.
Resistance 0/10K/100K/1 meg.
Capacity and dB ranges, etc.
Size 5" x 3½" x 1½" with batteries, test leads and instructions.

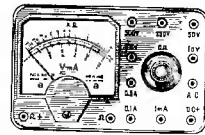

49/6

**1,000 ohms per volt
Model PT34**

0/10/50/250/500/1,000 volts A.C./D.C. 0/1/100/500mA D.C. Resistance 0/100k ohm.
Ideal pocket sized multi-tester for all radio and domestic work. Size 36" x 2½" x 1½" with battery, leads and instructions.

All Meters Fully Guaranteed for 6 months. Full Service Facilities.

MINIATURE CLEAR FACED Brand New PANEL METERS

0-50 microamp D.C.	39/6
0-500 " D.C.	32/6
0-1 milliamp D.C.	27/6
0-5 " D.C.	27/6
0-300 volts D.C.	27/6
"S" meter 1mA	35/-
"YU" meter	42/6

CRYSTAL MICROPHONES

ACOS 39-1. Stick Microphone with screened cable and stand (list 5 gns.), 32/6. P.P. 1/6.
ACOS 40. Desk Microphone with screened cable and built-in stand (list 50/-), 15/- .P.P. 1/6
ACOS 45. Hand Microphone with screened lead, very sensitive, 25/- .P.P. 1/6.
100 C. Stick Microphone with muting switch and screened cable, detachable desk stand and neck cord, 39/6. P.P. 1/6.
MC 24. Stick Microphone with muting switch and cable, 25/- .P.P. 1/6.
LAPEL. Miniature Microphone with clip. Ideal for recording, 15/- .P.P. 1/6.
BM 3. De Luxe Stick Microphone with muting switch cable, neckcord and detachable stand. Complete 52/6. P.P. 2/-.

(Illustrations of all types in our New Catalogue. 1/- post free.) FULLY GUARANTEED.

4-TRANSISTOR PUSH-PULL AUDIO MODEL PK-5 3

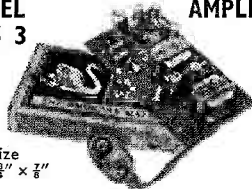

Size
3" x 1½" x ¾"

A ready-built miniature 250mW push-pull amplifier incorporating input and output transformers, 4 transistors, 9 volt battery snap cord, speaker and column connection leads. Ideal for use with record players, intercoms, hearing aids, tape recorders, etc. Complete with full instructions and circuit diagram.

PRICE 52/6 P.P. 1/6.
SUITABLE 2½ in. SPEAKER 16/6

NEW 44-PAGE CATALOGUE, 1/-



LIGHTWEIGHT HEADPHONES

- 2,000 OHMS
12/6
- 4,000 OHMS
14/6

HIGH EFFICIENCY

RUN YOUR RADIO OR AMPLIFIER FROM MAINS. BATTERY ELIMINATORS AND CHARGERS.

1. For PP3 or equivalent 9 volt Pocket Radio Battery. 18/6. P.P. 1/-.
2. For PP4, PP7, PP9, PP10. 9 volt Portable Radio Batteries up to 300mA. 49/6. P.P. 2/-.
3. De Luxe version of No. 1, also charges PP3 type batteries. 29/6. P.P. 1/-.
4. Rechargeable PP3 battery. Runs as long as 100 batteries. Complete with charger unit. 29/6. P.P. 1/-.

STEREO AMPLIFIER

4-Valve Amplifier with 2 watts output per channel to 3 ohms. Ready built, complete with Dials, Sockets and Knobs. Full tone, volume and balance controls. Crystal input. 220/250 volt mains input.

Fully Guaranteed **79/6** P.P. 2/-
Suitable 8" x 5" Speakers 49/6 Pair.

TYPE 38, TRANSMITTER RECEIVER

Complete with 5 valves. In new condition. These sets are sold without guarantee but are serviceable. **22/6** P.P.
7.4 to 9 Mc/s. 2/6
Headphones 7/6 pair. Junction Box 2/6.
Throat Mike 4/6. Aerial Rod 2/6.

GUITAR CONTACT MICROPHONE

High impedance Guitar Contact Microphone with screened lead. Plugs into any valve amplifier. Very sensitive. 12/6. P.P. 9d.

POCKET RADIO BOOSTER

Tubular unit, size 8" x 2½" dia., which plugs into earphone socket of any transistor radio. Performance increase is fantastic. Ideal for home or car. 30/- .P.P. 1/6.

STEREO PHONES

New stethoscope type stereo earphones with adjustable tubes. Fitted miniature jack plugs and leads. 2 x 8 ohms impedance. 27/6.

TRANSISTORS, VALVES, QUARTZ CRYSTALS
Hundreds of types listed in our new catalogue, 1/- post free.

OFFICE, WORKS OR HOME USE COMPLETE INTERCOMM. SYSTEMS

- 2-transistor transformer coupled, two speakers in moulded cabinets. Features 2-way Buzzer system and talking. Supplied complete with cable. **89/6** P.P. 1/6
- 4-transistor de luxe version, with 2-way calling and talking. Moulded cabinets, long battery life—very sensitive. With cable and batteries. **£7.10.0** P.P. 2/-

MAKE YOUR OWN PRINTED CIRCUITS

Complete kits supplied with all necessary chemicals, brush, dishes, etc. Fully detailed instructions. 3-boards 5½" x 3½". 19/6. P.P. 1/-

TRANSISTOR BABY ALARM

As previously advertised. **£5.10.0**

TELEPHONE AMPLIFIER

Speaker output from G.P.O. phone **£5.10.0**

TRANSISTOR SIGNAL INJECTOR

A new design pocket size tester for fault finding on valve or transistor radios, TV amplifiers, etc. Built-in indicator and batteries with detachable probe. 42/6.

NEW MINIATURE TELESCOPIC AERIALS

- 3½" closed, 14" extended. Complete with screw-in socket. 3/6. P.P. 6d.
 - 8½" closed, 38" extended, with threaded end. 6/6. P.P. 6d.
 - 9" closed, 64" extended. 17/6. P.P. 1/-.
- All types heavily plated.

BATTERY RECORD PLAYERS

- 6-7½ volt Garrard turntable with crystal pick-up. Plays 45 r.p.m. Ideal for above amplifier.



55/- P.P. 1/6.

- Suitable cabinet for amplifier and player, 17/6 P.P. 2/-.

HENRY'S RADIO LTD

PADdington 1008/9
5 HARROW ROAD, LONDON W2
Open Monday to Sat. 9-6, Thurs. 1 o'clock

PLEASE TURN TO BACK PAGE

Published in Great Britain by the Proprietors and Publishers Data Publications Ltd. 57 Maida Vale London W9

Printed by A. Quick & Co. (Printers) Ltd. Oxford Road Clacton-on-Sea England

Obtainable abroad through the following Collects Subscription Service Continental Publishers & Distributors Ltd. William Dawson & Sons Ltd. Australia and New Zealand Gordon & Gotch Ltd. Electronics Publications (Australia) South Africa Central News Agency Holland "Radio Electronica" Registered for transmission by Magazine Post to Canada (including Newfoundland)

COMPARE THE PRICES—COMPARE THE QUALITY AND PERFORMANCE!

★ DETAILS OF ANY MODEL ON REQUEST

★ IDEAL GIFTS ON ALL OCCASIONS

● FULL DETAILS OF ANY MODEL ON REQUEST—WRITE NOW ●



The fabulous 'Contessa' MK. II

★ combined portable and car radio ★

- NOW WITH 600mW MELLOWTONE OUTPUT ON MEDIUM AND LONG WAVES
- NOW FITTED HORIZONTAL TUNING SCALE WITH ALL STATIONS CLEARLY MARKED
- NOW SUPPLIED WITH SIX MULLARD TRANSISTORS AND TWO DIODES
- NOW FITTED RECORDING SOCKET AND CAR AERIAL SOCKET
- NOW SUPPLIED WITH TWO-TONE BEIGE OR TWO-TONE BLUE CABINET WITH GOLD FITTINGS

OVERALL SIZE
10½" x 7½" x 3½"

TOTAL COST

£10.19.6 P.P. 3/6

GUARANTEED THE VERY BEST OBTAINABLE

● Detailed Leaflet on Request ●

● All parts sold separately ●

The New "CONTESSA" 6-Transistor Portable Superhet Radio. Features simple printed circuit construction and fully illustrated building instructions, with all parts clearly marked and identified. Fitted with 8" Ferrite aerial. Double IFTs and the latest in components and design. Full tuning of both Medium and Long Wave bands with unbeatable selectivity and sensitivity. Clearly marked station dial and room-filling "MELLOWTONE" push-pull output are standard features. FULL AFTER-SALES SERVICE AND GUARANTEE

★ ALL THESE EXTRA FEATURES AT NO EXTRA COST ★

★ NEW HUGE PURCHASE REDUCES TOTAL COST ★

"CAPRI" POCKET-6 6-TRANSISTOR SUPERHET

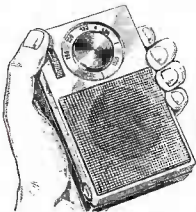

Size only
4½" x 2¾" x 1¼"
REALLY POCKET SIZE!

The most compact 6-transistor and diode radio with speaker available to the home constructor. Features the latest in miniature components and circuitry. Supplied with Mullard transistors and two-tone moulded cabinets in red/white or blue/white with gold fittings. All components are supplied in packets and clearly identified. A printed circuit is used with fully illustrated building instructions. Push-pull output coupled with a sensitive and selective circuit make the "CAPRI" hard to beat. Fitted Earphone/Record socket. Full tuning on medium waves with long wave Light.

TOTAL COST **£5.19.6** P.P. 2/-

★ Detailed Leaflet on Request ★
After Sales Service and Guarantee

POCKET TRANSISTOR RADIO
Special offer of brand new 6-transistor pocket radio. With leather case and phone. Tested and ready to use. **£5.19.6**
Ideal Christmas Gift. P. & P. 2/6

NEW 44 PAGE 10½" x 7½" ILLUSTRATED CATALOGUE FULL OF COMPONENTS AND UNITS. 1/- POST FREE

"QUINTET" MEDIUM AND LONG WAVE POCKET RADIO

PUSH-PULL SPEAKER OUTPUT

Size
5½" x 3" x 1½"

Red or Blue with Gold trim

Total Cost **99/6** P.P. 2/-

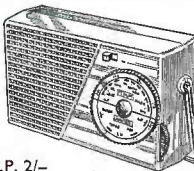

New Improved 5-Transistor and Diode Medium and Long Wave Printed Circuit Loudspeaker Radio. Features Ediswan transistors and plainly marked printed circuit with carded components. Now with better quality and greater sensitivity. Excellent results with full station separation guaranteed. Including Radio Luxembourg. Push-pull output up to 200mW. Fitted phone/record socket and car aerial socket.

Leaflet on request.

Full after-sales service and guarantee.

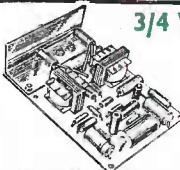

3/4 WATT TRANSISTOR AMPLIFIER

★ 1½ watt peak output.

± 3dB 70 c/s to 12 kc/s.

Output to 3 ohm speaker. 9 volt operated.

Details on request.

Built and Kit of Tested Parts

59/6 OR 52/6
P.P. 1/6 P.P. 1/6

A printed circuit high gain amplifier size 4" x 2½" x ¾" using Ediswan XB112, XB113 and XC171 Transistors. Ideal for Intercomm., Record Player, Tuner Amplifier or any application requiring a quality and reliable amplifier. New Improved Design.

We can supply most of the components specified on circuits published in this and other magazines and books. Let us quote for your circuit. Competitive prices.

IT'S TINY BUT POWERFUL "MINIRANGER"



PERSONAL M.W. RADIO 3-TRANSISTOR, 2-DIODE

Size 3" x 2" x ¾"

The smallest printed circuit transistor radio available for home construction. Full coverage of Medium waves and top band without any aerial or earth. Fitted calibrated dial, volume control and 9 volt battery. All stations including Radio Luxembourg are received with amazing clarity. Pre-tinned printed circuit clearly marked with component details.

● Simple to Build ●
Guaranteed Amazing Results

TOTAL COST OF ALL PARTS **59/6** P.P. 1/6

● Designed for your top jacket pocket ●
Circuit Diagram Free on Request

Medium and Long Wave Superhet Radio

Size
5½" x 3¾" x 2"

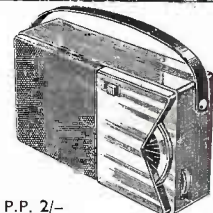

£7.19.6 P.P. 2/-

Modified version of previously advertised "PW" Superhet. Now with new style Two Tone Cabinet. First grade components and transistors. Printed circuit. Features matched set of 6 Transistors. New 2½" quality speaker and new illustrated building instructions.

PLEASE TURN PAGE

Henry's Radio Ltd

PADDINGTON 1008/9

5 HARROW ROAD LONDON W2

Open Monday to Sat. 9-6. Thurs. 1 o'clock