

BOOKS FOR THE TV ENTHUSIAST



"... A book that should be in every television dealers service workshop, and in every home-constructor's, for that matter."

*Journal of the Television Society*

"... The book will undoubtedly be of value to TV service engineers, particularly those who are not fully experienced in translating the appearance of faulty pictures into the necessary adjustments or receiver fault location."

*Wireless and Electrical Trader*

Lavishly illustrated by photographs taken from the screen of a television exhibiting the faults under discussion.

80 pages, size 8½" x 5½"

Price 5s. Postage 3d.

Edited by John Cura and Leonard Stanley, and illustrated with 150 "Tele-Snaps," this book caters for both the home viewer, and the more advanced constructor. We regard both these books as complementary, and have no hesitation in recommending them to all television servicemen and constructors.

68 pages, size 7¼" x 5"

Price 3s. 6d. Postage 2d.

Both books available from your usual supplier, or direct (Trade enquiries invited)

**DATA PUBLICATIONS**  
57 Maida Vale London W9



The

# RADIO CONSTRUCTOR

for the Radio and Television Enthusiast

Vol. 6  
Number 10  
JUNE  
1953



JUNE

1953

ALSO IN THIS ISSUE

THE "UNIVERSAL" LARGE SCREEN AC/DC TELEVISOR

"BASS-LIFT FOUR" RECEIVER  
SIMPLE AC/DC AMPLIFIER  
MAGNETIC RECORDING EQUALISATION  
Accurate Null Indicator · Radio Control Equipment  
AF Pre-Amplifier · Query Corner etc. etc.



**THE MODERN BOOK CO.**

**Sound Reproduction** by G. A. Briggs. 3rd edn. 17s 6d. Postage 6d.

**Amplifier Circuits** by N. H. Crowhurst. 2s 6d. Postage 2d.

**Radio Engineers' Servicing Manual**, edited by E. Molloy. 42s 0d. Postage 1s 0d.

**Personal Receivers** by E. N. Bradley. 3s 6d. Postage 2d.

**Radio Interference Suppression** by G. L. Stephens. 10s 6d. Postage 4d.

**Television Engineers' Servicing Manual** edited by E. Molloy. 42s. 0d. Postage 1s 0d.

**The Use of a.f. Transformers** by N. H. Crowhurst. 3s 6d. Postage 2d.

**TV Fault Finding** compiled by *The Radio Constructor*. 5s 0d. Postage 4d.

**The Radio Amateur Operator's Handbook** compiled by the Staff of *The Radio Amateur*. 2s 6d. Postage 2d.

**Inexpensive Television for the Home Constructor**. 2s 6d. Postage 2d.

**Television Receiver Practice** by R. Holland. 5s 0d. Postage 3d.

**The Amateur's Guide to Valve Selection** by Mullard. 1s 6d. Postage 2d.

**Radio Valve Data** compiled by *Wireless World*. 3s 6d. Postage 3d.

**The Radio Amateur's Handbook** by the A.R.R.L. 1953. 30s 0d. Postage 1s 0d.

We have the finest selection of British and American Radio Books in the Country. Complete list on application.

**19-23 PRAED STREET (Dept. RC) LONDON W2**

PADdington 4185

**SCOTTISH INSURANCE CORPORATION LTD.**



**62-63 CHEAPSIDE LONDON, E.C.2.**

**TELEVISION SETS AND SHORT WAVE TRANSMITTERS**

Television Sets and Short Wave Transmitters/Receivers are expensive to acquire and you no doubt highly prize your installation. Apart from the value of your Set, you might be held responsible should injury be caused by a fault in the Set, or injury or damage by your Aerial collapsing.

A "Scottish" special policy for Television Sets and Short Wave Transmitters/Receivers provides the following cover:—

- (a) Loss or damage to installation (including in the case of Television Sets the Cathode Ray Tube) by Fire, Explosion, Lightning, Theft or Accidental External Means at any private dwelling house.
- (b) (i) Legal Liability for bodily injury to Third Parties or damage to their property arising out of the breakage or collapse of the Aerial Fittings or Mast, or through any defect in the Set. Indemnity £10,000 any one accident.
- (ii) Damage to your property or that of your landlord arising out of the breakage or collapse of the Aerial Fittings or Mast, but not exceeding £500.

The cost of Cover (a) is 5/- a year for Sets worth £50 or less, and for Sets valued at more than £50 the cost is in proportion. Cover (b) (i) and (ii) costs only 2/6d a year if taken with Cover (a), or 5/- if taken alone.

Why not BE PRUDENT AND INSURE your installation—it is well worth while AT THE VERY LOW COST INVOLVED. If you will complete and return this form to the Corporation's Office at the above address, a proposal will be submitted for completion.

NAME (Block Letters) .....  
 (If Lady, state Mrs. or Miss) .....  
 ADDRESS (Block Letters) .....

JJB

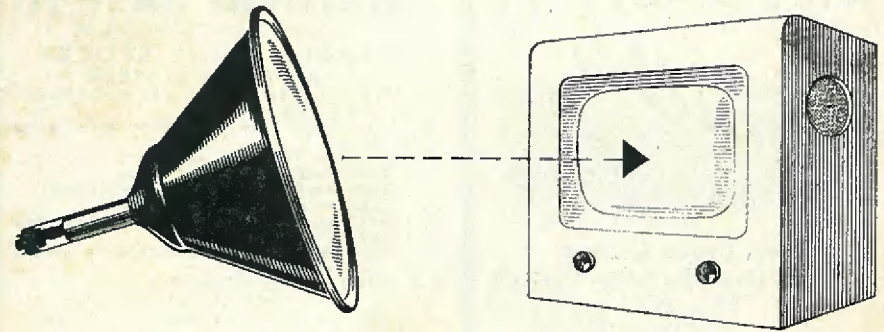

**Did you build your own T/V receiver?**

If so, and you have a 9" or 12" set and now want to convert to big-screen viewing, how better than by using an 'ENGLISH ELECTRIC' 16" T901 Metal C.R. tube.

To help you carry out the work our leaflet EV103A gives you the complete line and frame scanning information necessary, together with a suggested list of required components.

And why a T901 — because it offers you brilliance, long life, high safety

factor, ease of handling and withal it is British made.

It is the tube specified by the designers of the 'Tele-King' and 'Magnaview' circuits and 'Viewmaster' conversion circuit.

*Brilliant black and white picture focussing over entire screen area with excellent contrast range; high optical quality glass face plate; wide angle scanning (70°); fitted ion trap; overall length 17 1/8", diameter 16".*

**'ENGLISH ELECTRIC'**

**BRITISH MADE LONG LIFE METAL C.R. TUBE**

*If you have any difficulty in obtaining supplies write to:*

The ENGLISH ELECTRIC Co. Ltd., Television Department, Queens House, Kingsway, London, W.C.2.

**WIDE ANGLE TV**



Allen, Denco, Colvern  
Dubilier, Elac, McMurdo, Morgan  
STC, TCC

for the  
**"TELEKING"  
"VIEWMASTER" CONVERSION  
and "MAGNA VIEW"**

(Radio Constructor)  
also  
**TUBES, VALVES & CABINETS**  
etc. Price Lists on receipt of SAE

**H. L. SMITH & CO. LTD.**  
287/9 Edgware Road London W2  
Telephone Paddington 5891  
Hours 9 till 6 (Thursday 1 o'clock)  
Nr. Edgware Road Stations, Metropolitan & Bakerloo

For  
**SUCCESSFUL**  
wide-angle  
scanning

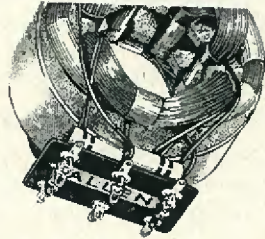

**ALLEN DEFLECTOR COILS**

70° Scan with minimum deflection defocusing High-efficiency castellated "FERROXCUBE" core. Suits any wide angle C.R.T. up to 27" double (d) Scan.

**LARGE SCREEN TELEVISION**  
Can only be achieved by using high efficiency components throughout. ALLEN can supply the complete range.

For prices and details of the full range of ALLEN components—Write to  
For circuit diagram of line and Time Base send 9d. and stamped addressed envelope to

**ALLEN**  
**COMPONENTS LIMITED**  
Crown Works 197 Lower Richmond Rd  
Richmond Surrey Telephone Prospect 9013

**ARTHURS HAVE IT!**

LONDON'S OLDEST RADIO DEALERS  
**LARGE VALVE STOCKS**  
**AVOMETERS IN STOCK**  
Avo Test Meters and Signal Generators and Taylor Meters  
Leak Point One Amplifiers and Tuning Units.  
Chapman Tuning Units.  
Crystal and Moving Coil Mics.  
Decca Replacement Heads and Pickups.  
Goodman's Axiom 150 Speakers.  
Partridge Output Transformers for Williamson Amplifier.  
All Components for the Radio Constructor's 16" Televisor.  
Weare & Wright Tape Deck £35.  
LATEST VALVE MANUALS  
Mullard, Osram & Brimar No. 4 5/- each  
Mazda 2/- each Postage 6d. extra  
**TELEVISION SETS, WIRE AND TAPE RECORDERS ALWAYS IN STOCK**  
Goods offered subject to price alterations and being unsold.

**Arthurs** Est. 1919 first

PROP: ARTHUR GRAY LTD.  
OUR ONLY ADDRESS: Gray House  
150-52 Charing Cross Road  
London, W.C.2.  
TEMPle Bar 583314 and 4765 WRITE FOR LISTS

**TELEVISION CABINETS**

All Sizes up to 16" Tube

Specially Designed for 'Radio Constructor' Set, and Illustrated on the September Front Cover

Price **£18:10** Carriage £1

SEND FOR ILLUSTRATED LEAFLET

**H. ASHDOWN**  
98 HERTFORD ROAD  
TOT 2621 EDMONTON N9

Recognised as the Most Reliable Valveholders



The Best Valveholders on the Market  
—specially chosen for the Magna-View  
Home Constructor's Television Set.

TYPES	B7C	-	-	-	BM7/U and XM7/U.
	B9A	-	-	-	BM9/U, XM9/U and BM9/UB.
	International Octal				B8/U and X8.4/U.

Wholesale Enquiries:—CYRIL FRENCH LTD., HIGH STREET, HAMPTON WICK, MIDDLESEX · KINGSTON 2240  
Manufacturers' Enquiries:—THE McMURDO INSTRUMENT CO., LTD., VICTORIA WORKS, ASHTEAD, SURREY · ASHTEAD 3401

# Your set deserves a Mullard LONG-LIFE TV TUBE

If you are building a television receiver, leave nothing to chance; choose a Mullard Tube. Mullard Television Tubes owe their high reputation for performance, reliability and LONG LIFE to the unrivalled facilities for research possessed by Mullard; to the complete control of manufacture from the production of raw materials to the completed product; and, in particular, to the ion-trap, which safeguards the screen from damage by heavy negative ions produced in the region of the cathode.

The Mullard MW43-64 LONG-LIFE television tube, together with its associated range of 'World Series' valves, is specified for the 'Universal', the new large screen AC/DC televisor.  
The MW43-64 is an all-glass tube with a 17-inch rectangular grey glass screen.

Other tubes available to home constructors include:  
MW22-16 9-inch screen.  
MW31-74 12-inch grey glass screen.  
MW36-24 14-inch grey glass rectangular screen.  
MW41-1 16-inch screen, metal cone.

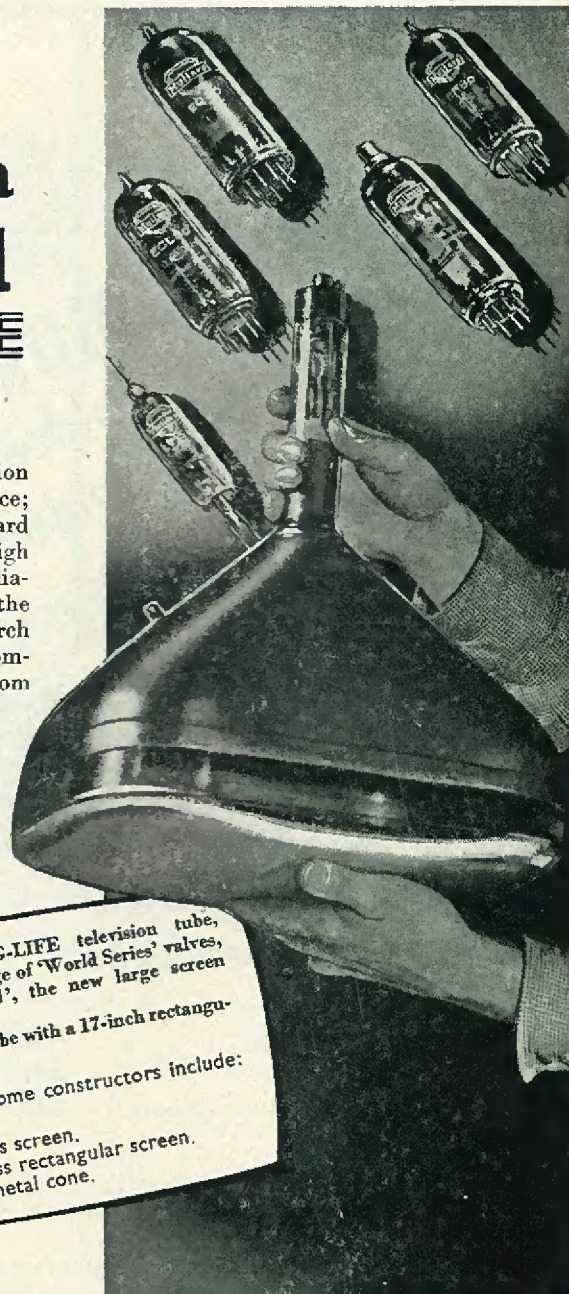

MULLARD LTD · CENTURY HOUSE · SHAFESBURY AVENUE · LONDON · W.C.2  
MVM229



## The Radio Constructor

Vol. 6. No. 10.

Annual Subscription 18/-

June 1953

Editorial and Advertising Offices—57 Maida Vale Paddington  
Telephone CUNingham 6518 London W9

Edited by C. W. C. OVERLAND, G2ATV

### CONTENTS

SUGGESTED CIRCUITS: AN ACCURATE NULL INDICATOR, by G. A. French.	502
IN YOUR WORKSHOP, by J. R. D.	504
VALVES AND THEIR POWER SUPPLIES, PART 7, by F. L. Bayliss, A.M.I.E.T.	506
MAGNETIC RECORDING EQUALISATION—WITH SOME AMPLIFIER MODIFICATIONS, by L. F. Sinfield, A.M.I.P.R.E.	510
BOOK REVIEW	514
"BASS-LIFT FOUR" FOR AC MAINS, by A. Carpenter	515
TRADE REVIEW	517
RADIO CONTROL EQUIPMENT, PART 4, by Raymond F. Stock	518
RADIO MISCELLANY, by Centre Tap	522
THE "UNIVERSAL" LARGE SCREEN AC/DC TELEVISOR, described by A. S. Torrance, A.M.I.P.R.E., A.M.T.S.	524
ASTIGMATISM IN ELECTROSTATIC CATHODE RAY TUBES, by C. R. Drayton.	528
AUDIO PRE-AMPLIFIERS, PART 3, by D. Nappin	530
A SIMPLE AC/DC AMPLIFIER, by James. S. Kendall, Assoc.Brit.I.R.E., M.I.P.R.E.	534
LET'S GET STARTED—(2) QUART FROM A PINT POT, by A. Blackburn	536
QUERY CORNER—A RADIO CONSTRUCTOR SERVICE FOR READERS	540
RADIO COMPONENTS EXHIBITION 1953, Visited by L. A. Chinnery, G311Z	542
FROM OUR MAILBAG	543
SOME USEFUL HINTS, by J. S. K.	544

### NOTICES

THE CONTENTS of this magazine are strictly copyright and may not be reproduced without obtaining prior permission from the Editor. Opinions expressed by contributors are not necessarily those of the Editor or proprietors.

THE EDITOR invites original contributions on construction of radio subjects. All material used will be paid for. Articles should be typewritten, and photographs should be clear and sharp. Diagrams need not be large or perfectly drawn, as our draughtsmen will redraw in most cases, but relevant information should be included. All Mss must be accompanied by a

stamped addressed envelope for reply or return. Each item must bear the sender's name and address.

TRADE NEWS. Manufacturers, publishers, etc., are invited to submit samples or information of new products for review in this section.

ALL CORRESPONDENCE should be addressed to *Radio Constructor*, 57 Maida Vale, Paddington, London, W.9. Telephone CUN. 6518.

*A Companion Journal to THE RADIO AMATEUR*

# Suggested Circuits for the Experimenter

The circuits presented in this series have been designed by G. A. FRENCH specially for the enthusiast who needs only a circuit and the essential relevant data

## No. 30 An Accurate Null Indicator

The accurate presentation of null indications as obtained from bridges and similar measuring devices can sometimes be a little difficult to achieve. When a high degree of accuracy is required it is usual to employ a meter or a cathode-ray indicator (Magic Eye) to indicate the point of balance. Very often, however, an aural method is employed, in which case the point of balance is given by an AF tone at minimum volume level.

This month's circuit illustrates a simple device which is capable of giving a very accurate presentation of balance. The indication is still of an aural nature, but the point of balance is not shown by changes in volume level. Instead, it is shown by variations of frequency of an AF tone; the null point corresponding to maximum frequency change. It is this point which gives the indicator its high degree of accuracy, since the ability of the ear to differentiate between audio frequencies (even when they closely approach each other) is greater than its ability to judge volume levels.

To use the indicator described here, it is essential that the bridge to which the indicator is connected is operated from AC instead of DC. The choice of AC has no effect on the AF tone heard by the operator, and its frequency may lie anywhere between, say, 10 Mc/s and 25 c/s.

A simple resistive bridge is shown in the diagram; but this is merely for purposes of illustration and may, of course, be replaced by any other type of bridge.

### Operation

The operation of the circuit is quite simple. A varying amount of AC from the bridge is fed to the CR circuit C1/R1. The values of these components are such that the rectified

negative voltage (relative to cathode) appearing at the grid of V1 very nearly equals the peak voltage of the AC output from the bridge.

The grid voltage of V1 varies, therefore, according to the AC obtained from the bridge. When this AC is at a minimum (corresponding to the point of balance) the negative grid voltage of V1 is at a minimum also, its anode current being, consequently, at a maximum. The result of this is that the voltage dropped across R2 is at a maximum also.

V2 is an RF oscillator which receives its anode voltage via R2. When the bridge is balanced, the action of V1 causes this anode voltage to be at a minimum. Owing to the fact that a simple oscillator (such as the tuned-grid circuit of V2) varies in frequency when its anode voltage varies, it follows that the frequency of V2 will vary as the bridge is balanced, maximum variation occurring at the point of balance. The oscillations generated by V2 are picked up on any receiver fitted with a BFO, whereupon the change in oscillator frequency is converted to a change of AF tone.

### Practical Details

The circuit shown here should offer little trouble in practice. The valves used may be of the 6J5 class, and, if desired, can be combined in a single double-triode. V2 should be capable of oscillating comfortably over the fairly wide range of anode voltages passed to it. The choke in the anode circuit of V2 should be an RF or an AF component according to the frequency of the AC used by the bridge. If the frequency of this AC is very low, C2 may have a value of 1  $\mu$ F. For higher frequencies 0.1  $\mu$ F should be sufficient.

The value of R2 will need to be determined

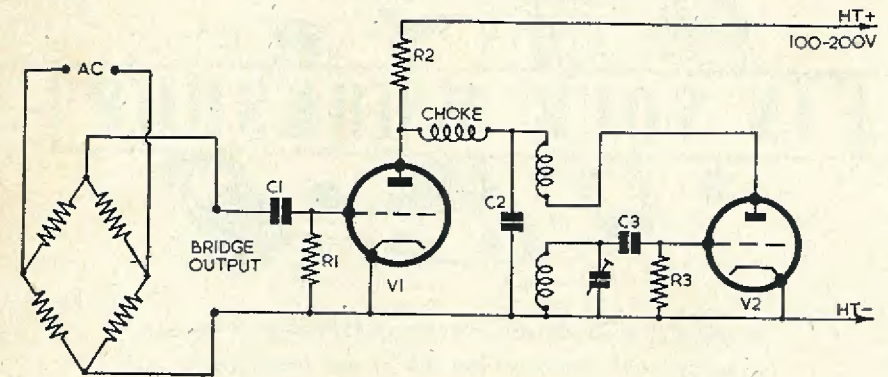

RC180

AN ACCURATE NULL INDICATOR

experimentally. It should be sufficiently high to cause a relatively large variation of oscillator frequency without dropping the anode voltage of V2 to too low a value at the point of balance. A value of 5 to 50 k $\Omega$  will probably be needed here.

The oscillator should work between 10 and

20 Mc/s, the actual frequency being unimportant. The receiver should be so set up that the point of balance is indicated by a fall in audio frequency, and not by a rise. Sufficient input to the receiver will, in most cases, be obtained by positioning its aerial lead close to the oscillator.



"Tell me, how long have you been suffering from reversed line scan?"



*In which J. R. D. discusses Problems and Points of Interest connected with the Workshop side of our Hobby based on Letters from Readers and his own experience.*

It is interesting to note how popular in the United States are commercially-made cathode-ray tube "rejuvenators" for television receivers. These rejuvenators are used with cathode-ray tubes whose emission has fallen with age, and it is claimed that they bring a large number of these tubes back to their original emission and brightness. They function by applying a greater heater voltage to the tube than is supplied by the set in which it is fitted and for which the tube was designed. Not quite so popular, apparently, are "reactivators." These are intended also to bring low-emission tubes back to normal and function on the "flashing" principle which was applied to battery valves many years ago. A reactivator subjects the tube heater to something like a 50 per cent overload for a minute or two, this being reduced to a slight overload which is held for a longer period. Reactivation does not seem to offer as many "cures" to worn tubes as does rejuvenation.

#### Rejuvenators

Rejuvenators function by permanently increasing the heater voltage to the tube; this being achieved usually by connecting a simple step-up auto-transformer between the heater voltage supplied by the receiver and the heater pins of the tube. The voltage increase given by the auto-transformer is around 25 per cent. Some rejuvenators use transformers with isolated primaries and secondaries, this being done mainly to obviate cathode-heater shorts which may occur at the increased temperature. One rejuvenator uses a transformer with a mains voltage primary. The heater voltage originally applied to the tube then heats a resistance element fitted to a bi-metal strip. On switching on the receiver the original heater voltage causes this strip to bend, thereby

switching in the primary of the rejuvenator transformer. This type of rejuvenator is especially useful for receivers with AC/DC power circuits.

Owing to the fact that the low-voltage transformers used in nearly all rejuvenators may be made very small indeed, these components can be more or less "hung in the wiring" or built into plug adaptor housings. All rejuvenators appear to have an adaptor plug and socket joined together by a short flexible harness, and are installed by simply unplugging the tube socket and fitting the adaptor socket in its place. The original set socket is then fitted to the rejuvenator adaptor plug. In one or two instances, however, the rejuvenator transformer is mounted in a case which has to be screwed to the set chassis or cabinet.

Many American technical radio magazines nowadays carry rejuvenator advertisements; and it is possible to obtain a very good idea of their respective physical sizes and trends in circuit development by studying these advertisements. The retail prices lie between three and ten dollars.

Rejuvenators seem to be becoming fairly standard servicing practice in the United States, so far as one can judge from isolated articles on this subject. Whether the same will occur in Great Britain is difficult to decide. So far as the home-constructor is concerned, of course, rejuvenator transformers would be very easy to make or adapt. One point not stressed in the American literature or advertisements, however, is that, whilst a rejuvenator may bring a new lease of life to a low-emission tube, it may also ruin it. Nevertheless, if a tube is in such a bad state that it would be thrown away in any case, the use of a rejuvenator transformer might not be disadvantageous

Another point which is also not stressed is the question of how long a tube stays rejuvenated at its new heater voltages. This is understandable, of course, because such a period of time can hardly be predicted. Apparently, increased lives of a year have been obtained; whilst, on the other hand, no one is surprised when the tube becomes "un-rejuvenated" all over again within a month.

Before concluding on this subject, I should like to point out, as my own opinion, the fact that some of the spectacular successes claimed to have been given by these rejuvenators might, perhaps, need to be taken with a pinch of salt. Low mains voltages and inefficient mains transformers are not unknown, even in the States. It might happen, in one or two cases, that a cathode-ray tube has been working for a long time at a heater voltage, say, 10 per cent lower than that it was designed for. Increasing that voltage by 25 per cent (or, even, increasing it just to the correct value), would be almost certain to result in higher emission for quite an appreciable length of time.

#### Cheap Rectifiers

I was very interested in R. W. Hill's article in the December issue in which he described how he managed to use a surplus double-triode as a full-wave rectifier by strapping together the anodes and grids of each section. It also brought back war-time memories to me (and doubtless to other readers) of some of the haywire power supply circuits we used during this period, when rectifiers and transformers could not be obtained.

I remember building one receiver (a four-plus-one with 6V6 output), in which a single home-made 6.3 volt transformer supplied all the heaters including that of the "rectifier." HT was obtained direct from the mains by half-wave rectification, and I found that American "metal" valves used to cope quite well with the resultant 200 volts or so which appeared between heater and cathode. The "rectifier" used was a 6J5 with grid and anode strapped! It says a lot for the manufacturer that it never broke down.

An even more spectacular circuit (for which I was not responsible!) gave half-wave rectification at 300 volts with no limiting resistor. The builder had fitted a 200 mA fuse in the HT circuit, but the ripple current used to burn it out now and again. The heater of the "rectifier" was at chassis potential. In this case, a metal 6L7 was used.

It seems incredible that valves can be so execrably treated and still continue to work. These two circuits, incidentally, are very definitely not recommended for present-day use!

#### Tag-Board Leakage

I recently had the task of servicing a receiver which had an HT leak. This leak showed a steady resistance of approximately 500 ohms between the HT positive line and chassis, and was a little difficult to discover. I eventually ran it down to a tag-board which had a hidden leak on the underside of the paxolin between an HT positive tag and a chassis-mounting rivet.

Leaks on the surface of an insulator of this type are common enough, although it is rare for them to have a constant value of resistance. They are usually caused originally by a spark which breaks down the material on the surface of the insulator, and so causes a fine carbon track. This assists further sparks until a definite leak or short is established. The fault is usually prevalent if the equipment has been kept for a long time in a steamy or humid atmosphere which had allowed condensation on to the surface of the insulator.

An easy way of discovering such a leak consists of connecting an ohmmeter between the two associated lines (such as HT positive and chassis in the case just mentioned), and lightly pressing suspected tag-boards and similar components one by one. As the unwanted carbon track makes contact to the circuit via solder tags or chassis-mounting nuts riveted to it, this pressure causes it to be momentarily connected and discovered, whereupon the ohmmeter needle flickers or shows a new reading.

The same sort of fault occasionally occurs in valve holders and switch wafers. In switch wafers it can sometimes be particularly difficult to find, since the leakage may occur in the small rotating disc in the centre of the wafer.

#### ASTIGMATISM IN ELECTROSTATIC CATHODE RAY TUBES

*(Continued from page 528)*

have been undone, and the spot will be elliptical once more.

The only method would appear to be to carry out the adjustments on a picture or test card. This can be a little tricky. It is not too easy to adjust two potentiometers at once and observe the effect accurately.

A rather simpler method, shown in Fig. 4, is particularly applicable if control of spot shape is required on one pair of plates only. This is to retain the single potentiometer control of shift, and to supply the final anode of the tube also from a separate potentiometer.



# Magnetic Recording Equalisation

—with some amplifier modifications

By L. F. SINFIELD A.M.I.P.R.E.

One of the chief difficulties in magnetic recording is to obtain correct frequency compensation in the amplifier.

If a recording is made on good grade tape, such as "Scotch Boy" tape at  $7\frac{1}{2}$ " second, with a head gap of between 0.5 and 0.75 "thou," then if the recording is made at constant current the playback amplifier will require approx. 18-20 db boost at 100 cycles, no boost around 2 kc/s and approx. 15-18 db boost at about 8 kc/s.

To obtain maximum signal-to-noise ratio it is obvious that the maximum recording level should be used, but the peaks should not extend into the saturation point of the tape. This is almost unavoidable, however, in general practical applications, but the number of such peaks can be kept down by good recording technique, and the best use of microphones and the best recording level can soon be determined with experience.

The fall-off in bass reproduction at a rate of 6 db per octave is a basic characteristic of

magnetic reproduction of a constant amplitude recording (similarly the bass fall-off in disc recording). Consequently, it is not advisable to emphasize the bass frequencies during recording as the tape would easily saturate. If the microphone response lacks bass, however, enough compensation can be added to correct it.

The drop at the high frequency end is due to the transfer characteristic between head and tape, and includes iron losses and gap effect losses. These are common both in recording and reproduction, so that an equal amount of top boost may be applied in each of these positions. If, in fact, all the boost were applied only on playback, the recording signal level at these frequencies would be correspondingly down relative to tape noise level, and signal-to-noise ratio would not be so good.

The usual type of simple compensation filter consists of a bridged-T network as in Fig. 1, and such an arrangement was used in the magnetic recorder described in the Sept., Oct. and Dec., 1952 issues.

The condenser C2 is shorted out on "record," giving top boost only. When C2 is in circuit on "play" both bass and treble boost results. While such a circuit can give correct bass compensation, the rate of rise at treble frequencies is not sharp enough to give perfect correction at the top end. It is important that negligible boost occurs in the region of 1500-2000 cycles relative to other frequencies, either on "record" or "play."

A method employed by some commercial recorders is to use an inductance tuned to about 7 kc/s. This method has many disadvantages, however—(a) expense, (b) it is prone to hum pick-up by magnetic induction, (c) the circuit "rings" on transients and the response to square wave testing is in general undesirable, unless some form of artificial hangover is required to compensate defects elsewhere in the system.

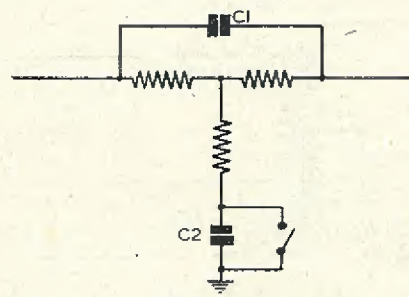

FIG. 1  
BRIDGED-T NETWORK  
SWITCH CLOSED ON 'RECORD'

RC194

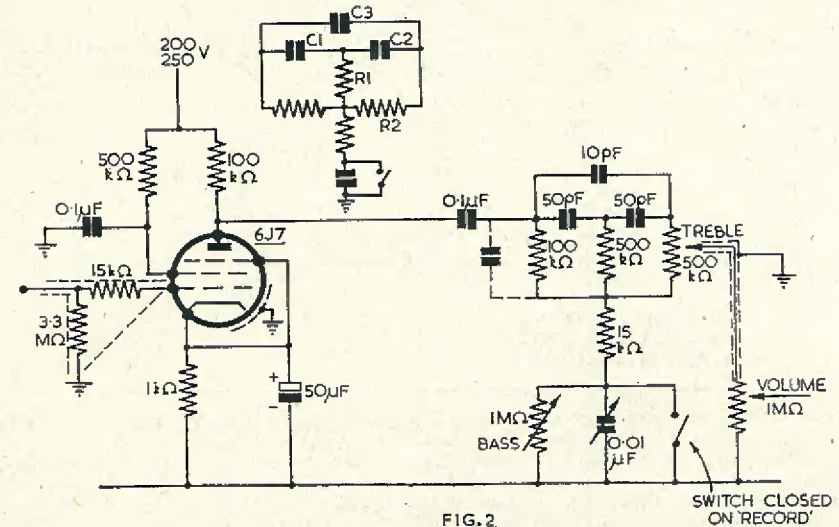

FIG. 2  
PRE-AMPLIFIER AND COMPENSATION NETWORK

RC195

After extensive tests with an oscillator and oscilloscope on a large variety of networks the circuit of Fig. 2 has been found to be most satisfactory. The bass boost action is similar to that of the bridged-T of Fig. 1. The treble boost, however, now consists of a two stage high pass filter C1/R1-C2/R2. The bridging condenser C3 corrects a small chip in the curve caused by phase shift. R2 is made a variable to have some form of boost control. This is effective on both "record" and "playback" to allow for acoustic and other conditions. The 1 MegΩ bass boost control is only effective on "playback," and this combination will be found to be most adaptable in practice.

The actual bass boost is rather more than the "calculated" network boost, as there is a reduction in shunting of the anode load at low frequencies, so giving greater stage gain in the valve.

Figures of gain, etc., at maximum boost are given at Fig. 3. These were taken with about a foot of screened lead to the 1 MegΩ output load (next stage grid resistor) to simulate actual installation conditions. This 1 MegΩ grid resistor should be in fact, a 1 MegΩ volume control to the second stage. The second stage should also be a pentode

in order to reduce input capacity caused by "Miller effect" which would attenuate high frequencies, especially at midway settings of the volume control.

The overall gain of the pre-amplifier and network at 1500 cycles (the point of maximum network attenuation) is 10.5 db, valve gain being 35 db and network loss 24.5 db. The output waveform is sinusoidal for similar input if input level to the 6J7 is kept below 0.5 volts. However, the output of microphones or tape heads is well within this limit.

If a condenser of 0.00025μF is fitted in parallel with the 100kΩ in the network, then the treble boost can be limited to 9 kc/s. Beyond this frequency the effective shunt on the anode load reduces the output. This condenser also improves the phase shift of the network, but gives a slight amount of treble boost at minimum position of treble control: +3 db at 10 kc/s; this amount is negligible, however, when compared with tape losses. Its fitting is optional.

The compensation given by this pre-amplifier and network almost perfectly compensates for tape losses in a good system. The amplifier following should be flat, preferably with negative-feedback. The output resistor for constant current recording should



Fig. 3. Relative gain of pre-amplifier and network

Frequency	Maximum treble and maximum bass			Minimum bass and minimum treble, db
	Record db	Playback db	Overall db	
50 c/s	-3.0	+23.75	+20.75	-3.0
100 c/s	-1.25	+20.75	+19.5	-1.25
200 c/s	0	+17.5	+17.5	0
500 c/s	0	+11.0	+11.0	0
1 kc/s	0	+ 4.75	+ 4.75	0
2 kc/s	+1.0	0	+ 1.0	0
4 kc/s	+5.3	+ 5.8	+11.1	0
6 kc/s	+7.5	+ 8.6	+16.1	0
8 kc/s	+8.7	+10.0	+18.7	0
10 kc/s	+9.3	+10.5	+19.8	0
Valve gain at 1500 c/s				+35 db
Network loss at 1500 c/s				-24.5 db
Overall gain at 1500 c/s				+10.5 db

be several times the impedance of the head at the highest recorded frequency. The bias should be about 50 kc/s and of sinusoidal waveform, with a rejector circuit to isolate it from the audio output. The correct bias level for good response will be found by experiment. On "playback" the frequency response of the head and any head matching transformer should be flat, with the possible

exception of a shunt resistor and condenser to give cut-off beyond 9 kc/s.

The pre-amplifier and network may also be used with a high fidelity pick-up for gramophone reproduction if the pick-up output is less than 0.3 volt. Bass and treble boost controls can be adjusted as required. Any treble cut required for scratch filter, etc., should be in the form of resistor and capacity shunt directly in parallel with the pick-up and should, therefore, be mounted on the player unit.

There is a slight drop in valve gain (independent of the network) at 50 cycles of about 3.0 db due to the value of the screen decoupling condenser. If it is desired to reduce this drop, then this condenser should be increased to 0.25µF or 0.5µF.

**Modification to Magnetic Recorder in Sept., Oct. and Dec., 1952 issues**

The recorder previously described can be improved by incorporation of this network in place of the original bridged-T.

After experimenting with the Qualtape head, certain improvements have been found possible. In its normal condition the fixing bolt shorts together the centres of the head cover-plates. Therefore, a continuous shorted turn is formed by the case and the fixing bolt around each pole piece. By insulating the bolt from the lower cover-plate, the shorted turn is eliminated and the inductance, impedance and output are increased and damping considerably reduced. Fig. 4 gives full details of the alteration.

In view of the increased impedance, the load resistance on the secondary of the input transformer should be increased to about 500kΩ.

Another alteration is in the deck layout. One of the guides is removed and the erase magnet mounted on a swinging arm.

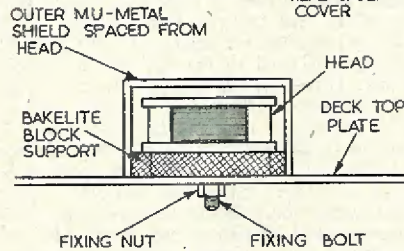
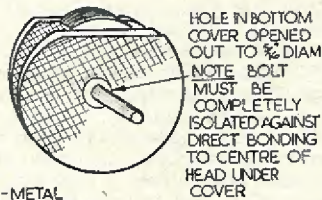

FIG. 4  
MODIFICATION TO HEAD TO PREVENT "SHORTED TURN" EFFECT

- A) REMOVE OUTER NUT
- B) " " BOTTOM PLATE
- C) " " INNER NUT
- D) OPEN HOLE IN BOTTOM PLATE TO 1/2" DIA
- E) REPLACE BOTTOM PLATE BUT DO NOT USE INNER NUT
- F) MOUNT HEAD ON INSULATED BLOCK AS SHOWN TO PREVENT BONDING TO BOLT

RC196

FIGURES FOR COMPENSATION NETWORK OF MAGNETIC RECORDER AMPLIFIER

(These are actual figures taken with calibrated attenuator and oscilloscope. The bass boost is actually greater than the calculated value as the shunting on the 6J7 anode load is reduced at low frequencies on "playback," so giving greater stage gain. The figures also allow for valve and stray capacities normally encountered, if built to the instructions which were given.)

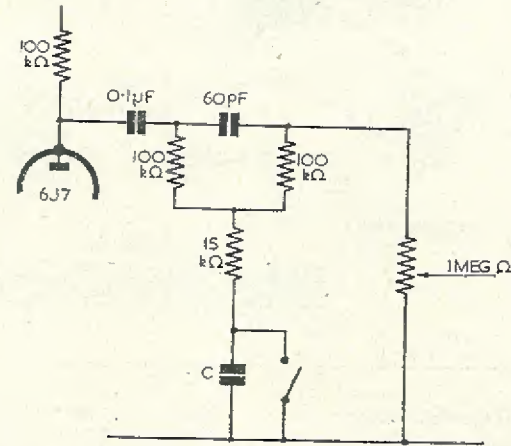

RC198

Alternative values are given for C=0.01µF and C2=0.005µF. C is shorted out as for "record" position and no bass boost occurs on this position.

Treble response is given for a trimmer set to a fixed .60 pF capacity. If the recorder circuit trimmer is set to zero, the treble response of the network will of course be flat with no treble boost—All figures in db lift.

C=0.01µF

Frequency	100 c/s	200 c/s	500 c/s	1000 c/s	2 kc/s	4 kc/s	8 kc/s
Record (C Out)	0	0	0	0	1.8	4.5	7.6
Play (C In)	17.5	14	6.6	1.3	0	3.0	6.3
Total	16.2	12.7	5.3	0	0.5	6.2	12.6

C=0.005µF

Frequency	100 c/s	200 c/s	500 c/s	1000 c/s	2 kc/s	4 kc/s	8 kc/s
Record (C Out)	0	0	0	0	1.8	4.5	7.6
Play (C In)	19.7	17	11.5	5.5	0	2.7	5.7
Total	17.9	15.2	9.7	3.7	0	5.4	11.8

Use 0.01µF for 7 1/2 ins/sec—normal heads—medium coercivity tape

Use 0.005µF for 15 ins/sec—normal heads—medium coercivity tape

These figures do not include other slight compensations incorporated in the amplifier.

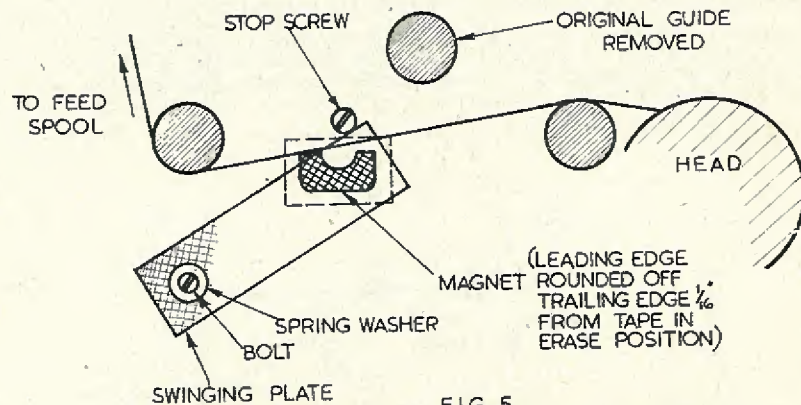

FIG. 5  
ERASE MODIFICATION TO REDUCE  
THREADING & TO STABILIZE TAPE FLATNESS

RC.197

There are several reasons for this.

- Less threading is involved
- As threading is similar on both "record" and "play" the frictional losses and load are equal, and so ensure correct speed.
- The greater "wrap" around the pillar adjacent to the head eliminates tape tilt which was found to occur when feed spool braking was light enough to eliminate capstan loading.

The arrangement is shown in Fig. 5. The magnet will produce least background

noise if the trailing edge is spaced about 1/16th inch away from the tape by tilting the magnet. The leading edge has been rounded and polished to prevent it scraping the coating off the tape.

A further modification incorporated was to increase the series constant current resistor in the amplifier from 50Ω to 100Ω, due again to increased head impedance.

The bias isolation choke can be made to give better rejection by tuning it and making it into a proper tuned rejector circuit. A value of about 0.02μF should be satisfactory for the tuning condenser.

## Book Review

TELEVISION RECEIVER DESIGN—I.F. STAGES, By A. G. W. Uijtens. 172 pages 114 illustrations. Price 21s. Distributed in England by Cleaver-Hume Press Ltd., 42a South Audley Street, London, W.1.

The Philips Technical Library has this latest addition, Book VIII.A, as a companion volume to those already established as standard references on radio theory. Dealing entirely with the I.F. stages in television receiver design, this present book adequately covers all the factors which need careful attention in order to produce maximum gain with required bandwidth. The attainment of satisfactory noise level, and the calculation of noise factor, is of particular interest where the design of "fringe area" receivers is concerned.

In an exposition such as this where one specialized branch of design technique prevails, it is inevitable that the mathematics of the subject should be given some prominence. The author has kept the mathematics as simple as possible in the main body of the book, and

gives the derivations of many of the formulae in the several Appendices.

Gain and bandwidth with two-terminal and four-terminal networks occupy only a few pages, but their applications in multi-stage amplifiers employing staggered tuning, and the response curves obtainable, are given fuller treatment. Distortion in double- and vestigial-sideband systems is discussed in another chapter.

The effects, and the use of, feedback in I.F. amplifiers is given over to a large part of the book. It is enlightening to read that the chassis can become a wave-guide for feedback energy, and that a remedy is to be found in the use of a long, narrow chassis.

The practical considerations of circuit design have not been forgotten; a chapter on this aspect deals with some typical examples of sensitivity, gain, selection of valves, staggered tuning and distortion.

There is no doubt that this reasonably-priced book can be of considerable value to the design engineer.

NORMAN CASTLE

# "Bass-Lift Four"

## For AC Mains

By A. CARPENTER

The receiver to be described was built originally as a simple 3-valve arrangement using an RF stage, diode detector and LF amplifier feeding into an output pentode.

This proved fairly satisfactory, but the output was not quite sufficient, and, as the author likes plenty of bass, experiments to obtain it still further decreased the output—as is usually the case. After various changes the following circuit was evolved.

### Circuit

As will be seen from Fig. 1, four valves are used. V1 is a high gain RF pentode supplying a good signal to the detector, and fed via a small trimming condenser (C5) to the second tuned circuit. This method provides a certain amount of variable selectivity, and when the best position is found should require no further adjustment.

Demodulation is obtained at the diode of V2, which is a duo-diode triode. The second diode, normally used for AVC purposes, is not used and can be connected to cathode.

The triode portion of V2 is usually used purely as an LF amplifier, but in this circuit it is arranged principally as a bass amplifier. The resistors R6, R7 and the condenser C10 cause the valve to discriminate in favour of the lower frequencies, and afford a considerable degree of bass lift. This is not achieved without a severe loss in gain, and the output from V2 is, therefore, only small.

HF is filtered out by R4 and C9. R5 is the diode load, C8 is the coupling condenser and R9 serves as grid leak. The grid is fed from the junction of R6 and R7.

Output from the anode of V2 is fed via C11 to the volume control potentiometer, R15, and thence to the grid of V3 which is another RF pentode. This valve acts well as an LF amplifier when connected as shown.

Coupling to the output valve is by means of a para-fed LF transformer with a ratio of 1.4. This was used in place of RC-coupling so that the negative feedback circuit, C17, R17, R18 could be used to cancel out distortion,

which may be as much as 10% in the output valve.

The introduction of feedback causes a decrease in gain, as may be expected, but this has been taken care of in the earlier stages.

Operation of the potentiometer R18 varies the amount of feedback, and with the values specified gives a wide range of tone control. With feedback at a minimum, speech is crisp and clear. As the control is rotated bass becomes more and more evident.

The writer uses a 10-inch speaker mounted on a sheet of asbestos 3ft 6in × 2ft. Reproduction is good and in the order of 5-6 watts. Bass is plentiful.

### Lower Supply

In the original receiver a selenium metal rectifier is used in conjunction with a half-wave mains transformer. This transformer is of ex-Govt. origin and has a secondary of 300V at 100mA, plus a 6.3V winding. Mains hum is not noticeable and so it was decided not to go to the expense of installing full-wave rectification as is usual.

Theoretically, and probably practically, full-wave rectification would be an improvement and this is a point to bear in mind when building this receiver. One point in favour of the metal rectifier is that it is cheap. It is also cool and requires no heater supply.

### Conclusion

No definite layout is shown as constructors will doubtless have varying ideas regarding this. The original was built on a metal chassis 12in × 8in × 2in, fitted with a black crackle-finished louvred lid 7in in height, both of ex-WD origin. No internal speaker is fitted and the underneath of the chassis is left open. In case of breakdown or alteration, all that is necessary is to turn the receiver upside down and the majority of the components are accessible immediately.

The four controls, tuning, wave-change, tone, volume-on/off are arranged along the front panel, in that order, from right to left.

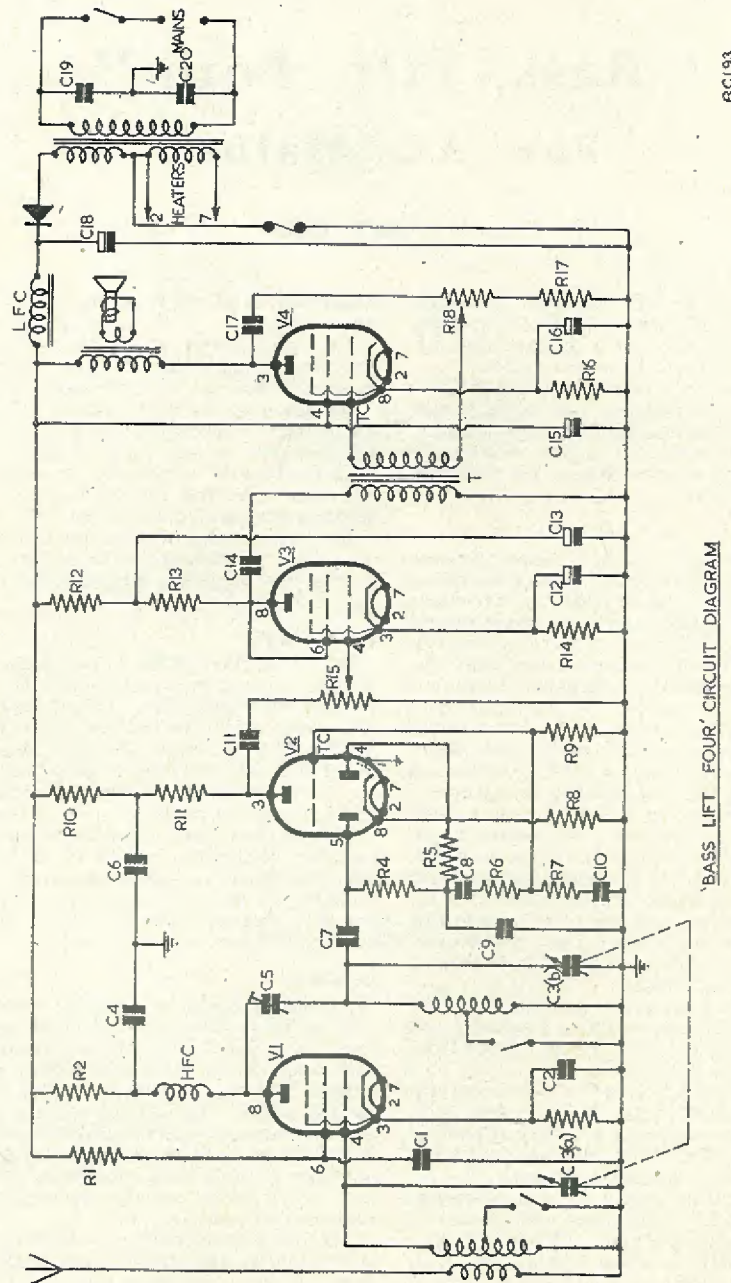

RC193

BASS LIFT FOUR-CIRCUIT DIAGRAM

## COMPONENTS LIST

## Resistors

R1	250 k $\Omega$
R2, R7, R17	10 k $\Omega$
R3	150 $\Omega$
R4, R10, R12	50 k $\Omega$
R5	500 k $\Omega$
R6, R11	100 k $\Omega$
R8, R14	1000 $\Omega$
R9	1 M $\Omega$
R13	20 k $\Omega$
R15	1 M $\Omega$ Pot. and switch
R16	490 $\Omega$
R18	50 k $\Omega$ Pot.

## Condensers

C1, C2, C10	0.01 $\mu$ F-350V
C3	500pF ganged with trimmers
C4, C8, C11, C14	0.1 $\mu$ F-450V
C5	100pF trimmer
C6	1 $\mu$ F
C7, C9	100pF
C12	25 $\mu$ F-12V
C13	16 $\mu$ F-450V
C15	32 $\mu$ F-500V

C16	50 $\mu$ F-12V
C17	0.002 $\mu$ F
C18	8 $\mu$ F-500V
C19, C20	0.1 $\mu$ F-2000V

Mains transformer-300V, 100mA; 6.3V, 1.5A  
(or see text)

Selenium metal rectifier; 250V, 100mA

Chassis-12in  $\times$  8in  $\times$  2in

LF Choke-20H, 100mA

LF Intervalve transformer 1:4 (Premier Radio or similar)

Aerial and RF coils, long and medium wave (Premier Radio)

2-pole 2-way Yaxley type switch

High Frequency Choke

Tapped output transformer

Four I0 valve holders

Fuse (2.5V bulb)

## Valves

V1, V3	— 6SH7
V2	— EBC33
V4	— EL32

## Trade Review

We have received from Kendall and Mousley, 99 Dudley Port, Tipton, Staffs., samples of their products for review. One of these, a pair of meter stands, was at once "snaffled" by Centre-Tap, and is described by him in *Radio Miscellany* in this issue.

The other items submitted consisted of a cabinet, front panel, chassis, and a pair of handles. These were stoutly constructed and nicely finished in black crinkle.

The prices charged are reasonable: for example, a cabinet 10 $\frac{1}{2}$ "  $\times$  12"  $\times$  10 $\frac{1}{2}$ " deep with light alloy panel costs 21s. A chassis to suit, measuring 10" square by 2 $\frac{1}{2}$ " deep, is available at 10s. 6d.

Items are obtainable in other colours than black. Brown, blue and green can be supplied, at 10% extra.

Another useful item, and one which we have not seen elsewhere, are metal plates punched to take an international octal or

similar valveholder, and designed to allow easy fitting in place of existing larger holders of obsolete types. These are also reasonably priced, at 3s 6d per dozen.

The firm also supplies valves, components, and sundry other items, and readers interested are invited to send a 2d stamp for their lists.

Clydesdale Supply Co. Ltd., 2-Bridge Street, Glasgow-C.5., have sent us copies of the new List -No. 8D and Supplement. These are charged at 1s 6d, which is refunded on the first purchase.

We cannot think of a more comprehensive list than this, with its 260 pages which, with the numerous illustrations, forms a most handy reference book apart altogether from its primary purpose.

Now available

DATA BOOK, No. 7

2/6

RECEIVERS, PRE-SELECTORS AND CONVERTERS

DATA PUBLICATIONS 57 Maida Vale London Telephone CUN 6518

# Radio Control Equipment

PART 4

By RAYMOND F. STOCK

## Manual Unit

A simpler but very effective device which also carries out the same function is the pulsing switch shown in Fig. 18, which I recently developed for another purpose (mentioned later).

*A* is an insulating arm conveniently cut from a  $\frac{1}{4}$ " thick perspex, and it is mounted on

the end of a short control shaft. The latter, complete with its bush, can be taken from a discarded potentiometer.

Pivoted on a 6-BA bolt at the end of the arm is a small swinging link *B*, which is normally kept at 90° to the arm by the light spring *C* soldered between the link and an 8-BA screw in the arm *A*.

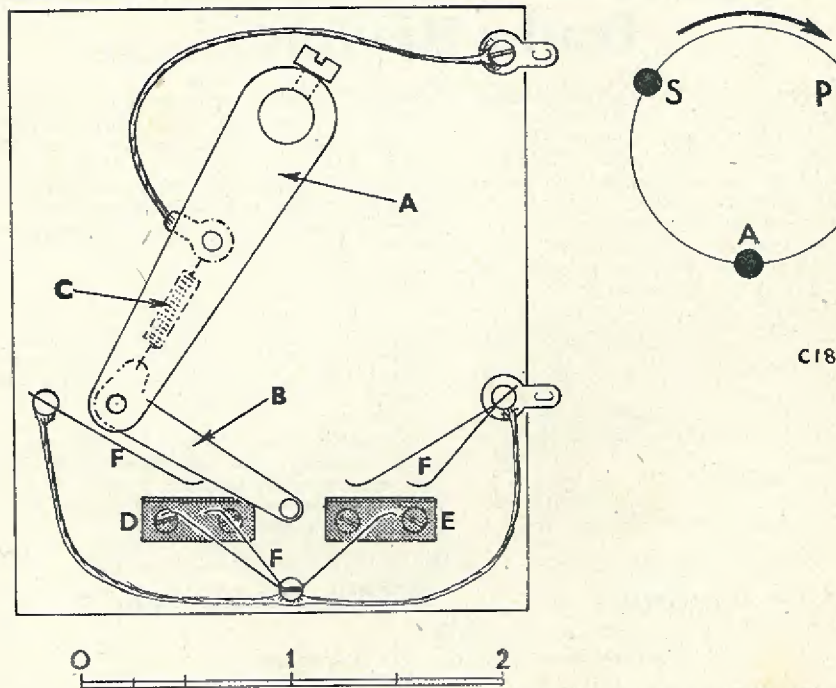

Fig. 18. Manual pulsing unit; scale in inches. In the sequence diagram *A*, *S* and *P* represent *Amidships*, *Starboard* and *Port*.

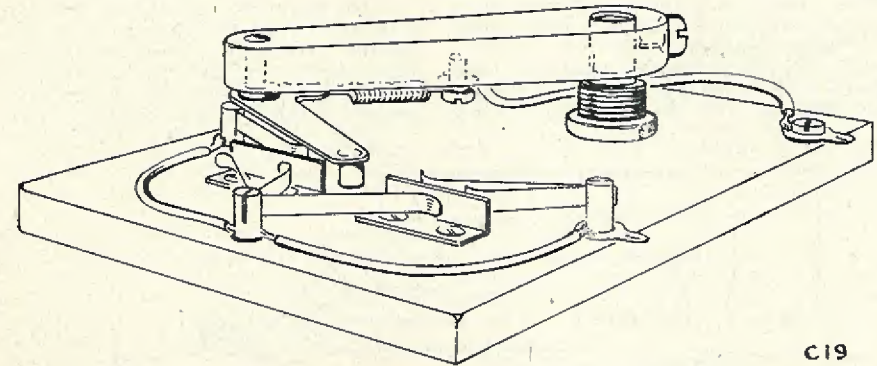

Fig. 19. Manual pulsing unit, complete on perspex base.

As the arm is rotated through its three positions, the link tends to move through an arc of a circle, but it carries a small peg at the end which interferes with the two guides *D* and *E*. These cause it always to move under them when travelling away from the centre, but trap it above them when travelling inwards. The peg therefore follows a kind of figure eight path as the arm *A* is rocked from side to side.

Several contact strips *F* are soldered to pillars screwed into the insulating baseboard, and as the peg moves through its path it brushes against these strips and in so doing keys the transmitter. The keying leads are taken, one to all the contact pillars, and one (via a copper pigtail) to the end of the spring *C*.

If the movement of the peg is studied against the small sequence diagram printed alongside, it will be seen that the correct number of pulses are sent to step the escapement round correctly.

In making this device, the peg at the end of link *B* should be allowed to pass well clear of the ends of guides *D* and *E*, or there may be a tendency for the peg to return along the incorrect path. The position of the peg at the ends of its travel is, of course, determined by the travel permitted to lever *A*.

The guides are made up from scraps of 18 swg brass sheet bent to shape, and sufficiently accurate dimensions may be taken from the scale in Fig. 18. The sketch Fig. 19 shows a view of the completed parts.

When either of these two pulsing units are used, a simple press button should be included in the control box, wired in parallel with the

pulsing contacts. This is useful for getting the mechanism in the model into phase, and enables the operator to correct any error which may creep in when under way. A means of sending signals by hand should always be available, as the chance of a spurious or undetected impulse is always present, and once the system gets out of phase it can be most confusing!

## Selector Mechanisms

A more complex and, therefore, generally more flexible way of using a sequence system is by utilising a circuit selector.

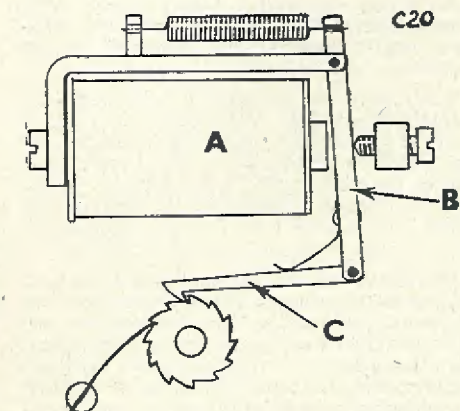

Fig. 20. Selector; operating mechanism

Most readers will know how these components work, but Fig. 20 is a guide to the construction of a typical unit.

A is the electromagnet which in radio control work is energised from the receiver relay contacts. B is its armature and C is a

In one scheme the selector can be regarded as the equivalent of an escapement, with a set sequence of positions provided by the various steps. Each step can then be wired to an electrically driven follow-up device and represents a definite rudder position. Initially

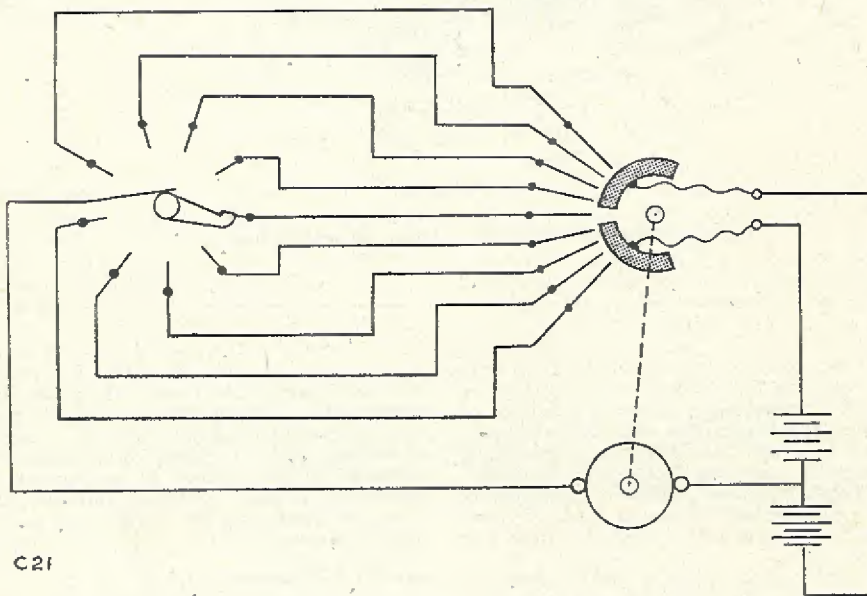

Fig. 21. 9-Way selector in simple steering unit.

pawl which works on a ratchet wheel. Very often a detent is provided against the wheel to prevent reverse rotation, as shown in the drawing.

Each time the magnet is energised, on receipt of a signal, the pawl rides over a tooth of the wheel; when the signal terminates, the armature returns by spring tension and carries the wheel round one tooth. A wiper arm (or arms) is mounted on the shaft of the wheel, and rotates over a ring (or rings) of contacts, thus switching various circuits.

Obviously, the limitations of this device are decided by the number of wiper arms and the number of positions, and an enormous number of combinations are available. In most cases the constructor will arrange these to his own requirements, but some illustrations of the commoner circuits in which selectors are used will be given.

this may seem no advantage over the escapement, but there are two important differences—the follow-up mechanism need not operate until the selector finally “homes” on a selected position, thus avoiding moving the rudder through unwanted positions. Secondly, the selector can work at very high speeds, so that a larger number of steps can be used in the sequence (providing finer control) without slowing down the response.

An example of this straightforward use of a selector is given in Fig. 21, which shows the circuit of a nine-step selector wired to give four port, four starboard, and one amidships position.

Each of the selector contacts is wired to its own brush, and these nine brushes bear upon the surface of an insulating disc driven at slow speed by a permanent magnet motor. Mounted on the disc are two copper segments with a small gap between them, and they are

polarized positive and negative by pigtail connections to a battery. Since the motor is connected between the battery centre-tap and the selector (common) it is supplied with power via one of the brushes—the one selected—and either of the two segments, whichever one the brush happens to be resting upon will decide the polarity of the voltage applied to the motor, and thus determine its direction of rotation.

This direction is such that the insulating space between the copper segments *always moves towards the supplying brush*. In effect, then, the gap between the segments homes on the selected brush, and the unit forms a simple follow-up device, sensitive to nine different positions.

radio connection strip bent into an arc.

Flexible insulated pigtails carry power to the two moving segments. The final power take-off to the steering gear can be by a push-pull rod pinned to the end of the operating lever shown, which moves with the disc. The lever on the rudder shaft can be the same length as the operating lever so that the two move in step, and in this case one obtains full control from port 20° to starboard 20° in 5° steps.

Any small commercial motor will do for a power unit, a number of inexpensive permanent magnet motors being available. As an index of performance the following notes may be of interest.

An electrically driven actuator was recently

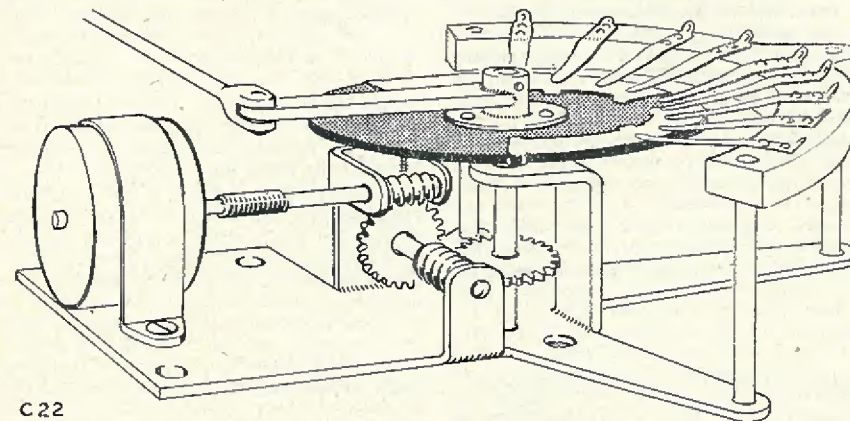

Fig. 22. 9-Position follow-up mechanism.

Fig. 22 is a drawing of an easily made unit on these lines. The small motor is coupled by a short length of spring to a reduction gear train which is most compactly made from two worm and wheel stages, as shown, but if these are not available the gear train from a small clock will do very well; often the motor can be coupled to the seconds hand shaft, which projects beyond the frame sufficiently to take a soldered coupling, and the final drive can be mounted on the hour shaft, thus giving a reduction ratio of 3600:1. The rest of the mechanism is cut away.

The contact disc shown is a circle of paxolin bolted to a brass hub; contact segments are cut with scissors from hard brass or copper foil having mounting lugs turned over through corresponding slots in the paxolin. Copper foil brushes are arranged firmly to bear on the disc at 5° intervals, their fixed ends being supported by a perspex arc; alternatively, they can be soldered to the tags of a suitable

made up using an *Electrotor* driving a gear train of 1000:1 ratio. On 4.5V applied to the motor, the current consumption (light) was 0.25A. A load of 1lb was then applied to the output lever, which had an effective radius of 1.7", and the current rose to 0.35A, the lever taking 4 seconds to move through 60°. A force of 1lb is, of course, far more than is needed to shift the rudder of a model boat, and in this case was designed to operate the steering gear of an armoured car model (total weight 8½lb).

Selector systems similar to the one described can be designed with any number of positions, the limiting factor being the time delay that can be accepted for operation through a complete sequence. Any selector should be capable of interpreting at least 10 pulses per second; in model work it is advisable to check the positive operating speed when the batteries have fallen to their accepted minimum voltage.

(To be continued)

## Radio Miscellany

TV and its alleged rival, the third dimensional film, have been much in the news of late, and this, added to my recent comments on colour and stereoscopic TV, seems to have provoked a number of letters from readers. So much so that I feel I am left with no other alternative than to treat these as the topics for the month. As so few details of the colour and stereoscopic processes have been made public it is only possible to consider them in a general sort of way, and we are still very much at the guessing stage about the probable date of their full introduction.

There is, however, one outstanding development which may have an important bearing on the proof of their practicability. I refer, of course, to sponsored TV. The Assistant Postmaster General recently revealed that 46 enquiries for sponsored TV licences had been received. There were also 26 enquiries about buying time in the sponsored programmes. The possibility of alternative TV programmes being available before the end of next year will, for many, make cheerful reading. Unfortunately the more alternative programmes we have, the narrower the chances of getting colour or stereoscopic transmissions become. All present systems require three times the bandwidth of monochrome TV, and the only way of squeezing them all in is to move them to still higher frequencies. Apart from disturbing the present allocations in the VHF spectrum, the further HF we go the more restricted becomes the range of each transmitter.

### Competition

Nevertheless, it is becoming increasingly important for these problems to be seriously tackled. We must regain our diminishing lead in technical developments. A couple of years ago, we, and America, had a very long lead over the rest of the world. But TV has expanded rapidly since then. According to Unesco, 55 countries are now engaging in some form of regular TV activity. Japan, Cuba and most of Latin America are all well in the running. Even the small republic of Dominica has had regular transmissions for over eight months!

Admittedly we have supplied much of the

transmitting equipment, but the sales of our receivers has not been in proportion. With the entry of Japan into the receiver market at cheaper prices, the need for retaining our technical superiority becomes paramount. The same, too, applies to a lesser degree to Germany. Before we can "sell" colour or stereoscopic TV to the rest of the world we must provide a system which necessitates only a cheaply-produced, reliable receiver and a daily service to prove its practicability.

Just how important the 3-D aspect will become is a matter of speculation. Colour seems to be not only the more important, but also the more logical step.

To meet a few requests, and for the sake of beginners, a brief review of the colour systems is included in augmentation of my comments of a couple of months ago. Two of them are based on the fact that by adding together in suitable proportions red, green and blue light, any desired colour can be produced. This may be achieved in two ways. Firstly by projecting them simultaneously, and secondly by scanning them consecutively. Just as it is impossible for the eye to detect a single "scan," repetition at a high rate presents an apparent single, complete colour picture to the human eye.

The principle of adding two or more colours to produce another—generally referred to as the "additive" system—has already been widely used in other fields. Painting, printing and filmcraft readily spring to mind. The disadvantage of additive systems for photographic and TV purposes is that it entails the use of filters. The high absorption of light in the colour filters reduces the recorded image to a dimness that demands an extremely high order of sensitivity or an intense subject lighting, or more usually a combination of both.

The subtractive system, widely used in cinematography, produces colour by subtracting from white—which is a combination of all colours.

A limited colour system can be obtained by employing only two colours, red and blue-green. In fact, a two-colour system was actually used in a pre-War Baird demonstration which employed a twin cathode ray

tube projecting two beams on the same fluorescent screen. The superpositioning gave a fairly wide and reasonably accurate colour range.

The RCA system has been developed on similar lines. Three separate images, after sorting out from the signal, are superimposed on the same screen. Such a system, although it means complication in the CRT, is theoretically practical and development will lead to its simplification. It would, however, make all our present equipment obsolete.

Not only are three separate beams each from their own "gun" required inside the tube, but a great many circuits in the receiver will have to be in triplicate. No wonder designers have given much thought to providing a means of producing colour with minor modifications and additions to our existing receivers.

### Mechanisation

The most direct way of adding colour to our existing system is mechanical. Again, of course, we are dependent on the mixing or subtraction of primary colours. Columbia developed a system using a revolving filter disc in front of the camera. A similar disc has to be rotated in synchronisation in front of the CRT of the receiver. It was used for

Unfortunately the development of colour TV in Great Britain, at least, is not solely based on the near-perfection of any system. It depends on the provision of programmes. No programmes—no receivers. No receivers—no programmes. Thus we find ourselves in a vicious circle, but having completed that circle we ourselves have gone round in another. We get back where we came in—sponsored TV! This might yet prove our ray of hope.

If sponsored TV doesn't develop colour it may very well help by relieving the BBC of some of its programme commitments so that they can open up new fields in experimental colour transmissions.

### Alternatives

Colour and stereoscopic TV must come, and we all want to see Great Britain in the vanguard. With the present set-up we are hamstrung to our 405 line, 50 traversal-interlaced f.p.s. system which we started in 1936! Would we decide on it again if we were free to choose to-day, and what alternatives are open to us? Firstly we can supersede it completely while we temporarily carry on the present system side-by-side with a modernised system, until the existing sets "wear out." This sounds very nice, but it's wasteful nationally and we still shan't know if the new system is going

## Centre Tap talks STEREOSCOPIC AND COLOUR TV about A GADGET

a time in America and a number of receivers sold, but it had to be discontinued by government intervention on the grounds that it would upset the Defence Programme.

Pye Radio, EMI, the Marconi Co. and the BBC are all carrying out experiments along these lines, and although satisfactory colour demonstrations have been given, just what sort of results could be achieved on ordinary domestic receivers in the home is rather problematical. Those of us who are still beset with nightmares of our disc-scanning days will find some difficulty to work up much enthusiasm for mechanical colour discs. Nor does anyone dare to commit themselves on the question of costs—not only the cost to the viewer but also at the transmitting end. We still need three times the bandwidth, and a move to the HF means lessened ranges and more relay stations.

RCA are making strenuous efforts to develop an improved all-electronic system, and those of us who think mechanical colour discs too high a price even for reasonably accurate colour, watch with eager eyes.

to prove the ultimate one.

Secondly, we can have a patchwork arrangement whereby we attempt to make existing receivers adaptable by minor modification (or additional stages) to gain partial improvements. Unfortunately the BBC seem to be moving along these lines. This sort of compromise has little to recommend it and there is always a danger that we shall land ourselves in such a tangle of makeshifts that further progress becomes impossible without, at some remote date, having to make a completely fresh start. Timidness on the part of the BBC may be storing up a much bigger hardship for viewers in future years.

The third possibility is wired TV. In any case VHF gives only a local range. Wired circuits could give nation-wide coverage with alternative programmes. The question of bandwidth no longer has to be solved. It would, however, be an enormous undertaking and might take years to get into operation even if there are no unexpected snags. By

[Continued on page 533]

# The "UNIVERSAL" Large Screen AC/DC Televisor

Part I. Described by A. S. Torrance, A.M.I.P.R.E., A.M.T.S.  
(By kind permission of IKOPATENTS LTD)

A recent survey of the electricity supplies in this country has surprisingly revealed that many people are still tied down to the limitations imposed by DC (direct current) mains. It was, therefore, decided to present a design encompassing both AC and DC mains, and which also covered all voltages from 200 to 250.

Fortunately, valves and equipment are available for this design, which is based on series heater-chain technique, and is approved by Mullard, Ltd.

Such a design also, of course, means that the intending constructor must bear in mind at all times the dangers attendant upon the chassis being at mains potential. This need for caution is particularly important whenever operating tests are carried out during the building period, when the chassis is not protected by the cabinet and a careless moment may have serious results. We do not intend to be macabre, but you will not be allowed to forget this highly important aspect of AC/DC technique, for we shall make constant reference to it.

The system also has its advantages, and the compact and remarkably lightweight design possible with this method is readily appreciated from the illustrations which will be appearing. A good idea may be obtained from the accompanying view of the chassis structure, which when properly installed in a cabinet will be perfectly safe for all members of the family to handle. On the structure shown will be the complete receiver; CRT, speaker, sound and vision strip, timebases and all the requirements to suit electrically the various mains supplies wherever it may appear.

All five transmitting channels will be covered by a modern superhet design and, of particular interest to fringe area dwellers,

a highly efficient sync circuit will be incorporated. We should like to make it clear, at this stage, that this is an assembly design for which all items will be available from commercial sources.

All the mechanical structure is being supplied by Denco (Clacton) Ltd., and may be obtained through your usual supplier. Valve holes, etc., will be ready drilled.

A device enabling external focus control, unusual with permanent magnet type focusing, has been incorporated into the design. This has been done to obviate the necessity to delve into the back of the set, and particularly to avoid any contact by the unwary with possibly live parts in a set operating under AC/DC conditions when a focusing adjustment is required. The Elac Duomag Focaliser to be used, is undoubtedly the most advanced type of PM focus unit, and an explanation of its functioning will be given later.

The cabinet, which will be available from Lasky's Radio, is also unusual and worthy of special comment. Basically a table model, the manufacturer will construct a lower section exactly conforming to the upper part in design and style. It is hoped in the near future to produce a first-class radio/gram unit for inclusion into the lower cabinet, thus creating stage by stage the complete home entertainment, which the reader may build in instalments.

To return to construction—Voltage selection will be achieved by resistors, one for the heaters and the other for HT. These resistors are tapped. Careful marking by the makers will avoid any possible confusion between the two, and in addition an explanation of their working will be given as the description proceeds.

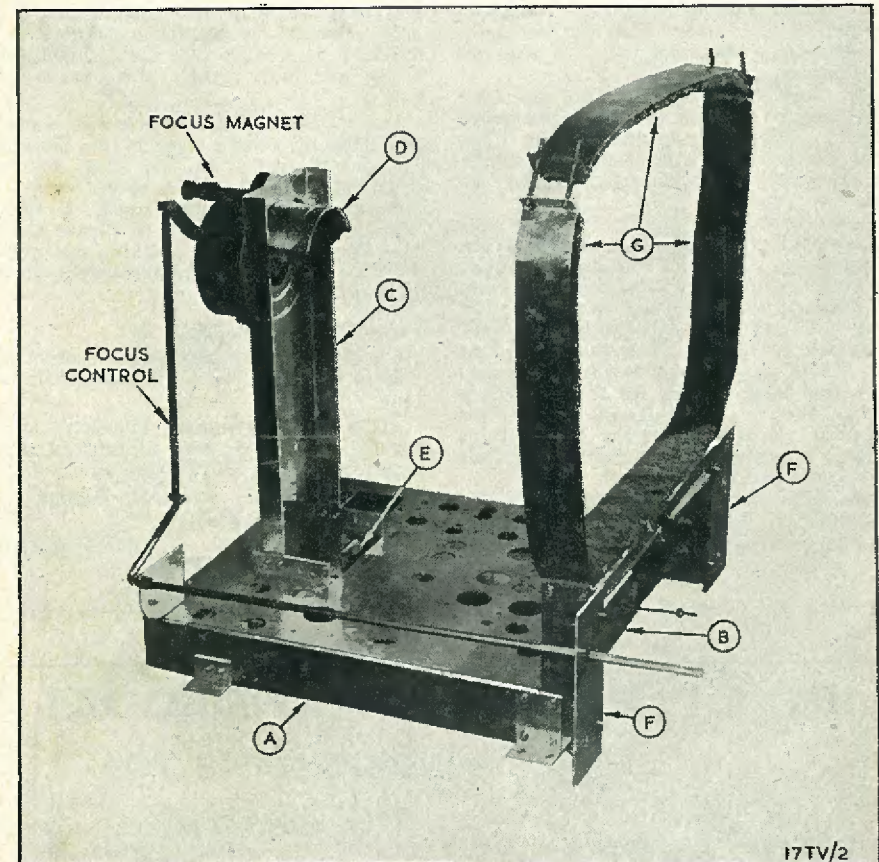

Illustration of complete assembly, annotated to indicate sections. See also diagrams on page 527.

A simple yet effective method of keeping the tube screen dustproof has been evolved, and this, together with a perspex protection guard, is permanently attached to the structure shown in the photograph.

#### Order of Assembling Chassis and Parts

First, study the photograph and sketches. To avoid any confusion which may have resulted from an overdrawn set of sketches, the valve holes and component drilling have been omitted.

The chassis A is the fundamental item, and all other parts are attached with BA nuts and bolts. The use of shakeproof washers is recommended.

Item B is bolted to the front of A. This is further strengthened by the two angle brackets

at the sides, which also provide eventual fixture to the base of the cabinet.

Next attach and assemble parts G. To the insides of these, stick with *Bostik* or other suitable adhesive four pieces of felting  $\frac{1}{4}$ " thick. Carpet felt cut into strips is very suitable.

Bolt into position the rear tube support C and, underneath, the section E with, at the same time, the two small angle brackets. Seen at the rear (sides), these also are used for cabinet fixing. (Note that the rear holes are used in the bent-up parts of the chassis).

D may now be loosely fixed in position, with four 6-BA screws, but these should not be tightened up until the deflection coils are purchased. It will be seen that provision has

been made for rotating the coils (for straightening the picture), and for a vertical movement for centralising the coils into line with the focus magnet.

The focus unit (fixed with four 1½" 2-BA bolts), may be attached to C and the external focusing device placed into position. The small supporting bracket is fixed as shown, and the two chassis bushes inserted front and rear.

Thread through, from the rear, the long angle-section of ¼" rod. Two half links are threaded on the rod between supporting brackets, the purpose of these being to prevent the long rod moving in and out. With two 4-BA nuts and bolts join the shorter crank to the arm on the focus magnet and the long rod. These are not bolted tightly, sufficient movement being allowed for them to act as pivots. Also for smooth, noiseless action cut two small pieces of rubber or PVC sleeving to serve as bushes over the bolts. A locking nut is added to both bolts.

Two 4-BA bolts (or 1/8" Whitworth) 2½" long, and one 1" long, with nine nuts are required for fixing the speaker. The sketch

and final assembly will explain this. The holes provided are accurately disposed to fit the Elac 5" speaker type 5/45. Eight 4-BA bolts, nuts and washers are necessary for part C.

It is not expected that anyone will encounter any difficulty at this stage of the assembly. The one thing that we can think of is the possibility that the longer 4-BA screws or bolts may not be easily secured. In such a case, it is quite permissible to use the nearest equivalent, 1/8", in either Whitworth or BSF threads—there should be no trouble in obtaining these.

**Parts Mentioned in Text**

Chassis, bushes, mechanical parts, and Wide Angle Deflection Coils, Denco (Clacton) Ltd.

Focus magnet (Duomag Focaliser) and 5" Speaker type 5/45, Elac (Electro Acoustic Industries Ltd).

17" Escutcheon, Prepared Perspex and Cabinets, Lasky's Radio.

*[To be continued]*

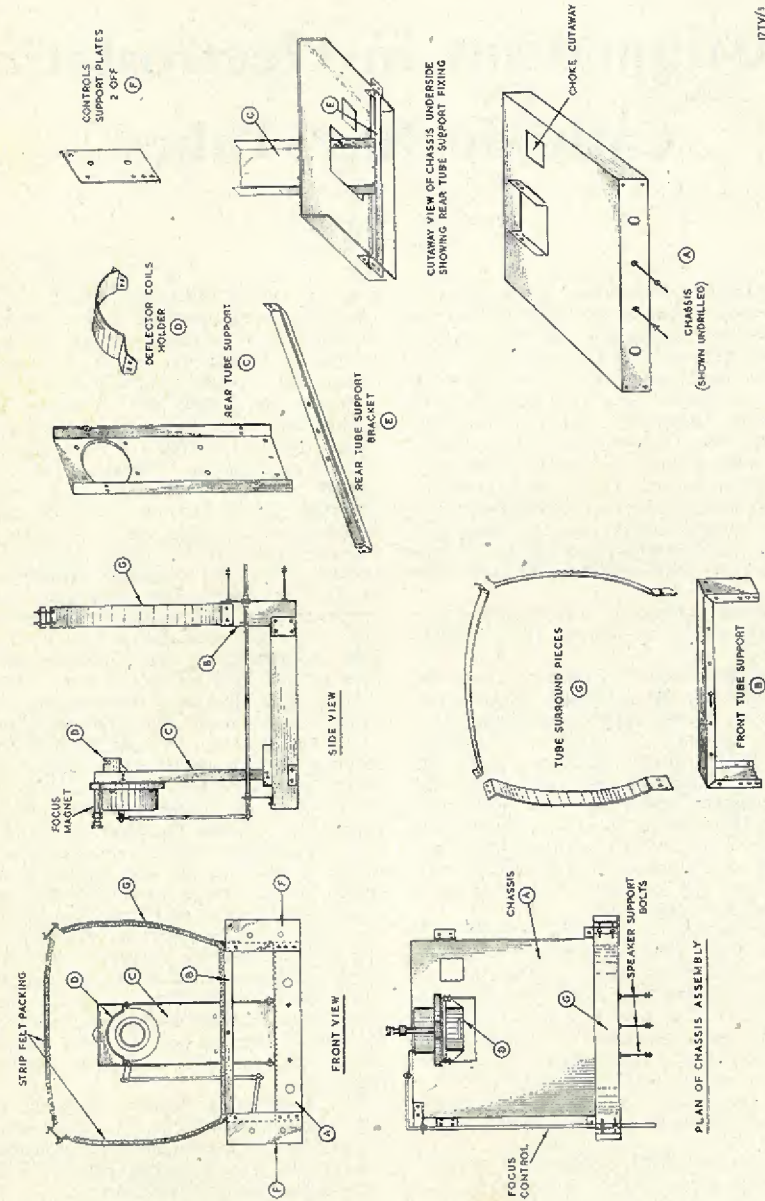

*Details of structure assembly. See text and illustration on page 525.*

**DON'T MISS THIS HANDBOOK!**

**INDISPENSABLE TO  
THE AMATEUR  
TRANSMITTER  
AND LISTENER**



It contains all those details of information which the transmitter and SWL constantly require. Right up-to-the-minute Amateur Band Prefix lists, both alphabetically and by country, Zone Boundaries, Call Areas, Mileage Tables, QSL Bureaux, "Q" and "Z" Codes, WWV Skeds, and much other information, as well as a selection of maps of DX areas.

Price 2/6. postage 2d.

**DATA PUBLICATIONS 57 MAIDA VALE LONDON W9**



# Astigmatism in Electrostatic Cathode Ray Tubes

By C. R. DRAYTON

Many amateur television experimenters have managed to get really well defined pictures from their war-surplus six inch cathode ray tube receivers. Many too must have reached the point where it seems impossible to improve no matter what is done in the way of band-width adjustment, video valve compensation etc. When this stage is reached it would seem to indicate that maybe the tube itself is the limiting factor. It is well known, of course, that these small tubes possess characteristics not ideally suited to television. In this connection, the writer has found it profitable to devote some attention to spot size and shape.

So far as size is concerned, the best procedure seems to be to use as high an EHT voltage as possible.

Quite often, however, there remains the defect which has been termed astigmatism. Astigmatism is usually apparent when focusing. It may be possible to detect two distinct positions of the normal focus control which give relative sharpness. At one point the scanning lines will be sharp, and horizontal picture detail somewhat lacking. The second point will give improved horizontal definition—the vertical elements of the picture will be sharp—but the scanning lines will have disappeared, or nearly so.

The effect is easily explained. Each pair of deflector plates acts as a focusing electrode but, being split into two parts, can only be effective as such on one axis. Thus, if the mean potential of a pair of plates is varied the spot will be compressed or elongated in one direction only. That focus does not vary to any extent when the tube is being scanned is due to the fact that with a push-pull timebase the mean potential of the plates does not change.

It does not necessarily follow that a little astigmatism is a bad thing. A spot which is slightly elongated in the vertical direction may give a "solid" and sharp picture. The effect is similar to that obtained by "spot wobbling" or spot squashing, and merely

serves to fill in the spaces between the lines. On a six inch tube the spaces between the lines are very narrow and little vertical spot elongation is tolerable, as the lines will soon merge and vertical detail will be lost.

Before attempting any correction it is as well to determine the degree of the defect, and whether or not both pairs of plates are involved. This is easily done if the timebase is disconnected and the stationary spot de-focused to about 3/16" diameter (the brilliance must first be reduced, of course). The spot is then moved from side to side, using one shift control only, and observing the spot shape as this is done. The experiment is then repeated, this time moving the spot up and down. In all probability it will be found that movement in one direction will have little or no effect on spot shape. Movement in the other direction, however, is likely to cause the spot to change from an ellipse with its major axis, say, vertical through an intermediate circular shape to an ellipse with its major axis horizontal. Fig 1 illustrates this. This is because altering the potential of one plate alone changes the mean potential of the pair. The fairly obvious remedy, and the one which is given in the text books, is to fit a second potentiometer to control the potential of the second plate of the pair which exhibits the effect. This enables the spot to be moved about the screen by adjusting the sliders in opposite directions, and thus maintaining the mean potential and the spot shape constant. It may be necessary to do this for both pairs of plates. Figs. 2 and 3, show the normal circuit arrangement and the modification respectively.

This method is capable of good results, but there are drawbacks. It might seem that the procedure would be to adjust the spot position to give a central picture, and then with a stationary de-focused spot as before, to adjust the shape. Unfortunately, when the spot is returned to its normal brilliance and re-focused the good work will probably

[continued on page 505]

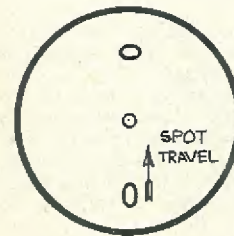

FIG. 1  
CHANGE OF SPOT SHAPE  
DUE TO SHIFT

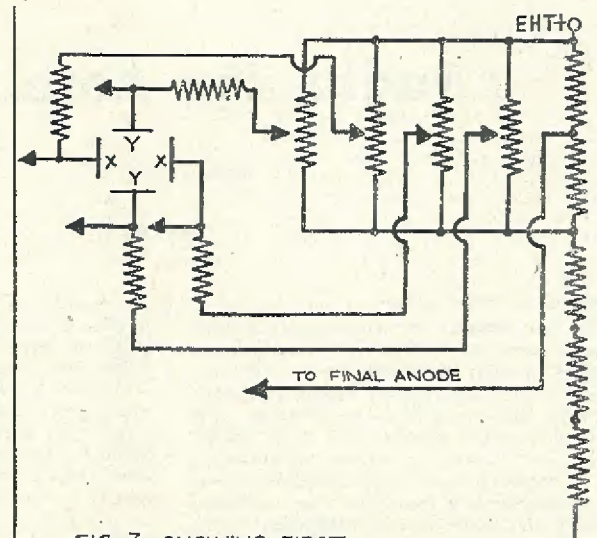

FIG. 3 SHOWING FIRST  
MODIFICATION OF POSITIVE  
END OF EHT NETWORK

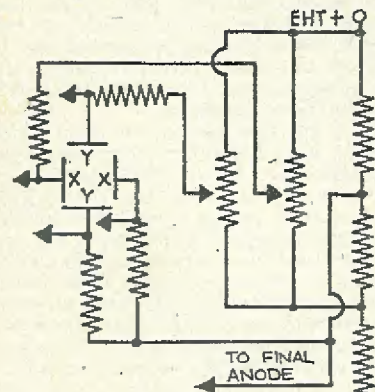

FIG. 2 SHOWING USUAL  
ARRANGEMENT OF  
POSITIVE END OF  
EHT NETWORK

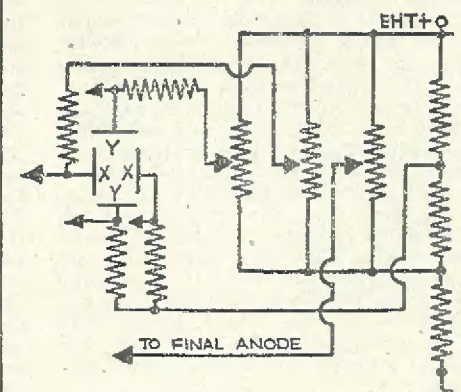

FIG. 4 SHOWING SECOND  
MODIFICATION OF  
POSITIVE END OF  
EHT NETWORK

RC136

# Audio Pre-Amplifiers

By D. NAPPIN

PART 3

## Design of a Pre-amplifier

The requirements for a pre-amplifier have already been stated; however, certain other problems present themselves.

As the pre-amplifier is necessarily a high gain unit, steps must be taken to reduce hum and other extraneous noises such as "Johnson" noise. Such noise is introduced mainly at the grid of the first stage, as the amplification at subsequent points in the circuit is not sufficient to cause any appreciable contribution to the over-all noise by extraneous signals introduced at these points.

To reduce noise in the input resistor, it must be of the high stability cracked carbon type, as the composition type often possess a very high noise level due to the semi-conducting properties of carbon.

This resistor is R1 in the circuit diagram (Fig. 6), which represents a pre-amplifier suitable for use with the quality amplifier described in a previous issue (May, 1952).

As the input circuit is of high impedance, it will be seen that hum may be very easily introduced electrostatically from either heater leads or mains leads. It is therefore advisable in construction to screen the grid lead, and to keep the heater leads close to the chassis. It may be found necessary to employ a centre-tapped resistor across the heater line, with the tap connected to a point on a potential divider across the HT line and earth of equal potential to the input valve cathode. The writer, however, has achieved a suitable low hum level with one side of the heater supply earthed.

The valve employed has a considerable effect upon the hum and random noise level, and may if badly chosen introduce microphony and acoustic feedback from the speaker. Thus it is seen that the valve must have a rigid electrode structure, to avoid microphonic vibration, and be suitably designed to reduce shot and partition noise. The heater is best of balanced helical construction to reduce the hum field. The Mullard EF37A has a suitable structure for this job, and is also available in

the miniature range on the B8A base as the EF40. A similar valve is the Brimar 8D5 or 6BR7 on the noval base.

The first stage employs a modified form of Williamson's single valve pre-amplifier, in which negative feedback is applied from anode to grid via a potential divider composed of either R7-C5 and R9, or R8 and R9. The latter position gives a level response with a gain of 1 where B, the

feedback ratio, is  $\frac{R_9}{R_8+R_9}$  As R9 is 22kΩ

and R8 220kΩ, this gives a gain of 11 or 21 db. The capacitor C5 introduces extra degeneration at high frequencies to cater for the top boost in Decca discs. If desired, this feature may be deleted from the pre-amplifier and incorporated in a plug-in equalizer. In this stage good HT decoupling is essential, and at least 16 μF was found necessary despite the power supply having a two stage filter with 32 μF smoothing capacitors.

To allow for larger inputs from radio feeder units, etc., a third position was provided on switch 5, allowing V1 to be cut out and feeding the input directly to the volume control R10. V2 is a normal voltage amplifier providing sufficient gain to counteract the loss in the tone control network. It will be noted that double decoupling is provided in the anode circuit, this being to provide reasonable attenuation of hum without the use of electrolytic capacitors.

Immediately consequent upon this follows the previously described frequency compensation circuit, feeding directly into V3 to avoid modification of its characteristics by shunting of the output. The valve V2 is preferably an EF37A or similar type, but due to the higher signal level it is possible to use an EF36 or 6J7.

The same comments apply to V3, which is again a simple voltage amplifier, although it may be possible to employ a 12AX7, a double triode on the B9A base, for these two valves.

All the circuitry following V3 is the variable slope steep cut-off filter, and if it is desired to

omit this the output may be taken from capacitor C38. The switch S3 provides various frequencies of cut-off and a straight through position where the stage functions as a negative feedback amplifier, B the feedback factor being given

$$\text{by— } \frac{R_{21} \times R_a}{R_{22} + R_{23} + R_{21} + R_a}$$

$$R_{29} + R_{30} + R_{32} + R_{22} + R_{23} + \frac{R_{21} \times R_a}{R_{21} + R_a}$$

where Ra is the AC anode impedance of V2. Assuming Ra to be 60 kΩ, this expression becomes

$$\frac{100 + 500 + \frac{60 \times 100}{160}}{100 + 100 + 500 + 100 + 500 + \frac{60 \times 100}{160}} = \frac{637.5}{1337.5}$$

The gain is therefore  $1 \frac{1337.5}{637.5} = 2.1 = 6.4 \text{ db}$

The resistor R33 is the slope control and its variation affects the feedback factor and thus the gain.

It may be seen by a similar calculation to that already performed that the gain when R33 is shorted will be  $\frac{1137.5}{637.5} = 1.8 = 5 \text{ db}$ . Thus

the maximum change in gain is 1.4 db. and as 3 db. is a just perceptible change 1.4 db. will be unnoticed. The capacitors C25-C37 with resistors R29, R30, R31 form the frequency sensitive parallel T network while C19, C20, C21 provide the required capacitance to cause a suitable phase shift around the feedback loop. C15-C18 provide in conjunction with R22 high frequency loss to counteract the rise in response of the unbalanced parallel T before resonance. R28 is included to provide a grid return for V4, a further EF36, via R32, R30 and R34.

## Further Notes

It has already been mentioned that good smoothing is essential, hence the power pack should be designed to provide 250 volts or thereabouts with an extremely low hum level. The writer has achieved good results using what is, in effect, two power packs in series employing separate smoothing. The pre-amplifier and radio feeder are fed by one power pack, while both in series supply the main amplifier for which a higher hum level is tolerable.

For the benefit of those who have laid in stocks of 6SH7's, it may be stated that this valve is quite suitable for V1 provided normal precautions to avoid hum are taken. It was found essential to well clean the valve base and socket with some form of cleaning fluid to remove flux residues and dirt, as leakage otherwise occurred from heater to grid.

Methylated spirits or lighter fuel may prove useful, although carbon tetrachloride should be better. The writer successfully employed a mixture of trichlorethylene and ethyl acetate for this purpose. A ceramic socket improves matters, as dirt is more easily detectable and removable from a glazed surface.

Some authorities claim that hum may be reduced by demagnetising the valve. The writer has not noted any appreciable difference in hum level by demagnetising a 6SH7; however, the metal envelope of this valve probably screens the electrodes from the influence of the demagnetising field. Readers who wish to try demagnetising valves may proceed by using a speaker energising coil of almost any resistance above 2000 Ω connected across the mains. A 1" diameter coil should serve to demagnetise miniature valves and those of the EF36, EF37 class; however, for such valves as the SP61 and EF50 a 1½" diameter coil will prove necessary.

NOTE. A misprint occurred in Part 1 of this series, in section (3) Non-Linearity Distortion, para. 3, where the ratio of intermodulation to harmonic distortion was given as "2J½". This should, of course, have been "2 × √2."

Fig. 6 and Component Values are given on next page.

## References

- (1) Roddam, T., *Intermodulation Distortion*, *Wireless World*, April 1950.
- (2) Cocking, W. T., *Diode Detector Distortion*, *Wireless World*, May 1951.
- (3) Williamson, D. T. N., *High Quality Amplifier*, *Wireless World*, October 1949.
- (4) *Correspondence*, *Wireless World*, December 1949.
- (5) Olson, H. F., *Elements of Acoustical Engineering*, pages 481-2.
- (6) West, R. I. and Kelly, S., *Pickup Input Circuits*, *Wireless World*, November 1950
- (7) Williamson, D. T. N., *High Quality Amplifier Modifications*, *Wireless World*, May 1952.

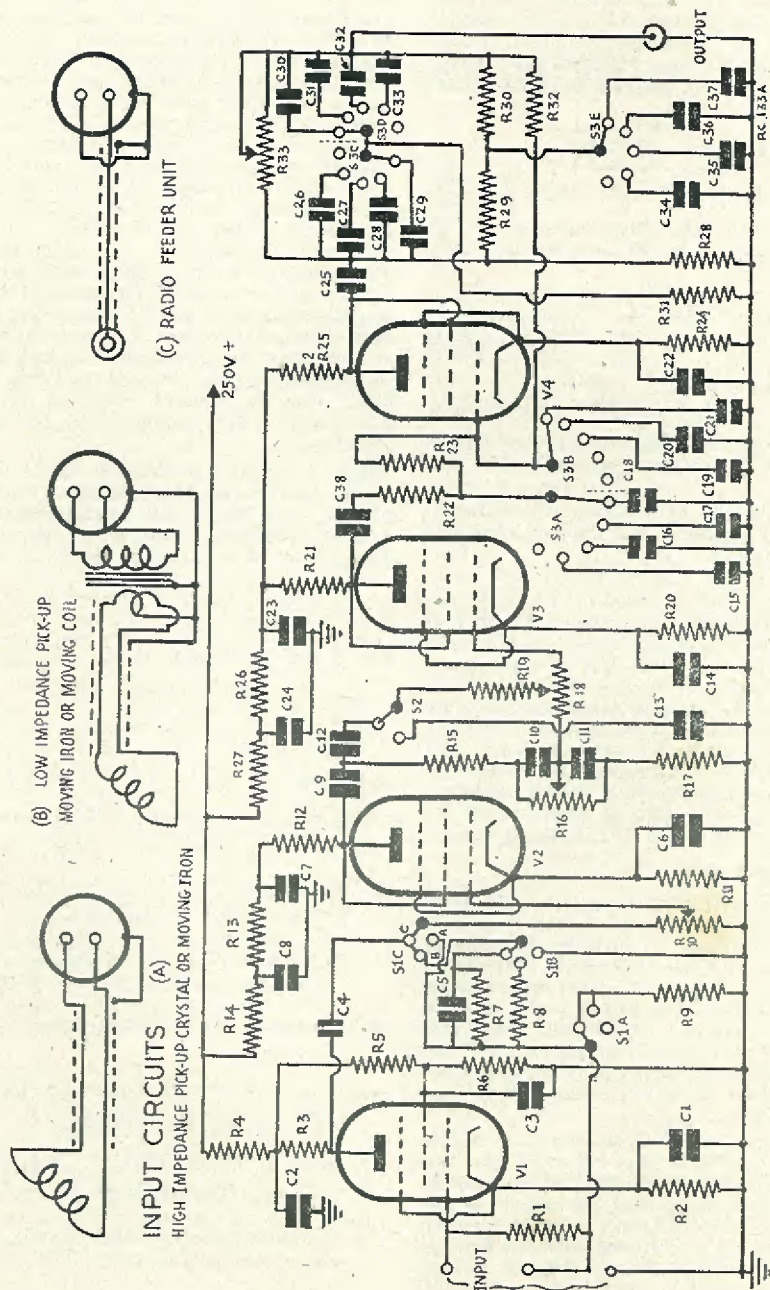

Fig. 6. Theoretical Circuits of Audio Pre-amplifiers

COMPONENT LIST

Resistors

- R1 500 kΩ 1/2W HS
- R2 4.7 kΩ 1/2W HS
- R3 220 kΩ 1/2W HS
- R4 47 kΩ 1/2W Composition
- R5 470 kΩ 1/2W HS
- R6 68 kΩ 1/2W HS
- R7 220 kΩ 1/2W HS
- R8 220 kΩ 1/2W HS
- R9 22 kΩ 1/2W HS
- R10 250 kΩ Logarithmic
- R11 3.3 kΩ 1/2W Compo
- R12 47 kΩ 1/2W Compo
- R13 22 kΩ 1/2W Compo
- R14 22 kΩ 1/2W Compo
- R15 100 kΩ 1/2W Compo
- R16 250 kΩ Logarithmic
- R17 10 kΩ 1/2W Compo
- R18 100 kΩ Linear
- R19 10 kΩ 1/2W Compo
- R20 1 kΩ 1/2W Compo
- R21 100 kΩ 1/2W Compo
- R22 100 kΩ 1/2W Compo
- R23 470 kΩ 1/2W Compo
- R24 3.3 kΩ 1/2W Compo
- R25 100 kΩ 1/2W Compo
- R26 22 kΩ 1/2W Compo
- R27 22 kΩ 1/2W Compo
- R28 1 MΩ 1/2W Compo
- R29 100 kΩ 1/2W 1%
- R30 100 kΩ 1/2W 1% or matched
- R31 50 kΩ 1/2W 1% or matched
- R32 470 kΩ 1/2W Compo
- R33 1 MΩ Logarithmic

Capacitors

Where no voltage rating or tolerance is given, these may be taken as 250V and 20% respectively.

- C1 50 μF 12V Electrolytic
- C2 16 μF 350V Elect.
- C3 0.25 μF 250V Paper
- C4 0.1 μF 500V Paper
- C5 100 pF Silver Mica 10%
- C6 25 μF 25V Elect.
- C7 0.5 μF 350V Paper
- C8 0.5 μF 350V Paper
- C9 0.1 μF 500V Paper
- C10 0.005 μF 500V Paper
- C11 0.05 μF 500V Paper
- C12 100 pF Silver Mica
- C13 1000 pF Silver Mica
- C14 25 μF 25V Elect.
- C15 100 pF Silver Mica 5%
- C16 200 pF Silver Mica 5%
- C17 300 pF Silver Mica 5%
- C18 500 pF Silver Mica 5%
- C19 50 pF Silver Mica 5%
- C20 100 pF Silver Mica 5%
- C21 250 pF Silver Mica 5%
- C22 25 μF 25V Elect.
- C23 0.5 μF 350V Paper
- C24 0.5 μF 350V Paper
- C25 0.1 μF 500V Paper
- C26 75 pF
- C27 100 pF
- C28 150 pF
- C29 200 pF
- C30 200 pF
- C31 150 pF
- C32 100 pF
- C33 75 pF
- C34 150 pF
- C35 200 pF
- C36 300 pF
- C37 400 pF
- C38 0.1 μF 500V Paper

Silver Mica  
1%  
or  
Matched

RADIO MISCELLANY

(continued from page 523)

way of an afterthought, we might also add, there could be no more pirates! Only this week somebody was quoting their number with a string of five noughts on the end.

Judged on present form, unless the unexpected happens (as it so often does) it looks as if alternative two will be the next step, and my guess is that sponsored TV may prove a two-fold blessing.

Gadget of the Month

From a number of specimens received for review from Messrs. Kendall and Mousley of Tipton, Staffs., a pair of meter stand ends took my eye. While their first appeal was largely prompted by novelty (I certainly cannot remember anything like them having previously been popularly marketed) their usefulness makes them worthy of recommendation for

workshop, control console, transmitting table or laboratory use.

They consist of a light, but rigid frame neatly finished in crinkle enamel, upon which panels of various lengths can be fitted. Thus a single meter, such as an "S" meter, or a whole row of instruments can be mounted at an angle of 45 degrees from bench or table level. This is an ideal angle for observing meter readings or other visual indicators, whether one is standing up or sitting, as well as making the best use of whatever illumination happens to be available. The price of the frame ends is 2s 6d per pair and panels of any required length can be supplied at 1s 9d for six inches plus 3d for each additional inch.

The address of the manufacturers will be found under the review of a selection of other items from their extensive range of laboratory and workshop metal-ware.

# A Simple AC-DC Amplifier

By JAMES S. KENDALL

ASSOC. BRIT. I.R.E. M.I.P.R.E.

There are on the market today some valves of very low heater consumption, only 100 mA in fact. Three typical examples, the UBC41, UL41 and UY41 are used in this circuit. The base used is the B8A, which is of the eight-pin, pin type; the valves, being of the all-glass type, alleviate the troubles due to the loosening of the valve base owing to the heat from the valve itself. The writer has had experience of quite an amount of this trouble with octal based valves, especially in some of the continental types where the base is very shallow.

The circuit is quite conventional, except for the bass lift circuit. It is well known that in recordings the level of the bass has to be cut so that the needle does not have to be moved excessively for the reproduction of the low notes. The anode load of the UBC41 is divided into two portions, separated by a small condenser joined to chassis. This has the effect of reducing the gain at the higher frequencies, and increasing it at the lower. The actual value of the condenser will depend to a large extent on the listener. There is no reason why several different values could not be joined to a wafer switch and so provide a selection. The writer, however, has found that one of 0.005  $\mu$ F is about right; it has an impedance of some 50,000 ohms at 700 cycles and only some 5,000 at 7,000 cycles. The higher the value of the condenser, the lower will be the value of the frequency that is lifted.

The coupling to the following valve, the UL41, is by means of a 0.01  $\mu$ F condenser, into a 1 M $\Omega$  resistor. These values of condenser and resistor do not appreciably affect the lower end of the audio range, but help to reduce the chance of motor boating in the amplifier.

The condenser chosen for the bias of the UBC41 was one of those very small ones made by T.C.C. whereas that for the output valve was a normal sized 50  $\mu$ F 50 volt job as it has to carry a much higher amount of AC.

The smoothing used was very efficient; two 32  $\mu$ F condensers of the hole-and-nut type made by Hunts were used in conjunction with a 10 Hy choke of 50 mA carrying capacity. As the condensers were so large, a

surge limiting resistance of 150 ohms is joined between the cathode of the rectifying valve and the reservoir condenser. If this resistor is omitted it is highly probable that the rectifier valve will be severely damaged in a very short time. The writer has had experience on more than one occasion of the valve pinch, in the older types of valves, being blown out through the envelope, with serious results to the valve!

The chassis used for the construction was one of the type "10" made by Kendall and Mousley of Tipton, Staffs. The fact that the amplifier is of the AC/DC type makes it unsuitable for use in a metal case, and if a wooden one is used plenty of air space must be given. The mains dropper used is in the form of a 40W 250 Volt lamp. This gives the correct amount of voltage drop when used on the 230 volt mains. The use of an electric light bulb for a dropper is by no means new; it has the effect of reducing the surge through the valves as it warms up very quickly. As the valves warm up and increase in resistance the current is reduced, and the resistance of the lamp drops so that any small voltage fluctuations of the mains are compensated for.

The components required are:—

- One Each UBC41, UL41 and UY41.
- Three B8A holders.
- One 0.25 M $\Omega$  volume control W/S.
- One 50 k $\Omega$  Tone control.
- One 2.2 k $\Omega$  resistor.
- One 1 M $\Omega$  resistor.
- One 300 ohm resistor.
- One 30 k $\Omega$  resistor.
- One 150 k $\Omega$  resistor.
- One 150 ohm resistor.
- Two 32  $\mu$ F 350 Volt or higher condensers.
- One suitable smoothing choke.
- One suitable output transformer.
- One 8  $\mu$ F 6 volt condenser.
- One 50  $\mu$ F 50 volt condenser.
- Two 0.01  $\mu$ F 350 volt condenser.
- One 0.005  $\mu$ F 350 volt condenser.
- One Lamp holder.
- One 250 volt 40 Watt Bulb.
- One suitable chassis.

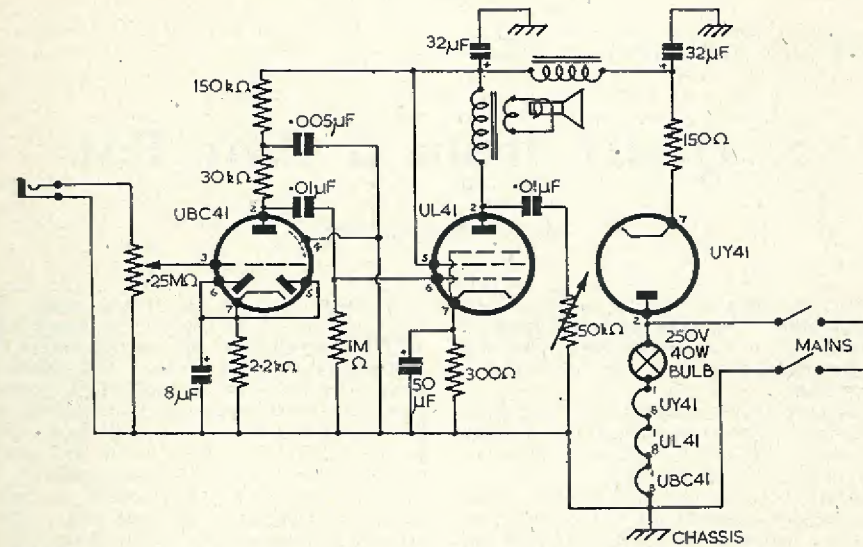

RC163

Theoretical circuit of AC/DC Amplifier.

## 625-Line Transmissions The Television Society to Start Experimental Service

Speaking at the Television Society's Annual Dinner on April 13th, Sir Robert Renwick, President of the Society, said that they would shortly be building an experimental 625-line transmitter in order to provide a service to both amateurs and the radio industry and thus help the export market.

It was realised that receivers intended for the continental standard of 625 lines could be more conveniently demonstrated and tested on a radio signal under working conditions, and with the approval of the radio industry, the Society has undertaken to operate a suitable transmitter.

Discussions are shortly taking place between the Society and B.R.E.M.A. on a suitable site and design of the equipment.

Sir Robert said: "I want to make it clear that this is an experimental project undertaken for the advancement of television technique, subject to Post Office approval, and will transmit still pictures for experimental purposes. We shall take advice from the B.B.C. and the industry and hope that the export trade will benefit accordingly."

The principal guest at the Dinner was Mr. David Jamieson, M.P., the Assistant Postmaster-General.

## An Improved 17 inch Rectangular Television Tube

Mullard Ltd., have recently made an addition to their range of Long-life Television Picture Tubes. It is the MW43-64, an all-glass rectangular tube with a 17in diagonal grey glass face.

A feature of this new tube is the incorporation of a new form of electron gun which is designed to give uniform focus over the whole screen. In this new gun assembly the functions of electron acceleration and pre-focusing, which have hitherto been combined by the first anode, have been separated by the inclusion of an additional electrode.

The first anode in the MW43-64 acts as an accelerator, having a potential of 200 to 410 volts with respect to the cathode. The second anode exerts a pre-focusing action on the electron beam, thus influencing the spot size and uniformity of focus. When the potential on this anode is zero or negative with respect to the cathode, the spot size at the centre of the screen and the width of the unfocused beam are such that optimum uniformity of focus is obtained over the whole picture area.

Further technical details of the MW43-64 can be obtained on application to the Technical Service Department, Mullard Ltd.

Let's Get Started . . . . .

## 2. Quart from a Pint Pot

By A. BLACKBURN

Don't let that title lead you astray. I am not suggesting you are getting something for nothing when you use an amplifier. But that you are getting more from the little that you already have.

Such a prospect is always attractive, particularly if the process of multiplication is a simple one. And in this article I intend to show you just how easily it can be done.

Amplification often requires the use of two more complex types of valve in addition to the triode we discussed last month, but once you have seen how the simple types of valve work, it is easier to understand the tetrode and pentode, with which we are going to deal, as they really have the same basic construction as the triode, with extra electrodes incorporated in them.

Although popular for many years, the tetrode valve has been largely superseded for amplification of very high frequencies by the pentode valve (see Fig. 1b). The screen in both types has a positive potential upon it, and therefore increases the current from the filament to the anode. We will not worry a great deal at this stage about the special characteristics of these valves—suffice it to say that the mutual conductance is higher than that which can be obtained with a triode. Usually, one can say that the higher the mutual conductance, the higher will be the amplification or "gain," as it is often called, of the valve.

The fifth electrode of the pentode is the suppressor grid, between the screen and the anode, which serves to overcome certain

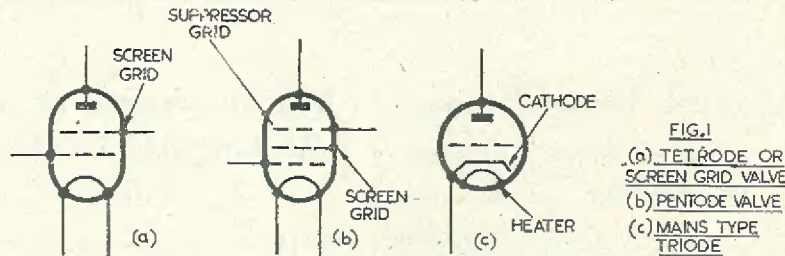

RC187

### More Electrodes

The tetrode valve, shown in Fig. 1a, has, in addition to the filament, anode and control grid of the triode valve, a fourth electrode placed between the anode and control grid. This is the screen grid which, by shielding the control grid from the anode, reduces the capacity between them, making the valve more stable for some types of amplification.

However, as we are only concerned in this article with simple amplification, more advanced systems will be dealt with at a later stage; I do not want to confuse readers now with half-explained complexities.

disadvantages present in an ordinary tetrode. There is a type of tetrode available nowadays from which such disadvantages are removed, by using plates, mounted in the electron stream between the screen and anode, to form the electron stream into a "beam." Because of this characteristic these plates are called beam forming plates and this type of valve is called a beam-tetrode.

All the valves so far described have only been suitable for use with DC filament supplies. If AC were used to heat the filament, the AC signal would cause the electron stream to vary and would, therefore, produce a small alter-

nating current in the anode circuit. In a practical design this would be evident as an objectionable hum. If, for example, we were to use the mains, via a transformer, to heat the filament, a 50 c/s hum would be superimposed upon the signal. You could, of course, overcome this by changing the AC voltage to DC by the use of a rectifier, but this would be expensive and clumsy. However, we can easily get over this problem by causing the filament to heat a small tube placed around it. This tube, called the cathode, is coated with a material which gives off electrons very easily, when heated. We now have a valve in which the filament emits no electrons at all, this duty being transferred entirely to the cathode.

A cathode may be incorporated in any valve, whether it be diode, triode, tetrode, or pentode, or even more complex types. And in general whenever a cathode is fitted, it is called a "mains" valve.

### Coupling

The primary points we have to consider in the design of a simple amplifier are as follows: (i) what it is we want to amplify; (ii) the overall gain; (iii) the power output.

The first of these is obviously of considerable importance to us. In this article we shall confine our attentions to the amplification of signals in the audio range, that is to say, those frequencies which you can hear. Suppose, for instance, we wished to amplify signals from a microphone, a gramophone pick-up, or the tiny audio signals present in the detector stage of a radio receiver, where these frequencies cover a range of approximately 30 to 15,000 cycles per second. For the purpose of our elementary design, we will consider the gramophone pick-up. The voltage produced by a crystal pick-up is about one volt at the very most. The problem with which we are faced is to amplify this signal, and finally

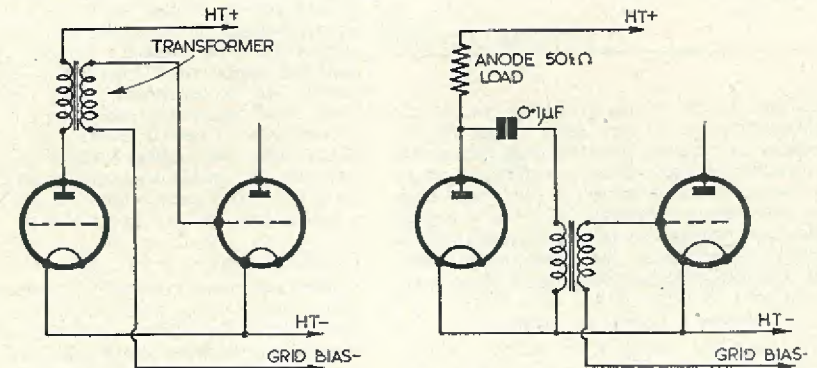

RC188

As a rule, filaments and heaters, as they are called in valves with a cathode, fall into a definite number of voltage ratings. Battery valves, that is those without a cathode, are normally 1.4 and 2V, AC mains types 4 and 6.3V, and AC/DC types, sometimes known as "universal" types, are in many voltages from 12 to 117.

Obviously with a mains type there is no battery problem, and economy of supplies is not so important, so that valves provide higher gain and power output than can usually be obtained in the battery range.

convert it into power, which brings us to points (ii) and (iii).

Normally one valve cannot produce sufficient gain to make such small signals comfortably audible in a room through a loudspeaker. Therefore the output of one valve has to be fed into other valves until sufficient gain has been achieved.

There are a number of ways of coupling one valve to another. Two of the more commonly used systems of coupling between valves are shown in Figs. 2 and 3. Fig. 2 shows transformer coupling. This is very simple and

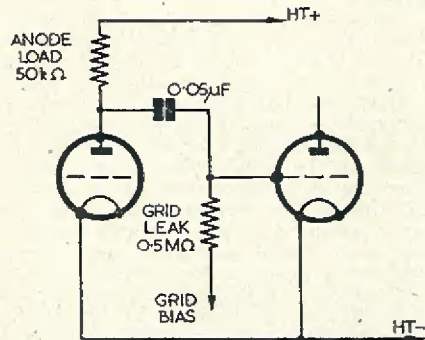

FIG. 3  
RC-COUPLING  
THE VALUE OF THE COUPLING CONDENSER  
MUST BE HIGH ENOUGH TO PASS THE  
LOWER FREQUENCIES, I.E. NOT LESS THAN  
0.01μF

RC189

economical, but if high quality, i.e. if the reproduction of a very wide range of frequencies, is required, then the transformer has serious limitations. Quite satisfactory results can be achieved, however, if the transformer is a well designed product. If it has a step-up ratio from primary to secondary, some voltage gain is obtained in the transformer itself. For example, if it had one volt in its primary and a step-up ratio of 5:1, then there would be 5V developed across the secondary.

Although the subject of the design of audio-transformers is a very deep one, which I do not here propose to go into, here is a word of guidance. Generally, the better the transformer, the larger it is. Recently, it is true, new techniques in this direction have resulted in the manufacture of very fine transformers of light weight and of reasonable size, but these are expensive in comparison with the older types which can be found in any friendly enthusiast's junk-box.

Another widely used coupling method is the resistance capacity system shown in Fig. 3. You will see that the valve has a resistance in its anode and, as in the simple amplifier described last month, the output voltage is developed across it. The output voltage at the anode is transferred to the grid of the next valve by a condenser. This condenser also serves to prevent the HT voltage in the anode of the first valve from reaching the grid of the second.

There is a point here which I know many people find confusing—I did myself. The signal voltage developed across the anode resistance is actually developed at the anode with respect to the HT end of the resistor. Now, in our circuit we have caused this voltage to be developed between the grid of the next valve and earth, the latter via the grid bias battery, the resistance of which is negligible.

To explain this, it must be appreciated that there are virtually two currents flowing in the anode load resistor: one is direct current flowing from the battery through the valve, and the other is the variation in this current, caused by the action of the valve. In other words, there is a direct current and an alternating current. Now, the HT battery is connected from the upper end of the anode load resistor to earth. However, the variation in current, i.e. signal current in the anode circuit, develops only a tiny voltage across the HT battery (due to the battery's internal resistance)—a voltage which can be ignored in comparison to the signal voltage developed across the load resistor. We may say, then, that the upper end of this load resistor, as far as the AC is concerned, is in series with a very small resistance (the internal resistance of the battery) and is connected to earth. In actual fact, the signal voltage is developed between the anode and earth because, as we have seen above, earth and HT are connected together from the AC point of view.

**Final Comments**

The resistance connected from the grid of the second valve to the grid bias battery is called the "grid leak." It would be as well to say a word or two here about grid bias. We will not go too deeply into the reasons for grid bias at the moment, but that does not mean that it is not important. The recommended grid bias value for every valve can be obtained from the valve table referred to last month. If, during your experiments, you should find that the recommended bias does not appear to give good results (wrong bias can usually be detected by severe distortion in the amplifier), then simply change the bias until the results improve. So much for grid bias—for the moment.

We will assume, in our specimen amplifier shown in Fig 4, that the input terminals aa are to be connected to a gramophone pick-up giving one volt maximum output, and that one watt is to be delivered to the loudspeaker. The voltage from the pick-up is applied to the triode V<sub>1</sub> grid through a volume control R<sub>1</sub>. This component merely "taps off" some of the voltage in order that the required

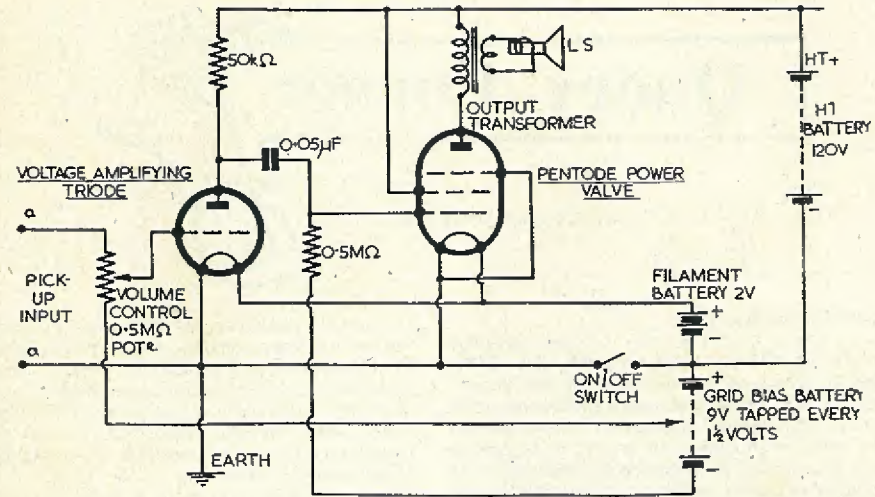

FIG. 4  
A SIMPLE GRAMOPHONE AMPLIFIER

RC190

volume level may be obtained. The output voltage from V<sub>1</sub> is applied to the pentode V<sub>2</sub> through a typical resistance capacity coupling network.

V<sub>1</sub> amplifies the voltage of the signal. V<sub>2</sub> converts this voltage into power. This is necessary because the loudspeaker cone has to vibrate and move about small quantities of air which strike the ear-drums in the form of sound. Movement of this air requires power. It will be seen from the diagram that in the anode circuit of V<sub>2</sub> there is a transformer, the secondary of which is connected to the loudspeaker. This transformer has a large step-down ratio from primary to secondary, and is called the output transformer.

The same remarks concerning good quality performance apply to output transformers as to coupling transformers. But whereas an output transformer must be used, a coupling transformer can be replaced by R-C (resistance capacity) coupling. So it would be to your advantage to see that your output transformer is of the best quality available. There is only one ratio for any set of circumstances that can be used for an output transformer, because it is used to correctly match the valve into

the loudspeaker. Incorrect matching results in distortion and loss of power. The ratio is determined from the following expression:

$$N = \sqrt{\frac{R_L}{R_s}}$$

where N is the ratio, R<sub>L</sub> is the recommended load for the valve, which can be obtained from the manufacturer's data, and R<sub>s</sub> is the speech coil impedance of the loudspeaker. Speech coil impedances are normally about 3 ohms for small speakers and 15 ohms for larger sizes.

Unfortunately, space does not permit me to give a design method for driving a loudspeaker with one watt from a crystal pick-up, but in a later article I shall be showing the steps involved in practical design.

Here we have dealt with the whys and wherefores of simple amplification. There is, of course, more to this technique than we have mentioned here, but these basic facts will apply to more complicated systems. Once these have been understood, the greater part of the groundwork in this particular aspect of radio will have been done.

# Query Corner

A Radio Constructor service  
for Readers

## Receiver Ventilation

A significant proportion of the enquiries which this Department receives are either directly about problems regarding ventilation, or they are about faults which have occurred due to inadequate ventilation. This subject is a most important one and it is surprising how frequently it is entirely overlooked by constructors who make an otherwise perfect job of a radio or television receiver. The effects of overheating in equipment are often most annoying, and can also be expensive.

The most obvious effects are caused by a change in value of components; these frequently manifest themselves as a change in

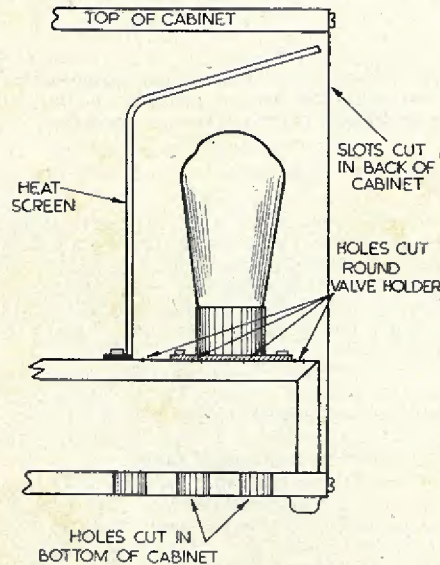

Fig. 1. Method of obtaining uninterrupted flow of air around a hot component.

frequency, probably allowing a timebase to fall out of synchronism or the local oscillator in a superhet to become detuned. Another and perhaps more troublesome result of overheating is that it may well have an adverse effect upon the life of certain components. Capacitors and metal rectifiers are particularly affected in this way.

Some idea of the importance of providing adequate ventilation is gained when it is realised that almost all the power which is drawn by a receiver is dissipated as heat within the cabinet. Steps must be taken to get this heat away from the power consuming components before it has a chance to reach other parts of the receiver. This is achieved by removing the warm air from around the chassis and replacing it by cooler air from outside the cabinet.

It is well known that warm air rises, so provision must be made for a free passage for the air both above and below a heat generating component. It is quite often difficult to obtain this space above a component, particularly if the receiver is of the semi-portable type, and under such conditions it is necessary to mount the hot parts at the rear of the chassis. Having done this, a heat screen is erected between them and the remainder of the receiver to channel the rising air out of holes in the back panel of the cabinet. This is not in itself sufficient, and holes must be drilled in the chassis to allow cold air to take the place of that which rises. Reference to Fig. 1 will indicate the general layout of this arrangement. In a standard receiver the greatest amount of heat is generated by power and rectifier valves and large voltage dropping resistors. Components such as these should be given the form of ventilation outlined above. To gain the free flow of air past a valve it is convenient to drill a series of small holes around its holder.

A particular layout may result in a hot valve being located near a frequency determining component which must be kept cool. When this happens, a series of holes should be drilled around the valveholder as already

described and a metal funnel made up to enclose the valve. The heat within the funnel will cause a steady current of air to flow up through the holes round the holder, past the valve and out of the top. An arrangement such as this not only prevents the heat reaching other components, but it also assists in cooling the valve.

Under-chassis ventilation is important; this is particularly so where air is drawn from below the deck to ventilate components which are located on top of it. In general a space should be left between the chassis and the bottom of the cabinet, or conversely the bottom of the cabinet should contain ventilating holes or slots and should be raised off the table. An alternative system is to drill holes in the sides of the chassis. However, regardless of the layout employed, the aim must be to obtain a free path of air past all hot components.

A particular problem of ventilation occurs in television receivers due to the necessity of screening the components of the line timebase. Such screening is necessary to prevent radiation affecting adjacent broadcast sets, and indeed it may well cause trouble in the television itself by direct pickup in the vision channel. It is normal to enclose the line output transformer, and the three or four valves which make up the timebase, in the screening can, with the result that a considerable amount of heat can be generated. Ventilation is most easily arranged by cutting some large holes in the top of the screen with a chassis cutter, and a series of smaller holes, about  $\frac{1}{8}$ " in diameter, around the sides of the screen near the chassis. Another series of holes are cut around the valveholders and provision made to provide a passage of air to the underside of the chassis as already discussed.

Enough has been said to indicate the general line of approach to the problem of providing adequate ventilation, and the fact that it is a problem which is worthy of serious consideration cannot be too highly stressed.

## Vision on Sound

*I have just completed my first television receiver, and have been successful in eliminating most of the more common faults, but one stymied me. The sound quality is poor and seems to be affected by the vision signal. Sometimes the sound is accompanied by a harsh buzzing sound.*

A. Welsh, Tewkesbury.

This trouble appears to be due to a part of the vision signal reaching the sound channel. The sound section of the set should be sharply tuned with a bandwidth which is probably in the region of 100 kc/s. The full curve of Fig. 2 indicates a typical sound and vision response for a lower sideband television

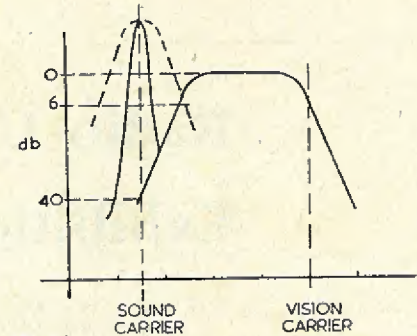

Fig. 2. Response curve of a lower sideband television receiver, showing how the sound response may overlap the vision pass-band.

receiver. It will be seen that the sound sensitivity is such that no significant part of the vision response curve falls within the sound pass-band. Now, should the sound channel be mistuned, or should it be correctly tuned but have too wide a pass-band, the two curves may overlap as shown by the dotted line of the figure. Under this condition a component of the vision signal will be accepted by the sound channel and may, in conjunction with the sound signal, cause severe overloading of one of the valves in the sound RF circuits. The cure is obviously a matter of checking the tuning and selectivity of the sound channel and making good any deficiency in these directions.

Whilst on the subject of tuning TV coils, it is worth pointing out how a false resonant point is sometimes mistaken for the correct tuning position. Most TV coils are tuned by means of adjustable cores, which pass down through the centre of the winding. Obviously, there are two positions of the core which give the same resonant frequency; one is as the core is entering the winding, and the other when it is leaving it on the opposite side. Now between these two positions the circuit may peak somewhere near the required frequency, but it may not actually be on tune. If this is occurring in the sound channel under discussion it will in all probability result in a response curve which has two resonant peaks, though not necessarily of the same magnitude. If this is, in fact, found to be so, the turns on the coil in question must be adjusted, or conversely, if the coil has a shunt capacitor it may be more convenient to change this for one having a slightly different capacitance. If a coil is tuning up correctly the resonant peak will be reached before the centre of the core has reached the centre of the coil.

## Radio Component Exhibition — 1953

Visited by

L. A. CHINNERY, G3IIZ

A private Exhibition, organised by the Radio and Electronic Manufacturers Federation, was viewed by a specially invited audience on April 14th to 16th inclusive. The Exhibition was officially opened at 11 a.m., Tuesday April 14th, by Sir Robert Renwick, Bart., President of the Radio and Electronic Manufacturer's Federation from the gallery of the Great Hall, Grosvenor House, Park Lane, London, W.1. Later, at 1 p.m., Sir Robert presided at a private opening luncheon, attended by the Minister of Supply, Mr. Duncan Sandys, M.P., who proposed a Toast to the Guests. An organised party of important buyers from the U.S.A. attended, establishing a precedent in Transatlantic radio marketing. It is also to be noted that the Federation plan to hold a similar exhibition later in the year, the venue being Stockholm.

Your contributor was invited and attempted to view through the eyes of the Radio Amateur and Home Constructor.

The first call was at Stand No. 105, where a display of the AVO range of products was to be seen. Their "Electronic Multimeter," a most comprehensive instrument, was first to catch the eye.

The name of Belling and Lee is not at all unknown in amateur radio circles, and this company were showing their popular products. These included plugs and sockets, aerial and other insulators, mains and ignition suppressors and valveholders, etc. Also featured was a thermal delay switch for TV receiver use.

Making investigations on behalf of the TV enthusiast, we visited the Aerialite stand, where a novel colour-photographed display analysed TV receiving locations and recommended suitable aerial systems. Vision aerials

of a variety of types were on show, including the "Aerfringe," a multi-element outdoor system for the fringe-viewer. Still with TV in mind, a visit was paid to the Mullard stand where an interesting exhibit was their long-life Rectangular picture tube. By virtue of a development in electron-gun design, the makers claim uniform focus over the whole screen area. On the Taylor Electrical Industries stand the instruments for television servicing were worthy of mention, including as they did the Television Wobbulator (260A) and the Pattern Generator (240A).

Audio enthusiasts will be pleased to note that Messrs. Birmingham Sound Reproducers Ltd., showed their new "Monarch" auto-changer. Features include three speeds and crystal "turnover" pickup. On the tape-recording side of the audio world, visitors were advised at the Truvox stand of that company's Tape Deck Mk.III, and other audio gear, including special speakers, etc.

Salford Electrical Instruments Ltd., were exhibiting the quartz crystals for which they are well known, together with equipment for crystal calibration and measurement of activity.

Erie Resistor Co. Ltd., showed the first printed circuitry that your contributor has seen "in the flesh," so to speak, and included their high voltage ceramicons and small-size type 7AD resistors. The well known transformers of Ferranti and Partridge were to be seen on their respective stands and the products of Messrs. Rola-Celestion Ltd., were displayed to good advantage. Other famous names represented at the Exhibition were Multicore, Telegraph Condenser Co. Ltd., N.S.F. Ltd. (Oak switches, potentiometers, etc.) and Hunts Capacitors.

from our



Mailbag

### General Purpose Test Meter

Dear Sir,

Referring to the diagram on p. 338 of the March issue, there is an error. The positive lead of the 4.5V battery should go to the positive test lead and NOT to the common switch arm. If this is left as per the diagram, there is no indication when in the "Ohms" position.—FRANCIS A. GRANT, G3FTV (Wakefield Yorks).

### Picture Tube Defects

Dear Sir,

Reference Gordon J. King's article on p.349 of the March issue:—When discussing heater/cathode S/C on a cathode modulated tube he, quite rightly, points out that a mains isolating transformer cannot be used to supply the heater. The objections mentioned are truly applicable to the normal type of heater transformer.

There is, however, a special transformer available for this particular application, at a reasonable price. The capacitive and leakage inductance losses are extremely low, and very little loss of definition is noticed. The secondary has tapings for 6.3, 4 and 2V heaters, plus a 3V tapping for low emission 2V tubes!

I am bringing this to your notice as I feel it may enable some constructors to avoid the rather tedious and possibly more expensive method of using two valves, as shown in the article.

The manufacturers of this particular transformer are Norman Rose, Ltd., Hampstead Road, London N.W.1.—A. WARD (Hayes, Middlesex).

### Valve Multi-Meter

Dear Sir,

It was with great interest I read the article by Mr. J. S. Reynolds in your April issue.

For the benefit of readers who may not have noticed, I should like to point out that at 1000 volts the resistor network passes 100  $\mu$ A, and according to Ohms Law passes 1 mA at 10,000 volts. An ex-Govt. 100  $\mu$ A FSD meter that I bought quite cheaply passes 100  $\mu$ A on all ranges, but allows me to load most circuits, especially TV EHT, without detrimental effects.

However, the basic circuit, if used in conjunction with the circuit by Mr. T. Hatton in the October 1950 *Radio Constructor*, which had a sensitivity of 100,000 ohms per volt, should prove a prize winner.—P. WILKENS (Southend-on-Sea, Essex).

### Can Anyone Help?

Dear Sir,

Would you please be so kind as to insert the following letter in your mag. under the "Can Anyone Help?" column.

I am desirous of building a really good class 'scope, and wonder if any "RC" readers have any circuit of tried and proven jobs using current range of valves, say, EF80, ECC80, ECL80, 0.1A type, to have response to 3 Mc/s, switched attenuator, "X" and "Y" shifts, cathode follower input, timebase up to 250 kc/s, and VCR138 or 139A.

I would greatly appreciate full details of any circuits or ideas of any readers on this subject.—L. A. BROWN (33 Barnoldby Road, Waltham, Lincs.).

Dear Sir,

Can anyone assist me to identify three metal rectifiers, purchased with a quantity of other ex-Govt. surplus components?

Each was 3" in length, have 28 fins, are grey in colour, and bear the following inscriptions:—

Positive End (Red)	Negative End (Black)
280/LU (or CO) /422B	V1A+B
280/LU 422 R (or B)	V1A+B
280/LU 422 R (or A, B or P)	V1C+D

I should be grateful if someone can advise me, if possible, the input and output voltages of these rectifiers, as I have no meters to hand.—STANLEY W. J. GREEN, (6 Elmwood Avenue, Baldock, Herts.).



## Some Useful Hints

By J. S. K.

### Precautions on Renewing the Output Valve

Often after the radio set has been running for a number of years a fault develops in the rectifier valve and it will not pass the required current. The H.T. voltage falls so that the electrolytics do not get their full voltage and tend to "De-Form," and renewing with a new valve can cause the components to rupture as the voltage applied is higher than the condensers are used to. Re-forming is essential and can be done quite simply by slowly raising the voltage across the condenser with current from a separate power pack. The condenser should be disconnected whilst re-forming. The voltage to which the condenser is raised should not exceed its rated maximum.

### Changing an indirectly heated rectifier valve for a directly heated one

Often the constructor or repair man sees that two rectifiers have the same current and voltage carrying capacity and thinks that they can be interchanged. For instance a GZ32 used in a T.V. receiver would appear to be able to be replaced with a 5U4G as they have the same voltage and current carrying capacity. The snag comes with the warming up times; with the 5U4G it is only a matter of seconds, whereas with the GZ32 it is longer than the rest of the valves. In the first case, the voltage fed into the set is 1.4 times the R.M.S., whereas in the second it may only be a few volts over the R.M.S. This can cause the electrolytics to rupture and cases have been met where they have exploded. Conversely a directly heated valve can be replaced with an indirectly heated one without fear of trouble.

### Increasing the size of the Reservoir Condenser

With the modern trend to use larger and larger condensers it is very tempting to cut down on the size of the choke and increase the capacity of the condensers. This can cause trouble as the reservoir condenser is charged by a series of short pulses rectified by the valve; if these are of too heavy a current the valve can be ruined quite quickly. If the maker's data sheets for the rectifier valves are consulted it will be found that a table of surge limiting resistors to be placed in series with the valve are given. These should be used. In the case of A.C. receivers it is good enough just to bring up the primary resistance to the required value, but in A.C./D.C. receivers the full value must be used.

### VERSATILE OSCILLOSCOPE ERRATA

There were one or two errors in the circuit diagrams of the oscilloscope given last month.

C22 is given in the Component List as 0.1  $\mu$ F, but appears on the diagram as 0.05. This component is not critical, and either value will be quite satisfactory.

Two resistors in the tube network bear the number R.40. The lower one going to the focus pot should be 300 K $\Omega$ , whilst that going to H.T. positive is 50 K $\Omega$ .

There should also be two 2 M $\Omega$  resistors in series across the shift pots, the centre tap going to chassis. The CRT used in the original design is a VCR 138.



**WIDE ANGLE TELEVISION COMPONENTS**  
FOR "MAGNAVUE" "ENGLISH ELECTRIC"  
AND BRIMAR CIRCUITS

**HAVE NOW BEEN CHOSEN EXCLUSIVELY  
FOR THE NEW AC/DC TELEVISION RECEIVER  
DESCRIBED IN THIS ISSUE**

#### SOUND & VISION COILS & CORRECTOR CHOKES

CH.1, CH.2, CH.3 . . . . .	2/6 ea.	L.5. (with condenser) . . . . .	3/9 ea.
L.1 . . . . .	4/6 ea.	L.7. (with condenser) . . . . .	3/6 ea.
L.2A/B . . . . .	2/9 ea.	L.12A/B (with condensers) . . . . .	8/6 ea.
L.3, 4, 6 and 8 . . . . .	2/6 ea.		

#### SCANNING COMPONENTS

Deflection Coil Assembly, WA/DCA.1 . . . . .	43/-	Focus Coil, WA/FCA.1 . . . . .	31/-
Line Linearity Control, WA/LC.1 . . . . .	7/6	Width Control, WA/WC.1 . . . . .	7/6
Frame Output Trans. WA/FMA.1 . . . . .	21/-	Line Output Trans. WA/LOT.1 . . . . .	42/-
Frame Blocking Osc., WA/FBT.1 . . . . .	16/-	Smoothing Choke WA/SC.1 . . . . .	19/-

Drilled Chassis complete with all Brackets will be available soon.

Obtainable from all reputable stockists or in case of difficulty direct from Works. For complete details of these and other products, send 9d for General Catalogue.

**DENCO (CLACTON) LTD. 357/9 OLD ROAD CLACTON-ON-SEA**

## Coronation QSL's

*Why not send a distinctive QSL this year?*

Special designs to celebrate Coronation Year, available from G6MN who has supplied 'special' QSL's for discriminating users all over the world.

Attractive "Coronation-1953" designs now available from . . .

**G6MN Castlemount  
Workshop Notts.**

# FREE

## A VALUABLE BOOK

which details the wide range of Engineering and Commercial courses of modern training offered by E.M.I. Institutes—the only Postal College which is part of a world-wide Industrial Organisation.

### Courses include training for:

City and Guilds Grouped Certificates in Telecommunications; A.M.Brit.I.R.E. Examination, Radio Amateur's Licence, Radio & Television Servicing Certificates,

General Radio and Television Courses, Radar, Sound Recording, etc.

Also Courses in all other branches of Engineering.

**NEW!**  
HOME  
EXPERIMENTAL  
KITS NOW  
AVAILABLE

**EMI**

Institutes  
associated with  
**MARCONIPHONE  
COLUMBIA**

**H.M.V. ETC.**

Courses £1 per  
from 4 month

**POST NOW**

Please send, without obligation, the FREE book. — E.M.I. Institutes, Dept. 179k, 43 Grove Park Road, Chiswick, London, W.4.

Name \_\_\_\_\_

Address \_\_\_\_\_



## CONDENSERS

The abbreviated ranges of two popular types given here are representative of the wide variety of T.C.C. Condensers available

### HI-K 'PEARL' CERAMICS

Capacity pF.*	Wkg. Voltage		Dimensions		Type No.
	D.C.	A.C.	Length	Dia.	
1.0	500	250	3.5 mm.	5 mm.	SPG
10.0	500	250			to
33.0	500	250	7 mm.	7 mm.	SPG
150	500	250			to
330	500	250			SPG
470	500	250			SPG

### HI-K MULTIPLE TUBULAR CERAMICS

Capacity pF.*	Wkg. Voltage		Dimensions		Type No.
	D.C.	A.C.	Length	Dia.	
2X 500	500	250	10 mm.	4.5 mm.	2CTH 310/W
2X 1000	500	250	10 mm.	4.5 mm.	2CTH 310/W
2X 1500	500	250	15 mm.	4.5 mm.	2CTH 315/W
2X 2200	500	250	22 mm.	6 mm.	2CTH 422/W
3X 500	500	250	15 mm.	4.5 mm.	3CTH 315/W
3X 1000	500	250	15 mm.	4.5 mm.	3CTH 315/W
3X 2200	500	250	22 mm.	6 mm.	3CTH 422/W

\* Guaranteed not less than stated values at 25°C.

**THE TELEGRAPH CONDENSER Co Ltd**

Radio Division: North Acton, London, W3 Tel: Acorn 0061

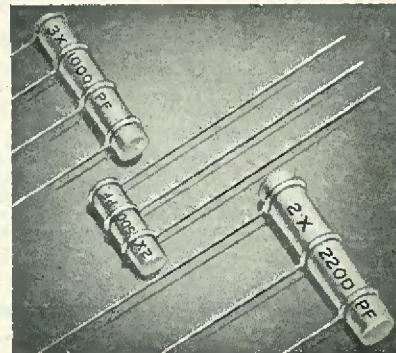
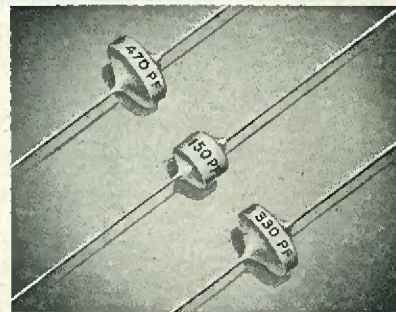

**NEW!**

## E.M.I. INSTITUTES EXPERIMENTAL KIT

### LEARN THE PRACTICAL WAY

A specially prepared set of radio parts from which we teach you, in your own home, the working of fundamental electronic circuits and bring you easily to the point when you can construct and service a radio set. Whether you are a student for an examination, starting a new hobby, intent upon a career in industry, or running your own business—this Course is intended for YOU—and may be yours at a very moderate cost. Available on Easy Terms. WE TEACH YOU: Basic Electronic Circuits (Amplifiers, Oscillators, Power Units, etc.) Complete Radio Receiver Testing & Servicing

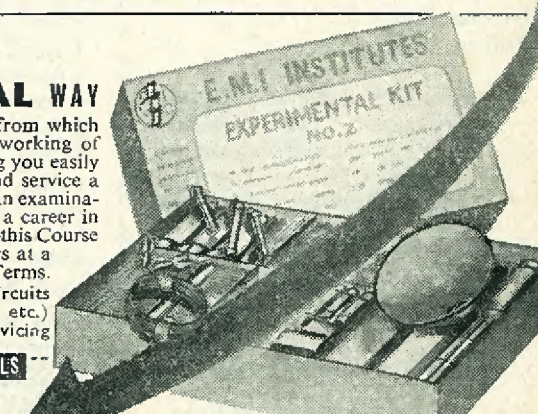

POST IMMEDIATELY FOR FREE DETAILS

TO: E.M.I. INSTITUTES Dept. 179 X  
Grove Park Rd., Chiswick, London, W.4

Name \_\_\_\_\_  
Address \_\_\_\_\_

**EMI INSTITUTES**  
Associated with **HMV**  
**MARCONIPHONE COLUMBIA &** His Master's Voice



## See the Coronation on Large Screen TV.

### Magnaview Tele-King, Viewmaster



#### DARK SCREEN FILTERS (LATEST TINT)

12 1/2 in. x 14 in. For 16 and 17 in. c.r. tubes, 19/6. 11 in. x 13 in. For 9, 10 and 12 in. c.r. tubes, 15/11.

#### PERSPEX

13 1/2" x 10 1/2" x 1/2". Neutral shade, slightly marked. 5/11 Per piece.

#### THE TELE-KING

Large screen television for home construction. Superhet, 5 channel. 32-page booklet and full-size wiring diagrams. PRICE 6/- POST FREE

#### THE MAGNAVIEW

Large screen television. Construction booklet. PRICE 4d. POST FREE

#### SPECIAL CORONATION C.R. TUBE OFFER.

Brand new and unused 12 inch ion trap cathode ray tubes. By famous manufacturer, 6.3 volt heater, 7-9 Kv, E.H.T. 35mm neck. Black and white picture. £11 19s 6d with slight screen blemishes. £12 19s 6d absolutely perfect. Carriage & insurance 15/- per tube extra.

### ELECTROLYTIC CONDENSERS

8 mfd. 450 v.w.	2/3	12+12 mfd. 350 v.w.	3/6
8 mfd. 500 v.w.	2/11	16+16 mfd. 500 v.w.	4/6
16 mfd. 350 v.w.	2/6	16+32 mfd. 450 v.w.	5/11
16 mfd. 500 v.w.	3/6	32+100 mfd. 450 v.w.	7/6
32mfd. 500 v.w.	4/11	60+100mfd. 350 v.w.	9/6
50 mfd. 350 v.w.	3/11		
60 mfd. 350 v.w.	3/11		
250 mfd. 350 v.w.	4/11		
8+8mfd. 450 v.w.	4/6		
8+16 mfd. 500 v.w.	4/11		
		BIAS	
		25 mfd. 25 v.w.	1/6
		50 mfd. 12 v.w.	1/6
		50 mfd. 50 v.w.	1/6
		75 mfd. 12 v.w.	1/-

ALL BRAND NEW AND GUARANTEED (NOT EX-GOVT.) All other types, Paper, Tubular, Waxed, etc., in stock.

#### CATHODE RAY TUBES MASKS

New aspect ratio.  
9in. Sorbo, 5/-  
10in. Double D. Metal 7/6.  
12in. 15/-  
12in. Flat Face, 15/-  
14in. Rect., 21/-  
16in. Double D., 31/6.  
17in. Rect., 27/6.  
12in. Soiled, 7/6.  
12in. Soiled, with fitted safety glass, 11/6.

#### THE VIEWMASTER

Television for the home constructor at its finest. 32-page booklet and 8 full size wiring diagrams. PRICE 7/6. Post Free. State station required

**15 INCH CATHODE RAY TUBE MASKS** No. 1. Cream rubber. Latest aspect ratio. Overall dimensions: 17ins. wide, 13ins. high. Price 17/6. Postage 2/- extra

**No. 2 Plastic**, incorporating gold finish tube escutcheon, and dark screen filter. Latest aspect ratio. Overall dimensions 15in. wide, 12in. high. Price 21/-. Postage 2/- extra.

#### ARMOUR PLATE GLASS

15in. Actual size, 18 1/2 in. x 19 1/2 in. x 3/8 in.  
7/11. 12in. Actual size, 13in. x 10 1/2 in. x 3/8 in.  
4/-. 9in. Actual size, 9in. x 8in. x 3/8 in.

#### T.C.C. VISCONOL WE HAVE HIGH VOLTAGE CONDENSERS ("CATHODRAY")

.001 mfd. 12.5 Kv., 7/6  
.001 mfd. 15 Kv., 10/-  
.001 mfd. 25 Kv., 18/-  
.0005 mfd. 25 Kv., 18/-  
.0005 mfd. 12.5 Kv., 10/-  
.1 mfd. 7 Kv., 15/-  
.04 mfd. 12.5 Kv., 7/6.  
Plastic case, single bolt fixing.

#### THE GOODS.

WRITE, PHONE, CALL. NONE TO BEAT LASKY'S

## LASKY'S RADIO

Lasky's (Harrow Road) Ltd. 370 HARROW RD PADDINGTON LONDON W9

(Opposite Paddington Hospital) Telephones CUNningham 1979 and 7214. All Departments.

Hours Mon. to Sat. 9.30 a.m. to 6 p.m., Thurs. half day 1 p.m.

MAIL ORDER & DESPATCH DEPARTMENTS 485/487 Harrow Road Paddington London W 10 Terms Pro Forma, Cash with Order, or C.O.D. on post items only. Postage and packing on orders value £1—1/- extra, £5—2/- extra, £10—3/6 extra. Over £10 carriage free. All goods fully insured in transit.

**6-VALVE V.H.F. SUPERHET RECEIVER CHASSIS.** Six channel switching, tuning 30.5 to 40mc/s. Receives TV, Fire, Taxis, many British and Continental amateurs, etc. Components include 30 ceramic trimmers, 30 small condensers, 30 resistances (1/2 to 1 watt), six valve holders, cans and covers. All complete for 7/6. Also offered complete with valves at 17/6. Drawings available, and modification for conversion to mains operation.

**RADIO-GRAM CHASSIS AND CORONATION FREE GIFT.** Choice of chassis—six wave Export Model at £15.15.0., or three wave Home Market Model at £10.17.6, carr. 4/6. Both types have five valves, gram pick-up sockets, flywheel tuning, negative feed-back, and measure 11 1/2" x 7" x 8 1/2". Free gift of 8" P.M. speaker, and/or special REDUCTION to 12/6 of a 10" P.M. speaker.

**ACCUMULATORS.** 2V., 14A/H. 1 1/2" x 1 1/2" x 6". 4/6. Post 1/-.

**MAINS TRANSFORMERS.** Brand new, by famous maker. Primary tapped 0, 205, 225, 245, 300 volts, at 200m/a. Secondary 5v. at 2A and 6v. at 7A. Tested. BARGAIN PRICE 12/6. Post 1/9.

**O.P. TRANSFORMERS.** Store-soiled, unused. Match all normal O.P. valves to 2-5 ohms speech coil. To clear at 1/9 Post 9d.

**CONDENSERS.** Store-soiled, unused. Tested. Two-gang, .0005mfd. tuning condensers offered at 2/9. Post 6d. Sale offer of 3 for 7/-.

Stamp for complete catalogue C.W.O. or C.O.D.

**DUKE & CO.**

621 ROMFORD ROAD LONDON E12  
Money back guarantee GRA 6677

**ROTARY CONVERTERS**

12V DC to 200V DC 50 MA £1 10 0  
24V DC to 230V AC 150 VA £6 0 0

S.A.E. FOR  
MODEL RAILWAYS EQUIPMENT  
PRE-WAR VALVES, TRANSFORMERS

**Lawrence Frankel**

MAIL ORDER  
134 Cranley Gardens London N10  
Telephone TUDOR 1404

**ADCOLA**  
(Regd. Trade Mark)  
**SOLDERING INSTRUMENTS**



Reg. Design No. 860302  
(British, U.S. and Foreign Patents)

Designed for wireless assembly and Maintenance  
Supplied for all volt ranges from 6/7v to 230/250v.  
3/16" Dia. Bic Standard Model 25/6  
Sole Manufacturers **ADCOLA PRODUCTS LTD.**  
Sales Office and Works: Cranmer Court,  
Clapham High St. London SW4 (MAC 4272)

**Indicator Unit SLC No. 5** Suitable for conversion into oscilloscope, using a 139A or a 3BP1 Tube. Unit consists of 3 valves, two VR65's and 1 VR66, condensers, 24 mfd. 500v working, tube holder and base, 4 potentiometers, 2 group boards containing 22 resistors, 17 condensers, three 4-way sockets, the whole mounted on a chassis 11" x 6" x 3" deep, complete with cover open at one end to take glass screen. 17/6. Post 2/6.

**Mine Detectors** Consisting of 2v amplifier, complete with valves, satchel, search coils, headphones, etc. Ideal for locating metals, hidden treasure, etc. 45/-, Carriage 3/6.

**Controllers Electric No. 1** Contains 5 push buttons 5 indicator lamp holders 1 telephone key switch, in small box 5 1/2" x 2" x 4" with 12 way Jones plug at rear. 6/6. Post 1/6.

**Receivers 1125** Complete with 2 valves. 10/6. Postage 2/6.

**Potentiometers.** Wire wound 300 ohm. 2/9. 10K. 2/6. Post 6d.

**Fuse Boxes** 4 way. Bakelite. 20a. Takes glass fuses. 2/6. 8 way, 3/6. Post 9d.

**Large Condensers** Oil filled. 10 watt. 3000 ohms. 2/-, Post 6d.

**Telescopic Aerials.** 4 section. 3ft long. 1" dia. 2 aerials contained in 3 foot canister. 9/-, Post 2/6.

**Slow Motion Dials** 6", 200-1 ratio, scaled 0-100, ref. 10A/15319, 4/6. Post 1/3.

Large new list, No. 10, now available. Price 6d inland. 1/6 overseas Air Mail.

**A. T. SALLIS**

93 North Road Brighton Sussex  
Telephone BRIGHTON 25806

**G4GZ's BARGAINS**

Pye plugs and sockets 8/- doz. prs. Double circ. jack plugs and sockets 2/6 pr. 24/- doz. prs. 25 pfd air spaced ceramic trimmers 7/6 doz. .01mfd mica condensers 500v. 4/6 doz. 807, EF50 ceramic v/hdrs. 1/- each. 10/- doz. 4 bank wafer switches each bank 2p 4w (Total 8p 4w) 4/6 each. 45/- doz. 6SH7 metal valves, slightly soiled ex equipment, all guaranteed 4 for 9/6, 27/6 doz. 954, 955, 956, 5/-, 6C4, 6AG5, 6J7G, 9002, 6/-, VS110A, 6U5G, 6/6, 6J7M, 1T4, 1S5, 1R5, 8/6, 12AU7, 12AX7, 12AT7, 3V4, 9/-, 6J6, 6V6G, 6SL7GT, 5Z4M, 5Z4G, MU12/14, 9/6, 6Q7G, 6F7, 6AQ5, 10/6.

All goods by return of post. Please add post/packing

**J. T. ANGLIN**

140 CLEETHORPE ROAD GRIMSBY Lincs  
Telephone 56315

**REP**

HIGH GAIN  
DUAL RANGE  
COIL WITH  
REACTION

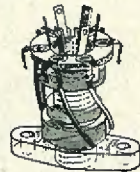

COMPLETE  
WITH  
2 BATTERY  
AND  
2 MAINS  
CIRCUITS

PRICE 4/- POST 3d.  
(Trade Supplied)

**Radio Experimental Products Ltd.**  
33 MUCH PARK STREET  
COVENTRY

**Small Advertisements**

Reader's small advertisements will be accepted at 2d per word, minimum charge 2/-. Trade advertisements will be accepted at 6d per word, minimum charge 6/-. If a Box number is required, an additional charge of 1/- will be made. Terms: Cash with order. All copy must be in hand by the 12th of the month for insertion in the following month's issue.

**WANTED** to buy or loan, Service Manual for Invicta T.103, TV. Box No. C119.

**WANTED** Volumes one, two and three of *Radio Constructor's* complete with indexes. Good price paid. Yates, Linwood Lodge, Knowle, Birmingham.

**WANTED** Metal case for CR100, front panel immaterial. A. Thornton, 110 Waterford Road, Ipswich, Suffolk.

**WANTED** 12" static CRT type VCR131, NC20 or VCR511A. Must be OK. Price etc., to Hill, 1 Hardwen Avenue, Lea, Preston, Lancs.

**WANTED** Information on Ex Gov. Receiver Identification Unit RDF No. 1. ZC13312. Henshaw, 23 Culver Road, St. Albans, Herts.

**WANTED** Service sheet for Romac TV 189. G. Caunt, 11 Crescent Green, Kendal, Westmoreland.

**WANTED** Two stage Preselector, built in Power Pack. 20 to 80 metres. T. Smith, 42 Wormholt Road, London, W.12.

**WHAT OFFERS** Globe King kit, new Xmas. Jenner, 53 Clifford Road, Hounslow, Middx.

**WANTED** HRO dial and S Meter. Your price for new or perfect condition. Haworth, 15 Regent Street, Haslingden, Lancs.

**FOR SALE** H.M.V. Television, Model 1804, 10 inch tube, going, what offers. Killick, 194 Lyham Road, London, S.W.2.

**FOR SALE** Peto-Scott "Trophy-8" Communication Receiver, 5 bands, 520 kc to 43 mcs, complete with speaker, good condition. £10 carriage paid. Box No. C121.

**FOR SALE** Eddystone S640 with speaker and S Meter, excellent condition £18. 25 watt Transmitter with Xtals, ideal for beginner, Clapp VFO, power packs, offers, delivered London area. Watton, 20 Edencourt Road, Streatham, London, S.W.16.

**FOR SALE** Master Oscillator Unit No. 1 (VFO), 2 range, 2 to 4 and 4 to 9 mcs, arranged Crystal control, complete with power supply 230 volts AC. New, £10. W. Makin, "Sevenoaks," London Road, Davenham, Cheshire.

**FOR SALE** 1155A with power pack, top band and 6SG7 RF. £5 or offers. Hartog, Elm Cottage, Debden Green, Loughton, Essex.

**FOR SALE** Few valves, B8A base, cheap. SAE Type numbers. Box No. C123.

**FOR SALE** *Practical Radio and Television* (Caxton) 3 Vols. Cost 95/-, accept 50/- or near offer. Box No. C120.

**HENRY'S**

5 HARROW ROAD LONDON W2

Open Mon. to Sat. 9—5.30 (Thurs. 1 p.m.)

Telephone PAD 1008/9 and 0401

**SPECIAL VALVE OFFER**

Pen EF50 Brand New (Ex-Units) 55/- set.  
**SET OF 5 MAINS VALVES**  
6K8CT, 6K7GT, 6Q7G, 5Z4, 6V6G or KT61, at 42/6 Set.

**SET 5 AC/DC VALVES**  
6K8GT, 6K7G, 6Q7G, 25A6G, 25Z6G at 42/6 Set.

**SET 5 AC/DC VALVES**  
6A7G, 6D6, 6C6, 43, 25Z5 at 42/6 Set.

**SET 5 AC/DC VALVES**  
12K8GT, 12K7GT, 12Q7GT, 35Z4GT, 35L6GT or 50L6GT at 42/6 Set.

**SET 5 AC/DC VALVES**  
12SA7GT, 12SK7GT, 12SO7GT, or 12SR7GT, 35Z4GT, 35L6GT or 50L6GT at 42/6 Set.

**SET OF 4 BATTERY MINIATURE 1.4v. VALVES**  
1R5, 1S5, 1T4, 1S4 or (3S4 or 3V4) at 32/6 Set.

**SET OF BATTERY VALVES 2 volt MAZDA TYPES**  
TP25, HL23/DD, VP23, PEN25 or QP25 at 27/6 Set.

**COMPLETE SET OF 10 SPECIFIED VALVES FOR "PRACTICAL TELEVISION" PERSONAL REC.**  
5- 6AM6, 2- 6AK5, 1- EA50, 1- 6J6, 1- 6J4 and 3BP1 C/R Tube in case at £5.12.6 Set.

**L.T. RECT'S**

6v. 1 amp G.E.C.	...	...	...	4/-
12v. 2 1/2 amp. Westinghouse	...	...	...	12/6
12v. 4 amp. S.T.C.	...	...	...	17/6
12v. 8 amp. S.T.C.	...	...	...	32/6

**S.T.C. RECT'S. E.H.T.**

K3 25 650v. 1 m/a.	...	...	...	4/7
K3 40 1000v. 1 m/a.	...	...	...	6/-
K3 100 8,500v. 1 m/a.	...	...	...	14/8
K3 200 10,500v. 1 m/a.	...	...	...	26/-

**H.T. RECT'S**

S.T.C. 150v. 120 m/a.	...	...	...	4/6
S.T.C. 250v. 250 m/a.	...	...	...	18/-
G.E.C. 1 m/a Meter Rect.	...	...	...	11/6

**RECEIVER R1355.** As specified for *Inexpensive Television*. Complete with 8 valves VR65 and 1 each 5U4G, VU120, VR92. Only 55/- carriage 7/6. Brand new in original case.

RF24 25/-, RF25 25/-, RF26 59/6, RF27 59/6.  
**CATHODE RAY TUBES**

VC97. Guaranteed full picture 40/-, carriage 5/-.  
VCR517. Guaranteed full picture 40/-, carriage 5/-.  
3BP1 Suitable for "scopes 25/-, carriage 3/-.  
Mu-Metal Screens 12/6. 6" Enlargers 18/6.

**PYE 45 Mc/s STRIP.** Special purchase of M.O.S. Type 3583 Units, Size 15"x8"x2". Complete with 45 mc/s Pye Strip, 12 valves, 10 EF50, EB34 and EA50, volume controls and hosts of Resistors and Condensers. Sound and vision can be incorporated on this chassis with minimum space. New condition. Modification data supplied. Price £5, carriage paid.

**INDICATOR UNIT TYPE 182A.** This unit contains VCR517 Cathode Ray 6" Tube, complete with Mu-metal screen, 3 EF50, 4 SP61 and 1 5U4G valves, 9 wire-wound volume controls and quantity of Resistors and Condensers. Suitable either for basis of Television (full picture guaranteed) or Oscilloscope. Offered BRAND NEW (less relay) in original packing case at 79/6. Plus 7/6 carriage.

**VCR517C BLUE AND WHITE TUBE**  
This Tube replaces the VCR97 and VCR517 without alteration and gives a full Blue and White picture. BRAND NEW in original crates, 45/-, plus 5/- carriage.

**"WEYMOUTH" 3-WAVE BAND COIL PACKS**  
Short, Med. and Long with Gram. Switch. Brand New Miniature type complete with circuit, 19/6. P.P. 1/6 Absolute bargain.

SEND 3d. FOR 28-PAGE CATALOGUE

[continued on page 551]

### FRED'S Radio Cabin

Olympic Coil Packs, 3 Wave Band	24/6
AC/DC Amplifiers	£3.15.0
AC. TRF Midget Sets	£6.10.0
Tyana Soldering Irons	16/9
Sleeving (12yds.)	2/9
400Ω w/w Pots	2/6
VR54	2/6
6K, 7K, 10K, 30K, w/w 2 Low Res.	1/6
50 pF and 20 pF Ceramic Trimmers	1/-
3P., 3w., WCS	2/3
Indoor T.V. Aerial	7/6
10 Amp Mains Filters	10/-
4P., 2w., WCS	2/6
8 way Jones Plugs 1/-	6 Pin, 6d.
3 Link Aerial Insulators	6d.
1", 1 1/4" Plastic Tube	1/- yard
Yaxley Wafers, 2P., 4w.	3d. ea., 2/6 doz.
.005/1,000 volt Tubular Condensers	6d.
.5 and .25, 350 volt	6d. ea., 4/- doz.
240,000Ω, 3w., Carbon	6d. ea., 4/- doz.
.0003 T.C.C., Mica Condensers	6d, each

77 NEWINGTON BUTTS  
ELEPHANT AND CASTLE  
LONDON SE 11

RODNEY 2180

### WORLD RADIO HANDBOOK

Seventh Edition, 1953. Price 8/6d.

New Edition—just published. Revised and enlarged—contains all information covering the world's broadcasting stations.

Compiled from authoritative data, **WORLD RADIO HANDBOOK** is an invaluable "Who's Who" and a ready-made log book for all in any way interested in Broadcast station listening on a world scale. The detail given is designed to facilitate easy identification of Broadcast stations, covering announcement procedure, interval signals, wavelength, personnel and station addresses and containing information about Television stations from all over the world.

**WORLD RADIO HANDBOOK** is recommended by such authorities as the United Nations Organisation, International Radio Union, and the United Nations Educational, Scientific and Cultural Organisation.

In the new edition, the United Nations publish the following message about **WORLD RADIO HANDBOOK**:

"To build a lasting peace it is essential to use every means of furthering understanding. The special contribution broadcasters and telecasters can make is by sending through the air, over all frontiers, news and pictures of what their peoples are doing and thinking and of how their work and their life fit into the story of man's struggle to master his environment and himself.

**WORLD RADIO HANDBOOK** brings together all the information needed by broadcasters and radio listeners desirous of following programmes in any other country. We find it indispensable ourselves and cordially commend it to others." Peter Aylen, Director United Nations Radio Division.

### VALVES BY RETURN

OZ4	6/6	6J5	6/6	12SC7	6/-	EF50	5/6
1A5gt	7/6	6J6	10/-	12SG7	5/-	EF54	5/6
1LD5	6/6	6J7	9/-	12SH7	5/-	EF91	10/6
1LNS	6/6	6K6	7/6	12SJ7	6/-	EL32	7/6
1R5	8/6	6K7gt	6/6	12SK7	8/-	EL35	5/-
1S4	8/6	6K7g	6/6	12SQ7	9/6	EL91	8/6
1S5	8/6	6K8m	10/6	12Y4	7/6	HL2	3/6
1T4	8/6	6K8g	10/6	15D2	4/-	KT24	5/6
1625	4/6	6L6g	10/6	35L6	10/-	KT44	9/6
2C26	5/-	6Q7	10/6	39J44	5/-	KT63	8/6
2C34	4/6	6SA7	9/6	50L6gt	10/-	KT66	10/6
2V3g	3/6	6SH7	6/-	75	12/6	KTZ41	7/6
3D6	2/3	6SL7	11/6	76	7/6	KTW61	7/6
3S4	8/6	6SN7	10/6	77	7/6	N78	10/6
4D1	3/-	6SQ7	7/6	2155G	5/-	P61	3/-
5R4g	12/6	6SS7	7/6	846Z4	7/6	PEN46	8/-
5U4g	9/-	6V6g	9/-	807	12/6	PEN220A	5/-
5Y3	10/-	6X5gt	7/6	956	3/6	QP21	7/6
5Z4	10/-	7C7	7/6	1626	4/-	RK34	3/6
6AB7	6/6	7D8	8/-	1632	7/6	S13Q	5/-
6AC7	10/-	7Q7	7/6	A915	5/-	SP41	3/-
6B7	9/-	8D2	3/-	D1	2/6	SP61	3/6
6B8	7/-	9D2	3/-	E1148	3/-	VR116	3/6
6C5g	6/-	10F9	7/6	EA50 3 for	5/-	VU39A	10/6
6CD6	11/6	12AT7	10/6	EB91	9/6	VU111	3/6
6CH6	9/-	12C8	9/-	ECC32	10/6	VU120A	3/6
6F6	8/6	12J5	5/-	EF36	6/6	VU133	3/6
6G6	7/6	12K7	12/6	EF39	6/6	U21	6/6
6H6	3/6	12SA7	8/6				

All the above Valves Tested, Boxed and Guaranteed Free replacement if faulty

LARGE STOCKS of NEW and EX-GOV'T COMPONENTS

The shop with the helping hand for Hams

### NORMAN H. FIELD

68 Hurst St., Birmingham 5 Telephone MIDland 3619

## IKOPATENTS

LTD.

Managing Director

E. G. O. ANDERSON

### Consultants

● RADIO

● TELEVISION

● ELECTRONICS

17 CRISP ROAD W6

RIVERSIDE 2678

## Small Advertisements

(continued from page 549)

**FOR SALE** Radio enthusiast disposing of complete Gear, including Text and Servicing Manuals, Rack and Bench combined. Instruments for servicing, in fact all one would expect to find. No reasonable offer refused. Box No. C122.

**FOR SALE** Ideal for sports or show ground, Amplifying Unit Type III (Ex WD) 200-230 volt, mike and gram input, 60 watt (4 KT66) output, with Parmeko horn speaker, £21. Elliott, 3 Burne Street, London, N.W.1.

**FOR SALE** VCR97 EHT Transformer, new, 30/-, pair PT15's, new, 5/- each, carriage extra. Farrar, Charlestown, Ackworth, Pontefract, Yorks.

**FOR SALE** Ever Ready "All-Dry" Portable, good condition, offers to Box No. C118.

**FOR SALE** Projection TV 25 kV EHT Unit complete, £7 10s 0d MW6-2 CRT, £6 10s 0d GEC 6505A, Mazda CRM92A CRT's, £8 10s 0d. Garrard RC70B, £8. All new, unused, guaranteed. F. Miller, 7 Montem Road, New Malden, Surrey.

**FOR SALE** R1155, brand new, no DF, 5 valves only. £7. Vickers, "Madryn," Bearsted, Near Maidstone, Kent.

**COMMUNICATION EQUIPMENT** for sale. EF54, Presselector, 4 switched bands, 32 mcs to 1.6 mcs continuous coverage, black crackle case, louvred, to match S640 Receiver, calibrated Eddystone full vision dial, slow motion drive. Controls, On/Off, RF Gain, Aerial/Rx change over, Wave change switch, pilot light. Power taken from Rx. £4. Box No. C124.

### TRADE

**FREE CATALOGUE** now available. Viewmaster. Tape, Gram, etc., at lowest prices. Swift Radio, 21 Hibbert Road, Harrow, Middlesex.

**OAK TYPE SWITCH SERVICE.** Multi-Way Switches made to specification, approx. cost 2/6 Clicker Plate + 2/- per wafer. Components new Vol. On/Off Switches, 1/4m, 1/2m, Long Spindle 3/-. Controls 100k, 250k, 500k 1/-, Ceramic Trimmers 5-80pf 5d, High Stability Resistors ±2% 9d, SM Condensers 6d each, Flex 1 1/4 yard 3 W.B. Coil Pack with circuit 19/- Box No. C117.

**I.P.R.E. PUBLICATIONS.** 5,500 Alignment Peaks for superhets 5/9. Sample copy *The Practical Radio Engineer* 2/-. Membership-examination particulars 1/-. Syllabus of TV and radio courses free and post free. Secretary, I.P.R.E., 20 Fairfield Road, London, N.8.

**FREE!** Brochure giving details of Home Study Training in Radio, Television, and all branches of Electronics, Courses for the Hobby Enthusiast or for those aiming at the A.M. Brit.I.R.E. City and Guilds Telecommunications R.T.E.B., and other professional examinations. Train with the College operated by Britain's largest Electronic organisation. Moderate fees. Write to E.M.I. INSTITUTES, Postal Division, Dept. RC28, 43 Grove Park Road, London, W.4. (Associated with H.M.V.).

**METALWORK.** All types cabinets, chassis, racks, etc. to your own specification. Philpott's Metalworks Ltd. (Dept. R.C.), Chapman Street, Loughborough.

**KENDALL AND MOUSLEY,** Manufacturers of Laboratory Equipment, chassis and instrument cases, also suppliers of B.V.A. valves, Radio and T.V. components. 99 Dudley Port, Tipton, Staffs.

**TRANSFORMERS.**—Manufactured to our specification and fully guaranteed. Normal Primaries. 425 v.-0-425 v. 200 ma., 6.3 v. 6 a., 6.3 v. 6 a., 5 v. 3a., 0-2-4-6.3 v. 3 a., ONLY 72/6. 425 v.-0-425 v. 200 ma., 6.3 v. 4 a., 6.3 v. 4 a., 5 v. 3 a. ONLY 50/-, 350 v.-0-350 v. 160 ma., 6.3 v. 6 a., 6.3 v. 3 a., 5 v. 3 a. ONLY 42/6. 250 v.-0-250 v. 100 ma., 6.3 v. 6 a., 5 v. 3 a. ONLY 32/6. The above are fully shrouded, upright mounting. Universal Mounting 350 v.-0-350 v. 80 ma., 0-4-6.3 v. 4 a., -0-4-5 v. 2 a. ONLY 18/6. Top shrouded, drop through 260 v.-0-260 v. 70 ma., 6.3 v. 3 a., 5 v. 2 a. ONLY 16/6. The following are upright mounting: EHT for VC97 Tube, 2,500 v. 5 ma., 2, -0-2 v. 1.1 a., 2 v.-0-2 v. 2a. ONLY 37/6. EHT 5,500 v. 5 ma., 2 v. 1 a., 2 v. 1 a. ONLY 72/6. EHT 7,000 v. 5 ma., 4 v. 1 a. ONLY 82/6.

**PLEASE ADD 1/6 PER TRANSFORMER POSTAGE.** TRANSFORMER, for use on trains, models, etc., giving outputs of 3 v., 4 v., 5 v., 6 v., 8 v., 9 v., 10 v., 12 v., 15 v., 18 v., 20 v., 24 v., 30 v., at 2 amps from normal mains input. ONLY 17/6 (postage 1/-).

**TRANSFORMERS.**—Ex. W.D. and Admiralty, built to more than 50 per cent. safety factor, with normal A.C. Mains Primaries. All Brand New and Unused. 300 v.-0-300 v. 200 ma., 5 v. 3 a., 6.3 v. 5 a., C.T., 20 v. 750 ma., 70 v. 100 ma. Weight 12 lb. ONLY 42/6 (postage, etc., 2/6). 330 v.-0-330 v. 100 ma., 4 v. 3 a. Weight 7 lb. ONLY 22/6 (postage 1/6). L.T. 5 v.-0-5 v. 5 a., 5 v.-0-5 v. 5 a., 5 v.-0-5 v. 5 a. By using combination of windings will give various voltages at high current. Weight 11 lb. ONLY 35/- (postage etc., 2/6). L.T. 6.3 v. 7.7 a., 4.2 v. 2.5 a., 4 v. 1 a. ONLY 19/6 (postage 1/6). EHT 1,400 v. 2 ma., 520 v. 10 ma., 300 v. 10 ma., 2 v. 1.5 a. ONLY 21/- (postage, 1/6).

Cash with order, please, and print name and address clearly. Amounts given for carriage refer to inland only.

### U.E.I. CORPORATION

The Radio Corner

138 Gray's Inn Rd. LONDON WC1

Open until 1 p.m. Saturdays. We are 2 mins. from High Holborn (Chancery Lane Stn.) and 5 mins. by bus from King's Cross.

## Small Advertisements

**FOR SALE** Eddystone S640, choice of two, mint condition, matching speakers; two German receivers and spares; model 18 receiver. Offers, buyer collects. Fawkes, St. Chloee Green, Amberley, Stroud, Glos.

**RADIO CONTROL** that model. Circuits, methods, unlimited advice. Details 3/6. Carter, A.M.I.E.T. 101A, High Street, Harlesden, N.W.10.

## RADIO AMATEUR

May Issue

Practical Frequency Modulation. Petrol Generator A.C. Supplies for Field Day. Grounded Grid RF Amplifiers. Buffers and Doublers. Bias Supply for the 807. Crystal Grinding. Broadcast Bands Review. Amateur Bands Commentary. On the Higher Frequencies. Round the Shacks—G8UA. Club News, etc., etc.

**CLYDESDALE**

Ex Services Electronic Equipment

Bargains in Ex-Service Radio and Electronic Equipment

**RECEIVER UNIT TYPE 25**

Ref. 10P/1L part of the TR1196 equipment.

Frequency range, 4.3-6.7 Mc/s.

Valves: 2/VR53 (EF39), 2/VR56 (EF36), VR55 (EBC33), VR57 (EK32), 2 1FT 460 Kc/s, plus various microcondensers, mic. and output transformers, pots, condensers, resistors, etc., connections brought to 10 pin Jones type chassis plug. Circuits are provided in the unit, which is totally enclosed in case, 8 1/2 x 6 1/2 x 6 1/2 in. Would make the basis of an All Wave Receiver, required tuning pack and power supply.

ASK FOR **39/6** POST PAID  
No. B/H299

(Conversion Data ("R. Con." Reprint), 1/6)

**FOR INEXPENSIVE TELEVISION R3170A RECEIVER UNIT**

ASK FOR **£4 : 12 : 6** CARRIAGE PAID  
No. B/H492

For "P.T." Beginner's Receiver

**MAINS TRANSFORMER** 200/250 v., A.C. Input. Output 350-0-350 v. 150 mA., 6.3 v. 4-4A, 4-5V. 3A. 3A. RT/MH22. **£1.50**

Choke WB104, 15/6.

Components price list free on request.

NEW LIST No. 8D gives details and illustrations of ex-service and other items. Price 1/6. (Credited on first 10/- purchase).

Order direct from: Telephone **SOUTH 2706/9**

**CLYDESDALE SUPPLY CO. LTD.**  
2 BRIDGE STREET GLASGOW G.5

Branches in Scotland England and North Ireland

**We are sorry . . .**

that we cannot repeat our December publicity offer, but as we are continually being asked for the L.M.S.2 coil-pack together with the specially matched pair of I.F. transformers we are now offering a parcel comprising these items. The price is surprisingly low at **£2.7.6 post paid.**

**L.M.S.2. Miniature Coil Pack**

- 38/6 Post & Pkg. 1/6
- \*3 wave band.
- \*High quality—outstanding performance.
- \*Only 5 wires to solder—one nut to tighten.

**Miniature 465Kc. I.F. Transformers**

- 12/- Post & Pkg. 1/-
- \*Specially matched to L.M.S.2. Coil unit.

Supplied Separately or in bargain parcel.

5" Loud Speakers brand new nearly all sold last few 11/6 post paid

**DEAL COMPONENT CO.**

105 Evering Road N16

**Small Advertisements**

(Continued from page 551)

**Announcement**

**New Service for the Amateur and Experimenter**

A stamped addressed envelope will bring you details of the new series of blue-prints of aerial tested circuits, from single valve to six and seven valve superhets. In the near future, kits of parts will be offered, both for the home constructor and the Amateur Transmitter and Receiver. Coming off the drawing board shortly is a Simple Communications Receiver circuit. Further announcements will be made shortly concerning equipment for the T/V home constructor, including wide band pre-amplifiers, etc., at prices which will be right for your pocket. Get your name and address on the files NOW by sending your S.A.E. to J.H.G. Box No. C107.

**AMATEUR STATION RECORD CARDS, 6" x 4"**, best quality card, for recording that QSO and full details of the contact. An invaluable aid to quick reference of stations worked etc., 3/- per 100 from Data Publications, 57 Maida Vale, London, W.9.

**"GLOBE-KING"** (Regd.) Miniature Single Valve Receiver gets real Dx. Amateur Radio enthusiasts, should send for free copy of interesting literature and catalogue (enclose stamp for postage). Write to makers: Johnsons (Radio), 46 Frair Street, Worcester.

**BOOKBINDING.** Volumes of *Radio Constructor* and *Radio Amateur* fully bound, imitation leather, gold lettering, 7s 6d post free. Prices for other publications on application. Jerome Alcock; **CHEADLE**, Stoke-on-Trent.

**JOIN THE ISWL.** Free services to members including QSL Bureau, Translation, Technical and Identification depts. Dx certificates, contests and activities for the SWL. Monthly magazine "MONITOR" duplicated, containing articles of general interest to the SWL and League member, 10/6 per annum, post free. ISWL HQ, 86 Barrenger Road, London, N.10.

**BLUEPRINTS.** High Gain 10 Metre Converter, with a de-luxe circuit comprising EF91 RF stage, ECC91 double triode mixer and oscillator, EF92 IF amplifier, with stabilised voltage supply via a 7475. 1s 8d post free with full instructions. A.S.W.P., 57 Maida Vale, London, W.9.

**REPRINT** Converting the TR1196 Receiver. Full details on converting this unit, which may be purchased quite cheaply, into a very sensitive all-wave receiver. 6d post free. A.S.W.P., 57 Maida Vale, London, W.9.

Miller's "PANL"—the air drying black crackle enamel. From dealers 3s 6d jar or direct 4s 6d including postage. —8 Kenton Park Crescent, Kenton, Middx.

**OSMOR**—for efficient coils, coilpacks etc. Send 3d stamp for FREE circuits and lists. Dept RCC, Osmor Radio Products Ltd., Borough Hill, Croydon, Surrey. Tel. Croydon 5148/9.

**VALVES, VALVES, VALVES.** 12AT7, 12AX7, 12AU7, 6J6, 9/-; EF91, EC91, 6X4, 7/6; 6AL5, 6/6; EF92, 6C4, EAC91, 6/-; Skillman, 74 Franchise Street, Weymouth.

**INSTRUMENTS RECTIFIERS** 1 MA 6/-; 230V AC to DC F.W. Rectifiers 300 MA £1/0/0. 3A £9/0/0, 5A £12/0/0—many others S.A.E. LAWRENCE 134 Cranley Gardens, N.10.

**"YOU CAN RELY ON US"**

**COILS**  
Wearite "P" Coils. All types in stock including AF.1, RF.1. Price 3/-  
Midget I.F. Transformers Type 800. 21/- per pair. Standard Type 500/501 (465Kc/s) 20/- per pair

**HIGH IMPEDANCE HEADPHONES**  
New Ex-Government Price 12/6 per pair.

**SCOTCHBOY TAPE**  
1200ft Reels 35/-  
Spare Reels 4/3

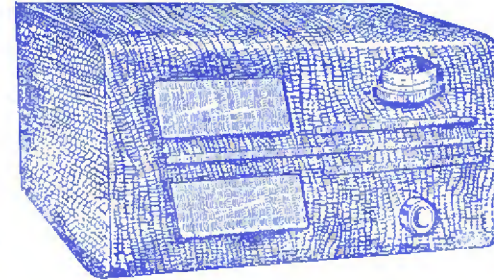

**COILS**  
Osmor Midget iron-cored "Q" Coils 4/- each. Leaflet on request.

Coilpacks Type H.O. 52/-; LM 43/4, MTS 54/2, TRF 43/4 all including Tax.

**TRIMMERS**  
All new Postage Stamp Ceramic. 4-70pf 8d; 40-100pf 10d; 20-150pf 1/-; 100-550pf 1/3.

**LINECORD**  
3-way 3a at 60 ohms per foot 6d ft., 2a at 100-ohms per foot 8d ft.

**The "MAXIMITE" AC/DC SUPERMIDGET SUPERHET — Full Plans 1/-**

**WAVECHANGE SWITCHES**  
Midget rectangular Type, 2P2W 2/6, 2P3W 2/6. Midget Circular Type IP12W, 2P6W, 3P4W, 4P3W, each 3/6.

Standard Yaxley Type (2 Bank) 2P11W, 4P5W, 6P3W, 8P4W, 7/6 each.  
All above are NEW and have 2" Spindles

**METAL RECTIFIERS**  
RM1 5/3, RM2 6/3, RM3 7/-, RM4 21/-, K3/45 8/2, K3/50 8/8, K3/100 14/8. Westinghouse 36EHT100 29/4, 14A86 20/4, 14D36 11/-, WX6 3/9, VVX6 3/9.

**RADIO SERVICING COMPANY**

**T.C.C. CONDENSERS**

Midget Picopack, 1mfd 350v, 2mfd 150v, 10mfd 25v, 20mfd 12v, each 2/6.  
Visconol High Voltage. +001 6kv 6/-, +001 12kv 10/-, +001 15kv 10/-, +01 6kv 10/-, +1 7kv 20/-, Micadiscs, 500pf 1/6, Type 543, -1 500v 1/3, 750v 1/6

**ENGRAVED KNOBS**  
1 1/2" WALNUT or IVORY...Volume, Focus, Contrast, Brilliance, Brightness, On/Off, Record/Play, Tone, Bass, Treble, Wavechange, Tuning, Radio/Gram., Brill/On/Off, S.M.L.Gram. All 1/6 each.

(Dept. K) 444 WANDSWORTH ROAD, LONDON MACaulay4155 SW8

**RADIO BOOKS**

VALVE TECHNIQUE (RSGB)	3/9	WORLD RADIO HANDBOOK (O. Johansen)	8/9
RECEIVERS (RSGB)	3/9	HOW TO LISTEN TO THE WORLD (O. Johansen)	1/11
TELEVISION INTERFERENCE (RSGB)	2/3	INEXPENSIVE TELEVISION (ASWP Ltd.)	2/8
SIMPLE TRANSMITTING EQUIPMENT (RSGB)	2/3	TV FAULT FINDING (ASWP Ltd.)	5/3
RSGB CALL BOOK	3/9		
WORLD RADIO VALVE HANDBOOK (O. Johansen)	11/9		

Above prices inclusive of postage, etc.

**DATA PUBLICATIONS**

Lyon Court 57 Maida Vale London W9 Telephone CUN 6518