



# Radio Constructor

Vol. 2, No. 5

Annual Subscription 16/-

December, 1948

Editors:

ARTHUR C. GEE, G2UK

W. NORMAN STEVENS, G3AKA

Technical Editor:

LIONEL E. HOWES, G3AYA

Advertisement & Business Manager:

C. W. C. OVERLAND, G2ATV

## Editorial

**T**ELEVISION is big news these days. Manufacturers report that they simply cannot cope with the demand—sets cannot be turned out in sufficient quantity to meet the orders. Our own series on a home-built televisor has revealed to us that the constructor is also bubbling over with enthusiasm. And other publications are finding their television articles meet with great approbation. Even the lay press are finding room to squeeze in quite a lot about television in their meagre space! And, of course, our new magazine "Television News" has been launched in the interests of the viewer. Yes, television is big news.

Arising from these observations, the staff here have been discussing the many points that arise. One of these points is that of the television receiving licence. Whilst not presuming to pose as moralists it is a hard fact that more than half of those who own receivers do not possess the necessary licence! Take the official figures: There are now almost 60,000 licences issued to television set owners—but the manufacturers state that they have sold around 100,000 receivers. Add to that the not inconsiderable number that have been built at home and it takes no Euclid to see that probably half of the set owners are, if not actually dishonest, somewhat forgetful! As a gentle reminder, we would point out that an ordinary sound receiver licence does not cover a television set. The television licence costs £2 but the ordinary radio licence will be taken into consideration so that it will not cost £2 extra per year, merely £1. Have you got yours?

Then we discussed the popularity of our own series of articles. Wholesalers, and retailers are constantly seeking further supplies from us and

unlucky readers are continually writing in to say they have missed an issue. With the present paper restrictions there is little we can do, unfortunately, regarding the Radio Constructor generally. However, since our series 'Inexpensive Television' has even more accentuated the shortage of copies, and since this series is appearing in the midst of what can only be described as a boom in Television, we decided that the least we could do was to reprint the articles in booklet form. This will be of vital interest to those who have missed one or more of the instalments, and will also allow those who have not been able to place a regular order for the magazine to have the full details of what undoubtedly has proved one of the most popular features ever published in these pages.

In addition to the original articles, which have been revised, extra data will be included, such as two pages of actual photographs from the screen, showing typical faults.

## THE Television Situation

One thing is very clear. More articles on television are wanted. We have started the ball rolling by describing our own surplus-gear receiver but we would greatly appreciate a few articles on the subject by those who have successfully constructed receivers and so forth to their own design. May we have the pleasure of considering your contributions?

W.N.S.

## NOTICES

THE EDITORS invite original contributions on construction of radio subjects. All material used will be paid for. Articles should be clearly written, preferably typewritten, and photographs should be clear and sharp. Diagrams need not be large or perfectly drawn, as our draughtsman will redraw in most cases, but relevant information should be included. All MSS must be accompanied by a stamped addressed envelope for reply or

return. Each item must bear the sender's name and address.

COMPONENT REVIEW. Manufacturers, publishers, etc., are invited to submit samples or information of new products for review in this section.

ALL CORRESPONDENCE should be addressed to *Radio Constructor*, 57, Maida Vale, Paddington, London, W.9. Telephone: CUN. 6579.

AUTHENTIC AND UP-TO-THE-MINUTE INFORMATION ON VHF, BROADCAST BAND AND AMATEUR ACTIVITIES IS GIVEN IN OUR MONTHLY PUBLICATION "SHORT WAVE NEWS."

# Housing that Receiver

By Capt. G. A. CHAPPEL

VQ4GSW

FROM time to time the average radio constructor is called upon to make some permanent or semi-permanent radio receiver installation in the home. It is at this point when the bread board or "haywire hookup" must emerge from the precincts of the experimenter's den and grace an occasional table or a side-board, perhaps a bedroom, with artistic grace equal to receiver performance (we hope)—and more.

There is no very great difficulty presented to a handyman in constructing his own cabinet, provided that the points enumerated in this article are adhered to.

In these days it is not easily (or cheaply) possible to secure the nicely veneered plywood or other usual commodities necessary to permit one to construct a conventional cabinet.

## *Presenting an article on a rarely discussed subject*

For those aspiring to woodwork

It is however quite possible to construct a most graceful cabinet of unusual type and design. Accordingly, the author desires to present some data, ideas and general principles which were conceived—and put into practical form—whilst he was in Africa, where suitable timber for more conventional cabinets was not, at that time, easily obtainable. It is at this juncture that the common broomstick looms to the fore—yes, good cabinets are possible by utilizing broomsticks—plus a few pieces of wood strip, which is quite easy to obtain. The cabinet can be made to any desired dimensions from a variety of designs as suggested below. Naturally, there is ample scope for initiative and ingenuity in drawing up a final design—but the material information given will prove of sufficient value for the individual to produce a cabinet of pleasing appearance at a low cost. No overall dimensions are given in the accompanying drawings, since these measurements will in all probability vary according to the dimensions of the assembled receiver chassis on hand and, in any event, the individual invariably desires to effect some change in design proportions in order to satisfy his own tastes.

As an indication of approximate cost, a cabinet 12" long by 8" high by 7" deep will cost something in the region of 5/- or so, whilst a radio-gram cabinet should cost only a few pounds.

Before proceeding with constructional information, however, it is desirable to take full account of all the factors involved in choosing suitable dimensions such as to permit manufacture of an efficient unit embodying an adequate layout. Only too often, a good cabinet design is spoiled by rough and ready measurements, assembly and finish—the result being, not infrequently, a converted "soap box" cabinet, plastered with sufficient thick paint to disguise defects of construction.

The following information should be digested fully before proceeding with any actual construction, and time spent reading the following paragraphs will be well repaid.

### **How to decide upon overall dimensions.**

Careful thought should first be given to the question of overall inside dimensions of the cabinet and, to aid the constructor, the following pointers may prove of some assistance. Firstly, measure the overall dimension of the receiver and for this, ensure that adequate consideration is given to accommodation of the loud speaker, normally, with the greater majority of present day receivers, the tendency is to mount the loud speaker on the left hand or right hand side of the chassis front—the latter normally being suitably cut out to receive approximately one third of the speaker diameter. Sometimes, however, the constructor may desire to mount the speaker separately. In noting down the dimensions, therefore, it is essential to ensure that adequate provision is made for the speaker.

Only too often, the method employed is to make a cabinet to just accommodate the receiver, whilst the speaker unit is inserted into any odd space which happens to be available. A really small receiver may be produced employing this method, admittedly, but the aural performance is rarely one for complement. The speaker should, therefore, receive *first* consideration in laying out a receiver and it must be remembered that whilst almost any diameter and quality of loud speaker may suffice, a little extra consideration in this direction will prove that prime importance must be attached to the problem.

It may be argued that, for a reasonably large type of speaker unit (say 10" diameter), a certain degree of baffle effect is desired to the rear of the

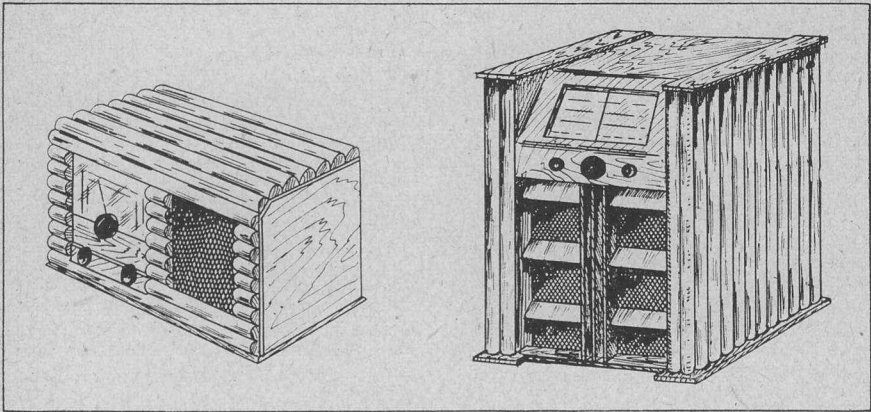

Typical examples of the attractive cabinets that can be made on the " broomstick " principle.

unit, and consequently, that suitable arrangement of components in close arrangement will conduce to this end. To a very small and limited degree, such an argument can hold good—but only up to a point—and the point is as follows:—Low frequency excursions of the cone occur at low audio frequencies; these low frequencies require greater input power levels, however, in order that the excursions may take place. Consequently, a greater amount of air will be displaced about the speaker cone and, therefore, a greater air impulse will strike the baffle media. Clearly, then if this media consists of components arranged in tight mechanical formations, then it is simple to appreciate that mechanical resonance effects may quite easily be produced within them. This effect is particularly applicable to many types of valves—with consequent electrical oscillations occurring in the associated circuit—the resultant oscillation being fed back to the speaker via normal channels in the output circuit—with most distressing results, which may show up as a heavy "boom" or, worse—a whole gammut of low frequencies.

so that, after six or seven drapes the hole will only be a couple of inches in diameter—the last drape having no hole cut in it at all. Separation of the drapes should be in proportion to the speaker diameter—and these may be determined by experiment. Quite naturally, all drapes must be fixed securely at all edges with respect to the cabinet and the material used should be thick felt or something similar—each piece being approximately one half inch thick. With this method, it is of course essential that the speaker be housed in a separate compartment for full baffle effect.

In turn, this means that the volume control can only be turned up a fraction of its total travel—with obviously low volume level limitations. If a baffle effect is desired at the rear of speaker, then design a suitable cotton wool pad—or, better still, use a succession of spaced drapes—each drape being cut with a hole in the centre—and the first drape being hung immediately behind the speaker proper. The diameter of the hole in the first drape should be roughly equivalent to the speaker diameter. Each successive drape should have a reduced hole size,

**Ventilation.**

The subject of adequate ventilation is an important one and it is essential to ensure that adequate means are provided in order to permit heat to be conducted away from the receiver without damage to components or, for that matter, the cabinet itself.

With battery operated receivers, of course, these remarks do not apply quite so strictly—but by battery receivers is implied a receiver of the HT and LT battery type—not to vibrator driven equipments!

Consideration must be given to the following factors:—

**(A). Electrolytic and paper capacitors.**

The manufacturer invariably tabulates the maximum working temperatures which may be tolerated. If adequate space is not available to permit a reasonably well ventilated layout—then don't hesitate to fix a metal deflector plate between the capacitor and the source of heat radiation.



**(B). Resistors.**

Power resistors must be well ventilated and should be so placed that their radiated heat will not be absorbed by nearby components.

As in the case of electrolytic and paper capacitors, do not hesitate to arrange a shield round the component—say, on three sides. A heat conveying duct can then be arranged over the top of the unit, so that rising heat can be conducted out at the rear of the receiver.

**Ducts.**

Remember that hot air rises and is replaced by cooler air. Accordingly, ensure that an adequate supply of cool air enters the receiver. Essentially, the upper conveying duct must be so arranged that the end above (or just behind) the component is at a lower level than the end at the back of the receiver, otherwise outward conduction of hot air will not be encouraged. In point of fact, of course, a "negative" slope will only result in zero ventilation together with a consequent increased temperature rise inside the set.

**(C). Loud speakers.**

Ensure that no excessive temperature rise occurs within the vicinity of the speaker cone, otherwise considerable damage may be effected.

**(D). Dials.**

Dials of the celluloid type must not have a prolific heat source nearby, otherwise the results will be disastrous! If there be any doubt in the mind of the constructor—then place a 16 swg aluminum or steel shield at the rear of the dial.

**(E). Metal rectifiers.**

It is becoming increasingly popular to use the selenium and similar type of rectifier for high tension supply.

The correct mounting of the rectifier unit is in the horizontal plane, so that heat dissipation and cooling is even over all the fins.

In some post war receivers, it is becoming usual to mount these rectifier units vertically. This is quite incorrect, since the rising air from the lower fins passes the upper ones, hence, the top fins receive an excessive temperature rise. Selenium type rectifier elements will run only up to a fixed maximum temperature. This temperature limit is generous, but, quite naturally, exceeding this temperature is bound to result in a break down sooner or later.

Accordingly—ensure that these units are adequately ventilated.

**(F). The Cabinet.**

Essentially adequate arrangements must be made to prevent damage to the cabinet. It is a good scheme to line the top inside of the receiver with a sheet of asbestos. A piece of aluminium or steel can then be mounted on top of this (between the asbestos and the receiver). It is a good plan to allow approximately one half inch

space between the asbestos and the metal shield to obtain additional air circulation. Naturally, provision must be made so that the issuing air is permitted to pass through the back of the receiver—and holes can be cut for this purpose.

**(G). General.**

By observing the above precautions, huge dividends will be paid particularly with respect to universal type receivers. The "dividends" will take the following forms:—

- i. Fewer breakdown of components.
- ii. Greatly reduced fire risks.
- iii. Prevention of cabinet deterioration.
- and iv. Reduced risk of cabinet finish being injured—particularly at the top.

**Additional pointers to chassis accommodation.**

Allow approximately one half inch clearance between each side of chassis and cabinet side wall.

In the following suggested designs, an "open" type of cabinet bottom has been devised, in order to ensure adequate entry of cool air. This requirement is fully accommodated by fitting small feet, one at each corner, on the cabinet underside.

We may now proceed with finalising the overall dimensions.

Ascertain that there will be adequate room for the tuning dial and associated devices.

A small sketch and half an hour of serious study will save much wasted time and money—later!

**Order of construction.**

The cabinet sides should first be made, followed by the front, top and bottom, in that order. This method will facilitate alteration due to changes of plan, etc., during construction. Finally, the back of the cabinet should be made.

Having taken all the foregoing remarks and suggestions into consideration we can now proceed.

**Cabinet sides.**

The sides of the cabinet are constructed of broomstick dowel, arranged, normally, in the vertical plane. These dowels are first cut to the correct length, after which they may be either cut longitudinally, for half round section or, if it be preferred, may be retained in the full round section. No difficulty has been experienced when cutting the dowels along their length, provided that the job is undertaken carefully and slowly. The author used an ordinary 3 foot saw for sawing of dowels and a tenon saw for cutting the remainder of the cabinet.

The next operation is to lay the dowels down side by side on a flat surface and carefully line them up. Two lengths of batten may then be fixed across the dowels, using good glue and small wood screws, as shown in drawing (a) inset. When the fabricated sides are ready, they may be trued up with a plane and finished off with sandpaper to make a square assembly. As will be seen from drawing (a), the leading (front) dowel should, for appearance sake, be of full



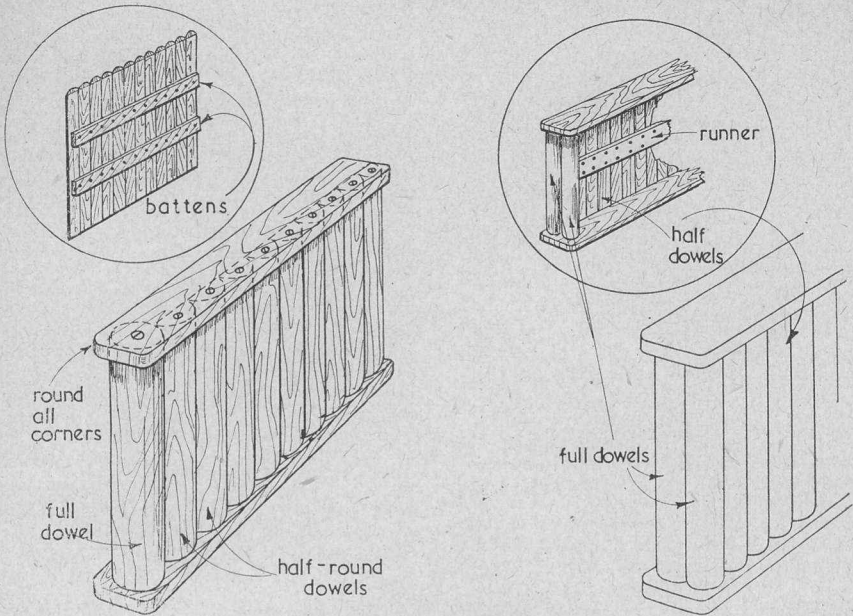

CABINET SIDES

(a). Single dowel ends. Make certain that the left-hand sides are made with rounded portion of dowels facing outwards—as above.

(b). Using two full dowels at ends. Runners (see inset) may be either one double or two singles.

round section. For a small cabinet, one section only will suffice, for a large cabinet, however, it will probably be desirable to have two full sections side by side at the front as shown in drawing (b). The reason for this is that the cabinet walls may be given the appearance of greater thickness—the net effect being to convey the impression of heavy construction. The next operation is to prepare the top and bottom runners. These runners may consist of deal or similar wood. For a small cabinet with one full dowel at the front,  $\frac{1}{4}$ " or  $\frac{3}{8}$ " thickness strip may be used, whilst for a cabinet employing two full dowels,  $\frac{1}{2}$ " or  $\frac{5}{8}$ " thick timber will impart the desired appearance. The overall length of strip will be equal to: Dowel diameter x number of dowels (side by side) plus  $\frac{3}{4}$ " (for  $\frac{3}{8}$ " overhang) front and rear of cabinet.

other than to note that, if desired, the cross runners may consist of half round section dowel instead of a flat strip.

Cabinet front and top.

The front of the cabinet will normally have to be designed to accommodate the type and size of dial available and the arrangement of controls. Accordingly, a few suggested designs are given in drawings (c) and (d). As will be seen, the front may be either separate from, or combined with, the top of the cabinet, as may be desired. Naturally, the placing of the loudspeaker will considerably influence the final layout. It is felt, however, that the constructor will find a suitable design from the drawings presented in this article. The separate top and front may consist of old "bread-boards" from the junk box (see drawing (e)), provided that they are in good condition and are mechanically sound. Either a wire gauze or a cloth covering may be used, as desired and these must be applied after all holes and apertures have been cut to receive dial, loudspeaker cut-out and controls. The material may then be affixed and carried into the larger apertures, being secured from behind with small tacks.

In the case of cloth, the application of thin glue is a great help, but the glue should be applied

The width of the strips should be equal to the width of the front wall, plus  $\frac{3}{4}$ " for  $\frac{3}{8}$ " overhang each side.

Fixing of the strips is effected with good glue and small countersunk screws. The strips should be prepared to receive the screws and the surface recessed to secrete the countersunk type head. Plastic wood may then be applied over the screw heads and, when dry, the top and bottom should be sand papered to the desired finish. Drawings (a) and (b) should require no further explanation.

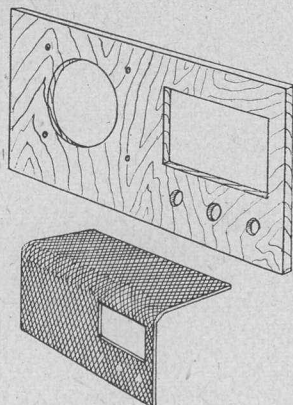

(c). Cabinet Front.

When cut, cover with fret material, or gauze, to cover the entire front panel, leaving opening only for dial and control knobs. The gauze to cover both the top and the front of the cabinet, as in lower drawing. Note that the gauze (or cloth) should be taken beyond the back edge of panel.

to the edges and rear of the wood after being stretched over the front and top. Tin tacks will assist holding whilst the glue is setting.

A further type of construction is shown in drawing (d). For this purpose, a sheet of thin model aeroplane ply wood or thick balsa wood is first cut to size. The openings for dials, speaker and controls then being cut. Half section dowel may next be cut to the desired length to cover the backing thus formed and may be affixed with glue. Small nails may finally be driven into the dowels from the rear. If balsa wood is used,

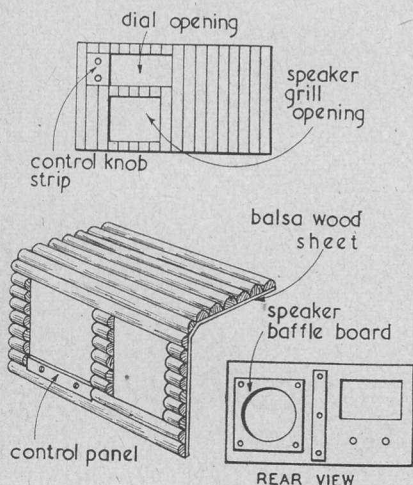

(d). Alternative method.

it will be found desirable to use small washers beneath the nail head in order to prevent penetration of the nail through the backing material; a large head carpet tack is admirable for application in this scheme, for obvious reasons.

Either a separate control knob panel may be used, as shown or, alternatively, the dowel itself may be drilled, though appearance is inclined to suffer in the latter case.

When dry, the combined top and front may be sand papered, as desired.

As will have been observed, no dimensions have been given, since these will depend greatly upon the factors already discussed. In order to act as a guide, however, all cabinets constructed by the author were so arranged that the top of the cabinet was fixed to the underside of the top runners, at each end. Small screws were driven from the underside for this purpose.



(e). Top edges to be rounded as shown.

#### Cabinet bottom.

The cabinet bottom should be designed to permit entry of cool air as was explained at the commencement of this article. We also have to effect some economy of material, for obvious reasons in addition to the cost factor. A design embodying all three of these factors is given in drawing (f) and it is felt that no additional constructional information will be required.

Drawing (g) shows the general details of assembly of the bottom to the cabinet sides.

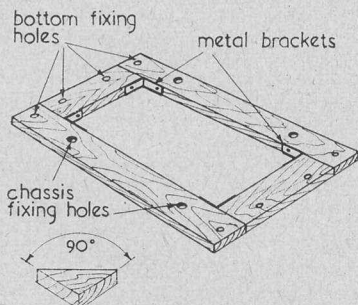

(f). Cabinet Bottom.

The four members should be glued and pegged, or screwed at angle from the end. The small sketch shows a wood finish which can be used as an alternative to the metal bracket for fixing the side member to the cross member.

**Finish.**

The question of finish must, of necessity, be left to the requirements of the reader. A few

suggestions may not be out of place, however. accordingly, the table given below will serve as a general guide.

Specification.			
	Member(s)	Material	Finish
(a)	Sides	Wood	} Sprayed Enamel or polished, as desired
	Top	Wood	
	Front	Wood	
(b)	Sides	Wood	} Enam. or Polished Plain "
	Top	Gauze face—combined	
	Front	Gauze face—	
(c)	Sides	Wood	} Enam. or Polished Plain "
	Top	Cloth face—combined	
	Front	Cloth face—	
(d)	Sides	Wood	} Enam. or Polished " "
	Top	Wood	
	Front	Gauze or Cloth	

The majority of broomstick dowels are made from birch and these polish up quite well. Wax or French polish may be used.

If a scheme of enamel finish is used, however, it is essential to choose a good quality enamel. Several thin coats should be applied rather than one thick one and each coat must be thoroughly dry before the next coat is applied. Fine sandpaper can be used to ensure a good undercoat and should be applied prior to the application of successive layers.

It is a tedious job to apply an even coat of enamel by brush and the author has successfully used a 'Flit' spray for the purpose. Employing this method not only makes painting a pleasure, but it is also possible to blend colours on the cabinet to give a very pleasing effect.

**Colour Blending.**

Colour blending is an art. It is not beyond the capabilities of the average reader to produce pleasing designs, however, and the following suggested schemes may prove of some assistance. A word in the reader's ear at this juncture; experiment with your colours on a scrap piece of wood before applying your scheme to the actual cabinet.

**Undercoats**

The undercoat must first be selected and, once agreed upon, the successive coats applied as already described above. The undercoat may normally be chosen as a base to match existing interior decoration schemes and it will probably be found that pastel shades of pink, orange, yellow and grey will serve admirably, whilst high gloss colours in cream, white, red or black may make a suitable alternative. Gold, if properly prepared and applied makes a most attractive finish, but this is by no means simple to apply when in the normal household form.

**Secondary colours**

Black, white, silver and grey are suitable colours to use for secondary designs, to mention

only a few. The secondary colour should only be applied as a single coat, however.

**Combinations**

The following combinations are representative of generally employed colour schemes:—

Primary Colour	Secondary Colour
Cream	Black or Red
White	Black, Blue or Red
Black	White, Silver or Gold
Blue	Grey
Grey	Maroon
Red	Grey, White or Orange
Pink	Blue
Gold	Black
Silver	Black, Red or Violet

(continued on page 445)

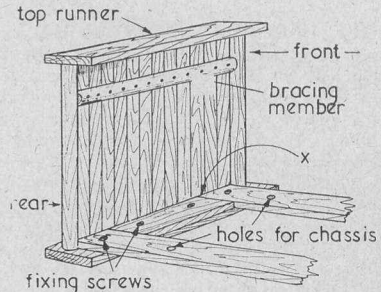

(g). General details of assembly of cabinet bottom and sides.

For Fig. (G). Showing general details of Assembly of Cabinet bottom and sides.

The cabinet top may be fixed in a similar manner and long fillets may be used for extra strength if desired. A fillet can also be added at 'X' for additional strength. Where the bracing member meets the end dowels sufficient clearance should be left for the front panel.



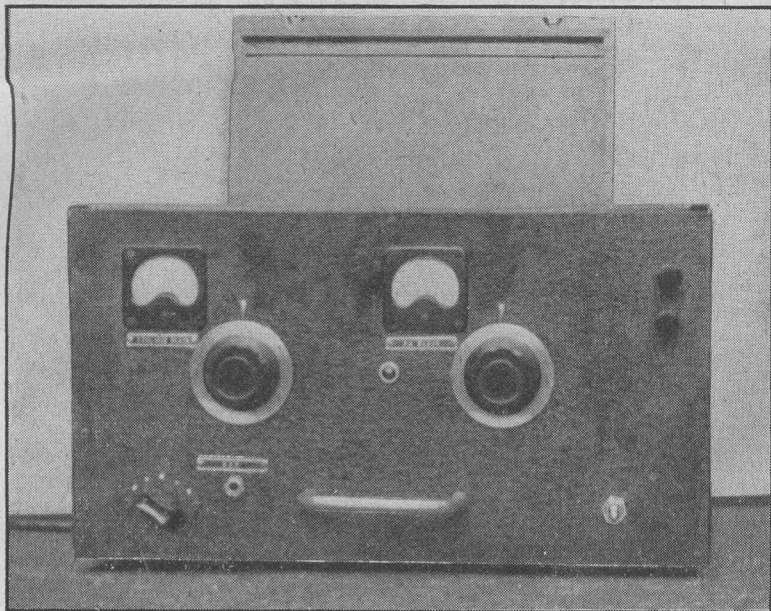

## Table Top Transmitter

A compact 35 watt COPA  
constructed and described by

*Gene Zap*

**T**HIS self-contained CO-PA for AC mains operation has proved itself both as a very efficient 25—35 watt transmitter and as an exciter for a high powered RF stage which it is hoped to have an opportunity to describe at a later date. As will be seen in the photographs it is housed in a completely enclosed cabinet with ample ventilation and a hinged lid for easy band changing. A crystal selector switch is fitted to enable rapid change to various spots in the band or for switching in a VFO when required. This switching, of course, may be omitted and the crystal socket mounted on the front of the panel for quick change.

The simplicity in both construction and operation, no neutralising being necessary, makes it an eminently suitable design for the newly licenced amateur for whom it may well serve as an exciter for a more ambitious rig later or as a permanent stand-by. A stand-by transmitter is an essential piece of equipment in every Shack, helping as it does to avoid the temptation to rush a job when re-building in order to get back on the air quickly.

The circuit, a conventional and popular 6V6 crystal oscillator and 807 power amplifier, is quite straightforward and some amateurs will no doubt prefer to build it in a form which lends itself readily to the more general rack and panel construction. The writer prefers the growing tendency to use separate cabinets as this system makes for easy re-arrangement for changing to QRP, medium or QRO working, avoids straggling connections from separate power supplies and provides better screening. In any case rack and panel formation can easily be simulated by merely stacking the cabinets one upon the other.

### Metering.

Permanent metering is fitted to both CO and PA tanks but economy can be effected by using one meter provided either with switching or by metering jack with suitable shunts. As an additional refinement a separate meter can be added to read the grid current to the 807, or as in the original the CO anode meter can serve this dual purpose. Separate meters are shown in the circuit diagram.

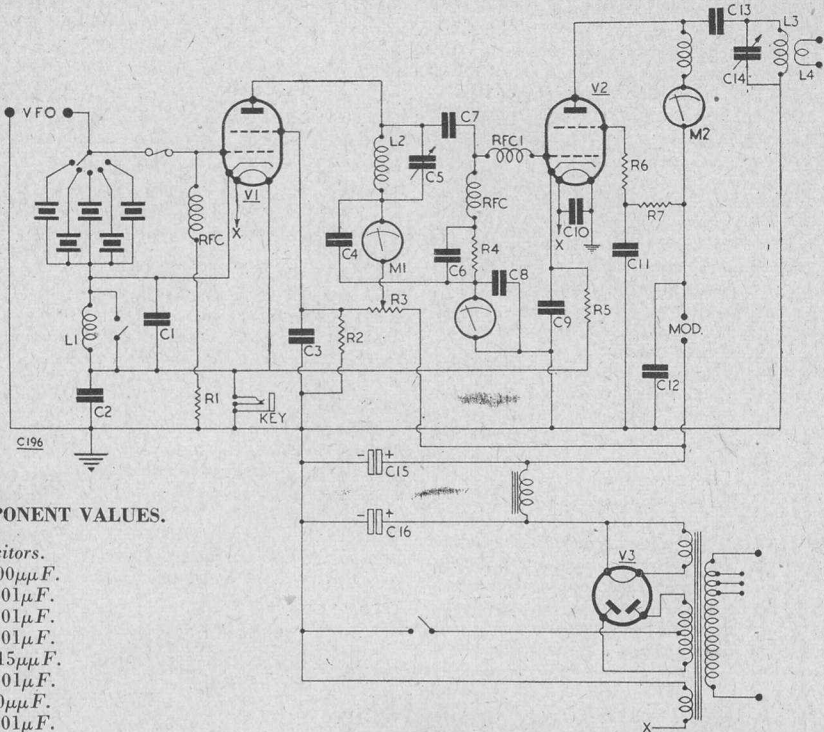

COMPONENT VALUES.

Capacitors.

- C1, 100 $\mu$ F.
- C2, 0.01 $\mu$ F.
- C3, 0.01 $\mu$ F.
- C4, 0.01 $\mu$ F.
- C5, 115 $\mu$ F.
- C6, 0.01 $\mu$ F.
- C7, 40 $\mu$ F.
- C8, 0.01 $\mu$ F.
- C9, 0.01 $\mu$ F.
- C10, 0.005 $\mu$ F.
- C11, 0.01 $\mu$ F.
- C12, 0.002 $\mu$ F.
- C13, 0.001 $\mu$ F.
- C14, 115 $\mu$ F.
- C15, 16.0 $\mu$ F.
- C16, 8.0 $\mu$ F.

Meters.

- M1 50mA
- M2 150mA
- Grid current meter 15mA

Resistors.

- R1, 47,000  $\Omega$  (2)
- R2, 15,000  $\Omega$  (15).
- R3, 7,500  $\Omega$  (25).

- R4, 27,000  $\Omega$  (1).
- R5, 250  $\Omega$  (5).
- R6, 100  $\Omega$  (1).
- R7, 50,000  $\Omega$  (10).

- L1, L2, L3: Tuning Coils (See chart on page 443).
- RFC Short wave chokes.
- RFC1 see text.
- L4 Link.

N.B.—Figures in brackets following resistor values represent wattage ratings.  
Inductors.

- V1, 6V6
- V1, 807
- V1, 5U4

One side of V1 heater should be taken to earth and not to other side of key as shown in circuit diagram.

The 6V6 is used either as a tritet (for doubling or quadrupling the crystal fundamental), or as a simple CO by shorting out the cathode coil by means of a switch. In the original model this switch is inside the cabinet as in any case the lid has to be opened for coil changing, etc., and it certainly precludes wrong or thoughtless use which might have fatal consequences for the crystal. The oscillator tank must on no account be tuned through the crystal fundamental without this switch being closed; even although it has the protection of a fuse.

With the oscillator used as a tritet and multiplying in the anode circuit, several possible outputs are available with the minimum number of crystals, but a reduction of efficiency will result if the 807 is used as a doubler rather than as a simple power amplifier. Operation is easily possible in the 28 Mcs band from 7 Mcs crystals

if the 807 is used as a power doubler but much higher efficiencies are obtained by quadrupling in the CO. Alternatively the experienced amateur might use a 6L6 in place of the 807 for multiplying, followed by the 807 as the PA. In this case only normal receiving type components need be used with reduced HT (as in the oscillator stage) with link coupling to the new PA where the heavier duty components would be transferred.

Coils.

Suitable coil sizes are to be found in the table and it is to be noted that the cathode and CO tank coils are each on standard 1 $\frac{1}{2}$ " ribbed plug in formers. The PA tank coils are self supporting 2" diameter plated copper tube for 10, 20 and 40 meters. The 80 and 160 meter tank coils are wound on 2" formers, ribbed for preference but plain paxolin may be used. The wiring throughout

should be kept as short and direct as possible particularly in the grid and crystal circuits.

The crystal selector switch and crystal holders must be mounted as close as possible to the CO valve holder in order to keep shunt capacitances at a minimum especially with harmonic cut crystals intended for operating on the higher frequencies.

#### Power.

The mains transformer should be capable of delivering an output of 500 volts at 200 mA and at this figure will comfortably run to 35 watts if needed. The bias is obtained by a combination of grid leak and cathode resistor and no biasing battery is needed; thus retaining the compact form which was the writer's original intention.

It will be seen that the 807 is screened by a can and is horizontally mounted—horizontal mounting is not detrimental to this valve. If for layout considerations vertical mounting is preferred, screening may be achieved by mounting "through" the chassis or more simply by using a can as in the original.

Both the capacitors C5 and C14 are of 115 $\mu\mu$ F and C5 must be fully insulated from the chassis. C14 can well be of the normal good quality receiving type. The .001  $\mu$ fd. capacitor isolating the HT from the final tank coil and the 807 screen by-pass capacitor should be of 1,000 volts working type. The components throughout are all of standard design except the air spaced RF

choke in the grid of the 807, (RFC1). This consists of ten turns of 20 enamelled swg. wire formed round any suitable cylinder to give a finished size of  $\frac{5}{16}$ " diameter.

The slider on the 7,500  $\Omega$  resistor in the oscillator circuit should be adjusted to give a voltage of 250 on the anode—the screen voltage will be rather less than half that figure.

#### Keying.

It will be noted that keying is effect in the common cathode return of both stages and with reasonably short leads there should be no trace of key clicks but if the constructor wishes any conventional click filter may be fitted. A filter may alternatively be fitted to the key itself. The key plug is of the self closing type to obviate further switching or shorting, when phone is used.

#### Modulation.

Terminals are provided at the rear of the chassis to provide for normal anode and screen modulation and any good audio equipment capable of giving up to 15 watts will be satisfactory for 100% modulation. The terminals can be shorted by a metal strip when the transmitter is used for CW operation, although this will not be necessary if the unit is used with the modulation transformer connected.

#### Operation.

The switch in the HT negative lead is used for

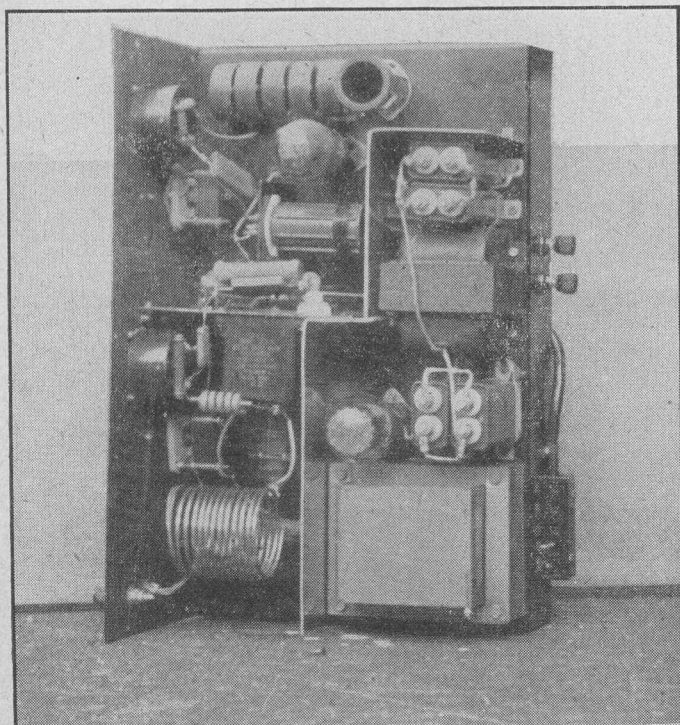

*Top view of the transmitter showing the lay-out of the principal components, as shown in the photograph. Care should be taken to ensure adequate screening between stages. The power supply may be seen in the rear compartment, with the CO stage in the left-hand part (top in the photograph), and the PO stage in the right-hand compartment.*



transmit/receive purposes, leaving as it does the valve heaters warmed ready for action the whole time. After switching on the mains a full half minute should be allowed before the HT circuit is made. It is essential to always make certain that the proper crystal and coils are in circuit and until one has become familiar with the capacitor settings both should be set to minimum capacity before switching on. If to be used for c.w. the "Modulation" terminals should be shorted (or connected through the modulation transformer secondary).

Make certain that you are operating on the fundamental (or the correct harmonic of the crystal) for the band intended. An absorption wavemeter is the simplest method of achieving this.

The oscillator is brought to resonance as

indicated by the dip in its associated meter and the appearance of a reading the PA grid current meter. The PA is then tuned for maximum output and any further adjustment of the CO stage that may be necessary. The crystal circuit should never be tuned to maximum output unless under load, i.e., the PA is correctly tuned. The RF voltage developed across the crystal (and the heat) is reduced when delivering power.

The 807's maximum grid current is 5 mA but a current of only 3 mA is ample for loading up to 25 watts.

The adjustable coupling coil, L4, is, of course, coupled to the "cold" end of the PA tank coil. It can well consist of 16 gauge systoflex covered wire. For newcomers to the transmitting side a half-wave dipole aerial is generally both the simplest and most certain of giving good results.

## Coil Data

Freq.	Cathode Coil (L1)	Oscillator Tank Coil. (L2)	P.A. Tank Coil. (L3)
In Mcs.	Number of Turns.		
1.7	32	60	48
3.5	12	30	24
7	7	15	12
14	—	8	6
28	—	4	4

All cathode and Oscillator Coils and 1.7 and 3.5 P.A. coils wound 22 SWG enamelled. PA coils for 7, 14, and 28 Mcs. are spaced 12 gauge plated copper tube.

## "Facts about Philips"

This is the title of a new booklet produced by Philips Electrical Ltd., the purpose of which is to draw attention to the great variety of products manufactured by Philips.

This attractive little publication is bright in appearance and style, and is extremely readable. Profusely illustrated, and including photographs of the larger factories, "Facts about Philips" describes briefly the whole varied range of Philips products which includes radio, television, lamps, high frequency generators, industrial diamond dies, welding machines, medical equipment, etc.

"Facts about Philips" will serve as a general reminder that Philips activities extend over a much wider field than is usually realized by consumers of specific products.

## Catalogues Received

**Clydesdale:** List Number 5 of ex-Government electronic and radio equipment is now available. This 48-page catalogue contains details of numerous receivers, oscillators, amplifiers, and other items of interest to radio enthusiasts. The list may be obtained on application to Clydesdale Supply Co., 2, Bridge Street, Glasgow, C.5.

**Laskys Radio:** A duplicated Bulletin of surplus gear is obtainable from Laskys Radio, 370, Harrow Road, Paddington, London, W.9.

**Duke & Co.** A comprehensive list of valves, equipment and miscellaneous components, including television EHT transformers, is contained in the list mailed by this firm. Copies may be obtained from Duke & Co., 219, Ilford Lane, Ilford, Essex.

## NEW DENC0 TECHNICAL BULLETIN.

DTB3 has just been issued. It deals with Coil Turrets and is priced at 3/-. A review of this publication will appear in the next issue.

# Query Corner

A "Radio Constructor" service for readers

## Transformers in Parallel.

"I have two mains transformers, one giving 350V at 90 mA and the other 350V at 80 mA., which I wish to incorporate in a power pack to provide 350V at 170 mA. Is it in order to parallel connect the two transformers to provide this current?"  
L. Jones, Cleethorpes.

It is never advisable to connect two sources of power in parallel with one another unless some equalising device is employed. This applies to power supplies, generators and batteries, but for the purpose of this explanation, we will consider the effect of connecting two similar batteries in parallel across a load.

Fig. 1 shows the batteries feeding power into the load resistor R, the internal resistance of the batteries being represented by  $r_1$  and  $r_2$ . Now if the voltage of  $B_1$  is 119 and that of  $B_2$  is 121, there will be a potential difference of 2V existing between the two batteries, which will result in current flowing from  $B_2$  to  $B_1$ . The magnitude of this circulating current may be easily calculated by Ohms Law, thus:

$$\text{Current } I_c = \frac{r_1 + r_2}{121 - 119} \text{ and may be considered as being entirely separate from the current which flows through the load resistor. The circulating current has the effect of reducing the terminal voltage of one battery and increasing that of the other. This effect is due to the current flowing from positive to negative in one battery and from negative to positive in the other, reference to Fig. 1 should make this clear.}$$

In normal practice it is found that one battery will discharge more quickly than the other, so that their voltages will, in due course, become equal and the circulating current will be zero. However, when power is drawn from two mains transformers, which are connected in parallel, the circulating current will not diminish with time, and it is quite likely that this current plus the normal load current will be sufficient to overload one of the transformers. This brief explanation should prove sufficient to show the inadvisability of parallel connecting sources of power, and in applications where it is required

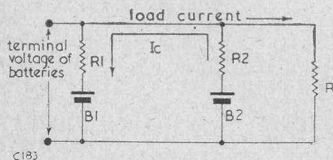

Fig. 1.

to share the load current between, say two transformers, an alternative method should be adopted. For example in the majority of cases it should be possible to divide the load between the power supplies. In the case of a receiver this might be easily accomplished by supplying the output stage from one supply and the remaining stages from the other supply. Such an arrangement means that two rectifier valves and two separate smoothing circuits must be employed but the combined cost of these components will normally be less than that of a new transformer.

## Mains Dropping Resistors.

"Whilst living in a district supplied with DC, I used a small American AC/DC receiver for local station reception, and the results were satisfactory. Upon moving to an AC district the performance of the set was noticeably worse, and on checking various voltages and currents, I found that although the heater current was correct (0.15 amps), the HT voltage was only 80V. Can you offer an explanation and a remedy for this matter? I have carefully checked over the components in the HT circuit and everything appears in order.

K. Lewis, Salisbury.

When the 115 volt AC/DC American receivers are sold in this country it is normal practice to add a line cord to maintain the heater current at the value specified for the valves in use. This of course is in order, but the HT current is also drawn through the line cord. Now on DC operation the current passed by the rectifier is constant and is taken into account when the resistance of the line cord is calculated.

On AC however, conditions are somewhat different as the rectifier passes current only on the positive peak of each cycle, and the peak value of this current might easily be ten times the steady current passed by the rectifier when the set is operated on DC. This peak current, in flowing through the line cord, results in a voltage drop occurring on each positive peak of the mains voltage. This instantaneous voltage drop has little effect upon the filament current of the valves but is sufficient to seriously reduce the HT voltage.

When a receiver primarily intended for 115 volt operation is to be used on an AC mains voltage exceeding 200v. the solution to this problem lies in the use of separate voltage dropping resistors for the heater and HT circuits. The method of connection for the extra component will be made clear by reference to Fig. 2., which

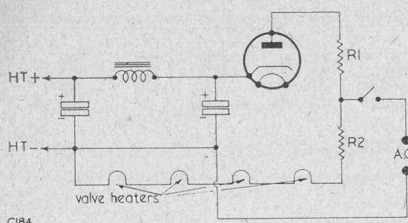

Fig. 2.

Theoretical circuit of a typical AC/DC Power Supply. R1 is the HT regulating resistor and R2 is the line cord.

shows a typical power circuit of a Universal receiver.

The value of the heater voltage dropping resistor may be found by the use of Ohms law, but the value of the HT voltage dropper is not easily calculated, as it only conducts pulses of current on positive peaks. Its value is best determined by trial and error methods, but it will generally be found to be in the region of 600 Ω.

**Bias Time Constant.**

*"I have noticed that the values of cathode bias by-pass capacitors vary considerably from stage to stage. What determines the values of these components and how may they be calculated?"*

*D. Ryan, Rochester.*

The capacitor used to by-pass the cathode bias resistor is for the purpose of maintaining a constant bias on the valve regardless of the variations in the anode current produced by the signal voltage on its grid. If the by-pass capacitor is omitted or is of too low a value the

voltage at the cathode of the valve will tend to follow the variations in the grid voltage. Under these circumstances the cathode voltage will be in phase with that on the grid, and will result in a reduction in the gain of the stage.

In order to obtain maximum stage gain the reactance of the by-pass capacitor should be not more than one tenth of the value of the bias resistor at the lowest frequency which it is desired to reproduce.

*HOUSING—(continued from page 439).*

**General form**

The secondary colour should only be applied as a tinge of colour change, at the sides and three quarter top and front of the cabinet. Do not overdo this coat, otherwise the full effect will be lost.

Remember, however, gaudy colours may suffice for a small receiver, but a large cabinet should present a rather more dignified appearance

**Conclusion**

The simple design schemes as outlined in this article may be extended to provide the design of a floor or desk type transmitter, a radio gram or a television receiver cabinet.

This is especially welcome when the apparatus has to be installed in a lounge or any other situation where the XYL can see it.

Naturally, the amateur can utilize his ingenuity in all directions and many schemes will undoubtedly suggest themselves.



**Xmas 1948**

*The Editors, Contributors  
and Staff of*

*"Radio Konstruktor"*  
*join in wishing our readers,  
wherever they may be,  
the best wishes for a  
Merry Xmas  
and a Happy New Year*



**"Query Corner" Rules**

- (1) A nominal fee of 1/- will be made for each query.
- (2) Queries on any subject relating to technical radio or electrical matters will be accepted, though it will not be possible to provide complete circuit diagrams for the more complex receivers, transmitters and the like.
- (3) Complete circuits of equipment may be submitted to us before construction is commenced. This will ensure that component values are correct and that the circuit is theoretically sound.
- (4) All queries will receive critical scrutiny and replies will be as comprehensive as possible.
- (5) Correspondence to be addressed to "Query Corner," Radio Constructor, 57, Maida Vale, Paddington, London, W.9.
- (6) A selection of those queries with the more general interest will be reproduced in these pages each month.



# CLYDESDALE

For Bargains in Ex-Services Electronic Equipment

BRAND NEW, in maker's original packing.  
Ex. U.S.A.A.F.

## PANORAMIC GUNNERY TRAINER MK.I. *Made by De Vry*

Containing a 35mm. SOUND FILM PROJECTOR.

Complete with soundhead photo-cell CE-2, 150 watt projection lamp, condenser and projection lenses, etc.  
A Sound Amplifier, with four valves, 2/6SJ7's, 6F6, 5Z4, etc.

A Control Amplifier, with three valves, 6SJ7, 2051, 6X5, VR150/30, 2/CX-25 photo-cells, etc., also Spares Kit, with 6 projector lamps, 6 each other lamps, 3 photo-cells, 12 valves, etc. Operating manual and reel of safety film.

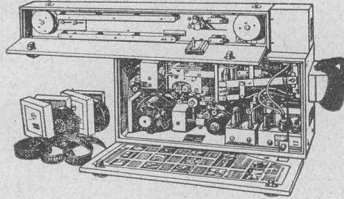

The equipment is all mounted in a wood case 48½ x 19½ x 10½ ins. which also has the automatic rewind film magazine.

Operating voltage 115V. 60c/s. 405 Watts.

Ideal for amusement parks or entertainment in the home as it stands, or could be altered.

CLYDESDALE'S PRICE ONLY **£35** CARRIAGE PAID

Packed in a wood case.

BRAND NEW

### R.C.A. VIBRAPACK

Input 6 volts. Variable output: 200-240V. 40-50 ma. Complete with non-synchronous Oak vibrator OZ4 rectifier, output switch, battery leads with clips, cord fuserholder, battery switch and octal plug, in metal case 4½ x 4 x 6 ins.

CLYDESDALE'S PRICE ONLY **37/6** each. POST PAID

BRAND NEW, in maker's sealed wrapper.

### EX. U.S. A.A.F. JEFFERSON-TRAVIS, SYNCHRONOUS VIBRAPACK U.F.I.

Outputs 150/120 volts 30/50 ma. choke/capacity smoothed also L.T. and Bias.

Complete and self contained vibrator Power Unit for 12 volts input, plus 4½ ft. screened input lead fitted with crocodile clips, with circuit in metal case 7 x 4½ x 6 ins. finish black.

CLYDESDALE'S PRICE ONLY **19/6** each. POST PAID

BRAND NEW, in maker's cartons.

Ex. U.S.A.A.F.

### MALLORY SYNCHRONOUS VIBRAPACK

Input 12 volts, output 250 volts, 70 ma. Complete unit, totally enclosed and fully screened. Dim. 5½ x 2½ x 5 ins.

CLYDESDALE'S PRICE ONLY **19/6** each. POST PAID

BRAND NEW, in maker's cartons.

Ex. U.S.A.S.C.

### BC-728 RECEIVER

A self-contained 6 valve, push-button s/het for portable or car use.

Range 2-6 mcs. in 4 pb-stages, with 3/1T4's, 1R5, 1S5, 2/3S4's, complete with L.S., battery and vibrator packs, weight 23½ lbs. Rev. size 12¼ x 7½ x 5½ ins.

CLYDESDALE'S PRICE ONLY **£9/9/0** each. CARRIAGE PAID

Kit of Spares available at 37/6d.

Ex. U.S.A.S.C.

### INTERPHONE AMPLIFIER 3611, by Bendix

A two valve mic amplifier, 6SJ7, 6V6, complete for 24V. operation, in metal case 9 x 6½ x 5½ ins.

CLYDESDALE'S PRICE ONLY **25/-** each. CARRIAGE PAID

BRAND NEW.

### PARMEKO TWIN P.A. LOUDSPEAKER

Plastic moulded twin horns, with fitted line transformer.

CLYDESDALE'S PRICE ONLY **£3/15/0** each. CARRIAGE PAID

BRAND NEW, in maker's cartons.

### 38 A.F.V. XMTR/RECEIVER UNIT with Power and L.F. Amp. Unit

Frequency 7.3-9 mcs. 6 valves, 3/VP23's, 2/V248A's, SW75 (pen), metal rectifiers, Vibrapak, for 12 volts in two units. Xmtr/Rcvr size 10½ x 4 x 6 ins. Power Amp. 11½ x 4 x 6½ ins., plus spares, aerial and Instruction Book (less junction cable).

CLYDESDALE'S PRICE ONLY **79/6** per set. CARRIAGE PAID

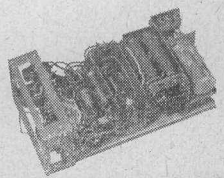
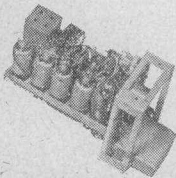

Don't miss this exceptional bargain

All metal Tubular construction lightweight rigid.



Aerial 9 ft. 3 ins.  
 Receptor 9 ft. 7 ins.  
 Crossarm 4 ft. 11½ ins.  
 for approx 50 mcs. mts to mast or bracket with 39 ft. of 80 ohm co-axial cable.

CLYDESDALE'S PRICE ONLY **21/-** CARRIAGE PAID  
 or packed in a wood case 28/6d.

BRAND NEW.

**A.C. TO D.C. RECTIFIER UNIT**

A well constructed unit, made by S.T.C. Input 200-250 volts, A.C. Output 220 volts, D.C. at 1.5 amps unsmoothed, in metal case 22½ x 15½ x 11 ins.

CLYDESDALE'S PRICE ONLY **£8/10/0** CARRIAGE PAID each.

Cat. No. E525. Single section variable capacitor, max. cap. 350 pf. ceramic insulation, (Cylidon type) at 1/11d. each. Post paid.

Cat. No. E526. "Clydon" single section variable capacitor, max. cap 600 pf. ceramic insulation at 3/11d. each. Post paid.

Brand New

METAL RECTIFIERS

Cat. No.	Type.	V.A.C.	V.D.C.	D.C.ma.	Size ins.	Price
E274.	F.W.	170	200	90	4½ x 1½ D.	5/3d.
E275.	H.W.	130	125	25	3½ x ¾ D.	3/3d.
E277.	H.W.	150	150	30	4 x ¾ D.	3/9d.
E281.	F.W.	12	4	100	1½ x ¾ D.	3/6d.
E285.	F.W.	20	12	750	2½ x 2 x 6½	5/-
E287.	H.W.	36	WX6	0.25	Westcor.	1/-

NEON LAMPS.

P.O. type neon lamp, unmounted 7 mm. dia. x 1 in. 110V. striking at 55V. requires limiter resistance wire end, at 2/9d. each. Post paid.

E269. Neon lamp, S.B.C. fitting, 110V. striking at 55V. length 1½ ins., at 2/6d. each. Post paid.

E270. Tubular neon lamp, end contacts, striking at 130V. requires limiter resistance length 8½ in. dia. ½ in. at 3/6d. each. Post paid.

Silicon Crystal Diode.

CV 102, plug-in type at 5/- each. Post paid.

5-way Cable, screened and covered, at 1/3d. per yard. Minimum quantity 12 yards, 12/- . Post paid.

6-way Cable, screened and covered, at 1/6d. per yard. Minimum quantity 12 yards, 15/- . Post paid.

Co-axial Cable.

Coil (12 yds.) first class co-axial cable. approx. 80 ohms. 12 mm. at 7/6d. per coil. Post paid.

Any length top grade co-axial cable 52 ohms 12 mm. at 6d. per yard. Minimum length 20 yards, 10/- . Post paid.

Insulated Sleeving.

1mm. 1/- doz. 2mm. 2/- doz. 3mm. 2/6d. doz. 4mm. 3/- doz. 5, 6, 7, 8, 10, 12mm. 3/6d. doz. assorted colours, 1, 2, 3, 4 mm., mainly black 6, 7, 8 mm. transparent 10, 12 mm. Special offer. Dozen assorted sizes for 1/9d. post paid.

BRAND NEW, in maker's carton.

**UNIVERSAL ELECTRIC MOTOR**

For 200-250 volts. AC or DC mains by simply wiring, data supplied. Very useful for light bench work, develops better than 1/10h.p. speed in excess of 2,500r.p.m. a lin. spindle is available for driving when the fan is removed. Motor Generator, type 29. In. 24V. 16a. Out. 1,200V. 200ma. Size 11 x 5½ x 5½ ins.

CLYDESDALE'S PRICE ONLY **25/-** each. CARRIAGE PAID



BRAND NEW. Ex. R.A.F.

**MORSE PRACTICE SET**

Key and Buzzer, with Headphones, battery and Service Signalling Manual.

CLYDESDALE'S PRICE ONLY

**15/11** complete POST PAID

Send now for Illustrated Lists. Please print Name and Address

**CLYDESDALE SUPPLY CO LTD** • 2 BRIDGE STREET GLASGOW - C.5

'Phone : SOUTH 2706/9

VISIT OUR BRANCHES IN ENGLAND, SCOTLAND AND NORTHERN IRELAND

# Inexpensive Television

By G2ATV & G3AYA

## Part 4

Fig. 1 shows the network associated with the 5CP1 Cathode Ray Tube. All resistors may be of the half watt, variety, and standard potentiometers are used for VR1-VR4. Potentiometers VR3 and VR4 are at rather a high potential, and therefore the necessary steps for insulating the cases and spindles from chassis should be taken. Preferably, they should be mounted on a strip of material, say paxolin or bakelite, which can then be mounted on the front panel by stand-off insulators. Insulated extension rods may then be used on the spindles, which will protrude through the front panel. VR1 is the BRILLIANCE control, VR2 is FOCUS and VR3, VR4 are the vertical and horizontal shift controls.

The number referred to on the circuit diagram, at the exits of the tube electrodes, refer to the base, pins 12, 13, 6 and 4 being blank. If a

separate heater supply of 6.3v is available for the cathode ray tube, it has been found preferable to connect Pin 2 (cathode) to either pins 1 or 14. This heater supply must be isolated from the negative rails (chassis) if this connection is to be made. If the spot has a ripple on it when testing, try connecting Pin 2 to the other heater pin. However, if a heater winding is used that will have either the centre tap or one side earthed, this connection between heater and cathode should not be made. The grid connection Pin 3 goes direct to the cathode of the 6J5 phase splitter, this cathode being at a positive potential somewhat above the negative rail. If the cathode of the CRT was taken to the negative line, damage would result, therefore R1 is included as a safety measure. When the slide on VR1 is at the R1 end of its track, there will be a negative potential

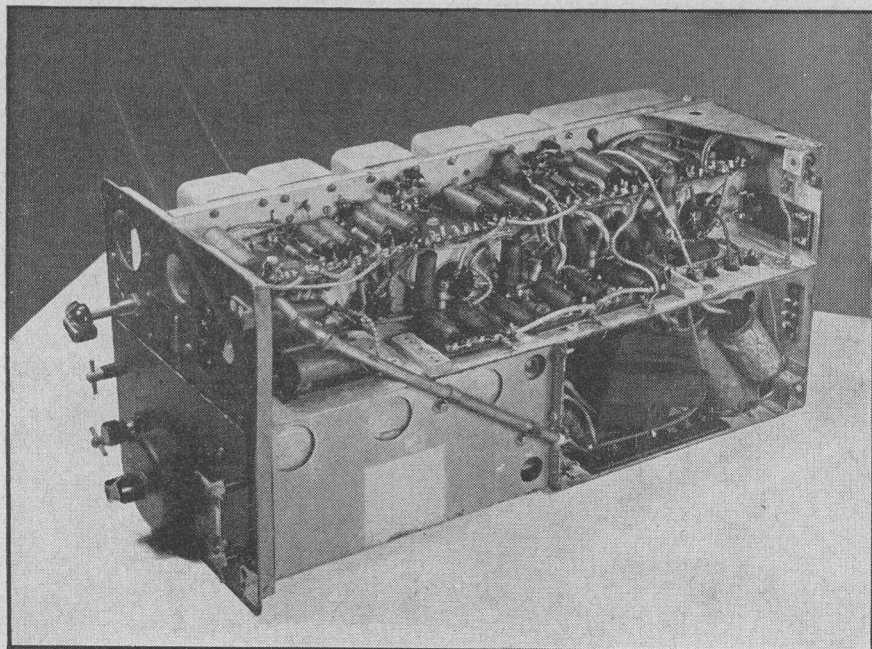

Fig. 1



at this point, with respect to the negative line. It can therefore be seen that these two potentials are arranged to be approximately equal, but of opposite polarity to each other, therefore they cancel out giving the effect of the cathode ray tube grid, reaching zero volts, with respect to its cathode. The vertical and horizontal deflector plates are brought out to pins 10 and 11, and 7 and 8 respectively, and the connections for correct operation are as follows: Pins 7 (CRT) via high voltage coupling capacitor to pin 5 on LINE AMPLIFIER (6SN7) valve-holder. Pin 8 (CRT) via H.V. capacitor to pin 2 LINE AMPLIFIER valve-holder. Pin 10 (CRT) via HV capacitor to pin 5 FRAME AMPLIFIER. Pin 11 (CRT) via H.V. capacitor to pin 2. FRAME AMPLIFIER. Just one word with reference to these amplifiers; the input from their respective time bases is on pin 4 (grid) in each case. R12-R15 are decoupling resistors of 1 MΩ each, half watt size being ample. R1-R7 are also half watt. In the case of R8-R11 the one watt variety are preferred due to the extra length between ends, thus reducing the possibility of "flash over." One the side of the CRT envelope, a connection will be seen and is referred to in Fig. 2 as "SC." This is the INTENSIFIER connection, and it goes to the final EHT voltage (4,000). The correct method of mounting is such that this connection (SC) is directly above, and may be viewed from the top.

**The Vision Receiver.**

The vision receiver consists of the R1355 in conjunction with the RF25 unit. It will be found necessary to fit a power unit for HT and LT supplies, and by removing the existing 80v 2,000 cps power supply sufficient space will be available for fitting a 250v 50 cps power supply. The mains transformer should be rated at 250-0-250v 80mA HT and 6.3v-6A 5v-2A. The LT consumption is rather heavy, as each SP61 (VR65) consumes 0.6A heater current. An economy may be effected by removal of either one or more of the IF stages, depending upon the distance of the receiver from the transmitter.

The vision receiver consists of the detachable RF unit (which comprises the RF, mixer, and oscillator sections), five IF stages, diode detector, video frequency amplifier, cathode follower, and the power supply. Several modifications to the R1355 are necessary before this unit will operate correctly. Removal of the existing 80v power pack is quite a simple job compared with the fitting of the 250v 50 cps supply. The LT line can be traced quite easily, as the wiring is carried out in blue sleeving in both the RF and IF units. (one side is earthed). The HT line is traced by the red and white sleeving. The last SP61 valve at the end of the IF strip (rear of chassis) is the cathode follower, and removal of this valve is optional. The screen grid of this valve (pin 4) goes to HT+ line via a 100Ω resistor, so if you connect the output from the power supply to the far side of this resistor you will have your R1355 HT line correct. Power supply connections to

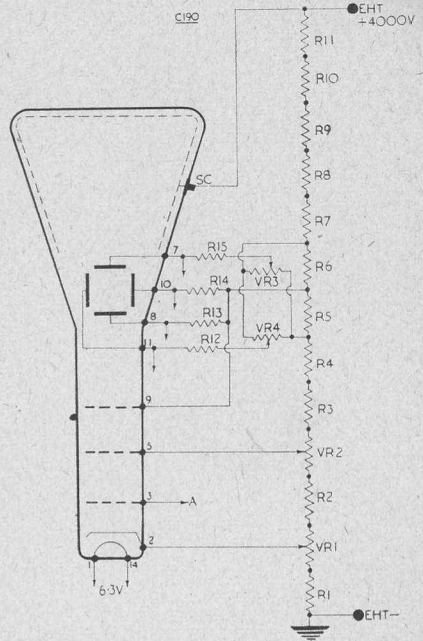

Fig. 2

**COMPONENT VALUES FOR 5CP1 NETWORK.**

R1, 20K Ω	R8, 470K Ω	R15 1M Ω
R2, 220K Ω	R9, 470K Ω	VR1, 500K Ω
R3, 220K Ω	R10, 470K Ω	VR2 500K Ω
R4, 220K Ω	R11, 470K Ω	VR3, 1M Ω
R5, 220K Ω	R12, 1M Ω	VR4, 1M Ω
R6, 220K Ω	R13, 1M Ω	
R7, 220K Ω	R14, 1M Ω	

the RF 25 unit are shown in Fig. 4. Fitting of a gain or contrast control is the next modification, this being quite a simple job. A 5 kΩ potentiometer is mounted on the front panel, one end of the track going to pin 3 on the W plug, and the slider being connected to chassis—the pins on the plug are numbered.

The third modification is the removal and bridging of the .005 μF coupling capacitor in the VF stage grid circuit, or alternatively it can be short-circuited. The last IFT, situated at the rear of the R1355 chassis, contains the diode circuit, and also this .005 μF capacitor. It is mounted on a paxolin strip, and as it is the only tubular capacitor in this IFT box, it should easily be recognised. The switch marked Z-X-Y-N may be removed, as it has no use at all for television, and was used only for radar purposes. It interferes in no way with the circuit, and if removal is not contemplated, it should be switched to position N and left alone. The output from the vision receiver terminates

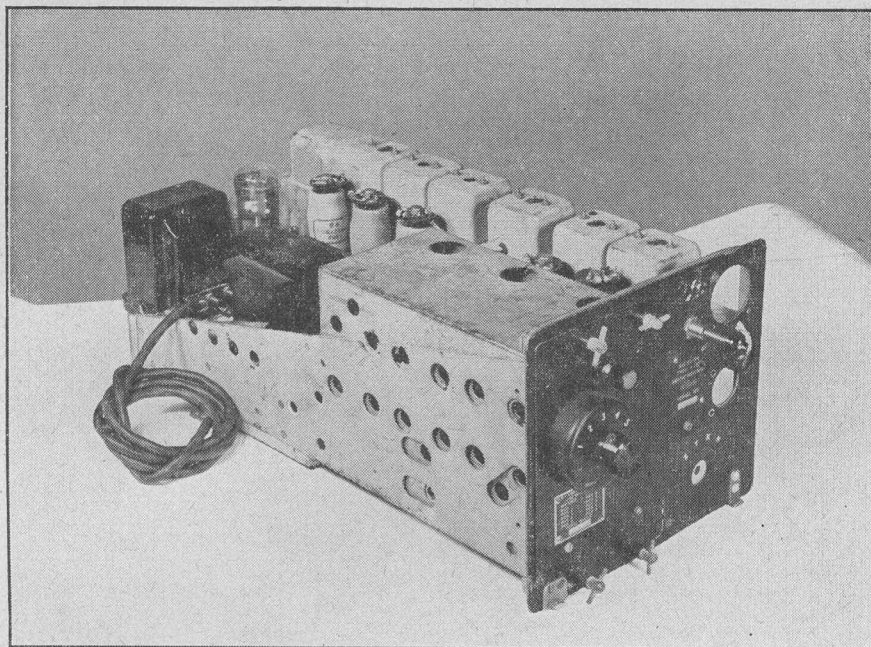

Fig. 3

at the pye plug on the front of the R1355 unit, and in our case was removed and fitted at the rear of the chassis, from there a co-ax lead being taken to the time base unit input. The RF unit should be switched to position 2, and the appropriate trimmers bearing this number on the side of the unit should be tuned towards resonance in this order; Oscillator, Mixer, and RF. The Oscillator section is situated at the rear, and the RF section at the front of the unit, and the respective trimmers are contained in each section for all five positions. This operation cannot be carried out properly until the whole equipment is ready, as the television picture itself is the only indication of correct alignment. In the photographs accompanying this article of the vision receiver, it will be noticed that the last valve on the IF strip has been removed. This is the cathode follower output stage, and for our purpose there is no advantage in retaining it, unless there is to be a considerable length of coaxial cable between this chassis and the time base unit.

This now means that the video frequency amplifier is the last valve on the strip, and it was to this stage that we made the final modification, at least final to the date of writing this article. It should be clearly understood that we make no claim that this television cannot be in any way improved, and we are in fact constantly experimenting with a view to improving results. It is claimed, though, that at this stage results are sufficiently good to enable the viewer to obtain, not merely pictures, but really good entertainment. Other readers will, no doubt, try out ideas that have not occurred to us, and we therefore invite them to pass on their experiences to us, so that we may, in turn, pass them on to other readers through the medium of these pages.

To get back to our modifications. It was found that the video amplifier stage would not handle, without overloading, a signal sufficiently large to enable the cathode ray tube to be fully modulated. This problem was solved quite easily, by simply replacing the bias resistor—which varies around 200  $\Omega$  in the models that we have seen—by one of 68  $\Omega$ . This value need not be strictly adhered to, any value between this and 100  $\Omega$  will be found to be satisfactory. The cathode resistor is paralleled by a 0.005  $\mu\text{F}$  capacitor in the original model, the purpose of which is to reduce the amount of feedback on the higher frequencies. We found that replacing this capacitor by one of 0.1  $\mu\text{F}$  gave a much more

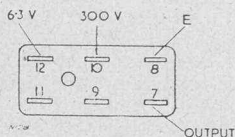
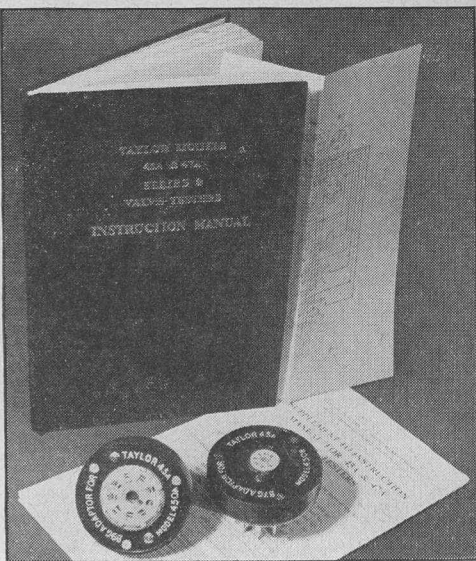

Fig. 4

# TRADE NOTES



**Taylor Electrical Instruments Ltd., Valve Supplement.** The Valve Supplement at present being printed is an eight-page booklet tabulating some 158 types of valves with their respective switch settings. This supplement should be used with the comprehensive Instruction Manual supplied with each Valve Tester.

In the preparation of the publication careful consideration of both the technical and non-technical reader has been given. The written material is reinforced by carefully prepared illustrations.

The contents of the Instruction Manual are divided into three sections. The first deals in a general way with a description of the instrument, the second deals with the controls and operation and the third contains a Valve Chart giving some 2,000 types of valves with their respective switch settings.

This Valve Chart is kept up to date from time to time as new valves are manufactured and as in the Valve Supplement mentioned above.

The Instruction Manual is beautifully printed on special super calendered paper with a good stiff cover, the book comprises 87 pages measuring 8½ ins. long and 5½ ins. wide—this book can be bought separately, and is priced at 3/6d.

**Valve Adaptors.** The following adaptors are available so that tests can be carried out on valves,

for which suitable sockets are not provided on the Valve Tester pads.

Model 450A B9G Base

(For Series 1 Valve Testers only).

Model 450B B7G (M7) Base

(For Series 1 Valve Testers only).

Model 450C B8A Base

(For Series 1 and 2 Valve Testers).

Model 450D B7G (M7) Base

(For Series 1 and 2 Valve Testers).

Model 450E Telefunken Base

(For Series 1 and 2 Valve Testers).

Model 450F SC5 Base

(For Series 1 and 2 Valve Testers).

Model 450/BLANK

Blank Adaptor.

These adaptors are designed to fit into the 9 pin British Valve Base (Br.9).

*(INEXPENSIVE TELEVISION—  
continued from page 448)*

brilliant and contrasty picture, but suggest that the individual constructor may like to experiment with this value to suit his own requirements in this respect. For reception of television sound some may contemplate using another R1355 or R1426, and as we have tried this also, we can recommend it as an ideal alternative to the RF unit plus normal all-wave receiver. Fitting of a power pack, output stage, and gain control are of course necessary. The cathode follower is replaced by an output valve (6V6 or similar) and sufficient drive will then be obtained to fully load a 10 in. loud speaker. The gain control can be on the IF stages as fitted in the vision receiver.

**OUR NEXT ISSUE . . . .**

. . . . will contain another instalment of Inexpensive Television. Also a Multi Purpose Meter, by W. Oliver, G3XT, as a further article in our "surplus" gear features. Other items will be a QRP phone transmitter by G. Pennington, a Short Wave Battery Superhet by P. Lumb, Trouble Shooting by W. Frerk, Radio Miscellany by the one and only Centre Tap and other interesting contents.



# Local Station Receiver

## A quality receiver devised by

LEN MILLER

**T**HERE are no doubt many home-constructors who, in their enthusiasm to obtain quality for local station and gramophone reception, have built 'super' output amplifiers capable of shaking the very foundations of their homes when turned full up, yet to their disappointment have to admit that, at normal 'quiet listening' volume, it sounds no better than the average commercially-made domestic receiver.

Many constructional articles on 'quality' amplifiers have appeared in print during the past decade, and this article is not just another case of 'fools rushing in.'

I have listened very carefully and critically to well-designed 30 and 60 watt amplifiers (807's and negative feedback and what-have-you) and really wondered if it is worth it. Expensive chokes and transformers and high-voltage smoothing capacitors do not grow on trees.

Fully realising that I was about to tread on dangerous ground (for who am I to argue with the Experts)? I set out to design my own local station quality receiver.

My requirements were simple and straightforward. Good quality at normal room volume, absolute reliability over a long period of time, i.e., the elimination of possible premature capacitor and valve failures, and a receiver that could be tuned by the completely non-technical member(s) of the family. The latter requirement being best accomplished by pre-set tuning, switch controlled, this was incorporated in the finished receiver.

To obtain a really trouble-free power pack, I used a 300-0-300 volt transformer and a comparatively small reservoir capacitor of  $2\mu\text{F}$ ., two filter chokes and two  $8\mu\text{F}$ . smoothing capacitors. All of these were 600 volt working and *paper* dielectric. These paper types are comparatively cheap these days and should prove to be very much more trouble-free than their electrolytic counterpart, as far as possible breakdown is concerned.

The no-load or surge voltage is therefore in the region of 425 volts which is of course safely handled by the 600 volt working capacitors.

However, being a true conservative (morally and not necessarily politically), I decided in the interests of reliability not to tolerate a surge voltage of 425, so I used a field energised speaker of  $5,000\ \Omega$  which I connected in parallel with the D.C. output after the first stage of smoothing, as shown in Fig. 1. This single stage of smoothing is ample to eliminate any possibility of objectional hum from the field winding and of course it meant that a surge voltage just doesn't exist, as the 40 or so mA flowing through the field winding keeps the output voltage well down while the receiver valves are heating up.

The 'no-load' voltage now turned out to be 250, dropping to a steady 220 when the receiver valves drew current, a change of only 30 volts with a load varying from 40 mA to 120 mA. This I considered to be very satisfactory, and is no doubt due to the small value of reservoir capacitor—almost choke input. It was originally

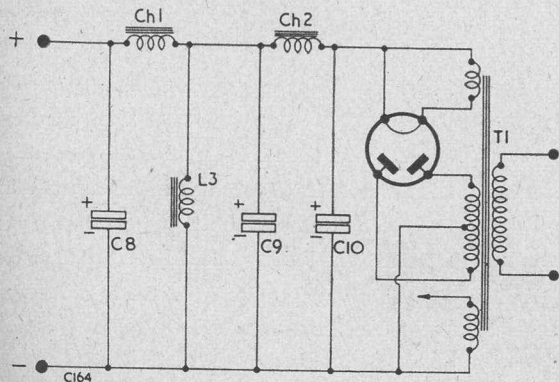
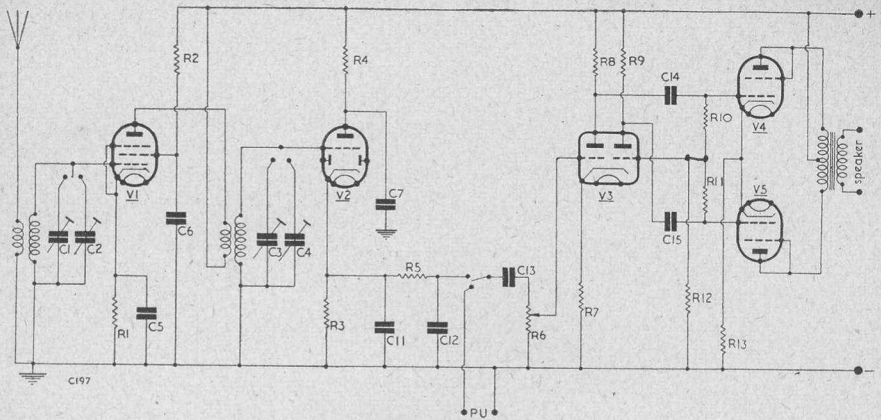

Fig. 1. The Power pack. If a PM speaker is used L3 can be substituted for a 5,000 10 watt resistor.

Component values are:—  
C8  $8.0\mu\text{F}$ . C9  $8.0\mu\text{F}$ .  
C10  $2.0\mu\text{F}$ . Ch.1 10H  
200-300  $\Omega$  smoothing choke.  
Ch.2 10H. 200-300  $\Omega$  smoothing choke. L3 Speaker Field.  
T1 300-0-300V. 150mA, 6.3V and 5V.



COMPONENT VALUES.

Capacitors:

- C1, C3: 120 $\mu$ F trimmers.
- C2, C4: 300 $\mu$ F trimmers.
- C5, 0.1 $\mu$ F.
- C6, 0.1 $\mu$ F.
- C7, 8.0 $\mu$ F (paper).
- C11, 100 $\mu$ F.
- C12, 100 $\mu$ F.
- C13, 0.1 $\mu$ F.
- C14, 0.1 $\mu$ F.
- C15, 0.1 $\mu$ F.

N.B.—The 120 $\mu$ F trimmers peak Light programme and the 300 $\mu$ F trimmers peak Home programme.

Resistors.

- R1, 200  $\Omega$
- R2, 100,000  $\Omega$
- R3, 100,000  $\Omega$
- R4, 20,000  $\Omega$
- R5, 10,000  $\Omega$
- R6, 1M  $\Omega$
- R7, 3,000  $\Omega$

- R8, 50,000  $\Omega$
  - R9, 50,000  $\Omega$
  - R10, 300,000  $\Omega$
  - R11, 300,000  $\Omega$
  - R12, 100,000  $\Omega$
  - R13, 250  $\Omega$
- Valves.
- V1, 6K7.
  - V2, 6Q7.
  - V3, 6N7.
  - V4, V5, 6L6.

Junction of R10-R11 should be shown joined across to grid of 6N7 (top of R12) and not blank as shown in circuit diagram.

intended to use true choke input (no reservoir) but the available voltage was then slightly too low for my purpose.

The next problem was the choice of output valves, I decided on two 6L6's triode connected (anode and screen of each valve strapped).

According to my Handbook, a single 6L6 used as a triode consumes 40 mA at 250 volts on the anode when the grid is biased 20 volts, and gives a power output of 1.3 watts. Heaven alone knows what percentage of total harmonic distortion is presumed to be present when the full 1.3 watts is reached. Handbooks do not seem to bother about mentioning this small detail, but I assume their figures are based on a maximum of 5% total, so let us leave it at that.

But these characteristics rather appealed to me. I have always previously used pentodes and decided to try triodes for a change. A 2A3 requires a grid drive of 45 volts to obtain its maximum output of 3.5 watts at 250 volts on the anode, and I figured that if I used two 6L6 triodes in push pull I would still only need 40 volts grid-to-grid drive to get somewhere near the same output as a single 2A3. True, two 6L6 triodes only give an output of  $2 \times 1.3 = 2.6$  watts which is at least in theory still a lot less

than 3.5 watts, but as we all know that in practice two valves in push-pull class A we get more than double the output of a single valve. Perhaps the reason for this has something to do with core saturation and the output transformer, but we will leave that for the experts to explain, and continue.

It meant that a single triode pre-amplifier with a reasonable gain would give me all the noise I required when fed from the output of a crystal pickup, and I definitely do not like a two-stage pre-amplifier on account of hum trouble (and the elimination of same).

As you will see on inspecting Fig. 2, I used a 6N7, the first section as the pre-amp., and the second section as a self-balancing phase splitter. This worked fine; hum level low and no complaint re quality.

Now, the trouble was that my available D.C. supply was only 220 volts. Take off 20 volts for bias, and another 10 for output transformer drop, and I am working my 6L6's with 190 volts on the anode.

With some misgivings I connected up and switched on. My previous receiver used a single 6F6 with 315 volts on the anode (this is the maximum voltage allowed according to the Handbook), but (once again quoting the Hand-

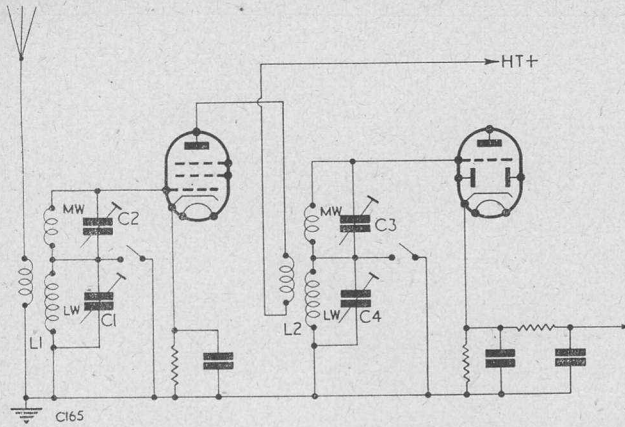

Fig. 3. Suggested alternative tuning arrangement for listeners in the Midlands, where the long wave Light Programme is better received.

L1 and L2 are dual range coils. C1, 2, 3 and 4 are 300 $\mu$ F trimmers.

book) I got 5 watts of presumably undistorted output. This same previous receiver used to over-load before my 12" Rola did. That 6F6 used to get hot.

Reverting to my new receiver—it has now warmed up and ready to play. On records it sounded very good—the undistorted output was very much greater than that obtained with the single 6F6 receiver. I switched over to radio, and tuned in the locals on the appropriate presets. The quality was (to me) astounding. Due to the very poor selectivity of the RF stage, top note response is good (greatly superior to that of a standard super-het) and the infinite impedance detector is obviously a great improvement over the diode from the point of view of quality.

With the available 190 volts on the anodes of the 6L6's (actually in practice it is nearly 200 volts, as the bias developed across the cathode resistor is now nearer 17 than 20) each valve is consuming only about 35 mA and run quite cool. The emission should last a long time under these conditions.

Perhaps you will agree with me that one of the best tests of a radio receiver is to listen to the reproduction from a distance when it is working rather on the loud side. If it sounds like the OW beating the carpets, the quality is not all that should be desired. This receiver is now reproducing the 10 o'clock news in the 'downstairs back' at just slightly above normal room volume (about as loud as your next door neighbour plays his radio on a summer's evening) and I can hear every word clear and crisp in my den in the 'upstairs front box-room'.

According to the Handbook, the output of my amplifier is little if any more than 2 watts, but according to my own ears (and I have been a professional musician for 22 years) what "watts" those 2 watts are! (If you don't believe it and you reside anywhere near Southgate, N. London, come and hear it for yourself. Contact me through the Editor!)

BOOK REVIEW

**Eye of Britain.** Published by the British Broadcasting Corporation, 32 pp and cover, price 2/-.

"Television, the miracle, is in Britain, now, a daily entertainment. Like heavier-than-air flight, or penicillin, or atomic energy, it has become an accepted feature of post-war living." These opening words point to the mood of this interesting booklet. It tells the story of the "miracle's" progress and what it has to offer. It comments on freak reception and hints that one day, maybe, we will have international television. It unfolds the story of the behind-the-scenes activities which go into a television production and tells us what makes television "tick." The OB boys get their due mention also.

The main object of this publication, however, is to commemorate the part played by the B.B.C. Television Service in the XIVth Olympiad. Norman Collins, the Television Controller, tells me that every Olympic competitor from overseas has been sent a copy of the booklet. Some unusual action pictures of the Games are only a few of the many fine photographs in this lavishly illustrated publication. The last page is in the form of a postscript by the Controller and he sums up the booklet and reassures prospective viewers that the existing 405-line system will be retained for some considerable time.

One of our contributors (who, for security reasons, shall be nameless) considers that "two bob is a bit steep." Your reviewer, however, hastens to assure viewers that in his considered opinion "Eye of Britain" can be highly recommended as an enlightening souvenir booklet. Something to read and enjoy now—something to look back on in years to come. And—something to show those who are undecided if television is really "worth while."

W.N.S.



# Improving Selectivity

Some notes on an important topic

By

C. L. CRANE

**I**N spite of the many advances in radio receiver and component design that have taken place in recent years, the steadily increasing crowding of the radio frequency spectrum is generally considered to deny you many of the pleasures of listening, unless you build or buy a very elaborate communications receiver.

The main requirements of a good radio receiver are summed under three S's—Stability, Sensitivity and Selectivity. Careful attention to design and construction can give a very fair answer to the first two in a small receiver. It is proposed to deal here with the factors that influence selectivity in the amateur's four or five-valve receiver. In order to discriminate between signals on adjacent frequencies on short waves, especially on the amateur bands, a high order of selectivity is required.

The frequency response of a typical parallel tuned circuit is shown in Fig. 1. It can be seen how the voltage gain at the resonant frequency is higher than at any other, but a strong signal at 29 Mcs or 31 Mcs could easily swamp a weak one at 30 Mcs. For satisfactory reception of speech it should be possible to have so little relative gain at 29.995 Mcs or 31.005 Mcs, that signals at these frequencies cannot be heard. For telegraphy, a complete cut off at  $\pm 100$  cps might be an aim. The curves become sharper and narrower if more than one tuned circuit is used, but without regeneration the straight

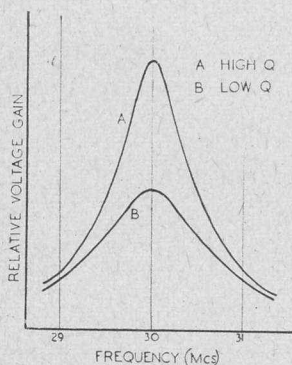

Fig. 1. Response curve of a typical parallel tune circuit.

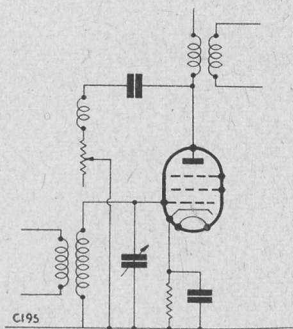

Fig. 2.

receiver is not satisfactory at such frequencies. Regeneration is achieved by a circuit such as that of Fig. 2, and the result of the coupling from anode to grid of the valve is effectively to increase the Q of the tuned circuit. When Q becomes infinite the circuit oscillates and this must be avoided for normal reception. The main disadvantage of this circuit in a straight receiver is the difficulty in maintaining the necessary large amount of regeneration with ease and stability over a wide tuning range.

Many amateurs use a superhet circuit with one stage having an intermediate frequency of 465 kcs. One or two signal frequency tuned circuits are not adequate to reject second channel interference from a strong carrier on short waves.

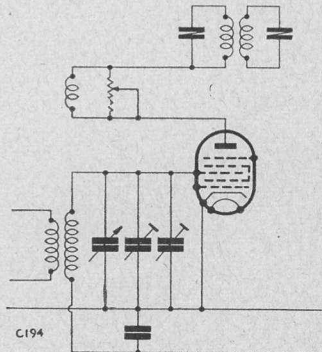

Fig. 3.

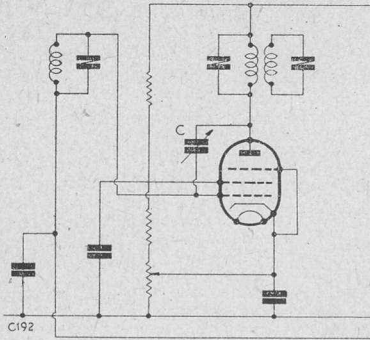

Fig. 4(a)

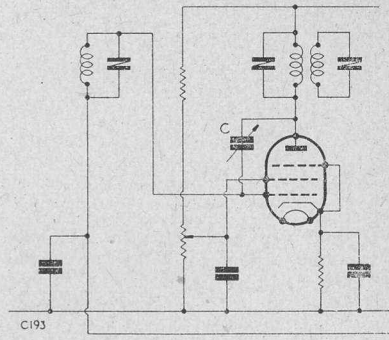

Fig. 4(b)

The circuit of Fig. 3. shows a method of overcoming this difficulty in such a circuit by a third winding on the signal frequency coil of the frequency changer. If the added coil has, say, one-third to one-sixth of the number of turns of the tuned coil and R is a volume control of about 10,000  $\Omega$  coupling should be arranged so that the valve oscillates when about three-quarters of R is in circuit. If the valve will not break into oscillation and the coupling coil is correctly polarised, more turns must be added. In the circuit C<sub>1</sub> is the tuning capacitor ganged to the oscillator tuning. C<sub>2</sub> is an air spaced trimmer or perhaps 30 $\mu$ F maximum capacitance in parallel with C<sub>1</sub> in addition to the normal trimmer C<sub>3</sub>. C<sub>2</sub> and R must be controlled from the front panel of the receiver.

It will be found that a change in the value of R causes a change in the tuning of the input circuit. For normal reception R must be tuned to the position of zero resistance and C<sub>2</sub> to the position of minimum capacitance. Ordinary trimming must be carried out with the controls in these positions. When it is required to free a signal from second channel interference or interference on any but an adjacent channel, R must be increased until the desired effect is obtained.

Retuning should then be accomplished by increasing C<sub>2</sub>. In this way one frequency changer stage can give results equal to the first few stages of a double superhet. Incidentally, a small fixed amount of regeneration in the frequency changer often effects a great improvement in a small broadcast receiver.

One or two 465 kcs intermediate frequency stages do not give a discrimination between adjacent signals sufficiently sharp for amateur band listening. Sharper selectivity could be obtained with a lower IF but here the "second channel" bogey comes in again.

Design points for high selectivity are :-

1. High Q IF transformers.
2. Low IF transformer coupling.
3. High impedance frequency changer and IF valves.
4. High diode load resistance, say one or two Meg  $\Omega$  or better still a lower anode bend detector which imposes no load on the tuned circuit.

Regeneration in the IF amplifier will narrow the response curve still further and this can be increased until a speech signal is just intelligible, giving maximum rejection on adjacent channels. For CW reception the received band can be still further reduced. Suitable circuits for IF amplifier stages using a variable-mu valve are shown in Fig. 4. C is a small additional capacitance between anode and grid and can be easily obtained by running a short length of wire from the grid circuit near the anode lead. This should be adjusted so that when the cathode voltage is low or the screen voltage high, the valve begins to oscillate. The value of R is chosen in (a) to give a cathode voltage up to about 25 and in (b) to give a screen voltage up to about 100, and variation of R causing variation of valve gain allows adjustment of selectivity at will. Reducing the gain of the valve to achieve larger band-width need not be feared, however, as only about 5 dB reduction is required to give a wide audio frequency response. One of the circuits shown in

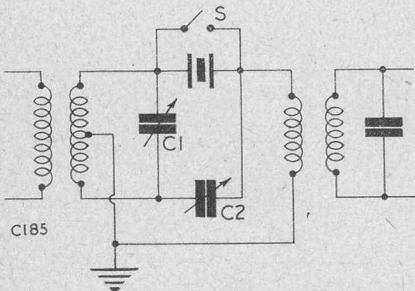

Fig. 5.

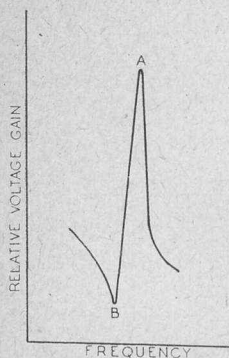

Fig. 6.  
Response curve of an  
IF amplifier with  
crystal filter.

Figs. 2 or 3 could also be used giving no decrease in gain but control is less smooth.

A good crystal filter is an advantage in any amateur receiver, but the careful design is required to avoid a serious loss of gain. Fig. 5 gives a useful circuit in which the selectivity obtainable may be varied somewhat by altering the value of  $C_1$  from the resonant position. Closing the switch  $S$  makes the circuit perform like a normal wideband IF filter.  $C_2$  is the crystal phasing capacitor which may be a  $15 \mu\mu F$  variable. This capacitor can be adjusted to reject a nearby signal which appears at  $B$  in Fig. 6, when the desired signal is at  $A$ . The position of  $B$  may be changed over a small range.

Increasing IF selectivity to any useful extent means severe frequency distortion, and if the receiver is required for broadcast reception, a wide range of selectivity control is needed. For CW reception the crystal filter is superior to regeneration, but the methods outlined above can give results on speech reception as good as any crystal arrangement.

#### AC/DC VALVES.

Messrs. The Edison Swan Electric Company Ltd. have sent along a copy of their folder dealing with Mazda valves in the AC/DC range which we feel will be of interest to many readers. The folder gives details of base connections and figures of ratings and typical operating values. Copies are now available on application to 155, Charing Cross Road, London, W.C.2.

#### WORLD RADIO HANDBOOK FOR LISTENERS

##### Important Notice to Broadcast Station Listeners

We are pleased to announce that we are now in a position to supply copies of the above-named publication to readers. It will be remembered that this publication was reviewed in our September issue.

Published and edited by O. Lund Johansen of Copenhagen, this book is published in several languages, including English, two or three times each year. It is an invaluable reference book for those interested in short wave broadcasting. It

gives, in alphabetical sections, details of every station of note, with frequencies, call-signs, power, schedules, interval signals, details of station personalities and a host of other interesting and useful material. It also lists medium and long wave stations. From the identifications angle, the Handbook deals with the type of programme radiated, the musical score of identification chimes, etc., and other hints of great interest in tracking down stations. Another very useful item is the inclusion of data on whether each station verifies reports and, if so, what form the QSL takes.

As we have already said, in the review referred to, this book is most beautifully produced on "heavy duty" paper with an attractive card cover and is well illustrated with pictorial maps. It would grace the most exclusive listener's shack!

Every keen SWL must get a copy of this Handbook—now! Address your orders to "World Radio Handbook," 57 Maida Vale, London, W.9. The price of the Handbook is 6/6—and it is worth every penny!

(NB: If you have any friends who may be interested send along their names and addresses and we will forward them illustrated brochure and order forms.)

#### BRIEF SPECIFICATION OF THE WINDSOR\* MODEL 35A

##### A NEW RADIO FREQUENCY MEASURING INSTRUMENT.

This is a mains operated instrument for frequency measurements in all amateur bands up to 60 Mcs. with an accuracy of better than  $\pm 0.1\%$ .

The equipment comprises, a stable variable frequency oscillator calibrated from 1.7 to 2.0 Mcs. a 100 Kcs. crystal controlled oscillator, a detector valve to enable beats to be heard in headphones, and power supply.

The variable frequency oscillator is inherently stable and has ceramic insulation throughout. Its calibration can be checked against harmonics of the crystal oscillator and small corrections made by a panel trimmer. A set of tuned circuits is provided, each pre-tuned to the centre of an amateur band, so that by selecting any one, the harmonics over that band are greatly intensified. On the 10 and 6 metre bands, where several harmonics can be heard, a simple chart enables positive and instantaneous harmonic identification without calculations.

The instrument may be used:—

1. To measure transmitter frequency.
2. To calibrate receivers over the amateur bands.
3. To monitor transmissions.
4. To measure frequency drift of transmitters and receivers.

Dimension of instrument is 12in. x 8in. x 6in.  
Mains consumption approximately 8 watts.

\*Taylor Electrical Instruments, Ltd.



# DISCS versus THE REST

## (IS DISC RECORDING OBSOLETE?)

By K. KEMSEY-BOURNE

Recording men and other sound enthusiasts are frequently asked "Hasn't the disc recording system become obsolete, and won't it soon be replaced by the other methods of recording, on film, tape and wire, that are being developed?"

The answer to both these interesting questions is "No—decidedly not." The disc system is not obsolete—the contrary it is developing continually—and although magnetic and optical methods will augment discs they will not altogether replace the disc system, either in the home or in broadcasting studios.

### The Disc System.

The more obvious advantages of the commercial 78 r.p.m. disc system we can summarise as follows:—

1. It is established and a large repertoire is available.
2. It is handled easily by non-expert operators. Whatever the demerits of automatic changers may be, these devices do not require technical skill to work them.
3. Continuous performance is possible (with two turntables) if necessary.
4. Any part of any disced recording is instantly available.
5. Storage is simple, and if reasonably treated the discs and their sound tracks do not deteriorate.

To these more or less domestic-scale considerations may be added the following, referring to both 78 and 33.3 r.p.m. recordings, for broadcasting purposes:—

1. Editing from discs is easy, i.e., selecting given passages in rapid succession from a number of recordings. This is useful for quick digests of speeches, commentaries, news reports, etc., or for illustrations in talks on music.
2. Copies of discs are easily made in small or large numbers. Each month the BBC uses 20,000 discs and sends recordings of many programmes to Colonial and foreign networks.

### Film, Tape and Wire.

What are the alternative systems? First are the film systems, meaning the Philips-Miller system which records mechanically and plays back optically, and the various systems as used in the cinema (variable-area or variable-density) which are both recorded and played back

optically. Secondly come the magnetic systems, on tape, wire or even disc.

### Philips-Miller Film System.

This uses a 7mm wide film finely coated with a gelatine layer of black mercuric sulphide instead of photographic emulsion. A V-shaped cutter is modulated by the audio programme signals and makes hill-and-dale cuts in the black gelatine of the moving film, leaving a variable-width, transparent, sound track which is reproduced by projecting a pencil of light through it on to a photocell. Unlike other sound-on-film systems no processing is needed, and the recording is playable directly after rewind. The film speed is 1 foot/second, and a 10 inch spool of film plays for 15 minutes. This system is expensive.

### Photographic Recording.

There are many different systems used for photographic recording for sound films, but the general principle is to focus a fine beam of light on to the moving, sensitised film and vary either the intensity of the light or the width of the narrow beam itself. In either case the overall variation results in a modulated track that is developed photographically. Since some processing is needed, immediate playback is impossible. Playback is by light-beam and photocell, as with Philips-Miller. At the 16mm sound-film speed of 7 inches/second it is possible to record up to 5,000 c.p.s. 35mm film moves at 18 inches/second and can be used up to 10,000 c.p.s. Mass copying is possible. A sound-on-film method was marketed before the war for domestic use, but there are difficulties of expense, film-drive, noise reduction devices, patent and copyright infringements, etc., in the mass production of any such recordings. It does not seem likely that sound-on-film will be used for purposes other than the cinema, where visual and sound tracks must go together.

### Magnetic Recording.

In magnetic systems the modulations are recorded by the variation of magnetic flux of a moving metal wire or tape, or of a plastic tape or disc in which fine magnetic particles have been dispersed. All magnetic systems have the great advantage that the recording may be erased and the wire, tape or disc can be re-recorded again and again, and the great disadvantage that there is no way of making a large number of copies easily or quickly. Magnetic recording is not new—

Poulsen discovered the possibilities fifty years ago—but credit for its development must go to Germany, where the Magnetophon evolved. The tape now used is 0.002 inches thick and  $\frac{1}{4}$  inch wide, made of cellulose acetate coated with fine ferric oxide. Wire systems use steel (0.5—0.9% carbon) or plated wire of 0.015 down to 0.004 inches diameter. With stainless steel wire moving at 24 inches/second recording up to 10,000 c.p.s. with a signal/noise ratio of 60db is possible. A portable speech recorder uses 10 inch plastic discs coated with ferric oxide; the disc plays for 3 minutes, can be re-used at least 1,000 times and can be simply sent through the post. No magnetic system needs processing, and there is no wear and tear on playback, which is by magnetic pickup, but the recordings are not always permanent.

#### Domestic uses.

As far as personal or domestic uses are concerned film and magnetic systems may be useful in that film, wire or tape lengths can be joined together to give long playing times, enough for complete symphonies, plays or operas, without any breaks and at good quality of reproduction. This sort of facility would be most advantageous if one had magnetic recording apparatus, so that a radio transmission could be recorded in one's absence to be played back later; the recording could be dubbed on to disc for permanence, and the tape erased for re-use. Two disadvantages of spool methods will be obvious to the reader:—

1. Rewinding is necessary before replaying is possible.
2. Editing, or picking out a passage, is difficult.

#### New Development on Discs.

We don't need to be crystal gazers to see that the shellac (or plastic) disc will hold its own for mass-produced short recordings, and that tape or film systems would be useful for long recordings but not necessarily cheap. Even at present, anyone with two playing discs can put on a truly continuous opera, symphony or other programme. In the last month American Columbia started to issue commercially discs playing up to 20 minutes on one side of a 12 inch vinylite record. This is done by cutting 250—300 grooves/inch at 33.3 r.p.m., instead of the normal 96 grooves/inch at 78 r.p.m. The micro-groove is 0.003 inches in diameter, and requires a playback stylus having a tip radius of 0.001 inches. Pickup pressure is  $\frac{1}{5}$  oz. weight on the disc. The discs vary in cost, but a top-rank 12 inch disc is to cost about 24/- (4.85 dollars) and this will carry a complete work that would normally take a 6—7 disc album.

#### EDITORIAL FOOTNOTE.

At present, fast becoming popular in the United States are microgroove gramophone records, marketed by the Columbia Company, an organisation that is world famous. No

announcements have been made in Great Britain so far, but when, and if, the time comes, the demand should be sensational. The high-lights of these recordings are that 12 inch records have an approximate playing time of 50 minutes. Immediately one will visualize a complete symphony, or to the 'lowbrow,' a jam session on one record. Compared with the normal record, which at present has a playing time of about 9 minutes, (both sides) the advantages will be obvious. One disadvantage, however, is that these records are recorded at  $33\frac{1}{2}$  r.p.m. which is half the speed of a normal recording, i.e., 78 r.p.m. Therefore, if your gramophone, or phonograph, has not provision for  $33\frac{1}{2}$  r.p.m. recordings, these new records will be useless to you, but a small matter like that certainly will not deter the enthusiast. The fidelity is as good, if not better, than that of ordinary recordings, according not only from the technical angle, but from the extensive listening tests also. It will naturally be realised that the number of grooves are considerably greater, more to the inch, and therefore the dividing wall or 'land' is also considerably finer. The stylus tip radius had to be reduced, and many other problems cropped up, and gave the designers and technicians many headaches. Low needle pressure and a different type stylus radius are essential for these recordings. Suitable stylus radius being .001 inch and pick-up pressure for correct tracking should be approximately  $\frac{1}{5}$  ounce, or less. Therefore with a light-weight pick-up, and the use of VINYLITE for the recordings, background noise and needle scratch are virtually non-existent.

## INEXPENSIVE TELEVISION

### New Booklet for Television Enthusiasts.

So sorry to bring up the subject of television again! The fact is, however, that it is difficult to keep the word out of our minds these days.

Since the start of the series of the above title, we have been shown time and time again that for large numbers of our readers it is a regular monthly routine to search high and low for their copy of the "Constructor." Some are lucky—others less fortunate. At present we cannot alleviate the situation for reasons too well-known to discuss here.

We can, however, detect that in recent months the Inexpensive Television series has been the cause of renewed and vigorous assaults on book-stalls. So popular has been the series that we have decided to commence work on a booklet which will comprise the complete details of the television set. This will be issued in our Data Booklet series and supplies will be available by Christmas.

The price of this indispensable booklet will be 1/6d. plus 2d. postage, and orders can now be accepted from readers. Send now and be sure of YOUR copy!

# SMALL ADVERTISEMENTS

Readers' small advertisements will be accepted at 3d. per word, minimum charge 3/-. Trade advertisements will be accepted at 6d. per word, minimum charge 6/-. If a Box Number is required, an additional charge of 1/6 will be made. Terms: Cash with order. All copy must be in hand by the 10th of the month for insertion in the following month's issue.

## TRADE

QSL's and G.P.O. Approved Log Books. Samples free.—Atkinson Bros., Printers, Elland.

COMPONENTS for all circuits in this Journal. Eddystone, Raymart, Wearite stockist. Send for lists. Smith, 98, West End Road, Morcombe. Order now '640' Rx £27/10/0, Westealt units £7/15/0, "P" Coils 3/-. etc. Quick Service.

AMERICA'S RADIO JOURNALS AGAIN AVAILABLE. One year's post free supply RADIO NEWS 25/-; AUDIO ENGINEERING 20/-; RADIO CRAFT 21/3; Q.S.T. 33/-; for full list of all other magazines send s.a.e to Willen Ltd., (Dept. 18), 101 Fleet Street, London, E.C.4.

CRYSTALS. Brookes, with certificate, 3516.2—7014.5—7416—7159—7190 kcs. 20/- each. Also 7175—7250—7270—in ½ in. spaced holders 12/6 each.—Box 116.

TELEVISION MAGNIFYING LENSES of famous make. To fit any and every make of receiver. JUST IN. OUR PRICE from £5/19/6.—Duke & Co., 219, Ilford Lane, Ilford, Essex.

DUKE & CO. CLIENTS. Stamps only please when sending for lists of valves from 3/6d. and receivers.—219, Ilford Lane, Ilford, Essex.

G6MN for the "best" QSL's and approved log books, send for samples: G6MN, Bridge Street, Worksop, Notts.

COPPER WIRE. Enamelled, Tinned, Cotton, Silk-covered. All gauges. Screws, nuts, washers, soldering tags, eyelets. Ebonite and laminated Bakelite panels. Coil formers. Covered wires, ear-phones, etc. List S.A.E. Post Radio Supplies, 33, Bourne Gardens, London, E.4

## PRIVATE

SALE. 100 watt multiband TX. Xtal/vfo-pp 807s Class B modulator and xtal mike. A neat, smart, efficient table top rig. SAE for details. £40 or near offer. Box 115.

SALE. SX24, very good condition. Can be seen by appointment. Price £25 or offer. SX28 wanted. ISWL/G1044, 1, Culross Buildings, Battlebridge Road, N.W.1.

EDDYSTONE 504 RX General Coverage 30.5 Mcs. to 580 Kcs. Excellent condition, £42. Eddystone 5-10 Converter with Power Pack Coils for 28, 41, 50 and 60 Mcs. £15. Can be seen by appointment.—E. Coates 4, Victoria Road, New Barnet, Herts.

Sale. 1224A receiver in brand new condition, in 100% working order—£4/5/0. E. W. Jordi, 103, Gloucester Road, South Kensington, London, S.W.7.

EDDYSTONE 640., new April, perfect condition, £20 or near offer. New acorns, 954-955-956, most RCA boxed, 7/6. G2AAS, "Lynthorpe," Boston Road, Horncastle, Lincs.



We have the finest stock of British and American radio books in this country.

Write or call for complete list—

**THE MODERN BOOK COMPANY**  
(Dept. RC)

19-23 Praed Street, London, W.2

## SAMPLE PRICES . . . .

EF50 6/-; EF55 7/6; SP61/41 4/-; EB34 2/-;  
EA50 4/-; 5U4G/5Z4G 7/6; 6AC7 6/-; 6SN7  
6/-; 6SL7 6/-; 6B8G 6/6; MHL6 6/-;  
807 7/6; RK34 7/6. 32 mfd. 350v 3/-;  
16 mfd. 450v 4/-; 8 mfd. 450v 3/6; 8 mfd.  
350v 3/-; Mains Transformers 350-0-350,  
6.3 & 5v. 19/6 and 24/-; Mains Droppers .2A and  
.3A 4/6.

Ex-Govt. C.R.T. Units and others; components; everything for the amateur and constructor.

**GARLAND RADIO (Dept. R.C.)**

4, Deptford Bridge, London, S.E.8

Phone: TIDeWay 3965.

No Shop keeps all you want—we keep more than most. That's why people say—

*"You'll probably get it at*  
**SMITH'S**  
*of Edgware Road"*

Pay us a visit and see for yourself

**H. L. SMITH & CO. LTD.**

287-9 EDGWARE ROAD, LONDON, W.2

Near Edgware Road Met. and Bakerloo

Phone PAD. 5891 :: Hours 9-6 (Thurs. 1 o/c.)

## BARNES RAD-ELEC CO.

12 Pipers Row, Wolverhampton

New 10 Valve Type 69 chassis in case less valves and dynamotor, 22/- bargain in components: Canadian powerful 12 Volt Battery Amplifiers with 6K6 and OZ4 valves, complete 25/-; less valves, 15/-; Tested R1116 All wave sets 8 valve 2 volt special leaflet, 3d.; get on mailing list for latest bargains: New Television 6H units (callers only) 79/6, (these will be unobtainable soon); 1147B receivers (callers only) 55/-; desk mikes with stand and switch, better than M. Coil, 12/6; (ideal for Xmas) 5 m/a 2 in. MC Meters, 9/6; 500 micro amp., 10/-; Biggest component stocks in Midlands, give us a call.