

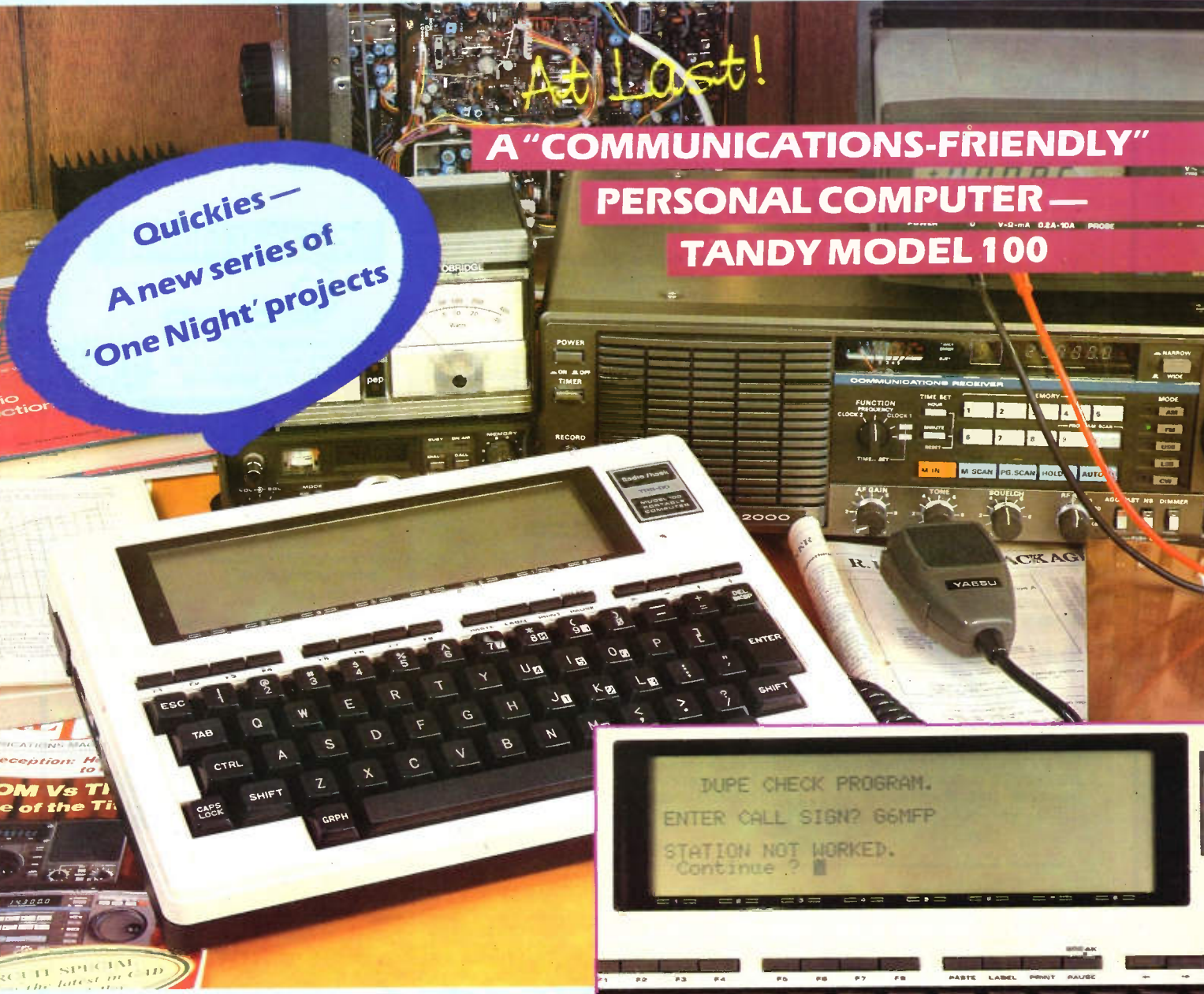
MORGAN

# RADIO & ELECTRONICS WORLD

ISSN 0262-2572  
AUSTRALIA  
CANADA \$2.95c  
NEW ZEALAND \$2.20c  
HOLLAND F7.15

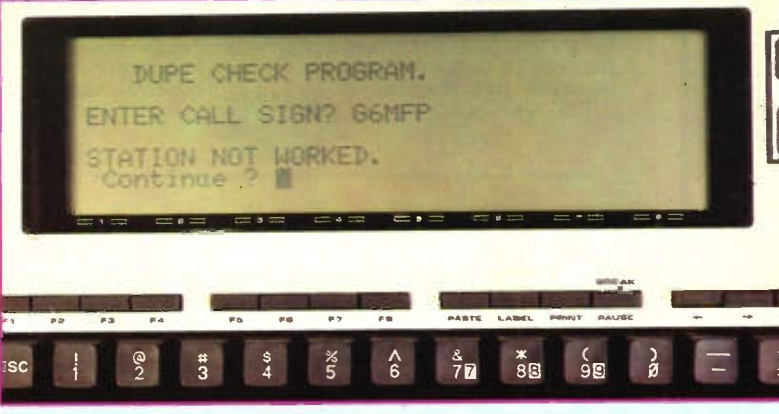
THE COMPLETE COMMUNICATIONS MAGAZINE

85p



**A "COMMUNICATIONS-FRIENDLY" PERSONAL COMPUTER — TANDY MODEL 100**

**Quickies —  
A new series of  
'One Night' projects**



**Designers Update**

**DX-TV Converter**

**A Digital FAX Scan Converter**

**An Analogue Probe**

**REWTEL Update**

# AKD

## Hand held PRECISION DIRECTION FINDER

A compact unit for pinpointing the location of Radio Frequency Transmissions

Requires PP3 type  
battery - (Not  
supplied)

# NEW

AS SUPPLIED TO  
BRITISH TELECOM

- Facilitates the tracing of interference, "bugs", illegal transmissions, case emissions etc.
- Special aerial supplied gives range up to 50 metres for a transmission of 2 watts erp.
- Can be used with standard 50 ohm directional aerials for general direction finding over greater distances.
- Audio monitor - 1 watt into 8 ohms.
- Earpiece provided.
- Suitable for FM, AM, SSB, CW.
- Battery operated (9 volt PP3 type).
- Night light.
- 2 year guarantee.

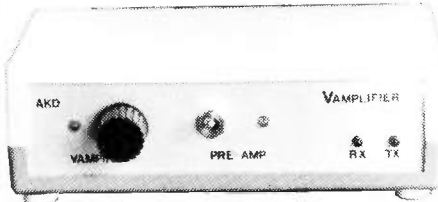
MODEL PDF-11M  
covering the 27MHz  
Citizens Band



CONTENTS  
Precision Direction Finder  
Portable Aerial  
Instruction Manual  
Earpiece

£59.95

## VAMPLIFIER Model VA1



Combined Signal Booster and RF Variable Attenuator for optimum reception on 27 MHz under difficult band conditions.

Features

- Low noise FET Pre-Amp
- Variable RF Attenuator (to reduce the worst effects of "Bleedover")

£29.95

## CB SIGNAL BOOSTER



Low noise high quality FET Pre-Amp with 24 Dbs gain Automatic R.F. switching

£14.87

## HIGH QUALITY TVI FILTERS

### HIGH PASS FILTER (HPF1)



This is a standard TVI Filter and will provide 70 Db of rejection. Features a built in braid breaker.

£6.75

### HNF2



This is a standard TV1 Filter with the braid break filter. Tuned to reject CB signals and will provide better rejection in the more difficult cases of CB interference.

£7.25

### NOTCH FILTER (TNF2)



This unit is for severe cases of CB interference. Featuring tuned filter on both inner and outer conductors. Also available tuned to amateur radio bands.

£7.50

### BRAID BREAKER



For the suppression of interference borne down the coaxial braid.

£6.75

## CB VAMPIRE



R.F. Switched Attenuator which should reduce the worst effects of "Bleedover" suffered on many brands of transceiver.

£14.37

## CAR RADIO FM BOOSTER



This Booster greatly improves the reception of VHF/FM car radios.

£10.92



FACTORY APPOINTED DISTRIBUTORS

# TELECOMMS

189 LONDON ROAD NORTH END

SEND **£1** For our full catalogues/lists and receive a £2 voucher against your first purchase.

SAME DAY DESPATCH  
on our  
HOTLINE

Simply phone - quoting Barclay or Access number for immediate despatch of items listed

ALL PRICES INCLUDE VAT AND DELIVERY TO U.K. MAINLAND



PORTSMOUTH (0705) 662145

TELEX: 869107  
TELCOM G.

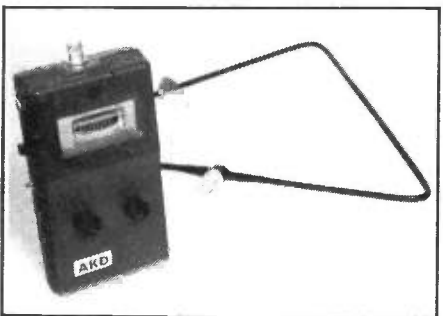
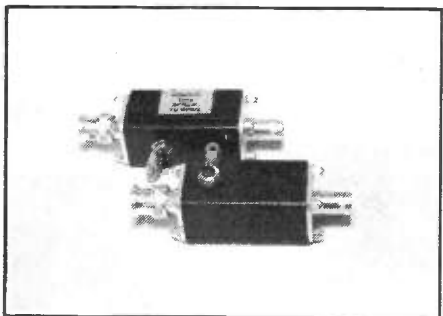
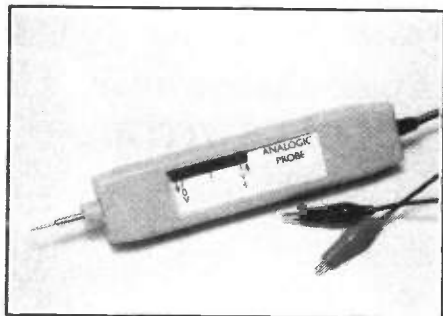


**EDITOR**  
William Poel  
**ART EDITOR**  
Sally Bennett  
**PRODUCTION MANAGER**  
Kim Mitchell  
**ADVERTISEMENT MANAGER**  
John White  
**CONSULTANT EDITOR**  
Paul Coster

# RADIO & ELECTRONICS WORLD

**AUGUST 1983**

**CONTENTS**



## Projects

Analogic Probe	— Pulsating project	8
Tape Controller	— Data Brief 1	11
Synthesiser Control System III	— Concluding round-up	14
Crystal Reference	— One Night Wonder	22
Test Card EPROM Expansion	— More displays	38
Continuity Tester	— Circuit Block	41
WB RF Amplifiers	— Two basic designs	50
RMS-to-DC Converter	— Data Brief 2	65
DX Converter	— Get 'tuned in'	68

## Features

Euro-broadcast TV Services	— Station information	20
Amateur Radio World	— Amateurs' articles	24
Zilog Z8000	— The penultimate part	25
Welcome To The Airwaves	— Getting started	31
Polar Orbiting Satellites	— How to find them	40
Digital FAX Conversion	— More on Meteostat	52
ATV On The Air	— Amateur pictures	58
Designer's Update	— Graphic details	60
HF Rx II	— Feature revisited	73
Notes From The Past	— Looking back	80
Comment	— New directions	90

## Reviews

PDF-11M	— The right direction	36
TV Aerials	— Broad analysis	42
Tandy Model 100	— A communications computer?	46
2m Synthesiser	— Wood and Douglas kit	78

## News

Bulletin Board	— If it's news...	7
Next Month's R&EW	— Popular preview	13
Events	— Local 'goings-on'	59
Video News	— Slow motion	64
REWTEL Update	— Roland's revelations	74
SWN	— Short waves	76
DX-TV	— Shorter waves	76
New Products	— Take your pick	82

See page 89 for details of subscriptions and back orders

CAPTION COMPETITION — see page 50 for details

**Editorial & Advertising**  
(0277) 213819  
117a High Street  
Brentwood, Essex  
CM14 4SG

<b>Accounts Design &amp; Production Computing Projects</b>	Jack Burrows FCA Martin Sheehan Helen White Jonathan Burchell Adrian Barnes	<b>REW TEL</b>	(0277) 232628 Roland Perry
<b>Technical Enquiries</b>			(0277) 213819 Keith Collins

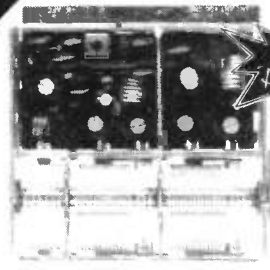
**PLEASE NOTE**  
 Closed for Stocktaking  
 Fri 29th July to Mon 1st August  
 inclusive

# CLEARANCE SALE

## While Stocks Last!

**FURTHER QUANTITY PRICES ON APPLICATION**  
 Minimum order value (inc standard Ambit lines) £2

**ITEMS SOLD ONLY AS SEEN**  
 (+15% VAT + 60p p&p)



*New Low Price!*

**£4.00** each

**FF317 TUNERHEAD**  
 88-108MHz; 10.7 IF  
 2 x 366pF AM Cap  
 40-10317

*New Low Price!*



**10p** each

**4 pole change over TOGGLE SWITCH**  
 53-50200

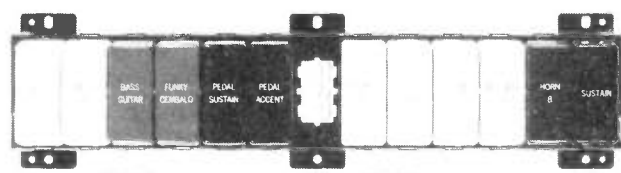
**3 pole 3 way ROTARY SWITCH**  
 53-50403



*New Low Price!*

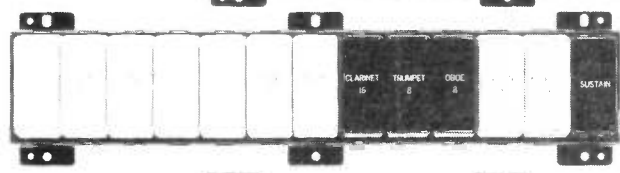
**30p** each

## ORGAN SWITCH BANK RANGE

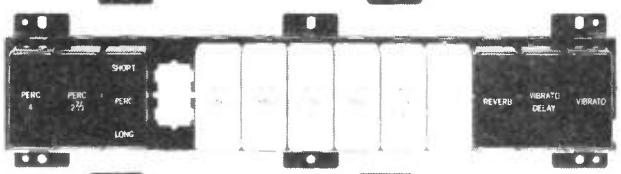


**53-50052**  
**£1.00**

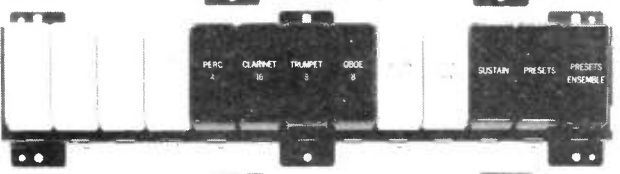
**53-50053**  
**£1.00**



**53-50054**  
**£1.00**



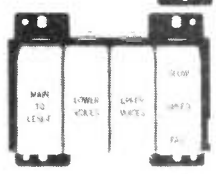
**53-50055**  
**£1.00**



**53-50212**  
**£1.00**



**53-50004**  
**£0.50**



- ★ 2 pole change over type
- ★ 15° throw angle
- ★ 0.05A, 30V DC

**AMBIT INTERNATIONAL**

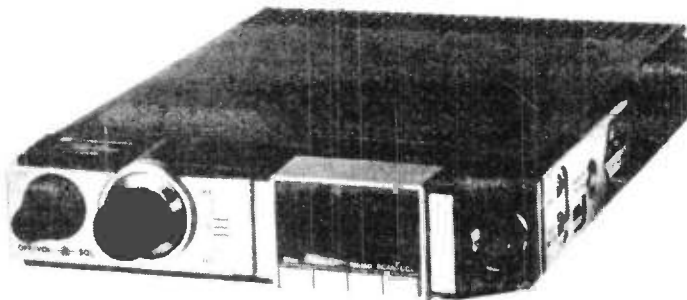
200 North Service Road, Brentwood, Essex CM14 4SG. Tel: (0277) 230909 Tlx: 995194





# Lee Electronics Ltd

## TWO NEW SLIMLINES FROM STANDARD C7900 70cms - C8900 2mtr



Prices: C7900 - £239 inc & C8900 - £219 inc

### SPECIFICATIONS

<b>General</b>	
Frequency coverage	144-146MHz
Mode of operation	F3
Voltage	DC 13.8V
Power drain	2.8 Amp TX. 0.4 Amp RX-Standby
Polarity	Negative only
Dimensions (H x W x D)	31 x 138 x 178 mm
Weight	1.1Kg
<b>Transmitter</b>	
RF power output	10 watt minimum
Spurious emission	60dB
Maximum deviation	± 5 KHz
Modulation	Reactance modulation
<b>Receiver</b>	
Sensitivity	- 10dB (12 dB SINAD)
Bandwidth	± 7.5 KHz (-6dB)
Receiver system	Double superheterodyne
Intermediate frequency	1st IF 10.7 MHz 2nd IF 455 KHz
Selectivity	More than 60 dB
Squelch sensitivity	- 16 dB
Audio output	2W (into 8 ohms with 10% THD)

The specifications for both sets are the same, it's the frequency that's different!!

We have improved and enlarged our workshop facilities to provide a better service for our customers.

At long last Standard have released the C5800. They have taken a long time to satisfy themselves (and us) that there are no bugs to sort out. I hear you snigger "No Bugs?" Ask any 5800 user what they think of it!!

### SPECIFICATIONS

#### 1. General Specifications

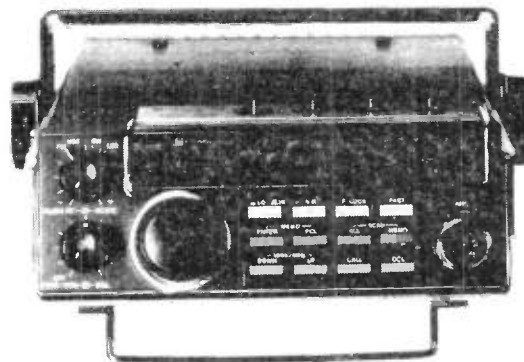
Transmission frequency	144.00000 - 147.99999MHz (E) 144.00000 - 145.99999MHz (W)
Type of emission	FM (F), SSB (A), CW (A)
Frequency stability	±300Hz within 1-60 minutes after power on 50Hz every 30 minutes
Power supply	13.8VDC
Power consumption	Transmission: HI 4-7 amp LOW; 1.5A Reception standby: 450mA
Microphone input impedance	600Ω
Antenna impedance	50Ω
AF output impedance	4 or 8Ω
Grounding system	Negative
Dimensions	149mm (W), 55mm (H), 218mm (D)
Weight	1.90 kg

#### 2. Reception Specifications

Reception system	FM: Double super heterodyne SSB, CW: Single super heterodyne
Intermediate frequency	FM: 1st IF 10.7MHz 2nd IF 455kHz SSB, CW: 10.7MHz
Sensitivity	FM: 0.19µV (12dB SINAD) SSB, CW: 0.15µV (10dB S/N)
Pass bandwidth	FM: ±6kHz, SSB, CW: 2.2kHz
Selectivity (60dB)	FM: 25kHz, SSB, CW: 4.2kHz
Squelch selectivity	0.15µV (FM)
AF output	More than 2W (into 8 ohms with 10% THD)

Price: £359 inc.

## C5800 MULTIMODE



#### 3. Transmission Specifications

Power output	25W/1W
Modulation	FM: Reactance modulation SSB: Balanced modulation
Maximum frequency tolerance	±15 × 10 <sup>-6</sup> (-10 - +50°C)
Spurious attenuation	60dB
Carrier suppression	40dB
Undesired side band suppression	40dB
Maximum deviation	±5kHz

These specifications are subject to change without notice in the event of improvements.

400 EDGWARE ROAD,  
LONDON W2  
01-723 5521 Tlx 298765

Normally return of post delivery  
but allow up to 7 days.



NEAREST TUBE:  
EDGWARE ROAD  
PADDINGTON

OPENING TIMES  
9.30am-5.30pm Mon, Tues, Wed, Fri.  
9.30am-1pm Thurs.  
10am-4.30pm Sat.

# Soundex Professional Audio Products

Peak Programme Meter Systems, Drive Amplifiers, Meter Movements,  
Audio Measuring Sets, On-Air and Rehearsal Lights



## BROADCAST SPECIFICATION SOUND MONITORING EQUIPMENT

from

**ambit**  
INDUSTRIAL MARKETING

Soundex have for many years been designing and producing high performance Peak Programme Meter driver amplifiers and associated products

Our products are renowned for quality, performance and economy and are widely used by the BBC, IBA, British Telecom and top broadcasting and recording studios throughout the world

The range comprises Free-Standing PPM Systems, PPM Measuring Sets and Driver Amplifiers meeting BS 5428, DIN 45406 and IEC 268 specifications in addition to low cost units of high performance

Separate Meter Movements are offered in a range of sizes and a choice of 1 to 7, -12 to +12dB including dual pointer types

Other products include a free-standing Audio Frequency Sound Measuring Set to CCIR 468-2, a free-standing PPM Measuring Set to BS 5428 and IEC 268 specifications together with a range of On-Air and Rehearsal Lights

Literature giving full technical specification, dimensional drawings and installation data for individual products is available on request

**aim**

200, NORTH SERVICE ROAD, BRENTWOOD, ESSEX. CM14 4SG  
Telephone: (0277) 231616 Telex: 995194 AMBIT G  
DATEL (0277) 232628 RS232 300 BAUD

# BULLETIN BOARD

## ★ ★ ★ Nota Bene ★ ★ ★

### Video Boom

The number of video recorders in use in Western Europe will climb to well over 15 million units by end of 1983, and 15% of the 100 million European TV households will be scheduling their viewing habits to suit their own requirements and accessing alternative programming available on pre-recorded cassettes.

Analysis from Mackintosh International shows that the UK is spearheading this video revolution. In the few years since the domestic video recorder established itself as a mass consumer product, more than 4 million UK households have bought or rented machines and a staggering 27% of UK homes will have video recorders by the end of this year.

Consumer spending on pre-recorded videocassettes in Europe is already well in excess of £1-billion per annum, though current business relies heavily on feature film rental.

### Setting Standards

A group of 20 companies from the electronics, camera and magnetic tape industries have announced agreement on basic specifications for the magnetic disc to be used in electronic still camera systems (still video camera based on magnetic recording). Future plans call for work on finalising further specifications as well as promoting their standardisation within the related industries.

In August 1981, Sony Corporation announced the electronic still camera as a new application in electronics technology. As a result of the great interest engendered by that announcement, Sony called on Hitachi, Canon and Matsushita to join with other domestic and foreign electronics, camera and magnetic manufacturers in a series of technical discussions on the electronic still camera system. Just as a standard film is used in traditional still photography, the group quickly realised that standardisation of the magnetic disc to be used in this system was an indispensable prerequisite for commercialisation of the electronic still camera. Consequently, a great deal of attention was given to developing the specifications for this magnetic disc.

The 20 companies involved are: Asahi Optical, Canon, Fuji, Hitachi, Konishiroku Photo, Matsushita, Minnesota Mining and Manufacturing, Minolta, Mitsubishi, New Nippon Electric, Nippon Kogaku, Olympus, Philips, RCA, Sanyo, Sharp, Sony, TDK, Toshiba and Victor.

Highlighted this month is some 'hot news' for satellite fanatics: *At one of the meetings at Goddard Space Centre on Wednesday 4th May, Jan King and Dick Daniels, recently returned from Karou, gave the update information that there had been a major delay to Areane/Phase IIIB Flight. Hence their return. If they had a telephone call from ESA by 10th/11th May they would return for flight fuelling and thus a June 3rd Launch. As of today (11th May), no such call has been made and therefore the Launch seems doomed to yet another HOLD at least for June 3 plus three weeks.*

*Trouble has been found in the third stage fuel pump (as per L05) and instrumentation control system. As the ESA Programme would appear to rise or fall on this Launch, the French are being understandably exact in all their checking. I can only say that we will give update information as received on all our NETS until Launch. The Launch NET will take on the same form as we had for UOSAT.*

*7-10 days prior to Launch. AMSAT will broadcast (on 14,280kHz and 21,280kHz during their early evenings) the state of play. We, AMSAT-UK will probably get the information via twisted pair in any case, I or Richard will be on 3,780kHz and 144.280MHz at the usual 7.00 pm NET times every night until Launch.*

*On Launch day, I will be on 3,780 and/or 7,080 plus 144,280 with G3RWL and one or two others to give information as it happens. It is hoped that the University of Surrey will assist with the direct link telephone if our link with Karou is bogged down in the MUF (or whatever).*

*All stations checking into any NET please observe:*

- 1) Short overs*
- 2) Good manners to other users*
- 3) Be patient. Last time, UOSAT Launch, we had excellent reports of a well conducted, full of information NET, which even the non-satellite user enjoyed. Let's keep it that way.*

## SNIPPETS

### Fibre Optics

A contract for the development and supply of a Fibre Optic High Integrity Local Area Network (HILAN) has been signed between Scicon International Limited and Beale Electronic Systems Limited (BES). Under the terms of the contract, BES will develop the HILAN in close collaboration with Scicon, and both companies will manufacture the system.

BES estimate that sales of the HILAN will exceed £2.5M per annum.

### Oric Offer

Oric Products International will be mounting a summer promotion from 1st July until mid-September offering a start-up pack of software valued at £40 absolutely free with every 48K machine sold.

The software package will contain four tapes — Home Finance, Teach Yourself BASIC, Oric Flight and Multi Games. Although the titles are subject to change the proportions of one home business, one educational and two games programs will remain unchanged.

### Handling Heathkit

Zenith Data Systems has appointed Maplin Electronic Supplies to handle the distribution of its range of electronic kit products marketed under the Heathkit brand-name. This appointment allows Zenith to concentrate on its rapidly expanding microcomputer operation.

Maplin Electronic Supplies is a major UK supplier of electronic components and a leading distributor of home and hobby computer products. A selected range of Heathkit products, including kits and training courses, will be added to the existing product range that Maplin handles.

### Ferranti And The Beeb

Ferranti Computer Systems Limited has recently concluded a contract with Computer Dealer Support Limited of Oldham to undertake the servicing of the successful BBC microcomputer system. This contract is expected to be the first of a range of servicing agreements with Computer Dealer Support Limited which will eventually cover other products.

### British Software

Britain's biggest computer users, British Telecom and the Ministry of Defence, have for the first time joined forces to underwrite the development of new software projects.

Along with GEC and Plessey, they are jointly funding the development of CHAPSE (CHILL and Ada Programming Support Environment). This will speed the introduction of two high-level computer languages — CHILL and Ada — to be used in future real-time telecommunications and defence computing projects.

The work will be carried out by Ada Group Ltd (AGL), a consortium of four British software and computing firms — SPL International, Systems Designers, Software Sciences and ICL. AGL has been working on the Ada project, funded by the Department of Industry and MoD, for the last four years and its members represent a major part of Britain's expertise in such a high level language development.

### Mounting Olympus

The increasing importance of British Aerospace to its European partners as suppliers of communications satellites to a world-wide market was emphasised by Mr Peter Hickman, Managing Director of the Space and Communications Division of British Aerospace, speaking in London at the 1983 Satellite Summit organised by the American journal "Satellite Week".

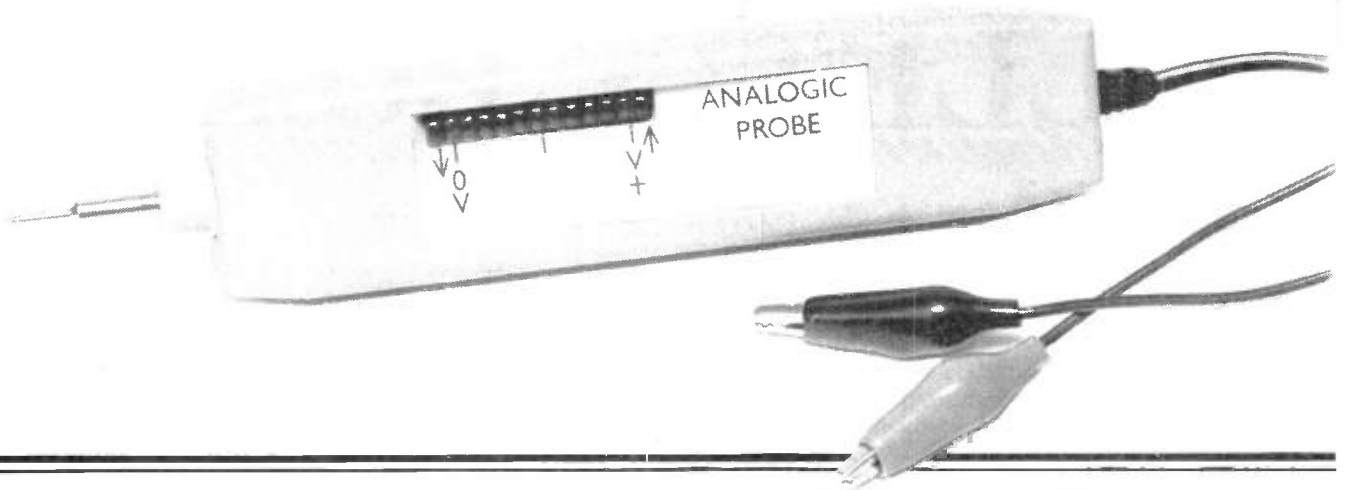
Mr Hickman announced plans for the world-wide marketing of a new class of multi-purpose communications satellites called OLYMPUS, which will be the largest and most powerful commercial satellites yet built and are expected to provide a substantial proportion of the world's business service.

### REWgrets

*FRG 7700 Memory Expansion (June '83):* The diagram in Figure 3 showed a wire coded 'white-violet'. It should read 'WHITE(4) +5V'. Also the switch mentioned in the text is available from Ambit International.

*Central Heating Controller (July '83):* A couple of errors here — finally, IC2 should be 7211A and not 7211AM, and secondly a section of text was omitted from the 'Start-Up Procedure'. Readers wishing to obtain copies of the latter should write in (enclosing a SAE) to receive the missing instructions. Finally, EPROMs and program listings are available at £5 and £2.50 respectively, from D A Pickles, 96 Perran Avenue, Fishermead, Milton Keynes.





# ANALOGIC PROBE

A valuable test instrument for identifying logic levels and pulse signals.

Design by Barry Dawson, MA(Cantab), G8XXY.

Normally, logic probes are designed for use with a single logic family such as TTL or CMOS and are carefully optimised to match the characteristics of that family closely. However, few real circuits consist exclusively of one type of logic, and even the archetypal TTL digital system based on a microprocessor will probably contain circuits such as an RS232 interface running on  $\pm 12V$  supplies.

The analogic probe was inspired by working on a wide range of complex, mixed technology circuitry where a single dedicated probe would not normally be very useful. The probe will indicate logic levels in all kinds of TTL and CMOS logic (at all normal supply voltages), and give useful indications across a wide range of analogue and interface circuits.

The probe contains two functional blocks; a bidirectional edge detector and an analogue level indicator. The edge detector indicates the presence of any fast transitions, with separate indication of +ve and -ve going edges. The level indicator uses a bargraph display to indicate the level of the input, automatically referenced to the supply voltage.

The probe operates from a supply voltage of 4V to 24V (or  $\pm 12V$ ), with little change in its performance or current consumption. Despite the large number of LEDs flashing in operation, the current switching circuitry in the probe maintains a fairly constant 50mA consumption. The edge detector controls two LEDs, a red one indicating +ve going edges and a green one for -ve going edges. Each edge triggers a LED 'on' for 100ms, whilst a continuous pulse train causes constant illumination of both LEDs. Pulses as short as

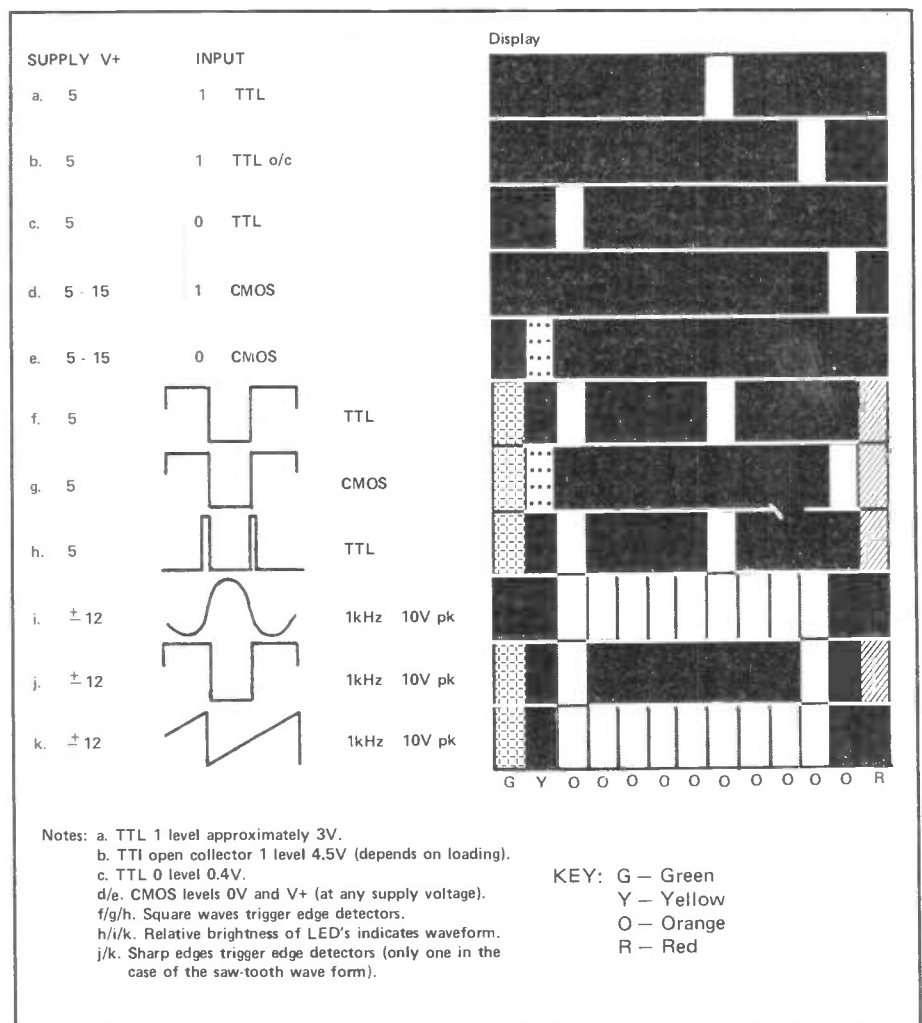


Figure 1: Some of the displays that can be obtained with the probe and their corresponding significance. Note that the list is not exhaustive.



## PARTS LIST

### Resistors

R1	910R 2%
R2	150R
R3	680R
R4,5,18,19	10k
R6,7,8,9	1M
R10	68k
R11	1k 2%
R12,13	47k 2%
R14	820R
R15,16,17	47R

### Capacitors

C1	10u 25V tantalum
C2	1u 35V tantalum
C3,4	100n ceramic
C5,6	100p polystyrene

### Semiconductors

IC1	LM3914
IC2	4538B
Q1	BC337
Q2,3,4	BC307
Q5,6,7	BC237
D1	1N4004
LED1	red LED
LED2	green LED
LED3	yellow LED
LED5-14	orange LED
D2,3,4	1N4148
ZD1	BZY88C15V

### Miscellaneous

Probe case, IC sockets (2 off), wire, solder etc.

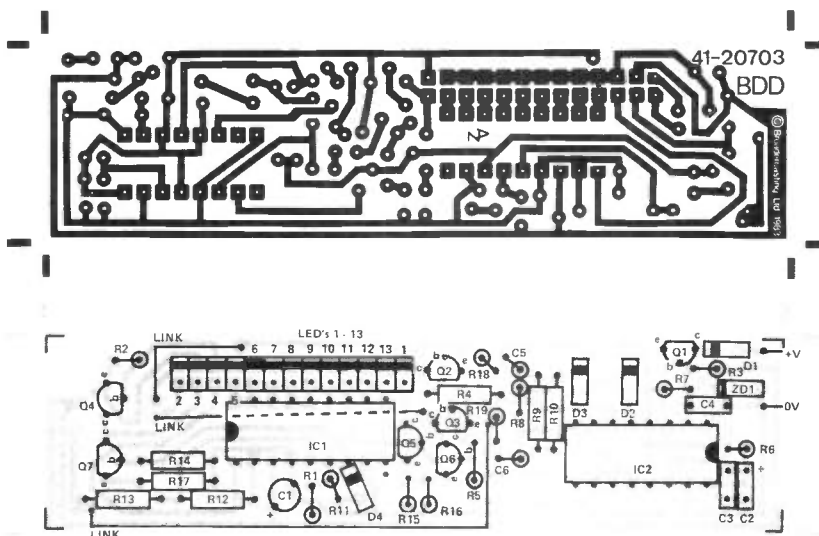


Figure 3: Foil pattern (top) and component overlay.

### Testing

After thoroughly checking the PCB, attach the probe tip and the supply cable (supplied with the case). Connect to a 5 or 6 volt supply/battery and the yellow LED *only* should light. Touch the probe tip onto the +ve supply and the yellow LED should go out, the top orange LED should light and the red and green LEDs may flash. If all is now well, disconnect and re-check the PCB and all components.

### Operation

This compact device can give a great deal of information about the state of all kinds of circuits, but it does require some experience to get the best from it. A function generator and an oscilloscope will enable the displays given to be verified and expanded to gain experience. Then it's off into some real circuitry – good luck!

■ R&EW

# CASSETTE MECHANISM

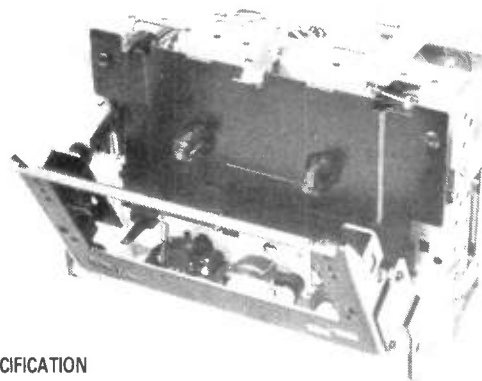
- ★ Full Solenoid Operation
- ★ Complete with Canon Heads
- ★ Front loading
- ★ Simple IC Control Logic

This month's databrief reveals the design of suitable logic control, using the recommended IC's to drive the solenoids.

To follow soon a tape counter mechanism, a simple add-on to know where you are.

For special large quantity orders a variety of heads can be supplied, for details contact Ambit Industrial Marketing.

Full data can be obtained by sending £1.95 plus A4 SAE.



### SPECIFICATION

Rated Operating Voltage: Motor +12V DC ±10%, Solenoids +12V DC ±10%  
 Installation: Vertical or Horizontal  
 Wow and Flutter: >0.08% WRMS (JIS)(Test Tape: TEAC MTT-111)  
 Spooling Time: FF or REW >115 seconds (TDK DC-60)  
 Tape Speed: 3,000 Hz ±2%  
 Motor Consumption: (Play, FF, REW) >100mA  
 Heads - REC/REP: Canon H3332-0202 (2 channel sendust)  
 Erase: Canon H53211-02 (2 channel, double gap, metal capable)

Description	Stock No.	1-24	25-99	100-
TN3600-01 deck	72-03600	28.00	26.00	22.00
BA843 Cassette deck control IC	61-00843	1.95	1.85	1.65
LB1288 Darlington Driver (for solenoids)	61-01288	1.35	1.25	1.05

Postage and packing 60p per order.  
 VAT not included.

### AMBIT INTERNATIONAL

200 North Service Road, Brentwood, Essex CM1 4 4SG. Tel: (0277) 230909 Tlx: 995194

**PLEASE NOTE**  
 Closed for Stocktaking  
 Fri 29th July to Mon 1st August  
 inclusive



## Cassette deck control circuits

The BA843 from ROHM has been especially developed for the electronic control of tape deck functions where the actual mechanical operations required are controlled or assisted by solenoid action, or electronically switched.

Features include:

1. Input key signals have a latching function, allowing use of non-interlocking keys.
2. Internal logic circuitry to prevent damage in the event of two keys being accidentally pressed together.
3. Automatic reset to stop mode upon application of power.
4. Internal pull-up resistors on all input pins, allowing direct connection of input keys with an adequate noise margin.
5. Output circuitry drives DTL, TTL, CMOS or transistor loads.
6.  $1^2L$  process — low power consumption with no static handling problems.

The BA843 has 8 inputs (1-7 & 9), six of which are for operational inputs (Play, Stop, F/F, Rew, Pause and Record) and the other two are memory and accidental record prevention (AR). Output pins 10 to 15 are for Rec, Pause, Rew, F/F and Off, and seven output modes (Stop, F/F, Rew, Play, Pause, Rec/Play and Rec/Pause) are available.

Other modes are not available as direct outputs from the BA843, but simple diode logic

### SPECIFICATION

#### Absolute Maximum Ratings

V <sub>CC</sub> MAX	(Supply Voltage)	+7V
P <sub>d</sub>	(Dissipation)	500mW
T <sub>op</sub>	(Operating temp range)	-20 to +75°C
V <sub>i</sub> max	(Input voltage range)	-0.3 to V <sub>CC</sub>
V <sub>o</sub> max	(Output voltage range)	V <sub>CC</sub> V

may be used at the outputs to initiate such functions as cue and review (ie, Play, Pause and F/F, or Play, Pause and Rew solenoids selected together respectively).

### ELECTRICAL PERFORMANCE:

Item	Symbol	Min	Typ	Max	Unit
Supply voltage range	V <sub>CC</sub>	4.5	—	5.5	V
High Level Input Voltage	V <sub>IH</sub>	2.0	—	—	V
Low Level Input Voltage	V <sub>IL</sub>	—	—	0.8	V
Low level input current	I <sub>IL</sub>	—	—	-4.0	mA
Input open voltage	V <sub>Iopen</sub>	3.2	—	—	V
High level output voltage	V <sub>OH</sub>	2.4	—	—	V
Low level output voltage	V <sub>OL</sub>	—	—	0.4	V
High level output current	I <sub>OH</sub>	-1.1	—	—	mA
Current consumption	I <sub>CC</sub>	—	—	60	mA

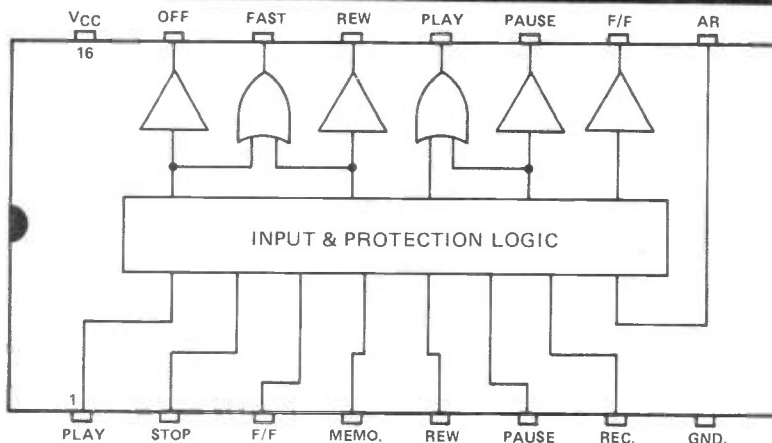


Figure 1: Pin Arrangement of BA843

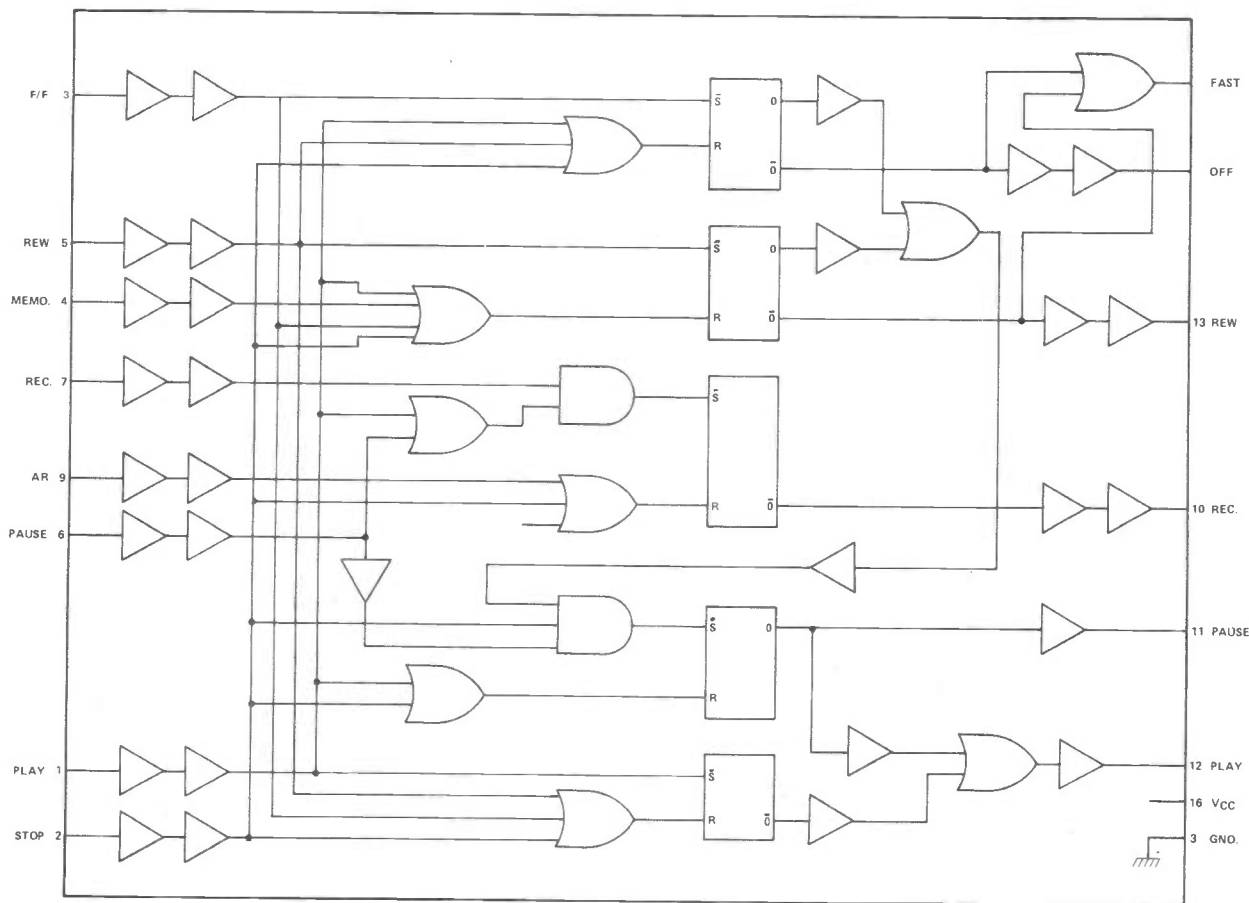


Figure 2: Block Diagram for BA843

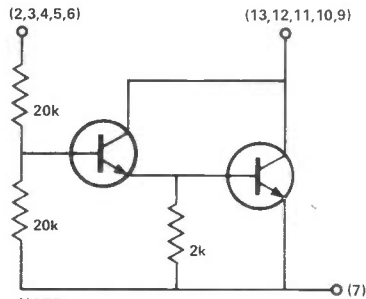
**FEATURES:**

High maximum drive current 400mA  
 High dissipation 1.15W  
 Wide supply voltage range 5.0 to 20.0V  
 Wide operating temp range -20 to +80°C  
 High current amplification >2000

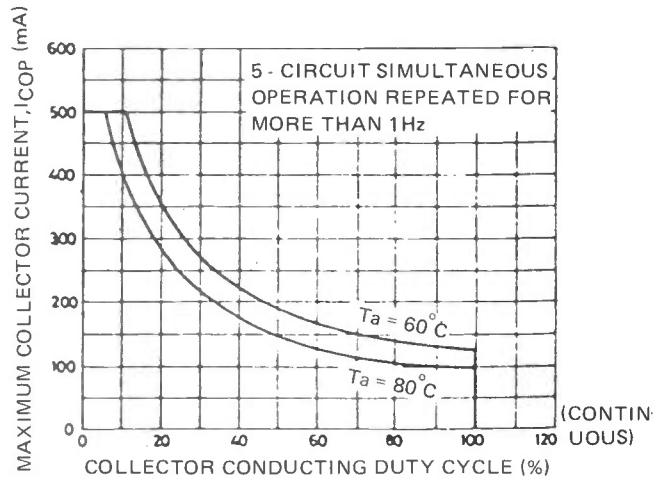
**APPLICATIONS:**

Relay, solenoid or motor drive  
 Digit or segment driver (LEDs etc.)  
 Interface for MOS-Bipolar logic  
 Power amplification or fan-out extension

OPERATING TEMPERATURE:  $T_{OP} = -20$  TO  $+80^{\circ}C$   
 STORAGE TEMPERATURE:  $T_{ST} = -40$  TO  $+125^{\circ}C$



NOTE:  
 PINS (1,8,14) = N.C.  
 SUBSTRATE CONNECTED TO PIN (7)



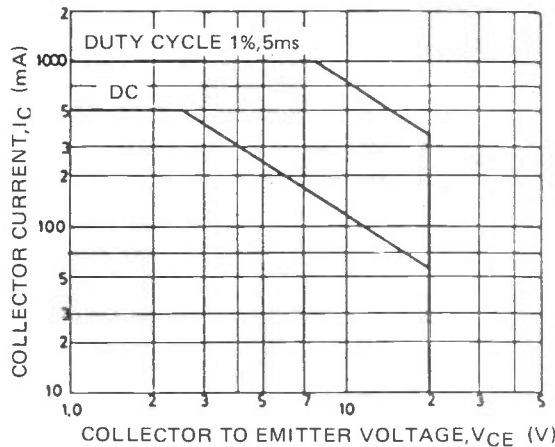
Graph 1:  $I_{cop}$  vs. Duty Cycle for LB1288

**ABSOLUTE MAXIMUM RATINGS:**

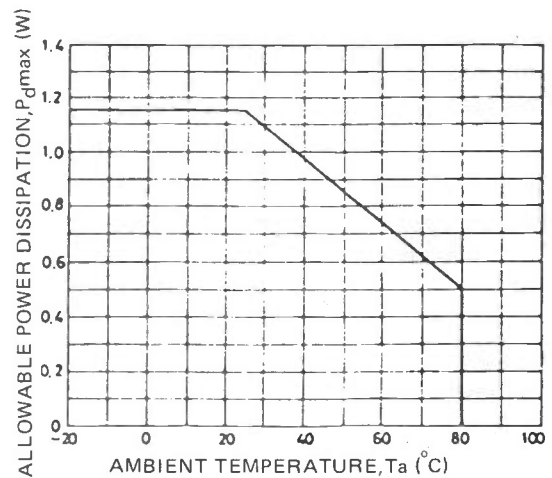
Collector-base voltage	$V_{CBO}$	20V
Collector-emitter voltage	$V_{CEO}$	-0.7 to +20V
Power dissipation	$P_{dmax}$	1.15W
Input voltage (per unit)	$V_{IN}$	-0.7 to +45V
Collector Current (per unit)	$I_C$	500mA
Junction Temperature	$T_j$	125°C

The Sanyo B1288 is configured as a five stage Darlington transistor array (NPN transistors), capable of high current drive. The tables set out some of the features and applications for the device. In use, it makes an ideal complement to the main control circuit.

Figure 3: Internal circuit of LB1288



Graph 2:  $P_{dmax}$  vs.  $T_a$  for LB1288



Graph 3: LB1288 ASO

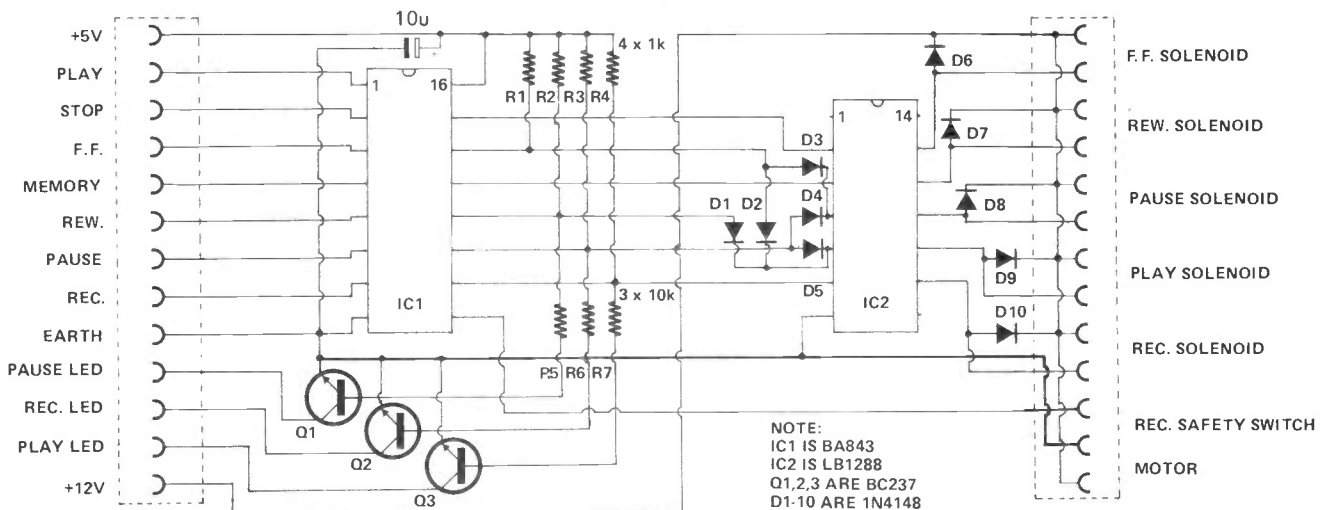


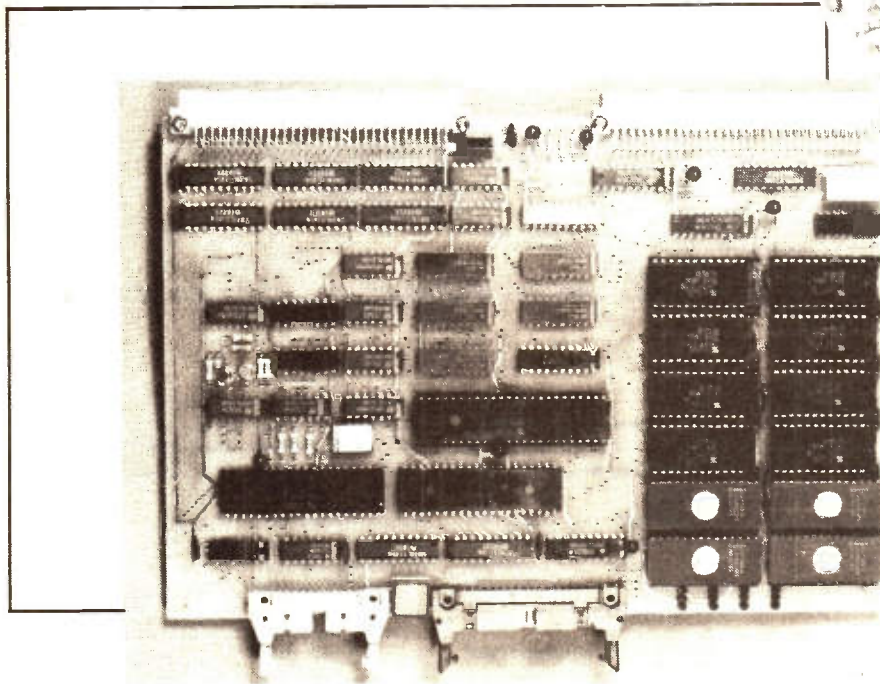
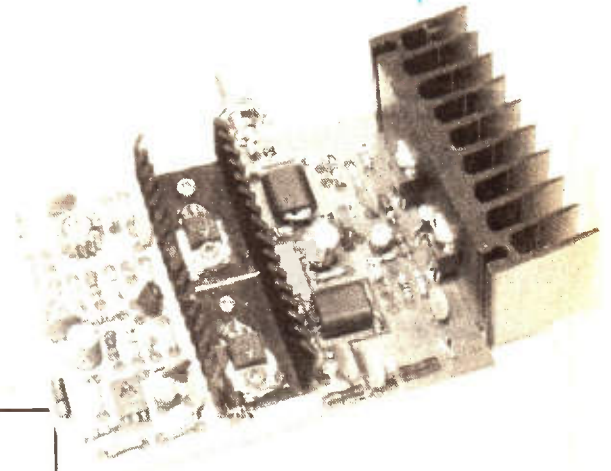
Figure 4: Typical Application with Basic Functions

# In the Next Issue of R&EW

The Complete Communications Magazine

## Wideband HF Linear

Disturb the air-waves with our 10W 2-30MHz RF amplifier. This low distortion design features push-pull output stages, active biasing and an input stage which can be driven from mixer outputs.



**ZILOG Z8000  
COMPETITION**

Win a complete  
Z8000  
development  
system

Next month, in conjunction with Arcom Control Systems, we are running an easy-to-enter competition, based around the Zilog Z8000 tutorial series (yes, you'll need to have read lessons 1-5). Arcom are donating one of their single board computers as the prize. It runs the Zilog Z8000 and uses the latest technology — Zilog's new support SCC CIO, CMOS RAM and PALs for on-board logic — to produce a fast, powerful computer supported by a sophisticated monitor.

### PLUS:

- Distortion Analyser — *high quality test gear.*
- Weather Facsimiles — *using our digital scan converter.*
- REWTEL routines — *software for the NASCOM.*

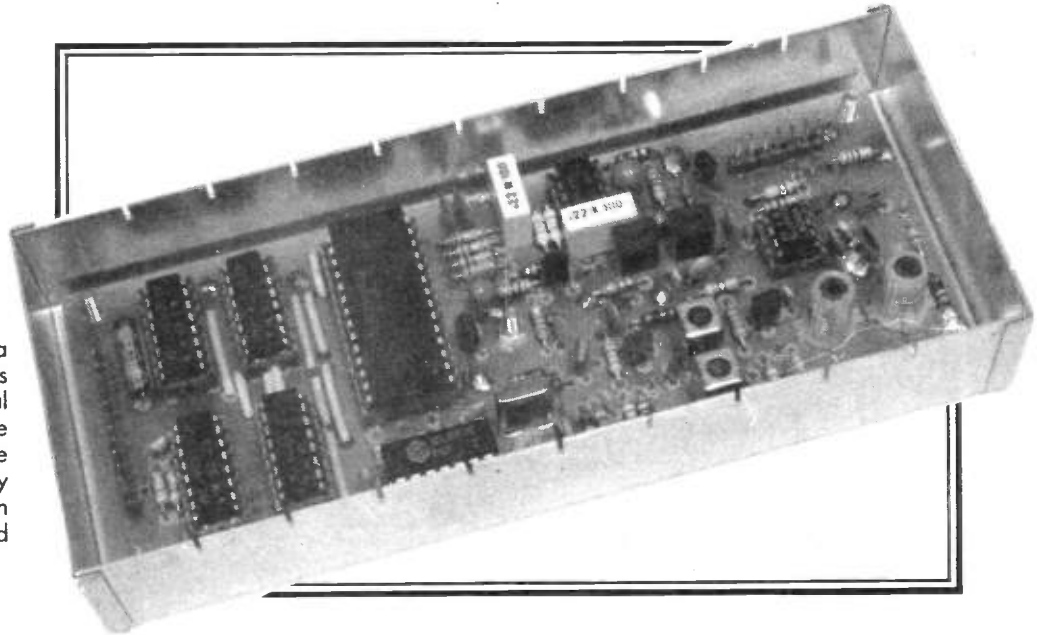
*September Edition — On Sale 4th August*



# SYNTHESISER CONTROL SYSTEM III

The concluding part of this project, by Ian Chapman, describes the synthesiser/mixer board.

Having discussed the development of a versatile synthesiser control system, it is now necessary to consider how that digital circuitry interfaces with, and programs, the MC 145151. In this section, the Synthesiser/Mixer containing the circuitry necessary to build a complete system, with the exception of the VCO, modulator, and frequency multipliers, is discussed.



## Circuit Description

The MC 145151 phase-locked-loop frequency synthesiser (IC 105) handles both digital and analogue signals. In *Fig. 1* it can be seen that the digital inputs and outputs interface to the main control board via PL1, whilst the analogue signals are associated with the VCO and reference oscillator stage (for a complete description of the MC 145151, see the data sheet in *R&EW* for March '82).

A + regulated voltage is needed by the MC 145151 and the four CMOS devices (ICs 101-4), which have to interface to TTL logic levels from the main board, and this is supplied from the +10V line to the synthesiser/mixer board by IC106, a 78L05. The 10V line also appears on connector PL4 (pin 12), which feeds the main control board.

A two-stage binary counter is required on this board to provide the strobing for the main board on address lines A0 and A1. For economy of packages, a CMOS 4060 14-stage counter/oscillator is used. The values of timing capacitor and resistors are not critical – those quoted cause the oscillator to run at about 11kHz (90 microsecond period). Outputs Q4 (divide by 16 = 1.5ms) and Q5 (divide by 32 = 3.0ms) are fed

via connector PL4 pins 3 and 4, to the main board (see *Fig. 3*). The reset line (pin 12 on the 4060) is wired low, to enable continuous counting. Pins 1, 2 and 3 of the 4060 are brought out to Pins A, B and C respectively. These outputs of 2.4Hz, 1.2Hz and 0.6Hz are available for use during adjustment of the loop filter circuit values when optimising its damping and lock-up time parameters to suit the chosen VCO circuit characteristics.

The MC 145151 requires a 14-bit parallel data word to select the desired frequency. Two of these bits can be hard-wired to ground (N12 and N13), since they do not change over the entire frequency range. The other 12 bits are obtained from the main control board as three 'chunks' of 4-bit data on the bus 00-03. The three lines S1, S2 and S3 are used to strobe this data into three 4-bit latches (ICs 101-3) each time that it appears on the bus. The outputs from these three latches are presented to the MC 145151 as a 12-bit parallel word, as required.

The Transmit/Receive input of the MC 145151 (pin 21) is *not* used in this design. Grounding this pin serves to add an offset to the selected division ratio in order to provide an IF offset on receive. However, since this requirement has already been met within the 2532 EPROM on the main control board, which has the additional advantage of catering for repeater and other shifts at the same time, T/R is left unconnected (an internal pull-up disables the offset addition).

The fixed reference division ratio is set by programming the control inputs RA0, RA1 and RA2 (set to 0, 1 and 1 respectively). The crystal oscillator (Q 101) is fed both to 'OSC IN' (pin 27 of the 145151) and to Q 102, which is a doubler stage. Q 103 is a x2 multiplier for 2m and a tripler

for 70cms. It produces an output frequency of 60.250MHz (70cms) or 40.1667MHz (2m). This local oscillator frequency is fed to the double balanced mixer, IC 108, along with the VCO output frequency, which ranges 68.1-73.3MHz (70cms) or 44.43-49.33MHz (2m). The difference frequency is fed via a low-pass filter and a buffer amplifier stage (Q 104) to 'Fin' – pin 1 of the 145151.

An RC network and a Schmitt trigger (IC 109) are used to perform "deglitching" in this design. One input of each NAND Schmitt trigger gate is wired high, so that the gates can, in fact, be regarded as Schmitt inverters. When the PLL is in lock, the input to the first device will be almost +5V, as the output on LD is predominantly high and the capacitor does not have time to charge through the resistor during the "glitch". Thus, the input is high and the output is low (at point X). However, when the PLL is out of lock, a stream of wide pulses will appear on 'LD'. The capacitor will be charged when LD goes low and discharged when LD goes high. The 'smoothing' effect of the RC network ensures that the stream of pulses from pin 28 is interpreted as a logic zero by the Schmitt trigger input, producing a logic high at its output (point X).

Since the polarity of the 'out-of-lock' indicator that is desired will depend on the particular application, this is selectable by appropriate linking on the underside of the PCB. If link XY is made, the output from the first Schmitt trigger is fed directly to a ZTX 108 (Q 105) transistor which has an open-collector output. If link YZ is made, the output signal is inverted before it is fed to the transistor. Pin 7 on the connector PL2 carries this 'out-of-lock' signal from the board (see *Table 1*).

Link	PL 2 connector Pin 7
XY	OPEN when in lock GROUND when OUT of lock
YZ	OPEN when OUT of lock GROUND when IN lock

Table 1



# SYNTHESISER CONTROL

## Design

**Fig. 2** shows the block diagram of a synthesiser that will accommodate either the 70cm or the 2 metre band and which can be built using a combination of the control logic and the mixer board to be described. Since the MC 145151 cannot handle RF signals in excess of about 25MHz when used with a 5 volt supply, Motorola recommend a down-mixing technique using a single crystal oscillator at 10.04167MHz. This reference signal is divided by 2410 (within the MC 145151) to produce a comparison frequency of 4.1667kHz.

The 10.04167MHz signal is also frequency-multiplied in order to produce a local oscillator signal with which the input frequency from the VCO unit is mixed. The resulting difference signal is fed to the programmable divider input of the MC 145151. Phase comparison then produces an error signal voltage, which is fed via a Loop Filter circuit to the VCO in order to stabilize its output frequency.

## Construction

The synthesiser/mixer unit has been designed to fit into a screened box. Before mounting any components on the PCB, it is recommended that the bare board be used as a 'stencil' to facilitate the marking out of the 5 fixing holes in the box. Either 6 BA or 8 BA, 3/4" countersunk screws can be fitted from the underside, and secured with a nut on the inside of the box to space away the PCB.

Referring to the layout diagram (**Fig. 3**), the components should be mounted in the following order:

1. Jumper links across top of PCB.
2. Through-board pins.

3. IC sockets and MOLEX connectors.
4. Toko coils and inductors.
5. Resistors, capacitors and diodes.
6. Transistors and 5 volt regulator (IC 106).

The other ICs and the crystal should *not* be fitted at this stage; nor should 'Y' be linked to either 'X' or 'Z' yet. Note that C19 is not a real capacitor, but is produced by stray capacitance across PCB tracks.

Where the end of a capacitor or resistor is shown to be connected to the ground line on the circuit diagram it should be soldered to top and bottom sides of the board. The two Toko transformers must also be grounded in the same fashion and their tuning cores adjusted to be level with the top of the can.

## Aligning The RF

A +10V regulated supply can now be connected to the input tags adjacent to PL1 on the synthesiser/mixer board. Measurements are made as follows:

1. Check that the on-board regulator (IC 106) is operating correctly by measuring the voltage at pin 3 of IC 105. This should be +5 volts  $\pm$  5%.

2. Check that this same voltage appears on pin 16 of ICs 101-104. Then switch off the power.

3. Temporarily connect an LED and series resistor (1k) from the +10V line to the collector of Q105, which is brought out to pin 7 of PL 2.

4. Temporarily connect a lead from the PCB point 'Y' to IC104 pin 3 ('C' on circuit diagram).

5. Insert IC 104 and switch on the +10V supply. The LED should now be flashing at about 0.6Hz. Switch off the supply and remove lead from pints 'Y' and 'C'. Leave IC 104 in place.

6. Using a multimeter on 2.5 volt range (or similar), with the negative lead to chassis, measure the voltages at TP1 and TP2, which should both read about 0.2 volts DC. Switch off supply.

7. Solder in the 10.0417 MHz crystal and, with the multimeter again connected to TP1, switch on supply and measure voltage, which should have increased to about 0.4 volts.

8. If all is well, transfer the multimeter to TP2 and adjust the cores of T1 and T2 for maximum reading. The correct (20MHz) tuning point of these coils will occur when the cores are within about one turn or so of the top of the coil can. Another tuning point occurs when the coils are screwed in about 3 to 4 turns - this should be ignored as it corresponds to the 30MHz harmonic. Readjust both cores alternately several times to obtain the greatest voltage at TP2. This voltage should now be in the order of 1 volt.

9. If all is well, transfer the meter to TP3 and adjust L1 and L2 for maximum voltage reading. Ensure that, for the 70cm version, you have fitted YELLOW coils, and for the 2 metre version, VIOLET ones. When correctly adjusted, the cores of L1 and L2 should also be within a turn or so of the top of the coil former, and the maximum voltage at TP3 will then be around 1.2 volts for 60MHz (YELLOW coils), and as much as 4 volts or so for 40MHz (VIOLET coils).

10. If a frequency counter is available, it can be coupled, by a single turn loop, to L2, and the frequency output adjusted by means of trimmer C7 to 60.25MHz (70cm version) or 40.1667 (2 metre version). If no frequency counter is available, then adjustment can be made against known signals on the board when the complete system is running.

## Voltage Controlled Oscillator

The heart of any synthesiser is the Voltage Controlled Oscillator and, for this reason, great care should be taken to ensure that it is both electrically and mechanically sound since poor design technique in this area can result in significant noise modulation and instability of the output carrier.

The frequency/voltage characteristic of the VCO should be chosen such that the frequency swing is no more than necessary after allowing sufficient reserve at each extremity of the tuning range to cope with overshoot, thermal variations of oscillator component values and such-like. The coverage should not span both transmit and receive oscillator frequencies, since better performance is achieved by bandswitching with a diode controlled by the PTT line. A suitable diode can switch in an extra capacitor to give a low-frequency shift when forward-biased in the 'RECEIVE' mode, whilst also providing the means to frequency-modulate the VCO when it is

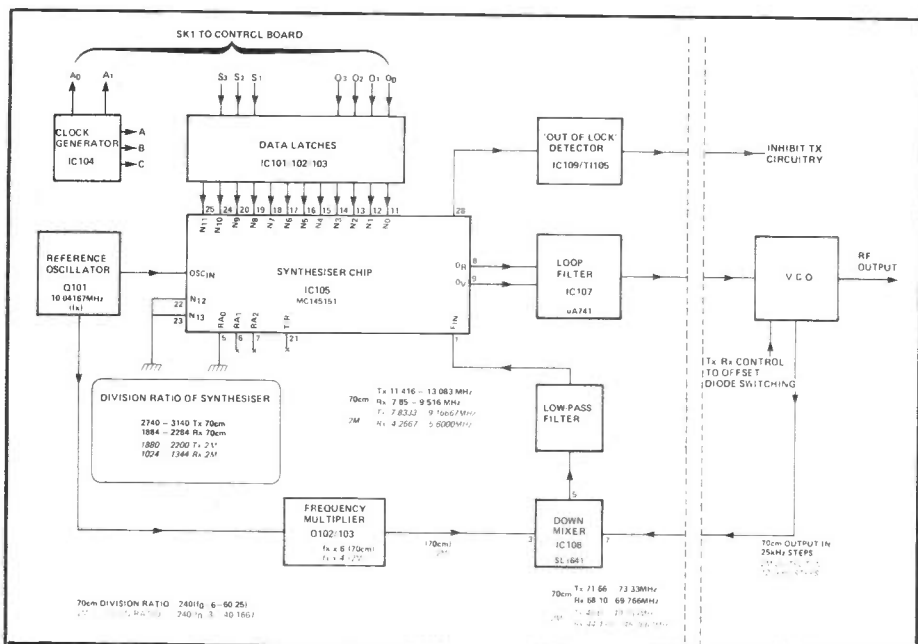


Figure 2: Block diagram of the Synthesiser/Mixer (both versions).



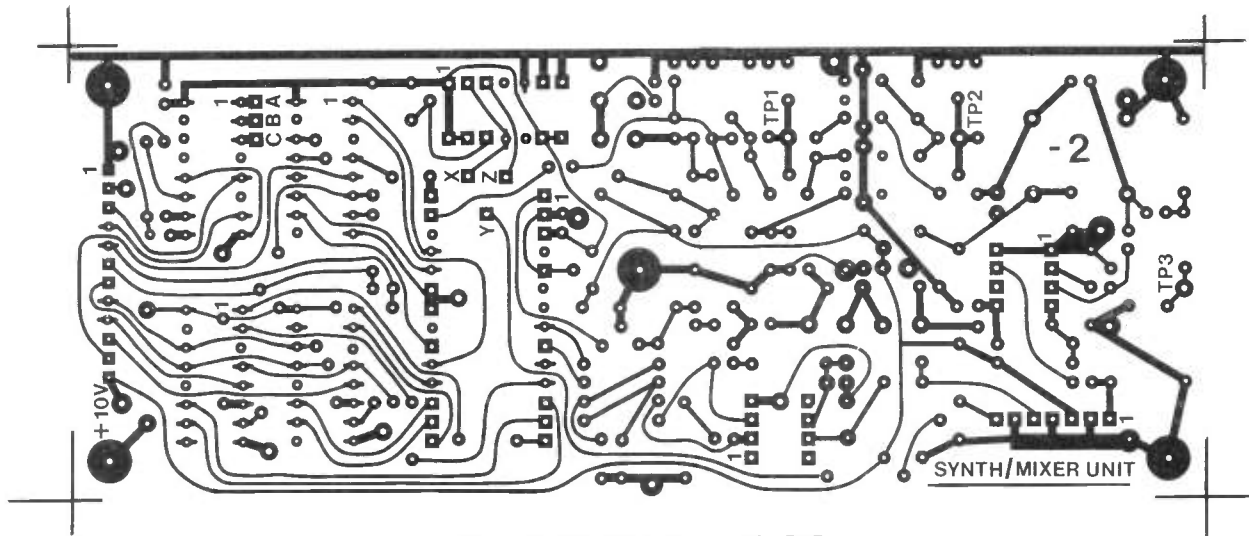


Figure 3a: The foil pattern on the PCB.

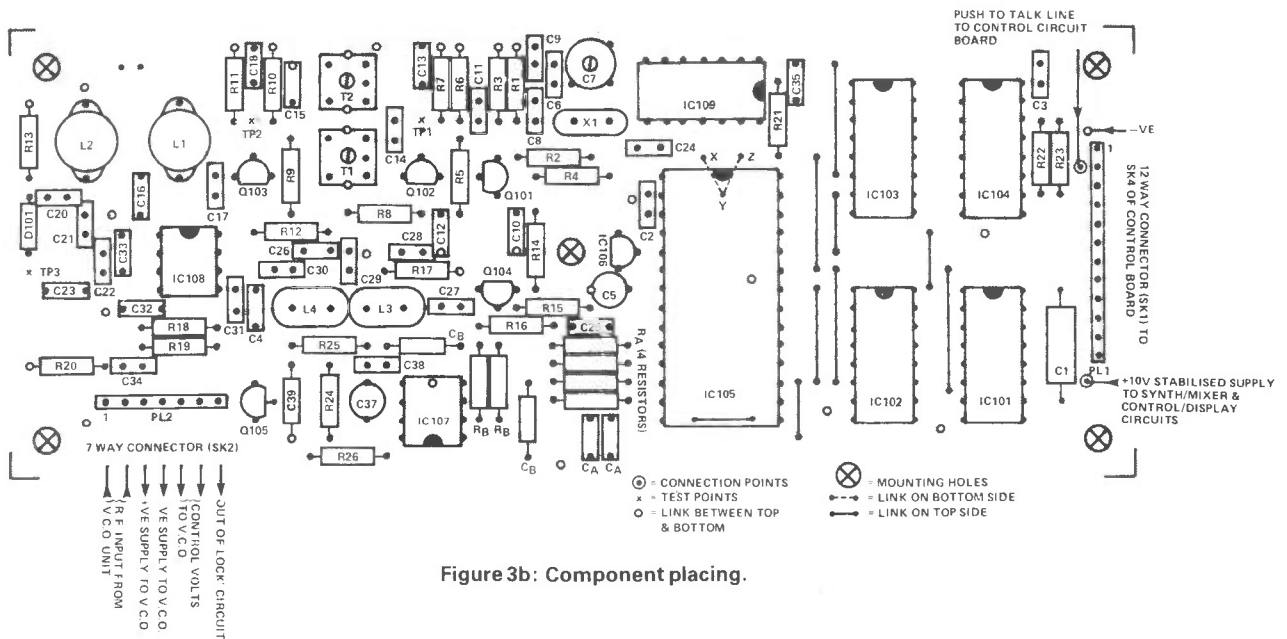


Figure 3b: Component placing.

reverse-biased on 'TRANSMIT'.

A junction FET (such as the J 310) can form a very good low-noise oscillator at VHF, and will function well in a Hartley or Colpitts configuration up to at least 150MHz. It should be built into a small screened box with a printed circuit tuning inductor to reduce microphony, and leadless decoupling capacitors to prevent stray resonances. A double-sided PCB should be used to provide an earth-plane.

For frequencies above about 150MHz, a better circuit can be designed using the same device in a grounded-gate arrangement, with drain-source feedback introduced by a small capacitor. The FET gate can be connected directly to the circuit earth-plane, thereby minimising stray inductance and improving stability. Whatever arrangement is chosen, the RF outputs to the transmitter driver stages and to the receiver local oscillator chain must

both be very well buffered, as also must the separate feed from the VCO to the synthesiser/mixer board. Efficient decoupling of the power supply and DC switching lines is essential in order to reduce the stray pick-up of unwanted signals – particularly those associated with the reference frequency of 4.1667kHz.

The original design was built to provide an output in the 72MHz band in order to modify existing equipment, and provide band coverage of 70cm in 24kHz steps. Simple alterations to this design produced a 2 metre version, which was capable of covering that band in 12 1/2kHz steps. However, a constructor building the system without such constraints could achieve a much better result by operating the VCO at a rather higher frequency.

For 2 metres, the VCO could function directly at final frequency without the need

for any frequency multipliers, although to operate with the synthesiser system described here it would be necessary to divide the 144MHz signal by 3 where it feeds the synthesiser/mixer board. This is not as difficult as it sounds, since Plessey produce a single chip ECL divider, the SP 8720, which is ideally suited to this application. Buffering of the VCO at the divider and good supply filtering will ensure satisfactory operation.

The 70cm VCO could operate at around 144MHz, although there are advantages in running at half-frequency (215-220MHz), since doubler circuits for both transmitter, and receiver local oscillator would be straightforward to construct, other harmonics being rejected easily using miniature Toko helical filters. The same divide-by-three IC could then be used to provide the synthesiser/mixer board with the required 72MHz input.

# SYNTHESISER CONTROL

## Loop Filter

Assuming, then, that a suitable VCO design has been chosen and built, it will be necessary to determine its frequency-voltage characteristic, in order to start calculating the loop filter component values. This can be measured using the set-up shown in **Fig. 4**, which also illustrates one typical 48/72MHz VCO circuit.

For a range of control voltages applied to the varicap diode, in both transmit and receive modes, the output frequency should be recorded. Ideally, the lowest desired operating frequency should be attained at around 20-25% and the highest at around 75-80% of maximum voltage. This allows for overshoot of the control signal from the loop filter, as well as thermal drift in the VCO. Having determined the average frequency swing per volt, the VCO conversion gain can be calculated from the formula  $K_o = 2\pi$  multiplied by (frequency change in Hz/control voltage change in volts), where  $K_o$  is expressed in radians per second per volt.

## Testing

Once a set of component values has been calculated using the references at the end of this article, the complete system should be assembled and power applied. If the basic checks for dry joints, shorted PCB tracks, reversed transistors, capacitor polarisations and inter-unit wiring have been satisfactorily completed, together with the setting-up described earlier in this article, everything should be OK.

A receiver covering the VCO tuning range, or harmonics of it, and an oscilloscope are almost essential for fault-finding and final adjustment. Remember that the parallel programming inputs of the MC 145151 are static once a channel has been selected, so that the selected division ratio can be determined by reading each input pin as a binary '0' or '1', and calculating accordingly.

With an LED and resistor connected to pin 7 of PL2 (see notes on setting-up of synthesiser/mixer board) and 'X' linked to 'Y' underboard, the LED should go out when phase lock is achieved. Temporarily shorting out the VCO input should cause the LED to light, verifying that this circuitry is functioning.

The loop filter characteristics should now be measured to confirm that they meet the required performance in terms of lock-up time, frequency response and damping, and changes should be made if necessary.

If it is intended that the VCO be modulated, as would be the case in an FM transmitter, then rather more care will be necessary in correctly arranging the loop cut-off frequency, since unwanted phase shifts in this part of the system can give problems of modulation distortion. The circuit of **Fig. 5** will enable the filter lock-up

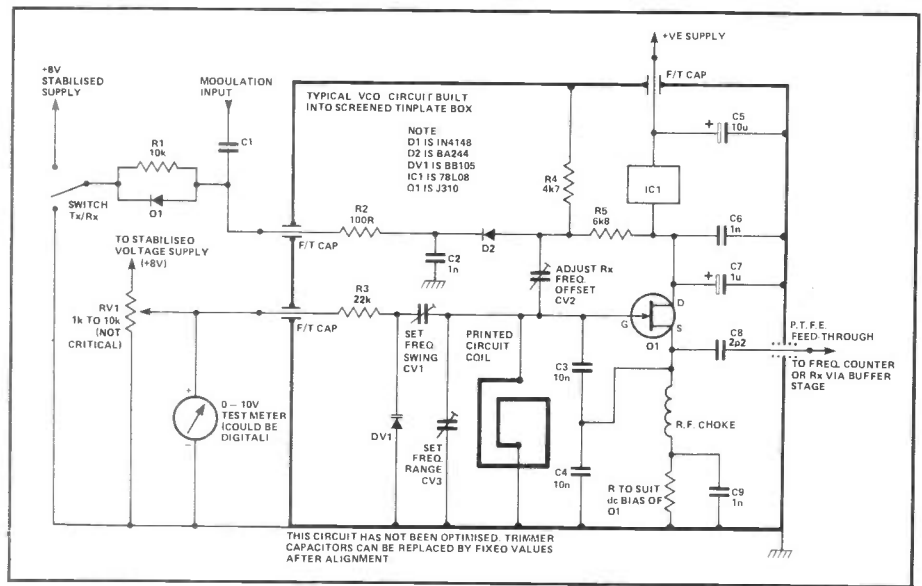


Figure 4: VCO test circuit to determine frequency/voltage characteristic.

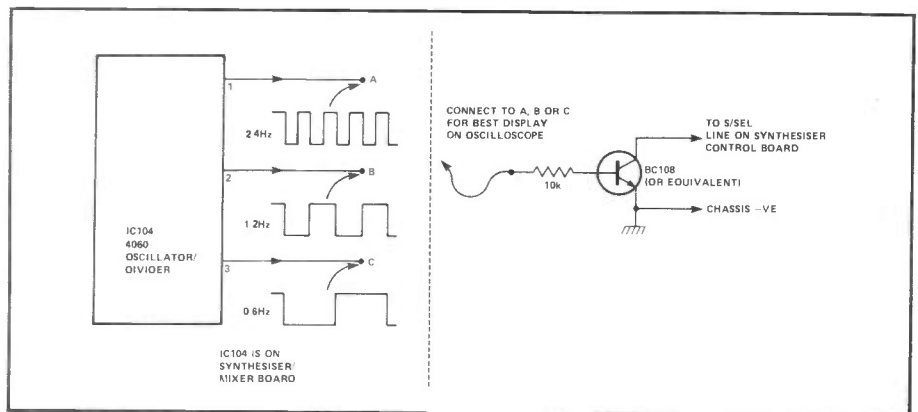


Figure 5: Set-up to measure 'Loop Filter' response.

time and damping to be measured on an oscilloscope.

Referring to **Figs. 3a and 3b** in part 1 of this project (R & EW June 1983 page 15), the S/SEL line on the control circuit can be used to switch the synthesiser rapidly between two frequencies — one set up on the thumb-wheel switch and the other set up on the rotary switches. If SW4 is left open, and the S/SEL line is taken to the collector of the transistor shown in **Fig. 5**, then frequency switching will occur at one of three rates, depending on which of the three outputs 'A', 'B' or 'C' from IC104 is selected. If the oscilloscope is triggered on one edge of this switching signal, the transient response can be seen by connecting the Y input to the output of the loop filter at pin 5 of PL2.

Whilst the only satisfactory way to measure the noise and spurious performance of a synthesiser is to use a VHF spectrum analyser, most good quality amateur receivers covering the appropriate frequency range will readily reveal any severe problems. Modulation

quality, excessive reference-sideband levels and VCO microphony can all be assessed and suitable steps taken to improve them if necessary.

## References

1. "Design of phase-locked-loop circuits" — Howard M. Berlin
2. "Phase-locked-loop systems data book" — Motorola (1973)
3. MC 145151 data sheet — Motorola
4. "An ADF frequency synthesiser utilising phase-locked-loop ICs" — Motorola Application Note AN564
5. "Phase-locked-loop design fundamentals" — Motorola AN535
6. Motorola data sheets for: MC 12040 MC 4344/4044
7. "Radio Communications Handbook" — Plessey Semiconductors

## STOP PRESS...

A few points, which have arisen following publication of the first two parts of this

project, are listed below:

1. Figure 1, June '83, p.13 – the displays should read 433.275 (70cm) and 145.2875 (2m) respectively. Also "SW4" should read "S4".

2. Throughout the text, references to switches are given as S1, S2 etc, whereas they should read SW1, SW2 etc.

3. References to Fig. 5 as the list of channels in the main EPROM (IC7), are inappropriate – Fig. 5 is the program for the code converter EPROM (IC2).

4. Reference to Fig. 2 has been omitted from the text on p.47, though it should be clear where these omissions have occurred

Finally, please note that the 'standard' EPROM contains every channel in each band, plus all the commonly-used channels duplicated for rapid access in the other modes.

Ready programmed EPROMs for the synthesiser controller will be made available to suit both 2 metre and 70cm versions. A selection of common frequencies are contained within the standard EPROM which should cater for most UK and European operators, but special IF offsets and/or channels can be provided on request at extra cost.

■ R&EW

### PARTS LIST

#### Resistors (All ¼ Watt 5%)

R1,2,13,26	10k
R3,25	4k7
R4,7,8,12,15,20,24	100R
R5,9,21	22k
R6,10,14	2k2
R11	330R
R16	220k
R17	820R
R18	560R
R19	470R
R22	47k
R23	470k
Ra	(4 off, see text)
Rb	(2 off, see text)

#### Capacitors

C1	22u 10V elect
C2	100n monothilic
C3,4,10,12,13,15,16,18,23,25,26,32,33	10n disc
C5	22u 10V tantalum
C6	33p submin. ceramic
C7	3-36p foil trimmer
C8	220p submin. ceramic
C9	120p submin. ceramic
C11,17,24	47p submin. ceramic
C14	10p submin. ceramic
C19	(see text)
C20	3p3 submin. ceramic
C21	56p submin. ceramic
C22	470p med. ceramic

C27,31,34,39	In med. ceramic
C28,30	12p submin. ceramic
C29	27p submin. ceramic
C35	1u tantalum
C36	680p med. ceramic
C37	47u tantalum
C38	(not fitted)
Ca	(2 off, see text)
Cb	(2 off, see text)

#### Semiconductors

D101	1N4148
IC101,102,103	4042
IC104	4060
IC105	MC 145151
IC106	78L05
IC107	741CN
IC108	SL1641
IC109	4093
Q101,105	ZTX 108
Q102,103,104	BF 241

#### Miscellaneous

L1,2 (70cm version) S18 4.5 YELLOW.  
L1,2 (2m version). S18 7.5 VIOLET.  
L3,4 Toko 144LY-4R7.  
T1,2 Toko 199CA-127EK.  
X1 10.0417MHz crystal.  
8 pin DIL IC socket (2), 14 pin DIL IC socket, 16 pin DIL IC socket (4), 28 pin DIL IC socket, PCB plug (12 way), PCB plug (10 way), PCB shell (12 way), PCB shell (10 way), Crimp terminals (19), PCB pins, PCB, case, nuts, bolts etc.

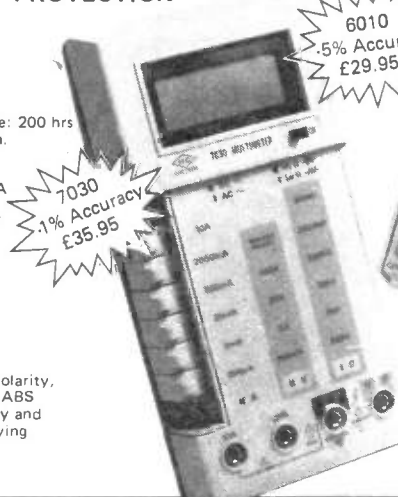
# Accurate Digital Multimeters at Exceptional Prices

28 RANGES, EACH WITH FULL OVERLOAD PROTECTION

#### SPECIFICATION MODELS 6010 & 7030

- 10 amp AC/DC
- Battery: Single 9V drycell. Life: 200 hrs
- Dimensions: 170 x 89 x 38mm.
- Weight: 400g inc. battery.
- Mode Select: Push Button.
- AC DC Current: 200µA to 10A
- AC Voltage: 200mV to 750V
- DC Voltage: 200mV to 1000V
- Resistance: 200Ω to 2MΩ
- Input Impedance: 10MΩ
- Display: 3½ Digit 13mm LCD
- O/Load Protection: All ranges

**OTHER FEATURES:** Auto polarity, auto zero, battery low indicator, ABS plastic case with tilt stand, battery and test leads included, optional carrying case.



#### NEW ANALOGUE METER WITH CONTINUITY BUZZER AND BATTERY SCALE

NEW HM102 BZ £13.00

#### NEW HM 102 BZ SPECIFICATION

- DC Voltage: 0-25, 1, 2.5, 10, 25, 100, 250, 1000 volts 20,000 ohms/volt.
- AC Voltage: 0-10, 25, 100, 250, 1000 volts 10,000 ohms/volt.
- Decibels: -20 to +22dB
- DC Current: 0-50, 500µA, 0-5, 50, 500mA
- Ohmmeter: 0-6 Megohms in 4 ranges. 30 ohms Centre Scale
- Power Supply: One 1.5V size 'A' battery (incl)
- Size & Weight: 135 x 91 x 39mm, 280gr.

#### HM 101 POCKET SIZE MULTIMETER SPECIFICATION

- DC & AC Voltage: 0-10, 50, 250, 1000 volts, 2000 ohms/volts
- Decibels: -10 to +22dB
- DC Current: 0-100mA
- Ohmmeter: 0-1 Megohm in 2 ranges, 60 ohms Centre Scale
- Power Supply: One 1.5V size 'A' battery (incl)
- Size & Weight: 90 x 60 x 29mm, 92gr. incl. battery
- Price: £5.50

Add 15% to your order for VAT. P&P is free of charge. Quantity discount for trade on application.

## ARMON ELECTRONICS LTD.



Cottrell House, 53-63 Wembley Hill Road, Wembley, Middlesex HA9 8BH, England

Telephone 01-902 4321 (3 lines)

TELEX No 923985

# EURO-BROADCAST

COUNTRY	ORGANISATION	STATION ABBREVIATION	TRANSMISSION SYSTEM	COLOUR SYSTEM
ALBANIA	Radio Televizioni Shqiptar	RTS	B, D & G	—
ALGERIA	Radiodiffusion Television Algerienne	RTA	B	SECAM
AUSTRIA	Osterreichischer Rundfunk GmbH	ORF	B & G	PAL
AZORES	Radiotelevisao Portuguesa	RTP	B	PAL
BELGIUM	Belgische Radio en Televisie Nederlands Uitzendingen (Flemish Service); Radiodiffusion—Television Belge de la Communauté Culturelle Francaise (French Service)	BRT } RTB }	B & H	PAL
BULGARIA	Boigharska Televizia	BT	D & K	SECAM
CYPRUS	Cyprus Broadcasting Corporation	CBC/RIK/PIK	B & H	PAL
CZECHOSLOVAKIA	Ceskoslovenska Televize	CST	D & K	SECAM
DENMARK	Danmarks Radio	DR	B & G	PAL
EGYPT	Egyptian Radio & Television	EBT	B	SECAM
EIRE	Radio Telefis Eireann	RTE	I	PAL
FINLAND	Oy. Yleisradio Ab	YLE	B & G	PAL
FRANCE	Television Francaise	TF1	E, L & L1	SECAM (L & L1 only)
	Antenne 2	A2	L	SECAM
	France Regions—3	FR3	L	SECAM
GERMANY(D.R.)	Deutscher Fernsehfunk	DDR—F	B & G	SECAM
GERMANY(F.R.)	Arbeitsgemeinschaft der öffentlich-rechtlichen Rundfunkanstalten der Bundesrepublik Deutschland Affiliated Networks: Sudwestfunk (Baden-Baden) Sender Freies Berlin (Berlin) Radio Bremen (Bremen) Hessischer Rundfunk (Frankfurt-am-Main) Norddeutscher Runkfunk (Hamburg) Westdeutscher Rundfunk (Köln) Bayerischer Rundfunk (Munich) Saarlandischer Rundfunk (Saarbrücken) Suddeutscher Rundfunk (Stuttgart)	ARD } SWF } SFB } RB } HR } NDR } WDR } BR } SR } SDR }	B & G	PAL
	Zweites Deutsches Fernsehen	ZDF	B & G	PAL
GIBRALTER	Gibraltar Broadcasting Corporation	GBC	B & G	PAL
GREECE	Elliniki Radiophonia Tileorassis	EPT	B & H	SECAM
HUNGARY	Magyar Televizio	MTV	D & K	SECAM
ICELAND	Ríkisutvarpid—Sjónvarp	RUV	B	PAL
IRAQ	Broadcasting Service of the Republic of Iraq	BSI	B	SECAM
ISRAEL	Israel Broadcasting Authority	IBA	B & H	PAL
ITALY	Radiotelevisione Italiana	RAI	B & G	PAL
JORDAN	Jordan Television Corporation	JTV	B & G	PAL
LEBANON	Compagnie Libanaise de Television	CLT	B	SECAM
LIBYA	People's Revolutionary Broadcasting Corporation	PRBC	B	SECAM

KEY TO TRANSMISSION SYSTEMS					
System	No. of Lines	Vision BW(MHz)	Modulation Vision	Sound	sound sub-carrier(MHz)
A	405	3	Positive	AM	-3,5
B	625	5	Negative	FM	+5,5
I	625	5,5	Negative	FM	+6,0
E	819	10	Positive	AM	+11,15
L	625	6	Positive	AM	+6,5
G,H	625	5	Negative	FM	+5,5



# TV SERVICES

COUNTRY	ORGANISATION	STATION ABBREVIATION	TRANSMISSION SYSTEM	COLOUR SYSTEM
LUXEMBOURG	Radio-Tele-Luxembourg	RTL	L	SECAM
MADEIRA	Radiotevisao Portuguesa	RTP	C	PAL
MALTA	Xandir Malta (Tele-Malta Corporation)	TMC	B	PAL
MONACO	Tele-Monte-Carlo	TMC	B	PAL
			L	SECAM
			G	PAL
MOROCCO	Radiodiffusion-Television Marocaine	RTM	B	SECAM
NETHERLANDS	Nederlandse Omroep Stichting	NOS		
	Affiliated Networks:			
	Algemene Vereniging Radio Omroep	AVRO	B & G	PAL
	Katholieke Radio Omroep	KRO		
	Nederlandse Christelijke Radio Vereniging	NCRV		
	Televisie Radio Omroep Stichting	TROS		
	Omroepvereniging VARA	VARA		
	Omroepvereniging VPRO	VPRO		
NORWAY	Norsk Rikskringkasting	NRK	B & G	PAL
POLAND	Telewizja Polska	TVP	D & K	SECAM
PORTUGAL	Radiotevisao Portuguesa	RTP	B & G	PAL
ROMANIA	Radiodifuziunea Televiziunea Romana	TVR	D & K	—
SPAIN	Radiotelevision Espanola	RTVE/TVE	B & G	PAL
SWEDEN	Sveriges Radio	SR	B & G	PAL
SWITZERLAND	Schweizerische Post-Telephon-und Telegraphenbetriebe;	+PTT		
	Schweizerische Radio-und Fernsehgesellschaft;	SRG	B & G	PAL
	Societe Suisse de Radiodiffusion et de Television;	SSR		
	Televisione Svizzera Italiana	TSI		
SYRIA	Syrian Broadcasting & Television	SBT	B	SECAM
TUNISIA	Radiodiffusion-Television Tunisienne	RTT	B	SECAM
TURKEY	Turkiye Radio-Televizyon Kurumu	TRT	B	PAL
UNITED KINGDOM	British Broadcasting Corporation	BBC	A & I	I/PAL
	Independent Broadcasting Authority	IBA		
	Affiliated Networks:			
	Anglia Television	—	A & I	I/PAL
	Central Television	—		
	Border Television	—		
	Channel Television	—		
	Grampian Television	—		
	Granada Television	—		
	Harlech Television	—		
	HTV	HTV		
	London Weekend Television	LWT		
	Scottish Television	STV		
	Television Wouth West	TSW		
	Thames Television	—		
	TV South	TVS		
	Tyne Tees Television	TTTTV		
	Ulster Television	—		
	Yorkshire Television	YTV		
	TV-AM	TV-AM		
U.S.S.R.	Televidenie Sovietskovo Soiuza	TSS	D & K	
YUGOSLAVIA	Jugoslavenska Radiotelevizija	JRT		
	Affiliated Networks:			
	Radiotelevizija Beograd	TVB	D & H	PAL
	Radiotelevizija Ljubljana	RTV		
	Radiotelevizija Novi—Sad	RTNS		
	Radiotelevizija Pristina	RTP		
	Radiotelevizija Sarajevo	—		
	Radiotelevizija Skopje	—		
	Radiotelevizija Titograd	—		
	Radiotelevizija Zagreb	RTZ		



# A new series of projects, designed by Stephen Ibbes, which can be built, tested and working in an evening. We begin with a Crystal Calibrator.

Each month during this series, we will present a small design which can be built in a few short hours. These will include indicators, calibrators, timers, checkers, etc, aimed at the beginner. The projects will be easy to build, either on veroboard or PCBs (PCB designs will be given), but no casework details will be given, so that the finished projects can either be mounted in existing equipment or in separate enclosures. At the same time it is hoped that the circuit descriptions will be straightforward enough for those just starting to build projects to understand.

## Crystal Calibrator

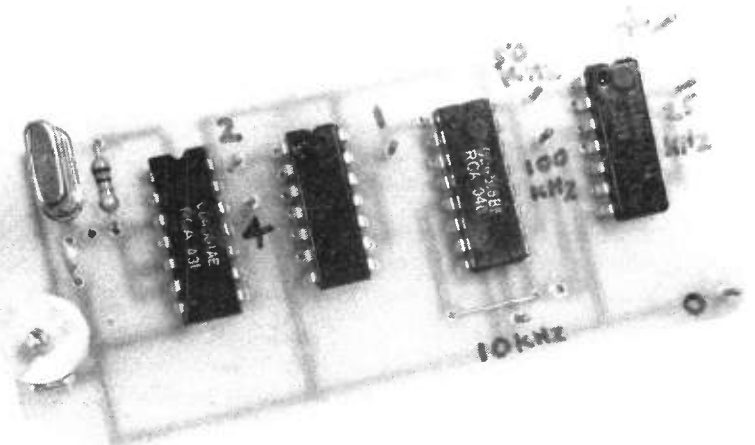
There is quite often a need for a reasonably accurate signal source in the constructor's shack, and this little piece of test equipment generates square waves at 4MHz, 2MHz, 1MHz, 100kHz, 50kHz and 10kHz, all with one crystal and 4 ICs. A crystal frequency of 4MHz is used since it is very common and most component suppliers have it as a stock item.

## Construction

Veroboard construction is possible with care, but a PCB is easier. Mount all the components the correct way round and then check carefully before applying power. Trim TC1 against some sort of reference or frequency meter, then the unit can be mounted in a

## Circuit Description

IC1a and b comprise the oscillator circuit, with TC1 incorporated to adjust the crystal 'onto frequency'. IC1c is used as the 4MHz output buffer, and IC1d acts as a buffer to the next IC, a dual flip-flop. Each half of this 4013 divides the frequency by two, so we have 2MHz at pin 1 and 1MHz at pin 13. The output then goes into a 4518 dual divide-by-ten (IC3) to give 100kHz at pin 5 and 10kHz at pin 13. The 100kHz signal also drives another flip-flop to give 50kHz at pin 1 and 25kHz at pin 13 of IC4.



suitable box. I used a verobox, with an SUE bank to switch the output to panel mounted sockets. The frequency will vary slightly as the battery runs down and if constructors are worried about this, a voltage regulator can be easily included to stabilise the voltage and make the unit more reliable.

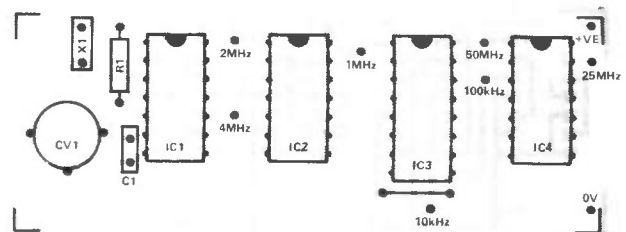


Figure 2: The component overlay.

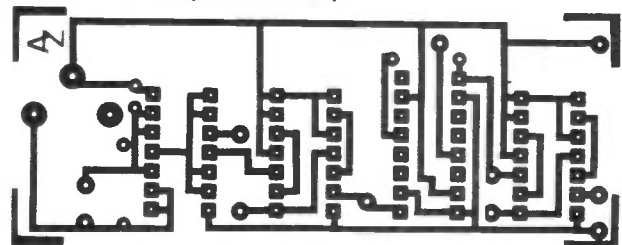


Figure 3: Foil pattern

■ R&EW

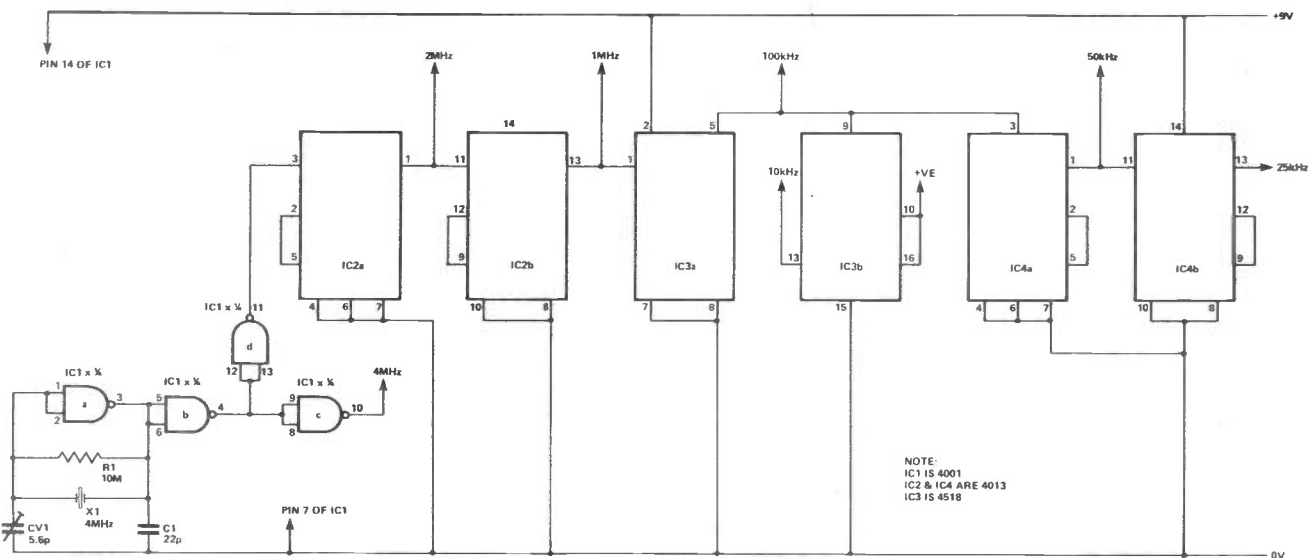


Figure 1: Circuit diagram of the calibrator.



£145 Kit £110  
+ VAT (p & p £2.50)



£220 Kit £160  
+ VAT (p & p £4.50)



£79 Kit £49  
+ VAT (p & p £2.50)



£49 Kit £36  
+ VAT (p & p £1.50)



£145 Kit £110  
+ VAT (p & p £1.50)

#### NTL04 POWER SUPPLY

0-30V, 0-2.5A ● voltage setting with 10T pot. giving 0.1V resolution ● fully protected floating output ● selection of current limiting or current foldback mode ● 3 digit displays for voltage & current with 0.1% FSD accuracy ● automatic dissipation control ● line stability 0.01% for  $\pm 10\%$  mains voltage change ● load regulation 0.02% for 100% load change ● ripple 2mV typ. ● transient response < 50 $\mu$ s

#### NTL05 POWER SUPPLY

0-50V, 0-3A ● voltage setting with 10T pot. giving 0.1V resolution ● fully protected floating output ● automatic changeover from constant voltage to constant current mode ● 3 digit displays for voltage & current can be used for external measurement: range 9.9V to 99.9V, 0.1V resolution: 0 to 5A 0.01A resolution, meter accuracy 0.01% FSD ● automatic dissipation control ● line stability 0.01% for  $\pm 10\%$  mains voltage change ● load regulation 0.01% for 100% load change ● ripple 1mV typ. ● current stability with current control 0.1% + 1mA typ. ● transient response < 50 $\mu$ s ● LED function indicators

#### XR2206 FUNCTION GENERATOR

frequency range 10Hz to 220kHz ● linear setting over 6 ranges ● waveforms: sine, triangle, square ● sawtooth & negative pulse at approx. twice the set frequency available ● distortion of the sine wave < 1% at 1kHz ● output AC for all waveforms adjustable: 0-10mV, 0-100mV, 0-1V, impedance approx. 5 ohms ● output SYNC square or negative pulse TTL compatible

#### DT155 DIGITAL THERMOMETER

alternate reading of 2 measuring points ● temperature range -55 C to +100 C ● resolution 0.1 C ● 3 digit 18mm red LED display ● automatic changeover of the probes at 10 sec interval with LED indication ● sensor probes can be located at a distance of up to 100m from the instrument ● mains supply for permanent operation ● brushed anodised alum enclosure 136 x 47 x 115mm (W x H x D) ● choice of 3 sensor probes

LM 135 -55 C to +100 C £10 Kit £8  
LM 235 -40 C to +100 C £8 Kit £6  
LM 335 -10 C to +100 C £6 Kit £4

#### DT600 DIGITAL THERMOMETER

precision thermometer with one Pt100 platinum film probe to BS1904 grade 11 covering -70 C to +600 C in 2 ranges: -70 C to +199.9 C, resolution 0.1 C, -70 C to +600 C, resolution 1 C ● lineariser circuit guarantees accuracy of 0.2%  $\pm 1$  digit over entire range ● measuring rate 3/sec ● response time 10sec to 99% in moving water ● memory switch ● 3 wire probe connection allows measurement over extension cable up to 25m ● probe with handgrip, 1.5m spiral cable & 5pole DIN socket ● battery 9V PP3 for approx. 30h operation ● low battery indicator

Our kits contain all the material required for the assembly including pcb, enclosure, annotated front plate & all electronic parts. A comprehensive assembly manual is provided with step by step instructions & circuit description.

P.T.M.  
elektronik



**NEW**

### WOG2206 SWEEP GENERATOR

- makes easy work of establishing and displaying on the oscilloscope frequency responses of equalisers, active filters, crossover networks, audio amplifiers, etc.
- excellent function generator: frequency range 0.2Hz to 200kHz
- professional appearance at low cost
- save pounds and enjoy assembling kit version

function generator: 0.2Hz to 200kHz with linear setting over 6 ranges ● waveforms: sine, square, triangle ● sine wave distortion < 1% at 1kHz ● sine & triangle continuously adjustable from 1.5mV to 15Vpp; square wave in 4 steps from 12mV to 12V ● DC offset adjustable for sine & triangle waves  
sweep generator: sweep rate of 0.5sec to 10 sec ● internal sweep linear 100:1, logarithmic 500:1 (1000:1 typ.) ● trigger output 5V TTL

£115 Kit £70

+ VAT (p & p £2.50)

Prices are subject to 15% VAT



**FREL LTD.**

ELECTRONIC DESIGN & MARKETING  
RW1 HOLMBUSH INDUSTRIAL ESTATE  
MIDHURST WEST SUSSEX GU29 9HX  
TELEPHONE MIDHURST (073 081) 2635

# Who Stocks a Range of PIEZO ACOUSTIC SOUNDERS with prices that start below 20p?



**WE DO!**

**aim**

**ambit industrial marketing**

200 North Service Road, Brentwood, Essex CM14 4SG  
Telephone (Consumer Sales/Enquiries) 0277-230909.  
Telephone (Industrial Sales/Enquiries) 0277-231616  
Telex 995194 AMBIT G  
Data 24hrs (RS232/300baud) 0277-232628 — REWTEL.

- Orders for in-stock items despatched same day (up to 4pm receipt).
- Hours — (consumer sales) 8am-7pm Mon-Sat; (Industrial) 8am-6pm (Mon-Fri).
- Retail Sales 9am-6pm Mon-Sat \*Industrial Sales 'Take-Away' by arrangement.
- Industrial accounts available on application: 2 Trade, 1 Bankers Ref.

# AMATEUR RADIO WORLD

Compiled by Arthur C. Gee, G2UK

A couple of months ago (15th May), the most spectacular radio blackout occurred, which effectively closed down all communication on the amateur bands from 10 metres right through to 80. Things seemed normal at eight o'clock in the morning, but by nine o'clock all bands were dead. So much so, that my first inclination was to check over the aerial system, the receiver, aerial relays and so on. It was comforting to hear a local station saying exactly the same thing to another local and to realise they too had gone out to see if the sky-wire was still there! All bands stayed dead for most of the morning and it was not until the afternoon that things were back to normal.

Such a fade-out is now called a "Sudden Ionospheric Disturbance" – SID. The cause is thought to be sudden bursts of solar radiation from a part of the sun's surface facing the earth, so that the ionosphere surrounding that part of the earth facing the sun is intensely ionised; to a degree far exceeding normality. Ionisation of the lower D layer occurs, so that radio waves from the earth's surface passing up towards the ionosphere are absorbed in the highly ionised D layer, thus do not pass through to the upper F layers. So, no propagation takes place by reflection from these higher layers and only very local ground-wave communication can occur.

It was established in the 1930s that these fade-outs were related to the appearance on the sun of solar flares. These phenomena are sudden releases of radiated energy occurring in the vicinity of active regions on the sun. They eject atomic particles and emit radiation across the entire range of the electromagnetic spectrum, from X-rays to radio waves. The first flare to be recorded was seen in 1859 by the English Astronomer Richard Carrington and was visible in white light, a rare phenomenon indeed as usually they cannot be seen at all against the brilliance of the sun. They are normally observed nowadays through light filters which remove all but one band of light wavelengths. The filters pass the light from Hydrogen or Calcium, by which the flares can be seen.

A flare reaches its maximum brightness within a few minutes and declines slowly thereafter, its total duration varying from a few minutes to several hours. They are classified into five groups labelled from 1 to 4 and a group labelled "S"; Group 4 being the largest.

Enquiries revealed that a major flare occurred at 0839 hrs UTC on Sunday 15th May 83, the radio effects of which lasted about an hour – it was of Type 2. It gave heavy radio noise on 10cms and bursts of radio noise were heard on several other radio frequencies. It was accompanied by a weak proton flare for an hour or so.

So those amateurs who were trying to have their usual Sunday morning skeds and nets on that day, may have been unsuccessful, but at least they had the interesting experience of witnessing a true SID of considerable magnitude.

Our hopes that AMSAT's Phase III satellite would be launched in June have not been fulfilled due to various "glitches" which have resulted in a series of further delays. Apparently the motor which gave trouble on the previous ill-fated launch is giving trouble again, as is some of the control equipment. So we must continue to wait!

Oscar 8 has been giving some cause for concern. Battery temperatures have been running high, for some time, for reasons which are a bit puzzling. It seems the batteries are overcharging. So its usual operating program of so many days in Mode A and so many in Mode J, has been interrupted and the control stations are controlling as seems best day-by-day. So, some days Mode J will be on the usual Mode A days and some days both Mode A and J will be on together. Also, some days it will not be on at all. So check both Modes before assuming it's "suddenly died"!

Karl Jansky, one of the pioneers of Radio Astronomy, was the first to establish that radio waves did come from outer space. This was made public on 27th April 1933. The 50th anniversary of this event was celebrated in the USA by some special moonbounce tests conducted from the National Radio University at Green Bank, West Virginia, under the guidance of Dr. Tom Clark, W3IWI, President of AMSAT. The huge telescope there, 140 feet in diameter, was used to provide some really powerful moonbounce signals, so that those radio amateurs interested in this form of amateur activity could have a chance of making some contacts on this difficult mode. The tests were quite successful, some 200 contacts being made, though it was the "big boys" who were mostly the lucky ones, rather than those with less sophisticated equipment, for whom the tests were primarily designed.

■ R & EW

**Solar Flares. Seen Edge on they resemble huge flames appearing over the edge of the sun. Seen from above, they appear as large areas of radiation.**





# MEMORY AND PERIPHERAL MANAGEMENT

## MEMORY MANAGEMENT

The microprocessor began as a four-bit-wide device that could handle simple tasks in certain control systems, games, and similar products. It could do these tasks more flexibly and at less cost than alternative devices composed of discrete logic circuits. For these applications, few circuits, including memory, were needed. As the practical capability of large-scale integration (LSI) increased, processors with increasing power, both in data size and instruction set, have become manufacturable. The memory needs of present day applications have more than kept pace.

The eight-bit machines, like the Z80, first made possible the construction of microprocessor systems that could emulate many of the abilities of mini- and large computers. This opened applications in several fields outside small control systems. With these new applications has come a need for more and more memory to complement the power of the microprocessor itself. In mathematical terms, a more powerful instruction set means new types of computations can be attacked with a microprocessor. It is generally impossible to foresee the amount of time and memory needed to complete any computation picked at random. Thus, it is important to have as fast a processor and as much memory on hand as possible.

With the Z8000 microprocessor, instruction-set and memory-addressing capabilities have now entered the realm of standard (mini and large) computers. One task, therefore, is to provide and *efficiently organize* enough memory for the most general tasks to which the Z8000 might be applied, even though memory is still a scarce resource, possibly shared by multiple, complex computing tasks. The segmented-address feature of the Z8001 is one basis for beginning to attack this problem of *memory management*.

Memory is a resource for computations, as is the instruction set of the particular machine being used. There are two basic reasons for wanting to manage its use: it must be made available to all computations (users or tasks) that need it, and it must be partitioned when properties are uniquely defined for particular memory regions.

In any physical system, only a finite amount of memory exists. Some of this memory can be fast and directly accessible to running programs as RAM or ROM. Usually, because of cost and addressing limitations, this is only a small portion of total system memory. The remaining memory can serve two purposes: long-term storage (tape or disk) or intermediate, medium-speed backup storage (disc, bubble, or drum). This backup storage serves to make physically-addressible memory (RAM or ROM) appear larger to programs than it really is, or at least to appear as large as the processor's full addressing capability (8M bytes per Z8001 space). Such backup storage is optional. It can be made to provide *virtual memory* in complex system designs, because it and the memory manager effectively simulate an extension of last memory.

### Memory Partitions: Pages and Segments

Making memory available to programs is typically a task divided between hardware in a memory controller and software in an operating system. Memory can simply be made available in one full-sized space defined by the addressing range (65,536 bytes for 16-bit addresses), or it can be broken into partitions that are allocated to programs as needed. In some systems, this partitioning is related to the need for virtual-memory implementation, here the partitions are of equal size and are called *pages*. In other systems, variable sized partitions, called *segments*, are defined as the system runs; these segments may themselves be broken into pages for the purpose of efficient virtual memory implementation. (The Z8001 can address 128 segments, each as large as 65,536 bytes.) In any case, the allocation of physical memory in pages or segments provides one essential feature of effective memory management: *physical addresses are meaningless* to anything but the operating system; only *logical addresses* are emitted by programs running under the system. The system will map logical to physical addresses as needed.

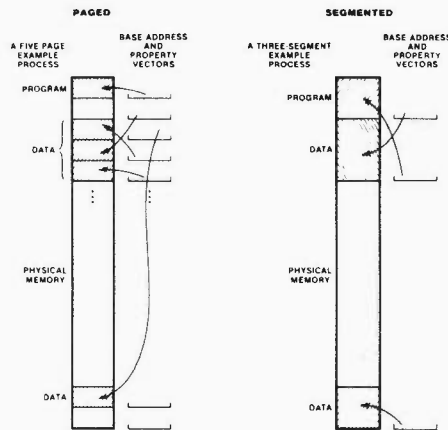


Figure 1  
Memory Partitions: Pages and Segments

### Relocation and Reentrancy

Divorcing the addresses used by all but the system programmer from those used to reach physical memory cells allows the operating system to place programs and their data anywhere it chooses within physical memory and still have them run properly. This is *relocation*. It depends, of course, on memory-control hardware that is programmable by the operating system dynamically. Such hardware will allow any address emitted legally by a program to be translated into the proper physical address holding that program or its data. (For the Z8001, such a programmable device, the Z8010, is available for memory management, but its specific capabilities will be described in a separate course.)

Dynamic relocation allows the operating system to provide efficient operation and other benefits to multiple users. A program may be physically located anywhere in memory and still be accessed by whatever logical addresses were defined when the program was assembled/compiled and linked. Thus, it can easily exist as exactly *one copy* of itself, but be used at the same time by many other programs, as if they were linked with it. A single copy of an editor program can, therefore, serve a hundred time-sharing system users, provided the system keeps their data (files) separate. This is *reentrancy*. Each program (task or user) being run by the system has its own logical starting address, which can be associated with any physical address — the address of the shared program, for instance. As long as data is kept in each user's space and the shared program contains only instructions, it is reentrant and can perform its service for each user in a sharing sequence defined by the operating system. Obviously, the savings in memory space are large and increase with the number of users. However, the memory-management hardware must translate logical to physical addresses and may need reprogramming to change the logical-physical relation as each user begins to run. There are both clear and subtle design considerations for these systems, and a combination of memory segmentation and paging with virtual support may be needed in the most general applications.

### Page/Segment Properties

Apart from relocation and reentrancy, memory management typically also implies that *properties* be established for memory pages and segments. For the Z8000, an examination of its *status outputs* suggests some useful properties that might be identified by management systems (some are allowed by the Z8010). *System versus normal mode*, for instance, can be used in multitask applications to segregate memory devoted to the operating system from memory assigned to tasks or users. Similarly, data, stack and instruction memory can be segregated for both system and normal mode — to prevent accidental execution of data. In the Z8002, this

allows six spaces of 65,536 bytes each to be distinguished. In the Z8001, this defines six spaces of 128 segments, each of 65,536 bytes, for a total of 48M bytes.

Memory management could thus consist of monitoring the AD15:0, SN6:0 (Z8001), ST3:0, and N/5 lines from the CPU to see if the present access is proper. If the access properties do not match those defined for that address (or segment) when the system was programmed, then some complaint to the operating system (a segment trap in the Z8001) can be registered by the memory controller/manager. Note that memory management is not a meaningless concept in Z8002 system designs, but requires custom hardware and software support.

Other properties can be assigned to page/segment areas according to the needs of the system being designed. Read-only areas are protected from unhappy accidents, execute-only are protected from accidents and theft. Some properties might relate to use by devices other than the CPU (say a DMA). These properties might also periodically be logically disconnected from the CPU, for instance, so that a new program area can be loaded or a closed file can be written out on disc. Memory management in general, therefore, is not CPU-centered but memory-centered. It relates the logical and physical structures as necessary to make memory efficiently available to devices on the system bus other than the CPU.

### Z8001 Segmentation with the Z8010 MMU

The Z8001 provides a firm basis for segmented memory management via segmented addressing and its provision for segment trap processing. External hardware (custom or the Z8010 Memory Management Unit) must be designed into the system to provide the particular features required. Segment numbers emitted by the Z8001 are logically distinct from the values on AD15:0 (the offset). Still they can be used in the simplest implementations as additional address bits that select among 128 64K areas for each relevant status output.

A segmented address, however, can be exploited more thoroughly when the supporting hardware (say a Z8010) is programmed to allow full relocation. The segment number then accesses the memory manager's internal memory at a particular set of locations. Those locations in turn provide a *previously programmed* descriptor for that segment. The descriptor not only defines the segment's properties (for example, read only), it also defines part or all of its starting location in physical memory.

The Z8001 and Z8010 are designed to work together in this way, and the actual address transformation used by the Z8010 is shown below.

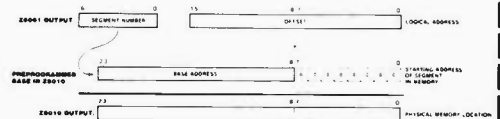


Figure 2  
MMU Address Translation

The segment number is simply an address into internal Z8010 RAM which produces a 16-bit, preprogrammed value. That value is then effectively shifted left eight bits and added to the offset portion of the logical segmented address. The result is the physical address of the target memory cell. This is under the control of the operating system which programs the Z8010 appropriately, perhaps before each user/task is run. Note that a 23-bit segmented logical address produces a 24-bit linear physical address, and that properties (system/normal, read/write etc.) are also stored in each segment's descriptor in the Z8010.

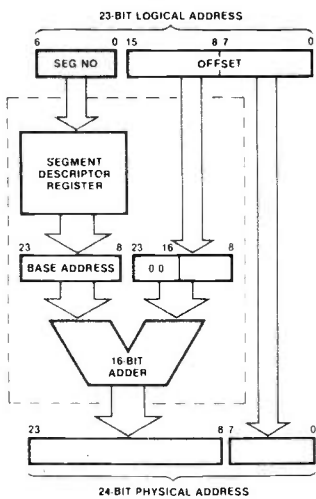


Figure 3  
Physical Address Generation in the MMU

The internal RAM access in the memory controller must be done before the offset is valid (during  $\overline{AS}$ ), so that the addition can take place. The Z8001 emits segment numbers *early*, in T3 or T4 of a preceding memory cycle, to give the Z8010 (or a custom memory manager) a chance to begin its work. The addition time then becomes critical in determining the speed of memory access. Addition has been simplified by allowing the lower offset byte (A7:0) to bypass the Z8010 and simply be concatenated logically to the rest of the computed physical address. Because of the implied timing concerns, the Z8010 must see the same clock as the Z8001. It is, therefore, not a Z-Bus peripheral, but a synchronous, CPU-support device.

Properties defined for each segment must be verified by the Z8010 for each memory access. The Z8001 must supply full status information to the Z8010 in a typical configuration:

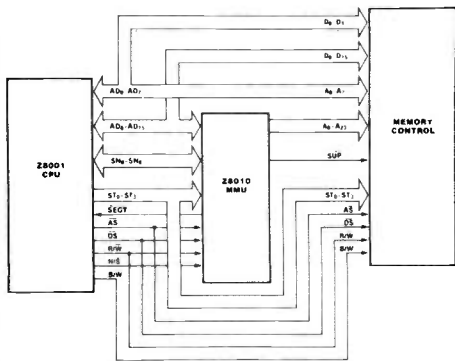


Figure 4  
The MMU in a Z8000 System

Thus, for instance, an attempt to write on a segment previously defined as read only by the system will cause the Z8010 to emit a segment trap request to the Z8001 (via SEGT), and tell memory to ignore the write attempt (via SUP).

Because nearly all status lines propagate to the Z8010, it can be programmed to enforce distinctions between data and program, and system and normal mode memory segments. Furthermore, in keeping with one purpose of segmentation, it will allow an upper or lower bound to be set on the size of a segment. Traps can thus be generated for a variety of violations. Depending on how they are serviced, these traps maintain the integrity of the overall system and allow the main features of segmented memory management to be realized. (Of course, the Z8010 is used here only as an example of memory-management hardware.)

#### Managing Memory Dynamically

It is important to understand that memory is managed *dynamically* as tasks/users run. Each program and data area needed to run a user is simply a relocatable set of memory segments, each of which has associated properties. Thus, segment numbers used by each program in addressing itself and its data have nothing to do (from the user's standpoint) with where those segments actually reside in physical memory space. Physical memory can be allocated to hold different users simultaneously, even if their programs contain some segmented addresses with identical segment numbers.

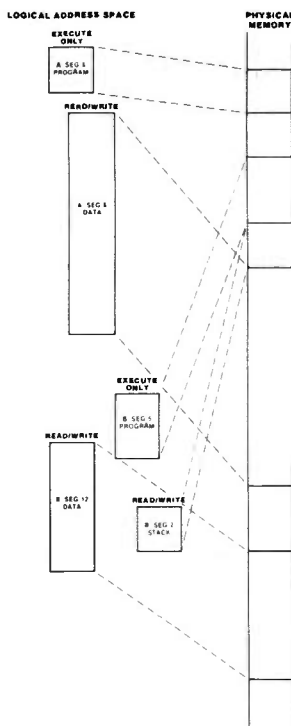


Figure 5  
Mapping Logical Segments to Physical Memory

In the above example, users A and B both refer to segment 5, but view independent *logical* addressing spaces whose segments have a variety of sizes and other properties of logical significance. However, the physical location of these spaces is irrelevant to their operation:

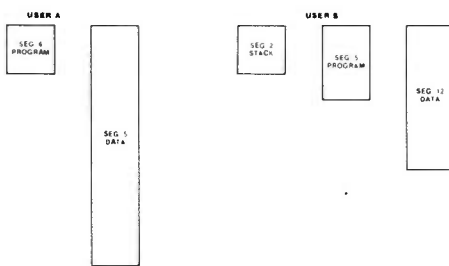


Figure 6  
Two User's Logical Address Space

Logical, segmented addresses used by programs can be mapped to any physical area (of sufficient size) by the operating system. Thus, segments can be *shared* from user to user as the system deems necessary. Reentrant programs can, of course, be shared as outlined earlier, and so can data: (see Fig. 7)

Though one user refers to the shared area as segment 2, the other user can choose to call it segment 7. So long as the system knows the data is to be the same and shared (such as a common file), it can manage the addressing appropriately when each user runs, by suitable control of memory-management hardware (e.g., some Z8010s). In some systems, in fact, one might simply devote sets of memory managers like the Z8010 to each user, enabling those programmed for user A's relocations when A runs, then disabling those and enabling B's when B's turn comes, and so on.

#### Segmentation Traps

Memory management is more than mere relocation and classification of memory areas. It must be supported by system software that responds effectively when errors occur — such as when a segment's bounds are overstepped or its properties are violated. For that reason, segmentation-trap routines can be invoked during the execution of *any* instruction that accesses memory.

A trap may be due to a clear error, such as a normal-mode access to a system-mode segment. Or, it may be an integral part of the overall management scheme. For example, it might be a warning that a Z8000 stack is about to overflow (its lower bound underrun), this allows the trap routine to find more memory for the stack before a fatal overflow. Trap processing may also be one mechanism for virtual-memory management.

#### Virtual Memory Management

Segments for all running users/tasks might not fit into available physical memory. Therefore, for some users only *some* of their segments may be in memory when they are to run. If the segments that are missing are marked in the memory manager (say a Z8010) as being nonexistent, a trap will occur at the *first* reference to any of them. In this case, the trap routine could read long-term or intermediate storage (disc, drum, etc.), retrieve the missing segments as they are needed, and restart the trapped access. Space for them must, of course, be found by bumping one or more other segments from memory. This, done effectively, gives the appearance, for each user, of a physical address space as large as the logical space, even though a user's actual physical memory may be small.

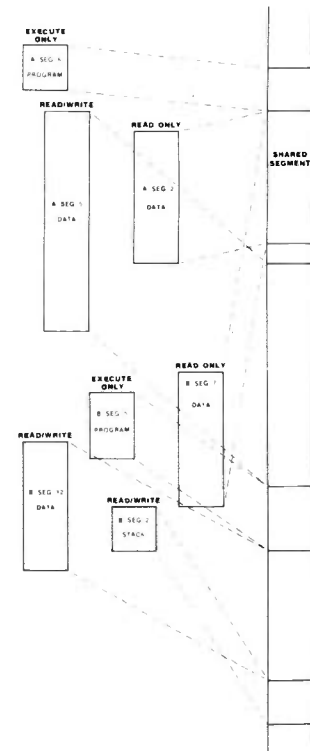


Figure 7  
Two Users Sharing a Common Segment

It is, therefore, important in an effective virtual-memory-management system to keep track of which segments have been used, how often, and in what way. Obviously a segment that has not been used at all since last being loaded into memory is a logical target for bumping when another segment must be brought in. Finer decisions, based on frequency of use, may need to be made if too few unused segments exist. Typically, the most frequently accessed segments should be kept in memory as much as possible. This leads to the notion of a *working set* or kernel of memory segments. For efficient servicing of a particular user/task, these segments should be identified by the memory manager and not only be kept in fast memory as much as possible but also be kept there as a unit. Without this statistically-identified working set in memory, the user cannot run efficiently.

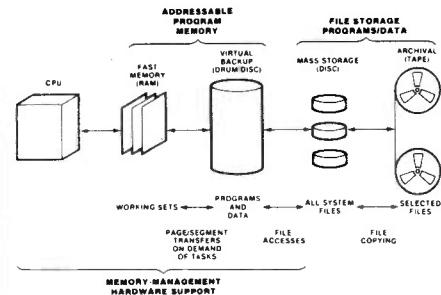


Figure 8  
A Large-System Memory Configuration

Virtual memory is clearly an extension of the simplest forms of memory management, whether segmentation is used or not. In Z8001-Z8010 systems there is some support for elementary management procedures that can be extended by system software to allow some forms of virtual memory simulation. For instance, the Z8010

maintains a primitive record of segment usage. Segments that have been written on can be distinguished from those that have only been read, and both can be distinguished from those that have never been accessed. This is not generally sufficient to establish true working sets for users, but it allows management software to identify segments that have or have not been used. For example, it can allow such software to decide whether or not to spend time writing a segment back to long/intermediate-term storage if it is to be bumped. Segments that are portions of files and have not been written on (thus not changed) need not be rewritten to disc, for instance

### Demand Paging

Finally, it is important to understand that memory segmentation, used alone, requires a continuous physical chunk of memory for each logical segment, whatever its size. When such a system services many users/tasks over time, segments of widely-ranging size are brought in and out of memory. Whatever procedure is used by the management software, holes inevitably develop and none may be large enough to hold the next segment needed by a user. Thus another segment must be bumped, or the manager must reassign existing segments to coalesce holes into a usable piece of memory. This, in general, is a difficult mathematical problem that has no method of guaranteed solution (no algorithm). It was a significant limiting factor in early timesharing systems

One approach to solving this fundamental problem is called *demand paging*. Just as segments can be moved into and out of memory as tasks need and release them, paged memory can be managed in the same way. Since pages are all of equal size, there are no holes going to waste and virtual-memory-management software can concentrate on statistical analysis of each task's page demands to establish working sets. Demand paging, of course, requires a larger hardware investment, since relocation, property and usage data must be provided for each physical page.

This leads to a tradeoff, because mathematical analysis and experience both show a clear relationship between page size and optimal performance in virtual-memory systems: up to a point determined by the seek and transfer times of the backup (virtual) storage (drum, disc, etc.), the smaller the page size (in words) the better. Values in the range of tens to hundreds of words are typical. When files are also paged, page size determines storage compactness, because on the average, half of the last page of any file is empty.

Segmentation can be imposed on a paged hardware environment, to gain many advantages of both approaches. The Z8001 and Z8010 cannot, however, support more than straightforward segment management based on relocation, sizing, protection and other access parameters.

## PERIPHERAL MANAGEMENT

### Z-Bus Peripheral Interface

As the first of a family of Z-Bus processors, the Z8000 interacts with Z-Bus peripheral devices in a straightforward manner. Furthermore, because Z8000 timing cycles are modular, the timing of I/O transfers is quite similar to that of memory transfers — with the addition of one default wait state (TWA).

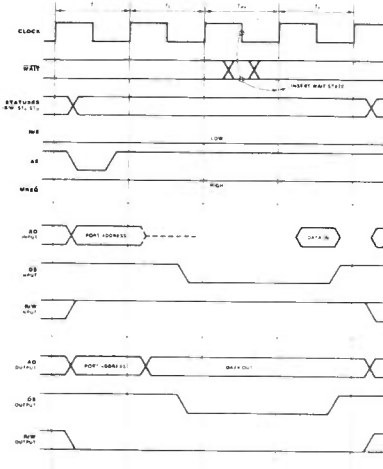


Figure 9  
I/O Transfer Cycle Timing

Because only AD15:0 are used to address normal Z-Bus devices, segmentation mode in the Z8001 has no effect on I/O operation. The Z8002 and Z8001 thus deal identically with I/O devices. Because address and data

transfers are asynchronous, all peripheral clocks may be independent of the CPU clock. Clock, therefore, is not a Z-Bus signal and would only be needed if non Z8000-family peripherals (Z80, for instance) were used.

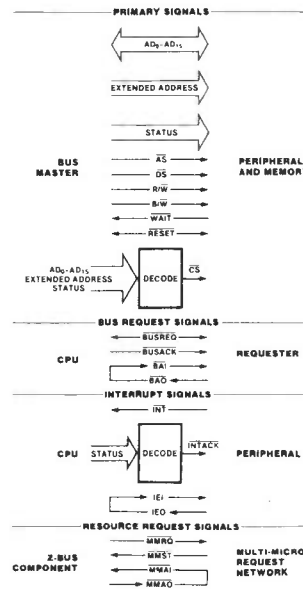


Figure 10  
Z-Bus Signals

The status outputs from the CPU (ST3:0) can be used for various purposes. The ST3:0 lines can and should be decoded to acknowledge peripheral interrupts; they can also be used to define two 16-bit peripheral address spaces by conditioning chip selects with the special/normal I/O distinction: (see Fig. 11)

### Basic Z-Bus Transactions

There are four basic types of Z-Bus transactions: memory, peripheral, bus-sharing, and multiprocessor. The latter three types are discussed here.

### Peripheral Transactions

From the standpoint of a normal Z-Bus peripheral, general interactions with a Z8000 require normal asynchronous addressing. This ultimately activates a chip

ST3:ST0	MEANING
0000	INTERNAL OPERATION
0001	MEMORY REFRESH ACTIVE
0010	I/O REFERENCE
0011	SPECIAL I/O REFERENCE
0100	SEGMENT TRAP ACKNOWLEDGE
0101	NONMASKABLE - INTERRUPT ACKNOWLEDGE
0110	NONVECTORED - INTERRUPT ACKNOWLEDGE
0111	VECTORED - INTERRUPT ACKNOWLEDGE
1000	DATA MEMORY REQUEST
1001	STACK MEMORY REQUEST
1010	DATA MEMORY (EPU)
1011	STACK MEMORY (EPU)
1100	INSTRUCTION FETCH, NTH WORD (CODE MEMORY)
1101	INSTRUCTION FETCH, FIRST WORD (CODE MEMORY)
1110	EPU TRANSFER
1111	RESERVED

Figure 11  
The ST Outputs

select input to a particular peripheral, followed by an asynchronous data read or write of byte or word size. Since 16 bits of addressing are provided and normal/special I/O is a possible segregation, 131,072 peripherals could be distinctly accessed — segmented (extended) addresses being relevant only for Z-Bus memory transfers.

If *interrupt generation* is allowed, then each peripheral to be serviced in that manner must have its interrupt output line (INT) connected to the appropriate interrupt input (NMI, VI, or NVI) of the CPU. In addition, each peripheral must receive an acknowledgement of its interrupt from the CPU via its INTACK input. This signal is decoded from ST3:0 by user-designed hardware to provide an *acknowledge signal* appropriate to the particular interrupt line on which the peripheral made its interrupt request.

### Priority Daisy Chain

It is generally necessary to include more than one peripheral in the set serviced by a particular type of interrupt (NMI, VI, NVI). In this situation a priority or ranking is also typically established for each peripheral in an interrupt set. The Z-Bus definition supports a particular method of connection called a *priority daisy chain*:

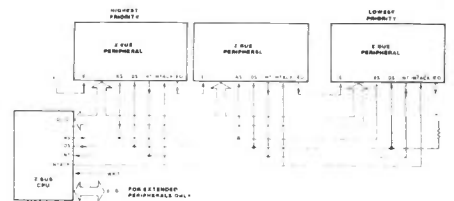


Figure 12  
Z-Bus Peripheral Daisy Chain

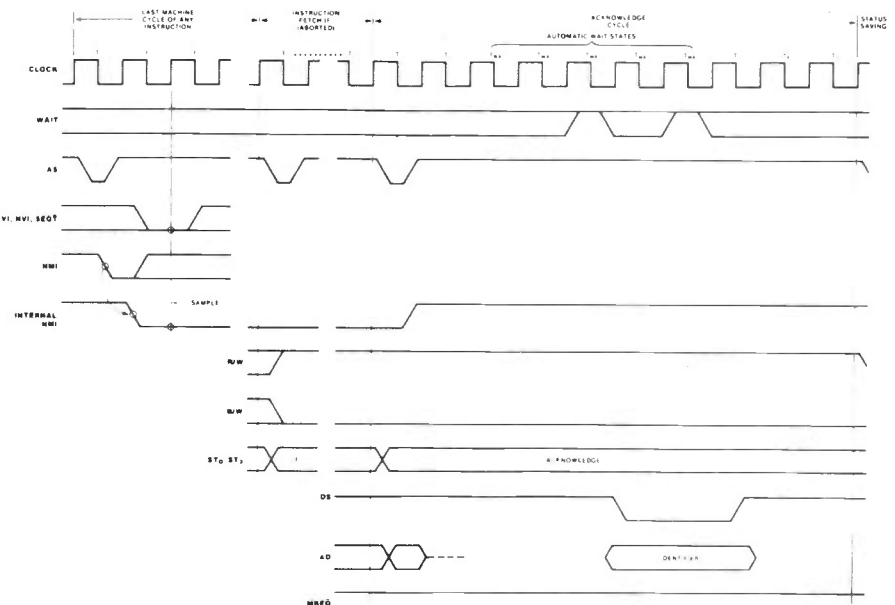


Figure 13  
Interrupt Acknowledge Timing

Two signals, IEI (Interrupt Enable In) and IEO (Interrupt Enable Out), link the chained peripherals. Each peripheral can tell, via its IEI line, if a higher priority device (to its left in the figure) has received an acknowledge signal from the CPU and is being serviced.

A given peripheral must obey at least the following rules to be a socially acceptable member of a Z-Bus daisy chain:

- Copy IEO from IEI unless it has received acknowledge;
- Pull IEO low and begin service if acknowledge is received for its INT request and IEI is high;
- Provide slight delays in making such decisions to allow for daisy-chain propagation time; and,
- When service is complete, release IEO so lower priority devices that have been waiting can get service.

The Z8000 provides, via its *interrupt-acknowledge cycle*, adequate time for such daisy chains to settle priority conflicts for simultaneous interrupts from chains as long as ten peripherals. Five default wait states are included in the acknowledge portion of the cycle; they determine when an interrupt vector may be sent from the peripheral to the CPU. (see Fig. 13)

In a normal protocol, interrupting peripherals on a chain assert INT until acknowledge is received (after the current CPU instruction terminates). They resolve priority by looking at IEI when DS goes low. The winning peripheral is then considered *under service*. It lowers IEO, releases INT, perhaps sends back a vector when DS goes high, and awaits the running of its service routine.

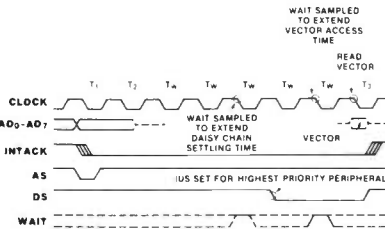


Figure 14  
Peripheral Daisy Chain Timing

Apart from the default wait states, Z-Bus peripherals can delay their priority resolution by asserting WAIT in the clock period before DS goes low. The winner can delay its vector response by again asserting WAIT as needed.

Peripherals connected to the VI input of the Z8000 are not alone in being able to respond with vectors during acknowledge. The content of the 16-bit bus is sampled by the CPU at T3 in the cycle and this value is pushed on the system stack. Any service routine run in response to any interrupt may actually receive useful information in this way. The peripherals on a VI chain are, of course, obligated to respond with an 8-bit value on the low half of the bus. This value is then used to index into the VI subarea of the status area. The high-order byte is, therefore, freely usable even in the VI case, so long as all 16 data lines propagate between peripheral and Z8000.

**Byte and Word Peripherals**

Memory and I/O transactions are logically quite similar in the Z8000. Thus, *byte or word peripherals* may be used, as long as bytes that are to be read by the CPU are put on the right half (or both halves) of the bus by the peripheral. Address line A0 determines this. If A0 is high, the Z8000 will execute an input byte (INB) instruction by simply reading the lower eight data lines. If A0 is low, the upper byte will be read. The position (odd or even) of a peripheral in the I/O address space is important, but only during reads (and acknowledge), the Z8000 duplicates written bytes during output byte instructions, just as it does when dealing with memory writes.

**Interrupt Service Routines**

Normally, interrupt requests result in *context switches* within the Z8000 (by status changes). These cause particular interrupt subroutines to run when the acknowledge cycle is complete. At this instant, one peripheral will know it is under service and it will be ready to handle reads and/or writes produced by its service routine. When the routine has completed its tasks, however, the peripheral must be told it is no longer under service. With Z-Bus devices, this is done simply by writing to a control register within the peripheral. A service routine can thus terminate a peripheral's current activity, do whatever other bookkeeping is required, and finally execute an IRET instruction to restore the Z8000's status (FCW and PC) to the values in effect before the interrupt occurred.

**Nested Interrupts**

Service routines can also be interrupted if the FCW contains interrupt bits that are on. This is, of course, under the routine's control. Such *nested interrupts*, however, must also prevent more than one peripheral from thinking it has the CPU's attention. The IEI-IEO daisy chain also handles this. A peripheral knows if it has interrupted and been acknowledged. If acknowledge re-occurs and its IEI line goes low, it knows that a higher priority device has gone under service and the original service routine is not running. This nesting is totally dependent on the value of FCW established in the status area for the first interrupt routine and on any EI (enable-interrupt) instructions it might have executed.

Within the Z-Bus family, peripherals themselves may be compounded of standard building blocks some of which are *not* true Z-Bus devices. The Z8038 buffer is a Z-Bus component, but its depth may be extended with interposed Z8060s, which are not Z-Bus devices.

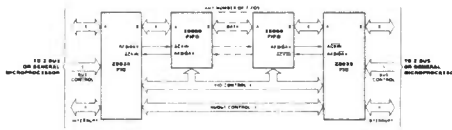


Figure 15  
An Extended FIFO Storage Peripheral

**System Bus-Sharing**

CPUs like the Z8000 possess the ability to remove themselves from the system's address/data bus if necessary. For example, a request by a DMA (direct-memory-access) device can be made via the BUSRQ line to the Z8000 during any of its instructions. At the end of the current memory, I/O or other cycle, the request will be acknowledged, the Z8000 will float its bus connections (see Lesson 1) and the DMA can use these to access memory at will.

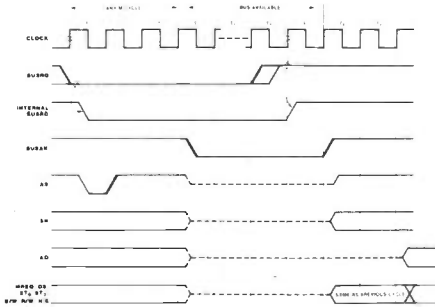


Figure 16  
Bus Request and Acknowledge Timing

When the bus-sharing device is finished, it releases BUSRQ and the Z8000 (or other waiting device) resumes bus activity.

Just as daisy chains can be used to resolve priority of simultaneous interrupt requests, so can they be used with bus requests.

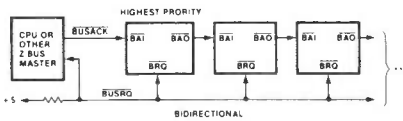


Figure 17  
Bus Request Daisy Chain

The Z-Bus structure allows *nonpreemptive* (no nesting) sharing of the bus. BUSRQ provides both a request path and a busy-bus indicator to all bus-sharing devices. The protocol is, therefore, that a device must first look at BRQ to see if it is busy. If it is, the device waits. If it is not, the device asserts BUSRQ (same line) and waits for the acknowledge signal (BUSACK) to propagate through the chain to its BAI input. When this occurs, as it eventually should, it raises BAO to forestall lower priority devices and then goes on to use the bus. When done, it simply releases BUSRQ and copies its BAI line to its

BAO line. This process is similar to interrupt daisy chaining except that nesting is impossible and the daisy chain signals are negative logic values.

**Resource Sharing in Multiprocessor Systems**

Multiple Z8000s may also share a resource and the Z8000 has been designed with some instructions and signals to allow this. The micro-in and micro-out lines ( $\mu I$ ,  $\mu O$ ), in conjunction with instructions that read and alter their values (MBIT, MSET, MRES and MREQ), are used here. They allow the system designer to write algorithms for managing chains of Z8000s which share a common resource in a *priority-managed, non-preemptive* way. The MREQ instruction, in fact, implements an algorithm that is complete and satisfactory for most purposes.

Given a device to be shared, along with some simple logic and some Z8000s, the Z-Bus definition allows a sharing structure to be created:

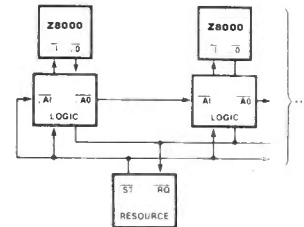


Figure 18  
Resource Sharing Daisy Chain

The resource (say a printer or a network path) simply exhibits a busy/free status output ( $\mu ST$ ) and accepts requests for use via an input ( $\mu RG$ ). The status line doubles as an acknowledge that feeds the priority daisy chain. The highest priority Z8000 is simply the one which observes resource status with no interference:

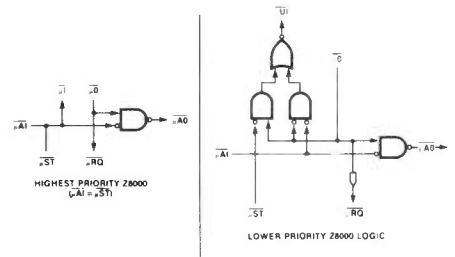


Figure 19  
Resource Sharing Logic

Lower priority Z8000s simply see either status or the daisy chain, depending on whether they have made a request ( $\mu O$  low) or not ( $\mu O$  high).

The protocol for sharing is: look at resource status (via  $\mu I$ ), if busy, terminate in failure; if not busy make a request (via  $\mu O$ ), float  $\mu AO$  and wait for acknowledge (via  $\mu I$ ), if after waiting the proper time no acknowledge appears, terminate indicating failure; if acknowledge occurred, terminate indicating success so that a service routine can use the resource; when done with the resource, release the request ( $\mu O$ ) and propagate the daisy chain input. This procedure is designed to let Z8000s communicate with a resource over great distances. Thus, the right time to wait when looking for acknowledge depends on communication path delays and must be established for each Z8000 empirically.

The Z8000's MREQ instruction, in fact, implements the entire algorithm. It uses the content of a word register to establish the waiting time, and it uses the S and Z flags in FCW to signal success or the type of failure to the system program. Note that this is essentially a system I/O instruction and, like all I/O, it can only be executed in system mode. The waiting time is determined by decrementing the register named in the instruction, at one-seventh the CPU clock rate, until zero is reached. The MREQ instruction is not interruptible and can be used to generate delays up to 90mS for 4-MHz clock rates if the resource-sharing function is not used.

The Z-Bus thus provides a wide variety of structures and device management in Z8000 systems. It is important to remember that it is a *logical specification*—timing signals, defining their electrical properties and timing relationships, and defining several levels of bus complexity — from simple to extended addresses for instance. It is not a physical structure in the sense of pin and connector specifications. That is up to the designer.



# Quiz for Lesson 4

## QUESTIONS

- For a program to be reentrant and shared by multiple users, it must:
  - A. Contain only instructions.
  - B. Be copied in memory once per user accessing it.
  - C. Exist only in virtual memory.
  - D. Be accessed by only one user at a time.
- Which of these Z8001 signals could be used to define memory segments?
  - A. SYSTEM/NORMAL.
  - B. ST3:0.
  - C. SN6:0.
  - D. All of the above.
- The Z8001 emits a segment number on the SN6:0 signals:
  - A. With the segment offset during a T1 cycle.
  - B. Once at the beginning of each program.
  - C. In T3 or T4 of a preceding memory cycle.
  - D. Asynchronously.
- A segmentation trap routine could be used to:
  - A. Support virtual memory management.
  - B. Issue a warning concerning memory usage and allocation.
  - C. Signal illegal memory accesses.
  - D. All of the above.
- Use of virtual memory involves:
  - A. Having to use a memory segmentation scheme.
  - B. Transferring files between physical memory and long-term or intermediate storage devices.
  - C. Addressing memory that does not exist.
  - D. The need for larger physical memory.
- The number of possible I/O peripheral address spaces for the Z8000:
  - A. Depends on whether segmentation is implemented.
  - B. Is larger for the Z8001 than for the Z8002.
  - C. Is defined by the ST3:0 signals.
  - D. Is defined by the SN6:0 signals.
- The Z-Bus structure allows:
  - A. Neither nested interrupts nor nested bus sharing.
  - B. Both nested interrupts and nested bus sharing.
  - C. Nested interrupts but not nested bus sharing.
  - D. Nested bus sharing but not nested interrupts.
- In a system without resource-sharing, the MREQ instructions can be used:
  - A. To generate timing delays.
  - B. To request a memory cycle.
  - C. As a NOP instruction.
  - D. To generate an illegal instruction trap.
- In a virtual memory system:
  - A. All users' segments are in physical memory at all times.
  - B. Some users' segments are in physical memory at all times.
  - C. Logical space sometimes appears smaller than physical address space.
  - D. Some users' segments may not be in memory when their programs are ready to run.
- Which of the following is *not* one of the four basic types of Z-Bus transactions?
  - A. Memory.
  - B. I/O.
  - C. Peripheral.
  - D. Multiprocessor.



## CAPTION COMPETITION

### Win this fabulous Akigawa AD901 multimeter



A FULL AUTO-RANGING  
DMM WITH 3½ DIGIT  
DISPLAY & CONTINUITY  
BLEEPER, PLUS:

- ★ Input impedance: (voltages) over 10MΩ AC-DC
- ★ Input impedance: (current) 200mA range, 1Ω
- ★ Automatic display of symbols, functions, polarity, decimal point and over-range.
- ★ DC Volts (AUTO) 200mV-2-20-200-1000V
- ★ AC Volts (AUTO) 2-20-200-600V
- ★ DC current (AUTO) 0-200mA, 10A
- ★ AC current (AUTO) 0-200mA, 10A
- ★ Resistance (AUTO): 200Ω-20kΩ-200kΩ-2000kΩ
- ★ Diode test facility
- ★ Dimensions: 160x80x30mm

To enter, simply write your suggested caption to the photograph on a postcard and send it to:

AUG '83 CAPTION COMPETITION,  
Radio & Electronics World,  
117a High Street,  
BRENTWOOD,  
Essex  
CM14 4SG

## CAPTION COMPETITION

# Q I N Q U I I O L U O N S

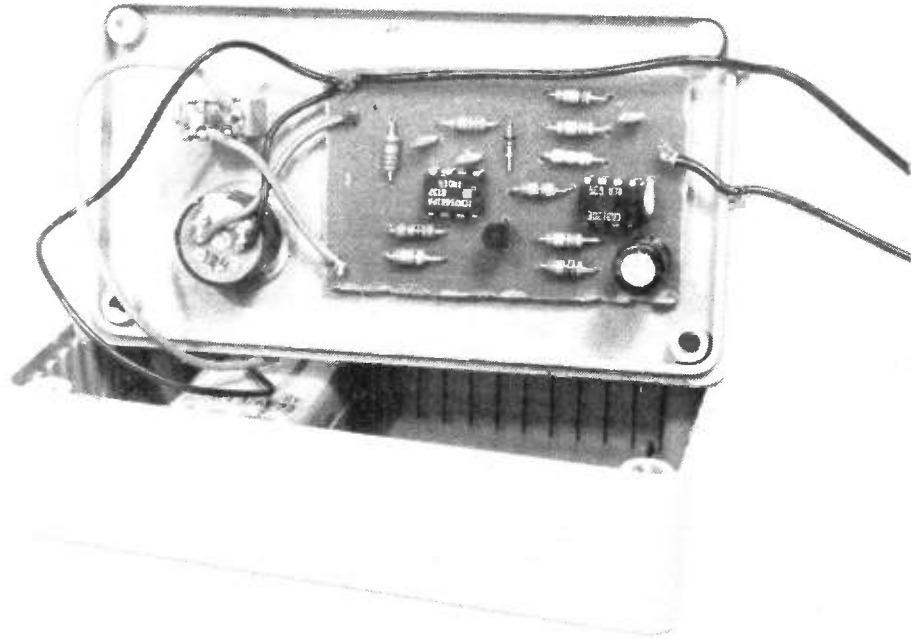
An extremely sensitive continuity tester.

Design by Colin Edwards.

This circuit provides a means of checking the wiring on a PCB or wired board with all the components inserted. At first glance its fairly straightforward, but with this circuit a very low voltage is applied to the board avoiding damaging any delicate components or obtaining misleading results from turning on semiconductor junctions.

The voltage between the probes is about 90mV and the unit will only sound on a resistance of less than 2 ohms.

Using a normal 555 timer, the current drawn when idle is about 15mA, so if you forget to turn it off, the battery soon goes flat. For a small investment (less than the cost of one PP3) a CMOS 555 can be used and the standby drain is reduced to less than 2mA. When the probes make contact the drain is 100mA – so don't leave it sounding for long.



## Circuit Description

Resistors R1 and R2 provide a voltage reference of 90mV. IC1 and Q1 form a voltage follower and hence produce 90mV across R6 and the probes. When the probes are shorted together the current required to maintain 90mV on R6 increases and so does the voltage at the top of R5.

While the voltage on the emitter of Q1 is low, R5 holds the timer (IC2) reset low. As soon as the voltage on R5 reaches approximately 2V, the reset is removed and the timer oscillates producing an audio tone.

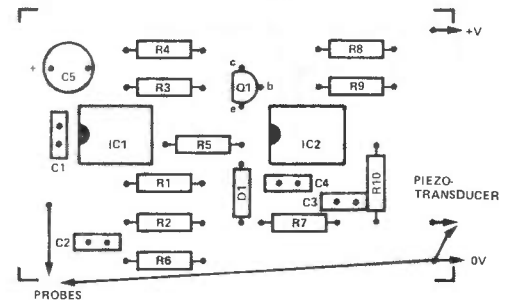
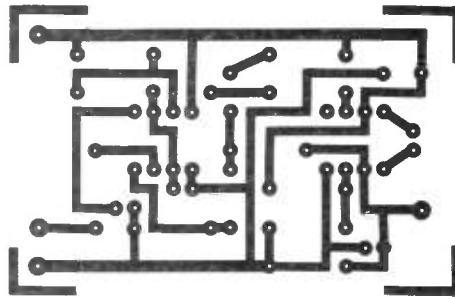


Figure 1: The PCB foil pattern (left) and component overlay (right) for the tester

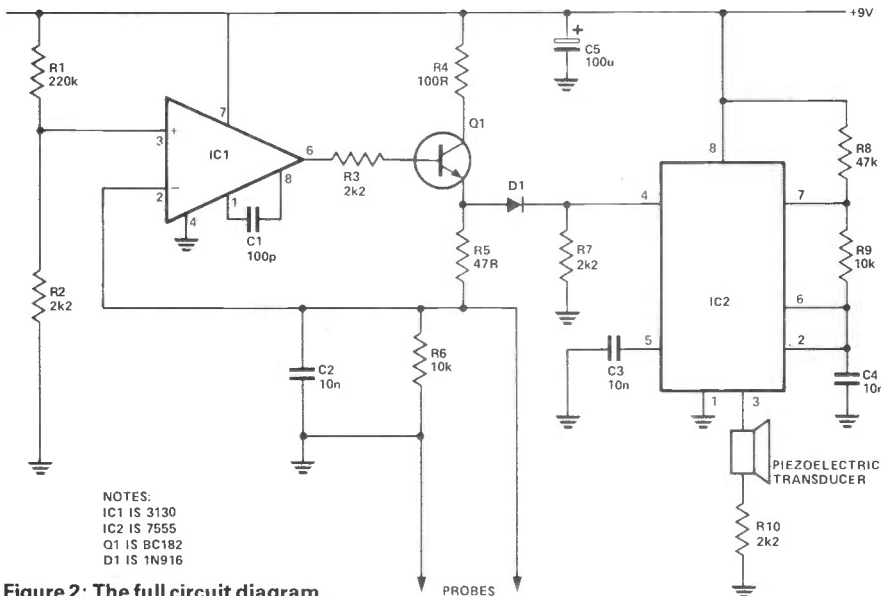


Figure 2: The full circuit diagram.

PARTS LIST	
<b>Resistors</b>	
R1	220k
R2,3,7,9	2k2
R4	100R
R5	47R
R6,9	10k
R8	47k
<b>Capacitors</b>	
C1	100p ceramic
C2,3,4	10n ceramic
C5	100u 16V al. electrolytic
<b>Semiconductors</b>	
D1	1N916
Q1	BC182
IC1	3130
IC2	7555
<b>Miscellaneous</b>	
Two test probes, PP3 battery, piezoelectric transducer.	

■ R&EW

RADIO & ELECTRONICS WORLD

# WELCOME ABOARD THE AIRWAVES

## A complete guide to getting started as a Radio Amateur. Compiled by Stephen Ibbs.

Since the introduction of CB there has been a considerable upsurge of interest in amateur radio. The World Administrative Radio Conference was held at Geneva in 1979 so that nations might discuss the various frequencies desired for TV, broadcast radio, defence, satellite telecommunications etc. Amateur Radio was defined as "a radiocommunications service for the purpose of self-training, intercommunication and technical investigations carried out by amateurs, that is, by duly authorised persons interested in radio technique solely with a personal aim and without pecuniary interest." This rather weighty sentence deserves closer examination. Leaving aside "radiocommunication", and what it actually is, there are three motives for amateur radio.

### 1. Self Training

This has unfortunately sunk to quite a low order of priority in many amateurs' minds, partly due to the influence of CB. Whilst it is wrong to hanker nostalgically for the old days of crystal radios and cat's whiskers, there are advantages in home construction, for instance, because the amateur is learning more about the electronics side of the hobby. Tremendous satisfaction can be gained from building a very simple piece of test equipment. The converse is also true however – radio operators not interested in home construction should not be condemned as second class. Amateurs interested primarily in operating, object to the implication that because they didn't build the rig they are not real amateurs. Self training also relates to operating procedure, and anybody listening to some popular bands or any band during a contest will realise the need for more self training. A contest is generally where amateurs try to get as many contacts as possible within certain restrictions. The effect of these can be devastating with overcrowding, treading on each others transmissions, bad manners etc. There is a body of opinion that believes that there are far too many contests, many arranged unilaterally, blocking off the bands for normal amateur use.

### 2. Intercommunication.

This is surely the central core of amateur radio and its appeal – the ability to talk to somebody anywhere in the world. My very first listening session with a battered old receiver brought in a very faint Italian station (unusual in itself as many amateurs will tell you – they are always tremendously powerful), telling somebody in America about a recent Italian earthquake. There is a world-wide network, whereby amateurs can confirm their contacts with each other by sending confirmation cards, known as QSL cards, and many people set great store by their collections.

The contact, however, does not have to be by voice. It can be by RTTY (teletype), morse code, or by television – yes, amateurs are allowed to transmit their own television pictures, and it is not as difficult as the BBC/ITV would perhaps suggest. Signals can be bounced off the ionosphere, off meteors, satellites, and even the moon, each demanding a different technique, skill and enthusiasm.

### 3. Technical Investigations

This obviously links up with self training and a great deal of experimental work still goes on – it has not yet all been discovered. Boundaries of communications are being broken all the time with the developing satellite systems and the new semiconductor devices for microwave work becoming cheaper and more available. Some of the most challenging work comes from operating very low power and trying to establish long distance (DX) contacts. A club exists which promotes low power work called the QRP club (these letters will be explained later), which promotes the use of very low power transmitters, often very simple to make.

### What Is Radio?

It all started in 1864 when J C Maxwell put forward the theory that invisible waves, as yet undiscovered, could travel through the air like sound and light, all being part of the electromagnetic spectrum. Nobody believed him. Then in 1888 H Hertz proved him right – if a wave of high enough frequency could be produced, it could be launched from a wire into the atmosphere. He developed a spark gap transmitter – a device that generated high voltage pulses between two spheres (Fig. 1). When another two spheres were placed some distance away – with no direct connection – sparks could be seen jumping

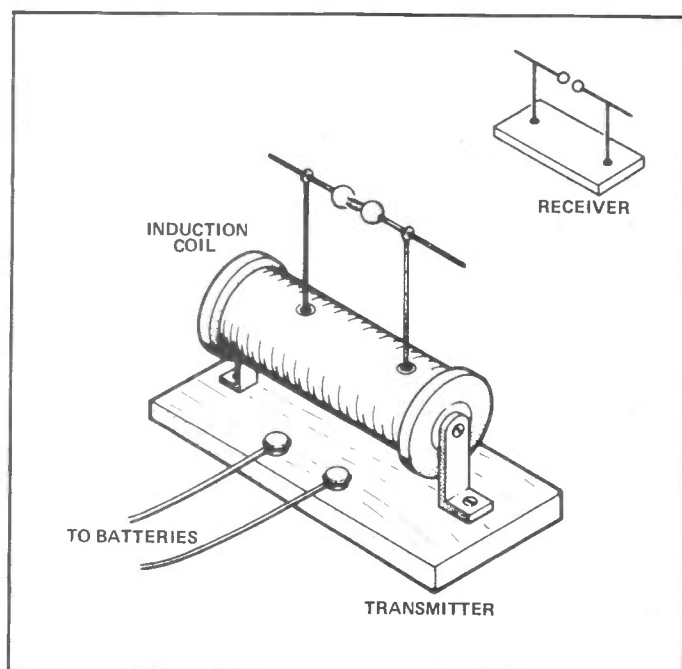


Figure 1: A 'Spark-gap' transmitter and receiver.

between the two receiving spheres. Wireless communication was born, because if the spark generation at the transmitter could be controlled, or modulated, the spark production at the receiver would follow the changes, and if done according to a system, messages in a coded form could be transmitted. Morse code is the simplest way of modulating the transmitter by switching it on and off in a set pattern.

Most people know that light waves vary in length, with red being longer than blue. Similarly, radio waves vary in length with different characteristics as the wave gets shorter. The size of the piece of wire needed to get the radio wave into the atmosphere (aerial), is directly associated with the wave's length – hence the plethora of different sized aerials for the various amateur bands. The early radio experts believed that all wavelengths below 200m (above 1.5MHz) were useless and so amateurs were pushed into this area. Far from being deterred, amateurs were soon contacting each other across the oceans, and the authorities realized that the usable radio spectrum was far wider than they had expected. The result was that they started taking huge chunks back off the amateur. With the rapidly increasing demand for radio, amateurs the world over are always under pressure from governments who want the amateur bands for their own use. However, we have retained several bands from HF, through VHF, UHF, microwave etc, up to 24 gigahertz (24,000 million cycles per second – though most activity is below 500MHz).

### A Licence To Transmit And Receive

There are two types of licences, A and B, and if the test of proficiency in morse code is not taken amateurs can apply for a B type licence, assuming the other qualifications are met, (see later), which allows use of any amateur band above 100MHz – the two most popular being 144 – 146 known as '2 metres' because of the approximate wavelength of the frequency, rapidly becoming overcrowded, and 430 – 440 known as '70cms'.

Many amateurs like to operate whilst mobile in a car and range can be limited because of aerial problems. To alleviate this, several 'repeaters' have been designed and built by amateurs for anybody to use but with priority to mobile or portable operators. These are completely automatic, sited usually on top of a hill. They pick up an amateur's transmission on the repeater frequency and retransmit it, usually with an increase in power. Good location of the repeater means that the signal can get further before being absorbed or reflected by hills and buildings. A comprehensive repeater system exists in most countries for both 2 metres and 70cms and most amateurs can tell you where the 'local box' is sited. Voluntary contributions are encouraged to help finance the repeater, but they are free and open for any amateur to use. Only one person can transmit at a time, because the box can't distinguish between two input signals on the same frequency.

Amateurs are all issued with a 'call sign' and each country has a different prefix – England being G----, Scotland being GM----, Australia is VK---- and New Zealand ZL----. Some (eg, Pacific Islands), may have only one amateur on them, so when he transmits the radio waves go crazy as thousands of amateurs try to contact him and get the precious, rare QSL card. Once the morse test has been passed, an 'A' licence can be applied for which allows use of all UK amateur bands – effectively meaning being let loose on the world. You will no doubt hear a lot of complaints about the morse test being archaic, why the test when CBers are on an HF 27MHz band. However, many are in favour of the morse test, because morse (known as CW) is by far the most effective form of communication and can be deciphered amidst large amounts of background noise. It is quite true that it is very easy to distinguish amateurs by their morse sending style and once mastered it is a surprisingly relaxed form of communication.

The RST code	
Readability	
<b>R1</b>	Unreadable.
<b>R2</b>	Barely readable, occasional words distinguishable.
<b>R3</b>	Readable with considerable difficulty.
<b>R4</b>	Readable with practically no difficulty.
<b>R5</b>	Perfectly Readable.
Signal Strength	
<b>S1</b>	Faint, signals barely perceptible.
<b>S2</b>	Very weak signals.
<b>S3</b>	Weak signals.
<b>S4</b>	Fair signals.
<b>S5</b>	Fairly good signals.
<b>S6</b>	Good signals.
<b>S7</b>	Moderately strong signals.
<b>S8</b>	Strong signals.
<b>S9</b>	Extremely strong signals.
Tone	
<b>T1</b>	Extremely rough hissing note.
<b>T2</b>	Very rough ac note, no trace of musicality.
<b>T3</b>	Rough, low-pitched ac note, slightly musical.
<b>T4</b>	Rather rough ac note, moderately musical.
<b>T5</b>	Musically modulated note.
<b>T6</b>	Modulated note, slight trace of whistle.
<b>T7</b>	Near dc note, smooth ripple.
<b>T8</b>	Good dc note, just a trace of ripple.
<b>T9</b>	Purest dc note.

Table 1: Details of the RST code.

### The RSGB

The body which exists to formulate policies and present them to the government is the Radio Society of Great Britain, which attempts to advise amateurs, represent their views and hopefully protect their interests. Amateur journals will reveal a great deal of unrest about the attitudes, real or imaginary, being displayed by the RSGB. Vitriolic statements have been voiced and written down, but possibly the truth lies in a failure of communication, and an inertia invariably present in large organisations. The RSGB seems to be primarily interested in protecting and enhancing the HF bands, with VHF, UHF and microwaves being thought of as a bit freakish. Whether this is a genuine attitude is irrelevant, because enough people believe it to make it an issue to be dealt with since most of the unrest comes from amateurs operating above 100MHz.

### Who's Who Of Radio Amateurs

Enough politics – how do radio amateurs recognise one another? There does not exist a freemason-like hand shake for hams and so radio societies and clubs throughout the country organise radio rallies – huge gatherings at country parks, exhibition halls etc where the latest black boxes can be purchased (commercial rigs, invariably from Japan, invariably black, a phrase often used to run them down in favour of a home-brew rig in a bent aluminium tin with a magically superior performance), cheap components are available and swaps can be arranged. In my own area of the West Midlands the local rallies occur at the National Exhibition Centre Birmingham, Drayton Manor Park, Elvaston Castle, Littleover School (Derby), Telford Shopping Centre. Most magazines,



# WELCOME ABOARD THE AIRWAVES

including R&EW, publish dates and venues and they are great for putting faces to call-signs and getting bargains – recommended for everybody who has an interest in amateur radio.

## Banding Together

The bands that an amateur can operate, range from 1.81MHz (known as Top Band) to 24 GHz where operation is experimental to say the least, and construction technique is probably aided by a microscope and micrometer. The HF bands (up to 30MHz) exhibit different characteristics, many of which are dependent on the sun. Rays ionise the atmosphere, and this causes certain radio frequencies to be bent and reflected back to earth, acting as a mirror so that signals can bounce off it, sometimes several times, to get all round the earth. Of all the HF bands, probably 14 — 14.350MHz, known as 20 metres, is the most consistent and popular for DX work. 21 – 21.450MHz is also a popular band, not for having thousands of Americans on, but because the bottom segment has 'novice Americans' able to transmit and receive slow morse, and listening to them is a good way of learning CW. 28 – 29.7MHz has very similar characteristics to the CB band so close to it, but the difference is that amateurs can operate up to 400 watts PEP and have exotic aerial arrays.

VHF bands incorporate 70.025 – 70.5MHz, very scarcely populated, which is a pity because it has characteristics that probably make it a better band for mobile work than 2 metres. Rumours are always around that we are going to lose the band – which is admittedly why I have never bothered to equip myself for it. Also in the low VHF region, some amateurs have been granted a special licence for investigative work at 50MHz (occupied by the old VHF TV network), and many are optimistic about getting a slice of frequencies around 50MHz eventually. This could be very interesting because American amateurs, for instance, already have the band, meaning that commercial equipment is available and DX contacts possible. R&EW has already published a design to enable operation on this band, should we ever get it.

Without doubt, the 2 metre band is one of the most popular amateur bands – being available to new licencees – with an abundance of equipment, home brew designs, etc, being available. It is a rare amateur that does not have a 2 metre rig, and one result of this, and the extensive repeater network, is that the band is rapidly getting overcrowded, generating a greater interest in 70cms. Unfortunately, it is also one of the worst bands for offenders without an amateur licence, which prohibits (amongst other things) bad language and transmitting without the call sign being given.

Partly as a desire to get away from this, many migrate up to the 70cms band, which has an increasing amount of equipment becoming available. It is very similar to 2 metres, but because the frequency is much more affected by buildings, hills etc, distance contacts are more difficult.

The once totally ignored microwave bands, the lowest being 1.3GHz are attracting more interest and some repeaters have appeared. Techniques are more difficult, and good quality cable and connectors are a must (the popular PL259/S0239 used in CB rigs are not recommended). The additional millimetres of PCB track can make all the difference between working and a dud, so it is not recommended for beginners. However, there does still exist the experimental thrill of hearing somebody else – anybody else.

## Amateur Accoutrements

With all these bands available, how do you use them? What equipment is available and how is it driven? To listen to a signal, you need a receiver and to communicate with others

<b>QRG</b>	Will you tell me my exact frequency? Your exact frequency is . . . . . kHz.
<b>QRH</b>	Does my frequency vary? Your frequency varies.
<b>QRI</b>	What is the tone of my transmission? The tone of your transmission is . . . . . (amateur T1–T9).
<b>QRK</b>	What is the readability of my signals? The readability of your signals is . . . . . (amateur R1–R5).
<b>QRL</b>	Are you busy? I am busy. Please do not interfere.
<b>QRM</b>	Are you being interfered with? I am being interfered with.
<b>QRN</b>	Are you troubled by static? I am troubled by static.
<b>QRO</b>	Shall I increase power? Increase power.
<b>QRP</b>	Shall I decrease power? Decrease power.
<b>QRQ</b>	Shall I send faster? Send faster.
<b>QRS</b>	Shall I send more slowly? Send more slowly.
<b>QRT</b>	Shall I stop sending? Stop sending.
<b>QRU</b>	Have you anything for me? I have nothing for you.
<b>QRV</b>	Are you ready? I am ready.
<b>QRX</b>	When will you call me again? I will call you again at . . . . . hours.
<b>QRZ</b>	Who is calling me? You are being called by . . . . . (on kHz).
<b>QSA</b>	What is the strength of my signals? The strength of your signals is . . . . . (amateur S1–S9).
<b>QSB</b>	Are my signals fading? Your signals are fading.
<b>QSD</b>	Is my keying defective? Your keying is defective.
<b>QSL</b>	Can you give me acknowledgement of receipt? I give you acknowledgement of receipt.
<b>QSO</b>	Can you communicate with . . . . . direct or by relay? I can communicate with . . . . . direct (or by relay through . . . . .).
<b>QSP</b>	Will you relay to? I will relay to . . . . .
<b>QSV</b>	Shall I send a series of VVVs? Send a series of VVVs.
<b>QSY</b>	Shall I change to another frequency; Change to transmission on another frequency (or on . . . . . kHz).
<b>QSZ</b>	Shall I send each word more than once? Send each word twice.
<b>QTH</b>	What is your location? My location is . . . . .
<b>QTR</b>	What is the correct time? The correct time is . . . . . hours.

Table 2: Amateur 'Q' codes (a question mark indicates the interrogative form).

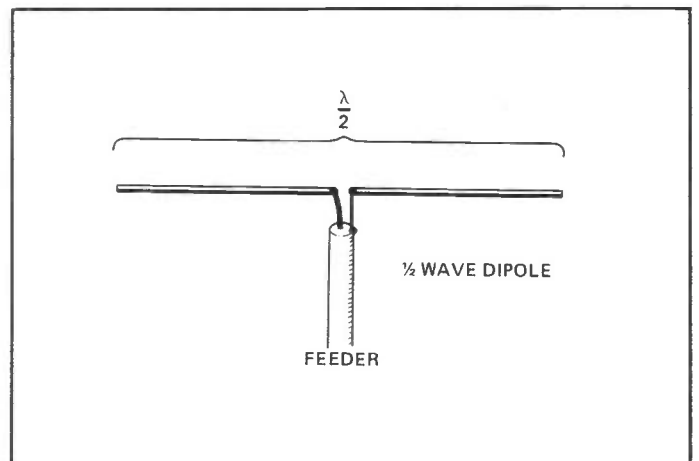


Figure 2: Basic half-wave dipole aerial.

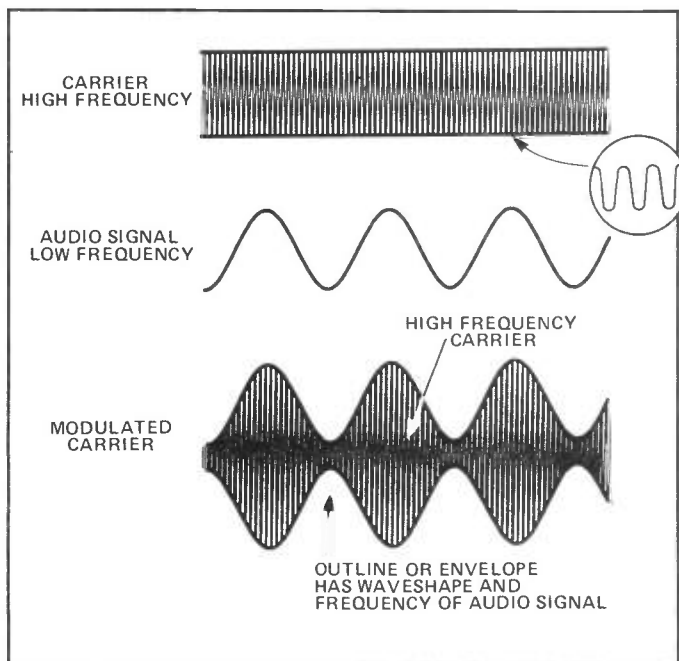
you need a transmitter. Combine the two together and you have a transceiver. A brief glance at any radio magazine will show that each manufacturer has *the* definitive rig – the one by which all others are judged. Most are now bristling with microprocessors (computer controlled), lights and beeps, to the extent that we are surely only one step away from rigs doing the actual contact for us.

The main requirement for a receiver is: sensitive – able to hear faint contacts; selective – able to isolate them so that they are separate from other transmissions; and stable – when found the contact isn't lost due to the receiver frequency drifting away. Many books have been written about receiver design and anybody preparing for the RAE will soon come in contact with TRF, heterodyne, front end, cross-modulation; terms that may sound alarming but in fact very soon make sense (see R&EW July '83).

A transmitter needs to produce the desired frequency at the desired power, with some sort of modulation applied, whether by voice, morse-key etc. It too must be very stable otherwise the receiving station will need constant adjustment to stay with the transmission. If the power is not sufficient, it is possible to add power amplifiers to boost the output up to (and beyond) the legal limit. These are called 'linear' because they amplify with no distortion – very important if the transmission is SSB (single sideband), but not as efficient as a 'class C' amplifier which produces more distortion but is suitable for FM transmissions.

## Some Technicalities

Earlier on, we mentioned the word 'modulation' – the means by which a radio wave is affected to carry information or speech from the transmitter to the receiver. To try and explain the different types in a couple of sentences is impossible, but at the risk of over-simplification the following may help. A radio wave can be drawn as in **Fig. 3**. If this is combined with another



**Figure 3: Amplitude modulation — a HF signal is modulated by an audio signal, varying its amplitude.**

signal (eg, a sine wave), the effect will be: the carrier now being affected in its strength/loudness/amplitude. The wave has been amplitude modulated (AM). Instead of a sine wave, it can also be controlled by speech, music etc, and the result is what you

<b>QRA</b>	Address
<b>QRG</b>	Frequency
<b>QRI</b>	Bad note
<b>QRK</b>	Signal Strength
<b>QRM</b>	Interference from other stations
<b>QRN</b>	Interference from atmospheric or local electrical apparatus
<b>QRO</b>	High power
<b>QRP</b>	Low power
<b>QRT</b>	Close down
<b>QRX</b>	Stand by
<b>QSB</b>	Fading
<b>QSD</b>	Bad sending
<b>QSL</b>	Verification card
<b>QSO</b>	Radio contact
<b>QSP</b>	Relay message
<b>QSY</b>	Change of frequency
<b>QTH</b>	Location

**Table 3: The use of 'Q' codes as nouns.**

hear on the long and medium wave broadcast bands. The disadvantage is that it uses up a lot of radio space, called bandwidth. If **Fig. 3** is looked at again, it will be seen that one half (sideband) of the diagram is a mirror of the other (carrying identical information), so if only half was transmitted the receiver would still collect all the necessary information, but with only half the bandwidth being used. A study of the various processes involved has shown that half the transmitter power is used in transmitting the original carrier wave, which in itself carries no information. If this can be cut out, more power can be concentrated on sending out the information. However, this is not as simple as it may sound, because the receiver has to put back this carrier wave, albeit at very low power, to understand the transmission, otherwise it's like coding a message and then throwing away the code. This form of transmission is known as SSB (single sideband), and receivers equipped for it will have a CIO (carrier insertion oscillator) or BFO (beat frequency oscillator) control to reinsert the carrier (if this is not adjusted properly the reception sounds like 'Donald Duck').

Instead of affecting the amplitude, the carrier wave can be modulated by moving its frequency slightly from side to side. Information can be sent depending on how far it moves and how quickly. This has proved to be an extremely effective form of communication, known as FM (frequency modulation), and very high quality transmissions can result. For amateur radio communication, such quality is not needed and effective speech transmission only needs about 5kHz bandwidth ( $\pm 2.5\text{kHz}$  either side of the centre frequency). Known as narrow band FM, it enables many channels of communication to be crammed within a small frequency band. FM, for various reasons, tends to be easier to resolve (tune in), and tends to cause a lot less interference to other radio users.

## Investigating Interference

A radio transmitter can be a very complicated piece of equipment, particularly if a synthesiser is used. This generates the various radio frequencies needed to operate over a full amateur band, eliminating the need for separate frequency generators (oscillators). Unless great care is taken, spurious radio frequencies can emerge and mix with each other to cause interference. Even a rusty bolt on an aerial mast has been known to cause interference. However, it should be said that

very often the fault lies within the receiver. Part of the revenue for the amateur and CB licences goes to provide an interference investigation department, and no doubt many amateurs will have experienced the somewhat unnerving arrival outside the front door of a yellow van with aerials all over it. Loaded with sophisticated equipment, these test the transmissions and trace the cause of the interference, hopefully with little blame resting on the amateur. The licence does require that transmissions 'cause no undue interference to other radio users' and note that word 'undue'.

To eliminate all interference is virtually impossible and sometimes tact and diplomacy are called for to say whether the tiny, imperceptible mark on the TV screen is acceptable or unacceptable. Various sorts of interference aids, suppressors, braid breakers, filters, ferrite rings etc, are available and are usually effective in solving the problem. Attention to detail when setting up the station also helps to reduce potential causes of interference. Good quality connectors and leads should link the various items of equipment together. Most modern transceivers have good filtering on the output to get rid of all but the desired frequency. Otherwise a filter, low pass for the HF bands, band pass for the VHF/UHF bands, should be inserted in the path to the aerial, which needs to be well tuned and matched.

## Special Duties

Under the terms of the licence, amateurs are required to assist in times of emergency. An organisation called the Radio Amateur Emergency Network (formerly known as RAEN, now RAYNET) was established for this purpose. It is curious that if CB operators help the police in an operation, it receives wide media coverage, yet the highly efficient RAYNET groups receive few accolades. When there was an ambulance strike some time ago, radio amateurs provided the important communication services to control the St John's ambulances. They have also been vital factors in finding missing persons, or helping during floods etc.

RAYNET went through a period of uncertainty last year, whilst licences were being reviewed, but I was assured at the NEC rally that all is now fine and they are back with renewed vigour.

Another amateur organisation, The Radio Amateur Invalid and Blind Club (RAIBC) is worthy of mention here. Radio is a marvellous hobby for the disabled or handicapped, and this society exists to help them overcome their difficulties; from passing the exam to operating. Able amateurs help by installing equipment and aerials, whilst others design special aids (eg, a talking frequency meter, or an automatic power/SWR meter). Their publicity handout states: "There are now ways of overcoming almost every obstacle, even deafness, by adapting standard equipment, positioning microphones etc to suit the needs of each individual".

One final organisation worth mentioning is BYLARA — The British Young Ladies Amateur Radio Association. The term 'young' is employed in its widest possible sense, and stems from the common amateur abbreviation 'YL', meaning a female. There is a rapidly increasing number of female operators, and far from the traditional image of being an all-male preserve, they have proved to be effective and competent operators.

## ADDRESSES

Home Office,  
Radio regulatory dept,  
Radio regulatory div,  
Licensing branch (Amateur),  
Waterloo Bridge House,  
Waterloo Road,  
LONDON SE1 8UA

RAIBC,  
Mrs. Frances Woolley G3LWY  
9 Rannoch Court,  
Adelaide Road,  
SURBITON,  
Surrey KT6 4TE

BYLARA,  
Anglica Voss (Editor, mag),  
PO Box 49,  
COLCHESTER,  
Essex CO4 3SF

RSGB,  
Alma House,  
Cranborne Road,  
POTTERS BAR,  
Herts EN6 3JW

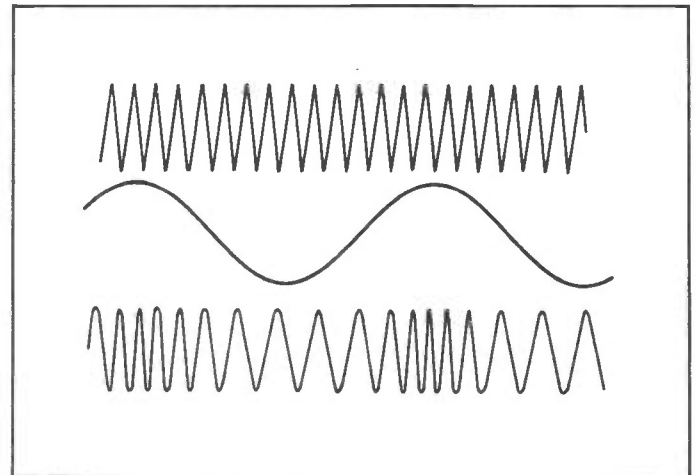


Figure 4: Frequency modulation — again the HF signal modulated, but by varying its frequency.

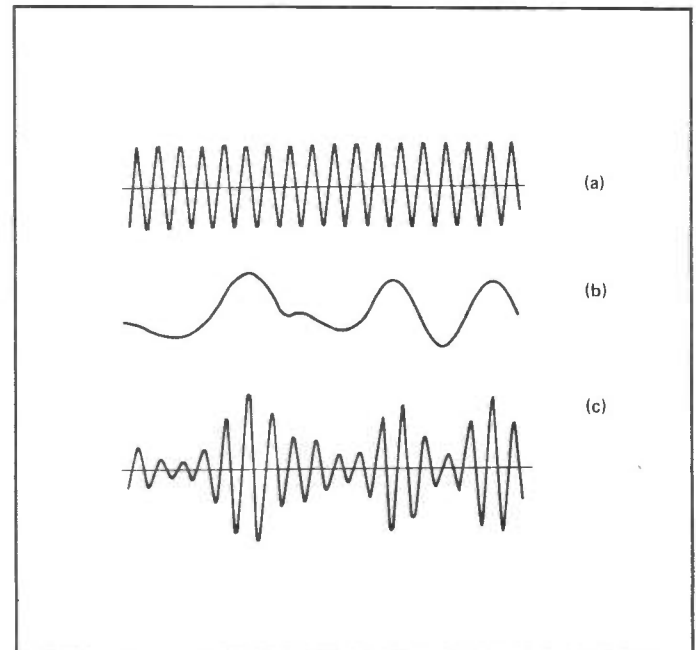
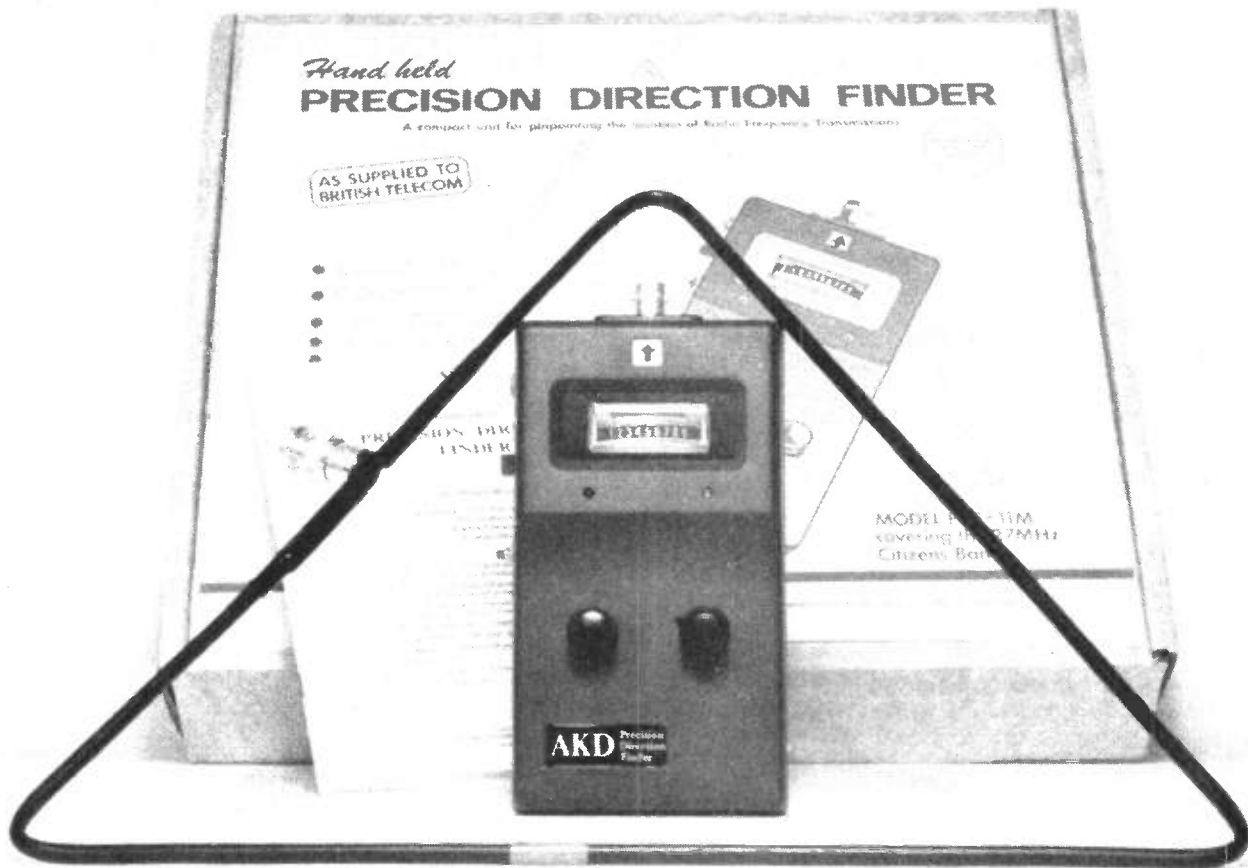


Figure 5: Amplitude modulation for telephones. The HF signal (a) is modulated by a speech waveform (b) to produce the speech modulated signal (c).

## LIST OF RECOMMENDED BOOKS

- 'How to become a Radio Amateur' (Home Office, Waterloo Bridge address)
- 'A Guide to Amateur Radio' (RSGB)
- 'Radio Communications Handbook', 'Vols 1 & 2 (RSGB)
- 'Radio Amateur Handbook' (ARRL)
- 'Passport to Amateur Radio' (IPC), Westover House, West Quay Road, Poole, Dorset.
- 'Radio Amateurs' Examination Manual' (RSGB)



# PDF – 11M

**A hand-held Precision Direction Finder from AKD.**

**Review by John Mills.**

The Precision Direction Finder (PDF) recently announced by AKD of Hendon, provides a compact unit for pinpointing the location of radio frequency emissions centred around the 27MHz Citizens' Band. As distinct from standard direction finding receivers, the PDF is designed for definitive location of close proximity radio transmissions.

As the unit is essentially of broad-band design, it is not necessary to know the exact frequency within the band.

The PDF-11M is supplied with a very compact antenna, unusually designed in the shape of a triangle. It gives the PDF a range of up to a few hundred metres, dependent on the ERP of the offending transmitter. For longer distances, the standard antenna can be replaced by a beam antenna which will increase the range considerably. However, it will only give an approximate bearing and once homed in, the special aerial should again be used to pinpoint the source.

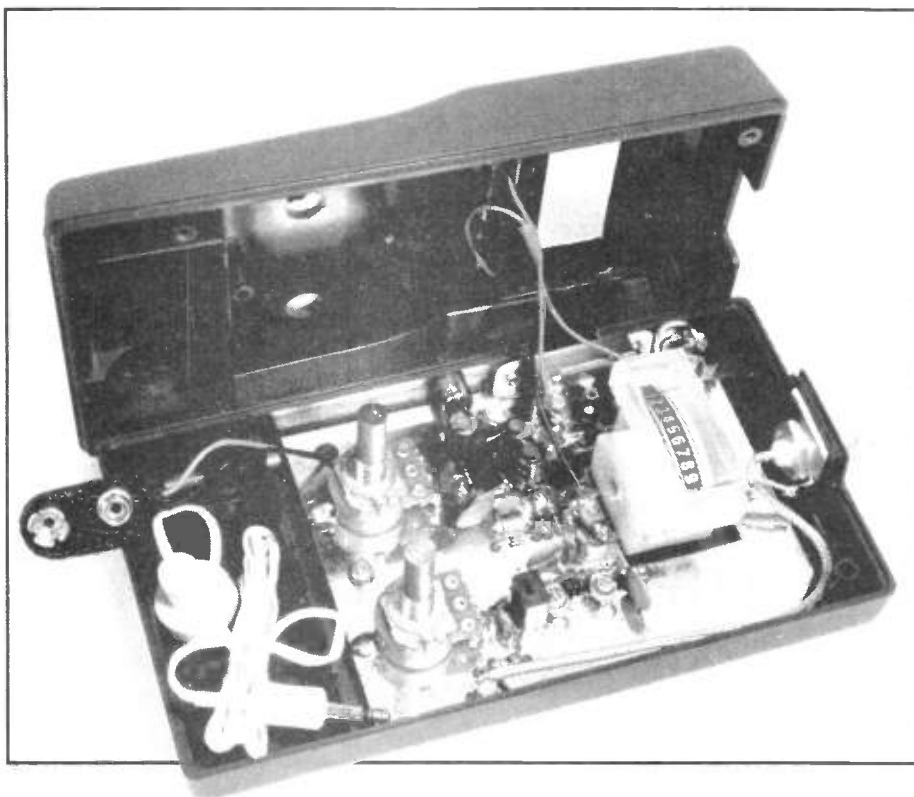
The PDF has both audio and visual cues to locating the signal. Either meter strength indications can be selected, or both meter and audio together via a slide switch on the case side. This switch also functions as an on/off for the unit. Audio and meter levels are controlled by two variable controls on the front, one for audio output from the built-in 1W audio amp, and the other to keep the meter reading from going "off the end" when closing in on the source. Two LEDs indicate which functions are selected, and the meter can be illuminated by a small pushbutton located on the side. Audio output is via a 3.5mm jack socket to either the earphone supplied, or any external speaker required. The antenna is connected via a BNC socket thereby allowing other antennas to be connected without difficulty. Power is supplied by a PP3 or similar (not supplied) and battery life depends on the number of times the audio monitor is in use.

## Use And Abuse

The PDF has many other uses other than straight 27MHz CB direction finding. Any radio bugs using frequencies near to 27MHz can be traced easily, also the unit will track down fluorescent lights, dirty heating thermostats and will locate accurately, case radiation hot spots from transmitters.

Since the PDF is a broad band unit, the audio monitor has to take the form of an AM detector. Naturally, it will resolve AM, but it will also cope with FM transmissions – the audio resolved from FM transmissions will be of a lower level than AM. SSB cannot be resolved, but is still detectable. As SSB is a constantly varying signal, it is very difficult to DF anyway. The audio monitor's function is to enable the user to determine that the correct signal is being tracked when more than one transmission is being received.





The PDF is robustly constructed in a brown hand held case. The antenna acts as a pointer, when fixed to the case, and full operating instructions are provided on the back of the unit.

Supplied with the PDF is a very well written handbook which covers basic operation, along with comprehensive instructions for basic direction-finding, how to recognize and handle reflections and adjacent transmissions along with general notes on the care of the PDF. The PDF carries a two-year guarantee against faulty workmanship or defective components.

The PDF can be supplied to special order for most frequencies within the HF spectrum and AKD hope to offer models for VHF use in the near future. The existing PDF, however, does cover the 10m Amateur Band with no loss of performance and it makes a useful field strength indicator for tuning antennas or for comparisons between different antennas.

Units are currently being supplied for use by British Telecom and are available from AKD's sole distributors — Telecomms of Portsmouth.

■ R&EW

Eurocard

Eurocard  
Switched Mode



30, 50, 55,  
& 60Watt versions



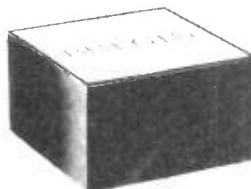
Base Mounting  
Switched Mode

**Power Supplies**

Encapsulated



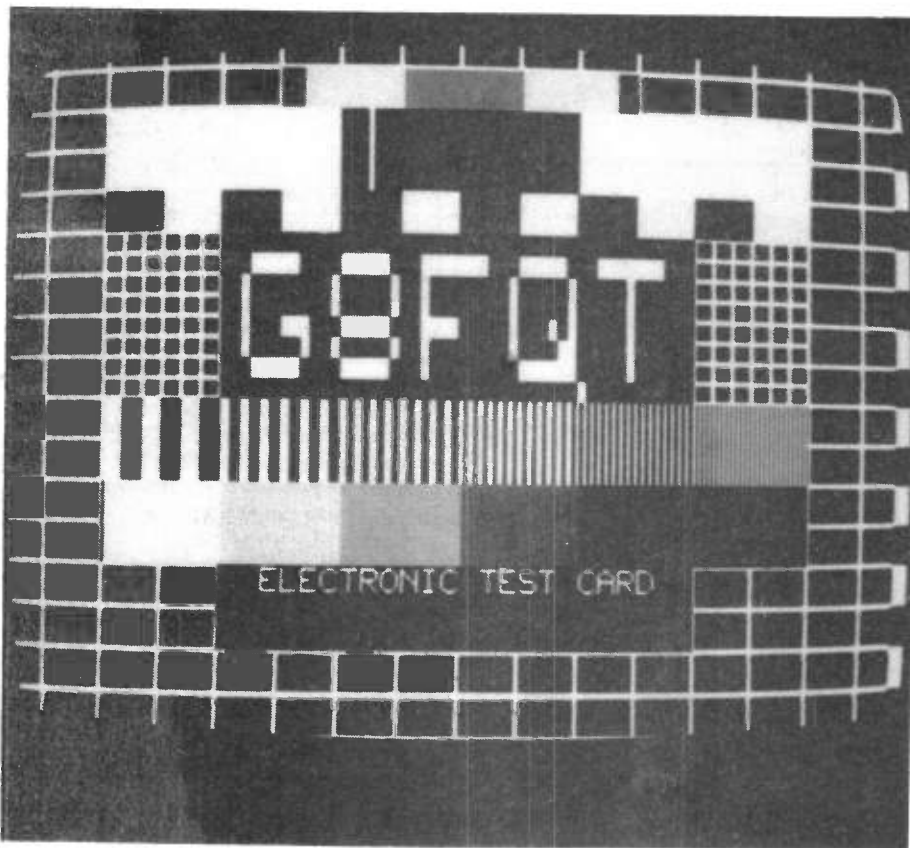
250 & 110V  
Input versions



New catalogue now available.



**A.F. Bulgin & Company P.L.C.**  
Electrical & Electronic Component Manufacturers  
Bypass Road Barking Essex IG110AZ England  
Telephone 01 594 5588 Telex 897255



# TEST CARD

## EPROM EXPANSION

**A compact, plug-in board to expand the display capabilities of last month's Test Card Generator. Design by Colin Edwards.**

Having now used the prototype of the electronic test card on the air, it has become apparent that a range of extra displays would be useful. This can be achieved by changing the original EPROM for another, programmed to generate a different display. A more practical alternative is to use a larger EPROM, together with a small switching circuit, which allows for any one of three displays to be selected from the front panel.

Both of the new patterns shown use the large print format, as did the original callsign. One of the displays is for use in establishing contact, by giving basic information to adjust aerial beam headings and complete log entries. The other consists of a 'message' which must be sent by video only for contest use.

Each of the display formats can hold a page of text in large or small characters, or a test card.

In order to store all three displays in one EPROM, an 8Kx8 (2764) device is required. This replaces the 4Kx8 EPROM

(2732) and socket on the original PCB. As well as having an extra address input, the 2764 has four extra legs, so an adaptor board is required to mount the EPROM and provide addressing logic. In the original 2732, only half of the device was used for the display format (2Kx8), so with a small amount of switching logic, three displays, the sequencing logic and character generator can be fitted into a 2764. Of the 24 pins on the socket, 23 can be connected directly to the adaptor board, with only one link.

### Construction

First wire the PCB link, after which the board can be assembled as detailed. Connect a stiff piece of tinned copper wire, on the solder side from point X. Next cut legs 1,2,23,27 and 28 from IC2 socket flush with the board on the solder side, so they connect only with the track on the adaptor.

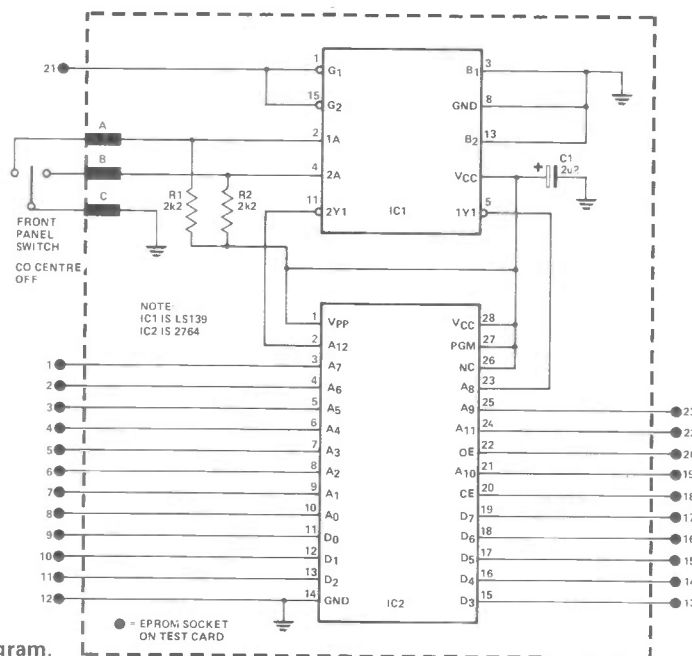
### Circuit Description

The function of this circuit is to convert the address used by the 2732, to address a 2764, without wasting any space by duplicating data.

When the most significant address (A11) to the 2732 goes 'high' the character generator is being accessed. As this is identical for all display formats, the top two addresses on the 2764 are both forced 'high' regardless of the switch position, so that all formats share the same character generator and sequencing data.

The display pattern is stored in the bottom half of the 2732 and is accessed when A11 is 'low'. In the case of the 2764 there are now 3 display blocks available, in the 64K bytes, which are selected using a switch and address decoder IC. The decoder allows the top two address bits of the 2764 to be selected by the switch when A11 (point X) is 'low', and forced 'high' when A11 is 'high'.

Trying to find an IC that performed the required switching function proved difficult and the one chosen (74LS139) is connected in an unusual configuration. This is an example of using the truth table of an IC, rather than the normal function described at the top of the page in the data book.



**Figure 1:**  
Circuit diagram.

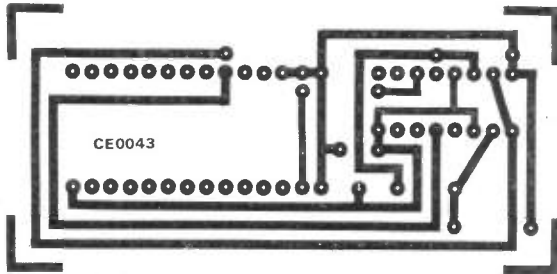


Figure 2: Foil pattern.

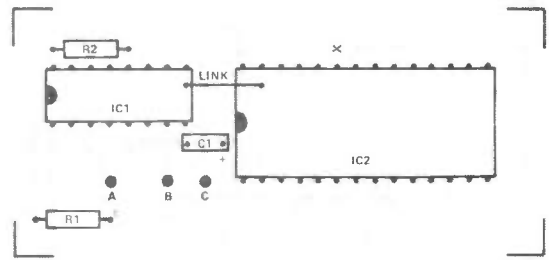


Figure 3: Component overlay for the expansion unit.

**PARTS LIST**

**Resistors**

R1,2 2k2

**Capacitors**

C1 2u2 16V tant bead

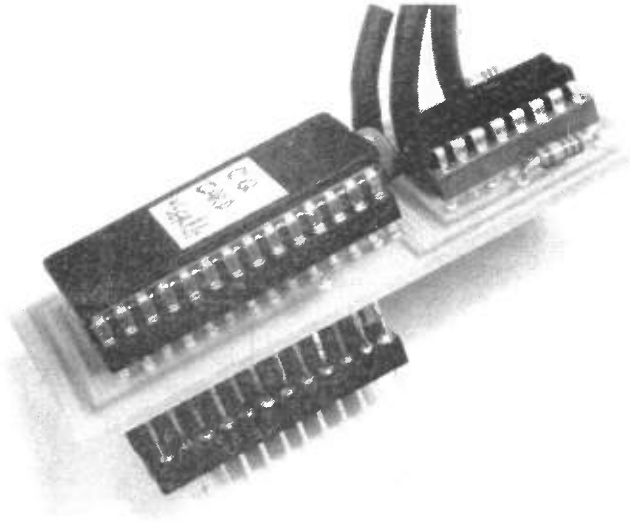
**Semiconductors**

IC1 74LS139

IC2 2764

**Miscellaneous**

PCB, 28 pin wire-wrap socket, wire, switch



Then remove the socket from the Test Card PCB and solder the adaptor board to the same location with pin 3 of the 2764 replacing pin 1 of the 2732. The wire link from the adaptor is pulled taut and soldered into pin 21.

■ R&EW

**Northampton Communications**  
**6MTR - 2MTR - 70CM CONVERSIONS//TRANSVERTERS FOR CB RADIOS**

2 MTR TRANSVERTER KIT	£ 68.95
RX UNIT KIT ONLY	£ 38.95
HARDWARE FOR ABOVE (i.e. case, switches, etc)	£ 9.95
COMPLETE ASSEMBLED UNIT	£ 98.95
TX UNIT ONLY FOR RX UNIT	£ 30.00
6 MTR CONVERSION KIT	£ 59.80
ASSEMBLED UNIT inc. RADIO	£129.95
70 CM RX UNIT KIT	£ 44.95
70 CM TX UNIT KIT	£ 48.95

Available soon repeater shift for all kits.  
 Above equipment works on all modes ie: AM,FM,SSB, & CW.  
 HOT LINE PROBLEM SERVICE (Technical)  
 Northampton (0604) 38202  
 TUESDAY & THURSDAY 14.00 hrs. to 17.00 hrs.  
 ASK FOR: EVAN G8 KHC or COLLIN G3 VMU  
*Trade enquiries by headed letter only please*  
 Attn. G. Austin G6 NYH.  
 All TX Kits above are sold subject to purchaser holding current Amateur Radio TX Licence.

Northampton Communications Limited  
 76 Earl Street, Northampton.  
 Telephone: (0604) 33936

**MASTER ELECTRONICS NOW!**  
**The PRACTICAL way!**

You will do the following:

- Build a modern oscilloscope
- Recognise and handle current electronic components
- Read, draw and understand circuit diagrams
- Carry out 40 experiments on basic electronic circuits used in modern equipment
- Build and use digital electronic circuits and current solid state 'chips'
- Learn how to test and service every type of electronic device used in industry and commerce today. Servicing of Radio, T.V., Hi-Fi and microprocessor/computer equipment.

by **SEEING** and **DOING**

**New Job? New Career? New Hobby? Get into Electronics Now!**

**FREE!** COLOUR BROCHURE

Please send your brochure without any obligation to

NAME .....

ADDRESS .....

.....

BLOCK CAPS PLEASE

POST NOW TO:

**British National Radio & Electronics School**  
 Reading, Berks. RG1 1BR

I am interested in

COURSE IN ELECTRONICS as described above

RADIO AMATEUR LICENCE

MICROPROCESSORS

LOGIC COURSE

OTHER SUBJECTS

REW8/822

# POLAR ORBITING SATELLITES

## Part II

### Terry Weatherley talks about how to find Weather Satellites

The recent article describing Polar Orbiting Weather Satellites and showing some of the pictures received from them (R&EW March 1983) generated a lot of correspondence. The most frequently asked question was, "How do I find the Satellite?". It is hoped to answer this question.

The Polar orbiters transmit in the 136-138MHz band. The American NOAA series use 137.5MHz, and 137.62MHz, as their prime frequencies. Obviously continual monitoring of these frequencies will eventually bring success, but such a method is time consuming to say the least. The Polar Orbiters, as their name suggests, have orbits which take them almost over the North and South Poles. The NOAA series are placed in orbits which are described as "sun synchronous". This type of orbit takes the satellite over an observer at the same 'local time' each day for any location. Currently NOAA 6 is the morning satellite and NOAA 7 the afternoon one. Once the 'local' orbit has been found, it should be possible to hear the former and the following orbits on subsequent days.

To predict when satellites can be heard from a given location, it is necessary to have certain reference parameters. The minimum requirements are:- the orbital period and the time the satellite crosses the equator together with the point at which the satellite crosses the equator. This crossing point is conventionally given in degrees West of Greenwich.

Such data, as it applies to the NOAA satellites, is obtainable on a regular basis from the National Oceanographic and Atmospheric Administration in the United States. The information is given as a reference orbit for each satellite for the first day of the month. As an example, here is the data as received for February 1983.

	NOAA 6	NOAA 7
Orbit No.	18968	8295
Date/time 01 Feb.	0053.81Z	0030.65Z
Long. Asc. Node	80.28W	143.28W
Nodal Period	101.1474	101.9784
Inc bet. Orb.	25.28	25.50
Frequency	137.50	137.62

Given this data and making certain assumptions about the behaviour of satellites in near circular orbits, it is possible to predict the equatorial crossing times of the satellite for any day in the following month. Predictions for longer periods are



unreliable because of error introduced by the gradual changes that occur in the orbital parameters. To calculate the reference orbit for any day in the month is fairly straightforward using a pocket calculator. There now follows a worked example for 15th February 1983. As an aid to understanding it is suggested that the reader follows the instruction on a calculator.

#### Data required for 15th February 1983 NOAA7.

Input to calculator the number of days since the reference orbit 14.  
 Multiply by 1400 (no. of mins in day) 21060  
 Divide by 101.9784 (period of Sat.) 197.6889  
 Thus since the reference time on 1st of February to the same time on 15th February there have been 197.6889 orbits. We now have to calculate the time taken to travel .6889 of an orbit. So back to the calculator.  
 Subtract 197 .6889  
 Multiply by 101.9784 (period) 70.25291  
 Thus on 15th February the satellite crossed the equator some seventy minutes before the reference time (00.30.65). On a piece of paper subtract 70.25 mins from 00 hrs 30.65 mins. This will give a new reference orbit time.

hrs	mins	
00	30.65	
- 1	10.25	
23	20.4	on the 14th of February 1983

To find the crossing point divide 70.25291 by 4 17.56322  
 Thus the satellite crossed the equator 17.56 degrees East of the reference crossing point  
 $143.28 - 17.56 + 125.7$  degrees West.  
 So a reference orbit for 15th February is 23 hours 20 minutes 24 seconds on the 14th February crossing the equator at 125.7 degrees West.

Subsequent orbits for the day are obtained by adding 1 hour

```

5 REM SATELLITE PREDICTION PROGRAM BY TERRY WEATHERLEY
10 CLS
20 PRINT ""
30 A$="WHERE'S THAT SATELLITE?"
40 PRINT TAB(8)A$
50 PRINT ""
60 PRINT " This simple program will calculate the time of each
equatorial crossing of the satellite for the day requested."
70 PRINT ""
80 PRINT " The program uses a simple iterative loop and the further
the wanted day is from the Reference Orbit the longer it takes.:"
90 PRINT "It is suggested that Orbital data more than a month old should
not be used because of changes in orbital parameters"
100 F=TIME+500
110 REPEAT
120 UNTIL TIME=F
130 CLS:PRINT CHR$(7)
140 PRINT ""
150 INPUT " THE NAME OF THE SATELLITE",N$
160 PRINT "CHR$(7)
170 INPUT " THE ORBITAL PERIOD IN MINUTES?"Period
180 PRINT "CHR$(7)
190 INPUT " THE REFERENCE ORBIT NUMBER?"N
200 PRINT "CHR$(7)
210 INPUT "REFERENCE ORBIT DATE(DD:MM:YY)"RDay,RMonth,RYear
220 IF RDay>31 OR RMonth>12 OR RYear >100 THEN PRINT "Please re-enter
data":GOTO 210
230 INPUT "REFERENCE ORBIT TIME(HH:MM:SS)"Rhr,Rm,Rs
240 IF Rhr>23 OR Rm>59 OR Rs>59 THEN PRINT "please re enter figures and
press RETURN each time":GOTO 230
250 INPUT "REFERENCE CROSSING POINT "DC
260 CLS
270 PRINT TAB(13)"DATA ON FILE"
280 PRINT ""
290 PRINT "Name of satellite      ";N$
300 PRINT
310 PRINT "Orbital Period          "Period;" mins."
320 PRINT
330 PRINT "Date of reference orbit   ";RDay;" / ";RMonth;" / ";RYear
340 PRINT
350 PRINT "Time of reference orbit    ";Rhr;" : ";Rm;" : ";Rs
360 PRINT "CHR$(7)
370 INPUT "ENTER day month year for display ",day ,month,year
380 CLS
390 PRINT "Orbital Data for ";day;" / ";month;" / ";year
400 PRINT ""
410 PRINT TAB(6)"ORBIT";TAB(20)"TIME";TAB(30)"DEGREES W"
420 Rtime=(60*Rhr)+Rm+(Rs/60)
430 FOR J=1 TO RMonth:READ dayno:NEXT:W=davno+RDay :RESTORE 610
440 FOR J=1 TO month:READ dayno:NEXT:T=dayno+dav :RESTORE 610
450 IF W>T THEN T=365+T
460 Rtime=Rtime+Period :N=N+1
470 IF Rtime>1440 THEN Rtime=Rtime-1440:W=W+1
480 DC=(Period/1440)*360/DC
490 IF DC>360 THEN DC=DC-360
500 IF W>T THEN 530
510 IF W<T THEN 590
520 GOTO 460
530 H=INT(Rtime/60)
540 M=INT(Rtime-(H*60))
550 S=Rtime-((H*60)+M):S=INT(S*60)
560 E=DC*0.5:E=INT(E*10)/10
570 PRINT N,H;" : ";M;" : ";S"E
580 GOTO 460
590 INPUT "DO YOU WANT TOMORROW'S DATA(Y/N)".a$:IF a$="Y"
THEN T=T+1:GOTO 460
600 IF a$="N" THEN STOP
610 DATA 0,31,59,90,120,151,181,212,243,273,304,334,

```

Table 1: Source code for the satellite locator.

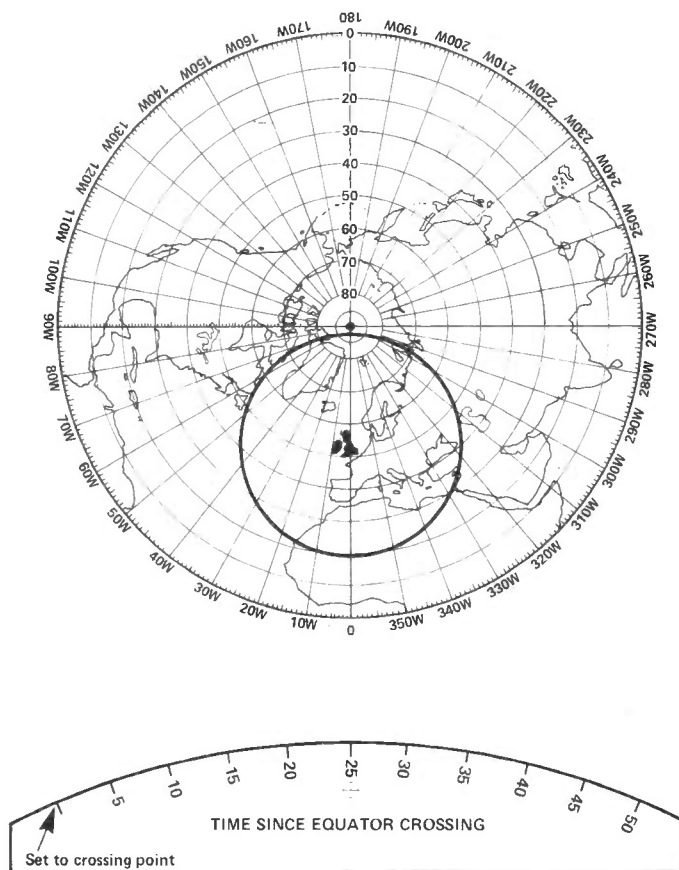


Figure 1: Satellite finder (drawn to scale). The lower curved rule is fixed over the centre of the map and rotates to give satellite positions.

42 mins to the time and 25.5 degrees to the equatorial crossing.

It will be readily seen that orbital predictions can be prepared by personal computer. A simple utility program for the BBC Micro is given (Table 1). This is very much a users program and is not 'idiot proofed'. It can be added to, adjusted etc to suit the individual's needs. The program is self explanatory and invites the user to input the reference data. This is then displayed as data on file and the user is asked to input the date for which data is required. This is then displayed as:-

Orbit Number	Time	Crossing point
--------------	------	----------------

The other piece of equipment required is the satellite finder depicted in Fig. 1. This consists of a Polar Projection map of the northern hemisphere together with a cursor showing the path of a satellite. If the figure is mounted on thin card, cut out and pinned together with a paper fastener it will enable the user to find the satellite at any instant in its orbit.

The cursor is rotated until the arrow points to the equatorial crossing point. The cursor now traces out the satellite's track over the earth's surface. While the satellite is within the area bounded by the thick circle it can be heard in central UK. The time the satellite comes into and goes out of range can be calculated using the 5 minute markers on the cursor.

If a directional antenna is used for reception the satellite finder will show the direction to point the antenna.

Armed with pocket calculator and the satellite finder it should now be fairly easy to find the satellite.



# AERIALS

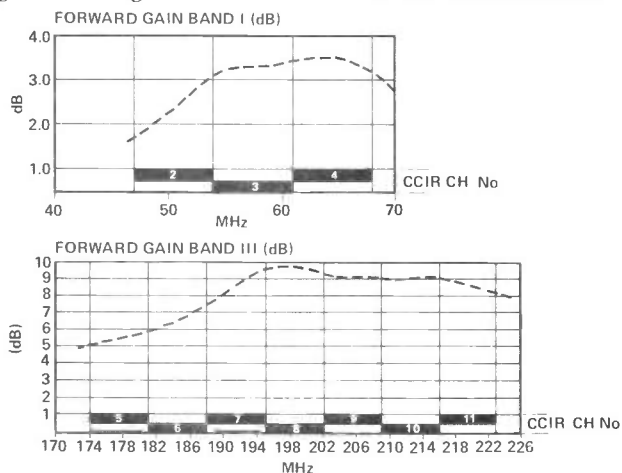
## FOR TV & RADIO

**Garry Smith and Keith Hamer present a definitive survey of the latest in aerial developments.**

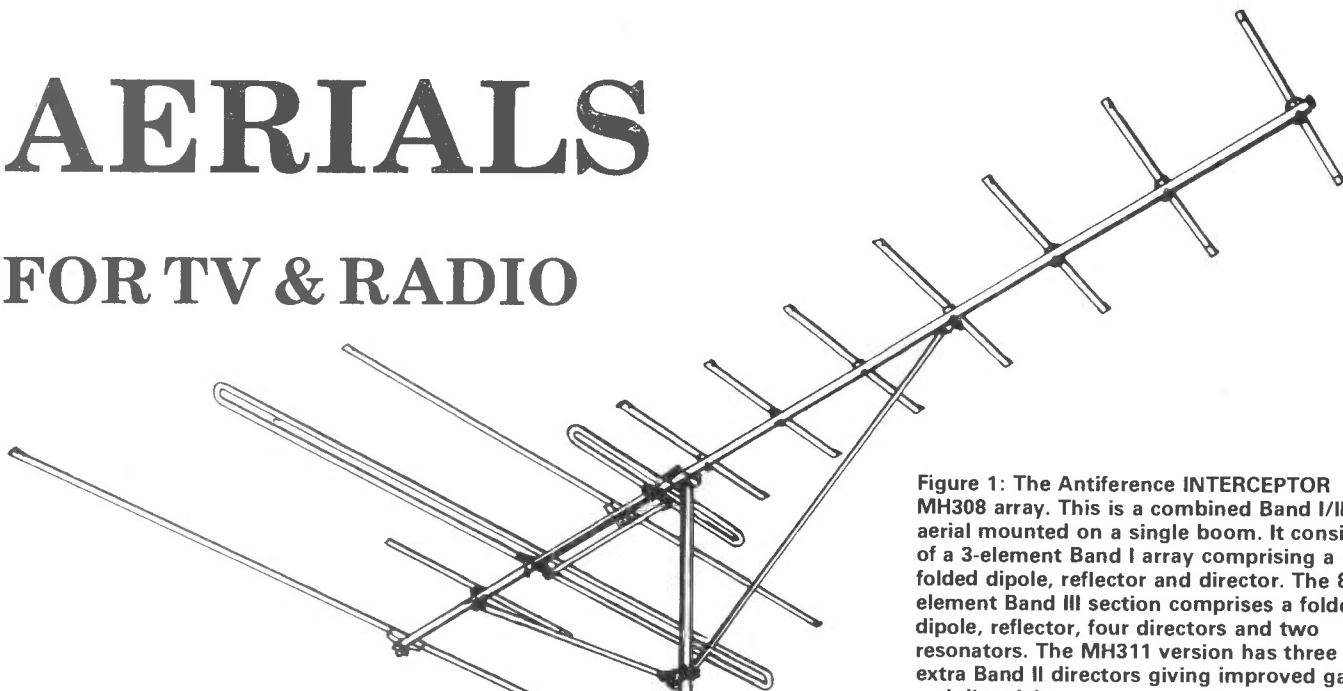
The advent of satellite and cable television has sparked off a growing interest in being able to receive additional radio and television programmes. A visit to any major European city will reveal spectacular aerial systems in use, towering above every building, with arrays of many shapes and sizes aimed in all directions. Perhaps the Europeans have a lust for programme material foreign to them, or maybe they are taking advantage of what the airwaves have to offer.

Along the East and South coast of England, many European TV and FM transmissions can be present on a daily basis. In most parts of the UK, one or more neighbouring IBA regions can be received providing a minimum of five television channels. On the FM radio band many distant ILR stations are available. If an extra IBA region is present via the aerial used for local viewing, there is every possibility that the use of a high-gain aerial of the correct channel group, and suitably aligned, will produce a remarkable improvement. If several regions are available, but in different channel groups, a wideband UHF array and rotator can be used, the cost of which will be justified by the dedicated viewer.

The correct choice of receiving aerial is very important and a glance through the various manufacturers' sales literature will



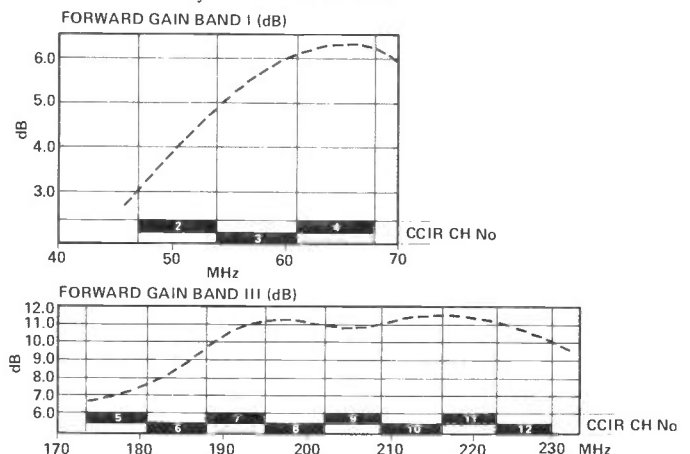
**Figure 2: Gain characteristics of the Antiference INTERCEPTOR array, type MH311.**



**Figure 1: The Antiference INTERCEPTOR MH308 array. This is a combined Band I/III aerial mounted on a single boom. It consists of a 3-element Band I array comprising a folded dipole, reflector and director. The 8-element Band III section comprises a folded dipole, reflector, four directors and two resonators. The MH311 version has three extra Band II directors giving improved gain and directivity.**

reveal a bewildering selection. Factors such as the type of receiving aerial used and the terrain over which the signal must travel, will influence the success of reception; a secluded receiving site, in a valley location for instance, will hamper the chances of extra channels.

An array must not be selected on the merit of gain performance alone. Its directional properties and front-to-back ratio must also be considered if problems due to co-channel signals are to be avoided. This particular problem is increasing as more Channel 4 relays are introduced. During periods of enhanced tropospheric propagation conditions, co-channel interference will become more apparent. The DX-TV enthusiast who relies upon various modes in ionospheric propagation for results will be only too aware of this.



**Figure 3: Gain characteristics of the Antiference INTERCEPTOR array, type MH473. The aerial (not shown) comprises a 4-element Band I array (double-driven folded dipoles plus reflector and director) giving up to 6dB gain. 21 colinear directors, 3 colinear reflectors and 3 resonators provide up to 11.5dB gain in Band III.**

### Broadcast Reception Aerials

The design of most broadcast receiving aerials has been based upon the tried-and-tested Yagi principle, comprising a half-wave dipole cut to the required frequency with parasitic elements mounted in front and behind. Often, only one element mounted behind is used and this is known as a reflector, although the trend is to use a multi-element reflector on the more elaborate arrays to achieve a good front-to-back ratio. The reflector is usually 5% longer than the dipole.

MODEL	PEAK GAIN (dBd)	HORIZONTAL ACCEPTANCE	FRONT TO BACK RATIO (TYPICAL)	NUMBER OF ELEMENTS
ABM 5	6.5	52°	12	5
ABM 8	10.0	42°	15	8
ABM 12	11.5	33°	18	12

**Table 1: Technical characteristics of Jaybeam ASTRABEAM Wideband Band III arrays covering CCIR channels 5 to 12.**

Parasitic elements mounted progressively in front of the dipole are known as directors. Increasing their number will increase the gain of the system and enhance its directional properties. The Yagi array is an inherently narrow-band system and attempts to broaden the bandwidth will result in a lowering of gain throughout its operating range. Consequently a wideband system will be a compromise in terms of gain and bandwidth for a given number of elements, when compared with an array cut to one specific frequency. As a rule-of-thumb guide, the reflector is cut to the lowest required frequency and the dipole cut approximately to mid-band. The directors are often cut to the higher end of the spectrum and where several are used the gain at the upper end becomes higher than at the lower end. This arrangement is often beneficial since signal losses increase with frequency.

The log-periodic design is an inherently wideband array, but unlike the Yagi, all the elements are dipoles, cut to respond to different frequencies. This type of array is more complex structurally than the Yagi, and at a given frequency only part of the array contributes to the gain, making it lower in relation to the number of elements when compared to the Yagi design. On the credit side, it has an exceptional front-to-back ratio and a very clean polar response with few side-lobes. In the past the log-periodic array has only been commercially available in the UK for UHF, and used in primary signal areas where ghosting is a problem. In the USA, rotatable log-periodic systems have been popular at VHF television frequencies (55-220MHz), where several local TV channels are available. The excellent polar characteristics help to discriminate against unwanted transmissions which could be a problem if a standard Yagi design was used.

## Bands I, II and III

VHF television Bands I and III are, at present, the domain of the DX-TV enthusiasts, apart from a few itinerants such as cordless 'phone users. For Band I frequencies, commercially produced arrays are available, but only in channelised form. Wideband systems covering this band are obtainable from specialist manufacturers, albeit a compromise in terms of gain and bandwidth. Where space permits, it may be worth investing in channelised arrays for this band to help

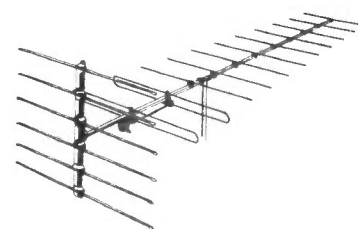
Antenna	Number of Elements	Forward Gain dB	Front to Back Ratio dB	Acceptance Angle	*Channel Coverage
LP 7	7	+ 8.0	29.0	+33°	All channels in Band III
HC 103A	4	+ 5.5	18.0	+30°	All channels in Band III
HC 105	6	+ 9.0	30.0	+27°	5, 6, 7, 8, 9, 10, or 11
HC 1010	11	+ 12.0	30.0	+19°	5, 6, 7, 8, 9, 10 & 11
HC 205	7	+ 9.0	25.0	+30°	All channels in Band III
HC 208	10	+ 10.5	28.0	+30°	All channels in Band III
HC 2011	13	+ 11.0	32.0	+35°	All channels in Band III
HC 2015	17	+ 11.5	33.0	+35°	All channels in Band III
MC 103	4	+ 7.5	20.0	+20°	2, 3 or 4 (Band I)

**Table 2: Technical data for the Antiference EXPLORER range of Band III antennas.**

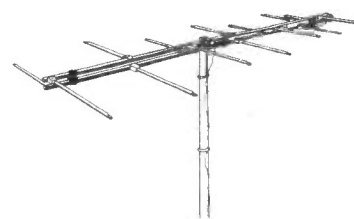
discriminate between unwanted transmissions, such as 6-metre amateur activity and the promised PMRs.

It is possible to make one's own array for Band I using 1/2-inch diameter alloy tubing. It is usually cheaper too, but hardware such as element-to-boom clamps and dipole boxes may be difficult to acquire. Some enthusiasts have opted for an inconspicuous system based on crossed dipoles where a large Yagi array is impractical. The dipoles are cut to the centre of the band, at approximately 55MHz, with each element 50 inches in length. The dipoles are mounted horizontally and at right-angles to each other. The output of each dipole can be selected independently by means of a switch, or phased together to provide omni-directional coverage. The system has zero gain, but fortunately Sporadic-E signals frequently attain extremely high field strengths. The system is also ideal when used as a search array.

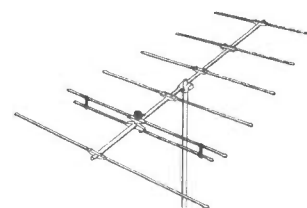
Commercially manufactured Band III aeriels are generally the wideband multi-element Yagi type, although one UK company produces a log-periodic array. Needless to say, these are intended for the export market and channelised Yagis are cut to the CCIR channels E5 to E11. Combined Band I/III arrays are available – the main attraction being the single boom structure. Unfortunately, the outputs are combined to form a



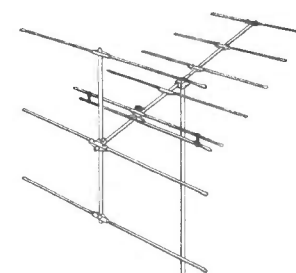
**Figure 4: The Antiference EXPLORER HC2015. This is a 17-element double-driven broadband array.**



**Figure 5: The EXPLORER LP7. This is a 7-element log-periodic aerial.**



**Figure 6: The Antiference FM264T. This is a 6-element "Trumatch" array suitable for distant and fringe reception areas.**



**Figure 7: The Antiference FM284T. An 8-element "Trumatch" aerial suitable for extreme fringe areas.**

Model	Number of Elements	Peak Gain (dBd)	Horizontal Acceptance Angle	Front to Back Ratio (typical)
SBM 2	2	3.0	70°	12dB
SBM 3	3	6.0	60°	15dB
SBM 4	4	7.0	59°	15dB
SBM 6	6	8.5	56°	16dB
FM 9S*	9	9.5	48°	27dB

**Table 3: Technical characteristics of the Jaybeam STEREOBEAM VHF FM radio aerials covering 88 to 102 MHz.**

\* The Jaybeam SUPERFRINGE FM 9S VHF FM array comprises folded dipole, triple reflector assembly and five directors. single one which can prove to be a disadvantage for the DX-TV enthusiast wishing to include various filter/amplification options for each band.

## Out-of-Band Transmissions

The OIRT FM radio band used by Eastern European countries, such as Russia, Poland, Bulgaria, Czechoslovakia, etc occupies the 64 to 73MHz spectrum. Commercially available arrays are unobtainable in the UK specifically for this band although specialist manufacturers may oblige. The same remarks apply to certain OIRT television channels in use between 77 and 92MHz.

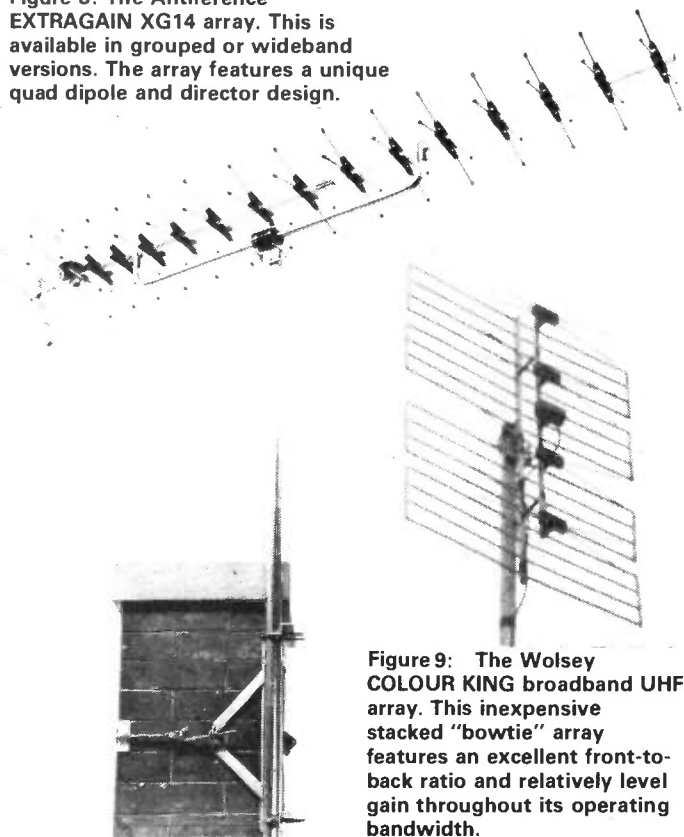
## FM Radio

For long-range reception, or where several local stations are available, the use of an array with a multi-element reflector is recommended. The high front-to-back ratio offered will minimise problems caused by unwanted signals arriving from the rear.

## Bands IV & V

For long-distance reception at UHF there is more diversity in receiving-aerial design, than for any other band. Most DX-TV enthusiasts prefer to use a wideband array at UHF mainly for operational ease, despite its reduced gain. Cost effectiveness is

**Figure 8: The Antiference EXTRAGAIN XG14 array. This is available in grouped or wideband versions. The array features a unique quad dipole and director design.**



**Figure 9: The Wolsey COLOUR KING broadband UHF array. This inexpensive stacked "bowtie" array features an excellent front-to-back ratio and relatively level gain throughout its operating bandwidth.**

MODEL	GROUPS AVAILABLE	PEAK GAIN dB	HORIZONTAL ACCEPTANCE ANGLE	FRONT to BACK RATIO Typical
JBX 21	A, B, C/D	16.0	22°	22dB
MBM 66	A, B, C/D	15.0	29°	16dB
LBM 2	WIDEBAND Ch.21 to 68	8.0	44°	23dB

**Table 4: A selection of Jaybeam UHF arrays comprising of the MULTIBEAM 'JBX' 'MBM' grouped series plus the LBM2 log-periodic array which features almost constant gain throughout the UHF spectrum.**

another consideration, especially since tropospheric conditions rated as 'excellent' may be present for only a few days each year. Although grouped arrays are superior in terms of performance, it can be argued that this approach is only justified where reception of certain distant transmissions is possible on a regular, or even daily, basis.

Two forms of wideband aerial are popular; the Continental-styled Yagi (see Fig. 8) and the stacked "bowtie" (see Fig. 9). The Yagi is favoured by some enthusiasts because of its directional characteristics, but, inherent in its design, the highest gain occurs at the upper end of the UHF spectrum. The semi-sideband version has gained popularity since most UHF DX appears within Band IV. This type of aerial usually covers channels 21 to 50 and is sometimes designated Group "K". The Antiference semi-wideband type carries this suffix, but other manufacturers often have different codings.

The stacked bowtie system offers a more uniform level of gain throughout all the UHF channels, but at a lower level than the Yagi. One of its main disadvantages is its very wide capture angle. This leads to greater co-channel reception problems than the Yagi, but in terms of cost it is cheaper and more compact.

Over the past two years, both types of system have been evaluated, resulting in the following observations using a Wolsey Colour King and an Antiference XG21 array.

**Table 5: UHF Receiving Aerial Channel Groups and Colour Codes.**

21-34	A	RED
39-53	B	YELLOW
48-68	C/D	GREEN/BLUE
39-68	E	BROWN

## Stacked "Bowtie"

This was found to perform very well in terms of gain over the entire UHF spectrum. The acceptance angle was perhaps too wide and problems with co-channel reception did occur. This was very noticeable when compared with a Yagi. On the credit side, this disadvantage could be exploited as it made an ideal "search" array, where the operator would be more conscious of signals arriving from a wider area. The aerial provides a very inexpensive wideband UHF receiving system. Fortunately, the extremely wide acceptance angle can be reduced by using more than one array. A double or even a quad system can be utilised. This will also enhance the overall gain. Low-loss inductive combiners are available for this purpose.

## Semi-Wideband Yagi

A group "K" version was used simply to maintain a reasonable gain over the channel range 21 to 50, whereas the 21 to 68 version exhibits a very low level of gain throughout the lower group "A" channels. The off-screen results, observed from fringe transmitters, suggested that the gain was no more impressive than for the stacked "bowtie" aerial. The narrower acceptance angle was impressive, however, and many of the co-channel problems associated with the bowtie array were not as prominent. Unfortunately, towards the lower Band IV channels, the acceptance angle became noticeably wider and rejection of semi-local relay transmitters seemed no more impressive than for the other type of system.

Having a group C/D local transmitter introduced problems with the semi-wideband array due to cross-modulation effects on some channels throughout its normal operating range, even with the array beamed in a different direction. This was due to

Manufacturer	LABGEAR				ANTIFERRENCE		WOLSEY						
Type	CM 7060	CM 7065	CM 7066	CM 7068	UNIPLUS UP1300/W	UNIPLUS UP1300/V	NOVA	ORBIT	SUPA-NOVA	SUPA-NOVA	SPECTRUM XL	COSMOS	CLEAR SOUND
Frequency Coverage (MHz)	UHF 470-860	VHF+UHF 40-860	UHF 470-860	A: 470-581 B: 615-733 C/D: 687-860	UHF 470-860	VHF 40-230	UHF 470-854	UHF 470-854	VHF 41-254	UHF 470-854	UHF Groups A, B or C/D	Band I: 41-68 or Band III: 174-254	FM Band 88-108
Gain (typical) dB	10	26	26	A: .29 B: .28 C/D: .27	10 - 14.5	19	19	16 (min)	11	22	10	25 (minimum)	20 (min)
Noise Figure (typical) dB	1.8	Less than 2	Less than 2	4	2.5 - 3.0	2.5	4	4	4.5	3.5	1.5 - 3.5 (device)	5	1.9 (device) 3.5 (Amp)
Maximum Output (mV)	40	40	50	100	50	30	40	100	50	50	Data Not Available	100	40

**Table 6: Technical data for commercially-available mast-head amplifiers.**

the unpredictable polar response on the channels above its designed bandwidth and the use of a wideband amplifier (470-860MHz) only aggravated the problem. Under these circumstances, the use of stub filters may cut to the offending transmission may offer a solution to the problem and should not be overlooked.

## Mast-Head Aerial Amplifiers

Nowadays most commercially available pre-amplifiers use broadband techniques, which ensure reasonably constant gain throughout the operating bandwidth. Experience has shown that unless the amplifier used has a lower noise figure than the tuner in the receiver, it is unlikely to offer any viewable improvement in the signal unless it is used at mast-head to compensate for cable losses. For DX-TV work, the use of a mast-head aerial amplifier is recommended at UHF, but it should be borne in mind that overload can easily occur if operated close to a local transmitter. This may produce cross-modulation and other spurious effects. Amplifiers for UHF reception are available in wideband (470-860MHz) or grouped (A, B, and C/D) versions.

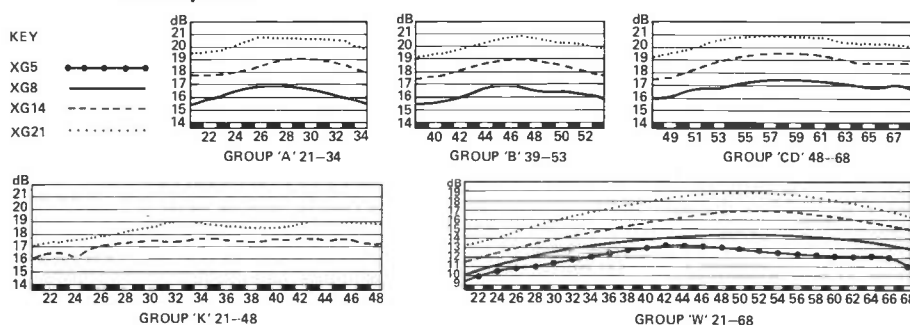
Some manufacturers produce amplifiers covering the 40 to 860MHz spectrum. The use of such amplifiers can be a problem when utilised for Band I or Band III frequencies due to overloading from out-of-band sources. For instance, when operating close to local UHF transmitters the local UHF group may appear in Band I or Band III. Also, FM radio break-through may occur on the lower channels of Band III (CCIR channels E5 and E6, even at a distance of 25 to 30 miles. To overcome these problems, various bandpass filtering techniques can be employed. In the case of FM breakthrough in Band III, the Band III section of a VHF TV diplexer can be connected to the input of the amplifier to act as a high-pass filter. The Band I input must be terminated with a 75-ohm resistor.

## Conclusions

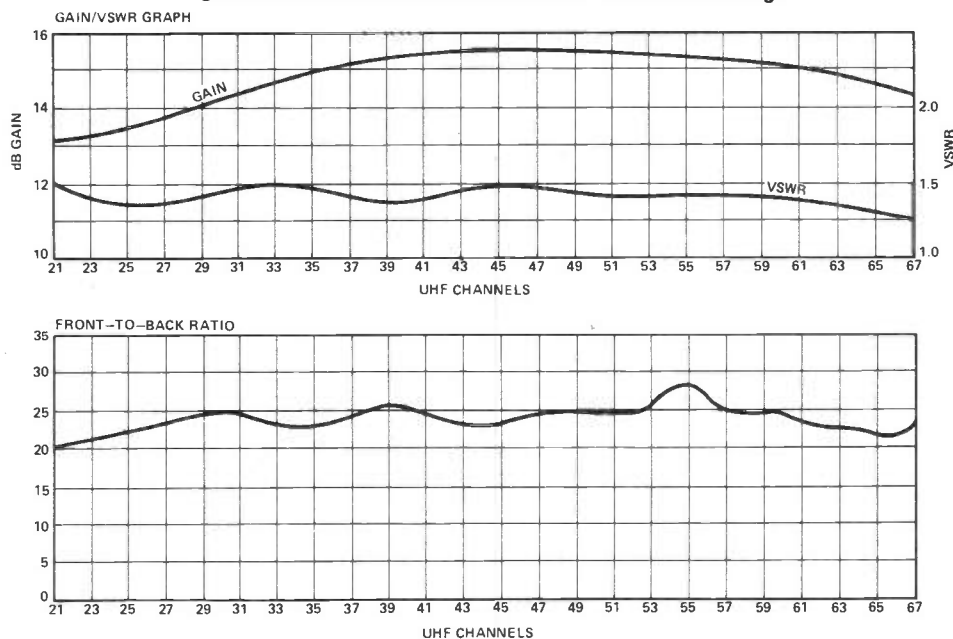
All the manufacturers featured in this article are able to supply

	CHANNEL GROUP	FORWARD GAIN dB	FRONT/BACK dB	ACC. ANGLE DEGREES
A	21 - 34	19	30 - 33	± 11 - 14
B	39 - 53	20	31 - 37	± 10 - 12
CD	48 - 68	19	31 - 33	± 10 - 12
K	21 - 48	17	31 - 31	± 12 - 14
W	21 - 68	16	30 - 37	± 10 - 14

**Table 7: Performance data for the Antiferrence XG21.**



**Figure 10: Forward gain characteristics of the Antiferrence EXTRAGAIN range.**



**Figure 11: Performance characteristics for the Wolsey COLOUR KING.**

aerial systems and accessories to fulfil most receiving requirements. However, it could be noted that their European counterparts tend to produce more elaborate and sophisticated arrays for television and FM radio.

**R&EW**

The authors wish to thank the following manufacturers for supplying invaluable information about current aerials and amplifiers:-

- Labgear Limited, Abbey Walk, Cambridge CB1 2RQ
- Antiferrence Limited, Bicester Road, Aylesbury, Buckinghamshire
- Wolsey Electronics, Cymmer Road, Porth, Mid Glamorgan CF39 9BT
- Jaybeam Limited, Kettering Road North, Northampton NN3 1EZ.

Our special thanks to Wolsey Electronics and Antiferrence Limited for supplying products for evaluation.



# TANDY MODEL 100

First there was the ZX80/1, then there was the Spectrum/BBC/Oric — and now popular personal computers take another bound ahead with the first personal portable computer that meets the needs of the communications user and enthusiast in one compact package.

William Poel had to send the R&EW spies to scour the arctic wastes of Canada to find a Tandy shop still left with a model of the machine that is currently sweeping the USA.

In a time of continued general industrial indifference (perhaps recession is becoming the accepted norm after 5 years or so!), the miraculous infallibility of the personal computer market is still hard to believe — even if you happen to be involved in the industry. Offerings launched amid a combination of extreme oversell and inadequacy of supply, still manage to make their promoters rich men and women.

It's hard to think of a similar industrial phenomenon in history, although maybe there's a clue in some of the recent national press advertising by Sinclair that has been alluding to Henry Ford's famous model T motor car.

Hardbitten observers have all but given up trying to predict the depth of the seemingly bottomless public appetite for new microcomputers and games programs. The fact that the industry revolves around hardware products that aren't yet on the market, and software that would benefit from the attentions of Rentokil, only compounds the seeming

illogicality of the way the business operates — in the kingdom of the visually disabled, the partially sighted are making a lot of money.

## The Model 100

The philosophy of what gives a PC appeal, is far from a precise science. The marketplace is so broad that almost anything will sell to persons who have suddenly got the idea that a computer is *the* thing to be aquired. Logical choice, and in particular selection of the best technology is one of the last considerations that applies — a fact often related by pioneer Adam Osborne, whose own concept of wrapping a known and relatively unexciting technology in a very convenient package, complete with software, display and the world's favourite operating system is still one of the best around for computer 'users'.

The Model 100 exploits this technique by using very conventional technologies and concepts. Like an 8085 CPU, 24K of usable RAM and a LCD display, yet it still manages to be an excellent device for the

computer 'user'.

This is because the 8085 (like the rest of the system) is implemented in CMOS.

The LCD is 8 lines by 40 characters, and the system comes complete with a familiar version of Microsoft BASIC, a very friendly text processor, and a serial communications package that goes to the lengths of a built-in direct dialling telephone modem (though only for US customers, while BT and Tandy get their act together). Our model had the US standard modem built-in, and glancing inside reveals a familiar MC14412 MODEM device (it's not too tricky to apply CCIT filter frequency standards to the active filter section — not recommended, of course!).

Taking the lid off the Model 100 is a less painstaking feat than with many machines — you see so many old friends nestling inside — Hitachi for the RAM and LCD, OKI for the CPU, and no computer is complete these days without an ALPS full travel keyboard.

Without getting hands on the NEC 8201 personal computer, it seems like a



reasonable guess that Tandy have commissioned the model 100 from the same stable, so if NEC get their computing marketing organised in the UK, we may yet see a second source available.

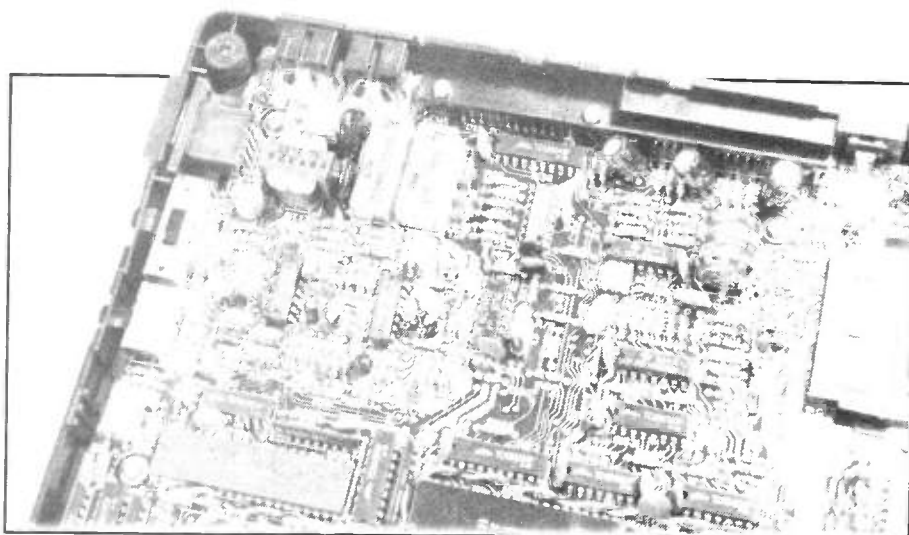
The real casualty of the portable war is Epson's HX20, which is knocked sideways by the Model 100. Perhaps the frenetic launch promotion, the enormous number of 'franchised' dealers and very hard sell at a time when there was next to no software available (not even a word processor) was indicative of some awareness that the HX20 might be rather short lived on the marketplace.

The Model 100 is not a cheap computer, but we're going to leave the price until later because we don't want readers to form any opinions just yet. It isn't an alternative to the ZX81, Spectrum or Dragon for example. In fact it even gives the BBC model B (with disk) a run for its money. The model 100 is, however, a computer that you will never tire of. The communications capability permits it to swap files with most computers that have anything like an RS232 facility, so you can use it as a portable companion for when you can't get near the main system — or more usually, you can't be bothered to heave the computer, a cassette or disk drive, a monitor and all the leads to the nearest available power point. This is not to say that the model 100 is to computing what a music centre is to hifi, only that it operates on a totally new and exciting plane for most enthusiasts to explore.

### The Hardware

The Model 100 is supplied in an A4 package, with a 'real' keyboard and an LCD that contains enough space for something really meaningful to take place. The 'mental buffer' seems to be ideally matched to the Model 100 display — in other words, by the time you get to the end of a screenful, the words written at the top of the screen are only of archival interest, as opposed to those influencing immediate writing.

The battery requirement is fulfilled by 4 AA pen cells. Tandy recommend Alkaline batteries, suggesting 20 hours average life



expectancy. NiCads do not work, which must be one of the most negative aspects of the machine. There is a separate NiCad RAM support battery which charges from the main power source, so you don't lose data or programs when the batteries require charging.

The low battery warning LED is a useful indicator of impending shutdown. If you forget to switch off, the Model 100 does it for you after 10 minutes of non-activity: the default setting of a user programmable function. An AC adaptor is available, although disappointingly this is an extra.

The superb keyboard includes 8 programmable function keys, plus 4 fixed functions and four cursor keys. Thank heavens you don't access half the cursor functions via the shift. There's a supershift function ('code'), and a graphics function, plus a keypad conversion key that allows rapid numeric data entry via a calculator style keypad at the right hand of the alphanumeric keyboard.

The delightful display has a viewing angle adjustment control, and the I/O is via a real D-type RS232 connector. Two 8 pin DIN sockets (of different configuration) provide for the telephone line connection and the cassette interface. There's a mini-D for a bar code reader (when is someone actually going to do something with this frequently threatened facility?), and switching for power, modem type and configuration.

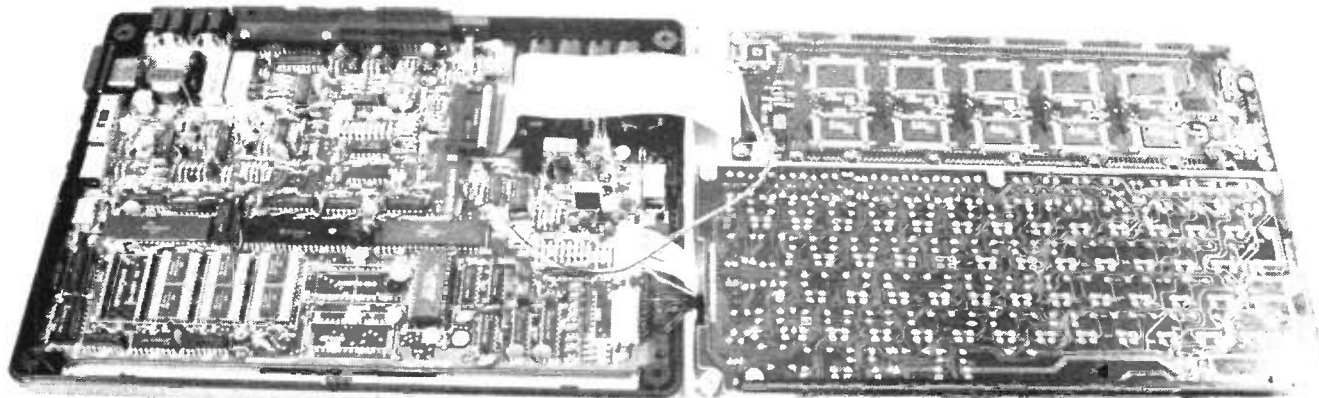
### The Software

Tandy include several ROM-based bits of software that really make the machine work from the first switch on. The text processor is reminiscent of 'Wordstar', using similar control code cursor commands, which are also duplicated via the cursor keys. It does everything required of it, except transmit text files to the printer using linefeed/ carriage return (more of this later).

There are two sub-functions within the text processor, named 'ADDRSS' and 'SCHEDL', which create files of names, addresses and telephone numbers (that can be used to set up the autodial feature), and a scheduler for creating an electronic diary/memopad. Both these facilities make use of the text processor's 'FIND' function to search out phone numbers by simply entering the name — or the day's events by searching for the date.

Since the files thus created are standard text (DOCUMENT) files, they are word processable, transmittable and printable. A top flight executive can leave his model 100 connected to the phone line, with the modem (30 baud duplex) switched to 'Answer', whilst his secretary phones in details of his schedule for the next day, together with any other messages, electronic mail etc.

The BASIC is compatible with most other implementations of Microsoft BASIC, but



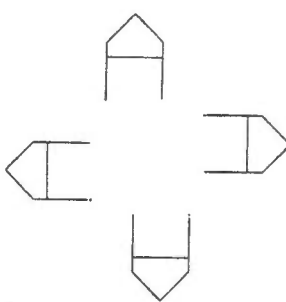
\* CHARACTER SET

```

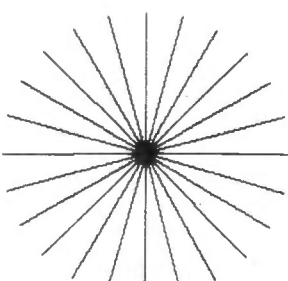
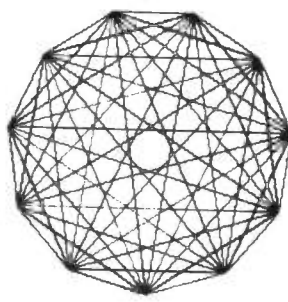
0"#$%&'()*+,-./0123456789
:;<=>?@ABCDEFGHIJKLMNOPS
TUVWXYZ[\]^_`abcdefghijklmnop
nopqrstuvwxyz{|}~☒

```

\* ROTATE 0 TO 3



PLOTTING ABILITY

CALCULATE PROGRAM

-----LIST OF STOCK-----

NAME	COS T	P.	SUBTOTAL
DOG	23	30	690
CAT	35	26	910
HORSE	230	8	1840
COY	215	25	5375
LION	3200	3	9600
TIGER	2890	5	14450
ELEPHANT	5890	3	17670
WHALE	6800	32	217600
UNICORN	13800	2	27600
DRAGON	29800	1	29800
TOTAL			325535

\*\* LINE TYP 0-9 \*\*

Figure 1: Print-out obtained from the listing on the facing page

like everything else in the package, the handbook documents the details sufficiently well for a beginner to teach themselves from scratch. Also, unlike most other machines on the market, you don't have to fiddle around and try to save the program to cassette when time runs out on the session. Then there's the communications facility, so you can transmit your problem file to a 'bigger' system for debugging — it can then be returned to your system to run.

## Communications

The communications facilities (like all the other Main Menu functions) are accessed by placing the cursor over the TELCOM title on the main menu and pressing ENTER. The Model 100 then prompts the user with details of the current status of the serial communications port, and the dialling pulse format (default to 10 pps) - which is prefixed by an "M" if the Modem is invoked, which automatically enforces a 300 baud format.

If the user defines another set of values for the baud rate, word length, parity etc., the MODEM is disabled, and the D connector takes over. In this mode, files can be set up to receive and transmit data for application like RTTY and ASCII data reception.

The direct dialling facilities also allow details of system logon procedures to be stored away in the address file, so that you can autodial REWTEL (and other fine databases), "logon" with passwords etc., and get straight into the session without further ado. When Tandy and BT get their act together for approval of the Modem system.

UPLOADING files from the Model 100

to the serial output is simply a matter of setting the communication protocols, pressing the UP function key, entering the filename and line width, and pressing return. As at the time of writing, the system doesn't offer the option of line feeds with the carriage returns, nor does it offer a page length setting feature. We're looking into this, since although uploading a file to a CP/M system then permits the file to be manipulated by a word processing programme for subsequent printing and page formatting, this isn't exactly ideal for many users who would like to use the Model 100 as a complete system in itself.

The parallel printer port is the very common Centronics format, and no problems were experienced getting it going. We used the very natty colour graphics plotter made by ALPS for Tandy, and this provided a simple (if slow) listing facility, and all the delights of the four colour graphic functions available from BASIC. Just the thing for logging a panoramic view of band conditions and labelling the signals with their frequencies?

## Early Days

We haven't had the Model 100 long enough to get deeply inside its capabilities, other than to discover that it's the first computer that is going to provide the communications enthusiast with a "packaged" approach that means that the applications and not the programming is the "thing".

We hope to have an AMTOR package before long, and work is proceeding with the RTTY system. On a more general note, we would like to start to build a library of communications and RF design programs from readers, especially now there's a medium for running them that doesn't need

to be hidden inside a lead lined box. We will pay for publication in the first place, plus you will receive a further royalty every time a copy is downloaded via REWTEL's program distribution system REWSOFT

## Anything You Can Do

One rather revealing aspect of recent Tandy products like the superb colour printer/plotter and the Model 100 is the fact that neither of these products is actually manufactured by Tandy. Uncle Clive has the clout (and might have had the sense) to knock on ALPS and NEC's door to get the machinery into the UK under the Sinclair name. And at least he would have been able to deliver the goods in this instance.

The dangerously amateur marketing policies of the UK computer industry have already succeeded in sinking in one of the early producers of a very good machine (the original NASCOM). The equally dangerous and imperious "Not invented here" syndrome could well be the undoing of one or two more. Especially if they persistently fail to deliver the much vaunted and promoted goods.

Watch out for Tandy's carefully orchestrated Model 100 press launch on July 3rd., 1983 - and marvel at the fact that everything they'll be talking about might actually be available at their stores the next day. Are you receiving us up there in The Fens?

Will this machine (and those that are bound to follow it) change the attitudes of that vociferous band of radio amateurs who are passionately opposed to anything faintly to do with computing? There could be some lively correspondence in the next few issues.

```

5 DIM A(10,2)
20 REM ***CHARACTER SET***
30 LPRINT LPRINT CHR# (18); "S1" LPRINT "C0" LPRINT "C0" LPRINT CHR# (17)
40 LPRINT LPRINT
50 LPRINT " * CHARACTER SET "
60 LPRINT CHR#(18); "S2" LPRINT CHR#(17)
70 FOR I=02 TO 127
80 LPRINT CHR# (I);
90 NEXT I
100 LPRINT : LPRINT CHR# (18); "S1" LPRINT "C1" LPRINT CHR#(17)
270 REM
280 REM ***ROTATE 0 TO 3 ***
290 LPRINT : LPRINT
300 LPRINT " * ROTATE 0 TO 3"
310 LPRINT CHR#(18); "S9" LPRINT "M80,-100"
320 FOR I=0 TO 3
330 LPRINT "0"; LPRINT "PA"
340 NEXT I
350 LPRINT "M0,-230" LPRINT "S1" LPRINT "C2" LPRINT CHR#(17)
360 REM
370 REM *** LINE TYP 0-9 ***
380 LPRINT : LPRINT
390 LPRINT " ** LINE TYP 0-9 **"
400 LPRINT : LPRINT CHR# (18)
410 FOR I= 0 TO 9
420 LPRINT "L"; I
430 LPRINT "J 210,0"
440 LPRINT "R -210,-25"
450 NEXT I
470 LPRINT "S1" LPRINT "C3" LPRINT CHR#(17)
480 REM
490 REM ***PLOTTING ABILITY**
500 LPRINT : LPRINT
510 LPRINT "PLOTTING ABILITY"
520 LPRINT CHR# (18); "L0"
530 LPRINT "M100,-160" LPRINT "I"
540 FOR I= 0 TO 350 STEP 15
550 S = I / 180 * 3.14159
560 X= SIN (S) * 100.5: Y = COS(S) * 100.5
570 X= INT (X): Y = INT (Y)
580 LPRINT "D"; X; Y LPRINT "H"
590 NEXT I
600 LPRINT "M0,-250"
610 LPRINT "I"
620 S = 2*3.141592625 / 11
640 FOR I = 0 TO 10
650 A(1,1) = INT (SIN (I * S) * 100.5)
660 A(1,2) = INT (COS (I * S) * 100.5)
670 NEXT I
680 LPRINT "M"; A(0,1); : A(0,2)
685 C = 2
690 FOR I = 0 TO 4
700 K = 0
705 C = C + 1: IF C>9 THEN C = 0
706 LPRINT "C"; C
710 FOR J = 0 TO 10
720 K = K + I * J
725 IF K>10 THEN K = K - 11: GOTO 725
730 LPRINT "D"; A(K,1); : A(K,2)
740 NEXT J
750 NEXT I
755 LPRINT "D"; A(K,1); : A(K,2)
760 LPRINT "M0,-200" LPRINT "C0"
770 LPRINT CHR#(17)
1000 REM CALCULATE PROGRAM
1010 LPRINT "CALCULATE PROGRAM"
1020 LPRINT CHR#(18); "S0" LPRINT "C1" LPRINT CHR# (17)
1025 LPRINT : LPRINT
1030 LPRINT "-----LIST OF STOCK-----"
1035 LPRINT CHR#(18); "C2" LPRINT CHR#(17)
1040 LPRINT : LPRINT
1045 LPRINT "NAME"; TAB(14); "COS T"; TAB(23); "P"; TAB(28); "SUBTOTAL"
1048 LPRINT CHR# (18); "C0" LPRINT CHR#(17)
1050 S = 0
1060 READ N
1070 FOR J=1 TO N
1080 READ NM#,C,M
1090 ST = C * M
1100 S = S + ST
1101 A# = NM#
1102 IF LEN (A#) = 9 THEN GOTO 1105
1103 A# = A# + " "
1104 GOTO 1102
1105 B# = STR# (C): D = 7 - LEN (B#)
1106 FOR I = 0 TO D
1107 A# = A# + " "
NEXT I
1108 A# = A# + B#
1109 B# = STR# (M)
1111 FOR I = 0 TO 6 - LEN (B#)
1112 A# = A# + " "
NEXT I
1113 A# = A# + B#
1114 B# = STR# (ST)
1115 FOR I = 0 TO 10 - LEN (B#)
1116 A# = A# + " "
NEXT I
1117 A# = A# + B#
1118 LPRINT A#
1120 NEXT J
1125 LPRINT CHR#(18); "C3" LPRINT CHR# (17)
1130 LPRINT "-----"
1140 LPRINT CHR#(18); "C1" LPRINT CHR#(17)
1150 LPRINT TAB(18); "TOTAL"; TAB(30); S
1200 DATA 10
1210 DATA "DOG",23,30
1220 DATA "CAT",35,26
1230 DATA "HORSE",230,8
1240 DATA "COW",215,25
1250 DATA "LION",3200,3
1260 DATA "TIGER",2890,5
1270 DATA "ELEPHANT",5890,3
1280 DATA "WHALE",6900,32
1290 DATA "UNICORN",13800,2
1300 DATA "DRAGON",29800,1

```

■ R&W

# SELECTRONIC

Radio, TV and Radio Communication  
Specialists

## 934 MHz UHF Radio Equipment

An easily installed radio system, with uses for small businesses, from home to small boats and a useful home to car two-way private radio system. Range available from this equipment - mobile to base 10 - 15 miles; base to base up to 100 miles (conditions permitting).

*We have in stock the full range of Reftec equipment, i.e. Mobile Transceiver MTR 934/1 plus full range of aerials and fittings, etc.*

- ★ STOCKISTS OF AMATEUR RADIO EQUIPMENT: Yaesu, Trio, F.D.K. Tonna, Jaybeam, Revco etc.
- ★ REPAIR & MODIFICATIONS BY EXPERIENCED & QUALIFIED STAFF.
- ★ CREDIT TERMS AVAILABLE

*For further information please ring:  
Mike Machin on (0268) 691481.*

**Tandy**  
AUTHORISED DEALER

203, HIGH STREET,  
CANVEY ISLAND



## ONE OFF EPROM PROGRAMMING

From Your HEX Table — For Your Development

- ▶ Programming of all popular, single rail EPROMs, with device either supplied by you or us.
- ▶ Any number of bytes programmed. Indicate 'don't care' addresses.
- ▶ Normal delivery 2-3 days, - excl. postage.

DEVICE TYPE	SUPPLIED BY US	YOU
2716 -450nS	12:50	9:50
2716 -350nS	15:50	9:50
2732 -450nS	20:25	15:75
2732 -350nS	22:25	15:75
2532 -450nS	20:25	15:75
2764 -450nS	27:00	21:00

all prices inclusive of VAT (15%) and carriage.

Audio Visual Development Department,

*Stephen Greaves Photography Limited*

Tel: — Bristol  
19 Queen Victoria Rd., Westbury Park, Bristol BS6 7PE.(0272) 732176

## TALK TO THE WHOLE WORLD

Study now for the  
**RADIO AMATEUR'S  
EXAMINATION**

We have had 40 years successful experience  
in training men and women for the  
G.P.O. Transmitting licence.



FREE R.A.E. brochure without obligation from:—

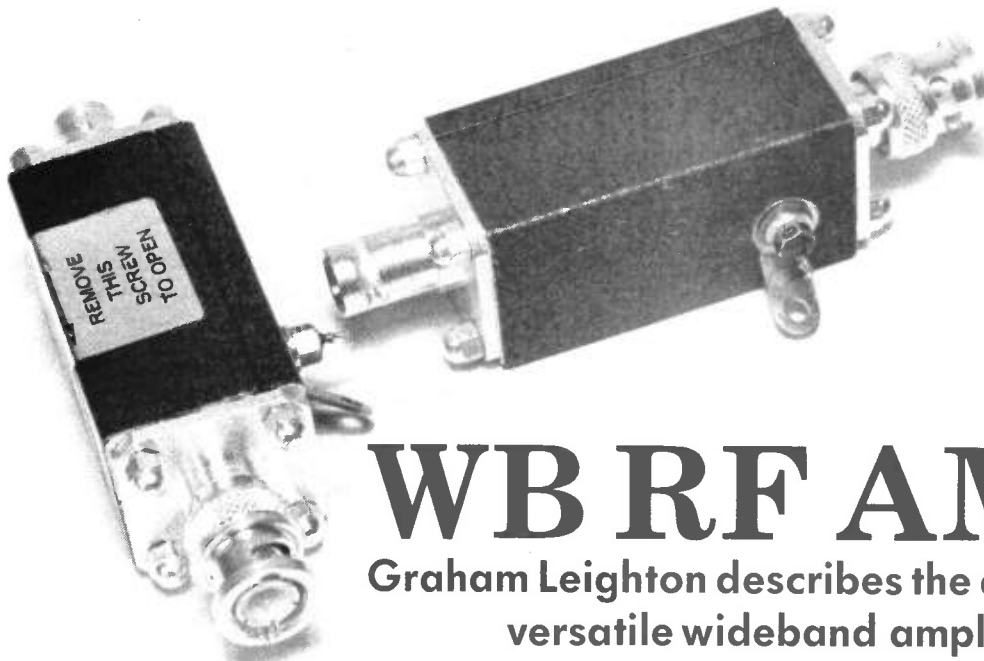
**British National Radio & Electronics School**  
READING, BERKS. RG1 1BR

Name .....

Address .....

REW8/817

BLOCK CAPS PLEASE



# WB RF AMPS

Graham Leighton describes the design of two versatile wideband amplifiers.

A wideband RF amplifier can be a very useful piece of test equipment for the experimenter or radio enthusiast. The two extremely simple designs given here are housed in screened boxes, which have connectors that allow them to be easily inserted in-line. The total frequency coverage of the two amplifiers is from below 10MHz to 900MHz.

## LF Amplifier

The SL560 IC, which is described by Plessey as a 300 MHz gain programmable amplifier, has been configured here to give a gain of about 14dB up to 100MHz.

## VHF-UHF Amplifier

This is based on a NEC thin film hybrid which was designed for use as a TV preamplifier. The specifications of the MC5229 are given in *Table 1*. The noise figure of this amplifier is low enough to make it usable as a general purpose RF preamp (this being its original application) as well as for use as a piece of test equipment. Although the input and output impedances are nominally 75R, in practice the increase in VSWR should not cause many problems. The original

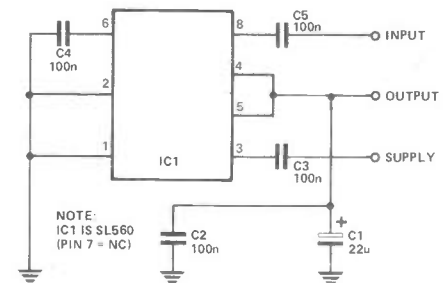


Figure 2: Circuit of the 100MHz LF amplifier.

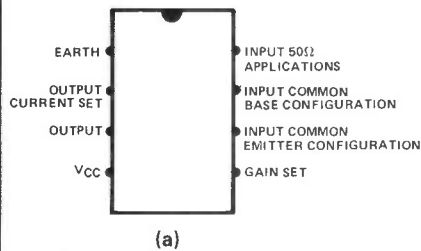
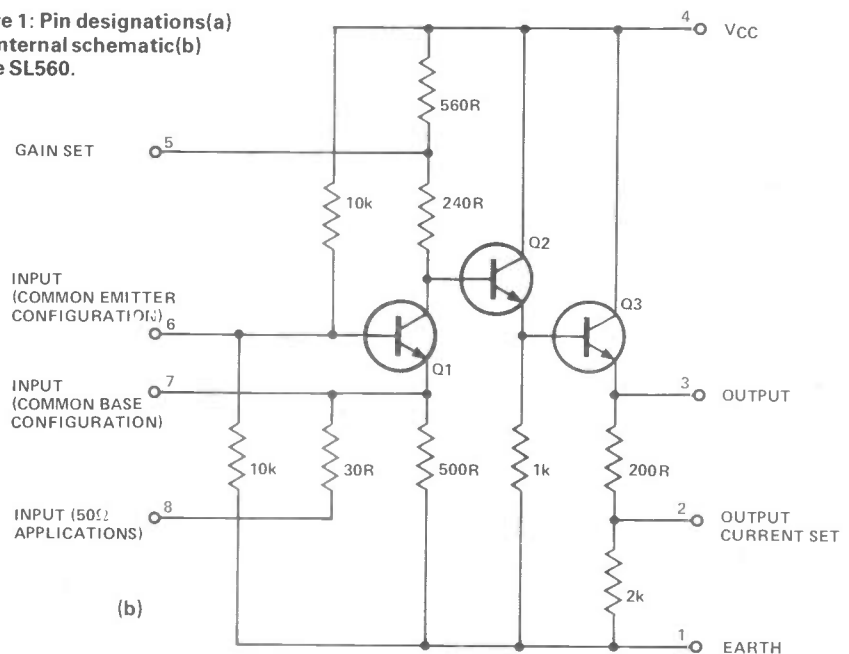


Figure 1: Pin designations(a) and internal schematic(b) of the SL560.



## Circuit Description

The transistors used in the SL560 have a low noise figure and a transition frequency ( $f_T$ ) in excess of 1GHz. Q1 is normally operated in common base, which gives a well defined low input impedance. Full voltage gain is produced by this transistor and the output is buffered by two emitter followers Q2 and Q3. The collector load resistance of Q1 is split, the junction being brought out to pin 5. An external capacitor may be used at this point to provide roll-off. The input transistor may also be used in common emitter mode by decoupling pin 7 and using pin 6 as input. This gives a low noise figure of 2dB (source resistance = 200 $\Omega$ ) and a gain of up to 35dB.

SYMBOL	PARAMETERS AND CONDITIONS	UNITS	MIN	TYP	MAX
ICC	Operating Current at $V_{CC} = +17V$	mA	36	41	46
G	Gain at $f = 30 \sim 900MHz$ , $Z_{out} = 75R$	dB	17	17.5	18
$\Delta G$	Gain Flatness at $f = 30 \sim 900MHz$ , $Z_{out} = 75R$	dB		$\pm 0.8$	$\pm 1.2$
RL <sub>in</sub>	Input Return Loss at $f = 30 \sim 900MHz$ , $Z_{out} = 75R$	dB	7.5		
RL <sub>out</sub>	Output Return Loss at $f = 30 \sim 900MHz$ , $Z_{out} = 75R$	dB	7.5		
ISO	Isolation, $f = 30 \sim 900MHz$	dB	25		
NF	Noise Figure, $f = 30 \sim 900MHz$	dB		5.0	6.5
IM <sub>2</sub>	2nd Order Intermodulation Distortion at $f_1 = 90MHz$ , $f_2 = 100MHz$ , $f = f_1 + f_2$ , $V_{out} = 100dB\mu V$	dB	-50	-55	
IM <sub>3</sub>	3rd Order Intermodulation Distortion at $f_1 = 200MHz$ , $f_2 = 210MHz$ , $f = 2f_2 - f_1$ , $V_{out} = 100dB\mu V$ $f_1 = 700MHz$ , $f_2 = 750MHz$ , $f = 2f_2 - f_1$ , $V_{out} = 100dB\mu V$	dB	-60	-65	
P <sub>out</sub>	Output Power at 1dB Compression, $f = 500MHz$ , $Z_{out} = 50R$	dBm		10	

Table 1: Specifications of the MC5229.

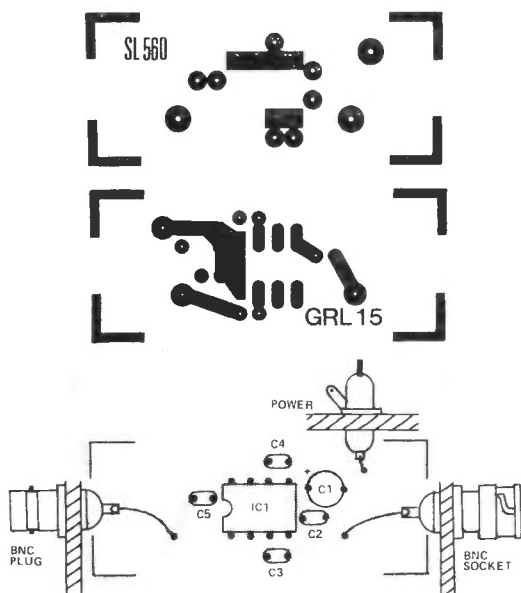


Figure 4: The PCB foils and component placing for the LF amplifier.

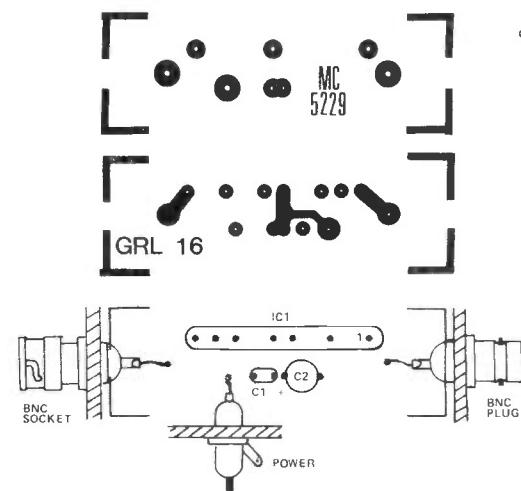


Figure 5: The VHF-UHF amplifier foils and overlay.

prototype was made for use with a spectrum analyser and noise generator for noise figure measurements. The thin film circuit was simply 'rested' on a brass strap soldered between two tags inside the box. If this method is used, great care must be taken not to break the pins when forming them.

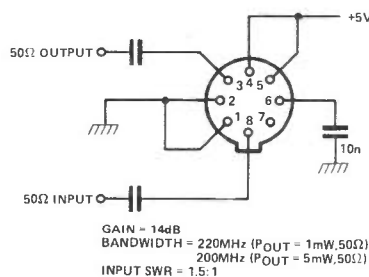


Figure 6: Basic configuration for SL560 circuits.

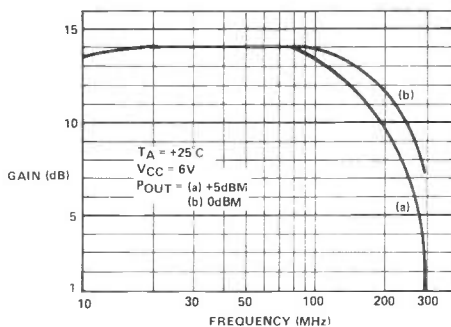


Figure 7: Frequency Vs Gain for the basic circuit in Figure 6.

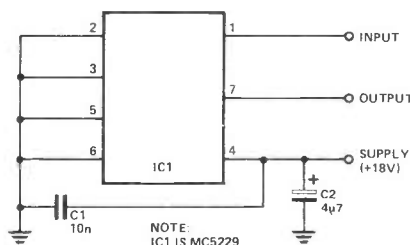


Figure 8: Circuit diagram of the VHF-UHF amplifier.

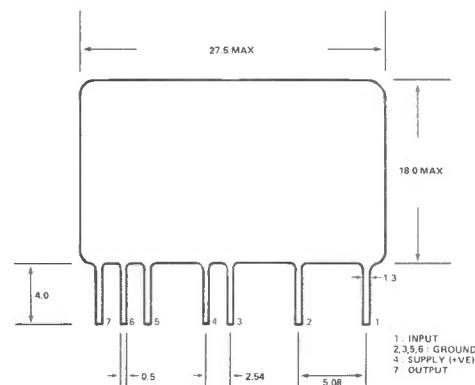


Figure 3: The MC5229 pin-outs.

## Construction

Both amplifiers use a double sided PCB, one side being the earth plane. Any earth connections should be made directly to the top of the PCB. The connector-box has two earth tags which are used to support the board and make an earth connection. When fitting the board, make sure that the track on the underside cannot short out to the case. In order to minimise stray pickup and to prevent supply borne interference, it is best to use feedthrough capacitors on the supply input.

## Testing

There really isn't much to test with these designs. Just check the supply current (typically 41mA for the MC5229 and 20mA for the SL560, at supplies of 17V and 6V respectively). Using a receiver, check that there is an increase in signal, noise and signal/noise ratio when the amplifier is in-line with the aerial or other signal source.

## References

- Plessey Semiconductors, Broadband Amplifier Applications.
- Plessey Linear IC Databook
- NEC MC5229 Data

### PARTS LIST – SL560

#### Capacitors

- C1 22u 35V tantalum
- C2-5 100nF monolithic

#### Miscellaneous

Case (RS), Power connector, PCB etc.

### PARTS LIST – MC5229

#### Capacitors

- C1 10nF monolithic
- C2 4u735V tantalum

#### Semiconductors

- IC1 MC5229

#### Miscellaneous

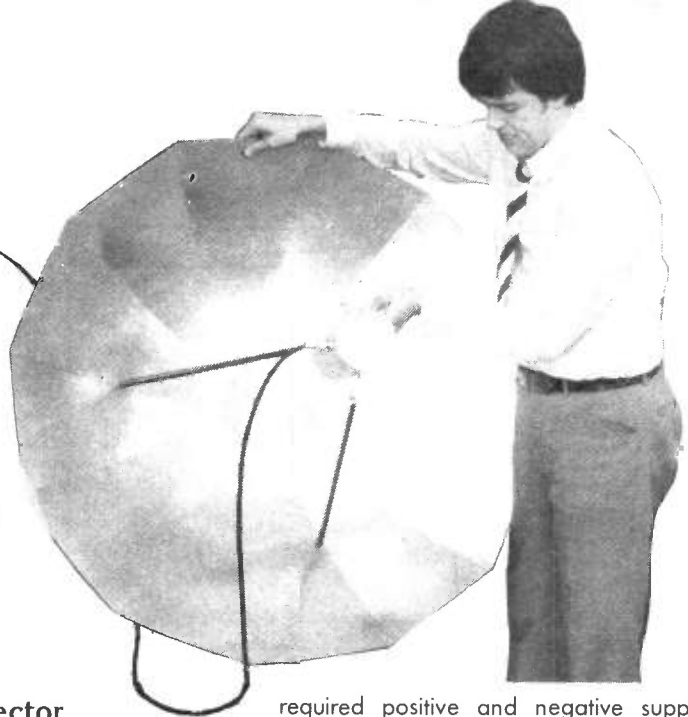
Case (RS), Power connector, PCB etc.



# WEATHER SATELLITE RECEPTION

## Part II

William Poel follows up our introduction to Meteosat reception with a look at baseband considerations.



There are two readily available converters for 1.8GHz Meteosat applications, one from Microwave Modules and the other described by UY3UMV from VHF Communications. The R&EW Meteosat station uses the latter version, which produces the right results to obtain clear pictures from its 1.2m dish.

The 137.5MHz "IF" can be either the DC3NT receiver (described in the 4/79 and 1/80 editions of VHF Communications), an adapted R&EW UOSAT receiver, or any of the various 2m converters that have appeared from time to time.

We do not intend to get deeply into the RF intricacies in this series, since much already exists on these subjects covered in the references at the end of the previous instalment

Recent work has shown that the fax demodulation and display section of this system works with a variety of other HF weather information services, and also appears to be suitable for modification of the UOSAT CCD image format, and general SSTV applications

### From The Detector

The block diagram of this module (ref YU3UMV/001) is shown in *Fig. 1*. The APT WEFAX signal is firstly filtered in a bandpass filter and demodulated. The analogue video signal is sampled and converted in an 8-bit A/D converter. Only 6 bits are required for 64 grey levels, which are then converted into a serial format. Synchronization is obtained from the 2.4kHz APT/WEFAX sub-carrier and all clock signals are obtained from a PLL, which is synchronized to the 2.4kHz sub-carrier. This is followed by a chain of dividers.

Additional circuits provide the initial synchronization (initial phasing) of the image. These circuits recognise the synchronizing sequences present in the video signal and reset the line-frequency divider. It is possible for the image to be manually synchronized if these circuits are not able to recover the synchronizing pulses from the signal due to a poor signal-to-noise ratio.

The power supply provides all the

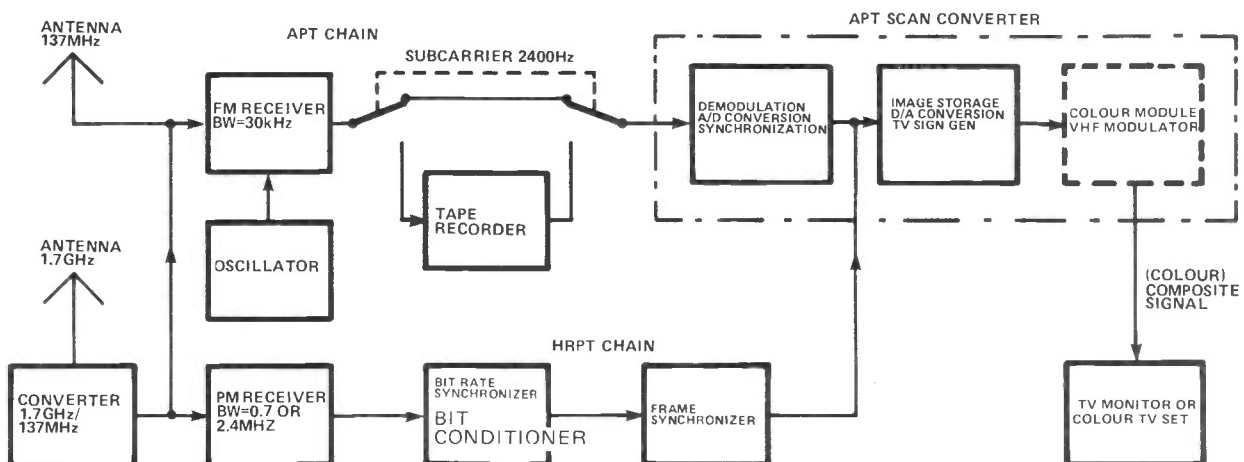
required positive and negative supply voltages from a 12V6 external supply (negative ground), which need not be stabilised. This means the unit is portable and can be driven from a car battery if required. The board also includes a 1MHz clock oscillator, which is used to drive the TV sync generator on the storage module.

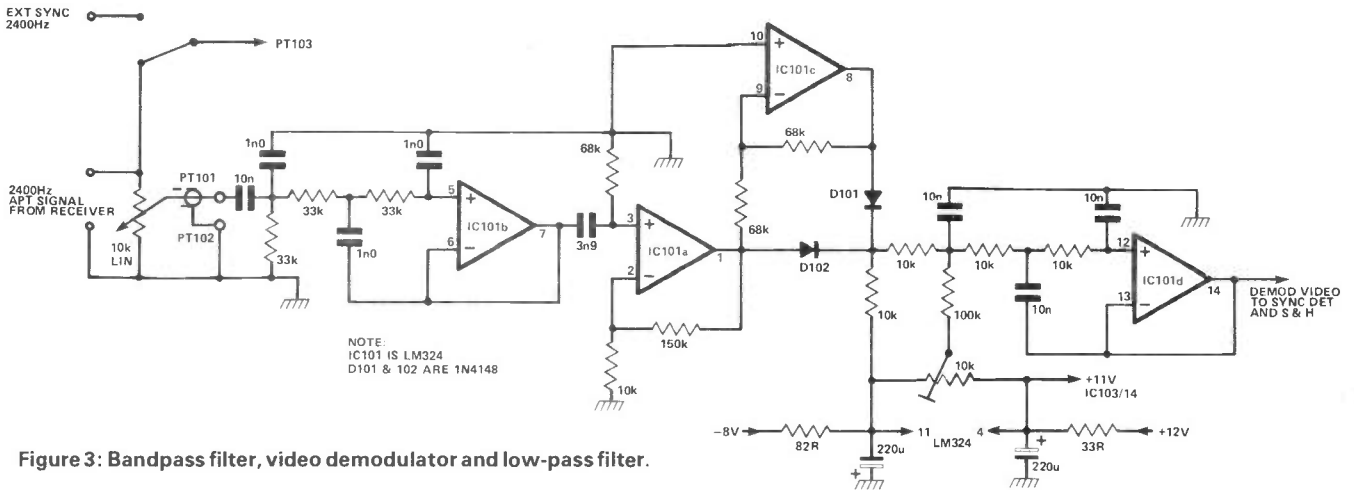
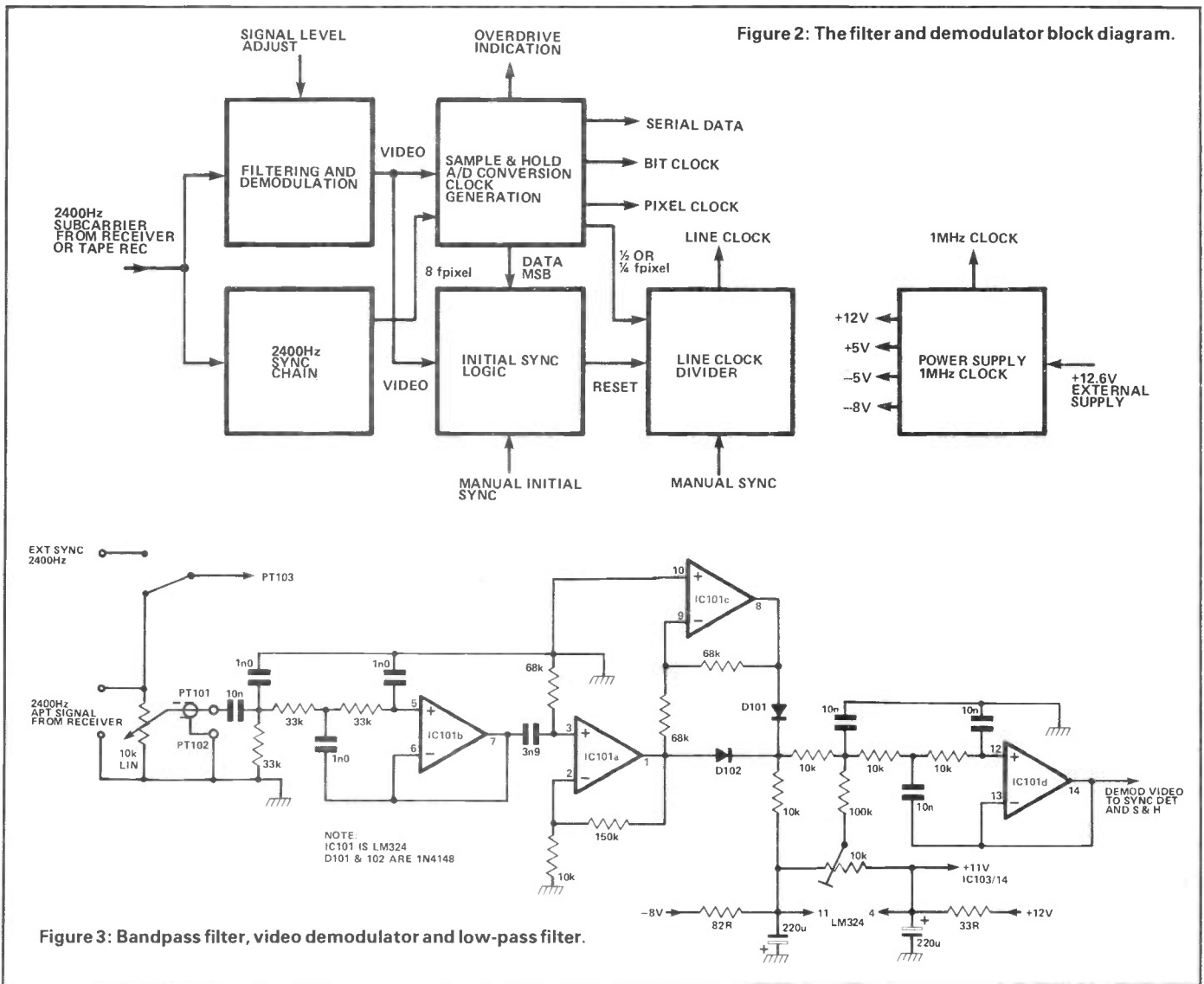
In order to describe the complex circuit more easily, we'll divide it into six parts. Each part corresponds to one block in *Fig. 1*. All external connection points for input and output signals, potentiometer switches, etc, are prefixed with Pt.1 for module 001.

### Filter And Demodulator

The filter and demodulator block is shown in *Fig. 2*. The level potentiometer, R 101, is accommodated on the front panel, and is followed by a bandpass filter for the APT/WEFAX signal. This is followed by the second amplifier for the LM 324, which drives an AM-demodulator with D101 and D102, followed by a lowpass filter for the video signal.

Figure 1: Block diagram of a APT/WEFAX/HRPT station.





The circuit was designed to accept the APT signals provided by a typical FM demodulator (TVA 120 or similar). Since the APT signal only contains useful information between 800Hz and 4000Hz, the S/N ratio can be considerably improved by filtering out-of-band noise. Also the FM-modulators on board the satellites do not employ pre-emphasis, thus the demodulated S/N will deteriorate with the square of the modulation frequency, which means that it is particularly important to filter out noise components above 4kHz and to use a good lowpass filter in conjunction with an operational amplifier. The filtering below 800Hz is less demanding, and it is only necessary to efficiently suppress any 50Hz power-line frequency interference. This can be obtained by correct selection of the coupling capacitors.

The second operational amplifier drives a full-wave rectifier AM demodulator. Experiments have shown that it is not necessary to have a very good balance of

the demodulator, and a simple inverter is satisfactory (using the third section of the op-amp). In addition to the required video signal, a very strong component at twice the sub-carrier frequency (4.8kHz) is present at the output of the rectifier. This should not be fed to the sample- and-hold circuit and is therefore filtered out in an active lowpass filter using the remainder of the op-amp.

### Synchronizing Chain

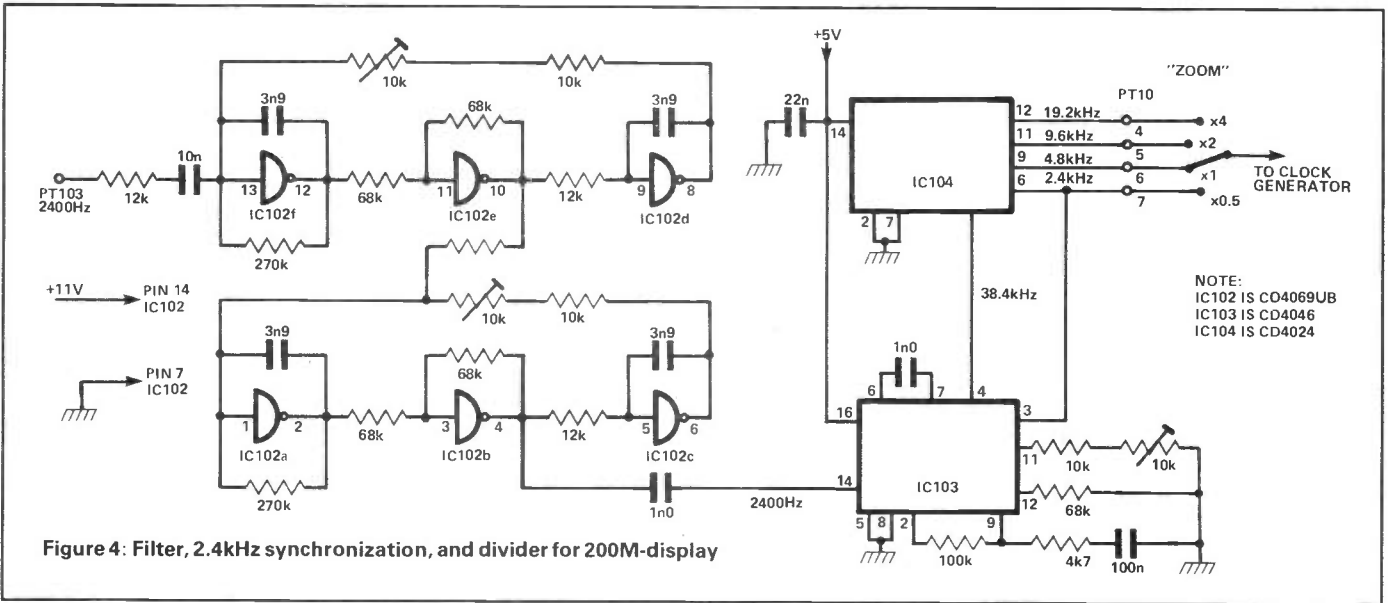
Fig. 3 shows the 2.4kHz synchronizing chain, which comprises a two-stage, narrow-band 2.4kHz filter and a PLL-circuit with subsequent divider that generates all required frequencies for the clock generator. All these are phase-locked to the subcarrier signal.

CMOS inverters are used as active components in the 2.4kHz filter since they have a smooth, well defined symmetrical limiting characteristic. This is not true for all conventional, operational amplifiers, which are subject to saturation, ringing,

unbalanced limits, and similar problems when operated with high-level signals. The circuit used here allows wide tolerances of both active and passive components of the filter, and the high input impedance of the CMOS inverters allows a wide choice of R and C values. It is only important that CMOS gates of the A or UB series are used, since the B series has too high a non-compensated gain and usually oscillates in feedback circuits.

The output of the filter is capacitively coupled to the self-biasing input of a CD 4046 PLL. Two components require noting: the 68k resistor, at pin 12, is not really necessary for operation, but ensures a good start-up for the VCO under any switch-on conditions. Wide tolerances are allowed for the VCO of the CD 4046 and it may be necessary to modify the value of the VCO capacitor between connections 6 and 7.

Phase comparator 1 (EX-OR gate) is used, since some input pulses might be missing due to noise and/or deep



modulation of the 2.4kHz sub-carrier. The VCO oscillates nominally at 38.4kHz, which is 16 times the sub-carrier reference frequency.

The VCO frequency is divided by 16 in the CD 4024 binary counter. Frequencies of 19.2kHz, 9.6kHz, 4.8kHz, and 2.4kHz are present at the outputs of the CD 4024. These frequencies drive the clock generator via a selector switch on the front panel and result in the pixel sampling frequency when divided by 8.

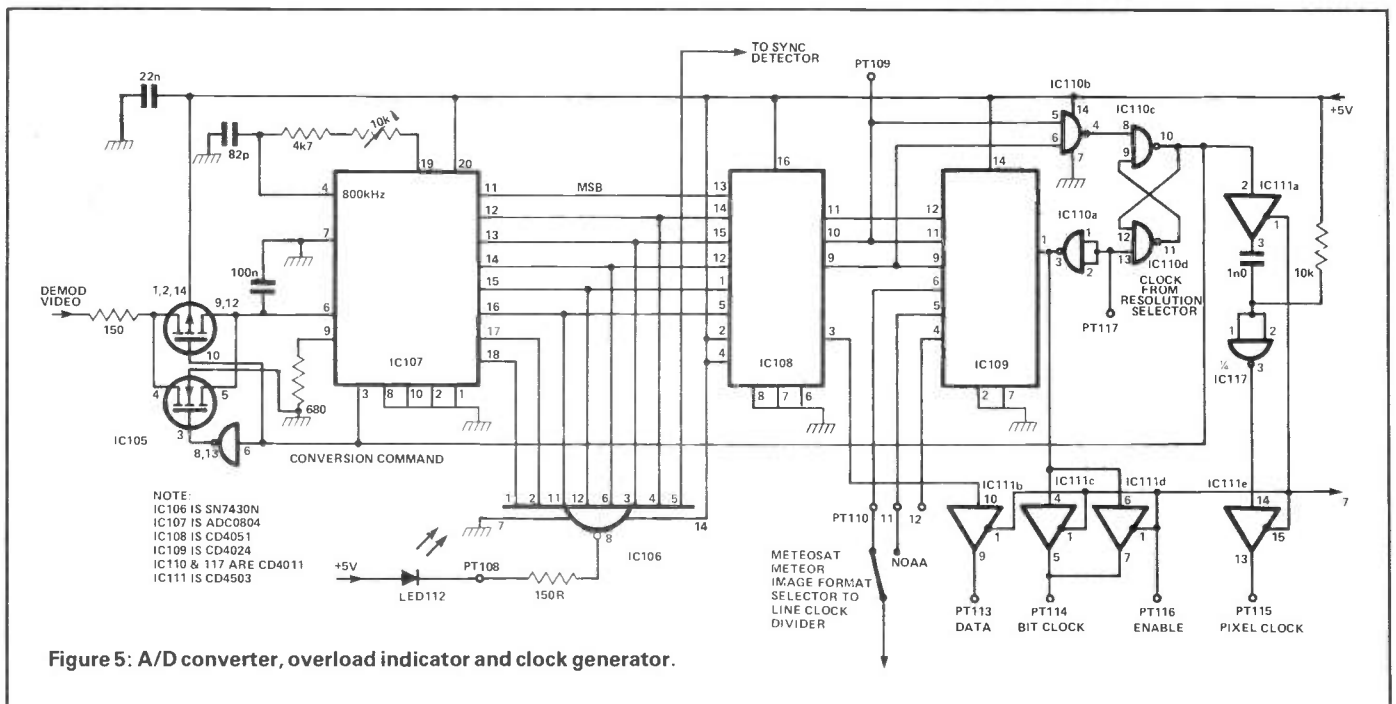
The choice of the sampling frequency is not trivial, and several factors have to be considered. The data rate of an APT signal is approximately 3200 words per second. Since this is limited by the transmission channel bandwidth, there is no point

having a higher sampling frequency. Furthermore, the sampling frequency must also be adapted to the size and format of the frame memory available. Since that memory (256 x 256 pixels) is smaller than the APT image format (800 x 800 pixels), it should be possible to display the complete image at reduced resolution, or to use various enlargements or zoomed sections of the image at higher resolution, or even original spatial resolution – made possible by changing the pixel sampling frequency.

In theory, there is no relationship between the sampling frequency and the APT/WEFAX sub-carrier frequency. In practice, however, the residual sub-carrier frequency or its harmonics have to be

filtered out carefully from the video signal. If these components reach the sample-and-hold circuit, they will heterodyne with the sampling frequency (or its harmonics) and will be visible as vertical bars in the image, (diagonal bars, if the two frequencies do not have a constant phase relationship to one another). In the case of 64K (256 x 256) memory, it is possible to select 2400Hz or sub-harmonics as sampling frequency.

Since no heterodyne products, except a DC component, will be produced below the sampling frequency, less filtering of the video signal will be required. However, it is important that the sampling frequency is phase-locked to the sub-carrier frequency, which also results in other advantages (eg,



providing an excellent tracking of tape-speed variations when displaying recorded images).

**Table 1** gives the possible display formats on selecting the sampling frequencies; 2400Hz, 1200Hz, 600Hz, and 300Hz.

## A/D Converter And Clock Generator

As can be seen in **Fig. 4**, a CMOS transmission gate (CD4007) is used as a sampling switch. The input impedance of the A/D converter, ADC 0804 (National Semiconductor), is sufficiently high so that no additional amplifier is required for the hold function (100nF capacitor). The 680R resistor, from pin 9 (Vref) to ground, defines the dynamic range of the A/D converter from 0V to approximately 2V.

The ADC 0804 has an internal clock oscillator (Schmitt-trigger gate), which is provided with external components connected to pins 19 and 4. R106 is aligned to 800kHz. A clock frequency of 800kHz provides a conversion time of approximately 100 us. The conversion is started at the leading edge of the conversion-command signal (see **Fig. 5**), and when conversion is completed the data is transferred to the output storage of

Zooming resolution switch Bit Clock	Sampling frequency	METEOSAT WEFAX	NOAA APT 1)	METEOR 240 lines/min.	METEOR 120 lines/min. 2)
19.2 kHz	2400 Hz	x 2	x 2	x 2	---
9.6 kHz	1200 Hz	x 1	x 1	x 1	x 2
4.8 kHz	600 Hz	---	VIS + IR	---	x 1
2.4 kHz	300 Hz	---	---	---	---

**Table 1: Possible image formats of the 64kByte storage module.**

the ADC 0804. An 8-input NAND gate detects the over-range, which is displayed by a LED on the front panel. This indicator is very useful for adjusting the signal level at the input of the video demodulator correct – the appropriate potentiometer is adjusted when the LED just starts blinking, which indicates that the dynamic range of the A/D converter is being fully utilised without excessive clipping.

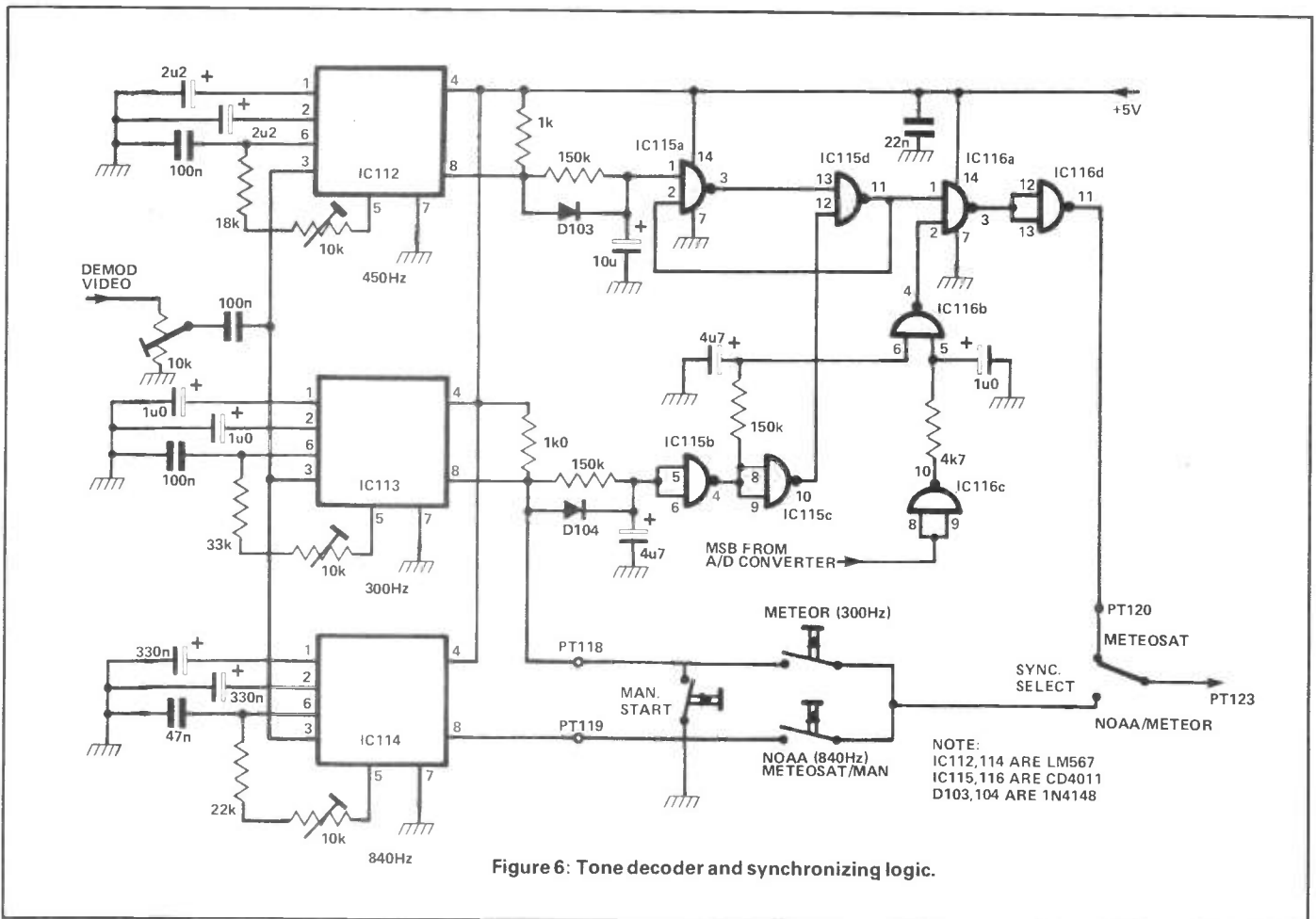
The parallel data at the outputs of the ADV 0804 is serialized in the multiplexer (CD4051) where the two lowest-valency bits are suppressed. The radiometric resolution of 6 bits for 64 grey levels is determined at this point.

The multiplexer, CD 4051, is driven by divider, CD 4024, and this converts the parallel data into serial form being fed to pin 3 of one of the buffer amplifiers, from where it is fed via Pt 113 to the digital

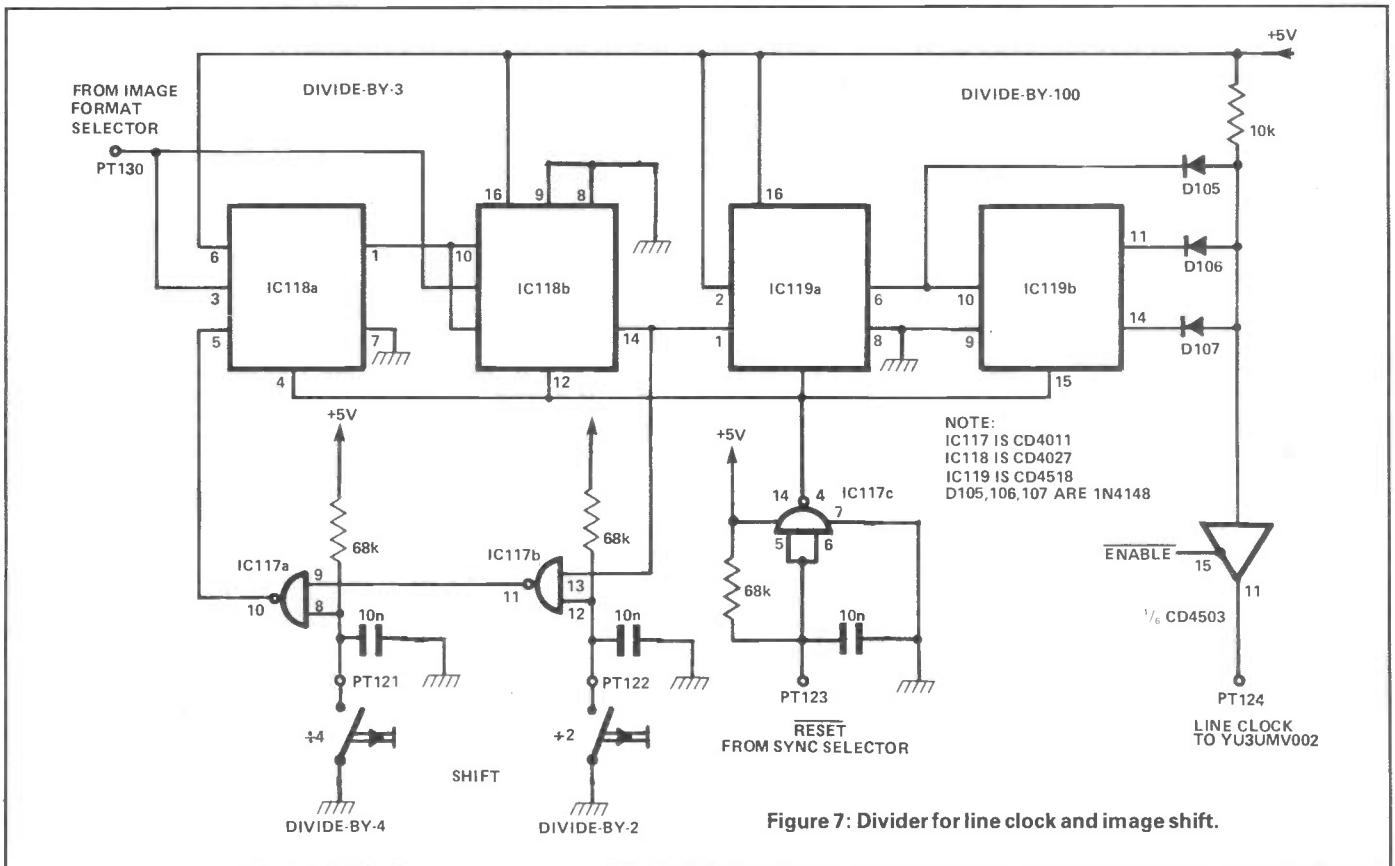
memory module (YU3UMV/2) for storage.

The clock generator also includes decoder logic to generate the conversion command and pixel clock. Serial data, coherent bit-clock, pixel-clock, and line clock are fed via tri-state buffer amplifiers (CD4503) switched on when the enable input, Pt 116, is grounded (if, however, Pt 116 is connected to +5V, this will disable the tristate buffers so that the signals from another source, such as a frame synchronizer used in the high resolution system outlined in the last article, can be fed to the store).

The line sampling clock is derived from the pixel sampling clock. It is important here to know that the line sampling clock is only equal to the image line frequency when the maximum geometrical resolution is to be retained. If an image is to be displayed at reduced resolution, it is not



**Figure 6: Tone decoder and synchronizing logic.**

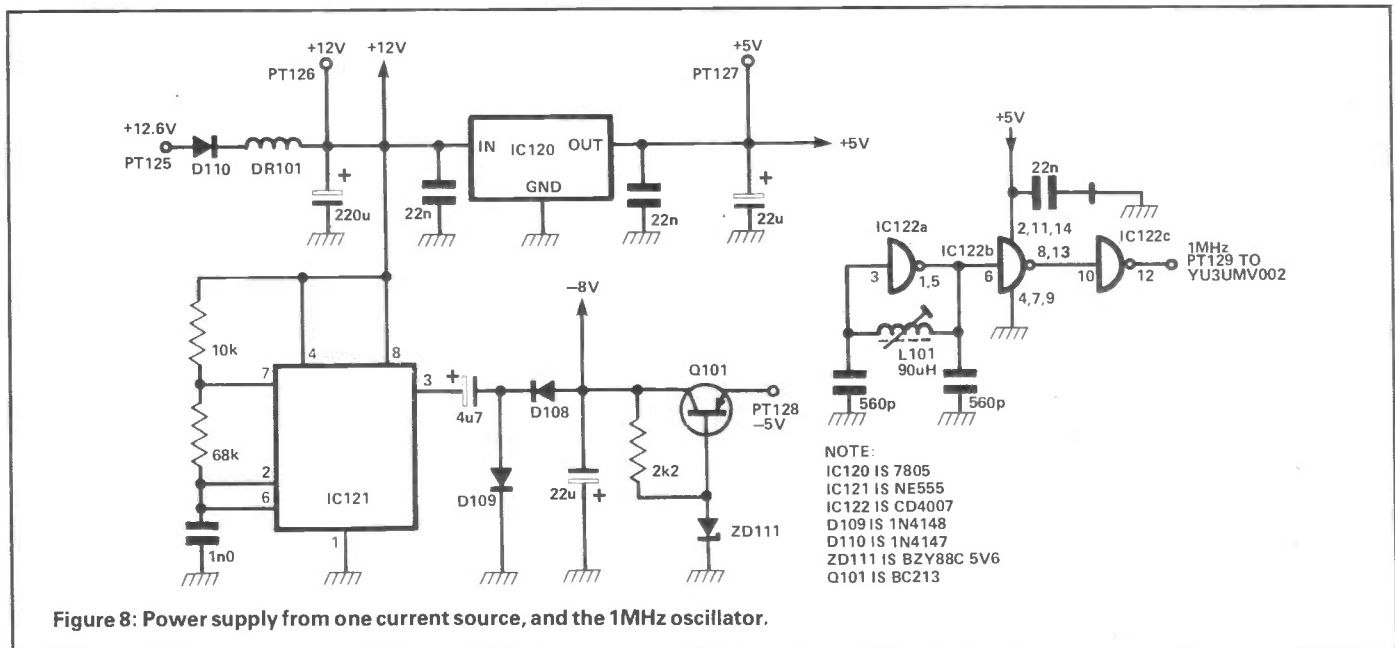


only necessary to reduce the pixel sampling clock to lower the horizontal resolution, but it is also necessary to reduce the line sampling clock to reduce the vertical resolution. This avoids geometrical distortion (wrong aspect ratio). For example, if the image is to be displayed at half of the original resolution, then the pixel sampling gate should be lowered to half of the maximum sampling rate, and

only every second line of the image should be written into the memory. This means that the ratio between the pixel sampling frequency and the line sampling frequency remains constant for a fixed image format and memory size. In the case of a 256 x 256 memory displayed on a TV-screen having a 4:3 aspect ratio, the ratio between the two sampling frequencies is 600 for geostationary satellites such as

METEOSAT and both METEOR standards, and 1200 for NOAA satellites.

Half the pixel sampling frequency is available at the outputs of divider IC109 (pin 6). A further division by 300 is performed by the line clock divider (IC118 and IC119 in Fig. 7) which provides the required ratios of 600 or 1200 between the two sampling frequencies. Auxiliary outputs are provided for other satellite





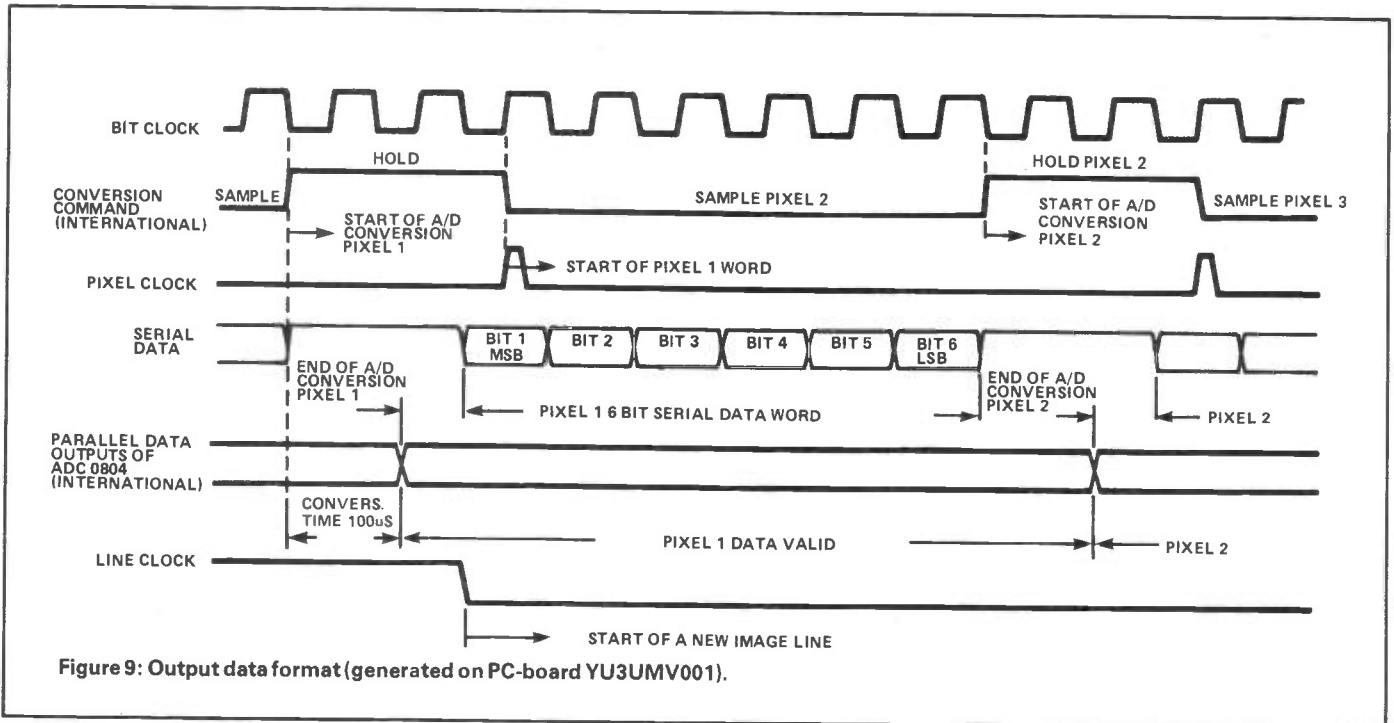


Figure 9: Output data format (generated on PC-board YU3UMV001).

standards, for example for the (very seldom active) METEOR IR (Infra Red) transmissions which require a ratio of 150 between the two sampling frequencies

The auxiliary outputs are Pt 109 and Pt 112.

### Synchronizing Logic

The initial synchronizing logic (see Fig. 6) can operate automatically by decoding the start and stop tones of the geostationary WEFAX transmission, or manually by decoding the synchronizing pulses of METEOSAT, NOAA, or METEOR.

Three PLL tone decoders of the LM567 series are aligned to 300Hz, 450Hz and 840Hz. Since very high capacitance values would be required in the output-filters (pin 1) of the first two decoders (IC 112 and IC113), external delay gates are connected to their outputs (pin 8). The 300Hz and 450Hz decoders control an RS flip-flop to implement the automatic start-stop function.

A delayed 300Hz pulse connects the highest-valency bit (MSB) from the A/D converter to the reset of the line clock divider. The synchronizing pulses which immediately follow the 300Hz start tone, synchronize the line divider automatically.

The LM567 is a narrow-band tone decoder and it is not very suitable to detect very short tone bursts such as the horizontal synchronizing pulses of the NOAA and METEOSAT images (7 cycles). The operation of the 840Hz detector is not very reliable since it is also sensitive to image patterns, similar to synchronizing pulses, and to noise. So it is sometimes

necessary to repeat the manual synchronizing process. On the other hand, METEOR satellites with 120 line/min, have far longer synchronizing bursts (16 cycles) but, unfortunately, the frequency of these bursts is not exactly 300Hz and a separate tone decoder would be required to obtain better results.

However, the S/N ratio is usually very poor at the beginning of signal acquisition when receiving polar orbiting satellites, especially when using simple omnidirectional antennas.

### Line Clock Divider

The line clock divider (Fig. 7) comprises two dividers. The first is a divide-by-three (IC118 and two NAND-gates [IC117]), which is followed by a divide-by-100 (IC 119). The divide-by-three divider can also be preset to divide by two or by four, using two push buttons. In this manner, a slightly higher or lower line clock frequency can be generated to manually shift the image in either (horizontal) direction.

The amount of shift is proportional to the time the pushbuttons are depressed. The diodes at the output to the CD4518 (IC114) are connected as an AND gate to narrow the output pulse. This is required for some satellite standards — for instance, to receive the METEOR IR-images (20 lines/min).

### PSU And 1MHz Oscillator

The power supply (see Fig. 8) also supplies the stabilised voltages for module 002. The nominal value for the external voltage at Pt 125 is 12V6. However, the whole unit

will operate between 10 and 15V5 at normal ambient temperatures. The overall current drain is in the order of 400 to 450mA. Diode D110 protects the circuits against incorrect polarity and the RF choke suppresses the pulses from the digital circuits in order to ensure that they are not fed to the receiver via the power supply line.

A three-terminal voltage regulator supplies a voltage of  $\pm 5V$ ; it should be mounted on a suitable heatsink (or cabinet). No insulation is required since the heatsink of the 7805 is grounded. A clock generator based on NE 555 is connected as a multivibrator and its output (AC) voltage is fullwave rectified in order to obtain approximately  $-8V$ . The  $-5V$  supply voltage required is obtained using a simple Zener diode/transistor regulator.

This same module is also equipped with a 1MHz LC-oscillator, from which the horizontal and vertical TV-frequencies on the memory module are derived. Since the format of the TV-signal generated on the store module does not correspond exactly to CCIR (320 lines instead of 312.5 lines per frame), a variable oscillator is preferable to a crystal oscillator. Practical experiments have shown that some TV monitors (or modified TV receivers) are more sensitive to variations of the line frequency (loss of horizontal synchronization), whereas others are more sensitive to fluctuations of the frame frequency (interference with the 50Hz power lines). This can be compensated for, by careful alignment of L101.

# ATV On the Air

PRESENTED BY  
ANDY EMMERSON, G8PTH

To newcomers, working foreign ATV stations seems more than a little exotic. To seasoned ATVers, it comes as a welcome bonus now and again. You don't have to live in the South of England to work the Continent (though it can help) and, in fact, the skill of working far-off stations is more down to interpreting propagation conditions than where you live. All that follows is written with 70cm in mind, but most applies to the higher frequencies as well.

## Getting a Lift

Unless you live in Dover or Folkestone you probably won't be able to work The Continent under flat conditions, so you'll need a "lift". Enhanced tropospheric propagation, as it is more properly called, occurs mainly in late spring and early autumn but can happen at any time of the year, even in deepest winter. The mechanism of lifts is well described in books like the RSGB VHF/UHF Manual, so it only remains to recognise an opening when it occurs. Usually things are pretty lively on two metres, though not always so, and unusual stations coming in off the back of the beam on your broadcast TV reception may be a better guide. Falling atmospheric pressure after steady, warm weather is a good sign. Practical experience points to from 4 to 6 pm being a good time, and then late evening, say 8 to 9 pm. Sometimes things fade out after this, at other times they improve until conditions are wide open around 1 am. The next morning things are usually as good (but everybody is in bed, unless it's Sunday).

Openings tend to favour one direction — possibly France, but not Germany or the Netherlands, or vice versa. Long water paths are useful: stations on the East Coast always do well, but many inland stations work long distances too. There seems to be a "clan" of regulars who watch for openings, both on this side of the water and on the other side and you tend to see these folk again and again.

Strange effects occur during openings, and two stations just twenty miles apart may be beaming in the same direction and see completely different signals, as their transmissions get



F6BEZ with an intricate electronic testcard indicates that he is monitoring 144.7MHz.



F8MM (Mickey Mouse!) has a sliding window in the middle of the testcard. At the moment he is sending 73s, but the message varies.

trapped in ducts. What's more, they can send each other pictures without causing mutual interference. If QRM does become a nuisance, shifting a couple of megahertz up the band usually solves the problem. I have crystals for both 435 and 438.5 in my transmitter for this reason.

## Standards And Introductions

For coordinating things on two metres, the most obvious channel is the international TV calling frequency of 144.75MHz, though in the South of England you may well find it cluttered with 'amateurs' trying to work the French repeater. For this reason the French also use 144.17 (FM as well as SSB), and this is catching on elsewhere. As soon as you have made contact, you move off the calling frequency. Vision frequencies are not entirely standardised — most Continental stations tend to use 434.25 (with 5.5MHz intercarrier sound), but you will encounter Dutch stations with vision on 439.25 as well. All French ATVers use 438.5 with positive modulation, which may cause you problems if you don't have a dual standard receiver, but more and more stations there have an auxiliary negative modulation transmitter. You may well encounter SECAM colour from France as well, so if you are into broadcast TV-DX with a multistandard receiver as well, you will be at an advantage.

Since the opening is doing the work for you, high power is not essential, though it does help if there is a lot of QRM or conditions are only slightly up. With ten watts it is quite feasible to work 200 miles or more, and fifty watts will easily get P5 pictures to Holland or Belgium. Reports on picture quality are normally given in the universal P1 — P5 scale which we know, though the French tend to say B1 — B5. The older German system on a scale of 9 points from B1 — B9 is also in use and some stations will give you a percentage report, so 80% is equivalent to P4. For some obscure reason ATVers seem to be poor QSLers, so remember to have a camera ready. If you have

a video recorder you can make a permanent record of contacts – if you remember to switch it on. It's so easy to get carried away in the excitement.

When establishing contact and giving reports, English tends to be the 'lingua franca', which makes things easier for us. Dutch and Belgian stations in particular put us to shame with their excellent English, though some Germans and French tend to know only their own language. Then it's all down to pigeon English or recollections of what you learned — or didn't learn — at school. Sometimes, of course, you cannot speak anyway — ducting conditions may well favour 70cm but not two metres, or else your QSO partner may have a deaf two metre rig, or perhaps the QRM may just be too bad on two metres. Then it's all down to felt pens and messages scribbled hurriedly on the back of a testcard. An electronic callsign inlay to your picture or a TV typewriter with large letters is a great help too.

Sometimes the reason why you cannot raise the station is because it is a repeater. The Germans have a system of repeaters with input on 24cm and output on 434.25MHz; being well sited, these repeaters propagate well during lifts and DBOTW is quite often seen.



Laurent, F1BJB, in Amiens is one of the "regulars" and pops up whenever conditions are up. Like F8MM he is also active on 1255MHz.

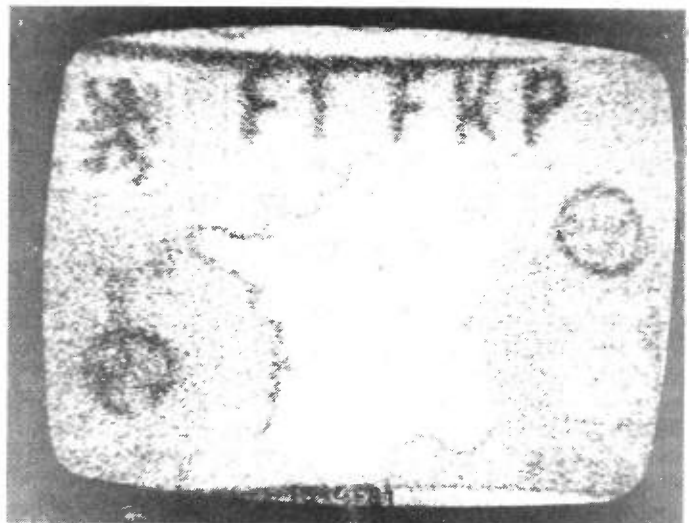
## Long Distance

In case you are wondering what the record distance is for an ATV contact I am not quite sure, since nobody seems to be keeping official scores. In October 1981, Phil Johnson GJ8KNV is believed to have worked some OK1 (Czechoslovak) stations and in October 1975 Ray Mohamed G8EGC worked 835 km to DK3NZ in Germany. Other long distance contacts have been EA1CR in Spain to F3YX near Paris (November 1979) and F1AJD who was seen in Holland at the same time (1000km). Any claims to beat these will be most welcome!

That's it for this month: I hope it has given some inspiration and food for thought. If you have any comments, questions or perhaps you would like to suggest a topic for coverage in this column I'll be delighted to hear from you via the Editor. Feedback is always welcome, so why not drop me a line?

■ R&EW

Pictures by Ryn Muntjewerff.



Jean-Marie, F1FKP, in Lens is another old stager. His testcard is distinctive enough to be recognisable even with the "wrong" modulation.

## EVENTS: MOBILE RALLIES

### AUGUST 1983

July 10th	Worcester & DARC, Annual Mobile Rally	Longleat Park, Warminster	Brian Jones, G8AS0
July 16-24th	BAE 18th Annual Exhibition	The Shelter, Esplanade, Penarth	British Amateur Electronics Club
July 17th	Sussex Mobile Rally	The Racecourse, Brighton	Worthing 200572, G4HUJ
July 24th	McMichael/Burnham Beeches ARS Maidenhead & Dist. ARC Rally	McMichael Sports Club, Bell Hill, Stoke Poges	Slough 24541-5
July 24th	Anglian Mobile Rally	Stanway School, Colchester	G3YAJ
August 7th	RSGB National Rally	Woburn	RSGB
August 14th	Derby Mobile Rally	Lower Bemrose School, Derby	G4EYM
August 28th	BARTG Rally	Sandown Park, Esher	Edward Batts G8LWY

# DESIGNER'S UPDATE

Our new series of Designer's Update will, each month, feature a range of circuits and ideas within one or two specific areas of electronics. Some of the devices featured will be recently introduced types, while others will fall into the class of 'old-favourites'. Not all of the applications mentioned will be fully developed as the aim of the series is to stimulate readers into undertaking their own design work.

## Michael Graham begins the series with a look at graphic equalisers and fluorescent displays

Many of you will be familiar with the uses to which spectrum analysers and graphic equalisers are put, but for those of you less familiar with the equipment, we'll briefly describe them.

A graphic equaliser is used to compensate for poor listening-room acoustics and to make allowance for the differing responses of cartridges, amplifiers and speakers etc. The graphic equaliser is probably best thought of as a sophisticated tone control, in place of the two familiar tone controls (bass and treble). A typical graphic equaliser will have ten 'tone controls'. Each channel, instead of being a simple low or high pass filter, will be bandpass design. The centres of the filters' pass bands will be chosen to span the entire audio frequency. A suitable series of centre frequencies for a ten band design would be 16kHz, 8kHz, 4kHz, 2kHz, 1kHz, 500Hz, 250Hz, 125Hz, 62.5Hz and 31.25Hz.

The above frequencies are chosen to give a spacing of one octave between

each band centre. The Q of each filter block will normally be about three, which means that there will be some interaction between the various filters but that the whole of the audio band can be adequately covered with only the ten filters. Each band filter should offer at least a  $\pm 10\text{dB}$  control range, but  $\pm 15\text{dB}$  is a better design aim.

Figure 1 shows the filter characteristics of a typical graphic equaliser, while Fig. 2 shows it in a reproduction chain along with some additional components.

### In The Pink

A pink noise generator is used to generate noise that has equal energy content in each octave of the audio range (a design for a white/pink noise generator appeared in March's R&EW). This is fed, via the graphic equaliser, to the amplifier/speaker combination to be 'equalised'. If the speaker and the listening-room's acoustics were ideal, a measurement of the

noise level at any part of the spectrum would be no different to a reading at any other part of the audio frequency range. It's probably not too suprising to find that, in general, the absolute level of noise throughout the band, will vary and the graphic equaliser's job is to boost or cut the frequencies to compensate for these variations.

### Graphic Design

Construction of graphic equalisers has changed with the times. Ten years or so ago, a graphic equaliser would have consisted of a series of LC filters — the resulting equipment being large, heavy and expensive.

About five years ago, the 'approved' method of realising an equaliser was to use a series of LC gyrators — this design approach is still very much used today. Fig. 3 shows the design of one section of a gyrator-based graphic equaliser with Table 1 giving the capacitor values to provide the centre frequencies shown above. The highest band (16kHz) is still best implemented by an LC filter as a gyrator would be rather prone to noise

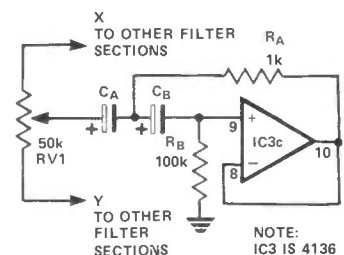


Figure 3: One section of a gyrator-based equaliser.

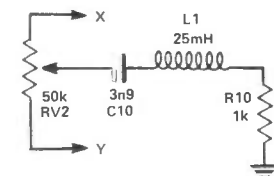


Figure 4: The HF section still uses an LC filter.

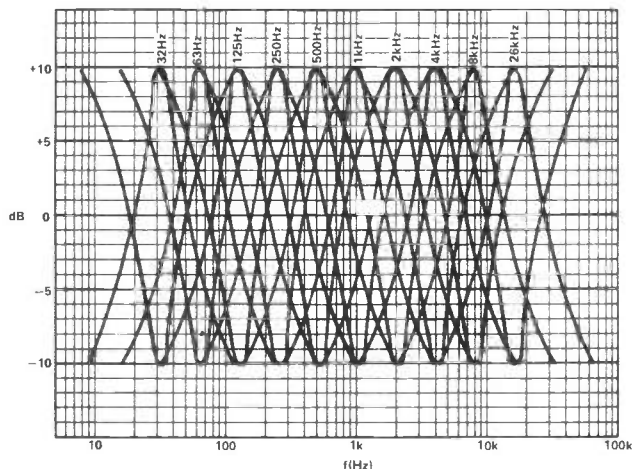


Figure 1: Filter characteristics for a typical graphic equaliser.

CENTRE FREQUENCY	31.25	62.5	125	250	500	1k	2k	4k	8k
CA	2.2	1u0	470n	270n	120n	68n	33n	15n	8n2
CB	120n	68n	33n	15n	8n2	3n9	2n2	1n0	470r

Table 1: Centre frequencies for Figure 3.

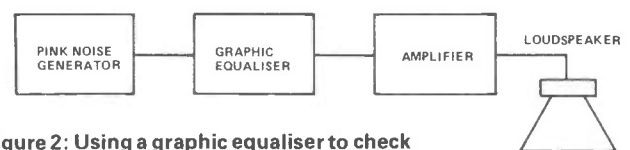


Figure 2: Using a graphic equaliser to check room acoustics.



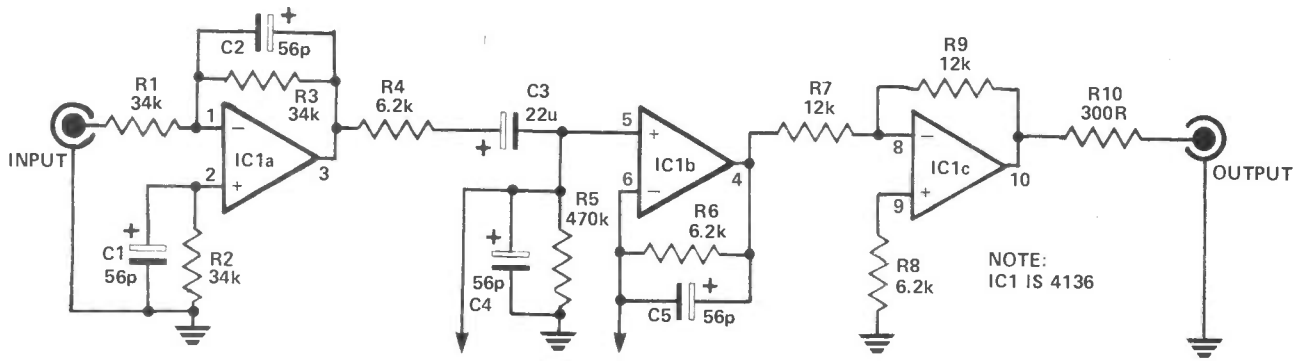


Figure 5: Input buffer and output line driver circuits.

and hum pick-up at this frequency (Fig. 4 shows the circuit of this section).

The filters form the major part of a gyrator. The only other circuitry required is an input buffer and output line driver. Fig. 5 shows the design for these stages.

Graphic equalisers are usually constructed with a set of slide switches along the front panel in order that the exact status of the filter can be readily ascertained. Some of today's equalisers have replaced the sliders by two touch

buttons per channel and a LED display. Implementing this with discrete components would be very costly. However, ALPS manufacture a pot that is operated by touch buttons and contains the LED display — exactly what is required.

### Techniques On Display.

In many applications, LEDs either in the form of seven segment displays or as dot matrices of individual diodes, are an acceptable choice for a display system. Where 'high resolution' or a large amount of alpha numeric data is to be displayed at once, LEDs are not suitable. The major factor in this case is the high current requirement of each light emitting element. A matrix of 10x10 LEDs, with each running at a modest 10mA, would require 1 amp if all were illuminated — clearly not suitable if portable use is envisaged.

CRT displays are certainly capable of providing even the highest resolution, but suffer from similar power supply problems. In addition they are too fragile for use in many applications.

LCD displays largely overcome the disadvantages of the displays mentioned above, but again have a minus point against them in that they do not emit light — a problem in many applications. They also feature a rather sluggish response that is too slow for information displays in many real time applications.

Flourescent displays overcome most of the disadvantages of the other displays but, in fairness, we'll start by mentioning the aspects that may mitigate against their use. The first is that they are fragile. That does not mean that they have to be treated with 'kid gloves', but it does mean that they will not take too kindly to being dropped either. The other slight disadvantage is that they require multiple power supplies and that one of these must be AC.

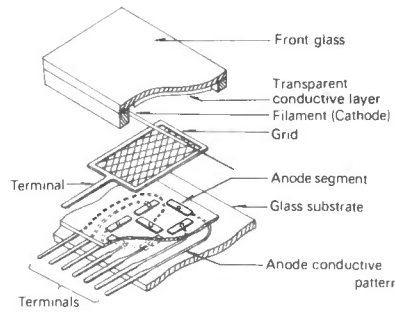
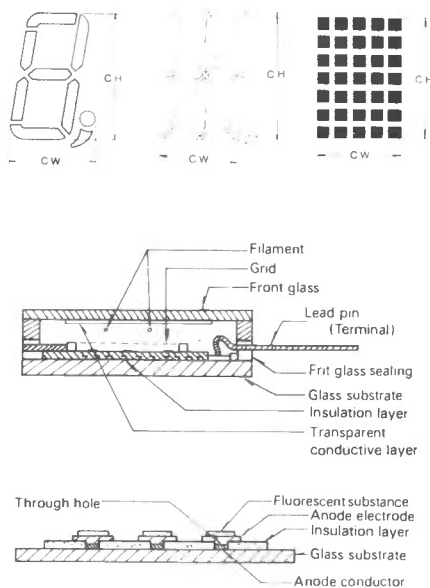


Figure 6: Basic building blocks of fluorescent display.

### What's On Offer

Futaba are probably the leading supplier of flourescent displays with a range of devices for almost every application. Fig. 6 shows the basic building blocks of the displays while Fig. 7 shows just some of the range of displays (Fig 8 shows a typical display schematic).

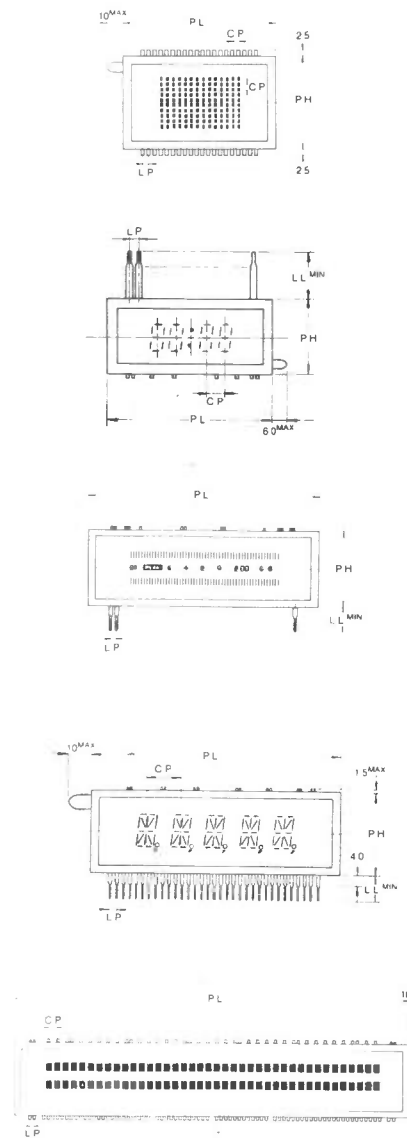
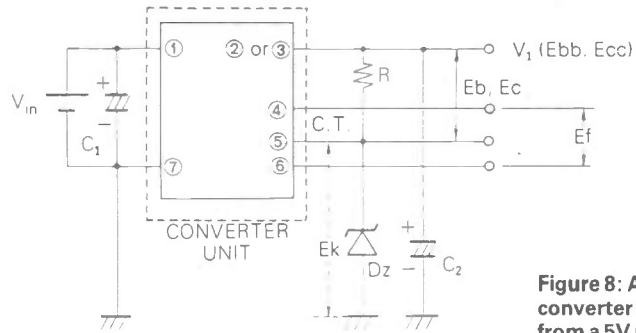


Figure 7: There are a wide range of displays available.

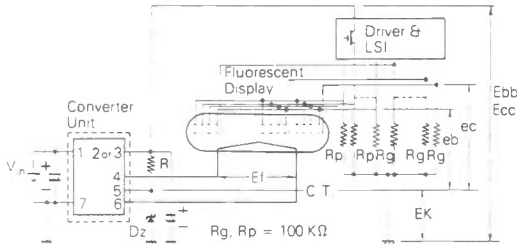


## Power Supplies

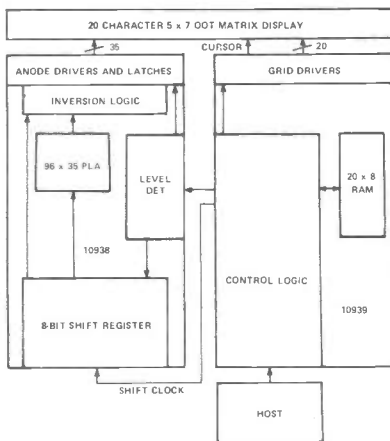
As mentioned earlier, the displays demand a number of supplies which has in the past limited their use. Recent developments in semiconductor design have meant that converter units capable of producing the necessary supplies from a single 5V rail have become available. **Fig. 8** shows the way in which such a unit is used in a typical application. C1 and C2 are storage capacitors, while the Zener diode and resistor are required in order that the correct cathode voltage is produced.



**Figure 8: A voltage converter operating from a 5V rail (Futaba).**



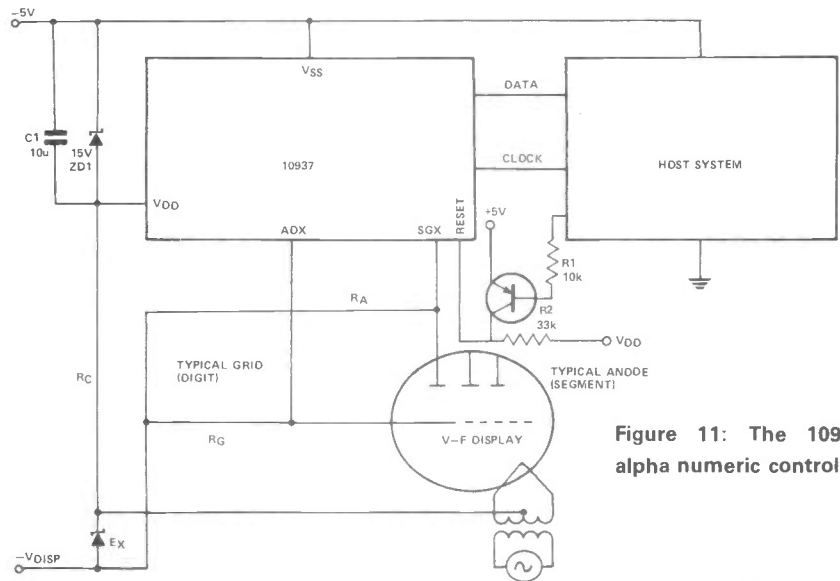
**Figure 9: Application circuit using the converter of figure 10.**



**Figure 10: Block diagram of the dot matrix controller.**

## Display Controllers

If a bar-graph readout is to be realised with a fluorescent display, the techniques



**Figure 11: The 10937 alpha numeric controller.**

are very similar to those used with LED displays and devices such as the LM3915 can be used. If, however, a dot matrix or alpha numeric display is required, the logistics of control can be rather too much for discrete circuitry. Fortunately, Rockwell produce a series of display controllers that overcome any difficulties in this area.

**Figure 10** shows the block diagram of their 10938 and 10939 controller for dot matrix displays. It can cope with a 20 character display and is cascable to 80 or more characters. The font is a standard 5x7 matrix and a separate cursor driver output is available. Data can be entered in

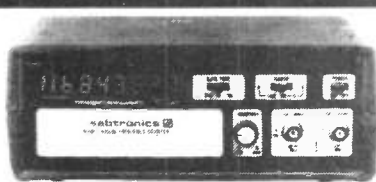
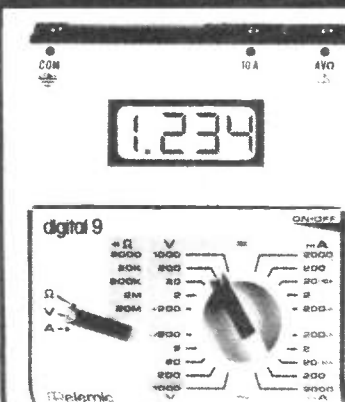
either parallel or serial form making the controller an extremely versatile device.

**Figure 11** shows the block diagram of the 10937 alpha numeric controller. This is a 16 character display driver with a serial input capability. It is suitable for use with 14 or 16 segment displays.

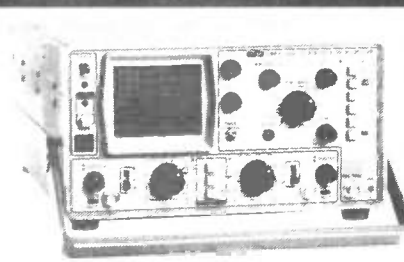
Using a suitable display, PSU converter and controller IC, an RS232, 16 character alphanumeric display could be designed with the minimum of external components. It would run from a single supply rail (5V), and thus be used in portable equipment.

■ R&EW

## LOW COST PROFESSIONAL TEST INSTRUMENTS



- ★ FREQUENCY COUNTERS
- ★ ANALOGUE METERS
- ★ DIGITAL METERS
- ★ FUNCTION GEN
- ★ OSCILLOSCOPES
- ★ POWER SUPPLIES
- ★ LOGIC PROBE
- ★ SCOPE PROBES



Write or phone for illustrated Test Instrument catalogue and price list.

**BLACK STAR LTD.**  
9A, Crown Street, St. Ives,  
Huntingdon, Cambs. PE17 4EB.  
Tel: (0480) 62440 Telex: 32339



## BLANDFORD COMPUTERS

Computer Division of O&J House Ltd.

TANDY COMPUTER DEALERS

Model IV now in stock.

Carrying case for  
Models II & IV disc drives,  
printers, software.

Repairs, part exchange  
and second hand Tandy equipment

Higher Shaftesbury Road,  
Blandford Forum  
Dorset DT11 8SS

Blandford 53737 (std. 0258)

5 lines inc evenings and weekends

**J. BIRKETT** 25 THE STRAIT, LINCOLN Tel: 20767

*Stockist of*  
**Wood & Douglas Kits**

*Available from*  
our Shop and at most  
Amateur Radio Rallies

McMichael Amateur Radio Society

## MOBILE RALLY

Talk-In S22 (GB2MRS)

Sunday 24th July at 11am

Sefton Park, Bells Hill, Stoke Poges, Slough.

# Who Stocks Connectors for RF, AUDIO, VIDEO, MAINS, PCBs, etc.?



**aim**

**ambit industrial marketing**

200 North Service Road, Brentwood, Essex CM14 4SG  
Telephone (Consumer Sales/Enquiries) 0277-230909.  
Telephone (Industrial Sales/Enquiries) 0277-231616  
Telex 995194 AMBIT G  
Data 24hrs (RS232/300baud) 0277-232628 — REWTEL.

- Prices exclude VAT except where otherwise shown.
- Postage and Packing 60p per pre-paid order.
- Orders submitted using Ambit Stock Codes will be processed first.
- Orders for in-stock items despatched same day (up to 4pm receipt).
- Hours — (consumer sales) 8am-7pm Mon-Sat: (Industrial) 8am-6pm (Mon-Fri).
- Retail Sales 9am-6pm Mon-Sat \*Industrial Sales "Take-Away" by arrangement.\*
- Industrial accounts available on application: 2 Trade, 1 Bankers Ref.

# VIDEO NEWS

## More from the World of Video, by Peter Luke, including the latest news on half speed recorders.

A year or so ago, the pages of video trade and consumer magazines were full of articles regarding the so-called war between the formats. The importance of the rivalry between the two major systems, VHS and Beta, was blown up out of all proportion by the media and today such items rarely make an appearance. What was a war, has become a happy co-existence. Things are now cosy enough for some manufacturers to produce both types of machine.

Ferguson led the way in the 'each-way-bet' approach when they took on board, badge engineering, JVC machines to complement their relabelled Philips V200 models. Sanyo have recently gone down the same road by purchasing the Fisher Group. Sanyo are Beta backers in their UK guise, while Fisher are VHS in this country. With these two formats representing around 80-90% of the market, it means Sanyo, with a machine for either format across a large range of prices, are well positioned to secure a large slice of the market.

### Spot The Changes

JVC's portable, the HR-C3, is due to appear in a number of slightly different forms in the next few months. This VHS-C recorder will appear under both the Ferguson and Nordmende logos, when it will respectively be known as the VideoStar C 3V40 and the V150.

Ferguson are putting the recorder, together with a small, now — JVC camera, in a £1000 package that also includes a battery, charger, leads etc.

Nordmende are to offer the recorder at £599 while their compatible C150 camera will set you back £519.

### Slow Pace Quickens

Half speed video recorders are the flavour of the month at the moment with two new machines available from dealers now.

Hitachi's VT-17 is, as well as being their first half speed recorder, also the first front

loader from the company. At £599, the recorder features a 5 event, 14 day timer and Dolby noise reduction. The machine uses a four head system to implement the half speed facility and, like Toshiba's Beta machine, this has the added benefit of making the recorder's still frame performance impeccable.

Picture quality is said to be degraded by only 6% and this, say Hitachi, should go unnoticed by the majority of people. The same is not true of the audio performance, however, as the slow linear tape speed, less than half that of an audio cassette player, means that even with noise reduction techniques, sound is only just acceptable. The half-speed facility is well worth having though, especially at the very reasonable price of the VT-17.

JVC have entered the half speed stakes with the HR7655 — a modified version of their established 7650. Not surprisingly, Ferguson are offering the 3V32 half speed recorder at the same time.

### New Chassis

Ferguson have moved into the cut throat end of the Colour TV market with a new chassis designated the TX90. Two new models based on this design are to be known as the 37104A and 27104C — the difference between models being restricted to the colour of the cabinet.

The sets are 14" colour portables and are priced at £169. At this level they are aimed very much at the cheap far eastern sets which have been selling rather well of late.

### Levy Questions

The question of whether or not a levy will be raised on all blank tapes in the future, has once again raised its head. This time, it's the Association of Independent Producers who are claiming that they are losing out on royalty payments as a

consequence of tape piracy.

Most people — apart from bodies like the AIP — agree that a blank tape levy is a far from ideal, indeed some would say unfair, way of compensating copyright owners for lost revenue. When this sort of topic comes up in the popular press, it's odds on that some pundit will be quoted as saying that if only the tape recorder manufacturers would offer some cooperation, the problem could be solved with some modifications to a recorder's hardware.

Leaving aside the fact that there would seem to be very little to motivate the likes of Sony, JVC etc, into any such moves, think of the technical issues. The problem is that a video recorder playing back a recording through an unmodified TV must produce a standard modulated vision signal. A standard modulated video signal can be recorded by a second recorder.

In the States, distortion of the sync pulses was seen as a way of preventing copies. This relied on the fact that a TV set's flywheel sync circuits would cope with sync pulses that would cause trouble to a recorder's servo circuitry.

Very soon after the first tapes 'copyguarded' in this fashion were available, things called sync stabilisers came onto the market. Of course these devices were not designed to permit copyguarded tapes to be duplicated but, by pure chance, they happened to do just that.

The fact is that while the requirements of a TV's RF input are almost identical to that of a recorder's there is very little that can be done to prevent duplication. Any simple form of protection — possibly inverting the video signal on the tape and selling an adaptor to re-invert the signal — could be simply countered by the pirates.

If various interest groups insist on having their slice of the cake, it looks like a tape levy is the only workable solution.

**NOW! 1/2 SPEED!**



"...AND ESPECIALLY USEFUL FOR SHOWING TAPES OF ASSEMBLY METHODS TO WORKERS IN BRITISH INDUSTRY.."

## A true RMS-to-DC converter

The AD536A is a complete monolithic IC, performing true RMS-to-DC conversion with a performance comparable or superior to discrete or hybrid circuits costing far more. A very useful feature is the auxiliary logarithmic output giving the added facility (after conversion) of a decibel reading with a dynamic range of 60dB. Using an externally supplied reference current, the 0dB level may be set to correspond to any input from 0.1 to 2 volts RMS.

The input circuitry will withstand overloads well in excess of supply voltages, the output is short-circuit protected and loss of supply voltage(s) with signal present will not cause failure.

- ★ True RMS-to-DC conversion
- ★ Laser trimmed to high accuracy
  - <0.2% error (AD536AK)
  - <0.5% error (AD536AJ)
- ★ Wide Response:
  - computes RMS of AC and DC signals
  - 300kHz bandwidth:  $V_{RMS} > 100mV$
  - 2MHz bandwidth:  $V_{RMS} > 1V$
- ★ Signal crest factor of 7 for 1% error
- ★ dB output with 60dB range
- ★ Low power: 1mA quiescent current
- ★ Single or dual supply operation

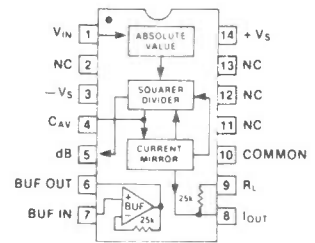
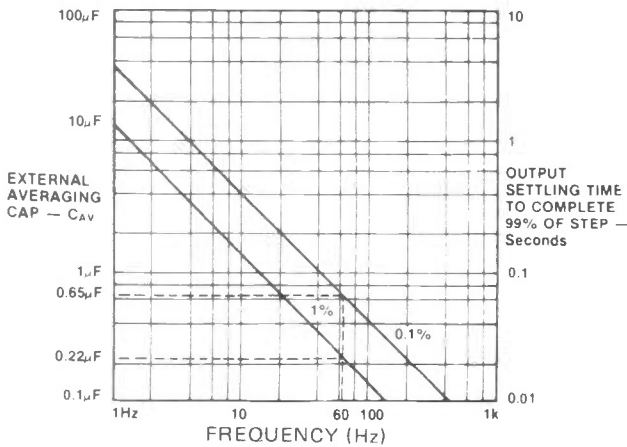


Figure 1: Pin designations and internal block.



Graph 1: Values of CAV for % reading error and settling times.

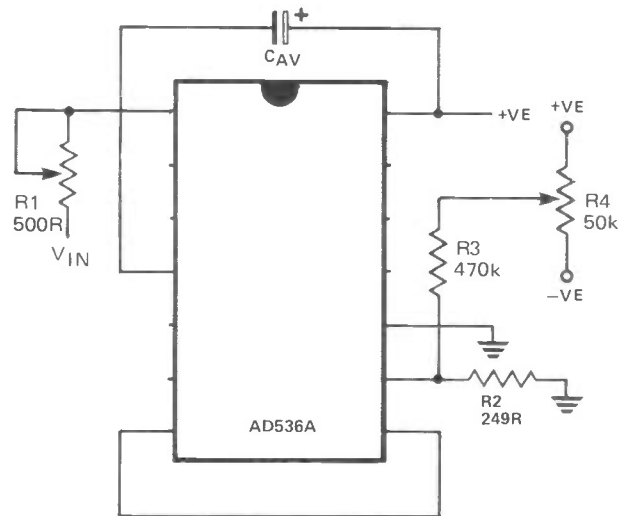


Figure 2: Optional external gain and output offset trimming

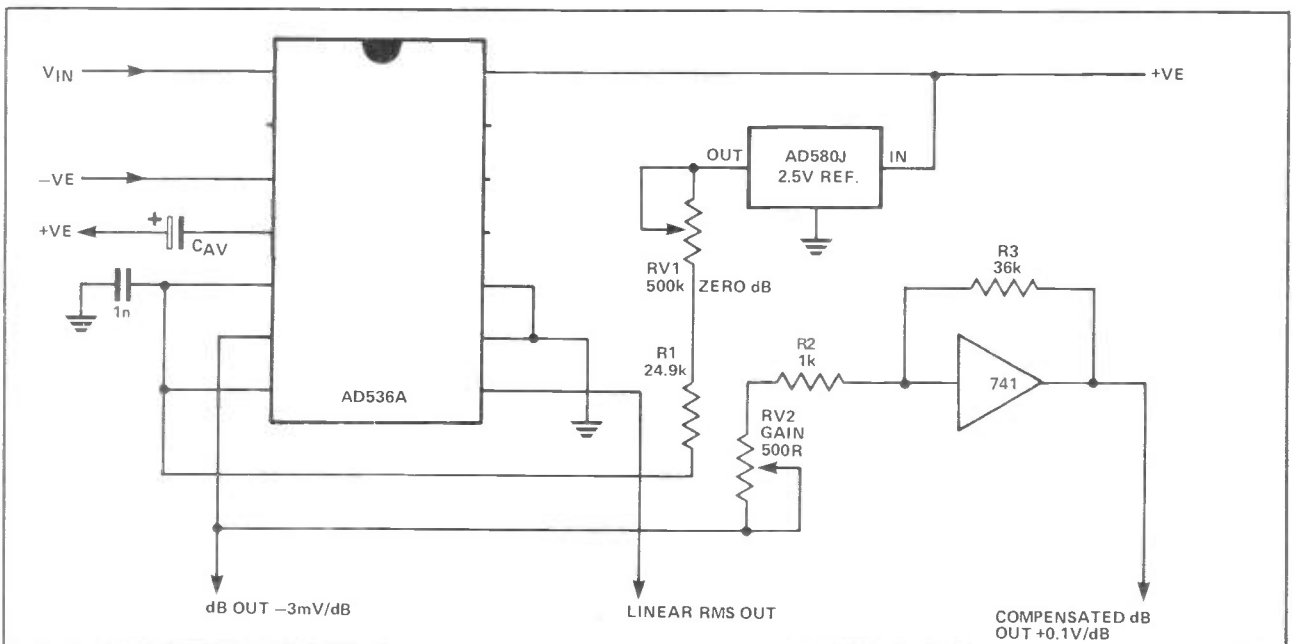


Figure 3: dB connection

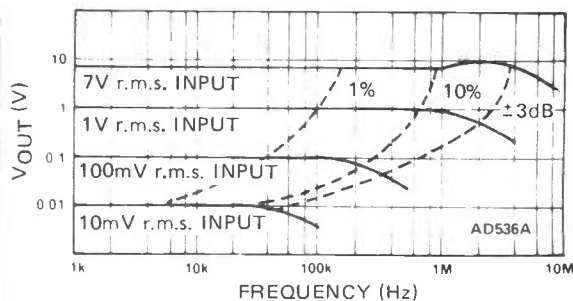
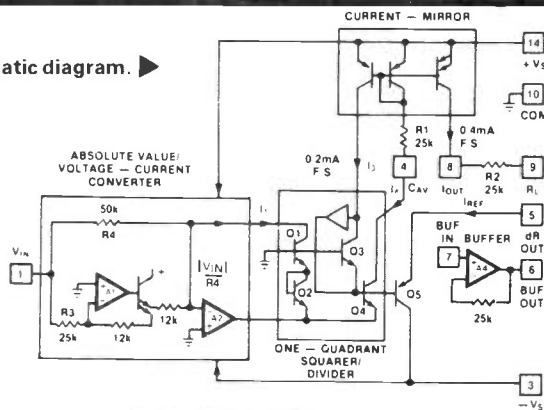


Figure 4: Schematic diagram.

Graph 2: Frequency Response



( $V_S = \pm 15V$  unless specified)

The only external components required to perform measurements to the specified accuracy is the averaging capacitor, the value of which determines the low frequency AC accuracy, ripple level and settling time. The low IQ makes battery operation quite feasible from single or dual supplies between 5 and 36 volts total.

For use on the low signal ranges, the measurement accuracy may be further improved by using the Fig. 2 layout. R4 trims the output offset, but puts 249R in series with a 25K internal resistor (RL) increasing the scale factor by 1%. This is trimmed out by R1.

The device employs one solution of the RMS equation that overcomes the dynamic range limitations inherent in a straightforward computation of RMS. The actual computation performed follows the equation:

$$V_{RMS} = A_{vg} (V_{IN}^2 / V_{RMS})$$

$V_{IN}$ , which can be AC or DC, is converted to a unipolar current  $I_1$ , by an active rectifier.  $I_1$  drives one input of the squarer/divider, which has the transfer function:

$$I_4 = I_1^2 / I_3$$

The output current,  $I_4$ , of the squarer/divider drives a current mirror through a low pass filter formed by an internal resistor and the external capacitor  $C_{AV}$ . If the time constant is much longer than the longest period of the input signal, then  $I_4$  is effectively averaged. The current mirror returns a current  $I_3$  which is equal to  $A_{vg}(I_4)$  back to the squarer/divider to complete the RMS equation thus:

$$I_4 = A_{vg} [I_1^2 / I_4] = I_1 \text{ (RMS)}$$

Figure 3 shows a circuit for dB measurements. 0dB is set by R1. The op-amp provides a more convenient scale and allows compensation of the 0.3%/°C temperature drift of the dB circuit. Calibration is as follows:

1. Set  $V_{IN} = 1.00V$  DC
2. Adjust R1 for dB out = 0.00V
3. Set  $V_{IN} = +0.1V$  DC
4. Adjust R2 for dB out = -2.00V

Any other dB reference level can be used by setting  $V_{IN}$  and adjusting R1 accordingly. Adjusting R2 for the correct gain automatically gives the correct temperature compensation. (R3 should be 1k 1% + 3500ppm PTC resistor for most accurate  $T_c$ )

Table 1: Electrical characteristics ( $T_{amb} = 25^\circ C$  unless specified).

Notes:

1. Accuracy is specified for 0 to 7V rms dc or 1kHz sine wave input.
2. Error vs crest factor is specified as an additional error for  $iV$  rms (200mV) rectangular pulse input, pulse width = 200uS
3. Input voltages are expressed in volts rms and error is percent of reading.
4. Measured at buffer output with buffer input tied to common.
5. Accuracy is specified for 0 to 200mV rms dc or 1kHz sinewave input. Accuracy is degraded at higher rms signal levels.

R&EW

Parameter	Conditions	Value	Units
<b>Conversion accuracy</b> Total error Internal trim Temp coefficient Supply voltage error d.c. reversal error External trim error	Fig 2 <sup>1</sup> 0 to 70°C    Fig 3 <sup>1</sup>	$\pm 5$ ( $\pm 0.5\%$ of reading) max $\pm 0.1$ ( $\pm 0.01\%$ of reading) max $\pm 0.1$ ( $\pm 0.01\%$ of reading) $\pm 0.05\%$ of reading $\pm 3$ ( $\pm 0.3\%$ of reading)	mV mV/°C V/V %
<b>Error vs crest factor</b> <sup>2</sup>	CF = 1 to 2 CF = 3 CF = 7	Specified Accuracy -0.1% of reading -1% of reading	
<b>Frequency response</b> <sup>3</sup> Bandwidth for 1% additional error (0.1dB)  $\pm 3dB$ bandwidth	$10mV < V_{IN} \leq 100mV$ $100mV < V_{IN} \leq 1V$ $1V < V_{IN} \leq 7V$ $10mV < V_{IN} \leq 100mV$ $100mV < V_{IN} \leq 1V$ $1V < V_{IN} \leq 7V$	6 40 100 50 300 2	kHz kHz kHz kHz kHz MHz
<b>Ave time const CAV</b>	Fig. 6	25	ms/ $\mu F$
<b>Input characteristics</b> Signal range  Safe input, all supplies Input resistance Input offset voltage	  $V_S = \pm 5V$   	$\pm 20$ $\pm 5$  $\pm 25$ max $16.7 \pm 25\%$ $\pm 2$ max	V peak V peak V peak V k $\Omega$ mV
<b>Output characteristics</b> Offset voltage vs temperature vs supply voltage Voltage swing  Output current Short circuit current Output resistance	    $V_S = \pm 5V$   	$\pm 2$ max $\pm 100$ $\pm 0.1$ 0 to +10 min 0 to +2 min + 5000, - 130 min + 20 0.5 max	mV $\mu V/^\circ C$ mV/V V V $\mu A$ mA $\Omega$
<b>dB output</b> Error  Scale factor S.F. temp coeff $I_{REF}$ $I_{REF}$ range	 $7mV \leq V_{IN} \leq 7V$ rms   $0dB = 1V$ rms  	$\pm 0.5$  -3 -0.03 5 to 80 (20 typ.) 1 to 100	dB  mV/dB dB/°C $\mu A$ $\mu A$
<b>I<sub>OUT</sub> terminal</b> Scale factor Output resistance Voltage compliance	rms input	$40 \pm 25\%$ $10^8$ - $V_S$ to (+ $V_S - 2.5V$ )	$\mu A/V$ $\Omega$ V
<b>Buffers amplifier</b> I/O voltage range Input offset voltage Input current Input resistance Output current Short circuit current Small signal bandwidth Slew rate	 $R_S = 25k\Omega$      2k $\Omega$ pull down	- $V_S$ to (+ $V_S - 2.5V$ ) min $\pm 4$ max 100 typ (300 max.) $10^8$ + 5000, - 130 min 20 1 5	V mV nA $\Omega$ $\mu A$ mA MHz V/ $\mu S$
<b>Power supply</b> Voltage range, dual single Quiescent current	  full $V_S$ , temp range	$\pm 3$ to $\pm 18$ + 5 to + 36 2 max (1 typ.)	V V mA
<b>Temperature range</b> Operating range Storage range		0 to + 70 - 55 to + 150	°C °C



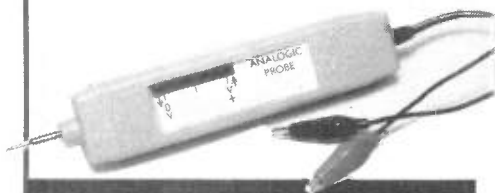
# PROJECT PACKS

## ANALOGIC PROBE

Novel and very useful piece of test equipment for analysing logic circuits with a wide range of logic levels — TTL, CMOS, RS232 etc. Kit includes all components, LEDs, PCB and case.

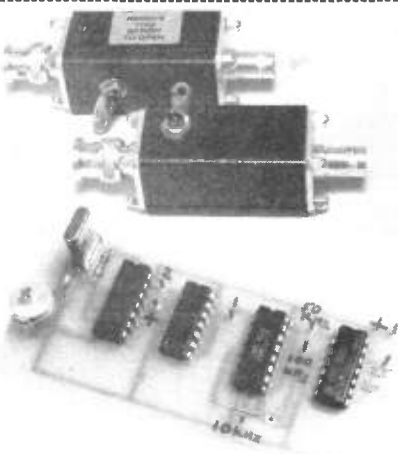
Stock No.  
41-00703

Price  
**£17.40**



**PLEASE NOTE**  
Closed for Stocktaking  
Fri 29th July to Mon 1st August  
inclusive

All prices include VAT @ 15% Please  
allow 21 days for delivery. Postage  
& Packing 60p per order.



## WIDE BAND RF AMPS

Pair of low noise wide band amplifiers.

VHF:

Gain (10-100MHz) < >10dB  
Supply voltage 6V  
Current consumption 20mA

VHF/UHF:

Gain (30-1000MHz) >10dB  
Supply voltage 17V  
Current consumption 41mA

Kits include all components, PCB and case with silver plated BNC sockets.

## CRYSTAL CALIBRATOR

Crystal reference calibrator with outputs at 4MHz, 2MHz, 1MHz, 100kHz, 50kHz and 10kHz.

Kit of parts with, xtal, all components and PCB.

Stock No.  
41-00801

Price  
**£4.97**

Type	Stock No.	Price
VHF	41-00802	<b>£15.40</b>
VHF/UHF	41-00803	<b>£22.10</b>

Send your order to:  
**Ambit International, 200 North Service Road  
Brentwood, Essex, CM14 4SG  
Tel: (0277) 230909  
Access/Barclaycard Welcome.**

# PROJECT BOARDS

High quality fibre glass printed circuit boards for R&EW projects and data briefs.

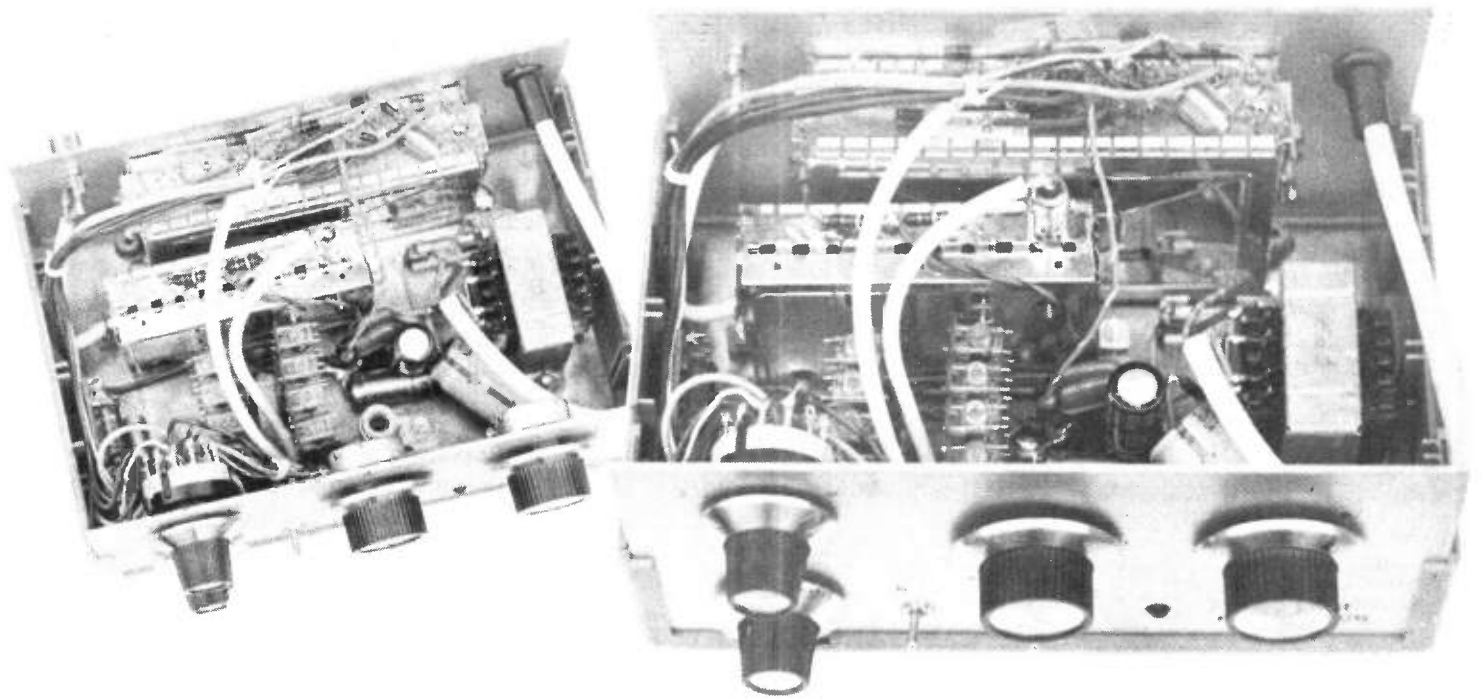
Issue	Description	Stock No.	Price
<b>AUGUST</b>	Analogic Probe	41-20703	<b>1.30</b>
	WB Amp — VHF	41-20802	<b>0.92</b>
	WB Amp — VHF/UHF	41-20803	<b>0.92</b>
	Crystal Oscillator	41-20801	<b>0.86</b>
<b>JULY</b>	Z8 Backplane	41-20601	<b>£6.10</b>
	SSB for SX200-N	41-20704	<b>£0.98</b>
	CSP1001	41-20706	<b>£0.55</b>
<b>JUNE</b>	LCD DFM Main Board	41-20603	<b>£7.24</b>
	LCD DFM Display	41-20604	<b>£1.81</b>
	500kHz Pre Amp	41-20605	<b>£0.92</b>
	200MHz Prescaler	41-20606	<b>£0.92</b>
	600Mhz Prescaler	41-20607	<b>£0.92</b>
	KB4438 (Undrilled)	41-20602	<b>£0.67</b>
<b>MAY</b>	Rew Vox	41-20405	<b>£0.87</b>
	Audio Limiter	41-20501	<b>£3.79</b>
	IR Volume Control	41-20503	<b>£2.48</b>
	100W Power Amp	41-20504	<b>£5.25</b>
	PA Protection Board	41-20505	<b>£1.40</b>
	Rewbichron 2 Logic Board	41-20506	<b>£6.07</b>
	Rewbichron 2 Display Board	41-20507	<b>£3.79</b>
<b>APRIL</b>	FM IF Amp	41-20401	<b>£2.41</b>
	18W PA	41-20404	<b>£4.83</b>

All prices include VAT @ 15% please allow 21 days for delivery. Postage & Packing 60p per order.  
Send your order to **Ambit International, 200 North Service Road, Brentwood, Essex CM14 4SG.**

SEND YOUR ORDER TO:

**ambit** INTERNATIONAL

200, NORTH SERVICE ROAD  
BRENTWOOD, ESSEX  
CM14 4SG  
Telephone : (0277) 230909



# DX-TV CONVERTER

**Our regular DX-TV authors, Keith Hamer and Garry Smith, describe a special tuning system for DX reception on a domestic TV.**

For over a decade, the dual-standard television receiver has enjoyed popularity amongst DX-TV (long-distance television) enthusiasts because of its dual-bandwidth IF strip. This can be exploited to give a choice of wideband (5.5MHz) or a more selective narrowband (3MHz) IF on any of the TV bands once the system switching has been suitably modified. Acquiring and modifying such a receiver today quickly loses its appeal when factors such as

spares availability, the amount of renovation necessary before modification and age are taken into consideration – hardly an easy job for anyone not engaged in television servicing.

There are several manufacturers (for example, Grundig, Sony, Plustron and JVC) who are able to supply multi-band monochrome or colour receivers, some of which cater for more than one sound standard. The 5-inch JVC CX610 G8 is

such an example and will resolve the UK 6.0MHz, Western European 5.5MHz and Eastern-block 6.5MHz sound. It also resolves PAL and SECAM transmissions.

Such receivers are capable of excellent results, especially when a strong signal is present, but their main disadvantage is inadequate selectivity. The effects are only too apparent during a Sporadic-E opening in Band I or a tropospheric lift in Band III where non-standard channel

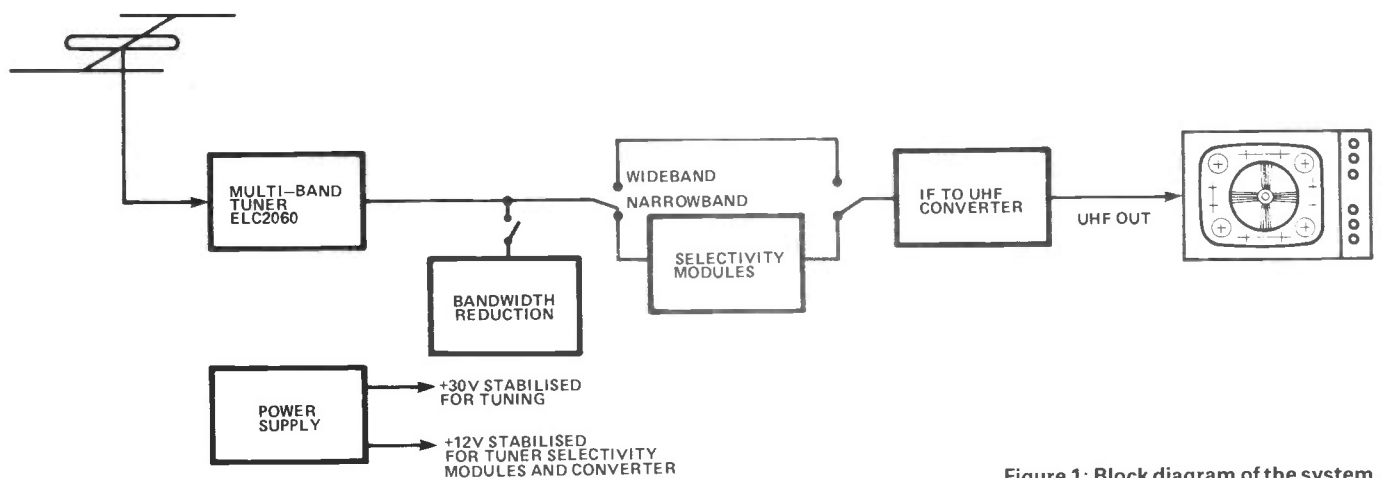
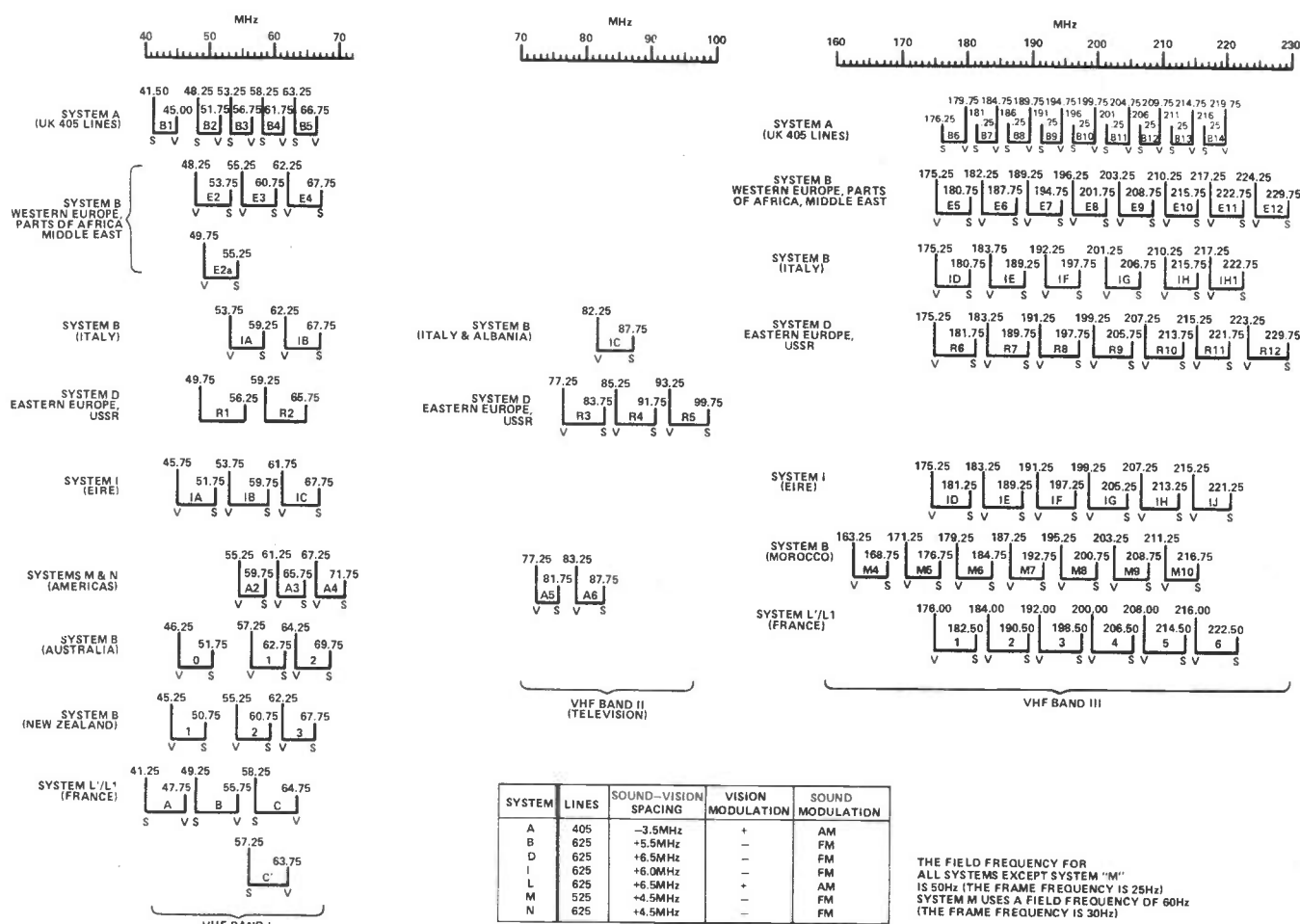


Figure 1: Block diagram of the system.



**Table 1: VHF TV channel allocations and transmission standards.**

allocations exist. The overlapping of channels is an unavoidable consequence (see *Table 1*). If strong signals are present on channels 1A and E3, for example, the result will be two pictures floating until the stronger one prevails. The presence of a strong local 405-line transmission may also present problems if its sound or vision carrier lies close to the required DX channel (incidentally, the 405-line video appears as a mass of unlocked white line syncs because positive video modulation is used for system 'A').

All television transmission standards currently in use throughout the world, dictate a relatively wide IF bandwidth in the order of 5 to 6 MHz, whereas the obsolescent 405-line standard requires a mere 3MHz. The exception is America and dependent countries, where 4.2MHz bandwidth is required. Ideally, for DX-TV, where crowded VHF bands exist, particular attention must be paid to receiver selectivity. A reduced IF bandwidth improves selectivity and also the gain over a given number of IF stages; but at the expense of picture definition. On weaker signals definition is inevitably lost and so an improvement in gain and selectivity is desirable. On stronger signals

a wider bandwidth may be preferred since it will enhance the quality of the picture.

## Design

Two years ago, we investigated the possibility of an experimental DX-TV tuning system which could be connected to the aerial socket of any modern single-standard receiver. Such a system has many advantages over the traditional practice of receiver modification. For instance, it solves the problem of mains isolation which is always present when adding extra switches and controls. A further advantage is the ease with which video recordings of DX reception can be made – the output signal will be at UHF. The system makes use of up-converter techniques, in which the IF output of a multi-band tuner is converted to a spare UHF channel.

Video modulators are available cheaply. One provides the basis of the IF to UHF converter; the section consisting of two stages of amplification preceding a passive diode mixer stage. This was found to be quite adequate in practice.

The varicap tuner unit chosen for the system was the inexpensive ELC 2060. Band I coverage extends well into the FM

radio spectrum to approximately 100MHz while the lower end of Band III extends to well below the 2-metre band. On two tuner unit samples the amateur television band below channel 21 could be resolved without difficulty, although a third unit would not cover this band. The ELC2000 could be used as an alternative unit, but the Band I coverage does not extend as far. The connections are identical for both types of tuner.

Tuning is effected by means of two rotary controls, one for main tuning and the other for fine tuning. Calibrations were applied directly to the front panel and this has proved to be both adequate and functional, especially on the VHF bands. For UHF however, we prefer to use local and semi-local transmitters as markers, thus avoiding cluttered channel designations.

Due to the large frequency range of the 'Band I' coverage of the tuner, it was decided to split this into two ranges: 45 to 70MHz (Band I) and 70 to 100MHz (actually, Band II). This allows easier tuning. The lower limit of Band III was fixed at approximately 160MHz.

A bandpass circuit (comprising L1 and C5) was included to reduce the IF

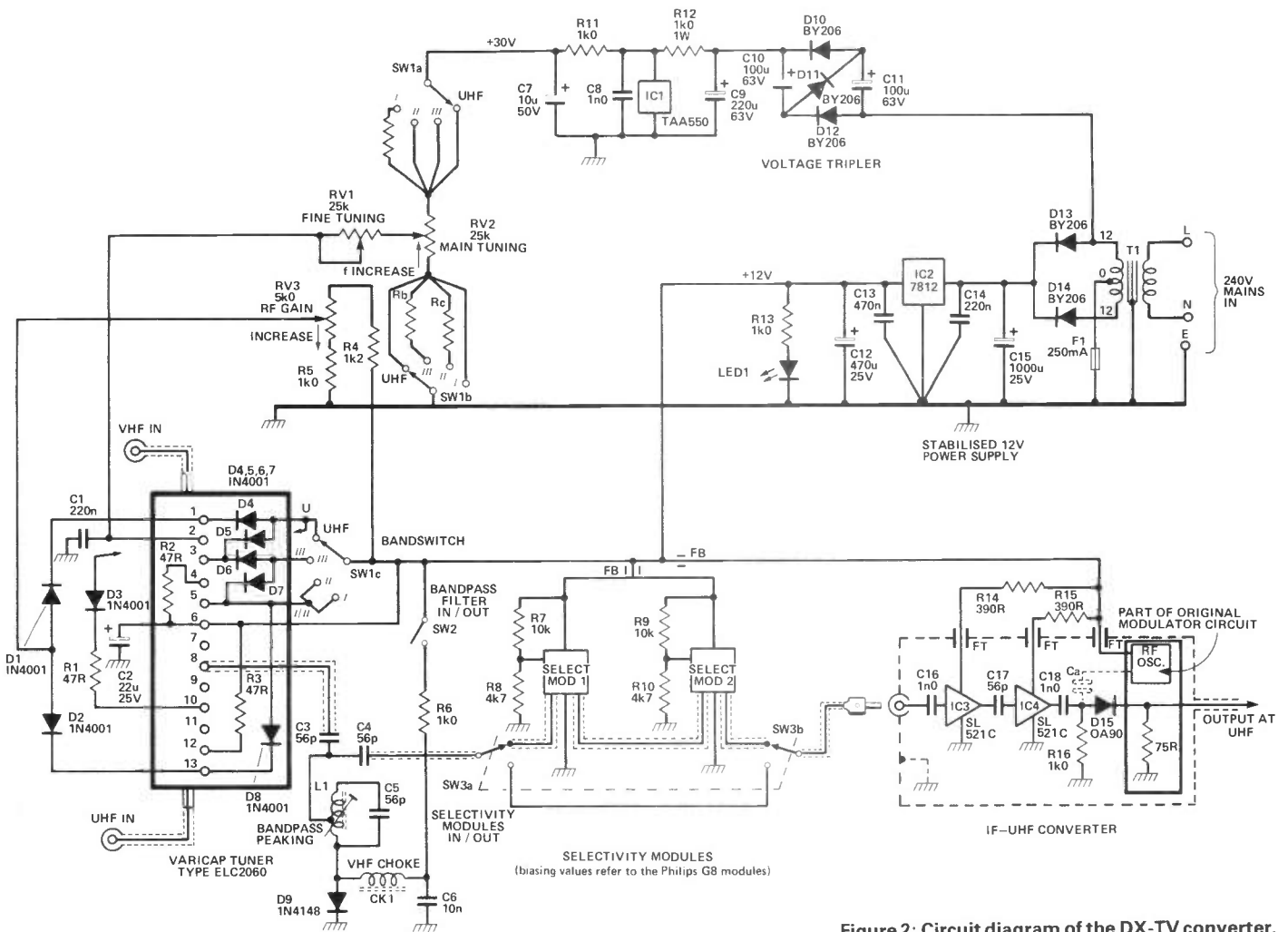


Figure 2: Circuit diagram of the DX-TV converter.

## Circuit Description

The complete circuit diagram of the DX-TV converter is shown in **Fig. 2**. The stabilised 12 volt supply feeding the tuner, selectivity modules and IF-UHF converter, is derived via a 7812 IC regulator fed from a full-wave rectifier circuit. The 30V tuning voltage supply rail is perhaps a little unconventional because it is fed from one half of the centre-tapped transformer secondary winding via a voltage tripler circuit. This consists of D10, D11, D12, C9, C10 and C11. The supply is stabilised by IC1. Tuning is effected by the MAIN tuning control RV2 and the FINE tuning control RV1. SW1a and SW1b were included to limit the tuning range within each band by bringing into circuit Ra, Rb and Tc for Bands I,

III and II respectively. The values should be determined experimentally, since the tuning range may vary between different tuners. Resistor values used in the prototype are: Ra=47k, Rb=15k and Rc=10k. It wasn't necessary to include limiting resistors for the UHF band.

RF gain adjustment is provided by RV3 and applied to pins 1 and 13 of the varicap tuner via isolation diodes D1 and D2. Diodes D4 and D8 take the appropriate AGC input pin high, to reduce gain depending whether UHF or VHF is selected. Diodes D3 to D8 supply the appropriate tuner pins with 12 volts via the BANDSWITCH control, SW1c.

When the full IF bandwidth is required, filter L1 and the selectivity modules are switched out of

circuit by SW2 and SW3a/b respectively. The tuner IF output is then passed via C3 and C4 directly to the input of the IF-UHF converter.

The bandpass filter (consisting of the L1 and C5) is brought into circuit by forward biasing D9, which is connected between the earthy end of L1 and chassis. Bias is applied via SW2, R6 and choke, CK1.

Wideband amplifiers IC3 and IC4 amplify the IF signal prior to mixing. The RF output of the oscillator in the original modulator circuitry is coupled to the mixer diode D15 via Ca which consists of two 35-40mm lengths of insulated tinned copper wire twisted together. Two output frequencies are produced - one at the oscillator frequency plus IF and the other at minus the IF. Both outputs appear within the UHF Band IV.

bandwidth, but a dramatic improvement in selectivity was obtained by fitting a couple of selectivity modules. These are often fitted in colour TV front-ends in which IF response shaping takes place prior to feeding a wideband IF amplifier. We adopted a similar approach and were fortunate in obtaining modules from an early type of receiver - the Philips G8 colour chassis, circa 1970-76. The Philips type seemed ideal because a stage of IF amplification is also provided within the module. By peaking the module, a more

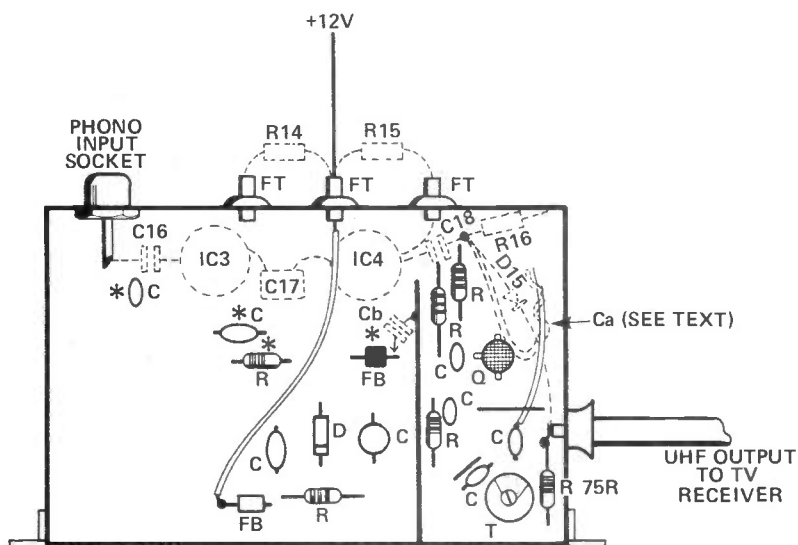
dramatic reduction in bandwidth was obtained compared to the sample circuit of L1 and C5. The increase in gain was, of course, an added feature.

Adjustment of one of the centre cores (Lc) provided a very sharp notch, and we were able to completely reject a strong channel B4 vision carrier from channel E4, 500kHz. The other cores were adjusted for optimum results. A second filter was added to remove B4 sound splatter from channel R2. This arrangement provides a very narrow IF bandwidth and excellent

selectivity which is ideal for meteor-shower and weak signal work, but picture degradation is noticeable on strong signals.

## Construction

The prototype DX unit is of semi-modular construction and a specially prepared PCB isn't required. However, the various modules and sub-assemblies are attached by means of 4BA solder tags soldered to a copper laminate board which acts as a chassis. It should be noted that the



**Figure 3: Internal layout of the modulator.**

selectivity module cans were removed to preserve space and no instability or interaction problems were encountered.

The prototype was housed in a plastic case. We should point out that the layout is very compact (experience in cramming a quart into a pint pot may be called for!) Fortunately, the layout isn't too critical and a larger case could be used.

The various band-switching diodes are best connected directly to the tuner pins before attempting to secure the tuner to the rear plate of the case and the copper board.

It may be advisable to experimentally position the components, if the suggested

layout is used, before getting too carried away drilling holes in the wrong places! The bandpass coil L1 consists of 6 to 7 turn of a low-loss coax inner tapped at 2 turns and spaced over 7/8" on a 3/8" former.

### Modulator Modifications

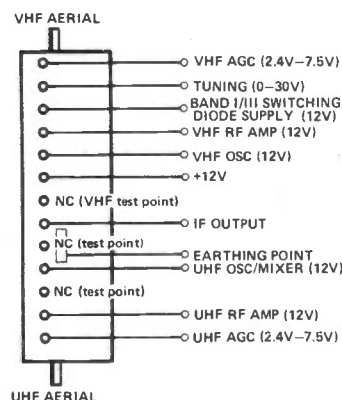
Remove the small PCB sub-panel and disconnect the GREEN supply wire. The video input components (shown with an asterisk on *Fig. 3*), consisting of a 1p8 and a 12p capacitor, 4k7 resistor and the link with the ferrite bead, should then be removed. The video input connection pins may also be removed. A small portion of the internal screening is removed and holes are then drilled in order to mount the three feed-through capacitors and the phono input socket. To attach the module to the PCB chassis, fit a couple of 4BA solder tags at each end of the casing as shown. Pins 1 and 4 of the SL 521c are removed and suitable holes are then drilled in the modulator PCB to mount the ICs. Solder a 1p8 capacitor (Cb - the one removed from the video input circuit will suffice) on the underside of the modulator's PCB to the points shown in *Fig. 3*.

### Alignment

Before aligning the unit, ensure that the 12V and 30V supplies are present and that the RF gain voltage range is 2V4 to 7V5

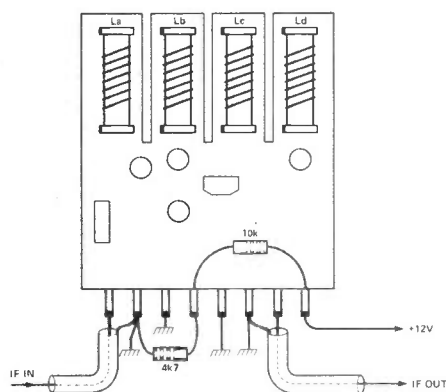
measured on the appropriate tuner pins. The values of R4 and R5 can be altered if necessary to achieve this. IF alignment is possible without the aid of a signal generator, although one is useful for confirming the tuning ranges and to calibrate the DX channels. Alternatively, the DX channels may be calculated by referring to any known local or semi-local 405-line channels which may be present.

Set the RF gain to maximum, switch L1 out of circuit, bring the selectivity filters into circuit and unscrew their cores until they protrude approximately 2mm above the formers. Set the tuning to the upper portion of Band III or UHF and tune through the lower UHF channels of the television receiver until a noise 'peak' is observed. This should occur 4 to 5 channels above and below the blip caused by the IF-UHF converter oscillator. If not, set the DX unit to another band or the tuning to a different part of the band; repeat the tuning operation of the receiver. Once the noise peak is located, adjust the IF coil of the multiband tuner for maximum noise on the

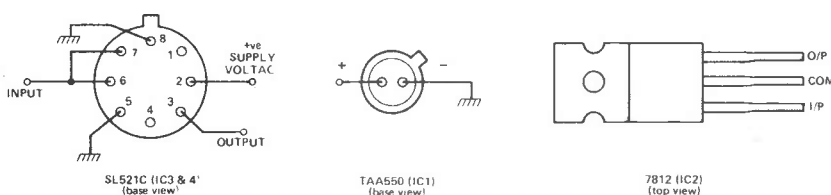


**Figure 6: Connections for the ELC 2060/ELC 2000.**

screen. The noise should dramatically decrease with the selectivity filters switched out. Feed in a UHF signal, switch L1 into circuit and adjust for maximum gain. Adjust the IF output coil to broaden the response on 'wideband' if necessary (that is, with L1 and the selectivity modules switched out of circuit). The selectivity filters can be peaked for best results if required and just a single filter may suffice. On the prototype the first filter was used as a notch to remove B4 vision from channel E4 by adjusting Lc and setting the other cores for maximum rejection consistent with maximum gain. Similarly the second filter was adjusted to remove B4 sound splatter from channel R2. Repeat the alignment procedure until optimum results are obtained. On a received signal, further improvement in gain and selectivity could sometimes be obtained by adjusting the fine tuning of the television receiver. On the prototype, the converter output appeared around



**Figure 4: G8 selectivity filter connections (viewed from component side).**



**Figure 5: Pin-outs for IC1-4.**



# DX-TV CONVERTER

## PARTS LIST

### Resistors

R1,R2,R3	4R
R4	1k2 (see text)
R5	1k (see text)
R6,R11,R13,R16	1k
R7,R9	10k
R8,R10	4k7
R12	1k (1W)
R14,R15	390R

### Potentiometers

RV1	25k Linear
RV2	25k Log
RV3	5k Linear

### Capacitors

C1	220n 250V polyester
C2	22u 25V elect
C3,C4,C5,C17	56p silver mica
C6	10n 50V disc ceramic
C7	10u 50V elect
C8,C16	1n 50V ceramic
C9	220u 63V elect
C10,C11	100u 63V elect
C12	470u 25V elect
C13	470n polyester
C14	220n polyester
C15	1000u 25V elect

### Semiconductors

D1-D8	1N4001,1N4148, etc
D9	1N4148

D10,D11,D12,D13,D14

BY206,1N4004, etc

IC1 TAA550  
IC2 7812  
IC3,IC4 SL521c  
(Classed as 'radar amps' from J. Birkett, 25 The Strait, Lincoln, LN2 1JF).

### Miscellaneous

Varicap tuner type ELC 2060 (Sendz Components, 63 Bishopsteignton, Shoeburyness, Essex SS3 8AF). UHF Modulator (Sendz Components), Selectivity Modules (the ones used in the prototype were the Philips G8 type obtained ex-equipment), small tagstrip, knobs, mains lead, mains input grommet, P-clip, 3 coax sockets, 3 feedthrough capacitors 1nF, 2 ferrite beads, red LED 0.2 in. with holder, 4BA solder tags, PCB base to suit case, 20mm fuse holder, 3/8" coil former with core, nuts, bolts, phono plug and socket, thin flexible coax for internal RF wiring, mains transformer 6VA miniature 12V-0V-12V, 250mA quick-blow type fuse (20mm), 4-way 3-pole rotary, miniature toggle, miniature DPDT toggle switch, VHF choke 1A 5uH.

channels 21 and 30 and despite the presence of strong semi-local transmissions no particular problems were experienced. The converter oscillator output frequency may be shifted slightly by adjusting the trimmer.

### In Use

Several units based on this particular up-conversion principle have been constructed over the past two years. They have performed well during Sporadic-E and tropospheric openings. On very strong signals, picture degradation does tend to occur where an extremely narrow bandwidth is used. Fortunately, this is where the alternative IF response settings come into their own.

During the 1982 Sporadic-E season, broadcast television signals were received from virtually every European country including Morocco. As for aerials, a simple dipole mounted horizontally and clear of obstructions may be adequate for Sporadic-E reception. Each element should be cut to approximately 50 inches, that is, around channel E3.

■ R&EW

## PUT THIS VALUE TO THE TEST!

**PLEASE NOTE**  
Closed for Stocktaking  
Fri 29th July to Mon 1st August  
inclusive

### HM102 BZ

- ★ 20kΩ/VOLT
- ★ CONTINUITY BUZZER
- ★ EXPANDED & LOADED  
1.5V & 9V BATTERY  
RANGES
- ★ 10A RANGE
- ★ 19 RANGES

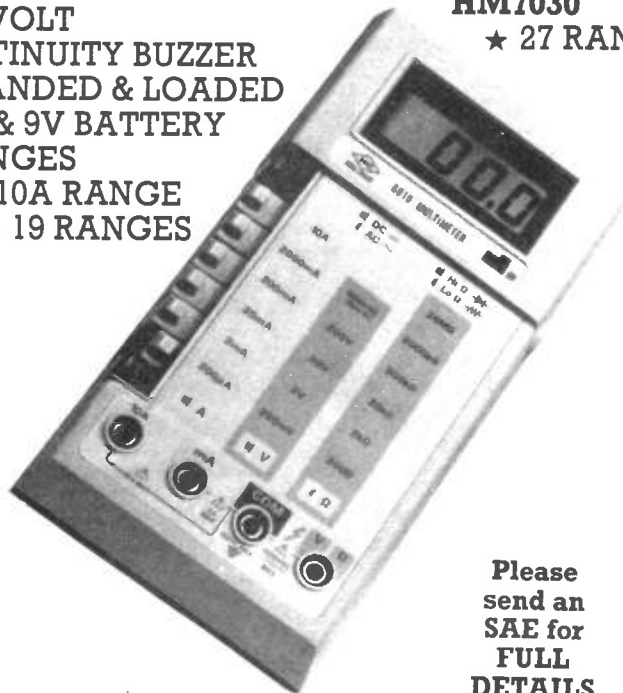


**£12.50**  
EX-VAT  
56-01020

★ test leads  
supplied

### HM6010 — HM7030

- ★ 27 RANGE LCD  
DMM's



- ★ 10A  
CURRENT  
RANGE

0.5% basic  
accuracy

**£33.00**

ex VAT

Stock No.

56-06010

0.1% basic  
accuracy

**£43.00**

ex VAT

Stock No.

56-07030

Please  
send an  
SAE for  
FULL  
DETAILS

**ambit INTERNATIONAL 200 North Service Road, Brentwood, Essex CM14 4SG**

Telephone (Consumer Sales/Enquiries) 0277-230909 — Telephone (Industrial Sales/Enquiries) 0277-231616 — Telex 995194 AMBIT G  
Data 24hrs (RS232/300baud) 0277-232628 — REWTEL. ● Prices exclude VAT except where otherwise shown. ● Postage and  
Packing 60p per pre-paid order. ● Orders submitted using Ambit Stock Codes will be processed first. ● Orders for in-stock items  
despatched same day (up to 4pm receipt). ● Hours — (consumer sales) 8am-7pm Mon-Sat; (Industrial) 8am-6pm (Mon-Fri).

# HF RX Design II: POSTSCRIPT

Due to the popularity of this series, we asked the author — Jon Dyer — to update the latest part.

The following text has been re-arranged from the original article (July '83). Also the various corrections have been added.

## In-Band Intermodulation

This is where two signals within the IF passband intermodulate to produce extra products. It is normally of little significance in HF communications except where multi-channel 'Voice Frequency Telegraphy (VFT)' systems, such as 'Piccolo', are in use. A typical level of performance for a good receiver is for a product of -40dB with reference to two in-band signals.

## Cross Modulation

When modulation from an unwanted signal transfers itself across and 'modulates' the wanted signal, the effect is called cross modulation. It is due to non-linearities in the early receiver stages, and sometimes the same modulation will re-appear on each adjacent signal tuned in. Cross modulation is a third order effect, so good third order IMP performance will tend to mean good cross modulation performance. Looking at Fig. 7, the cross modulation may be specified as the level required (in dBu) for a 30% modulated carrier greater than (say) 20kHz off-tune to cause 3% cross modulation. A level of 70 to 90dBu can be considered good.

## Blocking

Blocking, or de-sensitising, is similar to cross modulation, but in this case the large off-tune signal causes a reduction in wanted signal output. It is specified as the signal required to reduce wanted output by 3dB. It can often be caused by a strong CW signal, causing gain to go up and down with the keying. Figure of 90 to 110dBu can be considered a good performance, for a wanted 1mV(EMF) signal.

## Causes And Cures

As previously mentioned, dynamic effects are caused by large off-tune signals driving the receiver into non-linearity. There are three ways of improving performance: preventing the off-tune signals getting in, improving the linearity of the early stages of the receiver (prior to and including the roofing filter) and reducing the level of all signals. This latter method works because the response to unwanted (dynamic) signals falls off at a faster rate than for wanted signals (Fig. 4).

The third approach is implemented by means of a front-end attenuator or by a wideband AGC loop (separate from the main AGC loop), which operates on the RF amplifier on large signals only and can be thought of as being an automatic attenuator. Both methods have the disadvantage of reducing receiver sensitivity, so other solutions must be found.

The first method involves the use of sub-octave filters or some sort of pre-selector tuning. It can be very effective in reducing second order effects, but third order products can be too close for any sort of tuning to have an effect.

The only real solution is to improve linearity, using the second method. Bipolar transistors are particularly poor in this respect, but FETs are approximately square-law devices and are therefore very good in terms of third order effects,

though not so good for second order products. Linearity can be improved by using high voltage supply rails and keeping pre-roofing filter gain down to a minimum — consistent with required sensitivity — therefore keeping noise levels down.

The mixer may be a double balanced, switching-type, diode mixer, with volts of local injection to switch hard and thus improve linearity. Components normally considered to be linear, passive, and reciprocal must be carefully checked to ensure that they are. This especially applies to ferrite cores, used for RF coils and transformers, and crystal filters, which are often non-linear and non-reciprocal (ie, of different characteristics if connected the 'wrong' way round).

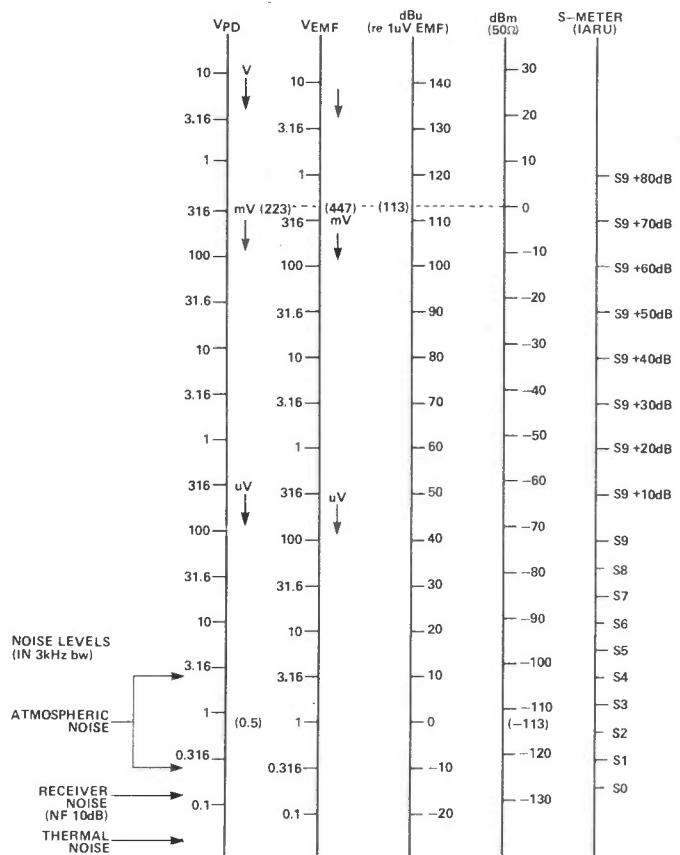


Figure 10: Relationships between levels specified in V(EMF), V(PD), dBu and dBm (50Ω). Also shown in S-meter response (IARU), which specifies that S9 is at 100uV(EMF) with S-point spacing at 6dB intervals.

The practice of fitting protection diodes at the receiver input (often found on marine main-receivers), will also cause non-linearity, as will diodes used to switch filters etc. If all these points are carefully watched, linearity can be made very good — the intercept at ≥140dBu. This sort of performance should ensure that IMPs and cross modulation products are below atmospheric noise on HF.

Finally, there was a small misprint in Table 1. Under the 'Blocking' sidehead, the last line should read "...EMF (60dBu) signal".

# REW TEL

# UPDATE UPDATE UPDATE

To coincide with the release of the second level of REWTEL software this month, Roland Perry reviews REWTEL's basic principles of operation.

REWTEL operates on the standard BT DATEL200 service. This service provides a data transmission medium of up to 300 baud over the public switched telephone network. Data is converted into tones, which are in turn decoded at the far end back into data. Since we may wish to have a simultaneous two-way conversation (or operate in full duplex to use the technical jargon), four distinct tones are used. Two are for data transmission from the 'originate' end (the person who dialled the call) and two are for data transmission back from the 'answer' end (the person who answered the ringing phone). The tones are handled by a piece of equipment called a MODEM. Some have a switch on them so that they can be used at either end of a call, but others are fixed. In particular, acoustically coupled modems are often originate only, as they are mainly used with some sort of terminal at the originating end and there are legal difficulties about using such a modem into a computer at the answer end. Directly connected modems often have an auto-answer feature which allows an incoming call to be accepted and routed to a computer without human intervention.

As well as an originate modem, the REWTEL user requires a terminal, VDU or personal computer programmed to operate as a dumb terminal. The data format is 8 data bits with 1 stop bit; although the eighth data bit will be ignored when received at the computer and transmitted as a zero from the computer. Pages are 16 lines of 64 characters. Various personal computers make good dumb terminals (Epson HX20, Tandy TRS80 and TRS80 Model 100, Nascom, Apple IIE, Sirius and the BBC Model B have all been demonstrated or reported as operating satisfactorily).

To access REWTEL the user must dial the number (0277 232628) and wait for the REWTEL computer to automatically answer the telephone. This will take at most three rings. The user should then attach his originate modem and wait to be

asked for a subscription number. If the user is not a subscriber then merely 'return' will suffice. The sign-on message will follow.

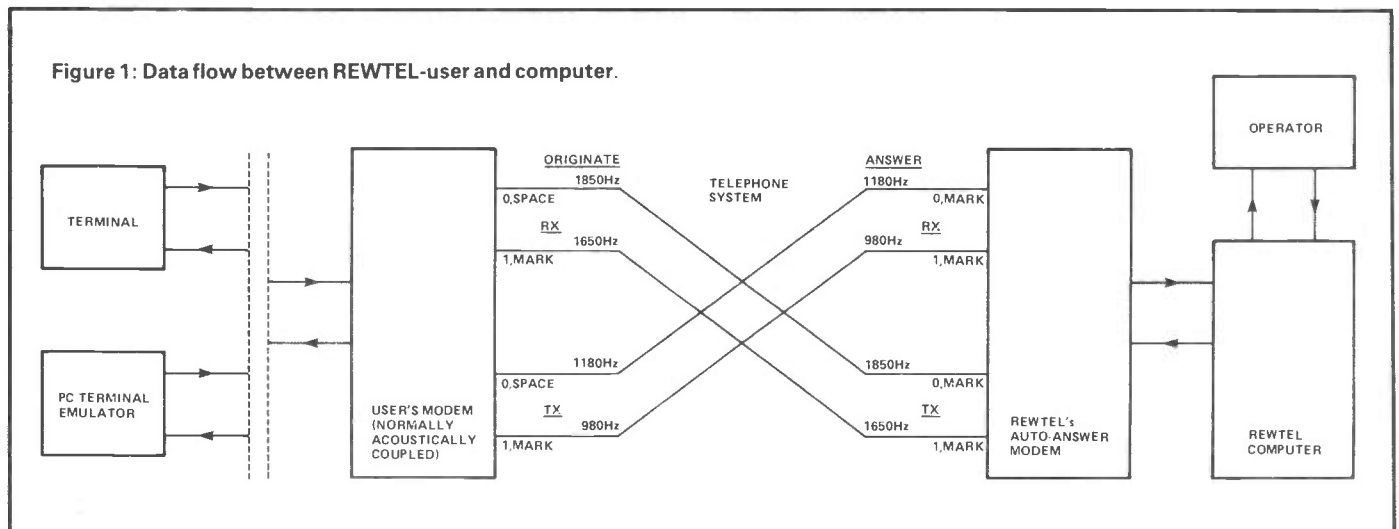
### After The Sign-on

The REWTEL database, like Gaul, is divided into three parts. Initially the user is logged into the 'INFO' section but can swap into the 'BULLETIN' or 'UPDATE' sections (or back to 'INFO') by mentioning those words as keywords at the prompt. Pages of information are retrieved by nominating a number of keywords. The REWTEL program first looks for occurrences of the words BULLETIN, UPDATE or INFO in case a switch to a different database is required. It then looks for pages in the database which contain all the (remaining) keywords. The titles of these pages are displayed along with the page numbers. If there is only one page which contains (within the title and the text) all the keywords, then that page is immediately displayed. If there are more than five titles, then the opportunity is given every five titles to abort the search or look at a particular page.

One particular page is displayed by typing the page number (eg \*6667) or by specifying enough keywords to uniquely define it. To abort a page in full flow type 'return' and it will abort at the next line end. At the end of the page, REWTEL will transmit a bell character and pause. The pause is to avoid losing the top of the page on 16 line displays. To continue, type 'return'.

### Bulletin Board Facility

One of the joys of REWTEL is the bulletin board, where users and subscribers leave one another and the operator messages and sometimes see a reply. Anyone can leave a message — use the single keyword CHALK (it writes on blackboards !). The message can then be entered followed by a suggested title. At some stage the system operator will read out the accumulated



input and edit them. This process involves tidying up the acceptable bulletins, correcting spelling etc and censoring any bulletins intended for the operator only. In this way, in particular requests for subscriptions are not broadcast.

## Subscriber Specials

REWTEL knows what the time is and tells you at every prompt to help you gauge the phone bill. If you are not a subscriber, it also 'times-out' after eight minutes. This gives other users a chance to access the system — subscribers are allowed unlimited time.

A number of outside organisations contribute to the information and services available via REWTEL. Computer Answers magazine will accept questions left as Bulletins on REWTEL and soon an index of ACC/PCW clubs will be added. Ambit International offers a component price/delivery and ordering service to REWTEL subscribers, which is entered by using the keyword 'SHOP'. REWTEL is interested in increasing the number and variety of such contributions and welcomes advances from commercial organisations who feel REWTEL has something to offer them.

## Version 2 Features

New to version 2 are a number of features requested by users. The most important is that all titles appear in reverse chronological order, that is, the newest one is shown first. The Bulletin database particularly benefits from this innovation. Searches can be resumed after a page has been displayed at an

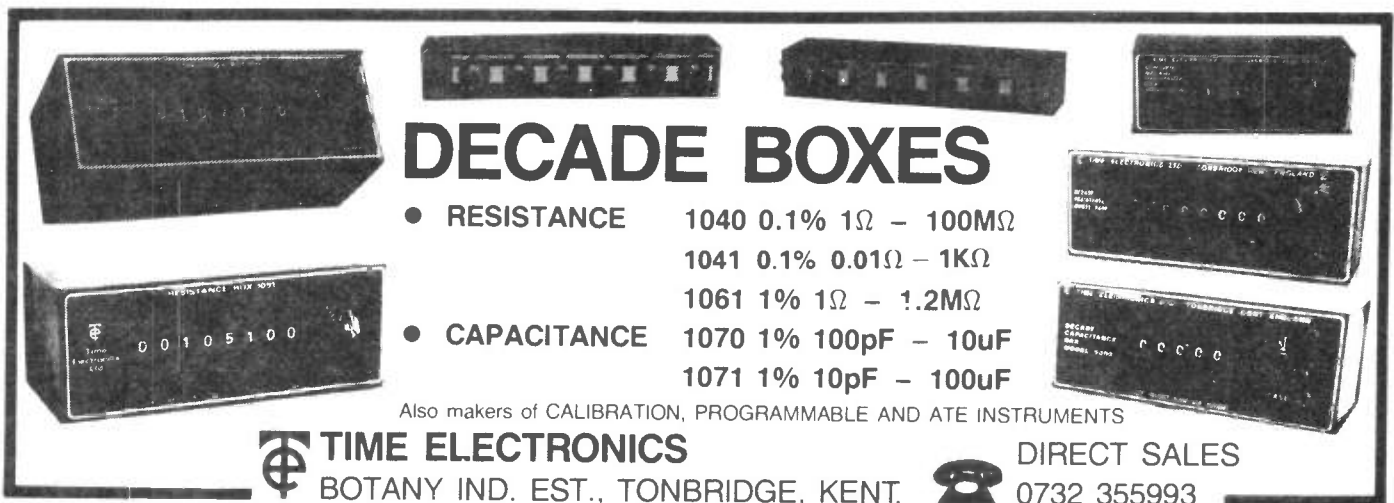
'every fifth page' prompt.

The whole way in which pages are selected from the database has been changed. The main effect is to speed up searches that previously took a very long time, at the expense of short searches. Up to eight keywords can be specified and the search takes longer as more keywords are used. Searches will be faster if uncommon words are used. Try not to use very common words that will appear on vast numbers of pages and which therefore will not concentrate the search very effectively anyway.

Most of the keyword editor has been withdrawn leaving only the 'slash-feature'. This allows the user to append a temporary set of keywords to the end of the last set used, in order to concentrate the search. The new set is added for only one search and should be typed in after a / character at the start of the line. Most often this allows selection of /PAGE1, /PAGE2 etc when a search has revealed a set of pages which the user requires to scan, without having to remember all the page numbers.

Finally there is now a two-way conversation facility whereby the operator can see what the user is typing and send him messages. If you see one of these messages then there really is a person at the REWTEL end who might like a chat. The user should reply using a single quotation mark at the start of the line which will then send the message to the operator rather than initiating a search.


■ R&EW



## DECADE BOXES

<ul style="list-style-type: none"> <li>● RESISTANCE</li> <li>● CAPACITANCE</li> </ul>	<table border="0"> <tr> <td>1040</td><td>0.1%</td><td>1Ω</td><td>–</td><td>100MΩ</td> </tr> <tr> <td>1041</td><td>0.1%</td><td>0.01Ω</td><td>–</td><td>1KΩ</td> </tr> <tr> <td>1061</td><td>1%</td><td>1Ω</td><td>–</td><td>1.2MΩ</td> </tr> <tr> <td>1070</td><td>1%</td><td>100pF</td><td>–</td><td>10uF</td> </tr> <tr> <td>1071</td><td>1%</td><td>10pF</td><td>–</td><td>100uF</td> </tr> </table>	1040	0.1%	1Ω	–	100MΩ	1041	0.1%	0.01Ω	–	1KΩ	1061	1%	1Ω	–	1.2MΩ	1070	1%	100pF	–	10uF	1071	1%	10pF	–	100uF
1040	0.1%	1Ω	–	100MΩ																						
1041	0.1%	0.01Ω	–	1KΩ																						
1061	1%	1Ω	–	1.2MΩ																						
1070	1%	100pF	–	10uF																						
1071	1%	10pF	–	100uF																						

Also makers of CALIBRATION, PROGRAMMABLE AND ATE INSTRUMENTS



**TIME ELECTRONICS**  
BOTANY IND. EST., TONBRIDGE, KENT.

**DIRECT SALES**  
0732 355993

# microdot II

**CW/RTTY/AMTOR/ASCII Communications Terminal**

**'ADD-ON' OPTIONS**

- Built-in 2 colour 40 column printer (£190)
- Battery back-up of memory (£30)
- AMTOR/ASCII modules (£28):-  
(Available Summer '83)
  - \* FEC, ARQ and 'listen' modes
  - \* ASCII transmit and receiver
  - \* Automatic PTT line



**NEW**

**STANDARD FEATURES:**

- \* Green phosphor screen
- \* Conventional keyboard legended for all functions
- \* 10 user memories for transmit text preparation
- \* Transmit/receive CW (morse) and RTTY (teleprinter)
- \* Fixed text stores
- \* Char. by char. and 'page' transmission modes
- \* Full duplex working
- \* Users callsign programmed
- \* Self check facility
- \* Printer port (parallel, centronics compatible)
- \* External video port
- \* PTT control
- \* Phase coherent AFSK generator
- \* Real-time clock

**CONTACT US TODAY at POLEMARK Limited, Lower Gower Road, Royston, Herts SG8 5EA. Tel: Royston (0763) 47874. Or call at one of our dealers listed below:**

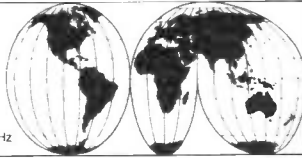
Northern Communications, 299-303 Claremount Road, Claremount, Halifax, W Yorkshire Tel: Halifax (0422) 40792	South Wales Communications Ltd., Graig-y-Master, Penycaemarw, Nr. Usk, Gwent Tel: Wolvesnewton (02915) 552	Amateur Radio Exchange, 373 Uxbridge Road, Acton, London Tel: 01:992 5765
---	---	--

★ **STOP PRESS:**  
SSTV board to be available in the Autumn

## SHORT WAVE NEWS FOR DX LISTENERS

Frank A. Baldwin

All times in GMT, bold figures indicate the frequency in kHz



In the last few issues we have been bringing to readers' attention some of the Latin American stations that may be logged on the 60 metre band (4750 to 5060); the first two articles dealing with the relatively easy-to-receive transmitters and last month's instalment presenting the so-called 'medium' ones. The difficult-to-receive LAs will be reviewed in following issues, meanwhile a continuation is made here with the Brazilian and Peruvian stations I have listed under 'medium'.

The Federative Republic of Brazil is the fifth largest country in the world, exceeded only by Canada, China, the USA and the USSR. The capital is at Brasilia, lying 960 km North West of Rio de Janeiro and is one of many cities designed to open up the vast interior, being inaugurated in 1960.

Radio Ribamar in Sao Luiz can be tuned in on 4785 where it operates from 0800 to 0400 with a 5kW transmitter. This one is often logged despite the presence of another Brazilian on this channel - Radio Brasil in Campinas with a schedule from 0700 through to 0500 with 1kW. Usually, the former overrides the latter.

On 4812 it is possible to hear Radio Itatiaia in Belo Horizonte the capital city of Minas Gerais state. The schedule is around-the-clock and the power is 5kW.

Radio Cultura de Campos, Campos is on the air from 0830 to 0230 with a power of 2kW and is to be found on

4955 although there is another Brazilian on this frequency from 0900 to 0300 with 1kW - Radio Marajoara sited in Belem - so it will be necessary to hear a clear station identification to sort out these two transmitters.

Then there is a long time favourite of mine - Radio Timbira in Sao Luiz with a 2.5kW transmitter working to the schedule 0900 to 0500 on 4975; Radio Cultura in Guaiaba on 5015 around-the-clock with its 5kW and sometimes marred by the co-channel Brazilian Radio Pioneira in Teresina with 1kW from 0700 to 0400. For the former signal then, listen after 0400. As with all Brazilian stations, the language used is Portuguese.

One of the most often reported Peruvians is Radio Atlantida in Iquitos on 4790 where it is scheduled from 1030 to 0500 (Sunday from 1130 to 0400) with a 1kW transmitter. This one is a good 'marker' for Peru - if you can receive this one reasonably well then the chances are that other Peruvians on the 60 metre band will be coming through fairly well.

Lastly, we have a very old 'friend' of mine, Radio Andina on the somewhat odd frequency of 4996 where it has been busily working away for some years now. Located in Huancayo, capital of the Junin department set in a high valley of the Andes (3300 metres asl) it has a power of 1kW and is scheduled from 1000 to 0500 - although the closing time varies on occasions.

## Around the Dial

### Senegal

Dakar on 4890 at 2309, OM in vernacular, presumably a newscast in the National Service (Chaîne Nationale) which is on this channel from 0600 through to 0900, from 1155 to 1600 and from 1715 to 0100. Most programmes are in the French language with some short periods in various local vernaculars.

### Libya

SPLAJBC (Socialist People's Libyan Jamahiriyah Broadcasting Corporation) Tripoli, 'Radio Voice of the Arab Homeland' on 11815 at 0017, OM with a newscast in Arabic in the External Service which operates on this frequency from 1745 through to 0400.

Tripoli on 17930 at 1002, OM with a newscast mainly concerned with local affairs. This is the Domestic Service in Arabic operating here from 1100 to 1745. At the end of the news there followed some militaristic marching songs.

### Qatar

Doha on 21525 at 1015, OM with quotations from the Holy Quran in the Domestic Service which is on this channel from 0900 through to 1300.

### Algeria

Algiers on 17885 at 0952, YL with songs in Arabic complete with local-style musical backing in a Domestic Service programme. The Domestic Service is on this frequency from 0000 to 2310.

Algiers on a measured 7246 at 0646, OM with songs in Kabyle together with a programme of typical Arab-style music. This is the National Network 2 on this frequency from 0500 through to 2200.

### Iraq

Baghdad on 21585 at 0943, YL (Young Lady) with several songs in Arabic, complete with music in a transmission of the Domestic Service which may be heard on this point of the dial from 0000 to 2305.

### Tunisia

Sfax on 7225 at 0456, OM with quotations from the Holy Quran in a programme of the Domestic Service which is on this channel from 0430 to 2330.

### Nigeria

Lagos on 7255 at 0450, interval signal of a series of rapid drum beats, the National Anthem at 0456 followed by YL with station identification in English, a short religious service, an English languaged newscast of world events, a commentary on the news, a local newscast and press review. Announced as the 'West African Service'. Drums, identification and the news in French at 0600.

### Saudi Arabia

Riyad on 7290 at 0417, OM with announcements in Arabic interspersed with a few bars of a military march - all in the Domestic Service which is on this channel from 0300 to 2300.

### South Africa

Johannesburg on 7270 at 0420, OM with a programme all about current affairs in Africa in an English transmission for South, Central and East Africa and the Middle East, scheduled from 0300 to 0430. Station identification and programme details at 0425, interval signal and then into a french newscast at



April showed an improvement in meteor shower activity due to the Lyrids around the middle of the month. Sporadic-E propagation usually appears towards the end of April, but only a couple of small, insignificant openings were noted this time. Reception, via SpE, lasted only a matter of a few minutes. However, at the time of writing SpE activity has at last been forthcoming, albeit down on other years. An intense opening to Central Europe occurred on May 2nd when the MUF reached 80MHz.

April 1st saw the reception of five countries including the Netherlands (NOS) on channel E4 via a marginal improvement in tropospheric conditions. Czechoslovakia (CST) were noted on R1 with the EZO-type test card (see R & EW April 1983) at 1213 BST and later with the FuBK electronic test card carrying the identification 'CST01'. The blank PM5544 pattern from TVP-Poland was seen at 1216 on channel R1 and at 1304, also on R1, the Hungarian interlude caption 'SZUNET' appeared. Austria made a brief appearance on channel E2a at 1305 BST with the 'ORF FS 1' PM5544.

On the 6th, East Germany was present via meteor shower (MS) reflection at 1231 on E4

(62.25MHz vision). Also noted via MS was Austria with their Telefunken T05 monoscopic test card on channel E2a (49.75MHz). It should be noted that ORF-Austria occasionally display important announcements across the PM5544 which obliterate the central area. Such an event was noted on the 7th.

Signals from Hungary (Magyar Televizio) were observed on the 10th with the 'MTV-1 BUDAPEST' PM5544 test card on R1 at 0807. At around lunchtime, the multi-burst electronic pattern was received. This test signal precedes the PM5544 prior to programme commencement.

The colour test card from TSS (Russia) made a brief entrance on April 20th at 1229BST. This pattern was featured in the November 1982 edition of R&EW. Also noted on the same frequency (49.75MHz) were signals from Czechoslovakia, Austria and Hungary.

A short Sporadic-E opening consisting of programme material was seen on the 23rd from 1355BST on channels R2 and E4. On April 30th, another SpE opening occurred with reception of the colour test card from TVE-Spain on E2 and E4 with the aerials directed towards the south.

### Identifying Signals

Further difficulties with station identification can arise during programme hours. Fortunately many services show imported material which, in many cases, contain subtitles. The DX-TV enthusiast needs to be fairly conversant with foreign languages to take advantage of this. Clock captions and news programmes seem to be safe methods of identifying signals, but beware, it is sometimes easy to make a mistake with the identity of a programme source as the names of countries appearing on captions

during a news bulletin can be misleading.

Possibly, one of the better ways of identifying stations during programme hours is to watch weather forecasts. The signal will usually be emanating from the country most under scrutiny by the forecaster. Local weather charts are particularly useful in this respect.

The general direction in which a signal is being received may also give a clue to its origin. For instance, a signal arriving from the south-east on channel E3 would possibly be Yugoslavia. We say 'possibly' because the typical skip distance via SpE is about 800 miles and Yugoslavia is the only country using channel E3 at that distance from the UK. However, the signal may be short-skip and may prove to be West Germany or Switzerland. If the signal is only present on E2, then it is unlikely to be Yugoslavia since there is only a very low-power relay station operating on this channel. Conversely, in West Germany and Switzerland the E2 transmitters have ERPs of 100kW. Therefore by a process of elimination it is usually



Romania's daily News programme radiated from studios at Bucharest. Photo courtesy of Televiziunea Romana.



0430 to Central Africa and Europe.

SABC Johannesburg on 4835 at 1850, OM announcer with a programme of recordings featuring Bing Crosby. This transmitter operates in English language and is on the air from 0348 (Saturday from 0430, Sunday from 0500) to 0555 and from 1520 (Sunday from 1455) to 2155 (Saturday until 2205). The power is 100kW. Johannesburg on 25790 at 1526, OM with the station identification then a programme of replies to listeners' letters in an English transmission directed to Central, East and West Africa, the Middle East and Europe and timed from 1300 to 1600.

#### United Arab Emirates

Dubai on 21655 at 0950, local-style songs and music in a programme of the External Service, on this frequency from 0900 to 1745.

#### Lebanon

"Voice of Hope" on 6215 at 1820, YL announcing a programme of evangelical songs, all in English. This one operates from 0400 to 2310, the address for listeners letters being given as c/o The Arizim Motel, Metulla, Israel.

#### Egypt

Holy Quran Station, Cairo on 9755 at 1757, OM with quotations from the Holy Quran. This station is on the air from 0200 to 0900 and from 1200 to 2100 to the Middle East and Europe. All programmes are in Arabic.

Cairo on 17745 at 1125, YL with a newscast in Arabic in a "Voice of the Arabs" transmission which is scheduled from 0600 to 1400 on this channel and directed to the Middle East, Africa and Europe.

#### Equatorial Guinea

Radio Nacional, Bata on 4925 at 1858, OM with a song in vernacular backed by the typical fast rhythmic music of the locality - once heard never forgotten. This one operates to the schedule 0430 to 0700 and from 1000 to 2200, the power being 100kW. If you cannot log this one on 4925 then tune to 5004, at which point on the dial it appears to operate alternately for short periods of some days.

#### Clandestine

"Voice of the Resistance of the Black Cockerel" on 4950 at 1905, OM with a heated speech in a vernacular. This station supports the UNITA cause and is hostile to the Angolan government.

#### Zaire

"Radio Candip", Bunia on 5066 at 0428, OM with a talk in vernacular ending with a military march. Programmes are of an educational nature and are broadcast from 0400 to 0730 and from 1500 to 2000 (Saturday from 0400 to 0730 and from 1230 to 1730; Sunday 1230 to 1830). The power is 1kW.

#### India

AIR (All India Radio) Delhi on 7280 at 1520, OM with a newscast in Hindi followed by YL with station identification and the news in English from 1530 to 1545, OM with a news commentary until 1545, all in the Domestic Service which is on this frequency from 1235 to 1545.

AIR Delhi on 11620 at 1815, OM with station identification followed by a programme of Indian music in an English transmission of the General Overseas Service. This particular programme is aimed at the UK and West Europe from 1745 to 1830 and from 1845 to 1945

on this channel.

AIR Delhi on 10335 at 1538, OM with a newscast in English which is scheduled on this channel from 1530 to 1545 in the Domestic Service.

#### Pakistan

Islamabad on 21802 at 0955, OM's with songs in Urdu, local-style music in a World Service presentation to the U.K. and timed from 0715 to 1100.

Karachi on 21485 at 1520, OM with a news commentary in Urdu in a programme in that language directed to the Persian Gulf and the Middle East and timed from 1330 to 1600.

#### North Korea

Pyongyang on 11660 at 1942, YL with a news commentary in the German programme for Europe, scheduled from 1900 to 1950. Also logged in parallel on 9360 and 6576. The English programme for Europe is timed to commence at 2030.

### Now Hear These

#### Bolivia

Radio Illimani, La Paz on 4945 at 0323, local pops, OM with station identification at 0325, the signal riding over Radio Caracol (identification at 0327) on the same channel. What a mix!

#### Clandestine

Voice of the Iraqi People on 7860 at 1655, OM with the Kurdish programme, timed from 1630 to 1700. At 1700 a marching song, OM with announcements and off after some military music at 1703. It was jammed - of course.

La Voz de Cuba Independiente Democratica on 5106 at 0325, OM with identification in Spanish, OM with a folk

#### Australia

Melbourne on 9570 at 0810, OM announcer presenting a programme of U.K. made pop records in an English programme for Europe, scheduled from 0700 to 0900 on this frequency.

Melbourne on 9760 at 0820, OM with a selection of pops in the English transmission for the Pacific Islands and Papua/New Guinea, scheduled from 0700 to 0845.

Melbourne on 17795 at 1130, OM with station identification and "Sporting Roundup" in an English programme for the Pacific, timed from 1100 to 1300 with this transmission.

#### Turkey

Ankara on 7105 at 0432, OM with music and songs in the Turkish programme directed at Turks abroad, to be heard on this channel from 0355 to 0605.

song and some local-style music. Thought to be Granada based.

#### Peru

Radio Huancavelica on 4885 at 0331, OM with a political talk in Spanish, it was anti-Shining Path, the local guerilla organisation noted for lightning raids on local stations, broadcasting a manifesto and then just as rapidly vanishing into the night.

#### Antartica

To end on a chilly note - Radio Nacional Arcangel, San Gabriel on 15474 at 0035, OM with a talk in Spanish after identification. It is manned by Argentinians!

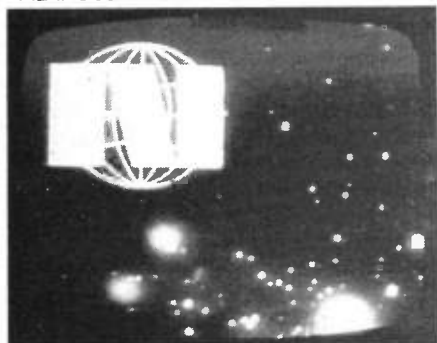
possible to short-list the country of origin.

Another useful clue may be gained by checking the Vertical Interval Test Signal (VITS) or the teletext code inserted at the top of the frame. A sketch can be made of its appearance following positive identification and used again at a later date. Unfortunately, these test inserts are changed periodically and, on occasions, are omitted altogether from some transmitters operating on the same network.

If any newcomers to the hobby experience difficulty in identifying any signals, we will endeavour to help. Please give channel details where known, the direction from which the signal originated, time of reception plus drawings or photographs of any clocks, captions or test cards noted.

#### Service Information

**Finland:** The YLE transmitter at Maarianhamina occasionally carries regional identification on the FuBK test card, namely "ALANDSSANDARE I KVALL". This outlet is



Identification caption used by the Norwegian News programme.

located on an island mid-way between Finland and Sweden and operates on channel E5 with 10kW ERP. Inhabitants of Aland are also able to receive Swedish programmes from Vaeddoe. This transmitter, to the north of Stockholm has an ERP of 200kW on channel E8.

There are three main Band I transmitters receivable in the UK which all radiate the Finnish YLE-1 programme:-

Transmitter	Ch	ERP
Tervola	E3	20kW
Ruka	E4	2kW
Vuokatti	E4	40kW

**Poland:** The new transmitter operated by TVP on channel R26 which was mentioned in a recent column is apparently located at Olsztyn and has an ERP of 1000kW.

**Denmark:** A regional television programme is to start on August 1st via the Soenderjylland transmitter on channel E7 with an ERP of 60kW. Danmarks Radio are to experiment with regional transmissions each weekend over the next two years.

#### Reception Reports

Meteor shower activity produced some remarkable 'pings' for Clive Athowe (Blofield, Norfolk). On the 8th, 10th, 11th and 16th of April he succeeded in receiving the TVR-Romania channel R2 transmitter situated at Bucharest displaying their distinctive monoscopic test card. Closer to home, the Polish test pattern (PM5544 type) was seen in SECAM colour on the 21st. On the 24th a few North German signals were noted during a short lift in tropospheric conditions.

Our Dutch correspondent, Gosta van der Linden, has described the intolerable condition of the airwaves around Rotterdam. Stereo



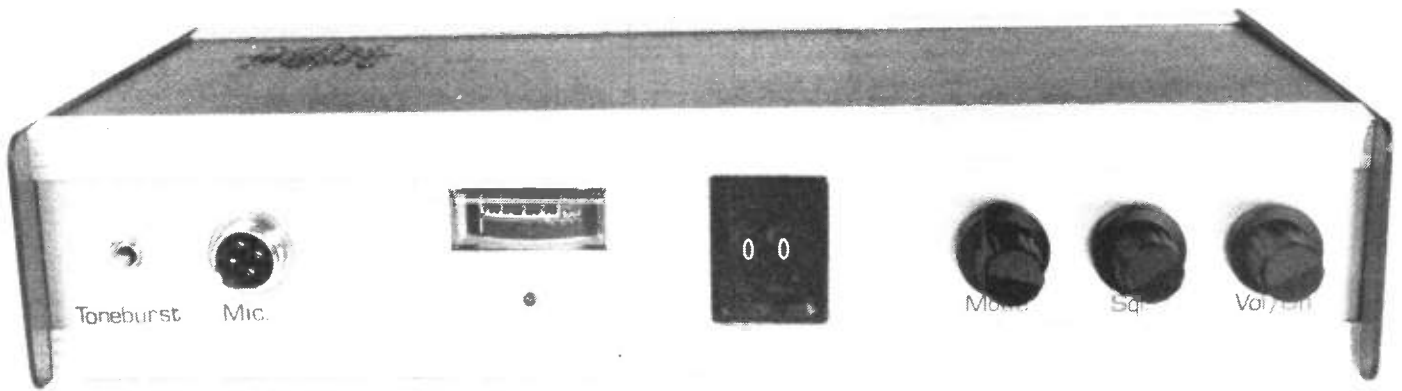
News programme from YLE-Finland called "TV UUTISSET". Photo by courtesy of Petri Poepponen, Finland.

pirates clutter the FM band while on the Dutch ATV band (430-440MHz) pirate stations play stereo music and video films. Between UHF channels 30 and 40 many pirate television stations are in operation, some with exceptional picture quality. Obviously the Dutch version of our Home Office is just as helpless and inefficient in dealing with such illegal transmissions!

While on the subject of amateur television stations, Andrew Webster of Billinge near Wigan has obtained an ATV converter. Then he discovered that his Panasonic VCR would already tune down to the required channel! He has received several amateurs in North Wales and Cheshire and would like to know if there are any call-sign location lists available.

Finally, according to Robert Copeman in Australia, the SpE season in The Antipodes has been very disappointing. On the other hand tropospheric DX has excelled itself but he hopes that F2 conditions will return to provide some really long-distance reception.

## Reception Reports



# 2m SYNTHESISER

Stephen Ibbs reviews a modular kit from Wood and Douglas.

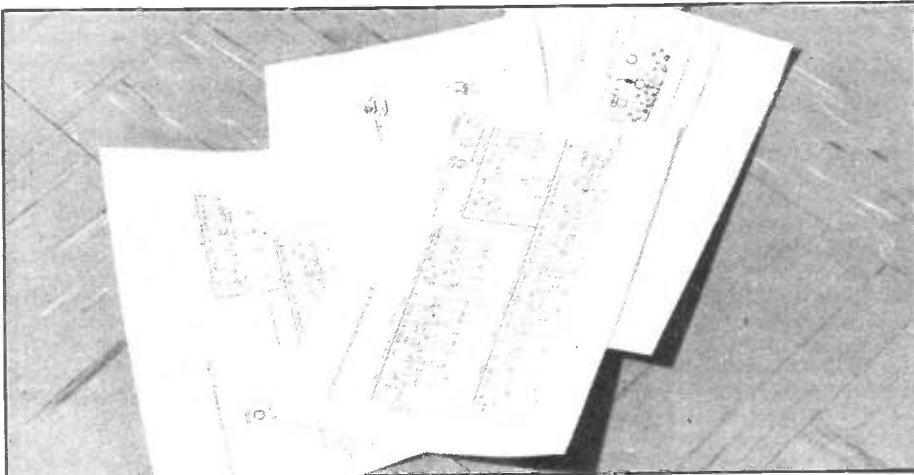
The complete W&D kit consists of: synthesiser, VCO and modulator, receiver, shortened transmitter strip and solid state relay. The first thing to do is carefully read all the documentation before constructing anything. Not only does this give a greater understanding, but it gets the reader familiar with the W&D style and ensures that any modifications are noted. Parts check lists are included, which show any changes to the specified components. The circuit diagrams are a bit daunting at first, but it soon makes sense.

The digital board was built first, with a double sided through plated, PCB, of excellent quality. However the through-plating does entail the constructor in some checking that the right component is being inserted. The overlay diagram was inadequate here, because it only shows the value, not the circuit identification. Apart from this, no problems were encountered, and the six-section testing procedure was accomplished easily.

## Opined Oscillations

The VCO also uses a double-sided fibre-glass board, but not plated through, and, like the digital board, care is needed because the component density is higher than normal. A frequency meter (or receiver) is needed to set up the VCO, and this should not be rushed as the range and sensitivity need careful attention. The text is easy to follow and proved to be trouble-free.

The two boards are connected together then as shown in a clear diagram. Once done, the unit locked up and delivered the correct frequencies. Then you can start on the receiver. Clearly design improvements have been made concerning the ceramic filters, and the CFSH M3 is now supplied. Unfortunately, the two filters would not fit the holes drilled. Redrilling was conceivable, but the ground plane was a problem, so I tried bending the legs... two days later replacement filters arrived! The



The diagrams supplied with the kit.

## SPECIFICATIONS

Coverage	144-146MHz
Output freq.	24MHz Tx, 45MHz Rx
Channel spacing	25kHz @ 144MHz
Offset	600kHz repeater
Toneburst	crystal controlled
Power	12V @ 100mA
	Out of lock inhibit
	CMOS, LS TTL Technology,
	2 d/s fibre-glass PCBs.
Size	digital board 4" by 3.5"
	VCO + Modulator 2" by 3.5"

best method is soldering in short lengths of tinned wire and attaching the filters to these – but clearly the board needs to be changed. (*W&D inform us that a new PCB design has been completed and will soon be available.*)

Joining the receiver to the synthesiser was very easy and a noise was heard in the speaker. A nice feature about the receiver and transmitter boards is that initial settings for the trimmers are given. This not only aids alignment but, particularly with the transmitter, gives a good indication of a fault if the trimmers are way off the recommended settings. There was a lot of noise coming out of the speaker until the thumbwheels were set. Changing to a simplex channel produced a sensible contact with which I could peak up the trimmers. Notes are added in the literature about improving the receiver's performance involving the purchase of a BF900 and constructing some coils.

After the receiver was checked to be working, these coils were formed and inserted, and there was a definite

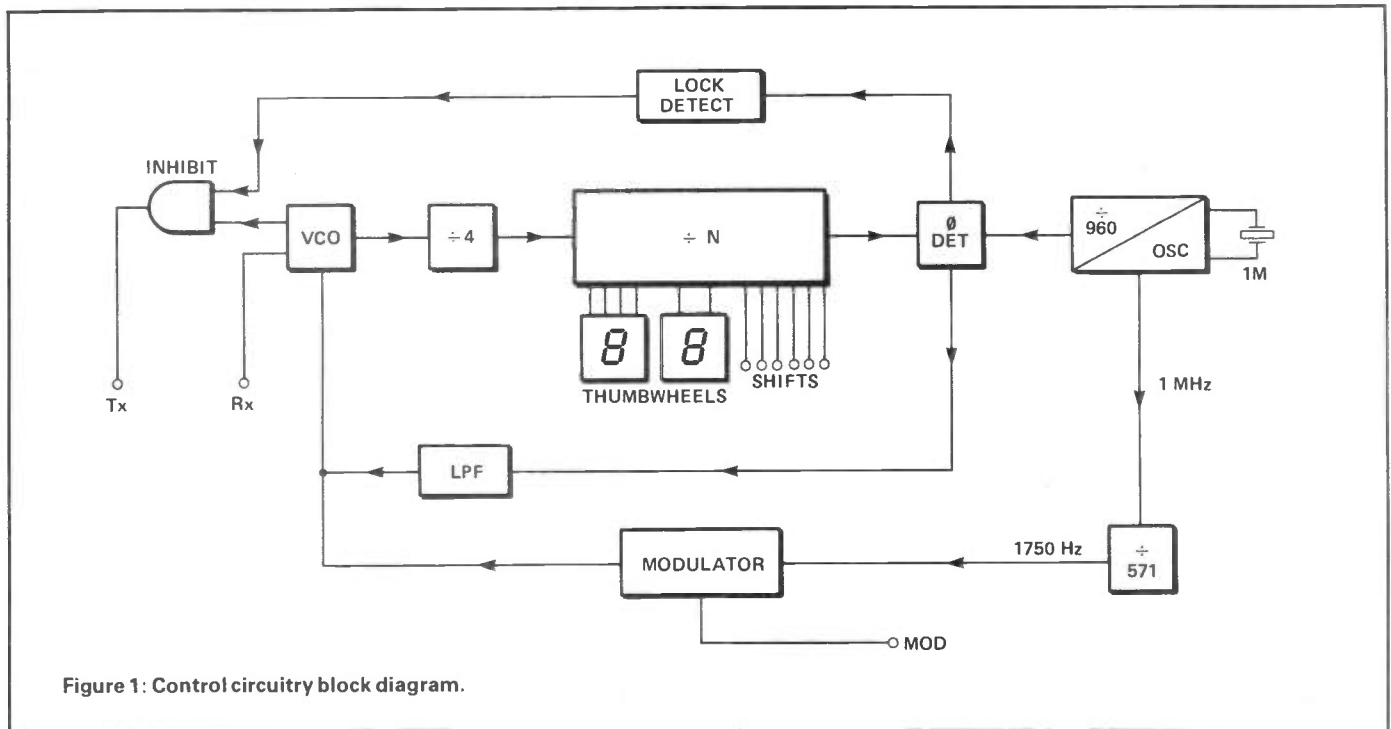


Figure 1: Control circuitry block diagram.

improvement in the front-end performance. I would have preferred to see them in the original kit; nevertheless it is good to see W&D updating their designs to improve the performance. The modulator was tested and found to be working satisfactorily.

### Turning to Transmit

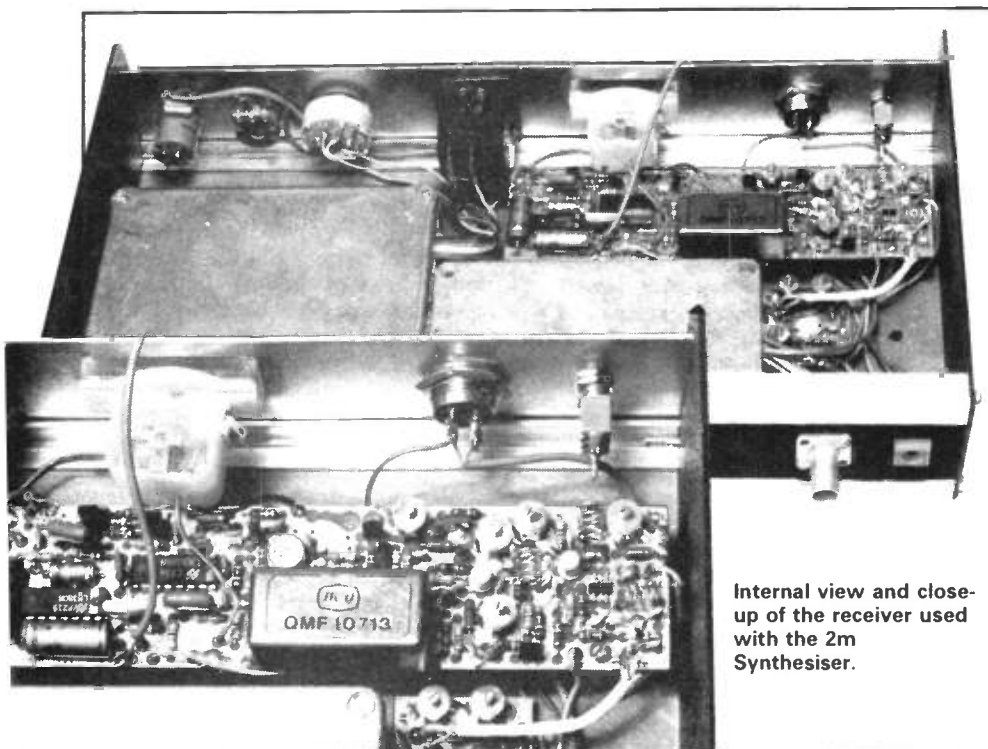
Compared to the receiver, the 2Y2T

transmitter strip was simplicity itself, and apart from the supply and aerial, requires only one coax connection to the synthesiser. Tuning up is done either with a 50R power meter or a dummy load with reflectometer. A current meter in the supply line will also peak nicely. Between 1½-2 watts can be expected and if all is well the output coax is connected to the appropriate terminal on the receiver board.

The rig was mounted in a Centurion DX4 case, and everything needs bolting down firmly to avoid microphony problems, particularly the synthesiser and VCO which should be in screened die-cast boxes for best performance. Thumbwheel switches were used for our unit, but a neater solution would perhaps be to use the recently introduced SRH202U rotary switch. This has a decoded output for a digital readout, the only disadvantage being that '0' will read '40'. However it is simple to build a small inhibiting network, decoding the necessary data lines to blank off the '4'.

### A Big Performer

The rig performs well, was easy to construct and align with the minimum of test equipment, and is recommended for anybody who has some building experience. W&D offer a range of preamps and PAs, and I have just completed the 10 watt FM10B and the 144PA4/S preamp to go with the rig, and they perform very well. The synthesiser can be modified for use with Storno, Pye 2200s etc, and has an auxiliary Tx output at 6MHz or 12MHz. W&D provide ready-built modules, pretested and aligned, and this can represent a saving in time and money if constructors are unsure about their building abilities. A full back up servicing facility is also available, and local amateurs who have taken advantage of this service tell me that they are well satisfied.



Internal view and close-up of the receiver used with the 2m Synthesiser.

# NOTES FROM THE PAST

The debate over what constitutes 'hi-fi' has gained new significance with the introduction of compact disc systems. Such developments were also a talking point 25 years ago — Centre Tap elucidates.

Last month I felt it necessary to apologise for giving over much of the column to gramophones and records. Apparently I need not have worried. Rarely has the postbag been so full. Many readers wrote asking for the catalogue number of the *Popular Science* magazine Test Disc which I mentioned was now available in the UK. Fortunately I was able to find time to reply to them all, but for the benefit of others who might have wondered, it is simply known as Test Disc No 1 and is issued by Allied Records Ltd (London). I was surprised that so many record dealers did not seem to know of the existence of this record — apparently they only sell them and would seem to have little interest in the contents.

Thinking of record dealers reminds me of their being bypassed as the result of the direct sale of records in a similar manner to that popularised by the various Book Clubs. I have had quite a few requests for my opinion on the quality of the recording of various "Club Records" — some of which sell for little more than a third of the price of records sold through the normal channels. As the choice of titles selected are those which would chiefly appeal to the serious music listener, the question of recording quality is obviously of considerable importance. I have heard one which sells for under 15 shillings, but as it was played on very indifferent equipment I must reserve judgement. The quality, however, was about the same as that of standard records played under the same conditions. I hope soon to have an opportunity of making a comparative check on real hi-fi equipment. I would put the emphasis on the word "real" — lately I seem to have been running into stuff which is hi-fi in name only! In the meantime, the views of any readers who have made comparative tests will be welcome.

The only "Club Record" I have heard played on a true hi-fi system was one (of a set of ten with monthly additions) sponsored by a record manufacturer. These 12in long plays cost a little over a pound, and the one I checked on seemed equal in all respects to the better standard recordings.

I have also heard a brief demonstration of the first stereo disc records (double sound track), recently issued by Pye. Properly used, they certainly give 3-D sound. By the phrase "properly used" I don't simply mean with the special equipment — that is obviously necessary. There is, however, an additional control, to give a balance between the two speakers. This and other incorrect adjustments can quickly falsify musical values, and I hate to think of what sort of sound people with more money than musical taste might adjust them to give. Apart

from this danger, it represents a considerable technical advance and will keep the keen constructor on his toes as soon as he realises his present hi-fi may soon be considered old-fashioned.

## A Job for Idle Hands

Among the letters received this month was one from a Luton reader. I rarely quote the nice things that readers, on occasions, say about this column; but this one is a little unusual, as it was written by a non-regular. He writes: "Like yourself, I have had a longish spell in hospital, and while there a friend brought me a bundle of old *Radio Constructors* to read. I haven't done any radio for years, although at one time I was a keen experimenter. The magazines certainly re-vitalised my former interest. I went more or less straight through the bundle reading all your Radio Miscellany articles which I enjoyed — especially the parts about Old Timers. I think it must have been the revival of old memories and a certain hint you dropped that rekindled my old enthusiasm".

"In one of your earlier articles you wrote at some length on rebuilding and modernising old receivers. Like most other families we had an old broadcast set at home, stuck away in the attic. So in the long weeks of post-hospitalisation at home I got busy with a new all-wave coil pack, miniature valves, a new dial and sundry modern components, all bought by post. I completely rebuilt the set, trying to keep it as much as possible like an exhibition piece. It works perfectly and I have now started to modernise another — a long-discarded portable".

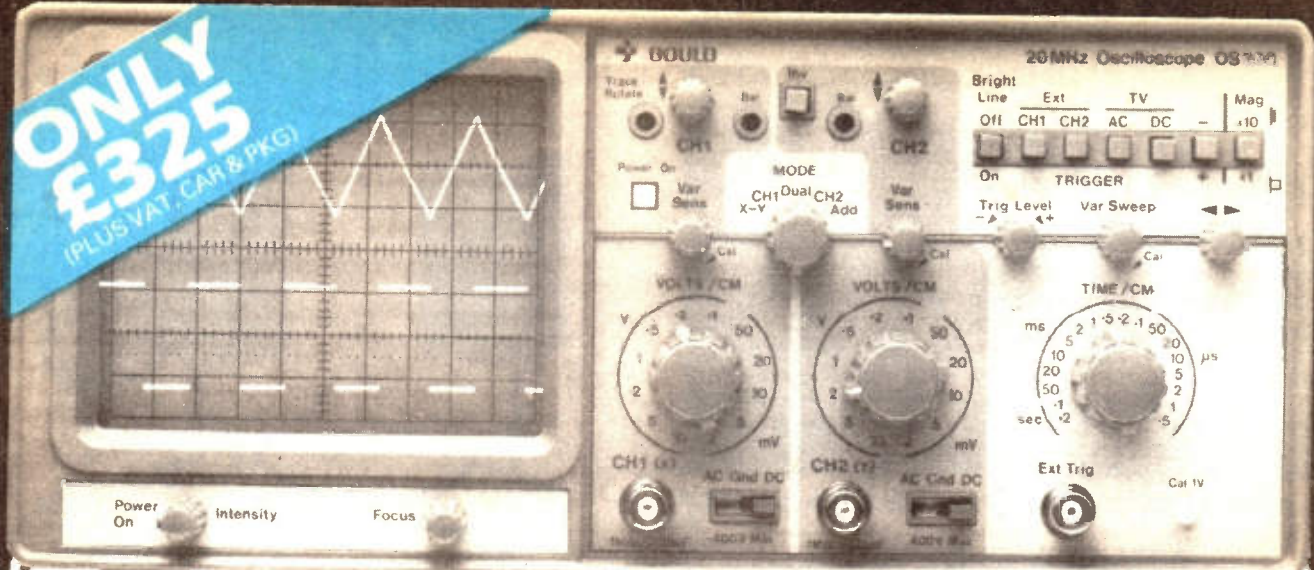
"I am convinced the idea, which came about as the result of reading your articles, materially assisted me in speeding up my recovery and made the long weeks of enforced idleness a pleasure instead of a period of boredom. Thank you for both the enjoyment and the idea I derived from your column, and I hope that you are now, like myself, fully recovered".

Thank you too, JS, for a most encouraging letter received just as I was about to again put my nose to the grindstone. Come to think of it, redesigning old sets must be an ideal way of pursuing constructional interests for armchair-ridden enthusiasts. No chassis bashing, octal-sized valveholder holes blanked off with miniature adaptors, doubtful components stripped out and modern parts fitted. No heavy benchwork, and it can all be completed with a few simple tools and a soldering iron — plus a couple of cushions in the back of the armchair to prop you up! I gladly pass the suggestion on for other readers to try out on their convalescent friends.

■ R&EW



# GOULD OSCILLOSCOPES SET A HIGHER STANDARD



## The Gould OS300 Dual Trace 20MHz Scope

A tough, professional instrument you can trust – at a price you can afford! ★ Max. sensitivity 2mV/cm. ★ Stepped and continuously variable attenuator and timebase controls. ★ D.C. coupled triggering and “active” T.V. sync separator. ★ ‘Add’ and ‘Invert’ for differential measurements. ★ X-Y facility.

Built to do more – safely, reliably and for longer. Ask for our 8-page data sheet for full details and applications information.



Gould Instruments Limited,  
Roebuck Road, Hainault, Ilford, Essex IG6 3UE  
Telephone: 01-500 1000. Telex 263785

10803

# GET THE COMPLETE PICTURE AT YOUR NEWSAGENT DURING JULY — OR DIRECT

— ORDER YOUR COPY NOW —

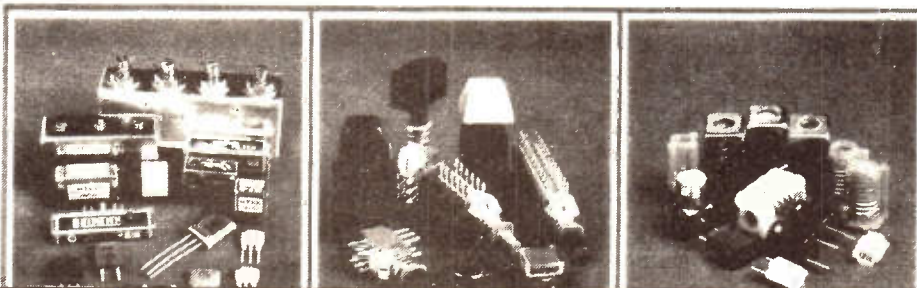
★ STILL THE ONLY CATALOGUE FOR THE COMPLETE RANGE OF COMPONENTS. BATTERIES, CRYSTAL FILTERS, RF POWER, MOSFET, TOKO COILS, CHOKES, ALPS PLOTTERS, SOLENOID CASSETTE MECHS ETC.

SUMMER '83

COMPONENTS FOR  
ELECTRONICS, COMMUNICATIONS & COMPUTING

**ambit**<sup>®</sup>  
INTERNATIONAL

WORLD OF RADIO & ELECTRONICS  
— CATALOGUE —



80p  
144 PAGES  
3 x £1 DISCOUNT VOUCHERS

- ★ FIRST WITH ON-LINE COMPUTER SHOPPING
- ★ FIRST FOR INNOVATION
- ★ FIRST FOR VALUE
- ★ FIRST FOR CHOICE
- ★ FIRST FOR SERVICE

**ambit**<sup>®</sup> INTERNATIONAL

200 North Service Road, Brentwood, Essex CM14 4SG  
Tel: (Consumer Sales/Enquiries) 0277-230909.  
Tel: (Industrial Sales/Enquiries) 0277-231616.  
Tlx: 995194 AMBIT G. Data 24hrs (RS232/300 baud) 0277-232628.



# Booth Holdings Bath

STAFF G3NXU G3XOD G8DPH  
6 GOLF CLUB LANE, SALTFORD  
BRISTOL BS18 3AA

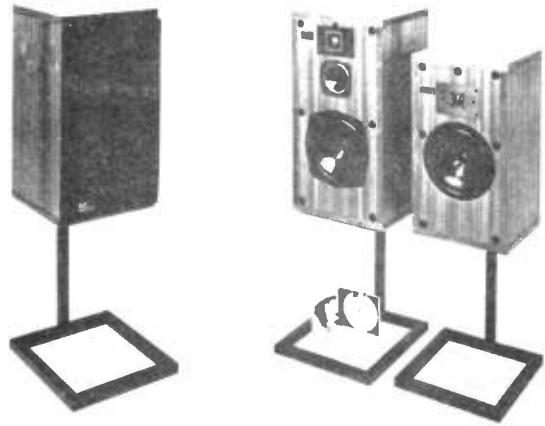
Transmitters receivers etc. All frequencies, well known makes, ICOM, FDK, Azden, Lowe, Sandard, Trio & Yaesu etc. Power supplies, Wavemeters, Test Meters, Frequency Counters. Welz SWR and Meters. Microwave modules equip. Quality equipment for amateur, PMR and marine use. Aerals, coax cable plugs. £1000 instant HP available and Access. Suppliers of radio equipment to Camel Trek Ltd, Kenya.

## — ADVERTISERS —

Any make up  
or copy enquiries  
Phone John White on

**0277-213819**

# NEW PRODUCTS



### IMF Speakers

Making their debut at CES Chicago '83 are two new models from IMF Electronics. The CM2a is a Compact Monitor of acoustic suspension design with ferro-fluid damped tweeter for increased power handling. It is the lowest priced IMF Electronics model for five years at £169.00 (inc VAT) per pair.

The CM3a is also of acoustic suspension design. It features both ferro-fluid damped midrange unit and tweeter for increased power handling. This advanced specification offers superb value and performance at £298.00 (inc) per pair.

Both models represent the latest developments in relatively small

loudspeakers, capable of monitor standards. The enclosures are rigidly constructed and internally braced to ensure that spurious resonances are avoided. Additionally the bass and ferro-fluid damped midrange units of the CM3a have their rear radiation absorbed in separate and tapered cabinet sections. Flat baffles and frameless foam grilles eliminate image smear caused by unwanted diffraction. Good crossover design ensures smooth impedance curves, efficient transfer functions and minimal inter-driver modulation.

*IMF Electronics Ltd.,  
Richardson Street,  
HIGH WYCOMBE,  
Buckinghamshire  
HP11 2SB*

	SPECIFICATION	
	<b>CM2a</b>	<b>CM3a</b>
Dimensions:	482 x 255 x 271 mm wide	572 x 280 x 302 mm wide
Drive Units:	200 mm Bass/Mid - laminated cone 25 mm Tweeter - soft dome, ferro-fluid	200 mm Bass Unit - plastic cone 100 mm Midrange - plastic cone, ferro-fluid 25 mm Tweeter - soft dome, ferro-fluid
Crossover Frequency:	3kHz	340Hz and 3.2kHz
Frequency Response:	54Hz to beyond audibility	45Hz to beyond audibility
Efficiency:	1m Pink Noise - 86dB for 1 watt	1m Pink Noise - 84dB for 1 watt
Matching Impedance:	8 ohms nominal	8 ohms nominal
Recommended Amplifier Power:	10-100 watts per channel RMS	20-150 watts per channel RMS
Net Weight:	13.4 Kilos (pair)	26.5 Kilos (pair)
Gross Weight:	17.0 Kilos (pair)	35.0 Kilos (pair)
Cabinet Finish:	Walnut Veneer with brown foam fronts - optional black lacquer with black foam fronts	Walnut Veneer with brown foam fronts - optional black lacquer with black foam fronts

### Spark Quenchers

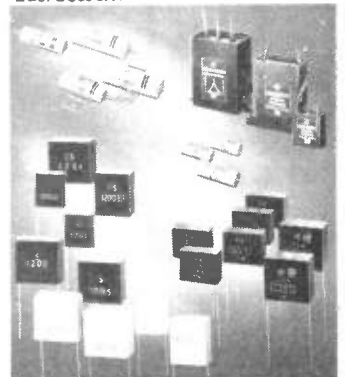
A new range of high quality, competitively priced C-R Combination Spark Quenchers are now available from Roxburgh Suppressors Ltd.

The Spark Quencher range is manufactured by Okaya Electric Industries Co Ltd of Japan, and most models are VDE, UL and CSA approved.

The main applications are in eliminating arc or glow discharge in electromagnetic devices and equipment (government legislation stipulates that manufactureres have to conform to very strict regulations regarding the suppression of any discharge between terminals and high frequency oscillations).

For further details of the extensive range of filter devices

available, please contact:  
*Roxburgh Suppressors Ltd.,  
Eagle Road,  
RYE,  
East Sussex.*



# CAR LINK TS-32

## CTCSS PROGRAMMABLE MICROMINIATURE ENCODER - DECODER

■ 1.25" x 2" x 0.4". SS32M CTCSS

■ Encoder. 1.45" x 0.8" x 0.13".

Crystal controlled, no test equipment required for installation.

All 32EIA tones programmable.

Compatible with all sub-audible CTSS systems.



SOUTHAMPTON  
**(0703) 619834**

**Car Link Communications Ltd.**

29e Parham Drive, Boyatt Wood Industrial Estate  
Eastleigh, Hants SO5 4NU

## A Megger-Star?

Thorn EMI Instruments Limited, of Dover, Kent, is launching a new generation of rugged toolbag instruments which, the company firmly believes, is expected to give Britain a competitive edge on foreign products – not only in this country but internationally.

The new Megger 1000 Series and the Avo 1000 Series between them offer capabilities in insulation and continuity testing, and general testing of electrical circuits. A

further four models are planned to be introduced from Autumn 1983 onwards.

Further details about the Megger 1000 Series and the Avo 1001 analogue multimeter are available from:

*The Sales Department,  
Thorn EMI Instruments Limited,  
Archliffe Road,  
DOVER,  
Kent  
CT17 9EN*



## Pack It Up

A new range of quick assembly, lightweight cushion packs called 'Shellpak', offering a high degree of protection for postage or shipment of vulnerable products, has been introduced by Abbott's Packaging Ltd.

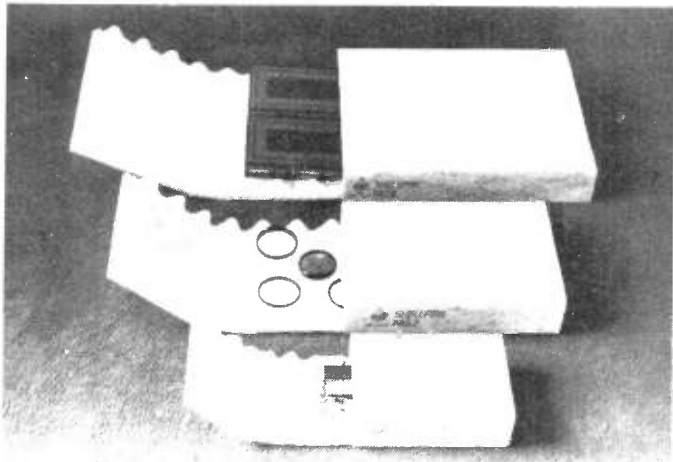
The structured cartons are manufactured from oyster finish corrugated board and are designed in two pieces comprising a pre-folded fitment, laminated with white, 16oz profile foam which, when closed and inserted inside its outer sleeve, immobilises and cushions contents against impact.

The most important potential application for 'Shellpak' is seen in the electronics industry for a range of products, including printed circuit

boards and semiconductors, although the excellent protective features of the pack are likely to make it of considerable interest to those despatching such delicate items as glassware, jewellery, photographic equipment, scientific instruments and precision engineering components.

'Shellpaks' are stocked in three standard sizes, the largest of which has interior dimensions of 360 x 280 x 50mm. Where sufficient quantities are involved, other sizes can be made to specification in a variety of stock boards, depending on application.

*Abbott's Packaging Ltd.,  
Gordon House,  
Oakleigh Road South,  
NEWSOUTHGATE,  
London  
N11 1HL*



# WOOD & DOUGLAS

## VHF/UHF COMMUNICATION PRODUCTS

**Have you read** the review in this issue of **R&EW** of our **2M FM Transceiver** kit?

**Are you worried** about spending that amount of money on such a complex kit?

**Are you surprised** that a **BRITISH** company can still produce equipment designs **AND** give a comprehensive friendly backup service for the complete range?

With **W&D** products your worries are unfounded and to give you an extra confidence and incentive we are offering exclusive to **R&EW** readers the following:

**144PAC + 144FM10A (10W Amplifier)**  
for **£100.00** inclusive VAT/p&p

(This offer is valid until 31/8/83 and please mention **R&EW** in your order)

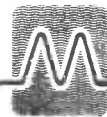
**All you will need** is a case, squelch and volume controls, speaker, microphone and a channel selector in BCD format.

**Delivery** on this offer as with all our product range is return of post providing stock at time of ordering.

**Telephone** your **ACCESS** or **BARCLAYCARD** order or post your cheque today to our commercial premises detailed below. Full detailed lists will be forwarded on receipt of a large SAE.

We know you will **enjoy** putting the modules together and if you can't make them work we will!

**UNIT 13, YOUNGS INDUSTRIAL ESTATE,  
ALDERMASTON, READING, RG7 4PQ  
Telephone (07356) 5324**



MICROWAVE MODULES LTD

## TUNE INTO THE WEATHER...

Using our Complete 'METEOSAT' Weather Satellite

We supply the complete system from antenna to video monitor, at the lowest price ever imagined for such a comprehensive system. View the entire globe on your video screen, or select any enlarged portion of the earth, for example Europe, as seen by the satellite from 20,000 miles above the earth. Both visible light picture and infra-red pictures can be selected, the latter giving useful temperature information.

Our complete system consists of the following items:

- 1. ANTENNA:** 1.1 metre diameter parabolic dish with feed, supplied in kit form to reduce costs and make transportation easier.
- 2. ANTENNA PREAMPLIFIER:** Gasfet low-noise preamplifier to be bolted onto the antenna, to overcome feeder losses and provide maximum sensitivity.
- 3. 1690MHz CONVERTER:** Frequency converter from 1690MHz to 137.5MHz to allow a conventional receiver to be utilised.
- 4. 137MHz RECEIVER:** The FM receivers, which demodulates the received encoded signal. Orbiting satellites on the 136-138MHz band can also be received using this receiver.
- 5. DIGITAL FRAME STORE:** The audio signal from the receiver is stored in a large Dynamic RAM memory, which then drives the monitor to provide a continuous display.
- 6. VIDEO MONITOR:** A high quality black-and-white monitor, with 25MHz bandwidth, ideal for displaying this type of image with excellent definition.

The above items are all that are necessary to obtain first-class pictures from Meteosat.

**ALL FOR £1295 + VAT**

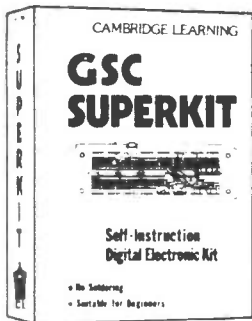
Individual items from the above system are also available.

**Write or phone for further details**

**MICROWAVE MODULES**  
BROOKFIELD DRIVE, AINTREE, LIVERPOOL L9 7AN, ENGLAND  
Telephone: 051-523 4011 Telex: 628608 MICRO G

# CAMBRIDGE LEARNING

## SELF-INSTRUCTION COURSES



### GSC SUPERKIT £19.90

Learn the wonders of digital electronics!

This practical kit for beginners comes complete with an instruction manual, components, and

EXP300 breadboard to teach you all the basics of digital electronics. The course needs no soldering iron; the only extra you need to buy is a 4½V battery.

Using the same board you can construct literally millions of different circuits.

The course teaches boolean logic, gating, R-S and J-K flipflops, shift registers, ripple counters, and half-adders.

It is supported by our theory courses

### DIGITAL COMPUTER LOGIC £7.00

which covers: basic computer logic; logical circuit elements; the design of circuits to carry out logical functions; flipflops and registers; and

### DIGITAL COMPUTER DESIGN £8.50

Our latest, most up-to-date course on the design of digital computers, both from their individual logic elements and from integrated circuits. You are first shown the way in which simple logic circuits operate and then, through a series of exercises, arrive at a design for a working machine.

Other courses available include:

MICROPROCESSORS & MICROELECTRONICS @ £6.50  
COMPUTER PROGRAMMING IN BASIC @ £11.50

**GUARANTEE** No risk to you. If you are not completely satisfied, your money will be refunded upon return of the item in good condition within 28 days of receipt.

CAMBRIDGE LEARNING LIMITED, UNIT 159 RIVERMILL SITE, FREEPOST, ST IVES, CAMBS. PE17 4BR, ENGLAND. TELEPHONE: ST IVES 0280 67426. VAT No 313026022

All prices include worldwide postage (airmail is extra - please ask for prepayment invoice). Giro A/c No 2789159. Please allow 28 days for delivery in UK.



- .....SUPERKIT(S) @ £19.90
- .....DIGITAL COMPUTER DESIGN(S) @ £8.50
- .....DIGITAL COMPUTER LOGIC @ £7.00

I enclose a cheque/PO payable to Cambridge Learning Ltd for £..... (\*delete where applicable)

Please charge my:

\*Access / American Express / Barclaycard / Diners Club / Eurocard / Visa / Mastercharge / Trustcard

Expiry Date..... Credit Card No .....

Signature.....

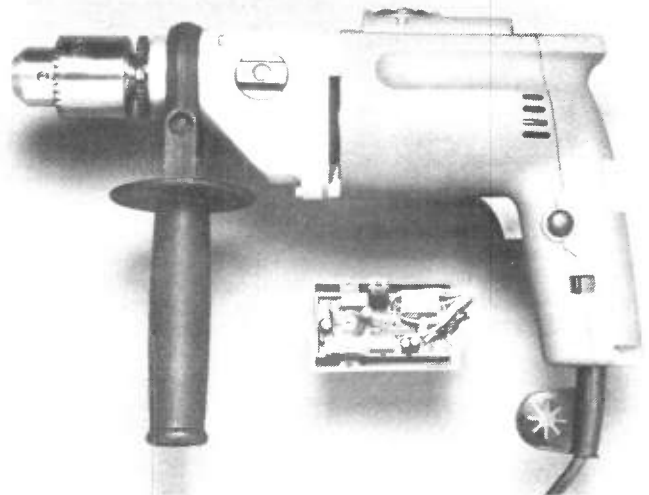
Telephone orders from card holders accepted on 0280 67426  
Overseas customers (including Eire) should send a bank draft in sterling drawn on a London bank, or quote credit card number.

Name.....

Address.....

Cambridge Learning Limited, Unit 159 Rivermill Site, FREEPOST, St Ives, Huntingdon, Cambs. PE17 4BR, England. (Registered in England No 1328762).

# NEW PRODUCTS



### Precision Speed Control

Ferranti Electronics has recently introduced the ZN411E which, with a minimum of external components, provides precise speed control for electric motors.

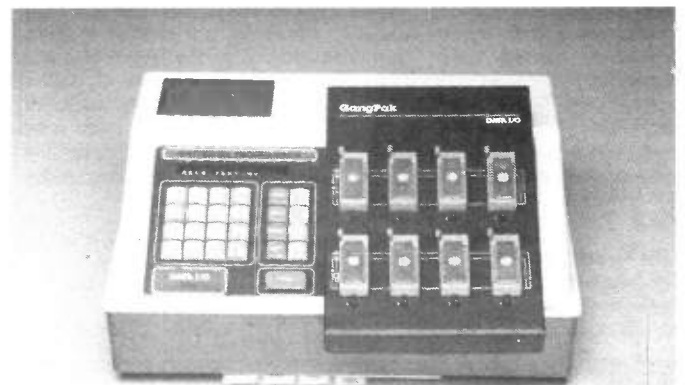
The ZN411 will operate from the AC mains or a suitable DC supply and has an on-chip shunt regulator. The circuit has a power down reset facility and 'soft start', whereby the speed builds up smoothly to the set speed.

The circuit produces negative triac firing pulses and has a triac retrigger facility. It can operate in an open or closed loop mode and the tachometer input is compatible with

Hall Effect devices. Full drive is available with inductive loads and a current limit is also included. A reversing input on the chip (when operated) will stop the motor, which then goes through the soft start to reach the speed set for the reverse direction. The speed is limited in the reverse direction.

The device is available in an 18 lead plastic package. Full details are available from:

*Ferranti Electronics Limited,  
Fields New Road,  
Chadderton,  
OLDHAM,  
Lancashire.*



### Gang Of Eight

A new Gang programming module is available from MSS (Microsystem Services), that will simultaneously program up to eight MOS PROMs, each with different data, in one operation. Known as the DATA I/O GangPak, the module will accommodate word widths of up to 64-bits, using an interface technique which enables a single word to be spread across several PROMs.

The new gang module, which is compatible with DATA I/O 29A and 100A universal programmers,

currently supports over forty industry standard 24 and 28-pin EPROMs and EEPROMs, using programming algorithms approved by each memory device manufacturer. Devices handled include the new single voltage EEPROMs, 16K x 8-bit EPROMs and 32K x 8-bit EPROMs. The machine will also read electronic signatures from JEDEC compatible 28-pin devices.

The ability to program a complete set of PROMs simultaneously, saves time by eliminating the need for separate

down-loading and programming operations. Data down-loaded from a host development system is automatically partitioned into the appropriate data blocks by the GangPak.

The GangPak further reduces programming time by employing the latest intelligent algorithms, which eliminate redundant programming pulses by checking memory cells after each pulse to see if they have been programmed.

The GangPak is completely software controlled and is configured for a particular device by a four-digit code.

A comprehensive range of test procedures is automatically carried

out by the module, including identification of devices which have been plugged into the wrong socket, illegal bit checks, blank checks and two pass verification ensuring the device is correctly programmed.

Further information on the GangPak module and all other DATA I/O programmers and modules is available from:

MSS,  
PO Box 37,  
Lincoln Road,  
Cressle Industrial Estate,  
HIGH WYCOMBE,  
Bucks.

### Pairs Of Trios

House of Instruments announce the first group in a brand new range of oscilloscopes from Trio. CS-1010, CS-1012, CS-1020 and CS-1022 are 10 MHz single and dual trace and 20MHz single and dual trace respectively.

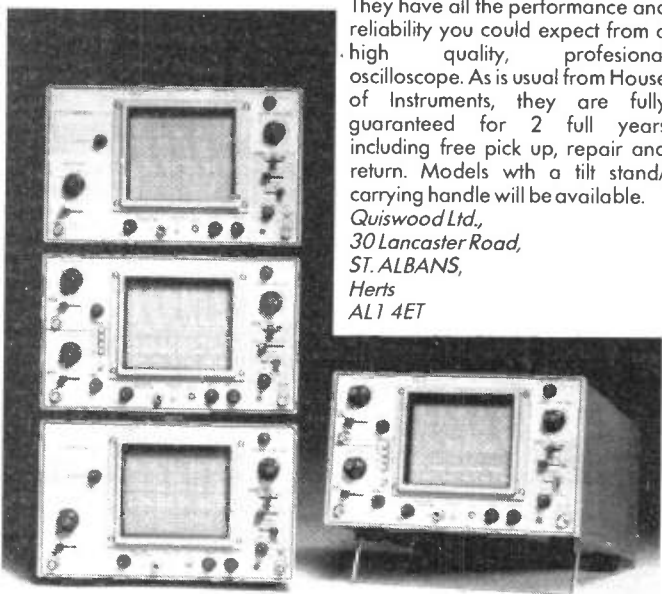
The new range have large 6 inch rectangular CRTs with illuminated inner-face graticule and high accelerator potential. This ensures a bright display with high resolution, eliminating parallax reading errors, easing waveform observation and aiding photographic recording.

Each model has extremely high input sensitivity of 1mV/cm, continuously variable to 5V/cm. 1mV/cm is particularly valuable in conjunction with the 20 nsec/cm to 0.5 sec/cm sweep speed for observing, in detail, complex low level and fast changing waveforms including video, digital, pulse and audio signals.

Some of the many features included as standard are: push button control of Ch 1, Ch 2, Add, Diff, Alternate and Chop MODES - front panel control of astig, trace rotate, scale illumination, focus, intensity and probe adjust - Ch 1 output and intensity modulation - auto, normal, X-Y and ext trigger modes - switchable Ch 1, Ch 2, line and ext SOURCE modes plus V MODE, in which the sweep trigger source is automatically selected by the vertical axis mode, particularly useful in alternate mode, since each channel input becomes its own trigger source - trigger level and slope selection - AC and video coupling with a new video sync circuit providing video clamping to enable quick sync of both vertical and horizontal circuitry and provides an amazingly stable sync.

These full feature oscilloscopes measure 260(W) x 160(H) x 400(D)mm and weigh from 8.1kg. They have all the performance and reliability you could expect from a high quality, professional oscilloscope. As is usual from House of Instruments, they are fully guaranteed for 2 full years including free pick up, repair and return. Models with a tilt stand/carrying handle will be available.

Quiswood Ltd.,  
30 Lancaster Road,  
ST. ALBANS,  
Herts  
AL1 4ET



# AUDIO ELECTRONICS

CALL IN AND SEE FOR YOURSELF      ALL PRICES INCLUDE VAT

---

## TEST EQUIPMENT CENTRES

ALL MODELS ON DISPLAY    OPEN SIX DAYS A WEEK

---

RETAIL • MAIL ORDER • EXPORT • INDUSTRIAL • EDUCATIONAL

### DIGITAL MULTIMETERS (UK C/P Free)

ALL MODELS 3 1/2 DIGIT UNLESS STATED

<b>HAND HELD</b>	■ With free carry case	<b>Beckman T110 As T100 plus Cont. test.</b>	<b>£67.85</b>
K025C=13 range 0.2A DC 2 meg ohm	£24.95	Sifam 2200B 21 range 2A AC/DC 20 meg ohm	<b>£39.95</b>
K030S=16 range 10A DC 2 meg ohm	£29.95	+Optional carry case £2.95	
K030C=26 range 1A AC/DC 20 meg ohm	£34.95	<b>BENCH MODELS</b>	
K055C=28 range 10A AC/DC 20 meg ohm	£39.95	TM355=27 range LCO 2A AC/DC	<b>£86.25</b>
6010+ 28 range 10A AC/DC 20 meg ohm	£34.40	TM355=29 range LEO 10A AC/DC	<b>£86.25</b>
7030+ As 6010 but 0.1% basic.	£41.30	TM351+ 29 range LCO 10A AC/DC	<b>£113.85</b>
K0615=16 range 10A DC 2 meg plus Hfe tester	£39.95	+Optional carry case £6.84	
189M 30 range 10A AC/DC 20 meg plus Hfe tester	£69.95	2001 28 range LCO 10A AC/DC plus 5 range Cap. Meter with case	<b>£108.00</b>
HB30 16 range 0.2A AC/DC 2 meg ohm	£41.95	TM451 4 1/2 digit LCO every facility (0.02% a)	<b>£171.00</b>
HB30/B As above plus cont. buzzer	£44.50	1503A 4 1/2 digit LCO every facility (0.05% a)	<b>£171.00</b>
HB31 22 range 10 AC/DC 2 meg ohms plus cont. buzzer	£58.95	1503HA 0.03% basic version of above	<b>£189.00</b>
DM2350 = 21 range 10A AC/DC 20 meg ohm miniature hand held auto range	£49.95	1504 true RMS version	<b>£201.25</b>
Beckman T10034 range 10A AC/DC 20 meg ohm	£56.35	Sifam 2500 24 range LCO 2A AC/DC	<b>£99.95</b>
		Metrix (ITT) professional 3 1/2 + 4 1/2 digit DMM's standard & true. RMS 4 models stocked	<b>£77.00 - £201.25</b>

### FREQUENCY COUNTERS

PFM200A 10MHz hand held pocket 8 digit LED	£77.60
8110A 8 digit LED bench 2 ranges 100 MHz	£77.00
8610B 9 digit LED bench 2 ranges 800 MHz	£113.85
8000B 9 digit LED 3 ranges 1 GHz	£178.00
TF040 = 8 digit LCO 40 MHz	£126.50
TF200 = 8 digit LCO 200 MHz	£166.75
■ Optional carry case £6.84	
<b>Prescalers</b> - extended range of most counters	
TP600 600 MHz	£43.00
TP1000 1 GHz	£74.00

---

### ELECTRONIC INSULATION TESTER

YF 501 500 V/0-100m with carry case    **£63.00**

### MULTIMETERS (UK C/P 65p)

HM102Z 20K/V 10A DC 22 range & cont. buzzer    **£13.50**

HM102Z 20 K/V 22 range & cont buzzer    **£14.95**

ETC5000/5001 21 ranges 50K/V Range doubler. 10A DC.    **£18.95**

TMK500 23 ranges 30K/V. 12A DC plus cont. buzzer.    **£24.75**

NH56R 20K/V 22 range pocket    **£10.95**

ETU 102 14 range 2K/V pocket    **£6.50**

830A 26 range 30K/V. 10A AC/DC overload protection, etc    **£23.95**

360TR 23 range 100K/V. Large scale 10A AC/DC plus Hfe    **£39.95**

AT1020 18 range 20K/V. Deluxe plus Hfe tester    **£18.95**

YN 360TR 19 range 20K/V plus Hfe tester / Metrix Professional multimeters in stock 3 models from    **£74.75**

### SIGNAL GENERATORS (220/240V AC)

**FUNCTION** : All sine/square/triangle/T.L. etc **TG100** 1 Hz - 100 KHz **£90.00**

**TG102** 0.2 Hz - 2 MHz **£166.75**

**PULSE**

**TG105** Various facilities 5 Hz - 5 MHz **£97.75**

**AUDIO** : Multiband Sine/Square

**LAG27** 10 Hz to 1 MHz **£90.85**

**AG20A** 20 Hz to 200 KHz (List £94.50) **£83.50**

**RF**

**SG402** 100 KHz to 30 MHz (List £79.50) **£69.50**

**LS617** 100 KHz to 150 MHz **£79.35**

---

### VARIABLE POWER SUPPLIES (UK C/P £1.00)

PP241 0/12/24V. 0/1A    **£35.00**

PP243 3 amp version    **£59.95**

PS 1307S 8/15V 7 amp twin meter    **£24.95**

### DIGITAL THERMOMETER

TH301 LCO -50 C to +750 with thermocouple    **£68.43**

---

### AC CLAMPMETER

ST300 0/300A: 0/600 VAC. 0/1 Kohm 9 ranges With carry case (UK C/P 65p)    **£28.50**

### DIGITAL CAPACITANCE METER

0.1 pf to 2000 mfd LCO 8 ranges **DM6013**    **£52.75** (Carry case £2.95)

---

### LOGIC PROBES

LP10 10 MHz    **£28.50**

DLP50 50 MHz with carry case and accessories    **£52.33**

### TRANSISTOR TESTER

Direct reading PNP: NPN. etc. **TC1** (UK C/P 65p)    **£21.95**

---

# AUDIO ELECTRONICS

Cubegate Limited

301 EDGWARE ROAD, LONDON W2 1BN. TEL: 01-724 3564

ALSO AT HENRY'S RADIO,  
404/406 EDGWARE ROAD, LONDON, W2. TEL: 01-724 0323

HENRY'S COMPONENT SHOP. TEL: 01-723 1008

Order by Post with CHEQUES/ACCESSES/ VISA or you can telephone our orders. All orders despatched within 5 days unless advised.

FREE CATALOGUE! SEND LARGE SAE (UK 20p)

ALL PRICES INCLUDE VAT

# AJH ELECTRONICS (G8AQN)

20 Barby Lane, Hillmorton, Rugby, Warwickshire CV22 5QJ  
Tel: Rugby (0788) 76473

## NEW! NEW! NEW!

**30 WATT 2 METRE LINEAR AMPLIFIER** in 'KIT' form, designed for use with the FT290R or any Tcvt with up to 3½ watts output. Minimum output 25 watts with 2½ watts drive, max. input 3½ watts. Suitable for SSB, FM, & CW. Built in Receive Pre-Amp giving 18dB gain from the popular 3SK88 mosfet. Fully RF switched or can be operated via Tcvrs PTT line. Supplied with ready drilled PCB size 82 x 90mm. Kit consists of all PCB components & 2 SO239 ae sockets FCB, 3 switches for ssb fm, Rx amp on/off, & power on/off, with all assembly instructions and circuit. The constructor will have to provide heat sink, case, & screws. Offered at the low introductory price of **ONLY £29.50**.

**MOTOROLA CAR CASSETTE PLAYERS** model 401 & BL512 etc, warranty returns and needing repair, supplied with circuit only **£5.00**.

### CRYSTAL FILTERS

**STC LQU/445/909B** 10.7 MHz ± 7½KHz BW @ 3dB. imp. 910 ohm. OK for FM, ex equip. **£4.00**.

**ITT024DE** 10.7 MHz ± 3½KHz BW imp. 810 ohm, new only **£6.00**.

**CATHODEON BP4133** 10.7 MHz for SSB 1sb only, imp. 200 ohm new **£5.00**.

**21.4 MHz ± 7½KHz BW @ 3dB OK FM**, imp. approx 2k ohm, new **£4.00**.

**TOYOCOM 6 MHz ± 6KHz BW @ 3dB OK FM**, imp 2k ohm ex-equip. **£3.00**.

**BOLT-IN FEEDTHROUGH CAPACITORS** 2BA size thread, 1000pf 500vw brand new and made for us by famous manufacturer, **ONLY 40p** each.  
Solder-in type 1000pf 500vw 3.2mm hole 50p per 10.

**3SK88 DUAL-GATE MOSFET** ideal replacement for most 2mtr Tcvt front ends only 1.1dB noise figure 26dB gain, also OK for 70cms. **PRICE REDUCED £1.00** two for **£1.75**.  
**3SK87** same as above but approx 3dB more gain. **£1.00** each.

**TRIMMER CAPS**, Airspaced 9mm sq. 15pf 20p ea. 30pf 35p. ea. solder in tubular ceramic 1-6pf 75p per 10.

**FILM TRIMMERS** all 10mm dia. 25pf 10p ea. 32pf 12p ea. 60pf (Dau) 20p ea. 7mm sq 1-10pf 12p.

**CERAMIC COMPRESSION TYPE** 10-40pf pc type 12p ea. 10-80pf pc type OK 2mtr PA up to 40 watts 15p.

**LOW PROFILE RELAY** OK for 2mtr AE switching will handle up to 75 watts 12v coil 2pco contacts **£3.00**.

**10.7 MHz CRYSTAL HC18/U** OK for FM detector IC etc. **£1.50**.

**TDA1010 9 WATT AUDIO IC** 9 pin sil. 12v with data **£1.75**.

**TF144H/4S MARCONI SIGNAL GENERATOR (AM)** 10Hz to 72MHz in 8 switched bands calibrated output 2µV to 2V into 50 ohms. modulation adjustable to 80%, internal crystal calibrator, in very good condition fully checked **£85.00** buyer to collect by arrangement.

**TF1066B/1 SIGNAL GENERATOR AM** FM 10-480 MHz mint condition **P.O.A.**

**TF8010/8S AM SIGNAL GENERATOR** 10-480 MHz mint **P.O.A.**

**S121 WAYNE KERR AUDIO GENERATOR** 10Hz to 120KHz in 11 switched bands output 0-30 volts into 600 ohm. plus high imp. output, valve type mains operated, tested and in good condition with copy of manual **ONLY £30.00** buyer to collect by arrangement.

**SEND FOR LATEST LIST OF COMPONENTS & TEST EQUIPMENT** at give away prices.

Please add 60p for post and packing, all goods where possible are sent by return of post. Callers only by appointment please. All prices include VAT at 15%.

# NEW PRODUCTS



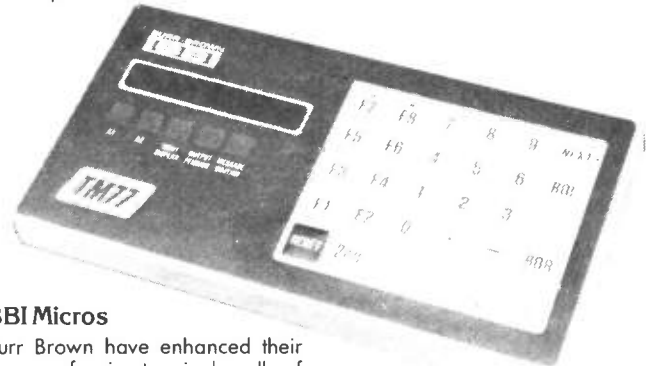
## 'Concept' Audio

Panasonic is about to set a new trend in one-piece audio, with the launch of the new SG-X10, a three-in-one system (turntable, cassette deck and tuner) including speakers. Competitively priced at around £120, the SG-X10 is set to appeal to music enthusiasts of all ages.

The SG-X10 combines sound quality with futuristic styling. The turntable section features an unusual, recessed sloping observation window in the dustcover and a unique drawer-type, auto-stop cassette deck which slides in and out and can be played in either position.

It is not only design, however, which gives the Panasonic SG-X10 its universal appeal. It also offers impressive technical specifications for the price. Power output is 10 watts per channel and the amplifier section features slide controls (tone, volume and balance) and auto-source selection with five LED indicators for instant reference to audio function.

Compact in size (375W x 136H x 327Dmm) the SG-X10 comes in matt black finish and includes a pair of full range bass reflex speakers. It is available through Panasonic's network of authorised dealers.



## BBI Micros

Burr Brown have enhanced their range of microterminals, all of which can now be supplied for operation over the extended temperature range of -25 to +85°C. In addition the TM71 and TM77 is now available with an RS422 serial interface.

The RS422 interface available on the TM71 and TM77 increases the number of applications for which the microterminals can be used. RS422, which is fast becoming the industry standard for serial digital communications, allows up to 99 microterminals to be multi-dropped on the same loop over distances of up to 1.5km. Communications between host computer and microterminal is in

serial ASCII at baud rates selectable between 300 and 18,200 baud.

Burr-Brown's microterminals are compact (216 x 114 x 15mm), can be easily mounted on any flat surface and provide a simple means of communicating with a computer or process control system. There is a choice of hexadecimal, decimal and alphanumeric keypads and 8, 12 or 16 character displays. One model even has a bar code reader. Most of the terminals also have LED status indicators which are controlled by the remote computer.

## Take Your Pick

Burr-Brown has introduced a new low-power monolithic operational amplifier that has a pair of independent differential inputs and a single output. Known as the OPA

201 Switchable Input Operational Amplifier (SWOP AMP), it allows either of the precision input stages to be connected to the output stage under control of an external TTL channel select signal. Drawing less than 500µA from a ±2.5V to



# magpie

## THE AUTOSCAN 5000 IS UNIQUE

IT'S PROBABLY THE ONLY SCANNING CB RIG IN BRITAIN TODAY - AND BRITISH DESIGNED AND BUILT TOO.

THIS IS THE START OF A NEW GENERATION OF QUALITY RIGS AND HAS ALREADY RECEIVED WIDE ACCLAIM FROM USERS AND REVIEWERS ALIKE - FAR OUTCLASSING OTHER PRODUCTS IN DESIGN, PERFORMANCE AND LOOKS.

IF YOU ARE A SERIOUS BREAKER YOU WILL BE CURIOUS ABOUT THE AUTOSCAN 5000. FIND OUT MORE FOR YOURSELF AND HOW YOU CAN TRY ONE BY WRITING FOR OUR BROCHURE TO THE MANUFACTURERS:

MAGPIE ELECTRONICS LTD., FREEPOST, ANDOVER, HANTS.

SP10 2BR (NO STAMP NEEDED) OR TEL: 0264 66361



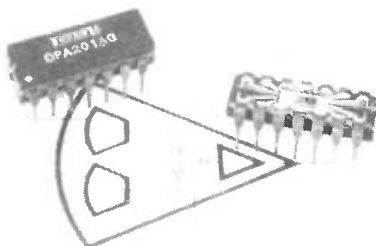
±18V power supply, the OPA 201 is ideally suited for use in battery powered equipment.

Both of the input stages have excellent characteristics, including a low offset voltage of 100µV maximum, a voltage drift against

temperature of only 1µV/°C maximum and a low 25nA maximum bias current.

The combination of low power consumption and good performance suit this unusual operational amplifier for use in auto-zero systems, variable gain two-channel multiplexers, switchable input instrumentation amplifiers and other systems.

*Burr-Brown International Limited,  
Cassiobury House,  
11-19 Station Road,  
WATFORD,  
Herts  
WD1 1EA*



### Series Of Designs

Pye Telecom's newly launched range of frequency-synthesised mobile radios offers up to 250 channels. Designated the MX 290 series, Pye has developed a new generation of advanced multi-channel mobile radios with the widest choice of options and facilities which enable systems to be tailored to users' requirements from a range of standard products.

The series features a completely new concept in mobile communications – a direct dialling facility, in both directions, that provides fully automatic interconnection from mobile to mobile and from mobile to radio to PABx telephone subscribers. This facility is provided by Pye's E31 signalling module with its plug-in control panel that mounts onto a standard variant of the mobile.

Microprocessor and CMOS circuits are used for optimum performance and high reliability and the series features keypad entry and the display of the selected subscriber's number. Optional features include mini-trunking with automatic voting, automatic paging and shortform dialling.

The heart of this new range of sophisticated transceivers is the frequency synthesiser, which eliminates the need for channel

crystals. The only crystals in the set are the high stability reference and receiver's second oscillator crystals. Fast customer frequency programming is achieved by means of a plug-in programmable read-only memory (PROM).

Available in all standard AM and FM bands on VHF and UHF, the MX 290 series is constructed from a zinc alloy chassis which forms a rigid die-cast frame with a finned heatsink and die-cast covers. The choice of plug-in control panels means users can upgrade or modify their existing equipment to suit changing system requirements. A series of plug-in signalling modules is also available, offering tone-lock and 6-tone sequential or digital signalling.

The carrier level detector provides signal strength information to the signalling units, which enables them to execute the correct system response or to select the optimum base station when used in trunking applications. Broad band characteristics allow wide frequency separation in multi-channel systems. Transmitter power output is 10, 15 or 25 watts depending on the frequency band or the type of modulation.

*Pye Telecommunications Ltd,  
St. Andrews Road,  
CAMBRIDGE  
CB4 1DW*



## GAREX (G3ZV1) SX200-N

THE  
SUPREME  
SCANNER



### COMPARE THESE FEATURES

- \* SPECIALLY DESIGNED FOR EUROPEAN MARKET
- \* MICROPROCESSOR CONTROLLED 32,000 CHANNELS
- \* AM & FM ALL BANDS
- \* WIDER COVERAGE: 26-58, 58-88, 108-180, 380-514MHz; includes 10m, 4m, 2m & 70cm Amateur bands.
- \* 5kHz & 12½kHz FREQUENCY INCREMENTS
- \* 16 MEMORY CHANNELS WITH DIRECT ACCESS
- \* 2 SPEED SCAN/SCAN DELAY CONTROL
- \* 2 SPEED SEARCH UP AND DOWN
- \* SEARCH BETWEEN PRESET LIMITS UP AND DOWN
- \* 3 SQUELCH MODES inc. CARRIER & AUDIO
- \* RELAY OUTPUT FOR Aux. CONTROL
- \* INTERNAL SPEAKER
- \* EXTERNAL SPEAKER & TAPE OUTPUTS
- \* LARGE GREEN DIGITRON DISPLAY BRIGHT/DIM
- \* AM-PM CLOCK DISPLAY
- \* 12V DC, 230V AC OPERATION
- \* 12 MONTH WARRANTY FACTORY-BACKED SPARES & 'KNOW-HOW' AND THE ALL-IMPORTANT PRE-DELIVERY CHECK BY GAREX THE

MAIN SERVICE & SALES AGENTS £299.00 inc VAT Delivered

**\*NEW\***      **\* REVCONE \***      **\*NEW\***  
A new top quality 16-element, all British made, VHF/UHF broadband fixed station aerial from Revco. Ideally suited to SX200 and other VHF/UHF Receivers.  
**PRICE £24.95 inc**

SR-9 monitor: 2m FM with 144-146 MHz full coverage VFO + 11 xtal controlled channels; ideal for fixed, /M, /P use. 12V DC operation £47.50 Marine Band SR-9, 156-162MHz, same spec. and price.

CRYSTALS FOR NR-56, SR-9, SR-11, HF-12, TM-56B All 2m channels from O(145.00) to 33(145.825). Also 144.80, 144.825, 144.85 Raynet at £2.46 (+20p post per order). Over 40 popular marine channels at £2.85 (+20p post).

RESISTOR KITS a top-selling line for many years. E12 series, 5% carbon film, 10Ω to 1M, 61 values, general purpose rating ¼W or ½W (state which)

Starter pack 5 each value (305 pieces)      £ 3.10  
Standard pack 10 each value (610 pieces)      £ 5.55  
Mixed pack, 5 each ¼W + ½W (610 pieces)      £ 5.55  
Giant pack, 25 each value (1525 pieces)      £13.60

NICAD RECHARGEABLES physically as dry cell: AA(U7) £1.30;

CU(U11) £3.35; PP3 £5.55. Any 5+: less 10%, any 10+: less 20%.

CRYSTAL FILTER 10.7MHz, 12½kHz spacing, ITT 901C £6.90  
10.7MHz, 25kHz spacing, type 914B or 909B £6.90

HT TRANSFORMER multi-tap mains pri., 5 secs: 35V 200mA, 115V 150mA, 50V 500mA, 150V 300mA, 220V 300mA £5.50

PYE RADIOTELEPHONE SPARES (s.a.e. full list) Ex. equip., fully guaranteed. Cambridge AM10

10.7MHz I.F. £3.65 2nd mixer £3 455KHz block filter 12½KHz

£9.40 ditto 25KHz £3. 455KHz AM IF £4.95 Audio bd. £1.95

WESTMINSTER W15/W30 AM Rx RF 68-88MHz or 148-174MHz

£6.95 10.7MHz IF (inc. 12½KHz xtal. filter) £8.25 2nd Osc £2.10

455KHz IF £5.65 455KHz block filter (12½KHz) £7.35 Squelch

£1.45 QZ06-40a (quick-heat) RF tested £1.95 Aerial relays £1.50

PYE SPARES ARE OUR SPECIALITY

COMPLETE UNITS ALSO AVAILABLE

GAREX FM DETECTOR and squelch conversion for Pye R/T equipment Ready assembled, full instructions. Tailor-made, easy-fit design, replaces existing squelch board, with minimum of modifications. For AM Cambridge £6.30; for Vanguard AM25B (Valve RX) £6.10; for Transistor Vanguard AM25T £6.95

MAIN DISTRIBUTOR OF REVCO AERIALS & SPECIAL PRODUCTS (trade enquiries welcome)



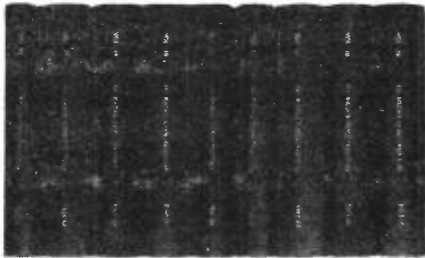
PRICES INCLUDE UK P&P and 15% VAT



GAREX ELECTRONICS

7 NORVIC ROAD, MARSWORTH, TRING, HERTS HP23 4LS  
Phone 0296 668684. Callers by appointment only.

## BARGAIN OFFER ANNUAL BOUND VOLUMES RADIO & ELECTRONICS CONSTRUCTOR



Each of these handsome bound volumes contain more than 150 practical articles in their 700-800 pages of text, published in 12 monthly issues of R&EC.

12 monthly issues to August 1978 (Vol. 31), 1979 (Vol. 32), 1980 (Vol. 33).

\* **Volume 33** contains Ian Sinclair's Databus Series — **How Microprocessors Work** Selection & Bussing, CPU Registers; Addressing Memory The Accumulator; Inputs & Outputs; Interrupts; Status Register; Signed Binary Arithmetic; Computing Languages.

**ONLY £4.95 each inclusive of post and packing.**

Subjects cover - Amplifiers, Amplifier Ancillaries, Calculators, Electronics, 'In Your Workshop', Receivers, Receiver Ancillaries, Television, Test Equipment etc. etc.

12 monthly issues to July 1974 (Vol. 27), 1975 (Vol. 28), 1976 (Vol. 29), (VOL. 30, SOLD OUT)

**ONLY £3.95 each inclusive of post and packing.**

Please send remittance payable to 'RADIO & ELECTRONICS WORLD' stating volumes required to:—

**DATA PUBLICATIONS**  
45, Yeading Avenue,  
RAYNERS LANE, HARROW  
Middlesex HA2 9RL

**PHOTO TECHNICS** for precision photographic services, artwork reduction, step and repeats, accurate secondary masters and drawing restorations. Complete circuit design and layout. Telephone: Paignton (0803) 559595.

**FOR SALE** HF Spectrum analyser in good condition. Offers invited. Telephone: New Mills (Derbyshire) 44971.

**TRIO R1000 RECEIVER**, 200kHz-30MHz. Digital readout. Mint condition. £200. Buyer collects. Phone: Cleveleys 823073.

**SHORT WAVE, CITIZENS BAND, AM-FM** Telecommunications supplies and accessories agents. Catalogue £1.50. Payable to: Communications Supplies/Accessories, 27 Ferndale, Teversham, Cambridge, CB1 5AL.

**ZX81 EPROM PROGRAMMER.** Program, copy, verify, List-2516, 2716, 2532, 2732 type eproms. Uses simple peek and poke commands. Copies and checks 4096 bytes in 430 seconds. Also enables user to run 8k of eprom based software. Fully built, boxed and guaranteed with software and instructions. £75 + £1 p&p. SAE for details to: JC Barker, 26 Topcliffe Mews, Morley Yorkshire, LS27 8UL.

**AIRCRAFT COMMUNICATIONS HANDBOOK.** (UK/Europe) including spot MF, HF, VHF, UHF frequencies, Military & Civil airports, air traffic control centres, long range stations, meteorological broadcasts, broadcast times, navigation beacons, co-ordinates, call signs, maps, etc. £7.50. p&p £1. PLH ELECTRONICS, 70 Vallis Road, Frome, Somerset, BA11 3EJ.

**AMATEUR ANTENNA** Silver 70-70cms 16dbd Gain Beam £31.95. Tiger LY6 9 dbd 2 Metre Beam £12.95. Tiger LY8 11 dbd 2 Metre Beam £19.50. Tiger LY10 14 dbd 2 Metre Beam £32.95. Two Year Guarantee on Above. ZL12 Mk2 13 dbd Gain Beam Antenna £32.95. ZL8 Mk 2 9 dbd Gain 5'-7" Long Boom £19.95. All above have Stainless Steel Parasitic Elements. Norcone 512 Wide Band Discone Antenna £25.95. Securicor Delivery (Extra) £4.50. Send cheque or money order today, made payable to ANT PRODUCTS or write enclosing SAE for full details. **Ant Products, All Saints Industrial Estate, Baghill Lane, Pontefract, West Yorkshire. Tel: 0977 700949.**

**AC LINEAR CIRCUIT ANALYSIS PROGRAMS** for Sinclair Spectrum (48K), BBC Model B and Grundy New-Brain microcomputers. Analyses circuits with up to 16 nodes and 60 components. Very easy to use. Cassette £35. To order — send cheque or telephone your name, address and Access or Visa number. Number One Systems, 9A Crown Street, St. Ives, Huntingdon, Cambs. Tel: St. Ives (0480) 61778 (24 hour answering).

**SAVE IT!!!** Save £££s when you buy our superb bargain box of assorted full spec. components. ALL NEW guaranteed at least 500 items for only £8.50 inclusive. Please allow up to 28 days for delivery. Fullers Supplies, 22 Verder Grove, Heronridge, Nottingham, NG5 9BH.

**CONVERT ANY TV** into large screen oscilloscope. External unit plugs into aerial socket of any TV. Uses approx £12 of easily obtainable components. Circuit & Plans £3. J. Bobker, 29 Chadderton Drive, Unsworth, Bury, Lancs.

**007 SPY.** Lets you stop and copy any Spectrum cassette. One cassette £3. Bobker, 29 Chadderton Drive, Unsworth, Bury, Lancs.

**OSCILSCOPE TUBES** (C.R.T.'s only). Dual beam. In G.E.C., Centronic makers cartons. Bargain £25 each. Ten £200. Postage extra. Phone: 0203-463999.

**LIST-A-RIG.** A service offered by G3RCQ Electronics to introduce buyers and sellers of used amateur equipment. Buying? It's free, just send an s.a.e. Selling/Wanted? Send s.a.e. for details on how to join the fast-growing list. List-a-rig is sent and updated daily; no waiting, no deadlines. LIST-A-RIG (REW) 65 Cecil Avenue, Hornchurch, Essex, RM11 2NA.

**RADIO AUSTRALIA,** Peking, Canada, Voice of America. A Vega 206 (6 x SW/MW/LW) pulls these and dozens more. £23.45. Year's guarantee. Return despatch. Radiowatch, Building 109, Prestwick Airport, KA9 2RT.

**ZILOG Z8000 DEVELOPMENT MODULE** Cost £1350. Will accept offers near half price. Phone: 01-794-7024.

**SCARBOROUGH.** Derwent Radio for Communications receivers, new, second hand. Good trade-in. Thousands of components, books, magazines. 5 Columbus Ravine, Scarborough. Tel: 0723-65996.

## CLASSIFIED ADVERTISEMENTS

Advertisements must be prepaid and all copy must be received by the 4th of the month for insertion in the following month's issue. The Publishers cannot be held liable in any way for printing errors or omissions, nor can they accept responsibility for the **bona fides** of Advertisers.

Underline words required in **Bold** type. Your name, address, and/or telephone number, if to appear, must be paid for. Telephone numbers count as two words. Please use **BLOCK CAPITALS**. Advertisements are accepted on the understanding that the details stated comply with the conditions of the Trade Description Act, 1968. — Cancellations must be notified by telephone or in writing by the 6th of the month preceding publication. Replies to Box Numbers should be addressed to: Box No. - **RADIO and ELECTRONICS WORLD**.

Where advertisements offer any equipment of a transmitting nature, readers are reminded that a licence is normally required. **Rate: 12p per word. Minimum charge £2.00** **Box No. 30p extra**

Send your copy to **RADIO & ELECTRONICS WORLD, Classified Ads., 45 Yeading Avenue, Rayners Lane, HARROW, Middlesex. Tel: 01-868-4854.**

**FOR SALE.** Pair Hi-Fi stereo headphones, Howland West Audio CIS-550. £10.00 o.n.o. Box No. 36.

**SUSSEX MOBILE RALLY.** A day by the sea with the family for £1. Brighton raceground. 17th July 10.30am—5.00pm. Free car parking. Good catering. Under cover.

**NATIONAL PANASONIC.** Auto stop stereo cassette deck RS-260USD. £35.00 o.n.o. Box No. 37.

**DIGITAL WATCH REPLACEMENT PARTS.** Batteries, displays, backlights, etc. Also reports, publications, charts, S.A.E. for full list. Profords, Copners Drive, Holmer Green, Bucks. HP15 65GF.

**ZX81 & SPECTRUM SOFTWARE.** Q.R.A. Distance/Bearing and Log. Complete with full contest score, graphic map of both Southern & Northern Europe all on one programme, only £4.95 inc. P&P Alan Parrott, 72 Godstone Road, Kenley, Surrey, CR2 5AA.

**INTRODUCTORY OFFER:** Solid state relay 240V AC @ 25 amps. List price £14.95. Our price £2.95 or 2 for £5.00. 150 top quality IC's in manufacturers tubes (complete with data) plus 10 red LED's and 2 opto-isolator IC's (worth £2.50 alone) for only £6.00. Prices include VAT and UK postage and a copy of our 50 page catalogue No.20, packed with thousands of mechanical and electronic bargains. J.A. Crew & Co., Spinney Lane, Aspley Guise, Milton Keynes, MK17 8JT.

## Take me to your Newsagent!

Newsagents often run out of copies of **R&EW** simply because it is the best value for money electronics magazine around. To make sure you don't miss a single issue, why not fill out the coupon and your newsagent will reserve a copy of every month's magazine ready for you to pick up at your leisure. Fill out the coupon **NOW** and drop it in when you pick up your morning paper.

**NEWSAGENT:** Please reserve me a copy of the **JUNE 1983**  
**RADIO & ELECTRONICS WORLD**  
and every succeeding issue until further notice.

NAME: .....  
ADDRESS: .....  
.....

## Back Numbers

Back issues of **R&EW** are available from: **R&EW Back Numbers Dept., 45, Yeading Avenue, Rayners Lane, HARROW, Middlesex HA2 9RL. Tel: 01 - 868 - 4854** All issues, with the exception of January 1982, are still available. All orders must be prepaid, the cost of each issue being **£1.00** inclusive of postage and packing. Photocopies of specific articles can be provided. The month(s) in which the article appeared must be stated. Due to the high staffing costs involved in providing this service we regret that we must charge **£1.00** per article. Again, all orders must be prepaid.

Overseas Agents: **Holland Electronics, 071 - 218822. Postbus 377, 2300 A. J. Leiden.**  
**U.S. Project Pack Agents, Box 411, Grenville, New Hampshire, NH030408. U.S.A.**

## Subscriptions

If you want to be sure of getting your copy of Britain's most informative Radio/Electronics magazine, **PLAY SAFE & SUBSCRIBE.**

Fill in the form below and send to: **R&EW Subscription Dept., 45, Yeading Avenue, Rayners Lane, HARROW, Middlesex. HA2 9RL. Tel: 01 - 868 - 4854**

I would like to subscribe to **Radio & Electronics World** for a year (12 issues). Please start my subscription from the ..... issue.

<b>SUBSCRIPTION RATE</b>	<b>UK</b>	<b>£13.00 per 12 issues</b>
	<b>Overseas</b>	<b>£13.50 per 12 issues</b>

I enclose a cheque/postal order/International Money Order\* to the value of £.....

Please debit my Access/Barclaycard\* account No. ....

for my order of £.....

\*Delete as applicable.

Signature:.....

Please use **BLOCK CAPITALS** and include postal codes.

NAME (Mr/Mrs/Miss).....

ADDRESS.....

POST CODE.....

# Comment

It's been a while since Jon Burchell and I had the opportunity to take as much part in the production of an issue of R&EW as we would have liked - there's been a lot going on in the 'background' which has taken most of our time over the past year or so. One of the ways we can help ourselves is to apply as much technology to the production of the magazine as possible, so that at least we are not going to get bogged down in the minutiae of things like actually getting the words stuck down once they're written.

Now we are pleased to say that we have assembled the ultimate system, where text written on portable editing terminals can be 'delivered' and turned into made-up pages within the space of about 5 minutes.

Since we have to suffer leadtimes of as much as 5 weeks when submitting adverts to other magazines, we are rather smug about the completion of this very long term plan to improve the production efficiency of R&EW to be the best in the business. We hope that we can also persuade our advertisers to take advantage of this remarkably short time from submission of price information to publication under the noses of the customers.

## One Night Stands

We frequently get asked for some digestible features, without losing sight of the basic aim of R&EW to remain reasonably 'State of the Art'. We've been looking out for some concise communications oriented projects for a while, and so we kick off in this issue with the start of a series from Stephen Ibbs.

Perhaps this will also help remind you that we are always keen to receive submissions of all types - not simply the 'big' projects, but plenty of the One Nighters as well, please.

## This Issue

The personal computer phenomenon seems unstoppable. Every time anyone introduces a new personal computer, the trade gasps in astonishment that the market seems able to support an almost infinite number of mouths. The latest such blockbuster is the Oric, which neatly and roundly upstages the Spectrum and also gives the BBC micros a run for their money.

However, if you read our review of the Epson HX20 earlier this year, you may recall that R&EW is rather keen on the concept of total portability, and also freedom from RFI. A fully CMOS computer with LCD and battery supply has to be a great deal more useful than the most sophisticated multi colour games playing machinery.

The complete lack of information from Epson about software availability has yet to be rectified, but meantime Tandy have saved us the trouble of bothering Epson any further, since the Tandy model 100 knocks all else into a reasonably cocked hat. At last we have the ideal 'users' computer, with enough of a display to be useful, and a range of built-in facilities that no longer insult the intelligence of the user.

It seems very likely that the Model 100 will actually overcome the legendary disinterest of the bulk of the amateur radio fraternity in computing matters, since here is a computer that provides completely portable RTTY, CW, AMTOR etc. facilities, can control transceiver functions, can help design your next homebrew project and can communicate with standard information services (like REWTEL, of course).

We'd like to think that the price tag won't be too much of a trauma. After all, it's the price of a good transceiver, and a great deal less weighty on the conscience if the 'welfare' of the wife and kids is likely to become a contentious point where pursuit of a hobby is concerned.

# Advertisers' Index

A.J.H. ELECTRONICS	86
AMBIT INTERNATIONAL	4,10,23,63,72
ARMON PRODUCTS	19
AUDIO ELECTRONICS	85
BINDIT	OBC
I. BIRKETT	63
BLACKSTAR	62
BNR&ES	39,49
BOOTH HOLDINGS BATH	82
BULGIN	37
CAMBRIDGE LEARNING	84
CAR-LINK COMMUNICATIONS	82
FREL LTD	23
GAREX	87
GOULD	81
S. GREAVES	49
O.J. HOUSE	63
LEE ELECTRONICS	5
MAGPIE ELECTRONICS	86
MICROWAVE MODULES	83
McMICHAEL	63
NORTHAMPTON COMMUNICATIONS	39
POLEMARK	75
SELETRONIC	49
SOUNDEX	6
SOUTH MIDLAND COMMUNICATIONS	IBC
TELECOMMS	IFC
TIME ELECTRONICS	75
WOOD & DOUGLAS	83

PUBLISHED BY BROADCASTING LIMITED © 1983  
 Subscription INLAND £13.00 OVERSEAS £13.50 Printed in England by LSG Printers Lincoln  
 Distributed by SM Distribution London SW9

All reasonable precautions are taken by R&EW to ensure that the information given to our readers is reliable. However we cannot guarantee it nor accept legal responsibility for it. Information and prices are correct at time of going to press. Reproduction of contents is possible with permission from the Editor. However short abstracts or references are allowable providing the source is given.

# South Midlands Communications Ltd

## FOR ALL YOUR COMMUNICATIONS REQUIREMENTS



**AMATEUR**



**HF. SSB TRANSCEIVERS**

**AMATEUR VHF/UHF**



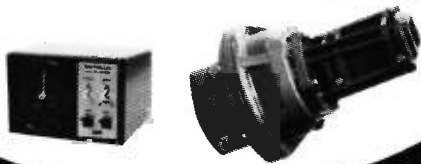
**MOBILE FIXED PORTABLE TRANSCEIVERS**

**HF GENERAL COVERAGE**



**TRANSCEIVERS**

**ANTENNA ROTATORS**



**MORSE KEYS**



**MK 706**

**HK808**



**COMMERCIAL**



**HF. SSB TRANSCEIVER**

**ANTENNAS MASTS & TOWERS**



**COMMUNICATIONS**



**RECEIVERS**

**H O APPROVED**



**P M R RADIO**

**MARINE RADIOS**

**HEAD OFFICE:  
MAIL ORDER:  
EXPORT ENQUIRIES:**

**S.M. HOUSE, RUMBRIDGE STREET, TOTTON, SOUTHAMPTON, SO4 4DP, ENGLAND.  
Tel: Totton (0703) 867333, Telex: 477351 SMCOMM G, Telegram: "Aerial" Southampton**

**SOUTHAMPTON**  
SMC Ltd  
36-38 Rumbidge Street  
Totton, Southampton  
Southampton (0703) 867333  
9-5.30 Mon-Sat

**LEEDS**  
SMC (Leeds)  
257 Otley Road  
Leeds 16, Yorkshire  
Leeds (0532) 782326  
9-5.30 Mon-Sat

**CHESTERFIELD**  
SMC (Jack Twendy) Ltd  
102 High Street  
New Whittington, Chesterfield  
Chesterfield (0246) 453340  
9-5 Tues-Sat

**BUCKLEY**  
SMC (TMP)  
Unit 27, Pinfold Lane  
Buckley, Clwyd  
Buckley (0244) 549563  
9.30-5.30 Tues-Sat

**STOKE**  
SMC (Stoke)  
76 High Street  
Tolke Pits, Stoke  
Kidsgrove (07816) 72644  
9-5.30 Tues-Sat

**GRIMSBY**  
SMC (Grimsby)  
247A Freeman Street  
Grimsby, Lincs  
Grimsby (0472) 59388  
9.30-5.30 Mon-Sat

**JERSEY**  
SMC (Jersey)  
1 Belmont Gardens  
St. Helier, Jersey  
Jersey (0634) 77067  
10-7 Mon-Sat



# History Repeats Itself!

Smartly bound, completely updated and revised, copies of R&EW projects.

Price  
**£1.20**  
each



### We've got them covered

- The Autobridge
- Lab Quality PSU
- 2m Power Amplifier
- Multiband Up Converter
- CB Selcall
- UOSAT receiver
- MSF clock.

We've been thinking of producing reprints of the most popular R&EW projects for some time now, but wanted to present them in an attractive fashion without making them too expensive.

When we saw the new Bindit machine we knew we had the answer.

R&EW Project Reprints are bound using the Bindit machine - completely updated and revised projects, perfectly bound between attractive covers.

We think that the Bindit System is such an effective way of collating documents that we feel many offices, schools, colleges etc., might like to know more about the system. For further information fill out the coupon below and send it to Epping Technical Associates Ltd., 94 Theydon Grove, Epping, Essex

Please send me further details of Bindit and accessories.

Name: .....

Address: .....

Postcode: .....

Make your cheques and postal orders payable to Radio & Electronics World clearly stating which reprints you would like (all previous articles from October issue onwards in complete form are available) and send your orders to:  
R&EW Project Reprints, 200 North Service Road, Brentwood, Essex, CM14 4SG.



Prices include VAT, postage and packing

