

THE UK'S BEST SELLING MAGAZINE FOR AMATEUR RADIO ENTHUSIASTS

AUGUST 1996 £2.20

# practical Wireless

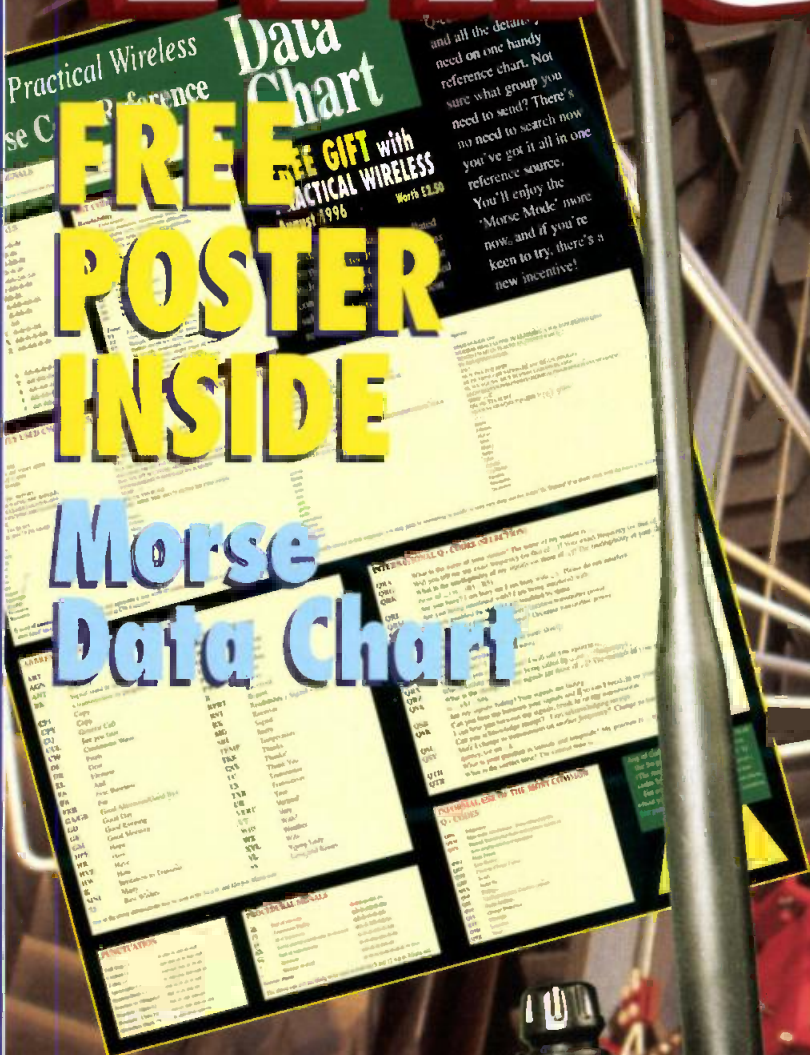

**FREE POSTER INSIDE**

**Morse Data Chart**

## The Kenwood Story -

The 'Lowe' Down on G3OQT's Japanese Prize Trip

### Build

- A Shack Alarm
- The Trolley mast

### Features

- Invisible Power - Hidden Power of The EMC Environment
- **New Series:** Carrying On The Practical Way

**YAESU FT-50R**



**REVIEWED**



Plus All Your Regular Favourites

**FREE READER'S ADS**

**NEW**

# Compact Dual Band Mobile FT-8000R

## Now, a dual band that's so advanced it's simple!



"So easy to operate, I didn't even need the manual!"

"High-tech features, too, like the enhanced Smart-Search™."



"Advanced performance, and simple to use. I knew Yaesu would be first with this."

"Yaesu did it again!"

Continuing Yaesu's leading edge engineering philosophy, the FT-8000R Compact Dual Band Mobile introduces industry-first features and no-nonsense operation for today's demanding Amateur. No puzzling key combinations on the FT-8000R: eight clearly marked keys and Yaesu's exclusive Omni-Glow™ display make operation a snap. Want to change bands? Just push the VHF or UHF Volume control!

The FT-8000R is the first mobile to provide superwide receiver coverage – from 110 to 550 MHz and 750 to 1300 MHz\*, receiving public safety, marine, and weather channels. Using Yaesu's exclusive Enhanced Smart Search™, the FT-8000R automatically seeks out and loads active simplex channels into up to 50 ESS memory channels in just seconds – ideal when traveling.

Built-to-last, the FT-8000R brings together the most-requested dual band features and a MIL-STD 810 rating for enduring performance. Dual receive (V+V, U+U or V+U), Crossband Repeat (bidirectional or one-way), up to 50 Watts of VHF power output (35 Watts on UHF) with High/Medium/Low selection on each band, and "plug and play" 1200 or 9600 bps packet are just a few.

Clearly a standout, the FT-8000R boasts 110 memory channels (55 per band including

one-touch "Home" channels) that store repeater shift, CTCSS encode tone, and packet baud rate. Other essential features include a Time Out Timer and an all-new S-Meter Squelch that opens based on the S-meter reading. Other options include a DTMF backlit microphone (another Yaesu first) and for a programming alternative, the ADMS-2C Personal Computer Programming Kit simplifies operation even more.

The FT-8000R is the most affordable, easiest-to-operate dual band mobile on the market today! Bring its high-tech performance features home with you. Available at your Yaesu dealer now!

## YAESU

...leading the way.<sup>SM</sup>

For the latest Yaesu news; hottest products, visit us on the Internet! <http://www.yaesu.com>

### Features

- Frequency Coverage  
RX: 110~550 MHz  
750~1300 MHz\*  
TX: 144~146 MHz  
430~450 MHz
  - 3 Power Output Levels  
2m 50/10/5 Watt  
70cm 35/10/5 Watt
  - 110 Memory Channels (55 per band, including "Home" channels)
  - Enhanced Smart Search™
  - CTCSS Encode
  - Time-Out Timer (TOT)
  - S-Meter Squelch
  - Dual Receive (V+V, U+U, V+U)
  - Crossband Repeat (bidirectional or one-way)
  - PC Programmable w/optional ADMS-2C
  - Intelligent Band Display (IBD)
  - Receiver Muting
  - Auto Power Off (APO)
  - MIL-STD 810 Rating
  - Omni-Glow™ Display
  - 1200/9600 bps Packet Compatible
  - Alternating-Band Memory Selection (ABMS)
  - DTMF Autodialer (one memory per band)
  - Accessories
- Consult your local Yaesu dealer.

\*Cellular blocked.

### FT-8500

Dual Band Mobile  
Detachable remote front panel, Alphanumeric Display, Spectra-Analyzer™, Digital Voltage Display, 110 memories in 5 banks, choice of microphones, offers high performance operating flexibility.



Specifications subject to change without notice. Specifications guaranteed only within amateur bands. Some accessories and/or options are standard in certain areas. Check with your local Yaesu dealer for specific details.

# Practical Wireless

AUGUST 1996  
(ON SALE JULY 11)  
VOL. 72 NO 8 ISSUE 1073  
NEXT ISSUE (SEPTEMBER)  
ON SALE AUGUST 8

## EDITORIAL & ADVERTISEMENT OFFICES

Practical Wireless  
Arrowsmith Court  
Station Approach  
Broadstone  
Dorset BH18 8PW  
☎ (01202) 659910  
(Out-of-hours service by answering machine)  
FAX (01202) 659950

PW's Internet address is:

@pwpub.demon.co.uk You can send mail to anyone at PW, just insert their name at the beginning of the address, e.g. rob@pwpub.demon.co.uk

## Editor

Rob Mannion G3XFD

## Technical Projects Sub-Editor

NG ("Tex") Swann G1TEX

## Production/News

Donna Vincent G7TZB

## Editorial Assistant

Zoë Crabb

## Art Editor Steve Hunt

Page Layouts Jon/Talbot & Marcus Hall

## Advertisement Manager

Roger Hall G4TNT

PO Box 948

London SW6 2DS

☎ 0171-731 6222

Mobile (0585) 851 385

FAX 0171-384 1031

## Advert Sales and Production (Broadstone Office)

Lynn Smith (Sales)

Carol Trevarton (Production)

Paul Orchard (Administration)

☎ (01202) 659920 - 9.30am - 5.30pm

FAX (01202) 659950

## CREDIT CARD ORDERS

☎ (01202) 659930

(Out-of-hours service by answering machine)

**Front Cover Photograph:** The background photograph showing Kenwood's r.f. anechoic chamber was kindly provided by Kenwood (Enjoy G30QT's Japanese trip on Page 26).

Copyright © PW PUBLISHING LTD. 1996. Copyright in all drawings, photographs and articles published in *Practical Wireless* is fully protected and reproduction in whole or part is expressly prohibited. All reasonable precautions are taken by *Practical Wireless* to ensure that the online and data given to our readers are reliable. We cannot however guarantee it and we cannot accept legal responsibility for it. Prices are liable to rise as we go to press.

Published on the second Thursday of each month by PW Publishing Ltd, Arrowsmith Court, Station Approach, Broadstone, Dorset BH18 8PW. Tel: (01202) 659910. Printed in England by Southampton Photo Offset Ltd, Southdown Way, Winchester, Hampshire, PO1 1JL. London Road, Wokingham, RG40 4AH. Tel: 0118 679 1989. Fax: 0118 679 8907. Telex: 8812945. S.A. Agents for Australia and New Zealand - Gordon and Gotch (Asia) Ltd - South Africa Central News Agency, Subscriptions INLAND £22, EUROPE £25, OVERSEAS (by ASP) £27, payable to PRACTICAL WIRELESS, Subscription Department, PW Publishing Ltd, Arrowsmith Court, Station Approach, Broadstone, Dorset BH18 8PW. Tel: (01202) 659920. PRACTICAL WIRELESS is also subject to the following conditions, namely that it shall not, without written consent of the publisher, be lent, hired, sold, or otherwise disposed of in any way of trade at more than the recommended selling price shown on the cover, and that it shall not be lent, sold, hired out or otherwise disposed of in a mutilated condition or in any unauthorised cover by any of trade, or altered to or as part of any publication for advertising.

History in practical matter whatsoever. *Practical Wireless* Published monthly for £35 per year by PW Publishing Ltd, Arrowsmith Court, Station Approach, Broadstone, Dorset BH18 8PW. Royal Mail International, 1st Yellowzone International, 87

Highway Court, Redbush, NJ 07068-1018, Second Class Postage paid at Doylestown, PA. Send USA address changes to Royal Mail International, c/o Yellowzone International, 2375 Pratt Boulevard, El Grove Village, IL 60007-5837. The USPS United States Postal Service number for *Practical Wireless* is 007075.

Practical Wireless logo

- 9 **EDITOR'S KEYLINES**  
Rob G3XFD asks are there enough amateurs for two national radio societies?
- 10 **RECEIVING YOU**
- 12 **NEWS 1996**
- 14 **NOVICE NATTER**  
Elaine Richards G4LFM has hints and tips for radio beginners of all ages.
- 16 **CLUB SPOTLIGHT**  
Is your club under Zoë's 'spotlight' this month?
- 18 **PRACTICAL WIRELESS SUBSCRIPTIONS**  
Just look at the benefits of taking out a subscription to your favourite magazine!
- 18 **RADIO DIARY**
- 19 **REVEX W200 SWR & POWER METER - REVIEW**  
Leighton Smart GW0LBI tests a piece of equipment that he considers essential for any amateur's shack.
- 20 **THE KENWOOD STORY**  
Richard McIachlan G30QT shares with you his recent trip to the Kenwood factory in Japan.
- 23 **NEW LAMP FOR OLD?**  
Richard O. Marris G2BZQ describes how you could use a valved receiver as a QRP transmitter.
- 24 **CARRYING ON THE PRACTICAL WAY**  
George Dobbs G3RJV is back with a regular new series, this month he describes a utility board.
- 26 **SHACK INTRUDER ALARM**  
Jack McKinney G1STZB shows you how to protect your shack from things that go bump in the night.
- 28 **THE HAIRPIN MATCH REVISITED**  
Roy Quantick G3UGL helps you understand an antenna matching method that's not widely used.
- 30 **INVISIBLE POWER**  
Gordon King G4VFV casts his 'technical eyes' over the electromagnetic environment that although invisible affects us in many ways.
- 36 **YAESU FT-50R - REVIEW**  
Read Clive Hardy G4SLU's comments on the latest radio from Yaesu and you'll see it's not just 'another hand-held report'.
- 38 **THE SPRAT TRANSCEIVER PART 2**  
The Rev. George Dobbs G3RJV describes the assembly stage of the Sprat 3.5MHz transceiver.
- 42 **UP THE POLE**  
Jack Frizzell G0LEO shares his design for the PW Trolley Mast antenna.
- 44 **ANTENNA WORKSHOP**  
David Butler G4ASR has the answers to two questions which are often asked about v.h.f./u.h.f. antennas.



- 46 **BOOK REVIEW - ELECTRONIC SERVICE MANUAL**  
'Tex' Swann G1TEX looks at a book which he feels could be an 'open learning' experience.
- 47 **EQUIPMENT SPECIFICATIONS**  
Ian Poole G3WYX looks at antenna gain.
- 48 **VALVE & VINTAGE**  
Ben Nock G4BXD gives the 'wireless shop' a military feel this month.
- 50 **VHF REPORT**  
David Butler G4ASR reports on the DX on the 50, 70 and 144MHz bands.
- 52 **HF FAR & WIDE**  
Leighton Smart GW0LBI delves into his postbag to bring you the latest news from the world of h.f.
- 54 **BITS & BYTES**  
Mike Richards G4WNC has the latest news from the 'computing in radio' scene.
- 56 **BROADCAST ROUND-UP**  
Peter Shore travels through the world of the broadcast bands.
- 57 **FOCAL POINT**  
Graham Hankins G8EMX has news and reports from the Amateur Television scene.
- 58 **BARGAIN BASEMENT**  
Looking for a bargain? - Look no further!
- 63 **BOOK SERVICE**
- 67 **COMING NEXT MONTH**  
Just look at what's on offer in *Practical Wireless* and *Short Wave Magazine* next month.

## 68 ADVERTISERS' INDEX

We apologise for the fact that the review of the MFJ-1780 antenna cannot be published due to technical reasons.



# SOUTH MIDLANDS CO

AOR ★ KENWOOD ★ DAIWA ★ COMET ★ YAESU ★ STRUMECH VERSATOWER ★ LAFAYETTE ★ HY-MOUND ★ CUSHCRAFT ★ TAIWA

## SMC OPEN DAY ★ SMC OPEN DAY ★ SMC OPEN DAY Saturday 17th August 9am - 5pm

AOR ★ KENWOOD ★ DAIWA ★ COMET ★ YAESU ★ STRUMECH VERSATOWER ★ LAFAYETTE ★ HY-MOUND ★ CUSHCRAFT ★ TAIWAN SERENE ★ HOKUSHIN ★ ICQM

- Camel Trophy Demonstration
- Free Raffle Draw
- Many Clearance Bargains

- American Licence
- Morse Tests (£18 fee +2 Passport Photo's needed)
- Hand Held Bargains

- Car Boot Sale - Free Spaces (Pre booked)\*
- Local Packet Cluster & 9600 Baud BBS Demo's
- Rig Diagnostic Checks
- Surplus Equipment Sale

• New UHF mobiles for packet from £39.00



- A display of the communications vehicle from this year's Camel Trophy Expedition.
- Demonstrations of SMC manufactured products including Hilomast, AEL transceivers and SMC antennas.

- A refreshment stall in aid of Leukaemia Research.
- Skilled staff on hand to answer any queries you may have on your new or old equipment.
- Representatives of the major manufacturers.

\* To book your free car boot space call Dave Hawnt on (01703) 251549.

**So Make A Note in Your Diary NOW - DON'T FORGET.**

### THIS MONTHS SPECIAL

#### FT-900 Remote Mountable HF Mobile Transceiver

**ONLY £899**



**SAVE £500**

Options: ATU2 Auto ATU £239 / FP800 Mains PSU £299

All discounts are based on recommended retail prices. CARR

Showroom/Mail Order 9.30-5pm, 9-1pm Sat Tel: (01703) 251549 Service Dept Tel: (01703) 254247 9-5 Mon-Fri SMC Sish

SMC Ltd HQ Southampton: S M House, School Close Chandlers Ford Ind Estate, East

ARE Communications: 6 Royal Parade Hanger Lane, Ealing, London W5A 1ET. Tel. 0181-997 4476 9.30am - 5.30pm Monday-Friday 9.30am - 1

SMC (Northern): Nowell Lane Ind. Estate, Nowell Lane Leeds. Tel. (01

★ AOR ★ KENWOOD ★ DAIWA ★ COMET ★ YAESU ★ STRUMECH VERSATOWER ★ LAFAYETTE ★ HY-MOUND ★ CUSHCRAFT ★ TAIWAN SERENE ★ HOKUSHIN ★ ICQM ★ TELEX ★ AEA ★ TOKYO HY-POWER ★ MFJ ★ MIRAGE KLM ★ HENRY ★ MANSON ★ REXON ★ AOR ★ KENWOOD ★ DAIWA ★ COMET

# COMMUNICATIONS LTD

★ SERENE ★ HOKUSHIN ★ ICOM ★ JRC ★ TELEX ★ AEA ★ TOKYO HY-POWER ★ MFJ ★ MIRAGE KLM ★ HENRY ★ MANSON ★ REXON ★

## DATA PRODUCTS

We now have the widest range of data products in the UK, and with our specialist knowledge of the products we must be by far the number one choice for packet equipment.

### AEA

PK12	1200 baud TNC.....	£129
PK96	9600 baud TNC.....	£219
PK232/MBX	Multimode data modem.....	£319
DSP232	Multimode data modem.....	£479
PK900	Multimode data modem.....	£479



### PacComm

Tiny 2	1200 baud TNC.....	£139
PicoPacket	12 baud portable TNC.....	£119
Spirit 2	9600 baud TNC.....	£199

### Kantronics

KPC3	1200 baud TNC.....	£139
KPC9612	1200+9600 dual port TNC.....	£275
Kam+	Multimode data modem.....	£395



### Symek

TNC2H	9600 baud TNC.....	£179
-------	--------------------	------

### BayCom Modems

USCC 4 port plug in card W/O Modems....	£107
---	------

### Modems

1200 baud	Plug in for USCC.....	£39
HF	Plug in for USCC.....	£59
9600 baud	Plug in for USCC.....	£79
Mini-Pak	1200 baud 9 pin 'D' plug.....	£69.95

\*FREE transceiver lead of your choice with every new TNC\*



PS120MIIA	PSU 3-15V 9/12A.....	£69.00	Carr
PS140MIIA	PSU 13.8V 12/14A.....	£72.00	D
PS304IIA	PSU 1-15V 24/30A.....	£129.00	D
RS40XII	PSU 1-15V 32/40A.....	£169.00	D



CN101L	1.8-150MHZ 15/150/1500W.....	£59.50	B
CN103LN	150-525MHZ 20/200W 'N'.....	£68.00	B
CS201	2 Way Switch SD239 1KW.....	£17.50	B
CS201GII	2 Way Switch 'N' 1KW PEP.....	£23.50	B
LA2080H	2M LAMP 1.5-5W IN 30-80W OUT.....	£136.00	B
DLA80H	2M/70CM Dual Band Amp 0.5-25W IN 80-60W Out Pre Amps.....	£345.00	C
DX10N	2m/70cm Duplexer UHF/N.....	£22.50	B
CPI0Y6	Cigar plug lead for FT530, etc.....	£6.50	A



They offer superb performance, innovative design, excellent build quality and outstanding value for money.

<b>HF Antennas</b>			
R5	10/12/15/17/20 vertical.....	£295.00	
R7	10 thru to 40m vertical.....	£389.00	
R7000	10 thru to 40m vertical.....	£389.00	
AV-3	14-21-28MHz vertical 4.3m long.....	£99.00	
AV-5	3-5-7-14-21-28MHz vertical 7.4m long.....	£169.00	
AP8A	8 Band Vertical.....	£229.00	
APR18A	Radial Kit.....	£54.00	
40-2CD	2-ele 40m Yagi.....	£499.00	
A3S	14-21-28MHz Yagi.....	£389.00	
A3WS	12/17m 3-ele Yagi.....	£299.00	
A103	30m Extension A3WS.....	£119.00	
204CD	4 ele 20m Yagi.....	£499.00	
154CD	4 ele 15m Yagi.....	£289.00	
D4	Dipole 10/15/20/40m.....	£259.00	
D3W	Dipole 12/17/30m.....	£199.00	
A4S	3-4 ele Yagi 10/15/20m.....	£449.00	

<b>VHF Antennas</b>			
AR-270	2/70 Dual Band Vertical 1.13m long.....	£69.00	
AR-270b	2/70 Dual Band Vertical 2.3m long.....	£95.00	
AR2	2m Vertical 1.2m long.....	£39.00	
AR6	6m Vertical 3.1m long.....	£59.00	
A148-10S	2m 10-ele Yagi 13.2 dBd.....	£72.00	
A144-20T	2m 10-ele Cross Yagi 12.2 dBd.....	£105.00	
13B2	13-ele 2m Yagi.....	£119.00	
17B2	17-ele 2m Yagi.....	£199.00	
A50-3S	3-ele 6m Yagi.....	£89.00	
A50-5S	5-ele 6m Yagi.....	£149.00	
A50-6S	6-ele 6m Yagi.....	£249.95	
424B	24-ele 70cms Yagi.....	£119.00	
22XB	2m 22-ele Yagi c/w polarization switching.....	£229.00	
738XB	70cms 38-ele Yagi c/w polarization switching.....	£219.00	

## TELEX HY-GAIN

<b>HF ANTENNAS</b>			
12AVQS	10-15-20m vertical, 4.1m.....	£109	C
14AVQ/WBS	10-15-20-40m vertical, 5.5m.....	£159	C
DX88	10-80m vertical.....	£315	C
DX77	10-40m vertical.....	£369	C
<b>ROTATORS</b>			
CD45	Medium duty meter controller.....	£315	D
HAM IV	Medium duty with break.....	£449	D
HAM V	HAM IV with digital controller.....	£749	D
T2X	H/duty with break meter controller.....	£369	C
T2XD	T2X with digital controller.....	£795	D



### COMET NEW PRODUCTS

CA-HV	HF/VHF Mobile Whip 7-14-21-28-50-144 * IDEAL FOR IC-706!!*.....	£99.95
CF-706	1.3-56 MHz/75-320MHz duplexer for CA-HV or similar.....	£44.00

### COMET ANTENNA ACCESSORIES

RS20	Mini Gutter Clip.....	£19.50
RS21	Mini Hatchback mount.....	£19.50
CK-3MB	Mini Cable Assembly.....	£26.50
WS-1M	Window Mount & Cable.....	£39.00

### COMET ANTENNAS

CBL-30	HF 1:1 Balun 1kW PEP.....	£23.50
CBL-200	HF 1:1 Balun 2kW PEP.....	£29.50
CF-30MR	HF Low Pass Filter 1kW PEP.....	£43.95
CF-50MR	6M Low Pass Filter 1kW PEP.....	£43.95
CF-30H	HF Low Pass Filter 2kW PEP.....	£69.00
CF-30S	HF Low Pass Filter 150W PEP.....	£25.00
CF-50S	6M Low Pass Filter 150W PEP.....	£25.00
CF-BPF2	2M Band Pass Filter 150W PEP.....	£49.95
CD-160H	PWR 1.6-60MHZ 20/200/2000W.....	£99.00
CMX-2	PWR 1.8-200MHZ 20/50/200W.....	£119.00

### COMET STATION ACCESSORIES

CA-7HR	7MHz Mobile Whip.....	£49.95
CA-14HR	14MHz Mobile Whip.....	£49.95
CA-21HR	21MHz Mobile Whip.....	£46.00
CH72S	2M/70CM Whip BNC.....	£18.50
CH600MX	2/70/23CM Whip BNC.....	£29.50
HR-50	6M MOBILE Whip.....	£49.95
CA2X4KG	2M/70CM Mobile Whip.....	£49.00
Z4	2m/70CM M. whip w/locking collar.....	£35.00
B-10	2M/70CM Mobile Whip.....	£21.50
B-22M	2m/70CM Mobile Whip.....	£44.95
CHL21J	2M/70CM Mobile Whip.....	£19.00
CA-258	2m/6m Mobile Whip.....	£29.00
CA-350dB	6M/10M Base Colinear.....	£149.00
ABC23	3 x 3/4 Base Colinear.....	£55.00
GP9N	2M/70CM Base Colinear.....	£135.00
GP15	6M/2M/70CM Base Colinear.....	£115.00
GP95	2M/70CM/23CM Base Colinear.....	£119.00

### COMET DUPLEXERS

CF-305	HF/VHF Duplexer.....	£25.00
CF-306A	HF/VHF/UHF Duplexer.....	£37.00
CFX-514	6M/2M/70CM Triplexer.....	£54.95
CFX-431	2M/70CM/23CM Triplexer.....	£49.00
CF-520	2M/6M Duplexer.....	£29.00

AGE: BASE ANTENNAS £9.50 MOBILE ANTENNAS £5.00 STATION ACCESSORIES £5.00

n (SMC HQ) Data Communications Hotline Tel: (01703) 254247 9.30am - 5pm for personal callers 9.00 - 9pm for telephone queries.

leigh, Hants SO5 3BY. Tel: (01703) 255111 Fax: (01703) 263507 Email: smc@tcp.co.uk

00pm Saturday Reg Ward & Co: 1 Western Parade, West Street, Axminster, Devon EX13 5NY. Tel. (01297) 34918 9.00am - 5.15pm Tues-Sat

3) 235 0606 9.30am - 5.00pm Monday-Friday 9.00am - 1.00pm Saturday

★ YAESU ★ STRUMECH VERSATOWER ★ LAFAYETTE ★ HY-MOUND ★ CUSHCRAFT ★ TAIWAN SERENE ★ HOKUSHIN ★ ICOM ★ JRC ★

## Radio Communication Handbook

**6TH EDITION**

One of the world's largest and most comprehensive guides to the theory and practice of amateur radio communication. An invaluable reference book for radio amateurs everywhere.



Price: **£21.00**

## Amateur Radio Operating Manual

**4TH EDITION**

Revised to include digital communications, 2m 'fox-hunting', microwaves and moonbounce for the first time. Both newly licensed and experience operators will find this book invaluable.



Price: **£12.23**

## Packet Radio Primer

**2ND EDITION**

For the radio amateur interested in connecting into the packet radio network, then this revised and expanded book covers all the recent developments taking you on from the basics right up to satellite operation.



Price: **£8.92**

## Test Equipment for the Radio Amateur

**3RD EDITION**

A wide range of test equipment is included, much of which can be made from the construction details provided. The essential reference book for your book shelf.



Price: **£10.97**

*The Best Amateur Radio Books Available  
- All from the RSGB!*

*(RSGB Member's prices on request)*



**RADIO SOCIETY OF GREAT BRITAIN**  
Lambda House, Cranborne Road, Potters Bar,  
Herts EN6 3JE. Sales Telephone: 01707 660888.

# AKD

UNIT 5, PARSONS GREEN ESTATE  
BOULTON ROAD, STEVENAGE, HERTS SG1 4QG.

## WAVEMETERS



The VHF Absorption Wavemeter for the 2 metre band. Range 120MHz to 450MHz. Meets licensing requirements. Can also be used as a field strength meter within

its range. Requires PP3 battery (not supplied).  
**£34 incl VAT. Add £1.50 P&P**

The VHF Absorption Wavemeter for the 4 & 6 metre bands. Range 50MHz to 70MHz. Meets licensing requirements. Can also be used as a field strength meter within its range. Requires PP3 battery (not supplied).



**£34 incl VAT. Add £1.50 P&P**



The HF Absorption Wavemeter covers the range 1.8MHz to 92MHz. Ideal for the law abiding operator. Requires PP3 battery (not supplied).

**£58.45 incl VAT. Add £2 P&P**

## TRANSCEIVERS CE approved

**£193.74 incl VAT** (Add £6 P&P)



★ 144.500-145.975 P1T tone burst. Listen on input. Facility 25kHz spacing 25/5 watts.

★ 70.250-70.4875 12.5kHz spacing power: 25/5 watts.

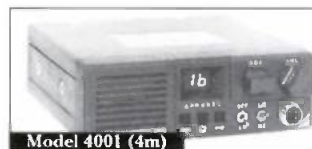

★ 50.010-51.990 20kHz spacing 25/5 watts.



★ 432.500-434.975MHz 25kHz spacing. Power 3 watts. P1T tone burst. Listen on input.



AKD internet details:- Web site: <http://www.kbnet.co.uk/akd>  
E-mail: [akd@kbnet.co.uk](mailto:akd@kbnet.co.uk)

**TEL: 01438 351710**  
**FAX: 01438 357591**

# C.M.HOWES COMMUNICATIONS

Mail Order to: Eydon, Daventry,  
Northants. NN11 3PT  
☎ 01327 260178



**SSB/CW Receiver**  
The DXR20 covers 20, 40 & 80M bands with optional extra band modules for 160M, 30M, 15M or 10M amateurs or 5.45MHz or 11.175MHz HF air. Many high performance features!  
DXR20 Kit: £39.90  
DCS2 "S meter" Kit: £10.90  
HAZOR h/ware pack: £28.90



**SWR Indicator**  
Build a great looking SWR bridge with the SWB30 kit and the new HA31R hardware pack. 160 to 2M bands, 30W. Custom aluminium case with printed and punched front panel, sockets, switch, knobs, nuts & bolts etc.  
SWB30 Kit: £13.90  
HA31R hardware: £18.90



**Morse Oscillator**  
The ST2 Sidetone/ practice oscillator gives a nice sinewave note. Plenty of volume. Works from your key or by RF sensing.  
ST2 Kit: £9.80  
HA12R hardware: £10.10



**Dual Bandwidth Audio Filter - £29.80!**

Clean up your reception!

• Reduce noise and interference! • Sharp SSB/Speech filter with faster roll-off than IF crystal filters! • 300Hz bandwidth CW filter • Printed and punched front panel • All aluminium case • Simply connects between radio and external 'speaker or 'phones • Suits all general coverage receivers & transceivers • ASL5 Kit plus HA50R hardware: £29.80

## Great projects to build with HOWES KITS!

### AA2 150kHz to 30MHz Active Antenna

The neat compact answer for those with limited space, holiday use, mobile operation etc. Two selectable gain settings, local or coax powering (12 to 14V). Good strong signal performance, IP3 +38dBm. Easy to build, and much liked by customers!  
AA2 Kit: £8.90 Assembled PCB Module: £14.90

### AA4 Active Antenna for scanners

Covers 25 to 1300MHz. Broad-band performance in a neat, compact package. Just 410mm (16") long. Excellent performance in a small space!  
AA4 Kit: £19.90 Assembled PCB Modules: £28.90

### AB118 Air-band Active Antenna

Optimised for long distance reception on 118 to 137MHz air-band. Tuned antenna with pre-amp & band-pass filter. Hear ground stations you've never heard before!  
AB118 Kit: £18.80 Assembled PCB modules: £27.90

### MB156 Marine Band Active Antenna

156 to 162MHz marine band active antenna system. "Pulls in" those distant signals!  
MB156 Kit: £18.50 Assembled PCB modules: £27.60



### Top Value Receiving ATU

CTU8. Covers 500kHz to 30MHz. Matches antenna impedance and helps reduce spurious signals and interference in the receiver. SO239 sockets.  
Kit (inc. hardware): £29.90  
Factory Built: £49.90



### Receiving ATU with balun

CTU9. All the features of the CTU8 plus a balun for balanced feeders, bypass switch for VLF etc. Additional terminals for balanced inputs, single wire and earth.  
Kit (inc. hardware): £39.90  
Factory Built: £69.90

Please add £4.00 P&P, or £1.50 P&P for electronics kits without hardware.

HOWES KITS contain good quality printed circuit boards with screen printed parts locations, full, clear instructions and all board mounted components. Sales, constructional and technical advice are available by phone during office hours. Please send an SAE for our free catalogue and specific product data sheets. Delivery is normally within seven days.

73 from Dave G4KQH, Technical Manager.

# New DX-394

MAJOR FEATURES

- ✱ **Frequency Coverage**  
LW 150 - 509.9kHz  
MW 510 - 1729.9kHz  
SW 1.73 - 29.9999MHz
- ✱ **Fine Tune**  
Fine tunes the reception signal, especially when you tune to SSB and CW
- ✱ **Step ▲, Step ▼**  
Selects the 0.1, 1, 5, or 10 (9) kHz tuning frequency step sequentially
- ✱ **Band**  
Selects LW (150-509.9kHz), MW (510-1729.9kHz), or SW (1.73-29.9999MHz) sequentially
- ✱ **LCD**  
Large LCD display with LCD signal strength meter



ONLY **£349.99**  
+ £10 p&p Part exchange welcome

Full specification A4 sheet available on request. Too many specifications and functions to list!



## SRP TRADING

SRP Radio Centre, 1686 Bristol Road South,  
Rednall, Birmingham B45 9TZ.  
Tel: 0121-457 7788/0121-460 1581  
Fax: 0121-457 9009

VOUCHER WORTH  
**£25** OFF THIS RECEIVER ONLY WITH  
**SRP TRADING**  
VALID UNTIL  
10th AUGUST 1996

# HAYDON COMMUNICATIONS

## HF TRANSCEIVERS

**YAESU FT-840**  
UK's best selling HF transceiver. RRP £850.  
SALE PRICE **£699.95**

**YAESU FT-1000MP (AC)**  
State of art HF transceiver.  
RRP £2849. **£2199.95**  
FT-1000MP (DC) RRP £2599 ..... Sale price £1999.95

**ICOM IC-706**  
HF transceiver with 6m + 2m. We're giving away a free P-2512 power supply with every transceiver sold. RRP £1285.  
SALE PRICE **£999.99** + FREE PSU worth £90

## HF ACCESSORIES

**P-2512** 25-30 amp power supply with variable volts (3-15). Dual meters (VS + amps) and over voltage protected.  
Most of our competitors are selling the 20A versions for the same price. RRP £99.95.  
OUR PRICE **£89.95**

**VECTRONICS VC-300DLP**  
UK's best selling ATU. 300W (PEP), dummy load, VSWR meter, 3 way ant, switch & balun for open wire feeders.  
RRP **£129.95**  
VC-300M 300W mobile ATU ..... £89.95

**PORTABLE 12V POWER STATION**  
Will deliver 50 amps peak. Charges from AC mains or trickle charge from car cigar lighter using lead supplied. Has 12AH sealed cell and dramatically reduces HF car electronics noise. RRP £54.95.  
OUR PRICE **£44.95**  
NEXT DAY DELIVERY £8.00

## VHF/UHF HANDHELDS

**YAESU FT-50R**  
New ultra compact dual band transceiver with wideband RX. 76-990MHz (AM, FM, FM-N). RRP £239.  
SALE PRICE **£289.95**

**ICOM IC-T7E** Rx available  
108-180/400-500/850-950MHz Compact dual band h/held. Incredible, everything you would possibly want incl CTCSS fitted as standard along with high power nicad + charger. RRP £329.  
OUR PRICE **£299.00**  
+ FREE speaker mic

**ALINCO DJ-190**  
2M handheld transceiver with wideband RX including Nicads & Charger. RRP £199.  
SALE PRICE **£169.95**

## VHF/UHF MOBILES

**YAESU FT-290RII**  
2M all mode transceiver. We're giving away a free FL-2025 25W matching linear with every 290 sold this month. RRP £759.  
SALE PRICE **£549.95**

FT-2200 2M FM mobile RRP £419 ..... Sale price £339.95  
FT-2500M 2M FM mobile RRP £399 ..... Sale price £599.95

**ICOM IC-2350H**  
Superb value for money dual band transceiver. 50W on 2m and 35W on 70cm.  
Introductory offer we are giving away a FREE magmount and dualband antenna worth over £50.  
OUR PRICE **£489.95** + FREE Magmount + Antenna  
IC-2710H Dual band FM mobile RRP £675 ..... Sale price £599.95

## A.E.A. PRODUCTS

DSP-232	OUR PRICE £479.95	free p&p
PK-232MBX	OUR PRICE £319.95	free p&p
PK-96	OUR PRICE £219.95	free p&p
PK-12	OUR PRICE £129.95	free p&p

## ACCESSORIES

### SWR METERS

**Nissei RS-402**  
125-525 MHz (200W) FWD/REV/AVE/PEP PWR + Full SWR Indicator and Meter Illumination.  
RRP **£69.95** P & P £4

RS-102 1.8-150MHz (200W) ..... £69.95

**TSA-6601** 144-44MHz (60W) pocket PWR/SWR meter  
**£34.95** (P&P £1.00)

TSA-6602 VHF/UHF ant matcher ..... £34.95 (P&P £1.00)

### HANDHELD MOUNTS

#### MA-339

Mobile Holder. Fits all h/held radios. Sticks onto dashboard of car.  
RRP **£9.95**  
QS-200 Air-vent h/held holder ..... £9.99  
QS-300 Desk top h/held holder ..... £19.99

### COAX SWITCHES

CX-401	4 way (SO-239) ..... £39.95
CX-401 'N'	4 way (N TYPE) ..... £49.95
CX-201	2 way (SO-239) ..... £16.95
CX-201 'N'	2 way (N-type) ..... £21.95

#### NB-30W

2M FM handheld amplifier 1/1.5W input 30W output.  
RRP **£49.95**  
NBD 30 dual band version of the above ..... £139.95

## MICROPHONES & EAR PIECES

### MICROPHONES

**MS-107 'K'** miniature hand microphone. Fits Kenwood, Yaesu, Icom and Alinco (Please specify brand of radio when ordering)  
RRP **£16.95** P & P £1

#### Nissei EP-300T

Over the ear earpiece with lapel mic & PTT. Fits Kenwood, Alinco, Yaesu or Icom (Please specify brand of radio when ordering)  
**£22.95** P & P £1  
This Ear/Mic comes with an "over the ear" earpiece as EP-300

#### Nissei EP-300

Deluxe over the ear earpiece. Fits all handheld radios.  
**£9.99** P & P £1

**LONDON SHOWROOM & MAIL ORDER:- 0181-951 5781/2 FAX:- 0181-951 5782**

Address:- 132 High St. Edgware, Middx HA8 7EL

Open Mon-Fri 9.30-5.30pm Sat 9.30-5pm. Close to Edgware underground station (Northern line) close to M1, M25, A406.

**WEST MIDLANDS BRANCH:- Unit 1, Canal View Industrial Estate, Brettel Lane, Brierley Hill, W Mids DY5 3LO**





MAIL ORDER  
TELEPHONE  
0181-951 5781/2

# SUMMER SALE



★★★★★ NEW PRODUCTS ★★★★★

- TAIWAN SERENE TSB-3608N**  
6M/2M 70CM base antenna 2.15/6.2/8.4dbi gain. Length 2.43M  
INTRO PRICE **£99.95**
- SP-350V** In line lightning surge protector.  
INTRO PRICE **£19.99** P&P £1

ANTENNAS

- SERENE BASE ANTENNAS** (P&P £8.50)  
TSB-3315 GF 144/70, 8.5/11dB (5.4m) ..... **£129.95**  
TSB-3301 GF 144/70, 6.5/9dB (3m) ..... **£69.95**  
TSB-3302 GF 144/70, 4.5/7.2dB (1.7m) ..... **£54.95**  
TSB-3303 GF 144/70, 3/6dB (1.1m) ..... **£39.95**  
TSB-3002 AL 144MHz, 6.5dB (2.8m) ..... **£39.95**  
TSB-3001 AL 144MHz, 3.4dB (1.4m) ..... **£29.95**  
V-2000 GF 6m/2m/70cm, 2.1/6.2/8.4dB (2.5m) ..... **£134.95**  
GP15N Comet 6m/2m/70cm 3.6/2.8/6.1 dBi (2.4m) ..... **£124.95**

- ACCESSORIES** P&P £2.00 on the following  
TSA-6001N Duplexer (+Coax) 2/70 ..... **£24.95**  
TSA-6003 Duplexer (Sockets) 2/70 ..... **£19.95**

- HIGH QUALITY NISSEI MOBILE ANTENNAS** P&P £4.50  
DB-7900 144/70 cms, (5/7.5dB) 1.5m ..... **£49.99**  
DB-770M 144/70 cms, (3/5.5dB) 1m ..... **£24.95**  
DB-1304 144/70 cms, (2.15/3.8dB) 41cms ..... **£19.95**  
DB-EL2E 144MHz, 4ths, 4.5dB (1.8m) ..... **£29.95**  
DB-285 144MHz, 4ths, 3.4dB (1.3m) ..... **£15.95**

- ACCESSORIES** P&P £2.50 on the following  
MT-1301 H/Duty Mag Mnt + Coax ..... Top Quality **£24.95**  
MT-3302 H/Duty Hatch/Trunk Mnt ..... Top Quality **£24.95**

- HF ANTENNAS** P&P £10  
R5 10/12/15/17/20 vertical ..... **£295.00**  
R7 10 thru to 40m vertical ..... **£389.00**  
AV-3 14-21-28MHz vertical 4.3m long ..... **£89.00**  
AV-5 3.5-7-14-21-28MHz vertical 7.4m long ..... **£159.00**  
AP8A 8 Band Vertical ..... **£199.00**  
A35 14-21-28MHz Yagi ..... **£349.00**  
Carolina Windom 2' 40-10m (66ft) ..... **£88.95**  
Carolina Windom 80-10m (132ft long) ..... **£84.95**

**HUSTLER RANGE NOW IN STOCK**

- 4BTV Four band HF vert 10, 15, 20, 40 1.5kW ..... **£169.95**  
5BTV Five band HF vert 10, 15, 20, 40, 80 1.5kW ..... **£189.95**  
RM-20 20m mobile (reduced length) 400W ..... **£24.95**  
C-32 Ball mount assy + plate (4ths fitting) ..... **£26.95**

SCANNERS

**AOR AR-8000** The ultimate handheld receiver covers everything from 500kHz-1900MHz all mode (AM, NFM, WFM, USB, LSB, CW)  
**SPECIAL OFFER £369.95**

**YUPITERU MVT-7100EX**  
Handheld scanner covers everything from 500kHz-1650MHz (all mode).  
RRP £419.95  
**SALE PRICE £319.95**

**NETSET PRO-44**  
Listen to aircraft, ham, marine and much more with this superb scanner. Covers 66-88/108-174/380-512MHz. RRP £169.95.  
**OUR PRICE £119.95**

S.W. RECEIVERS

**AOR AR-7030**  
Brilliant new all mode short wave receiver with synchronous AM + remote control. RRP £799.  
**OUR PRICE £749.95**

**SANGEAN ATS-803A**  
UK's best selling portable SW receiver with SSB.  
**OUR PRICE £129.95**

**SONY SW-100E**  
Award winning miniature SW receiver with SSB. RRP £219.95.  
**OUR PRICE £199.95**

- SW-7600G RRP £199 ..... our price **£179.95**  
SW-55 RRP £299 ..... our price **£259.95**  
SW-77 RRP £399 ..... our price **£359.95**

HANDHELD ANTENNAS

**T-2602** 2m/70cm/23cm (2/3/5.5dB) flexible antenna with wideband receive (14" long BNC).  
**OUR PRICE £22.95** P&P £1

**DB-770H** High gain 2m + 70cm telescopic antenna with wideband receive.  
**OUR PRICE £24.95** P&P £1

**TSA-6671** New ultra small BNC magmount. Allows you to use any existing BNC antenna from your scanner to transceiver on your car without having to purchase a car antenna. **OUR PRICE £22.95** P&P £1

**POLICE STYLE HOLSTER HHC-2**  
Matches all handhelds can be worn on the belt or attached to the quick release body holster.  
**£19.95** P&P £1

OPTOELECTRONICS

**OPTO SCOUT 3.1-Mk2**  
Mini frequency finder will capture and memorise up to 400 frequencies that can be recalled directly into the AR-8000. Supplied with antenna, nicads and fast charger. RRP £399  
**£399**

**OPTO CUB**  
10MHz-2.8GHz frequency finder. Supplied with antenna, nicads & charger. RRP **£139.00**

**NEW DB-32** A miniature wideband antenna. Receives 30 - 1200 MHz. Transmits 2m/70cm, BNC fitting only 1.5" long. It's superb for its size.  
**RRP £29.95** P & P £1

## SECONDHAND & EX DEMO BOARD

	<b>KENWOOD TS-850S</b> Immaculate condition. <b>£1199.95</b>		<b>YAESU FT-726R</b> 2M + 70cm all mode base <b>£699.95</b>		<b>KENWOOD TH-78E</b> Immaculate condition. <b>£349.95</b>
TS-450SAT	Immaculate condition ..... <b>£777.??</b>	FT-736R	Immaculate ..... <b>£1299.95</b>	TH-77E	Dualband h/held ..... <b>£199.95</b>
TS-440SAT	VGC ..... <b>£849.95</b>	FT-290RII	Ex demo ..... <b>£449.95</b>	DJ-580	Dualband h/held ..... <b>£339.95</b>
TS-430S	VGC ..... <b>£699.95</b>	FT-290RI	2M all mode ..... <b>£279.95</b>	DJ-560	Dualband h/held ..... <b>£199.95</b>
TS-830S	VGC ..... <b>£549.95</b>	FT-690RI	6M all mode ..... <b>£299.95</b>	FT-530	Dualband h/held ..... <b>£329.95</b>
TS-530SP	VGC ..... <b>£529.95</b>	TH-241E	2M mobile as new ..... <b>£289.95</b>	Standard C-520	Dualband h/held ..... <b>£229.95</b>
TS-140S	As new ..... <b>£749.95</b>	FT-730	70cm FM mobile ..... <b>£229.95</b>	Icom ICW2E	Dualband h/held ..... <b>£199.95</b>
TS-950S	Deluxe HF transceiver ..... <b>£1699.95</b>	FT-230R	2M FM mobile ..... <b>£199.95</b>	TH-215E	2M h/held ..... <b>£199.95</b>
TS-50S	HF transceiver ..... <b>£699.95</b>	DR-H06SX	6M FM mobile ..... <b>£269.95</b>	CT-1600	2M FM h/held ..... <b>£99.95</b>
FT-890	VGC ..... <b>£799.95</b>	TM-702E	Immaculate ..... <b>£449.95</b>	MVT-7100	H/held scanner ..... <b>£269.95</b>
FT-902	VGC ..... <b>£449.95</b>	DR-610	Ex demo ..... <b>£549.95</b>	Sony AIR-7	Airband receiver ..... <b>£179.95</b>
FT-901	VGC ..... <b>£399.95</b>	ICF-2001D	SW portable ..... <b>£229.95</b>	AR-3000A	Communication receiver ..... <b>£749.95</b>
FT-101	HF transceiver ..... <b>£299.95</b>	AR-3030	Communication RCVR ..... <b>£549.95</b>	HF-225	Communication receiver ..... <b>£399.95</b>
IC-738	Immaculate ..... <b>£1099.95</b>	FRG-7700	Communication receiver ..... <b>£299.95</b>	MCL-1100	with monitor with meteo upgrade as new ..... <b>£???.??</b>
TEN-TEC	Coursair II + PSU ..... <b>£699.95</b>	HF-150	Communication receiver ..... <b>£299.95</b>		

ALL OF THE ABOVE & MUCH MORE ARE AVAILABLE FROM EDGWARE BRANCH: 0181-951 5781/2

01702  
206835

# Waters & Stanton

## Alinco DR-605

2m & 70cms Mobile inc CTCSS\*  
Full Duplex - Cross-Band Repeat - 100 Memos  
\*Encode only



Super Price  
**£495**

## XPLORER

25-1300MHz

Locks onto any frequency in less than a second. Provides audio, frequency readout, tone codes, and deviation.



£149

## Portable 12v

Can run a 100W rig or Start your car!

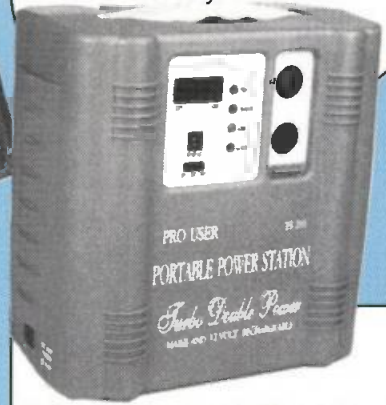

Delivers 50 Amps peak. Charge from AC mains or trickle charge from car cigar lighter. Dramatically reduces noise for HF operation. Runs a 100W rig for several hours.

World's Smallest Scanner



FT-736R  
£1999 **£1399**

WS-1000  
£349



UK's Smallest 70cm Handy



## YAESU - July Deals \*

Model	RRP	July Price
FT-1000MP-DC	£2599	£2049
FT-1000MP-AC	£2849	£2249
FT-990DC	£1999	£1599
FT-736R	£1999	£1399
FT-50R New	£329	£299
FT-840	£959	£789
FT-2500	£399	£329
FT-51R	£529	£399
FT-290RII	£599	£499

400 Memories and coverage from 500kHz to 1300MHz. It's a great performer

Alinco does it again. This is a complete 70cms handheld. Look at the price! Just £149 for a complete station.

## ADI 2m & 70cms

The Lowest AT-200 Price Ever!

2 Watts  
6 x AA dry cell pack,  
5 Watts on ext. 12V  
Rx 130 - 174MHz  
1750Hz tone  
DTMF built-in  
Programme Scanning  
Illuminated Keypad  
CTCSS Option

70cms AT-400 **£189.95**

SWR Meters



£69.95

## WATSON

## Base Aerials

Watson base station aerials give you top performance at realistic prices. Get the real thing and experience true performance. Each one is pre-tuned for the UK bands, encapsulated in fibre glass, and has stainless steel fittings.

From **£39!**

W-30 2m/70cms 3/5dB 1.15m	£39.95
W-50 2m/70cm 4.5/7.2dB 1.8m	£54.95
W-300 2m/70cm 6.5/9dB 3.1m	£69.95

## Power Supplies

3 Amps to 30 Amps - Fully Protected



The Only Ones To have Passed New EMC Regl

W-3A	3 Amp 12V current/volt protected	£22.95
W-5A	5 Amp 12V current/volt protected	£29.95
W-10A	10 Amp 12V current/volt prote	£49.95
W-10AM	10 Amp 3 - 15V variable	£59.95
W-20AM	20 Amp 3-15V variable	£89.95
W-30AM	30 Amp 3-15V variable	£119.95

## ALINCO DJ-190E

£199

This is the new exciting handheld from ALINCO. For an unbiased opinion, read the PW Review in the May issue. It's the ideal rig to keep in the car, in the brief-case, or to take on holiday. At our price you can afford to!

- \* 2 metre Handheld
- \* CTCSS Encode
- \* 1750Hz tone
- \* 40 Memories
- \* Wideband Receive
- \* Ni-cads
- \* AC Charger



## ADI AR-146 2m Mobile

Our Price  
**£269**

This rig is superb. It leaves the competition for dead! At our price you can't afford not to have 50W high power 2m FM in the car.

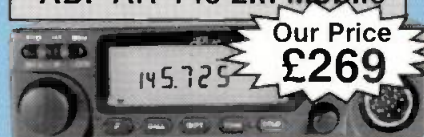

## DJ-G5 Dual bander

£489  
**£439**

Includes a host of exciting features. You get CTCSS built-in, 200 memories as standard and a wideband receiver covering 108-174 / 420-470 / 800-950MHz. You'll love its compact size and its electronic vol. / squelch controls. Send today for full details of tomorrow's handheld.



## JUST ARRIVED

Cushcraft R-7000 hf vertical plus optional 80m kit. (Beefed-up R-7) £369  
New Index Plus QRP rig-Phone

## ICOM - July Deals \*

IC-706	£1195	£995
IC-775DSP	£3699	£3099

ALINCO  
DX-70 In Stock



\* THESE DEALS END ON 31st JULY

**VISA Tel: (01702) 206835 / 204965 Fax: (01702) 205843 ACCESS**  
Shop & Mail Order 22, Main Road, Hockley, Essex. SS5 4QS  
24 Hour Answerphone and Fax. Open Mon-Sat. 9am - 5.30pm

# EDITOR'S

## Keylines

Rob Mannion's viewpoint on the World of Amateur Radio

Last month's *PW* 'News 1996' section (page 13) carried a 'Stop Press' story about the formation of the **United Kingdom Radio Society (UKRS)**. The press release sent in to the office (while I was away at the Dayton HamVention in the USA) clearly stated the aims of the new society.

The organisers announced that "the UKRS has been formed in response to overwhelming demand from all over the UK and will cater for enthusiasts in all aspects of the radio hobby". They also clearly stated their intention of taking demonstrations into schools and colleges to give youngsters an insight into the hobby. There were also statements from the organisers saying that they hoped to work in parallel with the RSGB would in effect produce a far wider 'reach' for Amateur Radio".

There aren't many Radio Amateurs in the United Kingdom...when you take into consideration the size of our population. And although I can't quote any realistic figures for those who are 'active', it's obvious even when you listen to the busy h.f. bands, the activities on v.h.f. and above...that there aren't many of us on the bands (even though you might think so on the congested bands at night!).

To be fair, the definition of an 'Active Amateur' should not really be defined as being someone with a microphone or Morse key at their fingertips. Being an 'Active Amateur' goes much farther than that. In my mind it covers all aspects of our hobby, from Morse to keyboard operating, and from satellites to ATV. It's all Amateur Radio.

For the reasons I've just mentioned I really don't think there is call for another national society within the

UK. Firstly, there just aren't enough of us to support two societies. Secondly, the International Amateur Radio Union will only recognise one national society. And that honour of course goes to the Radio Society of Great Britain.

### Two Societies?

If a (well populated by a very keen and supportive Radio Amateurs) country the size of the United States of America cannot support two national societies, how can our much smaller country possibly hope to support two? In my opinion, the efforts can only 'dilute' the efforts of both the RSGB and the UKRS. Remember "united we stand, divided we fall"!

Although I don't know all the background for the reason behind the formation of the UKRS, I know enough to

realise that its birth has been brought about because of dissatisfaction with the RSGB. Unfortunately however, I feel that by dividing the relatively small numbers of Radio Amateurs into smaller groups or organisations could be disastrous. I'm tempted to draw a parallel with the on-going tragedy in Eastern Europe. Surely that was a classic example of 'dividing and falling' followed by the inhumane chaos as the various groups of people (newly independent republics in the case of eastern Europe) jostle, manoeuvre and argue for the right to represent themselves and their own particular dogma.

You may not agree with the parallel I've drawn. But it's there to be seen and felt and has now appeared with the emergence of the UKRS.

Certainly, Radio Amateurs aren't going to start fighting physically. However, the result could be that chaos could reign and nobody could possibly benefit. That's why in my opinion a second 'national' society is **not the answer** to the perceived problems with our hobby in the UK.

### Annual Cost

I often get complaints from RSGB members (and former members) who complain about the annual cost of belonging to the Society. It's not cheap...but it's not expensive, especially when compared to some of the organisations I'm affiliated to (One of which costs me £200 a year to belong!).

You must not think 'Keylines' this month is an advert for the RSGB (even though I'm a member). Instead it's a direct plea on behalf of Amateur Radio in the UK. We must all rally together and work together. Instead of dividing we should reinforce our hobby.

Look at what we get for the RSGB Subscription every year. And to be sensible, even if it's only half the cost, what can a new society offer? It

certainly can't be national representation!

The RSGB has certainly got problems. Certainly there's still a slight 'snobbishness' which can still be detected, especially when they're dealing with the 'outside world'. But that's rapidly disappearing. And disappearing along with the snobbishness and 'London Radio Society' attitude is the 'Not invented here' syndrome.

### Not Invented Here

For those readers who don't know the term 'Not invented here' syndrome perhaps I'd

better explain further. It's literally the attitude adopted by many organisations who look askance at other attempts to achieve success, dismissing the attempts purely because whatever the other efforts are, they did not originate with that organisation. In a way it's perhaps a more subtle form of 'superiority complex'.

However, the RSGB is trying very hard indeed to grow and adapt to the modern world. Never have they been more approachable. All major shows now have an excellent representation from the Society, and regular headquarters 'open days' enable members to take full advantage and meet Society staff and Council Members.

To cap it all, the RSGB seems to have started the final dismantling of the 'London Radio Society' moulded image and 'Not Invented Here' syndrome by the appointment of last year's President, **Clive Trotman GW4YKL**. Clive, one of the new breed of 'Member's President's' entered Amateur Radio via CB! Surely, that must indicate to everyone the RSGB's change of attitude in a very positive way?

The way forward for Amateur Radio in the UK is not to fragment the hobby by introducing a new society. Our route must follow the direction of improving the existing society. The job has started...it's up to the members of the RSGB to continue the change, weed out old fashioned ideas, prejudice and attitudes and continue the change to the good. And if that means that you have to seek election to the Council, so be it. It's your hobby, your future and it should be your Radio Society of Great Britain.

*Rob Mannion  
G3XFD*

### New Name

We've got a new name on the *PW* team this month. As the photograph (it's got to be better than my usual 'mug' shot hasn't it!) shows, our Editorial Assistant Miss Shortland became **Mrs Zoë Crabb** on Saturday 1 June.

I've no doubt readers, especially those who contribute to 'Club Spotlight' would like to join us in congratulating the happy couple. Zoë should never be short of fresh bread because Ian her new husband is a baker. And if she ever 'burns her cakes' she'll be safe because he's a part time fireman too!

By the time this *PW* is on sale, Zoë will be back at work...looking forward to your Club magazine's entry for the new joint *PW*/Kenwood trophy (see 'Club Spotlight'). So, don't miss out...let's see your Club magazine or newsletter. Good luck to you and the new Mr & Mrs Crabb.



The Star Letter will receive a voucher worth £10 to spend on items from our Book or other services offered by Practical Wireless. All other letters will receive a £5 voucher.

# RECEIVING You

PW's Postbag. If your letter is published you'll win a prize.

**Letters Received Via The 'Internet'**  
Many letters intended for 'Receiving You' now arrive via the 'Internet'. And although there's no problem in general with E-Mail, many correspondents are forgetting to provide their postal address. I have to remind readers that although we will not publish a full postal address (unless we are asked to do so), we require it if the letter is to be considered. So, please don't forget to include your full postal address and call sign along with your E-Mail hieroglyphics! Editor

## Taken Seriously

Dear Sir

There's no doubt that car driving like Amateur Radio should be taken extremely seriously indeed. So here's a tip for when you get bored on a long car journey.

Pretend to be speaking into a dummy hand-held microphone whilst really speaking into your newly installed 'hands free' microphone, then when you get stopped you and the police can have a jolly good laugh at your joke.

By the way...the other day somebody said to me that the worst thing that could happen to you is for your recently erected h.f. Tri-bander to get blown down in a storm. Well recently I got knocked off my bike by a bus and broke my back, which makes that statement look pretty silly doesn't it?

Robert Walmsley  
G0DKW  
Northampton

**Editor's reply:** After you've disentangled yourself with the local constabulary Robert, we wish you a good recovery and a new bike. In the meantime I think we must all remember Amateur Radio is a hobby to be enjoyed. Take it too seriously and the enjoyment goes...that's the time to find another pastime.

## Denco Coils

Dear Sir

It was great news to learn in the June issue of *PW* that the Denco coil company are back in business.

I began my interest in radio and electronics over twenty years ago building

simple radios and r.f. projects which specified the Maxi-Q range of coils.

I recall that ranges three to five covered the h.f. bands. They could be either mounted on their threaded ends, by means of a plastic nut, or by plugging them into a B9A valve socket.

The coils were supplied packed with the data sheet inside aluminium cans which could be used for screening purposes, but more often than not. I would use them as housing for r.f. probes or more mundane uses such as storing nuts and bolts and small components.

I look forward to reading the feature on Denco and its products in a forthcoming issue of *PW*. I may even submit a few designs myself!

G. Cheadle G7WHE.  
York

**Editor's comment:** We look forward to receiving your ideas!

## Locator Systems

Dear Sir

Just a quick line about the article in the June *PW* on Locator Systems. Please

note that the current Locator system is **not** called 'Maidenhead'. True, the place where the system was first officially endorsed was the IARU Region 1 VHF managers' meeting held in Maidenhead in 1980 April; but all references to the system by both RSGB and IARU since first being mentioned in the 1980 November *RadCom* have sought to call it just 'Locator' (or 'World Wide Locator' if you wish to differentiate it from the older European-only Locator system that it replaced from January 1st 1985 onwards).

The 'M-word' is superfluous and meaningless. It may add confusion under weak signal conditions. The operator at the other-end is newly-licenced, hasn't heard of Locator systems before, hasn't got a good grasp of English, signals are weak, and they hear (or think they do) you say 'Maidenhead' and 'Location' and so puts you in the log as living in Maidenhead. I remember lots of jokes about 'What's the location of Maidenhead?' and 'Have they moved it?' back in the

early 1980s.

On c.w. the recommended form is to ask 'LOC?'; and reply 'LOC is IO90AR'.

On voice 'What is your Locator?'; 'My Locator is.....'.

In written form (QSL Cards, etc.) 'LOC' (or 'WW-Loc') will suffice.

There have also been proposals to add another 2 characters (using the digits 0 to 9) to increase the accuracy of the system to be more useful to microwave operators. The current sub-square (6-characters) are too coarse for accurate bearings to be calculated on short distant contracts. At present, NGR has to be used. As this only covers Britain, operators revert to full Latitude and Longitude (degrees, minutes, seconds) for European contacts - which is very long-winded. These proposed 'micro-squares' (8-characters) would simplify matters somewhat.

The 'Old' system wasn't called QRA for very long either. 'QRA?' is 'What is your Callsign/Station Name?'. That system was known as 'Locator' or 'QTH Locator' for many years (since mid-1970s), and is generally referred to as the 'European Locator' now (Abbreviation 'E-Loc').

I hope this clears up any confusion on the matter.

Ian Galpin G1SMD  
Poole

## Morse...Another Opinion

Dear Sir

I'm at a loss to know why it is every time that I pick-up a radio magazine, so much of it is given to the subject of Morse code. So I thought

it was time for me to add my thoughts to the list of so many others, and hopefully add another perspective.

We all came into this hobby of ours because we had an interest in radio, and I'm sure we have taken out the bits that interest us. I certainly have, whether it's Packet, AMTOR v.h.f./u.h.f. or f.m./s.s.b., Satellite operating SSTV or TV (the list is endless).

So, please tell me why is it there's all this controversy over an old operating system? If you are going to be selective over one part of the band, then it would have been sensible to have been selective over the rest.

For an example, those who wish to use frequencies above 1GHz should be qualified in the use of microwaves, and be fully aware of the dangers! Also those using Packet and RTTY be able to spell and type to an acceptable speed and so on.

So why is there a section of our community determined to stop h.f. being used for some of the above operations without first passing the code requirement?

Of course there are some who worked hard to get their Morse just so they could use 'phone on h.f. and haven't touched a key since. I'm sure we all know someone like that. Is it that if Morse were no longer a requirement there would always be the possibility it would fall into disuse, I don't think so.

There is a very old saying that 'One volunteer is worth ten pressed men'. So it's fair to say we could end up with a higher standard in Morse than we have today.

As you will soon see by

## Practical Wireless On CD ROM

Dear Sir

I saw on the QRP-Listing on the 'Internet' that the ARRL have produced a CD ROM with all of the 1995 *QST* magazines, including all articles, pictures and adverts.

Wouldn't this be an idea for some popular, practical, radio orientated

UK magazine to consider, or even the RSGB?

Nice idea?  
Frank Lee G3YCC  
North Humberside

**Editor's comment:** It's also an excellent way of obtaining 'instant' reference to magazines which (apart from archives) are unavailable. If you are interested in this form of magazine storage/reference please let us know.

## Dentist's 'Reading Rooms'

Dear Sir

I was interested to read Arthur Sharp's letter in 'Receiving You' (PW June) regarding magazines in dentist's waiting rooms. As a practising dentist and licenced radio amateur I regularly put copies of *PW* and *RadCom* in my waiting room and have been very pleasantly surprised to discover how many of my patients are interested in amateur radio.

I recently discovered my receptionist censoring the waiting room magazines by removing the above named publications.

When I questioned her motives I was told that every time one of my 'radio patients' came in I ran late. So, in the interest of the smooth running of the practice she thought she would try to stop me nattering about radio!

John Rowlands G4OJS  
Worcestershire

**Editor's reply:** Perhaps your receptionist thought she was 'extracting the root cause of the problem' John? But (unless your patient is a ventriloquist)...surely they can't delay your work too much by chatting. Most conversations between the dentist and I are very brief. I've yet to teach him Morse so he can read my 'finger taps' on the arm of the chair when my mouth is full of his hardware!

my callsign I'm a 'B' licencee. I can see some of you now shaking your heads saying another 'B' wanting a short cut to be the h.f. bands. And I can understand why you think like that, for my part nothing could be further from the truth.

My interest in Amateur Radio has and still is Satellite and TV operating. So much so that it's taken up quite a lot of my time in the last 12 years, and I can assure you I have not had any interest in h.f. except back in 1984 when I was first licenced.

I was flying to the Falklands in my capacity as a crew member with British Airways. We had a crew change which meant we were in Port Stanley for a few days.

So with this spare time I applied for a reciprocal licence. To my surprise I was issued a full 'A' licence. When I queried this I was told there was no requirement for a Morse test in the Falklands. So the whole amateur spectrum was open to me.

Of course I didn't have an h.f. rig only a 144MHz

hand-held, so I was unable to use my new licence to its full extent. My call is VP8BGU. Every year another colleague and I sent our £10 down to the Post Office in Port Stanley, our renewals duly arrived back approximately two weeks later.

A cautionary note here: don't think you can rush down to the Falklands get a licence come back and get a reciprocal. The VP call is not recognised in the UK. Even so a precedent has been set.

Do we still have the code requirement in the UK because 'I had to do it, so you have to mentality'? We are just about to enter the next Millennium. So let's sweep away these old ideas. Now would be a good time for change, so our hobby can progress and flourish.

Are we far sighted enough to let this come about? If we are, our hobby can only benefit, and become all the richer was wiser for it.

Anthony Hornby  
G1HBD/VP8BGU  
Berkshire

## Novice Prejudice

Dear Sir

Like the Editor stated in his 'Keylines' Editorial, I was somewhat dismayed to see what Chris Upton 2E1DTV had written in the May edition of *PW* regarding prejudice against Novice Radio Amateurs. I have heard that this is going on, but not experienced it in this area where we have a number of Novices who seem to be able to work all and sundry.

I said a long time ago that the name Novice was wrong, they are neither 'trainee' nuns nor monks as far as I know! The term should have been Class C licencees. Personally I feel this would have been acceptable to most and quite likely, at least reduced the risk of so called "snobbishness". I well remember the same thing happening when the first Class B licencees were issued.

Ron Wilson G3DSV  
Exeter

## Memories Of 1930s

Dear Sir

I saw the letter from Peter Reading G4FML in *PW* for June and your reply inviting memories of the 1930s. It brought back my own memories!

I didn't build the 30-line TV set mentioned, but a school fellow in Barnet, Fred Gear, brought his version to the school wireless club. We saw the disc go round and the 30 lines but not a picture because there was no transmission at that time of day.

The Nipkov disc, which through a spiral of square holes around its edge, scanned the flat plated neon light was soon succeeded by the mirror-drum and the mirror-screw. These apparently gave brighter pictures but I didn't see them working. My pocket-money didn't run to making anything complicated at the time, anymore than my skill does now.

Reader's letters intended for publication in 'Receiving You' must be original and not be duplicated. Letters are accepted on the understanding that they have only been submitted to *Practical Wireless*. Please ensure that your letter is clearly marked 'for publication in Receiving You' and that it has not been submitted to other magazines. We reserve the right to edit or shorten any letter.

The views expressed in letters are not necessarily those of *Practical Wireless*.

I was immobilised in bed through the Summer of 1933 and my father was given a batch of wireless magazines for me by an office colleague. The batch comprised *Amateur Wireless*, *Popular Wireless* and *Practical Wireless* and I read and re-read them.

Nothing about transmitting - all about receivers and an occasional blue line print free for the latest circuit by Camm, Scott-Taggart, etc.

In my convalescence I built my first crystal set in a cigar box. My doctor, visiting, said "Is that all it is"? Charming man. Living so near Brookmans Park, I could use the wire-mattress of the bed as an aerial. Later I built an 0-V-0 for short wave and heard, like Peter Reading, Schenectady although whether it was W2XAD or W2XAF I can't remember. Adding an a.f. transformer and valve to another 0-V-0 from a 'Modern Boy' (anyone remember it?) dual-range circuit gave me full loud-speaker strength from the National and Regional services and the bed-spring!

My interest in radio had really started in 1926 when an uncle installed for us his home-made two-valve (bright-emitter) set with swinging coil reaction. But I was only five and it was not the 1930s!

Gordon Lines G0ROH  
Surrey

**Editor's comment:** Fascinating stuff! Would anyone like to have a go and try 30-line (or similar) 'mechanical' TV on h.f. or v.h.f.? I'd love to try again as my original attempts at building 30 line equipment with my schoolboy Meccano failed.

## Neighbourhood Listening

Dear Sir

As a very keen s.w.l. plus an Area Neighbourhood Watch Co-ordinator, I am very concerned about the increasing number of radio amateurs who unwittingly broadcast over the airwaves that they are going on holiday, or will be away from home for specified periods. All one has to do is look up the address in the callbook and 'bingo', they have come up with the 'jackpot' of your entire shack.

A little thought before pressing the p.t.t. button could save a very big headache.

Maurice Thomas  
Truro



Send your letters to the *PW* Offices, marking it clearly for 'Receiving You'

# NEWS 1996

Compiled by Donna Vincent G7TZB

## The Future Of Amateur Radio

The Radio Society of Great Britain (RSGB) is in the process of conducting an opinion survey on the Future of Amateur Radio. All radio amateurs and short wave listeners, not just RSGB members, can take part in the survey.

Members of the RSGB will have received a copy of the survey with the July issue of *Radio Communication*. Non-members wishing to take part in the survey should apply for a form to **Future of Amateur Radio Opinion Survey, RSGB Headquarters, Lambda House, Cranborne Road, Potters Bar, Herts EN6 3JE** enclosing an A5 or A4 s.s.a.e. The deadline for returning completed forms is 29 July 1996.

## On Air With TVR

Every year the TVR Car Club of Great Britain organise a national rally where hundreds of enthusiasts from around the world gather to see TVR's ranging from the earliest designs to the latest models. This year the event will be held on 14 July at the National Watersports Centre, Holme Peirpoint, Nottinghamshire from 10am to 5pm where it's hoped that over 500 cars will be on display together with their latest model the Cerbera.

For the first time the TVR club has organised a Special Event Station, **GB8TVR**, to run in connection with the event. The GB8TVR station is being sponsored by **Martin Lynch & Son** and will be operational on 145.550MHz f.m. and 144.330MHz s.s.b.

Martin Lynch will be in attendance at the TVR rally in his own TVR (it's bright yellow so you won't be able to miss him!). Anyone working GB8TVR will have their QSO confirmed with a special TVR QSL card and will also have the chance to win one of ten Martin Lynch & Son T-shirts being given away throughout the day, make sure you are QTHR!

## Summer Party

**Chris Rees G3TUX** of the QRP Component Company is 'filling the gap' between the Yeovil and Rochdale QRP gatherings with his 'Summer Party'. Chris's party will be held on Saturday 3 August 1996 at **Our Lady of Lourdes Church Hall, Weydon Road, Haslemere** and will provide the opportunity for QRPers and like minded radio amateurs to gather for a natter and a bite of lunch.

There will be a small trade presence offering plenty of bits and pieces for the home-brewer as well as kits and low power rigs, together with a d.i.y. Bring & Buy facility (no computers, scanners or CB). Doors will open at 11am with lunch available from 12.30. Entry will be free, but lunch will be charged for.

There will be a talk-in by G3TUX/P on S22 and a raffle will be drawn at 3pm. Chris will be offering prizes for: The most original home-brew equipment brought along; The UK visitor travelling the greatest distance to attend (as the crow flies) and The visitor working the talk-in station from the greatest distance (en-route). For more information contact **Chris** on (01428) 641771.

## Brendan's Beaming Beacon

The Irish Radio Transmitter's Society's (IRTS) sponsorship and organisation of the Brendan Trophy (for the first 144MHz two-way terrestrial contact across the Atlantic) is now well known. Various groups are attempting to break the record as *PW* goes to press and if the Transatlantic barrier

is broken you'll see the results in the magazine.

Beacons are an extremely helpful guide to propagation, particularly so in the case of the possible American-Ireland 144MHz attempts. With this in mind **Jim Ryan EI3DP**, the IRTS President has shown his full support in a most practical way - by providing a specialised beacon.

The beacon, which is built, financed and operated by EI3DP will be inextricably linked with the

## Radio Waves

The passenger liner operated by Cunard, the *QEII* now has its own on-board amateur radio station. The station has been set-up by **Jim Barlow G3VOU**, Chief Radio Officer and **Andrew Eardley G3UXO**, The Ship's Doctor and uses radio equipment donated by Kenwood.

The *QEII*'s station is housed in a shack in the ship's radio room and includes a TS-50 h.f. transceiver and various accessories. **David Wilkins G5HY** of Kenwood commented "A surprising number of amateurs sail the seven seas and as Kenwood is always looking for ways of generating more interest in amateur radio we thought this an ideal opportunity".

So, if you're thinking about a travelling the waves and wish to operate while cruising the seas maybe you should consider booking a trip on the *QEII*!



attempt and the record transatlantic attempt and the Brendan Trophy (named after the pioneering Monk St. Brendan - 'Brendan The Navigator' - hence its nickname **Brendan's Beaming Beacon EI3DP/P**).

Brendan's Beacon will operate from Sunday 9 June for a period of three months with the call sign EI3DP/P, on a frequency of 144.480MHz using c.w. with an input power of 25W. The antenna is an 8-element horizontally polarised 'Quagi' mounted 20 feet above the site which is itself at 1600ft above seal level at 51.38.025N 10.00.058W (IO41XP) beaming towards USA and Canada.

Transmissions from Brendan's Beacon consist of (repeated every 60 secs): **TEST DE EI3DP/P EI3DP/P EI3DP/P QTH IO41XP**.

Any station in the USA or Canada which monitors the transmission and wishes to attempt a two-way QSO is invited to call a paging receiver number **+353 1 2032371**. This will contact a bureau service with alphanumeric message service. Paging receivers will be carried by **Tom EI4DQ** and **Dave EI4HT** and they are available on a 24-hour basis within 30 minutes of alert, ready to operate on the frequency 144.080MHz for the two-way attempt (on c.w. in the first instance).

Station operator **Jim EI3DP** will appreciate any reports from stations who might monitor the transmissions. Home address is as per call book. Tel: 00-353-21-632365 (home), or 00-353-21-504744 (work).

**Editorial note:** Jim EI3DP has told *PW* that there's a good chance that the (extremely interesting and pioneering) 'Brendan's Beacon' could continue over the winter months, providing long term monitoring possibilities. If you are interested in the project, please contact **Jim Ryan** direct. For my part, I congratulate EI3DP for his initiative and dedication and wish the project - and the challenge - well. **G3XFD**.

## Yaesu News

A new dual-band mobile transceiver, the FT-800R, has just been added to the already vast Yaesu range of equipment. The FT-800R features 108 memory channels, digital d.c. voltage display, wide multi-band receive, 50W of output power on v.h.f., 35W on u.h.f. and 3 levels with 10W medium and 3W low power also available.

Also featured on the FT-800R is the Smart Search facility, which automatically sweeps a band and then loads active frequencies into dedicated memory banks. Yaesu say this facility could be particularly useful for identifying repeaters when visiting unfamiliar places.

# YAESU YAESU YAESU

The recommended retail price for the FT-800R is £549 including VAT. There are also various optional extras available such as a dual-band CTCSS unit, DTMF microphone and quick release mobile bracket. Towards the end of the year an ADMS-1D Windows PC programme will also be available.

For more information on this latest offering from Yaesu you are invited to contact any of the Yaesu approved dealers. (*Practical Wireless* hopes to review the FT-800R in the near future).

## AMSAT Colloquium

Ron Broadbent G3AAJ has notified the Newsdesk with details of the 1996 AMSAT-UK Colloquium which is being held at the University of Surrey, Guildford, Surrey from July 25 - 29th. The Colloquium brings together like minded satellite enthusiasts from around the world and involves technical learning, fun, good food and the chance to meet the 'stars' of the satellite hobby.

Places on the '96 Colloquium are filling up fast so, if you want to join with fellow satellite enthusiasts on this five day event contact Ron Broadbent G3AAJ, Hon. Secretary/Treasurer at AMSAT-UK, London E12 5EQ. Tel: 0181-989 6741, FAX: 0181-989 3430 or E-mail: G3AAJ@amsat.org or r.broadbent@ee.surrey.ac.uk immediately and we're sure he'll be able to squeeze you in!

## Badger Boards

John Badger G4YZO proprietor of Badger Boards, the suppliers of all *PW* printed circuit boards (p.c.b.s) announced that due to recent illness his shop at 80 Clarence Road, Erdington, Birmingham has closed and that as from June 30 all enquiries should be directed to 87 Blackberry Lane, Four Oaks, Sutton Coldfield B74 4JF. Tel: (0956) 374918. John would like to thank all customers and friends for their continued support and assures them that he endeavours to keep Badger Boards going for as long as possible.

Please note that any attendance at the new Blackberry Lane premises will be strictly by appointment only and that all phone calls will be closely monitored and will only be accepted during the hours stipulated. The times for receiving calls will be 9am to 5.30pm Monday to Friday (Wednesdays will be a telephone service only).

John's RAE course, which he runs at Perry Common School will continue, with a new course starting in September. Unfortunately the computer classes have had to be dropped.

A full list of the p.c.b.s available from Badger Boards can be obtained by sending an s.a.e. direct to John at Blackberry Lane. The latest *PW* p.c.b. for the *PW* Codecard (July 1996 *PW*) is now available for £14.50 plus £1.50 P&P.

Finally, John has various amounts of stock of some of the older *PW* p.c.b.s (projects from 1979 - 1986), which he would like to offer to radio clubs at much reduced prices for their members to have a go at building (especially the Novice and younger members). If you think your club could benefit from some construction evenings contact John for full details and prices quoting *PW* as a reference.

## Dive-In To Success

The second *Practical Wireless* 'Dive-in To Defeat Diabetes' sponsored swim took place on Saturday 24th February at Ringwood Recreation Centre in the New Forest. 'Launched' by Anglia ITV Weatherman Jim Bacon G3YLA, the event was again sponsored by *PW* Publishing Ltd.

Members of *PW* Publishing staff, families, readers, friends and hospital personnel were raising money for the new Diabetes Centre at the Royal Bournemouth Hospital by swimming in the 30m pool (Location for BBC TV's 'The Brittas Empire').



Bob Burrows G6DUN and family from the Short Wave Shop in Christchurch 'jumped in' in a big way and along with acting as a focal point for sponsorship, also provided many of the junior swimmers and raffle 'stewards' for the enjoyable evening. Swimmers came from as far afield as Essex and Hertfordshire.

The total amount raised this year was £887, and Rob Mannion G3XFD (who just managed to do his 50 lengths this time) accompanied by Publishers Dick Ganderton G8VFH, Steve Hunt, and Kathy Moore presented the cheque to Diabetic Specialist Nurses Joan Everett and Pat Miles (either end of the cheque). Joan and Pat, who along with swimming themselves on 24 February, accepted the money on behalf of the hospital with extra support from Bob Burrows G6DUN and his family and friends during a ceremony at the Short Wave Shop on Friday 19 April.

## Obituary - Nigel Curzon G8CKZ

Amateur radio is full of 'characters' and Nigel Curzon G8CKZ who died after a long illness aged only 45 on April 27, was one of them. Nigel, was latterly well known by the Amateur Radio community for his former connections as a Director of Chandlers Ford based South Midlands Communications.

However, Nigel's connections with Amateur Radio went back many years before he worked for SMC. I remember him as a keen (and very superior!) 12 year-old who joined the old Southampton RSGB Group which met at Southampton University. With his enthusiasm, natural air of authority (even as a very young man) he endeared himself to the much older Southampton members. Over the years he became known as a very keen v.h.f. and u.h.f. operator, RAE and general amateur radio lecturer.

Nigel also formed a mainstay of what became known as the 'Brigade of Brollies', and if I remember correctly, actually started the 'Brolly carrying' fashion himself. This group, one of which was the late Richard Woodley G8CEH, seemed to have modelled themselves on the (then!) popular TV series 'The Avengers' - but without the bowler hats and Mrs Peel!

The 'Brolly Brigade' formed a nucleus of young and enthusiastic radio amateurs who all went on to carve out successful careers for themselves in radio and electronics. And yet another has passed on, but he's left a legacy behind him in the form of his many friends and memories of his anarchic sense of humour and zany approach to life. On behalf of his many friends and *PW*, I express my sympathies to Nigel's family on the loss of their son and brother.

Rob Mannion G3XFD



## Can You Help?

Tom Allison of 70 Alma Street, Sheerness, Kent ME12 2AZ needs help in finding a chip, type MSM 9520RS to repair his FT-707. He has been told that the chips are no longer generally available but would like to get his radio working again. If you can help please contact Tom direct.

# NOVICE

## Natter

For Radio Beginners Of All Ages

*Elaine Richards G4LFM has news of JOTA, advice on buying and selling equipment, 'Top Band' and 'Fox Hunting'.*

### Jamboree On The Air

Let me address the older members of the readership, those of you who hold an amateur radio licence and already have an established station. Over the weekend of October 19/20 the 1996 Jamboree on the Air (JOTA) will take place.

Last year, hundreds of youngsters took part in JOTA, from the youngest Beaver to the oldest Scout. Looking through the reports from the various groups, there were many areas which were not represented.

Why? Simply because no-one locally offered their services to set-up and run the special event

station. Now that's a real shame as the Cubs have a Communicators Badge they can work for, without an event like a JOTA station they have very little chance of completing that.

It isn't difficult to contact your local Beaver, Cub or Scout group, **John Fogg at the Scout Association, Baden-Powell House, Queen's Gate, London SW7 5JS** will put you in touch with your local group. If there already is a JOTA station locally, they are unlikely to turn away another volunteer.

The 7th Epsom (Methodist) Unit in Surrey ran their station overnight last year for extra interest and another volunteer or two might make that possible for

other Units. It was sad to read of a couple of groups who could only operate as a listening station and another who had to travel to another group to take part in the event.

Think about it. For younger readers, if you belong to a local Scout group, pester your leaders to put on a station in October! As I read through the reports from the various Units they seem to have had a brilliant time.

Other activities mentioned range from astronomy to outdoor cooking, and watching the MIR space station pass overhead to five-legged obstacle

courses! Several groups even camped out (in October - they must be mad!).

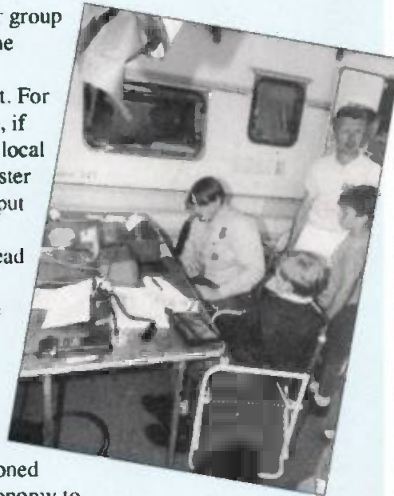

Last year hundreds of youngsters took part in JOTA.

### Buying & Selling

You can't always buy new kit, in fact most of us buy second-hand at some time or another. Sometimes you want to sell bits of kit as well when you are changing radios or antennas, etc.

So, what's the best way to either buy or sell? There are probably four main ways of buying or selling amateur radio gear.

The first is an amateur radio dealer, you can buy new or second-hand gear from them and you can trade-in your old radio for a new one too. This has lots of advantages as you will get some kind of guarantee with the equipment regardless of whether it's new or not.

The trouble is you may not have a dealer close at hand and this can make it more inconvenient if you have to travel long distances.

So, how about placing an advert, either in your local paper or in a radio magazine (such as 'Bargain Basement' in *PW*)? This can be successful if you happen to be reading the right magazine or paper at the right time.

I've seen several pieces of equipment offered for sale in our local 'free advert' paper. Obviously all the usual pros and cons apply when buying or selling through adverts.

Another convenient method is selling at a local radio clubs 'junk' or surplus sales. At these

sales you will often know the person selling the equipment you want to buy or know who you are selling to.

An aside to buying/selling through surplus sales is that the commission that the club charges on the sales boosts the funds and perhaps helps to keep your subs down! This is a relatively 'safe' way of buying equipment but you won't get any guarantees.

The fourth main method is selling at rallies. Nearly every radio rally that goes on in the UK will have a 'Bring & Buy'. They are a very popular part of the rally and bargains can be had for the eagle-eyed.

Bring & Buy stands are often very busy and trade

can be brisk. These are also usually run on a 'commission' basis and I think the current rate is about 10% of the selling price to the club or rally funds.

Because Bring & Buy is so popular it's a good way of selling your surplus equipment. If you're buying, then you still have no guarantees on the equipment. In saying that I haven't heard of very many horror stories about 'white elephant' buys.

If you are a buyer, just go careful that your enthusiasm doesn't get the better of you. Don't just grab the first 'bargain' you can see, find out all you can about the piece of equipment and then decide if you want to part with

your money.

If you are going to sell your equipment, how about writing a clear notice telling the buyers what the equipment is. When you are standing behind a barrier 2m or so from the equipment, it does help.

If you want to sell some equipment make sure you take all the relevant paperwork with you (like the manuals, etc). If you have the original boxes so much the better.

Give the equipment a clean-up - you know, dust it and get rid of the sticky fingerprints. When you get to the rally locate the Bring & Buy (it's usually well sign-posted) and take your equipment to the 'Booking In' position.

You will be asked to fill in some paperwork, it asks things like your name, address, the price you are selling the equipment for, will you accept a cheque, and then you usually have to sign to say the equipment isn't under a hire purchase agreement. Once you've done that, the equipment is taken and displayed on some sort of staging or shelving units.

All you have to do is return from time to time and see if the equipment has been removed from sight. Once someone has bought it you can return to collect your money, less the commission charged by the Rally.

Sometimes you will hear your name or callsign on the public address system asking you to return to the Bring & Buy, that usually means someone is making an



## Fox Hunts

Fox hunts in radio terms are nothing to do with chasing wild animals, but a great way to get into home construction whilst having some good clean fun. Radio Fox Hunts are rather like treasure hunts but instead of looking for visual clues you have to try and locate a concealed low power transmitter.

The Fox Hunts are organised as summer events by many radio clubs and usually operate using transmitters in the 144MHz band. This is chosen for its basic 'line-of sight' properties combined

with the fact that the majority of hand-portables are 144MHz rigs.

The home-brew aspect comes in in two ways. If you're really ambitious you could build your own dedicated direction finding (d.f.) receiver but for most operations the construction is confined to building a hand portable directional antenna.

There have been many designs for hand portable directional antennas and you can have great fun experimenting with all manner of unusual designs. One popular design of a few years ago was the HB9CV unit.

In addition to antenna design it

can be very handy to have some form of S-meter to help with the d.f. Whilst the usual liquid crystal display (l.c.d) barograph type may be adequate, a decent analogue meter takes some beating.

If your rig is out of guarantee and you have a good electronic knowledge you should be able to build an external S-Meter just for d.f. work. Although building your own equipment is all very well the real fun comes on the day.

I've known some devious hunters locate and then move the foxes just to cause mischief! If all this has sparked your interest but

your club doesn't run a Fox Hunt why don't you offer to organise one!

If you were watching Children's BBC during the half term you may have seen the programme *Activ8* when they did an item about Fox Hunting. The youngsters interviewed had 'a ball' chasing through the woods to find the hidden station who was well and truly hidden under a large bush. The programme also gave some good information about licensing and who to contact for more information - 10 out of 10 there.

offer outside the limits you set or are wanting more information before making the purchase. If you are intending to buy from the rally it can be a good idea to take cash.

Normally, I wouldn't suggest you ever carry large sums of cash on you, but this is different. Many people don't want to accept a cheque for their equipment (and you can often do a deal if you can wave the cash under the sellers nose!).

You don't usually have to fill out any kind of paperwork when you are buying in cash, the people running the Bring & Buy just fill out how much you paid and how much commission they've taken for the benefit of the seller.

## Top Band

Following on from last month's look at the receiving side of your rig, this month I want to look at (what was until 73kHz arrived!) the lowest transmitting band of all the h.f. bands. The 1.8MHz band or 'Top Band' as it's affectionately known, is probably one of the least explored by most amateurs.

It's a shame because the 1.8MHz band offers its own unique challenges that can be great fun. So, let's start with a look at the frequencies and power restrictions that go to make-up 'Top Band'.

The latest licence schedule shows that the frequency range from 1.810MHz through to 2MHz is available for amateur use. However, there are a few restrictions as the main part of the band from 1.850MHz through to 2MHz is restricted to a maximum power level of 15dBW as opposed to the usual 26dBW.

You also need to note that although UK amateurs have primary use of the band this is only on the condition of non-interference to other services outside the UK. In normal circumstances this presents no problem - you just need to be prepared to move if asked when propagation conditions are favourable.

The only exception is the narrow band between 1.833 and 1.850MHz where we have exclusive usage. When it comes to making best use of 'Top Band' you need to understand how it's effected by propagation

conditions.

As 'Top Band' is more akin to m.f. than h.f., the signals tend to behave rather like medium wave broadcast stations. Anyone who has lived through the hey days of the 'pirates' and **Radio Luxembourg** will recall that these signals came to life at night. This effect is caused by the highly absorbent D layer that soaks-up these frequencies leaving only the ground wave during the daylight hours.

At night time the situation changes radically and skip propagation is possible via the F2 layer. This mode can be used for inter-continental QSOs. Whilst this is theoretically possible all year round, this is limited by tropical storms in the summer that generate lots of static interference.

As a result, the best time for working DX is those dark winter evenings. So, why am I telling now I hear you say? If you're going to make the most of 'Top Band' DX you need to build yourself a decent antenna system, and what better time to build an antenna than in the summer!

As for a suitable design, there are lots to choose

from depending on the space available. All the usual dipoles, etc., can be used, but with a wavelength of around 160m they tend to be rather large!

One alternative is to go for a hula-hoop or directional-discontinuity ring radiator (DDR) as described in Les Moxon's *HF Antennas For All Locations* (available from the **PW Book Service** for **£13.99** plus P&P). This compact antenna

design comprises a 11m loop mounted just 1.3m above the ground and is reputed to produce very good results.

Whichever design you choose you can be sure of lots of fun and a terrific sense of achievement when you pull-in your first DX.

*Elaine G4LFM*

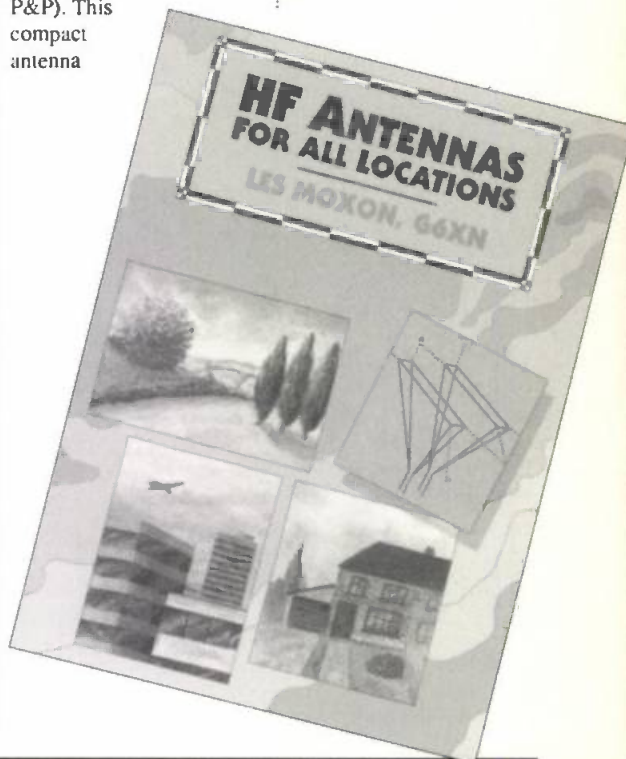

*That's all the 'natterings' for this month so, until next time cheerio and don't forget to write to me with your hints and tips for interesting radio. Letters should be sent to me at PO Box 1863, Ringwood, Hants BH24 3XD.*

**Zoë says:**  
 "keep the News and  
 those Club  
 magazines coming!"

# CLUB Spotlight

Compiled by Zoë Crabb

Your pages - your stories!  
 Have you moved into a new  
 club room, won a contest,  
 got a funny story or news of  
 a special event? Then let's  
 hear from you. Send in  
 your club logo too, if you've  
 got one. You never know,  
 you'll probably recruit new  
 members at the same time!

## Radio Days Exhibition

**Richard Newton GORSN** has written into 'Club Spotlight' with news of a community project called 'Radio Days', which took place back in February.

The Dorset Police Amateur Radio Society (DPARS) was started in 1992 by a small, but keen group of licensed amateurs and short wave listeners, all either serving Police Officers, Special Constables, Civilian Support Staff or retired colleagues. Since 1992, the Dorset Police Amateur Radio Society has been going from strength to strength.

We try and get involved with as much as we can locally by always attending the Wimborne (Flight Refuelling ARC's) Hamfest for example. We are a closed club by virtue of the organisation we represent. However, we welcome contact from other societies and clubs.

Members are always happy to make someone a cup of coffee on our Thursday club night at Bournemouth Police Station, by prior appointment only though I'm afraid. We are also quite happy to drink someone else's coffee! So, if you're interested in rescuing us from our own company, contact me at the address below.

The members take every opportunity that comes our way to get involved in community initiatives. This not only helps the hobby

but also Police/Public relations.

Now, when you get called to the Chief Superintendent's Office, it's not usually good news. Well, actually it is hardly ever good news! That is why I was a little concerned when I got summoned to present myself to the Bournemouth Divisional Commander.

You can appreciate my relief when he told me that he had heard of the Dorset Police ARS through our Press Office and that he wanted us to get involved in a community project that



the County Council had asked the Police to attend. He had thought of us, as the project was to be called 'Radio Days'.

'Radio Days' was a County Council initiative that took place at the Bournemouth Centre for Community Arts (BCCA), Haviland Road, Boscombe between the 13 and 16th of February. The whole event was planned by **Jeff Goodwin**, of the BCCA.

The event was an educational exhibition, comprising of two parts. A play, taking a lighthearted look at Marconi's early experiments in this area, and the first BBC radio station in Bournemouth, 6BM. Then a look at modern applications of radio. This is where the Police were asked for an input, to show how radio is used in the modern

emergency services.

The latter was the role that the Dorset Police Amateur Radio Society were asked if they could fill. A team comprising of myself **PC Richard Newton GORSN**, Control Room operators **Ray Singleton** and **Ted Bain 2E1EJC** and Station Desk Officer, **Bob Knight G6DZM** attended the event.

We set-up an exhibition that covered Police radio through the years and amateur radio. Over 200 school children from the area attended the exhibition, where they were introduced to Morse code and Packet. **Ray** also enthralled them with tales of bravery and daring in the Bournemouth control rooms, old and new.

Thanks to the generosity of **Sgt Tom Murphy** and the practical skills of **PC Clive Hardy G4SLU**, we were able to show a comprehensive display of Police Personal Radios from the PFI, issued in the early 1960s, up to the Motorola MASC HT600E. Most of these were from **Tom's** private collection. An amateur radio Special Event station was also set-up, (callsign **GB6BM**). From this station we contacted just under 70



(L-R) **Bob Knight G6DZM**, **Ted Bain 2E1EJC**, **Ray Singleton** and **Richard GORSN**

other stations, ranging from Serbia, Greece and the former Yugoslavia, to Eire, Germany and all over the UK. This was to commemorate the first BBC radio station in Bournemouth, 6BM.

We had a lot of fun, although it was essentially a closed exhibition for local schools. But the word soon spread and the BCCA were kind enough to let amateurs who turned up come down and meet us. Some even helped out, so a big thanks to all those who took the pressure off us for a little while.

Well, a schools exhibition could not go by without the Novice licence being represented. This was ably done by **Phil Mayer G0KKL**, who by the way, has a wicked sense of humour that could rival that of a Police Officer's any day of the week!

For all those concerned, the high point must have

been the interview conducted by **BBC Radio Solent**. This is where **Bob Knight** came into his own.

The tone was set early on by the interviewer, first talking to **Richard**, who was wearing his callsign next to his Christian name. "Richard Gorsen, that's an unusual name isn't it?" said the interviewer, mistaking **GORSN** as a name! Well, what can you say, it was live radio after all!

Then it was **Bob's** turn. When he was asked the question "What date was the radio station 6BM started up?" **Bob's** face was an absolute picture. Here was a man who was looking for a hole!

**Phil** was frantically trying to mouth the answer, to no avail. It goes without saying **Bob's** closest friends and colleagues were at this moment doubled up in laughter. Such is the comradeship in the service eh **Bob!**?

What seemed like an age passed, in reality perhaps only a second, and **Bob** said "Oh Nineteen hundred and frozen to death!" I think it was at this point that the last one of the on-lookers actually collapsed. Still, the BBC man took it all in good spirit, I think. That'll teach him to call me 'Gorsen'.

So, contrary to public belief, Police Officers do have a sense of humour. We would welcome closer



Pic 1: **Ray Singleton, s.w.l.**, pictured with some of the Dorset Police ARS's radio equipment.

contact with local clubs and would especially like to hear from Serving or Retired Police Officers who have an interest in the hobby living in the area.

We also have regular contact with the **Hampshire Police ARS**, **West Midlands ARS** and the **International Police Association Radio Club**. Are there any more Police radio clubs out there? I have heard rumours, but never seen any evidence!

If you'd like to know more, why not contact: **PC 915 Newton, Dorset Police Amateur Radio Club Secretary, Control Room, Bournemouth Police Station, Madeira Road, Bournemouth, Dorset. G0RSN@GB7SIG.**

## Examination Centre At Club Premises

The **Bishop Auckland Radio Amateurs' Club (BARAC)** meet every week at the Community Centre in the village of Stanley-Crook, County Durham from 7.30pm onwards. For several years, the club have been able to provide instruction leading to the RAE and more recently for the Novice RAE as well.

Students have then taken the actual examination, as external candidates, elsewhere. However, the club discovered that the 'students' were coming from much further afield, and on enquiry, the club found that they were now, almost alone in the county

## Restored Taxi

'Club Spotlight' has recently received a letter from **Max Freedman G0WHW**, a London cab driver. The taxi shown in the picture was originally bought by Max's father in 1937 for £385 and served in London until 1955, when it was retired through old age and general infirmity.

The taxi was kept alive in order to assist Max in learning to drive, but having accomplished this heroic mission, Max refused to let it die and restored it to its original glory, as a change from restoring vintage domestic radios! The taxi regularly attends vintage vehicle rallies all over the south of England and the London to Brighton Historic Commercial Vehicle Run, with some success. Max has even worked /M from it, with somewhat less success!



Max G0WHW and XYL with their 1937 Austin Taxi.

in providing tuition and that there was an increasing problem of finding examination centres.

Originally, for the benefit of their own students, they applied for the recently obtained approval to set-up an examination centre at the club premises. The club therefore is now able to offer examination facilities to their own students and to external candidates, who have been instructed elsewhere.

**Tim Bevan G6WBA** continues to instruct both for RAE and Novice RAE and is the appointed administrator for the BARAC Examination Centre. Any enquiries regarding tuition or use of the examination centre should be made to **Tim Bevan G6WBA** who is QTHR.

Any other enquiries should be addressed to the Club Secretary **Derek Perrey G4WUE** who is also QTHR.

## Election Time

At a recent AGM, the following were elected to the 1996/7 Executive Committee of the **Chichester & District Amateur Radio Club** held on 2 April 1996.

**Chairman**  
John Robertson G0KJU  
**Vice Chairman**  
Dave Burtenshaw G0AYV  
**Treasurer**  
John Francis G8ZTD  
**Secretary**  
John Stratfull G3IJS

## Members

John Chappell G4ZTQ  
Dave Clear G0KNU  
Hugh Duncombe G3XJN  
Dave Gilbey G1ITL  
Henry Kaminski G1NBX  
Yvonne Robertson 2E1CH  
Ted Turner G1VMG  
**Graham Swann G0WSD** continues to be President.

## Trowbridge Course

The **Trowbridge & District Amateur Radio Club** intend to run a radio amateurs examination course (C.G.L. 1. 765) starting in September 1996. The course will be held weekly in the village of Southwick, near Trowbridge, Wiltshire.

Further details can be obtained from the course tutor **Chris Parnell G0HFX** on (01225) 764874 (evenings) or from the club secretary **Ian Carter G0GRI** on (01225) 864698 (evenings).

## First Woman For GLARES

**Nancy Bone** is now the Secretary of the **Great Lumley Amateur Radio and Electronic Society (GLARES)**, which will have been formed for 25 years next year. Nancy is the first woman secretary of the GLARES and is in fact the first woman committee member in the last 25 years!

The society meet every Wednesday from 7.30pm onwards at the Community Centre in Great Lumley. Want to find out a bit more

- then contact **Nancy** at **49 South Street, Durham City DH1 4QP** or telephone on **0191-384 4055**.

## Car Boot With A Difference!

The **Milton Keynes & District Amateur Radio Society** are running their normal car boot sale (Sunday 1 September 1996), but with a difference this year. They hope to attract and establish the whereabouts, eventually, of some 12000 people who once worked at the **Government Code & Cypher Centre** in Bletchley Park, North Buckinghamshire.

Since a great number of them were 'communicators', it follows that they may have taken the Radio Amateur path at some time in their lives. The society would like to make this an annual get-together and hopefully bring news of old friends from all over the world.

The **Bletchley Park Trust** are keen to build up their growing database of former residents of the Park. New leads are being found through the continuous stream of visitors that come twice monthly to see the museum. Tel: (01908) 640404.

If you would like more details of this event, please contact **Des Shepherd G3LCS** (Station Manager GB2BP Bletchley Park) at **35 The Crescent, Haversham, Milton Keynes MK19 7AN**.

## Spotlight Trophy

**David Barlow G3PLE** has great admiration for Amateur Radio Club magazines and newsletters - and the people who put the hard work into producing them. So David, a retired Marketing professional and former member of the Birmingham Press Club who now lives in Cornwall, wrote to the **Rob Mannion**, Editor of *PW*, and **Zoë Crabb** (formerly *Shortland*) suggesting a special trophy for the best Radio Club Magazine or newsletter.

**Rob** and **Zoë** thought David's idea was an excellent way of encouraging the (often hard-pressed!) magazine and newsletter editors. **Dave Wilkins G5HY** of **Kenwood (UK) Ltd.** thought so too! The result is that a new award, The Spotlight Trophy, Awarded To The Radio Club Magazine of The Year by *Practical Wireless* and Kenwood (UK) will be presented at the Leicester Show in October.

So, let's see your magazine, whether it be weekly, monthly quarterly, glossy, duplicated A4, PC produced or whatever. They're all of interest and yours could win!

To enter your Club Magazine for the award, send two of your most recent club magazines and details on how they're published, to the *PW* Editorial offices at the very latest by **Monday 22nd July**. Remember to mark your envelope 'Spotlight Club Magazine Competition'.

The panel of judges: **Dave Wilkins G5HY**, **Zoë Crabb**, **Jim Bacon G3YLA**, **David Barlow G3PLE** and the Editor are looking forward to reading your club's magazine! Get busy, the spotlight's on!

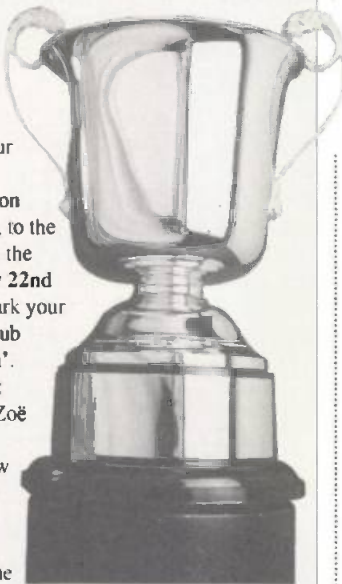

Send your club information to Zoë Crabb at the PW Offices.

# Q:

**WHY BOTHER TO  
SUBSCRIBE TO THE UK'S  
BEST SELLING AMATEUR  
RADIO MAGAZINE?**

# A:

**BY SUBSCRIBING  
YOU'LL GET THE  
EXTRA BENEFITS OF:**

- Getting *PW* delivered direct to your door every month.
- Avoiding cover price rises during the period of your subscription.
- Making extra savings on special offers throughout the year.
- Receiving your copy before *PW* goes on general sale.
- **AND** getting to the bargains in 'Bargain Basement' **FIRST.**



**Subscription Rates:**

UK	£25
Europe (1st Class)	£30
Airsaver	
(Rest of World)	£32
Airmail	
(Rest of World)	£37

Taking out a subscription is easy. All you have to do is to fill in the **Order Form** on page 62 of this issue or telephone the **PW Credit Card Hotline** on (01202) 659930 and quote **PW8**, then sit back and wait for your issues to come through your letterbox.

**Isn't it time you subscribed to  
Practical Wireless and got the  
VITAL COMPONENT to bring  
your hobby to life?**

# RADIO *Diary*

Compiled by Zoë Crabb

## 1996

**July 28:** The Rugby ATS 8th Annual Radio Rally will be held at the BP Truckstop on the A5, three miles east of Rugby and just 2.5 miles North west from junction 18 of the M1 motorway. Doors open from 10am and admission is £1 per car and facilities include a good cafeteria and toilets. Talk-in on S22 by GB8RRR. Further details from Peter on (01455) 552449 or Steve (for bookings) on (01788) 824214.

**\*July 28:** The Scarborough Amateur Radio Society Amateur Radio, Electronics and Computer Fair will be held at The Spa, South Foreshore, Scarborough. More details can be obtained from Ross Neilson G4ZNZ on (01377) 257074.

**\*August 4:** The RSGB Woburn Rally is being held at Woburn Abbey, Bedfordshire. Further details from Norman Miller G3MIV on (01227) 225563.

**August 11:** The 39th Annual Derby Mobile Rally takes place at the Littleover Community School, Pastures Hill, Littleover, Derby. Doors open at 9.30am. The school is located off the A5250 (Burton Road) south of Derby, one mile south of the village of Littleover and the A5111 Derby Ring Road. There will be a large flea market, tables by the hour, wide range of radio and computer traders, monster radio & computer junk sale run by the society - with silly prices, famous for many years, starts at 11am. There will also be a wide range of refreshments available. Ample accommodation if wet. **Martin G3SZJ, QTHR.** Tel/FAX: (01332) 556875.

**\*August 11:** Flight Refuelling ARS Hamfest 96 will take place at the Flight Refuelling Sports Ground, Merley, Wimborne, Dorset. The event will run from 10am to 5pm and will include the usual mix of traders, Bring & Buy, craft exhibitors, car boot sale and field events. Talk-in will be on S22. **Richard Hogan G4VCQ** on (01202) 691021.

**August 16:** Cockenzie & Port Seton Amateur Radio Club Radio Junk Night will be held from 1830 to 2130 in the Cockenzie & Port Seton Community Centre. Bring along your own junk and sell it yourself. Tables will be provided free of charge on a first come first served basis. Entry fee £1 and refreshments will be available. All money raised to go to the British Heart Foundation. **Bob GM4UJZ** on (01875) 811723.

**August 18:** The Red Rose Rally is being held at Horwich Leisure Centre, Victoria Road, Horwich, Nr. Bolton of J6 M61. There will be a cafe, bar, Bring & Buy, RSGB stand, special interest groups, parking for 300 cars, free cash draw every hour, children's activity room up to seven years, supervised by parent. Doors open at 10.30am and admission is £1, free for children. Talk-in on S22. **Albert G7RZW** on (01204) 62980.

**August 18:** The 7th Great Eastern Rally is to be held at the Cattle Market, Hardwick Narrows, Kings Lynn. Doors open at 10am (9.45am for disabled visitors). There will be an outdoor car boot area, a spacious indoor area with national exhibitors, a Bring & Buy, talk-in on S22, free parking, refreshments on site, easy access for disabled. It is a good family day out with Sunday car boot nearby and close to Hunstanton Beach & Sandringham House. For bookings and information contact **G0BMS** on (01553) 765614 or at **GB7OPC** or E-mail **len@feline.conqueror.co.uk**

**August 25:** The Galashiels and District Amateur Radio Society Open Day and

rally will be held at a new and larger venue, The Volunteer Hall, St. John's Street, Galashiels from 11am to 4pm. There will be a Bring & Buy, refreshments and a raffle. Talk-in on S22. (01896) 850245 or (01896) 755943 evenings only.

**August 25:** East Coast Amateur Radio & Computer Rally, Clacton Leisure Centre, Vista Road, Clacton-on-Sea. **Sharward Promotions, Upland Centre, 2 Upland Road, Ipswich, Suffolk, IP4 5BT.** Tel: (01473) 272002.

**August 26:** The Huntingdonshire Amateur Radio Society Annual Bank Holiday Monday Radio Rally is to be held at Ernulf Community School, St Neots, Cambridgeshire. Doors open at 10am and admission is £1. Refreshments available. Talk-in on S22. Further details from **David Leech G7DIU** on (01480) 431333.

**\*September 1:** The Bristol Radio Rally is being held at Brunel Centre, Temple Meads Stations, Bristol. Doors open at 10.30am to 4pm (disabled 10.15am). Admission is £1. There is ample under cover parking, refreshments, large Bring & Buy and talk-in on S22. Tel: (01275) 834282.

**September 1:** The Telford Radio Rally will be held at the Telford International Centre. Two large, purpose built exhibition halls offer a day for the whole family. Main dealers are already booked along with a Bring & Buy, flea market and many special interest groups represented. Parking is on site and it is easy to find, just off the M54 motorway. Further details from **Tony 2E1DXR** or via **GB7PMB** on (01743) 235619.

**September 7:** The Annual Wight Wireless & Computer Rally is to be held once again at Arreton Manor, near Newport, Isle of Wight between 11am and 5pm. There is no charge for admission to the Wireless Museum or the extensive gardens, lawns and grounds, with plenty of free parking. There is no charge for trade stands or the Bring & Buy sale, so bring all your surplus equipment. There will also be a collection for the Radio Invalid & Blind Club. The cafeteria will be open for the much needed 'cuppa'. Talk-in on S22. Further information on (01983) 567665.

**\*September 8:** The 15th Lincoln Hamfest will be held on the Lincolnshire Showground. Entry fee, £1.50. Morse test available, plus all usual attractions. Caravans welcome (Saturday night only). **Sue Middleton** on (01522) 525760.

**September 15:** The Central Lancaster Radio Rally are holding their rally at the Central Lancaster High School, Crag Road, Lancaster, five minutes from Junction 34 on M6 motorway. Doors open at 10.30am and the entrance fee is £1. **Susan** on (01524) 64239 or (01384) 896199.

If you're travelling a long distance to a rally, it could be worth phoning the contact number to check all is well, before setting off.

The Editorial staff of *PW* cannot be held responsible for information on Rallies, as this is supplied by the organisers and is published in good faith as a service to readers.

If you have any queries about a particular event, please contact the organisers direct.

Editor

\* Practical Wireless & SWM in attendance

# Revex W200 SWR & Power Meter



By Leighton Smart GWOLBI

**Regular author  
Leighton Smart  
GWOLBI takes a break  
from preparing his  
'HF Far & Wide'  
column to try out an  
essential piece of  
equipment in the form  
of a combined  
s.w.r./power meter.**

As a keen QRP operator, I speak as someone who sees power meters as an essential part of the amateur station. So, when I was asked to review the Revex W200 SWR & Power Meter for *PW*, it seemed a good idea.

I must admit I looked forward to the opportunity to compare results with my own Daiwa CN101 s.w.r./power meter. This, so I've been assured has been correctly calibrated by a friend of mine, and reads output power accurately.

However, as I don't have a full coverage h.f. rig at the moment, I enlisted the assistance of regular 'HF Far & Wide' contributor Steve Locke GW0SGL. Steve very kindly loaned me the use of his shack for an evening to carry out the on air test!

## Neat Unit

Upon opening the box, my first impression was how neat the unit is. With a black matt/sheen finish it would look the part in most amateur radio shacks.

The W200's relatively compact size - 60 x 165 x 100mm - makes it small enough to fit in most 'spare corners' on the operating table. This may suit those operators (like myself) who have very little 'elbow room' as far as their stations are concerned!

According to the single - sheet 'handbook', the meter is designed to read output power from 3 to 30MHz, which disappointed me a little, as I

would have liked to operate on 1.8MHz, as it's my favourite band.

The meter itself has three power ranges - 20, 200W and 2kW!

However, I was primarily interested in the 20W range as a low power operator. But the varied power ranges would of course benefit the amateur who uses much higher power levels.

Usefully, the meter

also has an 'average' and peak envelope power (p.e.p.) measuring facility to enable measurement on s.s.b. which can assist operators to avoid 'flat topping' and consequent splatter.

But whereas the markings of the s.w.r. measurement on the actual meter were large enough to read without any difficulty, the power markings however, were quite small. I found later that I had to put my glasses on and look closely at the meter when measuring power output.

Using the instrument on the s.w.r. side is straightforward. It's fitted with the normal CAL and SWR positions on the switch, along with the calibration control.

## In Comparison

So, I duly visited Steve, along with the W200 and my own meter. And after the preliminaries of connection lead construction were dispensed with, I was able to play radio and air-test the meter at the same time.

I decide to connect the W200 up in series with my own meter. Although, I must be honest and say I was unsure as to whether having two meters in line would create standing waves in the feedline which would perhaps cause one or other meters to read incorrectly, both as far as power and s.w.r. readings were concerned.

As I don't own a dummy load which will take 100W or more, I had to compare the power and s.w.r. measurements using the 'on air' method. It isn't a perfect way to do things, but was the only practical option I had.

After the usual s.w.r. checks, and the subsequent antenna tuning unit (a.t.u.) adjustments for a 1.2:1 s.w.r. on the W200 I started the tests. I measured power output at three levels 5, 50 and 100W, on the 3.5, 10, 14, 21, and 28MHz bands.

I found that the s.w.r. readings were more or less the same as my meter, with a very slight discrepancy between the two on 3.5MHz. The power levels differed very little on

28, 21, and 14MHz, by perhaps just a couple of Watts at 50 and 100W output.

The differing reading increased on 10 and 3.5MHz to a difference of somewhere in the region of 10W, with the W200 always reading lower than my own meter. But again, bear in mind this is **only a comparison**, and who is to say that my meter is accurate!

## Peak Envelope Power

I must say that I found the p.e.p. facility on the W200 far more responsive than the same facility on my CN101.

On the W200, the needle rose quickly, and was 'held' at a certain level for a couple of seconds or until a higher speech peak was attained.

My own meter just never responded anywhere as near as well as the W200 did when reading p.e.p. So, the W200 provided me with a more realistic idea of my actual p.e.p. output.

## Essential Part

There's only so much you can say about meters apart from acknowledging they are of course an essential part of any amateur's station, and there are so many to chose from! Although as far as the Revex W200 is concerned, I would certainly consider buying one, if only for the p.e.p. feature.

The power discrepancy is slight - after all, 10W difference at 100W is just 10%. My only personal gripe is the very poor quality of the accompanying information sheet, but that aside, the W200 is a versatile unit which will suit many radio amateurs.

**My thanks go to Waters & Stanton Electronics of 22 Main Road, Hockley, Essex SS5 4QS. Tel: (01702) 206835 for loan of the Revex W200 which is available from them for £49.95.**

PW

## Manufacturer's Specifications

Frequency range:	3 - 30MHz
Input r.f. power:	1W - 2kW
Impedance:	50Ω
Minimum power for r.f. measurement:	2 W
Power measurement accuracy at 50 Ω	5W (±500mW) 50W (±5W) 500W (±50W)
SWR value at 50 Ω:	1.1
Size:	60 x 165 x 100mm
Weight:	460g
Connector:	M - J Type.

# The KENWOOD Story

By Richard McLachlan G3OQT

*Richard McLachlan G3OQT of Lowe Electronics Ltd. recently had the opportunity to visit Kenwood Japan, the well known Japanese manufacturer of amateur radio equipment. So, read on to share the experience.*

# KENWOOD

As many readers of *PW* will know, for 15 years until 1992, Lowe Electronics Ltd. were the UK importers and distributors for Trio-Kenwood, the leading Japanese manufacturer of amateur radio equipment. Trio-Kenwood then set-up their own UK distribution centre for their well known hi-fi and car audio products in 1988.

Then in 1992 Trio-Kenwood decided to set-up their own private mobile radio (p.m.r.) marketing operation as well. With the facilities in place, it also seemed a logical step to take over the distribution of their own amateur radio products as well.

For a couple of years now, Kenwood has held an annual competition among their p.m.r. dealers to find the top dealer of the year. This year they decided to hold the same competition between the amateur radio dealers.

I was of course delighted when my Company, Lowe Electronics, won the competition and were awarded the prize of a trip to Japan as the guests of Kenwood to look round their factories and facilities. So, with great anticipation, a group of us assembled at Heathrow Airport in mid-April.

## **Another World**

The journey to Tokyo takes around 13 hours by air and takes you forward eight hours on the clock and into 'another world'. Although I had been to the Far East before, this was my first time in Japan, and I was looking forward to the experience.

Japanese society is very different to that in the West and a number of cultural differences soon become apparent. After a weekend to allow jet lag to subside and mix-in a little sightseeing in Tokyo, we were ready for the first trip - to the Kenwood factory at Yamagata in the North of Japan.

One fascinating feature of the internal flight from Tokyo to Yamagata (by Jumbo jet for a one hour trip!) was the unusual nature of the in-flight entertainment. The plane had a video camera in the nose which looked straight ahead and gave all the

passengers a pilot's eye view of the take off and approach phases of the flight on a wide screen.

As the plane came in to land, 300 pairs of feet kicked the left rudder to correct for the cross wind drift! (Does the whole world have a flight simulator on their PCs?)

## **The Factory**

Yamagata is a medium sized town at the Northern tip of the main island of Japan site of the factory, looks out over the Sea of Japan to Russia. It has a lot of light manufacturing industry such as electronics, as many Japanese corporations have based their manufacturing there because of the sky high rents in Tokyo.

The Kenwood factory is around six years old and occupies an area of 11000 square metres. It employs over 500 people and the average age of the work force is around 29.

The factory is very modern indeed, and I've never seen such a level of automation in an electronics factory. Extensive use is made of 'JIT' (just in time) techniques to ensure that the flow of raw materials and components keeps up with the production lines.

This particular factory makes all the Kenwood personal 'phones for their domestic market, which you see carried everywhere, even by children on their way to school. The personal 'phone assembly lines make 600 units a day and it's fascinating to watch them coming off the end of the line at that rate.

In many respects the environment is like an electronics factory in the West, except that there is obviously a much stronger work ethic. The production line keeps running, there is no conversation, and not a broadcast radio or a Walkman in evidence!

If part of the production line slows down, musical chimes sound to tell the workers on that part of the line to speed up to maintain the output rate. (We shall have to try that with our own receiver production line!).

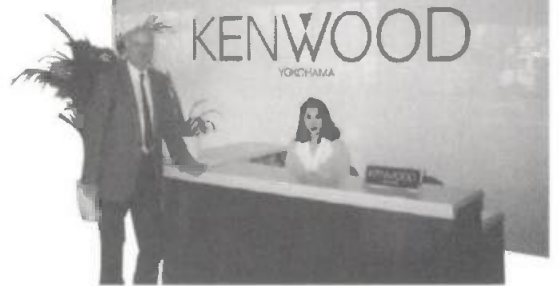

The Yamagata factory also makes all the Kenwood p.m.r. products, plus some of the amateur equipment such as base station and mobile transceivers. The production of the amateur hand-held equipment has been moved to Singapore to take advantage of the lower labour rates there.

Manufacturing wage rates in Japan are slightly higher than in the UK, but the cost of living is higher and there is not such a developed welfare system. The large companies providing for their employees many of the benefits that would come from the public sector here.

## **Automatic Insertion**

You may have heard of automatic component insertion machines, which take components from a bandolier and place them via a robot arm, in the correct position on the p.c.b. Well, the Kenwood factory has 16 of these in a line stretching from one side of the factory to the other.

When I was there, they were just setting-up a new machine which was inserting components at the rate of ten per second - just imagine that if you can! It was rather like one of those guns with the rotating barrels that fire the Uranium bullets at incoming missiles.

Closed circuit TV cameras are focussed in close-up on each component as it is offered up to the mounting hole. And if there are any small tolerance differences between where the hole should be and where it actually is, minor corrections are made to the robot arm. Programming information is transferred direct from the R & D facility at Yokohama some 960km away by optical fibre link.

The programming information is then used to set-up the automated production machines. This process eliminates the time consuming stage of preparing production drawings, etc.

At the end of the factory is the final test area, where rows of technicians are setting-up such



parameters as deviation, power output, microphone gain, etc. Every radio is 100% tested in every aspect, including talking into the microphone and listening to the audio quality.

There are five fully screened rooms where test routines are carried out. In addition, random samples are taken from the production line and put in an environmental chamber where they are taken to the limits of their temperature range while operating all the while. While I was there, I watched TM-733 dual-band mobile transceivers being put through this grueling test cycle.

### **Production Workers**

Production workers usually come to the work at the Kenwood factory straight from technical high school, when they have learnt electronics skills. They then receive extensive training in soldering and assembly techniques and only move to the production line when they are fully qualified, where they proudly wear their soldering proficiency badges on their arms.

Everybody including the managers wear very smart coloured jackets and the only way you can tell what job they do is by the colour. The whole place is scrupulously clean, air conditioned and the working environment is excellent.

After the factory visit, we were taken on a lightning tour of the area, calling in at some of the temples and had a most enjoyable visit to a Sake (Rice Wine) brewery (or perhaps distillery?). Then it was back to Tokyo on the flight simulator!

### **Tokyo City**

The city of Tokyo is around 80km across, and is the home of 25 million people. It's also one of the most expensive cities on Earth.

Rush hour in Tokyo starts at around 05.30 and continues until 10.00, with a repeat performance each evening. The public transport system

is of necessity, very well developed, highly efficient, spotless and absolutely punctual.

The pedestrian crossing outside our hotel was 50 metres wide. When the lights on the crossing changed a vast sea of people swarmed across every time.

One attraction of Tokyo not to be missed by radio enthusiasts is Akihabara, or 'Electric City'. This is an area reminiscent of the Lisle Street of my youth, where every sort of electrical and electronic bargain abounded.

In Electric City there are dozens of high rise blocks all stuffed to their seventh floors with computers, videos, hi-fi, cameras, radios, scanners, TVs, dish washers, camcorders, car audio, satellite equipment, etc., and mixed in with it all is amateur radio equipment.

All the very latest models of everything are launched in Japan first. For example I saw wall hanging TVs with 21 in full colour flat screens only 2in thick.

The best of the amateur radio shops is called **Rocket** (or at least that is what I am told the name translates to). I have been associated with the amateur radio retail business for many years and I have never seen such a wide range of stock!

Every single model from every manufacturer is on show, together with every conceivable accessory, antenna, bracket, mount, rotor, clamp, bearing, cable, etc. The list goes on forever.

Interestingly, there do not appear to be any demonstration facilities. Most radios are powered up, but there is no opportunity to try out an antenna.

Amateur equipment in Japan is not cheap, in fact the prices for the same equipment are higher than in the UK, despite the sales tax being only 3%.

The rents for the premises are astronomical. The high overheads means there are few cut price deals to be had.

One of the most interesting displays in Rocket was that of the in-car navigation systems. These products have evolved far more in Japan than anywhere in the world.

Not only do the navigation systems use GPS but also gyroscopically stabilised inertial navigation platforms as well. This keeps accurate position information when your car goes through a tunnel out of sight of a GPS satellite.

### **Research And Development**

After a series of business meetings with various senior Kenwood people, our party was invited to visit their Research & Development (R&D) facility at Yokohama. Yokohama is

the main sea port of Tokyo, and is located about an hour's train ride from the city centre.

The Yokohama Kenwood building is set in attractive parkland. It has six floors, and a tennis court on the roof for the staff surrounded at parapet level by an impressive amateur band antenna farm. There is of course an amateur station on site. **JAIYKX**, fully equipped with the latest Kenwood equipment.

Communications development work occupies one entire floor, with rows of over 100 engineers sitting at CAD workstations working solely on new products for the amateur and p.m.r. markets world-wide.

One of the most impressive sights was the r.f. anechoic chamber facility, which is used for testing the EMC performance of all Kenwood products. This massive construction cost over £1 million and is equipped with the latest state of the art signal analysis equipment.

After a very interesting meeting where we were able to input our thoughts for new amateur products to the people who design them. After which we strolled along the river bank back to the train station.

### **Return Visit**

Back in Tokyo, everybody wanted to pay a return visit to Akihabara for a longer look at the goodies on show. At the weekends, the main road through Akihabara is closed to traffic and the whole area becomes pedestrian only for the bargain hunters.

Very soon, our own British made Lowe receivers will be there on the shelves with all the Japanese products. We are eagerly looking forward to the results.

All that was left now was the 13 hour flight home, unfortunately with no flight simulator this time! I would like to thank Kenwood for their kind invitation and the opportunity to see their very impressive facilities, the staff of Lowe Electronics for their hard work in winning the Top Dealer prize, and last but not least you the customers for your continued support that made it all possible.

PW



The Yokohama Research & Development building has its own amateur band antenna farm situated on the roof.

# KENWOOD

Kenwood's r.f. anechoic chamber.

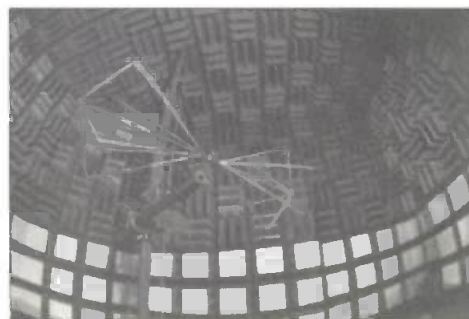

**INVISIBLE, FAR  
REACHING AND  
TAKEN FOR  
GRANTED?**

**YOU ARE  
NOT ALONE!**

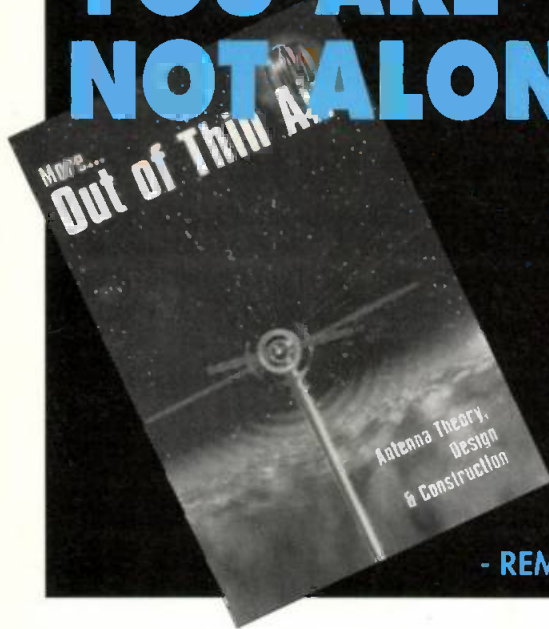

It is an unfortunate fact that many of our fellow 'beings' are simply neglecting their radio waves. Here at PW we believe that a radio wave is not just for Christmas but for life! They are an essential part of our hobby and if you don't 'launch' them off efficiently you'll not only lose advantage...you might lose the contact!

So, in order to help combat this growing menace within our community we are offering our readers the ultimate in 'antenna survival kits!'

Armed and fully equipped with *More Out of Thin Air*, you'll be ready to tackle projects including:

**A Portable Vertical Antenna For HF Operation** by Doug DeMaw W1FB and **Folded Dipole Antennas For The 18 and 24MHz Bands** by Steve Nicholls G0JFM.

For the v.h.f. enthusiast there's a chance to get onto six metres with **A Small Yagi For 50MHz** by Ken Willis G8VR together with antenna projects for 70 and 144MHz and many others, including the 'classic' **Slim Jim Antenna** by Fred Judd G2BCX.

Topped off with lashings of workshop features, theory and practical advice...your library is just not complete without this essential book!

*More Out of Thin Air* normally sells for £6.95 plus P&P. However, for this month only you can get your copy for £6.95 with free P&P! (UK only, overseas readers please add £2 P&P. To order your copy please use the Order Form on page 62 of this issue or call the Credit Card Hotline on (01202) 659930 quoting PWMTA8.

**Antenna  
Ignorance-  
Together  
we'll  
crack it!**

**- REMEMBER THAT RADIO WAVES ARE NOT JUST FOR CHRISTMAS!**

**£30  
WORTH OF  
VOUCHERS**

**CATALOGUE  
WAS £2.50  
NOW FREE**

Only the cost of a stamp

**THINK COMPONENTS - THINK CRICKLEWOOD**

- TELEVISION & VIDEO SPARES • RESISTORS & CAPACITORS • HI-FI GADGETS & SPEAKERS
- TRANSISTORS & I.C.'s • AUDIOPHILE CAPACITORS
- IN CAR AUDIO • COMPUTER BOARDS • TOOLS & TEST EQUIPMENT • PLUGS SOCKETS & LEADS



**Cricklewood  
Electronics**

PLEASE SEND ME A COPY OF THE CRICKLEWOOD CATALOGUE.

Name.....

Address.....

PW

Cricklewood Electronics Ltd, 40-42 Cricklewood Broadway, London NW2 3ET. Tel: 0181-450 0995 Fax: 0181-208 1441

**COLOMOR (ELECTRONICS) LIMITED**

**VALVES WANTED - NEW & BOXED**

KT66 - GEC .....	£35 each	DA100 - GEC .....	£100 each
KT88 - GEC .....	£50 each	4212E - STC, UK.....	£100 each
EL34 - Mullard .....	£12 each	PX25 - Globe shaped..	£90 each
EL37 - Mullard .....	£10 each	PX4 - Globe shaped .....	£50 each
DA30 - GEC .....	£80 each	ECC83/EF86 .....	£3 each

**SPECIAL OFFERS**

**Large stock of AR88 spares.** 19 Set leads/cable & junction boxes. 19 & 62 Sets for spares only. 88 Sets, C12's, C13's, C45's, etc. PSU's for C12, C45, PCR etc.

**Plus Valves:**

2C39BA	Siemens or Telefunken.....	£28.00 each
4CX250B	STC .....	£27.00 each
4CX250BM	Eimac .....	£37.00 each

OVER A MILLION OTHER VALVES IN STOCK. PLEASE ASK FOR A QUOTE.

**Also:**

27ft telescopic aerial mast .....	£27.00 each
Brand new kit bag (complete) for 27ft mast .....	£22.00 each
Pump up mast, type "Scam 40" extended height of mast 40ft. retracted height 7ft. 9in. max. headload 32kg. As new condition.....	£300.00 each
RCA 4366 HF Transmitter 2 to 20MHz .....	£500.00 each

Please ring for availability and price.

WE ALSO BUY OTHER TYPES OF NEW VALVES, AMPLIFIERS, TEST EQUIPMENT & COMPONENTS. FACTORY & WAREHOUSE CLEARANCE. CONFIDENTIALITY ASSURED!

Telephone or Fax list for offers.

Day Tel: 0181-743 0899 Fax: 0181-749 3934

**Colomor (Electronics) Limited**

**170 Goldhawk Road, London W12 8HJ**

Evening (to 10pm) Tel/Fax 01403 782275 Please quote ref PW



# New Lamp For Old?



By Richard Q. Marris G2BZQ

**Richard Q. Marris G2BZQ describes how you could use an older valved receiver as a QRP transmitter. So, don't part with that spare receiver yet!**

Fig. 1: Circuit of the typical (and very reliable) crystal oscillator p.a. type of transmitter that G2BZQ suggests could be incorporated with an older valved receiver to provide a QRP c.w. transmitter. Because of the type of oscillator (very 'rich' in harmonic output) it is imperative that such a transmitter should only be used with an efficient low pass filter, to reduce the possibility of TVI and BCI.

Fig. 2: Diagram showing possible 'extension' cabinet to enclose 'add on' transmitter. Many older valved receivers could incorporate the simple transmitter within their existing cabinets (see text).

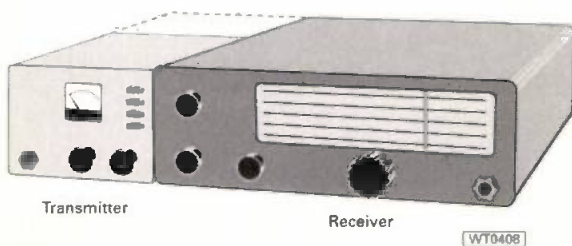

I recently dusted off and tested a valved receiver with a view to using it with a front-end v.l.f. converter. The quite excellent performance of the receiver had been forgotten over the years.

The receiver in mind was the Heathkit RA1 Amateur band receiver from the 1960s. It was a British made Heathkit model, using Mullard valves and the famous 'Electroniques' front-end.

*Editorial note: Ben Nock G4BXD featured the RA1 in 'Valve & Vintage', PW November 1995 page 68 and 69.*

The RA1 has an ancillary octal power socket, located at the rear (in common with most older valved receivers). It supplies 300V 25mA h.t. plus 6.3V a.c. 1A. output, enough power to drive a QRP transmitter using a single valve in a crystal oscillator p.a. circuit which could be housed either as a mounted-in unit or as an 'extended chassis' using p.c.b. material or aluminium.

## Octal Pentode

I chose the 6AG7, a rugged metal octal pentode valve which was used in military equipment. It's readily available at a reasonable cost.

So, I built a simple 7MHz band c.w. transceiver was quickly 'lashed up' before the circuit shown in Fig. 1, was arrived at. The refinement of the OA2 (V2) regulator 'locked' the screen voltage at 150V clearing away the small amount of 'chirp' on the signal.

An 80mA fuse, in the main h.t. line should protect the parent receiver in the event of a transmitter disaster. The transmitter could be antenna loaded to around 6W input or about 4W output. The total h.t. being taken from the

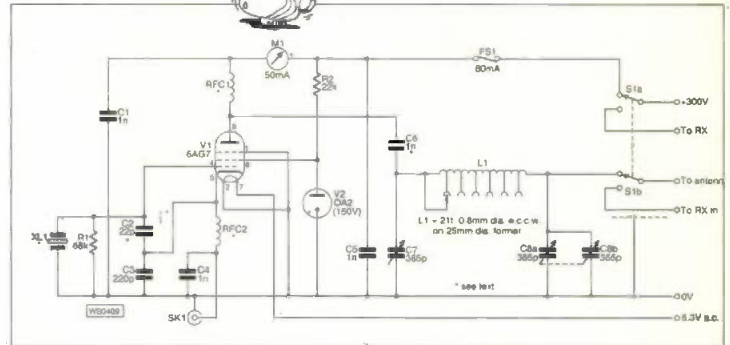

receiver was 28mA (3mA above the 'official' 25mA output from the octal socket, but the receiver seemed to be quite happy about this).

Next, I fitted a two section rotary wafer switch S1a and S1b to switch the antenna from receiver to transmitter. It also switches off the transmitter h.t. 'on receive'.

**Note: Because of the 'rich' harmonic output of the circuit, it's essential with the crystal oscillator p.a. transmitter to use extensive low pass filtering.**

## Maximum Loading

It's important to remember maximum loading, bearing in mind the valve and the receiver power supply (whichever receiver you're using). So, when you're tuning for 'dip'...do this as quickly as possible to stop overloading.

Various crystals can be used. There are plenty about for 1.8, 3.5 and 7MHz. You can use the crystals for harmonic operation on other bands, but this will reduce the efficiency of the transmitter.

Some valve receivers give 220 and 250V h.t. auxiliary output. In such cases the value of R2 will need changing to provide regulated 150V on the screen of V1. Of course the transmitter output will be lower but still usable.

**Warning: The transmitter should only be used with those receivers fitted with a mains transformer (Avoid 'AC/DC' types).**

Some valved receivers do not have the ancillary output socket. In this case, you can

remove the receiver output pentode valve and connect headphones (only) to the 1st audio stage. The power thus saved by removing the output pentode should be enough to drive a QRP transmitter. **But do check the receiver handbook and schematic and check the valve's power requirements.**

## Simple Idea

I hope that my simple idea will be of interest to readers who can adapt the idea to their own particular type of valved receiver. And of course the transmitter could be used with a separate p.s.u. in which case the anode current could be loaded to say 25 - 30mA.

In the meantime it's back to the original v.l.f. converter project, which started off all this idea! Somehow or other with me, one experimental project usually seems to trigger off several others!

PW

### Shopping List

R1	68kΩ	0.5W
R2	22kΩ	2W (wirewound)
Capacitors	350V d.c. working ceramic or silver mica	
C2	(between 22 and 30pF to ensure reliable oscillation)	
C3	220pF	
C1, 4, 5, 6	1000pF	
Variable Capacitors		
C8	365pF	airspaced good quality capacitor
variable	365 + 365pF	2 two-gang variable capacitor
C9		
V1	6AG7	
V2	OA2	
Miscellaneous		
1 octal (V1), and 1 B7G valve base for V2, RFC1 & RFC2 2.5mH r.f. choke (50mA minimum current rating). Crystals to suit frequency in use. 50mA full scale deflection (f.s.d.) meter, two-gang wafer switch, 80mA fuse, in-line fuse holder, holder		

# new series Carrying On - The Practical Way

By Rev. George Dobbs G3RJV

*We welcome the Rev. George Dobbs G3RJV back to PW with a regular new series. George aims to build on the experience shared with his original popular 'Getting Started The Practical Way' and this month he describes a useful receiver 'utility board'.*

Isn't it funny how words change their meaning in context? When I was a small boy many of the things around our house had the tell-tale 'Comma' mark on them to say they were 'utility items'.

'Utility Items' were made during the Second World War for civilian use. I recall my parents getting rid of them as quickly as possible, when they could afford to change them with 'proper' replacements.

## Severely Practical

The utility items were severely practical and the word came to mean something frugal, even mean, and inferior. The root meaning of the word 'usefulness' was lost in the often dismal nature of the things themselves.

During this series I hope to offer, from time to time, 'utility items'. But there will be nothing frugal or dismal about them.... I hope!

The projects will be useful items which readers can add to their collection of "that's handy" items around the radio shack. In odd cases you may be tempted to think that some of them may not be of use to you....but one day they may be!

I've often said that it's possible to build quite sophisticated equipment without expensive test equipment. The minimum is probably an analogue multimeter, a diode probe and a receiver.

The receiver would really need to be a general coverage type. You'll use it to detect and monitor oscillators and other radio frequency outputs.

Many of the oscillator outputs, by the very nature of signal processing, will occur outside the amateur bands. This can be a problem when the only receivers available in the radio shack are amateur bands only.

## Monitoring Signals

This simple project monitors signals over a wide range of frequencies. It represents the bare bones of a direct conversion receiver.

A direct conversion receiver is a simple, but effective receiver. The diagram Fig. 1 illustrates how they work. The principle is based upon a single mixing of signals.

The mixer receives the required radio frequency input signal and is also fed with an oscillator signal. The mixed products will include both signals and the sum and difference of both signals.

If the oscillator signal is at the required input signal frequency, the two signals will produce audio heterodynes either side of the required signal. In simple terms an audio signal will then be received on both sides of the input signal.

This type of signal monitor is of course known as a basic direct conversion (DC) receiver and is a basic way to detect c.w. or single sideband radio signals. An audio amplifier will then be used to increase the detected audio signals to drive a loudspeaker or headphones.

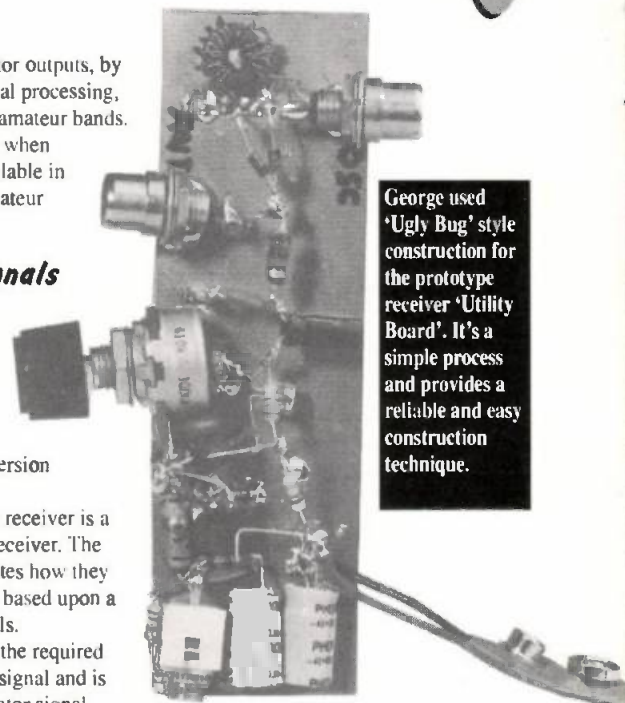

George used 'Ugly Bug' style construction for the prototype receiver 'Utility Board'. It's a simple process and provides a reliable and easy construction technique.

Fig. 1: (Below) Block diagram of a simple, but effective, direct conversion receiver. This basic receiver provides the 'Utility Receiver' project described

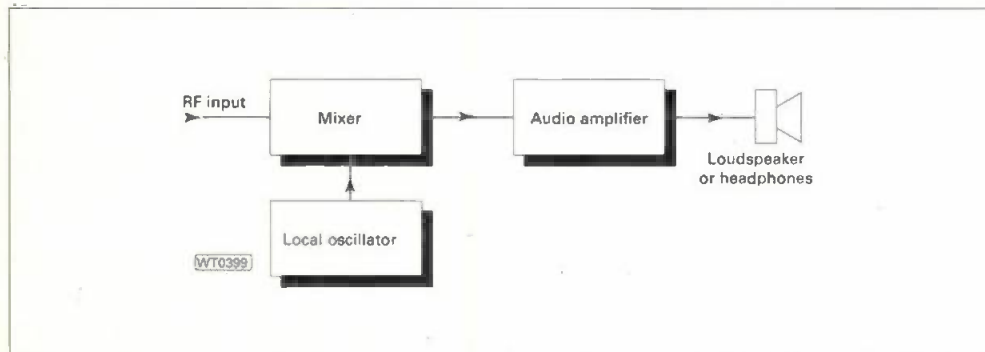

There are limitations to direct conversion. The sensitivity of the receiver depends upon on the amount of audio gain and selectivity depends upon whatever tuned circuits are present at the input of the receiver.

Better receivers tend to use the superheterodyne principle. They convert the radio frequency signal to an intermediate frequency (still at radio frequency) then finally, to the audio frequency.

Using the superhet method much of the selectivity and gain can be achieved at the intermediate frequency. But here we are looking for something to receive a desired signal rather than building a sophisticated 'bells and whistles' receiver.

## Original Requirement

My original requirement for the 'Utility Receiver' arose when I was building an s.s.b. generator board. I needed to listen to the single sideband signal at an output frequency of 9MHz.

So I quickly cobbled up a direct conversion receiver board. I then played with it for a little until it

performed to my satisfaction, and used it as a test receiver to listen to my 9MHz s.s.b. signal.

I used a signal generator to supply the local oscillator signal. Later I used a 9MHz crystal oscillator which I could pull either side of the required signal.

The diagram, Fig. 2, shows the Utility Receiver's final circuit. I've even used it to monitor the amateur bands with more than reasonable results.

and oscillator inputs. The audio output is taken to a 3.5mm jack socket also soldered directly to the board. The grounded end of the volume control (the right pin when viewed from the shaft end,) is also soldered to the board.

### Trifilar Transformer

Next stage of the project is winding the trifilar transformer, T1. Begin by cutting 3 lengths of enamelled copper

connections carefully at every stage.

### Easy To Use

The Utility Receiver board is easy to use. The oscillator injection can be provided from a purpose built oscillator or a signal generator.

For best results the unit requires between 300mV and 1V (peak-to-peak) of oscillator injection. As it stands, the antenna input is high



Fig. 2: Circuit of the 'Utility Receiver' board (see text).

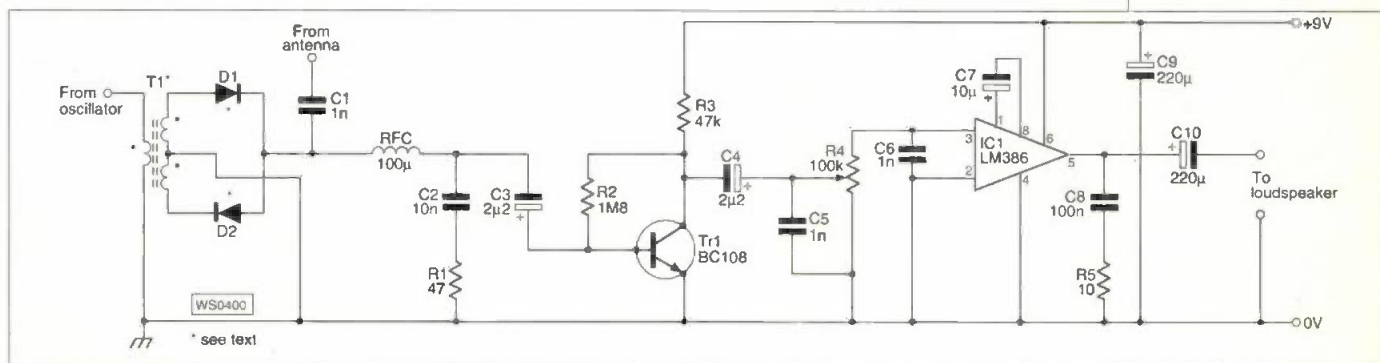

### The Circuit

The left-hand side of the circuit around T1, D1 and D2 is a simple diode mixer. The oscillator is fed into one winding of the trifilar transformer T1 and the input signal at the junction of the mixing diodes D1 and D2.

A radio frequency choke, RFC1, followed by a decoupling arrangement, C1 and R1 to remove residual radio frequency signals. The audio product is preamplified by a single transistor Tr1.

The final amplification is performed by the ever useful LM386 audio amplifier chip. This gives sufficient audio output to drive a small loudspeaker or a pair of personal stereo headphones.

The whole board was built 'ugly' style on a piece of scrap blank printed circuit board 100 by 30mm. This is a very convenient size.

'Ugly' construction is ideal for small projects. The principle is to use the p.c.b. as a groundplane. The components are then soldered direct to the board.

Each component which has a grounded (earthed) lead is soldered to the board. The free ends being used as solder points for the other components.

The LM386 audio amplifier i.c. is mounted 'ugly bug' fashion (upside down with its pins pointing upwards in similar fashion to a dead insect or 'bug'). This allows easy access to the pins but please remember to read the pin numbers the other way round.

I mounted two phono sockets directly on the board for the signal

wire to a length of 200mm. You can use 0.45 or 0.38mm (26/28s.w.g.) as these are ideal but the gauge is not critical, as long as it will fit on the core. The three wires are lightly twisted to form one wire ('barley sugar stick' style).

My method of trifilar winding is to secure one end of the three wires in a small vice or crocodile clip mounted firmly to a base. I then wrap the free end around a two inch nail and twist the nail until I have about 4 twists to every centimetre of wire.

Trim the ends of the twisted wires to tidy them prior to winding the transformer. Then wind 10 turns on the FT37-43 core. Each pass through the centre is one turn.

Cut the ends of the twisted wire to about 10mm and unwind the individual wires at each end. Each of the six individual ends must be scraped clean of enamel and tinned with solder.

Note that the circuit diagram shows a symbol at one end of each winding. This represents the beginning of the winding (the three wires that come out of one end of the core).

The wires must be connected as shown in the circuit diagram. You can identify the three windings by using a multimeter set on the ohms range.

One winding is used for the oscillator input and connected between the ground and the input socket. The remaining wires form a balanced winding for D1 and D2.

Join the beginning of one winding to the end of the other, this joint goes to ground. The two remaining wires go to D1 and D2. Check these

impedance which is ideal for test equipment work but to use the board as a receiver, some tuning would have to be added to the input.

Why don't you build this little board and keep it around the bench? You may be surprised how often it's used. Next month I'll suggest a couple of little additions to the project...making it even more useful!

PW

### Shopping List

#### Resistors

Carbon Film 5% (or any other type)

10Ω	1	R5
47Ω	1	R1
47kΩ	1	R3
1.8MΩ	1	R2

Variable rotary

100kΩ	1	R4
-------	---	----

#### Capacitors

Ceramic disc

1nF	3	C1, 5, 6
10nF	1	C2
100nF	1	C8

Electrolytic (16V working)

2.2μ F	2	C3, 4
10μ F	1	C7
220μ F	2	C9, 10

#### Inductors

100μ H	1	RFC
--------	---	-----

See text for how to make up T1

#### Semiconductors

1N914	2	D1, 2 (or any pair of small signal type diodes)
BC108	1	Tr1
LM386	1	IC1

Cheerio from George, see you next month.

# Shack Intruder Alarm

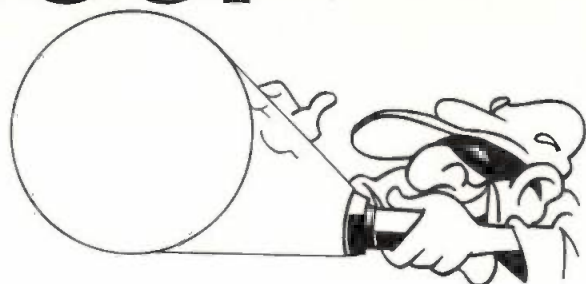

By Jack McKinney G13TZB

*Things that go bump in the night may not be your local friendly ghost. It's more than likely a suitable subject for Jack McKinney G13TZB's Intruder Alarm!*

I realised some years ago that, as access to the shack can be either through my garage, or directly through its own door, it was particularly vulnerable to intruders. An Intruder Alarm System for the shack and garage (the shack is in the rear part of the garage) was obviously necessary.

It's necessary by law to restrict the time for which an external siren may sound so, a timing circuit is used. This means that once the timing period has expired, the circuit has to be reset manually. But during the period from time-out to resetting of the alarm, the intruder can enter without fear, since the building is no longer protected.

From past experience, I have found that neighbours do not usually get unduly worried about an alarm sounding during the day and less so if it stops after some minutes.

I also know, from personal experience, that a loud unbearable siren in the shack will drive someone out. No one would want to stay inside long when the sound is painful. In addition, another siren may be fitted outside, in the hope that the Police may be passing and would hear it.

For an alarm system to be fully effective, a flashing light should be fitted outside, just above the door, which will stay on until reset manually. This gives an indication

that an illegal entry has been attempted.

Although a door alarm could be used, (either a microswitch or magnetic reed switch), I decided that a passive infrared (p.i.r.) detector would be much more effective. By using a p.i.r. and the circuit shown in Fig. 1, the alarm will re-activate itself and will again be ready for any further intrusions.

Perhaps it should be mentioned that p.i.r. detectors are movement detectors which are also activated by body heat. One detector will easily cover the area of a shack or garage.

When the disturbance stops the detector resets automatically and thus resets the alarm system. Had a door or window alarm been used and either left open when the intruder departed, then it would be impossible for the system to re-activate until either/both were closed.

## Alarm Basics

The basis of my alarm system is the 555 timer i.e. The trigger input to pin 2 has to be a negative pulse and of short duration. This is achieved by transistor Tr1, which is normally non-conducting as the p.i.r. contacts are closed when all is still.

In order to enter the shack without activating the alarm, a 'Keyswitch' is fitted in a convenient place. When the

p.i.r. contacts open (due to a movement in the shack) and the keyswitch is in the active (open) position, the base of Tr1 conducts. Transistor Tr1's collector voltage drop is coupled to pin 2 of IC1.

After the initial pulse, further pulses have no effect until the timing period has ended. The time delay of the alarm circuit is dependent on the values of R5/C5. The timing period is given by the formula:  
Time (in seconds) =  $1.1 \times C5 \times R5$  (where C is in Farads and R  $\Omega$ ).

The values shown will allow the alarm to remain operated for approximately four minutes. Increasing the capacitor value to 100 $\mu$ F will give a time delay of approximately nine minutes. Ideally the capacitor C5 should be a tantalum type, as the leakage current must be as low as possible.

The p.i.r. will reset when movement ceases and transistor Tr1 will again be non-conducting. But any further movement will once again initiate the alarm as before.

The contacts of the keyswitch in parallel with the p.i.r. contacts, when closed, make the p.i.r. ineffective. On leaving the shack you must always remember to operate (open) this switch. It's wise to use tamper-proof screws to secure the switch to the door frame and also to conceal or protect the cable to the alarm unit.

Perhaps I should mention at this point the 1mH choke (L1) and capacitor C1, at the base of Tr1. They ensure that the alarm is immune to both r.f. radiation and mains switching 'spikes'. It makes the alarm insensitive to inadvertent triggering due to long leads between the p.i.r. contacts (or keyswitch contacts) and the alarm box.

A switch (S1) is incorporated in the circuit to switch off the siren, rather than have to wait until the timing cycle has completed. If a light is fitted, then it requires a separate reset button. Since it is used to indicate that the premises have been violated, it will remain operated until manually reset, and immediate attention is required.

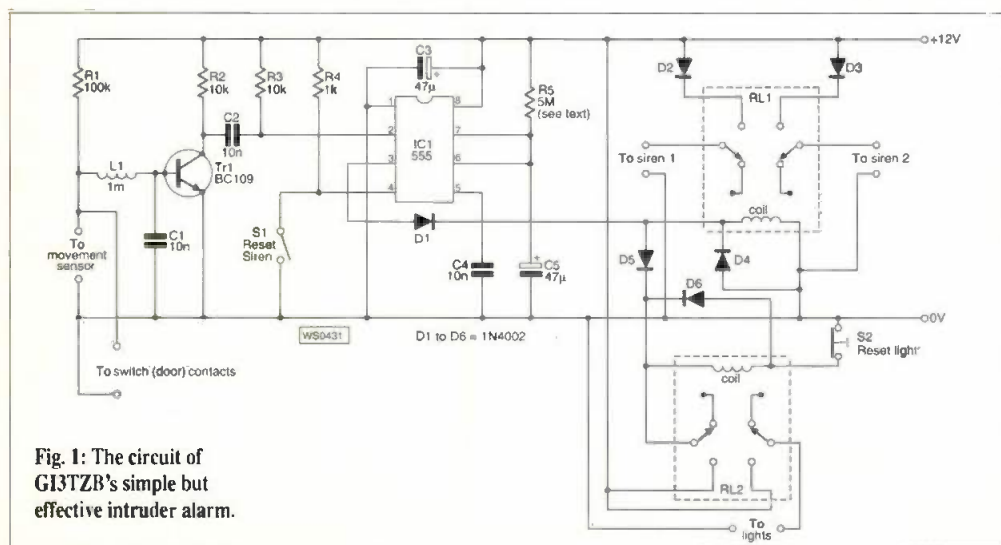

Fig. 1: The circuit of G13TZB's simple but effective intruder alarm.

## Construction Simple

Construction of the alarm unit is simple. My version was wired on stripboard and housed in an aluminium die-cast box measuring 171x121x55mm and includes both relays. The stripboard should measure approximately 95x60mm and was used instead of a p.c.b. I would recommend that a socket is used for IC1, making repair, should it ever be necessary, much easier.

The relays used must have pin spacing in multiples of 2.5mm to fit into the stripboard. I found that the holes had to be slightly enlarged to accept the relay pins.

The relays I used (because they were available) were RS type 349—658 (a 12V coil, resistance 205Ω). However I've found a cheaper range of relays and a type 351—572 (12 volts 220Ω), and they would appear to be suitable with similar pin spacing.

The practical layout could follow the circuit diagram fairly closely. The off-cuts from the resistors and capacitors may be used for links. The sirens are connected to the relay RL1 and should be mounted in convenient positions (one inside another outside the shack).

The second relay RL2 is connected in parallel with the coil of RL1 for the operation of the external light. A separate reset push button is required and it should be wired in series with the coil of the RL2 relay and the 0V line.

A diode is fitted in the lead from pin 3 of the 555 to the relay coil of RL1 to ensure that it will release promptly at the end of the timing period. Diodes D4 and D6 are to reduce back e.m.f. spikes. But diode D5 is to prevent the latch operation of the light control relay keeping on the siren relay.

If a light is not needed, then RL2 may be left out of the circuit. This also means that one of the push button switches may be omitted.

At this point it may be useful to mention that the push buttons are of different types. The alarm reset 'makes' when operated and the light reset is a 'break' when operated. In order to isolate the sirens from each other and more essentially from the supply (to avoid interaction with the other components), a diode is fitted in the positive lead to each.

I scored the plastic cover of the relays and glued them to the base of the die-cast box using epoxy resin. This leaves the contacts free for soldering to the connections of the tag strip. The Stripboard can be mounted to the die-cast box using Nylon bolts and nuts. A 4BA Nylon nut makes a suitable spacing washer between the stripboard and the case.

The unit should be installed in a position which is not immediately obvious to anyone entering the shack. In the interests of security I will not give any suggestions, but in any case, each person will have definite ideas on the location of the alarm.

The power unit (p.s.u.) shown in Fig. 2 is a simple regulated 12V supply using a three terminal device capable of an output of 2A (78S12). Only when the alarm is activated, will the current consumption be high and then only for a period of some minutes.

However, to ensure a long life, the regulator was mounted on the wall of a die-cast box 140 x 100 x 75mm using a generous coating of heatsink compound.

The rectifier is a bridge type rated at 4A/200V item. I also mounted this on the box wall, using heatsink compound, adjacent to the transformer.

The p.s.u. is fused for safety, but not switched, being supplied from the input side of the shack supply.

A switch could also be fitted to the p.s.u. It could also have a 'float' charged lead-acid battery fitted, but I didn't want to complicate things.

You could buy a commercial p.s.u. and a suitable one is listed in the Maplin catalogue under type number XM20W. It's quoted as having a continuous current rating of 3A.

The p.i.r. will require four wires - two for the supply and two for the alarm contacts. The 'tamper' contacts are not used. Select a p.i.r. which requires at least two 'events' within a short space of time before operating, so that false alarms are minimised. It is more convenient to wire the p.i.r. directly to the alarm box, as the 12V supply appears on the tag strip.

Siting the p.i.r. is important if false alarms are to be avoided and the purchase of a good p.i.r. is money well spent, and if you've never used one before, just a few tips:- Never point it directly at a window so that the sun will shine on the lens. Never mount it above a radiator and if various lenses are available, pick the short range wide angle lens.

## Powered Up

When the alarm is first powered up, it may go off. However, after it's reset,

it should settle down and operate as expected.

To deter the unwelcome, it's imperative that as much noise and discomfort as possible is generated. In addition to the sirens, a flashing light inside the shack as well as the light outside should help.

High Intensity strobe lights are now readily available and normally operate on 12V. I have fitted one outside the shack and the other inside above the operating desk. They're operated from a separate 28V supply controlled by the 'light' relay contact.

Use only low voltage lamps and sirens. **Never attempt to switch high voltages directly from the relay contacts in the alarm unit.**

However, I would strongly advise that an indicator of some type is fitted inside the shack. Even if you do not want to have a light outside, it will let you know should the alarm have been activated during your absence.

My alarm was constructed using components which were available. The details given refer to those components, so if different items are used, then the possibility is that different base connections will be necessary. This applies particularly to the relays and push-buttons.

The p.i.r. which I used was an RS type 625-299, but any good p.i.r. would be suitable, again a Maplin type DM12N could be used. The alarm has been in use for some time now and has proved to be very reliable.

PW



### Shopping List

#### Resistors 0.5W 5%

1kΩ	1	R4
4.7kΩ	1	R6
10kΩ	2	R2, 3
100kΩ	1	R1
4.7MΩ	1	R5 (or 5MΩ or similar)

#### Capacitors

##### Ceramic low voltage type

10nF	3	C1, 2, 4
220nF	1	C7
470nF	1	C8

##### Electrolytic 35V working

47μF	1	C3
2200μF	1	C6

##### Bead tantalum 16V working

47μF	1	C5
------	---	----

#### Semiconductors

555	1	IC1 (made by many manufacturers)
1N4002	6	D1, 2, 3, 4, 5, 6
78S12	1	IC2
BC109	1	Tr1
Bridge	1	D7-9 a 4A/200V working bridge rectifier.

#### Inductors

1mH	1	L1
-----	---	----

### Miscellaneous

You will also need need mains and hookup wire, suitable aluminium die-cast boxes, p.i.r. (RS 625-299 or Maplin DM12N), a security keyswitch, sirens, and lights, a piece of stripboard, one 12V 25VA transformer, a shrouded fuse holder and 300mA /250V fuse and short lengths of tag Strip.

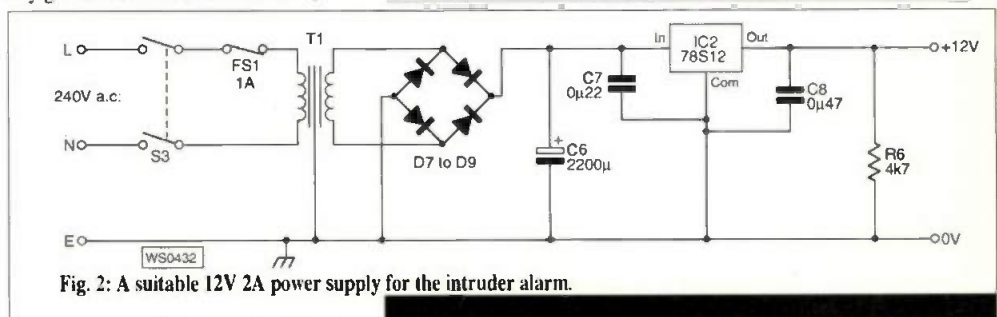

Fig. 2: A suitable 12V 2A power supply for the intruder alarm.

# The Hairpin Match Revisited

By Roy Quantick G3UGL

*Roy Quantick G3UGL describes an antenna matching method that is little used, possibly because it's not widely understood.*

Fig. 1: (right) General layout of a Hairpin (Beta) match suitable for an h.f. or v.h.f. Yagi. The adjustable shorting bar can be attached to the boom at its midpoint, as it's electrically neutral.

One of my constructional interests is home-brewing antennas (mainly Yagi arrays) for both h.f. and v.h.f. A project I completed earlier last year was a 6-element 70MHz Yagi using a 'Hairpin' matching system. The reason I decided to use this system (I'd not tried it before) was that it seemed to offer symmetry, both electrical and mechanical.

The principle of the Hairpin match is to slightly shorten the antenna element, and load it inductively to raise the input impedance. Some commercial manufacturers call this system a Betamatch, but electrically they are the same. See Fig. 1.

Published designs of Yagi arrays, for either h.f. or v.h.f. usually provide details of matching used in the design. But rarely do they describe the principle or operation, unless there's a dedicated chapter dealing with matching systems.

The particular matching system I'm describing doesn't appear in the RSGB's *Radio Communication Handbook*. Although, there's a design in Bill Orr's *Beam Antenna Handbook* for what he describes as an 'Inducto match'.

Bill Orr's Inducto match utilises the hairpin principle but he doesn't explain how it works, and the dimensions are calculated for a 14MHz 3-element Yagi. The ARRL book does actually provide a graphical process of calculation.

In the latest *ARRL Antenna Book* (16th edition) there are three designs for Yagi arrays using Hairpin

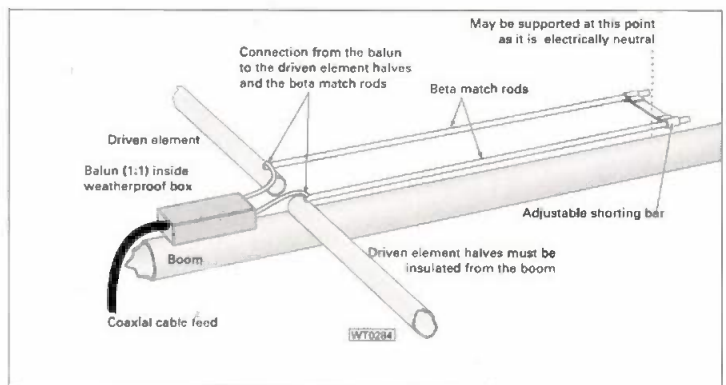

matching. But again, they give only fixed dimensions for the particular Yagi.

What if you're an experimenter, or you just want to change the design? And what if you are not able to find the exact aluminium rods or tubes, or to the published design? And what difference does it make? How critical are dimensions, along with many other questions.

The *ARRL Antenna Book* explanation including the graphical approach, does provide sufficient information to construct a Hairpin matching system for most applications. However, the reference to graphs and mathematical tables becomes tedious when trying out different diameter Hairpin rods or different spacing.

In the 70MHz Yagi array I worked on, I fabricated the complete split driven element and mounted the fixtures for the hairpin match. It was only at this point that I had the exact spacing of the hairpin rods.

So, despite all my preliminary calculations it was still necessary to do the exercise several times. It did eventually match (after I solved a problem with the v.h.f. balun), but I was never quite sure what I did to make it match.

Matching was a process of element adjustment, and moving the shorting bar for the lowest v.s.w.r. So, what was actually happening?

## Found Reference

Fortunately, I found a reference in the *ARRL Antenna Book* to the original work by Gooch, Gardner and Roberts, which was published in the *QST* in 1962. When I obtained a copy of the

article and saw the derivation of the graphs, I decided to produce a computer program to simplify the exercise.

I do not recall seeing these equations in any publication in recent years. Certain of the explanations still appear in the *ARRL Antenna Book* so I won't repeat them here.

For a worked example, I will assume that an 18MHz 2-element Yagi has been constructed, optimised for 18.139MHz, (the centre of the 'phone segment). It will be necessary to match a 50Ω feed line to the antenna.

The antenna input resistance is probably something like 12Ω with 0.1λ element spacing. It would be useful to measure the input resistance with a bridge at the antenna. (Either direct at the feedpoint or using an electrical half-wavelength of feed line).

It's a separate exercise to measure the correct 'electrical' length of coaxial cable. But it is important to have the driven element at the correct resonant length in the array when the resistance measurement is made.

If it's not possible to measure the input impedance, it will suffice to assume a value using the known element spacing and length and diameter ratios. One of the advantages of a computer is the ability to re-run the program instantly and see the effect of changing the input parameters.

The length of the driven element is made about 2% shorter to present a capacitive reactance at the chosen frequency. By introducing inductance (the hairpin) a low value of input impedance can be made much higher. See Fig. 2a and b.

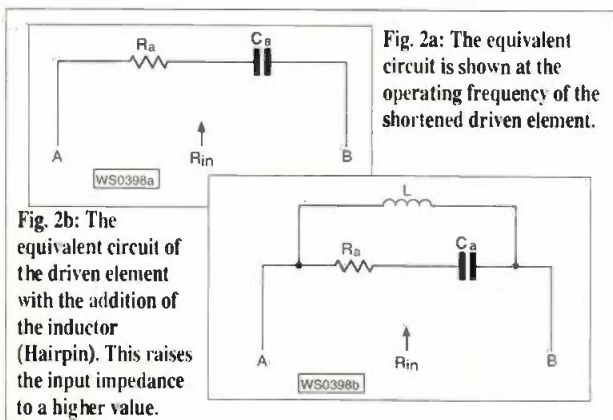

Fig. 2a: The equivalent circuit is shown at the operating frequency of the shortened driven element.

Fig. 2b: The equivalent circuit of the driven element with the addition of the inductor (Hairpin). This raises the input impedance to a higher value.



As a passing point of interest, a different, but related system of matching can be achieved by increasing the driven element length (about 2%) which introduces inductive reactance at the chosen frequency and the low value of input impedance can be raised by introducing capacitance (capacitance matching).

Let's return to our example Yagi at 18.139MHz. Here it will be assumed that the Hairpin rods are 6.35mm (0.25in) in diameter and the spacing happens to be 101.6mm (4in) centre to centre. (It is sufficiently accurate to assume 6 and 100mm for the dimensions).

You'll need to calculate the characteristic impedance and for characteristic impedance of the Hairpin ( $Z_0$ ). I suggest the formula for open wire feeders is used, and that is shown diagrammatically in Fig. 3. The drawing represents looking direct onto the ends of the line elements.

Using the values of 101.6 and 6.35mm for D and d, gives a calculated value of 415.42Ω for the  $Z_0$  of the hairpin line. Incidentally using notional figure of 100mm for the spacing and 6mm for the diameter of the rods, give a value of 420.31Ω for  $Z_0$  (about a 1% accuracy).

After calculating the characteristic impedance of the hairpin, the next step is to calculate the inductive reactance ( $X_L$ ). This is calculated using the following formula:

$$X_L = R_t \times \sqrt{\frac{R_a}{R_t - R_a}}$$

where  $R_t$  is the feedline impedance, and  $R_a$  is the input impedance of the antenna (this may be calculated, measured or assumed).

Substituting values for the individual terms gives

$$X_L = 52 \times \sqrt{\frac{12}{52 - 12}} = 28.48\Omega$$

It is now necessary to normalise the required 28.48Ω reactance to the characteristic impedance of the hairpin. This is achieved by dividing the value of  $X_L$  by the figure of  $Z_0$ . These two figures give 28.48 divided by 415.42 giving a result of 0.0694.

The resultant figure of 0.0694 is the **Tangent** of the angle of electrical length of the hairpin in degrees. Looking up tangent tables or by use of a scientific calculator will give a resultant angle of 3.97°.

To convert the angular length to a physical length (in millimetres) we use a constant of 292 100 divided by the frequency in MHz. This constant assumes a 97.5% velocity factor for open wire feeders.

Dividing the constant by the frequency gives us a physical length of 16 103mm for one wavelength of 18.139MHz in open wire (parallel line) feeders. One wavelength is, of course, 360°.

To complete the task and find the physical length of 3.97° of this line, divide 16 103 by 360 (giving the length of 1° which is 44.73mm). Then multiply this value by 3.97 to find the physical length of 3.97°. The maths

gives a length of 177.5mm which is how long the hairpin should be.

The length of 177.5mm is measured from the the driven element, to where the shorting bar should be attached for this particular example. Of course, should the input resistance be any different to our assumed value of 12Ω, then the position would be a little different,

From the computer printout, if the input resistance was 8Ω, the shorting bar would be positioned 136.6mm. If the input impedance is higher then the hairpin should be a little longer.

In practice the hairpin should be made a little longer and adjustable. The computer program will indicate the sizes of hairpin or Beta rods for matching multi-element Yagi arrays.

A close approximation of input impedance can be made if it's not possible to measure it by knowing the element spacing and length/diameter ratios, and a length can be determined by calculator or using the computer program. The final fine tuning adjustment would be made in the working position.

PW

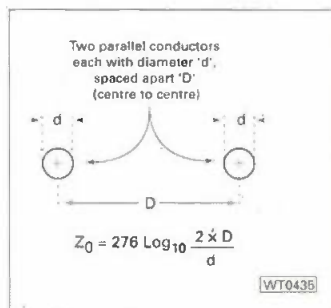

Fig. 3: The method used to calculate the characteristic impedance two parallel rods (diameter d) spaced D apart. The units of measurement are of no consequence as long as they are the same.

### References:

- 1: Roy Quantick 'A 20 metre Yagi and mast for the 20m band'. *Amateur Radia*. Dec 1987 P27 - 31, Jan 1988 P39 - 42.
- 2: Gooch, Gardner and Roberts (1962) 'The Hairpin match'. *QST* April 1962 P11-14, 146, 156.
- 3: *ARRL Antenna Book* 16th Edition P26 - 21.
- 4: *ARRL Antenna Book* 16th Edition P11 - 4.
- 5: *ARRL Antenna Book* 16th Edition P11 - 9.
- 6: Orr et al. *Beam Antenna Handbook*, 5th Edition P69 - 70 Radio Publications Inc. 6th Printing 1983.
- 7: *RSGB Radio Data Reference Book*. 5th Edition P21.

### Basic Program Listing

A copy of the short Basic program, used by Roy to calculate the hairpin line impedance is available by sending a stamped s.a.e. (marked Hairpin Listing) to the editorial offices.

## SPECIAL BUY!

# JUST ARRIVED - THE UK SCANNING DIRECTORY!

Just as this issue of *Practical Wireless* was going to press we received the first stocks of the new and up-dated edition of the already popular *UK Scanning Directory*. This book now in its 5th edition is said to be the most comprehensive radio book available.

The *UK Scanning Directory* contains over 42,500 nationwide spot frequencies and frequencies covered by the *UK Scanning Directory* are from 25MHz through to 1.8GHz. This book is now bigger than ever before with over 500 pages of frequency listings.

The *UK Scanning Directory* is available from the **PW Book Service** for £18.50 plus £1 P&P (UK), £2 P&P (overseas) however, for this month **only** you can get your copy for **£18.50 with Free P&P (UK only)**. overseas readers please add £2 P&P).

Don't miss out! To order your copy of the new *UK Scanning Directory* contact the **Credit Card Hotline** on (01202) 659930 quoting **PWUK8** or use the Order form on page 62 of this issue.

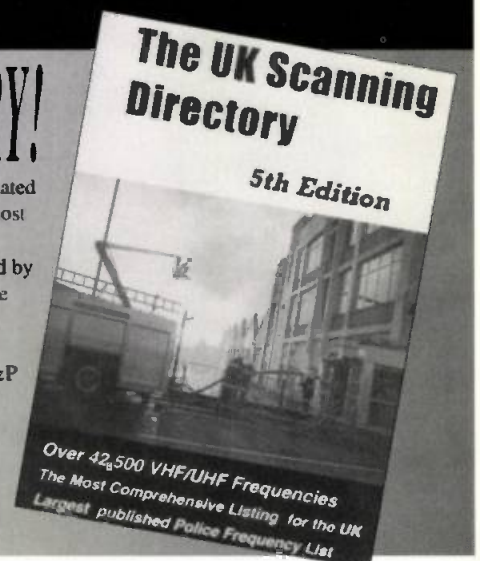

# Invisible Power



By Gordon King G4VFX

*Gordon King G4VFX casts his very experienced eye over an invisible environment that we can for the most part only imagine but which effects us in every facet of life and especially our hobby. There's no doubt that many operators will be surprised to find just how strong that electromagnetic field is...even from a hand-held transceiver!*

It has always been desirable working practice to have some idea of the strength of the signal field created by one's own transmissions at least around your own QTH and near neighbours. Information of this kind can help with a possible solution to breakthrough disturbances, which can affect a host of local domestic electronic equipment such as televisions, hi-fi systems, audio and video tape machines, record players, security lights and alarms and so forth.

Knowing the possible level of a signal field at the affected equipment can yield a clue as to the nature and magnitude of suppression that may be needed to resolve problems.

Now that the European Union regulations dealing with electromagnetic compatibility (EMC) of domestic electronic equipment of this kind has arrived, I would hope that a greater immunity than hitherto will be designed into the equipment making it less susceptible to electromagnetic fields than in the past.

Indeed, as from the first of January 1996 EEC regulation have made their mark. Since then it has been mandatory for almost all new electronic equipment to carry the indication 'CE' thereby pronouncing that it adheres to the relevant EMC requirement for r.f. immunity.

## Environmental Fields

It's noteworthy that the regulations will ultimately be linked to 'environmental electromagnetic fields'. This is where various environments will be classified in terms of r.f. sources and possible (expected) fields in such as urban, rural, residential, commercial, industrial, etc. locations.

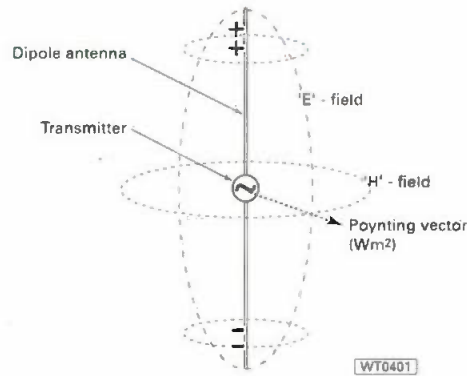

Fig. 1: EM radiation from a dipole antenna.

Clearly, the sort of linking demanded by the EEC regulations will provide the basis for the r.f. immunity requirement in any particular environment. However, there are bound to be local environments where the electromagnetic (EM) field persistently exceeds the r.f. immunity built into particular equipment to satisfy the basic European Union (EU) regulations.

For example, it's quite feasible that in locations close to r.f. processing plants, radio and television transmitters (including amateur radio stations) the level of signal field will be greater than any built-in immunity.

The extreme cases I've just mentioned will not be particularly catered for by the regulations. This is because the probability of domestic electronics being employed in such environments is relatively very low.

So, it's likely the radio amateur will be called upon to help solve a breakthrough problem. This is when having an idea of what a signal field is and its approximate strength would certainly be useful, while also providing a clue as to the immunity 'standard' of the affected equipment.

## Signal Field

A signal field in the context we're interested in constitutes invisible (though easily detectable) 'disturbances' within the local and space environments.

The field is created by the combined propagation of electric and magnetic fields from a transmitting antenna (in the case of radio signals) or other radiating source.

Just as water waves spread out from a disturbed point in a still pool of water, so radio waves spread out into space from a transmitting antenna. But in this case as a sphere (in free space) and at the speed of light (300 metres per microsecond).

The water wave analogy is interesting. This is because it illustrates that the water is not actually moving outwards to produce the waves, but in fact is just rising and falling and that progressive, larger diameter waves are formed until all the energy has been exhausted.

A signal field source can be represented as in Fig. 1. The transmitter coupling between the two elements of a dipole antenna

**continued on page 32**

Fig. 2: Emission from an isotropic radiator into free space.

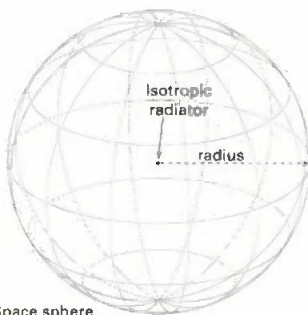

Space sphere surface area =  $4\pi r^2$

WT0402



# Amateur Radio Communications Ltd

38 Bridge Street, Earlestown, Newton-le-Willows, Merseyside WA12 9BA

OPEN Tue-Sat  
10am-5pm  
FREE PARKING

Use your credit  
card for same  
day despatch

## EVERYTHING FOR THE RADIO AMATEUR UNDER ONE ROOF!

Due to the amount of new equipment being sold our shelves are bending under the weight of trade-ins. Below is just a small selection of what is now in stock. Please phone for more details on these or any other items sought after.

TS-850SAT + DSP-100.....	£1575	FAX 1.....	£125
TS-120S + PSU.....	£399	BNOS TL50-28-25 Transverter.....	£199
TS-950SD incl. SSB filter.....	£1800	BNDS LP144-3-50 Linear.....	£TEL
FT-736R.....	£TEL	MM 28-144 Transverter.....	£75
FT-707 +FV-707DM/FC-707.....	£499	FRG-8800 + FRT-7700.....	£TEL
FT-102.....	£475	AKD-4001.....	£120
TS-140 + ATUP-300.....	£699	IC-24ET.....	£100
FT-480R + linear/SWR meter.....	£TEL	2 x NAVICO AMR-1000.....	from £140
IC-490E mint condition.....	£350	IC-M5 + Extras.....	£145
IC-229 VGC.....	£240	FT-767 + 2/6/70.....	£1300
2 x IC-765 + SP-20.....	from £1500	FT-747 + VC-300DLP/EP-920.....	£TEL
AR-3030 + converter/Collins filter.....	£599	FT-747 incl FM.....	£575
IC-R71.....	£675	AR-3030.....	£499
IC-R7000 + extras.....	£TEL	Alinco DR-510E boxed.....	£TEL
2 x NRD-525.....	£TEL	ERA Microreader.....	£99
Drake R-8E VGC.....	£650	Icom IC-U16T boxed.....	£TEL
2 x HF-225.....	from £350	MFJ-784 DSP filter.....	£150
HF-150.....	£250	ALM-203 + access.....	£75
AR-2001 boxed.....	£TEL	FRG-100 as new.....	£TEL
2 x AR-2500 boxed.....	from £275	IC-706 + AT-180/SM6 + lots accessories.....	£TEL
Lowr SRX-30D.....	£199	Tailtwister rotator.....	£250
Trio R-600.....	£TEL	PRO-2006.....	£150
AR-3000A.....	£699	R-1000.....	£275
Sony SW-77/SW-55/SW-100E.....	£TEL	TR-9000.....	£300
TS-440SAT boxed.....	£800	MX-7000.....	£325
FT-790R + Linear/S. kamp FP-80A.....	£TEL	FT-211RH.....	£175
TR-9130.....	£325	DJ-580 hand held.....	£TEL
FT-9010E.....	£450	FRG-7 + AT-1000.....	£199
IC-2E + extras.....	£105	TH-48E as new.....	£TEL
IC-4E + extras.....	£125	55' Motorized tower (heavy).....	£300
TH-41E.....	£125		
TH-21E.....	£99		
FT-102 + VFO/SPK/ATU.....	£TEL		
FT-101B.....	£TEL		

THE ABOVE IS ONLY PART OF OUR STOCKS,  
PLEASE PHONE FOR DETAILS. E&OE

**WANTING NEW KIT?**  
WHY NOT TAKE ADVANTAGE OF  
OUR INTEREST FREE SCHEMES.  
**DEPOSIT AS  
LOW AS 10%.**  
PHONE NOW FOR DETAILS

### ICOM SPECIAL IC-2350



Down in price.  
RRP ~~£649~~  
For a limited period you  
can buy this excellent  
dualband FM transceiver 50/30W at the price  
below - grab one while you can! A saving  
of over £150.

**£495**

### NEW DSP-232



**Special price  
£479**

Including FREE Windows Software worth  
£79! The latest all mode DSP driven TNC  
from AEA. Phone for details.

**HP available - up to 3  
years re-payment period**

We are 1 mile  
from J23 M6 & 4.5  
miles off J9, M62

### MASTS

Extends to 36'6..... £51.00  
Extends to 27'6..... £45.00  
Extends to 17'6..... £34.00

### MICROWAVE MODULES LINEARS

MML 144-30LS 30W O/P 1/3W I/P..... £99.95  
MML 144-100-10 100W O/P 10W I/P..... £199.95  
MML 144-100-3 100W O/P 3W I/P..... £219.95

Police style holster Watson WSC-1.....	£19.95
WEP-300 earpieces.....	£9.95
D/band antenna CW magnetic mount.....	£26.95
Kent Keys & Morse trainers.....	now in stock

### WATSON ANTENNAS

W-285 2m 1/8ths..... £15.95  
W-770 2m/70cms..... £24.95  
W-30 2m/70cms 3/5dB 1.5m..... £39.95  
W-50 2m/70cms 4.5/7.2dB 1.8m..... £54.95  
W-300 2m/70cms 6.5/9dB 3.1m..... £69.95

### WATSON POWER SUPPLIES

W-5A..... £29.95  
W-20A..... £89.95  
W-30A..... £119.95

### DRAE 24A PSU

£139.95 **£119.95**



Tel: 01925 229881/Fax: 01925 229882



## Listen to Your World!

Subscribe to *Monitoring Times*  
and *Satellite Times* Magazines

Do you own a radio, a shortwave receiver, a scanning receiver, or a ham radio? Then *Monitoring Times* is your magazine! Each monthly issue of *MT* offers 20 pages of worldwide, English language, shortwave broadcast schedules; departments on aero, military, government, public safety communications; broadcast band, satellite television, long-wave coverage; reviews of new products and radio-related software; technical articles and projects for the hobbyist; feature articles, and much, much more.

If it's on the radio, it's  
in *Monitoring Times*!

*Satellite Times* is the world's first and only full-spectrum satellite monitoring magazine, exploring all aspects of satellite communications, including commercial, military, broadcasting, scientific, governmental and personal communications as well as private satellite systems. The satellite industry's most respected experts contribute to every bi-monthly issue of *Satellite Times*, addressing both amateurs and experts alike.

If it's in orbit, *Satellite Times* covers it!



MAIL THIS SUBSCRIPTION FORM TO: PW PUBLISHING LTD., FREEPOST, ARROWSMITH CT. STATION APPROACH, BROADSTONE, DORSET BH18 8PW.

SUBSCRIPTION RATES INCLUDE SPEEDY AIR MAIL SERVICE!

1 YEAR *MONITORING TIMES* - £38 (12 ISSUES)

1 YEAR *SATELLITE TIMES* - £32 (6 ISSUES)

NAME \_\_\_\_\_

ADDRESS \_\_\_\_\_

POSTCODE \_\_\_\_\_

TELEPHONE \_\_\_\_\_

I ENCLOSE CHEQUE/PO (PAYABLE TO PW PUBLISHING LTD.) £ \_\_\_\_\_

OR CHARGE TO MY ACCESS/VISA CARD THE AMOUNT OF £ \_\_\_\_\_

CARD# \_\_\_\_\_

VALID FROM \_\_\_\_\_

THRU \_\_\_\_\_

SIGNATURE \_\_\_\_\_

TEL \_\_\_\_\_

CREDIT CARD ORDERS TAKEN ON (01202) 659930

FAX ORDERS TAKEN ON (01202) 659950

Continued from page 30

Fig. 3: (Right) Graph showing signal field in V/m and dB(V/m) over 1 to 1000m and at six ascending radiated powers.

causes positive and negative charges to flow into and out of the elements, and an electric field (E) is created.

The flow of current resulting from the linking of the opposing charges gives rise to magnetic lines of force and hence magnetic field (H). This is very similar to the electric and magnetic fields generated by any cable through which electric current flows.

### Exist Independently

The electric and magnetic fields in the waves exist in space quite independently without support of capacitance or inductance. They have a vector direction at right angles to each other and at right angles to the direction of propagation. (Remember that an

Fig. 4: (Below) Graph showing magnetic field in A/m and dB(A/m), also magnetic flux density in nanoTesla over 1 to 1000m and at six ascending radiated powers, where A/m equals (V/m)/377, and  $1.26\mu\text{T}$  equals 1A/m.

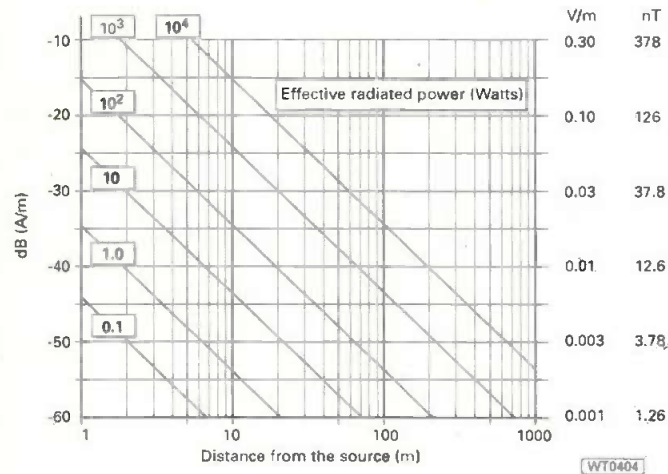
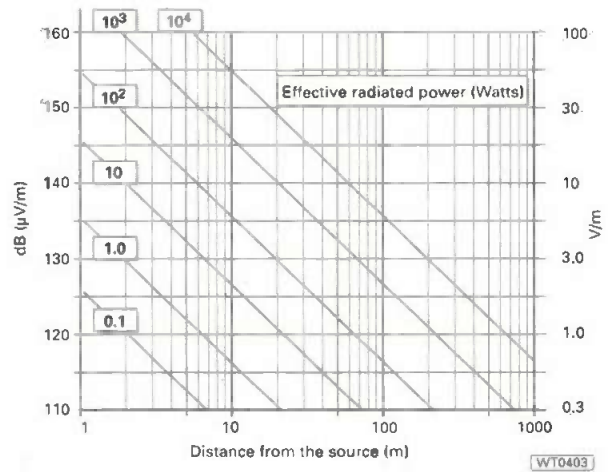

Fig. 5: (Right) Graph showing power flux density in W/m<sup>2</sup> and dB(W/m<sup>2</sup>) over 1 to 1000m and at six ascending radiated powers expressed in dB(W), where W/m<sup>2</sup> equals (V/m)<sup>2</sup>/377.

electromagnetic wave is polarised in the direction of the electric vector).

An EM field is endowed with two essential features, which are frequency (f) and wavelength (λ). Frequency goes from zero upwards, but at around 300gigahertz (GHz), corresponding to  $300 \times 10^9$  Hz, the onset of optical radiation occurs from infra-red through to ultra-violet and thence to frequencies which instigate ionising radiation, where electrically charged particles (ions) are formed by the loss or gain of atom electrons.

The wavelength of a wave corresponds to the velocity of propagation divided by the frequency in Hertz. This means that in the radio part of the EM spectrum the wavelength is most conveniently found merely by dividing 300 by the frequency in



MHz.

For example, the wavelength of a 150MHz is two metres. Conversely, the frequency in MHz can be found by dividing the wavelength, in metres, into 300.

### Signal Strength

The strength of the E field defines the signal strength in terms of volts per metre (V/m) or milli- or microvolts per metre (mV/m or  $\mu\text{V}/\text{m}$ ) at more distant points from the radiating source.

A decibel ratio may also be used, and this is where 0dB refers to  $1\mu\text{V}$ . Thus 1V/m would be 120dB( $\mu\text{V}/\text{m}$ ), 1mV/m as 60dB( $\mu\text{V}/\text{m}$ ) and  $10\mu\text{V}/\text{m}$  as 20dB( $\mu\text{V}/\text{m}$ ).

Strength of the H field is given in terms of amperes per metre (A/m). The ratio E/H is a constant whose value is  $377\Omega$  in free space (this is

called the characteristic impedance of free space).

The E and H fields alternate continuously in polarity, mirroring the radio frequency (r.f.) sine wave from which they derive. This means that once in propagation the E field is sustained at right-angles by the H field, with the two fields being in phase.

### Poynting Vector

The rate of energy transmission is called the Poynting vector. It's given in terms of Watts per square metre ( $\text{W}/\text{m}^2$ ) which derives from  $(\text{V}/\text{m})^2/377$  (free space impedance).

The diagram, Fig. 2, shows a 'sphere of space' at whose centre is a signal source radiating equally in all directions. This is known as an isotropic radiator.

Because the same amount of power flows through the surface of a sphere which surrounds a radiating source, regardless of the

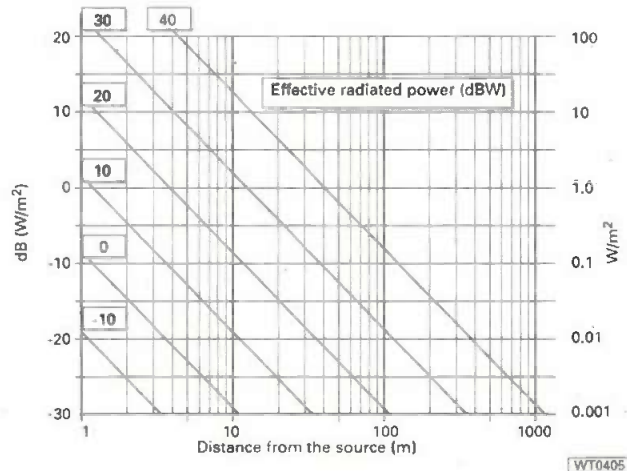



radius ( $r$ ), the power flux density (also given by  $W/m^2$ ) per unit area at distance  $r$  corresponds to the power of radiation (in watts  $W$ ) divided by the surface area of the sphere, or  $W/2\pi r^2$ .

The trick is now to combine the two expressions so that the signal strength can be determined at any distance from the source and at any power. The combination yields  $V/m = (30W)^{0.5}/d$ , where  $d$  is the distance from the isotropic source in metres.

The expression can be modified to take account of a half-wave dipole instead of the impractical isotropic source. It then becomes  $V/m = (49.2 W)^{0.5}/d$ . This is because a dipole has a power gain of 1.64 times, over an isotropic source, in its directions of maximum response.

Signal strengths in  $dB(\mu V/m)$  and  $V/m$  are given in Fig. 3, while Fig. 4 gives the magnetic field strengths in  $dB(A/m)$  and  $A/m$ , with the addition of magnetic flux density in nanoTesla ( $nT$ ) all at distances from 1 to 800 metres from the source and at six radiated powers from 0.1 to 10kW

The diagram, Fig. 5, gives the power flux density in  $dB(W/m^2)$

and  $W/m^2$  at six radiated powers from -10 to 40  $dB(W)$  over the same distances, all the graphs being based on the above expressions.

It's very important to bear in

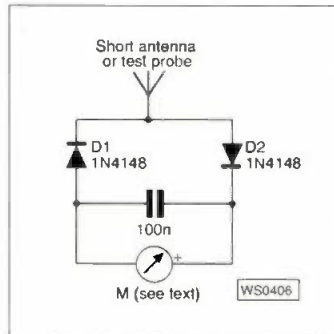

mind that the relationships between the various parameters only hold good at distances two or three wavelengths from the source. Very close to the source the relationships can be invalid owing to phase differences between the signal from different parts of the source.

When measurements are made there are also bound to be reflections which can add to or subtract from the radiated signal. This will be readily apparent when

a signal strength meter is taken for a 'walk' around your QTH with the transmitter in test mode (or when you adjust a u.h.f. TV when carrying out height-versus-gain tests.

### Detecting Device

The circuit of a very simple, though extremely useful r.f. detecting device is given in Fig. 6, while Fig. 7 shows the EM radio field round a typical QTH at a radiated power of 1W. The graphs can be used to calculate the field at different powers and distances.

As I mentioned at the beginning, with the arrival of the EMC regulations we're now in a far better position knowing the scale of signal level we are creating around our own QTHs and nearby neighbours. Forewarned is forearmed!

PW

Fig. 6: (centre) Circuit of simple field strength meter. The meter should be around 500 $\mu A$  full-scale, but for greater sensitivity a wide band amplifier could be incorporated.

Fig. 7: Possible EM environment around a QTH with a radiated power of 1W. The signal voltage field at different radiated powers and distances can be assessed from the graph in Fig. 3. The signal strength will be significantly affected by reflections.

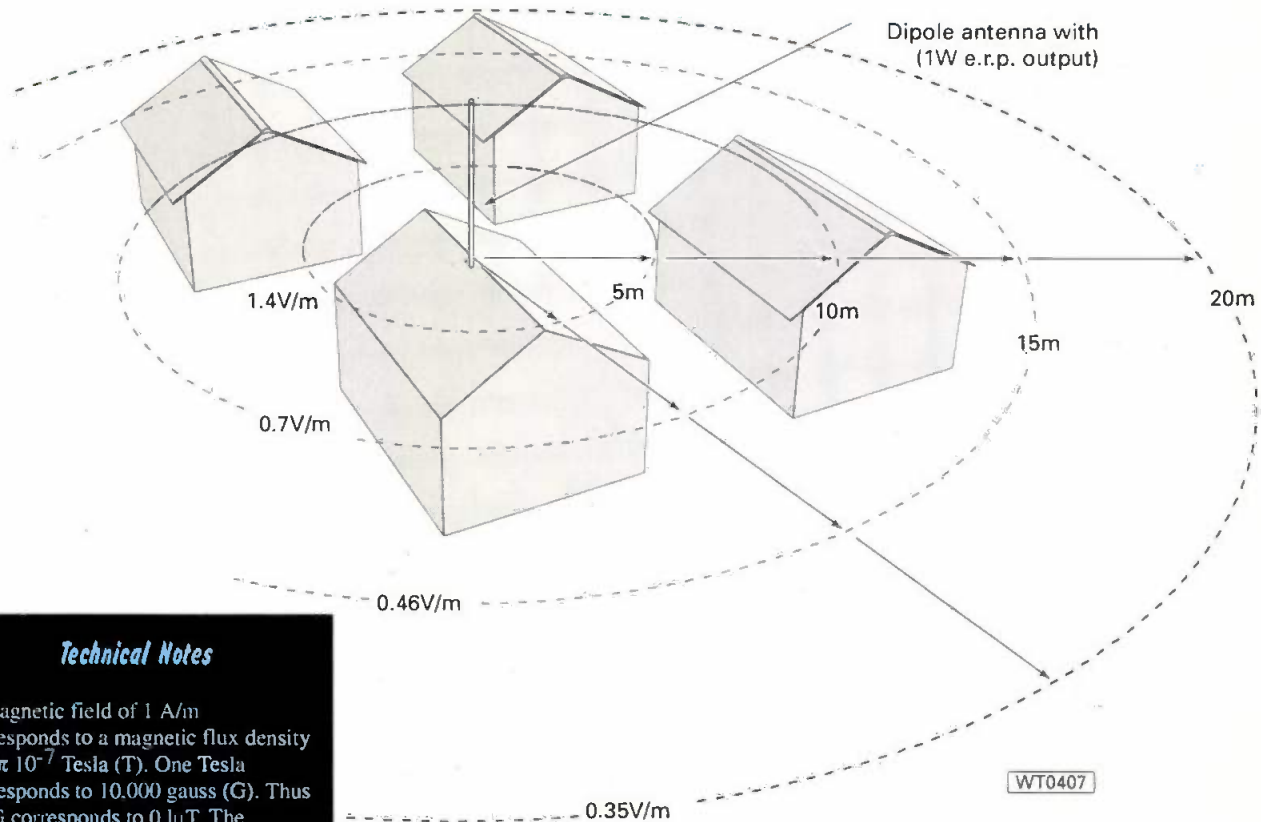

### Technical Notes

A magnetic field of 1 A/m corresponds to a magnetic flux density of  $4\pi \cdot 10^{-7}$  Tesla (T). One Tesla corresponds to 10,000 gauss (G). Thus 1mG corresponds to 0.1 $\mu T$ . The expression  $(49.2W)^{0.5}/d$  in the text means - the square root of (49.2 times the power) all divided by  $d$ .

# WHY PRICE WA

**W**hen Martin Lynch introduced the "Price Watch" logo into his advertising, he guaranteed to deliver incredible products at even more incredible prices. Whether new or second hand, Martin Lynch and his team monitor their competitors and adjust prices to ensure you are always getting the best deal, saving you time to concentrate on the actual product itself. When you next need to buy that important piece of radio equipment try Martin Lynch. We guarantee to offer service and low prices our competitors only dream about.

**5 YEAR WARRANTY IS AVAILABLE ON ALL MAIN PRODUCTS LISTED**

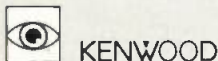

**Kenwood TS-870S HF DSP 100W HF transceiver**  
RRP £2399 Lynch Price: £1969  
Deposit: £369, 12 payments of £146.94. Cost of loan: £163.33 or  
Deposit: £369, 24 payments of £80.16. Cost of loan: £323.84

**Kenwood TS-790 2/70 multimode base station**  
RRP £1969 Lynch Price: £1699  
Deposit: £299, 12 payments of £128.57. Cost of loan: £142.84

**Kenwood TS-50S HF 100W mobile transceiver**  
RRP £1059 Lynch Price: £889  
Deposit: £89, 12 payments of £73.47. Cost of loan: £81.66

**Kenwood TS-60S 6 Metre 90W all mode transceiver**  
RRP £999 Lynch Price: £849  
Deposit: £89, 12 payments of £69.79. Cost of loan: £77.58

**Kenwood TRC-80 Commercial grade 100W HF transceiver**  
RRP £1169  
Deposit: £169, 12 payments of £91.84. Cost of loan: £102.08

**Kenwood TM-255E 2M 45W all mode transceiver**  
RRP £949 Lynch Price: £799  
Deposit: £89, 12 payments of £65.20. Cost of loan: £72.47

Martin Lynch can also offer finance terms upto 36 months. Deposits from a minimum of 10%. We welcome your part exchange against any new (or used!) product, provided its clean and in good working order. Call the Sales Desk today. APR: 19.9% Payment protection is also available.

All units are brand new and boxed and offered with full manufacturers RTB warranty. All prices quoted for cash/cheque or Switch/Delta card.

For credit card please add 2.5% to total value. Finance on all products is also available. (Subject to status).

**Kenwood TM-251E 2M 50W with 70cm RX transceiver**  
RRP £ 419 Lynch Price: £359  
Deposit: £59, 12 payments of £27.55. Cost of loan: £30.62

**Kenwood TM-733E 2/70 dualband remote head transceiver**  
RRP £ 729 Lynch Price: £629  
Deposit: £69, 12 payments of £51.43. Cost of loan: £57.16

**Kenwood TM-742E Tripleband 2/70, (6M option), R/H transceiver**  
RRP £ 879 Lynch Price: £ 749  
Deposit: £79, 12 payments of £68.14. Cost of loan: £147.68

**Kenwood TM-79E 2/70 DualBand handheld transceiver**  
RRP £ 479 Lynch Price: £409  
Deposit: £49, 12 payments of £33.06. Cost of loan: £36.74

**Kenwood TM-22E 2M slimline handle transceiver**  
RRP £ 254 Lynch Price: £219 Deposit: Too low for finance!

**Kenwood TM-42E 70cm slimline handle transceiver**  
RRP £ 289 Lynch Price: £249 Deposit: Too low for finance!



**YAESU**

**Yaesu FT-1000 Flagship 200W HF transceiver**  
RRP £3999 Lynch Price: £2899  
Deposit: £499, 24 payments of £120.24. Cost of loan: £485.76  
\* NEW Deluxe upgrade kit available for all FT-1000's only £299 (includes XFC/D/E/BPF1/TCXO-1) \*

**Yaesu FT-1000MP/DC E0SP 100w HF transceiver DC Version**  
RRP £2599 Lynch Price: £2099  
Deposit: £399, 24 payments of £85.17. Cost of loan: £344.08

**Yaesu FT-1000MP/AC E0SP 100w HF transceiver AC Version**  
RRP £2849 Lynch Price: £2279  
Deposit: £399, 24 payments of £94.18. Cost of loan: £380.51

**Yaesu FT-990/DC 100w HF base transceiver DC Version**  
RRP £1999 Lynch Price: £1599  
Deposit: £199, 12 payments of £119.39. Cost of loan: £132.70

**Yaesu FT-990/AC 100w HF base transceiver AC Version**  
RRP £2199 Lynch Price: £1799  
Deposit: £299, 12 payments of £135.27. Cost of loan: £123.31  
or Deposit: £299, 24 payments of £75.15.  
Cost of loan: £303.60

**Yaesu FT-900AT HF 100w mobile/base remote head HF transceiver**  
RRP £1649 Lynch Price: £1149  
Deposit: £199, 12 payments of £87.24. Cost of loan: £96.97

**Yaesu FT-840 HF 100w simple to use HF transceiver**  
RRP £959 Lynch Price: £729  
Deposit: £79, 12 payments of £59.69. Cost of loan: £66.35

**Yaesu FL-7000 500w solid state HF linear Amp, with auto ATU**  
RRP £2339 Lynch Price: £1999  
Deposit: £399, 24 payments of £80.16. Cost of loan: £323.84

**Yaesu FT-290R11 2m all mode 2.5w portable transceiver**  
RRP £ 599 Lynch Price: £479  
Deposit: £49, 12 payments of £39.49. Cost of loan: £43.89

**Yaesu FT-690R11 6m all mode 2.5w portable transceiver**  
RRP £ 649 Lynch Price: £539  
Deposit: £59, 12 payments of £44.08. Cost of loan: £48.99

**Yaesu FT-3000M 75w 2m FM transceiver \*NEW\***  
RRP £ 479 Lynch Price: £389  
Deposit: £39, 12 payments of £32.14.  
Cost of loan: £35.72

**Yaesu FT-51R 2/70 dualband handle, computer programmable**  
RRP £ 539 Lynch Price: £399  
Deposit: £49, 12 payments of £32.14. Cost of loan: £35.72

FREE ADMS SOFTWARE!

**Yaesu FT-50R The worlds smallest dualband 2/70 handle**  
RRP £349 Lynch Price: £299 Deposit: Too low to finance!

**Yaesu FT-736R Quad band all mode VHF/UHF transceiver, (270 fitted)**  
RRP £1999 Lynch Price: £1399  
Deposit: £299, 12 payments of £101.02. Cost of loan: £112.28 or  
Deposit: £299, 24 payments of £55.11. Cost of loan: £222.64

ADD 6M FOR ONLY £199!

## O.T.T. prices on used gear s

Have you noticed just how much some of our competitors are asking than two examples on our current used equipment list. Perhaps some want to check out the real value of that "used" piece of gear then ch... I'll give FREE unbiased advice on what you should be paying. If you free! Chris Taylor GOWTZ, Sales Manager.



### IC-736

The IC-736 from Icom is the only HF base station to offer so much in the way of features, for so little price.

Just look at what the IC-736 has to offer:

- A full 100 watts on all the HF amateur bands 160-10m (incl WARC)
- A full 100 watts on 6 metres
- A built in AC power supply - no noisy external power supply needed!
- Built in high speed auto ATU - no need for more external boxes!
- Dual antenna inputs, auto switching
- Dual display showing second split operating frequency

RRP £1969 Lynch Price: £1599  
Deposit: £299, 12 payments of £119.39. Cost of loan: £132.70  
or Deposit: £299, 24 payments of £65.13. Cost of loan: £263.12

**Icom IC-7750SP 200w HF twin RX HF Flagship transceiver**  
RRP £3699 Lynch Price: £3099  
Deposit: £499, 24 payments of £130.26. Cost of loan: £526.24

**Icom IC-706 100w HF, 100w 6m, 10w 2m all mode mobile transceiver**  
RRP £1195 Lynch Price: £999  
Deposit: £99, 12 payments of £82.65. Cost of loan: £91.87

**Icom IC-820H 2/70 dualband 35/45w base station**  
RRP £1795 Lynch Price: £1499  
Deposit: £299, 12 payments of £110.20. Cost of loan: £122.49

**Icom IC-2350H 2/70 dualband dual rx mobile transceiver**  
RRP £649 Lynch Price: £469  
Deposit: £69, 12 payments of £36.73. Cost of loan: £40.83

**Icom T-7E Dualband 2/70 miniature handle transceiver**  
RRP £329 Lynch Price: £299 Deposit: Too low to finance!

**MARTIN LYNCH**  
& Son

THE AMATEUR RADIO EXCHANGE CENTRE

140-142 NORTHFIELD AV  
0181 - 566 1120

# CATCH?



## A brand new Dual band Mobile for only £399.95?



**YAESU FT-5100**

**FT-5100 Dual Bander RRP £679. ML price £399.95. P&P £10. FINANCE AVAILABLE!**

**SAVE £279! (AND ITS NOT EX-DEMO!!)**

Why pay £499 for the "cheapest" alternative dual bander when you can have a new 35 watt on 70cm and a massive 50 watts on 2m transceiver from Yaesu? Retailing at £679, Martin has secured a large quantity of these compact and easy to use dual band transceivers at £279 off! No catch, these are not "EX-DEMO" units, (have you noticed how much EX-DEMO is being advertised?) - is that new piece you're ordering new, or has it been around the world 10 times?

### EASYWAVE - BY ICOM

The latest commercial 2 way handies operating on UHF. One licence at only £30 and ideal for business use indoors or out. Easy to operate with the absolute minimum of buttons. Supplied with wall charger and NiCad batteries. **ONLY £199 INCL. VAT.**

**SEE US AT THE LINCOLN HAMFEST ON SUNDAY 8th SEPT**

### 2M MOBILE

#### ADI AR-146 - now back in stock



First viewed at the Lynchy Open Day, the AR-146 is a real low cost FM mobile for 2 metres. Styled rather surprisingly on another main manufacturer's transceiver, this new offering from Taiwan is a 50 Watt 130-170MHz unit offered at a ridiculously low price. But who's complaining?

**RRP £269. DEPOSIT £49, 12 PAYMENTS OF ONLY £18.33, INTEREST FREE ZERO APR.**

### HEIL SOUND

**"As reviewed in RadCom" August 1996**

**Heil Proset-5** Professional Quality Boom Headset, dual padded earphones, flexible mic boom, includes HC-5 "Full range" insert for superb speech quality. Requires AD-1 cable ADAPTOR for KENWOOD/ICOM. **£119.95 incl. VAT**

**Heil Proset-4** Identical to Proset-5, but includes HC-4 "DX" microphone insert. Ideal for punching through the pileups. **£119.95 incl. VAT**

**Heil HC-4** Replacement microphone insert for existing fist or base microphones. With 100dB peak at 2KHZ and the low end rolled off sharply at 500HZ, (12DB per octave), the HC-4 is the ultimate DX mic insert. **£28.95 incl. VAT**

**Heil HC-5** Identical to HC-4, but High Articulation, offering superb SSB quality, rolls off sharply under 350HZ and above 3100HZ, peaking at 2.4KHZ. "Hi-Fi" SSB Audio. **£28.95 incl. VAT**

**Heil AD-WKY** Adapter leads to interface the proset Headset/boom microphones to 8 pin Yaesu, Icom or Kenwood transceivers. **£11.95 EACH**

### ANTENNAS

#### Cushcraft

- HF Antennas
- R7000 NEW!** Latest 10-4m vertical
- + 80m Option.....**£389.00**
  - R50 80m add on kit for R7000.....**£149.00**
  - R8 10/12/15/17/20 vertical.....**£295.00**
  - AV-3 14-21-28MHz vertical 4.3m long.....**£89.00**
  - AV-5 3.5-7-14-21-28MHz vertical 7.4m long.....**£159.00**
  - APBA 8 Band Vertical.....**£199.00**
  - APR18A Radial Kit.....**£49.00**
  - 40-2CD 2-4ele 40m Yagi.....**£469.00**
  - A3S 14-21-28MHz Yagi.....**£349.00**
  - A3WS 12/17m 3-4ele Yagi.....**£275.00**
  - A103 30m Extension A3WS.....**£115.00**
  - 204CD 4 ele 20m Yagi.....**£469.00**
  - 154CD 4 ele 15m Yagi.....**£279.00**
  - D4 Dipole 10/15/20/40m.....**£249.00**
  - D3W Dipole 12/17/30m.....**£189.00**
  - A4S 3-4 ele Yagi 10/15/20m.....**£439.00**

#### Tonna

- 6 metres**
- 20505 5 ele 10dB 3.45m.....**£89.95**
- 2 metres**
- 28004 4 ele 8.9dB 93m.....**£39.95**
  - 28009 9 ele 13.1dB 3.47m.....**£42.95**
  - 28089 9 ele portable.....**£47.95**
  - 28018 9 ele crossed.....**£79.95**
  - 28011 11 ele 14.1dB 4.62m.....**£72.95**
  - 28022 11 ele crossed.....**£105.95**
  - 28017 17 ele 15.3dB 6.57m.....**£89.95**
- 70 centimetres**
- 20909 9 ele 13.0dB 1.24m.....**£41.95**
  - 20919 19 ele 16.2dB 2.82m.....**£49.95**
  - 20438 19 ele crossed.....**£59.95**
  - 20921 21 ele 18.2dB 4.6m.....**£64.95**
- 23 centimetres**
- 20623 23 ele 18dB 1.75m.....**£45.95**
  - 20655 55 ele 21.5dB 4.64m.....**£69.95**

We also stock their range of power splitters and stacking frames.

### DSP FILTERS

#### TIMEWAVE & M/FJ

- DANMIKE DSP-NIR NEW DSP.....**£329.00**
- MFJ-784B All mode Tunable DSP.....**£249.00**
- DSP 9+ All mode DSP at only.....**£189.00**
- DSP 59+ As above but more features.....**£249.00**
- DSP 599zx NEW! Hyper speed processor, alpha display and more.....**£349.00**

**FOR THE LARGEST SELECTION OF USED EQUIPMENT IN EUROPE, CALL OUR FAXBAK SERVICE - TODAY**



### LCD DIGITAL CAMERA

#### CASIO QV-10A

A neat palm size digital storage camera which can store over 90 full colour digital images. Import the pictures into your PC with the supplied interface cable & software for either IBM compatible or MAC machines. Ideal for reprinting images on the Internet, SSTV via JVFAX and lots more. Outputs include direct video and serial for PC connection. **Supplied with all accessories including Software & Cables.**

**RRP £799 ML Price £479 NEW LOWER PRICE**

### MYDEL ANTENNAS

#### M-DEL MULTITRAP NEW

Built exclusively for MARTIN LYNCH, the new antenna is trapped for 80 through to 10 metres, uses heavy gauge multi strand plastic sheathed wire, heavy duty 1 kW traps and totals only 20 metres in length. The "MULTITRAP" is a fan type design, having 2 "legs" either side of the dipole centre. It's very easy to install, takes minutes to tune, guaranteeing an SWR of less than 1.5:1 on spot frequencies throughout the entire 5 bands. A far better alternative to the old GSRV antenna.

Impedance: 52 Ohm Weight: 2.5Kg  
Overall length: 20m Input socket: SO239  
Power Handling: 1kW  
Max SWR: 1.5:1 **£69.95 p&p £7.50**

AS REVIEWED IN RADCOM DECEMBER

## GET THE BEST OUT OF YOUR PACKET STATION WITH AEA

#### DSP-232 - THE MODE WARRIOR



**FREE PACKET FOR WINDOWS worth £69.95!**

The latest all mode DSP driven TNC from AEA. 9600 & 1200 Packet. All standard HF & VHF modes, two switchable radio ports, plus more.

**RRP: £499.95 SPECIAL INTRO PRICE: £479.95**

#### PK-900



**FREE PACKET FOR WINDOWS worth £69.95!**

When you're ready to step up from the best selling PK-232MBX, then take a look at the PK-900. Dual simultaneous ports, switchable via a single keystroke, will still allow the user to receive two signals at the same time. Internal firmware includes SIAM - Signal Identification & Acquisition Mode, automatically identifying the incoming mode of transmission - takes out the guess work! Add the optional 9600 baud modem and you're satellite ready! **£479.95**

#### PK-96



Whilst others are still having a five course lunch waiting for 1K of data to transfer, you can enjoy the incredible speed of using a new PK-96 and find yourself with hours of free time on your hands! The PK-96 takes over from where the old PK-88 left off. It comes standard with 1200 baud AFSK tone signalling, as well as 9600 baud G3RUH compatible direct frequency modulation, making the PK-96 an ideal high speed terrestrial, or satellite data controller. **£219.95**

#### PK-232MBX



Probably the best selling Data Controller in the world, the PK-232MBX is the Radio Modem to choose if you want all modes, including Morse Code, Baudot, (RTTY), Ascii, Amtor/Sitor 476 & 625, Pactor, HF & VHF Packet, B&W Fax b/fx, Navtex & Amtex. As with the PK-900, the PK-232MBX now includes "SIAM" and is compatible with the popular TCP/IP networking protocol via KISS mode. **£319.95**

#### PC-Pakratt for Windows

Operate the entire range of AEA controllers from one package. Run two controllers at once, run other programmes on your PC (in Windows), whilst controlling your data controller. Additional features include separate windows for mailbox operation, QSO Logging, file transfers and more. **£79.95**

#### PK-12



The very latest replacement for the PK-88, the tiny PK-12 not only comes with more features, but its cheaper too! The PK-12 is a 1200 baud VHF packet controller ideal for those of you who are looking at getting started in digital communications. Full-featured mail drop facilities including internal lithium battery back-up. **£129.95**

#### PC DATA MODEMS

**US Robotics "Sportster" 28,800 Data/Fax modem. £189 incl. VAT**

**ZOOM fax MODEM V.34IE. ML Price: £169 incl. VAT**

**Both modems are bundled with lots of FREE software!**



**The best internal modem available.**

# AVENUE EALING, LONDON W13 9SB

Martin Lynch is a licensed credit broker. Full written details are available on request. Finance is subject to status. **£&OE. £10 p&p on all major items.**



**TEL: 0181 - 566 1120**

**FAX: 0181 - 566 1207**

**FAXBAK: 0181 - 566 0 007**

**CUSTOMER CARE: 0181 - 566 0 566**

**WEB SITE: http://www.martin-lynch.co.uk**

**E-MAIL: sales@martin-lynch.co.uk**

# The Yaesu FT-50R - Review

By Clive Hardy G4SLU

*Clive Hardy G4SLU promises you that his review of the latest offering from the Yaesu designer's desk is not going to be 'just another hand-held' report. So....read on and find out!*

Close-up view of the Yaesu FT-50R. The £1 coin provides an indication of the transceiver's small size.



Now that you've started reading this article, stick with it! I know this is the umpteenth review of a hand-held, and that all dual-band hand-helds are all the same: black, small, not as small as they will be next year, and loaded with functions.

But I promise you this won't all be an essay version of the owner's manual. This isn't so much a review of the FT-50R, just a few impressions, and I was impressed.

If you just want the specifications, look somewhere else on the page (at the end of this article!). I'm not being dismissive of the radio's performance, but we all know it will do what the book says it will do.

Some of the things the FT-50R does I didn't find a use for. I just used it to talk to people.

Personally I get the feeling that hand-helds are going down the route that h.f. radios went about 15 years ago. Lots of bells and whistles. Some bells are useful, some whistles are pure gimmicks.

## First Impressions

First impressions must of course get a mention, and here they are. The FT-50R is about the size of a pack of cards, with knobs and an antenna attached.

The FT-50R is a seriously compact and robust looking piece of very modern technology. There is just a hint of a bygone age in the curving style of the front panel.

Just as we all do, I switched the radio on without reading a word of the manual. But had to start reading quickly, as the squelch is factory pre-set as 'open'.

There is a menu for selecting the settings of numerous options and this is accessed by pressing down the main knob. Usefully, the squelch setting is number one on the list.

Another very useful feature on the FT-50R is that all the repeater shifts are pre-set, and are activated when a repeater output

frequency is selected. Other transmit shifts can be selected.

## Frequencies Into Memory

I thought the best way to get what I wanted from the FT-50R was to put the frequencies I would use into memory, and just use the memory options. There are 100 memories.

So, I elected to put all the f.m. channels into memories, and scan the lot, about 30 in all.

To make it simple to identify a channel, each one can be given a four character name, such as SU22, or CLUB. Either frequency or name can be displayed, and memories can also store power settings and transmit offsets.

In scan mode the light can be set to illuminate the display when the scan stops on a frequency.

My one and only real disappointment was with the display. It's fine in good light, and in the dark with the back light on. In between it sometimes isn't quite so hot.

The clear plastic window in front of the display is convex and very shiny. The shape fits in with the overall curvy design, but must it be so shiny?

In moderate light levels the display is sometime hard to read unless viewed from just the right angle due to lowish contrast of the l.c.d., and reflections from that shiny plastic cover.

In side-by-side comparisons my 'cheapo' watch has a much clearer display. The light on the FT-50R which is a delightful shade of orangey red, only makes a noticeable impact when the ambient light level is pretty low.

## Battery Life

Battery life is a major factor with hand-helds. Everything is done to save power, particularly with respect to transmit power.

Various power output levels can be selected. But one of the best features of the radio is the option that reduces the output power

relative to the received signal.

The FT-50R uses a bit of technology borrowed from mobile telephones to 'balance' the output power with the incoming a signal level.



and it works. (Ideal when working through a repeater).

Only enough r.f. energy required to do the job is pushed into the ether. Very environmentally aware!

Sticking with transmissions, reports on audio quality from other stations were extremely complimentary. On receive only I found that a fully charged battery lasted over a day.

On transmit there seemed to be a fair amount of life in the battery. It must be that transmit save option!

With the light to moderate use I put the FT-50R to, the battery never died on me. I did charge it up most evenings. The supplied charger is pretty swift at squirting enough Volts into the battery to 'fill it up'.

## What Else?

What else did I like? Well, just like the advertising blurb says, the ergonomics layout of controls means that they are very well

## Manufacturer's Specifications

### Receiver

Frequency range	76-200, 300-400, 400-540, 590-999 (Inhibited on cellphone band)
Channel steps	5, 10, 12.5, 15, 20, 25 and 50kHz spacing
Current consumption	250µA (auto power off) 24mA (saver on) 200mA (receive) 55mA audio squelched)
Receiver type	Double conversion superheterodyne 45.1MHz and 455kHz
Sensitivity	v.h.f. 0.16µV for 12dB SINAD u.h.f. 0.18µV for 12dB SINAD
Adjacent channel selectivity	65dB
Intermodulation	65dB
Audio output	0.5W @10% distortion into 8Ω

### Transmitter

Frequency range	v.h.f. 144 -146MHz u.h.f. 430 - 440MHz
Power Output	5, 2.8, 1 and 0.1W (approximately)
Current consumption	1.5A (v.h.f. @ 5W output) 1.6A (u.h.f. @ 5W output)
Modulation	variable reactance (F2, F3)
Maximum deviation	± 5kHz
FM noise	better than -40dB (@1kHz)
Spurious emissions	better than -60dB (carrier)
Audio distortion	<5% @ ± 3kHz deviation
Microphone	Electret 2kΩ impedance

### General

Supply voltage	4 - 16V
Size	57 x 99 x30mm (width, height, depth) without antenna
Weight	335g (approximately) with FNB40 battery pack, antenna and belt clip
Antenna	YHA-58 helical (rubber covered) (uses SMA plug/socket)

placed for one-handed operation.

The volume control is around the base of the main knob and is dead easy to twiddle with either a thumb or forefinger. The push to talk (p.t.t.) button and tone burst button are similarly well placed and easy to operate. And the FT-50R fits comfortably in either hand.

What wasn't so ergonomically friendly was the belt hook that clips to the back of the battery. It's held there by a devilishly strong clip.

Beware of fingers colliding with parts of the mount as it releases! It can draw blood! Once the belt clip was off, it stayed off.

### Menu Option

I won't bore you with all the options and parameters that can be changed. There are about 30 items on the menu, which can be accessed via the key pad.

I found it simpler to whiz through the list to the item I wanted by turning the main knob. Setting any of the options is quite easy and straight forward. It only took a little while to remember all the important options, one of which could be labelled self-destruct! It allows you to change the c.p.u. settings. The

instructions (wisely) say "Don't do it"!

Although the FT-50R has CTCSS I didn't have cause to use it. Such a feature will probably become more important in years to come, but for now it's mostly a novelty. (I'm speaking as someone who's local repeaters do not use CTCSS for access - yet).

What is definitely a novelty is a feature called Auto Range Transpond System - ARTS. This allows similarly equipped radios to automatically beep at each other so they know they are in range.

If the radios don't get a beep for a minute an alarm sounds. I suspect there's a sort of RAYNET related usefulness there somewhere. I await Yaesu's withering explanation of my failure to see the civilisation moving relevance of the feature! There is also DTMF feature which I also didn't use.

### Wide Coverage

The FT-50R has a wide receive coverage, from 76 to 999MHz. There are gaps between 200 to 300 and 540 to 590MHz.

The appropriate mode is automatically selected, and the FT-

50R will only transmit in the amateur bands. This is sensible. It protects the user from accidental unauthorised transmitting.

Comparative tests with other hand-helds listening to the marine and air bands showed the FT-50R to be up there with the rest. The received audio was excellent in a.m. and f.m. modes.

The transceiver's 'wide' f.m. performance was, quite frankly, poor. This is a trivial matter as it's hardly the radio's main purpose.

Otherwise, the receiver's performance with the rubber duck antenna was very good. There is plenty of clear audio from the speaker.

The set has a neat SMA connector for the antenna. Perhaps this is to discourage the attachment of an external antenna. Like most hand-helds, the FT-50R receiver struggles with adjacent signals a bit when connected to many a dB gain external antenna, but what else can you expect!

A hand-held is a hand-held and not a miniature main station radio. Used as intended, the FT-50R works perfectly.

### Very Impressed

I used the FT-50R for a couple of weeks, and was very impressed with it. Only the display caused me a little concern.

Overall, the FT-50R is a neat little radio. A good performer. Nice shape. Nice size. Small and light enough to be carried in a shirt pocket.

The transceiver has well placed controls. Useful battery saving features. Extra receive coverage to add interest. I think it's well worth consideration.

My thanks for the loan of the review transceiver go to Yaesu UK Ltd., Unit 2, Maple Grove Business Centre, Lawrence Road, Hounslow, Middlesex TW4 6DR. Tel: 0181-814 2001. The FT-50R

is available from Yaesu dealers at £339 which includes a battery charger.

PW



The transceiver and associated power supply



# YAESU FT-50R

# The Sprat Part two Transceiver



By Rev. George Dobbs G3RJV

*The Rev. George Dobbs G3RJV describes the assembly stage of the Sprat 3.5MHz transceiver.*

The Sprat receiver fits on to a small double-sided p.c.b. The top side acts as a ground-plane. The constructor must pay attention to all grounded components and the crystal cases are all soldered to the ground-plane.

The diagram, Fig. 2.1, shows (RX) a ground connection for pin 16 (IC1) which is taken to a pad at the end of the chip adjacent to the word 'key'. This requires a wire link soldered to the pad and the ground-plane.

The three inductors L1, L2 and L3 require a ground connection. Remove the grounding tabs at the base of the can and bring a link wire through the p.c.b. which is soldered to the can and the groundplane.

In the case of L1 and L2 the link also connects to a pad which provides a ground connection for the tuned circuits. Make these ground connections first as they are easy to miss at a later stage.

Begin with the audio stages and build this section and associated power components. A 12V supply applied at R10 should result in the 'hiss' at the output stage, turning to a subdued 'roar' as a finger is placed on pin 3 of the LM386.

Now add Tr1 and its associated parts. A finger on C19 should produce an audio output that's reduced when the free end of D5 is grounded.

The next section for building is quite large because all the components around the MC3362 are added, perhaps as far as C5. A wire on pin 24 should produce some signals which can be tuned by R2.

Adjust the trimmer to allow an appropriate beat note from the carrier insertion oscillator (XL4/C16).

To set the frequency range, use either a frequency counter or a receiver tuning across the desired local oscillator (l.o.) range. Adjust the low end of the oscillator (with L4) to 7.933MHz. The tuning range should cover the c.w. end of 3.5MHz (+4.433MHz).

Finally, add the input components. To adjust L2 and L3 (band-pass tuning) across the c.w. portion of the band, 'peak up' signals on the band or a (very) low strength signal from a signal generator.

Setting-up a simple band-pass filter is somewhat of a compromise. Begin by peaking signals at either end of the band then re-adjust for a peak in the middle of the tuning range. Too sharp a peak at one end will produce an uneven distribution across the tuning range.

In my prototype, the receiver and the transmitter units were mounted into their own case. I used a **JAB Electronic Components Aluminium Box** type JA20 (114 x 76 x 38mm). The tuning control, R2, is mounted on a small L shaped bracket behind the front panel with a reduction drive fitted on the front panel along with the volume control potentiometer R8.

For tuning I used a Jackson miniature type Ball Drive (Maplin HB24V). A pointer wire is soldered on to the reduced speed section of the shaft.

## The Transmitter

The transmitter also fits onto a compact double-sided p.c.b.. The layout is shown in Fig. 2.2. Like the receiver, the transmitter board uses the top side of the board as a groundplane.

The two inductor cans (L5 and L6) are grounded via a through board wire which connects the underside pad to the top of the board. It's also soldered to the side of the can.

Grounding tabs of the various 'cans' are removed to save space. (The crystal case is soldered to the groundplane at one side).

The transmit board may be built a little at a time. The progress of the signal is checked through the circuitry as the stages are completed.

Signal tracing requires either the use of an oscilloscope or a simple diode probe. First check that an output is present from the receiver board.

Add the supply keying circuit (Tr5) and the regulator (IC4) to the transmitter board. Ground D6 (keying point) and check that the '12VTX' voltage appears on the collector of Tr5.

The buffer stage (Tr2) can be built and tested and the receiver l.o. connected, via a screened lead to the input of the BC183. Using the diode probe, or oscilloscope, check that an output appears at C31.

The next stage is to build the mixer circuit (around IC5) and the low-pass filter (to C42). With the signal present from the receiver oscillator, set the preset control (R14) at half to two-thirds from ground and key the transmitter.

The mixer output at C42 will be low, but should be audible in the receiver. If it's not, connect a short wire to C42 and bring it close to the receiver input. The capacitor, C37, may then be adjusted to adjust the transmitter frequency to give a b.f.o. note on the receiver.

The band-pass filter around L5 and L6 will require peaking for the best compromise output over the c.w. portion of the band. Final adjustments can be made at full power.

Build the rest of the transmitter as far as Tr4/C51. At this point quite a hefty signal will be present, something in the order of 2V of r.f. This is easily detected with the probe and meter.

The rest of the transmitter board can be completed prior to final testing and setting-up. Once the power amplifier stage has been built the transmitter must be tested with a 50Ω load present on the output.

## Trifilar Transformer

The only real (possible) problem in building the transmitter presents itself





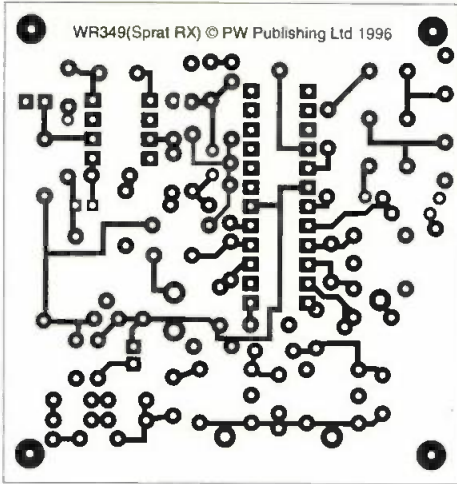

Fig 2.1

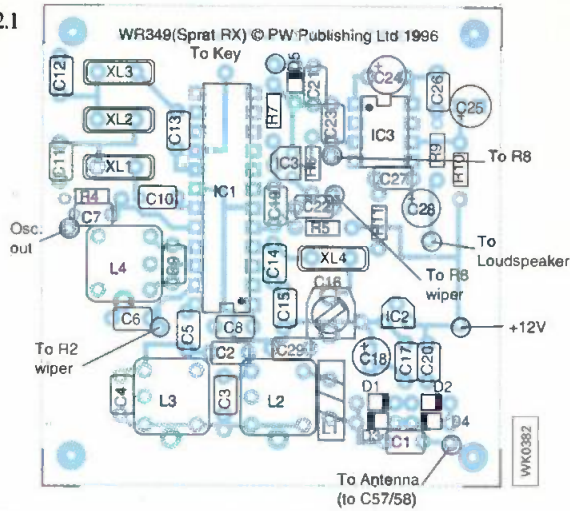

Fig. 2.1: The printed circuit and overlay details of the PW Sprat Receiver.

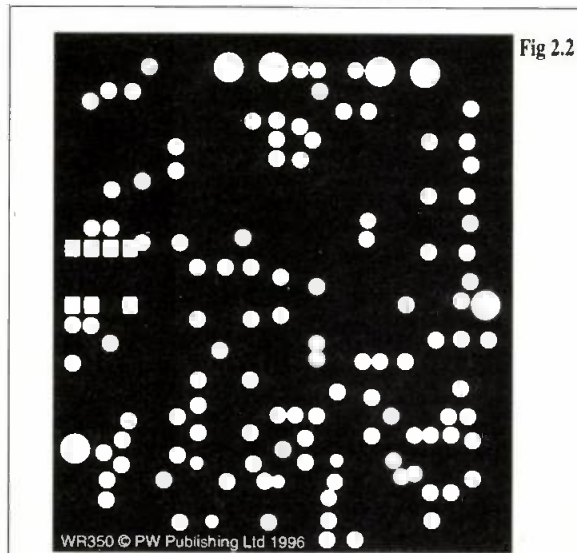
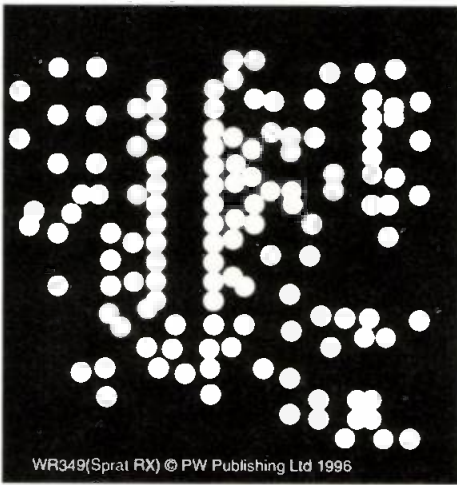
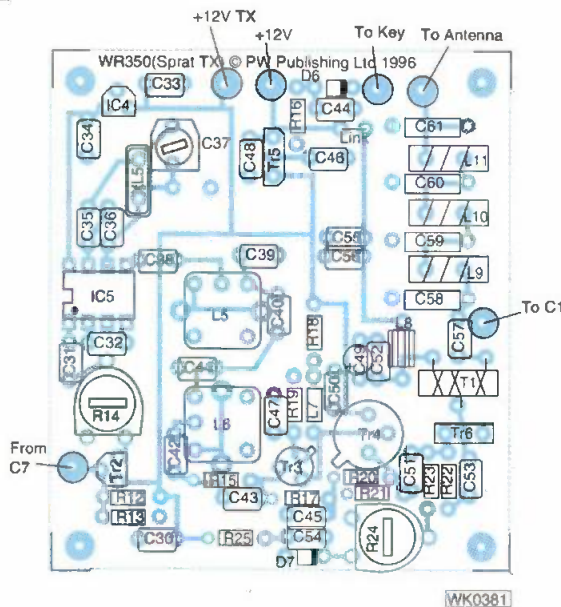
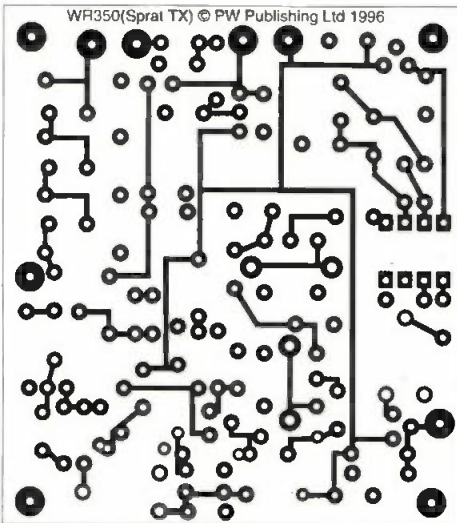

Fig. 2.2: The printed circuit and overlay details of the PW Sprat Transmitter.



with T1. (The trifilar wound transformer in the power amplifier circuit).

The transformer is easy to wind but the connections must be correct or it will not work. The winding is made using three wires, which for the purposes of winding can be considered as one wire.

Begin the process by taking three

lengths of the wire about 350mm long. These three lengths should then be lightly twisted together to form a 'single wire'.

Do not twist too tightly, about one twist every two or three millimetres is ideal. Then wind the five turn coil (treating the twisted wires as one wire) with each 'pass' through the centre of the core being one turn.

The circuit diagram (Fig. 1.2, published last month) shows all the 'start' points at the bottom of T1 with the corresponding ends at the top.

Lightly tin each end with a little solder. Then, using a multimeter on the Ohms range, you can sort out the beginning and end of each wire. Finally, arrange the wires (with the

All the parts of the Sprat are available from:  
**JAB Electronic Components,**  
Industrial Estate  
Rear of Queslett Motors, 1180 Aldridge Road, Great Barr, Birmingham B44 8PB

Continued on page 40

notional identities of wires 1 - 3) apart with beginnings and ends of each wire in line.

The start of wire 1 goes to L8, the end of wire 1 joins to the start of wire 2. The end of wire 2 goes to the drain of the power m.o.s.f.e.t. and to the start of wire 3. The end of wire 3 goes to C57. Finally...check carefully!

### Power Amplifier

Power amplifier setting up tests **must be performed with a 50Ω load** attached to the output. Perform all tests by keying the transmitter but lift the key line between each test.

At this point the input buffer preset (R14) around two thirds up from ground and the power amplifier biasing preset (R24) at about half way. The diode probe and meter are attached to the output from the low pass filter (L11/C61).

The aim is to set the output to 3W of r.f. power. Using the diode probe and a voltmeter, this is about 17V recorded on the voltmeter.

Key the transmitter and look for a reading on the voltmeter. Adjust the biasing control so that this is just under the required 17V. Then adjust the drive control R14. (It should increase the output as it is turned up, to a point when no significant increase is achieved. Back off the preset a tiny amount from this point).

Re-adjust R24, the bias control, for the desired 17V (3W). At this stage the band-pass filter inductors L5 and L6 can be re-peaked to optimum output across the whole c.w. band.

It may also be possible to increase the output by opening or squeezing the turns on the low pass filter inductors: L9, L10 and L11. You can also adjust the value of C37 to achieve the desired transmit offset by listening for the desired sidetone on the receiver.

The p.a. transistor **requires a heatsink**. There's little space left with the JA20 box, so, I used a small TO220 heatsink with the bottom fins cut away to avoid adjacent components on the board. To finish off mount the two JA20 cases base-to-base with a common front panel.

Sprat's now ready to swim! And my first QSO, even before the boards were cased, was with a GI station who gave me a report of 589 for my 3W into a doublet antenna! So, have fun building **your** Sprat and enjoy 'fishing' for the DX!

## Shopping List

### Resistors

#### Carbon Film 0.25W

2.2Ω	1	R11
22Ω	1	R10
100Ω	1	R19
220Ω	1	R21
470Ω	1	R15
1kΩ	2	R16, 22
1.5kΩ	1	R3
2.2kΩ	3	R4, 18, 25
6.8kΩ	1	R1
10kΩ	1	R9
22kΩ	4	R12, 13, 20, 23
33kΩ	1	R17
1MΩ	2	R5, 7
4.7MΩ	1	R6
<i>Miniature preset (horizontal)</i>		
220	1	R14
10kΩ	1	R24
<i>Variable (rotary 1W)</i>		
4.7kΩ	1	R2
20kΩ	1	R7 (or near value)

### Capacitors

<i>Sub-miniature Ceramic</i>		
3.3pF	2	C2, 40
<i>Monolithic Ceramic</i>		
47pF	4	C3, 4, 39, 41
68pF	2	C35, 36
100pF	2	C1, 9
180pF	4	C10, 11, 12, 13
220pF	3	C14, 15, 31
270pF	2	C43, 47
560pF	1	C38
1nF	1	C42
<i>Low Voltage Disc Ceramic</i>		
10nF	17	C6, 7, 8, 17, 20, 21, 26, 29, 30, 32, 44, 45, 46, 48, 50,
53, 54		
47nF	1	C23
100nF	9	C19, 22, 27, 33, 34, 51, 52, 55, 56
<i>Sub-miniature Polyester</i>		
100nF	1	C57
<i>Bead Tantalum (16V working)</i>		
10μ F	2	C18, 24
22μ F	1	C49
<i>Miniature Electrolytic (16V working)</i>		
220μ F	2	C25, 28
<i>Polystyrene (foil)</i>		
470pF	2	C58, 61
1.2nF	2	C59, 60
<i>Ultra-miniature (5mm) trimmer</i>		
7.5-50pF		C16, 37 (35pF is the nominal value)

### Inductors

18μ H	1	L7
KANK3333R	4	L2, 3, 5, 6
KANK3334R	1	L4
<i>Wound on Ferrite parts</i>		
L1		22 turns on an FT37-43 (0.38mm enamelled copper wire)
L8		12 turns on a ferrite bead (0.27mm enamelled copper wire)
L9, 11		25 turns on a T37-2 toroid (0.32mm enamelled copper wire)
L10		27 turns on a T37-2 toroid (0.32mm enamelled copper wire)
T1		5 turns trifilar wound on an FT37-43 toroid (0.32mm)

### Semiconductors

1N4148	6	D1, 2, 3, 4, 5, 6
2N5179	1	Tr3
2N3866	1	Tr4
78L05	1	IC2
78L06	1	IC4
BC183	1	Tr2
BZY884V7	1	400mW 4.7V Zener diode
IRF510	1	Tr6
LM386	1	IC3
NE602	1	IC5
MPP102	1	Tr1
MC3362	1	IC1
ZTX751	1	Tr5 (or any npn switching transistor)

### Miscellaneous

Four 4.4333MHz (colour burst) TV crystals, a 6:1 reduction gear for the tuning, two boxes (JAB type JA20) connecting wire, miniature coaxial cable, plugs sockets and knobs to suit, small pieces of thin aluminium, screws, nuts and stand-off pillars.

**RST LANGREX SUPPLIES LTD RST**  
**PHONE DISTRIBUTORS OF ELECTRONIC VALVES FAX**  
**0181 684 1166 TUBES AND SEMICONDUCTORS AND I.C.S. 0181 684 3056**  
**1 MAYO ROAD • CROYDON • SURREY CR0 2QP**  
**24 HOUR EXPRESS MAIL ORDER SERVICE ON STOCK ITEMS**

E.P.	EL95	2.00	PY901	1.50	6B6E	1.50	6S7GT	4.50
AZ31	5.00	EL360	18.50	QD02-8	12.00	6B6H	2.50	6S7GT
CL33	10.00	EL909-919	12.00	QD03-10	5.00	6B6J	2.25	6S7T
DY867	1.50	EM34	15.00	QD03-10 Mulli	15.00	6B6N	2.00	6UBA
E88CC Mulli	8.50	EM81	4.00	QD03-20A	15.00	6B07A	3.50	6V6GT
E190F	3.50	EM84	4.00	QD06-40A Mulli	30.00	6B7T	6.00	6X4
E190F	22.00	EM87	4.00	DV03-12	8.00	6B88A	6.00	6X5GT
EABC80	2.00	EN91 Mulli	7.50	U19	10.00	6B57	6.00	12AT7
EB91	1.50	EY81	2.50	UABCR0	1.50	6B96B	4.50	12AU7
EBF80	1.50	EY86	1.75	UBF89	1.50	6B9W7	1.50	12AX7
EBF89	1.50	EY88	1.75	UCH42	4.00	6B26	2.50	12AX7A GE.
EBL31	15.00	EZ80	3.50	UCH81	2.50	6C4	2.00	12B8A
ECC33	7.50	EZ81	3.50	UCL82	2.00	6C6	5.00	12B8E
ECC35	7.50	GY501	3.00	UCL83	3.00	6C86A	3.00	12BH7A GE
ECC38	3.00	GZ32 Mulli	8.50	UY89	4.00	6CD66A	5.00	12BY7A GE
ECC82	3.00	GZ33	6.00	UY41	12.00	6CL6	3.75	12DW7
ECC83	3.50	GZ34 Mulli	15.00	UY84	3.50	6CGT	7.50	12E1
ECC85	3.50	GZ37	6.00	UY41	4.00	6CH6	5.00	12HG7 12GN7
ECC88 Mulli	6.00	KT61	10.00	UY85	2.25	6CW4	8.00	30PL1/2
ECC91	2.00	KT66 China	10.00	VR105/30	2.50	6D5	5.00	30P19
ECC90	1.50	KT88 China	12.00	VR150/30	2.50	6DQ5 GE	17.50	3008(PR)
ECH35	3.50	N78	9.00	2739	10.00	6DQ8B	12.50	572B
ECH42	3.50	DA2	2.70	2803U	25.00	6EAB	3.50	805
EC981	3.50	D82	2.50	2D28	3.50	6E45	1.50	807
ECL80	1.50	DC3	2.50	3B28	20.00	6F6	3.50	811A
ECL87	3.50	D03	2.50	4CX250B STC	55.00	6FD7	7.50	812A
ECL83	3.50	PCF80	2.00	5R4GY	6.00	6GK6	4.00	813
ECL86	3.50	PCF82	1.50	5U4G	5.75	6H6	3.00	833A
ECL800	25.00	PCF86	2.50	5U4GB	5.75	6H5B	4.95	868A
EF37A	3.50	PCF801	2.50	8V4G	4.00	6J5	3.00	872A
EF38	3.50	PCF802	2.50	5Y5GT	6.50	6J6	3.00	831A
EF40	5.00	PCL82	2.00	SZ2	4.00	6J7	4.00	2090A GE
EF41	3.50	PCL83	3.00	SZ4GT	2.50	6JB6A GE	19.00	5791
EF42	4.50	PCL84	2.00	6AH6	4.00	6JS6C	20.00	5763
EF80	1.50	PCL85	2.50	6AK5	1.50	6JE6C	20.00	5814A
EF85	1.50	PCL86	2.50	6AL5	1.00	6JS6C GE	20.00	5842
EF86	10.00	PCL805	2.50	6AM6	2.00	6K6GT	3.00	6080
EF91	2.00	PD500	6.00	6AN5	5.00	6K7	4.00	6146B GE
EF92	2.00	PL26	2.50	6AH6A	4.50	6K8	4.00	6530A GE
EF183	2.00	PL81	1.75	6AQ5	3.25	6L6G	10.00	6803B GE
EF184	2.00	PL82	1.50	6AR5	25.00	6L6CC5V	12.50	7025 GE
EL32	2.50	PL83	2.50	6AS6	3.00	6L6CC GE	12.50	7027A GE
EL33	10.00	PL84	2.00	6AS7B	9.50	6L7	3.50	7199
EL34 Siemens	8.00	PL504	2.50	6AT6	2.00	6L06/6J6C	20.00	7380
EL39	4.00	PL508	5.50	6AU5GT	5.00	607	4.00	7501A
ECL80	75.00	PL509-519	7.50	6AU6	2.50	6RHH/6KKN8	12.00	698
EL41	3.50	PL802	4.00	6AV8A	3.00	6SA7	3.00	7587
EL81	3.00	PY81	1.50	6B7	4.00	6SCT	3.00	7868
EL84	2.25	PY88	2.00	6B8	4.00	6SG7	2.50	
EL86	2.75	PY500A	4.00	6BA6	1.50	6S7J	3.00	
EL91	3.00	PY800	1.50	6BA7	5.00	6SK7	3.00	

OPEN TO CALLERS MON-FRI 9AM - 4PM. CLOSED SATURDAY  
 QUOTATIONS FOR ANY TYPES NOT LISTED.  
 OVER 6000 TYPES AVAILABLE FROM STOCK.  
 OBSOLETE ITEMS A SPECIALTY.  
 TERMS C/WO/VISA / ACCESS MIN ORDER £10.00  
**P&P 1-3 VALVES £2.00, 4-6 VALVES £3.00 ADD 17.5% VAT TO TOTAL INC P+P**

# ALAN Essex Amateur Radio Services

**4 NORTHERN AVENUE, BENFLEET, ESSEX SS7 5SN**  
**7 days a week - 8am - 8pm 01268 752522**

## CASH CONVERTERS

We buy/sell Amateur Radios and Equipment.

We collect it, Test, Service and Air Check all equipment.

We pay cash same day or 24 hours by post.

So if you want the best used equipment just give us a call.

We have people just waiting for your used equipment.

Loads of clean second hand equipment in stock for re-sale.

Phone now for details.

**Callers by appointment only**

# PW SERVICES

## Queries:

**Practical Wireless, PW Publishing Ltd., Arrowsmith Court, Station Approach, Broadstone, Dorset BH18 8PW.**

We will always try to help readers having difficulties with *Practical Wireless* projects, but please note the following simple rules:

- 1: We cannot deal with technical queries over the telephone.
- 2: We cannot give advice on modifications either to our designs, to commercial radio, TV or electronic equipment.
- 3: All letters asking for advice must be accompanied by a stamped self-addressed envelope (or envelope plus IRCs for overseas readers).
- 4: Make sure you describe the problem adequately, with as much detail as you can possibly supply.
- 5: Only one problem per letter please.

**Back Numbers**  
 Limited stocks of many issues of *PW* for past years are available at £2.30 each including post and packing. If the issue you want is not available, we can photocopy a specific article at a cost of £1.50 per article or part of article.

Over the years, *PW* has reviewed many items of radio related equipment. A list of all the available reviews and their cost can be obtained from the Editorial Offices at Arrowsmith Court, Station Approach, Broadstone, Dorset BH18 8PW for a large stamped self-addressed envelope.

**Binders**  
*PW* can provide a choice of binders for readers' use. Plain blue binders are available, each holding 12 issues of any similar A4 format magazine. Alternatively, blue binders embossed with the *PW* logo in silver can be supplied. The price for either type of binder is £5.50 each (£1 P&P for one, £2 for two or more). Send all orders to PW Publishing Ltd., FREEPOST, Arrowsmith Court, Station Approach, Broadstone, Dorset BH18 8PW.

**Constructional Projects**  
 Components for *PW* projects are usually readily available from component suppliers. For unusual or specialised components, a source or sources will be quoted.

**Mail Order**  
 All items from *PW* are available Mail Order, either by post or using the 24hr Mail Order Hotline (01202) 659930. Payment should be by cheque, postal order, money order or credit card (Mastercard and Visa only). All payments must be in sterling and overseas orders must be drawn on a London Clearing Bank.

**POWER MODULE 240V I/P DC O/P 12/14V at 10 amps, curr limit, stabilised tested. £28.50. BENCH POWER UNIT Mil version of Sol AS.1412 240 I/P O/P 0 to 40V DC stab and 0 to 5 amps constant current, in Mil style case, tested. £65. STORNO RTs. Dash or Portable Low Band 60/80 Meg CQP.634 12.5Kc chan for 24V DC with spk/mike 12 chan with some crystals. £17.50 ea or 2 for £30. RADAR PPI IND ex Navy all transis 10" req ext DC supplies no info, fixed coil. £65. STATIC FREQ CONV. I/P nom 24c DC O/P 115V 400c/s 150/200 watts 1 phase sine wave stab, size 10x5x5" tested with connec. £95. WAVEMETER HEADS. Absorption type Micrometer tuned with charts O/P for 50/100 Ua meter 2 freq 1.9 to 5Gz & 7 to 14Gz £24 either freq. LENS UNIT ex slide proj 60mm dia with mount. £11.50. CAPS. H.D. 10K Uf 100V 28 amp ripple. 2 for £5.50. LARGE HEAT SINKS. 24x3x3" flat on one side, finned. £11.50 ea 2 for £18. INTERCOM UNITS. 5 chan for int 9V batt or ext 24V DC size 8x7x6" reqs remote spks. £17.50. RESISTORS. Metal clad 12/25 watt 1 ohm 1% okay spk loads 8 for £4.50.**

ABOVE PRICES ARE INCLUSIVE. GOODS EX EQUI UNLESS STATED NEW.

**A. H. SUPPLIES**  
 Unit 12, Bankside Wks, Darnall Road, Sheffield S9 5HA  
 Tel: 0114-244 4278

## G6XBH G1RAS G8UUS

**VISIT YOUR LOCAL EMPORIUM**  
 Large selection of New/Used Equipment on Show

AGENTS FOR: YAESU • ICOM • KENWOOD • ALINCO  
 Accessories, ReVex/Diamond range of SWR/PWR, Adonis Mics, Mutek products, Barenco equipment, MFJ products.

WE SPECIALISE IN ALL TYPES OF PLUGS, ADP, ETC  
 ★ ERA Microreader & BPS4 Filter, SEM Products ★  
 ★ Full range of Scanning Receivers ★

AERIALS, Tonna, Maspro, plus full range of base/mobile antennas.  
 BRING YOUR S/H EQUIPMENT IN FOR SALE  
 JUST GIVE US A RING

## Radio Amateur Supplies

3 Farnon Green, Wollaton Park, Nottingham NG8 1DU  
 Off Ring Rd., between A52 (Derby Road) & A609 (Ilkeston Road)  
 Monday: CLOSED. Tuesday-Friday 9.00am to 5.00pm. Saturday 9am to 4pm

**G6XBH G1RAS G8UUS Tel: 0115-928 0267**

# UP The Pole

## - The PW Trolley Mast

By Jack Frizzell GOLEO

*Jack Frizzell GOLEO describes a trolley mast that is ideal for small gardens, where a tilt-over mast won't fit.*

There are a considerable number of radio amateurs who suffer from space restrictions where antennas and masts are concerned. Even a tilt-over mast is not the answer with a number of beam designs. With some antenna designs, supporting spreaders touch the ground while the mast is still at a relatively steep angle. This makes access for tuning or other adjustments extremely difficult.

All the problems I've mentioned became very apparent when I decided to mount a VK2ABQ antenna (which has an eight metre diagonal horizontal spread), on an existing Tennamast tilt-over ground post and winch.

The only available space for installation was a rectangle of ground about nine by seven metres. There was also a garden shed and a greenhouse occupying a part of that area. A simple survey confirmed that, as access to the antenna, for tuning purposes, was a necessity, an alternative to a tilt-over mast would have to be found.

### Antenna Support

The solution was to design an antenna support based on the Tennamast equipment available that would rise and fall vertically, keeping the antenna in its operating place.

The drawing Fig. 1, shows the overall idea of the Trolley Mast. The 'trolley' part means a sliding sleeve which forms part of the system.

A standard 6.5m galvanised scaffolding pole is held in position on the pound post and carries a sliding sleeve which can be raised and lowered vertically up the mast. The hauling system consists of winch, galvanised halyard, and a small top pulley.

### Secondary Mast

As I've shown in the drawing of Fig. 2, the sliding sleeve can carry a secondary aluminium mast, clamped by two 'U' bolts to a stand-

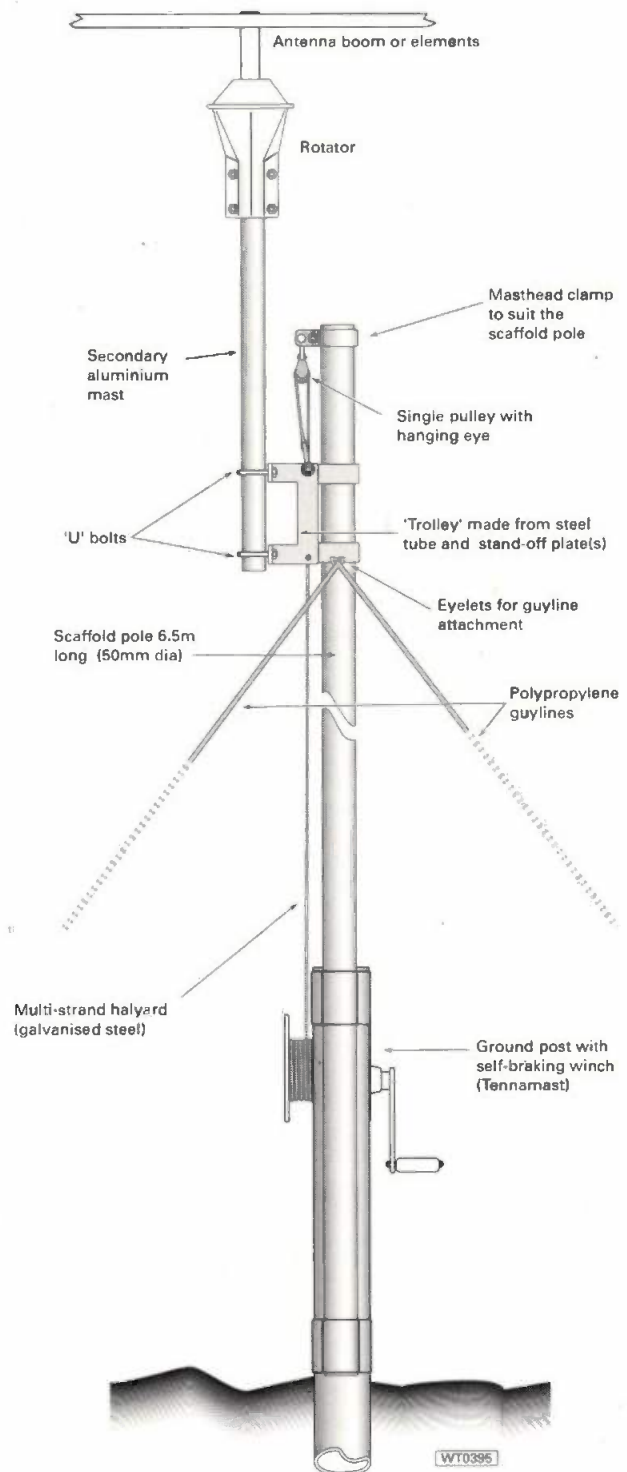
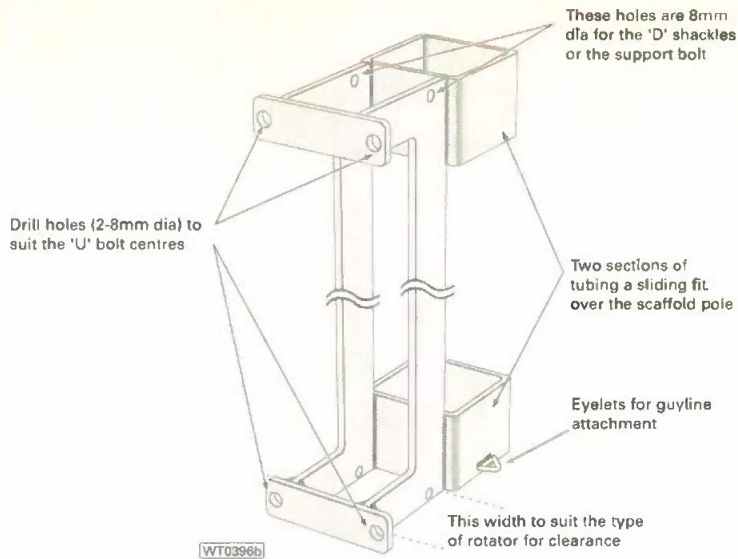

Fig. 1: The overall view of the PW Trolley Mast when hauled up. The mast's overall height is over 6.5m.

Tennamast Scotland  
81 Mains Road  
Beith  
Ayrshire  
KA15 2HT  
(01505) 503824



modification simplified the original design considerably, removing the earlier fitted locating peg and slotted sleeve needed to prevent slewing.

### Additional Safety

The hoisting cable used in this design is a high breaking strain galvanised steel yacht halyard to give additional safety. This, or a similar cable, I recommended for security.

Various devices to 'latch' the trolley to the top of the mast have been tried and discarded for the various reasons of:

(a) a tendency to remain locked at the top of the mast with no means of easy release, and

(b) the design (avoiding the use of springs which can break or snag), of a gravity held pivoting catch I decided was beyond those held by the average radio amateur. The unit is designed to be built by someone with access to a workbench, a hacksaw and a power drill. And, of course, a friendly local garage for welding.

The present trolley design self-locks by tilting slightly on the scaffold pole main mast when the guy lines are tightened. But another easily applied safety measure would be to use a twin top pulley.

A free-running secondary hoist rope running through the second pulley, in parallel with the steel halyard, could then be secured at the bottom of the mast when hoisting is complete.

Fig. 2: The Trolley as Jack GOLEO, designed it. It should have an overall height of about 550-600mm.

off bracket welded to the sleeve (or two short sections as illustrated). My original trolley was made from a scrap piece of square tube 550mm long already cut off at one end at 45°.

I would have liked the trolley a little longer, but beggars don't have the option of choosing! An alternative arrangement is shown in Fig. 3, which should have a similar length to that of Fig. 2.

The trolley, in Fig. 2, is made from two scaffolding collars spaced apart and joined by the stand-off plate, this should also work admirably. Clean off any galvanising before welding, and paint thoroughly with Hammerite or other suitable paint afterwards.

It's important that the stand-off bracket must give sufficient stand-off to permit the body of a rotator to clear the main mast (and top clamp) as the sleeve slides up and down. If, for example, the overall maximum diameter of the rotator body is 250mm, then the stand-off distance from the sliding sleeve should be at least 175-200mm. This stand-off should cover intrusive cable connectors boxes and other unplanned obstacles.

The stand-off plate ends with two small support plates welded across the upper and lower ends, drilled for the two 'U' bolts required to clamp the secondary mast in position.

Although the prototype shown has twin parallel plates a single plate could be used, and may even be left a full plate instead of the illustrated shape. But use whichever shape and layout that suits.

Two 8mm holes have to be drilled in the plate before it is welded in position. The lower hole is simply to attach a pull-down polypropylene cord to act as a reserve in the event of the sleeve

jamming for any reason.

The upper hole is drilled to accept a small 'D' (Sometimes known as a 'U') shackle for the hoisting halyard to be attached. It should be approximately in line with the exit edge of the small pulley at the top of the mast.

### Refinements

The present set-up has been working well for several years, but you might like to add refinements. The only addition I've made, was three small chain links welded to the main body of the trolley to attach three polypropylene guy lines.

The guy lines have a dual purpose. One is obviously to act as stabilisers in the ordinary way, but secondarily, they have the important function of preventing the sleeve and its attached secondary mast assembly from slewing around the main mast in a high wind. This

PW

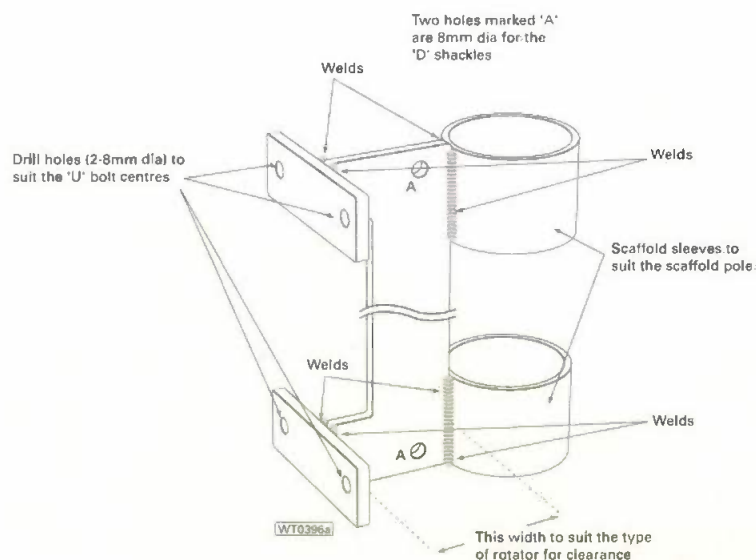

Fig. 3: An alternative type of trolley using scaffold sleeves and a single stand-off plate.

David Butler G4ASR, answers two common questions readers ask about v.h.f./u.h.f. antennas.

# Antenn

This time round instead of a complete constructional article I thought I would answer your questions relating to techniques for the spacing and stacking of antenna groups.

**Q** 'I would like to be active on the 50, 144 and 430MHz bands and want to put more than one Yagi onto a single mast. How do I do this without each antenna affecting the other?'

**A** It's common practice to mount a number of directive antennas onto a single mast section, as shown in the photograph, Fig. 1. In theory you should place the lowest frequency antenna right at the top of the mast with the higher frequency antennas below.

The theory of the lowest (frequency) - highest (height) is to put each antenna as high as possible in terms of wavelength. Antennas should, if possible, be mounted the greatest number of wavelengths above ground, this reduces any inefficiency caused by ground reflections.

Unfortunately mounting antennas high, normally means that the antenna with the greatest

**Fig. 2: Putting the lowest band antenna nearest the thrust bearing reduces the strain on the system due to wind loading.**

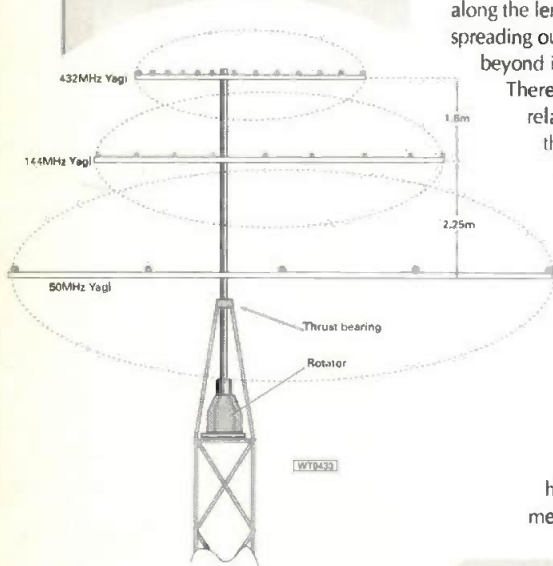

wind loading (the biggest) is then placed the furthest away from the rotator. This arrangement is far from ideal and will lead to premature failure of the stub mast or rotator or even both.

## Christmas Tree

In practice therefore, it's best to adopt the 'Christmas tree' arrangement by placing the largest antenna as close to the rotator as possible and the smallest (in terms of wind loading) right at the top of the mast.

In the case of a 50MHz Yagi the minimum height above ground should be at least 12m. Ideally of course the higher the better.

To be able to work out the optimum spacing between each antenna you need first to understand the term 'effective aperture'. The effective aperture can be thought of simply as the frontal area from which the antenna will extract signal power from the radio wave. Sometimes this is referred to as the 'capture' area.

The effective aperture or capture area should not be confused with the term physical aperture. In the case of Yagi antennas the physical aperture is smaller than the effective aperture.

The capture area of a Yagi antenna is approximately elliptical in shape. You can think of it looking something like a tube along the length of the boom, spreading out into a cone shape beyond its end.

There is a unique relationship between the gain/beamwidth of any given Yagi and its capture area.

Thus the multitude of simple antenna and Yagi designs and boom lengths will result in a multitude of different capture area shapes.

A half-wave dipole for example will have a shape measuring  $3\lambda/4$  by  $\lambda/4$

**Fig. 3: The E (electric) and the H (magnetic) field associated with a horizontally polarised antenna. Were it vertically polarised then the E and H fields would change places.**

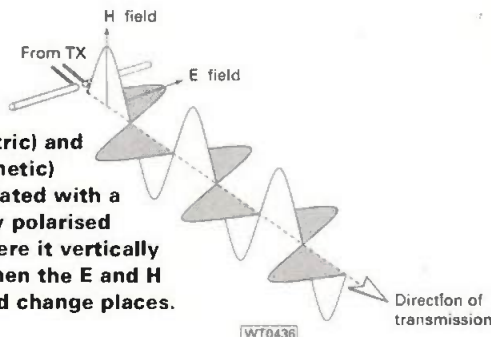

wavelength. On the other hand a 9-element 144MHz Yagi with 13dB gain may have an effective aperture approximately  $1.5\lambda$  diameter. Note that this aperture isn't a physical area that you can measure but it's one that you have to visualise.

The reasons for ascertaining (guessing) the capture area are two-fold. First it indicates the area in which large metallic objects must not be placed. Secondly it determines the minimum distance that should be used when stacking different antenna arrays above each other. (It also determines the correct stacking distance for similar Yagis but more on this later).

Many manufacturers will provide recommended stacking distances for two Yagis and you can use this as a guide to the size of the effective aperture. Simply look up the stacking distance and divide this figure by two.

## Stacking Antennas

When stacking antennas you should aim to ensure that the capture areas do not overlap. However, this is easier said than done.

So, in reality you may have to make some compromises. But by knowing the effects that each Yagi can have on another you'll be able to keep any degradation to a minimum.

Now turning back to our example with antennas for 50, 144 and 430MHz bands to be stacked above each other. I've shown this in the diagram, Fig. 2. Begin by placing the 50MHz Yagi as close to the rotator (or

thrust bearing) as possible.

However the obstruction caused by the rotator and vertical mast passing through a horizontally mounted Yagi will be insignificant providing it is at right-angles to the polarisation plane. This is an important fact to remember.

The 144MHz 9-element Yagi is placed no less than 2.25m above the 50MHz beam. This is the upper limit of the 50MHz beam capture area.

Again from manufacturer's data for minimum distances between antennas, the effective aperture size for a 9-element 144MHz Tonna is about 1.6m. As this distance is smaller than that for the 50MHz antenna, little or now interaction will take place.

The effective aperture for a 430MHz Yagi antenna is very unlikely to be greater than that for a 144MHz beam. So, finally the 430MHz beam can now be placed some 1.6m above the 144MHz antenna.

However, if the 3.85m length of stub mast, is too long for your particular circumstances there are a few more compromises that you can make. You could, for example, place the the 430MHz beam between the 50 and 144MHz antennas.

By putting the 430MHz antenna in between, you can cut the stub mast down to only 2.25m in length.

And that's all you need to do to stack antennas without affecting each other.

## Further Questions

If you have any further questions about antenna techniques for any frequency above 30MHz you can contact me at the address given in my monthly 'VHF Report' column. So, get stacking and or having those antennas for best results on transmit and receive.

# a Workshop

**Q** 'I want to try something more ambitious and use two Yagis on the 144MHz band. What advantage does this have and how do I join them together?'

**A** Providing you have a suitable method of supporting both antennas, two Yagis mounted one above the other (stacked) or side by side (bayed) may be preferable than having a single antenna. There are a number of reasons why this may be so.

Two short boom Yagis can provide a neat robust system without compromising forward gain. And its smaller turning circle may be more amenable to your neighbour.

The main advantage of stacked (or bayed) antennas is, that of additional forward gain and reduced beamwidth. In theory the limit for stacking gain is 3dB but in practice, accounting for all losses, you'll be lucky to achieve 2.5dB.

You may see this 2-3dBs as being a fairly insignificant increase in gain. But there's one more parameter that's far more important. To work consistent DX on the v.h.f. bands requires an antenna with high gain and a low angle of radiation.

Most medium boom length Yagis have a fairly broad vertical

pattern, some in excess of 30°. This large vertical spread of energy means that much of your valuable power is simply being wasted.

An easy solution to lowering the vertical radiation angle is to vertically stack two Yagis vertically together. This reduces the vertical beamwidth while at the same time maintaining the original horizontal beamwidth.

Conversely, if you bay two Yagis side by side, and you would reduce the horizontal beamwidth whilst leaving the vertical beamwidth the same. This reduced horizontal beamwidth may be useful for point-to-point packet radio links for example.

## More Theory

Now a little more theory before I show you how to calculate the correct stacking distance. The electromagnetic field emanating from an antenna will consist of an electrical vector and a corresponding magnetic vector.

The vectors are termed E (electric) and H (magnetic) components respectively and are at 90° to each other. Have a look at the drawing of Fig. 3, which shows a representation of the E and H fields from a simple horizontally polarised antenna. It's interesting to note that we use the E field as an indicator of the polarisation.

Antenna manufacturers often refer to E and H plane beamwidth or polar patterns. You will notice that most, if not all, Yagi antennas will have a wider vertical beamwidth than a horizontal beamwidth.

Calculation of the approximate stacking distance for horizontal polarisation is given by the formula:

$$D = \frac{\lambda}{2 \times \sin(\phi)}$$

Where  
 D = Distance in metres  
 λ = Wavelength  
 φ = 3dB beamwidth

As an example I'll use the data for a 144MHz 13-element Tonna Yagi. This antenna has an E-plane (horizontal) beamwidth

of 18.4° and an H-plane (vertical) beamwidth of 20.5°.

When calculating the vertical spacing, use the H-plane data. Similarly, for horizontal spacing use the E-plane data. Therefore the approximate vertical spacing between two 13-element Yagis will be:

$$D = \frac{2.08}{2 \times \sin(20.5)} = 2.97\text{m}$$

If you don't have any data regarding your particular Yagi you can use the simple rule of thumb that suggests using a vertical stacking distance is 0.75 x boom length. For the 13-element Tonna at 4.43m boom length, should have the stacking distance of (0.75 x 4.43) 3.3m.

Both these examples are very close to the Tonna reference data which indicates that the 13-element Yagi should have an H-plane spacing somewhere between 3.05 to 3.7m. Incidentally the 'somewhere' actually refers to whether you want the antennas set up for maximum forward gain, minimum side-lobe suppression or a bit of both.

In practice you probably won't notice any difference between the two settings. At my 'antenna farm' I've set up my four 17-element Yagis for a better side-lobe performance as I use the array for e.m.e. communication. Whether I have achieved this I can't really say. What is important is that you actually believe you have!

## Combining Antennas

Now it's only a matter of combining the Yagi antennas together. In my opinion the easiest way is to buy, or construct, a power combiner. Connection is then made from the combiner (sometimes called a splitter or divider) with coaxial cable to each driven element.

The cable must be of the same impedance as the Yagi and cut to exactly the same length. However, as the cable is not providing any impedance

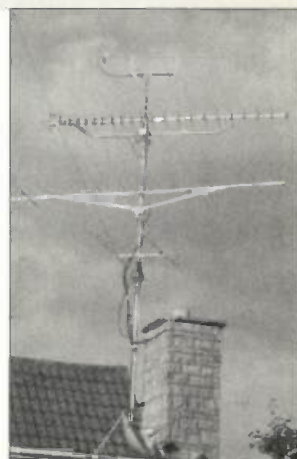

**Fig. 1: Four bands - one pole. But it's not very safe in terms of wind loading (see text).**

transformation the length, within reason, is not critical.

Another method is to use coaxial cable in a phasing harness as shown in the diagram, Fig. 4. The transmission line from each antenna must be equal in length and an odd multiple of a quarter wavelength.

In the case of the phasing harness, the coaxial feed line acts as an impedance transformer. Due to the 'transformer' action of each 75Ω line the feed impedance of each antenna seems to be 100Ω at the coaxial T piece. When the two antenna feed lines are connected in parallel at the T piece, the resulting impedance is close to 50Ω.

Whatever method you use it is vitally important to maintain the correct antenna driven element polarity.

PW

**Fig. 4: A phasing harness. The 75Ω coaxial lines should be equal in length and an odd number of quarter wave lengths (at the working frequency) long.**

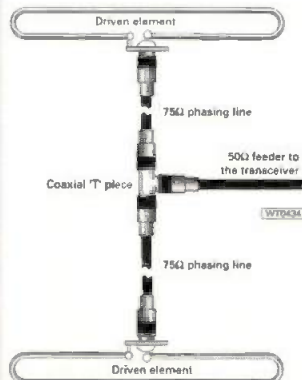

**Further Reading**  
*The VHF/UHF DX Book*, I. White G3SEK, ISBN 0-9520468-0-6.  
*VHF Handbook for Radio Amateurs*, W. Orr W6SAI, ISBN 0-933616-00-7.  
*Optimum Spacing of Directional Antennas*, G. Hoch DL6WU.  
*VHF Communications*, 3/1979, pp 154-161.

# BOOK REVIEW

## Electronics Service Manual

By 'Tex' Swann GITEX

*Our technical projects sub-editor 'Tex' Swann GITEX takes a look at the Electronics Service Manual (ESM) and asks is it an 'open learning' experience?*

I feel that one of the most important parts of any hobby such as radio, is building up a library. In these days it's a very costly thing to do, many authors have put a great deal of effort into putting information into many books. They can run into thousands for some hobbies.

How do you choose one book over another? Which gives the best value for money? These are just two of the many questions facing anyone trying to get started in any hobby.

In a technical hobby such as radio and electronics there is another problem. In any electronics pastime, the greatest problem confronting anyone trying to find information, is to find the information between the very basic and the more advanced.

There are many books covering both levels of information, what is missing is a good wide-ranging middleground book. This is where the *Electronics Service Manual* aims for. As its name suggests, *ESM*, is a service manual for many items of everyday electronics. But unlike many text books this is an 'open ended' package.

You start with the basic *ESM*, and then every two months you receive a supplement with around 160 pages of extra information. Even better is that you can change the information you will receive in future supplements.

The technique of ongoing information has been tried before by many publishers, but *ESM* is, I think, unique. If you find that a supplement is of little use to you, return it within a short time and

there is no charge.

What better 'open learning' could there be? Only what you want, not what the publisher thinks you want!

### Basics First

But let's have a look at the basic *ESM* first. To start off your learning package, you receive a large thick backed ring binder. This binder is large, it's about 310mm high, some 290mm wide and over 90mm thick.

The basic *ESM* is broken down into nine parts (A-I). These parts cover 'Safety', 'Underpinning knowledge', 'Practical skills', 'Tools' and 'Test Equipment', 'Reference data', 'Useful addresses' and, of course, an 'Index'.

Of the above sections the Underpinning knowledge is by far the most comprehensive. As it's laid out in sections (16 of them) it's difficult to say how many pages are in this section, but it's about 25mm thick.

Imagine the equivalent of half a pack of A4 copier paper, printed on both sides covering electrics, electronics, components, semiconductors (there's a slim section on valves), how to use data sheets and circuit diagrams and how to go about fault finding.

Completing this section is a section on radio, which includes some well laid out pages on r.f. amplifiers and matching circuits. Of course in this day and age, microprocessors are featured. Even the humble power supply unit hasn't been forgotten.

The one section shown at the front of the manual, 'Servicing Techniques', is actually not with the base manual. This section is covered in the various supplements.

As each manual is sent out the latest supplement is included free. The supplements supplied with the review copy contained sections on audio noise, distortion and loudspeakers and a section on colour televisions.

In the 'Servicing Techniques'

section was a section on audio amplifiers, how they work, how to fix them and most important I feel, a table of transistor replacements giving suggested complementary pairs for various voltage and power combinations.

The Technical notes section has a section on the floppy disk in IBM PCs. This complements the extensive section about IBM PCs that came with the base manual. In this there's a great deal of background information about the make-up of a PC and how to repair and upgrade one.

Also in the supplement supplied with the review copy was a section on video recorders and how they work. It then explains the difference between VHS and Betamax type recorders.

It's difficult to stop this review becoming just a list of the contents of the *ESM*, but the coverage of just the base manual is extremely good. The author **Mike Tooley** has done an excellent job of putting together a well produced 'open learning' package.

Mike Tooley, as Dean of Faculty of Technology at Brooklands College in Surrey, is very aware of the needs of students of electronics, whatever the industry. His expertise shows in the format of *ESM*, basic thorough, general but also specialised.

The *Electronics Service Manual* is available from and published by **Wimborne Publishing Ltd.**, of **Allen House, East Borough, Wimborne, Dorset BH21 1PF**. Tel: (01202) 881749. The base manual and a free latest supplement costs **£45.45 including P&P** with further supplements costing **£23.50 plus £2.50 P&P** or **£1 P&P** for other supplements ordered at the same time.

As an expanding knowledge base of electronics *ESM* is just what is needed by enthusiasts, you expand only those parts that interest you. But make sure you put up a strong shelf first, it could turn out to be mighty heavy!

PW

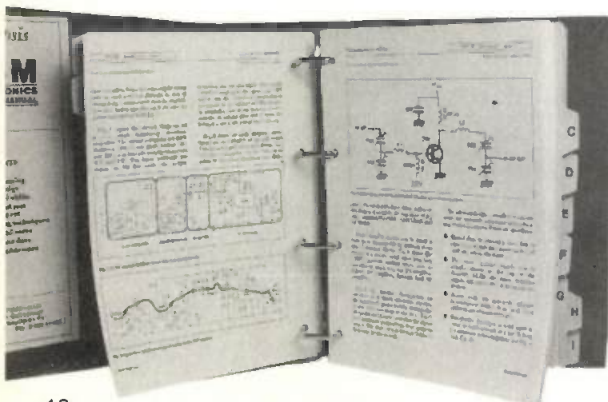



## EQUIPMENT

## SPECIFICATIONS

This month Ian Poole G3WYX unravels the mysteries behind antenna gain.

One of the major features which will determine the performance of any amateur radio station, be it listening or transmitting, is the antenna. Today's receivers, transmitters, and transceivers are very highly developed and offer excellent performance at remarkably low prices. Often let down by poor antennas.

Any improvements which can be made to the antenna can affect the whole station. Location, height, the type of antenna and a host of other factors all play their part in determining the overall performance of the antenna system.

Whilst it's possible to make many antennas, often we resort to buying ready-made types. This is because you know that their performance will reach certain standards, and also that they will be ruggedly built, and able to withstand the rigours of the weather.

When buying an antenna there are a number of specifications to look out for. Fortunately there are not as many as found with a transmitter or receiver, but those which are specified are just as important in giving a view to its operation.

One of the main factors of an antenna is its ability to pick-up or radiate signals. Will it receive or radiate a signal better than another one? If so by how much?

To look at how an antenna performs, it's first necessary to look at some of the aspects of how an antenna radiates a signal. I'll look at how an antenna radiates a signal because this is easier to visualise. However, it acts in exactly the same way for both transmitting and receiving.

## Polar Diagrams

An antenna does not radiate a signal equally in all directions. Take the example of a simple dipole. It can be imagined that the maximum radiating will take place at right angles to the wire, and there will be little radiation in the direction of the wire itself.

It's possible to take a plot of how well an antenna radiates in different directions. This is known as a polar

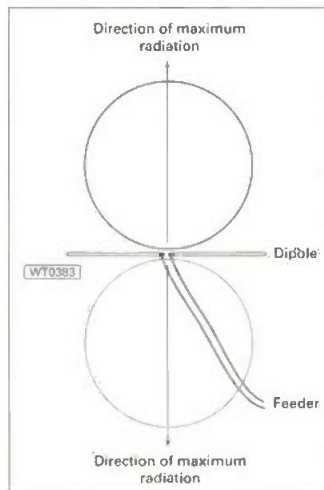

Fig. 1: Polar diagram of a dipole antenna system.

diagram, and an example of one for a dipole is shown in Fig. 1.

Plots can be taken for other types of antenna as well. In all cases it will be found that they radiate better in some directions than others.

## Radiate Better

It's possible to utilise the fact that antennas radiate better in some directions than others. As a given amount of power is delivered to the antenna, if it's not radiated in one direction, then it must be radiated in another.

The direction effect means that by only radiating the signal in a narrow beam the signal in this direction must be much stronger. It's this principle that directional beam antennas like Yagis use.

To illustrate the directional beam fact, the polar diagram of a typical Yagi is shown in Fig. 2. From this you can see that there is one direction where most of the radiation is 'focused'.

The direction where most of the radiation is directed is the major

lobe. There are also a number of minor lobes. These are always present, and cannot be totally eliminated.

One of the major lobes of interest is the one from the back of the antenna. The ratio between the front and back ones is called the front-to-back ratio, and is expressed in decibels. Unfortunately, the front-to-back ratio does not coincide exactly with the maximum forward signal, and compromise has to be reached.

## Antenna Gain

It is also of great interest to know what the 'gain' of an antenna is. To do this, it's necessary to compare the antenna with another standard.

There are two standards which are normally used when assessing gain. The most used is using a dipole as a reference, and like other ratios the gain is expressed in decibels (dB).

Sometimes the gain of an antenna will be compared against an isotropic source. This is an imaginary antenna which radiates equally in all directions.

As an isotropic source antenna cannot be made in practice, most

measurements are made against a dipole. It has been calculated that a dipole has a gain of 2.7dB over an isotropic source and therefore it's possible to calculate the gain of an antenna if its gain over a

dipole is known.

For example, if an antenna has a gain of 3dB over a dipole then it will have a gain of 5.7dB over an isotropic source.

When gains are being quoted it's necessary to mention what the antenna is being compared to. The letters dBd refer to gain in decibels over a dipole, and similarly dBi indicates gain over an isotropic source. It's worth noting that the gain over an isotropic source looks much better, and this will often be quoted by the designer or manufacturer.

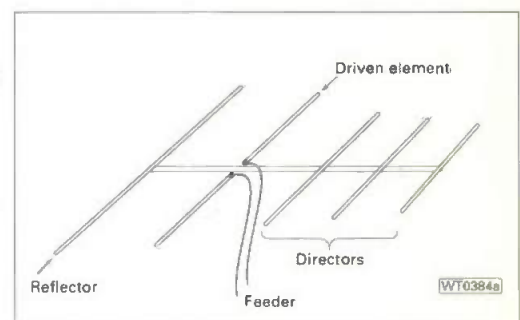
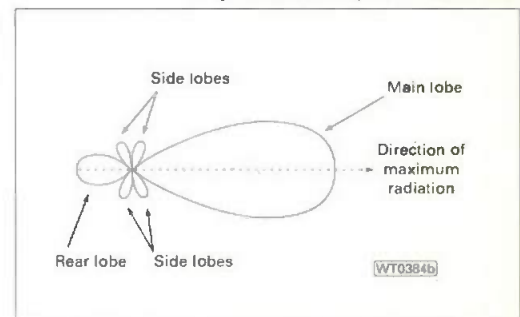

Fig. 2a & b: Yagi antenna (above)- Polar diagram of a Yagi antenna system (below).



*That's all for this month so cheerio for now. Next time I'll be looking at the limitations of antenna design.*

**END**

# Valve & Vintage

By Ben Nock G4BXD

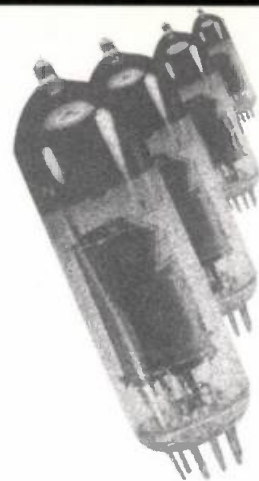

*This month PW's own vintage 'wireless shop' has a decidedly military look about it as Ben Nock G4BXD shares his interest in historical army equipment.*



**H**ello once again! It's my turn to man the valve & vintage 'shop'. Lots to cover this month so I'll press straight on with something quite different.

I start this month with mention of a Dutch museum which, for anyone who has a deep interest in military radios and how they were used, is an absolute 'gem'. I'm referring to the Airborne museum at Oosterbeek in Holland, see Fig. 1.

For those weak on history if I mention 'A Bridge Too Far' then the connection might be made. The bridge at Arnhem, Fig. 2, was the subject of that film, the push by the allies to force a route into Europe and thus shorten the war. As most of us know, this push was held at Arnhem and a legend was born.



**Fig. 1: The Airborne Museum in Oosterbeek in Holland, commemorating the 'Bridge Too Far' battle which took place in the Second World War.**

Occupying the very house (It was then the Hotel Hartenstein), that was used by the British forces as their last stand effort, the museum in Oosterbeek offers a superb display of equipment and material from the battle itself. Included in the collection are numerous radios, some displayed in very well constructed dioramas located in the very basement area where the events actually took place.

## Equipment Displayed

The equipment displayed in the museum include the 18, 19, 22, 38, 46, 76 sets and the R109 to name but a few. Many German military

radio sets of the period are also displayed along with a wide range of weapons and uniforms.

Although plenty of radios went in with the troops, the previous UK equipment preparations and 'setting up' and the differences in the terrain at Arnhem caused severe communications problems at the site.

Comments by Major Tony Hibbert (Ref. 1) stated "We took over the attic as it was the only place the wireless might work. There were six or seven of them and the place soon became rather conspicuous with aerials sticking



**Fig. 3: A mystery suitcased receiver. Can you help identify it? (see text).**

Honour without being deeply moved.

## Interesting Question

A recent letter from Keith Soutter in Kent has posed an interesting question. Does anyone recognise the small suitcased receiver shown in Fig. 3? This five valve set came into Keith's hands at a very low cost (I'll refrain from saying just how low in case it upsets the more serious collectors amongst us!).

The receiver is a two band set,

**Fig. 2: The famous bridge at Arnhem - setting of the famous battle, the subsequent film and the book A Bridge Too Far (see text).**

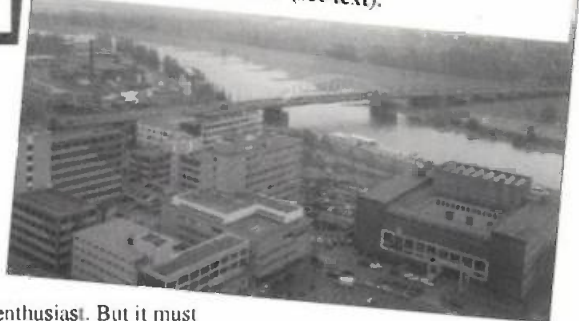

out of every window and tile hole".

The museum's collection of radio sets are a joy for the serious collector and enthusiast. But it must be remembered that the museum is there to honour the courage and actions of the airborne troops sent on a near impossible mission.

The little cemetery just north of the town is a most memorable place to visit, and to pay your respects at. I found it impossible to read more than a few names from the Roll of

covers 3.5 to 16 MHz, uses a 1A7G, 1N5G, 1H5G, 1A5EG and a 1N5EG (Although they may not be the original valves). The case measures 14 by 10 by 6 inches. If anyone can shed any light on this set, both Keith and I will be interested to hear from them.

John St. Leger, G3VDL has

Fig. 4: The WS No. 11 (see text).



written in from Devon, sending it in in a most unusual envelope, to agree with the "Real Radio Glows in the Dark" motto. He added "and it keeps the shack warm"! John, using a homebrewed transmitter, 807 p.a., and an Eddystone 888 receiver with wire aerials, has worked 259 DXCC countries. Well done John, keep it up.

Alec Seed, G3FOO has also written in to me. He was recalling his time with the old R1155 in 279 Squadron as part of Tiger force, along with memories of the B17 set-up using the Command series of equipment. Thanks for your letter Alex, I shall keep trying to get things right, as you pointed out.

### Real Old Timers

Now for a couple of real 'old timers'. (Photographs courtesy of Bob Warner in Kent). Firstly there's Wireless Set No. 11. see Fig. 4. This was a replacement for the wireless set No. 1, and the signal training pamphlet I have for this set is dated November 1938.

The WS No. 11 is a combined receiver and transmitter covering 4.2 to 7.7MHz. The set can operate on a.m. and c.w. with an output of about 500mW on low power, and 1.5W on high power a.m. (slightly more on c.w.), using an ATP7 p.a. valve.

Reception is provided by a single conversion superhet design with an i.f. of 475kHz. Two 'Westinghouse' metal rectifiers are used to recover the a.m. audio and the a.v.c. voltages.

The set has a similar feature to the WS No. 19 in that, on transmit, the b.f.o. oscillator is mixed with the local oscillator from the receiver to produce the transmit signal. The receiver r.f. amplifier then acts as the transmitter buffer amplifier (its tuned circuits already being on frequency of course) before passing the signal to the p.a. stage.

Six valves are used on receive and five on transmit, though three of these are common to both operations. (The photograph showing the No. 11 set actually shows the Australian version).

The Australian set was developed from the British version, arriving in early 1943. The equipment is pictured with its power supplies on the right, a.t.u. above right and spares box above. Next there's the R1082, Fig. 5, and the T1083 (Fig. 6) sets which preceded the R1155 and T1154.

I have a friend (Yes, just the one!) at the local Royal Air Force Association Club (RAFA) here in Kidderminster. Fred was a WOP/AG in the war, but before you go running to the race relations board, this WOP is a (W)ireless (OP)erator and the AG is (A)ir (G)unner!

Fred recalls those (fun?) days, the cold comfort of the RAF's Blenheim aircraft's mid turret that was also the home of the 1082/83 wireless equipment. He remembers the 'fun' involved in searching for the right coil (the receiver took two per band as did the transmitter).

The coils were located in a wooden holder down the side of the fuselage. After inserting the coils a chart had to be consulted to determine the frequency of operation. No digital read-out here then! Once all this was done and the set was up and running the Morse key was tucked away under the upper skin of the fuselage so tightly that it could only be reached with the finger tips.

Add to this the noise, the vibration, the cold, the fact that you also had to look out for enemy aircraft, and fire a big gun if they came near, it makes that tight little shack tucked under the stairs not seem quite so bad. Still, for all that Fred, I'd loved to have tried it for myself!

### Military Affiliations

I notice in various Packet messages and the like, that organisations military affiliations, the Royal Signals Amateur Radio Society (RSARS) and the RAFA for instance, are looking to increase the membership. I've also noticed that the RAFA allow 'friend members', enabling interested people to join, help and assist and enjoy of the benefits of such a club. Scanning the membership application for the RSARS recently, no such affiliation seems possible.

Now, with reducing levels of armed forces, and a tendency for fewer radio amateurs I think there's an opportunity waiting for the military affiliated societies. It's a road that could lead to an increase the membership, increasing the income of the society and therefore the benefits to those in need, by introducing a class of membership designed for those with a passionate interest in military radios, who could join, help, assist and generally play a part and be recognised.

I'm sure many military radio enthusiasts like myself would be only too happy to join and increase the membership, increasing the interest for all.

So, time to go. Don't forget that you can contact me as usual via GB7BBS.#28.GBR.EU, the PW offices, or direct at 'The Radio Room', 62 Cobden Street, Kidderminster, Worcestershire DY11 6RP. (s.a.e. please if you want a reply). And remember "Glowing heaters make for hot bottles"!

**On holiday in Dorset this summer? Why not visit the Royal Signals Museum in Blandford? It's open all week and will provide you with many hours of interest. Easy to find too (just follow the road signs off the A354 for 'Blandford Camp').**

Cheerio from Ben, see you in November.

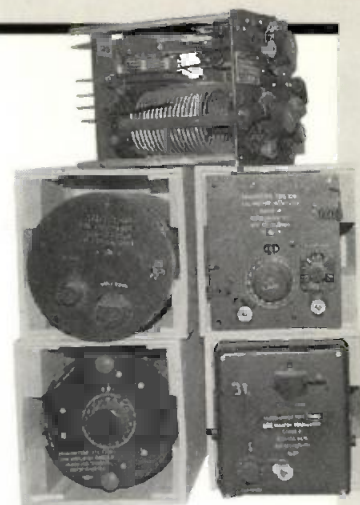

Fig. 5: The 1083 transmitter with associated coils (see text).

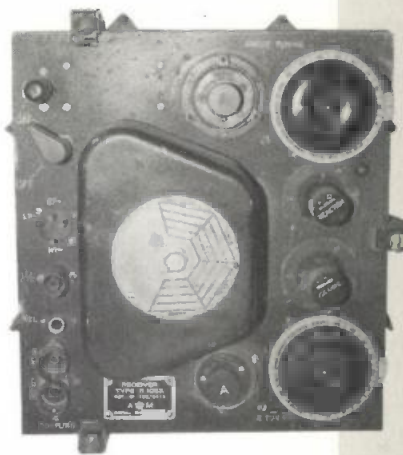

Fig. 6: The 1082 receiver (see text).

**Reference 1: Men of The Red Beret, Arnhem 1944. By Max Arthur. Page 202. No 11 set, 1082, 83 pictures by Bob Warner, Kent.**

# VHF REPORT

This month David Butler G4ASR has reports of DX galore on the 50, 70 and 144MHz bands.

Exactly as predicted in my previous columns the v.h.f. bands leapt into life with the onset of the Sp-E season. On the 50MHz band there were numerous European openings allowing contacts to be made up to 2000kms distant.

There were also a number of long distance openings, in excess of 5000kms, to Africa, Asia and North America. Conditions on the 144MHz band were equally good with some excellent openings into eastern Europe, Russia and Greece. And all of this was before the end of May!

So let's start straight away with reports of activity on the 50MHz band. Garry Ward G7TCD (I094) has been active on this band for only a few months having obtained an Icom IC-706 transceiver earlier in the year.

Garry mentions that he was pleased to see that I had provided details of a 50MHz antenna in the January *PW* 'Antenna Workshop' column. The kit of parts were ordered and Garry reports that the antenna was built in a day, being very simple to assemble and tune up.

A test transmission, with the antenna indoors, was made on low power and contact made immediately with a local Novice station 2E1DPL. The antenna was then erected on the chimney stack and further local contacts made.

All this occurred before the summer Sp-E season really got going so I don't have any news of DX worked. Any further reports Garry?

What was probably the first Sp-E opening of the summer season occurred on April 21. Between 1100-1430UTC, 50MHz operators in most parts of the UK were able to work into I, OE, OK and former YU with S9 reports.

## Many Active Stations

Among the many stations active during the Sp-E event was Gavin Stirling GM0WDD (I085). He uses a Kenwood TS-690 transceiver running 50W output into a small beam. Between 1200-1300 UTC he made s.s.b. contacts with stations in the Italian call areas I0, I2, I3, I4, I5 and with S53FO (JN76).

The station of Howard Kneale G7MIP (J002) also caught the event

on April 21. Using only 10W into an HB9CV antenna his first CQ call was answered by YT1AU (KN04), at a distance of 1660km.

Howard reports that this was his first ever contact via Sp-E and he was looking forward to the coming season with great anticipation. He did mention however, that he was frustrated at hearing all about the DX possibilities of the band and then discovering there was virtually no-one to contact outside of the main Sp-E season. Actually this is very true.

Most operators only seem to want to work S9+ DX stations and not investigate other weak signal propagation modes. Outside of the Sp-E season, the band is essentially dead to the casual listener.

Predictably with the onset of summer the 50MHz band soon came to life and from April 27 daily events began to be reported. Sporadic-E propagation during the following month of May was excellent with openings occurring on 75% of the days available.

According to my DX Cluster records over 42 European countries were worked from the UK during May. Some of the more interesting European DX stations to be worked included HA8BE, HB0LL, LX1JX, LZ1WR, SV2BZQ, SV5TS (Rhodes), T72EB/A, OY9JD, YO7VS, ZB2EO and Z32BU.

An unusual callsign which puzzled a few operators was SP1ER. This was none other than Dave Court OZ3SDL operating from the ERO headquarters building in Copenhagen, Denmark.

The beacon stations HV3SJ (Vatican City), JX7DFA (Jan Mayen Island) and JW7SIX (Svalbard) were heard on occasions but there was no other activity from these rare locations. Additionally many of the ex-Russian republics and Russia itself were also active. Stations included ER5AA (KN45), ES2RJ (KO29), EU6MS (KO45), LY2HM (KO15), R3VHF (LO16), RA3YO (KO73), UA1QL (KO99), UT3BW (KN29), UX0FF (KN45) and YL3AG (KO26).

Peter Lowrie G17JYK (I074) reports that the first signs of any 50MHz activity at his QTH in Co. Antrim was on May 9. At 1745UTC very strong signals were heard

coming from Spain and his first contact of 1996 was with EH1TA/P (IN63).

Peter mentions that his station is very simple consisting of an FT-690R running 3W into a dipole in the attic. He fixed the dipole in a north/south direction to give coverage into Europe and North America and was therefore very pleased to work the EH station as it was off the end of the antenna.

My views are that dipoles, especially when mounted under a roof, are fairly non-directional anyway. Peter mentions that last year he worked over 20 countries with his set-up including s.s.b. contacts with OH0, 9H and an acknowledgement of call sign, but not a completed contact, from a W5 station in Texas. This just shows what can be worked with QRP power and a bit of wire on this exciting band!

## Middle East Stations

On a number of occasions during May stations from the Middle-East area were worked by operators the length and breadth of the UK. For example 4X11F (KM72) in Israel was contacted by G4HBA (I080) in Devon and the station of 4X6UJ was worked by GI40PH (I064) situated in Northern Ireland.

A new station from Saudi Arabia, 7Z500, was worked by Geoff Brown GJ4ICD (IN89) in Jersey and the Cyprus beacon was heard by many operators including GW7SMV (I081) located in South Wales. The station of G3WOS (I091) near London worked 5B4AH (KM64) and operators on the south coast reported hearing the OD5SIX beacon located in Lebanon. Scotland appeared to be the only area of the UK that missed out on this DX.

Stations located in the African continent were also worked on the 50MHz band during May. The easiest of these to work were those situated about one or two Sp-E hops away. They included CN8FD and CN8HB in Morocco, CT3FT in the Madeira Islands, EA9IB in Melilla and EH8ACV and EH8BPX in the Canary Islands.

However, more elusive but much

weaker DX could also be found. Geoff GJ4ICD (IN89) worked TR8CA (JJ40) in Gabon on May 26 and 27, on both occasions around 1715UTC.

Geoff was also pleased to work 5T5BN in Mauritania on May 27. This station was also worked by other stations in southern England.

Propagation was also good in other areas of Europe around this period. The station of DL7QY (JN59) heard the Ascension Island beacon ZD8VHF (50.031MHz) on April 27 and on June 3 operators in Holland and Italy worked 9G1YR in Ghana.

## Transatlantic Openings

There were also three transatlantic openings from the UK to North America. These multi-hop Sp-E openings took place on three consecutive days between May 27-29.

To my knowledge there have never been any Sp-E openings to the States so early in the season. A really amazing start to the season. Let's hope it continues for many more months!

Although the first opening into the UK occurred on May 27 it appears that an opening on May 20 was the first transatlantic event of the year. This started around 2100UTC with OZ4VV copying the VE8BY beacon for over 30 minutes. Much further to the south EH8BPX (IL18) worked WA10UB (FN43) at 2119UTC followed up by contacts with VE1RG, VE1YX, K1GPJ and W3JO.

The first opening between North America and the UK on May 27 was a brief event between 1300-1400UTC. Signals were rather weak with only VE1PZ (FN85), VE1YX (FN74) and VE1ZZ (FN84) being reported.

The Canadians were apparently putting much stronger signals into central Europe working many stations in DL, OE, SP and S5. Another brief event lasting only minutes occurred on May 29 around 1920UTC. Signals were very weak, the best DX probably being that of WA8DXB (EN91) heard by Neil Carr G0JHC (I083).

Without doubt the best transatlantic opening was recorded on May 28 between 1800-2200UTC.

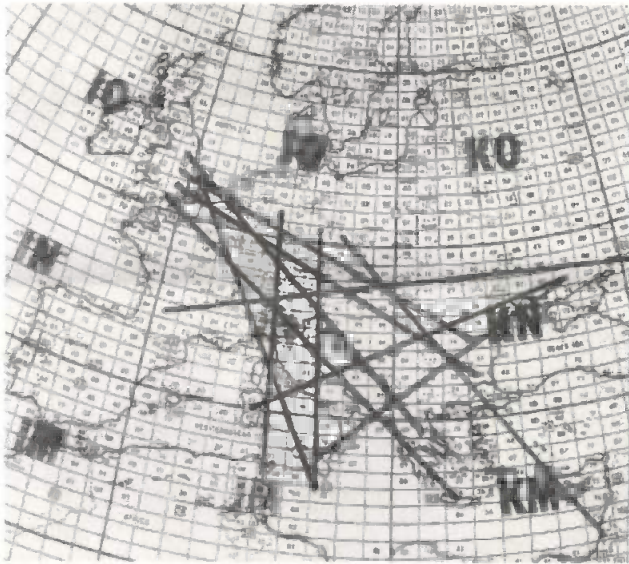

**Fig. 1: Sporadic-E openings on May 23 on the 144MHz band (see text).**

Stations situated on the western side of England and Wales (IO73-74, IO80-84) appeared to be in the best locations although some contacts were made from northern England (IO93-94).

The first signs of the transatlantic opening were detected by **Ted Collins G4UPS** (IO80) at 1806UTC when he heard the VE1PZ and VO1ZA beacons. From 1830UTC the opening became more extensive and contacts could be made with stations in the VE1, VE9, W1, W2 and W3 call areas.

Some UK operators also managed to find propagation into the W8 area. Neil G0JHC was very happy to get FP5EK (St.Pierre et Miquelon) in the log at 2020UTC.

At my QTH the propagation seems to be whistling around over my head! I could hear other stations to the north and south of me working the DX but for much of time I could hear nothing. This is typical of some Sp-E openings.

However, for a 15 minute period between 2015-2033UTC propagation landed in my locator square (IO81) and I was able to make c.w. and s.s.b. contacts with stations in VE9 and W1. But it was pretty marginal stuff and I even had to struggle to work VE1YX.

The force was definitely not with me that evening! It was however with the station of **Bob WA1OUB**. Bob managed to make 75 European contacts with stations located in 17 countries. A total of 44 QSOs were made with the UK, comprising of 2 x GD, 2 x GI, 4 x GM, 5 x GW and 31 x G.

### Activity On 70MHz.

Now I'll turn to news of activity on the 70MHz band. **Jon Wheeler G0IUE** (IO81) located in Wiltshire reports that both he and local stations **G0GXV**, **G1LJT** and **G8TTI** monitor 70.450MHz f.m. and all are keen to promote activity on this band. Jon uses an FT-726R driving a Microwave Modules transverter and an HB9CV antenna.

Now that summer is here it's a good time to remind you that an excellent indicator of Sp-E propagation is the appearance of eastern European f.m. broadcast stations within the 70MHz band. Although it's intended that these stations will eventually move to the segment 88-108MHz a number are still operating between 70.00-70.5MHz. They are located in HA, LY, OK, SP and YO, the most consistent probably being **Radio Gdansk** on 70.31MHz.

Unfortunately, apart from Cyprus and Gibraltar, there is no other DX activity on the 70MHz band. The beacon 5B4CY (KM64) is still operating on 70.115MHz and was heard by **G8GXP** (IO93) and **G8XVJ** (IO83) between 1230-1300 UTC on May 27. Apart from the beacon there appears to be no one with any 70MHz equipment in either of these countries at the present time.

There are however a number of stations in Europe and North America who are equipped with 70MHz receiving equipment. When Sp-E conditions are right you can hear them calling for cross-band contacts

on the nominated centres of activity. These cross-band working frequencies are 28.885, 50.185 and 144.185MHz with replies being carried out around 70.185MHz.

To generate interest in transatlantic propagation at 70MHz a personal beacon **G6YIN** has been designed by the **Microwave Modules A.R.T. Engineers** in Leeds. It operates on 70.050MHz using a 5-element DL6WU Yagi beaming 285° from locator IO93ET.

The **G6YIN** beacon runs in two modes of operation, 25W e.r.p. unattended and 400W e.r.p. attended. Reception reports can be sent to either **G6YIN** or **G8GXP**, preferably via the DX Cluster network.

If you own an IC-706 and want to make it work on the 70MHz band then read on. Apparently modifications have been made to this transceiver to allow it to produce 100W of r.f. at 70MHz. Hardware changes entail the addition of an extra integrated circuit and changes to the 50MHz output filter to extend its cut-off point to above 70MHz.

### Openings On 144MHz

Finally I'll turn to those Sp-E openings that occurred on the 144MHz band during the month of May. Remarkably there were five days, May 18, 19, 23, 24 and 27, when 144MHz openings occurred.

The season really did get off to an amazing start especially as the first two openings also coincided with a 24-hour RSGB 144MHz contest. Although the first event, on May 18, commenced around 1130UTC in mainland Europe it wasn't until 1530UTC that propagation began hotting-up in the UK.

At 1544UTC **John Regnault G4SWX** (JO02) heard SV4BGY (KM19) but conditions were very unstable at that time. An hour later the event had intensified although stations in eastern England were still right on the edge of the propagation.

**Lee Adams G4RKY** (JO01) heard some choice DX including LZ2PT, SV10E, SV2CKW, SV4BGY, YO3DMU, YU1EV, Z31EF and Z32ZP all with S9 signals. Unfortunately he was unable to crack the pile-up of ON and PA stations that were working this DX.

Lee did however, have positive results in an opening on the following day. Propagation on the 19th was in a similar direction to the day before and between 1525-1640UTC Lee made s.s.b. contacts with 18MPO, 18RAR, 1K8TOY, SV1DT, SV3KH, SV8CS and Z31DZ.

**Alec Trusler G0FIG** (IO90) caught the Sp-E opening on May 19 at 1620UTC. He managed to work 1K7UXY, LZ2FO and SV3KH, the Greek station being at a distance of 2243kms.

Users of the DX Cluster network could hardly have failed to notice that something was happening on May 23. Commencing at 1120UTC, stations in DL, OE, ON and PA started working shoals of DX situated to the east of them. This activity continued in excess of 4 hours and I've shown some of this on the locator map, Fig. 1.

At the start of the opening contacts were being made into the UA3 and UA4 call areas. Propagation then slowly moved to the south and stations located in I, IT9, LZ, SV, Z3 and 9H started to be worked.

Some of the more rare DX to be spotted at this time included OD5HD, TA1D, 3V8BB and 5B4/DL5MAE. **Graham Daubney F/G8MBI** (JN04) had Sp-E and field-aligned irregularities (f.a.i.) propagation for over eight hours! His best DX was an excellent contact with RZ6BU. The distance, a mere 2900kms!

At 1504UTC **Alec G0FIG** heard SV3BSF but signals quickly faded before contact could be made. About 30 minutes later propagation returned and Alec was able to contact a number of stations on s.s.b. including SV0EC, SV2JU, SV8XF/2, Z31DZ and Z32ZP. Phew, what a scorcher!

Propagation on the 144MHz band during the morning of May 24 was very much to the east and north-east of the UK. It came as no surprise that the 144MHz band would open up in this direction also.

Between 1120-1130UTC the station of **G4FUF** (JO01) made QSOs on the 144MHz band with UT21S (KN79), UR4IEF (KN79), UR5LX (KO70) and UR7IR (KN79). Finally an opening on May 27 allowed stations in Scotland (at last!) to contact stations in DL, OK and SP.

### Deadlines

It's deadline time again. If you did manage to make any Sp-E contacts this summer please let me know about it. Send reports, or any other news (to reach me by the end of the month) to **Yew Tree Cottage, Lower Maescoed, Herefordshire HR2 0HP**. You can also contact me via Packet radio @ **GB7MAD**, the DX Cluster @ **GB7DXC** or E-Mail via [davebu@mdlhr1.igw.bt.co.uk](mailto:davebu@mdlhr1.igw.bt.co.uk). Alternatively you can telephone me on (01873) 860679.

**END**

## HF FAR &amp; WIDE

Leighton Smart GWOLBI delves into the monthly h.f. reports to see what you've been up to on the bands recently.

I'm writing this month's column during the latter part of May. It's a month which has seen a number of Sporadic-E openings on 28MHz, some of which have been surprisingly strong, indicating that the 'E' season has well and truly arrived.

As I write, I can hear Russian stations coming through on my 28MHz rig, some as strong as S9. Conditions on the lower frequency bands are on the up to; 14MHz has recently been open well into the early hours, allowing some late night DX to take place. Even 21MHz has been regularly supporting African and South American signals during afternoon openings.

### The 1.8 & 3.5MHz Bands

I'm starting this time around with QRP operator **Eric Masters G0KRT** in Worcester Park, Surrey. He's been bashing away at the key as usual, with up to 5W of output power.

Eric's log for April/May indicates 1.8MHz c.w. contacts with ON5GL (Belgium) at 2055, and EI0CF (Republic of Ireland) at 2141. His 3.5MHz list includes QRP/QRP chats with GW3JSW at 0707, SP4EAK (Poland) at 2040, Novice station 2E0ANY at 1912, and G3MCK during the RSGB QRS (slow c.w.) contest. Eric uses a QRP Plus transceiver and a modified W3EDP antenna on all bands.

A warm 'HF Far & Wide' welcome to new reporter **Derek Blunden BRS171057** in Westlea, Swindon. Derek reports 1.8MHz s.s.b. reception of OY9JD (Faroe Islands) at 0300, and 4U1SCO at 1900. Turning the dial to 3.5MHz, Derek's log includes reception of FM5CD (Martinique) at 0100, KP4XS (Puerto Rico) and T77WI (Republic of San Marino) at 0300, plus P40V (Aruba Island) at 0400UTC.

Finally for the two lower bands, we come to **Carl Mason GW0VSW** in Skewen, West Glamorgan, who has been quite busy here. Using 100W c.w. and a G5RV antenna, Carl worked KA1ZEQ (USA) at 0621, UA2FCC (Kaliningrad) at 2057, EA7AIN (Spain) at 0536, and US0SU (Ukraine Republic) at 2119UTC.

### The 7MHz Band

The 7MHz band is the favourite of regular s.w.l. reporter **Charlie Blake RS96034** of Milton Keynes. He reports this month that 7MHz is improving again, with some interesting English speaking contacts being heard.

Charlie also explains that the reason for some of the very early loggings is that his dog keeps waking him up at all hours! It always coincides with some very good DX on the band. A real 'DX - hound' perhaps?

Charlie's large s.s.b. list this month includes reception of T15LRI (Costa Rica) working DL4HRH in Germany at 0635, ZL1ACE (New Zealand) in contact with I2WTY in Italy at 0618, LU5FAD (Argentina) working SP20FK in Poland at 0534, CM6BG (Cuba) in contact with SV1CID at 0540, YN8ZDK (Nicaragua) working SM5HPB at 0540, and VK2CP (Australia) in contact with F5SPJ in France at 0646UTC.

**Ted Trowell G2HKU** of Kent, says he's pleased that the earth mat laid under his magnetic loop antenna last year is at last covered with grass, which means he can finally mow it! Ted's log for 7MHz shows that he's been 'QRping' quite a lot of late.

The G2HKU low power accounted for c.w. contacts with VP2EFF (Anguilla), T14CF (Costa Rica) at 0700, with 3V8BB (Tunisia) at 1500, while his 'QRO' 70W made contact with VK3MR (Australia), PJ5AA (Leeward Islands) and VK2ZC (Australia) at around 0700UTC, as but a part of a long list.

Also having a crack at 7MHz this month is **John Heys G3BDQ** near Hastings, who has been on air - busy testing a Chelcom Window antenna. Using c.w. on the band, John lists 3V8BB (Tunisia), CX3AL (Uruguay) at 0010, S92SS (Sao Tome & Principe Island) at 2244 with a huge pile - up, UA0ACG (Asiatic Russia), and FG5GH (Guadeloupe) all at around 2300UTC.

### The 14MHz Band

The majority of reports, as usual, weigh heavily towards the 14MHz band. However noisy or congested this band is, it still carries the bulk of amateur DX traffic.

I'll begin this month's 14MHz slot with **Terry Ibbison G0VTI** of Wakefield, who uses a 50W Ten Tec Scout and an inverted 'V' G5RV dipole. Terry used all - s.s.b. on this band, and made contacts with VO1NP (Newfoundland) at 1113, JW6RHA (Svalbard Island) at 1339, 9G1BJ (Ghana) at 1950, PR7DB (Brazil) at 1152, and 9K2MU in Kuwait, who, says Terry was S3 with just 1W!

Next comes regular reporter **Don Mclean G3NOF** of Yeovil, who has been suffering from a heavy cold. Glad to hear you're back on the air Don! Don's regular propagation report indicates that 14MHz in particular has been open into the 'wee small hours', but that 18MHz has 'been patchy' recently.

Don's list this month shows his 14MHz s.s.b. contacts with HL2IOU (Korea) at 1613, J52AK (Guinea Bissau) at 0844, JA4AHV (Japan) at 1557, N600BFM (special call for the Olympic Games), XE3WAO (Mexico) at 2225, XX9AS (Macao) at 1719, QSL to KU9C, 5R8EN (Madagascar), QSL to F6AJA, 5X3A (Uganda) at 1946, QSL to PO Box 1030, Mbale, Uganda, 9G1BJ (Ghana) at 1948, and TJ1RA (Cameroon) at 1758UTC.

Now over to **Richard Evans G0VCW**, a QRP addict who hails from Rusden in Northants. Richard says that he's found conditions slightly better recently. Richard's 14MHz list includes low power contacts with K1GDH and AE2L (both USA) with 3W c.w., and 8P9EM with 10W p.e.p. of s.s.b.

Our regular Bristolian s.w.l. reporter **Gordon Foote G7NCR** (who sent in about five reports this month!) reports s.s.b. reception of 3V8BB (Tunisia) in contact with VE6PY (Canada) and NF6S (USA) at 1945, UR4FC (Ukraine) working G4VJM/P who was using a 2.2m whip antenna.

Gordon also heard UE1TTT (Russia) working GORQY at 1642,

RADIO AMATEUR OF MACEDONIA GREECE

SV2ASP/A  
MOUNT-ATHOS

TO	FRQ	DAY	MON	YEAR	GMT	HR	RT	MODE
RS96034		1	3	96	4	37	WVXK	S3B

MONK APOLLO  
DOCHIARIOU MONASTERY  
GR 630 87 MOUNT ATHOS  
GREECE

10/22  
1/VA

UR SWL RPT 15 00 IN LOG - 8000

You don't need a 'Halo' antenna to hear Monk Apollo on Mount Athos in Greece, just a decent receiver!

HZ1TA (Saudi Arabia) in contact with G4QJH at 1655, 9K2RA (Kuwait) working Leon G3HDJ in Northampton. Also logged was VU2AVG (India) working 1K5XIY in Italy at 1635, ZS6VJJ (South Africa) working LA3PU in Norway at 1617 and 7Q7KH (Malawi) in contact with various Europeans in a pile up. The pile-up, says Gordon, was subject to quite bad behaviour by certain amateurs who insisted in repeating their callsigns over the top of existing contacts.

Lastly for this band comes John G3BDQ, who has given up i.f. band DXing till autumn, and has turned his hand to the higher bands recently. John reports 14MHz s.s.b. contacts with HS0/G4UAV (Thailand), SU2MT (Egypt), YB1KGI (Indonesia), CN8DN (Morocco), BV1VA (Taiwan), TROBT (Gabon) and lastly 9K5MR (Kuwait).

### Signing-Off

It's signing-off time. Not enough space this month for a look at 21MHz and above I'm afraid, but my grateful thanks to our reporters for their information and the effort they make, which makes the column what it is.

As usual, reports to me (and photos of you and your stations!) to the address below by the 15th of each month. All the best DX for now. **Leighton Smart GWOLBI, 33 Nant Gwyn, Trelewis, Taff Bargoed CF46 6RD, Wales. Tel: (01443) 411459.**

END

# VALVES

We hold a large inventory of valves, many for radio ham use. Please call us with your requirements. We can supply most types from stock at sensible prices. We also buy valves new or used. Call us and tell us what you've got and we will give you an instant decision.

VISA/MASTERCARD ACCEPTED

Call or fax us on **01734 451737**

Vintage Audio, 850 Oxford Rd, Reading RG30 1EL

(Personal callers welcome)

## NRF2 NOISE REDUCTION FILTER



The NRF2 is a new "passive" Audio Filter, specially designed to improve audio selectivity. Its main use is to clean up the hash, whistles and splatter often experienced when trying to resolve SSB, FAX etc. with a receiver intended mainly for AM reception. Selectivity is about 2.2kHz at 6dB with negligible insertion loss.

Mounted in a neat little ABS case, measuring 7 x 5 x 2.5cms, it simply sits in line with your headphones or 'speaker. Input and output impedance is 8 ohms, although it will be found to work quite well with other impedance values. Connections - in and out - are by 3.5mm jacks but plug-in adaptors are included to permit use with the standard 14" type. No battery is necessary.

**READY BUILT! ONLY £16.50 plus £1 postage**

## LAKE ELECTRONICS

7 MIDDLETON CLOSE, NUTHALL, NOTTINGHAM NG16 1BX

TEL: 0115-938 2509

E-Mail: 100775,730@compuserve.com

## SPECTRUM COMMUNICATIONS

Unit 6b Poundbury West Estate, Dorchester, Dorset DT1 2PG. Phone and Fax 01305 262250

Opening times: 9-1 2-5 Tue-Fri, 9-1 Sat. Closed Sun & Mon.

RECEIVE PREAMPS 20dB gain, 100W handling	Box Kit	Box Built
Types RP2S, RP4S, RP6S, RP10S	£28.50	£44.00
Masthead versions RP2SM, RP4SM, RP6SM	£39.50	£49.00

TRANSVERTERS Low N/F, 15dB gain	Box Kit	Box Built
2M 3W drive. TRC6-2iL (TRC4-2iL built only)	£159.30	£225.00
10M 25mW drive. TRC2-10L, TRC4-10L, TRC6-10L	£150.80	£208.50
10M 0.5mW drive. TRC2-10bL, TRC4-10bL, TRC6-10bL	£159.30	£225.00

WEATHER SATELLITE RECEIVER	Box Kit	Box Built
137-138MHz 5 channel with scan and good signal meter, output LS & to computer	£127.40	£184.75
Computer interface WFAX, SSTV etc. JV FAX software version 7 supplied	£66.50	£99.50

SEND SAE FOR CATALOGUE OF AMATEUR KITS AND BUILT UNITS

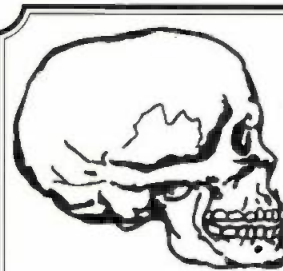

Don't leave it too late before you subscribe to

# PRACTICAL WIRELESS

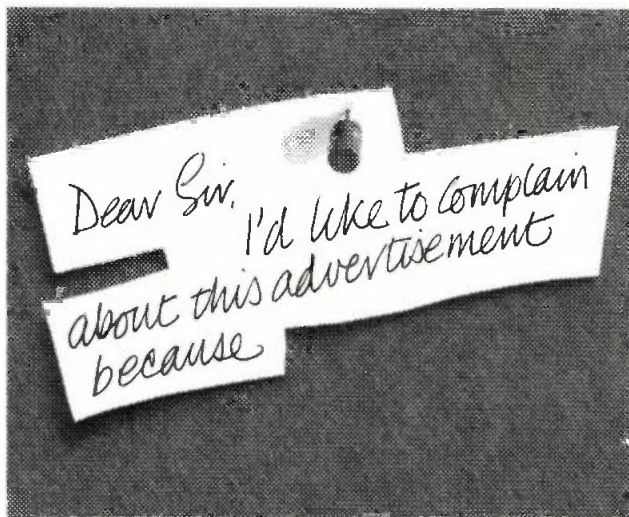

Most advertisements are legal, decent, honest and truthful. A few are not, and, like you, we want them stopped.

If you would like to know more about how to make complaints, please send for our booklet: 'The Do's and Don'ts of Complaining'. It's free.

**The Advertising Standards Authority.**

**We're here to put it right.**

ASA Ltd., Dept. Z, Brook House, Torrington Place, London WC1E 7HN.

This space is donated in the interests of high standards of advertising.

Practical Wireless, August 1996

## J. BIRKETT

Partners J.H. Birkett  
J.L. Birkett

**SUPPLIERS OF ELECTRONIC COMPONENTS**



25 The Strait  
Lincoln LN2 1JF  
Tel: 01522 520767

AMIDON RINGS T50-26 @ 8 for £1, T80-26 @ 5 for £1, T106-52 @ 35p, T130-52 @ 50p, T130-16T3 @ 75p, T141-603 @ 85p, T151-52 @ 80p, T200-40 @ £1.50.

TRANSFORMER 240 volt input, 12 volt 4.17 amp out @ £5 (P&P £1.50).  
AIR SPACED VARIABLE CAPACITORS 15+15PF £3.50, 10+10+20PF @ £2.50, 200+300PF (500PF) @ £3.50, 250+250PF @ £3.50, 250+250+20+20+20PF @ £3.50, 365+365+365PF @ £4.95, 300+400PF @ £3.50, 500+500+500PF @ £8.95. C804 type 5PF, 10PF, 25PF, 50PF, 100PF @ £3.50 each.

TEXAS FETS T1S14 similar to BF256 @ 6 for £1.

EX AIRCRAFT VHF TRANSCEIVER 1985 with 21 valves, 10 channel, 10 crystals, 24 volt dynamotor @ £30 (P&P £8.50).

ARCS2 VHF SPECTRUM GENERATOR AMPLIFIER UNIT with 2 x 6J4, 1 x 6AK5 valves, 3 gang capacitor, 18 crystals @ £5 (P&P £1.50).

EX-MILITARY COUPLING UNIT Type 9546 with servo motors gears etc. @ £5 (P&P £2.50).

COLLINS CONTROL ANTENNA UNIT No details. Number 5985-99-951-4615 @ £20 (P&P £5).

VHF GLIDE PATH RECEIVER Type R1965 @ £15 (P&P £5).

FETS 2N3819 @ 35p, J304 @ 25p, J230 @ 20p, MPF102 @ 45p, BF244 @ 40p, 2N4869A @ 45p, VHF-UHF J309 @ 55p, BFW11 @ 30p, BFW12 @ 30p, DUAL GATE MOS FET BF981 @ 35p, 4 for £1.20.

BLOCK PAPER CAPACITORS 4uf 850v.w. size approx 4 1/4" x 3" x 2" @ £3 each.

CRYSTAL FILTERS VERNITRON 100kHz DSB @ £4.50 each.

SPECIAL OMRON R.F. RELAYS Type G5Y-254P 2 pole change over 12 volt coil @ £3.

ACCESS, SWITCH and BARCLAYCARD accepted. P&P £1 under £10. Over Free, unless otherwise stated.

**C.M. HOWES KITS.** Available by post and for callers.

# BITS & BYTES - COMPUTING IN RADIO

Mike Richards G4WNC has news of a new computer interface, a CD-ROM, a circuit design package and a change to his E-mail address.

I've finally decided that I really can't justify keeping two E-mail accounts! Regular readers will know that I usually offer E-mail addresses via CompuServe and the Internet.

Whilst I have always been a keen fan of CompuServe, I have become increasingly disappointed with their service offering. Whilst Pipex give me excellent 14.4kbs plus local call rate access to the Internet, CompuServe have only limited speeds available locally.

There's also the question of network speed. I can access CompuServe by using an Internet gateway through my Pipex account, but when I do this, the log-on and subsequent data transfers always appear to be very slow - to the point where I often give up!

There's also the question of charges. Although CompuServe have reduced their rates, there are still incremental charges that can catch you out.

Despite the network problems, CompuServe does offer a very good, easy to use, software front-end with their WinCim package. Even this advantage is being rapidly eroded with the latest integrated software such as Netscape Navigator and Microsoft's Internet Explorer (more on this later).

The end result is that I have decided to cancel my CompuServe account and all my mail should now be directed to my Pipex address which is:

mike.richards@dial.pipex.com I will also be taking advantage of the Pipex free Web space and am busy putting together my own Web page that will contain many useful (I hope!) links to other radio related Internet sites.

## Home QSL Cards

My recent mention of home produced QSL cards has certainly sparked some interest from readers. Gareth Jones GW4KJW of Abergavenny makes his own using a program called *Timeworks* that came from a computing magazine cover disk about two or three years ago. To live-up to the card Gareth has drawn his own graphics, including a silhouette map of the UK.

Dave Hobro G4IDF uses Microsoft Works 3 combined with a Hewlett Packard Deskjet printer to produce his cards. Rather than fold the paper to create a double sided card, he prints on both sides of the original.

Another interesting option is to use standard QSL cards, but use a label printing program to enter the vital contact and QTH details. There are many programs around that can do this, but the *Smart n' Sticky* program from *Oakley Data Services* is particularly versatile. By far the simplest and most popular method of producing QSL cards is to use a desk-top publishing program such as *Microsoft Publisher*.

Albert Thompson GW01ZR, John Dart GW0WHU and John Robertson G-9992 have all written describing how they use the system. The trick is to use the Greetings & Invitation Wizard to create the card. This produces a birthday card-like design by folding a single A4 sheet. The great advantage of this system is a professional appearance without having to produce a double-sided print-out.

One thing that stands-out from all the letters I've received is that there appears to be a shortage of good quality radio related clip-art. A varied range of clip-art makes it very easy to produce sophisticated designs that rival professionally produced cards. If you know of any good sources of this type of clip-art please write to or E-mail me with the details.

## Just Released

The Public Domain & Shareware Library (PDSL) have just released what appears to be a very useful CD-ROM for PC users. Titled *Task Buster* it attempts to gather together some 2,323 applications and utilities for Windows and MS-DOS.

Although most of the *Task Buster* utilities will only be required from time-to-time, having them organised onto just one CD-ROM sounds to be very convenient. I shall be asking for a review copy for a later 'Bits & Bytes' but, for more information, you can contact PDSL at *Winscombe House, Beacon Road, Crowborough TN6 1UL. Tel: (01892) 663298.*

## Latest Browser

Microsoft have just announced the very latest version of their own Web browser. The browser is supplied as freeware and is available from their own software site (<http://www.microsoft.com>) or any of the normal mirrors.

One of the advantages of using Microsoft's own software is that it is written to work on all the standard Microsoft platforms. Versions of the new browser, *Explorer* are currently available for Windows 3.1, 3.11, '95, NT and Mac based systems.

A big bonus with the new browser is its speed when compared with Netscape's *Navigator*. Whilst some of this is due to *Explorer*'s technique of showing all the text before the graphics, this doesn't account for the whole speed difference, so it looks as though *Explorer* really does have the edge here.

Next in the range of goodies comes background sound, internal AVI, built-in search page and client side image mapping, to name just a few. In addition to the basic browser package you can download versions with built-in TCP/IP stack, dialler and a full mail package.



There are however, a few downsides that will give Netscape room to breath. The FTP option works fine but is very basic and freezes all activity until the marked file has been completely downloaded. There are also some Netscape 2.0 tags that are not supported.

Overall the new Internet Explorer provides welcome competition to Netscape's *Navigator* and is well

worth a try. The best way to get your copy is from Microsoft's Internet Explorer Home Page that can be found at:

<http://www.microsoft.com/ie/ieh.htm>

## Design Packages

I've seen a number of circuit design packages ranging from sophisticated and expensive professional systems through to very crude adaptations written in GWBasic. My latest discovery is a refreshingly simple, but competent, system from Brian Ellis in the United States.

Brian's design program is being distributed as shareware with a registration fee of just \$US26 should you decide you like it. As well as a good range of features, one of the main things that attracted me to the program is the excellent interface that makes the program a real pleasure to use.

Brian has obviously put a lot of thought into this aspect of the software. It's very unusual to see such a good presentation in such a compact program.

With so many modern packages demanding Windows, megabytes of memory and hard disk space, its great to see a new program that only requires a basic 8086 PC with just 640k RAM and 400kb of disk space. The operating system needs to be MS-DOS 2.1 or later with either a CGA, EGA or VGA monitor.

Despite the modest requirements, the program both looks and performs extremely well. So, what does it do?

The program starts with a simple menu giving the design options for resistors/capacitors/inductors, timer/oscillators, semiconductors and heatsinks. The appropriate option is selected by pressing a number key where upon you are presented with a more detailed menu.

Taking the Resistance menu as an example, you could carry-out the full range of Ohms Law calculation by



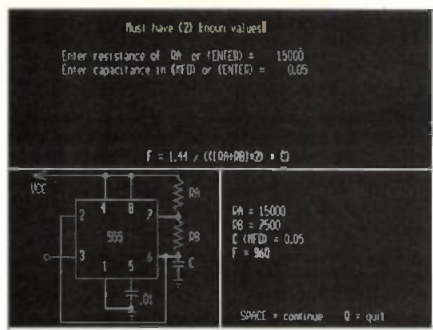

just supplying the variables to hand. As an example, to find the power dissipation and current you would just enter the voltage drop and resistance. This could be done for any two known values.

The same principles were applied to all the calculations in the program. If you're not too sure of your resistance colour codes, the program will tell you the resistance for a given colour code or vice-versa. This section even included the colour codes for resistance tolerance and reliability.

The semiconductor menu was particularly interesting for anyone building a simple class A amplifier stage and included common base, emitter, collector and transformer coupled circuits. There was even a menu for designing simple oscillators using the LM555, UJT

and PUT devices.

If you'd like to try this program it can be found at any of the Internet/BBS/shareware sites that hold the SimTel archives. It appears in several directories but the review version was taken from simtel/msdos/hamradio/ and the file name is ELCD11.ZIP. Don't forget to send off your registration if you find it useful.

## New Interface

Waters & Stanton Electronics have just announced the latest version of the Optoelectronics, Optolinx computer interface. This powerful interface adapts a wide variety of radios, scanners, decoders, counters and GPS receivers for connection to a standard RS-232 serial port.

The Optolinx computer interface features full control of the AOR 2700 and 8000 receivers using the supplied cable. This can be extended to cover the Icom R-7000, 7100 and 9000 receivers with an optional cable.

Optolinx also features compatibility with NMEA 0183 type receivers for GPS or LORAN positional information. This looks to be a very useful interface and should be available at around £129 by the time you read this. For more information contact Waters and Stanton Electronics at 22 Main Road, Hockley, Essex SS5 4QS. Tel: (01702) 206835.

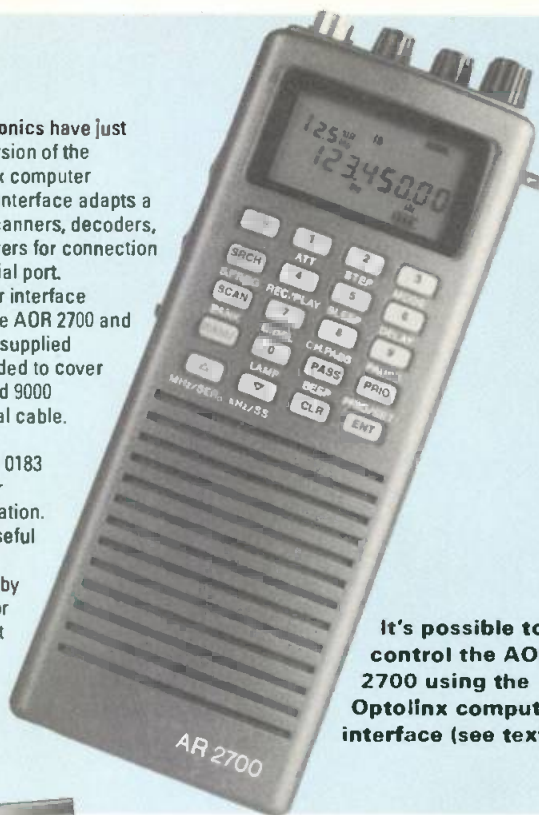

It's possible to control the AOR 2700 using the Optolinx computer interface (see text).

## Gibraltar Web Page

After reading the May edition of 'Bits & Bytes' Wilfred Guerrero ZB2IB sent an E-mail to tell me about the Gibraltar Amateur Radio Society Web page. Although the page is still under construction, it can be found at <http://www.gibnet.gi/~jimwatt> There's lots of information on Gibraltar plus some interesting links to other radio related sites.

That's all the computing news I've got for you this month, so until next time cheerio and keep your letters and news coming to me Mike Richards G4WNC, 'Bits & Bytes', at PO Box 1863, Ringwood, Hants BH24 3ZD or via E-mail to [mike.richards@dial.pipex.com](mailto:mike.richards@dial.pipex.com)

## Special Offers

### Special Offers

Here's the full list of reader's offers with all the latest software. Please leave up to two weeks for delivery.

#### IBM PC Software (1.44Mb disks)

- Disk A (Order Code DKA) - JVFX 7.0, HAMCOMM 3.0 and WEFAX 3.2.
- Disk B (Order Code DKB) - DSP Starter plus Texas device selection software.
- Disk C (Order Code DKC) - NuMorse 1.3.
- Disk D (Order Code DKD) - UltraPak 4.0.
- Disk E (Order Code DKE) - Mscan 1.3 and 2.0.

#### Printed Literature

- Beginners Utility Frequency List (Order Code BL).
- Complex Signals Utility Frequency List (Order Code AL).
- Decode Utility Frequency List (Order Code DL).
- FactPack 1 Solving Computer Interference Problems (Order Code FP1).
- FactPack 2 Decoding Accessories (Order Code FP2).
- FactPack 3 Starting Utility Decoding (Order Code FP3).
- FactPack 4 JVFX and HAMCOMM Primer (Order Code FP4).
- FactPack 5 On the Air with JVFX and HAMCOMM (Order Code FP5).
- FactPack 6 Internet Starter (Order Code FP6).

For the printed literature just send a self addressed sticky label plus 50p per item (£1.50 for four, £2.50 for seven and £3 for nine). For software send £1 per disk (£1.75 for two, £2.50 for three or £3 for four and £3.75 for all five) and a self addressed sticky label (don't forget I provide the disk!).

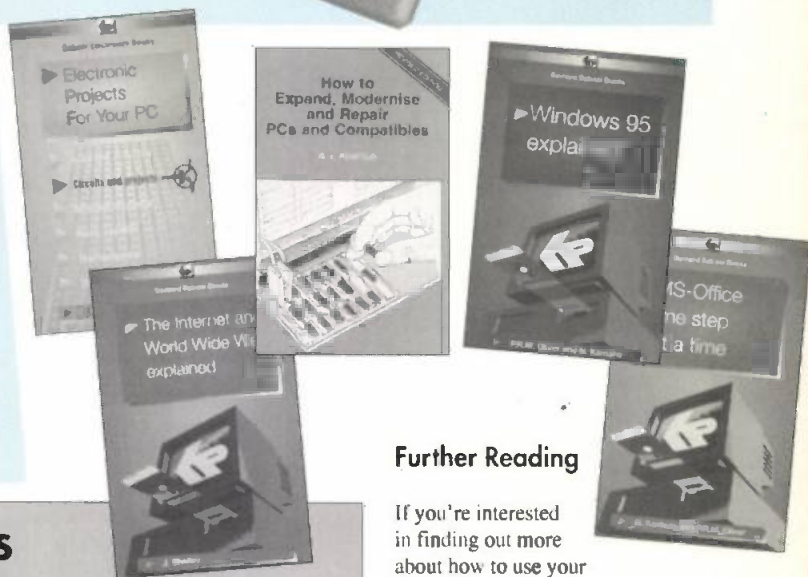

## Further Reading

If you're interested in finding out more about how to use your computer in connection with your radio set-up, the following books should interest you. All the books shown are available from the PW Book Service. To place an order please contact Shelagh or Michael on (01202) 659930. Remember to add £1 P&P per book ordered.

I hope you've enjoyed this month's column, cheerio for now and keep those letters coming to me Mike Richards G4WNC, 'Bits & Bytes', PO Box 1863, Ringwood, Hants BH24 3ZD. CompuServe 100411,3444: Internet [mike.richards@dial.pipex.com](mailto:mike.richards@dial.pipex.com)

END

# BROADCAST ROUND-UP

*Peter Shore has news of changes to the BBC's World Service, together with his monthly round-up of the latest broadcasting schedules.*

The largest change ever to be made to the BBC was announced on June 7 by **John Birt**, the Director General, with some of the greatest effects being felt by **World Service** at Bush House. In an unprecedented move, John Birt did away with the separate divisions which produce radio, television and World Service radio programmes, combining the programme production areas into a new super-division called BBC Production.

The areas which commission and schedule programmes were combined across all three types of output into BBC Broadcast. The World Service lost its autonomy in commissioning and producing English language programmes, which will now fall under the responsibility of the central BBC Broadcast operation.

World Service is now directly responsible only for the 40 or so language services from Albanian to Vietnamese, although they attract audiences of around 95 million each week against around 35 million for the 24 hour-a-day English service. All these changes have been put in place to help fund the BBC's vision for the future digital age.

At the end of May, John Birt unveiled his new ten year strategy, *Extending Choice in the Digital Age* which signified the BBC's move into digital satellite and terrestrial television, digital radio and multimedia. Watch closely!

Will BBC World Service continue as we know it? Will the BBC survive into the 21st century? It's certainly in the interests of McKinsey & Co, the firm of management consultants retained by the corporation at a reputed cost of six million each year to make sure the BBC does thrive for a good many years yet.

## Broadcast Schedules

Take the chance while you can to tune to **Channel Africa**, the overseas service of the South African Broadcasting Corporation. The Foreign Affairs Ministry of the South African government has decided to stop funding the short wave broadcaster, saying there is not

sufficient money available in government coffers.

Channel Africa broadcasts in English to Africa at: 0300-0500 on 3.22, 5.955; 0500-0600 on 5.955, 9.59; 1500-1800 on 3.22, 7.155; and 1600-1700 on 9.53MHz. You can write to the station at **PO Box 91313, Auckland Park 2006, South Africa** and visit the web site at: <http://www.sabc.co.za/units/chanaf/index.html>

The Portuguese transmitting station of **Radios Free Europe (RFE)** and **Liberty (RL)** closed down at the end of May. Both RFE and RL had built stations in the Iberian peninsula at Gloria and Playa de Pals to ensure first hop coverage into the Soviet Bloc.

But the availability of local stations who want to take RFE/RL programmes in the countries of eastern Europe has meant many fewer direct short wave (s.w.) broadcasts are needed. Medium wave (m.w.) and f.m. are the preferred means of delivery, but to buck the trend, in Lithuania RFE is broadcast on **Radio Vilnius** short wave transmitter at 9.71MHz at 1700-1800UTC.

Norway became the base of the **Voice of Tibet** in May. This new station was launched by Worldview International, the Norwegian Human Rights House and the Norwegian Tibet Committee. There is a daily 15 minute programme in three Tibetan dialects from 1145UTC on 15.445MHz. The **Democratic Voice of Burma** is also broadcast from Norway every day.

**Radio Yugoslavia's** English language service can be received at: 0000-0030 and 0430-0500 on 9.58 and 11.87; 1830-1900 on 6.10 and 9.72; 2030-2100 on 7.23 and 2100-2130 on 6.10 and 6.185MHz.

## Swedish Changes

Some minor changes have been made to **Radio Sweden's** English frequencies. At 0130UTC new 9.435 replaces 7.12MHz. At 0230UTC 6.09MHz replaces existing 7.29MHz. At 1330UTC, new 13.74 replaces 11.65MHz.

The new digital production system



## Radio Ulan Bator in Mongolia issues QSL cards for correct reception reports.

installed by Radio Sweden to reduce staff costs was hit by problems when it went live during May. All pre-recorded material is now stored on a hard disk and played out when needed.

Editing of programmes is also carried out electronically, with not a piece of quarter-inch recording tape in sight. The problem with digital technology is that when it works, everything is wonderful. When it goes wrong, however, it tends to do so catastrophically.

Listeners to some of Radio Sweden's first digital programmes were treated to the news being read simultaneously, as a pre-recorded programme was played out or with long gaps followed by a piece of filler music by **Roxette**, when the system went hopelessly wrong. **MediaScans** George Wood reports that things are now settling down, and less problems are occurring.

Radio Ulan Bator broadcasts in Russian, Chinese, Japanese, Kazakh and English for 10 hours a day and the station receives 2000 letters from overseas listeners every year. If you would like to contact the station, write to **PO Box 365, Ulan Bator, Mongolia**. The station issues QSL cards for correct reports.

Further south and east the **Voice of Malaysia** in Kuala Lumpur is on the air to Europe, Asia and Australasia daily at 0600-0830 on 6.175, 9.75 and 15.295MHz. And the station's parent organisation, **Radio Television Malaysia**, has a web site you might like to visit at: <http://www.asiacconnect.com.my:80/rtm-net/>

Kol Israel is on the air with English at 0400-0415UTC on 7.465, 9.435 and 17.545; 1400-1430 on 12.077 and 15.615 and 1900-1930 on 7.465, 9.435, 11.605, 15.615 and 15.64MHz.

## Publicity Material

Some publicity material recently arrived unexpectedly from **Radio Ulan Bator** in Mongolia a couple of days ago. It reports that the station's programme schedule is 0930-1000 on 11.85 and 12.085 and 1230-1300, 1500-1530 and 1930-2000 on 9.745 and 12.085MHz.

**That is all for this time round. Until next month, keep searching the bands for interesting stations and let me know if you find anything unusual. All letters to me c/o the PW Offices.**

**END**

# FOCAL POINT

In his bi-monthly look at the Amateur Television scene Graham Hankins G8EMX rounds-up all the latest news and views.

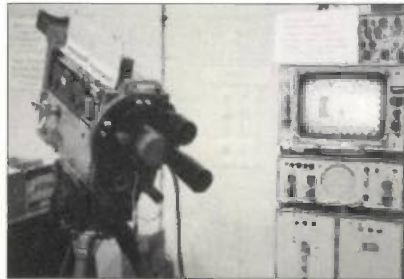

Before the days of the camcorder. This photograph shows a 1960 EMI 203 broadcast camera which can provide 405, 525 or 625 line pictures with provision for five lenses. The power/control tower has 172 valves and consumes 2kW!

A new Amateur Television (ATV) Production Section of the **British Amateur Television Club (BATC)** is the novel initiative of committee member **Norman Ash G7ASH**. The Section will concentrate on camera skills, video editing, lighting and studio presentation, and is open to everyone who has a domestic camcorder.

Video filming has a rapidly growing body of enthusiasts. Many enthusiasts have developed considerable expertise, either through Video Owners' clubs or from evening classes.

But video enthusiasts need not be licenced radio amateurs and may have no interest in the transmitting or receiving side of ATV. By creating a Production Section, Norman expects the BATC to broaden its appeal over a much wider membership than the current make-up of predominantly radio engineers.

*Rough Cut* is the Amateur Television Production Section's newsletter. In Issue 1, Norman says: "A big thank you to everyone who is supporting this new idea. It's very pleasing to see the obvious interest in the creative side of the hobby".

The ATV Production Section is due for launch during the **Conference of Amateur Television ('CAT '96)** at the **Post House Hotel, Crick, Northamptonshire** on Sunday September 1. This will be a specialist event with only a few traders but plenty of ATV related lectures and BATC members' exhibits.

## Correspondence

Now onto correspondence and a packet message from **John Koering DL4EBJ** in Germany. John says: "Hello Graham, Here is John DL4EBJ in Kleve near Dusseldorf. I'm very interested in exchanging ATV news of any kind, especially new circuits and ideas.

"I run the first 'ATV Home Page' on the Internet in Germany. The emphasis is projects, a few boards are closely described with circuits. Photos of ATV activity or technical projects are welcome for publication on the Internet"

John can be E-mailed at **jkoering@mail.regio.rhein-ruhr.de**. His ATV web site is at **http://www.regio.rhein-ruhr.de/hamradio/at** or contact John via packet **DL4EBJ @ DB0ACC.#NRW.DEU.EU**

Now for some microwave news from **John Simmons G6MPE** in Brighton: "Hello Graham, myself and **Roy G4WTV** have set up a 10GHz ATV full duplex link and the quality of the pictures we receive from each other is as though we had connected our cameras into each others monitor.

"I use two 600mm dishes attached to a rotator which takes some holding when windy! Roy uses similar equipment but he has two ex-BSB 350mm dishes. He transmits on 10.278GHz and I transmit on 10.425GHz"

John has developed substantial 3cm (10GHz) activity in Brighton. He continues: "Also we have **G1SBZ, G4PAP** and **G6FFH** locally who are active on 10GHz. Most days my transmitter is on for at least 12 hours a day, only switched off when I leave for work".

Now to the West Midlands where ATV home construction is alive and well says **Alan Banner G7UMW**: "Several of us regularly transmit and receive fast-scan ATV. I am active on 70cm (430MHz) using a home-brew 435/437MHz transmitter which drives a home-brew 2C39 valve linear amplifier. My 435MHz receive is via a converted tuner with i.f. strip and a home-brew pre-amplifier".

Video at G7UMW is generated by a BBC B computer, two cameras and a good old Betamax video recorder. (I've still got a Betamax myself Alan...never throw anything away! **G8EMX**)

Alan continues: "I can only receive on 1260MHz at the moment but have just ordered a 24cm (1270MHz) 1W transmitter kit from the Worthing Repeater Group, (an easy transmitter to build and only £60. **G8EMX**) so am eagerly waiting for the post".

There are two Fast-Scan ATV 'Nets' in the Midlands. Pictures on 435MHz and 1260MHz can be seen on Sunday mornings from about 1100

and on Tuesday evenings from about 2000. Regulars 'in vision' are **Arthur Bevington G5KS, John G7UNB, Alan G6WJJ, John G1GST** and **Brian G0KJG**.

Thanks for letting me know of all that simplex ATV, Alan. I would welcome similar information from elsewhere.

## Repeater News

**Brian Summers G8GQS**, Editor of *Line Out*, diligently sends me their newsletter *Line Out*. Latest report on the **GB3HV** repeater is:

A VIC20 Bargraph Usage page. Showing 2-3 hours daily use, with some days going off the chart!

Teletext. 100 pages of HAMTEXT, kept up-to-date with news.

Mast camera and 70cm (430MHz) receiver for installation later this year. The low-light camera and 70cm system are currently on test at the QTH of **John Stockley G8MNY**.

The Biggest 'bug' at the moment is the auto-tuning 70cm receiver which is being fooled by strong 70cm signals or 440MHz private mobile radio (p.m.r.) transmissions.

**GB3AT** Southampton. Now ready for installation. Plans are to link this repeater to **GB3HV**. Information courtesy *Line Out* newsletter.

**GB3RT** Coventry. This is now back up to full power after replacement of the mixer/PA feeder.

## Amateur Television A to Z

As promised in the previous 'Focal Point', here's a brief dictionary of common ATV terms:

**Alford-Slot Antenna:** Achieves an omni-directional field pattern while retaining standard ATV horizontal polarisation. Very popular at 1260MHz repeater installations.

**Amplitude:** All video sources produce a standard 1V peak-to-peak waveform, made up of 0.3V sync, 0.7V peak picture brightness.

**Antennas:** Usually multi-straight-element Yagis, but the multi-loop Yagi gives best gain/bandwidth. ATV results on 24cm. Mount all ATV antennas (including 144MHz ATV calling) horizontally.

**Black Level:** The voltage (within the 1V limit) at which video information starts. Needs to remain stable.

**Back Porch:** A time interval at zero video Volts before the start of the next picture line. Allows line flyback to be completed. Contains the colour burst (see 'C' next time).

**Black-and-White picture:** Video transmitted without colour information to save bandwidth, especially when using 435MHz.

There is quite a lot under 'C' so, I'll continue the A - Z next time.

Until next time, cheerio for now, keep those newsletters, photos, club magazines and Packet messages coming to me, **Graham Hankins G8EMX at 11 Cottesbrook Road, Acocks Green, Birmingham B27 6LE**. My full packet address is **G8EMX @ GB7SOL.#29.GBR.EU**

END

Advertisements from traders or for equipment that is illegal to possess, use or which cannot be licensed in the UK, will not be accepted. No responsibility will be taken for errors.

You should state clearly in your advert whether the equipment is professionally built, home-brewed or modified.

The Publishers of *Practical Wireless* also wish to point out that it is the responsibility of the buyer to ascertain the suitability of goods offered for purchase.

# BARGAIN

b a s e m e n t

Compiled by Zoë Crabb

FREE  
ADVERTS

Free adverts? Yes it's true! As of now, all adverts will be  
**FREE** of charge, to readers and subscribers.

Now's your chance to send in a photograph of your equipment (a good idea if it's really unusual) to accompany your advert. Please note that all photos will only be published at our discretion and are non-returnable.

When sending in your advert, please write clearly in **BLOCK CAPITALS** up to a maximum of 30 words, plus state your contact details. Please use the order form on page 62, which is published every other month. In the months between, a photocopy of the order form (with corner flash), or your advert written on a postcard (with corner flash) will be accepted - **no corner flash - no advert!**

Adverts are published on a first come, first served basis. All queries to Zoë on (01202) 659910.

All adverts should be sent to: Zoë Crabb, Bargain Basement Free Ads, Arrowsmith Court, Station Approach, Broadstone, Dorset BH18 8PW.

## For Sale

**50MHz CL6DX** create beam, £40. 50MHz linear 80W out, built-in p.s.u. and preamp, £40. Buyer to collect. Brass Morse key, £25. 13 Eddystone plug-in coils, £12. Bill, Bicester, Oxon. Tel: (01869) 241068.

**ADI AT-48** 70cm (430MHz) hand-held transceiver, 2 x AA cases, antenna, belt clip, wrist strap and manual, v.g.c., £120 o.n.o. Tel: Hants (01252) 623639 after 6pm.

**Alinco DR-112E** v.h.f. f.m. transceiver for amateur radio, full 144MHz spec, mobile 12V unit with Duplex and controller fist mic., along with manual, only, £80 o.n.o. Andy, Suffolk. Tel: (01449) 775395.

**Alinco dual-band hand-held**, v.g.c., inc. hand mic, case, etc., a bargain, offers around, £279. Kenwood 79E battery pack, £20 o.n.o. Tel: (01745) 730148 anytime.

**AOR AR2800** all-mode base scanner, 500kHz to 600MHz, 800 to 1300MHz, bargraph, 'S' meter, c/w Scanmaster GW2 GaAsFET wide band pre-amp, mains p.s.u., NiCads, telescopic antenna, mobile mounting bracket and manual, £225. Peter G3HEE, Lines. Tel: (01780) 55001.

**AR88** i.f. receiver, £125. Racal RA17, £150. Aircraft receiver R1116A, clean no mods d.f. socket missing, £35. Com-radios Murphy A262, Marconi 556, Cossor 32, Hacker Mayflower, all £25 each. P. Brown, 22 Raby Terr, Chilton, Ferry Hill, Co. Durham DL17 0JD.

**B40/C Naval comm. receiver**, 50s plus full manual, working, needs recon. any offers or exchange for smaller radio. Tel: Brighton (01273) 6911962.

**Butternut HF5B** 2-ele beam 10-20m (14-28MHz) inc. WARC bands, £100. Yaesu G-400 rotator controller and cable, £75. Buyer collects. Rich G4ZDG, Coventry. Tel: (01203) 602835 evenings.

**Collins 51-S1, 51ZY AN/PRC-10** complete with accessories.

**Wanted:** German WW2 sets SOE, SAS, WHY? Raenar Otterstad OZ8RO (Denmark), Hosterkobvej 10, DK-3460, Birkerød. Tel: 010-44 4281 5205.

**Collins 75S1** receiver, £225. Kenwood TS-820 boxed, £300. Icom 215 2m (144MHz), £65. Racal 1218 receiver large digital readout, £300. Yaesu FR101 receiver 2m (144MHz), 6m (50MHz), £175. Also shack clearance components. L. Huntley G4LW, Trowbridge, Wilts. Tel: (01225) 753166.

**FDK multi-II**, f.m., 2m (144MHz), 10W/1W 23 channels, auto scanning, four channels, mobile and fixed station accessories, manual, Bremi power supply and magnetic mount whip, bargain at, £85 the lot. Mike G4CUP, North Gloucestershire (01684) 592546.

**FR50**, £40. KW103, £25. FR400 with 2m/6m (144/50MHz), £70. Oscil: Cossor, £40 (1045K). Datong up-conv, £50. FT-401 (RX only), £70. TR2200 GX PP and charger, £50. Please collect. E. Ward G3JWC, Burton-on-Trent. Tel: (01283) 542164.

**FT-ONE general coverage all-mode transceiver**, memories extra filters c/w mic., manuals, excellent condition, £735. Tel: NW London 0181-455 8831 anytime.

**Hallcrafters HT37** transmitter and KW201 receiver, all in good working order, £110. Valves QQV03/20, £10 and QQV06/40, £22. QQV03-10, £7. G3AOY, Devon. Tel: (01803) 520065.

**Hewlett Packard u.h.f. signal generator**, model 616B, Sistron Doner counter/timer model 6153 (2). Offers. Tel: Dundee (01382) 817835.

**Howes DX20** receiver, 20, 40 & 80m (14, 7, 3.5MHz) bands plus all other boards, built-in notch filter, 'S' meter, professionally built, £75. Tel: Merseyside 0151-648 3031.

**Icom IC-R7000** all-mode communication receiver, excellent condition and working order, complete with both instruction and service manuals, box, IC-CK70 d.c. cable kit and mobile mount, £580. Peter, Bucks. Tel: (01494) 439217.

**Icom IC-R7000** receiver with professional mod for h.f. covers 0Hz-2GHz, manual and connectors, excellent condition, superb audio, £650 o.n.o. Buyer collects or pays carriage. Stevie GM0WRY, East Lothian, Scotland. Tel: (01875) 811477.

**Icom R-7000** (25-2GHz), direct entry, optional remote control with aerial, £600 o.n.o. Icom IC-707 h.f. all-band transceiver, only used for Morse practice, £600 o.n.o. A. L. Moore, Rainham, Kent. Tel: (01634) 261234.

**Icom R7000** v.h.f. u.h.f. receiver, stepless tuning no sproggies, clean receiver, 25MHz to 2000MHz all modes. May swap for R71E, £500 after recent overhaul. K. J. Faulkner, Sale Moor. Tel: 0161-905 3123.

**Info WW2** German Uboat wireless no KWEa, also New Zealand ZC1 MkII wireless set. Any help please, circuit diagrams, photos, etc. Mr Aldridge, Praise Camborne. Tel: (01209) 832154.

**Jaybeam Q6/2m** 2m (144MHz) quad antenna, £25. Jaybeam 44-4ele 70cm (430MHz) antenna, £25. Buyers collect. Star SG-10C printer suitable for C64 or C128, £35. Robert GM0CSN, Strathclyde. Tel: (01698) 286078 after 6pm.

**Junker Morse key**, £65. Broadcast receivers, Ferguson 356 3-band, £25. Murphy A362 3-band Bakelite, £35. Both working, valved, books, valve era 1930-70, s.a.e. for list. Code Master CWR610E c/w RTTY, £30. Ken G4UBP, Hastings. Tel: (01424) 444952 anytime.

**Kenwood TS-850SAT** as new, had little use with manuals and box, £850. J. Rabjohns G3YBG, Exeter. Tel: (01392) 74607.

**Kenwood R2000**, Timewave DSP-9 filter, Howes CTU30 a.t.u., Saisho radio cassette, Kent Morse trainer, G-QRP Morse tapes, extension speaker, headphones, manuals, leads, one lot, £350 buyer collects. John Goodson, Bognor Regis. Tel: (01243) 582723.

**Kenwood TS-450S** h.f. transceiver. Silent Key Sale G4BJU. Immaculate, hardly used due to illness, £675. Will deliver any reasonable distance. Jim G3KAF, Stockport. Tel: 0161-439 4952.

**Kenwood TS-830S MC25** mic, £500. Kenwood R820, £165. Both excellent condition. Redifon R551, £150. Good condition. Buyer collects. G. Sydenham, Suffolk. Tel: (01502) 715419.

**Kenwood TS-870** DSP, four months old, boxed, manuals, £1650, may take Icom IC-706 in part exchange. Also Icom IC-2WE dual-band hand-held, little used, boxed, charger s/mic, s/case, £260 o.n.o. Steve G4RVR, Chesterfield. Tel: (01246) 455323.

**Marconi** h.f. 0-30MHz spectrum analyser g.w.o. with trolley, 305lb weight, £175. J. Widdowson, Lincolnshire. Tel: (01205) 363170 evenings.

**Marconi signal generator** TF144, £35. Verner frequency counter, £70. Advance audio generator, £25. Transistor curve tracer (TEK), £125. 5in oscilloscope (TEK), £85. AVO valve characteristic meter, £125. Marconi modulation meter, £85. Michael Usher, Bedford. Tel: (01234) 354767.

**MFJ-986 differential T roller inductor tuner**, 3kW, v.g.c., almost new, £200. Tel: Milton Keynes (01908) 265546.

**Practical Wireless** back issues, 296 issues 1955-1981 including many complete years. Good condition. Sensible offers. Mrs Cryer, Swindon. Tel: (01793) 693527 evenings.

**Practical Wireless** editions dating from 1955 onwards - v.g.c. some with original pull-out projects - complete/enhance your collection - cash offers or swap good PC IBM or full h.f. RX/TX. Martin, Pembrokeshire. Tel: (01646) 602092.

**PRC2000 military h.f. manpack**, 4/20W, a.t.u., h/set, whip, charger, NiCads, keypad entry, workshop manual, general coverage TX/RX 300kHz to 30MHz, no tune 21-7.2MHz, MV1401 required, £250 o.v.n.o. Ken, Dorset. Tel: (01734) 225019 weekdays or (01258) 455507 weekends.

**Pye T30AM, W30AM** plus some newer ones, make a linear! Heavy but cheap, some manuals, too. Please 'phone for list. Tel: Inverness (01463) 731666.

**QST** 1932-79, 576 issues, £800. WW 1964-82, 228 issues, £300. Proc IRE (USA) Oct 1931-Dec 63. Sensible offers. Misc *RadCom*, *SWM*, *Amstrad*, *CPC* mags. David Hill G4JQM, Crawley. Tel: (01293) 882641.

**R-2000**, 0-30MHz, v.h.f. converter fitted, 118-173MHz, v.g.c., boxed with manual, £395. Colin, 112 Chichester Road, South Shields, Tyne Wear NE33 4HN.

**Racal RA17L**, excellent condition, half price, £100, will deliver Northampton area. This h.f. receiver covers 0-30MHz in 1MHz steps, provision for ext. v.f.o., ideal for s.w.l. Tel: Northampton (01604) 32662.

**Realistic PRO-2035**, 1000 channel wide band receiver, Tandy's best ever, as new, boxed, comes with six months warranty, two years extra warranty, current price, £329, bargain, only, £230 o.n.o. Tel: Glos (01684) 295770 anytime.

**SMC T3-170L** power and s.w.r. meter covers freq. 3.5-170MHz. Ideal for mobile or home. Good condition, £20. Craig G1OLT, Derbyshire. Tel: (0385) 228335 mobile or (01246) 410409.

**Telereader Comms.** decoder c.w., RTTY, ASCII, TOR, Morse simulator, video, printer port. Free mono monitor, chip on fascia but g.w.o. Only £70 o.n.o. Ian, Milton Keynes. Tel: (01908) 225532.

**Trio TR2300** 144MHz transceiver and 10W power amplifier with mic. charger, cover. £150 o.n.o. Also advance oscilloscope type OS15 with manual, £50 o.n.o. Buyer collect/pay carriage. G4BPW, Burton-on-Trent. Tel: (01283) 813395.

**TS-440S** auto a.t.u., boxed with manuals, £625 o.n.o. Tel: Kent (01304) 379580.

**Vibroplex original deluxe.** £90. MFJ 209 analyser, £86. MFJ 202B noise bridge, £45. BNOS p.s.u., series 'E' 10amp, £116. Diamond X50 dual antenna, £60. Icom IC3220E mobile, £332. All excellent condition at o.n.o. Phil, West Midlands. Tel: (01902) 843447.

**Yaesu 727** dual-band hand-held with new NiCad and charger, with extended coverage, £200 o.n.o. Two pairs of v.h.f. hand-helds, Midland 6ch, leather cases, £100. Communique p.m.r. with spare NiCads, charger, £100. John G4YMZ, Preston. Tel: (01772) 321637.

**Yaesu 757GX** transceiver with hand microphone and power lead in very good condition, £495, may take mobile 2m/70cm (144/430MHz) in p/x must be A1 condition. Base 2m/70cm also considered. Mr Smith, Anglesey, N. Wales. Tel: (01407) 710541.

**Yaesu FT-101ZD.** copy manual, £320. TR9000, box, manual, £260. Daiwa LA2065R linear (2m), £120. TR2200GX NiCads, charger, £85. Tokyo HX240 2m h.f. transverter, £120. Home-brew h.f. a.t.u., £40 plus others. Nick GOPBV, Worthing. Tel: (01903) 247607.

**Yaesu FT-200** trans-rec., mint condition, £190. Icom R70 ex. wk. order, £300. No offers. Trio 93-59DS, perfect, £90. Realistic, excellent condition, 160, £50. Tel: between Skipton and Keighley (01535) 635433.

**Yaesu FT-290** Mk1 2m (144MHz, m/m) portable, £200 o.n.o. FT-790 Mk1 70cm (430MHz m/m) portable, £225 o.n.o. Both with mic. carry case and manual. Kenwood TW4100E dual-band mobile (no mount), £275 o.n.o. Martin, Milton Keynes. Tel: (01908) 378944 evenings.

**Yaesu FT-290RII 2m** (144MHz) multi-mode, NiCads, matching Yaesu FL-2025 amplifier plus compatible RN Electronics 6m (50MHz) transverter, mint package, £595. Yaesu FT-840 h.f. transceiver, 500Hz c.w. filter, f.m. board, mint, £600. Rod G3TXA. Tel: N. London 0181-886 9974.

**Yaesu FT-707** h.f. transceiver, 100W a.m./s.s.b./c.w., no CB modsl, inc. WARC bands, although old, it's an ideal starter rig and it's in good condition, £275. John G0IUE, Wiltshire. Tel: (01225) 791645.

**Yaesu FT-747GX** f.m. fitted, boxed with instructions, microwave modules 10-2m transverter, 15amp p.s.u. 2m collinear vertical, complete, £500 o.n.o. or will split. Can be seen working. Andy S. Cave, Hull. Tel: (01430) 424855.

**Yaesu FT-757GX** h.f. all-mode transceiver, excellent condition, boxed, manual, mic., £435. Tel: Suffolk (01379) 783214.

**Yaesu FT-757GX**, nic, manual, c/w. SEM Tranzmatch, a.t.u., v.g.c., £370. Roger G0MDM, Watford, Herts. Tel: (01923) 675033.

**Yaesu FT-77** h.f.-TCVR 100W s.s.b./c.w./f.m. good condition (requires any external a.c.-p.s.u. 12V-20A or ok mobile), £295. Yaesu FC700 a.t.u. as new £95. Lowe HF-225 c.w. a.c.-p.s.u. and manual, mint, £295. Mr Shears G8KW, Sevenoaks. Tel: (01732) 883637.

**ZX Spectrum 48** + joystick, interface, printer, RTTY, TX/RX software, interface c/w TX/RX tape recorder, £75 post paid. Two Amstrad 1640 PCs, mono monitor, keyboard, mouse, printer, £80, exchange for scanner. John G3OAZ, Hants. Tel: (01256) 465126.

### Exchange

**Ekeo and Philco table radios,** Pye battery valve radio, Philips portable cassette recorder, Bush transistor radio, all or any for FRT-7700 a.t.u. or Perdio Park Lane/Piccadilly radios, L. Borthwick, 42 Eildon Road, Hawick, Scottish Borders, Scotland TD9 8ES.

**Kent Straight key** for any HK hi-mound similar. Allan G3JMO, Redcar. Tel: (01642) 486155.

**TH-79E c/w holders,** body desk, tele ant., manual, charger exchange for 10W transceiver, also wanted Easy Tune, Bill, Glasgow. Tel: 0141-562 4571.

**Yaesu FT-77 3.5-30MHz** multi-mode transceiver plus FT-700 a.t.u., all leads, microphone and manuals, boxed. In exchange for a dual-band v.h.f./u.h.f. multi-mode base station. Preferably Icom Trio/Kenwood. J. Davies-Bolton G4XPP, Country Durham. Tel: (01388) 747018 after 6pm or write direct to QTHR.

**ZEISS Jenaflex 35** camera lenses 50mm, 35mm (WA) 80/200 Tele Cokin filters. Holder Lens hoods F. gun manuals val, £250, m. cond FOR sim valve transmitter to work with a Yaesu FRG8800 receiver. N. McGeechan, Glasgow. Tel: (01698) 815565.

### Wanted

**4 FET SP115033 828,** 1 mechanical 455kHz BP filter 1000Hz, 1 crystal 455kHz BP filter 4000Hz, 1 RS232 interface card for Racal RA6790/GM receiver. Alberto Tosetti, via Pomba 24, 10123 Torino, Italy. Tel: 00 39 11 517 4404.

**16-pin interconnecting lead** for combined transmit receive operation for the Trio 599 RX and Trio 599 TX. Plus any help from past owners on setting-up and use. Ossie Gibson, Eastleigh, Hants. Tel: (01703) 267964 evenings or (01703) 613137 daytime.

**Any mod info for Yaesu FT-301S QRP** h.f. rig. Also Yaesu FT-75 h.f. mobile rig wanted. Pete

G1SFS, Bristol. Tel: (01179) 633306.

**Any valve receiver:** Trio 599 RX: 50R6 el. mono beam: FL50B TX: good h.f. linear: AR88 or RA17 receiver: or EC10: top band TX: antenna analyser. Please write, carriage paid. Ed Kelly E15DR, Cregganavar, Breaffy, Castlebar, County Mayo, Eire.

**Eddystone 770R Mk1** or 770R MkII, also Cossor changing oscillator or similar. E. F. C. Owen, 28 Chartfield Road, Reigate, Surrey RH2 7JZ.

**G2DAF G3PDM G4TDC** ultimate receivers or never completed projects, also panoramic adapter and sideband unit for use with RA17 series receiver. Tony, Worcester. Tel: (01905) 641759.

**Grundig 650** wanted for spares. Mike, 63 Williams Close, Hanslope, Bucks MK19 7BP.

**Heathkit IIW8** transceiver. Colour plastic screen for B&W TV 1082/83. Douglas Byrne G3KPO, Isle of Wight. Tel: (01983) 567665.

**Heathkit SB200** or Yaesu FL 2100Z linear amp, must be in good condition, also NAG linear for 2m (144MHz). Tel: Cleveland (01287) 653708 evenings or weekends.

**HF or SW receiver.** must cover amateur bands. Will pay up to £30. Also info on Roberts R404 receiver if possible. Nigel, West Runton, Norfolk. Tel: (01263) 837074.

**Instruction manual** (or copy) for standard dual-bander model C500E, your price and expenses. Also any extras, i.e. charger or battery pack. Mr L. Russell, Rochford, Essex. Tel: (01702) 546995.

**Manual or circuit diagram** for REF 6625-99-972-6157 crystal calibrator frequency CT432. Please contact Bill if you can help. Tel: Surrey (01737) 373426.

**Military radio sets** RXs, TXs, etc., British, USA, USSR.

equipment bought or swapped, eg. have TCs RX, R109, 62 Set, PCR2 for swap. Also military hardware wanted, army RAF, etc. Ben, Worcester. Tel/FAX: (01562) 743253.

**Old fashioned DP DT aerial switch** on porcelain base, spdt would help. Will collect within reasonable distance. Tel: Bournemouth (01202) 871903.

**R1155 Model N or L** (includes 1.5-3.0MHz band). Condition overhaulable and appearance OK. Top price offered. Collection possible. Big reward for Jones Plug retaining strips for T1154, R1155. P. Beckley, Newport. Tel: (01633) 853906 evenings.

**RX, 1.8-30MHz.** valved OK, late call book, head 'phones, speaker, ready to go! All wanted, deliver if possible? Tel: Surrey 0181-979 1956.

**Unemployed amateur** wants FT-101 or similar h.f. radio. Reasonable price paid. Jeff MOAEL, Merseyside. Tel: (01744) 819396.

**VFO 230** external v.L.o., must be in perfect working order. Tel: Wiltshire (01249) 653548.

**Yaesu FT-77S** 10W version h.f. transceiver, must be in very good condition and g.w.o. (with f.m. board if possible). Tel: Orpington (01689) 890227 after 6pm.

## YOUR ATTENTION PLEASE

Some adverts are being delayed because we cannot decipher the wording. Please take care writing your advert and use terms and abbreviations that are standard. Finally, don't forget to check your telephone number is correct.

Editor

## BARGAIN BASEMENT ORDER FORM

Please insert this advertisement in the next available issue of *Practical Wireless*.

PLEASE WRITE IN BLOCK CAPS **FOR SALE**  **WANTED**  **EXCHANGE**

Name .....

Address .....

Telephone Number .....

### CONTACT DETAILS FOR ADVERT.

Please only write in the contact details you wish to be published with your advert.

ie. do you want your name & address, or just your telephone number?

**Your advert, you decide!**

<h1 style="font-size: 4em; opacity: 0.5;">FOR SALE/ WANTED/ EXCHANGE</h1> <p>(30)</p>
---

(12)

# Classified Ads

To advertise on this page see booking form below.

Whilst prices of goods shown in advertisements are correct at the time of going to press, readers are advised to check both prices and availability of goods with the advertiser before ordering from non-current issues of the magazine.

## Wanted

**WANTED FOR CASH** Valve or solid state communication receivers Pre-1980. Preferably working and in good condition. Non working sets considered also domestic valve radios. Items of Government surplus wireless equipment and obsolete test equipment. Pre-1965 wireless and audio components and accessories. Pre-1975 wireless and TV books and magazines. Also, most valves wanted for cash. Must be unused and boxed. CBS, 157 Dickson Road, Blackpool, FY1 2EU. Tel: (01253) 751858 or Fax: (01253) 302979.

## For Sale

**TECHNICAL MANUALS**, AR88, CR100, R210, HR0. £5 each. Circuits £1.50. Hundreds available. SAE list. Bentley, 27 De Vere Gardens, Ilford, Essex IG1 3EB. Tel: 0181-554 6631.

**JAPANESE GAAS-FET**, RF power module, microwave TR's and devices for communication and industrial use. TYOSHIHARA OSAKA 564, JAPAN, Cable: TYOSHIHARA SUITA. FAX: 816-338 3381.

**SELLING BUYING P/EX** G3RCQ. Cash waiting, large used equipment stocks changing daily. Tel: 01708 374043 (Romford).

**RADIO BOOKS**. New and previously enjoyed. S.A.E. for lists. Old Time Supplies, PO Box 209, Banbury, Oxon OX16 7GR.

**SILENT KEY SALE**. TS530S, mike, manual, boxed. Enquiries Dave, G0IQI, Worthing. Tel: 01903 236780.

## Holidays

**NORTH WALES HOLIDAYS** - Caravan - bunkhouse - camping. Elevated rural site, two miles from beach, use of shack and antennas, open all year. Tynrhos, Mynytho, Pwllheli. Tel: 01758 740712.

## Valves

**VALVES GALORE** Most valves available from stock. Otherwise obtained quickly. Please send SAE stating requirements or telephone. **VALVE & ELECTRONIC SUPPLIES** Chevet Books, 157 Dickson Road, Blackpool FY1 2EU. Tel: (01253) 751858 or Fax: (01253) 302979.

**VALVES WANTED** for cash: KT88, £48; PX4, PX25 £50; DA100 £90; EL34, £10; EL37, £9; CV4004, £5; ECC83 £3. Valves must be Mullard/GEC, West European to achieve the price. Ask for our free wanted list. Prompt and courteous service. Visitors by appointment only (we are a very busy Export Warehouse). Billington Export Ltd. Billingshurst, West Sussex RH14 9EZ. Tel: (01403) 784961. Fax: (01403) 783519.

**VALVES- OVER 50000 STOCKED** Ham, Vintage, Military, Audio. SAE for FREE list to: Wilson Valves, (Jim Fish G4MH), 28 Banks Ave., Golcar, Huddersfield, West Yorks HD7 4LZ. Tel: 01484 654650. Fax: 01484 655699. Visa etc. Fast & personal service.

## TOP PRICES PAID

for all your valves, tubes, semi-conductors and ICs.

**Langrex Supplies Ltd.,**  
1 Mayo Road, Croydon,  
Surrey CR0 2QP.

TEL: 0181-684 1166. FAX: 0181-684 3056.

## Educational

**HEATHKIT EDUCATIONAL PRODUCTS UK DISTRIBUTOR/SPARES AND SERVICE CENTRE**. Cedar Electronics. 12 Isbourne Way, Broadway Road, Winchcombe, Cheltenham. Glos. GL54 5NS. Tel: (01242) 602402.

**CITY & GUILDS RADIO AMATEURS EXAM**. Pass your exam the easy way with an RRC home study course. For details write or phone THE RAPID RESULTS COLLEGE, Dept. JX400, Tuition House, London SW19 4DS. Tel: 0181-947 2211.

## Computer Software & Hardware

**JVFAX/SSTV, HAMCOMM, PktMon.** 9FD/25FD Tx/Rx Interface, programs, manuals, pictures £28.50. SASE for leaflets. Peter Lockwood G8SLB, 36 Davington Road, Dagenham RM8 2LR. Tel/Fax: 0181-595 0823.

## Shareware

## PC ELECTRONIC AND TECHNICAL PROGRAMS

LOW COST SPECIALIST LIBRARY  
GOOD QUALITY PROGRAMS THAT WORK

DESCRIPTIVE CATALOGUE AVAILABLE PRICED AT **£2.50**

Comes with £2.00 off money voucher to place against your first order

Phone/Fax for your catalogue from:  
**PDSI, Winscombe House, Beacon Road,**  
Crowborough, Sussex TN6 1UL  
Tel: 01892 663298 Fax: 01892 667473

## Miscellaneous

**VALVE ENTHUSIASTS:** Capacitors and other parts At attractive prices! Ring for free list. Geoff Davies (Radio), Tel: (01788) 574774.

**VALVE RADIOS** radiograms, amps, obsolete spares. Also repairs. Tel: 01689 898291 anytime. 91 High Street, St Mary Cray, Orpington, Kent. Open Friday, Saturday 10-4.

**VIDEO TAPE CONVERSIONS** to and from all modes NTSC, SECAM, PAL(M) PAL(N) also VIDEO 8 NTSC. Digital processing. Fast and economical service. Also cine conversions. Phone G4WMP 01932 846139.

## ORDER FORM FOR CLASSIFIED ADS PLEASE WRITE IN BLOCK CAPITALS

The prepaid rate for classified advertisements is 42 pence per word (minimum 12 words), box number 70p extra. Semi-display setting £13.90 per single column centimetre (minimum 2.5cm). Please add 17.5% VAT to the total. All cheques, postal orders, etc., to be made payable to the PW Publishing. Treasury notes should always be sent by registered post. Advertisements, together with remittance should be sent to the Classified Advertisement Dept, Practical Wireless, Arrowsmith Court, Station Approach, Broadstone, Dorset BH18 8PW. Tel: (01202) 659920, Fax: (01202) 659950

Please insert this advertisement in the ..... issue of Practical Wireless (if you do not specify an issue we will insert it in the next available issue of PW) for ..... insertion/s. I enclose Cheque/P.O. for £..... (42p per word, 12 minimum, please add 17.5% VAT to total).

Name: .....

Address: .....

Telephone No.: .....

Box Number @ 70p: Tick if appropriate.

Category heading: .....

**mutek limited**

0115 9729467

**DUAL BAND TRANSVERTERS**

for 6m and 4m are now available. Features low noise front ends for each band and a 20W dual band P.A. Receiver Noise figure is less than 2.5dB, high input intercept for strong signal conditions. Output variable 2 to 20W by front panel control. I.F. for either 2m or 10m available.

Visit our WEB PAGE at <http://ourworld.compuserve.com/homepages/mutek>  
PO Box 24, Long Eaton, Nottingham NG10 4NQ

**FAIRHAVEN**  
**RD500**

A NEW KIND OF RADIO RECEIVER

**SERVICE MANUALS  
& Technical Books**

Available for most equipment, any make, age or model.  
Technical Book and Manual compilations now on CD-ROM.  
Return the coupon for your FREE catalogue

**MAURITRON TECHNICALS SERVICES (PW)**

8 Cherry Tree Road, Chinnor, Oxon OX9 4QY.

Tel: 01844 351694. Fax: 01844 352554.

Please forward your latest catalogue for which I enclose 2 x 1st class stamps or  
£4.11 for the complete Service Manuals Index on PC disc plus catalogue.

NAME .....

ADDRESS .....

POSTCODE .....

Photocopy this coupon if you do not wish to cut the magazine

**Receivers**

**B.F.O. KITS** Resolves single side-band on almost any radio, £16.49. H. CORRIGAN, 7 York Street, Ayr KA8 8AR.

**DISCLAIMER**

Some of the products offered for sale in advertisements in this magazine may have been obtained from abroad or from unauthorised sources. *Practical Wireless* advises readers contemplating mail order to enquire whether the products are suitable for use in the UK and have full after-sales back-up available.

The publishers of *Practical Wireless* wish to point out that it is the responsibility of readers to ascertain the legality or otherwise of items offered for sale by advertisers in this magazine.

**IS YOUR CLUB PLANNING OR  
HOLDING AN EVENT OR RALLY?**



(01202)

**659920**

**TO FIND OUT ABOUT OUR SPECIAL  
ADVERTISING RATES FOR CLUBS**

**PW PCB  
SERVICE**

**PRACTICAL WIRELESS  
PCB SERVICE**

Printed Circuit Boards for *Practical Wireless* constructional projects are available from the Practical Wireless PCB Service.

The boards are made in 1.5mm glass-fibre and are fully tinned and drilled.

When ordering PCB's please state the article title, magazine cover date and the board number.

Mark your envelope **Practical Wireless PCB Service.**

Cheques to be crossed and made payable to: **Badger Boards.**

Please print your full name and address in block capitals and do not enclose any other *Practical Wireless* correspondence with your order.

*Please allow 28 days for delivery.*

Send orders and remittances to:

**Badger Boards, 87 Blackberry Lane, Four Oaks,  
Sutton Coldfield B74 4JF.**

**Telephone 0956 374918**

Mon-Fri 9am - 5.30pm

# Order Form

FOR ALL MAIL ORDER PURCHASES  
IN PRACTICAL WIRELESS

## SUBSCRIPTION RATES

### PRACTICAL WIRELESS – 1 YEAR

- £25.00 (UK)  £30.00 (Europe 1st class)
- £32 (Rest of World Airmailer)  £37 (Rest of World Airmail)

### SPECIAL JOINT SUBSCRIPTION WITH SHORT WAVE MAGAZINE – 1 YEAR

- £45 (UK)  £54 (Europe 1st class)  £58 (Rest of World Airmailer)
- £67 (Rest of World Airmail)

Please start my subscription with the ..... issue.

### BINDERS

- Please send me ..... PW Binder(s) @ £5.50 each
- £ .....

### Postal Charges:

£1 for one, £2 for two or more (UK). £2 per binder (overseas surface).

### BOOKS Please send me the following book(s)

..... £ .....

..... £ .....

..... £ .....

..... £ .....

..... £ .....

### Postal Charges:

£1 for one, £2 for two or more (UK).

£2 per book or £10 for five books or more (overseas surface).

### NEW FASTER NEXT DAY SERVICE (UK MAINLAND ONLY)

£4 per parcel (orders must be placed by 12 noon)

GRAND TOTAL ..... £ .....

Now fill in your name and address

**CREDIT CARD ORDERS TAKEN ON (01202) 659930**  
between the hours of 9.00am - 5.00pm. Outside these hours your order will be recorded on an answering machine.

### FAX ORDERS TAKEN ON (01202) 659950

Or please fill in the details ticking the relevant boxes, a photocopy will be acceptable to save you cutting your beloved copy!

To: PW Publishing Ltd., FREPOST, Arrowsmith Court,  
Station Approach, Broadstone, Dorset BH18 8PW

## PAYMENT DETAILS

Name .....

Address .....

Postcode .....

Telephone No. ....

I enclose cheque/PO (Payable to PW Publishing Ltd.) £ .....

\$ .....

or

Charge to my Access/Visa Card the sum of £ .....

\$ .....

Card No. 

--	--	--	--	--	--	--	--	--	--	--	--	--	--	--	--	--	--	--	--

Valid from ..... to .....

Signature.....

Telephone No.....

Orders are normally despatched by return of post but please allow 28 days for delivery. Prices correct at time of going to press. Please note: all payments must be made in Sterling.

**CREDIT CARD ORDERS TAKEN ON (01202) 659930**

**FAX ORDERS TAKEN ON (01202) 659950**

**STAR BUY!**

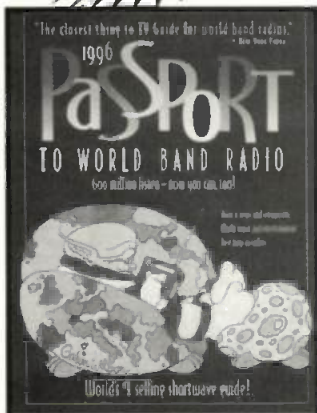

## Passport To World Band Radio at a Special Price!

If you thinking of exploring the fascinating world of short wave listening or if you've already discovered the pleasures listening holds then *Passport to World Band Radio 1996* is one book that **should** be in your collection. It's billed as the "World's No1 selling shortwave guide" and that's why we've picked it as this month's Star Buy.

*Passport to World Band Radio* gives you all the information you need to explore and enjoy the world of broadcast band listening. Contained within its 528 pages are features on international radio stations, receiver reviews and advice, together with details of the times and languages of broadcast stations listed by frequency. The 'blue pages' provide you with a channel by channel guide to the world band broadcast schedules.

Normal selling price of *Passport to World Band Radio* is £14.50 plus P&P, however, this month *Practical Wireless* readers can get their copies for just **£12.50 including P&P (UK)** or **£14.50 including P&P (overseas)**. So don't delay make sure you place your order today!

To order your copy of *Passport to World Band Radio 1996* either use the form above or telephone **Shelagh or Michael** on the **Credit Card Hotline** on (01202) 659930 and quote **PWSB8**. Offer open until **9 August 1996**.



# BOOK SERVICE

The books listed have been selected as being of special interest to our readers. They are supplied direct to your door. Many titles are overseas in origin.



TO ORDER: PLEASE USE THE ORDER FORM ON PAGE 62 OR TELEPHONE THE CREDIT CARD HOTLINE ON (01202) 659930 (24 HOURS)

## LISTENING GUIDES

### Airband

#### AIR BAND RADIO HANDBOOK 5th Edition

David J. Smith

Air band radio listening enables you to listen-in on the conversations between aircraft and those on the ground who control them, and is an increasingly popular and fascinating hobby. A new chapter on military air band has been added. The author, an air traffic controller, explains more about this listening hobby. 192 pages. £8.99

#### AIR & METEO CODE MANUAL 14th Edition

Joerg Klingenfuss

Detailed descriptions of the World Meteorological Organisation Global Telecommunication System operating FAX and RTTY meteo stations, and its message format with decoding examples. Also detailed description of the Aeronautical Fixed Telecommunication Network amongst others. 358 pages. £20.00

#### AIRWAVES 96

The Complete HF/MHF/JHF Aviation Frequency Directory

Much of the more obscure (especially military) information is made accessible in this volume. Not only are facilities/aircraft listed, giving their frequencies, but also there are reverse lists - when the frequency is known, the allocated user can be found.

Airways sectors are listed so much more clearly than in the Supplements. The main transponder code groups are included. In fact, the book covers all the way from h.t. up to u.h.f. 100 pages. £8.95

#### AIRWAVES EUROPE

This spirally bound book is published in a similar format to *Airwaves 95* and contains over 5000 aviation frequencies. There are v.h.f./u.h.f. civil and military airband frequencies given for 38 countries and their dependencies in east and west Europe. A must for airband enthusiasts both in the UK and Europe. 124 pages. £9.50

#### CALLSIGN 96

The Civil & Military Aviation Callsign Directory

Intended for the aircraft and radio enthusiast to use as a stand alone reference, or as a partner to *Airwaves 95*. Over 5300 military and 3000 civil callsigns are covered in detail. 144 pages. £8.50

#### FLIGHT ROUTINGS 1996

Compiled by T.T. & S.J. Williams

This guide was produced with the sole aim of assisting airband listeners to quickly find details of a flight, once they have identified an aircraft's callsign. Identifies the flights of airlines, schedule, charter, cargo and mail, to and from the UK and Eire and overflights between Europe and America. 140 pages. £5.60

#### HIGH IN THE SKY

Davis Barker & McKenzie

This new edition comprises ten sections. The first seven sections are an introduction of radios, antenna and radio communications, information about airways, sections covering v.h.f. and h.f. aeronautical communications, and a brief look at ACARS. The majority of the book is taken-up by section eight, which lists all known Selcalls in three different sequences (by airline/operator, by Selcall and by registration). The 9th section is devoted to Selcalls used by executive jets, these are separate, since these Selcalls are not always fixed. Mostly re-written this volume contains the all-important frequency listings for the aeronautical networks, airlines, the military and the commercial networks. 166 pages. £6.95

#### INTERNATIONAL AIR BAND RADIO HANDBOOK

David J. Smith

Described as the guide to world-wide air traffic control this companion volume to the *Air Band Radio Handbook* explains how air traffic is regulated internationally giving details of each country's system together with major airport radio frequencies. Related subjects include navigational aids, radio phraseology, flight plans and emergency procedures to name a few. This comprehensive book provides a insight into the complex world of air traffic control. 192 pages. £9.99

#### THE AIRBAND JARGON BOOK

Ron Swinburne

Designed to give the newcomer some guidance on what to expect from Airband and how to extract the most from listening to it.

This guide is essential reading for those not involved in the aviation industry. It gives a valuable insight to many aspects of aviation. Explained are the principles of Airband reception, aircraft instrumentation, radio services, weather navigation, etc. and air traffic control, to list but a few. Read this book and you could well be hooked. 72 pages. £6.95

#### UNDERSTANDING ACARS 3rd Edition

Aircraft Communications Addressing and Reporting System

Ed Flynn

Here is the information you need to understand and decode the Aircraft Communications Addressing and Reporting System, otherwise known as ACARS. Deals with the equipment needed as well as message format and type. 80 pages. £9.95

#### WORLDWIDE AERONAUTICAL COMMUNICATIONS FREQUENCY DIRECTORY 2nd Edition

Robert E. Evans

This book covers aeronautical radio communications, voice and digital, within the range of h.f. and v.h.f./u.h.f. frequency bands. Commercial, military and para-

military operations are included. Divided into logical sections, it provides useful information and frequencies on almost anything and everything airband. 260 pages. £19.95

#### WORLDWIDE AERONAUTICAL HF RADIO HANDBOOK

Maryn R. Cooke

This book lists high frequencies used by aircraft and aeronautical ground stations. It's divided into sections, Military, Civil, etc. and is designed for use by those who have previous little knowledge of h.f. communications as well as those who are already 'hooked'. 124 pages. £6.95

### Broadcast

#### A GUIDE TO THE WORLD'S RADIO STATIONS BP355

Peter Shore

As in 'Broadcast Round-up', his column in *PW*, Peter Shore has laid this book out in world areas, providing the listener with a reference work designed to guide around the ever-more complex radio bands. There are sections covering English language transmissions, programmes for DXers and S.W.L.s. Along with sections on European medium wave and UK f.m. stations. 266 pages. £5.95

#### POP WENT THE PIRATES

Keith Skues

A very comprehensive history of Pirate Radio. Thanks to *Pop Went The Pirates* the whole era of people seeking to provide a popular alternative radio service, under quite considerable opposition, will be remembered. I don't suppose we will ever see or hear the like of it again. £15.95

#### RADIO LISTENERS GUIDE 1996

Clive Woodyear

This is the eighth edition of this radio listener's guide. Simple-to-use maps and charts show the frequencies for radio stations in the UK. Organised so that the various station types are listed separately, the maps are useful for the travelling listener. Articles included in the guide discuss v.h.f. aerials, RDS, the Radio Authority and developments from Blaupunkt. 81 pages. £3.95

### Datamodes

#### GUIDE TO FAX RADIO STATIONS

15th Edition

Joerg Klingenfuss

The new edition of this super reference book covers the world's facsimile stations, their frequencies and methods of working. There is a section covering the equipment needed to receive FAX over the radio. To give you an idea of what is available there are many pages of off-air received FAX pictures. 392 pages. £20.00

#### GUIDE TO UTILITY STATIONS

14th Edition

Joerg Klingenfuss

This book covers the complete short wave range from 3 to 30MHz together with the adjacent frequency bands from 0 to 150kHz and from 1.6 to 3MHz. It includes details on all types of utility stations including FAX and RTTY. There are 19549 entries in the frequency list and 3590 in the alphabetical callsign list plus press services and meteorological stations. Included are RTTY & FAX press and meteo schedules. There are 11800 changes since the 10th edition. 604 pages. £35.00

#### POCKET GUIDE TO RTTY AND FAX STATIONS

Bill Laver

A handy reference book listing RTTY and FAX stations, together with modes and other essential information. The listing is in ascending frequency order, from 1.6 to 26.8MHz. 57 pages. £3.95

#### RADIOTELETYPE CODE MANUAL 13th Edition

Joerg Klingenfuss

This book gives detailed descriptions of the characteristics of telegraph transmission on short waves, with all commercial modulation types including voice frequency telegraphy and comprehensive information on all RTTY systems and c.w. alphabets. 96 pages. £14.00

### DXTV

#### DXTV FOR BEGINNERS

Simon Hamer

This A5 sized publication provides a useful introduction to what is described as a rewarding and captivating hobby. Continued within its pages are sections on 'The Early Years of Television', 'TV Broadcast Bands', 'Antennas', 'DX Receiving Systems' and much more. 31 pages. £3.95

#### GUIDE TO DX-TV

Keith Hamer & Garry Smith

This publication aims to generate ideas to enable newcomers and established DXers to improve their existing receiving systems. It is designed to complement *DXTV For Beginners*. 36 pages. £3.95

## PW BOOK SERVICE



(01202) 659930 (24 HOURS)

Internet orders: [bookstore@pwpub.demon.co.uk](mailto:bookstore@pwpub.demon.co.uk)

### Frequency Guides

#### 1996 Super Frequency List

Joerg Klingenfuss

This new CD-ROM has been designed for use with IBM PCs or clones running Windows 3.1. The CD-ROM comes complete with its own viewing software and includes 14000 frequencies that have been extracted from the Klingenfuss *Guide to Utility Stations*. This frequency listing is supplemented by 1000 abbreviations and 1200 formerly active frequencies. As this list was last updated in January '95 it's well up-to-date. £25.00

#### FERRELL'S CONFIDENTIAL FREQUENCY LIST 9th Edition

Compiled by Geoff Halligey

Spirally bound, this easy-to-use reference book covers 1.6 - 28MHz in great depth, all modes and utility services, with new reverse frequency listing showing every known frequency against each callsign, who's using what frequency and mode, what's that callsign? 544 pages. £17.95

#### PASSPORT TO WORLD BAND RADIO 1996

This book gives you the information to explore and enjoy the world of broadcast band listening. It includes features on different international radio stations, receiver reviews and advice as well as the hours and language of broadcast stations by frequency. The 'blue pages' provide a channel-to-channel guide to world band schedules. 528 pages. £14.50

#### UK SCANNING DIRECTORY 5th Edition

This spiral bound book lists over 42500 UK spot frequencies from 25MHz to 1.6GHz. Articles on scanning in the UK. 540 pages. £18.50

**WORLD RADIO TV HANDBOOK 1996 (50th Anniversary Issue)**  
Country-by-country listing of l.w., m.w. & s.w. broadcast and TV stations. Receiver test reports, English language broadcasts. The s.w.'s 'bible'. 608 pages. £17.95

### General

#### EAVESDROPPING ON THE BRITISH MILITARY

Michael Cannon

For the very first time a book has been published showing how to monitor British Military communications. All you need is a short wave receiver, lots of time and patience, and this secret world will open up to you, providing many hours of enjoyment. Also included is the largest British military callsign list ever to be published. 166 pages. £17.50

#### THE COMPLETE SHORT WAVE LISTENER'S HANDBOOK 4th Edition

Hank Bennett, Harry Helms & David Hardy

This book is a comprehensive guide to the basics of short wave listening. Everything you need to get started as an s.w.l. is explained in a clear and easily understood manner. Receiver's antennas, frequencies, propagation, Q-codes, etc. are all covered. 321 pages. £18.95

#### SHORT WAVE COMMUNICATIONS

Peter Rouse GU1DKD

Covers a very wide area and so provides an ideal introduction to the hobby of radio comms. International frequency listings for aviation, marina, military, space launches, search and rescue, etc. Chapters on basic radio propagation, how to work your radio and what the controls do, antennas and band plans. 187 pages. £4.50

### Marine

#### MARINE SSB OPERATION

J. Michael Gale

How do you stay in touch when you sail off over the horizon and into the blue? What you need is a single sideband radio, a marine s.s.b. This book explains how the system works, how to choose and install your set and how to get the best out of it. There is also a chapter on amateur radio with the emphasis on the increasingly important maritime mobile nets. 96 pages. £11.95

#### MARINE VHF OPERATION

J. Michael Gale

A v.h.f. radiotelephone is essential equipment for any sea-going boat, but what can you do with it? Who can you call, and how do you make contact? Which channel do you use, and why? What is the procedure for calling another boat, calling the family through the telephone system, or making a distress call? This book will tell you. 48 pages. £7.95

#### SHORTWAVE MARITIME COMMUNICATIONS

B. E. Richardson

Laid out with both the beginner and well-seasoned maritime radio enthusiast in mind this book provides the most accurate and detailed information in an easy-to-use format. In addition to the two substantial frequency lists provided there is information on all the various communication modes used by ships today. 195 pages. £16.50.

#### SHIP TO SHORE RADIO FREQUENCIES

Ken Davies

This A5 pocket-sized book provides all those with a sailing interest with a detailed listing of all the radio frequencies which they are likely to come across when sailing around Britain's shores. It is designed to be quick and easy-to-use and is therefore divided geographically into 10 sectors resulting in a clear concise format. 95 pages. £5.99







# Focus on the LATEST in Amateur Radio *in* **NEXT MONTH'S**

For the LATEST in Amateur Radio don't miss the September issue of *Practical Wireless* - IT'S THE VITAL COMPONENT!

## SPECIAL FEATURE!

David Butler G4ASR introduces you to I.F. propagation & techniques.

## BUILD!

The PW Rugby Transmitter Part 1 - designed by Dave Howes.

A Collapsible Super Loop Quad.

## FEATURES!

Trials & Tribulations of Taking the RAE.

RAE Course Round-Up - PW's guide to where you can take the RAE.

High Frequency f.m. DX.

**+** ALL THAT'S POSITIVE IN YOUR HOBBY!

Not forgetting our popular regular features 'VHF Report', 'Antenna Workshop', 'HF Far & Wide' together with your own personal favourites!

\*contents subject to change.

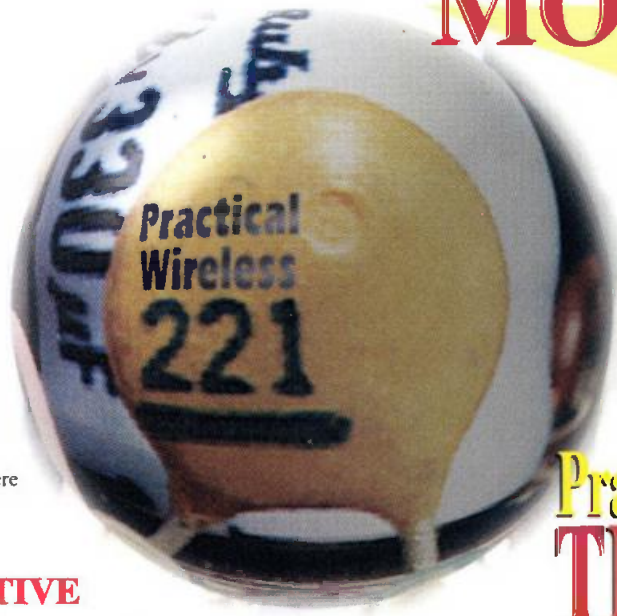

**BRAIN STORMIN'**

**BLOOD PUMPIN'**

**SOLDER DIPPIN'**

**RIG REVIEWIN'**

**WATT BUSTIN'**

**FUSE BLOWIN'**

**Practical Wireless - THE VITAL COMPONENT!**

**SEPTEMBER ISSUE ON SALE 8 AUGUST 1996 - DON'T MISS IT!**

short wave magazine

## THE FUTURE'S AIRBORNE

**This Month - July - Airband Special**  
**REVIEWED - WELTZ WS1000E** Hand held wide band scanner. **MAKING CONNECTIONS Part 2** - an in depth look at feeding antennas. **SWM 001 SQUAWK 2641 Mode C** - taking a look at Secondary Radar. **First Radio Over The Atlantic.** **The Receiver and The Computer - Royal Wedding or Messy Compromise?**

**Next Month - August Broadcast Special**

**Plus Regular Columns covering**  
 -Utility and Data  
 -Modes Listening,  
 -WXSATs, Scanning,  
 -Broadcast News-and  
 -Logs and much more.....

**On Sale Now!**  
\* Contents subject to change.

Listen to 73kHz  
with a  
VLF Converter  
from Datong Electronics

The new Amateur Radio frequency allocation covering 71.6 to 74.4kHz is going to be a challenge to all those people who enjoy building their own equipment. However, if you don't want to reinvent the wheel, why not take a look at Datong's VLF Converter.

With a frequency coverage of 0 to 500kHz the VLF Converter will not only allow you to listen to the new Amateur Band but everything else that happens at these low frequencies. The VLF signal is converted up to 28MHz so that you can listen on any Short Wave Receiver. Its high sensitivity means you only require a short antenna (thank goodness).

Built into a diecast aluminium box with two PL259 connectors. The VLF Converter fits between the antenna and the receiver input. The converter can be supplied by an internal 9 Volt battery or an external 5 to 16 Volt supply. The On/Off switch not only saves power, but switches the antenna directly to the receiver so that you don't have to remove the converter when it is turned off.

At a cost of £39.95 (inc. VAT & Postage) the VLF Converter is such good value for money that it will probably cost more to build a unit of the same quality.

For Converters, Filters and Active Antennas call now for a Catalogue.

**D**atong Electronics Ltd

Clayton Wood Close,  
West Park, Leeds.  
LS16 6QE  
Tel: 0113-274-4822  
Fax: 0113-274-2872

# YOUR LOCAL DEALERS

**SURREY**  
**Chris Rees**  
**G3TUX**  
The QRP Component Company  
PO Box 88 Haslemere Surrey GU27 2RF  
Tel: (01428) 641771  
Fax: (01428) 661794  
*Stockists of:*  
✓ Howes Kits ✓ Jones Keys  
✓ Vargarda Aerials  
✓ Bits n'pieces! © Lists

**MID GLAMORGAN**  
**SANDPIPER COMMUNICATIONS**  
Unit 5, Enterprise House, Cwmbach Industrial Estate, Aberdare, Mid Glamorgan CF44 0AE  
Tel: (01685) 870425  
Fax: (01685) 876104  
A full range of transmitting & receiving antennas available for the amateur commercial market.

**LONDON**  
**MARTIN LYNCH**  
G4HKS  
For all your amateur radio needs  
140-142 Northfield Avenue  
Ealing London W13 9SB  
Tel: **0181-566 1120**  
Fax: **0181-566 1207**

**SCOTLAND**  
**JAYCEE ELECTRONICS LTD**  
20 Woodside Way, Glenrothes, Fife KY7 5DF  
Tel: (01592) 756962 (Day or Night)  
Fax No. (01592) 610451  
Open: Tues-Fri 9-5; Sat 9-4  
KENWOOD, YAESU & ICOM APPROVED DEALERS  
*A good stock of new and secondhand equipment always in stock*

**KENT**  
**KANGA PRODUCTS**  
*For QRP kits*  
A variety of kits for RECEIVERS, TRANSMITTERS & TEST GEAR.  
*Send an A5 SAE for a free copy of our catalogue*  
Seaview House, Crete Road East  
Folkestone, CT18 7EG  
Tel/Fax (01303) 891106 0900-1900 Only

**SCOTLAND**  
**TENNAMAST**  
SCOTLAND  
Masts from 25ft - 40ft  
Adapt-A-Mast  
**(01505) 503824**  
111 Main Road, Beth, Ayrshire, KA15 2HT

**DORSET**  
**THE SHORTWAVE SHOP**  
Novice/C.B./Amateur/SWL Equipment.  
*Full range secondhand equipment always available.*  
18 Fairmile Road, Christchurch,  
Dorset BH23 2LJ  
Tel/Fax: 01202 490099

**AVON/SOMERSET**  
**QSL COMMUNICATIONS**  
We stock all makes of equipment for the Amateur and Listener.  
Part Exchange Welcome  
Unit 6 Worle Industrial Centre, Coker Road,  
Worle, Weston-Super-Mare BS22 0BX  
Tel/Fax: (01934) 512757

**SOUTHAMPTON**  
**SMC Ltd**  
Main Dealer for: Yaesu, Kenwood, Icom AOR & Cushcraft  
SM House, School Close, Chandlers Ford Industrial Estate, Eastleigh, Hampshire SO5 3BY  
Tel: (01703) 255111  
Fax: (01703) 263507

**LONDON**  
**HAYDON COMMUNICATIONS**  
*For all your amateur radio equipment.*  
NEW, SECONDHAND, EX-DEMO  
132 High St., Edgware, Middx HA8 7EL  
Tel: 0181-951 5781/2  
Fax: 0181-951 5782  
Open Mon-Fri 10-6, Sat 10-5  
Outside office hours 0589 318777

**NORTHWEST**  
**ARC Ltd.**  
*Everything for the radio amateur under one roof!*  
38 Bridge Street, Earlestown, Newton-le-Willows, Merseyside WA12 9BA  
Tel: 01925 229881  
Fax: 01925 229882

**ESSEX**  
**Coastal Communications**  
*Meeting your demands*  
FOR ALL YOUR AMATEUR RADIO NEEDS.  
19 Cambridge Road  
Clacton-on-Sea, Essex CO15 3QJ  
Tel: 01255 474292. Fax: 01255 476524  
Mon-Sat 9am-5pm; Wed 9am-2pm.

## Index to Advertisers

A H Supplies .....	41	Icom UK Ltd.....	cover iii	PW Services .....	41
AKD .....	4	J Birkett .....	53	RAS Notts .....	41
ARC Ltd .....	31	Lake Electronics.....	53	RSGB.....	4
Colomor Electronics.....	22	Langrex Supplies.....	41	SMC Ltd.....	2/3
Cricklewood Electronics ..	22	Maplin Electronics ..	cover iv	Spectrum Communications.....	53
Datong Electronics .....	68	Martin Lynch .....	34/35	SRP Trading .....	5
Essex Amateur Radio Services .....	41	Mauritron Technical Services .....	61	Vintage Audio Co Ltd.....	53
Fairhaven Electronics .....	61	Monitoring Times .....	31	Waters & Stanton .....	8
Haydon Communications.....	6/7	muTek.....	61	Yaesu UK Ltd.....	cover ii
Howes, C M .....	5	PCB Service .....	61		

ICOM

# IC-R8500

the super *wide*-band receiver with street-credibility



If you want to hear everything that's going down on the streets, then the R8500 is for you. Covering 100kHz~2GHz in all modes the R8500 gives you the chance to be a REAL nosey-parker! The R8500 includes IF shift, APF, direct RS-232C computer compatibility and will appeal to professionals and serious listeners who demand top performance - but not top prices.

**ICOM... manufacturers of top performing base-stations, mobiles, handheld transceivers and receivers.**

Icom (UK) Ltd. Sea Street Herne Bay Kent CT6 8LD.

General Operator: 01227 743000. Sales & Service: 01227 741741. Fax: 01227 741742.

INTERNET: <http://www.icomuk.co.uk/>

E-MAIL: [icomsales@icomuk.co.uk](mailto:icomsales@icomuk.co.uk)



**Count on us!**

# serious

# fun

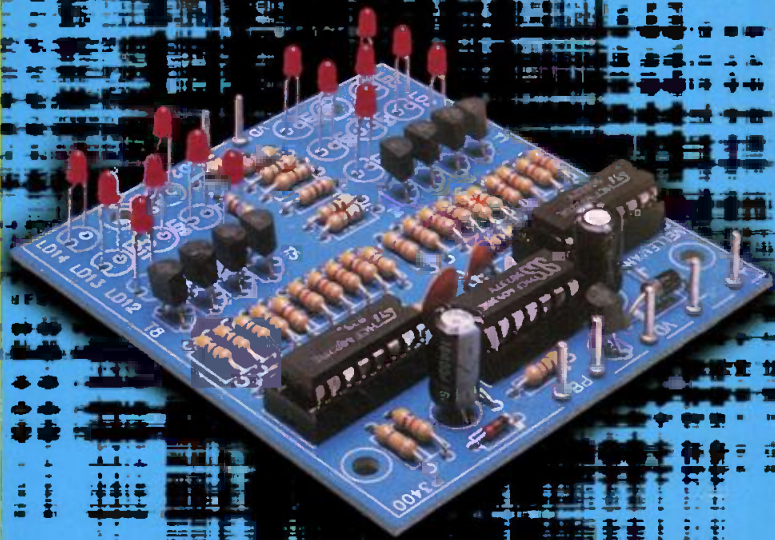

The new Maplin MPS catalogue is *the* essential electronic buyers' guide. Featuring everything from cables, tools and test equipment to capacitors, switches and optoelectronic components. And now combining the entire Maplin and MPS product range under one cover, with volume price breaks, for the first time ever. With over 2,000 *new* products to choose from you won't want to miss our new catalogue. Reserve your copy now.

Who said science had to be dull? Not us! The new combined Maplin MPS catalogue is bursting with exciting ideas - from a huge range of electronics kits, cycle computers and navigation systems, to personal hi-fi, disco gear and home video editors. All at our best prices and with discounts for larger orders. Give your spare time a boost - reserve your copy of the new Maplin MPS catalogue now.

The new **Maplin MPS** catalogue is out September 1996, *reserve your copy now*

only **£3.45** (free post & packing when you reserve your copy by 31 August)

Phone **01702 554 161**  
or visit your local Maplin store.

Also available from September at WH Smith and John Menzies.

# MAPLIN

MAPLIN ELECTRONICS plc,  
PO Box 3, Rayleigh, Essex SS6 8LR

**MAPLIN - 35 locations throughout the UK**

Barnsley (Wombwell), Belfast, Birmingham, Bradford, Brighton, Bristol, Cardiff, Chatham, Coventry, Dudley, Edinburgh, Glasgow, Leeds, Leicester, Liverpool, London (Edgware), London (Forest Hill), London (Hammersmith), London (Ilford), Manchester (Cheetham Hill), Manchester (Oxford Road), Middlesbrough, Milton Keynes, Newcastle-Upon-Tyne, Northampton, Nottingham, Portsmouth, Preston, Reading, Sheffield, Slough, Southampton, Southend, Stockport, Stoke-on-Trent

**MAPLIN MONDO SUPERSTORE** now open at 3 Regent Street, **LEEDS**. Look out for new stores opening in your area soon!