

JANUARY 1985 95p

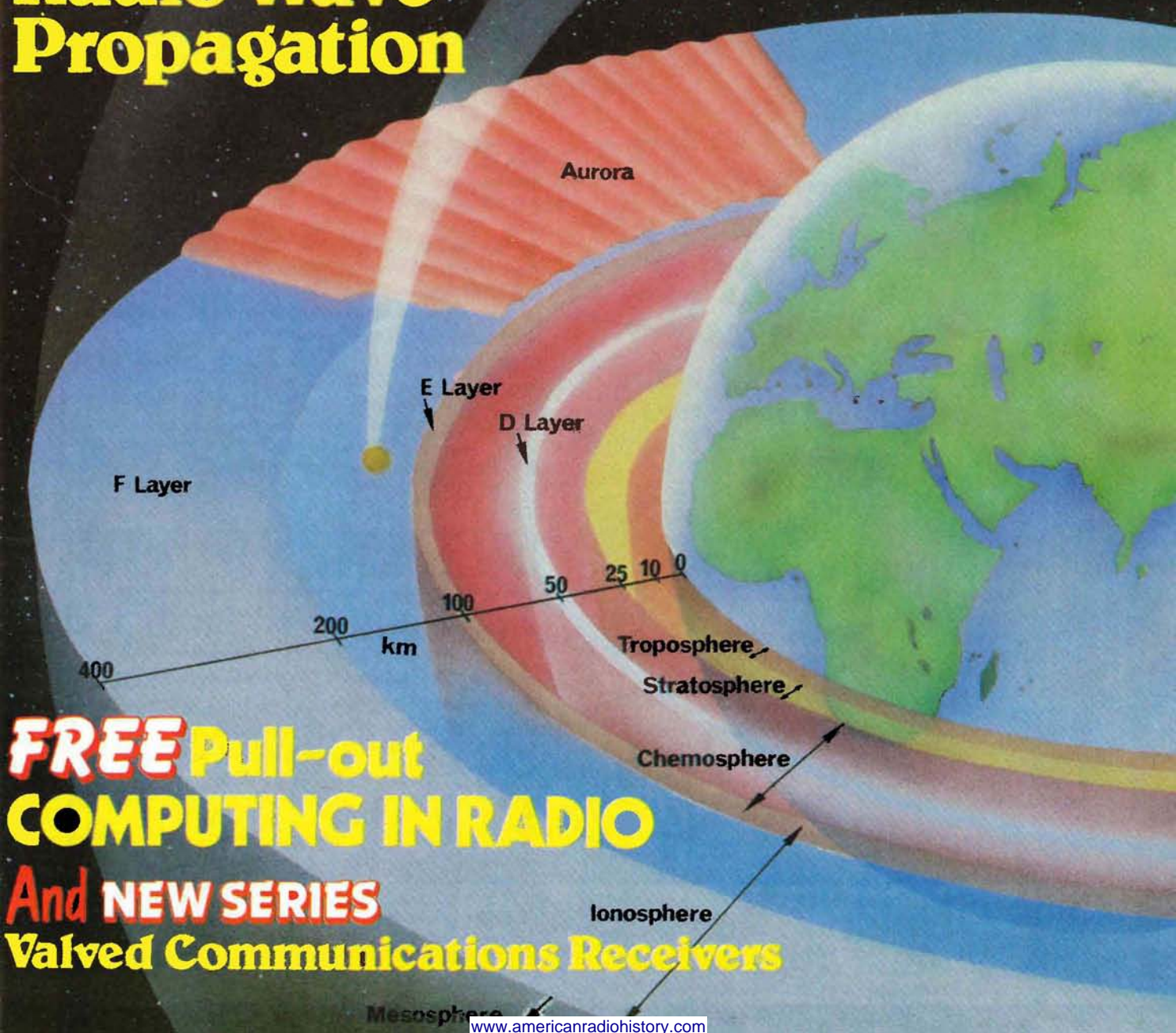
Australia \$1.60  
New Zealand \$1.75  
Malaysia \$4.95

ISSN 0141-0857

# Practical Wireless

THE RADIO MAGAZINE

**NEW SERIES**  
**Radio Wave  
Propagation**



**FREE Pull-out  
COMPUTING IN RADIO**

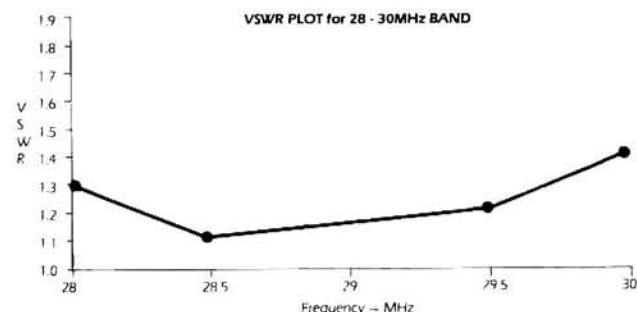
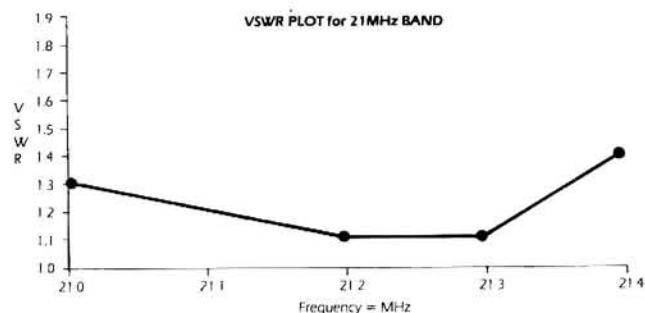
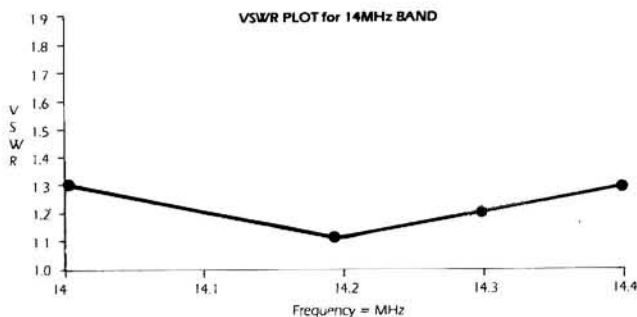
**And NEW SERIES  
Valved Communications Receivers**



# A New Approach to HF Antennae Design

Compare these performance figures of Hightech Antennae's **MBFr80** with the best 3 element antennae available today.

	Typical Spec. for 3 element Tri Band Beam	Hightech Antennae's Spec for MBFr80
	No. of Elements — 3	2 Parasitic + 1 Absorber Element
Front to Back Ratio	25dBd	43dBd
Forward gain	6dBd min.	Better than 4.5dBd
VSWR at Resonance	1.5 : 1	1.1 : 1
Max. Power Input	1kW (100% duty cycle)	2kW (100% duty cycle) 5kW peak
Input Impedance	50 ohm	50 ohm
Boom Length	4.2m	4m
Max. Element Length	8.7m	4.6m
Max. Wind Survival	75mph	100mph
Net Weight	16.3kg	8kg
Wind Load	80mph = 47kg	100mph = 23kg



The front to back ratio advantage from Hightech Antennae's **MBFr80** is 18dBd better than other antennae available today. Remember this is a 3 S-unit noise reduction in unwanted directions over and above other antennae.

6dBd = 1 S-unit

**Massive front to back ratio.** This is more important than forward gain on today's crowded amateur bands.

**Flat VSWR across all HF bands.**

**No need for the purchase of ATU's for those with solid state PA's.**

**No need for the purchase of baluns.**

A complete break with the coil and capacitor trap arrangement with, of course, its associated losses, restricted bandwidth etc.

Expandability: Extra parasitic element (director)

Extra absorber element for even greater front to back ratio.

With the conversion kits available, a 3 element, 3 band beam with an enormous front to back ratio will become the standard for others to follow

## H I G H T E C H

### Antennae (Scotland) Ltd

24, Gremista Industrial Estate, Lerwick, Shetland Is. ZE2 0PX

**To: HTA (Scotland) Ltd., 24 Gremista Ind. Est., Lerwick, Shetland Is. ZE2 0PX**

Please Supply .. **MBFr80 Antennae**  
@ **£189.95** incl VAT & P & P

Name (please print) \_\_\_\_\_

Address (please print) \_\_\_\_\_

Postcode \_\_\_\_\_

I enclose a cheque/PO payable to HTA (Scotland) Ltd value £ \_\_\_\_\_

or debit my Access Card No.

Cardholder Signature \_\_\_\_\_

**Credit Card Hotline 0595 - 5949** Please allow 28 days for delivery - Offer valid UK only.

# Practical Wireless

FOR THE **Radio** ENTHUSIAST ...

JANUARY 1985 VOL. 61 NO. 1 ISSUE 934

## Contents

## Staff

- 22 Radio Wave Propagation—1**  
*F. C. Judd G2BCX*
- 25 Kindly Note**  
Battery State Indicator—November 1984
- 26 PW "Teme" Modular Transceiver—3**  
*Rev G. C. Dobbs G3RJV*
- 34 Multiple Choice**  
Practice Questions for the RAE
- 36 Valved Communications Receivers—1**  
The National HRO  
*Chas. E. Miller*
- Pull-out Feature**  
Computing in Radio, Winter 84/85
- 49 Component Ratings for Beginners—2**  
*Roger Lancaster*
- 52 1984 Expedition to XQ Square**
- 55 Practical LC Filter Design—6**  
*Edward Wetherhold W3NQN*

## Regulars

- |                 |               |             |
|-----------------|---------------|-------------|
| 87 Advert Index | 19 News       | 18 PW RUIS  |
| 21 Benny        | 31 Next Month | 17 Services |
| 59 Club News    | 61 On the Air | 40, 54      |
| 17 Comment      | 32 Products   | Swap Spot   |

### EDITORIAL OFFICES

Practical Wireless  
Westover House  
West Quay Road  
Poole, Dorset BH15 1JG  
☎ Poole 671191

**Geoff Arnold T.Eng FSERT, G3GSR**  
Editor

**Dick Ganderton C.Eng., MIERE, G8VFH**  
Assistant Editor

**Steve Hunt**  
Art Editor

**John Fell G8MCP**  
Technical Editor

**Alan Martin G8ZPW**  
News & Production Editor

**Elaine Howard G4LFM**  
Technical Sub-Editor

**Rob Mackie**  
Technical Artist

**Kathy Moore**  
Secretary

### ADVERTISEMENT OFFICES

Practical Wireless  
King's Reach Tower  
Stamford Street  
London SE1 9LS  
Telex: 915748 MAGDIV-G

**Dennis Brough**  
Advertisement Manager  
☎ 01-261 6636  
☎ 01-261 6872

**Roger Hall G4TNT (Sam)**  
Ad. Sales Executive  
☎ 01-261 6807

**Claire Gerrish**  
Secretary  
☎ 01-261 6636

**Barbara Blake**  
Classified Supervisor  
☎ 01-261 5897

**Ian Sweeney**  
Make-up & Copy  
☎ 01-261 6570

**COPYRIGHT** © IPC Magazines Limited 1985 Copyright in all drawings, photographs and articles published in *Practical Wireless* is fully protected and reproduction or imitation in whole or in part is expressly forbidden. All reasonable precautions are taken by *Practical Wireless* to ensure that the advice and data given to our readers are reliable. We cannot however guarantee it and we cannot accept legal responsibility for it. Prices are those current as we go to press.

*Practical Wireless, January 1985*



# LOWE SHOPS

Whenever you enter a **LOWE ELECTRONICS** shop, be it Glasgow, Darlington, Cambridge, Cardiff, London or here at Matlock, then you can be certain that, along with a courteous welcome, you will receive straightforward advice. Advice given, not with the intention of "making" a sale, but the sort which is given freely by one radio amateur to another. Of course, if you decide to purchase then you have the knowledge that **LOWE ELECTRONICS** are the company that set the standard for amateur radio after-sales service. The shops are open Tuesday to Friday from 9.00 to 5.30 pm, Saturday from 9.00 to 5.00 pm and close for lunch each day from 12.30 till 1.30pm.

In **Glasgow** the **LOWE ELECTRONICS** shop (the telephone number is 041-945 2626) is managed by **Sim GM3SAN**. Its address is 4/5 Queen Margaret's Road, off Queen Margaret's Drive. That's the right turn off Great Western Road at the Botanical Gardens' traffic lights. Street parking is available outside the shop and afterwards the Botanical gardens are well worth a visit...

In the **North East** the **LOWE ELECTRONICS** shop is found in the delightful market town of **Darlington** (the telephone number is 0325 486121) and is managed by **Don G3GEA**. The shop's address is 56 North Road, Darlington. That is on the A167 Durham Road out of town. A huge free car park across the road, a large supermarket and bistro restaurant combine to make a visit to Darlington a pleasure for the whole family.

**Cambridge**, not only a University town but the location of a **LOWE ELECTRONICS** shop managed by **Tony G4NBS**. The address is 182 High Street, Chesterton, Cambridge (the telephone number is 0223 311230). From the A45 just to the north of Cambridge turn off into the town on the A1039, past the science park and turn left at the first roundabout, signposted Chesterton. After passing a children's playground on your left turn left again (between the shops) into Green End Road. Very quickly, and without you noticing it, Green End Road becomes High Street. Easy and free street parking is available outside the shop.

For **South Wales**, the **LOWE ELECTRONICS** shop is located in **Cardiff**. Managed by **Richard GW4NAD**, who hails from Penarth, the shop (the telephone number is 0222 464154) is within the premises (on the first floor) of **South Wales Carpets**, Clifton Street, Cardiff. Clifton Street is easily found, being a left turn off Newport Road just before the Infirmary. Once in Clifton Street, **South Wales Carpets** is the modern red brick building at the end of the street on the right hand side. Enter the shop, follow the arrows past the carpets, up the stairs and the "Emporium" awaits you. Free street parking is available outside the shop.

**LOWE ELECTRONICS** London shop is located at 223/225 Field End Road, Eastcote, Middlesex (the telephone number is 01-429 3256). The new shop, managed by **Andy G4DHC** is easily found, being part of Eastcote tube station buildings and as such being on the Metropolitan and Piccadilly lines (approximately 30 minutes from Baker Street main junction). For the motorist, we are only about 10 minutes' driving time from the M40, A40, North Circular Road (at Hanger Lane) and the new M25 junction at Denham. Immediately behind the shop is a large car park where you can currently park for the day for 20p. There is also free street parking outside the shop.

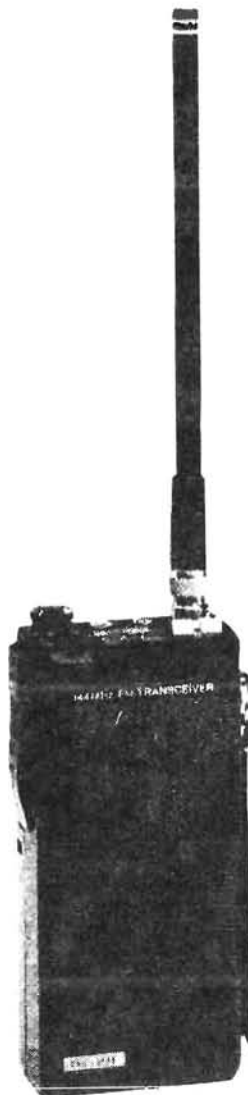
Although not a shop there is on the South Coast a source of good advice and equipment - **John G3JYG**. His address is 16 Harvard Road, Ringmer, Lewes, Sussex. (telephone 0273 812071). An evening or week-end telephone call will put you in touch with John.

Finally, here in **Matlock**, **David G4KFN** is in charge. Located in an area of scenic beauty a visit to the shop can combine amateur radio with an outing for the whole family. May I suggest a meal in one of the town's inexpensive restaurants or a picnic on the hill tops followed by a spell of portable operation.

## the hand sized handheld, the **TRIO TH21E**.

By now you will undoubtedly have heard about the **TRIO TH21E** hand sized hand held 2 metre FM transceiver. Over the past fourteen years I have watched amateur radio equipment develop from cumbersome to perfection. I remember **John, G3PCY**, showing me the first **TR2400** and our mutual amazement at how **TRIO** could put so much radio in such a small package. Later developments produced the **TR2500** and its 70 centimetre version, the **TR3500** and left me in no doubt that **TRIO** would soon produce a compact inside pocket transceiver. At the same time it became apparent that a simpler rig with performance would have great appeal. That transceiver is the **TH21E** and being typically **TRIO** is right first time. Size is not the most important feature, it's just the way the transceiver feels when picked up, impossible to put down. I am not going to give its dimensions, I will just say that it is hand sized, the true inside pocket transceiver. As an owner and with the rig always on your person the hobby of amateur radio expands to an all day event. Never miss a contact, never miss a friend.

- ★ 1 watt output in high power position, 150 mW in low position.
- ★ Full coverage of the 2 metre amateur band from 144 to 146 MHz.
- ★ Frequency selection by simple thumbwheel switches.
- ★ Full repeater facilities including reverse repeater.
- ★ The rig comes complete with nicad pack and charger.



**£175 inc vat.**  
includes nicads & charger.

## LOWE ELECTRONICS

Chesterfield Road, Matlock, Derbyshire. DE4 5LE.

Telephone 0629 2817, 2430, 4057, 4995. Telex 377482.

(Delivery of stock items normally by return of post)





# the TRIO two metre base station, the TS711E.

Several weeks have passed since I took delivery of my own TRIO TS711E. The Japanese home market model has returned whence it came and I am using the version designed specifically for the UK market. The rig is perfection epitomised. For today's two metre operator any base station with less facilities and performance than the TS711E would be far from acceptable. The TS711E's receiver performance in sensitivity and in its ability to reject unwanted adjacent signals is outstanding. I'm not talking about test equipment figures though undoubtedly these will soon be published. My own on air operating with the rig has enabled me to hear what I previously couldn't.

The transceiver covers the 2 metre band from 144 to 146 MHz in FM, USB, LSB and CW modes. When switched to the auto position the rig correctly selects mode according to frequency, a great advantage to the blind operator. Simple up/down frequency shift is provided both on the transceiver front panel and microphone.

IF shift is available, an essential when considering today's crowded 2 metre band. For more penetrating transmitted audio when working DX speech processing can also be switched in.

The TS711E has two separate VFO's and forty channels of memory. Each memory remembers frequency, operating mode, simplex or repeater shift and whether or not a tone burst is to be included. Frequencies stored in memory can be readily transferred to either VFO A or B. The VFO can be either free running as for SSB or CW operation or electrically switched to a "click" stop where it changes frequency in 12.5 or 5 kHz steps. The two VFO's can quickly be put on the same frequency, an aid when checking the position of a strong adjacent signal with one VFO whilst remaining on your operating frequency with the other.

Frequency scan on VFO can be either between or outside user set limits. On memory the transceiver can either scan the entire memory contents or be instructed to look at those frequencies of a particular mode. The TS711E has a timed hold on an occupied channel.

Both priority channel and the immediate recall of your local net frequency are possible with the TS711E.

For those with failing sight or a blind operator the TS711E is a dream come true, not only is the operating mode identified by the appropriate CW letter sent in tone (F for FM, U for upper side band etc.), other rigs just bleep but, when fitted with the VS1 optional board, a digitally encoded girls voice will announce both frequency and where applicable, whether the rig is switched to repeater shift.

TS711E 2 metres £758.00 carr £7.00  
TS811E 70 cmtes £878.00 carr £7.00



# DCS (digital code squelch) explained.

For many years amateurs up and down the country have used net frequencies. A particular channel which a group have used to keep in touch, not at the exclusion of general listening but when working in the shack. It was possible to pick an obscure frequency and for nobody other than those in the "net" to appear. Today, with many stations on the band that way of operating a net channel does not work. It is impossible in the more densely populated areas to find a frequency that will remain unused for many minutes. Those who have good locations have an even greater problem.

With the DCS system TRIO have introduced a simple method of providing a quiet net channel. The latest generation of TRIO transceivers, the handheld TR2600E and TR3600E, the mobile TM211E and TM411E and the base station TS711E and TS811E all have as standard DCS. DCS or digital code squelch to give it its full name uses digitally coded information to open the squelch on a programmed receiver. The transceiver sends, both at the beginning and end of the transmission your code. If the transceiver belonging to your friend is programmed with the same code and of course you are on the same frequency then you will open his squelch and be heard. If you transmit without the code then he will not hear you. The code takes the form of a 5 digit digitally coded data string. By using 5 digits 100,000 different combinations are possible. The various rigs each have different capacities of code storage, the handheld TR2600E/TR3600E can each retain three codes whilst the TS711E/TS811E base stations can each hold up to ten. The great advantage of the TRIO system over previous designs is that the DCS system is an integral part of the equipment and as such is simplicity itself to use. Being part of the rig the system uses the keyboard to impart the information and the display to visually confirm your entry.

In addition the DCS system will hold and transmit in decimal ASCII code the operators callsign. The information is included in the data string. Callsigns to a maximum of 6 digits may be stored. By using the optional CD10 call sign unit the incoming data is decoded and visually displayed. Not only that, the CD10 will store the callsigns of the last twenty stations that called you, assuming they have the facility.

The transceivers will also tell you if you have been called in your absence. The TR2600E/TR3600E have a yellow led which illuminates when the rig is activated. The base station TS711E/TS811E have a call alarm which beeps until cancelled.

Of course, if you want to get really sophisticated then the base station transceivers will handle group calls. If your TS711E/TS811E is called, not necessarily on the code on which the equipment is set, the transceiver will first check if that particular code is one of the ten stored and whether it is active. The term "active" means that although ten codes are stored each needs individually switching on otherwise it will be treated as not being there. If the particular code has been activated then the squelch will open and your rig will automatically move to the new incoming code so that you may reply. Of course, if it didn't then you wouldn't know which code had been used and would be unable to reply. Unbelievable!

The DCS system is not complicated, that's just my description. What I do advise is that before buying a new rig, check whether it has DCS, best of all pop into a LOWE shop and see the system for yourself.

Please beware of KEWOOD equipment with DCL. This is a totally different system and is only for the Japanese home market. DCL enables your rig to do all the above but also look together with the transceiver it is working for a clear channel, the rigs doing this by themselves without you doing a thing. It may be all right in Japan where there are no 2 metre repeaters and there exists a different style of operating but I am sure you will agree that here it is totally unworkable.

## LOWE ELECTRONICS

Chesterfield Road, Matlock, Derbyshire. DE4 5LE.  
Telephone 0629 2817, 2430, 4057, 4995. Telex 377482.

(Delivery of stock items normally by return of post)





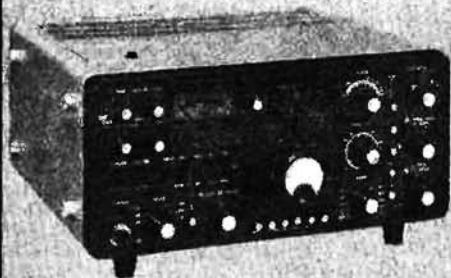


# South Midlands

\* FREE FINANCE • 2 YEAR GUARANTEE  
BRANCHES AT: SOUTHAMPTON, LEEDS, CHESTER

## CHRISTMAS SPECIAL OFFERS FROM S.M.C.

### FT902 LAST FEW



'D' & 'DE' MODELS  
ONLY **£599** inc  
(free sec delivery)

### FT102

DEMO AND SHOP  
SOILED MODELS TO CLEAR



ONLY **£599** inc  
(free sec delivery)



### FTV107R



TRANSVERTER MAIN FRAME  
ONLY **£30** inc  
(sec delivery £5)

144TV 2m module      £119 inc  
432TV 70cm module      £239 inc

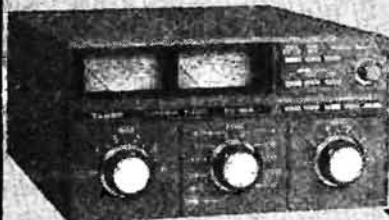
### FT790R



NOW DISCONTINUED  
LAST FEW  
**£299** inc  
(free post delivery)



### FC102 ANTENNA TUNER



**£159** inc  
(free delivery)

160-10m  
1.2kW  
PEP



### FT730R



70cm  
10W FM  
MOBILE

ONLY **£239** inc  
compare this price with  
other manufacturers models  
(free post delivery)

**ORDER NOW TO  
AVOID DISAPPOINTMENT**

John Doyle Transworld Comms.  
Neath (0639) 52374 day  
(0639) 2942 eve

STOCK CARRYING AGENTS WITH DEMONSTRATION FACILITIES

John Stringer SMC N. Ireland  
Bangor (0247) 464875

#### SMC SERVICE

Free Securicor delivery on major equipment.  
Access Barclaycard over the phone.  
Biggest branch agent and dealer network.  
Securicor 'B' Service contract at £5.00.  
Biggest stockist of amateur equipment.  
Same day despatch whenever possible.

#### FREE FINANCE

\* On many regular priced items SMC offers.  
Free Finance (on invoice balances over £120).  
20% down and the balance over 6 months or  
50% down and the balance over a year.  
You pay no more than the cash price!  
Further details on eligible items on request.

#### GUARANTEE

Importer warranty on Yaesu Musen products.  
Able staffed and equipped Service Department.  
Daily contract with the Yaesu Musen factory.  
Tens of thousands of spares and test equipment.  
Twenty five years of professional experience.  
● 2 years warranty on regular priced Yaesu products.



# Communications Ltd.

FREE, MAIN DISTRIBUTOR FACTORY BACKED

BUCKLEY, STOKE, GRIMSBY, JERSEY, EDINBURGH, N. IRELAND.



## YAESU No. 1 FOR FACILITIES AND PERFORMANCE

**FT209R**



**FT203R**



**FT290R**



**FT230R**



**AVAILABLE  
SOON!**

**NEW! FT703R  
NEW! FT709R  
(phone for details)**

**FT726R**



**MULTIMODE UHF, VHF, HF**

**FT757GX**



**ALL MODES STANDARD  
'NO OPTIONS'**



**FT77**



**FT-ONE**



**All models on this page  
Available on free finance.**

**FT980**



**FT680R**



**AVAILABLE SOON**

**NEW! FRG8800 HF Receiver**

**NEW! FT2700R Dual Band Full Duplex  
FM Mobile**

**NEW! FT270RH 45w 2m Mobile**

LEEDS  
SMC (Leeds)  
257 Otley Road  
Leeds 16, Yorkshire  
Leeds (0532) 782326  
9-5.30 Mon-Sat

CHESTERFIELD  
SMC (Jack Twendy) Ltd  
102 High Street  
New Whittington,  
Chesterfield  
Chest (0246) 453340  
9-5 Tues-Sat

BUCKLEY  
SMC (TMP)  
Unit 27, Pinfold Lane  
Buckley, Clwyd  
Buckley (0244) 549563  
9.30-5.30 Tues-Sat

STOKE  
SMC (Stoke)  
76 High Street  
Talke Pts, Stoke  
Kidsgrove (07816) 72644  
9-5.30 Mon-Sat

GRIMSBY  
SMC (Grimsby)  
247A Fraeman Street  
Grimsby, Lincs  
Grimsby (0472) 59388  
9.30-5.30 Mon-Sat

JERSEY  
SMC (Jersey)  
1 Belmont Gardens  
St. Helier, Jersey  
Jersey (0534) 77067  
10-7 Mon-Sat closed Wed

EDINBURGH  
SMC Scotcomm  
23 Morton Street  
Edinburgh EH15 2HN  
Tel: 031 657 2430  
10-5 Tues Fri, 9-4 Sat

BANGOR, N.I.  
SMC (N. Ireland)  
10 Ward Avenue  
Bangor, Co Down  
Bangor (0247) 464875

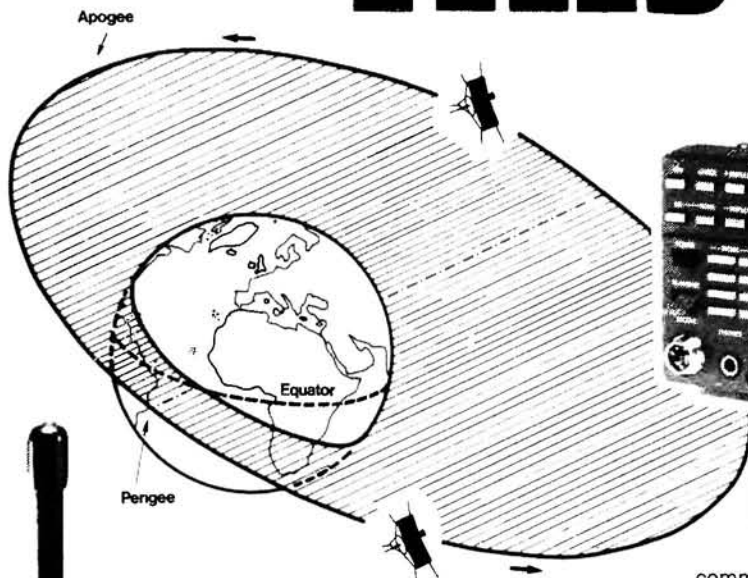
Southampton Showroom open 9-5.30 Monday to Friday 9-1pm Saturday

HEAD OFFICE  
&  
MAIL ORDER

**S.M.HOUSE, RUMBRIDGE STREET, TOTTON, SOUTHAMPTON, SO4 4DP, ENGLAND,  
Tel: (0703) 867333. Telex: 477351 SMC COMM G. Telegram: "Aerial" Southampton**



# ICOM IS OUT OF THIS WORLD



## IC-271 & 471

ICOM can introduce you to a whole new world via the world communications satellite OSCAR. Did you know that you can Tx to

OSCAR on the 430-440MHz IC-471 and Rx on the 2m. IC-271.

By making simple modifications, you can track the VFO's of the Rx and Tx either normally or reverse. This is unique to these ICOM rigs and therefore very useful for OSCAR 10 communications. Digital A.F.C. can also be provided for UOSAT etc. This will give automatic tracking of the receiver with digital readout of the doppler shift.

The easy modifications needed to give you this unique communications opportunity are published in the December '84 issue of OSCAR NEWS. Back issues of OSCAR NEWS can be obtained from AMSAT (UK), LONDON, E12 5EQ.

## BUT, ON THE OTHER HAND...

### IC-02E IC-04E, (70cm).

The new direct entry microprocessor controlled IC-02E is a 2 meter handheld jam packed with excellent features.

Some of these features include: scanning, 10 memories, duplex offset storage in memory and odd offsets also stored in memory. Internal Lithium battery backup and repeater tone are of course included. Keyboard entry is made through the 16 button pad allowing easy access to frequencies, duplex, memories, memory scan and priority.

The IC-02E has an LCD readout indicating frequency, memory channel, signal strength, transmitter output and scanning functions. New HS-10 Headset, with earphone and boom microphone, which operates with either of the following:- HS 10-SB Switch box with pre-amplifier giving biased toggle on, off and continuous transmit. HS 10-SA Voice operated switch box, with pre-amplifier, mic gain, vox gain and delay. The IC-02E continues to be available.



Thanet ICOM Thanet ICOM Thanet ICOM Thanet ICOM Thanet ICOM Thanet ICOM Thanet ICOM



# ICOM PRICES ARE DOWN TO EARTH.

(Please contact us or your local Icom dealer for current prices)

## IC-751

The IC-751 could be called the flagship of the ICOM range as it features 32 memory channels, full HF receive capability, digital speech synthesizer, computer control and power-supply options. The 751 is fully compatible with ICOM auto units such as the AT-500 and IC-2KL. The IC-751 now has a remote push-button frequency selector pad

Standard features include: a speech processor, switchable choice of J-FET pre-amp or 20dB pin diode attenuator and two VFO's, marker, 4 variable tuning rates, pass band tuning, notch, variable noise blanker, monitor switch, direct feed mixer in the front end, full break-in on CW and AMTOR compatibility.

The first IF is 70 045 MHz. Any XIT and RIT adjustment is shown on the display. The transmitter features high reliability 2SC2904 transistors in a low IMD (-32dB $\alpha$  100W) full 100% duty cycle. For more detailed information on this excellent set, please get in touch with us



## IC-290D

290D is the state of the art 2 meter mobile, it has 5 memories and VFO's to store your favourite repeaters and a priority channel to check your most important frequency automatically. Programmable offsets are included for odd repeater splits, tuning is 5KHz or 1KHz.

The squelch on SSB silently scans for signals, while 2 VFO's with equalising capability mark your signal frequency with the touch of a button. Other features include: RIT, 1KHz or 100Hz tuning/CW sidetone, AGC slow or fast in SSB and CW, Noise blanker to suppress pulse type noises on SSB/CW.

You can scan the whole band between VFO's/scan memories and VFO's. Adjustable scan rate 144 to 146 MHz, remote tuning with optional IC-HM1 microphone. Digital frequency display, Hi/Low power switch. Optional Nicad battery system allows retention of memory. What a great little transceiver!

Special Offer as from 15th January '84  
 IC-290D reduced to £469 and the IC-290E to £399. Also 70cm version IC-490E, £529.  
 Take advantage of this money saving offer.

**Agent** Gordon G3LEQ, or telephone Knutsford (0565) 4040.  
 Please telephone first, anytime between 0900 - 2200 hrs **Gordon also sells Yaesu products.**

You can get what you want just by picking up the telephone. Our mail-order dept. offers you: free, same-day despatch whenever possible, instant credit, interest-free H.P., telephone Barclaycard and Access facility and a 24 hour answering service  
 Please note that we now have a new retail branch at 95, Mortimer Street, Herne Bay, Kent. tel:69464. Give it a visit, BCNU.

**Thalet Electronics**  
 Dept 17W, 143 Reculver Road, Herne Bay, Kent.  
 Tel: (02273) 63859/63850

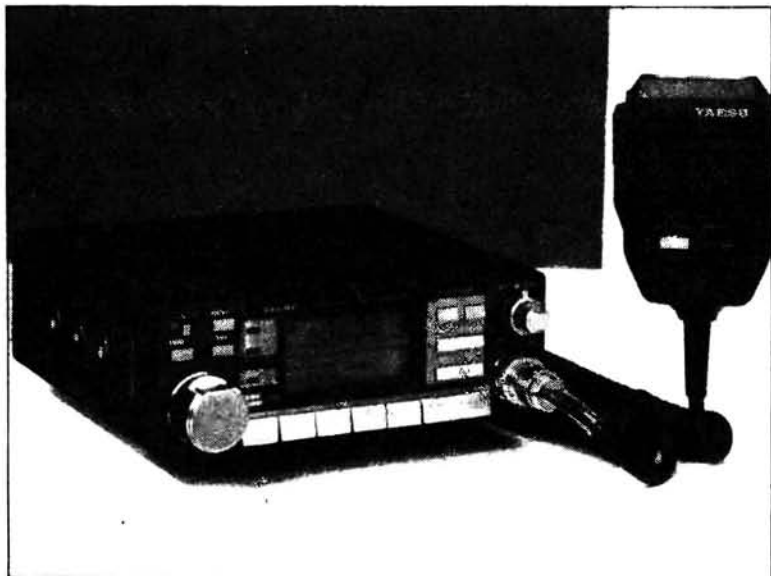


DRAE • TAU • ALINCO • TET • JAYBEAM • TAL • RSGB • CONNECTORS • CABLE • DATONG • MUTEK



- FACTORY APPOINTED IMPORTED
- FREE SECURICOR ON MAJOR ITEMS

# AMATEUR ELECTRONICS



## THE FT2700R 2M and 70cms FM DUAL BAND MOBILE

(Full details and prices available shortly)

**YAESU'S LATEST TECHNOLOGY, AVAILABLE SOON**

### THE FT270R THE VERY LATEST IN YAESU'S MOBILE FM TECHNOLOGY

(Full details and prices available shortly)



**INSTANT HP AVAILABLE**  
WRITTEN DETAILS ON REQUEST



### AGENTS

**WALES & WEST**  
ROSSCLARE GW3NWS  
0632 880146  
**SHROPSHIRE**  
SYD POOLE G3IMP  
0952 812834  
**NORTH STAFFS**  
BOB AINGE G4XEK  
0528 754553

### BRANCHES

**NORTHERN**  
AMATEUR ELECTRONICS UK/HOLDINGS,  
45 JOHNSTON ST., BLACKBURN  
0254-59595  
**YORKSHIRE**  
AMATEUR ELECTRONICS UK/HOOKER  
42 NETHER HALL RD., DONCASTER. 0302 25690

**504-516 ALUM ROCK RD.,**  
TEL: 021-327-1497 or 021-327-6313.



# AE LIMITED

- FACTORY BACKED EQUIPMENT
- FREEPOST — MAIL ORDER ENQUIRIES.



**FT209R**



**FT203R**



## YAESU'S HANDY PORT- ABLES

• **FT709R**

70cms version of the 209R. 430-440 coverage.

• **FT703R**

70cms version of the 203R. 430-440 coverage.

(Full colour brochure and specifications upon request).

**STOP PRESS** **FRG8800. THE NEW STATE OF THE ART FULLY COMPATABLE COMMUNICATIONS RECEIVER**

- LCD.  MULTICOLOURED S/SINPO "BAR GRAPH" INDICATOR.
  - YAESU CAT SYSTEM.  12 MEMORIES.  COMPATABLE WITH MOST PERSONAL COMPUTERS.
  - 21 BUTTON KEYPAD.  8 BIT CPU.  24 HOUR CLOCK.
  - SCANNING FACILITY.  ALL MODE SQUELCH.  IFs. 47.005MHZ. AND 455 KHZ.
  - COVERAGE 150KHZ to 29.999MHZ.  MODES.
- AM (WIDE/NARROW). SSB. (USB/LSB). CW (WIDE AND NARROW 800HZ).  
FM (NARROW) FM WIDE (OPTION). CONTACT US NOW FOR FURTHER DETAILS.

**EAST ANGLIA**  
AMATEUR ELECTRONICS UK/  
31 CATTLE MARKET ST.,  
NORWICH. 0603-667189

**SOUTH WEST**  
AMATEUR ELECTRONICS UK/UPPINGTON  
12-14 PENNYWELL RD., BRISTOL. 0272-557732

**EAST MIDLANDS**  
AMATEUR ELECTRONICS UK/RAS NOTTS  
3 FARNDON GREEN, WOLLATON PARK,  
NOTTINGHAM. 0602-280267

**S.E. MIDLANDS**  
AMATEUR ELECTRONICS UK/AJH  
151a, BILTON RD.,  
RUGBY, WARWICKS.  
0788 76478

FREEPOST —  
MAIL ORDER  
ENQUIRES



AMATEUR ELECTRONICS LTD  
FREEPOST  
BIRMINGHAM B8 1B6

### BIRMINGHAM 8.

OPEN 9.30 - 5.30 TUES-SAT. CLOSED MONDAYS.

• AKD • BNOS • DATONG • MUTEK • MICROWAVE MODULES • TONNA • HI MOUND • TET • JAYBEAM



# RADIO SHACK

FOR EVERYTHING IN

# AMATEUR RADIO

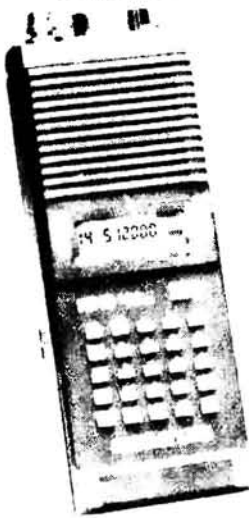
## TELSCAN SCANNER ANTENNAS

Indoor or outdoor, neat, and unobtrusive (without all the hairy legs) 60-600 MHz, 1 metre high.  
**£19.55 P&P £3.00**

**TELESCAN-Z**  
Scanner Antenna with built-in automatic pre-amp for weak stations and attenuator for strong ones.

**£49.95 P&P £3.00**

## PRO-30 Hand-held Scanner



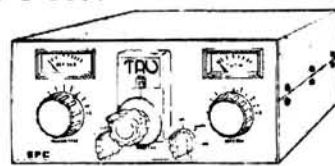
Covers 68-88 MHz VHF-Low, 144-148 MHz Ham, 108-136 MHz AM Aircraft, 138-144 MHz, 148-174 MHz VHF Hi, 380-450 MHz Ham, 450-470 MHz UHF-Low, 470-512 MHz UHF-Hi

Mains Adapter ..... **£6.99**

DC Adapter ..... **£4.49**

**£229.95**

## TAU SYSTEMS NEW TUNER SPC 3000 - THE GREATEST



**FROM STOCK £349.95**

## THE GREATEST TRANSCEIVER COLLINS KWM 380



**FROM STOCK-AFFORDABLE!**



## RADIO SHACK LTD

188 BROADHURST GARDENS,  
LONDON NW6 3AY

(Just around the corner from West Hampstead Station on the Jubilee Line)

Giro Account No. 588 7151 Telephone 01-624 7174 Telex: 23718



## GREAT OFFERS FROM SCARAB SYSTEMS

Choose from this professionally produced equipment from UK's leading radio software house.

### MPTU-1 tone encoder/decoder

This phase lock loop circuit is 100% reliable and extremely sensitive.  
**£69.70** (all plugs supplied).

### BBC Super morse code Tutor

This very sophisticated program includes many special features such as variable sending speeds and a 750 word vocabulary and enables your computer to test your ability to receive and **SEND** good clean morse.  
**£6.50** (cassette or disc).

### BBC Super QTH location finder

This large program comprises two parts and you can 'toggle' between them at any time. The first includes a point to point distance locator, radial ring score and outgoing and return bearings plus the Maidenhead Universal Locator system. The second part is a scoring log. **£7.50** (HF and VHF/UHF).



## SCARAB SYSTEMS

39 Stafford St, Gillingham, Kent ME8 5EN Tel: (0634) 570441

Please send me:

- MPTU-Rtty/Amor Terminal unit £99.70  Super QTH Locator Cassette £7.50  
 BBC Super Morse Tutor Cassette £6.50  Free details of other equipment and programs

I enclose a cheque/postal order for .....  
I wish to use my Access/Visa

Name .....

Address .....

Telephone .....

Signature .....

I understand that, if I am not fully satisfied, I can return the equipment with full reimbursement. 14 days delivery.



## COMMUNICATION RECEIVER



### uniden MODEL CR-201

**A compact communications receiver with full professional specifications and facilities.**

- FULL FREQUENCY COVERAGE OF 150KHz to 29.999MHz and 78 to 108MHz.
- MAXIMUM SENSITIVITY ON AM/SSB/CW, also FM, with NARROW/WIDE FILTER.
- MEMORY FOR ANY 6 AM/SSB and 6 FM FREQUENCIES, plus AUTOMATIC SCANNING BETWEEN ANY TWO FREQUENCIES.
- KEYBOARD ENTRY OF FREQUENCY SHOWN ON LCD DISPLAY.
- EXTERNAL SOCKETS FOR AERIAL, EARTH, HEADPHONES and LOUDSPEAKER.
- OPERATION FROM INTERNAL BATTERIES, 12V DC, or 240V AC.
- ONLY £189.75 inc VAT and P&P.**

Please allow 7-14 days for delivery

**LECMAR ELECTRONICS**  
Vectis Yard, Cowes, Isle of Wight  
Tel: (0983) 293996

DEALER ENQUIRIES INVITED

BARCLAYCARD ACCESS



**EAST LONDON HAM STORE  
 WHERE YOUR POCKET COUNTS**




**FREE DELIVERY ON ALL RIGS: Phone us last for best prices**

*DRESSLER U.K. WISH ALL THEIR CUSTOMERS PAST AND PRESENT  
 A VERY HAPPY CHRISTMAS AND A PROSPEROUS NEW YEAR*

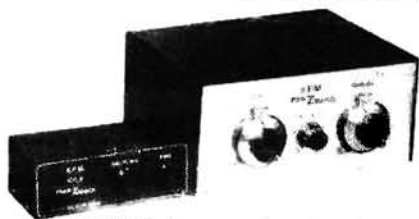
 <b>SX400</b> £595 INCLUDING FREE DISCONE ANTENNA	 <b>£345 AOR 2001</b> INCLUDING FREE DISCONE ANTENNA	 <b>ICOM R71</b> £699 INCLUDING DATONG AD270 ACTIVE ANTENNA	 <b>R2000</b> £435 INCLUDING DATONG AD270 ACTIVE ANTENNA
 <b>ICOM IC271E</b> £699 INCLUDING 9XY TONNA OR SWEDISH BRASS MORSE KEY	 <b>ICOM IC751</b> £1239 INCLUDING SWR200 METER OR 5 BAND TRAPPED VERTICAL ANTENNA	 <b>ICOM IC745</b> £898 INCLUDING SWEDISH BRASS MORSE KEY	 <b>ICOM ISO2E OR ICO4E</b> + FREE SPEAKER MIKE AT £259 ICO2E £269 ICO4E
 <b>TW4000</b> £470 INCLUDING DIAWA DUAL BAND ANTENNA + GUTTER MOUNT OR VS1	 <b>TR9130</b> £450 INCLUDING 9XY TONNA	 <b>FT726</b> + 70cm ± SATELLITE INC. FREE 9XY + 19XY TONNA + SWEDISH MORSE KEY	 <b>FT757GX+FC757+FP757HD</b> INCLUDING 5 BAND VERTICAL + SWEDISH BRASS MORSE KEY

**Spend £350 with us and we offer you over £3000 worth of FREE ACCOMMODATION in 50 different hotels in the U.K. for 2 over the whole of 84/85 as per our brochure.**

 <b>Swedish Key P.O.A.</b>	 METER WITH PEP/AVERAGE 10-20-100-200W. <b>SWC200 £80</b>	 <b>TS 711E</b> FOR £750 INC. 9XY TONNA OR SWEDISH MORSE KEY	 <b>TH21 P.O.A.</b>	 <b>TR2600 P.O.A.</b>
--	--	---	---	---

<p><b>dressler - ara 30 - active antenna</b>                  200 kHz ... 40 MHz</p> <p>Professional electronic circuitry with very wide dynamic range. Meets professional demands both in electronics and mechanical ruggedness. 120 cm long glassfiber rod-circuit build into waterproof 2.5 mm thick aluminium tube. Ideal for commercial and swl-receiving systems.</p> 	 <b>VHF POWER AMP.</b>	 <b>ARA30</b>
	<p>D200 2MTR. 300w F.M. 550w SSB £625                  D200S 2MTR. 400-500w 1Kw D.C. in £725                  D70 70cms 325w F.M. 500w SSB £725</p> <p><b>NEW MODEL DUE TO ARRIVE</b>                  1296 MWZ. 1w-in-10w out.</p>	<p>EVV200 GAAS 2MTR. 750W SSB £75                  EVV2000 GAAS 2MTR. 1KW SSB £80                  EVRPS receive 2MTR. only £45                  EVRPS receive 70cm. £49                  EVV700 GAAS 70cm. 500W SSB £80                  EVV70 GAAS 70cm. 100W £50                  EVV2 GAAS 2MTR. 100W £50                  VV200VOX GAAS 2MTR. 250W SSB £80                  INTERFACE £21                  DRESSLER ASA12 Mast Head Coaxial 2 in 1 out Switch with 'N' Connector £43                  1Hz-1GHz 1KW. PEP 0.15dB Insertion Loss</p>





**S.E.M. FACT 11.** It was very pleasant to get so many compliments on our products at the Leicester show.

**S.E.M. TRANZMATCH.** The most VERSATILE Aerial Matching (Tuning) Unit available. Matches 15-5,000 ohms BALANCED or UNBALANCED feeders up to 1 KW. Air coupled BALUN (no toroids) means no connection to equipment, which can cure TV1 both ways. An SO239 and screw terminals for CO-AX, END FED or TWIN FEEDERS. Size 8 1/2" x 4" x 7 1/2". 3.5-30MHz £80. 1.8-30MHz £90. The highly acclaimed EZITUNE built in (see below) £29.50 extra. 90% we sell have the EZITUNE option. All Ex-stock.

**NEW S.E.M. WAVEMETER.** Have you read your licence? Have you got a wavemeter? Produced following so many requests. 1.5-30MHz in 3 switched bands with a very nice meter. Only £29.50.

**S.E.M. INABIC KEYS.** No better fully auto keyer anywhere. Uses Curtis chip R.F. proof. Sidetone etc £38. A first class twin paddle key £17.50 Ex stock.

**BRAID BREAKER/HI PASS FILTER.** Stop TVI at TV. £6.50 Ex stock.

**RF NOISE BRIDGE.** Adjustable 0-infinity ohms 3" x 1 1/2" x 2" only. SO239s, 1-170MHz. Neat, accurate & economical. £34.50 Ex Stock.

**3 WAY ANTENNA SWITCH** 1Kw SO239s. Good to 2 metres. £17.50 Ex stock. Or 4th position to earth output £19.80 Ex stock.

**S.E.M. 2 METRE TRANZMATCH.** 5 1/2" x 2", 3" deep SO239s. £24.90 Ex stock.

**S.E.M. EZITUNE.** New circuit. Gives MORE noise & bomb proof operation.

Because no similar unit is made, it's usefulness is not appreciated until you have used one. Eliminates need for S.W.R. bridge.

Clean up the bands, increase your P.A. life by many times, by tuning up without transmitting.

Connects in aerial lead, produces S9 + (1 - 170MHz) noise in receiver. Adjust A.T.U. or aerial for minimum noise. You have now put an exact 50 Ohms into your transceiver. Fully protected, you can transmit through it, save your P.A. and stop QRM. SO239s. 3" x 1 1/2" x 2". £34.50 Ex stock. P.c.b. + fixing + instructions to fit in TRANZMATCH or any ATU £29.50 Ex Stock.

## NEW RANGE

### SENTINEL 2M LINEAR POWER/PRE-AMPLIFIERS

Feature either POWER AMP alone or PRE-AMP alone or both POWER AND PRE-AMP or STRAIGHT THROU when OFF. Plus a gain control on the PRE-AMP from 0 to 20dB. N.F. around 1dB with a neutralised strip line BF981.

Ultra LINEAR for all modes and R.F. or P.T.T. switched. 13.8V. SO239s.

Five Models: Ex. Stock

3/36. 12 times power gain, e.g. 3W in, 36W out. £70

1/36. 36 times gain, 1W in, 36W out. £80.

10/60. 10W in, 50W out. £86.

10/100. 10 to 100W. £138.

1/100. 1 to 100W. £148.

**POWER SUPPLIES** for our linears 6 amp £34. 12 amp £49.

**SENTINEL AUTO 2 METRE or 4 METRE PRE-AMPLIFIER** (R.F. Switched) 1dB N.F. and 20dB gain, (gain control adjusts down to unity) 400W P.E.P. power rating. Use on any mode. 12V 25mA. Sizes: 1 1/2" x 2 1/2" x 4". £29.50 \* Ex stock.

**PA5** Same specification as the Auto including 240V P.S.U. £33.00 \* Ex stock.

**SENTINEL 2 METRE PRE-AMPLIFIER.** No R.F. switch. £16.00 \* Ex stock.

**S.E.M. AUDIO MULTIFILTER** (A very good filter at a very good price).

The most versatile filter available. Gives "passband" tuning, "variable selectivity" and one or two notches. Switched Hi-pass, Lo-pass, peak or notch. Selectivity from 2.5KHz to 20Hz. Tunable from 2.5KHz to 250Hz. PLUS another notch available in any of the four switch positions which covers 10KHz to 100Hz. 12V supply. Sizes: 6" x 2 1/2" front panel, 3 1/2" deep, all for only £27.00 Ex stock.

**SENTINEL AUTO H.F. WIDEBAND PRE-AMPLIFIER** 2-40MHz, 15dB gain. Straight through when OFF. 9-12V. 2 1/2" x 1 1/2" x 3". 200W. £19.85 \* Ex stock.

**SENTINEL STANDARD H.F. PRE-AMP.** No R.F. switching. £12.82 \* Ex stock.

**12 MONTHS COMPLETE GUARANTEE INCLUDING ALL TRANSISTORS.**

Prices include VAT and delivery. C.W.O. or phone your credit card number for same day service. \*Means Belling Lee sockets add £1.90 for SO239s or BNC sockets. Ring or write for more information. Place orders or request information on our Ansaphone at cheap rate times.

Goods normally by return.

## PRACTICAL WIRELESS P.C.B.s

We have in stock PCBs for every Practical Wireless project from 1978, so delve into those back issues of Practical Wireless and find that project you promised yourself you would build, then give us a call and we will be pleased to quote you for the PCBs.

E.G. January 1980 AF Speech Processor WR068 £2.98  
Full Kit for above £23.50

This is just one of the many exciting projects you can build from Practical Wireless.

June 1983	PW RTTY	WR167	£4.50
July 1983	Marchwood Power Unit	WR161	£3.00
July 1983	PW Seven	WR169	£2.75
July 1983	PW Seven	WR168	£2.00
July 1983	PW Prescaler	WR172A	£3.00
July 1983	PW Prescaler	WR171	£1.75
Oct 1983	PW Capacitance meter	WR174	£2.75
Oct 1983	PW Digital calibrator	WR173	£3.50
	PW Dart	WR176/177/178	£3.75
	Bridport	WR182 (each)	£2.75
	Transceiver Box Unit	WR179	£4.00
	PW IF Signal Generator	WR175	£5.00
May 1984	Top Direction Receiver	WR183	£4.00
May 1984	Top Band Receiver	WR184	£4.30
June 1984	Auto Notch Filter	WR185	£3.25
		WR187	£2.50
		WR188	£2.50
		WR189	£4.45
	Bug Key with memory	WR190	£3.25
	Modifying FRG7	WR191	£2.50
	Remote MF Loop	WR192	£3.00
	Remote MF Loop	WR192/A/B	£6.50
	Bug Key with memory	WR193	£3.50
	Battery State Indicator	WR194	£3.50
	Modifying FRG7	WR195/A/B	£3.50
	Stable Tone Burst	WR196	£5.00
	PW Tema		

Suppliers of R.S. Components.

Please send Cash with Order

Barclaycard Visa

### C. BOWES

Unit 7, Kenwood Road, Reddish, Stockport, Cheshire SK5 6PH.

Tel: 061 432 9434

Goods by Return

## NEW THIS MONTH

### FIBRE OPTICS

Scoop purchase of single and twin cable. For use with visible light or infra-red. Core 1mm dia overall 2.25mm dia Single 50p/m; 20m coil £8.30. Twin 90p/m. 20m coil £11.00.

### PCB MOUNTING NI-CADS

Much sought after 4.8V 150mA batts with PCB mntg tags on 25mm pitch Batt size 25x16 Ø. Ideal for paralleling. 99p ea; 10+ 85p; 25+ 70p; 100+ 60p.

### STEPPING RELAY

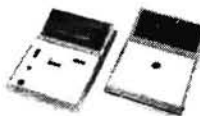
Schrack 2 pole 10 wty 24V DC (works down to 15V) only 39x20x24mm. Connexions by 0.1" pitch edge plug. Special low price £1.95.

### MINIATURE RELAYS

PCB mounting DPCO size 20x15x15mm. Available in 3, 9 or 12V. £1 each.

### NI-CAD CHARGER SCOOP!!

Ever-Ready model CH4. This charger will take up to 4 AA, C or D cells plus 2 PP3 if required. Smart two tone grey case 212x97x60mm. Only £7.95.



These digital multimeter cases are moulded in high impact black plastic and are offered at an extremely attractive price to clear stocks.

**DP2010** - 110x80x20mm, this too has cut-outs for range switches and terminals, with a smart aluminium fascia marked with ranges etc. Batter accessible by removable cover on back 75p.

**DP100** - Same size as above, but this was for use as a digital thermometer, so theres only a single 9mm Ø hole in the front panel 75p.

### VEROBOARD & RIBBON CABLE

Discontinued lines, some at less than 1/2 price!! e.g. Dipboard 158x165mm £3.50; 28W Grey ribbon £4/3m; Rad wirewrap wire 24AWG £2.50/100m Full details on List 18.

## 1984/85 CATALOGUE

84 page A4 size - Bigger, Brighter, Better - more components than ever before! With each copy there's discount vouchers, Bargain List, Wholesale Discount List, Bulk Buyers List, Order Form and Reply Paid Envelope. All for just £1.00!! Winter Supplement due out November - Send large SAE for your free copy

### RADIO/AUDIO PANELS

**Z908** - Panel 147x38mm with 2 x TDA1004 8W audio amp. IC's not soldered in! so they can easily be removed Also 1000/16, 1000/10 x 2 470/16 elec, ceramic discs, R's, also choke. (All easily removed). Stereo Amp? Only £3.00 (IC's cost £4 ea).

**Z909** - Another board which escaped the clutches of the flow solder machine - 103x39mm, this is an RF panel with a TDA1200 FM/IF chip & uPC1176C noise canceller + R's & C's inc. tants. Chips cost around £8 together. Price for panel £2.50.

**Z910** - 139x39mm, this panel has soldered in components - TCA4500A and TBA651R, AM radio with IF amp. Probably complete RF section of radio as IF's and trimmers are on board, + R's, C's etc. £2.50.

**Z911** - L shaped board 125x35mm. Looks like RF section of radio - BF194-5 etc + trimmers & IF's, but tuner is absent £1.00.

**Z912** - Same as Z909. only components have been soldered £2.50.

**Z913** - Another L shaped panel 135x40mm with non-soldered components including: BC549C x 2, BC208 x 3, BF241 x 2, BF194, coils, trimmers, R's, C's etc. £1.00.

### POWER/VU METER

Neat unit 40x40mm scaled 0-25 200uA movement. Only £1.00; 10 for £8; 25 £17; 100 £58.

Official orders welcome - minimum invoice charge £10. No. min. on CWO. Goods normally despatched by return of post

Our shop has enormous stock of components and is open from 9.30 Mon Sat. Come & see us!



**GREENWELL**

443B Millbrook Road Southampton

SO1 0HX Tel: (0703) 772801/783740

ALL PRICES INCLUDE VAT. JUST ADD 60p P&P





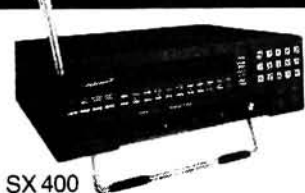
Bernie - let's wish all our friends a Merry Xmas & Happy New Year!



And may their cups overflow with Brenda's coffee!



# WHERE BETTER DEALS ARE MADE



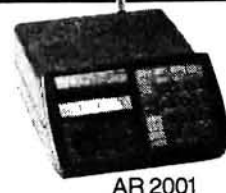
SX 400



YAESU 757 GX



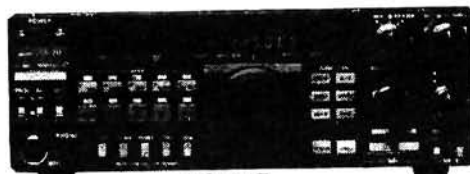
ICOM IC-R71



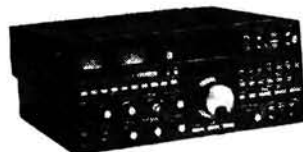
AR 2001



ICOM IC-745



TS 711E



YAESU FT-980 CAT SYSTEM

Kenwood's new Multi Mode Base Station  
PHONE FOR BEST PRICES OF NEW & 2ND HAND

## VERY SPECIAL OFFERS

- \*NEW FRG7700 + DRAE SLOW SCAN UNIT £488
  - \*NEW FRG7700 £325
  - \*FRG 7700 DISPLAY MODELS £299
  - \*DRAE SLOW SCAN £189
- From your radio receiver to your TV

## EVEN FASTER BUY MAIL ORDER



YAESU	£	KENWOOD	£	ICOM	£	MICROWAVE	£
FT1 HF Tx/Rx	1587.00	TS930S HF tcvr	1150.00	IC751 HF Tx/Rx	1,999.00	MML144/30LS	75.00
FT980 HF Tx/Rx	1329.00	AT930 ATU	150.00	ICP35 PSU	149.00	MML144/S0S	92.00
SP980 speaker	61.50	SP930 speaker	82.96	IC745 HF Tx/Rx	839.00	MML144/100S	149.95
FT102 HF Tx/Rx	719.00	TS430S HF tcvr	759.00	IC730 HF Tx/Rx	656.00	MML144/100HS	149.95
FC102 ATU	185.00	PS430 AC psu	119.00	PS15 PSU	119.00	MML144/100LS	169.95
SP102 speaker	55.00	SP430 speaker	31.00	ICR70 Rx	565.00	MML144/200S	245.00
FM/AM	49.00	AF250 ATU	277.00	ICR71 Rx	619.00	MML432/30L	139.95
FT77 HF Tx/Rx	479.00	MB430 mobile unit	12.00	FL45 filter	48.00	MML432/100	245.00
MRKT77 marker	10.95	FM430 FM mod	36.50	FL63 filter	39.00	MMC435/600	29.90
FP700 PSU	145.00	TS830S HF tcvr	758.00	IC2K1 1kw	1,349.00	MM2001	189.00
FC700 ATU	103.00	VFO230 VFO	258.00	IC271E 2m base	829.00	MM4001KB	299.00
MMB16 mount	14.40	AT230 ATU	143.00	IC271H 2m 100w	649.00	MMT144/28	109.00
FT757GX HF Tx/Rx	718.00	SP230 speaker	43.00	ICP25 PSU	89.00	MMT432/28S	159.96
FC757AT ATU	245.00	TS530SP HF tcvr	699.00	IC290 2m 25w	499.00	MMT432/144R	184.00
FP757GX PSU	145.00	VFO240 VFO	95.00	IC471E 70cm base	735.00	MMT1296/144	215.00
FP757HD PSU	179.00	TL130S HF tcvr	576.00	IC490E 70cm	495.00	MMC144/28	29.90
FL2100Z amp	599.00	TL120 200w 1 n	177.00	ICD2 2m h/hold	239.00	MMDO50/500	75.00
FT290R 2m Tx/Rx	279.00	MB100A mobile mount	19.50	ICD4 70cm h/hold	1.65	MMF144	11.90
FT290R 70cm Tx/Rx	279.00	SP120 speaker	27.99	HM9 speaker/mic	16.50		
FT209 2m Tx/Rx	239.00	SP140 speaker	14.49	LC3 case	6.95		
FT209 RH 5w	259.00	AT130 ATU	88.95	LC11 case	25.00		
NC11 charger	10.85	PS20 PSU	57.75	BP3 nicad	25.00		
NC nicads	22.00	TL922 2kw	960.00	BP4 AA	7.99		
CSC1A case	4.45	PHONE		BP5	48.00		
YHA/S Art	5.65	TS711E	458.00	DC112v	12.50		
MMB11 mount	28.19	TR9130 2m tcvr	49.00				
FL2010 amp	86.56	BO3A base	323.00				
FT208 2m h/hold	209.00	TR7930 2m tcvr	459.00				
FT708 70cm h/hold	189.00	TW4000A 2m/70cm	249.00				
NC9C charger	9.20	TS2600 2m H/H	73.90				
FNB2 pack	23.00	V6250 30w amp	54.90				
PA3 12v	16.00	ST2 charger	14.50				
MMB10	8.45	SC4 case	33.90				
FT203R 2m h/hold	175.00	MC1	17.00				
MH-12A2B mic	17.80	SMC25 speaker/mic	26.50				
MMB21 bracket	6.00	PB25 nicad	26.50				
FT230R 2m 25w	299.00	LH2 case	25.40				
FT230R 70cms 10w	239.00	BT1 AA case	5.98				
FT259 2m	778.00	DC25 12v	17.00				
430/726	299.00	TR2600 70cm H/H	279.00				
144/726	185.00	TM401A 70cm	310.00				
50/726	195.00	TM201A 2m	279.00				
SAT726	99.90	SP50 speaker	14.95				
		R600 Rx	272.90				
		R2000 Rx	436.00				

PRICES CORRECT AT TIME OF GOING TO PRESS ALL OFFERS SUBJECT TO AVAILABILITY.

WE CANNOT POSSIBLY LIST EVERY SINGLE ITEM WE STOCK. BUT WE DO CARRY ALL THE WELL-KNOWN BRANDS INCLUDING:

- ALINCO Rotators and VHF amps
- BNOS Power supplies and VHF amps antennas
- DIAMOND antennas
- JAYBEAM antennas
- T.E.T. antennas
- DRAE antennas
- ICS AMTOR slow scan antennas
- WRASSE antennas
- TONNA keys
- HI-MOUND wavemeters
- AKD HS antennas
- S.M.C. antennas
- F.D.K. antennas
- MICROWAVE MODULES
- MUTEK RTTY/CW/AMTOR
- TONO CONFIDENTIAL FREQUENCY LIST

PHONE FOR BEST PRICES FOR CASH, CHEQUE OR NORMAL H.P.  
CLOSED - Mondays OPEN Wednesdays  
TUES, WED, THURS, FRI 9.30-5.30.  
SAT 9.30-5.00.

ALL PRICES INC. VAT

LONDON:  
373 UXBRIDGE ROAD,  
ACTON,  
LONDON W3 9RH.  
Tel: 01-992 5765/6

NORTHERN  
38 BRIDGE STREET,  
EARLESTOWN, NEWTON LE WILLOWS,  
MERSEYSIDE WA12 9BA.  
Tel: 092 52 29881



more on your wavelength

AMATEUR RADIO EXCHANGE LTD



# R. WITHERS communications

## TRANSCEIVERS YAESU

FT757GX	£719.00
FT726R	£775.00
<i>(inc. 2mtr option)</i>	
FT209R/FNB3	£239.00
FT209/FNB4	£249.00
FT203R/FNB3	£175.00
FT 203R/FNB4	£185.00
NC15 Charger	£40.95
NC8 Charger	£54.95

## THE FULL YAESU RANGE KEPT IN STOCK

Always in stock ICOM, FDK, Kenwood, Mutek, Welz, Hi. Mound, D.N.T./LCL 10 metre FM Transceivers and of course our now very famous mod kit for the above rigs.

**RWC best seller complete mod. kit for DNT.M40/LCL2740 at £12.95 inc. postage, with complete instructions.**

## SPECIAL OFFERS

FT790R inc. Ni-Cads and Charger, plus FREE HB9CV 70cms. **£279.00**

FT708R inc free Ni-Cad Case & Charger, plus FREE HB9CV. **£199.00**

FTV707 + 2mtr module, complete usable on most Yaesu HF Transceivers. **£159.00**

FT730R or FT230R. Great Little Mobiles. Free Gutter Mount & Cable Assembly.

FT730R RWC Price **£249.00**  
FT230R RWC Price **£269.00**

With all H.F. Transceivers purchased up to Dec. 31st FREE 1/2 size G5RV and FREE Comm Headphones!

**That's RWC Value!**

## ANTENNAS ACCESSORIES

Hoxin 7/8 2 mtr **£15.95**

SMC 2m/70cm Colinear **£32.95**

Base Station Aerial **£18.95**

SMC 3x5/8 70cm **£12.50**

Hoxin 1/2 Wave 2 metre DC ground mobile comp with cable & plug RWC. **£12.50**

Sun 3x5/8 2mtr Base Colinear **£28.95**

RWC G5RV 1/2 size **£12.95**

RWC G5RV full size **£14.95**

G8KW/W3DZZ Traps. The pair **£9.50**

AJH 25 watt linear amp. 2 watts input kit **£29.95**

Case & Heatsink **£6.00**

Complete range of Revco Coils/Whips & Bases now in stock.

Also Tonna/Jaybeam/R.W.C. HB9 & CV.

## SCANNERS & RECEIVERS

Revco RS2000 Scanner V.H.F.-U.H.F. Air, Marine, Pair FM-AM 70 Memories, Gasfet Model **£259.00**

Extended Coverage (60-179 MHz) (380-520MHz) **£279.00**

Century 21D Gen Coverage Receiver **£199.00**

The fabulous SX400 now here, ask for RWC Price! Special offer on the terrific Revco Discone RU Antenna only **£28.99**

Always wanted, used equipment working or not. Ask about selling your old rig on our Special Commission Sale Agreement! PX, Welcome.

The AOR 2001 continuous coverage scanner in stock. 26-550MHz **£339.00**

All above inc. VAT + Carr.



MON, SAT 9.30-5.30 LATE NIGHT THURS/FRI  
Secondhand lists available/part exchanges welcome  
**STOCK ITEMS NORMALLY DELIVERED WITHIN 7 DAYS**  
Overseas customers welcome, we speak German and Japanese  
Telex: 334303 TXAGWM/G

**584 HAGLEY ROAD WEST, OLDBURY, WARLEY B66 0BS (QUINTON, BIRMINGHAM)**

Carriage At Cost

Tel: 021-421 8201/2 (24 HR ANSWERPHONE)

S.A.E. with all enquiries please.  
E. & O.E.

**VIDEO RECORDERS:** Philips N1500/1/2 series, colour, int 6/8 chan Rx,R.F. Mod, Analogue/Dig Clock with two cassettes & circs. N1500/1 £55, N1502 £65. **AERIALS:** Army telescopic 27ft 6 section, 5ft closed, 14Kg £28 (no guys) also Mast Kit 30ft 10 section 1" with accs & carrying bag £30. **WHIP AE:** 16ft 4 section with base insulator £8.50 also Whip Ae 10ft section 18" closed £4.50 also Long Wire Ae kit comprises 120ft flex insul wire, 4x chain link insul & 2 x 25ft cords £6.50. **TAPE RECORDERS:** Ferrograph Series 7 two chan £115 7 & Series 6 single chan £85 E.M.I. (MOD.RE301 series) two chan 7 1/2" 15" with book £65. **R.F.OSC DRIVE ASS:** Comprises 10 chan swt xtal osc 2 to 8Mc/s with crystals, the O/P from these is amplified by a wideband amp to bring O/P up to 2 watts into 50 ohm, req 24v DC supply, supplied with can swt etc approx size 8x6x2 1/2" £14.50. **L.V. POWER UNIT COMPONENTS:** Bridge rect potted 200 PIV 10 amps £2, Elec Conds 5000 Uf 50v £1.30. Heat Sinks fanned 4 1/4 x 4 1/2 x 1 1/2" with 2 x 2N3055s £2.30 also size 7 1/2 x 4 1/4 x 1" drilled for 2 x T.O.3 flat on one side £2.30. Trans.Pria 110/225/250v Secs 16v at 9 amps, 29v at 5 amps potted C core size 5 1/2 x 5 1/2 x 5" these will supply up to 15 amps using the 16v winding only without distriess on the 225v tap £14.50. **VALVE KITS:** with 2 x 6VGT, 2 x ECH35, 2 x L63 (6C5) 6x5 £4.50. **RADIOSONDE UNITS:** MK.II contains valve RF Osc on 27Mc/s and three sensors whose O/Ps are used to modulate RF O/P, sensors for Temp, Press & RH req 90/2v new cond with circ 7 chart £7.50. **SIG GENs:** Marconi TF144G HF unit 85Kc to 25Mc/s in 8 bands Var 1Uv to 1v metered O/P teated with inst book & leads, large bench unit £65. **VALVE VOLTMETERS:** Marconi TF1041B mains, 8 ranges of DC volts 300 MillIv to 1Kv, 7 ranges of AC volts 300 MillIv to 300V, 8 ranges of resist 50 ohms to 500Megs, as DC/ohms probe & AC/RF probe to 1500Mc/s in case size 11x8x7" tested with book £48. **ARMY RECT:** No. 7 I/P 200/250v or 12v DC these provide 80+80v for tellyprinters also 12v DC & 40v AC can also be adapted to give 240v AC from 12v DC I/P at 40 watts in wood case size 7x9x7" with circ £8.50. **TRANS H.D.LT:** type 240v to 5v at 30 amps & 6.3v at 15 amps potted £10.50. **RESISTANCE MATTS:** size 14x15" approx 500 watts available in 490, 320, 95 & 29 ohms £4.50 ea. **X.BAND W.M.** 9170 to 9470Mc/s with meter indication & var 0/100Db atten in case with connec £23.

Above prices inc Car/VAT. Allow 14 days for delivery  
Goods ex equipment unless stated new.  
S.A.E. with enquiry or 2 x 17p stamps for List 35.

## A. H. SUPPLIES

122 Handsworth Road, Sheffield S9 4AE  
Tel. (0742) 444278

## VALVES

Minimum Order £1		*Special Quality	VALVES VAT IS INCLUDED				
ECC83	0.65 EY51	0.95 QV03-12	4.20 5R4GY	1.80 6F8G	0.25 12AU7	0.60	
ECC84	0.60 EY81	0.65 SP61	1.80 5U4G	0.75 6F12	1.10 12AV6	0.55	
ECC85	0.60 EY86/87	0.60 TT.1	32.20 5V4G	0.75 6F14	1.15 12AX7	0.65	
ECC88	0.80 EY88	0.65 TT22	29.50 5Y3GT	0.95 6F15	1.30 12BA6	0.90	
ECC189	0.95 E280	0.70 UABC80	0.75 5Z3	1.50 6F17	3.20 12BE6	1.25	
ECC804	0.90 E281	0.70 UAF42	1.20 5Z4G	0.75 6F23	0.75 12BH7	3.00	
ECF80	0.85 GM4	5.90 UBF80	0.70 5Z4GT	1.05 6F24	1.75 12E1	18.95	
ECF82	0.65 GY501	1.30 UBF89	0.70 6/30L2	0.90 6F33	10.50 12J5GT	0.55	
ECF801	1.05 GZ32	1.05 UCC84	0.85 6A87	0.70 6F38	12.50 12K7GT	0.70	
ECH34	2.25 GZ33	4.20 UCC85	0.70 6A7	1.15 6G48	1.95 12K8GT	0.80	
ECH42	1.20 GZ34	2.75 UCF80	1.30 6A65	0.80 6G48A	1.95 12Q7GT	0.80	
ECH81	0.70 GZ37	3.95 VCB42	1.95 6AH6	1.15 6H6	1.80 12S7	0.85	
ECH84	0.80 KT88	10.95 UCH81	0.75 6AK5	0.85 6J16	5.85 12SH7	0.65	
ECL80	0.70 KT88	18.40 UCL82	0.95 6AK8	0.80 6J4	1.35 12S7	0.70	
ECL82	0.75 M14	2.80 UF41	1.35 6AL5	0.80 6J4W4	2.00 12S07	1.45	
ECL85	0.80 M16	2.80 UFR0	0.95 6AL5W	0.85 6J5	2.30 12S07GT	0.85	
ECL86	0.90 N78	9.90 UFR5	0.95 6AM5	4.20 6J6	0.90 12Y4	0.70	
EF37A	2.15 OA2	0.70 UL94	0.95 6AM6	1.50 6J6	0.65 13D3	2.80	
EF39	1.50 OB2	0.80 UM180	0.90 6AN8A	2.50 6J6W	0.90 13D5	0.90	
EF80	0.65 PCL82	0.95 UM84	0.70 6AQ4	3.40 6F8H	17.80 19AQ5	0.85	
EF83	1.75 PCL84	0.90 UY82	0.70 6A05	1.00 6K7	0.80 18G3	11.50	
EF85	0.80 PCL86	0.75 UY85	0.85 6A05W	1.80 6K7C	4.85 19G6	8.50	
EF86	0.75 PCL805/85	0.95 VRI05/30	1.25 6A6	1.15 6J5C	4.85 19H5	38.55	
EF89	1.80 PD500/510	4.30 VRI50/30	1.35 6AT8	1.90 6K0B	4.50 20D1	0.80	
EF91	1.80 PL200	1.10 X86	0.95 6AU6	0.80 6L8M	2.80 20E1	1.30	
EF92	1.50	2.80 X61M	1.70 6AV6	0.65 6L8G	3.70 20P1	0.85	
EF95	0.65 PL36	1.10 Z759	19.00 6AX4GT	1.30 6L8GT	1.80 25LEGT	0.95	
EF96	0.60 PL81	0.85 Z749	0.75 6AX5GT	1.30 6L18	0.70 25Z4G	0.75	
EF183	0.80 PL82	0.70 Z800U	3.45 6A6	0.80 6L20	0.70 35W4	0.80	
EF184	0.80 PL83	0.60 Z801U	3.75	0.70/1.20* 6Q7G	1.30 85A2	1.40	
EF312	0.70 PL84	0.95 Z803U	16.00 6BE60.60/1.20*	6S47	1.80	2.55*	
EF200	1.85 PL504	1.00 Z900T	2.45 6B6G	1.60 6S7L	1.50 807	1.60/2.40*	
EL32	1.10 PL508	2.40 1A3	1.40 6B16	1.30 6S7J	1.00 813	19.32	
EL34	1.80/3.50	PL509	5.80 1L4	0.50 6BQ7A	0.85 6S7K	1.40	
EL37	5.20 PL519	5.80 1R5	0.80 6B7	4.80 6B7R	4.80 8298	24.00	
EL82	0.70 PL802(SE)	2.95 1S4	0.45 6B8V	6.20 6B17GT	0.85 832A	3.80	
EL84	0.95 PY80	0.70 1S5	0.45 6B9V7	1.80 6SN7GT	0.80 866A	3.90	
EL86	0.80 PY81/800	0.85 1T4	0.45 6C4	0.50 6S07	0.95 865E	6.25	
EL90	1.00 PY82	0.80 1T4	0.80 6C6	0.50 6S6	1.50 20P1A	1.25	
EL91	6.50 PY88	0.60 1X2B	1.40 6CH6	8.20 6V8GT	0.60 955	1.20	
EL95	0.80 PY500A	2.10 2X2A	2.90 6CL6	2.75 6X4	0.95 955	1.20	
EL504	1.70 QV03/10	3.20 3A4	0.70 6CW4	8.50 6XS5GT	0.65 956	1.20	
EL509	3.95	7.50* 3A72	2.40 6CX8	3.80 6Y6G	0.90 9763	4.80	
EL519	6.90 QV03-20A	3828	12.00 6CY5	1.15 6Z4	0.70 6006	1.95	
EL821	8.20	21.50	19.50* 6D6	0.70 8D6	2.90 6080	5.30	
EL822	9.95	QV03-25A	3D6	0.95 6F6	1.60 11E2	1.90 6146	6.80
ELL80(SE)	2.80	36.50	3E29	19.00 6P6GB	1.10 12A6	1.00 6146B	6.80
EM80	0.80	QV06/40A	3S4	0.80 6F7	2.80 12AT6	0.70 6360	2.85
EM87	1.30	19.50/36.50*	4B32	18.25 6F8H	17.80 12AT7	0.85 6550	8.05

VALVES AND TRANSISTORS Telephone enquiries for valves, transistors, etc. Retail 7493934, trade and export 743 0899. **PRICES MAY VARY. POSTAGE:** £1-£3 50p; £3-£5 60p; £5-£10 80p; £10-£15 1.00p; £15-£20 1.50p; over £20 2.00p. Same day despatch.

**COLOMOR (ELECTRONICS LTD.)** 170 Goldhawk Rd, London W12  
Tel: 01-743 0899 or 01-749 3934. Open Monday to Friday 9 a.m.-5.30 p.m.





# MICROWAVE MODULES LTD

## SOMETHING FOR EVERYONE

### MMS1

#### THE MORSE TALKER



This unique product is a self-contained speaking morse tutor and, as well as a random morse generator, the MMS 1 incorporates a microprocessor speech synthesis system which provides talk back of random morse. This product is a truly cost effective means of obtaining a full class 'A' amateur licence, without having to rely on a third party for instruction.

#### FEATURES-

- ★ Wide speed range: 2.20 wpm.
- ★ Segmented alphabet choice for novices.
- ★ Variable group length - 1, 5, 50 characters. Truly random and accurate.
- ★ Internal loudspeaker. 12v DC operation. Available from stock.

£115 inc VAT (p+p £3)

### MMC 144/28 HP

144 MHz HIGH PERFORMANCE RECEIVE CONVERTER



Input frequency range : 144-146 MHz  
Output frequency range : 28-30 MHz  
Typical gain : 20 dB minimum  
Noise figure : 2 dB  
3rd order intercept point : +19 dBm (output)

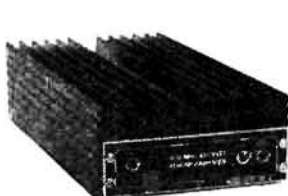
#### FEATURES

- ★ Excellent strong signal handling characteristics
- ★ Gasfret RF amplifier
- ★ High level double-balanced mixer
- ★ Harmonic-free, regulated oscillator

£42.90 inc VAT (p+p £1.25)

### MML 432/30-L

#### 70CM 30 WATT LINEAR AMP WITH RECEIVE PREAMPLIFIER



#### FEATURES-

- ★ RF Vox
- ★ 1 or 3 watts input (switchable)
- ★ Suitable for SSB & FM
- ★ 30 watts output
- ★ Suitable for use with rigs such as FT290R, FT208R, IC4E, C78, TR3500 etc. Available from stock.

£139.95 inc VAT (p+p £3.50)

### MML 144/30-LS

#### 2M 30 WATT LINEAR AMP WITH RECEIVE PREAMPLIFIER



#### FEATURES-

- ★ RF Vox
- ★ 1 or 3 watts input (switchable)
- ★ Suitable for SSB & FM
- ★ 30 watts output
- ★ Suitable for use with rigs such as FT290R, FT208R, IC2E, C58, TR2500 etc. Available from stock.

£75 inc VAT (p+p £3)

### MML 144/200-S

144 MHz 200 WATT LINEAR AMPLIFIER

NEW



#### FEATURES

- ★ 200 watts Output Power
- ★ Linear All Mode Operation
- ★ Suitable for 3, 10 & 25 watt Transceivers
- ★ Ga As FET Receive Preamp
- ★ Front Panel Selectable
- ★ Relative Output LED Bar Display
- ★ Equipped with RFVox & Manual Override
- ★ LED Status Lights for Power, Transmit, Preamp on and input level

£245 inc VAT (p+p £4.50)

### MTV435

#### 435MHz 20WATT ATV TRANSMITTER

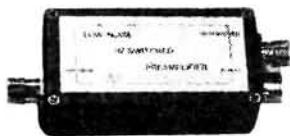


This high performance ATV transmitter consists of a dual channel exciter, video modulator and a two stage 20 watt linear amplifier. It is suitable for monochrome and colour transmissions, has two switch selectable video inputs, and includes a test wave form generator. Full transmit/receive switching is incorporated and aerial changeover is achieved by a PIN diode switch, which allows connection of the 435MHz aerial to a suitable receive converter, such as the MMC435/600 which is available at £29.90 inc. VAT, p&p £1.25. Available from stock.

£159.95 inc VAT (p+p £3)

### MMA144V

#### 2M RF SWITCHED PREAMPLIFIER



This RF switched low-noise receive preamplifier utilises the proven 3SK88 MOSFET in a noise matched design. Providing a power gain of 15dB and having a noise figure of 1.3dB, this unit will accept a through power of 100 watts. Available from stock.

£34.90 inc VAT (p+p £1.25)

### MMC144/28

#### 2M CONVERTER



This low-noise converter when used in conjunction with a 28-30MHz receiver will provide reception of the 2 metre amateur band. All that is required is a 12 volt supply and a suitable antenna. Available from stock.

£29.90 inc VAT (p+p £1.25)

### MM2001

#### RTTY TO TV CONVERTER



This converter contains a terminal unit and a microprocessor controlled TV interface and requires only an audio input from a receiver to enable a live display of "off-air" RTTY and ASCII on a domestic UHF TV set, or video monitor.

- ★ RTTY - 45, 50, 75, 100 baud
- ★ ASCII - 100, 300, 600, 1200 baud
- ★ Switchable input filter
- ★ Parallel printer output
- ★ UHF and Video outputs
- ★ 16-line, 64 character display
- ★ 12v DC operation

£189 inc VAT (p+p £3)

### MM4001 KB

#### RTTY TRANSCIVER

This package, when connected to a transceiver and a domestic UHF TV set provides a data communication capability at a cost of half of any similar system, for both RTTY and ASCII.

#### FEATURES

- ★ RTTY - 45, 50, 75, 100 baud
- ★ ASCII - 110, 300, 600, 1200 baud
- ★ Four message stores
- ★ Stored test functions (RY, QBF, etc)
- ★ Auto CO call
- ★ Full size Qwerty keyboard
- ★ Parallel printer output
- ★ UHF and Video outputs
- ★ 16 line, 64 character display
- ★ 12v DC operation

£299 inc VAT (p+p £4.50)

A COPY OF OUR CURRENT CATALOGUE DETAILING OUR ENTIRE RANGE OF PRODUCTS IS AVAILABLE BY SENDING A LARGE S.A.E. (25p), OR 40p IN STAMPS

ALL MICROWAVE MODULES PRODUCTS ARE FULLY GUARANTEED FOR 12 MONTHS (INCLUDING PA TRANSISTORS)



**WELCOME**  
Goods normally despatched within 10 days.

**MICROWAVE MODULES (PW)**  
BROOKFIELD DRIVE, AINTREE, LIVERPOOL L9 7AN, ENGLAND  
Telephone: 051-523 4011 Telex 628608 MICRO G  
CALLERS ARE WELCOME PLEASE TELEPHONE FIRST

E.&O.E.

**HOURS:**  
MONDAY TO FRIDAY  
9-12.30, 1-5.00



# Amcomm of London

INTEREST  
FREE HIRE  
PURCHASE ON  
MANY  
ITEMS

01-422 9585 FOR FAST DELIVERY

2 YEAR  
GUARANTEE  
ON MANY  
PRODUCTS

## HF TRANSCEIVERS

YAESU FT 980	1299:00
ICOM IC 751	1059:00
TRIO TS 930S	1150:00
YAESU FT 757GX	699:00
TRIO TS 430S	739:00
ICOM IC 745	799:00
YAESU FT 77	499:00

All accessories available for above.  
Carriage and VAT included.

## 2M TRANSCEIVERS FM

YAESU FT 230R 25w mobile	269:00
ICOM IC 27E 25w mobile	289:00
TRIO TM201A 25w mobile	269:00
YAESU FT 208R H/Held 3w	239:00
YAESU FT 209R H/Held 5w	259:00
ICOM IC2E H/Held	169:00
ICOM IC02E H/Held keyboard	239:00
FDK Multi 725x 25w mobile	239:00
YAESU FT 290R	Phone

Carriage and VAT included.

## 2M TRANSCEIVERS MULTIMODE

YAESU FT 726R 2M/70cms/6M/HF Basic	769:00
ICOM IC 271E 25w base stn	625:00
ICOM IC 271H 100w base stn	799:00
TRIO TR 9130 25w mobile	449:00
MULTI 750XX 20w mobile	349:00

Carriage and VAT included.

## 70CM TRANSCEIVERS

YAESU FT 790R Multimode portable	259:00
YAESU FT 703 H/Held	T.B.A.
YAESU FT 709 H/Held	T.B.A.
ICOM IC 4E H/Held	229:00
TRIO TW4000A 70/2M mobile	469:00
MICRO 7 3 channel 70cms H/Held	99:00

Carriage and VAT included.

## HF/VHF RECEIVERS

YAESU FRG 7700 RECEIVER	385:00
ICOM IC R70	539:00
ICOM IC R71	629:00
TRIO R2000	429:00
TRIO R600	259:00
AR 2001 25/550Mhx	★ STAR BUY ★ 325:00
NRD 515	965:00

Carriage and VAT included



## ANTENNA COUPLERS

THP HC200 1.8-30MHz 20w pep	82:95
THP HC400L 1.8-30MHz 350w pep	149:00
THP HC2000 1.8-30MHz 25w pep	T.B.A.
AMTECH 300B 1.8 300MHz 300w pep	54:00
ICOM IC AT500 AUTOMATIC	399:00
ICOM IC AT1000 AUTOMATIC	Phone
YAESU FC 757 AUTOMATIC	245:00
YAESU FC 102 WARC 2Kw	Phone
WELZ AC38 1.8 300MHz	73:95

VAT included. Amtech 300B 1.50 others £6 Securicor.

## TELEGRAPH ACCESSORIES

### Hi Mound Keys

HK 708 Hand Key with base	13:67
HK 707 Hand Key with base and dust cover	14:48
HK 706 Hand Key with base and dust cover	15:60
HK 702 Key with marble base and dust cover	29:65
MK 704 Dual lever paddle, no base	12:76
MK 705 Dual lever paddle marble base	23:78
COK-2 Practice oscillator	7:99
Swedish Brass	49:00
KENPRO Iambic Electronic Keyer KP100	75:00
KENPRO Iambic Memory Keyer	149:00
DAIWA DK210 Electronic Keyer	50:00

VAT included. Add £1 carriage per item.

## HEIL ACCESSORIES

HEIL HC3 Microphone Element	22:85
HEIL HC5 Microphone Element (Icom SM5/6)	25:40
HEIL HM 5 Desk Microphone (300Hz-3KHz) cardoid fwd	59:00
HEIL SS2 SPEAKER . . . see page 00	65:00
HEIL EQ300 Mic Equaliser	

when ordering equaliser state make of rig . . . . . 65:00

Carriage and VAT included.



## SWR/POWER METERS

WELZ SP200 1Kw	82:00
WELZ SP300 1Kw	115:00
WELZ SP400 150w	82:00
WELZ SP15M 200w	41:00
WELZ SP250 2Kw	57:75
TOYO TM1X 3.5 150MHz 120w	18:80
TOYO T430 145/430MHz thru line watt meter 120w	44:65
TOYO T435 145/435MHz thru line watt meter 200w	49:35

VAT included. Add £2 per item carriage.

## VHF LINEAR AMPLIFIERS

THP HL30V 0.5-3w in 30w out	39:99
THP HL82V 10w in 85w out	144:50
THP HL110V 10w in 110w out	179:95
THP HL160V 10w in 160w out	244:52
THP HL160V 25w in 160w out	209:73
MML 144/30LS	75:00
MML 144/50S	92:00
MML 144/100S	149:95
MML 144/100HS	149:95
MML 144/100LS	169:95
MML 144/200S	245:00

B.N.O.S. complete range also in stock.  
VAT included. Add £2 per item carriage.

## UHF LINEAR AMPLIFIERS

MML 432/30L	139:95
MML 432/50	129:95
MML 432/100	245:00
THP HL20U 1-3w in 20w out	77:99
THP HL45U 10w in 45w out	152:77
THP HL90U 10w in 90w out	268:59
ALINCO ELH250C	114:95

B.N.O.S. complete range also in stock.  
VAT included. Add £2 per item carriage.

Goods normally despatched by return.

Prices correct going to press, E. & O.E.

CLOSED MONDAY



# Amcomm

SERVICES LTD., 194 NORTHOLT ROAD, SOUTH

HARROW, MIDDX. HA2 0EN. ENGLAND. (Opp. South Harrow Underground Station)

TEL: 01-422 9585. TELEX: 24263





## Reports of Our Death...

... ARE GREATLY EXAGGERATED. Regular readers of *Practical Wireless* will know that an industrial dispute last summer delayed publication of our September issue by almost a fortnight. The after effects of this same dispute meant that the October issue was around a week late, but a new factor—a major organisational upheaval at our printers—was added to our problems for the November issue, so even that was a few days behind schedule hitting the bookstalls.

We hear that some frustrated readers chasing their newsagents for their monthly infusion of *PW* have been given the most amazing stories about why we weren't there on time. Theories put forward have included: "There isn't going to be a September (or whatever month) issue", or "They're bringing out a combined issue next month", even "They're delaying publication so that the date on the cover will be the same as the month it appears". An attractive idea, that, but publishing traditions have prevented us doing anything like it so far.

More worrying were stories along the lines of: "*Practical Wireless* has been taken over by another publisher" or "*Practical Wireless* has closed". Let me assure you that *PW* has not been taken over, let alone closed down!

You will, though, see a few changes in some of our regular features this month. Perhaps the first—*Computing in Radio*—hardly qualifies as a regular yet. Because of production difficulties,

this issue of *CiR* has not got its usual full-colour cover. Instead, it looks like one of our traditional pull-out supplements. We hope that we'll have things under control again for our next issue of *Computing in Radio*, which will appear in our May issue.

*On the Air* definitely qualifies as a regular feature and a popular one at that, and here we are making some alterations to keep pace with developing interests in new modes. The first of these is to separate RTTY news from *VHF Bands*, where it was not really at home since much of it related to h.f. bands operation. The new section will expand in time to include Data, AMTOR and Packet Radio. The second alteration is to introduce a section dealing with amateur satellite communications, and here we welcome a new contributor, Pat Gowen G3IOR. More changes are planned to follow as the need arises, but the other one beginning this month is to turn Eric Dowdeswell's *Club News* into a section in its own right, and take it out of *On the Air* altogether.

I hope that you'll find these changes helpful, and that you will continue to enjoy reading *PW* month by month, as much as we all enjoy producing it for you.

Geoff Arnold

### QUERIES

While we will always try to assist readers in difficulties with a *Practical Wireless* project, we cannot offer advice on modifications to our designs, nor on commercial radio, TV or electronic equipment. Please address your letters to the Editor, "*Practical Wireless*", Westover House, West Quay Road, Poole, Dorset BH15 1JG, giving a clear description of the problem and enclosing a stamped self-addressed envelope. Only one project per letter please.

Components for our projects are usually available from advertisers. For more difficult items, a source will be suggested in the "Buying Guide" box included in each constructional article.

### PROJECT COST

The approximate cost quoted in each constructional article includes the box or case used for the prototype. For some projects the type of case may be critical; if so this will be mentioned in the Buying Guide.

### INSURANCE

Turn to the "News" pages for details of the PW Radio Users Insurance Scheme, exclusive to our readers.

### CONSTRUCTION RATING

Each constructional project will in future be given a rating, to guide readers as to its complexity:

#### Beginner

A project that can be tackled by a beginner who is able to identify components and handle a soldering iron fairly competently. Generally this category will be used for simple projects, but sometimes for more complicated ones of wide appeal. In this case, construction and wiring will be dealt with in some detail.

#### Intermediate

A project likely to appeal to a wide range of constructors, and requiring only basic test equipment to complete any tests and adjustments. A fair degree of experience in building electronic or radio projects is assumed.

#### Advanced

A project likely to appeal to an experienced constructor, and often requiring access to workshop facilities and test equipment for construction, testing and alignment. Constructional information will generally be limited to the more critical aspects of the project. Definitely not recommended for a beginner to tackle on his own.

### SUBSCRIPTIONS

Subscriptions are available at £13 per annum to UK addresses and £14 overseas, from "*Practical Wireless*" Subscription Department, Room 2816, King's Reach Tower, Stamford Street, London SE1 9LS. Airmail rates for overseas subscriptions can be quoted on request.

### BACK NUMBERS AND BINDERS

Limited stocks of some recent issues of *PW* are available at £1 each, including post and packing to addresses at home and overseas.

Binders are available (Price £5.50 to UK addresses, £5.75 overseas, including post and packing) each accommodating one volume of *PW*. Please state the year and volume number for which the binder is required.

Send your orders to Post Sales Department, IPC Magazines Ltd., Lavington House, 25 Lavington Street, London SE1 0PF. All prices include VAT where appropriate.

Please make cheques, postal orders, etc., payable to IPC Magazines Limited.



# PW RADIO USERS INSURANCE SCHEME



Practical Wireless Radio Users Insurance Scheme was devised by Registered Insurance Brokers B. A. LAYMOND & PARTNERS LIMITED following consultation with PRACTICAL WIRELESS to formulate an exclusive scheme designed to meet the needs and requirements of: Amateur Radio Enthusiasts ● CB Radio Users ● Taxi Companies and Fleet Users with Radio Telephones. A copy of the Policy can be inspected at the offices of B. A. Laymond & Partners Ltd., or of Practical Wireless in Poole.



## SPECIAL FEATURES

● All Risks Cover ● "New Lamps for Old" Cover (as defined in policy) ● Index Linked Cover to combat inflation ● Includes Personal Liability cover against damages payments of up to £500000 to members of the public ● Licence protection—covers legal costs arising from any breach of your licence conditions ● Equipment covered anywhere in the UK, Channel Islands and Isle of Man, but not Northern Ireland and Eire ● Fixed Antennas (Aerials) covered ● Frequency, Power and SWR Meters and similar radio-related test equipment covered ● 30 days cover on Western Europe included Free of Charge ● Absolute Security as this scheme is underwritten by a leading member of the British Insurance Association on the London Insurance Market ● Practical Wireless radio receiver and transmitter projects covered (when stated in feature) ● Available to Clubs and Organisations† ● Available to Companies†

†Write directly to B. A. LAYMOND & PARTNERS LTD, for a special application form and full details enclosing the coupon below.

B. A. Laymond & Partners Ltd., Practical Wireless and the Underwriters wish to make it clear that it is an offence to instal or use a radio transmitter in the UK except under the authority of a licence granted by the Secretary of State and it is not their intention to provide cover for or to encourage or condone the illegal use of CB and/or other communications equipment.

Cover for property contained in vehicles is subject to a Limit of Liability of £250, increased to £750 where the vehicle is protected by a reputable audible alarm, correctly set and operational.

When the vehicle is unattended, mobile equipment secured so that tools or a key are required to remove it must be disguised or concealed from view. Portable and mobile equipment not so secured must be removed and placed in a locked boot (or removed and adequately concealed from view if the vehicle has no boot), or removed from the vehicle entirely. Equipment not in a secure building or vehicle must not be left unattended.

## How Much Will It Cost?

Claims will be settled after deduction of an excess in the following manner:

Sum to Insure	£1000	£3000	£5000
Annual Premium	£20	£35	£45

The premium is charged on sums insured in pre-selected bands. Thus equipment totalling £3750 would be in the band up to £5000, and the premium would be £45. Quotations for larger sums available on application.

Type of Loss	Excess
From saloon cars and hatchbacks with fully concealed luggage compartments	15% of claim (minimum £25)
From estate cars, vans and hatchbacks without concealed luggage compartments	25% of claim (minimum £25)
All others:	Sums insured up to £3000 Sums insured up to £5000
	£25 £50

## How To Insure

Complete the application form below to obtain immediate insurance cover. Photocopies will not be accepted

APPLICATION FOR PRACTICAL WIRELESS RADIO USERS INSURANCE SCHEME						PW1/85
Name in full (State Mr, Mrs, Miss or Title)						
Address						
						Post Code
Occupation		Age	Phone No. (Home)		(Work)	
I/We hereby apply to insure the equipment detailed below						
BLOCK LETTERS	Manufacturer's Name	Model	Serial No.	Description of equipment to be insured e.g. Base station; Mobile; CB; etc.		VALUE £
	1					
	2					
	3	Antennas (Aerials), s.w.r. meters, etc.				
Please continue list of equipment on a separate sheet if necessary						<b>TOTAL SUM TO INSURE £</b>
<p><b>DECLARATION</b> I/We hereby declare that 1. The sums insured represent the full replacement value of the equipment. 2. I/We have not* had insurance cancelled, declined, restricted or other terms imposed in any way other than the normal Policy terms. 3. This proposal shall be the basis of the contract and that the contract will be on the Underwriters normal terms and conditions for All Risks and Legal Costs/Expenses cover unless otherwise agreed 4. I/We have not* sustained any loss or damage to any radio communications equipment or been involved in litigation relating to use of radio equipment during the past three years, whether insured or not 5. All the above statements made in connection with this proposal are true and no material information has been withheld 6. I/We understand no liability shall attach until this proposal shall have been accepted by Laymond's and the premium paid in full and a Certificate issued.</p> <p>* If you have, please give details on a separate sheet.</p>						
Date		Signed		Rush us details of PW Club Insurance <input type="checkbox"/> PW Company Insurance <input type="checkbox"/>		
<p>DELAY IN ARRANGING COVER COULD COST YOU A GREAT DEAL OF MONEY COMPLETE THIS APPLICATION AND POST WITH YOUR PREMIUM MADE PAYABLE TO "LAYMOND'S" NOW ADDRESS TO: PRACTICAL WIRELESS (INSURANCE), B. A. LAYMOND &amp; PARTNERS LTD. 562 NORTH CIRCULAR ROAD, LONDON NW2 7QZ. TELEPHONE: 01-452 6611.</p>						



## **Shimizu SS-105S Transceiver**

Several readers have queried with us the availability of spare parts and the optional modules for this semi-kit rig. We contacted the UK importers, Lowe Electronics Limited, for further information, and their answer is reprinted here for the benefit of all interested parties.

**Sir:** I would like to thank *Practical Wireless* for this opportunity to reply to enquiries regarding the Shimizu SS-105S h.f. transceiver.

When we heard about the part "build it yourself" SS-105S we thought, here was a rig that would be very popular with many radio amateurs. A rig which would give its owner the satisfaction of building part of it himself and when completed would not only work but would not be dismissed as worthless home-brew, indeed would be acceptable as a traded-in item against another piece of equipment. In our enthusiasm for the

transceiver, we ordered a large shipment. It just shows you how wrong you can be! The Shimizu SS-105S was not popular and did not sell. One reason may have been that it was compared with the TRIO TS120V which was a recognised "marque" and certainly looked more "professional".

As time went by and the price of new stock slowly increased the existing stocks of the Shimizu remained at their original price and became extremely good value for money. The word was also getting round that the kit, as we had always known, when completed produced a fine transceiver. Various notables bought them and Geoff Arnold, the editor of *Practical Wireless* enthusiastically reviewed his own.

This brings us to present day. The rig is still available on the Japanese home market but if it were imported would currently cost in the region of £495, including VAT. At this price we consider

the rig uncompetitive and doubt that it would sell. Spare parts are no problem and our reputation here rests on being able to keep the owners happy. Items available as options, e.g. filters, additional boards, are different. When we stopped buying the transceiver we also stopped the purchase of f.m. boards, c.w. filters, etc. However, these can still be obtained but their price has virtually doubled. If owners still require that optional board or filter with which to complete the rig then please write to us and we will order them.

Prices for the optional accessories, based on current exchange rate are as follows: Noise blanker board £19.95; FM receive board £43.00; FM transmit board £24.00; Marker board £24.00; 500Hz c.w. filter £40.00, all including VAT.

*David E. Monkhouse,  
Advertising and Marketing Manager,  
Lowe Electronics Limited.*

## **New Digital Colour TV**

Mitsubishi Electric Corporation announce that they have recently developed the technology for a digital colour television receiver with a variety of special functions.

One function is to freeze any desired scene on the TV screen. This is made possible by storing digital video signals for one frame in a video memory. The set also enables the viewer to watch images from a video cassette recorder, or other sources, whilst watching another programme. The auxiliary screen within the main screen is one ninth of its area, and images can be switched between the main and auxiliary screens. The inset screen can be positioned at four different places on the main screen, and it is also possible to freeze the image on the inset screen.

Additionally, the screen can be divided into nine sections for simultaneous monitoring of nine different programs in the time-lapse mode, with the images being renewed at four second intervals.

Using the multiple screens, TV or video recorder images can be displayed in nine consecutive time-lapsed pictures, with intervals between shots variable to a minimum of  $\frac{1}{30}$  of a second. This function should prove particularly effective when viewing sporting events.

The Mitsubishi Electric Corporation intend to market the new digital colour TV in the latter part of 1985.

*Practical Wireless, January 1985*

## **VHF Sound Broadcasting Conference Opens in Geneva**

The International Telecommunication Union's regional administrative radio conference to plan the use of the v.h.f. sound broadcasting band (87.5 to 108MHz) opened on October 29 in Geneva. The United Kingdom's delegation is led by officials from the Department of Trade and Industry's Radio Regulatory Division and includes representatives from the Home Office Broadcasting Department, the BBC, IBA and the Civil Aviation Authority.

This six-week conference is the final session of a two-part conference of which the first technical session took place in 1982. It involves about 100 countries in Western and Eastern Europe (including the whole of the USSR) plus Iran and Afghanistan, and the whole of Africa.

The UK objectives for this conference are:

—to secure a further two national v.h.f. networks, one to enable BBC Radio 1 and Radio 2 to have separate networks, and the other for the introduction of a new independent national radio service;

—the provision of additional frequencies for the development of BBC and independent local radio;

—the maintenance of the existing v.h.f. networks and improvements to their coverage.

The background to the conference is

that v.h.f. sound broadcasting was previously confined internationally to the band 87.5 to 100MHz. Even less than that has been available to the UK, principally because of the presence of police and fire emergency land mobile services in the upper portion of that band so that UK v.h.f. sound broadcasting has been contained in the sub-band 88 to 97.6MHz.

In 1979, at a major World Administrative Radio Conference (WARC), it was decided to add substantially to the band by raising its upper limit to 108MHz. This presented considerable problems for the UK, because it thus became necessary to remove not only the emergency services (currently located between 97.6 and 102.1MHz), but also a very large number of mobile services operated by the public utility industries in the top four megahertz of the new band. At the 1979 Conference, therefore, the UK successfully negotiated a transitional security of tenure for the police and fire services (until the end of 1989) and for the services in 104–108MHz (until the end of 1995). This has made the development of proposals for eventual full broadcasting use of the band in the United Kingdom much more complicated. In addition the prospect of broadcasting stations operating right up to 108MHz creates complex engineering problems if we are to avoid interference to aviation services (instrument landing systems etc.) which lie in the next adjacent band.



## PW Contest Winners

For the second year running the first prize in what has become the best supported v.h.f. contest held in the UK, the PW 144MHz QRP Contest, was won by a Welsh station.

Once again the 1984 Welsh Amateur Radio Convention, held at Blackwood in Gwent on the 30 September, provided an ideal opportunity for the cup and certificates to be presented to the winners, by the esteemed hand of the President of the RSGB, Bob Barrett GW8HEZ.



First place in the contest went to the "Bug Bashers Contest Group" using the callsign GW4TTU/P who operated from the top of a mountain in YL25j square.

Our photograph shows, from l to r, RSGB President—Bob Barrett GW8HEZ, Tim G4VXE, Roger GW5NF, Kelvin GW4TTU and Chris G8TFI.

PW's Assistant Editor, Dick G8VFN took time off from manning the busy PW stand, leaving XYL Peggy to hold the fort while he took the photograph.

## G-QRP Club Winter Sports

The G-QRP Club will be running an activity period from 26 December, 1984, until 1 January, 1985, which they call their Winter Sports. Although it is not a contest it will be a series of periods with the object of making as many low-power contacts as possible. Times and frequencies allocated for each day are as follows (times in GMT):

0900 – 1000 14.060MHz  
1000 – 1100 21.060 and 28.060MHz  
1100 – 1200 7.030MHz  
1200 – 1300 3.560MHz  
1300 – 1400 10.106MHz  
1400 – 1500 3.560MHz  
1500 – 1730 21.060 and 28.060MHz  
1730 – 2000 14.060MHz  
2000 – 2100 7.030 and 10.106MHz  
2100 – 2200 3.560MHz  
2200 – 2300 14.060MHz

Reports, in the form of a summary of log and remarks, may be sent to: *Chris Page G4BUE, "Alamosa", The Paddocks, Upper Beeding, Steyning, West Sussex BN4-3JW.*

The G4DQP Trophy is awarded to the station judged to have made the biggest contribution to the Winter Sports Event.

## The G-QRP Club is ten years old

In 1974, George Dobbs, G3RJV, using home built low power amateur radio equipment found that he was working several stations who shared his interest in building and operating low power amateur radio equipment. In contact with Nick Carter, G2NJ, he found that there was no specialist group for QRP operators. A letter to an amateur radio magazine (*The Short Wave Magazine*) brought replies from around thirty radio amateurs with a similar interest. At Christmas 1974, G3RJV, produced a simple duplicated newsheet called *SPRAT* and The G-QRP Club was born.

The name *SPRAT* was suggested by Gordon Bennett, G3DNF, from the words Small Powered Radio Amateur Transmission and the first issue was sent to 32 people.

The Club quickly adopted a badge and a slogan, "Devoted to Low Power Communication". The G-QRP Club defined QRP as using a power not exceeding 5 watts d.c. input. The Club began a series of awards and trophies for achievement in low power communication. From the first issue, *SPRAT* began to reflect the interest of

members in design and construction of their own equipment. Over the years *SPRAT* has developed into an influential quarterly magazine, two-thirds of which is devoted to practical items for the home constructor. In 1982 the Club produced *The G-QRP Club Circuit Handbook*, which sold its 500 copies before it was printed. The *Circuit Handbook* is now published and sold by the RSGB.

For many years The Club grew steadily and by 1979 there were over 600 members. But in the two years between 1982 and the present time, The Club doubled its membership, which is now just under 3000, with members in 60 countries.

The G-QRP Club offers a range of awards for achievement, a data sheet service of circuit ideas, an internal QSL bureau, Morse training tapes, badges and other club insignia items. The Club has regular h.f. band skeds and activity periods to enable QRP stations to work each other on the air.

Full details of membership of the G-QRP Club can be obtained from the Membership Secretary, *Fred Garratt G4HOM, 47 Tilshead Close, Druids Heath, Birmingham B14 5LT.*

## New Electronics Shop

Skybridge Ltd. announce that they have opened a new shop at Dartford in Kent, where they intend to stock a very comprehensive range of products to interest the electronics enthusiast.

As well as the usual discrete components, the product range is divided into various categories, such as amateur radio, Computer, Audio and Electronics, Radio Control, Servicing, Test Equipment, DIY electrical, etc.

A technical library is available for customers' use, covering component data by product and manufacturer. Constructional literature is also provided for customers wishing to design their own projects.

A catalogue is currently being compiled so that a mail order service may be introduced. Although the thousands of lines stocked will all have individual stock numbers, Skybridge will continue to offer a procurement service for items not listed.

For further details, contact: *Skybridge Ltd., 441 Princes Road, Dartford, Kent. Tel: (0322) 91454.*

*Practical Wireless, January 1985*



## Brigadier H. E. Hopthrow

In October 1915, our sister magazine, *Wireless World*, published a photograph of some of the Wireless "Boys" of the Royal Engineers Wireless Corps and the associated text says, "Just as the Flying Corp are being trained at Marconi House, London, in the wireless branch of their service, so the Royal Engineers are having their wireless sections trained at different points in Great Britain." In this case it was the Glasgow Post Office.

Sixty-nine years later, Ron Ham had the pleasure of meeting and talking to one of the Wireless "Boys", Brigadier H.E. Hopthrow, who visited the Chalk Pits Museum, Amberley, Sussex, last



July, from his home in Cowes, to see and feel again the controls of a Marconi 50W Trench Set, which, between

1917 and 1918 was the type of equipment he used, in action, as a wireless operator at Lys, St Quentin, Ypres and the final pursuit. During one action the Brigadier had to destroy one of these sets to stop it falling into enemy hands and comments, "In retrospect what a very efficient instrument it was. Looking through my diary, 1917/18, there is no mention of one failing, nor can I recall that when taking a set from the four or five in store, that we identified any one as being better than another or as being a "favourite".

Brigadier Hopthrow is looking for a Marconi Trench Set for the Royal Engineers museum at Chatham, where he is helping to get the signals section together.

RH

## Space News

The UK Magnetospheric Particle Tracer Experiment spacecraft (AMPTE) which was launched by a NASA Delta vehicle during August 84 is scheduled to be used in conjunction with UOSAT - OSCAR - 11 for simultaneous particle wave measurements.

The effects of two releases of Lithium by the AMPTE satellite have been successfully observed and it is currently scheduled to release Barium during Christmas Day. This action should result in a spectacular artificial "Comet", visible to the naked eye from the ground.

Those interested in the reception of Meteorological (weather) satellites will

be interested to know that a quarterly magazine is published in the US entitled *The Journal of the Environmental Satellite Amateur Users Group*. Subject matter apparently includes such items as station construction details, WX Satellite status reports, meteorological studies, data receiving tips together with Soviet WX and UOSAT Satellite status reports. Further details available from: R. J. Alvarez, WD4MRJ, 2512 Arch Street, Tampa, Florida 33607, USA.

A new telephone answering machine has been introduced at the UOSAT Spacecraft Control Centre. In future the original (0483) 61202 line

will carry news bulletins on UO-11 whilst (0483) 61707 will provide details on UO-9 which had its third birthday on 6 October, 1984, and is currently predicted to have perhaps another 2 years of operational life.

## Can I Help You?

Are you the secretary, organiser or general dog's body of your local radio club or any other group whose functions may interest readers of *PW*? If so, let me know and I will endeavour to publicise your rally, get-together, whatever, through this column.

# Benny





# Radio Wave

Part 1 by F. C. Judd G2BCX

The ionosphere, with its layers of ionised rarified air as we know it today, must have existed for millions of years and yet that existence was unknown only 80 or so years ago at the time Marconi succeeded in transmitting the first wireless signals across the Atlantic Ocean.

Although at this time various theories had been put forward to explain why wireless waves could be propagated over long distances, no definite reason was established; at least not until Oliver Heaviside in England and A. E. Kennelly in America, suggested that there must be some kind of reflecting medium in the upper atmosphere that caused the waves to be returned to earth at considerable distances from the transmitter. This meant, that except for very short distances, the waves did not follow the natural curvature of the earth as had been supposed. Even Marconi himself was at a loss to explain why his signals had travelled such long distances but thought this might be due to some effect created by the sun.

Lord Rayleigh had also pointed out that wireless waves could not travel a quarter of the way round the surface of the earth any more than light waves could travel from some point on the surface of a sphere with a radius of 300mm to another point a quarter way round its circumference. He illustrated this by comparing radii with wavelength. For example, radius of the earth 6000km, wavelength 100m, ratio 60 000:1. Radius of sphere 300mm, wavelength (light)  $5 \times 10^{-4}$ mm, ratio 60 000:1<sup>(1)</sup>.

By about 1902 Heaviside and Kennelly had come to the conclusion that in the higher regions of the atmosphere there existed a conducting layer of some kind that "guided" wireless waves around the curvature of the earth. Although this conducting layer became known as the Heaviside layer, it was not proved by positive investigation and tests until much later. Nevertheless, the idea stimulated the enquiring minds of other scientists, notably Professor E. V. Appleton in England and G. Breit and M. A. Tuve in America.

## Proving the Existence of an Atmospheric Reflector

In an article published in *Wireless World*, 7 January 1931, Professor Appleton said, "Among the multiple paths (referring to wireless waves) there is usually a direct line of transmission straight from sender to receiver (ground wave) but very often the greater part of the signal we hear is due to waves which have made a trip to the upper regions of the atmosphere and back"<sup>(2)</sup>. He carried out tests to prove this and at the same time observed that a wave which had travelled to the same place but by two different routes could arrive with "phase" differences that caused the signals to fluctuate in strength and which we know as fading. See Fig. 1.1.

The first experiments to determine the actual height of the reflecting layer were conducted almost at the same time in both England and America. Although the various methods used confirmed the theories of Heaviside and



**Professor Sir Edward Appleton, Secretary of the Department of Scientific and Industrial Research 1939-1949. Nobel Laureate 1953. Born in Bradford in 1892 and died suddenly on 21 April 1965**

*photo courtesy of the Rutherford Appleton Laboratory, Chilton, Oxon*

Kennelly, there were differences between the results obtained by Appleton and other investigators. At the same time it was discovered that there was not one, but two, reflecting layers<sup>(3)</sup>. Up to this time the transmissions used for trying to establish the height of the conducting layers were modulated continuous wave and measurement of the extremely small time intervals involved was not very accurate. This was because the phase differences between the modulation of a direct and reflected wave were difficult to determine with any precision. The answer lay in transmitting short "pulses" of radiation that could be bounced off the reflecting layer together with a means of measuring the time taken for the pulse to travel up to the layer and return to earth as an "echo".

## The Pulse Technique

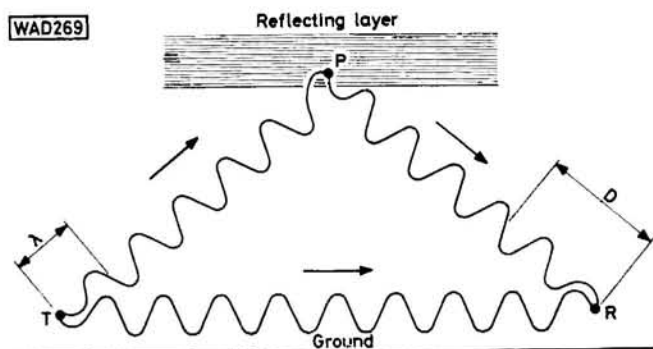
The first trials with pulse waves in 1925 by Breit and Tuve in America were successful in that the method



# Propagation

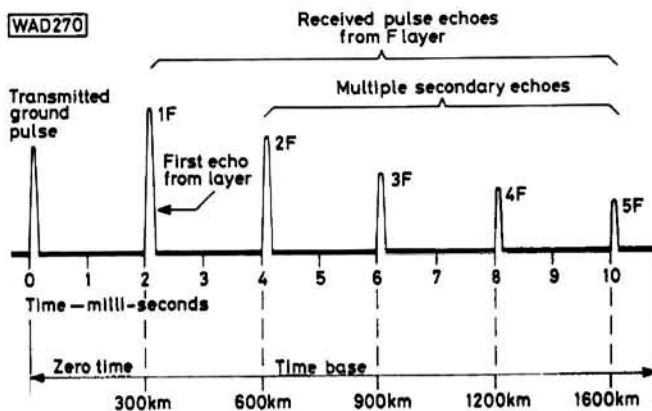
proved to be much more practicable but there were still discrepancies in the measurements until it was realised that the technique might be improved by shortening the duration of the pulses. This enabled the direct and indirect signal (echoes) at the receiver to be much more separated, i.e., more time was available for an echo of the pulse to be registered as a separate entity. An example of the method is illustrated in Fig. 1.2. The time scale or base is 10 milliseconds and the transmitted pulse is at zero time. It takes a finite time for the pulse to reach the layer and the same time for it to return to earth. In the example the leading edge of the return pulse, or echo, occurs at 2 milliseconds having taken 1ms to travel to the layer and 1ms to return. Since radio waves take 1ms to travel 300km, the height of the layer established from the first echo is in this case 300km<sup>(4)</sup>. The multiple echoes 1, 2, 3 and 4 etc., are the result of the transmitted pulse having made the upward and return journey several times, i.e. reflected from layer to earth upward again from earth to layer and then reflected to earth again and so on.

It must be remembered however that the method described, although still used today, is on a straight up and straight down basis, i.e. the pulses are transmitted from an antenna firing vertically and received by the same antenna, or one very close to it, as in Fig. 1.3. This does not provide a true height to the base of the layer but an effective or virtual height since the pulse must penetrate some way into the layer before being turned for its return journey to earth. When a wave arrives obliquely at a layer with ionisation density increasing toward the upper region of the layer, the top of the wave-front, whether pulsed or continuous carrier, travels more rapidly than the lower portion as illustrated in Fig. 1.4. The wave is bent round and leaves the latter at an angle equal to that at which it

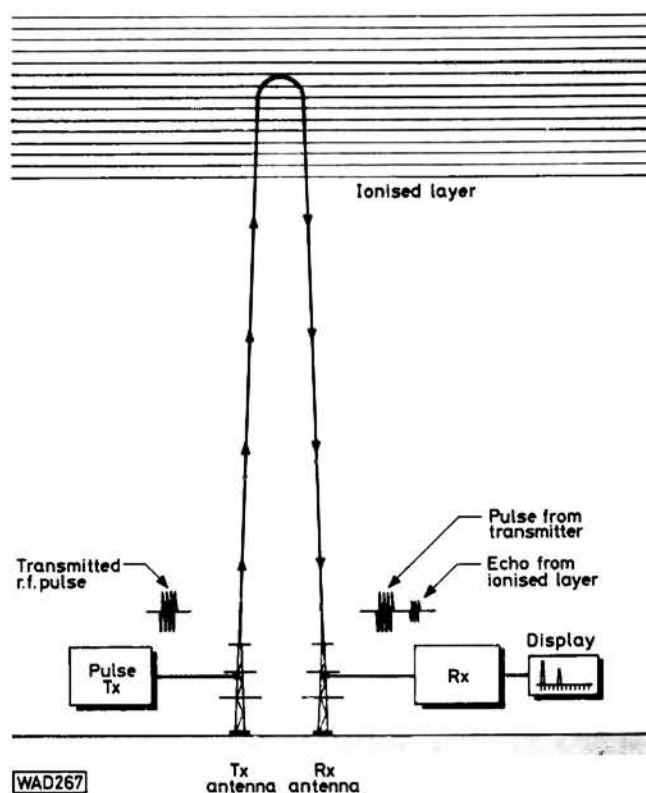


**Fig. 1.1:** The paths taken by radio waves travelling from a transmitter (T) to a receiver (R). The path of the reflected wave (TPR) is greater than the path of the ground-wave (TR) by an amount D. Signal amplitude increases when  $D = n\lambda$ . Amplitude reduction (fading) occurs when  $D = (n + \frac{1}{2})\lambda$ .

arrived. **Note:** The above is a somewhat simplified explanation of how a radio wave is turned within an ionised layer for reflection to earth. Much more detail concerned



**Fig. 1.2:** The transmitted pulse technique for ionospheric layer sounding (see text)

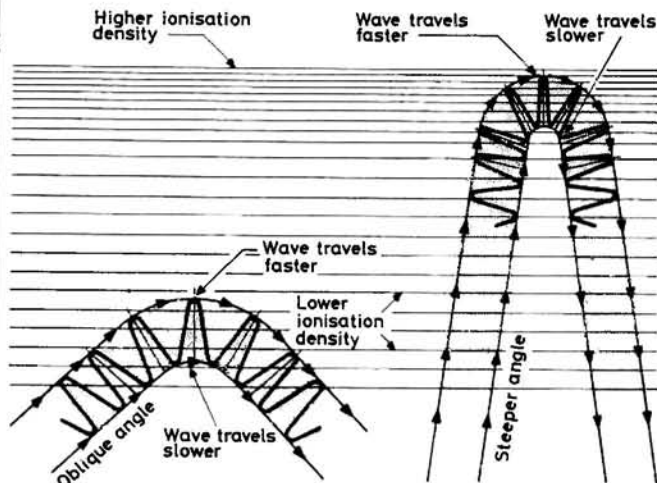


**Fig. 1.3:** Method of transmitting pulses vertically from ground to obtain a direct echo from an ionised layer



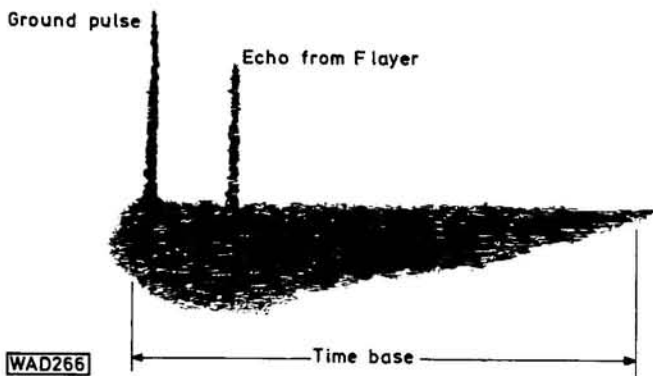
with the complexities of this occurrence can be found in the book *Sun, Earth and Radio* by Dr. J. A. Ratcliffe<sup>(1)</sup>.

The pulse technique required a linear time base and for this a cathode ray tube (c.r.t.) was adopted so that the transmitted pulse and echoes could be displayed simultaneously. An early experiment result obtained by Appleton and his co-workers using the c.r.t. in 1931 is shown in Fig. 1.5, and which later became the basis for the development of radar some four years later for the detection and location of aircraft. The example shown in Fig. 1.6, and which was recorded recently with modern equipment, provides a better illustration.



WAD268

**Fig. 1.4: Path of a radio wave through an ionised layer (A) at an oblique angle (B) at a much steeper angle**



WAD266

**Fig. 1.5: Earliest visual display of an echo from the E layer by E. V. Appleton using a cathode ray tube**

*Wireless World*

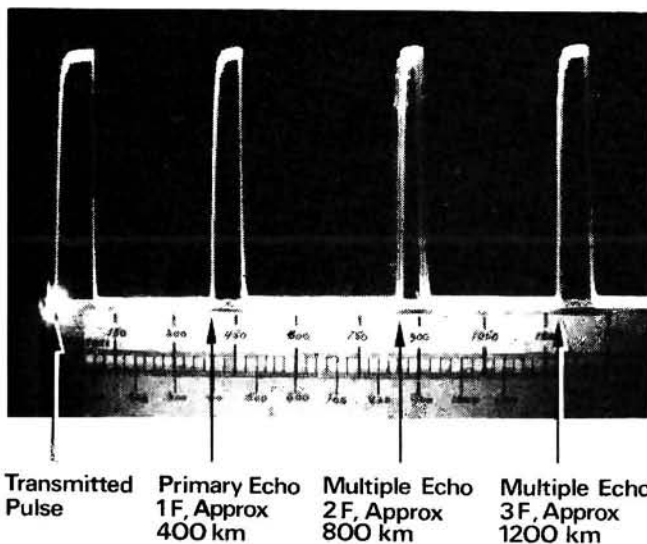
## The E and F Layers

It was during the years 1925-1927 that Professor Appleton and his assistants proved beyond doubt the existence of a reflecting layer at about 100km above the earth's surface and later discovered another layer at an average height of 250km. These are now known as the E and F layers respectively and as every DX operator knows, are capable of propagating radio waves around the earth with considerable efficiency. The term "ionosphere"

stemmed from E. V. Appleton and R. Watson-Watt. Special equipment using the pulse technique was later designed to cover a wide frequency range, using a frequency sweep system, so that "ionograms" as they were called, could be photographically recorded. From the data obtained from ionospheric soundings and scientific investigations into the nature of the higher levels of the atmosphere, it was finally confirmed that solar (ultra violet) radiation was responsible for the ionisation of the E and F layers and also for the daily, seasonal and solar cycle variations that occur.

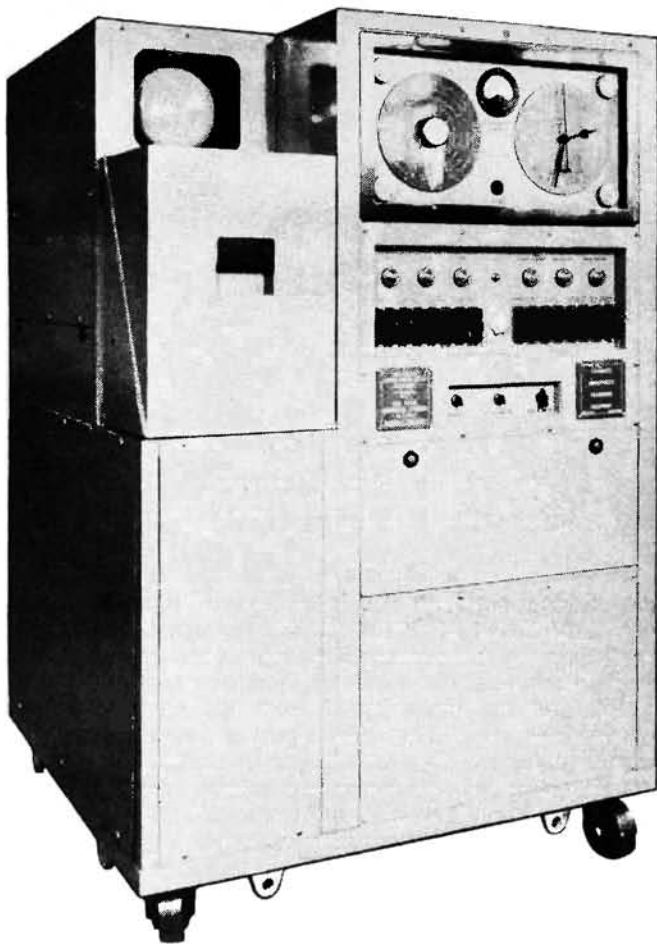
## The Ionosonde

The Ionosonde, or automatic ionospheric height recorder, like the one shown in Fig. 1.7 and manufactured by Union Radio, has been used at various chosen sites throughout the world and although the original design and development was by R. Naismith and R. Bailey<sup>(5)</sup> this was no doubt based on earlier apparatus by L. H. Bainbridge-Bell built in 1933 and used at the then Radio Research Station at Ditton Park, Slough<sup>(6)</sup>. Ionosonde equipment was put into operation at Slough in 1945 and covered a total frequency range of 0.68MHz to 23.8MHz in five bands. Photographic readouts covering the whole swept frequency range could be obtained in five minutes, or at the rate of 50 seconds per band. Various sequences could be used with regard to frequency range and a complete recording could be made automatically at 15 minute intervals. The Ionosonde could also be continuously operated over limited periods for eclipse observations and special events. The average transmitter peak pulse power was one kilowatt with slight variations according to the frequency band being used. On routine recordings, layer heights could be measured to the nearest 5km from about 100km to a maximum height of 1200km although for special purposes this could be extended to 2000km. The Ionosonde not only provided photographic records but also had a built-in c.r.t. monitor for immediate observation. The pulse recurrence frequency was 50 per second and the pulse width variable from 80 to 300 microseconds.



**Fig. 1.6: Echoes received from the F layer using modern equipment and a c.r.t. display. Note: scale shown not aligned owing to camera angle**





**Fig. 1.7: The special ionosonde equipment for automatic recording of ionised layer heights over a wide frequency range**

*photo courtesy of the Rutherford Appleton Laboratory, Chilton, Oxon*

## General Function of the Ionised Layers

The ionised layers were designated with letters of the alphabet by E. V. Appleton, the lowest layer known at a height of about 60 to 90km being called the "D" region because this is not strictly a layer but a relatively dense part of the atmosphere where atoms are broken up into ions by sunlight but recombine very quickly. The amount of ionisation therefore depends on the amount of sunlight and the region has the effect of absorbing the energy from a radio wave, particularly at frequencies in the band 3 to 4MHz and frequently as high as 7MHz.

Long distance communication is often assisted by "sporadic-E" which is due to highly ionised clouds that are randomly and sporadically formed at a height of around 100km, mostly during the months of June and July. If the ionisation is sufficiently dense h.f. signals can be prevented from reaching the F layer. Sporadic-E usually takes the form of "clouds" that drift at about 100km per hour although sometimes they are small and may only last for a few minutes or, in the case of meteor trail ionisation, for only a few seconds. If the ionisation is dense enough with sporadic-E, signals in the higher frequency regions, e.g. 20–30MHz, can be reflected as also v.h.f. transmission which at times can result in DX contacts (on v.h.f.) being

made at 3000km or more. It is because of the transient nature of these clouds that propagation by them is usually referred to as sporadic-E often abbreviated to "Es". The E layer itself is present every day from dawn to dusk and is completely different from sporadic-E.

Most long distance communication results from ionisation of the F layer, the most applicable amateur radio bands in the h.f. region being 3.5, 7, 14 and 21MHz. The layer height may vary from a little over 200km to as high as 400 to 500km depending on the time of the year, latitude and time of day and particularly the amount of sun spot activity. During the peak period of the 11 year maximum sun spot activity cycle, propagation via the F layer extends up to around 30MHz.

There is, of course, much more to the behaviour and nature of the ionosphere and more general information of use to DX operators can be found in the *RSGB Radio Operators Handbook* and the *ARRL Antenna Handbook*. Ionospheric physics is a highly complex, but nevertheless interesting subject. The book *Sun, Earth and Radio* by J. A. Ratcliffe provides a wealth of information about the physical aspects of the ionosphere and also the magnetosphere which are both very closely linked.

## References

1. J. A. Ratcliffe, *Sun, Earth and Radio*, World University Library 1970.
2. Prof. E. V. Appleton, *The Timing of Wireless Echoes*, *Wireless World* 7 January 1931 and 14 January 1931.
3. E. V. Appleton and G. Builder, *Proc: Physical Soc. paper*, Vol. 44 pp82 1932.
4. A. L. Green, *Early History of the Ionosphere*, AWA Technical Review Vol. 7 No. 2 1946.
5. Clarke and Shearman, *Automatic Ionosphere Height Recorder*, Frequency Range 0.65–25MHz, *Wireless Engineer* September 1953.
6. G. W. Gardiner, J. A. Lane and H. Risbeth, *Radio and Space Research at Slough 1920–1981*, *The Radio and Electronic Engineer* Vol. 52 No. 3 pp111–121.

## Part 2: Modern ionospheric sounding and more about the nature of the ionosphere.

### Kindly Note

#### Battery State Indicator—November 1984

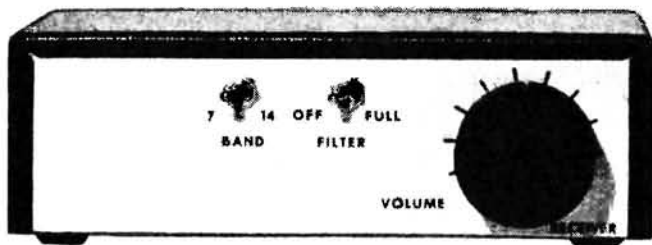
Unfortunately the orientation of l.e.d.s. D1/2 are shown incorrectly on the circuit diagram (Fig. 1). The a and k pin-out notations on the p.c.b. overlay should be transposed. No damage is likely to have occurred if built as originally shown—you just would not have had any indications.



# PW 'TEME' Modular QRP Transceiver

Part 3 by  
Rev. George  
Dobbs G3RJV

THIS MONTH—  
THE RECEIVER



Of all the projects that a radio amateur can build, a receiver probably rates as the most satisfying. Even the most seasoned constructor still thrills to the sound of the first signals emanating from a newly completed receiver. Remember the days when you dragged your hapless parents up to your room and clamped a pair of headphones around their ears to listen to the sounds of your first crystal set? No?—Well I suppose some people have to miss the formative experiences of life. This series of articles began with a basic transmitter module, to which was added a variable frequency oscillator. Used in conjunction with the receiver described here, these will give full transceive facilities.

## The Circuit

The receiver section uses the existing variable frequency sources on 7 or 14MHz from the transmitter sections of the project in a Direct Conversion Receiver. Direct conversion receivers are the simplest way to make a transceiver from a transmitter. The incoming signal is mixed with the local oscillator from the transmitter and the audio difference between the signals is amplified for reception of c.w. or s.s.b. signals. So the arrangement is simply a product detector followed by audio amplification. Perhaps it could be called a superhet receiver with zero intermediate frequency. Without intermediate frequency stages, which is where the majority of the selectivity and gain is produced in a superhet, direct conversion receivers do have inherent problems. The gain usually comes from the audio stages and the selectivity must either come from audio filtering or tight front-end input tuning, or both. This module attempts to overcome the worst shortcomings of direct conversion by having good input tuning, high audio amplification and narrow audio frequency filtering.

A block diagram of the receiver module is shown in Fig. 3.1. The incoming signal to be received ( $f_i$ ) is tuned in an r.f. stage and mixed with the signal from the transmitter

board local oscillator ( $f_o$ ). If the signals are some 750Hz apart the mixed difference between the signals will appear at the output of the mixer. Both signals are taken from the transmit board; the oscillator from the tuned predriver stage and the input signal from the transmit/receive changeover relay. The audio signal is passed through an active audio c.w. filter, which can be switched to wide or narrow positions, and thence to a volume control, the only adjustable control on the receiver module. The audio filter is a bandpass circuit for signals of 750Hz, a good listening tone for a c.w. signal. An integrated-circuit audio amplifier provides output for headphones or a small loudspeaker.

The receiver module has a small sidetone oscillator. This is to provide an audio tone to monitor the transmit keying. Such an oscillator is essential for those of us who find it difficult to send Morse without hearing the results. The sidetone oscillator is powered by the 12 KEY line available from the transmitter module. The front-end of the receiver, the r.f., mixer and filter stages, is powered by the 12 RX line which is only present in the receive mode but the audio amplifier is powered by the +12V line so that the sidetone can be amplified during transmission.

The complete circuit is shown in Fig. 3.2. Avid readers of *PW* will recognise the input and mixer sections of the receiver board as being the same circuitry as used in the author's *PW* "Severn" (*PW* May 1983). Many types of mixer could have been used but for cheapness and good overall performance this mixer circuit was pressed into service again. It uses three field-effect transistors in a Y configuration with 3Tr2 and 3Tr3 being a balanced mixer and 3Tr1 an r.f. amplifier feeding the source connections

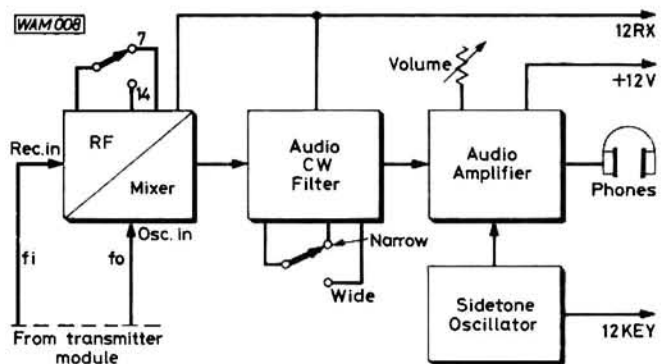
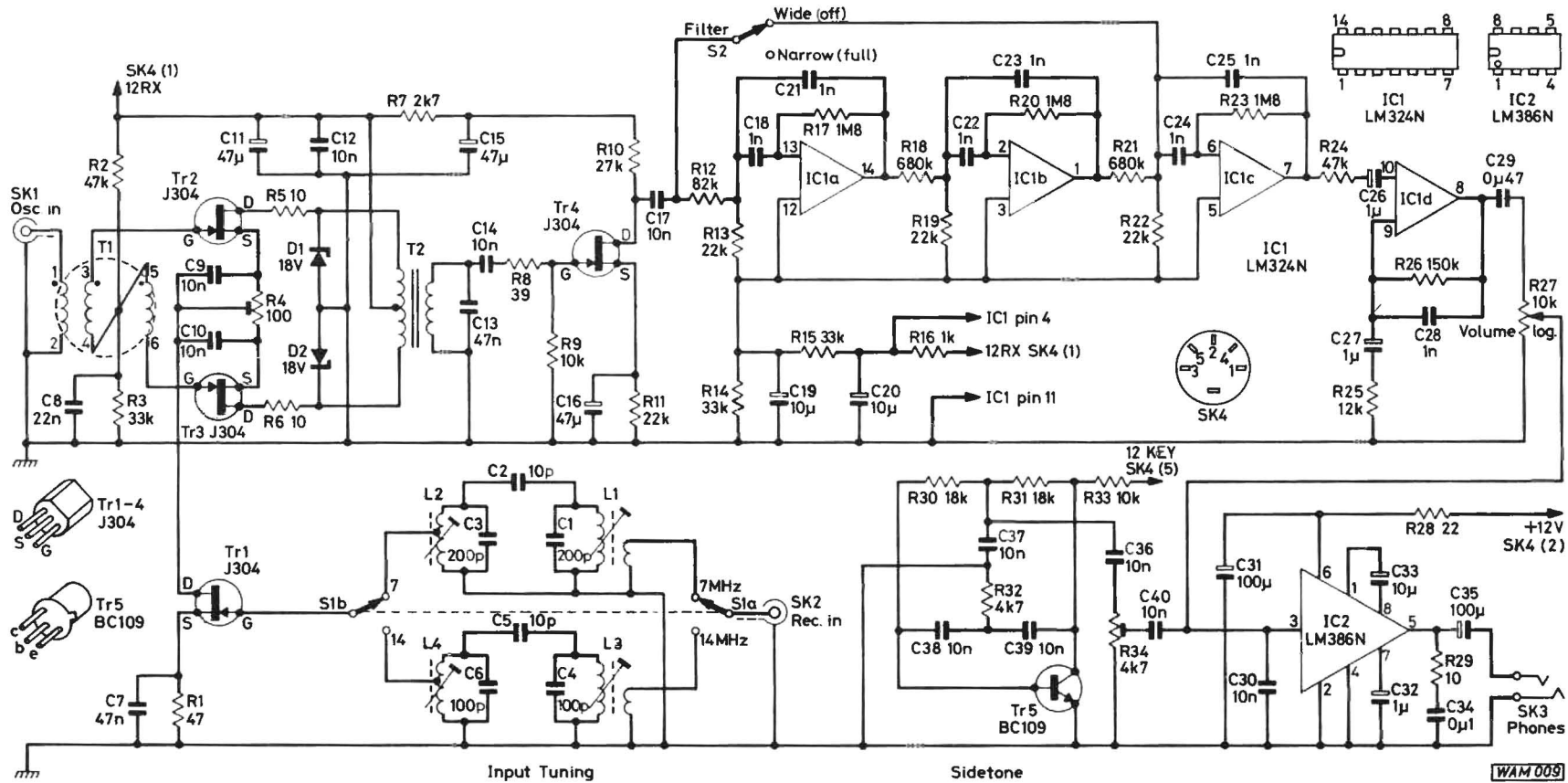


Fig. 3.1: Block diagram of Module 3, the Receiver



Fig. 3.2: Circuit diagram of Module 3, the Receiver



of 3Tr2 and 3Tr3. Transistors 3Tr2 and 3Tr3 are balanced by 3R4 and their outputs feed into a transformer 3T2. Two 18 volt Zener diodes, 3D1 and 3D2, prevent high-voltage transients from 3T2 damaging the transistors. The r.f. stage, 3Tr1, is switched between input tuned circuits for 7 or 14MHz. The input filters are bandpass-tuned pairs of tuned circuits loosely top-coupled with 3C2 or 3C5. The mixer transistors 3Tr2 and 3Tr3 require a balanced input from the oscillator and this is provided by trifilar-wound broadband ferrite transformer, 3T1. The output from 3T2 is decoupled by 3C13 and coupled by 3C14 into an f.e.t. audio pre-amplifier,

3Tr4, which feeds the filter circuitry around a quad operational amplifier 3IC1, the common LM324N. Three sections of this i.c. provide bandpass filtering at 750Hz, with switched options for all three stages or only the final stage. The fourth section, 3IC1d, drives the audio amplifier 3IC2 via the volume control, 3R27. The actual bandwidth of the filter has not been objectively measured but with all the filtering stages switched in, it operates as a very worthwhile c.w. filter. The LM324 proved its worth in this circuit providing four well-isolated stages at low current consumption. The LM386 is a useful small i.c. audio amplifier

designed to feed an 8 ohm output. The quiescent current is low and the output in the order of half a watt. The LM386 is a better alternative in the cheap price range (around £1.00 each) to the more popular, but less stable and more noisy, LM380. The sidetone oscillator circuit is a basic one-stage phase-shift audio oscillator keyed by the 12 KEY line. Unijunction sawtooth oscillators or 555 i.c. squarewave oscillators are probably more common in simple sidetone circuits, but the few extra components of this circuit are worth the effort for the pleasant sinewave tone. A soothing sidetone can make for more comfortable operating than a rasping tone from a simple oscillator.



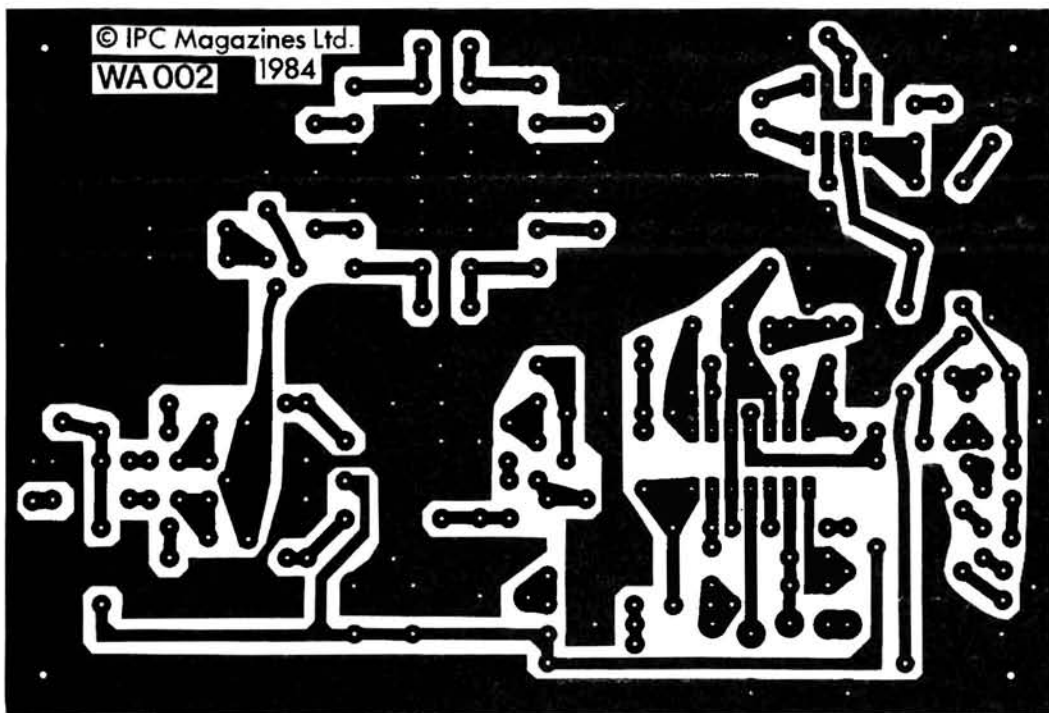
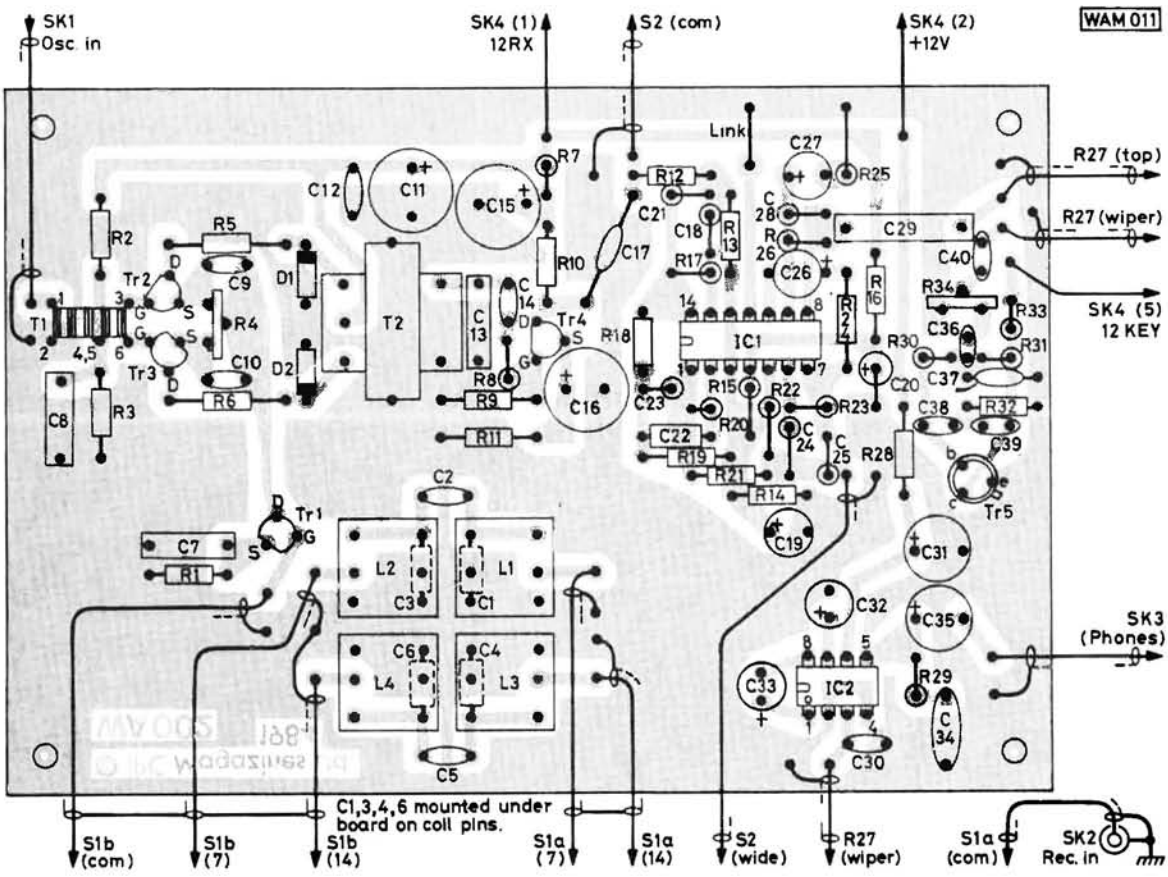


Fig. 3.3.: Full size p.c.b. track pattern and component layout for Module 3, the Receiver



### Construction

The whole receiver module is built on one printed circuit board as shown in Fig. 3.3. Receiver circuits are best built beginning at the audio output and working towards the inputs so that some intermediate testing of the circuit elements can be done. The circuit around the audio amplifier section, 3IC2, may be built as far back as the volume control, 3R27, and tested as an audio amplifier. With +12 volts applied at the top of 3R28, and a pair of suitable

headphones or a small 8 ohm speaker attached to the output, the amplifier may be tested using an audio source or just by placing a finger onto the top of 3R27 and listening for hum. Check that 3R27 is wired the correct way round so that volume increases as the control is turned clockwise. The sidetone oscillator can be built next and tested by applying the output to point A on the circuit for 3IC2. Preset potentiometer 3R24 is adjusted for a comfortable sidetone level, and this is independent of the setting of the main volume control.



The filtering section 3IC1 is arranged to give as much audio gain as possible without instability. The stages may be built in reverse order: 3IC1, d, c, b, a; and each stage tested in turn. The gain of the section is such that without its input connected to 3Tr4, the whole filter may oscillate when tested. This oscillation should cease when 3Tr4 is added. The overall gain of the filter section can be changed by altering 3R25. When the whole receive section is built 3R25 could require some individual adjustment. It is set to give maximum gain whilst retaining stability and it should be possible to turn 3R27 to maximum without the receiver audio stages oscillating. This may well require adjustment for some types of headphones.

When 3Tr4 has been added, the rest of the circuit must be completed for testing. Transformer 3T2 is a small audio-frequency type as used for driving push-pull output stages in transistor radios, but used in reverse. The LT44 driver transformer is suitable for this application but it may be possible to cull a suitable transformer from an old transistor radio with a push-pull output stage. The impedance ratio is some 20kΩ to 1kΩ or 2kΩ, centre-tapped. Ensure that the connections for 3Tr2 and 3Tr3 are correctly wired with the source leads connected to 3R4 and the drain leads to 3R5 and 3R6.

The winding details for the inductors are shown in Fig. 3.4. The most complex winding is the trifilar winding for the oscillator input transformer, 3T1. Although a T37-43 ferrite core is quoted in the chart, most similar ferrite cores of approximately 13mm ( $\frac{1}{2}$ in) outside diameter would do the job. Cut three lengths of 32s.w.g. enamelled wire (or 28s.w.g. if the former is large enough) long enough to give 12 turns around the core. Twist the three wires together to give around 8 twists per inch and wind the combined wires around the core for 12 turns. Identify the start and finish of each wire with an ohmmeter and connect into the circuit following the configuration shown in Figs. 3.4 and 3.2. The dot on each winding marks the beginning of that winding.

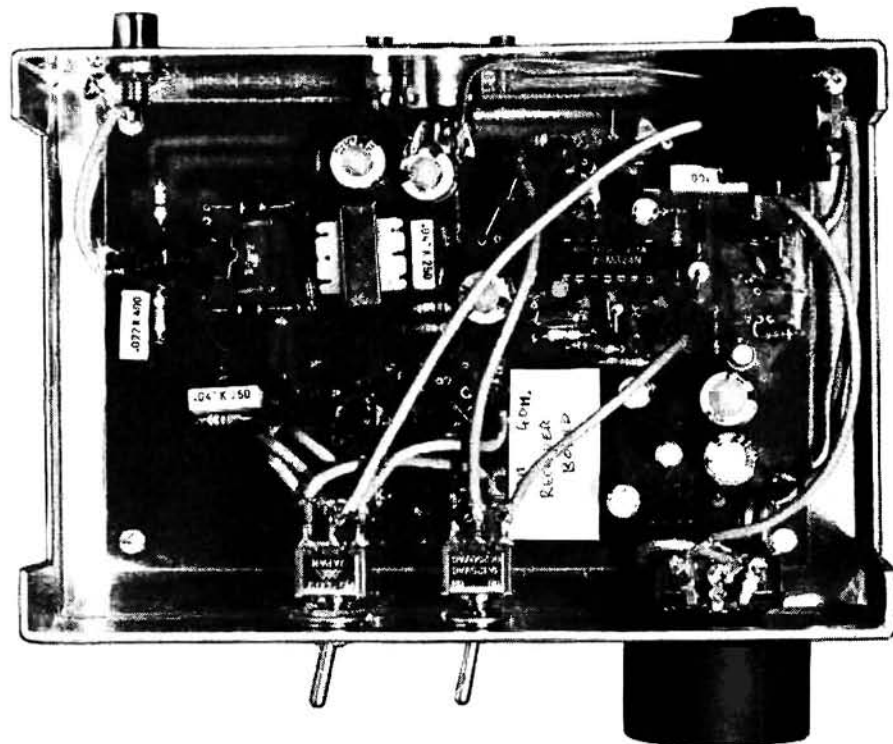
The input tuned circuit coils, 3L1 to 3L4, are wound on 4.8mm ( $\frac{3}{16}$ in) formers with an iron dust core. This former is part of an assembly which includes a base and a

screening can. A suitable commercial type is suggested in Fig. 3.4 but it may be possible to obtain surplus formers and cans of this type. They are very common in the surplus market. The coils are close-wound on the former, and short stiff wires soldered onto the base pins rise vertically up the sides of the former to provide connection points for the windings. The capacitors 3C1, 3, 4 and 6 which form part of the tuned circuits are miniature ceramic plate types soldered directly under the pins of the coil bases. The leads around the bandchange switch, 3S1, must be wired in screened cable. Miniature coaxial cable is ideal although the commoner thin microphone cable can be used. The final wiring is to add the input and output connections to the board. Phono sockets are used for receiver and oscillator input, a  $\frac{1}{4}$ in jack socket for the headphone connection and the +12V, 12RX, and 12 KEY lines are picked up in a 5-pin DIN socket from the other modules.

The receiver module, like the other modules, is built into a Minifordds J6 Instrument Case. The layout for the case is shown in the photographs. The front panel has only three controls. Miniature toggle switches provide the band selection and the filter bandwidth choice, whilst the volume control, 3R27, is controlled by a large knob. (In the prototype the same type of knob as used for the v.f.o. tuning control.) This means that the two most frequently used controls on the transceiver are large and easy to handle.

## Setting-Up

The receiver module requires a simple setting-up procedure to be completed before it can be used. The constructor must first ensure that the value chosen for 3R25 will allow the volume control, 3R27, to be turned up full without the audio stages oscillating. The d.c. operating condition of the three f.e.t.s in the mixer/r.f. stages must also be balanced. The value of 3R3 has been chosen to give equal voltages across the upper transistor pair (3Tr2-3) and the lower transistor (3Tr1). With no input from the oscillator, a meter on the drain circuit of 3Tr1 should show half the total voltage across the three f.e.t.s.



L1 = 22 turns 26 swg., link winding 4 turns  
26 s.w.g.

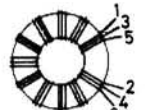
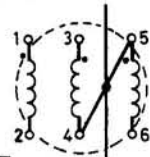
L2 = 22 turns 26 swg., tap at 17 turns

L3 = 14 turns 26 s.w.g., link winding 4 turns  
26 s.w.g.

L4 = 14 turns 26 s.w.g., tap at 10 turns

L1-L4 All wound on 4.8mm ( $\frac{3}{16}$  in) diameter  
formers (Maplin 722/1 or similar), with dust  
core, base and can.

T1 = 12+12+12 turns 32 (or 28) swg trifilar  
wound on T37-43 or similar ferrite core



WAM 010

Fig. 3.4: Coil winding details for the Receiver module



# ★ components

## MODULE 3 RECEIVER

### Semiconductors

#### Transistors

BC109	1	Tr5
J304	4	Tr1-4

#### Diodes

BZY88C18V	2	D1, 2
-----------	---	-------

#### Integrated circuits

LM324N	1	IC1
LM386N	1	IC2

### Inductors

L1-4 and T1 see text and Fig. 3.4  
T2 Maplin LT44 or similar (see text)

### Miscellaneous

Phono sockets (2); 2-pole  $\frac{1}{4}$ in jack; 5-pin DIN socket; Switch s.p.c.o. min. toggle; Switch d.p.c.o. min. toggle; Printed circuit board; Case, Minffordd J6; Feet, knob, etc.

### Capacitors

#### Polystyrene

1nF	7	C18, 21-25, 28
-----	---	----------------

#### Ceramic plate

10pF	2	C2, 5
100pF	2	C4, 6
200pF	2	C1, 3
10nF	11	C9, 10, 12, 14, 17, 30, 36-40

#### Polyester

22nF	1	C8
47nF	2	C7, 13
0.1 $\mu$ F	1	C34
0.47 $\mu$ F	1	C29

#### Electrolytic, 25V p.c. mounting

10 $\mu$ F	3	C19, 20, 33
47 $\mu$ F	3	C11, 15, 16
100 $\mu$ F	2	C31, 35

#### Electrolytic, 63V p.c. mounting

1 $\mu$ F	3	C26, 27, 32
-----------	---	-------------

### Resistors

#### $\frac{1}{4}$ W 5% carbon film

10 $\Omega$	3	R5, 6, 29
22 $\Omega$	1	R28
39 $\Omega$	1	R8
47 $\Omega$	1	R1
1k $\Omega$	1	R16
2.7k $\Omega$	1	R7
4.7k $\Omega$	1	R32
10k $\Omega$	2	R9, 33
12k $\Omega$	1	R25
18k $\Omega$	2	R30, 31
22k $\Omega$	4	R11, 13, 19, 22
27k $\Omega$	1	R10
33k $\Omega$	3	R3, 14, 15
47k $\Omega$	2	R2, 24
82k $\Omega$	1	R12
150k $\Omega$	1	R26
680k $\Omega$	2	R18, 21
1.8M $\Omega$	3	R17, 20, 23

#### Sub-min vertical pre-set

100 $\Omega$	1	R4
4.7k $\Omega$	1	R34

#### Log law pot., $\frac{1}{4}$ in spindle

10k $\Omega$	1	R27
--------------	---	-----

This will prevent 3Tr2 and 3Tr3 running at too low a voltage and being driven into regions below their pinch-off point. The input tuned stages are set up with a suitable r.f. source, for example a calibrated signal generator, or simply by listening on the band and adjusting the cores of the coils for maximum signal. In each case adjust the coil closest to the r.f. transistor, 3Tr1, first.

The setting up of the input tuned circuits is not too critical. Although a signal generator is useful, I initially set up the circuits by ear with signals on the band and a later check with a signal generator proved that little extra adjustment was required. It is also possible to make use of crystals which may have been used if the transmitter module was operated in its basic form. These can be placed into a small oscillator circuit and used as a simple signal generator. The constructor unsure about what cir-

cuit to use, could build up a breadboard version of the crystal oscillator used in the transmit module. The balance control for the mixer, 3R4, is best set up last of all. Do the initial setting-up with the 3R4 preset to its mid-point and then adjust it for best results with weak signals received in normal operating conditions. Although subjective, "on-the-hoof testing" has the advantage of achieving the actual results that are being sought.

In use it is better to set up the tuning control on the transmitter module for a peak on receive rather than a peak on transmit. On the prototype the tuning control on the transmitter has small markers to show the 7 and 14MHz tuning points. Turn the control to these points and then carefully tune for maximum signal strength on the receiver, the transmitter will take care of itself. This is especially so in the case of the 14MHz band where tuning for maximum transmitter output can produce a nasty note in the receiver. It is very quick and easy to change bands and tune up, once this has been done a few times.

Now the receiver module is in use, the RIT control comes into its own. Before it can be used it requires a little careful setting up. The simplest way is to set the transmit frequency offset controls, the presets 2R15 and 2R18 on the VFO/Doubler circuit, to correspond with the centre point of the RIT control, 2R12 (also on the VFO/Doubler circuit). Because this is a direct conversion receiver signals will be heard both sides of the zero beat. The individual has a little choice in how the r.i.t. is arranged. The control may be set to correspond exactly with zero beat of the transmit signal by adjusting 2R15 or 2R18 to match the frequency for the band in question with 2R12 (RIT control) in its centre position. Most direct conversion receiver users prefer to set the r.i.t. so that when the station to be worked is received at the audio frequency of the filter, the transmit frequency preset is adjusted so that the transmitted signal is on the exact frequency of that station. Thus the RIT control can be set at the centre point (marked on the front panel) for most normal usage and only adjusted to tune in stations that call off-frequency or drift off-frequency. This does mean that the user has to decide, before setting up the

## BUYING GUIDE

J304 field effect transistors may be obtained from J. Birkett, 25 The Strait, Lincoln, telephone (0522) 20767. See also the Buying Guide in Part 1 of this series

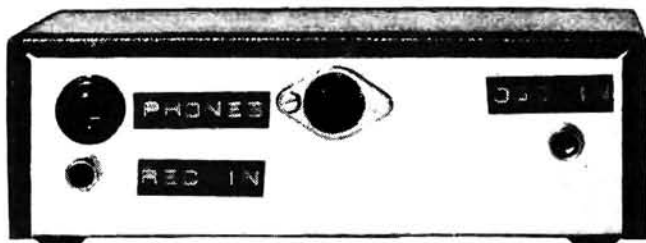
Approximate  
Cost

£23

Construction  
Rating

INTERMEDIATE





Rear view of the completed Receiver module

r.i.t., from which direction the station will be tuned in; from low-to-high, or from high-to-low frequency. I followed the convention of tuning in from high-to-low on 7MHz and low-to-high on 14MHz and set the r.i.t. accordingly.

Perhaps the best way to do the setting-up of the r.i.t. is to use the transceiver modules on the test bench feeding into a dummy load of 50 ohms and compare the signals with a little test oscillator and an existing amateur bands receiver. Again, crystals used in the basic form of the transmitter module could be used to provide a setting-up signal in a small test oscillator. Use the station receiver to set the test oscillator and the *PW* "Teme" transmitter output on the same frequency and adjust the modules so that they receive the test oscillator signals at the audio pitch of the filter centre frequency and transmit at the same frequency as the test oscillators. Perhaps a little fiddly but well worth spending some time on getting right as it is counterproductive to go on the air and be calling stations off frequency or have them calling you out of the peak frequency of the audio filter.

Another very simple way to do this adjustment is to have a local friendly amateur conduct a tune-up QSO with you. Get the station to call you and ensure that the receiver is set up so the filter peaks with the RIT control at the centre point. Then call him and adjust the transmit preset until you are on his frequency. This can also be done on the bench with an existing transceiver, which should either be a QRP transceiver or one set for very low r.f. output, and the *PW* "Teme" both running into dummy loads. This time conduct the tune-up QSO across the bench. Remember if the test is done on the air, get your friendly local station to reduce his power to a level that is only ample for the testing procedure and will not annoy other band users.

## Using the Modules

Once the setting-up is completed the *PW* "Teme" can be used in anger on the bands. The most satisfactory way to try out a first QSO is to arrange a sked. Not only does this ensure an instant first QSO but checks out the transceiver in use and allows for any final adjustments that might be required. The transceiver has semi-break-in and pressing the key will energise the transmitter, kill the receiver and bring in the sidetone. Remember to tune in signals from the direction which has been set up for the RIT control. The sophisticated could mark the RIT control so it can be set to tune from either side: very useful for avoiding QRM. Follow the usual QRP operating procedures. Avoid calling CQ, except for occasional "CQ QRP" calls on the QRP channels: 7030kHz and 14060kHz. Instead answer CQ calls or "tail-end" existing QSOs. Remember a QRP signal will probably be some two S-points down on a conventional signal but be bold and a surprising number of QSOs will result.

The next article will describe a suitable Standing Wave Bridge/Antenna Tuning Unit, plus mains Power Supply.

# Next month in *PW* On Sale 4<sup>th</sup> January

## Blow the cobwebs off your Morse with the



★ ★ ★ ★ ★ ★ ★ ★ ★ ★

### Modifying the FRG-7

An improved b.f.o.

## Plus

### "Introducing Short-wave Listening"

A new series by  
Charles Molloy

★ ★ ★ ★ ★ ★ ★ ★ ★ ★  
**PLUS YOUR FAVOURITE  
REGULAR ARTICLES**

## Order Your Copy NOW!



## New TV-DX Receiver

South West Aerials, the antenna and TV-DX specialists based at Parkstone in Dorset, inform me that they have in stock the Waltham 416 "Mini-Star", monochrome TV receiver with a 6 in screen, that was originally manufactured for the West German market.

The receiver, which is ideal for TV-DXing or viewing on European travel, is a dual-standard v.h.f./u.h.f. receiver for System B/G operation with 5.5MHz sound offset (see note below). Bands I, III and u.h.f. are covered and features include; continuous varicap tuning at both v.h.f. and u.h.f.; sharp selectivity and good sensitivity via four i.f. stages and the v.h.f. tuner has two r.f. stages.

A ten section telescopic whip antenna is provided, as is a separate 75Ω coaxial antenna socket. Power is derived from either a.c. mains or an external 12V d.c. source, and all plugs and cables are supplied.

Priced at £69.95, plus £3.75



carriage and insurance, the Waltham 416 "Mini-Star" is available from: *South West Aerials, 11 Kent Road, Parkstone, Poole, Dorset BH12 2EH. Tel: (0202) 738232.*

Note! South West Aerials can, for a small extra charge of £2.50, adjust the 5.5MHz sound offset to 6MHz, to conform to UK standards.

## New Low Cost Radio MODEM

Well known in amateur radio circles for their high quality AMTOR and RTTY terminal units, ICS Electronics Ltd. now introduce a new, versatile low cost terminal unit, entitled RM-1.

Requiring a 12V d.c. input at 150mA, the RM-1 connects to a home computer via either t.t.l. or RS232 level interfaces (both are supplied as standard). It can be used to send and receive RTTY or AMTOR at up to 100 Bauds with 170Hz shift. Also available are c.w. send and receive plus wide band ASCII at up to 1200 Bauds. European IARU tone standards are supported and the wide band receive mode can be used for receiving data transmissions from the UOSAT series satellites.

A range of software and cable packages for the RM-1 is available from ICS for many of the more popular home computers. Most other RTTY software on the market may also be used with the RM-1. It is plug compatible with other ICS terminal units.

Packaged in an attractive screen



printed enclosure and supplied with a comprehensive manual, the UK manufactured RM-1 lacks the extensive filtering of ICS's more sophisticated terminal units, but is ideal for most medium to strong signal applications.

Priced at £60.00 plus VAT and £1.50 p&p, the RM-1 Radio MODEM is available from: *ICS Electronics Ltd., PO Box 2, Arundel, West Sussex BN18 0NX. Tel: (024 365) 590.*

## If you please

Please mention this column when applying to manufacturers or suppliers featured on this page.

## BBC Radio Dial Keys

Many readers will be interested in a series of leaflets, produced by the BBC Engineering Information Department, that contain lists of frequencies and coverage maps of both national and local BBC radio stations. Additionally, information is provided on power, NGR, polarisation and height of the transmitting antenna. All very useful for the radio DXer.

To obtain copies, readers should apply to: *Engineering Publicity, Engineering Information Department, BBC, Broadcasting House, London W1A 1AA.*

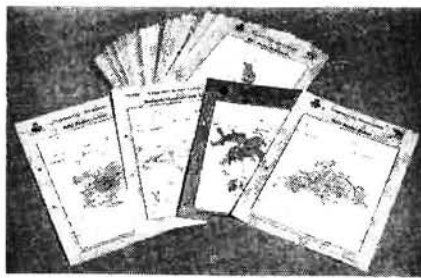
## Hand-held Capacitance Meter

Amongst the instruments on display on the Global Specialties stand at the International Test and Measurement Exhibition at Olympia, was a first time showing of their new Model 3000 digital capacitance meter.

The Model 3000 is a precision, battery powered instrument, designed for hand-held operation, whose features include a 3½ digit resolution over the capacitance range of 1pF to 2000μF, via eight selector switches, with accuracy to 0.2% of the reading. Readout is displayed on a large 12.5mm high numeric l.c.d., which also indicates low battery.

On the three lowest ranges an "adjust" control is provided to allow stray capacitance in the test leads to be nulled.

The Model 3000 digital capacitance meter costs £89.50, plus VAT and £2.50 p&p, and is available from: *Global Specialties Corporation, Shire Hill Industrial Estate, Saffron Walden, Essex CB11 3AQ. Tel: (0799) 21682.*



More on page 35



# THE CENTRE

LONDON'S NEWEST AND BRIGHTEST EMPORIUM

**4 Years in business,**

**NOW 4 year old prices\***



## CW - THE EASY WAY

The ideal way to learn morse code - get a G4HXZ morse tape. As well as a structured teaching course, it contains two simulated amateur licence tests that enable you to evaluate your own performance. The price also includes a Hi-Mound telegraphy key (HK 706/7) Only **£17.00** inc p&p.

## 23cm CONVERTER

Just plug this wonderful little gadget into the aerial socket of your television, plug the antenna into the box, tune to channel 36, and you're away. **£29.95.**

## CQ PHASER

This phasing harness will match two antennas on two meters but is easily modified for 70cms use. Only **£8.50** inc p&p.

## V.H.F. A.T.U.

The CQ ATU comes in a diecast box with external tuning knobs. It can handle up to 150W of through power. Just ask G4WGY how it works. Available in SO239, BNC or 'N' Type **£10.95** inc p&p.

\*  
Our  
Christmas  
present  
to you

Everyone has noticed how prices have rocketed in the last few years - well we have decided to do something about it! As a special Christmas present to our customers we are selling all the items in this advertisement at **FOUR YEAR OLD PRICES!** This offer is for the festive season only and prices will be back to normal in the New Year.

## ACTIVE INDOOR ANTENNA

This telescopic indoor antenna has been specially designed for flat dwellers etc. It covers all bands and eliminates the need for outdoor aerials. **£26.50** inc. p&p (requires a PP3 battery)

## G5RV ANTENNAS

G5RV multiband HF antennas - full or half size - only **£8.50** inc p&p.  
**HB9CV**  
2m + 70cm versions available. Mail order at **£9.50** each inc p&p.

We are probably this country's largest dealers in second hand radio equipment and we are always very keen to purchase more items. **Part exchanges are welcomed - anything considered!**

## SLIM JIMS

2 metre or 70cms available. Mail order price just **£6.50** each inc p&p.



10 MERTON PARK PARADE  
KINGSTON ROAD  
(JUNCTION MERTON HALL RD)  
LONDON S.W.19.  
TEL: 01-543 5150/4212  
MON-FRI 9.30-6.00 SAT 9.30-4.30



# GAREX THE SCANNER SPECIALISTS

## J.I.L. SX-200-N - THE SUPERIOR SCANNER

- ★ The choice of the professionals
  - ★ AM + FM all bands
  - ★ Wide coverage: 26-88, 108-180, 380-514MHz
  - ★ 16 memories ★ Positive action keyboard
  - ★ Proven reliability ★ 12v DC & 230v AC
  - ★ S-meter & 96-108MHz converter available
- £299

## REVCO RS-2000-E - THE VERSATILE SCANNER

- ★ 70 memories ★ AM + FM all bands
  - ★ Cover: 60-180, 380-520MHz
  - ★ Search & store of active channels
  - ★ All the usual search & scan functions
  - ★ 12c DC & 230v AC operation
  - ★ Counts activity of selected channel
- £259

## J.I.L. SX-400 - PROFESSIONAL SCANNER

- ★ Covers 26-520MHz (no gaps)
  - ★ AM + FM (manual, automatic or programmable)
  - ★ Computer interfacing for limitless memory, remote control & data logging
  - ★ Switchable channel spacing & I.F. bandwidths
  - ★ I.F. output terminals (10.7MHz & 455KHz)
  - ★ Specifications set by the professionals
- PHONE FOR LATEST PRICE

Regulated mains adaptor for SX-400 ..... £29.50

### ★ REVCO ★

A superb quality 16 element, all British made VHF/UHF broadband fixed station aerial from Revco. Ideally suited to all scanners and other VHF/UHF Receivers  
Covers 50-500MHz PRICE £27.45 inc

## ASK FOR OUR LIST OF SECONDHAND SCANNER BARGAINS

### ★ SPECIAL OFFER ★

CENTURY 21D communications receiver. 0.5 to 30MHz. CW, USB, LSB, AM & FM. Digital readout. Provisions for an external speaker and headphones. An excellent performer for only ..... £199

**CRYSTALS FOR NR-56, SR-9, SR-11, TM-56B.** We have a range of 2m & VHF Marine band crystals for these receivers at £3.00 each (+20p post per order). Please phone to check stock.

**RESISTOR KITS** a top selling line for many years. E12 series, 5% carbon film, 10Ω to 1m, 61 values, general purpose rating ½W or ¼W (state which).

Starter pack 5 each value (305 pieces) ..... £3.10

Standard pack 10 each value (610 pieces) ..... £5.55

Mixed pack, 5 each ½W + ¼W (610 pieces) ..... £5.55

Giant pack, 25 each value (1525 pieces) ..... £13.60

**DC/DC TRANSISTORISED INVERTERS** 12V input, 400V 200mA

rectified and fully smoothed output ..... £9.50

This unit is a chassis section cut from used R/T equipment, tidied, fully wired & tested. Free-standing but no luxuries like cabinet. 24v version - same price. SAE for details.

**SPECIAL OFFER discontinued line 12 or 24v to 380v inverter. £5**

We have in stock a very large range of spare parts for PYE RADIOTELEPHONES. Models include Olympic, Westminster, Whitehall, Europa, Mascots and PF70 Series. Parts also available for Cambridge, Vanguard etc. etc.

SAE FOR FREE EXTENSIVE LIST

**GAREX FM DETECTOR** and squelch conversion for Pye R/T equipment Ready Assembled. full instructions. Tailor-made, easy-fit design, replaces existing squelch board, with minimum of modifications. For AM Cambridge £6.30; for Vanguard AM25B (Valve RX) £6.10; for Transistor Vanguard AM25T £6.95.



MAIN DISTRIBUTOR OF REVCO PRODUCTS

PRICES INCLUDE UK P&P and 15% VAT

**GAREX ELECTRONICS**  
7 NORVIC ROAD, MARSWORTH, TRING,  
HERTS, HP23 4LS

Phone 0296 668684. Callers by appointment only

Goods normally despatched by return

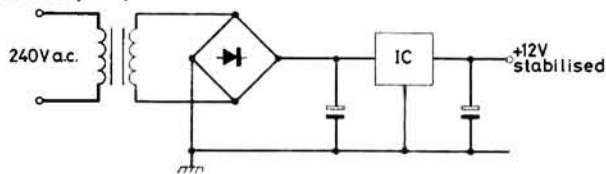
# multiple choice... multiple choice... QUESTIONS multiple choice... multiple choice...

If you are an aspiring RAE candidate or just feel like testing your knowledge of amateur radio these multiple choice style questions will fill your needs. The questions are typical of those appearing in both the RAE papers, but they are not taken from these papers. For the answers, together with explanatory notes to help you, please turn to page 58.

Paper 2 Section 3. Solid State Devices—typical power supply circuits

## Question 4-1

In this power supply, the integrated circuit (IC)



- a. converts a.c. into d.c.
- b. stabilises the output voltage
- c. prevents interference from the mains
- d. saturates the iron core of the transformer

Paper 2 Section 4. Receivers

## Question 4-2

The ability of a receiver to pick out a wanted signal from others close by in frequency is called its

- a. sensitivity
- b. selectivity
- c. stability
- d. screening

Paper 2 Section 5. Transmitters—modulation—principles

## Question 4-3

In a frequency modulated (f.m.) transmission the amplitude of the carrier

- a. is proportional to the amplitude of the modulating audio
- b. is proportional to the frequency of the modulating audio
- c. is proportional to the deviation of the modulating audio
- d. is constant

Paper 1 Section 1. Licensing Conditions—suffix to call sign

## Question 4-4

G1CJQ operating from a holiday chalet on Guernsey should sign

- a. GD1CJQ/A
- b. GJ1CJQ/A
- c. GM1CJQ/A
- d. GU1CJQ/A



## Handie Power

Just introduced to the UK by Lowe Electronics is a brand new 144MHz synthesised hand-held transceiver from Daiwa. Called the MT-20, the rig provides coverage of 144-146MHz in 5/10kHz steps, selected via thumbwheel switches.

The receive section features a double-conversion superhet (10.695MHz/455kHz i.f.), with quoted sensitivity of better than  $1\mu\text{V}$  for 30dB S/N, and attendant selectivity of  $\pm 7.5\text{kHz}$  at  $-6\text{dB}$  and  $\pm 15\text{kHz}$  at  $-60\text{dB}$ .

RF output of the basic rig, running from its own NiCad power pack, amounts to 1.5W (150mW low power selectable).

To regular readers, this format probably sounds quite familiar, however, the LA-20 linear amplifier, which has also just been introduced, allows true portable operation at high power. With its own integral NiCad pack the LA-20 will typically produce 10W r.f. output power. Power for the MT-20 in this configuration is supplied via a matching d.c. regulator/antenna interface unit. If used from a mobile/base station p.s.u. (13.8V) in excess of 20W of f.m. can reasonably be expected to be delivered.

Among the additional accessories is the LP-1 carrying case for the linear amplifier which incorporates a BNC antenna mount on the shoulder strap.

Prices for this equipment may vary with international exchange rates and should be verified with Lowe Electronics before any money is sent. However, the MT-20 144MHz f.m. transceiver will cost around £195, and the LA-20 around £80.

For further details, contact: *Lowe Electronics Ltd., Chesterfield Road, Matlock, Derbyshire DE4 5LE. Tel: (0629) 2817, 2430, 4057 and 4995.*



Practical Wireless, January 1985

## Unique Soldering Iron

Greenwood Electronics have recently introduced a product that should prove invaluable to the electronics hobbyist, engineer, wireman etc. Called the Oryx Portasol, it is a revolutionary, butane powered, portable soldering iron.

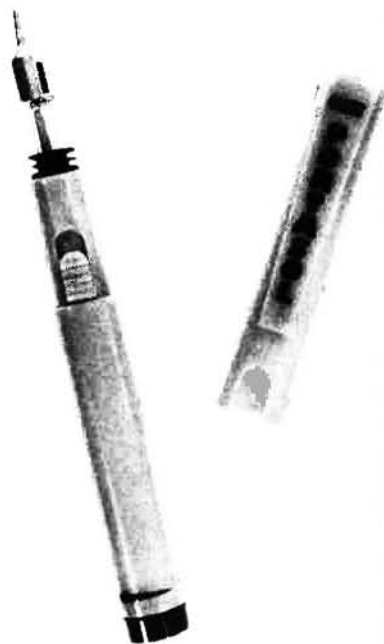
As the photograph shows, the Portasol resembles a chunky felt tip pen and measures 175 x 19mm diameter.

Working on an entirely different principle to conventional gas-powered irons, the Portasol generates no flame whatsoever during operation, but utilises the chemical energy of the butane gas being converted to heat by means of a patented catalytic converter in the tip.

The gas/temperature conversion rate is adjustable, allowing the tip temperature to be controlled over the range 250° to 450°C. Set to maximum, the iron delivers power equivalent to a 60 watt conventional electric soldering iron.

On its internal gas supply the iron will run for approximately 60 minutes and refuelling, which takes seconds, uses a standard butane cartridge, and is identical to filling a gas cigarette lighter.

Using the same principles as a lighter, the Portasol is just as safe to carry in the pocket and is ready for use anywhere. The protective cap houses an igniter to start the catalytic conver-



sion and replacement tips, which include the converter, are readily available.

In addition to the versatility of the Portasol, it has the added advantage of eliminating all risk of electrical damage to sensitive components.

Costing £17.25, which includes VAT and p&p, the Oryx Portasol is available from: *Greenwood Electronics, Portman Road, Reading, Berks. RG3 1NE. Tel: (0734) 595844.*

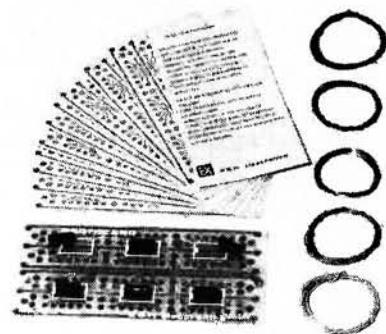
## Experimenter's PCB

E & H Electronics of Keighley, West Yorkshire, have recently introduced their Protocard, an experimenter's p.c.b. to assist in the easy construction of prototypes or the development of new circuits.

The Protocard system comprises: 10 plancards; six 16-pin d.i.l. i.c. sockets; 2 metres of solder; four 2 metre lengths of connecting wire and, of course, one Protocard p.c.b.

Each Protocard p.c.b. is ready-drilled for mounting the 16-pin i.c. sockets and the components are wired direct to large tinned copper pads on the track side of the p.c.b. In addition to a separate pad from each i.c. pin, five supply/signal rails traverse the board, also there are a number of independent connecting pads, some of which are configured to transistor patterns.

The re-usable Protocard system costs £8.50, including p&p, and is available from: *E & H Electronics, 33 North Street, Keighley, West Yorkshire BD20 3SL. Tel: (0535) 44103.*



## Please Note!

A number of our advertisers have asked us to advise readers that the prices of imported products are likely to change from month to month.

The reason behind these changes is fluctuating international exchange rates. So, readers are therefore advised that they would do well to check prices with suppliers prior to sending off orders.



**NEW SERIES**

# Valved Communications Receivers

by Chas. E. Miller

## 1—THE NATIONAL HRO

What makes a communications receiver worthy of being termed "classic", "historic"—or sometimes even both? For that matter, what exactly is a communications receiver anyway?

This last question should be easiest to answer, since by common consent a communications receiver is one dedicated to the reception of messages and information rather than entertainment matter. One school of thought has it that (with some justification) the inclusion of a beat frequency oscillator (b.f.o.) in the design is a deciding factor, but this is not invariably true. It must be appreciated that in the period of radio history covered by this series the sole purpose of a b.f.o. was to render audible continuous-wave (c.w.) signals to a Morse-trained operator. Military radios used to pass orders to semi-skilled personnel in plain speech had no need for a b.f.o., yet they cannot be considered as anything but communications receivers. In this series of articles we shall be looking at some notable examples of these.

### Performance Specifications

What of performance specifications? Some at least of the following are to be desired: A wide range of frequency coverage, divided into as many bands as convenient; superhet circuitry with one or more r.f. amplifiers preceding the frequency-changer; two or more i.f. amplifiers, ideally with variable selectivity; both manual and automatic gain of the r.f./i.f. stages available at will. There are many more detail refinements possible. Generally speaking extremely wide tonal response on the a.f. side is not as important as the clear reproduction of speech; good selectivity is just as essential as high sensitivity. But close adherence to these desirable points is no automatic guarantee that a receiver shall be a "classic".

There are numerous examples of groups of contemporary sets which have little to choose between them, but of which only one has become immortal and the others all but forgotten. Again, there are some receivers which would appear to have quite unremarkable specifications, but which have still managed to earn a special place in radio annals.

### Historic or Classic

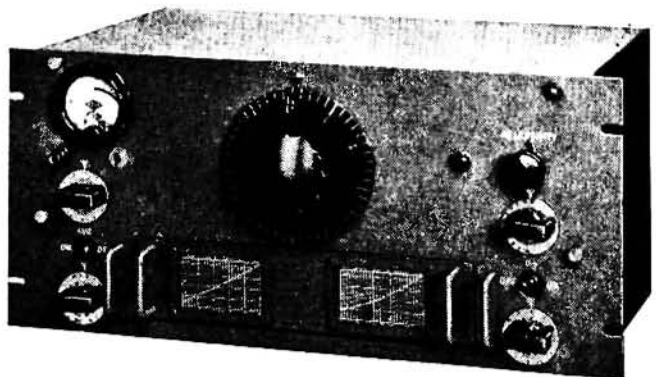
As far as the term historic is concerned, receivers so designated in this series are those which were either innovative or played a vital part in the development of radio communications. Classic is harder to define; in this particular context it is probably a combination of good electrical and mechanical design, plus that elusive quality "style", which when present impresses itself indelibly on

the owner or operator. These are the considerations which have guided the selection of receivers to be found in this series.

Communications receivers have been around for a long time—indeed, no other types were available for the first twenty years or so of practical radio, until the establishment of entertainment broadcasting in the 1920s. As far as private users were concerned most communications receivers for another 15 years were home-built t.r.f.s, but before the end of the 1930s commercially manufactured sets were available both in the UK and the USA, using superhet techniques and, in one celebrated example, a standard of performance hitherto unknown. We shall examine some of these.

The outbreak of the Second World War in 1939 gave a great impetus to the further development of communications receivers. Radio communications played a vital role in keeping the various military headquarters in touch with their fighting units; the land, sea and air forces all had widely differing needs to be satisfied. These ranged from compact, man-carried transmitter-receivers for infantry use, through medium sized sets for vehicles and aircraft, to some comparatively massive examples for warships and fixed installations.

Fortunately there were, on both sides of the Atlantic, numerous highly competent radio manufacturers well able to fulfil the requirements that arose. In many cases the normally fierce rivalry between competing firms was temporarily forgotten, and they would combine to produce jointly to a common design. (Even so, they nearly always managed to stamp their "personalities" on the finished articles, and it is not hard for a practised eye to determine which was responsible for a particular example).



The National HRO, rack model, taken from an advert circa 1942

*Practical Wireless, January 1985*



With the cessation of hostilities in 1945 vast amounts of military radio equipment became surplus to requirements and was released for sale to the general public. In this way a large number of communications receivers came into the hands of licensed amateurs and keen short-wave listeners, and their golden opinions have played no little part in making some sets "classic".

The original over-ordering of equipment for the military having been on the lavish scale associated with the spending of tax-payers' money, twenty years and more after the end of the war "brand-new" receivers were still on offer by surplus dealers. At about this time a rash of modifications for such sets began to appear in technical journals, all supposed to enhance the performance of the classics. In some cases real improvements were realised, whilst in others the gain was only marginal, especially in comparison to the amount of work required. Today these modifications are largely irrelevant, and even distasteful, as would be the "customising" of a vintage Rolls-Royce car. For this reason, any alterations suggested in this series will normally be confined to the restoration to original of the receiver concerned. Only those modifications which were and are essential to make the set suitable for civilian use, or otherwise have some real practical value, will be entertained. In any case, the criteria will be that the chassis and control panels of sets shall not be mutilated by the drilling of new holes, and that added valves and major components should match as closely as possible the originals. For instance, receivers employing octal-based valves shall not have "miniatures" implanted, no matter how great the temptation might be!

It is hoped that in this way a new generation of enthusiasts will be able to discover the appeal of classic and historic receivers and to appreciate how sound and efficient were the original designs. The articles in this series clearly cannot be as comprehensive as the original manufacturers' service manuals, but every attempt will be made to include enough information to make the vast majority of repair jobs possible. In many cases contemporary circuits, service notes and even operating instructions have been either reproduced or distilled where necessary, to give as useful a picture of the receivers as possible. Where appropriate voltage readings, etc., that are rendered different from original due to essential modifications will be quoted,

plus any helpful comments on changed operating conditions.

It is intended that the whole series should form a practical and dependable guide to the receivers covered. To this end the author will welcome any information from readers on particular idiosyncrasies they may have encountered on the part of individual models. Should sufficient material be obtained it will be incorporated into suitable appendices.

## The National HRO

The HRO has been chosen to commence this series because it can genuinely be termed both historic and classic. Not only is it one of the all-time greats, it was also the pioneer of its class. Its design represented a radical advance at a time when amateurs and keen short-wave listeners relied heavily upon t.r.f. receivers of technically limited performance. The HRO proved to be so good in service that its role was expanded to use in commercial radio links with great success. The design is now some half-century old, production commencing in the mid 1930s at the National Company's plant in Malden, Massachusetts. Age has not dimmed its reputation.

## General Specification

A nine-valve superhet with two r.f. amplifier stages, mixer with separate local oscillator, two stages of i.f. amplification, with variable selectivity and crystal filter. Diode detector followed by two stages of a.f. amplification; beat frequency oscillator. Wave band selection by plug-in coil sets; standard sets supplied with receiver coverage of 1.7-4MHz, 3.5-7.3MHz, 7-14.4MHz and 14-30MHz. Extra sets covering 50-100kHz, 100-200kHz, 180-430kHz, 480-960kHz and 900-2050kHz were available. Built-in S meter; manual controls for r.f. and a.f. gain, plus optional a.g.c. Jack for headphones, socket for loudspeaker (external unit); special rotary vernier dial for main tuning. Switches for b.f.o., a.g.c., h.t. standby, and S meter on/off. Rotary controls for selectivity, crystal phasing and b.f.o. pitch. Internal pre-set adjustment for S meter initial setting. Power supplies from external unit.

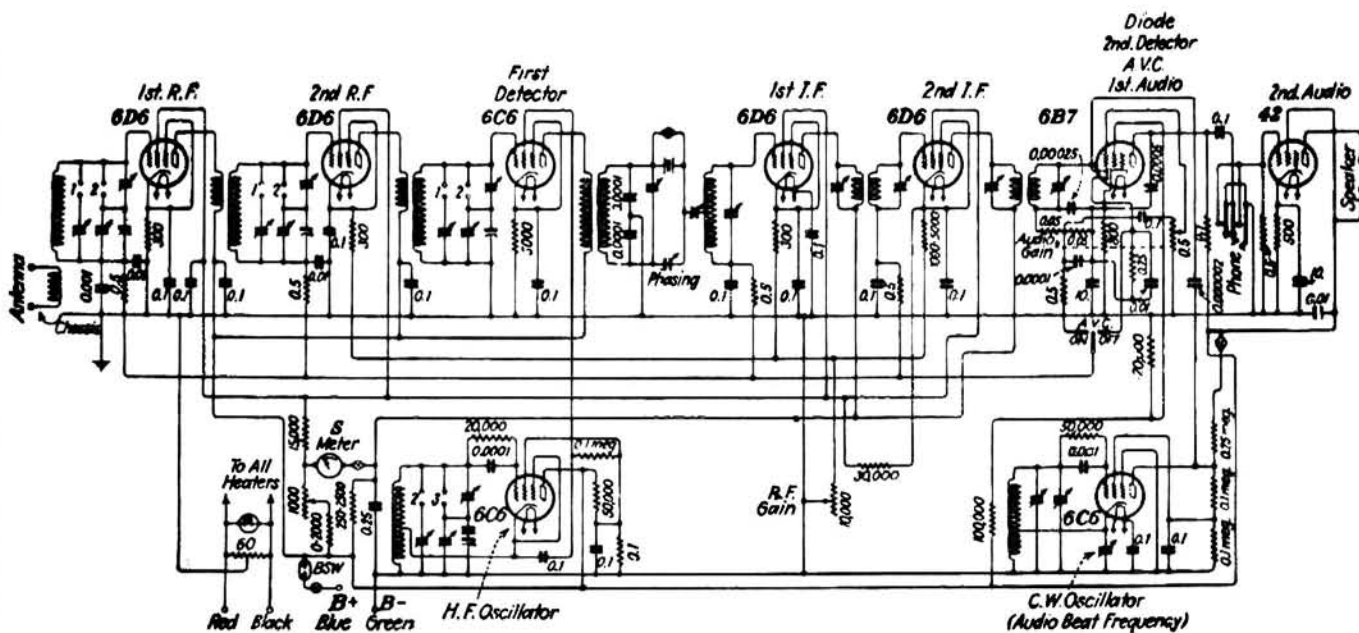


Fig. 1: Schematic diagram of the HRO receiver

(courtesy of the National Co., Inc.)



## Detailed Circuit Description

At one time the HRO was fitted with valves having 2.5V heaters. Later 6.3V equivalents were used. These were identical electrically and in basing, and valve sets may therefore be interchanged *en bloc* with, of course, due regard to the h.t. supply. In the following circuit description both 2.5V and 6.3V types are quoted, e.g. 58/6D6.

**Aerial input:** Terminals are provided for either single wire antennas plus an earth connection, or doublet type antennas; average input impedance approximately 500Ω. The first valve is a variable- $\mu$  r.f. pentode (V1,58/6D6) operating as an r.f. amplifier with fixed cathode bias and optional a.g.c. Tuned transformer coupling follows to a second r.f. amplifier (V2,58/6D6), which has optional a.g.c. plus manual control of gain by variation of cathode bias. Further tuned transformer coupling to G<sub>1</sub> of mixer valve (V3,57/6C6) which is a straight r.f. pentode with injection of signals from local oscillator (V4,57/6C6) to its G<sub>2</sub>; no automatic or manual control of gain is applied to the mixer.

The i.f. appearing at the anode of V3 is fed to first i.f. amplifier valve (V5,58/6D6) via a special transformer incorporating a crystal filter and variable selectivity facilities; the intermediate frequency is 456kHz. There is conventional transformer coupling from the anode of V5 to the second i.f. amplifier (V6,58/6D6). Both i.f. amplifiers are controlled either automatically or by the same manual control which acts on the second r.f. amplifier.

A conventional diode detector (D1, part of V7,2B7/6B7) supplies a.f. via a diode load/residual r.f. filter network to the a.f. gain control and thence to G<sub>1</sub> of the pentode section of V7. The a.g.c. voltage is tapped from the diode load network and in the AVC ON position of the switch is supplied to the control grids of V1, V2, V5, V6. In the AVC OFF position the a.g.c. line is earthed via a 250kΩ resistor and D2 of V7. Amplified a.f. signals at V7 anode are taken to the headphone jack via a 0.1μF d.c. blocking capacitor. There they feed either the headphones, or, when these are not plugged in, G<sub>1</sub> of the power output valve (V8,2A5/42). Note, no internal loudspeaker matching transformer is fitted and thus the loudspeaker sockets are at h.t. potential. Loudspeaker units **must** include a suitable transformer to present a 7kΩ load to the output valve. Also note that when a loudspeaker is not being used a shorting link must be placed across the sockets to prevent the output valve anode from "floating". Failure to observe this precaution can lead to serious damage to the valve.

The final valve is V9 (57/6C6), a conventional cathode-coupled oscillator forming the beat frequency oscillator. Output from V9 is taken to the detector diode via a 2pF capacitor. A continuously-variable tuning control is provided. The b.f.o. on/off switch interrupts the h.t. supply to the valve.

**Notes on the h.t. supply system.** At the time of the inception of the HRO it was common practice to obtain the various voltages required for valve electrodes from potential dividing and decoupling networks contained within the

power supply unit or section of a receiver. In the HRO, however, the voltages are obtained within the main receiver, and moreover the circuitry is bound up with the S meter operation. Therefore a detailed description of the h.t. supply arrangements will be of assistance in the understanding of the principles involved.

In the first instance it should be noted that an alternative version of the HRO, called the HRO-B, was produced for operation from storage batteries with the aid of a vibrator h.t. pack. Certain resistors within the set were altered in value to accept a nominal h.t. input of 180V as against the 230V of the standard model. Two values of resistance will be found on the circuit diagram on certain sections of the h.t. line as appropriate.

**HT circuitry in detail:** The h.t. enters the set at the B+ terminal and goes directly to the h.t. standby switch. From there further direct feeds supply the anode circuits of the r.f. amplifier; the anode and G<sub>2</sub> circuits of the mixer and local oscillator; anode of the first a.f. amplifier; the anode and G<sub>2</sub> of the output valve and, via the b.f.o. ON/OFF switch, the anode and G<sub>2</sub> of that valve. The G<sub>2</sub>s of the r.f. amplifiers and the anodes and G<sub>2</sub>s of the i.f. amplifiers are fed via the S meter network, thus: all G<sub>2</sub> voltages are common and obtained from a network consisting of a 15kΩ fixed resistor, a 1kΩ variable, and another fixed resistor with a value of between zero and 2kΩ according to the level of h.t. input. One side of the S meter is permanently wired to the junction of the 15kΩ and 1kΩ resistors. The anodes of the two i.f. amplifiers are supplied via a 200Ω/2.5kΩ resistor, the lower end of which is connected, via the S meter switch, to the other side of the meter. The h.t. feed to the r.f. gain control is also taken from this point. The whole effectively forms a bridge circuit, of which three legs are fixed resistors and the other the anode circuits of the valves controlled by a.g.c. The bridge is balanced by the r.f. gain control in the following manner: With a.g.c., b.f.o. and crystal filters switched off, and the selectivity control at maximum, the meter switch is depressed and the r.f. gain control advanced until the meter reads zero. This should correspond with a 9½ indication on the r.f. gain dial. After this the strength of any signal may be read off on the meter by simply switching in the a.g.c. and tuning for maximum reading. The a.f. gain may be set low or at minimum as convenient during the setting-up procedure, to avoid overloading of the output stage. Note that it is not possible to obtain continuous readings on c.w. stations, since the b.f.o. must be off when the a.g.c. is in use.

Should the S meter network become unbalanced, it may be re-adjusted as follows: Disconnect the antenna and switch off a.g.c. Set the r.f. gain control at 9½. With the aid of a small screwdriver adjust the 1kΩ variable resistor (mounted behind the S meter, near the AERIAL terminal) until the meter reads zero.

If non-standard power supply units are to be used with the HRO they must be rated at 230V, 75mA, and for the HRO-B 180V, 55mA. In both cases the 6.3V requirement is at 3.1A. The current drain of the 2.5V valves totalled no less than 9.55A and the chances of a suitable transfor-

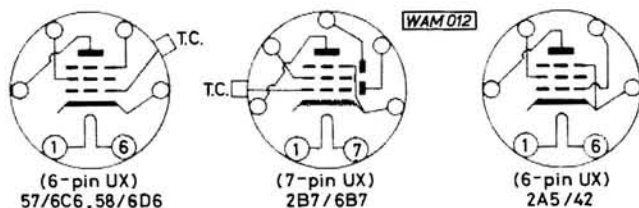


Fig. 2: Base connections for valves used in the HRO

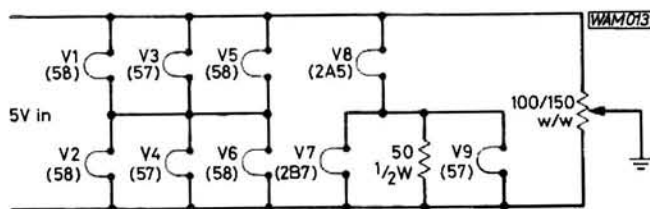


Fig. 3: Suggested series-parallel arrangement for 2.5V valves



mer being discovered lying around would appear to be slight. Clearly, the substitution of 6.3V valves would be the simplest way to overcome the problem, but should this be completely out of the question, and no facilities available for the winding of a special transformer, consideration may be given to the rewiring of the heater circuit for series-parallel operation at 5V, 4.8A. This voltage could be obtained from a large mains transformer intended for use with a 5V heater rectifier valve, such as the 5U4G. If this course were adopted the 6.3V winding normally accompanying the 5V supply could be used to power a rectifier having a 6.3V heater, such as the 6X5. The latter has an output of 75mA at 350V and is thus quite suitable for supplying the h.t. requirements. Note that neither side of the valve heaters in the HRO is earthed, making it a little easier to arrange them in series-parallel. A suitable arrangement is shown in Fig. 3. It will be advisable to raise the value of the hum-bucking potentiometer to between 100 and 120Ω. The dial bulb should be changed for a 6.3V type. Even with the lower current drain of the series-parallel heaters it will be necessary to use heavy duty feed cables, if these are to be long, to avoid voltage drop.

## Tuning System Notes

At first glance the dial of the HRO gives the impression of being distinctly old fashioned, since it bears no actual wavelength or frequency markings, but instead just a series of divisions. This apparent austerity conceals an ingenious micrometer-type calibration system which operates in conjunction with graphs mounted on the front of each coil set. As the tuning knob is turned a series of numbers appears in small windows cut into the periphery, giving counts in tens from 0-500. In conjunction with the fixed markers these permit very accurate setting of the control to any required number. The total number of turns is ten, and the reduction ratio, via a worm drive, to the tuning capacitor is 20:1.

The standard coil sets were designed to cover the American amateur bands, two to each set, plus the spectra between. On the terminal blocks for each set will be found four small, flat-headed screws. When these screws are in the left-hand position the normal coverage is obtained, as shown on the left-hand graph; if they are transferred to their right-hand locations the higher-frequency amateur band of the particular set will be expanded to take up 400 divisions on the dial. The calibration for this is given on the right-hand graph. **The B+ h.t. switch must always be in the off position during coil changing.**

**Use of the crystal filter and selectivity controls.** The use of these will be of great assistance in overcoming interference, static, and heterodynes. For modulated signals the filter is switched in by the phasing control, which is set at its mid point. The selectivity is adjusted for maximum (i.e. loudest background noise), and the RF/AF GAIN controls advanced as necessary. Signals may then be tuned in, bearing in mind that the selectivity will be in the order of only a few hundred Hz. Normally this restriction would reduce the intelligibility of speech, but since it is accompanied by significant reductions in interference there is a net gain. When a station has been tuned in to give reasonable intelligibility and is subsequently subject to interference from another, the result is usually highly detrimental. In this case the phasing control may be operated to reduce the interference sharply, sometimes completely. A similar procedure is used for c.w. reception, saving that the selectivity may be reduced to a very low level to remove interfering stations. The b.f.o. must, of course, be on and the a.g.c. off.

## Servicing Matters

The HRO was constructed to very high standards and even after more than 40 years may be expected to be in good shape generally. However, as with all pieces of radio equipment using valves, the various coupling and decoupling capacitors are vulnerable, especially during long periods of storage in perhaps adverse conditions.

The use of common feeds to a number of the valve complement electrodes in the HRO reduces the number of components involved and readers contemplating complete overhauls may consider that renewal of the lot is preferable to checking them out individually. Although the upper limit of h.t. voltage is nominally 230V capacitors for anode and G<sub>2</sub>, decoupling should be rated at 500V or more to preclude further trouble. Cathode decouplers, being required to work at very low voltages, seldom give much trouble as regards leakage, but any loss of capacitance may give rise to puzzling instability problems. The 10μF electrolytics on the cathodes of the a.f. valves will give much-reduced gain if their capacitance is low; the simplest test is to bridge them with a known good alternative. Note that any leak in the coupling capacitor from the anode of V7 to G<sub>1</sub> of V8 (via the headphone jack) will cause the last-mentioned valve to draw heavy anode current. In severe cases this may overload the bias resistor to the extent that its value will alter, and cross-checks should be made in this area. There are no h.t. smoothing capacitors within the set itself, but those within the power supply unit should be checked if it too has stood idle for some time.

## Realignment

This should not be undertaken unless there is definite reason to suspect that a fault exists (e.g. where trimmers have plainly been interfered with) and unless adequate test equipment is available. To preserve the performance of the HRO a wobulator and oscilloscope should be treated as essential for i.f. alignment. On the r.f. side signal generators should be checked against the well-known frequency-standard transmissions from MSF (Rugby) or WWV (Colorado) before trimmers are adjusted. Thereafter the normal procedure of padders at low frequency, trimmers at high should be followed. Aim to bring the response back to near that indicated on the tuning graphs, but **not** for perfection, which may well be impossible to attain. The quest may actually make matters worse if carried out unnecessarily or to extremes!

Excellence does not come cheap. In 1942 the HRO, with the standard set of four coils, cost \$329 for the table model. The power supply unit was \$29.50, whilst the matching loudspeaker added another \$18.25—a total of \$376.75. The additional coil sets cost between \$22 and \$40 each, totalling \$157, making a grand total for the whole shebang of \$535.75. At the prevailing rate of exchange this was equivalent to £133 and a few shillings. One could have bought a van to deliver the HRO for that amount of money in England!

**Part 2 of this series provides a full description, together with fault finding and servicing details, of the R1155**



# Swap Spot

Have ADM-3A interactive display terminal, full or semi duplex, RS232 interface, QWERTY keyboard with operator's handbook, D plugs and cables. Has been stored for 18 months. Would exchange for amateur radio gear, anything considered. R. Sharp. Tel: 0793 826325 after 7pm (Swindon). W438

Have Harvard 420M CB transceiver, patch lead, two s.w.r. meters, base station antenna and coaxial cable, mains power supply unit. All in good condition. Would exchange for ZX81 16K or 144MHz band hand held receiver. Tel: 0983 854850 (Isle of Wight). W443

Have pair IAS horn loaded speakers including stands (worth over £300 new) and Akai GXC730D (auto, rev, cont, play) about 10 hours use at most. Would exchange for Trio R2000, FRG-7700 with memory or Icom R-70. Abbey. Tel: Basingstoke 882825. W452

Have Creed 444 teleprinter plus p.s.u. Would exchange for 28MHz (10m) f.m. rig (converted CB?), oscilloscope or w.h.y. John. Tel: 0384 371246 (W. Midlands). W453

Have Multi 700AX 144MHz band 25 watt transceiver, 144/28 transverter, still under guarantee. Would exchange for IC-290E or FT-480R 144MHz band transceiver. Terry G4OXD. Tel: 0462 35248 after 6pm (Hitchin, Herts). W458

Have Minolta XD7 with Rokkor 35-70mm zoom lens, auto winder, quality flash gun, many accessories including carrying bag. All in pristine condition. Would exchange for Icom R-70 receiver. Ellis, Nursery Lane, Hookwood, Nr Horley, Surrey. Tel: 5073. W461

Have Dynamco series 72 dual beam 15MHz mains/battery portable 'scope complete with battery pack, carrying case, probes, manuals, etc. Would exchange for Myford Super 7, or similar, lathe on stand plus accessories. E. Foster, 45 Bath Street, Abingdon, Oxon OX14 1EA. Tel: 0235 32368. W468

Have Avo valve characteristic meter type VCM163, complete with original manuals. Would exchange for w.h.y. Also have Marconi a.m./c.w. signal generator type TF144H/4. Would exchange for w.h.y. G4UNM. Tel: 0983 402273. W471

Have Creed 444 and service manual, immaculate condition. Also have Dymar gear, four radios, one on 144MHz band, two chargers, one large, ten various sized batteries, portable cassette player. Would exchange for 144MHz mobile or w.h.y. Possible cash adjustment. Pete. 0952 616611 (Telford). W473

Have JVC XLV1 digital audio compact disc player (perfect sound reproduction) brand new, boxed and cost £549. Would exchange for TR-2500, TR3500 and charger. Would consider other 144 and 430MHz band rigs. Tel: 0442 61936 between 6 and 8pm (Hemel Hempstead). W475

Have National HRO h.f. receiver, 1.7—30MHz with spare new valve kit, p.s.u., etc. Would exchange for h.f. TX or w.h.y. Alfred Danty, 36a Avondale Avenue, Penshaw, Houghton-le-Spring DH4 7QS. W504

Have 400+ radio magazines, *Practical Wireless*, *Radcom*, *Short Wave Mag* and others. Would exchange for receiver, anything considered even non-working, provided complete. Sharp. Tel: 0793 826325 after 7pm (Swindon). W506

Have Ekco A704 valve RX, coverage 2.4—27MHz plus medium wave. Would exchange for HR phones or 8Ω speaker, w.h.y. Mike Rowntree. Tel: 0933 664385 (Wellingborough). W516

Have SEM audio multfilter in mint condition. Would exchange for "00" gauge model railway rolling stock. L. F. Hollis, 24 Crown Street, Brandon, Suffolk IP27 0NH. W555

Have Akai VC-X2E video camera, auto/manual focus, 6X power zoom, auto iris, Canon optics, value £500+. Would exchange for good mobile/base 144MHz multimode e.g. TR-9130, FT-480, IC-290 or h.f. receiver e.g. R-2000, FRG-7700M. Tel: 0625 614510 (Macclesfield). W517

Have 4½in reflecting telescope with motor drive, 3 eyepieces, etc. Would exchange for Centronics printer, must be compatible with Codemaster CWR610E. Also have Advanced Bridge Challenger. Would exchange for Datong FL3 Audio Filter. Tel: 0603 401538 (Norwich). W531

Have B40D receiver in good working order and R103 Mk 2 receiver not working. Would exchange for 144MHz transceiver hand held or portable or 430MHz 10 watt linear or 28/144MHz transverter. Roger Edwards G1IWZ, 113 Brookwood Ave., Barnes SW13 0LR. W532

Have Burndept Ex WD transceiver 150MHz, can be crystallised (receive section requires valve), ground to air comms with d.c. converter and folding dipole, plus handbook. Would exchange for w.h.y. Tel: Alloa 212243. W535

Have FT-290, 30W Alinco linear, Adonis mobile mic, 7/8 antenna, gutter mount, s.w.r. meter, 5-element beam and cables. Would exchange for FT-707 or w.h.y. h.f. Cash adjustment if necessary. Tel: 01-421 1513 (Hatch End). W541

Have Kodak Ektaflex colour print machine, Krokus 35mm enlarger, Rokkor lens, timer easel, filters and Quest vest. Would exchange for Yaesu FRG-7 receiver. G. R. Woodley, 16 Albert Street, St Barnabas, Oxford OX2 6AY. W545

I collect Technical Service information. Am willing to swap copies from my library for further data. Write with what you have and what you want. Radios, Televisions, Test, Vintage Wireless, etc. Maurice Small, 8 Cherry Tree Road, Chinnor, Oxon OX9 4QY. W557

Have Trio R-1000 general coverage receiver adapted for f.m. on all bands plus Yaesu a.t.u. All in excellent condition. Would exchange for small lathe with screw cutting facility or w.h.y. Tel: 0704 77227 (Southport). W566

Have 64 electronics magazines of various titles dating from 1968 to 1981. Send s.a.e. for list. Would exchange for 35mm camera in working order, looks unimportant, or w.h.y. Roy Thick, 6 Longlands Road, BB Leys, Oxford OX4 5BP. W568

Have Minolta X700 s.l.r. with 50mm and 28mm, 2X Macro converter flashgun and handgrip, filters, tripod, etc.—as new. Would exchange for any 144MHz band TX/RX portable multimode, or w.h.y. John Mullen, 24 Forth Crescent, Dalgety Bay, Fife. Tel: 822206. W579

Have Atari 600XL 16K computer plus 1010 cassette drive and software and BASIC manuals. Would exchange for Sony ICF-7600D, Uniden CR-2021 or Belcom LS202E. Tel: 01-870 4877 (Wandsworth). W585

Have Standard C5800 144MHz band multimode, 25 watts output, 144—148MHz. Mint condition, value £285. Would exchange for good v.h.f./u.h.f. scanner. J. B. Rose G1CFY, QTHR. Tel: 0303 38849 (Folkestone). W606

Have Standard 8900, 144MHz band f.m. transceiver, 10 watts, five memories, scanning, repeater shift. Would exchange for FRG-7700. Keith Dickens G4OCH. Tel: 0543 376366 (W. Midlands). W607

MORE ON PAGE 54

*Practical Wireless*, January 1985



# contents

Software ● Hardware ● News

Low-cost SSTV on the BBC-B

FORTH for the Radio Amateur

Review—G3LIV SSTV Terminal

## comment

Because of production problems this issue of *Computing in Radio* has had to be printed on the same paper as the main magazine. The most noticeable difference is the loss of full colour on the cover. The next issue of *CIR* is scheduled for inclusion in the May 1985 issue of *Practical Wireless* when we hope to have overcome the problems.

The computing side of radio is developing at an ever increasing rate making it very difficult for us to include everything of importance into *CIR*. This issue deals with SSTV using home computers—an area that seems to be growing in appeal as the use of a relatively low-cost computer enables the amateur to get into SSTV with the minimum of capital outlay, and still have the computer available for other uses.

As this issue goes to press Sinclair have announced a 48K Spectrum fitted into what appears to be a QL style keyboard, which should answer critics of the Spectrum keyboard. Also Commodore have introduced a new machine the Commodore 16 which with a "starter pack" price the same as the VIC 20 must surely kill off the latter machine. We will be bringing you details of these developments and others in future issues. Radio enthusiasts will of course be most interested in the levels of r.f.i. generated by these newcomers and this is one area where the manufacturers could do more. A metallic screen fitted at the factory—even a sprayed metallic coating inside the plastics case—would go a long way to keeping the nasties inside the computer where they belong. Which manufacturer will be the first to get to grips with this problem?

G8VFH



A 14MHz band slow-scan television picture received using the G3LIV SSTV Terminal reviewed in this issue ▶

◀ A 14MHz band slow scan television picture received using the home-constructed project, Low-cost SSTV on the BBC-B, described in this issue



# COMPUTING

# in radio



## The Ultimate Computer Game!

For all those interested in c.w. contests, or wish they could join in, then Doctor DX is the "game" for you.

With the module plugged into a Commodore 64 an amateur transceiver is displayed on the screen. By using various function keys the "transceiver" can be made to tune up or down the band or change bands.



As the "rig" is tuned stations sending Morse can be heard, along with the background noise. It gives the impression that a CQWW DX contest is underway, and different stations can be heard calling CQ and working one another.

All 304 DXCC countries are represented and the number of times a country is heard depends on the radio population of that country. Latitude and longitude can be specified for your station as can the time of day at the start of the contest, therefore, the countries heard are consistent with the propagation from your location.

A Morse key can be plugged into the Doctor DX and then you can join in the contest. The stations at the top of the "band" are slow Morse stations and at the bottom of the "band" are the more expert stations. Your score is kept on the screen.

Doctor DX is available from **ICS Electronics Ltd, PO Box 2, Arundel, West Sussex, BN18 0NX. Tel: 024 365 590, priced £96.95 inc. VAT with £1.50 p & p.**

## Spectrum RGB Output

Because the Spectrum only has a u.h.f. signal available this tends to result in the quality of the graphics being degraded and it can monopolise the family TV—not usually well received.

The answer could well be an RGB output driver module. Some of its main features are that it gives true t.t.l. level RGB on stan-

dard DIN socket, separate composite syncs, simply plugs into an expansion port, no separate power supply is needed and it doesn't affect the u.h.f. output.

The RGB output costs £29.95 plus 50p post and packing and is available from **Adapt Electronics, 20 Starling Close, Buckhurst Hill, Essex IG9 5TN. Tel: 01-504 2840.**

Advertisement



*"Run more than ten tasks on a ZX81-FORTH ROM?"*

Sure! More than 10 tasks simultaneously and, in some cases, up to 300 times faster! That's what replacing the basic ROM with the new FORTH does for the ZX81 — and more!

The brains behind the breakthrough belong to David Husband, and he's building Skywave Software on the strength of it. Already orders are flooding in and it's easy to see why.

The ZX81-FORTH ROM gives you a totally new system. In addition to multi-tasking and split screen window capability, you can also edit a program while three or four others are executing, schedule tasks to run from 50 times a second to once a year, and with a further modification switch between FORTH and BASIC whenever you like.

Return of post subject to availability.

The ZX81-FORTH ROM gives you a normal keyboard with a 64 character buffer and repeat, it supports the 16k, 32k, 64k RAM packs, it is fig-FORTH compatible and it supports the ZX printer.

The price, too, is almost unbelievable. As a "fit it yourself Eprom", complete with manual, it's just £25+VAT.

Add £3 p&p UK (£6 Europe, £12 outside Europe) and send your order to the address below.

**Skywave**  
**SOFTWARE**

David Husband  
73 Curzon Road, Bournemouth,  
BH1 4PW, ENGLAND.  
Tel: (0202) 302385.  
International +44 202 302385.

Advertisement

## RTTY/AMTOR BBC COMPUTER

G3WHO split-screen AMTOR program now available on Eprom. Uses ordinary terminal unit. Type-ahead, memories, clock, etc. RTTY program on tape, disk or Eprom.

**P. J. Harris,**  
10 Appleby Close, Great Ains, Alcester,  
Warks. B49 6HJ.  
Tel. 078981 377.

G3LIV Terminal units. Ideal for above program. Interface directly with BBC micro but will work with other computers. PC boards or ready built. Slow Scan T.V., P.C.B.'s and Built units with Software to Interface with BBC Computer.

**J. Melvin,**  
2 Salters Court, Gosforth, Newcastle,  
Tyne and Wear.  
Tel. 091 284 3028.

Excellent reviews of both products.  
SAE to either address for full details.

Advertisement

## GROSVENOR SOFTWARE (G4BMK)

3 SUPERB PROGRAMS FOR DRAGON 32/64 AND EXTENDED TRS80 COLOR

AMTOR stand-alone program. Requires a conventional RTTY terminal unit, plus our clock/PTT board. This system beats the AMT-1/2 for facilities, convenience and price!

RTTY The original, best and now even better with CW Indent, Ascii, scratchpad memories, receive standby mode, USOS etc. Can receive without any interface.

CW Transceive to 200 wpm. Auto speed tracking. The most effective decoder available at the price.

ALL THREE in a cartridge £69. Available separately from £10.75.

VIC20 CBM64 ATOM

RTTY split screen, type ahead, any baud rate, printer support, saveable memories OSO review etc. VIC20 £10; CBM64 £11; ATOM (Utility ROM) £16.

TERMINAL UNITS BY PNP COMMUNICATIONS

MF2 RTTY/Morse receive only — multi standard 170/425/850 shift. Built and aligned £37.37.

AMCK1 Amtor clock/PTT unit. Kit £15.80; Built £18.70.

SAE for details. State computer and call sign (if any):  
22 GROSVENOR ROAD, SEAFORD, EAST SUSSEX BN25 2BS  
Tel. (0323) 893378



## Circuit Analyser

Analyser is a program which evaluates the performance of electronic circuits. The program is a professional tool which analyses amplifier and filter circuits and enables the circuit designer to interactively improve them without the need for laborious breadboarding and bench testing.

Whilst the Spectrum is not the ideal computer for this type of work, it can perform a true engineering function. The program should be of great interest to those involved in both education and industry.



Circuits of up to 16 nodes and 60 components can be analysed for input and output impedance and gain at linearly or logarithmically spaced frequencies.

Components such as resistors, capacitors, inductors, transformers, op amps and both bipolar and field effect transistors can be simulated. Then the a.c. performance of circuits containing any combination of these components can be fully evaluated.

Once a circuit has been entered into the computer it can be stored on tape for further analysis at a later date.

The Spectrum version of the Analyser program costs £35 inclusive, there is also a BBC-B version available on cassette at £35 inclusive and on disc at £45 inclusive.

An improved version called Analyser 2 is available for the disc based BBC-B, this program does all that the Analyser program does plus many extra features, such as graphics output and library facilities. The Analyser 2 program costs £115 plus VAT.

All the programs are available from **Number One Systems, 9A Crown Street, St. Ives, Huntingdon, Cambs PE17 4EB. Tel: 0480 61778.**

## Cable Assemblies for Home Computers

Two types of Scotchflex flat cable/connector assemblies for linking microcomputers to peripheral equipment are now available. Because they are BBC compatible the cables will fit many microcomputers. The two versions available are for interfacing with a parallel printer and a disc drive.



Scotchflex Printer Cable (HA500P)—a 36-way Delta ribbon connector (Centronics-type) and a 26-way socket linked by a 1.25m length of flat grey cable. The socket is fitted with built in strain relief.

Scotchflex Disc Drive Cable (HA501D)—a 34-way card edge connector and a 34-way socket with strain relief linked by a 1.25m long cable.

Scotchflex cables are available in boxes of 100 from **3M UK plc, Yeoman House, 57 Croydon Road, Penge, London SE20 7TR (Penny Cartridge). Tel: 01-659 2323.** For smaller quantities 3M will be pleased to advise distribution outlets. 3M also make Scotchflex assemblies to customers' own specifications, including double disc drive cables.

## Power Buffers

Cambridge Microelectronics are retailing the Nike range of power buffers, these safeguard the microcomputer against momentary and short duration mains failures.

The power buffers are available for three computers at the present time the Oric Atmos, Sinclair Spectrum and Sinclair ZX81. Rechargeable NiCad batteries are kept charged by the mains power pack, and should mains be lost, the NiCad cells automatically take over supplying the computer.

The units include batteries and are ready to use. Each unit costs £19.95 inclusive and is available from **Cambridge Microelectronics Ltd., One Milton Road, Cambridge CB4 1UY. Tel: 0223 314814.**



## Mk3 G3LIV RTTY

This Mk3 terminal unit consists of two p.c.b.s to enable a suitably programmed computer to send and receive RTTY.

The receive p.c.b. decodes the incoming tones into a t.t.l. compatible signal, whilst the a.f.s.k. generator produces the necessary audio tones for transmit. In the case of the BBC-B with the G3WHO program the a.f.s.k. generator board is not required. The main receive board includes a mains p.s.u.

A 741 is used as a signal limiter after in-

itial filtering, and a further 741 is used as a post detector "chopper" to give a t.t.l. compatible signal, with the ability to switch between normal and reverse shifts. This saves you having to change sideband and retune the receiver if a signal is the wrong way round.

The active filters have switched centre frequencies to cover both amateur 170Hz and commercial 425Hz shifts. Two l.e.d. indicators are used to assist with correct tuning, to enable optimum copy under difficult conditions.

The board is suitable for Apple, Vic 20,

Pet, BBC, TI99, Atom, Com 64 and many other popular computers. It can be used with both Spectrum and ZX81 but as these have no I/O ports fitted then an extra interface is required.

The Mk3 G3LIV RTTY unit is available from **Mr J. Melvin G3LIV, 2 Salters Court, Gosforth, Newcastle, Tyne and Wear NE3 5BH. Tel: 0632 843028.** All assembled units are covered for six months parts and labour. Prices range from £6.80 inc for the p.c.b. receive only unit to £89 for the complete TX/RX unit with fitted a.f.s.k. board.



## Low-cost Slow-scan TV on the BBC-B

by Tim Collings G6GCM

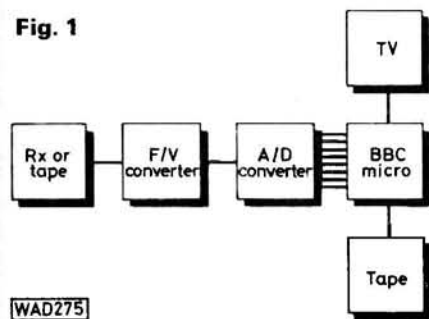
Slow-scan television (SSTV) has in the past involved a fair amount of expensive hardware to produce rather low quality non-permanent pictures. This project offers a low cost alternative with good results for those who already own a BBC microcomputer.

For those unfamiliar with SSTV, it is a method for the transmission of still photographs or drawings using a series of audio tones over a period of about eight seconds. The tones vary in frequency from 1500Hz representing black, to 2300Hz for white. A sync pulse of 1200Hz is sent at the end of each line with a longer sync pulse being sent at the start of each frame. Slow-scan signals may be heard regularly on the 14MHz band, normally around 14.230MHz upper sideband, Sunday mornings being a popular time. The other h.f. bands also have popular frequencies for slow-scan. When listening to these signals the sync pulse can be heard every eight seconds or so. Single sideband is the usual mode of transmission to allow the receiving station to adjust the audio tones to suit his decoder. In the past SSTV has been displayed on a long persistence screen, each frame being sent several times to refresh the display as it faded. More recently slow-to-fast scan converters and microcomputers such as the Robot series have been available.

With the arrival of the BBC model B computer, complete with high resolution graphics, programmable characters and an eight bit input/output port, low cost add-ons enabling quite high quality slow-scan pictures to be displayed become possible.

The system described here evolved from using a fast analogue to digital (A/D) converter with the BBC to produce a storage oscilloscope. It then seems quite obvious that placing a suitable frequency to voltage (F/V) converter before this will enable slow-scan (and also RTTY) tones to be digitised. With the correct sampling and display routines, a full slow-scan decode and display system is produced.

Fig. 1

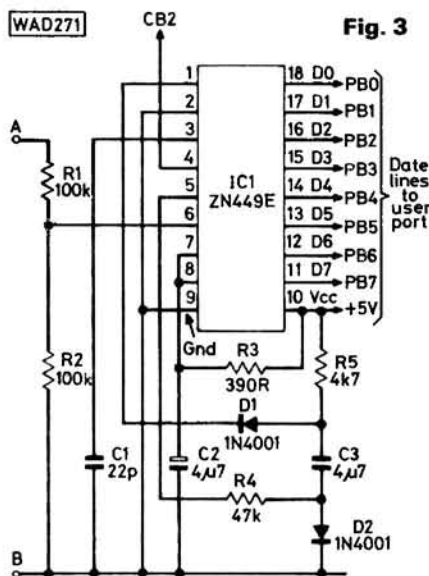


### Frequency to Voltage Converter

The audio signal which should be around 2.5 volts, available from the extension loudspeaker socket of most receivers or cassette recorders, is fed into a frequency to voltage converter (Fig. 2). This circuit is based on that provided by RS Components on their data sheet R3021. It has been modified to give a large voltage swing for the input frequency range used. Diodes D1-6 provide input signal conditioning to ensure that pin 11 does not go overvoltage. The circuit is set to provide an output of approximately 1.5 to 3.9 volts which varies linearly with an input frequency range of 1200 to 2300Hz. However the system will allow for frequencies outside this range which may be produced if the receiver is not quite tuned correctly or the transmitting station is sending off-frequency audio tones. A 9 volt battery is required to power this circuit. Note that the negative rails in the two circuits are not common. This is due to the fact that the F/V chip normally requires a dual supply of  $\pm 5$  volts but here has been modified to operate from a single supply.

### Analogue to Digital Converter

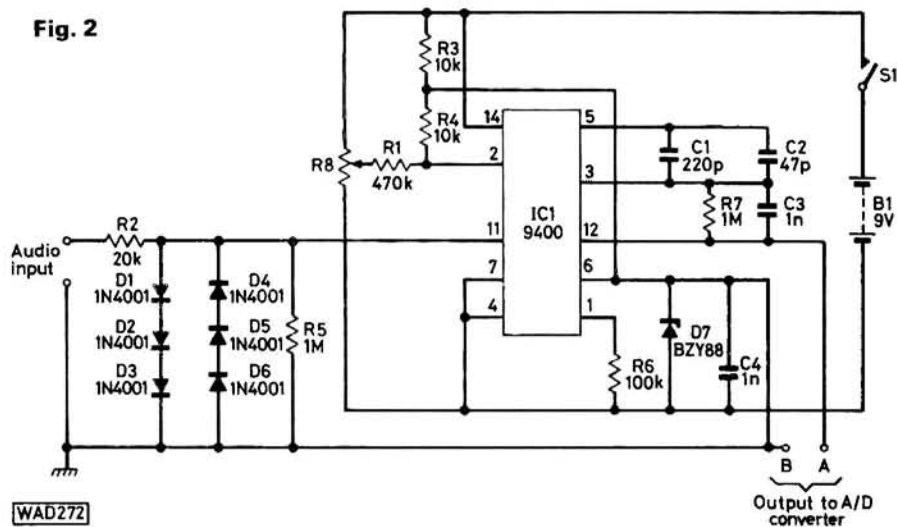
The output voltage is fed to an analogue to digital converter, and Fig. 3 shows the circuit, based on the applications sheet for the Ferranti ZN449E A/D converter. This



i.e. has a conversion time of eight microseconds—the A/D converter in the BBC is far too slow for this application. The digitised value of the analogue voltage is fed to the eight bit user port of the BBC micro. A handshake line to initiate the conversion and a 5 volt supply are also taken from the port.

Layout of the circuits is by no means critical. On the prototype they were constructed separately on stripboard and

Fig. 2





mounted in individual cases. This was to enable the A/D converter to be used on its own for other voltage measurements.

## The Software

Program description: There are two main routines used, a data capture routine and a decode/display routine.

The data capture routine scans the output from the A/D converter and stores the values in a buffer starting at address &1C00. The "PORTREAD" subroutine (see listing 1) actually looks at the output from the A/D converter 112 times before returning with a value. This is necessary as the output from the F/V converter consists of a d.c. 10kHz sawtooth waveform with maximum and minimum values changing linearly with input frequency. This presents no problem when using a meter to monitor the output but with the A/D converter taking samples over eight microseconds it is necessary to take several samples to ensure that the maximum voltage level of the waveform has been sampled and it is this value which is returned in location &8C and then stored in the buffer.

The decode/display routine examines each piece of data in turn and compares its value with that of the expected sync frequency value. This generates a value which points to a position in the look up table stored at &1B00 to &1BFF. This look-up table contains either 128, which represents a sync pulse, or the ASCII value of a character which has been defined in a BASIC program (see listing 2).

The program uses the facility of the BBC to redefine characters on an 8x8 matrix. In this application ASCII codes 230 to 246 are redefined but only to produce an 8x2 matrix (see Fig. 5).

By switching on the pixels in the 2x8 matrix one at a time, a 16 level grey-scale can be produced. ASCII codes 230 to 246 have characters going from zero pixels on for black to all on for white.

In mode 0 this allows a picture of 80 samples wide by 128 lines to be constructed. If each character space were to be plotted it would require a data buffer of 10K Bytes. As we only have 5K available every other point is plotted from data. Intervening points are calculated by taking the average of the points either side.

Listing 2 generates the look-up tables for the display routine and assigns the function keys.

## Entering the Programs

Before starting it is essential that a \*TAPE command is issued and the value of PAGE be set to &OE00 if discs or networks are normally used.

The final program has to be initially constructed as two separate routines due to the limited memory available after HIMEM has been brought down to &18FF to give space for machine code routines, look-up tables, data buffers and screen memory.

Type in listing 1 very carefully. Run the program and an assembly language listing should be produced. If this happens with no errors, save the program on tape. **DO NOT** switch off the machine or change mode or

## ★ components

Fig. 3

Resistors			
$\frac{1}{2}$ W 5% carbon film			
390 $\Omega$	1	R3	
4.7k $\Omega$	1	R5	
47k $\Omega$	1	R4	
100k $\Omega$	2	R1, 2	

Capacitors			
Sub-min. plate ceramic			
22pF	1	C1	

Ceramic			
4.7nF	1	C3	

Axial electrolytic 10V			
4.7 $\mu$ F	1	C2	

Semiconductors			
Diodes			
1N4001	2	D1, 2	

Integrated Circuit			
ZN449E	1	IC1	

### Miscellaneous

18-way d.i.l. i.c. socket; 20-way user part connector; 20-way ribbon cable; Veroboard.

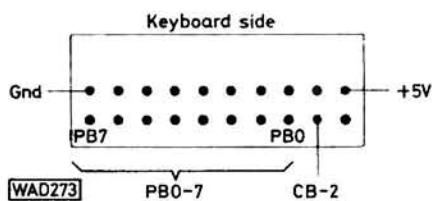


Fig. 4

reset HIMEM. Type in "new" then enter listing 2. Once completed save the whole lot using

\*SAVE SSTV 0E00 1AFF

This will produce a complete program to decode and display slow-scan signals. It may be loaded when needed by LOAD "SSTV"

## Adjustments

Once the A/D converter has been assembled and a suitable cable and plug connected it may be plugged into the user port which is clearly marked on the underneath of the BBC micro. Ensure the plug is round the right way—see Fig. 4.

Switch on the micro. If a continuous sound is heard from the speaker switch off immediately and check the circuit. If all is well and the normal start up message is printed on the screen, enter the following program.

```
10 ?&FE62=0:?FE6C=&A0
20 ?&FE60=0:FOR T=1 TO 100:NEXT
30 PRINT ?&FE60:GOTO20
```

## ★ components

Fig. 2

Resistors			
$\frac{1}{2}$ W 5% carbon film			
10k $\Omega$	2	R3,4	
20k $\Omega$	1	R2	
100k $\Omega$	1	R6	
470k $\Omega$	1	R1	
1M $\Omega$	2	R5,7	

Sub-min. horizontal pre-set			
100k $\Omega$	1	R8	

Capacitors			
Sub-min. plate ceramic			
47pF	1	C2	
220pF	1	C1	

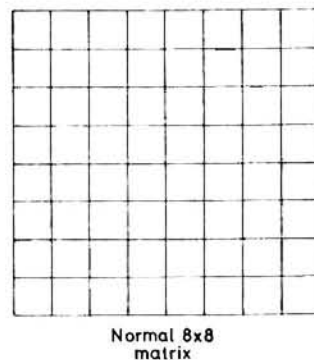
Ceramic Disc			
1nF	2	C3,4	

Semiconductors			
Diodes			
BZY88C5V1	1	D7	
1N4001	6	D1-6	

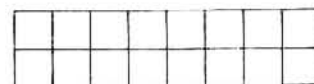
Integrated Circuit			
9400	1	IC1	

### Miscellaneous

14-way d.i.l. i.c. socket; 9V 6-F22 (PP3) battery; twin miniature battery connector; s.p.s.t miniature toggle switch; 0.1in Veroboard.



Normal 8x8 matrix



2x8 matrix used in display

WAD274

Fig. 5

Connect terminals A and B, as shown on Fig. 2, together. RUN the program. A series of zeros should appear on the screen. Whilst the program is running, connect a lead temporarily from terminal A to pin 10 of the ZN449E. The value on the screen should now read 255 (or very close to it).

Having established that the A/D converter is functioning correctly it may now be used, with the BBC, to adjust the F/V converter.



```

10 REM ASSEMBLY LOADER FOR SLOWSCAN
20 REM T L CULLINGS FEBRUARY 1984
30 REM
40 *T.
50 PAGE=&OE00
60 HIMEM=&15FF;MCST=&1900;PORT=&FE60;OP=&FEE3
70 FOR PASS=0 TO 3 STEP 3
80 F%>MCST
90 DOPTPASS
100\ DATA CAPTURE ROUTINE
110 SEI:LDA#&1C:STA&76:LDA#0:STA&75
120,SAMPLE
130 LDY #0
140 STA (&75),Y
150 INC &75
160 BNE FRED
170 INC &76
180,FRED
190 LDA &76
200 CMP &83
210 BEQ OUT
220 JSR PORTREAD
230 JMP SAMPLE
240,OUT
250 CLI
260 RIS
270,PORTREAD
280 LDX#70:LDA#0:STA&8C
290,AGAIN STA PORT
300 NOP:NOP:NOP:NOP:NOP:NOP:NOP:NOP
310 LDA PORT
320 CMP &8C
330 BCC dex
340 STA &8C
350,dex
360 DEX
370 BNE AGAIN
380 LDA &8C:RTS
390:
400:
410\ DISPLAY ROUTINE
420:
430,DISPLAY
440 SEI
450 LDA#&1C:STA&76:LDA#1:STA&75:STA&82:STA&83
460 LDA#1:STA&86:STA&7F:LDA#0:STA&77:LDA#1B:STA&78
470 LDA#0:STA &84:LDA#4:STA&85
480 LDA#1:STA&1C00
490 plot
500 LDY#0:LDA#1:EOR&7F:STA&7F:LMP#1:BNE Joe
510 JSR AVERAGE:JMP HENRY
520 .Joe LDA (&75),Y:SEC:SBCE&B1
530 .HENRY TAY:LDA (&77),Y
540 LMP#128:BNE FAINT
550 LDA&86:CMP#1:BEQ alreadyset
560 LDA#1:STA&86
570 LDA&84:SEC:SBCE&B:STA&84:CMP#248:BNEnotreducehi
580 DEC&85:LDA&85:CMP#255:BEQwayout
590,notreducehi
600 LDA#0:STA&82:STA&83:LDA#1:STA&7F
610,alreadyset JMFnextone
620,FAINT STA&8F
630 LDA&83:CMP#5:BEQnotinchix
640 LDA#23:JSR OP
650 LDA#4:JSR OF
660 LDA&82:JSR OP
670 LDA&87:JSR OP
680 LDA&84:JSR OP
690 LDA&85:JSR OP
700 LDA&8F:JSR OP
710 LDA#0:STA&86
720,notone
730 LDA&82:CLL:ADC#16:STA&82:CMP#0:BNEnotinchix:INC&83
740,notinchix LDA&7F:LMP#0:BEQgoagn:INC&75:BNEgoagn
750 INC&76:LDA&76:CMP#&30:BEQwayout
760 goagn JMP plot
770,wayout
780 LDA#4:JSR OP:LDA#28:JSR OP:LDA#0:JSR OP
790 LDA#31:JSR OP:LDA#39:JSR OP:LDA#30:JSR OP

```

```

10 REM SSV RX PROGRAM
20 REM T L CULLINGS JAN/FEB 84
30 REM TO COPY USE
40 REM #B. 8880 /OE00,1AFF
50 REM
60 REM KEY 0 DATA INPUT
70 REM "Y 1 AUTODET/DISPLAY
80 REM KEY 2 DISPLAY
90 REM KEY 3 DARKEN
100 REM KEY 4 LIGHTEN
110 REM KEY 5 INCREASE CONTRAST
120 REM KEY 6 NEGATIVE
130 REM KEY 7 RESTORE POSITIVE
140 REM KEY 8 TUNE RX
150 REM KEY 9 RUN
160 REM KEY 10 HSET AND OLD
170 REM
180 *T.
190 IF 7&100 < A0 OR 7&100 > 140 THEN *B&1=110 ELSE *B&1= &1C00
200 *KEY0:CALL0:VDU7:CLD:VDUS:CALLP:IM"
210 *KEY1:"CALLR:CLD:VDUS:CALLP:IM"
220 *-EY2:"PROCD:SEL:CLD:VDUS:CALLP:IM"
230 *KEY3:"B&1=(7&81+1):CLD:VDUS:CALLP:IM"
240 *KEY4:"B&1=1 &83-3:CLD:VDUS:CALLP:IM"
250 *KEY5:"PROCD:SEL:VDUS:CALLP:IM"
260 *KEY6:"VDU9,0,7,0,0,0:VDU9,7,0,0,0,0:IM"
270 *KEY7:"VDU9,0,0,0,0,0:VDU9,7,7,0,0,0:IM"
280 *KEY8:"PROCD:IM"
290 *KEY9:"RIN:IM"
300 *KEY10:"OLD:IM"
310 MODE0:HIMEM=&15FF:P=&190:IO=&1900:R=&51A&6
320 PROCD:SEL:7&F&E&C:&8AU: &FE&2=0
330 END
340 DEFPROCD:SEL:
350 RESTORE
360 DATA 230,230,30,31,231,231,232,232,232,233,233,233
370 DATA 234,234,234,235,235,235,236,236,237,237,238,238,238
380 DATA 239,239,239,240,240,240,241,241,241,242,242,243,243,243
390 DATA 244,244,244,245,245,245,246,246,246,246,246,246,246
400 FOR I=&1800 TO &1812:7=128:NEXT I:FOR I=&1813 TO &1844:READ A:7=I&NEX
410 FOR I=&1847 TO &1899:7=248:NEXT I
420 FOR I=&1901 TO &19FF:7=128:NEXT I
430 VDU23,246,255,255,0,0,0,0,0,0
440 VDU23,249,253,253,0,1,0,0,0,0
450 VDU23,244,247,189,0,0,0,0,0,0
460 VDU23,243,187,237,0,0,0,0,0,0
470 VDU23,242,185,237,0,0,0,0,0,0
480 VDU23,241,179,98,0,0,0,0,0,0
490 VDU23,240,170,87,0,0,0,0,0,0
500 VDU23,239,170,85,0,0,0,0,0,0
510 VDU23,238,166,149,0,0,0,0,0,0
520 VDU23,237,76,184,0,0,0,0,0,0
530 VDU23,236,138,84,0,0,0,0,0,0
540 VDU23,235,73,17,0,0,0,0,0,0
550 VDU23,234,68,18,0,0,0,0,0,0
560 VDU23,233,65,0,0,0,0,0,0,0
570 VDU23,232,32,2,0,0,0,0,0,0
580 VDU23,231,18,0,0,0,0,0,0,0
590 VDU23,230,0,1,0,0,0,0,0,0
600 ENDP:PROCD
610 DEFPROCD:SEL:
620 FOR I=&1812 TO &183:7=230:NEXT I
630 FOR I=&1831 TO &1848:7=248:NEXT I
640 ENDP:PROCD
650 DEFPROC:TUNE
660 REPEAT
670 7&F&E&0=0:CALL &192:
680 IF 7&8C = 110 THEN PRINT "OD LOW"
690 IF 7&8C = 178 THEN PRINT "OD HIGH"
700 IF 7&8C = 109 AND 7&8C=179 THEN PRINT "TUNED"
710 UNTIL (INKEY)=""&32
720 ENDP:PROCD
1000 CALL &192:PRINT "BEST POSITION"

```

```

800 LDA#1:JROP:CL:RTS
810 .AVERAGE
820 LDA&75:STA&7A:LDA&76:STA&7E
830 LDA (&7A),Y:STA&7E:LSR &7E
840 INC&7A:BNE TT:INL&7B
850,TT LDA (&7A),Y:LSR A:CLC:ADC&7E:SEC:SEC&81
860 RTS
870,autosest SEI
880 LDA #1:STA&75:LDA#&1C:STA&76
890 LDA #255:STA&81:LDY#0:STY&82
900,flash
910 LDA (&75),Y:LMP&81:BCSnotlower
920 STA &81
930,notlower
940 CMP&82:BCCNtohigher:STA&82
950,nothigher
960 INC&75:BNEflash:INC&76:LDA&76:CMP#&29:BNEflash
970 LSR&82:LSR&81:LDA&81:CLC:ADC&82:SEC:SBCE&20:STA&81
980 CL:RTS
990:
1000 NEXT

```

Place a blank cassette tape in the BBC cassette deck. Enter SAVE " " and hit the return key. Set the recorder on RECORD but DO NOT respond to the computer prompt to press the RETURN key again. Let the tape run for about two minutes. This will place a tone on the tape which will be used to adjust the frequency to voltage converter.

Press "ESCAPE" and rewind and remove the tape. Load the complete SSV program previously saved. Disconnect the tape deck from the cassette port of the micro and connect a lead from the extension speaker of the recorder to the input of the F/V converter. Set the recorder to maximum volume and adjust any tone control for maximum treble. Play the tape with the tone and enter GOTO 1000 on the BBC. This uses part of the sampling routine and will produce a series of figures on the screen. Adjust R1 to produce a reading on the screen of 189 or 190 (best position is

readings changing between the two). Press "ESCAPE" once R1 is set. The units are now set and calibrated to work with the software.

## In Use

It may be necessary to line the inside of the BBC's case with foil to reduce the interference it produces on any nearby h.f. receiver. Alternatively it may be better to record the slow-scan signals on tape and decode them later. If the latter course is chosen it is not necessary to ensure that the receiver is exactly tuned to produce the correct sync frequency as the software allows for a general frequency offset. Record the signals then connect the output socket of the recorder to the F/V converter, turn up the volume and press function key 0.

For off-air recording, run the program and then press function key 8 on the BBC. Connect the audio output from the receiver to the input of the F/V converter and tune to a slow-scan signal. Turn up the volume of the receiver, remember an output voltage of about 2.1 volts is needed. Tune the receiver until the screen displays a continuous stream of "TUNED". Press "SPACE" to exit this routine. Pressing function key 0 will now sample and display a frame of slow-scan.

Whether using tape or decoding direct from the receiver, it may be necessary to fine-adjust the decoding using keys 3 to darken or 4 to lighten. If the picture displayed is very seriously broken up it may indicate that the receiver has drifted. It may be retuned, or use key 4 to adjust the decoder to match. The routine does not frame the picture i.e. it does not wait for the frame pulse to be sent before storing data.



To do this would restrict its ability to decode off-frequency signals. For this reason I prefer to use a tape recorder and decode the signals later. The picture is then framed by adjustment of the tape position at the start of decoding.

Once a good picture is displayed, it may be saved in digital form on the computer's cassette by typing:

\*S. PICTURE 1C00 2FFF

The correct frequency off-set is also stored with the picture. This enables the

picture to be reloaded and displayed very easily using:

\*L. PICTURE 1C00

Then press function key 2 to display.

A summary of the assignment of the function keys is given:

F0—Sample and display picture

F1—Autoset frequency offset and display—worth trying if picture broken up.

F2—Reset grey-scale levels and display.

F3—Increase expected value of sync.

F4—reverse of F3 but by factor of 3 for quicker adjustment—useful for finding correct offset.

F5—Makes all levels above 50% illuminated 100% illuminated—useful for getting text from noisy signals (use F2 to reset).

F6—Produces negative picture

F7—Restores positive picture

F8—Tune routine

F9—Run

F10—Reset/old

# Feature

## FORTH for the Radio Amateur

by David Husband G8HJT

In the last article I described a Packet Radio system called SOFTNET which used FORTH, and this time I will describe a simple 24-bit I/O Port for the BBC Micro using the 1MHz expansion bus. Later articles will cover I/O Ports for the Sinclair Spectrum and ZX81, with FORTH and BASIC software for amateur radio uses.

A computer is only truly useful if it is able to drive hardware and part of the fun of having a computer is adding one's own hardware and developing software to drive it with. On the BBC Micro there are basically two routes which a user can take towards adding his own hardware. One of these is the 6522 USER Port, but this suffers from the limitation of only having 8 I/O lines and a couple of control lines. For most serious applications, direct access to the 6502 address and data buses are needed, and this is provided by the 1MHz bus.

Physically, the 1MHz bus is a 34 pin connector mounted at the front edge of the main BBC circuit board, being accessed from underneath the machine. A buffered databus and the lower 8 bits of the address bus are connected to this socket together with a number of useful control lines. Whilst the user could use this bus in many different ways, Acorn has decided how the bus should be used to enable compatibility with other devices.

Normal use of the 1MHz bus will permit up to 64K bytes of paged memory, 255 direct memory mapped devices and a paging register. The memory mapped I/O page is called "FRED" and the 64K memory pages are called "JIM". OSBYTES 92 hex, 93 hex, 94 hex and 95 hex are used to communicate with "FRED" and "JIM".

"FRED" is the space which we are going to use and this is actually Page FC hex in the BBC. "FRED" has been allocated by Acorn as follows:

- OFC00 hex to OFC0F Test Hardware
- OFC10 hex to OFC13 Teletext
- OFC14 hex to OFC1F Prestel
- OFC20 hex to OFC27 IEEE488 Interface
- OFC28 hex to OFC2F Acorn Expansion, currently unused
- OFC30 hex to OFC3F Cambridge Ring Interface
- OFC40 hex to OFC47 Winchester Disc Interface

OFC48 hex to OFC7F Acorn Expansion, currently unused

OFC80 hex to OFC8F Test Hardware

OFC90 hex to OFCBF Acorn Expansion, currently unused

OFCC0 hex to OFCFE User Applications

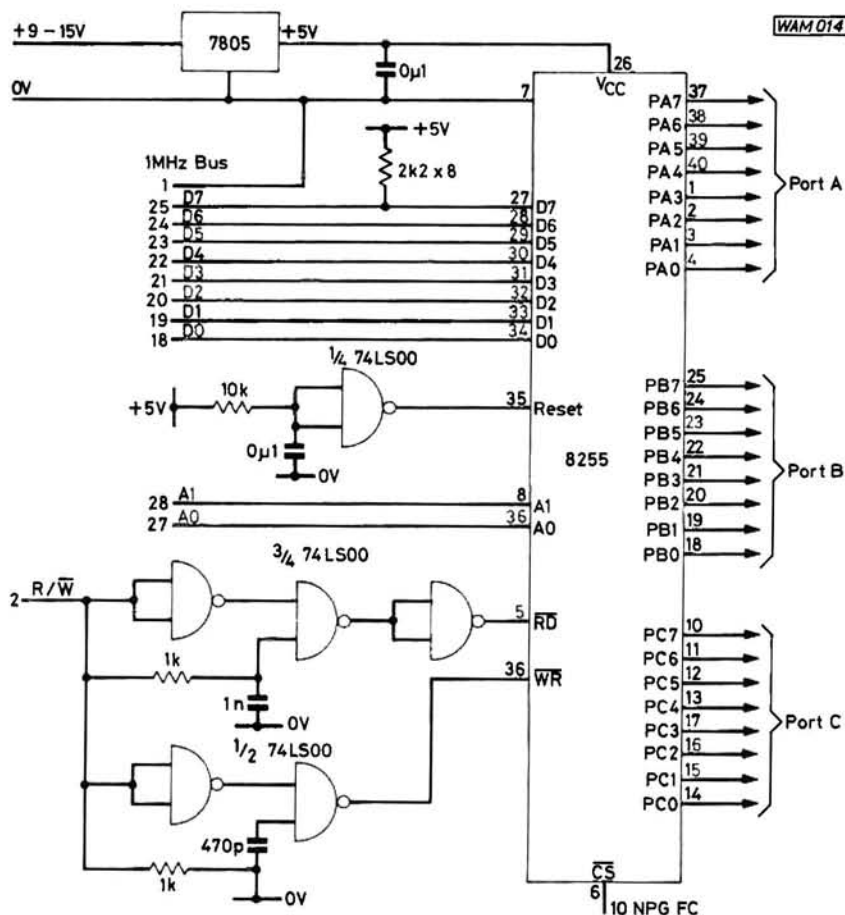
OFCFF hex Paging Register for "JIM"

From the above table, only OFCC0 to OFCFE hex is available to the user, this being a total of 63 address locations. A 24-bit I/O Port using the 8255 chip requires 4 locations, so this means that quite a large number of addresses are available, but for

very keen constructors who require more locations, either Page FD hex can be used or other "FRED" addresses. This does mean that the other hardware additions listed above cannot be added in the future if user hardware is already in the address location.

For the sake of simplicity, the I/O Port described does not completely decode Page FC and therefore "reflects" every four addresses from OFC00 hex to OFCFE. This is of no real consequence if the user only wants one 24-bit port, but for other applications such as using a number of 24-bit ports to give 48 or 96 control lines, another decoder chip must be added.

Devices using the 1MHz bus are not permitted to draw power from the BBC and therefore must have an external supply.





ing the 7805 regulator shown allows the user to power the card from a 13.8 volt d.c. supply if desired.

The 24 port lines are able to be configured under software control to be either inputs or outputs, or a combination. In either case, they are t.t.l. compatible, which means the user must not put less than 0V (i.e. negative voltages) or more than 5 volts on these lines. Deciding how to drive other devices is part of the fun of using ports, and once the mystery of using the software is dispelled, very powerful applications become possible.

The software following is merely an example of what can be done in BBC BASIC and many other ways will be described in later articles.

The 8255 is a most versatile port and is organised as three groups of 8 lines. In order to configure these lines the Command Register of the 8255 must be set-up by writing a byte which represents the way in which the port is to be used. We will send 88 hex to the control port to give us PORT

A and PORT B and half PORT C as outputs and the other half of PORT C as four inputs. So we have twenty output lines and four input lines.

The first routine called "initialise\_hardware" sets up the 8255 and some other variables for use in other routines.

PA% is the offset address of PORT A  
PB% is the offset address of PORT B  
PC% is the offset address of PORT C  
PD% is the offset address of PORT D (Command Port)  
CW4% is the command word sent to PORT D

os\_read% tells OSBYTE FFF4 to read the 1MHz bus

os\_write% tells OSBYTE FFF4 to write to the 1MHz bus

PROCw\_fred(addr,data) writes "data" to PORT (addr) so to make PORT A all 1's send PROCw\_fred(PA%,255)

100 DEFPROCinitialise\_hardware : PA%=0 : PB%=1 : PC%=2 : PD%=3

110 CW4%=&88 : os\_read%=&92 : os\_write%=&93

120 OSBYTE%=&FFF4 : PROCw\_fred(PD%,CW4%)

130 ENDPROC

140

150 DEFPROCw\_fred(addr%,data%) : A%=os\_write% : X%=addr%

160 Y%=data% : R=USR(OSBYTE%)

170 ENDPROC

180

190 DEFPROCr\_fred(addr%) : A%=os\_read% : X%=addr%

200 R=USR(OSBYTE%)

210 ENDPROC

220

A printed circuit board and all the parts for this port are available from: Skywave Software, 73 Curzon Road, Boscombe, Bournemouth BH1 4PW. Telephone (0202) 302385.

The next article will deal with interfacing the port to the real world and will describe software in FORTH and BASIC to enable Morse to be sent and received. Watch this space!!

73's de GBHJT

## reviews

### G3LIV SSTV Terminal

The p.c.b. for this SSTV receive unit is supplied with full constructional notes, components list, p.c.b. layout and software (on cassette tape). The six page instruction leaflet was more than adequate to construct and set-up the unit successfully.

The p.c.b. consists of two sections, the first deals with the frame and line sync pulses and the second section is for the recovery of video information. By following normal construction techniques and the p.c.b. layout given in the instructions no problems were encountered on the constructional side of things. Obviously the mounting of the front panel controls, an i.e.d., on/off switch and contrast potentiometer, will depend on the type of box the unit will be housed in finally. All the tests and results on the review p.c.b. were completed without the unit being in any type of box.

The unit is connected to the I/O port of the BBC-B computer via a 20-way ribbon cable and this cable carries all the signals plus power. The p.s.u. on the SSTV unit generates  $\pm 15V$  from the computer's own +5V line.

To set up the unit you do need some pieces of test equipment; a signal generator, voltmeter and an oscilloscope.

Firstly the sync circuits need to be correctly aligned and so a tone of 1.2kHz is needed on the input to the board, so that the sync circuit can be set for maximum signal. Once all the sync circuit adjustments are complete the video circuits must be correctly set-up before signals are received at their best. The two video filters need to be set up on 1.2kHz and 2.3kHz respectively for maximum output. The unit is then ready to test on air.

If you set the sync circuits up first, as

suggested in the instructions, then there are SSTV pictures recorded on the reverse side of the software tape that enable you to set the video circuits up.

All that is left to do is find an SSTV signal on air, 14.230MHz or thereabouts is favourite. The photographs shown with this review have all been taken off air on the 14MHz band.

The p.c.b. and software costs £17.50 inclusive and a completed and tested unit costs £97 inclusive. Both are available from **John Melvin G3LIV, 2 Salters Court, Gosforth, Newcastle, Tyne and Wear NE3 9BH**, to whom I offer my thanks for the review p.c.b.

G4LFM

Advertisement

#### RTTY and CW TRANSCEIVE with NO TERMINAL UNIT

This fantastic program interfaces direct with your rig, slashing the cost of previous systems. Split screen, type ahead, all the usual features and more. Tape and kit for the very simple interface for only £17.50. Connectors and ready-made interfaces available. For CBM64 and VIC20 (+ at least 8k). BBC-B coming soon CW-only version for SPECTRUM £10.

And four superb programs for CBM64, VIC20, BBC-B, SPECTRUM LOCATOR QTH or Maidenhead locator or lat/long. Distances, headings, contest points, converts between locator and lat/long. Tape £6.

LOGBOOK Date, band, mode, call and remarks. Superfast callsign search. Easy, fast updating of files. Screen/printer output. Tape £6.

MORSE TUTOR Britain's best. Learn fast in easy stages from absolute beginner to over 40 wpm. Join the hundreds who have succeeded with this program. Tape and full learning guide £6. For ZX81-16k also.

RAE MATHS All the practice and testing you need. Tape and comprehensive reference sheet detailing all you need to know £8. VIC20 needs expansion (any). For ZX81-16k also. Don't let maths make you fail. PASS with this program.

All programs are very easy to use and come with full instructions. Prices include p&p 1st Class by return. Add £1 per tape if outside UK or Ireland.

### technical software (PW)

Fron, Upper Llandwrog, Caernarfon, Gwynedd LL54 7RF. Tel. 0286 881886





# COMPONENT RATINGS FOR BEGINNERS

Earlier we examined the basic reasons for selecting components of adequate rating (voltage, current or power), something we must consider from the point of view of safety, quite apart from the component's value (e.g. resistance, inductance, capacitance, etc.) or other specifications. We will continue by looking at some other types of component.

## Transformers

These are expensive items and special care should be taken to choose one which is adequately rated for the job, and that includes a generous safety factor once again.

Both the primary winding and each of the secondary windings usually have the r.m.s. voltages and currents quoted.

The only voltage which should be applied to the primary winding is the voltage specified. The specified secondary voltages will be the result of applying this primary voltage. Safety factor does not apply to the voltages.

A secondary voltage of 6-0-6V means that the secondary is centre-tapped and that 6V r.m.s. is available from each of the outer connections, with the centre tap as a common connection, as shown in Fig 2.1.

The secondary currents quoted are the **maximum** currents which should be permitted to flow in any circuit connected to the secondary winding. In fact, for safety, choose a transformer whose secondary current rating is **double** the maximum likely to flow. There is no disadvantage in drawing any current lower than the rated current.

Sometimes, when **mains** transformers are advertised, the primary voltage and current are not quoted. This implies that the primary voltage should be the normal mains voltage of the country of origin (240V r.m.s. in the UK) and that the primary current rating will be adequate provided none of the secondary current ratings is exceeded.

Another specification which may be quoted is a rating in volt-amperes (VA) or kilovolt-amperes (kVA). This is merely the product of secondary voltage and maximum safe secondary current. It is equal to the sum of the VAs of all the secondaries.

The product of volts and amperes is usually watts, but voltage and current in a transformer winding are not necessarily in phase and their product cannot therefore strictly be termed watts. You need not worry about this subtlety, however, simply make sure that the volts and amperes product ( $V \times A$ ) you expect is well below the VA rating.

Occasionally, regulation may be quoted, expressed either as a decimal fraction or as a percentage. This is of minor importance to the beginner and is merely a measure of the quality of the transformer—the lower the regulation the better.

Failure to operate a transformer within its rated currents will result in overheating and a winding could "blow" just like a fuse. If the applied primary voltage is too high this could cause too high a current (with the same result) or a breakdown in the insulation between windings and/or turns; it will also increase the secondary voltages which could lead to further damage.

Matching transformers are usually specified by the input and output impedances which they are designed to match. They will be manufactured to cope with any voltage or current which may arise as a result of **normal use in the situation for which they were designed**, and this situation is usually described. The most common example is that of matching a transistor amplifier stage to a loudspeaker, in which case the chief criterion is to ensure that the transformer secondary is designed to match to the impedance of the loudspeaker being used. This could be 3, 5, 8 or 16 ohms, and if incorrectly chosen will result in poor sound quality.

## Diodes

Maximum forward current and peak inverse voltage (p.i.v.) are the two ratings we need to concern ourselves with when considering diodes. These will not be marked on the diode but the type number of the diode will, and each type of diode will have its ratings fixed for all diodes with that type number. So if you know what type of diode you must use, these ratings have already been taken care of for you.

If you have to choose a diode for a particular job, however, you must examine these ratings in advertisements or manufacturers' data.

Maximum forward current is the maximum current the diode can carry without overheating when it is forward biased; the overheating occurs for the same reasons as with resistors but this time the junction can be quickly destroyed beyond recovery. In a rectifier application, the maximum current the diode will have to carry is basically

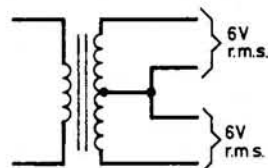


Fig. 2.1

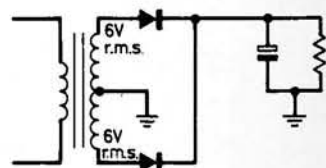
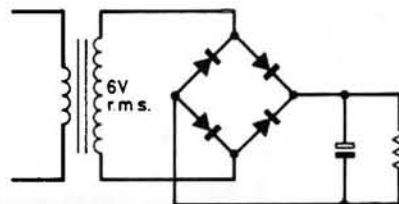


Fig. 2.2

WAM021



◀ Fig. 2.3



the maximum current the load (the circuit being fed with current) will draw; double this figure (for safety) to give the forward current rating you require.

The p.i.v. is the maximum voltage the diode can withstand across it when it is in the reverse biased state. If this is exceeded, the electric field existing across the depletion layer (the gap of high resistance semiconductor between anode and cathode) could cause a breakdown of the junction, from which it cannot recover.

In a half wave or full-wave (centre tapped transformer) rectifier application, the p.i.v. will be equal to **twice the peak value** of the a.c. being applied to it. For example, if the transformer secondary of Fig. 2.1 is connected to a full-wave rectifier circuit, as shown in Fig. 2.2, the p.i.v. of each diode must be at least  $(2 \times 6 \times 1.414) = 16.968\text{V}$ . Remember that the peak voltage of a sine wave is 1.414 times its r.m.s. value.

In a bridge rectifier system, as shown in Fig. 2.3, the p.i.v. each diode will experience is simply equal to the peak value of the a.c., i.e.  $6 \times 1.414 = 8.484\text{V}$ . For safety, choose a diode with a p.i.v. of at least double what you expect it will need to withstand.

Diodes of very small physical size can have very high forward current ratings (several amperes) and very high p.i.v. (several kV) and they are not too expensive, so you can easily afford a much more generous safety factor than 100 per cent in most cases.

Diodes used in signal detection circuits will have to withstand so little in the way of forward current or inverse voltage that these ratings do not need to be considered. The only criterion here is sensitivity, and as long as you choose a diode designed for the purpose you will be alright.

## Zener Diodes

These are operated in reverse bias condition, so forward current rating does not apply. Peak inverse voltage does not apply either, because the Zener action is to limit the reverse voltage to a pre determined figure, even if the open circuit voltage applied is greater, this figure being the Zener voltage and the most important of the two Zener ratings we have to consider.

The other rating is the power the Zener can dissipate when it is conducting (in the "reverse" biased condition of normal operation). This is determined by the product (Zener voltage  $\times$  maximum current likely to flow through the Zener). Once again, allow 100 per cent margin for safety.

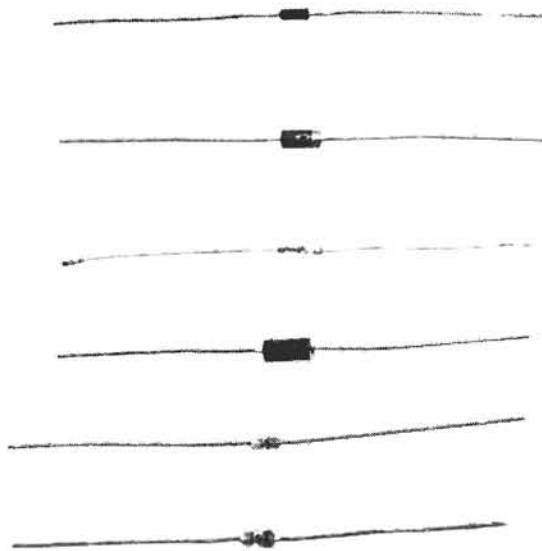
### Example:

i) A 4.7V Zener will carry a maximum current in operation of 100mA. Power = VI

$$= 4.7 \times \frac{100}{1000} = 0.47\text{W}$$

This is the maximum power the Zener is likely to have to dissipate, so choose a 1W component.

Sometimes the Zener voltage appears in the type number of the component but often it does not. Indeed, a single type number often covers a whole range of Zener voltages. For example, the BZY88 series includes 27 versions, each having a different Zener voltage of between 2.7V and 33V an additional number appears on the body to denote this, e.g. C4V7 (4.7V) or C6V8 (6.8V), etc. The letter C indicates the tolerance of the diode ( $\pm 5$  per cent). You must specify which voltage rating you require when ordering. The power rating (dissipation) will not appear on the body of the component, this is covered by the type number, so you would have to consult manufacturers' data publications or advertisers' lists to choose one with a big enough power rating for the job.



A selection of semiconductor diodes

## Transistors

The chief rating to be considered here is power, as with resistors. This time it is the power derived from the product (emitter current  $\times$  collector/emitter voltage),  $I_e V_{ce}$ —which has to be less than the transistor's power rating in order to avoid overheating and damage. If  $I_e$  and  $V_{ce}$  vary, it is the **average** values which are important.

Size and power rating (or dissipation) are related, the larger, high-rated transistors having a thick metal case (with bolt holes drilled in it for mounting purposes) to which the collector is usually connected. This case helps in the dissipation of heat by conduction and convection.

Typical figures are shown below as a very rough guide, but this is no substitute for consulting advertisers' or manufacturers' data:

- Types supported by own connecting wires (Fig. 2.4); smallest (body about 5mm diameter)—300mW approximately; larger (body about 8mm diameter)—1W approximately.
- Types in metal cases with bolt holes (Fig. 2.5); smaller (24mm between bolt holes)—2.5W approximately; larger (30mm between bolt holes)—5W approximately.

The two last-named types (b) will hardly ever be used in a situation where they develop as little power as that quoted above. They are intended to be mounted on **heat sinks**, in which event they can dissipate much more power, in some cases up to 30W for the smaller version and 250W for the larger, **provided that the sink is good enough for the job.**

A heat sink is a lump of metal, commonly aluminium, designed to remove heat from the transistor as quickly as possible. It is often finned to aid convection (fins should be positioned vertically) and painted matt black (to aid radiation).

The heat sink you use must be adequate for the power you expect your transistor to develop. In brief, the usual power rating quoted for the larger type of transistor is the maximum possible dissipation **with the transistor case temperature held at 25 degrees C.** It is the job of the heat sink to keep the temperature down to this level. Since temperature increases with power dissipated, the higher the power you expect to dissipate, the bigger the heat sink you will need. Determining the correct choice of heat sink is a



rather complex business and I would refer those readers who become this far involved to consult the articles on the subject by E. A. Rule (*PW* July/August 1983).

Because the body of the transistor is usually the collector connection and the heat sink is usually bolted to the earthed chassis, these two must be insulated from each other electrically in many applications. This is done by the use of mica washers between transistor body and heat sink and insulated bushes to isolate the mounting bolts from the transistor case. Mica is a poor conductor of heat, however, and silicone grease is used as well on all joining surfaces; this is an electrical insulator but a good conductor of heat.

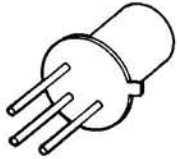
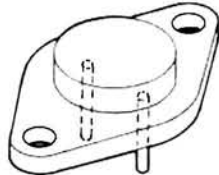


Fig. 2.4



WAM 022

Fig. 2.5

The smaller transistors (a) can also have small heat sinks pressed onto their metal bodies (again usually the collector) and since these are supported solely by the transistor connecting wires none of the previously mentioned problems arises, although power rating will not normally be as high as that of a larger type, even when the latter has no heat sink.

There are many other ratings and parameters that affect the choice of transistor type for a particular application, e.g. maximum reverse junction voltages, switching time, frequency response, maximum base current, leakage current, etc., but choosing the correct type (*pnp* or *npn*) with a big enough power dissipation are the most important.

For f.e.t.s (field effect transistors), the power rating is derived from the product (source current  $\times$  source/drain voltage).

Once again, allow 100 per cent for safety. If your transistor is going to develop 500mW, choose a 1W rated one.

## Integrated Circuits

Types are so varied that an in-depth study of the use to which they will be put is required before choosing the right one. Range of inputs and desired outputs are the chief items for consideration, and the ability of the chip to deliver sufficient output current to drive any subsequent stage. The only **rating** which applies is that of supply voltage; this should be as close as possible to the stated voltage requirement and safety factor does not apply.

## Valves

Power dissipation is again important. (Average anode/cathode voltage  $\times$  average cathode current) gives an estimate of power to be dissipated; double this for safety to decide what power rating of valve to use.

Maximum values for anode current and screen current are also quoted in valve data and these should not be exceeded in use. Optimum values of all anode and grid voltages will also be quoted and these should be as close as possible to the voltages present in use—safety factor does not apply here, these voltages are necessary for correct operation.

Heater rating is most important with valves. This is quoted in voltage and current, rather than power. The quoted voltage must not be exceeded, otherwise too much current will flow, the heater will overheat and “blow” like a fuse, then the valve will no longer work. On the other hand, if less than the rated voltage is applied, the valve will not perform as well as it should.

If the heaters are connected in parallel they will all need the same voltage applied (commonly 6.3V r.m.s.); their current ratings could all be different but the heater **supply** (i.e. transformer secondary winding) must be capable of delivering the **sum** of all these heater currents.

When valve heaters are connected in series, all the rated heater currents of all the valves must be the same (only **one** current will flow through all of them); the voltage ratings could all be different as long as the **sum** of all these voltages equals the supply voltage—if not, a series resistor to drop the excess voltage will be necessary.

The same comments apply to **lamps** as to valve heaters.

## Tolerances

These are quoted mostly for resistors and capacitors. Tolerance takes the form of a percentage, this being a measure of the possible error in the quoted resistance or capacitance value.

In resistors, the error could make the actual resistance value equally higher or lower than its marked value. For example, a 1k $\Omega$  resistor may be marked as such but with a silver band denoting a tolerance of  $\pm 10$  per cent, 10 per cent of 1000 $\Omega$  is 100 $\Omega$ , so the resistor could have any value between 900 $\Omega$  and 1100 $\Omega$  and still be a “genuine” 1k $\Omega$ ,  $\pm 10$  per cent component.

Capacitance tolerances are often quoted as having a higher tolerance on the high side than on the low side, because if a capacitor is higher in value than its marking states this doesn't generally matter if it is used in a common coupling or decoupling role, but if its value is lower than quoted this will cause a deterioration in the operation of the circuit compared with its design performance. For example, a capacitor may be advertised as 100 $\mu$ F, 10V, +50 per cent, -10 per cent. A 50 per cent error is 50 $\mu$ F, a 10 per cent error being 10 $\mu$ F. So the capacitor could have any value between 90 $\mu$ F and 150 $\mu$ F and still be within specification.

Tolerances are often shown as an extra coloured dot or band as follows for resistors:

No colour	= $\pm 20$ per cent
Silver	= $\pm 10$ per cent
Gold	= $\pm 5$ per cent
Red	= $\pm 2$ per cent
Brown	= $\pm 1$ per cent

Remember that with 4-band codings, the first three colours represent the resistance value and with 5-band codings the first four colours represent the resistance value.

## Conclusion

You should now appreciate the importance of component ratings from a safety point of view. There are many ratings and specifications of components other than those described in this article, which you would have to study in order to produce the best possible **design** for your project, and there are many books and articles published to enable you to progress in this direction, but at least you should now be able to experiment in safety and without wasting money on components which are totally unsuitable. ●



# 1984 EXPEDITION

Between 6 and 14 August 1984 the callsign GB2XQ was activated from QTH locator XQ80d, 15km North East of Glasgow. The following report catalogues the activities of this infamous DXpedition crew which was comprised of Walt, GW3NYY; Richard, GW8TVX; Chris, G8TFI; Jon, GW4LXO and Peter, GW6EWA.

Why XQ square? It was a difficult choice—a balance between rarity, accessibility and good take-off. This particular square seemed to have all three attributes.

The objective of the exercise was to give as many amateurs and s.w.l.s as possible the opportunity to cross off XQ square on their maps. It was also timed to coincide with the Perseids meteor shower so that amateurs outside of tropo range could do likewise via MS during the peak of the shower.

Planning for GB2XQ, our third and perhaps most successful expedition, was started in late August 1983. In fact, almost before the equipment was cold from the 1983 GB2XN event in Anglesey. Why so early, you may ask? To operate successfully on five bands *simultaneously* from home is quite a feat—to do it some 650km away on top of a mountain is a major lesson in logistics.

Initial requirements for such an event are: a group of dedicated amateurs (or are we lunatics?—a comment passed by another bunch of lunatics busily cycling from Land's End to John o' Groats) who have the spare time, equipment, operating skill and the odd few pounds set aside for a rainy day. Spare time because, with travelling, there was little left from 11 days' holiday. Equipment,

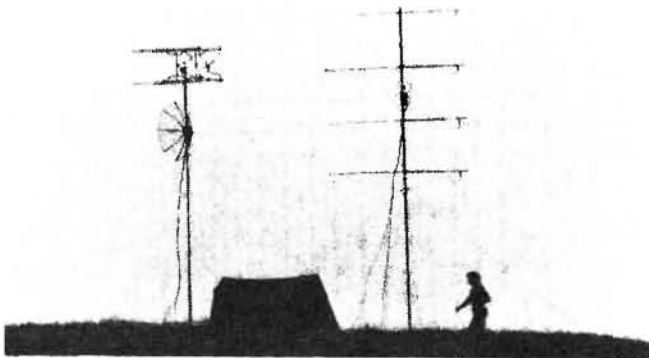
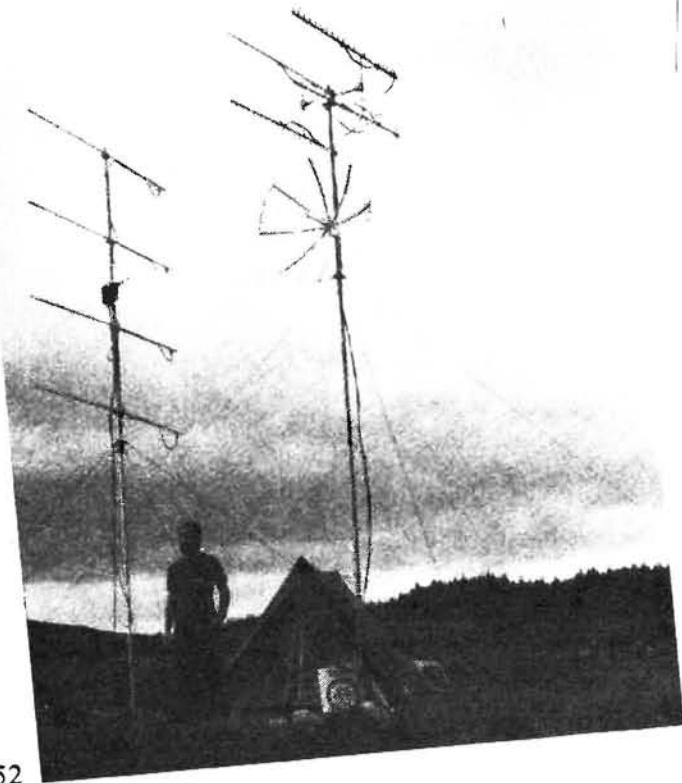
complete stations able to operate efficiently on h.f., 144 and 430MHz, 1.3 and 2.3GHz. This included transceivers, antennas, masts, tents, generators plus all of the other associated odds and ends. As for operating skills, this primarily concerned the MS activity, though a good ear for the daily pile ups was also needed.

Apart from a little drizzle on our first night, the weather was exceptionally good, sunny with little or no wind to speak of. Although no rainy days, a few pounds were required for the daily trips to the local garage for fuel, and the forays to one of the numerous hostelrys serving such good food. Other incidental expenses included, hire of a large van, a 4kVA diesel generator, accommodation and QSL cards.

After a good night's sleep and a hearty breakfast of coffee and chocolate biscuits (thank you Jon's Mum), a start was made on checking out the three possible sites. These had been viewed at an earlier exploratory visit during June. By noon final arrangements had been made and work commenced on setting up the two tents which comprised the station. The first, of the continental frame variety, housed the 144MHz and h.f. gear; the second, a much smaller ridge tent, housed the u.h.f. and microwave department.

Antennas were placed as close as practicable to the respective tents, such that beam headings could be altered relatively simply. Four masts were required, the first supporting the 144MHz Yagis and one end of the h.f. dipole; the second holding the other leg of the dipole. The third carried the 1.3GHz array and the 1.2m parabolic dish for 2.3GHz. Finally the fourth mast held four 430MHz Yagis, stacked vertically. Some five hours later we were operational and again experiencing the slow deep QSB associated with such highly obstructed paths. This time it was the Pennines, last year Snowdonia, but still the same overall effect!

Operating generally commenced at between



▲ Stalking through the dawn mists it's Jon, GW4LXO, about to "beam-up" PA0 on 430MHz

◀ As usual no compromises on the r.f. hardware—but the shack accommodation . . .



# I TO XQ SQUARE

0600–0800hrs, finishing some 17 hours later. During this time a few breaks were taken for meals and to attend to the generator. Two operators were always left on site, both day and night, either operating, or for security purposes.

Our MS operations were scheduled for the peak of the shower to ensure that QSOs were completed in as short a time as possible, allowing further skeds to be arranged on the 14MHz (20m) "v.h.f." net. During this stage of the expedition a two shift system was used to give continuous cover throughout the peak days. This entailed operating four hours on and then four hours off in pairs. Fortunately this was only required for three days and nights, as a state not unlike jet-lag is created, causing concentration problems in the latter hours of operation.

Returning to the main operating, I wonder how many people actually called us repeatedly whilst we were S9+, and finally gave up after cursing our deaf receiver, or our deaf operator? Hundreds I expect—I have done it myself on many occasions to other DX stations. It really is a different ball game being at this end of a pile up. What many stations fail to realise is that with 400W and an antenna array with 17.8dBd gain, even the side lobes can be as strong, if not stronger, than your average station. So whilst we were S9+ on some receivers, without a similar arrangement it was not always reciprocal. This tended to create a wall of very weak stations at all times. Some were occasionally successful in completing the QSO on QSB minimum but in the majority of cases caused a few problems. It was these stations that prompted the coining of a new term, namely "binaries" i.e. readability 0, signal strength 1 (or was it the other way about?) Anyway, just a series of signals composed of 0 and 1 as used in the Binary System.

During the operations we were visited by several of the local amateurs, both in groups and singly, who were interested in our operations. Unfortunately we were not always as attentive as we would have liked due to the tight

schedule we were often under, but we did endeavour to answer most queries. We even took on the role of stars during the video recording of the event, on two separate occasions.

## Equipment Used

The following list indicates the equipment on site:  
**7 and 14MHz:** Yaesu FT-901DM; dipole antenna; 100W output.  
**144MHz:** Yaesu FT-221R (muTek front end); Tempo 2002 valve linear; 2 × 14 el Cushcraft Junior Boomer Yagis at 8m a.g.l.; 400W output.  
**432MHz:** Belcom 707; K2RIW valve linear; MGF1412 GaAs-f.e.t. masthead pre-amp; 4 × 19 el Tonna Yagis at 8m a.g.l.; 400W output.  
**1.3GHz FT-225RD:** Microwave Modules transverter; SSB solid state linear, 2 × 7289 valve linear; MGF1402 GaAs-f.e.t. masthead pre-amp; 4 × 23 el Tonna Yagis at 7m a.g.l.; 175W output.  
**2.3GHz FT-225RD:** SSB transverter; 2 stage 3CX100 valve linear; 1.2m parabolic dish at 6m a.g.l.; 40W output.

## Operational Comments

**MS:** Reflections in general were numerous but compared with previous years were of short duration. Many stations on the s.s.b. random frequency could have been worked if only they had observed the 15 second break routine. Ap-

## SCOTLAND GB2XQ

### 1984 EXPEDITION TO 'XQ' SQUARE

REGION : STRATHCLYDE      QTH LOCATOR : XQ80d  
WAB : NS78. 320m A.S.L.      15k NORTH EAST GLASGOW

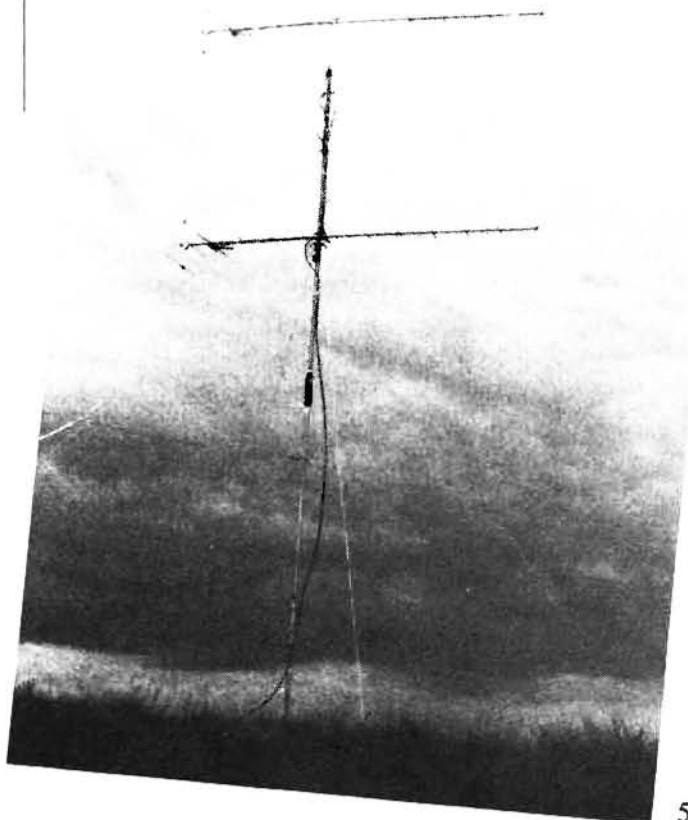
PSE/TKS FOR QSL VIA RSGB OR DIRECT TO  
P.O. BOX 21, SWANSEA, SA1 1ED.

Special thanks to Angelo's of Kilsyth  
for the excellent haggis suppers

▲ If you were one of the 1138 QSOs completed this card will soon be available for the shack wall

▶ The vertically stacked 144MHz Cushcraft Junior Boomers silhouetted against a menacing sky

*Practical Wireless, January 1985*





# 1984 EXPEDITION TO XQ SQUARE

proximately 85 per cent of pre-arranged skeds were completed. On c.w. the use of 2.5 minute periods greatly enhanced the "strike rate"; perhaps this should be used as the standard rather than 5 minutes? Numerous skeds were arranged at short notice on the "v.h.f." net on 14MHz.

**TROPO:** Conditions up to the 12th were average on all bands with southerly signals being affected by very deep slow QSB. On the afternoon of the 12th (1400 GMT) a visible duct appeared to the east which initially gave enhanced tropo conditions into OZ. This then gradually opened into D, PA and SM6/7.

The DL0PR beacon in EO square at times was S9+ on 144MHz and the OZ2UHF beacon on 430MHz (EP) produced similar results. On the morning of the 13th OZ's were still workable but at a much lower strength. The QSO with PA3DIJ, which is claimed as a first GM to PA on 2.3GHz, was completed on 12 August at 2125. PA0FRE and PE1GHG were worked at 2235 and 2238hrs respectively on the same evening.

No auroral activity was observed during the expedition, neither were any signals heard via E's although stations to the south were known to have made several good contacts during such an opening. The standard of MS operating was generally quite high and few G stations interrupted our MS skeds with tropo calls. There seems to be a greater awareness of MS operating procedures. We would like to thank the many G stations who stood by on the frequency whilst we worked some of the many continental stations calling us.

## Summary of Results

A total of 1138 QSOs were completed including 62 144MHz MS QSOs.

Band	Countries	QTH Squares
144MHz	22	92
430MHz	9	31
1.3GHz	6	17
2.3GHz	2	5

**Best DX:** 144MHz MS: HG1W/0 (LH) 2000km; OH7PI (NW) 1928km; OH5LK (NU) 1876km (all c.w.).

144MHz Tropo: SM6KJX (GR) 998km; SM6CMU (FR) 986km; DK1KO (FN) 943km (all s.s.b.).

430MHz Tropo: SM6KJX (GR) 998km; SM6HYG (FS) 964km; DK2NH (FN) 943km (all s.s.b.).

1.3GHz Tropo: OZ2OE (EP) 862km; OZ1FEF (EQ) 803km; PE1GHG (CL) 724km (all s.s.b.).

2.3GHz Tropo: PA3DIJ (DN) 729km; PE1GHG (CL) 724km; PA0FRE (CL) 718km (all s.s.b.).

The QSO with PA3DIJ is believed to be the first ever GM/PA QSO on 2.3GHz (729km).

On a lighter note we have one more claim to fame, this time with regard to a 1.3GHz band QSO . . . 1st 1.3GHz QSO by pushbike portable (or is it mobile?). This was carried out by GW8TVX/P (operating as GM8TVX at this time) using a Trio TR-2300 and Microwave Modules transverter. The antenna was a  $\lambda/4$  (short length of 15 amp fuse wire in the antenna socket), power output about 250-500mW; 5/9+ in both directions, distance approx. 8km, not line of sight!

## Swap Spot

Have teleprinters 7B, 54R and 54N. Also have two Studer C37 and a J37 (4-track) tape recorders. Would exchange for w.h.y. John Radley, 81 Drayton Avenue, West Ealing, London W13 0LE. Tel: 01-997 4835. W396

Have Yaesu FRG-7700 communications receiver, FRT-700 a.t.u., dipole antenna. Also have Bearcat 20/20FB scanner with disccone antenna. Total worth £550. Would exchange for Yaesu FT-726R or Icom IC-271H. Bob. Tel: 01-423 4820 or 01-965 6677. Cash adjustment if necessary. W411

Have 1155N with p.s.u. in good working order, 1155A with p.s.u. but not working. Also have early RAF wavemeter. Would exchange both for WS22 or the 1155N for a No. 19 set with connecting leads, junction box etc., also wanted manual for WS19 Mk3 plus connecting leads. Pete. Tel: 0235 34037 (Oxon). W413

Have HRO complete with manual, 9 coils from 50kHz-30MHz plus odds and ends. Would exchange for FRG-7 or similar h.f. receiver preferably with digital readout. Cash adjustment if necessary. Tel: 01-748 3627 ext 77. W418

Have KW2000 recently serviced by makers. Would exchange for Heathkit HW8. Tel: 0594 43329 after 6pm (Aylburton, Glos). W419

Have Yaesu FR-101DD receiver and Yaesu FR-50B receiver. Would exchange for Trio R820 receiver or would exchange only the FR-50B for FRG-7. J. Wright, 12 Norn Hill, Basingstoke, Hants RG21 2HD. Tel: 0256 68649. W423

Have Telequipment laboratory oscilloscope model D53, dual trace, 15MHz delayed timebase, twin plug-in amplifiers plus extra differential plug-in amplifier. Little used, complete with manual. Would exchange for FT-200 transceiver or similar. G4YKT. Tel: 0287 33241 (Guisborough, Cleveland). W424

Have ZX81 computer and 16K RAM pack also Sanyo computer cassette recorder, all as new. Would exchange for 144MHz band transceiver in good working order. Please write—L.T.M. 135a Watling Street, Gillingham, Kent. W429

Have Yaesu FT-221R 144MHz band transceiver in mint condition. Would exchange for model engineers lathe 3½in. Tel: Locks Heath 3757. W431

## PW "SWAP SPOT"

Got a camera, want a receiver? Got a v.h.f. rig, want some h.f. gear to go with your new GO? In fact, have you got anything to trade radio-wise?

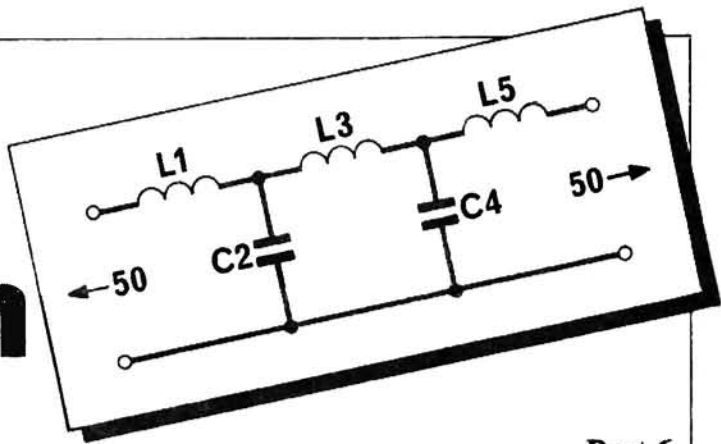
If so, why not advertise it FREE in our new feature SWAP SPOT. Send details, including what equipment you're looking for, to "SWAP SPOT", *Practical Wireless*, Westover House, West Quay Road, Poole, Dorset BH15 1JG, for inclusion in the first available issue of the magazine.

**A FEW SIMPLE RULES:** Your ad. should follow the format of those appearing above; it must be typed or written in block letters; it must be not more than 40 words long including name and address/telephone number. Swaps only—no items for sale—and one of the items MUST be radio related. Adverts for ILLEGAL CB equipment will not be accepted.



# Practical LC Filter Design

by Edward Wetherhold W3NQN



Part 6

The frequency scaling procedure explained in Part 4 is also applicable to the Cauer tables; that is, the frequencies and component values of both the lowpass and highpass designs are scaled by shifting the decimal points. To scale the designs from the 1–10MHz decade to the 10–100MHz decade, shift all frequency decimal points one place to the right (multiply by ten). The *C* and *L* decimal points shift one place to the left (divide by ten). The 50 ohm impedance level, v.s.w.r. and *As* values remain unchanged. To scale the designs to lower frequency decades, do the inverse, that is, the frequency decimal points are shifted to the left and the component value decimal points are shifted to the right. A convenient method of changing the lowpass table to the frequently used 1–10kHz decade is to change the frequency and component column headings from MHz, pF and  $\mu$ H to kHz, nF and mH. The table values may then be read directly. In the case of the Cauer highpass designs in Table 5.2, the “nF” heading will become “ $\mu$ F”.

Because the impedance level is still at 50 ohms, the component values will be awkward to work with in the 1–10kHz range; that is, the capacitor values will be too large and the inductor values will be too small for convenient realization of the design. This problem is solved by increasing the impedance level to 500 ohms, thus reducing the capacitor values to one-tenth of their 50-ohm value and increasing the inductor values to ten times their 50-ohm value.

## Impedance Scaling

If the desired impedance level differs from 50 ohms by a factor of 0.1 or 10, the designs are scaled by shifting the decimal points of only the component values. The frequencies and v.s.w.r.s remain unchanged. For example, to increase the 50 ohm impedance to 500 ohms, divide the capacitor values by 10 and multiply the inductor values by 10. The reverse is true if the impedance level is lowered. Note that inductance is directly proportional to impedance whereas capacitance is inversely proportional.

If the desired impedance level differs from the standard 50 ohms by a factor equal to a non-integer power of ten, such as 1.2 or 1.5, use the following scaling procedure:

1. Calculate the impedance ratio,  $R = Z_x/50$ , where  $Z_x$  is the desired new impedance in ohms.
2. Calculate the cutoff frequency of a “trial” 50 ohm filter using the equation  $F'50co = R \times F_xco$ , where  $R$  is the impedance ratio and  $F_xco$  is the desired cutoff frequency of the filter at the new impedance level.

3. From the 50 ohm table select a design having its cutoff frequency closest to the calculated  $F'50co$  value. The tabulated capacitor values are used directly, and the tabulated frequencies and inductances will be scaled to the new impedance level.

4. Calculate the exact values of  $F_xco = F'50co/R$ , where  $F'50co$  is the tabulated cutoff frequency of the selected “trial” filter. In a similar manner, calculate all the other frequencies associated with the desired design.

5. Calculate the inductance values for the new filter using the equation:  $L_x = R^2 \times L50$ , where  $L50$  are the tabulated inductance values of the trial filter design, and  $L_x$  are the new scaled inductance values.

For example, assume a 600 ohm Cauer lowpass filter is desired with a cutoff frequency of about 1.0kHz. We first frequency-scale the lowpass tables to the 1–10kHz decade to facilitate the calculations, and then scale the impedance to 60 ohms. The 60 ohm filter is then scaled to 600 ohms (by shifting decimal points) to complete the scaling process. The scaling steps follow with the same paragraph numbers previously used:

1.  $R = Z_x/50 = 60/50 = 1.2$
2.  $F'50co = 1.2 \times (1.0\text{kHz}) = 1.2\text{kHz}$ .
3. From Table 5.1, design 5.1–5 has an *F-co* of 2.27kHz which is closest to the  $F'50co$  of 1.2kHz and this “trial” design is selected for scaling. The tabulated capacitor values of 2200, 3900, 1800, 271 and 779nF are copied directly. These capacitance values are more familiar as 2.2, 3.9, 1.8, 0.271 and 0.779 $\mu$ F.
4. The frequencies of the final design are calculated by dividing the tabulated frequencies of design 5.1–5 by the scaling factor 1.2:

$$F-co = 1.27/1.2 = 1.06\text{kHz}, \quad F-3 = 1.45/1.2 = 1.21\text{kHz}$$

$$F-As = 2.17/1.2 = 1.81\text{kHz}, \quad F2 = 3.45/1.2 = 2.88\text{kHz}$$

$$F4 = 2.26/1.2 = 1.88\text{kHz}$$

5. The *L2* and *L4* tabulated inductance values are scaled by multiplying them by the square of the impedance ratio where  $R = 1.2$  and  $R^2 = 1.44$ :

$$L2 = (1.44 \times 7.85\text{mH}) = 11.3\text{mH}; \quad L4 = (1.44) \times 6.39\text{mH} = 9.20\text{mH}.$$

The design is now impedance scaled to 600 ohms by shifting the decimal points of the capacitance and inductance values to the left and right, respectively. The final scaled filter parameters are:

$F-co = 1.06\text{kHz}$	$C1 = 0.22\mu\text{F}$	$L2 = 113\text{mH}$
$F-3 = 1.21\text{kHz}$	$C3 = 0.39\mu\text{F}$	$L4 = 92.0\text{mH}$
$F-As = 1.81\text{kHz}$	$C5 = 0.18\mu\text{F}$	$F2 = 2.88\text{kHz}$
$As = 46.7\text{dB}$	$C2 = 0.0271\mu\text{F}$	$F4 = 1.88\text{kHz}$
v.s.w.r. = 1.21	$C4 = 0.0779\mu\text{F}$	$Z_x = 600\text{ ohms}$



Note that capacitors C1, C3 and C5 are still standard values, and although we wanted a 1.0kHz cutoff frequency, we will be satisfied with an  $F\text{-}co$  of 1.06kHz in order to use a SVC design.

**TABLE 6.1**

## VSWR, Reflection Coefficient and Passband Attenuation

For audio frequency applications, a v.s.w.r. specification is not appropriate—of more interest is the passband attenuation. The equations relating v.s.w.r., reflection coefficient and  $Ap$  were given in Part 2, Appendix A of this series; however, the reader will find the data in Table 6.1 more convenient for finding corresponding values of  $Ap$  and v.s.w.r. Also included are values of reflection coefficient ( $rc$ ) and return loss. Return loss =  $-20(\log_{10} p)$  where  $p = rc/100$ . This term is frequently used by r.f. engineers in defining the performance of a filter.

## Verification of Designs in Tables 5.1 and 5.2

The reader should initially view all design tables with suspicion unless several of the designs can be independently verified. Those having access to the Saal or Zverev references (see references 3, 4 or 6 in Part 1) can independently calculate lowpass design 5.1-15 by using the Saal or Zverev C0520 catalogue with a normalised  $F\text{-}As$  of 1.555724 and an  $As$  of 48.1dB. This is the catalogue that most closely corresponds to lowpass design 5.1-15. The 3.17MHz filter cutoff frequency and the 50 ohm impedance gives  $L$  and  $C$  scaling factors of  $2.51 \times 10E-6$  and  $1004.1 \times 10E-12$ , respectively. When the  $L$  and  $C$  normalised values given by Saal or Zverev are multiplied by the  $L$  and  $C$  scaling factors, the tabulated component values of lowpass design 5.1-15 will be duplicated with a difference of less than 1.5 per cent. The closeness of this match is sufficient proof that the data of design 5.1-15 is correct. The match is not better because the two designs are only approximately identical. Since the same computer program is used to calculate all the tabulated designs, it is reasonable to expect that all the designs are correct in a similar manner.

## Conclusion

This concludes the design portion of this series of articles on practical  $LC$  filter design. You now have sufficient information to quickly, conveniently and accurately obtain a design that will satisfy the majority of filtering requirements encountered by the radio amateur. Even the electronics technician and engineer will find these SVC filter tables useful in obtaining a design that is inexpensive and effective. Of course, the selection of the filter design is only the preliminary part of the design process. Equally important is the selection and assembly of the proper components so as to realise the full capabilities of the design. This aspect of passive  $LC$  filter design will be discussed in a future article. In the meantime, use the tables for your next filter design. Comments to the *Practical Wireless* Editor about your experiences in using the tables and suggestions for improvements will be appreciated.

REFLECTION COEFFICIENT (%)	MAX. RIPPLE AMPLITUDE (dB)	MAX. VSWR	RETURN LOSS (dB)
1.000	0.000434	1.020	40.00
1.517	0.001000	1.031	36.38
2.000	0.001738	1.041	33.98
3.000	0.003910	1.062	30.46
4.000	0.006954	1.083	27.96
4.796	0.01000	1.101	26.38
5.000	0.01087	1.105	26.02
6.000	0.01566	1.128	24.44
7.000	0.02133	1.151	23.10
7.576	0.02500	1.164	22.41
8.000	0.02788	1.174	21.94
9.000	0.03532	1.198	20.92
10.000	0.04365	1.222	20.00
10.699	0.05000	1.240	19.41
11.000	0.05287	1.247	19.17
12.000	0.06299	1.273	18.42
13.085	0.07500	1.301	17.66
14.000	0.08597	1.326	17.08
15.000	0.09883	1.353	16.48
15.087	0.10000	1.355	16.43
16.000	0.1126	1.381	15.92
18.000	0.1430	1.439	14.89
19.000	0.1597	1.469	14.42
20.000	0.1773	1.500	13.98
22.000	0.2155	1.564	13.15
23.652	0.2500	1.620	12.52
24.000	0.2577	1.632	12.40
25.000	0.2803	1.667	12.04
26.000	0.3040	1.703	11.70
28.000	0.3546	1.778	11.06

## NOTES

1. Reference in this series of articles to a filter design such as: "design 5.1-12" means line 12 of Table 5.1.
2. Throughout this series on  $LC$  filter design, for ease of reading, v.s.w.r. values are quoted as single numbers instead of in the usual ratio form. For example a v.s.w.r. of 1.52 as quoted for design 5.1-12 would normally be written as 1.52:1



# PHOTO ACOUSTICS LTD. Tel: 0908 610625

58 HIGH STREET, NEWPORT PAGNELL, BUCKS, MK16 8AQ



**TS 711E** – The TS 711E is a dedicated 2m multi-mode base station that has its own built-in power supply, speech processor and IF shift. Power output is at least 25 watts, often more. There are also two VFOs and forty memory channels. The VFOs have been designed specifically for use in a multi-mode rig. On SSB and CW you can have a free running VFO but the touch of a switch converts it to 5 or 12.5 kHz click steps. The memories will remember which VFO operation has been selected and whether repeater shift has been selected, or even if it is required.

Various scan options are available. The TS 711E will scan the band or the memories, holding for a few moments on occupied frequencies. It can also scan the memories looking at only those frequencies entered in a particular mode. There is also a programmable scan with memory channels 39 and 40 setting the upper and lower limits.

The optional VS1 board provides a voice synthesizer that gives full voice announcement of frequency and whether the rig is set to repeater shift. The mode of operation is indicated by the Morse code for the letters (F for FM, U for USB etc) being generated whenever the appropriate button is pushed.

Another major feature is the DIGITAL CODE SQUELCH. This is a built-in selective tone call system. An alarm is incorporated to let you know if you were called while out of the shack. Six letters or numbers can be sent as part of the selective call. This can be used to activate the optional call sign display and log that will keep a record of everyone who called you with DCS. This is probably the finest 2m base station available

**TS 711E**

**£792.15**

*A MERRY CHRISTMAS TO ALL OUR CUSTOMERS*



**TH 21E**

This tiny 2m handheld measures just 2.24ins wide by 4.72ins high by 1.1ins deep yet still gives a full one watt output.

**£179.48**



**TS 430S**

**NEW LOW PRICE  
£733.55**



**AOR 2001**

25-550 MHz continuous coverage – NO GAPS! Now available.

**£365.00**

We have in stock a selection of **Yaesu** and **Philips** p.m.r. equipment – including the new **Philips** radio-telephone. We also do Mail Order, please reply **Dept. P.W.**



**DRAE SSTV**



A complete receiver unit that can be upgraded to transceive with the plug in TX unit that will soon be available. An affordable way into the world of SSTV.

**£189.00**

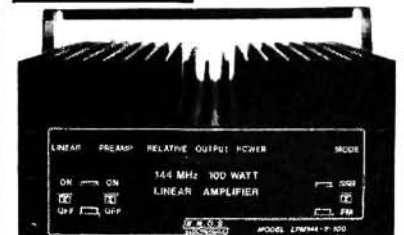
**SX 400**



**£598.00**

26-520 MHz – NO GAPS! The professional scanner. Available now, phone for latest price.

**B.N.O.S.  
ELECTRONICS**



WE have in stock a large selection of BNOS products including their Power Supply Units and Linear Amplifiers.

SPEND UP TO £1,200 INSTANTLY WITH A PHOTO ACOUSTICS LTD. CREDIT CHARGE CARD – APPLY FOR DETAILS PART EXCHANGE WELCOME, ASK FOR KERRY, ANDY OR ROY

Monday-Friday 9.30-5.30 – Saturday 9.30-4.30





**ALTRON**

**CHOICE OF PROFESSIONALS  
COMPACT LATTICE TOWERS and  
SLIMLINE TUBULAR MASTS**

TELESCOPIC—TILTOVER, FIXED—MOBILE FROM 6m UP TO 36m

Suitable for a wide range of civil and military applications such as:

**RADIO COMMUNICATION  
SURVEILLANCE & CCTV  
METEOROLOGICAL MONITORING  
AMATEUR RADIO  
AERO & MARINE NAV AIDS  
FLOODLIGHTING, ETC.**

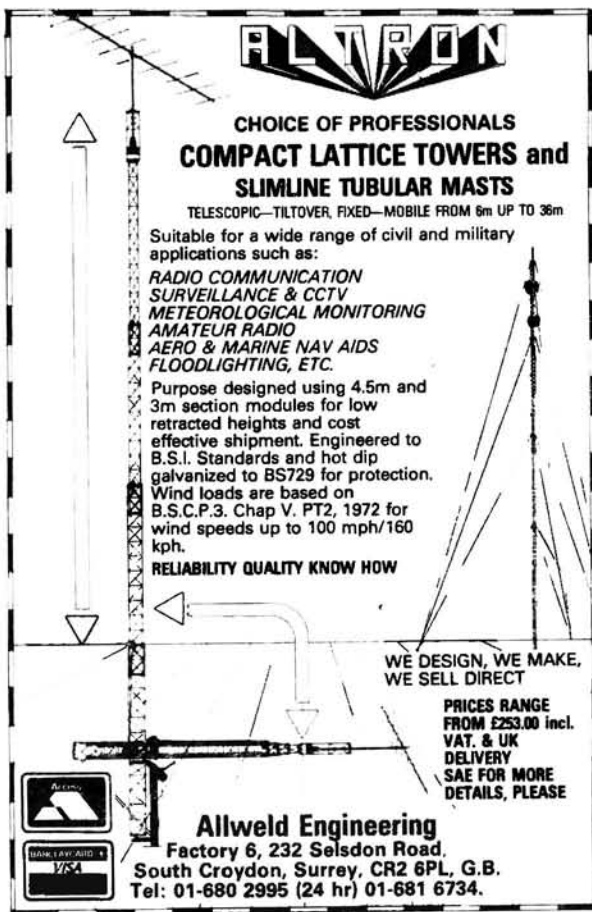
Purpose designed using 4.5m and 3m section modules for low retracted heights and cost effective shipment. Engineered to B.S.I. Standards and hot dip galvanized to BS729 for protection. Wind loads are based on B.S.C.P.3, Chap V, PT2, 1972 for wind speeds up to 100 mph/160 kph.

**RELIABILITY QUALITY KNOW HOW**

WE DESIGN, WE MAKE,  
WE SELL DIRECT

PRICES RANGE  
FROM £253.00 incl.  
VAT. & UK  
DELIVERY  
SAE FOR MORE  
DETAILS, PLEASE

**Allweld Engineering**  
Factory 6, 232 Seisdon Road,  
South Croydon, Surrey, CR2 6PL, G.B.  
Tel: 01-680 2995 (24 hr) 01-681 6734.



multiple choice... multiple choice...  
**ANSWERS**  
multiple choice... multiple choice...

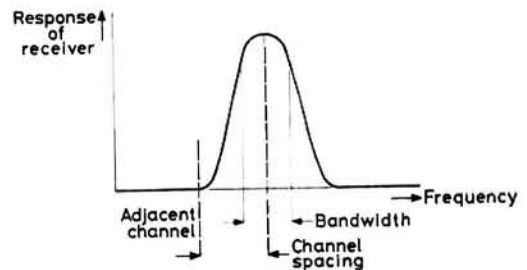
Are you cheating? if you are reading this page before page 34 then you are. Please turn to page 34 for the questions.

### Question 4-1. Answer-b.

There are a number of integrated circuits that will keep the output voltage constant up to a certain current. For example, the 78— series of voltage regulators will pass up to 1 amp. The last two figures indicate the stabilised voltage, e.g. 7805 is a 5V regulator, 7812 a 12V one.

### Question 4-2. Answer-b.

In a communications receiver the selectivity is achieved in the intermediate frequency (i.f.) stages. The selectivity is measured by the bandwidth: a narrow bandwidth means high selectivity.



### Question 4-3. Answer-d.

In an f.m. transmission the amplitude of the carrier stays constant regardless of any modulation. If a carrier is frequency modulated by a 1kHz tone, the carrier will move above and below its original frequency 1000 times per second. How far it will move (i.e. the deviation) will depend on how strong the tone is. Too much deviation will cause the signal to spill over into adjacent channels. Because its amplitude is constant, an f.m. signal cannot be demodulated by rectification, thus making it less likely than s.s.b. or a.m. to be "picked up" by audio equipment etc.

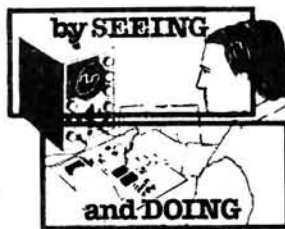
### Question 4-4. Answer-d.

The prefix letters for the UK are:

G	England	GD	Isle of Man
GM	Scotland	GJ	Jersey
GI	Northern Ireland	GU	Guernsey
GW	Wales	GB	special events stations, repeaters, beacons

## Master Electronics - Microprocessors - Now! The Practical Way!

- Electronics - Microprocessors - Computer Technology is the career and hobby of the future. We can train you at home in a simple, practical and interesting way.
- Recognise and handle all current electronic components and 'chips'.
- Carry out full programme of experimental work on electronic computer circuits including modern digital technology.
- Build an oscilloscope and master circuit diagram.
- Testing and servicing radio - T.V. - hi-fi and all types of electronic/computer/industrial equipment.



## New Job? New Career? New Hobby?

SEND THIS COUPON NOW.

**FREE! COLOUR BROCHURE**

Please send your brochure without any obligation to

OR TELEPHONE 05 0734 51515  
OR TELEX 22758 (24 HR SERVICE)



NAME \_\_\_\_\_ I am interested in

ADDRESS \_\_\_\_\_  ELECTRONICS

MICROPROCESSORS

RADIO AMATEUR LICENCE

CITY & GUILDS EXAMS

Other Subjects .....

**British National Radio & Electronics School Reading, Berks. RG1 1BR.**



Because of the ever growing popularity and effectiveness of the club news feature a slightly different format is now being used and the feature is being separate from the *On the Air—Amateur Bands* material. So, hon secs, PROs and all those responsible for club publicity, keep the information coming and we will publish it, however briefly. The copy deadlines are given at the end of the feature.

It hardly needs to be said that clubs listed here are always looking for new blood, both s.w.l.s and licensed amateurs, so visitors and potential members are invited to contact the person named or just go along to any meeting and make yourself known, and you will be very welcome.

**Acton, Brentford & Chiswick ARC G3IUI**  
**W. G. Dyer G3GEH, 188 Gunnersbury Avenue, Acton, London W3.** The Chiswick Town Hall, High Road, Chiswick, London W4 on Tuesday December 18 at 7.30 for a general discussion.

**East Antrim ARC G14KKK D. C. Simpson G14PRH, c/o 31 Beech Green, Doagh, Ballyclare, Co Antrim.** Second Tuesday at Fairview Primary School, Hillmount Avenue, Ballyclare at 8 pm.

**Aycliffe & Shildon ARC E. W. Bate on 0388 774466 or try 0325 314638.** Tuesdays at 8, the Sunnydale Leisure Centre, Middridge Lane, Shildon, Co Durham, with code and RAE classes. A video show will be held on December 11 with the Christmas night "do" on the 18th with basket supper and cabaret. Needless to say, no meeting on the 25th.

**Basingstoke ARC G3TCR G8JYN E. C. Thompson G4SQZ, 21 Wigmore Road, Tadley, B'stoke, Hants.** Second Tuesday at the Swan Inn, Sherbourne St John, near B'stoke, at 7.30. The seasonal social is on December 11.

**Biggin Hill ARC G4RQT G6TBH Ian Mitchell G4NSD, on (09598) 376.** Third Tuesdays at 8.30, St Mark's Church Hall, Biggin Hill, Kent. A junk sale is down for December 18. AGM time is January 22.

**Blackmore Vale ARS Bill Bailey G1GRG on (0963) 70969.** At the old coachhouse behind the Bell & Crown at Zeals in Somerset. Second Tuesdays are main meetings with lectures, demos and the like, with fourth Tuesdays devoted to chats and club projects plus RAE classes.

**Braintree & District ARS G4JXG G6BRH Jeff Roberts G6OIX on (0376) 47525 daytime or 44857 in the evenings.** First and third Wednesdays at 8, St Peters Church Hall, St Peters Close, Braintree, Essex. Own car park and talk-in on S15.

**Bridgend & District ARC Trevor Morgan GW4SML, 4 Rhiw Tremaen, Blackla, Bridgend, Mid-Glam.** The YMCA, Angel Street, Bridgend, first and third Fridays at 7.30, main meetings and natter nights plus on-the-air sessions respectively.

**Bristol ARC T. E. A. Rowe G8NNU on Bristol 559398.** Every Tuesday, 7.30 pm, at the YMCA, 6 Park Road, Kingswood with Morse code and RAE classes. Crime prevention is the subject for December 11 with Christmas Goodies on the 18th.

**North Bristol ARC G4GCT Ted Bidmead G4EUV, 4 Pine Grove, Northville, Bristol.** Fridays at the Self-Help Enterprise, 7 Braemar Crescent, Northville, making it December 28 for the Christmas Party, with the AGM in January.



# CLUB NEWS

Compiled by Eric Dowdeswell G4AR

Reports to: Eric Dowdeswell,  
57 The Kingsway, Ewell Village,  
Epsom, Surrey KT17 1NA

PLEASE MARK "CLUB NEWS"

**South Bristol ARC G4WAW Len Baker G4RZY on (0272) 834282.** Only a year old but sporting 100 members. Every Wednesday at 7.30, the Whitchurch Folk House, East Dundry Road, Whitchurch. December 12 is h.f. c.w. activity evening with a Christmas families social on the 19th. On January 2 G3OUK discusses "What's Legal".

**British Telecom HQ AR Group G4THQ J. A. Clarke, G3TIS, Room UM5A, Mondial House, 90 Upper Thames Street, London EC4.** Past and present employees of PO or BT welcome on net 3750kHz at 8pm Wednesdays under G4THQ.

**Bury RS PRO is M. G. Pritchard G3VNO, 56 Shelfield Lane, Norden, Rochdale, Lancs.** Tuesday evenings at 8, the Mosses Centre, Cecil Street, Bury, with principal meeting on the second Tuesday. Like December 11 when it is AGM time followed by cheese and wine.

**Cheltenham AR Assoc G5BK Gillian Harmsworth G6COH on C'ham 525162.** Fridays at the Stanton Room, Charlton Kings Library, C'ham, with the AGM on December 7.

**Cheshunt & District ARC G4ECT G6CRC Roger Frisby G4OAA on Hoddesdon 464795.** At 8 every Wednesday, Church Room, Church Lane, Wormley, near Cheshunt, Herts. Christmas dinner is at the Rose & Crown, Hoddesdon on December 12 with seasonal style video show on the 19th.

**Chichester & District ARC C. Bryan G4EHG, on Chichester 789587.** First Tuesday and third Thursday at the Fernleigh Centre, 40 North Street, Chichester at 7.30 in the Green Room. Net time is 7pm on S11 on Wednesdays. Christmas social to be held on December 20.

**North Cornwall RC John Heesom G4FHL on Camelford 770406.** Just completed one year and doing well. First Wednesdays at 7.30 at the RAOB HQ, Fore Street, Camelford and all welcome. Code classes by ex-marine RO G4WMJ.

**Coulsdon Amateur Transmitting Society G4FUR Richard Goring G6VYT on Dowlund 54319.** Second Monday and last Thursday at St Swithins Church Hall, Grovelands Road, Purley, Sy, at 8pm. AGM takes place on December 10.

**North Devon RC George Hughes, "Crinnis", Highwall, Barnstaple, N. Devon.** First Wednesdays of the month at new venue, Micro Chips, Castle Street, Barnstaple at 7.30.

**Droitwich ARC Gordon Taylor G4HFP on Stourport-on-Severn 3818.** At 8 pm second and fourth Mondays, Scout HQ, Union Lane, D'wich. New lady chairman is Jenny Veasey G4THU.

**Dunstable Downs RC G4ARD G8DDC. Phil Morris G6EES is on D'stable 607623.** Fridays at Chews House, High Street South, D'stable, Beds. A Christmas TV show is promised for December 7 with a party on the 21st. Note a junk sale on January 4.

**Ealing & District ARS G3UUP G8UUP Anton Berg G4SCR on 01-997 1416.** Tuesday evenings at 7.30, Hanwell Community Centre, 71a Northcroft Road, London W13.

**Edgware & District RS G3ASR John Copley G4RMD on Hatfield 64342.** Second and fourth Thursdays at 8, 145 Orange Hill Road, Burnt Oak, Edgware, Middx, with club net on 1.875MHz s.s.b. Mondays at 10pm. A junk sale is scheduled for December 13, with AGM on January 10.

**Exeter RS Roger Tipper G4KXR on (0392) 68065.** Meets at the Community Centre, St Davids Hill, Exeter, with December 10 revealing a new club project, with an award for the best effort. Christmas dinner is slated for January 5.

**Farnborough & District RS Sec is Don Mobbs G4MEE on F'borough 837581.** Meets at the Railway Enthusiasts Club, Access Road off Hawley Lane, F'borough, Hants. Meeting on December 12 is devoted to a Christmas social evening.

**Fylde ARS H. Fenton G8GG on Lytham St Annes 725717.** The Kite Club, Blackpool Airport, with access to the club's facilities for members. First and third Tuesdays with lectures, demos on first and code class and general get-together on the third. December 18 sees the Christmas Party in full swing. Club AGM is down for January 15.

**Glenrothes & District ARC GM4GRC GM3ULG Bob Lamont GM4LYQ. 132 Ballater Green, G'rothes, Fife.** Wednesdays at Provosts Land, Leslie, Fife, at 7.30. Code classes are run at the Balwearie High School, Kirkcaldy run by GM3YBQ and GM3PFQ.

**Hambleton ARS Sec is Dr. A. Wilson G3MAE on Great Smeaton 530.** This new club meets in Room C11 at the Allertonshire School, Northallerton, N. Yorks "fortnightly" which seems to be December 10 and 24.

**RS of Harrow Sec is Alison Wilson G6NDJ on (0923) 53642.** Every Friday at 8.15 pm, the Harrow Arts Centre, High Road, Harrow Weald, opposite the Alma pub, with talk-in on RB14. December 14 sees a "Spring Valley" computer lecture and demo while the Christmas festivities take place on the 21st January 4 should produce a "Used equipment extravaganza" or junk sale, presumably.



**Hastings Electronics & RC G6HH**  
**GIHHH** Sec is Dave Shirley G4NVQ on  
**Hastings 420608**. Main meeting third Wed-  
nesday at 7.45, the West Hill Community  
Centre, Croft Road, Hastings, with the club  
room at Ashdown Farm Community Centre,  
Downey Close (off Harrow Lane) open at 8  
every Friday. Code classes and contests a  
speciality plus RAE course running on Thurs-  
days. December 19 sees the Christmas do.

**Hilderstone RS Dr Ken Smith G3JIX**,  
**Staple Farmhouse, Staple, Canterbury, Kent**.  
Only a few months old the club intends to  
cater for all AR interests and appears to meet  
at the H'stone Adult Education Centre, St  
Peters, Broadstairs, Kent.

**Inverness ARC GM4TPF GMIDZU**  
**David Jones GM4SXD** on (08083) 240.  
Every Thursday evening at 7.30, the Cameron  
Youth Club, Planehill Road, Inverness.

**Ipswich RC G4IRC Jack Tootill G4IFF** on  
(0473) 44047. Second and last Wednesdays  
at 8pm, at the Rose & Crown, 77 Norwich  
Road, Ipswich, the clubroom being separate  
from the public bars. On December 12 the  
club does battle with the Stowmarket group in  
another quiz session.

**Isle of Man ARS Sec is Anthea Matthew-**  
**man GD4GWQ** on (0624) 22295. The society  
meets Mondays at 8pm at the Keppel Hotel,  
Crag-ny-Baa, IOM, with the AGM down for  
December 12. All interests catered for es-  
pecially contests. Newsletter *QSP* is a well-  
produced effort full of information.

**West Kent ARS Programme manager is**  
**Brian Guinnessy G4MXL, 99 Newlands**  
**Road, Tunbridge Wells, Kent** or (0892)  
**32877**. Every Friday at 8, the Adult Centre  
Annex, Quarry Road, T'bridge Wells. Club  
newsletter *QLF* caters for all tastes even to  
knitting for the lady members!

**East Lancashire ARC Stuart Westall**  
**G6LXU** on Accrington 393457. First and last  
Tuesdays at 7.30pm, the Conservative Club,  
Cliffe Street, Rishton, Lancs.

**Leighton Linslade RC Ian Jardine GIACQ**  
**on L. Buzzard 376741**. Looks like first and  
third Mondays at 7pm at the Vandyke Com-  
munity College, Room A64, Vandyke Road,  
Leighton Buzzard. Morse code classes are  
held every Wednesday evening at Newton  
Longville, run by G3XJO.

**Leith Nautical College AR & EC**  
**GM4AXG. Sec is Susan Beech GM4SGB**  
**at the College, 24 Milton Road East, Edinburgh**.  
A weekly constructional evening every Mon-  
day at 6pm in the electronics lab T2-4 with a  
wide range of equipment and facilities  
available plus h.f. and v.h.f. gear.

**Mansfield ARS Sec is Keith Lawson**  
**G4AAH, 233 Southwell Road West,**  
**Mansfield, Notts**. The Victoria Social Club is  
the venue for first Friday and third Tuesday  
of the month, located in Princess Street,  
Mansfield. A buffet disco is scheduled for  
December 7.

**Medway R & TS G5MW G8MWA Andy**  
**Wallis G4TQS** on (0634) 363960. At St  
Lukes Church Hall, King William Road,  
Gillingham, Kent, where on December 14  
there will be a junk sale, a Christmas social  
on the 21st but no gathering on the 28th.

**Midlands ARS Tom Brady G8GAZ** on  
**021-357 1924**. Meets at its HQ at 294a Broad  
Street, Birmingham B1 with gatherings every  
night of the week including computer sessions,  
plus catering facilities at weekends to take  
care of contest operations.

**Newark & District ARC Contact Michael**  
**Gayler G4SDZ** on (0636) 702076. First  
Thursday of the month at 7.30, the Palace  
Theatre, Appletongate, Newark. Morse code  
tuition is available.

**ARC Nottingham G3EKW G6CW**  
**G8IUT Jim Towle G4PJZ** on N'ham 624764.  
Every Thursday at 7.30pm, the Sherwood  
Community Centre, Mansfield Road, N'ham.  
On December there will be a talk on an EI  
DXpedition with the Christmas social on the  
20th. An activity night is planned for the 27th.

**Oldham ARC Details from Fiona**  
**Butterworth G4SPX** on 061-652 8862. Meetings  
every Monday at 8.30, the Wheatsheaf Hotel,  
Derker Street, Oldham. A Christmas evening  
is planned for December 20.

**Salop ARS G3SRT Diane Parslow G4XBI**  
**is the sec at 1 Willington Close, Little**  
**Harlescott Lane, Shrewsbury**. Thursday eve-  
nings at 8pm, the Olde Buck's Head,  
Frankwell. There will be a talk and slide show  
of the G3UDA/G3VWH DXpedition to GM-  
land, on January 3.

**Southdown ARS P. G. Henley G8IQO** on  
(0323) 763123. First Monday of the month at  
7.30, the Chaseley Home, South Cliff,  
Eastbourne, with the date of the Christmas  
social not known at press time. But the AGM  
is on January 7. Late note:—social to be held  
at the Red Lion at Stones Cross on Friday  
December 7, with disco and buffet. Other ac-  
tivities include a computer course now in full  
swing.

**Southgate ARC R. F. Snary G4OBE** is  
**Publicity Manager, on 01-360 6555**. Second  
Thursday of the month at St Thomas' Church  
Hall, Prince George Avenue, Oakwood, Lon-  
don N14, close to the Underground station.  
AGM time is December 13.

**South Tyneside ARS Sec Tony Adamson** is  
**on (0632) 567305**. Defunct for several years,  
this club has been formed from the old South  
Shields & District ARC. It meets every Mon-  
day at the Martec Club in the grounds of the  
S. Tyneside College, entry via the Grosvenor  
Road entrance. All aspects of AR will be  
covered in its activities and new members are  
most welcome.

**Spenn Valley ARS G3SVC Sec is Tim**  
**Clough G4PHR** of 37 Park Avenue, Mirfield,  
W. Yorks. HQ is the Old Bank Working  
Men's Club, Mirfield, Thursdays at 8pm. The  
Christmas gathering is on December 13. On  
January 10 G8HUA will deal with fast scan  
TV.

**Stockton & District AR Group G4XXG J.**  
**A. Walker G6NRY** on (0642) 582578. Every  
Wednesday at 7.30pm, the Billingham Com-  
munity Centre with code classes by G4PVN  
and RAE instruction by G4DXP and  
G6DJO.

**Stowmarket & District ARS M. Goodrum**  
**G3ZQU** on Stowmarket 676288. First Mon-  
days at the Maltings Entertainment Centre op-  
posite the railway station. On January 7 pres-  
ident G4BJO delivers part two of his talk on  
weather and propagation.

**Stratford-upon-Avon & District ARC Sec**  
**is David Boocock G8OVC** on S-upon-A  
**750584**. Second and fourth Mondays at  
7.30pm, the Control Tower, Bearley Radio  
Station, near Stratford. On December 10  
G6DCL holds forth on p.c.b. design and  
manufacture. No meeting on the 24th.

**Street & District ARS Colin Webber**  
**G4SCD** on (0458) 45145. First Tuesday at  
Strode College.

**Sutton & Cheam RS Sec is Alan Keech**  
**G4BOX** at 26 St Albans Road, Cheam, Sy.  
Third Friday of the month at 7.30pm, the  
Downs Lawn Tennis Club, Holland Avenue,  
Cheam. The Christmas Get-together is  
scheduled for December 21 at the clubroom.  
Make a note of G4BUE expounding on QRP  
matters on January 18. Who better?

**Swale ARC G4SRC Brian Hancock**  
**G4NPM** on (0795) 873147. Mondays at 8  
pm, the Ivy Leaf Club, Sittingbourne, Kent.

**Taunton & District ARC G3XZW L. S. J.**  
**Forde G4ZLF** at 23 Laburnum Road,  
**Wellington, Somerset**. Each Friday at 7.30 in  
the basement of the County Hall, The Cres-  
cent, Taunton.

**Tiverton (SW) RC G4TSW G. Draper**  
**G4ZNV** on (03634) 235. Monday evenings at  
7.30, the Queens Head in Tiverton, where  
various antennas have been erected. The an-  
nual club dinner takes place on Friday  
December 14.

**Todmorden & District RS Social sec is E.**  
**Tipping of 3 Cliffe Villas, Longfield Road,**  
**Todmorden, Lancs**. First Mondays at 8pm at  
the Queens Hotel, Todmorden.

**Torbay ARS G3NJA G8NJA Brian Wall**  
**G1EUA** on Teignmouth 78554. Every Friday  
and last Saturdays of the month at Bath Lane  
which is at the rear of 94 Belgrave Road, Tor-  
quay. But Saturday December 22 is  
Christmas party time.

**Verulam ARC Hilary Clayton-Smith**  
**G4JKS** on St Albans 59318. Meets at the  
RAFA HQ, New Kent Road, off Marl-  
borough Road, St Albans, on second and  
fourth Tuesdays at 7.30pm. However on  
December Tuesday 18 the main meeting will  
be the club's AGM followed by a film show  
with seasonal refreshments.

**North Wakefield RC G4NOK G6WRS**  
**GB2NWR Sec is Steve Thompson G4RCH**  
**on (0532) 536633**. Every Thursday at 8pm,  
the Carr Gate Working Mens Club with  
Christmas dinner on December 7 and a  
general knowledge quiz with the White Rose  
RC on the 12th. A lecture and visit is planned  
for the 20th.

**Wessex Amateur Wireless Club Wendy**  
**Stacey at Spinney House, 16 Crane Drive,**  
**Verwood, Wimborne, Dorset**. Fortnightly  
Tuesdays at the Cricketers in Wimborne,  
which is December 18 the Christmas Social  
then for 1985 its January 8 with Nick Foot  
G4WHO talking on ATV.

**Wimbledon & District RS New sec is**  
**George Cripps G3DWW. 01-540 2180**.  
Second and last Fridays of the month at St  
John Ambulance HQ, 124 Kingston Road,  
Wimbledon, London SW19, starting at 8pm  
with refreshments later.

**Wirral ARS G3NWR Cedric Cawthorne**  
**G4KPY** on 051-625 7311. The Parish Hall,  
Heswall, behind the church, on the first and  
third Wednesdays at 7.45.

**Wirral & District ARC G4MGR G8WDC**  
**Gerry Scott G8TRY** on 051-630 1393.  
Second and fourth Wednesdays at the Irby  
Cricket Club, Irby, Wirral.

**Wolverhampton ARS Sec is Keith Jenkin-**  
**son BR584269** on W'hampton 24870. Every  
Tuesday night at 8 pm, the W'hampton Elec-  
tricity Sports and Social Club, St Marks  
Road, Chapel Ash, W'hampton. Provisional  
date for the Christmas social evening is Tues-  
day December 18 at the Anchor Inn, Coven.

continued on page 76 ▶▶▶

Practical Wireless, January 1985



# ON THE AIR

## AMATEUR BANDS

Reports to: Eric Dowdeswell G4AR, 57 The Kingsway, Ewell Village, Epsom, Surrey KT17 1NA.  
Logs by bands in alphabetical order.

Following on from last month's discussion of the various modes of transmission of h.f. signals via the ionosphere we can now sum up the variations and decide what we can expect from the amateur bands during the day and night as well as seasonal changes from winter to summer.

**28MHz** F2 layer propagation during daylight but very dependent upon sunspot activity with very good DX even with low power during years of sunspot maximum. Mainly north/south paths during sunspot minimum around middle of the day. Occasional European openings during sporadic E events.

**21MHz** F2 layer during daylight, again best during sunspot maximum, with the F1 layer assisting DX during the evening periods. However, the band can close for long periods of a day or more during sunspot minimum, but when open then DX seems best at around dawn and dusk.

**14MHz** Open day and night during sunspot maximum with daytime openings predominating during minimum periods. The F2 and E layers are effective during daylight forming the F1 layer after dark.

**7MHz** The E layer causes skip distances of the order of 800km in daylight, disappearing after dark to leave the F layer to produce the DX in the dark zone. The main problem with 7MHz is the very high level of BC station operation producing excessive QRM for much of the time.

**3.5MHz** Absorption by the D layer restricts the range in daytime to around 300km with long DX ranges during hours of darkness especially during the winter. Stations in the more northerly regions can experience DX conditions for 24 hours of the day during the winter time.

**1.8MHz** The absorption by the D layer again cuts down the daytime range to around 80km but at night the F layer provides medium range communication. During the winter period DX is increased but high noise levels at stations enjoying the local summer season can interfere with DX.

To sum up, on the various layers affecting communication it can be said that the D layer is only present during daylight and it then tends to absorb signals. The E layer also exists only during daylight but it reflects signals. The F layer is present most of the time being the F1 layer during daylight but tending to split to form the lower F2 layer at night.

More information for those swotting for the Morse code exam. The Dutch radio society's HQ station PA0AA

transmits every Friday from 1615Z until 1945Z starting with code at 12 w.p.m. with news in Dutch (good practice!) and then in English followed by beginners Morse, an RTTY session, repeating the news bulletins in Dutch and English. On the last Friday of the month at 2000Z there is code at 12 w.p.m. until 2030Z when it is speeded up in six steps to 40 w.p.m. The frequencies on which to listen are 3.603MHz, 14.103MHz and 144.8MHz for those in the south east of the country.

### Around the HF bands

My anonymous reader "s.w.l. of South Humberside" writes again with another query, wondering how he can decide whether signals he hears are coming via the long path or the short path. In general short path predominates but there are occasions, especially on the 14MHz band, when signals come via the long path.

To start with, signals between any two points on the earth's surface take a great circle path (lines of longitude are great circles, lines of latitude are not) so there will always be two options for the signal if we assume the transmitting antenna is omnidirectional. The amateur having a beam antenna will turn it to the short path in the normal course of events. When the path is all in darkness, more or less, as is the path to VK in the early mornings from the UK on 14MHz, better signals are obtained over the long path via the South Atlantic. In the early evenings here the short path via Asia is predominant.

Occasionally an echo may be heard on a signal which means that signals are being received from both long and short path routes with the slight difference in time due to the greatly differing path lengths being heard as an echo. This effect is not infrequently heard on signals from the west coast of North America in the late afternoon, again mainly on 14MHz.

**Anthony Cross** of Bath, Avon, has returned to the fold after a long absence finding the 28MHz band dead, 21MHz not too bad and 14MHz fairing pretty well which just about sums up the current situation. Tony has now acquired an Icom R71 with a Global AT1000 a.t.u. plus a horizontal wire in a Vee configuration. He logged VE3LKV/H18 and T15EWL on about 3.787MHz at 0600Z. On 7MHz it was just CO2HQ around 7.082MHz. The 14MHz band produced



by Eric Dowdeswell G4AR

9Y4TAM, EL2BA, A92DZ with cards to G3VIE, HH2JR (QSL KA5V), KL7H, VP8PU, Z21GN and ZD7CW. His best on 21MHz were 9Y4NW at 2100Z, A71BJ, A92DZ again, TR8JYC and YC6RO at 1400Z.

**Paul Price** in Merthyr Tydfil in Mid-Glamorgan has a Sony ICF2001 and a telescopic whip but it seems Father Christmas may improve on this. On 3.5MHz he heard 3X4EX and 5B4BD, on 7MHz just OE8JAK/YK of note, while on 14MHz things were better with TK5FF, A71AD, D44BC, F5RV/TK (TK is a new prefix for Corsica), Y11BGD, JY3ZH, S79WHW and YB4FW. Up to 21MHz and CT3ET (QSL POB 22, Port Au Santo), HH2MC, J28EB and YCOBYZ with cards to POB 96 Jakarta.

**Mick Newell** who used to help with the DX reporting is now G1HGD so congrats OM and we wish you plenty of DX in the future. Mick managed to get a job straight from school which is very encouraging these days. Mick, of Kenilworth, Warks, is now very active on the 144MHz band albeit only with a ground plane antenna. Unfortunately in the November '84 issue we had Mick's call sign wrong, our apologies to Dr. J. A. V. Pritchard G1HGO and Mick G1HGD.



**Geoff Sims G4GNO** is a member of the British Rail ARS and shows us his appropriately designed QSL card. The engine is a Johnson Compound built in 1902 and restored to its original Midland Railway livery in 1959



# ON THE AIR

A further log from **Anthony Cross** of Bath shows VP5CC, TG9AL, TISEWL and YS9RVC all on about 3795kHz at around 0530Z. At much the same hour he found CO2GB and D44BC around 7050/75kHz. At 2000Z on the 14MHz band he caught DJ0SB/C6A, VP8ASO and 3D6AA. Between 1300 and 1400Z on 21MHz he logged VU2JXO (QSL WA3TLB), FM7BX and VQ9AC.

**Bob Parsey BRS85875** of New Malden, Sy, has a Trio 9R59D and Heathkit SB101 plus a 40m-long wire about 5m above ground and heard EA6ET on Top Band on s.s.b. On 3.8MHz it was just HZ1AB but on 7MHz he logged JA5BJC, VK3AJJ and 7X2CR (POB 2, Algiers). The 21MHz band produced just 9J2BO (QSL POB 98, Kazembe) and VU2GI of POB 6674 Bombay.

A Realistic DX302 adorns the shack of **Marcus Walden** of Harrogate, Yorks, fed from a 20m-long wire in the attic. From Antarctica came 4K1GAG (QSL UQ2OC) on 14MHz plus, on 21MHz, CX6CB, CS3EK, TU2IN (QSL K3HBP), ZS6CR.

**Andy Durrant** now of Swindon, Wilts, has been busy with his AR88 and Vee antenna of two 40m-long wires although they are only about 5m apart at the far end, a little too small for optimum reception on the h.f. bands. His best catches on 14MHz were A2TO at 0945Z, HK0EU and HK0FBF working each other, JY5CD, KP5WK/MM the ice breaker *Northwind* off Iceland, KL7XD, 4N7NS (YU-land), 7X2LS, 8P6AK and 9H4M on Gozo Island. Down to 7MHz for CM0K in Cuba, CP8RJ and D44BC around 06/0700Z, plus HH2Q, VK2AVA and VK7AZ in the early mornings, then ZL1AIZ and a couple of other ZLs around 0745Z.

Studies have hampered **Dave Richardson** up in Oadby, Leics, but his FRG-7 produced 7X5AB on 3.8MHz, A4XJQ, AP2AU, HI8LC (QSL Box 88 San Domingo), HV2VO with QSLs to I0GPV, S79WHW, VQ9DX, YI1BGD, and 9K2RA. Dave has 20m and 75m-long wires.

From London W6 **Denis Norton** has also been very busy at the salt mine so a short log this month from his FRDX 500, a.t.u., Datong FL2 audio filter and 20m-long wire. On 21MHz just YC4FAU with the following QSL QTH: Tobing (YC4FAU), Belitung Island, Indonesia, and 6W1KY. On 14MHz VS6CT working XU1SS, not heard, XJ7EIK special event station for the Pope's visit to Ankara, Turkey, YI1BGD and 4S7CF.

With one exception **Roger Edwards** of Barnes, London, kept to the popular 14MHz band with his FRG-7700 and long wire. He got BV2B, KL7H, XJ3FHL, XT2BR, 5Z4DE, 9J1OX, TF5AKU on 14MHz and just C30LBX on 3790kHz. Roger casually remarks that he is now the proud owner of callsign G1IWZ so we wish him well on the bands. He is also busy with the code in order to get his "A" licence.



**GM4TCW/MM? Not quite. Anne Edmondson on the Esplanade at Kirkcaldy, Fife**

Incidentally, "s.w.l. of South Humber-side" mentioned at the beginning of this piece mentions that he is aged 87 and "still learning"! Please forward your full address OM as I should like to write to you direct.

The IOM club has been very active this year with local expeditions using both the h.f. and v.h.f. bands under the call GD4IOM. Sec **Anthea Matthewman** writes to say that QSLs are being sent out as fast as possible. As can be imagined the number of QSOs made runs into thousands.

As readers will have realised the USSR has introduced a new system of call signs, just to confuse everybody! Briefly, the first letter will be either R or U, the second letter showing the particular republic within the USSR. The RSFSR will be A,N,V,W and Z replacing the old UA1,2,3,4,6,9 and 0. B,T and Y replace UB5 for the Ukraine. C is Byelorussia, was UC2. D is Azerbaijan, was UD6. F is Georgia, was UF6. G is Armenia, was UG6. H is Turkoman, was UH8. I is Uzbekistan, was UI8. J is Tadzhik, was UJ8. L is Kazakh, was UL7. K is Kirghiz, was UM8. O is Moldavia, was UO5. P is Lithuania, was UP2. Q is Latvia, was UQ2, and R is Estonia, was UR2. The letters E,K,S,U and X are not used.

The letter following the number, in combination with the number for the RSFSR, will indicate the oblast. The second letter in combination with the third letter will show the oblast for the remaining republics. With the exception of W,X,Y and Z the fourth letter of the call will be reserved for club calls. There may or may not be a fifth letter.

## QRP corner

Regular reader **Phil Dykes G4XYX** of Poole in Dorset is still sticking to his QRP activities on the 28MHz band with his modified CB rig and about 10W p.e.p. input on s.s.b., plus half wave dipole. As is normal with the current phase of the sunspot cycle the main paths open have been on a general north/south direction. Phil heard many stations from the South American area but only managed to work PY7SA in Recife for a 20 minute QSO. Others worked included EA5EVC, EA7EBA, five EA8 stations, and EA9IB for a new country, all around 18-1900Z. One station EA8AGQ was also QRP with 9W and a three element Yagi beam.

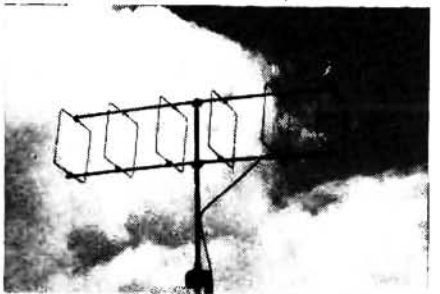
**Bill Stevenson G4KKI** of Swinton, Manchester, has not been very active on QRP, spending his time building a double sideband/c.w. transmitter based on the *PW Dart* design, but working on 3.5MHz and delivering about 1½W. Also under construction is a wideband (1.8 to 28MHz) linear amplifier to give around 10W. Bill also plays around with kites trying various configurations. With his Lowe SRX30 he has heard K3ZO and KV9S on the 3.5MHz band and TR8JLD and 5N9GM on 21MHz.

## VHF Forum

This is the first of a series on v.h.f./u.h.f. matters concerning the amateur bands, mainly 144MHz (2m) and 430MHz (70cm), similar to that which has been appearing on h.f. happenings, but as the first notice was only given in last month's *PW* it is too early to expect any replies in time for this issue. I understand from the editor that there are separate articles on amateur satellites and amateur TV in the pipeline.

Propagation paths on the v.h.f./u.h.f. bands are really quite different from those obtaining on the h.f. bands where reception is generally either via the ionosphere or direct ground wave. There are other less known paths but they are the exception rather than the rule. Most v.h.f. local contacts are essentially over line-of-site distances or a little further due to refraction effects. After that we have to rely upon what is known as tropospheric propagation, or tropo, a ducting effect dependent on special conditions existing in the atmosphere immediately above the earth's surface, when the air, instead of becoming cooler as height increases, becomes warmer forming a duct.

This phenomenon, or inversion, sometimes forms ducts extending over hundreds or even a couple of thousand kms or more, the signal travelling up to the duct, along it, and then being reflected down again. Only recently contact was made from the UK to the Canary Islands on both 144MHz and 430MHz over distances of some 2613km and 2787km. The weather maps we see on TV are very



**The Halbar six-element quad initially used by the author on the 144MHz band. The ribbon at the top corner of the reflector, right, shows wind direction so that the beam may be turned into wind during gales and the like. A nine-over-nine element Tonna has since replaced the quad**



# ON THE AIR

useful in this respect often indicating when such a "lift" is likely to occur. It tends to follow a high pressure area when the weather has been fine over the UK but is beginning to decline and moving east or south east with a cold front taking its place from the west or south west, indicated by a drop in barometric pressure. This is not a hard and fast way of predicting a lift much depending upon the different air temperatures involved. Sometimes the lift will occur before the fall in pressure. The recent excellent lift on October 14 and 15 was a case in point where, as far as I was concerned, the lift faded out before the barometric pressure dropped. During the two days DX as far as East Germany was worked as well as the northern-most parts of Scotland.

Actual lift conditions are quite unpredictable in their extent. Often a local station may be heard in contact with a choice bit of DX giving perhaps an S9 report with the DX quite inaudible a few km away. The only answer is to hang on and hope for a suitable change in conditions, which may occur after a few minutes or several hours. I suppose this uncertainty is what gives the v.h.f./u.h.f. bands their special attraction. Much like the vagaries of the ionosphere on the h.f. bands.

One does not need to listen very long on the v.h.f. bands before hearing stations exchanging five figure code groups with references to "squares". This is a locator system pinpointing one's geographical position, sometimes known as the QRA

or even QTH system. Unfortunately ambiguity creeps in, even over an area as small as Europe, although the DX callsign is sufficient to overcome this. For example square LD occurs twice, in Bulgaria and in northern Norway, but that is not likely to lead to confusion.

As from 1 January 1985 a new system, the Maidenhead system, will be introduced which is worldwide in application but uses six characters instead of five. The RSGB is publishing a suitable Maidenhead map for Western Europe for £1.58 to members and £1.78 to others, inc p/p.

The "square" is basically the same for both systems, being, in fact, rectangles of two degrees longitude wide by one degree latitude high thus varying in area depending upon the position of the square, being smallest in the north and largest in the south towards the equator. Computer programs are becoming available which purport to convert the existing squares into the new Maidenhead numbering but there seems some doubt as to whether it is very accurate over large areas. The conversion can be done accurately by a series of simple mathematical steps. This was covered in the October issue of *RadCom* and the July issue of *SW Magazine*.

My own QRA locator is ZL59b, the ZL indicating the main square which is broken down into 80 smaller squares designated by the number. The smaller squares are broken down again into nine lettered squares giving the last letter of the group which is always shown as a small letter, but the small letter "j" is not used here, so they run from "a" to "i".

So all will be confusion until quite a few months have gone by in the year.

There are quite a number of amateurs on the air who have computers at the ready to give the new Maidenhead numbers to those who find it hard to work out. The squares system of designating a location is very important as it forms the basis of several achievement certificates that are available on the v.h.f. and u.h.f. bands as well as giving a non-English-speaking amateur an immediate indication of one's location, providing they have a squares map of course!

**Stephen Beare** of Feoch, near Truro, Cornwall, was a regular contributor to the h.f. bands feature but he is now licensed and is active on the 144MHz band with an FT290R. In anticipation of passing his Morse code test he is also acquiring a KW Argosy rig and a.t.u.

**John Fell G8MCP** down in *PW's* HQ in Poole has sent me some info on his station which runs an Icom 202S and homebrew solid-state linear running some 70W output to a 19-element MET NBS Yagi antenna at 10m above ground level. He also has a MuTek dual-BF981 masthead amplifier to help the signal along. During the tropo lift on October 15 John worked several GMs as far north as YR and ZR squares, DLs and many QRP G stations in the north of the country.

So here endeth the first v.h.f./u.h.f. Forum and readers are invited to write in with their experiences on these bands, by the 15th of the month please, direct to me at the QTH given at the beginning of the feature.

This is the time to thank all the readers that have kept me supplied with material during the past year and to wish you all a Very Happy Christmas and prosperous New Year.

## MW BROADCAST BAND DX

Reports to: Charles Molloy G8BUS, 132 Segars Lane, Southport PR8 3JG.

"I am intrigued by your reference to the comparative ease of American DX in the early days of broadcasting," writes *PW* reader **G. A. Taylor G8AKN**. DXing is probably the wrong word. In the twenties it was even possible at times to listen to the programmes from the other side of the Atlantic. Why can't we do this today? Receivers are now more sensitive and selective than the early ones. The stations are still there, some of them are not so far away as might be thought. St John's in Newfoundland is 3700km from QTH, about the same distance as Cairo.

In the 1920s there were only a few stations on the air so it was easy to find spaces where weak, distant stations could be heard. Today the band is full of powerful transmitters. In Europe, where the spacing between stations is 9kHz, there are 120 channels available for use by several hundred transmitters whose combined output must be well over 100 megawatts! Frequency sharing is inevitable. Even a powerful and selective communications receiver cannot separate

two stations operating on the same frequency.

A moveable directional antenna is the answer. Fortunately on the medium and long waves but not on the short waves, we can make use of the directional properties of a frame antenna — the old frame antenna of the early days of wireless. The frame antenna has two nulls which are directions from which little or no signal is picked up. Rotate the antenna until a null points towards a station and that station will disappear or be reduced to a very weak signal. If two stations share a frequency and they are in different directions, then it should be possible to null out either of them and listen to the other on its own.

### Loops and Domestic Receivers

The DXers medium wave loop antenna, developed from the early frame antenna, is a powerful tool. It is only one



by Charles Molloy G8BUS

metre square so it can be used manually by the DXer as he sits beside his receiver. The loop has a tuning control to peak up the signal so it adds some selectivity to the set up. Anyone interested in loops should read my article MW/LW Loop Aerials in the *PW* publication *Out of Thin Air*. It gives constructional details as well as discussing the principles involved.

Before becoming too euphoric about the loop we should note that it cannot be used with a receiver that has an internal antenna of its own. If you try, you will find that the loop appears to have no directional properties and its tuning control has little effect. A signal being nulled out by the loop will still reach the receiver



# ON THE AIR

from its own antenna. These days almost every domestic receiver has its own internal antenna for the medium waves. If in doubt, tune round the band. If you pick up stations with no external antenna connected, then there must be an internal one. Many readers are not aware that there is a problem and some of them write to me asking for information about a loop suitable for use with their portable. The DXers m.w. loop can only be connected to a communications receiver, a car radio or to a vintage valve receiver. The latter would be designed for use with an external antenna and earth, and should have A and E sockets at the rear for this purpose. You plug the loop into these two sockets.

There is a way round the problem for the experimenter. The internal antenna, wound on a ferrite rod or slab is also directional. If you attach the entire receiver to the loop so that the two can be rotated together and provided the nulls of the two antennas line up, i.e. point in the same direction, then you are in the business of nulling out interference. The article MW/LW Loop Aerials discusses this too.

## DXing with a Portable RX

The ordinary domestic portable can be used for DXing on its own. Since the internal antenna behaves like a loop, you can null out unwanted stations just by turning the receiver, rotating it on its vertical axis. Pick up is really not enough for reception of North America but you can use a portable for local radio DXing. Moreover this is an excellent way to start DXing on the medium waves especially if you get hold of a copy of *Dial Search* which contains frequency lists, maps and instructions how to work out the bearings of m.w. stations from your own location. *Dial Search* is on sale in the BBC Bookshop at Bush House or it can be obtained direct from Wilcox (PW) 9 Thurrock Close, Eastbourne BN20 9NF. At the time of writing it costs £2.75 post paid (UK) or 15 IRCs abroad.

A final point about domestic listening. If you find it difficult to hear a station try moving the receiver slightly. You may be nulling it out! I did this once with a bedside receiver and it was a little while before I realised that the most convenient

position for the set was the worst for picking up our local station.

"I have been picking up a number of local radio stations" writes M. Bell from Reading who uses a Sony ICF 2001 receiver along with the multiband dipole described in the June 1984 issue of *PW*. Stations heard included Radio Cambridge on 1026kHz at 1228, Radio Kent on 1035 at 1206, Radio Leicester on 837 at 1346, Chiltern Radio on 792 at 1216, Devonair on 666 at 1155. "Something I found useful when trying to log local radio stations is page 590 of Channel 4s CEEFAX, service which gives details of new radio stations, antenna sites, power output and frequencies. The IBA have a guide to local radio stations which is free and can be obtained by ringing 0962 822444," continues our reader. The IBA list can also be had by writing to the Engineering Information Department, Crawley Court, Winchester, Hampshire SO21 2QA.

The British DX Club have sent me a copy of the fourth edition of their booklet *Radio Stations in the United Kingdom*. It has lists of m.f. transmitter, v.h.f. transmitters, postal addresses, transmission times, background information. There are the sections "looking ahead" and "reception reports". The latter is of particular interest and it starts off "almost all UK radio stations will readily verify reception reports with a confirmation card or letter, providing they are correct and well presented. Return postage (either mint UK stamps or an IRC) should always be enclosed." The booklet can be obtained by sending 50p in English currency or stamps or 3 IRCs to BDXC-UK, 10 Hemdean Hill, Caversham, Reading RG4 7SB.

## Readers' Letters

John Masterton who lives in Kirkintilloch near Glasgow has sent me an interesting log of stations picked up with a "small radio of the Walkman type". The highlights included Isle of Man on 1386kHz (190km away). Monte Carlo 1458kHz (1500km) Sweden 1179 (1350km), Warsaw (1630km) Moscow (2520km) Albania (1400km). "I have written to show DXers discouraged by the cost of equipment that with a little patience, DXing, if not easy, is possible using cheap and some say nasty equipment." There are no nasty radio receivers! At one time I used a home

BALTIMORE, MARYLAND

WBAL

Maryland's Most Powerful Broadcast Voice

QSL card from WBAL sent in by Bill Kelly

Phillies  
1210WCAU-AM

Sticker from WCAU sent in by Bill Kelly

made one valve portable when cycling/camping and would have been delighted with one to today's pocket sets. It is surprisingly a lot easier to get going on the medium wave than on the short waves. You can have a lot of fun and hear interesting DX with a domestic especially if you exploit the directional properties of the receiver's antenna.

"I am organising the ordering of a book entitled *Whites' Radio Log* directly from the publishers in the United States" writes Steve Whitt. "This book is a 136 page paperback (A5) that lists all US and Canadian broadcasting stations with listing by location, frequency, and call sign." *Whites' Radio Log* was reviewed in this column in the January 1984 issue of *PW*. "I can supply copies for £4.75," concludes Steve who points out that future orders may well have to take account of the poor dollar exchange. Enquiries, with a s.a.e. should go to 103 Foxhall Road, Ipswich IP3 8JZ.

## Ken Brownless

Medium Wave DXers will be saddened to learn of the passing suddenly, on September 27, of Ken Brownless. For nearly 30 years Ken was editor/publisher of *Medium Wave News*; an achievement by any yardstick. Ken was a bachelor who lived alone and the only information available at the time of writing has come from the solicitor looking after his estate.

No-one can replace Ken. Whether *MWN* can continue without him is at the time of writing, uncertain.

# SW BROADCAST BANDS

Reports: as for Medium Wave DX, but please keep separate.

In those parts of the world lying between latitude 30°N and 35°S and in a few remote parts of Asia, local broadcasting has traditionally been on the tropical bands rather than on the medium waves. The tropical bands will be found between 2.3MHz and 5.1MHz, between the

medium waves and the international shortwave broadcast bands. In some areas the high level of static makes the medium waves unattractive. In others it is the ability to cover large sparsely populated areas with a low power transmitter.



by Charles Malloy G8BUS



# Tandy®

## Tune In To The World With Realistic®

### A Direct-Entry PLL Communications Receiver



**£219<sup>95</sup>**

■ Hear International News, Music, Ham on Shortwave, Plus LW/AM/FM Broadcast Stations

**Realistic DX-400.** Our finest portable receiver ever! Lighted tuning meter and LCD digital frequency. Microprocessor controlled plus phase-locked-loop direct-entry pushbutton tuning. Six AM and six FM memory channels. Auto-Scan finds new stations fast. Wide/narrow selectivity controls plus fine-tuning. Built-in speaker, headphone jack. Covers 150-29,999 kHz and 87.4-108 MHz. AC/battery operation. Batteries extra. **20-207.**

### 16-Channel Portable Programmable Scanner

Covers 68-88 MHz VHF-Lo, 144-148 MHz Ham, 108-136 MHz AM Aircraft, 138-144 MHz, 148-174 MHz VHF Hi, 380-450 MHz Ham, 450-470 MHz UHF-Lo, 470-512 MHz UHF-Hi

**£229<sup>95</sup>**

■ Now You Can Listen To Aircraft, Hams and More - Wherever You Go No Crystals To Buy!



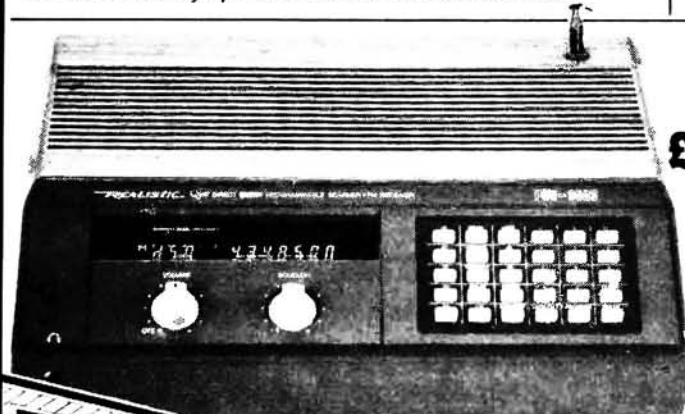
**Realistic PRO-30.** Scan up to 16 of your favourite channels continuously, or search a selected frequency range for new or unpublicised channels. Scan and Search in two speeds. Two-second Scan Delay, selectable for each channel prevents missed replies. Has jacks for external antenna and earphones. Requires six "AA" batteries or mains or DC adapter. Memory backup requires four silver-oxide batteries. **20-9131**

### ... And A 60-Channel Programmable Scanner

**£279<sup>95</sup>**

■ Listen to Aircraft, Hams, VHF Marine and More - Even Your Favourite Standard FM Stations

**Realistic PRO-2003.** No crystals to buy - direct keyboard entry of 20,584 frequencies! Use the search circuit to find new channels. Has 2-speed scan and search, Scan Delay, individual channel lockout, priority function and variable squelch control. Bands: VHF-Lo 68-87 MHz; FM Broadcast 88-107 MHz; VHF-Air AM 108-136 MHz; Ham 138-148 MHz; VHF-Hi 148-174 MHz; 410-450 MHz; UHF-Lo 450-470 MHz; UHF-Hi 470-512 MHz. Mains operation or 12V DC negative ground. Memory requires 9V battery. **20-9117**



### Take A Look At Tandy, Today!

Visit your local store or dealer and see these and many more sale bargains. We service what we sell - over 2800 exclusive lines!

See Yellow Pages For Address Of Store Nearest You

**OVER 9,000 STORES & DEALERSHIPS WORLDWIDE**

Prior to this advertisement, all quoted regular prices have been charged during the last six months at the Tandy Store, Tameway Tower, Bridge Street, Walsall, West Midlands. WS1 1LA.



Known As Radio Shack In The U.S.A.

Prices may vary at Dealers  
Offers subject to availability



**NEW**



**Alinco ELH230D**  
 1-3/30 Watt 10dB Preamp  
 Fully Remote and R F Switched  
**Only £64.95 inc VAT**

**AR1002**  
**Rotator**  
**£37.50**  
 inc VAT



**METERS**

- SWR15 Single SW/Field Strength 3.5-10MHz **£9.80 inc VAT**
- SWR25 Twin Meter SWR/Power/Field Strength 3.5-150MHz **£13.50 inc VAT**
- UH74 Single Meter SWR/Power 5/20/120W 144 and 432MHz **£22.15 inc VAT**
- SWR200B Twin Meter SWR/Power 3.5-150MHz **£40.25 inc VAT**
- TAL172 Single Meter professional SWR/Power 5/25/100W 148-174MHz Optional Mounting Bracket available **£37.95 inc VAT**
- T435 Twin Meter 144/432 SWR/Power 20W/120W **£43.15 inc VAT**

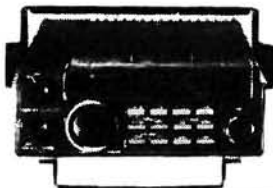
**ADONIS MICROPHONES**

- AM803 Desk Compressor Mic with Head and Swan Neck **£68.45 inc VAT**
- 202HD Head Set with Control Box and Fet Head **£42.95 inc VAT**
- 202FX Swan-Neck Fet Mic with Control Box **£43.25 inc VAT**
- 202S Flexible Neck Clip Mic with Control Box **£29.50 inc VAT**
- HW7-7T Head Set Boom Mic for Trio **£31.95 inc VAT**
- HW7-7I Head Set Boom Mic for Icom **£31.95 inc VAT**
- HW7-7Y Head Set Boom Mic for Yaesu **£33.00 inc VAT**
- MS10 Visor Speaker with Memory Pad **£16.50 inc VAT**



**STANDARD C5800**

The most advanced 2M multi-mode yet, with 25 watts output in all modes  
**£399.00 inc VAT**  
 Spare Mounting Bracket  
**£10.75 inc VAT**



**MORSE KEYS**

- HK707 Straight Up/Down Keyer **£15.00 inc VAT**
- BK100 Semi-Automatic Bug **£24.70 inc VAT**
- HK702 Up/Down Keyer on Marble Base **£28.75 inc VAT**
- MK702 Manipulator **£28.75 inc VAT**
- MK704 Squeeze Paddle **£14.00 inc VAT**
- MK705 Squeeze Paddle with Marble Base **£28.75 inc VAT**
- MK1024 Automatic Memory Keyer **£120.00 inc VAT**
- EK150 Semi-Automatic Keyer **£85.40 inc VAT**
- EMK1A Morse Code Practise Oscillator **£9.20 inc VAT**

*All prices are correct at time of going to press and are inclusive of VAT. Postage and Packing extra.*

**STANDARD C8900**

- C8900 New Slim fully synthesized 2M 10W Mobile with 5 Memories, Scanning facilities and digital read-out etc **£239.00 inc VAT**
- Can be installed on its own or stacked with C7900 (70CM)
- C7900 70CM 10W Mobile with 5 Memories, Scanning, 10MHz coverage and digital read-out etc. **£249.00 inc VAT**



**400 EDGWARE ROAD,  
 LONDON W2  
 01-723 5521 Tlx 298765**



Normally 24hr despatch but please allow 7 days for delivery



**NORTHERN AGENTS:  
 JOE BELL, G4PMY  
 UNIT 3  
 THOMAS STREET  
 CREWE**

Tel. No. 0270 582849

**SOUTH WEST AERIALS**



**£69.95**

The **WALTHAM 416** is a VHF/UHF 6" screen mono TV for System B/G operation (5.5MHz sound) and is ideal for serious TV/DXing, or Continental travel and domestic use. Operation is via mains power or an external 12 volt source (all plugs and leads supplied). This receiver has a modern moulded cabinet and carrying handle, the controls are in a conveniently recessed but easily accessible position on the top of the television.

The 416 features extremely good sensitivity and sharp selectivity with its 4 individually tuned IF stages. All bands (VHF and UHF) feature continuous varicap tuning for ease of operation. Tuning controls and a clear scale readout are situated at the front of the receiver. **ALL** Band 1 & 3 TV/DX channels are covered, together with all UHF channels 21-68. Aerial input is via a 75 ohm coaxial socket, in addition a strong ten section whip antenna (40" extended) is provided at the rear. Two internal speakers for maximum sound quality are another feature of the 416. The **WALTHAM 416** is a modern and reliable export receiver made for the W. German market. South West Aerials are the sole UK distributor for this model.

**WALTHAM 416 6"** screen VHF/UHF mono TV (5.5MHz sound) inclusive of VAT **£69.95** plus £3.75 carriage and insurance (adjustment to 6MHz sound is available at an additional cost of £2.50). Delivery 3-5 days. **Send 60p for our NEW extensive 1985 CATALOGUE** detailing Aerials (DXing and domestic), Amplifiers, Filters, Rotators etc. Customer consultancy available to solve difficult reception problems. TV/FM DXing our speciality (include SAE with all enquiries please). **ACCESS & VISA** mail and telephone orders welcome.

**SOUTH WEST AERIALS (PW)**  
 11, Kent Road, Parkstone,  
 Poole, Dorset BH12 2EH. Tel: 0202 738232.



**DEWSBURY ELECTRONICS**



**GAMMA TWIN**  
**2 METER FOLDED**  
**1/2 WAVE ANTENNA**

Copyright Gamma Aerial Products 1982.

This antenna is based on the very popular and successful 'SLIM JIM' design. The **GAMMA TWIN** has the following unique features:

- ★ VERY LOW ANGLE OF RADIATION
- ★ ADJUSTABLE RADIATOR (140-150MHZ)
- ★ COMPLETELY WEATHERPROOF CONNECTING BOX
- ★ VERTICAL FIX DIRECTLY TO MAST

**£7.95** incl. V.A.T. + £1.40 p&p

Dewsbury Electronics offer a full range of Trio Equipment always in stock. We are also stockists of **DIAWA - WELTZ - DAVTREND - TASCOS TELEREADERS - MICROWAVE MODULES - ICS AMTOR - AEA PRODUCTS - DRAE.**

Dewsbury Electronics, 176 Lower High Street, Stourbridge, West Midlands.  
 Telephone: Stourbridge (0384) 390063.  
 Instant finance available subject to status.  
 Written details on request.



Please allow 10 days for delivery.





# ON THE AIR

After dark, signals from the tropical bands are propagated well outside the target area. They do, literally if they can find a path of darkness, travel round the world. The problem confronting the medium wave DXer is interference from other broadcasting stations. The tropical band DXer is faced with QRM from commercial stations. In regions where the tropical bands are not used for broadcasting they are allocated to non-broadcasting users.

The listener in temperate regions will hear low power broadcasting mixed with Morse, RTTY, picture transmission and other "weird" noises. We are now moving away from short wave listening to DXing. There is little to be found at entertainment value, though if you accept the challenge and succeed in picking up, identifying and occasionally listening to some of these elusive broadcasters you will derive a lot of satisfaction from it.

## Tropical Band DXing

The main tropical band, known among DXers as 60 metres, lies between 4.7MHz and 5.06MHz. This is the band for the beginner. The other two bands are 90 metres (3.2-3.4MHz) and 120 metres (2.3-2.5MHz) and they are a lot more difficult than the 5MHz band. There are many DXers who have yet to pick up their first station on the 2.4MHz band.

Ideally, the DXer should have a good external antenna joined to a communications receiver via an antenna tuning unit. In practice he will have to use what is available. A table receiver with whip antenna is not the ideal set up, especially during TV hours when interference from TV receivers may be severe, but it should be able to pull-in some DX in the small hours. The whip antenna is hardly adequate for the weak signals we are looking for, but overcoming problems is the name of the DXing game.

## When to Listen

Knowing when to listen is half the battle. You won't hear anything at all in the middle of the day. At this time of year it is possible to pick up Asia starting about one hour before sunset. Listen on 4.800MHz for Hyderabad in India, on 4.760 for Pakistan, on 4.960 for China, on 5.005 for Nepal, 4.980 for Kashmir. Try, too, at 1900 on 4.920 for Brisbane in Australia.

Africa is audible any time of the year. Listen at sunset for Lesotho on 4.800, Cameroon on 5.010, Sao Tome 4.805, Dakar 4.890, Zambia 4.910, Niamey Niger 5.020. Latin America, too, can be picked up at any time of the year, during the night right up to sunrise. Try 4.780 and 4.800MHz for Venezuela, 4.795 for Peru, 5.045 for Brasil, 5.095 for Colombia, 4.825 for Costa Rica. These are only a small selection from the numerous broadcasts to be heard on the 5MHz band.



QSL card from Radio Budapest sent in by Andrew Hill

## Tropical Bands Survey

A good, up-to-date frequency list is essential. The *Tropical Bands Survey*, which is in English, is published annually by the Danish Short Wave Clubs International. The *TBS* lists stations in frequency order giving power, location, times of transmission. Stations are also placed in the following categories, often reported, regularly reported, seldom reported, not reported but known to be active, possibly inactive, seasonal frequency.

The *TBS*, which is compiled from reports from DXers throughout the world, is available to non-members of the DSWCI for 7 international reply coupons. IRCs are obtainable from main Post Offices in the UK and cost 35p each. Send them to the DSWCI, Tavleager 34, DK-2670, Greve Strand, Denmark.

## The 11MHz Band

The first short wave station I ever picked up was on the 25 metre band. 25 metres is now an obsolete but still widely used name for the 11MHz band. The official limits are at the moment 11.700 to 11.995MHz. They are due, under the World Administrative Radio Conference plan to be extended to 11.650 and 12.050. In practice you will find broadcasting anywhere between 11.600 and 12.100 and you will find it at any hour of the day or night.

Medium range signals come in well on 11MHz during the daytime. Listen for Spain on 11.690, Vatican Radio on 11.740, Saudi Arabia 11.870, Romania on 11.940. After dark the long distance paths that during the day were open on higher frequencies, move down to 11MHz. Try 11.620 for India, 11.700 for Radio Clarin in the Dominican Republic, Argentina on 11.710, Kuwait on 11.675, Japan 11.705, Liberia 11.830, Taiwan 11.725, Radio RSA on 11.900.



QSL card from Radio Polonia sent in by Andrew Hill

As we move further towards the sunspot minimum and higher frequency bands become less useable, it is worth searching round the 11MHz band at any time of the 24 hour period but especially during the daytime.

## European DX Council

The EDXC which is an umbrella organisation for short wave listeners' clubs in Europe does much co-ordinating work during the year and it issues publications and guides of use to short wave listeners and DXers. The second edition of its club list is now available. It gives information about the EDXC member and observer clubs, including details of their publications, membership fees, particular specialisation plus other useful information.

Short wave listeners who are thinking of joining a short wave club and who wish to know what clubs are established in Europe and elsewhere, will find this list useful. It is available from the EDXC, PO Box 4, St Ives, Huntingdon, Cambs, England PE17 4FE for 50p (UK) or three IRCs worldwide (airmail one IRC extra).

Also available from the EDXC is a 90 minute cassette of a selection of speeches and papers presented at the 1983 EDXC conference which took place in London. The cassette is priced at £2.75 or 18 IRCs in Europe; £3.00 or 21 IRCs by airmail to the rest of the world.

A note from Secretary General Michael Murray says "an apology to your readers. Due to the huge demand we are now out of print with the Yaesu Musen FRG-7700 receiver file". Why not do a reprint Michael? I'm sure it would be appreciated.

## Readers' Letters

A cry for help from New Zealand comes in a letter from *PW* reader Eric Barker who was disappointed that the EDXC receiver file for the FRG-7700



# ON THE AIR

was unavailable. "I am only interested in the possible modifications and the user comments. I already have the brochure and circuit." Can anyone help? If you can supply a photocopy or a loan of the original please write to Eric at 6A West Hoe Road, Orewa, New Zealand.

"I have recently acquired a Selena B210 receiver" writes **Tom Hambly** of Hove who is very pleased with his new set. It pulled in All India Radio on 11.620 at 1915, Buenos Aires on 15.345 at

2230, the Voice of Greece on 11.645 at 1920.

In reply to **David Edwardson** of Wallsend who has an R600 communications receiver which is connected by coaxial cable to a 30m long outdoor antenna. The coaxial screen is earthed to a 1 metre ground rod. David reports interference from TV sets which is very bad on the tropical bands and he wonders if I can suggest a remedy. I wish I could! This interference seems to be via the mains either direct to the receiver or by radiation from the house wiring. A battery operated receiver operated close to a win-

dow and used with a short external antenna run directly away from the house, usually brings an improvement. For tropical band reception it might be worth modifying the standard medium wave loop antenna so that it resonates on the 5MHz band. Remove turns until this happens. The loop will not work properly on the 5MHz band after dark and you will not be able to null out QRM, but it might reduce or even null-out TV buzz. David has managed to pull-in, after TV hours, Hyderabad with English news on 4.860MHz at 0032 and Radio Capital in Venezuela on 4.850 at 0557.

## VHF BANDS

Reports to: **Ron Ham BRS15744, Faraday, Greyfriars, Storrington, West Sussex RH20 4HE.**

Another look at keeping atmospheric pressure records, 50MHz band activity in South Africa, a short tropo opening and although the sun still remains quiet, aurora has been reported, magnetometers have been fluttering and despite the generally poor conditions on the 28MHz bands, readers have a surprisingly large number of beacon signals in their logs.

### Solar

"Those blank discs in the October *PW* are a pretty fair representation of what the sun looked like lately-hi," writes **Ted Waring**, Bristol. "Completely blank discs", writes **Patrick Moore**, Selsey, who observed the sun on many days between September 17 and October 5. Although a similar report came from **Cmdr Henry Hatfield**, Sevenoaks, he did see, with his spectrohelioscope, 4 filaments on September 18, 6 on the 22nd, 7 on the 26th and 15 on the 29th and a few quiet prominences on the 18th and 26th. For my part, I recorded a few small bursts of solar radio noise at 143MHz during my midday observations on September 16 and October 7, 11 and 15.

"The major storm of September 25, which I observed, has been confirmed and was related to a coronal hole and reconfiguration of the magnetic field on the sun", writes **Ron Livesey**, Glasgow, Auroral co-ordinator of the British Astronomical Association. **Karl Lewis**, Cornwall, told Ron that his magnetometer recorded storm conditions on the 23rd, 24th and 25th and was very unsettled on the 19th, 20th, 26th and 27th. **John Toone**, Boothstown, reported seeing what appeared to be an auroral glow between 2030 and 2050GMT on the 19th and Ron confirmed that his magnetometer was disturbed that evening and points out that this was a 27 day reoccurrence of a magnetic disturbance noted during the evening of August 23.

### Aurora

On September 22, **Dave Coggins**, Knutsford, noted lots of h.f. signals with

rapid flutter type QSB and he warned his good friend **Tony Usher G4HZW** to keep an ear on 28MHz. Both were up early on the 23rd and although they heard nothing at that time on the 28MHz band, around mid-afternoon Tony worked a station in Colwyn Bay via aurora and heard several auroral E type signals from Scandinavia. Dave promptly switched to the 144MHz band and heard **GI4OPH**, **GM4HIG** and **GM4OGM** via auroral c.w.

### The 50MHz (6m) Band

"This may seem strange to you but, here in Port Elizabeth the 50MHz activity is on par, if not better than 144MHz f.m.", writes **Johan Harmse ZR2EC** and adds, "we have applied for a 50MHz beacon licence and we are now eagerly awaiting the go ahead as all the equipment is ready. The proposed beacon will be known as **ZS2SIX** with a power output of 10W c.w. into a turnstyle antenna and situated on our local university building, some 20 stories high, with a good take off. The operating frequency is 50.005MHz, so do keep a listen out for us from January 1985". Like many other stations, Johan uses a modified, ex-army, C42 transceiver, Fig. 1, on 50MHz and by using 4- and 5-element Yagis they regularly work distances up to 300km



Fig. 1: **Johan Harmse** using his modified ex-army C42 transceiver



by **Ron Ham BRS15744**

and during a good tropo opening, 1350km, Durban to Cape Town was achieved, with only 3W f.m., by **ZS1ABD** and **ZS5AV**. "Fortunately we have in our midst, **Mike Bosch ZS2FM** who is an absolute authority on the band and the mods to the C42 were conceived by **Mike** and **Graeme ZS2OD**", said Johan, who also told me that as from September 21, amateurs in Durban, East London, Cape Town and Port Elizabeth, will be trying to work stations in Australia and New Zealand, via the Aurora Australis, on 50-600MHz. Good luck to all concerned and we will look forward to the results.

### Meteor Scatter

During the evening of October 13, **Simon Hamer**, **Bert Mills** and I, at my QTH, received many strong bursts of signals from television transmitters on Ch.R1 49.75MHz, due to meteor trail reflection. This was confirmed by **John Mason**, Barnham, a council member of the BAA, who heard a large number of



Fig. 2: QSL card from **ZS5VHF** sent in by **Ted Owen**







# ON THE AIR

Dave Coggins received signals from the 144MHz beacons in Angus GB3ANG and Wrotham GB3VHF each day throughout September and the Cornish beacon GB3CTC, which is a fair haul for a v.h.f. signal to Dave's QTH in Cheshire, on the 10th and 15th. I check the Wrotham beacon daily with a vertical dipole feeding my receiver and its strength averages around 539 but it perked up to 559 on September 23 and 26 and October 1, 11, 12, 13, 14 and up to 589 during the tropo opening on the 15th. Lower down, on the 28MHz band, the story is very different. "I have never heard conditions so bad as this last few months" writes Bert Glass BRS 32693, Plymouth, although, like John Desmond and Ted Waring, he logged the 3 German beacons on October 14 and a few others. "The period of bad conditions continued and even deteriorated, I heard a lot of amateurs complaining about it", writes Chris van den Berg on October 10. "Another very poor beacon return this time", says John Coulter and, "I think that this has been the leanest month for conditions so far and it will no doubt get worse" comments Dave Coggins. All too true lads, I found the same but collectively, your logs, along with those of Henry Hatfield, Bill Kelly, Ted Owen, Ted Waring and my own log made a reasonable beacon picture when I put all your findings together, Fig. 2. Ted Owen, Malden, sent a report to Bruce Dunn ZS5XT, about the signals he received from the Durban beacon ZS5VHF on 28-202MHz and on the QSL card which Bruce sent in reply, Fig. 3, he says that the transmitter runs 4 watts to a vertical dipole, 6m a.g.l., from a site some 580m a.s.l. and the picture of Durban was taken in the mid 1970s.

## Tropospheric

The atmospheric pressure measured at my QTH with a Barograph, or in other

words, a recording barometer, began this period on September 16 at 30.0in (1015mb) and ended very high at 30.4 (1029), but instead of going into a lot of text to describe the months changes in pressure, I have plotted it on a graph, Fig. 4, by using and slightly rounding the readings from my master chart at noon and midnight each day. This can be done at any QTH where there is a barometer handy. Apart from the peaks at 30.0, the lowest that v.h.f. operators like to see it, on the 16th and 27th, the pressure was low until it suddenly surged up on October 5 and giving the start to several days of good v.h.f. and u.h.f. DX.

During the evening of September 27, Bill Kelly using a SX200N scan receiver and a discone antenna heard several amateurs working through the 144MHz repeaters in Caernarvon GB3AR, Caldbeck GB3AS and Moel-y-Parc GB3MP. At 0130 on October 11, using the same type of receiver, I heard stations from Leicester and Norfolk working through GB3VA on R6. During the 15th and 16th, the repeater network was full of stations, I heard EI3BEB and GJ4ODX putting in a "rock crushing" signal via, I think, an EI repeater at Mt Leinster on R2 and a local GW QSO on R7. "Conditions fantastic" said one amateur on 144MHz s.s.b. and I agreed, having just logged a 58 s.s.b. signal from G6DZH in Worcestershire with a vertical dipole feeding the internal v.h.f. converter on my Trio R2000. His signal, like many others at that time would have been exceptionally strong if I had used the correct antenna and pointed it in the right direction.

Contests are usually good for DX because, whatever the atmospheric conditions are like, there are a lot of stations on the air and there is no better chance to log the portable stations who are on high ground with a good take off for their signals in all directions. During the IARU VHF and SWL Contest, early in September, George Haylock G2DHV, Sidcup, using a Trio 2100 on the 144MHz band found conditions very good, mostly to the north west and south east and he worked 8 stations at distances of over 150km in-

cluding 1 in Belgium and 4 in France, 12 over 200kms with 1 GJ and 4 GWs and 5 over 300kms, G3IGO/P, G4VWH/P his best DX, GW4CZZ/P, ON6HZ/A and PE1JQJ/P. Although the conditions were generally poor for the 70MHz Trophy Contest held on September 16, George in QRA locator area AL, using QRP 0.2watts worked G3ZAM/P in ZK and G3PJX/P in ZL squares.

## Band II

At 1400 on September 30, Simon Hamer, New Radnor, received BBC Radio Lancashire, via the Lancaster relay on 103.3MHz and ILR Hereward on 102.8MHz. Bill Kelly heard the test transmissions from the new ILR station on 96.8 for the Norwich area due to start its regular service on October 5 and he says that Radio Luxembourg announced f.m. transmissions on 88.5, 92.5 and 97MHz. Bill uses a Grundig Satellit 600 and its own telescopic antenna for Band II DX. Harold Brodribb has a Roberts R505 and although he is very pleased with its selectivity he is concerned about the increasing number of local stations and the chance that they will make Band II DXing impossible. "I fear that Band II DX is going the same way as medium wave DX", said Harold. Lets hope not Harold, but we all know that frequency space is at a premium in all parts of the spectrum. Damien Read sent a report to GB Radio which he heard on 104MHz and with their acknowledgement came a copy of the station magazine and some information leaflets. I counted several French Dutch and German stations between 87 and 102MHz at 2050 on October 10 and while Harold was listening to Dutch stations in the band on the 12th, I logged a number of French stations between 96 and 101MHz using the v.h.f. radio section of my Plustron TVR5D, with its own rod antenna, in the car park at Scotney Castle. During the evening of the 14th, John Williams, Charlton Kings, received a strong signal from RTE at Mt Leinster and as a result of his warning, I tuned the band and counted at least 10 foreign stations between 87 and 100MHz.

# TELEVISION

Reports: as for VHF Bands, but please keep separate.

Amateur Television reports from England, Scotland and Wales, activity in Bands I, III and u.h.f., a booklet by Simon Hamer, a DXTV converter, SSTV pictures and sporadic-E openings in India and the UK, provide the beef of my column this time.

## Amateur (fast scan) Television

"It is estimated that over 50 stations in central Scotland are now able to receive

amateur television pictures, with more than a dozen able to transmit, a big improvement over the last two years", writes Norrie Macdonald GM4BVU, Hamilton. He adds, "A number of new ATVers have joined the central Scotland ATV net on Monday evenings and the activity is spreading to other nights as well". Among the new stations transmitting are GM1BVK and GM4UBJ and receiving video are GM1AYT, GM6KTP, GM8BBA and GM8YBP.

During the Moray Marathon, organised by Moray District Council, the



by Ron Ham BRS15744

Moray Firth Amateur TV Club GM8AVT, transmitted live pictures of the race to a receiving station at Cooper Park from two sites, one at Covesea about 7km north on a high part of the road between Lossiemouth and Hopeman



# TIME STEP ELECTRONICS LTD

## FRG7 OWNERS ARE GOING — DIGITAL AND SIDEWAYS

And you can join them by using our custom designed DFC70 digital frequency counter. The DFC70 is specifically designed for the FRG7 and gives rock steady read out on all bands with 100Hz resolution. Signal frequency is computed and displayed unambiguously on a state of art LCD display specially made for us in Japan. It is not necessary to drill any holes and only one wire has to be connected to a well marked test point in the receiver.

**DFC70 Kit £21.95 Built and tested module £26.95**  
Will also work with the Lowe SRX30 and Drake SSR1.

With our new FM7 adaptor module, you will be able to receive sideways modulation (FM as it is otherwise known). Our superb state of art FM detector uses the very latest 3359 chip from Motorola, and has a built in IF filter and a variable squelch control for noise free monitoring. Although specially designed with the FRG7 in mind, it will happily work with other receivers or transceivers with a 455KHz IF amplifier. The FM7 will add a whole new dimension to your listening activities. You will of course be able to follow legal CB contacts but you will also hear the exciting DX being worked by amateurs on 10 metre FM. Used in conjunction with our DFC7 counter, you can accurately tune to a specific CB or amateur channel and so be sure that you will not miss whatever goes on. **Kit Price £12.95. Tested Module £15.95 P&P £1.00 (VAT inc.).** For FM reception on receivers with any IF up to 50MHz, the FM 42 is the answer to all your problems. *Please state frequency required when ordering.* **Kit Price £16.95. Tested Module £21.95 P&P £1.00 (VAT inc.) 10.7MHz version FM107 £13.95. Built and tested module £16.95.**

## TIMOTHY EDWARDS MK2 144 MHz PRE-AMP HEAR IT LIKE YOU NEVER HEARD IT BEFORE

We are proud to announce that the well known RF consultant Timothy Edwards has given us the exclusive marketing rights to his new 2 metre pre-amp. Timothy Edwards RF designs are used by British Telecom amongst others and so you can be sure that this pre-amp will perform to perfection. It employs the incomparable BF981 which has a better noise figure at 2M than the often used 3SK88. Spec. Size (tiny) 34mm x 9mm x 15mm (same as Mk1) Noise figure 1.0db Gain 26db. 2M PRE kit **£4.95.** Built and tested module **£9.95.** For Commercial use on 60 to 200MHz Built only **£14.95** (state frequency required). Versions for 156 and 137MHz kit **£4.95** Built and tested module **£10.95.**

**TRANSISTOR** 2 N6456 MHz 30 PoutW 60 Pin W 1.25 Volts 13.8 Price £5 (inc) Not 3SK88 but BF981 Better 2M noise figure 0.6db £1.40 (inc) (inc) ZTX 501 Gen purpose PNP 0.5A. 20 for £1.25 (inc) **BARGAINS**

## NEW LCD COUNTERS

At last a new range of 5 digit LCD counters that will cover up to 200MHz and give 1KHz resolution to 39MHz. Ideal for most short wave receivers using common IFs. Similar to the FC177 but cheaper! Supply voltage 5-15V dc. Will operate on 26 different IF offsets. If this counter range won't do what you want probably nothing will. Works with all of Tony Bailey G3WPO designs, ask for conversion data.

**DFC40 0-4MHz £14.95 built DFC41 0-32MHz £18.50 kit DFC42 0-200MHz £21.95 kit**

**LNA144.** OUR ace RF designer Timothy Edwards has done it again! In line 144MHz RF switched pre amp which needs no modification to any rig. Just put it in the co-ax feed, supply 12V and your deaf rx will have ear ache. Uses the BF981 with a total of 4 tuned circuits for the best out of band rejection. The relays are 500ohm gas filled with earthed metal cans and are good to over 800MHz. This was originally designed for 'British Telecom Satellite Division' hence the provision for gold 14GHz SMC connectors 1dB noise figure and 18dB gain is guaranteed to improve all standard rigs on 144-146MHz. Will fit in standard diecast box (not supplied). Try one in the car under a wing mounted aerial and be surprised. **LNA144 kit £16.95. Built and tested module £26.95.**

**2M CONVERTER.** At last a cheap design to allow you to listen to the fascinating world of two metres. Use with any HF receiver that covers 2-4MHz (the FRG7 is ideal) to cover the complete band including SSB-DX, FM simplex and, of course, the love them or hate them Repeaters. The sensitivity is 0.5uV and can be upgraded later to the ultimate of 0.1uV by the use of either of our Pre-Amps.

**DCC144 kit £9.95 Built and tested module £16.95**

**2M MONITOR RECEIVER.** A superb design featuring crystal and ceramic filters coupled with the MC3359 and BF981 results in an almost bomb proof monitor. Single channel with squelch and 500mW audio amplifier. No coils to wind and little alignment required. Uses standard crystals from 'PM Electronics'. **MON2M Kit £19.95.** Built and tested module **£29.95.** New 4 Metre version **MON4M kit £21.95.** Built and tested module **£31.95.** **Marine (156MHz) MON156M kit £21.95.** Built and tested module **£31.95.** For professional use on 18-200MHz built and tested module **£38.50** including crystal.

**FRONT END MODULE 47-300MHz.** A ready built and aligned module covering all of 47 to 300MHz in 2 ranges. Use with the FM107 IF module for a tunable FM RX covering 4m 2M TV and PMR bands. Standard 10.7MHz IF output. The uses for this amazingly versatile module are nearly endless. A version is available with a standard TV IF output for DX TV. **EF4200 £27.95. EF4200TV £23.95.**

**TONE BURST.** Probably the smallest crystal controlled unit available. 1750Hz ±0.1Hz. Supply 5-15V. Will fit in the tiniest of rigs or even microphones.

**TBI Kit £8.50.**

**Built and tested module £12.95.**

**TOP BAND CONVERTER.** Listen to the other local nets and DX on 160m with any 2m SSB receiver. Does not need a large aerial and will comfortably out perform most commercial receivers.

**UC160 Kit £9.95**

**UC160 built and tested £16.50**

**WEATHER SATELLITE RECEIVER.** The hard work taken out of a Weather Satellite Station. Based on the enormously successful 2M monitor but specially designed to allow satellite reception with only a small aerial. Supplied with a crystal for 137.5MHz for immediate use. Be ahead of everybody with weather reports, already in use by progressive farmers.

**WSAT Kit £27.95.**

**Built and tested module £37.95**

**GAS FILLED RF RELAY.** New Japanese 50 ohm low loss gas filled RF relay. Only 0.3dB loss at 433MHz with up to 35 watts input. Ideal for switching pre-amps and aerials. VSWR 1.5:1 at 1GHz. 12 volt coil. **DR12V £4.95.**

All prices include postage and VAT. Send 35p for individual data on any of the above. Mail order only. Please allow up to 28 days for delivery.

**TIMESTEP ELECTRONICS LTD, WICKHAMBROOK, NEWMARKET, SUFFOLK.**

TELEPHONE NO. 0440 820040 (TECHNICAL ENQUIRIES 3.00 TO 4.00 PM ONLY) TELEX 817015 TIMEST G





# Amcomm of London

## HEIL'S MAGIC BOX

Is changing the way the world hears SSB, FM and CW

Now for the first time, a new ingenious compact sound system allows you to hear weak signals like never before, sort out the rare ones and listen to quality like you have never heard from your receiver, handle talkie or scanner. Usually, accessory speakers are no more than 50 pence speakers in fifty pound boxes. Their efficiency, frequency response and distortion levels are terrible and since most all of the new transceivers have less than one watt of audio, our ability to understand becomes very difficult.

The new SS-2 Heil Sound System contains two five watt amplifiers, a 3.5" woofer with a half pound magnet a 1.5" tweeter with a 12 dB per octave passive crossover network. The tweeter is crossed over at 1500 Hz., right where the response of the human ear starts to fall off and the huge woofer fills out the mid-range and low frequency response. No single cheap speaker can begin to give you this type of response.

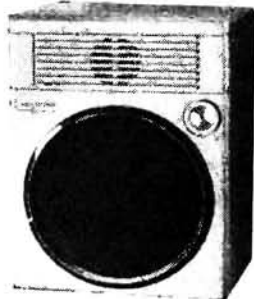
The second five watt amplifier can be used to drive a second speaker enclosure and will be used in a dual diversity system using the Heil parametric equalization system which will be introduced very soon.

When most receivers are running at a comfortable listening level, their little one watt amplifiers are being pushed into extreme distortion levels. The extended response, the added efficiency and additional output power will lower your noise floor, reduce noise and allow you to copy signals that were heretofore impossible to hear.

Mobile optional with the new Heil Sound System is unbelievable. The 5 watts of output and the tweeter system really adds to the articulation factor making signals so much easier to copy. The system makes handle talkie receivers come alive! An accessory mounting bracket will allow easy under the dash mounting for the SS-2.

The SS-2 measures 3 1/2" x 5" x 3 1/2". It weighs 2 lbs. and is housed in a high impact silver beige case. Power requirements are 12-13.8 volts D.C. at 400 M.A. A red L.E.D. is mounted on the front panel for power up indication. All input/output connections to the amplifier is made through a 5 pin D.I.M.

You can own this great new addition to your station but we suggest that you hurry, as there probably is someone calling you right now that your present speaker isn't reproducing. Discover the world of high quality audio, today!



THE SS-2



TWO 5 WATT AMPLIFIERS



3.5" WOOFER with huge magnet

SS-2 Sound System inc. VAT & Carr. **£65.00.**



Amcomm Services Limited, 194 Northolt Road, South Harrow, Middlesex HA2 0EN.

Telephone: 01-422 9585. Telex: 24263 TARDIS G

Closed Monday

See main ad. on page 16

**NEW**

## DRAE SLOW SCAN TELEVISION RECEIVER



Provides an affordable entry to the exciting world of SSTV

• £189 (Inc VAT) for a complete receive unit

Access

Delivery of stock items despatched within 24 hrs.

- Simple upgrade to full transceiver with plug in TX module (available soon)
- Latest design all on a single PTH Glass Fibre PCB.
- Receives European and US standard transmissions. Add a new dimension to your H.F. receiver with a DRAE Slow Scan Television Receiver. Simply connect between any receiver and a standard television or video monitor to watch slow scan pictures from all over the world. Previously the preserve of a devoted few the DRAE SSTV receiver brings Slow Scan within the reach of the average amateur. Available from Stock at time of going to Press.

Prices			
VHF WAVEMETER	£27.50	SSTV Receiver	£189.00
MORSE TUTOR	£52.00	24 A Power Supply	£110.00
3 WAY VHF SWITCH (SO239)	£15.40	12 A Power Supply	£79.50
3 WAY UHF SWITCH (N Type)	£19.90	6 A Power Supply	£53.50
2 Metre Preset ATU	£11.80	4 A Power Supply	£34.00

Prices and Details of Commercial Power Supplies+DC/DC Converters on request

DAVTREND LTD. Sanderson Centre, Lees Lane, Gosport, Hampshire PO12 3UL Telephone 0705 520141

BRITISH MADE

# DRAE



# ON THE AIR

and the other at Lesmurdie Road some 3km north east of the outskirts of Elgin. The latter was to show the runners after the start and again toward the end of the event. Over 200 competitors from all over Scotland took part in the 42km race through towns and villages in the area which began and ended in Cooper Park, Elgin.

The photograph shows, L to R, GM6UHC, GM4VRA, GM4PMT and GM8AZS preparing to erect their club station in the park, who, along with GM4CUQ, GM4HMN, GM4IZY, GM4WJA, GM4XKG and GM8ETF, televised the event. Well done all, this is another fine example of the good public relations work being undertaken by members of the ATV fraternity. Over in Wales, Bert Mills GW3LJP, Rhayader, hopes to be active again by December with ATV on the 430MHz band using a home brew transmitter and a Commodore VIC-20 computer for the colour graphics. In the past, using mainly valve type equipment, Bert has exchanged pictures with stations in Holland. Down South the Crawley and District Video Repeater Group, have built a 10GHz ATV repeater to be sited on a high spot in

Crawley (ZL80h), and field trials have shown good coverage of the north Sussex and Surrey areas. The power output will be 20W e.r.p. from an Alford slot antenna and the input/output frequencies are 1249 and 1318.5MHz respectively, using f.m. mode and a 6MHz sound channel. The repeater, costing about £150, has been constructed from easily obtainable parts and circuits and the logic is the GB3US sound repeater system with a vision detector and switching circuits added. The caption generator is a Cropedy Electronics test card giving callsign, QTH locator and input frequency. For further details please contact G6LVN QTHR or G4TVC on 0293 28612.

## SSTV

"For some months now EI3CZ, EI6EU and myself have been very active on the 3.5MHz band and would welcome others to join us", writes Ted Brooks GD4HOX, Braddan, who operates SSTV on 3.730MHz most Saturdays at 1430, Sundays at 1015 and often during the week around 1315. What about it lads and lasses, keep an eye out for Ted and do let me know how you get on.

During the month prior to October 14 Peter Lincoln, Aldershot, received slow scan TV pictures from several DLs and

OZ3WP on a German net on the 7MHz band around 0730 and on the 14MHz band, he copied CQs from HB0AWQ, Fig. 2, HA5JI Fig. 3, IICEL Fig. 4 and 15 seconds monochrome callsign Fig. 5 and QTH location Fig. 6, from I3XQW while he was in QSO with DL1HBN. "His signals are always received here at good strength and his video is excellent with good contrast, focus and definition", said Peter. Your pictures, past and present, have certainly whetted my appetite. Peter and I hope to have a receiver working soon using a 48K Spectrum computer and the SSTV programme from Scarab Systems, fed from my Trio 2000.

"A newcomer to SSTV on 14.230MHz on October 5 was N4HRO using a Tandy 80C colour computer and K6AEP software", writes Richard Thurlow G3WW, March. He tells me that G4DYB and G4NJI now have the latest Volker Wrasse SC-1s with 48 seconds single frame colour in addition to the existing 24 seconds single frame colour. "Several times I have been asked on the telephone to compare my Robot 450C with the SC-1, but this is very difficult with their different frame speed capabilities and both being excellent in their separate ways", said Richard who reports that KP4YD is on most mornings and that on September 22, VK3TE was worked. During the previous month



Fig. 1



Fig. 2



Fig. 3



Fig. 4



Fig. 5



Fig. 6

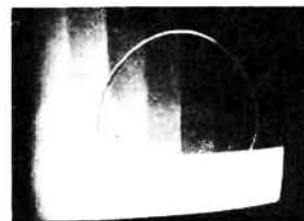


Fig. 7

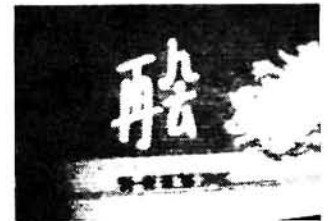


Fig. 8



Fig. 9



Fig. 10



Fig. 11

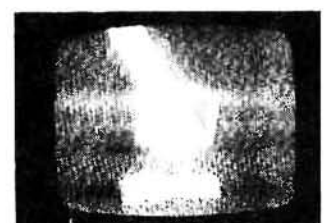


Fig. 12



right ▶ Fig. 13



far right ▶ Fig. 14



# ON THE AIR

Richard found band conditions poor with many CQ SSTV calls going by unanswered.

## Report from India

During sporadic-E disturbances on August 4, 5, 17, 20, 21 and 26, Major Rana Roy, received colour bars on Ch. 4 in Band I from Delhi, Fig. 7, captions from a Chinese station on Ch. 3, Fig. 8 and from the USSR on Ch. 2, Figs 9 and 10. He also watched a recording of the opening ceremony of the Los Angeles Olympic Games from China, an Arabic play from Dubai and ballet, a meeting between high officials, test cards, feature films and documentaries from the USSR.

While a tropospheric opening was in progress between September 13 and 19, Rana saw adverts for Pepsi-Cola and Marlborough cigarettes, and American film, *The Wild and The Tame* and a Pakistani film, international free-style wrestling and station idents from Rawalpindi TV on Ch. 8 in Band III. At 2000 on the 19th, he watched Ms Shaista Zaid, Fig. 11, giving the news in English.

## Band I

Congratulations to Tim Anderson, Bexhill, on passing the RAE who will soon, with his callsign G1JWR, be active on the v.h.f. bands and sending reports to my column. As for DXTV, Tim has been keeping a daily graph of propagation since the beginning of 1984 and says, "The sporadic-E season seemed to end rather abruptly this year and far too early! it didn't really start until May and died off in early August". During the 171 days between April 1 and September 17, Tim noted some form of sporadic-E, ranging from 5 minutes to all day openings on 109 days and since mid-July, he logged most European countries via sporadic-E. Tim also identified pictures via meteor trail reflection from Austria, Czechoslovakia, Germany, Norway, Poland, Sweden and the USSR on 22 days. Among the signals he received during the year was an interlude caption, Fig. 12, which Tim logged on Ch. E3 and thinks that it came from RTP Portugal,

"Can any of your readers confirm this?" asks Tim.

Although Band I is now generally quiet, Harold Brodribb, St Leonards on Sea, received a test card from TVE 1, Spain on Ch. E4 at 0901 and a glimpse of the word TOTO at 1441 on Ch. R1, on September 26. Simon Hamer, New Radnor, logged a test card scribed RS-KH from Czechoslovakia at 1330 on October 1, Keith Hamer, Derby, received pictures from Italy on Chs. Ia and Ib on the 14th and I saw a test card from Poland at 1450 on the 15th.

"I've had good responses from TV stations", writes Philip Hodgson, Stamford, who received a QSL letter from Dr J. Berger of ORF Austria wishing him more DX reception and saying that reports of ORF on Ch. E2 have come in from all over Europe and in particular, from England, Finland and northern Germany. Philip also had a QSL folder, with transmitter maps from NRK Norway and a colour QSL showing a test card from TVE Spain. Philip uses a Plustron TVRCS5D and has certainly been rewarded for his good DXing and the quality of his reports to the stations concerned.

"The D-100 DX TV converters which we have designed and built are proving popular with DX-TV enthusiasts both in the UK and abroad", writes Keith Hamer and adds, "The D-100 offers wideband and narrowband facilities which is most useful with weak signals as one DXer found out recently and phoned to say that he was watching Greek TV (EPT) on Ch. E3, via sporadic-E, thanks to the narrowband of the converter." A leaflet about this converter is available from Keith at HS Publications, 7 Epping Close, Derby, DE3 4HR. Keith, one of the authors of the book on test cards, is a keen TVDXer himself and sent me a picture of a Yugoslavian news caption, Fig. 13, which he received on Ch. E3.

## Tropospheric

During the first week-end in September, Tim Anderson took one of his Plustrons to his old QTH in Stroud and in the afternoons received a slow fading negative picture at the lower end of Band III from the French Canal Plus and he also sent in a photograph of a colour bar caption, Fig. 14, which he received earlier in the year, via tropo, from FR3.

On September 30 and October 7,

Simon Hamer took his Hitachi 2300 receiver to Penyfforest Hill, some 680m a.s.l., and with its own telescopic antenna he logged u.h.f. signals from Bromsgrove, Carmel, Hannington, Llandrindod Wells, Mendip, Moel-y-Parc, New Radnor, Oxford, Ridge Hill, Sandy Heath, Sutton Coldfield, The Wrekin, Wenvoe and Winter Hill. "All crystal clear," said Simon, who, on the 7th also logged Ireland's RTE 1 in Band III from Kippure and Mt. Leinster. Simon has produced an 8 page booklet entitled, *TVDX for Beginners*, now being published by HS Publications, 7 Epping Close, Derby, DE3 4HR, at £1.65 inc post and packing in the UK and surface mail world wide, add 65p for air mail. Simon has written this based on his own wealth of experience in the DXTV field with a view to putting the newcomer on the right track and to encourage the reader to take up this fascinating hobby. On the subject of booklets, HS publications are also responsible for *Teleradio News*, a bi-monthly journal mainly for the television DX enthusiast at a cost of £6 including surface mail for 6 issues, or £8.50 via airmail. The current edition, No. 13, is the journal's first birthday issue and among the items are Technical Topics by Dave Lauder BSc, of the Long Distance Television Reception Group, a summary of subscribers logs and pictures compiled by the UK editor, Garry Smith, a variety of news items, ITV Test Cards by Tim Anderson and TV DX in The Lebanon, all of which I found enjoyable and informative reading.

As soon as the atmospheric pressure went high between October 6 and 15, see Fig. 4 VHF Bands, conditions for Band III and u.h.f. improved with several, short life, tropospheric openings. At 1445 on the 9th, I received a weak picture on Ch. E10, possibly from Belgium, co-channel interference, severe at times, in the u.h.f. band during the evenings of the 13th and 15th, strong signals from France around Ch. E5 and a test card from Belgium BRT TV2 on Ch. E10 at 1316 on the 15th. Later in the evening I saw part of a Sherlock Holmes film from RTE in good colour. Harold Brodribb received a very clear test card scribed RTBF-1 Leglise Canal 11, at 0750, programme details from Germany's ARD on Ch. E8 at 0825, a faint picture on Ch. E10 at 0905 and RTE news followed by football results from Eire at 1710 on the 14th.

## SATELLITES

Reports to Pat Gowen G3IOR, 17 Heath Crescent, Hellesdon, Norwich, Norfolk NR8 6XD.

The decline of the sunspot cycle, with a number of serialised days showing a zero count over the past two months, with worse to come for the h.f. DX seeker in the next two years before the cycle ascends again to the 1990-1991 maximum, has moved numbers of DX seekers to utilising the OSCAR 10 satellite.

Although virtually immune from the vagaries of ionospheric propagation, even satellites are effected to some degree. The recent aurorae have given spells of reverse polarisation circularity, high noise and noticeable attenuation to the downlink signal. Periods of high m.u.f. (maximum useable frequency), par-



by Pat Gowen G3IOR



# ON THE AIR

ticularly "E" ionisation, can produce both extension of normal horizon, and yet screen the downlink when the satellite is at low angles above the horizon. Good tropospheric openings also give problems, with high noise ducting into the receiver, and rapid rates of fading on the signals. Several observers have noted that at times a totally different elevation angle of uplink and downlink antenna is required in order to overcome the difference between the 435MHz uplink and 145MHz downlink beams!

Despite these few problems, which are more of propagational interest than of detraction, it can be safely said that at this time of solar poverty, OSCAR 10 is the best and most reliable DX band of all.

Already ON7HP, K5ADQ and I have "OSCAR 10 DXCC", from the 110 countries now known to be active. Some quite rare callsign prefixes are regularly active on the satellite, Table 1 lists some worth listening for.

The OSCAR 10 satellite is now out of eclipse, and able to operate on an improved schedule, being only off from a mean anomaly of 219 to 234 each day, and going to Mode "L" (1269MHz up, 436MHz down) weekdays between m.a. 100 to 116 (one hour).

"RS-6" ceased its active life in the third week of September 1984, after having completed 12175 orbits and 19778 hours of transponder operation. RS-5 will replace it as a transponder, intermitting with Robot and codestore message use. No degradation is apparent with the RS5, 7 or 8 satellites, as is the case with OSCAR 9, which has completed three years of service.

Table 1

Station	Usual frequency (MHz)	Mode	Notes
A71AD	145-920	s.s.b.	Mike, only station in Qatar
C30LAI	145-932	s.s.b.	Andorra DX-pedition
WB5LJB/DU6	145-918	s.s.b.	a W6/DU6 also active
EA8CS	145-868	c.w.	EA8AAE also active on s.s.b.
FK8CR	145-910	s.s.b.	FK1BG, FK1RF and FKOAM also on
F08FB	145-935	s.s.b.	new station from French Polynesia
FR7DA	145-917	s.s.b.	Robert, Reunion Island. FR1AC also on
FY7AZ	145-929	s.s.b.	French Guiana, home of OSCAR 10
H44PT	145-920	s.s.b.	Peter on Guadalcanal, Solomon Is.
HC1FG	145-940	s.s.b.	first station on O-10 from Ecuador
HL1EJ	145-875	c.w.	also QRV s.s.b., as is HL3UJ
HZ1AB	145-905	s.s.b.	W operators in Saudi Arabia
JY9CF	145-932	s.s.b.	Colin, Amman. JY9ZZ also on, JY1 soon
KG6DX	145-928	s.s.b.	on Guam (some KG6's are in California)
KL7M	145-936	s.s.b.	some four Alaskan stations now active
KV4AD	145-909	s.s.b.	Bert, St. Thomas, also QRV c.w.
NP4GD	145-866	c.w.	Ed from Puerto Rico
P29ZFS	145-921	s.s.b.	only station from Papua New Guinea
PZ1AC	145-856	c.w.	only operator from Suriname
SV7RV	145-902	s.s.b.	believed to be on Rhodes
TI2NA	145-957	s.s.b.	only one from Costa Rica
TR8BL	145-949	s.s.b.	Luciano, good signal, but RX down
TU2IE	145-940	s.s.b.	TU2IT also now on from Ivory Coast
TZ5FE	145-907	s.s.b.	only one on satellite from Mali
VS6HI	145-919	s.s.b.	VS6HH and XMT also regularly active
VK9ZW	145-901	s.s.b.	the very rare Willis Is.
YB0AQT	145-915	s.s.b.	YB3ARL and others also on
YJ8RW	145-930	s.s.b.	Bob on New Hebrides
ZD8LM	145-956	s.s.b.	Lee, very active from Ascension Is.
ZK2RS	145-944	s.s.b.	only station on from Nuie Is.
ZR3AL	145-915	s.s.b.	ZS3B also very often operational
Z22JW	145-920	s.s.b.	Z25JJ now in ZS5
3D2JS	145-945	s.s.b.	Fiji, very difficult from G
9M2CR	145-924	s.s.b.	Colin very active, 9M2PW also

In addition there is considerable activity from VK, JA, W and many European countries.

## AMSAT-UK

Mr R. Broadbent G3AAJ,  
Hon. Sec. AMSAT-UK.  
94 Herongate Road,  
Wanstead Park,  
London,  
E12 5EQ

## UOSAT

University of Surrey  
Dept. of Electronic &  
Electrical Eng.  
Guildford,  
Surrey,  
GU2 5XH

## Information

Updated information on the University of Surrey Satellites may be obtained by telephoning Guildford (0483) 61707 for OSCAR 9 details, and (0483) 61202 for OSCAR 11 content.

Satellite	OSCAR 9	OSCAR 10	OSCAR 11	RS 5	RS 7	RS 8
Epoch Time	84273.37377839	84277.06052018	84265.21359828	84270.16226739	84275.14840318	84271.02350192
Inclination	97.6040°	25.7678°	98.2318°	82.9532°	82.9545°	82.9545°
RAAN	249.6657°	175.2081°	327.0799°	88.4127°	81.7359°	90.0971°
Eccentricity	0.0004284	0.6053937	0.00113527	0.0009736	0.0021848	0.0019055
Arg. of Perigee	101.7517°	311.3032°	351.4789°	254.2730°	169.3424°	307.1710°
Mean Anomaly	258.4210°	10.5933°	8.6131°	105.7276°	190.8136°	52.7595°
Mean Motion (r.p.d.)	15.26432330	2.05844218	14.61903966	12.05054867	12.08686423	12.02947950
Decay Rate (r/d <sup>2</sup> )	2.403e-5	-1.2e-06	1.08e-06	4e-08	4e-08	4e-08
Epoch Rev	16543	983	2973	12210	12307	12199
SMA (km)	6861.590	26106.554	7062.246	8033.833	8017.723	8043.217
Anom. Period (min)	94.337625	699.558148	98.501682	119.496634	110.13760	119.705927
Apogee (km)	506.524	35535.433	694.114	1683.026	1657.816	1693.773
Perigee (km)	500.645	3925.946	675.008	1667.382	1622.781	1663.120
Beacon (MHz)	145.825	145.810	145.826	29.451	29.501	29.502

The above table gives all the elements required for computers and calculators for tracking all running amateur satellites, and will provide accurate tracking for a three month period.





by Ron Ham BRS15744

For many decades, electro-mechanical teleprinters were used for the transfer of the printed word between two points by both wired and wireless systems. No doubt some of these majestic machines, used by the Armed forces, Government departments, Industry, News agencies, the Post Office and the Press, are still in use, others are in museums and possibly the bulk have been replaced with computers.

Briefly, in the late 1950s a number of radio amateurs purchased such machines when they became available on the surplus market and began exchanging RTTY signals on the amateur bands, I believe the first in the UK was in September 1959 between Arthur Gee G2UK and Bill Brennan G3CQE on 3.6MHz. Later in the year, Bill made the first G/VE QSO with Jim Hepburn VE7KX. The British Amateur Radio Teleprinter Group, who celebrated its Silver Jubilee in June 1984, was granted affiliation to the RSGB in 1961 and now has more than 2000 members and a fine quarterly journal called *DATAKOM*. Throughout the years, BARTG have kept in touch with their members and kept up with the latest state of the art, a policy which is still encouraging more and more radio enthusiasts, especially s.w.l.s, to add RTTY to their stations. It is much easier today, with the special programmes for micro-computers and dedicated terminal units readily available, to get started with RTTY than it was when BARTG was formed. For some time now I have included this fascinating subject in my VHF column but the time has come for a progressive journal like *PW* to have a separate page for the teleprinter enthusiast, so, here we are lads and lasses, from this issue on, let's make a go of it.

## Contests

With their good record of being twice runners up and once third in the BARTG v.h.f. contests, members of the Worthing and District Amateur Radio Club went to their usual site on Chanctonbury Ring, a

high spot on the Sussex downs, to take part in the Autumn VHF Contest during the weekend of October 13 and 14. Their station G3WOR/P, using Trio TR-9000, Microwave Modules 100W linear, two 16-element Tonna antennas on a 12m high mast and a modified ATS Vitel terminal unit, mainly loaned by Doug Love G8BBI, was operated by Jim Alderman G4JBA, Keith Leggett G4JKZ and Len Wooller G8GEZ, made just over 100 QSOs, thirty more than their previous best. Doug told me afterwards that they were all pleased with their efforts especially as they had stations from Belgium, France, Eastern Germany, Guernsey, Holland, Wales and northern G in their log.

## Station Reports

Among the DX stations logged by **Peter Lincoln** BRS42979, Aldershot, during the month prior to October 14, were AL7DR, EL2AT, TR8DX and 9M2DW along with some from South America including a Brazilian using a ZY2 prefix and a few from Japan at reasonable strengths. Recently, Peter received a QSL card from YO8FR in reply to his RTTY report and now has this station confirmed on both RTTY and SSTV. "Quite a few amateurs operate in both modes", says Peter, who also has 5B4CV confirmed and is awaiting a reply from a KP4.

In Rhayader, **Bert Mills** GW3LJP, plans to have RTTY equipment on the air by the new year, using a Commodore VIC 20 computer with extended memory and will be exchanging test signals with Bill Cook GW1IVS, Nantgwyn, on 144MHz and Bill will listen out for Bert's h.f. transmissions. Both are active members of the North Powys RAYNET Group and often are the liaison link with the South Powys Group.

Between September 16 and October 15, I copied 26 call areas, CN, CT, EA, EL, DL, I, IT9, HA, OE, OD, OH, OK, PA, PY, SM, SP, UB, VE, VK, Ws 0, 1 and 2, YO, YU, Y2 and 8R around

14.090MHz and only 2, CE and LA, around 21.090MHz. Among the DX was VK5CW at 0820 on the 19th and a first for me, 8R1RBF, Guyana, around 1320 on the 13th. **Norman Jennings**, Rye, once remarked about the large number of Italians using RTTY, so I analysed my log and found from the 80 plus stations I copied during the period, 23 were Italians followed by 8 from the USSR and 6 each from Finland and Poland. I use a Trio 2000 receiver with a long wire antenna and a Tono Theta 550 communications terminal and the frequencies of 14.090 and 21.090MHz are at my finger tips in the Trio's memory. Also in the memory is the frequency of the RSGB's 144MHz beacon at Wrotham and at the end of its three callsign sequence it sends a short bit of RTTY, "RY RY RY GB3VHF WROTHAM KENT (AL52J) 51 19 10N, 00 17 20E", a useful signal to play with.

## Dedicated Books

Among the interesting articles in the Autumn issue of *DATAKOM* is one for beginners by the editor Ian Wade G3NRW, entitled Tuning in RTTY Signals, which really gets to the heart of the subject. For further reading, there is Chapter 10 in Volume 1 of the RSGB's *Radio Communication Handbook*, 5th Edition, and our own publication, *Introducing RTTY*. Another source of information is the BARTG news, transmitted on the first and third Sundays of each month, under the callsign GB2ATG, on 14.090MHz at 0730, to VK and ZL, 1530, 75 deg to the far east and 1900GMT, 300 deg NW to the USA.

## CLUB NEWS

▶▶▶ continued from page 60

No meetings on the 25th or New Year's Day. **Worcester & District ARC D. W. Batchelor G4RBD** on W'cester 641733. Meetings rotate around the Odd Fellows Club in New Street, W'cester and the Old Pheasant also in New Street. There is a skittles and social evening on Monday December 17 at the Old Pheasant.

Remember that *Practical Wireless* is

published about the first Friday of the month with a cover date for the following month. The table gives deadlines for future issues.

May I wish all club secretaries, PROs and all those who have written in to Club Time during the past year a Very Happy Christmas and keep the copy coming during the New Year which I trust will be prosperous for all.

Cover Date	Deadline	For events from early:
March	December 15	February
April	January 15	March
May	February 15	April
June	March 15	May



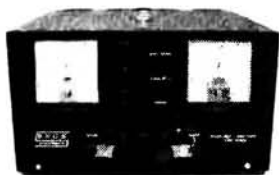


# B.N.O.S.



## THE POWER SUPPLIERS Maximise your signal...

### POWER SUPPLIES



Reliable and Rugged Design that enables you to obtain the maximum performance from your system

#### "A" series power supplies

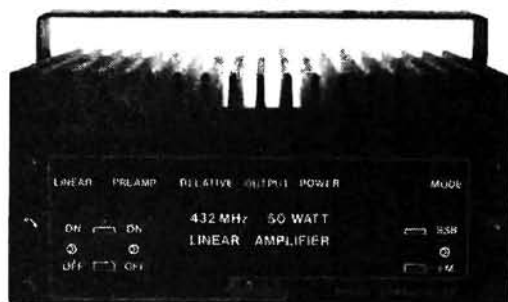
- Continuous rated output
- Over voltage crow bar
- Over current protection
- Fully R.F. protected
- Large current meters

12/6A 13.8V. 6 A CONTINUOUS a/p £52.90  
 12/12A 13.8V. 12 A CONTINUOUS a/p £95.45  
 12/25A 13.8V. 25 A CONTINUOUS a/p £138.00  
 12/40A 13.8V. 40 A CONTINUOUS a/p £276.00



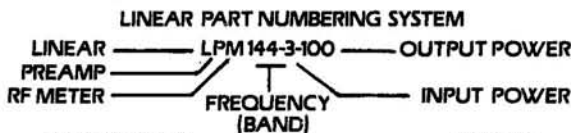
- ALL PRICES INCLUDE V.A.T.
- AVAILABLE DIRECT FROM MANY U.K. AGENTS AND AT MOST RALLIES AND EXHIBITIONS

### LINEARS



#### 70cm LINEARS

If Performance, Reliability and a Product that gives you total control and maximum Flexibility is important to you, then our range of 70cm 50W Amplifiers are what you have been waiting for.



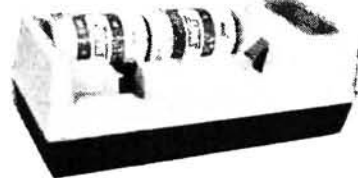
LPM 432-1-50 .....£184.00  
 LPM 432-3-50 .....£184.00  
 LPM 432-10-50 .....£155.25

#### 2 METRE LINEARS

Performance and Reliability is Designed in so that they always give you 100%

L144-1-100 .....£143.75  
 LPM 144-1-100 .....£172.50  
 L144-3-100 .....£143.75  
 LPM 144-3-100 .....£172.50  
 L144-10-100 .....£120.75  
 LPM 144-10-100 .....£149.50  
 L144-25-160 .....£178.25  
 LPM 144-25-160 .....£207.00  
 L144-3-180 .....£207.00  
 LPM 144-3-180 .....£235.75  
 L144-10-180 .....£207.00  
 LPM 144-10-180 .....£235.75

### NICADS & CHARGERS



#### NICADS

Format	Cap. (AH)	Height (mm)	Diam. (mm)	Prices	1-9	10-24	25-99
AAA	0.18	45.0	10.51	1.47	1.39	1.32	
1/2AA*	0.10	17.4	14.7	1.38	1.31	1.24	
1/4AA*	0.225	25.0	14.7	1.04	0.99	0.94	
AA	0.50	49.5	14.7	1.08	1.02	0.96	
AA*	0.50	49.5	14.7	1.14	1.08	1.02	
NEW AA (SUPER)	0.60	49.5	14.7	1.18	1.12	1.08	
1/2A*	0.45	28.0	17.2	1.18	1.12	1.08	
RR*	1.20	42.1	22.6	1.86	1.76	1.66	
C	2.20	49.7	25.9	2.85	2.70	2.56	
D (SUB)	1.20	60.5	33.5	2.85	2.70	2.56	
D	4.00	60.5	33.5	5.06	4.80	4.56	
D*	4.00	60.5	33.5	5.10	4.84	4.60	
F*	7.00	94.0	33.5	7.36	6.98	6.62	
SP*	10.00	91.3	41.7	POA	POA	POA	
PP3	0.11	49x26.5x17.5		4.52	4.29	4.07	
PP9	1.2	81x52x66		POA	POA	POA	

\* DENOTES SOLDER TAGS FITTED

AC1 SAFT MAZDA AA CHARGER, CHARGES 1 to 4 AA CELLS — £5.75

PC3 SAFT MAZDA PP3 CHARGER, CHARGES 1 or 2 PP3 CELLS — £5.75

MC4 JACKSON MULTICHARGER, CHARGES 2 or 4 AA, C or D CELLS £7.00

MC6 SAFT MAZDA MULTICHARGER, CHARGES 1 to 4 AA, C or D CELLS, or 1 or 2 PP3 CELLS £8.75

- POSTAGE FREE ON ALL MAINLAND UK ORDERS OVER £5
- THOSE UNDER PLEASE ADD 60p

- SECURICOR DELIVERY AVAILABLE ON ALL ITEMS - £2.50 PER ORDER.



B.N.O.S. Electronics (Dept RC) Ltd.  
 Bigods Hall Great Dunmow  
 Essex CM6 3BE Tel: (0371) 4677





# Manufacturers of Aerial Components

THE ORIGINAL NAME IN AERIAL EQUIPMENT FOR OVER 20 YEARS.

CURRENTLY MARKETING A FULL RANGE OF PRODUCTS FOR AERIAL MANUFACTURERS AND RIGGERS.

CHIMNEY AND WALL BRACKETS (HOT DIP GALV OR PAINTED), MAST CLAMPS, LARGE & SMALL, GARDEN MAST EQUIPMENT, EQUIPMENT FOR ALL TYPES OF AERIALS.

INSIST ON GENUINE SHELLEY COMPONENTS FROM YOUR LOCAL STOCKIST OR PHONE US DIRECT FOR YOUR FREE CATALOGUE

113 Worcester Road, Hagley, Near Stourbridge, West Midlands DY9 0NG.

Telephone: Hagley 885905 (3 lines) Telex: 336300

Telephone: (0376) 271 17 (24-Hour Ansaphone Service) (0376) 42494

Telex 987911



Hay Lane Braintree Essex CM7 6ST



NEW VALVES National, Varian, Mullard, RCA, ITT				R. F. TRANSISTORS Many other types available															
DA42	17.50	EL803S	9.95	8AU5GT	4.50	8GF5	2.10	2N3375	11.30	2SC1209D	0.64	2SC2283	9.00	MRF475	4.40	SD1077	1.60	SD1220-1	9.50
EB0CC	14.00	EL821	9.95	8AU8A	1.60	8GH8A	3.00	2N3553	2.00	2SC1213A	0.40	2SC2287	11.00	MRF476	2.20	SD1078	28.50	SD1222-STUD	11.00
EB0FL	13.10	EM84	2.00	8AV6	2.55	8GJ5A	1.80	2N3632	12.50	2SC1213C	0.20	2SC2289	12.50	MRF477	12.50	SD1080	1.55	SD1224-STUD	13.00
EB1CC	12.95	EN32	1.25	8AV8A	2.65	8GJ7	1.65	2N3733	14.25	2SC1222	0.50	MRF492	27.50	SD1080-F	7.50	SD1228-F1	10.95		
EB2CC	3.20	EN91	0.80	8AZ6	3.80	8GK6	1.95	2N3866	1.20	2SC1241	15.00	2SC2347	0.30	MRF497	18.50	SD1080-F	7.50	SD1228-F1	10.95
EB3CC	3.90	EN92	3.30	8BA6	1.60	8GV8	3.90	2N3926	11.26	2SC1251	10.00	2SC2369	2.00	MRF515	2.80	SD1088	26.00	SD1228-STUD	10.95
EB9F	9.25	EZ35	1.85	8BA8A	2.75	8GV6	3.00	2N3927	11.82	2SC1260	1.11	2SC2370A	18.00	MRF517	3.50	SD1088	28.50	SD1244-B	12.75
EB9GC	8.50	EZ41	2.45	8BE6	1.90	8GV6	3.00	2N4416	0.75	2SC1303	8.00	2SC2379	15.00	MRF520	18.00	SD1088	40.10	SD1256	6.95
EB9ZC	6.50	EZ80	1.95	8BH6	2.00	8H6	3.00	2N4427	1.20	2SC1306	1.00	2SC2395	15.00	MRF544	25.70	SD1115-2	7.50	SD1262	15.00
E130L	23.50	EZ81	1.85	8BU6	1.85	8HA6	3.05	2N5090	13.90	2SC1307	1.50	2SC2407	1.00	MRF546	26.10	SD1115-7	2.10	SD1270	3.75
E180F	8.50	EZ90	2.00	8BK4C	4.15	8H96	3.05	2N5100	2.25	2SC1311	0.40	2SC2420	18.00	MRF548	30.85	SD1127	2.50	SD1272	10.85
E180CC	7.50	PCL805	1.85	8BL6	68.50	8H65	4.00	2N5160	4.80	2SC1311E	0.33	2SC2494	16.00	MRF750	6.50	SD1131	3.25	SD1272-2	10.95
ES070	27.50	PL509	5.50	8BL7GTA	3.80	8H75	3.85	2N5190	1.50	2SC1314	25.00	2SC2509	8.00	MRF848	48.00	SD1133	9.50	SD1278	13.75
EBB1	1.95	PL519	5.75	8BL8	1.45	8H05	1.95	2N5589	6.00	2SC1318	0.40	2SC2531	1.30	MRF901	2.75	SD1133-1	10.00	SD1278-1	13.75
EBB31	1.30	QOV02-6	19.50	8BM6	93.85	8H08	2.60	2N5590	8.50	2SC1368B	1.00	2SC2538	1.10	MRF904	2.95	SD1134-1	2.50	SD1285	12.75
EBF89	1.80	QOV03-10	9.50	8BM8	3.95	8H08	3.95	2N5591	8.00	2SC1368B	0.50	2SC2539	15.00	MRF911	43.00	SD1135-1	10.25	SD1317	8.00
EC90	1.85	QOV07-50	12.00	8BN8	3.75	8H26	2.75	2N5643	13.00	2SC1424	1.35	2SC2540	24.95	MRF915	2.90	SD1134-B	10.00	SD1303	2.50
ECC32	2.50	QV03-12	4.50	8B05	2.95	8J5	3.15	2N5913	2.50	2SC1509	6.00	2SC2545E	0.29	MRF916	30.00	SD1134-STUD	7.10	SD1318	2.10
ECC40	12.12	4CX2908	(EIM/AMF)	8BR8A	2.95	8J5GT	2.95	2N5945	15.63	2SC1520	0.45	MRF920	0.45	MRF920	12.00	MRFB004	2.00	SD1135-3	12.00
EC70	3.70		49.00	8BK6	2.75	8J8	2.20	2N5948	15.63	2SC1588	0.45	MRF212	12.00	MRFB004	30.00	SD1138	7.20	SD1405	2.10
ECC81	1.60	4CX2808 (NAT)	39.50	8BZ6	2.50	8JA8	3.00	2N6080	6.00	2SC1589	5.00	MRF221	12.05	SD1005	8.20	SD1136	11.70	SD1407	27.50
ECC82	1.60	4CX350A (EIM)	70.00	8C4	1.85	8JB8	4.00	2N6081	8.75	2SC1622	0.33	MRF229	3.50	SD1005	2.10	SD1143	9.45	SD1407MP	55.00
ECC83	1.60	4CX350A (AMP)	88.00	8CA4	1.65	8JB8A	4.20	2N6082	9.00	2SC1623	0.30	MRF231	12.38	SD1012-3	10.00	SD1143-1	10.00	SD1410	21.05
ECC85	2.20	4CX350F	72.00	8CA7	3.50	8JC6A	3.50	2N6083	12.00	2SC1688	19.00	MRF232	13.50	SD1012-4	10.90	SD1144-1	2.50	SD1410-1	21.00
ECC89	2.00	4CX1800A	440.00	8CB8A	1.90	8J6BC	4.95	2N6084	13.20	2SC1674	0.28	MRF233	14.30	SD1013	10.00	SD1144-1	7.95	SD1410-3	21.00
ECC91	3.00	4CX1800B	370.00	8CFB	1.90	8J6BA	3.85	2N6084	8.00	2SC1675	0.20	MRF234	15.00	SD1014-6	10.80	SD1201	7.35	SD1412	36.00
ECC189	2.10	4CX1000D	785.00	8C37	2.25	8JH8	2.25	2N6085	6.50	2SC1678	1.25	MRF237	3.10	SD1015	17.50	SD1202	7.50	SD1412-3	24.00
ECF80	2.20	4D21	3.70	8CH6	9.95	8JX8	2.20	2N6255	3.45	2SC1729	18.00	MRF238	12.80	SD1018-B	13.00	SD1212-4	6.00	SD1413	18.00
ECF86	2.50	4D32	84.75	8CJ3	3.20	8JM8	3.95	2SC730	2.70	2SC1730	0.25	MRF239	20.00	SD1019	23.10	SD1212-7	4.00	SD1414	36.00
ECF801	1.65	4PFB0C	250.00	8CJ6	10.95	8K5C	3.95	2SC731	17.00	2SC1740D	0.20	MRF240	24.50	SD1019B	23.50	SD1214	8.70	SD1415	30.00
ECH81	2.50	4X150A	42.50	8CK6	11.50	8K6GT	2.75	2SC732	0.25	2SC1765	4.75	MRF243	35.00	SD1022	1.50	SD1216	11.00	SD1416	30.00
ECL82	3.50	5500A	225.00	8CL6	3.30	12AT6	1.70	2SC741	2.50	2SC1815Y	0.28	MRF245	30.00	SD1074	16.10	SD1219-1	18.00	SD1421	38.00
ECL83	2.50	5AR4	3.50	8CM5	2.30	12AT7	1.60	2SC821	6.60	2SC1906	0.33	MRF247	30.10	SD1078	18.50	SD1219-4	18.00	SD1426	24.00
ECL86	3.90	5AS4A	3.50	8CH6	2.45	12AU6	3.95	2SC828B	3.70	2SC1907	0.45	MRF289	15.00	SD1078	18.50	SD1219-1	18.00	SD1428	24.00
EF40	8.50	5B254M	24.00	8CQ6	2.20	12AU7A	1.60	2SC829B	0.25	2SC1945	2.81	MRF264	11.00						
EF90	2.75	5C22	128.00	8CW4	6.50	12AV6	2.00	2SC890	8.50	2SC1948	19.75	MRF309	42.00						
EF95	4.70	5CX1800A	535.00	8CV5	2.90	12AX7	1.80	2SC891	16.00	2SC1948A	16.50	MRF316	73.00						
EF96	2.60	5D22	78.00	8CV5	3.80	12AX7WA	4.80	2SC892	0.87	2SC1947	9.88	MRF317	17.50						
EF99	2.30	5R4	8.00	8CY7	2.90	12BE4A	2.90	2SC900F	0.87	2SC1955	7.20	MRF321	35.00						
EF91	2.95	5R4QV4/B	3.75	8CZ5	3.15	12BA6	2.00	2SC998	4.17	2SC1966	11.00	MRF323	35.00						
EF92	2.20	5R4W0B	17.90	8DA7	2.30	12BE4T	3.00	2SC991A	18.00	2SC1967	15.00	MRF325	63.00						
EF93	1.60	5R6	8.00	8DC6	2.46	12BE6	0.945	2SC995	0.21	2SC1968	17.50	MRF327	70.00						
EF94	1.80	5U4GB	2.50	8DC8	1.50	12BM7A	2.50	2SC945F	0.21	2SC1988A	22.00	MRF329	58.08						
EF95	2.70	5UJ1	40.00	8DJ8	1.00	12BY7A	2.85	2SC952	0.60	2SC1989	3.00	MRF342	19.50						
EF183	2.75	5V4GA	2.75	8DK6	3.95	12BZ6	3.70	2SC982	3.70	2SC1970	0.45	MRF421	38.85						
EF184	2.00	5Z4GT	1.90	8DT5	2.30	805	42.00	2SC994	2.50	2SC1971	4.00	MRF422	42.00						
EF1200	2.95	8AH6	3.50	8DW4B	2.30	807	2.90	2SC998	3.90	2SC1972	11.00	MRF426	23.00						
EK90	1.10	8A8	2.50	8E5	4.20	810	50.00	2SC1001	9.90	2SC1978	7.75	MRF427A	21.00						
EL34	3.50	8ALW	1.90	8EL4A	2.45	811A	14.90	2SC1011	5.36	2SC2001	1.60	MRF428	67.00						
EL38	2.30	8AK5W	2.90	8EH5	1.65	812A	19.90	2SC1070	1.15	2SC2026	0.75	MRF428A	75.00						
EL38	4.95	8AK6	1.95	8EH7	2.75	813 (NAT)	28.50	2SC1096L	0.90	2SC2053	0.80	MRF433	16.21						
EL81	10.95	8AL5	1.95	8EJ7	2.00	813 (RCA)	85.00	2SC1096M	0.90	2SC2097	36.00	MRF449A	18.25						
EL82	7.85	8AL5W	1.90	8EJ4A	1.70	814	17.20	2SC1117	1.20	2SC2111	15.00	MRF450	11.90						
EL84	2.95	8AM6	2.90	8E8B	2.10	8133A	61.50	2SC1120	12.50	2SC2100	14.00	MRF453	14.00						
EL85	2.80	8AM6	9.15	8EJ7	2.85	843	10.00	2SC1121	24.00	2SC2103	28.00	MRF453A	14.00						
EL91	9.10	8ANBA	1.70	8EJ6	3.00	843A	48.30	2SC1122	18.00	2SC2105	15.00	MRF456	21.00						
EL90	7.85	8A05A	2.95	8F06	2.00	857B	708.00	2SC1182B	0.90	2SC2109	1.60	MRF454A	24.00						
EL500	2.80	8A05W	1.90	8FH6	16.50	866A	15.50	2SC1185	8.95	2SC2118	9.00	MRF455	18.00						
EL503	39.00	8A08	2.20	8F07	2.25	866	24.00	2SC1189	4.85	2SC2221	5.50	MRF455A	21.00						
EL508	6.50	8A08	12.00	8F55	2.25	873A	18.00	2SC1176	14.00	2SC2233	0.90	MRF456	18.95						
EL519	8.75	8A56	5.50	8GB5	2.80	922	12.50	2SC1177	8.43	2SC2237	10.00	MRF460	24.00						
EL803	9.95	8AS7G	7.20	8GE5	2.90	927	17.80	2SC1178	18.00	2SC2261	17.00	MRF472	4.40						

ALSO AVAILABLE:

A replacement guide to dozens of Motorola Transistor part numbers. Stocks of original RF Devices from such manufacturers as: MOTOROLA, RCA, GE, TRW, MSC, ACRIAN, TOSHIBA, FUJITSU, NEC, MITSUBUSHI, PHILIPS, AMPEREX and other



# WATERS & STANTON ELECTRONICS

18/20 MAIN ROAD, HOCKLEY, ESSEX. Tel: (0702) 206835  
12 NORTH STREET, HORNCHURCH, ESSEX. Tel: (040 24) 44765

## UNBEATABLE PRICE

**M750XX SSB-CW-FM**  
144 - 148MHz  
20 watts output. Digital display.  
Dual VFO. Repeater operation.  
Noise blanker. 70cms option.  
Up/Down mic. R/T.



**OUR PRICE £349!**

Send for leaflet.

Absolutely complete

## SPECIAL OFFER!

Padded communication headphones fitted 1/2" jack plug - post free **£5.95**

### TRIO

TS930S HF tcvr.	£1250.00
AT930 ATU	£157.00
SP930 Speaker	£85.84
TS430S HF tcvr	£733.00
PS430 AC pau	£135.00
SP430 Speaker	£32.40
AT250 ATU	£290.00
MB430 Mobile Unit	£12.55
FM430 FM mod.	£37.00
TS830S HF tcvr.	£793.00
VFO230 VFO	£270.00
AT230 ATU	£150.00
SP230 Speaker	£45.45
TS530SP HF tcvr.	£898.00
VFO240 VFO	£95.00
TS130S HF tcvr.	£598.00
TL120 200w 1ln.	£185.00
MB100A Mobile mount	£19.50
SP120 Speaker	£29.20
SP40 speaker	£15.80
AT130 ATU	£103.00
PS20 PSU	£57.75
TL922 2kw	£1821.00
TS780 2m/70cm	£334.00
TR9130 2m tcvr.	£479.00
BO5A base	£51.70
TH21E 2M Micro.	£179.00
TW4000A 2m/70cm	£510.00
TR2500 2m h/held	£257.00
VB2530 30w amp.	£77.00
ST2 charger	£57.00
SC4 Case	£15.00
MS1	£25.00
SMC25 Speaker/Mic.	£17.70
PB25 nicad	£27.70
LH2 case	£26.60
BT1 AA case	£6.25
DC25 12v	£17.75
TR3500 70cm h/held	£277.00
TM401A 70cm	£325.00
TM201A 2m	£295.00
SP50 speaker	£15.67
R600 Rx.	£285.00
R2000 Rx.	£456.00
VC10 VHF conv.	£122.00
MC50 mic.	£34.50
MC80/S6 mic.	£56.00
MC80 mic.	£40.75
MC42S mic.	£16.70
MC55 Mobile Mic.	£41.75
LF30A LFP	£23.50
HC10 Clock	£75.00
DM81 GDO	£78.90

### YAESU

FT1 HF Tx/Rx	£1908.00
FT980 HF Tx/Rx	£1282.00
SP980 Speaker	£56.10
FC102 ATU	£159.00
SP102 Speaker	£57.90
FM/AM	£49.85
FT77 HF Tx/Rx	£479.00
MRK777 marker	£10.85
FP700 PSU	£145.00
FC700 ATU	£105.00
MMB16 Mount	£14.95
FT757GX HF Tx/Rx	£758.00
FC757AT ATU	£249.00
FP757GX PSU	£140.00
FP757HD PSU	£179.00
FL2100Z amp	£549.00
FT290R 2m Tx/Rx	£309.00
FT790R 70cm Tx/Rx	£299.00
NC11 charger	£10.75
NC nicade	£22.00
CSC1A case	£4.80
YHA/5 Ant.	£5.75
MMB11 Mount	£28.75
FL2010 amp	£99.00
FT208 2m h/held	£209.00
FT708 70cm h/held	£189.00
NC9C charger	£9.60
FNB2 pack	£23.00
PA3 12v	£16.85
MMB10	£8.80
FT203R 2m h/held	£185.00
MH-12A2B mic.	£17.90
MMB21 bracket	£7.85
FT230R 2m 25w	£269.00
FT730R 70cms 10w	£239.00
FT726R 2m	£339.00
430/726	£270.00
144/726	£155.00
50/726	£200.00
SA7726	£100.00
FRG7700 Rx	£385.00
FRG7700M Rx	£455.00
MEMO	£75.00
FR77700	£48.30
FRA Ant.	£43.95
FF5 LFP	£10.75
FRV7700E	£94.25
YM24A mic.	£23.75
MH-1B8	£16.85
YD148A mic.	£26.45

## SECONDHAND BARGAINS

Cash or part exchange on all good clean gear.  
FOR QUOTATION  
TEL: (0702) 206835  
LOOKING FOR BARGAINS!  
Telephone or send for our used equipment list.  
3 months warranty.

### ICOM

IC751 HF Tx/Rx	£1239.00
ICPS35 PSU	£165.00
IC745 HF Tx/Rx	£898.00
IC730 HF Tx/Rx	£859.00
PS15 PSU	£135.00
ICR70 Rx	£599.00
ICR71 Rx	£699.00
FL45 filter	£45.00
FL63 filter	£46.00
IC2KL 1kw	£1450.00
IC271E 2m base	£599.00
IC271H 2m 100w	£899.00
ICPS25 PSU	£36.00
IC290D 2m 25w	£469.00
IC471E 70cm base	£799.00
IC490E 70cm	£329.00
ICO2 2m h/held	£259.00

### FDK

M725X 2m 25w	£239.00
M750XX 2m 20w	£349.00
EXP430 70cm Trtvr.	£289.00
Palmcomm II 2m h/held	£135.00
ATC720 AM Rx	£179.00
RX40 FM Rx	£142.00

### NEW ITEMS FOR WINTER

TRIO TH21E FM Micro Transceiver	£179
TRIO TH41E FM Micro Transceiver	£199
TRIO TM211E 2M FM Mobile	£377
TRIO TM411E 70cm FM Mobile	£431
TRIO TR2600 FM Handheld	£281
TRIO TR3600 70cm Handheld	£299
TRIO TS711E 2M Base Station	£792
TRIO TS811E 70cm Base Station	£898
YAESU FRG8800 Receiver	£525
YAESU FT209 Handheld	T.B.A.

BBC & ACORN COMPUTERS

### TONNA

20505 50mHz	£33.15
20104 144mHz	£14.95
20109 144mHz	£17.70
20209 144mHz	£20.00
20118 144mHz	£32.40
20113 144mHz	£31.00
20117 144mHz	£37.50
20419 430mHz	£20.70

### SPECIAL

**G5RV 5 BAND DIPOLES**  
80-10m. Overall length 102ft.  
with 32ft. of 300 ohm feeder.  
Ready built with insulators and SO239 connector provided.  
Simply connect to 50 ohm cable.  
£16.95 p&p £1.50

### STOP PRESS:-

Panasonic DRB600	£399
Sony IC7600	£179
Toshiba MSX Computers	£279

### WELZ DIAMOND GH22

**6-5dB**  
**144-146 MHz**  
No other aerial matches its performance and price  
**£32.50**  
Carriage £4.00.

### AR2001 £265



This popular receiver covers 25 to 550MHz with no gaps. Comprehensive scanning, channel spacing, and broad and narrow filters make this a number one choice. Send for leaflet.

### NEW STOCKS JUST ARRIVED! PANASONIC RF-3100 SYNTHESIZED RECEIVER



**£219 inc. VAT**

TRULY PORTABLE! 230v AC, 12v DC or int. batts.

- ★ 31 bands 150KHz - 30MHz.
  - ★ VHF FM 87.5 - 108MHz.
  - ★ SSB - CW - AM.
  - ★ RF gain control.
  - ★ Digital display + S-meter.
- Undoubtedly super value and ideal as a good basic gen. coverage receiver. Come and hear our demo model. SAE for leaflet.

## MAIL ORDER - SAME DAY DESPATCH

Carriage: Items under £10 - £1.00. Over £10 - £1.50. Larger aeriels £5. Securicor £6. Retail callers welcome. Mon-Sat 9-5.30pm. E.C. Wed. 1pm.

## QUARTZ CRYSTALS

**STOCK CRYSTALS**  
Crystals for 2 meters  
HC25 £2.15 for one crystal, £1.96 when 2 or more purchased. HC6 £2.15 for one crystal, £2.05 when 2 or more purchased.  
**TX CRYSTALS** HC6/U 4 & 8MHz 30PF  
**RX CRYSTALS** 44 Mhz Series Res  
**CHANNELS IN STOCK** RO to R7, S11, S20 to S23  
HC25/U 12 Mhz 30 & 44 Mhz Series Res RO to R7, S8, to S23 40PF & S32  
HC25/U 18 Mhz 25 & 14/15 Mhz 20 & RO to R7, S8, to S23 20PF & S32  
HC25 Scanner XTLS RO to R7, S8, to S23 (Not SR9) & S32  
Full list available on request, please send SAE  
4 metre Crystals for 70.26 in HC6/U at £2.40 each.  
TX 8.78250, RX 29.78000  
70cm Crystals £5.00/pr or £2.50 each.  
For Pye PF1 PF2 & PF70 series Wood & Douglas and FDK Mult U11. Sub (433.2) SU20, RB0, RB2, RB4, RB6, RB10, RB11, RB13, RB14, RB15.  
Also for Multi U11 only. SU12, SU16, SU18.  
Converter Crystals in HC18/U at £2.85 each.  
22.000 38.666 70.000 96.000, 116.000, 101.500 116.000.

Frequency Standards £2.75 each.  
HC6/U 200kHz, 1000kHz, 3.50MHz, 5.00MHz, 10.000MHz, 10.700MHz, HC18/U 100kHz, 7.000MHz, 10.700MHz, 48.000MHz, 100.000MHz. Also HC6/U 200kHz 455kHz £3.25 each.  
Toneburst, I.F. & MPU Crystals in HC18 £2.25 each.  
7.168MHz (For 1750 Hz Tone), 10.245 (For 10.71 F.), 3.2768, 5.0688, 14.3180 15.0000  
YAESU Crystals for FT101's, FT901 & etc. £4.00 each. Many available ex stock. (A list is available on request, please send SAE).

FUNDAMENTALS FREQUENCY RANGE	PRICE	OVERTONES FREQUENCY RANGE	PRICE
5 to 50 kHz	£21.00	3rd OVT 21 to 65 MHz	£4.55
50 to 150 kHz	£11.00	5th OVT 60 to 170 MHz	£5.10
150 to 500 kHz	£7.80	5th OVT 110 to 125 MHz	£7.40
160 to 999 kHz	£11.90	7th OVT 125 to 175 MHz	£10.00
1 to 1.5 MHz	£10.75		
1.5 to 2 MHz	£5.10		
2 to 6 MHz	£4.75		
6 to 21 MHz	£4.55	2 to 175 MHz 2 to 3 weeks	
21 to 25 MHz	£8.50	5 to 999.9 kHz 6 to 8 weeks	
25 to 30 MHz	£8.50	1 to 1.499 MHz 3 to 4 weeks	

MADE TO ORDER CRYSTALS

Unless otherwise requested fundamentals will be supplied for 30pf load capacitance and overtones for series resonant operation.  
HOLDERS. PLEASE SPECIFY WHEN ORDERING—else HC25/U supplied for XTLS above 3MHz HC13/U 6-200kHz, HC6/U & HC33/U 170kHz-175MHz, HC18/U & HC25/U 2-175MHz.  
DISCOUNTS: Price on application for 10+ units to same frequency/spec. or bulk purchases of mixed frequencies. We supply FREE xtals for use in U.K. repeaters.  
COMMERCIAL CRYSTALS. Available on fast delivery and at competitive prices. Please send for list stating interests.  
EMERGENCY SERVICE: For XTALS 1 to 125MHz. Add the surcharge for each XTAL. Days refer to working days 4 days + £12, 6 days + £7, 8 days + £7, 8 days + £5, 13 days + £3.  
CRYSTAL SOCKETS HC25 £0.20 ea. HC6 £0.25 ea. Minimum Order Charge £1.50, unless ordered with crystals.  
TERMS. Cash with order post inc. U.K. & Ireland. Cheques & P.O.'s to QSL Ltd. A stamped addressed envelope with ALL enquiries please.



**QSL**  
MARKETING LTD

### ALL PRICES ARE EX VAT PLEASE ADD 15%

P.O. Box 19  
Erith Kent DA8 1LH

Telephone: 01-318 4419 24 Hr Answer: Erith (03224) 30830  
Telex: 8813271 GECOMSG (Attention QUARTSLAB)



# FREQUENCY COUNTERS

HIGH PERFORMANCE  
HIGH RELIABILITY  
LOW COST

EX-STOCK  
DELIVERY

The brand new Meteor series of 8-digit Frequency Counters offer the lowest cost professional performance available anywhere.

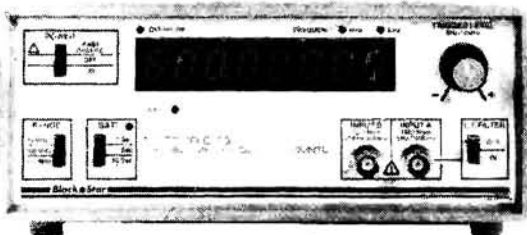
- ★ Measuring typically 2Hz – 1.2GHz
- ★ Sensitivity <50mV at 1GHz
- ★ Setability 0.5ppm
- ★ High Accuracy
- ★ 3 Gate Times
- ★ Low Pass Filter
- ★ Battery or Mains
- ★ Factory Calibrated
- ★ 1 Year Guarantee
- ★ 0.5" easy to read L.E.D. Display

PRICES (Inc. adaptor/charger, P & P and VAT)

METEOR 100	(100MHz)	£111.55
METEOR 600	(600MHz)	£141.45
METEOR 1000	(1GHz)	£192.05

**NOW AVAILABLE WITH  
T.C.X.O. OPTION**

Illustrated colour brochure  
with technical specification  
and prices available on request.



Designed and  
manufactured  
in Britain.

**Black★Star**

BLACK STAR LTD (DEPT. P.W.), 4 Stephenson Road, St. Ives,  
Huntingdon, Cambs. PE17 4EB, England.  
Tel: (0480) 62440 Telex: 32339

## HALBAR for quality aerials

All our aerials are supplied with mast clamps and have an impedance of 50 ohm.

### 2 METRE AERIALS

G5/2m – 5 element (transportable) £12.50 (a). G5XY – 5 element crossed £17.00 (a). G7/2m – 7 element £15.50 (b). G7XY – 7 element crossed £22.00 (c). G9/2m – 9 element £18.50 (c). G9XY – 9 element £28.00 (c). HB9CV – 2 element fold-up version £9.99 (a). QD – Double diamond SSB 12dBi aerial, tuning circle 22" £15.50 (d). QDX – The QD with the addition of two 3 element yagi booms increasing the gain to 14dBi £21.00 (d). VBS/2m – Colinear 5dBi N-socket fed £17.00 (a).

### 70cm AERIALS

5EL70 – 5 element yagi end-mounted £6.50 (a). 9EL70 – 9 element end mounted £9.99 (a). QUAD6 – 6 element quad end-mounted £12.50 (a). G15/70 – 15 element yagi with support boom, N-socket fed £19.50 (b). VBS/70 – Colinear 7dBi N-socket fed £21.00 (a).

### 23cm AERIAL

QUAD13 – 13 element quad, 16dBi N-socket fed end-mounted £18.00 (a).

### OTHER AERIALS

QUAD/934 – 13 element quad N-socket fed for 934MHz £18.00 (a). PMR – 4 element yagis in the band 70 to 80MHz £12.50.

### CONNECTORS (silver plated 50 ohm)

URM67/RG213 cable entre BNC plug £3.00. H100/URM67/RG213 cable N-plugs £2.50. URM43/URM76 cable N-plugs £2.50. URM43/URM76 cable BNC plugs £1.25.

Extremely strong tilt clamp giving up to 80 degree tilt from the horizontal. £6.50 including P&P.

Postage: (a) £2; (b) £2.50; (c) £3; (d) £4. Connectors: up to three items 35p. Prices include VAT. VISA.

Full specification for our range of aerials available for a SAE.

Goods are sent by return of post or may be collected from the factory.

**HALBAR AERIALS**  
**UNIT 1, BURY WALK, BEDFORD MK41 0DU.**  
**Tel: (0234) 44720.**

FOR QUALITY COMPONENTS  
BY MAIL ORDER

# ELECTROVALUE



**FREE  
44 PAGE  
PRICED AND  
ILLUSTRATED  
CATALOGUE  
ON REQUEST**

**FREE POSTAGE  
GOOD DISCOUNTS  
GOOD SERVICE  
THOUSANDS OF  
STOCK ITEMS  
PHONE YOUR ORDER  
ACCESS OR  
BARCLAYCARD**

**ELECTROVALUE LTD** 28 St. Jude's Road, Englefield Green, Egham,  
Surrey TW20 0HB Phone Egham (0784) 33603 Telex 264475  
North Branch, 680 Burnage Lane, Manchester M19 1NA  
Phone 061 432 4945  
Please mention this publication when replying



## TONO FOR RTTY. 5000E

From the famous TONO stable comes the new THETA – 5000E now ready to send and receive AMTOR as well as CW, RTTY, and ASCII

Features include:- 5" high resolution monitor displaying 400chr. x 16 lines x 2 pages, ARO/FEC, time clock, Selcal (Selective calling), high speed RTTY demodulator – up to 300 bauds (600 baud using TTL level); 3 shifts (170, 425 and 850 Hz) and two tones (2125 and 1275 Hz); manual or automatic Tx/Rx. Battery back-up memory (72 chars x 7 channels and 24 chars x 5 channels); type ahead correctable buffer memory. Morse code 5 – 100 wpm (variable weights) + autotrack on receive; CW practice feature with random generator; Automatic CR/LF with wrap around display; Automatic letters code insertion; Printer interface; Bargraph LED meter for tuning, TOR A, B and L – the list goes on and on..... Power requirements by the way are AC mains or 13.8v DC.

**ICOM**

**Thanet Electronics Ltd**

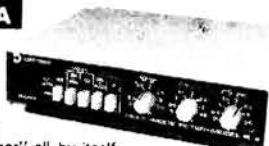
143 Reculver Road, Herne Bay, Kent, Tel: (02273) 63859/63850.



## AUDIO FILTERS MODELS FL2, FL3, FL2/A

Model FL3 represents the ultimate in audio filters for SSB and CW. Connected in series with the loudspeaker, it gives variable extra selectivity better than a whole bank of expensive crystal filters. In addition it contains an automatic notch filter which can remove a "tuner-upper" all by itself. Model FL2 is exactly the same but without the auto notch. Any existing or new FL2 can be up-graded to an FL3 by adding Model FL2/A conversion kit, which is a stand alone auto-notch unit. Datong filters frequently allow conversion copy when otherwise a QSO would have to be abandoned.

Prices: FL2 £89.70, FL3 £129.37, FL2/A £39.67



## ACTIVE RECEIVING ANTENNAS

Datong active antennas are ideal for modern broadband communications receiver - especially where space is limited.

- highly sensitive (comparable to full size dipoles).
- Broad: and coverage (below 200 kHz to over 30 MHz).
- needs no tuning, matching or other adjustments
- two versions AD270 for indoor mounting or AD370 (illustrated) for outdoor use
- very compact, only 3 metres overall length. ● professional performance standards.

Prices: Model AD270 (indoor use only) £51.75 Both prices include mains power unit. Model AD370 (for outdoor use) £69.00



## MORSE TUTOR

The uniquely effective method of improving and maintaining Morse Code proficiency Effectiveness proven by thousands of users world-wide.

- Practise anywhere, anytime at your convenience.
- Generates a random stream of perfect Morse in five character groups
- D70's unique "DELAY" control allows you to learn each character with its correct high speed sound. Start with a long delay between each character and as you improve reduce the delay. The speed within each character always remains as set on the independent "SPEED" control
- Features: long life battery operation, compact size, built in loudspeaker plus personal earpiece.

Price: £56.35

Our full catalogue plus further details of any product are available free on request. All prices include VAT and postage and packing. Goods normally despatched within 3 days subject to availability.



write to dept. PW.  
Spence Mills, Mill Lane  
Bramley, Leeds LS13 3HE  
England  
Tel (0532) 552461

**DATONG ELECTRONICS LIMITED**

Barclaycard, Access Orders - Tel (0532) 552461

# RST

MAIL ORDER CO.  
Langrex Supplies Ltd.,  
Climax House,  
159 Fallsbrook Road, Streatham SW16 6ED  
SPECIAL EXPRESS MAIL ORDER SERVICE

AZ31	2.75	EM81	2.50	PL509	6.00	5AK5	5.99	6L6G	3.00
CL33	4.00	EM87	2.50	PL519	6.00	6AL5	1.50	6L6GC	3.50
DY86/7	1.50	EN91	6.50	PL802	6.00	6AM6	6.02	6L7	2.50
DY802	1.50	EY51	2.75	PY33	2.50	6AN5	4.75	6LQ6	7.50
EB8CC	8.42	EY86	1.75	PY81	1.50	6AN8A	3.50	6Q7	3.75
E180F	10.20	EY88	1.75	PY82	1.50	6A05	2.25	6SA7	3.00
EB10F	1.25	EY88A	3.00	PY83	1.25	6AR5	3.50	6SC7	2.75
EB10F	35.48	EY88B	1.50	PY88	2.00	6AS6	6.86	6S7J	3.25
EB10F	1.50	EY88C	1.50	PY800A	4.00	6AS7G	8.75	6SK7	3.50
EB91	1.50	EY88D	1.50	PY800B	1.50	6AT6	1.25	6EK7	3.25
EBF80	1.50	EY88E	1.50	PY801	1.50	6AU5GT	5.00	6SL7GT	3.00
EBF89	1.50	EY88F	1.50	QQV02-6	31.80	6AU6	2.50	6SN7GT	3.00
EC91	8.00	EY88G	1.50	QQV03-10	23.50	6AW8A	3.75	6SS7	2.75
EC93	4.50	EY88H	1.50	QQV03-20A		6B7	3.25	6SG7M	2.50
EC93	4.50	EY88I	1.50	QQV06-40A	48.38	6B8	3.25	6U8A	2.25
EC93	1.75	EY88J	1.50			6B8A	3.25	6V6GT	2.25
EC93	1.75	EY88K	1.50			6B8B	3.25	6X4	2.00
EC93	1.75	EY88L	1.50			6B8C	3.25	6X5GT	1.75
EC93	1.75	EY88M	1.50			6B8D	3.25	12AX7	1.75
EC93	1.75	EY88N	1.50			6B8E	3.25	12BA6	2.50
EC93	1.75	EY88O	1.50			6B8F	3.25	12BE6	2.50
EC93	1.75	EY88P	1.50			6B8G	3.25	12BY7A	3.50
EC93	1.75	EY88Q	1.50			6B8H	3.25	12HG7	4.50
EC93	1.75	EY88R	1.50			6B8I	3.25	30F1/2	1.38
EC93	1.75	EY88S	1.50			6B8J	3.25	30P4	2.50
EC93	1.75	EY88T	1.50			6B8K	3.25	30P9	2.50
EC93	1.75	EY88U	1.50			6B8L	3.25	30P13	1.80
EC93	1.75	EY88V	1.50			6B8M	3.25	30P14	1.80
EC93	1.75	EY88W	1.50			6B8N	3.25	572B	3.00
EC93	1.75	EY88X	1.50			6B8O	3.25	572B	3.00
EC93	1.75	EY88Y	1.50			6B8P	3.25	572B	3.00
EC93	1.75	EY88Z	1.50			6B8Q	3.25	572B	3.00
EC93	1.75	EY88A	1.50			6B8R	3.25	572B	3.00
EC93	1.75	EY88B	1.50			6B8S	3.25	572B	3.00
EC93	1.75	EY88C	1.50			6B8T	3.25	572B	3.00
EC93	1.75	EY88D	1.50			6B8U	3.25	572B	3.00
EC93	1.75	EY88E	1.50			6B8V	3.25	572B	3.00
EC93	1.75	EY88F	1.50			6B8W	3.25	572B	3.00
EC93	1.75	EY88G	1.50			6B8X	3.25	572B	3.00
EC93	1.75	EY88H	1.50			6B8Y	3.25	572B	3.00
EC93	1.75	EY88I	1.50			6B8Z	3.25	572B	3.00
EC93	1.75	EY88J	1.50			6B8A	3.25	572B	3.00
EC93	1.75	EY88K	1.50			6B8B	3.25	572B	3.00
EC93	1.75	EY88L	1.50			6B8C	3.25	572B	3.00
EC93	1.75	EY88M	1.50			6B8D	3.25	572B	3.00
EC93	1.75	EY88N	1.50			6B8E	3.25	572B	3.00
EC93	1.75	EY88O	1.50			6B8F	3.25	572B	3.00
EC93	1.75	EY88P	1.50			6B8G	3.25	572B	3.00
EC93	1.75	EY88Q	1.50			6B8H	3.25	572B	3.00
EC93	1.75	EY88R	1.50			6B8I	3.25	572B	3.00
EC93	1.75	EY88S	1.50			6B8J	3.25	572B	3.00
EC93	1.75	EY88T	1.50			6B8K	3.25	572B	3.00
EC93	1.75	EY88U	1.50			6B8L	3.25	572B	3.00
EC93	1.75	EY88V	1.50			6B8M	3.25	572B	3.00
EC93	1.75	EY88W	1.50			6B8N	3.25	572B	3.00
EC93	1.75	EY88X	1.50			6B8O	3.25	572B	3.00
EC93	1.75	EY88Y	1.50			6B8P	3.25	572B	3.00
EC93	1.75	EY88Z	1.50			6B8Q	3.25	572B	3.00
EC93	1.75	EY88A	1.50			6B8R	3.25	572B	3.00
EC93	1.75	EY88B	1.50			6B8S	3.25	572B	3.00
EC93	1.75	EY88C	1.50			6B8T	3.25	572B	3.00
EC93	1.75	EY88D	1.50			6B8U	3.25	572B	3.00
EC93	1.75	EY88E	1.50			6B8V	3.25	572B	3.00
EC93	1.75	EY88F	1.50			6B8W	3.25	572B	3.00
EC93	1.75	EY88G	1.50			6B8X	3.25	572B	3.00
EC93	1.75	EY88H	1.50			6B8Y	3.25	572B	3.00
EC93	1.75	EY88I	1.50			6B8Z	3.25	572B	3.00
EC93	1.75	EY88J	1.50			6B8A	3.25	572B	3.00
EC93	1.75	EY88K	1.50			6B8B	3.25	572B	3.00
EC93	1.75	EY88L	1.50			6B8C	3.25	572B	3.00
EC93	1.75	EY88M	1.50			6B8D	3.25	572B	3.00
EC93	1.75	EY88N	1.50			6B8E	3.25	572B	3.00
EC93	1.75	EY88O	1.50			6B8F	3.25	572B	3.00
EC93	1.75	EY88P	1.50			6B8G	3.25	572B	3.00
EC93	1.75	EY88Q	1.50			6B8H	3.25	572B	3.00
EC93	1.75	EY88R	1.50			6B8I	3.25	572B	3.00
EC93	1.75	EY88S	1.50			6B8J	3.25	572B	3.00
EC93	1.75	EY88T	1.50			6B8K	3.25	572B	3.00
EC93	1.75	EY88U	1.50			6B8L	3.25	572B	3.00
EC93	1.75	EY88V	1.50			6B8M	3.25	572B	3.00
EC93	1.75	EY88W	1.50			6B8N	3.25	572B	3.00
EC93	1.75	EY88X	1.50			6B8O	3.25	572B	3.00
EC93	1.75	EY88Y	1.50			6B8P	3.25	572B	3.00
EC93	1.75	EY88Z	1.50			6B8Q	3.25	572B	3.00
EC93	1.75	EY88A	1.50			6B8R	3.25	572B	3.00
EC93	1.75	EY88B	1.50			6B8S	3.25	572B	3.00
EC93	1.75	EY88C	1.50			6B8T	3.25	572B	3.00
EC93	1.75	EY88D	1.50			6B8U	3.25	572B	3.00
EC93	1.75	EY88E	1.50			6B8V	3.25	572B	3.00
EC93	1.75	EY88F	1.50			6B8W	3.25	572B	3.00
EC93	1.75	EY88G	1.50			6B8X	3.25	572B	3.00
EC93	1.75	EY88H	1.50			6B8Y	3.25	572B	3.00
EC93	1.75	EY88I	1.50			6B8Z	3.25	572B	3.00
EC93	1.75	EY88J	1.50			6B8A	3.25	572B	3.00
EC93	1.75	EY88K	1.50			6B8B	3.25	572B	3.00
EC93	1.75	EY88L	1.50			6B8C	3.25	572B	3.00
EC93	1.75	EY88M	1.50			6B8D	3.25	572B	3.00
EC93	1.75	EY88N	1.50			6B8E	3.25	572B	3.00
EC93	1.75	EY88O	1.50			6B8F	3.25	572B	3.00
EC93	1.75	EY88P	1.50			6B8G	3.25	572B	3.00
EC93	1.75	EY88Q	1.50			6B8H	3.25	572B	3.00
EC93	1.75	EY88R	1.50			6B8I	3.25	572B	3.00
EC93	1.75	EY88S	1.50			6B8J	3.25	572B	3.00
EC93	1.75	EY88T	1.50			6B8K	3.25	572B	3.00
EC93	1.75	EY88U	1.50			6B8L	3.25	572B	3.00
EC93	1.75	EY88V	1.50			6B8M	3.25	572B	3.00
EC93	1.75	EY88W	1.50			6B8N	3.25	572B	3.00
EC93	1.75	EY88X	1.50			6B8O	3.25	572B	3.00
EC93	1.75	EY88Y	1.50			6B8P	3.25	572B	3.00
EC93	1.75	EY88Z	1.50			6B8Q	3.25	572B	3.00
EC93	1.75	EY88A	1.50			6B8R	3.25	572B	3.00
EC93	1.75	EY88B	1.50			6B8S	3.25	572B	3.00
EC93	1.75	EY88C	1.50			6B8T	3.25	572B	3.00
EC93	1.75	EY88D	1.50			6B8U	3.25	572B	3.00
EC93	1.75	EY88E	1.50			6B8V	3.25	572B	3.00
EC93	1.75	EY88F	1.50			6B8W	3.25	572B	3.00
EC93	1.75	EY88G	1.50			6B8X	3.25	572B	3.00
EC93	1.75	EY88H	1.50			6B8Y	3.25	572B	3.00
EC93	1.75	EY88I	1.50			6B8Z	3.25	572B	3.00
EC93	1.75	EY88J	1.50			6B8A	3.25	572B	3.00
EC93	1.75	EY88K	1.50			6B8B	3.25	572B	3.00
EC93	1.75	EY88L	1.50			6B8C	3.25	572B	3.00
EC93	1.75	EY88M	1.50			6B8D	3.25	572B	3.00
EC93	1.75	EY88N	1.50			6B8E	3.25	572B	3.00
EC93	1.75	EY88O	1.50			6B8F	3.25	572B	3.00
EC93	1.75	EY88P	1.50			6B8G	3.25	572B	3.00
EC93	1.75	EY88Q	1.50			6B8H	3.25		



# WOOD & DOUGLAS



## VHF/UHF COMMUNICATION PRODUCTS

Despite the threat of BIG BROTHER hanging over us, 1984 has been a happy and busy year for the W & D team. We would like to take this opportunity to thank all our customers for making it so, and to wish everyone a Happy Christmas and a prosperous New Year.

### JUNE \* MIKE \* CHERYL \* MIKE \* DI \* MIKE \* DAVE \* ROSE \* ALAN

Package Prices	Kit
1. 500mW TV Transmit	(70FM05T4 + TVM1 + BPF433) 35.00
2. 500mW TV Transceiver	(As 1 above plus TVUP2 + PSI 433) 60.00
3. 10W TV Transmit	(As 1 above plus 70FM10 + BDX35) 65.00
4. 10W TV Transceiver	(As 2 above plus 70 FM10 + BDX35) 90.00
5. 70cms 500mW FM Transceiver	(70T4 + 70R5 + SSR1 + BPF) 75.00
6. 70cms 10W FM Transceiver	(As 5 above plus 70FM10) 105.00
7. 2M Linear/Pre-amp 10W	(144PA/S + 144LIN10B) 40.00
8. 2M Linear/Pre-amp 25W	(144PA4/S + 144LIN25R) 42.00
9. 70cms Synthesised 10W Transceiver	(RS+SY+AX+MOD+SSR+70FM10) 150.00
10. 2M Synthesised 10W Transceiver	(RS+SY+SY2T+SSR+144FM10A) 120.00
11. 2M Crystal Controlled 10W Transceiver	(RS+TS+BPF+144FM10+SSR) 85.00
12. 70cms Linear/pre-amp	(70LIN4 + 70PA2/S) 45.00
70cms EQUIPMENT	CODE ASSEMBLED KIT
<b>Transceiver Kits and Accessories</b>	
FM Transmitter (0.5W)	70FM05T4 48.00 28.75
FM Receiver (with PIN RF c/o)	70FM05R5 65.40 45.80
Transmitter 6 Channel Adaptor	70MC06T 21.30 14.25
Receiver 6 Channel Adaptor	70MC06R 25.20 17.90
Synthesiser (2 PCB's)	70SY25B 88.00 62.25
Synthesiser Transmit Amp	A-X3J-06F 34.15 22.10
Synthesiser Modulator	MOD1 8.95 5.50
Bandpass Filter	BPF433 6.50 3.30
PIN RF Switch	PSI433 7.55 5.35
Converter (2M or 10M i.f.)	70RX2/2 27.10 20.10
TV Products	
Receiver Converter (Ch 36 Output)	TVUP2 27.50 22.80
Pattern Generator (Main PSU)	TVPG1 42.25 36.50
TV Modulator (For Transmission)	TVM1 9.85 5.75
Ch 36 Modulator (For TV Injection)	TVMOD1 9.80 5.50
Power Amplifiers (FM/CW Use)	
50mW to 500mW	70FM1 18.45 12.80
500mW to 3W	70FM3 23.45 17.80
500mW to 10W	70FM10 41.45 33.45
3W to 10W	70FM3/10 23.95 18.30
10W to 40W	70FM40 65.10 52.35
Combined Power Amp/Pre-Amp (Auto Changeover)	70PA/FM10 56.60 40.15
Linears	
500mW to 3W (Straight amp, no changeover)	70LIN3/LT 27.90 19.90
3W to 10W (Auto Changeover)	70LIN3/10E 41.05 30.15
1W to 7W (Auto Changeover)	70LIN10 44.25 32.50
Pre-Amplifiers	
Bipolar Miniature (13dB)	70PA2 8.10 6.50
MOSFET Miniature (14dB)	70PA3 9.65 7.50
RF Switched (30W)	70PA2/S 24.25 15.25
GaAs FET (16dB)	70PA5 20.10 12.80
6M EQUIPMENT	
Converter (2M i.f.)	6RX2 28.40 20.80
2M EQUIPMENT	
<b>Transceiver Kits and Accessories</b>	
FM Transmitter (1.5W)	144FM2T3 39.35 26.30
FM Receiver (with PIN RF Changeover)	144FM2R5 65.50 47.20
Synthesiser (2 PCB's)	144SY25B 78.75 60.05
Synthesiser Multi/Amp (1.5W O/P)	SY2T 27.90 20.85
Bandpass Filter	BPF 144 6.50 3.30
PIN RF Switch	PSI 144 7.55 5.35
Power Amplifiers (FM/CW Use)	
1.5W to 10W (No Changeover)	144FM10A 24.15 18.50
1.5W to 10W (Auto-Changeover)	144FM10B 36.11 26.25
Linears	
1.5W to 10W (SSB/FM) (Auto Changeover)	144LIN10B 38.40 28.50
2.5W to 25W (SSB/FM) (Auto Changeover)	144LIN25B 40.25 29.95
1.0W to 25W (SSB/FM) (Auto Changeover)	144LIN25C 44.25 32.95
Pre-Amplifiers	
Low Noise, Miniature	144PA3 8.60 7.40
Low Noise, Improved Performance	144PA4 12.86 8.40
Low Noise, RF Switched, Full Changeover	144PA/S 24.30 15.30
GENERAL ACCESSORIES	
Toneburst	TB2 6.70 4.25
Piptone	PT3 7.50 4.25
Keytone	PTK3 8.75 6.05
Relayed Keytone	PTK4R 12.70 8.20
Regulator (12V, low differential)	REG1 6.95 4.40
Solid State Supply Switch	SSR1 5.85 3.70
Microphone Pre-Amplifier	MPA2 6.10 3.50
Reflectorimeter	SWR1 6.35 5.35
CW Filter	CWF1 8.55 5.80
TVI Filter (Boxed)	HPF1 6.95 -
FM TV MODULES	
50mW 420MHz Source (Video Input)	UFM01 26.95 19.80
50MHz i.f. Processor	VIDIF 54.25 38.95
Varactor Multiplier (Boxed)	WDV400/1200 63.95 -
1250MHz Downconverter	1250DC50 69.95 -

Further details on our product range will gladly be forwarded on receipt of an A5 size SAE Technical help is available by phone (NEW NUMBER) during normal office hours. Kits are usually available by return of post but please allow 28 days for unforeseen delays. Please add 75 pence to your total order for postage and handling. Credit card orders are gladly accepted, please give us a call.

ANYONE CAN SELL A KIT ... REPUTATION SELLS OURS

UNIT 13, YOUNGS INDUSTRIAL ESTATE  
ALDERMASTON, READING RG7 4PQ  
Tel: 07356 71444 Tx: 848702



# COMMUNICATION CENTRE OF THE NORTH

The largest range of communications equipment available in the North. Full range of receivers, transceivers, antennas, power supplies, meters. Ali tubing - wall brackets etc.

We are the original amateur radio suppliers in the North West with 20 years experience in all types of equipment.

We are the only official TRIO stockists in the North West. Full range of equipment on display. Guaranteed after sales service.

## RECEIVERS

TRIO R600 Solid State Receiver	£272.00
TRIO R2000 Solid State Receiver	£436.00
JRC NRD515 Receiver	£965.00
YAESU FRG7700 Receiver	£385.00

Wide Band Scanning Receiver AR2001,  
25-550 MHz £365.00  
R532 Airband Receiver £186.00

Please send SAE for full information and up-to-date prices as these fluctuate to change in sterling rates.

For the caller a wide range of Aluminium Tubing, Clamps, etc. at competitive prices, i.e. 12" x 2" Ali Tubing £9.00.

Full range of RSGB and ARRL publications in stock.

Part Exchanges welcome. Second hand lists daily.

Send S.A.E. for details of any equipment.

HP terms. Access/Barclaycard facilities.

Open 6 days a week. 24 Hour Mail Order Service.

Phone 0942-676790.

# STEPHENS JAMES LTD.

47 WARRINGTON ROAD,  
LEIGH, LANC. WN7 3EA.

## DRAGON, BBC, SPECTRUM DEALERS

BBC B Computer 1.2.O.S. .... £399.00	R.T.T.Y. Circuit Board including instructions ..... £7.00
1.2 ROM ..... £8.00	BBC/Slow Scan Program & Board £17.50
Graphics Rom ..... £33.00	Computer Dust Covers ..... £3.00
Microvitec Monitor ..... £228.00	Cannon 1080A Printer (inc. Cable) £350.00
Sanyo Green Monitors ..... £90.00	CP80 Printer (inc. Cable) ..... £230.00
Disc Drives from ..... £150.00	Printer Cable (BBC or Dragon 32) £12.80
Joysticks (Pair) ..... £17.80	Dragon 32 Disc Drive (inc. Controller) ..... £275.00
Wordwise Word Processor ..... £39.00	Joysticks (pair) ..... £14.90
Acorn Electron ..... £199.00	2X Spectrum 48K ..... £129.00
All connectors, plugs and sockets for BBC, ribbon cable, discs C.20, C.15, C.12, cassettes etc. in stock.	Memotech 512 ..... £325.00
R.T.T.Y. Program for BBC.B ..... £7.50	New Tatung Einstein computer, Send for leaflet ..... £499.00
R.T.T.Y. Eprom Version ..... £20.00	

## DRAGON SERVICE CENTRE

Full service and repair facility - spare parts in stock

Wide range of software for BBC, Dragon 32, ZX Spectrum etc. Please send SAE for full list. Post and package on small items £2.00. All available mail order. Access and Visa. 24 hour phone. All prices include VAT at 15%. Goods in stock by return of post.

## S P ELECTRONICS

48 Linby Road, Hucknall, Notts NG15 7TS.  
TEL: Notts (0602) 640377.

## AMATEUR ELECTRONICS UK

G6X8H



**R.A.S. (Nottingham)**  
Radio Amateur Supplies  
Tel: 0602 280267

G8UUR



### Visit your Local Emporium

Large selection of New/Used Equipment on Show

#### AGENTS FOR:

F.D.K.  
AZDEN  
ICOM  
YAESU  
FORTOP ATV

#### ACCESSORIES:

Weiz Range  
Microwave Modules  
Adonics Mics  
Mutek Pre-Amps  
Bareco Mast Supports  
DRAE PSU and Wave Meters

AERIAL, Tonna, Halbar, New Diamond Range of Mobile Whips

#### PLUS OWN

'Special' Q.R.P. GW5 HF5 Band Beams  
JUST GIVE US A RING

Monday: CLOSED Tuesday-Saturday: 10.00am to 5.00pm

3 Farndon Green, Wollaton Park, Nottingham,  
Off Ring Rd, between A62 (Derby Road) & A609 (Ilkeston Road)



# MJI 102 — A NEW NUMBER IN BRITISH 'SCOPES.....



**SIMPLE OPERATION**  
**FULLY AUTOMATIC TRIGGER**  
**SINGLE BEAM**  
**100mV to 50V/DIV. SENSITIVITY**  
**10mS to 1μS/DIV. SWEEP**  
**X-Y FACILITY**  
**LIGHTWEIGHT and COMPACT**  
 and at a very lightweight price

**£129<sup>95</sup>**

SEND FOR DETAILS NOW !

**M J Instruments**

HILLTOP HOUSE, THINGOE HILL,  
 BURY St. EDMUNDS, SUFFOLK. IP32 6BE

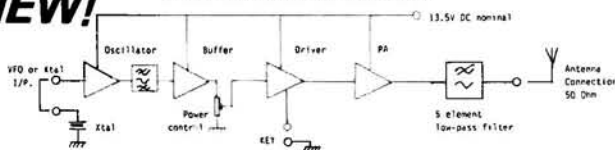
## C. M. HOWES COMMUNICATIONS

**FUN TO BUILD KITS BY MAIL ORDER**

Enjoy the fun and satisfaction of "home-brew" equipment with one of our kits. All HOWES Kits come complete with a good quality fibre-glass printed circuit board that is drilled and tinned. The part locations are screen printed on the board for easy assembly. All board mounted components are supplied, as are full clear instructions. Our kits are designed so that even a novice constructor will meet with success. Choose a worthwhile winter project from our expanding range:-

**NEW!**

### CTX80 Low Power CW TX for 80M



The HOWES CTX80 is a simple, easy to build low power transmitter for the 80 Meter amateur band. The CTX80 is crystal controlled, but has provision for connection of an external VFO. One crystal is included in the kit. The CTX80 kit contains all you need to get on 80M CW — apart from an antenna, Morse Key and receiver, how about using it with our DcRx 80M Direct Conversion Receiver?

#### Brief Details

- ★ Fully adjustable output power up to about 5W RF output.
- ★ 5 element LC lowpass output filter.
- ★ Key click suppression built in.
- ★ Crystal supplied with kit.
- ★ Provision for 3 crystals on the PCB.
- ★ Provision for external VFO.
- ★ Provision for adding AM modulator.
- ★ 4 transistors.
- ★ Only one coil to align.
- ★ Nominal 13.5V DC operation.
- ★ PCB size: 5 by 2 inches (128 by 51 mm).

**CTX 80 Kit £12.95.** Not yet available in assembled form.

#### DcRx DIRECT CONVERSION COMMUNICATIONS RECEIVER

The DcRx is our very popular single band receiver. Hundreds of these kits have been sold to both beginners and experienced amateurs. Use it with our CTX80 transmitter to make a simple low power station that is fun to use for holidays and portable use as well as for the GRP home station. Three versions of this receiver are available, one covers the 20 or 30M band, one covers 80M, and a new version covers 160M (Top Band). The kit includes ready-wound coils and is intended to be suitable for the first time builder. If you do ever have a problem with the kit, we have a fixed price repair and calibration service. The DcRx will drive a loudspeaker or headphones, and operates from a 12V battery or power supply. A case and two tuning capacitors are the only major parts to add to finish your receiver. We have suitable capacitors at £1.50 each while stocks last. (These are not suitable for the 160M version which requires larger value items).

**DcRx Kit £14.80. Assembled PCB module £19.90.** State which band you require.

**139 HIGHVIEW  
 VIGO, MEOPHAM,  
 KENT, DA13 OUT.  
 ENGLAND.**

**FAIRSEAT (0732) 823129**

The HOWES CM2 is an easy to build, versatile, microphone unit. The kit builds into a high quality desk microphone or small mobile microphone unit for "hands free" operation in the car. The kit contains an electret condenser microphone capsule capable of very good audio quality, and an easily assembled preamp unit that incorporates a Plessey "VOGAD" chip for automatic control of modulation levels. You can speak loudly or softly, close to, or further away from the mic and full modulation level is automatically maintained.

The CM2 has an on-board voltage regulator so that the unit can work from 8 to 14V DC. There is a miniature relay incorporated in the design for transmit/receive switching of the associated transceiver, yet the total current consumed by the unit is only about 30mA from a 9V battery.

The quality of the audio produced by the HOWES CM2 has been favourably compared over the air with some of the most expensive mics on the market. It is ideal for both FM and SSB, CB and Amateur use. A bass roll-off option is included that helps keep down low frequency bumps, thumps and car noise when used under mobile conditions. You could easily build this unit into a small case for dash or sun-visor mounting in the car, with a remote transmit switch mounted on the gear stick. The facility for remote transmit/receive switching is built into the CM2.

Like our very popular AP3 speech processor, with which the CM2 shares some common circuitry, there is no need for a separate on/off switch. The unit only draws current when in the transmit mode, so ensuring good battery life. The circuit board is fairly small to enable it to be built into a compact case, but we have been careful in our design to ensure that it is not at all fiddly to build as a result.

This kit is suitable for the novice constructor, no test equipment is required and there is only one easy adjustment to make to set the output level to suit your radio.

In terms of performance and audio quality, the HOWES CM2 Communications microphone kit must offer some of the best value on the market. We anticipate a big demand for this kit and have priced it accordingly. There must be a place for a "hands free" quality microphone in your shack or car.

**CM2 Kit £10.25. Assembled PCB module + Mic capsule £13.75.**

**XM1 mk2** Our super crystal calibrator with EIGHT output marker intervals. Built in voltage regulator and ident facility. Very handy around the shack, as well as keeping you "legal"!  
**XM1 mk2 Kit £16.80. Assembled PCB module £21.30.**

**AP3 AUTOMATIC SPEECH PROCESSOR.** This item is very well known on the air, over 1000 units sold, as described by G4KQH in the September 83 issue of "Ham Radio Today". Add some extra "punch" to your signal and "get out" that bit better. **AP3 Kit £15.90. Assembled PCB module £21.40.**

**ST2 CW SIDE-TONE or PRACTICE OSCILLATOR.** The ST2 provides a nice sounding note for monitoring your sending or Morse practice. Approx 1W output at 800Hz into an 8 Ohm load. 12V operation. Direct connection to your key, or the ST2 will work by RF sensing on rigs of as little as 1W on the HF bands. A volume control is included with the kit. **Kit £7.30. Assembled PCB module £10.80.**

If you would like more information on any kit, simply drop us a line, enclosing an SAE. We have an information sheet on each product. Delivery normally within 7 days.

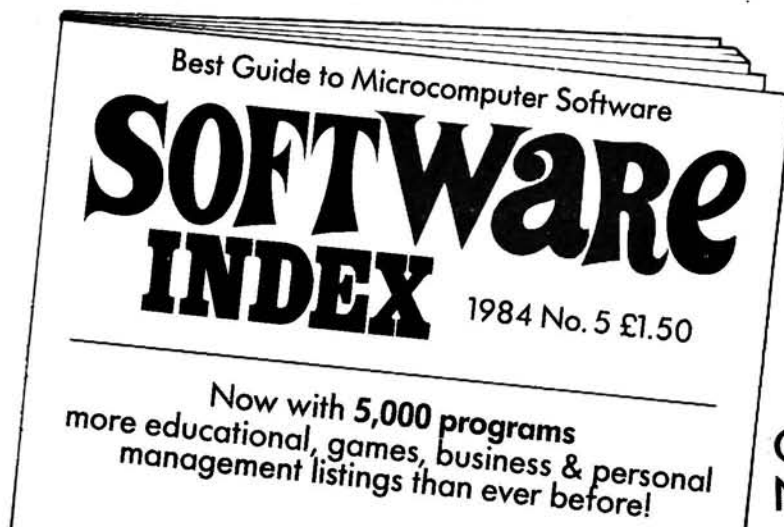
**73 from Dave, G4KQH Technical Manager**  
 Please add 60p P&P to your total order value.



# Have you one of these?



## Then you need one of these



**ON SALE  
NOW!**





# SMALL ADS

The prepaid rate for classified advertisements is 38 pence per work (minimum 12 words), box number 60p extra. Semi-display setting £12.60 per single column centimetre (minimum 2.5 cms). All cheques, postal orders etc., to be made payable to Practical Wireless and crossed "Lloyds Bank Ltd". Treasury notes should always be sent registered post. Advertisements, together with remittance should be sent to the Classified Advertisement Dept., Practical Wireless, Room 2612, IPC Magazines Limited, King's Reach Tower, Stamford St, London. SE1 9LS. (Telephone 01-261 5785).

## NOTICE TO READERS

*Whilst prices of goods shown in advertisements are correct at the time of closing for press, readers are advised to check with the advertiser both prices and availability of goods before ordering from non-current issues of the magazine.*

When replying to Classified Advertisements please ensure:

- (A) That you have clearly stated your requirements.
- (B) That you have enclosed the right remittance.
- (C) That your name and address is written in block capitals, and
- (D) That your letter is correctly addressed to the adviser.

This will assist advertisers in processing and despatching orders with the minimum of delay.

## Receivers and Components

**BOURNEMOUTH/BOSCOMBE.** Electronic components specialists for 33 years. FORRESTERS (National Radio Supplies) late Holdenhurst Rd. now at 36, Ashley Rd. Boscombe. Tel. 302204. Closed Weds.

**CRYSTALS** Made to order for any purpose and large stocks of standard frequencies for computers, modems, etc. Amateur CW (DRP) frags £4.00 and CB conversion crystals at £4.50. **PROGRAMMABLE OSCILLATORS (PXO)** for baud rates, MPU, and freq markers £12.50.

**FILTERS** Crystal, monolithic, mechanical and ceramic for all standard IF's. Special 10.895MHz for big improvement to most CB rigs at £4.50 each.

S.A.E. FOR LISTS. PRICES INCLUDE VAT AND POST

**P. R. GOLLEDGE ELECTRONICS**  
G3EDW, Merrlott, Somerset, TA16 5NS  
Tel. 0480 73718

**RADIO CANADA**, Peking, Australia, Voice of America. A Vega 206 (6x SW/MW/LW) pulls these and dozens more. £23.95. Year's guarantee. Return despatch. **CORRIGAN RADIOWATCH**, Building 109, Prestwick Airport, KA9 2RT.

## Educational

**RADIO ELECTRONICS.** Learn the basics with our easy to follow **BASIKITS** projects starting at £1.20. Send s.a.e. for details. **STAPLECRAFT**, Staple Farmhouse, Staple, Canterbury, Kent CT3 1JX.

## Educational - Cont.

**COURSE FOR CITY & GUILDS**, Radio Amateurs Examination. Pass this important examination and obtain your licence, with an RRC Home Study Course. For details of this and other courses (GCE, Career and professional examinations, etc.) write or phone: **THE RAPID RESULTS COLLEGE**, Dept JX15, Tuition House, London, SW19 4DS. Tel. 01-946 7272 (9am-5pm) or use our 24hr Recordcall Service: 01-946 1102 quoting Dept JX15.

## Aerials

**G2VF D.I.Y. H.F.** long and medium wave frame antennas. S.A.E. for details. **F RYLANDS**, 39 Parkside Avenue, Millbrook, Southampton.

**50M (165ft) AERIAL WIRE.** Strong PVC covered copper - £4.80 inc. Post. **W. H. WESTLAKE**, Clawton, Holsworthy, Devon.

## 8 TRAP DI-POLES

Data Sheets, Large 24p  
SAE Aerial Guide 75p

**G2DYM, UPLOWMAN,  
TIVERTON, DEVON**

Callers Welcome by Appointment ONLY Tel: 03986 215

**VHF AERIALS**, new designs, 28-170MHz OIRT/TV, amateur 28-144, UOSAT, AB/MB, etc. Folder s.a.e. **AERIAL-TECH**, 33 Cherville Street, Romsey, Hants SO5 8FB.

## Books and Publications

**IDEAL GIFT** for the home listener: **DIAL-SEARCH** 3rd edition, 48 pages clearly listing broadcasting stations Europe & UK. 2 maps. £2.75 includes postage. **WILCOX (PW6)**, 9 Thurrock Close, Eastbourne BN20 9NF.

## Veteran & Vintage

**VINTAGE RADIO'S** over 200 stocked. 1920-1950s. Valve Radio's-Amps etc. Repaired/Restored. **RADIO VINTAGE**, 250 Seabrook Road, Seabrook, Hythe, Kent. Phone anytime' (0303) 30693.

## Software

**MORSE DECODER.** For the 1K ZX81 16K ZX81 16/48K SPECTRUM. Full spaced alpha numeric decoding plus most punctuation. Works on clean signal fed into EAR socket 100% MACHINE CODE, AUTO SCROLL, ADJUSTABLE SPEED 8/40 wpm. Introductory price £6.00. PLEASE STATE WHICH COMPUTER. We believe these programs are the most friendly and reliable yet. **CATRA SOFTWARE**, 3 Pedmore Close, Redditch, Worcs. B98 7XB.

**MORSE READER PROGRAMMES.** Off air onto screen Programmes for BBC B, Spectrum ZX 81, Dragon, Amstrad 464, Commodore 64 and any Vic 20. Sinclair computers need no interface, others use simple one transistor (BC107) interface. Programmes self tracking 8/30 WPM. All connections to existing sockets. Cassette with full instructions and circuit, £6.00. **J. E. PRICE**, 4 Housman Walk, Offmore, Kidderminster.

**"DIDI-DIDA"** New Morse Tutor for CBM64 is the best yet and its many features will improve your receiving and sending ability. Cassette £7.00 inc. Disc £9.00. **MORAY MICRO COMPUTING**, Enzie Slackhead, Buckie, Moray AB5 2BR.

**MORSE READING PROGS.** Work on clean signals without hardware interface. ZX81 1K Unexpanded Memory. Translated code with word and line spaces for easy reading. Automatic scroll action. £7 incl. Spectrum 16/48K. Scroll action with 10-page scrolling memory, instantly accessible page by page. £8 incl. All types variable speeds. Feed signal direct into Ear socket. **PINEHURST DATA STUDIOS**, 69 Pinehurst Park, West Moors, Wimborne, Dorset BH22 0BP.

**SPECTRUM 48K.** Station-Master, superb guide to BBC/ILR MW/FM Transmitters. Full details of all Transmitters within a given distance of any U.K. location, plus 'Radar Plot' showing distances and direction, aiding aerial orientation. Ideal present! £4. **JOHN ALDRED**, Truants, Aylesbeare, Exeter, Devon.

## ORDER FORM PLEASE WRITE IN BLOCK CAPITALS

Please insert the advertisement below in the next available issue of Practical Wireless for ..... insertions. I enclose Cheque/P.O. for £ ..... CAT. heading .....  
(Cheques and Postal Orders should be crossed Lloyds Bank Ltd. and made payable to Practical Wireless)


NAME .....

ADDRESS .....

### PRACTICAL WIRELESS

Classified Advertisement Dept., Room 2612,  
King's Reach Tower, Stamford Street,  
London SE1 9LS Telephone 01-261 5785  
Rate 38p per word, minimum 12 words.  
Box No. 60p extra.

Company registered in England. Registered No. 53626. Registered Office: King's Reach Tower, Stamford Street, London SE1 9LS.

1/85



## Service Sheets

**BELL'S TELEVISION SERVICES** for service sheets on Radio, TV, etc. £1.50 plus SAE. Service Manuals on Colour TV and Video Recorders, prices on request. SAE with enquiries to B.T.S., 190 Kings Road, Harrogate, N. Yorkshire. Tel. (0423) 55885.

### TECHNICAL INFO SERVICES 76 Church St - Larkhall - Lanarks

**FULL SIZE SERVICE SHEETS**  
Any radio, audio £2.50 + I.s.a.e.  
CTVs/Musc £3.50 + I.s.a.e. complete set

Worlds largest collection  
service manuals 30's - date  
from £4.50-£35 each.

**Comprehensive T.V. Repair Course**  
**Complete Radio Service & Repair Course**  
**ONLY £9.50 EACH**

Repair data/circuits almost  
any named TV/Video for £10.50

*S.a.e. brings any quotation*  
*FREE 50p mag. inc. service sheet!*  
*Pricelists unique elect. publications*

**FOR FAST QUOTES**  
**RING 0698 883334**

## For Sale

**BUYING OR SELLING?** Contact the used equipment centre for the best deal. 25 years of amateur radio experience, friendly advice, full no quibble guarantee on all equipment. Heard about our exchange plan, buy & try? Why not contact me, David Cole G3RCQ, Hornchurch 55733, evenings/weekends or send sae for full details & current list of equipment. G3RCQ 65, Cecil Avenue, Hornchurch, Essex. Urgent daytime enquiries 01-594 3435.

**AMATEUR RADIO EQUIPMENT**, Bought, Sold, Exchanged. For the Best Deal, Guaranteed! Phone Dave, on 025 587 663 or 04024 57722 SAE for list to G4TNY ELEC TRONICS, 132 Albany Road, Hornchurch, Essex RM12 4AQ.

**YAESU RECEIVER FRG 7700/FRA 7700** as new. Cost £429. Sacrifice £220 ono. 01-650 5028.

**COLLECTION** of very old glass radio valves & speakers amplifiers. Bereavement reason for sale. Reasonable offers. MOTTRAM 62249.

**AMATEUR RADIO EQUIPMENT** bought, sold, exchanged. Lists on request. R & S RADIO (G40WY), Weymouth 0305 786930.

**MANUALS BOUGHT/SOLD**. Quick service. S.A.E. BIRKETT, 41 Halvarras Road, Playing Place, Truro. 862575.

**PRACTICAL WIRELESS'S** and Short Wave Magazines. 1950s and 1960s. OFFERS. Tel. 0844 291060.

## Miscellaneous

**HEATHKIT**. U.K. Spares and Service Centre. CEDAR ELECTRONICS, Unit 12, Station Drive, Bredon, Tewkesbury, Glos. Tel. (0684) 73127.

**QSL CARDS**. Gloss or tinted cards. SAE for samples to TWROG PRESS, Dept PW, Penybont, Gellilydan, Blaenau Ffestiniog, Gwynedd.

## Miscellaneous - Cont.

**FREE!** Parcel of Components worth £10. Send only 80p postage! D. HORSLEY, 113 Clarf Road, Braintree, Essex.

**WAVEGUIDE, FLANGES & DISHES**. All standard sizes & Alloys (new material only) from stock. Special sizes to order. Call EARTH STATIONS 01-228 7876. 22 Howie Street, London SW11 4AR.

**SUPERB INSTRUMENT CASES** by BAZELLI, manufactured from PVC. Faced steel Vast range. Competitive prices start at a low £1.50. Punching facilities at very competitive prices. Suppliers only to Industry and the Trade. BAZELLI, (Dept No. 25), St. Wilfrid's, Foundary Lane, Halton, Lancaster LA2 6LT.

### ZX RTTY/MORSE READER

This Program enables the 48K Spectrum to decode 45.5 Baud radioteletype and morse code signals directly from your radio. No extra hardware required - simple connection via Computer EAR socket. Price £5.00. Also for 48K Spectrum-Morse TX/RX Program with morse tutor. No extra hardware required. Price £7.50. For 16K Spectrum-Morse RX Program with morse tutor Price £5.20. For 1K ZX81-Morse RX Program. Price £5.20. All Programs 100% Machine Code

**P. ANDERSON,**

**Wellands, Pilton, Shepton Mallet, Somerset.**

**BURGLAR ALARM EQUIPMENT**. Ring Bradford (0274) 308920 for our catalogue or call at our large showrooms opposite Odsal Stadium.

**QSL CARDS**, printed to your own design on white or coloured gloss card. SAE for samples to: THE NUTLEY PRESS, 21 Holmethorpe Avenue, Redhill, Surrey RH1 2NB.

### MORSE CODE PREPARATION

Cassette A: 1-12 wpm for amateur.  
Cassette B: 12-25 wpm for professional examination preparation. Each cassette is type C90.

Price of each cassette (including booklets) £4.75.  
Morse key with separate battery (PP3) - driven solid-state oscillator and sound transducer produces clear tone for sending practice. Price of key with electronic unit £7.75.

Prices include postage etc. Europe only.

**MH ELECTRONICS (Dept PW)**

**12 Longshore Way, Milton Portsmouth PO4 8LS.**

**NEW AND SURPLUS** components and equipment now in stock. Also amateur, F.M. and T.V. aerials and a complete range of burglar alarm equipment. Write or phone for price list. SPECTRUM RADIO AND ELECTRONICS LTD., 36 Slater Street, Liverpool L1 4BX. Tel. 051 709 4628.

### NEED A SPECIAL MAINS TRANSFORMER?

Use one of our transformer kits.

*SAE for details*

**Tidman Mail Order Ltd (Dept PW)**  
**236 Sandycombe Road, Richmond,**  
**Surrey. Phone 01-948 3702.**

**RECEIVE TWO METRE AMATEURS** on your C.B. Sensitive quartz convertor, just plugs in. Covers popular simplex channels and all repeaters. £22.50 inclusive. SAE more details. VIDEO WORLD, (M. RATHBONE), 7 Wesley Street, Southport, Merseyside.

**NEW LOCATOR SYSTEM** (Maidenhead). QRA to QTH conversion. Dec deg conversion. Distance calculation. DX beam headings. QTH to d.m.s. conversion etc. CBM64 Apple. Cassette £6.50. Disc £8.50 inc. p&p. MORAY MICRO COMPUTING, Enzie Slackhead, Buckie, Moray AB5 2BR.

### LOSING DX?

**LONG WIRE ANT?** Outside or INDOOR, boost DX with a 0.1-30MHz Antenna Tuner, adapts to absorption wavemeter etc, £25.20, ideal for FRG7700 etc or 10w tx.

**RARE DX UNDER QRM?** DIG it OUT with a Tunable Audio Notch Filter, between your receiver and speaker, BOOST your DX/QRM ratio, 40dB notch, £17.40.

*Each fun-to-build kit includes ALL parts, instructions, case etc, by-return postage and list of other kits.*

**CAMBRIDGE KITS**

**45 (PN) Old School Lane, Milton, Cambridge.**

It's easy  
to complain  
about  
advertisements.  
But which  
ones?

Every week millions  
of advertisements appear  
in print on posters or in  
the cinema.

Most of them comply  
with the rules contained  
in the British Code of  
Advertising Practice.

But some of them  
break the rules and  
warrant your complaints.

If you're not sure  
about which ones they  
are, however, drop us a  
line and we'll send you  
an abridged copy of the  
Advertising Code.

Then, if an  
advertisement bothers  
you, you'll be justified in  
bothering us.

The Advertising  
Standards Authority.  
If an advertisement  
is wrong,  
we're here to put it right. ✓

ASA Ltd, Dept 2 Brook House,  
Torrington Place,  
London WC1E 7HN

This space is donated in the interests  
of high standards of advertising.



# INDEX TO ADVERTISERS

A.H. Supplies .....	14	M.H. Electronics .....	86
Allweld Engineering .....	58	Microwave Modules .....	15
Amateur Radio Exchange .....	13	M & J Instruments .....	83
Amateur Electronics U.K. ....	8, 9	Number One Systems .....	88
Amcomm Services .....	16, 72	P. Anderson .....	86
Birkett, J. ....	88	Photo Acoustics .....	57
B.N.O.S. ....	77	Quartzlab .....	79
B.N.R. & E.S. ....	58	Radio Shack Ltd. ....	10
Blackstar .....	80	Random Electronics .....	88
Bowes, C. ....	12	R. Withers Comms. ....	14
Cambridge Kits .....	86	R.A.S. Nottingham .....	82
C.Q. Centre .....	33	R.F. Devices .....	88
Colomor Electronics .....	14	R.S.T. Valve .....	81
Commutech .....	88	Scarab Systems .....	10
Datong Electronics .....	81	Selectronic .....	88
Davtrend .....	72	S.E.M. ....	12
Dewsbury Electronics .....	66	Shelley (Halesowen) Ltd. ....	78
Dressler (U.K.) .....	11	Skybridge Ltd. ....	81
Electrovalue .....	80	Skywave Software .....	42
G2DYM Aerials .....	85	South Midlands Comms. ....	4, 5
Garex Electronics .....	34	South-West Aerials .....	66
Golledge Electronics .....	85	S.P. Electronics .....	82
Greatch Electronics .....	78	Stephens-James Ltd. ....	82
Greenweld .....	12	Tandy .....	65
Grosvenor Software .....	42	Technical Info. Services .....	86
Halbar .....	80	Technical Software .....	48
Harris, P.J. ....	42	Thacker, A.H. ....	88
Hightech Antennas .....	Cover 2	Thanet Electronics .....	6, 7, 80
Howes, C.M. Comms. ....	83	Tidman Mail Order .....	86
Lecmar Electronics .....	10	Timestep Electronics .....	71
Lee Electronics .....	66	Ward, Reg & Co. ....	Cover 3
Lowe Electronics .....	2, 3	Waters & Stanton .....	79
Maplin Supplies .....	Cover 4	Weirmead .....	88
Melvin, J. ....	42	Wood & Douglas .....	82

## A SOUND IDEA...

Take out an annual subscription for **PRACTICAL WIRELESS** and have your copy of Britain's leading magazine for radio enthusiasts delivered direct to

your door. Every month you'll receive the latest product news plus projects, techniques and reports from the amateur and broadcast bands.

### SUBSCRIPTION RATES

U.K.	£13.00
Overseas	£14.00

**COMPLETE  
AND POST  
THIS  
ORDER FORM  
TODAY!**

## Practical Wireless SUBSCRIPTION ORDER FORM

Annual Subscription Rates  
U.K. £13.00  
Overseas £14.00  
(Students: deduct £1 and quote Student number)

Complete this form and post it, with payment or credit card authorisation to:  
**Practical Wireless**  
Subscription Dept.  
Oakfield House,  
35 Perrymount Road,  
Haywards Heath,  
West Sussex RH16 3DH

POST COPIES TO

NAME \_\_\_\_\_

ADDRESS \_\_\_\_\_

POST CODE: \_\_\_\_\_

I enclose my cheque/P.O. payable to IPC Magazines Ltd. for £ \_\_\_\_\_  
Charge my credit card A/C at quoted rate

\_\_\_\_\_   

Card valid from: \_\_\_\_\_ to \_\_\_\_\_

Signature \_\_\_\_\_

**27**



## SPECIAL PRICES ON SURPLUS EQUIPMENT

Racal RA17 receivers, high grade communications receivers, 500kHz/30MHz in 30 effective bands from **£195.00**. Eddystone receiver 730/4, 500kHz/30MHz in 5 bands **£145.00**. All in excellent condition. Carriage **£15.00**. Sanyo RP8880 9 bands portable communications receivers **£125.00**. Pye Westminster W15 low band AM **£30.00**, p&p £2.50. 27ft telescopic mast with guys, insulator etc £25.00 collected. High impedance headphones with book mic, new **£7.50**. Avo valve testers **£35.00**, p&p £4.00. New 28 range digital multimeters **£40.25**. PCR receivers, LW/MW/SW, untested less PSU **£20.00**, p&p £5.00. 10ft whip aerials **£4.00**, p&p £1.50. Creed teleprinters **£25.00**. Various single and double beam oscilloscopes, signal generators, valve testers, output meters etc always in stock. Surplus circuit book containing circuits and notes on many surplus receivers, transceivers etc **£7.50**. Send 50p for illustrated catalogue, includes £1 voucher. Over 500 sets in stock. Avo's amateur rigs wanted for cash. New shop open at 218 St Albans Rd. Come and see the bargains!

**WEIRMEAD LTD, 218 St Albans Road, Watford, Herts. 0923 49456**  
Access/Visa Welcome Goods in stock, delivery 7 days

# SELECTRONIC

RADIO, TV AND RADIO COMMUNICATION SPECIALISTS

## THE UK'S LEADING SUPPLIER OF 934 MHz PERSONAL RADIO EQUIPMENT AND ACCESSORIES

- ★ A full range of Reftec, Cresbyte and Nevada Products
- ★ Everything you need for 934MHz, plugs, cables, masts, towers, SWF/signal metres, aerials, switches etc.
- ★ The largest stock available anywhere
- ★ We now stock the Full Range of MET Antennas inc. 934

THE ONLY AUTHORISED REFTEC SERVICE DEALER

We have practical and technical experience. Please call us for friendly help and advice. Credit terms and mail order facilities available

For further information please ring Mike Machin on (0268) 691481



**203, HIGH STREET, CANVEY ISLAND, ESSEX**



G6YHB  
G6YHC  
G4UVJ  
G1MAM

Marconi A.F. wattmeter CT44, 200 microwatts to 6 watts in 10 ranges switched 2150 ohms. £30. P&P paid. Marconi H.F. wattmeter CT211, high power 70 ohms 25 watts, low power 52 ohms, 1 watt. £25. P&P paid. Ex-Gov. 27ft telescopic aerial close to 5ft. Good condition, complete with all base & fittings £45. P&P paid. Callers welcome £25. Pye Pocketphone Nightcall for PF1/TX/RX. New boxed £17.00. Whip aerial Ex-Gov. 4ft collapsible £1.00. Steel 2 in Interlocking Mast sections 4ft. Price £4.00 each P&P paid, min. 5. Crystals HC6U Ex Equip. 5,000 mc/s, 7,000 mc/s, 8,000 I.M.C. mc/s, 9,000 mc/s. Also Glass Crystal 100 Kc/s, to fit B7G base. All at £2. P&P paid. Ni-Cad batteries for Pye PF1 RX. 5 for £2 P&P paid. Min. order 5. All these batteries are ex-eq. but good condition.

**Bargain Parcels** 14 lbs at £10, 28 lbs at £20 and 56 lbs at £40, P&P paid. Contains pots, res., diodes, tagboards, caps., chassis, valve holders etc. Good value save £ £'s. Lucky dip service. AVO 7X. Tested. Ex eq. £40 P&P paid. Brand new Carbon resistors 1 & 1/2W approx. 550 in each mixed pack £5.00 P&P paid. Marconi AM Signal Generator. CT 452A 10 Kc/s to 72 mc/s. £100 P&P paid. Fibreglass aerial sections. 3ft x 1 1/2in dia. Push in type. £2.50 per section, min 5. P&P paid. Airline 62 headsets boom mike 300ohms as new £20 P&P paid.

Opening times: Monday-Friday 8.30am-5.00pm, Saturday 8.30am-12am  
Please allow 14 days for delivery. Mainland only.

**A. H. THACKER & SONS LTD**  
HIGH STREET, CHESLYN HAY NEAR WALSALL, STAFFS.

## R.F. LINEAR AMPLIFIERS

	D.C. Supply	Power In	Power Out	Preamp Incl.	Kit	Ready Built & Tested
2 METRES	13.8v	2.5w	25w	No	£29.95	£39.95
	13.8v	10/10w	50w/50w	yes	£29.95	£43.95
	13.8v	2.5w	50w	Yes	£44.95	£57.95
	13.8v	2.5w	100w	Yes	£89.95	£109.50
	13.8v	10w	100w	Yes	£77.50	£96.50
	13.8v	25w	100w	Yes	£65.85	£84.95
	28v	10w	50w	Yes	£28.95	£42.95
70 cms	28v	10w	80w	Yes	£68.50	£82.95
	28v	10w	150w	Yes	£138.50	£158.50
	13.8v	1w	10w	No	£29.95	£42.50
	13.8v	1w	40w	No	£74.50	£86.50
	13.8v	10w	40w	No	£59.50	£69.50
	13.8v	10w	80w	No	£89.95	£94.50

Kits include pre-drilled case/heatsink and all parts except RF Input/Output connectors. Pre-amp gain -22dB, Noise Factor - <1.5dB, Auto Switching ch angeover.

POWER TARREN 13.8v 5-7 amp Regulated P.S.U. £19.95

SUPPLIES RFD 13.8v 20 amp Regulated P.S.U. £86.50, Built £79.80

NEW - Interested in A.T.V.? Why not run 80 watts, 40 watts or 10 watts Peak Sync. Power with our combined P.A./modulator?

Terms: Post & Packing £1.20 (p.s.u. £4.50). Please allow 28 days for delivery.

S.A.E. for further information to: **R.F. DEVICES**  
49 Roxholme Terrace, Leeds LS7 4JH. Telephone (0632) 623125

## ELECTRONICS C.A.D. "ANALYSER"

Performance analysis of linear circuits using the BBC Model B and Spectrum 48K.

Simulates resistors, capacitors, inductors, transformers, bipolar and field effect transistors and operational amplifiers in any circuit configuration.

Performs frequency response analysis on circuits up to 16 nodes and 60 components for phase and gain/loss, input impedance and output impedance.

Ideal for the analysis of active and passive filters, audio, wideband and RF amplifiers, linear integrated circuits etc.

"Analyser" can greatly reduce or even eliminate the need to bread-board new designs.

Used by industrial and university R and D departments world wide.

Low Cost. Prices from £20. Very easy to use.  
Payment by Access or American Express.

For further details write or phone:  
**NUMBER ONE SYSTEMS**

Department PW, 9A Crown Street,  
St Ives, Huntingdon, Cambs. PE17 4EB.  
Tel: 0480 61776 Telex: 32339

## J. BIRKETT

25 THE STRAIT,  
LINCOLN LN2 1JF. TEL 02077

VMOS POWER TRANSISTORS. VN10KM @ 50p, VN90AA @ 80p, WM 211 @ 40p

FETS like 2N3819, J304 @ 6 for £1.00, E304 @ 7 for £1.00.

VHF-UHF SIGNAL TRANSISTORS 2N518 @ 25p, BF184 @ 20p, BF180 @ 20p, 2N5179 @ 50p, 2N518 @ 50p, BF90 @ 60p.

MULLARD CRYSTAL FILTER 470KHz LP1175 @ 95p, 455KHz @ 50p.

ITT CRYSTAL FILTER 10.7MHz BW 6KHz @ £5.00.

TOYCON CRYSTAL FILTER 10.7MHz BW 7.5KHz with 2 Transformers @ £4.60.

FEED THRU NUT FIXING 3000 volt INSULATION 6 for 50p.

MULLARD VARIABLE CAPACITORS 500+170pF @ £1.50.

TAPE RECORDER MECHANICAL DIGITAL COUNTERS 3 for £1.15.

CMOS DUAL TIMER 7556 at 3 for £1.50.

50 OHM BNC SOCKETS @ 3 for £1.15, BNC PUSH ON PLUGS @ 3 for £1.00

RF POWER TRANSISTORS, BLW60R 1.5 to 175MHz, 45 Watt 12 Volt @ £7.50, BLY97, 175MHz, 24 Volt, 4 Watt @ £3.00, BLY55, 175MHz, 12 Volt, 4 Watt @ £2.50, 2N5990, 12 volt, 10 watt, 175MHz @ £4.75, PT4577, 1200MHz, 2 watt, 12 volt @ £2.20, BF6R4, 4 watts, 24 volt, 470MHz @ £4.00.

ELECTROLYTICS WIRE ENDED 500UF 25VW @ 15p, 1000UF 16VW @ 20p, 1000UF 25VW @ 30p, 2200UF 40VW @ 60p, 4700UF 15VW @ 25p, TAG ENDED 2200UF 40VW @ 50p, 2200UF 85VW @ 85p, 4700UF 63VW @ £1.15, 15,000UF 10VW @ 25p.

144MHz WAVELENGTH METER KITS WITH INSTRUCTIONS @ £4.65.

MORSE OSCILLATOR KIT WITH INSTRUCTIONS @ £1.65.

POWER TRANSISTORS 2N6212 PNP 350 Volt 2 Amp @ 3 for £1.20.

WOOD AND DOUGLAS KITS AVAILABLE BY POST AND FOR CALLERS. LIST SAE  
ACCESS AND BARCLAYCARD ACCEPTED. P&P Under £5.00, 50p Over FREE.

Goods normally by return.

## GENERAL COVERAGE RECEIVER KIT FCR 130

Model FCR 130 Receiver kit - Only £75.30 inc VAT p & p £2.40 Delivery by return

- ★ 30:1 Geared analogue tuning
- ★ 3 Band switch with spare position
- ★ Tape record socket
- ★ Headphone socket
- ★ Signal Meter
- ★ Internal speaker + On/Off sw.
- ★ A.F. Gain and Tone Control
- ★ C.W. A.M. SSB.



This is a complete kit which allows you to build and learn as you go. Suitable for anyone who has an interest in radio and can manage a soldering iron. It really is within the scope of most beginners. You don't have to be a 'semi-professional amateur' to understand how it works as we supply very comprehensive and complete instructions, written in plain language. Well speced components so its OK for fat fingers! The receiver tunes, in 3 bands from 1 to 30 Mhz. Solid aluminium tuning and control knobs and base panel. Black anodised front panel. Nice to build... nice to look at... nice to own.



**COMMUTECH (Devon) LTD**  
Chapel Street, Holsworthy, Devon EX22 6AR.  
Tel: (0409) 253504

## ANTENNAS TONNA (F9FT)

1296MHz OR 1269MHz OSCAR UPLINK	23 element	£25.90(b)
50MHz	4x23 element - power splitter	£140.00(a)
5 element	- stacking frame	
144MHz	ALSO AVAILABLE FOR 1250MHz	
4 element	*denotes available for 50Ω or 75Ω	
5 element crossed	all others 50Ω ONLY.	
9* element fixed	PORTABLE ALUMINIUM TELESCOPIC MASTS	
9* element portable	4x1m £20.70(a)	3x2m £24.15(a)
9* element crossed	4x2m £36.66(a)	
13 element portable	GALVANISED STEEL TELESCOPIC MASTS	
17* element fixed	2x3m £30.48(a)	3x3m £54.77(a)
435MHz	4x3m £88.41(a)	5x3m £118.60(a)
9 element	STACKING FRAME KITS FOR 4 ANTENNAS	
19* element	POWER SPLITTERS FOR 2 AND 4 ANTENNAS	
19* element crossed	ANDREW LDF450 HELIAX COAXIAL CABLE	
21* element 432MHz	ROTATORS - COAXIAL CABLE-CONNECTORS	
21* element ATV		
144/435MHz		
9 & 19 element Oscar		

PLEASE ADD CARRIAGE AS SHOWN (a) £4.00. (b) £1.95. ALL PRICES INCLUDE VAT AT 15%

Cash with order, ACCESS - VISA - Just telephone your card number for immediate despatch.

FOR FULL SPECIFICATIONS SEND 40p FOR CATALOGUE  
Callers welcome, but by telephone appointment only please. Goods by return.

**RANDAM ELECTRONICS (P)**

12 Conduit Road, Abingdon, Oxon OX14 1DB. Tel: (0235) 23080 (24 hours)



# REG. WARD & CO. LTD.

1 WESTERN PARADE, WEST STREET,  
AXMINSTER, DEVON, EX13 5NY.

THE SOUTH-WEST'S LARGEST AMATEUR RADIO STOCKIST

## Trio

TS930S	9 Band TX General Cov RX	1195.00 (-)
TS830S	160 10m Transceiver 9 Bands	758.00 (-)
AT230	All Band ATU/Power Meter	143.91 (7.00)
SP230	External Speaker Unit	42.09 (7.00)
TS530S	160m-10m Transceiver	668.61 (-)
TS430S	160m-10m Transceiver	779.55 (-)
PS430	Matching Power Supply	119.43 (3.00)
SP430	Matching Speaker	30.99 (7.00)
MB430	Mobile Mounting Bracket	12.00 (2.00)
FM430	FM Board for TS430	36.48 (-)
TS130S	8 Band 200W Pep Transceiver	576.66 (-)
SP120	Base Station External Speaker	27.99 (7.00)
AT130	100W Antenna Tuner	96.95 (2.00)
MC50	Dual Impedance Desk Microphone	32.98 (2.00)
MC35S	Fist Microphone 50K ohm IMP	15.49 (1.50)
LF30A	HF Low Pass Filter 1kW	22.49 (1.00)
TR7930	2M FM Mobile	323.30 (-)
TR9130	2M Multimode	458.72 (-)
TV4000A	2M/70cm mobile	488.70 (-)
TM201A	2M 75W mobile	279.00 (-)
TM401A	7cms FM 12W	310.32 (-)
TR2500	2M FM Synthesised Handheld	243.36 (-)
TR3500	70cm Handheld	265.85 (-)
TR2600	New 2M FM Synthesised Handheld	P.O.A. (-)
ST2	Base Stand	54.98 (1.50)
SC4	Soft Case	14.49 (1.00)
SMC25	Speaker Mike	17.00 (1.00)
PB75	Spare Battery Pack	26.50 (1.00)
MS1	Mobile Stand	33.91 (1.00)
R600	Gen. Cov. Receiver	272.83 (-)
R2000	Synthesiser 200KHz 30MHz Receiver	437.75 (-)
HC10	Digital Station World Time Clock	71.96 (1.50)
H55	Deluxe Headphones	24.48 (1.50)
SP40	Mobile External Speaker	14.98 (1.50)

## Linear Amps

TONO (G series)		
2M40G	2m, 1-3 W in, 20-35W out, preamp	79.00 (2.50)
2M90G	2m, 10-15W in, 70-90W out, preamp	115.00 (2.50)
2M130G	2m, 10-15W in, 110-130W out, preamp	159.00 (2.50)
4M70G	70 cms, 3-15W in, 40-60W out, preamp	179.00 (2.50)

## MICROWAVE MODULES

MML144/30-LS	inc preamp (1/3 w i/p)	75.00 (2.50)
MML144/50 S	inc preamp, switchable	92.00 (2.50)
MML144/100-S	inc preamp (10w i/p)	149.95 (2.50)
MML144/100 HS	inc preamp (25w i/p)	149.95 (2.50)
MML144/100-LS	inc preamp (1/3w i/p)	169.95 (2.50)
MML432/30L	inc preamp (1/3w i/p)	139.95 (2.50)
MML432/50	inc preamp (10w i/p)	129.95 (2.50)
MML432/100	linear (10w i/p)	245.00 (2.50)

## B.N.O.S

LPM 144-1-100	2m, 1W in, 100W out, preamp	172.50 (2.50)
LPM 144-3-100	2m, 3W in, 100W out, preamp	172.50 (2.50)
LPM 144-10-100	2m, 10W in, 100W out, preamp	149.50 (2.50)
LPM 144-25-160	2m, 25W in, 160W out, preamp	207.00 (2.50)
LPM 144-3-180	2m, 3W in, 180W out, preamp	235.75 (2.50)
LPM 144-10-180	2m, 10W in, 180W out, preamp	235.75 (2.50)
LPM 432-1-50	70cm, 1W in, 50W out, preamp	184.00 (2.50)
LPM 432-3-50	70cm, 3W in, 50W out, preamp	184.00 (2.50)
LPM 432-10-50	70cm, 10W in, 50W out, preamp	155.00 (2.50)

## SWR/PWR Meters

HANSEN		
FS200	1.8-150MHz 20/200 Pep	59.95 (2.00)
FS210	1.8-150MHz 20/200 Auto SWR	59.80 (2.00)
FS5E	3.5-150MHz 20/200/1000W H	41.00 (2.00)
FS500H	1.8-80MHz 20/200/2000W H	77.80 (2.00)
FS710H	1.8-80MHz 15/150/1500W H	97.75 (2.00)

WELZ		
SP15	1.8 160MHz PWR/SWR	41.00 (2.00)
SP45	130-470MHz PWR/SWR	59.75 (2.00)
SP10X	1.8 150MHz PWR/SWR	28.75 (2.00)
SP200	1.8-180MHz PWR/SWR	82.00 (2.00)
SP250	1.8-60MHz PWR/SWR	57.25 (2.00)
SP300	1.8 500MHz PWR/SWR	115.00 (2.00)
SP350	1.8-500MHz PWR/SWR	69.95 (2.00)
SP400	130-500MHz PWR/SWR	82.00 (2.00)
SP600	1.8-500MHz PWR/SWR	106.00 (2.00)

TOYO		
T430	144/432 120 W	44.65 (2.00)
T435	144/432 200 W	49.35 (2.00)

YAESU		
YS200	1.8 60MHz	52.90 (2.00)
YS2000	1.8 60MHz	69.79 (2.00)

HQ1 MINI BEAM  
10 - 15 - 20  
ONLY £169.00 (6.00)

## Icom Products

IC751	HF Transceiver	1239.00 (-)
IC745	HF Transceiver	896.00 (-)
IC730	Mobile HF Transceiver	659.00 (-)
PS15	P.S. Unit	135.00 (4.00)
PS30	Systems p.s.u. 25A	259.00 (-)
SM6	Base microphone for 751/745	36.50 (1.00)
IC290D	2m 25w M/Mode	469.00 (-)
IC271E	2m 25w M/Mode Base Str.	699.00 (-)
IC271H	100W version of above	889.00 (-)
IC25H	2m 45w FM	358.00 (-)
IC77E	25W FM mobile	358.00 (-)
IC45E	70c 10w FM	24.50 (1.00)
ICBU1	B/U Supply for 25/45/290	599.00 (-)
ICR70	General Coverage Receiver	699.00 (-)
ICR71	General Coverage Receiver	259.00 (-)
IC02E	2m H/Heid	199.00 (-)
IC2E	2m H/Heid	69.00 (2.00)
ML1	2m 10w Linear	259.00 (-)
IC4E	70cm H/Heid	269.00 (-)
IC04E	70cm H/Heid New Model	56.35 (-)
BC35	Base Charger	18.55 (0.75)
HM9	Speaker mic	5.50 (0.65)
IC3	Carrying Case	27.50 (1.00)
ICBP3	Std Battery Pack	52.80 (1.00)
BP5	High Power Battery Pack	5.00 (0.50)
CP1	Car Charging Lead	7.00 (0.75)
DC1	12v Adaptor	1.00 (0.50)

## Mutek Products

SLNA 50	50MHz Switched preamp	44.90 (1.50)
SLNA 144s	144MHz Low noise switched preamp	39.90 (-)
SLNA 145b	Preamp intended for 290	227.40 (1.50)
GLNA 432e	70cm Mast head preamp	149.90 (1.50)
RPCB 144ub	Front end FT221/225	74.90 (1.00)
RPCB 251ub	Front end IC251/211	79.90 (1.00)
BBA 500u	20-5000MHz Preamp	29.90 (1.50)
GFBA 144e	2m Mast head preamp	29.90 (2.50)
SBLA 144e	2m Mast head preamp	8.00 (2.50)
RPCB 271ub	Front end for IC271	27.90 (1.50)
TVHF 230c	2M-FM Transceiver	334.90 (5.00)

## Datong Products

PC1	Gen. Coverage	137.40 (1.50)
VLF	Very Low Frequency	29.90 (1.50)
FL2	Multi-band audio filter	89.70 (1.50)
FL3	Audio filter for memory	129.00 (1.50)
ASP/B	1/3 speech clipper	82.80 (1.50)
ASP/A	1/3 speech clipper for Yaesu	82.80 (1.50)
ASP	1/3 speech clipper for Yaesu	89.70 (1.50)
D75	Manual R/F speech clipper	56.35 (1.50)
D70	Morse Tutor	56.35 (1.50)
MK	Keyboard Morse sender	137.40 (1.50)
RFA	RF S-meter pre-amp	33.90 (1.50)
MPU	Auto mute with mains p.s.u.	51.75 (1.50)
MPU	Auto mute with mains p.s.u.	69.00 (1.50)
MU	Auto mute with mains p.s.u.	6.90 (1.50)
TK-14/28	2m converter	39.67 (1.50)
TP1	Top squelch unit	46.00 (1.50)
ANF	Automatic notch filter	67.85 (1.50)
SRB2	Auto Woodpecker blanker	86.25 (1.50)

## CW/RTTY Equipment

Tono 3000E	Reader/Sender	P.O.A. (-)
Tono 550	Reader	299.00 (2.50)

## MICROWAVE MODULES

MM2001	RTTY to TV converter	189.00 (1.50)
MM4001	RTTY terminal	269.00 (1.50)
MM4001KB	RTTY term with keyboard	299.00 (2.00)

## HI-MOUND MORSE KEYS

HK702	Up down keyer marble base	27.00 (1.50)
HK703	Up down keyer	28.15 (1.50)
HK704	Up down keyer	19.25 (1.50)
HK705	Up down keyer	13.57 (1.50)
HK706	Up down keyer	15.90 (1.50)
HK708	Up down keyer	13.00 (1.50)
HK802	Up down solid brass	82.85 (1.50)
HK808	Up down keyer	39.95 (1.50)
MK704	Twin paddle keyer	12.00 (1.50)
MK705	Twin paddle keyer marble base	24.65 (1.50)

KENPRO		
KP 100	Squeeze CMOS 230/13.8v	79.50 (2.50)
KP200	Memory 4096 Multi Channel	169.50 (2.50)

## Yaesu

FT1	HF Transceiver	P.O.A. (-)
FT980	HF Transceiver	1329.00 (-)
SP980	Speaker	61.55 (2.00)
FT102	HF Transceiver	719.00 (-)
FC102	Tuner	185.00 (2.00)
FV102DM	VFO	239.00 (2.00)
SP102	Speaker	55.00 (2.00)
AM/FM	U-t	49.00 (1.00)
FT77	Mobile HF Transceiver	479.00 (-)
FP700	PSU	145.00 (5.00)
FC700	Tuner	103.85 (2.00)
FT77s	10w version	449.00 (-)
FMU77	FM Board for FT77	28.55 (1.00)
FT757	HF Transceiver	719.00 (-)
FC757	Auto A.T.U.	245.00 (2.00)
FP757HD	Heavy Duty PSU	179.00 (2.00)
FP757GX	Switched Mode PSU	145.00 (2.00)
FT480	2m M/Mode Transceiver	399.00 (-)
FL7050	Linear Amplifier	119.00 (2.00)
FT290	2m M/Mode Port Transceiver	279.00 (-)
FT290	With M/Mode front end fitted	309.00 (-)
FL2010	Linear Amplifier	66.55 (1.50)
FT790	70cm M/Mode Port/Transceiver	259.00 (-)
MMB11	Mobile Bracket	28.19 (1.50)
NC11	Carrier Case	10.55 (1.00)
CSC1	Carrying Case	4.45 (1.00)
YHA15	15cm Helical	5.65 (1.00)
YHA44D	14cm Jwawe	9.00 (-)
YMA4	Speaker Mike	19.25 (1.50)
FT230	2m 25w FM	269.00 (-)
FT730	70cm 10w FM	239.00 (-)
MMB15	Mobile Bracket	14.65 (1.50)
FT20	NEW 2m H/Heid	P.O.A. (-)
FT20	NEW 2m H/Heid	P.O.A. (-)
FT208	2m H/Heid	209.00 (-)
FT1708	70cm H/Heid	189.00 (-)
MMB10	Mobile Bracket	8.45 (1.00)
NC9C	Charger	9.20 (1.00)
NC8	Base/Station Charger	56.75 (2.00)
CA3	Car Adaptor/Charger	16.00 (1.00)
CA3	Spare Battery Pack	23.00 (1.00)
CA3	Speaker Mike	22.50 (1.50)
CA3	2m Base Station	275.00 (-)
FT76R	70cm Module for above	259.00 (2.50)
FRG700	HF Receiver 15-30MHz	385.00 (-)
FRG700M	As above with memory	455.00 (-)
FR7700	A.T.U for above	48.25 (1.50)
MH188	Hand 600 Bpm mic	15.70 (1.50)
MD188	Desk 600 Bpm mic	56.00 (1.50)
MF1A3B	800m mobile mic	18.95 (1.50)
YH77	Lightweight phones	12.50 (1.00)
YH55	Padded phones	12.50 (1.00)
YH1	L/weight Mobile H/set-Boom mic	15.75 (1.00)
SB1	PTT Switch Box 208/708	17.00 (1.00)
SB2	PTT Switch Box 290/790	14.50 (1.00)
QTR24D	World Time Clock	35.00 (1.00)
FF501DX	Low Pass Filter	28.99 (1.00)
YP150	Wattmeter/Dummy Load 150w	99.00 (2.00)

## Power Supplies

DRAE		BNOS	
4 amp	34.00 (2.00)	6 amp	52.90 (2.50)
6 amp	53.50 (2.50)	12 amp	95.45 (3.00)
12 amp	79.50 (3.00)	25 amp	138.00 (4.00)
24 amp	110.00 (4.00)	40 amp	276.00 (4.00)

## Aerial Rotators

9502B	3 core Lighter Duty	57.50 (2.50)
AR40	5 core Medium Duty	98.90 (2.50)
KR400	Med/H Duty	99.94 (3.00)
KR500	6 core Elevation	126.50 (3.00)
KR400RC	6 core Medium Duty	118.45 (3.00)
CD45	8 core Heavy Duty	149.50 (3.00)
KR600RC	8 core Heavy Duty	167.90 (3.50)
HAM1V	8 core Heavier Duty	264.50 (5.00)
TXZ	8 core Very Heavy Duty	332.35 (5.00)

## Switches

Sigma	2 way SO239	11.50 (1.00)
Sigma	2 way 'n' Skts	15.50 (1.00)
Welz	2 way SO239	20.75 (1.00)
Welz	2 way 'n' Skts	37.00 (1.00)
Drae	3 way SO239	15.40 (1.00)

## Miscellaneous

DRAE	Wavemeter	27.50 (1.50)
T30	30W Dummy load	7.10 (1.00)
T100	100W Dummy load	28.00 (1.50)
T200	200W Dummy load	41.40 (2.00)
CT300	300W Dummy load	58.00 (2.50)
DRAE	2m Pre-set A.T.V.	11.80 (1.50)
	Altai Dip Meter	49.00 (2.00)

**AERIALS BY:- JAYBEAM -  
HYGAIN - G. WHIP - TET -  
MINIBEAM - USUALLY  
IN STOCK**



(Tel: 0297-34918)



**CLOSED MONDAY/OPEN TUES-SAT 9:00-5:30**  
(closed for lunch 1:00-2:00)

REG G2BSW

STOCK ITEMS NORMALLY DESPATCHED WITHIN 48 HOURS RODNEY G6LUJ

Instant credit  
also available



Mail/Telephone order by Cheque or Credit Card.  
Cheques cleared before goods despatched.



Delivery prices  
shown in brackets



# HUNDREDS OF NEW LINES



The amazing Maplin Catalogue is here again! The new edition is packed with hundreds and hundreds of new electronic components to bring you right up to date with all the latest developments. As all home constructors agree (and a good many professionals too) the Maplin Catalogue is the one essential piece of equipment they really need. And now with all our **prices on the page** the Maplin Catalogue is better value than ever.

On Sale From 10th November 1984.

Pick up a copy as soon as it's published at any branch of W.H. Smith or in one of our shops. The price is still just £1.35, or £1.75 by post from our Rayleigh address (quote CA02C).

Post this coupon now for your copy of the 1985 catalogue.  
Price £1.35 + 40p post and packing. If you live outside the U.K.  
send £2.40 or 11 International Reply Coupons.  
I enclose £1.75.

Name .....

Address .....

.....

.....

PW1/85



**MAPLIN**  
ELECTRONIC SUPPLIES LTD

Maplin Electronic Supplies Ltd. Mail Order: P.O. Box 3, Rayleigh, Essex SS6 8LR.  
Tel: Southend (0702) 552911. • Shops at: 159-161 King Street, Hammersmith,  
London W6. Tel: 01-748 0926. • 8 Oxford Road, Manchester. Tel: 061-236 0281.  
• Lynton Square, Perry Barr, Birmingham. Tel: 021-356 7292.  
• 282-284 London Road, Westcliff-on-Sea, Essex. Tel: 0702-554000.  
• 46-48 Bevois Valley Road, Southampton. Tel: 0703-25831. All shops closed all day Monday.