

MAKING AN AUTOMATIC TIME SWITCH

PRACTICAL 13

SEPTEMBER
1958

EDITOR: F.J. CAMM

WIRELESS



CONTENTS

A FLASH UNIT
A TEST PROBE
TRANSMITTING TOPICS
CONVERTING THE R1155
SERVICING RADIO RECEIVERS
THERMION'S COMMENTS
Etc. Etc. Etc.

*A S.W. Portable
Battery Two*

RUSH to RELDA WE OFFER THE FINEST SELECTION OF EQUIPMENT

PLESSEY SPEAKERS
7in. x 4in. elliptical 3 ohms, 18/6.
5in. circular, 3 ohms, 17/6.

COMMUNICATION RECEIVER R.1155. This magnificent receiver covers 5 ranges: 75-200 Kc/s, 200-500 Kc/s, 600-1,500 Kc/s 3-7.5 Mc/s, 7.5-18.5 Mc/s. Fully tested before despatch. Complete with N type drive circuit and instruction booklet, £8/10/-, Carr. 10/-.

PICTURE FRAME AERIAL
Incorporates m w and l/w aerial with provision tuning out unwanted signals, noise, etc. Size 8 1/2 x 11 1/2 x 1 1/2, magnificent appearance. Brand new with full instructions, 12/6. P. & P. 2/6.

WHEATSTONE BRIDGE. Consisting of four stud switches: 0-10 ohms, 0-100 ohms 0-INF. Galvanometer centre zero F.S.D. 2.5 mA. Ranges easily extended. Housed in oak cabinet 16 x 7 1/2 x 6in. Complete with instructions, 40/- P. & P. 4/-.

No. 46 TRANSMITTER/RECEIVER for R/T and M.C.W. for frequencies between 3.6-9.1 Mc/s. Fixed crystal controlled. Weight 9lb. Size 6 1/2in. x 12in. x 4in. Complete with 6 valves and circuit. Less crystals and coil units 50/-.

MICROPHONES, BRAND NEW. Throat, magnetic, 4/6; Throat, carbon, 3/6; No. 8 carbon with switch, 6/6; No. 7 moving coil, 8/6.

TELEPHONE HANDSET. Brand new 12/6. P. & P. 1/-.

HEADPHONES — BRAND NEW. High resistance 4,000 ohms, 11/6. P. & P. 1/6. Low resistance 120 ohms, 6/6. P. & P. 1/6.

COMPLETE HEADPHONE AND MICROPHONE ASSEMBLY. A must for every Constructor and "Ham," consists of moving coil, padded headphones and "press to talk" microphone, 10/- P. & P. 3/6.

I.F. TRANSFORMERS. 465 kc/s. 7/6 pair. P. & P. 1/-.

866A VALVES. New and Boxed, 13/6. P. & P. 1/6.

AMERICAN ROTARY CONVERTORS. With cooling Fan. Input 12 v. D.C. Output 250 v. at 90 mA. Completely suppressed. Only 17/6 each. P. & P. 3/6.



WALKIE/TALKIE SET

Type 38 complete with 5 valves. Covers 7.4-9 Mc/s. operates on dry batteries. Brand New but not tested or guaranteed. **22/6** P. & P. 3/-.

RELDA TRANSFORMERS

Interleaved and impregnated. Primaries 200-230-250 v. 50 c/s.
250-0-250 v. 80 mA., 6.3 v. 3.5 a.; 4 v. 4 a.; 0-4.5 v. 2 a. 22/6
350-0-350 v. 80 mA., 6.3 v. 3.5 a.; 4 v. 4 a.; 0-4.5 v. 2 a. 22/6
250-0-250 v. 100 mA., 6.3 v. 3.5 a.; 5 v. 2 a.; 6.3 v. 1 a. 25/6
300-0-300 v. 100 mA., 6.3 v. 3.5 a.; 5 v. 2 a.; 6.3 v. 1 a. 25/6
6.3 v. 2.75 a. Filament transformers ... 7/6
0-12-15-20-24-30 v. 2 a. Filament transformers ... 20/6
0-5-11-17 v. 4 amps. Battery charger type ... 22/6

2-way TELEPHONE KIT



25/- P. & P. 3/6.
Install your own intercom !!! with this brand new kit consisting of 2 "press to talk" hand



telephones, long life battery, 100ft. of flex and simple wiring details. Ideal for garage, office, home, etc.

HEARING AID BARGAINS !!

Hearing aid ear piece, with lead, 4/6. Crystal mic inserts, postage stamp size, 3/6. The above are used in modern deaf aids. Order now, limited supply.

No. 18 TRANS/RECEIVER

A portable, self-contained Transmitter/Receiver for Telephone and C.W. Range approx. 10 miles. Frequency 6.9 Mc/s (50-33.3 metres). Valve line-up: 3 ARP-12, 2 AR-8, 1 ATP4. Complete with aerial, H.T. and L.T. meter. Weight 20 lb. size 8 x 10 x 17in. Only **60/-** Carr. 10/-.

813 VALVES U.S.A. 70/-

BENDIX RECEIVER MN 26.C.

Covering 150-1,500 kc/s in 3 bands. Valves used 5-6K7, 2-6N7, 2-6J5, 1-6F6, 1-6L7. Complete with switching motor and dynamotor. With circuit. **80/-** Only Carr 8/6

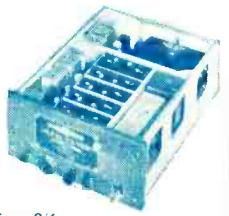

No. 19 SET ATTACHMENTS

Supply units	30/-
Variometers	20/-
Headphone and microphone assembly	13/6
Morse key assembly	4/6
12ft. aerial	12/6
Control box, single	5/6
Control box, double	8/6
Test meter	19/-
Circuit and instruction book	2/5

INFRA-RED MONOCULAR

Ideal for night viewing, etc. Complete with push button power unit and focus lenses. Brand new in beautiful carrying case. Originally cost Govt. £40. Our Price 25/- P. & P. 3/6.

R.T./APN-1 ALTIMETER TRANSCIEVER. Complete with 14 valves: 3 12S17, 4 12SH7, 2 12H6, 1 VR150, 2 9004, 2 955. Famous Wobbulator Unit. Dynamotor. Relays 3,500 ohms and 6,500 ohms. A.F. amplifier. Receiver section covers 400-450 Mc/s. Transmitter sweeps 418 to 462 Mc/s. Ideal for model control work, etc. Only 35/-, carriage 10/-.

VIBRATOR POWER PACK. Input 12 v., output 150 v. at 100 milliamps. Brand New. Price 20/- P. & P. 3/6.

METERS. 500 micro-amp. 2in. circular, calibrated 0-15 and 0-600 volts, 17/6. 0-1 mA. 2in. square, 22/6. 1 amp. H.F. 2in. circular, 5/6. P. & P. 1/6 on each.

AMERICAN MIDGET ACCUMULATORS. 36 volts, lead acid type. 2/6 ea. P. & P. 1/-.

RELAYS. 6,500 ohms and 3,500 ohms. 8/- pair. Post paid.

COLVERN WIRE WOUND POTENTIOMETERS. 25 watts 50k and 100k. Price 6/- each.

TANK PERISCOPE. American type. 7/6.

MALLORY JACK PLUGS. 2 contact, 3/6 or 4 for 10/-.

MUIRHEAD VERNIER SLOW MOTION DRIVES. Scaled 0-180 deg. Ratio 25 to 1. 3in. dia. 10/6. P. & P. 1/6.

ARMOUR RECORDING WIRE. U.S.A. top quality on original reels. Length 3,700 yds. 10/- P. & P. 1/6.

LUMINOUS MAGNETIC MARCHING COMPASS. Pocket size. Brand new with instructions. Only 12/6. P. & P. 1/-.

HOOVER ROTARY TRANSFORMER. 11.5 volts input, 490 volts output and 6 volt input, 230 volts output at 65 mA. 27/6.

ACCUMULATORS. 2 volts 16 A.H. (unspillable). Ideal for 6 and 12 volts supply, etc. Brand new original cartons. Size 4in. x 7in. x 2in., 5/6 each. P. & P. 1/6. 3 for 15/- P. & P. 3/6. 6 for 27/6. P. & P. 5/-.



32a, COPTIC STREET, LONDON, W.C.1.
AND
87, TOTTENHAM CT. RD., LONDON, W.1.

All post orders and correspondence to:
(Dept. 'P') 32a, Coptic Street, London, W.C.1.

EMI "HIS MASTER'S VOICE" MARCONIPHONE · COLUMBIA

Announce NEW PRACTICAL WAY OF LEARNING AT HOME

NEW — completely up-to-date methods of giving instruction in a wide range of technical subjects specially designed and arranged for self-study at home under the skilled guidance of our teaching staff.

NEW — experimental outfits and lesson manuals are despatched on enrolment and remain the student's property. A tutor is allotted to each student for personal and individual tuition throughout the course.

Radio and television courses, with which specially prepared components are supplied, teach the basic electronic circuits (amplifiers, oscillators, detectors, etc.) and lead, by easy stages, to the complete design and servicing of modern Radio and T/V equipments.

If you are studying for an examination, wanting a new hobby or interest, commencing a career in industry or running your own full-time or part-time business, these practical courses are ideal and may be yours for moderate cost. Send off the coupon to-day for a free Brochure giving full details. There is no obligation whatsoever.

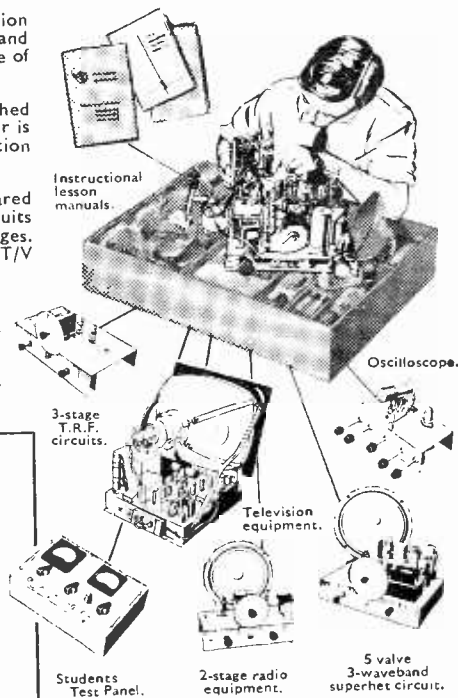

Courses with Equipment

RADIO · SHORT WAVE RADIO
TELEVISION · MECHANICS
CHEMISTRY · PHOTOGRAPHY
ELECTRICITY · CARPENTRY
ELECTRICAL WIRING · 'HI-FI'
DRAUGHTSMANSHIP · ART etc.

E.M.I. Factories at Hayes England.



EMI INSTITUTES

Fill in for **FREE BROCHURE**
 E.M.I. INSTITUTES, Dept. 32 X, London, W.4.

Name Age (If under 21)

Address.....

.....

(I am interested in the following subject(s) with/without equipment)

(We shall not worry you with personal visits)

1C107

FREE

BLOCK CAPS PLEASE

SEPT./58

The only Home Study College run by a World-wide industrial organisation

BENTLEY ACOUSTIC CORPORATION LTD. THE VALVE SPECIALISTS

38 CHALCOT ROAD, LONDON, N.W.1

Primrose 9090

EXPRESS SERVICE!!! C.O.D. ORDERS RECEIVED BY 3.30 P.M., EITHER BY LETTER, PHONE OR WIRE, DESPATCHED THE SAME AFTERNOON...

ANY PARCEL UP TO £10 INSURED AGAINST DAMAGE IN TRANSIT FOR ONLY 6d. EXTRA. ORDERS OVER £10 INSURED FREE.

Grid of valve types and specifications, including part numbers, ratings, and descriptions. Columns list various valve models like 6A16, 6L6G, 12A17, etc., with their respective characteristics.

NEW METAL RECTIFIERS, FULLY GUARANTEED

Table listing metal rectifier models (DRM1B, DRM2B, etc.) with their specifications, including current ratings and component counts.

HIVAC MINIATURE VALVES

Table of Miniature and Midget valves, showing types like XF40, XF74, XF15, etc., and their electrical ratings.

Hivac or Metal rectifier technical leaflet free on receipt of S.A.E.

TERMS OF BUSINESS:—CASH WITH ORDER OR C.O.D. ONLY. POST-PACKING CHARGES 6d. PER ITEM. ORDERS VALUE £3 OR MORE POST FREE...

ALL VALVES NEW, BOXED, AND SUBJECT TO MAKERS' 3 MONTH GUARANTEE. FIRST GRADE GOODS ONLY. NO SECONDS OR REJECTS.

PLEASE ENQUIRE FOR ANY VALVE NOT LISTED. 3d. STAMP, PLEASE.

WANTED

MEN

READY TO MAKE THE MOST
OF SKILLED TRAINING

See the next three pages

The Regular Army will make a skilled man of you

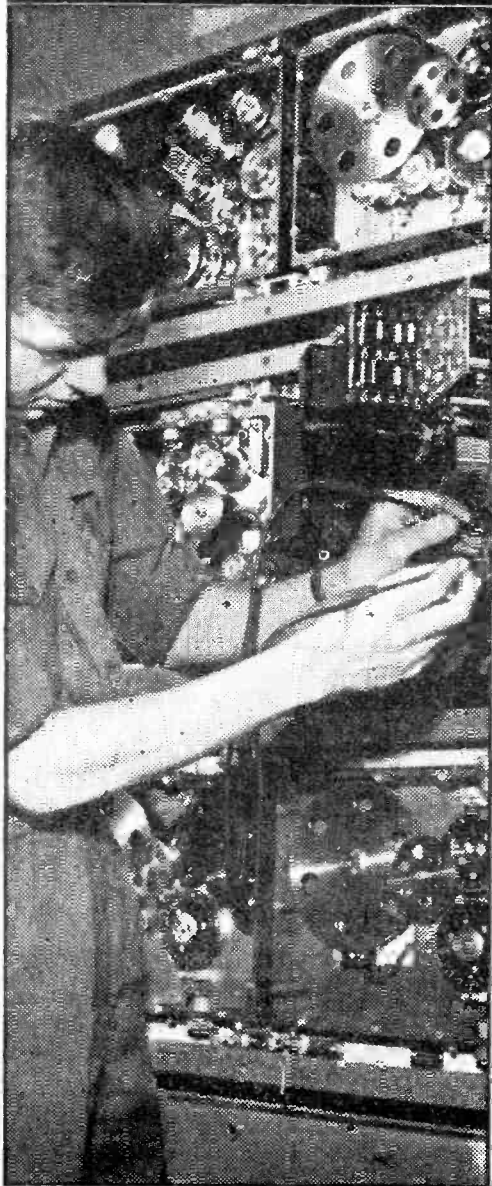

FIRST-CLASS TRAINING

in key trades covering Electronics, Electrical Engineering, Radar, Metallurgy, Motor Engineering, Physiotherapy, Laboratory work, etc., etc.

AND FULL PAY FROM THE WORD GO! IF YOU ARE OVER 17½

Who's the man who gets ahead these days? The *skilled* man of course. If you are already skilled there are wonderful prospects in the Army and there's no place like the modern Army for learning a modern trade. In today's Army, the technician is the key man—who else can maintain the rockets, the radar, the electronic equipment that gives an Army its teeth?

The army can accept the skilled man with a guarantee that he will be employed in his trade.

(continued at head of next page)

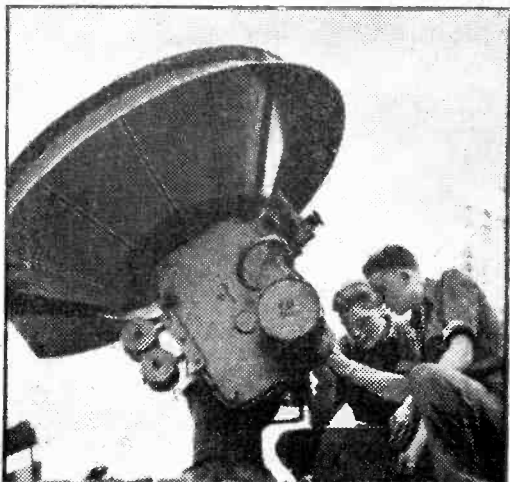

Testing sector switch on aerial of radar A.A. no. 3, mark 7.

(continued from foot of preceding page)

The Army also wants the brightest young men in Britain *now* to train. It wants to train them to be the nucleus of the most highly-developed fighting force in the world. Standards are high—you must be fit, you should have G.C.E. or its equivalent. Prospects are higher still. You can earn good money from the word go and you get first-rate training, as thorough as any in the country.

NO 'OIL RAG' STUFF—YOU REALLY LEARN THE TRADE

When the Army teaches you a trade, you really learn everything.

No spending your first two years turning a nut on a conveyor belt.

The fully-trained man in the Army knows his subject like the back of his hand.

THERE'S £1,000 A YEAR OR MORE WAITING FOR THE TOP MEN—PLUS PENSION

Yes, key technicians in the Army today, who are married, can collect as much as £20 a week or more. Promotion comes fast to the capable and ambitious man. These £20-a-week soldiers are often Warrant Officers under 30. Remember too, the advantages of Army Life—free uniform, free meals, special-rent married quarters, and plenty of leave on full money. Many technical Warrant Officers go on to a commission.

AND AFTER? SECURITY!

The trained technician who leaves the Army is assured of a good job in civilian life. Everyone wants the man with know-how—and after 22 years you'll have the added advantages of a good pension and a terminal grant. All the technical trades are recognised by the Trades Unions or professional bodies concerned.

YOU CAN EVEN START AT 14½

Even if you're still at school, you're old enough to start training for a key technical post in the Army. You can join an Army Apprentices School, earning a decent wage from the start. You get the time of your life, and technical training that gives you a flying start.

COMPARE THESE RATES

Here's what you can earn in the Modern Army.

As a Private on joining and during initial training £5.1.6 (or £6.2.6 if you enlist for 9 years).

When you have completed your training and become a technician

Private	£8. 11. 6
Corporal	£10. 10. 0
Sergeant	£12. 12. 0
Warrant Officer Class II	£15. 1. 0

Promotion to those ranks is quick if you are good. More, of course, when you're married, and there are also special overseas allowances.

Turn over for more details of the finest life in the world

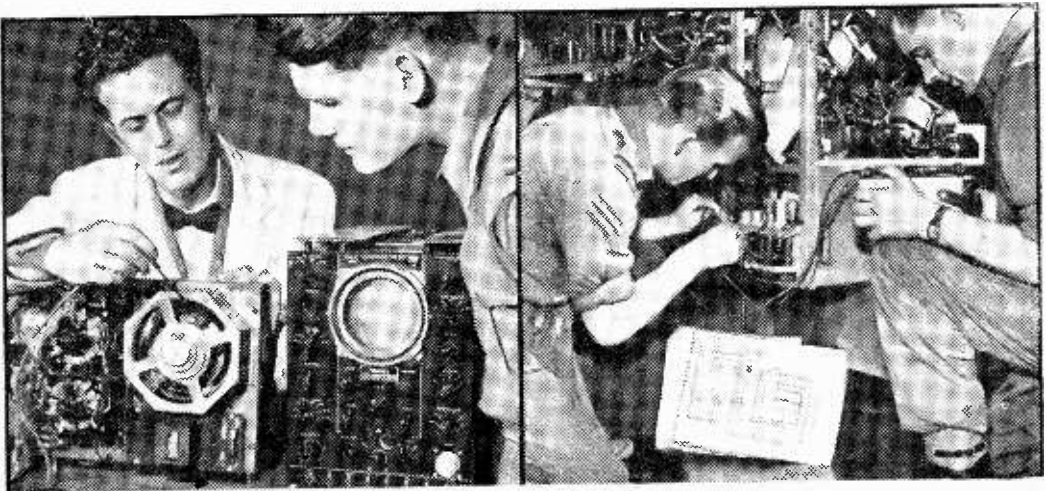

Showing a unit from a no. 11 predictor.

Working on the display unit of the radar A.A. no.3, mark 7.

The Army of today's all right!

Forget anything your Grandad ever told you about Army life! Instead, ask the young Regular of today what it's like. He'll tell you straight—it's a real man's life, with plenty of travel, sport, and adventure. Conditions in the Army today are better than they've ever been before—and getting better all the time. The British soldier is the finest workmate in the world—you get a sense of comradeship you won't find anywhere else. But what you get as well, today, is a real pride in technical training. He's got a technical training as thorough as any firm in the country could give him. He's got security—and he knows where he's going. Today, when he goes back to Civvy Street, the trained man has a good chance of getting a plum job in industry, with more technical knowledge than most of his contemporaries. Don't forget that the long service man has a good pension as well.



**IF YOU THINK
YOU COULD BE
ONE OF THE
PICKED MEN
POST THIS TODAY**

TO THE WAR OFFICE (MP/6) LONDON . SW1

Without committing myself in any way, I would like to know more about the opportunities for skilled training in the Regular Army.

NAME

ADDRESS

TOWN COUNTY

AGE NEXT BIRTHDAY

EDUCATIONAL QUALIFICATIONS

.....

SPEAKER BARGAIN



12in. Hi-fidelity loudspeaker. High flux. Permanent magnet type with standard 3 ohm speech coil. Will handle up to 12 watts. Brand new by famous maker. Price 32/6 plus 3/6 post and insurance.

500 WATT STEP DOWN TRANSFORMER

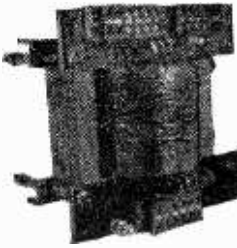

With output tapped from 110 v.-155 v. in 3 volt steps, massive transformer which will withstand considerable overloading. Price 45/- plus 5/- carriage (up to 250 miles).

DON'T STUMBLE IN THE DARK



Install 2-way switches. Our outfit comprises: 30 yds. Multi-core cable, two 2-way switches, two wood blocks. Full instructions. 19/6 each, post and insurance 2/6.

NOW 2 MODELS Turret Tuner

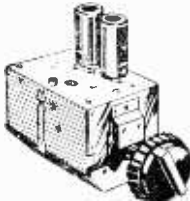

Brand new stock, not surplus, with coils for Band 1 and III complete with valves. Model 1 I.F. output 33 3/3 Mc/s. Series heaters Model 2 I.F. output 16/19 Mc/s. Parallel heaters. With instructions and circuit diagram, 79/6. With knobs 3/6 extra, post and insurance 2/6.

Yours for 10/- down and 17 weekly payments of 10/- or cash price

£8.10.0.

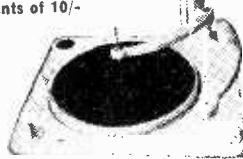

The latest, most up-to-date Record Player made by the famous B.S.R. Company. Using Hi-Fi Crystal Pick Up and fitted with every modern device. Definitely a record changer which will give years of trouble-free music. Not surplus but the current model. Price £8/10/- or 10/- deposit and 17 weekly payments of 10/-, carriage and insurance 5/-.

THIS MONTH'S SNIP

This fine cabinet as illustrated but less control knobs is available this month at special snip price of 12/6 plus 3/6 post and insurance. Size is 13 1/2 in. x 9 in. x 4 in. and it is nicely covered in two tone I.C.I. fabric.



Remote Control Contactor

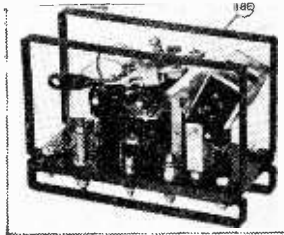

Double pole, rated for 30 amps. D.C. but suitable for much higher current on A.C. magnetic arch blowouts and asbestos arch shields. Coil wound for 220 v. D.C. but take turns off and it will be suitable for A.C., or if you prefer, work off A.C. with rectifier. Many applications such as remote switching of motors, banks of lamps, banks of heaters, etc., etc. Energising coil can be operated off Thermostat, Toggle Switch, Push Button or our vacuum delay switch. Size overall is 10in. x 8in. x 4 1/2 in. Original cost probably over £5, our price 13/6 each plus 3/6 carriage and insurance.

COIL PACK SNIP



Covers the Medium Waveband 200-550 metres and two short wavebands 35-120 metres and 13-42 metres, for 465 k.c. I.F. Extremely well made, supplied complete with diagram of connections. Only 9/6, plus 1/6 post and insurance.

FLUORESCENT LIGHTS

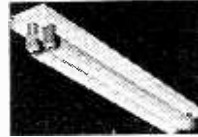

These are complete fluorescent lighting fittings. Built-in ballast and starters—stove enamelled white and ready to work. Ideal for the kitchen, over the work-bench and in similar locations. Single 40. 4ft. 3in. long, uses a 40 watt tube. Twin 20. Uses 2 20-watt standard tubes. Price for either type 39/6, with tubes. Carriage and ins. up to 150 miles 5/6, up to 250 miles 7/6.

DON'T BE CAUGHT LIKE THIS



CAR STARTER CHARGER KIT

All parts to build 6- and 12-volt charger which can be connected to a "flat" battery and will enable the car to be started instantly. Kit comprising the following:

Mains transformer.....	22/6
5-amp rectifier.....	17/6
Regulator Stud Switch.....	3/-
Resistance Wire.....	2/-
Resistance Former.....	2/6
Mains on/off Switch.....	2/6
0.5 amp. Moving Coil Meter.....	12/6
Construction Data.....	1/6

Or if bought all together price is 52/6, plus 3/6 post and packing.

Rectifier Bargains

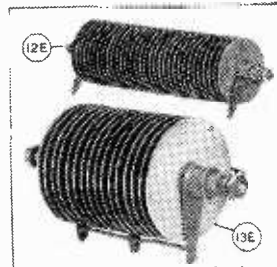

Selenium rectifier type 1-500 v. 1 amp half-wave, easily rebuilt into full wave or multiple type contains 30 35 mm discs. Price 8/6, plus 1/6 post. Type 2. 36 volt 9 amp, easily rebuilt into six full wave charger rectifiers suitable for 6 or 12 volt batteries at 3 amps, contains 24 84 mm. discs. Real bargain at 19/6, plus 1/6 post.

ELECTRONIC PRECISION EQUIPMENT, LTD

Post orders are dealt with from Eastbourne, so for prompt attention please post your orders to C6, Grove Road, Eastbourne, marked Department 7.

42-46, Windmill Hill Ruislip, Middx. Phone: RUISLIP 5780 Half day, Wednesday.	66, Grove Road, Eastbourne, Sussex. Half day, Saturday.	29, Stroud Green Rd., Finchbury Park, N.4. PHONE: ARChway1049 Half day, Thursday.	266, London Road, Croydon. Phone: CRO 6558 Half day, Wednesday
--	---	--	---

Band III Converter

Suitable for Wales, London, Midlands, North, Scotland, etc. All the parts including 2 EF80 valves, coils, fine tuner, contrast control, condensers, and resistors. (Metal case available as an extra.) Price only 19/6, plus 2/6 post and insurance. Data free with parts or available separately 1/8.



All-Mains Amplifier



Powerful three-valve mains amplifier ideal for dances, parties, etc. Complete less chassis, cabinet and speaker (available if required)—data 1/6 (free with parts). Price 19/6, plus 2/6 post and insurance.

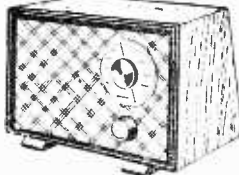

The Skysearcher

This is a 2-valve plus-metal receiver set useful as an educational set for beginners, also makes a fine second set for the bedroom, workshop, etc. All parts, less cabinet, chassis and speaker, 19/6. Post and ins. 2/6. Data free with parts or available separately, 1/6. 3-valve battery version also available at the same price.



Tube Tester and Re-Activator

We can supply all the main components for making this unit which will not only test Cathode Ray tubes but also will re-activate them, supplied complete with full instructions. Price £3, plus 2/6 post and ins.

Tubes but also will re-activate them, supplied complete with full instructions. Price £3, plus 2/6 post and ins.

A.C./D.C. Multimeter Kit

Ranges: D.C. volts 0.5, 0.50, 0.100, 0.500, 0.1,000. A.C. volts 0.5, 0.50, 0.100, 0.500, 0.1,000. D.C. milliamperes 0.5, 0.100, 0.500. Ohms 0.50,000 with internal batteries, 0.500,000 with external batteries. Measures A.C./D.C. volts, D.C. current and ohms. All the essential parts including metal case, 2in. moving coil meter, selected resistors, wire for shunts, range selector, switches, calibrated scale and full instructions, price 19/6, plus 2/6 post and insurance.



SUPER SENSITIVE (2,000 O.P.V.) MULTIMETER KIT

17 ranges including D.C. volts to 1,000 v., A.C. volts to 1,000 v., D.C. milliamperes to 500, ohms to 2 meg., capacity and inductance. All the essential parts, including metal case, selected resistors, wire for shunts, selected switches, calibrated scale and instructions, 32/6, plus 2/6 post and ins.

Medresco Hearing Aid

As supplied by National Health, completely overhauled and in good working order with six months' guarantee. Only £2.15.0 plus 2/6 post and ins. Complete with earphone and new ear plug but not batteries, these can be supplied as an extra for 5/- per set. Instructions showing how to convert to pocket radio available free if requested.



Short Wave Communications Receiver R208. 10/- Down & 15 Weekly Payments of 10/-

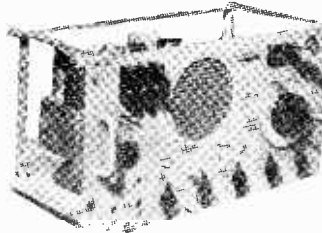

This is a super short wave receiver covering 5-30 metres (10-60 mc/s). Uses 6 valves, Has R.F. stage, 2 I.F. stages B.F.O. etc. Muirhead instrument driver, two internal power packs, mains and battery version pack. Complete with own P.M. speaker. Provision for phones and speaker muting. Complete in metal transit case; size approx. 24 x 18 x 12; weight 70lb. Suitable A.C. mains, 100-250 and 6 volt battery. In perfect condition, practically unused. Tested before despatch and guaranteed. Handbook free with each. Price 28/19/6, carriage and insurance 15/-. Or 10/- deposit, plus 15/- carriage, and 15 weekly payments of 10/-.

Famous Transmitter Virtually Given Away

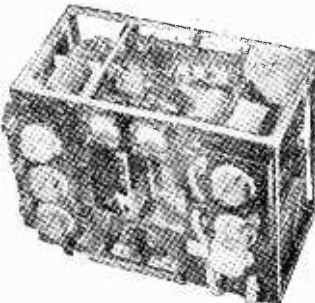

The famous R1154—unused but slightly soiled and not tested. Covers 200-500 kc/s, 3.5-5 Mc/s and 5.5-10 Mc/s. Has unique "click stop" mechanism (7 stops) and permits selected frequency to be held, returned to, etc. Hartley oscillator, power amplifier, keying and speech. Wonderful breakdown value meters, relays, switches. Complete with valves—real bargain at 29/6, plus 10/- carriage.

W.D. Circuit Details

Diagrams and other information extracted from official manuals. All 1/6 per copy, 12 for 15/- American Service Sheets

A.1134	R.109
BC.348	78 receiver
BC.312	76 receiver
R.103A	E28/ARC5
BC.342	E118/A
RA-1B	RA-1B
R-208	AR88D
R-1155	AN/APA-1
R-1124A	78
R-1132A/R-1481	R.T.18
R-1147	CAY-46-AAM-
R-1224A	-RADAR
R-1082	A.S.B-3
R-1055	Indicator G2A
B.C.1206-A/B	Indicator A.S.B.3
B-455-A (or-B)	Indicator G2
B-454-A (or-B)	Indicator 6K
B-453-M-A (or-B)	R.F. unit 24,
Transmitter T1154	R.F. unit 25
Fifty-eight walkie talkie	R.F. unit 26
Frequency meter	R.F. unit 27
B.C. 221	Wireless set No. 19
	Demobbed valves

TV Masks

Latest type grey crystalate.
14in 10 - 17in. 12 -
Plus 1/- post.

Unused and Boxed Valves

OZ4	9/-	6F5	9/6	7B5	12/6
1A4	9/-	6F6	7/6	7C7	12/6
1A6	9/-	6F7	12/6	7D5	9/6
1F7	12/6	6F8	9/6	7D9	9/6
1L18	8/6	6F92	10/6	7H7	8/-
1L46	8/6	6G6	7/6	7K8	12/6
1N56	3/6	6H6	2/6	7R7	10/-
1LD5	3/6	6J5	5/6	7S7	10/-
1T4	7/6	6J7	6/-	12H6	8/6
1R5	7/6	6K6	7/-	12SH7	8/6
1S5	7/6	6K7	5/-	12S7	8/6
1T5	7/6	6L5	5/-	12S7	8/6
2A5	12/6	6L6	9/-	25B5	12/6
2A6	12/6	6L7	10/7	26	10/-
2A7	12/6	6N7	8/6	27	10/-
2D13C	5/-	6R7	9/-	28D7	3/6
3A2	4/6	6S7	9/-	31	7/6
3A4	4/-	6SA7	8/-	32	7/6
3D6	5/-	6SG7	8/-	34	12/6
3Q4	7/6	6SH7	6/-	39/44	10/-
4D1	2/6	6SJ7	8/6	41	9/6
5U4	8/6	6SK7	6/-	42	8/-
5Z3	12/-	6SL7	8/-	43	10/-
5Z4	9/6	6SN7	7/6	57	10/-
6A6	12/6	6SQ7	9/-	58	10/-
6AG5	6/6	6SS7	9/-	71	9/6
6AC7	6/6	6T7	12/6	75	12/6
6AG	10/-	6TH8	12/-	77	8/-
6B4	5/-	6U5	8/6	83	12/6
6B7	10/6	6V6	8/6	84	8/6
6B8	4/-	6X5	7/6	807	6/6
6BQ6	12/6	6V6	9/-	954	3/6
6C4	6/6	6Z5	15/-	1625	10/6
6C6	6/6	7A2	12/6	805	80/-
6CB	5/-	7A7	9/6	913	90/-
6D6	6/6				

T.V. Service Sheets

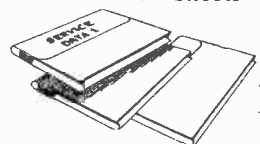

100 sheets covering the most popular post-war Televisors by leading makers—Cossor, Ekco, Ferguson, Pye, etc. £1 post free.

More Summer Sale Bargains

Cabinet Safety Switch for cutting current as door opens, double pole 15 amp. Also makes good foot-switch. 8/6 plus 2/- p. & l.

Instrument type Slow Motion Drive with engraved scale and locking device. 8/6 plus 2/- p. & l.

Selenium Rectifier rated 36 v. at 6 amp. full wave. Easily rebuilt into four 12-18 v. 3 amp. full wave charging rectifiers. 17/6 plus 2/- p. & l.

Diode, 500 v. 1 amp., easily rebuilt into full wave or multiple type rectifiers. It contains thirty-one 45 millimetre discs. 10/- plus 2/- p. & l.

Neon Lamp, midge type ended. Ideal for making mains tester or for any of the dozen-and-one applications to which a neon can be put. 2/-

Instrument Transformer, Input 200-230 v., output 6.3 v. at 3/4 amp., and two separate 85 v. 10 milliamp windings which can be joined in series or parallel. 8/6, plus 1/6 post & packing.

3in. Meter Moving Coil, flush mounting, really beautifully made by G.E.C. Two types available 500-0-500 microamp and 1 milliamp. i.s.d. 37/6 plus 2/- p. & l.

Indicator Lamp for panel mounting, complete with bulb. 2/6.

Fuse Carrier for panel mounting, complete with fuse. 2/6.

Winking Eye, telephone or circuit indicator. 5/-.

Motor Snip

Miniature motor 2 1/2 in. long x 1 1/2 in. diameter, laminated poles and armature, separate winding for reversing. Operates off 20-30 v. D.C. or off A.C. former. Original cost at least £3 each. Snip price for one month only 6/6, plus 1/6 postage and insurance.



Sapphire Needles

Unrepeatable bargain—new and perfect—two types available: miniature E.M.I. and Standard (trailer). Sale price 1/- each or 10/- doz.



Morganite Potentiometers

Single and 2 gang types available, standard size with good length spindle all new and boxed. Single types 1/- each, values available: 5K, 10K, 25K, 50K, 100K, 250K, 1 meg., 2 meg. Gang type, 3/- each—values available: 5K, 5K., 100K, 100K., 1 meg., 1 meg., 1.6.



Yaxley Switches

3-pole, 2-way	1/3
12-pole, 2-way	1/6
3-pole, 3-way	1/6
6-pole, 3-way	2/-
2-pole, 4-way	2/-
6-pole, 4-way	2/6
4-pole, 5-way	2/6
2-pole, 6-way	2/6
1-pole, 7-way	2/6
1-pole, 12-way	2/6
6-position shunting switch	2/-

Double-pole mains switch for attaching to Yaxley switches. 1/6 Discount of 10% allowed where a dozen of one type ordered. Special quotes 144 or over.

For Your Lab.

Resistance substitution boxes are great time savers and you really cannot have too many of them. Here then, is an opportunity to acquire these at a very low rate. Our R.S. Kit, available for only 8/6 plus 1/6 postage, comprises a 50 w. precision variable resistor, six 2-3 watt fixed resistors, one 6 position switch, two knobs, and instructions. This unit, when made up, will give an infinite variability over the range 100 ohms to 2 meg.

All for less than the price of the cabinet

Fine walnut veneered table receiver cabinet complete with metal chassis, three colour glass scale, back plate and scale mounts, as illustrated but less knobs. Offered at less than the price of the cabinet. **namely 39 6** plus carriage and insurance.



Charging Switchboard

Offered at about one-twentieth of original cost. This is an excellent Government switchboard. It contains three reverse current relays, one voltmeter, one main ammeter, two secondary ammeters and three variable resistors for controlling circuits. These are original cases. Price £2 15/- Carr. 10/-

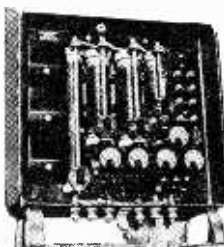

Latest AVO Testmeter



Can be yours for only 10/- deposit and 19 payments of 10/- weekly. Like all AVO meters it is a very fine instrument; it has a sensitivity of 10,000 ohms per volt and 19 most useful ranges as follows—D.C. volts 0-1 meg. (5 ranges), resistance 0-2 megs. (2 ranges) (complete with test leads). Immediate delivery. Cash price £9.10.0.

Telephone Repeater No. 1, Mark I



This equipment is for amplifying tele- phone signals in both directions of traffic and also to remedy line distortion of speech. It is intended for use with two wire or four wire circuits, has four amplifiers and is in fact two quite independent repeaters mounted on the same panel and having a common power supply. The power supply may be operated from a 12 volt car battery or from standard A.C. mains. The units are absolutely new in original packing complete with spares and instructional manual. Price £20 each.

Huge Ministry Purchase R.1155—yours for £2 down

Frequency 75 kc/s to 18 Mc/s, 10 valves, metal case. Robust receiver, cost over £60 to make—will give years of service, very little used. Price £10 or 5 payments of £2.



Carr. & transit case 15/- ex.

Summer Sale Bargains

7 Valve 5 Waveband superhet chassis, H.F. stage an magic eye. Crused but may be slightly soiled and need servicing—less valves, power pack and tuning scale. Contains really fine coil pack which alone would cost twice what we are asking for the whole unit. Price with circuit diagram, £2.15.0. Carriage and insurance 7/6.

Screened Cable, Rubber covered flexible with metal braiding, ideal for microphone or gramophone extensions. 4d. per yd., 30/- per 100 yds.

10 Valve Superhet, 1 1/2 meter experiment but unused, complete with valves, easily converted for Band III, 29 6, carriage and packing 7/6.

Auto Transformer, Totally enclosed. Primary 200/250 v., Secondary, 110/120 v. rated 200/250 v., 27/6, carr. & ins., 2/6.

Filament Transformer, 6.3 volt 3/4 amp., tap to primary 8 f.

Transformer Suitable A.F. or low R.F., new tested, O.K. most circuits, 6/6.

Midge Output Transformer, standard pentode matching, 4 6.

Midge Output Transformer, Special for battery sets, pentode matching, 4/6.

4in. T.V. Cabinet by famous maker, cost over £4 to make, new and perfect. 15/-, carriage 4 6.

Metal Rectifier, 250 v. 60-80 milliamps, ideal for mains set or instrument of to replace that expensive valve. 4/6

Constructors Parcel, 5-valve superhet chassis, 15 x 15 x 2 with three waveband glass scale, pulleys, drive head, etc., 9/6, plus post and insurance, 1/6

Toggle Switch, Standard metal body type with round dolly, fixing ring and on off indicating plate, 1/3 or 12/- doz.

For Extra Power Plug, 7 029 three-core cable, 500 v. grade, 70/- for 100yd. Coil carriage 5/-.

Thin Paxolin Panels, Size 8in. x 5in. 2/6 doz.

Midge I.F. coils 465 kc/s but with feedback winding for economy circuits, 6/6 pair.

Mains Transformer, Standard 230 v., input 250-0-250 at 80 mA., 6.3 v. at 5 A., 12/6.

Connecting Wire P.V.C. Covering, All colours. Sale price 2/6 per 100 ft. coil or 5 coils different colours, 10/- the lot.

50 Assorted Resistors, Well mixed and useful values 1 and 1 watt, 5/- or 50.

Diode, but 1 watt, 6/6 for 50.

1 Mfd 350, Small tubular metal cased condensers made by Dubilier, 2/6 doz.

Loudspeaker 8in. energised field, 3/6, carriage 3/6.

6ft. Unbreakable Mains Lead, Type of lead fitted to electric razors, makes fine lead for test meters and any other devices where subject to continuous bending. Twin figure eight construction, soft cream P.V.C. covered. Normally costs 2/- per yard—we offer three leads for 2/-.

Welding Transformer, 12v-50 amp., continuous rating—intermittent rating for spot welding—exceeds 2,000 amps, 45/-, carriage and packing 5/-.

Metal Rectifier, Equivalent of RM5-250 mA., 250 v., 12/6.

Cathode Ray Tube VCR517, 7 6, carriage, etc., 9/6.

Thermal Relay Vacuum Relay with book of interesting circuits, 4 6.

ELECTRONIC PRECISION EQUIPMENT, LTD

Post orders are dealt with from Eastbourne, so for prompt attention please post your orders to 66, Grove Road, Eastbourne, marked Department 7.

42-46, Windmill Hill, Ruislip, Middx. Phone: RUISLIP 5780. Half day, Wednesday.

66, Grove Road, Eastbourne, Sussex. Half day, Saturday.

29, Stroud Green Rd., 286, London Road, Finsbury Park, N.4, Croydon. Phone: ARCHWAY 1049. Half day, Thursday. Half day, Wednesday.

R.S.C. A8 ULTRA LINEAR 12 WATT AMPLIFIER

High-Fidelity Push-Pull Amplifier with "Built-in" Tone Control. Pre-amp. stages, high sensitivity. Includes 5 valves (807 outputs). High quality sectionally wound output transformer, specially designed for Ultra Linear operation, and reliable small condensers of current manufacture. **INDIVIDUAL CONTROLS FOR BASS AND TREBLE** "Lift" and "Cut". Frequency response 3 db. 30-30,000 c/c.s. Six negative feedback loops. Hum level 71 db. down. **ONLY 70 millivolts INPUT** required for **FULL OUTPUT**. Suitable for use with all makes and types of pick-ups and practically all microphones. Comparable with the very best designs.

For **STANDARD or LONG - PLAYING RECORDS**. For **MUSICAL INSTRUMENTS**, such as **GUITARS, etc. OUTPUT SOCKET** with plug provides 300 v. 20 mA. and 6.3 v. 1.5 A. For supply of a **RADIO FEEDER UNIT**. Size approx. 12-9-7in. For A.C. mains 200-230-250 v. 50 c/c.s. Outputs for 3 and 15 ohm speakers. Kit is complete to last nut. Chassis is fully punched. Full instructions and point-to-point wiring diagrams supplied. Unapproachable value at **£7/15/-** or factory built 45/- extra. Carriage 19/-.

£7-15-0

If required louvred metal cover with 2

COLLARO RC54 3-SPEED AUTO-CHANGERS with Studio pick-up. Brand new. For 110 v. 50 c.p.s. A.C. mains. Price with 110 v. to 200-250 v. Auto Trans. only **£8 19/6**. Carr. 5/6.

COLLARO CONQUEST 4-SPEED AUTO-CHANGERS with high fidelity Studio pick-up. Latest model. Brand new. Cartoned. For 200-250 v. 50 c.p.s. A.C. mains. Our price **£8 19/6**. Carr. 5/6. Credit Terms. Deposit 3 gns. and 6 monthly payments of 21/6.

COLLARO 4-SPEED SINGLE-PLAYER with separate pick-up, as fitted RC457. For 200-250 v. A.C. mains. 4 gns. Post 3/9.

PICK-UP ARMS complete with Hi-Fi turnover crystal head. ACOS P54. Limited number brand new, perfect at approx. half price. Only 29/9.

LG3 MINIATURE 2-3 WATT GRAM AMPLIFIER. For use with above or any other single or auto-change units. Output for 2-3 ohm speaker. For 200-250 v. 50 c.p.s. A.C. mains. Overall size 6 1/4 x 4 1/2 in. Controls: Vol. and Tone with switch. Guaranteed 12 months. Only 55/9.

SUPERHET FEEDER UNIT. Design of a high quality Radio Tuner Unit (specially suitable for use with any of our Amplifiers. Delayed A.V.C. employed. The W.Ch. Sw. incorporates Gram position. Controls are Tuning, W.Ch. and Vol. Only 250 v. 15 mA. H.T. and L.T. of 6.3 v. 1 amp. required from amplifier. Size of unit approx. 6-7 in. high. Complete alignment procedure. Point-to-point wiring diagrams, instruction and priced parts list with illustration. 2/6. Total building cost. **£4/15/-**. For descriptive leaflet send S.A.E.

LINEAR L45 MINIATURE 4/5 WATT QUALITY AMPLIFIER. Suitable for use with Collaro B.S.R. or any other record playing unit, and most microphones. Negative feedback 12 db. Separate Bass and Treble Controls. For A.C. mains input of 200-250 v. 50 c/c.s. Output for 2-3 ohm speaker. Three miniature Mullard valves used. Size of unit only 6-5 1/2 in. high. Output for 2-3 ohm speaker. Guaranteed for 12 months. Only **£5/19/6**. Send S.A.E. for illustrated leaflet. Credit Terms: Deposit 22/6 and 5 monthly payments of 22/6.

LINEAR "DIATONIC" 10-14 WATT HIGH FIDELITY PUSH-PULL ULTRA LINEAR AMPLIFIER. For 200-250 v. A.C. mains. Valves ECC83, ECC83, EL84, EL84 miniature Mullard. Self-contained Pre-amp. Tone Control stage, and separate Bass and Treble Controls. Independent "Mike" and Gram input sockets are provided. Output Matches for 3 and 15 ohm speakers. Only 12 Gns. or Deposit 29/9 plus 10/- carr. and 9 monthly payments of 26/9. Send S.A.E. for leaflet.



carrying handles can be supplied for 13/6. Additional input sockets with associate Vol. control so that two different inputs such as Gram and "Mike" or Tape and Radio can be mixed, can be provided for 13/- extra. Guaranteed 12 months.

TERMS on assembled two input model: **DEPOSIT 25/6** and nine monthly payments 25/6. **HIGH-FIDELITY MICROPHONES** and **SPEAKERS** in stock. Keep cash prices or credit terms if supplied with amplifier.

R.S.C. 4-5 WATT A5 HIGH-GAIN AMPLIFIER

A highly-sensitive 4-valve quality amplifier for use with a horn, small club, etc. Only 50 millivolts input is required for full output so that it is suitable for use with the latest high-fidelity pick-up heads, in addition to all other types of pick-ups and practically all "mikes". Separate Bass and Treble Controls are provided. These give full long-playing record equalisation. Hum level is negligible being 71 db. down. 15 db. of negative feedback is used. H.T. of 300 v. 25 mA. and L.T. of 6.3 v. 1.5 A. is available for the supply of a Radio Feeder Unit, or Tape-Deck pre-amplifier. For A.C. mains input of 200-230-250 v. 50 c/c.s. Output for 2-3 ohm speaker. Chassis is not alive. Kit is complete in every detail and includes fully punched chassis (with base-plate) and point-to-point wiring diagrams and instructions. Exceptional value at only **£4/15/-**, or assembled ready for use 25/- extra, plus 3/6 carr., or Deposit 22/6 and 5 monthly payments of 22/6 for assembled unit.



LINEAR LT45 HIGH QUALITY TAPE REPRODUCER AMPLIFIER. With "built in" power pack and output Ready for stage. For Tape Decks Use. ONLY with High or Low Impedance. Playback and Erase. Heads, such as Lane, Truvox, Collaro, Brennell. Carr. 7/6 etc. For A.C. Mains 230-250 v. 50 c.c.s. Linear frequency response of ± 3 db. 50-11,000 c/c.s. Negative feedback equalisation. Illustrated leaflet 6d.

SENSATIONAL OFFER STAAR GALAXY 4-SPEED MIXER AUTO-CHANGER. A precision manufactured unit with a motor which virtually eliminates "wow" and rumble. Pitted pick-up with dual sapphire tipped stylus. For 200-250 v. A.C. mains. Limited 5 t o e k s . O n l y Brand new, cartoned. Carr. 4/6. Portable cabinet. Staar Changer, LG3 Amplifier, 6 1/2 in. Speaker. 11 GNS. Carr. 7/6.

12 GNS.

£4-19-6

TERMS: C.W.O. or C.O.D. No C.O.D. under 21. Post 1/9 extra (order £2. 2/9 extra under £5. All goods supplied subject to terms and guarantee as detailed in current catalogue. Open 9 to 5.30; Sat. until 1 p.m. Catalogue 6d. Trade list 5d. S.A.E. with all enquiries.

R.S.C. 30 WATT ULTRA LINEAR HIGH-FIDELITY AMPLIFIER A10

A highly sensitive Push-Pull high output unit with self-contained Pre-amp. Tone Control Stages. Certified performance figures compare equally with the best expensive amplifiers available. Hum level 70 db. down. Frequency response ± 3 db. 30-31,000 c/c.s. A specially designed sectionally wound ultra linear output transformer is used with 807 output valves. All components are chosen for reliability. Six valves are used, EF86, EF86, ECC83, 807, 807, GZ33. Separate Bass and Treble Controls are provided. Minimum input required for full output is only 12 millivolts so that ANY KIND OF MICROPHONE OR PICK-UP IS SUITABLE. The unit is designed for **CLUBS, SCHOOLS, THEATRES, DANCE HALLS or OUTDOOR FUNCTIONS**, etc. For use with Electronic ORGAN, GUITAR, etc. For use with standard or long-playing records. **OUTPUT SOCKET PROVIDES L.T. and H.T.** for a **RADIO FEEDER UNIT**. An extra input with associated vol. control is provided so that two separate inputs such as Gram and "Mike" can be mixed. Amplifier operates on 200-250 v. 50 c.c.s. A.C. Mains and has output for 3 and 15 ohm speakers. Complete kit of parts with fully punched chassis and point-to-point wiring diagrams and instructions. If required by cover as for A8 can be supplied for 18/9. The amplifier can be supplied factory built with 12 months' guarantee, for **£13.19.6. TERMS: DEPOSIT 36/9** and 9 monthly payments of 31/9.

11 GNS.

R.C.A. 20 WATT RE-ENTRANT SPEAKERS, 15 ohms or 600 ohms matching. For Outdoor work. Only 8 GNS. **P.M. SPEAKERS**, All 2-3 ohms, suitable for use with LG3, L45, A5, or A7 amplifiers, 5in. Goodmans, 17.9. 7 x 4in. Elliptical Blac., 19.9. 6in. Goodmans, 17.9. 8in. Rola, 18.9. 10in. R. 27.9. 10.5 x 8in. Elliptical Goodmans, 29.9. 12in. Plessey, 29.11. 10in. W.B. "Stentorian" 3 or 15 ohms type HP 1012 10 watts. hi-fidelity type. Recommended for use with our A8 Amplifier. £4/10/9. 12in. Plessey 9 ohms 10 watts. (12,000 lines). 59/6.

PLESSEY DUAL CONCENTRIC 12in. 15 ohms HIGH FIDELITY SPEAKERS (12,000 lines) with built in tweeter (completely separate elliptical speaker with choke, condensers, etc.), providing extraordinarily realistic reproduction when used with our A8 or similar amplifier. Rated 10 watts. Price only **£5/17/6**.

M.E. SPEAKERS 2-3 ohms, 8in. R.A. Field. 600 ohms, 11.9.

R.S.C. 3-4 WATT A7 HIGH-GAIN AMPLIFIER
For 230/250 v. 50 c/c.s. Mains input. Appearance and Specification, with complete KH with diagrams, £3 15/- Assembled 22/6 extra. Carr. 3/6.

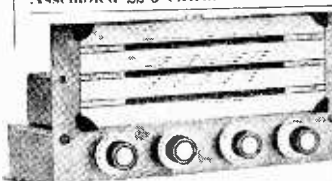

AM/FM RADIOGRAM CHASSIS HIGH QUALITY 6-8 WATT PUSH-PULL OUTPUT

For 200-250 v. Mains. Long wave, Medium, V.M. and Gram. Complete with 8 B.V.A. valves. Guaranteed 12 months. Only 22 GNS. Or Deposit £2/12/- and 9 monthly payments of £2/12/-

RADIO SUPPLY CO. LTD.

www.americanradiohistory.com
LTD. Callers to Maude St. (Opp. Parish Ch. School) Leeds 2

Stern's "fidelity" TAPE RECORDERS

- THEY INCORPORATE . . .**
- Choice of the latest **COLLARO** or **TRUVOX** Tape Decks
 - The model **HF/TR2** "fidelity" **AMPLIFIER**
 - **ROLA/CELESTION** 10 x 6in. P.M. Speaker
 - 1,200ft. reel **EMI** Tape
 - **ACOS** Crystal Microphone



THIS POPULAR RECORDER IS OFFERED INCORPORATING EITHER . . .

★ **THE NEW MK IV COLLARO TRANSCRIBTOR DECK** or ★ **THE NEW TRUVOX MK IV DECK.**

- You WON'T BUY better value
- Truly "Hi-Fi" RECORDINGS are obtainable
- Call in and HEAR THEM or send S.A.E. for ILLUSTRATED LEAFLET

PRICE INCORPORATING COLLARO DECK £49.10.0

CREDIT SALE. Deposit £12.8.0 and 9 Monthly Payments of £4.10.8.
H.P. TERMS. Deposit £24.15.0 and 12 Monthly Payments of £2.5.11.

PRICE WITH TRUVOX DECK INCORPORATING REV. COUNTER . . . £52.10.0

CREDIT SALE. Deposit £13.2.6 and 9 Monthly Payments of £4.16.3.
H.P. TERMS. Deposit £26.5.0 and 12 Monthly Payments of £2.8.8.
 (Plus £1.10.0 carriage & insurance of which £1 is refunded on return of Packing Case.)

A TAPE PRE-AMPLIFIER and ERASE UNIT



STERN'S MODEL HF/TRIP—A completely assembled Pre-amplifier with

own Power Supply. Can be supplied correctly matched for use with Truvox or Collaro Decks and incorporates Recording Level Indicator and Monitoring facilities. Please send S.A.E. with any enquiry. **PRICE £11.10.0** (Plus 5/- carr. and ins.)

SPECIAL REDUCTION WHEN PURCHASED WITH DECK.

"fidelity" TAPE AMPLIFIER HF/TR2 with Separate SMALL POWER SUPPLY UNIT £16.0.0

H.P. TERMS: Deposit £8 and 9 months of £1.
CREDIT TERMS: Deposit £4 and 9 monthly payments of £1.9.4. When ordering please advise make of deck in use. Send S.A.E. for full details.

HOME CONSTRUCTORS. We can supply a COMPLETE KIT OF PARTS to build this TAPE AMPLIFIER for £12 (plus 5/- carr. and ins.). The Assembly Manual, Practical Diagrams, etc., are available for 2/6.

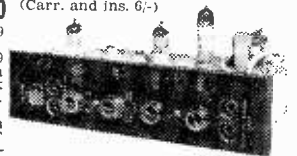

Can be supplied to correctly operate with Collaro & Truvox Decks.

HOME CONSTRUCTORS

BUILD YOUR OWN RECORDER . . . We offer

- (a) The **HF/TR2 AMPLIFIER and POWER UNIT**, both assembled, with the **TRUVOX MK. IV TAPE DECK** **£38.10.0**
- ALTERNATIVELY** the Amplifier and P/Unit as a **KIT OF PARTS** **£35.0.0**
- (b) The **HF/TR2 AMPLIFIER and POWER UNIT**, both assembled, with the **TRUVOX TAPE DECK** incorporating **PRECISION REV. COUNTER** **£41.10.0**
- ALTERNATIVELY** the Amplifier and P/Unit as a **KIT OF PARTS** **£38.0.0**
- (c) The **HF/TR2 AMPLIFIER and POWER UNIT**, both assembled, with the **NEW MARK IV COLLARO TRANSCRIBTOR DECK** **£36.0.0**
- ALTERNATIVELY** the Amplifier and P/Unit as a **KIT OF PARTS** **£32.10.0**

TO COMPLETE THE RECORDER . . . We offer
 The Portable Carrying Case
 Acos Crystal Mike . . . Rola 10in. ALL carr. (Plus 7/6
 6in. P.M. SPEAKER . . . 1,200ft. FOR **£9.0.0** & ins.)
 Plastic Tape.

SPECIALLY REDUCED PRICES FOR COMBINED ORDERS—ADD TAPE TO YOUR EXISTING AMPLIFIER . . . WE OFFER YOU

- (a) The Model **HF/TRIP TAPE PRE-AMPLIFIER** together with the **TRUVOX MK IV TAPE DECK** **£35.0.0**
- (b) **ALTERNATIVELY** as in (a) above but Truvox Deck incorporating **PRECISION REV. COUNTER** **£38.0.0**
- (c) The Model **HF/TRIP TAPE PRE-AMPLIFIER**, together with the **NEW MK IV COLLARO TRANSCRIBTOR DECK** **£32.10.0**

PLEASE INCLUDE 12/6 to cover cost of carriage and insurance. **HIRO PURCHASE** and **CREDIT SALE TERMS** are available on all equipment (excluding Kits of Parts). Send S.A.E. for details.

NOTE: The Deck switches of the Transcriber have to be "wired-up." We will complete this wiring for use with either HF/TR2 or the HF/TRIP for an extra £1.

THE NEW COLLARO "TRANSCRIBTOR" MK. IV DECK is in stock at **£24.0.0**. WE ALSO HAVE A FEW OF THE **MK III TRANSCRIBTORS** at **£17.10.6**. (Carriage and Insurance is 10/- extra.)

A Selection of RADIOGRAM CHASSIS enabling "MODERNISATION" of that OLD RADIOGRAM

ALL ARE THE LATEST AM/EM DESIGN

- The Dulci Model H.3 **£20.17.0**
- The Dulci Model H.4 **£24.6.6**
- The Dulci Model H.4/FP **£29.3.10**
- The **ARMSTRONG** → **PB 409** **£29.8.0**
- The **ARMSTRONG AF 105** **£37.0.0**

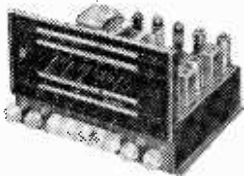

We also have the latest **FM** or combined **AM/FM RADIO TUNING UNITS.**

- The Dulci FM Tuner incorporating Power Supply **£17.10.3**
- The Dulci AM/FM Tuning Unit having own Power Supply incorporated **£20.17.0**
- The TSL FM Tuner incorporating Power Supply **£18.18.0**

The above are just a few examples—we have others. Send S.A.E. for full data on any chassis. Credit Sale and H.P. Terms are available.

"FRUSTRATED EXPORT ORDER"

The Corsor Model 527, X 4-Valve "All dry" Battery Transportable.

Offered **£6.15.0** Plus 5/- carr. for & ins.

Consists of a 4-valve Superhet Receiver covering Medium Waveband 197-575 metres, and two Short Wavebands 13.6 to 136 metres. The new low consumption valves are incorporated and the whole is accommodated in an attractive robustly made case. Battery required is 90 volts and 1.4 volts (price 19/6) and is external to case.

STERN'S "F.M." TUNING UNIT

A 5-valve Tuner incorporating the latest Mullard Permeability Tuning Heart and a "Magic Eye" Tuning Indicator.

PRICE ASSEMBLED £14.10.0

READY FOR USE (Plus 7/6 carriage and insurance.)
TERMS: (a) **HIRO PURCHASE:** Deposit **£7.5.0** and 9 monthly payments of 19/4.
 (b) **Credit:** Deposit **£3.12.6** and 9 monthly payments of **£1.6.7**.

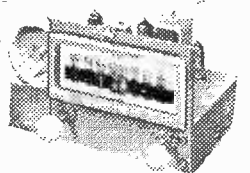
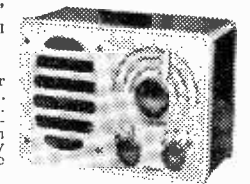

HOME CONSTRUCTORS—You can build this unit for **£10.10.0**. Full Assembly Instructions are available for 1/6.

HOME CONSTRUCTORS—BUILD YOUR OWN "HI-FI" LOUDSPEAKER SYSTEM

WITH W-B'S WELL-KNOWN RANGE OF READY-TO-ASSEMBLE CABINETS. ALL ARE BEAUTIFULLY MADE AND FINISHED AND VERY EASILY ASSEMBLED. ONLY A SCREWDRIVER IS REQUIRED. THEY ARE PACKED FLAT IN CARTONS AND COMPLETE WITH SCREWS.

SEND S.A.E. FOR LEAFLET.

STERN RADIO

LIMITED (Dept. P.W.)

PLEASE SEND S.A.E. WITH ALL

1958 NEW LOOK MULLARD DESIGNS FOR THE "Hi-Fi" ENTHUSIAST

THE VERY POPULAR MULLARD "5-10" MAIN AMPLIFIER

MULLARD'S NEW 2-STAGE PRE-AMPLIFIER - TONE CONTROL UNIT

THE NEW MULLARD "3-3" MAIN AMPLIFIER

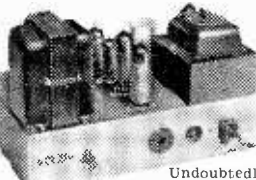

Undoubtedly the most successful amplifier yet designed, and used in conjunction with the new Mullard Pre-Amplifier, an undistorted power output of up to 10 watts is obtained. Thoroughly recommended to the "Hi-Fi" enthusiast who contemplates a very high quality home installation. In addition the versatility of the equipment makes it quite suitable for use in small halls, etc. We supply complete to MULLARD'S Specification with specified valves and components including the latest PARMEKO Ultra-linear Output Transformer and the PARMEKO Mains Transformer which has power available to drive Radio Tuning Unit.

COMPLETE KIT OF PARTS £10.00
 Alternatively, we supply **ASSEMBLED and TESTED £11.10** (Carriage & Insurance 5/- extra.)
 This "5-10" with the latest **PARTRIDGE ULTRA-LINEAR OUTPUT TRANSFORMER** for **£1.60** extra

A completely new design employing Two EF86 valves, and in particular designed to operate with the Mullard range of Power Amplifiers, but also perfectly suitable for other makes, etc.

Briefly it incorporates:

- Equalisation for the latest R.I.A.A. Characteristics.
- Input for variable reluctance.
- Magnetic Pick-Ups.
- Input for Crystal Pick-Ups.
- Input for Tape replay.

(a) Direct from High Impedance Tape Head.
 (b) From a Tape Amplifier or Pre-Amplifier.

- Sensitive Microphone Channel.
- Wide range Bass and TREBLE Controls.
- Attractive Perspex front control panel.
- Our Kit is strictly to MULLARD'S SPECIFICATION. **£6.60**

COMPLETE KIT OF PARTS
 Alternatively, we supply **ASSEMBLED and TESTED £8.00** (Carriage & Insurance 5/- extra.)

Based entirely on the present very popular "3-3" model and designed to operate in conjunction with the new 2-stage PRE-AMPLIFIER (shown left) thus providing all the facilities associated with the more expensive "Hi-Fi" Equipment. We recommend it as the IDEAL HOME INSTALLATION where very high quality is desired at the lower volume level (up to 3 watts). We supply completely to MULLARD'S SPECIFICATION including the latest PARMEKO Output Transformer, specified Valves and Components. Has power available to drive a Radio Tuning Unit.

COMPLETE KIT OF PARTS £7.00
 Alternatively, we supply **ASSEMBLED and TESTED £8.00** (Carriage & Insurance 5/- extra.)

Please enclose S.A.E. if ILLUSTRATED and alternatively, the COMPLETE ASSEMBLY Lists and Practical Drawings, etc., are available at 1/6 each.

SPECIAL PRICE REDUCTIONS . . .

- (a) THE COMPLETE KIT OF PARTS to build both the "3-3" MAIN AMPLIFIER and the 2-STAGE PRE-AMPLIFIER-CONTROL UNIT . . . **£12.10.0**
 - (b) THE COMPLETE KIT OF PARTS to build the "5-10" MAIN AMPLIFIER and the 2-STAGE PRE-AMPLIFIER-CONTROL UNIT . . . **£15.15.0**
- PRICES FOR THE "5-10" ARE SUBJECT TO £1.60 EXTRA IF THE PARTRIDGE TRANSFORMER IS REQUIRED.

- (a) The "3-3" and the 2-STAGE PRE-AMPLIFIER both ASSEMBLED and TESTED . . . **£15.0.0**
 CREDIT: DEPOSIT £8.15.0 & 9 Monthly Payments of £1.7.6 H.P.; DEPOSIT £7.10.0 & 9 Monthly Payments of 19/-
- (b) The "5-10" and the 2-STAGE PRE-AMPLIFIER both ASSEMBLED and TESTED . . . **£18.18.0**
 CREDIT: DEPOSIT £4.15.0 & 9 Monthly Payments of £1.14.7 H.P.; DEPOSIT £9.9.0 & 12 Monthly Payments of 17/6. When ordering include an extra 7/6 to cover Carriage and Insurance.

THE NEW COMPLETE MULLARD "5-10" AMPLIFIER

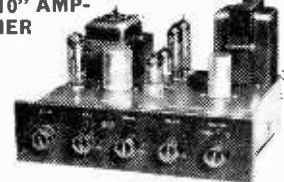

Designed for a simple domestic installation with Genuine High Quality reproduction up to a maximum of 10 watts. Separate BASS and TREBLE Controls are incorporated with switched inputs for 78 and L.P. Records plus Radio Tuning Unit. We incorporate SPECIFIED COMPONENTS and NEW MULLARD VALVES. We also give the purchaser the choice of two of the best ULTRA-LINEAR OUTPUT TRANSFORMERS made—first the latest by PARMEKO, LTD., and also the latest by PARTRIDGE (£1.60 extra). We also supply the PARMEKO MAINS TRANSFORMER, and this has extra power available to supply a Radio Tuning Unit.

The Control Unit can easily be detached from the Amplifier Chassis for use in a remote position.

COMPLETE KIT OF PARTS £11.10.0 (PARMEKO Transformer)
 Alternatively, we supply **ASSEMBLED and TESTED £13.10.0**
 Credit Sale, Dep. £3.7.6 and 9 Monthly Payments of £1.4.11. H.P. Terms, Dep. £6.15.0 and 3 Monthly Payments of 19/6. Send S.A.E. for ILLUSTRATED LEAFLET or 1/6 for the COMPLETE ASSEMBLY MANUAL.

THE NEW COMPLETE MULLARD "3-3"

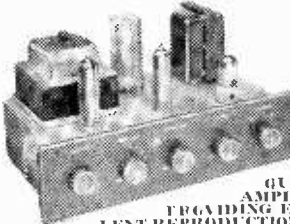

A VERY HIGH QUALITY AMPLIFIER BRAGGING EXCELLENT REPRODUCTION AND HAVING AN ATTRACTIVE PERSPEX FRONT PANEL.

COMPLETE KIT OF PARTS £7.10.0 (plus 6/6 coverage and insurance).
 Alternatively supplied **ASSEMBLED and FULLY TESTED £8.19.6** (plus 6/6 coverage and insurance).

The complete specification is available for 1/6. Developed from the very popular 3-valve 3-watt Amplifier designed in the Mullard Laboratories. Our kit is complete to MULLARD'S SPECIFICATION including supply of specified components, Mullard valves and a PARMEKO OUTPUT TRANSFORMER.

We also include switched inputs for 78 and L.P. records, plus a radio position. Extra power to drive a Radio Tuning Unit is also available.

THE IDEAL AMPLIFIER FOR A SMALL HIGH QUALITY INSTALLATION

The Portable Case will also accommodate almost any make of Autochanger and is attractively finished in Maroon and Grey Rexine.

WE ALSO SUPPLY SEPARATELY—
 (a) The 2-Stage (plus Rectifier) . . . **£4.2.6**
 (b) CASE PORTABLE CARRYING . . . **£3.17.5**
 (c) P.M. SPEAKER . . . **13/9**
 Carriage and Insurance 4/- extra.

NOTE ONLY NEW HIGH GRADE COMPONENTS and MULLARD VALVES are supplied with these Kits—We do NOT use "Surplus" or "Cheap" components.

RECORD PLAYERS

The Very Latest Models are In Stock. **MANY AT REDUCED PRICES!!!**
 TRANSCRIPTION UNITS — AUTO-CHANGERS, SINGLE RECORD PLAYERS

Send S.A.E. for ILLUSTRATED STOCK LIST A FEW CASH BARGAINS

- The latest ISRR MONARCH 4 SPEED MINER AUTO-CHANGER. Entirely complete with Crystal Pick Up **£7.19.6**
- The latest COLLARO 4 SPEED AUTO-CHANGER — Complete with the Studio "O" Pick Up (Also available with the low gain Studio "P" Pick Up for £8.15.0.)
- The latest COLLARO 4 SPEED SINGLE RECORD PLAYER complete with Studio "O" Pick Up **£6.19.6**
- The COLLARO "JUNIOR" 4 SPEED SINGLE RECORD PLAYER, complete with separate Crystal Pick Up **£4.10.0**

(This high output Crystal Pick Up is available separately for £1.12.6.)
 Carriage and Insurance on above Units 5/- ex.

SPECIAL CASH ONLY OFFER !!

This very attractive PORTABLE AMPLIFIER CASE together with a good quality GRAM AMPLIFIER and a matched P.M. SPEAKER.

ALL for **£8.7.6** ONLY (plus 7/6 carr. & ins.).
 The Amplifier consists of a 2-Stage design incorporating 3 modern B.V.A. valves and has separate BASS and TREBLE CONTROLS.



109 & 115 FLEET ST., LONDON, E.C.4.
 Telephone: FL Eet 5812, 3/4.
CORRESPONDENCE

BRIMAR 6T8

The Brimar 6T8 is a triple-diode triode in which one diode has a separate cathode. The triode section has a high amplification factor making the valve suitable for use in AM/FM receivers in the demodulation and first stage audio circuits. The diodes may be used in series shunt limiter circuits, for example, in the audio sections of

television and communications receivers, followed again by the triode, section for A.F. amplification.



Near Equivalents
EABC80 DH719
6AK8

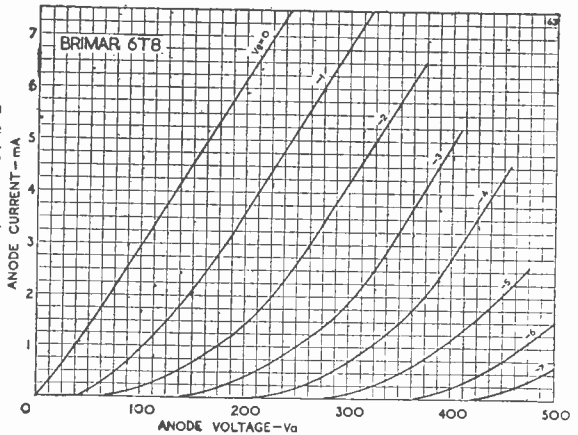

Typical Triode Operating Characteristics as an R.C. coupled amplifier.

Anode Supply Voltage	250	250 volts
Anode Load Resistor	0.25	0.25 megohm
Grid Resistor	1.0	10 megohms
Cathode Bias Resistor	3	0 kilohms
Peak Output Voltage	43	40 volts
Stage Gain (for 24 V peak to peak output)	42	42-
Distortion (for 24 V peak to peak output)	1	5%

Keep this for further reference or write to the Publicity Department for a data sheet.

Standard Telephones and Cables Limited **FOOTSCRAY SIDCUP KENT** Footscray 3333

Yours the easiest way!

How would you like to have one of the newly stylised and redesigned M.I.P. Series 100 Multi-Range Test Sets on your bench almost by return of post? It's easy, you just send 47/6 as deposit and pay the rest in six monthly instalments of £1.16.0. The cash price is £12.7.6. Post the coupon for full details.

21 RANGES

- covering
- 10-1000 d.c. volts
- 10-1000 a.c. volts
- 100 Microamps to 500 Milliamps d.c.
- 100 Microamps a.c.
- 0 to 1 Megohm
- 0 to 10,000 ohms

★ **There is also the SERIES 90**

Terms for the Series 90 Test Set (19 self-contained ranges ac/dc 200 micro-amps 5,000 ohms per volt).

Deposit 35/- and six monthly payments of 28/10. (Cash price £9.15.0).

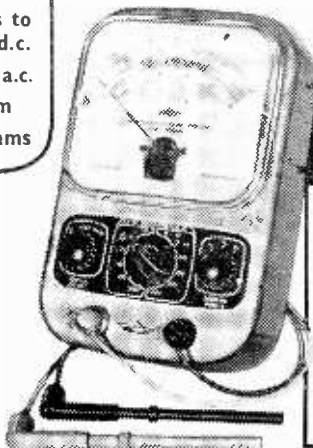

MULTI-RANGE TEST SET - SERIES 100

TO MEASURING INSTRUMENTS (PULLIN) LTD.
Electrin Works, Winchester Street, Acton, London, W.3
Please send illustrated leaflet of the series 100 Test Set with details of new easy payment scheme

Ditto, Series 90

* Please indicate instrument required.

NAME
ADDRESS

E958

PRACTICAL WIRELESS

EDITOR : F. J. CAMM

26th YEAR
OF ISSUE

EVERY MONTH
VOL. XXXIV, No. 621, SEPTEMBER 1958
COMMENTS OF THE MONTH

BY THE EDITOR

THE RADIO SHOW

THE Radio Show opens its portals to the public on August 27th and closes on September 6th. There are no indications as this issue goes to press (some weeks before the Show opens) of any startling developments in the field of radio, but early indications show quite clearly that the accent will be on stereophonic sound. Several manufacturers are producing stereo receivers, and a few new tape recorders will be shown. Receivers will reflect the great advances in the use of transistors and of printed circuits. With minor exceptions, prices will be maintained at last year's levels. As usual, the side shows put on by the Service Departments and by the BBC will be major attractions. There are also important improvements in the catering arrangements and visitors will be able to have their meals or their afternoon teas in greater comfort. A few firms will be catering for the constructor—firms who built their businesses on the constructor market and have never regretted it although they have entered the manufactured receiver market. The exhibitors will be more or less as last year with an odd newcomer and a few absentees. Television will of course "hold" the floor, to a greater extent than hitherto, but here again there are no outstanding developments except the tendency towards larger tubes. The 9-in. tube is obsolescent.

Next month's issue will be specially devoted to a review of the Show. We hope that every reader visiting Earl's Court will make a point of calling on us at our Stand No. 108, ground floor.

EX-GOVERNMENT APPARATUS

ONCE again may we draw the attention of readers buying ex-Government apparatus to the importance of ascertaining from the suppliers whether instruction literature is available. We mention this because daily we receive a large post asking for such literature which we are quite unable to supply. All supplies were exhausted years ago. It is for this reason that we are unable to help readers who wish to modify such receivers.

PRINTED CIRCUITS

WE have now received a sufficient number of letters on the subject of printed circuits to enable us to form an opinion as to the number of readers interested. It has been a mixed bag, the keen experimenters pointing out that such receivers leave no room for circuit alterations and experiment, whilst others interested in really midget receivers see in the printed circuit the means of designing a really tiny receiver of the battery type. Others require mains receivers of the domestic type. As an experiment, therefore, next year we shall produce a design making use of a printed circuit.

"BEGINNER'S GUIDE TO TELEVISION"

COPIES of the "Beginner's Guide to Television" are now available at 7s. 6d., by post 8s. 3d., from the Book Department, address as on this page.—F.J.C.

Our next issue, dated October, will be published on September 5th

Editorial and Advertisement Offices :
PRACTICAL WIRELESS

George Newnes, Ltd., Tower House,
Southampton Street, Strand, W.C.2.

(C) George Newnes Ltd., 1958.

Phone : Temple Bar 4363.
Telegrams : Newnes, Rand, London.
Registered at the G.P.O. for transmission by Canadian Magazine Post.

SUBSCRIPTION RATES

including postage for one year

Inland - - - 19s. per annum.
Abroad - - 17s. 6d. per annum.
Canada - - - 16s. per annum.

CONTENTS :

	Page
Editorial	507
Round the World of Wireless	508
Adapting the R1155	510
A Six Transistor 2-Wave	
Pocket Superhet	511
A Multivibrator Test Probe	515
A Full Compass Electric	
Organ	517
An Electronic Flash Unit ...	519
On Your Wavelength	523
Beginner's Constructional	
Course	524
An Automatic Time Switch	527
A S.W. Portable Battery	
Two	533
Stereo On Disc	536
Transmitting Topics	541
Servicing Radio Receivers...	549
News From the Trade	554
Programme Pointers	558
Open to Discussion	561

The Editor will be pleased to consider articles of a practical nature. Such articles should be written on one side of the paper only, and should contain the name and address of the sender. Whilst the Editor does not hold himself responsible for manuscripts, every effort will be made to return them if a stamped and addressed envelope is enclosed. All correspondence intended for the Editor should be addressed: The Editor PRACTICAL WIRELESS, George Newnes, Ltd., Tower House, Southampton Street, Strand, W.C.2. Owing to the rapid progress in the design of wireless apparatus and to our efforts to keep our readers in touch with the latest developments, we give no warranty that apparatus described in our columns is not the subject of letters patent.

Copyright in all drawings, photographs and articles published in PRACTICAL WIRELESS is specifically reserved throughout the countries signatory to the Berne Convention and the U.S.A. Reproductions or imitations of any of these are therefore expressly forbidden. PRACTICAL WIRELESS incorporates "Amateur Wireless."

ROUND THE WORLD OF WIRELESS

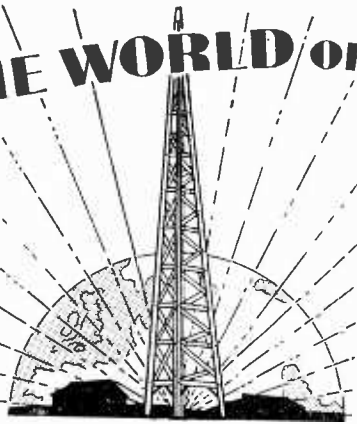

Broadcast Receiving Licences

THE following statement shows the approximate number of Broadcast Receiving Licences in force at the end of May, 1958, in respect of receiving stations situated within the various Postal Regions of England, Wales, Scotland and Northern Ireland. The numbers include Licences issued to blind persons without payment.

Region	Total
London Postal	1,032,443
Home Counties	1,037,801
Midland	764,445
North Eastern	959,012
North Western	736,397
South Western	638,669
Wales and Border Counties	396,370
Total England and Wales	5,565,137
Scotland	681,698
Northern Ireland	178,695
Grand Total	6,425,530

The Radio Show

WILL readers please make a note of our stand number at the Radio Show: (No. 108, ground floor), where all readers will be welcome. The Radio Show takes place from August 27th to September 6th.

Pocket Transistor Receiver

IN reply to numerous correspondents, transistors for the Pocket Transistor Receiver, details of which were published on pages 372 and 373 of our July, 1958 issue, are obtainable from Oakfield Radio, Oakfield Road, Davenport, Stockport and Radio Component Specialists, 337, Whitehorse Road, West Croydon, Surrey.

Education Exhibition

THE entire range of technical education facilities provided by the Mullard Educational Service to schools and technical colleges throughout the country were featured at a special exhibition held at the Electronics Centre, Mullard House. The exhibition ran from July 8th to July 11th. Every aspect of the service was illustrated in the various displays and, in addition, a programme

are kept in a fully charged condition by float chargers. Thus, in the event of a failure or reduction of the public electricity supply the system will continue to function normally.

In operation the system will prevent serious wastage of ships' time caused by delays in locating tugs and launches and directing them to where they are needed. Previously this work has been carried out either by a messenger launch which had first to seek out the required vessel before instructions could be passed on, or by hailing the required vessel from the Harbourmaster's lookout.

The equipment was supplied through Marconi's agents in Pakistan, International Industries Limited, and the installation work was carried out with the assistance of the Karachi Depot

By "QUESTOR"

of instructional films and filmstrips was presented continuously during the exhibition.

V.H.F. Radio Aids Harbour Control

A MARCONI V.H.F. radio system has been installed by the Karachi Port Trust to improve the efficiency of the port operation and control the movements of tugs and pilot launches in the harbour and its approaches.

Marconi 10 watt F.M. transmitter/receivers arranged for duplex operation have been used throughout.

The scheme provides for fixed stations in the offices of the Harbour Master, Dock Master and Mechanical Engineer and five mobiles fitted in the three tugs and two pilot launches under the control of the Harbour Authorities. Power supply for the fixed stations is provided by batteries which

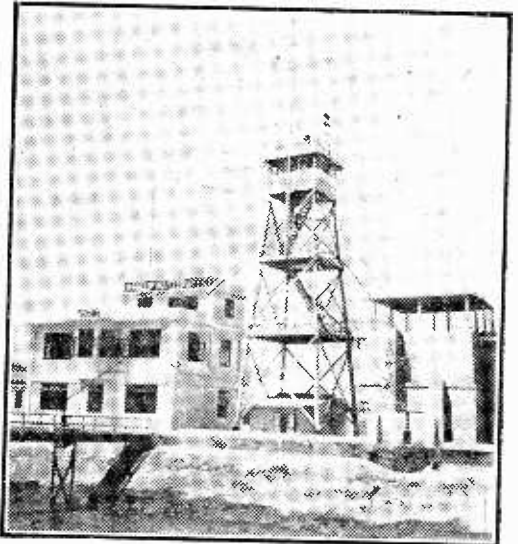

A view of the Harbour Master's office and signal tower at Manora Point on the west side of the Karachi natural harbour. The Marconi fixed station equipment is installed in the office building (note aerial mast with dipole) and can be controlled either from there or from the signal tower. See "VHF Radio Aids Harbour Control."

of the Marconi International Marine Communication Co. Ltd., who have also secured a maintenance contract.

BBC Appointment

MR. W. E. C. VARLEY, Associate I.E.E., has been appointed assistant superintendent engineer, transmitters, on the retirement of Mr. C. W. Skinner, M.B.E., after more than 33 years' service.

"Beginner's Guide to Television"

THE Beginner's Guide to Television," a companion volume to our "Beginner's Guide to Radio," is now available at 7s. 6d. or by post 8s. 3d., from the offices of this journal.

Radar Speed Tests

MARCONI'S WIRELESS TELEGRAPH CO., LTD., announce the production of the first radar speed check equipment to be designed and manufactured in Great Britain. The device is known as Peta (Portable Electronic

Traffic Analyser). Peta removes one of the major objections to the use of radar as a means of checking the speed of road vehicles in that it can discriminate between individual vehicles even under conditions of dense traffic. It will provide separate readings on vehicles which are only 8ft. apart and will automatically "lock on" to any individual reading if so desired. The speed range of the equipment is from 2 m.p.h. to 80 m.p.h., but this can be extended if required. The accuracy of speed assessment is within 1 m.p.h.

Chassis to Requirements

A. C. M. ELECTRONICS LTD., 61, Osborne Road, Acton, London, W.3, state that they are prepared to make chassis, formed and drilled, to individual readers' requirements.

Peta—Technical Details

PETA employs the Doppler effect of frequency change which occurs when electromagnetic waves are reflected from moving objects. This principle, in conjunction with the extremely narrow horizontal beam-width of the radiated signals (between 3 deg. and 4 deg.), provides simplicity of design, portability and high accuracy of measurement, giving the user a device which calls for no technical skill in its operation. An extensive use has been made of transistors and printed circuits in order to achieve compactness and light weight.

The transmitted beam is reflected from

the vehicle concerned and is picked up by the receiver, which measures the difference in frequency between the transmitted signal and the received one.

75 Years of Progress

ON 2nd May, 1958, Standard Telephones and Cables Ltd. attained its seventy-fifth anniversary. On that date, three-quarters of a century earlier, J. E. Kingsbury, who had made a special study of the telephone and who the year before had written the first handbook on telephone practice ever to be published, opened an office in Moorgate Street to handle the telephone business of the Western Electric Company in Great Britain. From that modest agency, begun with a staff of three only seven years after the invention of Bell's telephone, there has grown up the present S.T.C. organisation—one of the greatest telecommunications engineering firms in the world, employing over 24,000 people at seven major factories and other locations throughout England and Wales.

"Here is the News"

THE BBC has just published an interesting pamphlet entitled "Here Is The News" illustrated with photographs, which explains how the BBC News Services work in sound as well as vision.

New Donegall Disc

A NEW Donegall 7in. L.P.R., 45 r.p.m. is of the Kestrels singing Be My Girl, We Were Young, I Like Your Kind of Love and Down by the Riverside. Lord Donegall is specialising in the production of high-fidelity dance records.

The International Ham-Hop-Club

THE INTERNATIONAL HAM-HOP-CLUB which is described as "The Radio Amateurs' Own Holiday Club," has been formed "for the sole purpose of providing mutual aid facilities for both licensed radio amateurs and S.W.L.'s to enable them to visit each other in their own homes." The secretary is Mr. G. A. Partridge, G3CED, 17, Ethel Road, Broadstairs, Kent.

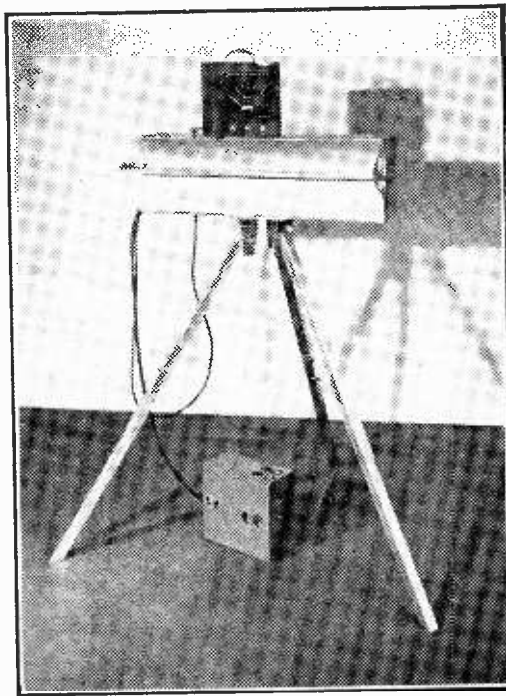

This photograph shows one of the new models of "PETA." Other models are being manufactured. See "Radar Speed Tests."

THE R1155 CONVERTER

Adapting for Use With Other Receiver Types By R. H. Wright

ALTHOUGH the R1155 converter described in the February issue of PRACTICAL WIRELESS, 1958, was originally designed to enable signals between 1.6 to 3.0 Mc/s and 18.5 to 31.5 Mc/s to be received on the R1155 receiver, it is possible to use it in conjunction with other receivers. Since the converter is not now being used with the R1155 it is unnecessary to separate the H.T. negative and earth lines and these may now be common. The circuit is shown in Fig. 1.

Under the original arrangement, the incoming signal was mixed with the locally-produced oscillation (L2/C4) to produce the intermediate frequency of 465 kc/s and, since the anode circuit of the frequency changer valve (C8/L3) was tuned to this frequency, the I.F. signal passed through C7 to the aerial input of the R1155. The receiver would then be tuned to 465 kc/s and the whole arrangement formed a double superhet. receiver.

The Denco coils specified for the converter (Blue range for the aerial coil, L1, and Red range for the oscillator coil, L2) are designed so that provided the two tuning capacitors C1 and C4 are ganged or, if separate, kept approximately in step, the I.F. produced will always be 465 kc/s. This signal can only be fed into a receiver which normally tunes to this frequency. However, if the receiver with which it is now desired to use the converter will tune to a frequency of, say, 560 kc/s, the converter may be used provided that the two tuning capacitors C1 and C4 are individually tuned and the oscillator circuit tuned to a frequency 560 kc/s higher than that received by the aerial circuit. The incoming signal will then mix with the locally-produced oscillation to give an I.F. of 560 kc/s.

It will now be necessary to replace the anode coil L3. For an I.F. of 465 kc/s a Denco Blue range 1 coil is suitable, but this coil will only tune to about 525 kc/s and so, for an I.F. of 560—or thereabouts—a Blue range 2 coil will be required. As before, connection is made to the two tags separated by a paint spot. Changing the I.F. in this way will, of course, modify the range normally covered by the coils but this modification will decrease in effect as the range increases.

Denco also manufacture a range of oscillator coils (White range) which will produce an I.F. of 1,600 kc/s and these may be used instead of the Red coils if the co-operating receiver will tune to this frequency. In the case of receivers such as the Type 19, which tunes from 2 to 8 megacycles, the White range oscillator coil may be used and C1 and C4 tuned individually to

give an I.F. of 2 Mc/s, the receiver should then be tuned to this frequency. With such an I.F., L3 (Fig. 1) should then be a Blue range 3 coil.

If an A.G.C. line is available in the receiver it may be extended and connected to the grid of the converter triode-hexode, otherwise C2 and R5 should both be omitted.

The converter will require a H.T. supply of 250 volts and 6.3 volts for L.T. to the valve heater.

COMPONENTS REQUIRED FOR FIG. 1.

- C1, C4—300 pF. variable. Alternatively 500 pF. capacitors may be used with a 0.001 mfd (mica) fixed capacitor in series with each.
- C2—0.01 mfd.
- C3, C6, C9—0.1 mfd. 350 volt working.
- C5, C7—100 pF.
- C8—300 pF. pre-set.
- Cp—Padding capacitor—This value depends upon the oscillator coil in use and should be as follows :
 Red range 3, 1.67 5.3 Mc/s (180/57 metres) 1,100 pF.
 White range 3, 1.67 5.3 Mc/s (180/57 metres) 340 pF.
 Red range 5, 10.5, 31.5 Mc/s (28/9.5 metres) none.
 White range 5, 10.5, 31.5 Mc/s (28/9.5 metres) 2,000 pF.
- R1—200 ohms, 1 watt.
- R2—68,000 ohms, 1 watt.
- R3, R4—47,000 ohms, 1 watt.
- L1/L2—Denco octal based plug-in coils.
 Blue for aerial tuning coil and Red for 465/560 Kc/s I.F., White range for oscillator if I.F. is to be 1,600 Kc/s or thereabouts.
- L3—Denco Blue range chassis mounting coil. (For range number see text).
- R5—470,000 ohm, 1 watt.
- Valves.—Osram X65, X61M, Mullard ECH35.

Fig. 1.—
The revised circuit.

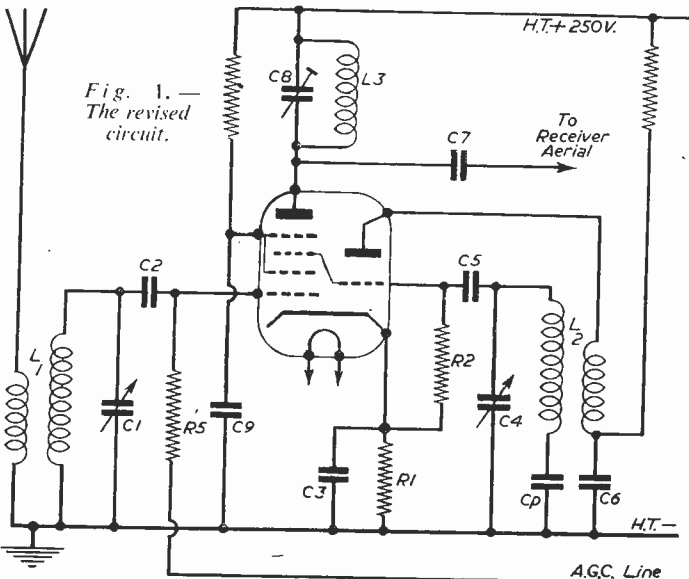

A Six Transistor 2-Wave Pocket Superhet

SUITABLE FOR RECEPTION ON BOTH
WAVEBANDS IN ANY LOCATION

By A. J. Lewis

(Continued from page 454, August
issue)

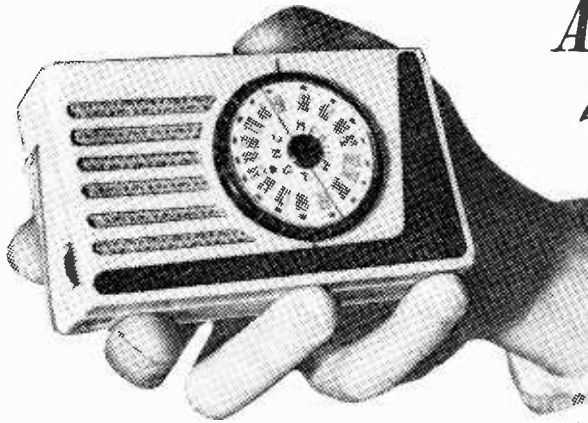

THE black Perspex inlets are omitted in the dimensions of the case given in the diagram and can be added as required. The wire handle is bent from 1/16in. steel piano-wire. It must be bent sufficiently accurately to clip firmly into the groove provided in the back of the case. The front of the case is made first. When the four sides have been carefully cut out they are cemented to the chassis. The sides of the case should protrude above the chassis about 3/32in. so that when the front panel is cemented in place the dial-plate just protrudes above it. Dimensions are not given for the back of the case as this is best "tailor-made" to fit the front. Remember to leave 1/16in. groove for the handle. The Perspex bracket holding the earpiece jack is cemented on to the underside of the chassis.

A hole corresponding to the retaining bolt on the earpiece jack must be cut in the back half of the case.

The Dial

When the front of the case has been completed the dial may be made and fixed on.

To make the dial, cut a circular piece of 1/16in. Perspex 1 11/16in. diameter and cement this firmly with chloroform on the circular plate on the tuning condenser. There should be a 1/16in. rim around the dial-plate. The final dial is drawn with a mapping pen and black ink and is pasted on to the dial-plate. To complete the assembly a circular ring of 3/8in. Perspex is cut. 1 11/16in. inside diameter and 1 15/16in. outside diameter. This ring is rounded off with a file and

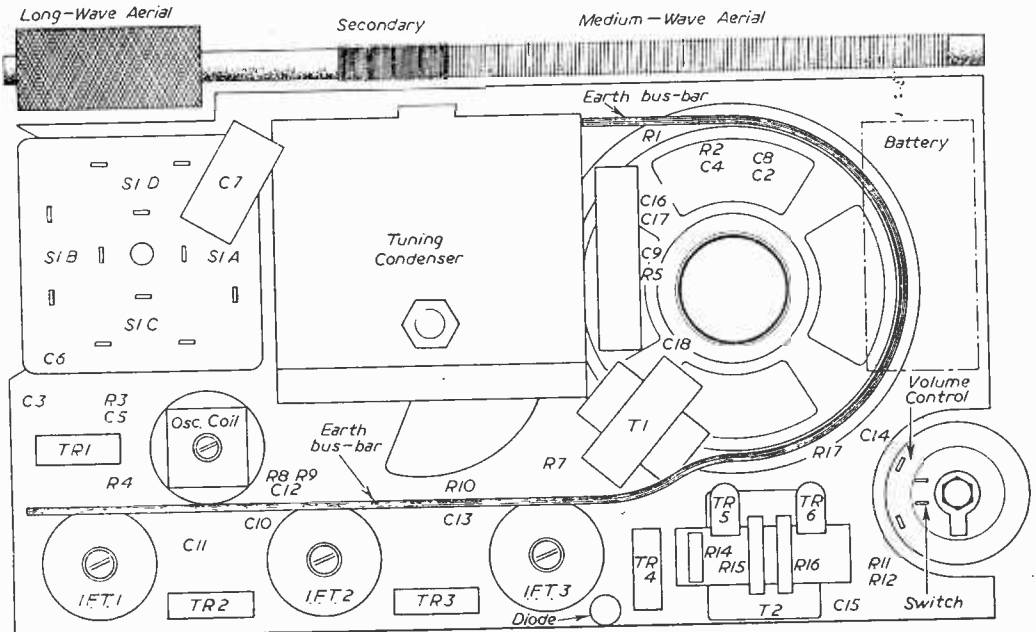

Fig. 4.—Approximate position for component placing. Some components are shown, but where there is no room component numbers are used.

given a grooved edge. The ring is then cemented around the dial on to the previously mentioned 1/16in. rim.

Next a 1 11/16in. diameter 1/16in. clear Perspex disc is cut and by cementing it round the edges is fixed on top of the dial. The 1/16in. centrepiece in the photograph is added last and is purely ornamental. Care must be taken not to let the chloroform smear on the dial.

Earpiece Jack

The earpiece jack shown in the photograph cannot be mounted at this stage because it is fixed by a Perspex bracket to the case of the set (on top of the volume control and adjacent to TR).

The jack shown in the photograph is of American origin and is unfortunately not available here. However, there is a miniature jack and jack plug made by Fortiphone which is about the same size, and there is a midget jack made by Bulgin which is somewhat larger and will have to be cut down to fit in the space in the receiver.

Wiring

The following procedure for layout and wiring should be carefully observed. A length of 16 s.w.g. wire is passed through the hole marked E on the chassis as shown on the right-hand side of Fig. 3, and is soldered to the lug on IFT1. This wire is then bent to lay flat against the tops of the I.F. transformers and is soldered to the previously mentioned wire holding T1 in position. The earth bar is then bent down so that it runs round the rim of the loudspeaker aperture. Finally, the earth bar is bent away from the chassis and is soldered to the curve on the bottom of the tuning condenser (see Fig. 4). Next a small screw is passed through the hole in the chassis marked SCREW, in Fig. 3, and a small solder tag is bolted to the underside to form an H.T. anchor point for R17. Next the positive

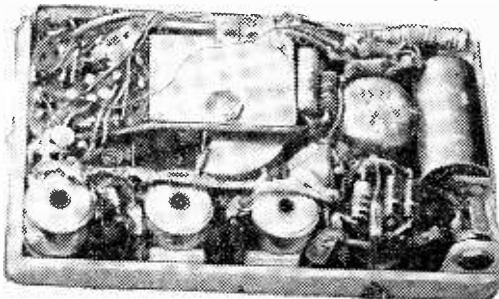

An inside view of the receiver, showing compact arrangement of components.

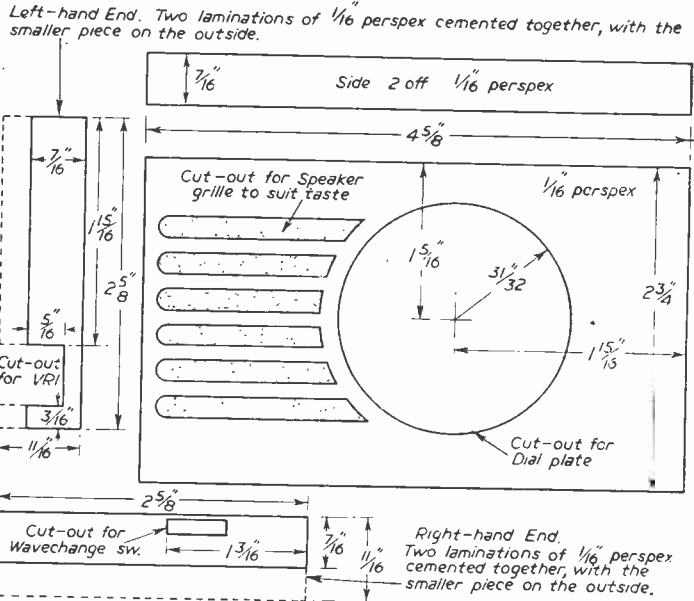
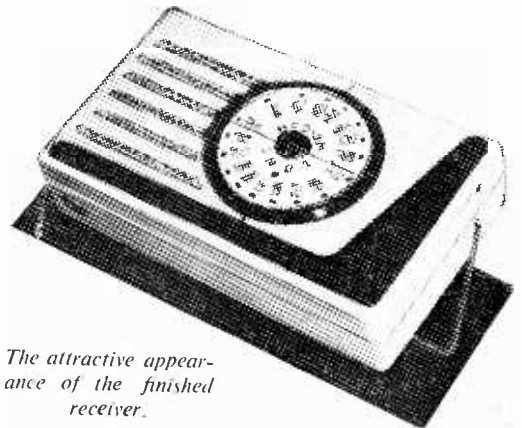

Fig. 6.—Dimensions of the front of the base.

and negative connections from the battery clip are made. The H.T. wire from the switch on the volume control is joined to the solder tag. Extreme care must be taken when soldering the connections on VRI as it is very delicate, and if



The attractive appearance of the finished receiver.

the soldering iron is applied more than once to the contacts the track will be ruined.

Where it is necessary during the wiring to use insulated wire, very thin PVC covered wire should be used. The surplus lengths of wire from T1 and T2 are ideal for this purpose. All resistors and condensers used should be first wrapped round with Sellotape to minimise the risk of short circuits. As the wiring on top of the chassis is rather compact it is wise to press the wires into the chassis with the soldering iron to keep them firmly in place.

Following the layout shown in Figs. 3 and 4

the receiver should be wired from back to front, i.e., from loudspeaker back to the aerial. By this means each stage may be tested when completed and any faults easily located. Two words of warning regarding transistors. Make sure that the transistors are inserted in their sockets the right way round, and that the battery polarity is correct.

The earpiece jack should not be soldered in until the set is completed to facilitate handling

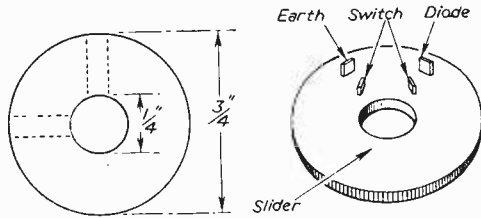

Fig. 5.—Details of the circular Perspex bush.

the chassis. This means temporarily joining the red lead on T2 to the H.T. solder tag.

When the A.F. amplifier has been completed it may be tested by applying an A.F. signal to the positive side of C18. If no signal generator is available, touching the base of TR4 with a screwdriver should produce an audible click in the loudspeaker. Next the circuit around TR3 should be wired as far back as R8, R9 and C12. An I.F. signal of 480 kc/s applied to pin 1 on IFT2 should be clearly heard. This procedure is repeated for TR2 and TR1. As the aerial can cause some misleading results it should not be wired in until the I.F. stages are aligned and are stable. For this purpose, R1, R2 and C4 may be temporarily joined to the base of TR1. If the A.F. and I.F. stages are functioning correctly it should be possible to hear an I.F. signal when the signal generator lead is held an inch or two away from the receiver. If it is possible to hear such a signal, final adjustments to the I.F. transformers can now take place. The rather high I.F. of 480 kc/s was chosen as giving the most whistle-free results on both wavebands. The value of R14 is critical and must be chosen to compromise between tone and current consumption. It will also vary with individual transistors. With a milliammeter inserted in the negative supply the zero signal current consumption should be 4-5 milliamperes. If it is higher than this, R14 should be reduced in value provided that reasonable quality of reproduction is maintained. If the consumption is less than 4 milliamperes and output is unduly low or distorted, R14 should be slightly increased in value.

As this receiver will be mostly carried in the pocket all current measurements should be taken in a warm atmosphere (about 65 degrees F).

Aerial

When considering selectivity and background noise it is unwise to have too much gain from the I.F. stages, and, therefore, as with most receivers of this type, most of the useful gain has to come from the aerial and frequency changer. In view of the low battery voltage used (in order to prolong battery life), particular care must be taken in

adjusting the aerial to compensate for the comparative lack of conversion efficiency over the low frequency part of the medium band. The ferrite slab used in the prototype receiver was sized 4 3/8 in. X 3/4 in. X 1/8 in. and was cut from Repanco part No. F.S.2. The windings supplied with this aerial are of no use. The slab, as supplied, is 5 1/2 in. long and must be cut down to 4 3/8 in. by filing a groove right round the aerial slab and then snapping off the surplus 1 1/4 in. in a vice. If any other make of ferrite slab is used the winding for the medium-wave will probably need modifying. The ferrite slab may have to be filed round the edges before the long-wave aerial (wireless telephone) will slide on. To wind the medium-wave aerial first wrap a piece of stiff card around the slab and then bind this round with Sellotape along the length of the card with the adhesive side *outwards*. The primary consisting of 92 1/2 turns of 9/45 Litz wire is wound on first. The winding should be 2 13/16 in. long. The secondary consists of 6 1/2 turns of the same wire wound in between the primary and starting at the extreme end of the primary. The whole assembly is then withdrawn from the slab and the stiff card former is withdrawn. The aerial will now slide quite freely along the slab. The ends of the windings are secured in place with Sellotape. When the alignment has been completed the aerial assembly may be fixed to the chassis with Sellotape bound round the tuning condenser frame.

Alignment

The alignment of the I.F. stage has already been dealt with earlier so the following paragraphs will deal with the aerial and oscillator

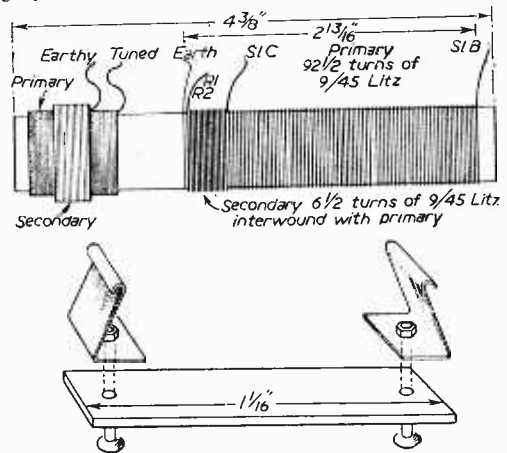

Fig. 7.—(Top) Layout of the slab aerial. (Bottom) An exploded view of the construction of the battery clip.

stages. The more time that is spent on detail tracking adjustments, the more sensitive the finished receiver will be.

To fix on the dial cut out a circular piece of 3/8 in. Perspex as shown in Fig. 5. Clamp this circular bush firmly in a vice and carefully drill and tap two holes through the side of the bush

in the position shown by the dotted lines in Fig. 5. This bush is screwed securely to the shaft of the tuning condenser. The screws should be filed so that they do not protrude from the bush. Next cut a circular piece of the 1/16in. Perspex 1 13/16in. in diameter, with a centre hole of 3/8in. diameter. This disc is cemented with chloroform to the bush on the tuning condenser, so that the whole presents a flat surface on which the final dial can be mounted. For the purpose of alignment a temporary dial may be drawn on paper and pasted on. The markings can roughly correspond with the positions shown in the photograph of the completed receiver.

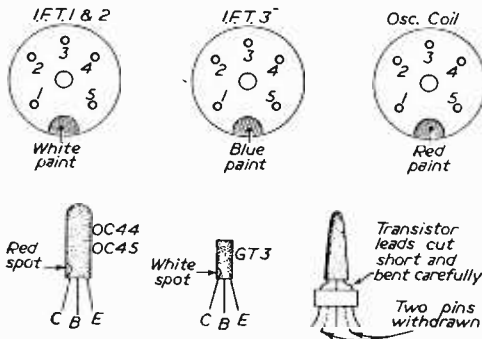

Fig. 8.—Pin connections of the transistors.

The medium-wave should be aligned first. The long-wave aerial is fixed on the slab in the position shown and wired in circuit. C2 and C8 are not wired in at this stage. C3 and C6 are very small capacitances, which in the prototype receiver were finally omitted after much experiment. According to the wiring of the individual receiver they may be necessary but they should be left out if possible. With the signal generator loosely coupled with the aerial inject a signal of 548 kc/s (corresponding to AFN Munich). Adjust the oscillator core until this signal is heard with the vanes of the tuning condenser practically fully closed. Next inject a signal of 1550 kc/s (BBC Third Programme), this should be heard with the vanes partially open. If it cannot be heard the value of C7 should be checked.

If this signal appears in between 200 and 250 metres it may be necessary to add a small condenser of about 3 pF (C6). Only when the extreme high- and low-frequency ends of the band are correctly placed on the dial should adjustment of the aerial winding take place. If the receiver is inclined to whistle with the vanes of the tuning condenser fully open, try adding a 3 pF condenser across the aerial (C3). All adjustments are now best made on actual stations. Select a station towards the L.F. end of the band and peak it up by sliding the aerial backwards and forwards. The final position of the winding should be about 1/8in. from the end of the slab to avoid excessive coupling with the long-wave winding and if in order to peak up a station on the L.F. end of the band it is necessary to slide the aerial farther along the slab than this, try adding another turn or two to the winding. If the station peaks when the aerial is withdrawn

from the slab, try taking off a turn or so. This procedure should be repeated on stations all over the band. Try also compressing or expanding the end two or three turns of the aerial. With patience extremely accurate tracking can be obtained. If, despite all efforts, the response at the L.F. end is poor, try reducing slightly the value of R3. This should not be attempted until the long-wave is adjusted as it may lead to instability on the long-wave. Once the slug of the oscillator coil has been finally adjusted for the medium-wave, the long-wave can be aligned. The simplest method of doing this is to temporarily fix the large trimmers in place of C2 and C8. By carefully adjusting these trimmers it should be possible in most areas to get loud reception of the four most powerful stations, Luxembourg, 1293 metres; the BBC Light Programme, 150 metres; Europe No. L. 1622 metres and Paris Inter, 1829 metres. Then, disconnecting the oscillator trimmer, C8 may be finally wired in place. The exact value of C8 will probably have to be made up with small fixed condensers as the value shown is only approximate. The same procedure is repeated with the aerial trimmer.

Atoms for Peace

A REMOTE handling manipulator, which incorporates a new lateral displacement mechanism and which can be used with stereoscopic television, as well as a wide range of nucleonic and electronic instruments are to be exhibited by the Pye Instrument Group at the Atoms for Peace Exhibition in Geneva from September 1-14, 1958. The main feature is the master slave manipulator shown by Pye Atomics Division. A lateral displacement mechanism has been fitted to enable the operator to remain seated. An optional extra is the stereoscopic television which aids judgement of distance when viewing remotely while a standard industrial camera makes possible the close observation of objects within the cave. Foot pedals have been fitted to control the television units, lateral displacement and horizontal lifting motion of the slave arm so that the operator need not remove his hands from the manipulator controls. Two Labgear instruments have been fitted to the control facia for internal radiation measurement and alarm purposes.

Doppler Navigator

DURING the past few months a number of airlines have been evaluating various doppler navigational devices and reports being received indicate that some trouble is being experienced in the operation of these equipments over sea. The Marconi Doppler Navigator Type AD.2300 includes in its specification a guaranteed performance over seas of Beaufort Scale 2 or greater, at all altitudes between 50ft. and 50,000ft. During recent weeks an exhaustive series of trials has been carried out with an AD.2300 installation in a Canberra aircraft, the aim of which has been to confirm the predicted performance so that there should be no doubt as to what the equipment would do when operated by the airlines.

A MULTIVIBRATOR TEST PROBE

A Compact Signal Generator for Field Servicing

By A. Gunn

THE piece of apparatus about to be described was developed to meet a definite requirement; that of a very compact signal generator for field servicing.

Circuit

A well-known multivibrator design is used. As is generally known, an analysis of a square wave, such as is generated by this circuit, reveals it to be composed of a fundamental frequency and

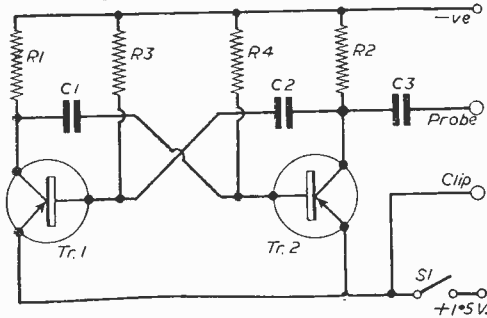

Fig. 1.—The circuit diagram.

an exceedingly large number of harmonics, which, in the case of an A.F. fundamental, extend well into the R.F. band. This property of the square wave renders it a considerable asset for quick fault-finding in radio receivers and A.F. amplifiers, since it can be injected at any point in any stage and will give a response at the output.

Specification

It was decided that for maximum convenience and portability, the multivibrator should be built into the form of a small test probe, fitting easily into the hand. This entailed miniaturisation, and therefore transistors. The battery is self-contained and the finished article presents a neat and efficient appearance. The circuit diagram is given in Fig. 1.

Construction

The container used was a thin aluminium canister measuring about 3in. long and 1½in. wide, with a screw-on cap; in

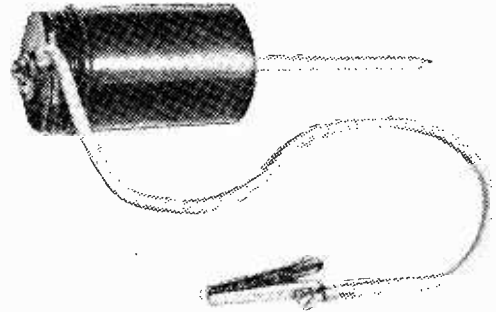

the author's prototype, a container of this design which had held capsules of a patent medicine was utilised. A small section of groupboard, about 1in. wide or thereabouts, is cut to length and bolted to the cap by means of a small L-angle and 6 B.A. nuts and bolts. Also in the cap is located the on/off switch. No accurate measurements are given because the layout is in no way critical, and the constructor can follow his own taste but the suggested layout in Fig. 2 is probably the most practical and compact.

Connection is by 14/0076 PVC covered wire. The transistor leads are kept as near their full length as possible, and sleeved with 1mm. systoflex. Take care to grip the connecting leads with a pair of long-nosed pliers when soldering, so that the heat cannot travel up the lead and destroy the transistor. Use a hot, clean soldering iron and make joints quickly. The transistors work

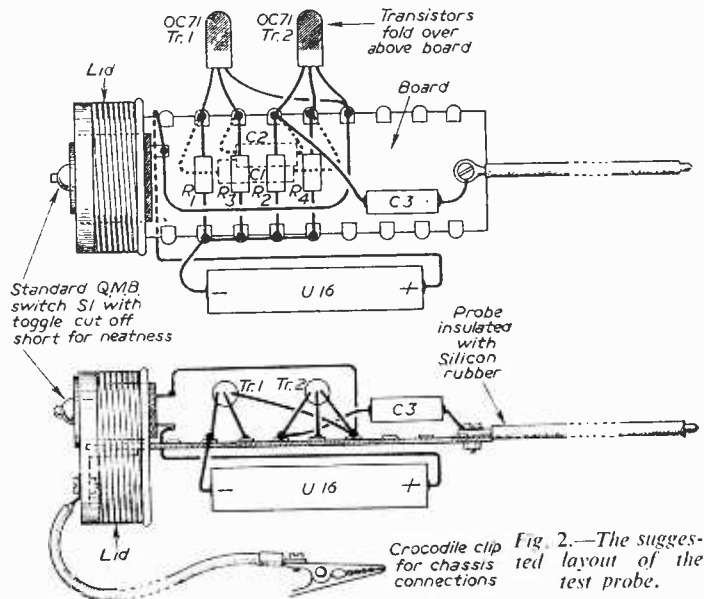
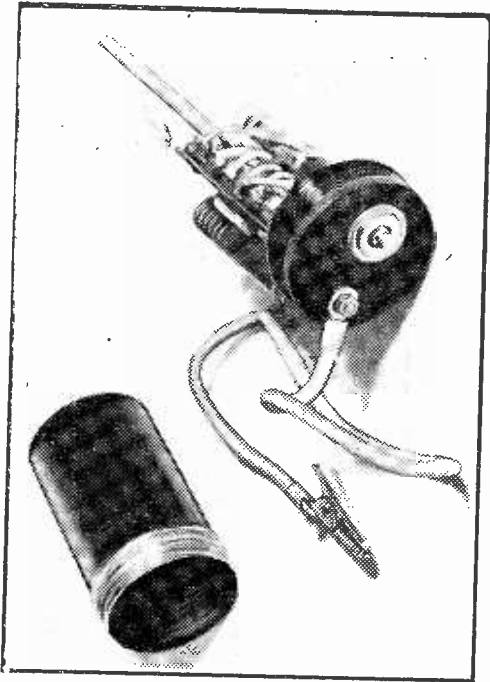

Fig. 2.—The suggested layout of the test probe.

perfectly suspended by their own rather stiff leads, and as they are non-microphonic, no trouble arises from this method of suspension. While OC71s are specified, photo transistors, type OCP71, work just as well if they are first painted to exclude light. The finished "Chassis" is sheathed in 1in. polythene tubing to prevent shorts to the case. The prototype had its case enamelled black, and the probe itself is made of a 4in. length of steel wire, pointed at one end, and with an eye formed on the other for securing to the groupboard. This is shielded with a length of silicon rubber, and protrudes through a grommetted hole in the base of the can.

Characteristics

The circuit will operate on much higher voltages (up to about 6V.), but its performance is



Photograph shows a general view of the test probe.

good even on $1\frac{1}{2}$ volts, and in the interest of portability, the U16 cell is best. The output is

COMPONENT VALUES

R1—1.5 K.	W.
R2—1.5 K.	W.
R3—27 K.	W.
R4—27 K.	W.
S1—QMB switch.	
C1—0.005 μ F 350 v.	Minicap.
C2—0.005 μ F 350 v.	Minicap.
C3—0.01 μ F 350 v.	Minicap.
Tr. 1—Mullard OC71.	
Tr. 2—Mullard OC71.	
S1—S.P.S.T.—Modified as diagram.	
Battery : $1\frac{1}{2}$ v. dry cell (Eveready U16).	

630 mV measured on a valve voltmeter, and the unit will drive a 12in. loudspeaker with a 15 ohm voice coil so that the output is ample for all tests. The frequency of the fundamental in the proto-

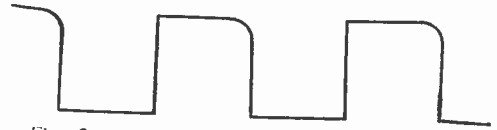

Fig. 3.—A diagram of the output waveform.

type was exactly 4 kc/s. The output waveform is almost perfectly square and is shown in Fig. 3.

Use for Faultfinding

Using the completed generator is extremely simple. The unit under test is switched on and flying lead of the probe is connected to the chassis. The probe is then used to work back from the signal input to the output until the 4kc note appears, when the fault can be localised and located.

Approach Aid for Aircraft

V.H.F. Automatic Direction Finding Equipment

BRITAIN'S lowest-priced V.H.F. automatic direction-finding equipment has been developed by Ekco Electronics Ltd. and was recently demonstrated for the first time to the Press, airline operators, airport authorities and overseas air attachés.

Selling at between £2,000 and £2,300, this new Ekco Type CE178 Automatic Direction Finder costs less than half the price of any other comparable British equipment on the market. This considerable saving has been achieved without affecting, in any way, the reliability or accuracy of the equipment.

Rotating Aerial

The Ekco Type CE178 is a V.H.F. cathode-ray direction finder giving automatic display of the sensed bearing of transmissions on any one selected frequency in the 118-132 Mc/s band. The low cost, and high efficiency, are obtained by using a rotating aerial, instead of a static aerial, incorporating an expensive goniometer, and more elaborate associated equipment.

Maintaining Aircraft Time Schedules

A prototype of the Ekco Direction Finder has been installed at Southend Municipal Airport for the past 12 months and has been in constant operational use for over 6,000 hours, passing some 50,000 bearings to aircraft. The combination of this automatic Direction Finder and the Ekco Approach Aid has assisted the Air Traffic Control Staff at Southend Airport to increase the traffic handling capacity under all weather conditions and speed up the traffic in instrument meteorological conditions, enabling airline operators to maintain their time schedules.

A Full Compass ELECTRIC ORGAN—2

CONVERTED FROM A
PIANO-ACCORDION

By R. Woodcock

(Concluded from page 471, August issue)

WITH regard to the type of fan, the exhaust type as fitted in office windows, etc., is of no use, the pressure they provide being in the region of $\frac{1}{4}$ in. water gauge. This leaves us with a number of alternatives. Most vacuum cleaner fans are more than capable of providing the necessary pressure and volume but are very noisy and even with such acoustic insulation as it is possible to provide would be unsuitable unless the organ is to be used in a dance hall or somewhere similar where the noise level is already very high. The fan

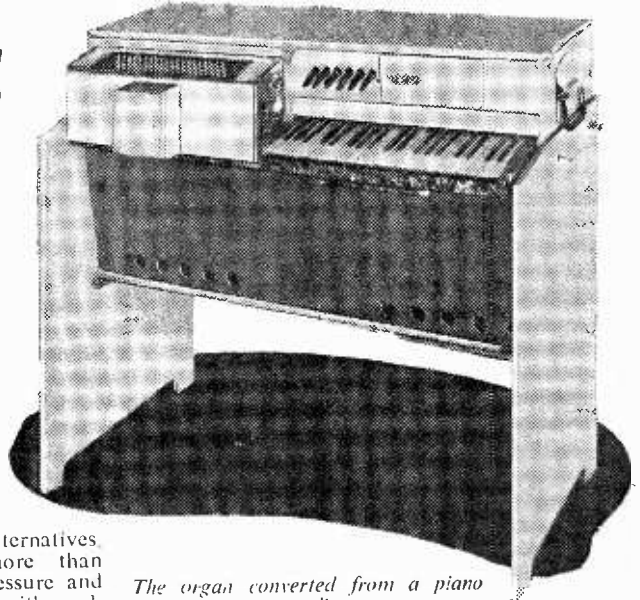

The organ converted from a piano accordion.

shown is of the centrifugal type running at about 2,800 r.p.m. The impellor (or blades) is about 6 in. diameter by about $1\frac{1}{4}$ in. wide, and any fan of similar proportions should prove satisfactory. It is mounted inside the box on four rubber anti-vibration mounts and exhausts through a rectangular hole at the rear, into a long narrow felt-lined box. This serves to damp out a lot of air noise and the sketch shows more clearly the path which the air takes. The greater the number of zigzag paths the quieter the air will be, but too many may cause too great a drop in pressure and a compromise must therefore be made.

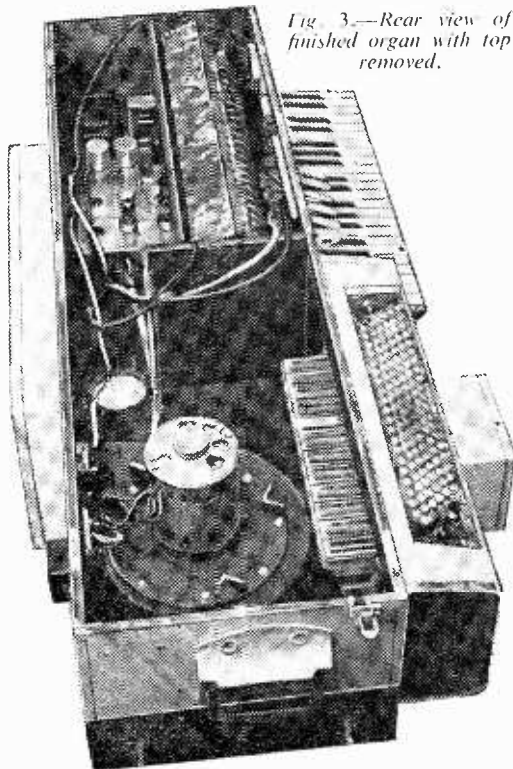

Fig. 3.—Rear view of finished organ with top removed.

Microphones

The bass and treble are picked up by separate microphones. The treble unit has a crystal microphone insert (one of the 4s. 6d. variety), anti-vibration mounted on elastic bands on the rear of the false front. The frequency response of this type of microphone tends to accentuate the higher harmonics of the treble reeds and provides very rich notes for the tone-changing pre-amplifier.

The bass unit has a wooden box screwed on to the front in which is mounted a 4 in. M.C. loud-speaker. This when used as a mike, is quite suitable for picking up the low notes which form the fundamental basses found on an accordion and the fact that the high frequency response of such a speaker, when used as a microphone, is very poor is of no importance as the higher order harmonics of the bass channel are in any case purposely removed in the pre-amplifier.

Pre-amplifier

This has separate bass and treble channels. The treble channel includes the circuitry for changing the tone according to the setting of the stops and provides the necessary vibrato modulation. The bass channel amplifies the bass and at the same

time cuts off the higher harmonics which makes the bass notes very mellow. No stops or vibrato are applied to the bass as this is used only for accompaniment of the treble. There are one or two points about vibrato which are worth mentioning. Most electronic organs use a frequency-modulated vibrato which, of course, causes the notes to "vibrate" up and down the scale for about half to one semitone. Now when using

STOP SYSTEM	
A	— Vibrato, on/off
B	— Bass, full/mellow
D	— Brilliant
E	— Mellow
C and D	— 1st voice
D and E	— 2nd voice
F	— Full treble
(See Fig. 2)	

Treble

to produce a note, it is very difficult to frequency-modulate this subsequently. The Hammond Organ Company use a system consisting of an electrical delay line in combination with a rotating switch and condenser, but this is beyond the scope of the average amateur and the Wurlitzer Organ Company use a special phase-modulating circuit which gives an apparent frequency modulation combined with an amplitude modulation. In the interests of simplicity, however, it was decided to use an amplitude-modulated vibrato. This is the cinema-organ type of vibrato and causes the volume of the note to waver; preferably at something between five and eight cycles per second. Providing that this is not too heavy it can sound quite pleasant and can also be produced very simply. Fig. 2 circuit shows the component values, and most of these are in no way critical.

Very briefly the operation of the circuitry is that the first amplifier valve obtains its H.T. from the anode resistor of an R.C. oscillator oscillating at vibrato frequency. This causes the gain of the amplifier valve to vary in sympathy. If the anode resistor of the R.C. oscillator is made into a potentiometer, it will be possible to vary the depth of vibrato to enable the most pleasing setting to be obtained; the vibrato frequency being altered by varying the potentiometer which forms part of one of the grid resistors. The bass channel is merely a straight single-valve amplifier, a tone control being coupled to the output. This can be cut out by operating a stop marked "full bass" and makes the bass both sharper and heavier.

Separate volume controls are fitted which enables the bass and treble to be balanced. The outputs are combined and fed into a foot-operated volume control and thence into the main amplifier which can be of any type giving a large enough output, 20-30 watts should be sufficient for a hall holding 200-300 people.

The Stops

These are fairly straight-forward, the system being similar to that used on the Hammond "Solovox." In the interests of simplicity, however, only one resonant circuit has been used, the switching system enabling this to be placed either in series to produce a "trough" in the frequency response, or in parallel to produce a "peak." The "wood-wind" stop can, of course, only be used in conjunction with other stops and a rough idea of the tones which the combinations produce is given in the circuit.

Foot Control

Many types of control will no doubt suggest themselves. One such control has already been described in PRACTICAL WIRELESS and the one used here differs only in so far as it is spring-loaded to return to the "off" position by means of a clock spring anchored to an aluminium pulley which actuates the potentiometer. The potentiometer should be of the wire-wound type as the average carbon-track type very soon becomes noisy.

Loudspeaker

It will be noticed that this is split into treble and bass sections. The dividing network is exactly as described in the past issue of PRACTICAL WIRELESS, below 1000 c/s being handled by a 12in. 20W Goodmans L.S. and above 1000 c/s by a 4in. speaker feeding a multi-cellular horn.

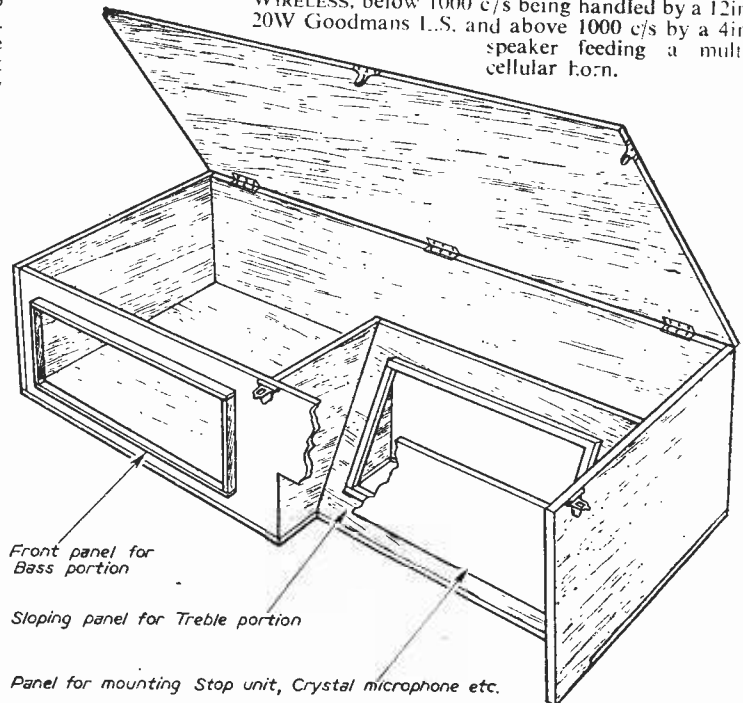

Fig. 4.—Main box before assembly.

An Electronic Flash Unit

AN INEXPENSIVE EASILY CONSTRUCTED
100 JOULE UNIT

By H. Guy

(Concluded from page 459, August issue)

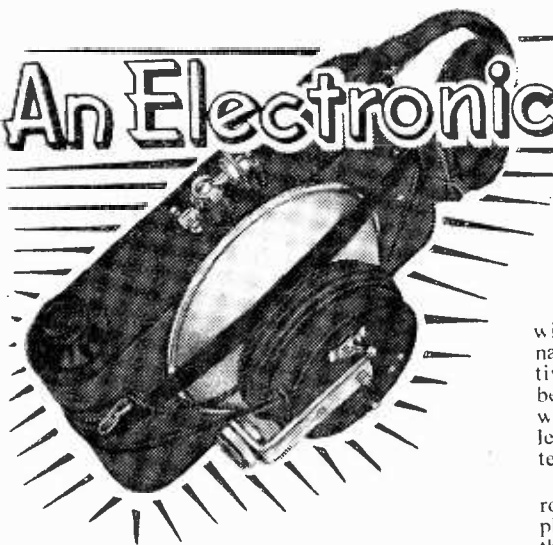

SWITCH S2 is in fact a button mounted on the rear of the reflector to the tube and is used to test the operation of the electronic flash unit. Two leads are shown in the circuit which normally connect to the synchro flash contacts on the camera used in conjunction with the apparatus via the usual synchro lead and plug available from most photographic dealers.

Circuit Arrangement

As shown in Fig. 2 the circuit is accommodated in two separate units, namely the battery case and the lamphead. The vertical broken line in the figure indicates how the circuit is distributed, the two assemblies being linked via a length of twin PVC lead of length to suit the user.

The battery box therefore houses the batteries, the "100/50 joule/OFF" switch (S1) and the electrolytic condensers C1 and C2 with their charging resistors R1 and R2. Now the ultimate size of the battery box is determined by the batteries to be used. In the photograph of the model constructed for this article, it can be seen that four Drydex 67.5v. batteries, type DM539, were used. The choice was governed by the size of the case that it was intended should be used, and in this connection a leather toilet case that happened to be available proved very useful.

The photographic journals frequently advertise leather and other cases that would be suitable for this particular application though the enterprising reader will probably attempt the construction of his own battery case which can be made in metal, wood, leather or whatever material the reader wishes.

To assist in determining the required size of case, an alternative 67.5 v. battery (Ever Ready B101) size is $3\frac{1}{2}$ in. \times $2\frac{1}{2}$ in. wide and $1.5/16$ in. deep with press-stud type terminals on the $2\frac{1}{2}$ in. \times $1.5/16$ in. face. The Daly type electrolytic condensers are each $4\frac{1}{2}$ in. high \times 2in. diameter and have solder tag terminals on one end.

If 90v. batteries are used, the Ever Ready 90v. type B131 unit measures $3.23/32$ in. long \times $1\frac{1}{2}$ in.

wide and $3.11/16$ in. high and has press-stud terminals on the "length and width" face. Alternatively a smaller Ever Ready unit, the B126, may be used measuring $2.21/32$ in. long \times $1.29/32$ in. wide and $3.13/16$ in. high. A 3-pin socket on the length and width face provides the battery terminals.

The most convenient mounting position for the rotary switch S1 is in the lid as shown in the photograph where it is most easily accessible when the case is slung over the shoulder. The resistors R1 and R2 can be soldered directly to the contacts where they will be self-supporting. Fig. 3 shows the arrangement.

The remainder of the circuitry is mounted on the assembly panel associated with the reflector as supplied by Messrs. General Electronics, and the test flash button is mounted on the cup (also supplied by the above manufacturers), which acts both as a protective cover to the assembly, and as a convenient mounting point for the lamphead. For this latter purpose, as shown in the appropriate photographic view, a bracket is supplied with the cup.

A toggle switch provided with the assembly panel is not used in this design.

The arrangement of components on the

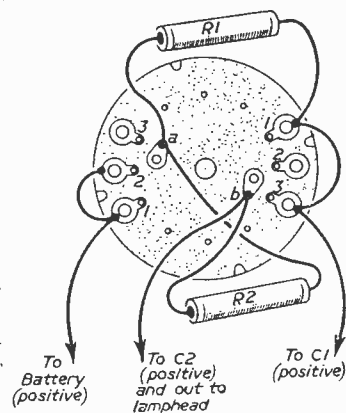

Fig. 3.—Details of the rotary switch.

assembly panel is not critical except in the case of the neon lamp which must be positioned so that it is visible through the hole left for this purpose in the protective cup. Components, of course, should not foul the button within the cup and due care must be taken to ensure that the cup will not short-circuit any wiring when it is fitted.

The high voltage output from the secondary of the triggering coil is developed at the single wire emerging from one end of the triggering transformer T. It should be kept as short as possible.

The only important rule to observe is that of clean and careful soldering of the flex connecting the battery box to the lamphead for reasons previously outlined.

Testing the Circuit

Having completed the wiring, connect the batteries and switch on the unit to step 2, the 50 joules output position.

Both condensers will now commence to charge and after about 10 seconds the neon lamp should start to flash. If it fails to do so the batteries should be switched off and the circuit checked, *but at all times it should be remembered that the condensers can provide a lethal shock if they have charged up.* Before checking the circuit, therefore, it is advisable to press the "test flash" button when a flash may or may not be seen from the discharge tube.

No flash almost certainly implies a circuit fault. If the flash occurs, but the neon fails to give the required "fully charged" indication, then the value of R4 should be reduced to 1.8M. Reduction of the value of C4 to 0.05 μ F may assist in making the neon flash.

Using the Flash Unit

The equipment attains its full output efficiency after a certain "running in" period defined by the time taken for the electrolytic condensers to acquire their full capacity. This period may be several hundred flashes during which time the nett light output increases.

The life of the recommended capacitors, however, is far in excess of 50,000 flashes.

The battery life, too, is no problem. In fact from a battery discharge-current point of view

the recommended batteries are entirely adequate. Their limiting characteristic in this application is only their shelf life.

Some final points on the characteristics of operation of the equipment: The circuit is arranged so that when the apparatus is finally switched off the condensers are both connected in parallel and they will, of course, be at least partially charged at this time. The test flash button must therefore always be depressed before the equipment is stowed away since it is not recommended that the condensers be left in this condition indefinitely.

The switch should not be idly flicked from position 2 to 1 since condensers C1 and C2 normally charge at different rates and a very heavy current can flow when the condensers are part-charged if suddenly they are connected in parallel at switch position 1. This current will damage the switch contacts over a period of time.

As a rule photographs taken of scenes that have been directly illuminated by flash tubes, whether bulb-type or electronic, have a rather soot and whitewash appearance and in use therefore the flash produces the most uniform type of illumination when "bounced" from the surroundings of the scene. This is usually only practicable with indoor photography at fairly close quarters, but in general if conditions are sought which prevent deep shadows occurring, satisfactory results should be obtained.

Outdoor photography in bright sunlight often produces prints with too high contrast, an effect which can be offset by the use of the electronic flash. This technique has been very successfully used in the sunnier parts of the Continent where what would be regarded by the average Englishman as very favourable weather, can be the subject of conflicting ideas and, literally, contrasting views in photographic circles.



READING AMATEUR RADIO SOCIETY

Hon. Sec.: C. H. Williams, 43, Greyfriars Road, Reading, Berks.
AT a general meeting held on June 28th last the following officers were elected.

Mr. C. H. Williams (G2BYM), Hon. Sec.

Mr. G. H. W. Boys (BRS19891), Hon. Treasurer.

Meetings are held on the last Saturday in every month at: Palmers Hall, West Street, Reading.

The general meeting commences at 7.30 p.m. but instructional periods are given between 6.30 p.m. and 7.30 p.m. by Mr. Price (G8SP) and Mr. Hutchence (G3IKA) in Morse and technical for the benefit of SWL's and those training for R.A.E. examinations.

Instructional classes are prior to general meetings at present but if the demand is sufficient a separate intermonthly meeting will be arranged.

The Society participated in the last field day and although the weather was bad a very useful experience was gained by all.

A very interesting programme is envisaged for the coming months and a welcome is offered to all interested in Amateur Radio.

THE BRITISH AMATEUR TELEVISION CLUB

Hon. Sec.: D. S. Reid, 27, Rose Valley, Brentwood, Essex.

THE British Amateur Television Club will be holding its fourth Amateur Television Convention on Saturday September 6th, from 10 a.m. to 7 p.m. in the Conway Hall, Red Lion Square, Holborn, London, W.C.1. There will be displays of amateur built television equipment in operation, and among the many attractions will be pictures received from the Club's outside broadcast van, as well as demonstrations of colour television. Both members and non-members of the Club will be very welcome; the charges for non-members are as follows: All day, 5/-; admission after 2 p.m., 2/6.

Tickets will be on sale at the door, but further particulars and also tickets are available from any of the following:

D. S. Reid, 27, Rose Valley, Brentwood, Essex;

J. E. Tanner, 16, Norfolk Drive, Chelmsford, Essex;

D. W. E. Wheele, 56, Burlington Gardens, Chadwell Heath, Romford, Essex.

TEES-SIDE AMATEUR RADIO CLUB

Hon. Sec.: Allen L. Taylor, 12, Endsleigh Drive, Middlesbrough, Yorks.

ON June 28-29th the club set up under emergency conditions at a country cottage at Potto in the Cleveland district of N. Yorks, three transmitters: a 30 watt all-band, and a 160 80 meter both home brew, and a 19 set. The antennas were two 132ft. end fed wires, and a "95 RV" dipole.

We worked some European stations and one Canadian. Log conditions were not exceptional.

160 meter arrangements worked well, and about 19 mobility sought us out on Sunday afternoon. All operation was on phone and went off smoothly.

Operators were G3KBD, G3LXG, G3JYH, G3LCZ, G3INQ, G3JOO, G3JMO two young SWL's.

Forthcoming meetings in August are 1st and 15th at the Hon. Sec's QTH.

Everyone welcome!

(continued on page 565)

HOME RADIO OF MITCHAM

(Dept. P), 187 LONDON ROAD, MITCHAM, SURREY. MIT 3282

London and Home Counties distributors for Panda Transmitters.

We are stockists for:—EDDYSTONE, PANDA, ARMSTRONG, DULCI, DENCO, JACKSON BROS., WB STENTORIAN, REPANCO, TELETRON, GOODMANS, OSMOR, WHARFEDALE, GRAYSHAW, BULGIN, etc.

THE STENTORIAN H.F.1016

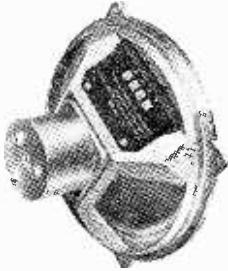

NO OTHER HI-FI SPEAKER HAS ALL THESE FEATURES. 10in. die-cast chassis, 16,000 gauss magnet, 10 watts handling capacity. Universal speech coil for 3, 7 and 15 ohms. Frequency response 30 to 15,000 c.p.s. Patent cambrie cone. Delivery now from stock. **PRICE £3.0.0.**

JASON "MERCURY" F.M. TUNER

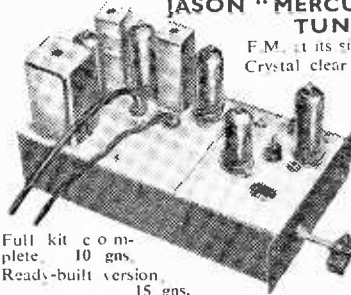

F.M. at its simplest and best. Crystal clear Hi-Fi reception with the programme you want at the turn of a switch. Foster Seeley discriminator and full A.F.C. Constructional data and price list. 24. post paid.

Full kit complete 10 gns.
Ready-built version 15 gns.

POWER PACK FOR F.M. TUNERS

Complete kit of parts with ready punched chassis for A.C. mains Output 200 v. approx. at 50 mA and 6.3 v. at 2 amps. Ideal for F.M. tuners, etc. **PRICE £3.5.0.** plus 2/- post. Ready built and tested, **£2.5.0.** plus 2/- post.

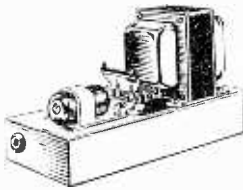

MULLARD 3-3 AMPLIFIER

Separate Bass and Treble controls and suitable for gram, radio, mic. or guitar inputs. Really amazing quality and performance. Has shaken many Hi-Fi enthusiasts. 3 ohms output. Ready wired, assembled and tested. New attractive bronze front panel.

PRICE £8.8.0. plus 2/6 post.

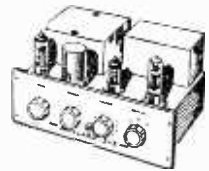

THE "THREE DEE"

A really successful dual-range radio using germanium diode and three transistors. Loudspeaker reception and negligible running costs from 7½ volt battery. Ideal for bedroom, workshop, caravan or second radio. Many hundreds in daily use. Chassis size 6in. x 4in. x 2in. Full constructional data with point-to-point diagram and price list. 1. - post paid.

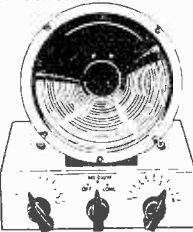

I.T.V. PRE-AMP.

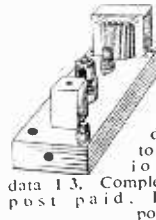

High Gain Band III preamplifier gives amazing improvement to your Commercial TV picture especially in difficult areas. No need to touch your television. Full constructional data 13. Complete kit of parts, **£2.14.0.** post paid. Ready built, **£3.14.0.** post paid.

MICROPHONE INSERTS

SPECIAL OFFER of brand new boxed A.C.O.S. 17-3 crystal microphone inserts. Ideal for amplifiers, intercoms, electric guitars, deaf-aids. Limited number only at 5/- each, post paid.

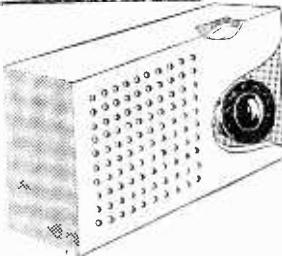

RADIO IN YOUR POCKET EVERYWHERE. The amazing MINI-7 pocket portable gives loudspeaker results on internal aerial. Build one for your holidays and be the envy of your friends. Can be assembled in four easy stages. Full constructional data and price list. **PRICE 1.9.** post paid.

PYE MOZART

BRILLIANT NEW 10-WATT HIGH FIDELITY AMPLIFIER. Compact, easy to install and operate. The Pye MOZART has a commanding lead in technical quality and modern streamlined appearance. Pick-up compensation, 4-position filter, record equalisation, three speaker impedances. Full details on request, or please call for demonstration. **PRICE 22 gns.**

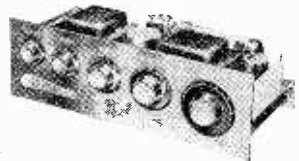

DULCI H4T2

Brand new A.M./F.M. tuner unit with own power pack. Modern streamlined appearance and attractive front panel. Long, Medium, Short and F.M./V.H.F. Magic-eye tuning. Suitable for any amplifier. Full specification on request.

PRICE £24.19.0.

Full range of DULCI amplifiers and chassis stocked.

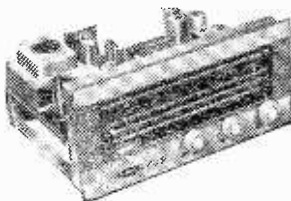

SPECIALS

T.C.C. 8 mfd. 600 v. block type condensers, 6/-.
T.C.C. 16 mfd. 350 v. tubulars, 1/6. Single-screened microphone cable, 6d. yd. Neon tester screwdrivers, 3/9. Please add postage.

JUST OUT. New 1958 edition of the HI-FI YEAR BOOK. 10/6 plus 1/3 post. All you want to know about Hi-Fi and equipment.

NEW COSSOR F.M. RECEIVER KIT. Printed circuit model 701K complete with six valves, loudspeaker, modern dial and very comprehensive instructions for building. The Home Constructor Kit with the backing of COSSOR the pioneers of kits since 1927. Delivery from stock. **PRICE £15.15.0.**

STEREO! Now available the Ronette stereo cartridge, fits Collaro Studio and similar pickups. **PRICE £3.9.6,** post 6d.

WEYRAD

"H" TYPE COILS— FOR MANUFACTURERS, SERVICE ENGINEERS AND INDIVIDUAL CONSTRUCTORS

These coils are supplied in individual aerial, H.F. transformer and oscillator versions for each band. The iron-dust cores are fitted with a threaded brass stem which permits fine adjustments of the inductance without risk of damage to the cores. The coils are mounted by means of a single 6 B.A. screw. Circuit connections are made to four soldering tags at the end of the former.

Recommended for many circuits, including the "Practical Wireless" AC/DC 3-valve Superhet (Feb., 1956 issue) and the "Radio Jack" (July, 1958 issue).

ALL BANDS ARE AVAILABLE FOR DELIVERY FROM STOCK

RETAIL PRICE.....**3/9** EACH

ILLUSTRATED FOLDER.....3d.

A.M./F.M. RECEIVER BOOKLET.....2/6.

WEYMOUTH RADIO MANUFACTURING CO., LTD.
CRESCENT STREET, WEYMOUTH, DORSET

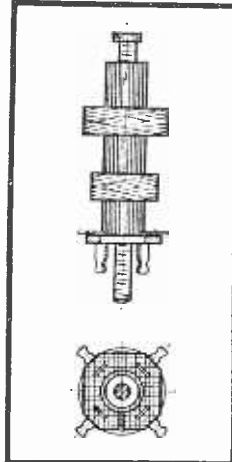

RANGES :

- Band 1 800-2,000 mtrs.
- Band 2 250- 800 mtrs.
- Band 3 190- 550 mtrs.
- Band 4 90- 250 mtrs.
- Band 5 33- 100 mtrs.
- Band 6 16- 50 mtrs.
- Band 7 12- 37 mtrs.

Coils are coded according to type and range :

- HA1 = Band 1 Aerial
- HH1 = Band 1 H.F.
- HO1 = Band 1 Oscillator

Train for a Wonderful future
in **RADIO & TELEVISION...**

Radio and Television techniques are continually advancing and their applications ever increasing. These fields offer to the trained technician a career with an assured and remunerative future.

Here is your opportunity to enter for:—

1 YEAR COURSE Full-time day course in the Principles and Practice of Radio and Television. Designed for the training of Radio and Television Servicing Engineers and others similarly engaged in the Electronics industry. Next course commences September 9th, 1958; others in January and May, 1959.

The E.M.I. College of Electronics, Dept. 32,
10, Pembridge Square, London, W.20
Telephone: BAYswater 5131, 2.

The College is part of the E.M.I. Group... Britain's foremost electronic engineers... Pioneers of the world's first public television service.

THE E.M.I. COLLEGE OF ELECTRONICS



NEW! NEW! NEW!

POCKET SIZE UNIVERSAL METER Model 122A

Sensitivity 5,000 o.p.v. A.C. and D.C.

A small 21-range instrument ideal for the enthusiastic amateur. Accuracy: 3% D.C. 4% A.C. A high sensitivity moving coil centre pole type meter with 2 1/2" scale is fitted.

RANGES

- Volts D.C. 0.3-15-30-150-300-1,500.
- Volts A.C. 0-15-30-150-300-1,500.
- Milliamperes D.C. 0-15-30-150-300-1,500.

Amperes D.C. 0-15. Resistance 10 ohms-1 megohm. Automatic overload protection fitted to meter movement.

Price: **£9 5. 0. PROMPT DELIVERY**
Or on CREDIT SALE TERMS:

See it at Stand 212 Radio Show

ALL TAYLOR Instruments available on HIRE PURCHASE and 7 DAYS' APPROVAL

Write for full details and catalogue:

TAYLOR ELECTRICAL INSTRUMENTS LIMITED
MONTROSE AVENUE, SLOUGH, BUCKS.

Telephone: Slough 21381 Cables: Taylins, Slough



Size: 4 1/2" x 3 1/2" x 1 1/2"
Weight: 14 ozs.
Leather carrying case available price £1.12.0.

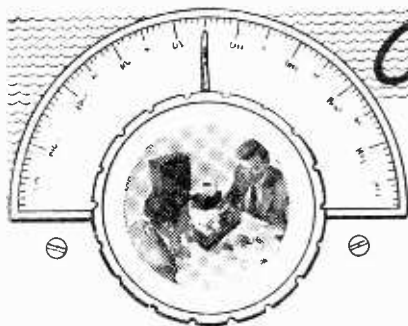

On Your Wavelength

BY THERMION

American Slanguage

I DO seriously suggest the the BBC adopts my suggestion to drill some of its artistes, especially those of American origin, and those English people who endeavour to ape the American slang and to imitate the drawl of the negro, on the matter of pronunciation of English words. The English language, as a result of the cinema, radio and television is being corrupted and falling into desuetude by the impact of the nasal drawl and the broadening of vowel sounds, and the tendency needs to be arrested before we become completely Americanised. The Americans have always had difficulty with our vowel sounds. Here are a couple of gems I heard recently: "Ketch a farling staa and poot it in your parket." "Tarmy" for "Tommy." "Thangs" for "things." I am sure that some of these broadcasters would alter their pronunciations if they were shown their lines as they pronounce them. The BBC is particularly keen on correct pronunciation. It should equally insist that those who entertain over the air should speak correctly. Even illiterates can be taught!

Those Credits

MR. I. W. SKILLING, of 132, West End Lane, London, N.W.6, tells me that he was concerned in the production and "design" of such credits. Very naturally, therefore, he disagrees with my views since if credits vanish so will his job. He tells me that a lot of people spend a considerable amount of time and effort in producing entertainment for congenial idiots, which shows what some of those "concerned in the production and design of our entertainments" think of the general public, and it accounts for the inanity of the productions. Most of the credits relate to nonentities, doing office boys' work. Mr. Skilling, apparently, likes to make up a long list of everyone associated with the production and to achieve this time-waster would call the office boy the director of communications. A few names of the important people concerned with the production are all that is required. When the cinemas, radio and television start reeling off these long lists of names, I am reminded of a host of people battening like barnacles or parasitic appendages on to the work of the author—who quite often only gets credit as an afterthought. Fortunately, a large number of readers have written in agreement with my views, and I hope the BBC will take heed and not waste further programme time.

Radio Components at the Show

NOTWITHSTANDING the appeal which has been made several times in this journal for manufacturers not to neglect the constructor and for the sponsors of the Exhibition to devote some space to the home constructor, this year's Radio Show will, alas, contain nothing of special interest to the experimenter.

In view of the large and abiding interest in set construction, there is room for some new companies to be formed for the manufacture and supply of components such as transformers, chokes, tuning units, etc., and to cater for the market which other manufacturers have neglected. Notwithstanding this, the old hands will gravitate towards Earls Court if only to meet old friends and to chat about those halcyon days.

Part of my pleasure in visiting the Radio Show is in meeting readers, even those who occasionally disagree with my views.

I shall be at the show most of the day and most of the evenings, and I shall hope to see you there.



Mr. J. E. Austin's Den. He lives at Bearsted, and is seen here working on an electronic organ.

A Beginner's CONSTRUCTIONAL COURSE-III

6.—MORE DETAILS OF FITTING A SEPARATE VOLUME CONTROL AND OTHER MODIFICATIONS

By E. V. King

TWO more coils are required and are mounted as shown in Figs. 26 and 28. They need not be more than $\frac{1}{4}$ in. from the corresponding medium-wave coils. Be very careful to get the red tags in the correct position or all your wiring could be done wrongly. It is then very difficult for the beginner to sort it all out (the author still remembers the muddles he used to get in in his early days!).

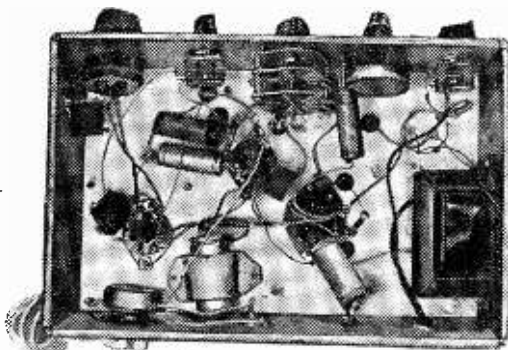

An underview of the receiver.

The beginner should, to save much annoyance, stick tiny labels on the coil tags, calling them "red," "X," "Y" and "Z." All four coils will be thus marked.

Another rotary switch is now required (a toggle switch must not be used). A two-pole one-way switch is required, although one similar to the gram/radio switch could be used, in which case one set of contacts would not be required.

Examine the switch very carefully, noting the tags which become joined in one position and which are open circuit in the other. Do not mount the switch until you are sure how it works. Mount it between the

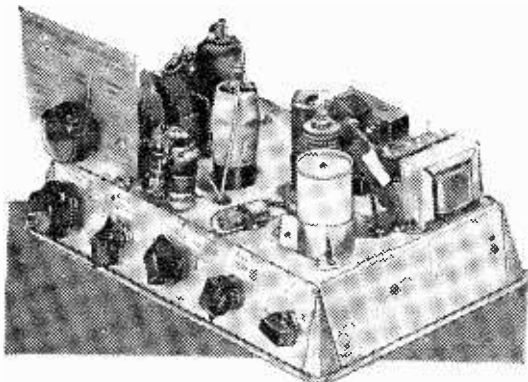

gram/radio switch and the tone control, see Fig. 26.

Wiring the Detector for Long Waves

Remove the earthing wire from tag "X" on the PHF2 and solder it to tag "X" on the new PHF1. Now wire tag "X" on the PHF2 to the "red" tag of the PHF1. Remove the lead going to "Z" on PHF2 and attach it to "Z" on the PHF1. Now join "Z" on PHF2 to "Y" on PHF1.

Take one switch contact to earth and the other contact of the same "bank," 55 (these two contacts are ones which are joined together in one switch position), to the junction of "X" (PHF2) and "red" (PHF1). Use as short a lead as possible. The circuit is shown in Figs. 23, 28 and 32.

Testing the Detector Circuit

Remove the aerial from the front end of the receiver and switch on. Now attach a good, long aerial to the "red" tag on PHF2. Although the tuning will be flat you should now be able to receive at low volume both long and medium bands. If you do not get reception you have wired in the coils and switch incorrectly, note that the trouble cannot be in the "Y" to "Z" windings so far. Now attach the aerial via any

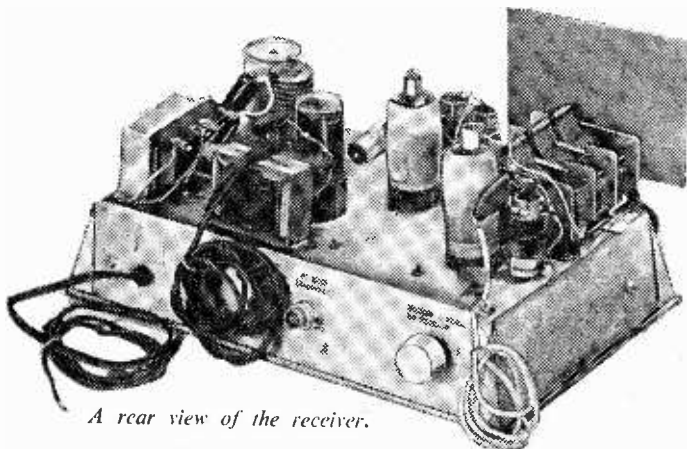

A rear view of the receiver.

small condenser greater than 300 pF to the "Y" tag of the PHF2. You should now receive both bands with greater selectivity though less volume. If you do not, then (assuming you did use a good aerial) the trouble lies in your wiring of the "Z" and "Y" connections to the coils.

Wiring the H.F. Stage for Long Waves

Do not proceed with this until the detector stage has been wired and tested. Remove the earthing wire from the "X" tag of the PA2 and attach it to "X" on the PA1. Join "X" on PA2 to "red" on PA1.

Remove the earthing wire from "Z" on the PA2 and attach it to "Z" on the PA1. Join "Z" on the PA2 to "Y" on the PA1.

Earth one tag of the other "bank" of the switch (S4) and wire the other tag with as short a lead as possible to the junction of "X" PA2 and "red" PA1. Make sure that the switch contacts for this circuit correspond to those for the detector. Both P1 coils are cut out when medium waves are required.

Testing and Retrimming the Receiver

Plug in the receiver, attach the aerial to the proper position (to C1) and switch S4 and S5 so that they are shorting out the P1 coils. You will now receive medium waves as you did before.

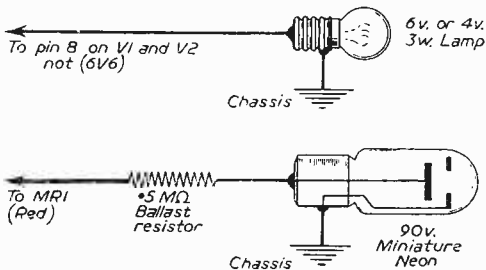

Fig. 33.—Connections for warning/dial lamps.

Carefully adjust the trimmers for optimum strength on a weak station with the condenser vanes open as previously stated. Very little adjustment will be required, especially if all leads have been kept as short as possible. When the receiver is finished the slightest movement of either trimmer should cause a drop in volume. If, on trimming, the receiver oscillates reduce setting of R2 and continue trimming. Feed back "wires" may be added if necessary, or reduced or taken away, as previously described.

Now switch S4,5 to long waves. Adjust the tuning gang condenser and you should receive the Light Programme at fair strength. If you are using a poor aerial reception will not be so good as on the medium waves, but many continental stations can be received. The tuning is flatter but if you wish you may fit them across from "X" to earth on each coil. 50 pF is a suitable value and all leads should be kept short (say, not longer than 1in.) or feed back trouble will crop up. If these trimmers are added (the author found no need to do so) then they are only adjusted on the long waves and are adjusted after

the medium-wave trimmers have been set. The medium-wave trimmers will affect the long-wave coils, but the long-wave trimmers (if fitted) will not affect the medium-wave coils.

All leads *must* be kept short. Do not use screened cable as it introduces trimming difficulties which are difficult for the beginner to sort out. Screening increases the stability of the receiver, but at the same time introduces "capacity" to the tuned circuits which have to be compensated for by the trimmers. These would thus have to be altered or paralleled to get the receiver in proper trim. This would be very difficult for the beginner.

Parts required to carry out these modifications together with their functions in the circuit (Fig. 23):

R14. 5k potentiometer (not critical). This is used to control the amount of high audio-frequency signal by-passed by C18. That is, it functions as a top cut tone control.

R15. 1 megohm $\frac{1}{4}$ watt (brown, black, green). This is a grid leak for V2 grid when switched to gram. It prevents a charge accumulating on V2 grid. When using a crystal pick-up it provides a suitable load.

C17. Bias electrolytic condenser, 12v. working, 12 mfd. (not critical). This provides a steady bias on V2 grid by acting as a "reservoir" or "smoother" for the voltages obtained by the cathode current having to pass R12 and thus causing voltage drops according to the signal received. The mean of these voltage drops is produced and held steady by this condenser.

C18. This has been changed to .005 mfd. This is a small H.F. by-pass condenser and is made smaller as additional control is now afforded by C8 and R14.

C18. .1 mfd. 600v. working. This is the tone control by-pass, see R14 above. If the set should oscillate violently a large voltage can be produced across this capacitor, hence its high working voltage. Needless to say no radio of this type should be allowed to oscillate.

Pick-up Socket

Pye sockets, P.O. jack or co-axial types are all suitable. Use screened lead, i.e., polythene covered co-axial, for the pick-up wires for safety and freedom from hum.

S2/S3. Two-pole two-way rotary with insulated operating knob. The beginner should try and get one with two wafers for simplicity, but both switches could be on one wafer. S2 changes the grid input of V2 to "gram" or "tuned circuit" at will, while S3 changes the anode load from that required for "amplifier" to that for "anode bend detection" respectively.

S4/S5. Two-pole one-way rotary switch with insulated operating knob. These switches, which are operated by one knob, short out the long-wave secondaries of the two tuned circuits when medium-wave reception is required.

L3/L4 Wearite PA1 and PHF1 Coils

These are mounted and wired in series in all respects with the original medium-wave coils. The primaries are left in series all the time, but the long-wave secondaries are cut out by S4/S5 when medium-wave reception is required.

The complete circuit of Fig. 23 will now have been wired and should be in perfect working order. It is intended in this contribution to add further modifications and to give details which will enable the amateur to service and find faults in this receiver.

Warning Lamps

It is good policy to fit a warning lamp to all mains or battery operated equipment to guard against the unit being left on possibly for weeks on end. With battery equipment especially, very small wattage lamps are essential. On this radio the main consideration is the ability of the mains transformer to supply current for another filament. If you have used SP41's (VR65a) then the current required without the lamp will be near enough 3 amps. if this is, or is a little above, the rating of the transformer it would be unwise to fit a lamp in the filament circuit. Using SP61's (VR65) the current required without the lamp will be near enough to 2 amps only. See Fig. 33 for circuit.

Thus, as long as you are not going to overload the transformer, you can wire in a warning lamp (or dial lamp) by taking one tag of the lamp to earth and the other to tag 8 on any convenient valve base. A suitable lamp would be 4 or 6 volts, 3 watts. This would take between $\frac{1}{2}$ and about 1 amp of current.

If you are using a speaker transformer as a filament transformer it would be unwise to load it with a lamp and the best method is to fit a neon.

On the prototypes the author used a small ex-govt. 90 volt neon which was soldered directly on to the chassis, but of course a holder (small bayonet cap, single pole) could have been fitted. The neon is wired between earth and (via $\frac{1}{2}$ megohm resistor) the red tag of the MR1. The resistor is necessary or an excessive current would burn out the lamp. Unlike a filament lamp the neon will give almost everlasting service, especially if the series resistance is a high one as suggested. The lamp is also a useful indication as to the state of the main H.T. supply. If C12 or C13 should break down to earth the lamp will cease to operate. If this condition lasted long of course MR1 would be ruined. If MR1 became open circuit (i.e., a connecting wire to black tag) the neon would not light. If MR1 ceases to rectify (and C12 and 13 have not broken down) the lamp lights in a different way, see Fig. 34.

Microphony

The beginner may have noted that if he touches the detector valve a loud drumming sound comes from the speaker. Some valves, especially when in the detector position, show this property to a remarkable degree. About one in six of the VR65's purchased show rather too much microphony, the one showing this property most should be placed in the H.F. socket (or try the output position if you are not using a 6V6).

Microphony in itself is not harmful unless the speaker is near the valve or the receiver is being subjected to mechanical vibration such as

would be the case with a car radio. When this T.R.F. receiver is placed in a cabinet any tendency to microphony will be aggravated. The author has made up many of these receivers for friends and has always cured any such tendency by swapping valves as stated. Other standard methods are to mount the valve on a sprung base or to damp it, using felt padding, etc. (a bad policy as it can cause overheating). The speaker should not of course be mounted on the chassis directly, but on the wooden "baffle" of the cabinet.

Gramophone Switching Using Leaky Grid Detection

Some enthusiasts may wish to revert to the original system of detection shown in Figs. 9 and 24. The reader will recall that leaky grid detection is most sensitive to small signals but is more likely to give hum troubles and the switching needed for gram. working is rather more complicated.

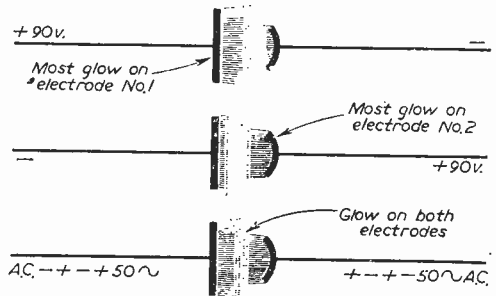

Fig. 34.—Effect of polarity on neon.

You may revert to this system satisfactorily if:—a. A cocoa tin screen is placed round and over V2 arranging the lid on top with a slot under it for connections to top cap.

b. The receiver is retrimmed.

c. Another bank, one pole two-way, will have to be added to S2 and S3. This may mean the purchase of another switch.

The additional switch is then used to switch in a bias resistance (400 ohms would be suitable) and condenser as shown in Fig. 35.

This is necessary as otherwise the valve would distort very badly when switched to the gram. position.

The author would suggest this modification only to enthusiasts who wish to receive distant stations, not those who wish to use the receiver for ordinary local station listening.

(To be continued)

JOIN THE PRACTICAL GROUP

Edited by F. J. CAMM

PRACTICAL TELEVISION	1/3
PRACTICAL HOUSEHOLDER	1/3
PRACTICAL MECHANICS	1/3
PRACTICAL MOTORIST & MOTOR CYCLIST	1/3

They are all published monthly

An Automatic Time Switch

A Device for Switching a Radio and Tape Recorder On and Off at a Preset Time

By E. N. Romley

THE construction of this time switch fulfilled a long-felt want. When looking through the *Radio Times* one sees programmes of interest which are broadcast when it is not possible to listen; perhaps it may be during working hours, or perhaps it may be during an evening when another engagement has the prior call.

From time to time simple devices have been described for switching a piece of apparatus on at a predetermined hour and there are available on the commercial market, time switches or clocks which will do this job. What the writer wanted was an inexpensive time switch which would switch apparatus on and off.

With this device the tape recorder and radio

case and to remove the hands. The clock face is then removed. Usually this is a metal disc, its face being enamelled and the hours and minutes marked on it. A new face is made out of fairly stiff cardboard and the hours and minutes inscribed on it. A second cardboard disc is made the same size as the first but it is not marked in any way.

After marking the hours and minutes on the card it should be temporarily fitted in place of the original dial and the hands replaced. Now note the circle described by the hour hand. Usually the hands are bent a little at the extremities; if this is not the case, then they can be bent slightly. The idea is to fit brass contactors in a circle round the face. Two circles are required, one for the minute hand and one for the hour hand. The circle for the hour hand will be the inner circle and it should be so arranged that when the hour hand reaches the hour, the hand makes contact with the contactors.

Contactors are made quite simply and brass paper fasteners can be used. They should be pushed through the cardboard face from the rear and bent over, the bend being in a clockwise direction. The contact between the hand and the contactor should be firm enough to make a good contact, yet not too firm so as to exercise undue drag on the motion of the hands. They should be arranged so that the hour contacts are not touched by the minute hand or false triggering of the switching will take place.

In the case of the minute hand, contactors are fitted at each five-minute station. Fig. 3 shows a sectional view of the scheme.

When the contactors have been fitted, thin wires

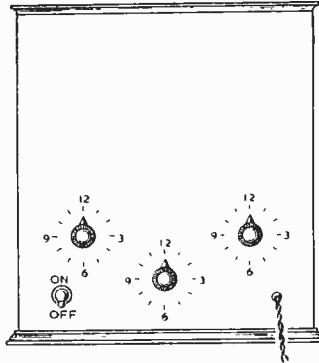
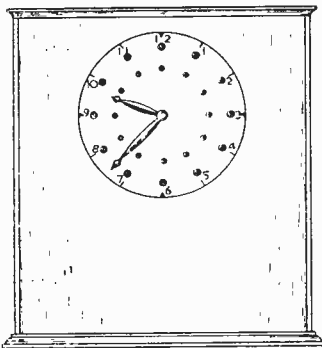

Fig. 1. (Left)—A front view. Fig. 2. (Right)—A rear view of the unit.

are preset. The radio tuned to the desired transmitter, and the volume level adjusted in conjunction with the input control of the tape recorder to effect a satisfactory recording. The on/off switches of the tape recorder and the radio are left in the "on" position and the mains feed is taken via the auto time switch. At the appropriate time, the switch switches on the power, the programme is recorded, and at the end the switch switches the power off.

The apparatus consists of an inexpensive 24-hour clock, with three twelve-position switches and a relay, all mounted in a simple wooden case.

The face of the clock is fitted with contactors, the circuit being completed via the hands of the clock. Fig. 1 shows a front view and Fig. 2 a rear view.

Modifying the Clock

The first job is to take the clock out of its

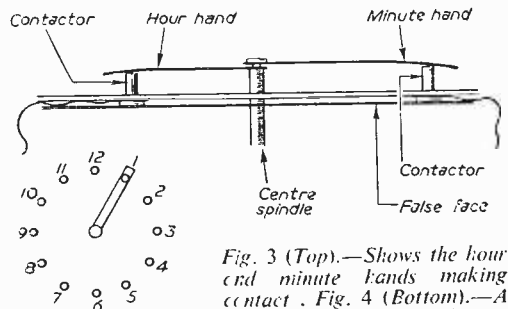

Fig. 3 (Top).—Shows the hour and minute hands making contact. Fig. 4 (Bottom).—A front view of the switch.

arc soldered on the heads of the paper fasteners. It is preferable to use different coloured wires to make identification easy. The second cardboard disc is fitted behind the first so as to insulate the brass studs from the clock mechanism. Glue can be used for this.

The new cardboard dial can be fitted to the clock and the hands replaced, the clock being fitted back into its case or mounted by some other method in the wooden case.

The wooden case can be made in any manner desired. It should be big enough to accommodate the clock mechanism and the switches together with a battery and relay. The switches can be mounted at the front or at the rear as desired.

The Switches

Single point twelve-way switches are required, two to select the hour and minute

for switching on and one to select the time for switching off. Switching on can take place at any five minute period from hour to hour, i.e., from the hour, five minutes past, ten minutes past, fifteen minutes past . . . and so on.

The off switch is arranged to switch the apparatus off from any time from switch-on time up to one hour later.

When the apparatus is to be used with a recorder (tape) then the amount of recording time required will depend upon the length of the programme to be recorded, or the length and speed of the tape. Many tape recorders, recording at a standard speed of $3\frac{1}{2}$ in. per second will run for three-quarters of an hour. Recorders with slower tape speeds or employing the 7 in. diameter spool tapes will run at the rate of $1\frac{1}{2}$ hours for one side of the tape when adjusted to $3\frac{1}{2}$ inch running per second.

An average programme will not last longer than one hour so the necessity for recording longer than one hour will not often arise. However, should the necessity arise, and the tape length and speed allow, then a simple modification can be made to run the apparatus over the one-hour period by the use of another one-point twelve way "off" switch. The method will be described later.

Making a Switch

It is a fairly simple matter to make a switch suitable for this work. The switch can be made on a plywood board or piece of hardboard. Twelve bolts with nuts and locking nuts are required to make the stud contacts. They should be arranged around the periphery of a circle as shown in Fig. 4.

At the centre of the circle is mounted a spindle which can be a long bolt, to which is fastened the spring contactor arm and a knob. The

method is shown in Fig. 5. The spring contactor arm should be made of springy brass and should be shaped as shown in the diagram. It is important to note that the width of the arm should be such that it will bridge across two contacts when passing from one to the next. In other words, as the arm moves from, say, contact 1 to contact 2, it will be actually on contact 2 before it has left contact 1, yet when it is central on contact 2 the edges do not touch contacts 1 or 3.

The reason for this is to allow a smooth transition from one contact to the next. If the spring falls into a space between contacts it will be likely to jam—in any case some force will be necessary to get it to "ride up" on to the next contact.

When the switches are made up then they can be mounted on a strip of wood fixed to the back of the clockcase as shown in Fig. 6.

The wooden clock case should be large enough and deep enough to accommodate a small battery, a relay (the standard Post Office 3000-type relay), and the switches. This is shown in Fig. 6.

The Relay

The relay used will depend largely on the type available. There are many ex-Government relays about and their codes are too numerous to mention. The main requirement is that it should operate from a small battery requiring a drain of only a few milliamps (a standard deaf-aid battery can be employed or a small H.T. battery as used for portable receivers).

The majority of the 3000-type relays have been designed to operate at voltages from 24-50 volts. A relay of the high resistance type is most suitable as the current drain is small. The relay will be operated the whole time the apparatus is switched on and therefore current drain must be kept to a minimum.

Further, as a look at Fig. 8 will show, the relay must be able to operate in series with a resistance R and for this reason alone, a low resistance relay is not suitable.

Another requirement of the relay is that it must have four contacts, two of which must be heavy duty type as these switch the mains on and off. Quite

often a rummage about in the spares box will produce a suitable relay and it is an easy matter to interchange contacts should one be found with suitable contacts but too low a resistance, while another has a suitable resistance but unsuitable contacts.

(Continued on page 531)

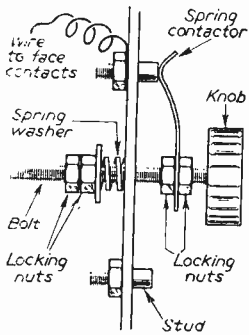

Fig. 5.—A sectional view of the switch.

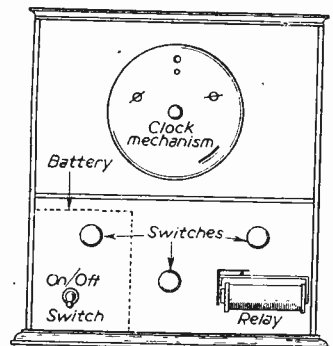

Fig. 6.—The interior of the clock case.

data for AUDIOPHILES*

EF86 ECC83

EL34 GZ34

EL84 EZ81

Audiophiles all over the world are demanding Mullard audio valves for their high quality sound equipment. And who can blame them when they know that the Mullard World Series of Audio Valves is the finest in the world. Fill in the coupon below for free data on Mullard World Series Audio Valves.

* *Audiophile—Enthusiast for high quality sound reproduction who is satisfied with nothing but the best.*

This popular book is available now from most dealers, price 3'6d. It contains designs and full constructional details of the new Mullard EL34 High Quality 20 Watt Amplifier, a Mullard Band II F.M. Tuner, pre-amplifiers for the Mullard EL34 Amplifier and for the popular Mullard 5 Valve 10 Watt Amplifier, together with other useful technical information.

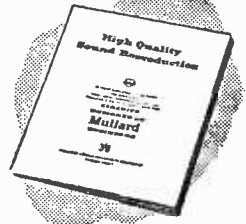

Mullard

WORLD SERIES
AUDIO VALVES



Mullard Ltd., Publicity Division
Mullard House, Torrington Place,
London, W.C.1.

COUPON
To Mullard Ltd., Publicity Division
Please send me, free of charge, leaflets on the Mullard World Series of Audio Valves, and details of "High Quality Sound Reproduction".

NAME

ADDRESS

MVM 349

ADCOLA

PRODUCTS LIMITED
(Regd. Trade Mark)

SOLDERING EQUIPMENT

ILLUSTRATED

3/8" Detachable bit type (List No. 64)

Protective Shield (List No. 68)

Catalogues sent FREE

Telephone 33 :
MACaulay 4272
& 3101



British and Foreign Pat.

Reg. Designs, etc.

Head Office, Sales :

ADCOLA PRODUCTS LTD.

Gauden Road,
Clapham High St., London, S.W.4

NO ROOM IN YOUR HOUSE?

Blacknell portable buildings, which are available in standard timbers or rot-proof Western Red Cedar, are ideal for use as Workshops, Dark Rooms, Studios, etc. Strong inner wall sections give perfect support for work benches and radio apparatus. Specially made for the quick and easy installation of electrical power and heating. Blacknell give highest quality with lowest cost. Shed prices from £13.10.0 cash or on easiest H.P. terms.



- ★ LOWEST POSSIBLE DEPOSITS
- ★ FREE DELIVERY—(England and Wales)
- ★ 2 YEARS TO PAY
- ★ COMPLETE SATISFACTION GUARANTEED

The handsome COUNTRYMAN shed is only £23.2.6 cash (6' x 6') or 92 6 deposit and 8 monthly payments of 52 3. Also available over 12, 18 or 24 months. It reaches you in sections which take practically no time to erect and lasts for a lifetime. Also in 10 other sizes up to 18' x 6'.

There's a wide range, too, of large BLACKNELL Buildings which can be used as Clubrooms, Pavilions, etc., at very low prices.

Write today for our FREE 50-page Catalogue to :

H. & H. BLACKNELL LTD.

Dept. 47/3, FARNBOROUGH, HANTS. Tel. : 2071
Farnborough Showground open to visitors at Pinehurst Ave., (Rear of Rex Cinema) Mon. to Sat. 9 a.m. to 5 p.m. Sun. 10 a.m.-5 p.m.

YOU CAN BUILD A POCKET RADIO IN 1 HR.!

LOOK!



BUILD THIS POCKET RADIO FOR ONLY 37/6

AT LAST! In response to many requests we now present the **HIGH EFFICIENCY PENTODE "SKYPOCKET,"** a beautifully designed precision **POCKET RADIO.** No radio knowledge needed!—**EVERY SINGLE PART TESTED BEFORE DESPATCH!** Our simple, pictorial plans take you step-by-step. This set has a remarkable sensitivity due to painstaking design. Covers all medium waves 200 to 550 Metres. Size only 5 1/2 in. x 3 in. x 2 in. in Strong, Transparent case with panel, cover and ivory dial. A really personal phone, pocket-radio with **DETACHABLE ROD AERIAL.** Self-contained all-dry battery operation. Average building time 1 hour. **Total Building Cost—including Case, High Efficiency Pentode Valve, etc., in fact everything down to the last nut and bolt—ONLY 37/6,** with plan, Postage, etc., 2/- C.O.D. 2/- extra. (Parts sold separately. Priced Parts List, etc., 1/6.) Demand is certain to be heavy—so **SEND TODAY!**



47/6

Build this exceptionally sensitive high efficiency Pentode radio. Uses unique assembly system and can be built by anyone without any radio knowledge whatever in 45 minutes. Handsome black-crackle steel case with specially made black and gold dial with stations printed. Size of radio only 6 1/2 in. x 5 in. x 3 in. Covers all Medium and Long waves—uses only one all-dry battery. H.T. consumption only 1 to 1.5 mA. Uses personal phone. Ideal for Bedroom, Garden, Holiday, etc. Many unsolicited testimonials. *Mr. Norton, of Oxford, writes: Yesterday evening on the Medium waveband, I counted 32 separate stations! I am very pleased with the set, which is well worth the money. BUILD THIS "SKYROMA" "NEW" Total building cost—everything down to the last nut and bolt—47/6 (Postage, etc., 2/-) with full set of clear, easy-to-follow plans. (Parts sold separately. Priced Parts Lists, etc., 1/6.) C.O.D. 2/- EXTRA.*

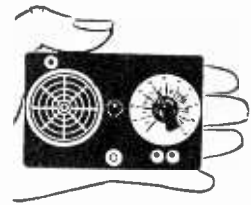

BUILD THIS 2 TRANSISTOR RADIO FOR ONLY 47/6

WE'VE DONE IT AGAIN!... our design department in response to a great many requests have designed this "SKY PINIE" **Vest-Pocket TWO-TRANSISTOR PLUS DIODE RADIO** which gives a superb performance. It is highly sensitive. Size only 4 1/2 in. x 3 1/2 in. x 1 in., the weight under 7 ozs.—yet it is a **THREE-STAGE** receiver covering all medium waves, working entirely off a tiny "pen-light" battery, which costs 6d.—fits inside the case—and lasts many months. Uses personal phone and has push-button **LUMINOUS On-Off Switch.** Every part tested before despatch! **SPECIAL STEP-BY-STEP PLANS** for **ABSOLUTE BEGINNERS.** Total building cost including case, transistors, etc.—everything down to the last nut and bolt—**ONLY 47/6** with plans. Postage, etc., 2/- C.O.D. 2/- extra. (Parts sold separately. Priced parts list, etc., 1/6.) As the building cost is absolutely rock-bottom "it might increase later." **DEMAND! WILL BE VERY HEAVY—PURCH YOUR ORDER TODAY!**

CONCORD ELECTRONICS (DEPT. PWI)

69 PRESTON STREET, BRIGHTON.

Best Buy at Britain's

20,000 OHMS PER VOLT Precision 856G Multimeter. 4 1/2 in. square large scale meter. Measures A.C./D.C. volts 0 to 3, 12, 60, 300, 600, 1,200, 6,000. D.C. Current 0 to 60 mA, 300 microA, 3, 30, 120, 600 mA/Amps and 12 Amps. Ohms 0 to 6,000, 600 K, 60 Megohms. Also Decibels. In smart polished wooden carrying case, with hinged lid and handle. Size 10 x 9 x 5 1/2 in. Complete with leads, prods and batteries. Guaranteed in perfect working order. **£9.19.6,** post 4/- **AVOIDERS.**—3 range universal meter, for A.C. and D.C. volts, A.C. and D.C. current and Ohms. Large easy-to-read 5 in. mirror scale. B.S.I. standard. Complete with batteries and guaranteed in first-class working order. **£8.19.6,** P. & P. 4/- **MULLARD GM41401 C. & R. BRIDGES.**—50 Ohm to 10 Megohms in 4 ranges: 10 pF, to 10 mF, in 3 ranges. For 50 c/s A.C. mains. In perfect working order. **£7.10.0,** P. & P. 3/6 **HRD COMMUNICATIONS RECEIVERS,** complete with 9 coils. From 21 gns. S.A.E. for full particulars. **R1155B,** with latest drive, first class condition, **£7.19.6,** R1155N **£12.19.6,** S.A.E. for full particulars. **A.C. MAINS POWER PACKS.** Outputs 300v, 110 m Amps. D.C.: 6.3 v, 4.5 Amps.; 6.3 v, 1.5 Amps. Size 7 1/2 x 6 1/2 x 6 1/2 in. high. Latest type potted transformer and choke. Complete with 5Z4G rectifier and in perfect condition. **ONLY 42/6,** post paid. **VIBRATOR PACK.**—Input 6 v. D.C. Output 200 v. D.C. 100 m/Amps. Fully smoothed and R.F. filtered. Size 9 x 5 x 6 1/2 in. Complete with QZ4 and vibrator. Brand new, 25/- **CR109 SPARES KIT'S,** complete, 15 valves, 2 of U50, DH63, KT63, X69 and 7 KT68. Output transformer, resistors, condensers, potentiometers, PK screws, pilot lamps, drive cord, etc. ALL BRAND NEW, 59/6, post 4/6. **MINIATURE 373 I.F. STRIPS.**—For F.M. tuner described in April and May P.W. Complete with 3 of EF91, 2 of EF92 and EB91. A fresh release enables us to offer these once again. BRAND NEW with circuit, 42/6. OR less valves, 12/6. Post either, 2/6. **TRANSFORMER BARGAIN.**—For testing A.C./D.C. sets in safety. 230 v. input, output 230 v. 100 watts. 22/6. P. & P. 2/6. **TRANSFORMER BARGAIN.** Input 0-200/250 tapped. Outputs 250-0-250 v. 80 m/Amps.; 5 v. 2 Amps.; 6.3 v. 4.5 Amps. Upright mtg. BRAND NEW. Boxed. Ex-Admiralty made 1952. A fine 50 c/s mains tranny for **ONLY 16/6,** post FREE. **AVONINOR LEATHER CASES.**—Brand new, with straps, 7/6. **PLEASE ADD POSTAGE OR CARRIAGE ON ALL ITEMS**

CHARLES BRITAIN (RADIO) LTD.
 11 Upper Saint Martin's Lane, London, W.C.2
 TEMple Bar 0545

Shop Hours 9-6 p.m. (9-1 p.m. Thursday). Open All Day Saturday.

The new

MOTEK-K9

TAPE DECK

This superlative all British Deck with three speed control knob is designed to allow easy fitment and simplicity of operation. The many outstanding features place this Deck in a class alone.

Details on request
 Patents pending

List 21 gns

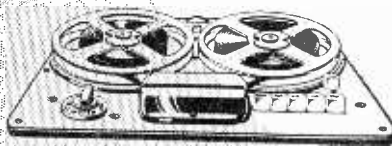

MODERN TECHNIQUES

Wedmore Street, London, N.19. Tel: ARCHway 3114

Although the actual current carried by the mains contacts is not heavy, there is likely to be a heavy surge current at the moment of switching on and switching off.

Bearing these requirements in mind it should be fairly easy to find a suitable relay. It is thought that by giving the general requirements a constructor would be able to adapt a relay to his requirements.

Having found a suitable relay it will be necessary to make trials on its operating ability when in series with a resistance R . The actual circuit shown in Fig. 8 will be discussed in detail later, but there are one or two points to note at this stage to assist in selection of the relay and its associated battery.

The mains is switched on and off by the relay contacts 3 and 4. When the relay is switched on the mains is connected through to the radio receiver and/or tape-recorder and when the relay is switched off the mains is disconnected. The relay remains operated during the whole period the radio is switched on. The relay is released by short-circuiting the battery supply. It is obvious that it is impracticable to put a direct short circuit across the battery and so the resistance R is inserted with the relay power supply.

When switching off the relay, an earth is applied to the relay side of R , thus cutting the current from the relay. As soon as the relay is released (this takes only a few milliseconds) then the short-circuit is taken off R .

The battery voltage and the value of the resistance R must be so chosen that the relay will operate comfortably with R in series with it.

If a spare volume control is available or a potentiometer of small value (say up to 2,500 ohms or so), then R is made a variable component and can be adjusted to a nicety.

Relay Contacts

It has been mentioned that two of the contacts of the relay must be heavy duty types. With regard to the other two contacts some important points must be observed.

Relay contacts can be made "early make" or "early break." This means that an early make contact is one in which the contacts close as soon as the relay armature starts to restore itself, of an early break contact, the contacts open as soon as the relay armature starts to restore itself. A contact can be made early make or early break simply by bending the upper or lower set of contacts either to or away from its partner.

As an example, if the separating distance between two contacts is made very small, then they will close just as soon as the armature starts to close. Such contacts are early make. If the separating distance between two contacts is increased so that they close only just before the armature has fully operated, then they are termed early break (or, if you like, late make), as they will be broken as soon as the relay starts to release.

It is important that the contacts numbered 2 in Fig. 8 are of the early make type or there may be difficulty in getting the relay to release. It is equally important that they do definitely break

when the relay is released, or the relay will be held operated.

An on/off switch is put in series with the relay operating circuit to switch the whole device in or out of operation.

Wiring

Wiring from the clock face contacts to the switches can be completed. This is perfectly straightforward but care must be exercised to ensure the correct contacts are wired together. If Fig. 7 is studied it will form a pattern for subsequent switches. Contact 12 on the clock face is wired to contact 12 on the switch. Contact 1 on the clock face is wired to contact 1 on the switch, and so on.

First the hour contacts are wired to the hour switch, and then the minute contacts to the minute switch.

If it is desired simply to switch apparatus on at a pre-determined time and not to switch it off again automatically, then the auto-off switch can be omitted. If the auto-off switch is to be used,

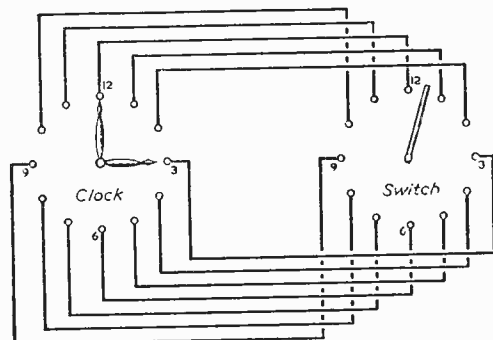

Fig. 7.—Wiring of the clock contacts to the rotary switch.

then its contacts must be paralleled with those of the minute switch.

Circuit Operation

The circuit operation should be clear from Fig. 8. The central arms of the switches are wired into circuit using flexible wire (pigtailed). (It is a good idea to fit a stop to the switch so that it does not rotate continuously or the wire connection to the central spindle will become rapidly worn.)

In Fig. 8 we have shown a skeleton circuit so as to make the operation clear. The circuit is shown as switching on at one o'clock and switching off at half-past one.

When the switches have been adjusted to the required time, the on/off switch is operated. When the hour hand reaches one o'clock at the same time that the minute hand reaches 12 o'clock the time will actually be one o'clock and the circuit for the relay will be made, from the battery, through the on/off switch, through R through the relay, through the hour switch on the contact 1 to the clock, through the hour hand, through the minute hand to the contact 12 to the minute switch and through to

earth (common). The relay will operate. Contact one will hold the relay so that it remains operated after the hands have moved. Contact 2 of the relay prepares the release circuit. Contacts 3 and 4 connect the mains to the radio receiver and/or tape recorder.

As the hour and minute hands move off, the operating circuit for the relay will be broken, but the relay will continue to hold over its contact 1.

When the minute hand reaches the "half-past one" position a circuit is made from common earth, through relay contact 2, through the minute hand (shown on half-past by the dotted line), through to the contact on the auto-off switch, and back to the junction of the relay and resistance R. The relay will be effectively short-circuited and will release. When it is fully released, relay contacts 1 and 2 open and so

spindle as shown in Fig. 8. This will mean that the short circuit is made from earth, through contact 2, through the hour hand auto-off switch through the hour hand contact, to the minute hand, back to the minute auto-off switch through the rotor arm and back to R.

General

Make sure that the contacts are kept clean and watch especially those switching the mains on and off. These contacts may become pitted with frequent use. What is inclined to happen is that a point is built up on one contact and a pit in the other, and if the point is left to grow a time will come when the two contacts will not separate from each other on release.

Check that the hour and minute hands, where they make contact with the brass contactors, are kept clean and bright. A poor contact here will prevent the relay from operating.

Note that all points shown as earth on the diagram are commoned together. It is not necessary to connect such points to true earth.

The relay should be kept balanced: by that we mean that operating contacts should be on either side of the central "buffer block" on top of the relay. It is a good idea to keep the mains contacts on one side and the other contacts on the opposite side.

Where a relay has more contacts than are actually required, they can be removed quite easily. However, care should be taken to ensure that the load exerted on the armature by the spring sets is sufficient to make the armature release properly.

If any difficulty is experienced with the armature sticking, then ensure that the pole face of the electromagnet is clean, and also the inner face of the armature. Extra tension can be exerted on the armature by bending the spring sets, but if too much pressure is put on, then the relay will have difficulty in operating in the first instance. A happy medium between the two must be struck.

New Grundig Factory

GRUNDIG (GREAT BRITAIN) LIMITED have moved their factory and offices to new and larger premises at Sydenham. This move has been made necessary by the rapid growth of the company who, with added space and room for expansion, hope to narrow the gap between demand and supply of Grundig products. The new address is: Grundig (Great Britain) Limited, Newlands Park, Sydenham, London, S.E.26. Telephone number: Sydenham 2211.

The showroom and publicity and advertising department remain at 39, 41, New Oxford Street, London, W.C.1.

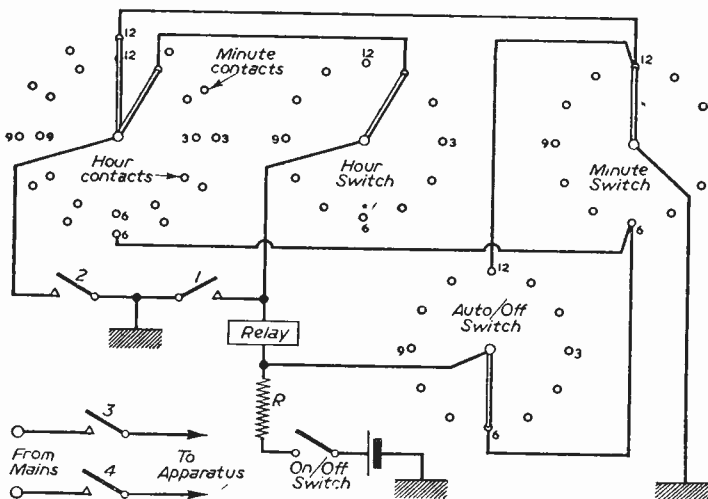

Fig. 8.—A schematic diagram of the automatic time switch.

there is no operate circuit for the relay and it will stay released.

It should be noted at this point that if it is desired to make the relay operate at, say, the half hour, it is necessary to ensure that the contactor on the clock face will stretch at least half way between two figures on the dial. It should, in fact, stretch as far as possible, allowing the minimum of separation between adjacent contacts on the hour section.

If, for example, the contact is short and the hour hand ceases to make contact with it by the quarter past, then the relay will not switch at the half past.

Long-period Operation

To make the switching period extend over one hour it is necessary to make a fourth switch. This is made in the same way as the other switches and forms the second part of the auto-off switch. The contacts are wired to the hour switch contacts.

The earth via contact 2 is taken to the rotor arm of the switch instead of to the clock

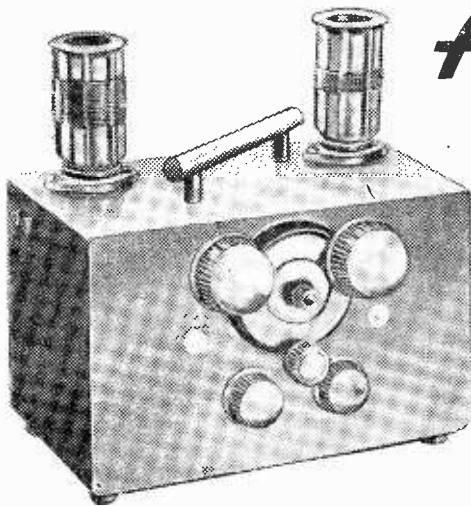

A.S.W. Portable Battery Two

A MIDGET 2-VALVE BATTERY RECEIVER

By A. Caspers

A .0002 mfd variable condenser has been included in the aerial lead-in.

Coils

The Eddystone 4-pin SW coils used with this set permits a large waveband to be covered, and

THE following considerations governed the designing constructions of this small 2-valve dry battery short-wave receiver. It had to occupy a minimum of space. It had to be light, and I set myself the limit of just over 5lb. inclusive of set and batteries.

I required a set which would give me a good variety of programmes at any hour of the day or night; that tied me down to short waves. The initial outlay was to be low, and the cost of battery replacement kept to a minimum.

The high-tension supply was derived from a couple of grid bias batteries joined in series, the low tension being supplied by a 3 volt twin cell cycle-lamp battery. Furthermore, grid bias was supplied to the circuit from a small single-cell battery, and this helped to ensure fidelity of reception.

The Circuit

It will be seen from the circuit diagram (Fig. 1) that the wiring is very simple. The lay-out is unorthodox in so far as the normal connections to the screened grid (S.G.) and controlled grid (C.G.) tappings of each valve have been reversed.

If such a circuit is used in conjunction with IC5GT/G valves, these valves will oscillate at a sufficiently low voltage to allow two grid bias batteries, coupled in series, to act as a high tension unit.

Also, if the valve filaments are placed in series, an ordinary 3 volt cycle lamp battery can be used.

The stages of the circuit are linked by transformer, as opposed to resistance coupling.

For smooth reaction, the transition from the non-oscillating to the oscillating condition must take place gently.

LIST OF COMPONENTS

- 4-pin Eddystone coils.
- 2 coil holders (4-pin valve-holders).
- .0002 mfd aerial trimmer.
- .0001 mfd variable condenser—Tuning.
- .0003 mfd variable condenser—Reaction.
- .0001 mfd fixed condenser.
- 5 meg ohms grid leak.
- Short wave high frequency choke.
- 50,000 ohm potentiometer.
- 0.01 m.f.d. fixed condenser.
- Transformer.
- Switch.
- 2 IC5GT/G valves and valve-holders.
- Headphones.
- Carrying handle.
- Tuning knobs, plugs, plug sockets.
- 2 G.B. batteries.
- 1 3 volt, twin celled, cycle-lamp battery.
- 1 1 volt single cell battery.
- Rubber stops.

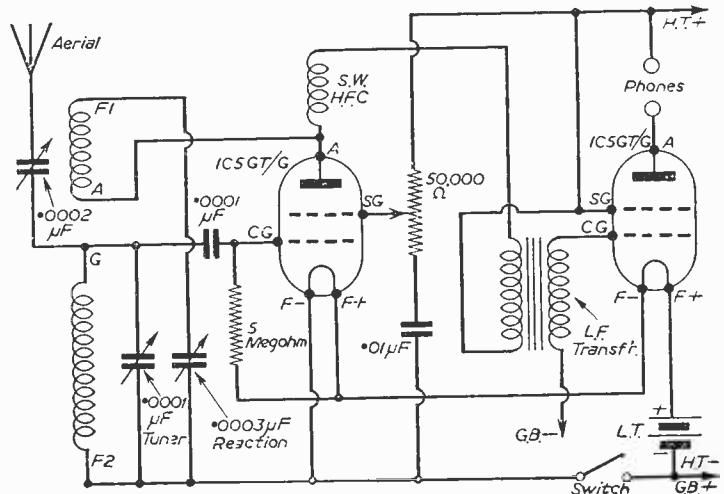
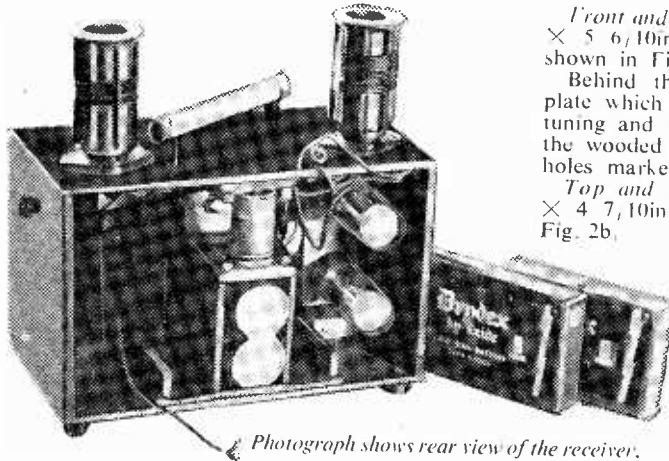

Fig. 1.—The circuit diagram.



Photograph shows rear view of the receiver.

the inclusion of two 4-pin valve-holders on the upper surface of the set allows a reserve coil to be carried whilst the other is in use.

The Cabinet

This is constructed of 3-ply wood with the exception of the sides, which should be somewhat thicker.

The measurements and details of the individual pieces are as follows :

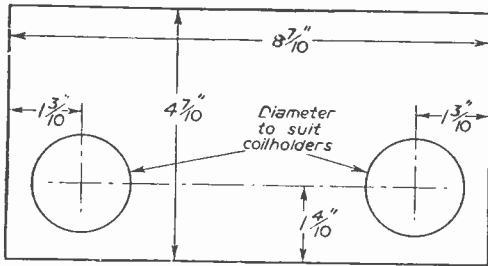
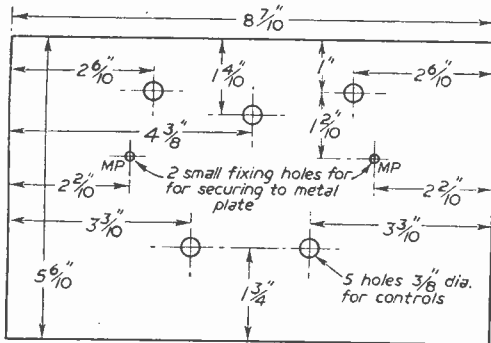

Fig. 2a (Above).—Drilling details for the front of the set. Fig. 2b (Below).—Drilling details for the top of the set.

Front and Back.—Each piece measures 8 7/10 in. \times 5 6/10 in., the front piece being drilled as shown in Fig. 2a.

Behind the front piece is included a metal plate which will act as a common earth to the tuning and reaction panel condenser. It is secured to the wooded panel by bolts passing through the holes marked "M.P."

Top and Bottom.—Cut each piece 8 7/10 in. \times 4 7/10 in., and drill the top as indicated in Fig. 2b.

The distance between the uprights of the carrying handle (a modified door handle) should be approximately 3 1/2 in., and each respective upright should be set in position about 1 1/4 in. in from the front or rear of the top. Exact measurements cannot be given here as slight variations are bound to occur.

The Sides.—These are constructed of slightly thicker wood (say 5-ply) and each side measures 5 3/10 in. \times 4 7/10 in. (Fig. 2c).

The Battery Holder

Pieces of 3-ply wood cut to the following dimensions:

- 4 7/10 in. \times 3 1/5 in. one piece
- 2 4/5 in. \times 3 1/5 in. two pieces
- 1 4/5 in. \times 3 1/5 in. one piece

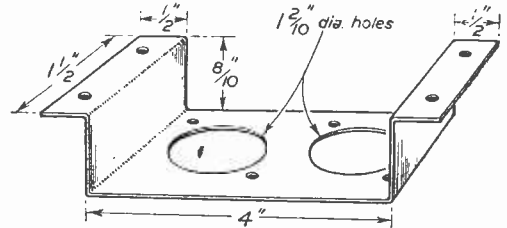

Fig. 4.—The metal strip for carrying 1C5GT, G valve-holders.

- 4 7/10 in. \times 3 in. one piece
- 3 1/5 in. \times 1 in. two pieces

They are then fitted together to form the holder (Fig. 3).

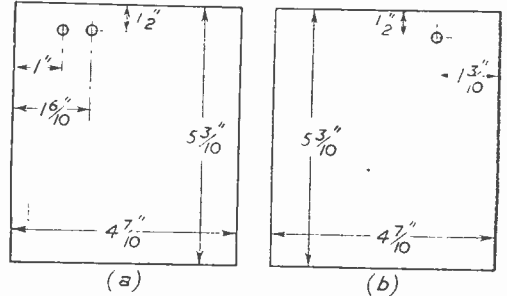

Fig. 2c.—The sides of the receiver.

It will be seen from this diagram that the piece of 3-ply wood measuring $4\frac{7}{10}$ in. \times 3in. acts as a backing to this unit and before being placed in position it should be trimmed to measure $1\frac{4}{5}$ in. across the top.

As indicated in the diagram, two metal plates are cut and fixed in position to act as battery contacts. Thus, the 3-volt twin cell cycle-lamp battery (L.T. supply) can be easily slipped into position, its individual prongs having first been

MP = Metal Plate

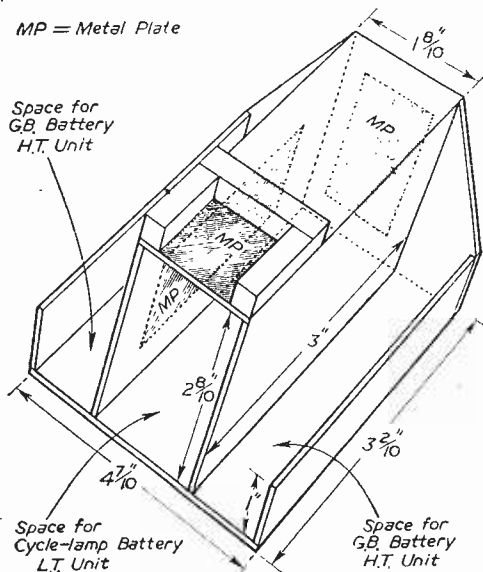

Fig. 3. The battery holder.

adjusted to make good contact with the metal plates. It will be noted also that a further metal plate has been affixed to the top of this unit, where it serves to make contact with one pole of the $1\frac{1}{2}$ single cell battery (G.B. supply). Three

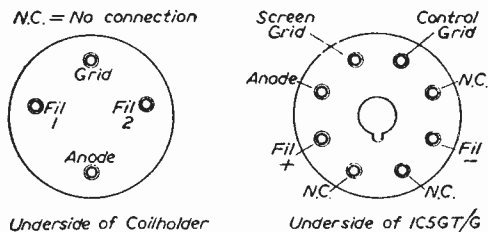

Fig. 5.—Details of the valve connection.

small pieces of wood, placed around this plate as shown help to steady this battery.

The Valve-holder Unit

The valve-holder unit should consist of a strip of firm metal measuring $6\frac{3}{5}$ in. \times $1\frac{1}{2}$ in., cut, bent and drilled as indicated in the diagram (Fig. 4).

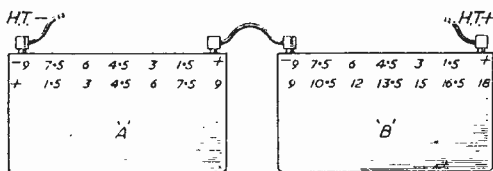

Fig. 6.—The high tension unit. The two grid bias batteries "A" and "B" are coupled in series, so giving the progressive voltages shown in the lower set of figures.

The Battery Supply

Low Tension. This is supplied by a 3-volt twin cell cycle-lamp battery which fitting into the receptacle made for it, makes contact with the metal plates provided. The metal strips can be bent outwards to ensure even firmer contact.

Grid Bias. A small single-cell $1\frac{1}{2}$ -volt battery makes a good source of supply and lasts almost indefinitely. It fits into the space between the undersurface of the top of the set and the upper side of the L.T. receptacle (see below).

The metal plate provided at those points again provides a large area of contact which can be made even firmer, if desired, by springing one of these plates away from the surface.

High Tension. The method, whereby the two grid bias batteries are coupled in series to provide a maximum H.T. supply of 18 volts, may need some elaboration.

No difficulty should be experienced, however, when it is realised that the 9 volt reading on a G.B. battery represents true negative, whilst the + is equivalent to 9 volts positive. Then if two G.B. batteries, A + B, are coupled in series, the following will pertain.

The H.T. negative line from the set will be taken to the true negative (9 volt) socket of battery A. The + (9 volt positive) socket is then joined by a short piece of wire to the -9 volt socket of battery B. Finally, the H.T. positive supply is connected to the + (positive) end of this same battery (see Fig. 6).

Switch on the set. Advance the reaction control until the set breaks into oscillation and a whistling sound is heard, and then turn back until the oscillation just dies away.

Smooth reaction is essential and if "Ploppiness" is experienced when passing from the non-oscillating to the oscillating stage, the 50,000 ohms potentiometer will need to be adjusted until this fault has died away.

As the tuning control is altered it is frequently found that the reaction control needs to be reset.

From time to time "Deadspots" will be experienced when oscillation cannot be obtained, nor any stations received. An adjustment of the .0002in. aerial trimmer often sets matters right.

This set will function efficiently with only a short throw-out aerial.

The range is world-wide when a good aerial system is employed.

STEREO ON DISC

The First Releases of Stereo Records are Now on the Market

By J. Gordon

IT is now well known that in order to secure the "3-D" sound illusion, usually referred to as stereophony, two sound channels, preferably in complete isolation, are required between two microphones in the studio or concert hall and two loudspeakers in the listening room. The channels may consist simply of conductors connecting the microphones to the loudspeakers, radio links or a recording medium of some kind, such as magnetic tape or an ordinary disc record. In this article we are going to be concerned essentially with the recording and the reproduction within the single groove of a gramophone record. This



Fig. 1.—A diagram illustrating lateral recording.

system of stereo recording is now well under way, and already the first releases of stereo records bearing the Nixa (Pye) label are available to the general public.

Lateral Recording

Let us briefly recapitulate the features pertaining to the recording of a single channel in the groove of a gramophone record. The sound waves falling upon the microphone are changed into very weak electrical impulses whose pattern follows the sound waves. These electrical impulses or signals are greatly amplified and are then applied to an electromagnet in the recording

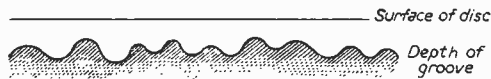

Fig. 2.—A diagram illustrating hill and dale recording.

head. This results in the intensity of magnetism so produced varying in direct sympathy with the sound waves, and the recording head is so designed that an armature, carrying the recording stylus, is caused to vibrate in a way that results in the recording stylus itself oscillating from side to side (laterally), also in sympathy with the original sound waves falling upon the microphone.

During the recording process, the record blank is rotated at a constant speed beneath the chisel-edge of the recording stylus, and since the recording head slowly moves radially over the surface of the disc, the stylus cuts a spiral groove which is modulated in accord with the sound patterns, as, of course, would be expected. This is known as lateral recording, and a section of a groove recorded in this way is shown in Fig. 1.

On playback, the reproducing stylus traces the modulated groove and is caused to vibrate as did the recording stylus during the recording process. However, the pick-up, in which the reproducing stylus is inserted, is a form of electrical generator, and thus produces an output voltage which is a fairly reasonable replica of the voltage first applied to the recording head. This is connected to a radio set or amplifier for the reproduction of the recorded signal.

Hill and Dale Recording

With the lateral method of recording, the depth of the groove remains constant, or nearly so, as the recording is made. There is, however, another method of recording sound on a disc in which the groove depth varies in sympathy with the recording signal. Instead of producing a wavy lateral groove, this method evokes undulations at the base of the groove, as shown in Fig. 2, and for this reason is usually referred to as hill and dale recording. This idea was exploited in the original phonograph of Edison, but for various technical reasons it was dropped in favour of the lateral method which is used to-day.

It will be understood, of course, that a pick-up for the reproduction of a lateral recording requires to provide an output for side to side movements of the stylus, while a pick-up for the reproduction of a hill and dale recording will need to give an output for up and down movements of the stylus.

Combining the Two Systems

A very clever arrangement of combining the two recording systems, to produce a "stereophonic" record on a single groove was evolved in the early 1930s by the British engineer A. D. Blumlein.

The idea was perfected and protected by patents, but the time was not then ripe for the commercial realisation of a stereophonic disc. The patents lapsed, and it was not until comparatively recently that the idea was again brought into the open and investigated in the light of the developments of the gramophone

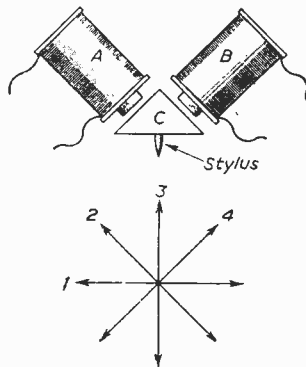

Fig. 3.—The basic features of a stereo recording head or pick-up, early days in the 1930s. The diagram below shows the movements of the stylus.

ing was accurate, and it would appear that the stereo disc has a great future in front of it.

There are two ways in which the two-channel modulation can be impressed upon the single groove of a disc, and both methods were detailed in Blumlein's patents. In effect, the two methods are complementary, and differ essentially from the phasing aspect of the signals in the two channels. One method is known as lateral-vertical recording, and the other as the 45-45 method. The 45-45 method has been adopted as the standard, and it is to this pattern that the current stereo discs have been recorded. To give the reader a brief idea of the system to start with, the 45-45 system

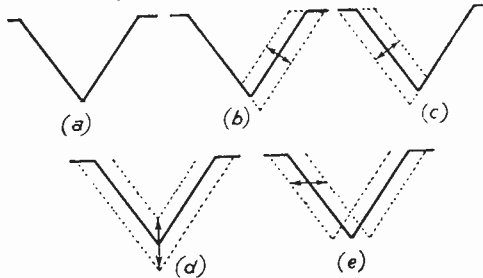

Fig. 4.—Diagrams showing how the groove is modulated by the stereo signals. (a) No modulation. (b) Modulation of the right-hand channel. (c) Modulation of the left-hand channel. (d) Modulation of both channels with in-phase signals (hill and dale recording) and (e) Modulation of both channels with out-of-phase signals (lateral recording). The recording head is "phased" so that the record produces in-phase signals from the loudspeakers when the pick-up stylus is actuated laterally.

can be described as the recording of two separate sound channels in a single groove, and each wall of the groove carrying one channel; the arrangement is termed 45-45 because each wall of the groove is at an angle of 45 deg. in relation to the surface of the disc.

In order to acquire a better understanding of the system, let us consider the diagram in Fig. 3. This may represent the very basic features of a recording head or pick-up, but let us consider it as the recording head. Parts A and B are the coils into which the recording signals are fed, and through the centre of these coils or bobbins are metal cores which, when the coils are energised by the signals, attract the armature C on which the stylus is secured. There is, of course, a permanent magnet related to the system, but from first principles this can be forgotten. For the sake of this discussion it should be considered that armature C is able to move in any direction as the result of attraction by the electromagnets.

Now, if the stylus in the diagram represents the recording cutter, and a groove is cut with the coils unenergised, a cross section of the groove can be represented by (a) in Fig. 4. If coil A only is energised by the recording signal the stylus will oscillate in the direction as indicated by arrowed-line 2 on the accompanying vector diagram, and this will modulate the groove as shown by the dotted lines in Fig. 4 (b). If coil

B only is energised, then the stylus will oscillate in the direction of arrowed-line 4 and this will modulate the groove as shown in Fig. 4 (c).

When both of the coils are energised simultaneously, however, the movement of the stylus will depend upon the relative phase of the two signals. If the signals are in-phase, the stylus will oscillate in the direction of vector line 3, which, of course, imparts a hill and dale modulation on the groove, as illustrated in Fig. 4 (d). If the signals are exactly 180 deg. out of phase, then the stylus will oscillate from side to side, as indicated by vector line 1, and this will impart an ordinary lateral modulation on the groove as shown in Fig. 4 (e). Variations in phase and amplitude of the signals will result in varying degrees of either kind of modulation, and on a complex pair of signals the groove is of a considerably complex nature.

It is obvious, of course, that the signal in one channel is applied to coil A, and the signal in the other channel to coil B. Since the pick-up itself has two "sensing" elements or generators, and is of comparable pattern to the recording head, it follows that the complex oscillations of the reproducing stylus as it traces the two-channel groove will match those of the recording stylus during the recording process, and voltages of reasonable match to those applied to the stereo recording head will occur across the generating systems of the stereo pick-up.

Standards

There have been various standards set with regard to stereo discs and recording methods. A notable stipulation is that the disc shall be recorded in a way that equal in-phase acoustical signals are provided from the loudspeakers when the reproducing stylus is actuated in a lateral direction - Fig. 4 (e). This condition would exist, for example, by an announcer standing midway between the two microphones or directly in front of the stereo microphone system at the studio.

However, it will be remembered that in order to secure a lateral cut the signals applied to the recording head must be of opposite phase. Thus, in order to comply with the above stipulation

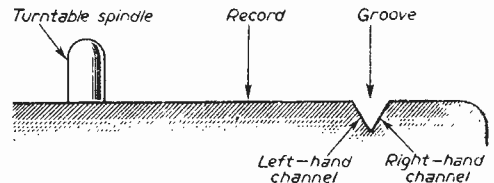

Fig. 5. - Showing how the channels are recorded on the two walls of the groove.

the signals have to be reversed in phase at the recording head. This simply means reversing the connections on one coil, but it is this phasing concept which marks the difference between the lateral-vertical system and the 45-45 system.

The advantages of the out-of-phase, or 45-45, system are (1) the record produced is "compatible" and can be played with a monaural pick-up provided (a) the tracking weight does not exceed about 3-4 grammes, (b) the radius of tip of

the reproducing stylus is in the region of 0.0005in. (half thou.) and (c)—*most important*—the pick-up possesses a high value of vertical compliance (small stiffness in the vertical direction); since this latter attribute is rarely present on monaural pick-ups, it seems hardly worth the risk to use stereo records in this way. (2) it increases the signal-to-noise ratio since the recording can be made at a higher level.

Another standard is that the right-hand channel should be actuated by the modulations on the wall of the groove which faces the axis of the record, and that the left-hand channel should be actuated by the modulation on the wall of the groove which faces away from the axis of the record. This is shown in Fig. 5.

It is also recommended that the reproducing stylus shall have a point radius within the limits of 12.5 and 15 microns (approximately 0.0005in.).

There is another point regarding the phasing aspect of the two channels, and that is, since the reproducing pick-up needs to be phased likewise, a stereo pick-up can be used to play a monaural record, provided the record has not been badly misused.

As a final point, it should be understood that the rate of wear of a half thou. stylus increases fantastically with increase in tracking weight. The tracking weight should be kept down to something like 3 grammes, if possible; if not, it would pay to use a diamond in order to avoid the frequent replacement of a sapphire.

New Whiteley Products

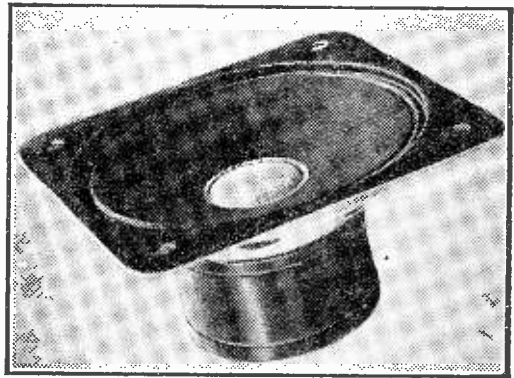
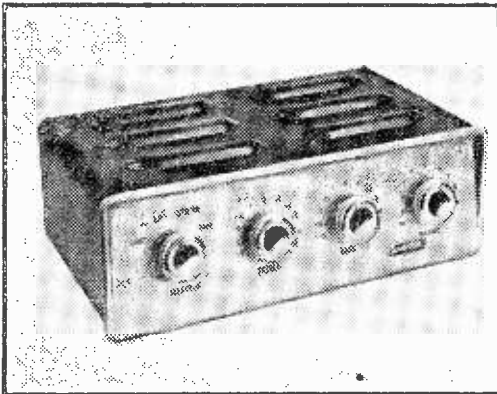

(Left) The WB.8 Amplifier which is a compact unit built on one chassis similar in style to the WB. Major control unit. It is suitable for either cabinet or shelf mounting and is intended for use with crystal pick-up, tuner units and tape reproducers having their own pre-amplifiers. (Right) The T.359 Cone Tweeter Unit which provides a very high standard of reproduction when used in conjunction with Stentorian 10in. or 12in. units.

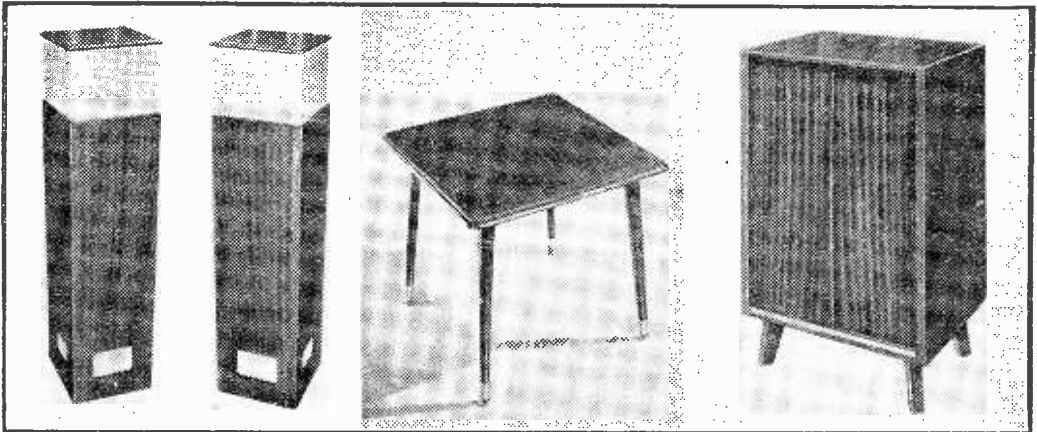

(Left) Column speakers which when used as a matched pair are primarily intended for stereo reproduction in the home. The floor area occupied is much smaller than that which would be taken by two conventional cabinet model loudspeakers of similar performance. (Centre) The Welbeck TV table which is of contemporary style finished in polished walnut, and fitted with self-aligning gliders. It is supplied packed flat ready for instant assembly. (Right) The Prelude Record Storage Cabinet which has a capacity for 250 to 300 records.

BEST VALUE FOR MONEY IN CONVERTERS.

I.T.A. high gain converter. ALL CHANNELS—ALL AREAS—ALL SETS. (For twin feeder input use a matching transformer at 5/- extra). Direct switching I.T.A. to B.B.C.): internal power pack: valves PCF80 and PCC84; moulded cabinet 8½" x 4" x 6". No alteration to your set; fitted in 10 mins. 12 months' guarantee.

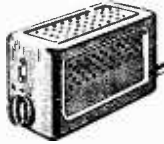

£5.50 p. & p. 3/-

EXTENSION SPEAKER in walnut finish cabinet. 6½" high quality speaker. P.M. 2-3 ohm. ONLY 29/6 (p. & p. 3/-). Brand new.

NEW ADMIRALTY release of transformers. Brand new condition: all 230 v. 50 c.p.s. input. Type 1 output 500-0-500 at 250 ma., 50/- (10/- carr.). Type 2 1 kv. at 2 m.a. and 2 v. 2 A. (2/- p. & p.). Type 3. 22 v., 23 v. or 24 v. at 5 A., 15/- (3/- p. & p.). Type 4, useful heater trans. 4 v. 5 A.; 5 v. 2 A.; 5 v. 3 A.; 6.3 v. 9 A.; 6.3 v. 2 A.: 20 - (p. & p. 5/-).

GUITAR AMPLIFIER. Two inputs, light oak cabinet with carrying handle, separate bass and treble controls. Write for illustration and details. Price. £6.15.0, plus 5/- p. & p. Two valves and metal rectifier. Mains.

The lowest priced complete 3-SPEED RECORD PLAYER on the market. Deep blue rexine carrying case 15" x 13½" x 6½". A.C. only. 5" speaker. B.S.R. Regent single player. ONLY £11.11.0 (4/6 p. & p.).

AUTOMATIC RECORD CHANGERS COLLARO CONQUEST with manual play also. Turnover crystal pick-up. 4-speed mixer. A.C. mains 200-250 v., see illus.



ALSO Collaro single player AC1/554, 4-speed, turnover crystal, pick-up with "T" head, £6.16.6 (3/6 p. & p.).

£8.10.0 5/- p. & p.

B.S.R. MONARCH 4-speed Mixer Autochanger at only £7.10.0 (5/- p. & p.). LIMITED SUPPLY.

GRAMOPHONE AMPLIFIER with 6½" (or 7" x 4") SPEAKER

WHY PAY MORE? ONLY 60/- (POST 3/-)
Mains and Output Transformers. Metal Rectifier. ECL82 Valve. Tone and Volume Controls. On-off switch. Plenty of Volume. Fully Guaranteed. Two Knobs supplied.

BATTERY ELIMINATOR. Converts your Battery Set to Mains. For 4 Low Consumption Valves (DK96 range). 90 v. 15 mA. and 1.4 v. 250 mA., 42/6 (2/6 Post). 200-250 v. A.C. Size 5½" x 3½" x 2".

Posted Orders to Camberley, please. Delivery by return. Terms:—One-third down and balance plus 7/6 in four equal monthly payments. Applicable to all items. Postage with down payment.

GLADSTONE RADIO

82B, High Street, Camberley, Surrey, and 3, Church Road, Redfield, Bristol. Tel.: 51207.

VALVES • SAME DAY SERVICE

All Guaranteed New and Boxed

1.4v. midget. 1R5. 1S5. 1T4. 3S4. 3Q4. 3V4. DAF91. DF91. DK91. DL92. DL94; ANY 4 for 27/6.

1A7GT	13/6	6U4GT	11/-	DAF96	8/6	EF35	9/6	PL92	8/6
1C5GT	13/-	6V8G	7/6	DFC99	10/6	EF39	7/6	PL83	10/6
1D3	12/6	6V3GT	7/6	DFY89	11/-	EF43	14/-	PY89	8/-
1H5GT	11/-	6X4	7/6	DF96	9/6	EF91	6/9	PY81	8/-
1N5GT	11/-	6X5GT	6/6	DH76	7/6	EF92	5/6	PY82	8/-
1R5	8/-	7B5	12/6	DH77	7/6	EL33	18/9	PY83	8/6
1S1	10/-	7C3	8/-	DK32	19/6	EL38	22/6	PZ30	18/-
1S3	7/6	7C5	8/-	DK92	8/6	EL41	9/6	R19	13/-
1T4	7/-	7C6	8/-	DK96	8/6	EL42	11/6	SP41	3/6
1U5	6/6	7H7	8/-	DL33	9/-	EL31	8/9	SP61	3/6
3A5	13/6	7S7	9/-	DL35	13/-	EM89	9/6	U25	15/-
3Q4	8/6	7Y4	8/-	DL96	8/6	EM81	10/-	U50	7/6
3Q5GT	8/6	12AH3	9/-	EABC89	9/6	EY31	11/6	U76	7/6
3S4	7/6	12AT7	8/-	EAF42	5/6	EY89	13/6	U79	7/6
3V4	8/6	12AU7	7/-	EB91	5/6	EZ40	7/9	UABC89	9/-
5U4G	8/-	12AX7	8/-	EBC33	7/6	EZ41	10/9	UAF42	9/6
5V4G	11/9	12K7GT	7/6	EBC41	9/6	EZ89	6/6	UBC41	8/6
5Y3GT	7/6	12K9GT	12/6	EBF89	8/9	EZ81	9/-	UBP89	8/6
5Z4G	9/6	12Q7GT	7/6	ECC82	8/-	PW4/500	10/6	UCC85	9/-
6AL5	5/6	12Z3	7/6	EC92	7/6	Z332	11/-	UCH42	9/-
6AM5	5/-	14S7	15/6	ECC83	8/-	KT33C	8/6	UCH81	9/6
6AM6	6/9	19AQ5	7/6	ECC84	9/6	KT63	6/6	UCL83	14/6
6AQ5	7/6	25A9G	13/6	ECC85	9/6	MH4	6/-	UP41	8/-
6AT5	7/3	25L9GT	8/6	ECF89	10/6	MU14	9/-	UP42	15/-
6BA5	7/-	25C4G	9/6	ECF92	11/-	N18	8/6	UP89	9/-
6B3G	7/-	25Z3GT	9/6	ECH41	16/9	PCF81	9/-	UL41	8/6
6BH3	9/-	31L5GT	9/6	ECH33	10/-	PCF89	9/-	UL44	22/6
6BJ6	7/-	35Z4GT	7/6	ECH42	9/-	PCF82	10/-	UL91	8/6
6BR7	8/6	35Z5GT	9/6	ECH81	8/-	PCL82	10/-	UR1C	12/6
6BW6	7/6	43	12/6	ECL81	11/9	PCL33	12/-	UY21	15/-
6BW7	7/6	50CD9C	24/6	ECL32	11/9	PEA4	12/-	UY41	6/6
6CD9G	25/-	50L5GT	8/6	EPY4	8/6	EPY4	8/6	UY35	8/-
6F3G	6/6	AZ31	11/6	EP39	6/-	PEN38C	14/6	VP4B	14/6
6K7C	4/6	B38	15/-	EP41	9/6	PEN46	6/-	VP41	6/6
6KTGT	8/-	CL33	18/9	EP42	11/6	PL33	15/-	W76	7/6
6K8G	7/9	D77	5/6	EP50 (SYL)	10/-	PL38	22/6	W77	5/6
6QTGT	6/6	DAC32	11/-			PL31	18/-	Z77	6/9
6SL7G	7/6							Z715	8/3
6SN7G	7/6								

Postage 6d. per valve extra. Any Parcel Insured Against Damage in Transit 6d. extra.

READERS RADIO

24, COLBERG PLACE, STAMFORD HILL, LONDON, N.16 STA. 4587

TRANSISTORWISE



"RECO" ONE (200 to 500m)

Complete kit with ferrite rod vari Q aerial. 3 position on/off and wave band switch. Personal phone, etc. Case size 11" x 4" x 4". Yours for 30/- and 2/- p.p.



"RECO" MIDDY TWO

This receiver is similar to the Middy-3, but is less sensitivity control. Amazing performance. Covers medium and short wave band or medium and long waves 3/6 extra. Nothing else to buy. Complete kit with balanced armature output unit 49/6 or with "Sonotone" miniature dynamic earpiece 55/-, p.p. 2/3.



"RECO" SPECIAL TRANSISTOR THREE

This fine receiver has now been greatly improved with the addition of a handsome looking chromium plated telescopic aerial 11½ in. closed, 48 in. extended. Has sensitivity control and High "Q" Fer-rod-aerial. Complete kit with choice of "Sonotone" miniature earphone or balanced armature output unit which, in areas of reasonable signal reception, can be mounted inside case. Case size 6 in. x 4 in. x 1½ in. with red plastic ornamental unit cover. 77/6. Less telescopic aerial and with balanced armature output unit 65/-, p.p. 2/6.

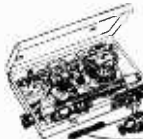

"RECO" MIDDY THREE

Small in size, big in performance. Ideal for invalids. Take it on holiday. Vost pocket size 4 in. x 3 in. x 1 in. In areas of reasonable signal reception receives local stations on built-in ferrite rod Vari "Q" aerial. Covers either to 50 metres. Complete with three transistors and pencil. Price including "Sonotone" miniature earphone with moulded ear insert and lead 65/-, p.p. 2/3. Overseas orders. Carr. 19/- extra.

All "Reco" kits with ferrite rod aerials can now be supplied either for medium and long waves (3/6 extra) or medium and short wave band. Case finish for Middy 3, Red/Black. No extra charge. Pictorial wiring diagrams parts price list for all the above. 2/6 the set.

RADIO EXCHANGE CO., Dept. P.W.
27A, Harpur Street, BEDFORD. Phone: Bedford 2387.

TRANSMITTING TOPICS

ADDING A P.A. STAGE

By O. J. Russell, B.Sc.(Hons.), G3BHJ

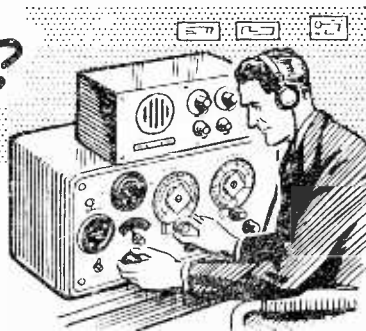

THE owner of a simple crystal oscillator rig soon begins to think of a more ambitious installation. With a straight crystal oscillator, for example, his input is restricted to around the 10 to 15 watt mark. Also, of course, his aerial loading adjustments will react on to the oscillator, so that the optimum output will be a little short of that obtainable from an amplifier stage. Moreover, phone operations will generally require yet a further compromise with oscillator output for good results.

The solution, of course, is to add an amplifier stage to the oscillator, so that the benefits of a P.A. stage may be obtained. These benefits not only overcome the sensitivity of an oscillator rig to aerial loading, but also permit of a considerably higher power input. Several operators known to the writer have had excellent results, plus a number of snags to overcome, with C.O./P.A. installations. In fact many well-known DX stations also use crystal-controlled rigs. One benefit of the P.A. stage is the flexibility it confers in operating conditions.

A typical C.O./P.A. circuit is shown in Fig. 1. We may assume that the ubiquitous 807 is employed as the P.A. stage. With an 807, the biasing of the valve is important. As shown in Fig. 1, battery bias may be employed, with or without gridleak bias. Thus, one may battery-bias the 807 grid with the full Class C bias required for operation at the H.T. employed. This bias may be determined from the official operating instructions for the 807, but generally speaking the operator may have to provide up to 60 or more volts of battery bias. This is an item that is more of a nuisance than otherwise. One way out is to battery-bias the 807 so that it draws less input than its rated dissipation when not excited, and to make up the Class C bias by a gridleak. To avoid purchase and upkeep of batteries, one simple method is to modify the P.A. for cathode bias as in Fig. 2. A by-passed cathode resistor gives enough "stand-by" bias so that the P.A. valve does not draw more than its rated anode dissipation during non-transmitting periods. When transmitting the full Class C bias is developed by means of a gridleak.

Naturally enough those who

have a spare tetrode will probably prefer to use one of the clamp tube circuits previously described, whereby the P.A. tube is protected from excessive dissipation by the clamp valve reducing the P.A. screen voltage when there is no grid drive. A simple type of clamp circuit is shown in Fig. 3. While the clamp tube is a certain safeguard for the P.A. valve, it is often backed up by a small amount of cathode bias as well. Thus a 47 ohm cathode resistor bypassed by a .01 condenser forms an additional safeguard. Such a cathode "safety" resistor will not prevent the amplifier valve from drawing more than its rated dissipation should the clamp tube fail, or the H.T. switched on before the clamp tube has warmed up or if the clamp tube has been removed. However, a safety resistor of this type will limit the current drawn by the P.A. valve, and may make the difference in an emergency between "blowing" the P.A. tube and saving it. The writer's own pair of 807s during some ten years of intermittent operation have several times accidentally turned red-hot due to a bias failure. Their survival and present-day operation in the main transmitter is ascribed to the use of such

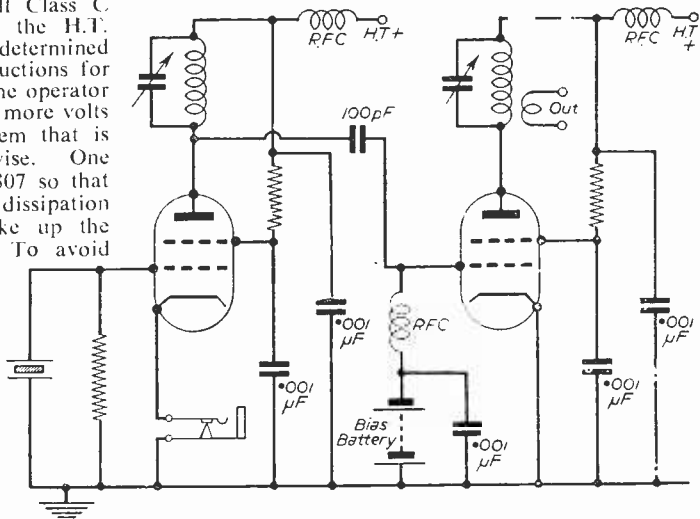

Fig. 1.—A crystal oscillator driving a P.A. stage. Battery bias provides the full Class C bias.

a "safety" resistor, which limits the extent to which plate current rises in a bias or clamp tube failure.

Some general recommendations about operating

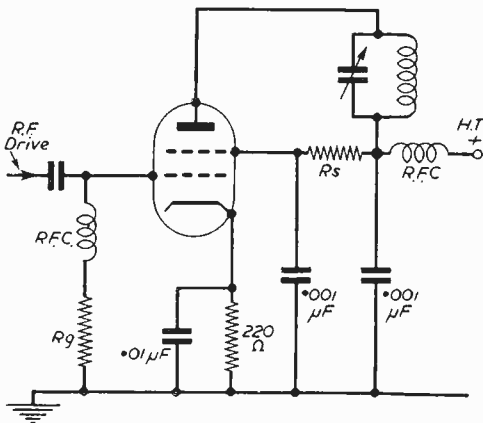

Fig. 2.—A P.A. stage using gridleak bias with protective cathode bias during "standby" periods.

the P.A. stage may be of interest. The beginner may, in fact, operate the P.A. stage from the same pack of, say, 300 or 350 volts that was used to operate the crystal oscillator, at any rate for provisional trials. If the pack is capable of, say, 100mA output, a useful 30 to 35 watts P.A. input may be run. In fact the H.T. applied to the crystal oscillator may be reduced via a dropper resistor and still give adequate P.A. grid drive, while permitting the P.A. to draw as much input as is possible from the pack. Later on a separate "QRO" pack for the P.A. may be used, and with this one 807 may be driven to 60 watts and if a second 807 is added a very healthy input of some 120 watts is available. Thus a very creditable signal may be radiated with very inexpensive gear. With a number of surplus crystals QRM may be avoided and a respectable DX score achieved. In fact one recently licensed amateur in about three months of operation is known to have a DX countries worked score of nearly 40 using such a type of rig. Moreover, many other "rock bound" beginners are known who have had very excellent results with simple gear, and who have found their experience invaluable for handling more complex transmitters. Moreover, the P.A. stage may be used with or without a rebuild as the P.A. for a multistage VFO driven transmitter, so no "waste" ensues. Moreover, the low cost of simple crystal-controlled rigs and their ease of operation are valuable initial "training" steps. Also with limited construction time a newly licensed ham can get on the air quickly with a simple C.O./P.A. rig and build his advanced VFO controlled "big rig" at leisure, while enjoying QSOs on the simple type of rig.

However, to adjust the P.A. stage for optimum results, the prudent operator will "monitor" several strategic points. If enough meters are available, Fig. 4 shows how the P.A. grid current, P.A. anode current and screen voltage should be

simultaneously monitored. This extravagance with meters may be reduced if only one "multi-range" meter is available by placing closed circuit jacks, as shown in Fig. 5, to read grid, screen and plate current in turn with one meter. However, it is good practice to have permanent meters in both anode and grid circuits to give continuous readings. For initial trials, either the screen current or screen voltage should be measured to make sure that screen ratings are not exceeded.

Assuming that we have full metering, the P.A. stage should be coupled to the crystal oscillator. If the operator is trying a "QRP" test with the 300 or 350 volt pack used with the crystal oscillator, then a screen resistor of around 4.7K to 10K should be selected. If a 450 to 500 volt supply is used a 15 to 25K screen resistor should be used. However, for safety, the preliminary tests should be at a low anode voltage of 300 to 350 volts, and if a higher voltage pack is around reserve it for later—or use a 4K "safety" resistor in series with the anode lead to the P.A. "just in case."

The first test is for grid drive, and this is made without voltage applied to the P.A. stage. Fire up the crystal oscillator and observe that grid current flows—provided of course that the P.A. valve heater is on! Preferably some control over excitation is desirable, so that a variable coupling capacitor to the crystal oscillator (Fig. 6) is used. A typical 160pF variable will be quite suitable. Also a "power level" control in the anode of the crystal oscillator is desirable, such as a 5K slider adjustable 10 or 25 watt wire wound resistor. These adjustments will enable the "range" of grid excitation possible to be explored without using H.T. on the P.A. The 807 is in fact operating as a "power diode" in these tests. Assuming that a 25K gridleak is in use for the 807 one should be able to get grid drive from 1mA upwards. In fact, under these

(Continued on page 545)

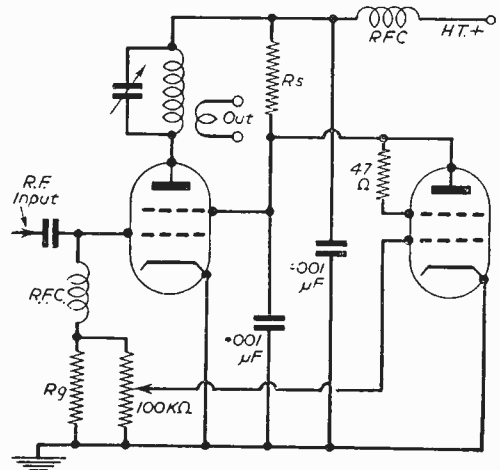

Fig. 3.—A simple clamp tube protected P.A. stage. A 6L6 or a 6V6 will be suitable for use with the 807 P.A. valve.



FOR VALVES—GUARANTEED NEW AND BOXED

AC6PEN 6/6	ECL82 13/-	HL23DD 8/6	PEN25 5/-	UF89 10/6	ISS 7/6	6CH6 7/6	6X5G 7/-	19BG6G 24/4
AC/THI	EF22 8/6	K40N 9/-	PEN44 27/10	UL41 10/6	IT4 7/6	6D6 5/-	6X5GT 7/-	20D1 16/-
ATP4 3/6	EF36 6/-	KF35 8/6	PEN45 27/10	UL44 27/10	IU5 7/6	6F6G 7/6	6/30L2 12/6	20F2 27/10
AZ31 12/6	EF39 6/6	KK32 23/-	PEN46 7/-	UL46 24/4	2C26 1/6	6F6M 7/6	7B7 8/6	20P1 27/10
CBL31 24/4	EF40 14/6	KLL32 8/6	PEN220A	UL84 11/6	2X2 4/6	6F13 14/-	7C5 8/-	20P3 24/4
CCH35 24/4	EF41 9/9	KT24 5/-	PENA4 4/-	UU6 20/11	3A4 7/-	6F15 14/-	7C6 8/6	20P5 20/11
CL33 20/2	EF42 14/-	KT33C 10/-	OP21 7/6	U08 27/10	3D6 5/-	6G6G 4/6	7D6 13/6	25A6G 11/6
CY31 17/5	EF50 4/-	KT36 27/10	R16 27/10	UY41 8/6	3Q4 9/6	6H6 2/6	7H7 9/-	25L6GT 10/-
DAF96 10/6	EF54 6/-	KT55 12/6	R19 13/6	UY85 10/-	3Q5GT 9/6	6H6GT 2/6	7Q7 9/-	25Y5 9/9
DF96 10/6	EF80 9/-	KT66 15/-	SP41 3/-	VP2B 8/-	3S4 8/-	6J5M 6/6	7S7 9/6	25Y5G 9/9
DH63 9/-	EF85 9/-	KT66 15/-	SP41 3/-	VP13C 3/6	3V4 9/-	6J6 6/-	7Y4 8/6	25Z4 9/6
DK96 10/6	EF85 9/-	KTW63 7/6	T41 24/4	VP23 6/6	4D1 3/6	6J7G 6/6	8D2 2/9	25Z5 10/-
DL96 10/6	EF89 10/6	ME91 7/6	TH2 9/-	VP41 8/6	SR4GY 9/6	6J7M 9/-	9D2 3/6	25Z6 10/-
DM70 8/6	EK32 8/6	MH41 7/9	TP25 27/10	VR105/30 8/-	SU4G 8/-	6K6GT 7/-	10F1 27/10	30F5 11/6
EASO 1/6	EL32 5/6	MSP4/5 12/6	U10 10/6	VR116 4/-	SY3G 8/-	6K7G 5/-	12A6 6/6	30F11 11/6
EABC8010/-	EL33 20/2	MSP4/7 12/6	U14 (DW 4/500)	VR150/30 9/-	SZ4G 10/-	6K7M 6/9	12AH8 11/6	30P4 21/7
EAF42 10/6	EL38 27/10	N37 18/1	U22 8/-	VU120A 3/6	6A7 13/-	6K8G 8/6	12AT6 10/6	30P12 12/6
EB34 2/-	EL41 11/-	EF55 10/-	U25 14/6	VU39 (MU12 1/4) 8/9	6A8G 10/-	6K8GT 10/-	12A77 9/-	30PL1 12/6
EB41 9/6	EL42 12/-	N78 12/6	U26 13/6	U37 27/10	6AC7 6/6	6K25 20 11	12AU6 10/6	35L6GT 9/6
EBC33 7/6	EL84 10/6	OZ4 5/6	U37 27/10	U45 15/-	6AG5 5/6	6L7 7/6	12AX7 9/-	35W4 8/6
EB41 9/6	EL42 12/-	P61 3/6	U45 15/-	U50 8/-	6AK5 6/6	6N7 7/6	12BA6 9/6	35Z4GT 8/-
EBC33 7/6	EL84 10/6	PCC84 10/-	U50 8/-	U329 14/6	6AL5 6/6	6P28 27 10	12BE6 10/6	35Z5GT 9/-
EBF41 10/-	EM34 10/6	PCF80 13/6	U329 14/6	U403 17/5	6AM6 6/6	6Q7G 9/-	12BH7 11/6	42 8/-
EBF8J 10/6	EM80 10/6	PCF82 12/6	U404 11/10	X79 11/6	6AQ5 7/6	6Q7GT 9/-	12H6GT 3/-	50C5 11/6
EBF89 18/1	EM81 11/6	PCL82 12/6	U801 31/4	Y63 9/-	6AT6 8/6	6SA7GT 8/-	12J5GT 4/6	50CD6G 31/4
EBL21 24/4	EY51 13/6	PCL83 14/6	UABC80	Z309 9/6	6AU6 10/6	6S7G 7/6	12J7GT 10/6	50L6GT 8/6
EBL31 24/4	EY85 13/6	PLB3 27/10	UAF42 10/6	Z359 9/6	6B4 5/-	6S7 7/6	12K7GT 8/6	75 11/6
ECC91 7/6	EZ40 9/-	PLB1 16/-	UB41 9/6	Z759 9/6	6B8G 4/6	6SH7 6/-	12K8GT 8/6	77 7/6
ECC84 10/3	EZ41 10/-	PLB2 8/6	UBC41 10/-	IA3 3/6	6BA6 7/6	6S17 8/6	12Q7GT 8/6	80 8/6
ECC85 9/6	EZ80 8/9	PLB3 11/6	UBF80 9/6	IA5GT 6/-	6BE6 8/-	6SK7 6/-	12SC7 1/6	142BT 3/6
ECF8J 13/6	EZ81 11/10	PX25 12/6	UCC8420/11	IC2 11/6	6BG6G 24/4	6SL7GT 8/-	12S7G 7/6	185BT 34/9
ECF82 13/6	EZ90 8/-	PY80 9/-	UCF80 23/-	IC5GT 12/6	6BH6 16/-	6SN7GT 7/6	12S7 5/6	210DDT 4/6
ECH21 24/4	E1148 2/-	PY82 9/-	UCH42 10/6	ID5 12/6	6B16 9/-	6SQ7 9/3	12SH7 5/6	210VPT 3/6
ECH35 10/6	FW4/500	PY83 10/-	UCH81 11/6	IH5GT 10/6	6BR7 11/6	6U4GT 14/-	12S7 8/-	807 6/6
ECH42 10/6		PZ30 20/11	UCL82 23/-	IL4 6/6	6BW6 8/6	6U5/6G5 8/6	12SK7 6/-	954 2/-
ECH81 11/-	GZ32 10/-	PEN4DD 27/10	UCL83 25/9	IL5 3/6	6BW7 10/-	6U5G 8/6	12SL7 8/-	955 4/9
ECL80 13/6	H30 5/-	PEN4VA 15/-	UF41 10/6	IN5 10/6	6C4 7/6	6LUTG 8/6	12SN7GT 17/6	956 3/6
			UF85 10/6	IS4 10/6	6C5GT 6/6	6V6G 7/-	12SQ7 8/6	9001 5/6
					6C6 5/-	6V6GT 7/-	14S7 14/6	9003 5/6
					6C8G 5/-	6V6M 8/6	15D2 7/9	9004 5/6
					6CD6G 31/4	6X4 7/6		9006 5/6

* GUARANTEE

All valves are new, boxed and fully covered by manufacturers' guarantee. Every valve is tested before despatch.

* RETURN POST SERVICE

All orders received by letter, phone or wire receive immediate attention and are posted the same day.

* INSURANCE SERVICE

Valves can be insured against damage for only 6d. extra per order.

Our 1958/9 Fully Illustrated

CATALOGUE

of components and accessories invaluable for enthusiasts and engineers—is now available.

Send 1/- in stamps for your copy today.

NAME

ADDRESS

PW



103 LEEDS TERRACE
WINTOUN STREET
LEEDS 7

TERMS: Cash with order or C.O.D. Postage and Packing charges extra, as follows: Order value 10/- add 1/3; 20/- add 1/9; 40/- add 2/6; £5 add 3/6. Minimum C.O.D. fee and postage 3/-. For full terms of business see inside cover of our catalogue. Personal shoppers 9 a.m. to 5 p.m. Monday to Friday. Saturday 10 a.m. to 1 p.m.

SPECIAL OFFER

20,000 OHMS PER VOLT TESTMETER

Just purchased from the Air Ministry these magnificent American PRECISION Testmeters provide 31 ranges for reading Voltage, Current and Resistance, 6 Decibel ranges, 7 Output ranges, and facilities for testing Electrolytic and Paper Condensers. Single switch control, meter size 4 3/4 in. x 4 1/4 in., with Red and Black Scales, mounted on Black and Silver Panel, size 8 3/4 in. x 7 in., which is fitted into sturdy wood carrying case with removable hinged lid and compartment for leads, etc., the overall size being 10 in. x 9 in. x 6 in. Has 7 D.C. Voltage ranges up to 6,000 volts at 20,000 ohms per volt, 7 similar ranges at 1,000 ohms per volt, 7 similar A.C. ranges at 1,000 ohms per volt, 7 D.C. Current ranges from nought microamps to 12 amps, 3 Resistance ranges up to 60 Megohms, 6 Decibel ranges from -12 to +70 DB, 7 Output ranges up to 6,000 volts. Supplied with test leads, internal batteries, and operating instructions. Case finished medium oak, and fitted with leather handle.

IN FIRST CLASS CONDITION, OVERHAULED & CHECKED BEFORE DESPATCH.

ONLY £9-19-6 (post, etc., 4/-)

Further details on receipt of S.A.E.

COLLINS' TEST TRANSMITTERS. Special offer of these famous American Transmitters. Frequency Range 1.5-12.0 Mc/s in 3 bands. Employs 7 valves, 2 of 1B25 in P.A. Stage, 1025 buffer and 1B21 modulator stage, 3 of 12A6 in Oscillator stage. Radio Telephone or Radio Telegraph. Provision for VFO or Crystal Control 4 Crystal positions. Has Plate and Aerial Current meters. IN BRAND NEW CONDITION. ONLY £12.10.0 (carriage, etc., 15/-).

MURHEAD SLOW MOTION DRIVES. A really precision product of this famous maker. 3 in. in diameter and fitted to removable white back plate marked 0-180. Overall diameter 4 in. BRAND NEW IN MAKER'S CARTONS. ONLY 10/6 (Post 1/6).

12 VOLTS AMERICAN DYNAMOTOR. Delivers 220 volts at 100 mills. Ideal for running Car Radio or Electric Shaver, etc., from Car Battery. ONLY 32/6.

6 V. VIBRATOR PACKS. Output approx. 130 v. at 30 mA., fully filtered and smoothed. Complete. BRAND NEW. ONLY 12/6.

R1155 SUPER SLOW-MOTION TUNING ASSEMBLY. As used on all late model 1155s. Easily fitted to "A" sets, etc. BRAND NEW. ONLY 12/6.

EHT TRANSFORMERS. 5.5 kV. (Rect.) with 2 v. 1 a., 79 6. 7 kV. (Rect.) with 2 v. 1 a., 89 6. 2.5 kV. (Rect.) with 2-0-2 v. 1.1 a., 2-0-2 v. 2 a. (for VCH97 tube, etc.). 42 6 (postage 2/- per trans.).

POCKET VOLTMETERS.—Read 0-15 volts and 0-300 volts A.C. or D.C. BRAND NEW AND UNUSED. ONLY 18 6.

CRYSTALS. British Standards 2-pin 500 kc s. 15-. Miniature 200 kc/s 10/-.

ROLA 6 1/2 in. P.M. SPEAKER. Mounted in grey cracked metal cabinet 9 in. x 9 in. x 4 1/4 in., with volume-control. Ideal for use with receiver, or as extension. BRAND NEW. ONLY 27/6. (Post 2/6).

MAIN ISOLATING TRANSFORMER. Manufactured by Vortexion. Fully shrouded. Will provide true 1:1 ratio from nominal 230 v. Primary. Rated at 100 watts. BRAND NEW. ONLY 32/3. (Post 2/6).

HARRIS ELECTRONICS

(LONDON) LTD.

138 Gray's Inn Road, London, W.C.1.

(Phone TERMINUS 7937)

Please include carriage costs on ALL items.

(Open until 1 p.m. Saturdays. We are 2 mins. from High Holborn (Chancery Lane Station) and 5 mins. by bus from King's Cross.)

A SMALL DEPOSIT will bring you enough parts to make a complete:—

TRANSISTOR POCKET RADIO

(Size 5 3/4" x 3 1/4" x 1 1/4") using a printed circuit.

★ Send for FREE PRICE LIST (all parts sold separately) and/or 3/- for new simplified instruction booklet with suggested circuits and assembly details.

FULL MEDIUM & LONG WAVE COVERAGE for as little as **£9.19.6**

OUR CIRCUITS OFFER HIGH SENSITIVITY HIGH SELECTIVITY using
3 RF Transistors 1 gn. each
2 LF Transistors 10/- each

all specially selected to give **HIGH OVERALL GAIN** with A.V.C.

● Miniature Loud-speakers only 1 1/2 in. deep x 2 3/4 in. diam. **27/6**

● Miniature oscillator and I.F. coils 1 1/2 in. high 3/4 in. diam. **8/-**

● Jackson 00 twin gang tuning condenser with intersection screen **10/6**

● Attractive High Impact Polystyrene Cabinet with fittings for tuner, trimmers, speaker and circuit board **8/6**

MANY OTHER SUB-MINIATURE COMPONENTS AVAILABLE.

SPECIALISED ELECTRONIC COMPONENTS, LTD.,
8, ECCLESTON SQUARE, LONDON, S.W.1.

MAIL ORDERS ONLY.

FREE TO AMBITIOUS ENGINEERS!

This 148-page Book

Have you sent for your copy?



'ENGINEERING OPPORTUNITIES'

is a highly informative guide to the best-paid Engineering posts. It tells you how you can quickly prepare at home on "NO PASS—NO FEE" terms for a recognised engineering qualification, outlines the widest range of modern Home-Study Courses in all branches of Engineering and explains the benefits of our Employment Dept. If you're earning less than £20 a week you cannot afford to miss reading this unique book. Send for your copy to-day—FREE.

WHICH IS YOUR PET SUBJECT?

Mechanical Eng.
 Electrical Eng.
 Civil Engineering
 Radio Engineering
 Automobile Eng.
 Aeronautical Eng.
 Production Eng.
 Building, Plastics,
 Draughtsmanship,
 Television, etc.

GET SOME LETTERS AFTER YOUR NAME!

A.M.I.Mech.E.
 A.M.I.C.E.
 A.M.I.P.E.
 A.M.I.M.I.
 L.I.O.B.
 A.F.R.Ae.S.
 B.Sc.
 A.M.Brit.I.R.E.
 CITY & GUILDS
 GEN. CERT.
 OF EDUCATION
 etc., etc.

--- FREE COUPON ---
 Please send me your FREE 148-page 'ENGINEERING OPPORTUNITIES'

NAME

ADDRESS

Subject or Exam. that interests me.....

British Institute of Engineering Technology, 409B, College House, 29-31, Wright's Lane, Kensington, W.8.

BIET

conditions, several mils. of grid drive should be attainable.

These grid drive figures will not mean too much, as they will alter somewhat when H.T. is applied to the P.A. stage. However, before applying H.T. to the P.A. stage, we assume the reader has fitted a tank circuit that will tune to the band of operation, say the 7 Mc/s band. It helps if the tank is roughly tuned to the right frequency, and this may be done by using it as an absorption wavemeter and observing the reaction of the crystal oscillator when inductively coupling to it, a simple "grid-dip" technique. Also it is a great help to have the H.T. "off" switch handy when applying H.T. to a P.A. for the first time. With this in mind, start the crystal oscillator and, with a milliamp or two of grid current flowing, throw on the P.A. H.T. Don't watch the grid meter drop back when you do this: watch the P.A. meter! The P.A. anode current meter will indicate a high current. Rapidly tune the P.A. tank circuit and observe the sharp "dip" point at which the current falls to a low value. Careful tuning will locate the "dip" point at which the P.A. tank is resonated to the operating frequency. A neon held near the P.A. anode tank circuit should glow brilliantly. Typical dips may vary according to tank circuit efficiency, but from an untuned plate current of over 100mA, a dip to thirty, twenty or even ten or less mAs is typical. Generally, with an efficient tank, the dip should be sharp and steep with an on tune current of only a few milliamps.

Switching off, we are ready to put the P.A. through some loading trials. The "artificial aerial" circuits previously described may be used. However, a simple lamp load is quite adequate. Make a coil of a couple of turns that can be easily and tightly coupled to the P.A. tank coil. Solder across this an appropriate wattage lamp, say an

automobile bulb or a domestic 25 watt lamp that will meet the expected (or hoped for) P.A. output. Switch on the P.A. again and satisfy yourself that, by coupling the lamp load cautiously

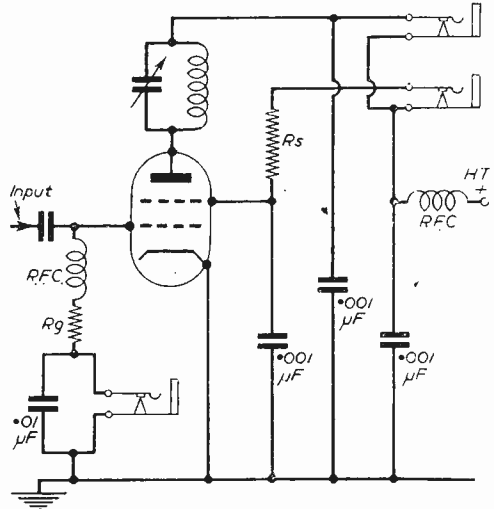

Fig. 5.—If only one meter is available closed circuit jacks should be fitted to monitor anode grid and screen currents in turn.

into the P.A. tank, you can load up the P.A. In so doing observe that the P.A. anode current meter reading increases as you couple power out of the tank circuit, and that the sharp "on-tune dip" becomes flatter as the P.A. meter reading increases. Check, by tuning the P.A. condenser, that maximum light in the bulb corresponds with the "minimum current" position on the meter.

Finally, fix the lamp load coil in a position that gives a reasonable readings. Adjust the grid drive and observe the meter readings. Adjust the grid drive and note that, beyond two or three mAs of drive current, the P.A. anode input and power output (as indicated by the bulb light) remain about the same. In fact, too much grid drive will actually reduce power output, and screen metering will reveal that with excessive grid current the screen draws an excessive current, so that with a screen dropper circuit this high screen current will actually cause a drop in screen voltage. One should not reduce the screen resistor too far to compensate as one may overload the screen. In fact, with an 807, good R.F. output is available at a grid drive of less than one milliamp. Almost full output is obtained at 1mA, and an increase of up to say three milliamps produces hardly any extra output. Beyond this figure of grid drive output will actually start to fall off between the 3 and 5mA grid drive positions. Thus, under these conditions, it will be found that the maker's figures for C.W. operation of the 807 will be confirmed. Anode modulated phone actually requires up to 5mA drive, the point at which C.W. output starts to fall, because the extra drive is needed for the modulation peaks. However, one will find that good output at 1½mA is

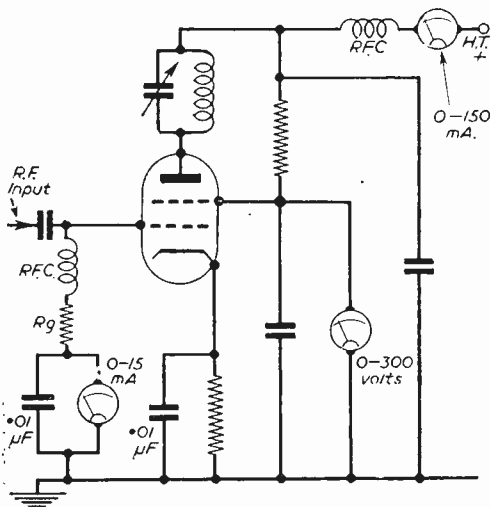

Fig. 4.—In setting up the P.A. stage screen voltage as well as grid and anode current should be metered. Permanent metering of grid current and anode current is, in any case, desirable.

obtained, and that 2½mA is just about optimum for C.W. operation.

Having obtained a reasonable amount of grid drive, and a "reasonable" anode input and out-

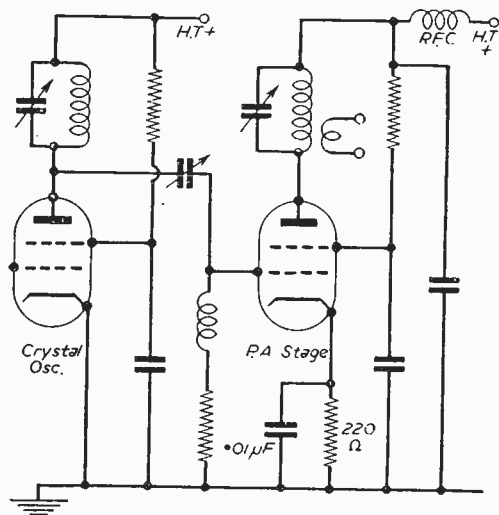

Fig. 6.—A variable drive control may be achieved by using a variable coupling condenser.

put, the operator will probably find that he is nowhere near the "book" conditions. On a low anode voltage, of course, of around 300 volts, around twenty watts is a "good" input. In fact, screen voltage should be kept down to about 250 volts using a 5K screen resistor, as some screen resistance is needed to avoid accidentally high screen currents when tuning up. "Tuning up" will reveal a marked dependence of screen current upon loading and drive conditions, a fact seldom stressed these days. When the preliminary low voltage tests have engendered confidence, the 807 P.A. may be run with 500 or more volts on it. Note, however, that the screen resistor must be increased to prevent the screen voltage exceeding 300 volts, and a 270 volt figure is considered the limit by British makers. However, the operator will quickly find that there is quite a difference between 270 volts and 300 volts screen voltage operation. Start off, therefore, with a 33K screen resistor for 500 volts H.T. operation, and a 47K resistor for 600 volts operation. Tune up and experiment with lamp loads until you get the "feel" of how tuning and loading adjustments interact with plate current and screen voltage. Particularly observe how screen voltage varies with slight tuning maladjustments, and finally reduce the screen resistor until you can be certain that when "normally" loaded you will not exceed the 300 volts figure on the screen. Here the clamp tube circuit is invaluable, as during preliminary loading the clamp control can be turned to a reduced power level which actually means the screen volts are lowered. Thus, if a clamp tube protected

P.A. is always tuned up at a reduced power setting, the screen resistor can be adjusted to give correct screen volts when correctly tuned and loaded, so that maximum P.A. efficiency and power input can be achieved. In any case the loaded P.A. current should not exceed 100 mA with an 807 P.A. stage.

Having found how the P.A. reacts to loading, drive adjustment and screen voltage setting, the operator is ready to put his P.A. on the air. Loading the antenna will mean adjusting tuning and loading of the aerial tuner and tap settings so that the P.A. is loaded to full power as previously achieved with a lamp load. Preliminary lamp load tests, however, will reveal a great deal about the "feel" of the P.A. controls, and enable aerial loading to be quickly accomplished when the radiating aerial is attached. Under some conditions the aerial tuner may be found to "pull" the P.A. tuning, but resonating the P.A. minimum dip will be found to occupy only a slight readjustment of the P.A. tuning condenser, unless some undesirable condition is encountered. Finally, with 600 volts on the anode and around 10 mA of anode current, a healthy 40 watts or more of carrier should be available, with a corresponding boost of QRK on received signal reports. In fact, as loading can be pushed further with a P.A., and as the percentage efficiency of a P.A. is a little more than a plain crystal oscillator, the improvement in radiated R.F. over a ten watt crystal oscillator will be well over six times, and almost two "S" points increase in radiated signal should result. With such a P.A. input world wide DX—according to the band of operation of course—may be worked. However, several new licences have found, for example, that 40 metre C.W. operation from about 21.00 G.M.T.

PRACTICAL TELEVISION AUG. ISSUE NOW ON SALE PRICE 1s. 3d.

Our companion journal which is now on sale keeps you up-to-date with all the latest developments in the field of television. The heart of the television set, the tube, is described in detail in an instructive article. Recording TV on Tape is also featured with a description of a recent demonstration together with full descriptive matter of the apparatus used. For the servicing engineer there are articles on television troubles, their symptoms and how they may be cured and full servicing details of the Pye V54C. Both these articles are fully illustrated.

A form of alignment procedure suitable for the majority of sets and a method of overcoming heater-cathode tube shorts are further interesting articles. A buyer's TV guide is the first article of a series which should appeal to those readers who are contemplating purchasing a new receiver and finally we go back to the early days of television by describing early types of apparatus used under the title of The Birth of Television.

Regular features include Telenews, Your Problems Solved, Underneath the Dipole, News from the Trade, etc.

Our specialist buying knowledge and reputation ensure a square deal... and enable us to



offer the best for your money!

ALL-WAVE RADIOGRAM CHASSIS 3 WAVEBANDS 5 VALVES

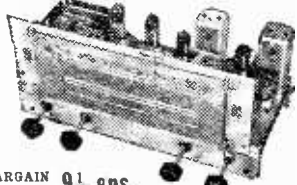

S.W. 16 m. 50 m. LATEST MIDGET
 M.W. 200 m. 500 m. B.V.A.
 L.W. 800 m. 2,000 m. SERIES
 Brand new and guaranteed. A.C. 200-250 v., 4 pos. W.C. socket. Short-Medium-Long-gram. P.U. socket. High Q dust core coils. Latest circuit technique, delayed AVC and neg. feedback O.P. 1 watts. Chassis size 13 1/2 x 5 1/2 x 2 1/2 in. Dial 10 in. x 4 1/2 in. Hor. or Vert. station names. Walnut or Ivory knobs to choice. Aligned and calibrated ready for use. Sensitivity and Quality at Low Cost. Carr. and Ins. 4/6.
7 Valve De Luxe, push-pull EL41 version, 7 watt output, with H Duty Output Transformer, £12.10.0. Carr. & Ins. 5/.

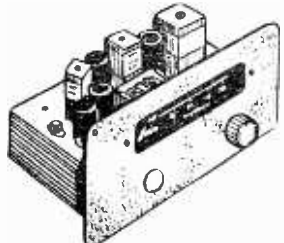

JASON P.M. TUNER UNIT, 87-105 mc s.
 Designer Approved Kit of parts to build this modern highly successful unit, drilled chassis and superior type diad. Valve cans and all quality components, etc. for only 5 gns., post free. Set of 4 spec. EF91 or equivalent valves. 30 x 2 x 2 in. free. Illust. handbook with full details. 2 x post free, or Free with Kit, 48 hr. Alignment service. 7 and 2 - p.p. ASD NOW Jason's Mercury Switched P.M. Tuner with A.F.C. Complete Kit only 8/ gns., plus 2/6 p. & p. Set of 3 x EF90 valves. Special Price, 21/-.

BARGAIN PRICE 9/ gns.
 For 10 in. speakers to match. 20 - and 25 - P. & P. 1/6.

NEW BOXED VALVES ALL GUARANTEED

1R5, 1T4 7/6	DF96 9	EF41 10	6P9F82 10/8
1R5, 1R4 7/6	DF96 9	EF80 10	6P9L83 12/6
5R4, 3V4 8/-	DF96 9	EF80 10	6P9L81 14/6
5Z4 9/6	DF96 9	EF91 9/6	6P9L82 10/-
4AT5 8/6	EFAB780 9/6	EF41 10	6P9L83 11/6
6K7 8/6	EF8191 6/6	EF81 11	6P9Y80 9/6
6K8 8/6	EF8141 10/6	EF85 11	6P9Y81 9/6
6Q7 8/6	EF853 9/6	EF51 12	6P9Y82 8/6
6N87 8/6	EF854 12/6	EF80 14	6P9Y83 10/6
6X4 7/6	EF970 12/6	EF40 8/6	6P9Z2 8/6
6X4 7/6	EF982 12/6	EF280 8/6	6P9Z5 12/6
6X5 7/6	EF942 10/6	EF281 8/6	6P9Z42 10/6
7C5 9/-	EF981 10/6	EF114 9/6	6P9Z41 10/6
7Y4 8/6	EF980 12/6	EF984 10/6	6P9Z41 10/6
DAF96 9/6	EF982 12/6	EF980 10/6	6P9Z41 8/6

SPECIAL PRICE PER SET
 1R5, 1T4, 1R5, 1R4 or 3V4, 10/6 ... 27/6
 1R5, DF96, DAF96, 10/6 ... 37/6
 6K8, 6K7, 6Q7, 6V6, 5Z4 or 6X5 ... 35/6

ELECTROLYTICS ALL TYPES NEW STOCK
 Tubular Wire Ends ... 32, 32 350 v. B.E.C. 5/6
 25 25 v. 50 12 v. ... 2/8
 50 50 v. 4 500 v. ... 2/8
 100 25 v. 2 450 v. ... 2/8
 8 450 v. T.C.C. ... 2/16
 8 4 450 v. B.E.C. ... 4/6
 8 16 450 v. T.C.C. ... 5/6
 16 450 v. B.E.C. ... 3/6
 16 500 v. Dub. ... 4/6
 16 16 450 v. T.C.C. ... 5/6
 22 250 v. B.E.C. ... 4/6
 22 500 v. Dub. ... 5/6
 50 50 350 v. B.E.C. ... 6/6

VOLUME CONTROLS. 10,000 ohms to 2 Meg. ohms. All Long Spindles, Midget type. Gear, 1 year. Log Ratios Less Switch D.P. Switch 3/4 4/9

RECONDITIONED TV TUBES
 RE-VACUUMED and RE-ACTIVATED - guaranteed 6 months.
 12 in. Mullard, Mazda, etc., £6.10.0 (as available)
 14 in. Mullard, Mazda (reco.), £7.0.0.
 17 in. Mullard, Mazda (reco.), £8.10.0.
 Carr. & Ins. 12/6.

AND NOW new Heater, Cathode and Con. assemblies fitted to your own tube - reconditioned virtually as new. Only 20/- extra.
 Fully Guaranteed, 7-10 days delivery. Regret only Mullard and Mazda types at present.

I.F. TRANSFORMER—465 kc. s.
 Brand new ex-manufacturer's midget I.F.T. size 2 1/2 in. x 1 1/2 in. dia. dust core tuning. Latz wound coils, High Q. Bargain offer, 7/6 pair.

Listed above are only a few items from our very large stock. Send ad. stamp today for complete Bargain List.

TERMS: C.W.O. or C.O.D. Kindly make cheques, P.O.s, etc., payable to T.R.S. Post Packing upto 10/7d., 1lb. 1/1, 3lb. 1/6, 5lb. 2/-, 10lb. 2/-. Hours: 9 a.m.-6 p.m. 1 p.m. Wed. Open all day Saturday.



RADIO COMPONENT SPECIALISTS (Est. 1946)

70 BRIGSTOCK ROAD, THORNTON HEATH, SURREY (THO 2188)
 50 yards Thornton Heath Station.
 Buses: 130A, 133, 159, 166 (913)

RECORD PLAYER BARGAINS
 1-sp. BSR (1100) 92 6. 4-sp. COLLARO JUNIOR, £4.10.0. 4-sp. GARRARD (4 S.P.), £7.15.0. Carr. & Ins. 3/6.

AUTO CHANGERS New Reduced Prices.
 BSR 4 sp. (F.A.S.) £7.19.8. COLLARO 4 sp. (comp. set), £7.19.6. 4 sp. GARRARD (R.P. 141) £10.5.0. Carr. & Ins. 4/6.
 All above units are latest models and are fitted with modern styled Tweight Atl. P.U. with turnover head and twin sapphire stylus.

RECORD PLAYER CABINETS
 As illustrated in previous issues.
 Contemporary style, rexine covered cabinet in mottled red with cream interior. Size 18 1/2 x 14 1/2 x 8 1/2 in., fitted with all accessories, including speaker baffle board and plastic feet. Space available for all modern amplifiers and autochangers, etc. Uncon. record player mounting board 14 x 13 in.
Cabinet Price, £3.3.0. Carr. and Ins. 2/6.

2-VALVE AMPLIFIER Mk. 1.
 200 250 v. A.C. Modern circuit with High gain EL84 output and double wound Mains Transformer, variable tone and volume controls, wired and tested with 6In. Speaker and O.P. Trans. complete with knobs and drilled ready to fit Baffle Board in above cabinet. Only £3.12.6. Carr. & Pack. 2/6.

2-VALVE AMPLIFIER Mk. 2.
 200 250 v. A.C. Specification as above but a higher fidelity and greater output (approx. 3 watts) is obtained by using latest Twin Stage Triode-pentode Valve H.F.22 and negative feedback Tone Control. Complete wired and tested as above £3.19.6. Carr. & Pack. 2/6.

SPEAKER FRET. Expanded Bronze analysed metal 8 x 8 in., 2 3/4 x 12 x 8 in., 3 1/4 x 12 x 12 in., 4 6/8 x 12 x 12 in., 6 1/4 x 24 x 12 in., 9 x, etc.

TYGAN FRET. (Max. width 5 1/2 in.) 12 in. x 12 in., 12 x 12 in., 8 1/4 x 12 x 2 1/2 in., 4 x, etc.

TRANSISTOR RECORD PLAYER
 Ready wired Push-Pull Transistor Amplifier using latest 4 C.E.C. Transistors. Genuine 1 w. output into standard 3 ohms speaker. Superb quality with neg. feedback circuit. Var. Tone and Volume controls. Special size to fit in a Player Cabinet. Amplifier 5 GNS. x 5 in. Speaker, 20 - P. & P. 2/6.
 Latest STAAR 15 p.p.m. Record Player Unit with Flexibly self-heating Stylus. Lightweight and contemporary styled constant speed from 1 1/2 - 6 v. Battery. Only 92 6. P. & P. 3/-.

Record Player Cabinet to fit above units. Attractively covered in Red rexine with white polka dot relief. Fitted with modern styled Fret and surround. Cabinet size. Bargain Price, 55/- P. & P. 3/6. Send for special booklet giving full details.

MULLARD 3-3 QUALITY AMPLIFIER
 A first-class Hi-Fi Companion Unit to the Jason Tuner. H Duty Mains Trans. allows for H.T. and L.T. Power supply. Mullard latest circuit, 3 valves, 3 watt. Freq. response 40 c/s - 25 Kc/s for 1 db with special sectionalised O.P. Trans. Fused Chassis, all components, valves, etc. Only £8.10.6. Body wired and tested. 8 GNS. Carr. and Ins. 2/6.

COLLARO TAPE TRANSCRIPTION Mk. 4
 This latest Tape Deck featured as an advertising offer. Limited stocks. New and sealed in cartons. Bargain 22 GNS. Post Free.
EMITAPE Recording Tape—Special Offer (Type 88 (Stand.) Type 19 (Long Play))
 30m. 175ft. 7/- 250ft. 9/-
 50m. 600ft. 19/- 500ft. 26/-
 75m. 900ft. 24/6 1,200ft. 31/6
 75m. 1,200ft. 30/- 1,800ft. 45/-

ALL NEW & BOXED.
 Resistors in 100's, 50's, 1/6 each. 50's, 2/6.
 RESISTORS. Full Range, 10 ohms - 10 Megohms. 200, 1 w. 5d., 1 w. 6d., 2 w. 9d., 100, 1/2 watt, 1 w. 5d., 1 w. 7d., 500, 1 w. 9d., 1 w. 1/6.
 1/2, 1/4, 1/8 watt, 1 w. 1/6 (10 ohms - 100 ohms 2 x). MIKES. Crystal Types.
 Collaro Studio Model. Lead and back ph. 45 - ACOS 251 Hand or Desk Type, 27/6.
 ACOS 22 2-Ditto with on-off 31/6.

C.R.T. Heater Isolation Transformers
 New improved types—mains prim. 200/250 v. tapped.
 All Isolation Transformers now supplied with alternative on boost, plus 25% and plus 50% boost taps, at no extra charge.
 2A type 12 6 1/2 P. x 1 1/2 P. 10/6
 4A type 12 8 P. x 1 1/2 P. 10/6
 6A type 12 8 P. x 1 1/2 P. 10/6
 8A type 12 8 P. x 1 1/2 P. 10/6
 10A type 12 8 P. x 1 1/2 P. 10/6
 12A type 12 8 P. x 1 1/2 P. 10/6
 Other ratings in range of production.
 5/8 in. size and tap terminated for easy fitting.

TRANSFORMER & COIL WINDING CAPACITY AVAILABLE FOR PROTOTYPES & SMALL RUNS.

DIOMATIC FREQUENCY CONTROL

SWITCHED F.M. TUNER

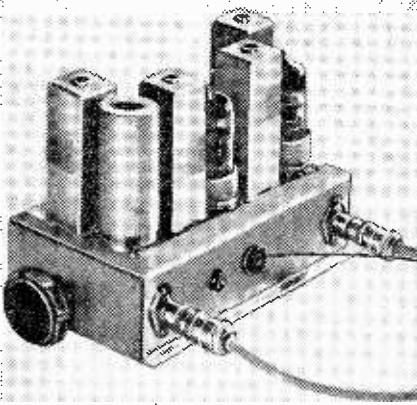

All parts, including valves, £7/19/6
 Coils set, including diomatic control circuit, £2/10/-
 Complete set of parts, less valves, £6/5/-
 Chassis, switch and mid-gate trimmers, 12/6
 Instructions included with parts, 2/-
 Alignment service, 10/6

This extremely successful and very popular SWITCHED TUNER is giving very good results in all parts of the country. The DIOMATIC CONTROL which was originated and developed by us gives a control 10 times as accurate as a reactance valve. The complete circuit is now well known and utilises double valves

enabling an extremely compact construction on a chassis only 3in. x 5 1/2in. The HIGH FIDELITY output stage incorporates a cathode follower which may also be used as a preamplifier delivering 10 VOLTS. Our alignment service guarantees to make every tuner built to our instructions and with our parts operate as we claim and give satisfaction to the builder.

C. & G. KITS, Dept. F.M.

285, LOWER ADDISCOMBE ROAD, CROYDON, SURREY
 MAIL ORDER ONLY

BARGAIN OFFER THIS MONTH ONLY

An amplified Record Player with TWO loud-speakers built in, playing on 4 speeds, for only **10 GNS.**



IMPOSSIBLE TO REPEAT

Send remittance with 3/- extra for c./packing to:

THE E. & G. RADIO CENTRE LTD.

33 Tottenham Court Road, London, W.1

Telephone: MUSEum 6667

REPANCO

TRANSISTOR CAR RADIO COMPONENTS

COILS

- Medium Wave Aerial Coil, Type XMA16 ... 10/-
- Medium Wave H.F. Coil, Type XMF17 ... 10/-
- Long Wave Aerial Coil, Type XLA18 ... 6/9
- Long Wave H.F. Coil, Type XLF19 ... 6/9
- Oscillator Coil for above Coils, Type XO15 ... 5/-

All Coils are miniature and enclosed in screening cans size 1/2in. x 1/2in. x 1 1/16in. Ferrite cores.

Tuning with standard 500 pf ganged capacitor these coils will cover 800-2,000 metres and 198-550 metres.

I.F. Transformers, Type XT6 and XT7 (I.F. frequency 455-475 kc) ... 10/- each

TRANSFORMERS

- Interstage Transformer, Type TT11 ... 10/-
- Output Transformer for 12-volt Radio, Type TT12 12/6
- Output Transformer for 6-volt Radio, Type TT13 12/6

All coils and transformers are boxed with circuit and practical wiring diagram of all-transistor car radio.

Send S.A.E. for latest Repanco Component Catalogue.

RADIO EXPERIMENTAL PRODUCTS LTD.

33, MUCH PARK ST., COVENTRY

Tel. 62572

EXPRESS ELECTRONICS

ROSEDENE LABORATORIES
 KINGSWOOD WAY, SELSDON, SURREY

VALVES NEW, TESTED AND GUARANTEED

1AC6	9/6	5BE6	7/-	12AU7	7/6	DL94	8/-	KT33C	9/6
1C1	8/-	5BR7	10/6	12AX7	8/-	DL96	9/-	IN17	7/6
1C2	9/6	5BW6	7/6	12J7GT	10/-	EABC8J	8/6	IN18	8/6
1C3	9/-	6BW7	8/-	12K7GT	8/-	EB91	6/9	IN19	8/-
1F1	8/6	6CH5	7/-	12K8GT	12/6	EB41	10/-	PCC84	9/-
1F3	7/6	5C10	9/-	12Q7GT	8/-	EBF8J	9/6	PCF80	10/6
1FD1	8/6	6D3	6/9	16A5	9/-	ECC81	8/6	PCF82	10/6
1FD9	7/6	5F12	7/-	25L6GT	7/6	ECC82	7/6	PL82	9/-
1P1	9/-	5F15	9/-	25Z4G	8/6	ECC83	8/6	PY81	8/6
1P10	7/6	5J5GT	5/6	35L6GT	9/-	ECC81	10/6	PZ30	17/6
1P11	8/-	5J5GT	8/6	35W4	8/6	ECC81	10/6	U52	8/-
1R5	8/-	5J7GT	8/6	35Z4GT	8/-	ECC82	10/6	U76	8/-
1T4	7/6	6K7G	5/6	3763	10/6	ECH42	10/-	U78	7/-
1S5	7/6	5L6G	10/6	377	6/9	ECH81	8/-	UBC41	8/6
1U5	7/-	5Q7GT	8/6	DAF91	7/6	ECH8J	13/6	UCH42	10/-
3A5	10/6	6SL7GT	7/6	DAF96	9/-	EF37A	9/-	UF41	8/6
3Q4	8/-	55N7GT	8/-	DF91	7/6	EF41	9/-	UL41	10/-
354	7/6	6V6G	7/6	DF96	8/6	EF8J	8/6	UY41	7/6
3V4	8/-	6V6GT	7/6	DH76	8/-	EF91	7/-	W76	8/-
5U4G	8/6	5X4	7/-	DH77	7/6	EF92	5/6	N142	8/6
5Z4G	9/6	6X5GT	7/6	DH142	8/6	EL41	10/-	X17	8/6
6AK6	6/6	757	8/6	DH150	10/-	EL84	9/6	X18	9/6
6AL5	6/9	3D3	7/-	DK91	8/-	EY51	12/6	X142	10/6
6AM5	7/-	12AH8	10/6	DK92	9/6	EZ4J	8/6	X150	10/-
6AT6	7/6	12AT6	8/6	DK96	9/-	EZ8J	8/-	Z77	7/-
6BA6	7/6	12AT7	8/6	DL92	7/6	EZ81	8/-	ZD17	7/6

MATCHED PAIRS

EL84 23/-, 6V6G and GT 17/-, 6BW6 18/- per pair.
 Push Pull O.P. Transformers for above 3-15 ohm 14/5.

SETS OF VALVES

DK91, DF91, DAF91, DL92 or DL94.....	27/6
DK96, DF96, DAF96, DL96.....	35/-
1R5, 1T4, 1S5, 354 or 3V4.....	27/6
12K8, 12K7, 12Q7, 35L6, 35Z4.....	35/-

Postage and packing, 6d. Over £1 post free. C.O.D. 2/6.

Servicing Radio Receivers

THE DECCALIAN 88

By Gordon J. King, A.M.I.P.R.E.



THE Deccalian 88 (Decca Radio and Television), illustrated in Fig. 1, falls truly in the range of semi-portable hi-fi record reproducers. As may be seen from the complete circuit of the amplifier in Fig. 2, two Mullard EL84 power pentode valves are used in a push-pull output stage, and are arranged in the circuit to provide in the region of 8 watts of audio at a remarkably low level of distortion.

In part, this is accomplished by the liberal exploitation of negative feedback, which cancels harmonic and intermodulation distortion, while also reducing the source impedance of the output stage and thus providing a good damping factor. A low source impedance is desirable in a record reproducer of this kind since it serves to damp the loudspeakers, which may not be damped acoustically as well as speakers correctly loaded to a reflex enclosure. Good damping, of course, results in a good transient response, and eliminates that sluggishness to staccato sounds.

The circuit is well designed, and special attention has been given to such things as matching of the loudspeakers to the valves and the working condition of the valves so that a low distortion figure is maintained.

Loudspeakers

The reproducer features two loudspeakers, an 8in. X 5in. elliptical unit for the lower range of audible frequencies, and a 4in. unit for the higher frequencies. The treble unit is energised through a 5 mF capacitor which gives a cross-over in the region of 4 kc/s.

A jack socket for the connection of an external loudspeaker system is also featured. The insertion of the jack plug automatically removes the internal speaker system from across the output transformer so that mismatching effects and loss of power are avoided.

The external speaker system must have an impedance of 3-5 ohms so as to secure a correct match to the output stage. The 3 ohm Decca corner speaker is recommended by the maker where it is required to reap the full benefit of the hi-fi capabilities of the amplifier.

Phase Splitter

The EL84s are driven by a cathode-anode loaded phase splitter stage (V2B), being formed by one of the triodes of the Mullard ECC83 double-triode valve. It is important that the load resistors, R20 and R22, are perfectly balanced with regard to value, so that equal but opposite drive voltages are applied to the grids of the output valves.

Failure of optimum balance here or in the output stage itself will represent a cause of unnecessarily high second harmonic distortion owing to incomplete cancellation of the distorted anti-phase waveforms.

Driving the phase splitter is the other triode section of the ECC83. This is arranged in the

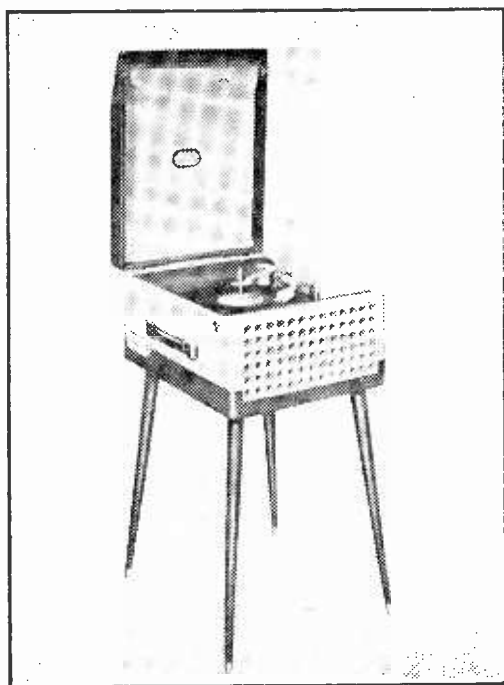

Fig. 1.—A general view of the Deccalian 88.

form of a voltage amplifier, being necessary in view of the less than unity gain of the phase splitter (the gain of this type of splitter is in the region of 0.9). Negative feedback is introduced at the cathode of the voltage amplifier, the feedback voltage being obtained from across a separate winding (points EF) on the output transformer, and applied to the cathode circuit by way of R23 and C16 in parallel. The value of R23 governs the degree of voltage which is fed back, as also does resistor R16 in the cathode circuit of V2A. Capacitor C16 tends to correct for phase shift in the output transformer which occurs towards the high-frequency end of the sound spectrum. Without this component there is a possibility of the feedback turning positive and resulting in high-frequency "ringing" and instability. It should be noted that the first 1,000 models leaving the factory had the feedback voltage taken from point C on the secondary winding of the output transformer; a feedback tertiary winding was not included on these versions, and point D on the secondary winding was connected to chassis to complete the feedback circuit. The circuit has approximately 20db of feedback.

Baxandall Tone Control

A common feature of hi-fi amplifiers and control units, though rarely seen in record reproducers, is the independent treble and bass tone

control system utilising negative feedback. This is the well-known Baxandall circuit, after the name of the designer.

The circuit is focused around V1B, which is the second triode of the other ECC83 valve used in the Deccalian. The operation of the circuit relies upon frequency-selective negative feedback, the feedback loop being by way of the anode of the valve, through the frequency selective components, and back to the grid. The bass and treble lift and cut are confined to each end of the audio spectrum, thus permitting the extreme frequencies to be lifted or reduced as required without disturbing the response at the centre of the spectrum.

The tone control is fed from the first voltage amplifier comprising V1A and associated components. To the grid of this valve is connected the volume control, and the components in front of the volume control, i.e., R1, R2, R3 and C1, serve to equalise the response of the pick-up and match the pick-up to the valve. It will be noticed that there is no cathode by-pass capacitor on V1A; this is to provide a degree of negative current feedback and to equalise the overall gain in relation to the pick-up used.

The pick-up adopted is the Acos Hi-G range Type GP59-1 turnover crystal, with sapphire styli. The GP59-1 is designed specifically for high-gain amplifiers, and thus has a small output

(Continued on page 553)

CONDENSER AND RESISTANCE VALUES.

- | | | | |
|-------------------------|-------------------|-------------------|---------------------|
| C1—200 pF | C14—50 μF (Elec.) | R9—3.3K Ω | R22—47K Ω* (.5w.) |
| C2—0.1 μF | C15—.05 μF | R10—68K Ω | R23—560 Ω* |
| C3—.005 μF | C16—.001 μF | R11—47K Ω (1w.) | R24—20K Ω* |
| C4—.005 μF | C17—16 μF (Elec.) | R12—100K Ω | R25—220K Ω* |
| C5—140 pF* | C18—5 μF (50v.) | R13—20K Ω | R26—100 Ω (4w.) |
| C6—32 μF (Elec.) | R1—1M Ω | R14—2.7K Ω (.5w.) | R27—220K Ω* |
| C7—0.1 μF | R2—470K Ω | R15—220K Ω | R28—20K Ω* |
| C8—.02 μF | R3—470K Ω | R16—180 Ω | R29—8.2K Ω (4w.) |
| C9—25 μF (25v.) (Elec.) | R4—3.3K Ω | R17—2.2K Ω | R30—47 Ω |
| C10—670 pF | R5—150K Ω | R18—8.2K Ω | R31—47 Ω |
| C11—.05 μF | R6—100K Ω | R19—220K Ω | VR1—470K Ω (volume) |
| C12—32 μF (Elec.) | R7—100K Ω | R20—47 Ω* (.5w.) | VR2—.5M Ω (Base) |
| C13—.05 μF | R8—470K Ω | R21—2.7K Ω (.5w.) | VR3—1M Ω (Treble) |

All resistors 1/2 watt unless otherwise stated.

* Close tolerance.

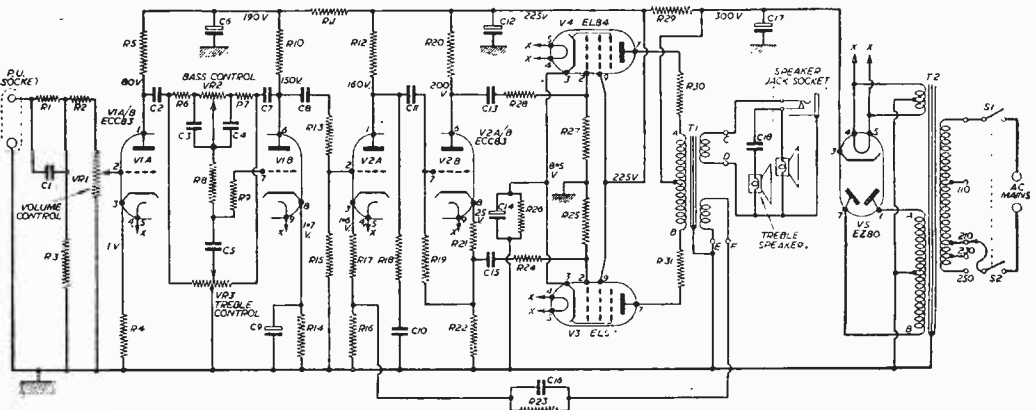

Fig. 2.—The circuit diagram of the Deccalian 85.

Wanted!

QUALIFIED MEN AND WOMEN

Industry and Commerce offer their best posts to those with the qualifications—appointments that will bring personal satisfaction, good money, status and security. As part of a modern industrial organisation, we have skilled knowledge of what is required and the best means of training personnel for present day and future requirements. We specialise also in teaching for hobbies, new interests or part-time occupations in any of the subjects listed here. Write to us to-day for further information. There is no obligation of any kind.

PERSONAL & INDIVIDUAL TRAINING IN —

- | | | | |
|---------------------------------------|----------------------------|-------------------------------|--------------------------------|
| Accountancy | Draughtsmanship | Mathematics | Sales Management |
| Advertising | Economics | M.C.A. Licences | Sanitary Engineering |
| Aeronautical Eng. | Electrical Eng. | Mechanical Eng. | Salesmanship |
| A.R.B. Licences | Electrical Instal. | Metallurgy | Secretaryship |
| Art (Fashion, Illustrating, Humorous) | Electronics | Motor Eng. | Servo Mechanisms |
| Automobile Eng. | Electronic Draughtsmanship | Painting & Decorating | Shorthand & Typing |
| Banking | Eng. Drawing | Photography | Short Story Writing |
| Book-keeping | Export | P.M.G. Certs. | Short Wave Radio |
| Building | Gen. Cert. of Education | Police Production Eng. | Sound Recording |
| Business Management | Heat & Vent. Eng. | Production Eng. Planning | Television Communications |
| Carpentry | 'Hi-Fi' Equipment | Radar | Television Time & Motion Study |
| Chemistry | High Speed Oil Engines | Radio | Tracing |
| City & Guilds Exams | Industrial Admin. | Radio Amateur (C & G) Licence | Transistors |
| Civil Service | Jig & Tool Design | Radio Engineering | Welding |
| Commercial Subjects | Journalism | Radio & Television Servicing | Workshop Practice |
| Commercial Art | Languages | Refrigeration | Works Management etc., etc. |
| Computers | Management | | |
| Customs Officer | Maintenance Eng. | | |

Also courses for GENERAL CERTIFICATE OF EDUCATION, A.M.I.H.&V.E., A.M.S.E., A.M.Brit.I.R.E., A.M.I.Mech.E., A.M.I.E.D., A.M.I.M.I., A.F.R.Ae.S., A.M.I.P.E., A.M.I.I.A., A.C.C.A., A.C.I.S., A.C.C.S., A.C.V.A., City & Guilds Exams., R.T.E.B. Servicing Certificates, R.S.A. Certs., etc., etc. Moderate fees.



The E.M.I. Factories at Hayes, England.
The only Home Study College
 operated by a world-wide
 manufacturing organisation

EMI
INSTITUTES

NEW! Courses with **PRACTICAL EQUIPMENT**

in RADIO • TELEVISION • MECHANICS
 CHEMISTRY • ELECTRICITY
 DRAUGHTSMANSHIP • PHOTOGRAPHY etc., etc.

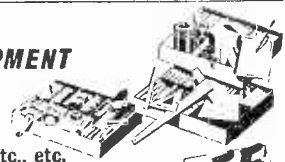

POST THIS TODAY

To: E.M.I. INSTITUTES, Dept. 32K, London, W.4.
 NAME _____ AGE _____
 (if under 21)
 ADDRESS _____

I am interested in the following subject(s) with/without equipment

SEPT 1958 (We shall not worry you with personal visits)

FREE

BLOCK
 CAPS
 PLEASE

IC92

-Part of "His Master's Voice" Columbia, etc., etc.

Armstrong

AM/FM Radiogram chassis

MODEL PB409 (Illustrated) 28 gns.

A High Quality Radiogram replacement unit

- 9 valves ● 6 watts Push-Pull output ● Negative Feedback
- 4 wavebands including VHF ● Quick action Piano Key selectors ● Separate Bass and Treble controls ● Magic Eye

MODEL AF105 £37

AM and FM Tuners and High Fidelity Amplifier on one compact chassis

- 10 valves ● 10 watts Push-Pull output ● 20 dB Negative Feedback ● 5 wavebands including VHF ● Independent wide range Bass and Treble controls with visual indicators ● Magic Eye

Post this coupon for descriptive literature or call at your local High Fidelity dealer, or at our Holforday showrooms, for full demonstration.

BLACK CAPITALS PLEASE

NAME

ADDRESS

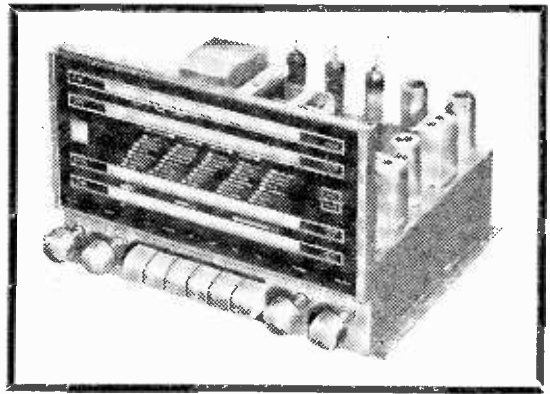

Armstrong have been making radiogram chassis for almost 25 years and have always concentrated on the requirements of those who demand the highest quality. You may wish to modernise your existing radiogram, or build a new and up-to-date reproducing system. In either case . . .

an **Armstrong** is the answer!

LYONS RADIO LTD.

Dept. M.P., 3, GOLDHAWK ROAD, SHEPHERDS BUSH, LONDON, W.12

Telephone: SHEPHERDS Bush 1729

RADIO EXHIBITION. Once again, for the convenience of our out-of-town Customers who like to pay us a visit whilst in London, we are holding a grand **BARGAIN SALE** commencing with the opening of the Radio Show, 25th August. Our premises are just over a mile from Earl's Court, Buses No's 11, 72, 623 and 630 from Hammer-smith Broadway pass our door. If in Town don't miss this opportunity of securing some of the many bargains which will be displayed, all at **CLEARANCE PRICES**. Examples—2 R. Tubes from 5-. Chassis for components from 2-. R.1392's from 50-. R.1155's from 35-. etc., etc.

MIDGET EARPHONES. Balanced armature type, just the thing for transistor receivers, suitable for high or low impedance output. Size 1 1/2" dia. x 1". Price 5/9, post free.

RECTIFIER VALVES, Type 888A, new, guaranteed. PRICE ONLY 14/6 each. 1" post if ordered separately.

METER BARGAINS. Moving Coil type centre zero 50-0-50 mA., 2 1/2" dia. projection mtg. PRICE ONLY 7/6. Thermo-couple type 0 1 Amp., 2" sq. flush mtg. PRICE ONLY 5/6, Post free.

SWITCHES. Bulgin Pattern, single hole fitting, ex equipment. Single Pole 3A-250 v. 6 for 5/6 or 9/6 doz. Double Pole 1A-250 v. 6 for 7- or 11/6 doz. Substantial reduction for orders of 100 or more.

V.F.O. UNITS. Frequency range 1.5 to 20 Mc s. Ex Air Ministry units of exceptionally high grade and advanced design, enabling a setting accuracy to within a few hundred cycles to be achieved. More fully described on page 402 July issue of "P.W." PRICE £7.10.0, carriage 12/6.

ALFRED PADGETT

40, MEADOW LANE, LEEDS, 11

Tel.: CLECKHEATON 99

MAINS TRANSFORMER.—220 volt Prim. Sec. 250-250, 30 mA. 5 volts at 2 amp., 6.3 volts at 1.5 amp. 6/6. Post 2/6.

PHILIPS TRIMMERS.—3-30 f.p., 4d. each. Post 4d. 3/6 doz. Post free. Tool for same, 6d. Post 4d.

MAGIC EYE.—Y63 with Holder, Base and Panel Brackets, 4-. Y63 only. 2/6. Post 1/3. **FUSE HOLDER.**—Single Hole Panel Mounting. 8d. Post 8d. 8- per doz. Post free.

SMALL PANEL.—With two Metal Condensers 50 MF. 12 volt. 6d. Post 6d. 5- doz. Post free.

PAPER CONDENSERS.—New and Boxed. 8 MF. at 350 volts. 1/6. Post 1/3. Doz., 14-. Post free.

NEW RECEIVER TYPE 3645.—The cleaned up 1355 complete with 7 valves VR65, less 5U4 and 6X5. But otherwise complete. 12/6. Less valves, 6/6. Carriage 8-.

SMALL BELLING & LEE TERMINALS.—Removed from equipment. 3d. each. Post 4d. 2/9 doz. Post free.

BRASS JACK SOCKETS.—3d. each. Post 5d. 3- doz. Post free.

NEW, BOXED, 12 volt Vibrator Unit: 350 volt at 150 milli, complete with spare vibrator. 35-. Carriage 8-.

TELEVISION.—12in. chassis complete, less valves. Bush, Pre, Ultra, Cassor, etc., 15-. Carriage 5-.

SPEAKERS.—8in. and 6 1/2in. P.M., less transformer. Removed from television sets, 7/6. Post 2/6.

TELEVISION VALVES.—Most types, removed from break up. 3/6 to 10-. S.A.E. for types.

TELETRON TYPE FX. 25



Self-tuned, Dual-wave Ferrite Rod Aerial, 15/- each.

Designed for use in pocket Transistor receivers. Descriptive folder with circuit-component layout, and wiring instructions for a three-Transistor regenerative receiver. Price 6d. NO aerial, earth or tuning condenser required. Operates speaker from 3 Penlight cells. All parts, including cabinet and chassis, available from component stockists.

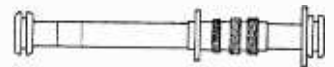

Miniature Transistor IFTs & Osc coil for 315 kc/s, 6/6 ea. 1RM/2 Transistor Ferrite Rod Aerial, 10-. Available from component stockists.

Stamp for complete lists and circuits.

THE TELETRON Co. Ltd.
266 Nightingale Rd., London N9
HOW 2527

voltage. The replacement styli type numbers for standard and microgroove records respectively, are SK1 and SK2 in sapphire, and DK1 and DK2 in diamond. Styli are easily replaced; the worn one is removed by gripping the shank with a pair of fine tweezers and pulling towards the turnover knob, and the replacement is fitted in the reverse manner, ensuring that the flaps or "ears" are properly positioned over the drive reel. Styli are colour coded thus: green, standard sapphire; violet, standard diamond; red,

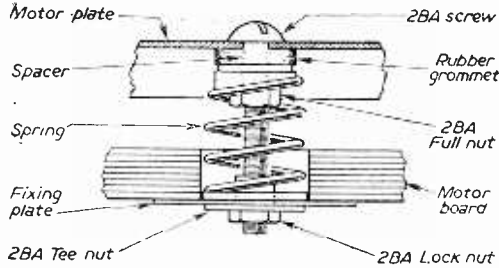

Fig. 3.—Showing the method of spring suspension of the autochanger to the motor board.

microgroove sapphire and black, microgroove diamond.

The Garrard Model 120 4D autochanger is normally installed. This is not fitted in exact accordance with the Garrard booklet for various technical reasons, but to clarify this point, details of the method of fixing are given in Fig. 3.

In order to avoid acoustic feedback between the pick-up and the loudspeaker and to avoid rumble effects on the reproduction, the screws which secure the record changer to the motor board must be removed; the player must be freely suspended on its spring mounting.

Removing the Chassis

This is a fairly simple exercise, which first requires the removal of the front and rear sloping panels, these being secured with wood screws and cup washers. The motor board should next be removed (wood screws again), whilst discon-

necting the mains from the motor terminal block and the pick-up plug from the amplifier. The mains leads from the 3-pin socket should also be removed. The nut securing the extension loudspeaker jack socket should be removed (on the outside of the cabinet) by means of a correctly fitting spanner to prevent damage. The loudspeaker leads are next disconnected and the pilot lamp bracket removed (wood screw). After slackening the amplifier chassis fixing screws, the chassis can be pulled clear of the cabinet, but before connecting to the mains, ensure that the motor leads are insulated (these are "hot" to mains).

The chassis itself is isolated from the mains supply by reason of the mains transformer so there is no danger of electric shock here. As will be seen from the circuit, the H.T. power is supplied by a full-wave rectifier circuit, using a Mullard Type EZ80 valve. There is a single heater winding, supplying both the rectifier and valve heaters. The pilot bulb is also energised from this source, and should be rated at 6.3 volts 0.3 amp (MES type).

Servicing Notes

Complete failure of the instrument is usually caused by H.T. failure, a faulty rectifier valve, for example. If this trouble is proved, however, it is a good policy, before making a replacement and switching on, to check for a short or low resistance on the H.T. line. If a low resistance or a short is indicated, the electrolytic capacitors should be checked for insulation resistance. Open-circuit of the H.T. filter resistor R29 represents another cause of failure, but this trouble is evidenced by the output valves (both of them) being considerably below the expected temperature (they operate hot normally).

Poor quality and one valve cold (or warm) should lead to a check of the emission of the cold valve and a check of the anode voltage. Open-circuit of one half of the primary may be responsible.

If the circuit is "live" up to V2A from the output end, suspect low emission of V1A, B or open-circuit of R11.

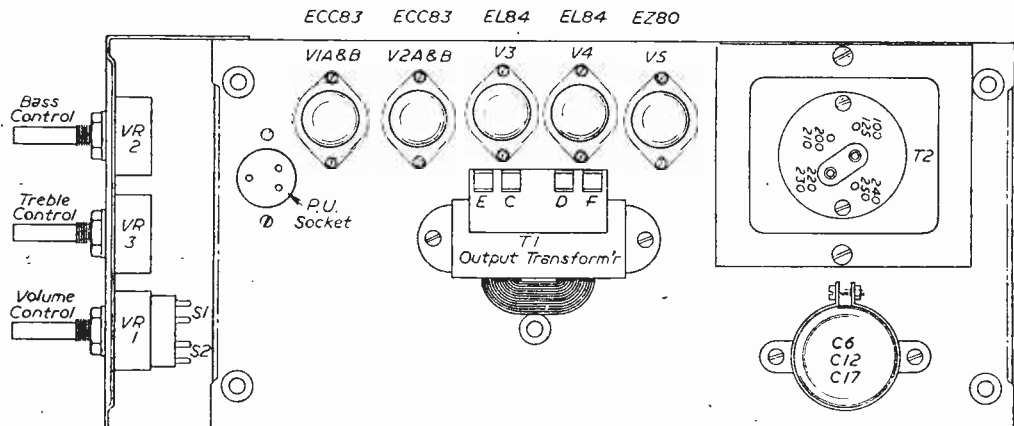

Fig. 4.—Top view of the chassis.

NEWS FROM THE TRADE

LATEST DEVELOPMENTS
OF RECEIVERS AND
COMPONENTS

VIDOR "RIVIERA" CN.444

VIDOR are pleased to announce the release of the "Riviera" CN.444, an upright A.C. mains/battery portable. This new model is housed in an attractively styled wooden cabinet finished in hard-wearing plastic fabric of contrasting shades of red and mushroom with gold trim, and a flexible carrying handle. It covers the long and medium wavebands and will operate from 200 to 250 volt A.C. mains, or for battery operation uses a Vidor L.5550 combined 90 volt H.T. - 7½ volt L.T. The high efficiency circuit employs

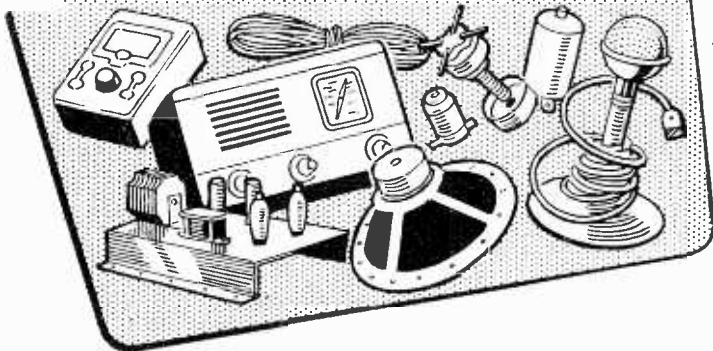

It has numerous applications in radio and communications, particularly under conditions where its unspillable characteristics are important, in portable instrumentation, lighting, aircraft and guided missiles, and other light electrical fields.

The container and lid of the cell are moulded in translucent high impact polystyrene, and the lid is a specially designed one-piece moulding cemented to the container by a technique which ensures a leak-proof joint.

A vent, which provides an exit for gasses, and which incorporates a trap for acid spray, is moulded integrally with the lid. The vent outlet is so designed that it is virtually impossible for it to become blocked either by dirt or by an object resting on top of the cell.

A filler plug, with a broad slot for tightening with a coin, is located alongside the gas vent. This arrangement, keeping the acid trap and gas vent separate from the filler plug, enables a more effective type of trap to be used.

The cell terminals consist of metal inserts moulded in the lid into which are screwed small bolts with insulated heads. When these bolts are tightened the cable ends are clamped firmly against lead alloy strips. These strips are positioned in recesses in the cell lid and are connected by lead burning to the connecting pillars which rise from the group bar. Special rubber bushes are fitted round the pillars where they pass through the lid and these bushes ensure a leak-proof joint at the cell lid.

This method of terminal connec-



The Exide 2-volt 8Ah cell.

(Continued on page 557)

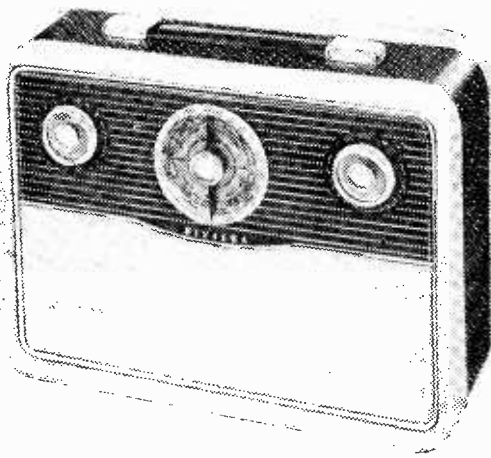

The Vidor "Riviera" C.N.444 mains/battery portable.

four low-consumption valves and a sensitive 8in. ferrite rod aerial. Station selection is made simple by the use of a large slow-motion dial clearly marked with station names.

The "Riviera" is now available from stock, retail price £13 5s. 4d., plus £5 2s. 2d. purchase tax (17½ gns.), battery extra.—Vidor Ltd., Erith, Kent.

UNSPILLABLE 2-VOLT CELL

A COMPLETELY unspillable Exide 2-volt 8Ah cell, type MFB9, has been produced by Chloride Batteries Ltd. for portable light electrical duties. Filled and charged, this compact, powerful cell weighs only 1lb. 5oz., and is capable of providing high discharge current, with high terminal voltage, over a wide range of temperatures.



AVOMINORS in leather case, with leads, fully tested. £5/10/-. Packing and Carriage 2/6.

BRAND NEW ORIGINAL SPARE PARTS FOR AR88 RECEIVERS
L.F. TRANSFORMERS 1st, 2nd, 3rd, 4th (for type D) 12/6 each or complete set of 6, 80/-.

L.F. Transformers. CrYstal Load, 12/6 each.
Plates escutcheons (for D and LF). 15/- each.

Dials (for type D), 10/- each.
Logging dial (for D and LF), 10/- each.
Filter Chokes (for D and LF), 22/6 each.

Output Transformers (for LF), 30/- each.
Crystal phasing (D), 2/6 each.

Antenna trimmers (LF and D), 2/6 each.
Filter Condensers 3 x 4 μF, £2/10/-.

Condensers 3 x .25μF (D and LF), 2/6 ea.
3 x .01μF (D and LF), 2/6 ea.

RF Antenna inductors (D and LF), 7/6 each.
Mains transformers (LF), £3 each.
Medium knobs (for LF and D), 2/6 each.
Small knobs (for LF and D), 2/- each.

INTERMEDIATE FREQUENCY TRANSMITTER. TMJ (cw and phone) 200/400 kc/s, 150w. output, built-in P.S.U. Manufactured by Bendix Radio Corp. Meas. 6ft. 4in. x 2ft. 6in. x 2ft. 2in. Bargain price without valves £45. Transport in U.K. £7/10/-.

ROTARY CONVERTER UNIT. Input 11.5-12.5 v. D.C. Output 300 v. 200 mA. D.C. 30/-, postage and packing 15/-.

R-109A RECEIVERS. Covering 2-12 Mc/s. 6 v. D.C. New and tested. £45/-. Carriage paid.

SLIDING RESISTANCE. 2 barrels. rotary action, 0.25 ohms, 20 amp. 12/-, post and packing 3/6.

HIGH RESISTANCE HEADPHONES. 4,000 ohms. Brand new, ex-W.D., boxed. Type C.H.R., or D.H.R., 10/6 per pair.

LOW RESISTANCE HEADPHONES. Brand new. Type C.L.R., or D.L.R., 5/- per pair.

VALVES

1D8, 4/-; 3B24 3/-; 5U4G 6/8; 6AG7 8/-; 6AK5 4/6; 6B4G 4/6; 6J6 3/6; 6K7GT 6/-; 6K8GT 8/-; 6SJ 7/6; 6SL7GT 5/-; 6SN7GT 5/6; 6SQ7 7/-; 53A 3/-; 446A 15/-; 613 (RCA) 80/-; 955 1/6; VR105-30 5/-.

AMPERITE RELAY VALVE 5 No. 4 G 7/6.

C.R. TUBE 5CP1 42/6.

CRYSTALS 1N21 2/-, 1N21B 5/-, 1N22 7/6.

All valves tested and guaranteed. Postage and packing 6d. per valve.

P. C. RADIO LTD.
170 GOLDHAWK RD.,
W.12 SHEpherds Bush 4946

MODULATION TRANSFORMERS (U.S.A., Collins), primary imp. 6,000 ohms. C.T., secondary 6,000 ohms, 20 W., 9/6 each.

MICROPHONE TRANSFORMERS. Balanced input 30 or 250 ohms. U.S.A. manufacture. 7/6. Post and packing 1/6.

813 CERAMIC VALVEHOLDERS 3/- each. P. & P. 1/6.

COMPLETE V.F.O. UNIT from TX53. Freq. range in 4 switched bands from 1.2-17.5 mc/s. Two V.T. 501s as oscillator and buffer, 807 as driver, two 5130s as voltage stabilizers. Output sufficient to drive two 813s in parallel. Slow motion drive directly calibrated in mc/s. Provision for crystal control, metering of buffer and driver stage. Power requirements 400 v. and 6.3 v. D.C. Can also be used as low power transmitter. In excellent condition with valves and circuit diagram. £5. P. & P. 15/-.

AMERICAN HANDY TALKIE. Type B.C. 611, including two operating crystals (5-6 Mc/s. band). £19/19/-. Postage and packing, 10/-.

MAINS POWER SUPPLY UNIT FOR No. 19 WIRELESS SET made by R.C.A. of Canada. 115 v. A.C. Brand new 115. P. & P. £1.

FIELD TELEPHONE. D. Mk. V, fully tested, complete. £4 5/0 per pair. P. & P. 10/-.

CONDENSERS, RESISTORS, COILS-TRANSFORMERS, etc. Very large selection in stock. BUZZERS SIGNALING TRAINING. Bakelite or wooden base, adjustable buzzer key. New 7/6. P. & P. 2/-.

MORSE KEYS, 8 amp. New 2/6. P. & P. 1/-.

TANNOY LOUDSPEAKERS. New, £1. P. & P. 3/-.

PERSONAL CALLERS WELCOME

LASKY'S RADIO



GOLLARG 4-SPEED MIXER AUTO-CHANGERS

R.C. 456 Incorporating auto and manual control. Complete with Studio crystal p.u. and sapphire stylus. List £13.17.0.

Lasky's Price £7.19.6. Post 3/6.

B.S.R., type UAB, 4-sp., with latest B.S.R. full P.U., £6.19.6. Post paid.

MICROPHONE BARGAIN

ACOS type 33/1. Crystal hand or table microphone incorporating specially designed acoustic filter. Flat response 30-7,000 cps. Omni-directional. Suitable for tape recording, public address, etc. Attractive plastic case. Brand new in original cartons. List price 50/-.

Lasky's Price 29/6. Post 1/6.

LASKY'S FULLY TRANSISTORISED PORTABLE

FOR HOME CONSTRUCTION

Entirely New! Note these Star features.

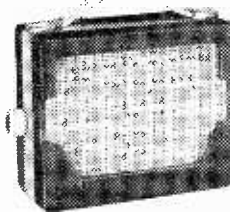

★ Printed Circuit 6½in. x 2½in. ★ 200 milliwatts p.p. output. ★ Uses 7 Transistors and 1 germanium diode. ★ Ferrite rod aerial. ★ Fully tunable. ★ 6 v. power supplies. Very low consumption. ★ Choice of 7 x 4in. elliptical or 3½in. P.M. Speaker. ★ Choice of cabinet. **CAN BE BUILT FOR £9.19.6**

Circuit Diagram and building instructions, 1/6 post free.

Carr. 3/6

BUILD THIS BATTERY PORTABLE FOR ONLY 7 GNS.

(only batteries extra)

or as a mains battery job with 200/250 v. A.C. Power Unit for only 9 Gns.

Carr. and Pkg. 3/6.

Lasky's 4-valve med. and long wave superhet Portable equals the performance of ready-built portables costing many pounds more! Thousands in use. YOU can build it in an hour or so. The printed circuit, plus the building instructions makes construction amazingly easy and accurate. Build yours now.



Circuit diagram, and building instructions, 1/6 post free.

SOLDERING IRONS HALF PRICE!

Famous SOLON make, ex-Govt., new and unused. Pencil bit, 65 w., 230/250 v. A.C. D.C. List 27/6

Lasky's Price

16/6 Post 1/6.

Spare Bits. 1/- ea. Spare Elements (state voltage), 5/9.

LASKY'S (HARROW ROAD) LTD.

42, TOTTENHAM COURT ROAD, W.1.

Telephone: MUSEum 2605.

370, HARROW ROAD, PADDINGTON, W.9.

LAD 4075 and CUN 1979.

Open all day SATURDAY. Half-day Thursday.

PLEASE ADDRESS ALL MAIL ORDERS TO HARROW ROAD.

YOURS ON 7 DAYS' FREE APPROVAL! **THE ESSENTIAL REFERENCE for AMATEUR or ENGINEER!**
Encyclopaedia of RADIO & TELEVISION



NEW! UP-TO-THE-MINUTE! COMPREHENSIVE! AUTHORITATIVE!
 Complete A-Z guide, packed with clear explanations and valuable reference data, meets the practical man's every need!

AMAZING OFFER TO READERS OF "Practical Wireless"

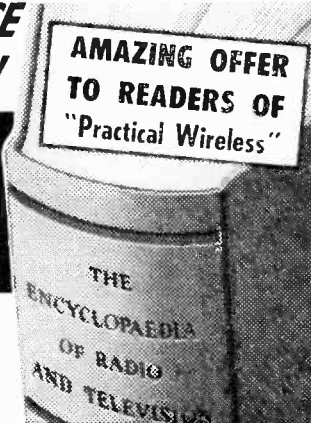

SEND NO MONEY NOW!

To: Dept. E.B.26, People's Home Library (Othams Press Ltd.), Basted, Sevenoaks, Kent.
 Please send me WITHOUT OBLIGATION TO PURCHASE "Encyclopaedia of Radio and Television." I will EITHER return the book in good condition, postage paid, within 8 days, OR send down payment of 11/6 eight days after delivery, followed by 2 monthly instalments of 10/- (31/6). ALTERNATIVELY, I will send the cash price of 30/- eight days after delivery.

Signature..... Occupation.....
 (Persons under 21 will be sent a Guarantor Form.) Age, if under 21.....
 Put tick where applicable: Cash Terms Householder
 Furnished Premis. Unfurnished Premis. Hotel
 Live with Parents Lodgings
 USE BLOCK LETTERS BELOW

NAME Full Postal ADDRESS
 Firmly affix 24 stamp in margin.....
 E.B.26/Sept. 58.

Essential to the keen amateur, radio engineer, apprentice or student. Covers every aspect of theory and practice of radio, TV, radar, etc. New edition, with appendix covering recent developments.
AMAZING VALUE!
 De Luxe Edn., cash price: 30/- or 11/6 down, 2 payments of 10/- (31/6).
DO THIS NOW!

Fill in form and post in 2d. stamped, unsealed envelope to Dept. E.B.26, People's Home Library, Basted, Sevenoaks, Kent. Offer applies in U.K. and Eire only, closes Sept. 30.

736 PAGES
 Nearly 800 ILLUSTRATIONS
 OVER 3,000 A-Z ENTRIES

Aerials; Amplification; Audio-Frequency Transmision; Communication Systems; Detection; Distortion; Feedback; Measuring Instruments; Modulation; Oscillators; Radar; Symbols; Testing & Fault Tracing; Transmision; Valves; Vision Frequency Transmision; V.H.F.; Wave Propagation, etc.

Build your own TAPE RECORDER "ASPDEN"

Tape Deck and Amplifier Kits

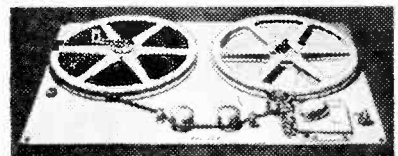

TAPE DECKS. 2-speed, twin track, easy to assemble kits with finest motor, Ferruxbe heads and full instructions.
 Model 582 for 5in. spools, kit £8.5.0.
 Model 782 for 7in. spools, kit £9.5.0.
 Either model assembled and tested, 30/- extra.
AMPLIFIER kit. 2 1/2 watt, record/replay, 2 recording positions, neon indicator, etc., £5.18.0. Power Pack kit for above. £2.18.6 (both without valves). Carr. and packing extra.

You can obtain high quality as Mr. E. T. of Sussex, who writes:—
 "The performance is very good, in fact some of my friends say that it is equal to any of the more expensive recorders."
 At a very low price, as Mr. R. C. K. of Durham, who writes:—
 "Many people who have heard it have been staggered that such quality can be obtained for such a low price."
 Build your recorder now.

Send STAMP for full particulars to:—
W. S. ASPDEN Stanley Works, Clevedon Road, Blackpool, Lancs.

REPANCO

HIGH GAIN TRANSISTOR COMPONENTS

STANDARD RANGE

Ferrite Slab Aerials Type FS2. Designed for Long and Medium Wave reception with transistor portable superhet receivers. Slab size 5 1/2 in. x 1 1/2 in. x 5/32 in. Complete with fixing brackets, 13/6.
Combined Oscillator and 1st I.F. transformer Type OT1. 13/16 in. sq. x 1 1/2 in. I.F. Frequency 315 Kc/s., 11/6.
2nd I.F. Transformer (315 Kc/s.) Type TT2, 5/-.
3rd I.F. Transformer (315 Kc/s.) Type TT3, 5/-.
 I.F. Transformers enclosed in iron dust pots with slug tuning.
Push Pull Interstage Transformer Type TT4. Ratio 1 : 1 C.T. Stack size 1 1/2 in. x 1 1/16 in. x 7/16 in., 8/6.
Push Pull Output Transformer Type TT5. Ratio 15 : 1 C.T. Size as TT4. Matched to 3 ohm speaker, 8/-.
MINIATURE RANGE.—For pocket receivers.

Ferrite Slab Aerial Type FS3. Medium Wave only. With fixing grommets. Size 3 in. x 3 in. x 5/32 in., 7/6.
Oscillator Coil Type XO3. Medium Wave only. Overall size 3 in. dia x 1 in. Enclosed in Ferrite pots, 5/-.
I.F. Transformer Type XT6. Suitable for 1st and 2nd I.F. 455 Kc/s. Size 3 in. sq. x 1 1/16 in., 10/-.
I.F. Transformer Type XT7. Designed for 3rd I.F.T. or detector I.F.T. 455 Kc/s. Size as XT6, 10/-.
Push Pull Interstage Transformer Type TT9. Ratio 1 : 1 C.T. Radiometal Core. Size 3 in. x 3 in. x 13/32 in., 12/6.
Push Pull Output Transformer Type TT10. Ratio 8 : 1 C.T. Matched to 3 ohm speaker. Size as TT9, 12/6.
 Practical and Theoretical circuits enclosed with each Repanco Transistor Component.

JUST RELEASED. "THE MINI-7" a new personal portable transistor receiver. Size 5 1/2 in. x 3 1/2 in. x 1 1/2 in. Send 1/9 P.O. for instructions.

Mail Order and Trade:
RADIO EXPERIMENTAL PRODUCTS, LTD.
 33 Much Park St. COVENTRY
 Tel.: 62572

Wholesale Enquiries and Export:
REPANCO, LTD.
 O'Brien's Buildings
 203-269 Foleshill Rd. COVENTRY
 Tel.: 40594

tion is remarkably free from corrosion troubles in service and is capable of standing up to considerable mechanical abuse, such as over-tightening, while any force exerted on the terminal bolt or to the external wiring is transferred directly to the cell container walls rather than to the internal assembly.

Porvic microporous separators are used, which permit the cell to be stored under suitable conditions in a dry, unfilled state for an unlimited period without deterioration.

The MFB9 measures $3\frac{3}{16}$ in. wide \times $1\frac{1}{16}$ in. long \times $4\frac{3}{16}$ in. high and has a capacity of 8 Ah at the 20-hour rate of discharge.—Chloride Batteries Ltd., Clifton Junction, Manchester.

NEW CELESTION LOUDSPEAKER

THE Celestion "Colaudio" loudspeaker embodies two distinct techniques in order to provide a satisfactory answer to the ever-widening demand for reproduction that will satisfy the most discriminating listener to broad-



The Celestion "Colaudio" loudspeaker.

cast and recorded music of all types. The "Colaudio" provides a substantially level response from 30-15,000 C.P.S.

Utilising a 15in. direct radiator loudspeaker specially designed to produce the lower frequencies with the utmost fidelity, a particular feature of this bass unit is the 3in. voice coil. This lends itself to a more efficient magnet assembly and gives a superior drive to the cone, whereby a better balance to the frequency range it covers is obtained.

The suspension is of the dust-proof annular type, permitting free cone excursion whilst reducing lateral movement to a minimum and the cone edge termination is a surround of plastic foam.

The high-frequency reproducer incorporates two direct radiator pressure type units, mounted in column form within the cone of the bass radiator. The feature of this arrangement enables the higher frequencies to be dispersed over a wide area in the horizontal plane with a narrow vertical lobe, minimising unwanted reflections and improving efficiency.

Another feature of this column is found in its mounting. This enables the vertical position to be adjusted to suit the position in which the loudspeaker is mounted in the cabinet.

The main housing is cast, coupling rigidity with accuracy to form a pleasing design, and is finished

in black crackle with silver trim to the metal mesh protecting the face of the high-frequency unit. Retail price, £32 10s.—Rola Celestion Ltd., Thames Ditton, Surrey.

A LOW VOLTAGE PENCIL IRON

THE "Browleco" Low Voltage Pencil Iron has been designed for instrument and electronic work. It weighs only $1\frac{1}{2}$ oz., and has

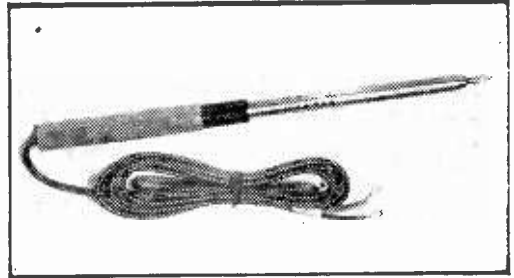

The "Browleco" low voltage soldering iron.

an overall length of 8in. The element is wound on to an insulated copper alloy bit holder, designed to act as a heat storer, into which various size copper bits can be fitted. It gives excellent conductivity to the working tip and takes approximately two minutes to heat up. The standard voltage is 6 or 12 but the elements can be wound specially up to 50 volts. The iron is suitable for working from a battery or a double wound transformer. Fitted with the standard $\frac{1}{16}$ in. bit, 2 yards of flex and suitable for 6 or 12 volt supply. Price 19s. 6d.—Brownings Electric Co. Ltd., Green Street, London, E.13.

IMPROVED MOTEK K9 TAPE DECK

THE manufacturers have added yet another new feature to the many already incorporated in the "Motek" tape deck.

A safety record button has been added which



The improved Motek K9 tape deck.

makes accidental erasure from the tape quite impossible. The importance of this feature cannot be over emphasised in view of the large number of expensive pre-recorded tapes now in use.

A new colour leaflet is available from the manufacturers and gives full details on the "Motek" deck. The list price of 21 gns. remains unchanged.—Modern Techniques, Wedmore Street, London, N.19.

Programme Pointers

OUR CRITIC, MAURICE REEVE, REVIEWS SOME RECENT PROGRAMMES

Jack Buchanan

JACK BUCHANAN was an idol both of the straight and musical comedy stages for many years and justly so. His death made a "Jack Buchanan" BBC show a foregone conclusion. It turned out to be a very engaging programme, well contrived and well performed. The cast was a lengthy and glittering one, and many of the old hit favourites brought memories rolling back.

Light Music Festival

Six concerts, forming a "light music festival" were given in the Royal Festival Hall by the BBC Concert Orchestra under Vilem Tausky, and a number of big shots in the light entertainment world.

"Light music." Can such a term be correctly defined? To use it as the antonym of "heavy" would clearly be misleading as many of the lightest works, e.g., Mendelssohn's *Midsummer Nights Dream* music are classic of the purest vintage. Its universal application, of course, is to class it as music of an inferior quality to the classics; music which cannot find a place on a high-class concert programme; and this definition is perfect for the purposes of this festival's programmes. A few numbers might have been considered acceptable in the quiet and privacy of one's home in front of the radio set: the vast bulk was rubbish scarcely fit to accompany the washing up or the carpet vacuuming. And it sounded all the more incongruous coming from a concert hall performed before a seated audience.

There were some good performances by the various soloists, and Mr. Tausky and his forces turned up manfully and nobly. But the combined effect, even to the light music fan, was rather like a banquet of ice cream, chocolates, birthday cake and ginger pop. Musical rather than gastronomic indigestion resulted.

Toast of the Town

Toast of the Town is the successor to the ill-starred Saturday Night Variety Bill. And, unless it is handled with great care, I can see it going the same way. So far, it seems little more than a boost for the artists appearing, with Eamonn Andrews as toastmaster doing the boosting. I suppose it is the first duty of a toastmaster to sing the praises of those to whom he is about to raise his glass. One would be very shocked were it otherwise. But, engaging as Mr. Andrews can be, he not only does an awful lot of talking in this programme, but is entirely without humour. Otherwise the bill is designed on very similar lines but with well-known persons rather than variety stars filling it.

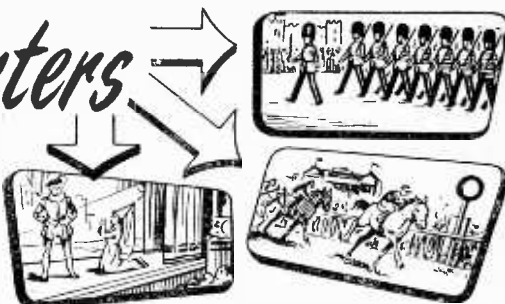

Marie Antoinette

Hilaire Belloc wrote a famous *Life of Marie* (bread or cake) *Antoinette*. In tribute to him it was done into two "sequences for broadcasting" by Robert Speight, and produced by Val Gielgud.

The first was "The Flight to Varennes" and the second, "Death of a Queen." The French Revolution will always be the most romantic and popular of historical subjects for drama, fiction or biography: it contains everything the most avid imagination wants to feed on. These two programmes didn't furnish as much pure excitement as, say, *The Scarlet Pimpernel* would but their substance and language were vastly superior.

Seven Years Solitary

Another documentary, but of quite a different character, was *Seven Years Solitary*. Narrated by Michael Burr and with a script compiled by Wyn Knowles, it related the experiences of Dr. Edith Bone during seven years imprisonment by the Communists in Budapest. A former Hungarian communist and married to an Englishman, Dr. Bone was arrested on a more or less trumped-up charge of espionage, sentenced to fifteen years, confined in the most horrible conditions and set free during the recent Hungarian uprising. She displayed amazing courage and fortitude.

The Merchant of Venice

Shakespeare is always among the favourite and most successful radio script writers. By listening in "blind," he becomes as abstract as music: one is never distracted by scenery, costumes or personalities—those most controversial qualities of stage, screen or TV.

The Merchant of Venice, one of the top favourites, came over well with Harry Andrews as Shylock, Irene Worth as Portia and Tony Britton as Bassanio at the head of a strong cast. Producer was Michael Bakewell.

Tributes

In *The Death of a Queen*, the sequence was compiled by Val Gielgud who also produced.

Good-bye, Mr. Chips. Good-bye, Robert Donat. The BBC, through the medium of many of his friends and colleagues, paid a moving tribute to a much loved and star crossed stage, screen and radio star. Narrator, Laurence Gilliam.

KINGSMERE SUPPLIES LIMITED

All Goods Post Free. (Export extra.)

MAIL ORDER HOUSE

TERMS: Remit with Order or C.O.D.

Built to the highest specifications, these chassis offer the finest value to the enthusiast.

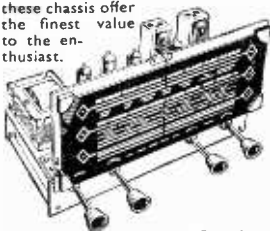

ALL BRITISH RADIOGRAM CHASSIS. 3 WAVEBANDS 5 MULLARD VALVES

Brand new and guar. A.C. 200/250 v. Short-Medium-Long-Gram. P.U. High Q dust core coils. Latest circuit technique. AVC and neg. feedback. 4 watts. Chassis size 13½ x 5½ x 2½ in. Aligned and calibrated ready for use. Quality at Low Cost. Chassis isolated from mains.

BARGAIN PRICE 9 gns.

Matched Speakers, 5in., 6in. x 4in., 6½in., 8in., all 17/6 ea.



BRAND NEW AND BOXED

OUR PRICE **£7-5-0**

LIST PRICE £9-15-0

IDEAL FOR USE WITH OUR CHASSIS

Voltmeters, 2in. scaled 0/25 v., 0/250 v. D.C. in Leather Case, 9/6
Acos Crystal Mike, Sub-miniature inserts ready for use ideal guitars, recorders, etc. ... 3/6

Output Transformer, Mullard "510" ... 25/-
Mains Transformer, Mullard "510" ... 35/-
Output Transformer, "Pentode" ... 3/9

Resistors, 50 mixed values, 10/-
Ceramic Condensers, 50 ditto, 15/-
Miniature IK Carbon pot., 1/-
Ivory Knobs, 1in. dia., Gold Filled, 9d.
Microphone Transformer, 50 : 1, 2/6
T.V. Smoothing Condenser, 100+200 mfd., 275 v., 7/6
Valve Holders, I.O., M.O., B9a, B7g, B8a, B9g, B8g, 6d. ea.

90-DAY GUARANTEE VALVES ALL BRAND NEW

6/6	1/6	5/6
5U4	95A	IT4
6K8G	EA50	6K6GT
6N7M	E1148	807
6V6G		SP61
6X5G	2/6	EF92
6K7M	6K7G	DF91

Twin Gang .0005 mfd. Standard, 6/6
Ditto, with Slow Motion Drive, 7/6
Toggle Switch SPDT (insul.), 1/-
7in. (Metal) Tape Spools, 2/3
25 pf Miniature Tuning Condenser, 2/6
5½in. Grundig (Plastic) Spools, 3/-
Volume Controls, All values 5K to 2 meg., with switch, 4/9; less switch, 3/-
Long spindles.

COLLARO JUNIOR PLAYER

4 speed, our bargain price ... 90/-
Ready cut mounting board ... 5/-
3-Watt Amplifier & Speaker ... 70/-
Amplifier Player Cabinet ... 45/-

SPECIAL PRICE PER SET

6K8G, 6K7G, 6Q7G, 6V6G, 6X5G... 27/6
IR5, IT4, IS5, 3V4 or 354... 25/-
Matched Pairs 6V6G ... 12/6
Valve Boxes, All Sizes ... 2/- doz.

BSR 4-SPEED SINGLE PLAYER Model TU9. Our bargain price, 95/-
Ready cut mounting board, 5/-
3 Watt Amplifier & Speaker... 70/-
Amplifier Player Cabinet... 45/-

FOAM COURT WAY, FERRING, WORTHING, SUSSEX

Build your own HI-FI

—with an entirely **NEW** range of Hi-Fi units and cabinets!

Imagine the pleasure of having this magnificent Hi-Fi equipment in its beautiful contemporary style furniture for your home... and experiencing an entirely new realism in sound reproduction. Yet the Emistructor Hi-Fi will save you money and give you all the extra fun and satisfaction of building it yourself—and being able to service and maintain it afterwards. Special instruction manuals guide you at each stage and teach you all about the equipment in simple terms as you build. No skill or experience is needed—only a few simple tools.

Emistructor equipment is made to the highest quality standards and is a product of E.M.I. Institutes Ltd.—part of a Company world famous for sound recording and reproducing equipment.

There is a wide variety of equipment and cabinets at different price levels to suit individual tastes and requirements. The range varies from a complete Hi-Fi installation with separate speaker enclosures to a simple all-in-one compact system for those with more modest requirements. All equipment is suitable for stereo or non-stereo reproduction of records. Full details and complete specifications will be sent with our free Brochure.

EMISTRUCTOR

"HIS MASTER'S VOICE" · CAPITOL · COLUMBIA
PARLOPHONE · MGM · etc.

Associated with one of the world's largest recording organisations comprising:—



FREE BROCHURE—POST TODAY

To "Emistructor", (Dept. H.F. 32)
43 Grove Park Road, London, W.4.

Please send, without obligation, details of your Hi-Fi equipment

NAME
ADDRESS

MAKE SOUND JOINTS SIMPLY BY USING Multicore

ERSIN MULTICORE

Contains 5 cores of extra-active, non-corrosive Ersin Flux. Prevents oxidation and cleans surface oxides.

SIZE 1 CARTON

5/-

HANDYMAN'S CARTON

Suitable for 200 average joints. 6d.



Wherever precision soldering is essential, manufacturers, engineers and handymen rely on MULTICORE. There's a MULTICORE SOLDER just made for the job you have in hand. Here are some of them.

SAVBIT TYPE 1 ALLOY

A specially formulated alloy to reduce the wear of soldering iron bits. Contains 5 cores of non-corrosive Ersin Flux and is ideal for all soldering purposes.



SIZE 1 CARTON 5/-

Available in three specifications.

BIB WIRE STRIPPER AND CUTTER

Strips insulation without nicking wire cuts wire cleanly, splits extruded flex 3/8 each



HOME CONSTRUCTORS 276 PACK

In addition to the well-known Home Constructors Pack (containing 19ft. of 18 s.w.g. 60/40 alloy) a similar pack is now available containing 40ft. of 22 s.w.g. 60/40 alloy especially suitable for printed circuits.



MULTICORE SOLDERS LTD.,

MULTICORE WORKS, HEMEL HEMPSTEAD, HERTS. (BOXMOOR 3636)

- COLLARO Mk IV Tape Transcriptors — £25.0.0.
- AVO MULTIMINOR — — £9.10.0.
- W.B. H.F. 1016 Speaker — — £8.0.0.
- W.B. HF. 1012 Speaker — — £4.19.9.
- COSSOR 3 valve 3 watt Amplifier Kit, complete with 2 speakers — — £9.15.0.
- COSSOR 6 valve FM Receiver Kit, with 10in. x 6in. Speaker — — £15.15.0.
- GARRARD TA Mk. 2 4-speed Single Record Unit with GC2 P.U. — — £9.15.8.
- TRANSISTORS (selected). Red Spot, 9/-; White Spot, 15/-; Yell./Gr. Spot (A.F.), 10/-; Yell./Red Spot (R.F.), 21/-; Mullard OC44, 40/-; OC70, 21/-; OC71, 24/-; OC72, 30/-. Ediswan: XA102, 40/-; XA101, 35/-; XB102, 21/-; XB103 24/-; XC101, 30/-.

ALL The Above Items Sent Carriage Paid.

COMPONENTS

still Available for ALL OSRAM and MULLARD Amplifier and F.M. Circuits.

WE ARE STOCKISTS FOR

Erie, Radiospares, T.C.C. Dubilier Condensers, Wearite-Osmor, Denco, REP (Repanco), Telatron, Elstone, Partridge, W.B., Elac, J.B. Tuning Condensers, Emitape, Scotchboy, Bulgin, Westinghouse, Brimar, Mullard, etc. etc. Viewmaster and Teleking Spares.

Send 3d. stamp for Lists.

L. F. HANNEY

77, LOWER BRISTOL ROAD, BATH

AN ELECTRONIC ORGAN FOR THE HOME CONSTRUCTOR

Simple and straightforward instructions for building an inexpensive musical instrument specially designed for amateur use in church, hall or home. Valuable features of its construction are the small dimensions. No electrical measuring instruments are required in order to set up this organ. If you can use a soldering iron, drill and screw-driver you can build it at home.

15/- by A. Douglas. Postage 1/-

A BEGINNER'S GUIDE TO TELEVISION, by F. J. Camm. 7/6. Postage 8d.

BASIC MATHEMATICS FOR RADIO & ELECTRONICS, by F. M. Colebrook & J. W. Head. 17/6. Postage 1/-.

TV FAULT FINDING, a Data Publication. 5/-. Postage 6d.

PRACTICAL WIRELESS SERVICE MANUAL, by F. J. Camm. 21/-. Postage 1/-.

THE RADIO AMATEUR'S HANDBOOK, by A.R.R.L. 1958 ed. 32/6. Postage 1/9.

THE MODERN BOOK CO.

BRITAIN'S LARGEST STOCKISTS of British and American Technical Books
19-23 PRÆD STREET, LONDON, W.2.

Complete Catalogue 6d. Phone: PADdington 4185. Open 6 days 9-6 p.m.

BENSON'S BETTER BARGAINS

CONVERTERS (ROTARY) 24 v. D.C. to 50 v. A.C. 4 A., 40/-; 110 v. D.C. to 50 v. A.C. 23 (rail 7/6). Mic. Inserts, G.P.O. carbon, 2/6. EAR-PIECES, inserts, bal. armature type, 2/6. BLOCKS, Greeco, 10-way, 2/-. JUNCTION BOX No. 3, with 41/12 v. buzzer and press switch, 4/6. MORSE TRAINER SET with buzzer and key, wired for 41 v. battery, 8/6. R107 V. Amplifier, new, less valves, 27/6 (p.p. 5/-). VALVE CV16 (Disc Seal Triode) in brass waveguide, 15/-. RELAYS (G.P.O. 3,000 type 500 Ω 8-pole change-over, 6/-; Siemens hi-speed 145 Ω, 5/6. CRTs. CV351 (Cossor 22A), 5/10/-; el. X v. gas focus: green, 1.5 kV., 17/6; CV354 (Cossor 20 K.), 5/10/-; el. X, Y and focus: white, 3 kV., 17/6. RF24 (new type), 20-35 mc/s. (F 15 mc/s.), with 2 EF91, 1 EF93, motor tuned, new, 30/- (p.p. 3/6). POWER UNIT 358. Outputs: D.C. 200 v., 100 mA. and A.C. 12 v. 2 A. on mains 200-250 v. input, or 12 v. D.C. input; dual purpose, 50/- (rail 8/6). BC928A Indicator Unit, with 31B1 CRT and all valves, new, 50/- (rail 7/6). BC908D Frequency Meters, 150-235 mc/s. cavity tuned, new, 40/- (rail 5/-). INDICATORS, Type 196, with one each, 811n and 3in. CRTs, etc., 50/- (rail 10/-). DRIVES: slow-motion, Admiralty 200: 1 ratio, scaled 0-100, 5/6. COMMAND RECEIVERS, brand new, 6 valves, med. wave (0.92-1.5 mc/s), 97/6; used 82/6 (post 3/6). Conversion data and circ. to CAR RADIO, 1/6. EF STRIP 373, new, with valves, 37/6, less valves. 10/- VIBRAPAKS 6 v. D.C. to 250 v. 80 mA., smoothed, cased, 22/6. 12 v. to 250 v. 60 mA., 20/-; Mallory 12 v. to 120 v. 35 mA. synchron. 10/6 (p.p. 3/6). VIBRATORS, Mallory G626C 12 v. +pin, 7/6. BRAND NEW R.F. 26, 20/- (post 3/-); EF27, good cond., 18/-. DYNAMOTORS (post 3/6); 12 v. to 250 v., 80 mA., 11/6; 6 v. to 250 v., 80 mA., 12/6. R1155 S.M. DRIVES "N" type, new, 10/6. METERS, contain 2 separate micro-amp movements and 2 neons, new, 8/6. (Cross-over needle (L.R) 100 μA twice; good condition, 8/6 or 1 mA. x 2, 8/6. LIST AND ENQUIRIES: S.A.E., please! Terms: C.W.O. Postage extra. Immediate despatch.

Catalogue and Post: W. A. BENSON (P.W.) 136 Rathbone Road, Liverpool, 15. NEF 6853
Catalogue: SUPERADIO (W'chapel) LTD. 116, Whitechapel, Liverpool, 2. ROY 1130.

COPPER WIRE

ENAMELLED, TINNED, LITZ, COTTON AND SILK COVERED. RESISTANCE WIRES.

1 oz., 2 oz. & 4 oz. REELS.

All gauges available. B.A. SCREWS, NUTS, WASHERS, soldering tags, eyelets and rivets. EBONITE AND BAKELITE PANELS, TUFNOL ROD, PAXOLIN TYPE COIL FORMERS AND TUBES.

ALL DIAMETERS. Latest Radio Publications. SEND STAMP FOR LISTS.

SPECIAL OFFER

G.E.O., B.T.H. & WESTINGHOUSE GERMANIUM CRYSTAL DIODES

1/- each. Postage 3d.

Diagrams and three Crystal Set Circuits Free with each diode.

A large purchase of these fully GUARANTEED diodes from the manufacturers enables us to make this attractive offer.

CRYSTAL SET INCORPORATING THE SILICON CRYSTAL VALVE Adjustable Iron Cored Coil. RECEPTION GUARANTEED Polished wood cabinet, 15/-, post 1/6 A REAL CRYSTAL SET, NOT A TOY

POST RADIO SUPPLIES 33 Bourne Gardens, London, E.4

Open to Discussion

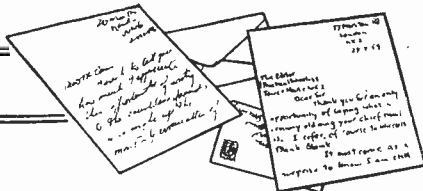

The Editor does not necessarily agree with opinions expressed by his correspondents.

A Short-wave Receiver

SIR.—I have recently constructed a short-wave receiver employing a set of Denco "maxi Q" coils (with reaction windings) in the detector stage as shown in the illustration. The circuit has for some time been working successfully with

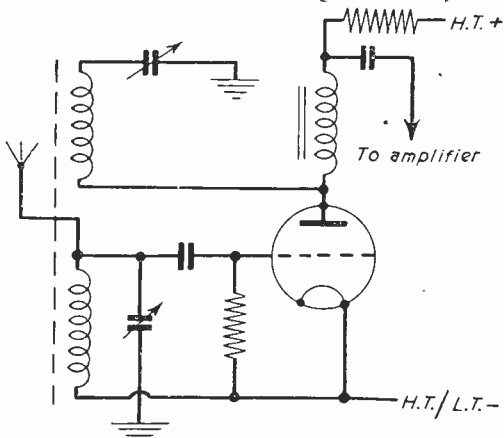

S.W. receiver trouble.

a 100ft. end-fed aerial. Now, however, it will only receive the North Home Service from 20-60 metres, and will not even emit its usual faint hissing noise with any other coil. I have checked every part throughout the set, and I have also cleaned all contacts, replaced valves, etc., to no avail. Can any reader make any suggestions as to how I can rectify this trouble?—J. ANDERSON (Cheshire).

R1155: Information Wanted

SIR.—I desire to use an R1155 type N set for D.F. purposes on board a small yacht. Do any of your readers know what additional equipment is normally used in conjunction with the R1155 and how much of this is available on the surplus market?—C. P. BROWN (Mons.) and R. I. THOMPSON (Auckland, N.Z.)
[See September, 1956, issue.—Ed.]

R1143a Conversion

SIR.—Can anyone help me in the conversion of the R1143a receiver type 71 into 5 or 10 metres operation?—W. FARMER (Leicester).

Frequency Coverage of the R.F.24 Unit

SIR.—I would like to know the frequency coverage of each of the five ranges on the R.F.24, also the output of each range. I wonder if any readers can help?—D. JONES (Wales).

Correspondents Wanted

SIR.—I am 15 years of age, and interested in amateur radio (receiving only), and wish to correspond with amateurs of the same age.—B. STEVENSON (Cambridge).

Stereo Reproduction

SIR.—May I just say how very interesting the BBC stereo test was: I used two rather old table models of different makes but more or less the same tone, each having an 8in. speaker. I was quite able to tell the direction of all moving things and could easily place the players in the orchestra. It was not a manufacturers' stunt as a reader suggests or an effort to make the sound "stand out," it was to give the listener a chance to sense the position of everything in the broadcast scene, which a single reproducer cannot do. One must not forget that there were two independently matched microphones using separate broadcast channels used to get the stereo effect. I cannot see how headphones could be satisfactory as, when used, one only hears sound through them with no indication of direction of sound at all. All good credit to the BBC engineers for putting on the test and making it a worth-while difference to an ordinary sound broadcast.—L. JOHNS (Devon).

Whilst we are always pleased to assist readers with their technical difficulties, we regret that we are unable to supply diagrams or provide instructions for modifying commercial or surplus equipment. We cannot supply alternative details for receivers described in these pages. WE CANNOT UNDERTAKE TO ANSWER QUERIES OVER THE TELEPHONE. If a postal reply is required a stamped and addressed envelope must be enclosed with the coupon from page iii of cover.

Non-soldered Connections for Transistors

SIR.—I find that when using transistors the safest way to avoid damage to them by soldering is to cut short lengths of rubber-covered flex, about 1½in. long, bare one end only and solder the strands of

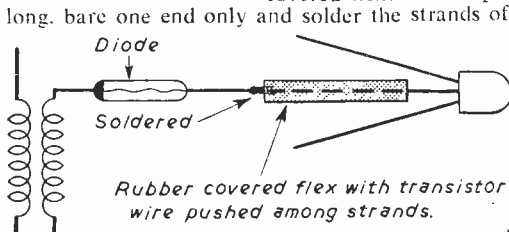

Non-soldered connections.

flex to the components in the set, then push the transistor wires into the other end. This makes a good connection as the casing round the flex grips the transistor wire firmly, and the transistors can be withdrawn should it be necessary without damage to them.—W. REED (nr. Wigan).

Rain Detection by Radio

SIR.—I have recently built a two valve receiver which does not incorporate A.G.C. In general usage the L.S. output is quite loud. However, on occasions the output is very considerably reduced. These occasions coincide with a belt of rain between the receiver (Orpington area) and the transmitter.

It is generally known that radio waves are attenuated by certain atmospheric conditions, but to the best of my knowledge, a quick method of rain detection by radio has never been used. My idea is to replace the L.S. by a V/V. The H.T. voltage and the filament current should be monitored and receiver conditions should remain constant. All that is required is for the receiver to be switched on and the V/V dial read. This will indicate if there is (a) no rain; (b) slight rain; (c) heavy rain, within 30 miles or so from the receiver. I would welcome comments from readers of PRACTICAL WIRELESS on this suggestion.—P. D. RENVOIZE (Orpington).

Printed Circuit Midget Receiver

SIR.—I have just read that you are having second thoughts on the proposed issue of a midget receiver incorporating a printed circuit. You say that there hasn't been a large response in reply to your request, but I assure you that the demand for such a set would be enormous.

I think the very nature of a midget set using transistors makes a printed circuit necessary, and you must be fully aware that ultra-midget sets are being sold by their thousands in the U.S.A.

What is wanted is a set capable of receiving three stations on the medium wave band (ignore the L.W.) such as the Home, Light and Luxembourg. Preferably preset tuning. I do not think that the quality matters much.

I suggest that you design a six transistor set with a $1\frac{1}{2}$ 3 ohm speaker (printed circuit) no larger than 3in. \times 2in. \times 1in. (the magnet of the speaker could protrude outside the case). This would, I suggest, be a proper pocket receiver, and there is no pocket receiver on the market yet in Britain.—J. SHANAHAN (Manchester).

Aerial Hint

SIR.—Having tried several aerials on my radio, I could not get one to my satisfaction. Then I found a long curtain rod and wound it with a 50ft. aerial, pegging one end to the curtain rod, then I placed the whole across the top of the window frame, the results were amazing, perhaps other readers would like to try this?—G. PRESTON (Sparkhill).

Unusual Phenomenon

SIR.—I was recently working on a small signal tracer, the amplifier consisting of only two

valves, namely GP61 and 6VG. I was experimenting with various resistive loads in anode and screen of the SP61 and checking voltages with a 2,000 o.p.v. meter. Having omitted the screen by-pass condenser and checking the screen voltage with the meter, I was very surprised to hear a morse transmission through the speaker. This transmission consisted of the call sign G.B.Z. repeated *ad inf.* (and also *ad nauseam*) between 5.45 and 6.30 p.m.—S. G. ASTBURY (Fenton).

Another Odd Effect

SIR.—Once or twice a week, while listening to BBC programmes, we hear, quite clearly the caw caw caw that a pilot hears at the inner beacon when doing old R.A.F. standard beam approach—probably obsolete now.

This seems strange enough on medium waves, some miles from an aerodrome, but one evening recently, the radio feeder was switched off and only the amplifier was on but we all heard the familiar caw caw quite distinctly. The radio feeder was tuned to the Northern Home Service, but switched off and disconnected from the amplifier which was connected to the gramophone pickup.

I should be very interested if you or any reader can explain this. Can the signal be coming in through the main supply?—D. A. NEWELL (Lumb in Rossendale).

"A Tape Economiser"

SIR.—In the PRACTICAL WIRELESS an article appeared under the heading of "A Tape Economiser." The circuit shown was in fact nothing more than a simple series resistive attenuator network. The circuit included a 200 pf. capacitor, the correct function of which is to compensate for the high frequency discriminating nature of the cable used to connect the network between the circuits concerned. It is well to point out here that to raise the frequency response of a tape recorder requires either: (a) increasing the tape speed, or (b) reducing the effective gap of the heads. Using the latter method, a gap of 0.002in. will result in the following figures: freq. response, 30 c/s—16 kc/s at $7\frac{1}{2}$ in./sec. 30 c/s—10 kc/s at $3\frac{3}{4}$ in./sec. The remaining factors are determined by the associated electronic circuits.—R. BENNETT (Clutton).

TV Sound on Radio

SIR.—I constructed the transistor booster amplifier as described in the February issue of your magazine, but on testing in the manner stated I heard speech on the earphones and was very surprised to discover that it was a BBC television programme. I also wonder if any of your other readers have had a similar experience. I live approximately three miles from the Crystal Palace mast.—B. K. MIDDLETON (Catford, S.E.6.).

Behaviour of Aerial

SIR.—I have not yet had the good fortune to see a lucid non-mathematical exposition of the precise behaviour of an aerial under the
(Continued on page 565)

MAXI-Q REGD.

TRANSISTOR COMPONENTS

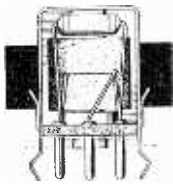

ACTUAL SIZE

I.F.T.13. MINIATURE 1st and 2nd I.F. TRANSFORMER, 9/6 each.
These transformers are wound on ferrite pot cores with an adjustable core for tuning. The aluminium screening can measures 17/32in. x 11/16in. high and is provided with two fixing clips. Nominal frequency: 470 kc/s. Q=110.

I.F.T.14. MINIATURE 3rd I.F. TRANSFORMER, 9/6 each.
Construction and dimensions as I.F.T.13. Nominal frequency: 470 kc/s. Q=130.

TOC.1. MINIATURE TRANSISTOR MEDIUM WAVE OSCILLATOR COIL, 9/6 each.
Construction and dimensions as I.F.T.13. For use with FSA.1.

PRINTED CIRCUIT CHASSIS, punched complete, 14/-.

FSA.1. MEDIUM WAVE FERRITE SLAB AERIAL, 7/6 each.
Wound on a ferrite slab with easily adjusted inductance for ease of alignment. Nominal coverage: 540-1550 kc/s. Overall dimensions: 4in. x 7/8in. x 3/16in. Tuning condenser: Jackson '00' gang with internal screen. Aerial section: 208 pF. Oscillator section: 176 pF. Padder: 200 pF.



CIRCUIT DIAGRAM AND COMPLETE ASSEMBLY LAYOUT FOR BUILDING THE MAXI-Q 6 TRANSISTOR MEDIUM WAVE RECEIVER IS AVAILABLE AT 6d.

GENERAL CATALOGUE covering technical information on full range of components, 1/- in stamps.

TRADING TERMS for direct postal orders, C.W.O. plus appropriate postal charge. Please send S.A.E. with all enquiries.

DENCO (CLACTON) LTD. (Dept. P.W.), 357/9 Old Road, Clacton-on-Sea, Essex

STOP PRESS: TREBLE LIFT INDUCTOR FOR THE MULLARD TYPE "C" TAPE AMPLIFIER. Wound in ferroxcube pot core assembly. Price 22/6.

BARGAINS AT THE WALK-AROUND-SHOP

MAINS TRANSFORMERS 230-250 volts 50 c/s.
Heater 6.3 v., 1.5 A., 6/6, plus 1/- carr. **Miniature Mains** 230 v. at 40 mA and 6.3 v. at 1.5 A., 12/6, plus 1/- carr. **Charging** 9 v. and 17 v. at 3 A., 15/6, p.p. **Mains Isolating** 250 v.-220 v. or 250 v.-110-0-110 v. out OR double wound auto 250 v. in, 110 v. out, 5/-, carr. 1/6. **Heavy-duty mains charging** (Admiralty Pattern). Primary screened from secondary. Totally enclosed in 7 x 6 x 8in. **£1.1.0** p.p. black steel case—terminals inside lid.

OUTPUT TRANSFORMERS

Plessey standard miniature output transformers. Ratio 45 : 1 and 55 : 1, 4/6, p.p. Please state ratio required.

MULTI-RANGE TEST METER

Ranges 0-1.5 v. 0.3 v.; 0-60 mA.; 0-500 and 0-5,000 ohms. Easily read open scale. Simply extended to provide useful pocket fault finder. Size 2 1/2 x 3 1/2 in. Brand new, **8/6**. Carr. 1/6.

ANTENNA RELAY UNIT

Contains 2 1/2 in. panel mounting 2 mA. meter with separate thermo-couple for measuring R.F. and change-over relay. In metal case 3 1/2 x 4 1/2 x 3 1/2 in. **12/6**, post paid, with ceramic stand-off terminals.

MICROPHONES

Acos crystal inserts, 4/6, post paid. American throat microphones type T.S.300, including socket, 3/-, post paid. **Airscrew** type electro magnetic microphones with switch, 2/2, post paid. **Carbon** type in black crackle case, 12/6, post paid.

PROOPS BROS. LTD.

Dept. P.
52, Tottenham Court Road, W.1.

LANgham 0141

Hours :
9 to 6. Thursdays, 9 to 1 p.m.
Open all day Saturday.

STEREO KITS FROM JASON

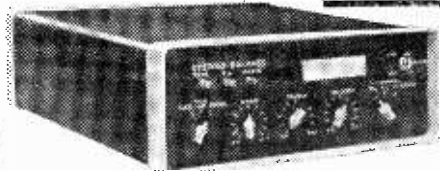

NEW DESIGNS FOR YOU TO BUILD

Be ready for stereo sound with a Jason Stereophonic Pre-amp. Two designs are offered. Model J.4-4 (8 valves) is for the more experienced constructor. It has sufficient gain to play off a tape head. This is the model as designed by Mr. H. Lewis York, and described in *Hi-Fi News*. Model J.2-2 (4 valves) is a somewhat simpler version of the original design, and less complicated to build. Both can be used for single-channel working.

MODEL J.4-4. Complete with drilled chassis, instructions, etc., but without 8 valves **£16.10.0**
MODEL J.2-2. As above, but without 4 valves **£12.18.0**

See the complete Jason range of Audio, **STAND**
Tuning, Tape and instrument equipment
National Radio Show, Earls Court **441**

THE JASON MOTOR & ELECTRONIC CO.

3-4(P) Gt. Chapel Street, Oxford Street, London, W.1.
(Between Oxford Circus & Tottenham Ct. Rd. Stns. Und.) Phone : **Ger. 0273/4**

SOLDERING EQUIPMENT

BY



PRECISION SOLDERING INSTRUMENTS for the ELECTRONICS INDUSTRY

- Comprehensive range
- Robust & Reliable
- Light weight
- Rapid heating
- Bit sizes 3/32in. to 3/8in.
- All voltage ranges 6/7v. to 230/250v.
- Prices from 19/6

Illustrated is the 25w. 3/16in. replaceable bit model with safety shield.

British and Foreign Patents. Registered designs. Suppliers to H.M. and Foreign Governments. Agents throughout the world.

Brochure No. S.10 sent free on request. Sole proprietors and manufacturers:

LIGHT SOLDERING DEVELOPMENTS LIMITED

106 George Street, Croydon, Surrey.

Phone: CROYdon 8589 Grams: Litesold Croydon



G2AK: This Month's Bargains

—HI-FI EQUIPMENT—

VOLTMETERS. Dual range 0-5 v. and 0.103 v. voltmeters, M.C. 1,000 Ω/v. Ranges easily extended. With test prods and leads. Complete in solid leather carrying case, 6 1/2 in. x 5 in. x 2 1/2 in. A gift at 25/- post free.

12 V. MINIATURE ROTARY TRANSFORMER. Output 360/310 v., cont. rating, or 70 mA intermittent, only 4 1/2 in. x 2 1/2 in. overall. OUR PRICE 21/- each or £2 for 2. P. & P. 2/-.

AMERICAN 807s. New, boxed, 4 for 25/-, or 7/6 each, post free. QVO4/7 valves, 8/6 each.

HEADPHONES. H.R. Type 4,000 ohms, very sensitive. Only 12/6 pr. Post 1/6. C.L.R. type (low res.), 8/6. Post 1/6.

SHADED POLE MOTORS, for tape recorders or gram. units, adjustable voltage, 3-hole fixing, only 15/- or 27/6 pr. P. & P. 2/-.

NATIONAL TYPE R300U pillar-mounting choke, 1 mH-300 mA, 3/- ea.

CHOKES. 2.5 mH, 120 mH pie-wound R.F. chokes, 2/- each. 3 or more post free.

AERIAL WIRE. Copper, 7.25 stranded: 140ft., 10/-, 70ft., 5/-, Hard Drawn 14g: 140ft., 17/-; 70ft., 8/6 P. & P. 2/-.

RIBBED GLASS 3in. AERIAL INSULATORS. 1/6 ea. or 6 for 7/6. P. & P. 1/6.

CONDENSERS. 8 uF 600 v. Trop. 750 v. normal condensers. NEW, ex W.D. stocks, 5/6. P. & P. 1/6.

ABSORPTION WAVEMETERS, 3 to 35 Mc/s in 3 switched bands. Complete with indicator bulb. 17/6 post free.

CHAS. H. YOUNG LTD.

Dept. 'P', 110, Dale End, Birmingham, 4. (CEN 1635)

No C.O.D. on orders under £1.

Please Print Your Name and Address.

THE BARGAIN OF THE YEAR



BERIC (EVER-READY) BATTERY RADIO

4 Mullard Valves

MW 200-550 m SW 20-75 m

Brand New in Sealed Cartons.

BELOW COST £5.19.6.

While they last.

CASH ONLY CARRIAGE PAID
Cancelled Export Order.

Not a kit. A factory built Super-sensitive All Dry Battery Receiver. Uses Ever Ready B136 or B103 obtainable everywhere.

H. P. RADIO SERVICES LTD.,

51, County Road, LIVERPOOL. 4.
Tel.: AINtree 1445.

157, St. Johns Road, LIVERPOOL. 22.
and The Cross, ORMSKIRK.

Established 1935.

TRANSISTOR SPECIALISTS

OUR NOTES WILL HELP THE BEGINNER AND MANY OTHERS

If you have been disappointed with Transistor circuits try the Morco Reflex Circuit.

This and other simple circuits are described in our notes sent to anyone sending 8d. in stamps to

MORCO EXPERIMENTAL SUPPLIES

8 and 10, Granville Street, Sheffield, 2

Tel.: 27461

FM and HI-FI Components

DENCO F.M. TUNER circuits	1s. 6d.
RADIO CONST'R. F.M.	2s. 0d.
MULLARD AMPLIFIERS	3s. 6d.
G.E.C. 912 PLUS AMPLIFIER	4s. 0d.
G.E.C. F.M. PLUS TUNER	2s. 6d.

Separate price lists available on request to

J. T. FILMER 82, DARTFORD RD., DARTFORD, KENT.

Tel. Dartford 4057.

FIRST-CLASS RADIO COURSES...

GET A CERTIFICATE!

QUALIFY AT HOME—IN SPARE TIME

After brief, intensely interesting study—undertaken at home in your spare time—YOU can secure your professional qualification. Prepare for YOUR share in the post-war boom in Radio. Let us show you how!

FREE GUIDE

The New Free Guide contains 132 pages of information of the greatest importance to those seeking such success-compelling qualifications as A.M.Brit.I.R.E., City and Guilds Final Radio, P.M.G. Radio Amateurs, Exams., Gen. Cert. of Educ., London B.Sc. (Eng.), A.M.I.P.E., A.M.I.Mech.E., Draughtsmanship (all branches), etc., together with particulars of our remarkable Guarantee of

SUCCESS OR NO FEE

Write now for your copy of this invaluable publication. It may well prove to be the turning point in your career.

FOUNDED 1885—OVER

150,000 SUCCESSES

NATIONAL INSTITUTE OF ENGINEERING

(Dept. 461), 148, HOLBORN, LONDON, E.C.1.

influence of one complete cycle of a radio frequency wave taken in slow motion from the first instant of approach through maximum to zero.

It could be said that the familiar graph showing the distribution of voltage and current along an aerial already provides the information necessary, but it ignores the physics of the subject.—P. ASHDOWN (Lydiate).

High Quality A.M. Receivers

SIR.—I regret that in the drawing of the circuit diagram of my High Quality A.M. Receiver on page 292, June issue, I omitted to show a capacitor, which should be connected from the junction of IFT4 and V10 anode to earth. Its value should be 0.01 μ F, 250 V.W.—R. COUVELA.

The Quad Aerial

SIR.—I should like to report on the Quad aerial described in your June issue. I have tried this out in the Furness peninsula, in a location which is average for the district and the results are nothing short of amazing. I supported the aerial, in the loft, by laths nailed to rafters and floor joists, with cross-laths lashed to them. A good signal was obtained using the aerial element only, but was improved by addition of the reflector. But the interesting point is that the

same aerial drives ITV perfectly also. Stations are Holme Moss and Bolton—Channels 2 and 9, but I also received sound on Channels 5 and 8. The aerial has 5ft. sides and the reflector, 2ft. behind, has 5ft. 3in. sides. I intend trying the effect of a director of 4ft. 9in. sides, 2ft. in front of the aerial. This is not required here, but should prove interesting.—MR. F. GATES (Ulverston).

Loudspeaker Enclosure

SIR.—The last piece of equipment I have built is the Loudspeaker Enclosure, by W. Auther Adams. I have built a previous one, pre-war, but only using one speaker, but this one must be heard to know natural reproduction.

The only difference I have made is a 10in. Golden Whaferdale pre-war speaker for bass with the chamber lined with vermiculite held in place by muslin. I have not cut out for the 5in. \times 3in. treble speaker, but have mounted a Lorenz treble speaker LPH65 on a sub-baffle fixed at the back of the top chamber at an inclined angle.

The whole effect is that the instrument or person speaking is actually in the speaker enclosure, every sound clear and natural no matter what volume. Same for records or F.M. radio.—G. L. BRADLEY (Hove).

NEWS FROM THE CLUES

(Continued from page 520)

THE SLADE RADIO SOCIETY

AUG. 15th—Visit to the Birmingham City Police Radio Room at Steelhouse Lane.

Aug. 29th—Display of Members' Apparatus—held in conjunction with the competition for the "Enterprise Trophy."

Sept. 12th—"Applications of R.F. Heating," by Mr. R. Ryder (Member).

Sept. 26th—"Radio Control of Models" by members of the Birmingham Group of the Internal Radio Controlled Models Society.

The Club Station (G3JBN) at The Church House, is available for the use of members for constructional purposes. Instructional Morse code classes are held on every Tuesday and Thursday, at 7.45 p.m. Slow Morse transmissions are radiated on the air each Monday evening from Station G3AYJ on 1.9 mc/s at 8 p.m.

Full particulars of the Society and its activities may be obtained from the Hon. Secretary:

Mr. C. N. Smart, 110, Woolmore Road, Erdington, Birmingham, 23.

Visitors to the Society's meetings, which commence at 7.45 p.m. prompt, and to the Club station are cordially welcome.

ALLHALLOWS SCHOOL RADIO CLUB

President: J. F. Pound, Middlemist House, Allhallows School, Rousdon.

IN our Radio Club at school we have been experimenting with Transistors, both A.F. and R.F. We have also converted a 19 set as in the April and May issues of PRACTICAL WIRELESS.

The ex-president of the club has designed us a two transistor set, using a White Spot R.F. transistor and a two transistor, transformer coupled amplifier using Green/Yellow spot transistors. If anyone would like to see the circuit I will send one on.

Our 19 set conversion has only had the amplifier added as yet and we have found it works best with the original 6K7 R.F. amplifier with an untuned input. We attempted to keep the original B.F.O. and A.V.C. stages but this proved to be totally impractical. The power unit we used was obtained from a Modulator Type 67, obtainable from John Anglin, 385, Cleethorpe Road, Grimsby, price 45/-.

Hoping this information will be useful.

EAST LANCs RADIO SOCIETY OF GREAT BRITAIN

Hon. Sec.: M. Barnsley, "Greenways," 11, Cemetery Road, Denton, Manchester, Lancs.

CITY & Guilds Radio Amateurs Examination Course.

Evenings: Tuesday—Theory. Thursday—Morse and Practical Work.

Enrolment will take place on Monday and Tuesday, 15th and 16th September, and the course will commence on Tuesday the 23rd. September providing that a sufficient number of students enrol.

The course will take place in the Openshaw Technical College, Further Education Dept., Whitworth Street, Openshaw, Manchester, 11.

Further information can be obtained from the Registrar at the College or myself: Hon. Sec. South Manchester Radio Club, c/o "Greenways", 11, Cemetery Road, Denton, Manchester, Lancs.

Courses already established at the college cover the C. & G. Radio Servicing courses for the Intermediate and Final Examinations together with Television Servicing Courses.

COURSES OF INSTRUCTION

THE following classes, organised by the East London R.S.G.B. Group, in conjunction with the Essex County Council, are available for all those interested in amateur radio, irrespective of whether they are members of any Society or of the general public:—

Radio Amateurs' Examination Course, Wednesday, 7.15 p.m. to 9.15 p.m.; 8 month course for those intending to take the examination.

Morse and Codes of Practice, Monday, 7.30 p.m. to 9.30 p.m.; 6 month course for those who wish to learn Morse up to G.P.O. requirements for an amateur licence. Arrangements have been made with the G.P.O. for those, who, in the opinion of the masters have reached the required speed, to be tested at the College in the evening by a representative of the Post Office. The venue for the above classes is: The Ilford Literary Institute, High School for Girls, Cranbrook Road, Ilford, Essex.

The fees for those living in the Essex County Council area are: 30s. for the R.A.E. course; 20s. for the Morse and Codes of Practice. Students from other parts of London will be admitted as out County students provided the local authority is notified. Enrolment nights: September 8th to 12th, 7 to 8.30 p.m. Classes commence the week commencing September 22nd, 1958. These classes have now been running for 11 years and over 165 students have passed the R.A.E. examinations. Those interested should, in the first instance, write to: Mr. C. H. L. Edwards, G8TL, 28, Morgan Crescent, Theydon Bois.

WESLEY EVENING INSTITUTE RADIO AND TELEVISION GROUP

Head of Institute: E. N. Fennell, B.Sc.(Econ.), F.R.G.S., L.C.P. Wesley Road, Stonebridge, London, N.W.10.

WE are fortunate to have Mr. Barnes again in charge next session. Classes will be run on Mondays and Wednesdays (7.0-9.0) commencing September 22nd. (Enrolment Sept. 15th) Fees will be 30/- per Session for one evening or 37/6 for two. We shall be glad to welcome any friends. You may enrol by post

MAKE A POCKET RADIO!



BUILD THIS FOR ONLY 35/-!

It's fascinating to build this "fantabulous" "TOM-THUMB" transistors radio—only the size of a small cigarette packet, yet a marvel of clarity giving unexcelled transistor reception over all the medium-waves. Personal phone circuitry gives loud and clear tone. Can be built by absolute novice in 30 minutes. Uses only penlight battery. Absolute beginners are assured of error-free building because of our SPECIAL INSTRUCTION MANUAL. It costs only 35/- to build the "TOM-THUMB."

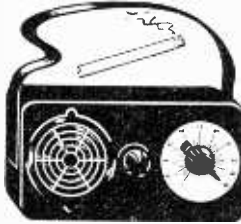

BUILD THIS FOR ONLY 38/-!

(cigarette shown for size)

It's fun to build this "POCKETPAL" tiny shoulder or pocket radio. So easy to build—it covers all the medium waveband with exceptional sensitivity. Features a high efficiency pentode valve. Personal phone ALLDRY battery operation (Batteries fit inside), slings over the shoulder—AERIAL IS INSIDE THE SLING LEAD!—or slips into pocket. Mini-size 3" x 2" x 5 1/2". Build in about 90 minutes WITHOUT ANY EXPERIENCE, using our "STEP-AND-CHECK" INSTRUCTION MANUAL. This "POCKETPAL" radio can be built for only 38/-.

Above prices include everything down to the last screw, including plans! Postage & packing amount to 2/-(C.O.D. 2/-). PARTS SOLD SEPARATELY, shopping list, etc., 1/6. EASY TO BUILD. HEAVY DEMAND SO SEND AT ONCE!

MERLIN LABS. (Dept. PWB), 4 The Drive, Hove.

SPECIAL OFFERS OF COMMUNICATION RECEIVERS

★ARR-3 F.M. RECEIVERS. 2 R.F. stages, two I.F. stages, Automatic Frequency Control; Frequency Range 62-70 mc/s., easily converted to V.H.F. BBC Band. PRICE with valves, modification instructions, modification kit and circuit diagram, £5.10.0, 15/- p.p.

★R-1155 RECEIVERS, reduced now to £7.10.0, 15/- p.p.

★P-104 (R-1392) V.H.F. RECEIVERS, from £3.10.0.

★EDDYSTONE 358X RECEIVERS. 40-31 mc/s continuous coverage, with set of ten coils and Mains Power Pack, all in perfect condition, £15.0.0, 30/- p.p.

230 V. A.C. MAINS POWER PACKS:

Output 300 v. H.T. at 200 mA and 12 v. L.T., £2.8.6, 10/- p.p.

Output 175 v. H.T. at 65 mA and 6.3 v. L.T., for Eddystone 358 Receivers, £1.15.6, 10/- p.p.

ROTATING BEAM AERIAL BASES. 2in. dia. x 6ft. high, with rotating handle (worm and worm gear) and azimuth indicator. 35/- 6ft. extension sections (max. of two per base), 15/- each, 12/6 p.p.

★LARGE STOCK OF VALVES AND METERS. Send s.a.e. for price lists.

TEST METERS, M.C. Movement. Ranges: 60 mA, 1.5 and 3 v. and 0-500 and 0-5-000 ohms. For use with an external battery. Complete with carrying strap, 9/6, 2/6 p.p.

Comprehensive Range of small components, resistors, condensers, switches, valve bases, all attractively priced, available in the self service section of our retail shop at:

85, TOTTENHAM COURT ROAD, LONDON, W.1.

Telephone: LANGHAM 8403

Z. & I. AERO SERVICES, LTD.,

Head Office: 14, South Wharf Road, London, W.2.

Telephone: AMBassador 0151/2

Please send mail orders and all correspondence to our Head Office.

We urgently require American Receivers BC-348 and AR-38D

TESTOSCOPE MAINS TESTER



For high and low voltage testing.
Standard Model: range 100/850 volts A.C. or D.C. Dual Model: range 1/30 an 1 100/850 volts A.C. or D.C.
Write for interesting leaflet 29F

Runbaken
MANUFACTURERS

BOOKLET—"Hints on Electrical Testing," post free 1/-.

IT IS SO EASY

Yes! YOU can build professional equipment without test gear! Over 100,000 enthusiasts have benefited from our Home Radio Constructor's Handbook, which gives full parts lists, circuits, etc., of many receivers, tape recorder, oscilloscope, feeder units, communications set, hi-fi amplifiers, power pack, crystal set, etc. (incl. "P.W." Coronets).

Packed also with data, construction, soldering and servicing hints, facts, formulae, colour code, etc. "Easy-as-A.B.C." FULL SIZED p.p. Construction sheets are available FREE with ORDER. Even the beginner gets professional results first time! This claim confirmed by many hundreds of genuine testimonials received. Introduced virtually at printing cost, we invite you to send 3/- TODAY for your copy.

NOWHERE IS THERE A BOOK SO VALUABLE TO THE NOVICE CONSTRUCTOR AND EXPERT!

RODING LABORATORIES

Hurn Airport, Christchurch, Hants

R.S.G.B. Amateur Radio Call Book 1958. 3/6. Postage 6d.

Electronic Novelties for the Constructor, by Bradley. 5/-. Postage 6d.

Radio Amateur's Handbook 1958. A.R.R.L. 32/6. Postage 1/9.

Primary Valve and T.V. Tube Manual No. 7. 6/-. Postage 8d.

Television Servicing Vol. 2, by Patchett. 6/-. Postage 6d.

Radin Control of Models, by Somrhoff. 5/-. Postage 6d.

High Fidelity Loud-speaker Enclosures, by Babani. 5/-. Postage 6d.

We also have a full range of Slide Rules and Drawing Instrument Sets. Send for list.

UNIVERSAL BOOK CO.

12 Little Newport Street, London W.C.2

(adjoining Lisle Street)

H.A.C. SHORT-WAVE EQUIPMENT

Noted for over 18 years for S.W. Receivers and Kits of Quality.

Improved designs with Denco coils! One-Valve kit, Model "C" Price, 25/- Two " " " " " " " " 50/-

All kits complete with all components, accessories, and full instructions. Before ordering call and inspect a demonstration receiver, or send stamped, addressed envelope for descriptive catalogue.

"H.A.C." SHORT-WAVE PRODUCTS (Dept. TH), 11, Old Bond Street, London, W.1.

VALVES—Guaranteed

EA50	2/-	SP41	4/-	G152	8/6	6SN7GT	
EB41	7/6	SP61	6/-	1D5	3/6	6AU6	8/6
EB91	6/-	TT11	3/6	1LN5	5/6	6U5	7/6
ECC33	8/6	VR18	5/-	4D1	4/-	6U5(UX)	
EP36	4/6	VR21	4/-	6AK6	7/6	6U7	8/6
EP37	7/6	VR65	3/6	6AL5	6/-	6U8	5/-
EP39	5/6	VR53	3/6	6BD6	6/-	6U9	8/6
EP50	5/-	VR91	4/-	6D8	6/-	7D3	7/6
EP80	8/6	VR137	4/-	6BE6	7/-	8D2	4/6
EL32	5/-	VT20	3/6	6BH6	5/-	9D2	5/-
EL81	12/6	VT50	3/6	6BW6	6/6	9D6	5/-
OZ4	5/-	VT51	4/-	6D2	6/-	12BA6	7/6
PG1	4/-	VU11	2/6	6E5	6/-	12BE6	6/-
PCF90	8/6	W77	5/-	6J5	6/-	12K7	8/-
PE1245		XP(1.5)	3/6	6KTG	4/6	15D2	6/-
		11/6	XSC(1.5)	6KT7	5/6	18	7/6
PY81	8/6		4/-	6SA7	8/-	20D1	12/-

Postage 6d. per valve, orders over £1 post free. (Also all components) TV Tubes, Perfect Condition (callers only) MW22 16, MW22/18, £4.0.0 each. Enquiries welcomed for all T.V., Radio, and Transistor Components.

TELEKIT SUPPLY Phone BEC. 3720.
104 High Street, Beckenham, Kent.

Let I.C.S. train YOU!

COURSES ON:—

- RADIO and TELEVISION
- SERVICING • ELECTRONICS

EXAMINATION COURSES FOR:—

- P.M.G.'s Certificate (Marine Radio Operators)
- C. & G. Radio Amateurs' Exam. (Amateurs' Transmitting Licence)

C. & G. Radio Servicing Certificate (RTEB) British Institution of Radio Engrs., etc.

Whether you plan to have your own business, to become an electronics engineer or to take up a career in industry, an I.C.S. Course will help you to succeed. You learn at home in your own time, under expert tuition. Moderate fees include all books.

LEARN-AS-YOU-BUILD

Practical Radio Course

A basic course in radio, electronic and electrical theory backed by thorough practical training. You build a T.R.F. and a 5-valve superhet radio receiver, signal generator and multi-tester.

Other Learn-as-you-Build radio courses are available

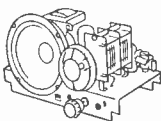

5-VALVE SUPERHET RECEIVER



MULTI-TESTER (Sensitivity 1,000 ohms per volt)

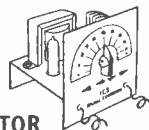

RF/AF SIGNAL GENERATOR

Post this Coupon TODAY! for FREE book on careers in Radio, etc., and full details of I.C.S. Courses.

INTERNATIONAL CORRESPONDENCE SCHOOLS

Dept. 170J, International Buildings, Kingsway, London, W.C.2

Name..... Age.....
(Block Letters please)

Address.....

Occupation..... 9.58

INTERNATIONAL CORRESPONDENCE SCHOOLS

SIGNAL GENERATORS

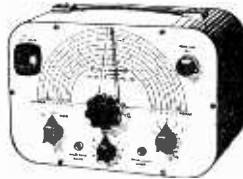

25/- deposit and 6 monthly payments of 21/6. Cash £8.19.6. Post and Packing 5/- extra.

Coverage 100 Kc/s-100 Mc/s on fundamentals and 100 Mc/s to 200 Mc/s on harmonics. Metal case 10in. x 6in. x 5in., grey hammer finish. Incorporating three miniature valves and Metal Rectifier. A.C. Mains 200/250 v. Internal Modulation of 400 c.p.s. to a depth of 30%. Modulated or unmodulated R.F. output continuously variable 100 millivolts. C.W. and mod. switch, variable A.F. output. Incorporating magic eye as output indicator. Accuracy plus or minus 2%.

25/- deposit plus P. & P. 5/- and 4 monthly payments of 21/6. Cash £4.19/6 plus P. & P. 5/-.

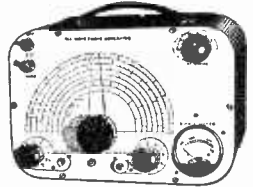

Coverage 120 Kc/s. 84 Mc/s. Metal case 10in. x 6in. x 4in. Size of scale, 6in. x 3in. 2 valves and rectifier. A.C. mains 230-250 v. Internal modulation of 400 c.p.s. to a depth of 30%. modulated or unmodulated R.F. output continuously variable 100 millivolts. C.W. and mod. switch, variable A.F. output and moving coil output meter. Grey hammer finished case and white panel. Accuracy plus or minus 2%.

COMPLETELY BUILT 8-WATT AMPLIFIER

A.C. mains 110-250 v. Size 10in. x 6in. x 2in. Incorporating 4 valves, H.F. pent. triodes 2 output pens. and rectifier. For use with all makes and types of pick-up and mike. Negative feed back. Two inputs, mike and gram., and controls for same. Separate controls for Bass and Treble lift. For use with Std. or L.P. records, musical instruments such as Guitars, etc. Complete with 8in. speaker and ready for use. Plus P. & P. 5/- £4.9.6

AC/DC POCKET MULTI-METER KIT

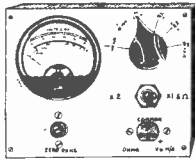

Comprising 2in. moving coil meter, scale calibrated in AC/DC volts, ohms and milliamps. Voltage range AC/DC 0-50, 0-100, 0-250, 0-500. Milliamps 0-10, 0-100. Ohms range 0-10,000. Front panel, range switch, wire-wound pot. (for ohms zero setting), toggle switch, resistor and rectifier. In grey hammer finish case.

19/6 Plus Built and tested P. & P. 1.6. 7/6 extra.

Point to point wiring diagram 1/-, free with kit.

B. S. R. MONARCH 4-SPEED

AUTOMATIC CHANGER

CURRENT MODEL. Will take 7in., 10in. or 12in. records mixed. Turnover crystal head. A.C. Mains 200/250 v. £6.19.6 Plus P. & P. 5/- or 25/- deposit plus P. & P. 5/- and 5 monthly payments of £1.7.0.



PORTABLE AMPLIFIER

Size 6in. long, 5in. high, 2in. deep. Will suit any type of crystal pick-up. Output approx. 2 watts. Incorporating ECC83 double triode. Cossor 142BT output pentode and contact-cooled rectifier. Fully isolated mains transformer for 230/250 49/6 Plus A.C. mains. Base, treble, and volume P. & P. 3.6 Controls. 5in. SPEAKER with O.P. TRANSFORMER purchased with the above. 18/6 plus P. & P. 1.6.

COLLARO MIXER 4-SPEED AUTOMATIC CHANGER

Model 457 (Continental) Type "O" Pick-up. Size 12in. x 13in. Minimum clearance above baseboard 5in., below 2in. 10 records. A.C. mains. 200-250 v. turnover crystal head. Brand new, fully guaranteed (suitable for use with the above amplifier). £8.19.6 Plus or 25/- deposit, plus P. & P. 5/- and 7 monthly payments of £1/5/0. Model 456. Similar to the above. £7/19 6. Plus P. & P. 5/-.

RADIO & T.V. COMPONENTS (Acton) LTD.

23 HIGH STREET, ACTON, LONDON, W.3

All enquiries S.A.E. Goods not dispatched outside U.K.

SITUATIONS VACANT

EXPEDITION TO ANTARCTICA.—Scientific Assistant (Ionospheric) required by the Falkland Islands Dependencies Survey for the operation and maintenance of special electronic Ionospheric recording apparatus at an Antarctic Base for 2 years. Commencing salary according to age in scale £400, rising to £540 a year, with all found, including food, clothing and canteen stores. Free passages. Liberal leave on full salary. Candidates, preferably single and aged 21-28 years, must be of good education, of high physical standard, and experienced in the servicing of radio or radar equipment. Genuine interest in life at an Antarctic Base essential. Write to the CROWN AGENTS, 4, Millbank, London, S.W.1. State age, name in block letters, full qualifications and experience and quote M3B/44628/PU.

THERE is a national shortage of Mercantile Radio Officers. Why not make Communications your career? You can be assured of a sea-going appointment after qualifying at The School of Marine Radio and Radar (A.S.T.), Hamble, Southampton. For details, apply Commandant, quoting A.12.

WIRELESS INSTRUCTOR wanted to assist in the preparation of Students for P.M.G. Certificates and/or City and Guilds Certificates in Telecommunications. Write giving full particulars of certificates held, radio experience and salary expected, in addition to board-residence or flat provided. **PRINCIPAL.** Wireless College, Colwyn Bay, N. Wales.

EDUCATIONAL

LEARN IT AS YOU DO IT—we provide practical equipment combined with instruction in Radio, Television, Electricity, Mechanics, Chemistry, Photography, etc. Write for full details to: E.M.I. INSTITUTES, Dept. PW47, London, W.4.

A.M.I. Mech.E., A.M. Brit. I.R.E., City and Guilds, etc., on "no pass—no fee" terms; over 95% successes. For details of exams, and courses in all branches of engineering, building, etc., write for 144-page handbook free. B.I.E.T. (Dept. 242B), 29, Wright's Lane, London, W.8.

INCORPORATED Practical Radio Engineers home study courses of radio and TV engineering are recognised by the trade as outstanding and authoritative. Moderate fees to a limited number of students only. Syllabus of Instructional Text is free. The "Practical Radio Engineer" journal, sample copy 2/-, 6,000 Alignment Peaks for Superhets, 5/9. Membership and Entry Conditions booklet, 1/-, all post free from the SECRETARY, I.P.R.E., 20, Fairfield Road, London, N.8.

WIRELESS. See the world as a Radio Officer in the Merchant Navy; short training period; low fees; scholarships, etc., available. Boarding and Day students. Stamp for prospectus. **WIRELESS COLLEGE,** Colwyn Bay.

CITY AND GUILDS (Electrical, etc.) on "no pass—no fee" terms. Over 95% successes. For full details of modern courses in all branches of Electrical Technology, send for our 144-page handbook free and post free. B.I.E.T. (Dept. 242A), 29, Wright's Lane, London, W.8.

RATES: 5/6 per line or part thereof, average five words to line, minimum 2 lines. Box No. 1/- extra. Advertisements must be prepaid and addressed to Advertisement Manager, "Practical Wireless," Tower House, Southampton St., Strand, London, W.C.2.

MATHEMATICS for Radio, 21/-
TUTORIAL MATHEMATICS, 200.
Buchanan St., Glasgow.

FREE! Brochure giving details of Home Study Training in Radio, Television, and all branches of Electronics. Courses for the Hobby Enthusiast or for those aiming at the A.M. Brit. I.R.E., City and Guilds, R.T.E.B., and other Professional Examinations. Train with the college operated by Britain's largest Electronics organisation. Moderate fees. Write to E.M.I. INSTITUTES, Dept. PW26, London, W.4.

THERE IS a national shortage of Mercantile Radio Officers. Why not make Communications your career? You can be assured of a sea-going appointment after qualifying at The School of Marine Radio and Radar (A.S.T.), Hamble, Southampton. For details, apply Commandant, quoting A.12.

T/V and RADIO.—A.M. Brit. I.R.E., City and Guilds, R.T.E.B. Cert., etc., on "no pass—no fee" terms. Over 95% successes. Details of exams, and home training courses in all branches of radio and T/V, write for 144-page handbook free. B.I.E.T. (Dept. 242G), 29, Wright's Lane, London, W.8.

SERVICE SHEETS

SERVICE SHEETS for sale and hire. Radio/TV, S.A.E. enquiries. J. PALMER, 32, Neasden Lane, N.W.10.

SERVICE MANUALS/SHEETS. Tel/Radio for hire, sale and wanted. Mixed Manuals and Sheets, 12 for 10/-, s.a.e. enquiry W. J. GILBERT (P.W.1), 24, Frithville Gdns., London, W.12.

ENGINEER has complete range Radio/TV Service Sheets, 4/- each. S.A.E. State model No. required; c.w.o. L. BRENNER, 23, Meadow Close, Barnet, Herts.

SERVICE SHEETS, Radio, T.V., 5,000 models. Lists 1/-; s.a.e. enquiries. TELRAY, 11, Maudland Bk., Preston.

RECEIVERS & COMPONENTS

COMPONENTS, Valves, Tubes, etc. Write or phone for free list. ARION TELEVISION, 4, Maxted Rd., Peckham, S.E.15. (New X 7152.)

LOUDSPEAKERS repaired promptly. **MODEL LOUDSPEAKER SERVICE,** Bullingdon Rd., Oxford.

METERS (NEW BOXED M.O.S.)
Ammeters, 6 in. round, switchboard mounting, moving iron, 50 cycles A.C., scaled 0-50. Price £4, postage 3/6.
Ammeters, 2 in. round, moving coil, complete with shunt, 5 m.a. basic movement, scaled 0-20. Price 10/6, postage 1/6.
Voltmeters, moving coil, 2 in. round, 10,000 ohms resistance, scaled 0-50. Price 10/6.
Postage 1/6.
Voltmeters, 2 1/2 in. round, moving iron, 50 cycles, scaled 0-300. Price 15/-, postage 1/6.
Voltmeters, 2 1/2 in. round, moving iron, scaled 0-500. Price 17/6, postage 1/6.
SPEED ELECTRICS, Eastwood, Notts.

FREE! POSTAGE

TRANSISTORS. Yellow/Green, 9/- each. R.F. TYPE, Yellow/Red, 20/- each.
MIDGET ELECTROLYTICS, 1.6 mfd. 3/6. 3 mfd. 6 v., 16 mfd., 12.5 v., 3/9 each.
CRYSTAL DIODES, 1/- each; 10/6 doz.
COILS & COMPONENTS by Repaco, Bulgin, Wearite, etc. All Post Free.

PETHERICK'S RADIO SUPPLIES
9A, Westcombe, Bideford, N. Devon.

RELAY(S) built to your specification. New components, 7-14 day service. **TELERELAYS LTD.,** 3, Chase Side, London, N.14. (PAL 1686.)

F.M. AERIAL offers from manufacturers. Indoor Dipole, with mast and base, 12/6; H P ditto, 22/6, post free. Send 1/- P.O. for our full T.V. Aerial Lists with illustrated parts catalogue and aerial data. Build your own aerials from our fully machined parts and save money. **SKYLINE WORKS,** Burnshall Road, Coventry.

"OSMOR NEWS," Information and circuit available for the following: Push-pull bias Osc. Coil, 7/6, as supplied to several tape recorder manufacturers. New Band I/III tunable Reflector. "P.W." Consul Car Radio. "R.C." 1-valve S. Waver. Transistor Regenerative Circuit. See page 573. **OSMOR RADIO PRODUCTS LTD.,** Sth. Croydon, Surrey.

MAINS FROM 12v. CAR BATTERY, American Dynamator Unit, runs 200/250 AC/DC radios, televisions, tape recorders, etc. from 12v. car battery, continuous duty, perfect, cost £25, 80/-; s.a.e. full details. **SCIENTIFIC PRODUCTS,** Cleveleys, Lancs.

COLLINS I.F. STATION 1.5 Mcs. to 12 Mcs. 4-Channel with Power Supply Units for 12 volt D.C., 24 volt D.C., 115 volt A.C. and 230 volt A.C. supply.

WIRELESS SET 10—with all ancillary equipment including Rotary Plus Vibrapack Power Unit, R.F. Amplifier, etc.

WIRELESS SET 31—Manpack Walkie-Talkie 40-48 Mcs.

WIRELESS SET 58—Canadian Walkie-Talkie 6-9 Mcs.

WIRELESS SET 88—Walkie-Talkie 4-Channel 40/42 Mcs.

R.C.A. TRANSMITTERS CRV52093—60-80 Mcs. Power Supply 115 volts A.C.

R.C.A. RECEIVERS CRV46068-A—60-80 Mcs. Power Supply 115 volts A.C.

MARCONI RECEIVERS R28/CR100—60 Kcs. to 30 Mcs (Gap 420-500 Kcs) 230 volt A.C.

HALICRAFTERS RECEIVERS S-27 and SX36. National H.R.O. spares "S" Meters 19/6 each. I.F. Transformers 12/6 each.

Morse Keys 2/6 each. Magslip Hunters, 3 inch, 4/6 each.

We have a large variety of the following. Please ask for lists. Switches, toggle and wafer. Fuses, various types and values. Jack Plugs and Sockets. Capacitors, fixed and variable. Ball-races. Potentiometers. Transformers. Rectifiers. Vibrator, synchronic and non-synch. Uniselectors. Relays. Carbon brushes for generators and dynamos.

H.P. or Credit Facilities on all goods.
Carriage and packing extra.

R. GILFILLAN & CO., LTD.
7, High Street, Worthing,
Sussex.

Tel.: Worthing 8719 or 30181.

RECEIVERS & COMPONENTS
(Continued)

MIDDLESBROUGH. Largest stocks on N.-East coast. Radio, TV components, F.M. Kits, Gram. Cabinets, Tape Decks, Leak Amplifiers, Valves, etc. Callers only. **FALMERS,** 106, Newport Road. (Phone: 3096.)

TELEVISIONS NEEDING ATTENTION. 9in.-10in. models, £4/10/- each, 12in. models, £6/6/- each. 15in. models and Philips Projection models £11/10/- each; immediate despatch; carriage paid. **BARKERS,** 325, Brockley Road, S.E.4. (TID 6752.)

FM-AM CHASSIS

PUSH-PULL OUTPUT — 7 VALVES
HIGH SENSITIVITY — GRAM INPUT
7 x 5" FULL VOLT SCALE
AFC—AVC—GUARANTEED
REDUCED TO £14
BEL SOUND PRODUCTS CO.
Marlborough Yard, N.19 Tel.: ARC 5078
20 mins. West End

POWER IN PACKETS. New stock of Batteries, tens of thousands of volts in all sizes inc. Nife cells, 162 x 12 x 3v, 87 x 64 x 4 1/2, 120 v, special line in condensers, etc. Send 1/- for new super 20-page catalogue, refundable on first order. Bargains galore in Motors, Instruments, Files, Condensers, and above all, Service. **R. J. DIGGINS,** 129-131, Radnor St., Hulme, Manchester, 15.

BRAND NEW VALVES. — EF50, SP61, 9004, 2/-; ECC32, 6K7, 2/6; 6K8, 6V6, KT8C, 5U4, MU14, 7/-; EY51, 10/-; ECL80, TS3, 12/6; p.p. 1/-. **HOBSONS,** 2, Branston Rd., Clacton, Essex.

GUARANTEED TELEVISION. 12in. 5-Channel models, first-class picture, £26 each, carriage paid. **THE GRAMOPHONE SHOP** 19-21, Brockley Rise, London, S.E.23.

BARGAIN OFFERS

200 WATT ROTARY CONVERTERS. 24 volts D.C. 11 amps. input, 230 volts A.C., 50 cycles. S.P. output through transformer, new ex Admiralty stock. £8.10.0, carr. 10/-.

ROTARY CONVERTERS FOR MOBILE TAPE RECORDERS. 24 volts D.C. input, 230 volts A.C., 50 cycles S.P., 75 watts output in portable metal case fitted meter, voltage regulator switch, input and output switches and fuses, as new, £5.10.0, carr. 10/-.

450 WATT ROTARY CONVERTERS. 24 volts D.C. input, 230 volts A.C., 50 cycles. S.P. Output .435 amps. £17.10.0, carr. 10/-.

THE LESDIX CRYSTAL SET, 35/- complete with headphones. A neat and attractive de-luxe Table Model Wireless Receiver which needs only a good aerial and earth for sweet, clear reception. In pastel shades of pink, green, orange and yellow.

METER MOVEMENTS. G.P.O. Linesman's Detectors D.C. moving coil reading 0.5 and 50 volts, 50 and moving millamps, in case with pointer, needing repair, 5/-, postage 2/-.

ELECTRADIX RADIOS

Dept. P. 214, Queenstown Road, Battersea, S.W.8. **MACaulay** 2159

AMAZING OFFER.—Originally £40-£100 each. Ekco, Pye, H.M.V., Marconi, Philips, Murphy, etc., 9-10in. Televisions, complete, not working, 50/- each; carriage paid; immediate despatch; 12in., £5/5/-; 15in., £9/-; Philips 17in. Projection Televisions, £9/15/-. **TOMLINS,** 127, Brockley Rise, London, S.E.23.

TELEVISIONS, 9in. models, £7/10/-; 12in. models, £13/10/-; 12in., 5-channel models, £19/10/- each, all working, carriage paid. Send for list. **TOMLINS,** 127, Brockley Rise, Forest Hill, S.E.23. (FOR 5497.)

ANNAKIN

1143A Equipment, less valves and crystals, Transmitter No. 50, 5 stage, USW, Good condition. Bargain at 2/8 ea., post 3/6. **Amplifier No. 165,** 2-stage Intercom amplifier, also 2-stage P.P. Modulator. Complete with 2 mike. output, A.F. coupling and modulation transformers. Only 3/-, post 3/-.

MORE BARGAINS

Mains Transformers. Ex-Govt. A.—10.0, 20.0, 22.0, 24.0v. Input, 310-230-0-230-310v. 60 ma., 6.3v. 2 a, 4v. 2.5 a Output. Inverted mtng. 15/- ea., post 2/6. B.—22.0, 24.0v. Input. Output tapped 32, 34, 36, 38v. at 2 a. Upright, 15/- ea., post 2/6. C.—25.0v. Input. 42.0-42.0v. 134 ma, 12v. 100 ma. Out. Potted. New, Boxed, 15/-, post 3/6.

A.F. Transformers. Ex-Govt. Microphone 100-1. Phones output, push-pull. Input (EF36 to P.P. EL32), all at 1/6 ea., post 9d.

Crystal Monitors Type 2. Has A.F. transf., choke, 1 p, 7 w, and on-off switches, lots of other parts. Less valves and crystals, 2/9 post 2/9.

Speakers, 2 1/2in. 5 ohm. P.M. in metal box. 15/- ea., post 1/6.

Metal Box with 16 Toggle Switches, 8/-, post 2/3.

Supply Units, No. 1 or 4 (for 19 Set), 20/- ea., carr. 6/6.

Money Back Guarantee. S.A.E. for Lists or Enquiries please. Sorry, No Export orders.

25, ASHFIELD PLACE, OTLEY, YORKS

WANTED

URGENTLY REQUIRED. new Radio, Television, or Industrial Valves. Also old and obsolete types. Cash prices offered for any quantity. Write, call or phone: MIT 6202, 201, Streatham Road, Mitcham, Surrey.

WANTED VALVES

All types for prompt cash. Must be new. State quantity.

WILLIAM CARVIS LTD.
103, North Street, Leeds, 7.

VALVES WANTED. ECL80, EY51, EY86, PL81, PCF80, and all Miniature Types. U25, 10C1, 10C2, 10F1, etc. 5Z4G, 6K8G, 6V6G. Brand new only. Prompt cash by return. R.H.S., 155, Swan Arcade, Bradford, 1.

ALL TYPES OF Valves wanted. PL81, ECL80, EY51, U25, PCF80, PZ30, U801, etc., etc., best cash price by return. **STAN WILLETTS,** 43, Spion Lane, West Bromwich, Staffs. (Tel.: WES 2392.)

CIRCUIT DIAGRAM of Western Electric Aircraft Receiver, type C.W. 46051A. Receiver Unit of RU16, wanted. **E. R. GEYER,** Blairhall Mains, Culross, Fife.

WANTED. Transreceiver TR1985, 1986 and 1987; Receivers B28, BC312; Green mark sub-assembly Units, 10P/2390, 10R/2391, 10D/2521; Power Supply Units, type 381; Rotary Transformers 10K/1957; Rotary Transformer type BD77. **R. GILFILLAN,** 7, High St., Worthing. (Tel. 8713.)

FOR SALE

TELEVISION TUBES
FACTORY reconditioned T.V. picture tubes. SIX months' guarantee.

	£	s.	d.
12in. MW31-74, CRM123, etc....	7	0	0
14in. MW36-24, AW36-21, etc....	7	15	0
17in. MW43-64, MW43-80, etc....	9	15	0
21in. MW53-20, MW53-80, etc....	13	10	0

CATHODE-RAY TUBE SERVICE
35, Broomwood Road, St. Paul's Cray
Orpington 21285

TAN IN 24 HOURS.—Super-tonic Sunray Lamps. Ultra-violet Infra-red combined; automatic exposure; controlled emission; all mains. Listed £7/10/-, our price, 80/-. S.A.E. illustrated brochure. Dept. 100, **SCIENTIFIC PRODUCTS,** Cleveleys, Lancs.

EVERYTHING FOR THE AMATEUR. Write for our new List catering for home engineers, Hi-Fi Fans, Tape Recording Fans, etc. Probably the most comprehensive in the trade. Price 1/-. **R.H.S.,** 155, Swan Arcade, Bradford, 1.

MAINS TRANSFORMERS

9/9 350-0-350 250 m.a. 6 v. heater at 5 amp. 4 v. at 5 amp. Isolated. Extra isolated winding for 2 or 4 v. tubes. Drop through type. Prim.: 200-250 v. Post & packing 3/9. 12/9 350-0-350 250 m.a. 6 v. at 5 amp. 6 v. at 5 amp. 4 v. at 4 amp. 22 v. at 5 amp. extra winding for 2 or 4 v. tubes. Pri.: 200-250 v. 50 cycles. Post & packing 3/9. 3/9 350-0-350 80 m.a. 2 heater windings 4 v. 5 amp. plus 4 v. 2.5 amp. Pri.: 200-250 v. Post & packing 2/9. **DUKE & CO.,** 621-3, Romford Road, MANOR PARK, E.12. IIF 6001-3.

NEW MAXI-Q switched F.M. Tuner, power pack, amplifier, 2 3in. speakers, in solid mahogany cabinet. Must sell, best offer accepted. Box No. 9.

MAINS RADIO IN YOUR CAR, complete unit, runs 200/250 AC/DC radio, television, tape recorders, etc., from 12v. battery, perfect, cost £25, 80/-, stamp full details. **SCIENTIFIC PRODUCTS,** Cleveleys, Lancs.

VALVE CARTONS by return at keen prices. Send 1/- for sample range and list. **J. & A. BOXMAKERS,** 75a, Godwin Street, Bradford, 1.

CABINETS

for EQUIPMENT
SPEAKERS
SUPPLIED

Write for
CATALOGUE.
A. L. STAMFORD
Dept. X28,
84 Weymouth Terrace,
London, E.2.



(Continued overleaf)

FOR SALE (Continued)

GUIDE TO HIGH FIDELITY SOUND. Send 4d. stamps for this illustrated catalogue of Hi-fi Chassis, Cabinets, etc. Gram bargains, Kits and "no interest" easy terms available. M. RICHARDS, Radio and T.V. Service, Carvoza Rd., Truro, Cornwall.

100 BAYS of brand new adjustable steel Shelving, 72in. high x 34in. wide x 12in. deep; stove enamelled, dark green; sent unassembled; 6-shelf Bay. £3/15/-; sample delivered free; quantity discounts. N. C. BROWN, LTD., Eagle Steelworks, Heywood, Lancs. (Tel.: 69018.)

"Cydon" & "Brayhead" Band III Tuners—still at Reduced Prices.

"Cydon" Tuners £7. 0.0
"Brayhead" £6.15.0

Please state model of receiver and channels required. All spares available for these tuners.

Co-axial Cable 5ft. yd. 100 yd. Coils. £1.18.0. Brand New Mazda C.R.M.171 17in. Tube. £18.10.0. Service Sheets, 8/- doz. mixed. Exact replacements for various Receivers, Transformers, Potentiometers, Mains Droppers, Metal Rectifiers, etc. All Post Paid. Mail Order Only.

RADIO SHOP

PLEASE NOTE: Next to Empire Cinema Buildings, Wakefield Road, Northampton, Yorks.

PROPERTIES

BERRYLANDS (Surbiton), adjoining station in a fully built-up area, parade of spacious shops with two floor upper parts just constructed. To be let or sold. Trades already reserved: Grocer and Provision Merchant, Greengrocer, Ladies' Outer- and Underwear, Shoe Repairer, Tobacconist and Confectioner, Dyers and Cleaners. Retail Builders' Merchant and Pet Shop. Full details: MESSRS. WHIDDINGTON, Chartered Surveyors, 133, High Street, Teddington. (KINGston 1216/7/8.)

B.B.C. - I.T.V. - F.M. - AERIALS

Band I (B.B.C.) Telescopic Loft, 19/6. External S/Dipole, 26/3. Band 3 (I.T.V.) 3 element loft array, 24/- 5 element, 32/6. External wall mounting 3 element, 33/9. 5 element, 41/3. Combined (B.B.C.-I.T.V.) Loft 1+3 element, 41/3. 1+5 element, 48/9. External wall mounting 1+3 element, 56/3. 1+5 element, 63/9. Room aerial, 12/9. Band 2 (F.M.) Loft "H" 28/- 3 element, 52/6. 4 element, 56/3. P.P. 2/6. Co-axial, 8d. yd. Co-axial plugs, 1/3. State channel when ordering. C.W.O. or C.O.D. S.A.E. for price list.

K.V.A. ELECTRONICS (Dept. 11) 189, Kent House Road, Beckenham, Kent. SYD. 2438.

Forrest

Transistor Transformers for Quality Equipment

H. W. FORREST (Transformers) Ltd. 349, Ha'sticks Green Road, Shirley Solihull, Warwicks. Tel.: Shirley 2483.

An ideal introduction to this fascinating and important new hobby . . .



RADIO-CONTROLLED MODELS by F. J. CAMM

Covers both radio and mechanical side of the equipment necessary and describes in detail practical examples. With 143 illustrations. CONTENTS Simple Steering Control Gear. A Single-valve Super-regenerative Receiver. A Two-Valve Transmitter. Control Box : Wave-meter : Interference : Layout. Second Channel Using the "Mark Space" System. A Proportional Steering Circuit and Reversible Sequence Engine Control Gear. Design Using a Glow-plug Engine and an Electric Motor in the Power Unit. A Six-valve Super-heterodyne Receiver. A Single-valve Crystal-controlled Transmitter. Control for Model Aircraft. Tuned Reeds and Audio Control. More About Model Actuators. Tuning Transmitting Aerials. A Bulb Model-control Frequency Meter. Auto-switch for Transmitters. A Radio-controlled Model Battleship. Building a Radio-controlled Model Aircraft.

12s. 6d. FROM ALL BOOKSELLERS or in case of difficulty 13s. 6d. from C. ARTHUR PEARSON LTD., Tower House, Southampton Street, London, W.C.2.

SPARKS' DATA SHEETS THE "SEAFARER"

Battery Two-valve offering New Interests and Thrills on Trawler, Ship-to-Shore, Aeronautical and 80/160 m. Amateur Bands Plus Normal Med. and Long-waves. A great little Set. Data Sheet, etc. etc. 3/8. All Components and Chassis available.

L. ORMOND SPARKS (P), VALLEY ROAD, CORFE CASTLE, DORSET

EDDY'S (Nottm.) LTD.

DEPT. P.W. 172, ALFRETON ROAD, NOTTINGHAM

SPECIAL BARGAIN

B.S.R. MONARCH 4-SPEED AUTO-MATIC CHANGER COMPLETE with high fidelity "turnover head." Type H.G.P. 37-1 capacity of 10 Records. Plays 12", 10" and 7" intermixed in any order. 70, 45, 33 and 16 r.p.m. For A.C. mains 100-250 volts. Exclusive MAG-DISK selector gives quickest and quietest change ever.

With full instructions. Brand New £6. 19. 6. Post & Packing 5/- extra.

MIDGET BATTERY ELIMINATORS to convert all types battery portables to mains operation. 57/6 each, 2/6 post, etc. Smaller than H.T. battery alone. (Please state make and model number.) New and Boxed.

ACOS CRYSTAL MIKES. List Price £2.10.0 our price 29/11, plus 3/- post & packing. Excellent for tape recorder, amplifiers, baby alarms, etc. Brand New and Boxed.

NEW METAL RECTIFIERS, FULLY GUARANTEED

Table with 4 columns: Model (RM1, RM2, RM3, RM4, RM5, W1, W2), Voltage (16/9, 7/3, 9/3, 19/6, 23/6, 3/6, 3/6), Current (WX3, WX4, WX6, 14A86, 14A97, 14A100, 14A124), and Price (3/6, 3/6, 3/6, 14A163, 14B130, 14RA1282, 14RA1283, 23/-).

ACOS CRYSTAL TURNOVER PICK-UPS. (2 Sapphire stylus), 29/11, post, etc., 2/6 extra. Brand New and Boxed.

25 x 25 mfd CONDENSERS. Midget. 1/3 each. Brand New.

ACOS MIKE INSERTS, 4/11 each. High quality. Can be used for tape recorders, baby alarms, musical instruments, etc. Post and packing 8d. extra. Brand New and Boxed.

THROAT MIKES, 1/-, post 6d. extra. Could be used for electrifying musical instruments.

SURPLUS NEW AND GUARANTEED VALVES

Table listing various vacuum tube valves (e.g., 1D5, 1R5, 1S5, 1T4, 5U4G, 5Y3G, 5Z4G, 5Z4M, 6AL5, 6AQ5, 6AT6, 6BR9, 6BA6, 6BJ9, 6F1, 6J5G, 6K7G, 6K8G, 6L3G, 6L8, 6Q7G, 6SN7GT, 6SK7GT, 6V6G, 6X4, 6X5CT, 7B7, 7C5, 7C6) with their respective specifications and prices.

Postage & packing 6d. per valve extra. Over £3 Free. S.A.E. with all enquiries.

Any parcel insured against damage in transit for only 6d. per order. All uninsured parcels at customers' risk.

YOU can build any of these at Low Cost!

A MINI TRANSISTOR RADIO

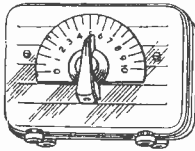

AN IDEAL PRESENT

A two-stage highly sensitive circuit uses a new super high gain transistor coil and mini tuning condenser. Gives remarkable performance. With step-by-step instructions. Beginners can't go wrong. Get your order in while prices are low. Send 2/- for wiring diagram and component price list.

37/6

Includes plastic case, ear-piece, batteries etc. All parts sold separately.

Ideal for:

- Late night listening.
- Children's nursery, etc.

TRANSISTOR POCKET RADIO



The ideal low cost transistor pocket radio for the beginner. The Two-Stage circuit utilises the new R.C.S. VARILOOPSTICK transistor coil. A specially designed miniature .0005 tuning condenser permits the receiver to be in a case which fits in the palm of your hand. Works for months off small battery costing 30/-

Can be built in 30 minutes. PRICE 30/-
All components are sold separately, full construction data, including plan to parts for 2/-.

WORLD WIDE SHORT-WAVE RADIO

EXPLORE THE WORLD ON SHORT WAVES!

Can be built for from our list of components which can all be purchased separately, covers 10-100 metres and is capable of receiving speech and music from all over the world. Price includes the famous 954 acorn valve and one coil covering 40-100 metres. Provision is made to increase to two or three valves and all components are colour coded. Send 2/- for point to point wiring diagram, layout and price list.

35/-

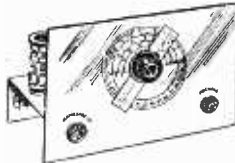

Post and packing : Under 10/- add 9d. : under 40/- add 1/6 : over POST FREE.

PERSONAL PORTABLE RADIO

THE SET FOR PERSONAL LISTENING

This little set was designed to give you a real personal portable radio that you can listen to anywhere without disturbing others. Use it on camping trips, in bed, in your office. Supplied with detachable rod aerial, it covers all the medium waves 200-500 metres. Average building time one hour. PRICE 35/-
Send 2/- for specification, point to point circuit and parts price list.

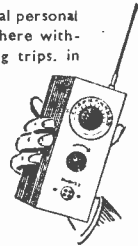

R.C.S. PRODUCTS (RADIO) LTD., 11, OLIVER ROAD, LONDON, E.17. (Mail Order only)

Visit the City's new acoustically designed

HI-FI Centre

COME AND HEAR THE LEADING MAKES IN AMPLIFIERS AND TUNERS

AMPLIFIERS BY		V.H.F. TUNERS BY		HI-FI SPEAKERS BY	
VERDIK	GOODSELL	ARMSTRONG	T.S.L.	GOODMANS	W.B.
ARMSTRONG	QUAD	LEAK	DULCI	PLESSEY	T.S.L.
ROGERS	LEAK	QUAD	GOODSELL	WHARFEDALE	G.E.C.
DULCI	W.B., etc.		ROGERS, etc.	LORENZ, etc.	

SPECIAL NEWS FOR ALL CONSTRUCTORS & RADIO HAMS !!!

In addition to the recent extension of our Hi-Fi Dept., We have now opened a new walk around Bargain Basement. Offering Exceptional Bargains galore of Manufacturers' and Govt. Surplus Components and Equipment, come and browse around.

IT WILL PAY YOU TO PAY US A VISIT

Electronics (FLEET ST) Ltd

Dept. E, 152/3, FLEET STREET, LONDON, E.C.4

Business Hours : Weekdays 9-6. Saturdays 9-1.

Tel. : FLEet 2833

PREMIER RADIO COMPANY

Tel.: AMBassador 4033

B. H. MORRIS & CO. (RADIO) LTD.

Tel.: MUS. 3451

207 EDGWARE RD., LONDON, W.2 & 23 TOTTENHAM COURT RD., LONDON, W.1



The "Petite"
PORTABLE

MAY BE BUILT FOR

£7.7.0

Plus p. & p. 3 -.

Batteries Extra. H.R. 10- (type B126) or equivalent, L.T. 1/6 (type AD35) or equivalent.

★ Size Only 8in. x 8in. x 4 1/2in.

★ Instruction Book 1 6.

PREMIER BATTERY ELIMINATOR, housed in two containers which are approx. the same size as AD35 and B126 Batteries. Kit 37,6 plus 2 - p. & p.

These two receivers use the latest type circuitry and are fitted into attractive cabinets 12in. x 6 1/2in. x 5 1/2in. in either walnut or ivory bakelite or wood (1 - extra). Individual instruction books 1/- each, post free.

2 BAND T. R. F
MAY BE BUILT FOR **£5.10.0**

Plus 3/- p. & p.

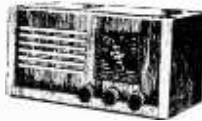

3 BAND SUPERHET
MAY BE BUILT FOR **£7.7.0**

Plus 3/- p. & p.



The "Petite"
PORTABLE & REPRODUCER

MAY BE BUILT FOR 13GNS plus 5/- p. p.

Batteries Extra. H.T., 10 - (Type B123 or equiv.); L.T. 4'U2's, 2/4.

45 r.p.m. Single Record Player ... (including P.T.) ... **£5.5.0**

"Petite" Components **£5.18.0**

Cabinet ... **£2.10.0**

★ Size 9 1/2in. x 9 1/2in. x 6 1/2in.

★ Weight, including Batteries, 7 lb.

★ 45 r.p.m. Single Record Player complete with pickup.

★ 6 volt Battery operated.

★ Incorporates Pick-up Head protection dome and automatic stylus cleaning brush.

Overall size 7 1/2in. x 6 1/2in. only.

★ Made by well-known British manufacturer.

★ Automatic Stop/Start.

★ Completely Battery operated

★ Attractive two-tone rexine covered case.

★ Construction simplicity itself.

★ Components available separately if required.

★ Instruction Book, 1/6.

ADDRESS ALL MAIL ORDER ENQUIRIES TO : (Dept. P.W.) 207 EDGWARE RD., LONDON, W.2

HOLE PUNCHES

ONE MINUTE TYPE

1/2 in. diameter	...	ca.	4/3
3/4 in. "	...	4/9	
1 in. "	...	5/6	

Postage and Packing 1/-.

SCREW-UP TYPE

1/2 in. diameter	B7G	...	6/6
3/4 in. "	B8A, B9A	...	7/-
1 in. "	7/6
1 1/16 in. "	8/-
1 1/4 in. "	Int. Octal	...	8/9
1 1/2 in. "	10/-
1 3/4 in. "	11/3
1 7/8 in. "	B9G	...	12/6
2 3/32 in. "	Meter	...	18/-

Postage and Packing 1/9.

Special Chassis made to order. Standard Chassis ex stock.

Oliver & Randall
LIMITED

40 Perry Hill, London
S.E.6

FORest Hill 8424

RADIO AND TELEVISION COMPONENTS

We operate a prompt and efficient MAIL-ORDER Service. 3d. stamp (only) for Catalogue.

JAMES H. MARTIN & CO.
FINSTHWAITE, NEWBY BRIDGE,
ULVERSTON, LANCs.

BUILD YOUR OWN TRANSISTOR RECEIVER

Using our Experimental Transistor Kit you can build a sensitive dual wave receiver for as little as 15/-.

By the addition of a few more components greater range and power is obtainable, and a full sized loudspeaker can be worked.

The receiver is supplied in Kit form, together with clear, illustrated instructions, and can be assembled in 30 minutes.

EXPERIMENTAL KIT

Price 15/- Post and Packing 1/- extra or send sixpence in stamps for illustrated plans and circuits of this and other receivers.

CENTRAL RADIO SALES

CENTRAL CHAMBERS
SMALL ST., BRISTOL 1

This offer applies only to Gt. Britain and Northern Ireland.

CABINETS & HI-FI EQUIPMENT

We can supply any Cabinet to your own specification.

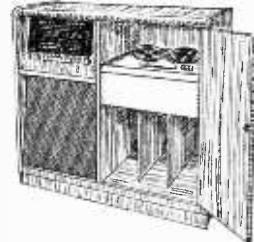

"The Serenade" £12.19.6

Veneered with finest selected walnut, beautifully polished to a medium shade: this attractive cabinet has generous storage space, with motor board sliding out smoothly on metal rollers.

We can also supply and fit this or any of our large range of cabinets with the latest Hi-Fi amplifiers, tuners, Transcription units, record changers, speakers, etc.

Send for the NEW fully illustrated equipment catalogue and our booklet showing full range of cabinets, etc., all available on easy terms.

LEWIS RADIO

120 (PW98) Green Lanes, Palmers Green
London, N.13. BOWes Park 1155/6
(Nr. The Cock Tavern)

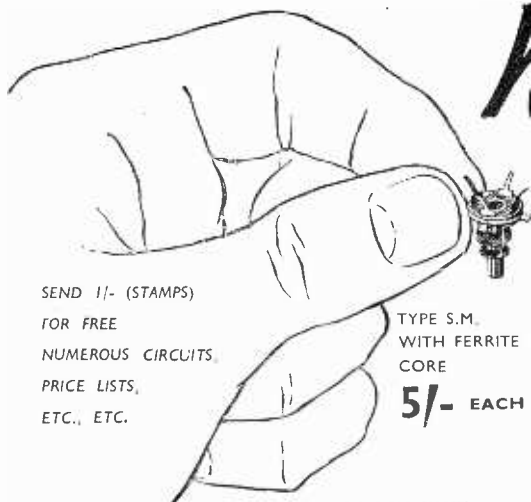

SEND 1/- (STAMPS)
FOR FREE
NUMEROUS CIRCUITS
PRICE LISTS,
ETC., ETC.

TYPE S.M.
WITH FERRITE
CORE

5/- EACH

New

SUB-MINIATURE
HIGH Q COIL
RANGE

"That's what I call
stupendous performance"

for SUPERHET—T.R.F.—
TRANSISTOR CIRCUITS

OSMOR

Dept. P.W. 26, 418, BRIGHTON ROAD, SOUTH CROYDON,
SURREY : Telephone : CROYdon 5148/9

Southern Radio's Wireless Bargains

TRANSRECEIVERS. Type "38" (Walkie-Talkie) complete with 5 valves, etc. New condition, untested by us, but serviceable, no guarantee. 22/6 each.
ATTACHMENTS for Type "38" Transreceivers. ALL BRAND NEW. PHONES, 15/6; THROAT MICROPHONES, 4/6; JUNCTION BOXES, 2/6; AERIALS, No. 1, 2/6, No. 2, 5/-; WEBBING, 4/-; HAVERSACKS, 5/-; VALVES, A.R.P.12, 4/6; A.T.P.4, 3/6. Set of FIVE VALVES, 19/- the set.
TRANSRECEIVERS. Type "18" Mark-III. Two Units (Receiver and Sender). Six Valves, Microammeter, etc. Metal Case. Un- tested. No guarantee, but COMPLETE..... £2 18s. 6d.
ATTACHMENTS for "18" Transreceivers. ALL BRAND NEW. HEADPHONES, 15/6; HAND MICROPHONE, 12/6; AERIALS, 5/-; SET OF 6 VALVES, 30/-.
RECEIVERS R.109. S.W. Receiver in Case, 8 valves. Speaker and 6-volt Vibrator Pack. Untested. No guarantee, but COM- PLETE..... £2 18s. 6d.
RESISTANCES. 100 Assorted useful values. New wire end. 12/6
CONDENSERS. 100 Assorted. Mica, Tubular, etc..... 15/-
BOMBSIGHT COMPUTERS. Ex-R.A.F. NEW. Hundreds of Components. Gears, etc. Ideal for Experimenters..... 43
LUBRIFA HOLE CUTTERS. Adjustable 1" to 3 1/2". For Metal, Plastic, etc..... 7/-
QUARTZ CRYSTALS. Types F.T.241 and F.T.243, 2-pin, 1/2" Spacing. Frequencies between 5,675 Kc/s, and 8,650 Kc/s. (F.T.243) 20 Mc/s. and 38.8 Mc/s. (F.T.241, 54th Harmonic), 4/- each. ALL BRAND NEW. TWELVE ASSORTED CRYSTALS, 45/- Holders for both types. 1/- each. Customers ordering 12 crystals can be supplied with lists of frequencies available for their choice.
MORSE TAPPERS. Std., 3/6; Extra Heavy on Base, 5/6.
TRANSPARENT MAP CASES, Plastic, 14" x 10 1/2". Ideal for Maps, Display, etc..... 5/6
DINGHY AERIALS. Ex-U.S.A. Reflector Type..... 4/6
STAR IDENTIFIERS. Type I A-N Covers both Hemispheres. 5/6
CONTACTOR TIME SWITCHES. 2 Impulses per sec., in case 11/6
POST OR CARRIAGE EXTRA, FULL LIST RADIO BOOKS, ETC., 3d.

SOUTHERN RADIO SUPPLY LTD.
11, LITTLE NEWPORT STREET, LONDON, W.C.2.
GERrard 6653

THE FAMOUS BENNETT COLLEGE
can train your mind to SUCCESS

THROUGH
PERSONAL POSTAL TUITION
A FREE book vital to your career!

Read how the famous Bennett College can help you to success! Send now for this recently published FREE book, "Train your mind to SUCCESS", which tells you about The Bennett College proven success in postal tuition... and how it can help you to success in your career



WHAT CAREER DO YOU WANT?

- Building
- Carpentry
- Commercial Art
- Diesel Engines
- Draughtsmanship
- Electrical Eng.
- Fine Engineering
- Mechanical Eng.
- Quantity Surveying
- Radio Engineering
- Surveying
- Telecomm tions
- Wireless
- Telegraphy and Telephony
- Acc'tnancy Exams
- Book-keeping
- Civil Service
- General Education
- Journalism
- Mathematics
- Salesmanship
- Secretarial Exams and many others
- GEN. CERT. OF EDUCATION

To The Bennett College (Dept. 1104N), Sheffield
Please send me, without obligation, a free copy of "Train your mind to SUCCESS" and the College Prospectus on:

SUBJECT _____
NAME _____ AGE _____
(if under 21)
ADDRESS _____ BLOCK LETTERS PLEASE

THIS COUPON
COULD BE YOUR
PERSONAL PASSPORT
TO SUCCESS.
Send it NOW!

Tel. : Mitcham 6201
Open Daily to Callers

RST

All Valves Brand New
and Fully Guaranteed

211, STREATHAM ROAD, MITCHAM, SURREY

SPECIAL 24 HOUR EXPRESS MAIL ORDER SERVICE

621	5/6	6C106G	27/-	7G5	8/6	128Q7	10/6	611T	15/-	D42	9/6	ECU34	14/6	EM81	11/-	KT36	23/6	PCU83	12/6	TH11	23/6	UC181	11/6
127	21/-	6D2	5/6	7D5	21/-	128N7	15/6	618PT	15/-	D83	6/6	ECU35	8/6	EY86	15/-	KT41	12/6	PENXA4	11/6	TP22	12/6	UC182	13/6
105	15/6	6H96	7/6	714	21/-	12Z3	15/6	92BU	27/-	D77	5/6	ECU40	17/6	EZ35	9/6	KT53	18/6	PENYA	11/6	TP23	23/6	UC183	16/6
106	10/6	6B3GT	10/-	718	21/-	14H7	7/6	75	17/-	D132	5/6	ECU81	8/6	EZ40	9/6	KT61	18/6		11/6	TP25	23/6	UF41	9/-
143	10/6	6F1	19/6	717	8/6	77	7/6	DA332	9/6	ECU92	9/6	EZ41	10/6	KT65	10/6	PENY5	8/6	U16	11/6	UF42	17/-	UF80	10/-
125	9/6	6F5	10/6	7K7	17/6	1487	14/6	78	10/6	DAF91	8/6	ECU84	10/-	EZ81	8/6	KT73	19/6	PL38	23/6	U24	27/6	UF85	10/-
117	8/6	6F12	8/6	787	12/6	19A03	9/-	89	9/6	DAF96	9/6	ECU85	10/6	EZ90	7/6	KTW61	9/6	PL81	16/6	U26	27/6	UF89	10/-
185	8/6	6F13	18/6	7Y4	7/6	19B6GG	21/-	85A2	15/-	DEB33	9/6	ECU85	10/6	EZ90	7/6	KTW62	9/6	PL82	9/6	U27	27/6	UF91	9/6
174	8/-	6F14	15/-	814	8/6	19C101	14/6	185BT	30/-	DF91	8/6	ECU91	7/6	FC2	14/6	KTW63	9/6	PL83	11/6	U28	23/6	UF146	21/-
115	10/6	6F15	15/6	91W6	13/6	30D2	23/6	304	8/6	DF93	8/6	ECU92	12/6	FC13	14/6	KTZ41	9/6	PL82	21/-	U29	23/6	UF147	9/-
129	12/6	6H6	3/-	10CL	13/-	20P2	23/6	304	8/6	DF93	8/6	ECU92	12/6	FC13	14/6	KTZ41	9/6	PL82	21/-	U30	8/6	UF148	18/6
301	10/6	6J3GT	6/6	10C2	23/6	20L1	23/6	305	8/6	DF93	8/6	ECU92	12/6	FC13	14/6	KTZ41	9/6	PL82	21/-	U31	23/6	UF149	15/-
307	9/6	6J6	7/6	10P1	23/6	20P3	21/-	322	9/6	DF93	8/6	ECU92	12/6	FC13	14/6	KTZ41	9/6	PL82	21/-	U32	23/6	UF150	18/6
384	8/-	6J7GT	10/-	10F3	21/-	20P4	23/6	329	9/6	DF93	8/6	ECU92	12/6	FC13	14/6	KTZ41	9/6	PL82	21/-	U33	23/6	UF151	18/6
3V4	8/6	6K7GT	10/-	10F9	19/6	20P5	21/-	AC2/PEN	DIH77	7/6	ECU91	9/6											
5H40	8/6	6K8GT	12/6	10P11	17/6	25A04	13/6		DIH107	10/6	ECU89	12/6	GZ32	11/6	MI1	8/6	PM202	15/6	U133	9/6	UY41	7/6	
5V40	8/6	6K5	18/6	10P12	17/6	25A04	13/6		DIH107	10/6	ECU89	12/6	GZ32	11/6	MI1	8/6	PM202	15/6	U133	9/6	UY41	7/6	
5V30G	8/6	6L1	15/-	10P14	19/6	25Y5	10/6	DIJ	23/6	DK91	8/6	E99	21/6	HE3	10/6	MI14	18/6	PM32	18/6	U191	18/6	UY85	8/6
5Z10	10/-	6L5	7/6	11D3	23/-	25Z4	9/-	AC1/PEN	DK92	11/6	EP37A	10/6	HL92	11/6	PM211	14/6	U52	8/6	UT7	16/6			
8A7	14/6	6L14	12/4	11D5	23/-	25Z5	10/-	15/-	DK95	9/6	EP39	7/6	HL133DD	21/-	PM82	8/6	U292	20/-	V148	15/-			
6A8	10/-	6L13	12/4	12A6	8/6	25Z6	9/6	AC5/PEN	DL33	9/6	EP40	15/-	11/6	MAP4	21/-	PM83	8/6	U301	21/-	W76	8/6		
6K47	6/6	6M22	13/-	12A7B	10/6	30C1	12/6	DI1	15/-	DL35	13/6	EP41	10/6	1W4/350	10/-	PM84	10/6	U329	21/-	W77	9/6		
6AL5	8/6	6J12D9	15/6	12A7B	8/6	30C5	12/6	AC1/PEN	DI12	8/6	EP42	12/6	1W4/350	10/-	N14	11/6	R10	22/-	U340	10/6	WN1M	12/6	
6AM5	8/6	6N7GT	8/-	12A77	8/6	30F1L	12/6	15/-	DI14	8/6	EP50(A)	4/6	1W4/350	10/-	N19	8/6	R19	19/-	U361	27/6	W142	8/6	
6AN5	5/6	6P1	16/-	12A77	9/6	30L1	11/-	AC1/PEN	DI16	8/6	EP59	8/6	10/6	N17	13/6	SD6	12/6	VABCS07	1W19	8/6			
6A95	7/6	6P25	18/6	12A77	9/6	30P4	21/-	AC1/PEN	DI16	8/6	EP59	8/6	7/6	KBC32	10/6	N108	18/6	SD4	15/6	10/6	X18	11/6	
6AT6	7/6	6P28	23/6	13BA8	8/6	30P12	12/6	AC1/PEN	BARCS9	9/6	EP86	15/-	KF35	10/6	N142	9/6	SD41	3/6	UAF42	10/6	X65	15/-	
6AU6	15/6	6Q7GT	19/6	12B25	9/6	30P15	10/-	17/6	PAM31	10/6	EP89	15/-	KL32	10/6	N153	11/6	SD42	12/6	UB41	12/6	X78	19/-	
6B8	4/6	6S7A7G	8/6	12B56T	7/-	35LAGT	10/-	AC1/PEN	BAF42	10/-	EP91	8/6	KL32	14/6	N159	10/6	SD61	3/6	UBC41	8/6	X79	19/6	
61A5	8/6	6S67	9/-	12J7GT	10/-	35W4	8/6	AC1/PEN	BB11	5/6	EP92	9/6	KL35	10/6	PCU84	9/6	T11	21/6	UBP90	9/6	Z86	22/6	
6B6	8/6	6S87	8/6	12K7GT		35Z3	19/-	AC1/PEN	EB91	5/6	EL32	5/6	KT2	7/6	PCF80	12/6	T1D4	18/6	UBP89	10/6	Z77	8/6	
6B6GT	21/-	6J7	8/6		10/3	35Z1	8/6	AZ1	15/6	EB93	7/6	EL33	18/3	KT32	9/6	PCF82	12/6	T1D13C	UCU85	10/6	Z152	8/6	
61B6	7/6	6S87	9/6	12K9GT		35Z5	10/6	AZ1	10/6	EB94	8/6	EL37	21/-	KT33C	12/6	PLC32	19/6		UCH42	10/6	Z119	8/6	
6BR7	13/-	6S12GT	8/6		12/3	408A	12/6	BZ3	15/6	EB96	9/6	EL38	23/6										
6BW6	8/6	6S87GT	8/6	12L7GT	8/6	418T	23/6	BZ5	8/6	EBF49	8/6	EL41	10/-										
6BW7	8/-	6U4GT	11/6	12L8A7	8/6	42	13/6	C1C	12/6	EBL1	25/-	EL42	10/-										
6BY6	8/6	6V6GT	7/6	12M7	8/6	42	14/6	CEB35	21/-	EBL21	21/-	EL41	17/6										
6C1	7/6	6X4	7/6	12MGT	8/6	50C3	10/6	CEB35	18/6	EBL71	21/-	EL41	9/6										
6C5GT	7/6	6V3GT	8/6	12MGT	8/6	50C12	10/6	CY1	15/6	EB30	12/6	EL30	8/6										
6C7	7/6	7B7	8/6	12M7	8/6	3	27/6	CY4	15/6	ECU4	8/6	EL31	8/6										
6C9	14/-	7C5	8/6	12M7	8/6	31	27/6	CY4	15/6	ECU4	8/6	EL31	8/6										

METAL RECTIFIERS NEW AND GUARANTEED

R1L 7/6	18A 1-1-8-1, 4/6	16R22-1-8-1, 8/6
R2C 8/6	18A 1-1-16-1, 6/6	18A 1-2-8-1, 11/6
R3 10/6	18R 1-1-1-1, 9/2	14A3, 18/6
R4 21/-	18A 1-8-2, 19/8	14A7, 23/3
R5 25/-	18A 1-2-8-3, 24/-	14A10, 23/-

TERMS OF BUSINESS C.W.O. or C.O.D.
2/9 PACKING CHARGE ON ALL C.O.D.
ORDERS. POSTAGE 3d. PER VALVE.

OBsolete Valves A SPECIALTY
QUOTATIONS GIVEN ON ANY TYPE
NOT LISTED.

R.L.D. CONSTRUCTION KITS

Introducing a new range of construction kits for the home constructor. All kits are absolutely complete and are supplied with the fullest possible instructions.

R.L.D. KIT No. 1. CRYSTAL SET. A modern crystal circuit built into a small plastic cabinet. KIT 18/- post free, less headphones.

R.L.D. KIT No. 2. TRANSISTOR AMPLIFIER FOR CRYSTAL SETS. A simple transistor amplifier which can be added to any crystal set. The addition of this amplifier will increase the volume in the headphones several times. No soldering instructions. KIT 27/6d. post free.

R.L.D. KIT No. 3. TRANSISTORISED CRYSTAL SET An up-to-date crystal circuit followed by a transistor amplifier built into a small plastic case. KIT 43/6d. post free. Less headphones.

HEADPHONES. Brand new (not ex-Govt.) light-weight high resistance headphones at 16/6d. per pair, plus 1/- post. Instruction sheets for any kit 6d. plus 3d. post.

WATTS RADIO (Mail Order) LTD.
54, Church Street, Weybridge, Surrey
Note: Closed for Annual Holidays, 9th to 23rd AUGUST

A Comprehensive Introduction!

FREQUENCY-MODULATED RADIO

by K. R. Sturley, Ph.D., M.I.E.E.
Head of B.B.C. Engineering Training Dept.

THIS book provides a comprehensive introduction to the theory, design, construction and servicing of F.M. receivers for the reception of the B.B.C. V.H.F. Service. Deals with various stages of the F.M. receiver, aerials, test equipment, etc., and will provide valuable information for the radio technician, the serious enthusiast as well as background details for service engineers. The main emphasis is on reception, but information is also given on transmission. 109 illustrations and 15s. FROM ALL BOOKSELLERS

In case of difficulty 16s. from GEORGE NEWNES LTD., Tower House, Southampton Street, London, W.C.2.

AC/DC Multimeter 48/-

Now with improved switches. Ranges: 3, 15, 60, 150, 600 v. DC; 15, 60, 150, 600 v. AC; all at 1,800 o.p.v.; 6, 60, 600 mA DC; Ohms up to 2M. Kit comprises: 500 μ A meter scaled 0-15 and 0-800, 1", shunts and High Stab. multipliers, pot., switches, GEC meter mov., circuit, instructions. No adjustments to make. 48/-, post free.

Meters 2in. Flush, moving coil, 500 μ A, scaled 0-500, brand new, 17/6, p. & p. 1/6. Suitable 40 range multimeter circuit, 9d. This circuit fairly crackles with ingenuity, is economical (about 13s. per range) all standard parts used, suits any 500 μ A meter, and introduces "Offset zero".

2.5 mA 2in. meter with 25, 250 mA shunts, 15/-.

Wirewound 1 Meg. 1% non-inductive, 2/6, p. & p. 6d.

METER RECTIFIERS. Brand new G.E.C. (Salford) Bridge 500 μ A or 1 mA., 6/6; 5 mA., 6/6. New Ex-Govt. Bridge 1.5 mA., 4/6, post 6d. on all rectifiers.

PLANT INSTRUMENT CO.,
25, Dominion Ave., Leeds, 7.

TELEVISION

The advance of Radio Technique will offer unlimited opportunities of high pay and secure posts for those Radio Engineers who have had the foresight to become technically qualified. How you can do this quickly and easily in your spare time is fully explained in our unique handbook.

Full details are given of A.M.B.R.I.A.E. (City & Guilds Exams., and particulars of up-to-date courses in Wireless Engineering, Radio Servicing, Short Waves, Television, Mathematics, etc., etc. We guarantee "NO PASS-NO FEE". Prepare for to-morrow's opportunities and future competition by sending for this very informative 144-page guide NOW-FREE and without obligation.

BRITISH INSTITUTE OF ENGINEERING TECHNOLOGY
(Dept. 24) COLLEGE HOUSE,
29-31, Wright's Lane, Kensington, W.8

ROTARY SWITCHES

Superior Wafer Switch by Renowned Manufacturer. Individually Boxed. Large purchase enables us to offer these Splendid Type Switches at fraction of cost.

Single Pole. 0 Position. 2 - each 18/- dozen.
3 Pole. 3 Pos. (2 Bank). 2/6 each. 22/- dozen
3 Pole. 3 Pos. (3 Bank). 3/- each. 30/- dozen.

SPECIAL OFFER:
1 of each type (12 Switches). 25/- Postage and Packing 1/3 each (or) 2/- dozen.

H.A.C. PRODUCTS (Switch Dept.)
11, Old Bond St., London, W.1.

I.F. STRIPS . . . POWER PACKS

SOUND & VISION, 1.P.s. 10.6. Famous manufacture valves (B7C). H.P. Amplifier. Frequency changer (1.F. - 1.F.8) = DIFT(8) = 1P(V) - DFT(V) and Video Amplifier. Less valves. Post 2/6.
SOUND & VISION (Hi-Fi), 25.6. Valve time up to 400 ft. 2-112L. Supply from P. Pack 290 v. H.T. 6.3 v. heaters. Less valves. Post 2/6. Torrot Tuner easily fitted.
TIME BASE, 4.9. Including can coils (35 mm. will stretch to 39 mm.). Focus magnet. Line O.P.P. Trans. and extras. Less valves. Post 1/6.
POWER PACK & AMP, 19.6. A MUST in every workshop. The basis of nearly every experiment or electronic instrument you make. Smoothed H.T. 295 volt. 250 m.a. L.T.s. 4 v., 6.3 v. and 4 v. (centre tapped). Also output stage (Pentode) with O.P.P. Trans. Less valves. Carr. 3/6.

TRANSFORMERS. Money Back Guarantee
MAINS POWER TRANS., 15.9. 225-0-225 v. 250 m.a. 4 v., 5 amp. 6.3 v., 5 amp. 4 v., 5 amp. (Centre tapped.) Post 3/6.
MAINS POWER TRANS., 9.9. 350-0-350 v. 250 m.a. 2.5 v., 3 amp. 5.3 v., 4 amp. 6.3 v., 4 amp. 4 v., 2.5 amp. 4 v., centre tapped at 3.8 amp. Post 3/6.
MAINS TRANS., 5.9. 280-0-280 v. 80 m.a. 6 v., 2 amp. 4 v., 2 amp. 4 v., 2 amp. Drop through. Post 3/6.
MAINS TRANS., 3.9. 350-0-350 v. 80 m.a. 4 v., 5 amp. 4 v., 2.5 amp. Post 2/9.

O.P. TRANS., 1.3. Salvage guaranteed. 2.5 ohms. Standard size. Post 1/-, 20 for £1. Post 3/6.
8in. P.M. SPEAKERS, 5.9. Limited quantity of these modern type speakers. They are all tested and 'Money Back Guaranteed.' They have a slight cone fault, that is repaired, not affecting the quality. Post on 1-2.6. 2-3/6.
COIL PACKS, 8.9. BARGAIN OFFER of pair of 465 1.P.s. 3 v. band coil pack. 2 gang condenser. Printed dial. Post 2/3.
GANGED CONDENSERS, 1.9. 2 gang & 3 gang. Salvage-guaranteed. .0005. Post 1/3.
T.V. AERIAL, 25.6. Vertical or Horizontal. For all I.T.A. Channels. Outdoor or loft. 3 element. Post 2/6.
CARE AERIAL, 6.9. Whip antenna, plated, 30in. long. Collapsing to 11in. 1-hole fixing. Post 1/-.
RECTIFIER, 2.9. 250 v. 100 m.a. Full or half-wave. Salvage-guaranteed. Post 1/3.
INSULATING TAPE, 1.6. 75ft. x 1/2in. wide. The electrician's friend. Post 9d.
SOLDER REELS, 1.6. 60-40. 3-core Erwin. 200. on plastic spool. Post 6d.
CO-AX CABLE, 6d. yard. Good quality. Cut to your required length. Post on 20yd. 1/6. 50-yd. 10yd. Post 3/6.
CHASSIS, 1.-each. 6 or 8 valve. Latest type midjet valve design, for AM or FM. NEW. Cadmium plated on steel. 12 x 7 1/2 x 2 1/2in. Post 1/9. 1 for 4.-. Post 3.-. 12 for 10.-. Carr. 5.-.
VOLUME CONTROLS, 2.6 doz. Assorted barrel of volume & tone controls. removed from working sets. Post 1/9.
VALVE SCREENING CANS, 1.- doz. Latest midjet. Aluminium 2 1/2 x 1 1/2 in. dia. Post 6d.
CINE RECORDING FILM, 6d. roll. Fast unexposed 16 mm. Perforations 1 side only. EBC-Ilford 54(91). Outdated, but reports good. 6d., 25ft. spool. Unopened tins of 12 rolls 6.-. Post on 1 roll 6d.
TRANSMITTER NO. 50, 6.9. EX-W.D. V.H.F. with coils, tuning condensers. Contain a wealth of parts for the amateur. Less valves (6). Drawing FREE. Post 1/9.
NICKEL-CHROME WIRE, 1.-. .014in. dia., on 50-yard spools. .002 dia. on 25-yard spools. Packed in ready-use tins, with run-out mechanism, special dulled finish. Rustproof. Ideal for gardeners and outdoor use. Post 9d. 25 for £1. post 2/6.
SPRING STEEL WIRE, 6d. .014 dia., on 50-yard wood spools. Post 9d. 25 for 10.-. post 2/6.

CHOKES
 250 m.a. 4.9. Salvage-guaranteed. P. & P. 2/6. 10 for 30.-. P. & P. 7/6.
 80 m.a. 2.9. Salvage-guaranteed. P. & P. 2/6. 10 for 20.-. P. & P. 7/6.
 60 m.a. 1.9. Salvage-guaranteed. P. & P. 2.-. 10 for 10.-. P. & P. 6/6.
TORCH LANTERNS, 6d. each. Ex-W.D. Including 2 bulbs. Uses 800 type. Post 1/6. 5 - doz., post 3.-. (Rate of 48. 22 - carr. 10.-.)
PIANO HINGES, 1.6 pair. Chrome. New. Tin. long. Post 6d.

Send 3d. stamp for FREE catalogue.

P. P. COMPONENTS LTD.
 219 ILFORD LANE, ILFORD, ESSEX. Phone: ILF 0295

owing to overwhelming response to our last advert, in this magazine your delay was unavoidable. Many items rapidly sold out, causing disappointment to those who ordered further supplies. P.P.C. regrets to any disappointed customers.

from one source

Denco, Repanco, J.B., T.C.C., Woden, Elac. McMurdo, Radiospares, Eddystone, Elstone. Bulgin, Belling & Lee, Hunts, Sorad. Acos. Brown, Mullard, Igranic, Cossor, Taylor, Avo, Henley, E.M.I., etc.

Orders dealt with day received

56 page illustrated catalogue No. 11, with 108 photographic illustrations, and over 2,000 new guaranteed lines by leading makers. 9d. post free.

ANNUAL HOLIDAYS

Please note we shall be closed August 18th-23rd, inclusive.

SOUTHERN RADIO and ELECTRICAL SUPPLIES

SORAD WORKS, REDLYNCH SALISBURY, WILTS

Genuine British Transistors
WHITE SPOT 13s. 6d.
RED SPOT 7s. 6d.

Green-Yellow. 10.-. Red-Yellow. 21.-. Also, Mullard & Mazda Types. Crystal Diodes, 1/3.
 The New "Mini-Seven" Circuit. 1.6.
 "Transeven" Portable Circuit. 1.6. (Kit now ONLY £10.12.6.)
 3-Transistor Radio Circuit. 11d.
FLY-BY-WIRE TUNERS - GUARANTEED
 16 mfd. 450 v. 150 mA. 1 1/2 x 1 1/2 2/4 each.
 8-8 mfd. 450 v. 100 mA. 1 1/2 x 1 1/2 2/9.
 8-16 mfd. 450 v. 100 mA. 1 1/2 x 1 1/2 2/9.
 50 mfd. 50 v. 1.6. 25 mfd. 25 v. 1.8.
RESISTORS: All Values 10%, 1 watt. 6d. each.

ALL PRICES ARE POST PAID.
 TERMS: C.W.O. or C.O.D. over £2.
 FULL COMPONENT LIST. 6d.
OAKFIELD RADIO
 44 OAKFIELD ROAD, STOCKPORT



The "TYANA"
Standard Soldering Iron

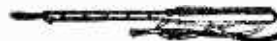

- Adjustable Bit.
- Weight approx. 4 oz.
- Heating Time 3 min.
- 40 Watt economy Consumption.
- Standard Voltage Ranges. 16/9.

Replacement Elements and Bits always available.

"DIPLOMA" HEADPHONES



Ideal for CRYSTAL SETS and also for use with TAPE RECORDERS

KENROY LIMITED
 152/297 UPPER ST., ISLINGTON, LONDON, N.I.

Telephone: Canonbury 4905-4663



AT LAST!

A REAL I.T.V. CONVERSION SERVICE

WE OFFER A COMPLETE AFTER-SALES SERVICE WITH ALL I.T.V. EQUIPMENT SOLD BY US.

Your problems settled by return Mail. Whether novice or expert, let our extensive I.T.V. experience ensure your success.

PRE-AMPS

I.T.V. SIGNAL BOOSTER AT 37/6 COMPLETE

- **SMALL.** Fits neatly in cabinet corner.
 - **EFFICIENT.** Simple but clever circuitry giving pentode gain and triode noise level.
 - **EASIFIX.** One-hole fixing to cabinet fillet. Plug-in feeder steals power from main T.V.
- STATE CHANNELS, SET MAKE AND MODEL WITH ORDER.
 Standard pattern suits most T.V.s using EF80 valves.

CONVERTERS

THE FAMOUS BRAYHEAD TURRET TUNER AT £6.19.6 COMPLETE.

● **EASIFIX.** Over 600 models converted by simple plug-in technique.

● **SPECIAL OFFER.** We can supply a modified version of our standard I.T.V. booster as an add-on fitment, thus improving I.T.V. performance.

Special at 25/- extra.

STATE CHANNELS, SET-MAKE AND MODEL WITH ORDER.

AERIALS

OUR 5-ELEMENT ADD-ON I.T.V. AERIAL 39/6 COMPLETE

with Universal Clamp and Stand-off Arm.

● **Diplexers and Low-Loss Cable** to order. State your needs or **ASK OUR ADVICE** with order.

WILSON

48, CATHAY, BRISTOL, 1

Mail Order only. Terms: C.W.O. Postage 1/6, above £2 free except aeriels 2/6.

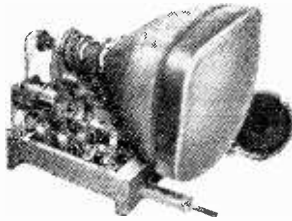

17in. T.V. CHASSIS, TUBE & SPEAKER, £19.19.6.

17in. Rectangular Tube on modified chassis. Supplied as single chassis covering B.B.C. channels 1-5, or incorporating Turret Tuner which can be added as an extra at our special price to chassis purchases, 50/-, giving choice of any 2 channels (B.B.C. & I.T.A.). Extra channels can be supplied at 7/6 each. I.F.'s 10.5-14 in cs. Chassis size: 12in. x 14 1/2in. x 11in. Valve line-up: 6SN7G, 6P25, EY51, 2-6D2's, EL38, EL41 and 6-EP1's. Similar chassis were used by well-known Rental and Hire Companies because of their stability and reliability.

With tube and speaker, £19.19.6. With all valves, £25.19.6. Complete and working with Turret Tuner, £28.9.6, 12 months' guarantee on the tube, 3 months' guarantee on the valves and chassis. Ins., Carr. (incl. Tube), 25/-.

14in. T.V. CHASSIS, TUBE & SPEAKER, £13.19.6.

As above with 14in. Round Tube. Chassis, valves and tube guaranteed for 3 months. With Tube and Speaker, £13.19.6. With all valves, £19.19.6. Complete and working with Turret Tuner, £22.9.6. Ins., Carr. (incl. Tube), 25/-.

HOME RADIO, 79/6

5 valve (octal) superhet. 3 wave band receiver. Can be adapted for your gram. P.C. at a little extra cost. A.C. Size: 9 1/2in. x 20 1/2in. x 11 1/2in. Two A.C.D.C. sizes: 9 1/2in. x 18 1/2in. x 11 1/2in.—9 1/2in. x 20 1/2in. x 12in. Wooden cabinets. Ins., Carr., 4/6. Please state mains and size required when ordering.



COMPLETE T.V. CHASSIS, 49/6

Made by famous manufacturer, R.F. E.H.T. unit included. Drawing 2/6, or FREE with order. Chassis in 3 separate units. (Power, S Video, Timebase inter-connected.) These chassis can easily be fitted into existing console cabinets, 1, 2, 3, 4, 5, 6, 7, 8, 9, 10, 11, 12, 13, 14, 15, 16, 17, 18, 19, 20, 21, 22, 23, 24, 25, 26, 27, 28, 29, 30, 31, 32, 33, 34, 35, 36, 37, 38, 39, 40, 41, 42, 43, 44, 45, 46, 47, 48, 49, 50, 51, 52, 53, 54, 55, 56, 57, 58, 59, 60, 61, 62, 63, 64, 65, 66, 67, 68, 69, 70, 71, 72, 73, 74, 75, 76, 77, 78, 79, 80, 81, 82, 83, 84, 85, 86, 87, 88, 89, 90, 91, 92, 93, 94, 95, 96, 97, 98, 99, 100. Channel 1-2-3-5 easily converted to I.T.A. Ins., Carr., 10/6.

Send for FREE Catalogue.
Liverpool St. to Manor Park—10 minutes.
OPEN SATURDAY ALL DAY.

RECTANGULAR T.V. TUBES

17in. £7.10.0.
12 MONTHS' GUARANTEE
14in. £5.10.0.

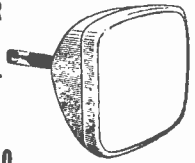

6 months full replacement, 6 months progressive. Made possible by the high quality of our tubes. Ins., Carr., 15/6. 9in., 10in., 14in., 15in. and 16in. round tubes—Our special offer of these sizes, £5. 12in. T.V. TUBES, £6. Three months' guarantee on round tubes. Ins., Carr., 15/6.

BEAUTIFUL EXTENSION SPEAKERS, 29/9

Fitted with 8in. P.M. Speaker "W.B." or "GOODMANS" of the highest quality. Standard matching to any receiver (2-5 ohms). Switch and Flex included. Unrepeatable at this price. Money back if not completely satisfied. Ins., Carr., 3/6.



8in. P.M. SPEAKERS, 8/9

At this price you can have one in every room. Let the lady of the house listen to that radio programme. With O.P. transformer fitted, 10/- Postage 2/6.

SOLO SOLDERING TOOL, 19/6

110 v. or 6 v. (special adaptor for 200 240 v., 10/- extra). Automatic solder feed. Including a 20ft. reel of ERSIN 60/40 solder and spare parts. It is a tool for electronic soldering or car wiring. Revolutionary in design. Instantly ready for use and cannot burn. In light metal case with full instructions for use. Post 2/6.

(Dept. 4) 621/3, ROMFORD ROAD,
MANOR PARK, E.12. ILF 6001/3.
THURSDAY CLOSED 1 p.m.

DUKE & CO.

COVENTRY RADIO

Audio & Component Specialists Unit, 1925 189-191, Dunstable Rd., Luton, Beds. HI-FI EQUIPMENT CABINETS IN STOCK

Record Housing: Nordik Range in Oak, Walnut, Mahogany.

- Speaker Enclosure... .. £5.17.6
- Equipment Cabinet... .. £5.19.6
- Record Cabinet (150 records)... £4.17.6
- Continental Bench... .. £4.17.6
- Potential Hi-Fi Cabinet... .. £19.19.6
- W.B. Prelude Speaker Cabinet £11.11.0
- W.B. Prelude Equipment Cabinet £13.13.0
- W.B. Prelude Corner Speaker Cabinet... .. £10.10.0
- W.B. Table Equipment Cabinet £9.19.6
- W.B. Senior Hi-Fi Console... .. £16.16.0
- W.B. Junior Hi-Fi Console... .. £12.12.0
- W.B. Junior Base Reflex... .. £9. 9.0
- W.B. Standard Base Reflex... .. £10.10.0
- W.B. Senior Base Reflex Corner £11.11.0

- B.K. AUDIO PLAN
- B.K. Speaker Cabinet... .. £16.19.6
- B.K. Equipment Cabinet... .. £17.19.6
- B.K. Record Cabinet... .. £16.16.0
- B.K. Continental Bench 48in... .. £7. 7.0
- B.K. Continental Bench 72in... .. £13.13.0
- B.K. Set 4 Legs tilt & glide feet £2. 2.0
- B.K. Set 4 Legs Plain Ebonyised 19.6

- SOUTHDOWN HI-FI Cabinet... .. £29.10.0
- R.C.A. Lowboy Cabinet... .. £18.10.0
- H.K.A. Chairside for Quad... .. £29.15.0
- HEALS Chairside... .. £37. 0.0
- BREARCLIFFE Equipment Cabinet... .. £30. 9.0
- ARMSTRONG Equipment Cabinet... .. £34.19.0

Leaflets available on request.

RES/CAP. BRIDGE 35/-

Checks all types of resistors and condensers.

Easy to Build Up Easy to Use
READY CALIBRATED

Stamp for details of this and other kits.
RADIO MAIL (Dept. PE)
Raleigh Mews, Raleigh Street, Nottingham

WIRING ACCESSORIES

Return of Post Service. Lowest possible prices consistent with high quality. Money back guarantee.

PVC Cable Flat Twin Twin with E. 3 Core

1.044	£1.18. 9	£2. 9. 5	£2.16. 5
3.024	£2. 9. 5	£3. 1. 8	£3.15. 8
3.036	£2. 9. 9	£3. 0. 3	£3. 2. 5
7.020	£4. 7. 3	£5. 9. 11	£6.12.11

TRS CABLE

1.044	£2. 3. 5	£2.13.11	£3. 0.10
3.024	£2.15. 4	£3. 5. 9	£4. 2. 6
3.036	£2.12. 6	£4. 5. 7	£5. 8. 0
7.020	£4.10. 2	£5.13. 5	£6.16. 2

Prices per 100 yds. All sizes stocked. Supplied in 25, 50, 75 or 100 yd. lengths. 7.020 and above cut to length—no cutting charge. Carriage paid on all orders over £2. Full range of accessories available. Send for complete lists.

F. HUNT & CO.

STEPCOTE HILL, EXETER.

Phone: Exeter 56687.

THE WAVEMASTER

TRANSISTOR PORTABLE

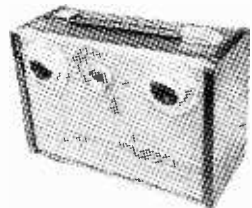

AN OLYMPIC WINNER

Pick of the World's Stations at your finger-tips.

Long and Medium Wavebands. Comprehensive assembly data and Components Lists, 1/6. Complete Receivers Available.

OLYMPIC RADIO COMPONENTS, LTD.

224, Hornsey Road, Holloway, N.7.

ASTRAL RADIO PRODUCTS

'HOME RADIO.' 32-page illustrated booklet. Simple wiring instructions for Crystal Set, 1, 2, 3 Valvers, 2-, post 3d. TRF COILS, 7- pr., post 6d. DUAL WAVE HF Coil with REACTION. Specified for 'Summer All Dry Portable'. A.C. Double Triode 1, etc., 4/6, post 3d. I.F. Miniature, 1/2 x 1 1/2 in. cans. Extra high 'Q'. Special offer, 9/- pr., post 6d. COIL PACKS. L.M.S. 36-, post 1/-, Crystal Set Coils. L. & M.W., 2/6, post 3d.

82 Centurion Road, Brighton

Morse Code operating . . . as a PROFESSION

45 years of teaching Morse Code is proof of the efficiency of the Candler system. Send 3d. stamp for Payment Plans and full details of all Courses.

CANDLER SYSTEM CO. Dept. 5LO
52b, Abingdon Road, London, W.8.
Candler System Co., Denver, Colorado, U.S.A.

Practical Wireless BLUEPRINT SERVICE

PRACTICAL WIRELESS

No. of
Blueprint

CRYSTAL SETS

2/- each	
1937 Crystal Receiver ...	PW71*
The "Junior" Crystal Set ...	PW94*
2/6 each	
Dual - Wave "Crystal Diode" ...	PW95*

STRAIGHT SETS

Battery Operated

One-valve : 2/6 each	
The "Pyramid" One-valver (HF Pen) ...	PW93*
The Modern One-valver ...	PW96*

Two-valve : 2/6 each	
The Signet Two (D & LF) ...	PW76*

3/6 each	
Modern Two-valver (two band receiver) ...	PW98*

Three-valve : 2/6 each	
Summit Three (HF, Pen, D, Pen) ...	PW37*

The "Rapid" Straight 3 (D, 2 LF (RC & Trans)) ...	PW82*
---	-------

F. J. Camm's "Sprite" Three (HF, Pen, D, Tet) ...	PW87*
---	-------

3/6 each	
The All-dry Three ...	PW97*

Four-valve : 2/6 each	
Fury Four Super (SG, SG, D, Pen) ...	PW34C*

Mains Operated

Two-valve : 2/6 each	
Selectone A.C. Radiogram Two (D, Pow)...	PW19*

Three-valve : 4/- each	
A.C. Band-Pass 3 ...	PW99*

Four-valve : 2/6 each	
A.C. Fury Four (SG, SG, D, Pen) ...	PW20*

A.C. Hall-Mark (HF, Pen, D, Push Pull) ...	PW45*
--	-------

SUPERHETS

Battery Sets : 2/6 each	
F. J. Camm's 2-valve Superhet ...	PW52*

Mains Operated : 4/- each	
"Coronet" A.C.4 ...	PW100*
AC/DC "Coronet" Four ...	PW101*

No. of
Blueprint

SHORT-WAVE SETS

Battery Operated

One-valve : 2/6 each	
Simple S.W. One-valver	PW88*

Two-valve : 2/6 each	
Midget Short-wave Two (D, Pen) ...	PW38A*

Three-valve : 2/6 each	
Experimenter's Short-wave Three (SG, D, Pow) ...	PW30A*

The Perfect 3 (D, 2 LF (RC and Trans)) ...	PW63*
--	-------

The Band-spread S.W. Three (HF, Pen, D (Pen), Pen) ...	PW68*
--	-------

MISCELLANEOUS

2/6 each	
S.W. Converter-Adapter (1 valve) ...	PW48A*

The P.W. 3-speed Autogram ... (2 sheets), 8/-*	
--	--

The P.W. Monophonic Electronic Organ (2 sheets), 8/-	
--	--

TELEVISION

The "Argus" (6in. C.R. Tube), 3/-*	
------------------------------------	--

The "Simplex" ... 3/6*	
------------------------	--

The P.T. Band III Converter 1/6*	
----------------------------------	--

All the following blueprints, as well as the PRACTICAL WIRELESS numbers below 94, are pre-war designs, kept in circulation for those amateurs who wish to utilise old components which they may have in their spares box. The majority of the components for these receivers are no longer stocked by retailers.

AMATEUR WIRELESS AND WIRELESS MAGAZINE STRAIGHT SETS

Battery Operated

One-valve : 2/6	
B.B.C. Special One-valver ...	AW387*

Mains Operated

Two-valve : 2/6 each	
Consoelectric Two (D, Pen), A.C. ...	AW403

SPECIAL NOTE

THESE blueprints are drawn in full size. The issues containing descriptions of these sets are now out of print, but an asterisk denotes that constructional details are available, free with the blueprint.

The index letters which precede the Blueprint Number indicate the periodical in which the description appears. Thus P.W. refers to PRACTICAL WIRELESS, A.W. to Amateur Wireless, W.M. to Wireless Magazine.

Send (preferably) a postal order to cover the cost of the Blueprint (stamps over 6d. unacceptable) to PRACTICAL WIRELESS, Blueprint Dept., George Newnes, Ltd., Tower House, Southampton Street, Strand, W.C.2.

No. of
Blueprint

SHORT-WAVE SETS

Battery Operated

One-valve : 2/6 each	
S.W. One-valver for American ...	AW429*

Two-valve : 2/6 each	
Ultra-short Battery Two (SG, det Pen) ...	WM402*

Four-valve : 3/6 each	
A.W. Short Wave World-beater (HF, Pen, D, RC, Trans) ...	AW436*

Standard Four-valver Short-waver (SG, D, I, P) ...	WM383*
--	--------

Mains Operated

Four-valve : 3/6	
Standard Four-valve A.C. Short-waver (SG, D, RC, Trans) ...	WM391*

MISCELLANEOUS

Enthusiast's Power Amplifier (10 Watts) (3/6)	WM387*
---	--------

Listener's 5-watt A.C. Amplifier (3/6) ...	WM392*
--	--------

De Luxe Concert A.C. Electrogram (2/6) ...	WM403*
--	--------

QUERY COUPON

This coupon is available until Sept. 5th 1958, and must accompany all Queries sent in accord with the notice on our "Open to Discussion" page. PRACTICAL WIRELESS, SEPT. 1958.

NEW! NEW! NEW! NEW! NEW! NEW!ANNOUNCING TWO COMPLETELY NEW EASY TO BUILD POCKET TRANSISTOR RECEIVERS
ALSO IMPROVEMENTS TO OUR USUAL RANGE

ANY OF OUR RECEIVERS may be built easily by the absolute beginner as well as the experienced from our complete pictorial step-by-step layout diagrams.

"THE MINOR-ONE"

(Supersedes the Mini-Two)



The smallest transistor radio offered on the market. Case size only 3 x 2 x 1/2 in. Variable tuning over medium waves. Home, Light and Third programmes without an aerial in areas of reasonable reception. Uses a three-stage reflex circuit of high efficiency. Total cost including hearing aid, long life miniature battery, circuit and complete layout diagrams and all components, post free. **52/6**

All Components Sold Separately. Circuit and shopping list free.

CALL AND HEAR DEMONSTRATION MODEL. Circuit diagram and shopping list free.

"THE MAJOR-TWO"

(Supersedes the Homelight-Two and Three)

TEN STAR FEATURES

- ★ 4 stage reflex circuit.
- ★ Selected transistors.
- ★ Variable tuning.
- ★ Highly sensitive.
- ★ Home, Light & Third.
- ★ Foreign stations (in good areas).
- ★ No aerial or earth.
- ★ Drilled and mounted chassis.
- ★ Economical.
- ★ Can be built in 1 hour.

We can supply all items including case and ear-piece to build this amazing little set for **72/6** post free.

All items sold separately.

CALL AND HEAR DEMONSTRATION MODEL. Circuit diagram and shopping list free.

**ENTIRELY NEW CABINET IN VARIOUS CONTEMPORARY COLOURS****"TRANSISTOR-8"**

Push-Pull Portable Superhet. CAN BE BUILT FOR £11.10.0. This Portable 8 Transistor Superhet is tunable for both Medium and Long Waves and is comparable in performance to any equivalent Commercial Transistor Set. Call and Hear Demonstration Model.

TEN STAR FEATURES

- ★ 8 Specially selected Transistors.
- ★ 250 Milliwatts Output Push-Pull.
- ★ Medium and Long Waves.
- ★ Internal Ferrite Rod Aerial.
- ★ Elliptical Speaker.
- ★ Drilled Chassis 8 1/2 x 2 1/2 in.
- ★ Point-to-Point Wiring and Practical Layout.
- ★ Economical. Powered by 7 1/2 v. battery.
- ★ Highly sensitive.
- ★ Attractive lightweight contemporary case. 325 mW. version 40/- extra.

Car Radio Conversion Components, 8/- extra.

COMBINED PORTABLE/CAR RADIO

Two sets for the price of one.

We can supply all these items including Cabinet for £11.10.0. P.P. 2/6. All parts sold separately. Circuit diagram and shopping list free.

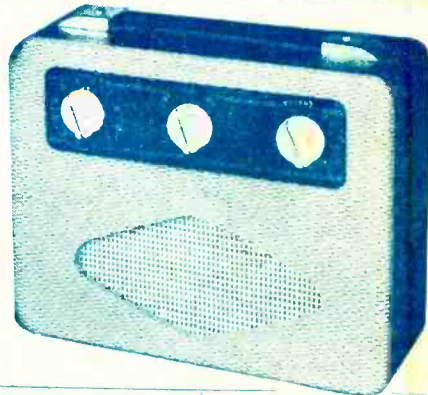
**NOW SUPPLIED WITH READY DRILLED CHASSIS "EAVES DROPPER"****THREE TRANSISTOR POCKET RADIO**

(No Aerial or Earth required) Variable tuning on medium waves. Total cost as specified including Transistors, Transformers, Coils, Condensers and Battery, etc., with circuit and plastic case. All items sold separately. Full practical layout diagrams. 70/- post free. With balanced armature ear-piece. 73/6. With Min. Hearing Aid, 86/-.

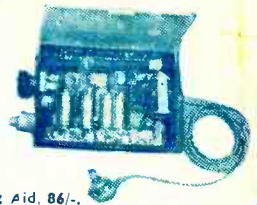
**TRANSISTORS**

JUNCTION TYPE PNP

Red Spot Audio Amplifier, 7/6.
White Spot 2.5 Mc/s osc./mixer, R.F. and I.F. Amp. 15/-.
Green/Yellow Spot Audio Amplifiers, 7/6.
Red/Yellow Spot 1.5 to 8 Mc/s osc./mixer, etc., 15/-.
Mazda XB102 Audio Amplifier, 21/-.
Mazda XA102 8 Mc/s osc./mixer, R.F. and I.F. Amp., 40/-.
Mazda XC101 Matched Pairs for Audio Outputs, 60/- pair.

SEND 6d. for 28-PAGE CATALOGUE

5, HARROW ROAD, EDGWARE ROAD,
PADDINGTON, LONDON, W.2.
OPEN MONDAY to SAT. 9-6. THURS. 1 o'clock

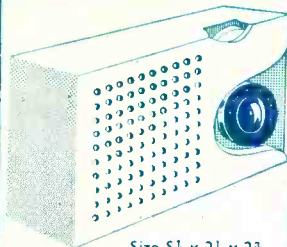

Size 5 1/2 x 2 1/2 x 2 1/2

- ★ Seven selected Transistors.
- ★ Push-Pull Output.
- ★ Internal Ferrite Aerial.
- ★ Drilled Chassis.
- ★ Practical Layout.
- ★ Medium Wave.
- ★ Long Wave 6/6 extra.
- ★ Attractive plastic case.

Send 1/6 for Instruction Booklet and Prices.

MINI-7 POCKET TRANSISTOR PORTABLE

ULTRA SENSITIVE!
ECONOMICAL!
HIGHLY SELECTIVE!
MAY BE BUILT FOR

£9.19.6

This Superhet is superior in performance to most commercial Transistor sets and costs less than half the price.

All components as specified can be supplied at an inclusive price of £9.19.6. P.P. 2/6.

HENRY'S (RADIO) LTD.

Opposite Edgware Road Station. PADDINGTON 1008/9