

A LOCAL STATION RECEIVER



Vol. 29 No. 561

JULY, 1953

EDITOR:

F. J. CAMM

PRACTICAL WIRELESS

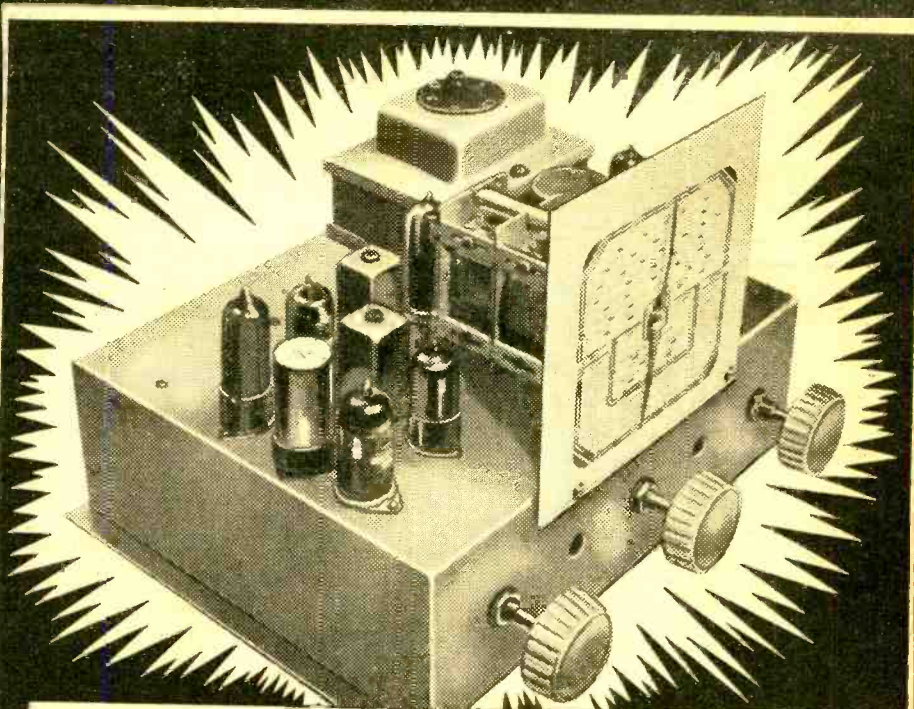

A Beginner's Superhet

IN THIS ISSUE:

A ONE-VALVE SIGNAL GENERATOR
BEGINNER'S SUPPLEMENT
A SPIN-WHEEL TUNING DIAL

A MULTI-RANGE TESTER
MORE ABOUT TRANSISTORS
NOISE AND THE R.1155

SIGNAL GENERATOR TYPE 10

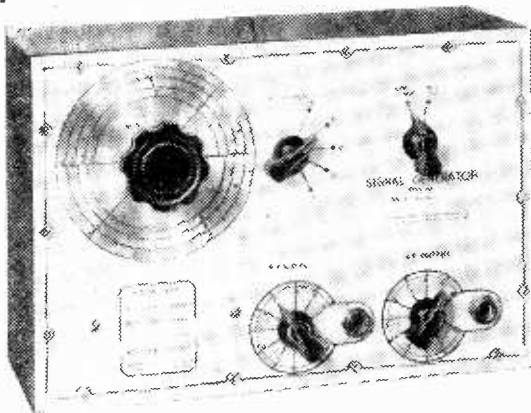

PRICE (U.K. ONLY)

£7-10-0

HOMELAB INSTRUMENTS LTD., 615-617, HIGH ROAD, LEYTON, E.10.
Telephone: LEY 5651

Specially designed to meet the needs of constructors and service engineers requiring a thoroughly reliable generator for radio and television alignment, etc.

- COVERAGE 100 KC/S—100 MC/S.
- DIRECTLY CALIBRATED.
- INTERNAL MODULATION 30 per cent.—400 c.p.s.
- C.W. or EXTERNAL MODULATION.
- VARIABLE 400 c.p.s. A.F. SIGNAL,
- ACCURACY ± 1 per cent.
- A.C. MAINS (double wound transformer tapped 110, 200/230/250 volts).
- GUARANTEED FOR TWELVE MONTHS.
- FULL OPERATING INSTRUCTIONS SUPPLIED.

Illustrated brochure and full details sent on request.

Armstrong

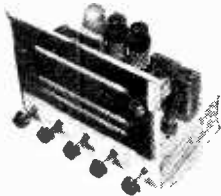

CELEBRATE
CORONATION YEAR
AND THEIR
21st ANNIVERSARY
OF QUALITY RADIO CHASSIS
WITH AN
OUTSTANDING NEW MODEL
FC 38

A HIGH CLASS CHASSIS AT AN
ECONOMICAL PRICE
£23.13.0 including tax

FOR REALISTIC RADIO & RECORD REPRODUCTION

- NEW AND IMPROVED TUNING SCALE
- MAGIC EYE TUNING INDICATOR
- BASS AND TREBLE LIFTS
- NEGATIVE FEED-BACK
- 8 WATTS PUSH-PULL OUTPUT
- 8 VALVES INCLUDING TUNING INDICATOR

BRIEF SPECIFICATION

Superheterodyne with I.F. amplifier at 460 kc and A.V.C. on Mixer and I.F. valves. A double diode triode valve for detector and automatic volume control, its triode section providing the first stage of audio amplification. The first section of a double triode valve provides further L.F. amplification and tone control, the second is arranged as a phase inverter feeding two beam power tetrodes operating in push-pull. All the necessary smoothing is incorporated in the chassis and no special field is required for this purpose. The output transformer is also in the chassis and any good quality P.M. loudspeaker with a speech-coil impedance of 3 ohms may be used.

WAVERANGE

16-50 metres, 190-550 metres, 1000-2000 metres. For A.C. Mains, 200-250 volts, 40-60 cycles.

ARMSTRONG WIRELESS & TELEVISION CO. LTD.,
WALTERS ROAD, HOLLOWAY, LONDON, N.7
Telephone: NORth 3213/4

12/6 AMPLIFIER 12/6

2v. Battery Type. COMPLETE TWO VALVE

IDEAL FOR MIC. OR GRAMOPHONE.
BRAND NEW IN TRANSIT CASE.

THROAT MIC.—Electro Magnetic, New, 4/6.
TANK AERIALS.—Two piece. Complete with Rubber Base, 6/6.
NEONS.—F.X.-W.D. New, Small B. Cap. 1/6 each.
MANBRIDGE CONDENSERS.—2 mfd., 250 volt, 1/-; 4 mfd., 800 volt, 2/6; 4 mfd., 1,500 volt, 4/6; 8 mfd., 400 volt, 3/6; 8 mfd., 1,000 volt, 6/-; .25 mfd., 1,200 v., 2/-.
ELECTROLYTIC TYPE.—New Stock, B.E.C. 8 mfd., 450 volt, 2/6; 8 mfd., 450 volt, 3/9; 16 mfd., 450 volt, 4/6; Dubilier, Dilitic, 16 mfd., 500 volt, 3/9.
METERS.—M.C. 3 1/2 in. dia., 3.5 K.volt, 9/6; M.C. 2 1/2 in. dia., 300 mA., 500 mA., 75 mA., 6/- each.; M.C. 2 1/2 in. square, 100 mA. FSD; 50 mA., 5/6 each.
THERMO-COUPLED AMMETERS.—2 1/2 in. sq., 4 amp., 5/6; 2 1/2 in. dia., 6/-; 2 1/2 in. dia., 5 amp., 5/6 each.

VALVES.

63 E.F.50 (Red Syl) 6/3		6/3		6/3	
VR116	4/-	ML6	5/-	1954	3/-
DL	2/-	VU133	3/-	1R1	8/-
Pen223	4/-	S110A	6/-	6N7	7/-
HL2	2/6	955	5/-	12SJ7	4/6
VU120	4/-	154	8/-	EC32	5/6
S130	6/-	6SH7	5/-	SP41	2/6
EL50	7/-	EP54	5/-	HL41	5/-
LD4	4/6	2C34	2/6	EBC33	7/6
6SK7	4/6	6A8	9/6	KT68	12/6
CV68	3/6	SP61	2/6	SG215	2/6
9001	5/-	EF36	4/-	6Q7	9/-
VR91	5/-	52A	10/-	PCC31	6/6
EB34	2/-	PT15	7/-	1R5	8/-
5U43	9/6	VU111	2/6	6K8	12/6
MU2	7/9	GSN7	12/6	6L6M	12/-
				QP21	9/-
				6X5	7/6
				CV73	5/-
				6A59	2/-
				3DS	5/-
				128A9	5/6
				VR21	2/6
				Pen46	5/6
				ECC32	6/6
				12A6	7/-
				12SH7	4/6
				6V6	10/-
				6K7	6/-
				6AC7	7/6
				807	8/-
				QP21	9/-

Carbon Resistors, 1/2, 1 W., Assortment 100, £1.
Potentiometers, All values to 2 Meg., 2/6 each.

VINER'S (Middlesbrough)
Radio Electrical

26, EAST STREET, MIDDLESBROUGH.
Tel.: (MID) 3418.

This is Britain's famous power amplifying tube - for years the favorite tube of experimenters and research laboratories, acknowledged in every country of the world to be the finest tetrode ever made. It is currently used in the Leak, Williamson, Radio Craftsmen and other fine amplifiers.

The KT66 is a versatile power tetrode with a number of useful applications. It may be used in the output stage of an audio-frequency power amplifier, either tetrode-connected for maximum sensitivity and power output or triode-connected for high quality working. In transmitting circuits using frequencies up to 30 Mc/s it may also be used as an oscillator or as a radio frequency amplifier.

A high slope, indirectly heated beam tetrode, the KT66 is suitable for either single or push-pull audio operation and may be employed as a beam tetrode with aligned grids. This alignment of the grids reduces losses in the screen and makes for the highest possible power conversion efficiency. With this system of construction high orders of power output may be obtained with a low screen dissipation, and the anode is designed to dissipate 25 watts continuously with a reliable life performance.

THE FINEST AUDIO TUBE EVER MADE! KT66

OPERATING CONDITIONS
 Single Valve Tetrode Triode
 A.F. Amplifier (1000V)

7-PIN "OCTAL"
 Pin 1 Not Connected

THE FAMOUS KT66 . . . IN USE ALL OVER AMERICA AND ACKNOWLEDGED TO BE THE FINEST BEAM TETRODE EVER MADE . . . IS AN **Osram VALVE MADE IN ENGLAND**

The photographic reproduction is taken from literature published in America by the British Industries Corporation and gives an entirely unsolicited tribute to this fine valve.

THE GENERAL ELECTRIC CO. LTD., MAGNET HOUSE, KINGSWAY, LONDON, W.C.2

BRITAIN'S LEADING SUPPLIERS
 OF
QUALITY EQUIPMENT
 FOR
TAPE RECORDING, TELEVISION, RADIO AND GRAMOPHONE

We can supply from stock everything you want for building your own quality equipment from a yard of wire to a Loud Speaker, costing £150. All merchandise tested and guaranteed. Lists available. Advice gladly given without obligation. If you want the best, go to Classic for it.

FOR CASH OR EASY TERMS

Some Classic Examples of Tape Equipment

Wearrite Tape Deck	£35.0.0
Bradmatic Tape Desk	£42.0.0
Truvox Tape Desk	£33.2.0
Lane Tape Desk	£16.16.0
Scophony	£65.0.0
Vortexton	£84.0.0
C.J.R. Portable	£119.10.0
Quad Tape R.	£18.16.0
Bradmatic Circuits	5.0
Bradmatic 6 RP Heads	£3.15.0
5 RP Heads	£3.5.0
5E Erase Head	£3.5.0
Spare Spools, 600 ft.	4.6
Spare Spools, 1,200 ft.	6.5
Tapes C.E.C., Scotch Boy or E.M.I.	£1.15.0

PERSONAL SHOPPERS:
 For side-by-side comparisons in large screen TV's, Tape Recorders, Loudspeakers, Amplifiers, etc., visit our newly-opened showrooms at Lower Addiscombe Road.

CUSTOMERS BY MAIL-ORDER:

Satisfaction guaranteed. Order in confidence. Our mail order dept. is at your service.

CLASSIC ELECTRICAL CO., LTD.

352/364, LOWER ADDISCOMBE ROAD, CROYDON, SURREY.

Telephone: ADDiscombe 6061-6062.

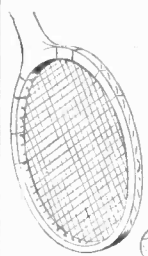

One fault MAY SPOIL

THE SET!

Designers of home constructor sets know that the smallest component can sometimes provide the biggest headache. Don't run risks. Solder those intricate joints with Multicore. Its 3 cores of extra-active non-corrosive Ersin Flux give it the highest liquefaction rate of any solder. Correct proportions of solder to flux prevent oxidation, actually clean surface oxides, and make 'dry' or H.R. joints impossible. You need no extra flux.



MULTICORE SOLDERS LTD.
 MULTICORE WORKS, HEMEL HEMPSTEAD, HERTS • BOXMOOR 3635

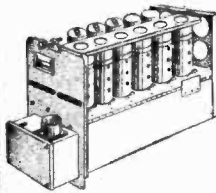

6 VALVE V.H.F. SUPERHET RECEIVER. Ex-W.D. (R.1124), but brand new condition. 30.5-40 Mc/s, I.F. 7 Mc/s. 6-channel switching. Covers T.V. sound, Fire, Amateurs, etc. Convertible to mains (A.C. or A.C./D.C.). Components include 30 ceramic trimmers, 30 small condensers, 30 resistances, 6 valve-holders, cans and covers, 2 transformers, 3 coils, etc. Our price 7/6, post 2/9. Also supplied complete with valves at 17/6. Drawings available, at 1/-.

RADIO TELEPHONES. Brand-new and boxed, American made transceivers. Frequency 53.75 Mc/s, visual range. Vibrator supplied for operation from 12-volt accumulator. Price per pair, £21, carriage 15/-.

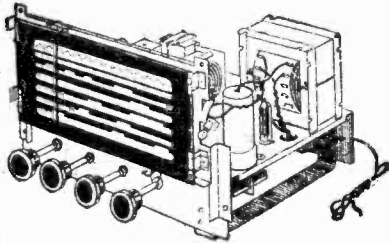

RADIOGRAM CHASSIS AND CORONATION FREE GIFT. 8in. P.M. Speaker offered free, or 10in. P.M. Speaker specially reduced to 12/6 with either of the following brand-new Radiogram Chassis. Export Model, 6 wave bands, at 15 guineas; Home Market Model, long, medium and short bands, at £10/15/6. Following details apply to both models. Negative feedback, fly-wheel tuner, 11½in. x 7in. x 8½in., and valve line-up 6BE6, 6BA6, 6AT6, 6BW6 and 6X4. Carriage free.

TUNING CONDENSERS. Unused, store soiled, .0005 mfd., standard size, 2/9 each, post 6d., or special offer of 3 for 7/-.

O.P. TRANSFORMERS. Will match all normal O.P. valves to 2-5 ohms speech coil, 1/9, post 9d.

T.V. TUBES. 9in., £3; 10in. and 12in., £5; and 15in., £6. Personal callers only as each tube shown working. Also some with slight faults at half price, ideal for test purposes, 2½in. projection tubes, slight faults but brilliant picture, 25/6, post 1/9.

LOUD HAILER. Very powerful P.A. system, working off 12 or 24 volts. Brand new. No valves to break or damage. Independent of electricity failures. Weatherproof. Consists of microphone and combined amplifier/speaker. Total weight 20lb. Our price, £8/17/6, carriage 5/6.

ACCUMULATORS. Brand new, 2 volt, 14 a/H, lead acid, 1½in. x 1½in. x 6in. Bargain, 4/6, post 1/-.

MICRO SWITCHES. Latest American midgets. 250 volt, 3 A., ½in. x ½in. x 1½in., 5/-.

INSULATING TAPE. New and wrapped, ½in. wide, ½lb. rolls, list price 3/6. Our price, 1/6.

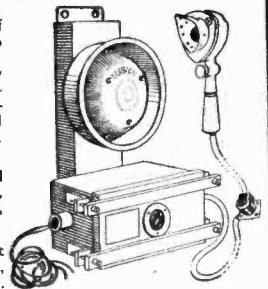

C.W.O.
OR
C.O.D.

DUKE & CO.,

621, ROMFORD ROAD,
LONDON, E.12. GRA. 6677.

STAMP FOR CATALOGUE.
MONEY BACK GUARANTEE.

HAVING TROUBLE IN "FRINGE" AREA RECEPTION?

Why not try our Television Pre-Amplifier, TPA.1 which is eminently suitable for "Magnaview" and "Teleking," indeed any A.C. receiver in extreme fringe and "difficult" areas. Its moderate power requirements, 6.3v. 3a. and 12 m/a. at 200v. are conveniently available in these sets.

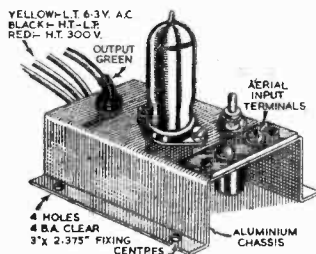

A noisy ragged picture obtained with the receiver operating at full gain is transformed into a clear display by the connection of this low noise amplifier. Connection is simplicity itself and leads are clearly marked on the illustration.

A model is available for each Channel and is priced at 29/6d. Retail.

Send 9d. for General Catalogue.

DENCO (CLACTON) LIMITED,
357/9 Old Road, Clacton-on-Sea, Essex

ALUMINIUM ALLOY SHEETS

Ex-Government Surplus

SUITABLE FOR CHASSIS, etc. (undrilled)

Limited Quantity Available

Type No. 1. 14½in. x 12½in. x 20 G., 2/6 each.

Type No. 2. 17½in. x 12½in. x 20 G., 3/- each.

Type No. 3. 26in. x 23in. x 20 G., Round Corners, 5/- each.

Type No. 4. 22½in. x 18½in. x 18 G., 5/- each.

SIZES STATED FOR TYPES NOS. 1 and 2 are the maximum rectangular pieces that can be cut from irregular shapes.

CARRIAGE PAID.

REDUCTION FOR QUANTITIES.

TRADE ENQUIRIES WELCOMED.

JOHN CASHMORE LIMITED,

Steel Department,

GREAT BRIDGE, TIPTON, STAFFS.

TIPTON 2181/5

GARLAND BROS. LTD

CHESHAM HOUSE, DEPTFORD BROADWAY, S.E.8. TEL.: TIDEWAY 4412/3
5 OBELISK HOUSE, LEWISHAM, S.E.13. TEL.: LEE GREEN 4038

GARLAND UEB RECORD PLAYBACK AMPLIFIER

A revised version of our popular amplifier, designed for use with the Truvox Tape Desk, Lane Tape Table, or Motek Tape Unit. New features include higher gain, magic eye record-level indicator, and smaller size to facilitate incorporation in portable recorders. Oscillator and power supplies are included and standard valves are used throughout. Supplied complete with 8 in. P.M. speaker. Price £13.2.6, plus 7/6 carriage and packing.

GARLAND AMPLIFIER ACH

A quality amplifier giving 4 watts output. All power supplies derived from transformer ensuring an isolated chassis. Fitted with treble and volume controls; output for 3-ohm speaker. Price £6.2.6, plus 5/- carriage, etc.

PAPER CONDENSERS

0.01 mfd., 500 v., 6d.; 0.01 mfd., 750 v., 6d.; 0.25 mfd., 500 v., 6d.; 1 mfd., 400 v., 6d.; 1 mfd., 500 v., 9d.; 1 mfd., 600 v., 1/-; 1 mfd., 800 v., 1/3; 1 mfd., 1,500 v., 1/-; 3 mfd., 750 v., 1/9.

DECALS. 500 4in. high white transfer letters and words for marking electronic equipment. Price 4/9 per book. The new Decals book for the amateur now available; 29 words per page, 4 pages radio and audio, 4 pages TV and scope, 2 pages misc. incl. Tx and Tape recording. 3/6 per book.

TYANA SOLDERING IRONS. Light weight, 40-watt irons with easily replaceable elements and bits. Voltages, 6v., 100/110v.,

200/220v., 230/250v. Price 16/9. "The iron that makes soldering a pleasure."

TYANA SOLDER GUNS. Instantaneous heat by transformer action, low voltage insulated bit. Weight 30 ozs, for 220-250 v. A.C. mains only; consumption 100 watts. Price 3 gns.

IGNITION SWITCHES. Low voltage, high current, in bakelite case. 9d. each. S.W. TUNING CONDENSERS. 160 pF. with fixing feet. Price 2/3.

ENGRAVED KNOBS. 1 1/2in. diameter, fluted in Walnut or Ivory, with the following markings: Volume, Vol-On-Off, Treble, Bass, Tone, Tuning, Wavechange, S-M-L-Gram., On-Off, Brilliance, Brilliance-On-Off, Contrast, Focus, RI-R2-PB. Price 1/6 each. Plain knobs to match, 1/3 each.

RECTANGULAR KNOBS. Walnut. Size 1 1/2in. x 3/8in., with gold indicating spot; to fit standard 1/2in. spindles. Price 6d. each.

GENERAL PURPOSE TRIODES. Type 7193, 6.3 volt heater, similar to 6J5G. Ideal for experimental work. Price 2/6 each.

TAPE RECORDER OSCILLATOR COILS. 6.3 mH, 45 kc/s, for high impedance heads only. Price 6/9 each.

AMPLION TESTMETER. 10 ranges A.C. and D.C. up to 500 v. Resistance up to 200,000 ohms, 1,800 ohms per volt A.C. and D.C. Price £5.

TWIN SCREENED CABLE. Suitable for carrying currents of up to 5 Amps.

ALL POST ORDERS TO DEPTFORD BRANCH

Cotton covered, 9d. per yard. Ditto uncovered, 8d. per yard.
HEADPHONES. 4,000 ohms, per pair, 11/-.

METAL RECTIFIERS. RMI, 125 v. at 80 mA, 3/11. RM2, 125 v. at 100 mA, 4/3. 14D/972, 250 v. at 25 mA, 6/6. 12 v. 2 A., 6/- 6 v. 1 A., 4/6. 12 v. 2 A., 12/6. 12 v. 2 1/2 A., 16/6. 12 v. 4 A., 21/-.

CERAMIC SWITCHES. Single pole, eight-way, 3/6 each.

BRENETTE MICROPHONES. We have been appointed sole distributors in Great Britain and Ireland of these new cell microphones. The following range is now available:

Type 7D. Directional in black and chrome case. Price, £4/13/6.

Type 9ND. Multi-directional ball type, in black and chrome. Price, £2/6/6.

Type 11A. Wide frequency response, in brown and chrome. Price, £6/17/-.

Type 13U. Highly sensitive with wide frequency response, in black and chrome. Price, £7/17/6.

BRENETTE MICROPHONE STANDS

—Desk type with flexible member to ease adjustment. These stands will suit all British and Continental Microphones. Price 16/6 each.

RECEIVING VALVES. 6SH7, 6/-; 7193, 2/6; 5U4G, 10/-; E114B, 2/6; 6USG, 7/6; 617G, 9/6; NGT1, 5/6; 6Q7G, 9/6; 6K7G, 8/6; KT61, 11/6; MSPEN/7 pin, 5/-; 5Z4, 9/6; 6X5GT, 8/6; 6J5GT, 5/-; 65L7GT, 10/6; 6V6, 9/6; CV73, 5/-; VU33, 2/6; 954, 2/-; 6BE6, 13/6; 6K6, 9/6; VU111, 4/-; VU133, 3/6; KTZ41, 6/6; VR54, 3/6; 1625, 4/9; 14H7, 9/6; 14J7, 9/6; 14R7, 9/6; UJ2, 6/6; 6K3G, 10/6; 6B4G, 6/-; 1625, 4/9.

CLYDESDALE

Bargains in Ex-Services Radio and Electronic Equipment

SPECIAL CABINET OFFERS

WALNUT FINISH WOOD RADIO CABINET

Dim., Int. 8 1/2in. x 15 1/2in. x 7 1/2in., approx. Ext. 9 1/2in. x 17 1/2in. x 8 1/2in., approx. with 3 W.B. glass dial, expanded metal L.S. grill, 3 1/2in. dia. fluted knobs.

Ask for No. P.H945.

25/-

POST PAID.

WALNUT FINISH CABINET with other items as H915, plus 2 gang 350 pF. Condenser, 5 valve holders (your choice), 3 bank wave-change switch 2-pole 5-way each bank, 15-8 mfd. 450 v. EL. cond. and clip, 2 speed S.M. drive, Drum, 1 pulley wheels, 9 assorted tag strips, 1 mez. volume control with switch.

Ask for No. P.H946.

45/-

POST PAID.

S-440-B V.H.F. TRANSMITTER CHASSIS

Partly stripped by the M.O.S. less valves, tuning coils and crystal, but otherwise fairly intact. A fine basis for V.H.F. Tx. or 144 Mc s.g. rig. Original frequencies 85-90 Mc s. valve types 3 RK24, 2 6N7, 6VB. Housed in louvered case, finished grey crackle. Dim., 14 x 8 x 7 1/2in.

Ask for No. P.H517.

27/6

POST PAID.

Circuit available at 1/3.

1132 V.H.F. R/T RECEIVER UNIT

10" Rack Mounting.

Range 100-124 Mc s.

A 10 valve superhet with 4 VR53 (EF39) VR54 (EF34), VR57 (EK32), 2 VR55 (SP61), VR58 (P81), VR57 (6J5G), plus stabiliser VS70 (7475). "S" meter, screened R.F. section B.F.O., etc., etc., in enclosed chassis, size 19 in. x 19 in. x 1 1/2 in., finish dark grey. Circuit supplied. Ask for No. P.H915.

£5.19.6 EACH

CARRIAGE PAID.

NEW CATALOGUE No. 8D.

Gives details and illustrations of Ex-Service and other items. Price, 1/6. (Credited on first purchase of 10/- value or over.)

Order direct from

CLYDESDALE SUPPLY CO. LTD.

2, Bridge St., Glasgow, C.5. Phone: SOUTH 2706/8
Visit our Branches in Scotland, England and N. Ireland

COMPACT TV.

The NEW 1355 Conversion data for all five Channels, Sound, Vision, T.B.'s, Power, on one 1355 Chassis.

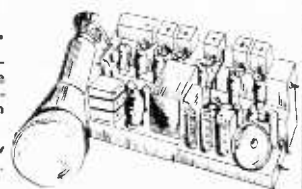

NEW EDITION, now only 2/8! (post free).

1355's in original cases, (carr. 7/6) 35/-.

NEW VALVES	AMPLIFIERS	RECEIVERS
EF50: Grey 4/6, Red (Sylvania) 6/6; SU4G 7/5.	with 'full instructions to convert into a miniature mains operated amplifier or receiver' complete with three valves. 19/6	5450, 4 EF54's (RF. mixer, LO multipliers), 2 EF39's (2.9 mcs IF's), EB34 (dec) 6/5 and 6/6 (audio) 65/85 mcs. Measuring 12 x 5 x 6, with circuit. (Post 2/-) 49/6
CHASSIS		
with 5Z4, VU120 (E.H.T. rect.) Transformer, choke, relay, etc. 12/6		

INDICATOR 182A	TRANSFORMERS
with 6in. C.R.T., 3 EF50's, 4 SP61's, SU4, dozens of resistors and condensers, 9 W/W pots, these are suitable for conversion to 'scope or TV. BRAND NEW (less relay) in original cases. Only 65/- Less EF50's and SU4G. 50/-.	230 v./24 v. 2A., 9/-; 230 v./115 v. 40 watts. 5/3. DINGHY TX CHASSIS (partly stripped), 7/6 to clear.

RADIO EXCHANGE CO.
14 ST. MARY'S STREET, BEDFORD
Phone 5568

Your set deserves a Mullard Tube

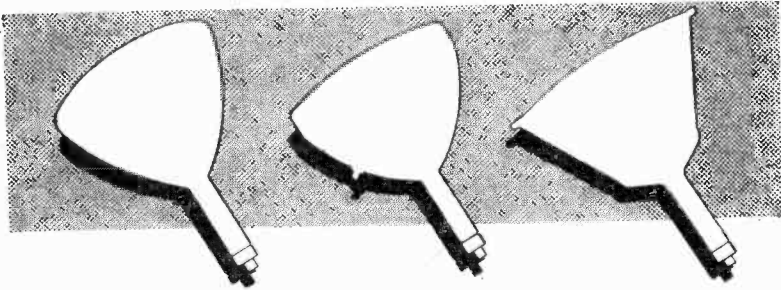

If you are building a television receiver, leave nothing to chance; choose a Mullard Tube. Mullard Television Tubes owe their high reputation for performance, reliability and LONG LIFE to the unrivalled facilities for research possessed by Mullard; to the complete control of manufacture from the production of raw materials to the completed product; and, in particular, to the ion-trap, which safeguards the screen from damage by heavy negative ions produced in the region of the cathode.

Tubes available for home construction include:—

- | | | | |
|---------|---------------------------------------|---------|----------------------------|
| MW22-16 | 9-inch screen | MW31-74 | 12-inch grey glass screen |
| MW36-24 | 14-inch grey glass rectangular screen | MW41-1 | 16-inch screen, metal cone |

Mullard *Long Life* T/V TUBES



MULLARD LTD., CENTURY HOUSE, SHAFTESBURY AVENUE, LONDON, W.C.2

MVM 206

- if you look for BIG RESULTS

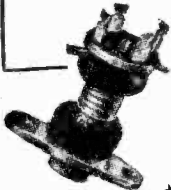

It's a knock-out—the vast improvement that arises from the use of OSMOR "Q" Range Coils. No wonder our customers are enthusiastic! They tell us these "mighty marvels in miniature" are super-selective and sensitive to a degree they never dreamed possible. And we guarantee them—they're the outcome of scientific research plus the highest technical ability. They put real punch into a set and score an easy win on these "plus" points.

- ★ Only 1in. high.
- ★ Packed in damp-proof containers.
- ★ Variable iron dust cores.
- ★ Fitted tags for easy connection.
- ★ Low loss Polystyrene formers.

COILPACKS now at new lower prices!—A full range is available for Superhet and T.R.F. Mains or Battery. Size only 1 1/2 in. high x 3 1/2 in. wide x 2 1/2 in. Ideal for reliable construction of new sets, also for conversion of the 2I RECEIVER TR.1196, TYPE 18, WAR-TIME UTILITY and others. Aligned and tested, with full circuits, etc. Fully descriptive leaflets available. We keep stocks of many radio components for use in published circuits, including:

"PRACTICAL WIRELESS"

3-Speed Autogram; Modern I-Valver; A.C. Band-pass 3; R1155 Converter; Modern High Power Amplifier-2; Attache Case Portable.

"WIRELESS WORLD"

No Compromise T.R.F.-2 Tuner (Osmor coils QA11 and QHF11 for M.W. and QA12 and QHF12 for L.W. are suitable, price 4/- each). Midget Mains Receiver (Osmor coils QA11 for M.W. and QA12 for L.W. are suitable. Price 4/- each).

MATCHED COMPONENTS

Various types of OSMOR Dials, Chassis, I.F.s, Speakers, Transformers, etc., to match our coils and coilpacks are all listed.

OSMOR

4/-
EACH



Dear Reader,
We can't mention all our products here, but shall be glad to receive your enquiries for Chassis, Tuning Condensers, Switches, Volume Controls and all other Radio Components. If its top quality components and a speedy, courteous service you are looking for—try Osmor. We really shall do our best for you.

radio products Ltd

(Dept. P.37), BRIDGE VIEW WORKS, BOROUGH HILL, CROYDON, SURREY. Telephone: Croydon 5148/9

FREE!

Send 5d. (stamps) for full lists of coils, Coilpacks and radio Components.

Practical Wireless

EVERY MONTH
VOL. XXIX, No. 561, JULY, 1953

Editor F. J. GAMM

21st YEAR
OF ISSUE

COMMENTS OF THE MONTH

By THE EDITOR

Small Firms at the Show

AN APPEAL TO COMPONENT MANUFACTURERS

WE have often commented that small firms do not support the National Radio Show at Earls Court. In view of the hundreds of thousands of constructors still actively engaged in building receivers, we are somewhat surprised that they do not take space and meet some of their customers in person. This journal has consistently taken space in every Radio Show since it commenced publication 21 years ago. During the run of the exhibition large numbers of constructors call at our stand to discuss designs and purchase blueprints. Year after year we are confronted with the question as to whether the firms making the components are exhibiting. In most cases they are not.

Accordingly, after the last Radio Show we made a careful analysis of the position and, as we suspected, we were told in every case that the reason for not exhibiting was the high cost of the space, apart from the additional high cost of having a special stand built and the incidental expenses of lighting and staff. We immediately, therefore, discussed this matter with those responsible for organising the exhibition, and this year a special section has been set aside for the smaller manufacturer, at specially reduced space prices.

We are astonished to learn from the Radio Industry Council that at the moment of going to press only one manufacturer has availed himself of this offer. We appeal, therefore, to all those firms supplying components for home constructors to reconsider the matter, so that this year there will be a representative section at the Show.

We appeal, too, to our advertisers to take space. The constructor market is lively, large and ever expanding, as our circulation figures prove. This important market should not be neglected nor the impression conveyed that it is moribund. Firms should find that their sales at the Exhibition will at least cover their costs.

In the short space of three years over 300,000 constructors have built TV receivers. Home-built radio receivers, however, have been in existence for over 30 years and it is fairly certain that there are at least 1,000,000 home-built

receivers in use to-day. Great Britain has one radio set per house compared with two and a half sets per house in the U.S.A. We have one television set per six houses against one set per two houses in America. This shows that the market has by no means reached absorption point and that there is a profitable untapped market awaiting firms with vision.

These smaller firms have apparently overlooked the publicity value of exhibiting, quite apart from the question of cash sales. Newspapers and periodicals devote considerable space to reviewing the exhibits, and this year we hope that a representative section dealing with an important national hobby, one responsible for training the skilled personnel for the services and the trade, will be there. Examples of kit sets could be shown and we are prepared in this journal to devote a special supplement to reviewing this section of the Exhibition alone.

We promise to give these firms all the support and advice they require and we invite them, therefore, to get into touch with us on the matter. We are quite prepared to offer our services to help make the constructors' section of the Exhibition a great success.

Components manufacturers are independent of radio and television only to the extent of 50 per cent. of their production. They could quite easily expand sales by returning to the market from which they originally built their business. This especially applies to those who are not manufacturing components for television receivers. We hope we shall see a considerable number of our friends in the trade at the Show this year.

INDEXES FOR "P.W."

A REMINDER to readers that each year we publish an index for each volume and it may be obtained from us for 1s. 1d. by post. We can supply most of the indexes for past volumes and they provide a ready means of turning up an article to which you may wish to refer without a long search. Whether you have your copies bound or not you would be well advised to purchase the indexes.—F.J.C.

ROUND the WORLD of WIRELESS

Increased Charge for Irish

THE cost of radio licences in Eire has been increased by five shillings to 17s. 6d. a year.

New Singapore Factory

CABLE and Wireless, Ltd., has announced that its new £232,000 submarine cable factory and depot, at Singapore, began production early in April.

The new factory is at Bukit Chermin. It will replace the company's old factory at Singapore, which was opened in 1887, and will be capable of manufacturing between eight and nine hundred nautical miles of submarine cable of all types annually, for the maintenance and development of the 20,000 miles sections in the Far East, of Cable & Wireless, Ltd.'s 155,000 miles Commonwealth cable system.

Broadcast Receiving Licences

THE following statement shows the approximate number of sound receiving licences issued during the year end, March, 1953. The grand total of sound and television licences was 12,892,231.

Region	Number
London Postal ...	1,756,506
Home Counties ...	1,475,324
Midland ...	1,331,943
North Eastern ...	1,761,826
North Western ...	1,368,511
South Western ...	1,035,009
Welsh and Border ...	681,890
Total England and Wales ...	9,411,009
Scotland ...	1,123,583
Northern Ireland ...	215,187
Grand Total ...	10,749,779

Better Service Needed

ADDRESSING members of the Radio and Television Retailers' Association at their recent conference, at Eastbourne, Mr. E. Cave, of E.M.I. Sales and Service, said: "Service can be one of your greatest assets. Your whole staff should be interested

in service and the better service you can offer your customers, the happier they will be."

Linked with this idea, the importance of a good window display was emphasised by another speaker.

Moon and Back

TWO American amateurs, Ross Bateman and William Smith, have transmitted short-wave signals at the moon on their own home-made apparatus using only 650 watts of power and have recorded the echoes received.

Their success follows three years of experimenting in their spare time, this being the first time that an amateur's limited finance and power has enabled him to perform such a feat.

Longer Components Exhibition ?

THE success of the tenth Components Show, organised by the Radio and Electronic Components Manufacturers' Federation at the Grosvenor Hotel in April, may induce the Federation to extend next year's exhibition from three days to four.

Sunday Variety

ON June 7th there will be a change in the Light Programme's Sunday night variety pattern when the "Pleasure Boat" series, starring Freddie Sales, Lee Lawrence and Julie Andrews, is replaced by Tony Hancock in a new "Star Bill" programme.

With Hancock will be Geraldine McEwan, Graham Stark, the Stanley Black Concert Orchestra, and the George Mitchell Glee Club. In the

first programme of the series Ted Ray will be the guest comedian, together with three visiting musical artists. The show will be run on the same lines as "Forces All Star Bill," which ended on May 26th.

Decca Radar

IN their annual report, Decca state that the company exported a million pounds' worth of marine radar equipment in the past year.

Protonic Microscope

THE College of France is now using a new microscope, the protonic microscope, ten times more powerful than the existing electronic microscope. The protonic microscope can magnify 600,000 times. The wavelength associated with the proton is much shorter, thus giving more separation than that of the electron. Molecules to be examined in the



Terry Thomas, the radio star who appeared in pantomime in South Africa last winter, was heard in the Bank Holiday variety show "Hip-hip-holiday." He is seen here showing some of his African spoils.

microscope have to be held in balance in a fine mesh metal screen or in holes of a fraction of a micron pierced in metals. Otherwise the instrument is like the electronic microscope. The proton used is that of the hydrogen atom, deprived of its satellite electron by a 100,000 volt discharge.

Requests from the Services

FOR some time the BBC has been examining the possibility of including in its domestic services a programme of request records chosen by serving men and women abroad for their families in Britain.

Trial programmes have already been broadcast and a regular series presented by Franklin Englemann, himself an ex-army man, under the title of "Link With Home," began in the Light Programme on June 15th, continuing on Monday evenings between 7.30 and 8.0.

The signature tune is a significant one for servicemen—"I'll Be Seeing You," and the messages will be read in the studio.

Uniaxial Microphone

FROM America comes the announcement of a new type of microphone, designed to be blast-proof. It is most sensitive to sounds arriving along the axis of the instrument—hence its name. It is claimed that it will withstand the blast from a .45 calibre pistol fired only five feet away.

3-D Radio

THE increasing interest in three-dimensional pictures, for cinema and television, is resulting in a parallel development for radio and cinema sound. This is known as "polyphonic," "stereophonic" as well as other names, and is merely the switching of a number of loudspeakers corresponding with the direction of sound in the picture. It is also stated that a new form of sound recording is being developed to give greater "depth" to sound broadcasts.

Hundred Up

THE popular "P.C. 49" series, with Brian Reece and Joy Shelton, has passed the "hundred programmes" mark and is still as successful as in the early days.

Produced by Vernon Harris, the first episode in the series, entitled "The Case of the Drunken Sailor," was broadcast on October 27, 1947, and it is a compliment to

the producer that so many well-known actors and actresses take pride in playing supporting roles in the serial.

Amateur's Bravery

THE Edison Radio Amateur Award has been awarded to D. L. Mullican, of Searcy, Arkansas, U.S., for staying at his transmitter for five days without a break for rest.

A tornado had struck Searcy in March, 1952, causing destruction in the neighbouring towns of Judsonia and Bald Knob and Mr. Mullican took over relief communications during the crisis.

Obituary

IT is with deep regret that the death is reported of Mr. Sidney Gernsback in Chicago, Illinois, at the age of 77.

He was the former vice-president of Gernsback Publications Inc., and the elder brother of Hugo Gernsback, publisher of "Radio-Electronics." Born in Luxembourg in 1876, he studied at the College of Luxembourg and the Lycée de Nancy in France, obtaining distinctions in chemistry and electricity. He went to the States in 1912 and from 1933 was the Chicago representative of "Radio-Electronics." His books included "Wireless Course in Twenty Lessons," "The Electrical Experimenter" and "S. Gernsback's Radio Encyclopaedia."

He leaves two adopted children, George Gernsback and Mrs. Marguerite Flegenheimer, who live in New York City.

Digit Recogniser

AN automatic digit recogniser has been developed in America by Bell Laboratories which translates spoken numbers directly into selective switching operations.

The numbers must be pronounced clearly into the telephone before the correct circuit can be selected.

Midget Transmitter

USING only a small 22½-volt hearing-aid battery for power, Mr. G. M. Rose, of New Jersey, contacted three stations, one over twenty-five miles away, on a transistor-transmitter on the 146 Mc/s amateur band.

Mr. Rose, who manages the advanced development group at a transistor factory, says that the complete transmitter, including the quartz frequency-control crystal, occupies no more space than a packet of cigarettes.

New British Standard

BRITISH Standard B.S. 1927: 1953, which has been prepared under the authority of the Acoustics Industry Standards Committee, is intended to promote the interchangeability of circular cone diaphragm loudspeaker units of similar size.

It is considered neither practicable nor advisable to attempt to include all types of loudspeaker in this standard and is limited to the type produced in the greatest quantity and for which the feature of interchangeability has greatest importance.



On the left messages are transmitted on an automatic Creed transmitter at the Civil Aviation Communications Centre, Croydon, Surrey. The messages are received on a reperforator (right), also made by Creed, Ltd.

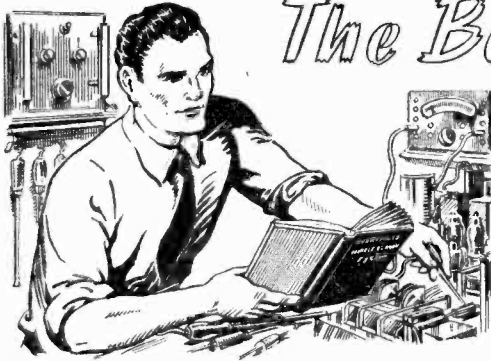

The Beginner's Guide to RADIO

The Third of a Series of Articles for Those
New to Radio. This Month I Explain How
to Add a Further L.F. Stage By F. J. Camm

LAST month I showed how to convert the One-Valver into a Two-Valver. This month I take the basic circuit a stage further, by adding another low-frequency stage so that the receiver will operate a loudspeaker.

The additional parts required are a valve, a valve-holder, a resistance, a fixed condenser and a *volume control*. They are illustrated in theoretical and actual form on this and the following page. Experienced experimenters will notice that I have not introduced grid bias, because the valves employed will operate quite satisfactorily at the high tension voltage specified without it. Next month I shall explain how to apply grid bias and the changes which are necessary.

I must, however, explain here the purpose of this bias. In low-frequency amplification, which we are employing here, it is essential that the grid of the valve shall be at a *potential*, of such a value that the applied signals will vary by an equal amount on the *anode curve*. When we come to deal with the characteristic curve of a valve we shall understand what this means; for the present it can be explained that all low-frequency valves normally require a *negative bias*. In battery sets, such as the present, the bias is generally applied by connecting a small battery between the grid return lead and the low tension lead. In some forms of mains-operated receivers, however, the bias is applied automatically by the insertion of resistances in the cathode lead.

Volume Control

Now regarding the volume control. A powerful local station will, of course, give a much stronger signal than a distant one and, therefore, it would overload the output stage of a receiver operating without grid bias. To give the operator a means of preventing this overloading a *volume control* is used. The volume control is a variable resistance incorporated in the resistance capacity coupled stage, which we dealt with last month. The loudspeaker will only handle a certain volume of sound, and if too strong a signal is fed into the valve connected to it overloading will take place, and there are two remedies for this. The first is to increase the handling capabilities of the valve by applying more high tension, and the second is to cut down the signal strength.

A number of receivers have the reaction control labelled "Volume Control," but this is not strictly correct. A volume control should be able to cut down the strength of any signal, but the reaction control can only build up the strength of received

signals, and cannot cut down below the original strength received by the detector. There are several different forms of volume control.

In conjunction with the ordinary type of low-frequency transformer there are two possible arrangements. One is to employ a variable resistance *shunted* across the primary of the transformer, and its value should be chosen so that when "all in" it does not have too great an effect upon the quality of reproduction. Of course, when the transformer is a high-class component, the presence of an external resistance across either primary or secondary will materially affect the response curve and the reproduction will be affected. In some cases, particularly in the cheap transformer line, the reproduction may be improved owing to the flattening of the curve. The value of the resistance should be about 100,000 ohms—not more. The second method is to shunt the secondary with a component of the type shown in Fig. 15 (part 17).

The loudspeaker, which replaces the earphones hitherto used, works on precisely the same principle. It is, indeed, a glorified earphone. The type of loudspeaker selected will depend, of course, on the circuit.

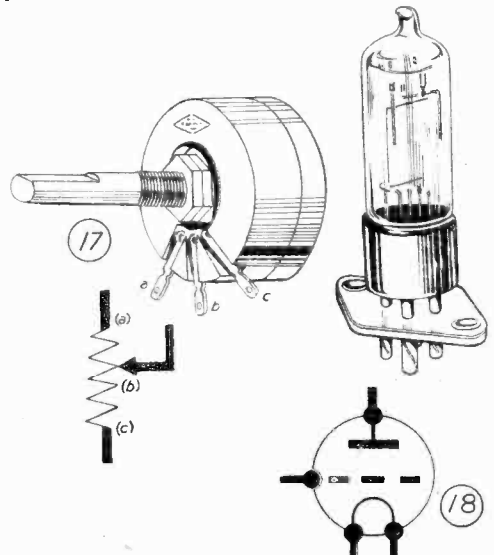

Fig. 15.—A volume control and the extra valve.

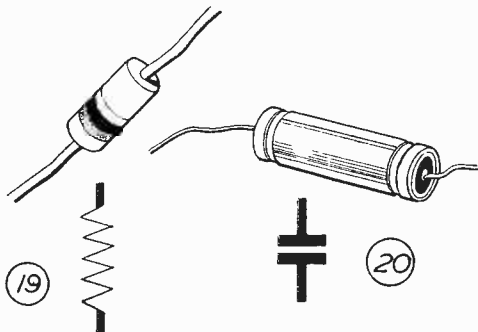

Fig. 16.—Two of the new components which form part of the R.C.C. coupling.

The early types of loudspeaker consisted of a strip of iron, fixed at one end, the free end being above and close to the pole of a small magnet. To the strip of iron, or armature as it is properly called, was fixed a thin rod on to which a cone diaphragm may be fixed. The windings of the magnet are connected in the output circuit of the last valve of the set. As the current changes, due to either speech or music passing through this magnet winding so the pull on the armature is varied, with the result that the vibrations are transferred to the cone, and so the sounds are made audible. It will be obvious that the armature will always tend to return to its normal position and this natural restoring force gives rise to its first fault, namely, resonance. Again, the current fluctuation due to a very low note, such, for instance, as the beat of a drum, are very great and should result in a large movement of the armature. As the armature is rather rigidly held, it must be arranged close to the pole piece in order that the weak impulses may affect it.

The *balanced armature* loudspeaker was introduced to avoid the principal fault of the first type of speaker, namely, resonance. The armature is less rigidly arranged in between two magnets. There is therefore an equal pull in each direction and this tends to make the armature move about a central position, avoiding the natural restoring force which was noticed in the simple type of movement. The gap between the magnets may be fairly large and so greater signal strength can be handled without risk of "chatter."

The inductor dynamic was the nearest approach obtained to the ideal in moving-iron speakers. In both of the previous movements it is obvious that as the iron armature is fixed at one end, there must necessarily be a certain amount of resistance to overcome in order to vibrate the armature and the tendency of the armature to return to its position of rest will always be present, no matter what electrical impulses are at work. This prevents the slow oscillation necessary to produce, say, a pedal note on the organ, and, in addition, the cone is not operated in a direct push-and-pull movement. The actual direction of the movement of the cone, to produce the true tones, should be what might be termed a "piston" movement: that is, it should move in a horizontal plane. Now, as one end of the armature in the speaker movements so far described is fixed, it is obvious that the operating reed is taken

through a small arc during its to-and-fro movement. This gives rise to a form of distortion.

To overcome all these defects in a moving-iron loudspeaker the moving-coil was produced.

Moving-coil Speakers

The moving-coil speaker is, of course, the best type of speaker yet designed and provided one of the best makes is obtained, either permanent magnet or mains energised is capable of giving reproduction identical with the original. At the point of the cone diaphragm a light ring of paper is fixed, round which is wound a coil of wire known as the "speech coil or winding." In the mains energised speaker a metal cylinder, having a central rod (the "pot" and "pole-piece"), contains a large winding which has to be connected to some source of direct current. The actual voltage depends on the design of the speaker and varies from 4 volts to 150 volts. In the other models the winding is replaced by a powerful permanent magnet. The speech winding is supported in a small gap surrounding the pole piece and this gap should be as small as possible. Usually it is approximately $\frac{1}{16}$ in. When the field is "excited," which means when the current is applied to it, a magnetic field is set up across the gap. The speech coil is connected to the output valve of the receiver and when the signal impulses flow through this speech winding it vibrates, travelling in and out of the gap. The edge of the cone is supported in some way, either by a ring of leather or rubber and, therefore, the cone makes a true "piston" movement, resulting in a faithful reproduction of the received sounds. The only faults with this type of speaker arise from faulty design and are: too heavy a speech coil and cone; resonance set up by the rubber or leather fixing ring; resonance due to the material of which the cone is made and one or two other little points.

To get the very best from a moving-coil speaker, a fairly strong signal is desirable, and as it can give such a good performance, the receiver should be

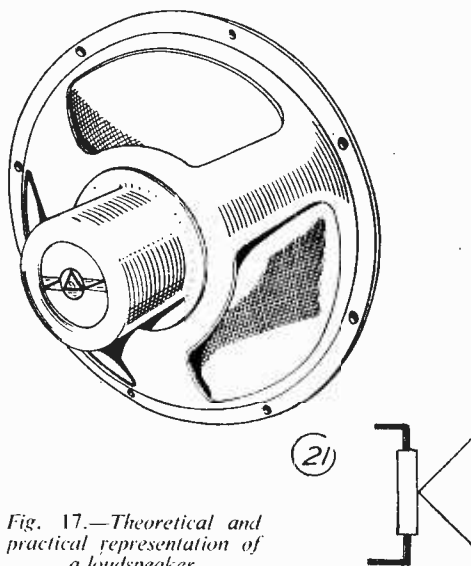

Fig. 17.—Theoretical and practical representation of a loudspeaker.

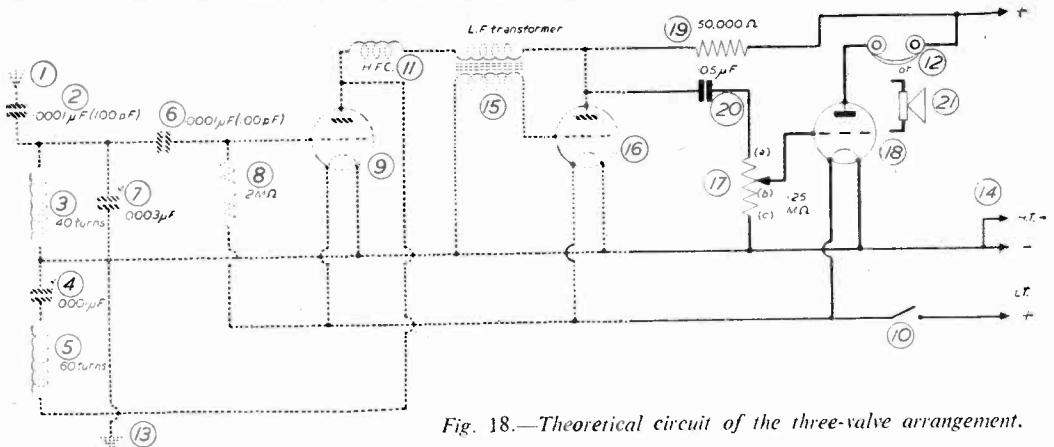

Fig. 18.—Theoretical circuit of the three-valve arrangement.

designed to give out a signal to justify the use of such a speaker. Particular care should be taken to look after the lower notes in the musical scale, as these can be dealt with so effectively by the moving-coil speaker.

Matching the Impedance.—No matter which type of speaker it is intended to use there is one point which applies to the *correct* employment of any speaker and that is, the impedance of the speaker must be matched to the output valve. This means that a certain valve will only give straight-line reproduction with a certain impedance in its anode circuit, and although valve manufacturers give this impedance figure in the leaflets accompanying their valves, unfortunately loudspeaker manufacturers do

not always give the impedance of their products. Usually, only the D.C. resistance is given and this does not enable one correctly to match up the speaker. There are on the market, however, certain output matching transformers which have various ratios, and if the listener desires to get the best from the set, one of these transformers or matching units must be included in the output circuit, and by adjusting it to various values it is possible suitably to match up the speaker. One final word. As the speaker can only reproduce what is fed into it, the choice of circuit should receive as much, or even more, care than the choice of speaker.

(To be continued)

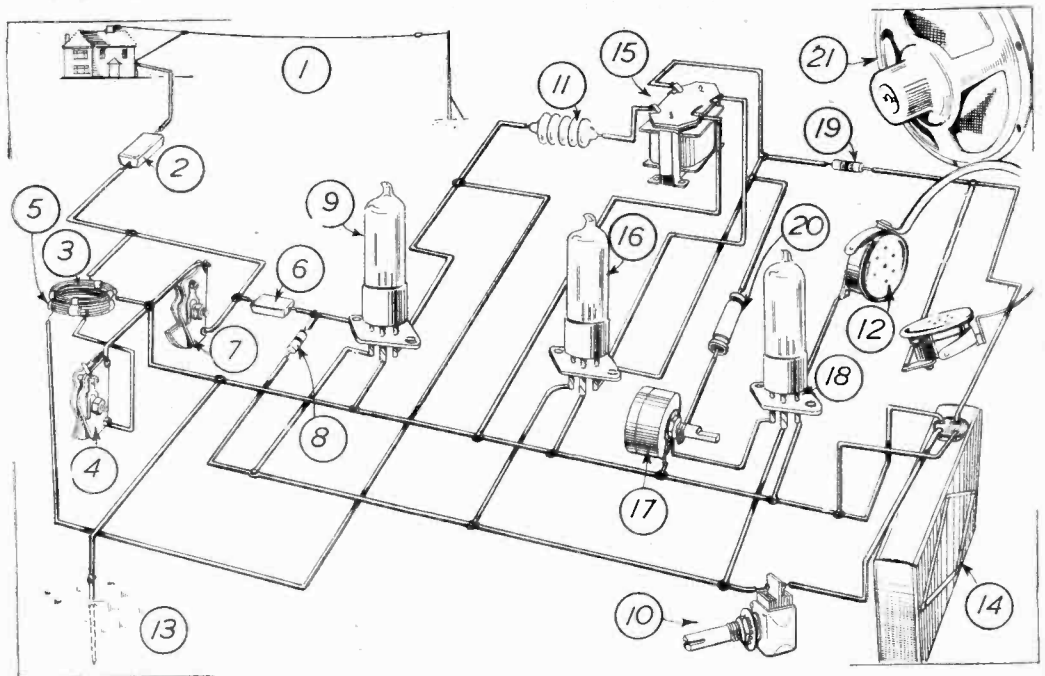

Fig. 19.—This is a pictorial arrangement of the above circuit, which may be easier for the novice to follow.

Musical Identification Signals

A SUMMARY OF SOME OF THE MORE POPULAR MUSICAL INTERVAL AND IDENTIFICATION SIGNALS USED BY FOREIGN TRANSMITTERS. A SPECIAL ARTICLE FOR THE LONG-DISTANCE LISTENER

MANY amateurs find their greatest interest is in the logging of long-distance stations, and the smaller and less unpretentious the receiver, and the farther away the station the greater the satisfaction. Unfortunately, for many, the language difficulty prevents satisfactory identification, but there is one form of signal which is fairly easily recognised and many foreign stations use these signals, in some cases at short intervals between items, and in other cases they are repeated for long intervals between separate transmissions. An interesting form of short-wave logging may consist of tuning the various musical items, but it should be noted that these may be heard on a number of different frequencies. Although many foreigners give details of the frequencies in use, these change according to the time and in some cases they are beamed in different directions, and thus may not be heard at a stipulated time owing to the signal being too weak on account of its directional properties. No guide can be given as to this, as listeners will reside in different parts of the world, and therefore the following data should be taken only as a guide.

Types of Signal

In some cases the musical item will be played on a piano, in others on an organ, by an orchestra or a solo instrument peculiar to the country. As a good instance most listeners will be familiar with the old English tune "Oranges and Lemons," and this is played by the BBC in four different ways. One may be heard on the Novachord and three on a Novachord-Celeste, these being of different duration. The tune is unmistakable and this is the pitch and timing:



Another familiar British signal which is familiar to listeners at home, as well as in all parts of the world is that used during the war to identify this country and which consists of the first few notes of the Beethoven — thus:



This is played on a pair of tympani.

Austria

Dealing now first with the principal European countries (in alphabetical order) the well-known "Blue Danube" of Strauss is unmistakable.



These four bars are repeated *ad lib.* It may be heard on a musical-box as well as in orchestral versions.

Other musical signals may also be heard from Austria and are as follows:



Again, these are generally played on a musical-box and are national or local folk tunes. As relays are made from different stations we do not propose to detail the individual stations but merely to give the country as in most cases this will suffice for identification purposes.

These are the principal musical signals heard from Austria, although one should not be surprised to hear "Rule, Britannia," which will identify a transmission by the British Forces Network in Austria.

Belgium

In Belgium there are transmissions in French and Flemish, each being identified by its particular melody. The French network plays the following extract



which is from Gretry's famous melody "Ou peut-on être mieux."

The Flemish network plays an extract from Rubens' cantata by Peter Benoit:



Czechoslovakia

There are a number of tunes played from Czechoslovakian stations, the principal ones being those played on harp, trumpet and a carillon. They are

quite unmistakable. From Prague the harp may be heard playing a Smetana air thus :



Macedonian relays are made from Prague centre with the trumpet fanfare from the march "The New Life," by Josef Suk, as follows :



Relays from Brno use the carillon, which plays the beginning of a folk song "Moravo, Moravo," which sounds like this :



Again, frequencies or wavelengths are not given, but the signals may be heard on long and medium waves as well as on the short waves.

Denmark

There are two programmes (somewhat corresponding to our Home and Light) broadcast from Copenhagen and certain relay stations, on medium and short waves. In addition to the announcements which generally include the word "Danmark" which will readily be identified, the Programme I transmission uses as an interval signal part of an old Danish folk-song :



Chimes, recorded from the Town Hall, Copenhagen, are also interspersed as an interval signal.

Programme II relays the following short air :



An overseas service is radiated on the short waves and each of these transmissions commences with the chimes of the Town Hall already mentioned, followed by the National Anthem. For their interval signal these transmissions take the first movement from "Som en rejselysten Flaade," which sounds like this :



Again most announcements introduce the name of the country followed by other identifications but in Danish.

Finland

Broadcasts from Finland may be heard on long, medium and short waves, Lahti on 1,181 metres being quite a popular long-wave signal. Amongst other stations, Finland also broadcasts the orchestral A, usually at 8.45 a.m. From Lahti and Helsinki the usual interval signal, based on an old Finnish melody, "Kantelemelody," sounds like this :



From Vaasa the first notes of "Vasa March" are heard :



whilst from Kuopio the first notes of a well-known song about the beauty of "Kallavesi" are played. The following is the air :



It will not be difficult to recognise Uleaborg which radiates the following melody in the form of Lapp yodelling :



It should be pointed out for those who have some knowledge of languages that confusion may exist on these stations (without the benefit of the musical identification) due to the use of Swedish in many of the announcements.

(To be continued.)

A Small Local-station Receiver

USING DEAF-AID VALVES THIS IS A MOST COMPACT RECEIVER FOR HEADPHONE RECEPTION ONLY

By N. J. Wadsworth, B.Sc.

THE receiver described below fills the need for a very small simply-operated receiver which will receive local stations at good earphone strength, using only a short flexible wire aerial. It may also be used as a high gain audio amplifier if desired. By using "deaf-aid" type valves it is possible to build a 3-valve, battery-operated receiver with continuous tuning covering both medium and long waves which, complete with batteries, measures only 4in. x 2.4in. x 0.9in. over knobs. Owing to the very low current consumption (500 μ A. at 22.5 v. and 25 mA. at 1.4 v.) the running cost is less than 0.4d. per hour. The controls are On/Off, Tuning and Wavechange. It is found that a volume control is unnecessary as to reduce volume it is only necessary to detune slightly (selectivity being low enough not to give "side-band slash") or move the aerial. The tuning gives continuous coverage, this being preferred to the pre-set type in that the received stations are not fixed and when one changes one's district no adjustments are needed.

Circuit

The circuit is shown in Fig. 1. It will be seen that it consists of a 3-valve resistance-capacity coupled A.F. amplifier using deaf-aid type valves. No grid leak is provided for V3 as it is found that when connected as shown, the grid potential is that of the negative end of the filament, which is the recommended operating point, and that when a large signal is applied it moves negative so the positive peaks just reach this potential. If there were a grid leak the behaviour would be the same, and a larger grid current would be drawn, possibly resulting in increased distortion. Thus a component is saved with no loss of performance. The paralysis time after a large overload proves to be short enough not to matter due to inevitable leakages and grid current (a resistance of 1,000 M Ω to earth would give a time constant of 0.1 sec.). C8 is necessary to prevent the high-frequency oscillation which otherwise occurs due to the high gain, high impedance, and small size of the amplifier.

V1 is used as a leaky grid detector with R1, its grid leak, returned to the positive side of the filament. Only one tuned circuit is used in order to keep the size as small as possible and to simplify tuning arrangements. As the coils are, of necessity, mounted very close to the walls of the case, some damping is inevitable, but it is found that by using wave-wound Litz wire coils, together with careful construction, the Q, including the losses due to the aerial, is over 50 on both medium and long waves. This is sufficient to separate all but very close stations, and in practice proves satisfactory if only local stations with high

field strength are wanted. Owing to the low working mutual conductance of V1 (about 30 μ A/V) it was found impossible to obtain a significant amount of reaction, and so none was used with a consequent simplification of switching problems.

In the original model the now obsolete Hivac type XWO.75A was used for V1 and V2 and took a filament current of about 30 mA. at 0.625 v. each. These may be replaced by the more recent, and smaller, XFW30, which only consume 12.5 mA. at 0.625 v. and give approximately the same gain. The output valve is Hivac type XFY21, which has an anode current of 380 μ A. at 22.5 v. and a filament current of 12.5 mA. at 1.25 v. with a mutual conductance of 410 μ A/V. The dimensions of these valves (excluding leads) are XFW30 8.0 mm. x 6.0 mm. x 27 mm., XFY21 9.8 mm. x 7.2 mm. x 38 mm. The anode current of the output valve is quite sufficient to produce adequate volume in a normal 2,000 Ω earphone, and, if desired, a number of earphones may be connected in series in the anode lead.

CONSTRUCTION

The Amplifier Panel

The audio amplifier V1-V3 with associated components is constructed on a $\frac{1}{32}$ in. paxolin panel. The layout of components on the underside is as shown in Fig. 2. Along one edge are 14 12 BA nuts and bolts, as shown, which make the connections to the valves on the opposite side of the panel. Connections to the phones are made by two 8 BA nuts and bolts in the position shown. In order to keep the total size small, miniature components are used throughout. The 0.01 μ F capacitors C3 and C6 and the 0.005 μ F C8 are Hunts' metallised paper type W99, which measure only $\frac{1}{16}$ in. in diameter by $\frac{1}{8}$ in. long, and C4, 0.04 μ F, is the same type, size $\frac{1}{8}$ in. dia. by $\frac{9}{16}$ in. long. They are 150 v. working. The intervalve coupling capacitors, C5 and C7, must

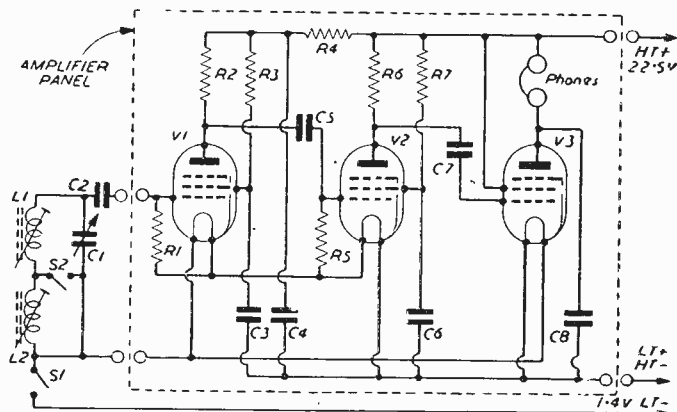

Fig. 1.—Theoretical circuit of the receiver. An aerial is joined to the junction of C1 and C2

have very high insulation resistance, which rules out some miniature types. The same Hunts' type may be used or other thinner and longer ceramic types. The resistors used are Erie type 5B, which measure 7/64in. in diameter by 9/32in. long and must be covered by a length of sleeving as they are uninsulated. If desired, one or two may be of the more easily obtainable "1/4 watt" type, Erie type 16, but owing to their larger size, 5/32in. dia. by 7/16in. long, the layout gets very crowded if many are used. Wiring should be kept as short as possible, and care taken to keep the input and output well separated.

The panel is removable and connections to it are made by means of wires brought out as shown. The details of this arrangement will be considered later.

The valves are mounted on the other side of the panel, as shown in Fig. 3. The wires are cut off at a suitable length and hooked round the appropriate bolt. Those going to the far row of bolts should have short lengths of sleeving slipped over them to prevent their touching the near row. It will be noted that the common filament leads of V1 and V2 are taken to the same bolt. When mounting the valves it is, of course, essential to get them the right way round and the red mark on the valve pinch, indicating the anode, should be used as a guide. To hold the top of each valve down a loop of cotton, or preferably thin elastic, is tied through small holes in the paxolin and slipped over the valve.

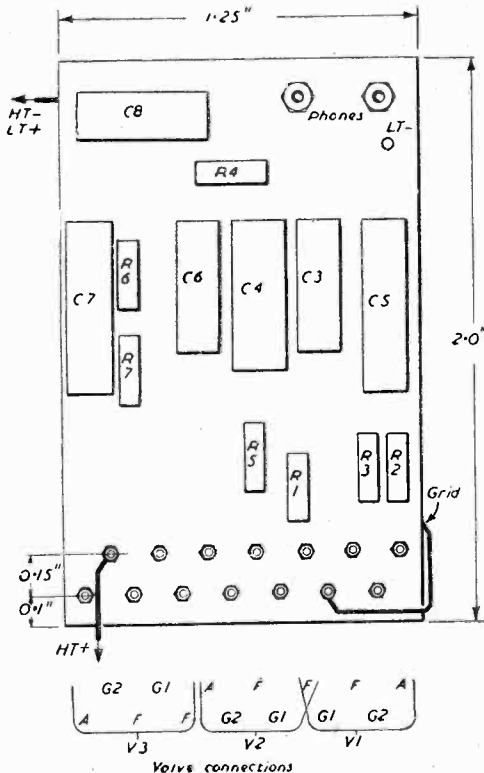

Fig. 2.—Underside of amplifier panel.

The Case

The layout of the case is shown in Fig. 3, its inside dimensions being 3.5in. x 2.1in. x 0.75in. It is made of thin wood, the bottom, the end opposite the controls and the lid being 1 mm. thick plywood, the control panel is made of 1/8 in. paxolin and the remaining two sides of slightly thicker (3/16 in.) plywood. The bottom and ends are glued to the sides, and the lid is fixed on by two pieces of black plastic tape. This makes a firm box and the plastic tape acts as a hinge. When completed the box may be painted with black, glossy dope, or any other finish preferred applied.

COMPONENT VALUES		
R1—1 M Ω.	C1—see text.	C8—0.005 μF.
R2—1 M Ω.	C2—100 pF.	L1—M.W. tuning coil.
R3—3 M Ω.	C3—0.01 μF.	L2—L.W. tuning coil.
R4—150 K Ω.	C4—0.04 μF.	S1—on/off
R5—5 M Ω.	C5—100 pF.	S2—wave change.
R6—1 M Ω.	C6—0.01 μF.	V1, V2, XFW30.
R7—3 M Ω.	C7—100 pF.	V3, XFY21

Inside at the right is the battery storage space. The batteries used are Ever Ready B122 for the 22.5 v. H.T. and either half a 3 v. pen torch battery or the Vidor Kalium V0107 for the L.T. The Kalium cell costs considerably more than the half pen torch battery but lasts much longer. On this load it is slightly more expensive in the long run but is more convenient as it does not need changing so often. The bottom of the box is raised here by 0.15in. by a piece of wood fixed to the bottom, so the batteries cannot rattle. Connections are made to the batteries by pieces of spring metal bent as shown and fixed to the walls by small nuts and bolts. These springs can be made from the remains of an old mica compression trimmer. A wire is taken from the L.T.—connection to the switch S1. The H.T.+ connecting spring is bent, on the other side of the bolt to the battery, into a small spring hook. The H.T.+ connection from the amplifier panel consists of a piece of bare wire projecting downwards which engages in this hook. The spring connecting H.T.— and L.T.+ is left loose on its fixing bolt and the long bare H.T.— L.T.+ connection from the amplifier panel placed behind it. When the batteries are inserted the spring keeps good contact between them and the wire.

The variable tuning capacitor C1 is a mica compression type and is constructed as follows. Two 250 pF compression mica capacitors, of a small type with a low minimum capacity and few plates, are taken to pieces and the ceramic base from one of them used as a template to drill fixing holes in the paxolin end in the position shown. Both ceramic bases are then broken to get the brass inserts that the controlling screw goes through. The central hole in the paxolin is then enlarged till the insert is a tight fit and the insert glued in position. The plates and mica from both trimmers are then reassembled in the one place on the paxolin, taking care to bend the plates slightly alternately one each way so they will spring apart when pressure is released. The place of rivets in the original trimmer is taken by small nuts and bolts. A small knob is now fitted to the centre screw of one of the trimmers, or a longer one

of similar thread, and this is screwed into its hole from the outside. When it is right through the plates a nut is put on its end, over a washer, and soldered on. If this is done securely it will be found that as the screw is screwed out the stack is compressed and its capacity increased. If any trouble is experienced due to movement of the plates or mica, a small paxolin strip may be glued to the paxolin panel on each side of the stack to prevent movement. In the writer's model the capacitor so formed had a capacity range of 70 pF to 350 pF, the low maximum capacity probably being due to kinking the metal plates while mounting them.

At the other end of the paxolin a hole is drilled and the remaining brass insert fixed in position. As with the other it should be pushed in from the outside, so the flange stops it slipping right through. A plate from another trimmer is then stuck flat on the inside of the paxolin with its hole clearing the screw to be put through. A second plate is then fastened at one end by a nut and bolt and bent to be parallel to but not touch the first. A screw with a knob on is then screwed through as before and a nut soldered on the end over a washer. When this screw is unscrewed the two plates are forced together and make contact. This is the on/off switch S1. If suitable knobs are not available they may be made from ebonite sheet.

The coils should now be mounted. Osmor "Q" coils are used as they are of small physical size, have adjustable iron-dust cores, and are wave-wound with Litz wire. L1 is type QA8 with the aerial coil, the smaller one at the top of the former, removed together with the tag ring. The mounting projections have to be cut short to fit the box and the continuation of the former below them removed. The remaining coil and former is then fixed to the wall as shown. This may be done by two 12 BA nuts and bolts passing through new holes drilled in

the shortened mounting projections or by "Durofix" cement. If possible, a combination of both methods should be used. Previous to finally sticking it in position, a hole should be drilled in the wall permitting adjustment of the dust core when mounted. This allows the range covered by C1 to be varied slightly.

L2 is Osmor "Q" type QA9 with the aerial coil, tag ring, mounting projections and continuation removed as for L1. Owing to the larger coil size it is not possible to fix this with nuts and bolts, and "Durofix" alone must be relied on. It seems quite satisfactory. No hole is made for adjusting the core, as it never needs touching after the initial setting up, and then it can be got at by removing the core from L1 and passing the blade of a screwdriver through L1 to reach it. Before finally fixing L2 in position, a small hole is drilled in the former at the top end and yet another plate from a trimmer is fixed on with a small nut and bolt. If the head of the bolt is inside it will still be possible to get a small screwdriver past to adjust the core. The plate projects beyond the end of the coil and a tapped hole is made in the paxolin opposite the end, enabling a screw to be screwed through to press against this flexible plate. A small piece of spring metal soldered to the coil side of S1 presses against this screw to earth it. This is S2, the wave-change switch. When soldering wires on to the plate mounted on L2 it is necessary to do it very quickly to prevent the coil former melting. When wiring up the coils, care should be taken to ensure that the outside of the coil is made the earthy end to reduce dielectric loss.

A hole is drilled in the paxolin by L2 to admit the aerial, a few feet of thin flexible PVC covered wire, and a notch is made in the exposed edge to allow the earphone cord to pass out.

(Concluded on page 394)

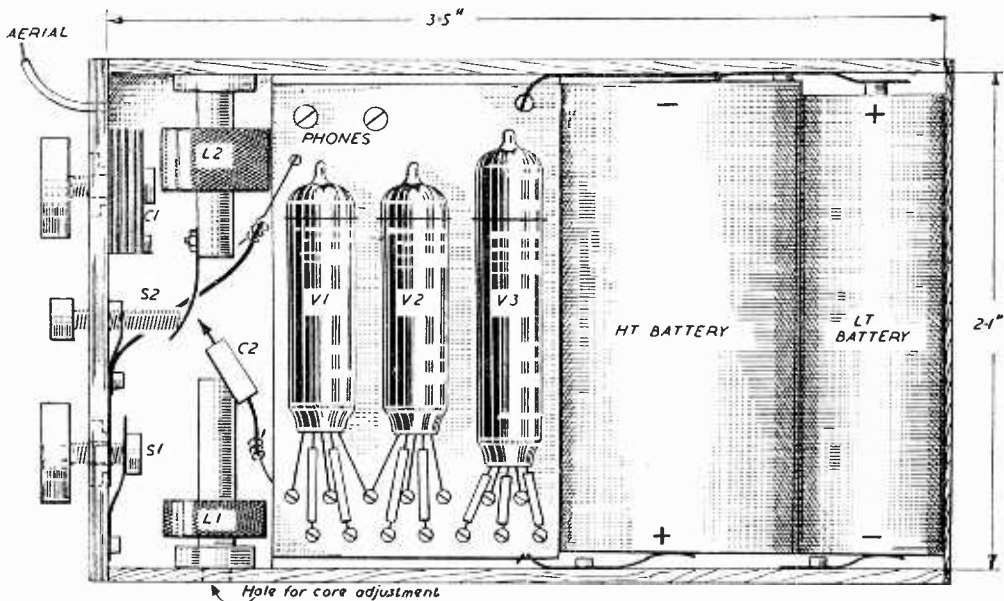

Fig. 3.—Pictorial illustration of the layout used in the original.

NOISE AND THE R.1155

IMPROVING THE PERFORMANCE OF THIS POPULAR EX-R.A.F. RECEIVER

By C. B. Cruickshank

THE main complaint against the ex-R.A.F. receiver R.1155 has been its high noise level. As most of the noise is generated within the valves, particularly the R.F. stage, the obvious thing to do is to install modern miniature tubes. For the average amateur this would be fraught with difficulties, mostly mechanical, though the cost of miniature valves will stop many reaching the stage of mechanical difficulties. There is also the problem of adjusting plate, screen and bias voltages, to say nothing of realignment.

It has been found that by substituting VR91's (EF50) for the R.F. stage and both I.F. stages, a considerable improvement in signal-to-noise ratio can be achieved without altering plate or bias arrangements. Alteration to the screen voltage is achieved by shorting out the 27K Ω resistor connected between H.T. line and pin four of the existing valveholder.

Unfortunately, EF50 valveholders (B9G) require larger holes in the chassis than international octal holders, and as the hole for the R.F. stage holder would have to be enlarged over the coil pack, with consequent possibility of cuttings shorting switching arrangements, the following method was adopted.

Changed Valves

Obtain three international octal valve bases—your local radio dealer will let you have three dud Int. Oct. based valves if you approach him properly—break the glass envelope and prise the bottom of the envelope away from the plastic base. Inside the base you will find a layer of brown-coloured cement (used for fixing the envelope to the base) which can be scraped out with a file. The wires from the envelope to the base are removed by applying a soldering iron to the pins and pulling the wire with pliers. After this operation it should be possible to see through each pin.

Set the prepared bases aside and solder short lengths of wire—say 3 in.—to pins 1, 2, 3, 7 and 9 of a ceramic B9G valve holder. Connect pins 4, 5, 6 and 8 together and take the wire to the centre tab on the holder so that there will still be about 3 in. of wire loose. Push the lead from pin 1 of the ceramic holder into pin 2 of the octal base and so on, as per the following table:

EF 50 Ceramic Holder		Int. Oct. Base
Pin 1	into	Pin 2
" 2	"	" 4
" 3	"	" 3
" 4, 5, 6 and 8	"	" 8
" 9	"	" 7

The lead from pin 7 of the ceramic base should be taken through a hole drilled in the side of the octal valve-base. The best position for this hole can

easily be seen after the various leads have been entered into the base.

Twenty-four gauge enamelled wire was used in the original conversion, and it should be emphasised that only the minimum amount of enamel should be removed for soldering purposes to avoid shorting valve electrodes.

By means of the wire ends pull the holder down on to the base. It will be found that the tags on the underside of the holder will fit inside the octal base. The next step is to scrape the enamel away from the wire where it protrudes from the valve base pins and solder the wire to the pins, clipping off excess wire. The adaptor is now ready, but should be checked with an ohm meter or torch bulb in series with a suitable battery, e.g., with one prod in pin 1 of the ceramic holder, continuity should be obtained only from pin 2 of the octal base, and so on.

EF50's are designed to operate with 250 volts on both screen and anode, so the screen resistors should be shorted as already described.

Operation

Insert an EF50 in the adaptor and put it in the R.F. stage first, solder the lead which sticks through the valve base to the lead which was formerly on the top cap of the replaced valve. Connect up to the power pack and be surprised at the vast improvement. Some indication of the improvement may be obtained when you consider that in the writer's set it was possible to hear a harmonic of TV sound around 17.3 Mc/s, which was just readable and no more with all controls wide open. After the conversion the harmonic was *partially closing the tuning indicator*.

Depending on the type of octal valve base obtained, it may be necessary to remove the screening can base from the chassis of the set to permit the valve to seat properly. In any case, the original screening can may be put in the junk box.

The conversion will result in a maximum increase of about 12 milliamps in H.T. consumption although heater current remains the same.

Ceramic holders have been specified because their tags are closely spaced and fit inside the valve base, whereas most Paxolin holders do not.

REFRESHER COURSE IN MATHEMATICS

Fourth Edition

By F. J. CAMM

8/6, by post 9/-

FROM

GEORGE NEWNES, LTD.,

Tower House, Southampton Street, Strand, W.C.2

A SUPERHET FOR BEGINNERS

CONSTRUCTIONAL DETAILS OF A 6-VALVE A.C. RECEIVER USING MINIATURE VALVES

By R. Hindle

THE receiver here described has been specially designed for the beginner who has never made a receiver before or for the reader who has not previously constructed any but the simpler type of receiver. At the same time, the results are very good and the design can be well recommended to the more knowledgeable constructor who is looking for a good sound receiver following more or less conventional lines but making use of the latest components and valves.

Circuit

It will be seen from Fig. 1 that six valves in all are used if the rectifier (V6) is included. V3 is a double-diode detector and V4 is an audio amplifier, and the two functions are commonly combined in a double-diode-triode so the circuit boils down to the popular four-valve plus rectifier variety. Separate valves are preferred for the present design because a better layout is obtained and the beginner will find it much easier to wire and to set up the receiver satisfactorily. It is technically preferred also because the need to adapt the circuitry to allow for the common cathode for diodes and amplifier is avoided, and a pentode can be employed for audio amplification, properly biased and set up to give high gain with a minimum of distortion.

The design has been developed round the new miniature valves. The beginner will most probably have no stock of valves and he will prefer to begin his set-constructing career with the latest components. The more experienced man, too, will find it refreshing to contemplate the use of these types in place of the more common octals.

Undoubtedly, the greatest difficulty of the beginner is to align his receiver correctly after construction, and clearly the first step is to choose tuning components that will require the minimum of adjustment and no special test gear. The easiest way is to purchase the tuning coils in pack form, prealigned by the manufacturer. The final adjustments have then merely to allow for the slight variations in wiring and construction, and these variations can be minimised by careful design so that leads are short and direct and cannot vary greatly as between one constructor and another. A coilpack fulfilling these requirements is the well-known and efficient Osmor, used in popular designs previously published in these pages.

The standard coilpack used in this design gives three ranges, i.e., long, medium and short wavebands. This will suit most people, but the pack is made also with two short wavebands and without the long waves. This could be substituted if more suitable to the constructor's purpose. On medium and long wavelengths the aerial is coupled into the grid circuit of V1 by virtue of C1. The aerial current develops a signal voltage across the condenser which is also in the tuned grid circuit, and consequently the voltage across it is injected into the tuned circuit. This circuit has a high Q and consequently a well-amplified signal appears at the grid of V1. The primary of the

short-wave aerial transformer, however, is too small to have much effect at these frequencies, even though it remains in the aerial circuit, but at the higher frequencies covered by the short-wave range the tables are turned; the reactance of C1 now becomes negligible and the short-wave primary takes control. This circuit avoids the need to introduce switching, with possible resulting loss, into the aerial circuit. A switch has to be used, of course, to select the appropriate tuned circuit for connection to the grid of V1.

The only difficulty with this "bottom end" coupling circuit is that the aerial lead tends to pick up hum interference, to which C1 presents a high impedance so that the hum potentials are passed to the grid of V1 and (via the AVC circuit) to later valves, where cross-modulation takes place and no subsequent measures can remove the hum. The R.F. choke across C1 completely eliminates this trouble, providing a comparatively low impedance to hum potentials, whilst having an impedance to R.F. signals sufficiently large not to upset the coupling arrangements. The self-capacity of the choke becomes part of the coupling capacity and so has no ill-effects. For this reason it is better to put the choke across C1 as shown, and not across from aerial to earth, because in the latter position the self-capacity of the choke is across the short-wave primary to the detriment of short-wave results. AVC is lead to V1 via the bottom ends of the aerial coils. Trimmers are shown across all coils, these being incorporated in the coilpack and consequently have not been given a "C" number. C1, C6, C7, C8 are also in the coilpack. VC1 is the grid-tuning condenser which is ganged to VC2, the oscillator tuning condenser.

V1 is a noval-based 12AH8 triode-hexode frequency changer. The usual 465 kc/s I.F. is used and so the triode section has to be made to oscillate at 465 kc/s above the signal frequency. The usual padders and trimmers are employed for the purpose of tracking (i.e., to ensure accurate ganging of the two tuning condensers), all these being in the pack. The padders (C7, C8) are also used for bottom-end coupling on medium and long waves, being common to both anode and grid circuits of the oscillator. On short waves a transformer is again used. The 100-ohm resistor R6 is introduced to stabilise the oscillator grid current at about the optimum value. This grid current serves to bias the oscillator by virtue of the voltage built up across the grid resistance, stabilised by the grid condenser C4.

V2 is a B7G based 6BA6 and is used as a normal I.F. amplifier, coupled by I.F. transformer to preceding and succeeding valves. AVC is fed via the secondary of the first transformer to the grid of the valve.

The signal rectifier is the right-hand half of V3, a B7G based double-diode type 6AL7, working into a series load, the volume-control VR1 being the load and R11, C13, C14 forming a filter to eliminate the intermediate frequencies that have now done their work and are no longer required. The AVC

COMPONENTS LIST

- C2, 5, 9, 12, 15, 19.—1 μ F. 250 v. Doublier type 410.
 C3, 11, 13, 14.—100 pF. Hunts type B822.
 C4.—50 pF. Doublier type S635.
 C10.—05 μ F. 250 v. Doublier type 410.
 C16, 18.—8-8 μ F. B.E.C. miniature elec.
 C17, 22.—25 μ F. 25 v. elec. Doublier type BR252A.
 C20, 21.—16-8 μ F. Doublier type CT16850. elec.
 R1.—100 K Ω . $\frac{1}{2}$ watt.
 R2, 3, 7.—33 K Ω . $\frac{1}{2}$ watt.
 R4.—220 Ω . $\frac{1}{2}$ watt.
 R5, 11.—47 K Ω . $\frac{1}{2}$ watt.
 R6, 9.—100 Ω . $\frac{1}{2}$ watt.
 R8, 10, 12.—1 M Ω . $\frac{1}{2}$ watt.
 R13.—500 K Ω . $\frac{1}{2}$ watt.
 R14.—22 K Ω . $\frac{1}{2}$ watt.
 R15, 18.—220 K Ω . $\frac{1}{2}$ watt.
 R16.—2.2 K Ω . $\frac{1}{2}$ watt.
 R17.—4.7 K Ω . $\frac{1}{2}$ watt.
 R19.—220 Ω . 1 watt.
 VR1.—220 Ω . 1 watt. Volume control with two-pole switch.
 I.F.T. 1, 2.—2 I.F. Transformers. Wearite type M800.
 One H.F. Choke. Osmor All Wave.
 Ch.—1 L.F. Choke. Osmor Smoothing Choke.
 One Output Transformer. Osmor single ratio for 6AQ5 to 3 ohms.
 One mains Transformer. 250-0-250 and 6.3 v. Osmor.
 One two-gang Condenser. 500 pF. Osmor.
 One Coilpack. Osmor type HO.
 One Dial. Osmor metal type LMS.
 One Drum, cord, drive, spring. Osmor.
 Two Valveholders. Noval (B9A).
 Four Valveholders. B7C.
 One Coaxial Plug and Socket. Belling.
 One P.M. Speaker, without transformer. Belling. 8in.
 V1.—12AH8. Brimar valve.
 V2.—6BA6. Brimar valve.
 V3.—6AL5. Brimar valve.
 V4.—6BR7. Brimar valve.
 V5.—6AQ5. Brimar valve.
 V6.—6X4. Brimar valve.
 One Chassis. Aluminum 10in. x 8in. x 3in. deep.
 Three Knobs. 1in. diameter.
 24 S.W.G. tinned copper wire.
 Sleeving. Coaxial cable and screened cable. 6BA nuts, bolts, washers. One soldering tag, with one insulated tag and earth. PVC transparent twin flex.

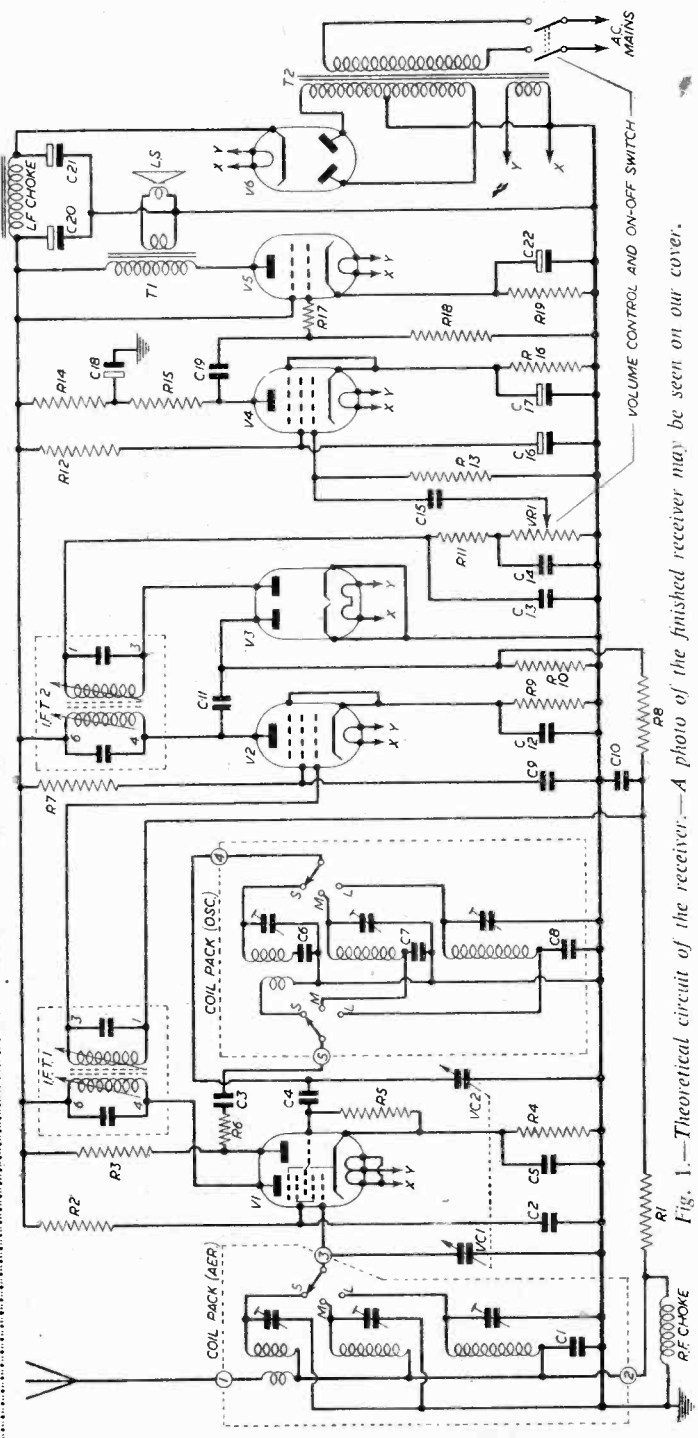

Fig. 1.—Theoretical circuit of the receiver.—A photo of the finished receiver may be seen on our cover.

-and now, a new **acos** Magnetic Pick-up

Both the G.P.32 and G.P. 31 have the same characteristics:—

- 1 Pleasing modern appearance. Provides a good standard of reproduction with normal equipment at a reasonable price.
- 2 The pick-up element incorporates a new "high permeability sintered bi-metal magnet" and employs a minimum number of moving parts.
- 3 Designed to feed into a pick-up load of 50,000 to 1,000,000 ohms and therefore suitable for use in conjunction with the majority of radio receivers.
- 4 Extremely robust and reliable with excellent tracking capabilities thus minimising distortion and record wear.

Output voltage :
 $\frac{1}{2}$ volt at 1,000 c/s.

Recommended load resistance :
not less than 50,000 ohms.

Tracking weight (G.P.32) :
56 grammes.

Tracking centres :
7 inches.



always well ahead

COSMOCORD LIMITED • ENFIELD • MIDDLESEX

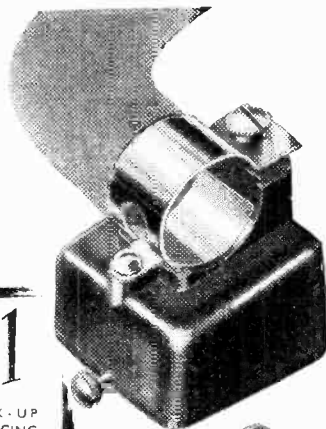

GP31
MAGNETIC PICK-UP
HEAD FOR REPLACING
EXISTING SOUND BOX
£1.1 Plus 6/9 P.T.
PRICE IN GT. BRITAIN



For Standard 78 R.P.M. Records only

GP32
MAGNETIC PICK-UP
£1.7 Plus 8/9 P.T.
PRICE IN GT. BRITAIN

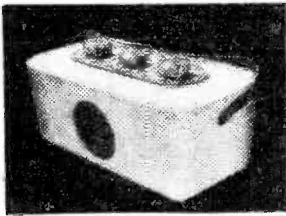

PERSONAL PORTABLE CABINET in cream-coloured plastic; size 7 x 4½ x 3in. Complete 4-valve chassis. Scale and 3 knobs. Takes miniature 90 v. and 7½ v. batteries, 9/- . P. and P 1/6.

2½in. P.M. Speaker to fit above, 13/6. Miniature output transformer, 5/-. Miniature wavechange switch, 1/6. Miniature 1-pole 4-way used as Volume and Off, 1/6. 4 87G valve holders, 2/-. Midget twin gang ½in. dia., ½in. long and pair medium and long-wave TRF coils ½in. long x ½in. wide; complete with 4-valve all-dry mains and battery circuit, 8/6. Condenser Kit, comprising 11 miniature condensers, 3/6. Resistor Kit, comprising 12 miniature resistors, 3/-. The above receiver (less valves and batteries) could be built for approximately 49/- . P. and P. 2/6. Valves to suit above, 10/- each.

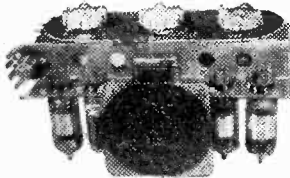

View of chassis as it would look when assembled with valves inserted.

Point to Point Wiring Diagram, 1/-.

D. COHEN

23, HIGH STREET, ACTON, LONDON, W.3

6

reel sizes

for every kind of
TAPE RECORDING

"Scotch Boy" Magnetic Recording Tape now comes in six reel sizes, to provide an even wider range of playing times for all private and profession tape recordings.

"Scotch Boy" offers uniform sensitivity, fidelity at low speeds, and high signal/noise ratio. Its medium coercivity (250 Oersted) makes for easy erase. Distortion and transfer are negligible.

Its cellulose acetate base gives strength and smoother operation in all makes of tape recorders.

300 ft. 600 ft.
1,200 ft.

2,250 ft. 2,400 ft.
3,000 ft. & 3,280 ft.



Another



Product

Used by the B.B.C.

Write for further particulars to: MINNESOTA MINING & MANUFACTURING CO. LTD 167 STRAND, LONDON, WC2 Temple Bar 6363

NEW!

**E·M·I INSTITUTES
EXPERIMENTAL KIT**

LEARN THE PRACTICAL WAY

A specially prepared set of radio parts from which we teach you, in your own home, the working of fundamental electronic circuits and bring you easily to the point when you can construct and service a radio set. Whether you are a student for an examination, starting a new hobby, intent upon a career in industry, or running your own business—this Course is intended for YOU—and may be yours at a very moderate cost. Available on Easy Terms.

WE TEACH YOU: Basic Electronic Circuits (Amplifiers, Oscillators, Power Units, etc.) Complete Radio Receiver Testing & Servicing.

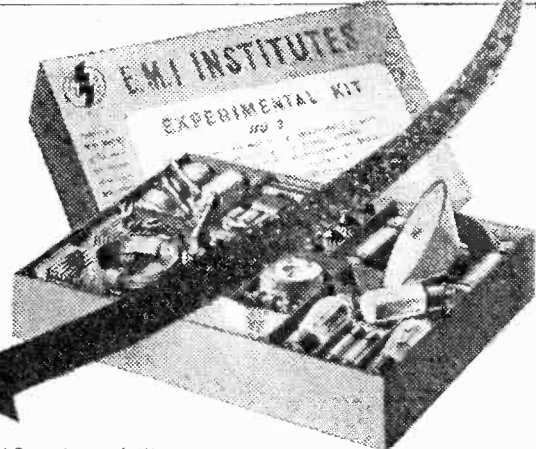

POST IMMEDIATELY FOR FREE DETAILS

TO: E.M.I. INSTITUTES Dept. 32X
Grove Park Rd., Chiswick, London, W.4

Name

Address

★Experimental Kits form part of the following courses: Draughtsmanship, Carpentry, Chemistry, Photography, Commercial Art, Etc.

EMI INSTITUTES
Associated with
MARCONIPHONE COLUMBIA & HMV

(His Master's Voice)

L.C.12

diode is fed direct from the anode of V2 to reduce the tuning hiss and uses the usual parallel load, R10, R8 and C10 being the AVC filter and time-constant determining network.

The audio signal passes to V4, a pentode amplifying valve type 6BR7, which has a noval base. The anode of this valve is decoupled by R14 and C18, R15 being the load and R16, C17 providing cathode bias. The output valve, V5, has a B7G base and is a type 6AQ5, resistance-capacity coupled and with a grid stopper (R17) in its grid circuit to prevent parasitic oscillation. The output transformer is selected to match the speaker speech coil to 5,000 ohms.

A miniature rectifier valve, V6, is also used, being a 6X6 with B7G base. This valve requires 6.3 volts for its heater but can stand 450 volts between heater and cathode so consequently a separate heater winding is not required. The transformer used has a 5-volt heater winding, but this will not suit the 6X6 and consequently is left unconnected.

Construction

The receiver is built on an aluminium chassis 10in. x 8in. x 3in. deep and as most constructors will buy this ready made Fig. 2 shows the drilling plan as on the top of the chassis. The handman producing his own chassis may prefer to drill it "in the flat" and he must remember that if he marks out according to Fig. 2 he will have to fold it so that the marks are outward. There is also the element of doubt that the components actually to be used may not conform exactly to the sizes of those used in the prototype and it is as well to make sure of this before drilling the metal. The best way for the beginner or less experienced person and, in fact, a method used often by the more experienced, is to draw out the drilling plan in full-scale on a piece of stout drawing paper rather larger than the size of the chassis so that there is a margin all round the drawing. The components are then tried for size on this drawing. When satisfied that all is in order the margins are bent down so that the paper sits snugly on the top of the chassis with the margins down the sides of the chassis, holding the paper firmly in contact with the upper surface of the chassis without a tendency to slip. The paper is then used as a template, the position of the holes being punched through with a sharply-pointed centre-punch. The round holes for valveholders and electrolytic condensers are best cut with a punch such as the Q-Max or Osmor, but if these are not available good results can be achieved, with care and patience, using a smaller drill and filing out with a round file or, for the larger holes, by drilling a series of small holes inside the circumference, again finishing off with a file. If these more laborious methods are to be used remember to scribe the hole to be cut out before commencing to drill so that an accurate guide is available whilst filing. Note that two sizes of valveholder are used,

the B7G base, requiring $\frac{3}{8}$ in. holes and the noval base requiring $\frac{1}{4}$ in. holes. The hole for the main smoothing electrolytic condenser alongside the rectifier valve is made $1\frac{1}{8}$ in. because this is the standard octal size of hole and a punch may be available. The other electrolytic situated between V4 and V5 is one of the miniature type having a diameter of $\frac{7}{16}$ in. and the hole for this is made $\frac{3}{8}$ in. the same as the noval bases. A somewhat larger component can be accommodated if the miniature cannot be obtained. The square hole for the mains transformer can be made by means of a series of small holes inside the outline, the centre being then knocked out and the hole finished with a file, or alternatively a single hole can be drilled and the hole cut by means of an Abrafile. Three of the $\frac{3}{8}$ in. holes are fitted with rubber grommets and are to allow leads to pass from above to below.

The positions of the holding down bolts for the valveholders are indicated to show the direction in which the valveholders are mounted, but it is suggested that these should not be drilled until the valveholder large holes are punched or filed out. Then the valveholders can be dropped into place, rotated until the pins are in the correct relative positions and the place for the holding down bolts can then be punched directly through the valveholder holes. The lesser experienced will find this much easier than trying to mark out all holes at the beginning. A similar procedure should be adopted for the electrolytic condenser clips, which are not marked on Fig. 2 because clips vary and the exact position of the holes is not important. In the case of these clips the method is as follows. Put the clip on the condenser so that the bottom of the feet are just flush with the bottom

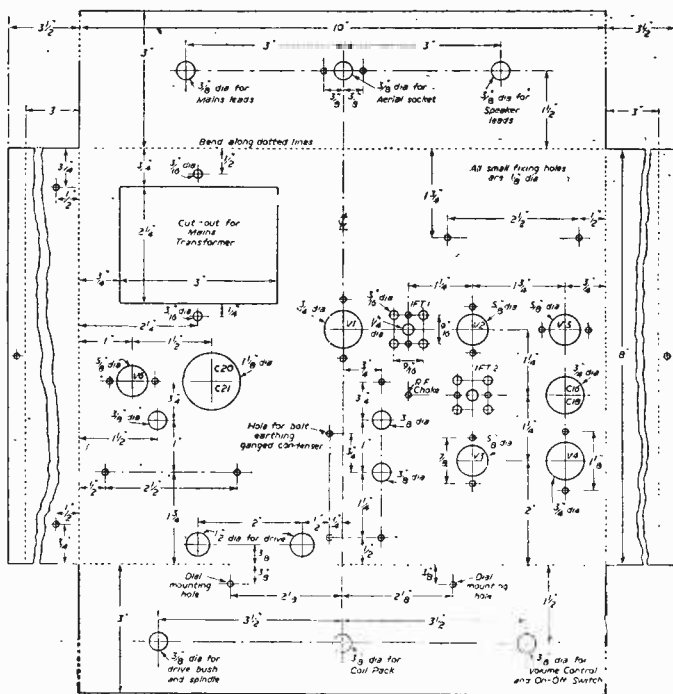

Fig. 2.—Chassis cutting, bending and drilling details.

surface of the condenser and screw up the bolt until the condenser is firmly gripped but not so tightly as to distort the aluminium can. Now sit the component over the hole punched in the chassis so that the tags are central and mark the position of the bolts with the centre-punch. As the holes for each component are completed try on the component to check the accuracy of the work and then put the component aside until all metal work is completed.

The I.F. transformers require very careful work, the holes requiring accurate placing to avoid a short-circuit of the pins to the chassis. If they are found to be slightly out when trying the component the fault can be corrected by the judicious use of a thin rat-tail file and when eventually the transformers are mounted the pins should be carefully examined to ensure that they are clear of the chassis.

The tuning condenser position is similarly critical because the spindle has to extend through the dial to carry the pointer but if it sticks out too far it will look bad and will not be easy to read. It is a good idea, having drilled the holes in the position indicated, to elongate them with the small rat-tail file in a direction towards and away from the dial so that they become slots about $\frac{1}{16}$ in. long. When mounting the condenser it can then be moved along the slots until the projection is correct. The positions indicated in the illustration are for a condenser with a 1 in. spindle. All the holes for holding down bolts are $\frac{1}{16}$ in. except those for the mains transformer which are $\frac{3}{16}$ in.

Fig. 2 gives the drilling at the front and the back of the chassis. At the front are only three large holes for the controls and two small ones for the metal dial. The small holes can be slotted vertically by means of the file, as suggested in the case of the variable condenser holding down bolts, so that the dial can be moved slightly to position the spindle centrally in the dial hole.

At the back, the central hole is for the coaxial socket which is used to feed aerial and earth into the receiver. Grommets are fitted into the other two holes, the left-hand one being for the mains lead and the right-hand one for the lead from the output transformer to the speaker, which, of course, must not have a transformer itself. If a speaker with transformer is to be used and it is desired not to remove the transformer the one in the receiver can be omitted and leads from the anode of V5 and H.T. positive brought out to the speaker, but if new parts are to be bought it is better to go in for a transformer as specified and a speaker without transformer.

Mounting the Components

When all drilling is complete the grommets can be fitted in the three holes on top of the chassis and the two at the back as indicated, and then components can be mounted. Start with the valveholders, taking care that they are mounted the right way round, with the pins disposed as indicated in the wiring diagram. This is essential if the short leads aimed at are to be obtained. The valveholders are dropped into their holes from the top. Put soldering tags under the holding down bolts as indicated on the wiring diagram and in these cases the aluminium under the soldering tag should be polished clean with fine emery cloth. It is impossible to take too much care in ensuring clean contacts wherever earthing contacts with the chassis are used and failure to do so is a common cause of such faults as instability, which are very hard to trace.

Next, mount the electrolytics and I.F. transformers, making sure that connecting tags are clear of the chassis when the component is screwed on. The smoothing choke and the output transformer follow, the latter being underneath the chassis, and then the mains transformer. The variable condenser has been left until others are mounted because it is a delicate part that must be handled with care, but it should now be fitted. Before doing so, however, solder a 4 in. length of connecting wire to each of the fixed vane tags underneath the condenser and bolt a soldering tag (again ensuring a clean contacting surface) to the hole indicated as ganged condenser earth so that the tag is above chassis. A piece of sleeving $2\frac{1}{2}$ in. long will be required on the wire nearest to the front of the chassis and a 2 in. piece on the wire to the rear section. The grommets supplied with the tuning condenser (if it is the type specified, of course, otherwise the feet may not be made to take grommets, in which case it might be found necessary to put washers underneath the feet to bring up the condenser spindle to the level of the dial hole) are fitted into the holes in the feet and the condenser can then be bolted down, interposing a washer between the bolt head and the grommet to prevent the head of the bolt from being pulled through the grommet. The connecting wires are passed through the two holes in the chassis previously fitted with grommets. The bolts are screwed until they are firm but not hard down, so that the condenser can float slightly in the rubber. Locking nuts should then be run on to the bolt. The drive drum should then be put on to the spindle with the hollow side to the front and the dial tried in place to see if it will fit properly but then put the dial aside until later.

Next, mount the drive spindle and volume control on the front and the coaxial socket at the back of the chassis. Now comes the task of threading the drive cord. The old hand will have his own way of doing this but for the sake of the beginner the following method has been found easy. With the vanes fully meshed lock the drum to the spindle with the hole in its circumference at the "9 o'clock" position (looking from the front). Now take a length of cord (say about 2 ft. ; it is as well to have a reasonable length to work with) and pass the two ends one up each of the cord holes from underneath the chassis. Pass the loop so formed over the drive spindle and into the slot in the driving head, drawing the two ends tight and holding them firmly so that the cord does not come out of the drive slot. Now bring the ends up round the drum, past the hole in the circumference and once round again, back to the hole, through which both ends are inserted. It is a little tricky to do all this whilst holding the cord firmly in the drive slot, but with a little patience it will be done. The two ends are tied firmly on to the loop of the spring so that the loop is held up to the circumference of the dial. The spring is now extended and the loop at the other end hooked on to the projecting finger across the drum. Now slacken the grub screws to free the drum from the spindle and turn the drive spindle back and forth, seeing that the movement is free. The spring will gradually take up the slack in the cord and a tight drive will be secured. Now return the hole in the drum to the "9 o'clock" position and open the condenser vanes about halfway, locking the drum to the spindle in this position.

(To be continued)

On your Wavelength

By THERMION

"Readers from No. 1"

I HAVE received a very large number of letters from readers who have taken this journal continuously from its first issue, in response to my request last month. They are all in nostalgic strain. A typical letter is that sent by Mr. J. F. Hitchcock:

"I am prompted by your invitation in this month's PRACTICAL WIRELESS to claim continuous purchase since No. 1 in 1932. I was then aged 11, and have not missed an issue yet. Unfortunately, all my pre-1940 copies (approximately 400 of them, as PRACTICAL WIRELESS was then a weekly issue) were destroyed—but I have my vivid memories of the various sets I used to build. My two most successful ones were the A.C. 'Fury Four' and the 'Vitesse' superhet, both of which gave sterling service over many years. In pre-war days my bedroom was an untidy kind of workshop-cum-sleeping accommodation—copies of PRACTICAL WIRELESS, accumulators, radio components, masses of wires from ceiling to floor, plus acid-burned sheets and blankets led to many threats from irate parents to 'throw the whole lot out of the window.'

"My most successful short-wave set was the 'Experimenter's S.W.2'—which gave me some amazing results—I well remember setting my alarm clock for 2 a.m. and getting up and searching round the short-wave bands for stations I could not receive during the evening. No wonder I was feeling tired each day at school; but in those days I just lived for wireless and all my pocket money was spent on my hobby. I remember the most useful gift I ever had was an eliminator—which supplied H.T. 150v. at 30 mA, plus L.T. and G.B. supplies—which eased the heavy financial drain of batteries and accumulators.

"My congratulations to PRACTICAL WIRELESS on its 21 years—here's looking forward to the next 21."

Many readers expressed their gratitude to this journal for their knowledge of radio garnered from its pages and which has enabled them in many cases to obtain important posts in the industry and the services.

Art Attack!

AS a result of my passing comment on art, in which I expressed a preference for radio classes in schools, it is only fair that I should permit one reader to answer for many who have written in similar strain.

What I really intended to convey was that it is more useful to-day, conditions being as they are, to train scholars in the practical crafts, or rather to lay emphasis on that training rather than to concentrate on the academic and the aesthetic. I did not mean to imply that I disliked art. It cannot be denied that art as a profession has few openings except for those trained in commercial art and it is, therefore, futile to train people for jobs which do not exist. Art, like music, should be a hobby or a sideline.

Each can only provide jobs for the lucky few, and I think my critics will agree that even those jobs do not always go to those having the greatest skill or merit—particularly in music. However, here is a letter from Mr. P. W. Feeseey, of Raynes Park:

"I, too, in common with Mr. T. W. Adams, feel that you made an unwarranted remark regarding the school art class (PRACTICAL WIRELESS, May and June). The remark is unfortunate in that some schoolmasters have helped to foster radio activities in their school. I well remember how, at my old school, we combined electrical, radio, art and handycraft activities in one of the art rooms to produce a most effective marionette theatre.

"It may be of interest to you to know that not all individuals in Chelsea to which you refer are training to be artists. Some attend an engineering college where, I can assure him, life is far from lazy.

"The world to-day may demand only commercial artists (for advertising and other utilitarian purposes) but as to what it 'requires,' that, to my mind, is one of the greatest failings of the human race to-day, in that it cannot appreciate what it really does require. This is reflected in the fact that many of the evolutions of engineering and science are misused, and also in the artless, hideous trends in design which are increasing every year.

"We technicians and scientists would be making a grave mistake by dogmatically insisting that the cold, proven facts of science are all that is needed in the world to-day; there is equally as great a need for the more aesthetic arts (of a genuine type) and that need is becoming, at present, ever more urgent."

The Effect of TV

THE newspapers continue to draw attention to the effect TV is having on national habits and family life. It is said that children are neglecting their homework, that attendances at cinemas and theatres are falling off, that the pubs are now half empty and that people are tending more to stay at home. Very true. It is equally true that less time is devoted to listening. That is inevitable. It is a good thing that national habits should change as science reveals the secrets from its Pandora's box. The same was said in 1932 when broadcasting commenced. The gramophone industry and the newspapers feared the competition of the new form of entertainment. After 30 years, however, we now know that these fears were groundless. For a few years people did spend their evenings at home listening to Murgatroyd and Winterbottom and other radio characters. As the novelty wore off, however, so did trade return to the cinema, etc. It was but a passing phase and so it will prove to be with television. People become more choosy and selective. They make dates with their radio or TV sets rather than as in the early pride of possession just sitting, listening or viewing and taking the programmes as they come.

VALVE Signal Generator

AN ALL-WAVE MODULATED INSTRUMENT FOR THE EXPERIMENTER

By F. G. Rayer

THE utility of a signal-generator is well known. It may be used for wavelength and frequency checking, and as an aid when aligning R.F., oscillator, or intermediate-frequency circuits. It will provide a signal of uniform strength so that the sensitivity of circuits can be compared, and can be used to locate the source of some kinds of receiver

For convenience, the generator uses dry batteries. A dry cell is used for filament current, and 20 to 40 v., obtained as convenient, for H.T. purposes. Due to the grid-blocking effect which arises, the anode current is well under 1 mA., and a small, "deaf aid" type H.T. battery can be used and would have a long life.

The whole generator is contained in a metal cabinet to reduce stray radiation. A reduction dial marked in degrees was used, but it would be possible to mark frequencies or wavelengths directly upon a suitable scale. In general, the dial with degree markings is easier to calibrate, since a graph may be drawn up to plot readings.

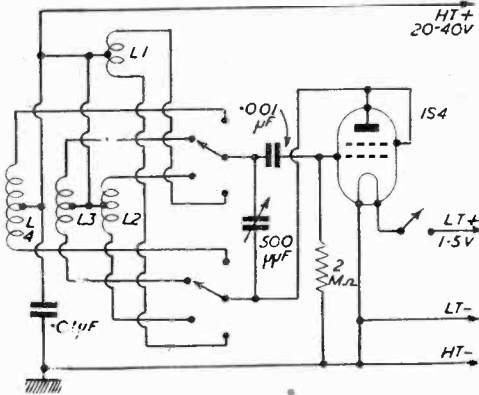

Fig. 1.—Theoretical circuit.

faults, especially in showing which stage is not operating.

The signal-generator described here has four wavebands, tuning from 20 to 2,000 metres. (With lower wavelengths, harmonics may be used, as will be explained.) Since an unmodulated R.F. signal is not audible with superhet receivers of ordinary type the circuit is so arranged that it goes in and out of oscillation at audio frequency. This is accomplished by the form of coupling employed, and the value of grid condenser and leak. It makes a second, audio-frequency oscillator valve unnecessary. The audio tone is in the neighbourhood of 500 cycles, according to the H.T. voltage.

The circuit is shown in Fig. 1, four bands being provided by means of a two-pole four-way Yaxley type switch. The coils cover approximately the following wavebands: L1, 20-70 metres; L2, 60-200 metres; L3, 180-650 metres; L4, 650-2,000 metres. The high waveband coverage arises from the circuit used and relatively large capacity of the tuning condenser, where the higher frequencies are concerned

The Coils

These are wound as shown in Fig. 2, a common former being used for L1 and L4. All the required winding details will be found in this diagram.

Two of the formers are fitted with brackets so that they may be mounted against one end of the case. The remaining former is mounted by means of a long bolt and spacing piece. Paxolin or ebonite tubing is equally suitable. If it is desired to use formers of other diameters, which may be to hand, a little experiment may be required to obtain a suitable wavelength coverage. The wavelength to which a coil tunes may be increased by increasing the number of turns, and vice versa. Small formers will require more turns than larger formers.

Each winding is centre tapped, the tappings of L2, L3 and L4 being made by taking loops of wire through a suitably-placed hole. L1 is tapped by

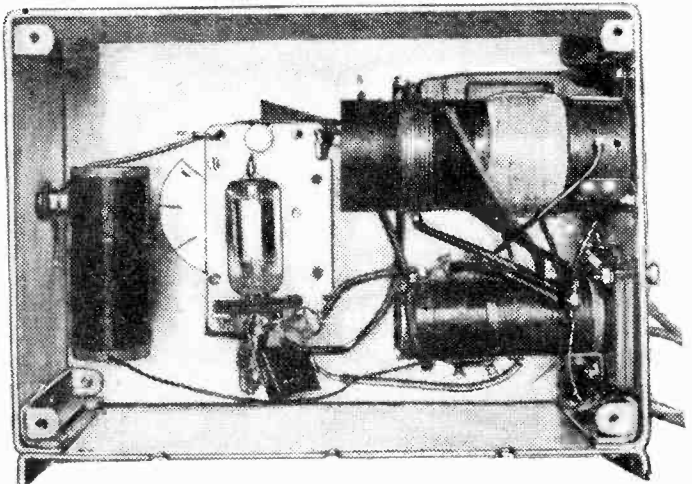

A view of the wiring. Compare with Fig. 3.

soldering a lead to the middle of its centre turn. A slight error made in counting the turns will not materially affect results, but the tappings should be at roughly the middle turn, in each case. The windings may be held secure with cellulose tape.

Constructional Details

The containing case is 7½ in. by 5½ in. by 3 in., the back being attached by screws passing into tapped brackets when construction is complete. The moving plates (or frame) of the tuning condenser must not be in contact with the panel. To achieve this, insulated material and bushes were used, when fixing. If an all-metal dial were used, precautions would have to be taken so that a short-circuit between condenser spindle and panel was not caused. Quite satisfactory results can be obtained by using a large control knob and dial, with no reduction drive.

The small, B7G type valveholder is mounted directly at the back of the condenser by means of small brackets. In Fig. 3 this holder is shown turned through 90 degrees so that wiring is clear. A 1S4 or equivalent valve is used. This is an output type, but the 1T4 or 1S5 types would not maintain oscillation on the higher frequencies unless the H.T. voltage were increased.

L2 is mounted directly on top of the .01 µF fixed condenser (which must not be omitted), all the centre-taps being taken to the H.T. positive tag of this component. A small push-pull on/off switch was fitted immediately below L4, for filament switching.

The "Output" terminal is insulated from the case. The very small coupling capacity required is obtained by taking one turn of connecting wire round the insulated sleeving of the lead going from tuning condenser to switch, as illustrated in Fig. 3.

With a valve inserted and batteries connected, the oscillator can be placed near a receiver to assure that it is operating. When receiver and oscillator are tuned to the same wavelength, the note of the oscillator should be heard. If the receiver is of low sensitivity, a short length of wire may be attached to the "Output" terminal, and the oscillator brought near to the aerial lead-in of the receiver. The audio note should be heard upon each waveband. If it is not, wiring and coil-windings of the affected bands should be checked.

Calibration

A high degree of accuracy can be achieved and maintained, provided no subsequent changes are made to internal wiring. One of several methods may be employed.

If an all-wave receiver with dial marked in wave-

lengths or frequencies is to hand, this can be used. It should be tuned to various wavelengths, and the signal-generator tuned until the audio note is heard. The wavelength may then be marked down. With this method, the accuracy obtained will be that of the receiver calibrations.

A similar method is to use the receiver, but to tune it accurately to stations of known wavelength. The signal-generator is then tuned carefully to the same wavelength.

Harmonics may be used to obtain further cali-

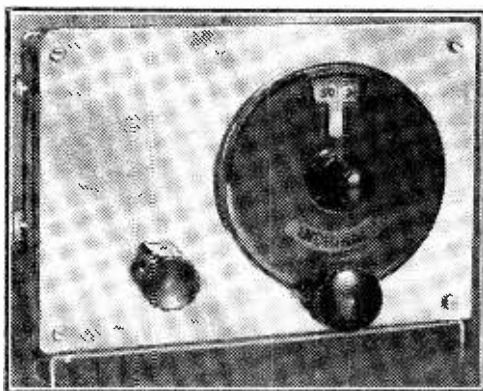

The panel layout of the instrument.

bration points, or to calibrate the signal-generator over wavelengths not tuned by the receiver. When the generator is tuned to a harmonic of the frequency to which the receiver is tuned, the audio note will again be heard, though at reduced volume. For example, if the receiver is tuned to 215 metres, the note of the signal-generator will also be heard when the latter is tuned to 430 metres. If necessary, the generator may then be left tuned to this wavelength, and the receiver tuned until the fundamental is heard (e.g., to 430 metres). The receiver tuning may then be left, and the generator tuned to 860 metres. In this way, a considerable number of calibration readings can be obtained.

That the generator is actually tuned to the fundamental, and not to a harmonic, may easily be established if necessary. To do this, the generator should be tuned slowly over lower wavelengths. If the note is not heard again, the fundamental was originally that tuned to. In short, the audio note will be heard when the generator is tuned to multiples of the receiver wavelength, but not when it is tuned to fractions of that wavelength. (E.g., if the receiver is tuned to 300 metres, the fundamental will be heard when the generator is tuned to 300 metres. When the generator is tuned to 600 metres, the harmonic will be heard. If the generator is tuned to 150 metres, however, no signal will be heard.)

If a calibrated signal-generator can be used, it is only necessary to set this to various wavelengths, tune in the signal on a receiver, and then tune the home-constructed generator to the same wavelength.

In all cases tuning should be

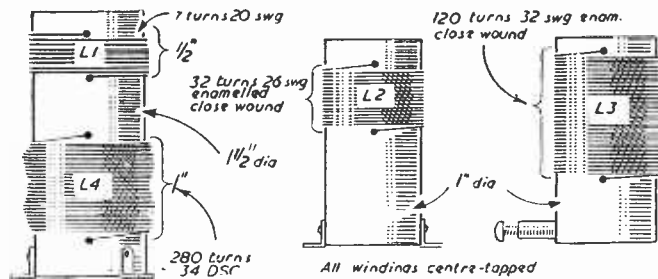

Fig. 2.—Winding details of the coils.

carried out as accurately as possible. Volume should be kept down, if necessary, by slightly removing the signal-generator from the receiver or aerial lead-in. If local stations are used for calibration, a very short piece of wire should be used for the receiver aerial. With a T.R.F. receiver with reaction, exceedingly accurate calibration can be achieved, since an error of even a few cycles per second will become audible as a beat note, if reaction is advanced to the oscillation point.

The tuning points may be marked upon a scale, or plotted on a graph. No attempt should be made to use the extreme ends of the scale, since these are not likely to be accurate. This is especially so when the tuning condenser is almost at its extreme minimum, where a movement of some degrees may make little or no difference in capacity.

Notes on Using

To align the I.F. stages of a superhet, the generator is tuned to the intermediate frequency. This is usually 465 kc/s (645.16 metres). A short lead with prod is connected to the "Output" terminal and applied to the frequency-changer anode. The I.F. transformers may then be tuned for maximum signal.

The generator may then be tuned to a suitable radio frequency within the normal tuning range of the receiver, and the signal injected at the aerial socket. Trimming of the signal and oscillator circuits can then take place, with padding or core-adjustment at a high wavelength on the same band, in the usual way.

The F.C. valve anode circuit should also receive any slight readjustment necessary to remove any error previously arising through the capacity of the test lead and prod.

In the case of a fault being suspected in the R.F., F.C., or I.F. stages of a superhet, the signal may be

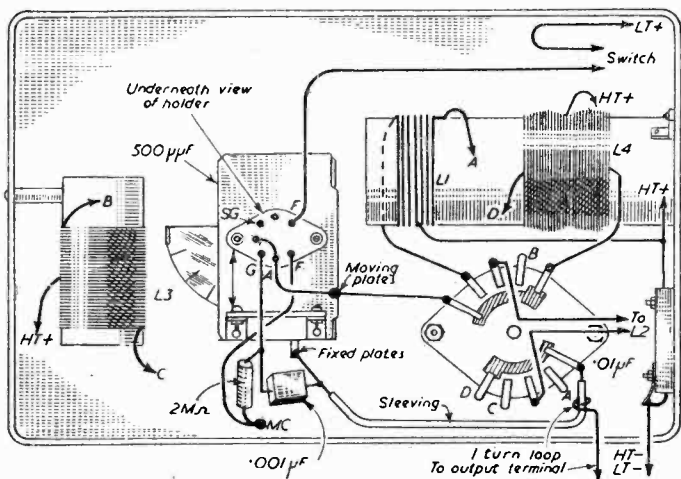

Fig. 3.—Wiring details and component layout.

injected at various points, working backwards from the D.D.T. stage. The point at which the fault arises will then become apparent.

The back should be fitted in place before the signal-generator is calibrated. The dial should be securely fitted so that the accuracy of calibrations can be preserved.

A SMALL LOCAL STATION RECEIVER

(Continued from page 383)

The L.T.—connection of the amplifier panel is brought out in the position shown in Fig. 2 and ends in a tightly wound cylindrical spiral with an inside diameter just large enough to take a wire. A stiff wire is taken from the junction of S1 and S2 to a position near to L2, where it can be slipped inside the spiral when the amplifier is in position. The grid connection is brought out in the same way and C2, a small 100 pF capacitor, is connected to the aerial side of C1. The wire from the other end is cut off by L1 in a convenient position for pushing into the grid spiral. All these wires should be tinned to ensure good contact.

Owing to lack of any radio frequency amplification, the set is only useful for local station reception, and reception depends very much on local conditions.

The amplifier may, of course, be used as a high-gain audio amplifier by connecting the microphone or other input between the grid spiral connection and L.T.—, for instance at S1. As an example of its sensitivity the following may be quoted. If a normal 2,000 Ω earphone is connected as indicated above and the stalloy diaphragm moved a few millimeters above the magnet poles, the Barkhausen clicks, due to the movement of domain boundaries or a change of the direction of magnetisation of individual domains in the stalloy may be heard easily. This effect is normally demonstrated with a large amplifier.

Book Received

"WIRELESS and Electrical Trader Year Book of Radio, Television and Electrical Appliances," 1953, 24th edition. Published by Trader Publishing Co., Ltd., 264 pages.

Since the "Wireless and Electrical Trader Year Book," was first published in 1925, it has become firmly established as the retailers' invaluable reference book to the radio and electrical industries.

In the 1953 edition, data of practical use to dealers in the new television areas and general reference and technical information have been carefully selected. Features include condensed specifications of current 1953 commercial television receivers (with such valuable facts as valves used, I.F. values, etc.), and information on valve and cathode-ray tube base connections, with over 200 valve base diagrams. These are invaluable to radio and TV engineers.

A new feature, re-introduced at the request of readers, is the Mains Voltage Directory and covers all the principal towns in Great Britain. The comprehensive list of the I.F. values of commercial radio receivers which have been marketed during the past five years has been revised and extended.

One of the principal aims of the Year Book is to assist traders to keep abreast of the constant change in the names, addresses, telephone numbers and products of the firms engaged in the radio and electrical industries.

ELECTRONIC PRECISION EQUIPMENT LTD

THE SUPERIOR 15"

- 15in. up to the minute Television for only £35, including Cossor Tube.
- H.P. Terms if required, i.e., send only £11/14/- deposit, then 12 monthly repayments of £2/7/-.
- Working models demonstrated at both our Fleet Street and Ruislip branches.

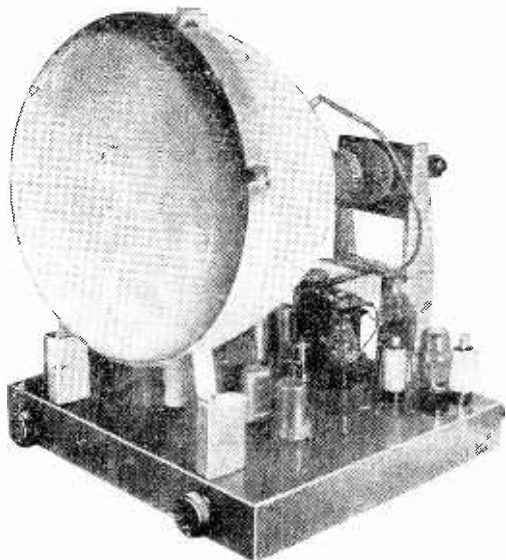

You will have noticed that the modern trend is towards larger pictures, in fact the 12in. tube is fast going the way of the 9in. and 10in. tubes for few manufacturers are using them in their latest models. However, you can be right up to date for we are now commencing delivery of a new constructor set using the Cossor 15in. tube type 85K. All the parts to build the set (as illustrated) will cost you only £35, including tube, and contrary to what might be expected, to get down to this very low price we have not sacrificed quality in any way, in fact, interlace, sensitivity and definition, are equal to the best commercial standards. The chassis provided is of generous proportions and will allow the inclusion of a Radio unit if one is wanted.

The whole has been so arranged as to be particularly suitable for our popular Coronation Console cabinet, but there is no reason whatever why it cannot be fitted into any well-made T.V. cabinet.

Technical features :

- A. Superhet circuit fed by R.F. amplifier.
- B. Particularly carefully dimensioned Video stage.
- C. Diode damped interlace network.
- D. Line and frame blocking oscillators.
- E. Fly back EHT.
- F. Optional voltage doubler for aluminisation effect

DATA. Full constructional data price 7/6, post free, is available on approval (if you decide not to make the set and return the data within 7 days 7/- will be refunded).

DEMONSTRATION. A made up chassis can be seen at Fleet Street, or Ruislip, and if you arrange to call during BBC transmission times, we will gladly demonstrate the excellent interlace and other qualities of which we are particularly proud.

HOW TO ORDER. All parts are available and total cost is £35, which includes 15in. tube, 18 valves, prepared metal chassis, in fact everything needed except cabinet and mask. Orderform and parts list is included with the 7/6 data.

H.P. Terms are available. Non-callers add £1 for carr. and ins.

ELECTRONIC PRECISION EQUIPMENT LTD

ADDRESS POST ORDERS TO :—DEPT. 7
ELPREQ HOUSE, HIGH STREET, WEALDSTONE, MIDDX.

Personal Shoppers must call at either :

42-46 WINDMILL HILL, RUISLIP, MIDDX.

Phone : RUISLIP 5780
(Half-day, Wednesday).

152-153, FLEET STREET, E.C.4.

Phone : CENTRAL 2833
(Half-day, Saturday)

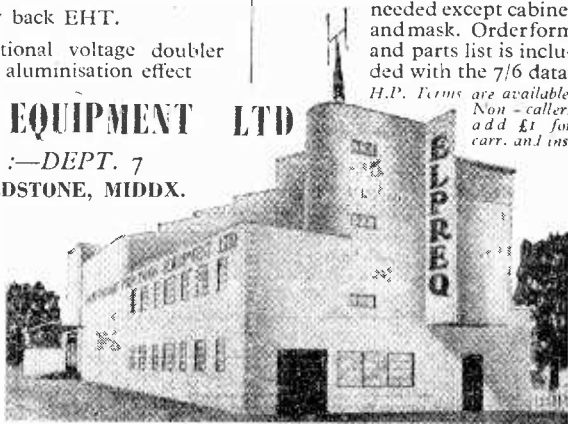

HENRY'S

EXCEPTIONAL VALVE OFFER

Ten EF50 Brand New (Ex-Units)	55/- Set
6K9G, 6K7G, 6Q7G, 5Z4G, 6V6G (or KT61)	42/6
1R5, 1S5, 1T4, 1S4 or (3S4 or 3V4)	32/6
TP25, HL23/DD, VP23, PEN25 (or QP25)	27/6
6K9G, 6K7G, 6Q7G, 25A6G, 25Z5 or 25Z6G	42/6
12K6GT, 12K7GT, 12S4GT, 35Z4GT, 35L6GT or 50L6GT	42/6
12SA7GT, 12SK7GT, 12SQ7GT, 35Z4GT, 35L6GT or 50L6GT	42/6
Complete set of specified valves for "P.W." Personal Rec. 5 6AM6, 2 6AK5, 1 6J6, 1 6C4, 1 EA50, and 3BPI C.R. Tube with base. 25/12/6.	
KT23C, 12/6; KT66, 12/6; GU50, 12/6; PX25, 12/6 (Matched Pairs at 25/- pair).	

"Weymouth Superhet 3-Wave Band Coil Packs." Short, Med., and Long with Gram. switch. Brand New Miniature type complete with circuit. P.P. 1/5; absolute bargain. 19/6d.

CATHODE RAY TUBES :

VCR37. Guaranteed full picture 40/-, carr. 2/-.
VCR57. Guaranteed full picture 40/-, carr. 2/-.
3BPI. Suitable for scopes and Tel. 25/-, carr. 3/-.
MU-METAL SCREEN for VCR37 or 57. 10/-.
VCR139A (ACR10) 35/-, Brand new.

INDICATOR UNIT TYPE 182A. This unit contains VCR517 Cathode Ray 6in. Tube, complete with Mu-metal screen, 3 EF50 4 SP61 and 1 5U4G valves, 9 wire-wound volume controls and quantity of Resistors and Condensers. Suitable either for basis of Television (full picture guaranteed) or Oscilloscope. Offered BRAND NEW (less relay) in original packing case at 79/6d. Plus 7/6 carr. "W.W." Circuit supplied Free.

25/73 TR1198 RECEIVER UNIT.—Complete with 6 valves. 2 EF50, 2 EF30, 1 EK32, 1 EBC33. In new condition. Circuit and Conversion Data Free. 39/6, carriage paid.

INDICATOR UNIT TYPE SLCS

This Unit is ideal for conversion for a "Scope" Unit or basis for Midget Television. It contains C.R. Tube type ACR10 (VCR139A) complete with holder and cradle also earthing clip. 1-VR66, 2-VR65, 24mid. 550v. wkg. condenser, potentiometers and a varied assortment of resistors and condensers. These Units are in a new condition and packed in wooden transit cases. The C.R. Tube will be tested before despatch. Dimensions 8 1/2 in. x 6 1/2 in. x 1 1/4 in. 57/6 plus 5/- carr.

VCR 517C Blue and White 6in. Tube. This Tube replaces the VCR37 and VCR57 without alteration and gives a full Blue and White picture. Brand new in original crates. 45/-, plus 2/- carr.

STROBE UNITS.—Brand New, in sealed cartons these contain 6 EF50s, 5 EA50s, 1 SP61, a host of condensers, resistors, transformers, chokes, relays, switches, 7 pots and 5 smoothing condensers. Size 18in. x 8in. x 7in. Only 67/6, plus 5/- carriage.

WALKIE-TALKIE TYPE "46." complete with 6 valves. 2VP23, HL23, DD, QP25, TP25 and ATP4, aerial rods, I.F. trans., 1.6 mc/s. mike trans. in new condition, but less transmitting components and coils removed by M.O.S. 35/-, carr. paid. (Less valves. 12/6.)

9in. ESCUTCHEON.—Brown bakelite. Suitable plate glass and mask for 9in. tube. Price 7/6 each.

No. 38 "WALKIE-TALKIE" TRANS-RECEIVER, complete with throat mike, phones, Junction Box and aerial rods in canvas bag. Freq. range 7.4 to 9 Mc/s. All units are as new and tested before dispatch. As supplied to Overseas police forces. £4/10/0. Complete with batteries. Spare battery, 10/-.

PYE 45Mc/s STRIP.—Special purchase of M.O.S. Type 3583 Units. Size 15in. x 8in. x 2in. Complete with 45 mc/s. Pye Strip, 12 valves, 10 EF50, EB34 and EA50, volume controls and hosts of Resistors and Condensers. Sound and vision can be incorporated on this chassis with minimum space. New condition. Modification data supplied. Price £5, carriage paid.

SEND POSTAGE FOR NEW 1953 COMPREHENSIVE 23 PAGE CATALOGUE : CONTAINING COMPONENTS & EX-GOVT. BARGAIN 3 Open Mon.-Fri. 9-5.30. Sat. 6 p.m. Thurs. 1 p.m.

5, HARROW ROAD, PADDINGTON, LONDON, W.2.

TEL.: PADDINGTON 1008/9, 0401.

FREE

A VALUABLE BOOK

which details the wide range of Engineering and Commercial courses of modern training offered by E.M.I. Institutes—the only Postal College which is part of a world-wide Industrial Organisation.

Courses include training for:

City and Guilds Grouped Certificates in Telecommunications; A.M. Brit. I.R.E. Examination, Radio Amateur's Licence, Radio & Television Servicing Certificates, General Radio and Television Courses, Radar, Sound Recording, etc. Also Courses in all other branches of Engineering.

NEW

HOME EXPERIMENTAL KITS NOW AVAILABLE

EMI
Institutes
associated with
MARCOPHONE
COLUMBIA
H.M.V. ETC.

COURSES FROM £1 PER MONTH

POST NOW

Please send, without obligation, the FREE book. E.M.I. INSTITUTES, Dept. 32K 43 Grove Park Road, London, W.4

Name. _____

Address. _____

1C 10EK

BUILD THIS LOW COST AMPLIFIER

for the amazing price of **15/-**

Send 2/- for layout, wiring diagram and assembly instructions which will be refunded on all orders over 10/- Post 1/-

- Ideal for boosting crystal sets.
- Can be converted to 2 valve for extra 5/- giving loudspeaker volume from crystal set.
- Kit includes chassis, valve, valve holder, resistors, condenser, wire, sleeving, switch and diagram.
- Will boost 1 valve sets to loudspeaker strength.
- Amplifier uses low drain valve.
- We specialize in radio components.

Send 6d. for our list of components. You will be amazed at our prices.

Mail order only:

R.C.S. PRODUCTS
(Dept. C)

11 OLIVER ROAD, LONDON, E.17



TRANSMITTING TOPICS

SIMPLE UNIVERSAL AERIAL TUNING NETWORK

By O. J. Russell

THE amateur transmitter is generally concerned with the provision of three types of loading circuit in order to transfer power efficiently to a radiating system. These are the Pi coupler for transferring power to wires of random lengths; a series-tuned circuit for Marconi systems, and feed systems requiring a low-impedance feed and a parallel-tuned circuit for high-impedance resonant systems. In addition, a certain amount of control is required over loading adjustments. These three basic circuits are shown in Fig. 1, and the position of suitable aerial or feeder current indicators—such as thermal ammeters—is also shown.

There is no need to construct three separate aerial loading devices, however, as the basic components shown in Fig. 2 can be combined to form a considerable number of aerial matching networks.

The layout is also one which may be varied to suit the experimenter's requirements. As considerable variations in the connections to the basic components can be used, it is possible to use leads ending in crocodile clips as a handy but untidy means of effecting connections, or to use banana plugs and sockets to effect connections between components. In Fig. 2 the ends of the components have been lettered to identify possible connections, and the various arrangements possible may now be considered.

End-fed Wire

The first type of radiating system we may require to match into a transmitter is the simple end-fed wire. If this is of random length, or even if it is a resonant length, many amateurs prefer the Pi network. This can be achieved by connecting E to A, B to C, and connecting E to C and to earth. This is obvious

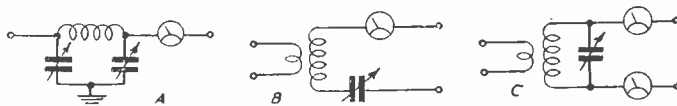

Fig. 1.—The three basic circuits.

The cost can be very small, as suitable aerial tuning condensers of around 160 pF have long been available on the surplus market. One type with wide-spaced sturdy brass vanes was in fact used in the aerial loading circuits of service transmitters and is sold at around 1s. 6d. The wide spacing enables it to withstand high inputs without flashover. Various other suitable surplus components can be found, and in any case in default of surplus components, standard transmitting condensers may be obtained from the firms catering for amateur requirements.

In this respect, it is advised that the coil be arranged to plug in to a suitable base, which can also accommodate a link coil contact. However, details of this type are left to the discretion of the individual constructor, with the note that for powers up to about thirty watts one can very well use plug-in coil formers of the type used for short-wave receivers without difficulty. Details of coils for all bands and aerials likely to be encountered can also be left to the constructor, due to the wide variations to be encountered in practice.

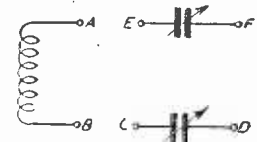

Fig. 2.—Basic components for the network.

enough, and is repeated in Fig. 3 (a). A series-tuned circuit for a single wire is shown at Fig. 3 (b), and only one condenser is used. For series-tuned feeders, or centre-fed systems, the symmetrical series-tuned system shown in Fig. 3 (c) may be used. For single wire systems requiring parallel tuning, the spare tuning condenser may be used to give a loading adjustment by placing it in series with the aerial. This can also be employed with twin feeders with possible slight unbalance in the system.

Parallel-tuned Systems

In the case of parallel-tuned systems, we have a choice of possibilities. We can use a single tuning condenser in cases where a medium value of tuning capacity is required, as upon, say, 40 metres. Where high values of tuning capacity are required, as upon the lower frequency bands, both condensers may be paralleled to give the required "high C," to retain an optimum LC ratio in the aerial tuning circuit.

Series Connection

For conditions—particular on the higher frequency bands (14 Mc/s., 21 Mc/s. and 28 Mc/s.)—where a lower value of tuning capacity is required, the two tuning condensers may be connected in series. This not only has the beneficial effect of halving the minimum capacity across the coil, but the fact that both condensers are separately adjustable is very helpful in adjusting the balance of the system. It is, in fact, at the higher frequencies where stray capacities and objects near the feeders can cause most disturbance that some control over feeder balance may be required.

Wide Scope

The range of conditions available by suitable interconnection of the components provides fairly completely for the range of frequencies from the top band of 1.8 Mc/s. to the 28 Mc/s. band. At the top band where the Marconi system is employed, the series tuning can employ one or both of the condensers in parallel, but it is unlikely that they will ever be required in series for 1.8 Mc/s. operation. It should also be noted that the alternate series and parallel possibilities with the parallel-tuned circuits is important for all of the amateur bands in maintaining a high LC ratio. In this respect the rejection of harmonics is improved by maintaining a reasonable LC ratio, so that the Q of the aerial tuning circuit is not too low. If the value of tuning capacity is maintained at about 2 pF per metre of operating wavelength, that is approximately 80 pF for 40 metres, this will be of value in keeping harmonic radiation down, with obvious benefits from the point of view of TVI troubles. A further point is that although feeders are shown tapped directly on to coils, it is, of course, perfectly permissible to tap the feeders down the coils if so desired.

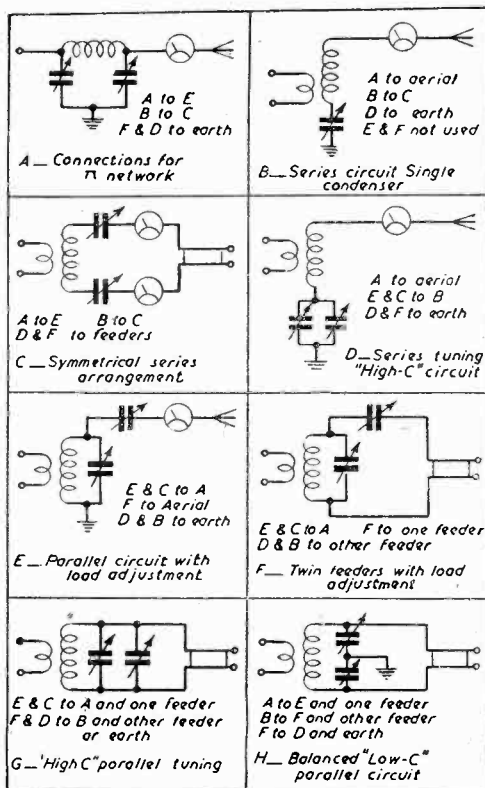

Fig. 3.—The various arrangements which are possible.

Radio on Everest

RADIO will play a decisive part during the final assault on Mount Everest which begins a few days after we go to press with this issue. More important even than the exchange of information on climatic and climbing conditions will be the morale boosting effect of regular contact between the mountaineers and their colleagues at the base camp.

Mr. George Rand, chief wireless operator to the expedition, said that whilst radio contact would facilitate load carrying, especially when low cloud made visibility difficult, the most important part played by radio would be to boost morale.

The decision to equip the 1953 Everest Expedition with portable radio transmitter-receivers was made only after exhaustive tests had been carried out to prove the reliability of batteries small enough to fit into a mountaineer's waistcoat pocket, yet robust enough to survive and perform perfectly in climatic conditions which ranged between high tropical humidity and sub-zero.

Nor were these the only qualities demanded by the expedition. Mr. Rand insisted upon delivery by air nearly three months before the batteries started their operational life.

Tests carried out in the laboratories of the Vidor-Burndep Group showed that the small radio battery

used by portable radio enthusiasts in this country would operate satisfactorily for 16 hours at a temperature of minus 10 deg. Centigrade. The battery would, therefore, allow 10-minute contacts to be made no fewer than 96 times.

Further laboratory tests gave equally good results in tropic temperatures and in conditions of high humidity. But because of the long journey involved and the various methods of transportation which would be employed between Britain and the summit of Everest, special protective sealing methods were employed to ensure perfect results on the mountain ascent.

Vidor-Burndep factories at South Shields, Dundee and Brechin, produced radio batteries and non-perishable rubber torches complete with batteries.

The batteries provided for the expedition will give a total operational life of 530 hours at minus 10 deg. Centigrade.

Most of the transmissions will be made within the tents at night. The aerial will be fitted outside and the operator will conserve the life of the battery by speaking to the base whilst lying inside his sleeping bag. Because temperature plays an important part in determining the life of a radio battery, the mountaineers will carry their batteries in special waistcoats designed to derive maximum body heat.

The total radio equipment, including all batteries, is under 300 lbs.

A MULTI-RANGE TESTER-1

FULL CONSTRUCTIONAL DETAILS OF A VERY HIGH QUALITY TEST SET WITH A SENSITIVITY OF 10,000 Ω PER VOLT

By E. N. J. Marguerit

THE necessity for everyone connected with wireless to have a reliable and accurate multirange tester, whether electronic or straight moving-coil type, need not be emphasised. However, it is sometimes beyond the average pocket to afford such an instrument, especially the former. It is with this in mind that the writer has designed the instrument to be described. It is not of the electronic variety as this would undoubtedly raise the cost; ex-W.D. valves are not really reliable enough to meet such an exacting demand. The progress made in the manufacture of instrument-type metal rectifiers enables them to give satisfactory rectification up to 100 Kc/s, provided that the shape of the input wave is sinusoidal. The error they introduce in the audio range can, for all practical purposes, be considered negligible. Therefore, a well-designed moving-coil multirange tester should be able to furnish all the measurements required by the experimenter or the service engineer, including the plotting of frequency characteristics curves of any amplifier.

The instrument to be described has a sensitivity of 10,000 ohms/volt on all voltage ranges. The accuracy on all ranges is 1 per cent., except on the resistance and low A.C. ranges where it is between 3 and 4 per cent.

The largest scale is 4½ in. long; it is traversed by a hair-line pointer. Parallax errors are avoided by the inclusion of a mirror.

The ranges covered are as follows:

D.C. Volts at 10,000 ohms per volt
0.1, 0.5, 1, 2.5, 10, 25, 100, 250, 500, 1,000.

D.C. Milliamps
0.1, 0.5, 1, 2.5, 10, 25, 100, 250, 500, 1,000.

A.C. Volts at 10,000 ohms per volt
0-10 volt and 0-100 volt on separate non-linear scale. 0-250, 0-500, 0-1,000.

Audio Voltages
Same as A.C. volts through an 0.1 μ F condenser.

Resistance
Eight ranges covering 0.01 ohm to 10 megohms. Giving indication of 50 megohms.

A special feature of the instrument is the possibility of mechanically offsetting the zero adjustment so that the pointer is brought on the centre of a special scale, enabling the instrument to be used as a galvanometer with a sensitivity of 50 μ A on either side of the zero.

The Meter

The basis of the instrument is a 100 μ A moving-coil meter obtained from ex-A.M. L/R unit No. 10Q/2, Model S52, Type 1. This unit contains two moving-coil meters having a linear deflection of 100 μ A for an angle of between 70 and 80 deg.; this was checked against a

standard instrument using the method described below. As they stand, the meters have 2 in. long pointers, and the most difficult operation in the construction of the instrument is to equip one of the moving-coil meters with a longer pointer without altering its sensitivity.

The author carried out this modification satisfactorily by replacing the original aluminium pointer by a long thin glass pointer. This is obtained by heating a length of "Pyrex" brand glass rod in the flame of a Bunsen burner until the glass is quite soft, when the rod is removed from the flame and the ends are drawn rapidly away from each other, resulting in a length of very fine glass rod which is then cut into pieces about 8 in. to 10 in. long from which the pointer is selected.

There are two methods of fitting the meter with its new pointer. In each case, the existing pointer, which consists of a length of aluminium foil covered with a phosphorescent coating, is removed. Care should be taken in this operation as the coating is reputed to be radio-active. Fig. 1 shows how the original pointer is secured to the moving-coil assembly; it is removed by easing the grip of the aluminium foil on the fixed

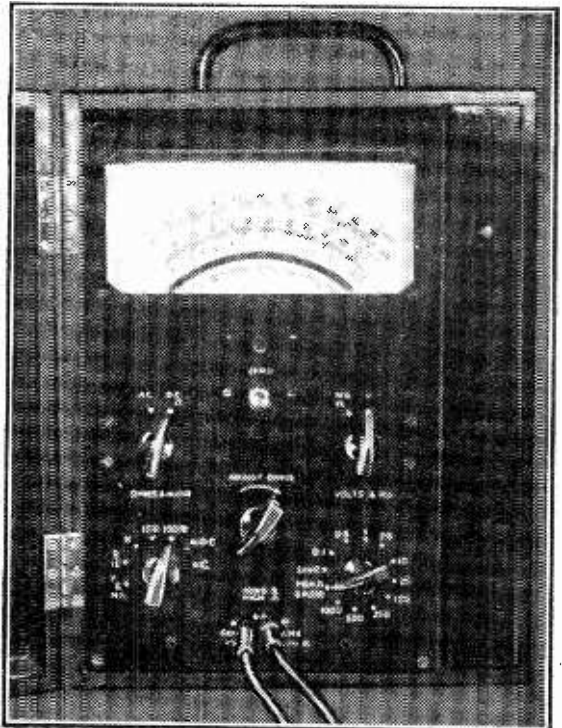

A view of the completed meter.

part of the pointer by means of a pair of tweezers, without exercising any undue strain on the jewelled bearing.

The first method consists in dismantling almost the entire meter and unless one possesses a set of jeweller's tools, including a miniature soldering iron, the job is not recommended. The idea, of course, is to have a means of ascertaining that the centre of gravity of the assembly has not been disturbed. Indeed, if this were upset, either by an overload or an underload, the finished instrument could only be used in a horizontal position. This is checked by resting the pointer on a pin held vertically in a cork or similar material, the resting point being the fixing hole of the pointer when attached to the moving-coil. If the pointer remains horizontal, then the balance is perfect; if it tends to fall towards the counterweight side, the glass implement should either be made thicker for the same length or longer for the same thickness; if it dips towards the opposite direction, then the procedure should be reversed. When a satisfactory balance has been obtained, the assembly is mounted back on the moving-coil; this is very delicate and calls for a lot of patience.

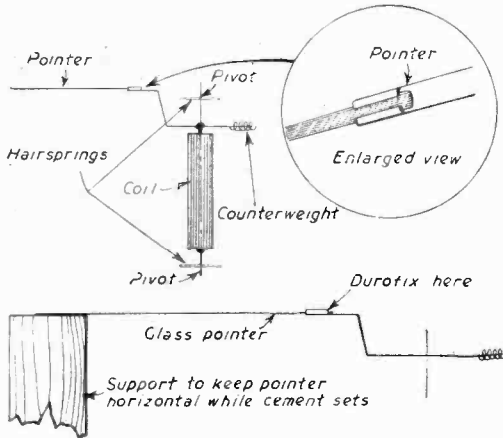

Fig. 1.—(Top) Details of the original pointer mounting.

Fig. 2.—(Bottom) Details of the modified pointer.

An Alternative

The second method is much easier as there is no dismantling to do, apart from taking off the original pointer. All that is necessary is to select a piece of glass rod drawn as described previously and having the following measurements:

- Length, 4in.
- Diameter, presumed uniform over the entire length, 0.006in. (measured with a micrometer).
- The weight of such a pointer is 0.0040 gms.

These measurements were deduced from a series of experiments performed on several meters of this type. Having selected such a rod, it is then fixed by means of Durofix cement on that part of the original pointer left on the moving-coil as shown in Fig. 2. The other end of the glass rod is supported in a horizontal position while the cement sets, either by holding it in

the hand or by letting it rest on a previously prepared support of the correct height. When the solvent has evaporated, the pointer is given a thin coat of Indian ink with a fine camel hairbrush. The meter is then ready to fit into the instrument.

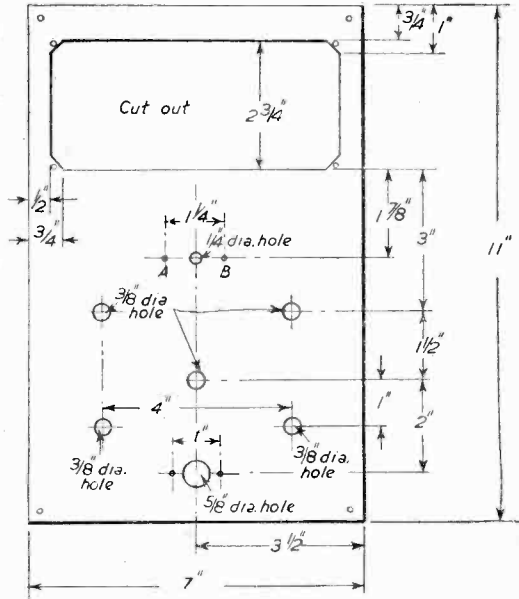

Fig. 3.—Details of the panel. Holes A and B are the fixing holes for the meter movement. All holes with no diameter indicated are to take 6 B.A. bolts.

Construction

The instrument is built on a panel of insulating material, such as Paxolin or Permal, 1/8 in. thick and

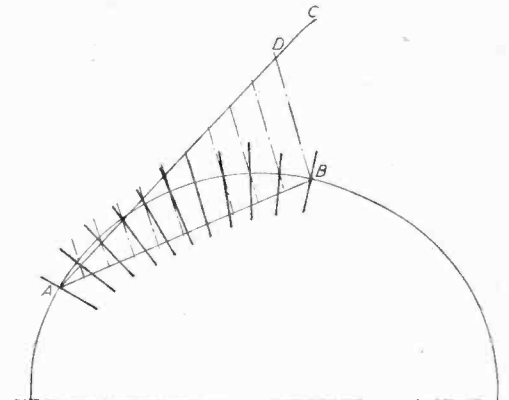

Fig. 5 (a).—Marking out the scale. Lines AB, AC, DB and all parallel to DB are drawn finely in soft pencil. When the arc is divided in ink they are rubbed out.

11 in. x 7 in.; a window 6 in. x 2 1/2 in. is cut with a fretsaw and the panel is drilled according to the diagram in Fig. 3. The underneath of the panel is divided across its length in two halves by a line marked with a scriber. This line is used later in the construction, as a reference point, in the positioning

rubber cement, and four 6 B.A. bolts 1 1/2 in. long and nuts. The length of these bolts is important.

The scale plate consists of a piece of aluminium 1/16 in. and 6 1/2 in. x 3 1/4 in.; one side of it is divided into two halves by a line which is made to coincide with the one dividing the panel, and the positions of the bolts are then marked on the scale, which is drilled accordingly. A rough, equally-divided scale is then drawn on a piece of stiff, white paper. It consists of two concentric circles, the radii differing by 1/8 in. The common centre of these circles lies on the dividing line produced, and the centre coincides with the pivot of the moving coil, which is also arranged to lie on the same line. By means of a protractor, an angle of 90 deg. is drawn from the centre, another angle of 70 deg. is then drawn from the same centre, and placed so that it forms an angle of 10 deg. on each side of the 90 deg. angle. The two angles are then divided into 10 equal parts. This is done by applying a well-known theorem of

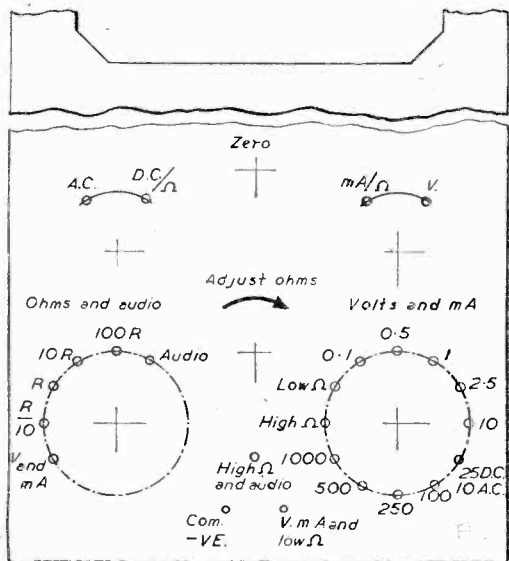
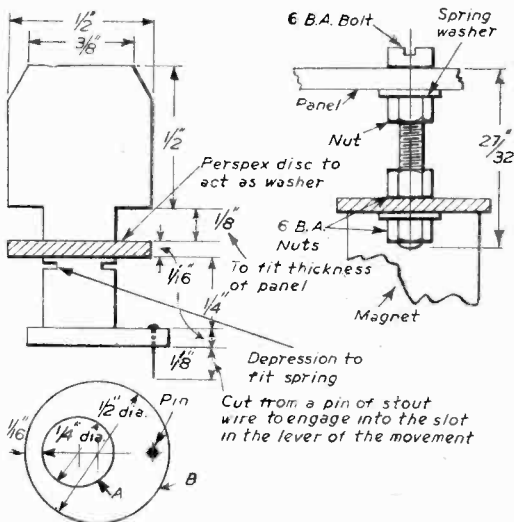

Fig. 4.—Details of panel indications. The dots and arrow are depressions in the panel filled with white paint. The legends are similarly treated. The knobs are small black pointer types.

of the scale. After drilling, the author's panel was engraved, the legends being as shown in Fig. 4. An alternative is to write the legends on a round piece of Bristol board in Indian ink; a hole is then cut in the centre to fit over the switch it is made for. A thin piece of perspex of the same size is then affixed in the same position. A rectangular piece of perspex, 6 1/2 in. x 3 1/4 in. and 1/6 in. thick is cut and drilled to fit over the window in the panel. It is attached on the underneath of the panel by means of Bostick or



Figs. 6 and 7.—Device for mechanically adjusting the zero of the instrument. The material is perspex. Disc B is secured to rod A by Perspex cement. The "zeroing" device is shown on the right.

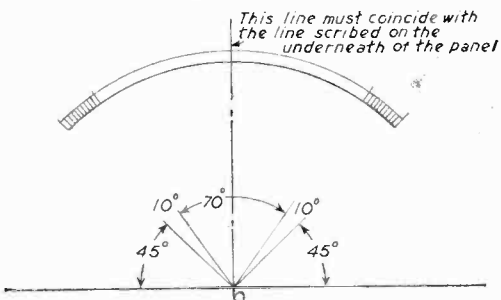

Fig. 5 (b).—Diagram of the finished temporary scale to find the angle of rotation of the pointer for a given current.

geometry. To divide an arc AB of a circle into a number of equal parts, join AB by a straight line. From A draw a line AC forming an arbitrary acute angle with AB. With a ruler placed on AC, mark a point D so that AD=say, 10 cm., between A and D mark 9 points each 1 cm. apart. Join DB, and by means of a set-square and ruler, draw lines starting from each of the 9 points and parallel to DB. To divide the arc AB into 10 equal segments, 11 radii are drawn, each passing at the intersection of the parallel lines with the arc AB (see Fig. 5a). The same procedure is applied to the other 10 deg. angle (see Fig. 5b). This scale is then cut to the size of the scale plate and glued on to it in such a way that its centre line coincides with the line dividing the aluminium

scale plate. This is only a temporary scale and its purpose is to measure accurately the angle of deflection of the meter pointer when a current of $100 \mu\text{A}$ is passing through it.

Before standardising the deflection, the device for adjusting the zero of the meter has to be made. It is constructed of Perspex, and full details are given in Fig. 6. The spring clip was taken from the centring device of a disused meter. Fix the device on the panel and secure the meter by means of two 6 B.A. bolts and nuts. The bolts are $27/32$ in. long and the fitting is as shown in Fig. 7.

After securing the meter on the panel, the temporary scale is fixed in place by means of the four

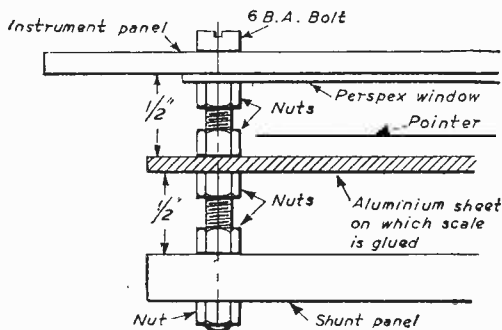

Fig. 8.—Method of mounting the scale so that it may be adjusted in relation to the pointer.

bolts securing the Perspex window. The correct spacing is shown in Fig. 8.

To exclude draught when calibrating the angle, it is necessary to enclose the whole of the instrument in a wooden box, which later on will serve as the case for the instrument. The author found that the ex-Service Transit Case No. 10C/3650 is ideal for the job. Its dimensions are 11in. \times 8 $\frac{1}{2}$ in. \times 4 $\frac{1}{2}$ in. The paint was scraped off, the surface smoothed with coarse and fine glass-paper and the box French polished. The case was partitioned to 7in. in width, the small partition providing a convenient compartment to store the leads and batteries.

Calibration

The principle of the calibration of the f.s.d. of the meter is to place the meter in series with a standard instrument such as the AVO Model 7 or preferably Model 8, then apply from an L.T. battery and potentiometer a current of $100 \mu\text{A}$ as read on the standard instrument. The angle of deflection can be measured on the specially prepared scale. The diagram for such a circuit is given in Fig. 9. The angle varies between 70 deg. and 80 deg. for $100 \mu\text{A}$. Having found the angle of deflection of the meter, one can proceed with the drawing of the final scale. This is drawn on a sheet of best Bristol board. Use of different colours of ink improves the clarity. There are seven scales. One each for the high- and low-resistance ranges; one for D.C. volts and mA, including the three ranges 1,000 volts, 500 volts and 250 volts; three for A.C. volts (two only if circuit in Fig. 10b is used); one each for 10 volts and 100 volts A.C.; the third one being for voltages above 100 volts A.C. up to 1,000 volts. The ranges below 10 volts are inoperative on A.C.; they are seldom required. The last scale is an

equally divided one with a centre zero for galvanometer use.

Electrical Circuit

Two possible circuits are given. Each one will be described individually.

The first one is shown in Fig. 10a. The same potential divider is used for A.C. as well as for D.C. volts measurements. This reduces the cost of the instrument but necessitates an additional scale for A.C. volts, as the values shown on the D.C. scale would be 1.11 times too small for A.C. volts. Alternatively, when measuring A.C. volts on the D.C. scale, each reading should be multiplied by 1.11, but this seems a tedious and unnecessary process when one has a series of measurements to make.

The potential divider consists of 10 Dubilier High Stability Carbon resistors with a tolerance of ± 1 per cent. Tolerances less than 1 per cent. up to 5 per cent. and 10 per cent. could, of course, be used, but naturally the overall accuracy is also reduced. In the author's opinion, this is not recommended, as the completed instrument, if well constructed, is capable of giving readings accurate to ± 1 per cent. on the last 40 per cent. of the scale. The values of the resistors in the potential divider are given in the list of parts on page 405.

The rectification of A.C. voltage is effected by means of four Westinghouse rectifiers, type WX1. These are connected to form a bridge, thus giving full-wave rectification. They resemble small resistors and are easily mounted on a tag-board.

D.C. current measurements are made by means of home-made shunts and calibrated on a bridge. They are made of Constantan (Eureka) wire, the temperature coefficient of which is 0.000014 deg. C. as compared with 0.00428 deg. C. for copper.

The idea of using a series-shunt circuit was not

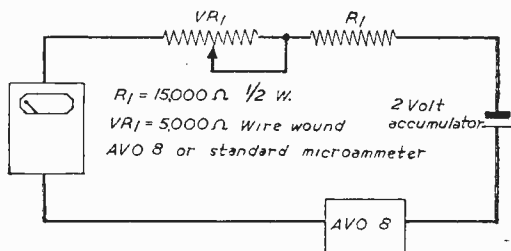

Fig. 9.—Method of measuring the angle of deflection. Adjust VR1 until the current read on the standard meter is $100 \mu\text{A}$, then measure the angle deflected by the pointer of the instrument being calibrated.

adopted as the latter is more difficult to calibrate by ordinary means.

The values are calculated as shown in the example given below. They will naturally vary with each individual moving-coil meter as they depend primarily on the resistance of the coil.

There seems to have been quite a controversy recently in one of the wireless journals as to the best way of measuring the resistance of the coil of a moving-coil meter. The author thinks that the following is a satisfactory method for general purposes.

(Continued on page 405)



OPEN TILL 6 PM SATURDAYS

TELEPHONES: AMBASSADOR 4033 & PADDINGTON 3271/2

PREMIER RADIO Company

(REGD.) B. H. MORRIS & CO (RADIO) LTD. EST. 40VRS.

THIS IS OUR ONLY ADDRESS (Dept. P.W.) 207, EDGWARE ROAD, LONDON, W2 (THIS IS OUR ONLY ADDRESS)

BUILD A PROFESSIONAL LOOKING RADIO SET AT LESS THAN HALF TO-DAY'S PRICE

We can supply all the parts to help you:

- Drum 22in. diam. 1/6
- Driving head 1/8
- Double pointer 1/8
- Spring 3d.
- Nylon Cord (crayd) 6d.
- Dial Front Plate 2/6
- Unrived Glass Dial, 180-350 and 800-2,200mc. With station names, new wavebands 1/6
- T.R.F. Coils, 180-550, 800-2,200 metres, pair 6/8
- Punched chassis, 3-valve plus rectifier T.R.F. Cabinet, Bakelite, in Walnut or Ivory or Wooden in Walnut finish 3/9
- Packing and insurance 2/6
- SEND 1/6 FOR EASY TO FOLLOW POINT-TO-POINT DIAGRAM AND CIRCUIT DIAGRAM, which shows how YOU can build the Receiver illustrated above.

THE COMPLETE KIT

to construct a 3-valve plus rectifier T.R.F. Receiver for use on 200-350 v. A.C. mains can be supplied at £19/8, plus 2/6 packing and carriage. Each Kit is complete in every detail, nothing has to be made or improvised. Easy to follow point-to-point diagrams are supplied, making construction very simple. The Dial is illuminated, and the Receiver housed in its cabinet size 12in. x 5in. x 5in. presents an attractive appearance. The valve line-up is: 717A—H.P. Pentode, VR11B—Detector, APT4—Output, and Metal Rectifier.

Wave band coverage is for the medium and long waves. Choice of 3 Cabinets: Bakelite in Walnut or Ivory, or Wooden (Walnut finish).

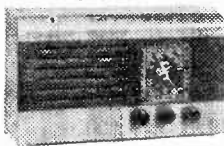

WILLIAMSON AMPLIFIER KIT

A complete kit of parts for the construction of the latest version of this famous amplifier complete with valves, output and mains transformers.

15 Gns.

P's 7/8 pkg., car. and ins.

WILLIAMSON AMPLIFIER TRANSFORMERS (To specification)

The Output Transformer 3.6 ohms sec. £4/4
The Mains Transformer PREMIER SP425A £3/7/6.

MOVING COIL MICROPHONE

Low impedance. Incorporates press-to-talk switch. Housed in strong black bakelite case. Dimensions: 2in. wide, 2 1/2in. high, 1 1/2in. deep.

Plus 1/6 post and packing. **19/6**
A matching transformer for high impedance can be supplied at 3/6 extra.

H.T. ELIMINATOR AND TRICKLE CHARGER KIT

All parts to construct an eliminator to give an output of 150 volts at 20 mA, and 2 volts to charge an accumulator. Uses metal rectifier, £2.

Govt. Surplus—Ex. W.D. STEEL AERIALS

Also ideal for fishing rods—A.L. BRAND VEIP 12ft. 3/4in. sections of copper-plated steel highly flexible tapering 1in. to 1/2in. Brand new in container, 6/9. Packing and carriage 1/6. Insulated Base 3/6. Webbing waterproof carrying case with shoulder sling, 2/6.

ACCUMULATORS

By world-famous maker, 2 volt, 10 amp. 4/11

Famous Set Manufacturer's surplus of ELECTRIC GRAM UNITS

Two-speed, 45 and 78 r.p.m. For playing standard and L.P. recordings. Complete with Turntable. For use on 200-250 v. A.C. mains. Each unit is in its original manufacturer's carton and is fully guaranteed. Limited quantity only available at approx. half list price.



£4.2.6
P's 2/6 pkg., car. and ins.

SPECIAL OFFER THE FAMOUS "CHANCERY" HIGH FIDELITY MICROCELL PICK-UP TYPE GPX for Standard and Long Playing



The Chancery Light Weight GPX Pick-up embodies certain unique features achieving a standard of performance not possible with normal magnetic or crystal pick-ups. The secret of the high standard of performance is in the use of the special microcell crystal cartridge assembly which has an unusually wide frequency response. The sapphire stylus is precision ground and semi-permanent. With two cartridges, 1 L.P. and 1 Standard. Price 52/8. Additional L.P. or Standard Cartridges can be supplied from stock at £11.16 each.

GRAMOPHONE UNITS

GARRARD Type 75. Latest 3-speed Autochange Unit complete with 2 Acos High Fidelity G.P.P. 19 Pick-up Heads. 1 L.P. and 1 Standard. Price 52/8. **£14.19.6**

GARRARD Rim Drive 78 r.p.m., complete with magnetic pick-up and turntable. Price 52/8. **£5.19.6**

COLLARO 3-speed single gram. unit, complete with head for L.P. and Standard recordings. Price 28/0. **£8.8.0**

Packing and carriage on each of the above units, 2/6.

B.S.R. "MONARCH" AUTO-CHANGER

This is a 3-speed automatic mixed record changer designed to play 12in., 10in., and 7in. records interchangeably in any order. Capacity 10 records, operates on 190-250-280 volts 50 C/s. A.C. New reversible dual stylus crystal pick-up has extended frequency range to 10,000 c.p.s. Self compensated for the L.P. lower frequencies with the Turnover frequency at the correct point. Price £16.10.3 plus 3/6 pkg., car.

LOUDSPEAKERS—TAX FREE!

- ELAC—2 1/2in. dia., Moving Coil, 15 ohms impd. 15/-
- PLESSEY—3in. dia., Moving Coil, 3 ohms impd. 15/-
- ELAC—3 1/2in. dia., Moving Coil, 3 ohms impd. 15/-
- ELAC—5in. dia., Moving Coil, 3 ohms impd. 14/6
- E.M.I.—8in. Elliptical, 15 ohms impd. 27/8
- PLESSEY—8in. dia., Moving Coil, 3 ohms impd. 14/6
- PLESSEY—8in. dia., Mains Energised, 3 ohms impd. (600 ohms field), with Pentode Transformer 22/6
- PLESSEY—8in. dia., Mains Energised, 3 ohms impd. (600 ohms field) 19/6
- PLESSEY—10in. dia., Moving Coil, 3 ohms impd. 23/6
- GOODMANS—12in. dia., Moving Coil, 15 ohms 28/8-/-
- Plus 5/- packing and carriage.
- VITA VOX—K12.20 12in. dia., Moving Coil, 15 ohms impd. £11.11
- Plus 5/- packing and carriage.

PREMIER MAINS TRANSFORMERS

All primaries are tapped for 200-230-250 v. mains—40-100 cycles. All primaries are screened. All L.T.s are centre tapped.

- SP175B, 175-0-175, 50 mA., 4 v. @ 1 a. 4 v. @ 2/3 a. 25/-
- SP250B, 250-0-250, 60 mA., 4 v. @ 1.2 a. 4 v. @ 3-5 a. 25/-
- SP300A, 300-0-300, 60 mA., 6.3 v. @ 2-3 a. 25/-
- SP300B, 300-0-300, 90 mA., 4 v. @ 2-3 a. 4 v. @ 3-5 a. 4 v. @ 1-2 a. 25/-
- SP301A, 300-0-300, 120 mA., 5 v. @ 2-3 a. 25/-
- SP301B, 300-0-300, 120 mA., 4 v. @ 2-3 a. 28/-
- SP302A, 250-0-350, 100 mA., 5 v. @ 2-3 a. 28/-
- SP302B, 250-0-350, 100 mA., 4 v. @ 2-3 a. 28/-
- SP351, 350-0-350, 150 mA., 4 v. @ 1-2 a. 4 v. @ 2-3 a. 4 v. @ 3-5 a. 30/-
- SP352, 350-0-350, 150 mA., 5 v. @ 2-3 a. 30/-
- SP375A, 375-0-375, 250 mA., 6.3 v. @ 2-3 a. 55/-
- SP375B, 375-0-375, 250 mA., 4 v. @ 2-3 a. 38/6
- SP501, 500-0-500, 150 mA., 4 v. @ 2-3 a. 4 v. @ 2-3 a. 4 v. @ 3-5 a. 47/-
- SP501A, 500-0-500, 150 mA., 5 v. @ 2-3 a. 6.3 v. @ 2-3 a. 6.3 v. @ 2-3 a. 50/-
- SP425A, 425-0-425, 200 mA., 6.3 v. @ 2-3 a. 6.3 v. @ 3-5 a. 5 v. @ 2-5 a. 67/6

WEYMOUTH MINIATURE I.F. TRANSFORMERS

465 Kc's iron core, permeability tuned—10.6 pair.

MINIATURE TUNING CONDENSERS

2 gang .0005 mfd. with trimmers, 6/9.

WEYMOUTH MINIATURE COIL PACK

Covering Med./Long/Short wave bands. Iron core coil, grad. position on switch. Dimens.: Height, 1 1/2in. Length, 3 1/2in. Width 2 1/2in. Spindle length, 2in. Price 19/6.

METERS

Large stocks available, a few of which are enumerated below—

Full Scale Deflection	Scale	Length	External Dimensions	Movement
5 A	1 1/2	2 1/2 x 2 1/2	R.F. Thermo	7/0
25 A	1 1/2	2 1/2 x 2 1/2	R.F. Thermo	7/6
3 A	1 1/2	2 1/2 x 2 1/2	R.F. Thermo	7/6
3.5 A	1 1/2	2 1/2 x 2 1/2	R.F. Thermo	7/6
4 A	1 1/2	2 1/2 x 2 1/2	R.F. Thermo	7/6
20 A	1 1/2	2 1/2 x 2 1/2	M/C	8/6
30 A	1 1/2	2 1/2 x 2 1/2	M/C	8/6
40 A	1 1/2	2 1/2 x 2 1/2	M/C	8/6
1.5 mA.	1 1/2	2 1/2 x 2 1/2	M/C	12/6
5 mA.	1 1/2	2 1/2 x 2 1/2	M/C	8/6
6 mA.	2	3 1/2 x 2 1/2	M/C	18/9
50 mA.	1 1/2	2 1/2 x 2 1/2	M/C	8/6
500 Micro/a.	1 1/2	2 1/2 x 2 1/2	M/C	15/6
20 V	2	2 1/2 x 2 1/2	M/C	8/6
40 V	1 1/2	2 1/2 x 2 1/2	M/C	8/6
1 mA.	2	3 1/2 x 2 1/2	M/C	25/-

1 mA METER IN PLASTIC CASE

The movement is 1 mA mounted in a case 3in. square and 3 1/2in. high. The scale is 2 1/2in. long and the dial is 2 1/2in. diameter. There is ample room in the case for a switch and multipliers. Internal Resistance 100 ohms. Price 27/6



MOVING COIL METER

A super quality Moving Coil Meter basic movement 2 1/2 in. diam. Scale dimension, 2 1/2in. Overall dimensions, 2 1/2in. diam., 1 1/2in. deep. Bakelite Case projecting thermo couple, reversing scale and rezeroing the meter, a high grade test instrument with any range above the basic F.S.D. may be built up. Price 4/9

TERMS OF BUSINESS:—CASH WITH ORDER OR C.O.D. OVER £1.
Please add 1/- for Post Orders under 10/-, 1/6 under 40/-, unless otherwise stated.

OZ4	9/-	6C4	8/6	6V6G	11/-
IAS	9/6	5X4	12/6	6Z5Y	10/-
IB4	10/6	6CS	8/6	OD3/V	14/6
IG4	8/6	6C5	9/-	6W5	11/6
IG5	6/6	6C8G	14/-	6X4	11/-
ILNS	6/6	6D6	9/6	6X5	10/-
ILA4	9/6	6F6	10/6	7A3	10/6
IP5	9/6	6G6G	9/6	7A7	9/6
IR4	9/6	6G8	9/6	7H7	10/-
IRS	13/6	6H6	7/6	7B7	10/6
IS4	12/-	6J5	7/6	7CS	12/6
IS5	12/-	6J6	14/6	7C6	11/6
IT4	11/-	6J7G/	9/-	7S7	14/6
ITS	10/6	6K6	10/6	7V7	10/6
IV	11/-	6K7M	9/6	7Y4	10/-
IC6	9/6	6K7G	8/9	12A6M	10/-
2A6	10/-	6K8	14/6	12K8	11/6
2X2	8/-	6L5G	8/6	12C8	10/6
3V4	11/-	6L6	12/6	12H6	6/6
5Y3	12/6	6L7	14/6	12J5	8/-
5Z3	13/-	6N7	14/6	12Y4	9/6
5U4	12/6	6P5	9/-	12SA7	10/6
5Z4	11/-	6Q7	12/6	12SG7	9/-
6A7	14/6	6R7	10/-	12SH7	8/6
6AC5	9/-	6SA7	9/6	12S17	9/6
6AC7	8/6	6SG7	9/6	12SK7	10/-
6AG5	9/6	6SH7	8/-	12SL7	9/6
6AQ5	11/-	6SK7	9/6	12SR7	8/9
6AM6	14/6	6SL7	11/6	14F6	10/-
6B4	8/6	6SN7	12/6	14S7	12/6
6B7	11/-	6T7	9/6	18	11/6
688	10/6	6TH8	9/6	19	9/6
6BR7	11/6	6U5	9/6	25AC5	9/6
6BW6	11/6	6U7	9/6	25L6	10/6

RADIO BULLS VALVES

246, HIGH ST. HADLESDEN W.M.D.

Please add 1/- Post.

HOME Broadcasters Self-energised Microphones Ex-Gov., 12/6

B.T.H. Germanium Crystal Diodes with Blueprint, 3/-

R O D Antennae 1-ft. sections interlocking extending. Copper-plated dozen 2/6

A V O Meters. All models available, also Model 8 £23

PIFICO All-in-One Radiometer for all Tests. A.C./D.C. 29/6

Please mark envelope (PW7)

Q-MAX Chassis Cutters all sizes in stock from 12/4

VCR97 Tubes 20/- Post 2/6

TYANA Soldering Irons. Weight 4 oz. Adjustable Bit. All voltages. 40 watt. 16/9

805 50/-
807 Br 16/6
84/6Z4 9/6
9004 7/6
954 5/6
955 6/6
956 6/6
1299A 8/-
1625 9/6
1626 9/6
7193 6/6
CI 10/6

AMPLION Test Meter, 1,800 ohms per volt. D.C. & A.C. £5

EASY TERMS All Taylor meters up to 10 months near Cash Price.

1B4	4/3
2A6	5/6
2A7	6/5
2B7	5/11
12A	3/-
26	2/10
34	4/3

TAYLOR Montrose 7-Range Multi-Meter, A.C./D.C., 50/-

25Z5	11/6	XP (I.5)	6/-	KTW61	8/9
25Z4	11/6	XH (I.5)	6/-	KTW62	8/6
28D7	8/6	ACDD	10/6	KTW63	8/6
31	9/6	CBL1	14/6	KTW73	10/3
32	8/6	CBL31	14/6	KTW74	10/3
33	9/6	CL4	13/6	KTZ41	11/6
35	9/6	DL2	9/6	L13	13/6
35L6	10/6	EBC33	9/6	HL4	10/6
35Z4	11/6	ECC31	12/6	N18	10/6
35Z5	11/6	ECL80	15/6	U71	10/-
37	9/-	EF36	9/6	U74	10/-
41	10/6	EC31	12/-	W76	10/3
42	11/6	ECH42	12/6	W77	10/-
45	11/6	EL3	14/-	X73	11/3
46	10/6	EL50	7/-	Z77	14/6
50L6	11/6	TH30C	16/-	4D1	10/4
58	10/-	TH62	10/-	8A1	12/6
75	17/-	UCH42	14/6	8D2	9/6
76	9/6	UF41	14/6	9D2	8/6
77	9/6	UY41	12/-	10D1	7/6
117Z6	11/6	D43	8/6	11D3	14/6
117L7	17/-	D63	8/-	15D2	16/6
117N7	17/-	D77	8/6	41MPT	8/6
805	50/-	DH73	11/-	SU2150A	14/6
807 Br	16/6	DH77	10/6	AC6PEN	8/6
84/6Z4	9/6	DL63	12/6	ACPI	8/6
9004	7/6	DL74	11/6	ACSP3	11/6
954	5/6	H63	7/6	HL13	10/6
955	6/6	HD24	13/-	HL23D	9/6
956	6/6	KT2	14/6	HL13DD	11/6
1299A	8/-	KT32	10/6	HL1320	10/6
1625	9/6	KT61	12/-	HL41	9/5
1626	9/6	KT66	11/6	HL41DD	12/6
7193	6/6	KT72	10/3	PEN25	10/5
CI	10/6	KT74	10/3		

THE FAMOUS BENNETT COLLEGE

can help your career through personal postal tuition

- in any of these subjects:*
- Accountancy Exams. * Aircraft Eng. & Radio * Architecture * Auditing * Book-keeping * Building * Carpentry * Chemistry * Civil Service * Commercial Art * Commercial Arithmetic * Company Law * Costing * Diesel Engines * Draughtsmanship * Electric Wiring * Engineering (Civil) * Electrical * Mechanical * Motor * Steam * Structural * Jigs, Tools & Fixtures * Journalism * Locomotive Eng. * Languages * Mathematics * Mining * Modern Business Methods * Plumbing * Police * Press Tool Work * Quantity Surveying * Radio * Salesmanship * Secretarial Exams. * Shorthand * Surveying * Telecommunications * Television * Textiles * Works Management * Workshop Practice

and GENERAL CERTIFICATE OF EDUCATION SUCCESS WILL BE YOURS

As a Bennett College Student your own Personal Tutor will coach you until you qualify, at your pace, with no time wasted. You will learn quickly, easily.

SEND TODAY FOR A FREE PROSPECTUS

TO THE BENNETT COLLEGE (DEPT. G-104), SHEFFIELD.

Please send me your prospectus on..... (Subject)

NAME

ADDRESS

.....AGE (IF UNDER 21)

PLEASE WRITE IN BLOCK LETTERS

HANNEY of BATH offers:

STANDARD VIEWMASTER. Constructor's Envelope. 7 6 : complete kit with vice, screwing, nuts and bolts, lens valve, tube and cabinet. GENUINE parts only. 431. OR in 7 easy stages: 1. 62 3 : 2. 42 9 : (Wenove 35 - 2 : 45 1 8 - 4 : 9 10 : 5. 410 4 : 6. 47 5 9 : 7. 67 8 : Individual Parts (any from separately). WB100 (sound and vision chassis). 18 6 : WB101. 18 6 : WB102. 18 6 : WB103. 42 - : WB103A. 52 6 : WB104. 15 6 : WB105. 43 6 : WB106. 25 6 : WB107. 32 6 : WB108. 33 3 : WB109 1. 2 or 3 (state tube type). 22 6 : WB110. 10 - : WB112. 21 6 : WB Console conversion kit. 35 - : 20 4 : 11D38. 11 7 : WX3 and WX6. 3 9 each : 3BEHT100. 29 5 : 36PHT50. 26 1 : 36EHT55. 23 8 : K3 100. 14 8 : K3 50. 8 9 : K3 45. 8 2 : T.C.C. Condensers. 47 10 - (any condenser supplied separately). Morganite pots. 5 - each : Morganite resistors. 35 3. Colvern pots. 22 6 : or CL1901. 3 3 each and CL1909. 22. 6 4. Belling Lee L707. 8 9. Puses. 6d. each. Weather Coils (with 1.9). 1.10n. 22 - : Wenove. 28 - : Bham. H.Moss and K-O-S. 30 - : Pre-amp coils. 4 - pair, any channel. Special condensers are also available for the WIDE ANGLE Viewmaster.

TELEKING. Constructor's Envelope. 6 -. Coils. 54 3 : Chassis Kits. 70 - : T.C.C. Kit. 47 4 3 : R.M. 4 rectifier. 21 - : Allen Wide Angle Components. 1.0.308. 50 - : FQ.235. 2 - : 1.0.300. 42 14 : FC.302. 35 - : GL.15 prism. CL.18. 10 - each : BT.314. 15 - : SC.312. 22 6 : AT.310. 30 - : OP.117. 9 - : Resistors and Pots, are detailed in our TK Supplement.

MAGNAVIEW. Constructor's Book from BRIMAR Valves. Denco coils. 41 2 : Chassis kit. 37 6 : Erie resistor kit. 39 2 : DENCO Wide Angle Components (also suitable for TK). WA DCAL. 43 - : WA FCAL. 31 - : WA LCL and WA WCL. 7 6 each : WA. F471. 16 - : Condensers and pots as per our Magnaview Supplement. ELAC Mark 2 PM Focus Rings (with Vrenier Control). R.17. 28 6 : R.20 30 - : R.25. 32 6 - : R.25. 52 6 : W.25. 57 6. Ion Traps. IT2. IT6. IT8 and IT9. 5 - each.

Now in preparation. A Constructor Envelope showing how to build the **SOUNDMASTER**. Not a cheap ready-built Tape Desk with an amplifier, but a professional-type instrument that can be assembled from precision-engineered parts without tools or previous experience. Designed by the designer of the Viewmaster. Mr. W. L. Flack, A.Soc. I.E.E., the Soundmaster incorporates twin-track, 3-speed ultra silent drive (3 motors), specially screened 3-watt amplifier and magic eye level indicator. Also in preparation. Constructor Envelope for the new **WIDE ANGLE VIEWMASTER** for 11n., 16n. and 17n. tubes.

Send 6d. in stamps for our **NEW LIST** details of the above two designs will be sent to all applicants as soon as available.

L. F. HANNEY
77, LOWER BRISTOL ROAD, BATH. Tel. 3811

Continued from page 402

The principle involved is that when a shunt is placed in the circuit of a milliammeter or microammeter reading full-scale deflection and adjusted so that the new reading is one half the original one, then the value of the shunt at that point is equal to that of the meter. The circuit used is shown in Fig. 11, the shunt is a wire-wound variable resistor of about 1,000 ohms. When the half-scale deflection is obtained, the variable resistor is taken out of the circuit without altering its setting and its value is measured on a standard ohmmeter or on a bridge. Hence the resistance of the moving-coil is found. It is desirable to add a resistor in series with the coil, the value of which makes a round number with the resistance of the coil. This resistor, known as "swamp" resistor, is made of insulated Constantan wire and wound on an insulated former.

How to calculate the value of a shunt for a given range:

Full scale deflection of meter : 100 μ A.
 Resistance of coil : say 473 ohms.
 Desired resistance of coil : 500 ohms.
 Value of "swamp" resistor : 27 ohms.
 Range of current to measure : 500 μ A.
 The shunt must carry a current of $500-100=400 \mu$ A or $4/5$ of total current. Therefore, resistance of shunt $\frac{500}{4}=125$ ohms.

Alternatively the following formula can be used

$$R_s = \frac{R_m}{N-1}$$

where R_s = resistance of shunt
 R_m = resistance of coil and "swamp."
 N = factor by which it is desired to multiply range of meter

The rest of the circuit consists of the ohmmeter and audio ranges.

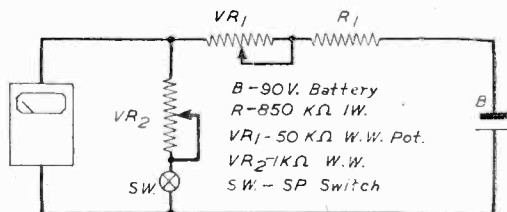

Fig. 11.—Method of adjusting the shunts. Adjust VR_1 with switch open-circuited, until full-scale deflection is obtained. Close switch and adjust VR_2 until instrument reads one half the previous current. Then VR_2 in ohms is the meter resistance. B must be a high-voltage battery.

The audio voltages are measured on the A.C. ranges by using a paper condenser, C, in series with the test leads. This condenser is automatically connected in the circuit when the instrument is switched to "Audio."

(To be continued)

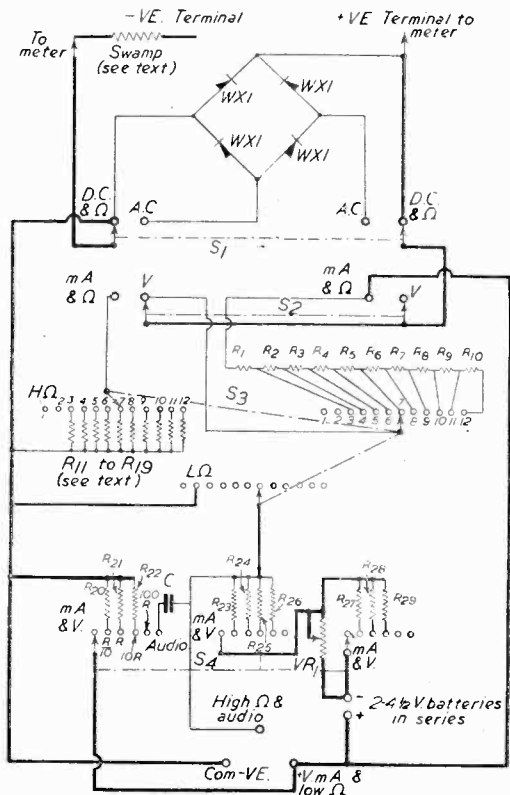

Fig. 10 (a).—One circuit arrangement of the complete meter. An alternative will be given next month.

LIST OF COMPONENTS

Circuit of Fig. 10a.

- Switches
 S1 } 2-Pole 2-way low contact resistance.
 S2 }
 S3—1 Pole 12-way 3 banks low contact resistance.
 S4—1 Pole 6-way 3 banks low contact resistance.
- Resistors (assuming meter resistance = 500 ohms).
 R1—500
 R2—4,000
 R3—5,000
 R4—15,000 } ohms 1w. Dubilier H.S. Carbon \pm
 R5—75,000 } 1%
 R6—150,000
 R7—750,000
 R8 { 1 Megohm } Dubilier H.S. Carbon \pm 1%
 { + 0.5 megohm }
 R9 { 1 Megohm } Dubilier H.S. Carbon \pm 1%
 { + 0.5 megohm }
 R10—5 \times 1 Megohm Dubilier H.S. Carbon \pm 1%
 R11 to R19—Home-made shunts calculated from
 $R_s = \frac{R_m}{n-1}$ (see text).
 R20—shunts (Eureka) for meter to read 100 mA f.s.d.
 R21—shunts (Eureka) for meter to read 10 mA f.s.d.
 R22—shunts (Eureka) for meter to read 1 mA f.s.d.
 R23—75 ohms $\frac{1}{2}$ W. Dubilier H.S. carbon \pm 2%.
 R24—800
 R25—8,000 ohms $\frac{1}{2}$ W. Dubilier H.S. Carbon \pm
 R26—87,500 } 1%
 R27—31 ohms $\frac{1}{2}$ W. Dubilier H.S. carbon.
 R28—235 ohms $\frac{1}{2}$ W. Dubilier H.S. carbon \pm
 R29—3,400 } 1%
 VR1—5,000 ohms W.W. 5 Watt
 C—0.1 μ F. 1,500 v. D.C. paper condenser.
 WX—1 Westinghouse Westectors.

Programme Pointers

By MAURICE REEVE

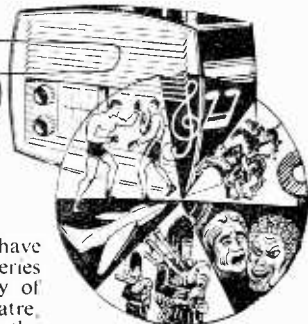

Music

ENGLISH music has had a curious and chequered history. Its leanest times were contemporaneous with the glorious outpourings of the European geniuses and may be said to have lasted from the death of Bach—Johann Sebastian—in 1750 to the death of Brahms in 1897, reaching its nadir in Victorian times. Since then it has known a great revival, occasionally scaling the heights in Elgar, Delius and Vaughan Williams. But it never knew greater days than during the reign of the first Elizabeth, when a series of master musicians poured out works for the lute, voices and other instruments which brought lustre and fame even to an age which lived with Shakespeare.

Thurston Bart, a young man of enviable gifts, has been presenting a set of nine programmes of "English Lute Music, 1540-1620" which have been as fascinating education as they have entertainment. Artists, too numerous to cite here individually, have performed works by Dowland, Ford, Morley, Handford, Newman, Jones, Tallis, Byrd, and many others: as well as Henry the Eighth and the irrepressible "Anon," a gentleman as ubiquitous in those days as "A. N. Other" is in modern sport.

Was it Romeo who said "If music be the food of love, play on"? And was it Sir Toby Belch who, saying he had "a reasonable good ear for music," called for the tongs and the bones? However, though either, or both, of these extremes of thought may contain the soul of the divine art, listening to this always captivating and frequently beautiful music served to show the constant stimulation Shakespeare's great love of music was ever receiving, and which he so frequently sublimated throughout his works.

Shakespeare

Writing of Will causes me to place next in my this month's list for review the second production in a new "Coronation Curtain-up" series, which was none other than Clemence Dane's "invention," "Will Shakespeare." This brilliant and moving piece sets out to fill in, to the authoress's fancy, what might have happened on some of the many blank pages in the poet's life. Miss Dane chooses for her central fancy that Marlowe was murdered by Shakespeare in a tavern duel over Mary Fitton, one of the Virgin Queen's ladies-in-waiting, and, of course, Shaw's "Dark Lady of the Sonnets." Coupled to this is the poet's harsh treatment of his wife, Anne Hathaway, and her voice calling to him from the "far, far better land."

Val Gielgud as Shakespeare, Mary Wimbush as Anne, Joyce Heron as Mary, Nancy Price as the Queen, Alexander Davion as Kit Marlowe, Leon Quartermaine as the actor Henslowe, and Eileen Thorndyke as Mrs. Hathaway, together with the authoress as narrator, all gave us a capital show.

The Theatre

Four instalments have taken place of a series setting out the story of Her Majesty's Theatre, that famous house in the Haymarket which we have all known for so long as *His Majesty's* and which, for most of us, has existed in its present guise, built by Sir Herbert Tree at the end of the Victorian era as Her Majesty's, all our lives. On listening to the excerpts of the various plays that first saw the light on its famous boards, one fairly reels at the kaleidoscopic pageant of life, history and colour witnessed by generations of its patrons. "The School for Scandal," "Pygmalion," "Hassan," "Trilby" and "Drake" are a few of the classics or neo-classics. "Chu Chin Chow," of course, still holds the blue riband of longevity. "Joseph and His Brethren" and "David Copperfield" were magnificent entertainment and spectacle. To-day Tree and his fellow workers look down on different scenes and different players, managers and writers, as they look down on a different age with different values and standards. Their thoughts will ever remain undisclosed.

These programmes, like BBC revivals of "The Merry Widow," etc., are good entertainment to a point: they fail to recapture the past largely because it cannot be recaptured.

Talks

The revival of Sir Arthur Grimble's talks, "Tales from the Pacific Islands," was very welcome. Sir Arthur is one of the best of broadcasters, and he recounts some fascinating reminiscences and experiences.

"Marshal Ney," J. C. Masterman's clever play on a dramatic subject, tells the story of how the magic name "Napoleon" and the thrilling news "escaped from Elba" caused this famous soldier to once more change sides and to go down to ruin after Waterloo. It made good radio and Howard Marion Crawford as the Marshal aroused all the old fascination which that period of history known as Napoleonic will, we hope, always possess. A pity we can't say the same for the Hitlerian chapter.

"Electra," in Gilbert Murray's translation, afforded Joan Hart with her biggest part for some time. She accomplished her task nobly.

"Antarctic Journey" largely failed to get to grips with Shackleton's incredibly marvellous story—incredible but for the fact of its being true. The "heave-ho" of the men when launching the lifeboat off the rapidly breaking ice was more reminiscent of John Snagge at the Boat Race than of the Antarctic. Duncan Carse was, I should imagine, excellent as Shackleton.

Footnote. Why are comedians invariably so much funnier in Workers' Playtime than in studio broadcasts?



PORTABLE TAPE RECORDERS

Brand New — Unused — Complete. Fully assembled and wired. Ready to operate. Attractive carrying case. Twin track recording. Instant play-back. Total playing time of 35 minutes. 8 Valves. A.C. Mains 200-250 volts. Fast rewind. Complete. Ready to switch on.

Write for full illustrated details and circuit diagrams. **LASKY'S PRICE £34.19.6** Carriage 10/- extra.

THE RECORDING AMPLIFIER, as used in the above recorder, can be purchased separately. Complete with 6 valves: 1 5Z4, 1 6J5, 2 6V6, 2 6J7, 5in. P.M. speaker, etc. Fully assembled and wired. Size: 15 1/2 in. wide, 8 1/2 in. deep, 6in. high. Circuit available.

Although new, these amplifiers are untested, and may have minor faults. The price has been reduced accordingly to £7.15.0 complete with valves. Carriage 10/- extra.

R1132 RECEIVERS, BRAND NEW AND UNUSED.

Complete with all valves, in original wood case. £3/19/6. Carriage 10/- extra.

SPECIAL CATHODE RAY TUBE OFFER

Brand new and unused 12in. ion trap C.R. tubes, 6.3 volt heater, 7-9 Kv. E.H.T. 35 mm. neck. Black and white picture. By famous manufacturer. £11/19/6. Screen has very slight blemishes. **£12/19/6 PERFECT.** Carriage and insurance 15/- per tube extra.

MAINS TRANSFORMERS

All 200-250 volts c.p.s. primary. Finest quality, fully guaranteed. **MBA.3.** 350-0-350 v. 80 mA. 6.3 v. 4 a., 5 v. 2 a. Both filaments tapped at 4 volts. An ideal replacement trans. Price 18/-.

MBA.5. 350-0-350 v. 125 mA. 6.3 v. 4 a., 5 v. 3 a. With mains tapping board. Price 27/6.

MBA.6. 350-0-350 v. 100 mA. 6.3 v. 3 a., 5 v. 2 a. With mains tapping board. Price 22/6.

MBA.7. 250-0-250 v. 80 mA. 6.3 v. 3 a., 5 v. 2 a. Both filaments tapped at 4 volts. Price 18/-.

AT.3. Auto transformer. 0-10-120. 200-230-240 volts, 100 watts. Price 17/6.

FILAMENT TRANSFORMERS

6.3 v. 1.5 a., 7/11.
6.3 v. 3 a., 12/6.
Special Transformer. 2 amps., with the following tappings: 3, 4, 5, 6, 8, 9, 10, 12, 15, 18, 20, 24 and 30 volts. **PRICE 17/6.**
FL.4. Heavy duty filament transformer. 6.3 v. 3 a., 6.3 v. 3 a., 5 v. 3 a. Shrouded, drop-through type. With mains tapping board. **Price 32/-.**

PERSPEN. 13 1/2 x 10 1/2 x 1/2 in. Neutral shade, slightly marked. 5/11 per piece.

TEST PRODS. Fused, with fully retractable points. Price 4/11 per pair.

ANTENNA ROD SECTIONS
Each rod is steel heavily copper plated. Any number can be fitted together. 12in. long, 1/4 in. diameter. **Price 2/6 per dozen post free.**

CAR RADIOS. A few 12 volt models left. **Price £15.19.6.** Carriage 10/- extra, send for details.

TANNOY PRESSURE UNITS
10 watts. 7.5 ohms impedance. **LAST FEW ONLY, 59/6.** Carriage 3/6 extra.

VIBRATOR PACKS

A large and varied selection available. 6, 12 and 24 volts. From 21/-.

CAR RADIO PLUG SUPPRESSORS, 1/6 each.

CONDENSERS

All types available from stock. Electrolytic, miniature bias, Mica and Tubular cardboard, ceramic and silver mica. Send us your requirements.

C.R.T. MASKS, Brand New

LATEST ASPECT RATIO
10in. 7/6
12in. 15/-
12in. flat face 15/-
14in. rectangular 21/-
16in. Double-D 31/6
17in. rectangular 27/6

SOLED OLD ASPECT RATIO

9in. sorbo. 5/-
12in. 7/6
12in. with fitted armour glass. (New ratio.) Cream. 11/6
12in. with fitted armour glass. (New ratio.) Black. 8/6

DINGHY AERIALS WITH REFLECTORS

As illustrated, wire mesh, complete with setting up instructions. Mast not supplied.

LASKY'S PRICE, 7/6. Post 1/6.

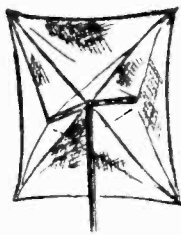

4 VALVE AMPLIFIER BRAND NEW AND UNUSED

For operation from 110-250 volts D.C. Uses 4 valves type PEN383. Very easily adapted for A.C./D.C. working. In wood cabinet size: 9 x 16 x 8ins. **LASKY'S PRICE 39/6. Carriage 7/6 extra.**

I.F. TRANSFORMERS

465 Kc's iron dust cores in cans, midget type. Size: 1 1/2 in. x 1 1/2 in. x 2 1/2 in. **Price 12/6 per pair.**
WEARITE TYPE 550. 445-520 Kc's. 12/6 per pair.
WEARITE TYPE 500. 450-470 Kc's. 12/6 per pair.

P.M. LOUDSPEAKERS

All less otrans, new and unused. First quality.
3in. Elac. 12/11
5in. Plessey 12/6
WEARITE 15/6
8in. 15/-
10in. 25/-

SUPERHET COIL PACKS

3 Wavebands: 12-35 metres: 35-100 metres: 200-550 metres: **Size: 4 x 4 x 3in. Price 16/-.**

OUTPUT TRANSFORMERS

40 mA Multi-ratio 6/11
80 mA Multi-ratio 14/11
80 mA Pentode 12/6
60 mA Plessey, 6,000 ohms 5/11
Standard pentode 4/11
Pentode 3/6
Midget pentode 4/3
Miniature pentode, 3S4, 1S4 4/6
PX4 Intervalve 8/6
5:1 Intervalve 5/11

15" C.R.T. MASKS

Latest aspect ratio. New and unused. No. 1 Rubber. Overall size: 17in. wide, 33in. high. **Price 17/6. Post 2/-.**
Plastic. Incorporating dark screen filter and gold finish tube escutcheon. Overall size: 15in. wide, 12in. high. **Price 21/-, Post 2/-.**

VALVES, 10,000 IN STOCK AT THE LOWEST POSSIBLE PRICES.

Write for complete list.

SPECIAL OFFER, 4 Valves: 1 each 1R5, 1T4, 1S5 and 3S4. LASKY'S PRICE 32/6. POST FREE.

50L6	10/-	1S4	9/-	1A5	9/-	6J7	6/6	EF39	7/6
35Z4	9/-	3S4	9/-	NSG	5/-	HL2	3/6	12K7	10/6
6AM6	9/-	1T4	9/-	XP	5/-	KT2	3/6	6L3	10/6
6H6	2/6	1R5	9/-	NH	3/6	6K3	13/6	EA50	2/6
EF50, Red		1S5	9/-	3Q5	9/-	U50	9/-	EB33	2/6
New Sylvania	12/6	1C5	9/-	6K7	6/6	ECH35	13/6	35L6	10/-

SMOOTHING CHOKES

20 mA, 40 H.	3/11
40 mA, 8 H.	3/11
40 mA, 10 H.	4/3
100 mA, 10-20 H.	5/3
120 mA, 10 H.	5/3
200 mA, 5 H. 50 ohms	12/6

TELEVISION SELENIUM RECTIFIERS

The very latest "Sentercell" S.T.C. range
K340, 3.2 kv. 7/6
K345, 3.6 kv. 8/2
K350, 4.0 kv. 8/8
K3100, 8.0 kv. 14/8
K3180, 12.6 kv. 21/6

S.T.C. METAL RECTIFIERS

RM1	3/11
RM2	4/6
RM4	21/-

AMPLIFIERS

4-Watt Model. Ex Government. Complete with 10 valves: 2 25L6; 1 6H6; 1 25Z6; 6 6SK7. For operation on 110 volts A.C./D.C. Balance and push pull. High, medium and low impedance inputs. A.C. G., etc. **LASKY'S PRICE £5.19.6** complete. No circuits available. Carriage 10/- per unit extra.

CRYSTAL DIODES

Germanium. Price 2/3 each. Post Free.

SUPERHET COILS

For 465 Kc's. 10-30 metres. Aerial and oscillator. 1/11 per pair. With Circuit. Postage 9d. extra.

T.C.C. VISONCOL HIGH VOLTAGE CONDENSERS

(Cathodry)
-001 mid. 15 kv. 10/-
-001 mid. 25 kv. 18/-
-005 mid. 25 kv. 18/-
-005 mid. 12.5 kv. 10/-
-1 mid. 7 kv. 15/-
-0.4 mid. 12.5 kv. 7/6
-0.01 mid. 12.5 kv. 7/6
Plastic case, single bolt fixing

EX-A.M.E. RECEIVER TYPE R1155.

Brand new and unused. Aerial tested before despatch. Supplied complete with 10 valves. Circuit: B.F.O. A.V.C. R.F. Amp. two I.F. Stages, Magic Eye, etc., etc.
5 Frequency ranges: 18.5-7.5 Mc/s.; 7.5-3.0 Mc/s.; 1,500-600 Kc/s.; 500-200 Kc/s.; 200-75 Kc/s.
Supplied in maker's original wood transit case. **LASKY'S PRICE, £11/19/6.** Complete. Carriage 12/6 extra.

USED MODEL R1155 RECEIVERS.

Aerial tested before despatch. Complete with 10 valves. **LASKY'S PRICE £7/19/6.** Carriage 12/6 extra.

FULLY ASSEMBLED POWER PACK AND OUTPUT STAGE FOR R1155 RECEIVERS.

For use on 200-250 volt A.C. mains. Wired and complete with valves. **LASKY'S PRICE, 79/6.** Carriage 5/- extra.

INDICATOR UNITS TYPE 233

Contains 1 c.r. tube type VCR97, and 11 valves: 3 EF50; 3 EB34; 3 SP61; 2 EA50. Also hundreds of components, resistances, switches, etc., etc. On metal chassis, in grey enamel metal case. Size: 18 x 6 x 8ins. **LASKY'S PRICE 69/6.** Carriage and packing 10/6 extra.

LASKY'S RADIO

Lasky's (Harrow Road), Ltd.,

370, Harrow Road, Paddington, London, W.9

Telephones: CUNningham 1979-7214. All Dents.

MAIL ORDER AND DESPATCH DEPARTMENTS: 485-487, HARROW ROAD, PADDINGTON, LONDON, W.10.

Hours: Mon. to Sat. 9.30 a.m. to 6 p.m.; Thurs. half day, 1 p.m. Postage and packing charges (unless otherwise stated); on orders value £1-1s. 0d. extra; £5-2s. 0d. extra; £10-3s. 6d. extra; over £10 carriage free unless specifically stated otherwise. All goods fully insured in transit.

COPPER INSTRUMENT WIRE (ex-stock)

SWG	Inch	ENAMELLED		TINNED		COTTON COVERED		SILK COVERED	
		2 ozs.	4 ozs.	2 ozs.	4 ozs.	2 ozs.	4 ozs.	2 ozs.	4 ozs.
16	.064	1/4	2/-	1/4	2/-	1/4	2/-	1/4	2/-
17	.056	1/4	2/1	1/4	2/1	1/4	2/1	1/4	2/1
18	.048	1/4	2/2	1/4	2/2	1/4	2/2	1/4	2/2
19	.040	1/4	2/3	—	—	1/5	2/3	1/6	2/5
20	.036	1/5	2/4	1/5	2/4	1/5	2/4	1/7	2/8
21	.032	1/5	2/5	1/6	2/5	1/5	2/5	1/8	2/10
22	.028	1/6	2/6	1/6	2/6	1/6	2/6	1/9	3/-
23	.024	1/7	2/7	1/7	2/7	1/7	2/7	1/10	3/2
24	.022	1/7	2/8	1/7	2/8	1/7	2/8	1/10	3/2
25	.020	1/8	2/9	1/8	2/9	1/8	2/9	1/11	3/4
26	.018	1/8	2/10	1/8	2/10	1/9	2/11	2/-	3/6
27	.0164	1/9	2/11	1/9	2/11	1/10	3/1	2/1	3/8
28	.0148	1/9	3/-	1/9	3/-	1/10	3/2	2/2	3/10
29	.0136	1/10	3/1	1/10	3/1	1/11	3/4	2/3	4/-
30	.0124	1/10	3/2	1/11	3/5	2/-	3/6	2/4	4/2
31	.0116	1/11	3/3	2/-	3/6	2/1	3/7	2/5	4/4
32	.0108	1/11	3/4	2/1	3/8	2/1	3/8	2/7	4/8
33	.010	2/-	3/5	2/2	3/10	2/3	3/11	2/10	5/2
34	.0092	2/-	3/6	2/3	4/-	2/4	4/2	2/11	5/4
35	.0084	2/1	3/7	2/4	4/2	2/6	4/5	3/1	5/8
36	.0076	2/1	3/8	2/6	4/5	2/7	4/8	3/3	6/0
37	.0068	2/2	3/10	2/7	4/8	3/-	5/6	3/5	6/4
38	.006	2/3	4/-	2/9	4/11	3/4	6/2	3/7	6/8
39	.0052	2/4	4/2	2/10	5/2	—	—	3/10	7/2
40	.0048	2/5	4/4	3/-	5/6	4/7	—	4/1	7/8
41	.0044	1/6 per oz.	—	1/9 per oz.	—	—	—	2/3 per oz.	—
42	.004	1/9	—	2/-	—	—	—	2/6	—
43	.0036	2/3	—	2/6	—	—	—	3/-	—
44	.0032	3/-	—	—	—	—	—	4/-	—
45	.0028	4/-	—	—	—	—	—	5/6	—
46	.0024	5/-	—	5/-	—	—	—	7/6	—

47 and 48 swg Enam. and 47 swg E.S.S.C. wires in stock. State needs. All above postage extra. POST ORDERS ONLY PLEASE. Send stamp for comprehensive lists.

EUREKA & CONSTANTAN RESISTANCE WIRES "ALL GAUGES STOCKED"

G.E.C. & B.T.H. GERMANIUM CRYSTAL DIODES

G.E.C. LATEST TYPE 5/16in. x 3/16in. B.T.H. LATEST TYPE MOULDED IN THERMO-SETTING PLASTIC Both Wire Ends for Easy Fixing. 4/6 each, postage 2 1/2d.

B.T.H. SILICON CRYSTAL VALVE

3/6 each, postage 2 1/2d. Fixing Brackets 3d. Extra. Wiring instructions for a cheap, simple but high quality Crystal Set included with each Diode and Crystal Valve.

CRYSTAL SET INCORPORATING THE SILICON CRYSTAL VALVE

Adjustable Iron Cored Coil. RECEPTION GUARANTEED Polished wood cabinet, 15/- post. 11d. A REAL CRYSTAL SET, NOT A TOY

CRYSTAL SET

As above, but with Germanium Crystal Diode, 16/-. Postage 11d.

B.A. SCREWS, NUTS, WASHERS soldering tags, eyelets and rivets. EBONITE AND BAKELITE PANELS. TUFNOL ROD, PAXOLIN TYPE COIL FORMERS AND TUBES, ALL DIAMETERS.

POST RADIO SUPPLIES

33 BOURNE GARDENS, LONDON, E.4 TEL: CL16502 4688 & 2021

CORONATION OFFER!

★ The coupon below will save you MONEY!

Let I.C.S. perfect your knowledge of radio and T.V. To mark the Coronation International Correspondence Schools Offer their standard Home Study Courses at specially reduced fees for a limited period only. These include RADIO ENGINEERING, RADIO SERVICE ENGINEERING, RADAR, ELEMENTARY ELECTRONICS, ADVANCED SHORTWAVE RADIO, RADIO T.V. TECHNOLOGY and training for the following examinations: B.I.R.E., P.M.G. CERTIFICATES FOR WIRELESS OPERATORS, C. & G. TELECOMMUNICATIONS, C. & G. RADIO SERVICING CERT. (R.T.E.B.), C. & G. RADIO AMATEURS, etc., etc.

But ACT NOW—Don't miss this chance of obtaining an I.C.S. training at reduced fees! Fill in the coupon, stating the subject in which you are interested, and POST TODAY.

Dept. 170C, I.C.S., 71 Kingsway, W.C.2.

INTERNATIONAL CORRESPONDENCE SCHOOLS

(Dept. 170C), International Bldgs., Kingsway, London, W.C.2. I am interested in your Coronation Offer.

Please send FREE Book on.....
 Name..... Age.....
 (Block letters, please)
 Address.....

Since 1945 I.C.S. have trained 150,000 ambitious men.

YOUR OPPORTUNITY!

We are holding a of brand new equipment at unrepeatable Bargain prices. Come to the Radio Centre and inspect at your leisure—or order from the selection listed below!

- ACTINA SUN LAMPS 5 s d.
- ACOS GP20 PICK-UPS 12 12 0
- ACOS MIC-30 CRYSTAL MICROPHONES 2 19 6
- BPL or Quadrant 1 MA 3'in. METERS 3 3 0
- BSE 3-VALVE Amplifier chassis-sprayed, anti-rust, 11 x 31 x 1 1/2in. ONLY 2 6
- BROWN 4,000 ohm M.C. Earpieces 2 15 0
- CONRAD LP GRAM UNIT 3 6
- *COLLARO 3/RCS21 Three-speed Auto Changer 2 5 0
- *COLLARO 3/RCS22 Three-speed Mixer Auto Changer 10 10 0
- *COLLARO 3/RCS23 Three-speed Mixer Auto Changer 12 12 0
- *COLLARO 3/RCS11 521 78 r.p.m. Auto Changer 8 8 9
- *N.B.—Crystal dual heads, 48 9 extra. Crystal LP or 78 Heads, 48 9 extra. Max. Heads, 25 - extra.
- DECCA 33B 33-1 8 r.p.m. RECORD PLAYER in resin case 8 19 6
- EKCO SOLDERING PENCILS, 6 or 12v. D.C. 17 6
- EXTENSION SPEAKERS in Plastic cabinet 1 5 0
- G.E.C. Safety Rubber-bladed FANS for A.C. mains 4 19 6
- HANDY UTILITY SANDER POLISHER 8 9 9
- 7 19 6

Summer Sale

- HANDY UTILITY ELEC. 2 s. d.
- TRIO SAW 12 12 0
- IVALIKE CRYSTAL SETS 10 0
- LOUDSPEAKERS 10in. P.M. LAMP SHADE & TABLE STAND 16 6
- MICROPHONES for Desk use Complete 7 6
- MILNES 10in. Hi-Fi Loudspeakers chassis 6 11
- METERS 8 8 0
- 0-250 amp meter 2 1/2in. dia. 10 0
- 0-3,500 volt D.C. METER, 9 1/2in. dia. 1 0 0
- 0-500 Microammeter 3 1/2in. dia. 2 7 6
- MAINS TRANSFORMER 400-0-400 v. 150 m/a with heater windings 1 15 0
- MAINS MOTOR 1 1/8 h.p. with 3-speed Reduction Gearbox (from 1 r.p.m.), D.C. mains 15 0
- PLESSEY 3-speed AUTO-CHANGER complete 16 0 0
- PAINT SPRAYER "SPRIDO" 12 6
- ROTHERMEL HAND MICROPHONE 2AD56 2 12 0
- RECTIFIERS, Selenium, 300 x 80-70 m/a 6 6
- TALLON 9in. Viewmaster Console Cabinets 10 10 0
- TALLON 9in. Viewmaster Table Cabinets 5 5 0
- TAMSA Oscillator Coils 8 11

Please add sufficient for post and packing. We also have a very large variety of miscellaneous quantities of Government surplus on show at the RADIO CENTRE. Come and pick out your bargain.

MAIL ORDER SUPPLY CO., The Radio Centre
 33, Tottenham Court Road, London, W.1.

More about TRANSISTORS

SOME FURTHER DETAILS OF THIS NEW "COLD CATHODE" VALVE

By F. E. Henderson

MANY readers of this journal are by now familiar with the modern crystal rectifier, which is finding its way into present-day radio equipment and many television receivers. The small size, robust construction and practically indefinite life of these little rectifiers have made them of very considerable interest to manufacturers of radio and television sets. Their satisfactory performance is leading to their more widespread use as replacements for the thermionic diode in many positions in the receiver.

Although the germanium crystal valve appears at first sight a very simple device, the successful manufacture of a consistent product has proved by no means simple. However, methods have been discovered to make not only crystal valves that rectify but also ones for use as amplifiers and oscillators.

We now see reports about complete amplifiers, radio receivers and even television sets functioning without the use of a single thermionic valve, and the question no doubt arises in many people's minds—is the new germanium triode, or "transistor" as it is called, really supplanting the thermionic valve?

To get our thoughts clear about this, let us briefly see how this "cold cathode" valve works, whether it can readily replace the thermionic valve, and whether it is likely to become a large-scale production reality in the near future.

What the Transistor is

Germanium is an element which is classed as a semi-conductor, that is, an element which has electrical properties half-way between an insulator and a metal.

When a metal point is brought into contact with a semi-conductor such as germanium (or silicon), there is an interchange of electrons at the point of contact, the net flow taking place from semi-conductor to metal point.

The transfer of electrons tends to accumulate a negative charge in the metal, while the semi-conductor is left positively charged. This state of equilibrium exists until an external voltage applied between the semi-conductor and the contact disturbs it and causes a flow of current.

When the metal point is made positive, the resistance offered to the electron exchange is reduced—this is the forward direction for applied voltage. The application of a negative voltage, however, gives rise to a high resistance, the value of which depends, among other things, on the impurity of the semi-conductor.

A germanium crystal of very small impurity content can withstand

"reverse" voltage of the order of hundreds of volts before "breakdown" occurs at the contact. Alternatively, with high impurity contents, diodes can be made which will only withstand reverse voltage of the order of a few volts, but which give high current for low "forward" voltages. Such diodes give very high rectification efficiency at small signal levels.

Before we can proceed and consider the next step, there is an important little bit of chemistry which must be understood.

If it were possible sufficiently to magnify a photograph of a piece of germanium (or any other element for that matter) we should see that its mass was composed of atoms of the element, each atom with its electron satellites, the whole forming a crystal lattice structure. If the germanium were a perfect crystal, there would be a regular crystal pattern; if the germanium were not perfectly pure, but contaminated with another element, the resulting crystal pattern would no longer be perfect, but would either have some excess electrons which could not fit into the structure or a shortage of electrons giving rise to gaps in the structure. These gaps are known as "holes." The presence of these excess electrons and "holes" gives rise to conductor properties. A crystal with surplus electrons will more easily part up with them than absorb more of them, while one with a deficiency of electrons will more easily absorb other electrons. In other words, the resistance to the flow of current is higher in one direction than the other, depending upon the nature of the semi-conductor, and its impurity content.

A specimen which conducts by electrons alone is called n-type since the current carriers are *negative*; a specimen deficient in electrons conducts by movement of the position of the residual "holes," and is called p-type since the current carriers are virtually *positive*. Thus, if germanium contains an impurity content which results in there being an excess of electrons, it will conduct by electrons flowing out of it (or by holes flowing into it): such germanium is n-type.

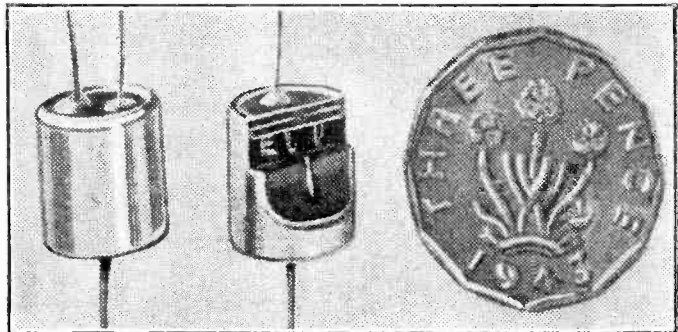

Fig. 1.—Actual sizes may be judged from this illustration.

If it contains excess holes it will conduct by electrons flowing into it (or holes flowing out of it): such germanium is p-type.

Point contact germanium diodes, we have seen, may be designed either with the purest germanium obtainable (to withstand high reverse voltage) or containing an impurity which will give it n-type characteristic (to give higher forward currents for a given applied voltage).

Elements which produce n-type germanium are arsenic, antimony and phosphorus.

Let us go one step farther.

Suppose we take a crystal of n-type germanium

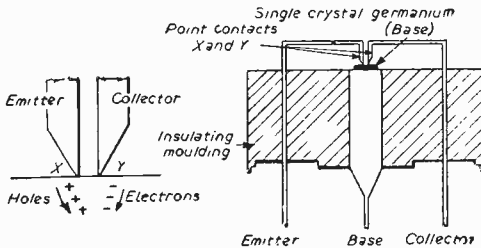

Fig. 2.—Germanium base (barrier layer).

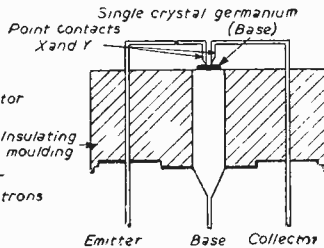

Fig. 3.—Point contact transistor (of the construction illustrated in Fig. 1).

and apply to it two metal points very close together. A potential applied between the germanium and one point X on Fig. 2 will cause an electron current to flow across the contact whenever the voltage on the metal contact is positive with respect to the crystal—in other words the point contact corresponds to the anode, and the crystal to the cathode in a thermionic valve. (The above assumes the second point contact Y open-circuited.) Now suppose we apply a voltage across the second point contact Y and the germanium but in the "reverse" direction, that is, with the crystal positive with respect to the metal point. Without the first positively charged contact X present, any current passing between Y and the crystal will be very small due to the fact that in this condition the crystal rectifier is in the reverse or high resistance condition. But the moment electron current flows into X, it is found that the current flow between Y and the crystal is increased; in fact the current passing between Y and the germanium can be about the magnitude of twice that flowing between X and the germanium.

The germanium crystal in this arrangement is known as the "base," the positively charged contact X as the "emitter," and the negatively charged contact Y as the "collector." (Fig. 3).

The arrangement described is known as a "point contact" transistor and features of its application and design will be explained later.

Next, let us revert to our p-type and n-type germanium for a moment. We saw how a germanium crystal with an impurity content to give an n-type characteristic is more ready to give than to receive electrons—in fact it has a surplus supply—while p-type germanium contains a number of spare "holes" to which electrons may fit.

From this it follows that a piece of p-type germanium in contact with a piece of n-type forms a natural rectifier, without any point contact, an arrangement which has its advantages by way of

greater current-carrying capacity, but also has its disadvantages at present principally concerned with difficulties of commercial manufacture, and also in its frequency limitation in use.

It also follows that as we progressed from the point contact diode to point contact triode, so with the p-n junction diode we can move one step farther to the junction triode—or "junction transistor."

Fig. 4 shows diagrammatically how this is arranged. In this case the two metal points X and Y in Fig. 3 are replaced by two small blocks of p-type germanium, while sandwiched between them is a thin layer of n-type germanium.

In this class of transistor the basic principles we saw operating with the point contact class still

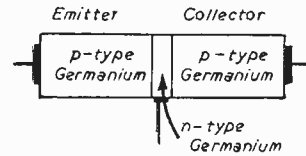

Fig. 4.—Thickness of r-type layer is less than 1/1000in. Diagram of one form of junction transistor (another form would be n-p-n, with p-type sandwiched layer).

hold. The one p-type corresponds to the "emitter" and the other p-type to the "collector" while the n-type is the "base." In operation, the collector is biased in the reverse direction and the emitter in the forward direction, the forward emitter current resulting from electrons attracted from the "base." A negative voltage applied to the second p-type germanium causes the desired increase to the collector current, which may be considered as a negative direction current in this case.

The junction transistor may be either of the p-n-p type, as illustrated in Fig. 4, or of the alternative n-p-n type, depending upon the method of manufacture. In operation, the n-p-n type makes the emitter negative and collector positive; the p-n-p

(Continued on page 413)

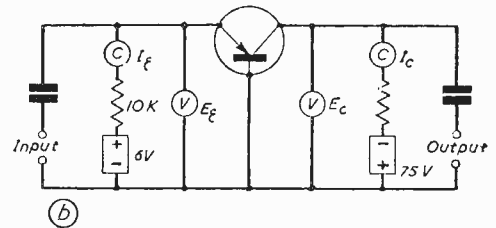
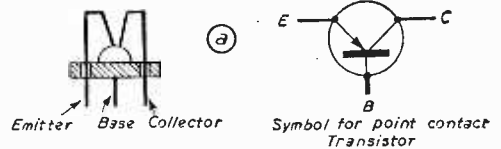

Fig. 5(a).—Diagram and symbol of transistor. Fig. 5(b).—Basic circuit for determining transistor characteristics.

RADIO SUPPLY CO.

(LEEDS) LTD.

32, THE CALLS, LEEDS, 2

Open to callers 9 a.m. to 5.30 p.m. Sats. until 1 p.m. FULL PRICE LIST, 5d. TRADE LIST, 5d. Please enclose S.A. with all enquiries.

Terms C.W.O. or C.O.D. NO C.O.D. under £1. Postage 1/1 extra under £1. 1/9 extra under £3.

SPECIAL OFFERS. Germanium Crystal Diodes, 2/9 ea.; Midget Mains Transformers (size approx. 2 1/2 x 3 x 2 1/2 in.). Screened Primary 200/240 v 50 c/s. Output 250-0-250 v 60 mA, 6.3 v 2.5 a. Only 11/9. Small Filament Transformers, 220/240 v. Input, 6.3 v 1.5 a output, 5/9. Auto Transformers (with separate at 6.3 v 1.5 a, 0-110-200-210-230-250 v 50 watts, 4/9 each.

BATTERY SET CONVERTER KIT. All parts for converting any type of Battery receiver to All Mains. A.C. 200-250 v 50 c/s. Kit will supply fully smoothed h.t. of 120 v 90 v or 60 v at 2 v to 40 mA, and fully smoothed i.t. of 2 v at 40 mA. Price complete with circuit, up to 1a. Price complete with circuit, point to point wiring diagrams and instructions, only 48/9. Or ready to use, 7/9 extra.

PERSONAL SET BATTERY SUPERSEDER KIT. A complete set of parts for construction of a Unit housed in Metal Case, 5 1/2 in. x 3 1/2 in., to replace Batteries where A.C. Mains supply is available. Input 200-250 v 50 c/s. Outputs 90 v 10 mA and 1.4 v 250 mA, fully smoothed. For 4-valve receivers. Price complete with circuit. Only 29/9. Or ready to use, 7/9 extra.

I.T. ELIMINATOR AND TRICKLE CHARGER KIT. Input 200-250 v A.C. Output 120 v 40 mA, fully smoothed, and rectified supply to charge 2 v acc. Price with steel case and circuit, 29/6. Or ready for use, 6/9 extra.

BATTERY CHARGER KITS
For Mains 200-250 v 50 c/s.
To charge 6 v acc. at 2 a., 29/6.
To charge 6 or 12 v acc. at 2 a., 29/6.
To charge 6 or 12 v acc. at 4 a., 49/9.
Above consist of transformer, full wave rectifier, fuse, fuseholder and steel case. The kits can be supplied fully assembled at an extra cost of 6/9 each.

EX-GOVT. VALVES (NEW)

Each	Each	Each
1T4 8/11	6SN7GT 11/9	1825 5/3
1S5 8/11	6SG7 6/9	35ZAGT 10/6
1R5 8/11	6V8G 8/11	35L6GT 9/11
3S4 9/9	6V8GT 10/6	D1 1/6
5Y3G 8/11	6X5SGT 8/9	EF36 6/11
504C 10/6	6/9	EF39 7/6
5Z4G 9/6	7C5 6/11	EB91 9/9
6AL5 9/9	8D2 2/11	EB99 7/6
6F6G 8/11	9D2 2/11	EF91 9/9
6AM6 11/9	954 1/11	MU14 9/6
6J5G 5/11	12H6 2/3	MS/Pen 5/9
6J7G 7/6	12K7GT10/6	RK34 1/11
6K7G 6/11	12K9GT10/6	SP4 5/9
6K9G 11/9	12L7GT10/6	SP61 2/11
6L6G 11/9	12SR7 7/9	U50 8/11
6GTG 9/11	15D2 5/9	VU120 2/11

CATHODERAY TUBES. (Full Picture)
VCR 517, 29/6, plus Carr. 5/-.
VCR139A, 19/6, plus Carr. 5/-.

EX-GOVT. ITEMS. Pvc coaxial plugs and sockets, 7/6 doz. prs. Belling-Lee moulded type 5-pin and 7-pin plugs and sockets, 1/11 pr. Int. Octal Valve Screening Cans, 3 piece, 1/3 each. 11/9 doz. Bak. Tubulars, .02 mid 5,000 v. 1/9. Meters M/C zinc scale 0-5 amps, 12/6.

ELECTROLYTICS (Current production. Not ex-Govt.)

Tubular Types	Can Types
8/F 350 v 1/9	8/F 450 v 2/3
8/F 450 v 1/11	8/F 500 v 2/11
8/F 500 v 2/11	16/F 450 v 2/9
16/F 350 v 2/3	24/F 350 v 2/11
16/F 450 v 2/9	32/F 350 v 2/11
16/F 500 v 3/11	40/F 450 v 4/11
24/F 350 v 3/6	8-8/F 350 v 3/9
32/F 350 v 3/6	8-8/F 450 v 3/11
32/F 500 v 5/9	8-16/F 450 v 4/6
8-16/F 500 v 4/11	16-16/F 450 v 4/11
25/F 25 v 1/3	16-32/F 350 v 5/3
30/F 12 v 1/3	32-32/F 350 v 4/11
50/F 50 v 2/3	32-32/F 450 v 5/11

A PUSH-PULL 3-4 watt HIGH-GAIN AMPLIFIER FOR £12/6. For Mains input 200-250 v 50 c/s. Complete kit of parts including circuit diagram and instructions. (Point-to-point wiring diagrams available for 1/6 extra). Amplifier can be used with any type of Feeder Unit or Plug-up. This is not A.C./D.C. with "live" chassis but A.C. only with 400-0-400 v trans. Output is for 2-3 ohm speaker. (We can supply a very suitable 10in. unit by R.A. at 3/-.) The amplifier can be supplied ready for use for £1 extra. Full descriptive leaflet 1/-.

MASTER INTERCOMM. UNIT with provision for up to 4 Listen-Talk Back Units. A high gain amplifier, engages speech and other sounds emanating from the rooms containing remote control units to be heard at the master control. The unit is in kit form and point-to-point wiring diagrams are supplied. A Walnut Veneered cabinet is included. Mains input is 200-250 v 50 c/s to 300-0-300 v trans. Sound amplification 4 watts. Price only £5/19/6. Listen-Talk Back Units can be supplied at 2/- each. Full descriptive leaflet 1/-.

EX-GOVT. SMOOTHING CHOKES

330 mA 5 H 50 ohms, potted	12/9
250 mA 40 H Tropicalised	17/6
220 mA 5 H 50 ohms, potted	10/9
100 mA 8-10 H 100 ohms	6/11
100 mA 5 H 100 ohms, Tropicalised	5/9
50 mA 50 H 1,250 ohms, potted	8/11

EX-GOVT. BLOCK PAPER MANSBRIDGE TYPE CONDENSERS
4/F 500 v T.C.C. ... 2/9
8/F 500 v T.C.C. ... 4/9

EX-GOVT. ITEMS (EX EQUIP.). Selenium Rects. 250 v 20 mA, 4/9. Smoothing Chokes, 100 mA 5 H 100 ohms, 4/6; 200 mA 10 H, 12/6. Valves: EB34 (KH9), 1/6; SP61, 2/3; EF50, 4/9. Mains Trans. 230 v Input, Outputs 350-0-350 v 160 mA, 6.3 v 6 a, 5 v 3 a, 29/6. Motor Generators, 12 v Input, Output 180 v D.C., 4/9.

R.S.C. MAINS TRANSFORMERS (FULLY GUARANTEED)

Interleaved and Impregnated. Primaries 200-230-250 v 50 c/s Screened.

TOP SHROUDED DROP THROUGH

250-0-250 v 70 mA, 6.3 v 2.5 a	12/11
260-0-260 v 70 mA, 6.3 v 3 a, 5 v 2 a	14/11
260-0-260 v 80 mA, 6.3 v 2 a, 5 v 2 a	15/9
350-0-350 v 80 mA, 6.3 v 2 a, 5 v 2 a	17/9
350-0-350 v 100 mA, 6.3 v 4 a, 5 v 3 a	23/9
300-0-300 v 100 mA, 6.3 v 4 v 4 a, c.t.	23/9
350-0-350 v 100 mA, 6.3 v 4 v 4 a, c.t.	23/9
350-0-350 v 150 mA, 6.3 v 4 a, 5 v 3 a	29/11
350-0-350 v 150 mA, 6.3 v 2 a, 6.3 v 2 a	29/11

FULLY SHROUDED UPRIGHT

250-0-250 v 60 mA, 6.3 v 2 a, 5 v 2 a	17/6
1/6 det. type 21-3 in	18/9
350-0-350 v 70 mA, 6.3 v 2 a, 5 v 2 a	18/9
250-0-250 v 100 mA, 0-1-6.3 v 4 a	25/9
0-4-5 v 3 a	25/9
250-0-250 v 100 mA, 6.3 v 6 a, 5 v 3 a	29/9
300-0-300 v 100 mA, 0-4-6.3 v 4 a, 0-4-5 v 3 a	25/9
350-0-350 v 100 mA, 0-4-6.3 v 4 a, 0-4-5 v 3 a	25/9
350-0-350 v 150 mA, 6.3 v 4 a, 5 v 3 a	33/9
350-0-350 v 160 mA, 6.3 v 6 a, 6.3 v 3 a, 5 v 3 a	45/9
350-0-350 v 250 mA, 6.3 v 6 a, 4 v 8 a, 0-2-6 v 2 a, 4 v 3 a for Electronic Eng. Television	67/6
425-0-425 v 200 mA, 6.3 v 4 v 4 a c.t., 6.3 v 4 v 4 a, c.t., 0-6-5 v 3 a, suitable Williamson Amplifier, etc.	51/9
450-0-450 v 250 mA, 6.3 v 6 a, 6.3 v 6 a, 5 v 3 a	65/6

5.0 V.T. TRANSFORMERS
E.B.T. 5 mA, 2-0-2 v 1.1 a, 2-0-2 v 1.1 a, for VCR97, etc. ... 35/-

ELIMINATOR TRANSFORMERS
Primaries 200-250 v 50 c/s. Output 120/40 mA ... 7/11

EX-GOVT. TRANSMITTER RECEIVERS. Type TR9. Complete with valves, 45/-, plus Carr. 5/-.

COAXIAL CABLE, 75 ohms. 1in., 10d. yard.

DIAL BULBS, M.E.S., 6.5 v 0.15 a, 8 v 0.15 a, 6/9 dozen.

SELENIUM RECTIFIERS, 230 v 50 mA, H.W. (small), 6/9. 120 v 40 mA, H.W. (small), 3/9. 2.6 v 1 a H.W., 3/11. 6/2 v 1 a H.W., 4/6. 6/2 v 2 a F.W. (bridge), 10/9. 6/2 v 4 a F.W. (bridge), 18/9.

CHASSIS, 16 s.w.g. Undrilled Aluminium. Receiver Type 6 x 3 1/2 x 1 1/2 in., 2/6; 7 1/2 x 4 1/2 x 2 in., 3/3; 10 x 5 1/2 x 2 in., 3/9; 11 x 6 x 2 1/2 in., 4/3; 12 x 8 x 2 1/2 in., 5/3; 16 x 8 x 2 1/2 in., 7/6; 20 x 8 x 2 1/2 in., 8/11; Amplifier Type (4 sided), 12 x 8 x 2 1/2 in., 7/11; 16 x 8 x 2 1/2 in., 10/11; 14 x 10 x 2 1/2 in., 20 x 8 x 2 in., 13/6.

SILVER MICA CONDENSERS, 5, 10, 15, 20, 25, 30, 35, 40, 50, 100, 120, 150, 200, 300, 300, 400, 470, 500, 800 (0.01 mfd), 2,000 pfd. (0.02 mfd) 5d. each, 3/9 doz. one type.

WILLIAMSON AMPLIFIER KIT. Complete in every detail and to author's spec. Only 14/9s.

VOLUME CONTROLS with long (1in.) spindles all values less switch, 2/9, with S.P. switch, 3/11.

WIRE WOUND POTS: 20 ohms, 5K, 20K, 25K, 50K (medium length spindles) 1/11.

P.M. SPEAKERS. All 2-3 ohms, 5in. Plessey 13/9, 5in. Goodmans, 14/9, 6in. Elac 14/11, 6in. Plessey with 5,000 ohm trans., 11/11, 6in. Goodmans 16/9, 8in. Plessey 15/9, 8in. R.A. Heavy Duty, 18/9, 10in. Rota 29/6, 10in. Plessey 18/6.

M.E. SPEAKERS. All 2-3 ohms, 6in. Rola field 700 ohms, 11/9, 8in. R.A. field 600 ohms, 12/9, 10in. R.A. field 1,000 ohms, 23/9, 10in. R.A. field 1,500 ohms, 23/9.

R.S.C. MAINS TRANSFORMERS (FULLY GUARANTEED)

Interleaved and Impregnated. Primaries 200-230-250 v 50 c/s Screened.

FILAMENT TRANSFORMERS

All with 200-250 v 50 c/s Primaries:	
2 a, 7/6; 0-4-6.3 v 2 a, 7/9; 12 v 1 a, 7/9	
6.3 v 3 a, 9/11; 6.3 v 6 a, 17/6; 0-2-4-5-6-3 v 4 a, 16/9; 12 v 3 a or 2 v 1.5 a, 17/6.	

CHARGER TRANSFORMERS
All with 200-230-250 v 50 c/s. Primaries: 0-9-15 v 1.5 a, 14/9; 0-9-15 v 3 a, 16/9; 0-9-15 v 6 a, 22/9; 0-4-9-15-24 v 3 a, 22/9.

SMOOTHING CHOKES

250 mA, 8-10 H, 100 ohms	16/9
250 mA, 3 H 100 ohms	11/9
200 mA, 3 H 80 ohms	5/9
150 mA, 6-10 H, 100 ohms	7/6
100 mA, 10 H 100 ohms	7/6
100 mA, 5 H 150 ohms	7/6
80 mA, 10 H 350 ohms	5/6
80 mA, 10 H 400 ohms	4/11

OUTPUT TRANSFORMERS

Midget Battery Pentode 66: 1 for 35A, etc.	3/9
Small Pentode, 5,000 Ω to 3 Ω	3/9
Small Pentode, 8,000 Ω to 3 Ω	3/9
Standard Pentode, 5,000 Ω to 3 Ω	4/9
Standard Pentode, 8,000 Ω to 3 Ω	4/9
Multi-ratio 40 mA, 30:1 4:5:1, 60:1 30:1 Class B Push-Pull	5/9
Push-Pull 10-12 Watts 5V6 to 3U2 or 15Z	14/9
Push-Pull 10-12 Watts to match 6V6 to 3-5-8 or 15Z	15/9
Push-Pull 15-18 Watts to match 6L6, etc. to 3 Ω or 15 Ω Speaker	22/9
Push-Pull 20 Watts, high-quality sectionally wound, 6L6, KT66, etc. to 3, 7.5 or 15 Ω (secondary in 4 sections of 3.75 each)	47/9
Williamson Output Trans. exact to author's spec	65/-

HAVEN'T YOU OBTAINED YOUR "MAXIMITE" plans?

A modern Super-Midget Superhet. only 6in. x 3 1/2in. x 2 1/2in. Latest modern miniature components used, to ensure maximum Gain *Sensitivity *Troublefree working. No surplus parts specified; therefore avoiding possibility of leaky condensers and inability to supply exact specified components over a lengthy period. The receiver operates on A.C./D.C. and large mainsdroppers. Linecord, etc., have been avoided. **FULL PLANS**, including point-to-point wiring, 1-, post free.

WAVECHARGE SWITCHES.—New Midget 2p. 2w.. 2p. 3w.. 2/6; 1p.12w.. 2p. 6w.. 3p. 4w.. 4p. 3w.. 3/6. Standard Faxley type: (two banks) 4 p. 5w.. 6p. 3w.. 8p. 2w.. 2p. 11w. 7/6. All above have 2in. spindles and are NOT Surplus.

METAL RECTIFIERS.—Westinghouse, 14A66. 20/-; 14D26. 11/-; WX3, WX6. 3/9; 36EHT100. 29/4; LT2 (12v. 11a.). 19/6; 1 m.a. Meter, 12/9; 36EHT40. 21/6; 36EHT45. 23/8; 36EHT50. 28/-; S.T.C. Type K3/100. 14.8; K45. 9/-; RM1. 5/3; RM2. 6/3; RM3. 7/-.

Q-MAX CUTTERS.—Chassis Punch complete with Key; 1in., 1 1/2in., 1 3/4in., 1 7/8in., 2in., 2 1/4in., 2 1/2in., 2 3/4in., 3in., 3 1/2in. Square, 24/3.

HUNTS MIDGET MOLD-SEAL COSS.—1 mfd. 150v., 1/6; .02 mfd. 150v., 1/6; .005 mfd. 350v., 1/6; .01 mfd. 350v., 1/6; .02 mfd. 600 v., 1/2; .001 mfd. 350v., 1/3; .02 mfd. 350v., 1/3; Midget Electrolytics; 32-32 mfd. 250v., 2in. x 1 1/2in., 9/-; 16 mfd. 350v., 4/-.

MAINS DROPPERS (New).—2a 950 ohms. 3a., 800 ohms. 5/-; Midget, 6/3; Linecord 2a. 100 ohms It., 3a. 60 ohms It., 8d. per ft. ADOLA Pencil Bit Irons. 200-220v., 230-250v., 25/6.

I.F. TRANSFORMERS.—RS/GH. 12/6; Wearite M800. 21/-; Super Midget RSRs. 21/-; All for 465 Kc/s, incl. Weymouth Pt type. 15/- per pair.

JACKSON.—Midget Perspex enclosed Twin Gang with Trimmers. 11/-; SLS Scale Drive Assembly. 27/6; SLS. 27/6; Full Vision. 13/9; Square-plane. 13/-.

COVERS PRESET WELD-WOUND POTS.—100, 250, 500, 1 K, 2 K, 2.5 K, 5 K, 10 K, 20 K, 25 K, 30 K, 3/3 each.

FILAMENT TRANSFORMERS.—200/240v. to 6.3v. 3 a., 12/6; 200/240v. 6.3v. 1 1/2 a., 8/6; 200/240v. to 3-30v. 2a., 24/-.

CHASSIS.—Four sides folded with Angle Brackets (aluminium). 6in. x 4in., 5/9; 8in. x 6in., 7/3; 10in. x 7in., 8/3; 12in. x 8in., 9/3. All 2 1/2in. deep. All prices include postage on chassis.

COILS.—All Wearite "P" type. 3/- each. Weymouth "H" type. 3/9 each; "K" type. 5/3; CT2W2. 10/6 a pair; CS3W3. 12/6 a pair; T.R.F. Coils. MW/LW, with reaction. 7/8 a pair. "Viewmaster" Coils. London. 20/-; Birmingham. Holme Moss, Kirk o' Shotts, Wenvoe, 28/6 per set.

VOLUME CONTROLS. Less Switch. 2/9; with switch. 4/3. Midget. 3/6 and 5/6. All values.

T.C.C.—Picopack 1 mfd. 250v., 2 mid. 150v., 10 mfd. 25v., 20 mid. 12v., 2/6; 100 mfd. 350v., 19/6; 250 mfd. 60v., 10/-; 2,500 mfd. 3v., 6/9; .001 mfd. 6 kv., 6/-; 12 kv., 10/-; 15 kv., 10/-; .01 mfd. 6 kv., 10/-; .1 mid. 7 kv. (Dubbler). 20/-.

CHOKES.—40 m.a. Midget 5/6; 50 m.a., 15H. 6/6; 90 m.a. 10H. 14/-; 70 m.a. 1,200 ohms 10H. 17/6; 250 m.a. 5H. 19/6; Surplus. 150 m.a. 5H., 7/6. R.F. Chokes, TV diode. 1/9. 2/-; M.W./L.W. 2/6; Audio 5,000 ohms. 10/-.

SCOTCH BOY TAPE.—1,200ft., 35/-; Spare reels. 4/6.

VIEWMASTER WB PARTS.—Width Control. 10/-; Boost Choke. 5/9; Frame Trans. 25/6; Line Transformer. 32/6; Focus Magnets. 22/6; Vision Chassis. 18/6; Sound and T.V. 18/6; Bracket. 6/-; Scanning Coils. 33/3.

RESISTORS.—Surplus 1 and 1 watt. 4d.; 1 watt. 8d.; Midget TV Type (New), 1 watt. 6d.; 1 watt. 8d. All standard 72 sizes stocked.

VIEWMASTER ENVELOPES 7/9 post free.

HIGH RESISTANCE HEAD-PHONES. 4,000 ohms. 12/6 a pair.

VALVES.—Special offer. KK32, KBC32, AC6/PEN, VP23, MS/PEN, KF35, TP25 all at 5/-. Pen25, 2D4, 61513T, 6X9C, 1T1, at 7/6.

"YOU CAN RELY ON US"

RADIO SERVICING CO.

444, WANDSWORTH ROAD, CLAPHAM,

LONDON, S.W.8. Telephone: MACaulay 4155
77, 77A, 163, 169 Buses. S.R. Station: Wandsworth Road. Open till 6.30 p.m. 1 o'clock Wednesday.

Our No. 12 Catalogue, price 1/-, Post Free.
Postage: Over £2 free, below 10/-, 6d.; £1. 9d. £2. 1/-.

FREE To AMBITIOUS ENGINEERS!

This 144-page Book

Have you sent for your copy?

'ENGINEERING OPPORTUNITIES'

is a highly informative guide to the best-paid Engineering posts. It tells you how you can quickly prepare at home on "NO PASS—NO FEE" terms for a recognised engineering qualification, outlines the widest range of modern Home-Study Courses in all branches of Engineering and explains the benefits of our Employment Dept. If you're earning less than £15 a week you cannot afford to miss reading this unique book. Send for your copy to-day—FREE.

--- FREE COUPON ---

Please send me your FREE 144-page "ENGINEERING OPPORTUNITIES"

NAME

ADDRESS

Subject or Exam that interests me
British Institute of Engineering Technology
409B, Shakespeare House,
17/19, Stratford Place, London, W.1

WHICH IS YOUR PET SUBJECT?

Mechanical Eng.
Electrical Eng.
Civil Engineering
Radio Engineering
Automobile Eng.
Aeronautical Eng.
Production Eng.
Building, Plastics,
Draughtsmanship
Television, etc.

GET SOME LETTERS AFTER YOUR

NAME!
A.M.I.Mech.E.
A.M.I.C.E.
A.M.I.P.E.
A.M.I.M.I.
L.I.O.B.
A.F.R.Ae.S.
B.Sc.
A.M.Brit.I.R.E.
CITY & GUILDS
GEN. CERT.
OF EDUCATION
etc., etc.

DIRECT FROM THE MANUFACTURER

DULCI RADIO/RADIOGRAM CHASSIS
A/C 100-120 & 200-250 VOLTS
Fully Guaranteed.

All chassis 11in. x 7in. x 8in. high. Latest type valves 6BE6, 6BA6, 6AT6, 6BW6, 6XA. Flywheel tuning. Negative feedback over entire audio section. Engraved knobs.

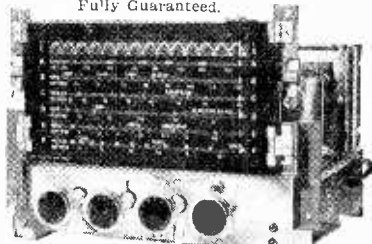

Model B3. Three Wavebands. Long, Medium, Short. Gram. switching on Change switch. 3 Position Tone. Price, Tax Paid **£12/12/0**

Model B3. Plus Push Pull Stage. As B3 with extra valve 6BW6. Output 6 watt max. Consumption 55 watt. Price, Tax Paid **£15/15/0**

Model B. Six Wavebands 11-115 metres continuous in 5 ranges (4 BANDSPREAD) and MW.185-550m. Six position Tone Switch (3 radio-3 gram). Price, Tax Paid **£15/15/0**

BUILT TO HIGHEST PERFORMANCE STANDARD & SPECIFICATION

Escutcheon for 9in. x 5in. dial. 4/9 extra. Matching speakers P.M. type 3 ohms. 8in. or 10in. available. Chassis sent under money back guarantee conditions against remittance. Free particulars from—

BIET

THE DULCI CO. LTD.,
97 VILLIERS RD., LONDON N.W.2. Telephone: Willensden 7773

(Continued from page 410)

type makes the emitter *positive* and the collector *negative*.

Problems

From the foregoing we can get an idea as to some of the problems facing the manufacture on a large scale of reliable high consistency transistors. Thus, the first necessity is to obtain a single perfect crystal. To this must be added a closely

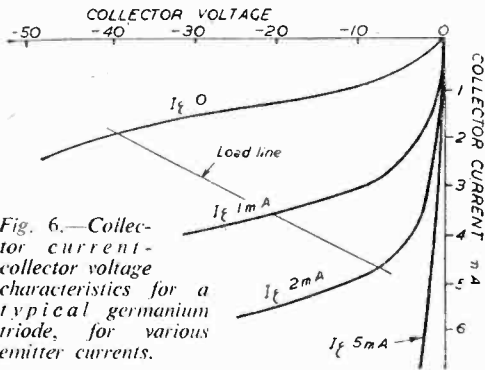

Fig. 6.—Collector current-collector voltage characteristics for a typical germanium triode, for various emitter currents.

controlled amount of another element to give an impurity content of about 1 part in 100 million.

With the point contact transistor the maximum clearance permissible between the points is only about five thousandths of an inch, and this clearance must be rigidly maintained in spite of severe mechanical shock or large temperature variations.

With the junction type transistor, not only must the degree of contamination of the p-type and n-type germanium be very closely controlled, but so must the thickness of the sandwiched layer, and all these problems must be faced and overcome before we can safely take the transistor out of the experimental field and place it alongside, and complementary to, the thermionic valve as a dependable commercial product. This day is surely coming.

How the Transistor Works

Our next stage is to apply the principles of the transistor to practical amplification circuits.

Fig. 5(a) shows diagrammatically and in symbol form a point contact transistor, and Fig. 5(b) gives a basic amplifier circuit for such a transistor. Meters are shown inserted for the purpose of measuring the

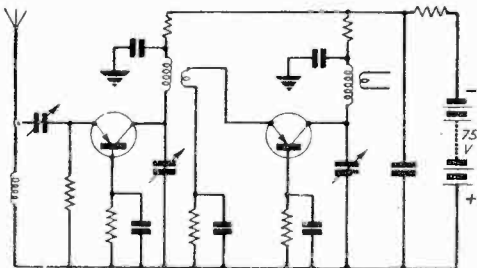

Fig. 8.—Germanium triode R.F. amplifier.

emitter voltage and collector current, and by plotting a graph relating collector voltage with collector current for a number of values of emitter current we can obtain a series of curves, indicated in Fig. 6.

By inverting the page, the similarity to a typical family of I_a-E_a curves for a triode valve becomes apparent, and on these we can superimpose a load line for the value of the collector load resistance.

So far so good; but here it is important to realise that we cannot use the transistor as a voltage amplifier exactly as we would a thermionic valve. This is because whereas in a valve the anode current is controlled by the grid voltage (and in receiving types, other than in some exceptional cases, grid current is normally absent) in the transistor, the collector current is controlled by the emitter current, which may be quite considerable.

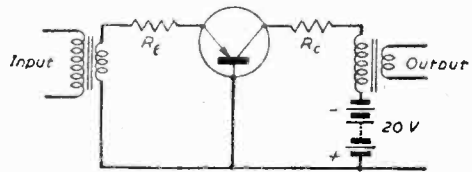

Fig. 7.—Circuit for current gain with point-contact transistor.

In a transistor a typical figure for the ratio of emitter current to voltage would be 100 to 1 mA/V. Hence the input impedance of the device is low.

On the other hand, the ratio of collector current to change in collector voltage is low, the reverse of the condition aimed at in valve operation.

Hence the output impedance of the device is high.

From these facts we see that a situation exists in a transistor amplifying circuit different from the usual valve circuit.

Referring back to Fig. 6, we see that with a load resistance in the collector circuit the change in collector current is relatively small, but a substantial voltage can be developed across the load resistance when positively biased voltages, and, therefore, current changes, are applied in the emitter circuit.

We must, therefore, take into account both current and voltage in applying the transistor to an amplifying circuit, and for this reason the device must be looked upon as an amplifier of *power*—not voltage, as in the valve.

The greatest obtainable power output from the

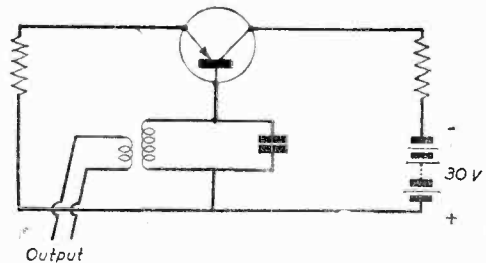

Fig. 9.—Germanium triode oscillator circuit.

crystal triode or transistor is very much less than that from a normal thermionic power valve—in their present stage only about 30 milliwatts—although with future development, particularly on the junction type transistor, some increase may be expected on this.

Practical Circuits

Now for some practical circuits to which the transistor can be applied as an amplifier or as an oscillator.

We saw that for the collector current to flow, the emitter must be positively biased with respect to the germanium base, and that in an operating condition there is a net flow of current flowing into the base from the collector. A resistance R_b in series with the base and the source of collector voltage will therefore have a potential drop across it corresponding to the current, and as this resistance is also in series with the collector current it will act as an automatic positive bias for the emitter.

Now the bias resistance is common to *both input and output* circuits, and it will be seen that here we have the condition for positive feedback, which may be enough to cause instability, and disastrous oscillation, to the point of destruction of the crystal.

This is because increase in collector current will cause an increase in voltage drop across R_b and a corresponding increase in the emitter bias voltage. This results in a rise in emitter current, a further increase in collector current, and so on, until the collector circuit ultimately becomes so large that the transistor will burn out.

Fortunately, this cumulative effect may be controlled by inserting limiting resistances in the collector and emitter circuits, and our practical amplifier becomes more like Fig. 7.

Only about 20 volts is required for the D.C. power supply if a high reactance (i.e. high A.C. to D.C.

resistance ratio) load is employed, such as with an output transformer, suitably designed for matching the high output resistance of the transistor into its final load.

In the point contact transistor the current gain is greater than unity, and very convenient oscillator circuits can be developed around this device. It is, however, not very suited to an audio-frequency amplifier because normally the power gain obtained is only about 20 db per stage of amplification and because transistor noise increases with decrease of frequency. Its main applications are in computers and electronic exchanges where limitations of gain and noise do not matter. In the junction type transistor, the current gain is always less than unity, and its main application is in low-frequency amplifiers; a low voltage (usually about 3 volts) power source only is necessary.

All the foregoing will show that it is not practicable to consider the transistor as a direct replacement for the valve in valve type circuits, but with appropriate circuit design, transistors may be connected in cascade to provide quite a considerable degree of amplification with a small expenditure of D.C. power.

A typical circuit for a radio frequency amplifier using point contact transistors is shown in Fig. 8 and a circuit whereby the device can be used for generating continuous oscillation in Fig. 9.

The germanium triode or transistor is an important development in the fields of radio communication, industrial control gear and in instruments such as computers. Its appearance will be commonplace in such equipment once the manufacturers have successfully transferred the device from an experimental to a large-scale production product, but we still have some way to go in that direction at the time of writing, and it must always be borne in mind that the crystal is complementary to the thermionic valve, and valuable service will be found for both.

News from the Clubs

COVENTRY AMATEUR RADIO SOCIETY

Hon. Sec. : K. G. Lines, 142, Shorncliffe Road, Coventry.
THE Mars/Cars Annual Inter-Club Transmitting Contest results are now being studied by the respective committees.

Mr. T. R. Theakston, B.Sc., gave one of his ever-popular talks on mathematics recently, when he guided members through the rocky path of Calculus with charm and humour.

Club Night-on-the-Air has been suspended for the summer months, but usual meetings continue fortnightly at the Y.W.C.A., Queen's Road, at 7.30 p.m.

The society were joint winners with Stourbridge and District Amateur Radio Society in the annual R.S.G.B. Affiliated Societies Contest, and thanks are due to Fred Bowman G3FAB for placing his rig at the Society's disposal for the event.

THE ROCHDALE RADIO AND TELEVISION SOCIETY

Hon. Sec. : J. Riley, 1, Darley Bank Britannia, Bacup.
WEEKLY meetings are held at 1, Law St., Sudden, Rochdale, at 7.45 p.m. and all interested in radio are invited to visit us, new members will be welcome.

The club will shortly be on the air with the club call sign of GMYD.

HASTINGS AND DISTRICT AMATEUR RADIO CLUB

Hon. Sec. : W. E. Thompson, 8, Coventry Road, St. Leonards-on-Sea, Sussex.

The committee thought when they laid plans to get members to make a simple receiver one evening that they would catch everybody napping. How wrong they were! From a handful of bits, two teams designed and constructed within an hour receivers to work in the 80 metre band.

The first-class communications receiver built by our member, F. Blakemore, using the CR100 tuning unit and the handbook, reflects great credit on his workmanship. Considering that he had never attempted making a radio receiver before, he fully deserved the praise everyone expressed for a fine job of work. He set himself a high standard, achieved it, and can justly be proud of it.

The club will be exhibiting at the Hobbies Exhibition, July 4th to 11th, inclusive, to be held in the Indoor Bowls Pavilion, Fatais Road, Hastings, during Carnival Week.

YORK AMATEUR RADIO SOCIETY

Hon. Sec. : G. F. Nottingham, G3DTA, 51, Carr Lane, Acomb, York.

THE club is open each Tuesday and Thursday, 7.30 p.m. to 10.0 p.m. and is situated in Fetter Lane, York. (Facing the rear of The Queens Hotel.) Thursday is the general meeting night and once a month talks, lectures and demonstrations are given. The last one on "Tape Recorders," with a practical demonstration of a very good home-built instrument by Mr. Linfoot (G3GCX), was very well received by all. It was decided

from one of the knobs is laid in, taking care that the grub screw is not covered. Lead is then added to fill up the tin, and if too deep for the boss which has been selected, this latter may be raised with a pair of pliers and the gas jet turned out to permit the lead to cool. The only difficulty likely to be experienced here is in accurately centring the boss, and to assist in this the tin may first be marked out and thin wires twisted round the boss and cut to hold the boss in the exact centre. If a lathe is available the block of lead may, of course, be turned down afterwards to make an accurate flywheel, but this is not essential.

The large drive is obtained by placing two shallow lids back to back, and driving through them three brass brads, riveting them or soldering them to make a large pulley. No great depth is required in the groove, but one edge is cut away as shown to accommodate the cord which is turned in and attached afterwards to a short spring soldered to the drum. The position is not critical. The second knob boss is then attached to the centre of this large pulley, either by soldering, or any other preferred means, again making certain that it is accurately centred.

Finally, the large rectangular sheet of aluminium or other metal is obtained and a hole drilled to accommodate the one-hole fixing bush in the desired position, and a further hole at the centre where the condenser spindle will come through. This will depend upon the position of the control spindle in relation to the chassis in use. The two pulleys from the curtain railway device are held at the top corners by short bolts and lock-nuts. When completed, the metal plate should be attached to the chassis, either

by means of small angle brackets attached to the top of the chassis, or by bolts through the front runner of the chassis. The nylon drive cord is wrapped round in the manner shown in Fig. 3, and the drive turned until the cord is drawn to its maximum position in one direction. Then a metal pointer is soldered to a small strip of thin brass which is clamped over the horizontal portion of the cord (at the correct end of the dial, of course), and the control rotated to wind the cord in the opposite direction. If the cord is not fully wound when the pointer is at the other pulley, a stop will have to be provided to avoid the drive being overwound with the result that the pointer will not always register in the same position. Alternatively, the pointer may be attached to the cord temporarily, and the pulleys placed in position only after the drive has been operated in order to find the scope of its travel.

When finished a piece of good quality Bristol board should be attached to the front of the metal plate and the drive attached to the condenser. Stations should be tuned on all bands and horizontal or vertical lines, as desired, should be ruled on the board and frequency, wavelength or station indications marked by logging. These may afterwards be filled in in coloured inks, and the whole protected by a sheet of glass held either behind a cut-out in the cabinet front, or on the drive plate by means of small blocks of rubber cut out and attached with suitable cement. An escutcheon may be made up in any preferred fashion, either with metal cut out, or thin picture frame moulding suitably coloured or varnished.

A New Tape Recorder

THE ELA Department of Philips Electrical Ltd., announce the release on the British market of a new magnetic tape recorder—type EL.3530: a portable, twin-track device designed for operation on A.C. mains, 50 cycles per second, on voltages between 110 and 245, and possessing a number of interesting features.

Simplicity of design, great ease in operation and quality of reproduction, are three of this new recorder's most important features among many others embodied as a result of Philips 25 years' experience in the making and marketing of sound reproducing equipment.

The twin-track recording of this new model is for a tape velocity of $3\frac{1}{2}$ in. per second, giving it a tape consumption which is one fourth of that of single-track recorders with a tape velocity of $7\frac{1}{2}$ in. per second. Music and speech reproduction are of the highest quality. The tape length of 600ft., on a $\frac{1}{2}$ in. diameter reel, affords a recording or play-back time of one hour. The particularly high magnetic qualities of the Philips tape ensure the elimination of noise and distortion in the sound reproduction. The same tape can be used thousands of times without any perceptible wear of the tape, or deterioration in the sound quality.

The equipment has 2 heads, the erasing and the combined recording/play-back head. During recording, the erasing head erases any previous recording still on the tape. During play-back the erasing head is switched off. Because of the high-frequency A.C. used for erasing and pre-magnetising the tape, sound reproduction is rendered more completely noise-free. A special advantage of this recorder is that the recording play-back head is de-magnetised

when changing over from recording to play-back, and vice-versa: this further eliminates noise.

A "magic eye," operative only during recording, indicates the recording level by lighting-up immediately the appropriate knob is put in the recording position. The "magic eye" serves also as a warning that the erasing head is switched on.

Play-back

The play-back amplifier has an output of 2.5 watts, fully sufficient for use in small halls. The built-in loudspeaker ensures clear and true-to-life reproduction over the audio-frequency range. There are output sockets for connection to an extension loudspeaker and to headphones for monitoring purposes. An output is provided on the recorder to enable recordings to be transmitted over lines to an existing amplifying system.

The recorder is supplied with a crystal microphone equipped with a table stand, and $1\frac{1}{2}$ yards of cable. The high sensitivity of this microphone enables it to be used, if necessary, at a considerable distance.

Telephone conversations can be recorded quite easily with this recorder by the use of the Philips Telephone Coil, type EL.3970. This coil needs only to be put under the telephone and connected to the 2mV, 0.5 Megohm input of the recorder. No connection with the telephone itself is necessary.

A programme indicator, type EL.3979, can be attached, if required, to the recorder. This can be used for noting accurately and finding quickly particular parts in a recording, and is likely to be of great help for educational institutions.

The complete equipment, which weighs 32lb., is supplied in a case covered with washable plastic. There are compartments in the lid for the microphone with table stand and 2 connecting cables.

Volume Controls

Midget Edison type. Lead spindles. Guaranteed 1 year. LESS SW. S.P. Sw. 3/- D.P. Sw. 4/- 4/9 ALL VALUES.—10K. to 2 MEG.

80 ohm COAX CABLE

STANDARD 1/2 in. diam. Polythene insulated. NOT EX. GOV. 10d. per yd. COAX PLUGS, 1/2 each. SOCKETS, 1/2 each. LINE CONNECTOR, 1/2

NEW BOXED

Table with 2 columns: Item code and Price. Includes items like 1A3, 1K5, 1S5, etc.

VALVES

Table with 2 columns: Item code and Price. Includes items like 12AX7, 12BK7, 12CK8, etc.

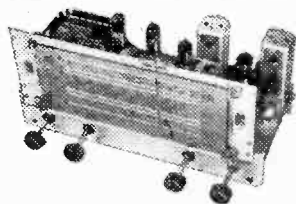

RADIOGRAM CHASSIS.—A.C. mains 200 250 v. 5 valve 3 waveband superhet. Latest technique incorporating delayed A.V.C. and N.M.I. feedback circuits.

BALANCED TWIN FEEDER per yard 6d. TWIN SCREENED FEEDER per yard 1/-. TRIMMERS Ceramic, 35, 50, 70 pf., 6d.; 100 pf., 1/3. 250 pf. 1/6. 600 pf., 1/3.

RESISTORS.—All Values: 1 w., 4d.; 1/2 w., 6d.; 1 w., 8d.; 2 w., 1/-.

WIRE-WOUND RESISTORS.—Best makes Miniature Ceramic Type.—5 w., 15 ohm to 4 K., 1/9.

W/W POTS.—Min. T/V Type Pre-Set. Fitted knob is knurled and slotted, 25, 50, 100, 200, 500 ohm, 1 K., 2 K., 3 K., 5 K., 10 K., 15 K., 20 K., 25 K., 30 K., each 3/-, 10 K., 25 K., Short sp., 3/6.

COILS.—Wearite "P" type, 3/- each. Midget Osamor "Q" type, 4/- each. All ranges.

O.P. TRANSFORMERS.—Tapped small pendulo. 3/9. Heavy duty 70 ma., 4/6. Ditto, tapped, 4/9. L.F. chokes 10 h., 65 ma., 4/6. 20/25 h., 100/150 ma., 12/6. 5 h., 250 ma., 1/5-. 15 h., 100 ma., 10/6.

MAINS TRANS.—Made in our own workshops to high grade specification. Fully inter-leaved and impregnated. Heater Trans., tapped print, 6/3 v. 11 amp., 7/6. 250-0-250, 80 ma., 6/3 v. 4 w., 3 y., 2/-, ditto 300-0-300 ditto 250-0-250, 21-. Viewmaster, auto type, 3/5-. Telesky, 30/-.

QUALITY P.P.O.P. TRANS. 20 w., special Stalloy 4 a. lams. Sectionalized, low leakage windings, primary inductance 7011, leakage inductance 0.075H. Secondary impedance 3 and 15 ohms. Primary impedance to individual requirements, fully shrouded and terminated 1.3 ns. Ditto, as above, 15 w. output, 21 zns. Part. Post and Packing 1/-. Please.

ELECTROLYTICS, ALL TYPES, NEW STOCK *8/450 v. B.E.C. 2/6 16+16 450 v. B.E.C. 5/6 *8/500 v. Dubilier 3/- 32/550 v. B.E.C. 4/- *10/500 v. Dubilier 2/6 *32/500 v. Dubilier 5/- *3+8/500 v. Dub. 4/6 *25/25 v. Dubilier 1/9 16/450 v. T.C.C. 8/6 *50/50 v. T.C.C. 2/- 16/500 v. Dubilier 4/- 60 mid. 350 v. T.C.C. 8/6 8+16/450 v. B.E.C. 5/- 250 mid. 350 v. 8/6 16+32/450 v. Hunte 5/6 T.O.G.L.E. SWITCHES. Ex-Govt. "On-Off", 6d. *1 in. Tub. wire ends. All others 6zn Type.

SPECIAL PRICE PER SET: 1R5, 1T4, 1R5 and 3B4 ... 32/6 1R5, 6K7, 6X7, 6V6, 5Z4 ... 40/- 10EF91 for Privat. Tele. A.C./D.C.T.V. ... 85/- VIEWMASTER. Set 12 valves, 48/10/-.

BARGAIN CORNER. Core solder 90/40, 10G, 5/8 1 lb.; 4d. yd. P.C. wire 19 to 22 s.w.g., per yd., 2/-; PVC Connecting wire, 10 colours. Single or Stranded, 2d. yd. BTG Valveholder and Screening Can. 1/6. V holders, octal, pan., 4d.; mounted, 6d.; EF50, BTG, 9/-, BVA, BVA, 1/-, BICA, 1/3.

LOUDSPEAKERS 2M, 3 OHM 3in. Plessey, 12/6. 5in. Lectra, 13/6. 6in. Plessey, 14/6. 8in. Plessey, 15/6. 10in. Plessey, 25/-.

KNOBBS, GOLD ENGRAVED.—Walnut or Ivory, 1 1/2 in. diam., 1/6 each. "Focus", "Contrast", "Brilliance", "Brilliance—On-Off", "On-Off", "Volume", "Vol.—On-Off", "Tone", "Tuning", "Trebble", "Bass", "Wavechange", "Radio-gram", "S. M., L., Gram.", "Record-Play", "Brightness", 2/6 Plain, 1/- each.

P. and P. Gd. £1 orders post free. Lists 3d. T.R.S. RADIO COMPONENT SPECIALISTS 307, WHITEHORSE ROAD, WEST CROYDON Tel: 719 1065 Mail Order: 71, MEADVALE ROAD, EAST CROYDON

★ NOW READY The Skyway TAPE RECORDING MANUAL

Complete Building INSTRUCTIONS for making a DE LUXE TAPE RECORDER

36 pages packed with information, drawings, plans and amplifier wiring diagrams PRINTED ON HIGH QUALITY ART PAPER

Direct from: FRITH RADIOCRAFT LIMITED, LEICESTER

3/6 PLUS 3d. POST

OR THROUGH ANY OF W. H. SMITH & SON'S BOOKSTALLS

REDUCED PRICES for SKYWAY RECORDING UNITS

Increased manufacturing facilities have made possible substantial price reductions on the RECORDING UNIT in either kit or complete form. We are now also able to offer kit parts separately or in sections, to meet the needs of those who already have motors and recording heads on hand. Easy payments are also available.

Table with columns: Recording Unit, Cash Price, Deposit, Monthly pmts. Includes rows for Recording Unit, Recording Amplifier, and Complete amplifier kit.

Parts Price List and Descriptive Leaflet on request. EXPORT AND TRADE ENQUIRIES FOR KITS, COMPLETE UNITS AND MANUALS ARE WELCOMED

FRITH RADIOCRAFT LTD. 69-71, CHURCH GATE, LEICESTER PHONE 58927

SHORTAGE OF RADIO & T/V ENGINEERS

The demand of Industry for our trained students is still greater than we can supply—and is likely to remain so for many years. We offer

FULL TIME DAY COURSE

1 year course in Principles and Practice of Radio and Television.

Next course commences 24th August, 1953.

Write for FREE BROCHURES giving details of the above, of our 3-year course, and of others.

E.M.I. INSTITUTES—the only college which is part of a great industry.

E.M.I. INSTITUTES (Dept. 32A)

10, PEMBRIDGE SQUARE
LONDON, W.2.

Tel: BAYswater 5131/2.

I.A.I.D.

Associated with
"H.M.V."
MARCONIPHONE
COLUMBIA
ETC.

SOUTHERN RADIO'S WIRELESS BARGAINS

TRANSMITTER - RECEIVERS. No. 18. Mark III. Brand new, complete in original packing cases. Complete with all attachments. Headphones, aerials, microphones, tappers, etc., and complete set of spares, including duplicate set of valves, £18.

TRANSRECEIVER No. 18. Mark III. As above less attachments. Complete with valves. Guaranteed perfect, £7/10/-, plus 7/6 carriage.

TRANSMITTER RECEIVERS (Walkie-Talkie). Type 38, Mark II. With 5 valves, microphone, headphones, aerial. Less batteries Fully guaranteed £4/15/-, post paid.

RECEIVERS. Telesonic, 4-valve battery portable. Complete with 4 Hivac valves. Contained in metal carrying case. Easily convertible to personal portable. Brand new, £2, including conversion sheet.

RECEIVERS R109. Complete with 8 valves, Vibrator pack for 6 volts. Contained in metal case with built-in speaker, 1.8 to 8.5 mcs. Guaranteed, £1/15/-, plus 7/6.

INDUCTION MOTORS, shaded pole A.C. 120/240 volts, 2,800 r.p.m. Ideal for recorders, models, etc., 23/-.

GRAMOPHONE MOTORS. Garrard induction 100/250 volts A.C., 78 r.p.m. Brand new with turntable, £4/17/6.

LUFBRA HOLE CUTTERS. Adjustable 3/16 to 3/8 in. ... 5/9

THROAT MICS., with lead and plug 4/6

PLASTIC MAP CASES, 14 by 10 1/2 in. 5/6

STAR IDENTIFIERS, A-N type, in case 5/6

WESTECTORS W x 6, W112 1/-

MARCONI aerial filter units 4/6

CONTACTOR Time Switches in case 11/6

REMOTE CONTACTORS for use with above ... 7/6

RESISTANCES, 100 assorted, wire ended 12/6

CONDENSERS, 100 assorted tubular and mica ... 15/-

G.E.C. MINISCOPES M861B. Brand new, in carrying case, with plugs, etc., £12/10/-.

WOBBULATORS, for above, £4/10/-.

Full list of Radio Books 2/6.

HUNDREDS OF FURTHER LINES FOR CALLERS.

SOUTHERN RADIO SUPPLY LTD.

11, LITTLE NEWPORT STREET, LONDON, W.C.2

GERrard 6653

Mine Detectors. Consisting of 2v. amplifier, complete with valves, satchel, search coils, headphones, etc. Ideal for locating metals, hidden treasure, etc. buried in ground. Price 45/-, Carr. 3/6.

Small Chassis. 4 1/2 x 8 1/2 x 1 1/2 in. Drilled for 3 valves. Volume control switch, 2/6. Post 11d.

Large Magnets as taken from magnetron units, weight approx. 9 lbs. Post 11d lift up to 30-40 lbs. Price 30/-, Post 2/6.

Keying Relays. As used in 1154 Transmitter. These contain 5 sets of change-over contacts and 2 sets of make contacts and have two 24v. coils. Brand new in maker's carton. Price 7/6, Post 1/3.

Direction Indicators. Containing two 50 micro-amp. meters, scale marked L and R. Brand new & boxed. 8/6, Post 1/3.

Crystals. Plug-in type 6510 KC, 8570 KC, and 8350 KC. Price 7/6, Post 6d.

Our new list, No. 10, now available.

Price 6d. inland, 1/6 overseas. Air Mail.

A. T. SALLIS

93, North Road, Brighton, Sussex

Phone: Brighton 25303.

MICROGRAM AMPLIFIERS



£3.19.6 P. & P 2/6d

Fits inside your record player leaving room for speaker. Dimensions 10in. x 3 1/2 in. x 2 1/2 in. 4 watts quality output. Suitable for all speakers and with standard or L.P. pick-ups. Built in powerpack for 200-250 v. A.C. only. Valves 6J7 and 6V6 available at 20/- per pair extra, if required. Other models up to 10 watts.

6d. stamp for illustrated details!

ELECTRO-ACOUSTIC LABS
TAIN—ROSS-SHIRE, SCOTLAND

NEW GOODS ONLY

CONDENSERS.—450 v. wkg., 1 mfd., 2/9; 4.32; 8.3; 16.46; 32.510; 8-8.48; 8-16.38; 16-16.69; 500 v. wkg., 1 mfd., 3-; 2.3-; 4.33; 8.3/8; 16.6-; 32.8-;

8-8.7-; 8-16.8.3; 16-16.9.6; 25 x 25 v., 25 x 50 v., 50 x 12 v., 2.3; 50 x 50 v., 2.6;

Tubulars, 500 v. wkg. up to .0005, 8d.; 1.0 .006. 9d.; to .04. 11d.; to .1. 1/2; .2. 2s. 1.6; .5. 2.3; Moulded Mica. up to .002.

1-; to .01. 1.6; Sil. Mica, 500 v. wkg. up to 100 pf., 9d.; to 500 pf., 1/-; to 1,000 pf., 1/2;

2,000; 3,000 pf., 1/3.

VOLUME CONTROLS.—Lg. Spdls., all Values, 3-; with Sw., 5-; with D.P. sw., 5/9; Semi Midg. type, 1, 1.1, 2 meg., 4-; with sw., 5/9; D.P. sw., 6/6

Wire Wound, less sw., 1 k. to 8k., 6/6; 100 k., 7/9.

RESISTORS.—All Std. values, 20% Tol. 1 w., 5d.; 1 w., 6d.; 1 w., 8d.; 2 w., 1/-;

10% Tol., 50% on ABOVE PRICES. Wire Wound, 3 w. to 5 k., 1/9; 5 w. to 5 k., 2/-;

10 w. to 10 k., 2/9. Terms: Orders up to 10/-, post 6d.; up to £1. 5d.; over, post free. Cash with order, no C.O.D.; lists 5d.

RADIOELECTRON

22, FRANCES STREET, SCUNTHORPE, LINCOLNSHIRE.

MAKE SOLDERING A PLEASURE!

BY USING THE "TYANA" SOLDERING IRON

Reg. Design No. E67804

The Perfect Small Soldering Instrument

- Adjustable Bit. ● Easy to Handle. ● Weight approx. 4 ozs. Overall length 11" of the iron and diameter of the bit 3/8". ● Heating Time 3 min. ● 40 Watt economy Consumption. ● Standard Voltage Ranges (other Ratings Available on Request) ● Long Life and Efficiency. ● Replacement Elements and Bits always available

Just the Convenient Iron Required for Intricate and Fine Soldering

Maintenance Service for Industrial users.

British made by:—KENROY LIMITED.

152/297, Upper Street, Islington, London, N.1

Telephone: Canonbury 4905-4663

SPARKS' DATA SHEETS

are the Satest and Finest Constructional Sheets of Guaranteed and Tested Radio Designs.

ALL-DRY BATTERY DESIGNS

THE "POCKET PAK." 1-valve Med-wave portable. Good phone signals.

THE "CHUMMY." 2-valve portable. Fine phone results M/L waves.

THE "MIDDY." 2-valver. M.L. waves. Fine speaker results. V Popular.

THE "BONNY." 3. A more powerful version of the above.

THE "CRUISER." 3-valve T.R.F. circuit. Good range and power. M.L. waves.

THE "SKIPPER." 4-valver. High sensitivity T.R.F. circuit. Safe any area. M.L. waves. A fine set.

THE "CORVETTE." 4-valve all-wave superhet. Great range and 1 very selective. Ideal for a portable.

Data Sheets of above, 3/2! each, post free.

Many other designs available. Send 2'd. stamp for my latest list.

L. ORMOND SPARKS (P), 43A, HIGH STREET, SWANAGE, DORSET.

SHORT-WAVE SECTION

VARIABLE SELECTIVITY IN SHORT-WAVE RECEIVERS

By T. W. Dresser

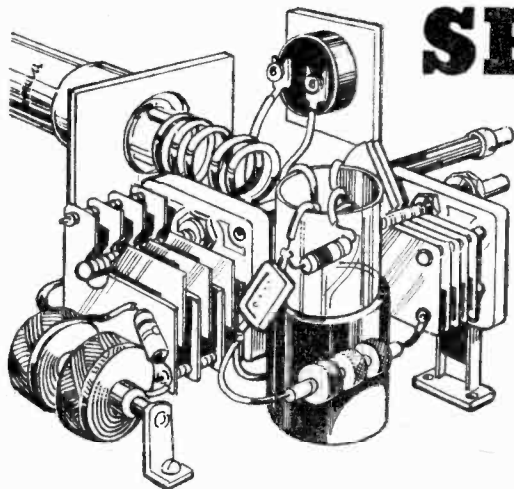

ONE of the principal difficulties the builder of home-constructed short-wave or communications receivers has to contend with is that of selectivity. There is little fun in assembling an elaborate receiver only to find that other stations mess up the sidebands of the wanted one or, due to frequency drift, swing right across it, periodically blotting it out. With the latter it is impossible to do anything, as overmodulation of the transmitter alone will cause frequency shift up to five per cent. or more and that is entirely in the hands of the transmitter engineer, but with the former condition it is possible to remedy the situation to some extent by means of selectivity control. That some such control is necessary will be obvious to anyone who regularly listens on the congested short-wave bands of to-day.

It happens to be one of the chief advantages of the superhet receiver that almost all the selectivity characteristic is concentrated in the I.F. amplifier, the R.F. section being devoted essentially to the elimination of second channel interference and straight amplification, and since the I.F. amplifier has only to deal with a fixed range of frequencies it is possible and practical to adjust the response curve to suit our requirements or even to suit a number of differing requirements. In fact, such an adjustment is necessary when it is desired to secure a good compromise between sideband cutting and interference from adjacent channels.

There are a number of ways in which this can

be achieved, the most primitive being a mechanical device which changes the distance between the coils (and therefore alters the coupling) but this is seldom encountered nowadays and, in any case, is far too difficult for the amateur to construct. This method, like most selectivity controls, has some drawbacks, principally loss of gain, but this is not of a serious nature and can usually be compensated for by driving the existing I.F. stages harder or adding a further stage if it is deemed necessary. That, of course, is at the discretion of the constructor. In Fig. 1 are given three basic circuits for I.F. couplings, in each case using two I.F. transformers placed back to back. There are other arrangements but in the main they are variations of those shown.

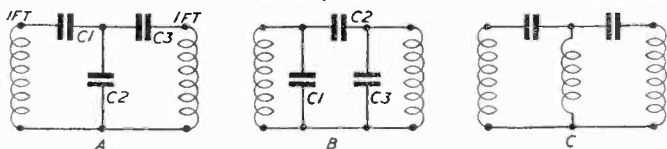

Fig. 1.—Capacitive reactance coupling.

The Circuit

The circuit in Fig. 1(a) provides capacitive reactance coupling by means of the common condenser C2, and the bandwidth may be varied by altering the value of this condenser. Fig. 2 is a practical rearrangement of this circuit which will provide bandwidths of from 7 to 12 Kc/s by switching condensers. This compares favourably with the majority of communications receivers, few of which have a narrower bandwidth than 6 Kc/s. Fig. 1(b) is a top-end coupled circuit in which the bandwidth can be controlled by varying the value of C3, and similar capacity condensers to those used in Fig. 2 will give a similar range of bandwidths. In Fig. 1(c) an inductance is substituted for the common coupling condenser of Fig. 1(a) and again, by varying the amount of

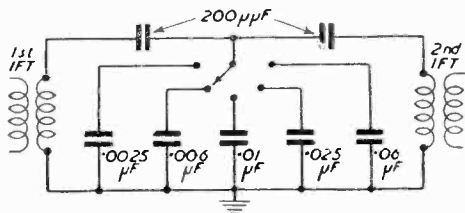

Fig. 2.—Practical arrangement of the Fig. 1 circuit.

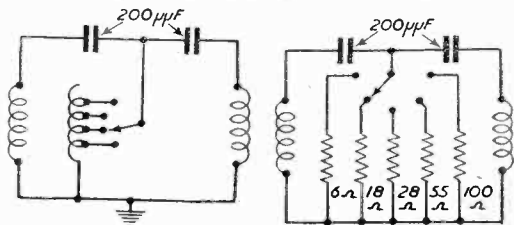

Fig. 3 and 4.—Further practical circuit arrangements.

inductance in circuit the bandwidth can be varied. Fig. 3 is a practical arrangement using a tapped coil and providing the same bandwidths as the previous circuits. The coupling inductance is wound on a bakelite former 2in. long by $\frac{3}{4}$ in. diameter with 65 turns of 24 S.W.G. enamelled wire, tapped at 11, 19, 27 and 38 turns from the earthy end of the coil. Similar control of selectivity can be secured by substituting resistors for the condensers in Fig. 2

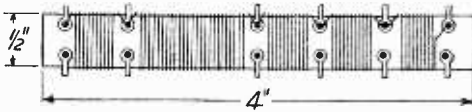

Fig. 5.—A practical coil arrangement.

and a practical circuit using them is given in Fig. 4. The values of the respective resistors are shown on the schematic, but it is possible that some difficulty may be met in obtaining such low values and it would probably be advisable to build up a resistance strip similar to that wound by the writer. The former was a bakelite strip $\frac{1}{8}$ in. thick by $\frac{3}{4}$ in. wide by 4in. long wound as in Fig. 5 with Eureka resistance wire. The taps were anchored to short lengths of 18 S.W.G. tinned copper wire bent tightly round the former close to the end of each section as shown. The 6 and 18 ohm sections were wound with 38 S.W.G. Eureka, the 28 ohm with 40 S.W.G. and the

55 and 100 ohm with 44 S.W.G. All windings were close wound.

There are numerous other methods for attaining the same end, such as the tertiary winding I.F. transformer, the circuit of which is given in Fig. 6. These were frequently used in older receivers but they are clumsy and cumbersome arrangements, and necessitate elaborate switching and special types of I.F. transformer which cannot readily be wound at home.

The theory underlying all these arrangements is somewhat involved—a moderate explanation would

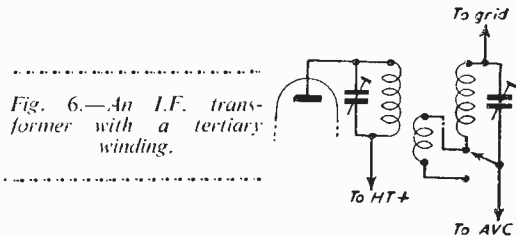

Fig. 6.—An I.F. transformer with a tertiary winding.

occupy the greater part of this journal—and for that reason it has been omitted, but for those who are interested reference can be made to the Radio Handbook by Langford-Smith, Radio Data Handbook issued by the Federal Co. of New York, Terman's Radio Engineering and the Proceedings of the I.R.E., vol. 23, page 594, June, 1935 and other sources.

Electronics Equipment at Farnborough

AT the Operational Display of Military Electronic Equipment, held at Farnborough, in May, Mullard, Ltd., exhibited a wide range of valves, electron tubes and magnetic material components.

Included in the display of valves and electron tubes were transmitting valves, hydrogen thyratrons, C.Z. multi-reflection tubes, magnetrons, klystrons, ranges of B9A and B7G miniature valves, rugged and reliable valves, battery and mains-operated sub-miniature valves, flying lead valves, photocells, instrument and radar cathode-ray tubes, image converters, stabilisers and voltage reference tubes, electronic flash tubes and cold cathode tubes.

An interesting valve included in the range of sub-miniature valves was the DC70 directly-heated triode. This valve can be used as a driven amplifier or oscillator in circuits operating at frequencies up to 500 Mc/s. It therefore offers important possibilities in extremely small and compact U.H.F. communications equipment.

Another valve that should prove of value to designers of telecommunications is the QQV03-20 R.F. double tetrode. Built in the butterfly construction, this valve can be used in conventional circuits at frequencies up to and well in excess of 600 Mc/s, and it has been specially designed to operate at high efficiency with low drive power. This valve is inherently rugged and is specially suitable for use in airborne and mobile telecommunications equipment. A further development in this class is the miniature R.F. double tetrode QQV03-10. This valve has been designed to dissipate 5 watts at each anode, and is primarily intended for use as a driver, frequency multiplier or output valve in competitive mobile

equipment working at frequencies up to 225 Mc/s.

Also on view was a compact experimental transmitter using QQV03-10 and QQV03-20 valves. This transmitter, using conventional valves only, operates at a frequency of 430 Mc/s with a high order of efficiency and power gain. It was demonstrated feeding 10 watts into a dummy load.

Other new valves and electron tubes shown included an inert gas-filled half-wave rectifier 3B28 for use in high-voltage rectifier circuits; a 12in. radar display tube MF31-95, and a flash tube LSD24 having an anode rating of only 1,000 volts.

Mullard magnetic materials and components shown included Ticonal cast and sintered permanent magnets, Magnadur ceramic permanent magnets, Ferroxcube core material, precision variable capacitors and displays of Varite resistors and concentric air dielectric capacitors. Also shown were protected radar magnets for magnetron applications.

Ticonal magnets are extremely stable and have a higher external magnetic energy per cubic centimetre than any other permanent magnet commercially available. As a result, they combine extremely high magnetic performance, small size and stability, thus allowing improved efficiency and a marked reduction in the size of many components used in electrical and electronic apparatus.

Magnadur magnets differ from other permanent magnets in that they are of ceramic structure. They combine the advantage of extremely high coercive force with high insulating properties. As a result, Magnadur magnets may be used in applications where the production of eddy-currents has previously precluded the use of permanent magnets.

An important event!

A new and greatly enlarged edition of **WEBB'S CATALOGUE**
(available beginning June)

52 large pages 11in. x 8½in. crammed with information covering all aspects of radio and electronics.

Whether you build your own apparatus or buy complete you will find what you want in this catalogue.

- RECEIVERS
- AMPLIFIERS
- TRANSMITTERS
- TAPE RECORDERS
- TEST GEAR
- LOUDSPEAKERS
- GRAMOPHONE EQUIPMENT

and all necessary components for home construction.

SEND 1/-
postal order or stamps

for the most comprehensive catalogue in the trade.

You will also be registered at Webbs (at no extra charge) for Webbs information service, keeping you up to date by post, with subsequent developments.

Our charge of 1/- covers both Catalogue and Information Service



14, SOHO ST., OXFORD ST., LONDON, W.1
Telephone: GERrard 2089

SHOP HOURS:
9 a.m.—5.30 p.m. SATS. 9 a.m.—1 p.m.

OUTSTANDING SCIENTIFIC BOOKS
AT ONLY A FRACTION OF THE
NORMAL PUBLISHED PRICES!

Join The Scientific Book Club

Members **BUY** Books published at
10/6, 12/6, 15/- for **ONLY 3/6**

Each month the Scientific Book Club brings to its members the fascinating story of the march of modern science, told in thoroughly dependable books by the front-rank scientific writers of our time—vivid, vital, constructive contributions to Man's unceasing struggle to solve the problems of the Universe. And although the ordinary editions of these books are sold to the general public for 10s. 6d., 12s. 6d. and 15s., THE PRICE TO MEMBERS OF THE SCIENTIFIC BOOK CLUB IS ONLY 3s. 6d.



Now is the time to join!

Remember, too, that Scientific Book Club selections are full-length and unabridged. They are printed on good quality paper, cloth-bound, with an attractive picture jacket. These are, we say with certainty, books that you will be glad to read, proud to own. The Scientific Book Club brings these great books to you each month; helping you to build up, at a sensational bargain price, a first-class collection of scientific books.

SOME RECENT SELECTIONS

THE COMMON SENSE OF SCIENCE by J. Bronowski (Published at 8s. 6d.); LIFE ON OTHER WORLDS by Sir Harold Spencer Jones (12s. 6d.); EVERYTHING HAS A HISTORY by J. B. S. Haldane (16s.); PROFILE OF SCIENCE by Ritchie Calder (16s.); BIRDS AS INDIVIDUALS by Len Howard (12s. 6d.). *Wonderful value!*

FILL IN THIS ENROLMENT FORM TODAY

To the Scientific Book Club, 121 Charing Cross Rd., London, W.C.2

I wish to become a member of the Scientific Book Club and agree to purchase the special edition of the selected book issued each month to members at a cost of 3s. 6d. (postage 6d.). I agree to continue my membership for a minimum of six books and thereafter until countermanded. *Practical Wireless*

- * I enclose 4s. (3s. 6d., plus 6d. postage) for my first book, and will pay for subsequent selections on receipt.
 - Or if you wish to save time, postage and postal-order costs, you may send an advance subscription. Six-months 24s. 0d.; twelve books 48s. 0d.
 - * I enclose 24s., 48s. (strike out amount not applicable).
- * Place ✓ in the space above, as required.

NAME.....

ADDRESS.....

Overseas enrolments must be accompanied by an advance subscription.

LYONS RADIO LTD.

3, GOLDHAWK ROAD, Dept. M.P.
SHEPHERDS BUSH, LONDON, W.12.

Telephone: SHEPherds Bush 1729

R.F. UNITS TYPE 27. These popular converter units having a frequency range of 65-85 Mc. are fitted with a three-gang tuning condenser, 2 VR136's and 1 VR137. In good used condition. PRICE 39 6. post 2/6.

A.C. POWER UNITS. Input 200-250v. 50 cps. A.C. Mains. Output adjustable 210-250 v. smoothed D.C. at 60/50 ma. In black crackle metal case, 7 x 6 x 8 ins. with instruction label and circuit diagram pasted inside cover. Rectifier employed is a full-wave selenium type. A brand new manufacturer's surplus line. PRICE 35 -, post 2/6.

AMPLIFIERS TYPE A. 1368. These are two valve A.F. amplifiers and can be used for intercom, purposes or as a microphone pre-amp. With slight mod. can also be used as a gramophone amplifier. Valves fitted are VR21 (210L.F) and VR35(QP21). Operated from 2 v. L.T. and 90-120 v. H.T. and 9 v. C.B. Housed in neat metal cases 7 x 5 x 4 in. Supplied with modification data in good condition. A REAL SNIP AT ONLY 10 6. post 2/-.

INDICATOR UNITS TYPE 62A. These are similar to the type 62 for which TV conversion details were recently published except that VR65's are replaced by VR91's. Principal contents are 12 VR91's, 4 VR65's, 3 VR92's, 2 VR54's, cathode ray tube VCR97, with mu-metal screen and holder, wire-wound pots, H.V. condensers, and stacks of other useful parts. Size 18 x 11 x 8 in. In good used condition and with C.R. tube TV picture tested to ensure freedom from cut-off. PRICE 26 10. carriage 8/6.

Hi.Q. T.R.F. Coils. Iron cored. AE & Det. or AE & HF. 7/- pr. I.F.T.s 465 Kc/s 2 1/2 x 3/4 dust cores, 12/6 pr. 5/Het Coils, AE & Osc. M & LW, 3/- ea. All new and boxed with Ckt. .0005 Midget Twin gang, 6/9. 1/2 watt. Resistors, 4d. ea. Plessey Gram Units with Hi-Fi P.U., 4/12/6. Stamp for list.

THE TELETRON CO.,
266, Nightingale Road, London, N.9

A REALLY SMALL RADIO RECEIVER

This radio receiver although as small in size as a matchbox, gives loud, clear reception of the BBC Home, Light and Third Programmes on the medium waveband, about 180-550 metres. The set also tunes the Light Programme on the long waves, 1500 metres. No catswhiskers, valves, or batteries are required, and the receiver works off a short indoor aerial in many districts.

PRICE **9/-** POST FREE

This offer applies only to Gt. Britain, Irish Republic and Northern Ireland.

SWIFT RADIO (W),
137, COTHAM BROW, BRISTOL, 6

Orders by post only.

COMMUNICATIONS RECEIVER R.1155. The famous ex. Bomber Command Receiver known the world over to be supreme in its class. Covers 5-wave ranges 12.5-7.5 mc/s., 7.5-3.0 mc/s., 1,500-900 kc/s., 500-200 kc/s., 200-75 kc/s. and is easily and simply adapted for normal mains use, full details being supplied. Aerial tested before despatch these are BRAND NEW AND UNUSED IN MAKERS' ORIGINAL TRANSIT CASES. ONLY £11-19-6.

A few used receivers, also tested working before despatch, are available at £7-19-6. A few of the R.1155 N model can also be supplied. This is the latest version which covers the Trawler Bands, and in addition is fitted with ultra slow motion tuning. Used, but tested working before despatch. ONLY £17-19-6.

A factory made Power Pack, Output Stage and Speaker, contained in a black crackled cabinet to match the receiver, can be supplied at ONLY £5.10.10. Operates receiver immediately.

DOUBLE TUBE PURCHASING RECEIVER & POWER PACK TOGETHER. Please add carriage costs of 10/6 for Receiver, and 5/- for Power Pack.

R.F. UNITS TYPE 26 & 27. The very popular variable tuning units, which use 2 valves EF54 and 1 EF53. Type 26 covers 65-50 mc/s (5-6 metres), and Type 27 covers 65-65 mc/s (3.5-5 metres). BRAND NEW IN MAKERS' CARTONS. ONLY 59 6.

VIBRATOR UNITS. 2-VOLT TYPE. America made, delivers 67 volts at 170 ma., 130 volts at 20 ma., and 1.4 v. L.T. Easily adapted for use with any battery receiver, full details being supplied. ONLY 50/- (postage 2/-).

6-VOLT TYPE, made by the National Co. of America for use with HRO Communication Receivers, supplying 155 volts at 25 ma., fully smoothed D.C. Complete with vibrator and 6X5 rectifier in black crackle cabinet, size 7 in. x 7 in. x 6 in. ONLY 39 6.

CONTROL UNIT TYPE 62A. Contains VCR97 tube with mu metal screen, 12 valves EF50, 4 of SP61, 3 of EA50, and 2 of EB31. Built on a two deck chassis containing hundreds of condensers and resistors, potentiometers, etc. IN BRAND NEW CONDITION IN MAKERS' TRANSPORT CASE. ONLY £7-10-0 (carriage, etc., 9/6)

ADMIRALTY TEST SET TYPE SE2. For 100,230 mcs, this contains standard 230 250 v., 50 c. AC Mains power pack, 21n. 500 microamp meter, and 7 valves as follows: 6X5, 6X6, 6X7, EA50, 1 each 6X5, VR137, CV172. Fitted in metal lined wood case with removable front. ONLY 50/- (carriage, etc., 10/-).

6-VOLT BATTERIES 90 A.H. By famous American maker. These have genuine brass rubber cases and are BRAND NEW & UNUSED IN MAKERS' PACKING. Size 8 1/2 in. long x 6 1/2 in. wide x 7 1/2 in. high. ONLY 30 6 (carriage, etc., 7/6).

205 AMPLEIFER. Ideal for conversion into a high gain TV pre-amp. Complete with 2 valves EF50. ONLY 15/- (postage, etc., 1/6).

TRANSFORMERS E.H.T. Upright mounting.
E.H.T. for VCR97 Tube. 2,500v. 5 mA., 2v.-0.2v. 1.1a., 2v.-0.2v. 2a. ... 37 6
E.H.T. 5,500v. 5 mA., 2v. 1a., 2v. 1a. ... 72 6
E.H.T. 7,000v. 5 mA., 4v. 1a. ... 82 6
Please add 2/- per transformer postage.
6in. MAGNIFYING LENS FOR VCR97 TUBE. First grade oil filled. ONLY 25/- (postage, etc., 2/-).

TELESCOPIC AERIAL. Pulls out of metal tube, 15in. long to 73in. BRAND NEW. ONLY 7/6 (post 10d.).

GERMANIUM CRYSTAL DIODES 18.
6A W/CD POTENTIOMETERS. Double 56 K. and Double 1 Meg., 7/6 ea.
CERAMIC 2-WAY 3-BANK SWITCHES, 7/6 ea.

TRANSFORMERS. Manufactured to our specification and fully guaranteed. Upright mounting, fully shrouded, normal primaries.
425v.-0.425v. 200 ma. 6.3v. 4 a., 6.3v. 4 a., 5v. 3 a. ... 35 0
350-0.353v. 160 ma., 6.3v. 6 a., 6.3v. 3 a., 5v. 3 a. ... 42 6
250v.-0.250v. 100 ma., 6.3v. 6 a., 5v. 3 a. 32 6
Please add 2/- per transformer postage.
Cash with order, please, and print name and address clearly. Amounts given for carriage refer to inland only.

U.E.I. CORPORATION
138 Gray's Inn Road, London, W.C.1
(Phone TERMINUS 7937)
(Open until 1 p.m. Saturdays. We are 2 mins. from High Holborn (Chancery Lane Station) and 5 mins. by bus from King's Cross.)

VALVES.—6J6, 6SN7, 6BW6, 6BA6, 6BE9, 6AG, 6SL7GT, 6K8CT, 6L6MET, 12BF6, 12BA6, 607, 6C4, VR105, EF39, 5Y3GT, EB33, 9 6, 717A, V570, V510A, V509, CV57, 9012, 6AT6, 6N7GT, VT501, GUGG (MAGIC EYE), 6V6GT, 6AM6 (8D), EF91, Z77, 6F12), 8-174, 185, 1U5, 3A4, 3V4, 6AG5, 7 6, 6BR6, 6BR6MT, PEN46, 12SL7GT, 12J5GT, 12SH7GT, 6AL5 (EB91, D77, 6D2), PEN25, 6 6, VR66, 1A5GT, VG128, 129A, 1625, VR137, VR56, 5 6, 7193, VR54, VR92 (EA50), 2 6, ECH35, EF77A, 15-, SPECIAL OFFER, EF92 (W77, 9D6), 6 6.

VALVE HOLDERS.—Int. Octal Amphenol, 2 for 3 or stripped, 1 6 for 2. EF50 Ceramic or Micalex, 1 6 for 3. B8A Amphenol with base screen, 2 6 for 3. British 4-pin Ceramic or Amphenol, 1- for 2. UX 7-pin Ceramic, 2 6 for 2. UX5-pin (for 807, etc.), 1 6 for 2. British 5-pin High Voltage Type, 1 6 each. EA50 Diode type, 6d. each. VCR97 Base, 2 6 each. EF50 Valve Retainers, screw type, 1 complete.

HEADPHONES.—S.G.B., 4,000 ohms, 17/6 pair. Balanced armature, 12 6 pair. Moving coil, 5 ohms, 7 6 pair. Midget Light weight, low impedance, 12 6 pair.

HEADSET ADAPTORS. High to Low Impedance, 2 6.

MARCONI AERIAL FILTER UNIT TYPE 916. Brand New, 5 6.

SWITCH BOX B/345.—Metal Case, 3 1/2 x 3 1/2 ins. deep, containing 2 small P.O. Jack Sockets, Yaxley Switch, Pointer Knob, etc., 3-, Brand New.

CONDENSERS.—Tubular approx. 2 1/2 in. long, 1/4 in. diameter, .01 mfd., 4,000 volt working; .01 mfd., 4,000 volt working, 2/- each. .25 mfd. 800 volt working, 1/- each.

CONDENSERS, SPRAGUE.—1 mfd., .5 mfd., 2 x 1 mfd., 600 volt working, 1/- each.

CONTROL UNIT TYPE 499.—Smart grey metal case, 5 1/2 x 4 1/2 x 2 1/2 in. deep, containing 200K POT, Epicyclic Drive, Yaxley Switch, Resistors, 2 Knobs, etc., Brand New, 6 6.

UNIT FOR STRIPPING.—Contains 11 mica Condensers (.001 etc. Midget .0005), 7 and 1 watt Resistors, 2 int. octal Valve holders, 2-, Brand New.

MOTORISTS, MOTOR CYCLISTS, ETC.—Brand New Lodge Plugs, 14 mm., 1 6 each

J. B. SERVICE (BEXLEYHEATH) LTD.,
5, Mayplace Road West, Bexleyheath, Kent

REP
HIGH GAIN DUAL RANGE COIL WITH REACTION.
Complete with 2 Battery and 2 Mains Circuits.
PRICE 4/- Post 3d.
(Trade Supplied.)
RADIO EXPERIMENTAL PRODUCTS LTD.
33, Much Park Street, Coventry



CITY OF COVENTRY EDUCATION COMMITTEE COVENTRY TECHNICAL COLLEGE
Session, 1953-54

ELECTRONIC ENGINEERING

Applications are invited for entry to the next 3-year full-time course commencing in September, 1953, from those requiring a comprehensive training to an advanced level in ELECTRONIC ENGINEERING, to qualify them for technical posts in radio, telecommunications, television and industrial electronics. The syllabus will cover the requirements of C. & G., Brit.I.R.E., and I.E.E. examinations. Entry age 16 years or over. Application forms and further information available from the Principal, Coventry Technical College.

W. L. CHINN, M.A.,
Director of Education
Council House, Coventry.

OPEN TO DISCUSSION

The Editor does not necessarily agree with the opinions expressed by his correspondents. All letters must be accompanied by the name and address of the sender (not necessarily for publication).

"For the Beginner"

SIR,—Having taken in PRACTICAL WIRELESS for some time, I should like to take the opportunity to thank you for thinking a little in regard to the beginners. I myself am one and I cannot find time to go to college, as I have on previous occasions, where the subject was made boring, as teachers are on another subject before the previous one has been fully understood. Your first of the series looks to me as though they are going to be interesting—more interesting than if I was at college, but I should (if you think it wise) like you to state values of components so that beginners like myself could get down to the job from the start.

I hope in due course to obtain the two books mentioned in the first of the series so I hope, for my sake as well as others, that you will keep this good work up.—T. J. DOUGHTY (Wolverhampton).

SIR,—May I congratulate you on your foresight in providing a long felt want in your new series, "The Beginner's Guide to Radio."

You must have thousands of readers like me, eager to build a radio set of their own and frustrated by lack of knowledge. But now at least—thanks to your efforts—the opportunity to learn presents itself.

Please carry on encouraging raw beginners like myself by providing as many articles as possible. Remember, the radio novice of to-day, through instructions of this nature, may well be the radio expert of to-morrow.—S. H. TAYLOR (Ramsgate).

Super-Regeneration

SIR,—As a raw beginner in wireless and having been bitten by the V.H.F. "bug," I was most interested in the article in the March 1953 issue on "Super-Regeneration," by E. G. Bulley, particularly as I am constructing to a circuit very similar to that in Fig. 2. I do feel that more emphasis should be given to the need for prevention of R.F. energy radiation, as in my possibly mistaken observation there was no indication to the operator that annoyance was being caused to the neighbours from a set without screening or an R.F. stage.—J. A. CUSDIN (Polegate).

L.F. Couplings

SIR,—If Mr. E. Wells, of York, wants to save himself a lot of trouble and expense, he would be well advised to steer clear of the D.C. coupling fads of Bonavia Hunt. There are strings of ampli-

fiers between the microphone and the loudspeaker, and Mr. Hunt believes passionately in the only one that does not use condensers.

Amplifiers with condenser couplings can achieve everything, and possibly more, than Mr. Hunt claims for his directly coupled systems, and without half the trouble to the amateur in getting them in order. I would like to have some technical proof from Bonavia Hunt to explain his extraordinary claims in this direction.—G. A. KNIGHT (Chelmsford).

SIR,—There are three possibilities concerning Mr. N. H. Crowhurst's passion for A.F. transformers for coupling (May issue).

(1) That he has not heard of the modern high gain valves.

(2) That he is able to afford high-class coupling transformers.

Mr. Crowhurst suggests that the modern preference for R.C. coupling is "that bad choice of values does not usually produce such obviously bad results as can occur when a transformer is seriously misused."

Most constructors who buy PRACTICAL WIRELESS usually build the published, carefully designed and tested sets. Bad choice of values doesn't come into it.

Surely cost is the main consideration. Compare the cost, and size for that matter, with a capacitor and resistor. How one can "effect a saving" I fail to see.

(3) That he is a salesman or even a director of a transformer manufacturers and gets them cheaper! —BRYAN A. COX (Hambrook).

In Defence of Super-Modulation

SIR,—With reference to my article in the June edition of PRACTICAL WIRELESS, I should like to correct the following error. On page 326 the impedance formula should be:

$$Z_0 = \sqrt{K-1} \cdot 276 \log_{10} \frac{D}{r}$$
 ohms, the logarithm being taken to the common base 10 and not as shown

$$\left(\frac{D}{10r}\right)$$
—WM. A. HOPE (Roxburghshire).

The Amateur Transmitter

SIR,—I could not agree more with Mr. Hector Coles' letter regarding amateur transmitting published in last month's issue of Open to Discussion.

A very narrow-minded situation surrounds the man, who, with a shed full of components and a genuine

Whilst we are always pleased to assist readers with their technical difficulties, we regret that we are unable to supply diagrams or provide instructions for modifying surplus equipment. We cannot supply alternative details for constructional articles which appear in these pages. WE CANNOT UNDERTAKE TO ANSWER QUERIES OVER THE TELEPHONE. If a postal reply is required a stamped and addressed envelope must be enclosed with the coupon from page iii of cover.

interest in radio, dares to be ambitious enough to have a go, and get on the air.

With a 2½d. stamp and a brief note, he sends to the G.P.O. for full details of how he can achieve his ambition. And I would bet any money that nine out of ten, after reading all the regulations and conditions, throw them on the back of the fire and turn to something else.

I speak, of course, for those chaps, and there must be very many, who haven't got a friend with a transmitter, or an Amateur Radio Club. Two things which make a great difference.

Our would-be "Ham" finds among other things that he has to pass a technical examination, the syllabus of which is enough to put anyone off. Then there is the Morse, which is stupid to say the least. The men who argue for this way of communications are, in most cases, ex-service men who have had to learn it.

I would suggest that the next Radio-Tele-Communications Convention clears the bilge off the thousands of kilocycles of short waves, and that the G.P.O. will create a band for the novice. A five-watt Crystal Control Transmitter would be the delight of thousands and in turn would bring the G.P.O. thousands, perhaps not with the same delight.

The whole thing reminds one of the old saying: "You can't go into the water until you have learned to swim."

We can only, once again, refer back to the good old days, when the only things you needed to get on the air were an excuse and a transmitter, and not qualifications and a morse key.—C. ROBERTS, (Worcester).

Quick Capacitor Tester

SIR,—I have built the quick capacitor tester as described in your January issue, and added a slight modification.

In the original model there is the likelihood of the condenser under test being left charged on switching off. If, however, a resistor is connected between contacts 2 on the lower two wafers of the switch (I have used a 10 K), the condenser will be automatically discharged on returning the switch to the central position, and the crocodile clips will then be safe to handle.—P. E. BAKER (N.5).

Contact Operation and Maintenance

SIR,—With reference to the article in the March issue on this subject, I would like to point out a consideration when using carbon tetrachloride in cleaning contacts. The practice of using carbon tetrachloride in cleaning electrical contacts is deprecated. Technical CCl₄ usually contains traces of free chlorine which, in the presence of moisture, may form hydrochloric acid, resulting in corrosion at a later time. Sliding contacts should, therefore, be cleaned occasionally with a lint-free cloth, either dry or moistened with a solvent such as varsol or benzol.—EINAR TOLLEFSEN (Egersund, Norway).

Watch Rate Recorders

SIR,—It would be much appreciated if you could assist me in securing some information concerning the electronic watch rate recorders there are at present in use by watch firms throughout the country.

I am particularly anxious to secure a copy of the circuit of such an instrument and perhaps a reader can suggest a source of supply of such information.

I may add that I have no intention of infringing any copyright, etc., as I am already more than familiar with the principle involved, also the practical layout, etc. The several refinements I do seek, however, are only obtainable by this method, i.e., to have a copy of a commercial circuit.—RONALD W. DYSON (Exeter).

Transistors

SIR,—Since transistors have already appeared in limited numbers on the American market, and are likely to appear at an early date on the British, experimenters will be eagerly looking forward to obtaining samples.

It should be pointed out that the price is bound to be high, probably between £3 and £4. Which definitely places them in the luxury class.

There is, too, a great pitfall in their use awaiting the unwary. They are as easy to burn out by overload—or by reversing the polarity of the applied voltage—as an instrument thermo couple.

I burnt out three of these in spite of every precaution.

So amateurs, be warned in time!

There is, unfortunately, considerable confusion of thought as to the valve parallel. In the point contact there are two whiskers and the germanium base.

The first whisker is called the emitter and is compared to the valve grid, but is *not* negative with respect to base or cathode as the valve is. It is about quarter-volt positive. Reversing this voltage won't cause damage. The second whisker is called the collector and is compared to the valve plate but is *not* positive with respect to base. It is negative. Reversing this voltage spells disaster.

There appears to be considerable confusion, too, as to proposed markings to distinguish base emitter and collector by the various British manufacturers. Is it too much to hope that they will agree on a standard marking, identical with the American? British manufacturers in the past have shown a lamentable weakness for individualism in the creation of standards and identifying letters, with the result that foreign countries invariably buy American valves, etc. Transistors are easily burnt out by surge currents such as due to deformed electrolytics, shorted or defective capacitors or to shop counter "testing," or experiments to which a lot of counter radio amateur mechanics are addicted. So when transistors do appear don't buy unless sealed. Don't use Government surplus capacitors which are, as a rule, at least 30 per cent. duds. Use only tested circuits. Pause and think 10 times before applying any voltage at all, and then only to the complete wired and checked instrument, receiver, deaf aid or whatever it may be. Used thus, transistors are asserted to have an almost indefinite life.

So much for the point contact. There is bound to be confusion, too, over the markings on the junction type.

I hope these notes will save impecunious experimenters from tragedies of transistor burn outs at three or four pounds sterling a time!—WM. J. LAW (Ealing).

DECALS

(paint transfers)

Labels for marking controls, etc. on radio and electronic equipment.

For direct application to panels, knobs, chassis, etc. No background, hard wearing, professional finish. Ministry of Supply approved.

Available in books containing large selection of carefully chosen words, approx. 1 1/2 in. high lettering. Decals are applied with water or varnish (or crackle finish), no tools or equipment necessary.

AMATEUR MK. II containing approx. 300 titles covering all aspects of amateur radio including T.V. tape recording, etc. Price, 3/6, plus 3d. post. Available in black or white.

STANDARD MK. II approx. 750 titles, covering all aspects of electronics, including spare letters and numerals in black or white. Price, 4/9, plus 3d. post.

ALEXANDER EQUIPMENT LIMITED.
CHILD'S PLACE, EARL'S COURT, LONDON, S.W.5
FREEmantle 6762

CONDENSERS. 3 Gang .0005 mfd. New and boxed. 7/6 ea. Solar 50 mfd. 12 volt, 1/- ea.

VALVES. (New but Unboxed).
EC54. Grounded Grid Triodes, 4/6, 3 for 12/6.

ECC31. Twin-Triodes, 4/6, 3 for 12/6.
ECC35 (6SL7). Twin-Triodes, 8/6, 3 for 24/-.

GTIC Thyratrons (New and Boxed), 4/6, 3 for 12/6.

Send 6d. for our 24-page Catalogue. Visit our Shop, open all week, inc. Sat.

Tel.: St. Albans 5951.

BOLD & BURROWS
12-18, VERULAM ROAD (A5),
ST. ALBANS, HERTS.

RADIO UNLIMITED

NEW BOXED VALVES. POST FREE

5/-	8/6	8/6	8/6	9/6	10/6	10/6
SP61	6K7	6V6	6J7	6Q7	6K8G	12Q7
12J5	6D6	6F6	6U5	5Z4	KT33c	25Z4
D63	6J5	1S5	U14	5U4	12K7	6SN7
9D2	6C5	1R5	807	354	12K8	6L6G
HL41	1T4	6X5	78B	80	35L6	KT61
6H6	757	1C5	7C5	Z77	25A6	6AT6

MAINS TRANSFORMERS
350-0-350, 6v., 5v., 4v., 4v., 80 MA., 18/6.

AMPLIFIER KIT (A.C. Mains)
Complete kit of parts, incl. valves, circuit and data, 59/6 post free.

Volume Controls. Special Offer
Plessey 500K, L/sp, non-sw., 6 for 10/-
ELM ROAD, LONDON, E.17. (M.F.F.) 4813

HOME RADIO OF MITCHAM

For all your

EDDYSTONE

Components and Receivers.

Send 8d. for fully illustrated short wave catalogue.

Open until 6.30 p.m. every day including Sats. (Weds. 1 p.m.)

HOME RADIO

187, LONDON ROAD, MITCHAM, SURREY. MIT. 3282.

"The QUALITY radio component specialists"

"ADCOLA" SOLDERING INSTRUMENTS

Regd. Trade Mark



Regd. Design No. 800302

(British, U.S. and Foreign Patents)

For Wireless and Television Assembly

The advanced design of the Adcola instruments meets the modern requirements of Television, Telecommunication and Radar Engineers

SUPPLIED FOR ALL VOLT RANGES FROM 6/7v. to 230/250V

3/16in. dia. Bit. Standard Model ... 25/6

1/2in. dia. Bit. Standard Model ... 28/-

3/16in. dia. Detachable Bit. Model... 33/6

Sole Manufacturers:

ADCOLA PRODUCTS LIMITED

GENERAL OFFICES & WORKS: CRANMER COURT, CLAPHAM HIGH STREET, LONDON, S.W.4. (MACaulay 4272)

COVENTRY RADIO

COMPONENT SPECIALISTS SINCE 1925

189, DUNSTABLE ROAD, LUTON

Phone: LUTON 2677

Eddystone Receivers (No. 740, No Tax) and Accessories. Components for Viewmaster, Tele-King, and Electronic Engineering T.V. Sets.

Stockists for:—

All B.V.A. and Tungram Valves

DENCO Coils.

RAYMART Accessories. WEYRAD Packs.

OSMOR Coils and Packs. WEARITE Coils and Packs.

Send 6d. for our New 50-page Catalogue.

C. & W. TEST INSTRUMENTS

A limited number of our high-grade Signal Generators and Multimeters are available once again for immediate delivery.

23 RANGE MULTIMETER MM3

A.C./D.C. volts to 2,500 v. at 4,500 Ω/v. D.C. current to 1 amp. Resistance to 5 megohms. Basic movement 200µA. Scale length 3 1/2 in. Price £8/0/0.

SIGNAL GENERATOR S.2.

Ranges 100 kc/s. to 70 mc/s. 400 cps. audio. Int. and ext. mod. Ladder and fine attenuator. Direct reading dial. Price £8/8/0.

12 months' guarantee all instruments.

Please send S.A.E. for Illustrated Leaflets.

C. & W. ELECTRONICS 61, CHURCH STREET, OSWESTRY, SALOP



"AUTOMAT" CHARGER KITS

This shows the No. 1 kit assembled into its case. Built in one hour, it is simple, foolproof and troublefree. All new material with full guarantee. Generous size components. No. 1 kit 6v/12v

2 amp. metal rectifier, 45 watt transformer ballast bulb for 2v., 6v., 12v. charger, 38/6d., post 1 8d., or with handsome steel case, 52/- plus postage 2-. Ditto but 3 amp. rect. and 65 watt. trans. 46/- or with case 58/6d., postage 2- "Renewat" Battery desulphator and conditioner for car or radio batteries. Radio size 1/8. Car size 3/4.

CHAMPION PRODUCTS.

43 Uplands Way, London, N.21.

Phone: LAB 4457.

GERMAN COMMUNICATIONS AND TRANSPORT EXHIBITION MUNICH



1953 20 June - 11 October

Information and Catalogue from: M. Neven de Mont, 133 Pall Mall, London S.W.1. Tel: Whitehall 6211

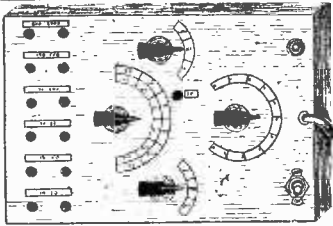

EQUIPMENT YOU CAN BUILD AT A REASONABLE PRICE
A NEW SIGNAL GENERATOR

We show above the Front Panel of our new Signal Generator, which gives 12 spot frequencies covering 6 wavebands, plus IF. Neat and compact, mains operated with A.F. and R.F. (modulated or unmodulated) outputs, and also a

NEW SIGNAL TRACER

Complementary to the Signal Generator and having the same dimensions. This piece of equipment enables you to listen to the signal at any point in a radio set from the aerial to the loudspeaker.

These two pieces of equipment form an efficient pair and are tools no radio man should be without.

Full description, working drawings, circuit diagram, priced parts list, point-to-point wiring charts and instructions for either.

PRICE 1/6 ONLY

or for both 2/6 the pair.

All components stocked

STAMP FOR CATALOGUE

SUPACOOLS MAIL ORDER OFFICE
98, GREENWAY AVENUE, LONDON, E.17

Best Buy at Britain's

P.C.R. 2 COMUNICATION RECEIVER covers 200-550, 900-2,000 and 13-49 metres. Has R.F. stage, two I.F.'s, 6V6 output for 2.3 ohm speaker. In tip-top condition and aerial tested. Complete with all six valves for only £7 10/- plus 10/- carriage. The mains-power pack for this set available at £3. plus 3/6 carr.

SKYRIDER DEFIANT SX24, by Hallcrafters—range 61 to 550 metres without any S.A.S. Specially designed for the American "ham." Complete with all valves and crystal. Price. £27 10/- plus 10/- carriage.

SKY CHAMPION S20R, a few still available—as advertised in May issue. Price £21. plus 10/-.

RT155 NEW. Price £11 19/6. plus 10/6 carr. Mains Power pack for this set at £4 10/- plus 3/6 carr. Send 1/3 for complete details of this excellent receiver.

NOTE—All the above receivers demonstrated at any time. Please send S.A.E. if further details are required.

RECEIVER 68P—A four-valve battery superhet. covering 100-200 metres. Complete with valves and circuit. Only 32/6.
RED SYLVANIA EF50 at 8/6. British types, tested, at 5/-, V7501 (TT11), 5/-, 2C34 (RK34), 2/6. CV6, 1/6, or 15/- per doz. post free.

UNIVERSAL AVOMETERS MODEL 40.—All checked and tested—have had little use. Price ONLY £3 19/6.

1 MULL-AMP METER, 2 1/2 in. square, panel mounting for only 15/-.

TELEVISION PICTURE FAULTS.—This fault-finding book has 63 pages and 150 actual screen photographs. Price 3/9. post paid.



CHARLES BRITAIN (RADIO) LTD.

11, Upper Saint Martin's

Lane, London, W.C.2. TEM 0545

Shop hours, 9-5 p.m. (9-1 p.m. Thursday)

—OPEN ALL DAY SATURDAY—



The "Fluxite Quins" at Work

"Our T.V. is far from O.K.,

It's needing some FLUXITE. I'll say.

The aerial's unsound,

That's the snag. I'll be bound,"

"Yes—nothing but 'owls' shouted EH.

See that **FLUXITE SOLDERING PASTE** is always by you—in the house—garage—workshop—wherever speedy soldering is needed. Used for over 40 years in Government works and by leading engineers and manufacturers. Of all ironmongers—in tins, from 1/- upwards.

FLUXITE

SOLDERING PASTE

A Staunch Companion to Fluxite Soldering Fluid.

SIMPLIFIES ALL SOLDERING

Write for Book on the Art of "SOFT" Soldering and for leaflets on CASE-HARDENING STEEL and TEMPERING TOOLS with FLUXITE.

FLUXITE Ltd.,

Bermondsey Street, London, S.E.1.

Amateur Radio Enthusiasts

THE INCOMPARABLE

GLOBE-KING

SINGLE VALVE S.W. RECEIVER
● WORLD-WIDE RANGE, 17-100 METRES ● CRYSTAL-CLEAR NOISE-FREE RECEPTION ● ELECTRICAL BAND-SPREAD TUNING ● EXTREMELY LOW RUNNING COSTS
Catalogue Free. Stamp for postpay.

JOHNSONS (RADIO)

46, FRIAR STREET, WORCESTER

BENTLEY ACOUSTICS Corp. Ltd.

38, Chalcut Road, N.W.1. PRImrose 9090

25L6GT 8/-	50L6GT 8/6	35L6GT 8/-
6V8GT 7/-	35Z4GT 8/-	6SN7GT 8/6
CSL7GT 8/-	IT4 7/-	616G 9/-
5Y3GT 7/6	6X5GT 7/-	12K9 8/6
6ABG 9/-	6R8GT 9/-	5Z4G 8/-
Y63 7/-	12SQ7GT 8/6	6N7 6/6
897 8/-	12AT7 9/-	12AU7 9/-
6SA7 7/6	6K7 4/6	6J5 4/6
757 7/-	7C5 6/6	7A4 7/-
7C3 7/-	7R7 7/-	7B7 7/-

All Guaranteed. Post 6d each.

Television, Radio, Record CABINETS MADE TO ORDER

ANY SIZE OR FINISH

CALL OR SEND DRAWINGS FOR QUOTATION

B. KOSKIE (DEPT. C.)

72-76 Leather Lane, Holborn, E.C.1

Phone: HOLBORN 4777

TESTSCOPE Mains Tester

For high and low voltage testing —1-30 and 100-350 volts A.C. or D.C. Write for interesting leaflet 29F.



RUNBAKEN · MANCHESTER

-Attack...

... now, and make your own electronic keyboard. Imitates almost whole orchestra. Variable attack puts the "plonk" in plucked strings. Full constructional details available. Send P.C. for free leaflet to ...

CIRCUITS & SUPPLIES, DARLINGTON, CO., DURHAM.

RADIO G200 ANNOUNCES

VALVES At 2/9: RK34/2C34, VR78, D1, 954, 12H6; at 4/6: 2X2/879, 4D1, VU111, GDT4C, NGT1; at 5/9: 12SH7, SP41/VR65A; at 7/6: 6U5G, 12SC7, 12SL7, EC52, EF54, VR136, CV73, 6C6, U78; at 8/6: 1619, OZ4, 6AG5, 6SK7gt, 2A3; at 9/6: 757, 7C5, 7B7, 7H7, 7R7, 7Y4, PT25H, VT46, IT4, 3A4, 3Q4, N18, W77, KT44, 6K7G/gt, 25L6gt, 35L6gt, 50L6gt, 35Z4gt, 6K6gt, KL35, PM2HL, 6D6, 6X5gt, 1R5, 1S5, 1S4, 3V4, 1A5gt, 1G6gt, 6B8g, 6CH6, 5Z4g, 65L7, 12AT7, 12AX7, 6AT6, 6AU6, 6BA6, 6B6g, 6BW6, 6X4, 6K8G.; at 11/6: X66, 12K8gt, 6J7, 5763, 2012, 801.

ARTHUR HOILE, 55, Union Street, Maidstone, Kent.

Phone: 18212.

THE Fidelity

7

All models have variable selectivity, high quality detector, triode output stages, 7 valve model illustrated £21-15-0. De-luxe 9-valve, £25-5-0. Major 10-valve, £32-15-0. Minor 6-valve, £17-10-0. Data sheets on request.

Fidelity Equipment
2 Amburst Road, Teacombe Cliffs, Sussex

H.A.C. SHORT WAVE EQUIPMENT

Noted for over 18 years for ... S.W. Receivers and Kits of Quality.

Improved designs with Denco coils: **One-Valve Kit, Model "C"** Price, 25/- Two " " " " " " " " 50/-

All kits complete with all components, accessories, and full instructions. Before ordering call and inspect a demonstration receiver, or send stamped, addressed envelope for descriptive catalogue.

"H.A.C." SHORT-WAVE PRODUCTS (Dept. TH, 11, Old Bond Street, London, W.1.

News from the Trade

"Osmor" Components

SOME interesting new accessories are available from the makers of the well-known Osmor Coils and coil parts. These include the following:

Jar Racks. The Type 1 "Jar Rack" for wall-fixing, holds eight jars and retails at 6s. 9d. Type 2 screws under a shelf and holds six jars, price 5s. 9d. retail. Standard 1-lb. jam-jars may be used, though not supplied, and ordinary metal lids used if required. These are invaluable for holding screws, nuts, bolts, etc.

"Two-one" Reversible Chassis Cutters. Two sizes are at present available. Size 2 cuts $\frac{3}{4}$ in. by $1\frac{1}{4}$ in. holes (price 18s. 9d. retail), and size 3, $\frac{3}{4}$ in. by $1\frac{1}{2}$ in. (price 22s. 6d. retail). Other sizes will be added according to demand. These cutters may be operated with a spanner or tommy-bar and used on steel up to 18 s.w.g., brass, and dural 16 s.w.g., and aluminium and copper 14 s.w.g. Ideal for valveholders, large grommets, etc.

Tommy Bars. For use with the above, price 1s. 3d. each retail.

$\frac{3}{8}$ in. Jiffy Punches. Hammer-operated, and for use on gauges of metal as above. Price 7s. 6d. each retail. $\frac{1}{2}$ in. jiffy punches are also available, price 8s. 9d. each retail. Other sizes are being added. These are easy to use and will withstand considerable wear. —Osmor Radio Products, Ltd., No. 2 Factory, Waldron Works, The Waldrons, Croydon.

Southern Radio—Change of Address

SOUTHERN RADIO & ELECTRICAL SUPPLIES are now operating from new improved premises at Sorad Works, Redlynch, Salisbury, Wilts.

A High Efficiency V.H.F. Power Tetrode

A V.H.F. valve which is one of the most efficient of its class in the world, is now being made commercially available by the Communications and Industrial Valve Division of Mullard Ltd. It is the hard-glass power tetrode QY3-125, and it is particularly recommended for use as an oscillator or R.F. amplifier in compact communications and allied electronic equipments operating in the V.H.F. range.

The outstanding characteristics of this valve includes low driving power, low power consumption, and unusually high power gains at very high frequencies. With a maximum anode dissipation of 125 watts, the QY3-125 will give an output of 375 watts at frequencies up to 120 Mc/s. It is constructed in hard-glass on the B5F base.

The principal characteristics of the QY3-125 are as follows: Filament voltage, 5.0 v.; filament current, 6.5 A.; anode voltage (max.), 3,000 v.; anode dissipation (max.), 125 W.; cathode current (max.), 270 mA.; frequency (max.) (full ratings), 120 Mc/s.; frequency (max.) (reduced ratings), 200

Mc/s.—Mullard, Ltd., Century House, Shaftesbury Avenue, London, W.C.2.

The Philips Disc-jockey

PHILIPS ELECTRICAL LTD. announce the introduction of the first of their range of record players; it is Model No. 424A, known as the Philips "Disc-jockey." The price is 11 gns. (tax paid). Supplies are now available.

This record player is designed to play all normal and long playing records.

An outstanding feature of the Philips "Disc-jockey" is the Philips double stylus "Featherweight" pick-up. This pick-up is so light that the needle pressure is no more than one-third of an ounce. Yet this has been achieved without the need for a counterbalance because the complete tone arm weighs only three-fifths of an ounce.

It is the combination of a very light needle pressure with overall lightness of the complete arm which gives the "Featherweight" pick-up its remarkable stability, preventing groove jumping and reducing record wear to a minimum. As is well known, every record surface has very small "ups and downs" over which the pick-up must travel. The inertia of the Philips "Featherweight" pick-up is so low that it can accommodate itself to variations, whereas heavy counterbalanced types simply plough through the record material. The Philips "Featherweight" pick-up obviates all this and gives perfect "tracking."

The pick-up head has two Philips sapphire needles which are ground and finished to the most exacting specification in Philips own factories. The microscopically accurate grinding of Philips sapphire needles reduces needle scratch and "chatter" to a negligible level. One needle is used for the normal 78 r.p.m. records and the other for the long-playing types. These needles are brought into play by a slight turning of the pick-up head and therefore the single pick-up head is suitable for all records. Another refinement is the inclusion of an auto-stop lever by means of which the "Disc-jockey" can be set so that the motor automatically stops at the end of the record. It will accommodate any type of record whatever the run-off groove or label size. The turntable is activated by a special three-speed motor developed by Philips themselves. This is a precision-built silent motor which is completely "rumble-free."

The Philips "Disc-jockey" Model No. 424A is housed in its own finely finished ribbed grey case, which measures 13 in. by $11\frac{1}{4}$ in. by $4\frac{1}{2}$ in. and weighs just 7 lbs. It has a flush-fitting handle and can be carried about in perfect safety due to felt cushions in the lid which hold turntable and pick-up in place. —Philips Electrical Ltd., Century House, Shaftesbury Avenue, W.C.2.

Editorial and Advertisement Offices
"Practical Wireless," George Newnes, Ltd., Tower House, Southampton Street, Strand, W.C.2. Phone: Temple Bar 4368.
Telegrams: Newnes, Rand, London.
Registered at the G.P.O. for transmission by Canadian Magazine Post.

The Editor will be pleased to consider articles of a practical nature suitable for publication in "Practical Wireless." Such articles should be written on one side of the paper only, and should contain the name and address of the sender. Whilst the Editor does not hold himself responsible for manuscripts, every effort will be made to return them if a stamped and addressed envelope is enclosed. All correspondence intended for the Editor should be addressed: The Editor, "Practical Wireless," George Newnes, Ltd., Tower House, Southampton Street, Strand, W.C.2. Owing to the rapid progress in the design of wireless apparatus and to our efforts to keep our readers in touch with the latest developments, we give no warranty that apparatus described in our columns is not the subject of letters patent. Copyright in all drawings, photographs and articles published in "Practical Wireless" is specifically reserved throughout the countries signatory to the Berne Convention and the U.S.A. Reproductions or imitations of any of these are therefore expressly forbidden. "Practical Wireless" incorporates "Amateur Wireless."

THE INSTITUTE of Practical Radio Engineers Home Study Courses are suitable coaching text for I.P.R.E. and other qualifying examinations. Fees are moderate. Syllabus of seven modern courses post free from SECRETARY, I.P.R.E., 20, Fairfield Road, London, N.8.

P.W. RADIO Feeder Mains Transformer, 16/-; H. L. BROWN, 18, Rowan Road, Walsall.

RADIO KIT, 4 valve, AC/DC, T.R.F. complete valves, less speaker. £2/10/-; COOK, 136, Basilidene Road, Hounslow, Middx.

METER RECTIFIERS, 1 m.a., 6/-; Transformers, 230v to 9 + 6v, 3s. 10/-; Selenium Rectifiers, F. Wave, 6/12v, 3s. 12/6; 5a. 15/-; Halfwave 300v, 120 m.a., 7/6; Full Wave Bridge, 250v, 1a, 15/-; S.A.E. for bargains list. LAWRENCE, 134, Cranley Gardens, N.10.

RESPONDER, 3118A, less 524, 64/-; Junction Box "240", 6/-; Amplifier, 1134A, less valves, 6/-; Pre-amp., 227A, less valves, 4/6; Traxn., 1083, less valves, 25/-; Blowers, 24V, 12/6; post free. ANNAKIN, 25, Ashfield Place, Otley, Yorks.

NEW AMERICAN SURPLUS—32/F, 450, 4in. x 2in. diam., 1/9 ea. 18/- doz.; ex new equip., aligned and sealed, amazing performance. 465 kcs I.F.T.s Wiring Instr., pair 7/6; ex equip. Transformers, 230v, in 6.5v, 0.5A output, 3/10 ea.; Silvania Red, VR91, 7/6; VR91, 4/6; VR65, 3/6; VR32, 2/-; 954, 1/6; s.a.e. for free list. Postage extra. **THE RADIO SERVICES**, Lr. Bullingham, Hereford.

DRAW AND CALCULATE that circuit with our Drawing Instrument Sets and Slide Rulers. Bargain prices and catalogue on request. Box 232.

MIDGET I.F.T.s high Q., 465 kcs. 2in. sq., 8/6 pr.; Coils, type "P" 2/3; "Q" 2/9; dual wave T.R.F., 5/6 pr.; same with reaction, 6/6 pr.; Crystal Coil, dual wave, 2/6 ea.; 8 mfd, 500v. Electrolytics, Ali Can. 1/9 ea., 18/- doz.; Multicoe Solder, 2/6 doz., yds.; Build a Set for £6/10/-, or a T.R.F. for £5/5/-, complete with all valves and cabinet. Book of concise instructions on both, 1/6, post free. Latest list with many other bargains. 3d. min. p. and p. 1/-; **SUSSEX ELECTRONICS LTD.**, Princes St., Brighton.

ELECTROLYTICS, capacity, voltage, size, type of mounting; price post paid. in that order: 16 + 32, 450/525, 1 1/2 x 2, clip, 5/6; 24 + 24 + 16, 350/425v, 1 1/2 x 2, clip 4/9; 60 + 200, 275/350v, 1 1/2 x 4 1/2, clip, 6/6; 1,000, 12v, 1 x 2, clip, 2/9; 4, 150v, 1/2 x 1 1/2, clip, 1/1; 60 + 100, 350/425v, 1 1/2 x 4 1/2, clip, 6/6; 500, 12v, 1 1/2 x 2, clip, 2/6; 8, 350v, 1/2 x 2, 2/-; 6,000, 12v, 1 1/2 x 4 1/2, lug, 4/6; 100 + 200, 275/350v, 1 1/2 x 4 1/2, 6/6; 100 + 175, 275/350v, 1 1/2 x 4 1/2, clip, 6/-; 8 + 16 + 16, 450/525v, 1 1/2 x 2, lug, 5/9; 32 + 32, 350/425v, 1 1/2 x 2, clip, 5/-; 2,000, 6v, 1 x 3, clip, 3/3; 8 + 16, 450/525v, 1 1/2 x 2, clip, 4/3; 2, 450/525v, 1 1/2 x 3, tag, 1/6; 2, 350v, 1/2 x 1 1/2, tag, 1/3; 8, 350/425v, 1/2 x 2, clip, 2/-; 16 + 32 + 8, 450/525, 1 1/2 x 3 1/2, lug, 5/9. All are Ali cans; some with sleeve; all new stock; all voltages WKG. with surge v. where marked. Television! Set of 3 Components, comprising line output trans. with E.H.T. winding, to give 7Kv, using EY51 (theater winding for EY51 also included), and fitted with width control. Scanning coils, low impedance line and frame, focus coil, optional high (10,000 Ω) or low (200 Ω). Set of 3, 42/-, plus 2/- post-ge. Diagram of line trans. supplied. **RADIO CLEARANCE LIMITED**, 27, Tottenham Court Road, London, W.1. (Telephone: Museum 9133.)

RATES: 5/- per line or part thereof; average five words to line, minimum 2 lines. Box No. 1/- extra. Advertisements must be prepaid and addressed to Advertisement Manager, "Practical Wireless", 3 Tower House, Southampton St., Strand, London, W.C.2.

BASS REFLEX Speaker Cabinet Kits, 12in. Speaker Model, 97/6; 10in. Speaker Model, 87/6; 8in. Speaker Model, 80/-; carriage 7/6; ready built, 7/6 extra. Send for list. Rexine-covered Record Player Carry Cases, Bass Reflex Cabinets made to your own specifications. Gramophone, Radio and Record Cabinets made to order. Send drawings for quotations or call. A. DAVIES & CO., Cabinet Makers, 3, Parkhill Place, off Parkhill Rd., London, N.W.3. (Gulliver 5775.)

RADAR UNITS, 15in. x 9in. x 8in. brand new (less relays), contains 14 variable resistors (2 wire wound 4w), a 4-way 6-bank wavechange switch, 4 ceramic EF50 bases, hosts of resistors and condensers, etc., chassis and case makes ideal amplifier; spotless cond., 10/6 (carr., 4/6); Moulded Mica Condensers, .001 mfd., .0006 mfd., .0003 mfd., .0001 mfd., 2d. each; 1.5 mA. meters by "G.E.C." new in original boxes, 2in. m/c, 7/6 (p. and p. 3d.). See "P. TV". May, for Meter bargains. "Hi-roc" miniature 1.5v Valves, type "XH", 7/6; fresh supply of new Canadian EF50s with 7/6 each. New bargains arriving daily; call or write for our free list. **SERVIO RADIO**, 156-8, Merton Rd., Wimbledon, S.W.19. (Phone: LIBERTY 6525.)

DID YOU KNOW . . . at one time we were leading Government Surplus Stockists—a fact which will be to your advantage if you call at our showrooms. We have left miscellaneous quantities of surplus electronic equipment, in very great variety and this will be offered at unheard of and unrepeatable Bargain Prices for a limited period. Do not fail to pay us a visit. A show-room is being allotted to the display of this material which can be inspected at your leisure. **MAIL ORDER SUPPLY CO.**, 33, Tottenham Court Rd., London, W.1. (Telephone: MUSEum 6677.)

RADIO OFFICERS urgently reqd. We train most in shortest period. Training fees payable after appointments. Secd. Scholarships available. Boarders accepted. 2d. stamp for Prospectus. **WIRELESS COLLEGE**, Colwyn Bay.

FREE! Brochure giving details of Home Study Training in Radio, Television, and all branches of Electronics, Courses for the hobby enthusiast or for those aiming at the A.M.Brit.I.R.E., City and Guilds Telecommunications, R.T.E.B., and other professional examinations. Train with the College operated by Britain's largest electronic organisation. Moderate fees. Write to E.M.I. INSTITUTES, Postal Division, Dept. PW28, 43, Grove Park Road, London, W.4. (Associated with H.M.V.)

TELEVISION COMPONENTS

for the
"Practical Television Receiver"
TELE-KING
VIEWMASTER, E.E. TELEVISOR
and VM wide angle modifications in STOCK

Price Lists available on request.

J. T. FILMER,
Maypole Estate, Bexley, Kent.
Tel.: Bexleyneath 7287

EVERYTHING for radio constructors. Condensers, Coils, Valves, Resistors, etc. Send stamp for list. SMITH, 98, West End Road, Morecambe. Quick service.

NEW VALVES WANTED, small or large quantities; all Television Valves and ECL80, EF80, EBC33, FN4/500, VU39, 6SJ7, 6V6, 6K8, 521, etc. etc. Prompt cash. W.M. CARVIS, 103, North Street, Leeds, 7.

"VIEWMASTER" Valves, exact to specification, guaranteed new and boxed, comprising 5 EF50, 1 6P25, 1 KT61, 1 EBC33, 1 EB91, 2 6K25, 1 6P28, set of 12 6E2/6, with EF91 or EF91, 7/6 extra (post and insurance 2/-); 14v miniatures, 1S5, 1R3, 1T4, 3S4, 3V4, 1S4, 1L4, 8A4, 7/6 each, set of any 4, 2/7/6; 6AM6, EF91, 6F12, Z77, 8D3, W77, EF92, 6AM5, EL91, N77, 12AX7, 7/9, any 8 for 56/-; EB91, 6AL5, HVR2A, 6/9; 6V6G, 6P6G, KT63, EF39, EF8, EF50, 20D1, 6C4, 7B7, 7C5, 7C6, 7H7, 7S7, 7Y4, 7/6; 524G, 5U4G, MU14, U22, U78, DH77, 6AT6, EBC33, 6J6, 6BA6, 6BE6, 6BW6, EC91, Pen.46, 12AT7, ECC81, EY82, PL81, 6F15, 6LD30, 8/6; PZ30, GZ32, EY38, 6J6, N78, 151/-, 6P25, UL46, 13/6; 6K25, 12/6; ECC81, U42, EB80, UB780, PL83, DK32, 1A7G, 12/-; PL82, PY81, 6L6G, KT66, 10F9, 10LD11, 10C1, 11/-; ECL80, EF80, EY51, PY80, UL41, EAF42, KT33C, 6F1, 6C9, 10F1, R10, 6F14, 10P13, 10/6; 2526GT, 6K8GT, 12K8GT, ECH42, EBC41, UBC41, DL35, 1C5G, DAC32, 1H5G, DL33, 3Q5G, 10/-; 6SN7GT, 6SL7GT, 6Q7GT, 12K7GT, 12Q7GT, 6V6GT, 2524G, 25A6G, EF41, 9/6; U50, 5Y3GT, 25L6GT, 35L6GT, 50L6GT, 35Z4GT, 6X5GT, U109, U404, UY41, UF41, E24, 9/-; 6K7G, 6/6; all new and boxed; postage 4d. per valve extra. **READERS RADIO**, 24, Colberg Place, Stamford Hill, London, N.16. (Telephone: STA. 4587.)

ANY QUANTITY ex-Govt. Valves, type V.T. 61A; prompt cash settlement. **RADIO SUPPLY CO. (LEEDS)** LTD., 15, Wellington St., Leeds, 1.

6A5s, 6SH7s, 12SC7s, etc., 4/4. List. **ROGERS**, 2, Matlock Avenue, Southampton.

WINWOOD for sale. New boxed Valves: 524, 6V6, 6K7, 6Q7, 6K8, 39/6 set; 1T4, 1S5, 1R5, 3S4, 31/- set; 12K7, 12K8, 12Q7, 35L6, 35Z4, 45/- set; special offer this month: dozen mixed Valves, 50/6, 25L6, 25A6, 6B8, 6U7, etc., all fit, tested, 30/-, post free. I.F. Trans., 465 kcs, midge, 9/6 per set. Stand 8/9 pr. Fil. Traxn., 6.3v, at 1.5a, 6/3. L/sprks., 3 1/2in, 12/6, 5in, 12/6, 6in, 13/6, 8in, 15/6, 10in, 19/6. V/ctrls., all values, 2/9, SP/sw., 4/3. Full list stamp, please. **WINWOOD**, 12, Carnarvon Road, Leyton, E.10. (Mail only.)

FLUORESCENT LIGHTING isn't expensive! A 4ft. 40 watt tube mounted on ceiling or wood batten costs only 24/- for control gear, plus 11/- for tube (bought locally). New control kits complete, 24/-. State voltage. **DYNALITE ELECTRICAL**, 38, Stevedale Road, Welling, Kent.

SITUATIONS VACANT

The engagement of persons answering these advertisements must be made through a Local Office of the Ministry of Labour or a Scheduled Employment Agency if the applicant is a man aged 18-64, inclusive, or a woman aged 18-59, inclusive, unless he or she, or the employment, is exempt from the provisions of the Notification of Vacancies Order, 1952.

AIRCRAFT Radio Mechanics, skilled in workshop practice, are required by Skyways at Stansted Airport, Essex. Apply, in writing, to the Personnel Manager, SKYWAYS LTD., 7, Berkeley St., W.1.

VALVES

All Guaranteed—
24 hours service

41MP	5/-	ECL80	11/6	6K7	6/-
41MPT	5/-	EF91	1/6	6K8	10/9
DDL4	4/6	EF91	1/6	5Z4	9/6
MH4	4/6	6BT (082)	4/6	FW4500	9/6
425PT	5/-	6SN7	10/6	EA50	2/6
CV68	5/-	VR65	4/6	954	2/6
2X2	4/6	VR66	1/6	1T4	8/6
8D2	4/6	SP41	4/6	1R5	9/-
9D2	4/6	VR116	4/6	1S1	9/-
5D2	4/6	VR34	2/6	1S5	9/-
KT44	5/-	MSPEN	4/6	12K8	9/6
AR6	4/9	EF50	5/-	5U4G	8/6
KT24	4/9	DET19	2/9	KTZ41	4/6
807	9/-	6L6	11/6	(VP4B)	4/6
50L8	9/-	35Z4	10/-		
EB33	9/-	6H6	5/-		
KT61	10/6	EF8	9/-		
APV4	9/6	QF7	10/-		
EF80	11/6	6V6	9/6		

AMPLIFIER CHASSIS.—Two-valve plus rectifier, two-stage audio amplifier for operation on A.C. mains, 200-250 volts, 50 cycles. Input circuitry is loaded to suit most high impedance needs. (Magnetic or crystal pick-ups.) Complete with valves. £3.15.0. Post 2/6.

MAINS TRANSFORMERS.—425-0-425, at 200 mA. 6.3, 6.3, 4a., 5v. 3a. Fully shrouded. 51" plus 2" post.

Co-axial Plug and Sockets. 6d. pair, post 3d.

RECTIFIERS.—RM2 S.T.C., 4/6. RM4, 18/6.

FILAMENT TRANSFORMERS.—6.3, 15a. Primary 240v. 22v. 6/9, post 6d.

CONDENSERS.—Dublin. 2in. mid-500v/2/6. 16 mid-500v/3/6. Bias. 25 x 25. 1/9.

MAINS DROPPERS.—3-750 ohms. resistance. 5/-.

TELEVISION.—Iron cores Coils. Contents. 14 permeability tuned coils and 1 R.F. choke. London and Holme Moss, 18/6.

SEMI-MIDGET IF465 k.c. Transformers. 17/6 pair.

TRIMMERS.—50 pf. 8d. Sprague 1-350. 7/6 doz. Dubliler .01. 62, 7/6 doz.

Mail Order Only.

REX RADIO 37, LOUIS STREET LEEDS, 7.

CORONATION BARGAINS

INDICATOR TYPE 62A. Contains VCR97. 21 Valves: 12-EF50, 4-SP61, 2-EB34, 3-EA50, hundreds of Condensers, Resistors and Pots, etc. Brand New in Transit Cases, 64 15s., carriage 9/6.

R1132A U.H.F. Receivers, complete with 11 valves, 4-EF39, 2-SP61, P61, 3.5V, V570, EB34, EK32, 5 mA. Meter, Brand New in Transit Cases, 59/6 with circuit. Carr. 7/6.

VALVES. Brand New, Guaranteed. 7/6: N37, N78, DH77, 35L6, 7/6 each. 1S4, 354, 155, 1R5, N18, N17, X18, Z77, D77, U78, W77, R17, 6/9 each. 5U4, 6SN7, VU39, 8/6 each. 6AK7, VP23 (ex units), 3D6, SP61, 3/6 each. ARP7, 6J7, EC52, 5/- each. 6K8, 9/6. RK34, 1/9. EA50, 1/9. Post 6d.

GERMANIUM CRYSTAL DIODES, wire end, Brand New, 2/-, post 3d.

STAN WILLETTS

43, SPON LANE, WEST BROMWICH, STAFFS.

WANTED. AR39, BC221, Eddystone 640, etc. Taylor, Avo Test Meters, Valves.

CONSTRUCTORS: BUILD THE PICNIC PORTABLE

Using our drawings and instructions, and easily-obtainable British components, you can build a portable receiver giving really good loudspeaker results without any aerial, earth, or external power supply. An unusual type of self-contained frame aerial gives maximum pick-up on both long and medium waves. Extra gain and sensitivity are obtained by the provision of an RF stage and a specially efficient output valve. This set is ideal for all occasions, indoors and out, where a portable source of listening is required. Illustrated instructions and point-to-point wiring diagram.

PRICE 3/6 POST FREE.

These instructions can only be sent to addresses in the United Kingdom and the Irish Republic.

V. G. COLES, 2 BROCKHAM TERRACE, WILLSBRIDGE, N. BRISTOL.

FREQUENCY CRYSTALS, 5.8 to 8.6 Mcs.

In 25 Kcs. steps. Odd 5/6. Spot 8/-.

A.C.-D.C. T.R.F. kit, assembled ready for wiring L. and M. band, complete with beautiful polished wood cabinet and 5in. speaker. £8/15/-.

TR1196 CIRCUIT 1.3. Any C.R.T. Unit to Oscilloscope. 2/9.

GERMANIUM DIODES, 3/9.

P.M. SPEAKERS, 8in., 20"- 5in., 14.6. 8in., 16/6. 10in. 27/6.

SELENIUM RECTIFIERS, F.W. 6 or 12v. 4 A., 22/6; 6 A., 30/-; 3 A., 14/6; 1 A., 8/6; 24v. 2 A., 30/-; 250v. 100 mA. H. W., 9/-; 80 mA., 6/6.

TRANSFORMERS, 200-240 volts, tapped 3-4-5-6-8-9-10-12-15-18-20-24 and 30 volts at 2 A., 21/6. One year guarantee.

NEW G.E.C. 0-75 MILLIAMMETERS. 11in. x 1 13/16in. 8/-.

M/C MICROPHONES AND TRANSFORMERS, 14/6.

EX-WD. PHONES, Low Resistance, 8/6.

MINIATURE VALVES, New, CK512AX, 9/-; 9001, 9002, 9003, 7/6; 6AG5, 15/4, 18/5. 1T4, 1R5, 10/8; 6AL5, 8/6; 12AT7, 6AM6, 6BR7, DH77, 6AT8, EY51, 6BE8, 12/6.

NEW VALVES, 35Z4, 35L6, 25Z4, 25L6, U291, VP4B, U50, 5Y3GT, 6K7GT, 6V8GT, 50L6, 42, 80, 11/-; 6K6GT, 11/76, 12/6.

0-500, MICRO-AMMETERS, 2in., 15/6.

MULTIMETER KIT, 2 1/2in. M/c calibrated meter. D.C. Volts 0-3-30-150-300 and 600, M.A. 0-60. Black ebonite case. Also reads 0-5-000 ohms with 1 1/2 battery. 24/6.

AERIAL RODS, 4ft., 3 sections, 6/-. Base 3/6.

ALL POST PAID IN U.K.

THE RADIO & ELECTRICAL MART

253b, Portobello Road, London, W.11. 'Phone: Park 6026

WILCO ELECTRONICS

VALVES.—Guaranteed. Govt. surplus.

1R5	10/6	6U5G	10/6	EF36	7/6
1S5	8/-	6V6G	8/6	EF39	9/6
1T4	8/-	6XCT	9/6	EF50	7/6
3V4	10/6	12A6	8/-	EK32	9/6
5U4G	8/6	12K8GT	12/6	EL35	11/6
5Z4G	8/6	12SH7	5/6	EZ40	10/6
6AC7	5/6	25L6GT	10/6	KT66	11/6
6H6	4/-	35L6GT	10/-	ML4	7/6
6J5GT	6/6	35Z4T	6/6	MSPEN	7/6
6L6	12/6	50L6GT	10/-	MSPENB	7/6
6K7GT	9/6	807	10/6	PEN46	10/6
6K8	8/6	B38	10/6	SP41	3/6
6R8G	12/6	DH77	10/-	SP61	5/-
6L6C	11/6	EB34	3/6	VR150	30/6
6N7G	10/6	EB33	9/6	V570	10/6
6SL7GT	9/6	EC52	6/6	W77	10/6
6SN7GT	10/6	EC54	6/6	Z77	11/6

SPECIAL OFFER
1R5, 1S5, 1T4, 3V4, 32/- per set.
10 EF50 Valves for 50/-.

COMPREHENSIVE LIST NOW READY, 6d.

204, LOWER ADDISCOMBE ROAD, CROYDON. Tel.: ADD 2027.

ELECTRAD RADIO

VALVE BARGAINS.—6AK5, EL91, EC91, 807, 8/6; 6J6, EF91, 9/-; 6C4, EF92, EA91, 6/6; 6K8, 6F33, 12AX7, 12AT7, 6SN7, 5Y3, 3A8GT, 9/6; 6BR7, 185BTA, 12/6; 6AG5, HL23DD, 6/-; VP23, 5/-; 9001, 4/-; EA50, 1/9.

VOLUME CONTROLS.—1 meg. with switch, long spindles, 4/-.
Postage 9d. on orders under £2.

77, NORTH STREET, BELFAST

PLEASE READ THIS !!

N.R.S. "SYMPHONY" AMPLIFIERS, fitted with the patent "three-channel system" giving independent control of Bass, Middle and Top, thus affording the maximum possible control of tone and compensation for recording deficiencies. Especially essential when mixing the playing of old and new 78's with the new L.P. records. Scratch control and negative feedback also incorporated. Woden transformers. Five-watt model only 10 gns.; 10-watt model (push-pull triodes), 15 gns. Carr. 5/-. When ordering, state output impedance required, if known.

BASS-REFLEX CABINET KITS, 30in. high, consist of fully cut patent acoustic manufactured non-resonant board, deflector-plate, felt, all screws, etc., and full instructions. 8in. speaker model, 15in. wide x 12in. deep, 85/-; 10in. speaker model, 16in. wide x 13 1/2in. deep, 97/6; 12in. speaker model, 17 1/2in. wide x 16in. deep, 107/6. Carr. 7/6. Ready built, 7/6 extra.

GARRARD 3-SPEED AUTO-CHANGERS. latest model RC75A, brilliant engineering job, special long arm for better tracking. Our special offer, £13.10.0, or complete with Acos GP19 and GP19 L.P. heads, £17.10.0, or two Decca XMS heads, £18.15.0. Carr. 5/-. Third head to take thorn needles for playing old 78's, 26/6.

MICROGRAM CABINETS, ex-manufacturer, brown rexine, carrying handle, room for 3-4 watt amplifier, gram unit and baffle for 6 1/2in. speaker, attractive gold speaker grille in front. While they last, 59/6, plus carr. and pack, 3/6. Amplifier to fit, £7.10.0.

DECCA 3-SPEED GRAM UNIT. £9.10.0.

NORTHERN RADIO SERVICES 16, Kings College Road, London, N.W.3

Tel.: PR1111, 8314.
Tubes: Swiss Cottage or Chalk Farm.
Buses: 31, 2, 13, 113, 187

CHEAPNESS WITH RELIABILITY!

10% discount off all non-proprietary items on our list if order exceeds £1.

CONDENSERS. mica 10, 15, 20, 30, 50, 75, 100, 120, 150, 200, 220, 300, 450, 540, 600, 700, 1,000, 1,300, 2,000, 2,200, 3,000, 4,000, 4,500, 4,700 pf. Paper 0.1 mfd. 500 v., 0.01 mfd. 1,000 v., all 3/6 doz. Ceramic 27, 180, 220, 500, 820, 1,000 pf. 5/- doz. 0.25 mfd. 350 v. small metal block, 3 for 1/9.

OUR GRAND SELECTION. 50 of above, 10/6. 6 mfd. 500 v. metal tubular, 7/6; 6/- doz. 0.25 mfd. 50 v. test, 1,000 v. wkr., 4/9.

TRIMMERS. Double 50 pf., 10d. each.

POTENTIOMETERS. New surplus, 3K, 50K, 100K, 300K, 2 M., 1/6. 500K in cartons, standard, 1/9.

OUR GRAND SELECTION. 50 of above, 10/6. 6 mfd. 500 v. test, 1,000 v. wkr., 4/9.

SEND 3d. for full list, which includes hundreds of VALVES at surplus prices.

Post paid on orders over £1, otherwise 6d.

REED & FORD 2A, BURNLEY ROAD, AINSDALE, SOUTHPOLE.

ASTRAL RADIO PRODUCTS (T. G. HOWELL)

Dual-wave H.F. coil as used in the original models. **SUMMER ALL DRY PORTABLE, B.7.G. BATTERY MINIATURES, THE MODERN I & 2 VALVES,** etc., 4/3, or with 5 circuits, 5/-, post and packing 3d. T.R.F. coils L. and M. wave as used in the original models. **ALL DRY 3 BAND 3,** August, 51, P.W., 3 BAND ALL-DRY 3, April, 53, P.W., 6/6 per pair, extra circuit inc. postage, 6d. T.R.F. coils as above but without reaction winding suitable for standard T.R.F. circuits or American set replacements, 5/6 per pair, postage 6d. "K" type coils as used in the original model. **A.C. BAND PASS 3,** 3/3 each coil. I.F.T.s 465 K/c miniature brand new, 6/- pair M.W. frame aerials, 3/6 each extra. High Q, 5/-

THE MODERN BOOK CO.

Radio Servicing Instruments, by E. N. Bradley. 4s. 6d., postage 3d.
 The Radio Amateur's Handbook by the A.R.R.L. 1953. 30s. 0d., postage 1s. 0d.
 Amplifiers, by C. A. Briggs and H. H. Garner. 15s. 6d., postage 6d.
 Reference Data for Radio Engineers, by S. T. C. 10s. 6d., postage 6d.
 Telephone, by J. Atkinson. Vol. One, 35s. 0d.; Vol. Two, 55s. 0d., postage 1s. 0d., each.
 Radio Engineers' Servicing Manual, by E. Molloy (ed.). 42s. 0d., postage 1s. 0d.
 Radio Engineering, by E. K. Sandeman. Volume Two. 55s. 0d., postage 1s. 0d.
 Magnetic Recording, by S. J. Bean. 25s. 0d., postage 9d.
 Mathematics for Telecommunications, by D. F. Spooner and W. H. Grinstead. 10s. 6d., postage 6d.
 Radio Engineering, by F. E. Terman. 50s. 0d., postage 1s. 0d.
 Vacuum-Tube Oscillators, by Edson. 60s. 0d., postage 1s. 0d.
 Receivers, Pre-Selectors and Converters. Data Book No. 7. 2s. 6d., postage 3d.
 World Radio Handbook for Listeners, edited by O. Lund Johansen. 1953. 8s. 6d., postage 6d.
 Radio Valve Data, compiled by Wireless World. 3s. 6d., postage 3d.

We have the finest selection of British and American radio publications in the Country. New revised catalogue on application.

19-23, PRAED STREET
 (Dept. P.7), LONDON, W.2
 PADDINGTON 4185.

CABINETS

Our latest illustrated catalogue of all types of Cabinets now available



A SPECIAL OFFER

Walnut Cabinet, complete with punched chassis, dial, backplate, drum, drive, spring, pointer and cord. 28/6 plus 2/6 p. and p.

CHASSIS

A.C., 5-valve 3 w/b Superhet Radiogram Chassis. Absolutely complete kit of parts including wiring diagram, £10/15/0. Or fully wired and tested, £12/10/0.

LEWIS RADIO CO.

(Dept. K.21),
 120, Green Lanes, Palmers Green,
 London, N.13. BOWes Park 6064

FIRST-CLASS RADIO COURSES . .

GET A CERTIFICATE!
 QUALIFY AT HOME—IN SPARE TIME

After brief, intensely interesting study—undertaken at home in your spare time—YOU can secure your professional qualification. Prepare for YOUR share in the post-war boom in Radio. Let us show you how!

FREE GUIDE
 The New Free Guide contains 132 pages of information of the greatest importance to those seeking such success-compelling qualifications as A.M.Brit.I.R.E., City and Guilds Final Radio, P.M.G. Radio Amateurs, Exams, Gen. Cert. of Educ., London B.Sc. (Eng.), A.M.I.P.E., A.M.I.Mech.E., Draughtsmanship (all branches), etc., together with particulars of our remarkable Guarantee of **SUCCESS OR NO FEE**
 Write now for your copy of this invaluable publication. It may well prove to be the turning point in your career.
FOUNDED 1885—OVER 150,000 SUCCESSES
NATIONAL INSTITUTE OF ENGINEERING
 (Dept. 461), 148, HOLBORN, LONDON, E.C.1

TWO AND SIX!

- brings you full information to build ALL of the following:—
- ★ 3-Valve 3-Band Superhet. Feeder.
 - ★ 4-Valve 3-Band Superhet. "Socru/Hi-Fi/Gram." Feeder.
 - ★ 5-Valve 3-Band A.C. Superhet.
 - ★ 5-Valve 3-Band A.C. D.C. S.het.
 - ★ 6-Valve 3-Band A.C. Superhet.
 - ★ 6-Valve 3-Band A.C. D.C. S.het.
 - ★ 3-Valve 2-Band "Local Station" T.R.F. Super Quality Feeder.
 - ★ Feeder Amplifier and Power Pack.
 - ★ Magic Eye Tuning Indicator Unit.
 - ★ Signal Tracer. A.C.
 - ★ 5-Watt Amplifier. A.C.
 - ★ 10-Watt Push-pull Quality Amplifier. A.C.
 - ★ Signal Generator. A.C. Etc., Etc., Etc.

DETAILS for construction, LARGE Blueprint circuits, COMPLETE parts lists, and TECHNICAL DESCRIPTIONS of these famous circuits are some of the good things in store for you in our COMPLETELY NEW 1953 "HOME CONSTRUCTOR'S HANDBOOK"! Also: Set Building and Servicing Hints, Facts and Formulae, Resistance Colour Code, Symbols, etc., etc., AND our current Catalogue, ALL FOR ONLY HALF-A-CROWN. DON'T DELAY. SEND FOR YOUR COPY TO-DAY!!
 Printed on glossy Art paper, this latest issue contains many improvements, and has been brought completely up to date. Over 50,000 copies now sold!!

AVAILABLE ONLY FROM:
RODING LABORATORIES
 (Dept. PW7), HURN AIRPORT,
 CHRISTCHURCH, HANTS.

MORSE CODE Training

Send for the Candler BOOK OF FACTS
 It gives details of all Courses which include a Special one for securing Amateur Licence.
CANDLER SYSTEM CO. Dept. S10
 52b, Abingdon Road, London, W.8.
 Candler System Co., Denver, Colorado, U.S.A.

WALTON'S WIRELESS STORES

The leading Midland Depot for all good Class Ex-Government surplus equipment and Valves.
 Of special interest to all T.X. hams. We stock a full range of spares for the popular Transmitter T113. Please state your requirements, our quotation will follow by return.
 Here are a few examples of the value of offer:
 13ft. Wooden Masts. 7 6 each. Carr. 2 6; In lots of 4. 24 - each. Carr. 3 -.
 Crystal Monitor Units, Brand new. 3 6 each. Post 1 6.
 100 - Ex-Government Condensers. Electrolytics, etc. 15 - for 100. Post 1 6.
 Motor Generators. 24 volt in., 230 volt A.C. out., 100 watts, £4 19 6 each. Carr. 5 -.
 Motor Generators, 110 volt D.C. in., 230 volt A.C. out., 200 watts. £7 10 - each. Carr. 5 -.
 Headphones, complete L.R. 7 6. Post 1 6.
 Headphones, complete H.R. 10 - . Post 1 6.
 Nuts, Bolts and Washers, mainly B.A. sizes, each box contains approx. 1,000 items. 3 6 Box. Post 1 -.
 1 H.P. Electric Motors. 230 volt 50 cycle, £4 13 6 each. Carr. 2 6.
 Send 3d. in stamps and S.A.E. for our latest list.

WALTON'S WIRELESS STORES
 48, Stafford St., Wolverhampton, Staffs.

CITY & RURAL

Immediate delivery from stock.
"VIEWMASTER"
 (LONDON—SUTTON—COLDFIELD—HOLME MOSS—KIRK O' SHOTTIS—WENVOE—NEWCASTLE—BELFAST)
 SPECIFIED COMPONENTS
SEND FOR STAGE 1 NOW—price £3.23 post free.
 Complete Kits, Stage-by-Stage and Single Components Supplied.
 "VIEWMASTER" ENVELOPES. 7-6.

NEW LANE TAPE TABLE. £17/10/-, plus 10/- carriage and packing.

PORTABLE TAPE RECORDER CABINETS, from £3 10 -
RONETTE "CORONATION" CRYSTALLINE MICROPHONES. 52 -
TAPE AMPLIFIERS, AMPLIFIER KITS, OSCILLATOR UNITS, & OSCILLATOR COILS, from stock.

LIST 210
 "SCOTCH BOY" TAPE, 35 -.
 "FERROVICOE" TAPE, 26 -.
 (1,200 ft. reels).

For Attention—Advice—Service write
CITY & RURAL RADIO
 101, HIGH STREET,
 SWANSEA, GLAM.
 Telephone: Swansea 4677

Practical Wireless BLUEPRINT SERVICE

PRACTICAL WIRELESS

No. of
Blueprint

CRYSTAL SETS

- 1/6d. each.
1937 Crystal Receiver ... PW71*
The "Junior" Crystal
Set PW94*
2s. each.
Dual-Wave "Crystal
Diode" PW95

STRAIGHT SETS

Battery Operated

- One-valve : 2s. each.
The "Pyramid" One-
valver (HF Pen) ... PW93*
The Modern One-
valver PW96
Two-valve : 2s. each.
The Signet Two (D &
LF) FW76*
Three-valve : 2s. each.
Summit Three (HF Pen,
D, Pen) PW37*
The "Rapid" Straight
3 (D, 2 LF (RC &
Trans)) PW82*
E. J. Camm's "Sprite"
Three (HF, Pen, D,
Tet) PW87*
Four-valve : 2s. each.
Fury Four Super (SG,
SG, D, Pen) PW34C*

Mains Operated

- Two-valve : 2s. each.
Selectone A.C. Radio-
gram Two (D, Pow)... PW19*
Three-valve : 2s. each.
Double - Diode - Triode
Three (HF Pen, DDT,
Pen) PW23*
Four-valve : 2s. each.
A.C. Fury Four (SG, SG,
D, Pen) PW20*
A.C. Half-Mark (HF
Pen, D, Push-Pull) ... PW45*

SUPERHETS

- Battery Sets : 2s. each.
F. J. Camm's 2-valve
Superhet PW52*

No. of
Blueprint

SHORT-WAVE SETS

Battery Operated

- One-valve : 2s. each.
Simple S.W. One-valver PW88*
Two-valve : 2s. each.
Midget Short-wave Two
(D, Pen) PW38A*
Three-valve : 2s. each.
Experimenter's Short-
wave Three (SG, D,
Pow) PW30A*
The Perfect 3 (D, 2 LF
(RC and Trans)) ... PW63*
The Band-spread S.W.
Three (HF Pen, D
(Pen), Pen) FW68*

PORTABLES

- Four-valve : 2s.
"Imp" Portable 4 (D,
LF, LF, Pen)... .. PW86*
1s.
The "Mini-Four" All-
dry (4 valve superhet) PW

MISCELLANEOUS

- 2s. each.
S.W. Converter-Adapter
(1 valve) PW48A*
(2 sheets), 7s. 6d.
The P.W. 3-speed Auto-
gram.
The P.W. Electronic Organ
(2 sheets), 7s. 6d.

TELEVISION

- The Practical Television Receiver,
(3 sheets), 10/6
The "Argus" (6in. C.R. Tube), 2/6

AMATEUR WIRELESS AND WIRELESS MAGAZINE STRAIGHT SETS

Battery Operated

- One-valve : 2s.
B.B.C. Special One-
valver AW387*
Two-valve : 2s. each.
A modern Two-valver ... WM409*
Mains Operated
Two-valve : 2s. each.
Consoelectric Two (D,
Pen), A.C. AW403

SPECIAL NOTE

THESE blueprints are drawn full size. The issues containing descriptions of these sets are now out of print, but an asterisk beside the blueprint number denotes that constructional details are available, free with the blueprint.

The index letters which precede the Blueprint Number indicate the periodical in which the description appears. Thus P.W. refers to PRACTICAL WIRELESS, A.W. to *Amateur Wireless*, W.M. to *Wireless Magazine*.

Send (preferably) a postal order to cover the cost of the Blueprint (stamps over 6d. unacceptable) to PRACTICAL WIRELESS, Blueprint Dept., George Newnes, Ltd., Tower House, Southampton Street, Strand, W.C.2.

No. of
Blueprint

SHORT-WAVE SETS

Battery Operated

- One-valve : 2s. each.
S.W. One-valver for
America AW429*
Two-valve : 2s. each.
Ultra-short Battery Two
(SG, det Pen) WM402*
Four-valve : 3s. each.
A.W. Short Wave World-
beater (HF Pen, D, RC,
Trans) AW436*
Standard Four - valver
Short-waver (SG, D,
LF, P) WM383*

Mains Operated

- Four-valve : 3s.
Standard Four-valve A.C.
Short-waver (SG, D,
RC, Trans) WM391*

MISCELLANEOUS

- Enthusiast's Power Am-
plifier (10 Watts) (3/-) WM387*
Listener's 5-watt A.C.
Amplifier (3/-) ... WM392*
De Luxe Concert A.C.
Electrogram (2/-) ... WM403*

QUERY COUPON

This coupon is available until July 6th, 1953, and must accompany all Queries, sent in accord with the notice on page 425.
PRACTICAL WIRELESS, July, 1953.

**A COMPLETELY ASSEMBLED
"ALL-WAVE" SUPERHET
CHASSIS**

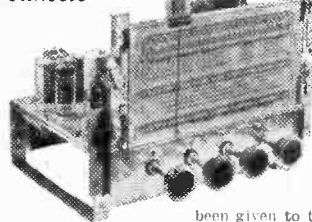

been given to the quality of reproduction which gives excellent clarity of speech and music on both Gram and Radio, making it the ideal replacement Chassis for that "old Radiogram," etc.

Brief specifications:—Model B.3.—Valve line up, 6BE6, 6BA6, 6AT6, 6DW6, 6X4. Waveband coverage, Short 16-50, Medium 197-570, Long 900-2,000 metres. Controls (1) Volume with on/off; (2) Tuning (flywheel type); (3) Wave change and Gram; (4) Tone (3 position switch operative on Gram and Radio). Negative Feedback is employed over the entire audio stages. Chassis size, 11in. x 7in. x 8in. high. Dial size, 9in. x 4in. Price, complete and READY FOR USE, excluding speaker, **£12 12**-. (Carr and Pkg. 7/6 extra.)

A DUAL CHANNEL PRE-AMPLIFIER and TONE CONTROL UNIT

This comprehensive PRE-AMPLIFIER and TONE CONTROL UNIT provides full control of Bass and Treble in conjunction with a main Volume Mixer Control. Can be used with any Amplifier and any Pick-up, the range of response controlled provided by the unit affording ample compensation for all types of Pick-up and all natures of recorders, i.e., English, American and Long Playing, without recourse to Pick-up correction. The extreme flexibility of the Bass and Treble Controls is such that the level of Bass and Treble can be set to suit any conditions irrespective of the volume output of the amplifier. The Unit measures only 7in. x 4in. x 2in., including self-contained Power Supply, and can be accommodated either on or away from the main Amplifier, i.e., in the front panel of a Cabinet or any other position. Price including drilled chassis, valves (6SN7 and 6F5), **£2 16 9**-. Complete assembly data is available separately for 1/3. Completely assembled and ready for use, **£5 5**-.

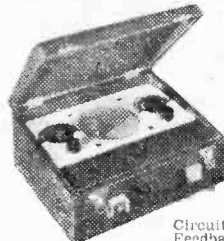

A MAINS OR BATTERY PORTABLE KIT

A midget 4-valve Superhet Portable Set covering medium and long wavebands. Designed to operate on A.C. mains 200-240 volts or by an "All-dry" battery. The set is so designed that the mains section is supplied as a separate unit which may be added at any time. The Kit therefore can be supplied for use as an "All-dry" Battery Superhet Personal Set which can be accommodated in the Atache Case as illustrated (size 9in. x 4in. x 7in.). This is attractively finished in lizard, maroon, dark green or blue rexine, (b) or as a Combined Mains/Battery Superhet Portable Receiver, for which a polished Wood Cabinet is available to accommodate both Mains Unit and Batteries together.

Circuit incorporates delayed A.V.C. and Pre-selective Audio Feedback. Kit is complete in every detail and includes ready-wound Frams Aerials, fully aligned I.F. Transf. and drilled chassis, etc. Overall size of assembled chassis 8in. x 4in. x 2in. This receiver as illustrated can be completely built for approx. **£10** (plus Mains Unit if required). Send 1/9 for the fully descriptive Assembly Book which includes Practical Layouts and complete price list of Components.

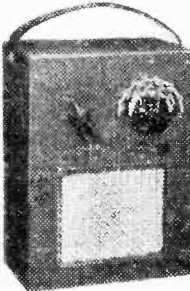

Complete instructions, layouts and price list, 1/3.

THE "MINI FOUR."—A 4-valve Battery Superhet Receiver, designed by "Practical Wireless" to receive 4 Pre-set Stations, no tuning being necessary. The complete Receiver can be built for **£9 10**-. (plus case 15/6). Send 1/6 for Assembly Instructions, Layouts and Component Price List.

THE "MINI TWO-THREE."—Complete diagrams and layouts from which either a T.R.F. 3-valve set or a 2-valve set (valves easily converted to the 3-valve) can be made for **£5 3**-. or **£4 3 6** respectively (plus case, 15/6). Full instructions, Layouts and Component Price List, 2/-.

THE "MINI TWIN."—The ideal set for the beginner. A simple 1-valve 2-stage Battery Set covering Long and Medium Wavebands. Can be built for **£7 6**, plus 9/6 for attractive Plastic Case and 14/9 for suitable headphones.

MODERNISE YOUR OLD RADIOGRAM FOR

£25

INCLUDING 10" P.M. SPEAKER

PLUS 10" CARRIAGE AND INSURANCE

MODEL B.3.—A 5-valve 3-waveband Superhet Receiver, for operation on A.C. mains 100-120 volts and 200-250 volts, employing the very latest miniature valves. It is designed to the most modern specification, great attention having

Brand New in maker's cartons, complete with mounting instructions.

- These units will auto change on all three speeds, 7in., 10in. and 12in.
 - They play MIXED 10in. and 12in. records.
 - They have separate sapphires for L.P. and 78 r.p.m., which are moved into position by a simple switch.
 - Minimum base-board size required 16in. x 12in. with height above 5in. and height below baseboard 2in.
- A bulk purchase enables us to offer these BRAND NEW UNITS at this exceptional price. Please include 7/6 packing, carriage and insurance.

A GENUINE SPECIAL OFFER!

PLESSEY 3-SPEED AUTO CHANGE UNITS

£11. 3. 6

(Normal price is £27/10/-)

THE "WIRELESS WORLD" 3-VALVE SET

A Midget 3-valve T.R.F. Receiver for operation on A.C. mains, covering long and medium wavebands. We are able to supply all of the components to build this set, as designed, and specified in the Feb. 1953 issue, including the drilled chassis, valves and moving coil speaker, etc. at the following prices:—To construct complete chassis, less dial and drive assembly, **£5 5**-. Ditto, including dial and drive assembly, **£6**-. To construct the complete Set, including dial and drive assembly and cabinet, **£7 3 6**-. Overall size of cabinet is 7in. x 5in. x 11in. A reprint of the designer's article, giving Circuit and Assembly Instructions (this is available separately for 9d.), together with a Practical Component Layout is included with each of above.

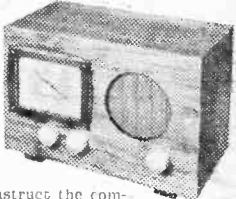

!! HOME CONSTRUCTORS !!

A CAR RADIO RECEIVER FOR £12

A design of a 5 Valve Superhet Receiver, employing an R.F. Stage for 9 or 12 volt supply.

Send 2/8 for the complete set of Assembly Instructions, CIRCUITS, LAYOUTS and POINT-TO-POINT WIRING DIAGRAMS, together with a complete component Price List.

THIS IS NOT AN EX-GOV'T RECEIVER. IT IS A NEW DESIGN EMPLOYING NEW COMPONENTS.

"Personal Set" Battery Eliminator

A complete kit of parts to build a Midget "All-dry" Battery Eliminator, giving approx. 60 volts and 1.4 volts. This Eliminator is for use on A.C. mains and is suitable for any 4-valve Superhet Receiver requiring H.T. and L.T. voltage as above or approx. to 60 volts. The kit is quite easily and quickly assembled and is housed in a light aluminium case size 4in. x 1 1/2in. x 3 1/2in. Price of complete kit with easy-to-follow assembly instructions, 42/6. In addition we can offer a similar COMPLETE KIT to provide approx. 90 volts and 1.4 volts. Size of assembled Unit 7in. x 2 1/2in. x 1 1/2in. Price 47/6.

A QUALITY "PUSH-PULL" AMPLIFIER

A Kit of Parts to build a 6-watt Push-Pull Amplifier for operation on A.C. mains 200-250 volts. Incorporates a simple arrangement to enable either a magnetic, crystal or light-weight pick-up to be used.

A 10-watt Output Transformer is designed to match from 2 to 15 ohm speakers. Tone control is incorporated. The overall size of the assembled chassis is 10in. x 8in. x 7 1/2in. High. Price of kit complete in every detail, including drilled chassis and valves, **£6 17 6**. Component layout is supplied. Price of assembled chassis, supplied ready for use, **£5 12 6**. Instructions layouts and price list 1/-.

* Send 9d. P.O. for our STOCK LIST, showing many KITS OF PARTS for Sets and Battery Chargers and "hundreds" of Radio Components. When ordering please include 1/6 to cover cost of postage and packing.

STERN RADIO LTD.

109, & 115, FLEET STREET, E.C.4. TELEPHONE: CENTRAL 5812/3/4.