

*W. G. ...*

**1/-**

Vol. 27, No. 533  
MARCH 1951

EDITOR:  
F. J. CAMM

# PRACTICAL WIRELESS

## ABSORPTION WAVEMETER



### IN THIS ISSUE

- The New "Practical Wireless" Encyclopaedia
- Which Oscillator?
- The Beverage Report
- Heater Supplies
- Bridges and Networks
- Variations at the Pierce Oscillator
- A Signal Tracer



**SUPERHET and T.R.F.**

The OSMOR "Q" Coilpack does not "whistle while it works" but gives you perfect performance in every way. And it saves time, money and hours

of wasted effort puzzling over complicated wiring circuits. Just 5 connections, 5 minutes' work and the job is done—and well done!

Send stamp for FREE new circuits, lists of Coils, Coilpacks, Dials and all Radio Components, etc.

\* New wavelength scales for Type A dials, 8/- each.  
**OSMOR RADIO PRODUCTS, LTD. (Dept. P10),**  
**BRIDGE VIEW WORKS, BOROUGH HILL, CROYDON, SURREY**  
 Telephone: CROYDON 1220.

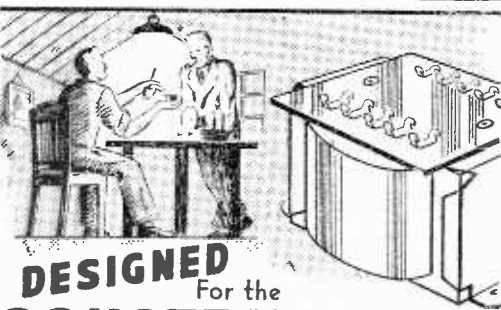

**DESIGNED** For the **CONSTRUCTOR**

UNIVERSAL 8 WATT OUTPUT TRANSFORMERS—T98—T99

No constructors' work bench is complete without one of these truly amazing output Transformers. Their Universal characteristics enable them to be used in a wide range of circuits. Covers any ratio from 11 : 1 to 105 : 1—the ideal component for all experimental work. TYPE T98 for single ended valves. TYPE T99 for push-pull. The superior design and high quality of Gardners Transformers ensure better home construction.

Fully descriptive literature on Somerford and Miniford Components will be sent upon request.

RETAIL PRICE  
**21/-**  
 CARRIAGE PAID

**GARDNERS RADIO Ltd**

SOMERFORD, CHRISTCHURCH, HANTS  
 Phone: CHRISTCHURCH 1025

**A new Super lightweight pickup**

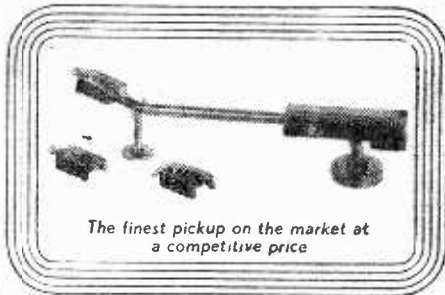

with interchangeable heads

- Green Spot for microgroove recordings
- Red Spot for modern standard recordings
- Yellow Spot for older standard recordings

These pickup heads are fitted with an easily replaceable armature system complete with a semi-permanent sapphire. Downward pressure 10-12 grams for standard recordings, and 5-7 grams for microgroove recordings

Prices: With one Head £4 0 0 plus £1 14 8 Purchase Tax  
 Extra Heads each £2 10 0 plus £1 1 8 Purchase Tax  
 Spare Armature System with sapphire 14/8 including Tax

Telephone: Hipperholme 6 9 1 6 9  
 Manufactured by



A. R. SUGDEN & CO. (ENGINEERS) LTD.  
 WELL GREEN LANE BRIGHOUSE YORKS.

**The Solder which is recommended for the View Master and other Television Kits**



As recommended by the designer, use only ERSIN MULTICOPE SOLDER—the Solder wire containing 3 cores of non-corrosive Ersin Flux. 60 ft. of 18 S.W.G. High Tin Television and Radio Solder, 60/40 alloy, is contained in Size 1 Cartons, Cat. Ref. C.16018. Price 5/- retail.

Obtainable from all leading radio shops.

In case of difficulty write to:

**MULTICOPE SOLDERS LTD.**

Mellor House, Albemarle Street, London, W.1. REGent 1411

# Wolf ELECTRIC SOLDERGUNS

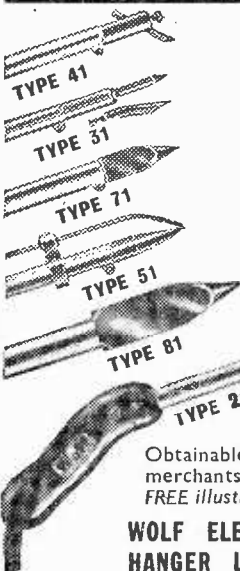

**OFF-STRAIGHT EASY-GRIP HANDLE  
PERFECT CONTROL  
QUICKER HEAT UP  
LOCALISED HEAT  
LOW CURRENT  
CONSUMPTION  
MAINTAINS CORRECT HEAT  
A MODEL FOR EVERY PURPOSE**

Obtainable from all leading tool merchants and factors. Write for **FREE illustrated technical literature**

**WOLF ELECTRIC TOOLS LTD.,  
HANGER LANE, LONDON, W.5.**

## THE NEW 1355 CONVERSION!

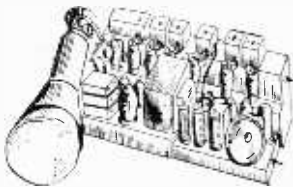

**SOUND, VISION, TIME BASES, POWER PACK and SPEAKER on One 1355 Chassis.** Data for London or Birmingham, 3/-. 1355's in original maker's cases, 55/-.

**ACCUMULATORS.** Brand New, multiplate, in non-spillable celluloid cases measuring 3 1/2 in. x 1 1/2 in. x 4 in. 7AH, 2v. ONLY 5/11. **SELF-ENERGISED HANDSETS.** Standard P.O. type handsets which require no batteries. JUST join them with twin leads and speak! **OUR PRICE 12/6 pair.** **RECEIVER 18** with 4 battery valves, covering 6-9 mc/s. "As New." 17/6. Complete with batteries, phones and circuit. 27/6. **H.T. BATTERIES.** 94v., 5/6 each. **AMPLIFIER 1135A** with EF39, EK32 and EL32, and our "10 min. conversion" data and circuit. 15/-. **RECEIVER 21** covering 4.2-7.5 and 18-31 mc/s, and complete with 9 valves, BFO and interference suppressor; these have slightly damaged knob spindles. ONLY 27/6. **TRANSMITTER 21.** Designed to operate with the above receiver (same frequencies), these will send CW, MCW or speech. Complete with control box key, valves and circuits, the PA coils and relays have been removed by the Ministry of Supply but may easily be replaced. 25/-. **VIBRATOR PACK 21.** The remaining section of the W/S 21, this, delivering approx. 150 v. at 40 mA, will supply the above receiver and transmitter, the three units being mounted behind the Tx panel and forming a very fine station. 15/6. Store soiled, 7/6.

**RADIO EXCHANGE CO.** 9, CAULDWELL STREET, BEDFORD. Phone: 5568

**G2AK**

*This Month's Bargains*

**G2AK**

**H.T. BATTERIES.** 120 volt, standard size and tappings. Not old stock. Special price, 7/6 each, plus 1/- post.

**RECEIVERS TYPE 18.**—Cover 6-9 mc/s, and are for battery operation. New condition. Only 17/6 each.

**MOVING COIL HEADPHONES** with moving coil hand microphone. Price 6/-.

**VIBRATOR PACKS.**—6 volt input. Output 180 volt 50 mA., fully smoothed. Price 19/6, plus post 1/6.

**TWIN RIBBON FEEDER.**—Heavy duty 300 ohm. 5d. per yd. Standard K25 300 ohm. ribbon, 9d. per yd. Co-Ax. cable, 1/2 in. dia., 70 ohm., 8d. per yd. 1/2 in. dia., 1/- per yd. Post on feeder and cable, 1/6, any length.

**CONDENSERS.**—01, 5,000v., 1/6; .02, 8,000v., 2/-; .01, 4,000v., 1/6; .03, 2,500v., 1/6.

**POTENTIOMETERS.**—5 watt wire-wound .20 k., 25 k., 2/-; 500 ohm and 2,000 ohm 50 watt wire-wound on 3in. Ceramic former, 3/6 each. Carbon Type Potentiometers, .50 k., 100 k., 1 meg., 2 meg., 1/6.

**TEST METER.**—7 ranges as follows: 1.5v., 3v., 150v., 6 mA., 60 mA., 5,000 ohms, 25,000 ohms, 2 1/2 in. dia. scale M.C. meter. Rotary selector switch. Black bakelite case, 6in. x 4 1/2 in. x 4 1/2 in., fitted with removable lid, also provision for internal batteries. Ranges can be extended very easily. Bargain price, 25/-, plus 1/6 post.

Please print your name and address.

**CHAS. H. YOUNG, G2AK**

All Callers to 110 Dale End, Birmingham  
CENTRAL 1635

Mail Orders to 102 Holloway Head, Birmingham  
MIDLAND 3254

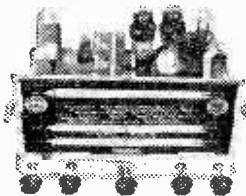

## Figures Talk!

Model ... ..	103
Stages of I.F. ... ..	2
Selectivity better than (kc/s) ... ..	7
Stages of A.V.C. ... ..	3
No. of Valves ... ..	10
No. of Wave Bands ... ..	3

**ADDING UP TO ONLY ... 19 Gns.**

No other radio chassis offers all that the Armstrong RF. 103 so efficiently provides at such a low cost.

### OTHER ARMSTRONG CHASSIS

**Model EXP. 83/3.** An eight-stage all-wave radiogram chassis is designed to provide quality radio and record reproduction for the "no-so-fich" £15.3.8. Plus P. Tax.

**Model 125/2.** The "Armstrong" triumph—a 14-valve all-wave radiogram chassis with short wave bands down to 10.9 metres. The chassis for the man who wants the best. £33.12.0. Plus P. Tax. **ARMSTRONG TELEVISION—MODEL TV.20.** A wide-range 21-valve instrument incorporating a 12in. C.R. Tube. £52.10.0. Plus P. Tax.

Write now for full information.

*Armstrong*

**THE CHASSIS PEOPLE**

Armstrong Wireless & Television Co., Ltd., Warlters Road, Holloway, London, N.7. Tel.: NORTH 3213.  
Sole Birmingham Agent: Hayes Company, 1, Alcester Road, Birmingham, 13.

**GOOD NEWS for the discriminating gramophone enthusiast!**



**SENIOR MODEL**

This has a handsome bakelite tone arm with offset head to facilitate tracking. This pick-up gives a superb performance. Old price, including Purchase Tax, 65/-.

**NEW PRICE 26/-**  
Purchase Tax 12/6



**MODEL S.8**

The well-known popular Pick-up, embodying the improved Rothermel Cartridge head. It gives a very high performance and is thoroughly recommended for all-round use. Old price, including Purchase Tax, 69/6.

**NEW PRICE 26/-**  
Purchase Tax 11/6



**MODEL U.48**

This has been expressly designed to bring high fidelity crystal reproduction within the reach of all. A thoroughly sound instrument with a remarkable performance. Old price, including Purchase Tax, 36/2.

**NEW PRICE 19/6**  
Purchase Tax 8/8

**GREAT REDUCTION IN PRICES OF ROTHERMEL CRYSTAL PICK-UPS**

To bring the more expensive models within the reach of the most slender purse, Rothermel Crystal Pick-ups have been greatly reduced in price. Now, the superb performance of these high-class instruments can be enjoyed by all.  
(This price reduction came into force on January 1st, 1950.)

**CONCERNING CRYSTALS**

ROCHELLE Salt Crystals lend themselves admirably for use in the construction of High Fidelity Electrical Pick-ups. The chief characteristics of these instruments are clearness of attack and extreme sensitivity, giving a large output voltage for direct connection to the domestic Radio Receiver. The Pick-up Cartridge consists of a bimorph crystal element coupled to a light stylus chuck. Due to the flexibility of the crystal, very little mechanical damping is required, resulting in an element having excellent characteristics with a rising low frequency response to compensate for recording deficiencies.

**JEWEL TIPPED NEEDLES**

These give hundreds of playings and improve reproduction with negligible wear on records. Straight, Trailer and Miniature types are available.

**CENTRALAB VOLUME CONTROLS**

Undoubtedly the finest Volume Control made, and fitted as standard by many leading manufacturers because of quality, reliability and smoothness of action. Has no direct rubbing contacts. Values from 500 ohms to 5 megohms, in long or linear law, plain or with single pole or double pole switch.

If your retailer cannot supply, write direct to the pioneers of Crystal Pick-ups.

**ROTHERMEL LTD.**

**ROTHERMEL HOUSE, CANTERBURY ROAD, KILBURN, LONDON, N.W.6**

\*Phone : MAIDA VALE 6066 (3 lines).

**By request**

At the request of many of our constructor friends, we give here full details of the famous range of Stentorian chassis.

Type	Cone dia.	Flux Density (Gauss)	Pole dia.	Gap length	Flux face	Total Flux	Speech coil Impedance (ohms)	Handling Capacity (Watts)	PRICES	
									With Trans. £ s. d.	Without Trans. £ s. d.
*S. 2.57	2½"	7,000	.375"	.033"	.093"	5,285	3	.3	—	15 6
*S. 3.57	3½"	7,000	.625"	.035"	.125"	11,500	3	2	—	16 6
S. 507	5"	7,000	.75"	.040"	.125"	14,000	3	2.5	1 5 0	17 6
*S. 610	6"	10,000	.75"	.040"	.125"	20,000	3	3	1 8 6	1 1 0
S. 707	7"	7,000	1"	.043"	.187"	27,650	3	3.5	1 10 6	1 1 0
S. 810	8"	10,000	1"	.043"	.187"	39,500	3	5	1 13 6	1 4 0
S. 912	9"	12,000	1"	.043"	.187"	47,400	3	7	1 19 0	1 9 6
S. 1012	10"	12,000	1"	.043"	.187"	47,400	3	10	2 11 0	1 17 6
S. 12135	12"	13,500	1.5"	.050"	.25"	106,000	15	15	8 8 0	7 7 0
S. 1814	18"	14,000	2.5"	.0625"	.312"	227,000	12	30	—	24 0 0

Further details of these speakers and of the famous Concentric-Duplex models gladly sent on request.

\* All chassis material is of Mazak 3 except S.2.57, S.3.57 and S.610 which are of Drawn Steel



**Stentorian**

**LOUDSPEAKER CHASSIS**

WHITELEY ELECTRICAL RADIO CO. LTD. · MANSFIELD · NOTTS



# Practical Wireless

19th YEAR  
OF ISSUE

EVERY MONTH.  
VOL. XXVII. No. 533. MARCH, 1951

Editor E. J. CANN

COMMENTS OF THE MONTH

BY THE EDITOR

## The Beveridge Report

**E**LSEWHERE in this issue we summarise the Beveridge Report on Broadcasting. In many respects it is a disappointing document. It consists of two volumes of 583 pages and 327 pages, respectively, and it includes the evidence given before the Committee, who held 62 meetings, by a large number of interested societies, institutions, trade associations, clubs and individuals.

The conflicting interests were incapable of consolidation and neither the Beveridge Committee nor any other could find a solution to the various problems which were raised. The main criticism of the B.B.C. has been its monopoly; the autocracy with which it governs broadcasting, and indeed, in some respects, endeavours to govern the private lives of its staff; the poorness of some of its programmes; its failure to develop television on a scale comparable with its importance, and its tendency to regard itself as an Empire which rules by some sort of divine right. Even the presentation of its accounts, which has come in for a great deal of criticism, would not be permitted an ordinary company under the Companies Acts in so vague a form.

Some of the recommendations of the Committee are most surprising. For example: "Aliens should be eligible for establishment." According to paragraph 456 of the Report the reason for this is that there are many foreigners who can better serve the B.B.C. in its overseas services because of their special knowledge of particular countries. That simply will not hold water, and, even if it did, in these grave times in world history, it is wise to see that those administering the most vital link in our communications should be purely English, especially after our experiences at Harwell. It is impossible to accept assurances of loyalty from foreigners. We have had that from many who have since proved to be traitors. Knowing how foreign powers work with the fifth, sixth and seventh columns, it is more than ever desirable that the B.B.C. should be purged. Do not let us wait to be wise after the event, as we have been in the case of atomic research. There are plenty of Englishmen able to fill every post in the B.B.C.

The suggestion for the development of very-high-frequency broadcasting is, of course, related to the technical side and it will meet with general approval. The main purpose of the Committee, however, was to criticise policy and not technical matters.

Lord Reith in his evidence said that it was "the brute force of monopoly that enabled the B.B.C. to become what it has, and to do what it did; that makes it possible for a policy of moral responsibility to be followed. If there is to be competition it will be of cheapness not of goodness." That seems to be an argument in favour of monopolies, for if it works with the B.B.C. it should work even better with ordinary commercial undertakings, which have to trade at a profit and present accounts in proper form. As Lord Reith was one mainly responsible for introducing the B.B.C. system which has given rise to the setting up of the Committee, and has been the subject of so much criticism, especially during his period of office, he was hardly one best qualified to criticise and to give an opinion of what he largely claims to be his own handiwork. If there had been no Reith there would have been no committee.

One of the recommendations is that the B.B.C. Charter in its suggested revised form should be reviewed every five years. We think that period too long. It should be not longer than every three years.

The Committee is on safer ground when it suggests that greater developments should take place in television. It has been the Cinderella too long, and in view of the large sum received by the B.B.C. it can handsomely afford to develop it, and quickly.—F.J.C.

### OUR CHANGE IN PRICE

Readers will have noticed that, commencing with this issue, the price of this magazine has been increased to 1s. We greatly regret that the costs of production which have continued to rise for a long time past have compelled us reluctantly to make this increase, which has been delayed as long as possible. Paper alone today is costing four times its pre-war price.

If we are to maintain the high technical standard we have set and give our readers and the trade the service to which they are entitled, no other course is open to us. The price increase will enable us to retain our high standard, and to continue to provide for our readers material written by all the leading authorities in this fascinating field.

# ROUND the WORLD of WIRELESS

## Broadcast Receiving Licences

THE following statement shows the approximate number of licences issued during the year ended 30th November, 1950.

Region	Number
London Postal .. .. .	2,338,000
Homo Counties .. .. .	1,650,000
Midland .. .. .	1,732,000
North-eastern .. .. .	1,893,000
North-western .. .. .	1,600,000
South-western .. .. .	1,063,000
Welsh and Border Counties ..	728,000
<b>Total England and Wales ..</b>	<b>11,004,000</b>
Scotland .. .. .	1,123,000
Northern Ireland .. .. .	207,000
<b>Grand Total .. .. .</b>	<b>12,334,000</b>

## New Transmitters for B.B.C.

THE British Broadcasting Corporation have placed an order for seven low-power transmitters manufactured by Marconi's Wireless Telegraph Co. Ltd., of Chelmsford, Essex. They are 2 kW. medium-wave broadcasting transmitters Marconi type TBM.631 and are specially suitable for broadcasting stations catering for a relatively small area, where long range is not of premier importance.

## B.I.R.E.

THE following meetings of the Institution will be held in February, 1951:

**LONDON SECTION.**—*Wednesday, February 21st:* Commencing 6.30 p.m. London School of Hygiene and Tropical Medicine, Keppel Street, Gower Street, London. W.C.1. "Electronics and Air Transport," C. H. Jackson, B.Sc., A.F.R.Ae.S., A.M.I.Mech.E.

**SOUTH MIDLANDS SECTION.**—*Wednesday, February 14th:* Commencing at 7.15 p.m. East Midlands Electricity Board, Coventry. "A Survey of Television Development and its Problems," H. J. Barton-Chapple, B.Sc., M.Brit.I.R.E.

**NORTH-EASTERN SECTION.**—*Wednesday, February 14th:* Commencing at 6.0 p.m. Neville Hall, Westgate Road, Newcastle-on-Tyne. "The Use of Foster's Theorem in Circuit Design," E. Williams, Ph.D., M.Brit.I.R.E.

**WEST MIDLANDS SECTION.**

—*Wednesday, February 28th* Commencing at 7.0 p.m. Wolverhampton and Staffordshire Technical College, Wulfruna Street, Wolverhampton. "Power Rectifiers," J. C. Milne.

## Broadcasting in Japan

AT present the Japanese Broadcasting Corporation is operating 116 transmitting stations in Japan. The first network operates 46 main stations and 33 relay stations from 5.30 p.m. to 11 p.m., and the second network operates 37 main stations from 6 p.m. to 11 p.m.

There are 9,000,000 receiving sets in use and 19 manufacturers market radio receivers at prices ranging from approximately £5 10s. to £11 10s.

At present no sponsored radio programmes are broadcast, but a Bill was recently passed by the Japanese Diet permitting the setting up of commercial radio stations on American lines, and it is expected that these will be in operation by about the middle of 1951. The leading Tokyo newspaper will probably be among those who will operate these sponsored programmes.

## New Studios for Hong Kong

THE authority responsible for the technical side of broadcasting in Hong Kong, Cable and Wireless Ltd., have placed an order for four large and three small studio control consoles with Marconi's Wireless Telegraph Co. Ltd. These will

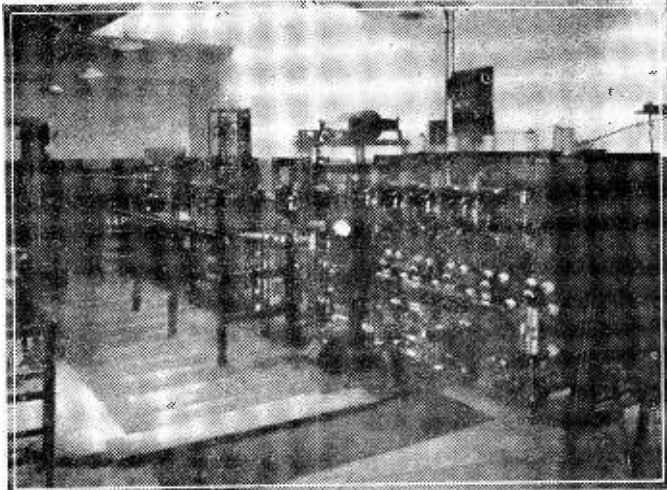

The first 2LO at Marconi House, used for broadcast transmissions from London from 1922 onwards. On the extreme left is the rectifier, next to which is the Master oscillator with its valve mounted in a cage on the top. The third panel contains the main oscillator with the high frequency circuit and the speech choke. On the right, the main and sub-modulator fitted with five valves.

furnish two complete sets of studios from which programmes will go out in English and Chinese.

Each studio set will comprise a drama studio and continuity suite (studio, engineers' control room and news studio). The two sets will share a large concert hall.

The large consoles (Type BD.501) have six low-level inputs and four high-level inputs. Thus the producer has at his disposal six microphones or gramophones, and four outside broadcast lines. The smaller consoles (Type BD.515) have three or four low-level inputs.

#### Suppressors—A.A. and R.A.C. Decision

**T**HE Standing Joint Committee of the Royal Automobile Club, the Automobile Association and the Royal Scottish Automobile Club met recently in London and considered numerous subjects directly affecting all motor users. Among the decisions taken was the following: To stress the need for providing all new vehicles with radio interference suppressors as part of their standard equipment and to encourage their use by the motoring public.

#### R/T Systems in East Africa

**B**Y the use of VHF multi-channel radio-telephone equipment East Africa plans to have the most progressive telephone communication system in the world. Within two years trunk connections will be possible to most points of the territories of Kenya, Uganda and Tanganyika without delay.

A Marconi experimental beam radio link, in operation between Nairobi and Nakuru for more than a year, has proved so successful that the East African Posts and Telegraphs Department intends to install many more VHF links.

In 1951 radio will link the telephone systems of Kampala and Jinja, Jinja and Nakuru, and Tanga and Dar-es-Salaam. By 1952 Nairobi will be linked with Mombasa, Mombasa with Tanga, and Dar-es-Salaam with Dodoma.

East Africa is ahead of most of the world in the use of VHF multi-channel links, and other British territories are likely to benefit from the experience and results obtained there.

#### B.B.C. Engineering Division Appointments

**T**HE B.B.C. announces the following new appointments in the Engineering Division.

Mr. F. C. McLean, M.B.E., B.Sc., M.I.E.E., S.M.I.R.E., becomes head of a newly formed group known as the Engineering Projects Group, composed of the Planning and Installation Department and the Designs Department. Mr. E. L. E. Lawley, M.Sc., M.I.E.E., succeeds Mr. McLean as head of the Engineering Services Group.

Mr. A. N. Thomas, A.M.I.E.E., succeeds Mr. T. C. Macnamara, A.M.I.E.E., who has resigned from the B.B.C., as head of the Planning and Installation Department.

#### Tower Crashes

**A** 608ft. tower, which was built at a cost of \$93,000 for station KHQ, crashed to the ground two days before it was due to be completed. It was up to nearly three-quarters of its final height of 826ft., and was a replacement of a similar mast which had been broken a year ago by a violent storm.

#### Iceland Expands Broadcasting Service

**F**OLLOWING their policy to provide the 122,000 inhabitants of Iceland with one of the world's finest broadcasting systems, the Iceland State Broadcasting Service recently opened a new transmitting station at Eidar. This new station was



*Proud Gold Coast police officers standing in front of one of their police vans recently equipped with a radio-telephone unit. Pye Telecommunications of Cambridge has installed a complete VHF radio telephone scheme for the Accra police services. The authorities report that they are enthusiastic about the results obtained from their Pye equipment.*

designed and constructed by Marconi technicians and includes a Marconi 5 kW. transmitter.

I.S.B.S. has now placed two further orders for broadcasting transmitters with the Marconi Company. The first is for a 5 kW. medium-wave air-cooled transmitter (type TBM672—similar to that installed at Eidar), to be erected at Akureyri. As in the case of the Eidar installation, where the 5 kW. installation replaced the existing 1 kW. Marconi transmitter, which will be re-erected at Höfn, the equipment for the Akureyri station includes a 76-metre radiator mast specially designed at the Marconi Works, Chelmsford, to withstand a wind velocity of 140 m.p.h. in a country where winds of 100 m.p.h. or more are a common occurrence in the winter months. The mast and the transmitter will be erected by Marconi engineers.

In addition to the new station for Akureyri, the Icelandic authorities are extending the existing system at the capital, Reykjavik, where their principal transmitting station is sited. For this purpose they have ordered a Marconi 20 kW. long-wave transmitter type BD.213 which, like the Akureyri transmitter, is under construction at the Chelmsford Works and due for early delivery. It will be installed alongside the existing Marconi high-power, long-wave transmitter.

# Bridges and Networks

Important Details of Every-day Circuit Principles

By A. M. ST. CLAIR

**T**HERE can be few items of circuitry technique more generally useful to the experimenter than a working knowledge of bridges and their close relatives, three-terminal networks. Load matching, control of frequency response, accurate measurement, time-base linearisation, these are but a few of the problems which yield easily to such a knowledge. The applications are legion, and no difficult mathematics is required.

The basis of the whole subject is the Wheatstone bridge. In Fig. 1, if a voltage  $E$  is applied between terminals A and B, and a meter is connected to

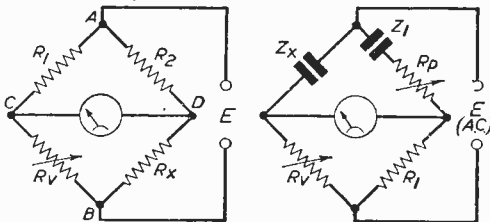

Fig. 1.—Standard Wheatstone bridge principle. Fig. 2.—Test circuit using the bridge principle.

C and D, we can arrange by a suitable choice of resistors that no current will flow through the meter. We then know that C and D are at the same potential. Now, the voltage  $E$  is divided by the arm  $R_1$ - $R_v$  into two parts, proportional to  $R_1$  and  $R_v$ , and by the arm  $R_2$ - $R_x$  into two parts, proportional to  $R_2$  and  $R_x$ ; so that, for the potential at C to be the same as that at D, we see that  $R_1/R_v = R_2/R_x$ . If  $R_1$  and  $R_2$  are accurate known resistors, and  $R_v$  is a calibrated variable, we can obviously determine the value of  $R_x$  by rearranging the bridge equation in the form  $R_x = R_v R_2 / R_1$ . The beauty of this method lies in the fact that it is independent of the value of  $E$ , and of the accuracy of the meter calibration. It can be made to cover a vast range of resistance values in one instrument by keeping  $R_1$  and  $R_v$  constant, and switching in a series of values for  $R_2$ , chosen so that the ratio of  $R_2$  to  $R_1$  is a simple figure to work with.

The next extension of the principle is to include the measurement of inductance and capacity. Any coil or condenser possesses a fixed impedance at a given frequency, and it is this impedance which is measured when using bridge methods. The impedance of a coil is  $2\pi fL$ , and that of a condenser  $1/2\pi fC$ , where  $f$  is frequency,  $L$  inductance, and  $C$  capacity. If we use the mains frequency of 50 cycles per second, then  $2\pi f = 314$ . Then the impedance of a coil becomes  $314L$  ohms, and that of a condenser,  $1/314C$  ohms. Here,  $L$  and  $C$  are in henrys and farads respectively.

Now consider Fig. 2. It is essential, when measuring impedance, to have another impedance of the same kind in the bridge, because of the phase-change introduced by a coil or a condenser.

Ignoring  $R_p$  for the moment, the circuit behaves exactly as Fig. 1, and we get, when  $R_v$  is adjusted for no reading on the meter,  $Z_x/R_v = Z_1/R_1$ , from which  $Z_x = R_v Z_1/R_1$ , where  $Z_x$  and  $Z_1$  are the impedances of the condensers concerned. Exactly the same equation holds for inductances, substituted for the condensers in the figure. The function of  $R_p$  is to balance out any resistive component of the condenser or inductance under test; from which it will be seen that the reference arm  $Z_1$  must always be a very high-quality part, having less effective series resistance than any part to be tested—or, what amounts to the same thing, it must have a very high "Q." The resistance  $R_p$  may be calibrated in terms of power factor.

If we cancel out  $1/2\pi f$  from each side of the equation of this bridge, and rearrange a little, we get the simpler form:  $C_x = C_1 R_1 / R_v$ . Hence, since the frequency parts cancel out, the readings of the bridge are independent not only of voltage and meter accuracy, but also of applied frequency.

## Another Network

Now let us consider in more detail the behaviour of one arm of such a bridge. It gives a network as in Fig. 3. Although simple, it is of common occurrence and very important. Compare, for example, a grid condenser and leak. Before we can deal with this circuit we must remind ourselves of the well-known fact that the voltage across a condenser lags a quarter-cycle, or 90 deg., behind the current, while that across an inductance is 90 deg. ahead. It is at this point that trigonometry is usually brought into the picture, and many a first-rate practical experimenter whose only crime is that of being just a little too far removed from his schooldays is arrested in his progress by a posse of sines, cosines, and tangents, and forced to give up in despair. Nevertheless, all the work required can be done by means of simple arithmetic and a sheet of graph-paper!

The point to note is that 90 deg. lag or lead. It means that you cannot add impedance ohms and

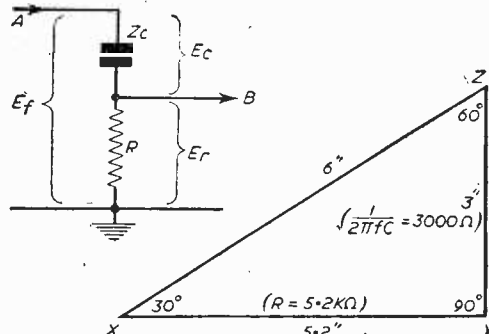

Fig. 3 (above)—An "arm" of a bridge circuit. Fig. 4 (below)—A geometrical method of calculating values.



resistance ohms together in a straightforward manner. You must add them along the sides of a right angle. You can do it by means of Pythagoras and Trig, or you can draw it. And, since most of the resistors and condensers we use are about the 10 per cent. to 20 per cent. tolerance mark anyway, you will not even lose noticeably in accuracy.

Suppose in Fig. 3 we apply a voltage E having a frequency f. We want to know all about the corresponding voltage obtained at B. Take a sheet of squared paper, and select a suitable scale—so many ohms per inch. Lay off horizontally a line equal to R. Say we call this XY (Fig. 4). From Y, draw a line at right angles, equal to Z, the condenser impedance. This right angle corresponds to the 90 deg. phase-shift in the condenser. Call it YZ. Join XZ and measure it. This is the total impedance of the two in series. The triangle you have drawn tells the whole story of the circuit. The three sides represent not only the impedances, but also the voltages. XZ corresponds to the total volts, E. XY is the voltage across the resistance, and YZ the voltage across the condenser. The angle at Z is the phase-shift across the condenser, and the angle at X is the phase-shift across the resistor. Since the phase-shift across the condenser represents a lagging voltage, that across the resistor is a leading one, to compensate.

The values for which Fig. 4 was drawn were 1  $\mu$ F + 5.2 K $\Omega$ , and the applied frequency was 50 cycles per second. This gives approximately 3,000 ohms for the impedance of C, and a scale of 1,000 ohms per inch was chosen. XY was therefore

drawn 5.2 in. long, and YZ 3 in. long. Measurement gave XZ as 6 in., and so the impedance of the pair at 50 c/s is 6,000 ohms. On measuring the angles, it was found that X was 30 deg., giving a voltage at B (Fig. 3) leading on E by 30 deg. Also, since the input voltage is represented by XZ = 6 in., and the output voltage by XY = 5.2 in., the fraction of the total signal which is available at B is 5.2/6, 0.866, giving a figure for the attenuation.

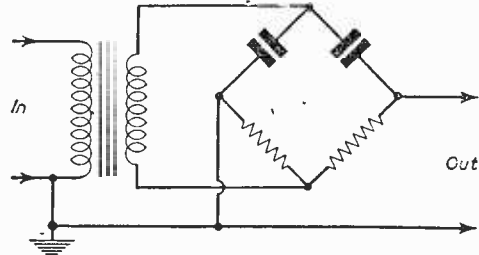

Fig. 5.—One method of arranging for stability.

**Leading or Lagging ?**

This method is applicable to any number of resistors, condensers and inductances in series. For each resistor, a horizontal line; for each condenser, a line vertically up; for each inductance, a line vertically down. Draw them all end-for-end, and the join of the first and last points is the total impedance of the combination. Regarding the end from which you started the graph as "live" and the other end as "earthly," the phase angle at any point is found by joining the corresponding point on the graph to the starting point and measuring the angle formed. If it slopes upward it is a leading voltage; downward, a lagging one. A group of resistors and impedances in parallel must be dealt with, just as parallel resistors, by the "Reciprocals" rule: i.e.,  $1/Z = 1/Z_1 + 1/Z_2 + 1/Z_3 + \dots$ . Work out "one upon" each component in turn, add the values thus obtained on a graph as before, and work out "one upon" the length of the line joining the two ends. This is the impedance of the parallel group. The angle at which this value should be entered on a graph of components, with which it is in series, is taken direct from its own "Reciprocals" graph. By these methods, using no mathematical weapons more formidable than a ruler, a protractor and ordinary arithmetic, the characteristics of any network may be found.

One of the most desirable features in a network developed for experimental circuitry is that it shall have three operative terminals. A standard type of bridge, which possesses four, suffers from the disadvantage that you can earth its input or its output, but not both; this often results in great trouble with respect to stabilisation, operation from common power supplies, and so on. It is sometimes possible to overcome this difficulty by feeding the bridge from a transformer and earthing the transformer primary (Fig. 5). This converts the bridge to a three-terminal network, but it is not always advisable, particularly if the bridge concerned is frequency-sensitive. A better scheme is the combination of two similar bridges. The bridge of Fig. 6a will balance for voltage when the condenser impedance and the resistance are equal, i.e., when  $R = 1/2\pi fC$ , which can be written  $f = 1/2\pi RC$ . At this frequency,

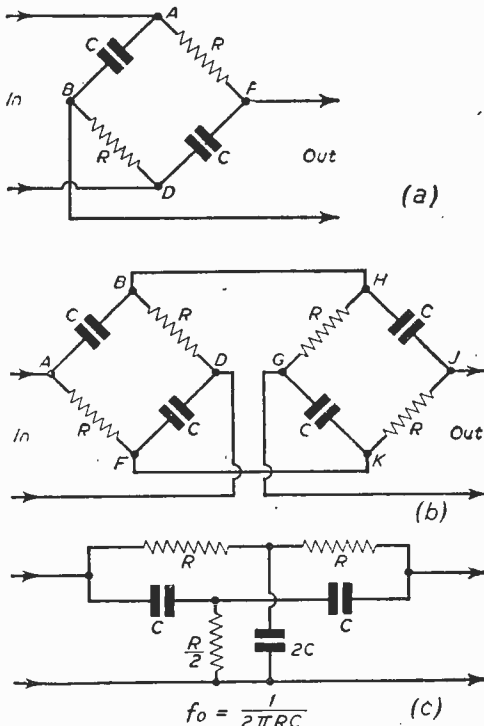

Fig. 6.—The development of a "twin-T" network.

though the voltages at B and F are equal, that at F is 45 deg. ahead of the input, and that at B is 45 deg. behind. So that at this particular frequency we have equal voltages at B and F, and we have reduced the phase difference between terminals by 90 deg. If we now take the output from terminals B and F to an identical bridge, as in Fig. 6b, we shall get a further relative phase-shift of 90 deg., bringing G and J in phase, still with equal voltages. Hence, no current will flow into a circuit between G and J so long as the input to A and D is at a frequency  $f=1/2\pi RC$ . At any other frequency, both bridges will be unbalanced and current will flow.

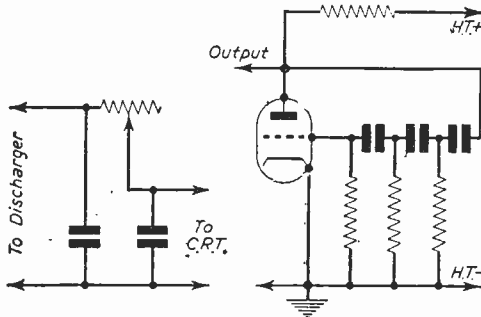

Fig. 7.—A modified time-base circuit arrangement.

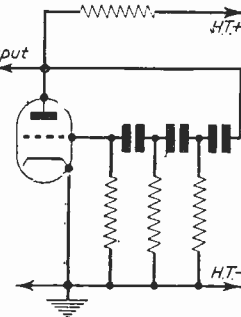

Fig. 8.—A stable oscillator circuit with 180 deg. phase shift.

But we now observe that since BDF and HGK are identical branches, the voltage at D must always be the same as that at G, so that D and G may be connected together without in any way affecting the operation of the circuit. This places resistances BD and HG in parallel, so that they can be replaced with one of value  $R/2$ , and similarly condensers DF and GK may be replaced by one of value  $2C$ . Redrawing the circuit with these changes gives Fig. 6c, the "Twin T" network, an exceedingly valuable device capable of removing a given frequency from a composite signal.

### Applications

Many applications as a filter, or an element in a frequency discriminating amplifier or an oscillator, spring readily to mind, and many more remain to be thought up.

The principle of combining two bridges in order to obtain a three-terminal network offers a field where there is much scope for experiment. It is not necessary that the bridges should be identical, but merely that there should be some point on each suitable for interconnection. Networks with many strange and some useful properties can be developed.

Here are a couple of specimen applications of the simplest of all R-C networks—that of Fig. 3.

The charging condenser of a time-base is replaced by the circuit of Fig. 7. The condensers are about half the value of that previously used in the T.B., or a little larger. The resistance is a  $\frac{1}{2}$  meg. having a good low minimum. Varying it alters the attenuation and phase-shift of the network to the component frequencies of the saw-tooth wave, hence altering its shape. Considerable improvement in linearity can be achieved by this means.

In the circuit of Fig. 8, each of the three sections

is calculated by means of a graph as already outlined to give a 60 deg. phase-shift at a selected frequency. Hence, the group of three gives a phase-shift of 180 deg. at this frequency, and the valve oscillates, provided the gain is greater than the attenuation in the network. For accurate work, allowance should be made for the shunting effect on each section of the one following. This oscillator is extremely stable. If gauged resistors are available, it can be made variable.

It will readily be seen that the whole field of R-C networks is one which offers great scope for interesting experiment.

## Marconi's Move

BEHIND the announcement by Marconi's Wireless Telegraph Co. Ltd., and The Marconi International Marine Communication Co. Ltd., of a change in their registered addresses from January 1st, 1951, lies a renewal of old associations with the early days of wireless, and particularly of broadcasting.

As from the first day of 1951, the registered offices of the two companies is at Marconi House, Strand, London, W.C.2 (Telephone number: Temple Bar 1577). The main business of both companies will continue to be conducted from Marconi House, Chelmsford, Essex, as before, but the Export Department of Marconi's Wireless Telegraph Co. and the Contracts Division of the Marconi Marine Co., will be housed in the Strand building.

### Link with 2LO Days

It was on the seventh floor of this building that British Broadcasting was born when the Marconi Co. first made regular broadcasts from 2LO in 1922, after several months of experimental broadcasting from their station (2MT), at Writtle. Later in the same year the British Broadcasting Co. was formed and took over the famous 2LO station.

The complete furniture of the studio consisted of two small tables, a piano, a settee and a microphone. The transmitter was built in an alcove in the corridor of the seventh floor outside the studio. Mr. Stanton Jefferies officiated at the piano in those days, and is, of course, still with the B.B.C.

In 1923 the B.B.C. opened new studios at Savoy Hill, and in 1933 the registered offices of the Marconi companies were moved to Electra House, on Victoria Embankment. Early in 1934, Marconi House was taken over by the Air Ministry, renamed Ariel House, and a link with the old days of broadcasting appeared to have been broken. The Air Ministry's relinquishing of the building, however, offered an opportunity to reforge this link, an opportunity of which the Marconi companies were quick to take advantage.

**NEW EDITION NOW READY**

**"PRACTICAL WIRELESS" CIRCUITS**

15th Edition

6/- or 6/6 by post from

GEORGE NEWNES LTD.,

Tower House, Southampton Street, Strand, W.C.2

# On your Wavelength

By THERMION

## Castors for Consoles

IT was a wise move on the part of the Editor to insist upon ball castors for the *Practical Television* console receiver. I should like to make a plea to all manufacturers of consoles to fit castors so that the set may easily be moved when it is desired to clean the carpets beneath them or to retrieve something which has fallen behind.

A console is a weighty piece of apparatus, and by the time it has been slewed and pushed out of the way, considerable damage can be done to the floor coverings. It seems such an obvious refinement that I wonder they have not been fitted before. They are cheap and can easily be fitted without adding to the selling price. All console receivers, I understand, sponsored by this journal and our companion journal, *Practical Television*, will have castors fitted.

Messrs. Tallon, who supply the cabinets for our television receiver, will fit these to all cabinets if requested to do so. This is a firm which is anxious to help all constructors in the matter of cabinets, which are not so easy to obtain to-day as they were before the war.

## L.P.R.

I HAD a number of letters as a result of my paragraph on L.P.R. The Decca Record Co. inform me that they have been selling 33½ r.p.m. long-playing records on the English market since June of last year, and prior to that they have manufactured and sold them in very large quantities over a period of two years in both America and Canada. They say that they have obtained a fine reputation in quality of recording, and that I can confirm from personal experience with one of their machines and one of their records, which they kindly loaned to me for test. I found, however, the lightness of the pick-up something of a drawback. Unless the machine was mounted dead level the pick-up tended, because of its light weight, to swing in and score the record. This may, of course, have been due to my lack of experience with L.P.R. I am, therefore, hopeful that I shall be able to accept their invitation to visit them and hear some of their long-playing records, and to inspect the machines which they make for playing them.

Another reader, Mr. J. F. K. Nosworthy, thinks that I am not getting as much out of L.P.R. records as I might be. He has also offered to demonstrate his long-playing equipment to me. In good time I hope to accept this and similar offers, and will faithfully record the results in this journal.

## Television by Wire

I KNOW that a great deal of research is going on at the present time into the question of canning television programmes—perhaps one of the greatest problems with which it is confronted if cost of production is to compare favourably with blind broadcasts. I was therefore interested in the statement made by the rediffusion group of broadcast relay companies, which relay the B.B.C. and

selected foreign broadcast programmes to over 3,000,000 people, that they have developed a practical system of television rediffusion which they are installing at home and abroad. Short of the canned programme, television by wire is the next best thing. Viewers are promised by this system interference-free television, and a choice of broadcast programmes brought to their homes for a weekly charge, which will include the hire of a receiver, full maintenance and replacement. One of the systems, a communal television aerial system, has been in operation in London flats and hotels since 1937, while another will supply simultaneous distribution of more than one television programme in addition to a choice of broadcast programmes.

## Scottish Jibes

IT seems a pity that the Scottish Nationalist Party, a curious body which is elated at the removal of the Stone of Destiny from its proper resting place, should damn the evidence it gave before the Beveridge Committee on broadcasting by such statements as the following: "The B.B.C. should strive to emulate the best, and we cannot imagine Drake, Shakespeare, Marlborough, Pitt and Florence Nightingale expressing themselves in the silken tones of eunuchs. Our Scottish announcers are, if anything, worse than the English: they seem less able to stand up to local laundering." Well, that last paragraph is a mild concession to the Sassenachs, but the general extravagance of the phraseology and the sneering references to the English who, after all, are best qualified to express the English language, shows that this quaint party will lose no opportunity of getting one in at the English. Personally, I prefer the dulcet tones of our English announcers, whose pronunciations of English words agrees most nearly with all dictionaries, including Scottish ones, than the guttural cacophonous gibberish of the average Scottish announcer. It is equally true to say that the famous gentlemen of the past whom they mention would certainly not pronounce the English language (remember that there is no such thing as a Scottish language—only a dialect!) as Rrrrobic Burrrrrruus would do, thank goodness!

## B.B.C. or E.B.C. ?

At least we can understand the English announcers. This is one reason why I particularly liked the view put before the Committee by the Royal Society of St. George: "Steps should be taken to prevent the exclusion of the words 'England' and 'English' in favour of 'Britain' and 'British.' The B.B.C. neglects English interests, culture and traditions." Is there any wonder when we remember the extent to which we have allowed Scotsmen since the time of Reith to infiltrate and largely possess the B.B.C.? I am astonished that no one suggested to the Committee that a higher proportion of Englishmen should be employed by the B.B.C., in view of the large number of foreigners who seem to have dug themselves in there.

# Disc-seal Valves

Some Details of a "Surplus" Valve for U.H.F. Work By E. G. BULLEY

VALVES of the above designation are available in limited quantities on the surplus market.

They are, however, known as planar valves and in the United States as lighthouse tubes, the latter designation being brought about by their resemblance to a lighthouse in their external appearance. Reference to the illustration will enable the reader to appreciate this point.

The design of such valves during the last war enabled radio engineers to produce transmitting equipment for the ultra-high-frequency ranges. Such valves, are, however, available on the commercial markets and are useful to the amateur in various frequency ranges.

They can be classified as those operating below 500 Mc/s and those above 1,000 Mc/s—the former range being suitable for more general purposes.

Valves of this nature are used mainly in grounded grid circuits, whether they be operated as L.F. or H.F. amplifiers. It is as well to mention, however, that as these valves are taken higher up the frequency scale, so the output and efficiency falls off. Furthermore, the frequency at which these valves will operate satisfactorily depends entirely upon the electrode voltages. Care should therefore be taken in following the characteristics specified by the particular manufacturer.

These valves are also used as c.w. and pulse oscillators, but whatever the actual application, the valve itself forms a part of the system in which they are being used. This is necessary, as otherwise the operating frequency could not be attained. Furthermore, these valves depend upon cavity resonators for their actual tuning and this does to an extent explain why they must be a part of the system, because as these valves are required to work in the U.H.F. range, efficiency is essential and could not be obtained without the valve being a part of the system.

## Inter-Electrode Capacity

The reader may wonder why it is necessary to have the various electrodes assembled on different discs, and each individual disc being sealed to the glass system. This, in fact, is very important, as it is an essential feature in the design of such valves to keep the inter-electrode capacities and the inductance of the leads to an absolute minimum. As a matter of interest, these discs are made from copper, kovar or nilo-K, the former being preferred, as the other two alloys contain a percentage of steel which should be avoided when operating in the U.H.F. range, owing to circulating currents in the metal.

Another important characteristic of such valves is that the active area of the anode is quite small and that the heat is conducted away from the anode face through the anode termination, the latter being more or less of the same diameter as that of the anode. Furthermore, the anode is cooled by radiator fins which are secured to the anode termination.

Connection to the anode is made via the anode

disc seal, and likewise the grid and cathode electrical connections are made to their respective disc seals. It may be as well to mention, at this stage, that the active areas of the various electrodes are in a horizontal plane to each other.

Many manufacturers silver plate the various discs, and this, as in ordinary H.F. valve practice, reduces the resistance to R.F. and does to an extent safeguard the seals themselves from cracking due to overheating by R.F. currents.

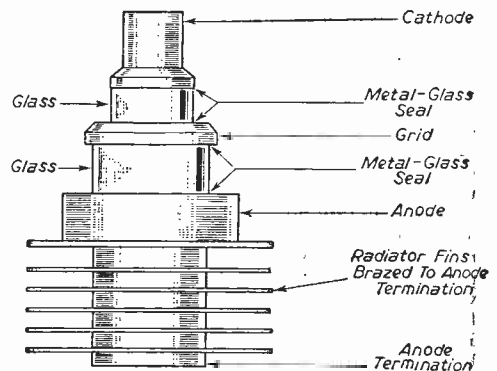

General view of the Disc-seal valve.

## Coaxial

As the name implies, the disc seals are coaxial, and the electrodes are assembled on these and arranged in order from the cathode, namely in a triode it would be cathode, grid and anode. The diameters of these disc seals increase as from the cathode.

Valves of this nature have indirectly-heated cathodes because of their very high thermal efficiency. It may be as well to mention, however, that tetrodes are now available in this type, but they are not obtainable on the surplus market.

Tetrodes and triodes of this design have many advantages over the conventional all-glass type of U.H.F. valves, as they are easily replaceable in the coaxial designed system. Amateurs who are fortunate to obtain a disc seal triode will undoubtedly have great fun in the construction of the coaxial system. Details of such systems and their values are always obtainable from the various manufacturers who like to encourage the amateur in his hobby.

## NEWNES' RADIO ENGINEER'S POCKET BOOK

By F. J. CAMM

5/-, or by post 5/6

Obtainable from booksellers, or by post from George Newnes, Ltd. (Book Dept.), Tower House, Southampton Street, Strand, W.C.2.

# Report of the Beveridge Committee

A Resumé of Some of the More Important Recommendations

By THE EDITOR

**T**HE Broadcasting Committee, under the chairmanship of Lord Beveridge, was appointed on June 21st, 1949, "To consider the constitution, control, finance and other general aspects of the sound and television broadcasting services of the United Kingdom (excluding those aspects of the overseas services for which the B.B.C. are not responsible) and to advise on the conditions under which these services and wire broadcasting should be conducted after December 31st, 1951."

The Committee has considered about 223 memoranda which, with other papers circulated to the Committee, amount in total to 368, in addition to a number of suggestions from members of the public. They have held altogether 62 meetings of the full Committee, in addition to interviews and inquiries by sub-committees or by individual members on behalf of the Committee at B.B.C. premises in London and the provinces and elsewhere. In particular, sub-committees visited Scotland, Wales and Northern Ireland and each of the English Regions. Two sub-committees visited the United States and Canada.

## Recommendations

The following is a summary of the recommendations made: After expiry of its current Charter, the British Broadcasting Corporation should be continued as the authority responsible for all broadcasting in the United Kingdom, including Television and the Overseas Service, subject to the changes in its constitution and powers set out in the Report, to express reservation by the Government of power to license a body or bodies approved by them to conduct on specified conditions television for public exhibition, and after consultation with the B.B.C. to license public authorities or approved organisations to maintain and conduct local broadcasting stations.

In addition to Governors forming the Corporation under the new Charter, the Government should appoint Broadcasting Commissions for Scotland, Wales and Northern Ireland respectively.

The new Charter should have no fixed time limit, but the working of the Corporation should be subject to a quinquennial review. While the existing powers of giving directions and of veto should be retained by the Government, the current independence of the Corporation in making programmes and in general administration should be continued.

The annual reports of the B.B.C. should be laid before Parliament and should include information on financial matters and reports from each of the three Commissions for Scotland, Wales and Northern Ireland.

## Review Every Five Years

The activities of the B.B.C. should be reviewed every five years by a small independent committee appointed by the Government. The first quinquennial review should include consideration of the action taken by the B.B.C. on such recommendations of the present Committee's Report as are approved by the Government.

The Charter should require the Corporation to take steps to bring its work under constant and effective review from without the Corporation. It should give the staff a means of discussing, through representative organisations, any question as to their terms and conditions of employment.

## Regional Autonomy

It should aim to delegate to the Broadcasting Commissions for Scotland, Wales and Northern Ireland such powers as may be necessary to secure their effective autonomy and establishing the maximum variety in programme material. It should aim to develop V.H.F. broadcasting with a view to better coverage of the whole country, and to increase the possibility of local stations. It should aim to develop television. The Government should be free to appoint committees for any purpose and to include on such committees persons who are not Governors.

## Overseas Services

For overseas services the present division of responsibility between the Government and the B.B.C. should continue.

## Licence Fee to Continue

For meeting the costs of home broadcasting the licence fee system should be continued substantially as at present.

## No Sponsored Programmes

During the first five years of the new Charter, the B.B.C. should receive all of the net licence income, and thereafter a percentage of it. The question of the liability of the B.B.C. for income tax should be referred to the Royal Commission on Income Tax. The annual accounts furnished by the B.B.C. for presentation to Parliament should contain much fuller information than at present. The present prohibition on commercial advertisements or sponsored programmes should be continued.

## No Minister of Broadcasting

There is no need for a Minister of Broadcasting. Subject to being satisfied that wavelengths not needed for home television or other prior purposes can be used for public-showing television, the



Postmaster General should be prepared to license their use by a responsible organisation or organisations established for the purpose. He should require the resulting pictures to be available to the B.B.C. and to others on financial and other terms approved by himself, and he should impose conditions preventing the new licensees from introducing commercially-controlled television indirectly into the sphere of viewers at home.

A Television Advisory Committee should be appointed to advise the Government in relation to the B.B.C.

### V.H.F.

The development of V.H.F. broadcasting should be regarded as important and urgent, and the terms of reference of the Television Advisory Committee should be enlarged to cover higher frequency broadcasting as well as television.

The plan for the V.H.F. development now under consideration by the B.B.C. should be revised to provide for the setting up of a sufficient number of local stations in selected areas as experiments, and the public should be given long notice which would affect the type of receivers they must have.

### Relay Exchanges

The B.B.C. on its technical side should be asked to report whether there are, in fact, any areas of bad reception which can be covered better by relays than by direct radio, and which it might cover in this way in pursuance of the general duty of providing complete service.

Subject to this, the relay exchange should be left to private enterprise. Relay operators should be granted a ten-year licence in the first instance, with power to take over compulsorily then, or by two years' notice on going concern terms.

The relay exchange licensing conditions providing that only British subjects may be directors of licensee companies should be reconsidered.

In sparsely populated areas where reception is specially difficult and the relay system is not so economical as to attract private business seeking a profit, the B.B.C. might itself seek a licence to operate relay exchanges as a method alternative to direct radio for securing coverage. The Corporation should take into immediate consideration the possibility of establishing supplementary television studios outside London, and till this can be done should adopt special measures to correct the weighting of studio television programmes by London.

### Public Representation Service

With a view to carrying out certain of the aims the Corporation should establish a public representation service which, in addition to taking over Audience Research and carrying it further on present lines, should include receipt of and report on criticisms and suggestions from outside; conducting, either by its own staff or by commissioning outside experts, critical reviews of home programmes of all kinds; systematic review of overseas programmes; suggestions for establishment of advisory committees and provision of secretariat for them; study of broadcasting methods and programmes in other countries; and might include also, publications, and helping the Governors to examine charges of injustice or favouritism in the

choice of performers, and charges of partiality in the organisation of talks and discussions.

### "Hyde Park" of the Air?

The Governors should consider whether it is reasonable to have a "Hyde Park" of the air. The allocation of opportunities for ventilation of controversial views should not be guided either by simple calculation of the numbers who already hold such views or by fear of giving offence to particular groups of listeners.

### Records of Broadcasts

They should consider whether any further steps are required to make records of broadcasts available to the public after they have been given. Broadcasting should not be governed automatically by regard to what will please the listeners.

### Elections

During the period of general elections there should be greater opportunities for party political broadcasting, both on a national and a regional basis. In the interval between elections there should be more, and not less, opportunity for free political debate. The three national Commissions might make different experiments in the field of political controversy.

### Television

Administrative distinction between sound broadcasting and television should be greater than between other parts of the broadcasting organisation. The Director of Television should have the fullest possible authority to deal with staff and performers and cover other aspects of administration, including accommodation, finance and establishment matters.

The question of raising the television licence fee should be considered when the B.B.C.'s present financial plan is being revised. Television in schools should be the subject of experiment. A special Television Programme Advisory Committee might be set up.

### Aliens and Union Attitude

Aliens should be eligible for establishment. In view of the damage done to the public by some of the restrictions now imposed by unions of performers, on recording of performances for repetition, on use of commercial gramophone records and in other ways, the Corporation should reopen negotiations with these unions with a view to securing agreements that will make possible the giving of the best broadcasting service to the public on terms securing the legitimate interests of the performers.

### Restrictive Practices

Where restrictions damaging to the public are being imposed by organisations other than those of performers—as in relation to use of films for television, televising of stage plays or televising of sporting events—and are not already the subject of negotiations, the Corporation should take whatever steps appear likely to secure removal of these restrictions on terms securing the legitimate interests of these organisations.

The Governors should consider improving the news service by presenting distinctive news bulletins in Regions and ensuring that events of national interest occurring in Scotland or Wales appear in the general news bulletins.

New Edition of a Famous Book!

# The "Practical Wireless" Encyclopaedia

Announcing the Twelfth Edition, Entirely Rewritten and Re-illustrated,  
of the World's Standard Work on Radio

**T**HE first edition of the only radio encyclopaedia, the *Practical Wireless Encyclopaedia*, was published in 1932 under the title of "The Wireless Constructors' Encyclopaedia." In that year PRACTICAL WIRELESS was launched, and in founding that journal the editor felt that the large public for which it was intended to cater should have at hand a really comprehensive volume arranged in encyclopaedic form which would serve the dual purposes of an instruction manual and a book of reference.

Radio was but ten years old in 1932, but radio experimenters had not up to that time any source of reference comparable to that which was available for other industries.

The production of a volume, as planned, which would encompass all of the various branches of radio science, all the formulæ and the constructional details necessary to the technician, the service engineer, the constructor, the student, the radio mechanic, the operators, the laboratory assistants, and the designers, was indeed a heavy task.

The success of the effort can be measured by the fact that the market has already absorbed twelve editions, comprising a total of over 300,000 copies in 18 years.

Copies have journeyed all over the world. They may be found aboard ship, in radio laboratories, in experimenters' dens, in workshops, in the remotest countries of the world, in libraries, in colleges, and in the reading rooms of scientific institutions.

In a new industry such as radio changes are rapid. New branches of the science are introduced, new methods and circuits are discovered, and the nomenclature expands in consequence. The task of revising each edition so that it reflected these changes in order that the readers' knowledge should be kept up to date was a heavy one, but as edition succeeded edition the author, Mr. F. J. Camm, made great efforts faithfully to record every fact, every figure, every new term, and every change in technique which had arisen after the previous edition had gone to press.

There is a practical limit to which expansion can go without unduly condensing standing matter and entirely upsetting the pagination and resetting the whole book. That limit was reached with the eleventh edition, and it was on the publisher's request for a twelfth that it was decided to reset, to re-illustrate, and to prepare an entirely new volume, but with the same underlying idea which had prompted publication of the first edition.

Since the eleventh edition went to press in 1946, a great deal has happened in the world of radio, and

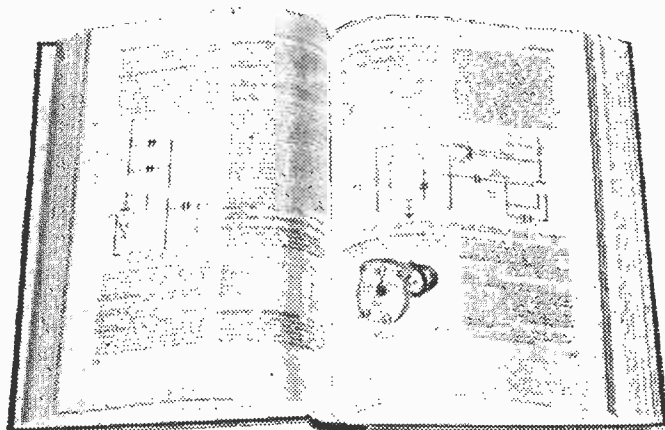

in this twelfth edition, upon which the author has been engaged during the past four years, the reader will find information on all of these new aspects.

The unchanging data such as definitions, standard terms, and formulæ such as Ohm's Law have, of course, been retained, and all of the matter which in the course of the years has become obsolete has been deleted. It was not found possible further to compress the previous volume to include the mass of new matter which it was the duty of the author to include. As he says in his Preface, "a book, like a boot, should comfortably accommodate what it is intended to contain," without undue compression.

The new volume, contains a large number of new sections on radar, television, remote control, oscillators, Kirchoff's Law, photo-electric cells, automatic station selection, car radio, electron multipliers, quartz crystals, amateur transmission, international call-signs, fault finding, building a television receiver, the colour code, aeriels, meters, table of short-wave stations, valvo data, official service terms, a complete series of modern radio circuits for receivers and amplifiers, etc., etc.

The practical information on the making of various components has been retained. The constructor, for example, will find in this twelfth edition information on the building of I.F. transformers, oscillator coils, mains transformers, coils and chokes, aeriels, testmeters, etc., etc.

Because of the alphabetical arrangement of the contents and the careful cross-referencing throughout the text, the reader is quickly able to consult the information he requires, and is guided to information which is germane to it.

There are no fewer than 554 illustrations in this 384-page volume, which costs 21s. from bookshops, or 21s. 10d. by post from the Book Dept., George Newnes, Ltd., Tower House, Southampton Street, Strand, London, W.C.2.

# Variations of the Pierce Oscillator

Circuit Ideas for the Amateur Transmitter and Experimenter

By O. J. RUSSELL, B.Sc., A.Inst.P. (G3BHJ)

**B**OTH the circuit of Fig. 1 and the more common tuned-anode crystal oscillator circuit were originally due to Pierce, but it is the circuit illustrated which is generally referred to as the Pierce circuit. Like the majority of circuits commonly employed in amateur transmitter practice, the circuit employs the parallel resonant mode of the crystal, and it can be readily seen that the modified Colpitts oscillator of Fig. 2 results if we draw a conventional parallel tuned circuit in place of the crystal in Fig. 1.

There are a number of points of interest in this apparently "utility" model crystal oscillator which has the merit of requiring no tuning adjustment, so that it can be operated over a wide band of frequencies by a simple replacement of the crystal.

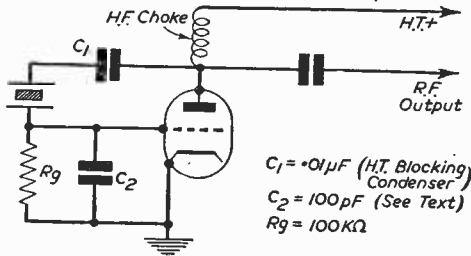

Fig. 1.—This is the circuit usually referred to as the Pierce Oscillator.

The anode choke, for example, must present an inductive reactance at the operating frequency for oscillation to take place. For normal amateur use, one of the sectionalised small receiving type short-wave chokes is highly satisfactory, but where a much larger choke of the old-fashioned type once used for broadcast reception and of high inductance is used, it is clear that only a minute proportion of stray capacity may prevent oscillation. In point of fact, the Pierce oscillator is a very reliable oscillator, which can be depended upon to operate with crystals of low activity. This readiness to oscillate is hardly surprising in view of the crystal forming the direct feedback path from anode to grid. In this connection, it should be realised that the condenser connected from grid to earth has a definite function to perform in proportioning the drive voltage applied to the grid. In conjunction with the anode-to-earth capacitance of the valve employed, the augmented grid to earth capacitance provides a control of the effective excitation ratio of total RF voltage applied to the grid. This is precisely the mode of operation of the normal Colpitts circuit, and, from the illustration in Fig. 3, it will be realised that if the grid to earth capacitance is increased, the grid excitation voltage is reduced, while the fraction of total RF voltage appearing at

the anode is increased through the usual capacity tapping considerations.

In practical operation with normal oscillator tubes, the grid to earth capacity can conveniently be 100 pF, although if desired, an adjustable trimmer of 100 pF maximum capacity may be used to cater for unusual conditions, or variations in oscillator valves. It should be realised that in the Pierce circuit, the full RF output voltage is developed across the crystal, so that in the interests of crystal life, the total high-tension voltage applied to the valve should not exceed, say, 250 volts for safety. Under such conditions, the oscillator will develop sufficient RF to excite a suitable RF tetrode such as the 807 type to at least 40 watts input, so that an ultra-simple transmitter developing

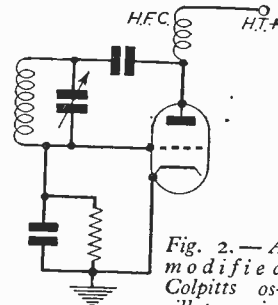

Fig. 2.—A modified Colpitts oscillator, in which a parallel-tuned circuit replaces the crystal of Fig. 1.

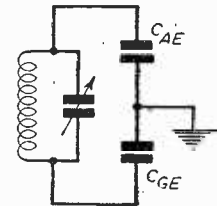

Fig. 3.—In this circuit condenser  $C_{AE}$  represents the aerial-to-earth capacitance and  $C_{GE}$  the grid-to-earth capacitance.

considerable power with only a single tuning control in the power amplifier anode circuit may be constructed. Such an assembly will also develop a useful amount of power by doubling in the 807 stage following the crystal oscillator. It should be realised that although a triode has been shown as the oscillator valve, and such triodes as the 6C5 and 6J5 type are quite suitable, the more usual pentode and tetrode types such as 6F6, KT66, QVO4-7, 6V6 and 6L6 are preferably used. Grid-leaks of 100,000 ohms are a convenient value, while a small screen Dropper of the order of 10,000 ohms or less should be used under the conditions of high-tension supply being restricted to 250 volts.

## Variations

While the Pierce oscillator itself is widely used, this cannot be said of the "hot cathode" variations on the Pierce circuit, which are illustrated in the three circuits of Fig. 4. These are clear variations of normal cathode regeneration techniques, and are of interest in leading to more complex combinations which should be of interest to amateurs, especially as they provide a very simple means of changing from crystal operation to variable frequency operation. While it is true that the modern amateur is operating very largely with variable frequency

oscillators, the use of crystals to provide indication and operation at the band edges is a very desirable feature of good operation, while a large number of network and similar group activities are also conducted on spot frequencies. A growing practice among workers upon ultra-high frequencies is to have a stand-by low-frequency, so that contact can be made in the case of unusual and interesting ultra-high frequency conditions, to inform other interested workers. All such applications are best achieved by crystal control, while crystal control

next stage. The logical development, is to use a tetrode or pentode oscillator valve, and to use the screen as the triode anode, while a suitable impedance or tuned circuit is employed in the anode circuit to obtain an increased output voltage. It is immediately clear, that the Lestet circuit developed in this manner provides the familiar tritet circuit of Fig. 5, while the less familiar circuit of Fig. 6 derives from a similar treatment of the triode circuit of Fig. 4b. In point of fact, the circuit of Fig. 6 is preferable to the usual tritet circuits, as if a normal tuned circuit is arranged to be substituted by a switch for the crystal, variable frequency operation is immediately available when required. In the interests of stability, it is necessary of course for the tuned circuit to operate with a high C, a fact still not appreciated very clearly by some writers for the amateur fraternity. As a typical example, satisfactory operation on both crystal and variable frequency operation has been found using for the tuned circuit a coil of eight turns close spaced on a 1 1/4 in. former, with fixed padding capacity of approximately 450 pF. experimentally adjusted so that the 80 metre band can be comfortably covered on a 160pF variable tuner-condenser. It is clear that the slight extra capacity of the capacity tapping section is of no importance in view of the restricted frequency range in any case necessitated by the use of large fixed swamping capacities for stability considerations.

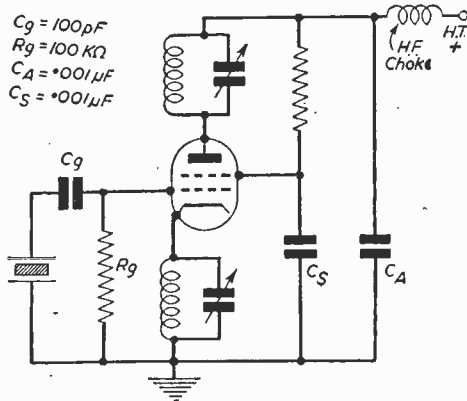

Fig. 5.—The standard Tritet circuit familiar to every amateur transmitter.

is almost mandatory for serious ultra-high-frequency working. The possibility of a simple switching means for obtaining crystal output from a normal variable frequency oscillator (VFO) is thus of considerable interest.

The circuits of the "hot cathode" oscillators of Fig. 4 are thus suggestive. Fig. 4a illustrates a circuit using a cathode choke for regeneration, while the circuit of Fig. 4b was popular at one time under the title of the "Lestet Oscillator." The circuit of Fig. 4c, which employs a capacitatively tapping system analogous to the tapped coil "electron coupled" oscillator circuits, is of particular interest as forming a basis for a rapid and simple means of changing over from crystal operation to variable frequency operation. In the capacity-tapped circuit, the condensers may be adjustable trimming types to allow of adjustment for specific operating conditions with a given oscillator valve. As a guide, the condenser CA should be between 10 to 30 pF, so that a 30 pF trimmer will be found suitable, while the capacity CB will be between 50 to 150 pF.

The circuits of Fig. 4 have the obvious disadvantage that in their triode forms output has to be taken off from the grid, so that only a limited output is available for driving the

Fundamental

It is to be noted that it is highly inadvisable to tune the anode circuit to the fundamental crystal frequency, a restriction similar to that with the normal tritet circuit. However, with only a choke in the anode, good fundamental output is secured, while a tuned circuit will give excellent second and third harmonic outputs. To avoid switching problems when changing from fundamental to harmonic operation, a convenient solution is to use a combination of a tuned circuit for harmonic operation in series with a choke for fundamental operation, as the anode load circuit. At fundamental frequencies, the tuned circuit will have a low impedance, so that the choke is the effective output impedance, while at the harmonic frequency the tuned circuit will provide adequate impedance. This applies to crystal operation only,

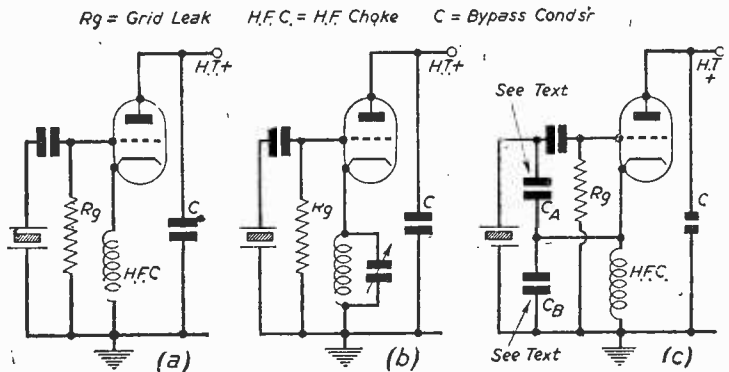

Fig. 4.—Three "hot-cathode" oscillators, (a) utilising a choke, (b) a tuned cathode circuit, and (c) a tapped coil of the electron-coupled type.

for if a tuned circuit in the anode is adjusted it will slightly affect the frequency of operation when using a tuned circuit in the grid circuit for variable frequency operation. It is good practice therefore to use only a choke in the anode output when variable frequency operation is required, so that the oscillator drives a further buffer-amplifier or frequency multiplier. With choke output, and driving a 6L6 buffer stage with an untuned grid circuit, adequate output up to the fourth harmonic has been obtained to drive a final 807 tetrode final stage, in a transmitter designed by the writer.

As a logical conclusion to the consideration of the above series of circuits derived initially from the simple Pierce Oscillator of Fig. 4, the circuit of Fig. 7 is presented. This is very closely analogous to the oscillators previously considered, and it is dangerous to tune the anode circuit to the crystal fundamental, as regenerative effects will produce a high probability of crystal fracture. As will be shown, crystal fundamental operation can be readily effected by use of the switch shown, while for normal harmonic operation good output is secured. When the switch shown is in the open condition, the grid and screen of the tetrode or pentode oscillator valve are used as a conventional Pierce oscillator with the screen performing the function of a triode anode. The normal pentode anode circuit provides for harmonic output, if the tuned circuit is tuned to the appropriate harmonic. For fundamental operation, the switch is closed, when the screen is automatically bypassed to ground, and the crystal is now effectively connected from grid to ground from the point of view of RF. If the tuned circuit in the anode is arranged to tune at crystal frequency, the circuit will now operate as a fundamental crystal oscillator of the familiar tuned anode type.

### Over-excitation

In conclusion, it should be realised that it is poor practice to operate a crystal oscillator under conditions leading to over-excitation of the crystal. This is particularly true to-day, when a number of crystals smaller physically than the larger crystals formerly used, are coming into use. Overheating

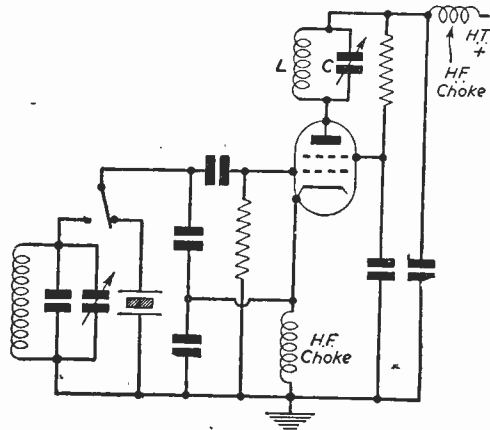

Fig. 6.—A modified Tritet circuit which has certain advantages as explained on p. 111.

of a crystal is a danger sign, and the makers' recommendations should be closely followed in regard to crystal current and operating voltages of the associated oscillator valve. This is particularly important, as even a very momentary increase of crystal current above the danger point can fracture the crystal. It is necessary, therefore, to ensure that under normal operation the crystal is well below the maximum permissible loading. Excessive crystal heating is likely to result in erratic frequency

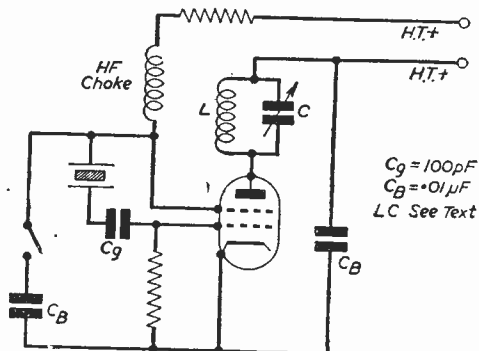

Fig. 7.—Another modification of the original Pierce Oscillator in which also the precaution must be taken of not tuning the anode circuit to the same frequency as the crystal.

jumps due to changes in the air gap, or of expansion of the electrodes in the case of certain types of crystal holders. The life of a crystal with proper care and use is indefinitely long, but its destruction under overload is a matter of micro-seconds. While recommendations as to the operating anode voltage of the oscillator tube are no protection against improper adjustment, provided only harmonic output is required, the pentode multiplier circuits can be operated up to at least 400 volts anode potential, with screen resistors of about 30,000 ohms to ensure a low screen potential. In the Pierce oscillator itself, where the crystal is subjected to the full RF potential, 250 volts anode potential should not be exceeded.

### Faraday Medal to T. L. Eckersley

T. L. ECKERSLEY, one of the most distinguished of the Marconi Company's senior research engineers, has been awarded the Faraday Medal, which is one of science's premier awards. It will be remembered that he was awarded a Fellowship of the American Institute of Radio Engineers in 1946 "for his outstanding contributions to the theory and practice of radio-wave-propagation research."

From the standpoint of practical communications, his invention of mathematical tools useful in the computation of radiated fields was an achievement of lasting value acclaimed by the whole radio world.

Before joining the Marconi Company in June, 1919, Mr. Eckersley had done notable work at the National Physical Laboratory, Trinity College, Cambridge, the Cavendish Laboratory, Cambridge, and as a member of the Egyptian Government Survey in 1913 and 1914.



# SIMPLE SIGNAL TRACER

A Unit for the Serviceman, Experimenter and Amateur

By F. R. MORLEY

**M**OST readers, whether they be amateurs, experimenters or servicemen, undoubtedly have receivers to service from time to time. The signal-tracer to be described provides, in the writer's opinion, the most rapid and easy way of locating snags in even the most complex superhet.

It is best used in conjunction with a signal generator, eminently suitable designs for which have appeared from time to time in the pages of PRACTICAL WIRELESS, perhaps one of the simplest being that described in the June, 1950, issue. A modulated signal is fed into the aerial terminal and the test probe is brought into contact with the grid of the first stage, be it detector, R.F. amplifier, or mixer. If the signal is heard "loud and clear" in the loudspeaker of the tracer, then the probe is placed on the anode. This check carried out through the R.F., mixer, I.F. and detector stages, should pin-point the location of the snag. If the snag is in the A.F. side of the receiver, the selector switch is turned to position 2, and a specially made-up lead plugged into the jack on the front of the tracer. This lead consists of a length of twin flex, connected at one end to a standard plug, and terminating in a crocodile clip (for earth connection) and an insulated test-prod. The crocodile clip is attached to the chassis of the receiver, and the test prod used as before. Position 3 of the switch is used when the output stage is suspect.

The rapidity of this fault-finding system will be apparent: it takes longer to describe than actually to carry out. It will be obvious, also, that the tracer can be used to test pick-ups, amplifiers and other audio-equipment.

## Construction

Construction is simple, and no snags should be experienced in the building and testing of the unit. The power supply and the two A.F. amplifiers are

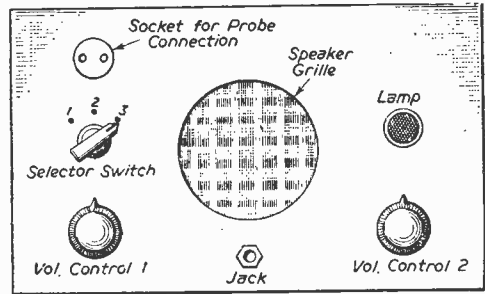

Fig. 1.—Details of a suitable panel layout.

mounted on a chassis of normal construction. In the writer's unit everything is contained in an ex-Government aerial-loading unit which measures some 10in. by 7in. by 6½in. A 3in. speaker was used for compactness. The power supply shown uses a bridge-connected metal rectifier, but this was due to having one at hand. No doubt a half-wave rectifier or a type 6x5 could be used equally well.

The probe detector unit is quite straightforward, and uses a 6Q7 because of the top-cap grid connection. An old electrolytic can, with round Tufnol or bakelite discs to seal the ends, makes a con-

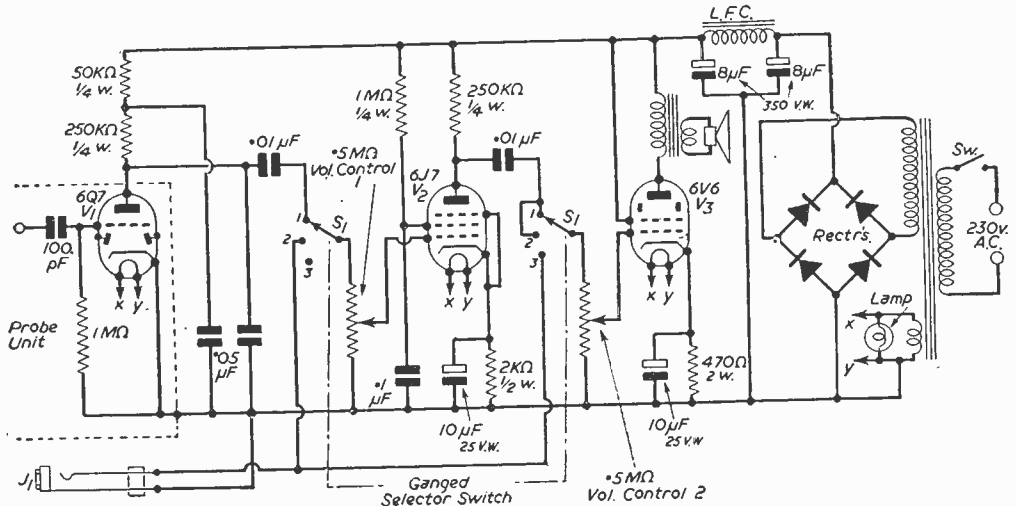

Fig. 3.—Circuit of the Signal Tracer.

venient housing for the 6Q7. A miniature ceramic 100 pF. condenser and a 1 MΩ resistor are mounted in the can as shown in the diagram. A twin-shielded cable connects to the probe, with the external shielding forming the earth connection. The cable terminates in a shielded two-pin plug, which screws into a suitable socket on the tracer.

#### Cost

The writer's unit was built mainly of junk-box parts, the only specially bought item being the case, which cost half-a-crown. In any event, a unit like

this pays for itself in time saved on many servicing jobs.

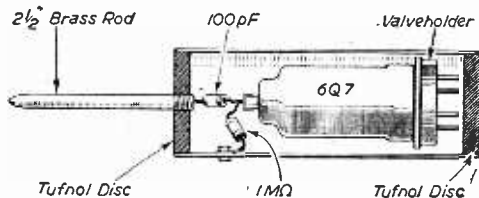

Fig. 2.—The test probe.

## News from the Clubs

### WORTHING AND DISTRICT AMATEUR RADIO CLUB

Hon. Sec.: F. Betterley, 42, Anweir Avenue, Lancing, Sussex. MEETINGS are held on the second Monday in the month at 7.30 p.m., at the Adult Education Centre, Worthing. There are slow Morse transmissions every Wednesday night, from 9 to 10 p.m. G.M.T., on top band 160 metres.

### READING RADIO SOCIETY

Hon. Sec.: L. A. Hensford (G2BHS), 30, Boston Avenue, Reading, Berks.

THE Christmas holiday reduced the number of meetings of the Reading Radio Society during December to one, at which questions from recent City and Guilds radio examination papers were discussed.

During February there will be a series of talks by local Hams on operating in the various amateur bands. These will work downwards in wavelength, to reach 10 metres and possibly the V.H.F.'s before the A.G.M. in March.

### HARROGATE RADIO SOCIETY

Hon. Sec.: F. Walker, 99, East Parade, Harrogate, Yorks.

THE smaller of the two rooms recently rented by the society has now been made comfortable and two Mullard film strip lectures have already been given. A class in basic radio theory has been arranged and is being given by Mr. E. Horsley on Friday nights at 7.30 p.m.

New members and visitors will be welcomed to the new premises at the rear of No. 14, Union Street.

### STOURBRIDGE AND DISTRICT AMATEUR RADIO SOCIETY

Hon. Sec.: W. A. Higgins (G8GF), 23, Kingsley Road, Kingswinford.

ADVERSE weather prevented the lecturer attending the December meeting. Discussed, and decided to form, educational group for technical and Morse training for non-transmitters.

### LOTHIANS RADIO SOCIETY (EDINBURGH)

Hon. Sec.: I. Mackenzie, 41, Easter Drylaw Drive, Edinburgh, 4.

THE society meets fortnightly at 25, Charlotte Square, Edinburgh, at 7.30 p.m.

An invitation to attend meetings is extended to prospective members.

### THE STOKE-ON-TRENT AMATEUR RADIO SOCIETY

Hon. Sec.: J. R. Brindley, B.Sc. (Eng.) (G3DML), 45, Rosendale Avenue, Chesterton, Newcastle, Staffs.

MEETINGS are held every Thursday at 8 p.m., at the Club H.Q. (rear "Cottage Inn," Oakhill, Stoke-on-Trent).

Parts of each evening are devoted to Morse classes, practical work and discussions on all relevant subjects.

Fortcoming events are:

February 8th—Impedance Matching.

February 15th—The Use of Germanium Crystals and other Diodes.

February 22nd—Voltage Stabilisation of Power Supplies. New members are always welcomed.

### DERBY AND DISTRICT AMATEUR RADIO SOCIETY

Hon. Sec.: Eric Shimmin, Leafmoor Mount, Derby Lane, Derby.

AT the annual general meeting of the above society, held on January 3rd, 1951, the following officers were elected:

President: A. G. G. Melville, F.R.C.S.

Chairman: W. A. Mead.

Hon. Sec. and Treasurer: E. Shimmin.

Assistant Sec.: F. C. Ward.

Contest Sec.: A. J. Smith.

### THE SLADE RADIO SOCIETY

Hon. Sec.: C. N. Smart, 110, Woolmore Road, Erdington, Birmingham, 23.

VISITORS to the society's meetings, which commence at 7.45 p.m. prompt, are cordially welcome. Full particulars of the society and its activities may be obtained from the honorary secretary.

Fortcoming events are as follows:

February 16th—Mullard film strip lecture: "Television—Part I."

March 2nd—Mr. C. H. Banks, of C.J.R. Electrical & Electronic Development, Ltd.: "High Quality Tape Recording."

March 16th—Mullard film strip lecture: "Television—Part II."

March 30th—Spring cleaning sale.

### THE BRIGHTON AND DISTRICT RADIO CLUB

Hon. Sec.: R. T. Parsons, 14, Carlyle Avenue, Brighton, 7.

THE A.G.M. was held on January 2nd and the club's activities during 1950 were reviewed. New officers elected for 1951 are:

Chairman: Capt. R. Dainty.

Hon. Sec.: Mr. R. T. Parsons.

Treasurer: Mr. E. Cole.

The programme for the new year is well under way. Talks, demonstrations and film strips are laid on. It is hoped to maintain the high standard set by the retiring committee, especially its chairman, Mr. Nield, and secretary, Mr. Hobden.

### WESTON-SUPER-MARE RADIO SOCIETY

Hon. Sec.: Will. Holley (G5TN), "Waverley," Worlebury Hill Road, Weston-super-Mare.

THE winter programme of the society is in full swing at the Y.M.C.A., 2, Bristol Road, and meets on the first Tuesday in every month.

All readers of PRACTICAL WIRELESS resident in this district are cordially invited to attend the meetings.

### BASINGSTOKE-DISTRICT AMATEUR RADIO SOCIETY

Hon. Sec.: L. S. Adams (BSWL565), "Roslen," 16, Brambly Drive, Basingstoke, Hants.

AT the annual general meeting recently it was decided to discontinue activities owing to lack of support from members. The final meeting took place on October 6th.

### EDINBURGH AMATEUR RADIO CLUB

Hon. Sec.: Alan G. Bruce, 89, Marchmont Road, Edinburgh, 9.

MEETINGS continue this year at Unity House, 4, Hillside Crescent, Edinburgh, every Wednesday at 7.30 p.m. The club transmitter will be on the air every alternate week under the call sign G3HJAM.

The coming months will include lectures on radar navigation aids, antennas, model control and audio amplifiers. A transmitting and receiving contest is being planned to be held in February.

Classes for the coming R.A.E. examination are being held again this year as last year's classes were very successful.

### NORTH KENT RADIO SOCIETY

Hon. Sec.: L. E. J. Clinch, 8, Windsor Road, Bexleyheath, Tel. 1303.

MEETINGS are held at H.Q., Fremantle Hall, Bexley, on the second and fourth Mondays in the month.

### NEW CLUB FOR SOMERSET

IT is proposed to form a club in the Street, Glastonbury and Wells district of Somerset. All who are interested are invited to write to Mr. M. E. Ingerfield, at 4, Ivythorn Road, Street, Somerset.

1951



**K51 HIGH-FIDELITY AMPLIFIER.** Complete with detachable remote-control, 6 watts push-pull output, negative feedback, distortion below 0.5 per cent. Frequency range 30-20,000 cps., separate bass and treble controls. Mic/RadioGram (33178) selector. Guaranteed for Two Years. £17.17.0. In Kit form, £14.14.0.



**RC TUNING UNIT.** Combined T.R.F./Superhet receiver, 4 valves, 3 wavebands. High sensitivity R.F. stage on all bands, 2 R.F. stages on T.R.F. reception, infinite impedance detector. Two Years' Guarantee. £14.18.6 inc. P.T.



**RG QUALITY TUNING UNIT.** Variable selectivity local station T.R.F. receiver. Employs two stages of R.F. amplification feeding into I.I. detector. Long and Medium wavebands. Guaranteed for Two Years. £8.14.2 inc. P.T.



**CATALOGUE.** Our fully illustrated catalogue makes interesting reading. May we send you a copy? Write today to:—

Our range also includes, of course, the **CONCERT MASTER Amplifier**, and **TRICORNE Speaker Chambers**.

Phone :  
WEStern  
3350

*Charles*  
**AMPLIFIERS**  
(SALES) LTD

181, KENSINGTON HIGH ST., LONDON, W.8

**SOUTHERN RADIO'S WIRELESS BARGAINS**

**R.3515 TELEVISION UNITS.** 21 valves with 6-stage 14 m/c. I.F. strip, recommended for ideal T.V. conversion by all experts. Brand new in original wooden cases. £3/10/-.

**R.1355 RECEIVERS.** Brand new and unused, as specified for Inexpensive Television. £2/5/-.

**T.R.1198.** 6-valve superhet receivers. Perfect and guaranteed. 22/6, plus 1/4.

**BENDIX COMB AND RECEIVERS.** B.C.454 (49-100 metres) B.C.455 (39-49 metres). Complete with 6 valves. Perfect condition. 35/- each, plus 1/4.

**THROAT MICROPHONES.** With Lead and Plug—Magnetic. 4/6.

**CONTROL CABLES.** 14 ft., with adaptors for B.C.453/4/5. 9/6 each.

**SPEAKERS.** Celestion 2 1/2 in. P.M. moving coil. 3/5 ohm. 17/6.

**WALKIE-TALKIE (TRANSRECEIVER).** Complete with 5 valves, throat microphones, headphones and aerial. Type 38. Mark II. Guaranteed working. £3/10/0. Carriage Paid.

**R.A.F. BOMBSIGHT COMPUTERS.** Complete, brand new, with majors, gyro gears, blowers, etc., etc. Ideal for model maker, etc. The best component value ever offered. 55/- each, plus 5/-.

**LUFERA HOLE CUTTERS.** Adjustable from 1/4 in. to 3/4 in. for use on wood, metal, plastics, etc. 5/6.

**CONTACTOR TIME SWITCHES.** By Smith or Verner. 10-hour movement with the thermostatic control. 2 impulses per second. Complete in soundproof case. 10/-, plus 1/4.

**HAND GENERATORS.** 6 volts at 5 amps. Complete with crank. 2/1/-.

**RADIO COMPASS INDICATORS.** with internal Selsyn motor. 3 in. dial. 13/6; 5 in. dial. 15/6.

**INVERTER UNITS.** Type (PE 206A) 206-A D.C. input 27 volts at 33 amps., 6.000 r.p.m. A.C. output, 80 volts, 800 cycles. Complete brand new with spares. £3/10/- each.

**CHANCERY LONG PLAYING ATTACHMENT G33.** For using L.P. Records on radioGram or Record Player with high fidelity Decca Pick-up. £6/5/-, including carriage and packing.

Full list of RADIO PUBLICATIONS, 2/4.

Please Note New Address :

**SOUTHERN RADIO SUPPLY LTD.**

11 Little Newport St., London, W.C.2  
GERrard 6653



*high fidelity*  
**M I C R O P H O N E S**

**FOR PUBLIC ADDRESS, RECORDINGS, AMATEUR RADIO TRANSMITTERS**

**TYPE MIC 22**



Incorporates the Acos "Fitercel" insert giving extreme sensitivity and high fidelity. Response substantially flat from 40-6,000 cps. Vibration- and shock-proof. Not affected by low-frequency wind noises. Two alternative mountings available as illustrated (MIC 22-2 and MIC 22-1).

Price £6 6s. 0d. (either model).

**TYPE MIC 16**



Incorporates the Acos Floating Crystal Sound Cell giving a response substantially flat from 30-10,000 cps. Unaffected by vibration, shock and low-frequency wind noise. Alternative mountings as shown (MIC 16-2 and MIC 16-1).

Price £12 12s. 0d. (either model).

COSMOCORD LTD., ENFIELD, MIDDLESEX.

# BUILD A PROFESSIONAL LOOKING RADIO AT LESS THAN HALF TODAY'S PRICE

Due to greatly increased production we are now able to offer these Kits at greatly reduced prices. Both are housed in attractive Bakelite Cases, size 12in. x 5in. x 6in.

Each Kit is complete in every detail, nothing has to be made or improvised. Easy to follow, point-

to-point diagrams are supplied, making construction very simple. They are for use on 200-250 volt mains, and both A.C. and Universal Models can be supplied.

The Dials are illuminated, and the receivers present an attractive appearance.

**T.R.F** Valve line up:  
6K7 H.F. Pentode.  
6SH7 Detector.  
CV1510 Beam Power Output in the A.C. Model.  
The A.C./D.C. Output Valve is 12A6. Both use Metal Rectifiers.

Waveband coverage is for the Medium and Long bands.  
Price £4/19/6 (carriage & packing 2/6d.), with Walnut or Ivory Cabinet.

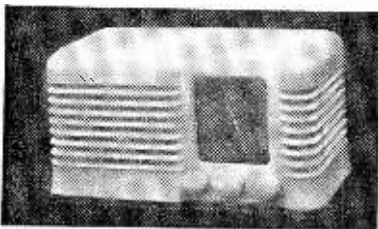

**SUPERHET** Valve line up:

6K8, 6K7, 6Q7 & CV1510 Beam Power Output in the A.C. Model.  
The A.C./D.C. Output Valve is 12A6. Both use Metal Rectifiers.  
Waveband coverage is 16-50, 190-540 and 1,000-2,000 m.  
Price £6/19/6 (carriage & packing 2/6d.), with Walnut or Ivory Cabinet.

Circuit diagrams only can be supplied at 1/6d. each. Cabinets only available at 17/6d.

**PREMIER RADIO CO.**

**COMPLETE CATALOGUE 6d.**

**MORRIS & CO. (RADIO) LTD**

ALL POST ORDERS TO OUR NEW FACTORY AT—  
740, HIGH RD., TOTTENHAM, N.17. Tottenham 5371-2-3.  
CALLERS TO 152/3 FLEET ST., E.C.4. Central 2833.  
207, EDGWARE RD., W.2. Ambassador 4033.  
This branch is open until 6 p.m. on Saturdays.

STUDY AT HOME

IN YOUR SPARE TIME

## THE BENNETT COLLEGE

*will set you on the right course for success*

You make sure of planned progress in the career of your choice when you let the most progressive, most successful Correspondence College in the world coach you through the post. By friendly, individual training we equip you with the specialised knowledge you must have for a well-paid key position. Make the first move TO-DAY—post the coupon below.

**ALL TEXT BOOKS ARE FREE!**

We send you as many volumes as the subject chosen demands, and they become your personal property.



IS YOUR CAREER HERE?  
IF NOT, WRITE FOR FREE ADVICE

- |                 |                    |
|-----------------|--------------------|
| Accountancy     | Engineering        |
| Blue Prints     | Languages          |
| Book-keeping    | Mining             |
| Chemistry       | Secretaryship      |
| Civil Service   | Shorthand (Pitman) |
| Commercial Art  | Wireless           |
| Draughtsmanship | Works Managers     |

To Dept. 104, THE BENNETT COLLEGE LTD., SHEFFIELD.

Please send me (free of charge)

Particulars of ..... Cross out line which does not apply

Your private advice about .....  
PLEASE WRITE IN BLOCK LETTERS

Name .....

Address .....

## SERVICE ENGINEERS' DATA

BRITISH SETS

Folder No. 1 containing 100 service sheets, covering British receivers which have been sold in big quantities, and which every service engineer is ultimately bound to meet. The following makers are included: Aerodyne, Alba, Bush, Cossor, Ekco, Ever-Ready, Ferguson, Ferranti, G.E.C., H.M.V., Kolster Brandes, Lissen, McMichael, Marconi, Mullard, Murphy, Philco, Phillips Pye, Ultra. Undoubtedly a



mine of information invaluable to all who earn their living from radio servicing. Price £1 for the complete folder

### AMERICAN SET DATA

Our folder No. 2 comprises 100 Service Sheets, covering most of the popular American type T.R.F. and superhet receivers which have been imported into the country. Names include Sparton, Emmerson, Admiral, Grossley, R.C.A. Victor, etc. Each sheet gives circuit diagram and component values, alignment procedure, etc., etc. Price for the folder of 100 sheets is £1, post free.

### MISCELLANEOUS PUBLICATIONS

These give circuit diagrams and details of ex-Government receivers and equipment. In practically all cases the information has been extracted from official publications. Separate booklets for each piece of equipment. Booklets available covering the following: R155, R209, R109, TR1196, TR18, BC349, BC312, R118, Wireless Set 22, R107, R103, BC221, BC342, Pre-Amp from RF27, Pre-Amp from Unit 208A, T.V. Receiver from 11-metre superhet for London or Birmingham, T.V. receiver from 3170, etc., T.V. receiver from 194 strip or 1355 strip. Dual-band T.V. receiver. Price of any of these booklets is 2/3 each.

### OUR BARGAIN CORNER

It will pay you to find time to call upon us at our Ruislip Showrooms. Our "Bargain Corner" is particularly popular as there are truly bargains to be picked up. For instance, last month we had R1155 receivers from £3.10.0 each, not complete, of course, but undoubtedly real bargains. Our premises are very close to Ruislip Manor Underground Station.

We close at 1 p.m. on Wednesday but remain open on Saturday afternoon.



**PRECISION EQUIPMENT**

7, Electron House, Ruislip Manor, Middx.

# Cathode-follower Radiogram Switching

A Method of Obtaining Non-distorting Volume Control

By D. H. NORTHCOTE

THE so-called "infinite impedance detector" is now widely used in quality radio-gramophone equipment designed for reception of local stations in addition to record reproduction. Those readers who have constructed such equipment may be interested in the following suggestions for deriving additional benefits from this circuit.

First, let us consider a conventional arrangement of the detector in a radio feeder unit (Fig. 1). This unit also contains the R.F. stages and, should the pick-up used be one with low output, possibly a pre-amplifier stage. For convenience, all the controls are often accommodated on the unit, and the output fed by screened cable to the more

the grid of the first A.F. amplifier on a separate chassis.

## Feed-back Loop

Now the present trend in amplifier design demands a high overall gain and the minimum phase shift, so that negative feed-back can be used to the best effect. Thus high-gain pentodes are favoured for voltage amplification in order to reduce the number of stages required, and so to decrease the amount of phase shift that takes place within the feed-back loop. Referring again to Fig. 1, we see, then, that the switching, the comparatively high resistance volume control, and the long (although admittedly screened) connecting lead are all in the grid circuit of a high-gain pentode; and if the pick-up used be of high impedance, or if a pre-amplifier is used, the impedance from the lead to earth, with the switch in the "gram" position, will be high. The danger of hum or instability occurring will be appreciated, and, of course, if this does arise it will be outside the feed-back loop.

In addition, a defect which is perhaps more important is that as the moving arm approaches the earthed end of the volume control a successive and considerable attenuation of the higher audio-frequencies takes place, a well-known phenomenon which can be proved both in theory and practice. The use of an R.F. volume control can overcome this disadvantage on radio reproduction, and a treble boost control can, after a fashion, give some compensation on gramophone. but this form of compromise is not very satisfactory, particularly since the advent of microgroove recording means that an amplifier must accept an input voltage which is a fraction of that obtained from standard records, and yet reproduce the latter without any distortion due to the volume control being turned well back.

## Improved Arrangement

These disadvantages can be overcome by the use of a simple circuit modification shown in Fig. 2. It will be seen that here the valve performs the dual function of a demodulator when switched to "radio," and of a cathode-follower, with class "A" biasing, in the "gram" position. A 2-pole 2-way switch is employed enabling the grid to be connected either to the tuned circuit or to the pick-up, while the other pole earths the R.F. filter condenser on "radio," and on "gram" shorts out the tuned circuit, preventing radio break-through. In the latter position the R.F. filter condenser is disconnected from earth so that the upper extreme of the audio spectrum is preserved. R2 in Fig. 2

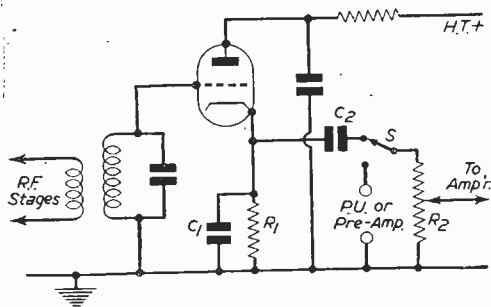

Fig. 1.—An orthodox circuit for infinite impedance detector, radiogram switching, and volume control.

cumbersome main amplifier and power pack, situated, say, in the base of a cabinet. In the circuit of Fig. 1 the detector may be almost any medium impedance triode, say a 6C5 for 6-volt operation. It functions as an anode-bend detector with a completely decoupled anode and the output taken from the cathode. Thus there is 100 per cent. negative feed-back over the stage, causing it to be very linear and to accept a wide variation of input without distortion. In addition, it presents an extremely high impedance to the tuned circuit, giving good selectivity. The gain, however, is slightly less than unity. The radio output voltage is developed across a 50,000 $\Omega$  cathode resistor R1, and the R.F. component is filtered off by a condenser C1, of from 100 to 300 pF capacity. Sometimes a bridge R.F. filter is employed, an R.F. choke or 10,000 $\Omega$  resistor with a further filter condenser being inserted in the lead from the cathode. The D.C. component is blocked in the usual manner by a condenser C2 of 0.1  $\mu$ F capacity and the output is fed via a "radiogram" switch and volume control R2 (normally 500,000 $\Omega$ ) as shown, to



is the normal cathode bias resistor for the valve used (for the 6C5 it will be  $1,000\Omega$ ) and its "earthy" end is joined to the "gram" contact of the switch via a one megohm grid leak R1 to provide correct conditions of bias. R3, the cathode load, is a  $50,000\Omega$  potentiometer, and serves as the volume control from which the output is tapped off via the usual condenser C2. Even if a pre-amplifier is not used, a  $.1\mu\text{F}$  blocking condenser C3 must be included in the unearthed pick-up lead so that the D.C. path through the pick-up does not upset the biasing conditions. Where a pick-up is connected in this fashion a resistor of the appropriate matching value may be connected across the pick-up leads before the blocking condenser.

### Advantages

With the circuit arranged as shown in Fig. 2 the following advantages are gained:

- (1) The "radiogram" switching is now in the grid circuit of a no-gain stage, and providing care is taken that the leads do not interact with the preceding R.F. stages on "radio," the chance of hum or instability arising here is greatly reduced.
- (2) The higher audio-frequencies are preserved for all settings of the volume control, while the A.C. damping on the detector is reduced when the control is turned down.
- (3) On both "radio" and "gram" the terminating valve on the feeder chassis is a cathode-

follower, which, by its nature, is eminently suitable for such a rôle, and a low impedance is now pre-

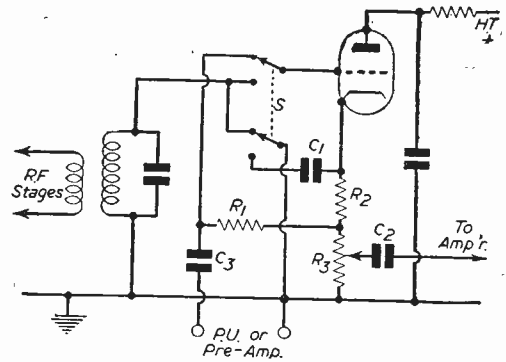

Fig. 2.—Detector with switching for cathode-follower operation on "gram," and modified volume control.

resented to the amplifier connecting lead, improving stability and reducing losses.

One final point: if in the original circuit the volume control also functioned as the grid leak for the first A.F. amplifier, then, of course, a fixed resistor must be provided for this purpose if the circuit of Fig. 2 is adopted.

## WHICH DIRECTION?

The Puzzling Problem of Current Flow Explained

By ERIC LOWDON

THE embryo radio-man must occasionally feel that the path of knowledge is indeed hard and stony. Especially when he comes across a simple circuit such as that shown in Fig. 1, where the direction of current is indicated by the arrow as flowing from negative to positive. This, he will tell you indignantly, is a complete contradiction of what he has learned in elementary electrical textbooks where current is invariably shown as flowing from positive to negative, as in Fig. 2.

What is he to make of it? Is he to assume, because a diode is shown in Fig. 1, instead of a resistor as in Fig. 2, that a valve has the property of reversing the current flow from the battery? Or can it be that there are two kinds of direct current—one kind that flows through valves in a direction opposite to that which flows through a resistance.

If we answer these questions correctly by telling him that the valve has no effect on the direction of the current flow and that there is only one kind of D.C. so far as direction of flow is concerned, that, in fact, the current flows in the same direction in both circuits though the arrows are pointing different ways, the poor chap is likely to feel completely bewildered.

Unfortunately, there does not appear to be any kind of logical reasoning which we can put before him to justify this anomalous state of affairs. All

we can do is to take him by the hand and lead him back through the years when electrical science was just an infant, and try to show him how it all came about.

### Early Knowledge

At one time, before electrons were discovered to complicate matters, nobody knew the direction in which an electric current flowed. They probably did not care very much either, but as a matter of convenience all the denizens of the scientific world got together and decided to say that it flowed round the external circuit from positive to negative. The terms positive and negative were plagiarised from the mathematicians; positive merely meaning a direction or quantity that is opposite to that which we have agreed to call negative. Having agreed on these points it was possible to evolve formulæ and rules that were universally understood and everybody was quite happy.

Then along came the electron theory of electricity, and the discovery of thermionic emission which gave us the valve. There was now little doubt that current really flowed from negative to positive and this, of course, let the cat among the pigeons with a vengeance. If only the old-timers had guessed correctly when they first established their convention there would be no confusion to-day. But they did not, and since the old convention was so firmly

established it has been allowed to remain as anyone can prove for themselves by reading through any electrical textbook. Radio-men, however, refuse to have anything to do with such old-fashioned notions, and in valve circuits the current is always shown in the direction of the electron flow from cathode to anode which is, of course, from negative to positive.

**Negative Anode**

While we are on this subject of positive and negative let us take a look at another question which is often a stumbling block to the novice.

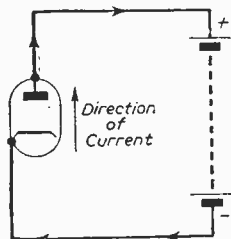

Fig. 1.—A simple circuit with current flow indicated.

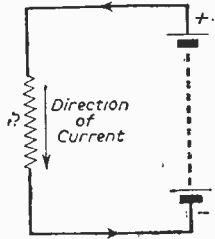

Fig. 2.—Text-books show current flowing as shown here.

One often reads in technical writing that when the grid of a valve swings in a positive direction—in a circuit such as that shown in Fig. 3—the anode “goes negative.” Since the anode is connected to H.T. positive via R, it may be a little difficult to see how it manages to go negative. Before we answer this question let us see if we can define a little more clearly what we mean by positive and negative.

It is often stated that the anode of a valve is so many volts positive. Now what exactly does this statement mean? A voltage cannot exist at one point in a circuit—it must exist between two points, and, therefore, to say that any point in a circuit has a potential of X volts positive or negative is meaningless. To be correct the voltage should be referred to some zero point in the circuit. For example, it would be correct to say that the anode is X volts positive to earth where earth is the zero reference point. In radio circuitry, however, there are certain voltages that are nearly always referred to the same point, and since this is generally understood by experienced radio-men this reference point is not always mentioned. The anode voltage is an example of this.

Nevertheless, there are occasions when it is necessary to mention the point to which the anode voltage is referred. For instance, look at Fig. 4. Here the circuit is identical to that of Fig. 3, but the anode is still positive to cathode or earth—but the anode in this case is marked negative! No, there is no misprint, it merely means that the anode voltage is now being referred to a different point in the circuit, in this case point A. There is a drop of voltage across R and so the anode is less positive to earth than is point A and, therefore, it is negative to A. If A is 300 volts positive to earth and the drop across R is 50 volts, then the anode is 250 volts positive to earth but 50 volts negative to A.

**A Reference Point**

And so we come to the earlier statement—when

the grid of a valve swings in a positive direction the anode goes negative. (Here, of course, the understood reference point for the grid voltage is the cathode.) As the grid swings positively with respect to cathode the current increases through the valve. This in turn means an increased volts drop across R so that the anode volts become less positive than before (with respect to earth). The new value of anode volts is thus negative to the original value

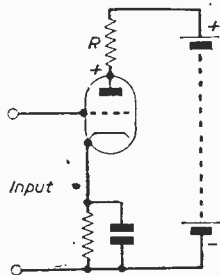

Fig. 3.—Simple valve circuit, showing polarity.

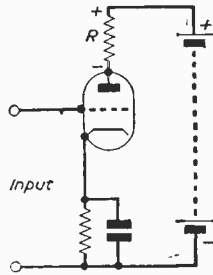

Fig. 4.—The arrangement of Fig. 3, but showing the anode as being negative.

which is the reference point in this case. In other words the anode has moved in a negative direction though it has not become negative to earth.

Similarly the statement that the grid swings in a positive direction does not necessarily mean that it is now positive to cathode. It merely means that the grid is less negative to the cathode than it was originally. For instance, if the grid has a fixed bias of -10 volts with respect to cathode and a signal of +5 volts is applied to it, then the resultant grid-cathode voltage will be -5 volts. The grid is still negative to cathode but it has moved in a positive direction.

To sum up, then, it will be seen that positive and negative are purely relative terms and the polarity of a fixed voltage or the direction in which a variable voltage is moving can only be determined in relation to another point in the circuit which for the moment is assumed to be zero.

**EMI in South Africa**

IN recent years there has been a great development in the field of secondary industry in South Africa, and many internationally famous manufacturers have established production plants there.

The latest world-famous organisation to set up a manufacturing plant in South Africa is Electric & Musical Industries Ltd. of Hayes, England, makers of the world renowned “His Master’s Voice” and Columbia gramophone records.

A factory site has been acquired in the vicinity of Johannesburg, on which a large modern factory is about to be erected. The manufacture of gramophone records in South Africa will give added opportunities to local talent, as the factory, in addition to pressing internationally famous recordings, will also press records specially suited to the South African market.

It is anticipated that the output will be large enough, not only to supply the local market, but also to supply an expanding export market.

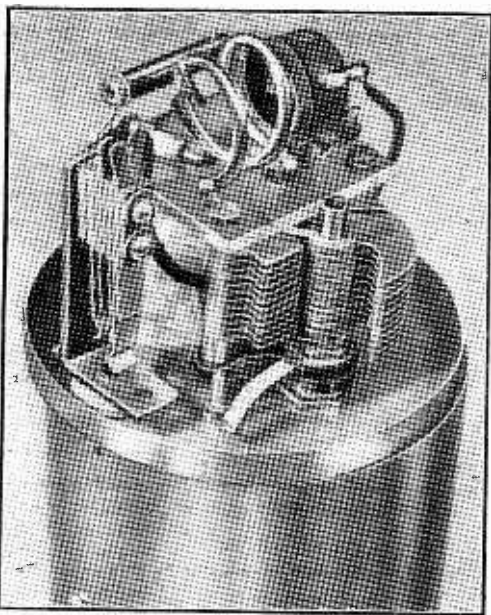

Fig. 2.—A “close-up” of the components mounted on the lid.

SEVERAL items which played important parts in the simple circuits of early transmitters and receivers became obsolete as radio developed, but with the advance of V.H.F. technique, and the return to simple circuits and arrangements, some components and ideas have made a come-back and are now in regular use again. The absorption meter is one of these.

The most obvious use of the wavemeter is also the simplest, but at the same time probably one of the most valuable. Quite one of the most difficult operations in V.H.F. work, is setting a superhet. oscillator stage to the required frequency, with certainty. It can be done by heterodyne methods, but as anyone with practical experience will agree, so many spurious signals and beats may occur that it is quite easy to set the oscillator frequency incorrectly. The absorption method is not subject to this ambiguity and it is not only the easiest, but also the quickest means available of checking the frequency, amplitude, and injection of the oscillator. Even if it served no other purpose, it would be worth while making up the instrument for this only.

Its other applications are of especial interest to television service engineers. One is the ease with which it can be used for rapidly locating a faulty valve or stage in the R.F. sections of a receiver; because of the amount of canning and screening in use, much time can be wasted on even this simple operation. Another use, which admittedly requires a little experience to apply, is that under standardised conditions it is possible to make reliable checks of stage gain in both vision and

# An Absorptic

A Modern Instrument

By A.

sound sections of a receiver in quite a short time; this again can be done without opening up the screening.

None of these applications could be described as precision operations, but precision is seldom required in the early stages of developing a receiver or locating a fault. In these circumstances, rapid indications are just as useful and much less laborious than the precise results given by laboratory methods. This is especially true in the V.H.F. field, where quantitative measurements may be open to suspicion and comparative results under controlled conditions are often a more reliable guide.

One of its earliest and most useful applications that the author found, was checking the resultant waveforms of a pattern generator during development. The ease with which the wavemeter can be linked in to convert the R.F. output of a generator into a demodulated input for the C.R.O., has to be experienced to be appreciated. Previously it had been necessary to set up a suitable receiver chassis for this purpose.

## General Design

The instrument itself can be a very simple piece of apparatus and allows considerable latitude both in construction and choice of components. As the circuit (Fig. 1) shows, it consists of a tuned circuit which is loosely coupled to the signal source, and the voltage induced at resonance is rectified by the crystal diode. The resulting D.C. is shown on the meter which thus forms the tuning indicator and shows the relative amplitude of the input signal. An output jack is included which disconnects the meter and replaces it with a load resistance. If the R.F. input is modulated, then the crystal diode functions as a detector, and the demodulated signal voltage can be taken out of the jack for either phones or with a modified load, for waveform examination on a C.R.O. The R.F. filtering is included so that if the output is used in this way, feedback will not take place from the external leads to the input source. If an external output from the wavemeter is not required, then both the jack and the filtering can be omitted.

The instrument illustrated in Figs. 2 and 3 is built into a copper screening can, 5in. high and 4in. in diameter. Screening is very desirable but

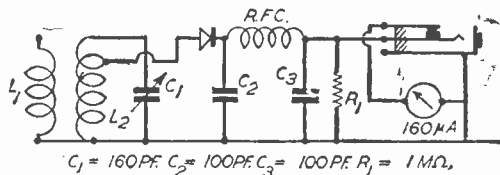

Fig. 1.—Theoretical circuit of the wavemeter.

# n Wavemeter

for all Types of Servicing  
FOLWELL

not really essential. Aluminium is equally suitable, and probably an ordinary tin box would be satisfactory. While compactness is an asset when in use, the diameter given makes rather a tight squeeze. The author had to shorten the pointer of the meter and select a tuning condenser of small dimensions. The tuning dial is also limited in size for the same reason.

The coils and the tuning condenser should be suitable for the band and coverage required. With the inductance suggested, the 160 pF tuning condenser tunes from just over 90 Mc/s to 35 Mc/s, which makes it suitable for the Alexandra Palace and Sutton Coldfield television apparatus, as well as the new F.M. station. If such a wide coverage is not required then a smaller tuning capacity can be used and the inductances suitably adjusted. If, as is often the case, it is also desired to cover the I.F. ranges of television superhets, it will be necessary to use separate coils for the purpose. Plug-in coils, or switching, can be arranged, but it is better to avoid these, and make another complete instrument. Considering the low cost and simple construction, it is not worth risking the loss of accuracy and reliability involved in coil changing. Another idea is to build the two units into one container and just switch the meter only. The objection to this is the increase in bulk and loss of convenience in use. As the required meters may be obtained from an ex-service Type 10Q2 Indicator (L. and R., crossed pointers, twin meter unit), sold at 5s. 11d., there is not much point in combining the instruments as the switch may cost more than the meter! There are, of course, several alternatives in regard to the meter. If a suitable microammeter is already on the bench, it can be used by plugging it into the jack outlet; this may be inconvenient in use. A meter can be purchased and built into the instrument in place of the surplus type suggested; this will increase the size slightly

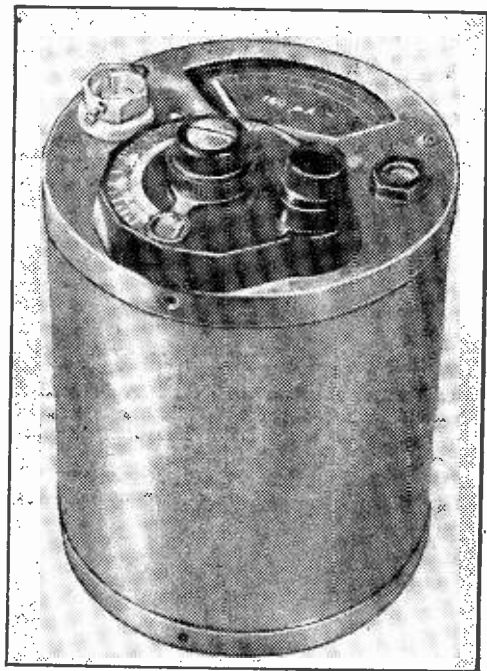

Fig. 3.—The finished wavemeter in its screening can.

and also the cost. The complete 10Q2 meter can be fitted as it is, and only one half of it used; the result will be rather bulky and heavy. Any of these methods should give satisfactory results; however, for readers who wish to use the type 10Q2 "surplus" meter, details of conversion and mounting are given at the end of this article.

### Constructional Details

The wavemeter itself is so simple that provided a few points are borne in mind, any method of construction may be adopted. The tuned circuit must follow normal V.H.F. practice and should also have a high Q. In the present case, L<sub>2</sub> consists of two turns, 3/4 in. diameter, of 12 s.w.g. copper; a smaller gauge could be used, but would be less rigid. The two turns are pulled out to make the coil an overall length of 3/4 in. and this is connected across the tuning condenser. The crystal diode is tapped on at a point half-a-turn down from the top end, using a very short piece of braided flexible wire. The exact point is not critical—a short lead is more important. The other end of the crystal is mounted in a rigid clip fixed near the coil. Soldering to the crystal caps is not permissible; small clips are easily made—keeping the capacity as low as possible, both across the crystal and to earth. British and American crystal diodes are opposite in polarity, as also are the L. and R. meters. Check for this before making the clips. If the meter and the crystal are connected in series with a single cell and 100KΩ resistor, the correct polarities are easily found. If surplus crystal

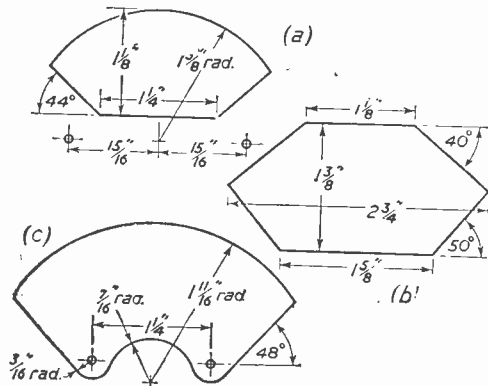

Fig. 5.—Details of the window, glass and new dial.

diodes are used, it may be necessary to select good specimens.

The only other important constructional point concerns the primary  $L_1$  and its connections. The former is slightly smaller in diameter than  $L_2$  and is close wound with two turns of 36 or 38 s.w.g. This is then mounted so that these turns are spaced  $\frac{1}{4}$  in. from the earthed end of  $L_2$ . Connect the adjacent end of  $L_1$  directly to the end of  $L_2$ . As the primary is a relatively high-impedance winding, parallel capacity must be kept as low as possible. The input lead is well spaced and taken as direct as possible to a low-capacity connector on the panel. A Pye co-axial connector is convenient for the purpose.

The only other components at R.F. are the filter condensers and choke; values are not critical, but leads should be kept as short as possible. The choke is a 3/16 in. former,  $1\frac{1}{2}$  in. long, close wound with a single layer of 40 s.w.g. enamelled copper wire. Most of these details are shown in the photograph on page 120. The complete instrument is shown on page 121.

The corresponding details for an instrument to cover the 13 Mc/s I.F. band are as follows: Using a  $\frac{1}{4}$  in. diameter former for  $L_2$ , wind 9 turns (tapped at 3 down) of 18 s.w.g., space wound to  $\frac{1}{4}$  in. long. For  $L_1$  use 6 turns of 36 s.w.g., close wound and spaced  $\frac{1}{4}$  in. from the end of  $L_2$  as before. These dimensions, with a 150 pF tuning condenser, give a range of 7.5 Mc/s to 35 Mc/s approx. An important point is that it is necessary to fit a 10 pF condenser in series with  $L_1$ , between the coil and the input socket. Without this, the primary resonates about in the centre of the band and produces some unwanted effects. The series condenser drops this resonance to an unimportant part of the band and also helps to maintain the high input impedance.

### Calibration

Calibration of the dial is so very easy when a signal generator is available, that it is hardly worth while discussing more elaborate methods. A generator output of about 50/100 mV. is required and is fed straight into the meter input. It is only necessary to set the signal generator to the required frequency and to tune it in on the wavemeter. With some types of service signal generators it may be necessary to change over to the second harmonic of the signal, in order to complete the high frequency end of the calibration. The calibration curve of the original instrument is shown in Fig. 4.

### Coupling Links

The wavemeter is intended to pick up its signal from the source through a very small, or stray capacity. It is necessary, therefore, to make up a few connectors for this purpose. Different types are required according to the stage under test, the method of construction, or type of valve used. If only Good/Bad indications are required any connector which will collect enough signal to be read on the meter will do. If, however, it is desired to take comparative readings or to set up repetition standards, then a little care and ingenuity are required in order to standardise the coupling between the wavemeter and the gear.

It may help the reader to have a few details of

some of the connectors which the author has found satisfactory. Note, however, that the capacity to earth *must* be kept as small as possible. If a Pye socket is used as an input on the meter, its connector should not be used. A skeleton clip of springy brass to fit on the centre pin is quite satisfactory. Three simple connectors will cover most applications. The first is used for the B7G miniature valves and was formed by winding two turns of insulated 22 s.w.g. copper wire round one of the valves and turning in the end. This makes quite a satisfactory capacity coupling to an oscillator valve, or, if it is running at an adequate signal level, to an R.F. amplifier. The coupling has negligible effect on the circuit under test and is made without opening up the receiver, merely by twisting off the small screening can, if fitted, and slipping the loop over the valve.

Another useful connector was made from the brass strip off a flashlamp battery; a piece of  $\frac{1}{4}$  in. sleeving was slipped over it and it was then bent over to form a hook-shaped end. This can be hooked over a grid or anode lead to form another capacity pick-up. A third, was formed from an old "banana" type valve pin broken out of the base. The tip was filed off up to the start of the slits, and then a piece of cycle valve rubber was slipped over, until it was flush with the end, for insulation. This forms a dual-purpose connector. The split banana plug, reinforced by the rubber, forms a hollow springy connector which can be pushed on to a solder tag, terminal shank, or a variety of places—and one in particular, referred to later. Its other function is as an insulated probe which can be pushed into a coil can or screening box through a  $\frac{1}{4}$  in. diameter hole, if one exists—or is provided for the purpose—and moved about until a reading is obtained on the meter.

These three connectors, each with about 6 in. of lead and a clip for the pin in the Pye socket, enable external readings to be taken from the B7G, B8A, and top grid, valve types. Metal types, EF50, etc., are not so easy. With access to the underside, the No. 2 or hook connector is suitable. However, external readings can be obtained for stage-by-stage testing, etc., by taking out the valve succeeding the stage to be tested, and connecting the meter into its grid socket. This can be done by pushing in a bit of wire but the writer dislikes such makeshift methods. A safe and reliable connector was made by making up a dummy valve base, but with only one pin—the grid. A spigot and key was made and fitted in the centre of a thin insulating disc, with a solder tag, and also a terminal (for a knob) on the top. This was plugged into a valve-holder and the position normally occupied by the grid pin carefully marked. A  $\frac{1}{4}$  in. 8 B.A. screw was filed for about  $\frac{1}{4}$  in. at the end until it would act as a valve pin. The screw head was filed smaller until the No. 3 banana connector could be pushed on to it, and it was then fitted in the disc to form the grid pin of the dummy base.

By the use of these simple devices the R.F. signal can be "sampled" at each stage in the majority of receivers. An earth connection is not necessary for many of the tests but is desirable when repetition or comparative readings are required. The writer uses a short "crocodile link" for this purpose. An 8 B.A. screw is tapped into the side of the Pye connector as a convenient anchorage for, one clip, while the other is clipped on to the chassis



close to the pick-up point. When using the dummy valve base, the chassis crocodile clip is put onto the solder tag fixed under the terminal knob. Obviously these are not the only methods of connection available but are put forward as suggestions. Readers will be able to invent others for themselves.

### Use of Cheap "Surplus" Meter

There are two types of the 10Q2 indicator, one of which is not suitable if it is desired to use the two meters separately. In this type, which, in the writer's experience is distinguished by the letters A.M. and the Crown moulded in the bakelite front of the case, only one magnet is used and the two meter movements cannot be separated.

The other type, packed in a slightly larger box, marked Type 1, model S52, has a plain front and contains two, quite separate, micro-ammeters. These appear to be high-quality movements and suitable for many purposes. As fitted in the case the pointer reaches the limit stop at about  $100 \mu\text{A}$ , but when fitting the new stop this can be extended to  $160 \mu\text{A}$ .

Both types of unit are fitted with a metal cover which in some cases comes off fairly easily; others are so tight that a hack-saw is about the only way to remove them without doing any damage. Warming, and the application of a few drops of paraffin, have been found helpful in other cases. Once the meter case is opened it is essential to take great care to prevent filings or dirt getting into the meter movements. This applies until the whole job is completed and fitted into its new container.

It is fairly simple to take out the movements and mount them singly. Fig. 5 gives templates, (a) for cutting the window, and the two fixing holes, (b) for glass for window, easily cut from an old photographic plate, and (c) for the new dial, cut from a thin piece of aluminium, cleaned up and made flat.

Proceed as follows. Open the meter case and take off the dial, next, take off the lead to the upper bridge at the tag, and then disconnect the lead from the lower bridge at the resistance bobbins. The upper connection is common to the frame. The lower bridge is insulated and forms the meter input. Take out and discard the bobbins.

A centre stop on the dial serves both pointers so when the movements are used separately it is necessary to make one new spring stop for each. Duplicate the existing spring stop—springy resistance wire is suitable—and fit, at this stage. Bend into their final positions after the new dial is fitted and scaled. Next, make the new dial plate and fit it temporarily. Two  $\frac{3}{16}$ in. 8 B.A. screws and nuts, and two  $\frac{5}{32}$ in. distance pieces are required.

The fixing holes used are close to the magnet and a pair of tweezers is very helpful in offering up the nuts to meet the screws. After making sure of the fitting, take off the dial, fit one of the 8 B.A. screws for holding and give two coats of matt black.

Next, cut the window hole—a fretsaw with medium/fine metal cutting blade is quick and neat—and drill one 6 B.A. and one 8 B.A. clearance holes, for mounting the meter. Check which is which as they are reversed for L. and R. movements. Fit the screws and two  $\frac{7}{16}$ in. spacers, then mount the meter and try the fit as before. If satisfactory,

take off the movement again, then cut and fit the glass for the window. A thin line of "Bostik" round the edge of the hole will make it dust-proof—and probably fix the glass at the same time. However, to make sure, before fitting the glass, cut three strips of thin tinplate or brass, bend to shape, and then solder into position, so that after the glass is stuck in place they can be bent down to form clips. It is not necessary to fit a zero adjuster on the front panel as both the top and bottom spring adjusters are accessible from the back.

The next stage is to set the limit stops for the pointer. Set these so that the pointer is checked before the moving coil reaches the limit of its

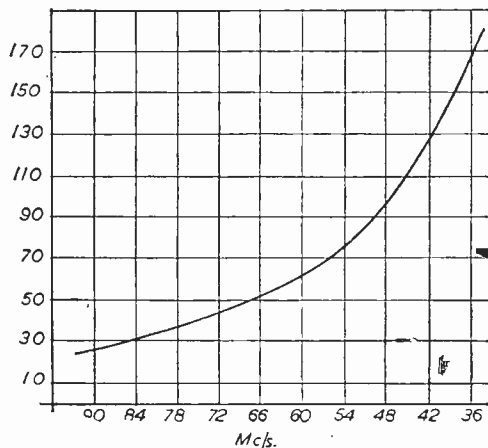

Fig. 4.—How the calibration curve is drawn.

rotation. Next fit and graduate the dial. The scale can be marked very neatly by using a pair of sharp dividers and scribing two concentric arcs.

Use just enough pressure to cut through the paint and leave a clean aluminium line. The centre point of the dividers is located in the middle of the slot of the small screw which adjusts the top pivot bearing of the movement. Use a precautionary finger and thumb to ensure that the point does not slip. Before drawing the arcs, make pencil dots on the dial to show the zero and maximum limits. As the meter is not used for quantitative measurements it is only necessary to sub-divide the sector into equal divisions to finish the job. If it is desired to shorten the pointer, steady the back end, and snip off the surplus with a pair of sharp scissors. The meter can now be bolted on to the panel and if all is in order, it is recommended that it is covered with a few strips of adhesive cellophane tape to form a dustproof cocoon.

## BUILDING THE "PRACTICAL TELEVISION" RECEIVER

Price 3/6, or 3/9 by post.

From GEORGE NEWNES, LTD., Tower House,  
Southampton Street, Strand, London, W.C.2.

# HEATER SUPPLIES

Using the Mains Input Windings of a Transformer for Valves with Odd Heater Ratings

By "ELECTRON"

IT often happens that one wishes to try out a valve which has an "odd" heater voltage, only to find that no source of supply exists; that is to say, the power transformer in use does not cater for such a heater voltage and the only course appears to be the provision of a separate heater transformer.

This does not, of course, apply to such contingencies as using the awkward valve in A.C./D.C.

heater winding cannot be earthed, as is normal, when connected direct to the mains as shown.

There is, however, one way in which this difficulty can be overcome. This is simply to isolate the windings used to supply the heater from the mains, but this can only be accomplished if the low (i.e., 200 volt) input tapping is used for the mains supply and the other (higher) windings are not required for input purposes. The 200 (or, in some cases, the 210) volt tapping is more often than not in the form of a loop and if this is carefully severed the two resulting ends can be brought out to separate terminals or tags. One of these ends is used for the mains input connection and the other is used for one of the rectifier heater leads. With such an arrangement (shown in Fig. 2) the heater windings can be earthed in either of the two general methods; by grounding one side of the heaters or by grounding the centre-tap.

## An Alternative

An elaboration of the theme is shown in Fig. 3, which gives the circuit for providing several valves

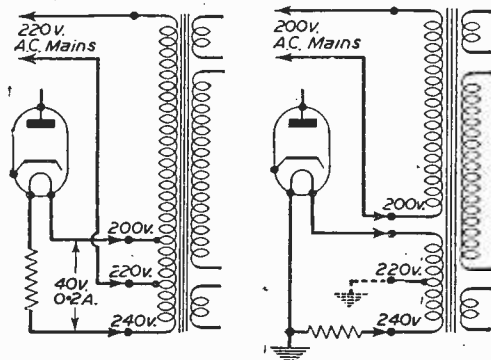

Fig. 1.—Obtaining 40v. for a heater.

Fig. 2.—This arrangement enables the heater to be earthed.

circuits, but the writer has in mind the occasions where a rectifier with an odd heater voltage is to be used, either in a complete piece of equipment or for an experimental hook-up. A separate heater transformer is one answer to the problem, but a less expensive method is readily available which, in fact, requires but one extra component—a resistor.

Almost every power transformer these days is provided with a selection of primary tappings so that the appropriate mains voltage can be applied. By utilising these primary tappings a heater supply for the "problem valve" can be obtained, advantage being taken of the tappings to provide the heater voltage for indirectly-heated high-voltage valves.

As an example, the normal power transformer is provided with mains input tappings of 200, 220 and 240 volts; measurement shows that there is approximately 44 volts available between the two extreme tappings (200 and 240 volts). Therefore, should the rectifier in question be of a 40-volt heater rating, then all that is required is a dropping resistor in series with one of the heater leads to reduce the supply to 40 volts. The circuit is shown in Fig. 1.

A word of warning here. This method is definitely not recommended for valves other than rectifiers or, possibly, output valves in view of the fact that the hum level would undoubtedly be too high for satisfactory operation, because the

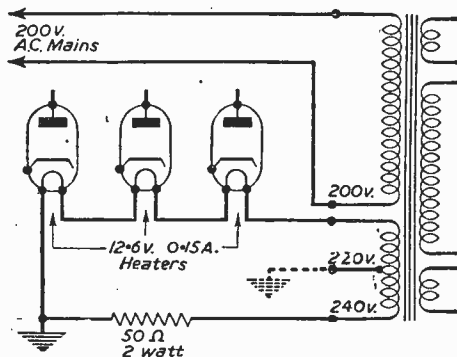

Fig. 3.—Feeding several valves on the lines suggested here.

with a heater supply from the mains input tappings. In the diagram, three 12.6 volt 0.15 amp. valves are shown wired in series, the excess 6 volts being taken care of by the inclusion of a dropping resistor. Incidentally, any combination of 0.15 amp. (or 0.2 amp.) valves may be used in such an arrangement with the proviso that the total voltage does not exceed around 44 volts and that the heater rating of each valve is the same. Valves with a greater heater current rating than 0.2 amp. are precluded on the grounds that the transformer primary windings will not carry such a high current, and therefore, the arrangement would hardly be practical.

In cases where it is desired to supply 6.3 volt valves from an existing 4-volt supply, or vice versa, the solution can be found in the provision of a

small auto transformer. Such a transformer is simple enough to make up, it is extremely inexpensive and, moreover, will prove a boon to have in the workshop as it will find ready use on a number of occasions.

### Making the Transformer

First of all, a discarded speaker transformer should be obtained, the core dismantled and the windings removed. It will be found that the cross sectional area of the core is usually in the region of 0.5 square inches, so that 12 turns per volt should be allowed. If the existing bobbin is in good condition this can be conveniently used for the new winding, but if it is damaged in any way another bobbin of the same dimensions will have to be made. Thin cardboard will be good enough for the job.

Wind 76 turns of No. 18 SWG enamelled copper wire on the bobbin, noting that a tapping at 48 turns will be required. When winding the wire, make sure that it is wound evenly, and that the insulation of the wire is not damaged in any way. The ends of the windings and the tapping can then be brought out to soldering tags, the two extreme end leads being the 6.3 volt connections and the beginning and tapping connections being the 4 volt connections.

Fig. 4 shows the described auto transformer with three 6.3 volt valves coupled to it. Four valves of 6.3 volt 0.3 amp. rating connected in parallel

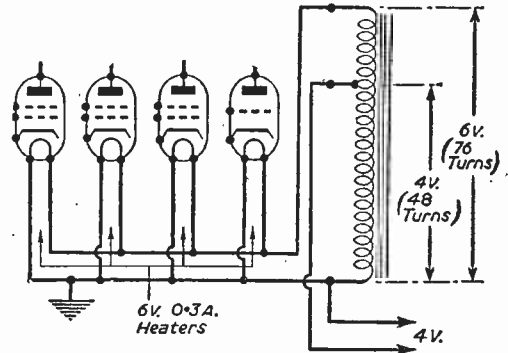

Fig. 4.—Using an auto-transformer.

is about the limit when using the transformer from a 4-volt source. (Or two 4 volt 1 amp. valves.) As shown in the diagram, the output from the transformer can be earthed, preferably one side to chassis.

## Designing Your Own Receiver—5

Advice and Guidance for the Beginner

By STANLEY BRASIER

IT will be seen from Fig. 4 overleaf that the potentiometer is made up of three sections, each of which will be carrying varying currents, therefore the calculation of values will be slightly more involved. However, since the voltage of 130 required at the screening grid is roughly half that of the voltage between the H.T. line and earth, it will be found that this voltage may be picked off from the junction of two resistors of roughly similar value. Note that values given in Fig. 4 are approximate only, and may be varied to suit requirements.

### Increasing Sensitivity

By now the results of our adjustments should have increased considerably the performance of the receiver and good stable results should be obtainable on the stronger transmissions. Although uncontrolled instability is to be avoided at all times, controlled instability (for want of a better term) can be arranged to take the place of the now lesser-used reaction system, and will considerably increase sensitivity and, under certain conditions, selectivity.

If, when the receiver is adjusted to its most sensitive condition, i.e., volume control at maximum, a little coupling is introduced between two otherwise stable circuits, instability will result and the receiver will burst into oscillation. At a point just prior to this condition, however, the receiver will be in its most sensitive state. So, if we can find a

means of controlling this oscillation at its threshold point we shall be in a position to maintain ultimate sensitivity. The existing volume control will do this because immediately the gain of the H.F. stage is reduced, oscillation will cease.

The most convenient point to provide coupling is between the grid circuits of the H.F. stage and detector stage. The capacitive coupling required is very small and use may be conveniently made of the capacity that exists between two twisted insulated wires, and, furthermore, provides a ready means of adjustment to the critical capacity. In practice it is only necessary to solder a short length of insulated wire (not flexible) to each fixed-plate section of the 2-gang variable condenser. The "hot" tag of each trimmer is a convenient point. Then with the receiver volume control at maximum and the circuits tuned to about 300 metres the wires are slowly twisted (removing the hand at intervals) until the receiver bursts into oscillation. This should cease when the volume control setting is reduced and thereafter be controlled by it.

### Disadvantages

A disadvantage of this system is that one setting of the coupling capacity does not provide consistent results throughout the entire tuning range. For instance, if, when oscillation just ceases at 300 metres, the receiver is tuned to 200 metres, the volume control setting would need to be reduced

again to preserve these conditions. Because of this the inherent sensitivity of the receiver has been slightly reduced. On the other hand, at 500 metres, it will be found that oscillation barely exists, if at all, with the volume control at maximum.

Despite this there is much to commend the system, and if the setting is effected at or just above 300 metres it will be found that good control is available over all but the highest wavelengths. Incidentally, there is room for experiment here. If an arm were affixed to the main tuning control, it would not be a difficult matter to arrange for this to actuate a switch (possibly a micro-switch) so that additional capacity is switched in just past the mid-scale position. By this means almost optimum sensitivity could be obtained throughout the whole tuning range.

Quite apart from these latter remarks it will be found that the detector anode bypass condenser will affect the point of oscillation to some extent and values between  $0.0001\mu\text{F}$  and  $0.0003\mu\text{F}$  may be experimented with.

During these adjustments further attention must also be given to the trimmers so that circuit disturbance may be compensated for.

Sometimes it may be found that instability exists in the early stages of operation and will only cease when the volume control is turned back considerably. In such cases it is probable that the screening of one or both of the leads to the valve caps will effect a cure.

### Tone Control

Finally, some experiments may be carried out with a view to adjusting the tone controlling arrangements to individual liking. The condenser and resistor connected across the primary of the output transformer function in conjunction with one another. A reduction of resistance or an increase in capacitance will have the effect of reducing the higher frequencies and vice versa. Variable tone control may be provided for by making the resistor variable.

### Loudspeaker

The beginner does not always realise that the size of a loudspeaker makes a tremendous difference to ultimate results. Many midget receivers incorporating small units are improved enormously in volume and quality when facilities are available to connect, say, a 10in. speaker, and this fact should be borne in mind.

### No Results

From the point where we connected the receiver to the mains we have assumed that signals of some sort were available, but it is not beyond the bounds of possibility that nothing is heard except a slight mains hum. Even this, however, would (probably) mean that the output stage is working but a simple test will prove it. This is accomplished by touching the grid pin of the output valve. If a loud hum is heard in the speaker it can be assumed that the stage is functioning. If not, tests must be made to find the faulty component, and a few minutes with a voltmeter and ohm-meter should suffice.

If the output stage is working, we can check the performance of the detector stage by rendering the H.F. section inoperative. This is simply achieved

by transferring the aerial to the fixed vane connection of the detector tuning condenser. If results are now obtainable it indicates a fault in the H.F. stage. So by the process of elimination it is possible to isolate the section to which the trouble is confined.

### A.C./D.C.

If the receiver was designed to operate from an A.C./D.C. system of supply the same principles of

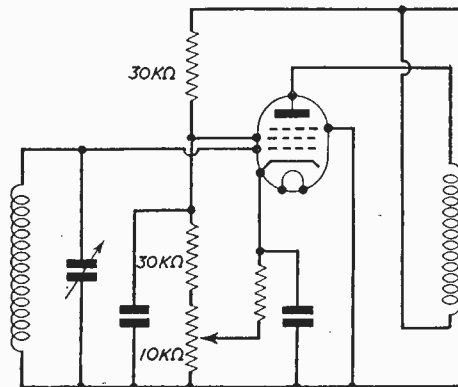

Fig. 4.—R.F. volume control. An alternative arrangement to the scheme which was given in Fig. 1.

testing will be applicable but when first connecting the receiver to the mains it is important to remember that the metal chassis may be "live" with respect to earth. If it is, a reversal of the plug in the A.C. mains socket will sometimes obviate this possibility, but on D.C. mains, of course, the receiver will operate only when the plug is correctly connected in respect of polarity. Under no circumstances should an earth connection be joined directly to the chassis of A.C./D.C. apparatus. If such a connection is necessary it should be made through a fixed condenser of  $0.01$  to  $0.1\mu\text{F}$ , having a voltage rating of at least 350, but preferably 500.

With universal receivers, too, it is important that the mains dropping resistor is accurately set to the value previously calculated (see earlier notes on the subject), before switching on. During tests the current flowing through the valve heaters should be checked—remembering that it is alternating current—or if this is inconvenient the A.C. voltage across each valve heater will indicate whether the resistance adjustment is correct.

In the interests of hum elimination, the detector heater should come last in the chain of heater connections so that it may be joined directly to the chassis. (See Fig. 2, September-October, 1950 issue.)

Another point worthy of noting in A.C./D.C. practice, is in respect of the low value resistor connected between mains input and the rectifier. Its value is about  $100\Omega$  and serves to protect the rectifier by reason of current limitation in the event of a short circuit on the output side of the rectifier. Often such a resistor is incorporated on the actual former of the mains dropping resistor, and in such cases may be an integral part of it, inasmuch as the H.T. lead is tapped off from a point  $100\Omega$  from the mains end.

(To be continued.)

You're SURE to get it at

# STERN'S

ESTABLISHED 25 YEARS

**A 4 Station A.C. Mains "Pre-Set" Receiver.** We now have available complete Assembly Instructions for the construction of a midget "Pre-Set" Superhet Receiver, showing also Wiring Diagram, Component Layout, and point-to-point connections. This Set will select 4 Stations, 3 on Medium Waveband and 1 on Long Wave by the turn of a Rotary Switch, no tuning being necessary. It is of midret size, and is simple to assemble, the completed chassis being 8 1/2 in. x 4 1/2 in. x 7 in. high, and can be completely built, including Valves and Moving Coil Speaker for £5-17-6. Price of Circuit and instructions 1/6 (plus 3d post).

**A Midget T.R.F. Battery Portable "Personal" Kit.** A complete Kit of Parts to build a midget 4-valve All-dry Battery Personal Set. Consists of Regenerative T.R.F. Circuit employing Flat Tuned Frame Aerial, with Denoo Iron Dust Cored Coil, thereby ensuring maximum gain for Single Tuned Stage covering Medium Waveband.

Valve Line-up: 1Y4 (R.F. Ampl.), 1Y4 (Detector), 1S5 (1st A.F.) and 3S4 (output). Includes latest Rola 3in. Moving Coil Speaker, and a Chassis already drilled and shaped. A consumption of only 7 mA ensures long battery life. The Kit is designed for a cabinet, minimum size 6 1/2 in. x 4 1/2 in. x 3in. Detailed Building Instructions, with Practical Layout and Circuit included with Kit, make assembly easy. Price for complete Kit, £3-18-9 (plus 16/7 P.T.). Suitable unpainted Cabinet, 6 1/2 in. x 4 1/2 in. x 3in., 12/9. Ever Ready B114 Battery, 10/3. Building Instructions, Circuit, etc., supplied separately, 1/-.

**"Wireless World" Midget A.C. Mains 2-Valve Receiver.** We can supply all components, including valves and M-Coil Speaker to build this set as specified in the March issue, at a total cost of £3/5/0. Reprint of detailed assembly instructions and circuit supplied separately for 9d.

**Mains or Battery Personal Kit.** A Kit of parts to build our new Midget 4-Valve Superhet "Personal" Set, covering Medium and Long Wave-bands and designed for Mains or Battery operation is now available. This 2-waveband superhet receiver is designed to operate on A.C. mains 200-240

volts, or by an "All-Dry" battery, either means being selected by the turn of a rotary switch. It is so designed that the mains section, size 4 1/2 in. x 3 1/2 in. x 1 1/2 in., is supplied as a separate Kit (which may be added at any time). The Kit can therefore be supplied either as an "All-Dry" Battery Personal Set, or by incorporating the mains section as a Midget receiver for combined Battery/Mains operation. The circuit incorporates delayed A.V.C. and pre-selective audio feedback. A Rola 3in. P.M. Speaker with a generous

sized output transformer ensures excellent quality reproduction. Two ready wound frame aerials and a drilled midget chassis are included. The overall size of chassis when completely wired is 8 1/2 in. x 4 1/2 in. x 2 1/2 in. Valve line-up IR5 (freq. ch.), 1Y4 (I.F. amp.), IS5 (diode det. and audio amp.), and 3S4 (output tet.). The set is easily built from the very detailed building instructions supplied, which includes a practical Component Layout, with point-to-point wiring diagram, and a circuit diagram.

Price of Complete Kit (less Mains Unit), including P.T., £6-13-9. Price of Mains Unit Kit, £1-17-6. A Walnut-finished Portable Cabinet to house this receiver is also available. Price 19/9. The complete assembly instructions mentioned above can also be supplied separately for 1/6.

**A complete Kit of Parts to build a Miniature "All-Dry" Battery Eliminator,** giving 69 volts H.T. (approx.) and 1.4 volts L.T. This Eliminator is suitable for use with any Superhet Personal battery set requiring H.T. and L.T. as above.

It is housed in a light aluminium case, size 4 1/2 in. x 3 1/2 in. x 1 1/2 in., and can therefore be accommodated in most makes of personal receivers.

Price of complete kit including detailed assembly instructions and layout £1-17-6. The Midget A.C. Mains 3-Valve Receiver circuit, as published in the "Wireless World." We can supply all the components to build this set, which covers Medium and Long Waves, for £2-10-0 (including complete assembly instructions). A reprint of complete assembly instructions can be supplied separately for 9d. (including postage).

★ Send 6d. P.O. for our NEW STOCK LIST, showing many KITS OF PARTS for Sets and Battery Chargers, and "hundreds" of Wireless Components. When ordering please cover postage and packing.

**STERN RADIO LTD., 109 & 115, FLEET STREET, E.C.4.** Telephone: CENTRAL 5814 & 2280

## E.M.I. TRAINING for the best posts

E.M.I. INSTITUTES, THE COLLEGE BACKED BY THE GREATEST ELECTRONIC INDUSTRY IN THE EMPIRE.

Daytime Attendance Courses

Radio, Television, and other Industrial Electronic subjects. Principles and Practice of Radio—1 year.

● Telecommunications Engineering—2 years, leading to City & Guilds Final Certificate. ● Electronic Engineering—3 years (including one year's practical training in E.M.I. Factories)—leading to C & G full Technological Certificate.

★ Next courses commence April, 1951. ★ Early enrolment is advised.

Moderate terms. Facilities for easy payment.

Write for free Brochure to the Registrar, Dept. 32

**E.M.I. INSTITUTES** Associated with "H.M.V." MARCONIPHONE COLUMBIA ETC.

10, PEMBRIDGE SQUARE, NOTTING HILL GATE, LONDON, W.2. TELEPHONE: BAYSWATER 5131/2



## MAINS TRANSFORMERS & CHOKES

All "Varley" products are manufactured from the highest quality materials.

Transformers, etc., are individually wound and have interleaved windings with ample insulation, ensuring freedom from breakdown.

The comprehensive range of Shielded and Open Type Transformers available meets the requirements of every circuit.

Write for list, etc.

Made by

**OLIVER PEEL CONTROL LTD**  
CAMBRIDGE ROW · WOOLWICH · S.E.18  
Telephone: WOOLWICH 1422

# Modifying the Type 18 Rx-2

Concluding Details of an Economical Three-waveband Battery Portable Superhet

By D. KEY

**A** PIECE of thin sheet insulation (Taxolin or oiled silk, etc.) should be put under the coilpack during fitting to avoid short-circuits to chassis. The connection to the front section of the tuning condenser should be arranged to have a clear run when the coilpack is being fitted.

## Connecting the Coilpack

Connections to the coilpack tags are as follows:

Tag 1 (H.T. to osc. anode): Connect to H.T. + via a 10,000-ohm resistor, and also to one of the spare 0.1 $\mu$ F condensers (C7), the other side of which should be earthed to a chassis tag.

Tag 2 (Osc. grid circuit): Connect to the front section of the 2-gang condenser, and also to the oscillator grid condenser via a lead through the large hole in the chassis.

Tag 3 (Osc. anode): Connect to Pins 3, 4 and 5 of V1A via a 100-ohm resistor.

Tag 4 (Signal grid of V1B and 2-gang condenser): Connect to the rear section of the 2-gang condenser. The top-cap connection to the grid of V1B is made from the top of this section.

Tag 5 (Aerial): Connect via a 50 pF silvered-mica condenser to the terminal for the throw-out aerial, where this is provided in the case or cabinet of the completed set.

Tag 6: Connect to the 2nd tag of the 4-way tag strip under the 1st I.F. transformer by means of the short length of brown lead mentioned earlier.

Tag 7 and 8 (Two leads from the coilpack trimmers): These leads connect to the frame aerial, which should be carefully disposed to avoid instability. The position shown in the photographs was found satisfactory, but the aerial should be kept well away from all metal parts, particularly steel parts.

Important.—An 80 pF silvered-mica condenser must be soldered across the 1st and 4th tags of the 4-way tagstrip under the 1st I.F. transformer, as shown in the under-chassis photograph (P1). The condenser tunes the primary of this transformer and is shown as Ct in Fig. 2. In the original circuit this I.F. transformer primary was tuned to 465 kc/s by C12 and C13 in series (Fig. 1), L4 having very little effect at this frequency.

## Testing and Alignment

First check all connections, and solder a low-resistance flexible lead to a firm chassis tag to act as L.T. negative connection.

The four remaining leads of the five-way connector on the author's receiver were as follows:

Red lead: H.T. positive (120 v.).

Buff lead: Chassis (H.T. negative and grid bias positive).

Yellow lead: Grid bias negative (-1.5 v.).

Green lead: L.T. positive.

Readers should carefully check the terminations of the leads on their receivers to avoid damage to their valves.

Connect the external aerial and make a coupling

loop as shown in Fig. 2. Put the High-Low H.T. switch to "Low," fit all the valves in their original sockets, and connect up the batteries, leaving the H.T. till last. Set the volume control to maximum.

Put the coilpack switch to medium-waves (the central position) and slowly swing the tuning condenser from minimum to maximum, when some signals should be heard. If not, rotate the frame aerial through 90 deg. and try again. If then no stations are heard, switch off and check connections.

## Oscillator First

When signals are heard, put the "High-Low" H.T. switch to "High." Then rock the tuning control either side of its position and slowly adjust the M.W. oscillator coil core with a bakelite, ebonite or plastic screwdriver, until the loudest signals are heard. If the station thus tuned in is not at the L.F. end of the M.W. band, swing slowly over the L.F. part of the range, and when a station is heard, readjust the core of the oscillator coil in the same way. If the first station heard was towards the L.F. end of the scale, well and good. Now slowly tune over the H.F. end of the scale until a station is heard, if necessary adjusting the aerial trimmer a little at a time. When a station is tuned in, adjust the M.W. aerial trimmer for maximum volume. Go back to the L.F. end station and readjust the core of the oscillator coil for maximum output. Return to the H.F. end station and again adjust the aerial trimmer for strongest signals.

Repeat these two adjustments until no further improvement is obtained.

## Without Generator

If no signal generator is available for aligning the I.F. transformers it may now be found possible to increase the output obtainable by carefully removing the wax from the adjusting slugs of the I.F. transformers and very gently and carefully adjusting them for maximum volume. It should not be necessary to move any of them very much, and only one (the primary of the 1st I.F. transformer) should be moved more than a small fraction of a turn.

When this has been done, switch to L.W., and set the tuning control midway. Adjust the L.W. oscillator cone until the long-wave Light Programme is heard (it may be of advantage to put a hand against the frame aerial), then tune the aerial loading coil for maximum volume.

## Short Waves

For the adjustment of the S.W. range a test oscillator is very useful, the cores should be adjusted for strongest signals at about 6.75 mc/s. with the tuning condenser at 30 deg. from the fully closed position, and the trimmers should be adjusted at about 11 mc/s., the condenser being at 150 deg. from the fully closed position.

**Probable settings:**

Osc. coil core : 3 to  $3\frac{1}{2}$  turns from top of former.

Osc. trimmer : Open 1 to 2 turns.

Aerial coil core :  $\frac{1}{2}$  to  $\frac{3}{4}$  turn from top of former.

Aerial trimmer : Screwed fairly firmly down.

**Pentode Output Stage and Loudspeaker**

As so far described, the receiver is capable of very strong signals on the principal B.B.C. transmitters and will give good results on a number of foreign stations. Short-wave reception is excellent, and clear, if the precautions described are taken. These results, of course, are obtained on headphones, but the majority of readers will prefer to fit a speaker.

**Power Stage**

Fig. 3 shows the circuit of a suitable power output stage, using a 1.4 v. valve. Two-volt valves are available (e.g., the Mazda Pen 25), but it is thought likely that readers will wish to use the smaller valve in order to have more space for the loudspeaker and output transformer.

To accommodate this stage, the headphone jacks and headphone transformer should be removed.

The volume control should be temporarily removed, and also the condensers under the chassis lying below the clear space thus produced.

Drill or punch the valveholder hole near the end of the chassis. By choosing suitable components it will be possible to fit the output transformer and loudspeaker in the space between the I.F. transformers and the front panel, which latter should be pierced for the loudspeaker.

The volume control should be situated and rewired so as to avoid coupling to the other valves, screened sleeving over the leads will assist here.

The HL23DD should be coupled to the output valve, as shown in Fig. 3.

**Alternative Valves**

The Mazda HL23 is a good alternative separate oscillator, permitting shorter wiring to the oscillator grid pin.

The Mazda TP25 frequency-changer may be used, giving greater battery economy, and more space above the chassis by freeing the valveholder for VIA.

The Mazda Pen 25 (or equivalent) is an alternative (2-volt) output pentode.

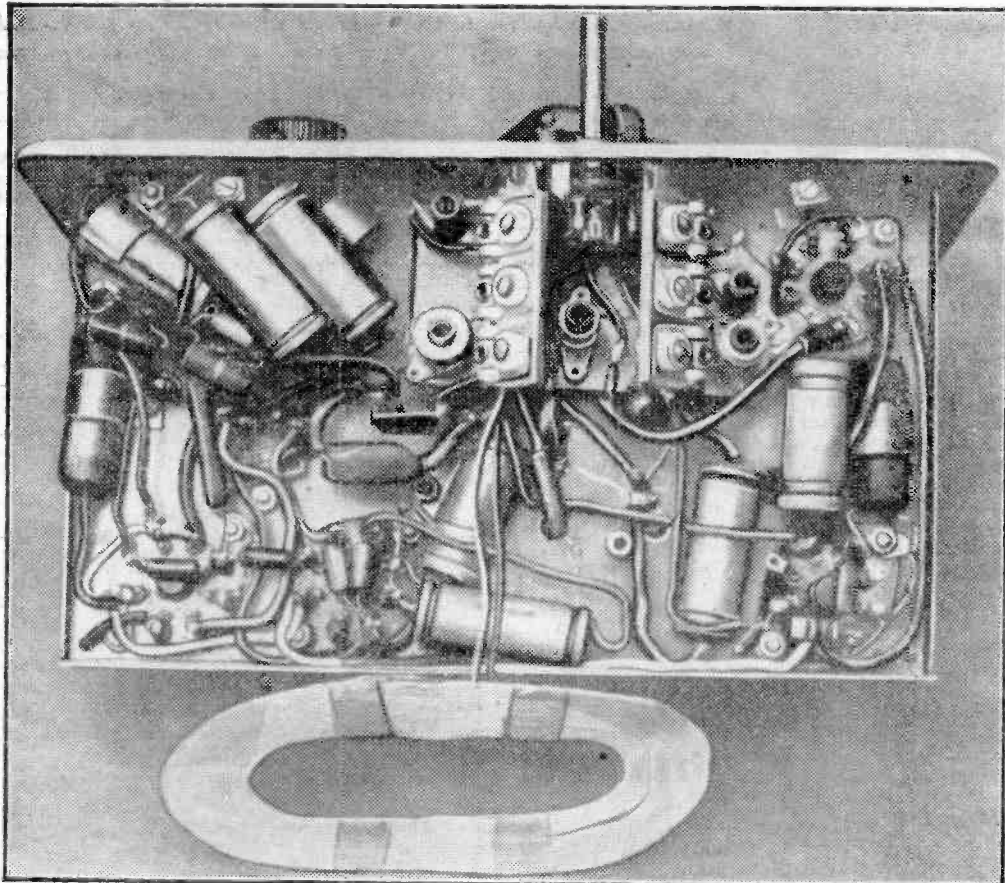

*View of the underside of the chassis, showing disposition of the various components. Views of the top of the chassis, showing valves etc., were given in last month's issue.*



# News from the Trade

## New Ekco Extension Speaker

**D**ELIVERIES are now commencing of the new Ekco extension speaker Model ES115. This is an 8in. dustproof permanent magnet fidelity speaker in a beige or maroon plastic case with contrasting plastic lattice grille. On/off and volume control is flush-fitting in the side of the cabinet.

The speaker will handle 3 watt output without

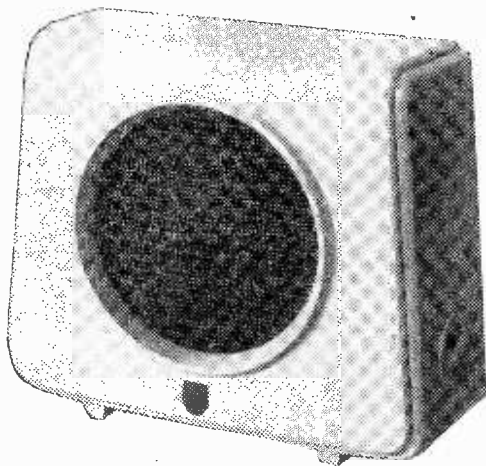

*The new Ekco extension loudspeaker.*

distortion and the price is 57s.6d. (tax free). Dimensions: 16in. wide x 10 $\frac{3}{4}$ in. high x 4 $\frac{1}{2}$ in. deep.

*E. K. Cole Ltd., Southend-on-Sea.*

## Miniature Transformer

**T**HE illustration on the right shows a new type of miniature transformer recently developed by J. Bell & Croyden.

The latest type of F laminations, hydrogen annealed, are utilised, and also a specially moulded bobbin. We think this is the smallest British-made transformer at present on the market. The primary consists of 5,000 turns 48 s.w.g. D.C. microamps, 200, 400, 1,000. Inductance, henries, 28, 22, 12. The secondary is normally 100 turns 38 s.w.g.

Messrs. Bell are now in a position to accept quantity orders at very competitive prices.

*J. Bell & Croyden, 117, High Street, Oxford.*

## Model "Micropak II"

**T**HE new Bonochoord Micropak II is a miniature one-piece hearing aid weighing only 5 oz. complete with batteries. The case is in satin-finish jeweller's gold, lacquered to minimise friction. Size is 3 $\frac{1}{2}$ in. x 2 7/32in. x 3/4in., with pocket clips on both sides, enabling the user to wear the aid attached to a garment from either back or front, as required.

A wide range flat response crystal microphone is concealed behind a decorative grille, recessed below the front surface of the case to reduce "clothes rub." Volume control is of the drum type, with independent selector switch.

Three stages of amplification, with pentode output, give a maximum air to air gain of 55 decibels. Overall response curve is sensibly flat, with either crystal or magnetic receivers for air or bone conduction.

Selective automatic volume control is incorporated, ensuring a maintained comfort level and freedom from loud noise. A.V.C. maximum output is 10 decibels below overall maximum. Tone control is provided by a base response curve in the A.V.C. position of the selector.

With the combination of high maximum gain and selective A.V.C., the "Micropak II" offers greatly improved intelligibility and relief from strain, particularly for those cases where the recruitment factor is present, and for those who use an aid for long periods daily. Running cost is less than one halfpenny per hour of use.

The Bonochoord low-drain circuit gives 350 hours of serviceable life from a 15 v. Ever Ready B.121 H.T., with 10 hours' L.T. life from a standard "pen" cell. Valves are "plug-in" interchangeable type and the chassis is replaceable in one minute. Retail price is 30 guineas, with 12 months' Free Service Guarantee.

*Bonochoord, Ltd., 48, Welbeck Street, London, W.1.*

## Increased Prices

**O**WING to increased material costs, Ace Radio, Ltd., are compelled to announce the following increases in the prices of radiograms:

Minnigram Model 33 RG—auto change radiogram, 50 gns. to 53 gns.

Minnigram Model 33 RGU—A.C./D.C. auto-change radiogram, 50 gns. to 57 gns.

Mayfair Model RG 635—single speed auto change, with record storage, 68 gns. to 70 gns.

Mayfair Model RGS 635—three speed auto change with record storage, 70 gns. to 75 gns.

Taylor Electrical Instruments, Ltd., also announce that it has been found necessary to revise the list price of the Model 30A Oscillograph. The new list price is £33 10s. 0d.

The price of Marconiphone Model ARG 27A five-valve autoradiogram for A.C. mains has been changed from 48 gns., plus purchase tax, to £55 plus £23 16s. 8d. purchase tax.



*A miniature L.F. transformer compared in size with a penny.*

# LASKY'S RADIO

**TYPE 6 INDICATOR UNIT.** BRAND NEW AND UN-USED. IN MAKER'S ORIGINAL CARTON. Contains 1 6in. C.R. tube, type VCR97 and 7 valves: 4 EF50, 3 EB34. Also 12 potentiometers, and hundreds of assorted components, resistances, condensers, etc. In metal case, grey enamelled, size 1 1/2in. x 8 1/2in. x 7 1/2in. Weight 28lb. **Lasky's Price, 90/-.** Carriage 10/- extra.

**WEARITE MINIATURE I.F.**

**TRANSFORMERS.** Iron dust cores. Frequency range 450-475 kc/s. Size 1 1/2in. high, 3/4in. x 3/4in. **Lasky's Price, 12/6** per pair. Post 6d. extra.

**ANTENNA ROD SECTIONS.** Still available as advertised in February issue of "Practical Wireless." Price 2/6 per dozen. Post free.

**CAR RADIO PLUG SUPPRESSORS.** Brand new ex-Government. Normally listed at 1/6 each. **Lasky's Price, 1/-** each. Post extra.

**SCREENED FIELD LOUDSPEAKERS.** 6 1/2in. p.m. Supplied with output transformer. Ideal for use with television receivers. **Lasky's Price, 10/-** each. Post 1/-.

**ELECTRICAL SPEAKERS.** 6 1/2in. Truvox. 3 ohms p.m. **Lasky's Price, 12/11.** Post 1/6.

**OIL-FILLED CONDENSERS.** 8 mfd. 1,000 v.w. With stand-off insulators. Brand new and perfect. **Lasky's Price, 7/6** each. Post extra.

**MAINS TRANSFORMER, TYPE MBA/4.** 200-250 volts 50 c.p.s. input. Output 270-0-270 volts 80 mfd.; 6.3v. 3a.; 5v. 2a. **Lasky's Price, 15/-.** Postage 1/6 extra.

**VALVES. ALL BRAND NEW, UNUSED AND FULLY GUARANTEED.**

Set No. W.P.1—6K8, 6K7, 6Q7, 5Z4, 6V6. **Lasky's Price, 35/-** the set.

Set No. W.P.2—12K3, 12K7, 12Q7, 35Z5, 50L6. AH GT. **Lasky's Price, 37/6** the set.

Set No. W.P.3—6CH35, EF39, EBC33, EL33, AZ51. **Lasky's Price, 39/6** the set.

Set No. W.P.4—6CH35, EF39, EBL31, AZ31. **Lasky's Price, 39/6** the set.

Set No. W.P.5—6CH35, EF39, CBL31, CY31. **Lasky's Price, 39/6** the set.

Set No. W.P.6—1T4, 1R5, 1S3, 1S4. **Lasky's Price, 30/-** the set.

Set No. W.P.7—K1W61, DH63, KT61 C50. **Lasky's Price, 34/-** the set.

Set No. W.P.8—K1W61, DH63, KT92, 25Z4. **Lasky's Price, 30/-** the set. All Valves sets post free.

All the above valves can be purchased separately, but save money by buying a set. Full price list of valves will be sent on application.

**MOVING COIL METERS.** All 2 1/2in. flush panel mounting, brand new and boxed. 0-10 m/a. 0-50 m/a. 0-150 m/a. 0-200 m/a. 0-300 m/a. 0-2 amps. 0-20 amps. 0-300 amps. **Lasky's Price, 12/6** each. Post free. Other types in stock, please enquire

**OSMOR TYPE "Q" COIL PACKS.** Supplied complete with circuit diagrams. Simple single hole fixing. S'het for 465 kc/s. I.F. These coil packs are adjusted and tested in actual frequencies. All prices include purchase tax. Long, medium, short (LMS) **40/4**, with H.F. stage, **58/8**. Long, medium and trawler band (LMTB) **42/10**. Medium, short, short (MSS) **42/10**. Batt. s'het with frame aerial, **45/10**. All post free.

## LASKY'S RADIO,

370, HARROW ROAD, PADDINGTON, LONDON, W.9. (Opposite Paddington Hospital.)

Telephone: CUNningham 1979 and 7214.

Hours: Mon. to Sat. 9.30 a.m. to 6 p.m. Thurs. half day.

Send a 2d. stamp with your name and address (in block letters please) for a copy of our current list of 'new manufacturers' surplus and ex-Government equipment. The Lasky's Radio Bulletin.

# 4 VALVE MAINS RADIO

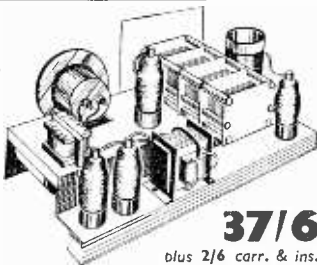

with

**37/6**

plus 2/6 carr. & ins.

## Miniature Loudspeaker

200-250 volt A.C. mains. Size approximately 10in. x 6in. x 5in. Low running costs, completely self contained. Receives medium waves, Home and Light, etc. Moving coil 1 1/2in. speaker. **ALL COMPONENTS, INCLUDING VALVES, CHASSIS, etc., INCLUDED. Build this fine set yourself—from easy Plans!**

## ELECTRICAL SETS

The Electrical Experimenters' Kit! **19/6**  
Stout compartment box contains **84** parts. This kit contains Coils, Magnets, plus terminals, wire, etc., and completely **1/6** post comprehensive Instruction Book, with instructions for making Voltmeters, Ammeters, Electric Motors, Bells, Dynamos, Buzzers, Telephones, etc.

**INSTRUMENT CO.** (Dept. P.W.), 6, HIGH STREET, THAME, OXON

## D. COHEN

Radio and Television Components

**POST ORDERS ONLY**

Line and frame coil assembly, frame coils not fitted but supplied wound with full instructions to fit. High impedance frame coil, low impedance line coil (matching transformer 8-1). Price 8/6.

9in. Rubber Mask (White) with TRIPLEX Glass. 10/-  
80 ohm feeder (thin).....per yard 8d.

**P.M. SPEAKERS**

Size	With Trans.	Less Trans.
3 1/2in.	---	9/-
5in. ROLA**	...	13/6
6 1/2in. TRUVOX	...	10/-
8in. ROLA	...	13/6
10in. ROLA	...	17/6
6 1/2in. R. & A. Cased Field with O.P. Transformer.....	11/6	---

Post and packing on each of above items.....1/- each

**MAINS TRANSFORMERS**

Primaries 200-250 v.

BULGIN, semi-shroud, drop-through, 280-280. 80 mA. 6 v. 3 amp., 5 v. 2 amp.....16/6  
320-320. 120 mA., 6 v. 4 amp., 5 v. 2 amp., 4 1/2 v. 1s. 6d.  
350-350. 70 mA., 6 v. 2.5 amp., 5 v. 2 amp., 15/-  
Drop-through type 280-280. 4 v. 6 amp., 4 v. 2 amp., 13/6.  
Similar to above, but drop-through or upright mounting, 14/6.  
250-250. 60 mA., 6 v. 4 amp. (to be used on common heater chain with a 3 x 5 rectifier), 14/6.  
Auto-wound. H.T. 280 v. 360 mA., 6 v. 3 amp., 4 v. 3 amp., 11/6.

**ELECTROLYTIC CONDENSERS**

50 mfd. 50 v. work, 1/9; 16-24 mfd. 350 v. work, 3/3; 100 mfd. 12 v. work, 1/3; 16-16 mfd. 450 v. work, 4/-; 50 mfd. 12 v. work, 1/-; 25 mfd. 25 v. work, 1/2; 16 x 8 mfd. 450 v. work, 3/9; 8 mfd. 450 v. work, 1/11; 250 mfd. 12 v. work, 1/3; 3 mfd. 500 v. work, 3/-; 16 mfd. 500 v. work, 3/9; 8 x 8 mfd. 450 v. work, 3/6. Ex-Government Metal Rectifier, 230 v. 60 mA. at 4/- each; 230 v. 80 mA. at 5/- each. Packing and postage 6d. extra. Ex-Government 8 mfd. with clip, 450 v. work, 1/- each. 12in. White Rubber Mask with armour plated glass, 15/- plus 1/- postage and package.

Stamp for List.

67, Raleigh Avenue, HAYES, Middlesex.

**Experimenters! Build the MATCHBOX RADIO SET**

With the aid of our full instructions you can build a complete radio set in a matchbox, using parts purchased from your radio dealer.

Tuning arrangements include a medium-wave inductor with station selector switch, and a long-wave coil for the B.B.C. Light Programme on 1,500 metres.

Demodulation is achieved by the use of a non-linear impedance unit of a new type, giving loud, clear reception.

This receiver works off a short indoor aerial in many districts, and being powered entirely by the incoming signal requires no batteries.

Full step-by-step instructions, working drawings, and theoretical wiring diagram.

PRICE 3/-. POST FREE.

**JOHN O'BEIRNE (W),**  
137, COTHAM BROW, BRISTOL, 6.  
MAIL ORDER ONLY.

**"ADCOLA" SOLDERING INSTRUMENTS**

Reg. Trade Mark



Regd. Design No. 800302

British Pat.: 604,555, U.S.A. Pat.: 2,518,265 and Foreign Patfs.:

Designed for Wireless and Television Assembly SUPPLIED FOR ALL VOLT RANGES FROM 67V. to 230/50V. The three Adcola Models covering the requirements of the Television, Telecommunication and Radar Engineers assure thorough jointing.

- 3/16in. dia. Bit. Standard Jointing ... 22/6
- 1/4in. dia. Bit. Standard Model ... 25/-
- 3/16in. dia. Detachable Bit ... 30/-

Sole Manufacturers:

**ADCOLA PRODUCTS LIMITED**

SALES & SERVICE: 50, CLAPHAM HIGH STREET, LONDON, S.W.4. Tele: MACaulay 4272

**FREE TO AMBITIOUS ENGINEERS!**

This 176-page Book



**'ENGINEERING OPPORTUNITIES'**

is a highly informative guide to the best-paid Engineering posts. It tells you how you can quickly prepare at home on "NO PASS—NO FEE" terms for a recognised engineering qualification, outlines the widest range of modern Home-Study Courses in all branches of Engineering and explains the benefits of our Employment Dept. If you're earning less than £12 a week you cannot afford to miss reading this unique book. Send for your copy to-day—FREE.

\*\*\* FREE COUPON \*\*\*  
Please send me your FREE 176-page "ENGINEERING OPPORTUNITIES"

NAME .....  
ADDRESS .....  
.....  
Subject or Exam. that interests me .....  
British Institute of Engineering Technology,  
409B, Shakespeare House,  
171/9, Stratford Place, London, W.1

**WHICH IS YOUR PET SUBJECT?**

- Mechanical Eng.
- Electrical Eng.
- Civil Engineering
- Radio Engineering
- Automobile Eng.
- Aeronautical Eng.
- Production Eng.
- Building, Plastics, Draughtsmanship
- Television, etc.

**GET SOME LETTERS AFTER YOUR NAME!**

- A.M.I.Mech.E.
- A.M.I.C.E.
- A.M.I.P.E.
- A.M.I.M.I.
- L.I.O.B.
- A.F.R.Ae.S.
- A.B.Sc.
- L.A.M.Brit.I.R.E.
- CITY & GUILDS
- MATRICULATION, etc.

**BIET**



**spells Quality in Tape and Wire Recording**

Heads, Amplifiers, Tape, etc.

**ORDER YOUR HIGH QUALITY TAPE MECHANISM NOW!**

Constructor's Envelope: Amplifier Equipment. 4/3 Post Free (G.B.)

"Magnetic Tape Recording," 4th Edition revised and enlarged. 7/- Post Free (G.B.)

Write for latest Price List.

**AUDIGRAPH LTD.**

Dept. MR6, 74, Great Hampton Street, HOCKLEY, BIRMINGHAM, 18.

5460c



**TELEVISION DEMONSTRATION**

of Sets and Components every Friday 8-10 p.m.

**TELEVISION CIRCUITS FOR THE CONSTRUCTOR**

New Second Edition 1/6 post free

**HAYNES RADIO Ltd.**

Manufacturers of the complete range of Television Receiving Equipment

QUEENSWAY, ENFIELD, MIDDLESEX

**PRATTS RADIO**

1070 Harrow Road, London, N.W.10

Tele: LADbroke 1731

(Nr. Scrubs Lane)

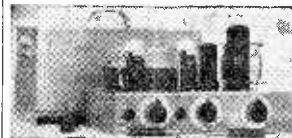

**AMPLIFIERS READY TO USE.**

MODEL A101F (as illustrated), 10 watt, 4 valve unit, neg. feedback, separate mike stage and separate mike and gram inputs, 2 faders and tone control. Input volts, mike .002 v., gram 21 v., £9-9-0. MODEL A181E, 6-valve unit with pull output of

18t watts, separate mike stage and separate mike and gram inputs, 2 faders and tone control, feedback over 3 stages. Input volts, .003 v. mike, .3 v. gram, £13-19-6. MODEL U101F, 6-valve, 10 watt unit, spec. as AC18E, for D.C./A.C. mains, £11.15-0. All above are complete with Case and chrome handles, outputs match. 3, 8 and 15 ohm speakers. MODEL A144C, A.C. or 144' D.C./A.C. 3 valve, 4 watt amplifier chassis. Output to 3 ohm, £5-5-0. All above carriage paid. As supplied to Hospitals, Schools, Clubs and for Domestic use. Stamp for fuller details.

**SPEAKERS, P.M.,** less transr. 5in., 11/8; 8in., 12/6. Plessey, 10in., 17/6; Truxon, 12in., 42/6; 8in., 16/6; 12in., 130/- W.B. (Stentorian), 2in., 15/6; 5in., 17/6.

**VALVES,** 6J5, 6J7, 5/6; 6K7, 6V6, 6F6, 6N7, 6Q7, 5Z4, 6X5, all 7/6; 1T4, 1R5, 1S5, 3S4, 1S4, all 7/-; 6K8, 25A6, 25L6, all 8/6; 6L6, 10/3. All Brand New and Unused.

**COILS, ETC.,** Wearite 'P' coils, all types, 3/- ea.; Weymouth 'H', 3/3 (except H11, H01, H41, 3/6). Osom 'Q' coil pack, 40/4, tax paid. Wearite M400B, I.F.S. 10/6 ea.; Standard type, 10/- ea.; Denco T.R.F. with reaction, L. and M.W., 6/6 matched pair. Dual-range coil with reaction, 4/6.

**TRANSFORMERS,** Plessey, 2 x 350v., 80 ma., 0.4-6v. 4a.; 0.4-5v. 2a., 18/9. Filament, 6v. 11a., 5/6; 6v. 3a., 12v. 11a., 4v. 4a., each 8/6 (all 230v. input). Speaker, 6V6 to 3 ohms, 3/11; IS4/3S4 Miniature O/Trans., 4/2; 6V6 P/P to 3, 8 or 15 ohms, 18/-.

**CONDENSERS,** Plessey, 8 mfd., 2/3; Bl. 8+8, 3/3; Plessey, 8+16, 3/9; 32+32, 6/- (all 450v.). T.C.C., 2 mfd., 4 mfd., 1/6 ea.; 5 mfd., 12v., 8/1 ea.; 1 x 500v., 1/- ea.; .001/23/5, .05, 1 x 350v., 6/1 ea. (none Ex-W.D.). Miniature 2-gang, .0005 mfd., 4/3; Standard, .0005, 3-gang, 6/9; 50 pF, presets, 4d. ea.

**MISCELLANEOUS,** Octal Bases, Paxolin, 4d.; Amphenol, 6d.; BRG paxolin, 9d. Chokes, 50 ma., 20 hv., 6/6; 90 ma., 10 hv., 10/6 150 ma., 10 hv., 14/3; 100 ma., 20 hv., 14/3. Dropper, 2a., 520 ohm or 3a. 800 ohm, with sliders and feet, 5/- Linecord, 3a., 60 ohms ft., 3-way, 4d. ft. All Goods New and Unused. C.W.O. or C.O.D. Post paid over £1.

# Programme Pointers

This Month MAURICE REEVE Deals with Some More Recent Programmes

"MUSIC MAGAZINE" was well in the van of those who honoured the great Finnish composer Sibelius on the occasion of his eighty-fifth birthday. They devoted the whole of their session to the master on December 10th, and many and graceful tributes were paid to all phases of his work. Not having written anything for more than twenty years, Sibelius wrote his last major work when Elgar, Strauss, Ravel, Delius and many other notable musicians were alive and flourishing. We must bear this fact well in mind before allotting him his exact place, on merit, in the musical cosmos of our time. But if anyone disputed his being one of the very greatest musicians, either of his own or any other time, they would, undoubtedly, be wrong. His seven symphonies are all masterpieces, and his breathing new life and originality—once he had thrown off the influence of his near neighbour Tchaikovski, which pervades the early ones—into this two-hundred-year-old art form is, perhaps, his greatest achievement.

By the way, the Russians may claim him for their glory, as Finland was a Russian province until he was well into his fifties, and therefore a Russian subject. The Czar's heir was styled Crown Prince of Finland, or something Finnish.

## "The Martyrdom of St. Sebastian"

Debussy's practically unknown masterpiece "The Martyrdom of Saint Sebastian" was done in truncated concert version by the B.B.C., under Albert Wolff. Michael Redgrave spoke the part of the Saint. Written in 1911 as incidental music to the mystery play of the same name by d'Annunzio, it was intended as a vehicle for the famous dancer of those days, Ida Rubinstein, who was to dance the title rôle. This, together with the secular and exotic character of the music as well as the libretto, brought a ban on its production and subsequent performance from, I think, the Cardinal Archbishop of Paris. In this case publicity must have been the soul of brevity, for it not only proved too much for the three artists, then at the height of their fame, but for the work itself, which has remained almost unknown.

Whilst not equal to the Debussy of the orchestral and piano masterpieces so honoured by all music lovers, it is far too good a work to be existing in such oblivion. All credit to those who contributed to this performance; it was not their fault that the work was stripped of most of its glamour.

## Clifford Curzon

At the symphony concert on November 29th, Clifford Curzon used the score for his impeccable

performance of Mozart's exquisite Concerto in C minor. The orchestra, under Sir Malcolm Sargent, played Elgar's massive A flat Symphony with great breadth and dignity.

## "Follies of the Air"

It is a pleasure to turn to a B.B.C. weekly feature with some natural and clever wit and humour in it. I refer to "Follies of the Air," with Ethel Revnell, Charlie Clapham, Sonnie Hale, C. Denier Warren, Len Hayes and Lisbeth Webb. The two sessions I recently heard struck me as being very good and better than most other B.B.C. weekly features of a similar type. Apart from Ethel Revnell's song on each occasion, which was of a type most people gave up singing 20 or 30 years ago, the script was good fun throughout. Producers are Harry S. Pepper and Gordon Crier, and the pianists Billy Mayerl and Ivor Dennis.

## "Life of Leslie Stuart"

I cannot imagine, for the life of me, what prompted anybody to imagine that "The Life of Leslie Stuart" should occupy three solid hours on three Sunday evenings. Firstly, there just wasn't the material to fill out the time with sustained interest. But far more important still is that we no longer have the type of comedian, singer or actor generally with the "gaiety" type of technique so absolutely necessary for putting this sort of stuff over. If it was just a question of people with good voices and pleasant stage deportment getting up and singing the lovely tunes that Stuart, Caryll, Rubens, etc., used to write, and making love to their settings, then we should undoubtedly be having 500-night runs of "Our Miss Gibbs," "The Arcadians," and all the lot of them, going on all the time. But not

## PROFESSOR BOFFIN

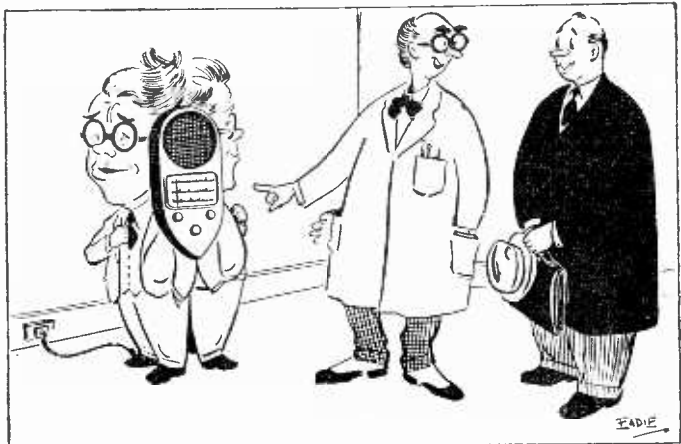

"I have a feeling this design should be accepted by the Festival of Britain people."

only has that type of show long since passed by, but the civilisation which gave rise to them has also. Leslie Stuart wouldn't earn a sausage-to-day minus the types of actors who, 50 years ago, swept his shows to triumph with all the éclat, verve and lacy petticoats of Edwardian days. If it could be done, then the life of Gertie Millar should, not yet, we hope, occupy an hour on 20 Sunday evenings.

### Lectures

The current series of Reith Lectures given by G. Z. Young on the subject "Doubt and Certainty in Science" is occupying eight Sundays. Bertrand Russell's original lecture—still the best, I feel, covered four. Four seems enough. Few people can commit themselves eight consecutive weeks; I certainly can't. We shall find ourselves in the position of having to either issue, or accept, our Sunday invitations to the formula that we shall be very pleased to come, or receive, on the understanding that the proceedings which may be in action between 9.15 and 9.45 will have to be suspended for the listening to the Reith Lecture. That would never do.

Two plays I liked were "The Moon and Sixpence" (Maugham) and "There's Always Juliet" (van Bruten). "Fly Away Peter," "First Lesson" and "The Matriarch" were more on the usual "Saturday Night Theatre" level. I am sorry the Sunday morning "I Was There" series had such a short run. "Red Letter Day" is not nearly so good. The "Round Britain Quiz" is as entertaining as ever and the general knowledge and quick thinking of Messrs. Brogan, Phillips, and company continue to amaze.

### Autumn Music

In the autumn season much good music is broadcast for our delectation. It seems even better than at other times, coming, as it invariably does, after the dearth of summer—a dearth which is a drought notwithstanding the drenching the Proms give us. Many lovely programmes have been put out recently. The first two B.B.C. Symphony Concerts, under Dobrowen and Gui respectively, were notable for their contrasting styles as well as for their individual merits. The pianists, Claudio Arrau and Francis Poulenc, and their concertos, the mighty Emperor—greatest of all—and Poulenc's own, were each as different and as meritorious as could be.

Arrau is the greater pianist, and, as he had the greater vehicle to show off in, he was thus far fortunate. He is a very fine artist and full worthy of handling Beethoven's masterpiece, which can only be said of a handful of pianists these days. That he is possessed of contrasting styles was proved last year when he played a delightful Neapolitan Suite by Poulenc himself.

It would be interesting to hear Mons. Poulenc in the "Emperor." This concerto, like much of his other work, glitters; it is icy cold and bracing, by which I do not wish to infer that it is entirely without a heart. It doesn't sound nearly so difficult as, say, Rachmaninoff. The quotation of an American tune—I forget which precise one, "Swanee River" or something—suggests a prospect of appreciative transatlantic audiences. Debussy's exotic and ravishing suite "Iberia,"

Muhler's enigmatic "Song of the Earth," and the ineffable Fourth Symphony of Brahms, were the chief orchestral items.

### Ireland's Concerto

Eileen Joyce was the soloist at the Royal Philharmonic Society's second concert of the present season, playing Ireland's concerto. Half Miss Joyce's glamour is lost (a) when she plays only one concerto per programme, or (b) when she uses the non-visual medium of broadcasting, whether playing two concertos or six. I wouldn't rave over her Ireland—I don't enthuse over her at any time. But Ireland's music is too forthright and uncompromising for her style, which is far better suited to the superficialities of Saint-Saëns, Grieg or Tchaikovsky. The B.B.C., under their old chief, were in first-class trim in, amongst other things, the first performance of a Rawsthorne symphony, "A Shropshire Lad," and a Vivaldi Concerto Grosso.

Their first concert of the season was a lovely affair with such masterpieces as a rarely-heard Roussel symphony, Elgar's "Introduction and Allegro," for string orchestra, and Delius's sea rhapsodie. Barbirolli and the Hallé were the excellent interpreters.

### Drama

The dramatic department has been creditably occupied since these notes last appeared. Chief event was the mourning of the passing of G.B.S., a lament which was marked by the substitution on the evening of his death of Christopher Fry's "Venus Observed" for the incomparable last act of the incomparable "Man and Superman"—Don Juan in Hell, a gracefully worded tribute by St. John Irvine, and the absorption of "The Critics" in Shaw for the whole of their session the following Sunday.

### G.B.S.

Which was the greatest Shaw play? I have no doubt we shall have plenty of opportunity of judging for ourselves in the near future. Incredible thought, but the old boy's centenary is only six years away!

### "The House of the Arrow"

This play by A. E. W. Mason was a successful dramatisation of a one-time best seller. Not a great deal of excitement was engendered, but it went with a good swing. It was good to be confronted once more with the lovely story of "A Tale of Two Cities" (some works of art, such as the Mona Lisa, Romeo and Juliet, Carmen, etc., are so justly famous that it is almost an impertinence to tag on the authors' names). The great story can be listened to, or read, again and again with never diminishing freshness. As with all great plots, as with great music, the events, or sounds, seem all the more exciting and wonderful for being expected; they are loved as well as looked forward to. The non-existence of a *Radio Times* for that week prevents my naming the individuals of an excellent cast except Eric Portman as Darnay. I can't imagine a better exposition of this dual character, half debauché and half noble self-sacrificing romantic, than Mr. Portman's. And I well remember Martin Harvey's.

**LONDON CENTRAL  
RADIO STORES**

**THE FAMOUS R1155 10-VALVE COMMUNICATION RECEIVER.** Equal to new. Frequency range 7.5 mcs. 75 kc/s. Five waveband. Complete 10 valves, including Magic Eye. Enclosed in metal case. Every Receiver aerial-tested. Complete with power pack and speaker for A.C. mains. 220-250v. £15. Carriage and packing. 10/6. Circuit booklet with every set.

**PHILIPS 6-VALVE COMMUNICATIONS RECEIVER.** 16-50, 200-550 and 800-2,500 metres. R/F, F.C. 21.F.S.D.D.T. Pentode Output. Spin-wheel tuning. In black metal case with built-in speaker. Complete with power pack A.C. 300-250v. Can be supplied with 12v. D.C. power pack if required. Brand New—ex-Govt. £17/10/0.

**WALKIE TALKIE RECEIVER and TRANSMITTER.** Complete. Type 38 Mk. 2, in perfect order. With 4 ARP12, 4 ATP4 Valves, 1 pair Throat Mikes, 1 pair of Headphones and Aerial in metal cabinet. With Wiring diagram. Less batteries. £4/2/6. Carriage Paid. New Condition.

**ANOTHER ASTOUNDING OFFER**

**PHILCO 5-VALVE RECEIVER.** Super Het. Long and Medium Wavebands, A.C. or A.C./D.C. 200/250 volt mains energised Speaker in Walnut cabinet slightly soiled. 90/-, plus 7/6 carriage and packing.

**BRAND NEW 2-VOLT VIBRATOR.** 7-pin. Self rectifying. 200 volts 60 mA. 7/6.

**UNISELECTOR SWITCHES.** 6-Bank, as new. 27/6 each.

**BLOWER MOTORS.** 12-24 and 80 volt. 12/6.

**CARBON MIKE INSERTS.** 2/-.

**NEW LOW RESISTANCE HEADPHONES.** 7/9 pair.

**SMALL WIRE WOUND SLIDING RESISTANCES.** 50 ohm, ½ amp. 5/6.

**SLIDING RESISTANCES.** 132 ohm, 2 amp. 25/-.

**VALVES OZ4.** brand new, 7/6 each.

**NEW U.S.A. HEADPHONES.** 200 ohms. 7/6 pair.

**NEW 6-VOLT ACCUMULATORS.** heavy duty 85 amps. Size 12 x 9 x 7. weight 47lbs. British made, £3/10/-

**NEW OSRAM PROJECTOR LAMPS.** 12 volt 100 watt, 9/6. Class F.

**NEW CARBON TUBE MICROPHONES.** 5/6 each.

**12 inch V.C.R.140 TUBES.** Blue Screen Magnetic Deflection, magnetic focus. 6kv. Heater 4v. In International Octal Standard Connections. £4/10/-

**VALVES EF50.** 5/6; SP41. 4v. 6.3, 3/6; 6J5, 3/6; EA50 and DL. 2/6 each. 100yds. P.B.C. COVERED COPPER WIRE. 1/20, 7/6.

**TELEPHONE HAND SETS.** 8/6.

**NEW 1/30 h.p. MOTORS.** 200 volt A.C./D.C. double ended, 37/6.

**THROAT MICROPHONES.** 3/- per pair.

**CAMERA MOTORS.** 24 volt, 7/6.

**MOVING COIL HAND MICROPHONES.** 30 ohm Voice Coil, 5/6.

**MIDGET BATTERY VALVES.** 1S5, 1T4, 1R5, and 3S4, 8/6 each. All new. We have a large stock of A.C. Mains Sets at greatly reduced prices, from £6 to £15, for callers to suit themselves.

**POTENTIOMETERS.** 10,000 ohms-wire wound, 2/6 each.

**MICRO-AMP. METERS.** 0.50, 2in. dia., 47/6.

**VOLT METERS.** 0.30, 0-3, centre zero reading, 17/6.

**VALVE-HOLDERS.** 9-pin Porcelain, suitable for EF50. 6/- per doz.

WE DO NOT ISSUE LISTS.

Carriage charges relate to British Isles only.

**23, LISLE STREET, W.C.2.**

Telephone: GERrard 2969.

**RECEIVER 25/73.** Part of the T.R. 1196. Covers 4.3-6.7 mcs., and makes an ideal basis for an all wave superhet, as described in this and other journals. Complete with 6 valves: 2 each EF36 and EF39, and 1 each EK32 and EBC33, and mod. data. ONLY 22/6 (postage, etc., 2/6).

**OSMOR ALL WAVE COIL PACK** recommended for the conversion 40/4.

**RECEIVER 18.** Part of the T.R. 18. Covers 6-9 mcs., and requires normal battery supply to operate. Complete with 4 valves: 3 of VP23 and 1 of HL23DD. ONLY 15/- (postage, etc., 2/6).

**H.T. BATTERY SUPERSEDER.** Operated from 2 v. accumulator, and delivers a constant and reliable source of H.T. Saves its cost in a few months. Originally made for the Canadian Forces, this unit also delivers 1.4 v. I.T., and is supplied with full details of easy modification for normal home use. ONLY 60/- (postage 1/6), or with two 2 v. accumulators in metal case ONLY 90/- (carriage 5/-).

**AMERICAN COMMAND SET BC454.** Contains 6 valves: 3 of 12SK7, and 1 each 12K8, 12A6, 12SR7. Specify type required, 33-50 metres 55/-, or 100-200 metres 59/9.

**RECEIVER R.3084.** A very sensitive unit containing 7 valves: EF50, 2 of EF54 and 1 each VU39A, HVR2, EA50, and also a 30 mcs. I.F. Strip with 4 mcs. bandwidth. BRAND NEW IN MAKERS' CASES. ONLY 75/- (carriage 7/6).

**10 VALVE 1½ METRE RECEIVER ZC8931.** Another extremely sensitive Radar unit. Contains 6 valves: VR65, 2 of VR92, and 1 each VR136 and VR137, and also 6 I.F.T.s. of 4 mcs. bandwidth. BRAND NEW IN MAKERS' CARTONS. ONLY 59/6 (carriage 5/-).

**INDICATOR UNIT TYPE 6.** Complete with 6in. C.R. Tube VCR97, 4 valves EF50 and 3 of EB34.

**BRAND NEW IN MAKERS' CASES.** ONLY 90/- (carriage 7/6). If you are making an oscilloscope this unit is specified for the "Wireless World" General Purpose Oscilloscope, full constructional data available price 9d.

**TELESCOPIC AERIALS** extending from 15in. to 102in. Just pulls out of a metal tubular case. Made for Canadian Forces. Very strong. ONLY 12/6 (post 10d.).

**HEADPHONES AND MICROPHONE SET.** A pair of high resistance phones fitted with rubber noise excluders, and a high grade carbon mike. BRAND NEW. ONLY 12/6 (post 10d.).

Cash with order please, and print name and address.

**U.E.I. CORP.,** The Radio Corner, 138, Gray's Inn Road, London, W.C.1. (Phone: TERminus 7937)

Open until 1 p.m. Saturdays. We are 2 mins. from High Holborn (Chancery Lane Stn.), and 5 mins. by bus from King's Cross.



*—if yours is a (rare) VALVE problem*

**ATP4 4/- only** (Post free)

**AMERICAN TYPES**  
OZ4, 8/-; IC5, 8/9;  
1LA4, 8/9; 1R5, 8/6;  
8/9; 1R5, 8/6;  
1T4, 8/6; 1S4, 7/9;  
1V, 9/6; 2A3, 11/6;  
2X2, 7/-; 3S4, 8/6;  
3T4, 13/-; 305, 9/6;  
5R4, 10/-; 5U4, 8/6;  
5X4, 13/-; 5Z3, 11/6

5Z4, 7/6; 5W4, 13/6; 6A3, 11/6; 6A8, 10/6;  
6AC7, 8/6; 6B4, 7/6; 6B7, 11/6; 6C4,  
9/6; 6B8, 8/6; 6AC5, 10/6; 6AC7, 8/6;  
6C5, 7/6; 6D6, 9/6; 6E5, 7/6; 6F6,  
7/6; 6F7, 8/6; 6C6, 9/6; 6G6G, 7/6;  
6H6, 4/9; 6J5, 5/6; 6J6, 11/6; 6J7, 7/6;  
6K6, 8/6; 6K7G, 7/6; 6K7GT, 6/9;  
6L6C, 9/6; 6L7, 8/6; 6N7, 8/6; 6C7,  
8/6; 6S47, 8/6; 6S48, 4/3; 11/3; 4/5; 9/6;  
6S7, 7/6; 6S7L, 8/6; 6S7J, 9/9;  
6SN7, 9/6; 6SS7, 7/6; 6T7, 8/9; 6V6,  
7/9; 6W5, 9/6; 6X5, 8/6; 7A7, 7/6;  
7A8, 7/6; 7B8, 7/6; 7C7, 8/6; 7V7,  
8/6; 12A6, 6/9; 12J5, 6/9; 12H6, 5/6;  
12SG7, 7/9; 12SH7, 7/9; 12SQ7, 7/9;  
12SK7, 7/9; 12SQ7, 7/9; 12SR7, 7/9;  
14F6, 10/6; 15, 10/6; 18, 10/6; 19,  
11/6; 2516GT, 8/6; 25A6, 8/6; 25Z5,  
9/6; 25Z6GT, 9/6; 32, 7/6; 39/4, 9/9;  
42, 10/6; 41, 9/6; 43, 11/3; 4/5; 9/6;  
58, 10/6; 75, 10/3; 78, 8/6; 77, 10/6;  
78, 8/6; 80, 9/9; 807 Amer., 8/9;  
84/6Z4, 9/6; 9001, 7/6; 9002, 7/6; 9003,  
8/6; 9004, 7/6; 954 Acorn, 6/6; 955,  
6/6; 866A, 14/6; 813, 4/9; 864, 12/-;  
863, 12/-; 805, 12/-; 1623, 9/6.

**BRITISH REPLACEMENT TYPES**  
210VPT, 8/6; SP2, 8/6; 210LF, 4/6;  
PMHF, 4/6; PM2A, 9/9; LP2, 4/9;  
QP2, 1/6; PD20, 10/6; ACTH, 18/6;  
SP1, 9/6; AC7, 7/6; 6S47, 7/6;  
D41, 6/9; VP4, 9/6; PENBA, 12/9;  
U10, 7/6; AC2PEND, 18/6; MUI2,  
8/9; FC13C, 9/6; FC13, 9/6; VP13C,  
10/3; HL13C, 7/6.

**SPECIAL TYPES**  
6D2, 9/6; ACSP3, 11/6; ACTP, 16/6;  
TP2620, 16/6; VP135, 10/6; TH23,  
11/6; TP22, 13/6; PEN453DD, 13/6;  
HL133D, 9/6; HL42DD, 12/6; PEN45  
DD, 9/6; PENC2, 10/6; VP1322,  
12/6; HL41, 7/6; PEN25, 9/6; HL23,  
4/9; TP25, 9/6; VP23, 8/6; HL22DD,  
6/6; PENCDD2530, 11/9; KT66, 10/6;  
U52, 10/6; KTW74, 10/3; DL7, 10/6;  
U71, 9/-; DH73, 10/-; X73, 11/3;  
KTW73, 10/3; KT72, 10/3; KT4, 9/6;  
KT74, 10/3; DH76, 9/6; U76, 9/-;  
W76, 10/3; KT32, 8/6; DH63, 7/6;  
KTW61, 7/6; U17, 9/6; H63, 7/6; X65,  
8/6; U74, 9/-; KT35, 10/3; CCH35,  
9/6; EF8, 9/6; EL33, 8/6; EF39, 7/6;  
EL32, 8/6; EK32, 8/6; EF36, 7/6;  
EBC33, 7/6; EM34, 7/6; EL34, 7/6;  
DL2, 8/6; 41MPT, 7/6; 202VP, 11/6;  
SU2150A, 14/6; C1, 10/6; C1C, 10/4;  
XP, 6/6; XH, 6/6; ECH35, 9/6; VR31,  
6/6; EF50 (not VR91), 16/6.

**EX-EQUIPMENT TYPES**  
VR65, 4/9; VR54, 3/9; 9D2, 6/9;  
VR6A, 4/6; VR56, 4/9; VR78, 3/9;  
8D2, 6/9; VR53, 5/3; VR55, 6/6;  
VR57, 6/6; VR92, 4/6; VT32, 6/6;  
S130, 6/6.

**NEW CV TYPES**  
VU133, 6/9; VR105, 10/6; VU111, 6/-;  
VR150, 10/6; VR136 (EF54), 6/6;  
VT31, 12/-.  
Subject to stock. We may send equivalents.  
Kindly mark envelope (P.W.). Order C.O.D. or C.W.O. POSTAGE 1/-.

**RADIO BULLS VALVES**  
246, HIGH ST., HARLESDEAN, NW11

## "YOU CAN RELY ON US"

FOR CLEAN COMPONENTS  
AT COMPETITIVE PRICES  
IMMEDIATE DISPATCH

**I.F. TRANSFORMERS.**—RS GB, Semi-Midget, 465 kcs., 12/6 pair. Wearite Midget M40B, 465, 21/- pair. Weymouth P4, 15/- pair.

**COILS.**—All Wearite "P" Coils stocked, 3/- each. MW iron-cored with reaction, 3/6. TRF matched pair, MW/LW with reaction, 7/6. Weymouth CS3W3, 11/6 pair. CT2W2, 9/6 pair.

**SPEAKER TRANSFORMERS.**—Super Midget for personals, 1S4, 3S4, DL92, etc., 4/3. Mains Midget Type, 3/9. Standard type, 4/8; 1, 4/6, 55; 1, 4/6, 69; 1 and 30; 1, 4/6. Push-Pull 6V6 to 3 ohms, 8/6.

**CHOKES.**—60 m/a Standard, 6/-, 40 m/a Midget, 4/6, 150 m/a, 14/6, 250 m/a shrouded 21/-.

**VALVE CANS.**—3 piece Aluminium, to fit Octal or D92 series Valves, 1/8.

**LINCORID.**—2 a 100 ohms per foot, 8d. ft. 3a, 60 ohms per foot, 8d. per ft.

**CERAMIC TRIMMERS.**—30 pf. 50pf., 9d. 100 pf. 1/-, 250 pf. 1/7, 500 pf. 2/-, 750pf. 2/3.

**TWIN G.A.N.S.**—0005 pf. Complete with rubber-mounted feet and slow motion driver, 8/6.

**SPEAKERS.**—Latest in stock, 8in. Mains energised 2,000 ohm field with pentode transformer, 17/6. R. and A. 6in. P.M., 11/9. Stockists of Haynes, Weymouth, Wearite, Viewmaster, Easybuilt Televisor and, 10,000 Valves, Surplus and List Price. Don't forget postage, chaps, and write for Catalogue No. 8 and Bargain Valve List. Price 3d.

## RADIO SERVICING CO.

444, WANDSWORTH ROAD,  
CLAPHAM, LONDON, S.W.8

Telephone: MACaulay 4155.  
77, 77A, 168, 169 Bus: S.R. Station,  
Wandsworth Road.

If you care to call at  
**MODERN  
ELECTRICS LTD.,**  
164, Charing Cross Rd., W.C.2  
Temple Bar 7587

we shall be pleased to  
demonstrate the G.L.

**"SOUND MAGNET"**  
Tape Recorder  
TWIN TRACK. 3 SPEED.  
10 watt. output.  
**49 gns.**

**THE  
"SOUND MIRROR"**  
Tape Recorder  
REALISTIC reproduction of  
MUSIC, SPEECH, SOUND effects,  
invaluable for the business man.  
**£69.10.0d.**  
S.A.E. please for catalogue.

### Every One A Bargain!

**METERS.** Portable Test Set fitted 2 1/2 in. flush meter D.C. moving coil reading volts 1.5, 3, 150. Milli-amps 6 and 60 ohms, 25,000 knife-edge needle zero adjuster and rotary switch. The whole in black bakelite case with working instructions, 29/6, post 2/-.

**D.C. GENERATORS.** 6 volt 5 amp. speed approx. 100 r.p.m. for hand drive, or with spindle for external drive, 25/-, post 3/-.

**SIGNAL GENERATORS** type 101 frequency range 370/640 Mc/s Piston attenuator max. output 100 mV. Prov. for internal sine mod. and exter. pulse mod. mains operated, 6/5. Several other models in stock, write for leaflet.

**WESTINGHOUSE METAL RECTIFIERS.** Transformer and Rectifier in vent. metal case 50 volts 3 amp. £4.10.0. 50 volts 1 amp. £6. 50 volts 5 amps. £9, carriage extra.

**TELEPHONE EXCHANGE,** manual 5-line with drop indicators, speaking and ringing keys operators call bell and terminals for operators headset, 75/-, carriage, 5/-, limited stock. 50-200 line G.E.C. automatic Telephone Exchanges, prices on application.

**TRANSFORMERS.** Auto Transformers. 230/110 volts 75 watts, 25/-, 100 watts, 30/-, 150 watts, 35/-, 200 watts, 40/-, 300 watts, 65/-, 1 K.W. £7.10.0. Booster Transformer 230 volts 50 cy. input 53 volts 15 amps. output, £4.10.0, carriage, 7/5.

**SUNDRIES.** Mercury Switches, solenoid type 15 amp. 5/-, post 1/-, Patch Cords 2-way, 2/3, 3-way, 2/6, Terminal Blocks 2-way, 6/-, doz. 3-way 9/-, doz. 125 watt Chokes for Osira Lamps, 21/-.

## ELECTRADIX RADIOS

214, Queenstown Road, Battersea, London, S.W.8.  
Telephone: MACaulay 2159

Hitch your AERIAL to a STAR.

**Skyway "Seven"**  
RADIOGRAM CHASSIS

3-wave S'het 16-2000m. Push-pull 6V6s. Separate POWER PACK for easy fitting.

Basic Parts cost less than (excluding valves) **£5**

Full home constructor design in FOUR EASY STAGES 1/6 post free

**Frith RADIOCRAFT Ltd.** PHONE 8927  
69-71 CHURCH GATE LEICESTER

## T. N. B. RADIO

166a, ROOKERY ROAD,  
BIRMINGHAM, 21

VIEWMASTER CONSOLE CHASSIS,  
2 tier, valveholders and screen, etc., 35/-  
500+500 CERAMIC TRIMMERS, 1/-  
THERMAL DELAY SWITCH, for  
H.T., 3/6.

FLEXIBLE COUPLINGS DRIVE up  
to 45 degs. 9d.  
15,000 VITREOUS RES., 10 watt, 6d.  
100 and 2,000 Pps., 3/- doz.

Full range of Radio and Television components stocked.

## H.A.C. SHORT-WAVE EQUIPMENT

Noted for over 15 years for . . .  
Short-Wave Receivers and Kits of quality.

One Valve Kit, Model "C" Price 20/-  
Two " " " " " " " " 43/-

These kits are complete with all components, accessories, and full instructions.

Before ordering send stamped, addressed envelope for descriptive catalogue.

"H.A.C." SHORT-WAVE PRODUCTS  
(Dept. TH), 66, New Bond Street,  
London, W.1.

## RADIO UNLIMITED

Elm Road, London, E.17 Tel: KEY 4813

GUARANTEED NEW AND BOXED VALVES, 6V6, 6K6, 6K7, 6N7, 6F6, 6C5, 6J7, 5Z4, KT601, VT109, EF39, EB33, EF36, 6AC7, 6L7, 6BR, 1T4, 1S4, 1C5, EL32, 6/6 each. Post free.

6L6, 6K8, ECH35, KT69, 5U4, 6SN7, 9/- each.  
Sylvania (Red) EF50, Brand new, 6/9 each, 4 for 22/6.  
Hundreds other types in stock. Stamp list.

**METERS.** 0-500 microamp., 6/6 each, 0-12/120 v. m'coil meter, 10/6 each.

**SPEAKER SPECIAL.** Lightweight P.M. 5in., 11/6; 6in., 12/6.

**EXTENSION SPEAKER.** 3in. Goodman's P.M., housed in alloy case, with V/control. Brand new, 15/- post free.

**V/CONTROLS.** 1 meg. 1in. spindle, 1 switch, 1/6.  
**V/CONTROLS.** 1 meg., 2 1/2in. spindle, W/switch, 3/3.

**SPECIAL OFFER**  
Brand new, P.A. Re-entrant speaker. Sensitive, Directional, Weatherproof. Offered at a fraction of the original cost.

35/- Carriage Paid  
**STOP PRESS**  
Sprague, .1, 400 v. condensers, 5/- doz.  
Thyratron valve, VT109, Brand new, 5/- each.

## RADIO G200 ANNOUNCES

Return Post Mail Order Service.

VALVES.—6J5GT, 4/-; 6AG5, 6/6; 6AM5 (BD3), 10/6; 6C4, 7/-; 6H6, 2/-; 6K7GT, 5/6; 6L5G, 6/6; 6N7, 6/6; 6N7G, 5/6; 6Q7G, 6/6; 6S7, 12S7G, 6SH7, 12SH7, 6/6; 12SK7, 6/6; 6X5GT, 6X5, 6/6; 7W7, 7H7, 7C5, 7/6; 45, 5/-; 78, 8/6; 80, 7/6; 83, 12/6; CV86 (RL37), 6/6; VR31, EF50, 5/6; EF39, 6/9; NR48 (EB33), 5/6; VR73 (D1), VR92 (EA50), 3/6; VR150-30, 8/6; T11, 4/6. Crystal and Cats Whiskers—9d. Twin crystal detectors, 3/6. ALSO HUGE STOCKS of Branded and rare type of valves at B.V.A. prices. Order these C.O.D. if you prefer.

## ARTHUR HOILE

55, Union Street, Maidstone, Kent  
phone: 2812.





The Editor does not necessarily agree with the opinions expressed by his correspondents. All letters must be accompanied by the name and address of the sender (not necessarily for publication).

#### Ex-W.D. Headphones

SIR,—I have just been reading the article on "Ex-W.D. Moving Coil Headphones," pages 102-4, in the March, 1950, issue.

With regard to the second and more commonly-met type, and the difficulty of unscrewing the cap, this is a quite simple matter if you know how.

While I was investigating one with a view to its conversion I hit on the solution. A careful examination of the back of the cap reveals that a hole has been drilled through the threads and a small 1/16in. diameter ball inserted to prevent unscrewing. It is not possible to drill the ball out as it is hardened, but it is a simple matter to drill a 1/16in. hole from the opposite side and then the ball can be pushed out with a small punch.

I hope the information may be of some use to your readers. I would mention that the hole in the back is plugged with composition which is quite soft and can be easily removed with a drill. The hole always appears to be located on the opposite side to the terminals, and in line with a small depression cut in the back of the case.—J. E. RICHARDS (Timperley).

#### Tractor Radio

SIR,—You may be interested to learn that radio programmes can be enjoyed by tractor drivers just as well as by motor-car drivers. I have a secondhand Pye car radio, which is bolted on to the tool-box mountings on a Ferguson tractor.

I connected the power line to the lighting switch; the special aerial lead had to be lengthened and fitted to a horizontal aerial mounted on the special bracket used for the tractor lighting set and number plate. Reception of all British and foreign stations is excellent, the only suppressors needed were one in the high-tension lead from coil to distributor and one small condenser on the coil.

Overtime during rush periods is now no hardship. I rely a lot on the Light programme from London.—PETER GAGE (Sudbury).

#### Push-button Volume Control

SIR,—Re the article on push-button volume control by D. Cave, in the June issue of PRACTICAL WIRELESS.

Although the idea in itself is sound, inasmuch as it undoubtedly removes the weakest point from a

radio set, it seems to me to have one or two failings for which I should like to suggest a cure.

Firstly, a five-button control occupies a large panel space and a fair amount of room inside the set; secondly, the grid connection is floating about inside the set, an easy prey to all forms of interference; and thirdly, many contacts to wear and oxidize.

My solution to the above is to fit a single-pole, six-way rotary switch. This can be a long spindle control, enabling it to be fitted near the valve control. The resistors can be soldered round the periphery, making a neat, compact control.

If necessary, the whole could be mounted in a screening can to avoid all interference.

The modern rotary switch (instrument type) is more or less self-cleaning, and much more stable than push-buttons.—A. H. MARCH (New Malden).

#### Modified Teleprinter

SIR,—In your September-October issue, A. W. Mann mentions the possibility of "A modified version of the Teleprinter" to transcribe Morse into plain language.

An automatic system which produced a printed transcription was developed by Messrs. Creed & Co., Croyden, about 35 years ago. The equipment was used extensively by the Post Office and newspapers—until last year the Press Association used it to supply news to provincial newspapers throughout the country, and some newspapers still use it on their "private wires."—(*Daily Express* and *Daily Herald*.)

The equipment comprises a keyboard perforator, resembling a typewriter, which punches holes in accordance with the Morse code in a 3-in.-wide paper "slip"; a transmitter (through which the slip is run), which carries contacts controlled by the holes in the slip; a receiving reperforator which, under the control of received signals, prepares a duplicate of the transmitting slip; and a printer (through which the receiving slip is run) which, controlled by the holes in the slip, prints roman characters. A storage device (the paper slip) is, of course, necessary because of the varying lengths of Morse characters.

A detailed description of the equipment is given in T. E. Herbert's "Telegraphy" (Pitman) in the chapter headed "High-speed Automatic Equipment."

Unfortunately for A. W. Mann's purpose, the

reperforator will only work satisfactorily from perfectly-formed, speed-controlled signals, and the cost is prohibitive—for the reperforator and printer about £500!—J. BROWN (Manchester).

### Training Service Engineers

SIR,—Your correspondents D. F. C. Smyth and Bernard F. Appleton, have one thing in common. They both have very good opinions of themselves as radio servicemen. Yet neither of them is a full-time service engineer. The former is not so, because he disagrees with R.T.R.A. wages. Does he not realise that the rates of pay agreed between R.T.R.A. and G.R.S.E. are minimum rates? I'm quite sure there are plenty of retailers willing to pay more than that agreed minimum to a really good serviceman. So to D. F. C. Smyth I say, "Let the R.T.R.A. dealers know your capabilities—if you are as good as you say you are, and can prove it, you'll get a job all right at a decent salary."

Mr. Appleton's letter is typical of many seen at various times in the Press. It relates the experiences of the set owner at the hands of the radio dealer and ends up showing how the honest dabbler eventually solves all the trouble at, of course, a minimum of cost. My own experience is very much the opposite. I have, sir, lost count long ago of the number of victims of the "dabbler." Many are the invoices, marked by the service department of which I'm in charge, that "cost has been increased due to inexpert attention." Mr. Appleton is hoping soon to be qualified. I hope he soon does and takes his place among fellow professional engineers. He'll find they are not so daft as at present he seems to think. In conclusion, may I state that I entirely agree with your editorial in the September-October, 1950, issue of PRACTICAL WIRELESS.—A. HARRISON (Regd. R.T.R.A.), West Hartlepool.

### Resistance and Ohm's Law

SIR,—With reference to the recent correspondence on this subject, I would like to say that resistance is the property of a circuit by virtue of which electrical energy is transformed into heat energy. It is independent of the values of E and I and depends only upon the form, dimensions and physical conditions of the conductor.

In order to measure resistance some sorts of units are required. These are obtained—by agreement—from the ratio  $R = E/I$  when the units of E and I are volts and amps respectively.

Thus the value of R is obtained initially by measurement, and whichever method is employed, voltmeter, ammeter, ohmmeter, substitution, bridge potentiometer, loss of charge, etc., we are essentially finding the ratio of the applied volts to the current—in amps—through the resistance. Even if we calculate the value of R, we still have to use I—the value of which is found initially by measurement as above.

Resistance follows logically after current and voltage have been defined; in fact, if units of current and E.M.F. or P.D. had not been considered first, resistance as we know it now would probably never have been conceived.

The form of Ohm's Law  $I = E/R$  is only of use to us if we know R (and E, of course), since R is

obtained by the measurement of the E/I ratio it follows that if Ohm's Law defines anything, it is resistance, particularly the unit of resistance, and should therefore be considered first in the form  $R = E/I$ .—SIMPLETON (S.W.1).

### Using VCRI40

SIR.—It may assist some fellow readers to know that I have used a VCRI40 tube for TV for over a year.

First, I exposed it to a 150 w. light 18in. away for about 50 hours. I think this reduced the afterglow slightly, but doubt if it was necessary, as the tube still glows for quite a while in the dark after exposure to normal room lighting.

Unless the picture is very bright the afterglow does not show up under normal viewing conditions, except after a "still" such as an announcer or the clock.

Due to the extra chemical layer there is slight diffusion which can, as in projective TV, be mistaken for being out of focus compared to a normal 12in. TV tube. For the average programme this is not serious and has the advantage of allowing viewing at close quarters without the line structure being too prominent. The colour is in my opinion better than any TV tube in darkness, but becomes a hard blue-white in artificial light. My tube was marked Max. H.T. 4,000 v., but I have run it on standard time bases and flyback EHT of 6 kV.

To sum up I would say that, taken on its own, the picture is absolutely satisfactory, but when compared with a standard 12in. tube or on Test Card C when, like me, you want the three Mc/s bars as well, then a TV tube is necessary.—M. WILD (Leeds).

### "Strange" Fault

SIR.—I was interested to read Baron G. S. Caruana's letter in the February issue of PRACTICAL WIRELESS, concerning the trouble he was experiencing with his D.C. version of the R1155, and trust that I might be able to throw some light on this matter.

The two valves which he mentions are valves type VR101 (R.A.F. nomenclature), and I have noticed myself that these particular types do not always have constant characteristics. Although the equivalent of the VR101 is usually given as DL63, this may not necessarily be true.

For instance, I have, at the time being, two VR101s on hand and I find that both of them, instead of drawing 0.3 amps, take slightly more than 0.6 amps heater current. It is very probable that the valves used by your reader also require a heavier heater current than the 0.3 amps provided by his circuit.

Incidentally, one of the valves whose heater current I checked was also marked "MHLD6." I can find no evidence of this type in current Marconi or Osram literature, the nearest (if such a term may be used) being the HHD4, a 4-volt 1-amp. double diode triode. It might be fairly safe to hazard a guess that this MHLD6 is a 6-volt version of the MHD4 (introduced possibly as a war-time measure); and it is interesting to note that the heater wattages of the two valves are similar.—J. R. DAVIES (W.C.1).

# HIGHSTONE UTILITIES

**Crystal Sets**, which are fitted with a permanent crystal detector. Why not have a set in your own room—10/6, post 6d. De Luxe receiver in polished oak cabinet, 18/6, post 1/-. Spare Permanent Detectors, 2/- each. When ordered separately, 2/6. With clips and screws, 2/10 post 3d.

**Headphones**, in good order, 4/6 and 5/6, post 8d. (better quality, 7/6). **New Headphones**, 10/- a pair. Balanced armature type (very sensitive), 12/6 a pair, all post 8d. **New Single Earpieces**, 3/6. **Bal. armature type**, 4/8; **ex-R.A.F. earpieces**, 2/-, post 4d. All headphones listed are suitable for use with our crystal sets. **Hand Microphones**, with switch in handle, and lead, 4/-. Similar instrument moving coil, 7/6, post 6d.

**Sparkling Plug Neon Testers**, with vest pocket clip, 3/3, and with gauge, 3/6, post 3d. **Soldering irons**, Streamlined iron, with two interchangeable bits, one each straight and curved, 200-250 w./10/-; **Standard Iron** with adjustable bit, 200-250w., 30 w., 11/-; **Heavy Duty Iron**, 150 w., 14/6, all post 6d. **Magnets**, Small ex. 2in. meters, 1/-, each, post 3d. **Telephone Hand Generator** with handle, 7/6, post 1/6. **Bell. 3.6. post 6d.**

**EX-R.A.F. 2-Valve (2-volt) Amplifiers**, can be used to make up a deaf aid outfit, intercommunication system, or with crystal set, complete with valves, 20/-, post 16d. Ditto, less valves, 10/-. **Wooden box to hold amplifier**, 2/- extra.

**Meters**, 10v., 2 1/2in. Rectifier (a.c.), in wooden carrying case, 14/6; 15 v., 2 1/2in. m.c., 9/6; 150v., 2in. m.c., 10/-; 3500v., 3 1/2in. m.c., 20/-; 6000v., 3 1/2in. m.c., 47/6; 15600v., 2 1/2in. m.c., double reading, 8/-; 100 m.a., 2in. m.c., 7/6; 3.5 amp., 2in. T.C., 5/-; 4 amp., 2 1/2in., T.C. in case with switch, 7/6; **Meter Movements**, 2in. size with magnet and case (500 microamp), 2/6. **Units containing two movements**, 5/-; All meters post extra. Money refunded if not completely satisfied.

**HIGHSTONE UTILITIES**, 58, New Wanstead, London, E.11. Letters only. New Illustrated List sent on request with 1d. stamp and s.a.c.



**The "Fluxite Quins" at Work**  
 "This aerial mix-up's absurd,  
 You don't need that wire, 'pon my word  
 To put your set right  
 All you need is FLUXITE,  
 Or a' will only be seen and not heard!"

See that **FLUXITE** is always by you—in the house—garage—workshop—wherever speedy soldering is needed. Used for over 40 years in Government works and by leading engineers and manufacturers. Of all ironmongers—in tins, from 1/- upwards.

The **FLUXITE GUN** puts **FLUXITE** where you want it by a simple pressure. Price 2/6, or filled 3/6.

## FLUXITE SIMPLIFIES ALL SOLDERING

Write for Book on the Art of "SOFT" Soldering and for Leaflets on CASE HARDENING STEEL and TEMPERING TOOLS with FLUXITE. Price 1d. each.

FLUXITE Ltd., Dept. W.P., Bermondsey Street, London, S.E.1

## RADIO COMPONENTS, EAST STREET, DARLINGTON

**BASS and TREBLE SEPARATOR**—Enables the use of separate speakers for bass and treble. Permits adjustment of amount of treble relative to bass, and also allows speakers of different impedance to be used. Kit of parts, £1 9 6

**SCRATCH FILTERS**—Give marked reduction of scratch level without serious effect on treble response..... £1 15 0

**WHISTLE FILTER**—Completely eliminates that annoying 9 kc/s inter-station whistle. Easily inserted in speaker leads and suitable for any impedance 2 to 30 ohms. Gives a very sharp, narrow cut, guaranteed better than 35 db, with negligible insertion loss..... £1 13 6

**SIGNAL GENERATOR**. Complete, portable signal source operating from internal batteries..... £2 10 0

Further details of any above items and catalogue of high fidelity equipment on request.

## MANUFACTURERS—We

hold large stocks of components and can offer Immediate Delivery of many components that are in short supply. Send us your enquiries or 'Phone: Luton 2677.

Express Delivery from

## COVENTRY RADIO

189, Dunstable Road, Luton

**2 VOLT BATTERY SUPER-HET.** 6-9 mcs. Chassis taken from the No. 18 Tx/Rx. Tested ready for use. 20/-.

**New IN34 CRYSTAL DIODES**, 5/3. **METERS**, M/c 0-300v, 2in, 10/-, 0-40v, 7/6. 250 mA, 2 1/2in., 10/-.

**MULTIMETERS**, 2 1/2in. Supplied as kit with black bakelite case, 6 x 4 1/2 x 1 1/2in. and resistors for D.C. ranges 0-3, 0-30, 0-150, 0-300, 0-600v, and 60mA. Scale also reads OHMS 0-5,000 with 1 1/2v. battery, 17/6.

**HEADPHONES and MICROPHONE** set. Packed in wooden boxes Operate with 4 1/2v. battery. 10/- a set.

**New Brown's Moving Reed HEADPHONES**. Best in the world. 7/6.

**POWERFUL SMALL MOTORS**, 3 1/2 x 2 1/2 x 2 1/2in., 115v. A.C./D.C. with reversible connection, 11/6.

**24v. AC/DC MOTORS** 5 x 3 1/2in., fitted with powerful blower fan. 14/-.

**R.C.A. 100 kc. CRYSTALS**. First Grade. 25/6.

**TRANSFORMERS** 230/24V. 1 amp. 13/6.

**SIGNAL GENERATOR**, 200 mcs., easily converted to 144 mcs. or TV bands. Complete with 6v. vibrator pack, in black metal case, 32/-; **SIG. GEN.** only, 11/6.

**ARMY CARBON MICROPHONE** with switch, new and boxed, 4/6. Trans. to match, 3/-.

**ADMIRALTY SLOW-MOTION DIALS**, 3 1/2 in. 100-1 with vernier. White ivorine dial. 0-100. Worm driven. Beautifully made, new and boxed, 8/6. All Carriage Paid. Money back Guarantee from—

## THE RADIO & ELECTRICAL MART

253b, Portobello Road, London, W.11. 'Phone: Park 6026.

**Preciton**

**5 VALVE RADIO-GRAM CHASSIS**

16-50, 190-550, 1,000-2,000 meters. Triode output stage. Iron core coils. Band-Pass input circuit. Fluo 1114 Perspex Scale. Volume & Tone Controls also operate for grammo. reproduction. Price £12.17.6. Data sheet on request.

**ELECTRO Acoustic DEVELOPMENTS**  
 18 Broad Road, Willingdon, Sussex.

## RADIOLECTRON

22, Frances Street, Scunthorpe, Lines. **New Goods Only.**

**CONDENSERS**.—ELECTYCE, 450 v. wkg. 4 mfd., 2/8; 8, 3/6; 16, 4/8; 8-8, 4/8; 2-16, 5/9; 16-16, 6/3; 500 v. wkg. 4, 2/8; 8, 3/2; 16, 4/3; 8-8, 4/9; 8-16, 6/1; 16-16, 6/11; 25X25V, 2/-; 25X50V, 2/3; 50X12V, 2/-; 50X50V, 2/6. **Tubeless**, 500 v. wkg. up to 03, 11/-; 05, 1/-; L.T. 25, 1/9; 5, 2/10; 1 mfd, 450 v. wkg., 2/9. **Moulded Mica**, up to .0003, 10d.; to .003, 1/-; .005 and .01, 1/6. **Sil. Mica**, up to 80 pf., 9d.; to 4500 pf., 1/-.

**VOLUME CONTROLS**.—Lg. 1/2in. dia. Spdls. all values, 3/-; with SW, 5/-; with D.P. SW, 6/-; **Midret Type**, 1 and 2 meg., 4/6; with SW, 6/6; with D.P. SW, 7/6; **Wire Wound**, 1 k. to 80 k., 5/8; 100 k., 6/9; with SW, 5 k. to 50 k., 7/3.

**RESISTORS**.—Carbon, all values, 1 watt, 4d.; 1 watt, 7d.; 2 watt, 1/-; **Wire wound**, 4d.; 5 watt, 50 to 2 k., 1/6; 3 k to 50 k., 2/3; 10 watt, 50 to 2 k., 2/3; 20 watt, 150 to 2 k., 2/9. **Mains Droppers** with F.T. cord, 3 way taps, 2A., 4/6; 3A., 5/-; **Lined cord**, 3 way 2A. or 3A., 1/11 yd. Terms—Orders up to 10/-, post 4d.; over, free. List 2jd. stamp.

## A FREE BOOK on Morse Code Training



There are Candler Morse Code Courses for Beginners and Operators.

Send for this Free "BOOK OF FACTS" it gives full details concerning all Courses

**THE CANDLER SYSTEM CO. (S.L.O.)**  
 121, Kingsway, London, W.C.2.

Candler System Co., Denver, Colorado, U.S.A.

**TX OUTPUT TEST SETS**, incorporating a 50 micro-amp moving coil meter, (2 1/2in. flush type), etc., 45/-.

**NON-POLARIZED CONDENSERS**, 20 mfd. 350 v., +10 mfd. 350 v., +5 mfd. 150 v., +5 mfd. 150 v. Aerovox tubular can (slightly dented), 2/3 each, or 5 for 10/-, post free.

**ELECTROLYTICS**.—8+8 mfd. 450 v.w., 2/9; 50 mfd. 50 v.w., 1/9.

**NEW BONED VALVES**.—9D6, KT33C, EL33, 10/-; ECH35, EF39, EBC33, EM34, VP133, VP, Z21, 210VP9, PEN220A, Y63, 1R5, 1T4, 1L4, 1S5, 354, 5U7, 6D6, 6/6; KT6W1, AT74, IS4, 6F8, 6K7M, 6X5, 6Y3, 7/6; 6C5GT, EP36, EL32, 6/6. Over 200 other brand new surplus valves available, including 4-volt and many scarce types. S.A.E. for List or with inquiries. Please add Postage on orders under 41.

## ELECTRAD RADIO,

64, Great Victoria Street, Belfast, N. Ireland.

**THE FAR EAST**

and the far west—our famous "HOME CONSTRUCTOR'S HANDBOOK" has been acclaimed the world over, and from the vast quantities sold, also from letters in our files, there is no doubt this book satisfies ALL interested in radio. If, by chance, you haven't had a copy you really are missing to-day's best value! Send to us NOW for the latest issue price 1/6. (Worth very many times this purely introductory price.)

- **30 TUNING UNIT.** 3-wave (iron-cored coils), s'het. coil pack, iron-cored I.F.T.'s, J.B. 2-gang, and latest 3-colour 8 x 6 dial. \*ALIGNED AND SEALED IN OUR STANDARD 5-VALVE RECEIVER. No further adjustments necessary! 69/9 inc.
- **40 TUNING UNIT.** Similar to above BUT WITH R.F. STAGE! 99/6 inc.
- **NEW AND IMPROVED CONSTRUCTION SHEETS!** These famous sheets have been improved and are now the last word in simplicity. You need no radio knowledge to build our elegant superhets! No test equipment required whatsoever.
- Our standard range of highest quality coil packs, chassis, components, etc., always available.
- Complete range J. B. dial units to match our coil packs, including S.L. 8 spin-wheel tuner, 25/- (or 20/9, instead of 1').

Remember—SERVICE TO OUR CUSTOMERS ABOVE ALL! is a maxim we constantly bear in mind, and our large Mail Order service, with its excellent packing department, ensures that all goods quickly reach your door in A1 condition.

MAIL ORDER ONLY DIRECT FROM  
**RODING LABORATORIES**  
(MAIL ORDER DEPT. W.M.)  
70, LORD AVENUE, ILFORD.

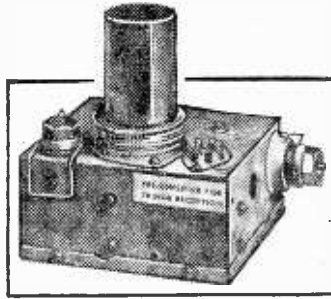

**TELEVISION PRE-AMPLIFIER**

Just the thing you have been looking for. This ex-Govt. 1-valve pre-amplifier is extremely sensitive and stable. It makes an amazing improvement in both vision and sound reception in all fringe areas. Now available for both London (type A) and Birmingham (type B).

Very small dimensions. Length, 4in. Width, 3 1/2in. Chassis depth, 1 1/2in. Overall depth to top of valve 4 1/2in.

Fitted with EF50 valve. Ready for use. Power requirements 6.3 v. L.T. 200/275 v. H.T. Coax., input and output sockets. Ideal for "The Viewmaster" "The Inexpensive Television Set." Electronic Engineering Television, and any commercial set with suitable power supply. Unique value at the price of

15/- (Post 1/-)  
All Tested and Guaranteed before despatch. Prompt Delivery. Obtainable only from  
**H.P. RADIO SERVICES LTD.**  
Britain's Leading Radio Mail Order House  
55, COUNTY ROAD, WALTON,  
LIVERPOOL, 4. Tel.: Aintree 1445

**BRAND NEW VALVES!**

(A) Makers' cartons.		(B) Unused and boxed.	
Type	A B	Type	A B
2X26	4/9 4/3	6N7GT	4/9 —
2X2	4/9 4/3	6Q7GT	6/9 —
3U4G	6/8 —	6XK7MorGT	6/3 4/9
5Z4M	6/3 5/9	6V6M	— 6/3
6AC7M	5/6 5/6	6V6G	— 6/3
6C4	6/9 6/3	6Y6G	— 6/3
6CS6M	4/9 4/3	12H6	3/- 2/-
6F6G	6/9 6/3	12SH7M	— 3/6
6J5M	5/3 4/8	12SK7M	— 5/-
6J6GT	3/9 —	807	6/3 —
6J6	10/- 7/9	8B34	2/8 2/-
6K7M	5/9 —	EC38(RL19)	— 5/-
6K7GorGT	5/9 —	KTW61	— 6/8

Special offer: EF50, 3/6; SP41, 2/6. Ex-equipment, sorted, but tested for satisfactory emission. (EF50 checked for soundness of glass seals.) Matching 2/- extra. Send for full list of REAL bargains. Examples: Condensers 6 mfd. 2,000 v. test. 3/6. Chokes: 20 hy. 80 mA., 6/8. Resistors from 2d. Condensers from 3d. All new. Post paid on orders over 15/-.  
**REED & FORD** (Mail Order Only), 46b, Grosvenor Road, Southampton, Lancs.

**STAN WILLETTS**  
43, SPON LANE, WEST BROMWICH, STAFFS.

**TR9 Short-wave Receiver**, 31-80 metres, complete with 6 battery-operated valves, two VR18, two VR21, VR27, VR118 or VR22, working order, 12/6, post 2/6. **U.S.A. Radar Unit**, containing 7 valves, three 12SH7, two 12H6, 12S7, VR150/30 and 12 of useful components, 19/6, post 2/6. **1355 Receivers**, brand new, with 11 valves, 55/-, post 7/6. SP61s (VR65), 2/6; brand new EF50 (VR91), RL37s (CV66), 6/6 each; EL32s (VT52), 6AC7, 5/- each; 615s, 3/6; 5U4, 6K8, 7/6 each. **Portable Test Meter**, 0-5,000 ohms, 0-60 m/a, 0-3 volts, brand new, 14/6, post 9d. **Brand New Volume Controls**, with switch 100k., 1 meg., 1/2 meg., 3/6 each. **Belling-Lee Cartridge Fuseholders**, 1/6 each. **Ex-Government Jack Knives**, 3/6 each, post 4d. **Brand New 12-volt Vibrators** (4-pin), 5/- each, post 4d.; 6-volt (5-pin), 5/6, post 4d.

**Cabinets of Distinction . . .**

- RADIOGRAM CABINETS
- RECEIVER CABINETS
- RECORD CABINETS
- DRAWER UNITS

Catalogue available on request.

**Chassis**

A.C., 5-valve 3 w/b Superhet Radiogram chassis. Absolutely complete kit of parts, including wiring diagram . . . **£10.0.0.**

Or fully wired and tested . . . **£11.15.0**

**Amplifiers**

Four to fifteen watts output. Wired, or in kit form, from . . . **£3.15.0**

Full details of above available on request.

**LEWIS RADIO CO.**

(Dept. K8.), 322, HIGH ROAD, WOOD GREEN, LONDON, N.22.  
Telephone -- BOWES Park 5997

**YOU can become a first-class RADIO ENGINEER**

We are specialists in Home-study Tuition in Radio, Television and Mathematics. Post coupon now for free booklet and learn how you can qualify for well-paid employment or profitable spare-time work.

**T. & C. RADIO COLLEGE**

Post in unsealed envelope, 1d. postage.  
To: R. Heath Bradley, T.C.R.C.,  
50, Harland Road,  
Southbourne, Bournemouth.

NAME.....  
ADDRESS.....  
P.112

**L.R.S.** FOR PROMPT & EFFICIENT SERVICE  
CASH OR EASY TERMS  
**ARMSTRONG ALL-WAVE CHASSIS**  
(incl. speaker and output transformer)  
Model EXP 83/3, Cash £18/17/1. Or £4/12/6 with order and 8 monthly instalments of 40/-

**COLLARO RADIOGRAM UNITS**  
A.C. 504 with Crystal Pick-up £6.4.5 cash or 35/- with order and 5 monthly instalments of 20/-.  
A.C. 505 with Crystal Pick-up. £8/0/7 cash or £2/12/0 with order and 6 monthly instalments of 20/-.

**The REMINGTON RANG ELECTRIC SHAVER**  
The Remington Rand Electric Shaver is the finest dry shaver made. It really does give a better, quicker, and more pleasant shave than the blade and soap method.  
The Foursome. Cash £7/18/6 or 30/- with order and 7 monthly instalments of 20/-.  
Free Trial on receipt of deposit.  
Brochure by return.

DELIVERY FROM STOCK  
**THE LONDON RADIO SUPPLY COMPANY** Est. 1925  
BALCOMBE, SUSSEX

# Impressions on the Wax

## Review of the Latest Gramophone Records

SIR THOMAS BEECHAM has been a recognised interpreter of Mozart for longer than many of us can remember. The nickname of the composer's "Jupiter" symphony has no obvious origin and the identity of the person who coined its use is not known. Last in the final group of three Mozart symphonies, the "No. 41 in C" ("Jupiter") is supremely classical and has been recorded on *Columbia LX1337-40*. Sir Thomas Beecham's interpretation conducting the Royal Philharmonic Orchestra is one to be eagerly sought by Mozart collectors.

Tchaikovsky's "The Swan Lake," Op. 20, will be welcomed by lovers of ballet music and Sir John Barbirolli conducting the Halle Orchestra gives a very fine interpretation of the music from this famous ballet on *H.M.V. DB9549-50*.

Two very interesting sets of records make their appearance this month and both are by famous pianists. The first is Rachmaninoff's "Concerto No. 3 in D. Minor," on *Columbia LX1352-6*. It features Maleczynski playing with the Philharmonia Orchestra, conducted by Paul Kletzki. The second set is of Schumann's "Etudes Symphoniques, Op. 13," played by Moura Lympany, on *H.M.V. 64051-3*.

In his 68 years Albert Roussel made contribution to the majority of musical forms. Influenced in almost equal parts by D'Indy and Debussy, he showed small interest in the sterner developments of "modernisation." This "Symphony No. 4 in A Major"—his last orchestral work—was first produced at one of the famous Pachelbel concerts in Paris a year after its composition (1934), and Herbert von Karajan conducting the Philharmonia Orchestra is to be congratulated for showing this work to the present-day public. This recording on *Columbia LX1348-51* will amend the absence of this work from our regular concert programmes.

All who listen to the records of Kostelanetz will surely not deny that his music is, indeed, worthy of consideration by all discerning music lovers. For his latest recording, on *Columbia DX1714*, he has chosen "Waltzes from 'Faust'" coupled with "Adagietto," by Bizet.

Records by that gifted piano team, Rawicz and Landauer, are always a musical delight and in their latest they give their own arrangement of "The Aunen Polka," by Strauss, coupled with "The Petite Waltz," by Heyne.

### Vocal

"No quiero tus Avellanas" and "Jota" are the two songs chosen by Spanish soprano Victoria de los Angeles on *H.M.V. D.41961*. The songs are by a

contemporary Basque composer, Jesus Guridi. He has, it appears, fine orchestral works to his credit as well, so it is hoped that this record may be a useful agent in making him better known. Gerald Moore plays the accompaniment.

Those famous duettists Anne Ziegler and Webster Booth are to be heard on *H.M.V. B10011*, singing "Such Lovely Things" and "Lift up Your Hearts." Lester Ferguson, who has rapidly come to the fore as a tenor makes an impressive recording on *Parlophone R3352* of "Forgive me Lord" and "Sleepy Eyes."

Under the title of "Serenade for You" Stephen Douglas sings a medley of love songs on *Columbia DX1717*. He introduces such favourites as "My Heart Stood Still," "Can I Forget You," "When I Grow too Old to Dream," "The Night is Young," "The Way You Look To-night" and "You and the Night and the Music."

### Variety

A British vocal team, the Beverley Sisters, introduce the popular "Ferryboat Inn" coupled with a "Cinderella" medley on *Columbia DB2786*.

The "Cock of the North," Peter Sinclair, is so well-known on the variety stage and over the air that he scarcely needs an introduction. His latest recording is "New Year Medley" and "Loch Lomond" on *Columbia DB2794*.

"The Thing," with Charles Forsythe, and "The Flying Saucer," with "Jennifer," on *Columbia DB2795*, is a clever record featuring two novelty hits of the moment. Charlie Forsythe hails from the disbanded trio, Forsythe, Seamon and Farrell, and Jennifer is the same funny little voice we hear in the B.B.C.'s programme "Ray's a Laugh."

"Bonnets to Blue" and "Thady you Gander" on *H.M.V. B10013* and "Circassian Circle" on *H.M.V. B10014* have been recorded under the auspices of the English Folk Dance and Song Society. 1951 being Festival of Britain year is a significant one for the Society who now nominate these two records as being valuable additions to the Festival of Britain party programmes—of which more anon. They are played by the Square Dance Band, directed by Douglas Kennedy.

"Hora Samba" and "The Flying Saucer," by Joe Loss and his Orchestra, on *H.M.V. BD6084*, is not in the "Dancing Time for Dancers' Series" but is a dance novelty record.

The Billy Mayerl Rhythm Ensemble has been in existence for over five years and is well known in sound broadcasting and television. Their latest effort is "The Dusky Aristocrat" and "Nola" on *Parlophone F2441*.

Editorial and Advertisement Offices:  
 "Practical Wireless," George Newnes, Ltd., Tower House, Southampton Street, Strand, W.C.2. Phone: Temple Bar 4363.  
 Telegrams: Newnes, Rand, London.  
 Registered at the G.P.O. for transmission by Canadian Magazine Post.

The Editor will be pleased to consider articles of a practical nature suitable for publication in "Practical Wireless." Such articles should be written on one side of the paper only, and should contain the name and address of the sender. Whilst the Editor does not hold himself responsible for manuscripts, every effort will be made to return them if a stamped and addressed envelope is enclosed. All correspondence intended for the Editor should be addressed: The Editor, "Practical Wireless," George Newnes, Ltd., Tower House, Southampton Street, Strand, W.C.2. Owing to the rapid progress in the design of wireless apparatus and to our efforts to keep our readers in touch with the latest developments, we give no warranty that apparatus described in our columns is not the subject of letters patent. Copyright in all drawings, photographs and articles published in "Practical Wireless" is specifically reserved throughout the countries signatory to the Berne Convention and the U.S.A. Reproductions or imitations of any of these are therefore expressly forbidden. "Practical Wireless" incorporates "Amateur Wireless."

## BOOKS

**R.S.G.B. "Amateur Radio" publications:** Transmitting Licence, 3pp., 1/-; Service Valve Equivalents, 32pp., 1/3; Transmitter Interference, 32pp., 1/6; Simple Transmitting Equipment, 52pp., 2/3; Microwave Technique, 68 pp., 2/3; Receivers, 96pp., 3/9; Valve Technique, 104pp., 3/9; V.H.F. Technique, 96pp., 3/9; R.S.G.B. Bulletin, current issue, 1/6. Five recent issues, 2/6. Prices include postage. **RADIO SOCIETY OF GREAT BRITAIN, 28, Little Russell St., London, W.C.1.**

**BRITISH SHORT WAVE LEAGUE,** founded 1935, world-wide membership. Monthly publication, "B.S.W.L. Review" (members only), covering all short wave radio interests. Many services and activity departments. Full information on application to: B.S.W.L., 53, Victoria Street, London, S.W.1.

**ALIGNMENT PEAKS.** Second edition. 5,000 superheterodyne alignment peaking frequencies, 4/9 post free. The Practical Radio Engineer, quarterly publication of the Institute, sample copy 2/- post free. Membership and examination data 1/- post free. Secretaries: I.P.R.E., 20, Fairfield Road, London, N.8.

**NEW YEAR—NEW IDEAS.** Mr. Bradley's best seller, "Personal Portables," is now in its second edition; new print, new cover and right up to date. The book gives complete data on building five loudspeaker-type midget sets, T.R.F. and superhet, and dozens of letters call it "the best 2/6 worth in radio." At 2/6 (2/8 post paid) it is remarkable value. So is our new book, "A Portable Television." Still the first and only book to describe a mains or battery driven 3in. or 6in. complete TV set in a small suitcase. Data for both areas. A gift at 3/2, post paid, from BRADBROOKS, Sennen, Penzance, Cornwall.

## RECEIVERS &amp; COMPONENTS

**T.R.9 TRANSMITTER-RECEIVERS** as will be described in a future issue, storage-soiled, but all valves checked; in wooden case. Carriage paid; P.O. for 20/- to "ELECTROMART," 14a, Broad Pavement, Chesterfield, Derbyshire.

**MIDGET Communications Receivers,** tunes from 16-2,000 metres, includes batteries, phones, etc., etc. Brand new; price £5/10/-, post paid. R. BOLTON, 42, Sward Rd., Tottenham, N.17.

**EVERYTHING for Radio constructors,** Condensers, Coils, Valves, Resistors, etc. Send stamp for list. SMITH, 98, West End Road, Morecambe. Quick service.

**TEST PRODS., w/plugs and leads, 2/6 pr.** Crystal Set Components: Carbon Hand Mics., 3/6; Trans. 1/-, List 2/6. CARTERS, 67, Bell Lane, Marston Green, Birmingham.

**RECEIVERS,** type 25 (TR1196), without valves, 6/6 each. Chassis, Cadmium plated steel, size 12in. x 6 1/2in. x 3in., punched 5 valve 5/6d., 1/6 each, 2 for 2/9. **BOLD & BURROWS,** 12, Verulam Road, St. Albans. (Tel.: 5951.) Stamp for lists.

**T.R.F. COILS, L. and M.W. with circuit, 4/6 pr.** 1 FTs 465KC High "G." 8/6 pr., 01 1,000v. 2/6 doz., etc. List from T. HOWELL, 29, McWilliam Rd., Brighton, 7.

**LARGE QUANTITIES** of the following units held in our stores and ready for immediate disposal: T.154 Transmitters at £10 each; Power Units, type 32, 33, 34, 35, at £4 each; T.R.1196 Transmitter/Receivers at £7/10/- each. J. J. TRADING COMPANY, Gatwick Airport, near Horley, Surrey. (Telephone: Horley 1510.)

**RATES:** 4/- per line or part thereof, average five words to line, minimum 2 lines. Box No. 6d. extra. Advertisements must be prepaid and addressed to Advertisement Manager, "Practical Wireless," Tower House, Southampton St., Strand, London, W.C.2.

**HANNEY OF BATH** offers: P.W. Televisor, set of coils with VF choke, 16/6 London, 18/- B'ham (inc. extra rejector coil), Alladin formers with core, 10d. each. W.W. Televisor (s-het), 20 coils, wound exactly to designers specification, London or B'ham, 45/-; Polystyrene and Exalite formers also available; also Ferrite resistors, TCC and Fabrite condensers as specified for both designs. Williamson Amplifier, Woden potted output, mains transformers and chokes; Gardner ditto, high stability resistors, ±1% silver mica condensers, matched resistors and matched valves at no extra charge. Comprehensive stocks of Erie and Morganite resistors, 1, 2, 1, 11 and 2 watt, 10 ohms to 10 meg.; TCC and Dubilier condensers; Wearite "P" coils (list id. stamp); close tolerance resistors and silver micas ex-stock for bridges and test gear. We supply components for all P.W., W.W., E.E. designs. Our return of post quotation only costs you a 2d. stamp. New, 1st class goods only—no surplus. TV list 2/6, stamp; general list 3d. stamp, please. Retail only. L. P. HANNEY, 77, Lower Bristol Rd., Bath.

**ELECTROSTATIC VOLTMETERS,** 0-3500, plug-in type 2 1/2in., 25/-; twin I.F. Filter Units 465 Kcs., 10/-, H.D. Framant Transformers, input 200-250v. output 2-0-2v. at 7 amps. 5v. and 6-0-6 at 8 amps. 35/-, Tubular W.W. Resistances, 4.8w 1/-, 10w 1/3, 20w 1/6, 60w 2/-. Assorted Resistors, 12/- gross. Condensers tubular, 30,000v 01 mfd. 15/-, 600v .01 mfd. Sprague, 6d. Electrolytics, 12v 50 mfd. 6d., 12v 4 mfd. 4d. Oil filled, 4 mfd. 600v 7/6, 5 mfd. 1000v 8/1, 4 mfd. 600v 5/-. BARRETT, 7, Upper Kent Street, Leicester.

## VALVES

**VALVES (guar. and boxed).**—EP91, 10/6; 6J6, VR91 (orig. box), EP55, 22/6; 25L6, 50L6, 12K8, 8/6; 6Q7, 5Z4, 5U4, 80, U14, 807, HVR2A, VU11, EK32, 6SN7, 12SA7, 0Z4, 12SC7, 1R5, 1T4, etc., 7/6; 6J7, 6K7, 6V6, VR55, VR56, VR53, 6B8, 6K6, 6/6; VR91 and VR136 ex equip., 6/-; 6J5, 5/-; VR65, 4/6; VR65A, 4/-; 6H6, 3/6; VR54, VR92, 2/6; D1, 2/-, P. and P. 6d. £1 order post free. Mail order to TRS, 71, Meadvale Rd., E. Croydon. Callers: 2, Pawsons Rd., Thornton Heath. (Tel.: THO. 1665.)

**EL50, U10, 2X2, 6P6G, 6K7G, 6N7GT, 6AG7, 6SG7, 6SL7, 7Q7, 7V7, 1T4, 1S5, 3A4, 3A4, 1R5, EF54, 0Z4, 12A6, 6X5G, RL16, EF36, EF39, 5130, RK34, EB33, 6C6, 6D6, 4/2, 80, 807, 5U4G, EW4/500, 6SK7, at 6/6; ML4, 6AC7, 6J5GT, at 4/6; EP50, 9003, at 5/6; VR105/30, VR150/30, 6K8, 6SN7, at 7/6; PX25, 6L6G, at 10/-; post 6d. under 20/- R. T. & I. SERVICE, 254, Grove Green Rd., London, E.11.**

**VALVES (new. bxd).** 6AC7, 6C5, 6J7, 6K6, 6K7, 6N7, 6V6, 6X5, KTW61, 5Z4M, 12A6, EF36, EBC33, 9001, 9003, all at 6/6 each. 1S4, 1S5, 1T4, 1R5, 3S4, 807, 6Q7, EF39, all at 7/6 each. Few only, KT66, 6L6G, 6L6M, at 10/- each. To-day's largest seller: Room to Room Telephone—two send/reve. units with conn. flex (no bats. needed) complete at 5/11 post free. Morse Trainers, key, buzzer, batt., manual and circuit, 7/6 post pd.; extra buzzer extension, 2/6 each. Many lines in stock. Stamp for list or enquiry: **LORNE RADIO SUPPLIES, "Mail Order," 7, Lorne Rd., Walthamstow, London, E.17.**

**T.V. AERIALS.**—Owing to excessive demand we have been reluctantly compelled to discontinue manufacture of all multi-element arrays and concentrate solely on Midlands H-type 1 wave spacing: 8ft. Mast, £2/19/6; 12ft., £3/17/6, complete with lashings, brackets, bolts, etc. H-type for mounting to customer's own mast, £2/2/-, C.W.O. Carriage paid. R.R.S., 395, Badsley Moor Lane, Rotherham.

**ET 4336 TX.** Instruction Book, 7/6. STANWELL, Kingadown, Sevenoaks.

**SENSATION!** Long Playing Records and Record Players by Decca now available from stock. Send 2/6 for list of first release Records and Record Players. Special offer: Decca dual-speed Motor 17-18 r.p.m. with turntable, £8, post 2/6; Decca lightweight Pickup, fitted Acos G.P. reversible head, presenting two alternative permanent sapphires for L.P. and standard recordings, £4, post 1/6; both as fitted in Decca 16-guinea Record Player; rexine covered Portable Case to house above or other motor and pickup, 50/-, ready fitted 10/- extra. Decca lightweight Pickup fitted G.P. 20 permanent sapphire head for L.P. recordings only, price 50/-. Symphony No. 1 (Amplifier) by N.R.S., independent control of bass, middle and top, separate scratch cut, negative feedback, for A.C. 200-250v., input for magnetic, crystal and hi-fi pickups, also tuner, 5-watt output; price 3 ohm model, £8/19/6, 15 ohm model, £9/7/6. No. 2 Public Address Amplifier, 12-watt push-pull output, special neg. feedback circuit, gram. mike and tuner inputs, 3, 7.5 and 15 ohms output, price 10 gns., complete kit, £9. No. 1 Quality Tuner, specially recommended for all quality Amplifiers, L. & M. wave T.R.F., neg. feedback detector, virtually distortionless, price of complete kit and constructional manual, 90/-, or ready built, £5/10/-. No. 2 Quality Superhet Tuner, L.M. and S waves, special bandwidth, large full vision dial assembly, as kit, £7/15/-, ready-built, £8/15/-. Send 2/6, now for new catalogue and bargain supplement. Terms c.w.o. or c.o.d. **NORTHERN RADIO SERVICES, 16, Kings College Rd., London, N.W.3.** (Phone: Primrose 8314.)

**MAGNETIC SOUND Recording Wire,** stainless steel, temporary wooden spools, approx. 1 1/2 hours running time at 2ft. per sec.; 14/- per spool. A. SMART, 40, Grange Rd., Halesowen, Worcs.

**CONSTRUCTORS' Bargain Kit, 42** assorted Condensers, ceramic, silver mica and tubular, including 6 electrolytics, all brand new and useful values, 15/-, Special line, 32 mfd 320v screw-type Cans, 2/6 ea. Volume Controls, silent and reliable, 4, 1 & 1 or 2 meg, 2/9 ea.; with switch, 4/6. **ELECTRONIX, 220b, Canterbury St., Gillingham, Kent.**

## REPAIRS AND REWINDS

**LOUDSPEAKERS** repaired promptly. MODEL LOUDSPEAKER SERVICE, 34a, Billington Road, Oxford.

**TRANSFORMERS.**—All types of Radio and Television rewound. New Components wound to your specification. Quotations by return. **NORTH WEST ELECTRICAL CO., 8, Duke's Ave., London, N.10.** (Tudor 8093.)

**VACUUM CLEANERS** and Gram. Motors, repairs our speciality. Armature rewinds, new bearings and commutators fitted, also transformers rewound, speakers repaired. Competitive prices. Trade enquiries invited. 2 to 5 days c.o.d. service. Send S.A.E. for price lists to: **A.D.S. CO. (V.E.M. Dept.), 261-3, Lichfield Road, Aston, Birmingham, 6. Est. 1935.**

**BRAND NEW** guaranteed goods. Mains Transformers, fully interleaved and impregnated, standard screened primaries 200-230-250v. Drop through types, with top shroud, 260-0-260v 70ma, 6.3v 3a, 5v 2a, 13/16; 250-0-250v 70ma, 6.3v 2a, 5v 2a, midget, 21-3-2 1/2in., 15/11; 350-0-350v 70ma, 6.3v 3a, 5v 2a, 16/11; 350-0-350v 80ma, 6.3v 3a, 5v 2a, 17/11; 350-0-350v 100ma, 6.3v 3a, 5v 2a, 21/9; 350-0-350v 120ma, 6.3v 4v, 5v 3a, 25/11; 350-0-350v 150ma, 6.3v 4v, 5v 3a, 27/9. Fully shrouded upright mounting types: 250-0-250v 60ma, 6.3v 3a, 5v 2a, midget, 21-3-3in., 16/9; 250-0-250v 100ma, 6.3v 6a, 5v 3a, 25/9; 350-0-350v 100ma, 6.3v 4v 4a, C.T., 0-4-5v 3a, 24/9; 350-0-350v 150ma, 6.3v 2a, 6.3v 2a, 5v 3a, 29/11; 425-0-425v 200ma, 6.3-4v 4a, C.T., 6.3v-4v 4a, C.T., 0-4-5v 3a, suitable Williamson amplifier, 49/9. Smoothing Chokes, 40ma 10h 360 ohms, 3/7; 80ma 12h 360 ohms, 5/3 ea, 45/- doz.; 100ma 10h 100 ohms, 200ma 5h 100 ohms, 7/6 ea. Output Trans.: 6V6 to 2-3 ohms (small), 1/11; push-pull 10w 6V6, 2x4-6L6 to 3-5-8-15 ohms, 15/-; Williamson type, exact to author's spec., 67/6. Ex-Govt. Valves (new, boxed), 9001, 1/11; 954, 955, 956, 6H6Met, 2/9; 6J5GT, 3/9; VU111, 4/3; 12A6Met, 5/3; 1R5, 1T4, 6/11; 1S4, 6/6; many other types in stock. Misc. Items: Ex-Govt. Aladdin Coil Formers, slug tuned 4/- doz. Receiver Cabinets, size approx. 16 1/2 x 9 1/2 x 7 1/2 in. cut for dial and speaker fitted speaker fabric and back finished in cream cellulose, 10/6 ea. T.V. Masks, 12in. cream, 2/9. Terms, c.w.o. or c.o.d. over £1. Post extra under £2. Full list 3d. Special list for trade 3d. **RADIO SUPPLY CO.**, 31, Hanover St., Park Lane, Leeds.

**SYNCHRONOUS MOTORS**, 200-250v, A.C., 50 cycles, clock type, 12/6 each, 1/- postage; suitable for model engineers. **UNIVERSAL ELECTRICAL**, 21a, City Rd., London, E.C.1.

**RF UNITS**, type 24, 25, and 24 mod. 27, all at 12/6 ea. (the latter are similar to 24 but cover 60-80 mcs). Field Telephone Sets, type D, 45/- pr. Phone Adapters, 3/6. Toggles, D.P.S.T., 1/-. Crystal Diodes, 3/6. Sec. 7 UHF Coils, dust cored with trimmers, 5/-. H.R.O. Receivers with valves and crystal, less coils, £11/10/-. Mallory Vibrator Packs, 12v, 150v 60ma, tested O.K., 9/6. R1132a, 100-124 mcs, 3/15/- CP. R1124 complete with 6 new 13v valves, 21/- ea. Yaxley type selectors, 1/9, 9/-, 12/- doz.; 6B ip, 11w 4/6. Fuses, 60a, to 10a, 3/- doz. assd. Flush Voltmeters, 0-20, 0-40, 5/-; 50-0-50 amp, 5/-, 1-5 ma meter Rectifiers, 7/6. Ferranti HD Intervale Tranny, 1-1, 7/6. 0.1 long spl. VCs morganite, 2/6. Assorted VCs and Pots, mainly morganite, 12/- doz. Metal Rees, 230v 80 ma, 3/9; 250 ma, 10/-; 24v 3a Bridge, 15/-; 110v 5a, £3/10/-; 230v 12a HW, 24/-; Jack Plugs, 1/-; Tanno, 1/2v pressure units PM, MC 5 ohms, £2 ea., 2G .0003 ves, 3/6; 2G .00015, 3/6. Telescopic Aerial Masts, 25ft., 25/-, 32ft., 32/-; Sangamo Weston Voltmeters, 0-150, 8in. dial in oak case, 1 ma 1000 ohm per volt, new, £3/10/-, 28v Miniature Blowers, complete with res. for 230v A.C. or D.C. mains, 17/6 ea. Ohmite 25 watt Vitreous Pots, 350 ohms, 4/6 ea.; 500 ohms 20 watt semi-variable res., 3/-; Rev. Counters 4 figure, 3/9; 3 fig. 2/9. Self Energised Mikes, 2/6. Mike Trans., 2/6. Carbon Mikes, 3/6. Mike Insets, 1/9. Coloured Knobs marked Brill, Focus, etc., 4/- doz., 36/- gross. House Meters, 230v 5 amp. A.C. 10/-; 10/-. 15v, 4/6. Valves, 6AK5, quarterly type, 15/-; EF39, 36, 50, EF32, 5/6; 2D2, 6D2, 4D1, 5/-; 15D2 8/6; XH, 5/-; others from 1/6. See our list. S.A.E. please. If interested in ex-Govt. Lens and Optical gear send for list. Booklet, How to Use ex-Govt. Lenses, etc., 2/6. H. ENGLISH, Rayleigh Rd., Hutton, Brentwood, Essex.

**CIRCUITS**, BC-453, 4, 5; 946; 1206; 624 conversion (AM/FM), double-tracer for scope, Tw./Tr. 60mc. converter; WS-18, 21Rx, Tx, 2/- each. 4. Manfield Circle, Capenhurst.

**PHOTO-ELECTRIC** meter components: Selenium Light Cell, 6/6; Micro-amp. Meter Assembly, 10/6; Perspex Case, 10/6. All standard Instructions, 2/6. All standard Photo-Cells in stock, s.a.e. for details. **G.F. PRODUCTS**, 22, Runnymede Avenue, Bristol, 4.

**EDDYSTONE POWER PACKS**, 38/6 ea. (see Jan. issue). Double circ. Jack Plugs and Sockets, 2/- pr., 18/- doz. Ass. Wax Tub. Conds., .01 to .5 mfd, 150v 100w wkg., 10/6 per 100. .002 mfd, 5KV Mica, 4 for 5/-; .001, .002, .0002, .0005 mfd, 500v Mica, 5/6 doz. Yaxley Sw. 2p. 6w, 3 for 5/-. All post paid. S.A.E. list J. T. ANGLIN, 106, Cleethorpe Rd., Grimsby.

**PRECISION MACHINED PARTS** made to your sample or drawing in small or large quantities. Perspex, Aluminium Sheetting, cut, drilled and milled up to your requirements. Enquiries welcomed.

**THE H.B.H. COMPANY**, Civic Chambers, Portland Crescent, Leeds, 1

**H.T. BATTERIES & CO.** H.T. battery, guaranteed. Still our best seller. 12 volt, guaranteed minimum, tapped 21-90-21 L.T. All-dry. All are tested before despatch. 3.4 low 16 set. **CAR SPOT LAMPS** and Head Lamps. Ex-L.P.T.B. Std.: 1 bolt fitting, 7/6 each. LAMPs, Ex-L.P.T.B. 24 volt 12 watt and 12 volt 12 watt. Std. B.C. fitting. Ideal for boats, caravans, etc. 9/- doz. **MOTOR BLOWER**, 1/3rd h.p., easily re-wound from 110 volt s/phase A.C. to 230, or will work from transformer or resistance. Forge type blower, 3 1/2in. diameter outlet. Motor is 2.65-3.450 r.p.m.; 1in. spindle. 50/- to clear. Carry over.

**WALKIE TALKIE**. A few left only at 17/6. Only 1 valve (ATP4) and 1 switch (send-receive) short. FREE set of drawings supplied with each one. Sec. 7 UHF VALVES. From 2p 6J5GT, SP41, EA50, EB34, 6H6, LP2, Valve SP61, 3/6. Valves at 5/9-12A6, TH233, VP133, HIL332, FEN333. Valves at 6/6-6V6, 1R5, 6K7GT, 603 and many more.

**TV LENSES**, 50/-, or "Filter" filled, 55/-, 8in., 9in. or 10in. only. **CHOKES**, Midget's, made by Lee's, 10 Henry, 50 mill, 300 ohms, 4 for 5/-.

**ANTI-FORGE ALARM**. The perfect anti-theft device for ALL vehicles. Easily adapted to Home Burglar Alarm. Full instructions, 7/6 each. **TINY TIMS**. Four-stroke design, press button. Has an output of 200 watts at 12 volts. New, £17/10.

**GERMAN INVASION CRAFT**, 20 to 30ft. x 6 to 8ft., inflatable, sizes as they come. Room required. Made of tough vulcanised rubber, 50/- each, car. extra. **COLLING HEAD BAND**. Not wire type, with single ear piece, 2s. 1/9 each. **ZENITH SLIDING RESISTOR**, 5 ohms 10 amps., rheostat wound on porcelain. Size 1 1/2 x 2in. diameter, suitable for light or motor controls, 5/6 plus 1/- post. **TUNING CONDENSERS**, 3-gang, 1in. spindle, 2/6.

**CABINETS**, Philco, walnut plastic, approx. 18 x 16 1/2 x 8 1/2in. 15/- plus 3/- carr. Money back guarantee if not satisfied. C.W. Ford, please, and allow sufficient for post or carr. Stamp ONLY for lists. 219, Ilford Lane, ILFORD, ESSEX. ILFord 0295.

**CARLTON COILWINDING CO.** "A Name to Note and Remember". Medium-Wave Coil Units for BC453, BC454, BC455, 10/- with Data. State which model required. Mains Transformers for above receivers, 3/6, for BC349 30/-, BC221 26/-. Inexpensive Television Mains Transformers for R1355, 3/6. For VCR97 C.R.T., 5/6. Filament Transformer, 0.4-5-6-3-12-6v, 2a, 12/6. Rewinding Service. Send for catalogue, 3d. Postage extra. Carco Works, Church Rd., Birkenhead, Phone 3585.

**ABSOLUTELY NEW** ex-Government Valves: 5Z4, 6V6, 6K7G, 6K7GT, 6AC7, 6SK7, 6X5GT, DDL4 (VR1191, 6J7G, 6SG7, 6B8, EBC33, 37, 12A6, 1C5, 6SCT, all at 5/9 each; 6V6, 1/6; SP41, 2/9 each; VR54, 6J5, VU111, 4/7; each; 807, 6Q7, EF39, 5U4G, 6F6C, 4/7; 6C6G, all at 6/3 each; 77, 78, 0Z4, 41, 42, 80, 7Q7, 3Q9, 1S4, H63, 1S5, LT4, 1R5, 3S4, 6C6, 6D6, 25A6G, 6L7, VR105/30, VR150/30, EF30, EL33, EF8, all at 7/- each. Carriage paid over 15/-. C.O.D., fee charged. Post orders only. **ALPHA RADIO SUPPLY CO.**, 5/6, Vince's Chas., Victoria Square, Leeds, 1.

**BUILD** an A.C./D.C. 3WB Superhet complete with cabinet, valves and all parts for £5, with our concise instructions. We still publish "The Cheapest List in England" for component kits, 3WB, 9/6. 1 x 350v Tub, 2/6 doz., etc., etc. **SUSSEX ELECTRONICS, LTD.** (W.), Princes St., Brighton.

**TAYLOR SIGNAL GENERATOR**, model 65B, as new, £10. PRYCE, "Avondale", Arbourne Gardens, Longden Rd., Shrewsbury.

**ETA COIL WINDER**, as new, £15. STANWELL, Kingsdown, Sevenoaks.

**WHAT OFFERS** for: Receiver, B.C. 312 N., W.W. 12w. Amplifier and Coupling unit, C.R. Test Set, type 44, 1355, with R.F. units 24, 25, 27. Box 198.

**TELEVISION** - The only school in Great Britain devoted solely to training in television. Postal course prospectus - Registrar, GUTHIC TELEVISION SCHOOL, 13, North Ave., London, W.13.

**NO B.N.R.S.** Student has ever failed to pass his examinations after completing our appropriate study course. Now in our eleventh year and this claim is still true. All our courses are conducted by correspondence and our syllabus includes Brit.I.R.E., City and Guilds exams. Also maths, physics and radar. Nothing succeeds like success and what we have done a thousand times is ready for your colleagues, we can do again for you - and all for £1/1- per month. Free booklet from **BRITISH NATIONAL RADIO SCHOOL**, 66, Addiscombe Road, Croydon, Surrey. (Telephone: ADDISCOMBE 3341.)

**WIRELESS**. Postal Course of Instruction for Amateur Radio Transmitting Licence complete with text book at a moderate fee. Apply **BRITISH SCHOOL OF TELEGRAPHY, LTD.**, 179, Clapham Road, London, S.W.9. (Est. 1906.)

**THE INSTITUTE** of Practical Radio Engineers have available Home Study Courses covering elementary, theoretical, mathematical, practical and laboratory tuition in radio and television engineering. The text is suitable coaching matter for I.P.R.E. Service, entry and progressive exams. Tuition fees at pre-war rates are moderate. The Syllabus of Instructional Text may be obtained, post free, from the **SECRETARY**, Fairfield Road, Crouch End, N.8.

**MERCHANT NAVY** and Air Radio. Here is an opportunity to train as Radio Officer. The big liners are open to you, but you must qualify for the P.M.G. Certificate. Day, Evening and "Radiocerts" postal courses. S.A.E. prospectus from Director, **THE WIRELESS SCHOOL**, 21, Manor Gardens, Holloway, London, N.7. (Estd. 30 yrs.) (Phone: ARC 3694.)

**SEE THE WORLD** - 600 Radio Officers required. Send 2d. stamp for prospectus to Britain's leading college. We train most, in shortest period, at lowest cost. **WIRELESS COLLEGE**, Colwyn Bay.



## Best Buy at Britain's COMMUNICATIONS RECEIVER

**TYPE R1155.**—A super set representing the finest possible value for money. The R1155 needs no description, but to those not familiar with the circuit we can offer an authoritative *Wireless World* leaflet at 9d., post free. All sets are supplied complete with 10 valves and air-tested before despatch. Any set gladly demonstrated to callers. In brand new condition and offered at **£9.10.0.** Despatched in makers' transit case for **£9.19.6.** In conjunction with the R1155 we offer an A.C. Mains Power Pack and Output Stage. This enables the R1155 to be operated direct from A.C. mains. Just plug in! Only **£3.10.0.** carriage paid.

**SHIPPING AND TOP BAND COMMAND SET.**—A 6-valve superhet covering 100-200 metres. Valve line-up: 3 of 12SK7, 1 of 12K8, 1 of 12SR7, 1 of 12A6—all metal valves. In black crackle case. Brand new and complete with valves, 59/6, post paid. Circuit diagram supplied free. For A.C. Mains operation this set will require a power pack giving 12v. and 250v. If 24v. batteries are available, we can supply a plug-in dynamotor for 15/-, post paid.

**RECEIVER TYPE 18.**—AS FEATURED IN THIS ISSUE OF "P.W." Complete with all valves. Only 17/6 post free. Brand new condition.

**OSMOR COIL PACK TYPE "B."** The recommended coil pack for the 18 set. Made for the job. **£2.5.10**, post free. **PAY US A VISIT THIS MONTH. HEAPS OF BARGAINS FOR THE PERSONAL CALLER.**



**CHARLES BRITAIN (RADIO) LTD.**

11, Upper Saint Martin's Lane, London, W.C.2. TEL. 0545  
Shop hours, 9-6 p.m. (9-1 p.m. Thursday)  
**OPEN ALL DAY SATURDAY**

## "GLOBE-KING"

Short Wave Kits and Components. Production fully booked up until new series commence Autumn, 1951. Watch this Magazine for later announcements:

**JOHNSONS (Radio) MACCLESFIELD**

## SUPACOILS

### OFFER

- ★ **COILS.**—A complete range of High Q variable iron dust cored coils in wavelengths 10-30, 15-50, 30-75, 75-200, 190-550 and 800-2,000 metres: Aerial, H.F. or Oscillator. —As recommended for the *Practical Wireless* 9 valve All-wave Superhet. 3/- each
- ★ **MODEL 30** famous 3 waveband superhet Coil Packs, aligned, 40/11 inc. full connection details and instructions given with every pack.
- ★ **MODEL 40** Coil Packs superhet pack with R.F. stage, aligned, 70/3 inc.
- ★ **MODEL 30 TUNING UNIT**, consisting of 30 Coil Pack, pair of "M.M." I.F. Transformers, matched 2 gang and attractive dial. Components aligned together as a unit and sealed. 69/9 inc.
- ★ **MODEL 40 TUNING UNIT**, similar with R.F. stage. 99/6 inc.
- ★ **CHASSIS.** Good quality aluminium chassis in stock for 5 v. Rec. 11/-; 6 v. Rec. 12/-; Amplifiers and Feeder Units etc., from 7/-
- ★ **J.B. SLS SPIN WHEEL** Tuning Assembly to suit Coil Packs and Chassis above 25/- each.
- ★ **GRAM** components of all types in stock.
- ★ **FREE.** Home Constructor's Handbook, containing 11 tested circuits forwarded Free with orders of 20/- or more, or obtainable for 1/6, from 1/-

**SUPACOILS MAIL ORDER OFFICE**  
98, Greenway Avenue, London, E.17.

## THE MODERN BOOK CO.

Television Receiving Equipment, by W. T. Cocking, 18s. Postage 8d.  
Wireless Servicing Manual, by W. T. Cocking, 12s. 6d. Postage 5d.  
Radar Simply Explained, by R. W. Hallows, 10s. 6d. Postage 6d.  
Sound Reproduction, by G. A. Briggs, 10s. 6d. Postage 6d.  
Basic Mathematics for Radio Students, by F. M. Colebrook, 10s. 6d. Postage 4d.  
Testing Radio Sets, by J. H. Reyner, 22s. 6d. Postage 9d.  
Outline of Radio, by Penrose & Others, 21s. Postage 9d.  
Cathode-Ray Oscillographs, by J. H. Reyner, 8s. 6d. Postage 4d.  
Short Wave Wireless Communication, by Ladner & Stoner, 50s. Postage 1s.  
Radio Valve Data, compiled by 'Wireless World', 3s. 6d. Postage 3d.  
Radio Servicing, by A. Marcus, 35s. Postage 9d.  
Radio Servicing Equipment, by E. J. G. Lewis, 25s. Postage 9d.  
The Magnetic Amplifier, by J. H. Reyner, 15s. Postage 6d.  
Thermionic Valve Circuits, by E. Williams, 12s. 6d. Postage 6d.  
Radio Data Charts, by R. T. Beatty, 7s. 6d. Postage 5d.

We have the finest selection of British and American radio books in the Country. Complete lists on application.

19-23, PRAED STREET,

(Dept. P.2.),

LONDON, W.2

PADddington 4185.

## WALTON'S OF WOLVERHAMPTON

Our New Year Bargain List is now ready. Have you received your copy? If not, you must miss Bargains. This month we are specialising in units for stripping. Brief details below:

**Unit No. 1.**—Transmitter Portion of a Four-Station Push-Button Installation, contains about 25/- worth of parts, 6/6, plus 1/- postage.

**Unit No. 2.**—Similar to above, about 30/- worth of parts, 7/6, plus 1/- postage.

**Unit No. 3.**—TX Portion of No. 18 Walkie-Talkie, 6/-, postage 9d.

**Unit No. 4.**—U.S.A. Radar Unit with Dynamotor and about 50/- worth of other parts, 18/6, postage 1/6.

Our lists show many more at prices from 3/6.

## WALTON'S WIRELESS STORES,

203, STAVELEY ROAD

(Mail Orders)

48, STAFFORD STREET,  
WOLVERHAMPTON

(Callers only)

## LYONS RADIO LTD.

3, GOLDHAWK ROAD, Dept. M.P.,

SHEPHERDS BUSH, LONDON, W.12

Telephone: SHEPherds Bush 1729

**STROBE UNIT, TYPE 68.** A radar unit containing a wealth of useful parts and valves, the principal components being: 6 VR91's, 1 VR116 and one 524, 3-4 mfd. metal cased paper condensers 600 v. wkg., wire-wound and carbon pots, a 230 v. 15-30 m/A, selenium rectifier, 2 relays, one 2,000 and the other 6,500 ohm resistors, switches, H.F. chokes, pilot light holder, resistors, t.a.7 bds., etc. In brand new unused condition. Overall size, 19 x 9 x 8 ins. Price, 55/-, carriage 5/-.

**AERIAL COUPLING UNIT, 441.** Fitted with an 0/2.5 A, thermocouple ammeter, variometer with graduated dial and rev. counter, a two-gang variable condenser about 15 pfd, each section and other useful parts. Fitted in wood case with lid size about 10 1/2 x 10 x 7 ins. Price, 10/-, post 1/6.

**SPECIAL VALVES.** All brand new and unused. VU120A, 6/6; EC52, 6/3; VU111, 5/-; CV67 with tuning unit (klystron), 5/-; postage, all types, 9d.

**RECTIFIER UNIT, TYPE 45 or 141.** Incorporating a metal rectifier, this unit was designed to supply the transmitter 1154. Input voltage is 200 to 250 v. A.C. mains. Output is 1,200 v. smoothed D.C. at 200 mA. The whole is housed in a metal ventilated case approx. 16in. high x 19in. x 8in. and weighs about 100lbs. Price 25, carriage 15/-.

**PRACTICAL RADIO.** For beginners wishing to commence the construction of Receivers. Price, 3/2, post paid.

**W.W. RADIO VALVE DATA BOOK.** Characteristics of 1,600 receiving valves. Price, 3/6, post paid.

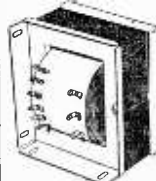

Mains Transformers UPRIGHT - DROP THROUGH - AS ILLUSTRATED.

Two Types Only

Guaranteed.

No. 1: 250-0-250v. 80

mA., 0-4-6.5v., 5 amp.

0-4-5v., 2 amp. No. 2:

Same, but 350v. Both

14/6, post 1/- for 1 to

HILLFIELDS RADIO,

8, Burnham 91 Road,

Whitby, Coventry.

## NOW AVAILABLE GERMANIUM CRYSTAL DIODES

LATEST, SMALLEST, SUPREME CRYSTAL DETECTOR.

Midget Size, 5/16in. x 3/16in.

Wire Ends for Easy Fixing.

4/6 each, postage 2/3d.

Wiring instructions for a cheap, simple but high quality Crystal Set included.

Technical Details and Selected Types available.

CRYSTAL VALVE or DIODE

Size 3/4in. x 1/4in., 3/6 each. Post 2/3d.

Fixing Brackets, 3d. extra.

## CRYSTAL SET

Incorporating Crystal Valve

Adjustable Iron-Cored Coil

Reception Guaranteed

Polished wood cabinet, 15/- post 9d.

Send S.A.E. for lists of copper wires,

screws, nuts, paxolin tubes, ebonite,

tufnol rod and panels, etc.

Copper wires, 14 s.w.g.-48 s.w.g. in

stock.

## POST RADIO SUPPLIES

33 Bourne Gardens, London, E.4

# Practical Wireless BLUEPRINT SERVICE

## PRACTICAL WIRELESS

*No. of  
Blueprint*

### CRYSTAL SETS

- Blueprints, 1s. each.**  
 1937 Crystal Receiver .. PW71\*  
 The "Junior" Crystal Set .. .. PW94\*

### STRAIGHT SETS

#### Battery Operated

- One-Valve : Blueprints, 2s. each.**  
 The "Pyramid" One-valver (HF Pen) .. PW93\*  
**Two-valve : Blueprints, 2s.**  
 The Signet Two (D & L F) .. .. PW76\*  
**Three-valve : Blueprints, 2s. each.**  
 Summit Three (HF Pen, D, Pen) .. .. PW37\*  
 The "Rapide" Straight 3 (D, 2 LF (RC & Trans)) .. .. PW82\*  
 F. J. Camm's "Sprite" Three (HF, Pen, D, Tet) .. .. PW87\*  
**Four-valve : Blueprints, 2s. each.**  
 Fury Four Super (SG, SG, D, Pen) .. .. PW34C\*

#### Mains Operated

- Two-valve : Blueprints, 2s. each.**  
 Selectone A.C. Radiogram Two (D, Pow) PW19\*  
**Three-valve : Blueprints, 2s. each.**  
 Double - Diode - Triode Three (HF Pen, DDT, Pen) .. .. PW23\*  
**Four-valve : Blueprints, 2s. each.**  
 A.C. Fury Four (SG, SG, D, Pen) .. .. PW20\*  
 A.C. Hall-Mark (HF Pen, D, Push-Pull) .. PW45\*

### SUPERHETS

- Battery Sets : Blueprints, 2s. each.**  
 F. J. Camm's 2-valve Superhet .. .. PW52\*

*No. of  
Blueprint*

### SHORT-WAVE SETS

#### Battery Operated

- One-valve : Blueprint, 2s.**  
 Simple S.W. One-valver PW88\*  
**Two-valve : Blueprints, 2s. each.**  
 Midget Short-wave Two (D, Pen) .. .. PW38A\*  
**Three-valve : Blueprints, 2s. each.**  
 Experimenter's Short-wave Three (SG, D, Pow) .. .. PW30A\*  
 The Perfect 3 (D, 2 LF (RC and Trans)) .. PW63\*  
 The Band-spread S.W. Three (HF Pen, D (Pen), Pen) .. .. PW68\*

### PORTABLES

- Four-valve : Blueprint, 2s.**  
 "Imp" Portable 4 (D, LF, LF, Pen) .. .. PW86\*

### MISCELLANEOUS

- Blueprint, 2s.**  
 S.W. Converter-Adapter (1 valve) .. .. PW48A\*

## AMATEUR WIRELESS AND WIRELESS MAGAZINE

### STRAIGHT SETS

#### Battery Operated

- One-valve : Blueprint, 2s.**  
 B.B.C. Special One-valver .. .. AW387\*  
**Two-valve : Blueprints, 2s. each.**  
 A modern Two-valver .. WM409\*

#### Mains Operated

- Two-valve : Blueprints, 2s. each.**  
 Consoelectric Two (D, Pen), A.C. .. .. AW403

### SPECIAL NOTICE

THESE blueprints are drawn full size. The issues containing descriptions of these sets are now out of print, but an asterisk beside the blueprint number denotes that constructional details are available, free with the blueprint.

The index letters which precede the Blueprint Number indicate the periodical in which the description appears: Thus P.W. refers to PRACTICAL WIRELESS, A.W. to Amateur Wireless, W.M. to Wireless Magazine.

Send (preferably) a postal order to cover the cost of the Blueprint (stamps over 6d. unacceptable) to PRACTICAL WIRELESS Blueprint Dept., George Newnes, Ltd., Tower House, Southampton Street, Strand, W.C.2.

*No. of  
Blueprint*

### SHORT-WAVE SETS

#### Battery Operated

- One-valve : Blueprints, 2s. each.**  
 S.W. One-valver for America .. .. AW429\*  
**Two-valve : Blueprints, 2s. each.**  
 Ultra-short Battery Two (SG, det Pen) .. .. WM402\*  
**Four-valve : Blueprints, 3s. each.**  
 A.W. Short-Wave World-beater (HF Pen, D, RC, Trans) .. .. AW436\*  
 Standard Four-valver Short-waver (SG, D, LF, P) .. .. WM383\*

#### Mains Operated

- Four-valve : Blueprints, 3s.**  
 Standard Four-valve A.C. Short-waver (SG, D, RC, Trans) .. .. WM391\*

### MISCELLANEOUS

- Enthusiast's Power Amplifier (10 Watts) (3/-) WM387\*  
 Listener's 5-watt A.C. Amplifier (3/-) .. WM392\*  
 Harris Electrogram battery amplifier (2/-) WM399\*  
 De Luxe Concert A.C. Electrogram (2/-) .. WM403\*

### HINTS COUPON

This coupon is available until March 5th, 1951, and must accompany all Practical Hints.  
 PRACTICAL WIRELESS, MAR. 1951

**BUILD YOUR OWN RECORD-PLAYER**  
with the easy-to-build  
**M.O.S. AI AMPLIFIER**

- \*High quality output
- \*Output four watts
- \*Low mains consumption
- \*Simple stage by stage easy to follow instructions
- \*No previous radio knowledge needed to get first class results
- \*All parts generously rated for long life

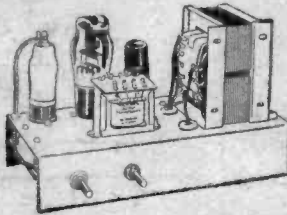

A.C. mains only

The amplifier YOU can build and be sure of success from the time you first switch on. It employs three valves in a well designed circuit. It has been specifically designed for use with high quality crystal pick-ups and the reproduction is of the highest standard. It can be used with magnetic pick-up, if desired.

For those who have any doubts about their ability to construct this amplifier, we offer the instruction manual separately. This contains fully detailed instructions besides the circuit, diagrams, photographs, parts list, and sections on operation, fault finding, etc.

The kit itself deserves special mention. It is complete in every detail down to nuts and bolts and solder tags. A chassis is supplied with all the holes drilled in the correct places, and all the resistances and condensers wired to a colour coded group board. Whole kit well packed in stout cardboard box. Great care taken in packing valves.

Instruction Manual, Post paid **3/6**

Complete kit, including Instruction Manual, Valves, etc. Post paid.

**£4 - 2 - 6**

10in. High Quality Speaker by famous manufacturer at the special price of **15/11**

(Note: this offer only applies to those purchasing the complete amplifier kit.)

**MINE DETECTORS**

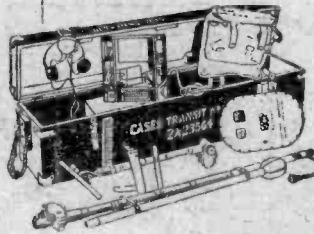

Price including working drawings **22/6**  
Carriage and packing **12/6**

Owing to stocktaking we are now clearing our remaining stocks of these Mine Detectors at a ridiculous price. It is anticipated that the demand will be heavy so—order now! These are absolutely complete and have never been used, but are store soiled, and are not guaranteed.

**EQUIPMENT**

3-valve battery operated amplifier in steel case, shoulder haversack, two search coils with poles, junction boxes, headphones, 2 spare valves, circuit diagrams, log book, connecting cables and sensitivity measuring stick, operating instructions. Packed in robust transit case.

**5/- SPECIAL 5/- METER OFFER**



Those who have already purchased the portable test instrument illustrated have a chance to obtain another to provide spares in case of damage to the main meter. The meters offered are new, but are defective in one way or another, but can be classed as "repairable."

Repairable PTI **5/- post paid**. Usually **15/- each**. **VOLT-Ohm MILLI-AMMETER**. 0-1.5 v. 0-3 v. D.C. 0-50 mA. 0-5000 ohms.

**M.O.S. MAIL ORDER SUPPLY CO., THE RADIO CENTRE**  
33, TOTTENHAM COURT ROAD, LONDON, W.1.  
Telephone: MU 5699 6667



**HOME STUDY**

backs radio experience with sound technical knowledge

MANY men who wished to link their radio experience with a sound technological background have received successful instruction by means of an I.C.S. Course. Its value has been proved not only to amateurs but to men who already have a professional interest in radio and television engineering, including those taking qualifying examinations. It is invaluable, also, to students who wish to prepare themselves for a job in this field. Courses of Instruction covering radio and, if necessary, television including the following:

Complete Radio Engineering, Radio Service Engineers Radio Service and Sales, Advanced Short-Wave Radio Elementary Electronics, Radar, Radio, and Television Technology.

And the following Radio Examinations: British Institution of Radio-Engineers P.M.G. Certificates for Wireless Operators City and Guilds Telecommunications

Write today for our FREE "Radio" booklet, which fully describes the above ICS Courses.

*International*  
**CORRESPONDENCE SCHOOLS**

Dept. PW14, International Bldgs., Kingsway, London, W.C.2

**HENRY'S**

**3547 RECEIVERS.** Absolutely brand new, in sealed manufacturers' packing cases. Incorporating 15 valves type EF50, 2 of SP61, EF26, EF33, 3 of EF34. Complete 45 mcs./l.f. Strip, motor dial and drive, pots, etc., etc. £6 only, inc. packing and carriage. Whilst they last!

**RECEIVER R.3084.** A very sensitive unit containing 7 valves EF60, 2 of EF54 and 1 each VU39A, HYR2, BA50, and also a 30 mc/s. l.f. Strip with 4 mc/s. bandwidth. BRAND NEW IN MAKERS' CASES. ONLY 75/- (carriage, 7/6).

**ELECTROLATIC OFFER.** By leading manufacturers. All metal can. 18 x 8 µF 500 v.w. can size 9 1/4 in. x 1 1/4 in. 3 for 10/-, 32 µF 450 v.w. (550v. surge) BE37F, can size 4 1/2 in. x 1 1/4 in. 3 for 13/6. Also 16 µF 500 v.w. size 2 1/2 in. x 1 1/4 in. 3 for 7/6, 8 µF 500 v.w. type CR850, can size 2 1/2 in. x 7/8 in. 3 for 7/-. Post paid.

**RECEIVER TYPE 21.** The receiver portion of the W/S 21 operating from 4.2-7.5 Mc/s. Double superhet from 18-30 Mc/s. Incorporating B.F.O. and crash limiter. Valve line-up 7-ARF12 (VP2) and 2-AR8 (HL23DD). Absolutely brand new, complete with circuit. Only 45/- complete. Vibrator Power Unit for above, brand new, 17/6 only.

**I.F. TRANSFORMERS.** Manufacturer's surplus. Iron-cored, 465 kc/s. Size 4 in. x 1 1/4 in. x 1 1/4 in. Per pair 8/6 whilst they last.

**FREQUENCY CONTROL CRYSTALS.** By American G.E. Co.—Octal base types. Following frequencies only: 2,500 kc/s, 3,500 kc/s, 4,500 kc/s, 6,200 kc/s., 8,000 kc/s.—at only each 7/6. New Condition.

**931A. PHOTO-CELL MULTIPLIER AMPLIFIER UNIT COMPLETE.** Incorporating 931A photo-cell, 2 valves type 6AC7, 6AG7, etc., etc. Can be adapted for use in window lighting warning systems, locating foreign bodies in liquids, flaws in textiles, burglar alarms, circuit switching, by relays, etc., etc. Panel size 9 1/4 in. x 4 1/4 in. Circuit diagram not available. Price 45/- complete, post free.

**SPECIAL VALUE IN MAINS TRANSFORMERS.** Parmeko 250-0-250, 80 ma 6.3 v. 2 a., half shrouded, drop through type. Electrostatic screen. Price 15/- only, plus 9d. post. Limited quantity.

**R3515 I.F. STRIP.** A complete I.F. Unit, comprising 6 SP61 I.F. Stages, tuned to 13.5 Mc/s., 1 EA50 diode detector, and 1 EF36 or EF39 output or video stage. A few modifications only are required to adapt this unit, which will give pictures of extremely good quality. Price, complete with valves, and fool-proof modification instructions, is 45/- inc. carriage and packing. Limited quantity only.

Send stamp for current Component Lists—Probably the most comprehensive in the trade

**5, HARROW ROAD, LONDON, W.2.**  
PADddington 1008/9 and 9401