

A.C.-D.C. MIDGET FOUR

# Practical Wireless

9<sup>D</sup>  
EVERY  
MONTH

Vol. 23. No. 489.

|| Editor: F. J. CANN ||

MARCH, 1947

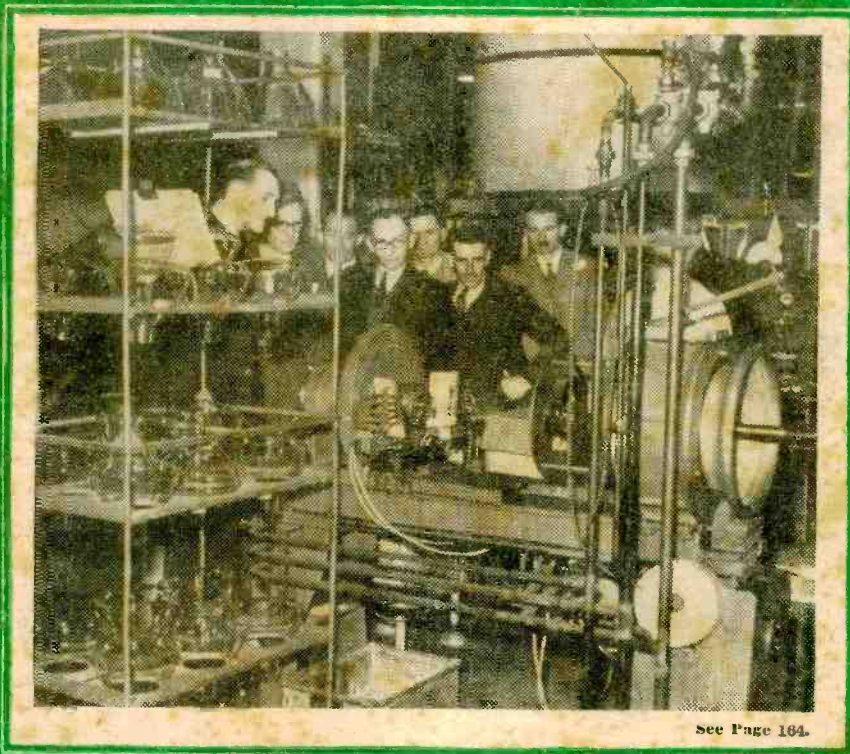

See Page 184.

## PRINCIPAL CONTENTS

A Television Sound Unit  
A Pocket Two-valver  
A 3-10 Metre Receiver  
The Fidelity Problem

|||  
Faults in Fault Finding  
Vibrator Power Packs  
The Vector Problem  
Mains Adapters

# TAYLOR *for the Best in Test Equipment*

MODEL  
**65B**



## ALL WAVE SIGNAL GENERATOR

1. Six wavebands cover from 100 kc/s to 46 mc/s.
2. Scale directly calibrated in frequency.
3. R.F. output controlled by coarse and fine attenuators.
4. 400 c/s internal oscillator provides 30 per cent modulation if required.
5. Unmodulated or externally modulated R.F. output available.
6. Up to 1 volt output of 400 c/s available for Audio tests.
7. Main filters are fitted reducing direct radiation to a minimum.
8. Operates from 110 or 200-250 volts A.C. mains, 40-100 cycles.
9. Dimensions: 12½ in. x 8½ in. x 6 in. deep. Weight about 10 lbs.

Taylor Model 65B is a reliable and accurate mains-operated portable Signal Generator. It is designed for all general Radio frequency and Audio frequency tests on Radio receivers or amplifiers.

Now available for quick delivery.

Price **£15.10.0**

Please write for illustrated leaflet.

**Taylor Electrical Instruments Ltd.**  
419-424 MONTROSE AVENUE, SLOUGH, BUCKINGHAMSHIRE  
Tel. Slough 21381 (4 lines) Grams: Taylor, Slough

## AMBITIOUS ENGINEERS

### HAVE YOU HAD YOUR COPY OF "ENGINEERING OPPORTUNITIES"?

Whatever your age or experience—whether you are one of the "old school" or a newcomer to Engineering anxious to hold your position under post-war conditions—you must read this highly informative guide to the best paid Engineering posts.

The Handbook contains among other intensely interesting matter, particulars of B.Sc., A.M.I.C.E., A.M.I.Mech.E., A.M.I.E.E., A.M.I.A.E., A.M.I.P.E., A.M.Brit.I.R.E., CITY & GUILDS, CIVIL SERVICE, and other important Engineering Examinations, outlines courses in all branches of CIVIL, MECHANICAL, ELECTRICAL, AUTOMOBILE, RADIO, TELEVISION, AERONAUTICAL and PRODUCTION ENGINEERING, DRAUGHTSMANSHIP, GOVERNMENT EMPLOYMENT, BUILDING and PLASTICS (the great peacetime careers), MATRICULATION, etc., and explains the unique advantages of our Employment Department.

### WE DEFINITELY GUARANTEE 'NO PASS—NO FEE'

If you are earning less than £10 a week you cannot afford to miss reading "ENGINEERING OPPORTUNITIES"; it tells you everything you want to know to make your future secure and describes many chances you are now missing. In your own interest we advise you to write for your copy of this enlightening guide to well-paid posts NOW—FREE and without obligation.

**BRITISH INSTITUTE OF ENGINEERING TECHNOLOGY**

409, SHAKESPEARE HOUSE, 17, 18 & 19, STRATFORD PLACE, LONDON, W.1.

**THE B.I.E.T. IS THE LEADING INSTITUTE OF ITS KIND IN THE WORLD**

# Practical Wireless

15th YEAR  
OF ISSUE

EVERY MONTH  
VOL. XXIII. No. 489. MARCH, 1947.

and PRACTICAL TELEVISION

Editor F. J. CAMM

COMMENTS OF THE MONTH.

BY THE EDITOR

## Television Production

**A**CCORDING to the Central Statistical Office, during the months of July-October, 1946, 2,621 television receivers were produced. Considering the number of firms engaged in the manufacture of television receivers this is somewhat disappointing. It is known that the demand is greatly in excess of this figure, and presumably there are production difficulties.

We feel, however, that the real reason is that firms are concentrating on the more fruitful radio market. The production figures for radio receivers for the home market for October, 1946, are 110,000 sets. Of course, whilst television remains a home service neither manufacturers nor the public are likely to be greatly encouraged. There seems little prospect now of the television service being extended to the provinces, at least for the next five years.

There is still lack of unanimity as to the best system of transmission to adopt, and, naturally, manufacturers are reluctant to commit themselves to a year's production programme if transmitting technique is likely to change. It would seem obvious that in the course of time the cumbersome cathode-ray tube as we know it to-day must go, and that some system of projection will take its place.

It seems possible also that a higher number of lines will be employed in the raster, giving better definition. As we have said before, the system at present used is practically the same as it was in 1939. It has not been found possible to introduce the developments and changes produced during the war.

### Servicing Frauds

**A**S a result of the remarks of our contributor Thermion on the service racket now being practised we have received a large number of letters confirmation of his criticisms.

Our readers are advised to warn those at home not to allow any caller either to undertake the servicing of the receiver on the premises nor to remove it for servicing. In the latter case, it is extremely unlikely, if the caller is a stranger, that you will see the receiver again. Even if you do, it either will not be

satisfactorily repaired, parts will have been removed, or even a different receiver may be delivered.

If it is repaired on the premises, it is unlikely that the householder will receive satisfaction, but he may be a pound or so worse off.

As some of those practising this type of fraud are known to the police, readers are invited to report to them any cases which come within their notice.

### Revival of the Clubs

**R**EADERS will have noticed that since the war finished Radio Clubs have reopened activities, and we are glad to be able to devote space to their reports. Club Secretaries are invited to submit reports of not more than 250 words in length, and they should be received not later than the 15th of each month. Such reports should, wherever possible, be informative.

We welcome photographs of clubrooms and of apparatus built by members of the clubs, particularly, also, descriptions of experiments which have been successfully carried out.

### Our Query Service Suspended

**O**NCE again may we remind readers that our Query Service is temporarily suspended owing to staff shortage. We hope to be able to reinstate later on in the year. We issue this reminder because some readers are continuing to send involved technical queries which cannot be dealt with while the present labour shortage exists. We hope our readers will understand our difficulties and appreciate that we shall reintroduce it at the earliest possible moment.

### Future Designs

**W**E have prepared a number of new designs, both mains and battery operated, and we shall publish these when components are available. We have refrained from publishing any of our own designs of receivers because of the component shortage, for such publication would inevitably mean that the designs would have to be modified to suit individual requirements to satisfy alternative components. The adaptation of a design in this way takes considerable time.

Editorial and Advertisement Offices:  
"Practical Wireless," George Newnes, Ltd.,  
Tower House, Southampton Street, Strand,  
W.C.2. Phone: Temple Bar 4363.  
Telegrams: Newnes, Rand, London.  
Registered at the G.P.O. for transmission by  
Canadian Magazine Post.

The Editor will be pleased to consider articles of a practical nature suitable for publication in "Practical Wireless." Such articles should be written on one side of the paper only, and should contain the name and address of the sender. Whilst the Editor does not hold himself responsible for manuscripts, every effort will be made to return them if a stamped and addressed envelope is enclosed. All correspondence intended for the Editor should be addressed: The Editor, "Practical Wireless," George Newnes, Ltd., Tower House, Southampton Street, Strand, W.C.2.

Owing to the rapid progress in the design of wireless apparatus and to our efforts to keep our readers in touch with the latest developments, we give no warranty that apparatus described in our columns is not the subject of letters patent.

Copyright in all drawings, photographs and articles published in "Practical Wireless" is specifically reserved throughout the countries signatory to the Berne Convention and the U.S.A. Reproductions or imitations of any of these are therefore expressly forbidden. "Practical Wireless" incorporates "Amateur Wireless."

# ROUND THE WORLD OF WIRELESS

## Post Office Engineer-in-Chief

THE Postmaster General announces the appointment of Mr. A. J. Gill, Deputy Engineer-in-Chief, to be Engineer-in-Chief of the General Post office on the retirement of Colonel Sir A. S. Angwin, K.B.E., D.S.O., M.C., T.D. Following on the Moscow Telecommunications Conference at which Sir Stanley Angwin headed the United Kingdom delegation, he will continue to handle the work of co-ordinating the interdepartmental preparation for the forthcoming International Conference dealing with the regulation of radio.

## "Philco" Christmas for Hospital Patients

PATIENTS of Walthamstow Isolation Hospital enjoyed the hospital's "brightest ever" Christmas last year, thanks to the efforts of local councillors and hospital staff, but even more so to Mr. J. Barnett, 828, High Road, Leyton, who, in six days, carried out work which normally would have taken four weeks to execute.

Although the work commenced only a few days before Christmas, Mr. Barnett succeeded in effecting the complete installation of a Philco receiver in every ward and in equipping each bed with headphones. The receivers installed are the popular Philco model A.535.

The inauguration of radio by the Mayor of Walthamstow and the presentation of gifts by Councillor Williams were the culmination of a really happy Christmas day.

## Television in Education

ONE lecture in the syllabus of the L.C.C. Training College, Shoreditch (autumn term), will rejoice the radio trade . . . for its significance, apart from its immediate interest. On Thursday, December 12th, Dan Godfrey, Ekco Radio Sales Manager, talked to "mature" students, winding up the series "The contemporary position in visual education," on a subject dear to his heart—"Television and its possibilities." The trade couldn't have a better propagandist. Dan Godfrey has been an enthusiast since the pioneering days . . . and is pioneering again in this vast new potential market. He says, "At present there are 13,700 schools making

regular use of radio . . . how great are the attractions of television as a complimentary teaching medium . . . what then is the reasonable anticipation of the industry in this field? . . . The industry and the education authorities . . . and most important of all the teachers themselves . . . should be getting together now to ensure that the programme in all its aspects is ready. Technically it is only a matter of time and a lot of hard thinking!" . . . That, from the chairman of the Television Promotion Committee, however unofficially it was said, is a signal for action!

## Broadcast Receiving Licences

THE following statement shows the approximate numbers issued during the year ended November 30th, 1946.

Region	Number
London Postal .. .. .	2,049,000
Home Counties .. .. .	1,369,000
Midland .. .. .	1,543,000
North Eastern .. .. .	1,649,000
North Western .. .. .	1,421,000
South Western .. .. .	904,000
Welsh and Border .. .. .	612,000

Total—England and Wales .. 9,559,000

Scotland .. .. . 1,036,000

N. Ireland.. .. . 154,000

GRAND TOTAL .. 10,740,000

## Head of New Mullard Laboratory

DR. C. F. BAREFORD, M.Sc., Ph.D., has been appointed manager and head of the new Mullard Electronics Research Laboratory at Cross Oak Lane, Salfords, near Horley, Surrey.

Dr. Bareford has had a wide range of experience. He took a first-class honours B.Sc. in Physics in 1930.

One year later he was awarded the M.Sc. degree, and in 1933 the Ph.D. degree for work on the spark discharge in vacuo. He worked in this field until 1934, when he joined the B.T.H. Company as a vacuum physicist. There he worked on the design of radio valves and other electronic devices. In 1936 he went to the Royal Naval Signal School at Portsmouth, which later became the Admiralty Signal Establishment. In these two establishments he has been engaged on research and development work connected with radio location, direction finding and telecommunications.

He has gone to the Mullard Radio Valve Company, Ltd., direct from the Admiralty and now he will be closely connected with the development of electronics as applied to industry.

## A.I.R.E. President

DR. W. R. G. BAKER, vice-president of the General Electric Company, Schenectady, has been elected president of the American Institute of Radio Engineers, in succession to Dr. F. B. Llewellyn.

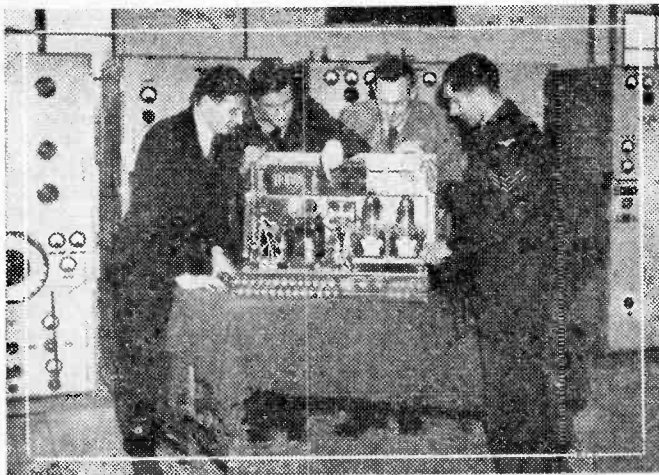

In the main British Radio Direction Finding Station at Bushmills, Ulster. Personnel examining one of the units. This station has now been handed over to the Ministry of Civil Aviation.

**British Sound Recording Association**

**T**HE following meetings are to be held at the Royal Society of Arts, John Adam Street, Adelphi, Strand, London, W.C.2:

Friday, February 28th, 1947.—L. E. C. Hughes, Ph.D., A.M.I.E.E.: "Problems of Sound Reproduction."

Thursday, March 27th, 1947.—P. T. Hobson: "Developments In Magnetic Wire Recording."

Friday, April 25th, 1947.—A. H. Watts: "Modern Direct Disc Recording."

Friday, May 30th, 1947.—D. O. Roe, B.Sc.: "Sound on Film and the Amateur."

All lectures commence at 7 p.m. promptly. Visitors are welcome if sponsored by a member.

**Electron Jubilee**

**T**HE Institute of Physics intend to mark the 50th anniversary of the discovery of the electron by Sir Joseph Thomson, O.M., by holding a series of meetings in London. They are co-operating with the Physical Society, and will stage an exhibition to remain open to the public for several weeks at the Science Museum, South Kensington. The meetings will be held on September 25th and 26th.

**I.E.E. War Memorial**

**C**W. SPIERS, J.P., a member of the Institution for nearly 50 years, has given to the I.E.E. Benevolent Fund an eight-acre estate at New Malden, Surrey. This will be used in the institution's scheme to provide homes for beneficiaries to the fund as a war memorial. It is stated that £10,000 has already been promised or subscribed to the fund.

**Mr. W. O. Heyne Resigns**

**T**HE resignation is announced as from December 31st, 1946 of Mr. W. O. Heyne, Joint Managing Director of The Plessey Co. Ltd., manufacturers of radio and aeronautical equipment at Ilford, Essex. Mr. B. G. W. Attwood, B.Sc. (Econ.), London, has been appointed a director of the company.

**Television for "Ideal Home" Exhibition**

**W**HEN the "Ideal Home" Exhibition opens on March 4th, a number of the larger radio firms will have radio and television exhibits. Demonstrations are to be given at fixed periods during the time the exhibition is open. Wiring arrangements will be made so that the B.B.C. radio and television programmes can be received during stated periods.



*A Romac handbag radio being presented to Mrs. E. Stanhope, as the last of the visitors to pay for entry to the "Britain Can Make It" Exhibition.*

**Radio Tracks Rockets**

**R**ADIO has replaced radar in some American rocket-tracking tests. It is claimed that rockets can now go well into the stratosphere and can be tracked throughout their flight, no matter how fast or how far they go. As the rocket is launched a V.H.F. station starts sending waves of 38.5 Mc/s, and these are picked up by a radio set carried in the rocket, and re-broadcast at double the frequency (actually 70 Mc/s). The returning waves are set "off beat" by the rocket's increasing distance from the starting point in what physicists know as the Doppler effect. By measuring this, observers can tell where their giant missile is, to as close as six feet. It is claimed that the scheme is more convenient and sure than radar.

**Vitavox Loudspeakers**

**I**N connection with the forthcoming tour to South Africa of their Majesties and the Princesses, special loudspeakers have been manufactured by Vitavox, Ltd., for installation in the royal suite in H.M.S. Vanguard. The illustration on the left shows the loudspeaker cabinet which is made in light oak to match the panelling in the sun lounge.

Other models supplied were cellulose sprayed to match the internal decorative scheme in the royal dining, sleeping and day cabins. The speakers are arranged for bulkhead mounting, and the front covers are removable for fixing and making connections. The moving coil loudspeaker units incorporated are Vitavox Type Kr2/10.

A programme selecting switch is controlled by the left-hand control knob for three alternative radio programmes distributed from receivers and amplifiers in the ship W/T office, the right-hand knob is the volume control, which consists of a stud type potentiometer. The panel carrying the control knobs is of ivory catalin, and the fret fabric is perforated white P.V.C. sheeting.

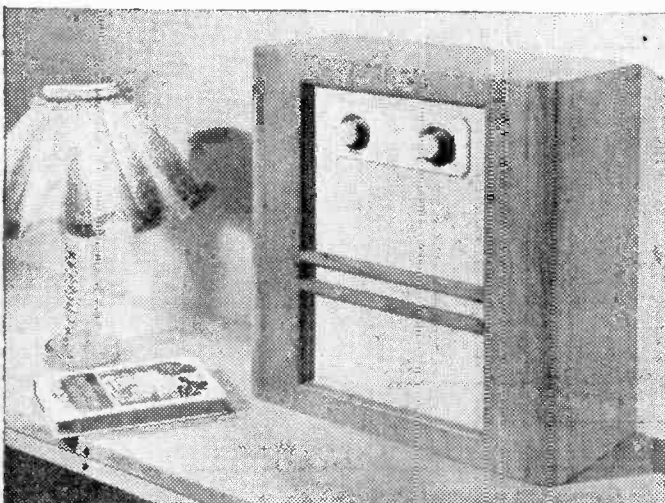

*One of the Vitavox speakers which is being fitted in the Royal suite on H.M.S. Vanguard.*

# A.C.-D.C. Midget Four

An Easily Built T.R.F. Circuit Using a Line-cord Supply. Described by C. A. HOOLEY

**T**HIS set was designed and built with the object of keeping the physical dimensions and weight to a minimum, in order that it could be carried in a small haversack. Being in the Services the above requirements are essential, as sudden moves from one place to another are quite common and everything has to be packed and carried.

The circuit (Fig. 1) is quite conventional and little need be said about it from a theoretical point of view. It was found desirable to keep the H.T. as high as possible to obtain maximum gain from the first two valves. The 50L6, however, should not have more than 120 volts applied to the anode or screen, so it was necessary to drop the H.T. applied to this valve via a 2,500 ohm 10 watt resistance so as not to overload the valve. The 2,500 ohms was made up with two 5,000 ohm resistances of 5 watt rating in parallel.

## Components

The coils used are Wearite P types, P.A.2 and P.H.F.2. A piece of paper was covered with shellac and wrapped over the grid coil of the P.H.F.2, and a reaction winding consisting of 38 turns of 34 s.w.g. enamelled copper wire was wound over the paper. This winding is treated with shellac to keep it in place.

It was found almost impossible to obtain a midget 2 gang .0005 mfd. tuning condenser, so the smallest obtainable was used. The dimensions are 2½ in. x 2½ in. x 2½ in. with the vanes open.

The inter-valve coupling transformer is a midget para-feed type with a ratio of 1 : 4. The dimensions are 1½ in. x 1½ in. x 1½ in. The output transformer is also a midget type with a ratio of 30 : 1. A ratio of 25 : 1

would be more desirable but could not be obtained. The dimensions of the output transformer are 1½ in. x 1½ in. x 1½ in.

The smoothing and reservoir condensers were combined 16-8 mfd. midget type, rated at 500 volts D.C. working made by Dubilier. A T.C.C. 16-8 mfd. Minipack 350 volts D.C. working could be used. The reaction condenser is a mica dielectric .0002 mfd. The speaker used is a Celestion 2½ in. type.

## The Line Cord

A three-core line cord is used to drop the heater volt down to 110 volts. The cord actually used is rated at .3 amps 70 ohms per foot. The resistance required in the line cord is 800 ohms, therefore the length used was 11ft. 6in. It could be replaced by 60 ohms per foot or 80 ohms per foot line cord, in which case the length required would be 13ft. 8in. and 10ft. respectively.

## Constructional Notes

The chassis (Figs. 2 and 3) is cut from 16 gauge aluminium and drilled and bent according to the diagram. Additional holes will be necessary through which to pass the wiring. These may be drilled to the reader's requirements when wiring. It should be noted that the lead from the anode of the detector to the reaction winding should not be allowed to go through the same hole as the grid feeds to the detector, or instability may result. All holes should be fitted with rubber grommets where it is intended to pass wire through them. The speaker is mounted with four 4 B.A. bolts; the top left-hand bolt is left long enough to screw on to the P.A.2 coil. The P.H.F.2 coil is mounted on one of the

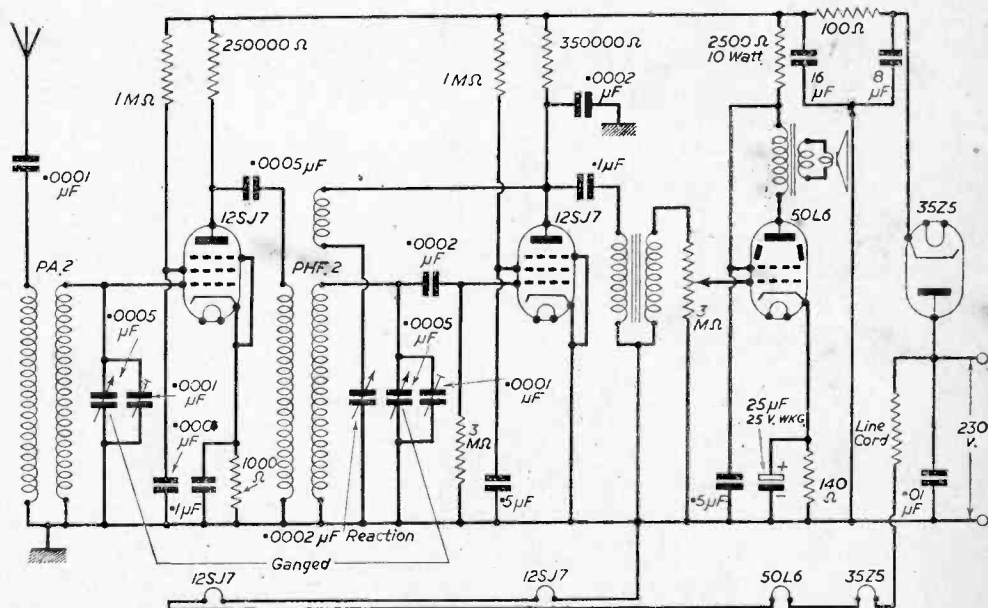

Note: Line Cord, 3 Core 3 Amps. 10 Ft. at 80 Ω Per Ft. 11 Ft. - 6 Ins. at 70 Ω Per Ft. 13 Ft. - 8 Ins. at 60 Ω Per Ft. Reaction Winding, 38 Turns of 34 S.W.G. Enamelled Copper Wire Wound Over Grid Coil P.H.F. 2

Fig. 1.—Theoretical circuit of the Midget Four.

4 B.A. bolts which hold the intervalve transformer in place.

**Mounting the Components**

The mounting of the major components is shown in Figs. 4 and 5 along with all measurements in Figs. 2 and 3. The wiring, once these components are in place, is quite straightforward and can be left to the reader's discretion. The reader is, however, advised to wire in all the heaters and valve base straps first so that resistors and condensers may be mounted above the valve bases.

**Wiring**

The wiring is carried out with 18 s.w.g. tinned copper wire insulated with sistoflex. The heaters, however, are wired with 16 s.w.g. tinned copper wire, again insulated with sistoflex.

The cabinet is made from lin. wood and the total dimensions of the complete set are 7 1/4 in. x 5 1/4 in. x 6 1/4 in. The total weight being 5 1/2 lb. The weight of the chassis alone is 3 lb. It was found desirable to place a piece of brass 6 in. by 2 in. in size over the valves and screwed on to the top panel of the cabinet, so as to dissipate some of the heat arising from the valves, the chief offender being the 50L6.

**Performance**

The sensitivity is well up to the usual standard for

this type of circuit; the selectivity being quite good. The tone when the set is outside the cabinet is a little high. There is a slight loss of the bass register (no doubt brought about by the midget transformers and midget speaker). When inside the cabinet, however,

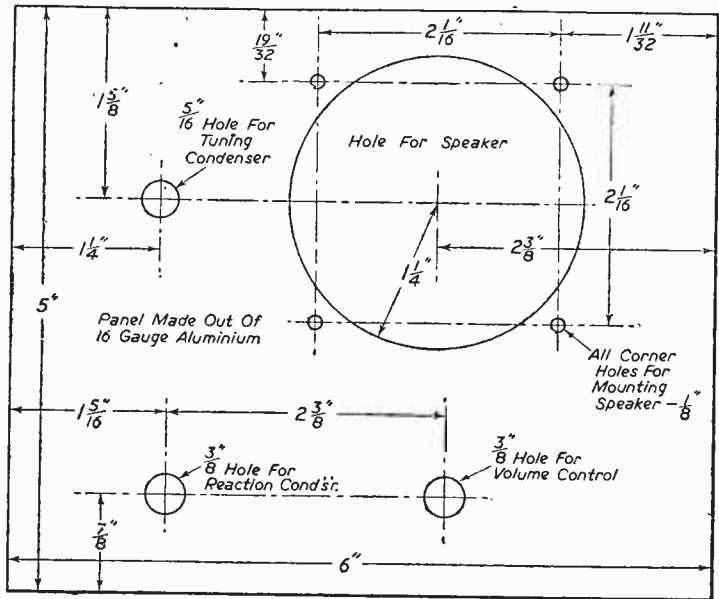

Fig. 2.—Panel setting-out and drilling details.

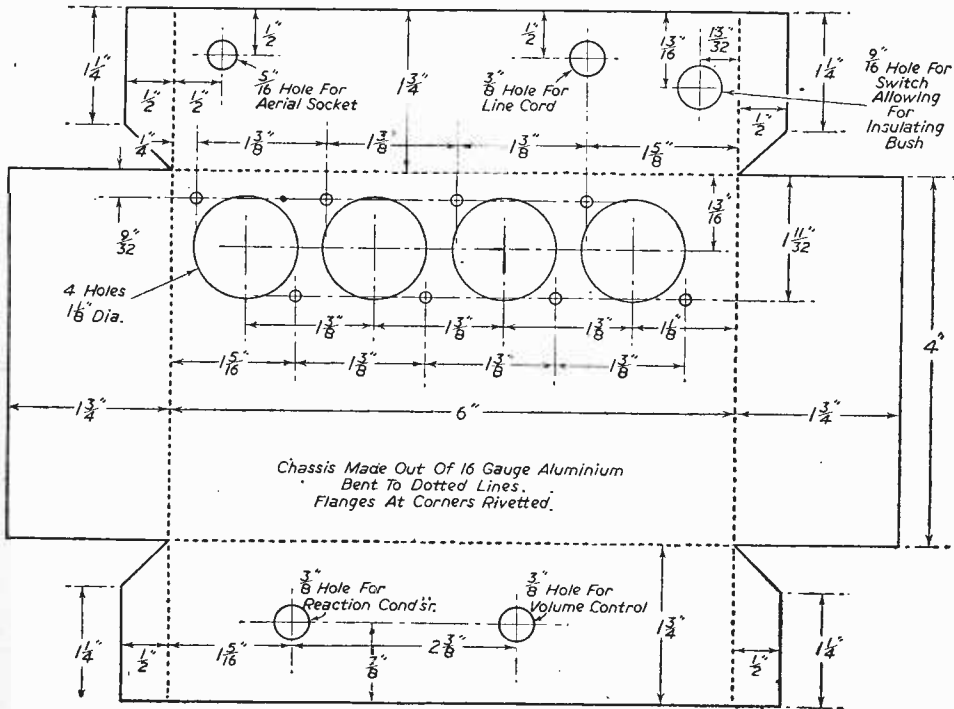

Fig. 3.—Chassis setting-out and drilling details.

the bass register comes through much better and the result is quite pleasant.

**Service Data**

The following voltage readings were taken by means

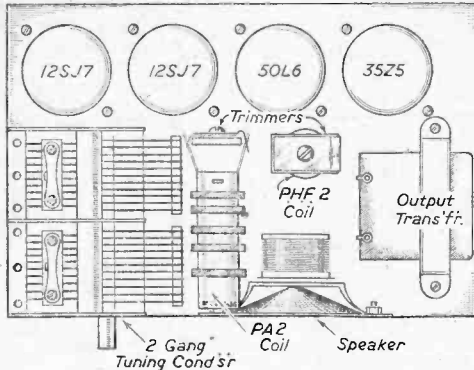

Fig. 4.—This shows the above chassis view of components.

of an AVO Model 40 and all referenced to chassis. No signal was applied to the set.

**D.C. Readings**

+ve lead of AVO connected to :	Reading.	AVO Range
Valve pin 8 of 35Z5 (cathode) ..	265 volts	480 volts
Smoothed rectifier output ..	260 volts	480 volts
Valve pin 8 of 50L6 (cathode bias)	7.7 volts	12 volts
Valve pin 4 of 50L6 (screen volts)	120 volts	480 volts
Valve pin 3 of 50L6 (anode volts)	110 volts	480 volts
Valve pin 8 of 12SJ7 detector (anode volts)	4 volts	120 volts
Valve pin 6 of 12SJ7 detector (screen volts)	5 volts	120 volts
Valve pin 8 of 12SJ7 R.F. amp. (anode volts)	8 volts	120 volts

Valve pin 6 of 12SJ7 R.F. amp. (screen volts)	4 volts	120 volts
Valve pin 5 of 12SJ7 R.F. amp. (cathode bias) ..	1 volt	120 volts

**A.C. Readings**

Input voltage 222 volts A.C. 50 cycles.  
Volts actually applied to heaters, 110 volts A.C.

**LIST OF COMPONENTS FOR A.C.-D.C. MIDGET FOUR**

- Valve 12SJ7.
- Valve 12SJ7.
- Valve 50L6 GT.
- Valve 35Z5 GT/G.
- Four valve bases.
- Coil P.A.2 (Wearite).
- Coil P.H.F.2 (Wearite).
- Two-gang .0005 mfd. tuning condenser with trimmers.
- .0002 mica dielectric reaction condenser.
- Para-feed inter-valve transformer, 1:4 ratio.
- Midget output transformer.
- 16-8 mfd. midget condenser (Dubilier).
- Speaker Celestion, 2 1/2 in.
- Line cord (see constructional notes).
- Volume control, 3 meg.
- Two resistances, 1 meg., 1/2 watt.
- One resistance, 350,000, 1/2 watt.
- One resistance, 250,000, 1/2 watt.
- One resistance, 3 meg., 1/2 watt.
- One resistance, 1,000, 1 watt.
- One resistance, 100 ohms, 1 watt.
- One resistance, 140 ohms, 1 watt.
- One resistance, 2,500, 10 watt.
- One fixed condenser, .0005 mfd.
- Two fixed condensers, .0002 mfd.
- Two fixed condensers, .1 mfd.
- Two fixed condensers, .5 mfd.
- Two fixed condensers, .0001 mfd.
- One fixed condenser, .01 mfd., 350 volts D.C. working.
- One electrolytic condenser, 25 mfd., 25 volts D.C. working.
- One switch, S.-P.-S.-T., Q.M.B.
- Metal for chassis (see constructional notes).

**Refinements**

For those who wish to improve the performance of the standard model described above, an H.F. choke may be made up as follows: A piece of paxolin tube 1/2 in. in diameter, and 2 in. in length has 4 discs (paxolin, each 1 in. in diameter and 1/16 in. thick with a centre hole of 1/16 in.) spaced 1/16 in. apart and shellaced on to it. A three sectional winding of 1,300 turns was then wound in the slots the ends being brought out to two terminals. It can be mounted in a similar manner to the R coils. This R.F. choke replaces the 250k anode load of 12SJ7 R.F. amplifier. The screen dropper of this valve is then reduced to 150,000 from 1 meg. The increase in R.F. amplification is such that the reaction coil has to be reduced or the set will go into uncontrollable oscillation. Therefore the reaction winding is reduced from 38 turns of 34 s.w.g. to 28 turns of 34 s.w.g.

A suggested position for the mounting of the choke is directly above the speaker transformer.

The bass response of the set may be improved by connecting a .02 mfd. condenser across the primary of the speaker transformer.

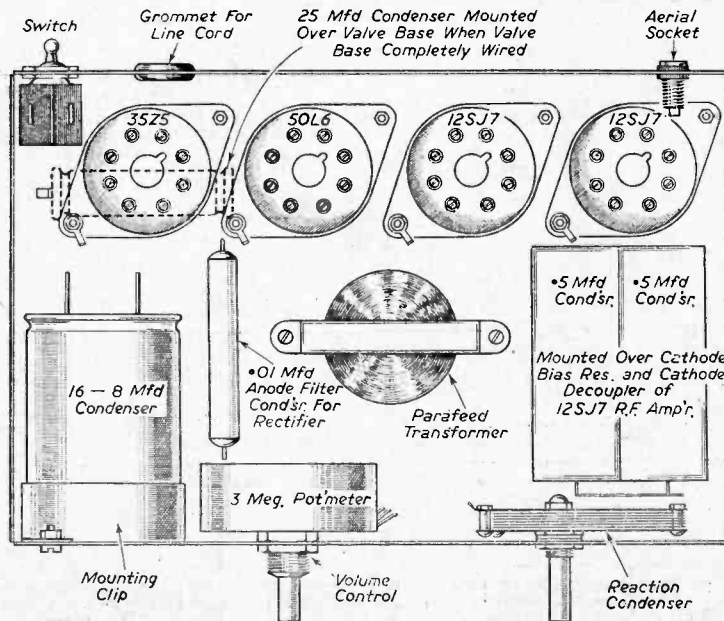

Fig. 5.—Under-chassis view of the Midget Four.



# Television Sound Unit

High Efficiency, Easy Construction, and Low Cost are the Main Features of This Piece of Apparatus.  
By C. SUMMERFORD

**T**HERE are, no doubt, many readers possessing good A.F. amplifiers, who would like to construct television sound units to use with such amplifiers, but who hesitate to do so because they are under the impression that these units are either inefficient or costly, and are in any case difficult to build. This is quite an erroneous impression.

The unit about to be described is one the writer built and has been using for the past four months, and a glance at the diagrams will show its great simplicity both in theory and construction. Furthermore, the cost has been kept down to a very low figure without impairing efficiency—actually about three guineas.

### The Circuit

Basically, the circuit is a straight one comprising two R.F. stages and a leaky-grid detector with reaction. The two R.F. valves are of the footless variety (Tungsram EF11's) which give quite a useful gain at television frequencies.

These Tungsram valves are identical with those of similar type number used in German aircraft and manufactured by Philips, and those readers who have been fortunate enough to acquire some of the latter may use them in place of the Tungsrams without fear of upsetting the circuit.

The chassis with its inter-circuit screens is constructed from 16 gauge aluminium, and when completed measures 13 in. x 6½ in. x 2½ in.; the deck screens are 5 in. x 6½ in.; and the sub-chassis screens 6½ in. x 2½ in.—all screens having a rim flange for bolting to chassis. Those who consider so much screening to be unnecessary are

advised to adhere to this arrangement, otherwise instability may be experienced.

No cathode bias is used on the R.F. valves, as they appear to be more stable with their cathodes connected directly to chassis; also, the high voltage ends of the screening grid dropping resistors are connected to the low voltage ends of the anode decoupling resistors. This, too, is done in the interests of stability, whilst at the same time the drop in usable gain is negligible.

### The Coils

The self-supporting coils are wound with 14 gauge tinned connecting wire on a ¼ in. former which is afterwards slipped out.

Each of the tuning coils is wound with 7½ turns spaced ¼ in., and the reaction coil has 5 turns similarly spaced. Cyldon 30 mmfd. trimmers are used for tuning, regeneration and intervalve coupling. These are obtainable ex-W.D. in banks of five at 1s. per bank, and are cut up with a hacksaw in the numbers required. As the frame acts as a common earth connection, it is only necessary in the case of the tuning and regeneration condensers to bolt this to chassis.

A bank of three is needed for the detector circuit—one for tuning and two connected in parallel for regeneration—one each for the two R.F. stages for tuning purposes and one for intervalve coupling between V2 and V3.

The two R.F. chokes are made by close winding approximately fifty turns of 26 s.w.g. enamelled wire on 3/16 in. formers which are then slipped out, upon which a slight springing action gives the choke

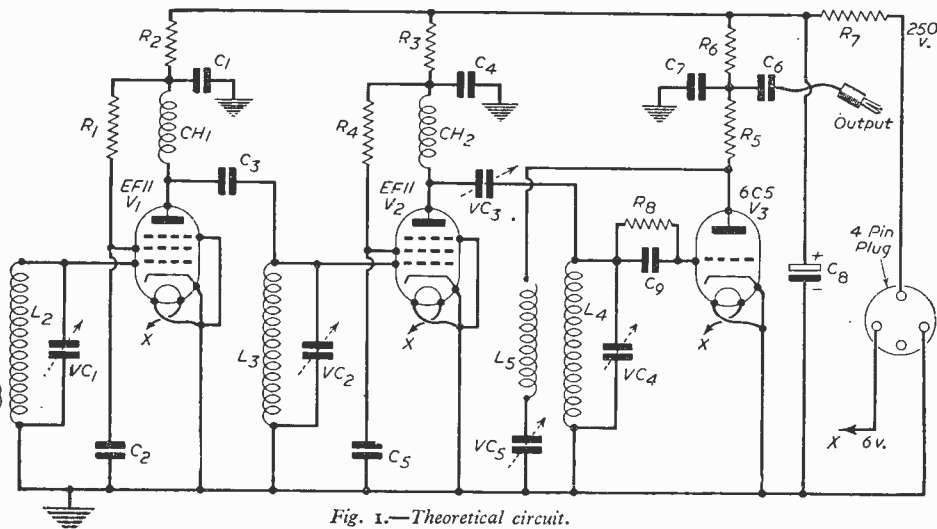

Fig. 1.—Theoretical circuit.

### LIST OF COMPONENTS.

- R1, R4—50,000 ohms, 1 watt.
- R2, R3—5,000 ohms, ½ watt.
- R5—10,000 ohms, ½ watt.
- R6—20,000 ohms, 1 watt.
- R7—3,000 ohms, 2 watts.
- R8—½ meg., ½ watt.

- C1, 4, 6—.01 mfd., 350 v. working.
- C2, 5—.001 mfd., 350 v. working.
- C3, 9—.0001 mfd., 350 v. working.
- C7—.0005 mfd., 350 v. working.
- C8—16 mfd. electrolytic, 500 v. working.

- L1—2 turns.
- L2—7½ turns.
- L3—7½ turns.
- L4—7½ turns.
- L5—5 turns.

- V1—Tungsram EF11.
- V2—Tungsram EF11.
- V3—Brimar 6C5.
- VC1 to VC5—See text.

CH 1 and 2—40 turns wound on diary pencil and slipped off; wire gauge 26 s.w.g. enamelled.

coils inter-turn spacing, thus making them very low loss.

### The Layout

To obtain symmetry of appearance together with good circuit layout, the three valves are in line, centred 2 in. from one side of the chassis. The R.F. valves are mounted on 1½ in. Eddystone stand-off insulators, whilst the detector is chassis mounted.

As the trimmer type tuning condensers are approximately 1½ in. in height and are mounted close to the valve holders, very short grid leads are obtained; in the case of the R.F. valves ½ in. long. The detector tuning condenser is mounted at the side of the valve and there is then just room to get the grid condenser and grid leak in between them if these are soldered in a vertical position.

Tuning coils are soldered directly to the R.F. valve grids and to the junction of the tuning and grid condensers of the detector, and the earthy ends are taken by the shortest route to chassis.

Both inter-valve circuits are choke capacity coupled, chokes being soldered directly in the wiring.

A 100 mfd. condenser is used for coupling  $V_1$  to  $V_2$ , and, as mentioned earlier, a 30 mfd. trimmer couples  $V_2$  to  $V_3$ . This latter must be suspended in the wiring, as otherwise the signal will be earthed.

A variable in this last position is definitely worth while, as a variation of capacity here has quite a marked effect on regeneration efficiency. The reaction coil is mounted end-on to the grid coil, one end of it connected to the detector anode and the other end to earth via the reaction condenser.

Although this type of regeneration is not often used, at the very high frequencies encountered in television, it nevertheless works beautifully in this particular unit.

The 6.3 volt heater winding on the mains transformer used to supply the valves in the unit should have the centre tap (if it has one) disconnected and taped, and one end of the winding earthed instead. Each valve may then have one heater connection taken to chassis, whilst a lead from the other is taken to the mains transformer via the four-pin plug, which also carries the H.T. to the unit.

### Tuning Adjustments

Tuning, regeneration and coupling condenser adjustments are carried out by turning a hexagon nut on the respective condensers. This is accomplished quite easily by using an Eddystone insulated extension rod. This rod has a brass collar and grub screw at each end, one of which should be removed. It will then push on tightly enough to turn the hexagon nut.

The aerial is coupled to the first stage by simply taking two turns of it around the earthy end of the aerial coil and leaving the end free. This arrangement applies only to inverted L and vertical aeriels, as these are the only types upon which the unit has so far been used.

Adjustment of the unit is best carried out by first increasing reaction until there is gentle oscillation, and then turning the detector tuning condenser until a signal is heard. The reaction may then be reduced and the R.F. stages separately adjusted. It will be noticed that as these are aligned the reaction will have to be continually reduced, but the unit should be kept on the verge of oscillation until all the circuits are properly adjusted.

A word of warning about body capacity. Do not lean across the receiver to carry out the above adjustments, because otherwise, coupling of the individual circuits by the operator's body is almost certain to take place, and accurate adjustment will then be impossible. When all tuning adjustments have been completed, the reaction can be reduced until it is well away from the oscillation point. A flat response curve will be thus ensured.

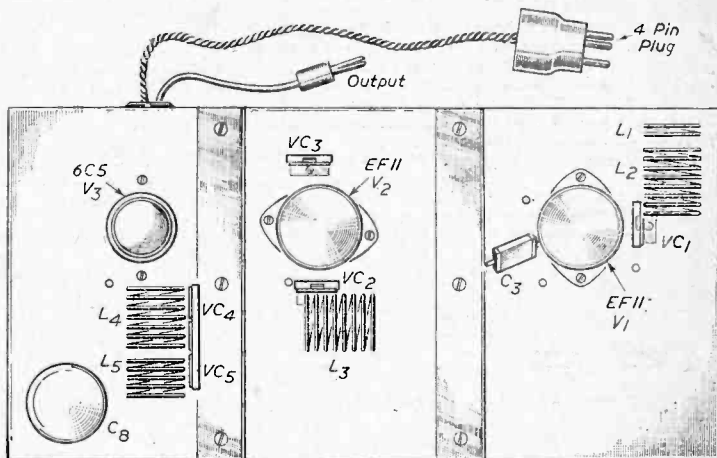

Fig. 2.—Details of the layout.

As mentioned above, the original model has not as yet been used on a proper television aerial, but judging from the results obtained at a distance of 35 miles from Alexandra Palace on ordinary broadcast receiver and short-wave aeriels, truly magnificent results should be obtained by using one of these.

Using an R.C. coupled amplifier comprising two triode amplifier valves and an output tetrode (two 6C5's and a 6L6) with heavy negative feedback over two stages, full loading of the output valve (approx. 6 watts) is achieved with the volume control two-thirds in.

Quality is superb and has a realism that is missing in the ordinary broadcast receiver.

In conclusion, it may be pointed out that two other valve types should work very nicely in this unit. They are Mullard E.F.50 and Mazda S.P.41. Both are high gain R.F. valves suitable for use on the ultra-short wavebands and are obtainable ex W.D. from advertisers in our advertisement columns.

As both of these valves need the same voltage for anode and screening grid, the separate dropping resistors and decoupling condensers can be dispensed with, and common decoupling resistors of about 3,000 ohms, with .01 mfd. decoupling condensers used instead. It will, of course, be necessary to fit different valve holders, but apart from these no other components will be needed. The S.P.41 is, of course, a 4-volt valve and so may only be used with a transformer having a 4-volt winding.

## MASTERING MORSE

By the Editor of "Practical Wireless"

3rd Edition.

1/-, or 1/2 by post, from George Newnes, Ltd.,  
Tower House, Southampton Street, Strand, W.C.2.

# Mains Adapters

Constructional Details of Units to Replace H.T. Batteries in Various Types of Receiver

By F. G. RAYER

**T**HIS unit will replace the high-tension battery used with battery-driven receivers. In common with most H.T. eliminators, it is not very suitable for using with a receiver with Class B output, but for receivers from one valve upwards it is useful, and it is also possible to dispense with the low-tension accumulator without involving too severe modifications in many instances, so that a battery receiver may be converted to mains operation.

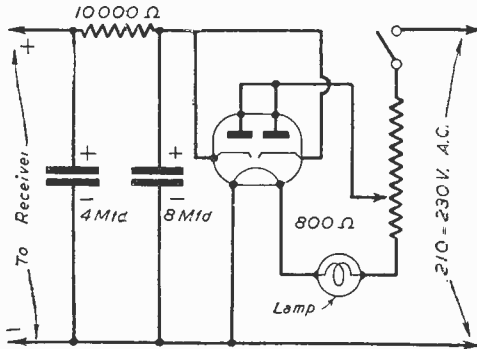

Fig. 1.—Basic circuit of the adapter described here.

**For One-valvers**

The rectifier circuit is shown in Fig. 1. Although there is no smoothing choke it will be found there is no hum, as two fairly large condensers, with a 10,000 ohm resistor, are used for smoothing. The layout for this circuit is shown in Figs. 3 and 4. A 25Y5 rectifier should be used if the wiring of the valveholder is carried out as shown.

As shown in Fig. 1, a .3 amp., 800 ohm maximum mains-dropper is used to reduce the mains voltage to the 25 volts required for the rectifier. A .3 amp., 6-volt bulb is also included in circuit as an indicator. The anodes of the rectifier are then fed from the centre clip of the mains-dropper, a position slightly below halfway down the resistor providing ample H.T. for a single-valve set.

A wooden chassis 4in. by 8in. is amply large, and

will leave room for a smoothing choke later if desired for use with a larger receiver.

All the wiring is shown in the diagrams. The chassis may be enclosed in a case with ventilation holes, the switch and indicator lamp projecting at one end. In use, it is merely necessary to take the leads normally run to the H.T. battery to the plus and minus terminals on the rectifier chassis. On trial, the H.T. supplied to the receiver may be adjusted by moving the centre clip on the mains-dropper resistor up or down as required.

In connecting the condensers follow the polarity as shown. The two wires to "A.C." should be of stout flex, fitted with a proper mains plug.

**For Multi-valve Receivers**

For larger receivers the smoothing circuit should be changed to that shown in Fig. 2. Here a choke is used instead of the resistor to provide the additional smoothing required (any component of about 60 henrys or so at 20-80 mA. is suitable). As the efficiency of the smoothing depends to some extent on the current taken by the receiver, it may be necessary to replace the 8 mfd.

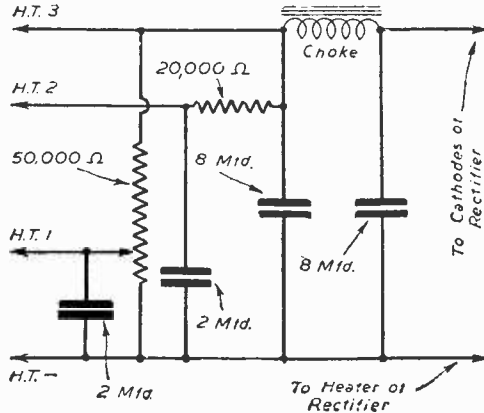

Fig. 2.—Modification required for more powerful receivers.

condensers by 16 mfd. components if a very large set is to be operated. (In this connection the maximum rectified current of the 25Y5 is 80 mA.)

Current of the H.T.1, fed from the potentiometer, enables any H.T. voltage between zero and maximum to be obtained, and may be used for the S.G. high-tension supply. If the S.G. high-tension is obtained from a resistance network in the receiver, this H.T.1 connection may be ignored.

H.T.2 is usually suitable for the detector and L.F. stages. If the detector only is to be fed from this point, and not more than 60-80 volts are required, the 20,000 ohm resistor may be increased to 50,000 ohms. If the detector is already fed from H.T.3 with anode and/or decoupling resistors and condenser, these connections should be left unchanged.

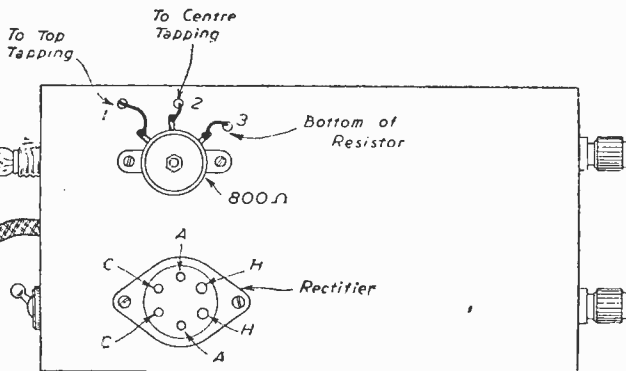

Fig. 3.—Top of chassis layout for the adapter.

The H.T.3 point is then used for maximum H.T. voltage, which will be about 150 volts in a battery receiver, and the variable centre clip on the mains-dropper may be adjusted as necessary.

#### Important

As with this circuit one side of the mains is connected directly to the earth-line of the receiver, it is advisable to remove the earth connection of the receiver, or insert in it a .1 mfd. condenser of 500 volts working. Otherwise, one side of the mains will be earthed, which should be avoided.

In some cases, a reduction in possible hum will arise from changing over the A.C. leads.

As the receiver is connected to one side of the mains, it is advisable not to handle metal parts, chassis, etc., unless the mains plug is withdrawn, to avoid the possibility of any shocks.

#### Dispensing with Accumulator

To avoid using an accumulator with the receiver, the battery valves should be replaced by mains types. In most cases this will result in having to change the values of anode resistors, etc., but the whole tuning assembly and general construction can remain unchanged. The alteration is particularly simple in a one- or two-valve receiver.

The mains valves used should have a similar current

rating to the current rating of the rectifier (.3 amp. in the 25Y5). It is then merely necessary to connect the heaters in series (the detector heater being taken to the earth-line), and reduce the value of the mains-dropper to compensate for this. Suitable valves for a small two- or three-valve receiver are the 6C6 (6.3 volts, .3 amp.) for H.F. and detector, and 43 (25 volts, .3 amp.) for pentode output. The anode current of the latter is

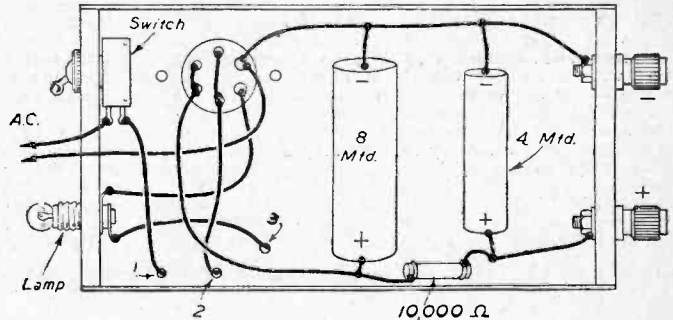

Fig. 4.—Underside of chassis and wiring.

not too high to prevent the use of an ordinary permanent magnet speaker using a transformer of fair size. To avoid damaging the speaker in cases of doubt, it may be fed from an L.F. choke and 1 mfd. condenser in the usual way.

## Earthed-grid Amplifier Valves

Details of Construction of a New Type of Valve for Very Short Waves

It is well known that the normal type of radio-frequency amplifying valve, usually a pentode, begins to lose its performance at frequencies exceeding a few tens of megacycles per second. Consequently, the majority of V.H.F. receivers are of the superheterodyne type, where most of the gain required to raise the signal to the level necessary for efficient detection is obtained at an intermediate frequency, where normal R.F. pentodes have satisfactory performance.

The mixer of the superheterodyne receiver may be preceded by one or several amplifying stages at the signal frequency. The advantages of using a signal-frequency amplifier are (a) improved signal noise ratio (or noise factor), (b) image-frequency rejection, (c) a reduction in the amount of beating oscillator power radiated, (d) the elimination of spurious signals at or differing by the intermediate frequency and (e) reduction of the effect of the beating oscillator noise which may be present when the intermediate frequency is a small fraction of the signal frequency.

#### The Construction of Earthed-grid Valves

The improvement in signal noise ratio arises from the fact that each stage of the receiver must introduce noise, and the percentage reduction in signal noise ratio falls as the signal level rises. Amplification in the first stage thus reduces the effect of noise in the succeeding stages, particularly at very short waves where mixers are noisy and introduce loss. It therefore improves reception unless the process itself introduces an amount of noise which offsets the advantage gained in later stages.

For some time these advantages were not available at ultra-high frequencies. Several types of valve have now been developed, however, which will give these advantages over existing mixers at frequencies up to more than 1,500 Mc/s.

There are numerous common features to these valves, the most important being a disc of copper sealed through

the envelope to form the grid connection. In order to derive maximum advantage from the shielding effect of the grid disc, the grid substantially fills a slot cut in the disc, the cathode being placed on one side of the disc and the anode on the other. The valve is held in its associated equipment by the disc, so that no form of base is required. The grid disc is particularly suitable for clamping between the outer conductors of coaxial lines, possibly between mica sheets, in order to form decoupling condensers. At lower frequencies, where coils may be used, the disc is clamped by spring clips to the side of the screening box; the circuitry of one stage of an amplifier is thus completely isolated from that of another.

In order to ensure the close spacing and accurate parallelism of the plane grid and cathode, these two electrodes are carried on mica insulators and mounted on a stem. On insertion into the envelope, the grid makes contact with its disc by means of eight springs. As these springs give eight parallel electrical paths, and are short, the grid to grid-disc inductance is very small. In order to make use of a well-known technique, the cathode is a normal rectangular tube coated only on the side facing the anode. The grid is wound and stretched in the usual manner. In order to reduce the input capacitance, most of the grid wires facing the back (non-emitting) surface of the cathode are removed, a small number being left at each end to maintain the rigidity of the grid.

The anodes vary according to the frequency at which the valve is expected to function. The simpler type used on the CV53 and CV82 are mounted on the pre-mount, and are box constructions of carbonized nickel. The CV16 and CV88 anodes are closed copper tubes sealed to the bulb and facing the grid disc.

The CV88 is an improvement on the CV16 in that, in place of a stem and wires, a copper tube is used as the cathode lead, the heater lead being inside. [*Proc., I.F.E.*]



# ON YOUR WAVELENGTH

By THERMION

## The Radar Association

**M**ANY hundreds of those associated with the development and operation of radar during the war have formed themselves into the Radar Association, the Hon. Sec. being C. W. Knight, 31, Currey Road, Greenford Green, Middlesex.

The first re-union dinner was held in January at the Chez Auguste Restaurant in Soho, when about 300 members were present. I was among the enthusiastic throng, the chairman being Group Captain C. H. Dorte, O.B.E. The toast of the Association was proposed by Squadron Leader A. J. O. Warner, secretary of the Royal Air Force Association, and the secretary replied.

Mr. F. J. Camm, responding to the toast for the Visitors and the Press, stated that he disliked the word radar, which he thought was giving an American hallmark to an English production. Radiolocation is, of course, a clumsy word, but we should surely be able to coin a shorter one ourselves without going to America or France for it.

This Association may become a most important one, for it should weld together all those who have experience in radar, and who may stand the country in good stead should unhappily another international emergency occur.

After the last war we made the great mistake of immediately dispersing our skilled personnel. This Association will provide a pool of knowledge on this new science and to make available to the electronic industry personnel with skill and experience. I wish it well. It seems possible that its membership would already have topped the 1,000 mark. All those who feel they have the necessary qualifications for membership are invited to get in touch with the secretary whose address I have given.

## A New Storage Battery

**I** HAVE just received details of a new type of electrical storage battery, reputed to have a cell potential of 3 to 4 volts, the cathode consists of mercury or an amalgam retained behind a porous diaphragm such as a clay cell, whilst the anode is a lead-oxide grid. The electrolyte is a mixture of sodium hydroxide and sodium sulphate solutions.

On charge, sodium is deposited on the cathode, and the anodic lead oxide is converted to the peroxide (referred to as super-oxide). On discharge the reverse action takes place, sodium hydroxide being reformed. It is important to note that the cathode must be specially shaped in order to prevent self-discharge of the battery whilst on open circuit.

## A New Selenium Rectifier

**I** HAVE also received details of German developments in the manufacture of selenium rectifiers. Two firms are engaged on this work on a large scale in Germany.

The rectifier consists of a specially treated layer of selenium between a nickel-plated iron base and a second electrode of a low melting point alloy. The selenium layer is heat-treated in order to give it the proper crystalline structure. Originally this layer was obtained by smearing molten selenium over the base plate, but more recently a hot-press method has been used. Briefly this consists of the following operations.

The base discs are flash coated with a layer of Bismuth and a thin base coat of selenium is then brushed on to the plate. Powdered selenium is next dusted on to the base-plates, which are then pressed under a polished steel plate. After smoking the finished selenium layers

over selenium trioxide, the second electrodes are applied, and then spray-gunned with carbon dioxide at a pressure of one atmosphere.

The electrode formation is effected by applying a potential of 5-20 volts to a series of selenium platessa that a D.C. pulsating current is produced in the rectified direction. This treatment is continued for a period up to 24 hours.

## Frauds and Quacks

**M**R. BELL, of Ambleside, writes with reference to my remarks on frauds and quacks. He says "I feel I must show a little of the other side of the picture.

"Every day one hears something like the following:

"'I only bought the H.T. a week ago.' (A glance at the code shows that it is a month or so old, or, maybe, was bought somewhere else.)

"'I never let anyone touch the set.' (By some means the G. B. taps have reversed themselves.)

"'I only use the radio for the news so the battery shouldn't be done already.' (Mrs. 'X,' next door, has already complained that she can't sleep for Mrs. 'Y's' radio.) I have come to the conclusion that the biggest *waster* in the radio business is *the customer*, and this is a quiet country district.

Furthermore, I would like to point out that several *leading manufacturers* will not supply (or rewind) mains transformers for their receivers. In one particular case, after waiting six months, a 'replacement' type was fitted with some difficulty.

"Osc. and band-pass coils are sometimes somewhat difficult to deal with, to say the least.

"Unlike the 'Ham,' who places no value on his time, the serviceman must account for every hour of his time and can't do these jobs for 'love.'

"In conclusion, if a person hands out a radio to someone unknown (thinking that he is going to get a cheap repair) he is just asking for it!"

## Sssush! Keep It Dark!

[Press Item.—There is a growing tendency, in many directions, for secret sessions, in which both Press and public are excluded when inquiries have to be set afoot into the conduct of public affairs, and the expenditure of public money is under discussion by our own "public servants" whose conduct and management are the subjects of investigation and inquiry. This opens the door to abuse, and even actual corruption in some cases.]

O hush-ye-mout! O hush-ye-mout!

(As Pussyfoot might say),

We're now in secret session met,

So nothing give away.

Why should the public be informed

Of how its cash is used,

Or how its trustful confidence

At times is much abused?

We have our little cliques to nurse,

Our "Blue-eyes" to reward,

But, keep this underneath your hat—

Don't blazon it abroad!

Should wicked Press-bounds nose around,

We make this frank confession,

We say "Buzz off! You can't come in

This is a Secret Session." . . .

Of course, the fault is ours, not theirs,

We've grown supine and tame,

Or else they would not try on us

This most deceptive game.

Truth never needs to fear the light—

None can that fact deride,

But "wangling" gets its finest chance

When doors are locked—inside.—"TORCH."

# A Pocket Two-valver

Constructional Details of a Miniature Receiver Which Can be Carried in the Pocket

**T**HIS receiver has been reduced in size as far as is possible without causing any particular difficulty in construction. Two pre-sets are used for tuning and reaction, in conjunction with a small, dual-range coil. Consequently construction is quite straightforward, special reaction or tuning assemblies not being required. Bearing in mind the low H.T. voltage used, results are fully up to two-valve standard, really good earphone reception being obtained on a fair number of stations with no earth and a few yards of wire used as a throw-out aerial.

The circuit is shown in Fig. 1. Two triodes, transformer-coupled, are used. No grid leak or condenser is used in the detector grid circuit, and the valve will

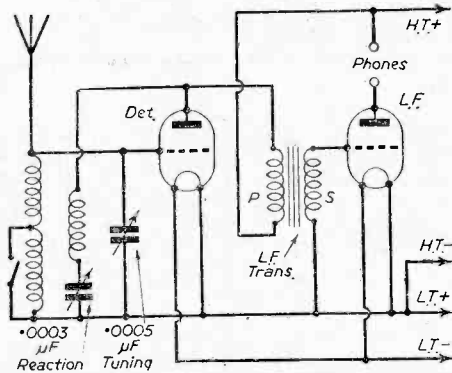

Fig. 1.—Theoretical circuit of the pocket two-valver.

oscillate easily without them provided the tuning coil is returned to the L.T. positive line.

## The L.F. Transformer

This must be a midget component with separate primary and secondary. A small "parafeed" transformer may be used if it is modified as follows:

Remove all the stampings from the bobbin, and the protective paper over the windings. Fix the bobbin to a spindle so that it can rotate freely and unwind the wire until the junction of the primary and secondary windings (which will be common in a "parafeed" component) is reached. A thin piece of flex is then soldered to the end of the winding left on the bobbin and the joint covered with tape. The flex is passed through a hole in the bobbin check, then tape or paper wound round the winding, close up to the checks each side. The winding which has been removed should then be replaced, each end being provided with thin flex connections passed through one check. Joints must be wrapped and the wire wound on evenly.

Primary and secondary will then be separate. In some cases the primary is the *outside* winding on the bobbin. In cases of doubt a resistance test, or experiment with temporary connections will show which winding is the primary, and which the secondary. Finally, all the stampings should be replaced in the bobbin.

## The Tuning Coil

If desired, this may be wound as shown in Fig. 2. A varnished cardboard tube is suitable, and 42 S.W.G. wire may be used. For the medium-wave winding 90

turns, side by side, are required. At the bottom of the coil 200 turns are wound in a pile for long-wave reception. Both windings must be in the same direction.

For reaction, 90 turns are wound on a strip of tape wound round the coil at the junction of medium and long-wave sections. The ends of this winding may be secured by thread. Connections are shown in Fig. 2. "G" is taken to the detector grid; "S" to wave-change switch. The two leads "R" are taken to the detector anode and reaction condenser. If no reaction can be obtained, these leads should be reversed.

If reaction is too violent on medium waves the reaction coil should be placed closer the long-wave section of the coil.

## Construction

A small case of the dimensions shown in Fig. 3, and 1 1/2 in. deep inside, should be made from thin plywood. To facilitate construction, the receiver is made upon a piece of ply 3 1/2 in. by 3 1/2 in., which can afterwards be placed in the case.

The circuit, in conjunction with Figs. 2, 3 and 4 (the latter diagram shows the valve connections), should enable wiring to be carried through easily. All the leads should be insulated. The ends of the coil windings, with thin sleeving slipped over, can be used for coil connections.

When wiring the pre-set condensers the sets of plates which contact the adjusting knob should be taken to the H.T. negative line. This will prevent hand-capacity. The coil may be mounted on a cork secured to the baseboard.

The valve-chassis shown in Fig. 4, should be about 2 in. long and 1 in. deep. It can be fixed by the rear runner to the base. The wave-change switch, made

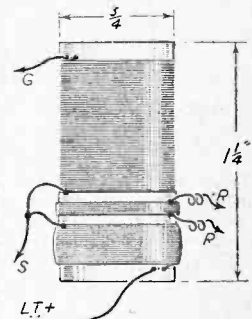

Fig. 2.—Details of the coil used in this receiver.

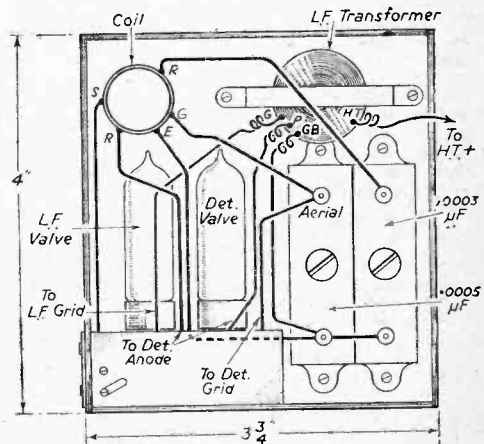

Fig. 3.—General layout and wiring details.

from two small bolts and a brass strip, is secured to the left of the chassis as shown.

Battery and 'phone connections are taken to a small socket panel (or a five-pin chassis valve-holder may be used) fixed to the outside case, near the chassis, when the other constructional work is done. On-off switching is achieved by withdrawing the L.T. plug.

**Operating the Receiver**

Valves of 1.5 voltage, of the Hivac detector-L.F. type, should be used with a 1.5 volt cell for L.T. For H.T., about 20 volts may be used.

A few yards of flex should be taken to the terminal marked "Aerial" in Fig. 3. The flex should be placed along the floor or picture-rail, etc., to act as aerial. If convenient, a metal spike pushed in the ground, connected to H.T. negative, may be used for earth, although sufficient volume will be obtained without this.

To increase reaction, the right-hand pre-set is screwed down. Tuning is carried out by adjustment of the left-

hand pre-set. If reaction is too fierce, the number of turns on the reaction coil may be decreased, or the H.T. voltage reduced. If it is desired to tune to the lowest end of the

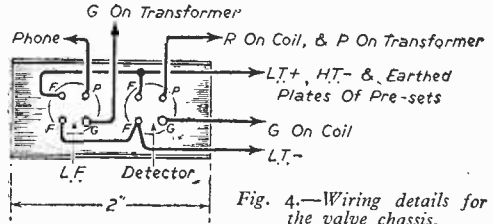

Fig. 4.—Wiring details for the valve chassis.

normal medium waveband, then some turns must be removed from the M.W. winding on the coil, as the tuning pre-set has a minimum capacitance of about .0001 md.

# Faults in Fault Finding

Inconclusive Tests are Often Made by the Inexperienced. How to Avoid These Pitfalls is Explained Here

IT is very easy to make a slip when carrying out even routine tests of a receiver, especially if a copy of the wiring diagram is not kept in sight. An example of this was exemplified recently when a thoroughly experienced experimenter made what he later found to

connecting the meter to one end of each of the two windings. To his surprise, a reading of approximately 380 volts was shown by the A.C. meter. For a few minutes the experimenter was stumped; and probably you would have been. It was not until he had made some additional tests with the transformer disconnected from its external circuit that he realised why a reading had previously been obtained—for there was no doubt that the component was in perfectly good condition and entirely free from inter-winding or core-winding leakage.

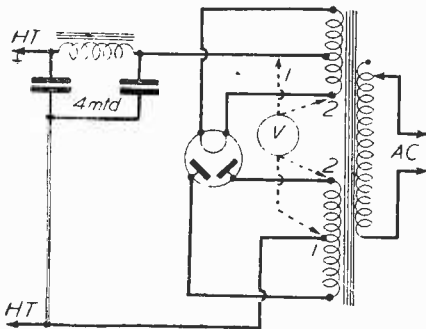

Fig. 1.—Points at which unexpected meter readings were obtained when testing a power unit using a full-wave rectifying valve and mains transformer.

**The Reason**

The explanation should be clear from Fig. 1. Have you spotted the slip? When the transformer was connected and the rectifying valve was removed from its socket there was no reading between the points marked 1, but there was one between those marked 2. If you do not see the fault, the explanation is that the supply was A.C., and that the circuit between the centre tapping of the H.T. winding and the L.T. winding was completed by the two smoothing condensers. These would have been insulators for D.C., but on A.C. an 8-mfd. condenser (the capacity of the two in parallel) has an effective resistance of only about 400 ohms at 50 cycles. When using a high-resistance meter such a resistance is negligible as far as the reading is concerned.

be a foolish blunder in checking through the mains unit of an amplifier.

Before connecting it to the amplifier valves he wished to make a test of the output and to ascertain that all voltages were correct. And, as he had made use of a mains transformer which had not been in use for some time, he thought it desirable to make sure that this was not below par. A high-grade multi-range meter was used, this being set to read A.C., and the voltage on each side of the centre tap of the H.T. winding of the transformer was measured. A similar reading of slightly under 400 volts was obtained for each half, which was correct, for the component was to be used with a full-wave rectifying valve taking up to 500 volts on each anode.

As a check for leakage between H.T. and filament windings, the meter was temporarily connected between the centre tapping of each. Of course, there was a voltage reading because the valve had not been removed from its holder. The valve was then removed and the test repeated; no reading. Another test was made by

**Measuring Anode Voltage**

A mistake is often made in determining the voltage applied to the anode of a valve. Even when a battery is used for H.T. supply you cannot tell the voltage by noting the tapping used to feed that anode, for there is always

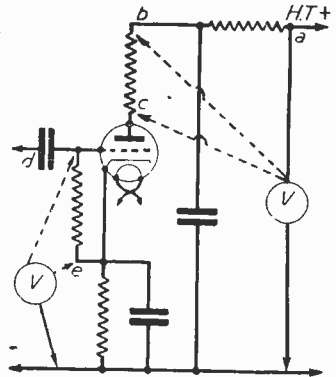

Fig. 2.—Espesial care must be taken when attempting to measure anode and grid voltages.

a resistance of some kind in the anode circuit. This might be only a few hundred ohms, through the primary winding of an L.F. transformer, or several thousand ohms, through a coupling and/or decoupling resistor. Thus, an initial voltage of 100 would be reduced to 50 if there were a series resistor of 5,000 ohms and the valve passed 10 mA. In the same conditions the voltage drop would be only 5 if the total anode resistance was only 500 ohms.

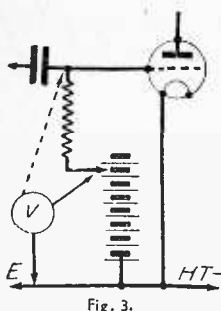

Fig. 3.

Fig. 3.—Full lines indicate the voltmeter leads when measuring the bias voltage in a battery set. There may not be any reading when the meter is connected as shown by the broken line.

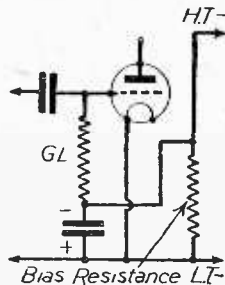

Fig. 4.

Fig. 4.—Usual connections for automatic bias in a battery set. The bias voltage is developed across the resistor.

The matter is not greatly simplified even when a good-quality high-resistance voltmeter is available, for reasons which are shown diagrammatically in Fig. 2. If the negative terminal of the meter was connected to the earth line, and the positive one to H.T.+ (the point marked a), the reading would be valueless. In the first place, the reading would not take into account the voltage drop across the two series resistors in the anode lead. In the second place, the resistance of the meter would be in parallel with that of the valve and its anode resistors in series; consequently, part of the H.T. supply would pass through the meter so that the reading would be slightly less than the voltage provided by the H.T. point.

**Parallel Resistances**

The position is not improved by transferring the positive lead from the meter to the points marked b and c. When connected to b, there is still the anode resistance in series with the valve anode, and when connected to c, there are actually three resistances in parallel; that of the valve (A.C. resistance or impedance), that of the meter, and that of the two resistors and H.T. supply all in series. It will be seen, therefore, that the indicated voltage might differ appreciably from the actual voltage. In fact, the only value of this test would be in finding whether or not an anode voltage was being applied to the valve. With a cheap, low-resistance meter it is even possible that no voltage reading would be given.

**Voltage from Current**

The only convenient method of determining the correctness of the applied anode voltage is, peculiarly enough, by measuring the anode current by means of a milliammeter. If this was inserted at the point marked c, the current consumed by the valve could easily be found (provided that the resistance of the meter was not high by comparison with that of the anode-circuit load). By comparing the current with that shown on the curves for the particular valve in use, it would be possible to obtain a fairly accurate indication of the actual plate voltage.

To permit of this being done, however, it would be necessary to know the grid-bias voltage. This could be

measured with sufficient accuracy for most purposes by connecting a high-resistance voltmeter between the earth line and the upper end of the bias resistor—in the case of a mains set—to the point marked e, in Fig. 2. It is important that the meter should have a very high resistance compared with the value of the bias resistor, because if this was not the case we should again have the position of two parallel resistances, the overall value of which is less than that of either component separately. A factor which might easily be overlooked is that a correct reading might not be obtained if the negative side of the meter was connected directly to the grid of the valve. In that case the grid-leak resistor would be in series with the meter, and since this might have a value up to one megohm or so, its effect would be marked. In normal running conditions there is not, of course, any voltage drop across the leak due to the fact that grid current does not flow—the bias is merely a potential applied to the grid.

The same conditions apply when dealing with a battery receiver, and in this case the meter should be connected between the positive end of the bias battery and the tapping point employed, not to the grid of the valve. This is illustrated in Fig. 3. When dealing with a battery set having automatic grid bias, as shown in Fig. 4, measurements should be taken in the same manner as for a mains set; that is, the high-resistance meter should be joined across the bias resistor.

**Anode Current Totals**

A mistake is sometimes made when checking the total of individual valve anode currents against the total current found by inserting the milliammeter in the H.T.—lead. It is frequently found that the sum of the currents is appreciably smaller than the single total reading. A search might then be made to find where leakage is taking place, but without result. This is because it has probably been overlooked that there is a potentiometer across the H.T. supply, used to feed the screening grids of the frequency-changer and I.F. valves, or to feed the S.G. of the H.F. valve. A correction must be made by connecting a milliammeter in series with the potentiometer to find exactly what current it is passing.

**Coil Testing**

Another fairly common mistake is often made by constructors wishing to check the resistance of coil windings, and also the change in resistance when the wave-change switch is operated. When an ohmmeter is not available—and few constructors have one

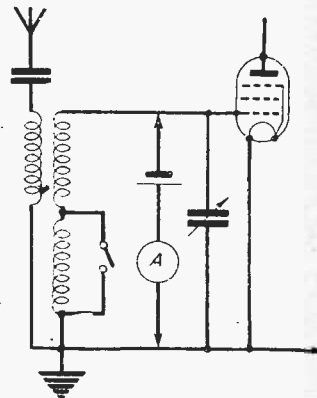

Fig. 5.—A simple method of measuring the resistance of a tuning coil set to medium and long waves.

—the best course is to use a low-resistance ammeter in series with a small dry battery, as shown in Fig. 5. Thus, if a 1½-volt dry cell was used in conjunction with an ammeter reading up to one amp., the readings at long- and medium-wave positions of the switch for a coil with resistances of 2 and 5 ohms for the M.W. and L.W. windings would be approximately .75 and .2 amp. If the method of using a milliammeter in series or parallel with a fixed resistor was employed (and this is often convenient and sufficiently accurate) the difference in readings probably could not be detected.



# The Fidelity Problem

Principles in the Design of High-quality Radiograms, and the Economics of the Layout

By W. J. DELANEY (G2FMY)

**T**HERE is a growing tendency for listeners wanting to build radio receivers and radiograms which give very much higher quality than one usually associates with the standard broadcast equipment. Requests are also being continually received by us for designs or blueprints of such equipment. A glance at the programmes of various manufacturers also shows that many are now specialising in what is becoming known as "High Fidelity" equipment. Loudspeakers, cabinets, gramophone records (Decca *ffff*) and even complete receivers (Decola and H.M.V.) show that there is obviously a demand for such equipment, but when one asks just what is meant by "High Fidelity," one finds

home. Tweeters are now things of the past, and it is interesting to note that the Decola utilises a well-built ordinary type of cabinet with three 12in. loudspeakers disposed to cover about 180 degrees for equal sound radiation.

### L.F. Circuits

The speakers above-mentioned will all handle satisfactorily 12 or 15 watts, which is all that is needed in the home. It may be pointed out that normally one does not run at such a volume, but the amplifier should be capable of such an output in order that transients and all ranges of music may be handled with no risk of overloading. This, then, governs the output stage, and calls for some form of push-pull. PX255 seems to be the most satisfactory type, although some prefer tetrodes with negative feed-back. Here again, individual choice will govern the exact type of valve, but the push-pull arrangement takes care of 2nd harmonic distortion, and many listeners prefer the "roundness" or "softness" of triodes as distinct from tetrodes. Again, it may be pointed out for guidance that the Decola uses PX255s and the H.M.V. KT66s. Sufficient early stages incorporating resistance-capacity coupling should then be included, and it is here that we come to the dividing of the ways.

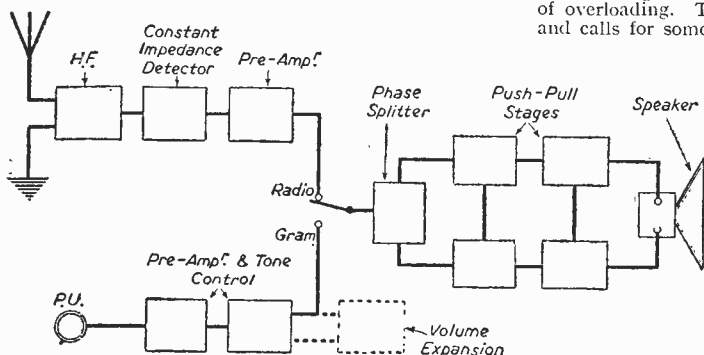

Fig. 1.—Block diagram of a high-fidelity radiogram.

that there is a wide difference of opinion. For instance, recently a reader asked if we had a blueprint for a battery-operated, high-fidelity radiogram giving about 2 watts output. Such equipment could never by any means be given the name of high-fidelity apparatus. On the other hand, it is not necessary that such equipment should give an output of 50 watts or more. But there is a very wide range of circuitry from which such equipment may be made, and therefore it is proposed here to go into some of the points which are concerned in up-to-date apparatus.

### Separate Circuits

Firstly, it must be stated quite definitely that separate circuits and almost separate apparatus are required for radio reproduction and for reproducing gramophone records. We will go into the reasons in a moment. Next, it is useless building an elaborate circuit and feeding it to a standard loudspeaker housed in a flimsy table-model cabinet. One must therefore start from the output end in order to consider just what is needed. Obviously, we must have a speaker specially designed for high fidelity. This may be of the multi-cone type, or one with a specially designed cone, capable of handling equally all frequencies from 30 to at least 12,000 c.p.s. Examples of these will be found in the Hartley Model 215, the Baker-Selhurst triple cone, the Voigt, etc. Whether or not these are housed in special sound chambers (or acoustic labyrinths) is best left to individual choice, as it is of little use building an elaborate cabinet to reproduce the lowest frequencies in a room filled with "hard" furniture and with unpapered walls. Boom and unwanted echoes will be the result. And a really good speaker in a well-made substantial radiogram cabinet will give all the bass that is required in the

The gramophone record, as everyone knows, has a reduced amplitude at the lower frequencies, and therefore one needs a compensated amplifier to restore the balance of the bass. This restoration is dependent upon the pick-up being used. The trend now is to use the moving-coil type of pick-up, and this calls for quite different correction from that needed for a crystal or magnetic pick-up. Alternatively, one of the special needle-armature pick-ups will require a different arrangement. The Valradio coil pick-up, for instance, has a

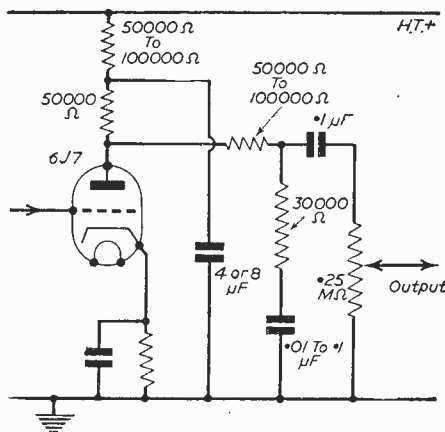

Fig. 2.—A compensated pre-amplifier to overcome gramo-record deficiencies.

tone-balancing circuit incorporated in the carrier-arm and therefore a special tone-control stage is not needed with that. With other pick-ups special bass-lifters will have to be employed. Obviously, with these, such controls must not be included in the radio side, so that the radiogram switch will have to be in the additional stage. Furthermore, the output from the coil pick-up is very small, and additional amplification is required

**The Radio Side**

We now come to the radio circuits. It will be found to-day that gramophone records played through an arrangement such as above outlined is very much better than radio, chiefly because of the large number of recorded programmes now being broadcast. It is only now and again that one gets a "live" programme which is better than the record—quite a different proposition from what one experienced before the war!

The constant impedance detector is undoubtedly the ideal, and this gives quite a small output, comparable with the better types of pick-up, so that such a stage calls for additional L.F. amplification just as in the case of the coil pick-up (Fig. 5). Therefore, this type of detector stage should not normally feed the phase-splitter or amplifier input stage. One good H.F. stage with vari-mu control will give most localities a reasonable signal from the "local" station, but if it is desired to reach out two such stages may be included, but it must be remembered that "high-fidelity" results must not be expected from long distances. Background noises (due to the valves or atmospherics, etc.) will ruin "quality" results.

Some listeners may prefer the diode detector, or even one of the special valve arrangements, such as the

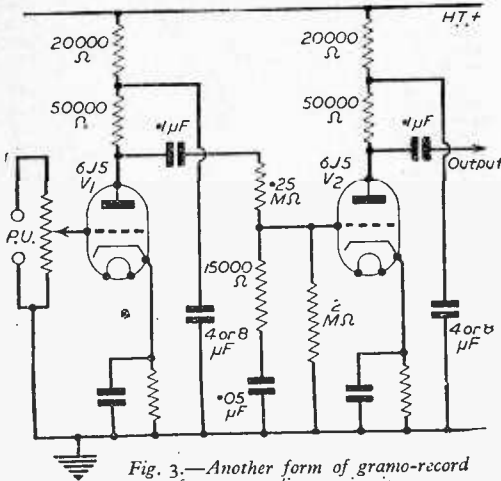

Fig. 3.—Another form of gramophone-record frequency adjuster circuit.

so that one has to include, say, a pentode stage which is only brought in when record reproduction is required. This stage can include tone compensation for other types of pick-up, and some listeners prefer to have separate bass and treble tone controls. These, in turn, can call for up to four valves, as normally it is not possible to obtain proper bass lift, one arrangement being to cut the top notes after the first stage and provide additional amplification for the rest of the frequencies, mixing them all before passing to the phase-splitter or first stage of the amplifier (Fig. 3). Where expense is to be considered a simple form of bass and treble control may be added after the pre-amplifier on the lines shown in Fig. 4 and will give reasonable control.

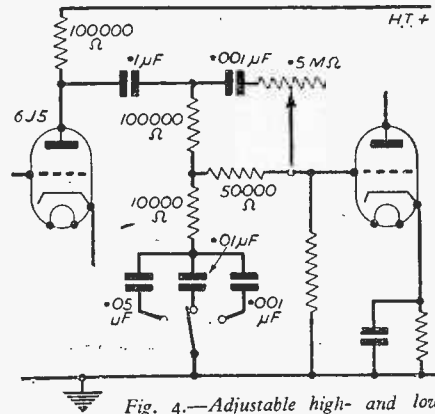

Fig. 4.—Adjustable high- and low-note controls in a pre-amplifier stage.

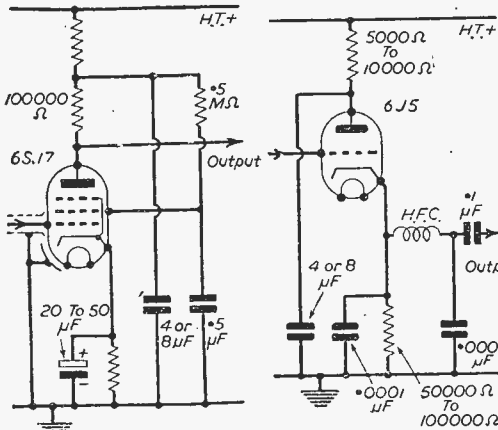

Fig. 5.—A high-gain straight line pre-amplifier stage.

Fig. 6.—An infinite-impedance detector stage.

"Kirkfifer," but the infinite-impedance detector seems to give the most satisfactory results where varying signal inputs are to be dealt with. Of course, where a purely local station only is to be received, then one can utilise the diode, or even a crystal detector, but the circuit requirements for these are not so straightforward as for the first-mentioned type of detector. The main drawback to this arrangement is the difficulty of applying A.V.C., but in most parts of the country it is possible to obtain a fairly large and steady input from at least one B.B.C. station, and it is therefore recommended that this be relied upon alone for the high-fidelity results. As soon as H.F. stages are added to increase range, the background noises go up and that means the inclusion of whistle or heterodyne filters and other devices to give a "clean" background, and with these top-note cut will follow. Highly-selective circuits, such as the superhet, are also ruled out from the really high-fidelity receiver class for similar reasons, although if one is forced to adopt them because of local conditions, then tuning should be flattened in the usual way and a really efficient magic-eye or similar tuning device included to ensure that side-band cutting does not take place—not relying upon the ear alone for this.

The above are the essentials of the modern high-fidelity equipment, and many refinements are possible. Cathode-follower output stages, remote tone-control units, volume expansion, are a few of these, and call for a separate article.

# PITMAN

## RADIO SIMPLIFIED

By John Clarricoats. This book by a well-known authority is a little masterpiece of clear instruction. It has been specially written to give a good basic knowledge of the subject in the shortest possible time. With 50 diagrams. 4/6 net.

## THE SUPERHETERODYNE RECEIVER

By Alfred T. Witts, A.M.I.E.E. An up-to-date book explaining the working principles of the superhet., and giving expert practical information on construction and maintenance. Sixth Edition. 6/- net.

## A FIRST COURSE IN WIRELESS

By "Decibel." A handy guide to wireless for beginners. Clearly and simply written, it employs a minimum of mathematics and is an excellent introduction to the more technical works on the subject. 5/- net.

## WIRELESS TERMS EXPLAINED

Also by "Decibel." This is an invaluable guide to the technical terms used in wireless. The meaning of every term is clearly explained, and illustrations are effectively used. Second Edition. 3/- net.

PITMAN, Parker St., Kingsway, London, W.C.2

Radio Books

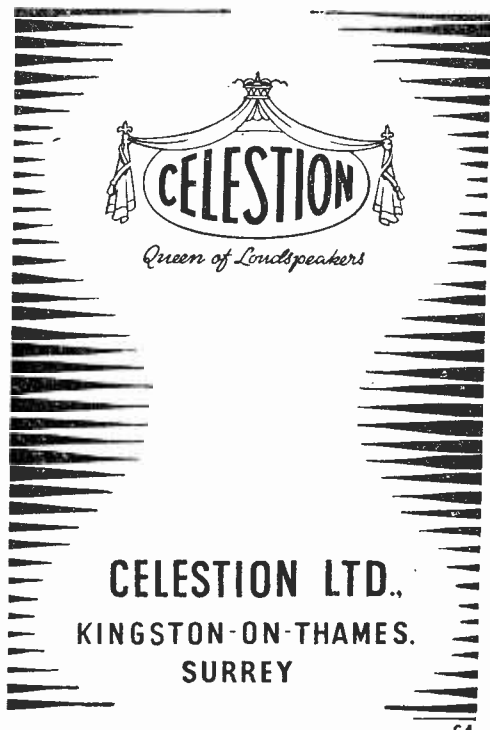

**CELESTION**  
*Queen of Loudspeakers*

**CELESTION LTD.,**  
KINGSTON-ON-THAMES.  
SURREY

c.4

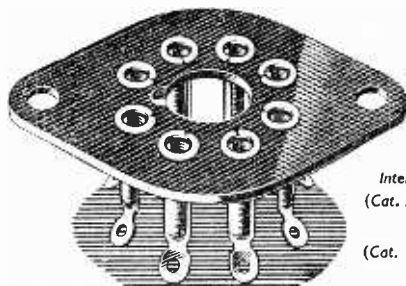

International Octal  
(Cat. No: VH 232/8)

Mazda Octal  
(Cat. No: VH 92/8)

# CLIX SINGLE PLATE OCTAL VALVEHOLDERS

(Standard 1 1/2" fixing centres)

These valveholders, incorporating the latest "CLIX" resilient sockets, will retain the valve under most exacting conditions. In use by leading Set Manufacturers for Home and Export Sets.

See current Price List for details of all Clix components

**BRITISH MECHANICAL PRODUCTIONS LTD.**  
21 BRUTON STREET, BERKELEY SQUARE, W.1  
Grams: TROLINX, WESDO. LONDON Phone: MAYFAIR 5543



## FOR THE RADIO SERVICE MAN, DEALER AND OWNER

The man who enrolls for an I.C.S. Radio Course learns radio thoroughly, completely, practically. When he earns his diploma, he will KNOW radio. We are not content merely to teach the principles of radio, we want to show our students how to apply that training in practical, every-day, radio service work. We train them to be successful!

### INTERNATIONAL CORRESPONDENCE SCHOOLS

Dept. 94, International Buildings, Kingsway, London, W.C.2.

Please explain fully about your instruction in the subject marked X.

Complete Radio Engineering  
Radio Service Engineers

Elementary Radio  
If you wish to pass a Radio examination, indicate it below.  
British Institute of Radio Engineers  
P.M.G. Certificate for Wireless Operator  
City and Guilds Telecommunications  
Wireless Operator, R.A.F.  
Wireless Mechanic, R.A.F.

Write to the I.C.S. Advisory Dept., stating your requirements. It places you under no obligation.

Name..... Age.....  
(USE BLOCK LETTERS)

Address.....





## The Smartest uniform out, Sir!

Ought to be. In the Royal Marines we get the best. We give it too. We do a real job, Chum, all over the world at sea and ashore. Sailors and Soldiers we are. Globe and Laurel — that's the badge. And we've got a list of battle honours long as your arm. And the chap who joins the Royals is a smart fellow. Take it from me.



**YOUNG MEN** between the ages of 17 and 23 can enlist now for 12 years service from the age of 18 (or date of entry if later). For full particulars apply to your nearest COMBINED RECRUITING CENTRE OR WRITE TO D.N.R., DEPT. 41/L, ADMIRALTY, LONDON, S.W.1.

Join  
the

# ROYAL MARINES

## THE COIL PICK-UP

The instrument that reproduces  
everything on the record

Frequency response :  
30—9,000 c.p.s.

Output :  
.03 Volts

Needle pressure :  
 $\frac{1}{4}$  to 1 oz. adjustable

Sold complete with Transformer and  
Equalizer.

Price Complete **£5-15-0** Purchase Tax **£1-5-7**

WRITE FOR FULL DETAILS

**WILKINS & WRIGHT,**  
LIMITED,  
Holyhead Rd., BIRMINGHAM 21.

# EX R A F



Transmitter-receiver for short waves 20-40 metres. Provision for crystal control. Uses standard headphones and microphones. Battery operated, requiring standard 120 volts h.t. and 2 volts l.t. Includes 9 valves standard English types. Six valves in receiver and three in transmitter. Circuit Rx, 2RF., Det., 2 Audio and Power. Tx, Osc. PA and modulator.

**£6 carriage paid**

THE STAMFORD RADIO CO.

199 Stamford St., Ashton-U-Lyne, Lancs.  
Telephone : ASHton 1964.

## COVENTRY RADIO

COMPONENT SPECIALISTS SINCE 1925.  
OUR

### LATEST LIST

of Radio Components will be available  
NEXT MONTH, may we send you  
a copy when ready?

Price 3d. Post Paid.

**COVENTRY RADIO,**  
DUNSTABLE ROAD, LUTON.

## SOUTHERN RADIO'S LATEST

ex Government Purchases

### MINIATURE COMMUNICATION RECEIVER

(M.C.R.I.)

A.C./D.C. complete with POWER PACK, 'PHONES, AERIAL, ETC., for immediate use on all voltages. 20 metres to 3,000 metres. 5-valves. Can be used with Loud Speaker. Brand New in original cartons. £10 : 10 : 0. Carriage and packing 5/6 extra.

Ex Government Morse Tappers, 1/6d. each, 15/- dozen. Buzzers, 1/6d. each, 15/- dozen, all brand new.

**SOUTHERN RADIO SUPPLY Co.,**  
46, LISLE ST., LONDON, W.C. Gerrard 6653

# On the Amateur Bands

A Monthly Report of Results and Conditions Experienced  
on the Short Waves.  
By "KAYAK"

## An Unpleasant Trend

**M**ORE and more British amateurs are reporting the pirating of their call signs. Whether this is due to the inability of the "pirates" to pass the necessary technical examination as set by the G.P.O. we do not know. In some cases ignorance of the licensing laws, together with the ease with which it has been possible for anyone to buy surplus government transmitters, may be responsible. In any case, the "pirating" of call signs is to be deplored.

G2FLK, Romford, tells us that one day recently he had, after one or two QSO's on the "top-band," moved down to the 3.5 Mc/s band for a quick look round, and upon his return to "top-band" came across a loud signal using his call. G6MU, Tooting, S.W.17, also reports a pirate using his call on this same frequency band. He tells us that the gentleman using his call is running a transmitter with an input of 200 watts and is giving QTH as Battersea, S.E.11.

These cases are only two of many recently brought to our notice. On the higher frequency bands the practice is even more rife. Needless to say, all cases of this nature should be immediately reported to the G.P.O.

## 28 Mc/s

Conditions on this band have now fallen off considerably. The band has been "dead" for days at a time and we ourselves have come across very little of interest. BRS 7594 finds conditions much deteriorated compared with those ruling in October and early November. However, he reports the following 'phones: FA8DX; PY5AQ; VE7AJN, British Columbia; VO2N, VO2X, both Newfoundland; VP6YB, Barbados, and American W6PDB; WOCV, Colorado; WRGT, North Dakota; and WVAT, Kansas. Among others listed were Maltese 1AB and 1L; ZB2A, Gibraltar; and South African ZS1T and ZS6GV.

## 14 Mc/s

This frequency remains reliably consistent as regards DX, and most reports this month are limited to this one band. From our own log we extract the following 'phone stations heard: ZL3KN; CN8BA, French Morocco; XACV, British Forces in Greece, A.P.O., Salonika; ZS2G, P.O. Box 168, East London; and VO6F, Labrador. This latter station, using an input of 50 watts and with a directional aerial system beamed into the United States, was R9 plus. Full QTH is United States Coastguard Station (Radio), Labrador. VO6K was heard to say that there were only two stations operating from Labrador, the other one being VO6L, run by the Canadian Army. However, this is incorrect, as a few minutes later we came across VO6F, who gave QTH as Goose Bay, Labrador. It would appear that the prefix VO6 is reserved exclusively for stations in Labrador, while VO2 is used by Newfoundland only.

On "key" a good signal was put over by J3AAD (Japanese QTH not known, but QSL's go to A.P.O. 301, San Francisco). Tasmania is one of the "rarer" Australian districts, so we were pleased to log VK7LJ who hails from that district. Nigerian

ZD2G was heard at good strength on two occasions as was VO2M, Cape Bonawesta, Newfoundland. VS9AN, Aden, was a consistent signal, as was Australian VK2EO, who was heard almost daily. The usual Pacific Coast Americans were heard, the best times for these being early mornings or early evenings.

Other unusual ones heard were PZ1AL, Surinam, Dutch Guiana, and Russian UAKAA. Russian prefixes and district figures are as many and varied as the types of notes produced. We are awaiting an official list of Russian district classifications, and hope to be able to include them in a later issue. However, it is fairly certain that stations with prefix UA are from Eastern Siberia or the Polar Regions. A warmer climate produced HZ4EA, Mekka, Saudi Arabia, who was a loud and consistent signal right on the H.F. edge of the band. Cards go to A.R.R.I.

Dennis Tyler informs us of ZK1AB, Cook Islands, and requires full QTH. Can any reader supply this? Another QTH required by him is that of XU1R. To us this latter call does not sound very genuine. Others reported (C.W.) are LU8EN; ZS5BZ; W6BS; ON3GE, Greenland; and OE1RE. This latter one is not DX, however. The prefix OE is assigned to Austria, but it is nevertheless of interest to see that this country is back on the "active" list.

D. L. McLean, Yeovil, Somerset, remarks that DX conditions have fallen off since November. During October/November he found conditions very good between 0630-0900 and again from 2200, but he now finds the band is "dead" at these times. He finds the band now peaks around 1900 hours. 'Phones reported by him include EK1AD, Tangiers; EL4A, Liberia; FG3FP, Guadeloupe; FYAE/Aircraft Mobile; YN1LB, Nicaragua; FF8FP, French West Africa; VP4TE and VP4TJ, Trinidad and Tobago; and VS7FF, Ceylon. Several interesting QTH's are forwarded, and we include them in our DX QTH list at the end.

Dennis Tyler, of Ilford, working with his two-valve receiver, sends along a comprehensive list of 14 Mc/s signals. Some from his list are HZ1AB, J. Anderson, A.P.O. 788, c/o Postmaster, New York City; VQ3TOM, P.O. Box 457, Dar-es-Salaam; CR9AG, Government Office, Macao; EL3A, c/o Vice Consul, Monrovia; and

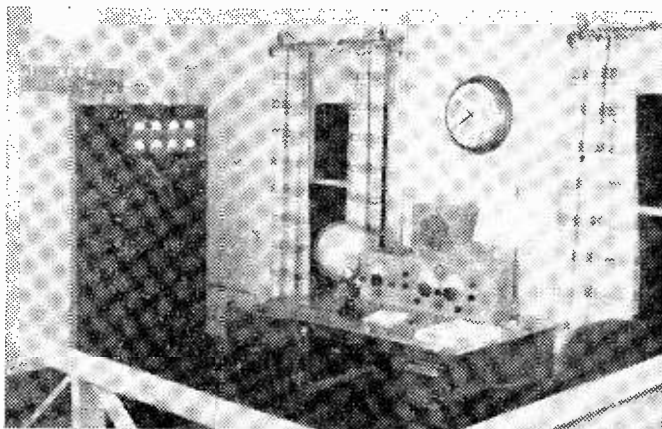

Amateur Station W9DAX at Chicago, Illinois. A neat and efficient layout.

CR4BK, Cape Verde Islands. Dennis remarks that the band is seldom productive after 2200 hours.

### 3.5 Mc/s

This frequency is good for North Americans from about 2300 onwards. G2FLK reports having heard TF3C, Iceland, on one occasion. TF3C was a good signal but few stations were fortunate enough to contact him. BRS 7954 reports several Canadian phones, and the following from Newfoundland: VO1A, VO2T, and VO2Q. Among his list of Americans are four from the fourth district, 4ALK, 4DCQ, 4GJS and 4IMJ. On this frequency these are real DX catches.

### Canadian Districts

The Canadian districts have been reorganised and the following list is up to date:

- VE1 Maritime Provinces.
- VE2 Province of Quebec.
- VE3 Province of Ontario.
- VE4 Province of Manitoba.
- VE5 Province of Saskatchewan.
- VE6 Province of Alberta.
- VE7 British Columbia.
- VE8 Yukon and Northwest Territories.

### DX QTH List

CR4BQ, c/o British Sea Cable Station, Cape Verde Islands.

XZ2KM, 379, Dalhousie Street, Rangoon, Burma.

ZC1AR, ZC6, Box 360, Cairo.

PZ1A, Rene Kowssolea, Box 679, Paramaribo, Surinam, Dutch Guiana.

XACP, Signals Officer, R.A.F. Station, Elmas, Sardinia, A.P.O. S 497.

FM8AC, Robert Martinon, Box 260, Forte-de-France, Martinique.

VO4J )

VO4M ) Harmon Field, Labrador.

VO4P )

ON3GC, Godthaab, Greenland.

FG3FP, c/o Pan-American Airlines, Dakar, French West Africa, A.P.O. 194, U.S. Army.

J3HKP, Kyoto, Japan, A.P.O. 20r, c/o Postmaster, San Francisco, California.

LU1ZN, Yacht "Gauchó," c/o Radio Club of Argentina, Buenos Aires.

PZ1W, Box 679, Paramaribo, Surinam, Dutch Guiana.

VQ2FR, F. Radeliffe, P.O. Box 111, Mufulira, N. Rhodesia.

XACV, British Forces in Greece, A.P.O., Salonika.  
 J3AAD, A.P.O. 301, c/o Postmaster, San Francisco.  
 HZ4EA, Mekka, Saudi Arabia. Cards to A.R.R.L.  
 W6OCA/13, B. Company, 58 Sig. Bn., A.P.O. 713,  
 c/o Postmaster, San Francisco.



A close-up of the transmitter at W9DAX.

FA8DX, QSL to W2DXF or W5KPI, whichever is operating.

XE1LE, P.O. Box 907, Mexico City.

## Marine Radar

**I**N May of last year the Government held an international meeting in London on Radio Aids to Marine Navigation, the proceedings of which were published recently. A second volume prepared from the scientific and technical documents presented to the meeting and dealing with the whole problem of radio navigational aids has now been prepared by the Ministry of Transport and has been published by His Majesty's Stationery Office (Radio Navigation Radar and Position Fixing Systems for Use in Marine Navigation, price 5s.).

After introductory chapters on the needs of the mariner for navigational aids, and on radio wave propagation as it affects them, the volume goes on to examine in detail all the radio navigational aids in existence or under development. One section deals with all aspects of radio direction finding, both from ship and from shore and including the different types of radio beacon. Another section covers hyperbolic systems of navigation, including Loran, Gee, Decca and other names familiar to many in the Services during the war. A large section is devoted to marine radar in all its forms, as a ship-borne instrument, as a shore installation for harbour supervision and in the form of radar beacons. This section also includes a specification for a ship-borne

radar set, drawn up by combining a knowledge of the user's needs with a knowledge of the technical possibilities. This should prove of great value to the radar manufacturer and the shipowner, because both will know that a set conforming to this specification will be in every way satisfactory.

### A Technical Book

The publication is essentially technical and gives a large amount of information unobtainable anywhere else. It will present many with their first picture of the far-reaching developments in radio navigational aids as a result of the war, and of the application of these developments to the safer and more efficient operation of ships at sea. It should prove of wide interest and invaluable as a textbook to all who are in any way interested in radio aids to navigation.

## Radio Engineer's Vest Pocket Book

3/6, or 3/9 by post from

GEORGE NEWNES, LTD., Tower House,  
 Southampton Street, Strand, London, W.C.2

# Practical Hints

## An Inspection Light

HAVING the need for a light for examining components, joints, etc., in awkward places when servicing, I made the hand lamp as shown. It was used in conjunction with a bell transformer.

The bulb holder stays in place by the tight fit of the flex in the handle, and the shield prevents the user from getting dazzled. The dowel was drilled out with an ordinary wheel brace and drill, starting at each end.—J. H. WILSON (Northenden, Manchester).

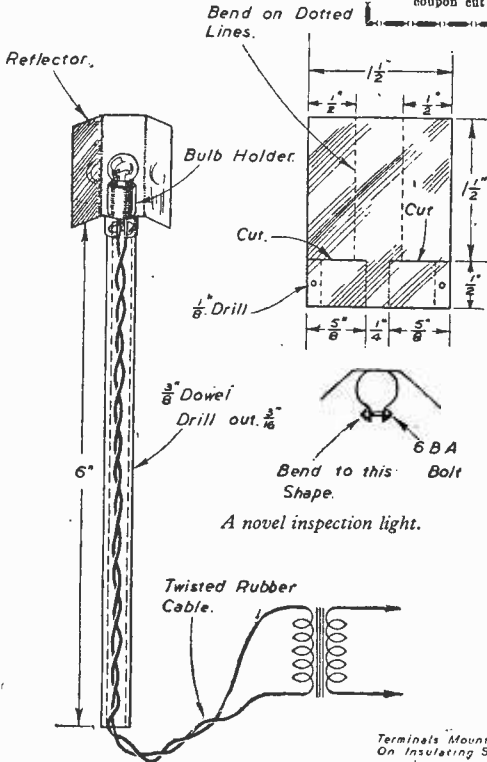

## THAT DODGE OF YOURS!

Every Reader of "PRACTICAL WIRELESS" must have originated some little dodge which would interest other readers. Why not pass it on to us? We pay half-a-crown for every hint published on this page. Turn that idea of yours to account by sending it in to us addressed to the Editor, "PRACTICAL WIRELESS," George Newnes, Ltd., Tower House, Southampton Street, Strand, W.C.2. Put your name and address on every item. Please note that every notion sent in must be original. Mark envelopes "Practical Hints."

## SPECIAL NOTICE

All hints must be accompanied by the coupon cut from page iii of cover.

tags connected internally to the moving arms of each section are shorted, as are two of the contacts in each section also. In the type of switch shown the contacts in each section operate diagonally opposite, so that the tags actually shorted, and the connections thereto, must be adhered to—that is, of course, if the exact order shown is wanted.—R. L. GRAPER (Chelmsford, Essex).

## Hook-up Adapter

HAVING experimented with various forms of hook-up adapters using plugs and sockets, etc., I have found that the most reliable method is that shown below.

A number of terminals of the insulated head type are mounted on a strip of insulating material which is, in turn, mounted on a block of wood, the latter having holes drilled in it to allow the entry of the lower part of the terminals with their mounting nuts.

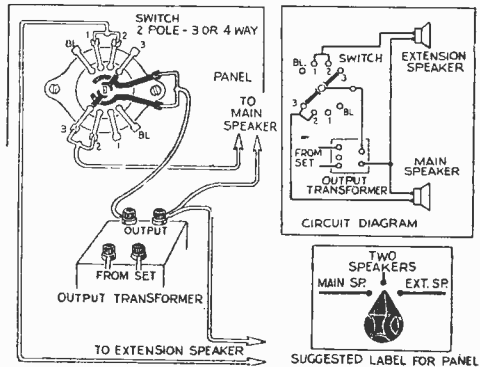

Mr. Graper's suggestion for loudspeaker switching.

A number of leads are then prepared with one of their ends terminating in any way in which it is likely that connections will be made in the course of your work. The other ends of these leads all terminate in spades suitable for the terminals on the block. Thus a large variety of robust temporary connections can be made between various pieces of apparatus.—JOHN H. MARR (Glasgow, N.).

## A Loudspeaker Switching Arrangement

ALTHOUGH the circuit shown, for speaker switching, is hardly likely to be original, I think the general arrangement, and the order of switching, may be of interest to readers.

As will be seen from the sketches, the arrangement is a simple three-way circuit for connecting two speakers individually, or together, in circuit. When both are in circuit they are in parallel.

The writer uses a wafer-type switch, which is a two-pole, four-way type, but as only three tags or contacts of each section are needed, a three-way switch would also be suitable.

As will be seen from the sketch, the

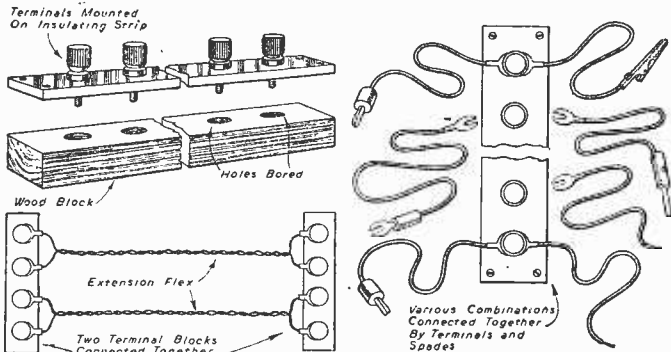

Handy connection leads.

**A** ONE-VALVE receiver capable of bringing in Argentine amateur transmitters on a 16ft. aerial is surely worth building, and whilst such performance cannot be guaranteed for every reception location, this small receiver has been proved over a length of time as a really excellent circuit with station-getting qualities dependent only on conditions. Every continent has been heard at full headphone strength, and a small amplifier gives full loudspeaker volume. The "programmes" heard during the testing period include aircraft-to-base conversations, police reports, 5- and 10-metre amateurs at all distances and, of course, the Alexandra Palace Television Sound programmes which, by a simple means of quench reduction, were brought in with good quality several miles from the transmitter.

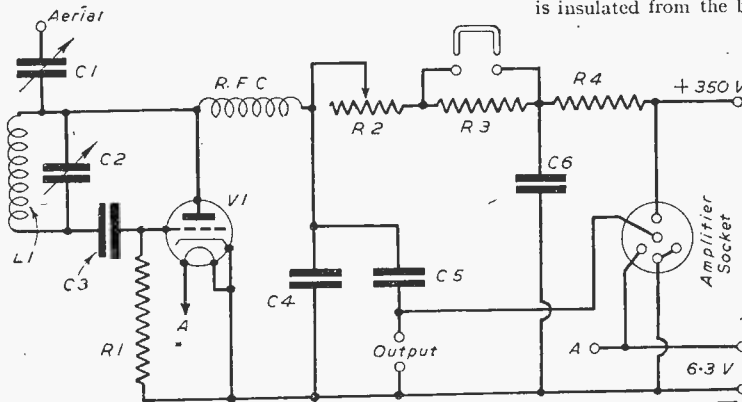

Fig. 1.—The receiver circuit.

Tuning the receiver is simplicity itself. A fairly loud hiss is heard as the condenser is rotated until a station is tuned in, when the hiss either diminishes or disappears altogether, leaving the signal clear and distinct. The tuning is broadened by the quenching action, quenching being the name given to the interrupting action of the secondary oscillation, so that at the highest frequency stations can still be selected without the need for a slow-motion tuning dial.

#### Circuit Details

The circuit, shown in Fig. 1, uses an Acorn 955 triode, and whilst this valve probably is not to be found in the stock of every amateur constructor, it is a worthwhile expenditure for any V.H.F. enthusiast, for it will work, in a suitable circuit, at frequencies up to 700 megacycles and can be used by the amateur transmitting man to give an R.F. output of 0.5 watt—sufficient driving power for further amplifying stages.

The efficiency of the receiver is due in no small degree to the layout and method of construction. The set is built on a heavy copper base 1/16in. thick, and no other metal is advised. Aluminium could be used, but iron or magnetic materials are definitely not suitable for V.H.F. receiver chassis.

The layout of the circuit is seen from Fig. 2 (page 156). The tuning condenser, C2, is mounted on Perspex, which has excellent insulating properties, though polystyrene sheet or thick paxolin board may be substituted, the support being kept small and not made into a panel. If desired, a slow-motion drive may be fitted, but in the original set a simple extension spindle is used, the condenser spindle and the extension handle, a short length of 1/4in. diameter ebonite, both being drilled and tapped for 6 B.A. for 1/4in. along their central axes and joined by a piece of 6 B.A. studding.

# A 3-10 Met

A Useful Self-regenerative

By E. N

Since both sides of the condenser are at H.T. potential above earth and are also at high R.F. potential, the condenser must be insulated from the chassis and driven through an extension spindle to prevent slight hand-capacity effects. A slow-motion drive is sufficient to give the necessary spacing between the hand and the condenser, and when fitted obviates the use of the extension spindle, so long as the slow-motion drive itself is insulated from the base.

#### Coil Details

The self-supporting coils, connected as shown by L1 in Fig. 1, are made of 16 s.w.g. D.C.C. copper wire, wound on 1/4in. diameter rod with turns touching. The coils are plugged into circuit by providing two sockets directly on the condenser lugs, the sockets being cylindrically shanked soldering lugs soldered to the condenser lugs, the coil ends being cut to length to plug into the cylindrical shanks. A thin tinning on the ends of the coils assists in making good contact.

Coil sizes are as follows:

- 2.5—4 metres, 4 turns.
- 4—6 metres, 9 turns.
- 5—10 metres, 16 turns.
- 8—12 metres, 21 turns.

The most useful coil is that of 16 turns, since it just covers the two amateur bands and, of course, the television wavelength. For 10-metre band work

#### COMPONENTS LIST FOR THE

- C1—Aerial coupling, 30 mmfd. trimmer or lower.
- C2—Tuning condenser, Raymart VC40X.
- C3—Grid condenser, Silver-mica, 100 mmfd.
- C4—Quench condenser, 0.003 mfd. Mica.
- C5—Output or coupling condenser, 0.1 mfd. 500 v.v.
- C6—Decoupling condenser, 8 mfd. 500 v.v.
- L1—Tuning coil, see text.
- R1—Grid leak, 240,000 ohms, 1/2 watt.
- R2—Quench control, 1 megohm variable (Pot.).
- R3—Quench stopper, 220,000 ohms, 1/2 watt.
- R4—Decoupling resistor, 51,000 ohms, 1/2 watt.
- R.F.C.—Plug-in R.F. choke. See text.
- V1—Acorn 955.
- Valveholder—See text.
- One pair sockets and plugs for R3.
- One pair sockets and plugs for headphone connection.
- One extension spindle, 1/4in. diam. ebonite rod, 2in. long.
- Two knobs, 1 tuning, 1 quench control.
- One side mounting 5-pin valveholder, amplifier connector.
- One copper base, 6 1/2in. x 4 1/2in. x 1/16in. with rubber feet.
- One paxolin panel, 4 1/2in. x 1 1/2in.
- One 3in. insulating pillar for C1.
- Two small brass brackets for panel mounting.
- One small brass clip for C6.
- One small brass clip for power cable.
- Four-pin plug for power connection.
- Cable, wire, screws, solder, etc.

#### COMPONENTS LIST FOR ALL-PURPOSE POWER PACK

- T1—Mains transformer, 230-250 volts in., 350-0-350 v., 100 mA., 5 v., 2 A., 6.3 v., 3 A., with screened primary.
- Ch 1—20 Henries, 100 mA., 500 ohms, L.F. choke.



# The Receiver

3-valve Set and Amplifier  
BRADLEY

exclusively, however, the 21-turn coil brings the band into the centre of the tuning range.

A feature of the circuit is the use of plug-in chokes. All too often a multi-range set for very high frequency work has deadspots in the reaction, caused by absorption effects in the R.F. choke. In the present circuit two chokes are used, one for the bands up to 5 metres and the other for the bands up to 12 metres, the second choke being used with the 5-10 metre coil. The chokes are wound on 1 megohm wire-wound insulated resistors, these proving very useful formers, 34 s.w.g. enamelled wire being used for the windings, which are in a single layer and wound with turns touching. The 5-metre choke is wound with 50 turns of wire, the 10-metre choke containing 75 turns, and whilst the larger choke can be used with all the coils if desired, it will be found to cause one or two deadspots on the lower waveranges.

The wire of the choke windings is soldered to the wire ends of the resistors, which are then bent and cut to length to suit the sockets provided for them, one at the valveholder anode connection and one on the condenser C4, as shown in Fig. 2. The sockets are again made by the cylindrical shanks of soldering lugs.

The valveholder is also home made, for although Acorn holders

can be obtained commercially, rather more clearance for the valve was required. The holder is made from a piece of 1½ in. diameter paxolin tube with ¼ in. thick walls, the tube being 1½ ins. long. The valve is seated in one end of the tube. With each Acorn are supplied five small clips to make the electrode connections. These clips are bent at right angles and fastened with 0 B.A. nuts and bolts to the tube, being set out along the angles given with the Acorn instruction sheet. The finished valveholder is shown in Fig. 3. The tube is held on the copper base by running two drill holes into the walls at the base of the tube, and then tapping these holes 6 B.A., the copper base being

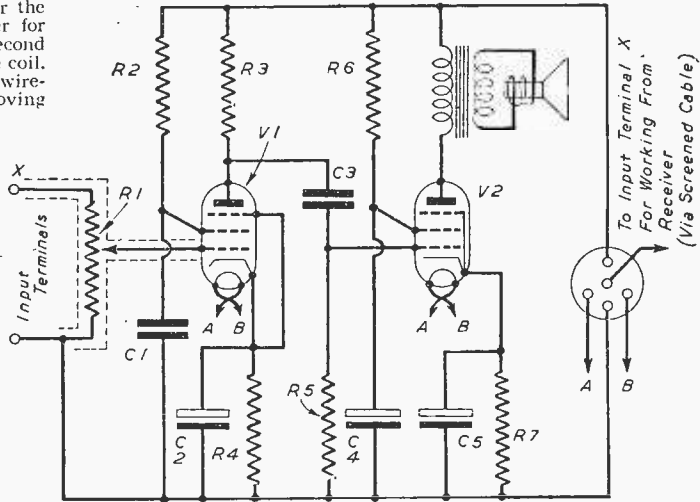

Fig. 5.—A general purpose amplifier for use with the receiver.

## SELF-REGENERATIVE RECEIVER.

- C1, C2—8 mfd., 500 v.v., electrolytic condensers
- B1—Fuse bulb (2.5 v. flashbulb).
- V1—5Y3G rectifier.
- S1—2-pole on-off toggle switch.
- One octal chassis-mounting valveholder.
- One 4-pin chassis-mounting valveholder (output socket).
- One fuse bulb holder.
- One chassis, steel, 8 in x 5½ in. x 3 in. or similar.
- Wire, solder, cable, etc.

## COMPONENTS LIST FOR THE GENERAL PURPOSE AMPLIFIER

- R1—Volume control, 1 megohm.
- R2—1.5 megohms, ½ watt.
- R3, R5—250,000 ohms, ½ watt.
- R4—1,200 ohms, ½ watt.
- R6—24,000 ohms, 1 watt.
- R7—150 ohms, 1 watt.
- C1, C3—0.1 mfd. 500 v.v.
- C2, C5—25 mfd. 12 v.v. bias condensers.
- C4—8 mfd. 500 v.v. electrolytic (small).
- V1—5Y3G.
- V2—PP6C.
- One octal valveholder, chassis mounting, V1.
- One British 7-pin valveholder, chassis mounting, V2.
- Loudspeaker with transformer (matched into 7,000 ohms).
- One 5-pin power and input plug.
- One 5-pin grid connector, American, V1.
- One output socket pair, for loudspeaker connections.
- One chassis, iron box, 6½ in. x 3½ in. x 1½ in. or similar.
- One knob.
- Wire, screened cable, cable, solder, etc.

drilled to suit the spacing. The valveholder is then bolted straight to the base with 6 B.A. bolts. The correct tapping and clearing drills for the work are Nos. 32 and 44.

C3 is supported by its leads between the tuning condenser and the grid clip on the valveholder, and a perfect component must be used since a failure here would apply H.T. voltage to the grid of the valve. The other condensers are chassis mounted, the chassis being raised on four small rubber feet, one at each corner, to give the bolt-heads clearance.

R2, R3, and the decoupling resistor R4, which with C6 need only be used when the set is to feed into an amplifier, are mounted on the paxolin sub-panel at the rear of the copper base.

All earth connections are brought to one point, the cathode clip on the valveholder, which in turn is grounded to the copper base by a direct wire of heavy gauge.

### Types of Aerial

The aerial is shown capacitively connected, and it has been found that reception is best with a simple half-wave aerial end-fed to the anode end of the coil. A longer aerial, of course, may be used, and a dipole aerial, centre-fed via a feeder line to a small 3-turn coil supported beside the anode end of the tuning coil, may be tested. C1, the aerial condenser, is of very small capacity and is mounted on an insulating pillar beside C2 for easy access. A 30 mufd. trimmer condenser has been used successfully, but an even smaller capacity may be tried if obtainable.

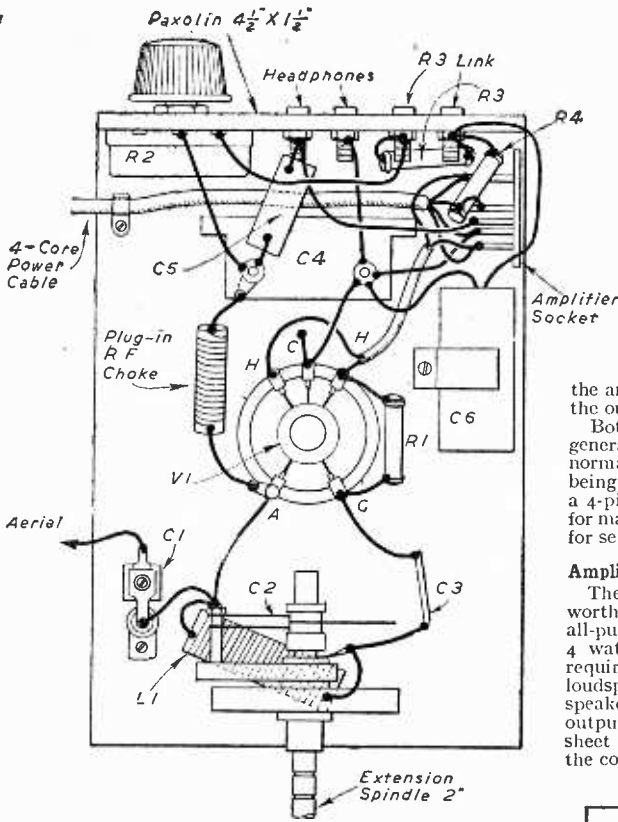

Fig. 2.—General wiring diagram.

A half-wave aerial for the 10-metre band should be about 16ft. long.

For ordinary reception R3 should be shorted out of circuit with its shorting link, R2 should be turned to its maximum resistance, and the aerial coupling C1 should be reduced as far as possible. Then, whilst rotating C2, gradually increase the aerial loading by increasing the capacity of C1 until deadspots appear in the tuning range—that is, where reaction and

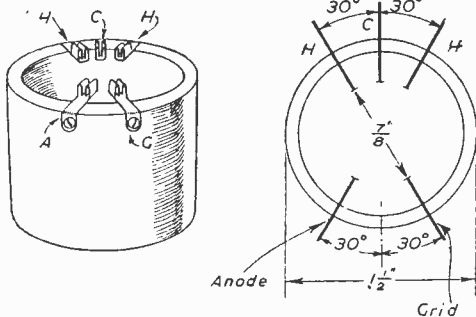

Fig. 3.—The acorn valveholder, showing angular layout for the connecting clips.

regeneration cease over short excursions of the condenser. Reducing the resistance of R2 will then cause regeneration to be resumed in the deadspots, when the receiver will be in a sensitive state and ready for working.

For television reception, with good quality, the shorting link across R3 is removed, putting the extra resistance into circuit. The aerial loading is increased, and the quench allowed to fade out, any strong signal then being tunable without regeneration distortion. It must be realised that the value of the resistance R3 is finally dependent upon the output voltage of the power pack, and some adjustment to suit individual cases may be necessary, although the value is easily found by experiment.

The output, via the 0.1 mfd. condenser, C5, can be fed either directly to headphones or to a small amplifier, and a 5-pin valveholder is mounted on the side of the receiver into which an amplifier can be plugged to make direct connection to H.T., heater and signal supplies. The heater pins carry 6.3 volts, the usual grid pin is the negative or earth lead, the anode pin carries the 350-volt H.T. supply, whilst the output from C5 is taken to the central pin.

Both receiver and amplifier are supplied from a general-purpose power pack. The circuit, perfectly normal, is shown in Fig. 4, the output once again being taken by a 4-pin plug (an old valve base) from a 4-pin socket. The power pack is thus available for many different purposes, and is used by the author for several different pieces of gear.

**Amplifier Arrangements**

The amplifier as used with the receiver is also worthy of consideration by amateurs requiring an all-purpose reproducer. The output, between 3 and 4 watts, is ample for most home purposes, whilst requiring nothing outstanding in the way of a loudspeaker, a Rola Type 8-Z permanent magnet speaker giving excellent results through a pentode output transformer. The amplifier is built into a sheet metal (iron) box measuring 6 1/2 in. x 3 1/2 in. x 1 1/2 in., the condensers and resistors being grouped round the

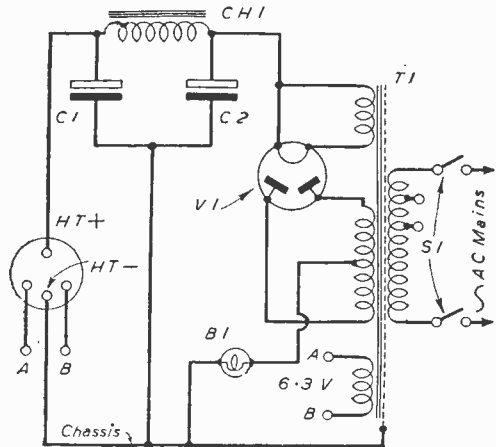

Fig. 4.—An all-purpose power pack.

valveholders and taking very little room, whilst the volume control is mounted horizontally below the chassis level. Screened cable must be used for the input line to avoid hum, the screening being carried on to the metal cover of the volume control and to the grid of the first valve.

Since there are only two valves in the amplifier, no anode decoupling is required, the largest component being the 8 mfd. condenser used for the screen stabilising of the output valve, but if a cylindrical condenser is obtained it will be no larger than the bias condensers and the amplifier can be kept to a small size.

# The Vector Problem

A Reader Criticises Dynatron's Articles and He Replies

**S**OME points of interest were raised by a reader, Mr. Hatch, after publication of Dynatron's article on valve vectors in our December issue. As the points are undoubtedly of interest to all readers who are following Dynatron's arguments, the reader's letters and Dynatron's replies are given below. The first criticism was as follows:

"I feel I must strongly object to the views held by Dynatron re valve vectors in his articles of October, November and December issues, since they are theoretically unsound and not in accordance with the facts.

"He states that the phase-angle between  $E_g$  and  $V_o$  is independent of the anode  $R_a$  and uses this assumption in his example of Fig. 1 (December). This assumption is incorrect and although with a pentode and the valves chosen the result will not be far wrong with a triode the conditions are quite different since  $R_a$  will be very much lower. Also, he implies that for any load with a

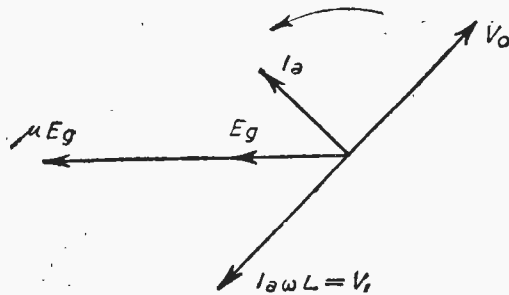

Fig. 1.— $E_g$  and  $\mu E_g$  are in phase in this vector.

$X/R = 60$  deg., the phase-shift will be the same. Again this is not so. He further implies that with a large inductance resistance in the anode circuit the phase-shift between  $E_g$  and  $V_o$  will approach 90 deg. The fact is that with an inductive reactance equal to about 10 times  $R_a$  the shift will be about 180 deg. exactly as for a resistance, but  $I_a$  will be about 90 deg. out of phase with  $E_g$ , and it is this last point which seems to be Dynatron's basic difficulty, coupled with the fact that he apparently does not accept the equivalent circuit as an Equivalent.

"According to Dynatron, the conventional views held about valve vectors are hopeless and every writer has his own method of presentation. I think the only disagreement at the present time is whether to show  $E_g$  and  $\mu E_g$  in phase as Fig. 1 or 180 deg. out of phase as Fig. 2. Both these examples show the conditions when  $\omega L = R_a$ , and starting with Fig. 1 first the instruction is drawn,  $E_g$  and  $\mu E_g$  in phase. Find the angle equal to  $\tan^{-1} \frac{X}{R} = 1 = 45$  deg. This gives the phase-angle between  $I_a$  and  $\mu E_g$ . Draw  $I_a$  lagging by 45 deg. The voltage across  $L$  will lead  $I_a$  by 90 deg., and this is represented by  $V_L$ . Draw a vector  $V_o$  180 deg. out of phase with  $V_L$  and this is the phase of the output voltage relative to  $E_g$ . In Fig. 2 we start with  $E_g$  and  $\mu E_g$  180 deg. out of phase and proceed as before except that we do not reverse the output voltage since we reversed  $\mu E_g$  to begin with. If we want to find the true direction of  $I_a$  we have to reverse it as shown by the vector  $I_{a2}$ . I do not think there is anything very difficult about this and it will give results which are in accordance with known facts, and I maintain that Dynatron's method does not, since he starts with an incorrect basic assumption that  $E_g$  and  $I_a$  must be in phase."—R. S. HATCH.

Dynatron's reply to this is as follows:

Your correspondent, Mr. R. S. Hatch, has brought out important, but complicated questions which I intend to cover in future articles. The "series-parallel" aspect of valve circuits has always been something of a problem. For example, the shunting effect of  $r_a$  in the case of a comparatively low resistance triode calls for drastic modification in any simple theory outlined for a purely inductive load—or, in other words, the load ceases to be "purely inductive."

As far as I am aware, there is only one textbook which makes any serious effort to cover elementary valve vector principles—*Admiralty Handbook of Wireless Telegraphy*, Vol. II. In my preliminary series I decided to keep to quite elementary ideas, such as the ones considered in Section "K," Figs. 2, 3 and 4 of the "Admiralty." I feel that  $r_a$  is a serious obstacle to beginners in trying to follow more complicated diagrams, hence the reason why I adhered rigidly to series-circuit ideas where  $r_a$  had no effect on the load constants. I expected objections on this score, but many textbooks are full of "idealised" cases—for the simple reason that only hopeless confusion could result from plunging into more complicated details before the "elements" are understood. Mr. Hatch's letter has now given added point to subjects which we shall discuss later—and I believe it is possible to give a simplified account of the more complex circuits.

However, I cannot agree with the "Admiralty" or any other account which arrives at a vector result depicting  $E_g$  and  $I_a$  out of phase. It seems to me a basic requirement that the A.C. space-current in a

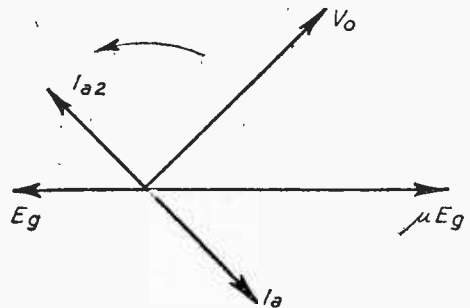

Fig. 2.—In this vector  $E_g$  and  $\mu E_g$  are 180 deg. out of phase.

valve shall be in phase with its cause  $E_g$ , e.g., that  $I_a$  reaches peak amplitudes at the same instants as  $E_g$  attains peak positive or negative values.

If any vector conventions necessitate showing these two quantities out of phase, then, so it seems to me, there must be a violation of some principle in the "conventions." I am neglecting, of course, the de-phasing which results at frequencies where electron transit-times alter the internal conditions.

Why do I find the concept itself impossible? Well, I don't know if Mr. Hatch has ever tried to visualise the matter; to show by a clear physical picture how a load in the anode circuit can react so as to cause a phase-shift between  $E_g$  and  $I_a$  in the internal grid-cathode space of a valve. If he can do so to readers of PRACTICAL WIRELESS, I will seriously consider revising my own ideas. I freely confess that my knowledge of "fundamentals" falls short of the ability to visualise what appear manifest impossibilities.

Suppose at the peak of a negative half-cycle  $E_g = -5v$ . By elementary theory, the number of electrons moving towards the anode must be a minimum, i.e.,  $I_a$  should also be at a minimum or peak negative value. Basically, the question is this: if an inductance is placed in the anode circuit, will this fundamental relation between the grid-cathode potential, and the resulting space-current, be modified in any way as regards *time-phase*? Will  $I_a$  reach peak negative value at some earlier or later instant than the one when  $E_g$  is  $-5v$ ?

Surely, the effect is simply to de-phase voltages in the anode circuit? I will leave the question to Mr. Hatch. The answer is most important to many vector conventions held at the present time.—DYNATRON.

Our correspondent replied to this letter as follows:

"I have to hand yours of the 26th November, and in reply to the question in the last paragraph, 'Can  $E_g$  and  $I_a$  be out of phase with an inductive anode load?' I state, as I did in my previous letter, that it can, and if you will peruse the accompanying graph

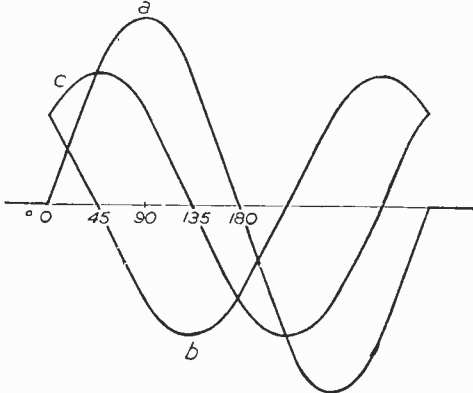

Fig. 3.—Mr. Hatch's graph to show  $E_g$  and  $I_a$  out of phase with an inductive load.

(Fig. 3) you will see how this comes about. The value of  $I_a$  depends not only on  $E_g$  but on  $V_a$  as well, and its phase will depend on  $V_a$  amplitude and phase to  $E_g$ . It is this neglect of  $V_a$  amplitude and phase to  $E_g$  that causes all the trouble.

"The curves are drawn for the case I outlined in my previous letter, i.e.  $R_a = \omega h$ , and since  $h$  is supposed to be phase, according to Dynatron's concept  $V_a$  should be  $\frac{90}{270}$  to  $E_g$  and if curves are drawn on this basis you will find the result quite impossible. For one thing, the maximum value of  $V_a$  will not correspond to the maximum rate of charge of  $I_a$ .

"I think the curve is self-explanatory but I will point out that the amplitude of  $I_a$  has no significance.

and  $V_a$  has been reduced to  $\frac{V_a}{\mu}$  for ease of adding. At any point on curve a or b above the zero the value is reckoned +, and below -. The curves are now added together and the result is c on curve of maximum electrostatic field between anode and cathode and hence  $I_a$ ."—R. S. HATCH.

To this Dynatron replies:

Mr. Hatch has given a graphical demonstration of how  $E_g$  and  $I_a$  can become out of phase with a reactive load, by working out the resultant effect of  $e_g$  and  $v_a$  when  $v_a$  is  $(180^\circ + 45^\circ)$  out of phase with  $E_g$ .

While I frankly agree that his argument is almost conclusive, there are still some difficulties about the view when trying to give an elementary exposition of vectors. I was aware, of course, that the effective electric field drawing electrons to the anode at any instant is  $(e_g + e_a/\mu)$ . In Mr. Hatch's example,  $e_a$

involves  $\sin(0 + 225^\circ)$ , thus appearing to demonstrate mathematically and conclusively that  $I_a$  and  $E_g$  will be at  $45^\circ$ .

It is one important point which, as far as I know, has never before been clearly explained in any textbook or article. Vectors are drawn showing  $E_g$  and  $I_a$  out of phase, but without a word of explanation. It does not materially alter vector relations for pentodes, because  $I_a$  is largely independent of  $e_a$ , but it does involve certain modifications in triode theory, which, however, do not affect the main phase-shift between input and output voltages.

In practical vectorising, too,  $\mu E_g$  is not a quantity that need enter into vector diagrams. We are mainly interested in  $\mu E_g$  when discussing equivalent valve circuits, when all the abstruse arguments about various conventions, etc., arise. I do not think the sign of  $\mu E_g$  is the only point on which there is still disagreement. As stated in my articles, the existence of a "supply voltage" at  $180^\circ$  to  $V_o$  has been consistently ignored and, among other things, I think this has an important bearing on equivalent circuits.

Another difficulty is the fact that the load is in series with valve, relative to  $\mu E_g$ , and in parallel relative to the output voltage  $V_o$ . One consequence of this is, as Mr. Hatch pointed out in his first letter, to make it impossible to get a "purely reactive" load in the anode circuit even with a reactance as much as 10 times  $R_a$ . Another is to cause a phase and frequency shift in an oscillator, as outlined in my next article—it is virtually impossible to have an "unloaded" LC circuit, because it is always shunted by the valve  $R_a$ .

Now, Mr. Hatch has raised another important modification in triode theory—the fact that a phase-shift is necessitated between  $E_g$  and  $I_a$ . With the Editor's permission, I shall explain all these matters in considerable detail in future writings, including valve equivalent circuits. Notwithstanding points in dispute and conceded so far, I feel that my article on valve vectors in PRACTICAL WIRELESS are accomplishing much more towards clarifying the whole subject than some of the more academic accounts in other journals.

While, therefore, I will concede that Mr. Hatch has proved his point concerning  $E_g$  and  $I_a$ , I had hoped there would have been much more discussion of some of the statements made in my articles, e.g., about what I have said in reference to  $V$  and  $V_o$ . Readers should be grateful to Mr. R. S. Hatch for pulling me up on the vector rules as applied to triodes, although it was my intention to deal with more involved matters later.

In my next "Technical Notes" I shall summarise and give more detailed explanations of the triode modifications to my vector theory which seem definitely established so far. If there are any other objections, now is the time to get them finally settled—but not including " $\mu E_g$ " and equivalent circuits for the present, please!—DYNATRON.

## REFRESHER COURSE IN MATHEMATICS

By F. J. CAMM.

8/6, by post 9/-

## THE SLIDE-RULE MANUAL

By F. J. CAMM.

5/-, by post 5/6

From: GEORGE NEWNES, LTD., Tower House, Southampton Street, Strand, W.C.2.

# Underneath the Dipole

Television Pick-ups and Reflections. By "THE SCANNER"

**R**IGHT from the days of crystal scratching, the technically-minded members of the family have been a source of annoyance to the others who are not so technically-minded. Conversely, the family radio expert has suffered untold agonies listening to a badly tuned receiver, forcibly kept at bay by his beloved relatives while they listen to a long radio play or some other absorbing broadcast. The situation becomes much more critical—even explosive—in those homes which house a television receiver, intensified by the dual technical hypnosis of sound volume or tuning trimmer, or, more attractive still, the multiplicity of picture brilliance, contrast, focus knobs, etc. And the "etcetera" covers quite a varied selection of controls, particularly in the old pre-war receivers. All of them offer hours of happy "fiddling" to the man who thinks he can get the reception just that little bit better!

The uninitiated stood dismayed before some of these early model high definition receivers, balefully contemplating a row of special extra knobs which were (sometimes) marked: *Vertical Sweep and Interlacing Control*; *Horizontal Synchronising*; *Horizontal Sweep*; *Astigmatism Shift*; *Vertical Shift*, and so forth, and then telephoned for a radio service man. The semi-initiates ventured to needle and toy with these knobs, to the detriment of the picture, which ultimately became so bad that he, too, would have to "phone for help. The real "ham," who had been weaned on dayzite, zincite, or carborundum-and-steel, and brought up through his most sensitive autodyne days without a squeal, soon learns what each knob does, and, at the slightest pretext, will brighten or darken the picture and make small tuning adjustments which, as usual, are likely to start a family war, if the rest of the family are indulging in a "viewing session."

## The Technical Hitch

Matters are complicated if, after feverish adjustments have been made for some minutes without result, a voice is heard apologising for a fault on the picture transmission and advising viewers to stand-by for two or three minutes while the engineers make adjustments at the transmitter. Then, when the sound and picture transmission is resumed, one's settings of the picture control knobs are all over the place. Far less disturbing is the occasional break-down of the sound side of the transmission, when (after an unexplained long delay), a title card is placed before the emitron camera announcing this fact. Viewers do not grudge the hard working B.B.C. engineers the pleasure of a spot of crystal scratching or valve changing; but it would be definitely more helpful if they were a little more prompt in telling us all what is happening.

## Post-war Designs

Fortunately, controls have been simplified a great deal in the post-war television receivers. As regards results, they are not a great deal better than the best of the pre-war jobs, excepting in such matters as reduction of interference troubles (from motor-cars and other man made static), and the increased brightness of the cathode ray tubes. Not all of the tubes are black and white; some of the sets which give otherwise excellent pictures have tubes

with a slight greenish tinge. The complete absence of any red rays in the emanations from the fluorescent screen on which the picture is formed gives a blueish effect when viewed in a room which is partially illuminated by tungsten lamps. This is due to the heavy emphasis on the red end of the spectrum in the light given out by tungsten lamps. Whether the set is new or old, viewing is far, far better in complete darkness.

## Production Technique Progress

Generally speaking, I think that the production technique at the Alexandra Palace is becoming quite polished, and a definite style of treatment is being formed. As predicted in this column some months ago, the "cut" from emitron camera to camera, as distinct from the dissolve, has become an established routine. On the whole, this new switching device is being used with restraint, and long shots, close-ups, reaction shots and "inserts" of letters or words of songs, etc., are introduced with a good theatrical sense of timing. The dissolve has by no means been abandoned; its dramatic value has increased with its less frequent use. "Tracking" shots have become a routine matter, too, but in some programmes—especially variety shows—their use is still overdone. The B.B.C. are to be congratulated at the high standard attained in this matter of "editing" the various types of shots to get the best out of television plays and all the other material. By way of contrast, the editing of the 1946 B.B.C. test film is poor, jerky in style and treatment, and not as good as the old 1937 test film that we all got to know so well. It would be worth re-editing the excellent film material embodied in the 1946 film and introducing into it the slower, smoother tempo to which we have become accustomed and like.

## The Camera Operator

Television camera operators at the Alexandra Palace studios and on outside broadcasts are by no means of equal excellence. Some of their work is first class, particularly on plays, where they faithfully follow the directions of the producer which reach them on headphones. At other times, their sense of timing camera



*A delightfully informal setting in one of the B.B.C. Television Studios, when children of the staff employees were entertained to a Christmas party. On the left a group of children are ringing handbells whilst the rest sing, led by Uncle Harry.*

"pans" is at fault, but as I believe they still have to rely on viewfinders which give an inverted image, they are working under difficulties. In setting up their camera positions, however, they should avoid composing their pictures so that the artistes' heads are too near the top of the picture, particularly on mid-shots of groups of people. This fault exaggerates the distortion which is normally present on many receivers which show a picture on the curved edge of the face of the tube or where the tube is, in fact, a little small for the size of the picture. Similarly, such groups of people should have adequate space on each side of them; otherwise, the outside men are apt to become alarmingly thin. Close-ups of faces would benefit by the use of longer focus lenses, which have the effect of flattening the features of the

victims, as well as flattering them. And there is still, too often, that "lost" look on the face of an artiste waiting for the camera to be switched off. But the technical side is forgotten by the viewer on the occasions when artistes who really seem to understand this new medium are being televised; their personalities are forcefully projected into thousands of homes without losing an atom of vitality. It is not always the stars who do this. Frequently, variety artistes who are hardly known at all, and whose material is not exactly first class, succeed through this mysterious flair for getting to grips with the cold, blood-thirsty emitron cameras. The Alexandra Palace producers are making a note of these outstanding television personalities, and the list is growing, slowly but surely. And so is the number of viewers who are enjoying them.

## Long Distance Relays

Some Interesting Details of a New B.B.C. Technique in Radio Relays

**T**HE success of the Test Match broadcasts has been due largely to a technical innovation in long-distance broadcasting.

Ten thousand miles separate this country from the short-wave transmitter at Shepparton, Victoria. In order to overcome the effects of space and time, and to counteract the vagaries of the ionosphere, engineers have made use, at a point on the world's surface roughly midway between Shepparton and the receiving station at Tatsfield, Surrey, of a "boosting" station for the short-wave programme. This relay station, comprising the up-to-date receiving equipment and high-powered transmitter operated by S.E.A.C. in Ceylon, acts as a direction changer and, if necessary, a wavelength changer for the Australian beam. At the same time it performs the function of a high power "booster" for a weakening Test Match programme. For the Test Match, it has insured against inferior quality and the possibility on occasion of no re-broadcast.

### Using a Relay

The B.B.C. Engineering Division has had in mind for some years the use of relay stations on long-distance routes. At the Commonwealth Broadcasting Conference held in London in 1945, full details were discussed. Difficulties, not always technical, have prevented very rapid development of the B.B.C. scheme. As these difficulties are being gradually overcome, there is reason to believe that relay stations will become a permanent feature in long distance-broadcasting. For one thing, the regular exchange of programmes between the various countries of the British Commonwealth would be greatly facilitated.

That the relay station does provide better reception over a long distance during a greater part of the day, and during hours when none would be obtainable by direct transmission, is accounted for in this way.

Long-distance broadcasts are transmitted across the world on short wavelengths. The short waves, as readers know, travel by way of the ionosphere, not over the surface of the ground. The ionosphere, the body of "electrified" gas lying in the high atmosphere, prevents the waves from escaping into space. It bends the waves round the earth so that they reach the far distant receiving point. The ionosphere is brought into existence by the action of the sun's rays. Consequently its condition varies greatly according to the time of day and season of the year. The wavelengths employed for long-distance broadcasting must suit the prevailing ionospheric conditions. For example, it is useless to attempt to send programmes on a very short wavelength through a part of the ionosphere which is in darkness, or on a longer wavelength during daylight. Over any route constantly changing ionospheric conditions necessitate, as the day advances, changes in the working wavelengths.

It will be realised, therefore, that the best condition for good communication is when the ionosphere is in a more or less uniform condition over the whole route between transmitter and receiver. For example, on a route of about four thousand miles when it is either midday or midnight half way between transmitter and receiver. If dawn is just breaking at the mid-way point, conditions would become difficult, for a wave which will suit conditions at the daylight end would be poorly propagated by the ionosphere towards the dark end of the route.

### Time and Weather Differences

In the case of very long routes—such as Australia to this country—uniform ionospheric conditions over the whole route rarely exist; for not only are there great time differences as between one end of the route and the other, but also greatly differing seasonal conditions as well. (It is mid-summer in Australia when it is mid-winter here.) Further than this, a radio wave, travelling from one point on the world's surface to another, will usually take the shortest possible route round the earth, and such a route may well lead into polar regions before it crosses the equator. Thus it may encounter the maximum possible difficulties in ionospheric conditions as it travels along.

When the Test Match commentary begins it is 7 a.m. of a winter morning here, while at the transmitter in Shepparton the time is 5 p.m. of a summer afternoon. The shortest route to Britain runs in a north-westerly direction from Shepparton, and arrives here from the direction of Denmark, traversing areas where it is afternoon, mid-day, fore-noon and early morning. If the programme is sent the other way round the world—as is possible—the route is in a south-easterly direction from Shepparton and arrives here from the direction of Trinidad. At the time mentioned, it therefore traverses the dark zone of the earth, going from late afternoon, through deep night to early morning. This example will serve to indicate that ionospheric conditions over such a long route are seldom completely suitable for one particular wavelength. At the time given, conditions are, however, by no means at their worst, for during several hours of the day it is practically impossible to effect communication at all. Whatever wavelength is then chosen will fail at some point or other on the path; as soon as conditions are right for it at one end they inevitably deteriorate at the other.

### Advantages Gained

A suitably located relay station can tremendously improve matters in the following ways:

- (1) It can, by receiving from the direction of Shepparton at its locality and re-transmitting in the direction of Britain, so change the actual route traversed

that the wave is kept away from areas such as the polar regions, where conditions are likely to be most unsuitable.

- (2) It can take the relatively weak (received) waves and, by passing them through its high-powered transmitting plant, so increase the energy at a mid-way point that the losses so far encountered are overcome, and much more energy is thus receivable in this country.
- (3) It can, when necessary, re-transmit on a different wavelength from that on which it receives. This is a tremendous advantage which overcomes the

varying ionospheric conditions. The wavelength suitable for the first part of the route is changed to another and more suitable one for the last part.

Any disadvantages which may result from this "juggling" with the programme at a mid-way point are, with modern receiving, transmitting and terminal equipment, negligible compared with the advantages gained. Broadcast listeners in this and other countries of the British Commonwealth, and in foreign countries, too, may therefore anticipate the time when long-distance relays will become a more regular and improved feature of broadcasting.

# Vibrator Power Packs

Working Principles and Circuit Details of the Vibrator  
Type of Unit. By F. BUTLER

**E**VERY constructor who has at any time ventured to build a piece of portable equipment has been faced immediately with one great problem—power supplies. Whether transmitter, receiver or amplifier, this problem continually arises, and no clear-cut answer can be given. Every case must be decided on its merits—the extent and method of moving the equipment, its power consumption, and, above all, where it is likely to be used. Even if it is intended to be used indoors, for example, a P.A. amplifier for dances, it cannot, if it is to be used over large areas of the country, rely easily on the mains supply owing to the possible variations in the mains voltage, not to mention the likelihood of D.C. In this case some variation of the D.C.-A.C. rectifier circuit may be found satisfactory, but any equipment which is likely to be used in the open at any time, or even indoors in some of the remoter rural districts, will need a self-contained power supply.

The L.T. supply presents little difficulty; accumulators are well tried and almost universally used unless considerations of size and weight, coupled with a low current drain, point to a dry cell. An accumulator is robust and reliable if properly looked after, whilst recharging facilities are normally available at any garage or radio shop. Although the first cost is somewhat high these days, the fee for recharging, which at any reputable establishment will include topping up and terminal greasing—normally the only maintenance necessary—is not excessive. If desired, a trickle charger could be constructed and charging carried out at home.

## The H.T. Problem

When, however, we come to H.T. supply our difficulties begin, for here the problem is by no means so easily solved. The dry battery has a considerable field of usefulness, but also great limitations. One is that once discharged it is of no further use to us, but must be thrown away, a waste of materials which makes this an expensive method of obtaining current. Also, the voltage of the battery is steadily dropping whilst it is in use and so the working of the gear will suffer. The voltage will drop eventually to a point where it is no longer sufficient to give satisfactory operation, and the battery will then have to be discarded, although there is still life in it. Of course, two half-discharged batteries may be wired in series to give a satisfactory voltage, but this doubles the weight, a grave disadvantage in mobile gear, and also, as the battery is discharged the internal resistance rises with a consequently very large resistance for two in series.

Another snag, often the final cause of a search for an alternative power source, is that the capacity of an H.T. battery is small and consequently the current limited. Two batteries may be wired in parallel to give double the current, but this is not to be recommended, partly on account of weight, and also, should

one battery be of a greater voltage than the other, the one of greater voltage will discharge through the other at a high rate until the voltages are equal. Naturally, the more current drawn from a battery the shorter its life will be, and generally the lower its efficiency. That is to say, if a battery will give 20 mA. for 10 hours before its voltage falls below the useful level, it will not give 20 mA. for five hours before reaching the same level, as might be expected, but will fall to it in a shorter time, another reason why a battery H.T. supply is often an expensive affair. It is difficult to lay down any particular maximum value for the current to be drawn from the battery as several factors affect this, such as whether the current is to be drawn intermittently, as in the case of a transmitter, or continuously, as in the case of a receiver, but, in default of any other information from the maker of the particular battery, 15 to 20 mA. should not be exceeded.

If it is desired to exceed this current considerably, some other method of H.T. supply must be resorted to, and the only practical alternatives left are a motor-generator or a vibrator, both fed from an accumulator, which, of course, means a considerable weight, but is practically unavoidable as has been seen. The relative merits of these two will be mentioned later. When the

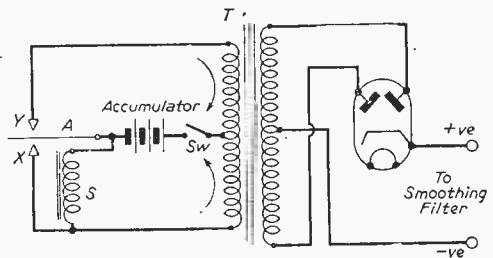

Fig. 1.—Main circuit features of the vibrator power pack.

author was confronted with a similar choice it was decided to use a vibrator fed from a six volt accumulator. The accumulator was a standard car type and this in itself is advantageous for any garage will supply and charge them (subject, of course, to present-day shortages). As this accumulator will also supply the L.T. current, it is convenient that the extensive range of 6.3 volt mains valves may be fed with heater current direct from it. The final advantage, and no mean one either, is that the equipment may, if necessary, be used direct from a six-volt car electrical system. In this case, however, an extra smoothing filter may be necessary if it is to be used with the engine running.

### Working Principles

The heart of the vibrator power pack is the vibrator unit itself, which, with a step-up transformer and a rectifier is all that is essential to provide an H.T. supply. Shorn of all its refinements the circuit is as simple as that, and that is how we will first consider its operation. A vibrator is usually in a sealed case with pins to fit a standard valve base. This may lead to some confusion about how it works but it is really only an interrupter, similar in principle to the make and break circuit of an electric bell. The transformer primary should be centre tapped and current pulses are fed alternately

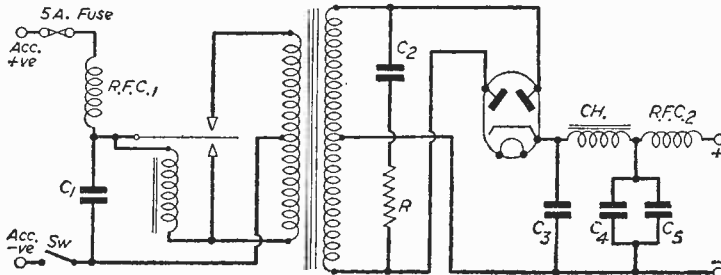

Fig. 2.—A practical vibrator circuit with necessary filters.

to each end of the transformer, a return to the battery being provided by the centre tap. Depending on the ratio of the transformer a higher voltage is induced in the secondary by the pulses and after rectification an H.T. supply will be available. As with any other rectifier a degree of smoothing is necessary but this will be dealt with later.

A glance at Fig. 1, will clear up any doubtful points. A is an armature or reed sprung so that it will remain central between the two contacts X and Y, without touching either of them until some force moves it. When the switch is closed a circuit is completed through the solenoid S, and the resultant flow of current will turn S into an electro-magnet, thus attracting the armature against contact X. When the armature touches the contact, current flows through one half of the transformer primary. Simultaneously, the solenoid S is shorted which leaves the armature free to return to its neutral position. Its inertia will, however, carry it past this position until it touches contact Y after which it will return to the central position. By now, however, the magnetic field around the solenoid is building up again and the cycle will be repeated. The pulses are flowing through the primary in opposite directions as indicated by the arrows, and so the effect on the secondary will be the same as an A.C. of similar voltage and waveform flowing through a primary half the size of the one in use. An alternating secondary voltage will, therefore, be produced, its value depending on the step-up ratio of the transformer.

It will be necessary to rectify this voltage and any type of rectifier may be used, full-wave valve rectification being used in the diagram. The D.C. output would still be useless for most purposes as it consists of a D.C. voltage which rises from zero to its maximum and falls again to zero either once or twice for every cycle of A.C. input to the rectifier, depending on whether half or full wave rectification is used. This can be overcome by the use of a reservoir condenser and a smoothing filter. The reservoir condenser is a large condenser which is placed directly across the output from the rectifier. Its name is almost self-explanatory, for the D.C. pulses are fed in and current is drawn out as required. There will still be considerable fluctuations of voltage, however, and a smoothing filter will be necessary. This consists of iron-cored choke and a condenser connected in series. If the fluctuating D.C. is analysed it will be found to consist of a D.C. voltage with an A.C. superimposed upon it. The choke of the smoothing filter offers a high

impedance to A.C., but only a low resistance to D.C., consequently most of the A.C. voltage will be developed across the choke, but very little of the D.C. The condenser, on the other hand, offers an almost infinite resistance to D.C., but very little impedance to A.C. (assuming it is of a fairly large size) and so almost all of the D.C. voltage, but very little of the A.C. will be developed across the condenser. So, by taking our supply from across the condenser we shall have an almost smooth voltage. If an exceptionally smooth supply is needed another smoothing filter may be used after the first, but this is very rarely necessary.

### Interference Suppression

One disadvantage of the vibrator power pack is its prolific generation and radiation of interference both audio and R.F. The audio interference, caused during rectification, is dealt with by the smoothing filter described in the last chapter and should cause little trouble. When present it takes the form of a hum, the frequency of which is either equal to, or double that, of the vibrator reed, depending on whether half or full-wave rectification is used. Full-wave rectification is the more desirable as not only is more power available, both halves of each cycle being used, but owing to the higher frequency of the pulses produced, the smoothing filter is more effective and there will be less chance of trouble with hum. Hum may be distinguished from R.F. interference or "hash" by its low pitch as compared with the rasping sound of hash. R.F. interference is caused by the sparking which occurs when the contacts break and is much more difficult to overcome than hum, although probably less expensive as small condensers and R.F. chokes, whilst used in fair numbers, are a good deal cheaper than iron-cored chokes and large capacity condensers.

Much of the difficulty will be avoided if proper precautions against hash are taken from the beginning when the unit is being designed and makeshifts do not have to be resorted to. The power unit must be completely screened; this cannot be over emphasised. If possible all joints in the casing should be soldered and where this is not possible, a tight fit must be ensured. In addition the output leads should be thoroughly screened and the

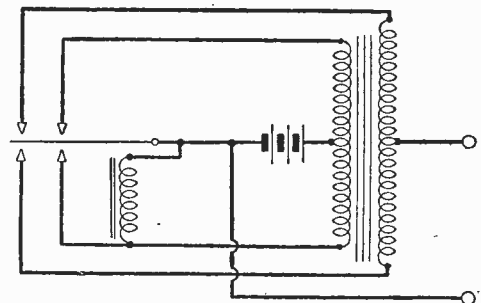

Fig. 3.—A synchronous vibrator.

accumulator leads twisted evenly so that they cancel the radiation from each other. When the contacts open, the magnetic field collapses almost instantaneously, causing a surge of very high voltage across the secondary, and it is necessary to place a "buffer" condenser here to absorb it. The correct value lies between .0005 mfd. and .03 mfd., and must be determined experimentally, as without this the sparking across the contacts is excessive and would shorten the life of the vibrator.



When correctly "buffered" sparking will be at a minimum as can be seen if the vibrator is not of the sealed type. Also the accumulator current will be at its lowest for a given H.T. output if a meter is available to make the measurements. In default of these methods, the interference may be picked up at the desired strength on a receiver by moving the aerial nearer to, or farther away from, the unit. Then as the condenser is varied it will be possible to judge when the interference is at a minimum. The buffer condenser should be rated at 1,500 volts and a resistance of 3,000 to 10,000 ohms wired in series to limit the current in case of a breakdown of the condenser.

All that now remains is to fit R.F. filters to the input and output of the unit. The input filter should consist of about 50 turns of suitable wire (depending on the current—say 10 s.w.g.), wound on a ½ in. former in series with the vibrator and a 1 mfd. condenser shorted across the input. If this is not successful the size of the choke may be varied. The output filter can be an ordinary R.F. choke from the spare box and a .1 mfd. condenser wired as before. Interference suppression should be carried out in three stages in the following order—thorough shielding of the unit and leads, finding the correct buffer condenser value, and finally the provision of input and output chokes. If adjustment of values, etc., in these stages is methodically carried out it will ensure that the minimum of R.F. interference is radiated and transmitted along leads, and prevent the frenzied insertion and change of components before satisfactory working is achieved. Sometimes it is necessary to connect a .00001 mfd. condenser from H.T. positive to the input positive. A test will show if it is helpful and if so it should be connected from the output pin itself. All the tests mentioned should be carried out with the unit supplying a receiver. Most of the interference will be picked up by the aerial, microphone and gramophone pick-up leads, which should therefore be shielded and kept as far as possible from the unit. It is also advisable to keep the vibrator and accumulator about three feet away from the apparatus if it is supplying and if this is convenient the leads should be made of sufficient length.

**Practical Circuits**

In Fig. 2 is shown a practical vibrator circuit with all the filters included. R.F.C.1 and C.1 form the R.F. input filter, being 50 turns and .1 mfd. respectively. C.2 is the "buffer" condenser of .005 mfd. and R the safety resistance of 5,000 ohms. C.3, a 4 mfd. condenser, is the reservoir, whilst CH (a 30H iron-cored choke) and C.4 (a 16 mfd. condenser) form the audio smoothing filter. The R.F. output filter consists of R.F.C. 2-2.5 mH. and C.5—1 mfd. All condensers are 500 volt working (assuming the output to be 250 volts), except C.2 which is 1,500 volts. The 5 ampere fuse is in case the vibrator sticks. If this happens there will be a low-resistance path through one-half of the transformer primary, which will quickly overheat, causing damage to the insulation. The rectifier may be of any type giving the desired current. To save the heater current a cold cathode gaseous valve or a copper oxide rectifier may be used, but if so the voltage drop will be greater and allowance for this must be made when choosing the transformer.

The alternating voltage output of a vibrator is usually about two-thirds of the input, that is, for a 6 volts D.C. input a 4 volts A.C. output will be produced. Knowing this, the transformer ratio may be easily

calculated by dividing this into the secondary voltage required. To obtain 200 volts from this 4 volts A.C., a step-up ratio of 50:1 would be necessary and a little should be kept in hand to cover losses. The frequency of the vibrator output will be between 90 and 180 cycles—usually 115—instead of the more common 50 cycles, and this, together with the fact that the waveform is more square than sinusoidal, will affect the transformer design. Specially-designed vibrator transformers may be purchased, but if one is not available any mains transformer having an appropriate high voltage winding and two 4 volt secondaries may be used. The two 4-volt secondaries are necessary as only half the winding is used

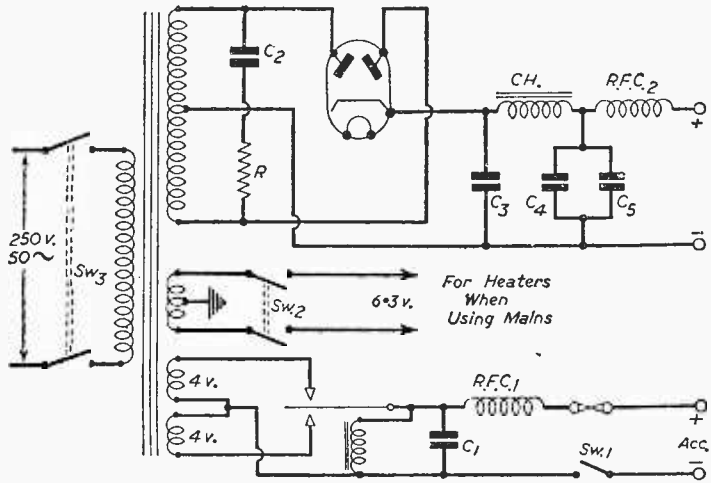

Fig. 4.—A "mains" unit for use on supply mains or with a vibrator.

for each pulse and so they must be joined together with the joint forming the centre tap shown in the diagrams.

Figs. 3 and 4 show two useful developments of this circuit. The type of vibrator discussed before is known as non-synchronous, whilst the type shown in Fig. 3 is a synchronous vibrator. The extra set of contacts make a rectifier unnecessary, as a careful examination will show. When the accumulator leads are correctly connected the centre tap of the secondary is always the H.T. positive, for the two halves of the secondary are switched as well as the primary. Unfortunately, this extra complication reduces the reliability a great deal and it also reduces the maximum H.T. output. A synchronous vibrator will not supply much more than 100 mA., whilst a non-synchronous vibrator will give about double this. A synchronous vibrator needs the same screening, smoothing and filtering as a non-synchronous.

A circuit of the type shown in Fig. 4 may appeal to anyone whose gear is used both indoors and outdoors, as it can be used on mains or vibrator. With S.W.1 closed and S.W.2 and S.W.3 open, it is a vibrator circuit working from an accumulator, while when S.W.1 is open and S.W.2 and S.W.3 are closed, it is an ordinary mains rectifier. A specially-designed transformer used to be available, but anyone who has a spare mains transformer with a 6.3 volts and two 4-volt secondaries can, with a little ingenuity, construct it. If this is done it will almost certainly be found that the output voltage is a good deal lower with the vibrator than when using the mains, due to the difference in waveform and frequency. However, if the secondary leaves plenty of voltage in hand this trouble may be overcome by inserting a resistance in the output positive lead and shorting it out when the vibrator is in use. Although a 6-volt vibrator has been mentioned throughout, they may also be obtained with 12 and 32 volt inputs. In all cases any special maker's instructions should be implicitly obeyed.

# Programme Pointers

In This Article the Disappearance of the Individual From the Concert Platform  
is Discussed by MAURICE REEVE

**T**HIS is the age of the orchestra, consequently of the symphony concert. The instrumental, one-man recital is almost a thing of the past. This is not to be wondered at to any very great extent if we survey the course the concert world has taken in the last twenty years or so.

For various reasons, social, political, economical, as well as cultural and ascetical, the virtuoso of international renown is either of a bygone age, or, if still with us, is so obscurely disguised as to be quite unrecognisable to those of us whose vivid memories of him go back to his heyday. By virtuosos I mean the star performers who, like Paderewski, Kubelik, Sarasate, Caruso, Tetrazzini, to name those who first spring to the memory, did, by training, advertising, presentation, and finally by achievement, monopolise the whole concert season in which they appeared. On the first appearance of their names on the front page of the daily press on Saturdays—the disappearance of which is eloquent testimony to the changed conditions—we used to rush for our tickets. Three or four such concerts, to all but the student or the pedagogue, between September and May were looked forward to, listened to, and recollected with awe, excitement and nostalgia.

## Yesterday and To-day

The difference in the state of affairs yesterday and to-day is hard to realise by those unacquainted with the days now gone, and I cannot attempt to describe it in the limits of this article. It was the age of personality as against modern collectivism. We used to go to hear, for example, Paderewski play Chopin; whereas to-day we go to hear Chopin. "Who played?" "Oh, so and so"—almost as an after-thought. This is an exaggeration as I have put it, taken literally, but it actually describes the tendency of the music-loving public of then and now. Life has so changed that manners and customs—life itself!—were bound to change with it. And with the switch over from individualism to collectivism, from arts and crafts to mass production, and the vast increase in recent years in the number of students who have interested themselves in instruments other than the piano, has come the rush into popular favour of the symphony concert to supersede the solo recital. The concerto (frequently advertised gratuitously as the theme song in popular films) and the symphony now reign supreme. The solo repertoire of the modern soloist is not a quarter of what his predecessors were continuously performing. But his stock of concertos is probably considerably larger. Many of to-day's best known artists have scarcely ever been heard "in recital," whereas those of yesterday were just as seldom billed to appear with orchestra.

Symphonies and concertos, concertos and symphonies! Many of these must be as well known to audiences to-day as were the solo works of Chopin, Schumann and Liszt in the virtuosos' heyday. Which reminds me, talking of virtuosos, of an original but quite untenable theory recently put forward by a French woman resident in the United States, to wit, that it is the *exécutant* and not the creator of music who is the bird that really matters. She holds that a work is nothing but a corpse, a mass of dots, dashes and scragglywigs, lifeless, meaningless and nonsense, until the great man, or woman, sits down at the keyboard or places that frail little stringed box thing under his chin and, by perfect playing of his instrument, brings the work to life.

The true artist is he, who, whilst recognising himself to be the servant of him who created what he sets out to

play, does so, nevertheless, in no cringing or servile manner. Placing his own individuality and personality at the service of the music he renders does not mean that he does not possess these virtues even to an abundant degree. Neither does it mean that he should swank it over the dead departed, and use the creative material bequeathed him merely as a vehicle in which to display whatever nimbleness and fleetness of finger nature and his own industry may have given him.

## The Work of a Critic

That the executive artist is a noble animal, sometimes, and has an important role to play in the musical cosmos, is for all to read in the delightful collection of the concert criticisms, and musical articles generally, of the eminent American critic Richard Aldrich in a hefty tome styled "Concert Life in New York, 1902-1923" (Putnam, 25s.).

All the great ones of the earth are here presented to us during the most brilliant years of their reign, and as they appeared at the height of their fame in the greatest musical centre the world has ever seen. It makes a delightful valed of nostalgic memories, and the way Mr. Aldrich strips the pants off some of those heroes and (forgive me, ladies) heroines of those days—artists whom we would pay homage to these days, and honour as prophets in their own countries—is diverting indeed.

An important and greatly abused part of a concerto is the cadenza—abused by that type of soloist who considers himself a wonderful fellow and much more important than the composer. Originally, and especially in the days of Mozart, the cadenza was an improvisation, or free fantasia, on the preceding themes which the soloist indulged in towards the end of the first and third movements of the work. It was a real improvisation in the fullest meaning of the term inasmuch as it was totally unrehearsed and unprepared. And it was an integral part of the work, the composer working the orchestral part up to an impressive climax on a dominant chord at which the soloist would commence his evolutions and permutations—the movement afterwards concluding with a bit of a kick-up, orchestra and soloist hand in hand.

It must have been a delightfully formal informality in keeping with that age of exquisite manners and courtesies. The modern composer-virtuoso has, however, altered that, and from a thing of delicacy and fascinating charm it now frequently descends to a mere display of glaring vulgarity and bombast in the worst possible taste, composed specially for the occasion.

It is no longer an improvisation. The most beautiful cadenzas are those written by the composers themselves, and which fully preserve the original intention of the thing. The best are Grieg's, Schumann's and Tchaikovsky's—lovely meditations, brilliant and poetic, which might easily have been made up on the spot but which are incorporated into the works and are part and parcel of their structures. Rachmaninov has followed this custom.

## OUR COVER SUBJECT

**F**IFTY members of the Surrey Radio Contact Club recently visited the Mullard Radio Valve factory at Mitcham, in Surrey. Our cover picture shows members of the committee of the club inspecting the working of a glass lathe. This lathe is used in the process of joining the thin necks of cathode-ray tubes to their large glass bulbs. Mr. K. W. Drummond, of the Technical Department of the Mullard factory (second from the left) is answering questions.



*Products of  
Quality & Reliability*

**MAINS TRANSFORMERS  
A. F. TRANSFORMERS  
SMOOTHING CHOKES  
THERMAL DELAY SWITCHES  
POWER RESISTANCES**

*Made by*

**OLIVER PELL CONTROL LTD**  
Telephone - WOOLWICH 1422  
CAMBRIDGE ROW · WOOLWICH S·E·18



**A PLEASURE TO USE**

Away with your old, out-of-date hand drill brace! Get your hand on this new "Leytool" drill and feel the difference in the perfect balance, the comfortable hand grip and the smooth, easy action. Note the steady power produced by the precision-cut gears, and the ease with which it does its job without the need for body pressure. Here is a noteworthy improvement in design on all previous hand drills . . . a precision-made tool without compare.

**PRECISION HAND DRILL**  
If any difficulty in obtaining locally, send your order direct, or write for fully descriptive leaflet. **24/-**

**LEYTONSTONE JIG & TOOL CO., LTD.**  
LEYTOOL WORKS, HIGH ROAD, LEYTON, LONDON, E.10.

*Soldering -*  
**then ELCO**

Eloco design and build soldering irons, machines, melting pots and special furnaces for all soldering needs to suit any voltage from 24v. up. There are many others.



Sole Agents:  
**ELCORDIA LTD.,**  
25 Westminster Bridge Rd., London, S.E.1  
Tel: WAterloo 6502/3

*Let ELCO Solve Soldering Problems*

**HENRY'S**  
5, Harrow Rd., Edgware Rd., W.2.

**THE BEST IN RADIO**

**MIDGET TWO-GANG** .00086, 2in. x 2in. 1 1/2in. Enclosed in Perspex, with Trimmers, 14/6.  
**MIDGET I.F. UNIT**, In aluminium can, 4 1/2in. x 2 1/2in. x 1 1/2in. Comp. 465 k/c/s, Midget I.F. Trans., 1T4 valve, 8 midget Resistors and Condensers, 15/- New and unused.  
**METER RECTIFIERS**, 5 m/a., 7/6.  
**T.C.C. PICOPACKS**, 20 mfd., 12 v., 10 mfd., 25 v., 2/6.  
**P.M. SPEAKERS**, Goodmans & Plessey, 6 1/2in., with Trans. 27/6.

Large Stocks of Guaranteed Components  
Send Stamp for 1947 Price List  
Phone: PADDington 2194.

**RADIO**

**SCOTLAND'S LARGEST STOCKISTS**  
Agents for  
**EDDYSTONE TANNAY & RAYMART**  
Write for Lists



**AMPLIFIER CASES**  
High grade. Black crackle finish with base shield. Excellent value. Chassis 15" x 6" x 2 1/2". Complete **35/-**  
Midget Cabinets. Pastel Shades. Inside sizes: 10 3/4" x 9 1/4" x 4 3/8" deep. **22/6**

**BUCCLEUCH RADIO MANUFACTURERS**  
Melville Terrace, Edinburgh.  
Phone Edinburgh 42803. Grams. Therm. Edin.

**CIRCUITS AND COMPONENTS**  
**"DORSET" SERIES**

**NEW BATTERY SUPERHET 4-VALVE ALL DRY 3-WAVE**  
**A.C. 5-VALVE 3-WAVE SUPERHET**  
**A.C./D.C. 5-VALVE 3-WAVE SUPERHET**  
**A.C./D.C. AMPLIFIER, 6-8 WATTS**  
**A.C./D.C. 4-VALVE T.R.F. MEDIUM WAVE WITH L.W. CONVERSION**

Manuscripts containing 5 or 6 pages of drawings, point to point wiring instructions, etc., 5/- each, post free: Theoretical circuit of superhets with parts price list, 2 1/2d. each.

**WELDONA RADIO ACCESSORIES, LTD., SWANAGE**

**L·R·S IN STOCK!**  
*(Immediate dispatch)*

Stuart Centrifugal Electric Pumps for all pumping purposes, garden fountains, etc.  
Morphy Richards Auto-electric Irons, post free 35/-  
Morphy Richards Cyldon Door Chimes, post free 49/6  
Avomitor D.C. Test Meters, £4. 4. 0  
Avominor A.C./D.C. Test Meters, £8. 10. 0  
(Supplied on Easy Terms if desired)  
Shavemaster 475 comb and cutter sets  
Leaflet of any item on request

**The LONDON RADIO SUPPLY Co.**  
Est. 1925  
**BALCOMBE SUSSEX**



Efficiency at  
HIGH FREQUENCIES

**"AMATEUR RADIO"  
4-BAND COIL UNIT**

A good foundation coil-pack for a simple reacting 5.VV. receiver. Wired complete with switch, trimmers and circuit diagram. Covers 30.9 to 1.44 Mc/s (9.7 to 208 metres).  
Price £11/10/0

**3-GANG CERAMIC Insulation  
TUNING CONDENSER**

capacity 160 p.f., with incomplete S.M. mechanism needing adaptation (condenser with 1 in spindle readily detachable) 14/6

**3-GANG PAXOLIN Insulation  
TUNING CONDENSER**

capacity 60 p.f., with flexible coupler 7/6

**SINGLE 200 p.f.  
TUNING CONDENSER**

paxolin insulation, complete with epicyclic drive ... .. 7/6

**MULTI-RANGE METERS  
(ex stock)**

AvoMeter Model 40 ... ..	£17/10/0
Taylor 85A—20,000 ohms per volt ... ..	£19/19/0
AvoMinor (D.C.) ... ..	£4/10/0
AvoMinor Universal A.C./D.C. ... ..	£8/10/0
Taylor Junior (1,000 ohms per volt A.C./D.C.) ... ..	£8/10/0
Evershed "Wee Megger" ... ..	£11/10/0

**"SATOR" SILVER MICA  
CONDENSERS**

Recommended as precise and stable capacitors. To your own specified assorted values ... .. Price per doz. 4/6

40 PF ... 3%	590 PF ... 1%
307 PF ... 1%	680 PF ... 1%
425 PF ... 1%	700 PF ... 10%
435 PF ... 10%	800 PF ... 1%
580 PF ... 1%	900 PF ... 1%

**WEBB'S RADIO**

14, SOHO ST., OXFORD ST., LONDON, W.1.

Note our SHOP HOURS : 9 a.m. to 5.30 p.m. Sats., 9 a.m. to 1 p.m.

Telephone : GERrard 2089

**RADIO SPARES**

**MAINS TRANSFORMERS.** Primaries 200-250 volts. Secondaries 350-0-350 volts.  
TYPE C. 100 ma. 4v. 6a. 4v. 3a. ... 34/6  
TYPE D. 100 ma. 6.3v. 5a. 5v. 3a. ... 34/6  
TYPE E. 120 ma. L.T.'s as Type C. ... 37/6  
TYPE F. 120 ma. L.T.'s as Type D. ... 37/6  
TYPE H. 200 ma. Three L.T.'s of 4v. 6a.+4v. 3a. Rectifier ... 47/6  
TYPE I. 200 ma. Three L.T.'s of 6.3v. 6a.+5v. 3a. Rectifier ... 47/6  
**Secondaries 500-0-500**  
TYPE J. 200 ma. Three L.T.'s of 6.3v. 6a.+5v. 3a. Rectifier ... 56/-  
TYPE K. 200 ma. Three L.T.'s of 4v. 6a.+4v. 3a. Rectifier ... 56/-  
TYPE L. 250 ma. Three L.T.'s of 6.3v. 6a.+5v. 3a. Rectifier ... 59/-  
TYPE M. 250 ma. Three L.T.'s of 4v. 6a.+4v. 3a. ... 59/-  
**Secondaries 400-0-400**  
TYPE R. 120 ma. 4v. 6a., 4v. 3a. ... 42/6  
TYPE S. 120 ma. 6.3v. 5a., 5v. 3a. ... 42/6  
**SPECIAL UNITS MANUFACTURED TO FRIENDS' REQUIREMENTS**  
Please note Types H to M have 2 of the L.T.'s centre-tapped. Owing to dimensions and weights of these types, kindly add 2/6 for carriage and packing.

**HEAVY DUTY MULTI-RATIO OUTPUT TRANSFORMER**  
120ma. 15 watts, tapping for 6L6s in push-pull, PX4s in push-pull, low impedance triode, low impedance pentode, high impedance triode, 27/6 ; complete instructions with each unit.

**OUTPUT TRANSFORMERS.** Special offer. Multi-ratio 30 : 1, 45 : 1, 60 : 1, 90 : 1, 7/6.

**SMOOTHING CHOKES.** 20 henrys, 20 henrys, 150 ma., 16/6 ; 30, 35 or 40 henrys, 200 ma. or 250 ma., 27/6.

WOULD FRIENDS PLEASE NOTE THAT OWING TO DEMAND FOR OUR TRANSFORMERS AND CHOKES WE HAVE CEASED TO STOCK OTHER RADIO COMPONENTS.

**H. W. FIELD & SON,**  
Cable Works, Station Road,  
HAROLD WOOD, ESSEX

**YOU  
can become  
a first-class  
RADIO  
ENGINEER**

We are specialists in Home-Study Tuition in Radio, Television and Mathematics. Post coupon now for free booklet and learn how you can qualify for well-paid employment or profitable spare-time work.

**T. & C. RADIO COLLEGE**  
NORTH ROAD, PARKSTONE, DORSET.

(Post in unsealed envelope 1d. postage.)  
Please send me free details of your Home-Study Mathematics and Radio Courses.  
NAME .....  
ADDRESS .....  
P. 78.

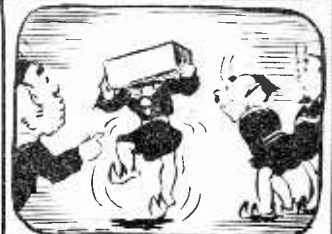

The "Fluxite Quins" at Work  
Cried Oh, "All I wanted to know Was why this old set wouldn't go!"  
Cried the lads, "Is it sound?"  
Whilst you're there, look around.  
"Does the wiring need FLUXITE?"  
grinned OH.

See that **FLUXITE** is always by you—in the house—garage—workshop—wherever speedy soldering is needed. Used for over 30 years in government works and by the leading engineers and manufacturers. Of all ironmongers—in tins, 10d., 1/6 and 3/-.

Ask to see the **FLUXITE** POCKET BLOW LAMP, price 2/6.

To **CYCLISTS** : Your wheels will NOT keep round and true unless the spokes are tied with fine wire at the crossings and SOLDERED. This makes a much stronger wheel. It's simple—with **FLUXITE**—but IMPORTANT.

The **FLUXITE** GUN puts **FLUXITE** where you want it by a simple pressure. Price 1/6, or filled, 2/6.  
**ALL MECHANICS WILL HAVE**

**FLUXITE**  
IT SIMPLIFIES ALL SOLDERING

Write for Book on the ART OF "SOFT" SOLDERING and for Leaflets on CASE HARDENING STEEL and TEMPERING TOOLS with **FLUXITE**, also on "WIPED JOINTS." Price 1d. EACH.  
**FLUXITE LTD. (DEPT. W.P.),**  
BERMONDSEY ST., S.E.1.

# News from the Clubs



Members of the Grafton Radio Society in the club workshop.

**GRAFTON RADIO SOCIETY (official North London Chapter of the British Short Wave League)**

Hon. Sec. : W. H. C. Jennings (G2AHB), 82, Craven Park Road, N.15.

**M**EETINGS every Monday, Wednesday and Friday, 7.30 p.m. Morse instruction (beginners and advance) every evening as above. A club library has been started, and this society now publishes its own monthly magazine entitled "QTH Grafton." Excellent workshop facilities enable members to construct their own apparatus. Technical advice is free. Large comfortable premises include canteen.

The first of the club's transmitters operating under the club's call sign G3AFT attained the distinction of third place in the All-England-Scotland-Wales and Ireland Inter-Club Transmitting Contest on 1.8 Mc/s. Readers who aspire to obtaining their own amateur transmitting licence may receive actual practical experience in operating the club's transmitters under fully qualified operators, and are invited to go and join the second Ops! A new section for VHF enthusiasts is being formed.

The S.W.L. Section is rapidly expanding. A very interesting examination of ex-German radar equipment provided members with new ideas for building H.F. receivers.

The annual fee is three shillings.

**WIGAN AND DISTRICT AMATEUR RADIO CLUB**

Hon. Sec. : H. King, 2, Derby Street, Spring View, Wigan.

**A**FTER a series of successful meetings, during which its membership was steadily increasing, the Wigan and District Amateur Radio Club has now reached the stage when, with a promising future ahead, a clear and practical long-termed policy can be resolved.

In Mr. L. McBlade (G3MG/A) the club has made an excellent choice for the office of president, and, although it is still sadly lacking in financial assets and technical literature, the enthusiasm of all concerned ensures its security in the future. Lectures and discussions of a varied nature have been arranged for alternate weeks during the next few months, and the assembling of a workshop is well on the way to completion. A junior section has been formed to accommodate younger members, and this branch is at present usefully and instructively occupied in the construction of equipment.

**THE WEST BROMWICH AND DISTRICT RADIO SOCIETY**

Hon. Sec. : R. G. Cousens, 38, Collins Road, Wednesbury.

**T**HIS society now meets every Monday, 7.30 p.m. at the "Gough Arms" Hotel, Jowetts Lane, West Bromwich.

On December 2nd, Mr. J. Walker (G5JU) gave an interesting demonstration of the new Eddystone 504 communication receiver.

On December 9th, Mr. A. Bevington (G5KS) gave a film show with sound-projection, the main feature being "The Cathode Ray Oscillograph," which was both instructional and entertaining.

The following are among the two dozen or so members: G5KS, G8NC, G2BJY, G2BXP, G3AGW, G3APZ, G3BCS—and enthusiasm runs very high.

**YORK AND DISTRICT SHORT WAVE CLUB**

Hon. Sec. : G. W. Kelley, 146, Melrosegate, York.

**C**ONTINUED progress is being made and the club now has 14 members, including four licensed amateurs.

Morse classes are held by G5KC, and three members are taking the next Amateur Examination.

New premises are being sought owing to lack of space at present meetings, and new members are welcomed.

**CANNOCK CHASE RADIO SOCIETY**

Hon. Sec. : K. R. Boot (G2FZG), 75, Beech Tree Lane, Cannock, Staffs.

**T**HE committee reports that arrangements are well in hand for the 56 Mc/s Field Day, and Club TX, and they propose to offer the results of their labour at the next meeting.

A "Brains Trust" session was held recently in which all took part: the following were the main points discussed: Parallel v. Push-Pull Class C Amps, Crystal Grinding, Operating Beam Aerials via the A.V.C. Circuit of the Receiver.

A junk sale has been decided for the next meeting, and Mr Morris (G3ABD) has agreed to be auctioneer.

New members will be welcomed, and details of meetings, etc., may be obtained from the above address.

**THE HALIFAX EXPERIMENTAL RADIO SOCIETY**

Hon. Sec. : L. Blagbrough, 39, Fountain Street, Sowerby Bridge, Yorks.

**M**EETINGS of the Halifax Experimental Radio Society are held in the Toc H rooms, 32, Clare Road, Halifax, Yorkshire, on Monday evenings at 7.30 p.m. on alternate weeks.

The society are at present negotiating with the G.P.O. for a transmitting licence so that a station may be built on the society's premises.

Much interesting work is being done by a group of members on the preliminary stages of remote-control of models by radio. It is hoped that the Model Aero Club will co-operate in these experiments.

The Morse class is proving popular among members who are wishing to apply for their licences, and good progress is being made.

All those who are interested in radio are invited to attend, and any information may be obtained from the secretary.

**RADIO-CONTROLLED MODELS SOCIETY**

Acting Sec. : R. Lawton, 10, Dalton Avenue, Whitefield, nr. Manchester. Telephone: WHITEfield 2781.

**O**N December 21st, 1946, a meeting of persons interested in the radio control of models was held in the Y.M.C.A., Manchester. This was the first meeting of its kind to be held on this subject, and it was called for the purpose of arranging closer co-operation between radio-control enthusiasts.

Interested enthusiasts from various parts of the country, representing all parts of the model movement, were present. Several of those present expressed their views on what they thought should be done to bring about the closer working together of radio control of model enthusiasts, and it was eventually decided that a permanent body be set up for the discussion, guidance and development of the radio control of models. This body will in future be known as the Radio-Controlled Models Society, and for the time being meetings will be held monthly in Manchester.

The society will be arranging several lectures in the very near future and hopes to have the well-known radio control of model aircraft enthusiast, Peter Hunt, as its first lecturer. All, whether they be young or old, beginner or expert, are invited to attend the meetings of this new society if they are at all interested in the radio control of models (aircraft, race-cars, speedboats, floats and launches, etc.), so readers who have been doing a little experimental radio-control work are invited to the meetings so that they can do their share towards helping in the development of the movement.

**CHEADLE (STAFFS) AND DISTRICT AMATEUR RADIO SOCIETY**

Hon. Sec. : V. Hughes (G3AVG).

**T**ERRIFIC enthusiasm has been shown and recently Mr. T. Mottram, J.P., Chairman of the Rural Council, performed the opening ceremony of the society's new premises.

Backed by the Rural and Parish Councils, a highly efficient staff of ham operators, a host of other dignitaries, the "shack" and workshops and our greenhouse!

Tea was served by three XYLs full strength. A demonstration, one Vic Scott (G3UB) gained four quip, enjoyed by the crowd via the L.S.

Cheadle claim to have the finest twice the size in the British Isles.

connected to the main supply, clean the room, really simple

# Notes from the Trade

## Scientific Instrument Manufacturers Form Electronics Section

**F**OURTEEN member firms of the Scientific Instrument Manufacturers' Association of Great Britain, Ltd., which in all comprises 88 firms and employs about 60,000 people, have formed an Electronics Section.

The first chairman is Capt. A. G. D. West, director of Cinema-Television, Ltd., and the firms forming the Section are: Baird & Tatlock (London), Ltd.; Baldwin Instrument Co., Ltd.; Cinema-Television, Ltd.; Adam Hilger, Ltd.; Henry Hughes & Son, Ltd.; Kelvin, Bottonley & Baird, Ltd.; Marconi Instruments, Ltd.; Mullard Wireless Service Co., Ltd.; Scophony, Ltd.; Short & Mason, Ltd.; The Sperry Gyroscope Co., Ltd.; Sunvic Controls, Ltd.; Taylor Electrical Instruments, Ltd.; Taylor, Taylor & Hobson, Ltd.

One of the main objects of the Electronics Section will be to further and improve the manufacture of British electronic instruments and apparatus, an industry which has experienced a rapid growth during the last few years.

The Section will encourage the design and manufacture of British electronic apparatus of the highest reliability and accuracy, both in research and industry, thus helping production at home and entering world markets abroad, where there are, at present, first-class opportunities for British goods that live up to the traditional reputation of British skill and craftsmanship.

## Ediswan Booklets

**M**ESSRS. EDISON SWAN ELECTRIC CO. are issuing a series of six booklets on electrons, the first of the group being "Electrons in Diodes."

The purpose of these publications is to provide an introduction to radio by explaining, in simple terms, the operation and functions of the various classes of valves. The books are intended, in the main, for elementary educational purposes, and will be available from the Technical Service Department of the company only upon application by educational establishments.

From the same company comes a neat pocket-size Mazda Valve Equivalents list, consisting of three ivorine sheets eyeletted at the corner so that all sides may quickly be referred to. Measuring 4in. by 3in., this reference aid gives the nearest Mazda equivalents in the Brimar, Cossor, Ever-Ready, Ferranti, Marconi-Osram, Mullard and Philips ranges, and also indicates which Mazda valves are most likely to be available.

## A.I.S. Coil Packs

**T**HE Model 30 Series of Coil Packs, manufactured by Aligned Instruments Services, have been developed to meet the needs of home constructors and to solve the problem of alignment where a signal generator is not available. Obtainable in nine types, five for use in superheterodyne receivers and four for T.R.F. operation, these coil packs are despatched from the factory pre-aligned and tested for gain. An important feature is that separate coils are used for each function, i.e., on three waveband types six coils are fitted, and on two waveband types four. All the coils are of very high "Q" and are fitted with adjustable iron cores. A uniform method of construction is used for all types which, in conjunction with the careful disposition of the component coils, maintains adequate screening between two sections. Connections to the coil packs are clearly indicated on the circuit diagrams which are provided with each and are made to a tag strip at the rear. In addition colour coded leads are provided for connection to the gang condenser. By means of these improvements the construction of very efficient receivers is simplified and the manufacturers are able to

supply circuits for complete receivers utilising them. Two very popular types are the Model 30 and the Model 30D, the former a superheterodyne type and the latter a T.R.F. type, each covering 16-50, 200-550 and 750-2,000 metres. The prices are £2 2s. and £1 15s. respectively. A Tuning Heart Unit, utilising the Model 30 Coil Pack, is now available and is supplied completely assembled and tested. This employs a 6K8G, 6K7G and 6Q7G, and the audio output is suitable for feeding into a quality amplifier. The unit requires 250 volts at 20 mA. and 6.3 volts at .9 amp., this being

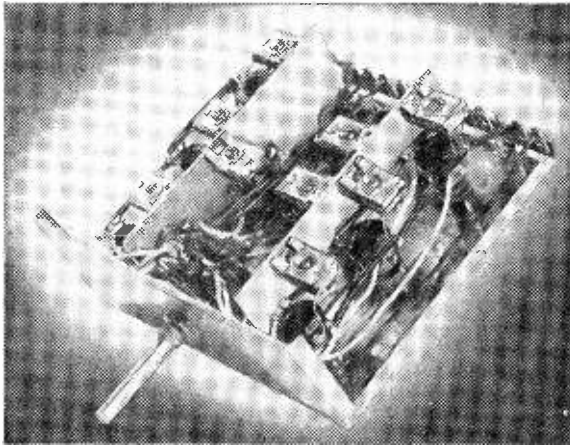

*This is the Model 40 Coil Pack manufactured by A.I.S.*

fed into a socket at the rear. The price is £8 ros., including purchase tax.

A further set of coils, known as Model 40, incorporates an H.F. stage, and is illustrated on this page. The price of this unit is £3 3s.

## New G.E.C. Audio-Frequency Millivoltmeter

**T**HOUGH designed primarily for the measurement of voltages at audio-frequencies (25-20,000 c.p.s.) in high-impedance circuits such as occur in communication equipment and in sonic frequency amplifying apparatus, the G.E.C.'s new audio-frequency millivoltmeter is ideal for use in A.C. electrical power engineering. The accuracy is approximately 3 per cent. full scale reading on all ranges with true sine wave output.

The circuit comprises a two-stage amplifier with negative feedback which stabilises the gain at 100. This is followed by a diode rectifier and a D.C. amplifier which has a degenerative action and so eliminates errors due to change in valve parameters. The amplifier is connected in a bridge circuit and the out of balance current indicates the voltage.

Although the instrument reads the peak value of the wave, it is calibrated in R.M.S. volts, assuming a sinusoidal input. The short-term overload capacity is extremely high and even if full mains voltage—say 440 volts—is accidentally applied to the lowest voltage range (15 millivolts) no damage will result if the instrument is disconnected quickly. The highest overload which can possibly be applied to the moving coil is approximately 100 per cent., and this is not sufficient to burn out the coil even if continued indefinitely.

The voltage ranges are 15, 50, 150 and 500 millivolts and 1.5, 5, 15, 50 and 150 volts. Frequency range is 25 cycles to 20 Kc/s and the consumption is about 50 watts. It operates from 200 to 250 volts, 40 to 100 c.p.s. supply.

**More Bargains for you!  
ELECTRADIX RADIOS**

**SUPERSEDERS.** H.T. Battery Super-seeder D.C./D.C. for Radio Receivers, 6 volt input, 110 v. 15 m.a. output; 12 volt input, 230 v. 30 m.a. output; last for ever and cost little more than a few months run on one H.T. battery; 5 1/2 in. x 3 1/2 in. x 3 1/2 in., ball bearings, model finish, 31/510. **TELEPHONES** For House and Office. Constructors Parts for Your Own Set-up.

**WALL TELEPHONE SETS.** Bracket Mike, vertical or horizontal, 10/-; Transformer and Condenser for same, 5/-; Magneto Bell fitted, 5/-; Switch Hook and Contacts, 2/6. Walnut Cabinet, 8 in. x 6 in. x 3 in., fitted terminals and connections, 5/-; Two L.R. Watch-pattern Earphone, 8/-; Hand Magneto Ringer, 10/-.

**SET AS ABOVE 30/- or 50/- PER PAIR.**

**BELLS.** Large Tangent I/C bell, 6in. gong, 230 volts A.C. New condition, 42/-; Circular A.C. bells, 5/8 volts, 6/6. House Bells, battery type, 2 1/2 in. gong, 5/9. Magneto bells, 5/-; Twin Bell Wire, 15/- per 100 yards. Bell Transformer, 230 v. 3.5.8 A.C., 7/6.

**SWITCHES.** Dewar key panel type 8-pole C.O. flush fitting, 5/-; Yaxley 3-pole 3-way, 3/6; 8 pole 1-way, 3/6. D.P.C.O. toggle switch 250 v. 1 amp., flush panel, 3/3; 8-way Lucas switch box, 3/6; 6-way 3/-; **DIMMER RHEOSTAT SWITCHES.** 1 ohm to 0 and off up to 3 amps., for regulation of 6 v. A.C./D.C. Charger subcircuit regulators. Model speed control, etc., 1-hole fixing and extra bracket for rack. Hollow knob has base for miniature bulb to glow when "ON"; new Aetna Co., U.S.A. Price 2/6 each. Postage 6d.

**BUTTON MICROPHONES** provide interesting experiments for making outside listeners, sound transmission, etc. These ex-G.P.O. Voice Units are under lin. diam., filled carbon granules and fitted mica diaphragm, 3/6 each. Special Transformer and Condenser, 5/-; Instruction Leaflet with each Button. G.P.O. Mike insets, 3/6. Special armoured inset, latest pattern, 5/-; useful for making a Home Broadcaster.

**RELAYS.** G.P.O. 1,000 ohms 2-S.P.C.O., 5/-; 500-1,000 ohms, 2-make, 5/-; 30 ohms 2-make 2-break, 5/-; Telephone type 2-coil polarised S.P.C.O. 325 ohms, 5/-; Siemens high speed keying relays two 500 ohm coils, 7/6 ea. Siemens slugged 200 ohms 1-break S.P.C.O., 5/-; We have a large stock of Relays for immediate delivery; send us your enquiries.

**TERMINALS** and Terminal Blocks. Belling Lee heavy bakelite terminals, 1/- each, or 10/- doz. Smaller model Belling Lee, all metal plated, 7d. each, or 5/- dozen. R.A.F. 10-way Terminal Blocks, bakelite case, 2/9.

**PLUGS and SOCKETS.** Red and Black insulated, single socket with plug, 1/3 pair; 2-way Radio plug and socket for table mounting, 1/-; 2-pin plug and socket for cord connections, 2/-.

**MULTIPLE CONNECTION STRIPS** of soldering tags, telephone type, moulded mounting, 60-way, 3/6. R.A.F. 10-way telephone terminal strips, bakelite, 2/9.

**PARCELS.** 7lbs. useful oddments for the junk box. All clean and dismantled from Government and other surplus apparatus, 7/6 post free.

Please include postage for mail orders.

**ELECTRADIX RADIOS**

214, Queenstown Road, London, S.W.8  
Telephone: MAcGaulay 2159

**THESE ARE IN STOCK**

**THE RADIO TUBE VADE MECUM.** By P. H. Brans. 12/6, postage 6d.

**RADIO TROUBLESHOOTER'S HANDBOOK.** By Alfred A. Ghirardi. 36/-, postage 10d.

**PRACTICAL WIRELESS SERVICE MANUAL.** By F. J. Cunnin. 8/6, postage 6d.

**WIRELESS COILS, CHOKES AND TRANSFORMERS.** By F. J. Cunnin. 6/-, postage 4d.

**RADIO ENGINEERING.** By F. E. Terman. 30/-, postage 8d.

**RADIO ENGINEERING HANDBOOK.** By Keith Henney. 30/-, postage 8d.

**FOUNDATIONS OF WIRELESS.** By M. G. Scroggie. 7/6, postage 4d.

**RADIO UPKEEP AND REPAIRS.** By A. T. Whitts. 7/6, postage 6d.

**THE SUPERHET MANUAL.** By F. J. Cunnin. 6/-, postage 4d.

**RADIO TECHNIQUE.** By A. G. Mills. 12/6, postage 5d.

**CLASSIFIED RADIO RECEIVER DIAGRAMS.** By E. M. Squire. 10/6, postage 4d.

**THERMIONIC VALVE CIRCUITS.** By D. Williams. 12/6, postage 6d.

**LUMINOUS TUBE LIGHTING.** By Henry Miller. 10/6, postage 4d.

**THE WIRELESS WORLD VALVE DATA.** 2/-, postage 2d.

We have the finest stock of British and American radio books. Write or call for complete list.

**THE MODERN BOOK CO.**

(Dept. P.12)

19-21, Praed St., London, W.2.

**4 VALVE A.C. MAINS REGENERATIVE SUPERHET RECEIVER FOR ULTRA SHORT-WAVE RECEPTION, 2.5-66mc/s. 4.5 to 12 meters.**

This has been designed to meet the many requests we have had for a set of this type. The model we constructed ourselves has been given exhaustive tests, and we can vouch for a first-class range and performance. The complete circuit is available at a nominal charge of 6d. per print, and we recommend the following valves and components for the construction of the set:

4 Denco coil formers (Polystyrene); 2 Denco coil bases (Polystyrene); 1 Weatite PA2 coil; 2-10 Henry 4-0 ma. L.F. chokes; 1 Gardner R106 mains transformer; 1 Utility micro-cursor dial, 100:1 ratio; 1 Ray-mart TXO dial, 0-100 degrees; 1 Black fluted knob; 1 Eddystone insulated adjustable mounting bracket; 1 Eddystone flexible coupler; 1 Panel bush, 1 in.; 1 Jack socket; 2 Denco Polystyrene feed through insulators; 1 voltage adjustment panel; 3 international octal valveholders; 2 Eddystone 60 pf. microcondensers; 1-8 x 8 mfd. Block condenser; 1-4 mfd. Block condenser; 1-30 pf. Trimmer; 9 Paper tubular condensers; 10 1-watt Resistors; 1 -1 watt Resistor; 1 -30,000 ohm volume control with switch.

Valves for the above: 6K8-14/- including tax; 6J7-12/10 including tax; 6F6-12/10 including tax; 6U6-17/- including tax. Aluminium chassis, ready drilled if necessary, with screens. All necessary nuts, bolts, wire, solder, tags, etc., for assembling. **ALL THESE VALVES AND COMPONENTS CAN BE SUPPLIED FROM STOCK.** The inclusive price of the components only is 47/5s. 6d. post free. Valves where required, 22/10s. 8d. extra.

Or we can supply all the valves and components as above, and construct and air test the set for you, for an inclusive cost of 120s. We already have many orders in hand, so to ensure quick delivery, post us your order without delay.

We can send against C.W.O. or C.O.D., whichever best suits you.

VALLANCES, 144, BRIGGATE, LEEDS, 1.

**J. BULL VALVES & SONS**

*The "Tube" Station*

**RADIO VALVES.** British and American from 5/10, all at official list prices, not inclusive since 1940.

**BRIMAR.** 1D8, 5B, 250A, E86, 6G8, 6K6, 6K7, 6S47, 6SN7, 6T7, 6V8, 7B8, 7B7, 7B8, 7C6, 7D5, 7Y4, 8D2, 9D2, 10D1, 11D3, 11D5, 12S87, 40D2, 2524, 42.

**COSSOR.** 4TPB, 4TSP, 18SPA, 41MP, 41MPT, 41MRC, 42mp Pen, 42-OT-DD, 42PTB, 203THA, 210DC, 210LF, 2201PT, 2201F, 220PA, 220TH, 506BU, 807, DD14, MP1PEN, MS/PEN, MS/PENB, MVS/PEN, MVS/PENB, OM6, PT4.

**HIVAC.** -XD, XH, XL, XP, X8G.

**MARCONIOSIAM.** -B30, D41, D42, D63, DA30, DL63, DL74M, DN41, GTIC, GU50, H30, H63, HA2, HD24, HL2, KT2, KT24, KT33, KTH1, T61, K63, KT66, KT74, KT95, KT61M, KTW33, KT244, KT263, KTZ73M, L63, LP2, MH41, M14, MS4B, MS14, N14, P2, PT26H, PX25, QP21, S23, U10, U16, U17, U18, 20 U31, U50, U52, U74, VMP4G, VMS4B, W21, W42, X1, X4H, X61M, X63M, X65, X71M, X72, Z14.

**M.A.Z.O.A.** -AC2PenDD, AC5Pen, AC5PenDD, AC6Pen, ACHL, ACHLDD, AC1P, AC2P, AC3P, AC4P, ACV1, ACV2, D1, DD207, DD620, HL21DD, HL23, HL231DD, HL41, HL41DD, HL421DD, HL139DD, HL4DD320, P41, P42, P43, P44, P45, P46, P47, P48, Pen383, Pen4531D, PenDD4020, QP25, QP230, SG215, SP22, SP41, SP2220, TH41, TH233, TH2321, TP22, TP25, TP26, TP2620, U403, U405, U46, U47, U48, V914, VP23, VP41, VP133, VP1322.

**MULLARD.** 2D4A, 2D18C, 5Y3, 6C5, 6B6, 6J7, 6L8, 607, 6R7, 16V4, AZ1, AZ31, CCH35, CL33, CY1, CX31, DAC32, DF35, DF51, DK32, DL35, DW2, DW4, 600, EA50, EB34, EBC3, EBC33, ECC31, ECH35, EF6, EF9, EF36, EF39, EF750, E82, EL2, EL3, EL32, EL33, EM34, EM35, FC13, FW4/500, HL13c, 1W4, 950, 1W4/500, KBC32, KF35, KK32, KL35, Pen4DD, Pen4VA, Pen428, Pen4A, Pen4H, PM2, Pm2HL, Pm12M, Pm202, QP23B, SP184, SB4B, SP13, SP15, PDD2A, TDD18A, TH2, TH4H, TH41C, TH30C, TTH, UR3C, VP4, VP4A, VP4B, VP13A.

**TUNGSRAM.** -524, 6B8, 6J5, 6TH8, 6V6, 6X5, 25Y3, 807, APP4c, APP4G, CB25S, DD13, DD818, ECH2, EP12, EB2, EL2, EL3, EL32, EL13, F13, F15, HP10H, HP1118, HP20H, HP218, HR210, MH118, MH4105, LD210, LL28, LP218, P16c, P16E, SP28S, SP4B, SP4S, SS210, VP4S.

**AMERICAN.** -024, 1A4, 1A5, 1A7, 1B4, 1B5, 1C5, 1D7, 1P5, 1E7, 1P4, 1P8, 1F6, 1F7, 1H4, 1H5, 1H6, 1L4, 1J6, 1LN5, 1N5, 1R5, 1S5, 1T4, 1T5, 2A6, 2A7, 2B6, 2B7, 5U4, 5V4, 5Y3, 5Z3, 5Z4, 6A4, 6A6, 6A6E, 6A8, 6A6E, 6B7, 6B8, 6C5, 6C6, 6D5, 6D6, 6D8, 6E6, 6F5, 6F6, 6G5, 6H5, 6J5, 6J7, 6J8, 6K5, 6K6, 6K8, 6L5, 6L6, 6L7, 6N7, 6A7, 6F6, 6G7, 68A7, 6SCT, 6SF7, 6S7, 6SN7, 6T7, 6U5, 6V6, 6X5, 6Y5, 7A6, 7A7, 7B5, 7B6, 7B7, 7B8, 7C5, 7C6, 7H7, 7S7, 7Y4, 10, 12A, 12AS, 12A6, 12B7, 125, 12K7, 12K8, 12Q7, 12S7, 12F7, 12S7, 12S17, 12Z3, 12Z5, 14A7, 15, 17, 18, 20, 22, 25Y3, 25Z4, 31, 32, 33, 34, 35Z5, 37, 38, 42, 46, 48, 49, 50, 53, 59, 57, 59, 71A, 77, 79, 80, 81, 82, 83, 89, 807, 954, 955, 956, 117Z6, 1250A, 9001, 9002, 9003, 9005, and 101 more types.

Order C.O.D. above listed numbers or equivalents (subject to stock). Please enquire for any valve you require, even if not listed. We may have it. Old and new types are arriving daily.

**THIS MONTH'S SPECIAL**

**PETER PAN MIDGET RADIO KIT**, complete from cabinet (black and white plastic) to the last screw: All components and valves guaranteed, valves, medium and long waves, A.C./D.C. Printed circuit diagrams and full instructions. £11/9/7, post free. C.O.D. or remit with order.

**J. BULL & Sons (P.W.)**  
245, High Street,  
Harlesden, N.W.10

# EDDYSTONE EQUIPMENT RACKS

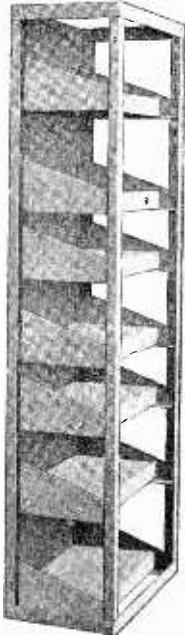

This rack comprises uprights, top and bottom frames, top plate, side brackets, front panel and chassis. The dimensions conform to international standards, the chassis measuring 17" x 10" x 2", the uprights 63" in length. Holes punched out in all members to facilitate assembly. Mild steel construction. Finish is glossy black, except panels, which are ripple black on the outside. Panels available in four sizes, ranging from 3 1/2" to 10 1/2". All items sold separately.

- Cat. No. 615/642, Pair front and rear Vertical Channels ... Set 50/-
- Cat. No. 617, Standard Chassis 11/-
- Cat. No. 616, Pr. of Frames (top and base) ... Pr. 21/-
- Cat. No. 636, Top Plate ... 10/-
- Cat. No. 618, Pair of Angle Brackets ... Pr. 10/6
- Cat. No. 622, 3 1/2" Panel ... 7/6
- Cat. No. 621, 7" Panel ... 9/3
- Cat. No. 620, 8 1/2" Panel ... 10/-
- Cat. No. 619, 10 1/2" Panel ... 10/9

It would be appreciated if private buyers will note that we supply only through Registered Retailers. We regret we cannot supply direct.

Write for Address of your nearest Eddystone Agent.

# EDDYSTONE

"Puts Perfection into Performance"

STRATTON & CO., LTD.,  
Birmingham, 31.

OFFERED AT A FRACTION OF COST!

EX-GOVT.  
1 1/2 METRE 10 VALVE  
SUPERHET UNITS



CIRCUIT COMPRISES  
1 Pre. amp., Osc.  
Mixer, 5 I.F., Det.,  
Video Amp. I.F.  
Frequency 12.  
Megs. Band-width  
4 Megs. Co-axial  
input and output  
sockets.

7  
GNS.

Carriage paid.  
Cash with  
Order. Special dis-  
counts to Trade,  
Radio Societies,  
etc., in lots of 25  
or more receivers.

IDEAL FOR CONVERSION INTO  
TELEVISION RECEIVERS  
OR 90 MEGS. F.M. RECEIVERS

External source of L.T. and H.T. supply is required. Manufactured to stringent Government specification by such famous makers as R.G.D., Pye and Murphy. Brand new and unused and in manufacturers' sealed cartons. Complete with 10 Mazda valves.

WIRELESS INSTRUMENTS  
(LEEDS) LTD.  
54-56 THE HEADROW, LEEDS, 1

## COULPHONE RADIO

Prop. C. COULBORN: G3AJM  
"THE RETURN OF POST MAIL  
ORDER SERVICE."

Note New Address:  
58, Derby Street, Ormskirk,  
Lancs.

New Goods Only—C.O.D. or cash with order. All orders over 5/- post free. A few of our lines are listed below, send 2d. stamp for latest 18-page catalogue.

Valves.—All B.V.A. and Tungstam, including American.  
Eddystone short wave gear. 2d. stamp for catalogue. S.W. Manual 2/6  
Mains Transformers.—Interleaved and Impregnated. For 200/250 v. mains, 300 v. 60 mA. 4 v. or 6 v. L.T.'s, 19/8; 350 v. 100 mA. 4 v. or 6 v. L.T.'s, 25/-; 450 v. 200 mA. with three L.T.'s, 4 v. or 6 v., 42/6.  
Smoothing Chokes.—40 mA. 5/-; 60 mA. 6/-; 90 mA., 7/-; 100 mA., 12/6; 250 mA., 21/6.  
Speaker Transformers. — Midget Power/Pen. 40 mA., 5/6. Std. size Push-Pull Universal, 60 mA., 6/6; Heavy Duty, P.-P. 21/- Extra H.D. 100 mA., 32/6.

Mains Dropper Resistors, with feet and two sliders. 2 amp. 4/3; 3 amp., 4/6. Resistors 1w. 6d; 1w. 9d.  
Loud Speakers P.M., 2 1/2in. 25/-; 3 1/2in. 28/8; 5in., 20/6; 8in., 23/6; 10in., 33/6.  
Witch Trans., 8in., 29/6; 10in., 39/6.  
Weymouth Tuning Coil Pack.—Completely wired. Short, Medium and Long Wave Superhet type for 465 kc/s. I.F., 36/6. Midget I.F.T.'s 18/9.  
Line Cord, 60/70 ohms per foot. 3 amp. Note price per yard, 2-way, 1/6; 3-way, 1/9.

Tuning Condensers.—Midget 2-gang .0005 with 2-speed drive, 16/6.  
Aluminium Chassis 3in. Deep. 10in. x 8in., 3/6; 12in. x 9in., 9/6; 14in. x 9in., and 16in. x 8in., 10/6; 20in. x 8in., 12/6.  
EXCLUSIVELY MAIL ORDER



present their latest  
30 TUNING HEART &  
MODEL 40 COIL PACK

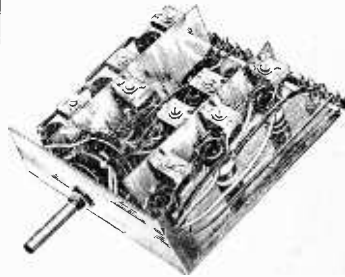

### MODEL 40 COIL PACK

The latest development in coil packs including an H.F. stage. Uses 9 iron-cored coils in All-wave Superhet circuit. Wavebands covered—15-50, 200-550, 750-2,000 metres. For use with 465 kc/s I.F. Aligned and gain tested before dispatch. Designed by the creators of the now famous 30 coil pack. Price 3 gns.

Send 1d. Stamp for "P.M." List

### MODEL 30 TUNING HEART

An all-wave superhet unit incorporating the famous 30 Coil Pack, suitable for use with any amplifier. Employs 6K8G, 6K7G and 6Q7G valves, and covers all stages from Aerial to first A.F. amplifier. Wavebands covered—16-50, 200-550, 750-2,000 metres. Requires 250 volts at 20 m.a. and 6.3 volts at 0.9 amps. Price 28 10s.

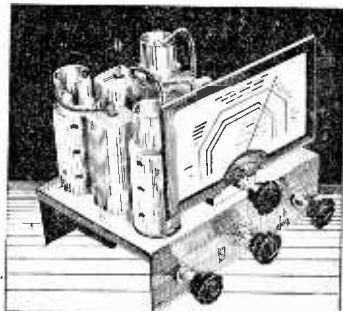

ALIGNED INSTRUMENTS  
SERVICES 1, COLWORTH  
RD., LEYTONSTONE, E.11



# Impressions on the Wax

## Review of the Latest Gramophone Records

### Guide to the Orchestra

**T**HIS month, Dr. Malcolm Sargent, conducting the Liverpool Philharmonic Orchestra, has recorded an interesting set of records of Variations and Fugue on a Theme of Purcell, by Benjamin Britten. Although this work is called "The Young Person's Guide to the Orchestra," people of any age who are interested in music which is both new and original will appreciate the wit and imagination of the composition, and the illustration it gives of what each individual instrument contributes and how it fits into the orchestra as a whole. Benjamin Britten shows first the full orchestra playing a theme of Purcell, then takes the orchestra to pieces and shows the four families of the instruments playing the theme followed by the individual instruments playing variations on it. Finally, in a brilliant fugue, he puts the full orchestra together again. Benjamin Britten is still in his early thirties, yet already has established himself as one of a very select group of young composers to whom we look for work of distinction. These records—Columbia DX1307-9—will be appreciated by those who already know and enjoy his music, and will be an admirable introduction to it for those who do not. A leaflet is presented with each set of records giving a commentary, prepared by Eric Crozier for the music score and reprinted by permission of the publishers. This can be read, if desired, during the playing of the records.

Another interesting set of records is Tchaikovsky's "Symphony No. 5 in E Minor," played by the Philharmonia Orchestra, conducted by Paul Kletzki on Columbia LX969-74.

### From the Films

**A** FILM which has recently been generally released and was seen by the King and Queen at the Command Performance is featured in the new Columbia recording. The Prelude from the film, *A Matter of Life and Death*, has been recorded by the Queen's Hall Light Orchestra, conducted by Charles Williams on Columbia DX1320. On the reverse side of this 12in. record the same orchestra play the theme from the film, *This Man is Mine*. It is a record that is well worth hearing.

Compton Mackenzie's novel of the Edwardian period has made a spectacular film with some very attractive music. The scenes have been very carefully designed to reproduce the authentic atmosphere of the early nineteen hundreds. On Columbia DB2225 the Two Cities Symphony Orchestra gives us the "Intermezzo" from the film, written by Nicolas Brodsky, who is expert in good music for the screen. "Carnival" is a Two Cities production, and the performance by their own orchestra, conducted by Charles Williams, gives an authoritative interpretation of the music.

*Blue Skies* is notable in many ways—a capital supporting cast, showmanlike staging and presentation and a cavalcade of Irving Berlin numbers, including his latest "You Keep Coming Back Like a Song." The generous selection on Columbia DB2273, played by Peter Yorke and his Concert Orchestra, includes "White Christmas," whose vogue was at its height four years ago, and of course the latest Berlin hit mentioned above.

### Conductor Composer

**E**RIC COATES must be one of the most successful writers of tuneful, well-wrought music in England to-day. He is a true Londoner, and some of his most strikingly successful music has been inspired by the capital. He has a full command of orchestration, whether in the whimsical vein of the famous "Three Bears—Suite" or in his vigorous marches. This month he conducts the London Symphony Orchestra in the "Three Bears—Suite" on Columbia DX1217.

The great violinist Fritz Kreisler composed fairly extensively for his own instrument, and many delightful short pieces have come from his pen. Two of his pieces "Liebesleid" (Love's Sorrow) and "Liebesfreud" (Love's Joy) are this month played by Andre Kostelanetz and his Orchestra on Columbia DX1321. The success won by Kostelanetz and his players in the United States has been phenomenal, and his recent concert over here, in the Albert Hall, was a great event in the season. Here then are two fresh examples of the eagerly looked for "Kostelanetz touch."

### H.M.V.

**O**UTSTANDING in the latest H.M.V. recordings is Verdi's "Requiem Mass," recorded in the Royal Opera House, Rome, with the orchestra and chorus of the Royal Opera House, Rome, conducted by Tullio Serafini on H.M.V. DB6210-19. Brahms was one of the first to acclaim Verdi's "Requiem": "It is a work of genius," he remarked. Posterity has endorsed his view, and the "Requiem" is now securely set among the great choral masterpieces of the world. Its main characteristic is passionate sincerity expressed in passages of high drama, and the almost operatic effect in some places, frowned at by a few critics, is simply due to the fact that Verdi put his inmost heart into opera, and where he is patently sincere he cannot very well avoid writing in his own chosen way. The cast in this recording includes Ghigli, Pinza, Stignani and Maria Caniglia with the orchestra and chorus already mentioned.

"Concerto for Pianoforte and Orchestra," by Delius is also an interesting recording this month. It has been made by Benno Moiseiwitsch and the Philharmonia Orchestra conducted by Constant Lambert on H.M.V. C3533-5. As it is impossible to give a detailed description of all the new releases here are a few that will appeal to all music lovers. "Overture Le Corsaire," Op. 21, recorded by the Royal Philharmonic Orchestra conducted by Sir Thomas Beecham, Bt., on H.M.V. DN6357; "Oboe Concerto," Parts I and II, recorded by Evelyn Rothwell (oboe) and the Hallé Orchestra conducted by John Barbirolli, on H.M.V. C3540; and finally "The Wine Song," sung by Webster Booth coupled with "I'll Change My Heart," sung by Anne Ziegler on H.M.V. B9518.

### Dance Music

**A**LL the latest hit tunes played by famous dance bands have been recorded this month and readers can take their choice from the following: "Ma! Lindy Lou" and "The Good Lord's Satisfied," sung by Archie Lewis with the Gerald Strings on Parlophone F2191; "Somewhere in the Night" and "I Love an Old Fashioned Song," on Parlophone F2192, and "I Love You for Sentimental Reasons," coupled with "I Guess I'll Get the Papers and Go Home," on Parlophone F2193, all of which are played by Gerald and his Orchestra; "Paul Jones," played by Victor Silvester and his Ballroom Orchestra on Parlophone F11339; and finally "Tin Pan Alley Medley—No. 76," played by Ivor Moreton and Dave Kaye on two pianos, with string, bass and drums on Parlophone F2185. These last two records introduce all the popular tunes of the moment.

## WIRE AND WIRE GAUGES

By F. J. CAMM. 3/6, or by post 3/9 from  
George Newnes, Ltd., Tower House, Southampton St.  
London, W.C.2.

### MARCONI MINIATURE COMMUNICATIONS RECEIVERS

A complete 5 valve AC/DC and battery communications receiver, measuring only  $2\frac{1}{2}'' \times 3\frac{1}{2}'' \times 9''$ . Frequency coverage 100 Kcs-15 Mcs. (20-3,000 metres) in 4 bands. Valve combination 4 1T4 and 1R5. Supplied ready for use with battery, pair headphones, set of 4 plug in coils, aerial and earth.

This set was designed for use by the resistance movements, and is packed in a metal container ready for dropping by parachute. Only £8 19s. 6d. (carriage and packing 1s. 6d.). BRAND NEW AND UNUSED

We have also the miniature AC/DC power pack ( $2\frac{1}{2}'' \times 3\frac{1}{2}'' \times 7\frac{1}{2}''$ ) which will make this set usable on AC or DC (100-250v.) priced at £3 each. Spare valves are available priced at 15s. each, or a set of 5 for £3 5s.

Send stamp for our comprehensive catalogue.



STEPNEY GREEN 24 NEW RD.  
2 7 6 0 LONDON E.1.

### LASKY'S RADIO

8 MFD. CONDENSERS, 150 v.v. Tubular Cardboard, 1/11 : 8 mfd. Condensers, 500 v.v. Tubular Aluminium Can. 4/- : 8+8 mfd. Condensers, 500 v.v. Tubular Aluminium Can. 5/6 : 16 mfd. Condensers, 500 v.v. Tubular Aluminium Can. 4/6.  
VALVE SCREENING CANS. Solid Construction to fit International Octal Valves. 2/3 each.  
WAVE CHANGING SWITCHES. Yaxley Type. 4 pole 2 way 2 bank. 2/6 each : 2 pole 5 way 1 bank. 2/3 each (midget) : 4 pole 3 way 1 bank. 2/11 each (midget).  
CAR RADIO ANTENNAE. 8ft. Telescopic. 4 section, side fixing, complete with screened lead-in cable. Canadian manufacture. 25/- each.  
TELEVISION AERIALS. Indoor Type. Loft fitting. 30/- each (callers only).  
8in. P.M. LOUD SPEAKERS, 21/- each, less Trans. ; 6in. P.M. Loud Speakers, 29/6 each, with Trans. ; All other sizes 2/1n. to 12/1n.  
CONDENSERS. 350/450 volts working. .1, .01, .05, .02, .001, .005, .0001, .0005. 6/- per doz., 5/76 per gross.  
COMPLETE SET OF CIRCUITS, and instructions for building All Wave Sheet. 2/6 each, post 1d.  
MIDGET OUTPUT TRANSFORMERS. Power and Pentode. 4/10 each. Midget Chokes, 360 ohms. 4/10 each.  
BRASS SPINDLE COUPLERS. 1in. with 2 grub screws. 6d. each, or 5/- per doz.  
LONG AND MEDIUM WAVE COILS. T.R.F., A.E. and H.F. High gain. Complete with circuit. 8/6 per pair. All other types of coils in stock. All types of Wearite P Coils in stock. 3/- each.  
I.F. TRANSFORMERS. High quality air spaced trimmers. 465 kc/s, 7/6 each, 14/- per pair. All goods carry our unconditional guarantee. Send 1d. for our Current List and Bulletin.  
Terms : Cash with Order. Pro Forma or C.O.D. (over £1). Post Extra.

### LASKY'S RADIO

370, Harrow Road, Paddington, W.9 (Opposite Paddington Hospital).  
Telephone : Cunningham 1979.  
Hours : 9.30-5.30. Open all day Saturday. Closed 1 o'clock Thursday.

## LONDON CENTRAL RADIO STORES

Ex-Govt. High Speed Relays with platinum contacts. D.C. resistance of coil 500 ohms. Enclosed in dust-proof brass box. Size 3in. x 1 1/2in. x 1in. New. 6/6.

"Westectors." Type W.X.6. New. 1/6 each.

Moving Coil Mike Inserts. Coil 30 ohms. 5/- each.

Ex-R.A.F. Tubular Bakelite Electrolytic Condensers, 8 mf., 150 volt working. 2/-.

Tuning Condensers. Single .0005. Best quality, air spaced, 1/4in. spindle. New. 3/6 each.

Condensers. Split Stator 2-gang. 10/6.

Yaxley Type Switches. 2-pole, 6-way. 2/6.

Vibrators. 12 volt, 4 pin. New, with holder. 9/6 each.

Wire Wound Pots. Resistance 400 ohms and 25,000 ohms. 1/9 each.

We have a stock of R.A.F. Valves, every one guaranteed. EF50, BL63, X65, MHL D6, SP41, EBC33, KTW62, 8D2, EB34. All at 5/6 each. For 6 at 4/6 each. Ask our price for three, six and twelve dozen lots.

Electro Magnetic Counters. 500 ohms coil. Counting up to 9,999. Operating from 25v. to 50v. D.C. Many Industrial and Domestic applications. (S.H. and G.P.O., all perfect). Postage 9d. 5/6.

Press Button Units, 4 or 5 way, with Buttons, 4/6 ; 7 or 9 way, with Buttons, 5/6.

Ex-R.A.F. Type 1154 Transmitters. Complete with 4 valves. Frequency coverage : 500 kc/s, 200 kc/s, 10 mc/s, 3 mc/s, 2.35 mc/s, 8 mc/s, 2.5 mc/s. Power input 1,200 v., 200 m/a. H.T., 6v. 4 amp. L.T. Chassis size 15in. x 13 1/2in. x 8 1/2in. In Metal Cabinet. Supplied in strong wooden case, with metal bound corners and carrying handles. Easily adapted for amateur use. Price, less Power Pack, £7.  
Without Valves and Meters. 30/-.

Ex-Army No. 58 MK1 Trans-Receiver. Frequency Range 6-9 mc/s. Complete with 8 valves, one pair phones and microphone. Carriage Paid, £5 15s.

23, LISLE ST., LONDON W.C.2

GERrard 2969

### TRANSMITTER-RECEIVERS

(Type 58 Mk. 1\*)

The most modern version of that very fine Canadian set, the 58 Mk. 1, this "Star" Model is now offered at only 2/6ths of the price. They are in Original Makers' Cartons as supplied to the Government, and are BRAND NEW and UNUSED. Each Set is supplied with 8 valves, 2 sets of headphones, 3 aeriols, Battle Battery, Haversack, etc., and Instruction Book. Complete and Ready to Switch on. Only £10 10s. 0d. (Carriage 5/-). Descriptive leaflet available. We can also supply, for those enthusiasts who purchased the Mk. 1 Chassis offered some months ago, the accessories to complete the working unit. Prices as follows : Set of Headphones and microphone, 22/6 ; miniature valves types 1S5, 1T4, 1R5, 3D6/1299, 17/6 ea. ; telescopic aerial, 15/- ; rod aerial, 12/6 ; Battle Battery, 20/-. Other Ex-Government Equipment offered this month :

#### WAVEMETERS

Class D No. 1 Mk. II. Range : 1,900-4,000 Kcs., 4,000-8,000 Kcs., with check frequencies up to 25 Mcs. Employ's twin crystal, 100/1,000 Kcs., and ensures + 2 per cent. accuracy. BRAND NEW and UNUSED in ORIGINAL ARMY TEAK CARRYING CASE, complete with Instruction Book and SPARE VALVE and SPARE VIBRATOR, only £6 15s. 0d., or a few only without spares at 35/- (carriage 3/6). Illustrated leaflet available.

#### R.A.F. "IDENTIFICATION FRIEND OR FOE" RADAR

R3002 Transmitter Receivers. Operates between 155-185 Mcs. Complete with 10 valves, as follows : 2 Type RK34, 1 type EF50, 4 type SP41, and 3 type DL, and 20 watts motor generator 12 v. input, 480 volt 40 ma output. Only 79/6 (carriage 4/-). For the Servicemen we also offer AMERICAN SERVICE MANUALS. Volume 1 Sperton-Emerson, Vols. 2 & 3 Crosley-Belmont, Vol. 4 RCA-GE-ADMIRAL, Vol. 5 Emerson Part II, Vol. 6 Stewart-Warner-Pada, 12/6 per volume or set of 6 vols., 65/-. Post orders only. C.W.O. S.A.E. brings current lists.

#### U.E.I. CORP.

32, St. Gabriels Road, London, N.W.2.

## SPARKS' DATA SHEETS

Provide full Constructional Details and Diagrams of Tested and Guaranteed Designs.

### THE UNIVERSAL FOUR

No. LO/14. A.C./D.C. T.R.F. Receiver. 3 Valves plus Rect. 3 1/2 Watts quality output. M/L Waves. Compact but not a Midget in performance. Data Sheet, 2/6.

### SPARKS' KIT O'PARTS

Complete Kit o' Parts (less batteries) for the One-Valve Midget Portable (MP.1), £2 ; Two-Valve Midget (LO/M), £2 7s. ; Tiny Two Portable (LO/T), £4 2s. ; Three-Valve ditto (LO/S), £5 14s. 6d. Data Sheets 2/6.

Other Kit o' Parts available shortly

Stamp for List and with Order.

L. ORMOND SPARKS (P)  
9, Phoebe Road, Brockley

S.E.4

Phone, Lee Green 0220

# Open to Discussion

The Editor does not necessarily agree with the opinions expressed by his correspondents. All letters must be accompanied by the name and address of the sender (not necessarily for publication).

## An Amateur's Views

**SIR**,—I have several criticisms to make on G3APA's opinions on short-wave listening. As Mr. Kendall states, there is no sense of achievement in logging high-power beam transmissions. His comparison between an operator and a SWL is not a fair one. Most operators use a communication set with anything up to 12 valves, whereas a SWL uses perhaps two or three valves. Mr. Kendall should also note that there are still many low-power commercial BC transmissions and these are considerably more difficult to log than Ham stations. I speak from experience. Since my interest in DX listening I have heard 32 countries on the BC bands, whereas I have heard 76 on the Ham bands. My Rx is a 1-v-1 home built and designed.

On the subject of QSLs. Many Hams refuse to QSL SWLs as I have found from bitter experience. I have sent out 23 reports to Ham stations. Each report has been very detailed and comprehensive and several of them covered half a dozen separate transmissions. Each report included a reply coupon. To date I have received 6 QSLs.

I do agree with his remarks on the higher frequencies, particularly 5m. and 10m. bands, although I have had little luck in building apparatus to work on the frequencies to my satisfaction.—A. W. ROBERTSON, BSWL 2550 (Crauford).

**SIR**,—May I, as a regular reader, enter the discussion on DX. I do so agree with the point of view taken by G. Kendall—G3APA. I have a photo of various cards sent to a G station for contacts worked in 1934. These men, VK, SU, VE, VU, etc., used power varying from 20 to 40 watts. Receivers were 0-v-2s and 0-SG-Pms—not 10-valve communication Rxs. Of our readers who consider high-powered commercials as DX, I should like to ask—what indeed would they call this work that I have just described? Even to-day I myself use an 0-v-2 battery-operated, with a 12ft. vertical—1ft. from the house and 2ft. off the ground—but DX, or what I call DX, is heard very well. These consist of W4, 5, 6, 7, VE, VU, KA, K4s and J—not forgetting VKs in the evening and early morning. For those who want DX—try 10 and 20 metres; real DX, get through the BC stations on 40 metres. Wishing your journal every success—73s from a satisfied reader.—W. E. Hains (Woodbridge).

**SIR**,—May I endorse Mr. G. G. Kendall's letter in your last issue re reports from listeners to "hams." Reports from any listener are most welcome and helpful, I would welcome any reports, in particular from the Herefordshire district—frequency 7,161 kc.s, 40-metre band. Will QSL, so let's have your reports, please.—H. C. GIBBINS (G3AWT), 156, Southampton Road, Far Cotton, Northampton, Norths.

## Moving-coil Headphones

**SIR**,—There are now on the market considerable quantities of moving-coil headphones, and their low price must be encouraging many to purchase them. Although the necessity for approximate matching is well known, some beginners may be endeavouring to use these 'phones with crystal or one- or two-valve receivers of simple construction, and be unable to obtain proper results.

Unlike ordinary earphones, these moving-coil 'phones require a matching transformer. Whereas ordinary high-resistance 'phones average 2,000 ohms or so, these 'phones are usually from 40 to 100 ohms. If connected directly to the receiver, reproduction is faint. Using an ordinary speaker matching transformer does not give much improvement as 5 to 15 ohms is more usual for a moving-coil speaker. In consequence, it is necessary to obtain or construct a suitable matching transformer, when the earphones can give a good performance.

If one is to be wound, between 200 and 500 turns will generally be necessary on the secondary. Cotton-covered wire of 26 s.w.g. is suitable for a small transformer, and several tappings may be made to enable the best ratio to be found. For small battery receivers, an old intervalve transformer may be used, the normal primary being retained and the secondary removed to accommodate the new winding.

For various reasons the earphones may have a different speech-coil resistance in each earpiece, with separate leads. In this case best reproduction will only be obtained when each earpiece is independently matched, which may be done by taking the separate leads to different tappings (found by trial) on the transformer.—F. G. RAYER (London, Glos).

## Recorded Programmes

**SIR**,—I think that it is about-is about-is about time that the B.B.C. did something-did something-did something about the recorded-recorded programmes which are inflicted on-inflicted on us almost every day.

Perhaps this wonderful new equip-recording equip-recording equipment is responsible—or the fe- or the female labour?—ROBERT C. BELL (Aableside).

## Contacts Wanted

**SIR**,—I am interested in 5- and 160-metre transmission and would like to correspond with SWLs in this country and abroad, in particular other SWLs in Gloucestershire.—LESLIE LEACH ("Prospect House," Cainscross Road, Stroud, Gloucestershire).

**SIR**,—I am one of the large band of radio enthusiasts, recently released from the Services, and anxious to make contacts with enthusiasts in Civvy Street.

My main interests are radio service engineering, talking picture engineering, and television.

I intend buying some test gear shortly and would like to contact other amateurs in Birmingham, with the idea of pooling knowledge, exchanging ideas, mutual aid and social contacts. I also wish to correspond with readers of PRACTICAL WIRELESS in India, Assam, Burma, Malaya and China, having visited these places during five and a half years' overseas service.

All letters will be answered.—R. W. MURRAY (151, Burbury Street, Lozells, Birmingham, 19).

## Odd Tuning Effects

**SIR**,—Replying to K. G. Richman's (January) query. My father has a portable set. He got the same results as Mr. Richman until recently. I suggested to him that he should put a positive bias on the valves. The set worked wonders and we found that the Light Programme and the "Ici Londres" station were quite

separate and both on the dial. I started wireless at the age of nine, and at thirteen I have built a three-valve mains set, a five-valve superhet, as well as countless crystal sets for friends.—J. D. COOK (S.W.12).

### Phasing in Valve Circuits

**S**IR,—I read with great interest "Dynatron's" article on phasing in valve circuits, and would like to present my own ideas. That, with a resistance anode load,  $E_g$  and  $V_o$ , are in opposite phase, is common ground. But I cannot, in spite of much that has been written by some authorities, escape the conclusion that the alternating  $I_a$  is in phase with  $V_o$ . The point at which I fall foul of "Dynatron" is his description of a current increase as a positive change. Presumably he here refers to the increase in the total anode current when  $E_g$  is positive and  $V_o$  negative. But I could easily sketch out a circuit, not necessarily a valve circuit, with a steady direct current flowing in it, in which the same half cycle of alternating current would decrease the total current. My whole point is that what settles whether a certain half cycle of A.C. is to be shown above or below the zero line is not whether it happens to increase or to decrease the total current when it is superimposed on a direct current (it might do either), but the instantaneous *direction* of the alternating component, and nothing else.

If we consider a source of alternating current having one terminal live and the other earthed, we can show the varying amplitude and phasing of the voltage at the live terminal by the familiar sine curve with a horizontal zero line, the positive half cycles being above the line and the negative below. In which direction are the electrons flowing when the live terminal is negative? Manifestly from the live terminal towards the load (we are assuming a resistance as load), for electrons flow from negative to positive in the external circuit. The current sine curve, in the above familiar case, would be shown in phase with the voltage curve.

Applying this reasoning to the valve circuits, when  $E_g$  is positive and  $V_o$  negative, the alternating component of the anode current is flowing, as we know, from the live terminal, the anode, towards the resistance load (incidentally increasing the total current). It is, therefore, in phase with  $V_o$  by the convention universally used. When  $V_o$  becomes positive, the alternating component must be supposed to be flowing from load resistance towards the anode, relatively, of course, which is the direction in which current would flow, in the case of a generator, on the positive half cycle. I recognise that "Dynatron" brings up the electrical equivalent of the familiar rule in mechanics that "action and reaction are equal and opposite," but believe that there is no need to call on it in this case, and that  $V_o$  and  $I_a$  are actually in phase with each other.—A. O. GRIFFITHS (Wrexham).

### Fahnstock Clips

**S**IR,—Your correspondent, A. W. J. Marsh, of Newport, I.O.W., whose letter appears in the January issue of PRACTICAL WIRELESS, may be glad to know that plated Fahnstock Clips may be obtained from Messrs. Ross, Courtenay and Co. Their address will be found in the London Telephone Directory.

Before the war they were also made in brass by Ward and Goldstone, Ltd., of Manchester.—J. POTTER (Manchester).

### The "XA" Call Signs

**S**IR,—I have noted with interest the remarks made in reference to the XA series of call-signs, contained in the article, "On the Amateur Bands," of your Jan., 1947 issue.

Whilst I wholeheartedly agree that we who have these call-signs are not "pirates," other points made are not strictly accurate. The XA series is not, as implied, allocated to stations operated by Services personnel in all occupied countries, but to those in the Mediterranean theatre only, i.e., Austria, Italy and Greece at the present time. Stations in the British and American zones of Germany, for example, will be found to have D2 and D4 call-signs respectively.

The XA series was originally inaugurated by A.F.H.Q. at the beginning of 1946, and licences are now issued by G.H.Q., C.M.F. Four frequency bands are permitted, which are: 7.15 to 7.3 Mc/s., 14.1 to 14.3 Mc/s., 28 to 30 Mc/s. and 58.5 to 60 Mc/s., and it is laid down that power input to final stages must not exceed 150 watts.

I trust that this information may be of interest to you and your readers, and would like to add, in conclusion, that reports of reception will no doubt be welcomed by all the XA "hans," who in many cases, are using makeshift equipments and modified Service sets, but in spite of that, are achieving remarkable results.—R. F. KILBY (A.R.S., XABO).

### Black Market Servicing

**S**IR,—I have been a reader of PRACTICAL WIRELESS for many years now and have studied it with much benefit to myself, particularly when you have published such articles as: "What is Miller Effect?", "The Tuned Circuit," "Kirchoff's Laws," and a host of others by your more regular contributors.

The result of this, together with much practical experimenting, is that I now have a fairly good knowledge of radio receivers, etc., and get a great kick from servicing them, and with all modesty I must say I have not yet failed to get a set working for the owner to whom I am a private "service engineer."

This brings me to the point I would like to express. In the January issue of PRACTICAL WIRELESS, our good friend "Thermion" warned readers of the "Black Market in Servicing." This was a timely and grand article indeed, and one I wholeheartedly agree with—yet somehow I felt prompted to write and remind "Thermion," and his readers, that in the midst of the rogues he describes so well there are a few private radio servicemen who foster a genuine desire to be honest with those who feel "so lost without their wireless sets." Such servicemen do not pursue their work for what they will get out of it, but for the satisfaction within themselves of having a customer express pleasure at having the set working again. I am sure "Thermion" will understand this sentiment, for it is only this spirit that makes possible the unselfishness which turns a job of work into a hobby and a pleasure. However "Thermion's" advice to readers not to entertain strangers who call and pose as radio experts is sound good sense, and fortunately for those of us who are straight, well—we just don't have to call on anyone anyway.

May I conclude by saying thank you for a grand journal and may the time soon come when it may be looked for each week.—GORDON J. GARMAN (Old Woking).

## BOOKS FOR ENGINEERS

By F. J. CAMM

Gears and Gear Cutting, 6/-, by post 6/6.

Workshop Calculations, Tables and Formulae, 6/-, by Engineers' Manual, 10/6, by post 11/-.

post 6/6.

Engineers' Vest Pocket Book, 10/6, by post 11/-.

Watches: Adjustment and Repair, 6/-, by post 6/6.

Screw Thread Manual, 6/-, by post 6/6.

Wire and Wire Gauges (Vest Pocket Book), 3/6, by post 3/9.

CLASSIFIED ADVERTISEMENTS

RATES: 3/- per line or part thereof, average five words to line. Box No. 6d. extra. Advertisements must be prepaid and addressed to Advertisement Manager, "Practical Wireless," Tower House, Southampton St., Strand, London, W.C.2.

MORE than 20 departments provide a short wave service to members of the BRITISH SHORT WAVE LEAGUE (founded 1935). Send 3d. for sample "Short Wave Review" and full details to—H.Q., 17, Bedford Road, London, N.22.

THE SHORT WAVE LISTENERS' ANNUAL, 1947 Edition, is now on sale. Over 80 pages essential data for DXers. 2/6 from local booksellers, or 2/9 direct from "Short Wave News," 57, Maida Vale, London, W.9.

MORSE & S.W. EQUIPMENT

"H.A.C." Short-wave Receivers. Famous for over ten years. Improved one-valve model now available. Complete kit of components accessories, with full instructions, now 19/3, postage 3d. Easily assembled in one hour. S.A.E. for free catalogue.—A. L. Bacchus, 109, Hartington Road, London, S.W.8.

RECEIVERS & COMPONENTS

EAST ANGLIAN HAMS.—All components for receivers and transmitters. Crystals, test gear, valves. Authorized distributors for Hamrad, Raymat, Eddyphone, Labgear. No lists yet but all enquiries dealt with promptly, send stamped addressed cheque—Newcastle, 22, Market Place, North Walsham, Norfolk. Telephone 219.

MAINS TRANSFORMERS.—Rewound or altered to specification. Quality output, amplifier and auto transformers a speciality. Send Trade card for special list.—Robert Re-Winding Co., 36, Rosslyn Hill, N.W.3.

TRANSFORMERS rewound. All types mains, output television, EHT and line. Pickups repaired and rewound. Prompt service. Trade enquiries invited.—North West Electrical Co., 21a, Goldhurst Terrace, N.W.6.

FORTHMINSTER TRANSFORMERS.—Mails. 350-9-350 80 ma., 4v. 4a. c.t., 4v. 2.5a. or with 6.3v. 3a. c.t., 5v. 2a. windings. 27/8. Output, 30 watt, 10 ratios from 20:1 to 140:1, all ratios for push-pull if required. 22/6. Standard multi-ratio, 6 ratios from 20:1 to 117:1, to suit 2-3 ohm speakers, c.t. primary, 7/2. Surrey mains transformers. 22/10-250 70 ma., 4v. 3a. c.t., 4v. 2a., or with 4.7v. 2a. c.t., 5v. 2a. windings. 22/6. Colvern wirewound potentiometers, 3 watt type, 2in. spindles: 10 and 50 ohms. 5/10. 2,000, 5,000, 10,000, 25,000, 50,000 ohms. 5/6; 100,000 ohms. 6/7. Chassis, 1 1/4 x 5 1/2 in., drilled 4 holes or 7 holes, steel. 2/6; aluminium. 3/6. Knobs, black or brown, all lin. bush with screw. 7in. 6/11, 1in. 7/11, 1in. 7/14, 1in. 9/1. Glass cartridge fuses, 1 1/2in., 1in., 7/11, 1in. 4/11, mid. 330v. can type electrolytic condensers, 8/4. Battery leads, P.V.C. multi-coloured, 3ft. 6in. long; 5-way, 3/-; 7-way 3/6. Resistors, 1 watt, 4d.; 1/2 watt 5d.; 1 watt 7d. Postage extra on all items. T. W. Comins, 399, Chiswick High Road, London, W.4. Phone: Chiswick 4530.

SURPLUS WIRE.—Rubber, and rubber cotton covered flexes. Screened flexes. One to six core insulated bell wires and many others. List and prices.—Mc. & B. Heat Control, Ltd., Mill Street, Harlow Common, Essex.

SPECIAL OFFER.—A chance to secure a first-class COMMUNICATION RECEIVER at less than half the price of the type of set we have for disposal a very limited number of factory converted ex-R.A.F. Model 1155 receivers. These have had a POWER PACK OUTPUT STAGE and head-phone jack included in the standard chassis. The wave range is 14.5 Mcs. to 75 Kcs. and the whole receiver is priced at 30 guineas. Also the famous Model 58 Walkie-Talkie complete with valves, aerials, phones and batteries as originally issued at 10 guineas.

Or with spare set of valves extra (£5 10s. in value), complete at 14 guineas. All above prices are carriage paid to your address. Terms Cash with Order. To avoid disappointment early ordering is essential. THE RADIO LTD., 401, London Rd., High Wycombe.

VALUE! MATT has it

SPEAKERS. 5 in., L/T. 15/6; 8 in., L/T. 22/6. All p.m.

ROTHERMEL CRYSTAL PICK-UPS. "Deluxe," £2 16s. 3d., inc. P/Tax.

CONDENSERS. .1, .01, .05 mfd., 9/- per doz. Line Cord. 3-way. 2/- per yd. .3 amp. 60 ohms, per ft.

SHUTTERD SOCKETS. Flush, 5 amp., 3 pin, 4/- each.

VOLUME CONTROLS. Centralab. Various values. L/S, 2/6. W/S, 3/6.

HEADPHONES. Special offer. 5/6 per pair, 2 pairs in box complete with lead and jack plug.

Largest Stock of B.V.A. and U.S. valves in England.

Let us have your enquiries.



152, Richmond Road, Kingston-on-Thames, Surrey

A FREE BOOK

for all interested in



MORSE CODE TRAINING.

These are Candler Morse Code Courses for Beginners and Operators.

Send for this Free "BOOK OF FACTS" It gives full details concerning all Courses.

THE CANDLER SYSTEM CO. (S.L.O.) 121, Kingsway, London, W.C.2.

Candler System Co., Denver, Colorado, U.S.A.



This new dual model gives 2 to 30 volts and 100 to 750 volts. Send for leaflet (A 24) on "Testing."

RUNBAKEN MANCHESTER

BULGIN

A Name famous in Radio



A. F. BULGIN & CO., LTD. Bye Pass Road, Barking, Essex. Tel: Rippleway 3474 (5 lines).

SUPERHET tuning unit, 70- complete with chassis, valve holders, efficient 3-wave coil unit, 2-rang, calibrated dial, knobs, drawings complete Receiver. Attractive cabinets. 65/- Early delivery. Trade enquiries subject—MORGAN OSBOIRNE, LTD., Southview Road, Warrington, Surrey.

CHARLES AMPLIFIERS have pleasure in announcing the opening of their new premises. Customers old and new will be welcome to try our famous Amplifiers of exceptionally High Fidelity and Tuning Unit. The latest in High Fidelity Speakers, decorative Baffles and equipment and latest records. Blueprints of our 3- and 7-watts Cathode Follower Amplifiers, which are meeting with an extraordinarily enthusiastic response, and our newest Tuning Unit, which is both an All-wave Superhet and a High Fidelity T.R.F. Unit. Prints with full-size point to point wiring diagrams, 2/6 each, 5/- the set of three. Complete kits or separate components supplied. Stamp for details.—Charles Amplifiers, 10, Palace Gate, Kensington London, W.8. (One minute from the Albert Hall.)

TRANSMITTING VALVES. 100TH. £6 5s.; T200, £9 9s.; RK20A, £4 14s. 6d.; 860 866A, 27/8; 35T, 45/-; RK25, £2, etc. All U.S.A. Types. Also Mullard and Standard TX Valves. R-1155, with Power Plug and Modification Details, £15 15s. Rectifier Transformers, £2 9s.; 275 Class "D" Wavemeters, £3. Control Units, 15/- Flexible Couplers, 2/6. Valve Screens, 2/-. TRANSMITTING VALVES A SPECIALTY. WRITE FOR LISTS, S.A.E.—Radiographic, Ltd., 68, Osborne Street, Glasgow, C.I.

VALVES.—PM3H, 5/10; 304, C.I. 8/6; MH4, MH1A, 9/2; 41X, 10/6; VP2, SP2, PM22A, IC5G, 5Y3G, 11/-; MH41, PX4, 11/7; XP, 12/6; VP4B, SP4, 6J7G, 6V6G, 42, KT63, 12/10; 6K8G, X63, FC4, 14/-; KT33C, 14/8; Wearite P coils, 3/-; Varley and Partridge transformers, trimmers, tubulars, electrolytics. New Goods Only. Write for list.—Radio Supplies, 56, Hughes Ave., Horwich, Lancs.

LIVERPOOL, 306, Rathbone Road, everything for the home constructor at lowest possible prices. Every advice and help to callers.

O. GREENLICK, LTD. ROTARY TRANSFORMERS. Brand new, ex-Govt. stock. Suitable for Car Radios, Mobile Amplifiers, Country House receivers, etc. Solid frame with fixing feet. These Transformers can be utilised for 6 or 12 volt input, and will give with 6v. input, output of 200v. at 50 m.a. for continuous operation, 150v. at 80 m.a. for periods up to 3 hours, or with 12v. input, output of 400v. at 40 m.a. continuous operation, 400v. at 80 m.a. for periods up to 3 hours. Size 7 1/2in. by 3 1/2in. Weight 6 lb. Cost £77/-. 25/- each. I.P.S. Weymouth iron-cored midget I.P.S. 465 kcs. per matched pair, 19/9; Weymouth All Wave Coil Pack at 36/6; Standard I.F.s, 465 kcs. 15/-; M. wave midget T.R.F. coils, per pair, 5/-; M/L wave coils with reaction, boxed with circuit, 7/6; the latest iron-cored T.R.F. coils, M/L wave, with adjustable iron cores, per pair, 10/6; Superhet coils, S.M.L. wave, per pair, 10/6; all coils supplied with circuit.

SPEAKERS. P.M. minus trans., 5in. at 20/6; 6in. at 27/6. ELECTROLYTICS. Tubular 8 mfd. 150v. at 2/6; 50 mfd. 12v. at 2/-; 200 mfd. 12v. at 1/6; Can type 8 plus 16 mfd. 500v. at 8/-; Block type 4 plus 24 mfd. 300v. at 4/-; BRUSH AND DIALS. Epicyclic drive, 3/3; Slow-motion drum drive, 3/-; Square Plane, slow-motion drive assembly, complete with glass, escutcheon, etc., size of dial 4 1/2in. x 3 1/2in., 11/6; Coloured all-wave Dials, Ivorine, 8in. x 3 1/2in., 2/-; 5 1/2in. x 5 1/2in., 2/6; Celluloid transparent dials, M/L wave, 6in. x 5 1/2in., 1/6. CHOKES. "Ultra" midget smoothing chokes, 360 ohms, 40/50 m.a., 5/-; Midget ditto, 50 60 m.a., 5/6; Standard ditto, 100 m.a., 5/6; heavy duty ditto, 150/200 m.a., 12/6.

CHASSIS. All with speaker cut-out for 6in. speaker and fully drilled all component holes, cadmium plated. The "Simplex" chassis, 4v., size 1 1/2in. x 4 1/2in. x 2in., 6/-; the "WSV" chassis, for the Weymouth Coil Pack, etc., size 1 1/2in. x 5 1/2in. 2 1/2in., 6/6. Comprehensive lists monthly, 2d. stamp, worth having.—A. F. BULGIN & CO., LTD., 34, Bancroft Road, Cambridge Heath Road, London, E.1. Phone: ST. Epney Green 1334.

**CHARLES BRITAIN (RADIO), LTD**  
**A Few selected lines from our latest list.**  
**TRF COILS** with reaction Medium, Long Wave with diagram, 9/6 pr. Superhet coils all wave Ae and Osc. with Diagram, 10/6 pr.  
**I.F. Transformers** 465 K/c, 12/6 pr. 2 Gang Condensers 405 Lf. feet and trimms 9/- ea.  
**SPECIAL OFFERS.** Moving Coil Mikes undamaged with metal Grille, 5/- ea.; damaged, 1/6 ea. Parcel of 36 assorted tubular condensers from 0001 to 0-5 mfd. All New, 10/6. Parcel of 72 New assorted resistors 1.1 to 1 watt from 100 ohms to 1 meg., 12/6. Special parcel of new and used goods, exceptional value £1, money refunded if not satisfied.

**SPECIAL PURCHASE** of Brand New Ex Govt. Miniature radio receivers, covering four wave bands, 20 metres to 3,000 metres. For A.C./D.C. or Dry Battery operation. Supplied complete with Earphones, Power Pack; Instructions and all Accessories. 27/19s. 6d. These receivers were used by the Resistance Movement. Limited number only available. Please order C.O.D.  
**NUMEROUS** other lines in stock including amplifiers, pick-ups, etc. Callers always welcome, trade supplied. Terms cash with order or C.O.D. over £1. Send for latest list.  
**Charles Britain (Radio), Ltd., Radio House, 2, Wilson Street, London, E.C.2.**  
**Phone: B15 2966.**

**KITS of Radio Receivers from 27/8/0.** 4 and 5 valve. All new materials. Table Models, Semi-Midget. Our latest Kit—Wylwyn Star 1947—has connections for Gramophone Pick-up and extensions to Loudspeakers. A.V.C. 6 hours average time for constructing. Full details and diagrams with each kit. C.W.O. or C.O.D.—Isherwoods, Reme House, 81, Plungington Road, Preston, Lancs. Tel.: 3348. Estd. 1936.

**MIDLAND RADIO COIL PRODUCTS**  
**Manufacturers of Radio-Frequency Coils, Chokes and Transformers.**

We draw your attention to our 1947 list which is now available on request against 3d. stamp. Our previously advertised components still available include:

**I.F. TRANSFORMERS.**—Maximum gain and selectivity, with dust-plunger tuning and Litz windings in the small screen dimensions of 1 1/2" square by 3 1/2" high. For 465 kc/s, boxed and guaranteed aligned. Per pair, 14/-

**IQSS SUPERHET COILS.**—Solve the problem of the home constructed superhet receiver. Aerial, H.F. and Oscillator coils covering the ranges 200 to 290 metres and 2,000 metres, with 0.0005 mfd. tuning. Air-cored, formers 1 1/2" by 2 1/2", double wound and colour coded. Each, 2/3

**IQS SHORT WAVE COILS.**—For the short wave set. These coils cover the ranges 10-25, 25-45 and 40-70 metres with 0.00016 mfd. tuning. Aerial, H.F. and Oscillator, double wound and colour coded. Each, 2/-

Write for our technical data sheet giving full details of the above coil sets. For straight and superhet constructors; they will make your ganging problems a thing of the past.

**VALVE SCREENS.**—3-piece Octal, new, complete. 9d. each.  
 Our list gives details of coil units, tuning hearts, instrument cases, hardware kits, component brackets, special coils, etc., etc. We hold comprehensive stocks of all small standard components.

Cash with Order or C.O.D. over 10/- All enquiries, 3d. stamp please.  
**MIDLAND RADIO COIL PRODUCTS,**  
**13A, Silver Street, Wellingtonborough, Northants.**

**THE** last word in Radio Kits! Really detailed Instructional Manuscript how to build best Lytle A.V.C. 6 valve receiver, 2/6. Absolutely complete Kit, incl. valves and super cabinet, £8. Advice free. All standard radio components supplied by return C.O.D. Send postage for current Bargain Lists—Northern Radio Services, 66, Parkhill Road, London, N.W.3. Tel.: Gulliver 1453.

**REWIND SERVICE.**—Transformers—Fields—Pickups—Speakers—New Cones and Speech Coils fitted—Armatures—Vacuum Cleaners—Gram, and Fractional H.P. Motors. All work guaranteed and promptly executed. Special Terms to the Trade. Send S.A.E. for Price List and Radio Spares.—A.D.S. Co., 261-3-5, Lichfield Road, Aston 6, Birmingham.

**REPAIRS** to loud-speakers. Cones, coils fitted. Fields altered, rewound. Output transformers, clock coils. Prices quoted. Satisfaction guaranteed.—L.S. Repair Service, 49, Trinity Rd., Upper Tooting, S.W.17. Closed Saturdays. Phone: Balham 2359.

## PRATTS RADIO

**1070 Harrow Road, LONDON, N.W.10**  
**(Nr. SCRUBS LANE)**  
**Phone: LADbroke 1734.**

**COILS.** Weymouth 3 wave coil packs, 38/6 each; L, M and S, wave coils, Aerial and Osc., 465 kc/s, 11/6 set; L and M, wave coils with reaction, 9/- pair; M, W. Coils, 5/6 pair; dual range coil with reaction, 4/6 each; set of 3 coils, 12-80 metres, 9/-; Wearite "P" coils, 3/- each.

**VARIABLE CONDENSERS.** .0005 mfd. 2-gang with trimmers, 12/6; less trimmers, 11/6; dielectric con., .0003 and .0005 mfd., 4/3 each; trimmers, 5/50 pf. 9d.; 50/250 pf and 50/500 pf., 4/7 each.

**TRANSFORMERS.** Mains 350-0-350v, 6v. and 5v. or 4v., 4v., 28/6; similarly only 2v., 4v., 5v., 6v. 120 m.a., 31/6; Speaker transformers, midget universal, 5/-; pentode, 5/9; multi-ratio, 7/6; 25 watt multi-ratio, 22/6; I.F. transformers, Weymouth midget, 19/6; standard 23/50 (465 kc/s); auto transformers, 110-230v, 100 watt, 25/-; **CHOKES.** Midget 60 m.a. 4/9; 20 hy. 60 m/a 360 ohms, 6/9; 20 hy. 500 ohms 150 m/a, 21/-; 20 hy. 450 ohms 250 m/a, 24/6

**CONDENSERS.** Most types in stock. **MAINS DROPPERS.** 3 amp. 800 ohm, 5/-; 2 amp. 1,000 ohm, 4/9 each (including fixing feet and sliders). Linecord, 3 amp., 60 ohms, per ft., 2 way, 7/4, ft.; 3 way, 8d. ft.

**MISCELLANEOUS.** Octal valve cans, 9d. each; knobs, 1in. to 2in., black or brown, 6d. to 9d. each; pointer type, 1/- each; volume controls, long and short wave, 3/-; with switch, 5/-; midget inter-valve transformers, 3-1 or 5-1, 5/6 each; valve holders, 7/4d. each; Amphenol grid, 9d.; fusesolders, 1 1/2in. single, 4/1d., twin, 7/1.

**SPEAKERS.** 6 M.L.T.R., 2 1/2in., 25/-; 3 1/2in., 29/-; 5in., 19/6; P.M.L.N., 22/6; 8in., 23/6. U31, 25/-; U32, 25/-; U33, 25/-; U34, 25/-; PX25, 6C5, 6N7, 12SQ7, EF89, almost all 20 battery valves, etc., etc. S.A.E. for Advice. List or Enquiries, Postage Paid over £2. C.W.O. or C.O.D. Buses 662, 664, 18B pass door.

**NEW UNUSED GOODS ONLY.**

**FRED'S RADIO CABIN**  
**M.C.R.-1.** Miniature Communication Receivers. 5 valve all wave superhet with regeneration. Covers in four bands 20 to 3,000 metres. Works from 90v. 7iv. batteries or from A.C./D.C. power pack, 95 to 230 volts. Price set with coil power pack, headphones, aerial and earth leads, and instructions, £10. Leaflet S.A.E. **POT-METERS EX R.A.F.** 400 ohms wire wound, 2/6.  
**M.X. H.A.F. VALVES.** VR65, VR65a, VT50L, VR54 all at 5/- each. Tested.

**AERIAL WIRE.** Enamelled 7/22 copper. 50ft. coils, 2/6. 100ft., 4/9.

**PRC VOLTAGE DROPPERS.** Midget in size. Low heat type. Single hole fixing. 100 ohms 2 amp., and 600 ohms 3 amp., 5/6 each.

**22 S.V.G. COPPER WIRE.** Approx. 16ft. Coils, 6d. Double 1/- coil.

**MORSE KEYS.** Ex Army No. 2 Mk. II, 7/6 each.

**VALVE SCREENS.** 3 section aluminium, fit international octal tubes, 2/- each.

**RADIO CONSTRUCTORS' MANUAL.** Crystal set to power amplifiers, 3/- copy. **RADIO INSIDE OUT.** A £5 radio course for 6/- per copy.

**VALVE MANUAL.** English and Yank bottles covered, 3/6 each.

**PILOT BULB SHUNTS.** 45 ohms, 5 watt, wire wound, 1/6.  
**5 WATT WIRE WOUND resistances.** in the following values: 150, 200, 250, 300, 350, 400, 500, 600, 700, 750, 800 and 1,000 ohms. Price 2/- each.

Power smoothing chokes for amplifiers, 450 ohms, 20 H., 150 m.a., 25/-; 450 ohms, 20 H., 150 m.a., 27/6 each.

**MULTI RATIO** speaker transformers, 8/6. Tapped sec. and prim. will match up anything.

30 watt **MULTI RATIO** output speaker trans., 22/6.

**TRF** midget parts in stock. Chassis, 3/6; dial scales, 1/9; octal valveholders, 8/-; 10 K, V.C. WS, 5/6; WCS, 3/6; dial bulbs, 8d.; 2 bulb holders, 6d.; 2 gangs, .0005, 12/6.

For sale 2 only CR100 all wave communication receivers, £50 each.  
**FRED'S RADIO CABIN,** 75, Newington Butts, Elephant and Castle, S.E.11 (one minute from Tube) London. Telephone: **RODNEY 2180.**

**TELEGRAPHIC**  
**Dept. SP., 157, Fore Street, Edmonton, N.18.**

Replacement chassis from stock. Factory assembled and Tested.

1. A.C.T.-stage R/gram, model 50A. All Wave with neg. feedback, £12 12s. 6d.  
 2. Dico, A.C./D.C., £13, plus P.T. £2 18s. 4d.

3. A.C./D.C. amplifier, 4.5 watts, £5 15s. All above available in kit form if required.

Material for Tuning Heart, comprising 3 blueprints, 50 coil pack and I.F.'s ready aligned, 2 gang, special chassis with holders and calibrated dial and drive, 4 kfs. post free.

Blueprint service. Complete practical and theoretical drawings which are the finest offered to the amateur. Model 50A. All Wave s'het., 5/-; Model 40, A.C./D.C. T.R.F., with neg. feedback, 3/6. Model 42, All dry Car Radio s'het., 3/-; Model 43, Mains trans. s'het., 3/-; Model 44, Battery T.R.F., 3/-.

Model 45, A.C./D.C. amplifier, 3/-; Circuit Model 50D, A.C./D.C. all-wave s'het., 1/8. Model 52, 10/12 watt Quality amplifier, 1/4.

Components. All wave dials and drives with station names, 5 x 5, 6/6, 7 x 4, 12/6. Wearite P. coils, 3/-; Aligned Instr. iron cored coils, all types at 4s. 6d. 30 watt Push-pull 0/trans., all ratios, 25/6. Small P. Chokes, 6/-; Silver mica condensers, 350 v., 4 or 6 v. L.T., 25/6. Speaker fret fabric, 2/- sq. ft. Cond. up to 1. 7/6 doz. Nuts and bolts, 2/6 gr. ass. Octal whdrs., 3/6 doz. Tag strips, 4 or 5 tags on one strip, 4/8 doz. 22 droppers, 42/- doz.

For full lists and details of kit designs, send stamp.

**TELEGRAPHIC, 157, Fore Street, Edmonton, N.18. Tott. 3386.**

**WE** can supply 2 gang .005 condensers from 10/- 16 x 8 mfd., 500 volts, 6/-; 16 x 8 x 4 x 4 mfd., 500 volts, 6/8; 16 mfd., 500 volts, 4/-; 4 mfd., 250 volts, 1/6. Summersby F.S., 465 kc/s, Litz wound, high Q, permeability tuned, 15/- pair. Summersby High Gain, Litz wound, iron cored tuning coils, super- and T.R.F., 8in. P.M. speakers with output transformers from 25/-.

pointers, etc.—Castle Radio, 101, Poverest Road, Orpington, Kent.

**THE NAME TO NOTE** for all kinds of radio and electrical metalwork to specification, modern rust-proofing, all shapes and sizes undertaken, and for tropical use. Components and sub-assemblies executed to meet recognised wiring and material standards. Consultation, advice without obligation: Write Dept. 03, Sea Rescue Equipment, Ltd., Chiltern Works, Clarendon Road, Watford, Herts.

**RADIO REPAIRS.**—English U.S.A. or Continental Repairs, guaranteed. Dioptrical Vision Aerial Co., 17, Mill Hill, Deal, Kent.

**EXPERIENCED** Electronic, Radio, Television, Research Development and Circuit Designer seeks post with prospects. Fully qualified Engineer. First-class references. Box 947, Aldridge, 1, Whitefriars Street, London, E.C.4.

**SITUATIONS VACANT**

**WANTED.**—Radio Mechanic to Align P.W. Super Het. Portable—Harris, 4, Coniston Rd., Tettenhall, Staffs.

**"ENGINEERING OPPORTUNITIES."** FREE 112-page guide to training for A.M.I.Mech., E.A.M.I.E.R., and all branches of Engineering and Building. Full of advice for expert or novice. Write for free copy and make your peacetime future secure.—B.I.E.T. (Dept. 242B), 17, Stratford Place, London, W.1.

**TUITION**

**RADAR, WIRELESS, TELEVISION,** etc. Being prepared for tremendous peace-time buying elements. Students of both sexes trained for appointments in all branches of radio. Boarders accepted. Low fees, 2d. stamp for prospectus.—Wireless College, Colwyn Bay.

**THE Institute of Practical Radio Engineers** have available Home Study Courses covering elementary, theoretical, mathematical, practical and laboratory tuition in radio and television engineering; the I.P.R.E. is suitable coaching matter for I.P.R.E. Service entry and progressive exams; tuition fees at pre-war rates—moderate. The Syllabus of Instructional Text may be obtained, post free, from the Secretary, 20, Fairfield Road, Crouch End, N.8.

# Practical Wireless BLUEPRINT SERVICE

## SPECIAL NOTICE

THESE blueprints are drawn full size. The issues containing descriptions of these sets are now out of print, but an asterisk beside the blueprint number denotes that constructional details are available, free with the blueprint.

The index letters which precede the Blueprint Number indicate the periodical in which the description appears: Thus P.W. refers to PRACTICAL WIRELESS, A.W. to Amateur Wireless, W.M. to Wireless Magazine.

Send (preferably) a postal order to cover the cost of the Blueprint (stamps over 6d. unacceptable) to PRACTICAL WIRELESS Blueprint Dept., George Newnes, Ltd., Tower House, Southampton Street, Strand, W.C.2.

### PRACTICAL WIRELESS

No. of Blueprint.	F. J. Cannon's A.C. Superhet 4	PW60*
	F. J. Cannon's Universal 4 Superhet 4	PW60
	"Quilltone" Universal Four	PW73*

### CRYSTAL SETS

Blueprints, 6d. each.	
1927 Crystal Receiver	PW71*
The "Junior" Crystal Set	PW94*

### STRAIGHT SETS. Battery Operated.

One-valve: Blueprints, 1s. each.	
All-Wave Unides (Pentode)	PW31A*
Beginners' One-valver	PW85*
The "Pyramid" One-valver (HF Pen)	PW93*
Two-valve: Blueprints, 1s.	
The Signal Two (D & LF)	PW76*
Three-valve: Blueprints, 1s. each.	
Selectors Battery Three (D, 2LF (Trans))	PW10
Summit Three (HF Pen, D, Pen)	PW37*
Hall-Mark Cables (D, LF, Pen) (RCY)	PW48*
F. J. Cannon's Silver Souvenir (HF Pen, D (Pen), Pen) (All-Wave Three)	PW49*
Cannon Midget Three (D, 2 LF (Trans))	PW51*
1936 Sonotone Three-Four (HF Pen, HF Pen, Westcoater, Pen) Battery All-Wave Three (D, 2 LF (RC))	PW53*
The Monitor (HF Pen, D, Pen)	PW55*
The Tutor Three (HF Pen, D, Pen)	PW61*
The Centaur Three (SG, D, D)	PW64*
The "C.H." All-Wave Three (D, 2 LF (RC & Trans))	PW72*
The "Ripple" Straight 3 (D, 2 LF (RC & Trans))	PW82*
F. J. Cannon's "Grapple" All-Wave Three (HF, Det. Pen, D)	PW78*
1938 "Triband" All-Wave Three (HF, Pen, D, Pen)	PW84*
F. J. Cannon's "Sprite" Three (HF Pen, D, Pen)	PW87*
The "Hurricane" All-Wave Three (SG, D, Pen, Pen)	PW89*
F. J. Cannon's "Push-Button" Three (HF Pen, D (Pen), Tet.)	PW92*
Four-valve: Blueprints, 1s. each.	
Beta Universal Four (SG, D, LF, C, B)	PW17*
Nucleon Class B Four (SG, D (SG), LF, C, B)	PW34B*
Fury Four Super (SG, SG, D, Pen) Battery Hall-Mark 4 (HF, Pen, D, Push-Pull)	PW34C*
"Acme" All-Wave 4 (HF Pen, D (Pen), LF, C, B)	PW86*
The "Admiral" Four (HF Pen, HF Pen, D, Pen (RC))	PW90*

### Mains Operated

Two-valve: Blueprints, 1s. each.	
A.C. Twin (D (Pen), Pen)	PW18*
Selectors A.C. Radiogram Two (D, Pen)	PW19*
Three-valve: Blueprints, 1s. each.	
Double-Diode-Triode Three (HF Pen, DDT, Pen)	PW23*
D.C. Ace (SG, D, Pen)	PW29*
A.C. Three (SG, D, Pen)	PW35C*
A.C. Leader (HF Pen, D, Pen)	PW35B*
D.C. President (HF Pen, D, Pen)	PW36A*
Udique (HF Pen, D (Pen), Pen)	PW50*
F. J. Cannon's A.C. All-Wave Silver Souvenir Three (HF Pen, D, Pen) All-Wave "A.C. Three (D, 2 LF (RC))	PW34*
A.C. 1936 Sonotone (HF Pen, HF Pen, Westcoater, Pen)	PW50*
Mains Record All-Wave 3 (HF Pen, D, Pen)	PW70*
Four-valve: Blueprints, 1s. each.	
A.C. Fury Four (SG, SG, D, Pen)	PW20*
A.C. Fury Four Super (SG, SG, D, Pen)	PW34D*
A.C. Hall-Mark (HF Pen, D, Push-Pull)	PW15*
Universal Hall-Mark (HF Pen, D, Push-Pull)	PW47*

### SUPERHETS

Battery Sets: Blueprints, 1s. each.	
45 Superhet (Three-valve)	PW40*
P. J. Cannon's 2-valve Superhet	PW52*
Mains Sets: Blueprints, 1s. each.	
A.C. 45 Superhet (Three-valve)	PW43*
A.C. 45 Superhet (Three-valve)	PW43*

### SHORT-WAVE SETS. Battery Operated

One-valve: Blueprint, 1s.	
Simple S.W. One-valver	PW88*
Two-valve: Blueprints, 1s. each.	
Midget Short-wave Two (D, Pen)	PW38A*
The "Fleet" Short-wave Two (D (HF Pen), Pen)	PW91*
Three-valve: Blueprints, 1s. each.	
Experimenter's Short-wave Three (SG, D, Pow)	PW30A*
The Perfect 3 (D, 2 LF (RC and Trans))	PW63*
The Band-spread A.W. Three (HF Pen, D (Pen), Pen)	PW68*

### PORTABLES

Three-valve: Blueprints, 1s. each.	
F. J. Cannon's E.L.F. Three-valve Portable (HF Pen, D, Pen)	PW65*
Parvo Flyweight Midget Portable (SG, D, Pen)	PW77*
Four-valve: Blueprints, 1s.	
"Imp" Portable 4 (D, LF, LF (Pen))	PW86*

### MISCELLANEOUS

Blueprint, 1s.	
S.W. Converter-Adapter (1 valve)	PW48A*

### AMATEUR WIRELESS AND WIRELESS MAGAZINE

#### CRYSTAL SETS

Blueprints, 6d. each.	
Four-station Crystal Set	AW42*
Luxon Tuning Coil for A.W. 42*	6d.
1934 Crystal Set	AW44
150-mile Crystal Set	AW45*

#### STRAIGHT SETS. Battery Operated.

One-valve: Blueprint, 1s.	
B.B.C. Special One-valver	AW38*
Two-valve: Blueprints, 1s. each.	
Melody Raiser Two (D, Trans)	AW38*
Full-volume Two (SG det. Pen)	AW39*
A modern Two-valver	AW40*
Three-valve: Blueprints, 1s. each.	
Lucerne Ranger (SG, D, Trans)	AW41*
45 5s. Three The Luxe Version (SG, D, Trans)	AW42*
Transportable Three (SG, D, Pen)	AW43*
Simple-Tune Three (SG, D, Pen)	WM271
Economy Pentode Three (SG, D, Pen)	WM337
"W.M." 1934 Standard Three (SG, D, Pen)	WM351*
E338 Three (SG, D, Trans)	WM354
1935 20 6s. Battery Three (SG, D, Pen)	WM371
PTP Three (Pen, D, Pen)	WM389*
Certainty Three (SG, D, Pen)	WM393
Midtune Three (SG, D, Trans)	WM396*
All-wave Winning Three (SG, D, Pen)	WM400
Four-valve: Blueprints, 1s. 6d. each.	
65e Four (SG, D, RC, Trans)	AW370
Self-contained Four (SG, D, LF, C, B)	WM331
Lucerne Straight Four (SG, D, LF, Trans)	WM350
25 5s. Battery Four (HF, D, 2LF)	WM381*
The H.K. Four (SG, SG, D, Pen)	WM384
The Auto Straight Four (HF, Pen, HF, Pen, DDT, Pen)	WM404*
Five-valve: Blueprints, 1s. 6d. each.	
Super-quality Five (C, HF, D, RC, Trans)	WM320
Class B	WM344
New Class B Five (2 SG, D, LF Class B)	WM340

#### Mains Operated

Two-valve: Blueprints, 1s. each.	
Conoelectric Two (D, Pen) A.C.	AW403*
Economy A.C. Two (D, Trans) A.C.	WM286
Three-valve: Blueprints, 1s. each.	
Home Lover's New All-Electric Three (SG, D, Trans, A.C.)	AW383*
Mantoloni A.C. Three (HF, Pen, D, Pen)	WM374*
415 15s. 1936 A.C. Radiogram (HF, D, Pen)	WM401*
Four-valve: Blueprints, 1s. 6d. each.	
All-Metal Four (2 SG, D, Pen)	WM329
Heinicke's Jubilee Radiogram (HF, Pen, D, LF, P)	WM386*

### SUPERHETS

Battery Sets: Blueprints, 1s. 6d. each.	
Varsity Four	WM595*
The Request All-Waver	WM407

Mains Sets: Blueprints, 1s. each.	
Heptode Super Three A.C.	WM359*

### PORTABLES

Four-valve: Blueprints, 1s. 6d. each.	
Holiday Portable (SG, D, LF, Class B)	AW393*
Family Portable (HF, D, RC, Trans)	AW447*
Tyers Portable (SG, D, 2 Trans.)	WM387*

### SHORT-WAVE SETS. Battery Operated

One-valve: Blueprints, 1s. each.	
S.W. One-valver for America	AW490*
Roma Short-Waver	AW492*

Two-valve: Blueprints, 1s. each.	
Ultra-short Battery Two (SG, det Pen)	WM409*
Home-made Coil Two (D, Pen)	AW440

Three-valve: Blueprints, 1s. each.	
Examiner's 3-metre Set (D, Trans, Super-regen)	AW438
The Carrier Short-waver (SG, D, P)	WM390*

Four-valve: Blueprints, 1s. 6d. each.	
A.W. Short-wave World-beater (HF, Pen, D, RC, Trans)	AW436*
Standard Four-valve Short-waver (SG, D, LF, P)	WM385*

Superhet: Blueprint, 1s. 6d.	
Simplified Short-wave Super	WM397*

### Mains Operated

Two-valve: Blueprints, 1s. each.	
Two-valve Mains Short-waver (D, Pen), A.C.	AW455*

Three-valve: Blueprints, 1s.	
Emigrator (SG, D, Pen) A.C.	WM392*

Four-valve: Blueprints, 1s. 6d.	
Standard four-valve A.C. Short-waver (SG, D, RC, Trans)	WM391*

### MISCELLANEOUS

S.W. 1-valve Converter (Drive 6d.)	AW329
Enthusiast's Power Amplifier (10 Watt) (1/5)	WM387*
Listener's 5-watt A.C. Amplifier (1/5)	WM392*
Radio Unit (2v.) for WM392 (1/5)	WM396*
Harris Electrogram battery amplifier (1/5)	WM399*
De Luxe Concert A.C. Electro-gram (1/5)	WM403*
New Style Short-wave Adapter (1/5)	WM388
Short-wave Adapter (1/5)	AW456*
B.L.D.L.C. Short-wave Converter (1/5)	WM405*
Wilson Tone Master (1/5)	WM406
The W.M. A.C. Short-wave Converter (1/5)	WM408*

## HINTS COUPON

This coupon is available until March 3rd, 1947, and must accompany all Practical Hints.

PRACTICAL WIRELESS, March, 1947.

All applications respecting Advertising in this Publication should be addressed to the ADVERTISEMENT DIRECTOR, GEORGE NEWNES, LTD., Tower House, Southampton Street, Strand, London, W.C.2. Telephone: Temple Bar 4363. CONDITIONS OF SALE AND SUPPLY: This periodical is sold subject to the following conditions, namely, that it shall not, without the written consent of the publishers first given, be lent, re-sold, hired out or otherwise disposed of by way of Trade except at the full retail price of 8d.; and that it shall not be lent, re-sold, hired out or otherwise disposed of in a mutilated condition or in any unauthorised cover by way of Trade, or affixed to or as part of any publication or advertising, literary or pictorial matter, whatsoever.

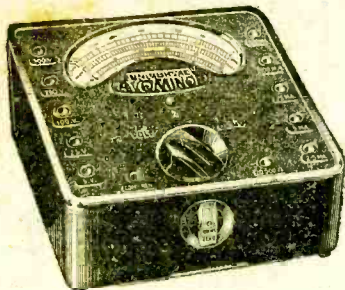

# 'AVO' Precision

## ELECTRICAL TESTING INSTRUMENTS

Registered Trade Mark

### The UNIVERSAL AVOMINOR

Electrical Measuring Instrument

A small but highly accurate instrument for measuring A.C. and D.C. voltage, D.C. current, and also resistance. It provides 22 ranges of readings on a 3-inch scale, the required range being selected by plugging the leads supplied into appropriately marked sockets. An accurate moving-coil movement is employed, and the total resistance of the meter is 200,000 ohms.

The instrument is self-contained for resistance measurements up to 20,000 ohms, and, by using an external source of voltage, the resistance ranges can be extended up to 10 megohms. The ohms compensator for incorrect voltage works on all ranges. The instrument is suitable for use as an output meter when the A.C. voltage ranges are being used. Supplied complete with leads, testing prods, crocodile clips, and instruction booklet.

Size: 4 1/2" x 3 1/2" x 1 1/2"      Nett weight: 18 ozs.

Sole Proprietors and Manufacturers:—

**AUTOMATIC COIL WINDER & ELECTRICAL EQUIPMENT CO., LTD.**  
Winder House, Douglas Street, London, S.W.1      Phone: VICTORIA 3404-9

D.C. Voltage	A.C. Voltage
0-75 millivolts	0-5 volts
0-5 volts	0-25 "
0-25 "	0-100 "
0-100 "	0-250 "
0-250 "	0-500 "
0-500 "	
D.C. Current:	Resistance
0-2.5 milliamps	0-20,000 ohms
0-5 "	0-100,000 "
0-25 "	0-500,000 "
0-100 "	0-2 megohms
0-500 "	0-5 "
	0-10 "

# PREMIER RADIO CO.

MORRIS & CO. (RADIO) LTD.

**MIDGET RADIO KIT.** Build your own Midget Radio. A complete set of parts, including valves, loudspeaker and instructions. In fact, everything, except cabinet, necessary to build 4-valve Medium and Long Wave T.R.F. Radio operating on 200-250 v. Mains, A.C. or D.C. Valve line-up, 6K7, 6J7, 25A6, 25V6. Wavelengths covered 200-557 and 700-2,000. Size, 10 1/2" x 4 1/2". Completely drilled chassis. Price, including tax, £6 17s. 6d.

An attractive bakelite cabinet can be supplied at 25/- extra.

**ALUMINIUM CHASSIS.** Substantially made of bright aluminium, with four sides.

**FERRANTI MOVING COIL METERS.** 2 1/2" diameter, flush mounting, calibrated 0-500 microamps, 21/-.

### LOUDSPEAKERS

Trans.	Make	Diam.	Capa.	Coil	Field	Price
Nil	Rola	5 1/2"	2w.	2-5	P.M.	21/8
Nil	Rola	6 1/2"	3w.	2-3	P.M.	22/6
Nil	Rola	8 1/2"	4w.	2-3	P.M.	24/-
Pentode	Rola	6 1/2"	3w.	2-6	1140 ohms	35/-
Nil	Gramplan	9 1/2"	6w.	15	P.M.	38/-
Pentode	R.A.	10 1/2"	5w.	2-3	P.M.	45/-
Nil	Celestion	10 1/2"	8w.	4-5	2100 ohms	50/-
Nil	Goodmans	12 1/2"	15w.	15	P.M.	28/15-
Nil	Vitavox	12 1/2"	20w.	15	P.M.	21

**MANSBRIDGE TYPE CONDENSERS.** Huge purchase of Military Surplus Paper Condensers. Superior quality, oil filled.

Capacity	Working Voltage	Size	Price	Per Doz.
2 mf.	1,000	4 1/2" x 1 1/2" x 1	2/6	20/-
2 mf.	600	3 1/2" x 1 1/2" x 1	1/3	10/-
1 mf.	600	2 1/2" x 1 1/2" x 1	1/-	8/-

**SUPERHET MIDGET RADIO KIT.** A complete kit of parts for a 2-valve superhet. Covers 15-50 and 200-547 metres. A.C. DC 200-250 v. 6K8, 6K7, 6J7, 25A6, 25V6. Size: 10 1/2" x 4 1/2". Completely drilled Chassis. Price, including tax, £8 5s.

An attractive bakelite cabinet can be supplied at 25/- extra.

**COMPLETE 1-VALVE LISTENING POST.** Consists of 1-valve receiver completely wired with coils covering 12-170 and 250-550 m. Valves, Headphones, Dry Batteries, Aerial Wire. Nothing else to buy. £3 17s. 6d.\*

**2-VALVE, SHORT-WAVE BATTERY KIT.** A complete kit of parts for a 2-valve receiver, covering 15-600 metres, including valves, coils, drilled chassis, H.T. and L.T. dry batteries, 60 last approximately 6 to 12 months. A pair of double headphones and full instructions. Price £3 10s.\* An extra coil can be supplied, covering 500-1,500 metres at 4/-.

**OUTPUT TRANSFORMERS.** A super production. By means of ingenious series-parallel arrangements, all windings are used at all times. Match any tube, single or push-pull to any voice coil 2-20 ohms, 7 watts, 22 6 ; 15 watt, 30 ; 30 watt, 49 6 ; 60 watt, 59 6.

**TYPE 103. Rotary Transformer.** Normal rating is 15 v. D.C. input. Output 300 volts 30 ma and 6.5 volts 3 a. D.C. By applying between 200 and 250 volts D.C. to the H.T. output side, the two low-tension windings may be used to charge accumulators. The 150 v. side will charge a 6-volt accumulator at 2-5 amps, the 6.5 v. side a 2-volt accumulator at 1-2 a. With a 12-volt input to the 15-volt side, 180 v. at 30 ma and 4 v. at 3 a. may be obtained. With a 6-volt input to the 6.5 v. side, 160 v. at 30 ma may be obtained. By extending the spindle with a bush with the frame and supplying 250 to 250 v. D.C. mains to the 200 v. side, the unit becomes a powerful high-speed electric motor, suitable for small drilling machines, etc. Similarly, it may be used with 6 or 12 v. input to the 6.5 v. or 15 v. side. It employs a powerful ring magnet and is of substantial construction costing originally over £7. A fortunate purchase enables us to offer these fundamentals at 10/-.

**1947 MODEL AC DC AMPLIFIERS.** 6 watts output. Super quality three stage push-pull. Suitable for mike or pick-up. In steel cabinet, £8 8s.

**COLLARO RECORD CHANGERS.** Latest model mixer changer. Select and repeat automatically. 8 records. Super magnetic pick-up. A few only. Delivery from stock. £19 7s. 6d.

**COLLARO PORTABLE RECORD PLAYERS.** Consist of a super quality induction type gramophone motor 200-250 v. A/C with autotap and high-grade magnetic pick-up. Mounted in a leatherette carrying case. Price £11 5s. A few only. Delivery from stock.

**PERMANENT MAGNET HORN LOUDSPEAKERS.** Handle 8 watts. Weatherproof. Complete with fixing bracket, horn mouth, 32 x 1 1/2", 3 1/2" deep. Soldered but unused. Usual price £12. On clear at £5 10s.

**GRAMOPHONE PICK-UPS**  
Rothermel Senior Crystal Pick-up, £9 18s. 3d.  
Cosmocond Crystal Pick-up, £1 17s.  
Goldring Magnetic Pick-up, £1 10s. 6d.

Send 2d. stamp for our September, 1946 list. Terms of business: cash with order, or C.O.D. over £1

ALL POST ORDERS TO 167, LOWER CLAPTON RD., LONDON, E.5.

Phone: Amherst 4723

ALL CALLERS TO 169, FLEET STREET, LONDON, E.C.4. Phone: Central 2833

Published on the 7th of each month by GEORGE NEWNES, LIMITED, Tower House, Southampton Street, Strand, London, W.C.2, and printed in England by W. SPEIGHT & SONS, LTD., Exmoor Street, London, W.10. Sole Agents for Australia and New Zealand: GORDON & GOTCH (A/asia), LTD. South Africa: CENTRAL NEWS AGENCY, LTD. Subscription rates, including postage: Inland 10s. 6d. per annum; Abroad 10s. per annum. Registered at the General Post Office for the Australian Magazine Post.